

**Figure 3 to § 571.227: Axis of Rotation
(For Illustration Purposes)**

[86 FR 74302, Dec. 29, 2021]

EFFECTIVE DATE NOTES: 1. At 86 FR 74302, Dec. 29, 2021, § 571.227 was added, effective Dec. 30, 2024.

2. At 88 FR 77532, Nov. 13, 2023, § 571.227 was amended by revising the definition of “Transit bus” in paragraph S4, revising paragraph S5.1(a), and revising the introductory text of S6.1.4, effective Dec. 30, 2024. For the convenience of the user, the revised text is set forth as follows:

§ 571.227 Standard No. 227; Bus rollover structural integrity.

* * * * *

S4. * * *

Transit bus means a bus that is equipped with a stop-request system sold for public transportation provided by, or on behalf of, a Federal, State, or local government and that is not an over-the-road bus.

* * * * *

S5.1 * * *

(a) Items separated from the vehicle and with a mass less than 60.0 grams that enter

the survival space will not be considered for this evaluation of survival space intrusion.

* * * * *

S6.1.4 The tilting platform is equipped with rigid wheel supports on the top surface as illustrated in Figure 3 of this section (figure provided for illustration purposes only). At each vehicle axle, the wheel closest to the platform's axis of rotation is supported. The rigid wheel supports are positioned to make contact with the outboard tire sidewall of the supported wheels with the vehicle positioned as specified in S7(a) to prevent sliding of the vehicle during the test. Each rigid wheel support has the following dimensions:

* * * * *

§ 571.301 Standard No. 301; Fuel system integrity.

S1. *Scope.* This standard specifies requirements for the integrity of motor vehicle fuel systems.

S2. *Purpose.* The purpose of this standard is to reduce deaths and injuries occurring from fires that result

from fuel spillage during and after motor vehicle crashes, and resulting from ingestion of fuels during siphoning.

S3. *Application.* This standard applies to passenger cars, and to multipurpose passenger vehicles, trucks and buses that have a GVWR of 4,536 kg or less and use fuel with a boiling point above 0 °C, and to school buses that have a GVWR greater than 4,536 kg and use fuel with a boiling point above 0 °C.

S4. *Definition.* *Fuel spillage* means the fall, flow, or run of fuel from the vehicle but does not include wetness resulting from capillary action.

S5. *General requirements.*

S5.1 *Passenger cars, and multipurpose passenger vehicles, trucks, and buses with a GVWR of 10,000 pounds or less.* Each passenger car and each multipurpose passenger vehicle, truck, and bus with a GVWR of 10,000 pounds or less shall meet the requirements of S6.1 through S6.4. Each of these types of vehicles that is manufactured to use alcohol fuels shall also meet the requirements of S6.6.

S5.2 [Reserved]

S5.3 [Reserved]

S5.4 *Schoolbuses with a GVWR greater than 10,000 pounds.* Each schoolbus with a GVWR greater than 10,000 pounds shall meet the requirements of S6.5. Each schoolbus with a GVWR greater than 10,000 pounds that is manufactured to use alcohol fuels shall meet the requirements of S6.6.

S5.5 *Fuel spillage; Barrier crash.* Fuel spillage in any fixed or moving barrier crash test shall not exceed 28 g from impact until motion of the vehicle has ceased, and shall not exceed a total of 142 g in the 5-minute period following cessation of motion. For the subsequent 25-minute period, fuel spillage during any 1 minute interval shall not exceed 28 g.

S5.6 *Fuel spillage; rollover.* Fuel spillage in any rollover test, from the onset of rotational motion, shall not exceed a total of 142 g for the first 5 minutes of testing at each successive 90° increment. For the remaining test period, at each increment of 90° fuel spillage during any 1 minute interval shall not exceed 28 g.

S5.7. *Alcohol fuel vehicles.* Each vehicle manufactured to operate on an al-

cohol fuel (e.g., methanol, ethanol) or a fuel blend containing at least 20 percent alcohol fuel shall meet the requirements of S6.6.

S6. *Test requirements.* Each vehicle with a GVWR of 4,536 kg or less shall be capable of meeting the requirements of any applicable barrier crash test followed by a static rollover, without alteration of the vehicle during the test sequence. A particular vehicle need not meet further requirements after having been subjected to a single barrier crash test and a static rollover test. Where manufacturer options are specified in this standard, the manufacturer must select an option not later than the time it certifies the vehicle and may not thereafter select a different option for that vehicle. Each manufacturer must, upon request from the National Highway Traffic Safety Administration, provide information regarding which of the compliance options it has selected for a particular vehicle or make/model.

S6.1 *Frontal barrier crash.* When the vehicle travelling longitudinally forward at any speed up to and including 48 km/h impacts a fixed collision barrier that is perpendicular to the line of travel of the vehicle, or at any angle up to 30° in either direction from the perpendicular to the line of travel of the vehicle, with 50th-percentile test dummies as specified in part 572 of this chapter at each front outboard designated seating position and at any other position whose protection system is required to be tested by a dummy under the provisions of Standard No. 208, under the applicable conditions of S7., fuel spillage shall not exceed the limits of S5.5.

S6.2 *Rear moving barrier crash.* (a) *Vehicles manufactured before September 1, 2006.* When the vehicle is impacted from the rear by the barrier specified in S7.3(a) of this standard moving at 48 km/h, with 50th percentile test dummies as specified in part 572 of this chapter at each front outboard designated seating position, under the applicable conditions of S7, fuel spillage must not exceed the limits of S5.5.

(b) *Vehicles manufactured on or after September 1, 2006.* When the vehicle is impacted from the rear by a moving deformable barrier 80 ±1.0 km/h with a 70

percent overlap, with 50th percentile test dummies as specified in part 572 of this chapter at each front outboard designated seating position, under the applicable conditions of S7, fuel spillage must not exceed the limits of S5.5.

(c) *Small volume manufacturers.* Notwithstanding S6.2(b) of this standard, vehicles manufactured on or after September 1, 2004 and before September 1, 2008 by a manufacturer that produces fewer than 5,000 vehicles annually for sale in the United States may meet the requirements of S6.2(a). Vehicles manufactured on or after September 1, 2008 by small volume manufacturers must meet the requirements of S6.2(b).

S6.3 *Side moving barrier crash.* (a) *Vehicles manufactured before September 1, 2004.* When the vehicle is impacted laterally on either side by a barrier moving at 32 km/h with 50th percentile test dummies as specified in part 572 of this chapter at positions required for testing to Standard No. 208 (49 CFR 571.208), under the applicable conditions of S7, fuel spillage must not exceed the limits of S5.5.

(b) *Vehicles manufactured on or after September 1, 2004.* When the vehicle is impacted laterally on either side by a moving deformable barrier at 53 ± 1.0 km/h with the appropriate 49 CFR part 572 test dummies specified in 571.214 at positions required for testing by S7.1.1, S7.2.1, or S7.2.2 of Standard 214, under the applicable conditions of S7 of this standard, fuel spillage shall not exceed the limits of S5.5 of this standard.

(c)(1) Notwithstanding S6.3(b) of this standard, vehicles having a GVWR greater than 6,000 lb (2,722 kg) may meet S6.3(a) instead of S6.3(b) of this standard until September 1, 2005.

(2) Notwithstanding S6.3(b) of this standard, vehicles having a GVWR greater than 6,000 lb (2,722 kg) manufactured on or after September 1, 2005 must meet the requirements of S6.3(b) of this standard unless they are excluded from S6.3(b) under the phase-in specified in this paragraph. Excluded vehicles must meet the requirements of S6.3(a) of this standard. For vehicles having a GVWR greater than 6,000 lb (2,722 kg) manufactured on or after September 1, 2005 and before September 1, 2006, the number of vehicles com-

plying with S6.3(b) shall be not less than 90 percent of:

(i) The manufacturer's average annual production of vehicles with a GVWR greater than 6,000 lb (2,722 kg) manufactured on or after September 1, 2002 and before September 1, 2005; or

(ii) The manufacturer's production of vehicles with a GVWR greater than 6,000 lb (2,722 kg) on or after September 1, 2004 and before September 1, 2005.

(iii) Vehicles that have a GVWR greater than 6,000 lb (2,722 kg) and that are manufactured on or after September 1, 2006 must meet the requirements of S6.3(b) of this standard.

(3) *Vehicles produced by more than one manufacturer.* For the purpose of calculating average annual production of vehicles for each manufacturer and the number of vehicles manufactured by each manufacturer under S6.3(c)(2)(i) and S6.3(c)(2)(ii) of this standard, a vehicle produced by more than one manufacturer shall be attributed to a single manufacturer as follows, subject to S6.3(c)(4).

(i) A vehicle which is imported shall be attributed to the importer.

(ii) A vehicle manufactured in the United States by more than one manufacturer, one of which also markets the vehicle, shall be attributed to the manufacturer that markets the vehicle.

(4) A vehicle produced by more than one manufacturer shall be attributed to any one of the vehicle's manufacturers specified by an express written contract, reported to the National Highway Traffic Safety Administration under 49 CFR 568.6, between the manufacturer so specified and the manufacturer to which the vehicle would otherwise be attributed under S6.3(c)(3).

(d) Notwithstanding S6.3(b) of this standard, vehicles with a GVWR of 6,000 lb (2,722 kg) or less that are manufactured in two or more stages or altered (within the meaning of 49 CFR 567.7) after having been previously certified in accordance with part 567 of this chapter may meet S6.3(a) of this standard until September 1, 2005. Vehicles with a GVWR of 6,000 lb (2,722 kg) or less that are manufactured in two or more stages or altered (within the meaning of 49 CFR 567.7) after having been previously certified in accordance with part 567 of this chapter and that

§571.301

are manufactured on or after September 1, 2005 must meet the requirements of S6.3(b)

(e) Notwithstanding S6.3(b) and (c) of this standard, vehicles with a GVWR greater than 6,000 lb (2,722 kg) that are manufactured in two or more stages or altered (within the meaning of 49 CFR 567.7) after having been previously certified in accordance with part 567 of this chapter may meet S6.3(a) of this standard until September 1, 2006. Vehicles with a GVWR greater than 6,000 lb (2,722 kg) that are manufactured in two or more stages or altered (within the meaning of 49 CFR 567.7) after having been previously certified in accordance with part 567 of this chapter and that are manufactured on or after September 1, 2006 must meet the requirements of S6.3(b).

S6.4 *Static rollover.* When the vehicle is rotated on its longitudinal axis to each successive increment of 90°, following an impact crash of S6.1, S6.2, or S6.3, fuel spillage shall not exceed the limits of S5.6.

S6.5 *Moving contoured barrier crash.* When the moving contoured barrier assembly traveling longitudinally forward at any speed up to and including 48 km/h impacts the test vehicle (school bus with a GVWR exceeding 4,536 kg) at any point and angle, under the applicable conditions of S7.1 and S7.5, fuel spillage shall not exceed the limits of S5.5.

S6.6 *Anti-siphoning test for alcohol fuel vehicles.* Each vehicle shall have means that prevent any hose made of vinyl plastic or rubber, with a length of not less than 1200 millimeters (mm) and an outside diameter of not less than 5.2 mm, from contacting the level surface of the liquid fuel in the vehicle's fuel tank or fuel system, when the hose is inserted into the filler neck attached to the fuel tank with the fuel tank filled to any level from 90 to 95 percent of capacity.

S7. *Test conditions.* The requirements of S5.1 through S5.6 and S6.1 through S6.5 shall be met under the following conditions. Where a range is specified, the vehicle must be capable of meeting the requirements at all points within the range.

S7.1 *General test conditions.* The following conditions apply to all tests.

49 CFR Ch. V (10–1–24 Edition)

S7.1.1 The fuel tank is filled to any level from 90 to 95 percent of capacity with Stoddard solvent, having the physical and chemical properties of type 1 solvent, Table I of ASTM D484–71 (incorporated by reference, see §571.5).

S7.1.2 The fuel system other than the fuel tank is filled with Stoddard solvent to its normal operating level.

S7.1.3 In meeting the requirements of S6.1 through S6.3, if the vehicle has an electrically driven fuel pump that normally runs when the vehicle's electrical system is activated, it is operating at the time of the barrier crash.

S7.1.4 The parking brake is disengaged and the transmission is in neutral, except that in meeting the requirements of S6.5 the parking brake is set.

S7.1.5 Tires are inflated to manufacturer's specifications.

S7.1.6 The vehicle, including test devices and instrumentation, is loaded as follows:

(a) Except as specified in S7.1.1, a passenger car is loaded to its unloaded vehicle weight plus its rated cargo and luggage capacity weight, secured in the luggage area, plus the necessary test dummies as specified in S6., restrained only by means that are installed in the vehicle for protection at its seating position.

(b) Except as specified in S7.1.1, a multipurpose passenger vehicle, truck, or bus with a GVWR of 4,536 kg or less is loaded to its unloaded vehicle weight, plus the necessary test dummies as specified in S6, plus 136 kg or its rated cargo and luggage capacity weight, whichever is less, secured in the load carrying area and distributed as nearly as possible in proportion to its GAWR. For the purpose of this standard, unloaded vehicle weight does not include the weight of work-performing accessories. Each dummy is restrained only by means that are installed in the vehicle for protection at its seating position.

(c) Except as specified in S7.1.1, a school bus with a GVWR greater than 4,536 kg is loaded to its unloaded vehicle weight, plus 54 kg of unsecured mass at each designated seating position.

S7.2 Side moving barrier test conditions. (a) *Vehicles manufactured before September 1, 2004.* The side moving barrier crash test conditions are those specified in S8.2 of Standard No. 208 (49 CFR 571.208).

(b) *Vehicles manufactured on or after September 1, 2004.* The side moving deformable barrier crash test conditions are those specified in S8 of Standard 214 (49 CFR 571.214).

S7.3 Rear moving barrier test conditions. (a) *Vehicles manufactured before September 1, 2006.* The rear moving barrier test conditions are those specified in S8.2 of Standard No. 208 (49 CFR 571.208), except for the positioning of the barrier and the vehicle. The barrier and test vehicle are positioned so that at impact—

(1) The vehicle is at rest in its normal attitude;

(2) The barrier is traveling at 48 km/h with its face perpendicular to the longitudinal centerline of the vehicle; and

(3) A vertical plane through the geometric center of the barrier impact surface and perpendicular to that surface coincides with the longitudinal centerline of the vehicle.

(b) *Vehicles manufactured on or after September 1, 2006.* The rear moving deformable barrier is the same as that shown in Figure 2 of Standard No. 214 (49 CFR 571.214) and specified in 49 CFR part 587, except as otherwise specified in paragraph S7.3 (b). The barrier and test vehicle are positioned so that at impact—

(1) The vehicle is stationary;

(2) The deformable face of the barrier is mounted on the barrier 50 mm (2 inches) lower than the height from the ground specified in Figure 2 of Standard No. 214 (49 CFR 571.214) (All dimensions from the ground in Figure 2, Front View should be reduced by 50 mm (2 inches.));

(3) The barrier is traveling 80 ±1.0 km/h; and

(4) The barrier impacts the test vehicle with the longitudinal centerline of the vehicle parallel to the line of travel and perpendicular to the barrier face within a tolerance of ±5 degrees. The test vehicle and barrier face are aligned so that the barrier strikes the rear of the vehicle with 70 percent

overlap toward either side of the vehicle. So aligned, the barrier face fully engages one half of the rear of the vehicle and partially engages the other half. At impact, the vehicle's longitudinal centerline is located inboard either of the side edges of the barrier by a distance equal to 20 percent of the vehicle's width ±50 mm (see Figure 3). The vehicle's width is the maximum dimension measured across the widest part of the vehicle, including bumpers and molding, but excluding such components as exterior mirrors, flexible mud flaps, marker lamps, and dual rear wheel configurations.

S7.4 Static rollover test conditions. The vehicle is rotated about its longitudinal axis, with the axis kept horizontal, to each successive increment of 90°, 180°, and 270° at a uniform rate, with 90° of rotation taking place in any time interval from 1 to 3 minutes. After reaching each 90° increment the vehicle is held in that position for 5 minutes.

S7.5 Moving contoured barrier test conditions. The following conditions apply to the moving contoured barrier crash test.

S7.5.1 The moving barrier, which is mounted on a carriage as specified in Figure 1, is of rigid construction, symmetrical about a vertical longitudinal plane. The contoured impact surface, which is 629 mm high and 1,981 mm wide, conforms to the dimensions shown in Figure 2, and is attached to the carriage as shown in that figure. The ground clearance to the lower edge of the impact surface is 133 mm ±13 mm. The wheelbase is 3,048 mm ±50 mm.

S7.5.2 The moving contoured barrier, including the impact surface, supporting structure, and carriage, has a mass of 1,814 kg ±23 kg with the mass distributed so that 408 kg ±11 kg is at each rear wheel and 499 kg ±11 kg is at each front wheel. The center of gravity is located 1,372 mm ±38 mm rearward of the front wheel axis, in the vertical longitudinal plane of symmetry, 401 mm ±13 mm above the ground.

S7.5.3 The moving contoured barrier has a solid nonsteerable front axle and fixed rear axle attached directly to the frame rails with no spring or other type of suspension system on any

wheel. (The moving barrier assembly is equipped with a braking device capable of stopping its motion.)

S7.5.4 The concrete surface upon which the vehicle is tested is level, rigid, and of uniform construction, with a skid number of 75 when measured in accordance with ASTM E274–65T (incorporated by reference, see § 571.5) at 64 km/h, omitting water delivery as specified in paragraph 7.1 of that method.

S7.5.5 The barrier assembly is released from the guidance mechanism immediately prior to impact with the vehicle.

S7.6 The moving barrier assemblies specified in S7.2, S7.3 and S7.5 are equipped with P205/75R15 pneumatic tires inflated to 200 kPa ±21 kPa.

S8 *Phase-In schedule.*

S8.1 *Rear impact test upgrade.* (a) *Vehicles manufactured on or after September 1, 2006 and before September 1, 2007.* For vehicles manufactured on or after September 1, 2006, and before September 1, 2007, the number of vehicles complying with S6.2(b) of this standard must not be less than 40 percent of:

(1) The manufacturer's average annual production of vehicles manufactured on or after September 1, 2004, and before September 1, 2007; or

(2) The manufacturer's production on or after September 1, 2006, and before September 1, 2007.

(b) *Vehicles manufactured on or after September 1, 2007 and before September 1, 2008.* For vehicles manufactured on or after September 1, 2007 and before September 1, 2008, the number of vehicles complying with S6.2(b) of this standard must not be less than 70 percent of:

(1) The manufacturer's average annual production of vehicles manufactured on or after September 1, 2005, and before September 1, 2008; or

(2) The manufacturer's production on or after September 1, 2007, and before September 1, 2008.

(c) *Vehicles manufactured on or after September 1, 2008.* For vehicles manufactured on or after September 1, 2008, the number of vehicles complying with S6.2(b) of this standard must be 100 percent of the manufacturer's production during that period.

S8.2 *Vehicles manufactured in two or more stages.* A final stage manufacturer or alterer may, at its option, comply with the requirements set forth in S8.2.1 and S8.2.2.

S8.2.1 Vehicles manufactured on or after September 1, 2006 and before September 1, 2009 are not required to comply with the requirements specified in S6.2(b) of this standard.

S8.2.2 Vehicles manufactured on or after September 1, 2009 must comply with the requirements specified in S6.2(b) of this standard.

S8.3 *Vehicles produced by more than one manufacturer.*

S8.3.1 For the purpose of calculating average annual production of vehicles for each manufacturer and the number of vehicles manufactured by each manufacturer under S8.1, a vehicle produced by more than one manufacturer must be attributed to a single manufacturer as follows, subject to S8.3.2:

(a) A vehicle that is imported must be attributed to the importer.

(b) A vehicle manufactured in the United States by more than one manufacturer, one of which also markets the vehicle, must be attributed to the manufacturer that markets the vehicle.

S8.3.2 A vehicle produced by more than one manufacturer must be attributed to any one of the vehicle's manufacturers specified by an express written contract, reported to the National Highway Traffic Safety Administration under 49 CFR part 586, between the manufacturer so specified and the manufacturer to which the vehicle would otherwise be attributed under S8.3.1.

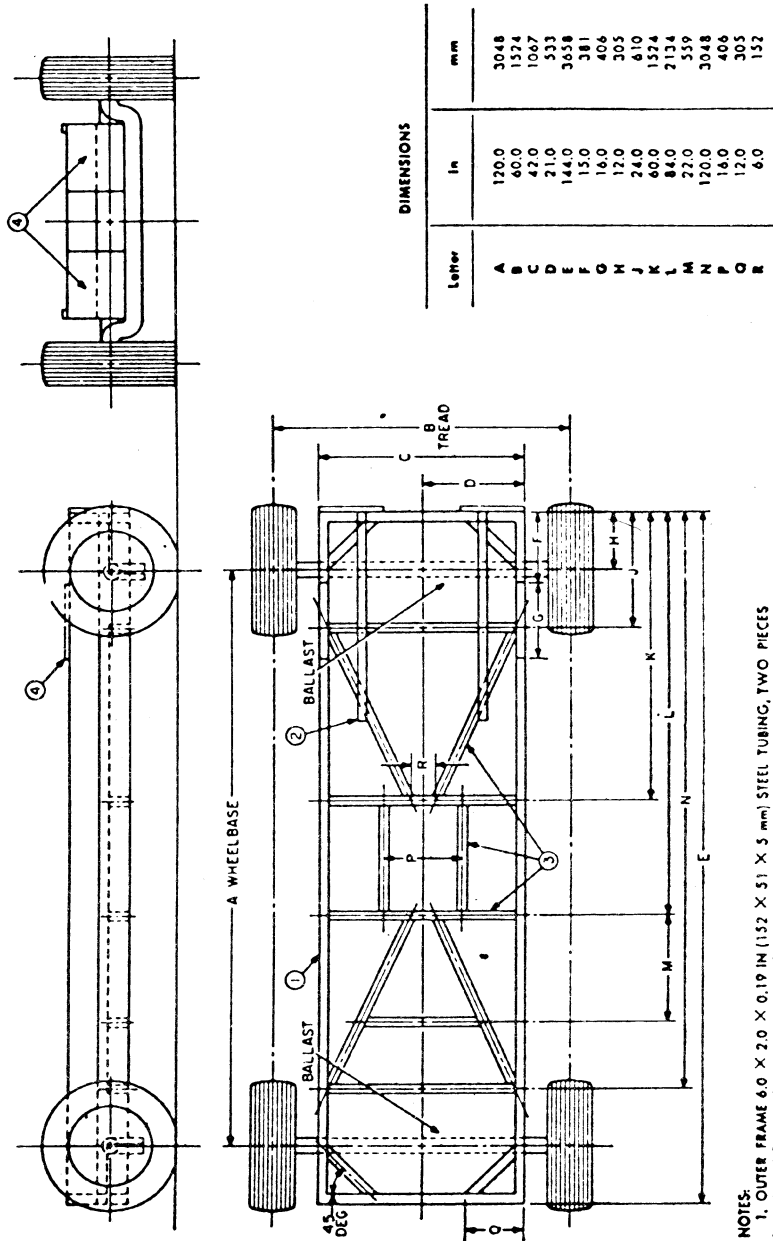

- NOTES:
1. OUTER FRAME 6.0 X 2.0 X 0.19 IN (152 X 51 X 5 mm) STEEL TUBING, TWO PIECES WELDED TOGETHER FOR A 12.0 IN (305 mm) HEIGHT.
 2. BALLAST TIE DOWNS.
 3. ALL INNER REINFORCEMENTS AND FRAME GUSSETS OF 4.0 X 2.0 X 0.19 IN (102 X 51 X 5 mm) STEEL TUBING.
 4. REINFORCED AREAS FOR BOLTING ON FACE PLATES.

FIG. 1—COMMON CARRIAGE FOR MOVING BARRIERS

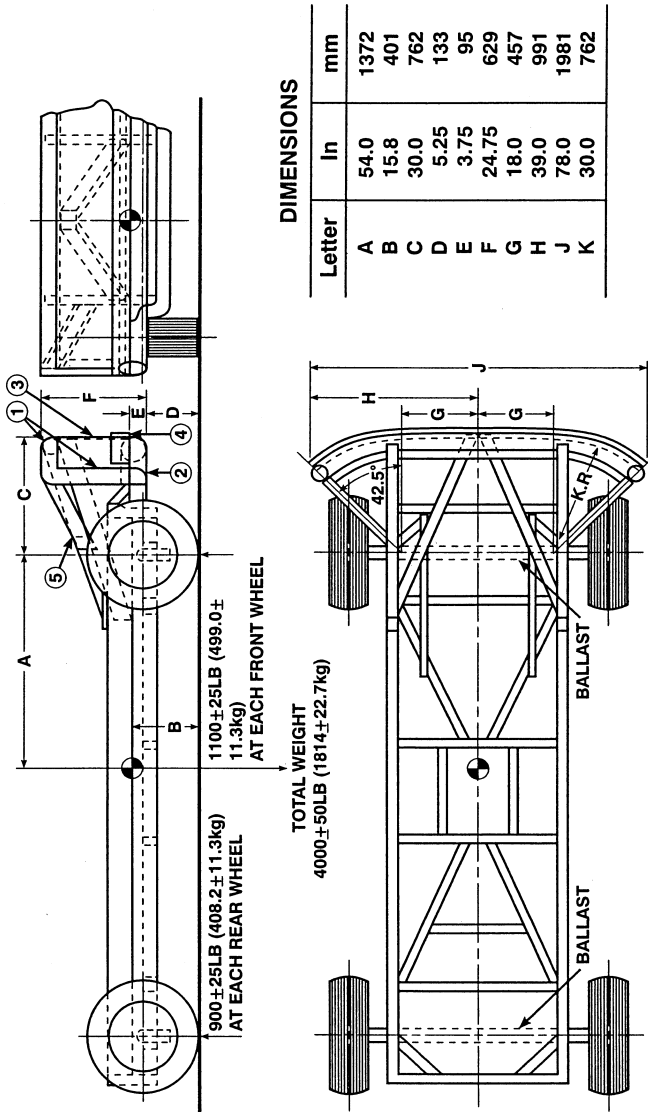

NOTES:

1. UPPER FRAME 4.0 IN DIA X 0.25 IN WALL (102 mm DIA X 6 mm WALL) STEEL TUBING (THREE SIDES).
2. LOWER FRAME 6.0 IN DIA X 0.50 IN WALL (152 mm DIA X 13 mm WALL) STEEL TUBING.
3. FACE PLATE 0.75 IN (19 mm) THICK COLD ROLLED STEEL.
4. LEADING EDGE 1.0 X 4.0 IN (25 X 102 mm) STEEL BAND, SHARP EDGES BROKEN.
5. ALL INNER REINFORCEMENTS 4.0 X 2.0 X 0.19 IN (102 X 51 X 5 mm) STEEL TUBING.

Fig. 2 – Common Carriage with Contoured Impact Surface Attached

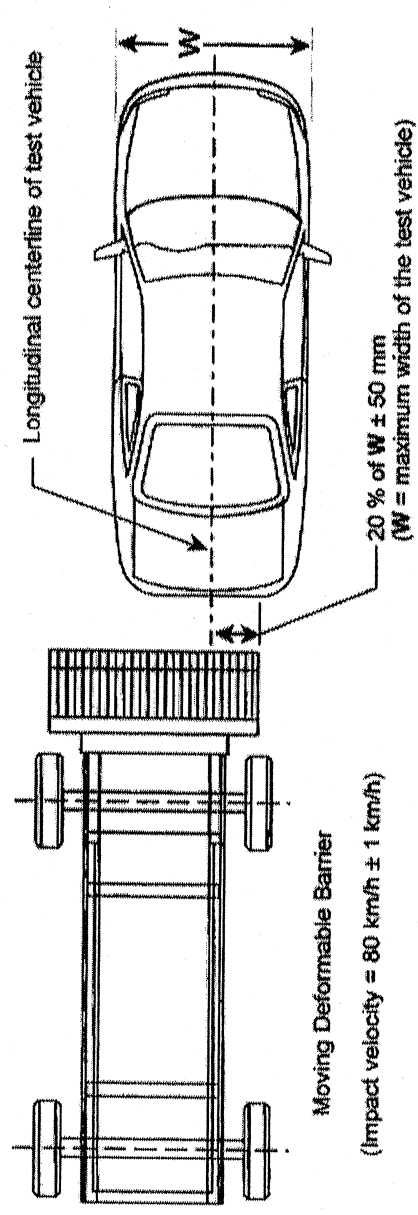

FIGURE 3 – MOVING DEFORMABLE BARRIER REAR IMPACT - 70 % OVERLAP

[40 FR 48353, Oct. 15, 1975]

EDITORIAL NOTE: For FEDERAL REGISTER citations affecting §571.301, see the List of CFR Sections Affected, which appears in the Finding Aids section of the printed volume and at www.govinfo.gov.