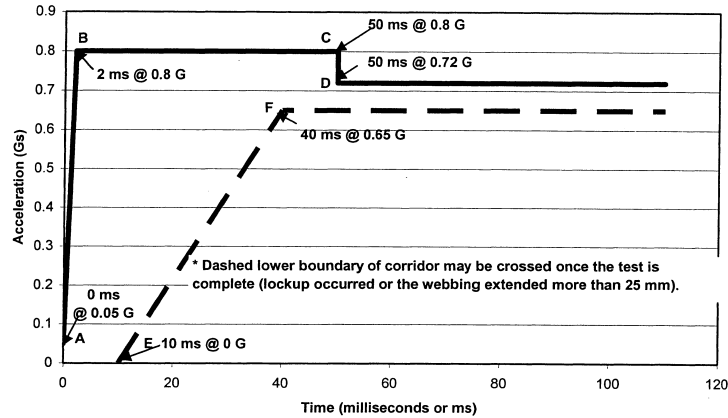

Figure 8: Acceleration Corridors



Reference Point	Time (ms)	Acceleration (g)
A	0	0.05
B	2	0.8
C	50	0.8
D	50	0.72
E	10	0
F	40	0.65

[44 FR 72139, Dec. 13, 1979]

EDITORIAL NOTE: For FEDERAL REGISTER citations affecting §571.209, see the List of CFR Sections Affected, which appears in the Finding Aids section of the printed volume and at [www.govinfo.gov](http://www.govinfo.gov).

**§571.210 Standard No. 210; Seat belt assembly anchorages.**

S1. *Purpose and scope.* This standard establishes requirements for seat belt assembly anchorages to insure their proper location for effective occupant restraint and to reduce the likelihood of their failure.

S2. *Application.* This standard applies to passenger cars, multipurpose passenger vehicles, trucks, buses, and school buses.

S3. *Definitions.*

*School bus torso belt adjusted height* means the vertical height above the seating reference point (SgRP) of the horizontal plane containing a segment of the torso belt centerline located 25 mm to 75 mm forward of the torso belt height adjuster device, when the torso

belt retractor is locked and the torso belt is pulled away from the seat back by applying a 20 N horizontal force in the forward direction through the webbing at a location 100 mm or more forward of the adjustment device as shown in Figure 5.

*School bus torso belt anchor point* means the midpoint of the torso belt width where the torso belt first contacts the uppermost torso belt anchorage. *Seat belt anchorage* means any component, other than the webbing or straps, involved in transferring seat belt loads to the vehicle structure, including, but not limited to, the attachment hardware, seat frames, seat pedestals, the vehicle structure itself, and any part of the vehicle whose failure causes separation of the belt from the vehicle structure.

## § 571.210

## 49 CFR Ch. V (10–1–23 Edition)

*Small occupant seating position* is as defined in 49 CFR 571.222.

### S4. Requirements.

#### S4.1 Type.

S4.1.1 Seat belt anchorages for a Type 1 or a Type 2 seat belt assembly shall be installed for each designated seating position for which a Type 1 or a Type 2 seat belt assembly is required by Standard No. 208 (49 CFR 571.208). Seat belt anchorages for a Type 2 seat belt assembly shall be installed for each designated seating position for which a Type 2 seat belt assembly is required by Standard No. 208 (49 CFR 571.208).

S4.1.2 (a) Notwithstanding the requirement of S4.1.1, each vehicle manufactured on or after September 1, 1987 that is equipped with an automatic restraint at the front right outboard designated seating position, which automatic restraint cannot be used for securing a child restraint system or cannot be adjusted by the vehicle owner to secure a child restraint system solely through the use of attachment hardware installed as an item of original equipment by the vehicle manufacturer, shall have, at the manufacturer's option, either anchorages for a Type 1 seat belt assembly installed at that position or a Type 1 or Type 2 seat belt assembly installed at that position. If a manufacturer elects to install anchorages for a Type 1 seat belt assembly to comply with this requirement, those anchorages shall consist of, at a minimum, holes threaded to accept bolts that comply with S4.1(f) of Standard No. 209 (49 CFR 571.209).

(b) The requirement in S4.1.1 of this standard that seat belt anchorages for a Type 1 or a Type 2 seat belt assembly shall be installed for certain designated seating positions does not apply to any such seating positions that are equipped with a seat belt assembly that meets the frontal crash protection requirements of S5.1 of Standard No. 208 (49 CFR 571.208).

#### S4.1.3 School bus passenger seats.

S4.1.3.1 For school buses manufactured on or after October 21, 2011, seat belt anchorages for school bus passenger seats must be attached to the school bus seat structure, including seats with wheelchair positions or side emergency doors behind them. Seats

with no other seats behind them, no wheelchair positions behind them and no side emergency door behind them are excluded from the requirement that the seat belt anchorages must be attached to the school bus seat structure. For school buses with a GVWR less than or equal to 4,536 kg (10,000 pounds), the seat belt shall be Type 2 as defined in S3. of FMVSS No. 209 (49 CFR 571.209). For school buses with a GVWR greater than 4,536 kg (10,000 pounds), the seat belt shall be Type 1 or Type 2 as defined in S3. of FMVSS No. 209 (49 CFR 571.209).

S4.1.3.2 Type 2 seat belt anchorages on school buses manufactured on or after October 21, 2011 must meet the following location requirements.

(a) For a small occupant seating position of a flexible occupancy seat, as defined in 49 CFR 571.222, the school bus torso belt anchor point must be 400 mm or more vertically above the seating reference point (SgRP) or adjustable to 400 mm or more vertically above the SgRP. For all other seating positions, the school bus torso belt anchor point must be 520 mm or more vertically above the SgRP or adjustable to 520 mm or more vertically above the SgRP. The school bus torso belt adjusted height at each seating position shall be adjustable to no more than 280 mm vertically above the SgRP in the lowest position and no less than the required vertical height of the school bus torso belt anchor point for that seating position in the highest position. (See Figure 4.)

(b) The minimum lateral distance between the vertical centerline of the bolt holes or the centroid of any other means of attachment to the structure specified in 4.1.3.1, simultaneously achievable by all seating positions, must be:

(i) 280 mm for seating positions in a flexible occupancy seat in a maximum occupancy configuration, as defined in 49 CFR 571.222; and

(ii) 330 mm for all other seating positions.

S4.1.3.3 School buses with a GVWR less than or equal to 4,536 kg (10,000 pounds) must meet the requirements of S4.2.2 of this standard.

S4.1.3.4 School buses with a GVWR greater than 4,536 kg (10,000 pounds)

manufactured on or after October 21, 2011, with Type 1 seat belt anchorages, must meet the strength requirements specified in S4.2.1 of this standard.

S4.1.3.5 School buses with a GVWR greater than 4,536 kg (10,000 pounds) manufactured on or after October 21, 2011, with Type 2 seat belt anchorages, must meet the strength requirements specified in S4.2.2 of this standard.

*S4.2 Strength.*

S4.2.1 Except as provided in S4.2.5, the anchorages, attachment hardware, and attachment bolts for any of the following seat belt assemblies shall withstand a 5,000 pound force when tested in accordance with S5.1 of this standard:

(a) Type 1 seat belt assembly; and

(b) Lap belt portion of either a Type 2 or automatic seat belt assembly, if such seat belt assembly is equipped with a detachable upper torso belt.

S4.2.2 Except as provided in S4.2.5, the anchorages, attachment hardware, and attachment bolts for any of the following seat belt assemblies shall withstand a 3,000 pound force applied to the lap belt portion of the seat belt assembly simultaneously with a 3,000 pound force applied to the shoulder belt portion of the seat belt assembly, when tested in accordance with S5.2 of this standard:

(a) Type 2 and automatic seat belt assemblies that are installed to comply with Standard No. 208 (49 CFR 571.208); and

(b) Type 2 and automatic seat belt assemblies that are installed at a seating position required to have a Type 1 or Type 2 seat belt assembly by Standard No. 208 (49 CFR 571.208).

S4.2.3 Permanent deformation or rupture of a seat belt anchorage or its surrounding area is not considered to be a failure, if the required force is sustained for the specified time.

S4.2.4 Anchorages, attachment hardware, and attachment bolts shall be tested by simultaneously loading them in accordance with the applicable procedures set forth in S5 of this standard if the anchorages are either:

(a) For designated seating positions that are common to the same occupant seat and that face in the same direction, or

(b) For laterally adjacent designated seating positions that are not common to the same occupant seat, but that face in the same direction, if the vertical centerline of the bolt hole for at least one of the anchorages for one of those designated seating positions is within 305 mm of the vertical centerline of the bolt hole for an anchorage for one of the adjacent seating positions.

S4.2.5 The attachment hardware of a seat belt assembly, which is subject to the requirements of S5.1 of Standard No. 208 (49 CFR 571.208) by virtue of any provision of Standard No. 208 other than S4.1.2.1(c)(2) of that standard, does not have to meet the requirements of S4.2.1 and S4.2.2 of this standard.

S4.3 *Location.* As used in this section, "forward" means the direction in which the seat faces, and other directional references are to be interpreted accordingly. Anchorages for seat belt assemblies that meet the frontal crash protection requirements of S5.1 of Standard No. 208 (49 CFR 571.208) are exempt from the location requirements of this section.

S4.3.1 *Seat belt anchorages for Type 1 seat belt assemblies and the pelvic portion of Type 2 seat belt assemblies.*

S4.3.1.1 In an installation in which the seat belt does not bear upon the seat frame:

(a) If the seat is a nonadjustable seat, then a line from the seating reference point to the nearest contact point of the belt with the anchorage shall extend forward from the anchorage at an angle with the horizontal of not less than 30 degrees and not more than 75 degrees.

(b) If the seat is an adjustable seat, then a line from a point 64 mm forward of and 10 mm above the seating reference point to the nearest contact point of the belt with the anchorage shall extend forward from the anchorage at an angle with the horizontal of not less than 30 degrees and not more than 75 degrees.

S4.3.1.2 In an installation in which the belt bears upon the seat frame, the seat belt anchorage, if not on the seat structure, shall be aft of the rearmost belt contact point on the seat frame with the seat in the rearmost position.

## §571.210

The line from the seating reference point to the nearest belt contact point on the seat frame, with the seat positioned at the seating reference point, shall extend forward from that contact point at an angle with the horizontal of not less than 30 degrees and not more than 75 degrees.

S4.3.1.3 In an installation in which the seat belt attaches to the seat structure, the line from the seating reference point to the nearest contact point of the belt with the hardware attaching it to the seat structure shall extend forward from that contact point at an angle with the horizontal of not less than 30 degrees and not more than 75 degrees.

S4.3.1.4 Anchorages for an individual seat belt assembly shall be located at least 165 mm apart laterally, measured between the vertical center line of the bolt holes or, for designs using other means of attachment to the vehicle structure, between the centroid of such means.

S4.3.2 *Seat belt anchorages for the upper torso portion of Type 2 seat belt assemblies.* Adjust the seat to its full rearward and downward position and adjust the seat back to its most upright position. Except a small occupant seating position as defined in 49 CFR 571.222, with the seat and seat back so positioned, as specified by subsection (a) or (b) of this section, the upper end of the upper torso restraint shall be located within the acceptable range shown in Figure 1, with reference to a two-dimensional drafting template described in SAE Standard J826 MAY87 (incorporated by reference, see §571.5). The template's "H" point shall be at the design "H" point of the seat for its full rearward and full downward position, as defined in SAE Recommended Practice J1100 JUN84 (incorporated by reference, see §571.5), and the template's torso line shall be at the same angle from the vertical as the seat back.

(a) For fixed anchorages, compliance with this section shall be determined at the vertical centerline of the bolt holes or, for designs using another means of attachment to the vehicle structure, at the centroid of such means.

(b) Except for seating positions on school bus bench seats, compliance

## 49 CFR Ch. V (10–1–23 Edition)

with this section shall be determined with adjustable anchorages at the mid-point of the adjustment range of all adjustable positions. For seating positions on school bus bench seats, place adjustable anchorages and torso belt height adjusters in their uppermost position.

S5. *Test procedures.* Each vehicle shall meet the requirements of S4.2 of this standard when tested according to the following procedures. Where a range of values is specified, the vehicle shall be able to meet the requirements at all points within the range. For the testing specified in these procedures, the anchorage shall be connected to material whose breaking strength is equal to or greater than the breaking strength of the webbing for the seat belt assembly installed as original equipment at that seating position. The geometry of the attachment duplicates the geometry, at the initiation of the test, of the attachment of the originally installed seat belt assembly.

S5.1 *Seats with Type 1 or Type 2 seat belt anchorages.* With the seat in its rearmost position, apply a force of 22,241 N in the direction in which the seat faces to a pelvic body block as described in Figure 2A, in a plane parallel to the longitudinal centerline of the vehicle for forward and rear facing seats, and in a plane perpendicular to the longitudinal centerline of the vehicle for side facing seats, with an initial force application angle of not less than 5 degrees or more than 15 degrees above the horizontal. Apply the force at the onset rate of not more than 222,411 N per second. Attain the 22,241 N force in not more than 30 seconds and maintain it for 10 seconds. At the manufacturer's option, the pelvic body block described in Figure 2B may be substituted for the pelvic body block described in Figure 2A to apply the specified force to the center set(s) of anchorages for any group of three or more sets of anchorages that are simultaneously loaded in accordance with S4.2.4 of this standard.

S5.2 *Seats with Type 2 or automatic seat belt anchorages.* With the seat in its rearmost position, apply forces of 13,345 N in the direction in which the seat faces simultaneously to a pelvic body block, as described in Figure 2A,

and an upper torso body block, as described in Figure 3, in a plane parallel to the longitudinal centerline of the vehicle for forward and rear facing seats, and in a plane perpendicular to the longitudinal centerline of the vehicle for side facing seats, with an initial force application angle of not less than 5 degrees nor more than 15 degrees above the horizontal. Apply the forces at the onset rate of not more than 133,447 N per second. Attain the 13,345 N

force in not more than 30 seconds and maintain it for 10 seconds. At the manufacturer's option, the pelvic body block described in Figure 2B may be substituted for the pelvic body block described in Figure 2A to apply the specified force to the center set(s) of anchorages for any group of three or more sets of anchorages that are simultaneously loaded in accordance with S4.2.4 of this standard.

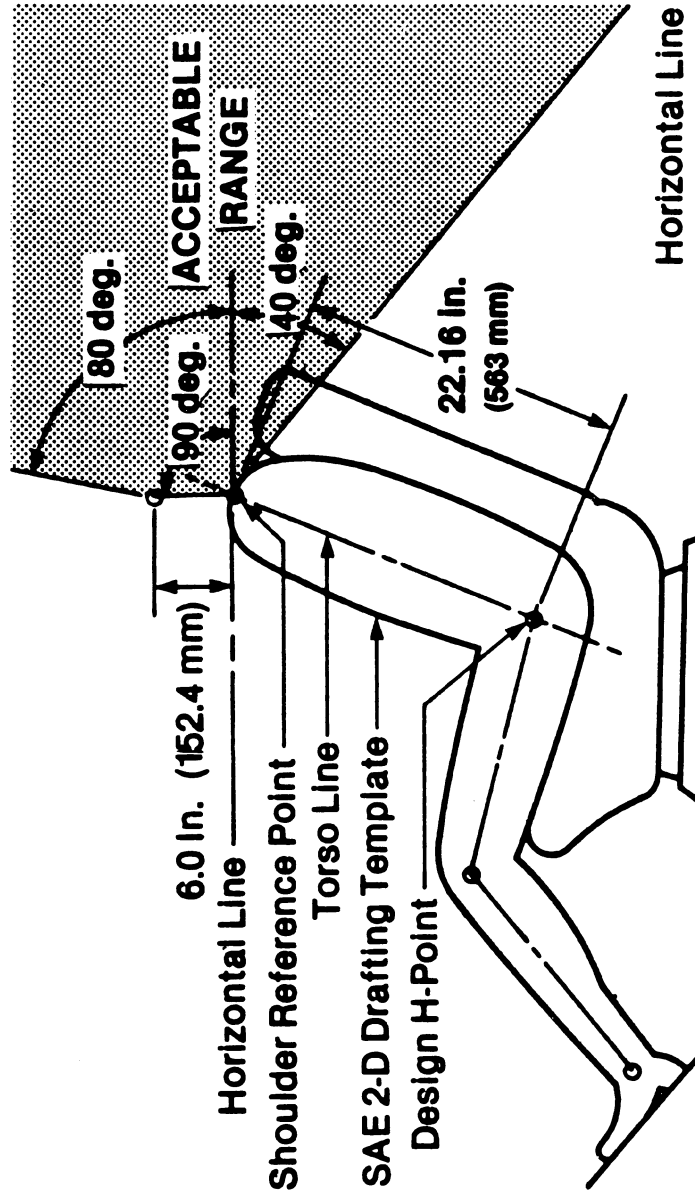
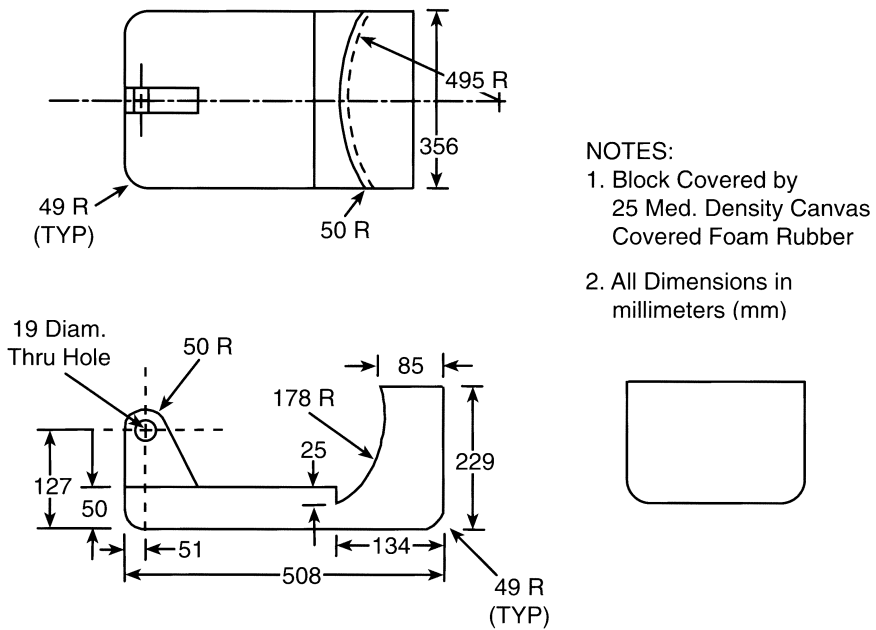
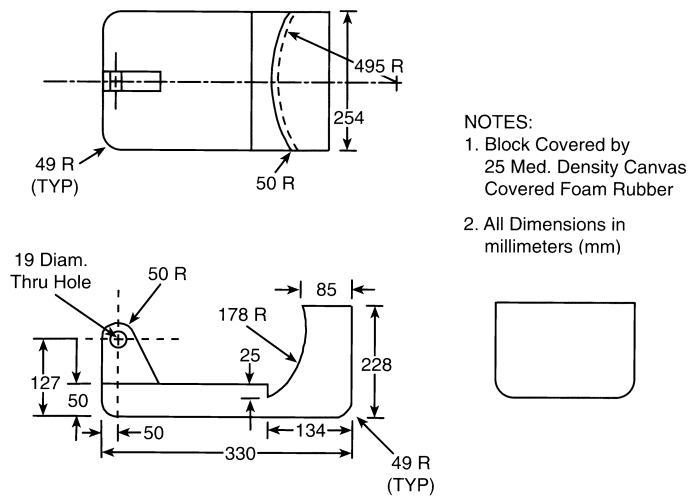

FIGURE 1 - LOCATION OF ANCHORAGE FOR UPPER TORSO RESTRAINT



**Figure 2A.—BODY BLOCK FOR LAP BELT ANCHORAGE**



**Figure 2B.—OPTIONAL BODY BLOCK FOR CENTER SEATING POSITIONS**

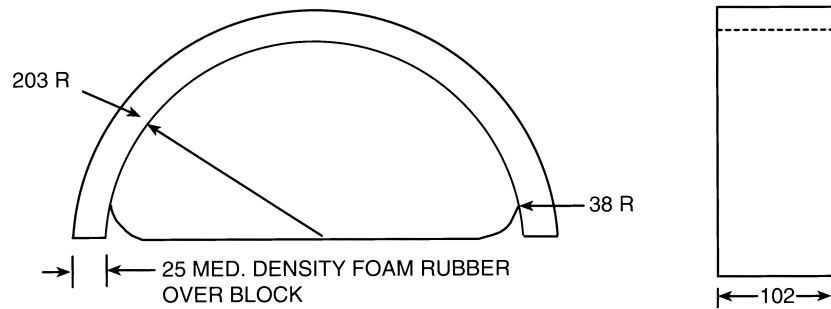

**Figure 3.—BODY BLOCK FOR COMBINATION SHOULDER AND LAP BELT ANCHORAGE**  
**All dimensions in millimeters (mm)**

S6. *Owner's Manual Information.* The owner's manual in each vehicle with a gross vehicle weight rating of 4,536 kg or less manufactured after September 1, 1987 shall include:

(a) A section explaining that all child restraint systems are designed to be secured in vehicle seats by lap belts or the lap belt portion of a lap-shoulder belt. The section shall also explain

that children could be endangered in a crash if their child restraints are not properly secured in the vehicle.

(b) In a vehicle with rear designated seating positions, a statement alerting vehicle owners that, according to accident statistics, children are safer when properly restrained in the rear seating positions than in the front seating positions.



School bus torso belt anchor point (vertical distance from the SgRP must be fixed or adjustable to at least 400 mm for a small occupant seating position and 520 mm for all other seating positions).

School bus torso belt adjusted height range (must adjust to within 280 mm of SgRP).

Seating Reference Point (SgRP)

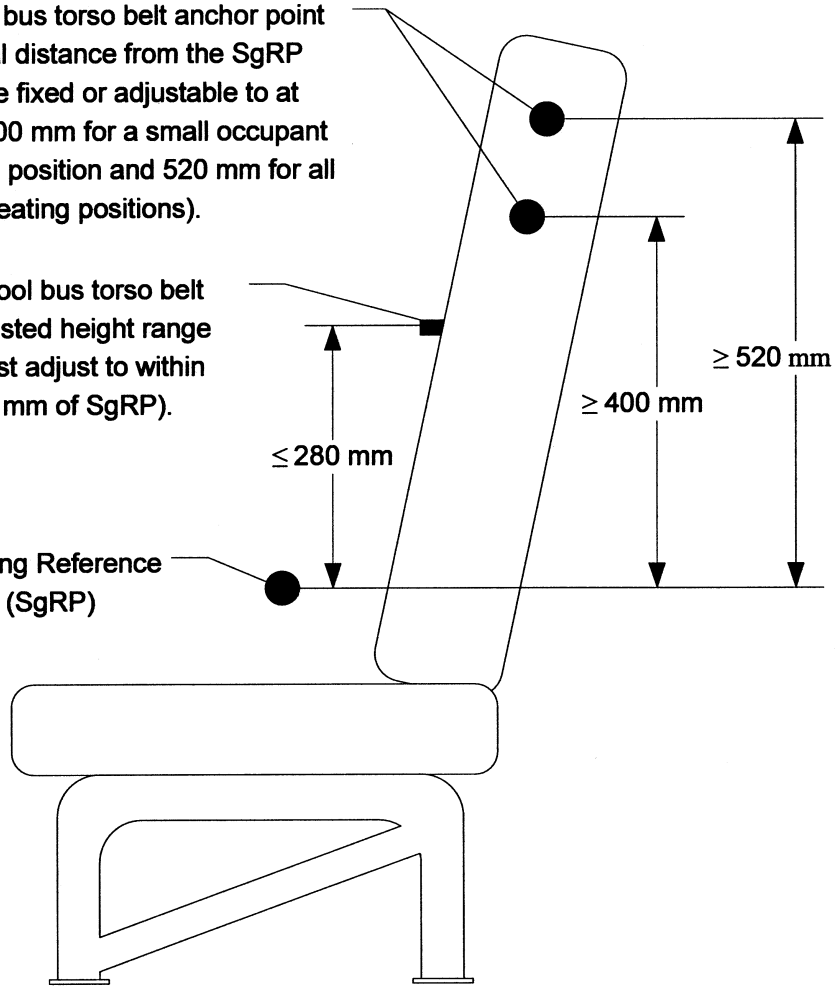
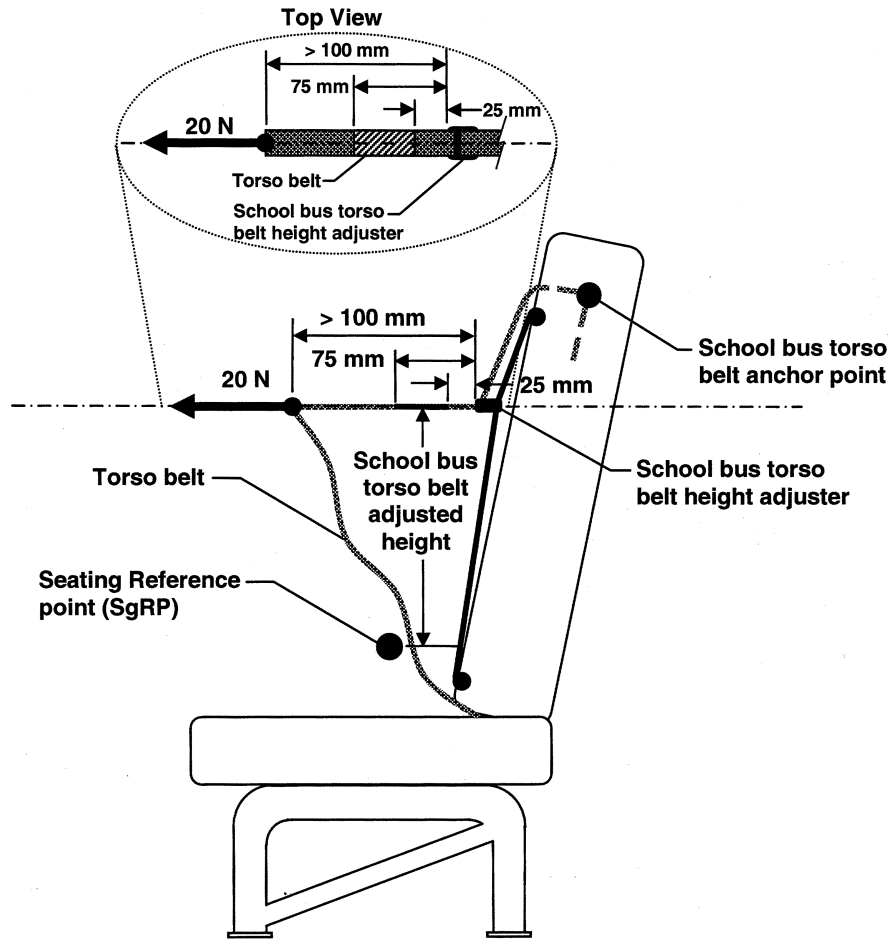

Figure 4 - Seat belt anchorage diagram



**Figure 5 – Minimum school bus torso belt adjusted height measurement**

[36 FR 22902, Dec. 2, 1971]

EDITORIAL NOTE: For FEDERAL REGISTER citations affecting § 571.210, see the List of CFR Sections Affected, which appears in the Finding Aids section of the printed volume and at [www.govinfo.gov](http://www.govinfo.gov).