



Advisory Circular

Subject: CORROSION CONTROL
FOR AIRCRAFT

Date: 7/25/91
Initiated by: AFS-340

AC No: 43-4A
Change:

1. PURPOSE. This advisory circular (AC) is a summary of current available data regarding identification and treatment of corrosive attack on aircraft structure and engine materials. Corrosion inspection frequency, corrosion identification, and corrosion treatment continues to be the responsibility of the operator and should be accomplished per this AC, the manufacturer's recommendations, or the operator's own maintenance program. The procedures presented in this AC are an acceptable means, but not the only acceptable means, of corrosion treatment. The information contained in this AC is applicable to aircraft for which the manufacturer has not published corrosion control information. Where the aircraft manufacturer has published a recommended corrosion inspection schedule and treatment program for a particular aircraft, that program should take precedence over the recommendations of this AC.

2. CANCELLATION. AC 43-4, Corrosion Control for Aircraft, dated 5/15/73.

3. RELATED READING MATERIAL.

a. Federal Aviation Administration (FAA) documents:

(1) Advisory Circular 65-9A, Airframe and Powerplant Mechanics General Handbook. Copies may be obtained from U.S. Department of Transportation, Distribution Requirements Section, M-443.2, Washington, D.C. 20590.

(2) Advisory Circular 65-12A, Airframe and Powerplant Mechanics Powerplant Handbook. Copies may be obtained from U.S. Department of Transportation, Distribution Requirements Section, M-443.2, Washington, D.C. 20590.

(3) Advisory Circular 65-15A, Airframe and Powerplant Mechanics Airframe Handbook. Copies may be obtained from U.S. Department of Transportation, Distribution Requirements Section, M-453.2, Washington, D.C. 20590.

b. Other documents:

(1) Naval Air Systems Command, NAVAIR 01-1A-509, Aircraft Weapons Systems Cleaning and Corrosion Control. Requests for this document must be referred to Naval Publications and Forms, Navy Aviation Supply Office, A.S.O. Code 10, 5801 Tabor Avenue, Philadelphia, PA 19120-5099.

(2) U.S. Air Force Technical Order 1-1-2, Corrosion Control and Treatment for Aerospace Equipment. Requests for this document must be referred to Warner Robins ALC/MMEDT, Robins AFB GA 31098-5609.

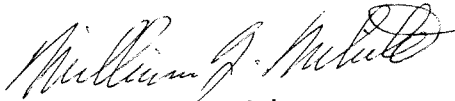

William J. White
Acting Director, Flight Standards Service

<u>Paragraph</u>	CONTENTS	<u>Page No.</u>
CHAPTER 1. GENERAL		1
1. BACKGROUND		1
2. CATASTROPHIC CORROSION EVENTS		1
3. CORROSION CONTROL PROGRAM		1
4.-199. RESERVED		2
CHAPTER 2. CORROSION THEORY		11
200. INTRODUCTION		11
201. BACKGROUND		11
202. DEVELOPMENT OF CORROSION		12
203. FACTORS INFLUENCING CORROSION		12
204. FORMS OF CORROSION		14
205. CORROSION AND MECHANICAL FACTORS		22
206. COMMON CORROSIVE AGENTS		26
207. MICRO-ORGANISMS		27
208. METALLIC MERCURY CORROSION ON ALUMINUM ALLOYS		29
209.-299. RESERVED		29
CHAPTER 3. EFFECTS OF CORROSION		41
300. GENERAL		41
301. EFFECTS OF CORROSION ON METALS		41
302.-399. RESERVED		46
CHAPTER 4. CORROSION PRONE AREAS AND PREVENTATIVE MAINTENANCE		51
400. GENERAL		51
401. EXHAUST TRAIL AREAS		51
402. BATTERY COMPARTMENTS AND BATTERY VENT OPENINGS		51
403. LAVATORIES, BUFFETS, AND GALLEYS		52
404. BILGE AREAS		53
405. WHEEL WELLS AND LANDING GEAR		53
406. EXTERNAL SKIN AREAS		55
407. WATER ENTRAPMENT AREAS		59
408. ENGINE FRONTAL AREAS AND COOLING AIR VENTS		59
409. ELECTRONIC PACKAGE COMPARTMENTS		60
410. MISCELLANEOUS TROUBLE AREAS		62
411. FACTORS IN CORROSION CONTROL		66
412. PREVENTATIVE MAINTENANCE		70
413.-499. RESERVED		85
CHAPTER 5. INSPECTION REQUIREMENTS		91
500. GENERAL		91

<u>Paragraph</u>	<u>Page No.</u>
501. FREQUENCY OF INSPECTION	91
502. RECOMMENDED DEPTH OF INSPECTION	92
503. PRIMARY APPROACH	93
504. NONDESTRUCTIVE INSPECTION (NDI)	93
505.-599. RESERVED	104
 CHAPTER 6. CORROSION REMOVAL TECHNIQUES	 111
 SECTION 1. SAFETY PROCEDURES	 111
600. GENERAL	111
601. GENERAL CORROSION CONTROL WORK PROCEDURES	113
602.-609. RESERVED	114
 SECTION 2. CORROSION REMOVAL TECHNIQUES	 121
610. GENERAL	121
611. STANDARD METHODS	121
612. PREPARATIONS FOR REWORK	121
613. PAINT REMOVAL	122
614. SPECIAL TECHNIQUES	122
615. FAIRING OR BLENDING REWORKED AREAS	123
616. CHEMICAL TESTING	128
617. CHEMICAL SPOT ANALYSIS OF MAGNETIC METALS	129
618. CHEMICAL SPOT ANALYSIS OF NONMAGNETIC METALS	130
619. SURFACE TREATMENT TESTING	131
620. POST IDENTIFICATION CLEANING AND REFINISHING	132
621.-625. RESERVED	132
 SECTION 3. MECHANICAL CORROSION REMOVAL BY BLASTING	 141
626. GENERAL	141
627. SAFETY PRECAUTIONS	141
628.-639. RESERVED	141
 SECTION 4. CORROSION DAMAGE AND REWORK LIMITS	 151
640. DISCUSSION	151
641. REMOVAL OF CORROSION	152
642. DETERMINING DEGREE OF CORROSION DAMAGE	152
643. DETERMINING REWORK LIMITS	153
644. DETERMINING MATERIAL THICKNESS REDUCTION AFTER CORROSION CLEANUP	153
645.-649. RESERVED	154
 SECTION 5. ALUMINUM AND ALUMINUM ALLOYS	 161
650. TREATMENT	161

<u>Paragraph</u>	<u>Page No.</u>
651. PROCESSING OF ALUMINUM SURFACES	161
652. REPAIR OF ALUMINUM ALLOY SHEET METAL	165
653. CORROSION REMOVAL AROUND COUNTERSUNK FASTENERS IN ALUMINUM ALLOY	166
654. EXAMPLES OF REMOVING CORROSION FROM ALUMINUM AND ALUMINUM ALLOYS	167
655.-659. RESERVED	169
 SECTION 6. MAGNESIUM ALLOYS	 181
660. TREATMENT OF WROUGHT MAGNESIUM SHEETS AND FORGINGS	181
661. REPAIR OF MAGNESIUM SHEET METAL AFTER EXTENSIVE CORROSION REMOVAL	181
662. IN-PLACE TREATMENT OF MAGNESIUM CASTINGS	182
663. EXAMPLE OF REMOVING CORROSION FROM MAGNESIUM	182
664.-669. RESERVED	185
 SECTION 7. FERROUS METALS	 191
670. GENERAL	191
671. MECHANICAL REMOVAL OF IRON RUST	191
672. CHEMICAL SURFACE TREATMENT OF STEEL SURFACES	193
673. REMOVAL OF CORROSIVE PRODUCTS FROM HIGH-STRESSED STEEL PARTS	193
674. SPECIAL TREATMENT OF STAINLESS STEEL ALLOYS	193
675. EXAMPLE OF PROCESS FOR REMOVAL OF CORROSION FROM STEEL PARTS	194
676.-679. RESERVED	195
 SECTION 8. PLATED PARTS	 201
680. CHROMIUM AND NICKEL PLATED PARTS	201
681. CADMIUM AND ZINC PLATED PARTS	201
682.-689. RESERVED	202
 SECTION 9. OTHER METALS AND ALLOYS	 211
690. NOBLE METAL COATINGS - CLEANUP AND RESTORATION	211
691. COPPER AND COPPER ALLOYS	211
692. TITANIUM ALLOYS	211
693.-699. RESERVED	212
 CHAPTER 7. SPECIAL PROBLEMS	 221
700. MERCURY SPILLS/CORROSION DAMAGE	221
701. CORROSION PROTECTION FOR AGRICULTURAL AIRCRAFT	223
702.-799. RESERVED	224

LIST OF ILLUSTRATIONS

Page No.

FIGURE 2-1.	SIMPLIFIED CORROSION CELL SHOWING CONDITIONS WHICH MUST EXIST FOR ELECTROCHEMICAL CORROSION.	11
FIGURE 2-2.	ELIMINATION OF CORROSION BY APPLICATION OF AN ORGANIC FILM TO METAL SURFACE.	12
FIGURE 2-3.	UNIFORM ETCH CORROSION	15
FIGURE 2-4.	PITTING CORROSION.	15
FIGURE 2-5.	GALVANIC CORROSION OF MAGNESIUM ADJACENT TO STEEL FASTENER .	16
FIGURE 2-6.	CONCENTRATION CELL CORROSION	18
FIGURE 2-7.	INTERGRANULAR CRACKING AND CORROSION ON A WINGSPAR CHORD . .	18
FIGURE 2-8.	SEVERE EXFOLIATION CORROSION OF A SEAT TRACK	19
FIGURE 2-9.	SEVERE EXFOLIATION CORROSION	20
FIGURE 2-10.	FILIFORM CORROSION	21
FIGURE 2-11.	FILIFORM CORROSION BEFORE AND AFTER PAINT REMOVAL.	21
FIGURE 2-12.	STRESS CORROSION CRACKING OF 7079-T6 FITTING	23
FIGURE 2-13.	STRESS CORROSION CRACKING STARTING AT A PIT IN CRES MATERIAL	23
FIGURE 2-14.	STRESS CORROSION CRACKING OF AN EXTRUDED SECTION	24
FIGURE 2-15.	FRETTING CORROSION AND CRACKING FROM CYCLIC LOADING OF LUG .	25
TABLE 3-1.	CORROSION OF METALS.	45
FIGURE 4-1.	EXHAUST TRAIL AREA CORROSION CONTROL POINTS.	51
FIGURE 4-2.	TYPICAL DAMAGE TO FLOOR AROUND LAVATORIES, BUFFETS, AND GALLEYS	52
FIGURE 4-3.	LANDING GEAR AND WHEEL CORROSION POINTS.	54
FIGURE 4-4.	INTERGRANULAR CORROSION OF 7075-T6 ALUMINUM ADJACENT TO STEEL FASTENER.	55
FIGURE 4-5.	CRACK AND SKIN BULGING CAUSED BY CORROSION	56
FIGURE 4-6.	SPOT-WELDED SKIN CORROSION	57
FIGURE 4-7.	HINGE CORROSION POINTS	58
FIGURE 4-8.	HINGE FAILURE CAUSED BY CORROSION.	58
FIGURE 4-9.	RECIPROCATING ENGINE FRONTAL AREA CORROSION.	60
FIGURE 4-10.	JET ENGINE FRONTAL AREA CORROSION POINTS	60
FIGURE 4-11.	SPAR CHORD LIFTING CAUSED BY CORROSION PRODUCTS.	64
FIGURE 4-12.	SKIN BULGING AROUND FASTENERS.	65
FIGURE 4-13.	OPENING OF A CORRODED LAP JOINT FOR REPAIR	65
FIGURE 4-14.	CLOSEUP VIEW OF A CORRODED LAP JOINT	66
TABLE 4-1.	GALVANIC SERIES OF METALS AND ALLOYS	68
TABLE 4-2.	GROUPING OF METALS AND ALLOYS.	69
FIGURE 4-15.	NORTH AMERICA CORROSION SEVERITY MAP	72
FIGURE 4-16.	SOUTH AMERICA CORROSION SEVERITY MAP	73
FIGURE 4-17.	AFRICA CORROSION SEVERITY MAP.	74
FIGURE 4-18.	SOUTH PACIFIC CORROSION SEVERITY MAP	75
FIGURE 4-19.	ASIA CORROSION SEVERITY MAP.	76
FIGURE 4-20.	EUROPE AND ASIA MINOR CORROSION SEVERITY MAP	77
FIGURE 4-21.	BLOCKED DRAIN PASSAGES RESULTED IN ACCUMULATION OF CORROSION CONTAMINATES AND MOISTURE.	78
FIGURE 5-1.	CORROSION FOUND AFTER REMOVING CARGO DOOR THRESHOLD COVERS .	93
FIGURE 5-2.	CORROSION UNDER CHIPPED AND LOOSE PAINT ON WING SKIN	94
FIGURE 5-3.	CORROSION INDICATED BY BLISTERING OF PAINT IN FUEL CELL. . .	95
FIGURE 5-4.	POPPED RIVET HEADS RESULTING FROM CORROSION PRODUCTS	95
FIGURE 5-5.	SKIN BULGING AROUND FASTENERS CAUSED BY PRESSURE FROM CORROSION PRODUCTS.	96

FIGURE 5-6.	CORROSION CRACKING BETWEEN FASTENERS ON A WING SPAR.	96
FIGURE 5-7.	FAYING SURFACE CORROSION ON WING SPAR CHORD WITH CORROSION CRACKING ALSO VISIBLE	97
FIGURE 5-8.	SEVERE CROWN STRINGER CORROSION.	97
FIGURE 5-9.	SPAR CHORD CORROSION	98
FIGURE 5-10.	REMOVAL OF FILLET SEAL FROM INTERNAL EDGE OF LAP JOINT EXPOSED FULL EXTENT OF CORROSION	98
FIGURE 5-11.	REMOVAL OF INSULATION BLANKETS EXPOSED CORROSION	99
FIGURE 5-12.	CORROSION DEVELOPED UNDER LEVELING COMPOUND INSTALLED DURING PREVIOUS REPAIR OF OVERWING EXIT.	99
FIGURE 5-13.	CORROSION BEHIND A STRUCTURAL COMPONENT ON A WING SPAR	100
FIGURE 5-14.	CORROSION DAMAGE AROUND FASTENER HOLES AND IN FASTENER HOLES.	100
FIGURE 5-15.	SEVERELY CORRODED LAP JOINT.	101
FIGURE 5-16.	LOCAL PAINT REMOVAL REQUIRED TO EXPOSE FULL EXTENT OF CORROSION.	101
FIGURE 5-17.	CORRODED AREA AFTER PAINT REMOVAL FROM WING SKIN	102
FIGURE 5-18.	ALODINE 1200 TREATMENT PRIOR TO PAINTING MAY HIGHLIGHT PRESENCE OF REMAINING CORROSION OR CRACKS.	102
TABLE 6-1.	ABRASIVES FOR CORROSION REMOVAL.	123
FIGURE 6-1.	BLENDOUT OF CORROSION AS SINGLE DEPRESSION	124
FIGURE 6-2.	TYPICAL EXAMPLE OF ACCEPTABLE CLEANUP OF CORROSION PITS.	125
FIGURE 6-3.	BLENDOUT OF MULTIPLE PITS IN CORRODED AREA	125
FIGURE 6-4.	PROFILE OF REWORKED CORRODED AREAS IN REGIONS OF LIMITED ACCESS.	126
FIGURE 6-5.	STEEL PARTICLES FROM FASTENERS OR NUTPLATES MAY CAUSE FUTURE CORROSION PROBLEMS IN ALUMINUM STRUCTURE.	126
FIGURE 6-6.	INCOMPLETE REMOVAL OF CORROSION PRODUCTS RESULTED IN REOCCURRENCE OF CORROSION	127
FIGURE 6-7.	INCOMPLETE REMOVAL OF CORROSION PRODUCTS RESULTED IN REOCCURRENCE OF CORROSION	127
FIGURE 6-8.	SEVERE CORROSION REQUIRING TRIMMING OUT OF DAMAGED AREA.	151
FIGURE 6-9.	CORROSION AT FASTENER HOLES REMOVED BY SPOT FACING	152
FIGURE 6-10.	CORROSION DAMAGE AND REWORK MEASUREMENT USING DEPTH DIAL GAUGE	154
FIGURE 6-11.	REMOVING OIL AND SURFACE DIRT.	162
FIGURE 6-12.	POLISHING AND BRIGHTENING ALCLAD SURFACES.	162
FIGURE 6-13.	CLEANING AND STRIPPING PAINT	163
FIGURE 6-14.	CLEANING AND INHIBITING CORRODED ALUMINUM SURFACES	164
FIGURE 6-15.	REMOVING EXCESS INHIBITOR SOLUTION	165
FIGURE 6-16.	APPLYING WAX TO CLEANED SURFACES	165
FIGURE 6-17.	REMOVING CORROSION PRODUCTS FROM ORDINARY STEEL SURFACES	192
FIGURE 6-18.	REMOVING CORROSION PRODUCTS FROM HIGHLY STRESSED STEEL PARTS.	192



17

18



19

20



CHAPTER 1. GENERAL

1. BACKGROUND. Corrosion is the electrochemical deterioration of a metal because of its chemical reaction with the surrounding environment. While new and better materials are continuously being developed, this progress is offset, in part, by a more aggressive operational environment. This problem is compounded by the fact that corrosion is a complex phenomenon. It can take many different forms and the resistance of aircraft materials to corrosion can drastically change with only a small environmental change.

2. CATASTROPHIC CORROSION EVENTS. Corrosion is most often thought of as a slow process of material deterioration, taking place over a significant period of time (examples being general corrosion, pitting, exfoliation, etc.). Other forms of corrosion degradation can occur very quickly, in days or even hours, with catastrophic results. These forms (such as stress corrosion cracking, environmental embrittlement, and corrosion fatigue) depend on both the chemical and mechanical aspects of the environment and can cause catastrophic structural failure without warning.

3. CORROSION CONTROL PROGRAM.

a. The possibility of an in-flight mishap or excessive down time for structural repairs necessitates an active corrosion prevention and control program. The type and aggressiveness of the corrosion prevention and control program depend on the operational environment of the aircraft. Aircraft exposed to salt air, heavy atmospheric industrial pollution, and/or over water operations will require a more stringent corrosion prevention and control program than an aircraft that is operated in a dry environment.

b. In order to prevent corrosion, a constant cycle of cleaning, inspection, operational preservation, and lubrication must be followed. Prompt detection and removal of corrosion will limit the extent of damage to aircraft and aircraft components. The basic philosophy of a corrosion prevention and control program should consist of the following:

- (1) Adequately trained personnel in the recognition of corrosion including conditions, detection and identification, cleaning, treating, and preservation;
- (2) Thorough knowledge of corrosion identification techniques;
- (3) Proper emphasis on the concept of all hands responsibility for corrosion control;
- (4) Inspection for corrosion on a scheduled basis;
- (5) Aircraft washing at regularly scheduled intervals;
- (6) Routine cleaning or wipe down of all exposed unpainted surfaces;

- (7) Keeping drain holes and passages open and functional;
- (8) Inspection, removal, and reapplication of preservation compounds on a scheduled basis;
- (9) Early detection and repair of damaged protective coatings.
- (10) Thorough cleaning, lubrication, and preservation at prescribed intervals;
- (11) Prompt corrosion treatment after detection;
- (12) Accurate record keeping and reporting of material or design deficiencies; and
- (13) Use of appropriate materials, equipment, and technical publications.

4.-199. RESERVED

CHAPTER 2. CORROSION THEORY

200. INTRODUCTION. This chapter briefly describes corrosion theory, the causes of corrosion, and the factors which influence its development. The various forms of corrosion and common corrosive agents are also described.

201. BACKGROUND.

a. Corrosion is a natural phenomenon which attacks metal by chemical or electrochemical action and converts it into a metallic compound, such as an oxide, hydroxide, or sulfate. Corrosion is to be distinguished from erosion, which is primarily destruction by mechanical action. The corrosion occurs because of the tendency for metals to return to their natural state. Noble metals, such as gold and platinum, do not corrode since they are chemically uncombined in their natural state. Four conditions must exist before corrosion can occur (see Figure 2-1):

- (1) Presence of a metal that will corrode (anode);
- (2) Presence of a dissimilar conductive material (cathode) which has less tendency to corrode;
- (3) Presence of a conductive liquid (electrolyte); and
- (4) Electrical contact between the anode and cathode (usually metal-to-metal contact, or a fastener).

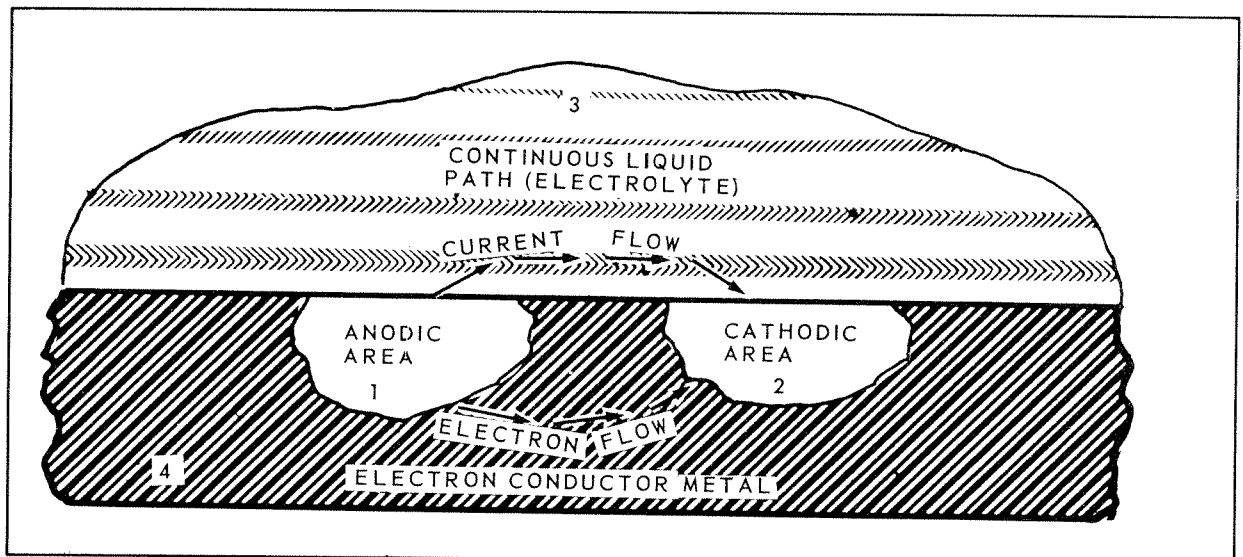

FIGURE 2-1. SIMPLIFIED CORROSION CELL SHOWING CONDITIONS WHICH MUST EXIST FOR ELECTROCHEMICAL CORROSION.

b. Elimination of any one of these conditions will stop corrosion. An example would be a paint film on the metal surface (see Figure 2-2). Some metals (such as stainless steel and titanium), under the right conditions,

produce corrosion products that are so tightly bound to the corroding metal that they form an invisible oxide film (called a passive film), which prevents further corrosion. When the film of corrosion products is loose and porous (such as those of aluminum and magnesium), an electrolyte can easily penetrate and continue the corrosion process, producing more extensive damage than surface appearance would show.

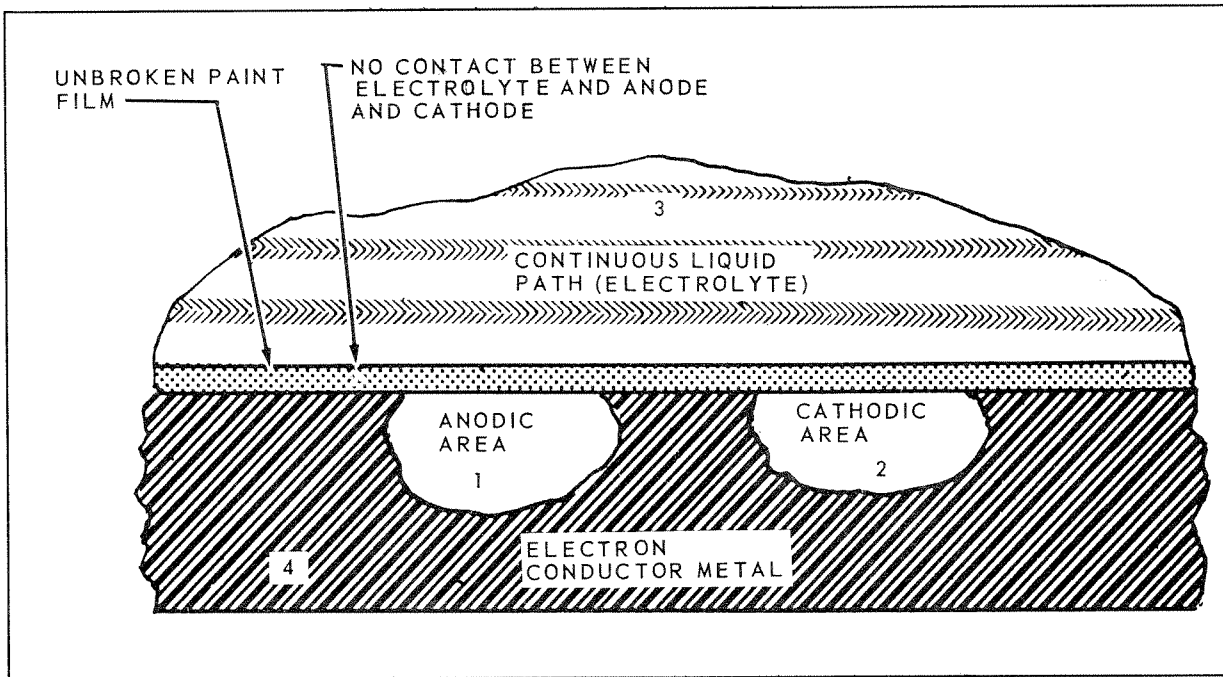

FIGURE 2-2. ELIMINATION OF CORROSION BY APPLICATION OF AN ORGANIC FILM TO METAL SURFACE.

202. DEVELOPMENT OF CORROSION.

a. All corrosive attack begins on the surface of the metal. The corrosion process involves two chemical changes. The metal that is attacked or oxidized undergoes an anodic change, with the corrosive agent being reduced and undergoing a cathodic change. The tendency of most metals to corrode creates one of the major problems in the maintenance of the aircraft, particularly in areas where adverse environmental or weather conditions exist.

b. Paint coatings can mask the initial stages of corrosion. Since corrosion products occupy more volume than the original metal, paint surfaces should be inspected often for irregularities such as blisters, flakes, chips, and lumps.

203. FACTORS INFLUENCING CORROSION.

a. Some factors which influence metal corrosion and the rate of corrosion are the:

- (1) Type of metal;
- (2) Heat treatment and grain direction;
- (3) Presence of a dissimilar, less corrodible metal (galvanic corrosion);
- (4) Anode and cathode surface areas (in galvanic corrosion);
- (5) Temperature;
- (6) Presence of electrolytes (hard water, salt water, battery fluids, etc.);
- (7) Availability of oxygen;
- (8) Presence of different concentrations of the same electrolyte;
- (9) Presence of biological organisms;
- (10) Mechanical stress on the corroding metal; and
- (11) Time of exposure to a corrosive environment.

b. Most pure metals are not suitable for aircraft construction and are used only in combination with other metals to form alloys. Most alloys are made up entirely of small crystalline regions, called grains. Corrosion can occur on surfaces of those regions which are less resistant and also at boundaries between regions, resulting in the formation of pits and intergranular corrosion. Metals have a wide range of corrosion resistance. The most active metals (those which tend to lose electrons easily), such as magnesium and aluminum, corrode easily. The most noble metals (those which do not lose electrons easily), such as gold and silver, do not corrode easily.

c. Corrosion is accelerated by higher temperature environments which accelerate chemical reactions and allow greater moisture content at saturation in air.

d. Electrolytes (electrically conducting solutions) form on surfaces when condensation, salt spray, rain, or rinse water accumulate. Dirt, salt, acidic gases, and engine exhaust gases can dissolve on wet surfaces, increasing the electrical conductivity of the electrolyte, thereby increasing the rate of corrosion.

e. When some of the electrolyte on a metal surface is partially confined (such as between faying surfaces or in a deep crevice), metal in this confined area corrodes more rapidly than other metal surfaces of the same part outside this area. This type of corrosion is called an oxygen concentration cell. Corrosion occurs more rapidly than would be expected, because the reduced oxygen content of the confined electrolyte causes the adjacent metal to become anodic to other metal surfaces on the same part immersed in electrolyte exposed to the air.

f. Slimes, molds, fungi, and other living organisms (some microscopic) can grow on damp surfaces. Once they are established, the area tends to remain damp, increasing the possibility of corrosion.

g. Manufacturing processes such as machining, forming, welding, or heat treatment can leave stresses in aircraft parts. This residual stress can cause cracking in a corrosive environment when the threshold for stress corrosion is exceeded.

h. Corrosion, in some cases, progresses at the same rate no matter how long the metal has been exposed to the environment. In other cases, corrosion can decrease with time, due to the barrier formed by corrosion products, or increase with time if a barrier to corrosion is being broken down.

204. FORMS OF CORROSION. There are many different types of corrosive attack and these will vary with the metal concerned, corrosive media location, and time exposure. For descriptive purposes, the types are discussed under what is considered the most commonly accepted titles.

a. Uniform Etch Corrosion. Uniform etch corrosion results from a direct chemical attack on a metal surface and involves only the metal surface (see Figure 2-3). On a polished surface, this type of corrosion is first seen as a general dulling of the surface, and if the attack is allowed to continue, the surface becomes rough and possibly frosted in appearance. The discoloration or general dulling of metal created by exposure to elevated temperatures is not to be considered as uniform etch corrosion.

b. Pitting Corrosion. The most common effect of corrosion on aluminum and magnesium alloys is called pitting (see Figure 2-4). It is first noticeable as a white or gray powdery deposit, similar to dust, which blotches the surface. When the deposit is cleaned away, tiny pits or holes can be seen in the surface. Pitting corrosion may also occur in other types of metal alloys. The combination of small active anodes to large passive cathodes causes severe pitting. The principle also applies to metals which have been passivated by chemical treatments, as well as for metals which develop passivation due to environmental condition.

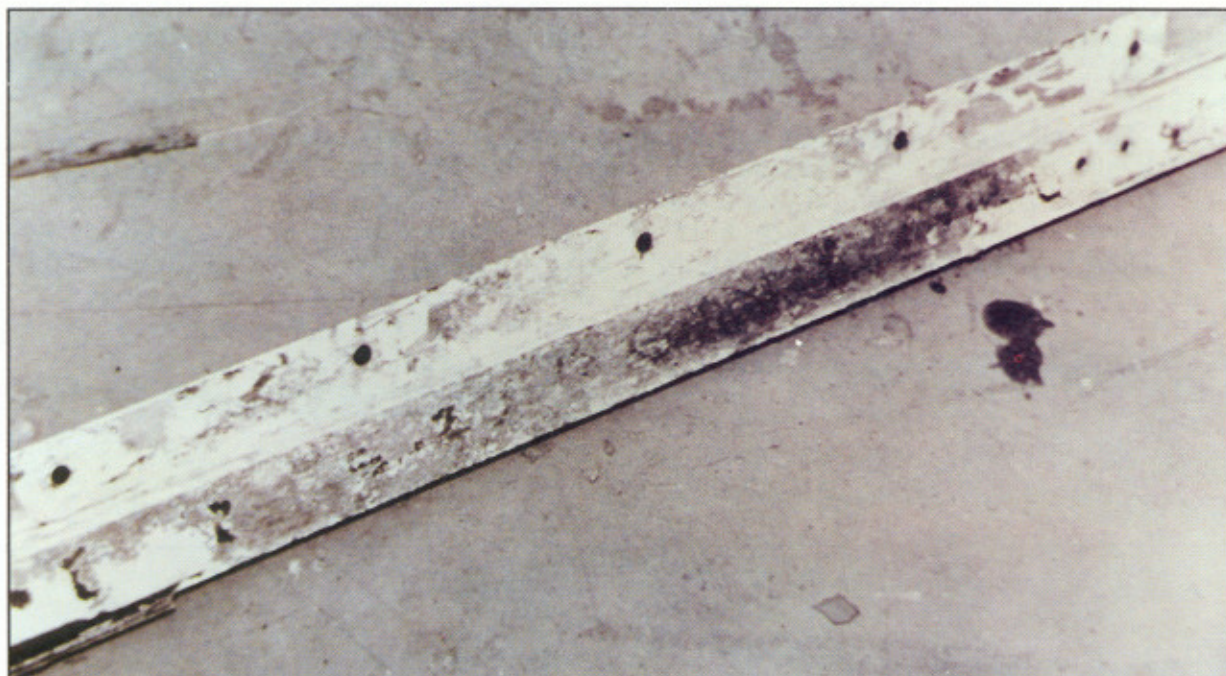

FIGURE 2-3. UNIFORM ETCH CORROSION

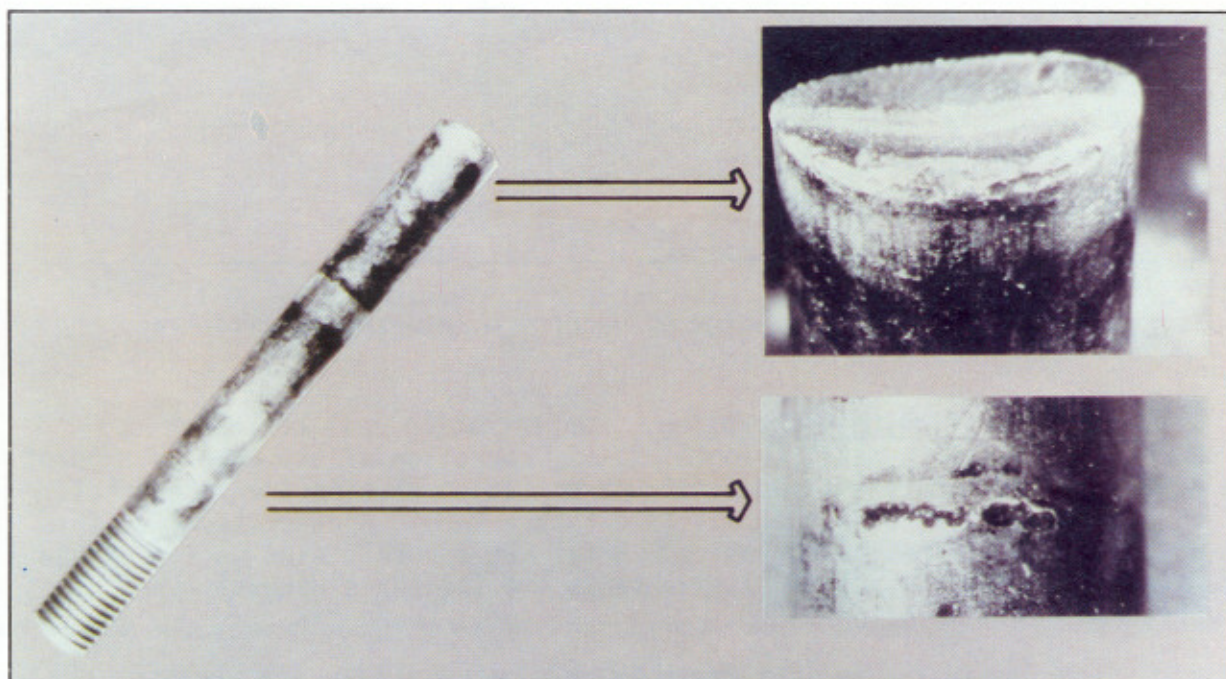

FIGURE 2-4. PITTING CORROSION

c. Galvanic Corrosion. Galvanic corrosion occurs when two dissimilar metals make electrical contact in the presence of an electrolyte (see Figure 2-5). The rate which corrosion occurs depends on the difference in the activities. The greater the difference in activity, the faster corrosion occurs. For example, magnesium would corrode very quickly when coupled with gold in a humid atmosphere, but aluminum would corrode very slowly in contact with cadmium. The rate of galvanic corrosion also depends on the size of the parts in contact. If the surface area of the corroding metal (the anode) is smaller than the surface area of the less active metal (the cathode), corrosion will be rapid and severe. When the corroding metal is larger than the less active metal, corrosion will be slow and superficial. For example, an aluminum fastener in contact with a relatively inert Monel structure may corrode severely, while a Monel bracket secured to a large aluminum member would result in a relatively superficial attack on the aluminum sheet.

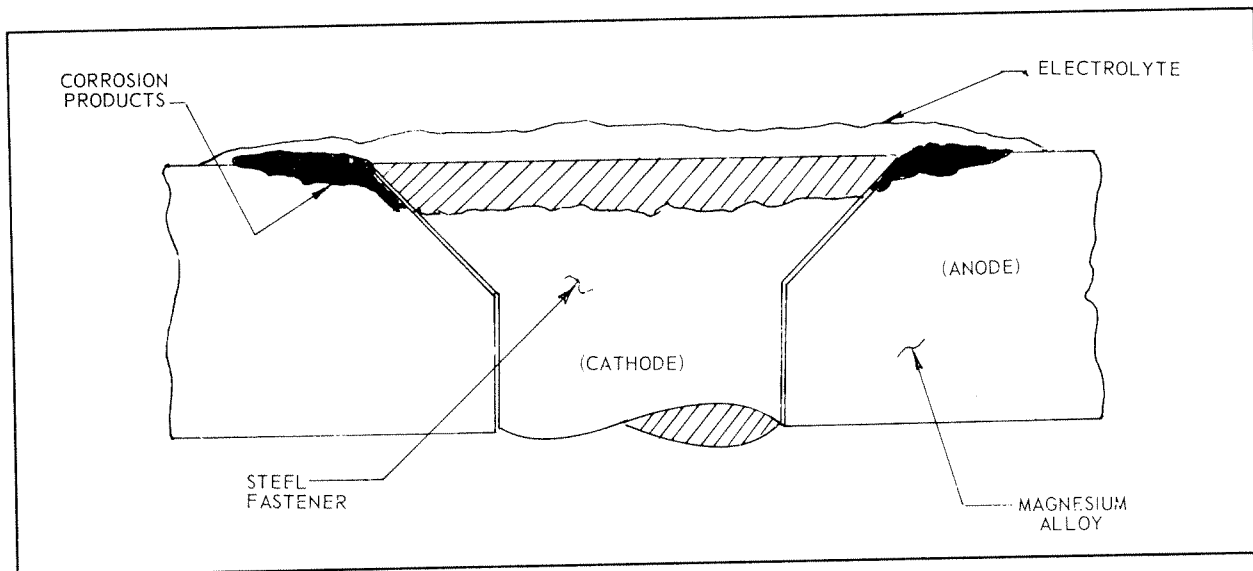

FIGURE 2-5. GALVANIC CORROSION OF MAGNESIUM ADJACENT TO STEEL FASTENER

d. Concentration Cell Corrosion. Concentration cell corrosion is corrosion of metals in a metal-to-metal joint, corrosion at the edge of a joint even though joined metals are identical, or corrosion of a spot on the metal surface covered by a foreign material (see Figure 2-6). Another term for this type of corrosion is crevice corrosion. Metal ion concentration cells, oxygen concentration cells, and active-passive cells are the three general types of concentration cell corrosion.

(1) Metal ion concentration cells. The solution may consist of water and ions of the metal which is in contact with water. A high concentration of the metal ions will normally exist under faying surfaces where

the solution is stagnant, and a low concentration of metal ions will exist adjacent to the crevice which is created by the faying surface. An electrical potential will exist between the two points; the area of the metal in contact with the low concentration of metal ions will be anodic and corrode, and the area in contact with the high metal ions concentration will be cathodic and not show signs of corrosion. Figure 2-6 illustrates metal ion concentration cell corrosion.

(2) Oxygen concentration cells. The solution in contact with the metal surface will normally contain dissolved oxygen. An oxygen cell can develop at any point where the oxygen in the air is not allowed to diffuse into the solution, thereby creating a difference in oxygen concentration between two points. Typical locations of oxygen concentration cells are under either metallic or nonmetallic deposits on the metal surface and under faying surfaces such as riveted lap joints. Oxygen cells can also develop under gaskets, wood, rubber, and other materials in contact with the metal surface. Corrosion will occur at the area of low oxygen concentration (anode) as illustrated in Figure 2-6. Alloys, such as stainless steel, which owe their corrosion resistance to surface passivity, are particularly susceptible to this type of crevice corrosion.

(3) Active-passive cells. Metals which depend on a tightly adhering passive film, usually an oxide for corrosion protection, such as corrosion resistant steel, are prone to rapid corrosive attack by active-passive cells. The corrosive action usually starts as an oxygen concentration cell. As an example, salt deposits on the metal surface in the presence of water containing oxygen can create the oxygen cell. The passive film will be broken beneath the dirt particle. Once the passive film is broken, the active metal beneath the film will be exposed to corrosive attack. An electrical potential will develop between the large area of the cathode (passive film) and the small area of the anode (active metal). Rapid pitting of the active metal will result as shown in Figure 2-6.

e. Intergranular Corrosion. Intergranular corrosion is an attack along the grain boundaries of a material. Each grain has a clearly defined boundary which, from a chemical point of view, differs from the metal within the grain center. The grain boundary and grain center can react with each other as anode and cathode when in contact with an electrolyte. Rapid selective corrosion at the grain boundary can occur with subsequent delamination (see Figure 2-7). High-strength aluminum alloys such as 2014 and 7075 are more susceptible to intergranular corrosion if they have been improperly heat-treated and are then exposed to a corrosive environment.

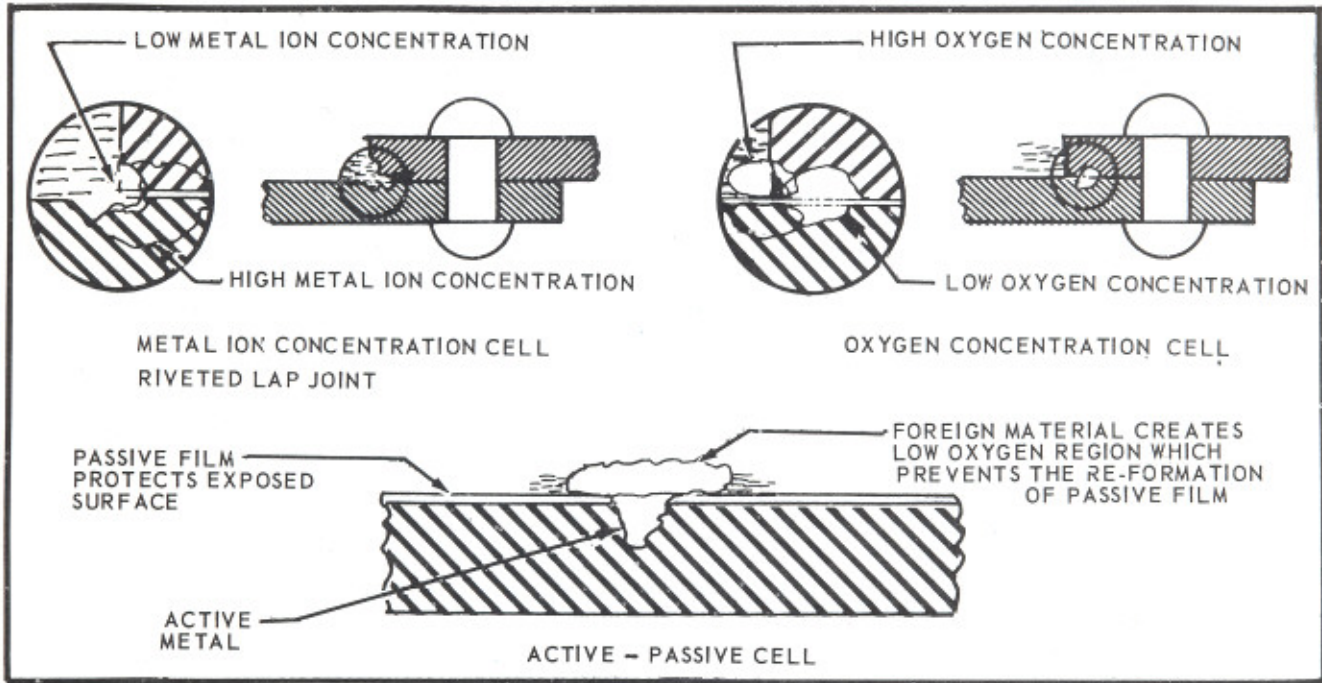

FIGURE 2-6. CONCENTRATION CELL CORROSION

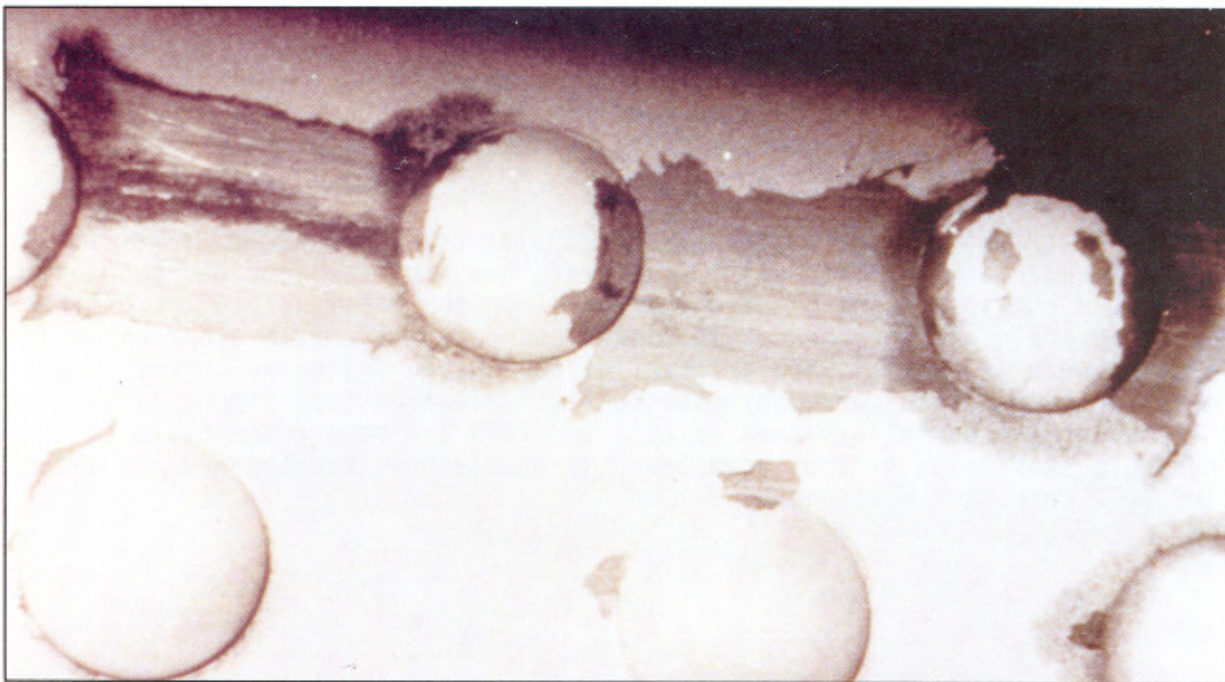

FIGURE 2-7. INTERGRANULAR CRACKING AND CORROSION ON A WING SPAR CHORD

f. Exfoliation Corrosion. Exfoliation corrosion is an advanced form of intergranular corrosion where the surface grains of a metal are lifted up by the force of expanding corrosion products occurring at the grain boundaries just below the surface. The lifting up or swelling is visible evidence of exfoliation corrosion (see Figures 2-8 and 2-9). Exfoliation is most prone to occur in wrought products such as extrusions, thick sheet, thin plate and certain die-forged shapes which have a thin, highly elongated platelet type grain structure. This is in contrast with other wrought products and cast products that tend to have an equiaxed grain structure.

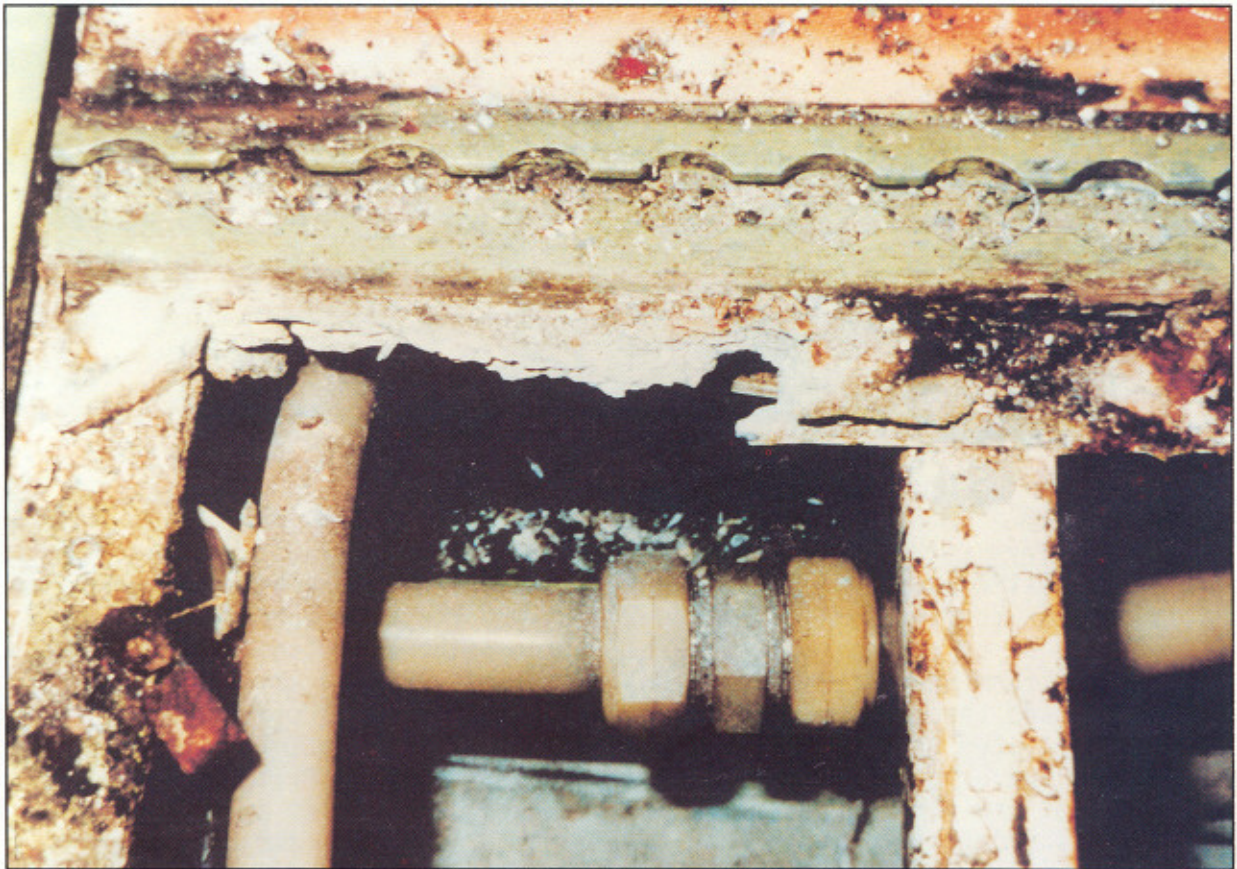

FIGURE 2-8. SEVERE EXFOLIATION CORROSION OF A SEAT TRACK



FIGURE 2-9. SEVERE EXFOLIATION CORROSION

g. Filiform Corrosion. Filiform corrosion is a special form of oxygen concentration cell corrosion or crevice corrosion which occurs on metal surfaces having an organic coating system. It is recognized by its characteristic worm-like trace of corrosion products beneath the paint film (see Figures 2-10 and 2-11). Filiform occurs when the relative humidity of the air is between 78 and 90 percent and the surface is slightly acidic. Corrosion starts at breaks in the coating system and proceeds underneath the coating due to the diffusion of water vapor and oxygen from the air through the coating. Filiform corrosion can attack steel and aluminum surfaces. The traces never cross on steel, but they will cross under one another on aluminum which makes the damage deeper and more severe for aluminum. If filiform corrosion is not removed and the area treated and a protective finish applied, the corrosion can lead to intergranular corrosion, especially around fasteners and at seams. Filiform corrosion can be removed using glass bead blasting material with portable abrasive blasting equipment and/or mechanical means such as buffing or sanding. Filiform corrosion can be prevented by storing aircraft in an environment with a relative humidity below 70 percent, using coating systems having a low rate of diffusion for oxygen and water vapors, and by washing aircraft to remove acidic contaminants from the surface, such as those created by pollutants in the air.



FIGURE 2-10. FILIFORM CORROSION

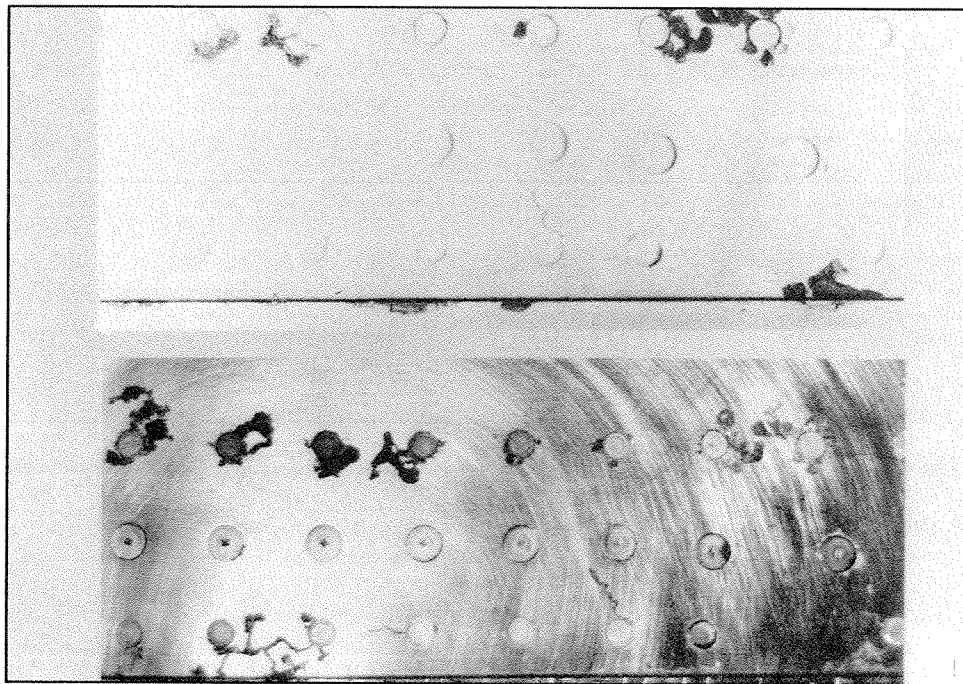

FIGURE 2-11. FILIFORM CORROSION BEFORE AND AFTER PAINT REMOVAL

205. CORROSION AND MECHANICAL FACTORS. Corrosive attack is often aggravated by mechanical factors that are either within the part (residual) or applied to the part (cyclic service loads). Erosion by sand and/or rain and mechanical wear will remove surface protective films and contribute to corrosive attack of underlying metal surfaces. Corrosive attack that is aided by some mechanical factor usually causes the part to degenerate at an accelerated rate compared to the rate at which the same part would deteriorate if it were subjected solely to corrosive attack. Environmental conditions and the composition of the alloy also influence the extent of attack. Examples of this kind of alliance are stress-corrosion cracking, corrosion fatigue, and fretting corrosion.

a. Stress-Corrosion Cracking. Stress-corrosion cracking is an intergranular cracking of the metal which is caused by a combination of stress and corrosion (see Figures 2-12 through 2-14). Stress may be caused by internal or external loading. Internal stresses are produced by nonuniform deformation during cold working, by unequal cooling from high temperatures, and by internal structural rearrangement involving volume changes. Internal stresses are induced when a piece of structure is deformed during an assembly operation, (i.e., during pressing in bushings, shrinking a part for press fit, installing interference bolts, installing rivets, etc.). Concealed stress is more important than design stress, because stress-corrosion is difficult to recognize before it has overcome the design safety factor. The level of stress varies from point to point within the metal. Stresses near the yield strength are generally necessary to promote stress-corrosion cracking, but failures may occur at lower stresses. Specific environments have been identified which cause stress-corrosion cracking of certain alloys. Salt solutions and seawater may cause stress-corrosion cracking of high strength heat-treated steel and aluminum alloys. Methyl alcohol-hydrochloric acid solutions will cause stress-corrosion cracking of some titanium alloys. Magnesium alloys may stress-corrode in moist air. Stress-corrosion may be reduced by applying protective coatings, stress relief heat treatment, using corrosion inhibitors, or controlling the environment. Shot peening a metal surface increases resistance to stress-corrosion cracking by creating compressive stresses on the surface which should be overcome by applied tensile stress before the surface sees any tension load. Therefore, the threshold stress level is increased.

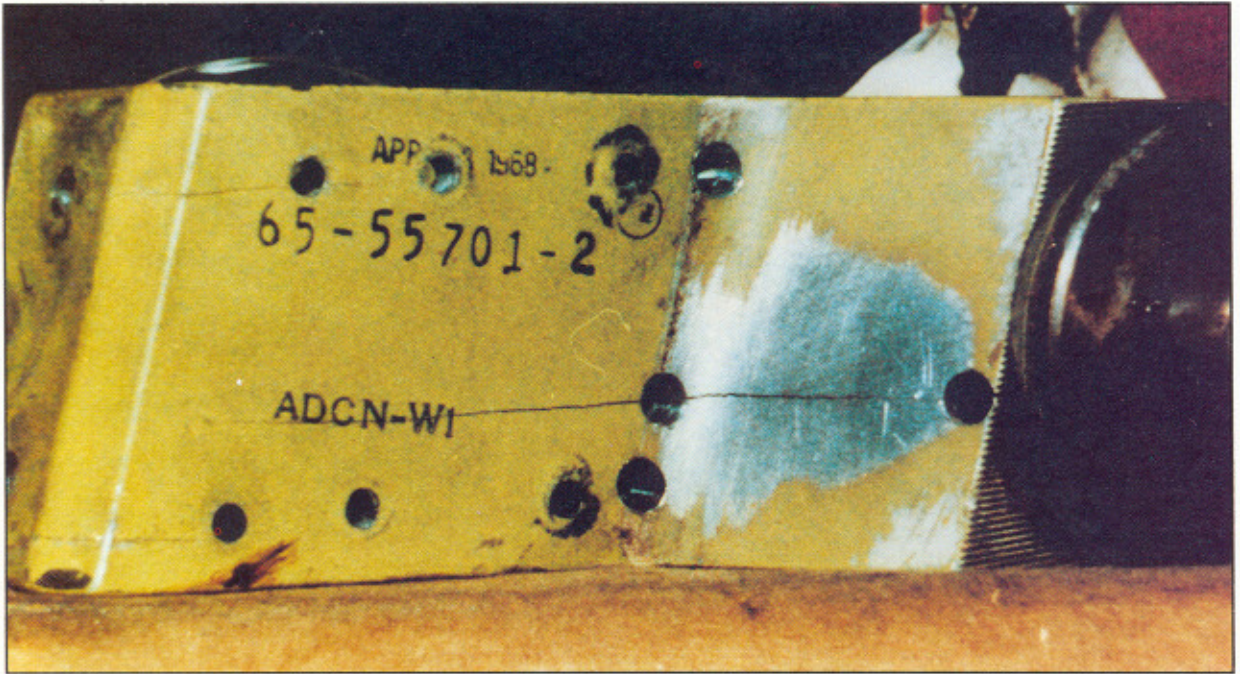

FIGURE 2-12. STRESS-CORROSION CRACKING OF 7079-T6 FITTING

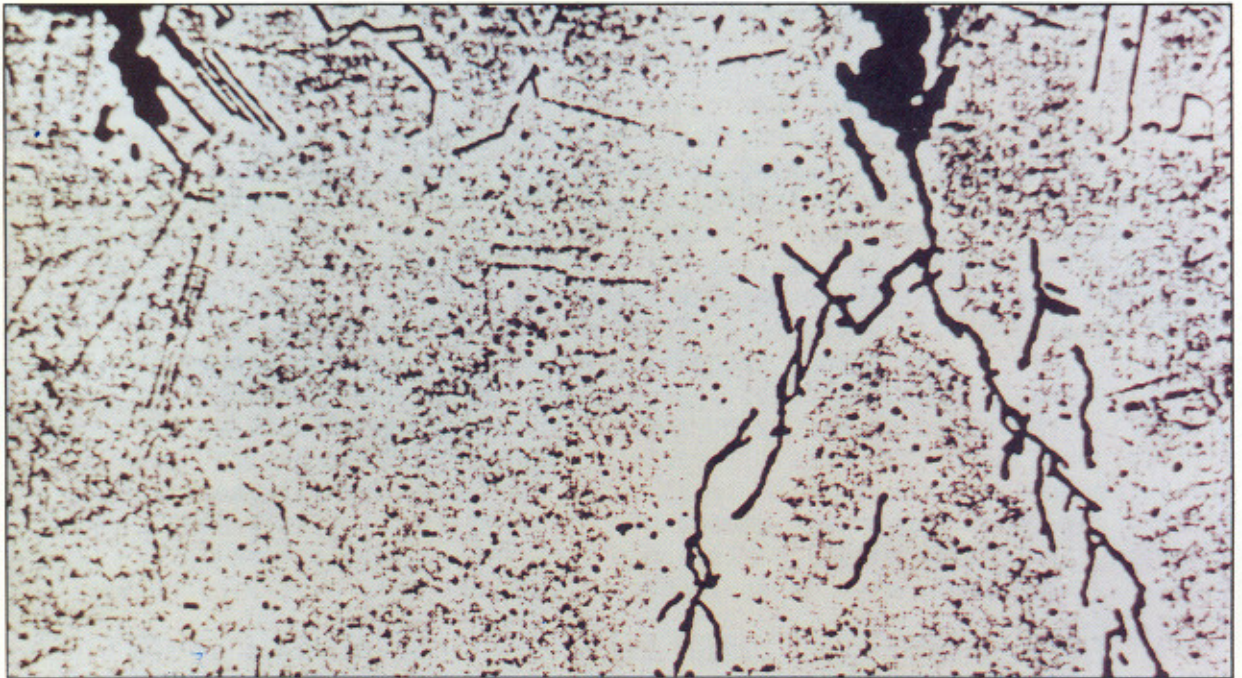

FIGURE 2-13. STRESS-CORROSION CRACKING STARTING AT A PIT IN CRES MATERIAL

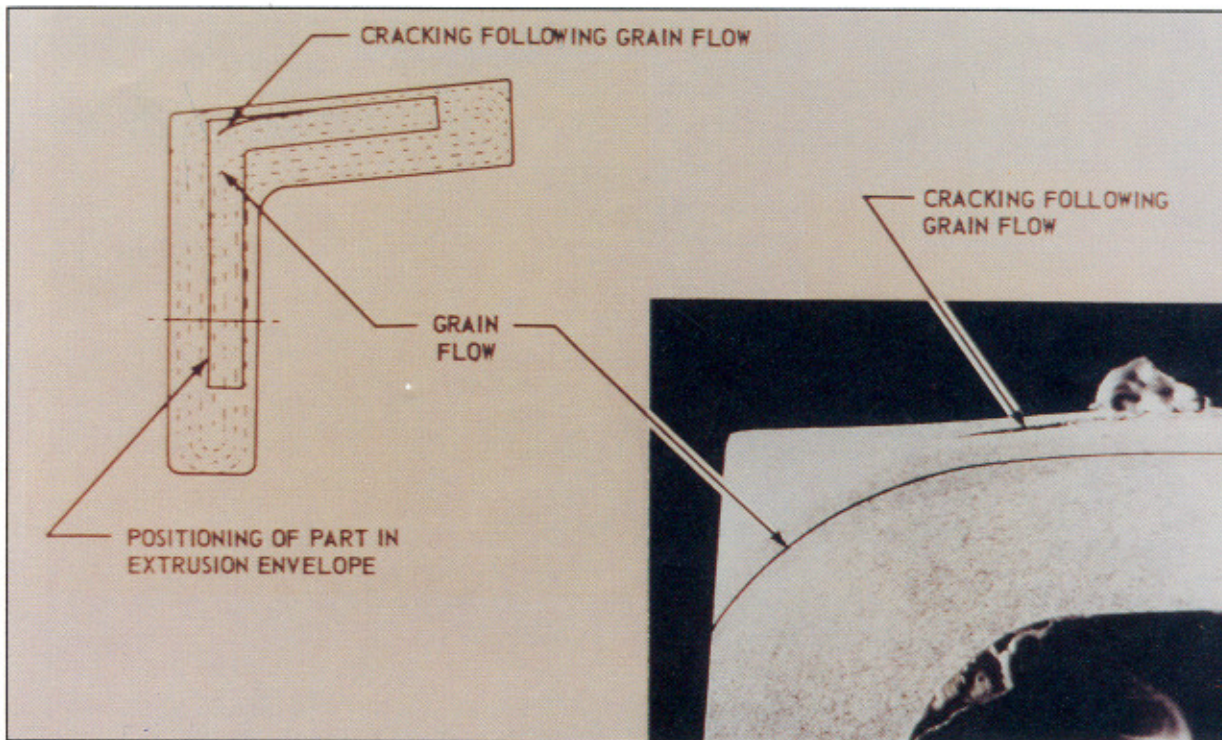

FIGURE 2-14. STRESS-CORROSION CRACKING OF AN EXTRUDED SECTION

b. Corrosion Fatigue. Corrosion fatigue is caused by the combined effects of cyclic stress and corrosion. No metal is immune to some reduction in its resistance to cyclic stressing if the metal is in a corrosive environment. Damage from corrosion fatigue is greater than the sum of the damage from both cyclic stresses and corrosion. Corrosion fatigue failure occurs in two stages. During the first stage, the combined action of corrosion and cyclic stress damages the metal by pitting and crack formation to such a degree that fracture by cyclic stressing will ultimately occur, even if the corrosive environment is completely removed. The second stage is essentially a fatigue stage in which failure proceeds by propagation of the crack (often from a corrosion pit or pits) and is controlled primarily by stress concentration effects and the physical properties of the metal. Fracture of a metal part, due to fatigue corrosion, generally occurs at a stress level far below the fatigue limit in laboratory air, even though the amount of corrosion is relatively small. For this reason, protection of all parts subject to alternating stress is particularly important, even in environments that are only mildly corrosive.

c. Fretting Corrosion. Damage can occur at the interface of two highly loaded surfaces which are not supposed to move against each other. However, vibration may cause the surfaces to rub together resulting in an abrasive wear known as fretting. The protective film on the metallic surfaces is removed by the rubbing action. The continued rubbing of the two surfaces prevents formation of protective oxide film and exposes fresh active metal to the atmosphere. Fretting can cause severe pitting (see Figure 2-15). Dampening

of vibration, tightening of joints, application of a lubricant, or installation of a fretting resistant material between the two surfaces can reduce fretting corrosion.

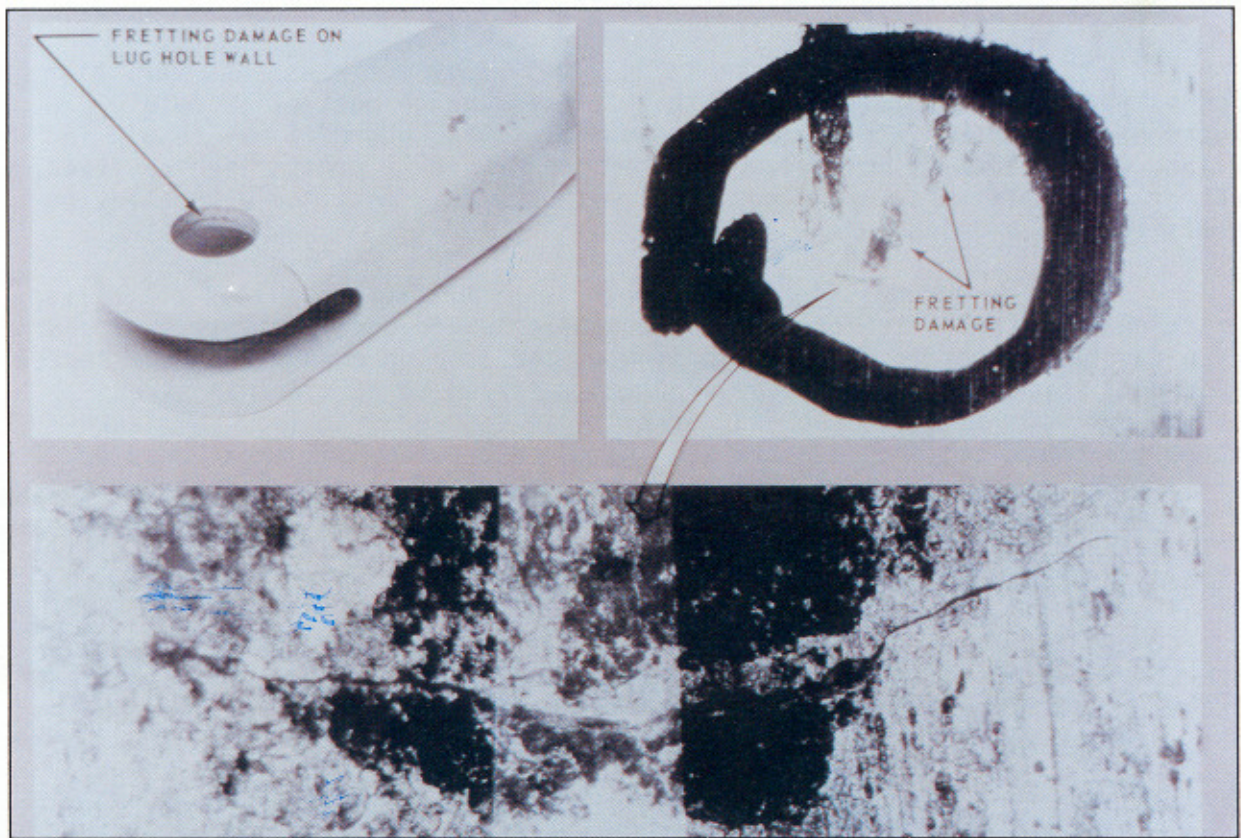

FIGURE 2-15. FRETTING CORROSION AND CRACKING FROM CYCLIC LOADING OF LUG

d. Heat Treatment. Heat treatment of airframe materials should be rigidly controlled to maintain their corrosion resistance as well as to improve their essential mechanical properties. For example, improper heat treatment of clad aluminum alloy may cause the cladding to incur excessive diffusion because the solution heat treatment is too long or at too high a temperature. This degrades the inherent resistance of the cladding itself, and reduces its ability to provide protection to the core aluminum alloy. Aluminum alloys which contain appreciable amounts of copper and zinc are highly vulnerable to intergranular corrosion attack if not quenched rapidly during heat treatment or other special treatment. Stainless steel alloys are susceptible to carbide sensitization when slowly cooled after welding or high temperature heat treatment. Post-weld heat treatments are normally advisable for reduction of residual stress.

e. Hydrogen Embrittlement.

(1) Environmentally induced failure processes may often be the result of hydrogen damage rather than oxidation. Atomic hydrogen is a cathodic

product of many electrochemical reactions, forming during naturally occurring corrosion reactions as well as during many plating or pickling processes. Whether hydrogen is liberated as a gas, or atomic hydrogen is absorbed by the metal, depends on the surface chemistry of the metal.

(2) Atomic hydrogen, due to its small size and mass, has very high diffusivity in most metals. It will therefore penetrate most clean metal surfaces easily and migrate rapidly to favorable sites where it may remain in solution, precipitate as molecular hydrogen to form small pressurized cavities, cracks or large blisters, or it may react with the base metal or with alloying elements to form hydrides.

(3) The accumulation of hydrogen in high strength alloys often leads to cracking, and this often occurs in statically loaded components several hours or even days after the initial application of the load or exposure to the source of hydrogen. Cracking of this type is often referred to as hydrogen stress cracking, hydrogen delayed cracking, or hydrogen induced cracking. Similar fracture processes can occur in new and unused parts when heat treatments or machining have left residual stresses in the parts, and have then been exposed to a source of hydrogen. For this reason, all processes such as pickling or electroplating must be carried out under well controlled conditions to minimize the amount of hydrogen generated.

206. COMMON CORROSIVE AGENTS. Substances that cause corrosion of metals are called corrosive agents. The most common corrosive agents are acids, alkalies, and salts. The atmosphere and water, the two most common media for these agents, may act as corrosive agents too.

a. Acids. In general, moderately strong acids will severely corrode most of the alloys used in airframes. The most destructive are sulfuric acid (battery acid), halogen acids (i.e., hydrochloric, hydrofluoric, and hydrobromic), nitrous oxide compounds, and organic acids found in the wastes of humans and animals.

b. Alkalies. Although alkalies, as a group, are generally not as corrosive as acids, aluminum and magnesium alloys are exceedingly prone to corrosive attack by many alkaline solutions unless the solutions contain a corrosion inhibitor. Particularly corrosive to aluminum are washing soda, potash (wood ashes), and lime (cement dust). Ammonia, an alkali, is an exception because aluminum alloys are highly resistant to it.

c. Salts. Most salt solutions are good electrolytes and can promote corrosive attack. Some stainless steel alloys are resistant to attack by salt solutions but aluminum alloys, magnesium alloys, and other steels are extremely vulnerable. Exposure of airframe materials to salts or their solutions is extremely undesirable.

d. The Atmosphere. The major atmospheric corrosive agents are oxygen and airborne moisture, both of which are in abundant supply. Corrosion often results from the direct action of atmospheric oxygen and moisture on metal, and the presence of additional moisture often accelerates corrosive attack, particularly on ferrous alloys. However, the atmosphere may also contain other

corrosive gases and contaminants, particularly industrial and marine environments, which are unusually corrosive.

(1) Industrial atmospheres contain many contaminants, the most common of which are partially oxidized sulfur compounds. When these sulfur compounds combine with moisture, they form sulfur-based acids that are highly corrosive to most metals. In areas where there are chemical industrial plants, other corrosive atmospheric contaminants may be present in large quantities, but such conditions are usually confined to a specific locality.

(2) Marine atmospheres contain chlorides in the form of salt particles or droplets of salt-saturated water. Since salt solutions are electrolytes, they corrosively attack aluminum and magnesium alloys which are vulnerable to this type of environment.

e. Water. The corrosivity of water will depend on the type and quantity of dissolved mineral and organic impurities and dissolved gasses (particularly oxygen) in the water. One characteristic of water which determines its corrosivity is the conductivity or its ability to act as an electrolyte and conduct a current. Physical factors, such as water temperature and velocity, also have a direct bearing on the corrosivity.

(1) The most corrosive of natural waters (sea and fresh waters) are those that contain salts. Water in the open sea is extremely corrosive due to the presence of chloride ions, but waters in harbors are often even more so because they are contaminated by industrial waste.

(2) The corrosive effects of fresh water varies from locality to locality due to the wide variety of dissolved impurities that may be present in any particular area. Some municipal waters (potable water) to which chlorine and fluorides have been added can be quite corrosive. Commercially softened water and industrially polluted rain water are usually considered to be very corrosive.

207. MICRO-ORGANISMS.

a. Microbial attack includes actions of bacteria, fungi, or molds. Micro-organisms occur nearly everywhere. Those organisms causing the greatest corrosion problems are bacteria and fungi.

b. Bacteria may be either aerobic or anaerobic. Aerobic bacteria require oxygen to live. They accelerate corrosion by oxidizing sulfur to produce sulfuric acid. Bacteria living adjacent to metals may promote corrosion by depleting the oxygen supply or by releasing metabolic products. Anaerobic bacteria, on the other hand, can survive only when free oxygen is not present. The metabolism of these bacteria requires them to obtain part of their sustenance by oxidizing inorganic compounds, such as iron, sulfur, hydrogen, and carbon monoxide. The resultant chemical reactions cause corrosion.

c. Fungi are the growths of micro-organisms that feed on organic materials. While low humidity does not kill microbes, it slows their growth and may prevent corrosion damage. Ideal growth conditions for most micro-organisms are temperatures between 68 and 104 °F (20 and 40 °C) and relative humidity between 85 and 100 percent. It was formerly thought that fungal attack could be prevented by applying moisture-proofing coatings to nutrient materials or by drying the interiors of compartments with desiccants. However, some moisture-proofing coatings are attacked by mold, bacteria, or other microbes, especially if the surfaces on which they are used are contaminated. Microbial growth occurs at the interface of water and fuel, where the fungus feeds on fuel. Organic acids, alcohols, and esters are produced by growth of the fungus. These by-products provide even better growing conditions for the fungus. The fungus typically attaches itself to the bottom of the tank and looks like a brown deposit on the tank coating when the tank is dry. The fungus growth may start again when water and fuel are present.

d. The spore form of some micro-organisms can remain dormant for long periods while dry, and can become active when moisture is available. When desiccants become saturated and unable to absorb moisture passing into the affected area, micro-organisms can begin to grow. Dirt, dust, and other airborne contaminants are the least recognized contributors to microbial attack. Unnoticed, small amounts of airborne debris may be sufficient to promote fungal growth.

e. Fungi nutrients have been considered to be only those materials that have been derived from plants or animals. Thus, wool, cotton, rope, feathers, and leather were known to provide sustenance for microbes, while metals and minerals were not considered fungi nutrients. To a large extent this rule of thumb is still valid, but the increasing complexity of synthetic materials makes it difficult or impossible to determine from the name alone whether a material will support fungus. Many otherwise resistant synthetics are rendered susceptible to fungal attack by the addition of chemicals to change the material's properties.

f. Damage resulting from microbial growth can occur when any of three basic mechanisms, or a combination of these, is brought into play. First, fungi are damp and have a tendency to hold moisture, which contributes to other forms of corrosion. Second, because fungi are living organisms, they need food to survive. This food is obtained from the material on which the fungi are growing. Third, these micro-organisms secrete corrosive fluids that attack many materials, including some that are not fungi nutrient.

g. Microbial growth must be removed completely to avoid corrosion. Microbial growth should be removed by hand with a firm nonmetallic bristle brush and water. Removal of microbial growth is easier if the growth is kept wet with water. Microbial growth may also be removed with steam at 100 psi and steam temperatures not exceeding 150 °F (66 °C). Protective clothing must be used when using steam for removing microbial growth.

208. METALLIC MERCURY CORROSION ON ALUMINUM ALLOYS. Spilled mercury on aluminum should be cleaned immediately because mercury causes corrosion attack which is rapid in both pitting and intergranular attack and is very difficult to control. The most devastating effect of mercury spillage on aluminum alloys is the formation of an amalgam which proceeds rapidly along grain boundaries, causing liquid metal embrittlement. If the aluminum alloy part is under tension stress, this embrittlement will result in splitting with an appearance similar to severe exfoliation. X-ray inspection may be an effective method of locating the small particles of spilled mercury because the dense mercury will show up readily on the x-ray film.

209.-299. RESERVED.



CHAPTER 3. EFFECTS OF CORROSION

300. GENERAL. Most metals are subject to corrosion, but corrosion can be minimized by use of corrosion resistant metals and finishes. The principal material used in airframe structures is high-strength aluminum alloy sheet coated (clad) with a pure aluminum coating (alclad) which is highly resistant to corrosive attack. However, with an accumulation of airborne salts and/or industrial pollutants, along with an electrolyte (moisture), pitting of the alclad will occur. Once the alclad surface is broken, rapid deterioration of the high strength aluminum alloy below occurs. Other metals commonly used in airframe structure, such as nonclad high-strength aluminum alloys, steel, and magnesium alloys, require special preventive measures to guard against corrosion.

a. Aluminum alloys, for example, are usually anodized (a chemical coating), or in some later generation aircraft an aluminum applied plating (ion vapor disposition (IVD)), then primed and possibly topcoated with paint.

b. Steel (except most stainless steels) and other metals, such as brass and bronze, require cadmium plating, zinc plating, IVD aluminum coating and/or conversion coating.

c. Magnesium alloys are highly susceptible to corrosion attack, especially where airborne salts and/or industrial pollutants are present, and require special chemical and electrochemical treatments and paint finishes.

301. EFFECTS OF CORROSION ON METALS. The characteristics of corrosion in commonly used aircraft metals (summarized in Table 3-1) are:

a. Magnesium. Magnesium is the most chemically active metal used in airplane construction and is highly susceptible to and difficult to protect from corrosion. Therefore, when a failure in the protective coating does occur, the prompt and complete correction of the coating failure is imperative if serious structural damage is to be avoided. Corrosion of magnesium is possibly the easiest type of corrosion to detect, since even in its early stages the corrosion products occupy several times the volume of the original magnesium metal. The beginning attack shows as a lifting of the paint film and as white spots on the surface, which rapidly develop into snow-like mounds or whiskers. Correction of damage involves the complete removal of corrosion and application of a chemical conversion coat and protective finish. Magnesium always requires protective coatings. Some magnesium parts in current aircraft have been originally protected by proprietary electrolytic processes, such as HAE and DOW 17 coatings. The HAE process can be identified by the brown to mottled gray appearance of the unpainted surface. DOW 17 coatings have a green to grayish-green color. Coatings of the electrolytic type are thicker than those applied by immersion or brushing. Electrolytic finishes cannot be restored in the field. When failure occurs, corrosion products should be removed, the bare magnesium should be touched up with chemical treatment solution, and the part repainted. Care should be taken to minimize removal of, and ensure repair of, these coatings.

b. Steel. Corrosion of steel is easily recognized because the corrosion product is red rust. When iron-base alloys corrode, dark corrosion products usually form first on the surface of the metal. These products are protective. However, if moisture is present, this ferrous oxide coating is converted to hydrated ferric oxide, which is red rust. This material will promote further attack by absorbing moisture from the air. The most practical means of controlling corrosion of steel is complete removal of corrosion products by mechanical means and by maintaining the protective coating system (usually a plating, often combined with a paint system).

c. Aluminum. Aluminum and its alloys exhibit a wide range of corrosive attack including: uniform surface, galvanic, pitting, intergranular, exfoliation, crevice, stress, and fretting corrosion (see Chapter 2, paragraphs 204. and 205.). Both bare and clad aluminum alloys resist corrosion in nonmarine areas. Where airborne salts and/or industrial pollutants are present, all aluminum alloys require protection. The corrosion product of aluminum is a white-to-gray powdery material which can be removed by mechanical polishing or brushing with materials softer than the metal. General surface attack of aluminum penetrates slowly but is accentuated in the presence of dissolved salts in an electrolyte. Considerable attack can usually take place before serious loss of structural strength develops. However, at least three forms of attack on aluminum alloys are particularly serious:

- (1) Penetrating pit-type corrosion through walls of aluminum tubing.
- (2) Stress-corrosion cracking of materials under sustained stress and corrosive environment.
- (3) Intergranular attack characteristic of certain alloys where clearly defined grain boundaries differ chemically from the metal within the grain.

d. Anodized Aluminum. Some aluminum parts are protected with an anodized coating. Aluminum oxide film on aluminum is naturally protective, and anodizing merely increases the thickness of the oxide film. When this coating is damaged in service, it can be only partially restored by chemical surface treatment. Therefore, when performing any processing of anodized surfaces, unnecessary destruction of the anodized surface should be avoided.

e. Titanium. Although titanium is strongly corrosion resistant, electrical insulation between titanium and other metals is necessary to prevent galvanic corrosion of the other metal. Frequent inspection of such areas is required to ensure that insulation failure has not allowed corrosion to begin. Under certain conditions, chlorides and some chlorinated solvents may induce stress-corrosion cracking of certain titanium alloys.

f. Cadmium and Zinc. Cadmium is used as a coating to protect steel parts and to provide a compatible surface when a part is in contact with other materials. Attack on cadmium is evidenced by white-to-brown-to-black mottling of the surface. Zinc forms voluminous white corrosion products. When cadmium and zinc plate show mottling and isolated voids or cracks in the coating, the

plating is still performing its protective function. The cadmium plate on iron or steel is still protecting until such time as actual iron rust appears.

NOTE: Any mechanical removal of corrosion products should be limited to metal surfaces from which the cadmium has been depleted.

g. Stainless Steels. Stainless steels are iron-base alloys containing 12 percent or more of chromium (as well as other elements). They consist of two types, magnetic and nonmagnetic. The magnetic steels are identified by numbers in the American Iron and Steel Institute (AISI) 400-series, such as 410, 430, etc. These steels are not as corrosion resistant as the nonmagnetic, which are identified by numbers in the AISI 300-series, such as 304, 316, etc. The AISI 300-series steels have nickel contents ranging from 6 to 22 percent, while the 400-series steels have nickel contents of only 2 percent. The corrosion resistance of these steels is due to their ability to form a protective oxide film on the surface. This "passive" film can be reinforced by treatment in certain chemical solutions. However, such steels will pit when exposed to harsh corrosive environments such as airborne salts and industrial pollutants. Particularly susceptible are crevices and other areas in which foreign materials collect. Corrosion can be prevented by keeping stainless steel clean.

h. Nickel and Chromium. Nickel and chromium are used as protective coatings and as alloying elements with iron in stainless steels. Chromium plating is also used to provide a smooth, wear resistant surface and to reclaim worn parts. Where corrosion resistance in a marine environment is required, nickel undercoat is used. The degree of protection is dependent upon plating thickness. Both of these metals form continuous oxide coatings that can be polished to a higher luster and still protect not only themselves but any underlying metal. Chromium coatings contain cracks, and corrosion originates at these separations.

i. Copper and Copper Alloys. Copper and its alloys are generally corrosion resistant. However, the effects of minor amounts of corrosion on copper electric components can appreciably degrade the performance of the components. The product of corrosion on copper is generally a bluish-green coating on the surface of the material. When coupled with most metals used in aircraft construction, copper is the less active metal and greatly accelerates corrosion of the other metals.

j. Silver, Platinum, and Gold. These metals do not corrode in the ordinary sense, although silver tarnishes in the presence of sulfur. The tarnish is a brown-to-black film. Gold tarnish is very thin and shows up as a darkening of reflecting surfaces.

(1) When silver is plated over copper there can be an accelerated corrosion of the copper, through galvanic action, at pinholes or breaks in the silver plating. This corrosion is known as "red plague" and is identifiable by the presence of a brown-red powder deposit on the exposed copper.

(2) "Purple plague" is a brittle gold-aluminum compound formed when bonding gold to aluminum. The growth of such a compound can cause failure in microelectronic interconnection bonds.

k. Tin. Tin is common on R-F shields, filters, crystal covers, and automatic switching devices. Tin has the best combination of solderability and corrosion resistance of any metallic coating. The problem with tin is its tendency to grow "whiskers" on tin-plated wire and other plating applications.

TABLE 3-1. CORROSION OF METALS

ALLOY	TYPE OF ATTACK TO WHICH ALLOY IS SUSCEPTIBLE	APPEARANCE OF CORROSION PRODUCT
Magnesium	Highly susceptible to pitting	White, powdery, snowlike mounds and white spots on surface
Low Alloy Steel (4000-8000 series)	Surface oxidation and pitting, surface, and intergranular	Reddish-brown oxide (rust)
Aluminum	Surface pitting, intergranular, exfoliation stress-corrosion and fatigue cracking, and fretting	White-to-grey powder
Titanium	Highly corrosion resistant; extended or repeated contact with chlorinated solvents may result in degradation of the metal's structural properties at high temperature	No visible corrosion products at low temperature. Colored surface oxides develop above 700 °F (370 °C)
Cadmium	Uniform surface corrosion; used as sacrificial plating to protect steel	From white powdery deposit to brown or black mottling of the surface
Stainless Steels (300-400 series)	Crevice corrosion; some pitting in marine environments; corrosion cracking; intergranular corrosion (300 series); surface corrosion (400 series)	Rough surface; sometimes a uniform red, brown, stain

Table 3-1. CORROSION OF METALS (CONTINUED)

Nickel-base (Inconel, Monel)	Generally has good corrosion resistant qualities; susceptible to pitting in sea water	Green powdery deposit
Copper-base Brass, Bronze	Surface and intergranular corrosion	Blue or blue-green powdery deposit
Chromium (Plate)	Pitting (promotes rusting of steel where pits occur in plating)	No visible corrosion products; blistering of plating due to rusting and lifting
Silver	Will tarnish in the presence of sulfur	Brown-to-black film
Gold	Highly corrosion resistant	Deposits cause darkening of reflective surfaces
Tin	Subject to whisker growth	Whisker-like deposit

302.-399. RESERVED.

CHAPTER 4. CORROSION PRONE AREAS AND PREVENTATIVE MAINTENANCE

400. GENERAL. This chapter lists corrosion problem areas that are common to most aircraft. Corrosion prone areas should be cleaned, inspected, and treated more frequently than less corrosion prone areas. The list is not necessarily complete for any specific aircraft, but could be used to set up a maintenance inspection program. Also included in this chapter are factors in corrosion control and preventative maintenance.

401. EXHAUST TRAIL AREAS. Both jet and reciprocating engine exhaust gas deposits are very corrosive. Inspection and maintenance of exhaust trail areas should include attention to the areas indicated in Figure 4-1. Inspection should also include the removal of fairings and access plates located in the exhaust gas path.

a. Gaps, seams, hinges, and fairings are some of the exhaust trail areas where deposits may be trapped and not reached by normal cleaning methods.

b. Exhaust deposit buildup on the upper and lower wing, aft fuselage, and in the horizontal tail surfaces will be considerably slower and sometimes completely absent from certain aircraft models.

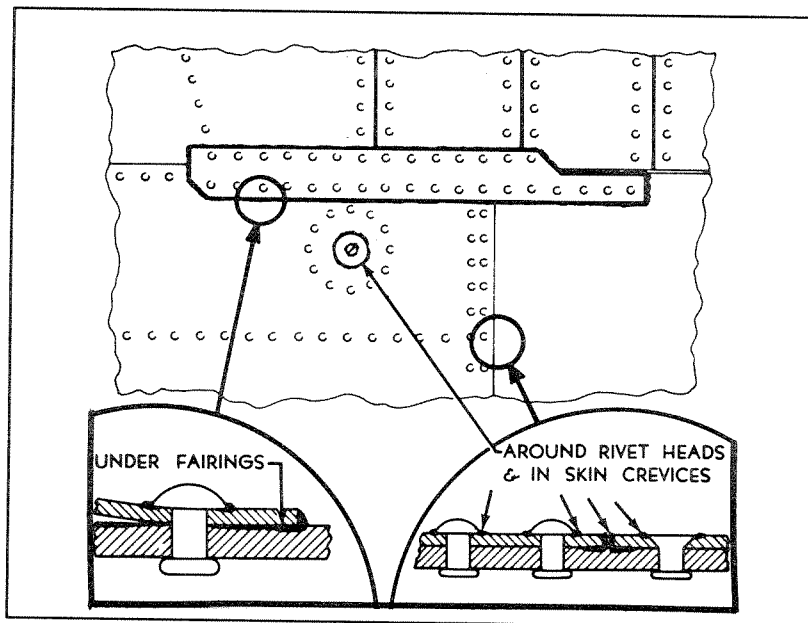

FIGURE 4-1. EXHAUST TRAIL AREA CORROSION CONTROL POINTS

402. BATTERY COMPARTMENTS AND BATTERY VENT OPENINGS. In spite of protective paint systems and extensive sealing and venting provisions, battery compartments continue to be corrosion problem areas. Fumes from overheated battery electrolyte are difficult to contain and will spread to internal structure. Unprotected surfaces will be subjected to corrosive attack. For lead-acid

batteries, frequent cleaning and neutralization of acid deposits with sodium bicarbonate solution will minimize corrosion. If the battery installation includes external vent openings on the aircraft skin, these areas should be included in the inspection and maintenance procedure. If aircraft batteries with electrolytes of either sulfuric acid or potassium hydroxide are in use, their leakage will cause corrosion. Consult the applicable maintenance manuals for the particular aircraft to determine which type battery was installed and the recommended maintenance practices for each. Cleaning of nickel cadmium compartments should be done with ammonia or boric acid solution, allowed to dry thoroughly, and then painted with an alkali-resistant varnish.

403. LAVATORIES, BUFFETS, AND GALLEYS. These areas, particularly deck areas behind lavatories, sinks, and ranges, where spilled food and waste products may collect if not kept clean, are potential trouble spots. Even if some contaminants are not corrosive in themselves, they will attract and retain moisture and, in turn, cause corrosive attack. Pay attention to bilge areas located under galleys and lavatories. Clean these areas frequently and maintain the protective sealant and paint finishes.

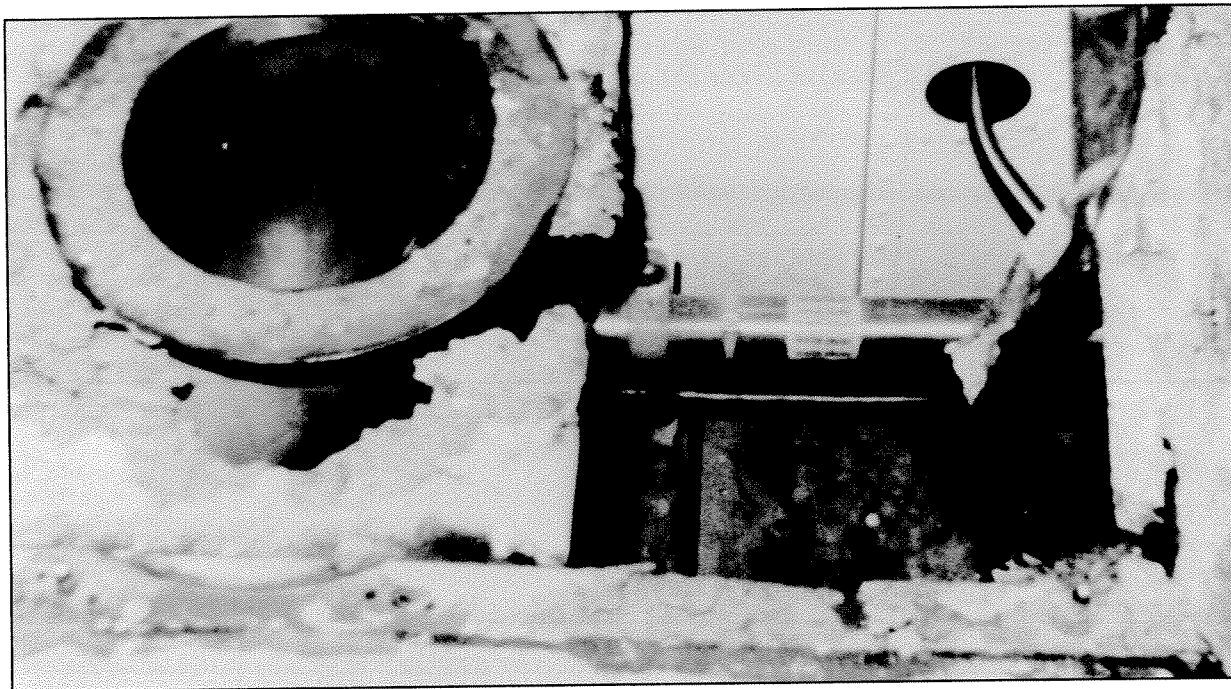

FIGURE 4-2. TYPICAL DAMAGE TO FLOOR AROUND LAVATORIES, BUFFETS, AND GALLEYS

404. BILGE AREAS. On all aircraft, the bilge area is a common trouble spot. The bilge is a natural sump or collection point for waste hydraulic fluids, water, dirt, loose fasteners, drill chips, and other odds and ends of debris. Residual oil quite often masks small quantities of water which settle to the bottom and set up a hidden potential corrosion cell. With the exception of water displacing corrosion preventative compounds, keeping bilge areas free of all extraneous material, including water and oil will insure the best protection against corrosion. A good vacuum cleaner and clean wiping cloths are necessary to clean such areas.

405. WHEEL WELLS AND LANDING GEAR. The wheel well area probably receives more punishment than any other area of the aircraft. It is exposed to mud, water, salt, gravel, and other flying debris from runways during flight operations (see Figure 4-3).

a. Frequent cleaning, lubrication, and paint touch-up are needed on aircraft wheels and on wheel well areas. Because of the many complicated shapes, assemblies, and fittings in the area, complete coverage with a protective paint film is difficult to attain. Thus, preservative coatings tend to mask trouble rather than prevent it. Because of the heat generated from braking, preservative coatings cannot be used on aircraft landing gear wheels.

b. During inspection of this area, particular attention should be given to the following trouble spots:

- (1) High strength steel.
- (2) Exposed surfaces of struts, oleos, arms, links, and attaching hardware (bolts, pins, etc.).
- (3) Axle interiors.
- (4) Exposed position indicator switches and other electrical equipment.
- (5) Crevices between stiffeners, ribs, and lower skin surfaces which are typical water and debris traps.
- (6) Magnesium wheels, particularly around bolt heads, lugs, and wheel web areas.
- (7) Exposed rigid tubing, especially at "B" nuts and ferrules under clamps and tubing identification tapes.

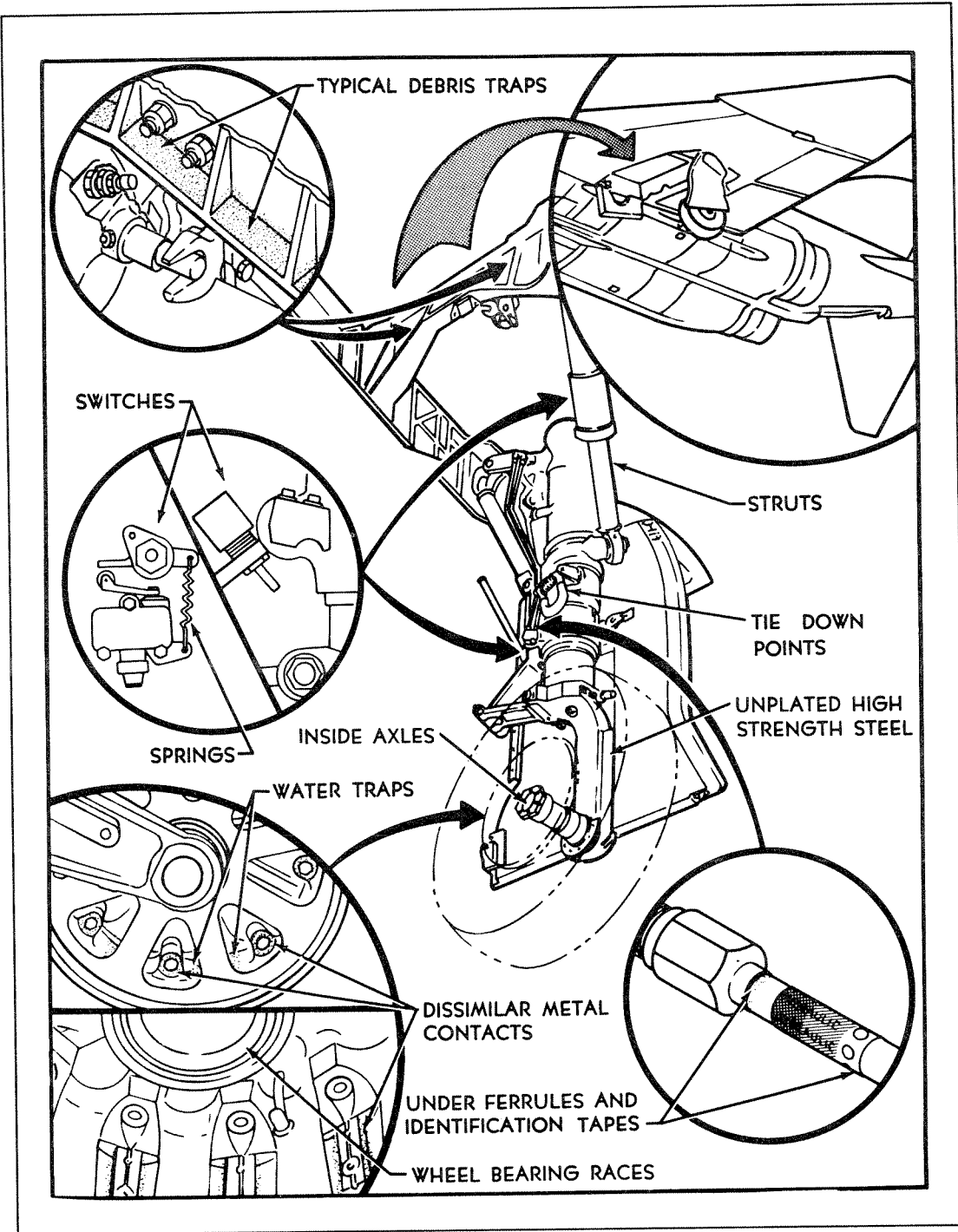

FIGURE 4-3. LANDING GEAR AND WHEEL CORROSION POINTS

406. EXTERNAL SKIN AREAS. External aircraft surfaces are ordinarily covered with protective finishes. In addition, paint coatings may be applied. The affected external aircraft surfaces are readily visible or available for inspection and maintenance. Much emphasis has been given to these areas in the past, and maintenance procedures are well established. Even here, certain types of configurations or combinations of materials become troublesome and require special attention if serious corrosion difficulties are to be avoided. Some of the common trouble areas, other than those attributed to engine exhaust deposits, are grouped as follows:

a. Steel, Titanium, CRES, and Nickel Alloy Fasteners. Fasteners and areas around these fasteners are trouble spots. These areas are subject to high operational loads, moisture intrusion, and dissimilar metal skin corrosion (see Figure 4-4).

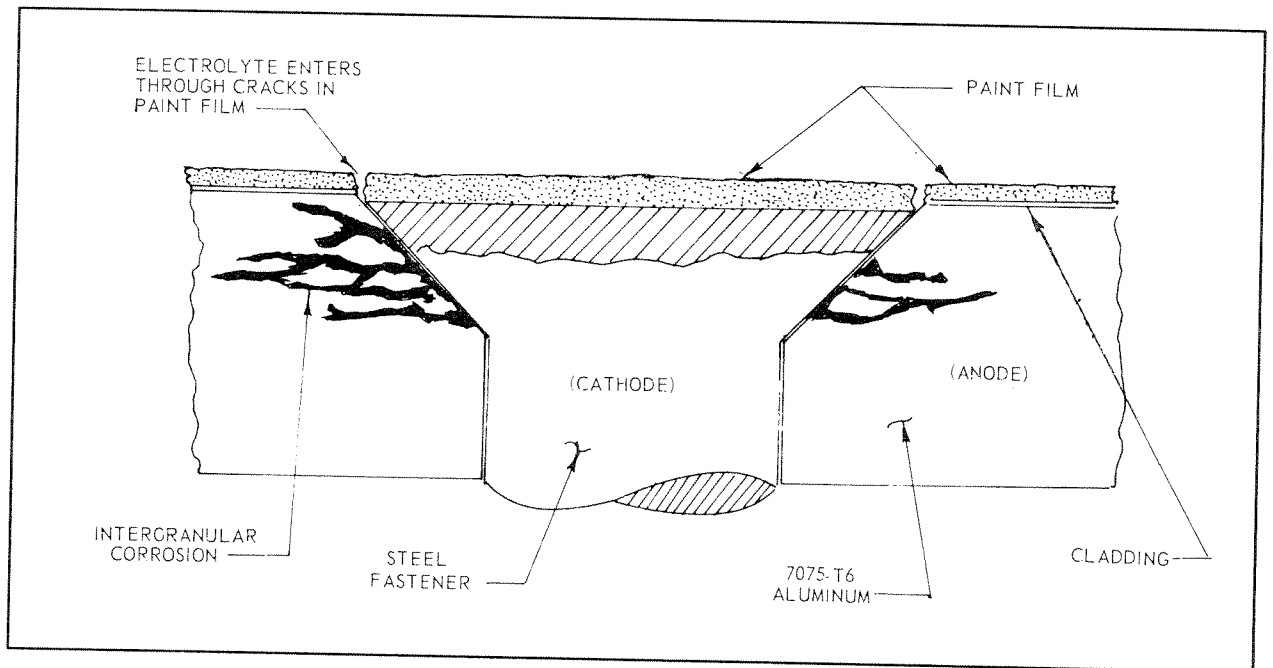

FIGURE 4-4. INTERGRANULAR CORROSION OF 7075-T6 ALUMINUM ADJACENT TO STEEL FASTENER

b. Faying Surfaces and Crevices. Similar to corrosion around fasteners, corrosion in faying surfaces, seams, and joints is caused by the intrusion of moisture and other corrosive agents. The effect of this type of corrosion is usually detectable by bulging of the skin surface.

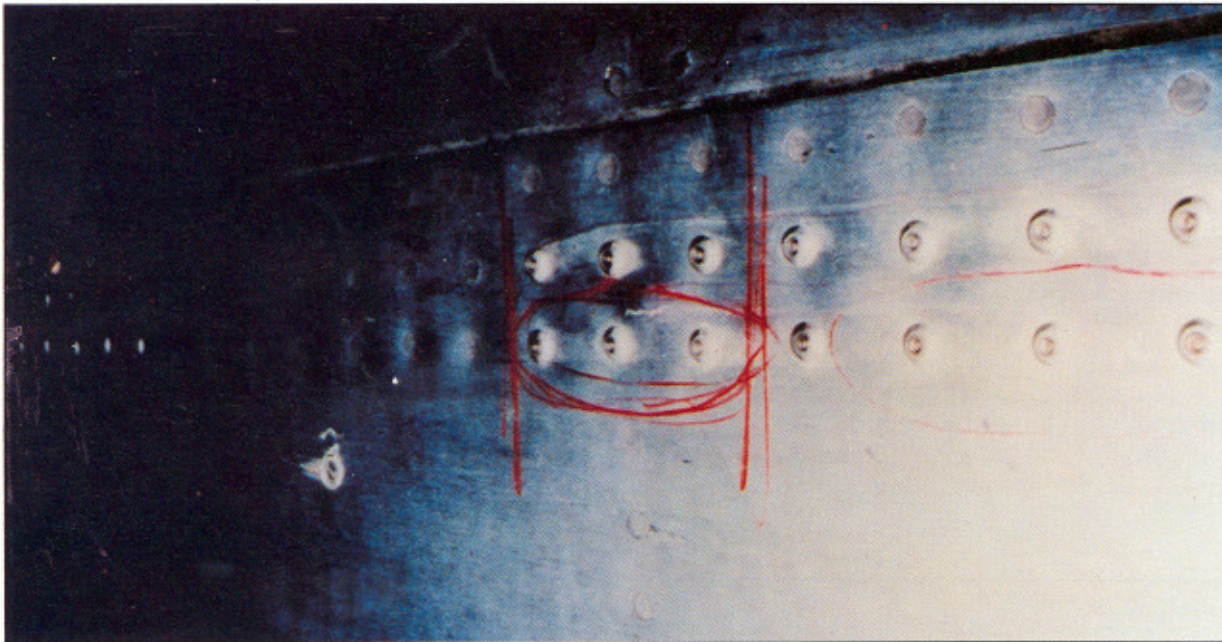

FIGURE 4-5. CRACK AND SKIN BULGING CAUSED BY CORROSION

c. Magnesium Skins. Properly surface treated, insulated, and painted magnesium skin surfaces give relatively little trouble from a corrosion standpoint if the original surface is maintained. However, trimming, drilling, and riveting destroy some of the original surface treatment which may not be completely restored by touch-up procedures.

(1) Some aircraft have steel fasteners installed through magnesium skin with only protective finishes under the fastener heads, and fillet sealant or tape over the surface for insulation. Further, all paint coatings are inherently thin at abrupt changes in contour, such as at trimmed edges. With magnesium's sensitivity to moisture, all of these conditions add up to a potential corrosion problem whenever magnesium is used.

(2) Any inspection for corrosion should include all magnesium skin surfaces, as well as other magnesium fittings or structural components, with special attention to edges, areas around skin edges and fasteners, and cracked, chipped, or missing paint.

d. Spotwelded Skins. Corrosion of this type construction is chiefly the result of the entrance and entrapment of moisture or other corrosive agents between layers of the metal (see Figure 4-6).

(1) Spotwelded assemblies are particularly corrosion prone. Corrosive attack causes skin buckling or spotweld bulging, and eventually spotweld fracture. Some of the corrosion may be caused originally by fabricating processes, but its progress to the point of skin bulging and spotweld fracture is the direct result of moisture or other corrosive agents

working its way through open gaps or seams. The use of weld-through sealing materials is expected to minimize this problem, but many in-service aircraft still have unsealed spotweld skin installed. This type of corrosion is evidenced by corrosion products appearing at the crevices through which the corrosive agents enter.

(2) Corrosion may appear at either external or internal faying surfaces, but it is usually more prevalent on external areas. More advanced corrosive attack causes skin buckling and eventual spotweld fracture. Skin buckling in this early stage may be detected by sighting or feeling along spotwelded seams or by using a straight edge.

(3) To prevent this condition, keep potential moisture entry points including gaps, seams, and holes created by broken welds filled with noncorrosive sealant.

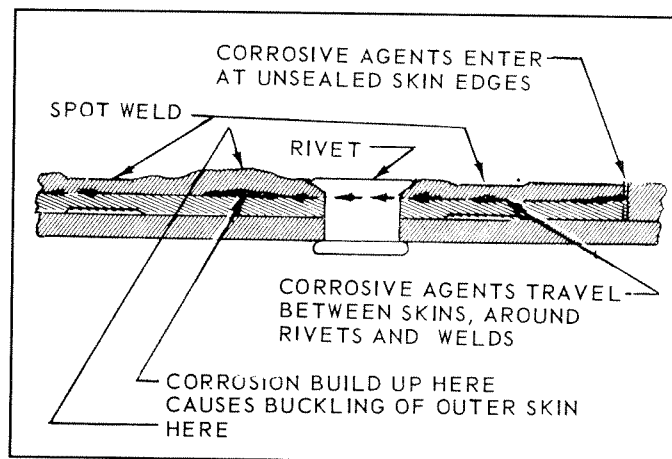

FIGURE 4-6. SPOTWELDED SKIN CORROSION

e. Piano-type Hinges. These are prime spots for corrosion due to dissimilar metal contact between the steel pin and aluminum hinge tangs. They are also natural traps for dirt, salt, and moisture. Where this type of hinge is used on access doors or plates, and actuated only when opened during an inspection, they tend to corrode and freeze in the closed position between inspections. When the hinge is inspected, it should be lubricated and actuated through several cycles to ensure complete penetration of the lubricant (see Figures 4-7 and 4-8).

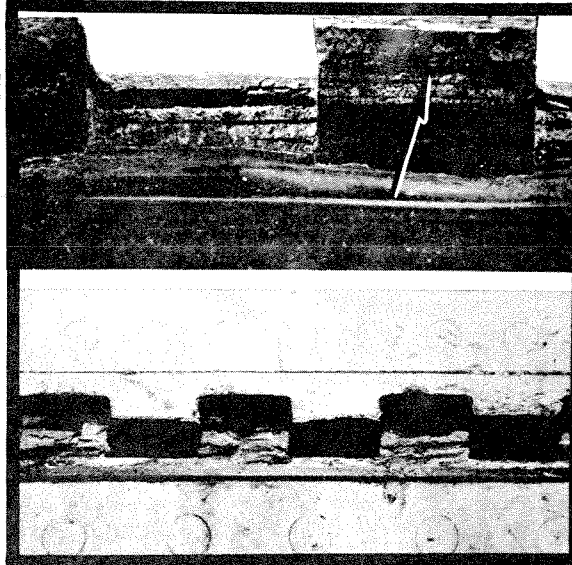
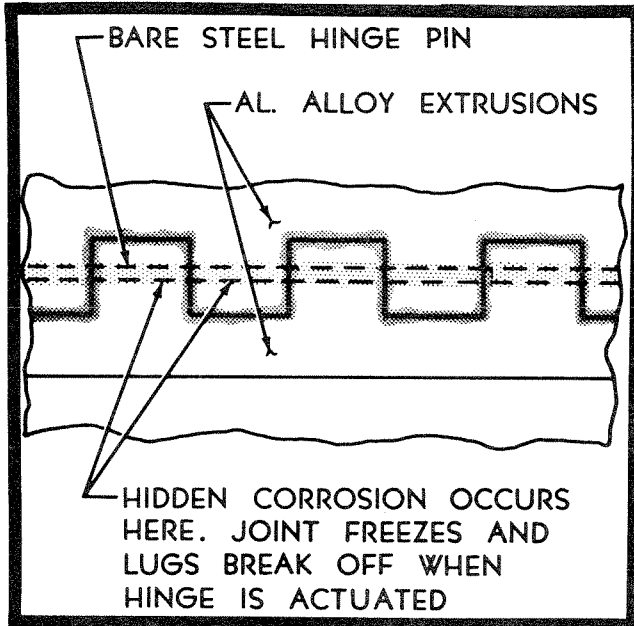

FIGURE 4-7. HINGE CORROSION POINTS

FIGURE 4-8. HINGE FAILURE CAUSED BY CORROSION

f. Heavy or Tapered Aluminum Alloy Skin Surfaces. Heavy or thick sections of most heat-treated aluminum alloys are susceptible to pitting or intergranular corrosion and exfoliation of the metal. When inspecting external skin surfaces, especially around countersunk fastener heads, look for white or grey powder deposits or metal exfoliation. This is usually first evident as small raised areas or bumps under paint film.

(1) Treatment of this corrosive attack includes removal of all corrosion products, i.e., exfoliated metal is blended and polished not to exceed the limits set by the aircraft manufacturer. If corrosion products remain after the limits set by the aircraft manufacture have been reached, contact the aircraft manufacturer or the Federal Aviation Administration (FAA) for authorized limits. The treatment is not complete until the restoration of protective surface finishes is accomplished.

(2) Protect reworked areas with a chemical conversion coating, sealant primer, and top coat if applicable. Reworked areas should be carefully watched for any indications of renewed corrosive activity.

g. Organic Composites. Organic composites used in aircraft can cause different corrosion problems than those normally associated with all metal structure. Composites such as graphite/epoxy act as a very noble (cathodic) material, creating the potential for galvanic corrosion. The galvanic corrosion potential coupled with different methods of attachment (i.e., adhesive bonding, stepped structures, locking mechanical fasteners, etc.) lead to multicomponent galvanic couples with the problem being particularly aggravated by high humidity and salt water environments. Application of aircraft sealants over the

dissimilar metal/composite junctions will prevent galvanic corrosion if moisture is completely excluded. However, since complete exclusion of moisture is virtually impossible under extended periods of flight operation, the most effective method of eliminating the voltage potential is to provide a nonconductive layer such as fiberglass/epoxy and/or sealant between the composite and dissimilar metal surfaces.

407. WATER ENTRAPMENT AREAS. Corrosion will result from the entrapment of moisture. With the exception of sandwich structures, design specifications usually require that the aircraft have low point drains installed in all areas where moisture and other fluids can collect. In many cases, these drains are ineffective either due to location or because they are plugged by sealants, extraneous fasteners, dirt, grease, and debris. Potential entrapment areas are not a problem when properly located drains are functioning, and the aircraft is maintained in a normal ground attitude. However, the plugging of a single drain hole or the altering of the level of the aircraft can result in a corrosion problem if water becomes entrapped in one of these "bathtub" areas. Daily inspection of low point drains is a recommended practice.

408. ENGINE FRONTAL AREAS AND COOLING AIR VENTS. Constant abrasion by airborne dirt and dust, bits of gravel from runways, and rain tends to remove the protective surfaces from these areas. Furthermore, cores of radiator coolers, reciprocating engine cylinder fins, etc., due to the requirement for heat dissipation, may not be painted. Engine accessory mounting bases usually have small areas of unpainted magnesium or aluminum on the machined mounting surfaces. With moist and salt or industrial pollutant-laden air constantly flowing over these surfaces, they are prime sources of corrosive attack. Inspection of such areas should include all sections in the cooling air path with special attention to obstructions and crevices where salt deposits may build up during marine operations (see Figures 4-9 and 4-10).

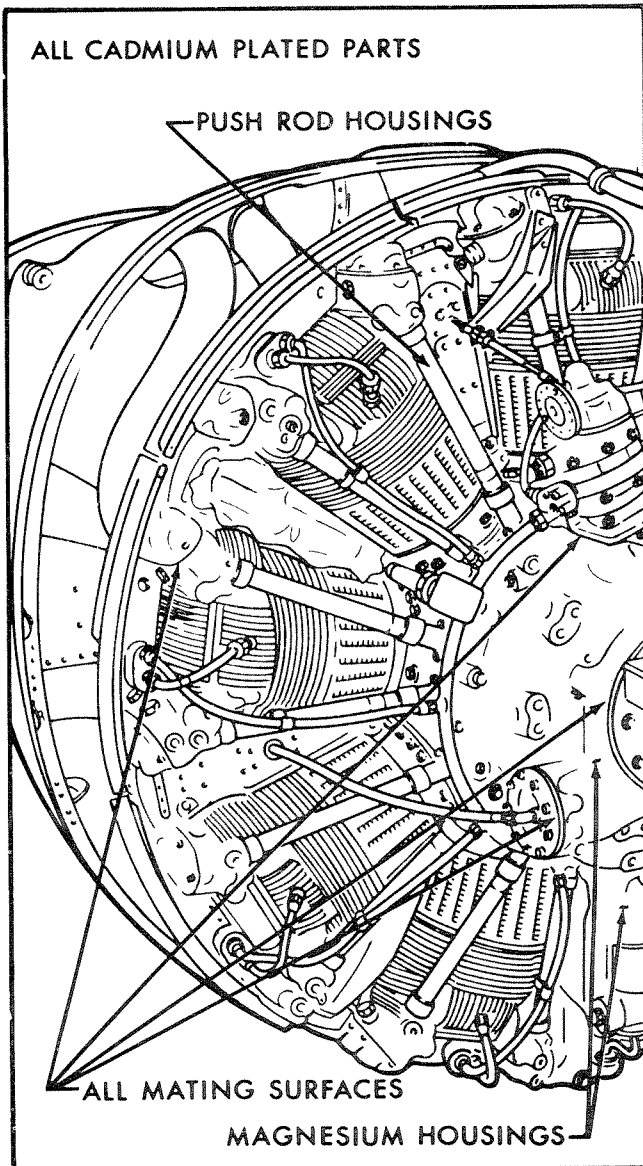

FIGURE 4-9. RECIPROCATING ENGINE
FRONTAL AREA CORROSION

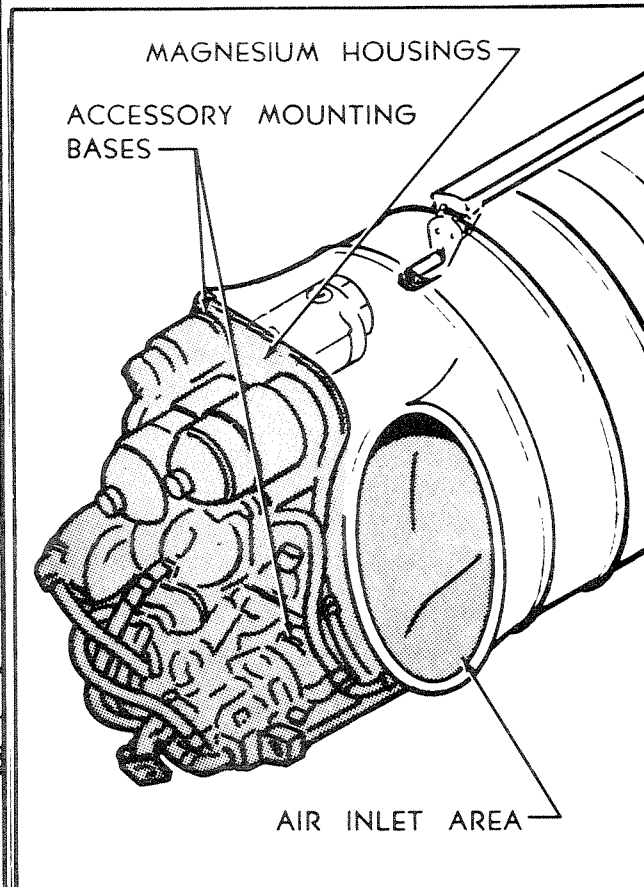

FIGURE 4-10. JET ENGINE FRONTAL
AREA CORROSION POINTS

409. ELECTRONIC PACKAGE COMPARTMENTS. Electronic and electrical package compartments cooled by ram air or compressor bleed air are subjected to the same conditions common to engine and accessory cooling vents and engine frontal areas. While the degree of exposure is less because of a lower volume of air passing through and special design features incorporated to prevent water formation in enclosed spaces, this is still a trouble area that requires special attention.

a. Circuit breakers, contact points, and switches are extremely sensitive to moisture and corrosive attack and should be inspected for these conditions as thoroughly as design permits. If design features hinder

examination of these items while in the installed condition, inspection should be accomplished after component removal for other reasons.

b. Treatment of corrosion in electrical and electronic components should be done only by, or under the direction of, qualified personnel familiar with the function of the unit involved as conventional corrosion treatment may be detrimental to some units.

c. Most corrosion that occurs on avionic equipment is similar to that which occurs on the basic airframe structure. The difference between avionic and airframe corrosion is that minute amounts of corrosion in avionic equipment can cause serious degradation or complete failure, while it would be unnoticed on larger structures.

d. Smog, smoke, soot, and other airborne contaminants are extremely corrosive to exposed avionic equipment. Many fumes and vapors emitted from factories or industrial complexes are highly acidic and greatly accelerate corrosion. An example is the corrosive effect of ozone, a product of many welding machines and large electrical motors. Complete degradation of rubber seals and damage to delicate components have occurred in equipment stored near ozone-producing equipment. Avionic shops and storage areas should have a filtered air-conditioning system.

e. Another man-made atmosphere is the aircraft environmental control system. These systems induce cooling air to the equipment. They may include a filter system that extracts moisture, and in some cases contaminants, from the air that enters the equipment. Failure to replace and/or clean a filter, or eliminate a leaky environmental seal, may cause a moisture or contaminant buildup that could cause a corrosive atmosphere within the equipment.

f. The control of corrosion in avionic systems is similar to that in airframes, with appropriate modifications. The general differences in construction and procedures between airframe and avionics relative to corrosion control are:

- (1) Less durable protection systems;
- (2) Small amounts of corrosion can make equipment inoperative;
- (3) Dissimilar metals are often in electrical contact;
- (4) Stray currents can cause corrosion;
- (5) Active metals and dissimilar metals in contact are often unprotected;
- (6) Closed boxes can produce condensation during normal temperature changes during flight;
- (7) Avionic systems have many areas to trap moisture;

(8) Hidden corrosion is difficult to detect in many avionic systems;

(9) Many materials used in avionic systems are subject to attack by bacteria and fungi; and

(10) Organic materials are often used which, when overheated or improperly or incompletely cured, can produce vapors which are corrosive to electronic components and damaging to coatings and insulators.

410. MISCELLANEOUS TROUBLE AREAS. A variety of additional trouble spots exists, and some are covered by manufacturers' publications. Most aviation activities can add a favorite to the following list:

a. Examine all flexible hose assemblies for chafing, weather checking, hardening, discoloration, evidence of fungus, and torn weather protective coatings or sleeves. Replace those hoses that are found to be discrepant.

b. Trimmed edges of sandwich panels and drilled holes should have some type of corrosion protection. A brush treatment with an inhibitor solution or the application of a sealant along the edge, or both, is recommended. Any gaps or cavities where moisture, dirt, or other foreign material can be trapped should be filled with a sealant. The adjacent structure (not the sandwich) should have sufficient drainage to prevent moisture accumulation. Damage or punctures in panels should be sealed as soon as possible to prevent additional moisture entry--even if permanent repair has to be delayed.

c. Control cables may present a corrosion problem whether carbon steel or stainless steel is used. The presence of bare spots in the preservative coating is one of the main contributing factors in cable corrosion. Cable condition should be determined by cleaning the cable assembly, inspection for corrosion, and application of an approved preservative if no corrosion is found. If external corrosion is found, relieve tension on the cable and check internal strands for corrosion. Cables with corrosion on internal strands should be replaced. Pay particular attention to sections passing through fairleads, around sheaves, and grooved bellcrank arms. External corrosion should be removed by a clean, dry, coarse rag or fiber brush. After complete corrosion removal, apply a preservative.

d. Topcoating materials (Buna - N, Polyurethane, and Epoxy) used in integral fuel cells are impervious to fuel but not completely impervious to moisture absorption. Since it is impossible to keep fuel completely free of water, moisture can penetrate through the topcoating materials and sometimes causes pitting or intergranular corrosion on aircraft structural parts. It has also been found that micro-organisms which live in the water entrained by fuel, particularly jet propellant types, feed on fuel hydrocarbon and hydrocarbon-type elastomeric coatings materials. These micro-organisms excrete organic acids, and dead micro-organisms act as a gelatinous acidified sponge which can deteriorate integral tank coatings and corrode the aircraft structure. Microbial corrosion can be minimized by preventing as much water contamination of the fuel as possible with well-managed storage facilities, adequate filtration of fuel, and drainage of water contamination from integral fuel cells which keeps the water moving and reduces the chance for the colonies of micro-organisms to develop. Micro-organic activity can be reduced by using a biocide

additive such as "Biobor JF" or equivalent. Solution strength and application frequency should be in accordance with the manufacturer's instructions.

e. Electrical connectors/components may be potted with a sealing compound to provide more reliability of equipment. The sealing compound prevents entrance of moisture into the area of connectors where the wires are attached to the pins.

(1) Rubber O-rings may also be used to seal moisture out of the mating area of pin connections and to prevent loss of pressurization in compartments containing bulkhead connectors.

(2) Moisture intrusion into electrical connectors can cause corrosion and an electrical failure. Suspected plugs should be disconnected, disassembled, solvent cleaned, and inspected for corrosion.

(3) When sealing provisions are not designed into the electrical component, these components can have moisture intrusion and internal corrosion.

f. Severe corrosion damage to the rear pressure bulkhead below the floor may occur as a result of contamination by fluids. Inspection for rear bulkhead corrosion may require extensive disassembly of components and fixtures to allow a thorough visual inspection. When inspection access holes are available, inspection by fiber optics is useful. Other nondestructive inspection (NDI) methods (x-ray, ultrasonic, and eddy current) are also available. However, these inspection techniques require specially trained personnel, NDI comparison standards, and suitable access. A regular inspection of the rear pressure bulkhead (both front and rear faces) below the floor level should be accomplished to prevent serious corrosion from occurring between the bulkhead and periphery doubler at the floor level. Such corrosion could weaken the bulkhead skin and cause sudden cabin pressure loss.

g. Some older aircraft have developed delaminations in cold bonded joints. Corrosion between the delaminated surfaces is caused by moisture intrusion along the edge of the mating parts or around fasteners securing the mating parts together. Localized bulging of the skin or internal structural component, usually around the fasteners, is the first indication of a corrosion problem (see Figure 4-11). Skin cracks or dished or missing fastener heads may also indicate severe corrosion in bonded joints. Corrosion which occurs between skins, doublers, and stringers or frames will produce local bulging or pulled rivets (see Figure 4-12). Corrosion that occurs between the skins and doublers or tear straps away from backup structure such as stringer or frame will not produce local bulging. An external low frequency eddy current inspection may be used to determine the extent of corrosion in the skin. Lap joints should be opened with wedges to determine the full extent of corrosion damage (see Figures 4-13 and 4-14). Internal visual inspection should be used to detect delaminated doublers or tear straps. A penetrating water displacement corrosion inhibitor should be applied to faying surfaces after corrosion removal and repair.

h. Flap and slat recesses and equipment installed in these areas, which are normally closed, may corrode unnoticed unless special inspections are performed.

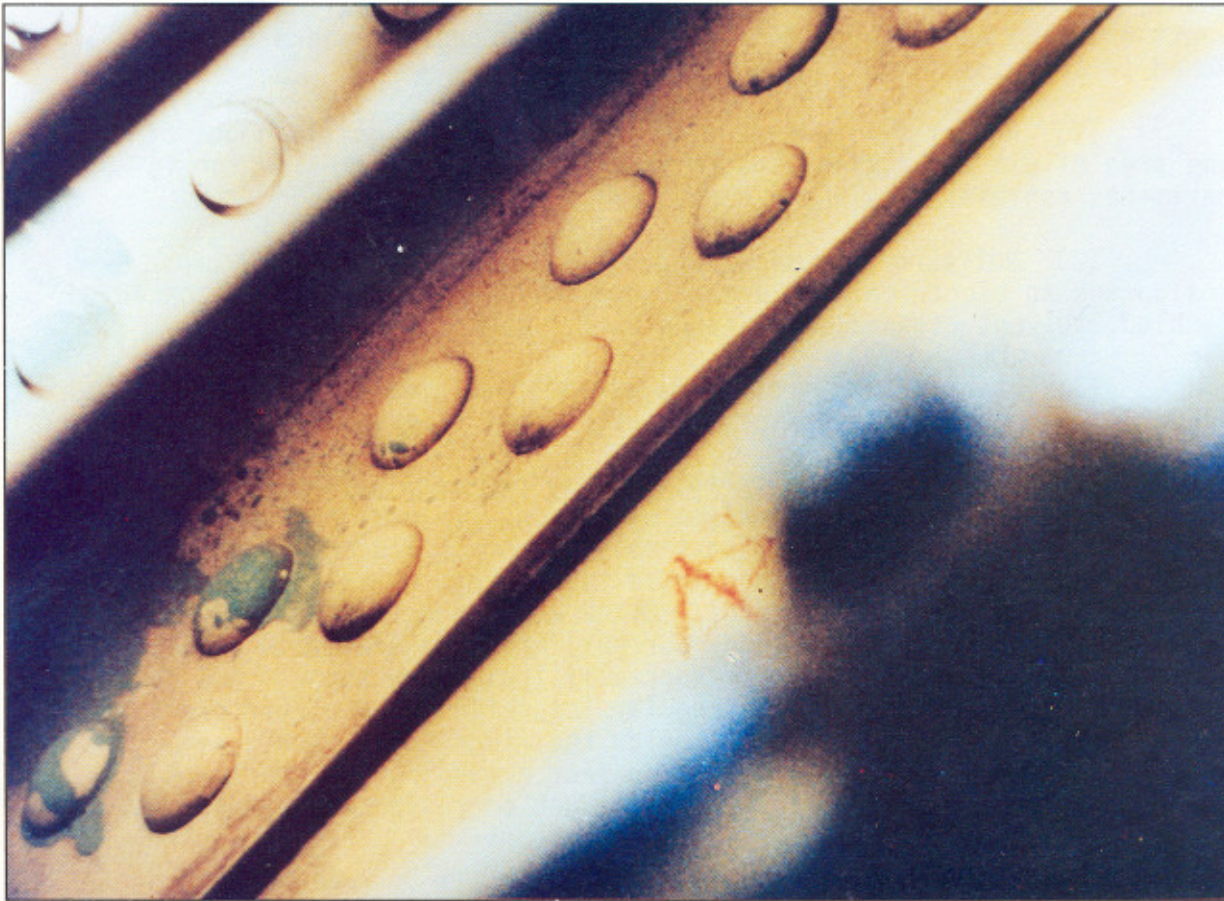

FIGURE 4-11. SPAR CHORD LIFTING CAUSED BY CORROSION PRODUCTS

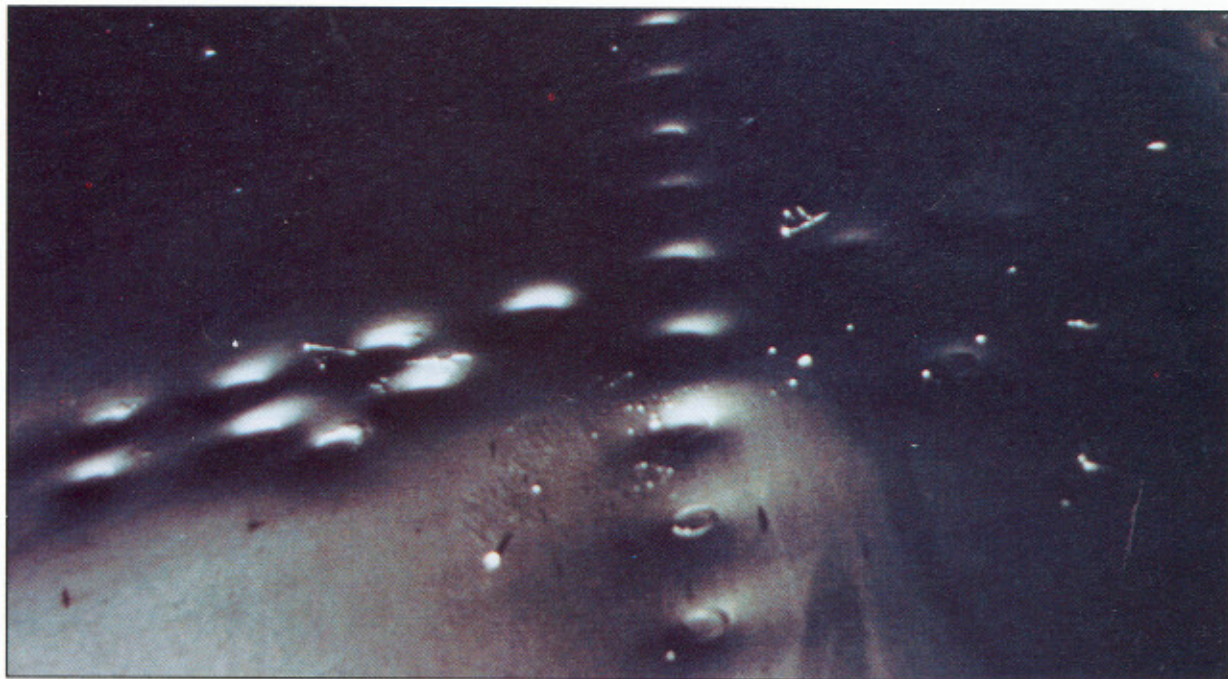

FIGURE 4-12. SKIN BULGING AROUND FASTENERS

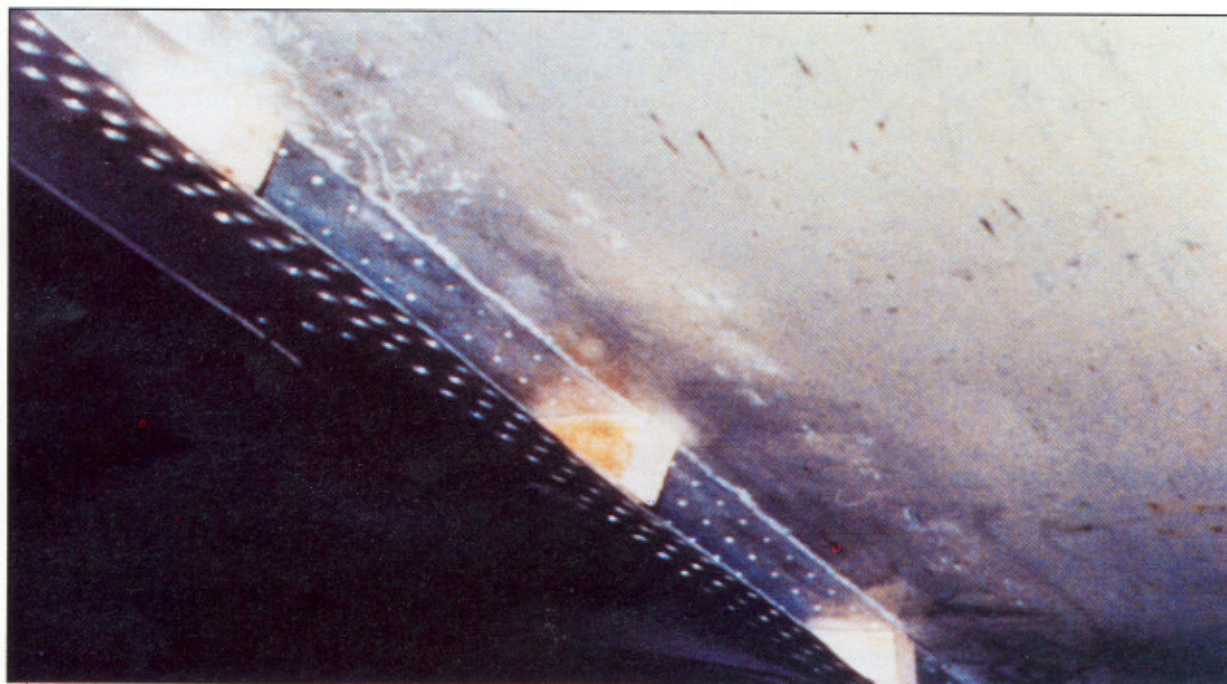

FIGURE 4-13. OPENING OF A CORRODED LAP JOINT FOR REPAIR

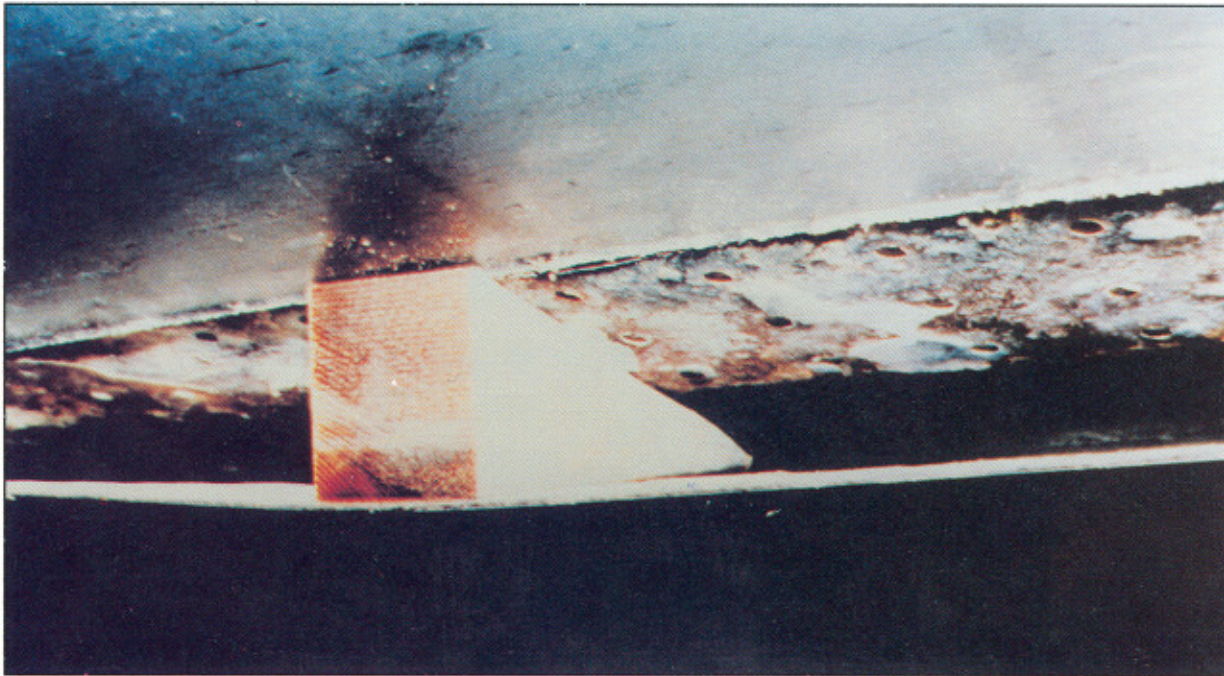

FIGURE 4-14. CLOSEUP VIEW OF A CORRODED LAP JOINT

411. FACTORS IN CORROSION CONTROL.

a. Corrosion Factors. The degree of severity, the cause, and the type of corrosion depend on many factors, including the size or thickness of the part, the material, heat treatment of the material, protective finishes, environmental conditions, preventative measures, and design.

(1) Thick structural sections are generally more susceptible to corrosive attack because of variations in their composition, particularly if the sections are heat-treated during fabrication. When large sections are machined or chem-milled after heat treatment, the corrosion characteristics of thinner sections may be different from those of thicker areas. Section size is based on structural requirements and cannot be changed for the purpose of controlling corrosion. From a maintenance standpoint, the correct approach is one of recognizing the need to ensure the integrity and strength of major structural parts and maintaining permanent protection over such areas at all times.

(2) In-service stresses and field repairs may affect the rates and types of corrosion. Aircraft structure under high cyclic stresses, such as helicopter main rotors, are particularly subject to stress-corrosion cracking. Also areas adjacent to weld repaired items often have corrosion due to insufficient removal of the weld flux, or, for some steels, buildup of a magnetic field. Areas such as these should be closely inspected for signs of corrosion and, when found, proper treatment accomplished.

b. Corrosion Control in Design. Since corrosion is the deterioration of metals resulting from reactions between metals and their environment, some corrosion control or means to minimize corrosion when the aircraft enters operational service should be introduced during the design phase. The corrosion issues discussed in this AC provide information to reduce the rate of corrosive attack by corrosion control measures introduced early in design.

(1) The nature of the material is a fundamental factor in corrosion. High-strength, heat-treatable aluminum and magnesium alloys are very susceptible to corrosion, while titanium and some stainless steel alloys are less susceptible in atmospheric environment. The aircraft manufacturer selects material for the aircraft based on material strength, weight, and cost, while corrosion resistance is often a secondary consideration. However, corrosion control should be considered as early as possible during the preliminary design phase.

(2) The use of more corrosion resistant materials in any design normally involves additional weight to achieve required strength. Since weight consideration is a major factor in the construction of airframes, the primary means of preventing corrosion is by use of protective coatings and proper maintenance procedures.

(3) The use of corrosion resistant alloys is not a cure-all for corrosion prevention. A common mistake is to replace a corroded part with a corrosion resistant alloy only to find that the corrosion has now shifted to another part and increased in severity.

(4) The problem of protection against corrosion is minimized if the material to be protected is intrinsically resistant to corrosion. Aluminum copper alloys are known to have better stress-corrosion resistance and better fatigue strength properties than aluminum zinc alloys; therefore, they are often used as the primary structural materials.

(5) Galvanic corrosion is created by dissimilar metals being in contact with each other. The galvanic series of metals and alloys (Table 4-1) is a factor that should be considered in the repair of aircraft. The further apart the metals listed in Table 4-1 are, the greater the tendency will be for galvanic corrosion. The metals grouped together in Table 4-2 have little differences in electrical potential; thus they are relatively safe to use in contact with one another. However, the coupling of metals from different groups will result in corrosion of the group having a lower number.

TABLE 4-1. GALVANIC SERIES OF METALS AND ALLOYS

Electrode Potential of Various Metals and Alloys (a)	
Metal or Alloy (b)	Potential, volts 0.1 N calomel scale (c)
Magnesium	-1.73
Zinc	-1.10
7072, Alclad 3003, Alclad 6061, Alclad 7075	-0.96
5056, 7079-T6, 5456, 5083, 214, 218	-0.87
5052, 5652, 5086, 1099	-0.85
3004, B214, 1185, 1060, 1260, 5050	-0.84
1100, 3003, 615, 6053, 6061-T6, 6062-T6, 6063, 6363, Alclad 2014, Alclad 2024	-0.83
Cadmium	-0.82
7075-T6, 356-T6, 360	-0.81
2024-T81, 6061-T4, 6062-T4	-0.80
355-T6	-0.79
2014-T6, 113, 750-T5	-0.78
2014-T4, 2017-T4, 2024-T3, and T4	-0.68 to -0.70 (d)
Mild steel	-0.58
Lead	-0.55
Tin	-0.49
Copper	-0.20
Bismuth	-0.18
Stainless steel (series 300, type 430)	-0.09
Silver	-0.08
Nickel	-0.07
Chromium	-0.49 to +0.018

(a) Data from Alcoa Research Laboratories.
 (b) The potential of all tempers is the same unless temper is designated.
 (c) Measured in an aqueous solution of 53g of sodium chloride + 3g hydrogen peroxide per liter at 25 degree C.
 (d) The potential varies with quenching rate.

TABLE 4-2. GROUPING OF METALS AND ALLOYS

GROUP I	Magnesium and Magnesium Alloys.
GROUP II	Aluminum, Aluminum Alloys, Zinc, Cadmium and Cadmium-Titanium Plate.
Group III	Iron, Steels - Except Stainless Steels; Lead, Tin and their Alloys.
GROUP IV	Copper, Brass, Bronze, Copper-Beryllium, Copper-Nickel Chromium, Nickel, Nickel Base Alloys, Cobalt Base Alloys, Carbon Graphite, Stainless Steels, Titanium and Titanium Alloys.

- NOTE:
1. Metals listed in the same group are considered similar to one another.
 2. Metals listed in different groups are considered dissimilar to one another.

c. Protective Finishes. Protective finishes provide protection for the base material from corrosion and other forms of deterioration. Protective finishes are divided into 2 separate categories, sacrificial and non-sacrificial. Sacrificial coatings include cadmium, zinc, and aluminum. Non-sacrificial coatings include hard plating (chromium and nickel), chemical conversion coatings, sealant, primers, and top coat.

d. Geographical Location and Environment. This factor concerns systems exposed to marine atmospheres, moisture, acid rain, tropical temperature conditions, industrial chemicals, and soils and dust in the atmosphere. Limit, whenever possible, the requirement for operation of aircraft in adverse environments.

(1) Moisture is present in the air as a gas (water vapor) or as finely divided droplets of liquid (mist or fog) and often contains contaminants such as chlorides, sulfates, and nitrates, which increase its corrosive effects. Condensed moisture which evaporates will leave its contaminants behind. Condensed moisture and its contaminants can also be trapped in close fitting, wettable joints, such as faying surfaces and be drawn along poor bond lines by capillary action.

(2) Salt particles, when dissolved in water, form strong electrolytes. Normal sea winds carry dissolved salt which makes coastal environments highly corrosive.

(3) Industrial pollutants (such as carbon, nitrates, ozone, sulfur dioxide, and sulfates) contribute to the deterioration of nonmetallic materials and can cause severe corrosion of metals.

(4) Warm, moist air, normally found in tropical climates accelerates corrosion while cold, dry air normally found in arctic climates reduces corrosion.

e. Heat Treatment. Proper heat treatment of materials is a vital factor in maximizing resistance to corrosion.

412. PREVENTATIVE MAINTENANCE.

a. Prevention. Corrosion prevention of aircraft structure depends on a comprehensive corrosion prevention and control plan, implemented from the start of operation of an aircraft, which includes:

(1) Adequately trained personnel in:

(i) Recognition of corrosion inducing conditions;

(ii) Corrosion identification techniques;

(iii) Corrosion detection, cleaning, and treating; and

(iv) Lubrication and preservation of aircraft structure and components.

(2) Inspection for corrosion on a scheduled basis.

(3) Thorough cleaning, inspection, lubrication, and preservation at prescribed intervals. Suggested intervals based on operating environment (see Figures 4-15 through 4-20) are:

(i) Mild zones -- Every 90 days;

(ii) Moderate zones -- Every 45 days; and

(iii) Severe zones -- Every 15 days.

(4) Prompt corrosion treatment after detection.

(5) Accurate record keeping and reporting of material or design deficiencies to the manufacturer and the FAA.

(6) Use of appropriate materials, equipment, and technical publications.

(7) Maintenance of the basic finish systems.

(8) Keeping drain holes and passages open and functional. Sealants, leveling compounds, miscellaneous debris, or corrosion inhibitors should not block drain paths (see Figure 4-21).

(9) Replacing deteriorated or damaged gaskets and sealants (using noncorrosive type sealants) to avoid water intrusion and entrapment which leads to corrosion.

(10) Minimizing the exposure of aircraft to adverse environments, such as hangaring away from salt spray.

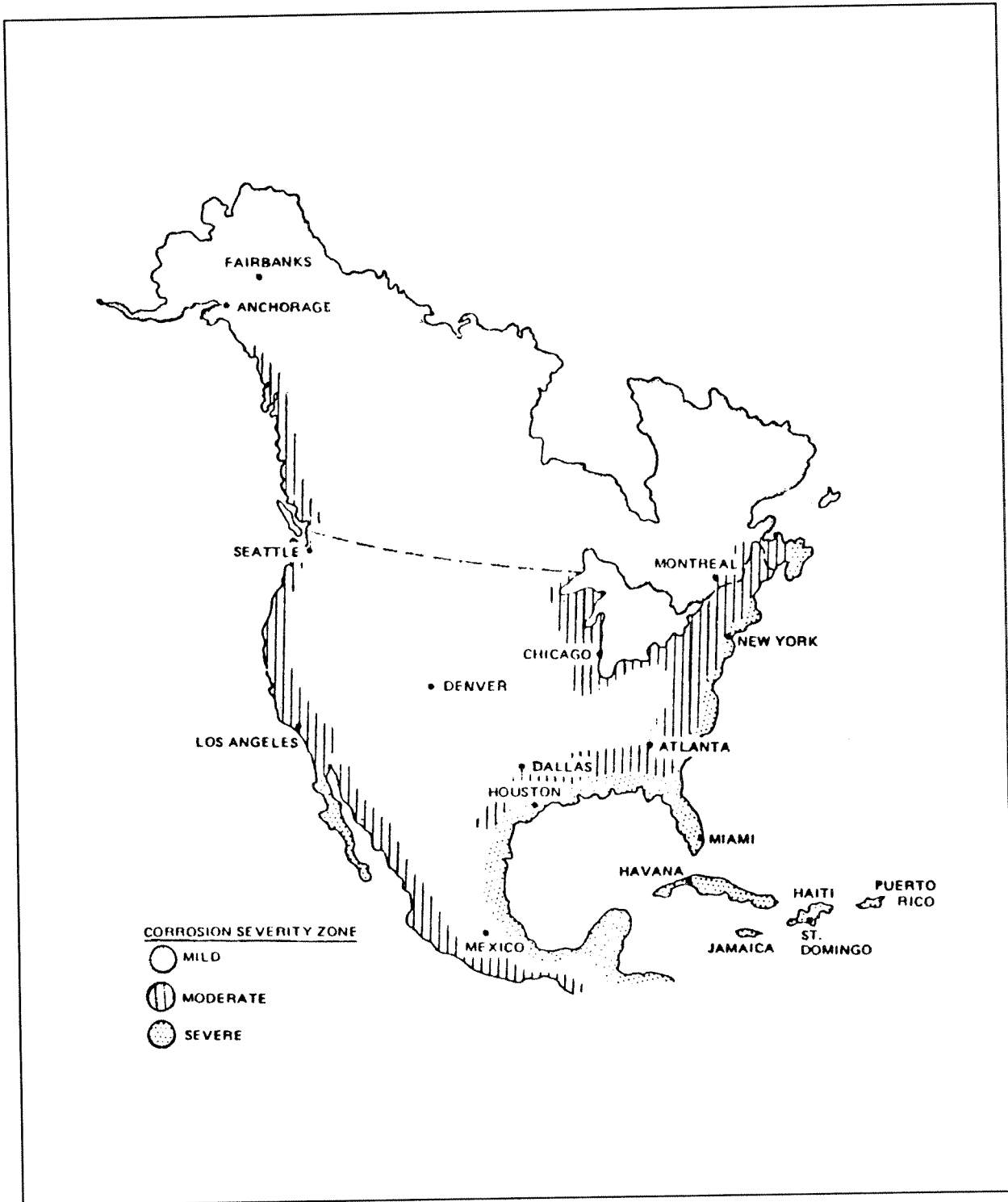

FIGURE 4-15. NORTH AMERICA CORROSION SEVERITY MAP



FIGURE 4-16. SOUTH AMERICA CORROSION SEVERITY MAP

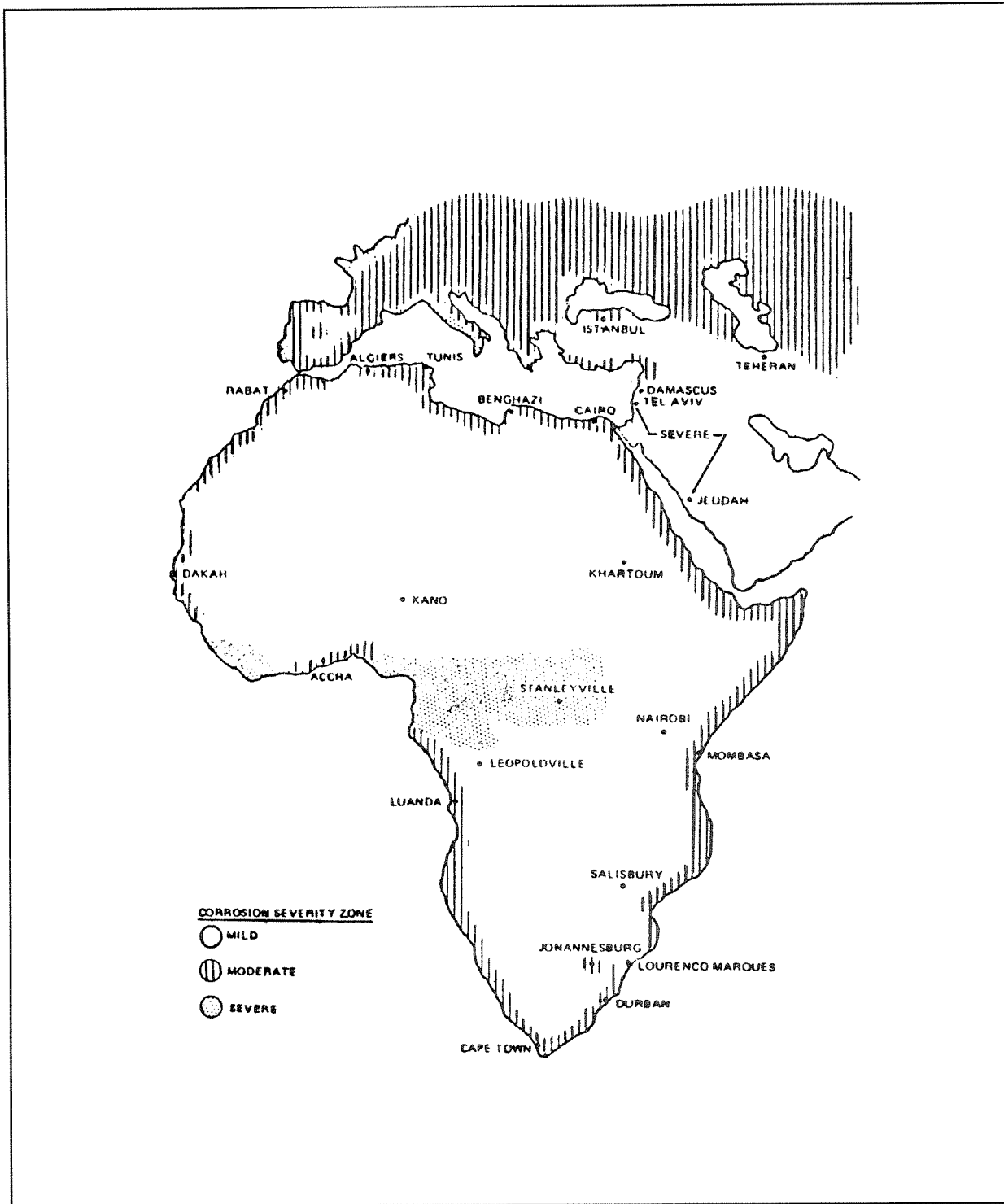

FIGURE 4-17. AFRICA CORROSION SEVERITY MAP

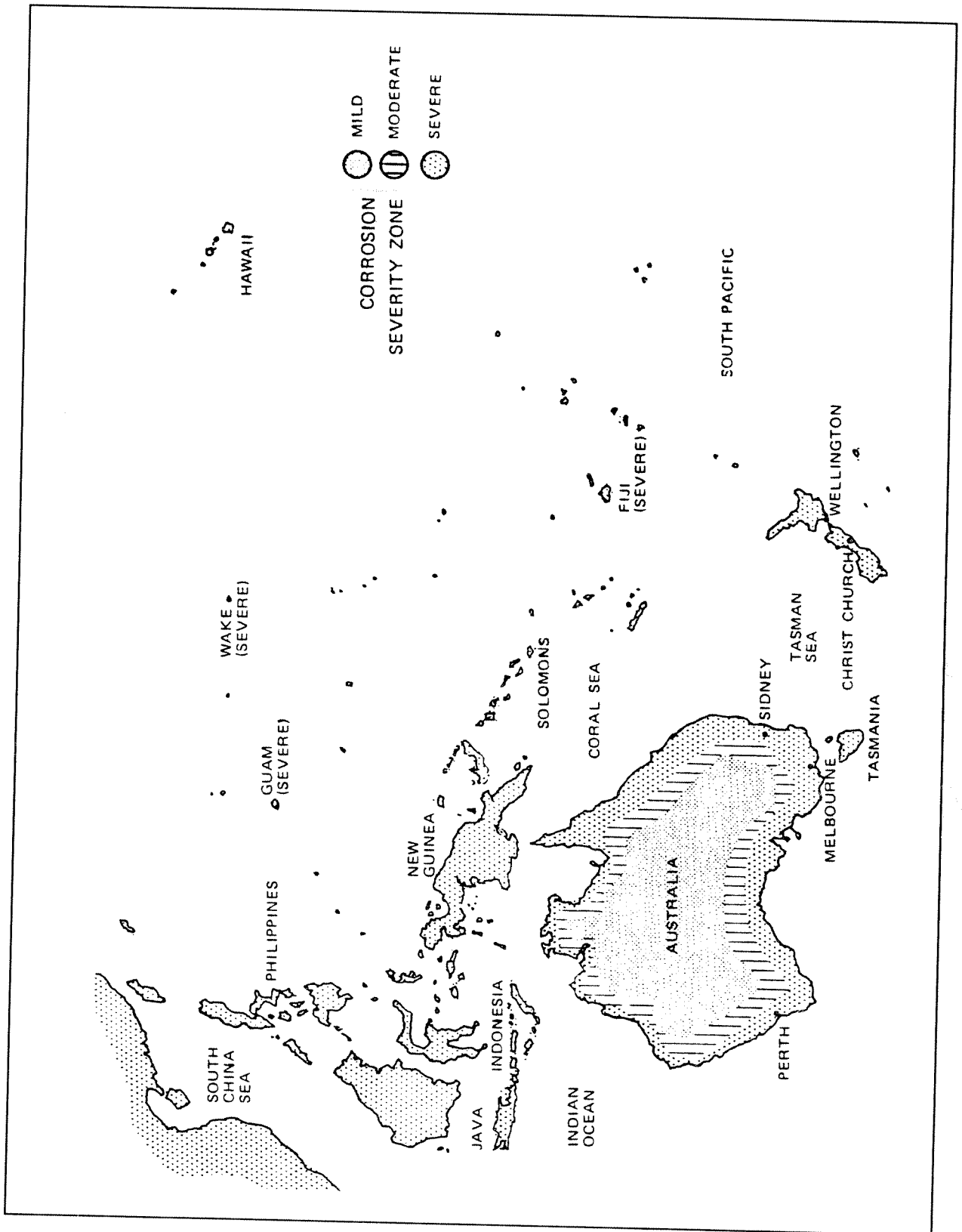

FIGURE 4-18. SOUTH PACIFIC CORROSION SEVERITY MAP

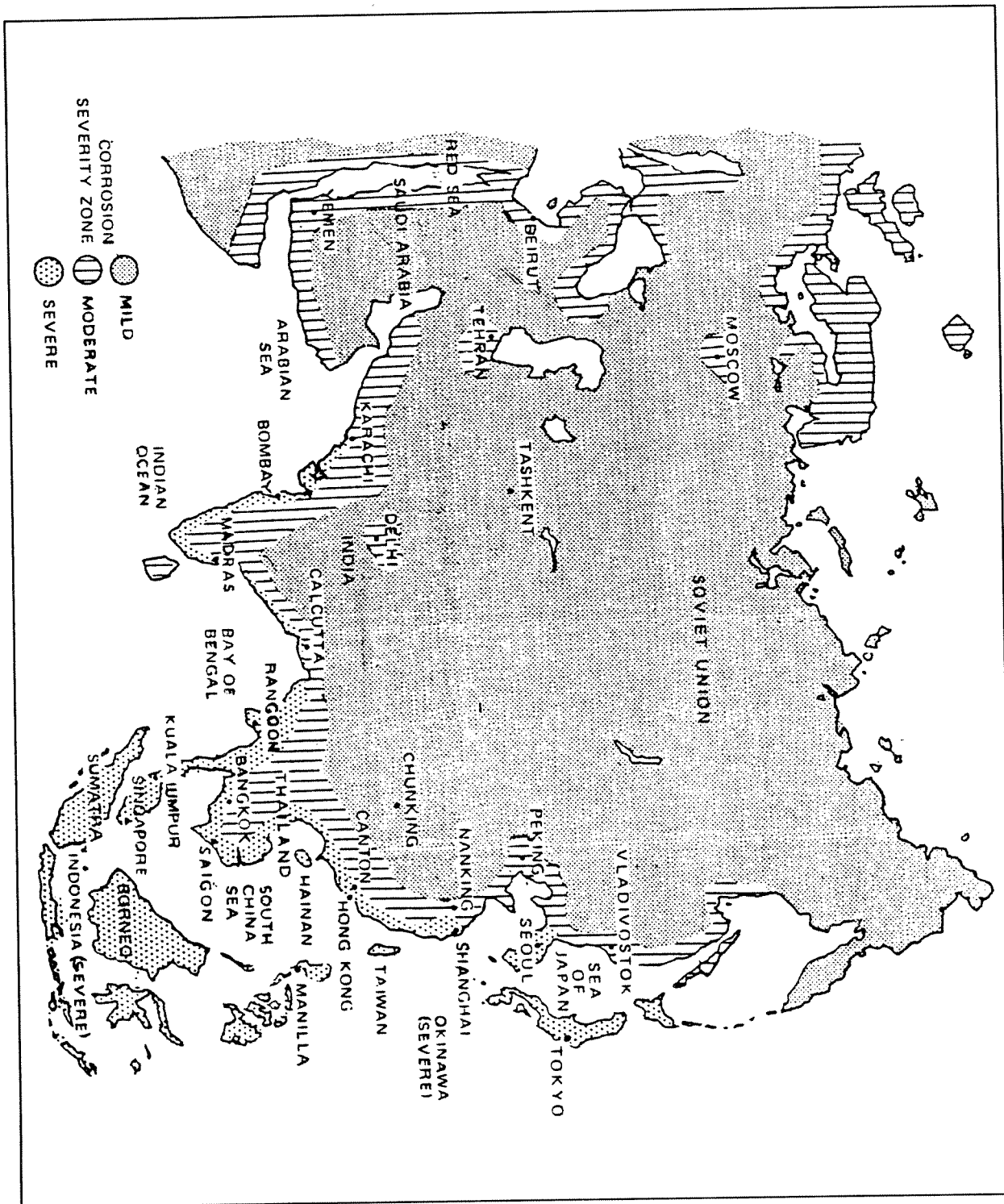

FIGURE 4-19. ASIA CORROSION SEVERITY MAP

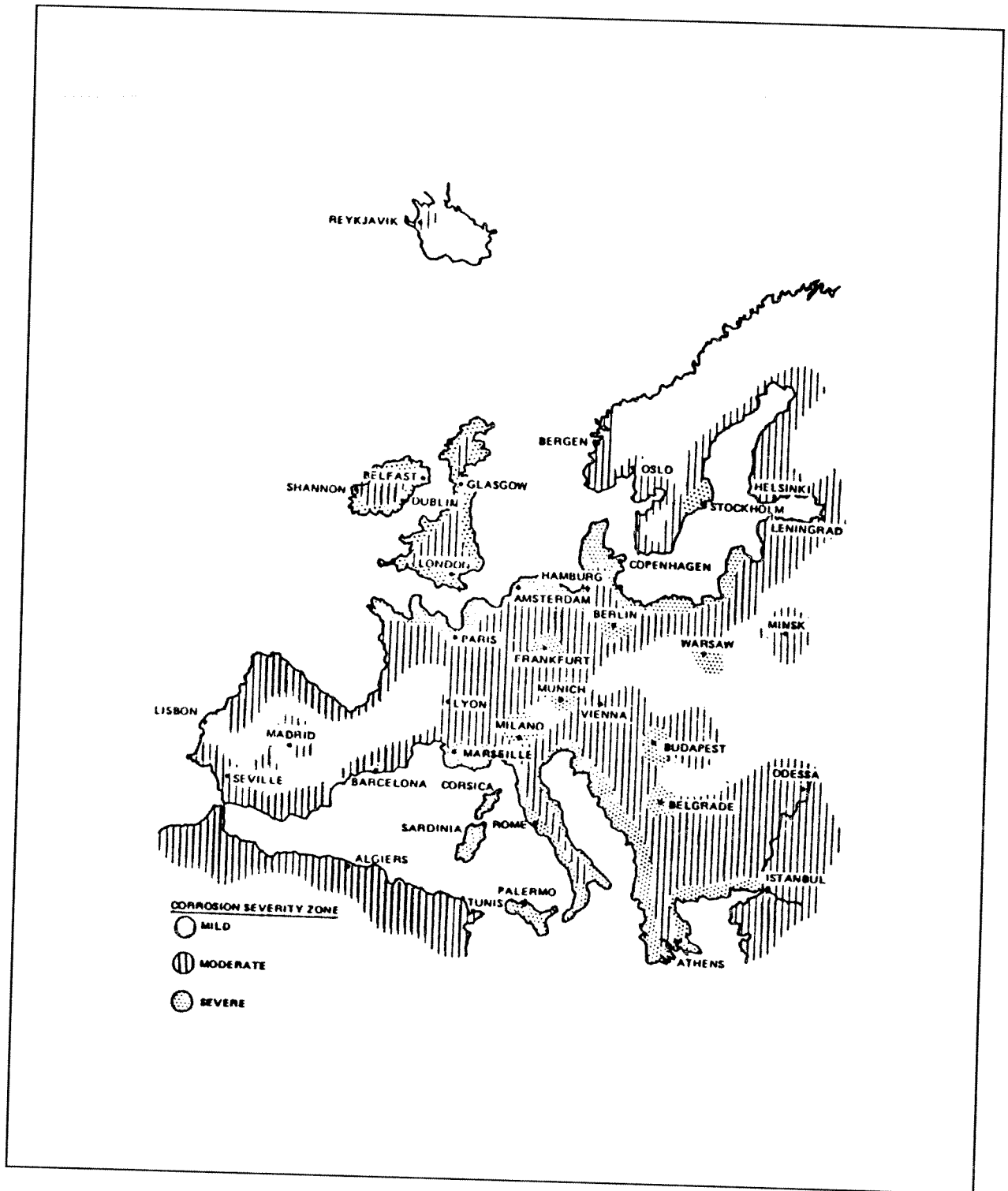

FIGURE 4-20. EUROPE AND ASIA MINOR CORROSION SEVERITY MAP

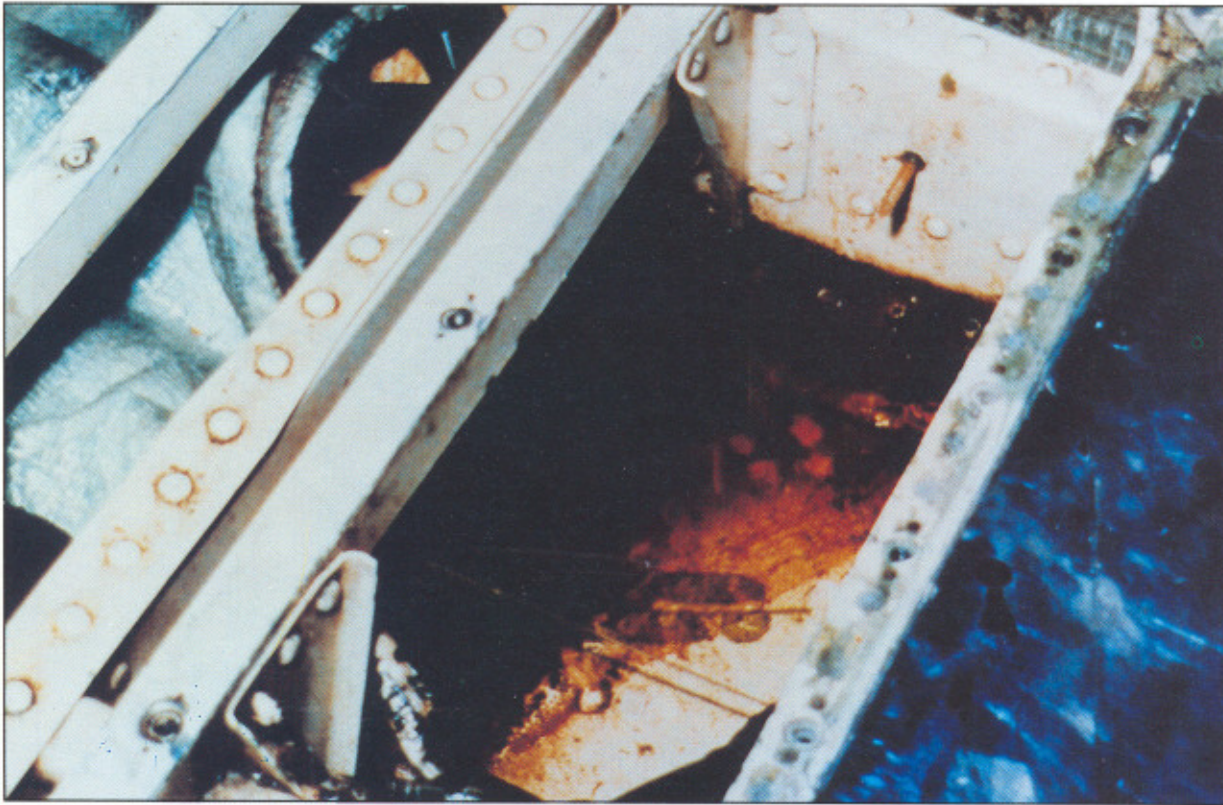

FIGURE 4-21. BLOCKED DRAIN PASSAGES RESULTED IN ACCUMULATION OF CORROSION CONTAMINATES AND MOISTURE

b. Cleaning Compounds.

NOTE: "More is not always better." Mixing more cleaning compound increases the pH of the solution which can do more harm than good. A cleaning compound should always be mixed in accordance with the manufacturer's recommendations.

(1) Cleaning compounds work by dissolving soluble soils, emulsifying oily soils, and suspending solid soils. There are several types of cleaning compounds, each of which cleans a surface using one or more of these mechanisms.

(2) Highly alkaline cleaning compounds (pH greater than 10) are not recommended. Moderately alkaline cleaners (pH between 7.5 and 10) conforming to MIL-C-85570, Types I and II, are recommended. Both types contain detergents, foaming agents, and solvents, and work in the same way as a detergent solution.

(3) High gloss spot cleaner conforming to MIL-C-85570, Type III, is recommended for cleaning exhaust track areas of high gloss paint systems. This material contains solvents, detergents, and suspended abrasive matter to remove soil by wearing away the surface that holds it.

(4) Thixotropic (viscous) cleaner conforming to MIL-C-85570, Type V, is recommended for cleaning wheel wells and replacement of some solvent cleaning where water rinsing can be tolerated. This cleaner contains solvents, detergents and some thickening agents. When applied undiluted to an oily or greasy surface, the cleaner clings long enough to emulsify the soil (about 5 to 15 minutes) and can then be rinsed away with fresh water.

NOTE: The use of solvents for cleaning operations is becoming more and more limited due to environmental regulations. Determine local requirements for waste disposal.

(5) Solvent emulsion cleaners conforming to MIL-C-43616 and MIL-C-85704 become emulsions when diluted. The solvent contained in the cleaner softens oily soils so that they can be emulsified by the detergent and rinsed away.

(6) Detergent solution cleaners conforming to MIL-D-16791 dissolve in water and clean by dissolving soluble salts, emulsifying low viscosity oils, and suspending easily removed dirt and dust. They are not very effective on grease, but are excellent cleaners for interior lightly soiled areas, plastics, and instrument glass covers.

(7) Cleaning solvents dissolve oily and greasy soils so that they can be easily wiped away or absorbed on a cloth. Solvents differ significantly in cleaning ability, toxicity, evaporation rate, effect on paint, and flammability. The use of cleaning solvents is intended for localized spot application only. A dry cleaning solvent conforming to P-D-680, Type II, is the most common cleaning solvent used on aircraft, due to its low toxicity, minimal effect on paint, and relative safety. Other solvents, such as alcohols, ketones, chlorinated solvents, and naphtha, are specialized materials and have restricted use. Refer to the manufacturer's maintenance and cleaning procedures for specific applications.

(8) Miscellaneous cleaning agents include:

(i) Plastic polish which contains mild abrasive matter to polish out scratches in canopy materials;

(ii) Alkaline chemicals used to neutralize specific acidic soils;

(iii) Sodium bicarbonate for electrolyte spills from sulfuric acid batteries; and

(iv) Monobasic sodium phosphate and boric acid for electrolyte spills from nickel-cadmium batteries.

(9) Steam cleaning is not recommended for general use on aircraft. It erodes paint, crazes plastic, debonds adhesives, damages electrical insulation, and drives lubrication out of bearings.

c. Cleaning Procedures.

(1) The following cleaning procedures are recommended:

- (i) Remove/disconnect all electrical power;
- (ii) Ground aircraft;
- (iii) Aircraft wash personnel should wear protective gear (gloves, goggles, aprons, etc.);
- (iv) Protect against water/cleaning compound intrusion (close doors, openings, cover vents, pitot static openings, cover wheels, etc.);
- (v) Accomplish pre-wash lubrication. Lubricate in accordance with applicable maintenance manual;
- (vi) Mix cleaning solution to manufacturer's recommendation;
- (vii) Use spray not a stream of water during aircraft wash;
- (viii) Do not use abrasive cleaning pads; and
- (ix) Rinse aircraft with fresh water to remove all cleaning compounds.

(2) The following postcleaning procedures are recommended:

- (i) Remove all covers, plugs and masking materials;
- (ii) Inspect and clear all drain holes;
- (iii) Inspect open and all known water trap areas for water accumulation and proper drainage;
- (iv) Lubricate aircraft in accordance with applicable maintenance manual; and
- (v) Apply operational preservation.

d. Preservation. The day-to-day application of corrosion preventive compounds is used to protect metal aircraft parts and components. They function by preventing corrosive materials from contacting and corroding bare metal surfaces. Many of these compounds are also able to displace water and other contaminants from the surfaces to be protected. Some also provide lubrication as well as corrosion protection. Corrosion preventive compounds vary in appearance and consistency from thick, black types to light oils. Some are

water displacing and others are not. The thicker compounds provide the best corrosion protection, are longer lasting, and are more difficult to remove. The thinner materials provide some lubrication and do not crack, chip, or peel but must be removed and replaced regularly to provide continuing protection.

e. Surface Treatment.

(1) An important step in the corrosion control process is the surface treatment of the metal with a prescribed chemical to form a protective film. Chemical surface treatments properly applied provide corrosion resistance to the metal and improve the adhesion of subsequently applied paints. These surface treatments, also known as chemical conversion coatings, chromate conversion coatings, chemical films, or pretreatments, are aqueous acid solutions of active inorganic compounds which convert aluminum or magnesium surfaces to a corrosion resistant film.

(i) Aluminum and aluminum alloys chemical conversion materials conform to MIL-C-81706.

(ii) Magnesium alloy chemical conversion materials conform to MIL-M-3171.

(iii) Ferrous metals, stainless steel, and titanium treatment prior to painting are limited to corrosion removal and cleaning.

(2) The surface should be prepared for application of the chemical conversion coatings.

(i) Feather the edges of paint along the edge of areas that have been chemically stripped prior to pretreatment and repainting to ensure a smooth, overlapping transition between the old and new paint surfaces.

(ii) Clean the area with a fine or very fine clean abrasive mat saturated with water.

(iii) Rinse by flushing with fresh water. Particular attention should be given to fasteners and other areas where residues may become entrapped. At this stage in the cleaning, the surface should be water break-free. A surface showing water breaks (water beading or incomplete wetting) is usually contaminated with grease or oil, which will later interfere with conversion coating, sealing, and painting.

(iv) If the surface is not free of water breaks, reclean the area with a solution of aircraft cleaning compound using the abrasive mat. Rinse thoroughly with water.

(3) Chemical conversion coating is applied by brush, sponge stick moistener, or nonatomizing sprayer to achieve a yellow to gold color for aluminum (usually 2 to 4 minutes) or greenish brown, brassy or brownish-yellow for magnesium (30 seconds to 2 minutes).

(4) Immediately rinse the part thoroughly with fresh water. Do not wipe with a rag or cloth.

(5) Allow the chemical conversion coated surface to dry a minimum of 1/2 hour and a maximum of 4 hours before painting.

f. Sealants.

(1) Sealants are one of the most important tools for corrosion prevention and control. They prevent the intrusion of moisture, salt, dust, and aircraft fluids, which can lead to extensive corrosion. For sealants to be effective, it is critical that the correct sealant be chosen for a specific area/situation and that it be applied correctly.

(2) Sealants are used for the following reasons:

- (i) Fuel tank sealing;
- (ii) Pressure areas;
- (iii) Weather sealing;
- (iv) Firewalls;
- (v) Electrical;
- (vi) Acid-resistant areas;
- (vii) Windows;
- (viii) High temperature applications; and
- (ix) Aerodynamic sealing.

(3) There are numerous sealing compounds available with different properties and intended use. Refer to the aircraft manufacturer's manual for specific information concerning selection of the sealing compound and proper application. Observe the warning and cautions of the manufacturer when using sealing compounds. Sealing compounds generally are divided into two major types, those requiring a curing agent and those which cure in air.

(i) Polysulfide, polythioether, and polyurethane sealing compounds consist of the base (prepolymer) and the accelerator (curing agent). When thoroughly mixed, the catalyst cures the base to a rubbery solid. Rates of cure depend on the type of base, catalyst, temperature, and humidity. A full cure may not be achieved for as long as 7 days.

(ii) Silicone sealing compounds generally consist of one component which cures by reaction with moisture in the air. If silicones are applied too thick or in such a way as to prevent moisture from entering the material, they may not cure at all. In addition, many silicone sealing compounds produce acetic acid (vinegar smell) while curing, which can lead to severe corrosion problems. The use of silicone sealing compounds on aircraft

should be limited to those non-corrosive products conforming to Specification (MIL-A-46146).

(iii) Some sealing compounds may require the application of a special primer or adhesion promoter prior to sealant application in order to develop a good adhesive bond with the surface. Use only those primers or adhesion promoters recommended by the product manufacturer.

(4) Sealant application procedures:

(i) Following the removal of corrosion and application of a chemical surface treatment, prime all surfaces, except internal fuel tank surfaces. If the surfaces have been contaminated following surface treatment, clean the area with cleaning solvent and a clean cloth. Dry the surfaces immediately with a clean cloth. Do not allow solvent to evaporate from the surface.

(ii) Mask off the area being sealed to prevent sealant from contacting adjacent areas during application and postapplication smooth-out operations. Examples of where masking may be beneficial are fillet sealing of exterior surface lap and butt seams.

(iii) When required by the manufacturer, apply a thin coating of an adhesion promoting solution. Allow to dry by evaporation without touching the area for 30 minutes to 1 hour before applying sealant.

(iv) Spatula type sealants may be applied with a non-metallic spatula or scraper. Avoid the entrapment of air. Work sealant into recesses by sliding the edge of the scraper firmly back over the recesses between the tape. Smoothing will be easier if the non-metallic scraper is first dipped in water.

(v) Sealant to be applied with a brush is applied and smoothed until the desired thickness is reached.

(vi) Sealant to be applied with a caulking gun will not usually require masking and is especially adaptable to filling seams or the application of form-in-place gaskets.

(vii) Sealant applied with a spray gun should be applied in a solid, continuous pattern.

(viii) Allow sealant to dry or cure to manufacturer's recommendations.

(ix) When required, prime sealant as soon as it no longer feels tacky, then topcoat as necessary.

(5) Faying surface sealant is applied between the contacting surface of two or more parts, and is the most effective seal that can be produced. It should be used for all assembly and, where possible, reassembly. Where at all possible it should be used in conjunction with fillet sealing. There are two types of faying surface seal installations, removable and permanent.

(i) The removable type is for access doors, removable panels, inspection plates, windows, etc. The sealant is normally applied to the substructure and a parting agent applied on the removable panel during sealant cure.

(ii) The permanent type is for sealing between parts of a structure that is permanently fastened together with a high adhesion sealant.

(6) The fillet, or seam, seal is the most common type found on an aircraft. Fillet seals are used to cover structural joints or seams along stiffeners, skin butts, walls, spars, and longerons, and to seal around fittings and fasteners. It should be used in conjunction with faying surface sealing and in place of it if the assembly sequence restricts the use of faying surface sealing.

(7) Injection sealing is used primarily to fill voids created by structural joggles, gaps, and openings. Use only those sealants recommended by the aircraft/equipment manufacturer. Force sealant into the area using a sealant gun. This method is a means of producing a continuous seal where it becomes impossible to lay down a continuous bead of sealant while fillet sealing. Clean the voids of all dirt, chips, burrs, grease, and oil before injection sealing.

(8) The fastener sealing method depends on the type of fastener. Fasteners are sealed either during assembly or after assembly. To seal a permanent fastener during assembly, apply the sealant to the hole or dip the fastener into the sealant, and install the fastener while sealant is wet. For removable fasteners, start the fastener in the hole and apply sealant to the lower side of the fastener head or countersink. To seal after assembly, apply sealant to the fastener head after installation.

(9) Sealing of fuel cells should be accomplished per the aircraft manufacturer's maintenance manual procedures.

g. Paint Finishes and Touchup Procedures.

(1) The primary objective of any paint system is to protect exposed surfaces against corrosion and other forms of deterioration. Operational uses for particular paint schemes include:

- (i) High visibility requirements;
- (ii) Identification markings;
- (iii) Abrasion protection; and
- (iv) Specialty coatings (i.e., walkway coatings).

(2) The paint system on aircraft consists of a primer coat and a topcoat. The primer promotes adhesion and contains corrosion inhibitors. The topcoat provides durability to the paint system, including weather and chemical resistance, along with the coloring necessary for operational requirements.

(3) Some aircraft surfaces (teflon-filled, rain erosion, walkways, etc.) require specialized coatings to satisfy service exposure and operational needs. For these surfaces, refer to the specific manufacturer's maintenance manual for the aircraft in question.

(4) The Environmental Protection Agency, as well as certain local air pollution control districts, has implemented rules which limit the volatile organic content (VOC), or solvent content, of paints applied to aircraft and ground support equipment. It is the responsibility of the user to insure that these rules are understood and obeyed. FAILURE TO COMPLY WITH CURRENT RULES CAN RESULT IN LARGE FINES.

(5) Much of the effectiveness of a paint finish and its adherence depend on careful preparation of the surface prior to touch up and repair.

(i) Aged paint surfaces must be scuff sanded to ensure adhesion of overcoated, freshly applied paint. Sanding requires a complete roughening of the paint surface and can be accomplished by hand sanding or with the use of power tools.

(ii) For final preparation, ensure that surfaces to be painted are free of corrosion, have been prepared and the surrounding paint feathered, have been cleaned, and have been conversion coated. Replace any seam sealants when necessary. Mask areas as required to prevent overspray.

(6) Spray application for touchup, overcoat and total repaint:

(i) Primers should be thinned with the applicable thinner as required and recommended by the paint manufacturer, stirred, and applied in even coats. Primer thickness varies for each type primer but generally the total dry film thickness is 0.6 to 0.9 mils (0.0006 to 0.0009 inch). You should be able to see through this film thickness. Allow primer to air dry prior to topcoat application in accordance with the paint manufacturer's recommendations. Normally topcoat application should occur within 24 hours after primer application.

(ii) Topcoats should be thinned with the applicable thinner as required and recommended by the paint manufacturer, stirred, and applied in even coats. Topcoat thickness varies for each topcoat but generally the total dry film thickness is 1.5 to 2.0 mils (0.0015 to 0.002 inch). Allow the topcoat to air dry in accordance with the paint manufacturer's instructions.

(A) Teflon-filled (antichafe) coatings should be applied over a primer in accordance with the manufacturer's instructions.

(B) Walkway compounds should be applied over a primer in accordance with the manufacturer's instructions.

413.-499. RESERVED.



4

4



4

4



CHAPTER 5. INSPECTION REQUIREMENTS

500. GENERAL. Except for special requirements in trouble areas, inspection for corrosion should be a part of routine maintenance inspections; i.e., daily or preflight. Overemphasizing a particular corrosion problem when it is discovered and forgetting about corrosion until the next crisis is an unsafe, costly, and troublesome practice. Inspection for corrosion is a continuing requirement and should be accomplished on a daily basis. If corrosion control is assigned to a special crew or group, maintenance checks should be scheduled in such a way that these crews may accomplish their inspections and necessary rework while access plates are removed and components are disconnected or out of the way.

a. Most manufacturers' handbooks of inspection requirements are complete enough to cover all parts of the aircraft or engine, and no part or area of the aircraft should go unchecked. Use these handbooks as a general guide when an area is to be inspected for corrosion.

b. Trouble areas, however, are a different matter, and experience shows that certain combinations of conditions result in corrosion in spite of routine inspection requirements. These trouble areas may be peculiar to particular aircraft models, but similar conditions are usually found on most aircraft.

c. The flight routes and bases of operation will expose some airplanes to more corrosive conditions than others. The operational environment of an aircraft may be categorized as mild, moderate, or severe, with respect to the corrosion severity of the operational environment. The corrosion severity of the operational environments around the world are identified in Figure 4-15 through Figure 4-20. The corrosion severity of any particular area may be increased by many factors including: airborne industrial pollutants, chemicals used on runways and taxiways to prevent ice formation, humidity, temperatures, prevailing winds from corrosive environment, etc.

501. FREQUENCY OF INSPECTIONS. In addition to the routine maintenance inspections, the following special requirements should be observed:

a. Aircraft operating in a severe environment should be inspected every 15 days.

b. Aircraft operating in a moderate environment should be inspected every 45 days.

c. Aircraft operating in a mild environment should be inspected every 90 days.

d. The aircraft should be washed prior to any inspection for corrosion.

e. Checks should be performed by a crew familiar with corrosion problems and the nature of their treatment.

f. Operators of low utilization aircraft should develop a corrosion inspection and repair program based on calendar time rather than flight hours. Due to the uncertainties that may be encountered in various operating environments, adjustments to the calendar time inspection interval should be made after analysis of corrosion inspection findings.

502. RECOMMENDED DEPTH OF INSPECTION. Generally speaking, the applicability of inspection requirements provides a ready means to insure adequate inspection of all compartments and interior aircraft cavities. When such general requirements are observed, along with a periodic check of the list of common trouble areas, adequate maintenance should be assured for most operating conditions. To assist in assuring complete coverage, the following summary is included:

a. Daily and preflight inspection. Check engine compartment gaps, seams, and faying surfaces in the exterior skin. Check all areas which do not require removal of fasteners, panels, etc., such as bilge areas, wheel and wheel well areas, battery compartments, fuel cell and cavity drains, engine frontal areas, including all intake vents, and engine exhaust areas.

b. Indepth inspections. In addition to the more common trouble spots that are readily available for inspection, remove screw-attached panels, access plates, and removable skin sections as necessary to thoroughly inspect the internal cavities. Inspection should also include removal of questionable heavy internal preservative coatings, at least on a spot-check basis. Inspect the interior of the aircraft in corrosion prone areas such as around lavatories, galleys, under floors, baggage compartments, etc. (see Figure 5-1).

c. Corrosion inspections should be accomplished at each annual inspection or other scheduled indepth inspections in which areas of the aircraft not normally accessible will be available for corrosion inspection.

d. Corrosion preventive compounds such as LPS3, Dinol AV5, or equivalent products and later advanced developments of such compounds may be used to effectively reduce the occurrence of corrosion. Results of corrosion inspections should be reviewed to help establish the effectiveness of corrosion preventive compounds and determine the reapplication interval of them.

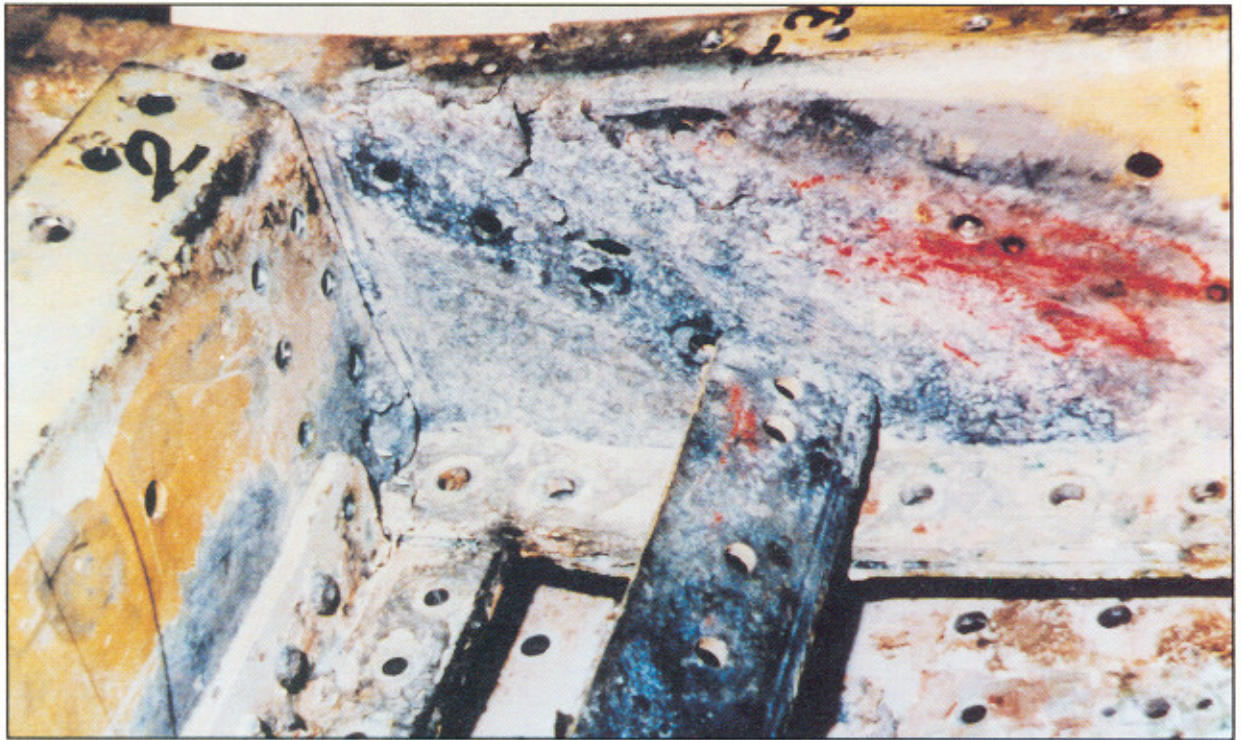

FIGURE 5-1. CORROSION FOUND AFTER REMOVING CARGO DOOR THRESHOLD COVERS

503. PRIMARY APPROACH. The primary approach to corrosion detection is corrosion inspections on a regularly scheduled basis. Early detection and treatment reduce costs, out of service time, and the possibility of flight or flight related incidents. All corrosion inspections should start with a thorough cleaning of the area to be inspected. A general visual inspection of the area follows using a flashlight, inspection mirror, and a 5-10x magnifying glass. The general inspection should look for obvious defects and suspected areas. A detailed inspection of damage or suspected areas found during the general inspection follows. The detailed inspection can be one or more of the following.

504. NONDESTRUCTIVE INSPECTION (NDI).

a. Visual Inspection. Visual inspection is the most widely used technique and is an effective method for the detection and evaluation of corrosion. Visual inspection employs the eyes to look directly at an aircraft surface, or at a low angle of incidence to detect corrosion. Using the sense of touch of the hand is also an effective inspection method for the detection of hidden well developed corrosion. Other tools used during the visual inspection are mirrors, borescopes, optical micrometers, and depth gauges. The following shows the type of corrosion damage detectable using the visual inspection method: Figures 5-2 and 5-3 show chipped, missing, and lifted paint;

Figure 5-4 shows dished and popped rivets; Figure 5-5 shows skin bulges or lifted surfaces; Figures 5-6 and 5-7 show cracks; and Figures 5-8 and 5-9 show corrosion products.

(1) The indications of corrosive attack can take several forms depending on the type of metal and the length of time the corrosion has had to develop. Corrosion deposits on aluminum and magnesium are generally a white powder, while ferrous metals vary from red to dark reddish brown stains.

(2) Sometimes the inspection areas are obscured by structural members, equipment installations, or for some other reason are awkward to check visually. Adequate access for inspection must be obtained by removing access panels and adjacent equipment, cleaning the area as necessary, and removing loose or cracked sealants and paints. Mirrors, borescopes, and fiber optics are useful in providing the means of observing obscure areas. Figures 5-10 through 5-18 depict some of these conditions.



FIGURE 5-2. CORROSION UNDER CHIPPED AND LOOSE PAINT ON WING SKIN

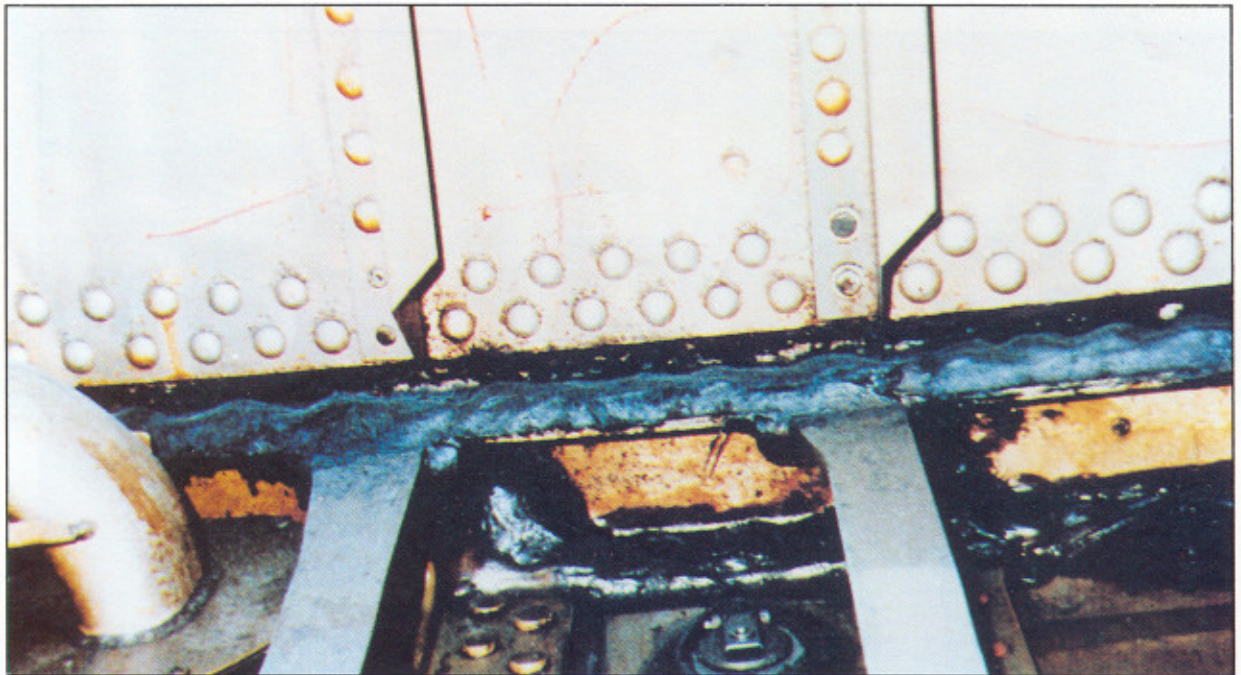

FIGURE 5-3. CORROSION INDICATED BY BLISTERING OF PAINT IN FUEL CELL

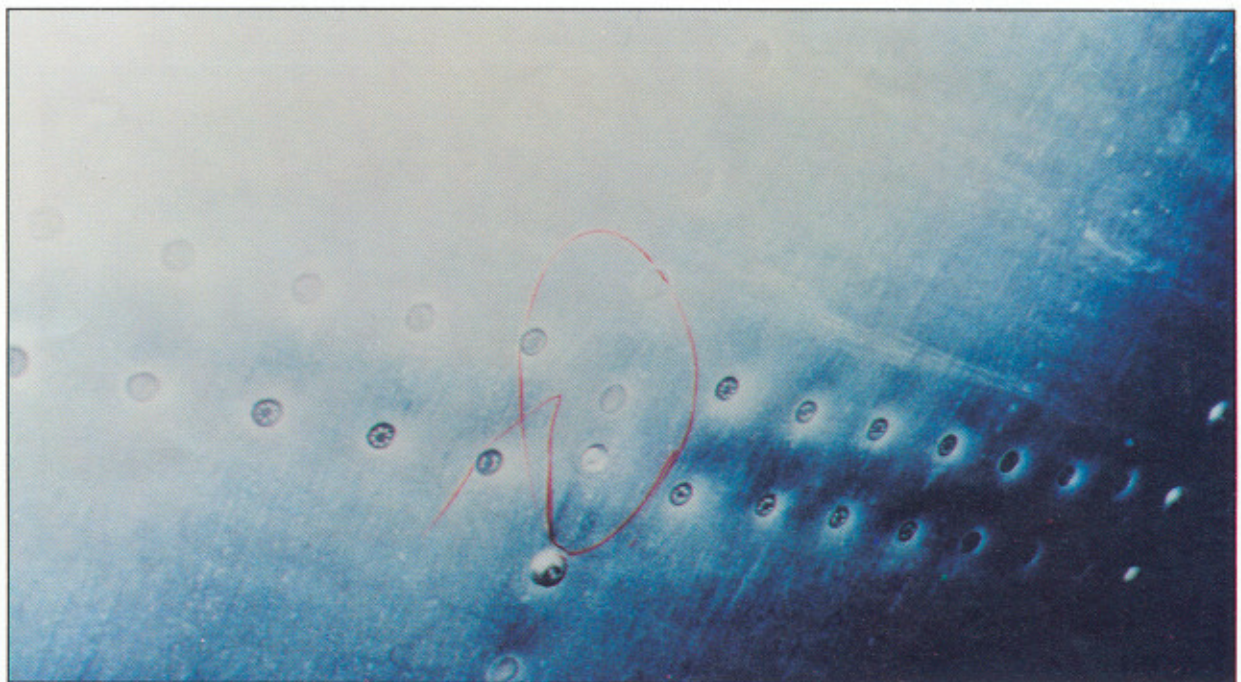

FIGURE 5-4. POPPED RIVET HEADS RESULTING FROM CORROSION PRODUCTS

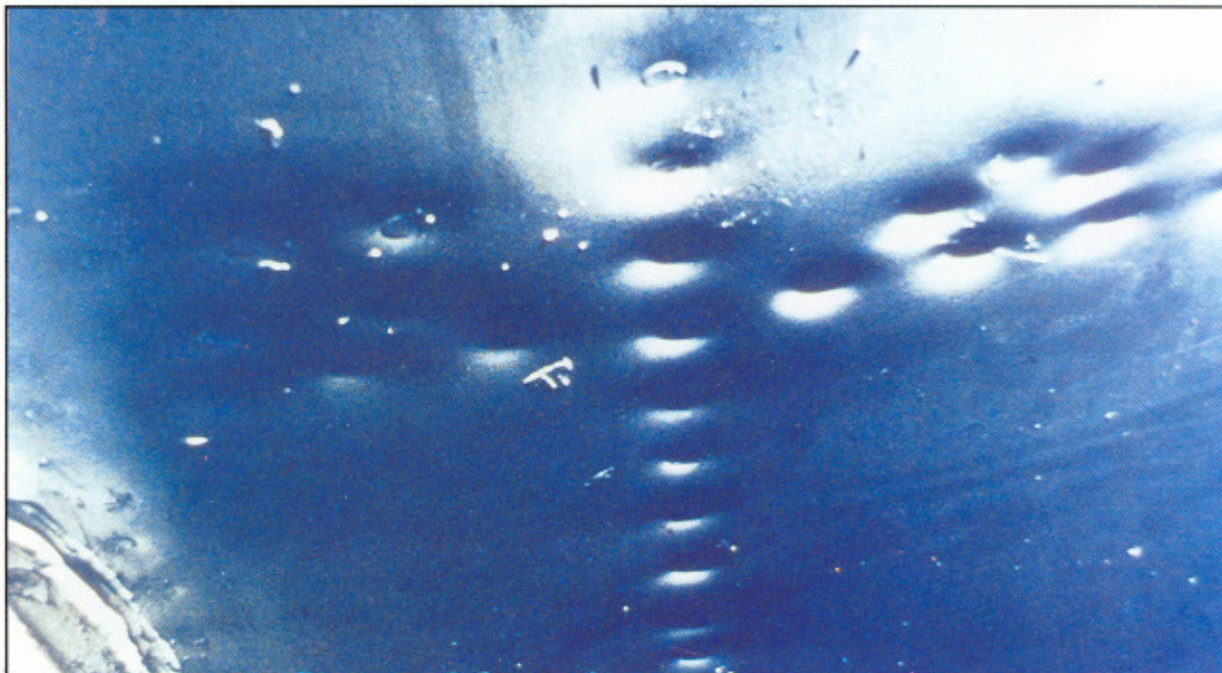

FIGURE 5-5. SKIN BULGING AROUND FASTENERS CAUSED BY PRESSURE FROM CORROSION PRODUCTS

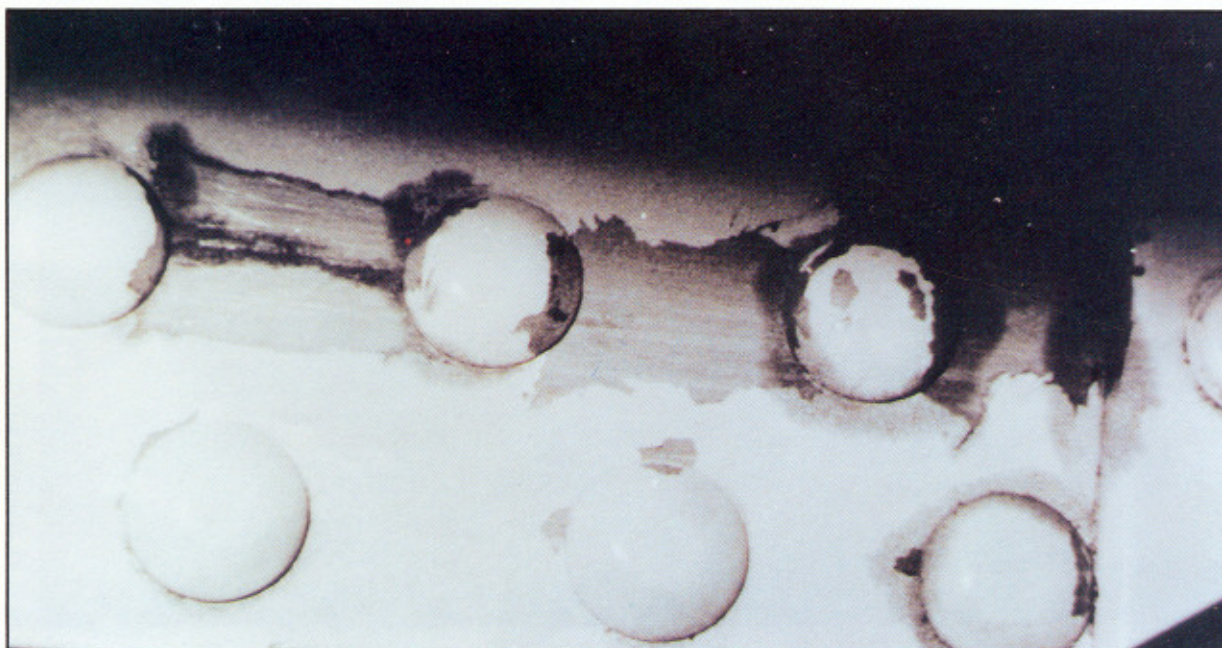

FIGURE 5-6. CORROSION CRACKING BETWEEN FASTENERS ON A WING SPAR

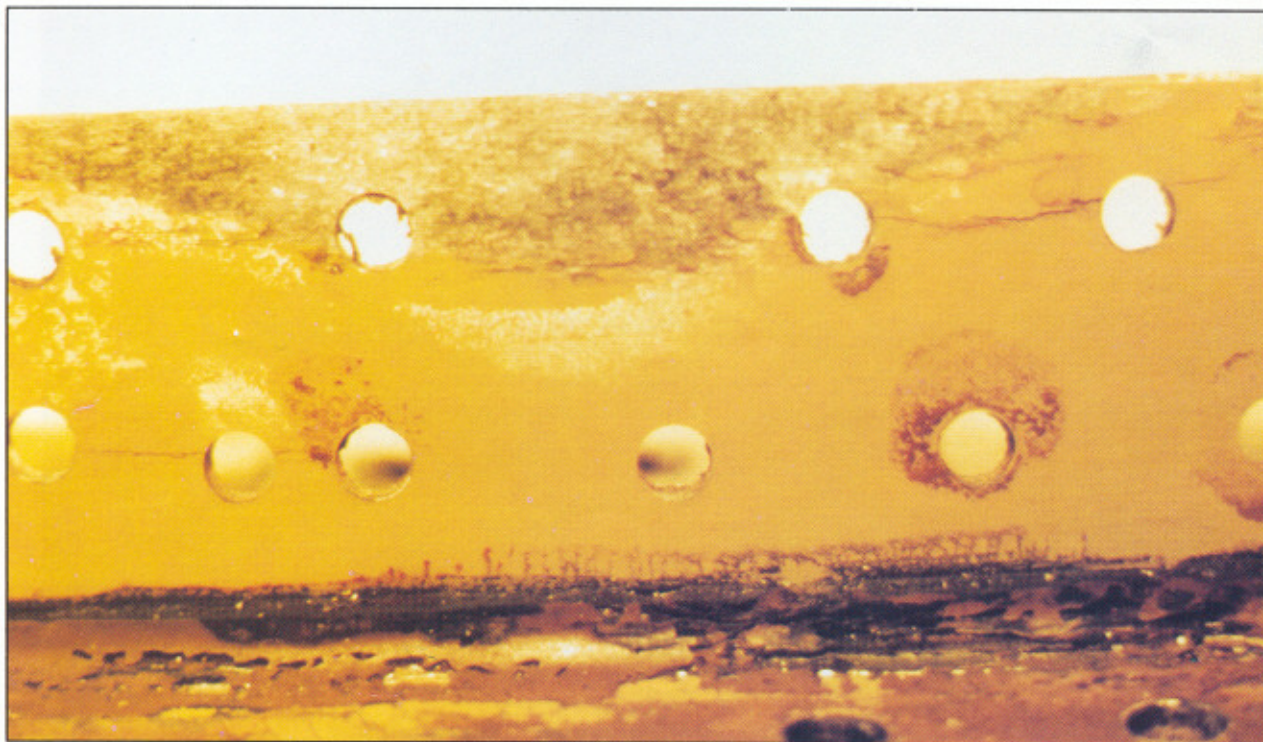

FIGURE 5-7. FAYING SURFACE CORROSION ON WING SPAR CHORD WITH CORROSION CRACKING ALSO VISIBLE

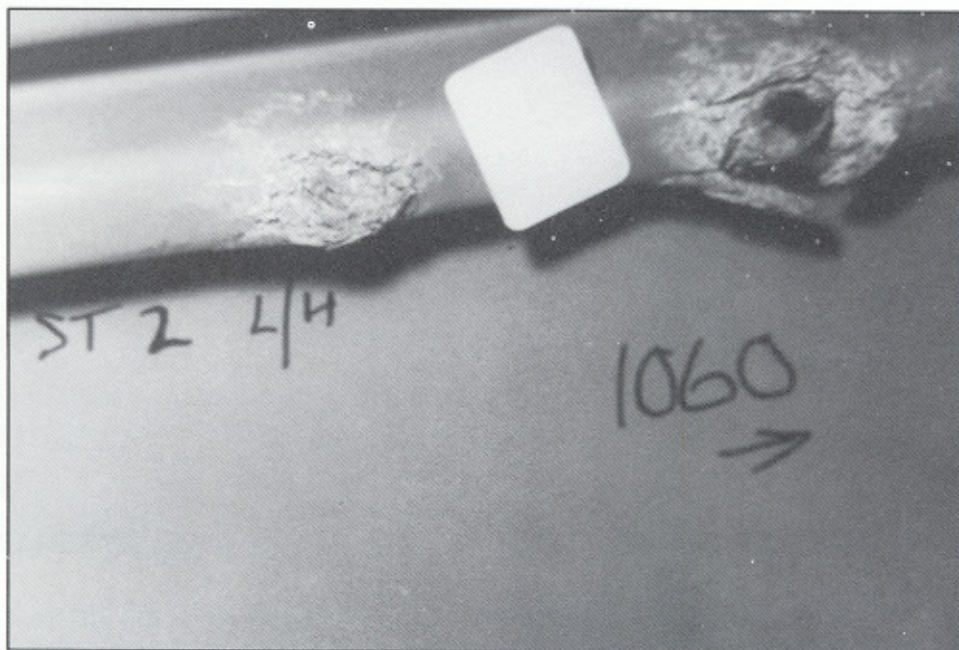

FIGURE 5-8. SEVERE CROWN STRINGER CORROSION

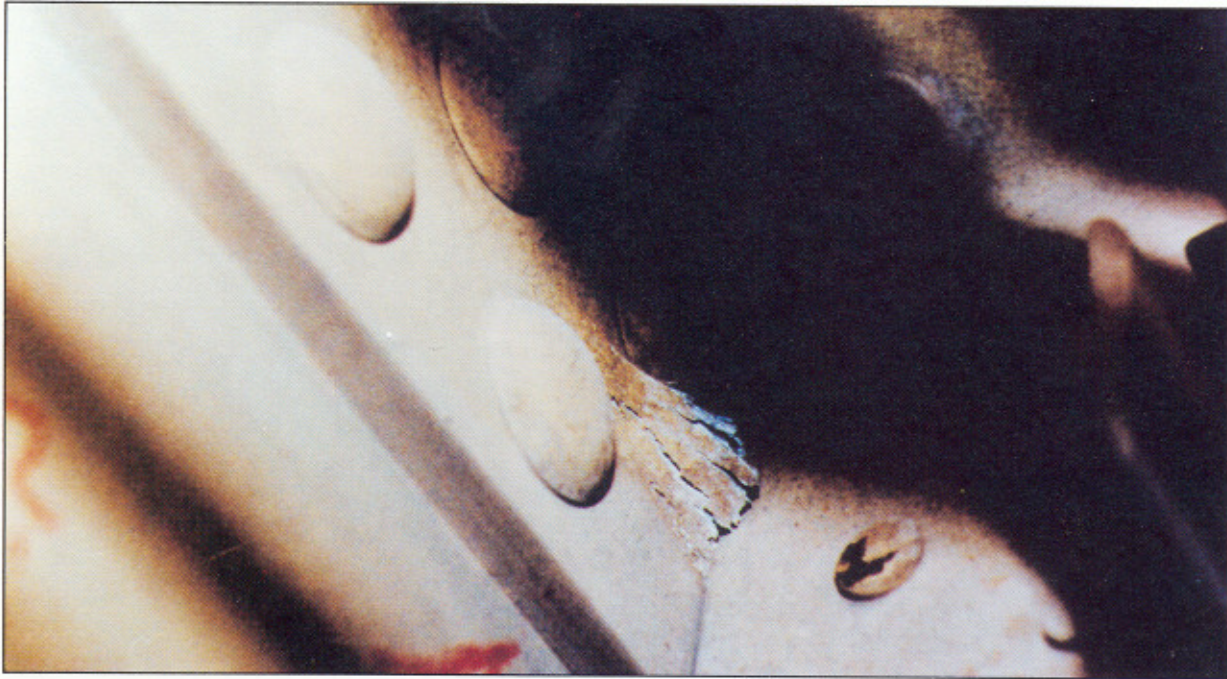

FIGURE 5-9. SPAR CHORD CORROSION

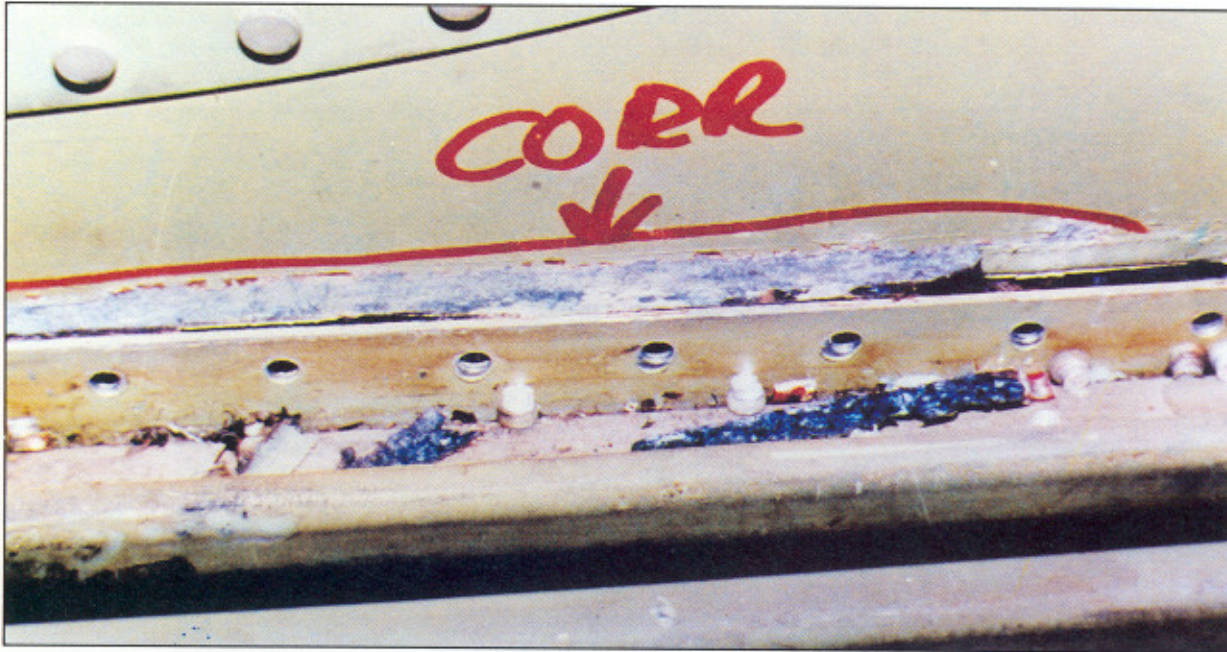

FIGURE 5-10. REMOVAL OF FILLET SEAL FROM INTERNAL EDGE OF LAP JOINT EXPOSED FULL EXTENT OF CORROSION

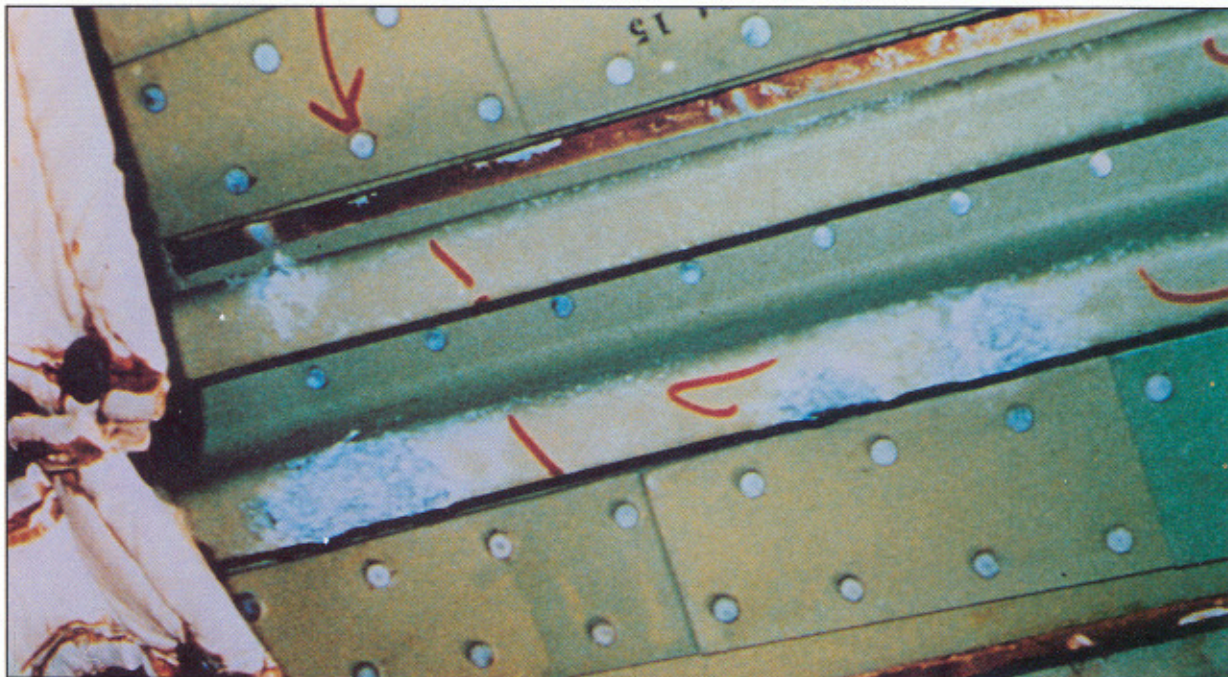

FIGURE 5-11. REMOVAL OF INSULATION BLANKETS EXPOSED CORROSION



FIGURE 5-12. CORROSION DEVELOPED UNDER LEVELING COMPOUND INSTALLED DURING PREVIOUS REPAIR OF OVERWING EXIT

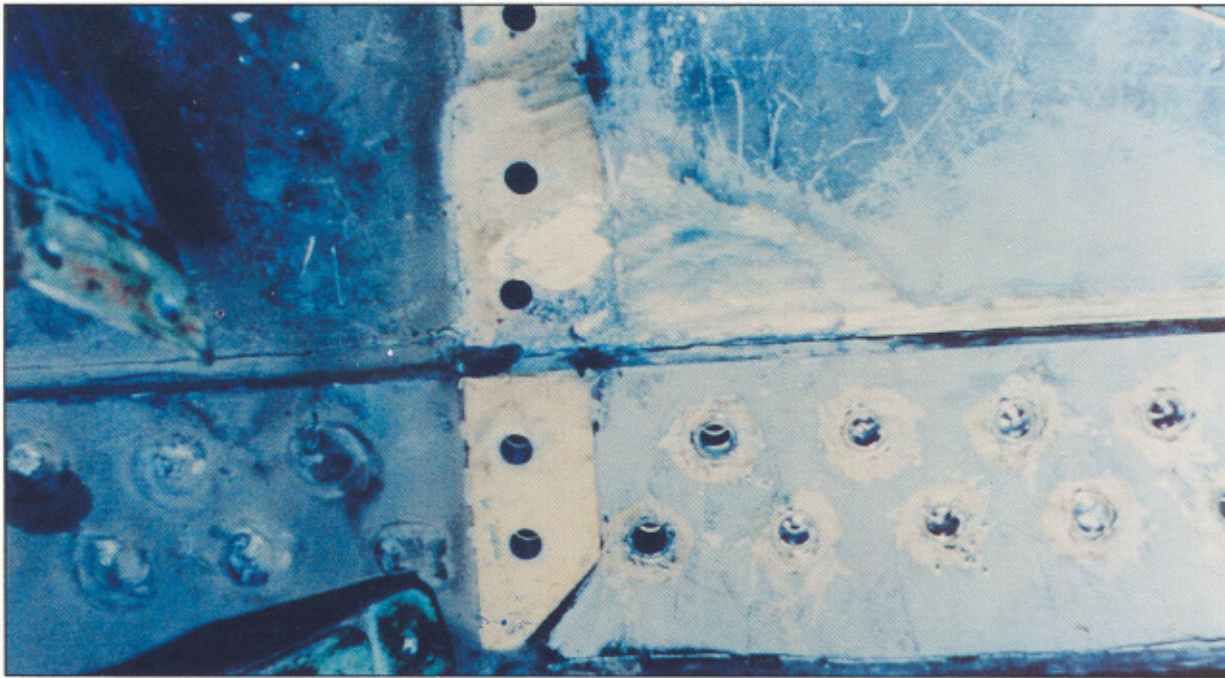

FIGURE 5-13. CORROSION BEHIND A STRUCTURAL COMPONENT ON A WING SPAR

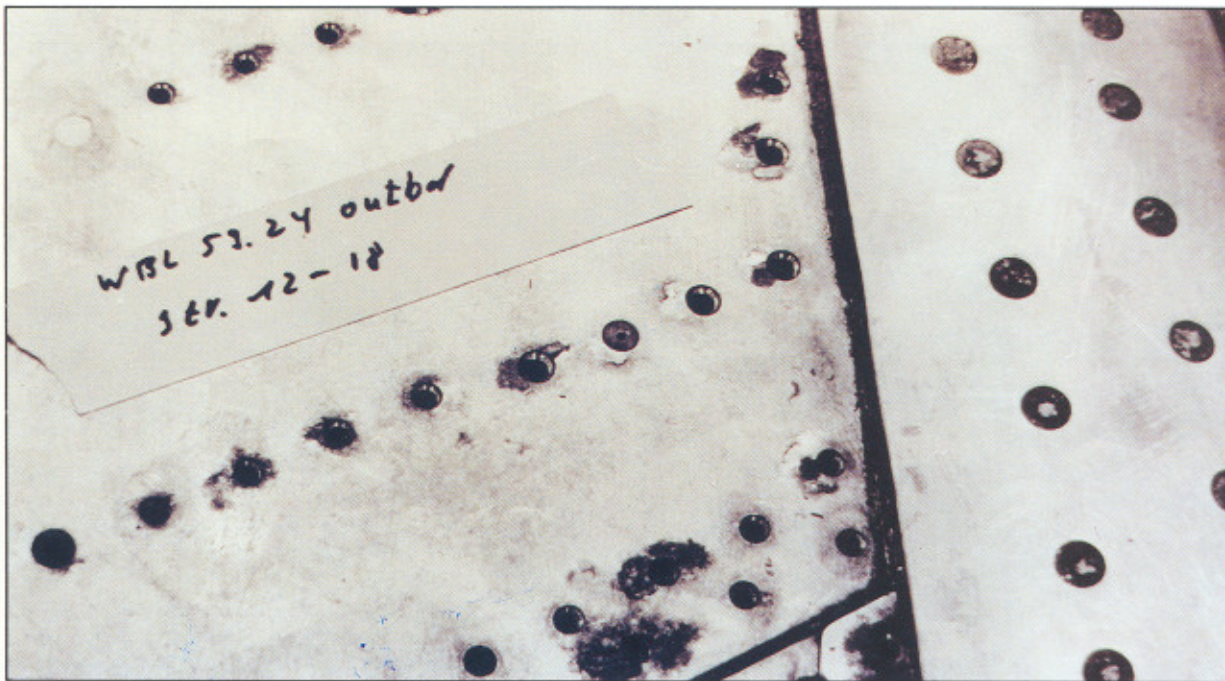

FIGURE 5-14. CORROSION DAMAGE AROUND FASTENER HOLES AND IN FASTENER HOLES

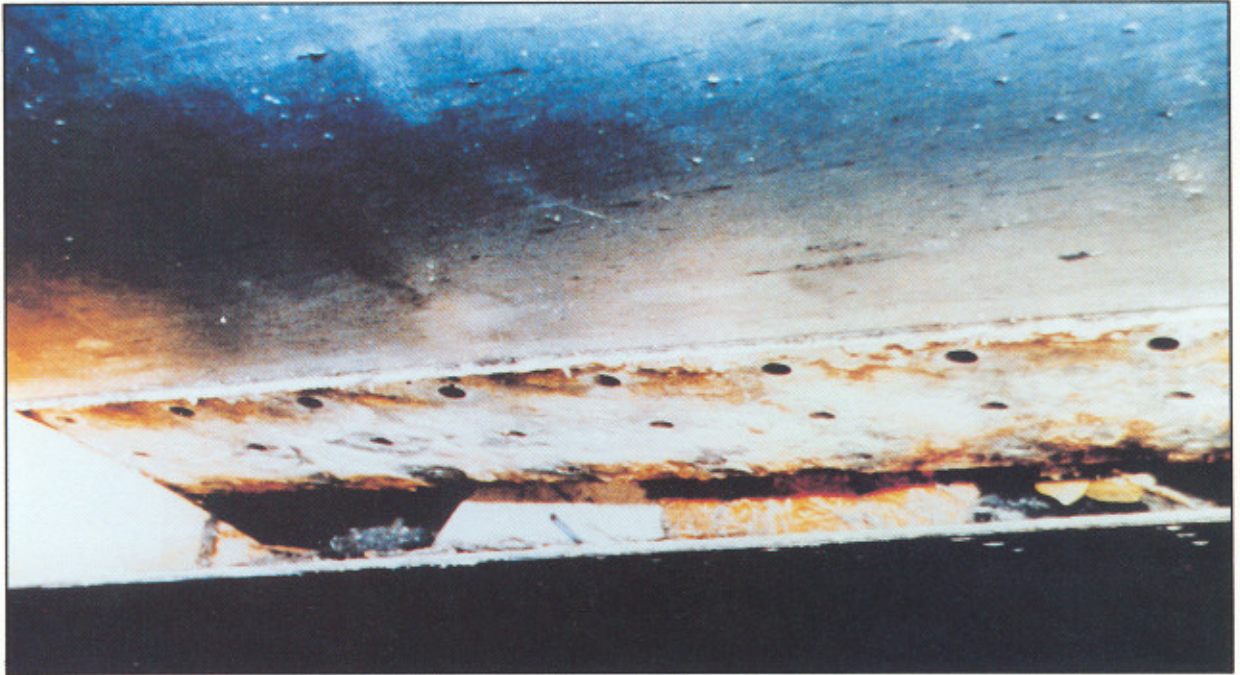

FIGURE 5-15. SEVERELY CORRODED LAP JOINT

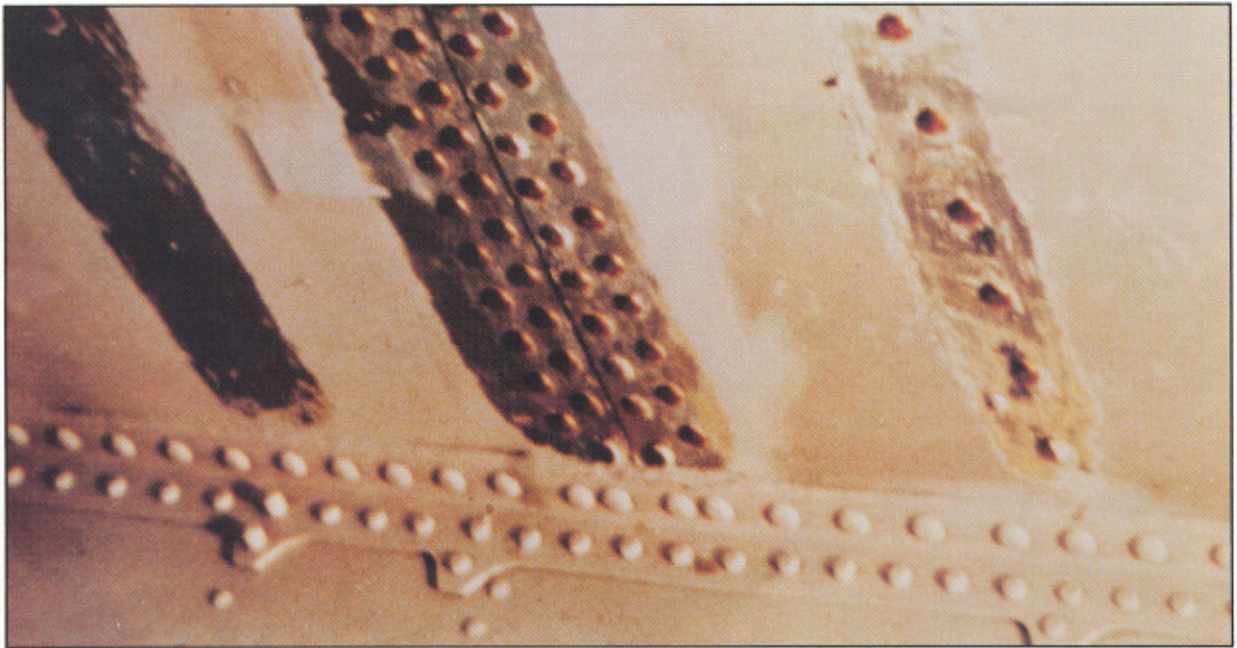

FIGURE 5-16. LOCAL PAINT REMOVAL REQUIRED TO EXPOSE FULL EXTENT OF CORROSION

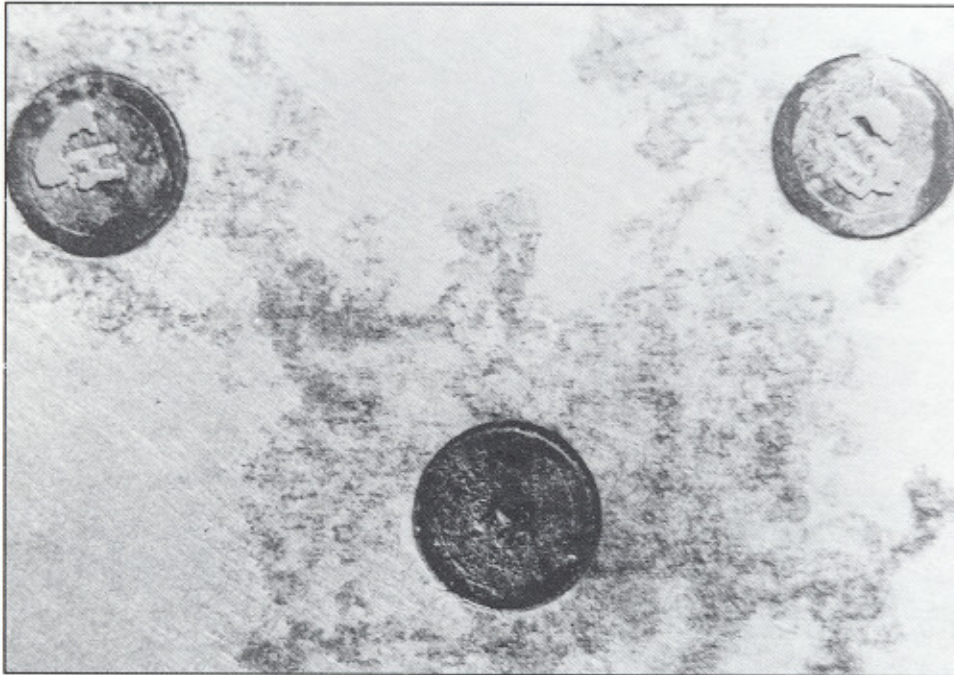

FIGURE 5-17. CORRODED AREA AFTER PAINT REMOVAL FROM WING SKIN

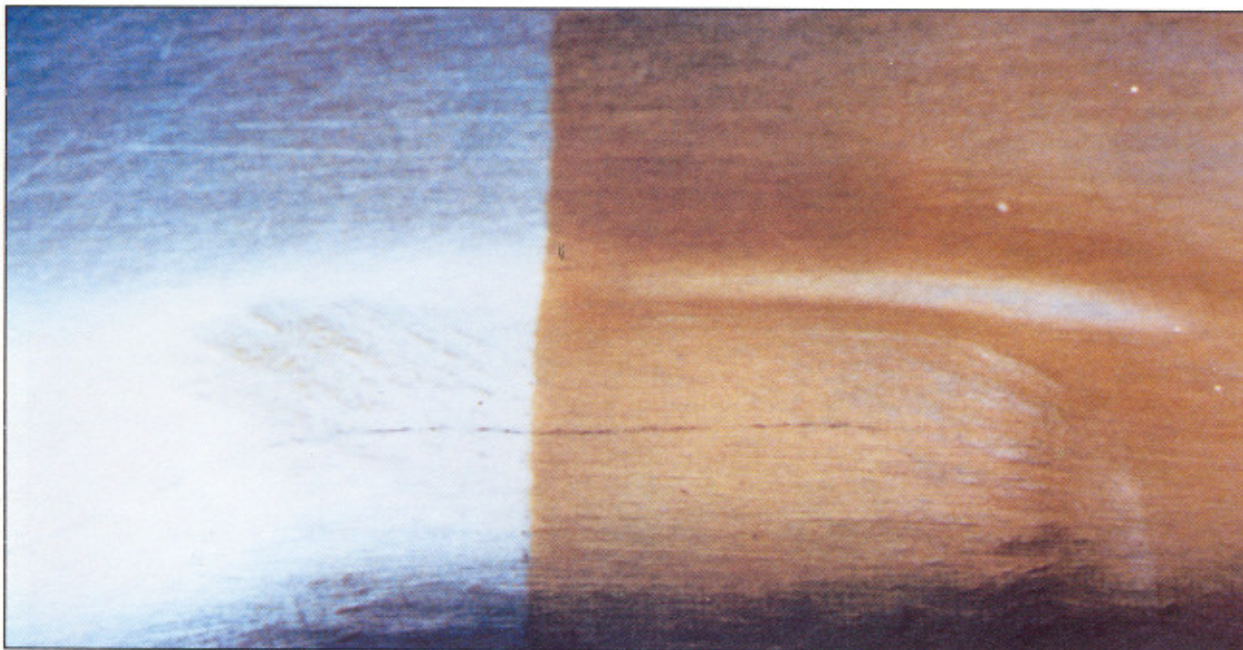

FIGURE 5-18. ALODINE 1200 TREATMENT PRIOR TO PAINTING MAY HIGHLIGHT PRESENCE OF REMAINING CORROSION OR CRACKS

b. Other Methods. In addition to visual inspection there are several NDI methods such as: liquid penetrant, magnetic particle, eddy current, x-ray, ultrasonic, and acoustical emission which may be of value in the detection of corrosion. These methods have limitations and should be performed only by qualified and certified NDI personnel. Eddy current, x-ray, and ultrasonic inspection methods require properly calibrated (each time used) equipment and a controlling reference standard to obtain reliable results.

(1) Liquid Dye Penetrant. Inspection for large stress-corrosion or corrosion fatigue cracks on nonporous ferrous or nonferrous metals may be accomplished by the use of liquid dye penetrant processes. The dye applied to a clean metallic surface will enter small openings, such as cracks or fissures by capillary action. After the dye has had an opportunity to be absorbed by any surface discontinuities, the excess dye is removed and a developer is applied to the surface. The developer acts like a blotter and draws the dye from the cracks or fissures back to the surface of the part, giving visible indication of the location of any fault that is present on the surface. The magnitude of the fault is indicated by the quantity and rate of dye brought back to the surface by the developer.

(2) Magnetic Particle Inspection. This method may be used for the detection of cracks or flaws on or near the surface of ferromagnetic metals (metals which are attracted by magnetism). A portion of the metal is magnetized, and finely divided magnetic particles (either in liquid suspension or dry) are applied to the object. Any surface faults will create discontinuities in the magnetic field and cause the particles to congregate on or above these imperfections, thus locating them.

(3) Eddy Current Inspection. Eddy current testing (primarily low-frequency) can be used to detect thinning due to corrosion and cracks in multi-layered structures. Low frequency eddy current testing can also be used to some degree for detecting or estimating corrosion on the hidden side of aircraft skins because, when used with a reference standard, the thickness of material which has not corroded can be measured. Low frequency eddy current testing can be used for estimating corrosion in underlying structure because the eddy currents will penetrate through into the second layer of material with sufficient sensitivity for approximate results. High-frequency eddy current testing is most appropriate for detection of cracks which penetrate the surface of the structure on which the eddy current probe can be applied (including flat surfaces and holes).

(4) X-Ray Inspection. X-ray inspection has somewhat limited use for the detection of corrosion because it is difficult to obtain the sensitivity required to detect minor or moderate corrosion. Briefly, x-ray works by passing high energy rays generated by an x-ray machine through the material being inspected. This exposes the special film placed on the opposite side of the material. Areas of high density are indicated on the film as underexposed areas, while areas of low density are indicated on the film as overexposed areas. Proper interpretation of the film will indicate whether defects are present. Moderate to severe corrosion or cracks can be detected using x-ray

inspection. However this method, like other NDI methods, requires a qualified and certified operator to obtain reliable results.

(5) Ultrasonic Inspection. Ultrasonic testing provides a sensitive detection capability for corrosion damage when access is available to a surface with a continuous bulk of material exposed to the corrosion. Ultrasonic inspection is commonly used to detect exfoliation, stress-corrosion cracks, and general material thinning. Ultrasonic digital thickness gages are not reliable for determining moderate or severe damage prior to removing the corrosion. Highly trained personnel should conduct the examination if any useful information is to be derived from the indicating devices.

(6) Acoustic Emission Testing. This method using heat-generated emissions can be used to detect corrosion and moisture in adhesive-bonded metal honeycomb structures. Acoustic emission testing can detect corrosion initiation as well as advanced corrosion.

505.-599. RESERVED.

CHAPTER 6. CORROSION REMOVAL TECHNIQUES

SECTION 1. SAFETY PROCEDURES.

600. GENERAL. General safety precautions, outlined in the following paragraphs, contain guidelines for handling materials with hazardous physical properties and emergency procedures for immediate treatment of personnel who have inadvertently come into contact with one of the harmful materials. Materials having hazardous physical properties are referenced to the pertinent safety precautions and emergency safety procedures. All personnel responsible for using or handling hazardous materials should be thoroughly familiar with the information in the following paragraphs.

a. Safety precautions. When required to use or handle any of the solvents, special cleaners, paint strippers (strong alkalis and acids), etchants (corrosion removers containing acids), or surface activation material (alodine 1200), observe the following safety precautions:

- (1) Avoid prolonged breathing of solvents' or acids' vapors. Solvents and acids should not be used in confined spaces without adequate ventilation or approved respiratory protection;
- (2) Never add water to acid. Always add acid to water;
- (3) Mix all chemicals per the manufacturers' instructions;
- (4) Clean water for emergency use should be available in the immediate work area before starting work;
- (5) Avoid prolonged or repeated contact of solvents, cleaners, etchants (acid), or conversion coating material (alodine solution) with skin. Rubber or plastic gloves should be worn when using solvents, cleaners, paint strippers, etchants, or conversion coating materials. Goggles or plastic face shields and suitable protective clothing should be worn when cleaning, stripping, etching, or conversion coating overhead surfaces;
- (6) When mixing alkalis with water or other substance, use containers which are made to withstand heat generated by this process;
- (7) Wash any paint stripper, etchant, or conversion coating material immediately from body, skin, or clothing;
- (8) Materials splashed in the eyes should be promptly flushed out with water, and medical aid obtained for the injured person;
- (9) Do not eat or keep food in areas where it may absorb poisons. Always wash hands before eating or smoking;

(10) Verify that the area within 50 ft. of any cleaning or treating operations where low flash point (140 °F or below) materials are being used is clear and remains clear of all potential ignition sources;

(11) Suitable fire extinguishing equipment should be available to the cleaning/treating area;

(12) Where any flammable materials are being used, equipment should be effectively grounded;

(13) If materials (acid, alkali, paint remover, or conversion coatings) are spilled on equipment and/or tools, treat immediately by rinsing with clean water, if possible, and/or neutralizing acids with baking soda and alkalies with a weak (5 percent) solution of acetic acid in water;

(14) Solvents with a low flash point (below 100 °F), such as methyl ethyl ketone (MEK) and acetone, should not be used in any confined locations;

(15) All equipment should be cleaned after work has been completed;

(16) Implement all company safety precautions;

(17) Check local environmental regulations for restrictions on the use of solvents, primers, and top coats; and

(18) Ensure disposal of waste material is per local environmental requirements.

b. Emergency safety procedures.

NOTE: PERSONNEL SHOULD BE THOROUGHLY FAMILIAR WITH THE FOLLOWING EMERGENCY SAFETY PROCEDURES PRIOR TO USING ANY MATERIALS WHICH ARE REFERENCED TO AN EMERGENCY SAFETY PROCEDURE PARAGRAPH.

(1) If exposed to physical contact with any of the following materials:

Methyl alcohol	Xylene
Methyl ethyl ketone	Petroleum naphthas
Methyl isobutyl ketone	Chromates
Toluene	Dichromates
Trichloroethylene	Acetates
Epoxy resin	Cyclohexanone
Methylene chloride	Cellosolve
Brush alodine	Carbon tetrachloride

Treat as follows:

(i) If splashed into eyes, do not rub.

(ii) Flush eyes immediately with water for at least 15 minutes. Lift upper and lower eyelids frequently to ensure complete washing.

(iii) If splashed on clothing or large areas of body, immediately remove contaminated clothing and wash body with plenty of soap and water. Wash clothing before rewearing.

(iv) If splashed onto an easily accessible part of the body, immediately wash with soap and water.

(v) If suffering headache or other obvious symptoms resulting from overexposure, move to fresh air immediately.

(vi) If vapors are inhaled and breathing has slowed down or stopped, remove person from exposure and start artificial respiration at once. Call ambulance and continue this treatment until ambulance arrives.

(2) If exposed to physical contact with any of the following materials:

Hydrofluoric acid	Phenol
Nitric acid	Cresols
Phosphoric acid	Tricresyl phosphate

Treat as follows:

(i) If splashed into eyes, quickly wipe eyelids with a soft cleaning tissue and immediately flush eye with gentle stream from a drinking fountain, cup, or other convenient water outlet while holding lids open. Call an ambulance and continue the flushing procedure until an ambulance arrives.

(ii) If splashed onto an easily accessible part of body, immediately drench affected area with water until ambulance arrives.

(iii) If splashed onto clothing or large area of body, immediately drench body and remove clothing while drenching until ambulance arrives.

(iv) If taken internally, begin following treatment immediately:

(A) If the person is conscious, cause vomiting by placing finger in back of the person's throat. Encourage the person to drink large quantities of water and repeatedly wash out the mouth.

(B) If the person is unconscious, do not give any liquid. Start artificial respiration at once. Continue until ambulance arrives. If person regains consciousness before ambulance arrives, proceed as in subparagraph (A).

601. GENERAL CORROSION CONTROL WORK PROCEDURES. The effectiveness of corrosion control depends on how well basic work procedures are followed. The following common work practices are recommended:

- a. If rework procedures or materials are unknown, contact the aircraft manufacturer or authorized representative before proceeding;
- b. The work areas, equipment, and components should be clean and free of chips, grit, dirt, and foreign materials.
- c. Do not mark on any metal surface with a graphite pencil or any type of sharp, pointed instrument. Temporary markings (defined as markings soluble in water or methyl chloroform) should be used for metal layout work or marking on the aircraft to indicate corroded areas.
- d. Graphite should not be used as a lubricant for any component. Graphite is cathodic to all structural metals and will generate galvanic corrosion in the presence of moisture, especially if the graphite is applied in dry form.
- e. Footwear and clothing should be inspected for metal chips, slivers, rivet cuttings, dirt, sand, etc., and all such material removed before walking or working on metal surfaces such as wings, stabilizers, fuel tanks, etc.
- f. Do not abrade or scratch any surface unless it is an authorized procedure. If surfaces are accidentally scratched, the damage should be assessed and action taken to remove the scratch and treat the area.
- g. Coated metal surfaces should not be polished for esthetic purposes. Buffing would remove the protective coating and a brightly polished surface is normally not as corrosion resistant as a nonpolished surface unless it is protected by wax, paint, etc. A bare skin sheet polished to a mirror finish is more resistant than a bare mill finished sheet when both are given regular maintenance.
- h. Protect surrounding areas when welding, grinding, drilling, etc., to prevent contaminating them with residue from these operations. In those areas where protective covering cannot be used, action should be taken to remove the residue by cleaning.
- i. Severely corroded screws, bolts, and washers should be replaced. When a protective coating, such as a cadmium plating on bolts, screws, etc., is damaged, immediate action should be taken to apply an appropriate protective finish to prevent additional corrosion damage.

602.-609. RESERVED.

SECTION 2. CORROSION REMOVAL TECHNIQUES

610. GENERAL. When active corrosion is visually apparent, a positive inspection and rework program is necessary to prevent any further deterioration of the structure. The following methods of assessing corrosion damage and procedures for rework of corroded areas could be used during cleanup programs. In general, any rework would involve the cleaning and stripping of all finish from the corroded area, the removal of corrosion products, and restoration of surface protective film.

a. Repair of corrosion damage includes removal of all corrosion and corrosion products. When the corrosion damage exceeds the damage limits set by the aircraft manufacturer in the structural repair manual, the affected part must be replaced or an FAA-approved engineering authorization for continued service for that part must be obtained.

b. For corrosion damage on large structural parts which is in excess of that allowed in the structural repair manual and where replacement is not practical, contact the aircraft manufacturer for rework limits and procedures.

611. STANDARD METHODS. Several standard methods are available for corrosion removal. The methods normally used to remove corrosion are mechanical and chemical. Mechanical methods include hand sanding using abrasive mat, abrasive paper, or metal wool, and powered mechanical sanding, grinding, and buffing, using abrasive mat, grinding wheels, sanding discs, and abrasive rubber mats. However, the method used depends upon the metal and the degree of corrosion. The removal method to use on each metal for each particular degree of corrosion is outlined in the following paragraphs.

612. PREPARATIONS FOR REWORK. All corrosion products should be removed completely when corroded structures are reworked as the corroding process will continue even though the affected surface is refinished. Before starting rework of corroded areas, carry out the following:

a. Position airplane in wash rack or provide washing apparatus for rapid rinsing of all surfaces.

b. Connect a static ground line to the airplane.

c. Prepare the aircraft for safe ground maintenance.

(1) Remove the aircraft battery(s), LOX container (if installed), and external hydraulic and electric power.

(2) Install all applicable safety pins, flags, and jury struts.

d. Protect the pitot-static ports, louvers, airscopes, engine opening, wheels, tires, magnesium skin panels, and airplane interior from moisture and chemical brightening agents.

e. Protect the surfaces adjacent to rework areas from chemical paint strippers, corrosion removal agents, and surface treatment materials.

613. PAIN T REMOVAL.

a. For small areas of metallic surfaces, paint may be removed by hand, using a medium grade abrasive mat. For larger areas, chemical paint removal is the preferred method.

b. Phenolic and non-phenolic chemical paint removers containing methylene chloride are recommended for paint stripping on metallic surfaces only. Chemical paint strippers containing acid should not be used as hydrogen embrittlement on high strength steel and some stainless steels will occur. The following procedure is recommended when using chemical paint remover:

(1) Mask acrylic windows and canopies, other plastic parts, rubber hoses, exposed wiring, composite surfaces, wheels and tires, and any other areas where the paint remover residue cannot be removed and refinishing cannot be accomplished;

(2) Remove sealants when required, by cutting away excess sealant with a sharp plastic scraper;

(3) Apply a thick, continuous coating of paint remover to cover the surface to be stripped;

(4) Allow paint remover to remain on the surface for a sufficient length of time to wrinkle and completely lift the paint. Reapply paint remover as necessary in the areas where paint remains tight or where the material has dried. Micarta scrapers, abrasive pads, or fiber brushes may be used to assist in removing persistent paint;

(5) Remove loosened paint and residual paint remover by washing and scrubbing the surface with fresh water and a stiff nylon bristle brush or an abrasive pad; and

(6) After thorough rinsing, remove masking materials and thoroughly clean the area with a solution of aircraft cleaning compound to remove paint remover residues.

c. For composite surfaces, paint removal should be done by mechanical removal techniques (scuff sanding) only. Composite surfaces include fiberglass, kevlar, carbon, graphite, and others. Due to the irregularities in composite surfaces (fiber weave), complete removal of the paint system can not be accomplished without surface fiber damage.

d. Mechanical paint removal may be done by hand or with fine or very fine abrasive mats or flap brushes on power tools. If power tools are used, care must be used to prevent removal of the base material.

614. SPECIAL TECHNIQUES. In special instances, a particular or specific method may be required to remove corrosion. Depending upon rework criteria, corrosion in a hole may be removed by enlarging the hole. Abrasive blasting may be required for removing corrosion from steel fasteners, side skins, or

irregularly shaped parts or surfaces. Whenever such special cases occur, the specified method for corrosion removal should be observed.

615. FAIRING OR BLENDING REWORKED AREAS. All depressions resulting from corrosion rework should be faired or blended with the surrounding surface. Fairing can be accomplished as follows:

a. Remove rough edges and all corrosion from the damaged area. All dish-outs should be elliptically shaped with the major axis running spanwise on wings and horizontal stabilizers, longitudinally on fuselages, and vertically on vertical stabilizers. (SELECT THE PROPER ABRASIVE FOR FAIRING OPERATIONS FROM TABLE 6-1.)

TABLE 6-1. ABRASIVES FOR CORROSION REMOVAL

METALS OR MATERIALS TO BE PROCESSED	RESTRICTIONS	OPERATION	ABRASIVE PAPER OR CLOTH			ABRASIVE FABRIC OR PAD	ALUMINUM	STAINLESS STEEL	PUMICE 350 MESH OR FINER	ABRASIVE WHEEL
			ALUMINUM OXIDE	SILICON CARBIDE	GARNET					
FERROUS ALLOYS	DOES NOT APPLY TO STEEL HEAT TREATED TO STRENGTHS TO 220,000 PSI AND ABOVE	CORROSION REMOVAL OR FAIRING	150 GRIT OR FINER	180 GRIT OR FINER		FINE TO ULTRAFINE	X	X	X	X
		FINISHING	400				X	X	X	
ALUMINUM ALLOYS EXCEPT CLAD ALUMINUM	DO NOT USE SILICON CARBIDE ABRASIVE	CORROSION REMOVAL OR FAIRING	150 GRIT OR FINER		7/0 GRIT OR FINER	VERY FINE AND ULTRAFINE	X		X	X
		FINISHING	400				X		X	
CLAD ALUMINUM	SANDING LIMITED TO THE REMOVAL OF MINOR SCRATCHES	CORROSION REMOVAL OR FAIRING	240 GRIT OR FINER		7/0 GRIT OR FINER	VERY FINE AND ULTRAFINE			X	X
		FINISHING	400						X	
MAGNESIUM ALLOYS		CORROSION REMOVAL OR FAIRING	240 GRIT OR FINER			VERY FINE AND ULTRAFINE	X		X	X
		FINISHING	400				X		X	
TITANIUM		CLEANING AND FINISHING	150 GRIT OR FINER	180 GRIT OR FINER				X	X	X

b. Rework depressions by forming smoothly blended dish-outs, using a ratio of 20:1, length to depth (see Figures 6-1 and 6-2). In areas having closely spaced multiple pits, intervening material should be removed to minimize surface irregularity or waviness (see Figures 6-3 and 6-4). Steel nutplates and steel fasteners should be removed before blending corrosion out of aluminum structure. Steel or copper particles embedded in aluminum can become a point of future corrosion (see Figure 6-5). All corrosion products must be removed during blending to prevent reoccurrence of corrosion (see Figures 6-6 and 6-7).

c. In critical and highly stressed areas, all pits remaining after removal of corrosion products by any method should be blended out to prevent stress risers which may cause stress-corrosion cracking. On noncritical structure it is not necessary to blend out pits remaining after removal of corrosion products by abrasive blasting, since this results in unnecessary metal removal.

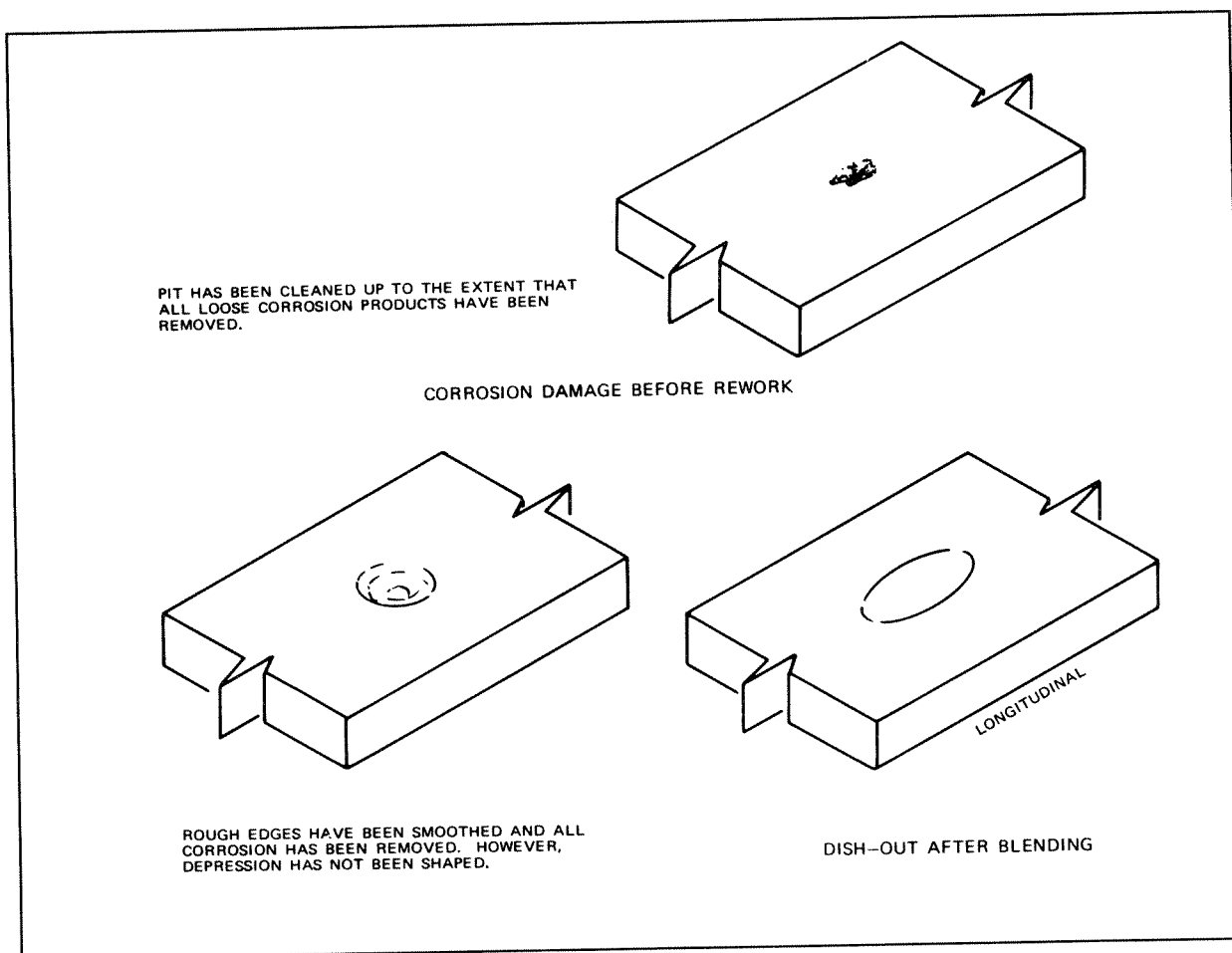

FIGURE 6-1. BLENDOUT OF CORROSION AS SINGLE DEPRESSION

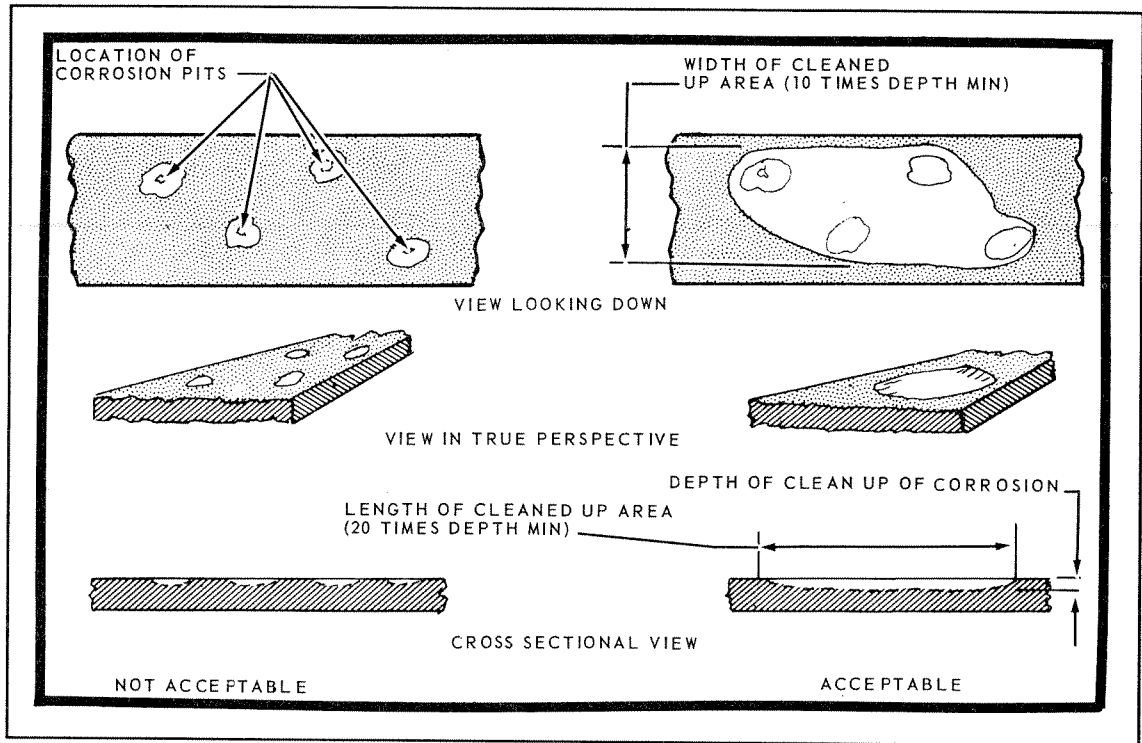

FIGURE 6-2. TYPICAL EXAMPLE OF ACCEPTABLE CLEANUP OF CORROSION PITS

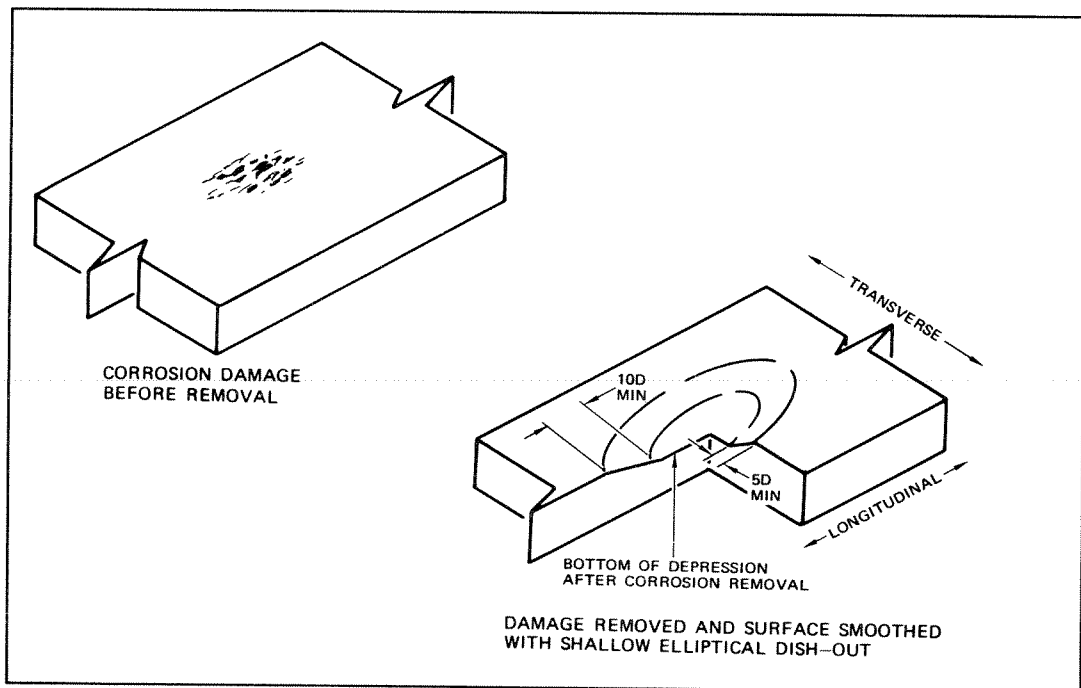

FIGURE 6-3. BLENDOUT OF MULTIPLE PITS IN CORRODED AREA

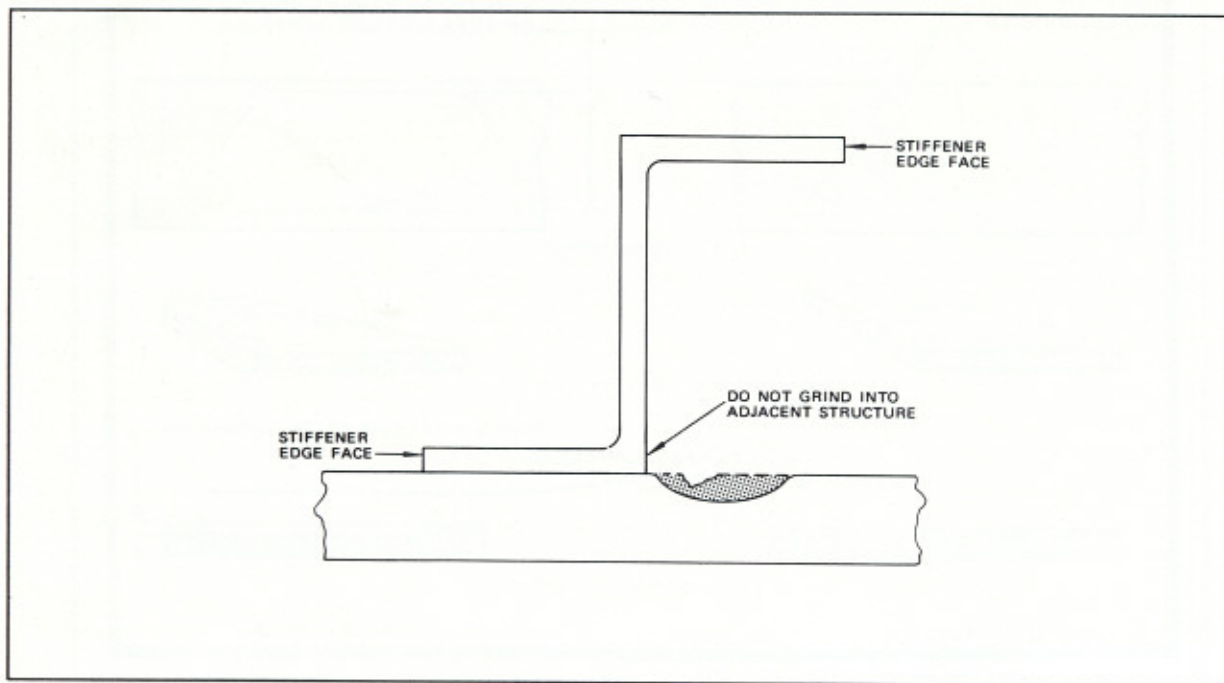

FIGURE 6-4. PROFILE OF REWORKED CORRODED AREAS IN REGIONS OF LIMITED ACCESS



FIGURE 6-5. STEEL PARTICLES FROM FASTENERS OR NUTPLATES MAY CAUSE FUTURE CORROSION PROBLEMS IN ALUMINUM STRUCTURE



FIGURE 6-6. INCOMPLETE REMOVAL OF CORROSION PRODUCTS RESULTED IN REOCCURRENCE OF CORROSION

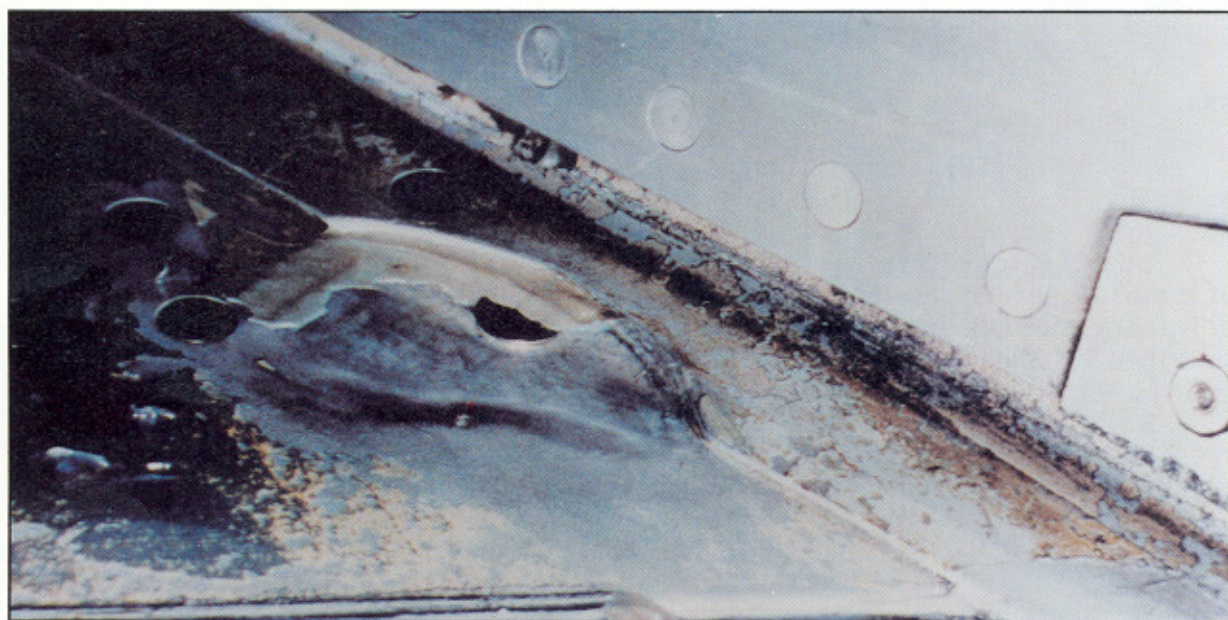

FIGURE 6-7. INCOMPLETE REMOVAL OF CORROSION PRODUCTS RESULTED IN REOCCURRENCE OF CORROSION

616. CHEMICAL TESTING.

a. A serious problem encountered in corrosion control is the identification of the metal on which corrosion occurs. The importance of this identification arises from the fact that all metals possess certain chemical characteristics that are common only to themselves and which vary greatly from metal to metal and from alloy to alloy of the same metal. Since these characteristics are common to all metals and their alloys, chemical cleaning solutions and chemical protective films will react differently with various metals. In some cases, this produces adverse reactions which can severely weaken or destroy the structural capabilities of the metal.

(1) The primary method of determining material identification is in the aircraft structural repair manual. When the structural repair manual is limited or when more information is required, i.e., heat-treat and protective finishes, the best source of material identification is the aircraft manufacturer, where an aircraft drawing can be reviewed.

(2) Chemical testing can be used when all other methods have been exhausted and when the following precautions are followed:

(i) Personnel should become thoroughly familiar with the safety precautions and emergency safety procedures, prior to performing any chemical testing.

(ii) Chemical spot testing should be accomplished by qualified personnel only.

(iii) Fasteners should not be identified by chemical spot tests.

(iv) High strength steel should not be identified by chemical spot tests.

b. Chemical testing for each type of metal should be accomplished on test samples before any tests are accomplished on the actual part. The preliminary surface preparation and primary classification of the metal may be determined by the following procedure.

(1) On the surface to be tested, choose an area where there is no corrosion and remove paint (if present) from a 1-inch square. Paint may be removed using hand sanding or an approved paint remover.

CAUTION: ADEQUATE PRECAUTIONS SHOULD BE TAKEN TO PREVENT PAINT REMOVER FROM CONTACTING COMPOSITE PARTS.

(2) Clean area of surface to be tested.

(3) Tentatively identify the exposed metal surface by visually comparing it with samples of previously identified materials, if available.

(4) Identify the metal as ferrous or nonferrous by placing a magnet on the exposed surface.

(i) Magnetic attraction classifies the base metal as a ferrous magnetic material (iron or steel).

(ii) The absence of magnetic attraction classifies the base metal as either an austenitic stainless steel or a nonferrous metal (aluminum, magnesium, etc.)

(5) Hardness test magnetic metals by a qualified person prior to chemical spot testing. If the metal is nonmagnetic, proceed with paragraph 618.

617. CHEMICAL SPOT ANALYSIS OF MAGNETIC METALS. The magnetic metals usually employed in aircraft construction are ferrous alloys (high strength steels and some stainless steels). These magnetic alloys, when plated, are generally plated with either chromium, nickel, zinc, cadmium, silver, or with a combination of these platings.

a. If a magnetic alloy has been plated with cadmium, zinc, or chromium, it will exert magnetic attraction. Nickel plating will show slight magnetic attraction even if the substrate or base metal is not magnetic.

b. If positive identification of the metal plating is necessary, the identification should be made after accomplishing a hardness test.

CAUTION: DO NOT PERFORM A CHEMICAL SPOT TEST ON STEELS HEAT-TREATED TO 220,000 PSI AND ABOVE.

c. Place a drop of 10 percent hydrochloric acid (HCL) on the prepared metal surface. Ensure that the surface is dry before applying acid.

(1) A rapid reaction producing a dark deposit indicates that the metal is zinc.

(2) A slow or no reaction indicates that the metal may be cadmium, chromium, nickel, or steel.

CAUTION: THE ADDITION OF SODIUM SULFIDE (Na_2S) TO ACID PRODUCES A POISONOUS GAS. ADEQUATE VENTILATION SHOULD BE PROVIDED WHEN THESE TESTS ARE BEING PERFORMED. DO NOT ALLOW LARGE QUANTITIES OF SODIUM SULFIDE (Na_2S) AND ACID TO BE MIXED.

d. After 1 minute, add a drop of Na_2S to the drop of HCL.

(1) A white precipitate identifies the metal as zinc.

(2) A yellow ring formed around a white precipitate identifies the metal as cadmium.

(3) A black ring formed around a white precipitate identifies the metal as iron or steel.

(4) A black precipitate indicates that the metal is chromium or nickel.

e. Confirm the cadmium, zinc, iron, or steel test by placing a drop of 20 percent nitric acid (HNO_3) on a fresh spot. After 1 minute, add a drop of Na_2S to the drop of HNO_3 .

(1) A white precipitate identifies the metal as zinc.

(2) A yellow precipitate identifies the metal as cadmium.

(3) A black spot identifies the metal as iron or steel.

f. Confirm the chromium test by placing a drop of 10 percent HCL on a fresh spot. Add a drop of concentrated sulfuric acid (H_2SO_4) to the drop of HCL. A color change to green after 1 or 2 minutes identifies the metal as chromium.

g. Confirm the nickel test by placing a drop of dimethylglyoxime solution on a fresh spot. Add a drop of ammonium hydroxide (NH_4OH) to the drop of dimethylglyoxime solution. A pink to red precipitate identifies the metal as nickel.

h. Clean and refinish as detailed in paragraph 620.

618. CHEMICAL SPOT ANALYSIS OF NONMAGNETIC METALS. The most common nonmagnetic metals used in aircraft construction are aluminum, magnesium, and austenitic steels (generally used as 18-8 stainless steel). The positive identification of these nonmagnetic metals is accomplished by the following procedure:

a. Place a drop of 10 percent HCL on the prepared metal surface and allow to stand for 1 minute. Ensure that the surface is dry before applying acid. (Zinc deposits on nonmagnetic metals will react with 10 percent HCL but will not produce a black spot.)

(1) A rapid or violent reaction that produces a black spot indicates that the metal is magnesium.

(2) A slow reaction indicates that the metal is aluminum.

(3) No reaction indicates that the metal is an austenitic steel or a nonmagnetic plating material.

b. If a reaction did not produce a black spot as noted in paragraph 618.a.(1), determine if zinc is present as detailed in paragraph 617.e.

c. If the results of paragraph 618.b. are negative (zinc not present), confirm the magnesium and aluminum tests by placing a drop of 10 percent sodium hydroxide (NaOH) on a fresh spot. Check for the following:

- (1) No reaction which will identify the metal as magnesium.
- (2) A reaction that produces a colorless spot will identify the metal as a bare-aluminum alloy.

d. If an aluminum alloy is identified as outlined in paragraph 618.c., further test to distinguish the different alloys by placing a drop of 10 percent cadmium chloride on a fresh spot.

- (1) A dark gray deposit forming within a few seconds will identify the metal as 7075 or 7178 bare-aluminum alloy.
- (2) A dark gray deposit forming within 2 minutes will identify the metal as 7075 or 7178 clad-aluminum alloy.
- (3) No deposit formation in the time specified for 7075 or 7178 clad will identify the metal as 2024 aluminum alloy (a faint deposit will form after 15 or 20 minutes).

e. Confirm the austenitic steel test by dissolving 10 grams of cupric chloride ($\text{CuCl}_2 \cdot 2\text{H}_2\text{O}$) in 100 cubic centimeters of HCL and placing a drop of the solution on a fresh spot. After 2 minutes, add three or four drops of distilled water to the drop of HCL solution and dry the surface. The appearance of a brown spot identifies the metal as an austenitic steel.

f. If no reaction was noted as outlined in paragraph 618.a or e., test for a plating material as detailed in paragraph 617.

g. If step f. reveals the presence of plating on the nonmagnetic metal, the plating should be removed by mechanical abrasion and the base metal identified by the visual and/or chemical methods outlined in paragraph 617.

h. Clean and refinish as required in paragraph 620.

619. SURFACE TREATMENT TESTING. The most common types of surface treatment for metals used in aircraft construction are: chemical conversion coatings, phosphate treatments for steels, and chromate treatments for aluminum. Other surface treatments include lacquer and chromate films. The identification of these surface treatments may be accomplished by the following procedures:

a. Phosphate treatment. The presence of a phosphate treatment on steel, zinc, cadmium, or aluminum can be confirmed by placing a drop of 20 percent nitric acid (HNO_3) on the surface and following this with two drops of ammonium molybdate solution. If the metal surface has had a phosphate treatment, a yellow precipitate will form.

b. Chromate treatment. Surface chromate treatments on zinc, cadmium, aluminum, or magnesium are highly colored and are indicative of the application of these treatments. However, a bleached chromate treatment may have been applied and then coated with lacquer to mask any residual iridescence for the sake of appearance. If so, visual detection of the chromate is impossible. To test for lacquer, proceed as directed in paragraph 619.c. It should be noted that the bleaching process used in a bleached chromate treatment lowers the corrosion resistance provided by the chromate film.

c. Lacquer finish. To test for lacquer, place a drop of concentrated sulfuric acid on the surface. If lacquer is present, the spot will rapidly turn brown with no effervescence. If lacquer is not present, the spot will not turn brown. If the metal is zinc, there will be no rapid effervescence. If the metal is cadmium, there will be no reaction.

d. Chromate film. To detect a chromate film on zinc and cadmium, place a drop of 5 percent aqueous solution of lead acetate on the surface. If the metal has been treated, the surface will show no discoloration for 10 seconds. If there is no surface treatment, an immediate dark spot will appear.

620. POSTIDENTIFICATION CLEANING AND REFINISHING.

NOTE: THE SOLUTIONS USED IN THE CHEMICAL SPOT TESTS ARE EXTREMELY CORROSIVE.

After identification of the metal is completed, clean the area as follows:

- a. Blot any remaining chemicals with a dry cloth.
- b. Swab the area several times with a water moistened cloth.
- c. Test the surface by placing a piece of litmus paper on the moistened surface. If the litmus paper changes color, repeat steps a. and b. until no color change occurs.
- d. Dry surface thoroughly.
- e. Remove corrosion, if present, and refinish the surface, as applicable.

621.-625. RESERVED.

SECTION 3. MECHANICAL CORROSION REMOVAL BY BLASTING

626. GENERAL. Abrasive blasting is a process for cleaning or finishing metals, plastics, and other materials by directing a stream of abrasive particles against the surface of the parts. Abrasive blasting is used for the removal of rust and corrosion and for cleaning prior to further processing, such as painting or plating. Standard blast cleaning practices should be adopted with the following requirements being made:

a. Any form of blast cleaning equipment may be used, but in-cabinet blasting is preferred.

b. External gun blasting may be used if adequate confinements and recovery are provided for the abrasives.

627. SAFETY PRECAUTIONS. Operators should be adequately protected with complete face and head covering equipment, and provided with pure breathing air. Magnesium creates a fire hazard when abrasive blasted. Dry abrasive blasting of titanium alloys and high tensile strength steel creates sparking. Care should be taken to assure that no hazardous concentration of inflammable vapors exists. Static ground the dry abrasive blaster and the material to be blasted.

a. The part to be blast-cleaned should be removed from the aircraft, if possible. Otherwise, areas adjacent to the part should be masked or protected from abrasive impingement and system (hydraulic, oil, fuel, etc.) contamination.

b. Parts should be clean of oil, grease, dirt, etc., and dry prior to blast cleaning.

c. Close-tolerance surfaces, such as bushings, bearing shaft, etc., should be masked.

d. Blast-clean only enough to remove corrosion coating. Proceed immediately with finishing requirement using surface treatments as required.

628.-639. RESERVED.

SECTION 4. CORROSION DAMAGE AND REWORK LIMITS

640. DISCUSSION. Corrosion evaluation will be required after general inspection and cleaning to determine the nature and extent of repair or rework. Local blending of corroded areas may be required to determine the total extent of the corrosion problem (see Figures 6-1, 6-2, 6-3 and 6-4). Corrosion damage classifications are defined as follows:

a. Light corrosion. Characterized by discoloration or pitting to a depth of approximately 0.001 inch maximum. This type of damage is normally removed by light, hand sanding or a minimum of chemical treatment.

b. Moderate corrosion. Appears similar to light corrosion except there may be some blisters or evidence of scaling and flaking. Pitting depths may be as deep as 0.010 inch. This type of damage is normally removed by extensive mechanical sanding.

c. Severe corrosion. General appearance may be similar to moderate corrosion with severe blistering exfoliation and scaling or flaking. Pitting depths will be deeper than 0.010 inch. This type of damage is normally removed by extensive mechanical sanding or grinding. Severe corrosion damage beyond the limits of the aircraft structural repair manual will require FAA-approved engineering authorization and may include the following typical corrosion repairs: trimming out of cracked and corroded areas (see Figure 6-8) or spot facing of fastener locations (see Figure 6-9).

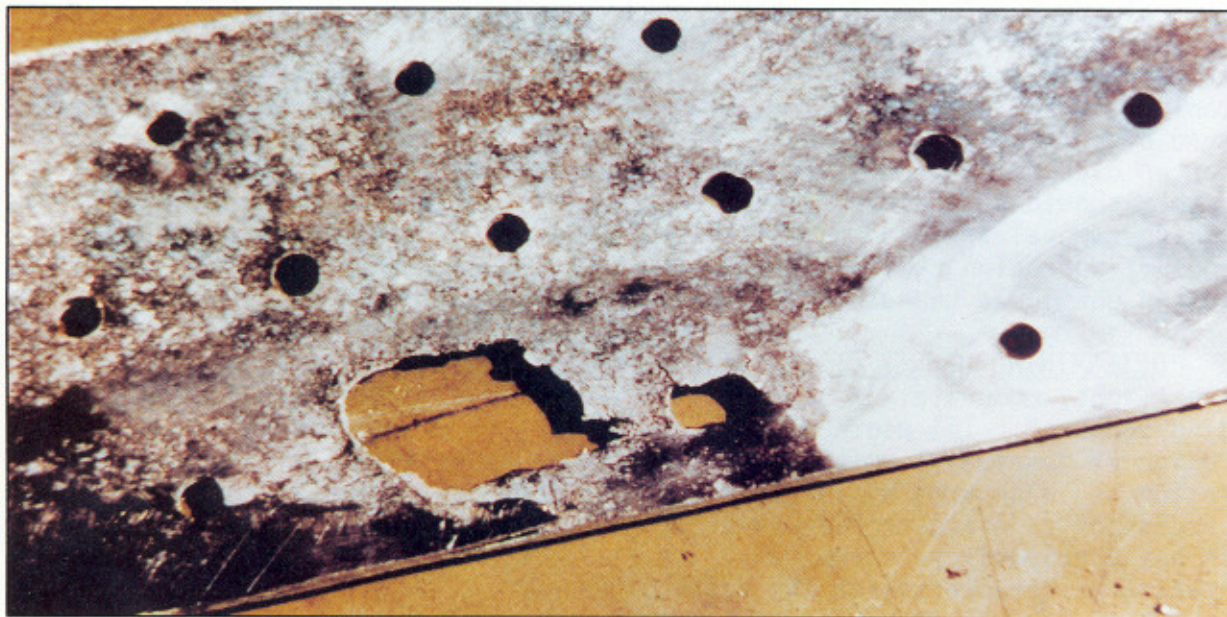

FIGURE 6-8. SEVERE CORROSION REQUIRING TRIMMING OUT OF DAMAGED AREA

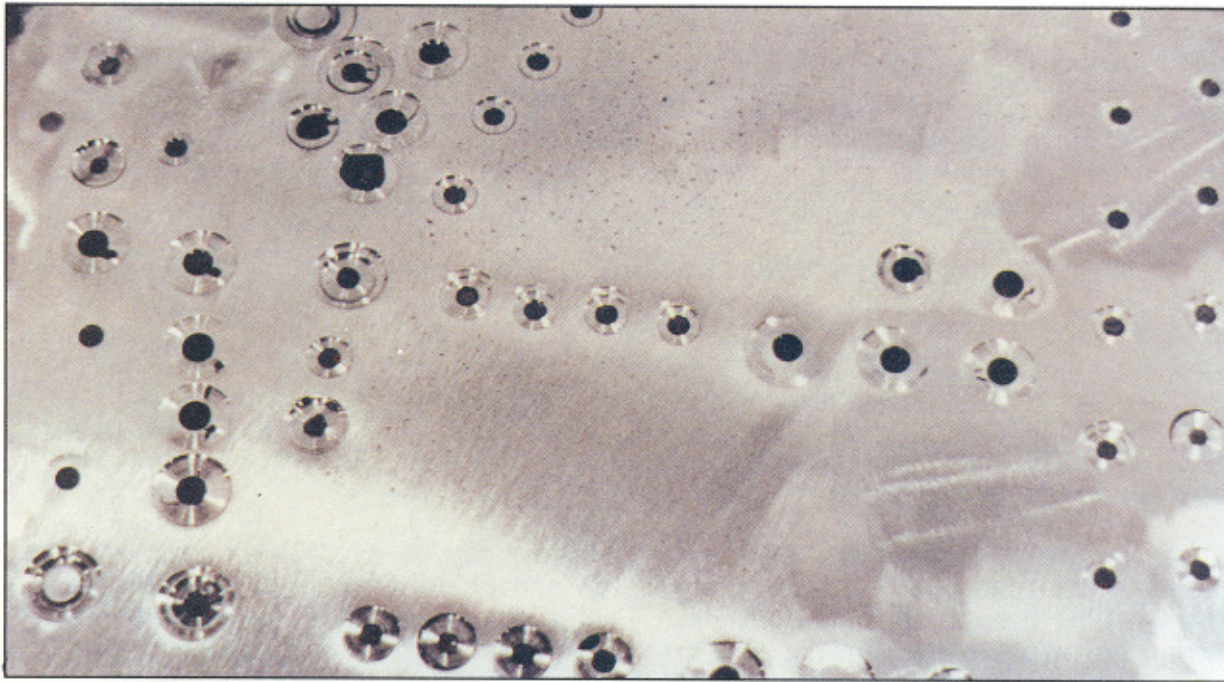

FIGURE 6-9. CORROSION AT FASTENER HOLES REMOVED BY SPOT FACING

641. REMOVAL OF CORROSION. There are two basic methods of corrosion removal, mechanical and chemical. The method used depends upon the type of structure, its location, the type and severity of corrosion, and the availability of maintenance equipment. Mechanical methods of corrosion removal are the most commonly used including: sanding, buffing, grinding, and section removal. Avoid the use of soft metal wire brushes (i.e., copper alloys) as residual traces of copper on cleaned metal will contribute to future corrosion. If brushes are used they should be stainless steel or nonmetallic. Mechanical methods of corrosion removal are used on all three levels of corrosion damage. Chemical methods of corrosion removal are limited to light corrosion and only in areas where the chemicals cannot migrate to other areas.

642. DETERMINING DEGREE OF CORROSION DAMAGE. Determine degree of corrosion damage (light, moderate, or severe) with a depth dial gauge, straight edge, or a molding compound. The depth of corrosion cannot be measured until all the corrosion is removed. Before measurements are made, visually determine if corrosion is in an area which has previously been reworked. If corrosion is in the recess of a faired or blended area, measure damage to include the material which has previously been removed. The following method outlines the process for taking measurements with the depth gauge.

- a. Remove loose corrosion products, if present.
- b. Position depth gauge as illustrated in Figure 6-10 and determine the measurement reading.

NOTE: The base of the depth gauge should be flat against the undamaged surface on each side of the corrosion. When taking measurements on concave or convex surfaces, place the base perpendicular to the radius of the surface as shown in Figure 6-10.

- c. Take several additional depth readings.
- d. Select deepest reading as being the depth of the corrosion damage.

643. DETERMINING REWORK LIMITS. The maximum allowable amount of material removed from any damaged surface may be determined from criteria contained in the allowable damage limit chart in the manufacturer's repair manual. If no criteria is given, contact the aircraft manufacturer for cleanup limits.

644. DETERMINING MATERIAL THICKNESS REDUCTION AFTER CORROSION CLEANUP. The amount of material which may be removed from a part or panel during corrosion cleanup is usually available in the manufacturer's allowable damage limit charts. To ensure that the allowable limits are not exceeded, an accurate measurement should be made of the material removed or material thickness remaining in the reworked area.

- a. Measurement of panel thickness after rework can be made using an ultrasonic tester. This method requires a qualified NDI operator and suitable test standards for calibration.

- b. Measurement of the depth of blended pits (material removed) can be made using a depth dial gauge (see Figure 6-10). If the depth dial gauge will not work, clay impressions, liquid rubber, or other similar means which will give accurate results may be used to determine material removed. In the event that material removal limits have been exceeded, the area or part should be repaired or replaced. If replacement or repair criteria is not contained in the repair manual, contact the manufacturer or the FAA.

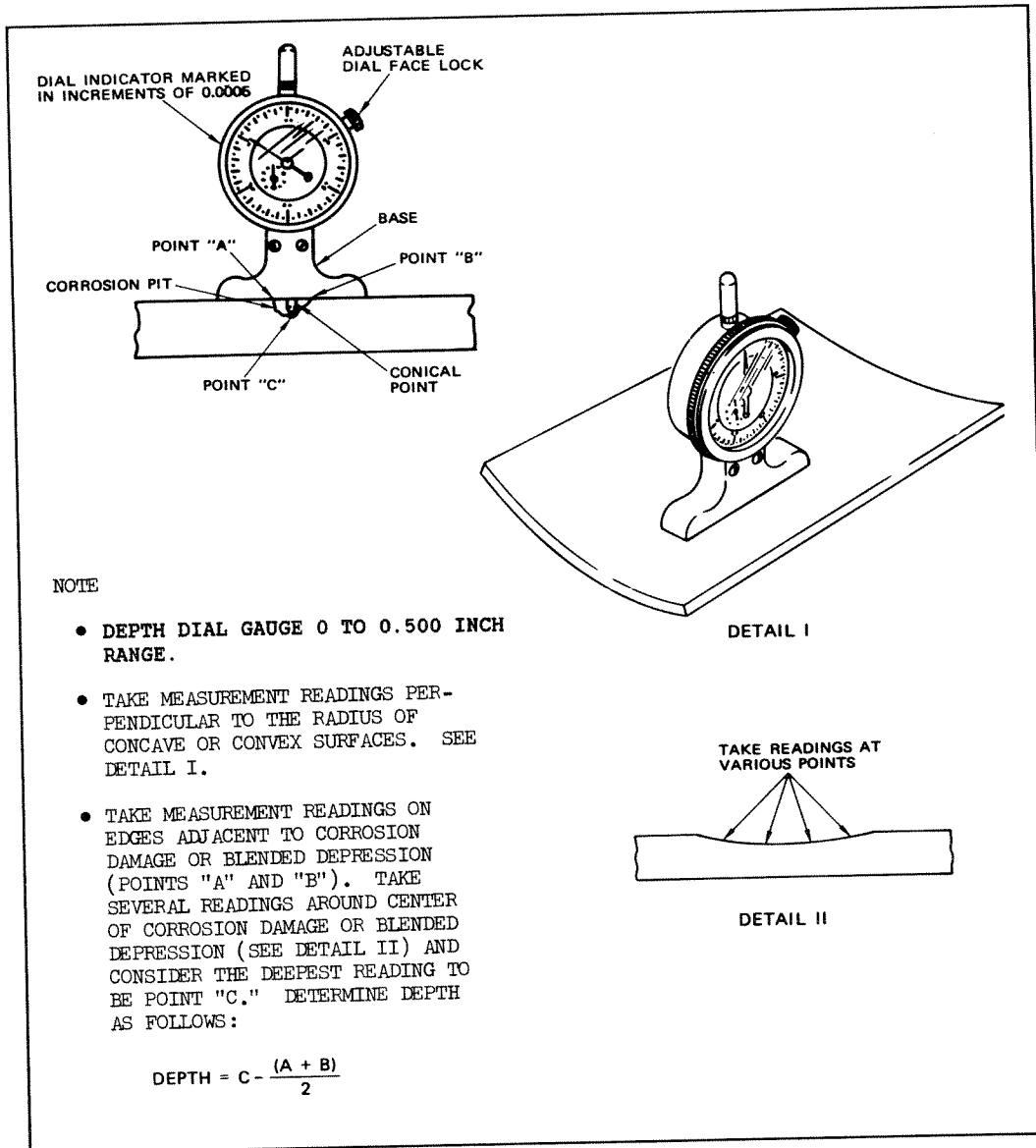

FIGURE 6-10. CORROSION DAMAGE AND REWORK MEASUREMENT USING DEPTH DIAL GAUGE

645.-649. RESERVED.

SECTION 5. ALUMINUM AND ALUMINUM ALLOYS

650. TREATMENT. In general, corrosion of aluminum can be more effectively treated in place rather than removing structural parts from the aircraft for corrosion treatment. Treatment includes the mechanical removal of the corrosion products, the inhibition of residual materials by chemical means, and the restoration of permanent surface coating. Details of treatment vary depending on whether the aluminum surfaces are to be left bare in use or are to be protected by paint coatings.

651. PROCESSING OF ALUMINUM SURFACES.

a. Bare aluminum surfaces. While few unpainted aircraft are used under marine conditions, some general information is included on the nature of alclad surfaces and their treatment. Relatively speaking, pure aluminum has greater corrosion resistance than the stronger aluminum alloys. Advantage is taken of this by laminating a thin sheet of relatively pure aluminum, one to five mils thick, over the base higher strength aluminum alloy surface. The protection obtained is good, and the alclad surface can be maintained in a polished condition (see Figure 6-12). In cleaning such surfaces, however, care should be taken to prevent staining and marring of the exposed aluminum, and more important from a protection standpoint, to avoid unnecessary mechanical removal of the protective alclad layer and the exposure of more susceptible, but stronger, aluminum alloy base material.

b. Additional processing of aluminum surfaces prior to paint finishes. Aluminum surfaces that are to be subsequently painted can be exposed to more severe cleaning procedures and can also be given more thorough corrective treatment prior to painting. Application of a paint finish requires proper prepaint treatment for good paint adhesion.

c. Special treatment of anodized surfaces. Anodizing is the most common surface treatment of aluminum alloy surfaces. Tank processing is accomplished during manufacture or rework of a part or component and frequently prior to its fabrication from sheet stock. The aluminum sheet or casting is made as a positive pole in an electrolytic bath in which chromic acid or other oxidizing agents produce a supplemental protective oxide film on the aluminum surface. Aluminum oxide is naturally protective and anodizing merely increases the thickness and density of the natural oxide film. When this coating is damaged in service, it can only be partially restored by chemical surface treatment. Therefore, any processing of anodized surfaces should avoid unnecessary destruction of the oxide film.

(1) Steel wool, steel wire brushes, copper alloy brushes, or severe abrasive materials should not be used on any aluminum surface. Aluminum wool, fiber bristle brushes, and mild abrasives are acceptable tools for cleaning anodized surfaces, but care should be exercised in any cleaning process to avoid unnecessary breaking of the protective film, particularly at the edges of the aluminum sheet (see Figures 6-11 and 6-13).

(2) Tampico fiber brushes are preferred and are adequate to remove most corrosion. Producing a buffed or wire-brush finish by any means should be prohibited. Take every precaution to maintain as much of the protective coating as practicable. Otherwise, treat anodized surfaces in the same manner as other aluminum finishes. Vacuum blasting is an acceptable corrosion removal method to remove surface corrosion. Vacuum blasting should not be used to remove intergranular corrosion.

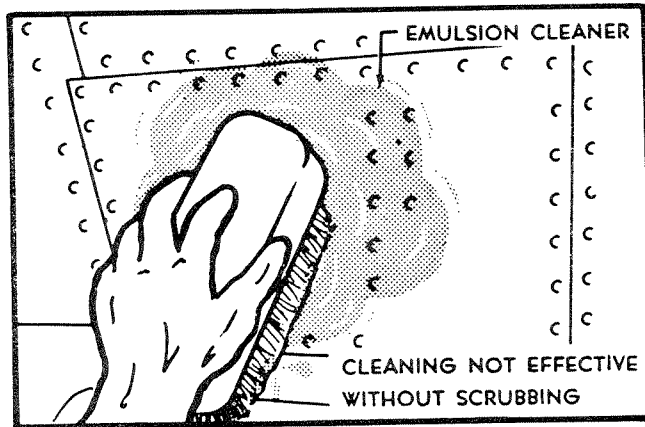

FIGURE 6-11. REMOVING OIL AND SURFACE DIRT



FIGURE 6-12. POLISHING AND BRIGHTENING ALCAD SURFACES

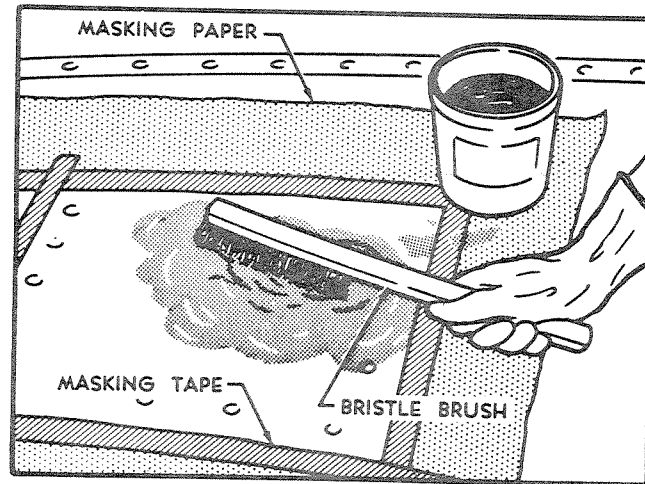

FIGURE 6-13. CLEANING AND STRIPPING PAINT

(3) Chemical conversion coating (Specification MIL-C-81706) is a chemical surface treatment used on aluminum alloys to inhibit corrosion and to provide a proper surface for paint finishing.

d. Special processing of intergranular corrosion in heat-treated aluminum alloy surfaces. Intergranular corrosion is usually more severe in heat-treated aluminum alloys and is a corrosive attack along grain boundaries of the alloyed aluminum, where the grain boundaries differ from the metal within the grain. When in contact with an electrolyte, rapid corrosion occurs at the grain boundaries. In its most severe form, actual lifting of metal layers (exfoliation) occurs. The mechanical removal of all corrosion products and visible delaminated metal layers should be accomplished in order to determine the extent of the damage and to evaluate the remaining structural strength of the component.

(1) Use metal scrapers, rotary files, or abrasive wheels to assure that all corrosion products are removed and that only structurally sound aluminum remains.

NOTE: THE USE OF A ROTARY FILE IS RECOMMENDED ONLY FOR SEVERE INTERGRANULAR OR EXFOLIATION CORROSION REMOVAL.

(2) Rotary files should be sharp to insure that they cut the metal without excessive smearing. A dull cutting tool will smear the metal over corrosion cracks or fissure and give the appearance that corrosion has been removed, when, in fact, it may not have been.

(3) Carbide tip rotary files or metal scrapers should be utilized since they stay sharp longer. Abrasive blasting should not be used to remove intergranular corrosion.

(4) Inspection with a 5- to 10-power magnifying glass or the use of dye penetrant will assist in determining if all unsound metal and corrosion products have been removed.

(5) When complete removal of corrosion has been accomplished, blend or fair using a ratio of 20:1 (length to depth) in the area of corrosion removal. Blending, where required, can best be accomplished by using aluminum oxide impregnated, rubber-base wheels.

(6) Chemical conversion coat the exposed surfaces completely and restore paint coatings in the same manner as on any other aluminum surface (see Figures 6-14, 6-15, and 6-16).

(7) Corrosion damage beyond the limits set in the structural repair manual should be repaired per a cognizant engineer or aircraft manufacturer's instructions that are FAA approved.

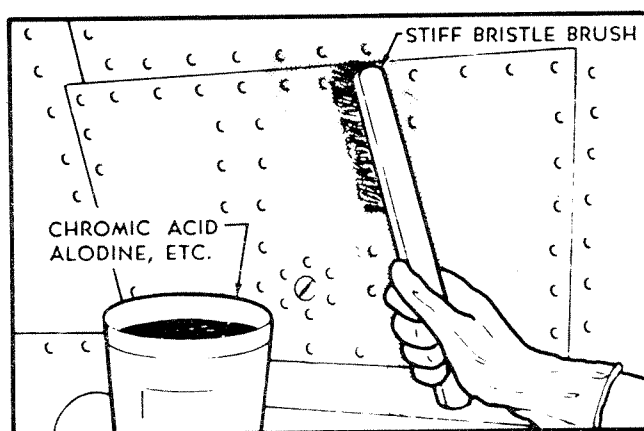

FIGURE 6-14. CLEANING AND INHIBITING CORRODED ALUMINUM SURFACES.

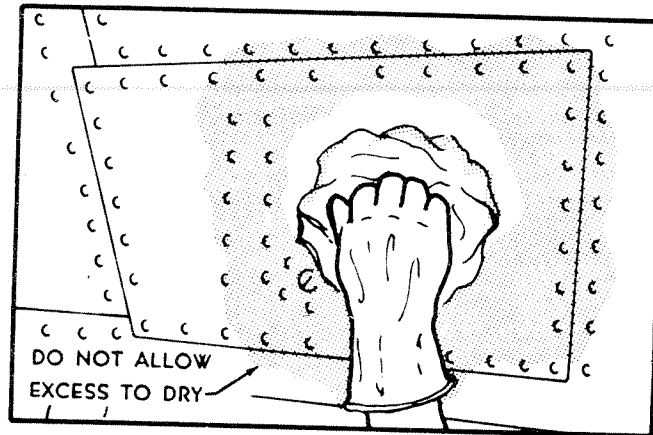

FIGURE 6-15. REMOVING EXCESS INHIBITOR SOLUTION

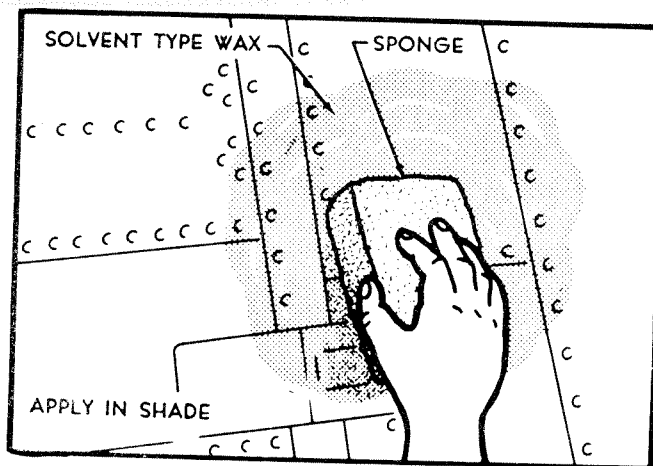

FIGURE 6-16. APPLYING WAX TO CLEANED SURFACES

652. REPAIR OF ALUMINUM ALLOY SHEET METAL. After extensive corrosion removal, the following procedures should be followed:

- a. If water can be trapped in blended areas, chemical conversion coat and fill the blended area with structural adhesive or sealant to the same level and contour as the original skin. When areas are small enough that structural

strength has not been significantly decreased, no other work is required prior to applying the protective finish.

b. When corrosion removal exceeds the limits of the structural repair manual, contact a cognizant engineer or the aircraft manufacturer for repair instructions.

c. Where exterior doublers are allowed, it is necessary to seal and insulate them adequately to prevent further corrosion.

d. Doublers should be made from alclad, when available, and the sheet should be anodized (preferred) or chemical conversion coated after all cutting, drilling, and countersinking has been accomplished.

e. All rivet holes should be drilled, countersunk, surface treated, and primed prior to installation of the doubler.

f. Apply a suitable sealing compound in the area to be covered by the doubler. Apply sufficient thickness of sealing compound to fill all voids in the area being repaired.

g. Install rivets wet with sealant. Sufficient sealant should be squeezed out into holes so that all fasteners, as well as all edges of the repair plate, will be sealed against entrance of moisture.

h. Remove all excess sealant after fasteners are installed. Apply a fillet sealant bead around the edge of the repair. After the sealant has cured apply the protective paint finish to the reworked area.

653. CORROSION REMOVAL AROUND COUNTERSUNK FASTENERS IN ALUMINUM ALLOY.
Intergranular corrosion in aluminum alloys often originates at countersunk areas where steel fasteners are used. Removal of corrosion in a countersink is impossible to accomplish with the fastener in place.

a. When corrosion is found around a fixed fastener head, the fastener must be removed to ensure corrosion removal. It is imperative that all corrosion be removed to prevent further corrosion and loss of structural strength. To reduce the reoccurrence of corrosion, the panel should receive a chemical conversion coating, be primed, and have the fasteners installed wet with sealant.

b. Each time removable steel fasteners are removed from access panels, they should be inspected for material condition including the condition of the plating. If mechanical or plating damage is evident, replace the fastener. Upon installation, one of the following fastener installation methods should be followed:

(1) Brush a corrosion preventive compound on the substructure around and in the fastener hole, start the fastener, apply a bead of sealant to the fastener countersink, and set and torque the fastener within the working time of the sealant (this is the preferred method);

(2) Apply the corrosion preventive compound to the substructure and fastener, set and torque the fastener; or

(3) Apply a coating of primer to the fastener, and while wet with primer set and torque the fastener.

654. EXAMPLES OF REMOVING CORROSION FROM ALUMINUM AND ALUMINUM ALLOYS.

a. Prepare the aircraft for corrosion rework as provided in paragraph 612 and remove corrosion products as follows. Observe the work procedures of paragraph 601.

b. Positively identify the metal as aluminum.

c. Clean the area to be reworked. Strip paint if required.

d. Determine extent of corrosion damage as covered in paragraph 642. To remove light corrosion, proceed with paragraph 654.e. To remove moderate or severe corrosion, proceed with paragraph 654.f.

e. Remove light corrosion by hand rubbing the corroded surface with tools, abrasives or by chemical means as follows. Do not use the chemical removal process at temperatures above 100 °F or below 40 °F.

(1) Protectively mask adjacent areas to prevent brighteners from contacting magnesium, anodized aluminum, glass, plexiglass, fabric surfaces, and all steel. Wear acid-resistant gloves, protective mask, and protective clothing when working with corrosion removing compounds. If corrosion removing compounds accidentally contact the skin or eyes, flush off immediately with plenty of clear water. Refer to safety procedures in paragraph 600.

(2) Dilute corrosion removing compound (Specification MIL-C-38334, Type I) with an equal volume of water. Mix the compound only in wood, plastic, or plastic lined containers. The diluted solution of corrosion removing compound may be applied by flowing, mopping, sponging, brushing, or wiping.

(3) Apply diluted solution to large areas with a circular motion to disturb the surface film and ensure proper coverage. The diluted solution should be applied starting at the lowest area and working upwards. The solution will be more effective if applied warm (140 °F maximum) followed by vigorous agitation with a nonmetallic, acid resistant brush or aluminum oxide abrasive nylon mat.

(4) Leave the solution on surface for approximately 12 minutes. Do not allow solution to dry on surface, as streaking will result. (On large exterior surfaces, remove solution by high pressure water rinse.)

(5) Wipe off solution with a clean, moist cloth; frequently rinse the cloth in clear water. Wipe the area several additional times with a fresh cloth dampened and rinsed frequently in clear water.

(6) Dry the area with a clean, dry cloth and inspect for corrosion.

(7) Repeat the procedure outlined in paragraph 654.e. if any corrosion remains.

NOTE: IF CORROSION STILL REMAINS AFTER THE SECOND ATTEMPT, MECHANICALLY REMOVE CORROSION AS DETAILED IN PARAGRAPH 654.f. OF THIS CHAPTER.

(8) After all corrosion has been removed, proceed with paragraph 654.f.(4).

f. Mechanically remove moderate or severe corrosion by the appropriate methods as follows.

NOTE: WEAR GOGGLES OR FACE SHIELD TO PROTECT AGAINST CORROSION PARTICLES THAT BREAK LOOSE AND FLY OFF. PROTECT ADJACENT AREAS TO PREVENT ADDITIONAL DAMAGE FROM CORROSION PRODUCTS REMOVED DURING MECHANICAL REMOVAL.

(1) Remove loose corrosion products by hand rubbing the corroded surface with tools or abrasives. Dry abrasive blasting using glass beads (Specification MIL-G-9954) sizes 10, 11, 12, 13, or grain abrasive (Specification MIL-G-5634) types I and III, may be used as an alternate method of removing corrosion from clad and nonclad aluminum alloys. Abrasive blasting should not be used to remove heavy corrosion products. Direct pressure machines should have the nozzle pressure set at 30 to 40 psi for clad aluminum alloys and 40 to 45 psi for nonclad aluminum alloys. Engineering approval from the aircraft manufacturer should be obtained prior to abrasive blasting metal thinner than 0.0625 inch.

(2) Remove residual corrosion by hand sanding or with an approved hand-operated power tool. Corrosion removal using power tools is generally done with flapbrush, rotary file, sanding pad, or abrasive wheel attachments. Rotary files should not be used on skin thinner than 0.0625. Select an appropriate abrasive from Table 6-1.

(3) Using a blend ratio of 20:1 (length to depth) blend and finish the corrosion rework area with progressively finer abrasive paper until 400-grit abrasive paper is used.

(4) Clean reworked area using dry cleaning solvent; do not use kerosene.

(5) Determine depth of faired depressions to ensure that rework limits have not been exceeded.

(6) Apply a chemical conversion coating to the corrosion rework area.

7/25/91

AC 43-4A

(7) Apply paint finish to the corrosion rework area.

655.-659. RESERVED.



4

8



2

6



SECTION 6. MAGNESIUM ALLOYS

660. TREATMENT OF WROUGHT MAGNESIUM SHEETS AND FORGINGS. Corrosive attack on magnesium skins will usually occur around edges of skin panels, underneath hold-down washers, or in areas physically damaged by shearing, drilling, abrasion, or impact. Entrapment of moisture under and behind skin crevices is frequently a contributing factor. If the skin section can be easily removed, this should be accomplished in order to assure complete inhibition and treatment.

a. Complete mechanical removal of corrosion products should be practiced when practicable. Such mechanical cleaning shall normally be limited to the use of stiff bristle brushes and similar nonmetallic cleaning tools, particularly during treatment in place under field conditions.

b. Any entrapment of steel particles from steel wire brushes, steel tools, or contamination of treated surfaces by dirty abrasives, can cause more trouble than the initial corrosive attack.

c. When aluminum insulating washers are used and they no longer adhere to magnesium panels, corrosion is likely to occur under the washers if corrective measures are not taken.

(1) When machine screw fasteners are used, they should be removed from all loose insulating washer locations in order to surface treat the magnesium panel.

(2) Where permanent fasteners other than machine screws are used, the insulating washer and fastener should be removed to ensure complete corrosion removal.

(3) When located so that water can be trapped in the counterbored area where the washer was located, use sealants to fill the counterbore. If necessary to fill several areas adjacent to each other, it may be advantageous to cover with a strip of sealant.

661. REPAIR OF MAGNESIUM SHEET METAL AFTER EXTENSIVE CORROSION REMOVAL. The same general instructions apply when making repairs in magnesium as in aluminum alloy skin, except that two coats of epoxy primer may be required on both the doubler and skin being patched instead of only one coat. Where it is difficult to form magnesium alloys in the contour, aluminum alloy may be utilized. When this is done, it is necessary to insure effective dissimilar metal insulation. Vinyl tape will insure positive separation of dissimilar metals, but edges will still have to be sealed to prevent entrance of moisture between mating surfaces at all points where repairs are made. It is recommended that only noncorrosive type sealant be used, since it serves a dual purpose of material separation and sealing.

662. IN-PLACE TREATMENT OF MAGNESIUM CASTINGS. Magnesium castings, in general, are more porous and more prone to penetrating attack than wrought magnesium skin. However, treatment in the field is, for all practical purposes, the same for all magnesium areas. Engine cases are among the most common examples of cast magnesium encountered in modern aircraft. Bellcranks, fittings, and numerous covers, plates, and handles may also be magnesium castings. When attack occurs on a casting, the earliest practicable treatment is required if dangerous corrosive penetration is to be avoided. Engine cases in salt water can develop "moth holes" and complete penetration overnight.

a. If it is at all practicable, faying surfaces involved should be separated in order to effectively treat the existing attack and prevent its further progress. The same general treatment sequence detailed for magnesium skin should be followed. Where engine cases are concerned, baked enamel overcoats are usually involved rather than other topcoat finishes. A good air drying enamel can be used to restore protection.

b. If extensive removal of corrosion products from a structural casting is involved, a decision from the aircraft manufacturer may be necessary in order to evaluate the adequacy of structural strength remaining. Structural repair manuals usually include dimensional tolerance limits for critical structural members. The FAA should be consulted if any questions of safety are involved.

663. EXAMPLE OF REMOVING CORROSION FROM MAGNESIUM. If possible, corroded magnesium parts should be removed from aircraft. When impossible to remove the part, make aircraft preparations detailed in paragraph 612. When using that procedure, observe the safety precautions and procedures of paragraph 600.

a. Positively identify metal as magnesium. (Refer to paragraph 618)

b. Clean area to be reworked.

c. Strip paint if required.

d. Determine extent of corrosion damage as detailed in paragraph 642. To remove light corrosion, proceed with paragraph 663.e. To remove moderate or severe corrosion, proceed with paragraph 663.f.

e. Remove light corrosion by light hand-sanding or chemically, as follows. Do not use the following procedure for adhesive bonded parts or assemblies, areas where the brush-on solution might become lodged, or local areas bared specifically for grounding or electrical bonding purpose.

(1) Remove loose corrosion with aluminum wool or abrasive mat, paper, or cloth.

(2) Mask off other materials and parts, especially rubber parts, bearings, and cast or pressed inserts to prevent contact with the treating solution or its fumes.

(3) Prepare corrosion treating solution in the following proportions: 1-1/2 pounds of sodium dichromate and 1-1/2 pints of concentrated nitric acid (HNO_3) per gallon of water. Mix as follows, but prepare and store the solution in clean polyethylene or glass containers:

(i) Fill a suitable container with a volume of water equal to 1/4 the desired total quantity of solution.

(ii) Add full quantity of sodium dichromate in proportions indicated and agitate solution until the chemical is dissolved.

(iii) Add water until quantity of solution is equal to approximately 2/3 the desired total quantity.

(iv) Slowly add total volume of nitric acid (HNO_3) to solution and mix thoroughly.

(v) Add remaining water until total desired quantity of solution is reached and stir until entire solution concentration is equal.

(4) Remove remaining corrosion by swabbing the corroded surface 1 to 2 minutes with the nitric acid (HNO_3) solution, then wipe dry.

(5) Rinse thoroughly with clean water while scrubbing with a mop, brush, or abrasive mat and wipe dry.

(6) Repeat the preceding sequence, as necessary, until all corrosion has been removed.

(7) After all corrosion has been removed, proceed with paragraph 663.g.

f. Mechanically remove moderate or severe corrosion. Wear goggles or a face shield to preclude injury from corrosion particles breaking loose and flying off. Protect adjacent areas to prevent additional damage from corrosion products removed when using this procedure.

NOTE: DO NOT USE CARBON STEEL WIRE BRUSHES OR SILICONE CARBIDE ABRASIVES ON MAGNESIUM.

(1) Remove heavy corrosion products by hand brushing with a stainless steel or fiber brush followed by vacuum abrasive blasting with glass beads, (Specification MIL-G-9954) sizes 10, 11, 12, 13; or grain abrasive (Specification MIL-G-5634) Types I or III. An air pressure at the nozzle of 10 to 35 psi should be used for direct pressure machines. For suction type blast equipment, use 50 percent higher pressure.

(2) Remove residual corrosion by hand sanding or with approved hand-operated power tool.

(3) After removing all corrosion visible through a magnifying glass, apply corrosion treating solution.

g. Fair depressions resulting from rework using a blend ratio of 20:1. Clean rework area using 240 grit abrasive paper. Smooth with 300 grit and final polish with 400 grit abrasive paper.

h. Determine depth of faired depressions to ensure that rework limits have not been exceeded.

i. Clean reworked area using a solvent to provide a water breakfree surface. Do not use kerosene.

j. Prepare and apply magnesium conversion coat conforming to MIL-M-3171, TYPE VI (DOW-19) as follows:

(1) Measure 1 gallon of distilled water into a clean polyethylene or glass container.

(2) Add 1.3 ounces (dry) of chromium trioxide or 1.3 ounces of technical grade chromic acid.

(3) Add 1 ounce of calcium sulfate dehydrate ($\text{CaSO}_4 \cdot 2\text{H}_2\text{O}$).

(4) Vigorously stir for at least 15 minutes to ensure that the solution is saturated with calcium sulfate. (Let chromate solution stand for 15 minutes prior to decanting.)

(5) Prior to use, decant solution (avoid transfer of undissolved calcium sulfate) into suitable usage containers (polyethylene or glass).

(6) Apply solution by swabbing until the metal surface becomes a dull color (the color can vary from green-brown, brassy, yellow-brown to dark brown). Under optimum conditions of temperature at 70 °F or above and fresh materials, the time required to properly apply magnesium pretreatment is usually 1 to 5 minutes. Under these conditions, 1 to 2 minutes of treatment should produce a brassy film, and 3 to 5 minutes a dark brown coating. Under adverse conditions, and if the desired specified finish color is not produced in the specified time, the treatment may have to be prolonged up to 20 to 30 minutes in some instances until the proper finish is effected. For good paint adhesion, a dark brown color, free of powder, is considered best. The color may vary in using different vendors' materials. Too long exposure to the brush-on solution produces a coating which will powder and impair adhesion of applied paint finish/films. Use caution in swabbing on the solution. Severe rubbing of the wet surface will damage the coating.

NOTE: HIGH PRESSURE SPRAYING OR RUBBING ABRASION WILL DAMAGE THE FRESH COATING.

(7) Rinse with clean water, then allow to dry at ambient temperature for a minimum of 1 hour (more in high humidity areas).

7/25/91

AC 43-4A

k. Apply primer and topcoat finish.

l. Remove masking and protective covering.

664.-669. RESERVED.



46

47



48

49



SECTION 7. FERROUS METALS

670. GENERAL. One of the most familiar kinds of corrosion is red iron rust, generally resulting from atmospheric oxidation of steel surfaces. Some metal oxides protect the underlying base metal, but red rust is not a protective coating. Its presence actually promotes additional attack by attracting moisture from the air and acting as a catalyst in causing additional corrosion to take place.

a. Red rust first shows on bolt heads, hold-down nuts, and other unprotected aircraft hardware. Red rust will often occur under nameplates which are secured to steel parts. Its presence in these areas is generally not dangerous and has no immediate effect on the structural strength of any major components. However, it is indicative of a general lack of maintenance and possible attack in more critical areas.

b. When paint failures occur or mechanical damage exposes highly stressed steel surfaces to the atmosphere, even the smallest amount of rusting is potentially dangerous in these areas and should be removed and controlled.

671. MECHANICAL REMOVAL OF IRON RUST. The most practicable means of controlling the corrosion of steel is the complete removal of corrosion products by mechanical means (see Figures 6-17 and 6-18). On high strength steel, corrosion removal by hand sanding is recommended. The use of powered tools is not recommended on high strength steel because of the danger of local overheating and the formation of notches which could lead to failure. However, it should be recognized that in any such use of abrasives, residual iron rust usually remains in the bottom of small pits and other crevices.

a. The best method to use on exterior surfaces is abrasive blasting which has the ability of removing nearly all rust.

b. Paint the cleaned metal surface as soon as possible after corrosion removal, and in any event do not allow the surface to become wet before painting.

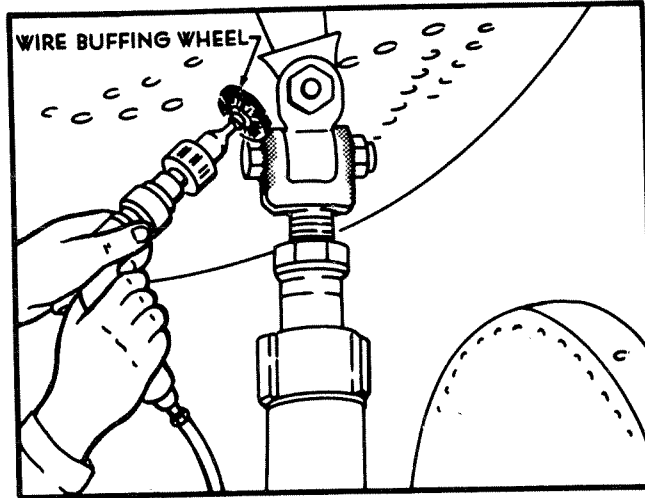

FIGURE 6-17. REMOVING CORROSION PRODUCTS FROM ORDINARY STEEL SURFACES

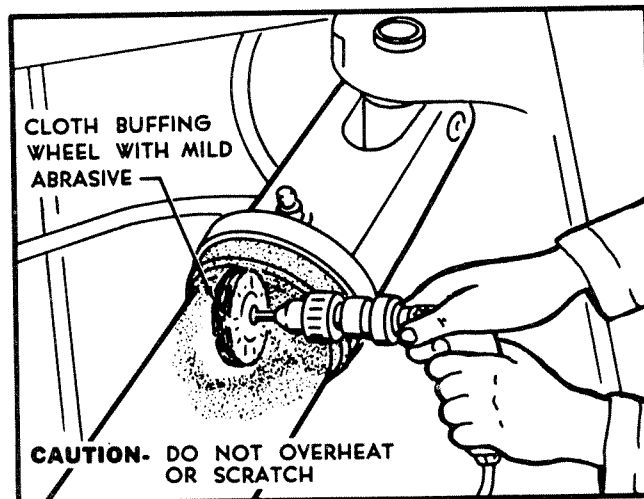

FIGURE 6-18. REMOVING CORROSION PRODUCTS FROM HIGHLY STRESSED STEEL PARTS

672. CHEMICAL SURFACE TREATMENT OF STEEL SURFACES.

NOTE: CHEMICAL SURFACE TREATMENT SHALL NOT BE USED ON HIGH STRENGTH STEEL PARTS WITHOUT ENGINEERING AUTHORIZATION.

a. There are acceptable methods for converting iron rust to phosphates and other protective coatings. Parco Lubrizing and use of phosphoric zinc preparations are examples of such treatment. However, these processes require shop installed hot tanks and are impracticable for use in the field.

b. Other preparations (i.e. phosphoric acid, naval jelly, etc.) are effective rust converters where tolerances are not critical and where thorough rinsing and neutralizing of residual acid is also possible.

c. These situations are generally not applicable to assembled aircraft and use of chemical inhibitors on installed steel parts is not only undesirable, but very dangerous. The possibility of entrapping of corrosive solutions, resulting in uncontrolled attack which could occur when such materials are used under field conditions, outweighs any advantage to be gained from their use.

673. REMOVAL OF CORROSIVE PRODUCTS FORM HIGH-STRESSED STEEL PARTS. Do not use wire brushes on high-stressed steel parts. Any corrosion on the surface of a highly stressed steel part is potentially dangerous, and the careful removal of corrosion products is mandatory. Surface scratches or change in surface structure from overheating can cause sudden failure of these parts. Removal of corrosion products may be accomplished by careful use of mild abrasive papers, such as fine grit aluminum oxide, or fine buffing compounds, such as rouge, on cloth buffing wheels.

a. It is essential that steel surfaces not be overheated.

b. Abrasive blasting is also a satisfactory corrosion removal method for high-strength steel located on aircraft exteriors.

c. After careful removal of surface corrosion, protective paint finishes should be applied immediately.

674. SPECIAL TREATMENT OF STAINLESS STEEL ALLOYS. Do not use chemical cleaners on stainless steels. Stainless steels are of two general types: magnetic and nonmagnetic. Magnetic steels are of the ferritic or martensitic types and are identified by numbers in the 400-series. Corrosion often occurs on 400-series stainless steels and treatment is the same as specified in paragraph 673. Nonmagnetic steels are of the austenitic type and are identified by numbers in the 300-series. They are much more corrosion resistant than the 400-series steels, particularly in a marine environment.

a. Austenitic steels develop corrosion resistance by an oxide film which should not be removed even though the surface is discolored. The original oxide film is normally formed at time of fabrication by passivation. If this film is broken accidentally or by abrasion, it may not restore itself without re-passivation.

b. If any deterioration or corrosion does occur on austenitic steels, and the structural integrity or serviceability of the part is affected, it will be necessary to remove the part.

675. EXAMPLE OF PROCESS FOR REMOVAL OF CORROSION FROM STEEL PARTS. If possible, corroded steel parts should be removed from the aircraft. When impossible to remove the part, observe the aircraft preparations and safety precautions in paragraph 601, 602, and 603. Chemical removal or chemical conversion coatings are not allowed on steel parts.

a. Positively identify the metal as steel as detailed in paragraph 617 and establish its heat-treated value.

b. Clean area to be reworked.

CAUTION: DO NOT USE ACID BASED STRIPPERS ON HIGH STRENGTH STEEL PARTS.

c. Strip paint if required.

d. Remove all degrees of corrosion damage from steels heat-treated below 220,000 psi as required by paragraph 655.e. Corrosion removal on steels treated to 220,000 psi and above should be accomplished only by hand sanding or dry abrasive blasting. (Refer to section 6 of this chapter.)

e. Mechanically remove all degrees of corrosion from steel parts heat-treated below 220,000 psi as follows.

CAUTION: USE GOGGLES OR FACE SHIELD TO PRECLUDE INJURY FROM FLYING PARTICLES. PROTECT ADJACENT AREAS TO PREVENT ADDITIONAL DAMAGE FROM CORROSION PRODUCTS REMOVED BY MECHANICAL PROCESS.

(1) Remove heavy deposits of corrosion products using a stainless steel hand brush. Abrasive blasting may be used as an alternate method of corrosion removal. Abrasive blasting should be accomplished using aluminum oxide (Specification MIL-G-21380) Type I, Grades A or B, grit sizes 25, 50, or 120; or No. 13 glass beads (Specification MIL-G-9954). An air pressure at the nozzle of 40 to 50 psi should be used for direct pressure machines when removing corrosion by abrasive blasting. Engineering approval from the aircraft manufacturer should be obtained prior to abrasive blasting metal thinner than 0.0625 inch.

(2) Remove residual corrosion by hand sanding or with approved hand-operated power tool.

(3) The surface is highly reactive immediately following corrosion removal; consequently, primer coats should be applied within 1 hour after sanding. After removing all corrosion visible through a magnifying glass, continue with paragraph 675.f.

f. Fair depressions resulting from rework using a blend ratio of 20:1. Clean rework area using 240 grit abrasive paper. Smooth with 300 grit and final polish with 400 grit abrasive paper.

g. Determine depth of faired depressions as required to ensure that rework limits have not been exceeded.

h. Clean reworked area with dry, cleaning solvent. Do not use kerosene.

i. Apply protective finish or specific organic finish as required.

j. Remove masking and protective covering.

676.-679. RESERVED.



4

)



2

Y



SECTION 8. PLATED PARTS

680. CHROMIUM AND NICKEL PLATED PARTS. Nickel and chromium platings are used extensively as protective and wear resistant coatings over high strength steel parts (landing gear journals, shock strut pistons, etc.). Chromium and nickel plate provide protection by forming a somewhat impervious physical coat over the underlying base metal. When breaks occur in the surface, the protection is destroyed.

a. The amount of reworking that can be performed on chromium and nickel plated components is limited. This is due to the critical requirements to which such components are subjected.

b. The rework should consist of light buffing to remove corrosion products and produce the required smoothness. This is permissible, provided the buffing does not take the plating below the minimum allowable thickness.

c. Whenever a chromium or nickel plated component requires buffing, coat the area with a corrosion preventive compound, if possible.

d. When buffing exceeds the minimum thickness, or the base metal has sustained corrosive attack, the component should be removed and replaced.

e. The removed component can be restored to serviceable condition by having the old plating completely stripped and replated in accordance with acceptable methods and specifications.

681. CADMIUM AND ZINC PLATED PARTS. Cadmium plating is used extensively in aircraft construction as a protective finish over both steel and copper alloys. Protection is provided on a sacrificial basis in which the cadmium is attacked rather than the underlying base material. Properly functioning cadmium surface coatings may well show mottling, ranging from white to brown to black spots on their surfaces. These are indicative of the sacrificial protection being offered by the cadmium coat, and under no condition should such spotting be removed merely for appearance's sake. In fact, cadmium will continue to protect even when actual breaks in the coating develop and bare steel or exposed copper surfaces appear.

a. Where actual failures of the cadmium plate occur and the initial appearance of corrosion products of the base metal develops, some mechanical cleaning of the area may be necessary but should be limited to removal of the corrosion products from the underlying base material.

b. Under no condition should such a coating be cleaned with a wire brush. If protection is needed, a touch-up with primer or a temporary preservative coating should be applied. Restoration of the plate coating is impracticable in the field.

c. Zinc coatings offer protection in an identical manner to cadmium, and the corrective treatment for failure is generally the same as for cadmium plated parts. However, the amount of zinc on aircraft structures is very limited and usually does not present a maintenance problem.

682.-689. RESERVED.

SECTION 9. OTHER METALS AND ALLOYS

690. NOBLE METAL COATINGS - CLEANUP AND RESTORATION. Silver, platinum, and gold finishes are generally used in aircraft assemblies because of their resistance to ordinary surface attack and their improved electrical or heat conductivity. Silver-plated electrodes can be cleaned of brown or black sulfide tarnish, as necessary, by placing them in contact with a piece of magnesium sheet stock while immersed in a warm water solution of common table salt mixed with baking soda or by using a fine grade abrasive mat or pencil eraser followed by solvent cleaning. If assemblies are involved, careful drying and complete displacement of water is necessary. In general, cleaning of gold or platinum coatings is not recommended in the field.

691. COPPER AND COPPER ALLOYS. Copper and copper alloys are relatively corrosion resistant, and attacks on such components will usually be limited to staining and tarnish. Generally, such change in surface condition is not dangerous and should ordinarily have no effect on the function of the part. However, if it is necessary to remove such staining, a chromic acid solution of 8 to 24 ounces per gallon of water containing a small amount of battery electrolyte (not to exceed 50 drops per gallon) is an effective brightening bath. Staining may also be removed using a fine grade abrasive mat or pencil eraser followed by solvent cleaning.

a. The stained part should be immersed in the cold solution. However, surfaces can also be treated in place by applying the solution to the stained surface with a small brush.

b. Care should be exercised to avoid any entrapment of the solution after treatment. The part should be cleaned thoroughly following treatment with all residual solution removed.

c. Serious copper corrosion is evident by the accumulation of green-to-blue copper salts on the corroded part. These products should be removed mechanically using a stiff bristle brush, brass wire brush, 400-grit abrasive paper or bead blast with glass beads, (Specification MIL-G-9954, size 13). When bead blasting, air pressure at the nozzle should be 20 to 30 psi for direct pressure machines. Do not bead blast braided copper flexible lines. A surface coating should be reapplied over the reworked area. Again, chromic acid treatment will tend to remove the residual corrosion products.

d. Most brass and bronze structural parts will be protected by cadmium surface plate. The mottling of the protective cadmium coat should not be removed, and mechanical surface cleaning should not be attempted unless actual copper corrosion products are beginning to appear. Under these conditions, any mechanical removal of the protective cadmium should be held to a minimum and limited to the immediate area of the copper attack.

692. TITANIUM ALLOYS. Titanium and its alloys are highly corrosion resistant because a protective oxide film forms on their surfaces upon contact with air. When titanium is heated, different oxides having different colors form on the surface. A blue oxide coating will form at 700 to 800 °F; a purple oxide at 800

to 950 °F; and a gray or black oxide at 1,000 °F or higher. Corrosive attack on titanium surfaces is difficult to detect. It may show deterioration from the presence of salt deposits and metal impurities at elevated temperatures so periodic removal of surface deposits is required.

a. Clean titanium surfaces until all traces of corrosion or surface deposits are removed using one of the following:

- (1) Stainless steel wire brush;
- (2) Hand sand with aluminum oxide abrasive paper or abrasive mat;
- (3) Dry blast with glass beads, (Specification MIL-G-9954) sizes 10, 11, 12, or 13, or aluminum oxide (Specification MIL-G-21380 Type I) grades A or B, using 40 to 50 psi air pressure at the nozzle for direct pressure machines;
or
- (4) Hand polish with aluminum polish and soft cloth.

b. Chlorinated Hydrocarbon cleaners should not be used on titanium alloys which are subject to elevated temperatures in service. Such solvents can cause stress-corrosion in titanium.

693.-699. RESERVED.

CHAPTER 7. SPECIAL PROBLEMS

700. MERCURY SPILLS/CORROSION DAMAGE.

a. The presence of mercury and mercury salts in air cargo is a definite possibility. Loading, unloading, and general shifting of such cargo can and does result occasionally in damaged containers, cartons, electronic tubes, etc., with subsequent possible leakage of mercury on aircraft structure.

b. Spillage of mercury or mercury compounds within an airplane requires immediate action for its isolation and recovery to prevent possible corrosion damage and embrittlement of aluminum alloy structural components, stainless steels (300 and 400 series), and unplated brass components such as cable turnbuckle barrels.

c. Mercury, by the amalgamation process, can penetrate any break in the finish (anodize/alodine), paint, and seal coating of a metal structural component. Bright, polished, shining, or scratched surface will hasten the process, as well as moisture. Mercury or mercury compounds attack the metal grain boundaries and seriously embrittle and reduce the strength of parts. Corrosive attack of freshly scratched aluminum alloy is very rapid, and complete penetration of sheet material is known to occur within 3 or 4 minutes.

d. Mercury is highly toxic and spreads very easily from one surface to another. It adheres to hands, shoes, clothes, tools, etc. The following precautions for mercury spills should be strictly followed:

(1) Avoid contact with surfaces suspected of being contaminated. Use wood or fiber sheets to support body while working in the area.

WARNING: DO NOT ATTEMPT TO PICK UP MERCURY BY HAND.

(2) Wear wing socks (shoe protectors) and protective (disposable) clothing in contaminated area to prevent scratching metal surfaces. Properly dispose of socks after use.

(3) Do not wear clothing used in contaminated areas on jobs in uncontaminated areas. Dispose of wing socks and protective clothing into unused metal container outside of aircraft. Contact the Waste Management Service or similar authority of the local State Health Department for instructions on proper disposal procedures for mercury.

(4) Have personal clothing cleaned. Wash shoes with soap and water. Clean all tools that have been used in contaminated area with steam or hot water and soap. Discard any drill bits used on mercury contaminated areas. Thoroughly clean vacuum cleaner, if used.

(5) Always wash thoroughly with soap and water after contacting mercury. Keep hands away from mouth. Do not eat, smoke, or blow nose without first washing your hands thoroughly.

(6) Appreciable amounts of mercury will vaporize at normal temperatures. A stagnant air will become dangerous to personal health.

WARNING: ALWAYS PROVIDE GOOD VENTILATION WHILE CLEANING MERCURY CONTAMINATED AREAS.

(7) Do not use cleaning aids such as solvents, solids, or polishes on contaminated area. Such materials may promote corrosion.

(8) If hands become contaminated with mercury while working with cleaning equipment, do not touch any exposed metal in surrounding area, as you may contaminate it.

e. Mercury spills, in some cases, have caused no adverse effects because of protective films of paint, dirt, grease, or oil. The fact that mercury spillage may not, in all cases, result in serious damage should not be relied on. Each instance of mercury or mercury compound spillage should be considered hazardous, and immediate action should be taken to safeguard the aircraft. Inspect for mercury and corrosion as follows:

(1) Determine point at which mercury was spilled. Remove any mercury on floor covering, and then remove covering.

(2) When mercury is found on floor, do not remove access/inspection plates, screws, rivets, bolts, etc., from floor. Any hole which is left open in the contaminated area of the floor may allow mercury to spread to structure underneath the floor.

(3) Inspect the metal floor, seat tracks, cargo rails, and adjacent structure for mercury and corrosion. Inspect skin and internal structure below point of spillage. Also inspect lowest point in fuselage below cargo compartment floor if mercury spill has occurred in cargo area. Mercury liquid will flow to lowest level.

(4) Inspect areas suspected of having mercury contamination using a 10X magnifying glass. If corrosion of aluminum has started there will be a light grayish "Christmas Tree" fuzz or gray powdery dust deposit, and severe structural damage may follow.

(5) If corrosion is evident and cleanup cannot be completed immediately, coat contaminated area with corrosion preventative compound or engine oil. This helps to slow down the corrosion rate and also helps to prevent spreading of mercury contamination.

(6) When mercury spills occur in lower cargo compartment, use a portable X-ray machine (if available) along the outside lower surface of the fuselage to check suspected hidden corrosion areas between the skin, stringers, and frames below the floor. Droplets of mercury will show on a radiograph as small white spots. Corrosion and embrittlement will appear as tree-like forms completely penetrating a structural component.

(7) Inspect bronze/brass control cable turnbuckle barrels for mercury discoloration. Replace if slightest discoloration is detected.

f. Removal procedure and precautions necessary when mercury is spilled are:

WARNING: VACUUM AIR PASSING OVER THE MERCURY DEPOSITED IN THE GLASS CONTAINER PICKS UP MERCURY VAPORS AND EXHAUSTS THEM FROM THE VACUUM CLEANER. AVOID BREATHING MERCURY VAPORS.

CAUTION: AN AIR HOSE SHOULD NOT BE USED TO DISLodge MERCURY FROM AIRCRAFT UNDER ANY CIRCUMSTANCES.

(1) Use a high capacity vacuum cleaner with a trap-type glass container attached to the large vacuum hose. The size of the pickup hose from the container should be about 1/4-inch in diameter to increase the amount of suction applied to the mercury. Due to the weight of mercury, the container will catch the mercury before it can enter the vacuum cleaner hose.

(2) An all rubber storage battery water syringe, or a medicine dropper, may be used to remove mercury if the trap-type glass container and vacuum cleaner are not available. Cellulose tape may be used to pick up very tiny particles of mercury.

(3) General cleanup and inspection (using equipment available) should be made immediately after spillage occurs or is detected.

701. CORROSION PROTECTION FOR AGRICULTURAL AIRCRAFT.

a. General. Practically all chemicals used in dusting and spraying operations are corrosive by nature and hasten deterioration of fabric, metal, and wood. It is essential to safe operation that precautions be taken to prevent corrosion and deterioration of wood, metal, and fabric. Cleanliness of the airplane is one of the most important precautions of all. If it were practicable and feasible to clean the airplane thoroughly; that is, give it a thorough dry washing inside and out after each day's work, probably no special corrosive preventative measures would be necessary.

b. Precautions. Since thorough daily cleaning is not practicable, the following precautions should be taken:

(1) All fittings and metal structures should be covered with two coats of epoxy primer, a heavy preservative, conforming to MIL-C-16173, grade 2 (paraloketone), or equivalent material. This coating should be applied to items such as wing-root fittings, wing-strut fittings, control-surface hinges, horns, mating edges of fittings and attach bolts, etc.

(2) Non-stainless steel control cables should be coated with paraloketone or equivalent protective coating, or should be replaced with corrosion-resistant cables.

(3) Periodic inspection of all critical portions of the aircraft structure should be made. Structural parts showing corrosion should be cleaned and refinished if the corrosion attack is superficial. If the part is severely corroded, it should be replaced.

(4) Experience has shown that additional access openings, to permit ready inspection of lower and rearward portions of the fuselage, are particularly desirable.

(5) Provide additional drainage and ventilation for all interiors to prevent collection of moisture.

(6) At the time of recovering, both metal and wood airplane structural members should be coated with epoxy primer (two coats), followed by dope-proof paint or wrapping with cellophane tape.

(7) Spray interiors of metal-covered wings and fuselages with an adherent corrosion inhibitor.

(8) Wash exterior surfaces with clear fresh water at least once a week. Interior surfaces should also be washed, taking care to prevent damage to electrical circuits or other items subject to malfunctioning due to moisture.

(9) Opening in the wings, fuselage, and control-surface members, such as tail-wheel wells, openings for control cables, etc., should be sealed as completely as possible to prevent entry of dust or spray.

702.-799. RESERVED.



6

7



8

9





1

2



3

4

