



National Transportation Safety Board

Washington, D.C. 20594

Railroad Accident Brief

Accident No: DCA-02-FR-013
Railroad: Norfolk Southern Railway
Train: Train 15T
Location: Farragut, Tennessee
Accident date and time: September 15, 2002, 11:20 a.m. eastern daylight time
Type of Accident: Derailment
Fatalities/Injuries: No fatalities or serious injuries
Property Damage: \$1.02 million

The Accident

About 11:20 a.m. eastern daylight time on September 15, 2002, westbound Norfolk Southern Railway (NS) train No. 15T derailed in Farragut, Tennessee, while moving at 38 mph. The train was made up of 3 locomotives, 56 loads, and 86 empties; a total of 142 cars with a gross weight of 9,948 tons. Two locomotives and the first 25 cars derailed. A tank car containing sulfuric acid was punctured, releasing a cloud of toxic fumes that prompted local responders to evacuate about 2,600 people from a 4.4-square mile area around the site. The evacuation lasted for about 2 1/2 days. Several local residents were treated for minor respiratory difficulties. There was no fire. Damages were estimated to be \$1.02 million. (See figure 1.)

At 8:30 a.m., about 2 hours 50 minutes before the derailment, eastbound NS train No. 721, en route to Knoxville, Tennessee, passed over the spring switch¹ from the Boyd Siding onto the main track. About an hour later, eastbound train No. 703 received an unexpected restricting signal indication² at the west end of Boyd Siding, which is about 2

¹ A *spring switch* is a switch equipped with a spring mechanism arranged to restore the switch points to their normal positions after they have been temporarily repositioned by the passage of a train. In the case of the East Boyd Siding, the switch was normally lined for movement along the main line. But the wheels of a train moving onto the main line from the siding would cause the switch points to move into alignment for that movement without the need for a crewmember to throw the switch. After the train had cleared the switch, spring pressure would realign the switch for the main line.

² With no traffic in the track block immediately ahead of train 703, the signal was expected to display a clear aspect.

miles from the east end of Boyd Siding. This signal indication required that the crew slow the train from the normal track speed of 50 mph to a speed, not to exceed 20 mph, that would allow the train to stop within half the visual range and short of any obstructions. The train crew reduced the train's speed and reported the signal indication to the train dispatcher, as the operating rules required.



Figure 1. Looking east at the derailment of NS train 15T showing fuming sulfuric acid from ruptured tank car.

At the east end of the siding, the crew of train 703 stopped short of the spring switch so the conductor could look at the switch before proceeding. He found that the left switch point (when facing west) was not seated tightly against the stock rail but instead had a 1/4-inch gap.³ A spring switch can be thrown manually by moving a lever beside the track. After operating the spring switch through its motion several times, the conductor found that the left switch point still failed to close completely, leaving about a 1/8-inch gap between the switch point and the stock rail. (See Figures 2 and 3.)

³ Such a gap could cause the wheel flange of a westbound train to strike the end of the switch point, thereby damaging the switch or causing a derailment. The gap would also account for the *restricting* indication the crew had received from the automatic block signal.

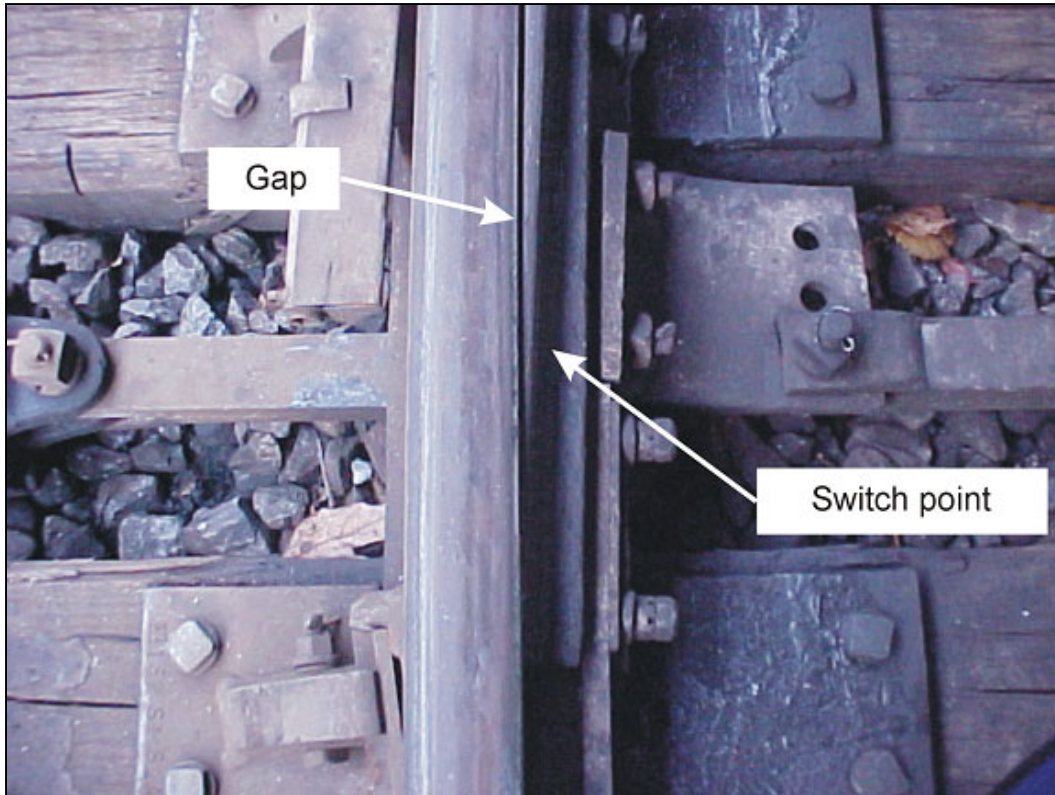

Figure 2. Gapped switch point.

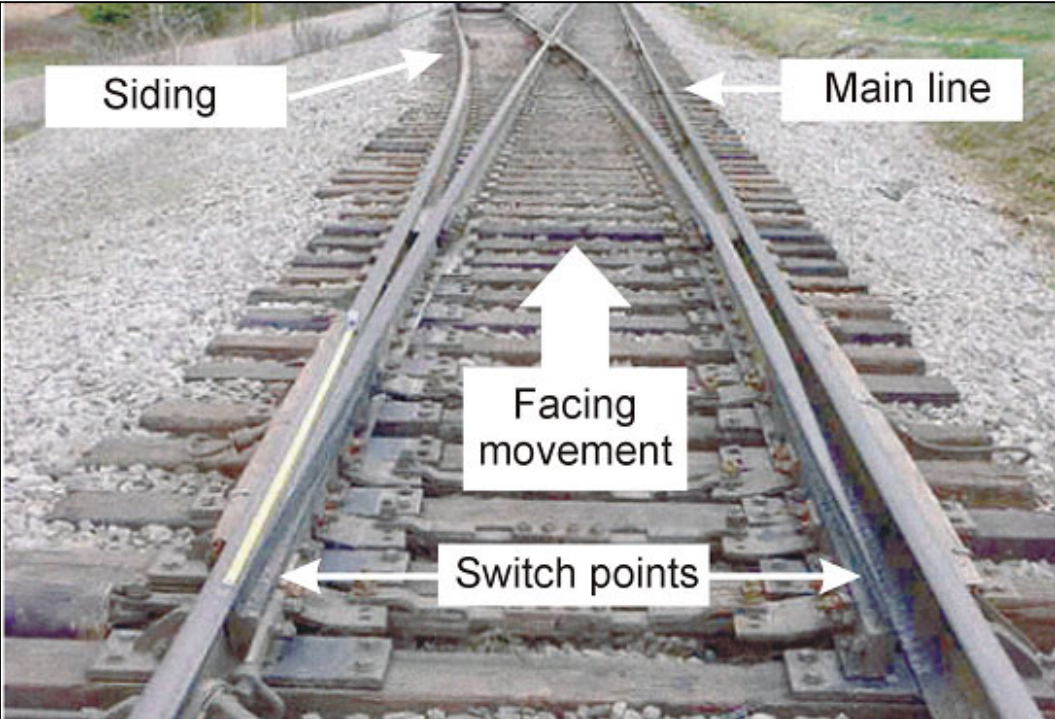

Figure 3. Spring switch similar to the East Boyd Siding switch where derailment occurred. Switch is aligned for main line movement.

The engineer of train 703 radioed the train dispatcher and reported that the switch points had not lined “back all the way to line up for the main line; you might need somebody to look at it.” The dispatcher replied, “Alright, I’ll get somebody headed that way.” Because an eastbound train movement was a trailing movement⁴ that would tend to force the switch points back into the correct position, train 703 proceeded through the switch without incident.

About 9:45 a.m., just after train 703 had cleared the switch, the train dispatcher called a signal maintainer to inspect the spring switch. The dispatcher advised the signal maintainer that he did not have to hurry because no trains were due to arrive at the switch soon. The maintainer ate breakfast and departed his home at about 10:20 a.m., arriving at the switch at about 11:00 a.m. The signal maintainer said that as he approached the switch, he could see the signal controlling westbound train movements and noted that it was showing a clear aspect, indicating that the switch gap had closed after train 703’s movement over it.

The signal maintainer said that when he arrived at the switch, he noted that the points appeared to be properly positioned. He said that he visually inspected the switch and noticed that the switch plates,⁵ while not really dry, “looked like they could use a little oil.” He said that he put oil on each switch plate. He walked from the heel block to the switch point and did not see anything unusual. (See Figure 4.)

In order to make an internal inspection of the switch to determine why the spring switch had gapped, the signal maintainer was required to get a track warrant to occupy the track and inspect the mechanical movement of the switch. The signal maintainer called the train dispatcher and told him that the switch appeared to be aligned properly and asked about a track warrant and any expected train traffic. The dispatcher told the signal maintainer that a freight train (train 15T) and a coal train were en route toward the switch. The signal maintainer replied, “Okay, all right, I will wait till these two [trains] get by [the switch] and holler at you.”

The signal maintainer, while waiting on the north side of the main line adjacent to the switch, heard the crew of train 15T call out the clear signal at east Boyd. According to event recorder data, train 15T approached the switch at about 38 mph.⁶ The engineer stated that as the locomotives moved over the switch, he felt a slight “tug,” and he, along

⁴ The east Boyd siding switch was oriented such that eastbound trains would make *trailing* movements through the switch; that is, they would enter the switch at the opposite end from the moveable switch points. Westbound trains would make *facing* movements; that is, they would reach the switch points first as they entered the switch.

⁵ Switch plates are between the switch points and the crossties and are elongated tie plates. The movable switch points rest on the switch plates.

⁶ Even though the authorized track speed at this location was 50 mph, train 15T was restricted to 45 mph because of a dimensional load (two U.S. Army tanks).

with the conductor, looked back and saw the train starting to derail. The train went into emergency braking at that time. The engineer said he immediately saw what appeared to be a smoke cloud coming from the train. The engineer radioed the train dispatcher by using the emergency 911 radio tone and advised him of the derailment and of the smoke. The signal maintainer also called the dispatcher, about 11:20 a.m., to report the derailment.

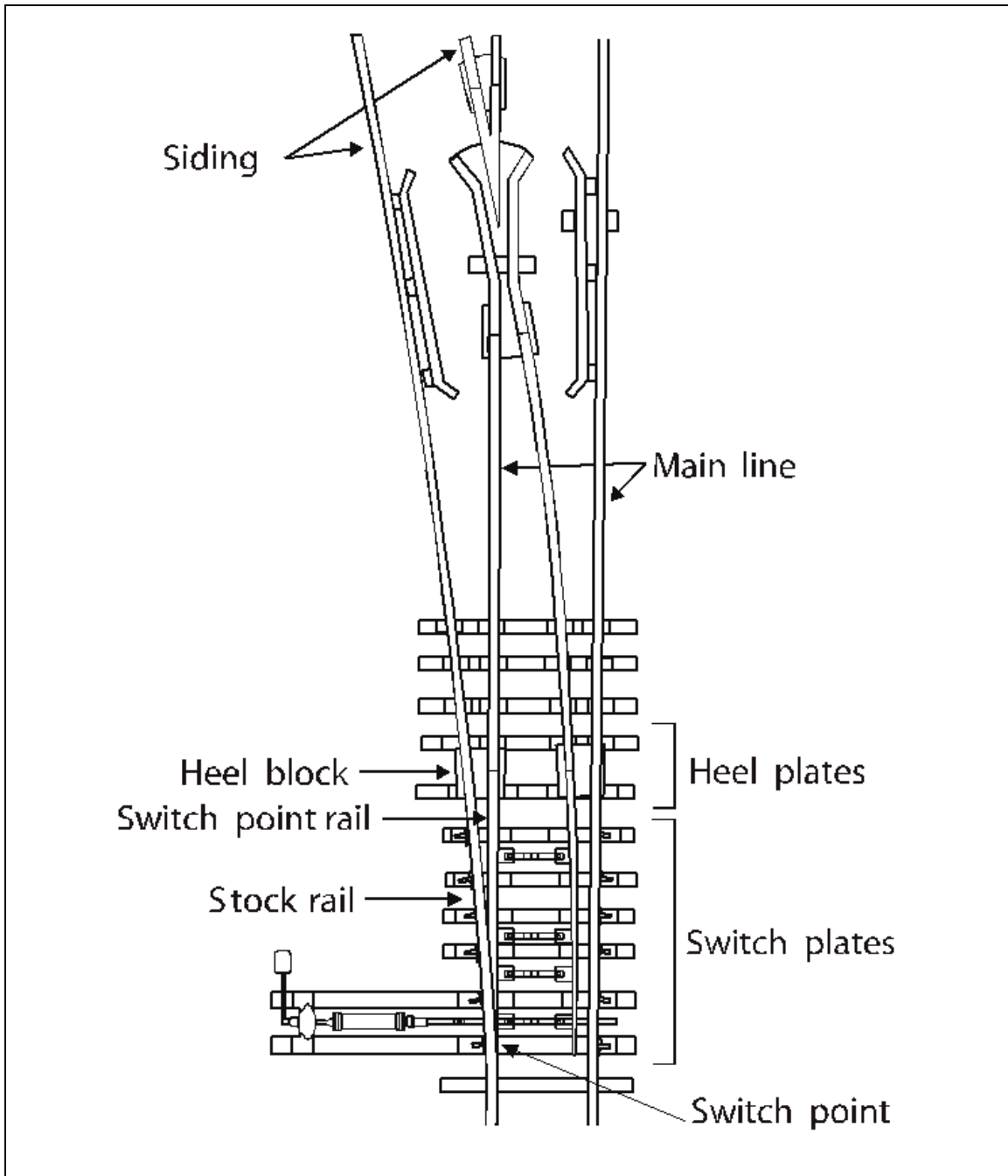

Figure 4. Diagram of a switch and turnout

NS had no specific procedure that required a functional test of a spring switch on a trouble call. The NS monthly and quarterly switch inspections (detailed in NS procedure MS 1914) require that the switch points be opened and the switch operated in both directions. The Federal Railroad Administration (FRA) minimum safety requirements for railroad track in 49 Code of Federal Regulations 213.135(b) also specify that each switch point shall fit its stock rail properly. The signal maintainer's initial visual examination did not reveal a problem, but he did not operate the switch before train 15T passed over it. NS operating rules did not specify that an inspection of a possibly defective switch should be completed before trains are allowed to operate through the area. NS procedures also did not address the reduction of train speeds after receiving a trouble call about the condition of a switch.

The train dispatcher summoned local police and emergency response personnel, who began arriving on the scene within 5 minutes of the derailment. The conductor's train inspection had revealed that the smoky cloud was fuming sulfuric acid escaping from the 18th car. As soon as the emergency personnel arrived, the conductor discussed the train consist with them. After considering the potential effects of the hazardous material spill, responders began evacuating the residential subdivisions surrounding the accident site.

NS dispatched emergency hazardous material cleanup crews to the site immediately after the derailment, and the cleanup was underway within several hours. The contractors placed soda ash and lime on the leaking sulfuric acid to neutralize it. NS and local officials constantly monitored air quality until the evacuation order was ended.

Postaccident inspection of the East Boyd spring switch revealed that a bolt was missing from the No. 4 throw rod. The missing bolt was 4 3/4 inches long and 3/4 inch in diameter. During the inspection, a 2 7/8-inch-long piece of the head section of what was believed to be the missing bolt was found approximately 80 inches back from the switch point, lodged between the base flanges of the left switch point rail and the left stock rail. (See figure 5.)

The head section of the switch throw rod bolt and the base of the stock rail and the base of the switch point showed marks and abrasions that were evidence of the bolt being lodged and thus obstructing the normal alignment of the two rails. At this location, the broken bolt section could interfere with the movement of the left switch point rail (when facing west) and cause a gap between the switch point and the stock rail. Although the switch points could be forced into alignment by a train making a trailing (eastbound) movement over the switch, the interference created by the lodged bolt made the points susceptible to gapping if they were disturbed, such as by a train making a facing (westbound) movement over the switch.

Because the bolt section was lodged at the base of the closed rails, it was not visible with the switch positioned as it was when the signal maintainer arrived. When the switch is operated and the rail sections separate, the switch point rail moves about 4 to 4 1/2 inches away from the stock rail. In this position, the heads of the throw rod bolts and the base of the rails are visible. The location of the missing bolt would also have been visible.



Figure 5. Postaccident reconstruction of broken bolt section as positioned before the derailment.

Probable Cause

The National Transportation Safety Board determines that the probable cause of the September 15, 2002, derailment of Norfolk Southern train 15T was (1) the decision by the train dispatcher and signal maintainer to allow the train to pass over the spring switch at maximum authorized speed before the switch had been adequately inspected or clamped closed and (2) the lack of company procedures requiring that train dispatchers, after receiving a report of a problem involving a main track switch, immediately stop trains or implement an appropriate speed restriction in the affected area.

Recommendations

As a result of its investigation of this accident, the National Transportation Safety Board makes the following safety recommendations:

To the Federal Railroad Administration:

1. Require that train dispatchers, upon receiving reports of potentially hazardous conditions involving a main track segment or switch, stop train movements or immediately implement an appropriate speed restriction for the affected area and remove the restrictions only after the completion of those inspections and/or repairs that are essential for the safe movement of trains. (R-03-4)

To the Norfolk Southern Railway:

2. Require that your train dispatchers, upon receiving reports of potentially hazardous conditions involving a main track switch, immediately stop train movements or implement an appropriate speed restriction for the affected area and remove the restrictions only after the completion of those inspections and/or repairs that are essential for the safe movement of trains. (R-03-5)

Adopted: July 21, 2003