

Small Arms Ammunition
at the International Exposition
Philadelphia, 1876



Berkeley R. Lewis



SMITHSONIAN INSTITUTION PRESS

City of Washington

1972

SERIAL PUBLICATIONS OF THE SMITHSONIAN INSTITUTION

The emphasis upon publication as a means of diffusing knowledge was expressed by the first Secretary of the Smithsonian Institution. In his formal plan for the Institution, Joseph Henry articulated a program that included the following statement: "It is proposed to publish a series of reports, giving an account of the new discoveries in science, and of the changes made from year to year in all branches of knowledge." This keynote of basic research has been adhered to over the years in the issuance of thousands of titles in serial publications under the Smithsonian imprint, commencing with *Smithsonian Contributions to Knowledge* in 1848 and continuing with the following active series:

Smithsonian Annals of Flight
Smithsonian Contributions to Anthropology
Smithsonian Contributions to Astrophysics
Smithsonian Contributions to Botany
Smithsonian Contributions to the Earth Sciences
Smithsonian Contributions to Paleobiology
Smithsonian Contributions to Zoology
Smithsonian Studies in History and Technology

In these series, the Institution publishes original articles and monographs dealing with the research and collections of its several museums and offices and of professional colleagues at other institutions of learning. These papers report newly acquired facts, synoptic interpretations of data, or original theory in specialized fields. These publications are distributed by mailing lists to libraries, laboratories, and other interested institutions and specialists throughout the world. Individual copies may be obtained from the Smithsonian Institution Press as long as stocks are available.

S. DILLON RIPLEY
Secretary
Smithsonian Institution

COVER: Self-winding, breech-loading wheel lock gun with tubular steel cartridge (Augsburg, 1638).
Bashford Dean Memorial Collection. Courtesy of the Metropolitan Museum of Art, New York.

Colonel Berkeley R. Lewis died 21 February 1972. Any inquiries regarding the content of this publication may be directed to Mr. Craddock R. Goins, Division of Military History, National Museum of History and Technology, Smithsonian Institution, Washington, D.C. 20560.

Contents

	<i>Page</i>
Introduction	1
<i>Chapter 1:</i> The Pioneers in Metallic Cartridges.....	3
<i>Chapter 2:</i> Ordnance at the Exposition.....	9
<i>Chapter 3:</i> Cabinet of Small-arms Ammunition.....	11
First Drawer: Paper Ammunition (Not Fixed).....	12
Second Drawer: Paper Ammunition (Fixed).....	13
Third Drawer: Transition and Patent Types (Fixed).....	15
Fourth Drawer: Rim Primed and Miscellaneous.....	17
Fifth Drawer: Foreign and Sporting Cartridges.....	23
Sixth Drawer: Modification of Charge.....	24
Seventh Drawer: Modifications in Bullet and Lubricant.....	28
Eighth Drawer: Anvils and Cap-primed Cases.....	29
Ninth Drawer: Modification in Caliber (Reductions).....	36
Tenth Drawer: Service Ammunition and Stages of Manufacture... ..	38
<i>Chapter 4:</i> Compiler's Comments	40
Service Ammunition, Rifle and Carbine, 1865–1876.....	40
Performance of Arms and Ammunition, 1865–1875.....	41
References	44
Glossary	45

Introduction

As the hundredth anniversary of the independence of the United States approached, extensive plans were made to celebrate that occasion by an International Exhibition to be held in 1876 in Philadelphia. A major consideration was the desire to show the world the technological development which had put this country in the front in many aspects of design and production. The Civil War had provided a tremendous impetus to new inventions and methods in the field of arms and ammunition. The United States patent system, the War, and the expanding economy combined to produce a spate of new ideas not achieved elsewhere at any time. The military forces of other countries had been interested observers during the Civil War, and thereafter moved rapidly to re-arm their troops with the newly devised breechloaders. The ideas for these, developed in this country, together with the know-how for their mass production, focused attention on the Centennial Exhibition. The big interest was military, but the expanding West assured firearms manufacturers a ready civilian market for new products. In 1866, all foreign governments realized that they had to change from muzzle loading to breech loading firearms. Having many thousand stands of old muzzle loaders on hand their first immediate preoccupation was to convert these to breechloaders. Literally hundreds of ideas were proposed to make such conversions, usually accomplished by cutting off a short piece at the breech, screwing on a new breech incorporating some sort of device for opening and closing it easily and securely. Most of these systems were rather clumsy, not adaptable to multishot capability, and the resulting arms were at once obsolescent because of their large calibers. Some of these designs, however, were very sound and have served for a long and useful duration, e.g., Remington rolling block,

Sharps drop block, Peabody, Ballard, Morse. The last had features still used in most firearms, such as enclosed cartridge head, rebounding firing pin, and spring loaded hook extractors. In the ten year period 1866 to 1876, inventors had been very active in designing new systems not inhibited by having to start with an old gun. At the beginning of this period there were practically no standardized cartridges.

Paper cartridges with powder and ball had been satisfactory for muzzleloading weapons, but they were fragile and subject to damage from moisture. More seriously, they were not adaptable to breechloaders, as they provided little or no seal for the joint between breech and barrel. Hence development of breechloaders and repeaters was directly tied to availability of suitable ammunition. Designers of effective early breechloaders had to come up with a practical cartridge too. It is still a truism that design of a good weapon must be concurrent with that of its ammunition.

The War Department display at the Centennial Exhibition was an important part of the material shown by the Executive Branch. Springfield Armory and the Frankford Arsenal each presented exhibits and actual sections of their shops in which visitors could watch rifles and ammunition being made. The ammunition production line of 19 machines constituted the first public display of automation as we now know it. In the official report on the Exhibition it was stated, “. . . no place seemed to arrest more the attention of the people, nor to hold them longer in contemplation, than that occupied by this machinery.”¹

¹ The Ordnance Department, U.S. Army, at the International Exhibition, 1876. 2 January 1877 letter of Lt. Col. S. C. Lyford, Representative of the War Dept. p. V. Government Printing Office, Washington, D.C. 1884.

By 1876, design and production of small arms ammunition had been rather well formalized. Further improvements were to be in detail and in process refinements rather than in major concepts. Smokeless powder, not then available, would later extend the capability of the cartridge, but the mechanical aspects had been worked out. Earlier breechloaders often used special cartridges not adaptable to any other arm. The field was wide open in the 1860s and many designers and inventors sought to devise a cartridge that would combine good ignition with a satisfactory seal at the breech. The National Armory at Springfield, Massachusetts, and Frankford Arsenal at Philadelphia worked intensively to these ends, concurrently devising machines for producing the cartridges they needed. The Services constantly sought flatter trajectory, which required smaller calibers with longer cases

in order to limit the recoil to acceptable limits. More powder produced the required higher velocity, but the bullet then had to be smaller as the product of these two is involved in the recoil calculation. In order to draw the longer cases that were called for by the military requirements, drawing and annealing techniques had to be perfected. Often by the time a requirement was met, the Services again raised the performance level specified. Many of the ordnance officers and civilian employees at the arsenal suggested new approaches, most of which they did not bother to patent. Often civilian inventors here and abroad saw and copied these designs and took out patents in their own names. Though the gun design field was nearly pre-empted by civilians, the opposite was true in cartridges. Frankford Arsenal led the world in design and production of small arms ammunition.

The Pioneers in Metallic Cartridges

The term cartridge is used to mean a self-contained ammunition for breech-loading arms, with bullet or shot, propellant, and means of ignition conveniently combined in a case, usually metallic, which also serves as obturation for the breech opening. The origins of such cartridges are uncertain, as little has been recorded about them, and many of the basic patents, issued abroad, are relatively unknown in the United States. Extensive research on late 19th-century patent litigations left considerable doubt about the early cartridge patents, their claims, and especially their capabilities and effectiveness. Erroneous classification of small arms ammunition specimens as dangerous explosives led to the discarding of most of the collections entrusted to public institutions. Consequently little accurate historical information on ammunition development is conveniently available.

The only published source on cartridge patents is the excellent digest of American, British, and French cartridge patents compiled in 1878 by Bartlett and Gallatin of the U.S. Patent Office.² In all three countries firearms and cartridges are classified separately, and cartridges for specific firearms are often described only in the corresponding firearms patent. The digest included cartridges shown in U.S. firearms patents, but only those listed among cartridge patents in England and France. American inventors apparently sought to protect their ideas by taking out patents abroad, but British and French inventors for some reason seldom bothered with patent protection here. Hence for lack of information we often credit Americans with originating inventions which were already patented abroad.

The following discussion on early cartridge pat-

ents is based mainly on the Bartlett and Gallatin Digest, amplified by a study of some of the actual patent papers and contemporary publications concerning their implementation. It was common for a design not to actually perform as claimed by the patentee. Sometimes this was the result of a faulty idea, but often it was due to lack of technical proficiency. As communications were often lacking, or at least slow, the ideas from abroad were either unknown or rendered obsolete by contemporary American innovations. The knowledge of deep drawing for cartridge cases, however, was probably more advanced in Europe than here in the early days of metallic ammunition, due to the earlier availability of breechloading shotguns, such as the Robert and Le Fauchoux.

The cartridge (*cartouche*, *cartrage*) probably had its beginnings about 1550, when bandoleers were used to carry measured powder charges to speed loading and to avoid handling loose powder in the presence of the burning match. The charges were held in little cases of wood, strung on the bandoleer (see plate 1*a*). Balls and priming powder were carried separately. By 1590 reference was made to ". . . cartrages with which musketeers charge their peeces both with powder and ball at one time."³ In 1620 the army of Gustavus Adolphus of Sweden was reported to carry measured powder charges in paper packets, which had the bullets attached.⁴ Though rifles and pistols continued to be loaded with loose ball predominantly, the use of the paper cartridge for muskets became quite general and persisted as long as muzzle loaders were in service.

Early in this period, powder and ball were combined in metal cases, but these were really stiff (not

² Bartlett and Gallatin, *Digest of Cartridge Patents*. Included in appendices 1, 2, and 3 of Lewis, "Small Arms and Ammunition in the United States Service."

³ Smythe, *Certain Discourses*.

⁴ Deane, *Deane's Manual*.

obturating) auxiliary breeches, were not expendable, and were generally limited to use in expensive custommade weapons (see frontispiece).

Fulminates had been known long before their use as a means of igniting charges in firearms. Pepys Diary mentioned the subject under the date of 11 November 1663. The first patent granted for a detonating ignition system (British pat. no. 3032), however, was to the Scottish clergyman and inventor Alexander Forsyth, in 1807. The percussion cap was developed shortly thereafter and continued as the favored means of ignition, which, with minor changes and the perfection of self-contained metallic cartridges, evolved into the modern primer. An American patent on the percussion cap was granted to Joshua Shaw on 19 June 1822. He claimed in his U.S. patent application to have originated the idea in England in 1814, but the honor is disputed by British gunsmiths Egg, Hawker, and Purdey, and others. Possibly conflicts of these claims with Forsyth's basic patent had precluded a British patent for the percussion cap at that time. A French patent for it was granted to Prelat, a French gunmaker who sketched and described a percussion cap in his 1818 patent claim. The idea had probably emanated from England.⁵ In any case, Shaw was recognized in the United States as originator of the cap in a practical form and was retained by the Government to install a machine for their making and to assist in their testing at Frankford Arsenal. Hall carbines using Shaw's percussion caps had been introduced in 1834, but these caps were procured from commercial sources. By 1845 the U.S. Army was manufacturing caps on a large scale, having adopted the percussion system in 1842.

When percussion ignition compositions were successfully adapted to guns in the early 19th century, the first sound approach to a satisfactory cartridge became feasible. The objectives were to combine all three elements—ignition, powder, and ball—into a unit, which would be sturdy and water repellent, and would provide an adequate breech seal. Gun designers, however, pursued the development of a breech seal, sacrificing the improvement of the internal system. Therefore, throughout the 1860s, otherwise excellent cartridges, employed external ignition systems.

On 12 September 1812 the Swiss inventor, Jo-

hannes Samuel Pauly, obtained a French patent covering a centerfire, breechloading gun which used an obturating cartridge, for which he also received a British patent (no. 3833, under the name Samuel J. Pauly) in 1814, and another (no. 4026) in 1816. The latter two were novel in using compressed air to ignite the fulminate instead of a mechanical striker. Although "improvements" on Pauly's ideas were patented in France between 1816 and 1824, Pauly's invention was the first practical use of the new percussion ignition compounds, by incorporating them with powder and ball into a complete cartridge. The cases were of heavy brass, sealing the breech by a tapered head, like a rubber drain plug. The first of them (1812) used a "patch" of detonating compound or a pellet which was placed in a shallow recess in the head (plate 1c). In 1814, he added a short percussion nipple, using a metallic cap (plate 1d). His 1816 shot cartridge (plate 1e) had a brass head equipped with a hollow screw in its forward face. The charge and shot were placed in a paper cylinder having a hard wad in the base. A hole in this wad was perforated by the head screw, through which ignition passed.⁶

Another big step was the Galy-Cazalat cartridge (French pat. no. 3355 of 1826). A parchment case contained an inside centerfire primer in its base (plate 1f). An X-ray photograph (plate 1g) shows the interior construction. This cartridge lacked only obturation and a means of extraction to be a complete cartridge in the modern sense.

In 1829, Clement Pottet received French patent number 3930 covering a removable base, with a pocket for fulminate (plate 1h). It was probably derived from the Pauly patent but it also covered a percussion cap on a base nipple, which, with his improvement (French pat. no. 12746 of 1855), evolved into the modern shotgun shell. This last design used a cardboard case and metal head with reinforcing wad inside. The cap screwed into the wad, holding the unit together. An Englishman, G. H. Daw, obtained British patent number 203 in 1861 covering minor improvements in the ignition of the Pottet case. This design has been the guide in construction of shot shells ever since (plate 4e).

The British Mark I Snider cartridge of 1867, (plate 1i) had the Pottet head, which was widely used in Europe during the period 1865–1880.

An English patent (no. 6137) was granted to Au-

⁵ Winant, *Early Percussion Firearms*, p. 48.

⁶ Reid, "Pauly, Gun Designer," p. 181.

gustus Demondion in 1831 for a paper case with a detonating tube protruding from the rear, which was struck by a simple main-spring-hammer combination (plate 1j).⁷ Another 1831 English patent (no. 6196), issued to Abraham A. Moser, describes a cartridge having a centerfire cap in its base. It was J. A. Robert's primed case (French pat. no. 8061), however, which eventually was developed into the rimfire by later omitting the composition from the center. This was done by Smith & Wesson, whose patented rimfire cartridge used a cardboard disk in the center of the base, thus restricting the priming composition to the rim. Since the priming is considerably more violent than the powder, minimizing the amount of priming used results in better control of the pressure generated in the cartridge.

P. Lepage's 1832 French patent (no. 5468) was for a heavy-walled brass case with a centerfire primer on attached nipple (plate 2a). Like Pauly's, the case did not provide a seal by expanding, only a mechanical one at the base.

Beringer's 1834 French patent (no. 8829) shows a nipple in a thick metal case, using a percussion cap (plate 2c). This was really a detachable breech, which included an idea for a removable base, and which he later (French patent no. 5545 of 1850) developed into a partly closed metal tube with a metal-covered wad carrying a cap inside the base (plate 2b).

In 1834, Danish army ordnance chief Voss introduced a breechloader with a metallic cartridge using external ignition (plate 2d). The cartridge, though it had good obturation and was 25 years ahead of several types used during our Civil War, was not included in the exhibition of 1876.

Le Fauchaux patented a breech action in 1835, with its cartridge. This was a paper case with a thin brass head. A pin entering a small hole at one side of the head struck a percussion cap placed against the opposite interior surface. It was this pinfire cartridge that made the Le Fauchaux gun the first good breechloader possible. This first pinfire, however, had no internal reinforcing, just the pin with its cap, (the pin being held in place by a thin wire passing through the head), so that a heavy charge caused failure around the pin hole (plate 2e). The final form of the Le Fauchaux cartridge was extensively used in revolvers by both sides in our Civil

War. These types are described in the 1876 collection.

Johann Nikolaus von Dreyse produced his needle-fire gun and its cartridge in 1827. He first used a round musket ball. After extensive tests, starting in 1836, Prussia ordered 60,000 von Dreyse rifles for field tests in 1841. They were made in secret at von Dreyse's Sommerda plant. The system was standardized for all Prussian infantry in 1848 (plate 2f) and remained in use until the Mauser was adopted in 1871.⁸ The loose-fitting bullet is carried by a pressed paper sabot which takes the rifling. The sabot base has a pocket for fulminate which is fired by the long needle-like firing pin, passing through the powder charge. The von Dreyse needle gun was the first military breechloader using a complete cartridge, which was shown in the 1876 collection.

In 1841 John Hanson and W. Golden obtained British patent number 9129 for a charged bullet, with fulminate in a base cavity. It was also designed with a small case attached to a ball, loaded only with fulminate or with both fulminate and powder. The same idea was included by Parisian inventor Flobert in his breechloader French patent (no. 8618) of 1849. This well-known action used the bulleted breech cap, a simple copper case, round ball, and fulminate priming sufficient to send the ball a short distance. This was really just a bullet stuck into a large percussion cap. An example of the Flobert-type cartridge of European origin is shown in plate 2a. It is characterized by absence of a distinct rim at the base, the cartridge not being positively positioned in the chamber by the rim, but only wedged in place by the taper.

In 1846, Professor Schönbein, a Swiss, introduced guncotton as a propellant for small arms ammunition, taking out a U.S. patent that year. Extensive experiments to determine safety factors and means for controlling the burning rate were conducted by Baron von Lenk, an Austrian. Some of his cartridges (plate 2h) which used finely braided material to slow burning were tested by the United States Army. These were the first clean burning smokeless cartridges. However an inadvertent double charge would burst the barrel, so they were not adopted.

Houllier's French patent (no. 1936) of 1846 was an improvement on the Le Fauchaux pinfire, reinforcing the head, and putting the cap in a recessed base washer. Houllier included in his patent

⁷ Greener, *The Gun and its Development*, p. 120.

⁸ Weygand, "Die Technische Entwicklung," p. 40.

claims copper or brass cases, with pin, rim, or centerfire priming. He also used thin copper or brass for the case to provide obturation. Thus just about all the basic requirements of a self-contained cartridge were patented by 1846, though actual production was limited by drawing techniques of making larger cases.

Chaudun's 1847 patent (no. 3801) for further pinfire improvements (plate 2*i*) was specifically designed for use in the Le Faucheux and Robert guns. One of his ideas was a hinged trap-door affair in the head to insert the cap, a small flash-hole entering the case from this compartment (plate 2*j*).

Being a British citizen facilitated obtaining a British patent. Thus American inventors sometimes got a Britisher to act as patentee, their agent, or assignee. Sometimes the U.S. patent took longer, so the British one had an earlier date. Another 1847 British patent (no. 11994) was granted to Stephen Taylor for a hollow bullet filled with powder, covered by a perforated cap (plate 2*m*). It is the same as an 1848 U.S. patent number 5699 issued to Walter Hunt. It is believed that Taylor, who filed the British patent, was an assignee of Hunt's.

Lenoir obtained French patent number 4088 in 1849, covering a horizontal inside pinfire cartridge (plate 2*k*). The pin struck a cap placed against the bullet base, thereby providing a solid anvil against which to hit the primer. This idea was resurrected in the United States about 20 years later in Frankford Arsenal experiments on ignition, but was considered impractical. The paper or fibre base did not provide an adequate seal.

In 1850, Joseph Needham patented (British pat. no. 14227) a double-barrel hammerless shotgun, using a special needle-fire cartridge (plate 3*a*). The paper combustible case had two wads in its base enclosing the cap, and reinforced by a zinc anvil. The firing pin entered a hole in the rear of the wad assembly. The unconsumed base was pushed forward by the next cartridge and became the top wad. Needham's gun was the first of its class, but the cartridges were expensive, could not be reloaded, and leaked into the action enough to cause trouble by fouling.⁹

In 1852 Charles Lancaster of England introduced another hammerless double-barrel shotgun, with a special "gastight" cartridge.¹⁰ This was a drawn

copper tube with closed base, thickened at the edge to form a rim, and thin in the center. Inside centerfire priming was held in place by a perforated disk, crimped into the rim (plate 3*b*). This cartridge was not reloadable, hence expensive to use.

Another British 1852 patent was that of Robert Adams, which covered a copper shell case, closed with paper and cover, and having the bullet stuck onto it by an integral lead rivet which also positioned a felt wad. This was for a percussion revolver with its usual external priming. The cartridge was not loaded into a chamber but was really only a convenient way to carry components, reminiscent of the old matchlock bandoleers (plate 2*n*).

W. W. Marston had an 1852 U.S. patent (no. 8956) for which obturation was provided by means of a leather base washer in a paper case, using external priming. These sealed the breech effectively, and the washer, being pushed ahead of the next load, cleaned the bore. The washer, however, was not moisture proof. Marston made a series of pistols, rifles, and muskets, using this type cartridge (plate 2*o*).

The "Volcanic" cartridge used in the well-known repeating firearms made by Smith & Wesson had its origin abroad. Charles Fusnot of Brussels won a first prize at the Belgian Exhibition in 1847 for his self-contained cartridge. A cavity in the base of the bullet held powder, sealed by a small disk carrying the detonating compound. This same idea was patented in France in 1854 (no. 10698) by Gaupillat (plate 3*c*).

Smith & Wesson received an American patent (no. 11496) in 1854, which described a copper case with a metal disk inside, holding the priming composition which was fired by a central striker. This was intended for use in their Volcanic arms, but never worked properly because of ignition uncertainty. Like the Flobert, it had no well-defined flange, just tapered a little under the head, wedging into the chamber when fired. Its pellet of priming inside the head rested on an anvil supported only by the powder. This combination obviously would cause misfires. Writing to the patent examiners in 1860, Oliver Winchester said that he had never been able to make the "improvements" of the Smith & Wesson's 1854 patent work reliably, but had used a hollow ball instead, and engaged Tyler Henry to work up a better cartridge. Smith & Wesson's

⁹ Greener, *op. cit.*, p. 136 (footnote 7).

¹⁰ *Ibid.*, p. 139.

1856 patent (no. 14147) described the “hollow ball” ammunition, as actually used in their Volcanic line of guns (plate 3*d-e*). It was a loaded ball with a base cavity containing powder and primer. The priming, consisting of fulminate on a cork-covered steel disk, formed the base seal.¹¹ The Smith & Wesson 1860 patent (no. 27933) covered a satisfactory rimfire cartridge about as we know it today. It had a straight case and a definite flange for the first time in the United States, though essentially the same as Houllier’s 1846 patent. Smith & Wesson used it in the Number 1 (caliber .22) revolvers which they started to manufacture in 1857. A feature peculiar to this cartridge was the perforated-paper base wad, which restricted the priming mixture to the rim of the case. The example shown in plate 3*j* is for the caliber .54 old model Ballard carbine, used during the American Civil War. An external characteristic of most cartridges made by Smith & Wesson, or under their patent, is a slightly dished unmarked head. This shape was thought to help distribute the priming composition. Otherwise the bullet and case resembled the familiar caliber .22 cartridge.

Maynard’s 1856 patent (no. 15141) was for one of the first successful U.S. cartridges using a metallic case and external ignition.¹² That illustrated in plate 3*f* is the original patent type.

Another 1856 U.S. patent (no. 15996) covered George A. Morse’s metallic centerfire cartridges. The common version had a rubber disk in the base, surrounding a cap held on a hairpin-shaped anvil which soldered to the case walls. In March 1858 he recorded two other cartridge patents, numbers 20214 (plate 3*g*) and 20727 (plate 3*i*). Though not included in his patent drawings, his caveat filed with them mentioned a centerfire cartridge without the rubber gasket, using only the cap for obturation. Plate 3*h* shows an intermediate type, with solid head. Thus Morse held the basic U.S. patent on features of the modern centerfire cartridge i.e., flexible metal case, crimped-in bullet, and a primer pocket in the head to receive a percussion cap, itself sealing the primer opening. His system for a breechloader using his ammunition was adopted by the U.S. Government in September 1858 as the best available method for converting muzzleloaders to breechloaders. Trial rifles and ammunition were

made, and arrangements were begun at Harpers Ferry Armory to convert rifles by the Morse method, but the start of the war and loss of the armory prevented completion of the work. His ideas, which included the rebounding firing pin, spring-loaded double-claw extractors, and other features generally found in subsequent rifles, were far ahead of his time.¹³

Gilbert Smith’s 1857 U.S. patent (no. 17702) covered a rubber cartridge case, with external priming. This was used early in the Civil War in the caliber .50 Smith carbines (plate 4*a*).

As usable cartridges were not readily available, inventors of gun mechanisms often had to design their own, usually favoring the gun design by making a cartridge which nowadays has a weird appearance. Their main preoccupation must have been to make the gun design at the expense of cartridge design.

Such an unconventional cartridge was covered by H. Genhart’s U.S. patent no. 16477, in 1857. It was for a revolver with horizontal wheel-like cylinder, in which the cartridges were loaded from the front and arranged like spokes. The cartridge has a metal priming tube protruding from the rear being the only American-patented cartridge of the detonator type (plate 4*b*)—like the Demondion of 1831.

The Mahlon J. Gallagher and Gladding cartridge (U.S. pat. no. 24730 of 1859) was another odd one, also patented in connection with a gun mechanism—the Schubarth conversion. The bulbous case contains an internal pinfire arrangement which is struck from the upper surface of the case, using the bottom as an anvil (plate 3*c*).

George P. Foster’s 1860 U.S. patent (no. 27791) added a grease-retaining ring to the cartridge used in the Burnside carbine, this being the first to put the grease inside the case (plate 3*d*). This served a double purpose. Besides helping seal the junction of breechblock and barrel, it put the grease, needed to keep the black powder fouling soft, under cover. Older bullets had been lubricated externally with a rather heavy beeswax-tallow mixture, which picked up all the dirt and sand in the vicinity when carried loose in the soldier’s pocket. This is probably the first really long case to have been made out of drawn brass. Evidently it worked well.

In 1863 a patent (no. 40978) was granted to Silas

¹¹ Lewis, “The Volcanic Arms.”

¹² Lewis, “Maynard Arms and Ammo.”

¹³ Lewis, “Morse Arms and Ammunition.”

Crispin, a U.S. Ordnance officer. It covered a case made of wrapped thin sheet metal, or metal and paper, externally primed. He assigned his patent rights to Thomas Poultney of Baltimore, whose name is better known. Cartridges of this type were used during the Civil War in large number, in Smith, Maynard, Burnside, and Gallagher carbines. The Burnside version is shown in plate 3*f*.

An 1866 English patent (no. 2711, patentee unknown) mentions a "base recessed for extraction." It seems to be the same idea incorporated in U.S. patent number 123,622 in 1872 (plate 3*j*) granted to G. H. Dupee.

English patent number 2628 of 1865 and U.S. patent number 57269 of 1866 cover J. H. Selwyn's idea for putting a centerfire cap in a tapered cartridge. Plate 3*g* shows it applied to the Burnside cartridge.

Colonel G. M. Boxer's British patent number 167 of 1866 (U.S. pat. no. 91818 of 1869) covers a wrapped case of metal and paper, with a base cup attached to a base disk by a hollow rivet which forms the primer pocket. It was the type adopted by the British in caliber .577 for the Snider arms, being manufactured initially at the Royal Laboratory at Woolwich, where Colonel Boxer was Superintendent. This cartridge incorporates several features of the 1863 Crispin patent (see above). A Snider Mark II cartridge is shown in plate 4*h*.

Hiram Berdan's U.S. patent number 53388 of 1866 describes a metallic cartridge having an outside centerfire primer recessed into the head. The primer pocket is an integral part of the case, the bottom of the pocket being bumped up to form an anvil. This cartridge was featured in the production of the Union Metallic Cartridge Company (UMC)

for many years and it is still the principal type used in Europe. Boxer's primer, which carries its anvil in the primer itself, has been the favorite in the United States though the loose anvil requires an extra handling of small metal parts which are subject to loss or can be improperly positioned. Pre-occupation with ease of decapping for reloading appears to have been the explanation of why this country dropped Berdan's superior American invention and adopted a foreign one. The original Berdan case had its flash hole off center, which made aligning a decapping punch quite difficult. They were later made with center flash hole but as currently produced usually have multiple holes, so the problem still exists of readily punching out the fired primer. Plate 4*i* shows a Berdan cartridge, that for the caliber .58 converted musket, which is typical of the UMC production of the period 1868-1880.

The profusion of ideas in the cartridge field in the years 1855-1875 has never been equaled since. The Frankford Arsenal cartridge collection prepared for the Centennial Exposition offers a unique coverage of that important period. Besides the great number of designs made and tested at Frankford and Springfield it includes the principal types made abroad as well as commercial types, both military and sporting, made in this country. At that time, patents were considered of secondary importance to getting the job done. But they had important bearings on the story, both as to sources of ideas, and compensation to the holders. Sometimes the Ordnance Department purchased patented cartridges whose basic idea had originated in Government shops.

2

Ordnance at the Exposition

Participation by the Executive departments of the Government in the Philadelphia Centennial Exhibition originated in 1873, when the Centennial committee on classification asked various Government officials for suggestions regarding the scope and nature of the exhibits. The Chief of Ordnance urged that a separate display be made of the nation's war materials. This suggestion was forwarded to President Grant with the committee's added thought that there be a collective exhibit of all the Executive departments. The proposal met with approval and an Executive order was issued on 23 January 1874, directing that a Board be appointed on behalf of the several Departments and the Smithsonian Institution, to prepare, arrange, and display articles pertaining to each. The Ordnance representative, Brevet Lieutenant Colonel S. C. Lyford, also represented the War Department, and the President designated him as chairman. Plate 5 shows the Government exhibition building, still in Fairmount Park, Philadelphia.

The Ordnance display, prepared under the direction of 1st Lieutenant Henry Metcalfe assisted by 1st Lieutenant C. W. Whipple, was arranged according to the following classifications: (a) cannon and carriages; (b) cannon ammunition; (c) small arms; (d) small-arm ammunition; (e) equipment leatherwork, etc.; (f) machinery; (g) miscellaneous. In connection with the ammunition display, a typical manufacturing line of metallic cartridge machinery (plate 6) was moved from daily use at Frankford Arsenal, along with skilled operators, both men and women, and placed in full operation. This demonstration was of great general interest and was the prime attraction in the Government building.

This assembly line was in actual cartridge production during the Exhibition. Visitors received small souvenir boxes (plate 7a) containing a set of pieces

showing the stages of manufacture of the standard .45-70 cartridge, with inside cup priming. The box contained a blank, five draw pieces, trimmed case, headed case, and primed case, as well as a primer-cup draw piece, an indented cup, and bullet. The souvenir cartridges were made in blank and in ball types (plate 7b), and had a special marking on the head, consisting of the dates 1776-1876, plus the initials USO (United States Ordnance) in monogram.

Starting in 1877 the Frankford Arsenal regularly used cartridge headstamps to show origin, type, and date of manufacture. Thus, FR 477 indicated manufacture at Frankford Arsenal, of a rifle load, in April 1877. The R designating a rifle load was necessary because both rifle and carbine cartridges were then using the same size case, varying only in powder charge and bullet. In later years the letter R indicated "rifle anneal," i.e., hard and springy to facilitate extraction in bolt-action rifles. Softer brass was used for machine guns to minimize case rupture.

One of the most interesting machines on display was the loader, which had been designed and built by Jabez H. Gill, Superintendent of small-arms ammunition manufacture at Frankford Arsenal. Common practice of the "plate-loading" process then used, involved several operations. The Gill loader performed all the operations on a single machine, with perfect safety. The priming, tapering, and other special cartridge machines had also been designed by Mr. Gill.

The items for the small-arms ammunition display at the Exhibition had been prepared under the direction of Captain William Prince at Frankford Arsenal. It included a cabinet with ten drawers of specimens—467 items—as well as several display boards which showed the progressive stages of manu-

facture of standard cartridges: the 1-inch Gatling, calibers .45 and .50 rifle, and caliber .45 revolver. Two variant types were included—the caliber .45 rifle cartridge as made by the U.S. Cartridge Company of Lowell, Massachusetts, and the Rodman-Crispin wrapped brass cartridge which had been made experimentally at Frankford Arsenal.

Following the 1876 Exhibition, the Frankford cartridge collection was retained at the Arsenal and displayed from time to time. After being shown at the Columbian Exposition in Chicago, 1892–1893 the collection was placed, with other historical material, in a small museum at Frankford Arsenal.

At the beginning of World War II, space was at a premium at the Arsenal, and the basement of

building number 40 (now the Post library) which housed the Museum, had to be cleared for other purposes. Colonel George A. Miller, Jr., then in charge of small-arms ammunition manufacture at Frankford, saw the boards and drawers of cartridge specimens piled on push carts, ready to be sent to the scrap yard. Recognizing the historical importance of this material, he had it diverted to one of the Ammunition Department buildings, and arranged to have it checked, re-arranged, and cataloged. The collection was retained in the custody of the Small Arms Ammunition Department until 1958, when it was sent to the Smithsonian Institution by Colonel Berkeley R. Lewis.

3

Cabinet of Small-arms Ammunition

Prepared at the Frankford Arsenal, Philadelphia, the first two drawers of this collection contained combustible cartridges, that is, their cases were made of paper, nitro-cellulose, skin, or other membrane. For use in service, some were loaded intact, others had to be broken apart and the contents loaded separately. With the latter, the enclosing paper was at times discarded, or often used as wadding between powder and ball, or on top of the ball. The last procedure was required with the older, round-ball load for the smooth-bore musket. Because of the large clearance between ball and barrel that was needed to permit facile loading when the bore was fouled from shooting, the ball was so loose at the start of an engagement that it would roll right out if the muzzle were depressed. Hence the instructions were to ram the paper cartridge remains down atop the ball, or for lack of anything else to use a wisp of hay or grass.

The third drawer contained transition cartridges, some of paper, others with foil or solid metal cases, provided with external priming. Some of them were the combustible type, with the powder charge encased in collodion, membrane, or shellac. The paper, compressed powder, and skin of these 100-year-old specimens has become very dry and brittle. When the collection was renovated in 1940, there were only enough intact specimens to fill two of the first three drawers. The specimens were consolidated and rearranged to occupy the first and

third drawers of the series, the second being discarded.

As the original second drawer has since been located, the remaining specimens have been restored to their original positions, leaving some spaces blank. Specimens missing from the original display are indicated by an asterisk (*) after the Frankford Arsenal Collection number and are illustrated, wherever possible, by similar examples. The complete original catalog descriptions of all specimens are given,¹⁴ amplified by measurements or other details of available specimens in cases where this would help identification.

Bullet diameters, for the most part, are the nominal or bore diameters of the arms involved. Measurements in parenthesis are actual bullet diameters, when available. In general, muzzleloaders used bullets somewhat smaller than the bore and breechloaders a little larger. Weights given are specifications from contemporary Ordnance manuals, with which few specimens will agree exactly, either with these weights or with other specimens from the same lot. Up to five grains variation may be expected. L = length in inches.

¹⁴ References to Ordnance Memorandum 14 have been left out and these details incorporated in the descriptions. Those to Frankford Arsenal Ammunition Test numbers have been omitted, as there is no record of these tests. See Metcalfe, Lt. Henry, *The Ordnance Department U.S. Army at the International Exhibition* (Washington, D.C.: Government Printing Office, 1884).

First Drawer: Paper Ammunition (Not Fixed)

No.	Name or Arm	Bore (R: rifle) (S: smooth)	Powder (grains)	Bullet	
				Diameter (inches)	Weight (grains)
1	Round ball for U.S. musket, M1842. L 2.2	S	110	.69(.65)	412
2	Buck (3) & ball, M1842. L 2.4	S	110	.69(.65)	550
3	Buckshot, M1842. L 2.8	S	110	.31(12 shot)	552
4	Round ball for U.S. rifle, M1841. L 2.6	R	75	.54(.525)	220
5*	Round ball for U.S. rifle, M1842. L 2.0 (This was probably a cartridge for the M1819 or M1827 pistols, which used this load, not regulation after 1834). See plate 22a.	S	60	.54(.525)	220
6*	Round ball for "Savage" belt pistol (This is evidently a mix-up. There is no known Savage pistol of this caliber. The round was probably for one of the early flintlock pistols, such as Harpers Ferry or 1808 contract models. Specimen missing.	?	65	.50	200
7*	Blank for rifle musket. L 1.2 (about) (No specimen available for photo.)	S	60	.58	—
8*	Elongated ball for U.S. musket, M1842. L 2.9 (Mefford's subcaliber ball)	S	110	.69	420
9	Elongated ball for Austrian rifle musket (Civil War purchase). L 2.3	R	75	.71	685
10	Elongated ball for Belgian rifle musket (Civil War purchase). L 2.5	R	70	.70	765
11	Elongated ball for U.S. rifle musket. L 2.3	R	80	.69(.685)	730
12	Same. L 2.2	R	80	.69(.685)	640
13	Elongated ball for Springfield rifle musket, 1863. L 2.5	R	60	.58	480
14	Elongated ball for Springfield and Enfield rifles. L 2.5	R	60	.577	495
15	Same.	R	50	.57	530
16	Same, with William's type I bullet. L 2.4 (A patented bullet with concave zinc washer under a base plug. Expanded and cleaned the bore when fired.)	R	60	.57	565
17	Same, type II. L 2.25	R	65	.57	465
18	Elongated ball for Enfield, English manufacture. L 3.0 (Originally listed for Springfield also, but much too small.)	R	60	.568	530

No.	Name or Arm	Bore (R: rifle) (S: smooth)	Powder (grains)	Bullet	
				Diameter (inches)	Weight (grains)
19	Elongated ball for U.S. rifle, M1841.	R	60	.54(.525)	570
20	Same.	R	60	.52	455
21	Elongated ball for Greene's B.L. rifle (Distinct by having bullet reversed in cartridge—base to front apparently. The cartridge was loaded with bullet to the rear however, a loose bullet being inserted ahead. The rear bullet acted as a seal and was pushed forward by the next cartridge.) L 2.5	R	70	.54	410
22	Elongated ball for U.S. pistol M1842. (Use of elongated bullets in pistols prior to the caliber .58 M1855 has not been noted. Round shown is M1842, with round ball, charge 35 grains.) L 1.55	S	30	.54(.525)	410
22A	Same, but M1836, with L 1.65	S	55	.54(.525)	220
23	Elongated ball for U.S. pistol—carbine, M1855. L 1.9	R	40	.58	450
24	Elongated ball for Colt's Army revolver, M1848. L 2.00 (For Dragoon, yellow paper.)	R	25	.44	260
25	Elongated ball for Colt's Navy revolver, M1851. L 1.6	R	15	.36	150

Second Drawer: Paper Ammunition (Fixed)

26*	Merrill, for rifle musket, M1842. L 2.6	R	60	.69	720
27*	Merrill, for rifled musketoon. L 2.3	R	50	.69	715
28*	Merrill, for Springfield rifle musket.	R	50	.58	455
29*	Merrill, for Merrill rifle. L 2.38	R	50	.56	425
30	Merrill, for Merrill carbine. L .64	R	40	.56	420
31	Merrill, for Merrill carbine, U.S. make. L 1.65	R	40	.56	420
32	Sharps, for Sharps rifle, caliber .54. L 1.83	R	60	.55	465
33	Sharps, for Sharps rifle, caliber .45. L 2.9	R	70	.47	260
34	Sharps, for Sharps rifle, caliber .40.	R	45	.41	170
35*	Sharps, for Sharps carbine. L 2.375	R	55	.52	450
36	Colt's, for Colt's revolving rifle. L 2.0	R	45	.56	490
37*	Colt's, for revolving pistol-carbine.	R	20	.44	260
38	Colt's, for Colt's Army revolver.	R	17	.44	205

No.	Name or Arm	Powder (grains)	Bullet	
			Diameter (inches)	Weight (grains)
39	Colt's, for Colt's Navy revolver.	12	.36	135
40*	Savage revolver, Navy.	10	.36	150
41*	Inserted paper for Springfield rifle musket. ("Inserted paper" the cartridge made under Gardner's Confederate patent at Richmond and Fayetteville. The bullet base was incised around the edge, the paper cartridge tube inserted, then swaged in place. The specimen bearing this number has its bullet enclosed in the paper in the conventional way; however, cartridges have been reported like this, enclosing a Gardner bullet. The charge shown is low for a Union cartridge.)	55	.58	475
42*	Hall's rifle	40	.54(.525)	395
43*	Chadwick's for Mississippi rifle, etc. (Specimen missing—Robert Chadwick of New York City made some combustible case revolver cartridges as well as for caliber .58 rifle.)	50	.54	420
44*	Gardiner's shell for Springfield rifle musket. (A hollow, explosive-filled lead bullet, fired by a powder-train fuse in its base.) L 2.1	60	.58	450
45*	Rebel, inserted paper for Enfield rifle, etc. (This is the usual Gardner's patent cartridge as mentioned under No. 41.) L 2.3	70	.577	500
46*	Shaler's three-piece sectional bullet. (The three pieces nested together and fired as one with buckshot effect.) L 2.5	55	.58	610
<i>Guncotton, paper</i>				
47	Johnson & Dow's combustible paper for Springfield rifle. L 2.0	60	.58	500
48	Same, for Enfield rifle. L 1.81	60	.574	480
49*	Same, for Sharps' carbine. L 2.06	50	.52	445
50*	Same, for Army revolver. L 1.75	25	.44	240
51*	Same, for Navy revolver.	17	.36	150
52	Linen and paper for Sharps' carbine. L 2.06	60	.52	450
53	Same, for Starr's carbine. L 1.96	50	.54	430
54	Same, for Union carbine. L 1.63	40	.54	390

Third Drawer: Transition and Patent Types (Fixed)

No.	Name or Arm	Description	Powder (grains)	Bullet	
				Diameter (inches)	Weight (grains)
55*	Hazard, compressed for R.M. 1842	Collodion varnish	70	.69	745
56	Same, for Springfield R.M. L 1.82	Collodion varnish	60	.577	490
57	Same, William's ball. L 1.70	Collodion varnish	60	.57	465
58	Same, for Colt's rifle. L 1.85	Collodion varnish	55	.57	480
59	Same, for U.S. rifle, M1841. L 2.045	Collodion varnish	70	.54	450
60	Same, for Sharps' carbine. L 1.845	Collodion varnish	50	.52	450
61	Same, Army revolver. L 1.3	Collodion varnish	25	.44	210
62	Same, Navy revolver. L 1.19	Collodion varnish	21	.36	140
63*	Hayes' patent for rifle. L 2.5 (Skin, reinforced with crisscrossed thread, and enclosed in paper tube with cloth tear strip.) (Figure 63 is cal. .57.)	Skin wrapped	60	.54	410
64	Same, for Army revolver. L 1.1	Skin wrapped	22	.44	205
65	Same, for Navy revolver. L 1.63 (Case marked: Capt. M. Hayes RN patent, skin cartridge, manufactured by Broux & Moll, London.)	Skin wrapped	17	.36	150
66	Hotchkiss compressed for Army revolver. L 1.5	Skin wrapped	22	.44	210
67	Same, for Navy revolver. L 1.4	Skin wrapped	17	.36	150
68	Same, for Requa Battery. (Billinghurst & Requa volley gun. Specimen shown is Hazard-type, believed for Hall's carbine, or perhaps Sharps rifle.)	?	65	.54	390
69	Same, for Savage Navy revolver. L 1.42	Skin	10	.36	150
70*	Bartholow's patent, compressed for M1842 smoothbore musket. No specimen.	Silk and shellac	65	.69	500
71*	Same, for RM, M1842, conical ball. L 1.88	Silk and shellac	70	.69	750

No.	Name or Arm	Description	Powder (grains)	Bullet	
				Diameter (inches)	Weight (grains)
72	Same, for Springfield R.M. L 1.75	Silk and shellac	65	.58	490
73*	Same, for Army revolver. L 1.34	Silk and shellac	20	.44	260
74*	Same, for Navy revolver. L 1.09	Silk and shellac	14	.36	140
75	Smith's rubber case for Smith carbine. L 2.00, case 1.47	Rubber	40	.50	380
76	Poultney's foil for Smith's carbine. L 1.75, case 1.34 (straight seam)	Foil inside of paper	40	.50(.52)	380
77	Same, diagonal seam. L 2.0, case 1.44	Foil inside of paper	40	.50(.52)	380
78	"Same, small chamber." (This specimen appears to be the cartridge for Gallagher's carbine. Diagonal seam. L 2.12, case 1.69.) Recess in drawer would not fit a normal Smith cartridge.	Foil inside of paper	40	.50	380
79	Poultney's foil for Burnside carbine. L 1.87 to 1.90	Foil and paper	40	.54(.56)	370
80	Same, for Maynard's carbine. Straight seam. L 1.69, case 1.19	Foil and paper	40	.50(.52)	330
81	Same, for Gallagher's carbine. Straight seam. L 2.12, case 1.69	Foil and paper	60	.50(.52)	440
82	Same, with soldered foil case. L 1.925, case 1.619	Foil	60	.50	410
83	Jackson's patent, tinned iron case, for Gallagher's carbine. L 2.66, case 1.619	Paper over tin	55	.50(.52)	430
84	Gallagher's carbine, paper-lined. L 2.02, case 1.692	Brass case	60	.50	435
85	Same, without paper liner. (Has more pointed bullet. Case has rounder base, with smaller diameter concavity.) L 2.087, case 1.692	Brass case	60	.50	435
86	Maynard, for Maynard carbine. (A number were made at Frankford Arsenal in 1860, with 40-grain charge and 343-grain bullet. The cases were tinned. An experimental type was made on special machines in 1865. This had a longer case, with front lubrication.)	Brass case	40	.50(.52)	340

No.	Name or Arm	Description	Powder (grains)	Bullet	
				Diameter (inches)	Weight (grains)
87	Burnside, for Burnside carbine. (Has more conical vent than usual. Some also made at Frankford in 1860, with 45-grain charge and 400-grain bullet tinned cases.)	Brass case	48	.54(.56)	380
88	Berdan sporting, 1865. (Hexagonal paper case to match twist of bore. Hole in head for external ignition.)	Paper; brass base	?	.55	?
89	Guncotton, Austrian (Baron von Lenk's development. Woven to control burning rate; stick to assure proper chamber space.) For photo see plate 2h.	Woven guncotton	20	.54	410
90*	Same, but without "button." (Small projection on bullet nose.)	Woven guncotton	28	.58	526
91	Barlow guncotton paper. (Nitrated purple paper wrapped to form cartridge.)	Rolled paper charge	40	.57	540

Fourth Drawer: Rim Primed and Miscellaneous

Rather uniform lack of identifying markings or other characteristics on the cartridges of this period requires that detailed measurements of some items be given, in addition to the obvious distinctions evident through photographs, sketches, or verbal descriptions. Even so, a few cannot be distinguished except by dissection or an x-ray photograph. As the extra details will only interest the researcher, they will be condensed as much as possible and given at the end of the description of each cartridge. The following code will be used throughout:

- O over-all length in inches
- C case length
- R rim diameter
- H head diameter
- N neck diameter, where pertinent
- M mouth diameter
- B bullet diameter, at point of greatest size accessible

In connection with bullet diameter note that the caliber first mentioned in the description is the nominal one, as stated in the original text of the collection catalog. This is presumed to be the bore diameter of the weapon, but in practice this often varied considerably from the measured bore. Many of the specimens have their bullets crimped into

the case in such a manner that the largest diameter of the tapering bullet is covered by the case mouth. When possible, the largest part of the bullet has been measured. In other cases, the diameter listed will be at the case mouth or largest exposed diameter.

Section I: Caliber .50, Service Musket Size

No.	Description
92	Poultney (Crispin) foil. Brass foil with iron head and separate brass primer pocket inserted, clinching the reinforcing wad. O-2.293, C-1.850. [Figure 1.]
93	Poultney (Crispin) foil. Zinc foil with iron head and separate brass pocket inserted, but not clinching the wad. Otherwise like No. 92. [Figure 1A.]
94	Poultney (Crispin) foil. Brass foil with brass base in one piece with impressed pocket. [Figure 2.]
95	Hotchkiss solid head, by Winchester. Primer pocket is pressed up from interior of base, enclosing small anvil of various patterns. Similar cartridges made at Frankford Arsenal in November 1868. [Figure 3.]

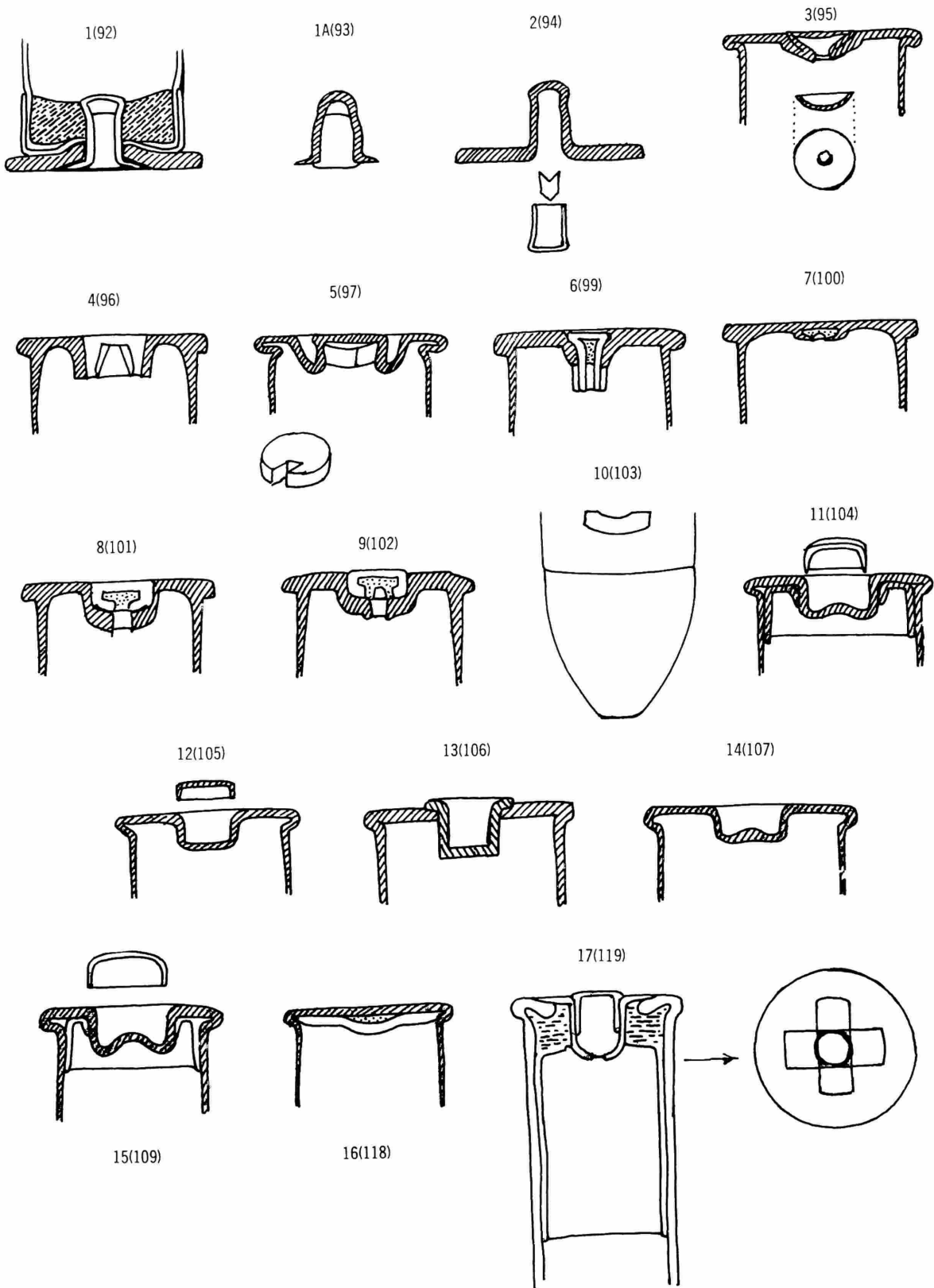

FIGURES 1-17.

- | <i>No.</i> | <i>Description</i> | <i>No.</i> | <i>Description</i> |
|------------|---|--|---|
| 96 | Hotchkiss solid head reloader. Pocket and Berdan-type return anvil pressed up from solid head. Base rounded at outer edge, square at inner. [Figure 4.] | 103 | Union Cartridge Company (Martin primed). Tested 2 November 1871. Single-fold rim, with copper-bar anvil. Bullet has rounder ogive than other Martin-type cartridges. O-2.286, C-1.761, R-.664, H-.560, M-.534, B-.513. [Figure 10.] |
| 97 | Remington Martin-primed copper Service cartridge, made in 1872 for the field trials of the Remington rifles then being tested by the Army. These Martin cartridges as made by different plants vary only in minor details. The Remington version has the re-entrant fold under the head, smaller primer cavity leaving more open space around the button at head end, and larger flat at bullet nose. Internally, the anvil is a notched copper disk. O-2.211, C-1.782, R-.670, H-.573, M-.537, B-.493. [Figure 5.] | 104 | Berdan, early form, brass, slightly necked case, with folded flange and shallow outside pocket. The burr of the pierced vent forms the anvil. Inside cup reinforce. Typical Berdan head as made by UMC. Flat-nosed bullet, flat .175 diameter. O-2.360, C-1.748, R-.675, H-.565, M-.535, B-.515. [Figure 11.] |
| 98 | Remington, 1874. Brass case with Berdan-type folded head. Reinforcing cup on binder's board wad around pocket. O-2.211, C-1.782, R-.670, H-.573, M-.539, B-.498. | 105 | Union Cartridge Company (Berdan-type), as furnished on order for 2,500,000 of 2 April and 24 November 1873. Reinforcing ring and return nipple anvil of the Berdan system. Bullet flat, .134 diameter. O-2.233, C-1.753, R-.652, H-.560, M-.541, B-.510. [Figure 12.] |
| 99 | Winchester (Millbank) primer. Thick folded flange. The primer is a flanged percussion cap inserted in a pocket without anvil. The primer is copper. O-2.279, C-1.779, H-.658. [Figure 6.] | <i>Section II: Miscellaneous Center Primed
Musket and Carbine Cartridges</i> | |
| 100 | United States Cartridge Company. Solid head copper case, inside-primed in a pocket pressed up from solid metal of the base, the walls of the pocket then closed down on the priming, forming an anvil. Cast bullet. This specimen has the headstamp characteristic of the Meigs' patent cartridges—"U.S. Cartridge Co., Lowell, Mass. Pat'd" plus "JM" in monogram. The last are the initials of Josiah V. Meigs, the patentee, who was superintendent of the U.S. Cartridge Company plant. [Figure 7.] | <i>No.</i> | <i>Description</i> |
| 101 | U.S. Cartridge Company. Solid head brass case, with outside priming, using Farrington's patent "improved" primer (slightly dished surface). Shallow primer pocket without anvil; smooth flat head. O-2.240, C-1.764, R-.663. [Figure 8.] | 106 | Early form of Berdan patent for .57 caliber. Inserted, thick brass, outside primer pocket, with flash hole and projecting burr off center. Copper case with flat head and flat-nosed bullet, flat .308. O-1.684, C-1.225, R-.647, B-.600. [Figure 13.] |
| 102 | U.S. Cartridge Company. Solid head, outside primed, as furnished on order for 2,000,000 of 24 November 1873. Differs from No. 101 in the base being convex and thicker, and the bullet longer, with deeper cannelures. O-2.358, C-1.776, R-.669. [Figure 9.] | 107 | Brass case, Berdan type, caliber .57, with shallow impressed primer pocket. Burr of vent forms the anvil. Flat-nosed bullet; flat .308. O-1.704, C-1.340, R-.730, H-.648, B-.605. [Figure 14.] |
| | | 108 | Caliber .44, Berdan type, with bottleneck brass case. Impressed shallow primer pocket, closed with primed disk; paper-patched bullet. O-2.383, C-1.689, R-.653, H-.517, N-.515, M-.450, B-.443. |
| | | 109 | Berdan type, made by Union Cartridge Company for Russian government. Caliber .42, charge 77 grains black powder, 375-grain bullet, paper patched. Bottleneck brass case with typical UMC Berdan head. O-2.908, C-2.257, R-.632, H-.517, N-.515, M-.450, B-.443. [Figure 15.] |

- | <i>No.</i> | <i>Description</i> | <i>No.</i> | <i>Description</i> |
|------------|---|------------|--|
| 110 | Ward Burton caliber .45, Berdan type, made by Union Cartridge Company. Load 85 grains powder, 400 grain bullet, paper patched. 1872 tests. O-2.318, C-1.796, R-.755, H-.658, N-.612, M-.481, B-.462. | | never tested but remained at the Armory. The caliber .69 Morse cartridges for the Army were made on contract (Muzzy), but it is likely that the smaller size was made at Frankford Arsenal to familiarize them with making metallic cartridges. There are two unexplained facets of this Morse production. First, no other mention has ever been noted of Navy interest in Morse. Second, the common Morse cartridge in collections is the caliber .58 size, tinned, said to have come from a case of them found years ago at Springfield Armory. Tinning was the Frankford practice in 1860, but the cartridge in the collection and that shown in Ordnance Memorandum 14 is the caliber .54. This has a bronze case, the anvil being of flat stock instead of the round wire found in other Morse cartridges. The thin rim is a flattened fold in contrast to the usual simple rim. It also uses a revolver cap, whereas the Army in using the Morse system insisted that the standard musket cap be used. No Morse arm has been mentioned that used a caliber .58 cartridge, though it was then the standard United States caliber. O-1.984, C-1.505, R-.687, H-.578, M-.575, B-.542. |
| 111 | Ernest's caliber .45 rifle, Berdan type, by Union Cartridge Company. Charge 52 grains, bullet 290 grains, paper patched. 1872 tests. Slightly bottlenecked brass case. O-2.148, R-.639, H-.518, N-.507, M-.482, B-.476. | 117* | Bolt anvil, cap perforating an India-rubber base, like Morse's. (This specimen is now missing from the collection. It may have been the caliber .58 Morse, illustrated, which fits the inlet in this drawer.) |
| 112 | Mead's explosive bullet cartridge, as used in 1874 Gatling gun tests. Service cartridge dimensions. Mead's patent, 10 December 1872, with fulminate charged capsule (cal. .22 cartridge less bullet) inserted in nose. Case like No. 104, with four pierced flash holes. | 118 | Williams' caliber .45 rifle, having his patented bore-cleaning bullet with base plug and zinc washer on its rear. The copper case has an inside disk anvil, crimped into the flange. Superficially it resembles a rim-fire cartridge. O-1.925, C-1.612, R-.583, H-.503, M-.480, B-.450. [Figure 16.] |
| 113 | Remington cartridge for Navy carbine, Model 1868. Inside-primed with iron cup, indents .264 from base. Readily confused with Frankford Arsenal cup-primed cadet cartridge, No. 451. O-1.753, C-1.320, R-.640, H-.559, M-.541, B-.543. | 119 | Spiral-wrapped off-white paper case, with fiber base and outside metal pocket for cap and anvil. Cap and base protected by a metallic cover (now missing) that forms the flange. Copper cap in zinc primer pocket. C-2.205, B-.450. [Figure 17.] |
| 114 | United States Cartridge Company, made for Navy. Solid head with Farrington's improved primer. Front lubrication (case covers bullet) otherwise Service case. Space in front of bullet filled with lubricant. C-2.235, R-.665, H-.567, M-.538. | | |
| 115 | Winchester solid head, slightly bottlenecked case, with very thick head and rim. Outside primed, with cruciform anvil, large center flash hole. Paper patched bullet. O-2.850, C-2.260, R-.635, H-.518, N-.497, M-.464, B-.442. | | |
| 116 | Morse's arch anvil, made for Navy, 1860. Morse patent No. 20,214 of 1858. The Army Ordnance Department made extensive tests and adopted the Morse system for converting muzzle-loaders to breechloaders. Only a few were so altered, however, before the Civil War delayed further work on modernizing for several years. The muskets converted to use the Morse cartridge at Springfield were caliber .69, a few rifles also being converted in caliber .54. These last were | | |

Section III: Rimfire Musket and Carbine Cartridges

<i>No.</i>	<i>Description</i>	<i>No.</i>	<i>Description</i>
120	Caliber .58, for Allen's alteration of Springfield rifle musket. Rimfire, copper case, with 60 grains of powder and 500-grain bullet having small flat tip. Made at Springfield Armory in 1865 and marked on head ".58 CAL." Small radial marks on the head were made by the fixture which spun the cases to distribute the priming composition in the rim. O-1.705, C-1.208, R-.711, H-.633, M-.622, B-.600. [Figure 18.]	126	Caliber .44, bottle-shaped rimfire case, same series, experiment no. 4,1865-66. Charge 45 grains, bullet 350 grains. O-2.022, C-1.138, R-.572, H-.518, N-.518, M-.477, B-.475.
121	Caliber .50, straight case rimfire; made in 1865 at Springfield Armory. Powder 60 grains, bullet 400 grains; head stamped "50 CAL." Three long crimps .500 from case mouth and .224 apart. O-1.893, C-1.472, R-.642, H-.560, M-.512, B-.520. [Figure 19.]	127	Similar, experiment no. 5,1865-66. Charge 40 grains, bullet 300 grains. O-1.710, C-1.010, R-.600, H-.518, N-.517, M-.477, B-.475.
122	Caliber .50, bottleneck rimfire case, made in May 1866 at Springfield Armory. Charge 65 grains, bullet 480 grains. Marked same as no. 121. O-2.095, C-1.333, R-.658, H-.569, N-.565, M-.538, B-.520. [Figure 20.]	128	Similar, experiment no. 6,1865-66. Charge 40 grains, bullet 350 grains. O-1.712, C-.880, R-.648, H-.565, N-.564, M-.460, B-.470.
123	Caliber .45 straight rimfire case, made in May 1866 at Springfield; one of Col. Laidley's experiments. Marked "45 CAL." Charge 65 grains, bullet 480 grains. O-2.939, C-1.829, R-.571, H-.498, M-.475, B-.473. [Figure 21.]	129	Same as last, except 300-grain bullet. O-1.575.
124	Caliber .45, bottle-shaped rimfire case, same series as no. 123. Charge 70 grains, bullet 480 grains. Marked "45 CAL." O-2.451, C-1.574, R-.619, H-.534, N-.530, M-.488, B-.459. [Figure 22.]	130	Caliber .50 straight rimfire case, same series, no. 8. Charge 55 grains, bullet 500 grains. O-2.159, C-1.238, R-.590, H-.502, M-.527, B-.519.
125	Caliber .44 straight rimfire case, same series, experiment no. 2,1865-66. Charge 45 grains, bullet 500 grains. O-2.507, C-1.409, R-.506, H-.453, M-.456, B-.459.	131	Spencer no. 56, caliber .56-56 rimfire, carbine cartridge. About 50,000 made at Frankford 1865-66. Charge 40 grains, bullet 450 grains. O-1.680, C-.910, R-.629, H-.555, M-.554, B-.550. Note that this cartridge entry refers to Ordnance Memorandum no. 14 in which a different cartridge is shown for the FA Spencer—one with longer case and most of the bullet covered, resembling the usual .56-50 Spencer. Two specimens marked "FA" are like no. 131, however, and several cartridges said to have been given to W. C. Dodge at Frankford as samples of their manufacture appear to be identical. The caliber .50 carbine (Spencer and others) cartridge was made experimentally at Springfield Armory in 1865.
		132	Spencer .56-50, made by Leet & Company, 1865. Tested April 1870. Charge 40 grains, bullet 395 grains. Three crimps, .375 from



18(120)

19(121)

20(122)

21(123)

22(124)

FIGURES 18-22.

- | <i>No.</i> | <i>Description</i> |
|------------|---|
| | mouth and .320 apart. O-1.617, C-1.15, R-.642, H-.550, M-.516, B-.506. |
| 133 | Spencer .56-56, made by Smith & Wesson, 1865. Charge 40 grains, bullet 440 grains. Small flat on bullet nose, with center bullet band wider than in other makes. O-1.641, C-.902, R-.646, H-.563, M-.562, B-.546. [I believe this specimen was made by Crittenden, Tibballs & Co., not by Smith & Wesson. The source of error may stem from its being cited under the license and labels of "Smith & Wesson patent."] |
| 134 | Caliber .52 for Sharps and Hankins rifle, as made by Leet & Company, 1865. Charge 55 grains, bullet 460 grains, with round nose, two exposed grooves, and linen patch, secured by boss on bullet base. O-1.754, C-1.154, R-.651, H-.557, M-.554, B-.543. |
| 135 | Caliber .44, for Ballard's carbine, made by Smith & Wesson in 1865. Charge .25 grains, bullet 205 grains. O-1.534, C-.969, R-.505, H-.432, B-.440. Note: some of these are "heel" bullets, the reduced part fitting inside the case mouth, and the larger part being greater in diameter than the case. |
| 136 | Caliber .44, for Henry carbine, by New Haven Arms Company, 1864. Headstamp a raised "H." Charge 30 grains, bullet 210 grains. O-1.374, C-.830, R-.515, H-.443, M-.442, B-.455. |

Section IV: Pistol Cartridges

- | <i>No.</i> | <i>Description</i> |
|------------|---|
| 137 | Inside cap, bolt anvil, single arch, caliber .44. This is for the French Perrin revolver, which was purchased by the U.S. during the Civil War. The nominal size is 11 mm (.438); case length .59. [Figure 23.] |
| 138 | Inside cap, bolt anvil, double arch, caliber .44. This is another French revolver cartridge, for the 12mm (.450) Rafael, also used in the Civil War. No rim or groove on case. Case length .53. [Figure 24.] |
| 139 | Outside cap, solid base, caliber .44. This is F. Alexander Theur's patent for the first alteration of Colt's Army revolver, Model 1860. Front loading was made necessary by the Rollin White patent, controlled by Smith & Wesson. Specimen no. 382 is an inside, cup-primed version of this same cartridge. [Figure 25.] |
| 140 | Outside cap, center flange, caliber .36. This is for the centerfire Crispin revolver. |
| 141 | Outside cap, front flanged, caliber .30, front loading. This revolver cartridge has a primer resembling I. M. Milbank's. [Figure 26.] |
| 142 | Outside cap, square-end case, caliber .36, exposed nipple. A Martin-primed revolver cartridge now occupies this space. (A car- |

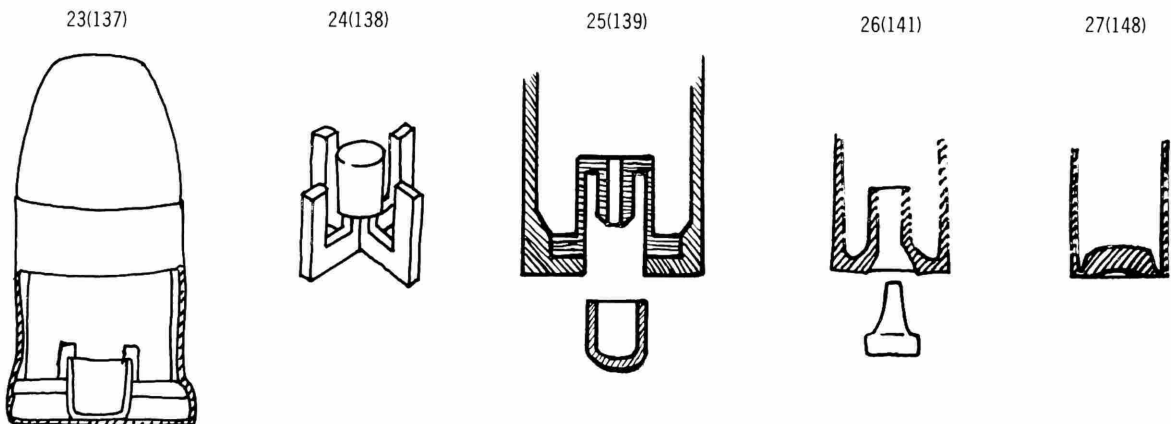

FIGURES 23-27.

<i>No.</i>	<i>Description</i>	<i>No.</i>	<i>Description</i>
	tridge which answers this description is for J. V. Meigs' magazine pistol, caliber .36. L-1.535, C-1.393, straight case .438, no rim, with steel-insert head, having a steel nipple.)		base, front lubricated. Made under the Ellis & White 1859 patent, No. 24726. For Plant's and other caliber .36 revolvers. C-1.118, H-.413.
143	Teat primed, caliber .44 spheroidal base, front lubricated, front flanged. Made under D. Williamson's 1864 patent, No. 41183. This is for the National caliber .45 front-loading revolver. C-1.520, H-.473.	147	Similar, but caliber .30, front flanged. C-.930, H-.305.
144	Teat primed, caliber .36, similar, except flattened teat. Made by National Arms Company, New York, in 1860. C-1.520, H-.329.	148	Rim primed, caliber .24, no flange, solid base, front lubricated. An unknown front-loading cartridge, probably made under the Ellis & White patent, for the system known as cup priming. C-.900, H-.270. [Figure 27.]
145	Similar, with round teat. C-1.268, H-.330.	149	Rim primed, caliber .30, center flange, spheroidal base. This is the caliber .31 Crispin cartridge.
146	Cup primed, caliber .40, no flange, concave		

Fifth Drawer: Foreign and Sporting Cartridges

<i>No.</i>	<i>Description</i>	<i>No.</i>	<i>Description</i>
150	English Boxer Snider, caliber .577; parts and stages of manufacture, showing sealed front cavity in bullet. This is the Mark VII cartridge.		enclosed in the paper base. Used in the Franco-Prussian War of 1872.
151	Assembled round, from components of No. 150, caliber .577, Mark VII Snider. Case usually identified by a single black band, as is the Mark VI, which has the wooden nose plug of bullet exposed.	157	French mitrailleuse, pasteboard with Pottet-type metal head. About caliber .50. Powder 180 grains, bullet 750 grains. The charge is compressed in six short cylinders. There was also a multiple ball load.
152	English Boxer Henry (forerunner of the Martini Henry) caliber .45. Long foil and paper case, with 360-degree cannellure .555 from mouth. Paper-patched 1.283", 480-grain bullet. This case proved too fragile in Service tests. O-3.247.	158	Prussian needle gun, M1872; paper; cylinder choked in front of bullet which is egg-shaped and carried in a compressed paper sabot. This sabot contains the cap in its base. Charge 74 grains, bullet 325 grains. O-2.20.
153	Same, foil only; bullet 1.265".	159	Same, but with explosive bullet having a percussion element in front. Charge 70 grains, bullet 431 grains, this cartridge has yellowish paper and is about .125 longer than the ball round; O-2.33 from base to tie string.
154	English Boxer Henry, caliber .45 (Martini Henry). Bottle-shaped foil case. Charge 85 grains, bullet 484 grains. Tested by Small Arms Caliber Board in 1872, being No. 51 of their report. Cupped wad under bullet. The Mark II cartridge.	160	Prussian new metallic; solid base, flange similar to Berdan type, with the powder space extending to the rear of flange. Paper-patched 438-grain bullet with round nose. This is the M1871 Mauser cartridge. That for M1871/84 had a flat-nosed bullet. [Figure 28.]
155	Similar, shortened, as made by Eley Brothers, for the Martini Henry caliber .45 carbine. The Mark I carbine cartridge.	161	Russian, made in Russia; phosphor bronze case (reddish); with Berdan anvil. Charge about 80 grains, bullet about 375 grains, patched. Lubricant at first a disk on bullet base. O-2.958, C-2.260.
156	French Chassepot paper cartridge (more often made of paper and silk), caliber .43 (11-mm). Charge 74 grains, bullet 388 grains. The cap is covered by a thin metal disk, in turn		

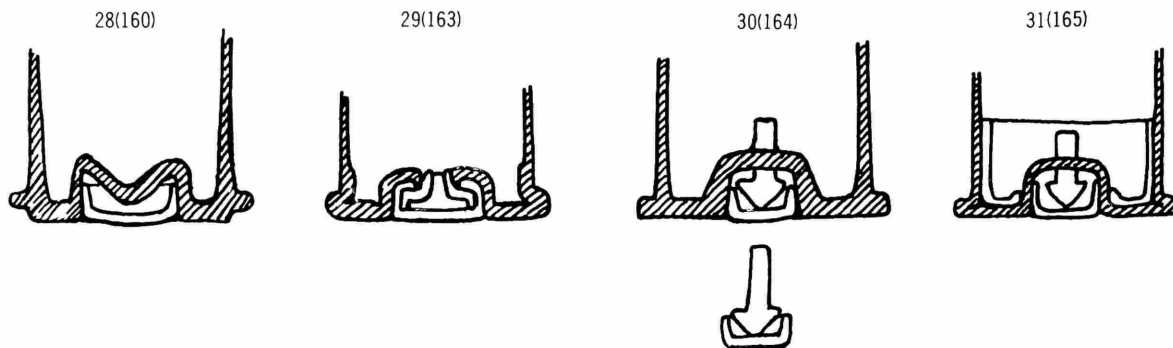

FIGURES 28-31.

- | <i>No.</i> | <i>Description</i> | <i>No.</i> | <i>Description</i> |
|------------|--|------------|--|
| 162 | Same, by Union Cartridge Company. Brass case, caliber .42. Charge 77 grains, bullet 373 grains, paper-patched, with lubricant disk on base and also dipped. O-2.978, C-2.256. | | |
| 163 | Austrian "Werndl," copper case; copper annular anvil in outside pocket, caliber about .44 (11.36-mm). Charge 65 grains, bullet 318 grains. Fired by Small Arms Caliber Board in 1872, and No. 53 of their report. O-2.396, C-1.643 (41.34-mm). Head marked "iv 1870 GR." [Figure 29.] | | |
| 164 | Dutch Beaumont rifle musket, caliber .45 (11.4-mm). Solid brass head, pocket cap, and anvil. Anvil has protruding extension through flash hole to use in knocking out the fired cap for repriming. Powder 68 grains, bullet 337 grains, caliber board test No. 31. O-2.407, C-2.004 (50.9-mm), B-.455 (11.6-mm). [Figure 30.] | | |
| 165 | Dutch carbine, caliber .45 (11.4-mm). Brass case with folded head and reinforcing cup; anvil similar to No. 164. Charge 50 grains, bullet 337 grains, with one wide and one thin cannellure. O-2.260, C-1.750 (44.5-mm). [Figure 31.] | | |
| 166 | Swiss, caliber .41, copper cased rimfire cartridge, as first used in the Milbank-Amsler conversion of small-bore Swiss muzzle-loading rifles, M1863/67. Later used in the bolt-action Vetterli rifle. Charge 60 grains, bullet 312 grains. Caliber Board No. 52. Head marking "T." O-2.200, C-1.498, R-.613, H-.536, N-.512, M-.434, B-.430 (10.9-mm). | 167 | Berdan sporting, for shot; return pocket and anvil, center flash hole plus four punctures, cap primed. Brass case, without head marking. Made by U.S. Cartridge Company. |
| | | 168 | Eley sporting, for shot. Pocket and anvil, cap primed. Pasteboard, with metal base. No. 12 (= 12 gauge). |
| | | 169 | Same, but No. 20 (= 20 gauge). |
| | | 170 | Same, except Le Fauchaux (pinfire) priming; No. 10 (= 10 gauge). |
| | | 171 | Leet sporting, for shot. Pocket and anvil, cap primed. Pasteboard, reinforced with metallic foil near metal base. Marked "C. D. LEET, SPRINGFIELD, MASS." |
| | | 172 | Same except pinfire. |
| | | 173 | Same as No. 171, except whole case reinforced with brass foil, plus 7/8-inch cardboard cup at base. |
| | | 174 | Le Fauchaux (pinfire) pistol cartridges, three calibers. |

Sixth Drawer: Modification of Charge

Caliber .50 Cartridges

During the period when most of these cartridges were being developed, the tendency was toward ever decreasing calibers and higher velocities. Un-

der these circumstances, the length of the powder charge became a critical matter. As it was of greatest importance to diminish the length of the powder

column, both to facilitate manufacture and to assure uniform ignition, extensive experiments were conducted at Frankford Arsenal. It had already been established that compressing the powder column would not give satisfactory ignition unless a central hole or some other means was provided to get the flash of the primer to the powder uniformly and rapidly. Tests were made to determine the effect of different degrees and kinds of compression, as well as the best method of perforating the charge. Because dense and light musket powders were found to act differently, two makes, Hazard's (densest and most highly glazed) and Oriental (lightest and dull-est), were selected and prepared. DuPont's rifle powder was tried in one series. It appeared that the depth to which compression penetrated diminished rapidly, hence the final cylinder of powder was densest next to the end where movement had been applied.

Three systems of compression were tried, cylinders compressed from the rear, from the front, and from both ends. Two ignition systems were compared, first a cylindrical hole entirely through the powder, of about 0.25 of-an-inch at its base, and second, a hole extending about nine-tenths of the powder length from the rear. This means of ignition, investigated by Ordnance, had also been tried by Colonel G. M. Boxer in his Snider cartridge (see p. 8). The exterior of the compressed powder had to conform to that of the cartridge case with enough clearance to allow for manufacturing variables. With this clearance allowance and the hole, enough powder space was wasted so that considerable compression was required just to equal the old loose charge. As the two types of powder compressed differently, adjustment was made in the cavity to equalize density. Charges were diminished by tenths of an inch, from 1.17 inch, the Service length, to 0.87 inch. Oriental powder being that used in the Service cartridge, was used for the first series of tests. Hazard's was used in the second, eliminating from the second series the fourth degree of compression, that having been found of no value in the first series.

It was found that compressed powder gave more uniform velocities, compression at both ends being preferred. The perforated charge was the best. Though some advantage was found with compressed charges, the expected reduction of length did not materialize, as the perforation and clearance used

up most of the space saved. Pressures and velocities both increased with compression, the former at a considerably higher rate. Considering these disadvantages and the added trouble in loading, the compressed charge idea was dropped. The British government, in 1888, used a compressed perforated charge of black powder in its first caliber .303 cartridge, in an attempt to attain maximum performance in a rather small case. Availability of newly developed smokeless powders made further efforts with black powder futile.

Pressure for these tests was determined by the Rodman pressure plug, the breech mechanism being tapped on the upper surface, about in the center, to receive the pressure piston fixture (Figure 32). Each cartridge intended for pressure test had a round opening in its side, temporarily covered with paper. This came opposite the opening of the pressure apparatus in the top of the chamber, the cartridge requiring indexing in loading.

With the earlier rimfire cartridges, this opening was made concentrically in the base of the case. Then the piston was in prolongation of the bore to the rear, in a solid housing which replaced the breech mechanism. In this arrangement it was necessary to unscrew the breech to load, then screw it up again. This system was very troublesome when using a fixed rest, while taking both pressure and velocity from the same shot. But the most serious objection was that it could not be used with center-fire ammunition.

In the sixth drawer, the first four specimens (nos. 175-178) are small bottles of the powder types used, Oriental, Hazard, and DuPont musket powder, and DuPont rifle powder, each protected by a cartridge case. The last five cartridges (nos. 240-244) show "patent" powders submitted by Sleeper and Gomez. Of these, numbers 240-243 vary only in the size of the charge; 15, 20, 25, and 30 grains respectively. The remaining space is taken up by cardboard wads. Number 244 is loaded with Gomez' "iron powder," in 20-grain pills. These were detonating, or very fast powders, placed between rolls of paper strip or with some other sort of arrangement to delay burning. These were tried in Europe but not adopted, as a small overload would burst the gun.

In the main series of cartridges (nos. 179-227), the only practical differences that can be observed are the method of priming and the case lengths. There is a perceptible difference in the appearance

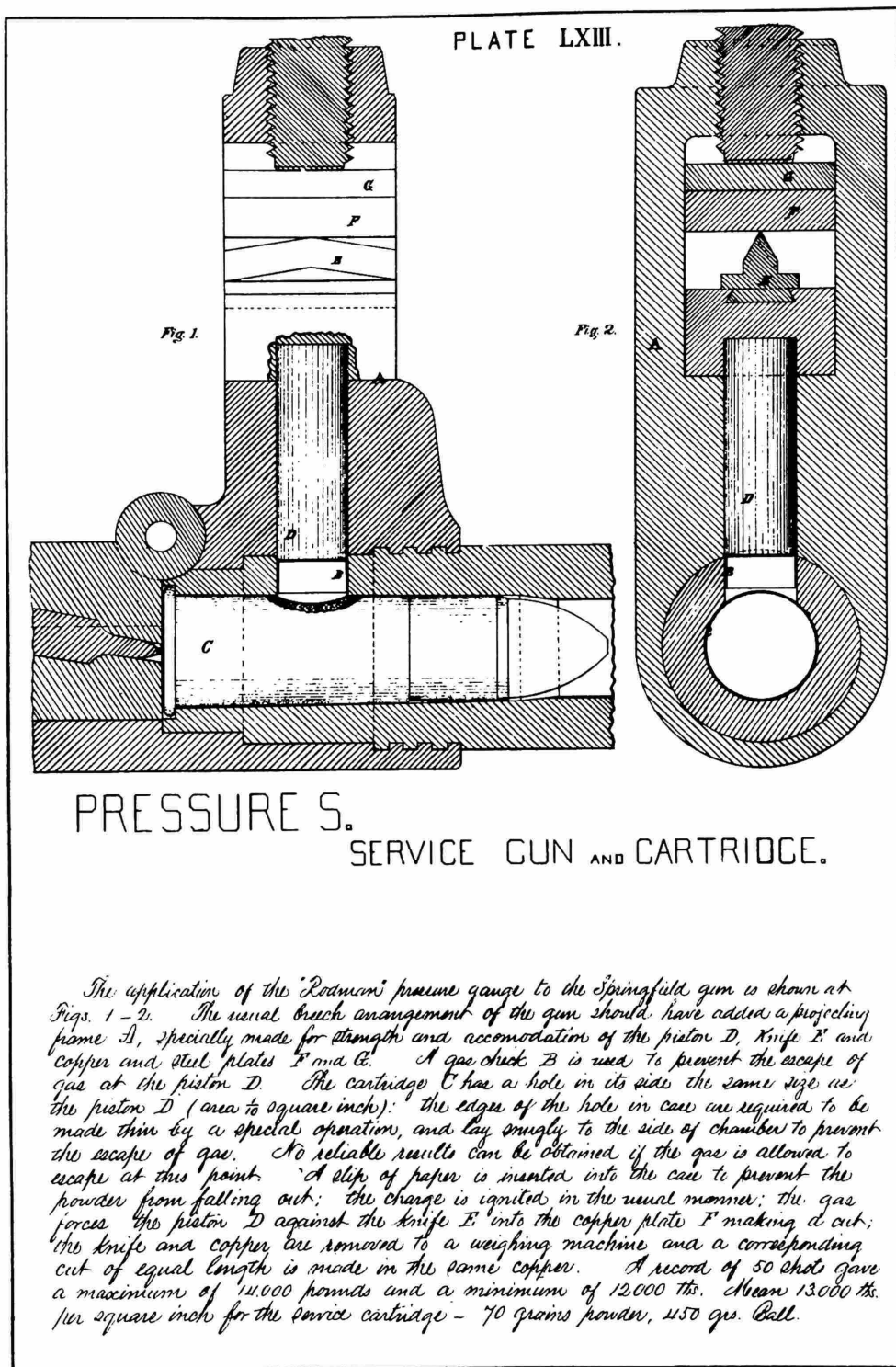

H. PETERS, PHOTO-LITHOGRAPHER, WASHINGTON, D. C.

FIGURE 32.

of the compressed powder, the dense Hazard powder retaining its granular appearance under compression, whereas the Oriental powder broke up considerably, with an appreciable proportion reduced to dust. This, however, is believed to be of only academic interest. Seven different case lengths and seven corresponding powder cylinder lengths (all 70 grains) are involved in numbers 179 to 227, all of them centerfire, inside-primed copper cases, with tinned-iron cup anvil. Thus there are really only seven distinct varieties identifiable as complete rounds, and one of these is the standard Service-length cartridge, varying only in the compressed charge inside. This form of charge can be detected in an x-ray photograph.

The tests of compressed powder for the main series were reported on 28 March 1870. The next series of specimens, numbers 228 to 239, are copper rimfire cartridges, loaded with powder having various degrees of compression. These have all been prepared for pressure tests by having a .375-inch hole made in the base, and covered with paper before loading. There are two series of six different case lengths each, varying only in the powder granulation.

No.	Description
179-182	Loaded with Oriental powder, perforated and compressed from the front. Powder lengths 1.17, 1.07, .97, and .87 inches, and case lengths 1.75, 1.65, 1.55, and 1.45 inches respectively. [Figure 33.]
183-186	Same as last, but compressed from the rear; same lengths.
187-190	Same, but compressed from both ends; same lengths.
191-194	Oriental powder, with conical rear cavity, compressed from front; same lengths. [Figure 34.]



FIGURES 33-34.

No.	Description
195-198	Same as last, but compressed from rear cavity, same lengths.
199-202	Same, but compressed from both ends; same lengths.
203-205	Hazard's powder, perforated, and compressed from front. Powder lengths 1.17, 1.07, and .97 inches; case lengths 1.75, 1.65, and 1.55 inches, respectively.
206-208	Same, compressed from rear; same lengths.
209-211	Same, compressed from both ends; same lengths.
212-214	Hazard's powder, conical rear cavity, compressed from front; same lengths.
215-217	Same as last, but compressed from rear; same lengths.
218-220	Same, but compressed from both ends; same lengths.
221-227	DuPont's rifle powder, compressed from rear, perforated. Powder lengths 1.17, 1.12, 1.07, 1.02, .97, .92, and .87 inches. Corresponding case lengths are: 1.75, 1.70, 1.65, 1.60, 1.55, 1.50, and 1.45 inches. This short series with rifle powder was tried for comparison with the others.
228-233	Hazard's FFG powder, 70 grains, compressed in the case, varying in the amount solidified from .05, .1, .15, .2, .25, and .3; and in corresponding case lengths of 1.67, 1.57, 1.52, 1.47, and 1.42 inches.
234-239	Same, except FFFG powder; same compression and case lengths. Obviously only the six different case lengths can be distinguished. These last tests were fired on 3 September 1870.

No.	Description	No.	Description
240-243	Sleeper's chlorate powder, 15-, 20-, 25-, and .30-grain charges.		three pills (as illustrated from General John Pitman's notes, n.d.) superimposed upon the empty cartridge case which is in the collection.
244	Gomez' iron gunpowder, 20-grain pills. Plate 32s shows the original charge of		

Seventh Drawer: Modifications in Bullet and Lubricant

Specimens numbered 245 through 291 show the details of various experimental bullets and lubrication systems tested in the centerfire caliber .50 Service cartridge. Numbers 292 through 310 were listed as "vacant" spaces in the original exhibit. Presumably, these were left vacant to allow spaces for future specimens at later exhibits. Many of these bullets vary only in the part covered by the case. In order to facilitate identifying cartridges thought to be from this series, the external differences are tabulated before listing the specimens.

Case variants

Standard 1.760-inch copper cases: nos. 245-247, 250-253, 255-259, 261-264, 271-273, 275-277, 279-290. Shorter than standard case: 1.725 inch: no. 278; 1.749: no. 246.

Longer than standard cases: 1.840: no. 248; 1.850: nos. 267, 274, 276; 1.860: nos. 268, 269; 1.890: no. 291; 1.940: no. 266; 1.960: nos. 249, 251, 254, 260, 265, 270.

Primer variants

Tinned iron bar anvil: nos. 245-246, 262-264, (Indents .105" from base).

Copper cup anvil: nos. 261, 279, 289-291 (Indentations .2" from head); 274-275, 278, 284-288 (Indentations .25" from head); all indents are .21" apart.

Tinned iron cup anvil: all others.

No.	Description	No.	Description
245	Bullet used in most bar anvil ammunition up to 1868.		under the bullet, added to the usual lubrication in the cannelures.
246	Experimental bullet with cannelure deepened to .04 inch to hold more lubricant. O-2.190, 1867.	250	Same, without the lubrication in cannelures.
247	Experimental bullet with cannelures deepened to .045, 1867.	251	Experimental front lubrication case, projecting on the front of bullet. Space filled with lubricant in addition to that in cannelures.
248	Bullet determined by Lt. Stockton's experiments. Used in Service from March 1868 to July 1870.	252	Experimental star patch of banknote paper, covering base and cylindrical surfaces of bullet; lubricant in cannelures.
249	Experimental, a disk of lubricant with wad	253	Similar, plus a disk of lubricant at base of bullet.
		254	Similar, but the base disk applied <i>outside</i> the patch.
		255-257	Experimental wrapped patch of banknote paper instead of star patch. These three correspond to numbers 252-254, except for type of patch.
		258	Experimental, the diameter of the bullet reduced by .005 inch.
		259	Experimental, the bullet hardened by addition of one-twelfth tin. (Note: The bullets with extra tin added have retained a clean bright surface, while the others have oxidized or darkened perceptibly).
		260	Experimental bullet, smooth, with lubricant in disk on base; wrapped patch.
		261	Similar, but smooth ellipsoidal bullet nose.
		262	Experimental bullet, smooth, hardened with one-twelfth tin, patched and lubricated with wax disks and wads, like the earlier Martini-Henry.
		263	Experimental bullet, with two broad cannelures (Benet) instead of the usual three narrow ones.
		264	Same, except lightened by 40 grains by cavity in base.
		265	Same, but lengthened to 2½ calibers (1.250), the weight preserved at 450 grains by base cavity.
		266	Same as last, but hardened by one-twelfth tin.

<i>No.</i>	<i>Description</i>	<i>No.</i>	<i>Description</i>
267	Like No. 265, except 2¼ calibers (1.125), 450-grain bullet. O-2.345.	281	Experimental; Weeks bullet No. 1; conoidal frustum on cylinder; three bearing rings, lubricated by greased wrapped patch.
268	Same, tin added.	282	Same, but No. 2; two bearing rings, lubricated by circular greased patch.
269	Like No. 267, except diameter reduced by .01 inch, 450 grains.	283	Same, but No. 3; smooth bullet.
270	Same, tin added.	284	Experimental carbine, reduced from rifle musket, 450 grains to 430 grains, by conoidal cavity in base.
271	Experimental sectional bullet (Farley's); front of bullet dowelled into rear; lubricant between sections.	285	Same, except reduced to 415 grains. Fired with various charges.
272	Similar, except rear of bullet dowelled into front. (Neither of these worked well.)	286	Same, but reduced further, to 400 grains. Various charges.
273	Experimental bullet; a conoidal frustum on a reduced conical frustum, flushed with lubricant. Bullet 1.0.	287	Same, reduced to 385 grains. Various charges.
274	Similar, 1.1 inches long.	288	Experimental carbine, reduced from 450 to 415 grains by making the front ellipsoidal. Fired with two different charges.
275	Experimental bullet; imitation of Swiss "Federal" bullet, Service weight, lubrication in cannellures.	289	Same, but reduced to 430 grains. Fired with two different charges, that of 55 grains being adopted as the standard carbine load, in 1872.
276	Resembling the Service bullet, but diameter ahead of front cannellure equal to the general diameter, the reduction to be effected by crimping the case. Used in Service ammunition from 21 July 1870.	290	Experimental; Hubbell's adaptation of the Prussian needle-gun bullet and sabot to metallic case. Fired with slight modifications, in three forms. A similar bullet-sabot combination was tried in the .45-70 cartridge.
277	Experimental Roberts bullet; blunt ellipsoidal front, broad shallow cannellure, and cavity in base. Lubrication in cannellure.	291	Experimental gas-check bullet; substantially like the Service, but made with an extension or lap around mouth of case, outside.
278	Experimental; Dimmick bullet No. 1; frustum of a conoid on frustum of a cone.	292-310	Vacant.
279	Same, but No. 2; frustum of a cone on a cylinder, two cannellures.		
280	Same, but No. 3; shallow dished cavity in base.		

Eighth Drawer: Anvils and Cap-primed Cases

Section I: Disk and Bar Anvils

(Standard 1.750 copper case unless otherwise noted).

<i>No.</i>	<i>Description</i>
311	Center swell-base; copper disk anvil, two vents; short .969-inch copper case. Charge 40 grains, bullet 450 grains. FA 1865. [Figure 35.]
312	Iron disk anvil, chamfered and crimped into flange; 360-degree ring crimp at base. Anvil has slot vent. Springfield, 1867. C-1.780. [Figure 36.]
313	Broad bar anvil, iron, chamfered and crimped into flange. Same crimp as last. Slot vent. Springfield, 1867. C-1.770. [Figure 37.]

<i>No.</i>	<i>Description</i>
314	Martin bar anvil, reinforced; tinned iron anvil with Benton's reinforce, held in place by two indents, .092 inch from base to center, .480 inches between ends of indents. Springfield, 1867. O-2.270, C-1.762, R-.668, H-.568, M-.544. (First made at Springfield in 1866, but without the reinforcing cup.) [Figure 38.]
315	Similar to no. 314, but as made at Frankford for Service use from October 1866 to March 1868. No reinforce. Indents .110 from base and .480 between, and the mark made by crimping tool edge is wider. Bullet 450 grains, with three cannellures. O-2.262,

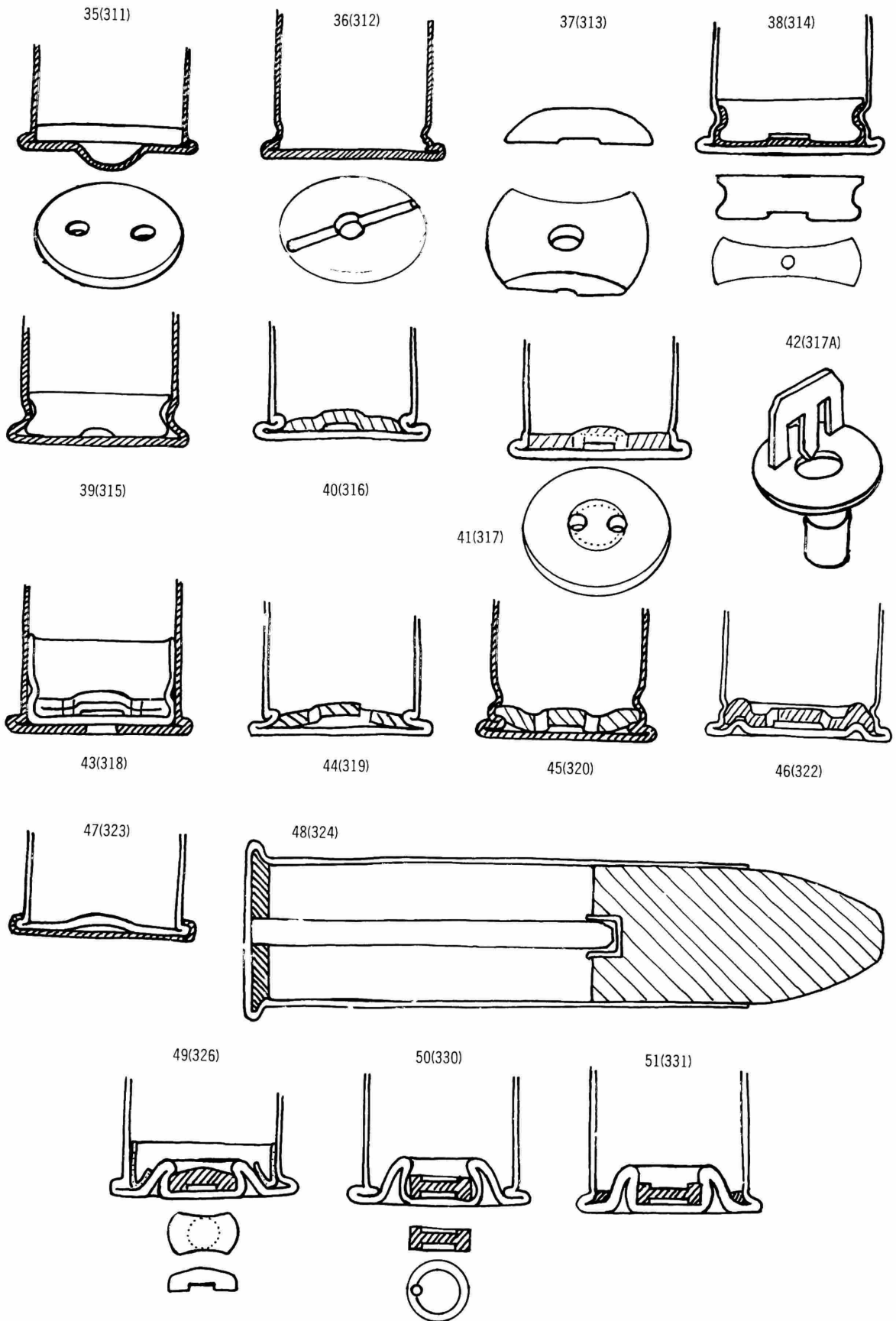

FIGURES 35-51.

- | <i>No.</i> | <i>Description</i> | <i>No.</i> | <i>Description</i> |
|------------|--|------------|--|
| | C-1.765, R-.667, H-.565, M-.540. [Figure 39.] | | flange. Case 1.775, reduced at front. Frankford, February 1872. [Figure 47.] |
| 315A | Variant, as used in Service. Appears to be a little longer overall than no. 315-2.284 vs 2.262—the latter having the bullet in no. 245, the former that of no. 248. O-2.284, C-1.785, R-.650, H-.563, M-.542. | 324 | Needle, or disk and bolt, anvil. Primer in base of bullet. Disk held by fold at head. Bolt is iron and pointed like a firing pin. Disk is brass. Looks like a rimfire cartridge. C-1.768. [Figure 48.] |
| 316 | Copper bar anvil, chamfered ends held by re-entrant fold, seen as ring at base. Springfield, 1870. C-1.783, R-.659, H-.565, M-.540. [Figure 40.] | 325 | Like last, but bolt squared up in front, like winding arbor. Frankford Arsenal. The first type tried, with a round bolt, simply flattened at the end, gave poor ignition. These cartridges can be distinguished from rimfires by their attraction to a magnet, but they cannot be told from each other by external characteristics. |
| 317 | Copper disk anvil, plain square edges, held in by indents .110 from base and .264 between. Frankford, August 1871. C-1.775, R-.665, H-.564, M-.545. [Figure 41.] | 326 | Martin primer pocket, made by a complex fold of the head. Short wide copper bar anvil, held in place by fold of pocket. Head has plain fold (not re-entrant). Inside reinforcing cup. Springfield—the original Martin primer cartridge. O-2.234, C-1.739, R-.672, H-.564, M-.542. [Figures 49.] |
| 317A | There is a variant of no. 317, in which the disk is beveled towards the rear. Indents are .100 from head and .259 apart. The head shows a pronounced ring opposite the disk chamfer, about .530 in diameter. Frankford, August 1871. C-1.785, R-.658, H-.563, M-.542. [Figure 42.] | | There was trouble with the head of this type cartridge. Tooling slightly out of adjustment would compress the flange too tightly. Then when fired, the case would fail at the rim, the crimped bullet sometimes pulling the case off the head, dragging it into the rifled part of the bore, and requiring considerable work to extract it. The same thing could be caused by defective metal. As this sort of defect could not be found in inspection testing short of firing several thousand rounds to find one bad case, the manufacture of this type case for Service use was terminated at Frankford in December 1871. |
| 318 | Copper disk anvil in reinforcing cup, both held by two large stab crimps .125 from base. One of Col. Treadwell's experiments with gas checks. The head has a .125 hole to increase sensitivity over the primer area. C-1.750. [Figure 43.] | 327 | Similar, but without reinforcing cup. Anvil either copper or tinned iron. Springfield, 1869. O-2.245, C-1.760, R-.667, H-.563, M-.542. |
| 319 | Copper disk anvil, chamfered, held in by re-entrant fold, seen as ring at base. Frankford, October 1871. C-1.757, R-.663, H-.568, M-.544. [Figure 44.] | 328 | Same, except brass case. Springfield, 1869. O-2.261, C-1.740, R-.663, H-.526, M-.548. |
| 320 | Copper disk anvil, expanding, held in by indents .154 from head and .180 between. Head shows ring .360 in diameter. Frankford, 1871. C-2.780, R-.664, H-.560, M-.543. [Figure 45.] | 329 | Same, with re-entrant fold above flange. Copper bar anvil, copper case. Springfield, 1870. O-1.143, C-1.760, R-.657, H-.565, M-.548. |
| 321 | Copper disk anvil, expanding, held in by knurl all around; has fold underneath. The 360-degree crimp is .155 from base, case reduced at front. Frankford, October 1871. | 330 | Same, but with double-indented copper disk anvil. Made at Frankford for Service |
| 322 | Copper disk anvil, corrugated, held in by knurl all around, .105 from base, which is corrugated. Frankford, September and October 1871 for test and Service. C-1.780, R-.659, H-.565, M-.542. [Figure 46.] | | |
| 323 | Covered base anvil, primed outside of base, priming covered by a flat cap embracing | | |

- | <i>No.</i> | <i>Description</i> |
|------------|---|
| | use from November to December 1871. The usual Martin-primed .50-70. O-2.265, C-1.755, R-.653, H-.563, M-.541. Deeper cup than in no. 329, hence appears to have more space around "button" at head. Rim tends to be a little thicker than in no. 329-.060 vs .050. [Figure 50.] |
| 331 | Martin pocket, single-fold head, reinforced with solder in flange. Frankford, 1872. C-1.739, R-.667, H-.563, M-.544. [Figure 51.] |
| 332 | Martin pocket, closed down without anvil. Frankford, 1873. C-1.750, R-.662, H-.574, M-.547. |

Section II: Cap-primed Cases

- | <i>No.</i> | <i>Description</i> |
|-----------------------------|--|
| Numbers 333 and 334 vacant. | |
| 335 | Benet narrow pocket saddle anvil, with small (.186 inch) cap. Short copper, folded-head case. Bullet similar to that used in the Service carbine. Single flash-hole at side of pocket. Frankford 1866. O-1.575, C-1.114, R-.644, H-.559, M-.556. [Figure 52.] |
| 336 | Similar, but brass case with larger (.245") primer, same bullet. Frankford, 1866. O-1.583, C-1.065, R-.656, H-.559, M-.562. |
| 337 | Solid nipple head; iron nipple in pocket in solid brass base of short brass case. Frankford, 1865. C-1.318. [Figure 53.] |
| 338 | Crispin foil and paper; pocket pressed in brass cup attached to base of wrapped case. Different thicknesses of foil tried, using different color paper—yellow and green have been noted. Service bullet, having one canelure exposed. Height of base .300. Frankford, 1867. O-2.245, C-1.532, R-.653, H-.561, M-.530. [Figure 54.] |
| 339 | Laidley arch anvil; iron "H" anvil reaching to bullet. Springfield 1866. Resembles rimfire cartridge. O-1.832, C-1.326, R-.666, H-.563, M-.528, B-.502 (ahead of crimp). [Figure 55.] |
| 340 | Laidley capped bar; inside cap on an arched iron bar, held in place by narrow indents, about .150 from base. Springfield, 1866. C-1.769. [Figure 56.] |

- | <i>No.</i> | <i>Description</i> |
|------------|--|
| 341 | Star cap receiver; inside cap and anvil contained in a star-shaped pocketed receiving plate. The base plate is held in position by the rim fold. Looks like rimfire cartridge superficially. Frankford, 1866. O-2.248, C-1.765, R-.662, H-.561, M-.545. [Figure 57.] |
| 342 | Cup cap-receiver; inside cup and anvil, contained in a pocket of the brass reinforcing cup. Cup held by two stab crimps .179 from base. Made at Frankford, February 1872. C-1.775, R-.667, H-.563, M-.546. [Figure 58.] |
| 343 | Reinforced pocket, brass case. Cup reinforce held in by pressing back the primer pocket, which is a separate piece from head. Frankford, 1872. C-1.757. [Figure 59.] |
| 344 | Plate flanged; brass base held on by a separate clinched primer pocket. This pocket is heavy brass, inserted from inside and clinched outside. Outside cap with spear-shaped anvil. Bottleneck brass case with paper-patched bullet. Frankford, 1872. O-3.014, C-2.365, R-.574, H-.500, N-.483, M-.439, B-.414. [Figure 60.] |
| 345 | Similar, except held together by primer pocket, inserted from outside and clinched on inside. Frankford, January 1872. [Figure 61.] |
| 346 | Wrapped brass metal foil, soldered into pocketed base cup. Outside cap and spearhead anvil. Base cap .288 inch. Frankford, January 1872. C-1.780. |
| 347 | Front ignition; wrapped brass foil case, soldered into brass base cup .310 inch high. Primer pocket extended nearly to bullet. Outside cap and bolt anvil. Frankford, 1872. C-1.940, R-.665, H-.562, M-.534. [Figure 62.] |
| 348 | Front ignition; copper case, pocketed for cap and spearhead anvil. The pocket prolonged in a small tube, nearly to the bullet. Base filled with solder. Frankford, 1872. C-1.759, R-.662, H-.561, M-.540. [Figure 63.] |
| 349 | Treadwell cube anvil; brass case, reinforced with inside ring. Pocketed for outside cap containing a cubical anvil. Plain flat head. Frankford, 1872. C-1.767, R-.667, H-.565, M-.540. |

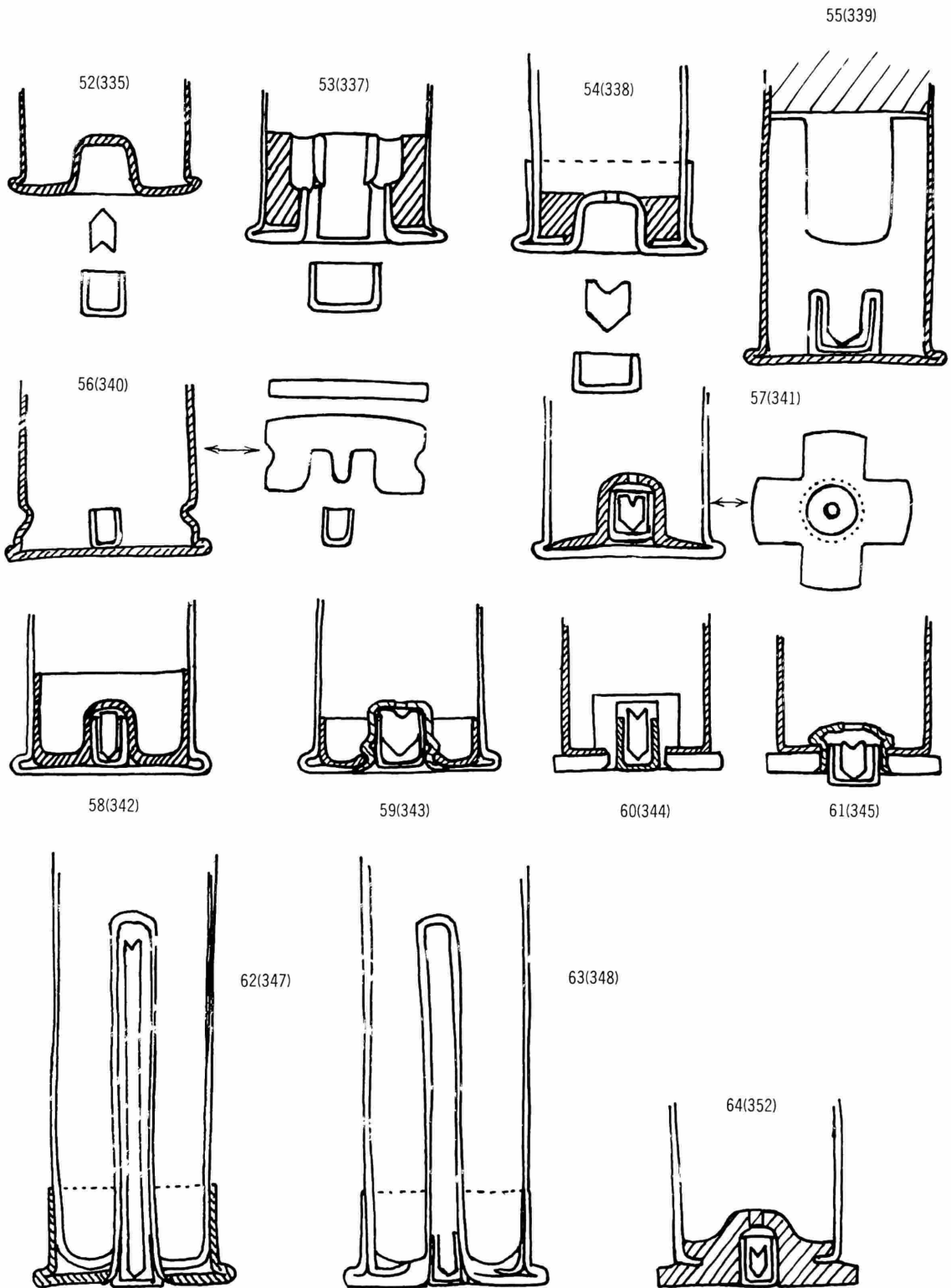

FIGURES 52-64.

- | <i>No.</i> | <i>Description</i> |
|------------|--|
| 350 | Same, except head reinforced with solder, without ring. No external means to distinguish between these last two. |
| 351 | Treadwell spherical anvil. Case reinforced with solder in flange. Pocketed for outside cap and spherical anvil. Frankford, 1872. Same as last two and indistinguishable from them externally. |
| 352 | Cast base; wrapped brass case, with soft metal base cast on. Pocketed for outside cap and spherical anvil. C-1.819, R-.667, H-.559, M-.545. [Figure 64.] |
| 353 | Berdan base, with typical Berdan pocket and reinforcing. Appears to be gliding metal case. Frankford, 1872. C-1.740, R-.667, H-.564, M-.540. |
| 354 | Berdan anvil, wrapped metal (appears to be gilding metal); base cup with pocket and Berdan return anvil. Usual reinforcing ring replaced by the wrapped metal and solder. Base cup .322 inches high. Frankford, 1872. C-1.792, R-.664, H-.560, M-.543. |

Section III: Cup Anvils

- | <i>No.</i> | <i>Description</i> |
|------------|--|
| 355 | Tinned cup anvil; straight case. Held in by crimps or indents, .255 from base and .186 apart. Service cartridge from March 1868 to September 1869. Frankford. O-2.236, C-1.760, R-.669, H-.563, M-.547. [Figure 65.] |
| 356 | Tinned cup anvil; cylindrical, slightly throated (.010) or necked case. Tinned cup held in by two crimps .255 from base and .186 apart. Service cartridge from September 1869 to August 1870. From this date, the standard case retained this .01 reduction, about .575 from mouth. Frankford. O-2.242, C-1.766, R-.665, H-.564, M-.533. |
| 357 | Side-vent, iron cup anvil (no hole in center), flutes leading from priming to sides. Cup shown below no. 355 is photo of eighth drawer. Cup held by indents. Indistinguishable externally from no. 356. |
| 358 | Copper cup anvil; substituted for tinned iron. Held by crimps .257 from base and .214 apart. Service cartridge from August 1870 |

- | <i>No.</i> | <i>Description</i> |
|------------|--|
| | to November 1871. Frankford. O-2.268, C-1.764, R-.663, H-.564, M-.544. |
| 358- | Cups of various materials and vents. Experimental. Frankford December 1870. [Plates 15, 38j, 45k.] |
| 359 | Corrugated base, copper cup anvil. Annular depression near edge of base. Springfield and Frankford, October 1870. |
| 360 | Plain base; double-crimped copper cup anvil; 360-degree crimp above cup .255 from base. |
| 361 | Corrugated base and double crimp .273 from base, combining characteristics of last two. Flatter bullet nose than no. 360. O-2.254, C-1.760, R-.670, H-.565, M-.545. |
| 362 | Corrugated base with indents in front of cup instead of crimp, .241 from base and .178 apart. Springfield and Frankford, November 1870. |
| 363 | Reduced case, copper cup anvil; held by reducing case diameter in front of it by .02 inch. Frankford, December 1870. O-2.274, C-1.769, R-.660, H-.566, M-.533. |
| 364 | Reduced case, copper cup anvil; similar to last, but reduced only .01 inch. Frankford, January 1871. |
| 365 | Shallow copper cup, reduced in depth and held by two crimps .197 from base and .175 apart. Service cartridge from December 1871 to January 1872. Frankford. O-2.291, C-1.765, R-.667, H-.564, M-.540. |
| 366 | Solder reinforce to copper cup anvil. Ring in head makes trough for solder on inside. Two crimps .210 from base and .192 apart. Frankford, January 1872. O-2.291, C-1.785, R-.665, H-.564, M-.540. |
| 367 | Cup anvil, with re-entrant fold at head as used on Martin cartridge. Reinforcing cup between cup and head. Cup held by 360-degree crimp .324 from base. Bottleneck copper case, caliber .45. Springfield, January 1872. [Figure 66.] |
| 368 | Solid head, copper-cup anvil. Flat head with square rim; cup held by two wide crimps .264 from base. Frankford, 1868. C-1.786. [Figure 67.] |
| 369 | Double case copper cup anvil, reaching to bullet. Looks like a rimfire externally. Single center vent. (A variant case is shorter and has two vents at sides of primer.) Frank- |

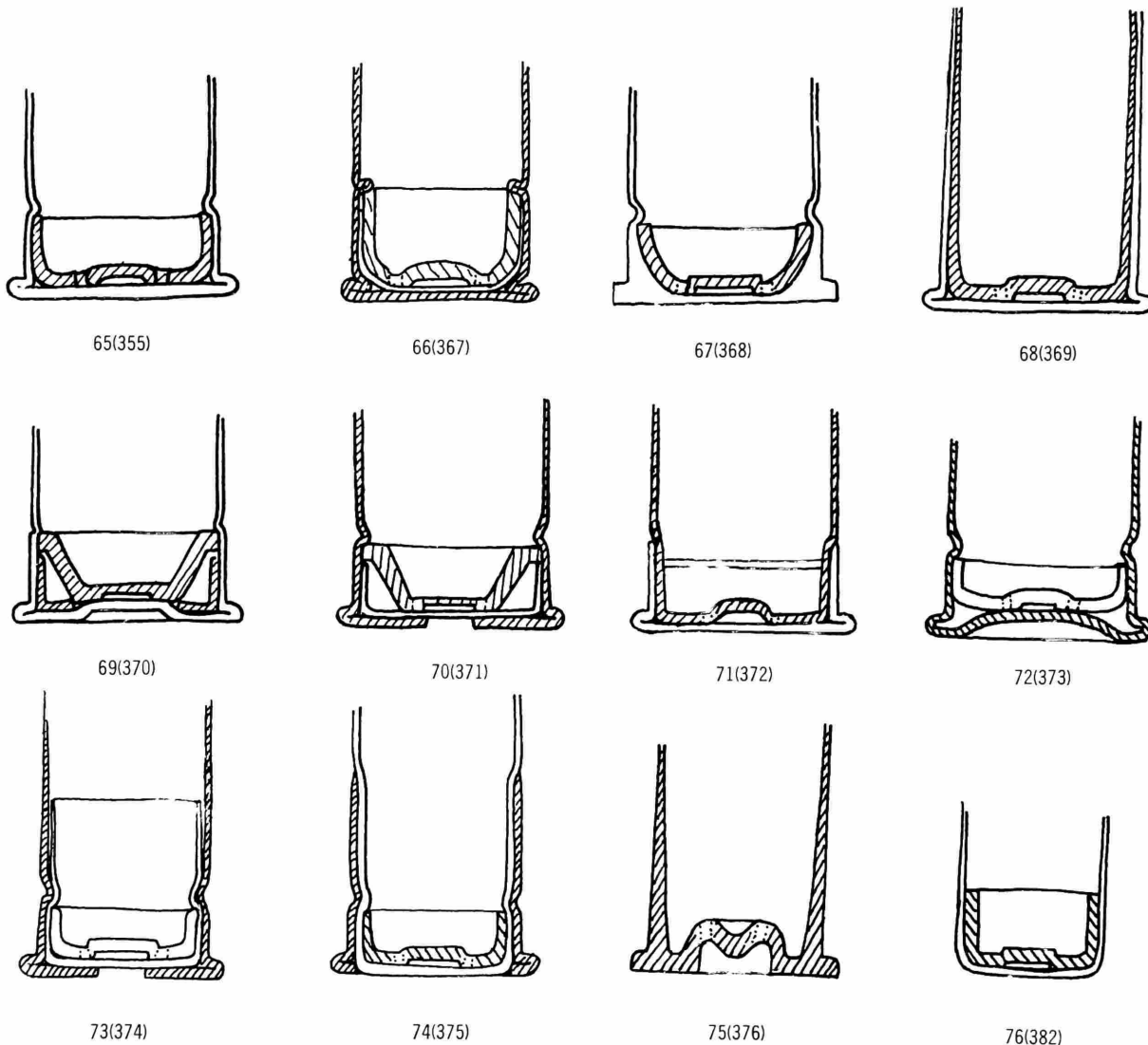

FIGURES 65-76.

- | <i>No.</i> | <i>Description</i> |
|------------|---|
| | ford, January 1872. O-2.212, C-1.782, R-.665, H-.565, M-.542. [Figure 68.] |
| 370 | Brass cone cup anvil; reinforcing cup between anvil and head. Center of head has .225 indent opposite priming. Cup held by two crimps .287 from base and .200 apart. Frankford, January 1872. C-1.760. [Figure 69.] |
| 371 | Similar to last, but has hole through base instead of indent. [Figure 70.] |
| 372 | Outside cup; case itself the anvil. Priming inside, covered by a .275-inch flanged cup. |

- | <i>No.</i> | <i>Description</i> |
|------------|---|
| | Frankford, 1872. C-1.804. [Figure 71.] |
| 373 | Copper cup, held against concave base, which yields on firing. Cup held by two wide crimps .264 from base and .225 apart. (This was also made in .45-70 size.) Frankford, June 1872. C-1.760. [Figure 72.] |
| 374 | Treadwell open base, double cup, as made for .45 caliber. Brass case. Copper cup anvil inside long reinforcing cup, held by two crimps .250 from base. Hole through base .146 inch. Frankford, 1873. [Figure 73.] |

<i>No.</i>	<i>Description</i>	<i>No.</i>	<i>Description</i>
375	Moore's collar flange, also .45 caliber. Plain, unflanged copper case, enclosed in .570-inch brass flanged collar. Copper cup anvil, held by two indents .230 from base and .08 apart. Inner case shows through .372 hole in head. Frankford, 1874. [Figure 74.]	380	Colt caliber .44 revolver. Martin primed. C-1.076.
376	Caliber .45 brass case, plain flat head, with Berdan-type anvil. Frankford, July 1874. O-2.533, C-2.096, R-.608, H-.508, M-.483. [Figure 75.]	381	Smith & Wesson caliber .44 revolver. Martin primed. C-.905.
377	Vacant.	382	Colt's caliber .44 revolver. Franklin's front extraction. Cup anvil held by usual two crimps. (Note: This system is F. Alexander Theur's patent no. 82258—General W. B. Franklin was vice president and general manager of the Colt Company, to whom the Theur patent had been assigned.) Made at Frankford, November 1868. C-.842. [Figure 76.]
378	Remington breechloading pistol. Tinned iron cup anvil. Caliber .50. C-.874.	383	Colt's caliber .38 Navy Revolver. Tinned iron cup anvil held by crimps .250 from base. C-1.020.
379	Same, except Martin primed. C-.904.		

Ninth Drawer: Modification in Caliber (Reductions)

Section I: Caliber .45

(All cases bottleneck, copper, tinned iron cups, made at Frankford unless otherwise noted.)

<i>No.</i>	<i>Description</i>	<i>No.</i>	<i>Description</i>
384	Charge 80 grains, 400-grain cannellured, 1.108-inch bullet. O-2.600, C-2.105.	396	Section bullet, hardened front, lead base to drive up the Schenkle sabot. (It was noted that this design failed entirely.) O-2.534, C-2.014.
385	Same, but 75-grain charge. O-2.527, C-2.010.	397	Charge 75 grains, bullet 440 grain, cannellured, and inserted only .2 inch. Base wad (lubricated) and dipped. Two cannellures exposed. Report of 1872 Caliber Board No. 26. O-2.715, C-1.805.
386	Same, but 70-grain charge. O-2.330, C-1.787.	398	Similar, but 425-grain smooth bullet, inserted .15 inch. Board No. 28. O-2.680, C-1.807.
387	Charge 80 grains, 420-grain, cannellured, 1.103-inch bullet. O-2.600, C-2.020.	399	Similar, but 485-grain smooth bullet, Laidley bullet, cannellured; six exposed. Caliber Board No. 29. O-2.804, C-1.718.
388	Same, but 75-grain charge. O-2.500, C-2.010.	400	Same, but inserted .45 inch, with 4 cannellures exposed. No. 30. O-2.829, C-2.000.
389	Same, but 70-grain charge. O-2.346, C-1.786.	401-402	Vacant.
390	Charge 80 grains, 440-grain, cannellured, 1.133-inch bullet. O-2.579, C-2.025.	403	(This and the next four all have straight cases, with Martin-type primers, copper bar anvils, and single fold heads.) Bullet 400 grains, four cannellures; one exposed. Charges 60, 70, 75, and 80 grains, all in same length case. Springfield, No. 39. O-2.780, C-2.188.
391	Same, but 75-grain charge. O-2.540, C-2.015.	404	Similar, all cannellures covered. Charge 70 grains. Springfield, No. 47. O-2.680, C-2.178.
392	Same, but 70-grain charge. O-2.365, C-1.780.		
393	Copper, shallow-cup anvil; 80-grain charge, 425-grain, smooth, patched 1.153-inch bullet, dipped and inserted .4 inch. O-2.688, C-1.985.		
394	Same, but 75-grain charge; bullet inserted .5 inch. O-2.604, C-1.990.		
395	Martini-Henry imitation. Martin-primed, with single fold head, reinforcing cup, and copper bar anvil. Hardened bullet, with patch and wad, to resemble Henry ammunition. Springfield. Raised headmark "70 GRS." O-3.055, C-2.255.		

No.	Description
405	Similar, but case shortened. Springfield Caliber Board No. 50. O-2.500, C-2.015.
406	Similar to last, with hardened 405-grain bullet. Charge 70 grains dense musket powder. Lubricant in cannellures. Bullet seated .61 inch. Springfield Caliber Board No. 58, and recommended for adoption. O-2.548, C-2.100.
407	Similar, but as first made at Frankford Arsenal, after adoption by War Department. Bullet has slightly dished base in contrast to ellipsoidal cavity in base of Springfield bullet. O-2.680, C-2.175.

Section II: Caliber .42

No.	Description
408	(Missing) 80-grain charge, 350-grain bullet, cannellured. O-2.6. Numbers 408 to 421 inclusive are all bottle-shaped.
409	Charge 75 grains, bullet 350 grains, cannellured. O-2.500, C-1.985.
410	Similar, with 70-grain charge. O-2.361, C-1.788.
411	Large Martin primer, with copper bar anvil, re-entrant fold head. Bullet 370 grains, 1.115 inch. O-2.616, C-2.033.
412	Like No. 409, except 370-grain bullet. O-2.404, C-2.005.
413	Like No. 410, except 370-grain bullet. O-2.352, C-1.786.
414	Like No. 409, except 80-grain charge, 385-grain bullet with rounder ogive, 1.088-inches, slightly dished base. O-2.535, C-1.994.
415	Like No. 409, except bullet like No. 414. O-2.465, C-2.015.
416	Like No. 410, with 70-grain charge, except bullet like No. 414. O-2.414, C-1.847.
417	Copper cup primed, charge 80 grains, bullet 350 grains, 1.060 inch, smooth, patched, inserted .4 inch. Base lubrication disk. O-2.650, C-2.028.
418	Similar to last, but bullet inserted .5 inch, with 75-grain charge. O-2.591, C-2.055.
419	Similar to last, but 1.115-inch, 370-grain bullet, inserted .4 inch; charge 80 grains. O-2.685, C-2.012.

No.	Description
420	Similar to last, but inserted .5 inch, with 75-grain charge. O-2.598, C-2.015.
421	Large Martin-type primer, copper bar anvil, re-entrant fold head. Bullet 1.1 inch, 373 grains, with ratchet grooves. Charge 75 grains. O-2.460, C-2.140.
422-427	Vacant.
428	Straight case, small Martin-type primer, with copper bar anvil. Bullet 370 grains, with four shallow cannellures; one exposed. Charges 70, 75, and 80 grains, using same case size. Springfield Caliber Board numbers 20, 21, and 22. O-3.088, C-2.455.
429	Similar, except 365-grain bullet with four deep cannellures (.02); one exposed. Charges of 60, 65, 70, 75, and 80 grains in same case. Springfield Caliber Board numbers 23, 34, 35, 36, and 38. O-3.095, C-2.465.
430	Similar, except cannellures all covered, charge 65 grains. Springfield Caliber Board number 48. O-3.000, C-2.450.
431	Similar, except shorter case, with 65, 70, and 75-grain charges. Springfield Caliber Board numbers 49, 54, and 55. O-2.782, C-2.327.

Section III: Caliber .40

(All cartridges in this section have small Martin-type priming, with a copper bar anvil. Numbers 432 and 433 have the re-entrant fold head; 434 and 435 have single fold heads with reinforcing cups; 439 through 447 have single fold heads without reinforcing cups. Springfield Caliber Board numbers 432 to 435 are bottlenecked, the rest straight cases.)

No.	Description
432	Charge 75 grains, bullet 350 grains, smooth, with paper patch. Base disk of thick felt wad with lubricant. Springfield, 1871. O-3.03, C-2.387.
433	Similar to last, but 80-grain charge and thin wad to increase powder space. Springfield, 1871.
434	Like 432, except added reinforcing ring at head, Springfield, 1871. O-2.992, C-2.378.
435	Like last, except 80-grain charge.
436-438	Vacant.
439	Charges 65, 70, 75, and 80 grains; bullet 350 grains, 1.101 inch, smooth, greased patch. Springfield Caliber Board numbers 2 to 9. O-3.214, C-2.484.

<i>No.</i>	<i>Description</i>	<i>No.</i>	<i>Description</i>
440	Charge 80 grains, 400-grain bullet, 1.255 inch, with seven cannelures (four exposed). Springfield Caliber Board number 10. O-3.430, C-2.502.	444	Like last, but bullet 1.110 inch, and inserted to cover four cannelures. Springfield Caliber Board number 45. O-3.100, C-2.505.
441	Charges 65, 70, and 75 grains. Bullet 350-grain, 1.093 inch, with four cannelures all covered by case. Springfield Caliber Board numbers 11, 12, and 13. O-3.042, C-2.510.	445	Like last, but bullet inserted to cover all cannelures. Springfield Caliber Board number 46. O-2.962, C-2.505.
442	Charge 60, 65, and 70 grains. Bullet 350 grains, 1.094 inch, with five shallow (.01) cannelures, three covered by case. Springfield Caliber Board numbers 14-18. O-3.152, C-2.504.	446	Charge 70 grains. Very light 1.025 inch bullet, 290 grains, smooth, greased patch. Springfield Caliber Board number 24. O-3.100, C-.480.
443	Charge 65 grains; bullet 340 grains, 1.084 inch, with five deep (.02) cannelures, three covered by case. Springfield Caliber Board numbers 19 and 44. O-3.177, C-2.487.	447	Charges 65 and 70 grains. Bullet 340 grains, 1.197 inch, hardened with one twelfth tin, five deep cannelures, all covered by case. Springfield Caliber Board numbers 59 and 60. O-3.004, C-2.476.
		448-449	Vacant.

Tenth Drawer: Service Ammunition and Stages of Manufacture

<i>No.</i>	<i>Description</i>	<i>No.</i>	<i>Description</i>
450	Caliber .50 musket; 70 grains of powder, 450-grain bullet, 143-grain copper case. Shallow copper cup primer anvil, held by two crimps .200 from base and .202 apart. The Service cartridge from January 1872 to 29 December 1873. O-2.250, C-1.760, R-.665, H-.562, M-.538.		taper). Copper cup primed copper case, crimps .264 from base and .179 apart. O-1.229, C-.881.
451	Caliber .50 cadet musket; 45-grain charge; 385-grain bullet. Made originally for the short chambered Remington Navy carbine, Model 1868. Copper cup primed, indents .257 from base and .175 apart. O-1.740, C-1.330, R-.661, H-.568, M-.543. Can be confused with Remington inside primed with iron cup cartridge No. 11.	454	Caliber .50 musket blank; 70- or 80-grain charge; case 1.5 inch closed by tar composition (later with wad and shellac). Iron cup primed. Adopted September 1868.
452	Caliber .50 carbine; 55-grain charge, 430-grain bullet with ellipsoidal front. Adopted January 1872. Shallow cup primer, indents .208 from head and .200 apart. O-2.170, C-1.790, R-.665, H-.563, M-.540.	455	Caliber .50 Gatling blank; charge 100 grains. Copper cup primed case 2.25 inches long. Powder compressed and mouth closed with varnish.
453	Caliber .50 pistol (Remington breechloader); 25-grain charge; 300-grain bullet. Made for Army Remington pistol after July 1871, and a similar one for the Navy (The Army type is bottlenecked, the Navy straight	456	Caliber .45 rifle; charge 70 grains; bullet 405 grains, hardened. The cartridge adopted by the Board, as made at Frankford in 1874. O-2.555, C-2.102.
		457	Caliber .45 carbine; charge 55 grains; bullet 405 grains, hardened. Copper case, copper cup primed, indents .210 from base and .200 apart. Made at Frankford from September 1873 to about 1876. Marked "U.S. CARBINE" on head to distinguish it from the rifle round. O-2.560, C-2.100.
		458	Caliber .45 Colt revolver; charge 30 grains; bullet 250 grains. Copper case, cup primed, with indents .200 from base. Frankford

<i>No.</i>	<i>Description</i>	<i>No.</i>	<i>Description</i>
	from September 1873 to about 1878. O-1.615, C-1.291, R-.503, H-.480, M-.480.		Copper cup primed case. C-.895, R-.489, H-.447, M-.415.
459	Caliber .45 blank, rifle and carbine; cup primed, crimps .215 from base, .175 apart. C-1.600, R-.608, H-.503, M-.484.	463	Musket powder for all small arms cartridges. Light "Oriental" for caliber .50, dense "Hazard" for caliber .45. Ingredients: sulphur, potassium nitrate, and charcoal.
460	Caliber .45 revolver blank. Copper, cup primed case, crimps .215 from base, .175 apart. C-1.066, R-.484, H-.462, H-.458.	464	Lead bar for bullets of all cartridges except the caliber .45 rifle and carbine.
461	Caliber .44 revolver (Smith & Wesson); charge 40 grains; bullet 225 grains. Copper case, cup primed, crimps .194 from base, made at Frankford from August 1871. O-1.466, C-.897, R-.485, H-.444, M-.442.	465	Alloy bar for bullets: Tin 1, lead 16. For bul- lets of caliber .45.
462	Caliber .44 revolver blank; charge 40 grains.	466	Japan wax. Generally used for bullet lubrica- tion.
		467	Bayberry wax: 8 parts wax to 1 part graphite. Preferred when Bayberry obtainable.

4

Compiler's Comments

Those who attempt to check other cartridge specimens against the measurements given in the foregoing catalog must remember that in most instances there was but a single sectioned specimen to measure. There were manufacturing tolerances on all these dimensions, some of which had to be held rather close, others did not matter. It will be noted that head and rim diameters were controlled rather well. Tolerances in other dimensions would normally be $\pm .004$ inch from the standard specification dimension.

A further complication in dealing with experimental types stems from the practice (still in effect) of keeping small stocks of empty primed cases on hand for convenience in making special small scale experiments or tests. Thus, in drawing such cases from stock, minor variations in case or priming might be introduced. Bar anvil, iron or copper disk or cup anvil, different types of retaining crimp,

Martin priming, and the like, might be encountered in a test lot of cartridges assembled to investigate a new bullet, or a different powder charge. As these elements function similarly, the variants made little difference in the tests being conducted, but do make it difficult for the collector or researcher in these fields to classify specimens.

In addition to the varieties officially used in the Service, many of the experimental cartridges were sent to the field unofficially in small quantities of a case or more in order to get a quick check on their effectiveness. Thus some of these types which were never officially adopted have been found at battle sites with Indians in the West.

A chronology of officially approved cartridge types for U.S. rifles and carbines during the period 1865 to 1876 has been extracted from the preceding data.

Service Ammunition, Rifle and Carbine, 1865–1876

<i>No.</i>	<i>Description</i>	<i>Date</i>	<i>No.</i>	<i>Description</i>	<i>Date</i>
120	Allin conversion of caliber .58 musket to use rimfire cartridge, .58–60–500, made at Springfield and marked on head “.58 CAL.”	1865		side primed. Springfield and Frankford. (Limited use.)	
121	Caliber .50 rifle. Straight-cased rimfire cartridge, .50–60–500, made at Springfield and marked on head “.50 CAL.” (Limited use.)	1865	315	Caliber .50–70–450, with Martin's tinned iron bar anvil, inside primed. Indents .110 inch from base.	October 1866 to March 1868
	Various experimental types for caliber .50 rifle. (Includes 122, 130, 312–314.) Center-fire, both inside and out-	1865–1866	355	Caliber .50–70–450, with tinned cup inside priming, in straight case. Indents .255 inch from base, and .186 apart.	March 1868 to September 1869
			356	Caliber .50–70–450, with tinned cup, in slightly	September 1869 to

No.	Description	Date	No.	Description	Date
	necked case. Indents .255 from base, and .186 apart.	August 1870		.200 from base and .202 apart. Final Service cartridge for the .50-70.	.202 December 1873
358	Caliber .50-70-450, copper cup anvil. Indents .255 from base and .214 apart.	August 1870 to November 1871	406	First .45-70 rifle cartridge in about final form made for trial by Springfield. Copper cup primed case.	1872-1874
322	Caliber .50-70-405, with copper disk anvil, 360-degree crimp, and corrugated head. 50,000 made for Service test.	September 1871 to October 1871	457	First carbine cartridge caliber .45-55-405, made at Frankford. Cup primed, indents .200 from base. Marked on head "U.S. CARBINE," to tell from rifle.	September 1873
330	Caliber .50-70-450, Martin-primed, with reentrant fold.	November 1871 to December 1871	456	First Frankford Arsenal production of Service cartridge for caliber .45-70-405 rifle. Cup primed, indents .200 from base. No marks.	1874-1882
452	Caliber .50-55-430 carbine, shallow cup primer indents .206 from head and .200 apart.	January 1872 to August 1873			
450	Caliber .50-70-450, with shallow copper cup, indents	January 1872 to			

Performance of Arms and Ammunition 1865-1875

In recent years much has been made of misfired and separated cartridge cases which have been found on sites of battles between U.S. troops and Indians during the years after the Civil War. At that time the Government was experimenting to determine the optimum arms and ammunition for use in the Service. In recent decades the quality of small arms and their ammunition has been so uniformly high that such excellent performance is taken for granted. This was not always the case. Arms and ammunition selected for Service use were tested by the Ordnance Department under the direction of special boards of officers appointed for the purpose. Before final approval extensive field tests in Army units were required.

One of the most important series of tests for selecting new weapons was conducted by the Board on Breechloading Small Arms, appointed on 28 June 1872 pursuant to an act of Congress and sometimes known as the "Terry" Board (from Brigadier General Alfred H. Terry, its senior member).

The tests conducted for arms subjected them to repeated firing and to the effects of dust and sand, rust, and defective ammunition to test their reserve strength. Ease of manipulation was judged by the

maximum rate of fire obtainable. Accuracy was checked at various combat ranges. The Service caliber .50 cartridge was used whenever it was practical to do so. The tests were as follows.¹⁵

Rapidity with aim: The number of shots, which fired in one minute struck a target of 6 feet by 2 feet, at a distance of 100 feet. Any cartridge missing fire was examined to determine the cause. (Only four or five cartridges in over 20,000 thus expended failed to fire from causes not due to the arm.)

Rapidity at will: The number of shots that could be fired in one minute, irrespective of aim.

Endurance: Each gun was fired 500 continuous rounds, without cleaning. The state of the breech mechanism was examined after each 50 rounds.

Defective cartridges: Each gun was fired once with each of the following types of defective cartridges: (1) cross-filed on head to nearly the thickness of the metal; (2) cut at intervals around the rim; and (3) with a longitudinal cut the whole length of the cartridge, from the rim up. A fresh piece of paper was laid over the breech to determine if gas escaped. Such tests showed whether the gun tested was

¹⁵ United States Government, Ordnance Memorandum No. 15, pp. 70-71.

sufficiently sturdy and gas-tight to be safely fired with defective cartridges, which allowed gas-pressure to escape from the case. The simulated defects were representative of those occasionally introduced in manufacture and overlooked by routine inspection. Statistically, a few such defective rounds will pass undetected by the inspector.

Dust: The piece was exposed in a box to a blast of fine sand-dust for two minutes; fired 50 rounds, replaced for five minutes, removed and fired 50 rounds more.

Rust: The breech and receiver were cleaned of grease and the chamber greased and plugged. The butt end was then inserted up to the chamber in brine for two days, exposed two days in the open air standing in a rack, and then fired 50 rounds.

Excessive charges: The arm was fired once with 85 grains of powder (normal load, 70 grains) and one 450-grain bullet, once with 90 grains and one such ball, and once with 90 grains and two balls. The piece was closely examined after each discharge. These loads corresponded to normal "proof" loads. Ability to withstand the excessive pressures thus produced assured safe functioning with regular loads and would presumably show up any dangerous defect.

The Board had begun its studies with a total of 99 rifles on hand for test and evaluation. These included all the principal foreign systems available, nine in all. These were the French Chassepot, the German needle-gun (two models), needle-gun carbine, German Mauser (Model 1871), Austrian Werndl, Bavarian Werder, Italian Vetterlin, and the British Martini-Henry. The initial series of tests had reduced the contenders to 21: Peabody, Whitney, Springfield-Stillman, Elliot, Ward-Burton, Epdegraff, Sharps (Civil War model converted to .50-70), Springfield, Remington-Ryder, Berdan-Russian, Freeman, Dexter, Lee, Roberts, Remington, Winchester, Broughton, Sharps (New Model), Remington Navy rifle (made at Springfield), the British Martini-Henry, and the Austrian Werndl.

When it became apparent that further tests would be needed to reach a decision, the following supplemental tests were performed.

First: The piece was fired with two defective cartridges (types 1 and 2, see p. 41), and then dusted for five minutes, the mechanism being in the mouth of the blow pipe and closed, the hammer being at half-cock. It was then fired six times, the last two

shots again being defective types 1 and 2. Without cleaning, it was dusted with the breech open for five minutes, and then fired four more shots. The piece was freed from dust only by wiping with the hand or pounding with the bare hand.

Second: The piece was rusted for four days after immersion as before (see "Rust"), and fired five rounds with a Service cartridge. Without cleaning it was fired five more rounds with 120-grain powder charge and a ball weighing 1200 grains. The gun then stood for 24 hours without cleaning, and was subsequently thoroughly examined.

Third: Ease of manipulation was tested by members of the Board.

The supplemental tests further eliminated many of the entries. A few examples will indicate the results obtained. The Sharps (Civil War converted model) failed the supplemental tests, being very hard to open; the lever was broken in the attempt. The Winchester could not be opened. The Remington Navy model was stiff and hard to operate after the second exposure. The Remington-Ryder failed; the hammer would not stay back, the extractor had to be pounded with a hammer to move, and the action opened with the foot. The Peabody passed the tests satisfactorily. In the first series of tests, the Springfield showed some gas escape at the sides, but worked well throughout. The cam stuck slightly after the first defective cartridge, but after freeing, worked well thereafter. In supplemental tests it opened and worked easily throughout and was in working order at the conclusion of the tests. It was fired an average of 11.59 shots per minute by soldiers and 8.51 by recruits.

Meanwhile, a "Small Arms Caliber" Board headed by Major J. G. Benton began studies on 13 May 1872 to determine the proper caliber for small arms. In this series of trials, the Board exhaustively tested¹⁶ three new calibers, .45, .42, and .40 in comparison with the caliber .50. In the .45, nine forms of barrels and 25 forms of ammunition were tried. In the .42, 11 forms of barrels and 26 of ammunition. In the .40, seven forms of barrels and 27 of ammunition. Seven styles of rifling were included, with ten different twists. Chambering and throating were modified. Powder charges varied from 60 to 85 grains, in 5-grain increments. Bullets varied from 290 to 484 grains, in various forms, cannellured,

¹⁶ United States Government, Ordnance Memorandum No. 15, pp. 437-438.

plain, and patched, with lubrication applied in various manners. Straight and bottlenecked cases were compared.

The ammunition tests of the Caliber Board determined that the cartridge design later known as the .45-70 was the best available. The Terry Board then selected the best six arms being tested and had them altered to caliber .45. These guns were the Springfield (modified M1870), Elliot, Remington (modified M1871), Freeman, Peabody, and Ward-Burton magazine carbines. After further testing and extensive trial by the Army in the field on 19 May 1873, the Board recommended the Springfield breechloading system in caliber .45 be adopted for small arms. As the Elliot had exhibited very great ease of operation with one hand, the Board recommended that some be made for further Cavalry trial. It also recommended the Ward-Burton as the best magazine gun tested, though not fully meeting the requirements. It suggested that a small number be made for further field trial.¹⁷

The Springfield carbine, caliber .50 (M1870), was tested in competition with Spencer, Sharps, and Remington carbines. It was found scarcely inferior to the Springfield rifle (M1868), and in all points except recoil was greatly superior to the others tested. However, a new caliber .45 carbine was adopted in 1873.

Many Service cartridges were test-fired at Frankford Arsenal in connection with routine acceptance inspection tests, and special tests of experimental cartridges. Results of such tests give a good idea of the reliability of this ammunition, at least while reasonably new. Storage stability must be determined by actual trial for protracted periods under adverse conditions. Most of the type ammunition here discussed became obsolete within a few years because of new developments; hence deterioration in storage was not fully determined, being of academic interest only. It was later found, however, that the fulminate type priming stood up better in tinned components. The critical area was the primer and primer-pocket, but it was easier to tin the entire case by dipping in an electroplating bath. In 1957 Frankford Arsenal received a report from an individual who had purchased a case of this tinned FA 1884 ammunition about 1925. He had just fired the last 250 rounds of it in 1957 and had experi-

enced only a few misfires with the whole case.

Between 1867 and 1868, 92,891 test cartridges had been fired in routine acceptance tests. Of 79,517 which had the bar anvil, 68 misfired, or one out of every 1,169. Of 13,374 with cup anvil, 7 misfired, or one out of every 1,910. Between March 1868, when cup priming was standardized, and 1 July 1870, 49,252 more cartridges were fired in tests, with only 8 failures from all causes. Only three were from Service cartridges, which comprised about two-thirds of the number tested. This rate was less than one per 6,000. Note that it is the custom to use for such "in house" tests, which are mostly done in machine rests or pressure fixtures, the cartridges rejected during manufacture for minor defects. Hence those accepted and shipped to the field should be a little better than those tested. As the primers of these types were inside the case, inspection after assembling the primer components was difficult. If the mix was a little too dry and the tooling a little out of adjustment, an occasional primer was fired during the tapering operation. This, of course, could not fire a second time, when attempted. An anvil not pressed quite hard enough, or a slight amount of oil in the case could also cause a misfire. In spite of these problems, the U.S. Service cartridge was then the best in the world. As other types (foreign or domestic private interests) came to the attention of the Frankford Arsenal, they were tested, and none outperformed the U.S. model—most were substantially inferior in reliability.

Minor modifications solved the problem of breaking firing pins in the caliber .50 rifles, Model 1868. No fracture occurred in test firing some 12,000 rounds of ammunition through six rifles. One rifle, Model 1868, was fired at Frankford over 10,000 times, using the same firing pin throughout, and replacing only one ejector spring.

With the lubrication then available—Japan wax and graphite—good results were obtained for targets of 20 to 25 shots, without cleaning. With continuous firing of 100 or more shots, the performance fell off rapidly, especially in dry weather. Bayberry wax was much better as a lubricant. The bayberry, however, is a wild plant and its annual production varies making it an uncertain source. This problem was the reason for the extensive tests of lubricants and methods of application that were described in drawer seven.

¹⁷ United States Government, Ordnance Memorandum No. 15, p. 49.

References

- Anonymous. *Les Armes a Feu Portatives des Armées Actuelles et Leurs Munitions*. Paris: L. Baudoin, 1894.
- . [Bound Briefs and Notes on Various Patent Suits.] New Haven, Connecticut: Winchester Library (n.d.).
- Bartlett, W. A., and D. B. Gallatin. *Digest of Cartridge Patents*. Washington, D.C.: U.S. Government Printing Office, 1878. [See also Appendices 1, 2, and 3 of Berkeley R. Lewis, "Small Arms and Ammunitions in the United States Service." *Smithsonian Miscellaneous Collections*, volume 129.]
- British War Office. *Textbook of Small Arms*. London: H. M. Stationery Office, 1904.
- Deane, J. *Deane's Manual of the History and Science of Firearms*. London: Longman, Brown, Green, Longmans & Roberts, 1858.
- Greener, W. W. *Modern Breechloader*. London: Cassell, Petter, & Galpin.
- . *The Gun and Its Development*. 8th edition. London: Cassell, Petter, Galpin & Co.
- Hackley, F. W., W. H. Woodin, and E. L. Scanton. *History of Modern U.S. Military Small Arms Ammunition*. Volume 1 (1880–1939). New York: The Macmillan Co., 1967.
- Lewis, Berkeley R. "Maynard Arms and Ammunition." *The American Rifleman* (Washington, D.C.), vol. 99, no. 8 (August 1951).
- . "Meigs and the U.S. Cartridge Co." *The American Rifleman* (Washington, D.C.), vol. 103, no. 6 (June 1955).
- . "Morse Arms and Ammunition." *The American Rifleman* (Washington, D.C.), vol. 103, no. 3 (1955).
- . "Small Arms and Ammunition in the U.S. Service." *Smithsonian Miscellaneous Collections* (Washington, D.C.: U.S. Government Printing Office), volume 129.
- . "The Volcanic Arms." *The American Rifleman* (Washington, D.C.), vol. 105, no. 11 (November 1957).
- Logan, Herschel C. *Cartridges*. Huntington, West Virginia: Standard Publications, Inc., 1948.
- Mattenheimer, Von A. *Die Patronen der Ruckladungs-Gewehre*. Darmstadt and Leipzig: Edward Zernin, 1868.
- Metcalfe, Henry. *The Ordnance Department, U.S. Army, at the International Exhibition*. Washington, D.C.: U.S. Government Printing Office, 1884.
- Ordnance Department, U.S. Army. "Letter of Col. S. C. Lyford, 2 January 1877" *Report of the Executive Department on the International Exhibition, 1876*. 2 volumes. Washington, D.C.: U.S. Government Printing Office, 1884.
- Pepys, Samuel. *Pepys's Diary*. Lord Braybrooke edition. London, 1825.
- Pitman, John. Notebooks, West Point Museum. 16 volumes (unpublished).
- Reid, W. "Pauly, Gun Designer." *Journal of the Arms and Armour Society* (London), vol. 2, no. 9.
- Schmidt, Rudolph. *Handfeuer Waffen*. Basel: B. Schwabe, 1875.
- Scofern, J. *Projectile Weapons of War*. London: Longman, Brown & Co., 1859.
- Smyth, John. *Certain Discourses . . . Concerning Divers Weapons*. London: Richard Johnes, 1590.
- Suydam, Charles R. *The American Cartridge*. Santa Ana, California: G. Robert Lawrence.
- Tackels, C. J. *Armes de Guerre*. Paris: Ch. Tannera, 1868.
- United States Government. *Ordnance Memorandum No. 8: Metallic Ammunition*. Washington, D.C.: U.S. Government Printing Office, 1868.
- . *Ordnance Memorandum No. 14: Metallic Cartridges*. Washington, D.C.: U.S. Government Printing Office, 1873.
- . *Ordnance Memorandum No. 15: Board for Selecting A Breech-System*. Washington, D.C.: U.S. Government Printing Office, 1873.
- . *Ordnance Memorandum No. 21: Ammunition, Fuses, Primers*. Washington, D.C.: U.S. Government Printing Office, 1878.
- Weygand, Herrman. *Die Technische Entwickelunge der Modernen Präcision-Waffen der Infanterie*. Leipzig: Fr. Luckhardt, 1872.
- White, Henry P., and Burton D. Munhall. *Centerfire American and British Pistol and Revolver Cartridges*. Washington: Sportsmen's Press, 1950.
- . *Centerfire Metric Pistol and Revolver Cartridges*. Washington: Sportsmen's Press, 1948.
- Winant, Lewis. *Early Percussion Firearms*. New York: William Morrow & Co., 1959.

Glossary

Ball, bullet: These terms are used for the same thing in this catalog, though the former, strictly speaking, should be reserved to describe a round ball as used in smooth-bore guns.

Cap, primer: These terms are interchangeable, meaning the small metallic cup containing a detonating composition which is used for igniting a cartridge. In the United States the word primer is more often employed today, though cap was the preferred term in the late 19th Century. The British still use cap.

Crimp: A deformation made in a cartridge case to retain some element of the cartridge in position. Crimping has been used to hold the primer in the primer pocket, to hold a bullet in place, and to hold the anvil of an inside-primed cartridge securely. A ring crimp goes completely around the case and was at times called a knurl crimp, being put on with a rotating tool. Stab crimps may be simple circular punch marks, or may extend longitudinally for some distance. A

roll crimp, often used at the case mouth, leaves the edges of the case slightly reduced in diameter, and turned in.

Externally-primed: Priming not an integral part of the cartridge, which has merely a hole in its base to admit the flame from the primer. An example is the old-fashioned percussion cap, placed on a steel nipple in the vicinity of the breech.

Inside-primed: Priming composition placed inside the cartridge case, struck by the firing pin either transmitting its blow through the head itself, or by an internal pin extending to the priming.

Obturation: Sealing to prevent gas leakage. May be accomplished by a mechanical fit or by expansion and subsequent contraction of relatively thin metal.

Outside-primed: Priming placed in a pocket on the exterior surface of the case, the flame passing through one or more small openings (vents) to the powder inside.

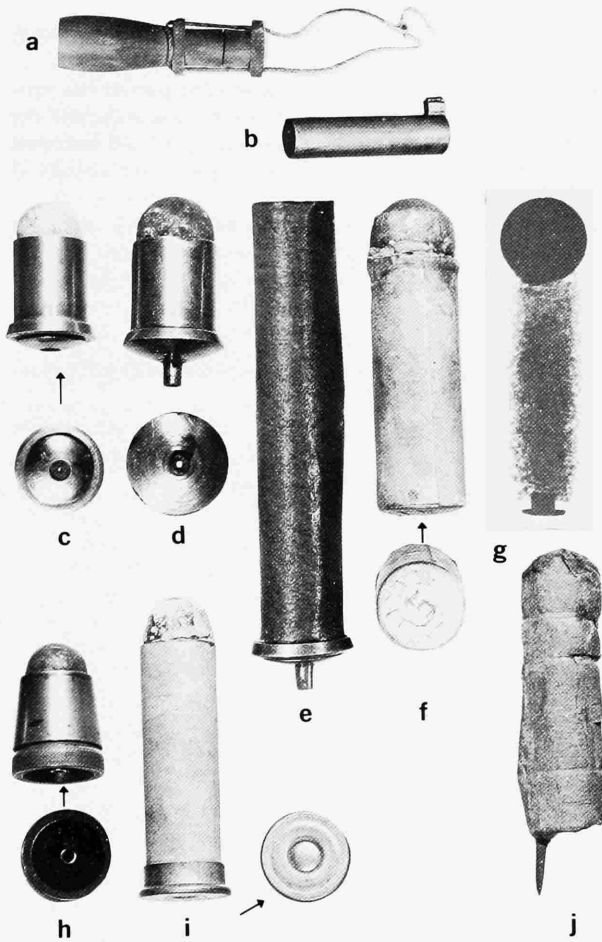

PLATE 1.—*a*, Powder container from musketeer's bandolier. Courtesy Winchester Museum. *b*, Auxiliary chamber from wheel-lock breechloader 1638. Metropolitan Museum of Art. *c*, Pauly cartridge using patch or pellet of detonating compound. *d*, Pauly cartridge using nipple for percussion cap. *e*, Pauly shot cartridge. *f*, Galy-Cazalat cartridge. *g*, Same; X-ray of interior (Lewis, 1956, pl.35). *h*, Pottet cartridge. *i*, Mark I Snider cartridge, with Potter-type head. *j*, Demondion cartridge.

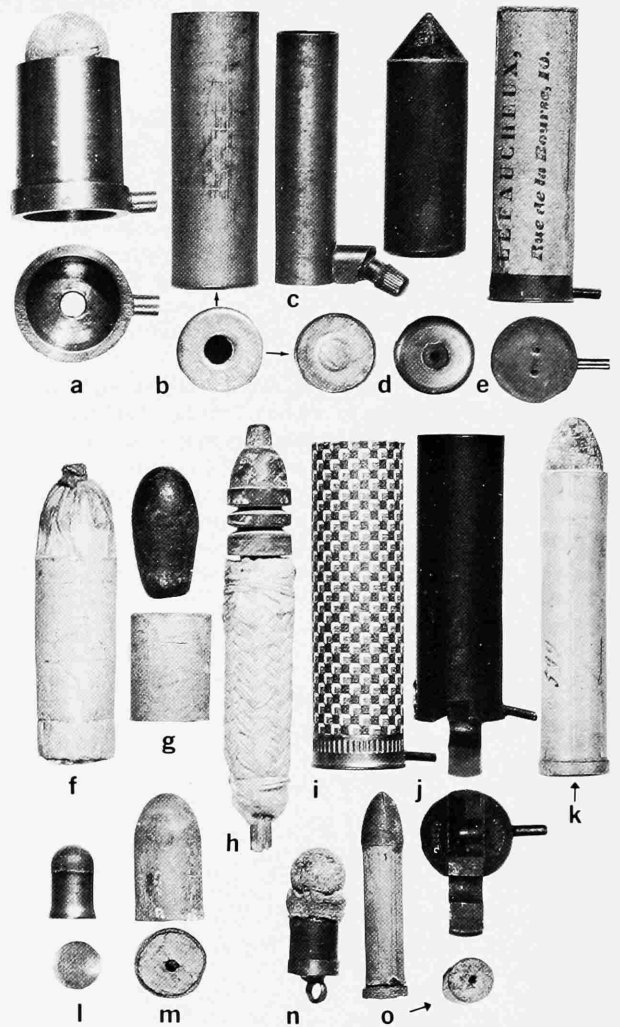

PLATE 2.—*a*, Le Page cartridge. *b*, Beringer self-primed cartridge. Primer disk shown to side of head. Head marked "BERINGER BVT, PARIS," one of earliest use of headstamp. *c*, Beringer-type cartridge. Specimen may be Minesinger's. *d*, Cartridge for Voss (Danish) breechloader. *e*, Original type Le Fauchaux pinfire cartridge. *f*, Prussian needle-gun cartridge, M1842. *g*, Sabot and bullet for *f*. *h*, Guncotton cartridge. *i*, Chadun's improved pinfire cartridge. *j*, Chadun "tailgate" cartridge for Robert and Le Fauchaux guns. *k*, Lenoir horizontal (inside) pinfire cartridge. *l*, Flobert cartridge. *m*, Hunt cartridge. *n*, Adams revolver cartridge. *o*, Marston rifle cartridge.

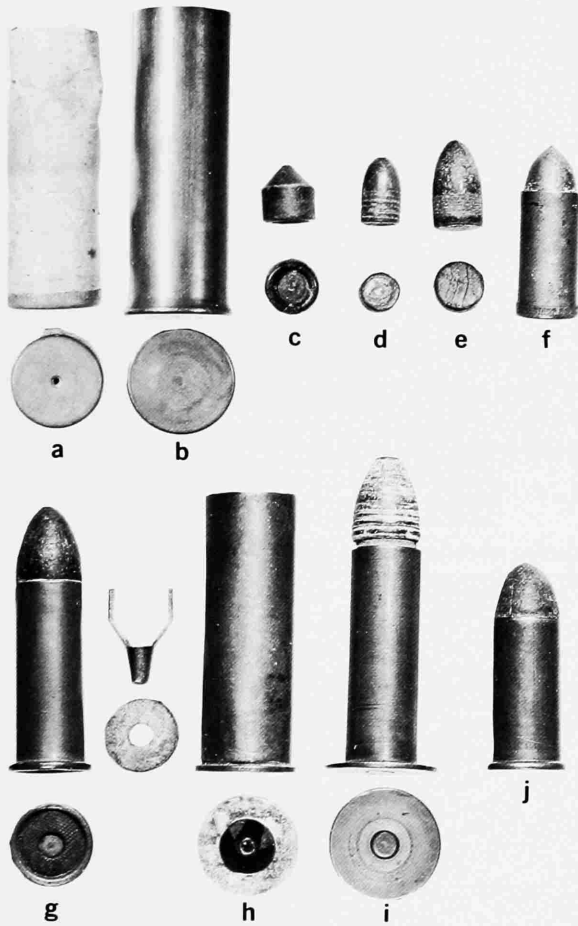

PLATE 3.—*a*, Needham needle-fire shotgun cartridge. *b*, Lancaster inside-primed shotgun cartridge. *c*, Gaupillat "charged ball" cartridge. *d*, Smith & Wesson No. 1 Volcanic cartridge. *e*, Smith & Wesson No. 2 Volcanic cartridge. *f*, Maynard's first patented cartridge, with base cover. *g*, Morse, rubber base cartridge, caliber .54 (Frankford Arsenal). *h*, Morse, solid base cartridge, with rubber obturator disk. *i*, Morse, solid head cartridge, cap for seal. *j*, Smith & Wesson's patent rimfire cartridge, for Ballard carbine.

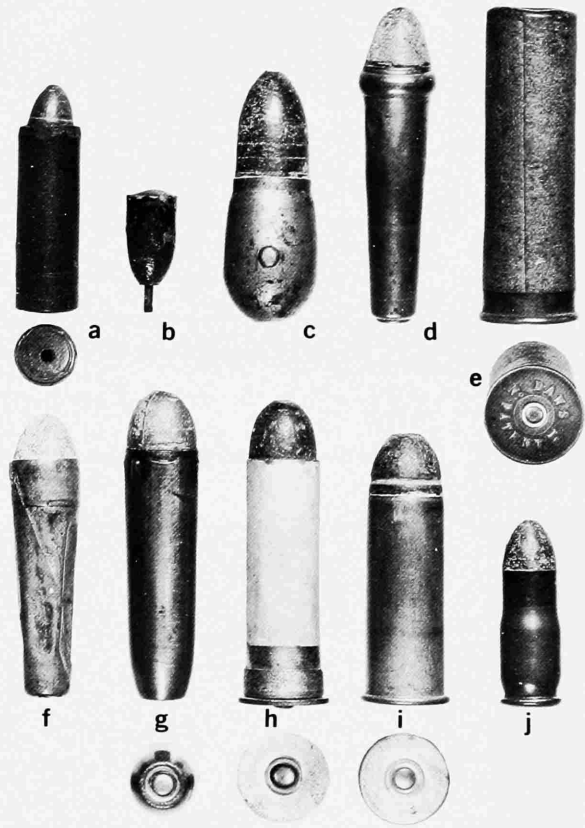

PLATE 4.—*a*, Smith rubber case cartridge, for caliber .36 rifle. *b*, Cartridge for Genhart revolver. *c*, Gallagher and Gladding cartridge for Schubarth converted musket. *d*, Foster's grease ring as used on Burnside cartridge. *e*, Daw shotgun cartridge. *f*, Poultney and Trimble (assignees of Crispin) foil and paper cartridge. *g*, Selwyn's patent centerfire cartridge for Burnside rifle. *h*, Boxer cartridge, Mark II Snider. *i*, Berdan cartridge, early form with inserted primer pocket. *j*, Dupee cartridge with extracting groove at head.

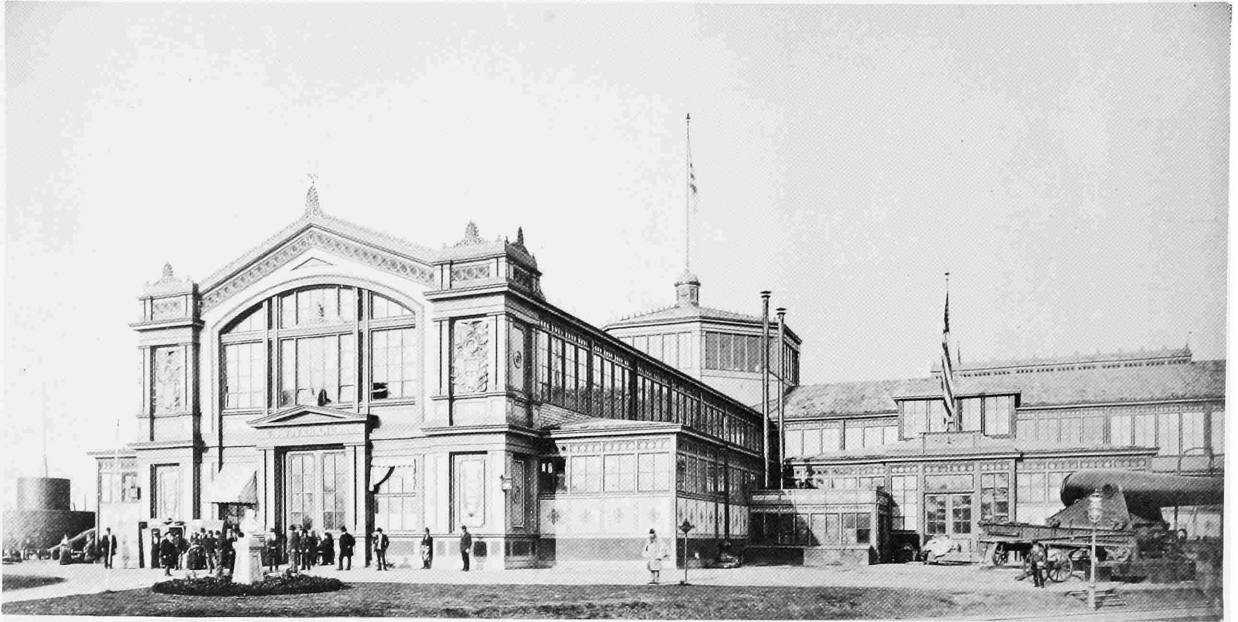

PLATE 5.—U.S. government exhibit building at the 1876 Centennial Exhibition. Brady photo.

PLATE 6.—U.S. government exhibit of cartridge making machinery at the 1876 Centennial Exhibition. Brady photo.

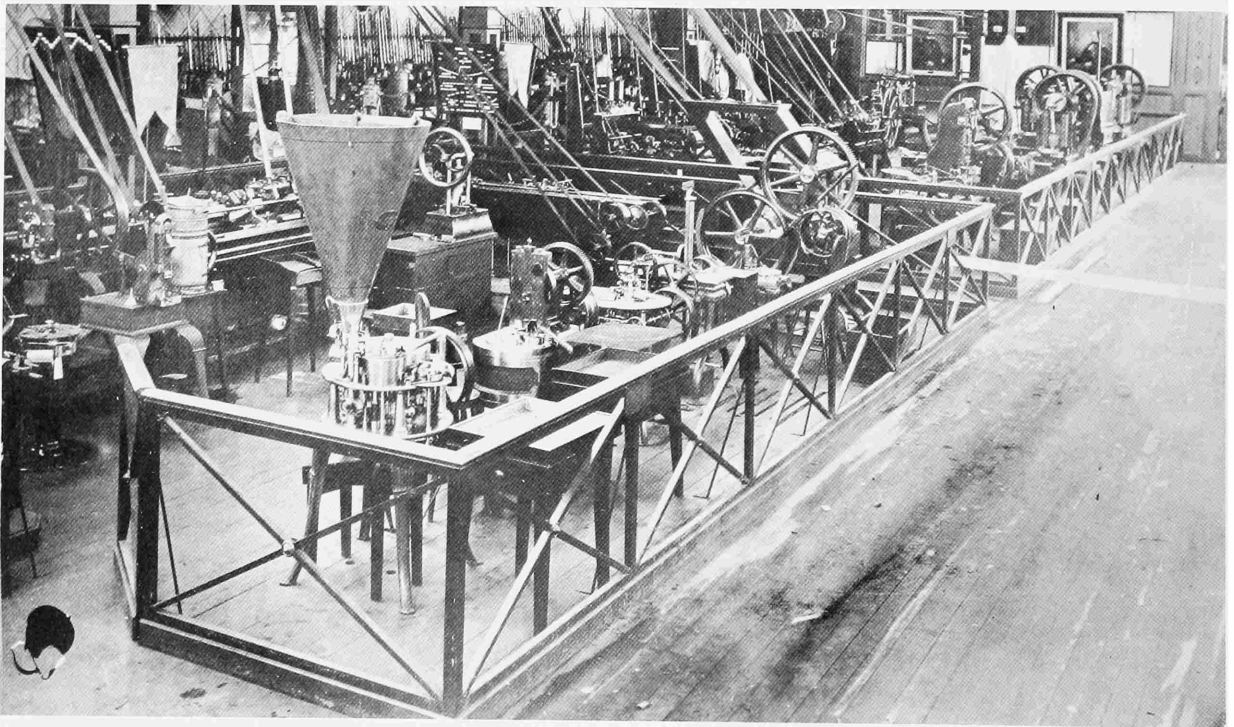



PLATE 7.—*a*, Souvenir box of specimens showing stages of manufacture of the U.S. caliber .45 cartridge, as made on the Exhibition grounds. *b*, Blank disk from which case is made. *c-g*, Successive draws in forming the case. *h*, Trimmed case. *i*, Anvil. *j*, Bullet. *k*, Headed case. *l*, Complete cartridge, showing head marking.

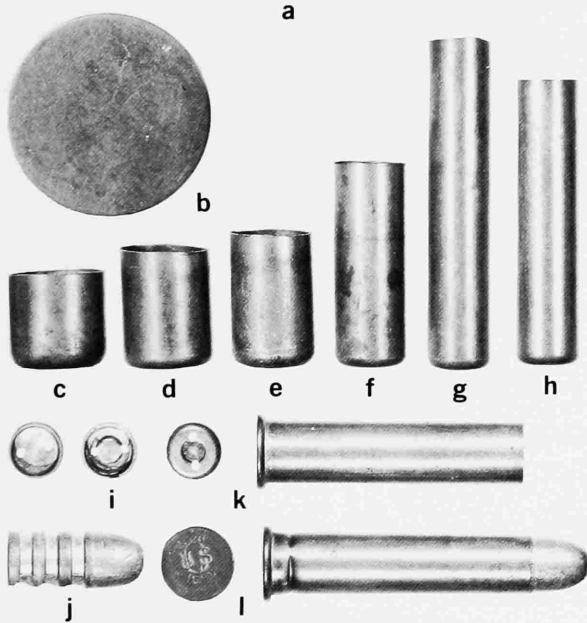
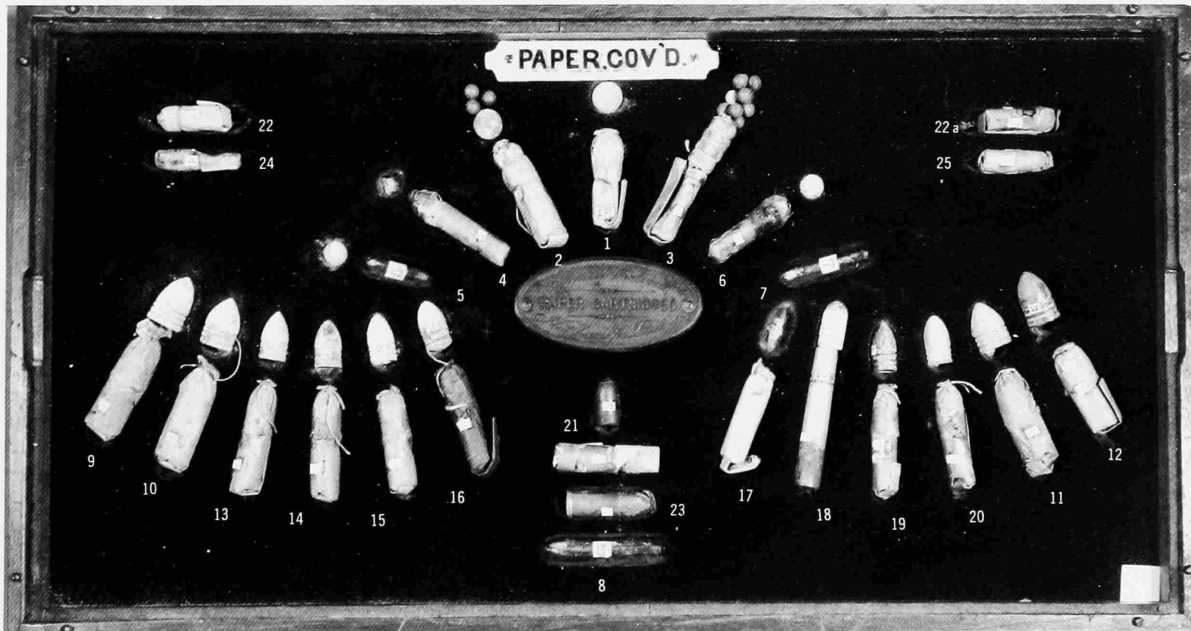

PLATE 8.—First drawer: Paper ammunition (not fixed), specimens 1 to 25.



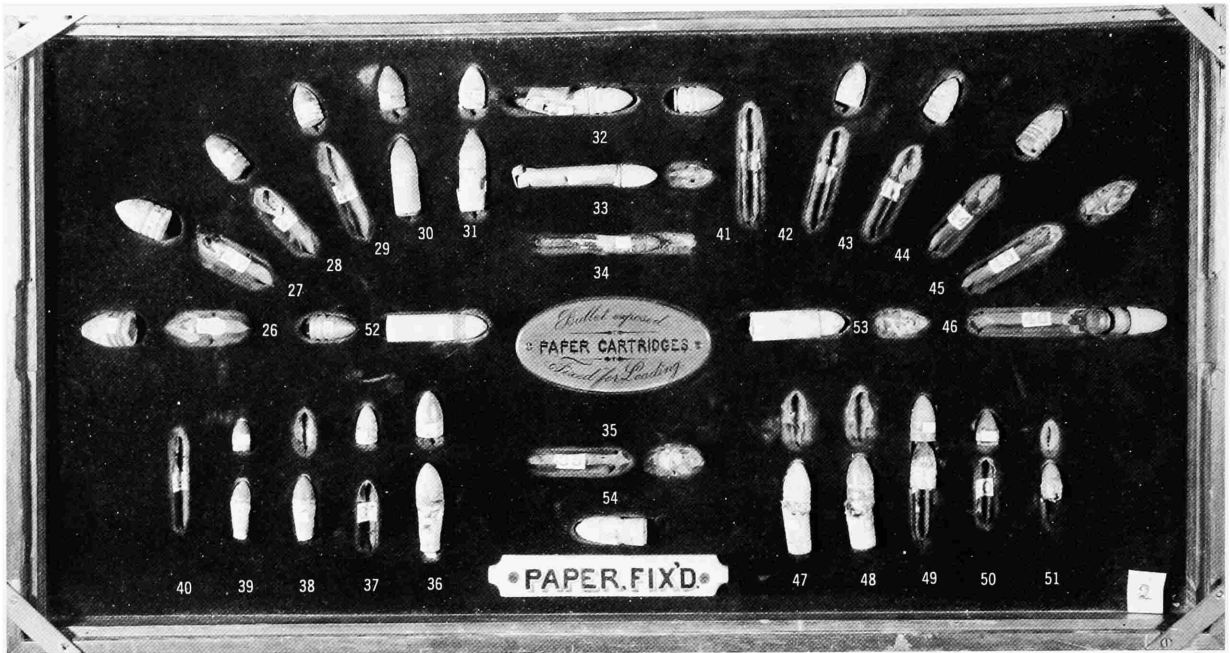

PLATE 9.—Second drawer: Paper ammunition (fixed), specimens 26 to 54.

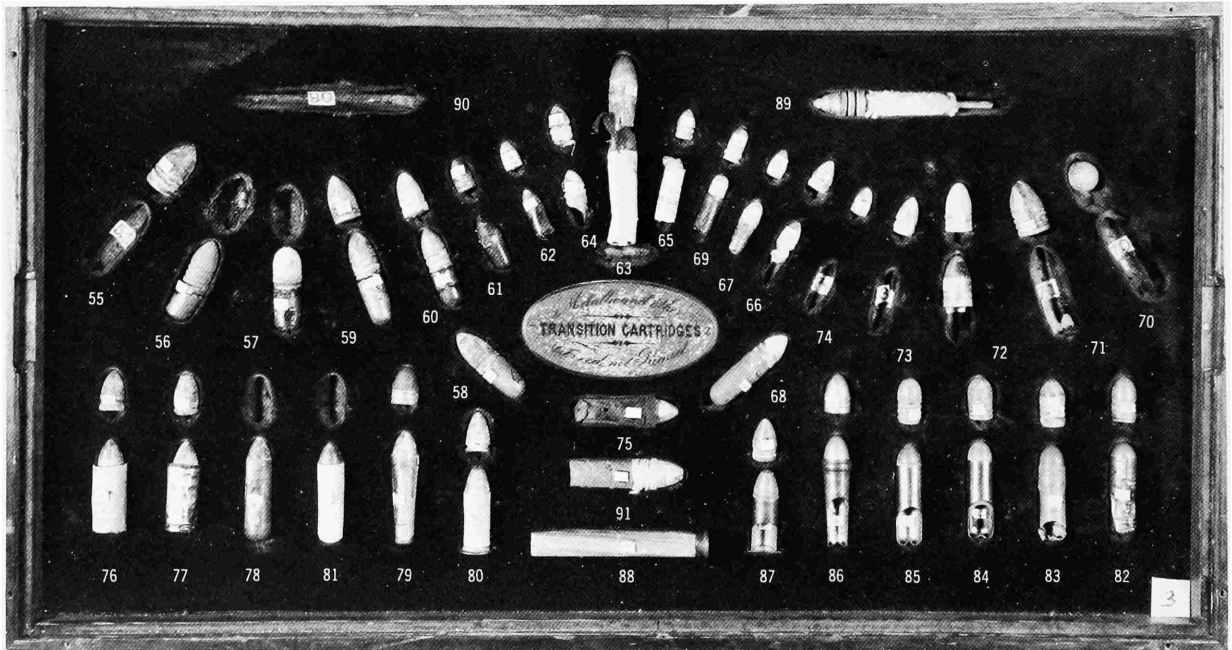

PLATE 10.—Third drawer: Transition and patent types (fixed), specimens 55 to 91.

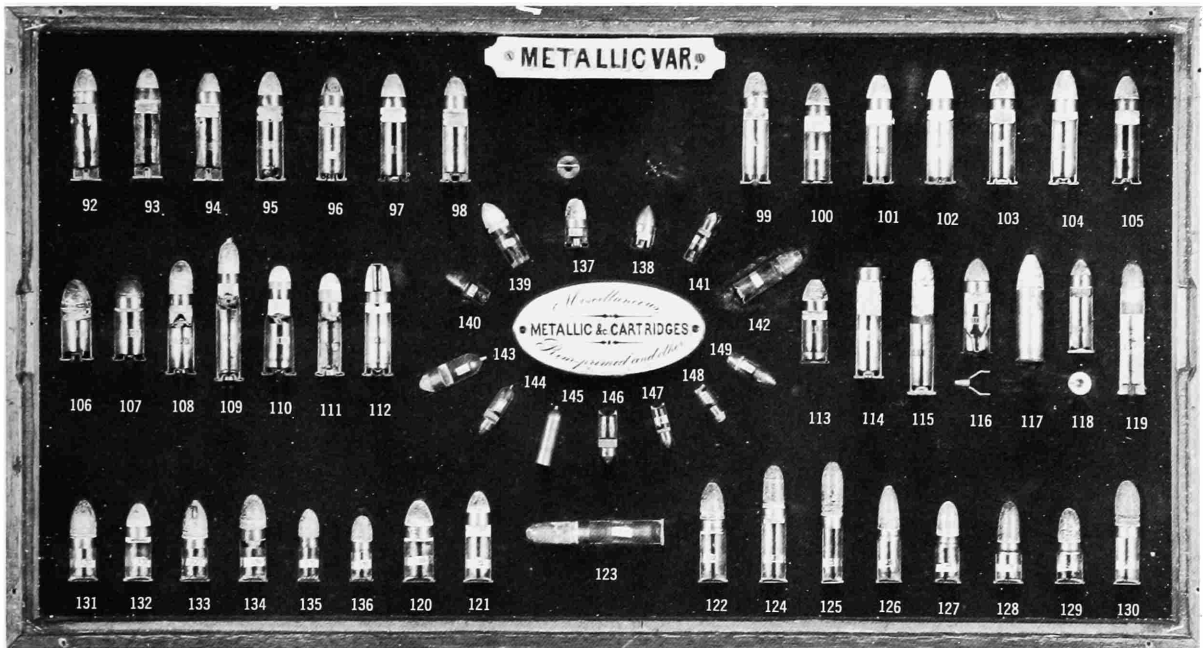

PLATE 11.—Fourth drawer: Rim primed and miscellaneous, specimens 92 to 149.

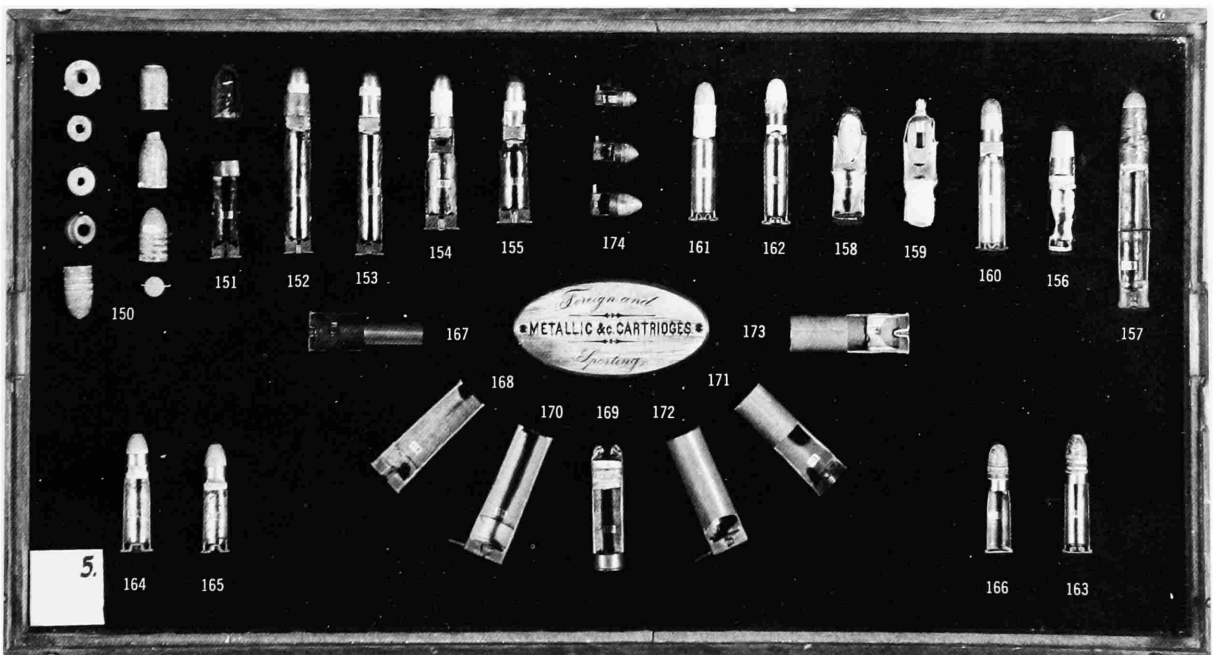

PLATE 12.—Fifth drawer: Foreign and sporting cartridges, specimens 150 to 174.

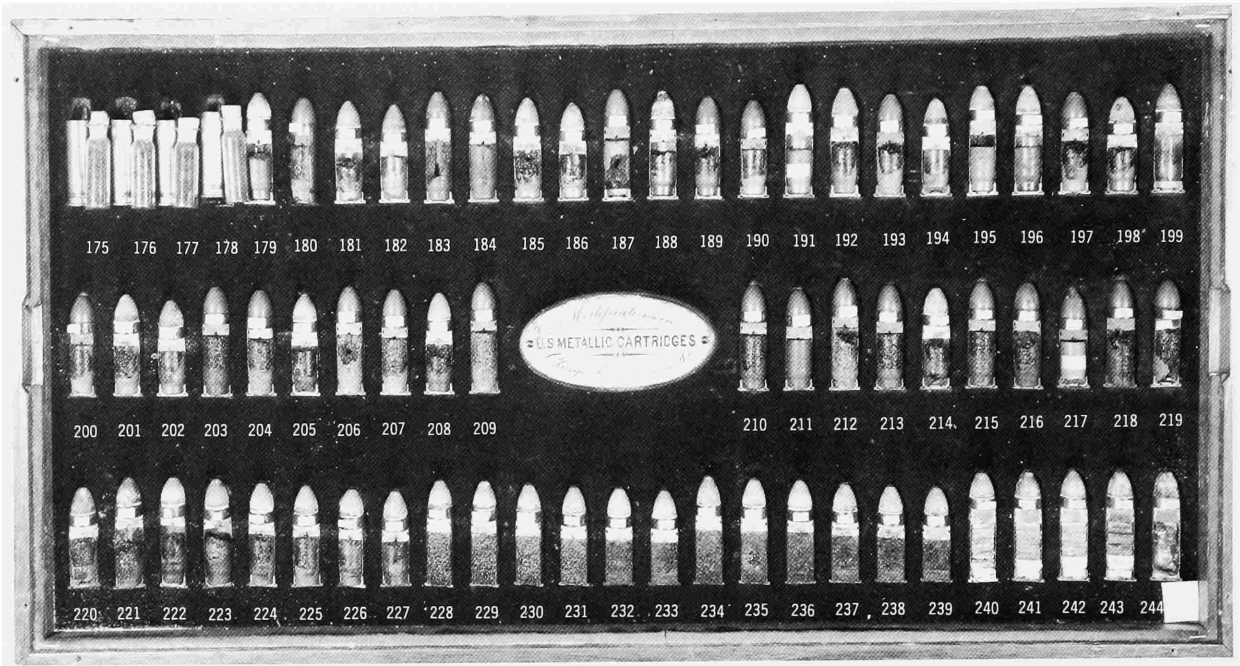

PLATE 13.—Sixth drawer: Modification of charge, specimens 175 to 244.

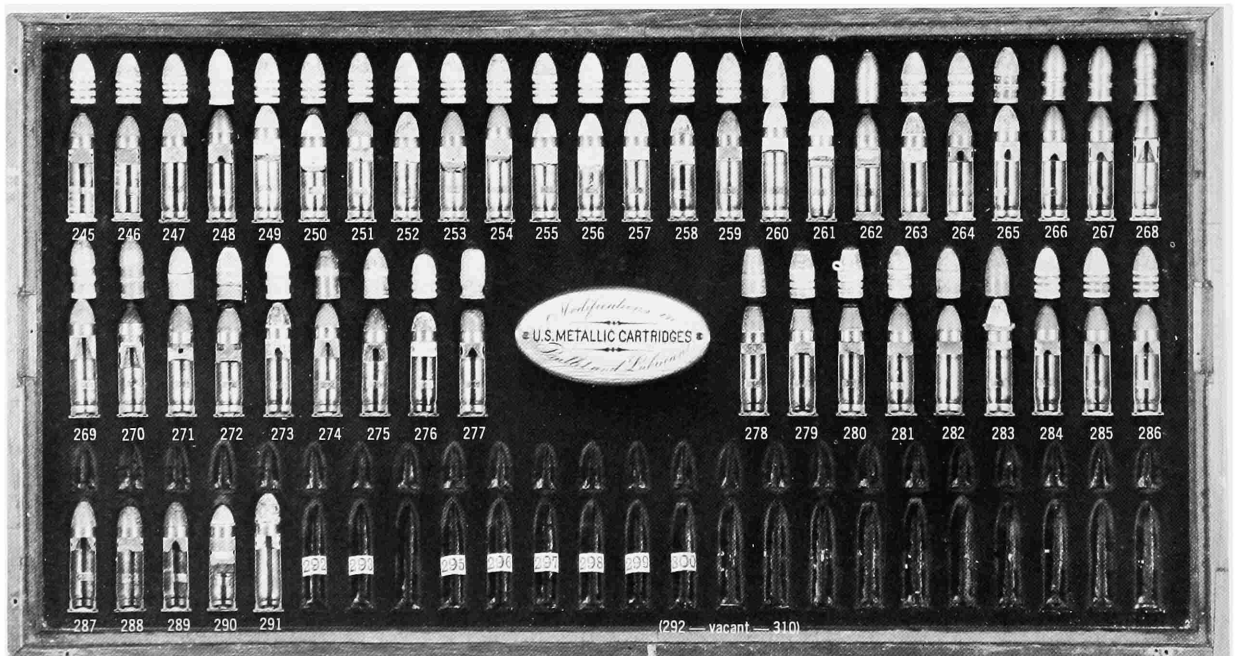

PLATE 14.—Seventh drawer: Modifications in bullet and lubricant, specimens 245-310.

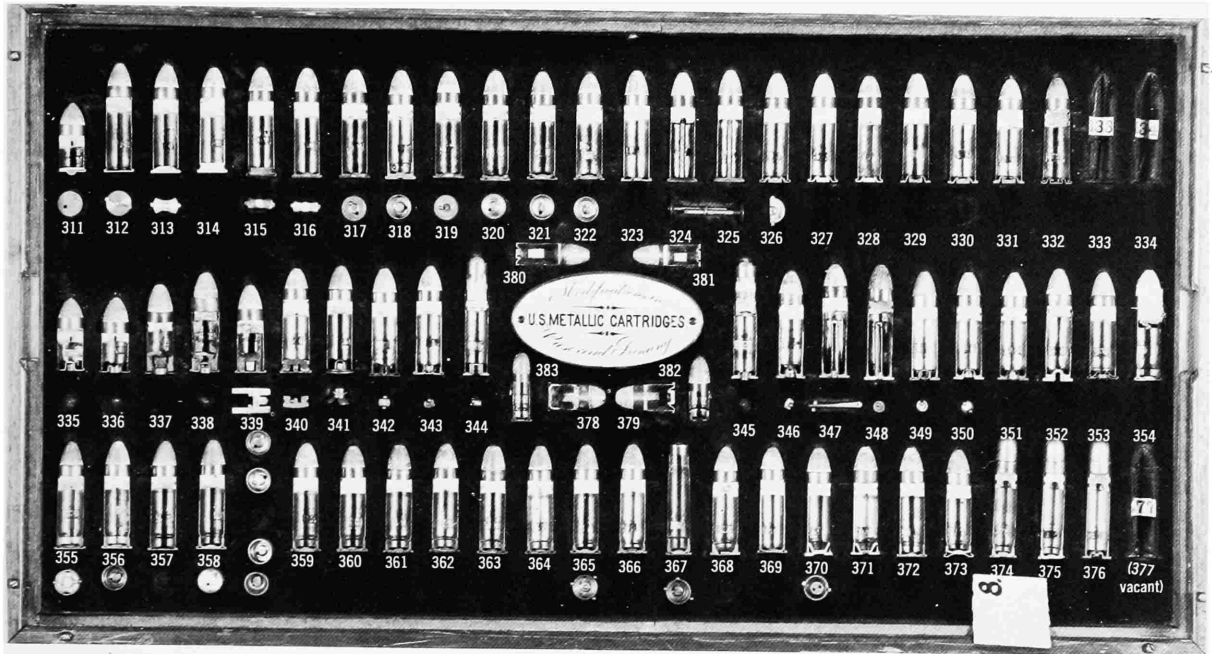

PLATE 15.—Eighth drawer: Anvils and cap-primed cases, specimens 311-383.

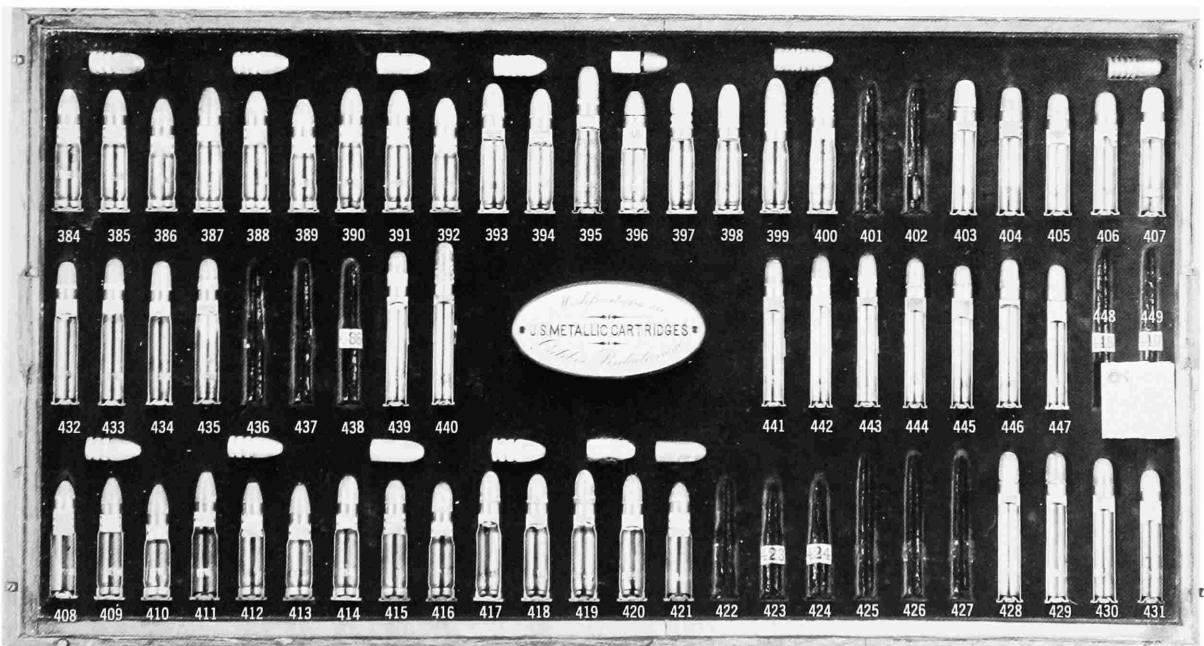

PLATE 16.—Ninth drawer: Modifications in caliber (reductions), specimens 384-449.

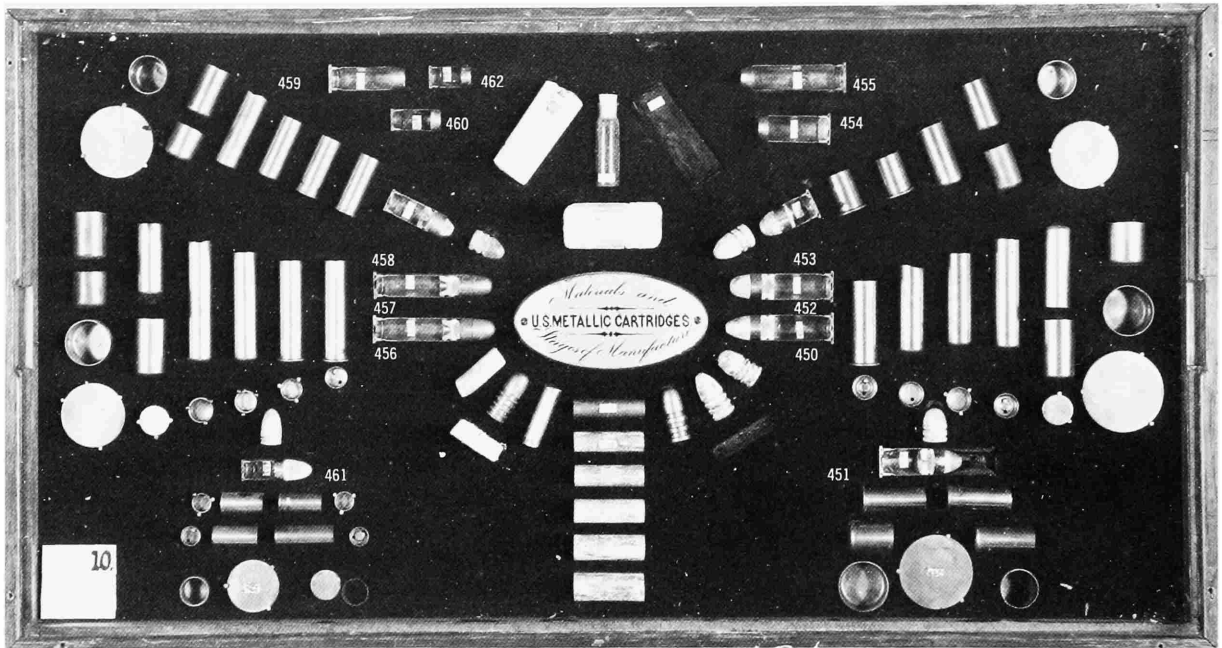

PLATE 17.—Tenth drawer: Service ammunition and stages of manufacture, specimens 450-467.

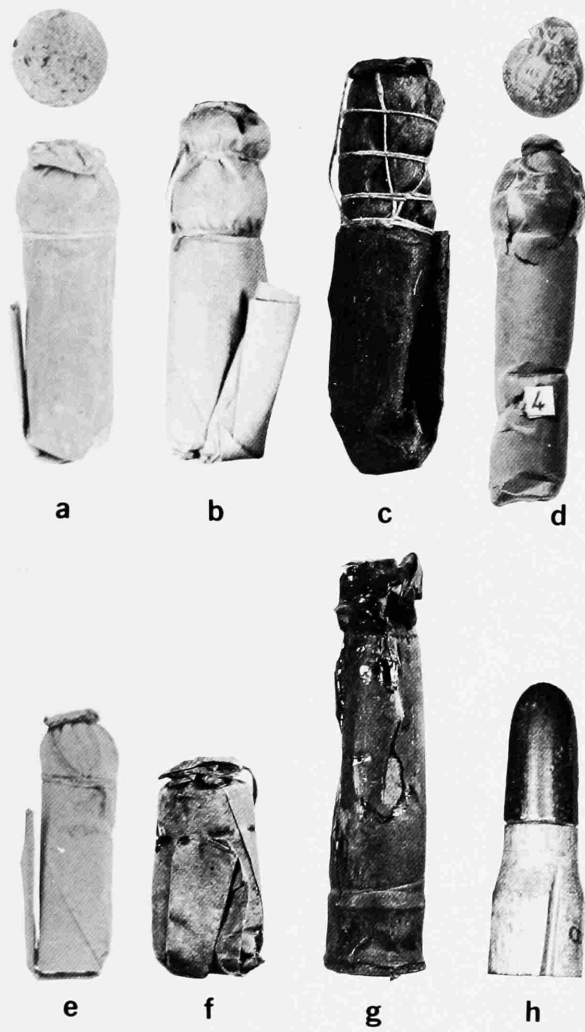

PLATE 18.—Specimens from first drawer: *a*, No. 1; *b*, No. 2; *c*, No. 3; *d*, No. 4; *e*, No. 5; *f*, No. 7 (for caliber .69); *g*, No. 8; *h*, bullet for No. 8.

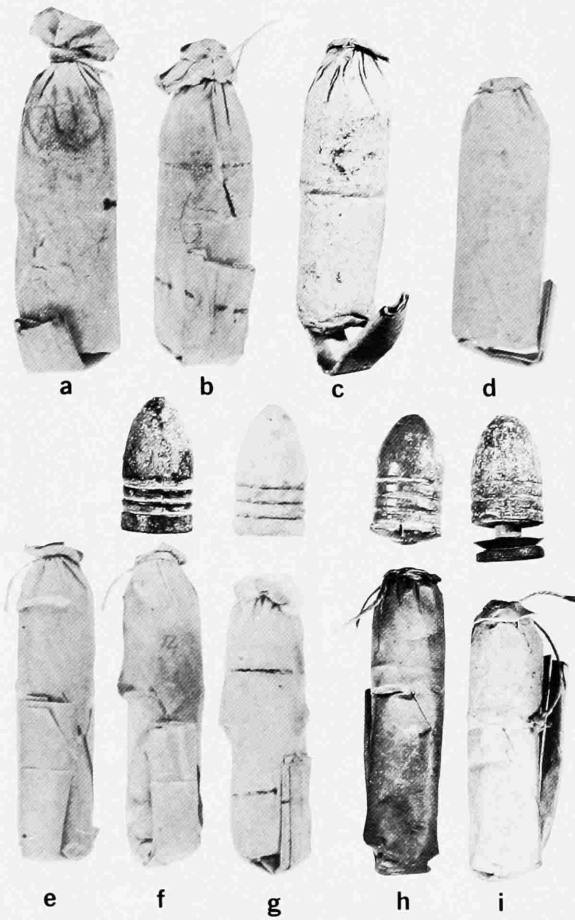

PLATE 19.—Specimens from first drawer: *a*, No. 9; *b*, No. 10; *c*, No. 11; *d*, No. 12; *e*, No. 13; *f*, No. 14; *g*, No. 15; *h*, No. 16; *i*, No. 17.

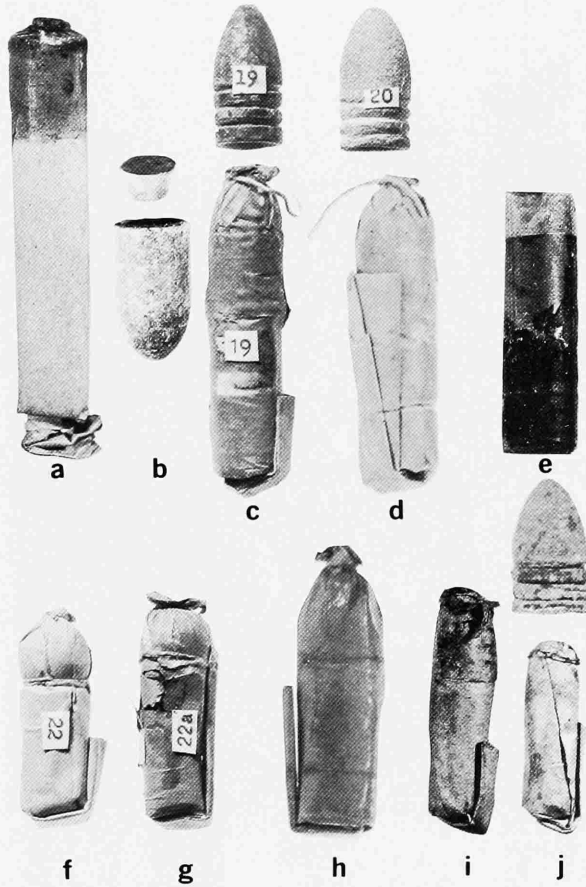

PLATE 20.—Specimens from first drawer: *a*, No. 18; *b*, bullet for No. 18; *c*, No. 19; *d*, No. 20; *e*, No. 21; *f*, No. 22; *g*, No. 22A; *h*, No. 23; *i*, No. 24; *j*, No. 25, bullet above.

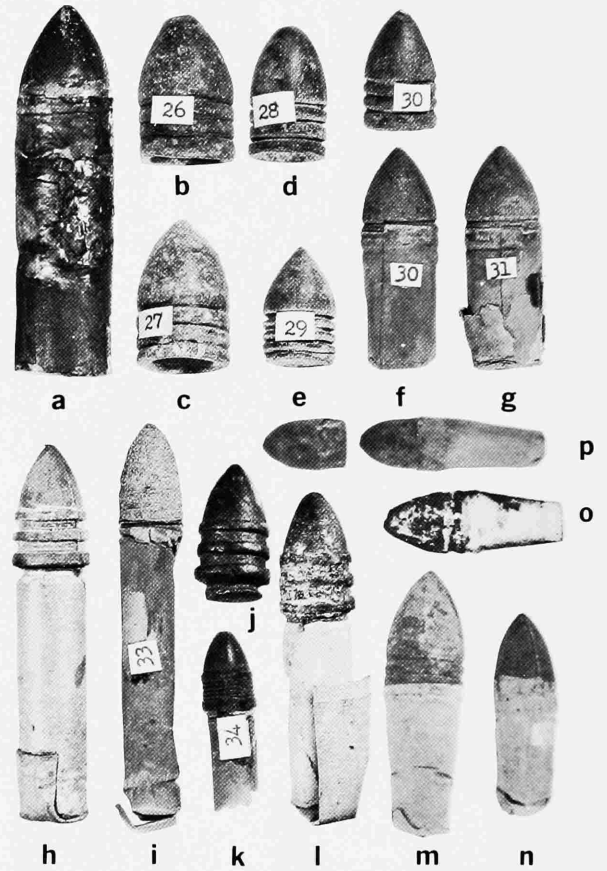

PLATE 21.—Specimens from second drawer: *a*, No. 26; *b*, bullet for No. 26; *c*, bullet for No. 27; *d*, bullet for No. 28; *e*, bullet for No. 29; *f*, No. 30 (bullet above); *g*, No. 31; *h*, No. 32; *i*, No. 33; *j*, bullet for No. 35; *k*, No. 34; *l*, No. 35; *m*, No. 36; *n*, No. 37; *o*, No. 38; *p*, No. 39.

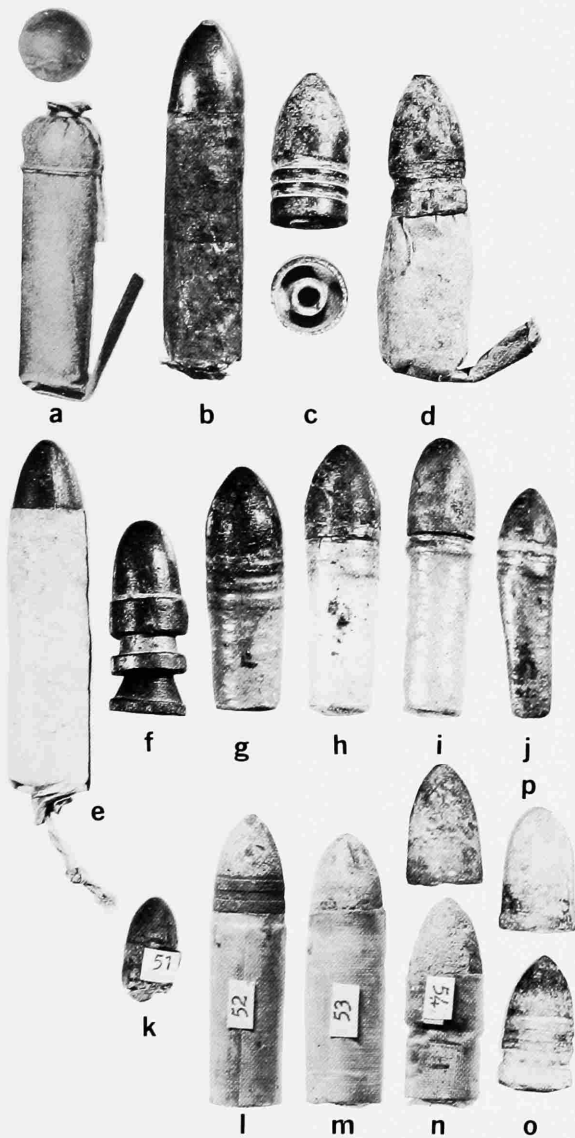

PLATE 22.—Specimens from second drawer: *a*, No. 42; *b*, No. 44; *c*, bullet for No. 44; *d*, No. 45; *e*, No. 46; *f*, bullet for No. 46; *g*, No. 47; *h*, No. 48; *i*, No. 49; *j*, No. 50; *k*, No. 51; *l*, No. 52; *m*, No. 53; *n*, No. 54. [*o*, *p*, bullet above *n*, unidentified; they are not in any of the Frankford Arsenal drawers.—CRG.]

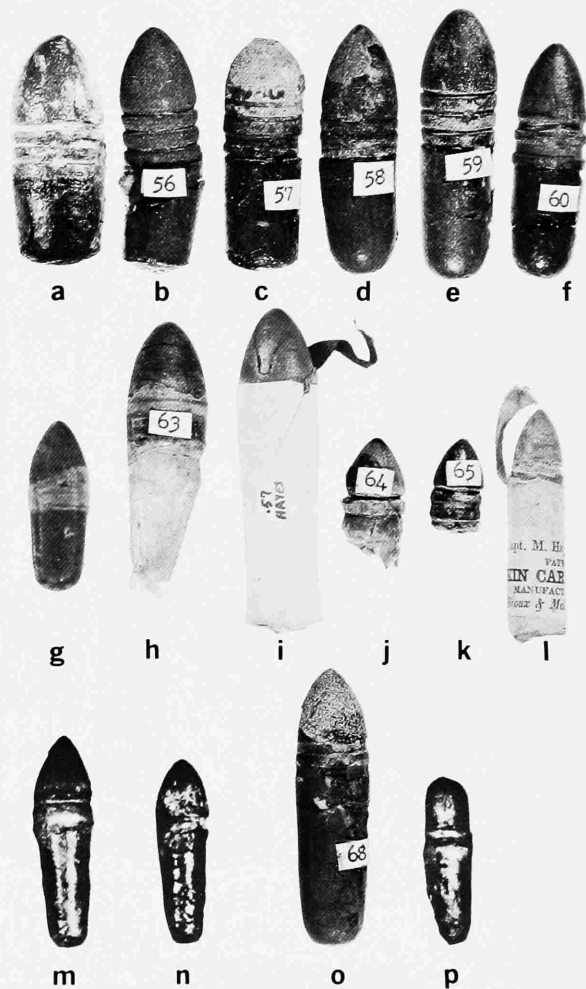

PLATE 23.—Specimens from third drawer: *a*, No. 55; *b*, No. 56; *c*, No. 57; *d*, No. 58; *e*, No. 59; *f*, No. 60; *g*, No. 61; *h*, No. 63; *i*, below No. 63; *j*, No. 64; *k*, No. 65; *l*, below No. 65; *m*, No. 66; *n*, No. 67; *o*, No. 68; *p*, No. 69.

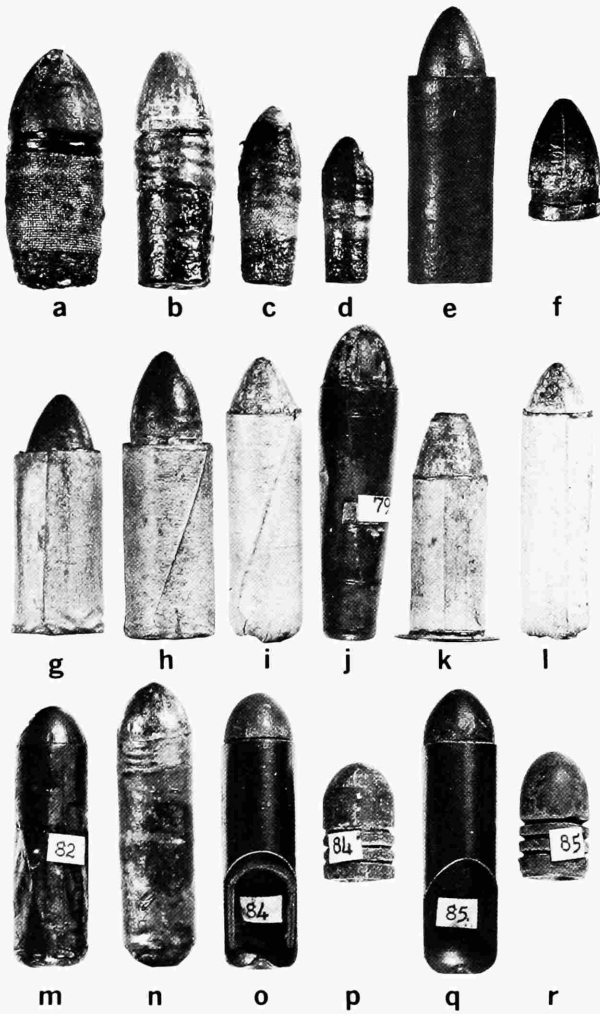

PLATE 24.—Specimens from third drawer: *a*, No. 71; *b*, No. 72; *c*, No. 73; *d*, No. 74; *e*, No. 75; *f*, bullet for No. 75; *g*, No. 76; *h*, No. 77; *i*, No. 78; *j*, No. 79; *k*, No. 80; *l*, No. 81; *m*, No. 82; *n*, No. 83; *o*, No. 84; *p*, bullet for No. 84; *q*, No. 85; *r*, bullet for No. 85.

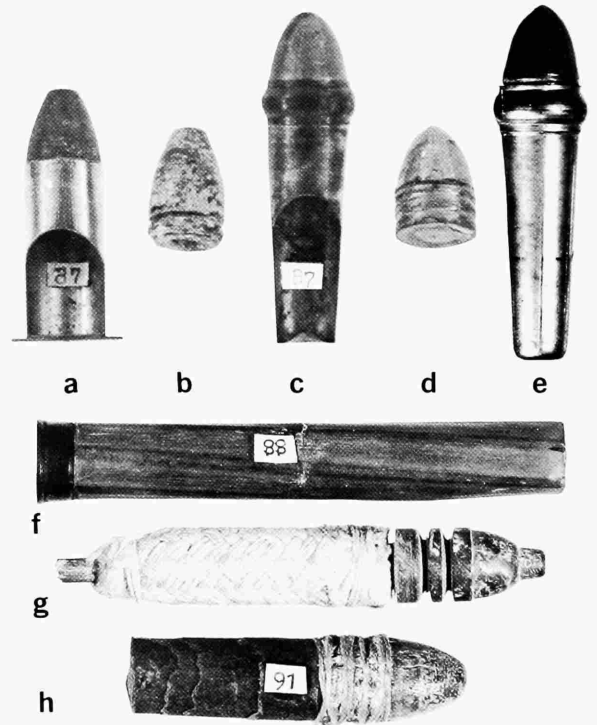

PLATE 25.—Specimens for third drawer: *a*, No. 86; *b*, bullet for No. 86; *c*, No. 87; *d*, bullet for No. 87; *e*, Frankford Arsenal type; *f*, No. 88; *g*, No. 89; *h*, No. 91.

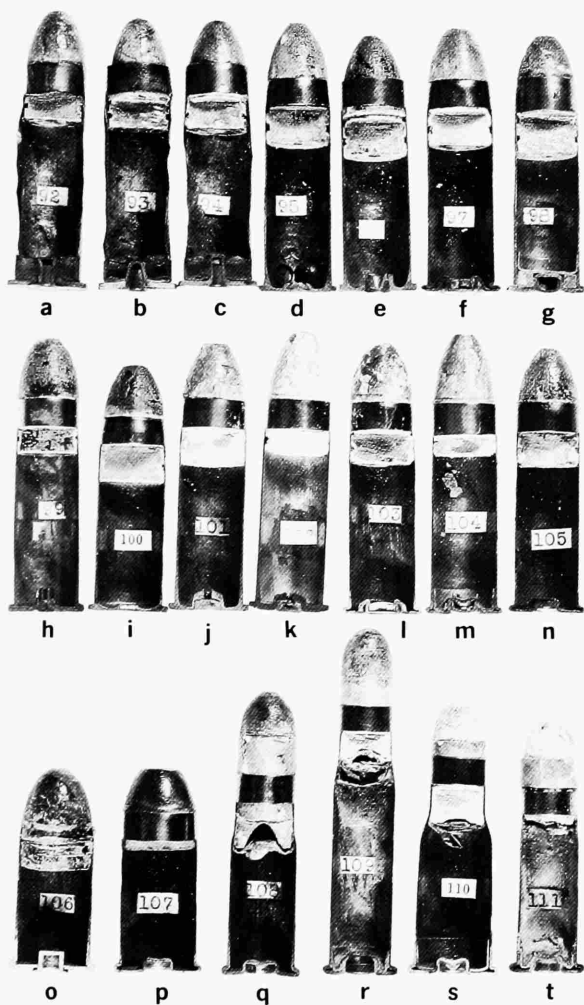

PLATE 26.—Specimens from fourth drawer: *a*, No. 92; *b*, No. 93; *c*, No. 94; *d*, No. 95; *e*, No. 96; *f*, No. 97; *g*, No. 98; *h*, No. 99; *i*, No. 100; *j*, No. 101; *k*, No. 102; *l*, No. 103; *m*, No. 104; *n*, No. 105; *o*, No. 106; *p*, No. 107; *q*, No. 108; *r*, No. 109; *s*, No. 110; *t*, No. 111.

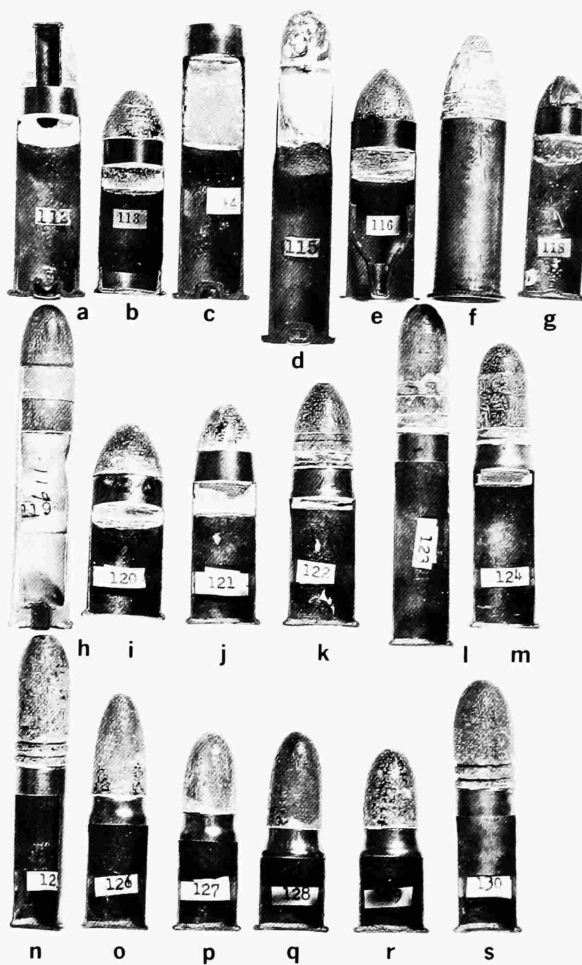

PLATE 27.—Specimens from fourth drawer: *a*, No. 112; *b*, No. 113; *c*, No. 114; *d*, No. 115; *e*, No. 116; *f*, No. 117; *g*, No. 118; *h*, No. 119; *i*, No. 120; *j*, No. 121; *k*, No. 122; *l*, No. 123; *m*, No. 124; *n*, No. 125; *o*, No. 126; *p*, No. 127; *q*, No. 128; *r*, No. 129; *s*, No. 130.



PLATE 28.—Specimens from fourth drawer: *a*, No. 131; *b*, No. 132; *c*, No. 133; *d*, No. 134; *e*, No. 135; *f*, No. 136; *g*, No. 137 (anvil above); *h*, No. 138 (anvil above); *i*, No. 139; *j*, No. 140; *k*, No. 141; *l*, No. 142; *m*, No. 143; *n*, No. 144; *o*, No. 145; *p*, No. 146; *q*, No. 147; *r*, No. 148; *s*, No. 149.

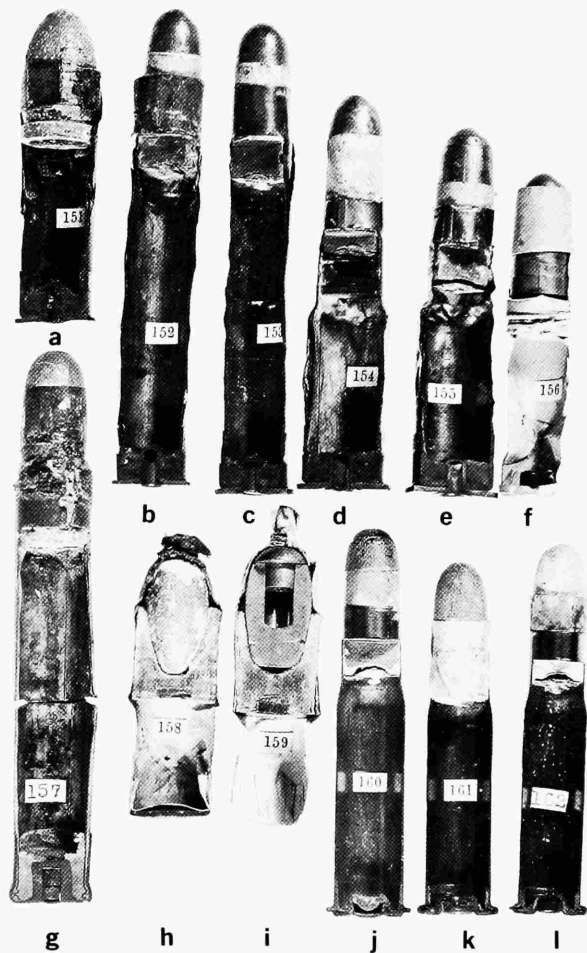

PLATE 29.—Specimens from fifth drawer: *a*, No. 151; *b*, No. 152; *c*, No. 153; *d*, No. 154; *e*, No. 155; *f*, No. 156; *g*, No. 157; *h*, No. 158; *i*, No. 159; *j*, No. 160; *k*, No. 161; *l*, No. 162.

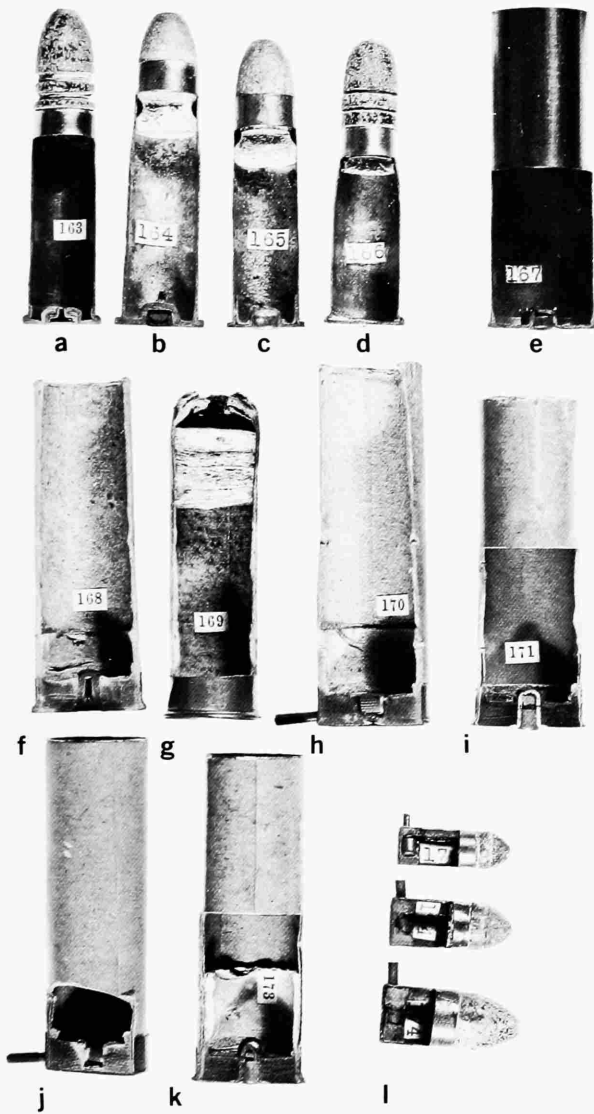

PLATE 30.—Specimens from fifth drawer: *a*, No. 163; *b*, No. 164; *c*, No. 165; *d*, No. 166; *e*, No. 167; *f*, No. 168; *g*, No. 169; *h*, No. 170; *i*, No. 171; *j*, No. 172; *k*, No. 173; *l*, No. 174.

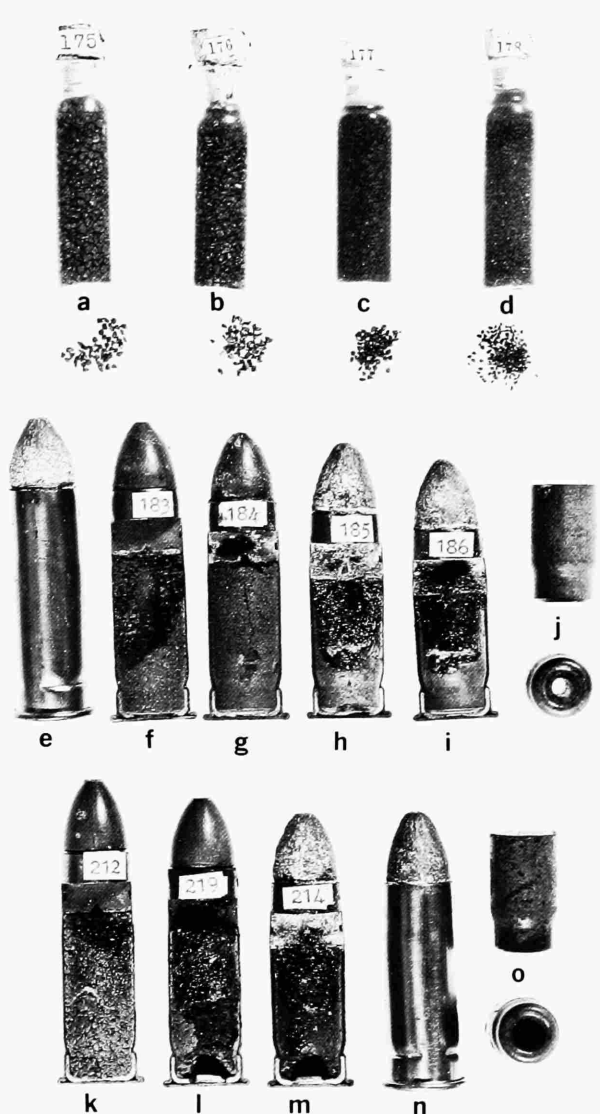

PLATE 31.—Specimens from sixth drawer: *a*, No. 175 Oriental musket powder; *b*, No. 176 Hazard musket powder; *c*, No. 177 DuPont musket powder; *d*, No. 178 DuPont rifle powder; *e*, No. 183, example of 1.75-inch case; *f*, No. 183, example of Oriental powder series perforated grains; *g*, No. 184, 1.65-inch case, example of Oriental powder series perforated grains; *h*, No. 185, 1.55-inch case, example of Oriental powder series perforated grains; *i*, No. 186, 1.45-inch case; *j*, typical perforated charge; *k*, No. 212, 1.65-inch case, Hazard series with conical cavity; *l*, No. 219, Hazard series with conical cavity; *m*, No. 214, 1.55-inch case, Hazard series with conical cavity; *n*, No. 214, 1.55-inch case; *o*, Typical conical cavity charge.

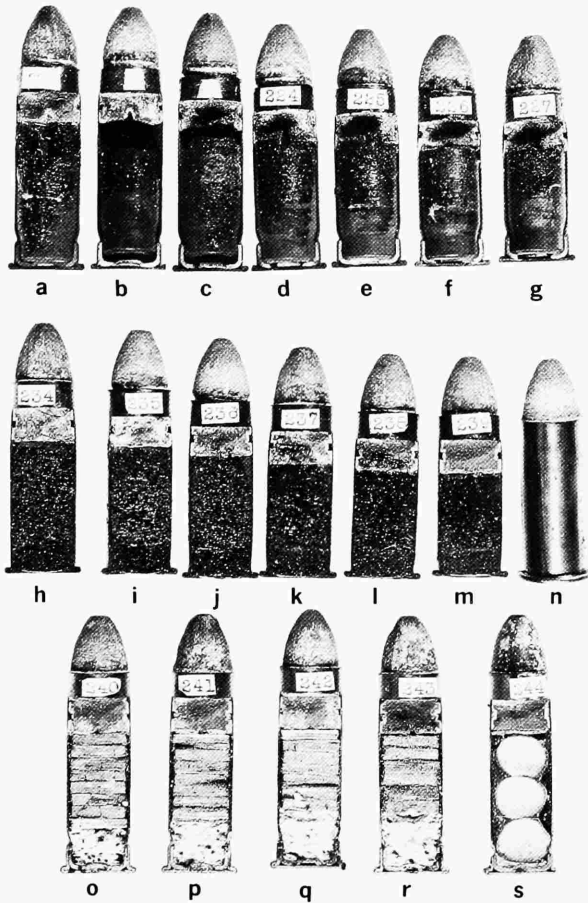

PLATE 32.—Specimens from sixth drawer: *a*, No. 221, 1.75-inch case; *b*, No. 222, 1.70-inch case; *c*, No. 223, 1.65-inch case; *d*, No. 224, 1.60-inch case; *e*, No. 225, 1.55-inch case; *f*, No. 226, 1.50-inch case; *g*, No. 227, 1.45-inch case; *h*, No. 234; *i*, No. 235; *j*, No. 236; *k*, No. 237; *l*, No. 238; *m*, No. 239; *n*, No. 239, 1.45-inch case; *o*, No. 240; *p*, No. 241; *q*, No. 242; *r*, No. 243; *s*, No. 244.

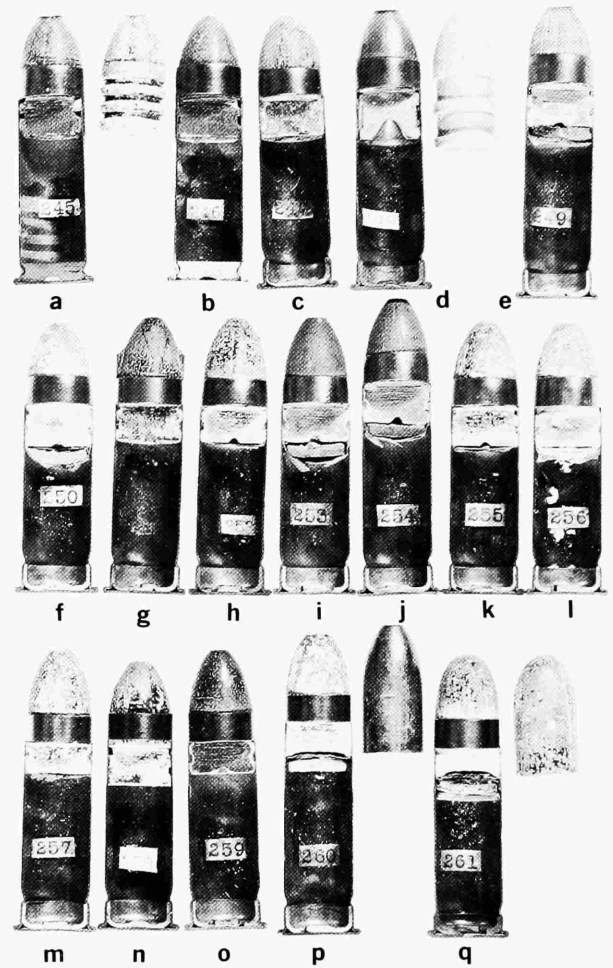

PLATE 33.—Specimens from seventh drawer: *a*, No. 245, bullet to right; *b*, No. 246; *c*, No. 247; *d*, No. 248, bullet to right; *e*, No. 249; *f*, No. 250; *g*, No. 251; *h*, No. 252; *i*, No. 253; *j*, No. 254; *k*, No. 255; *l*, No. 256; *m*, No. 257; *n*, No. 258; *o*, No. 259; *p*, No. 260, bullet to right; *q*, No. 261, bullet to right.

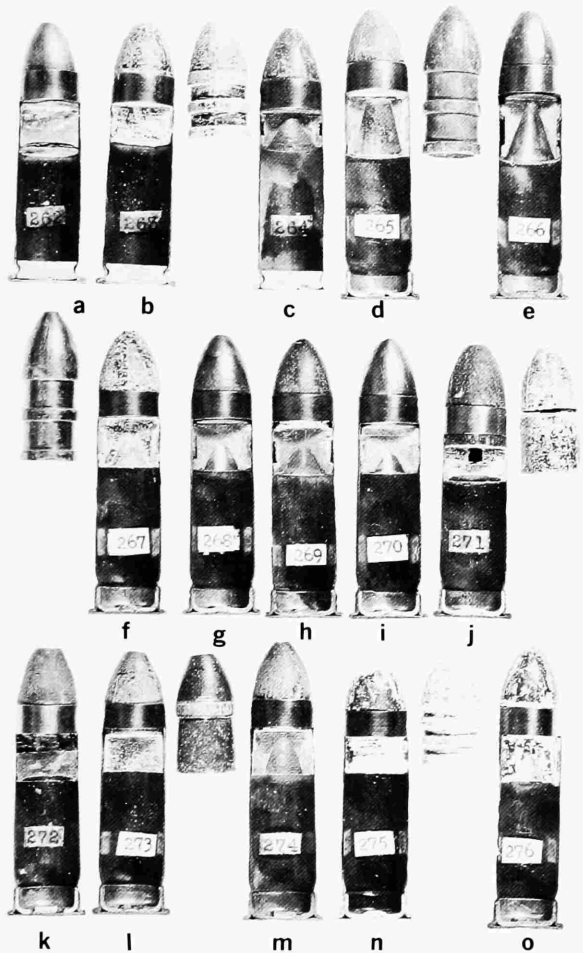

PLATE 34.—Specimens from seventh drawer: *a*, No. 262; *b*, No. 263, bullet to right; *c*, No. 264; *d*, No. 265, bullet to right; *e*, No. 266, bullet left of *f*; *f*, No. 267; *g*, No. 268; *h*, No. 269; *i*, No. 270; *j*, No. 271, bullet to right; *k*, No. 272; *l*, No. 273, bullet to right; *m*, No. 274; *n*, No. 275, bullet to right; *o*, No. 276.

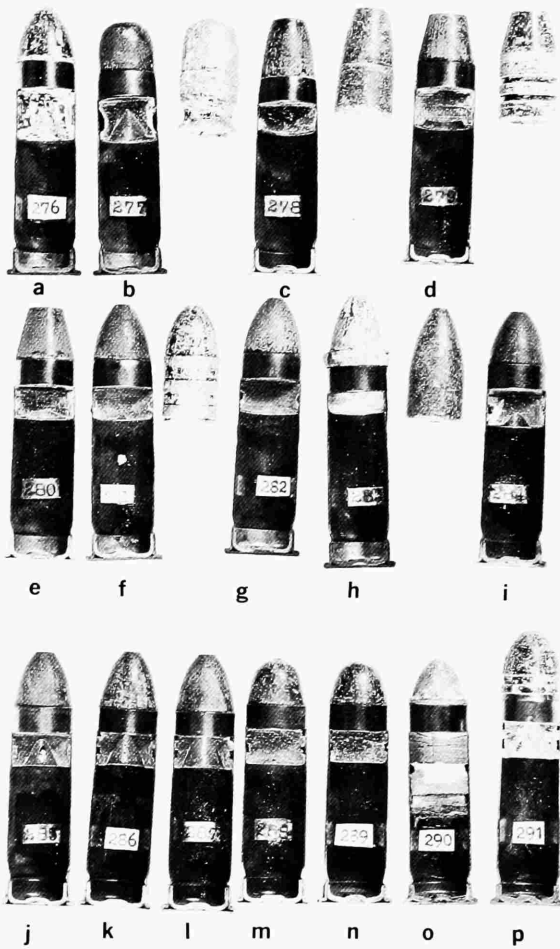

PLATE 35.—Specimens from seventh drawer: *a*, No. 276 (duplicate); *b*, No. 277, bullet to right; *c*, No. 278, bullet to right; *d*, No. 279, bullet to right; *e*, No. 280; *f*, No. 281, bullet to right; *g*, No. 282; *h*, No. 283, bullet to right; *i*, No. 284; *j*, No. 285; *k*, No. 286; *l*, No. 287; *m*, No. 288; *n*, No. 289; *o*, No. 290; *p*, No. 291.

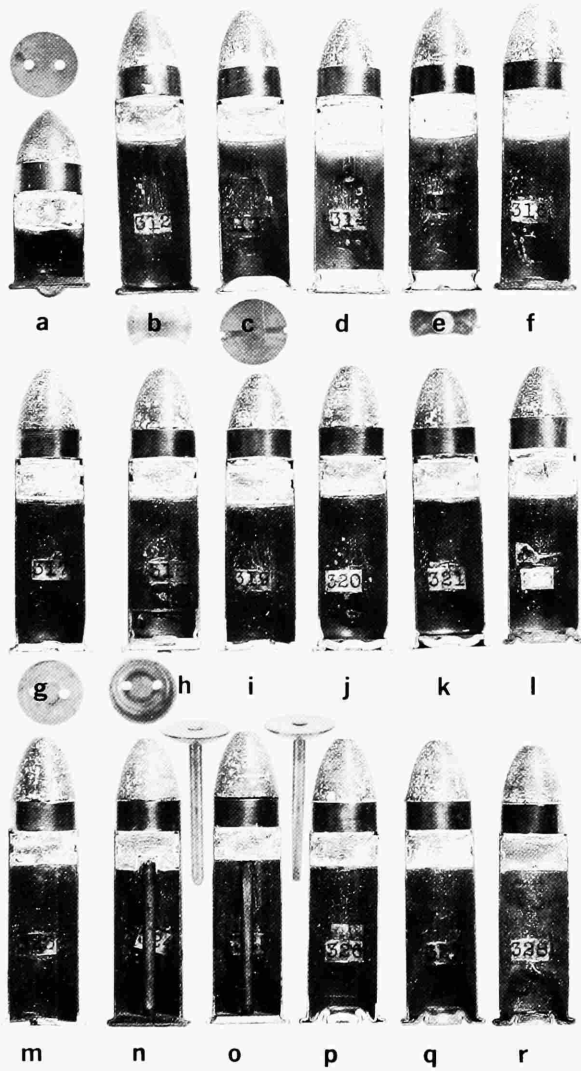

PLATE 36.—Specimens from eighth drawer: *a*, No. 311, anvil above; *b*, No. 312, anvil below; *c*, No. 313, anvil below; *d*, No. 314; *e*, No. 315, anvil below; *f*, No. 316; *g*, No. 317, anvil below; *h*, No. 318, anvil below; *i*, No. 319; *j*, No. 320; *k*, No. 321; *l*, No. 322; *m*, No. 323; *n*, No. 324, disk and anvil to right; *o*, No. 325, disk and anvil to right; *p*, No. 326; *q*, No. 327; *r*, No. 328.

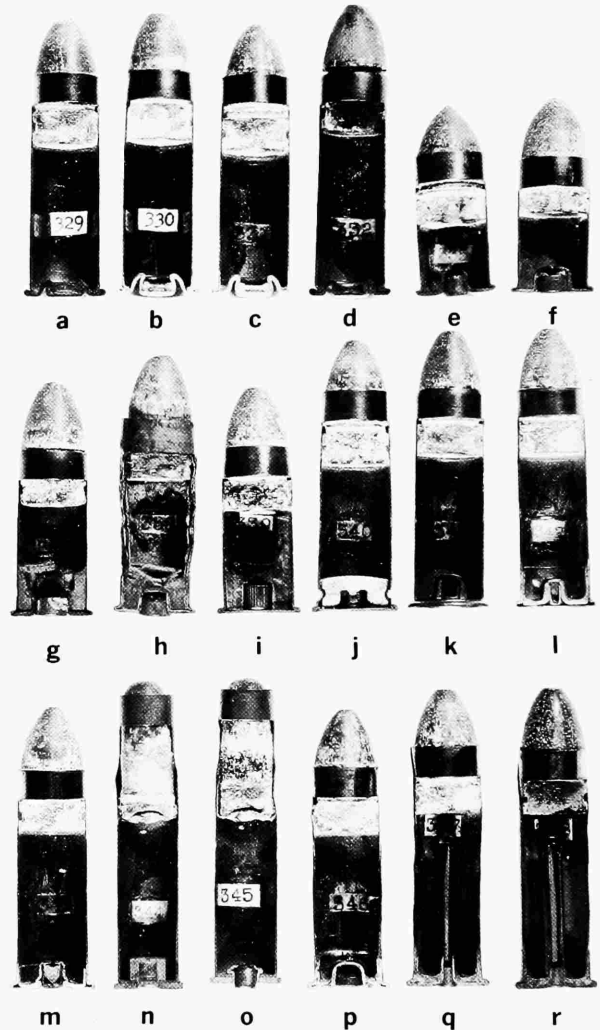

PLATE 37.—Specimens from eighth drawer: *a*, No. 329; *b*, No. 330; *c*, No. 331; *d*, No. 332; *e*, No. 335; *f*, No. 336; *g*, No. 337; *h*, No. 338; *i*, No. 339; *j*, No. 340; *k*, No. 341; *l*, No. 342; *m*, No. 343; *n*, No. 344; *o*, No. 345; *p*, No. 346; *q*, No. 347; *r*, No. 348.

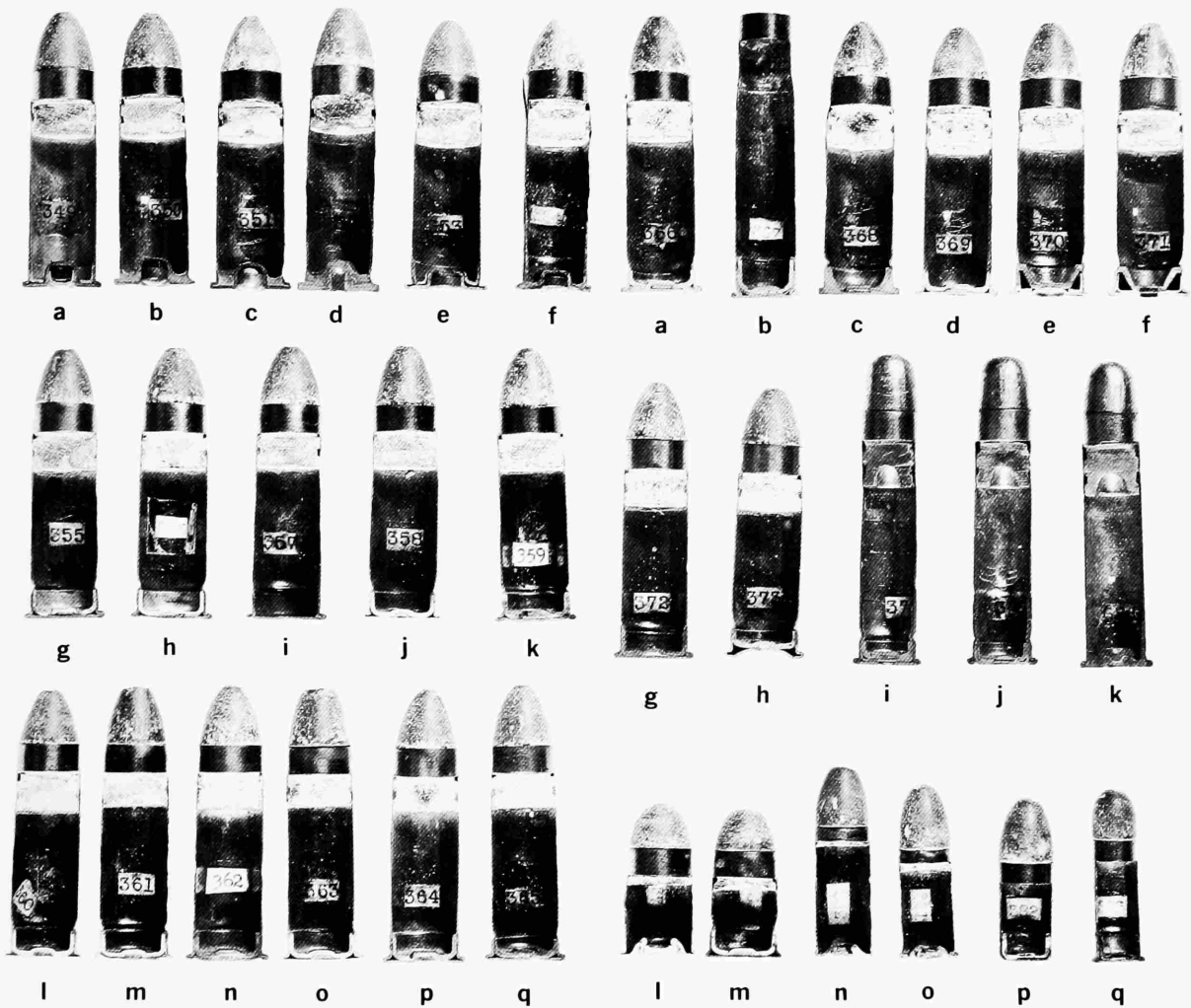

PLATE 38.—Specimens from eighth drawer: *a*, No. 349; *b*, No. 350; *c*, No. 351; *d*, No. 352; *e*, No. 353; *f*, No. 354; *g*, No. 355; *h*, No. 356; *i*, No. 357; *j*, No. 358; *k*, No. 359; *l*, No. 360; *m*, No. 361; *n*, No. 362; *o*, No. 363; *p*, No. 364; *q*, No. 365.

PLATE 39.—Specimens from eighth drawer: *a*, No. 366; *b*, No. 367; *c*, No. 368; *d*, No. 369; *e*, No. 370; *f*, No. 371; *g*, No. 372; *h*, No. 373; *i*, No. 374; *j*, No. 375; *k*, No. 376; *l*, No. 377; *m*, No. 378; *n*, No. 380; *o*, No. 381; *p*, No. 382; *q*, No. 383.

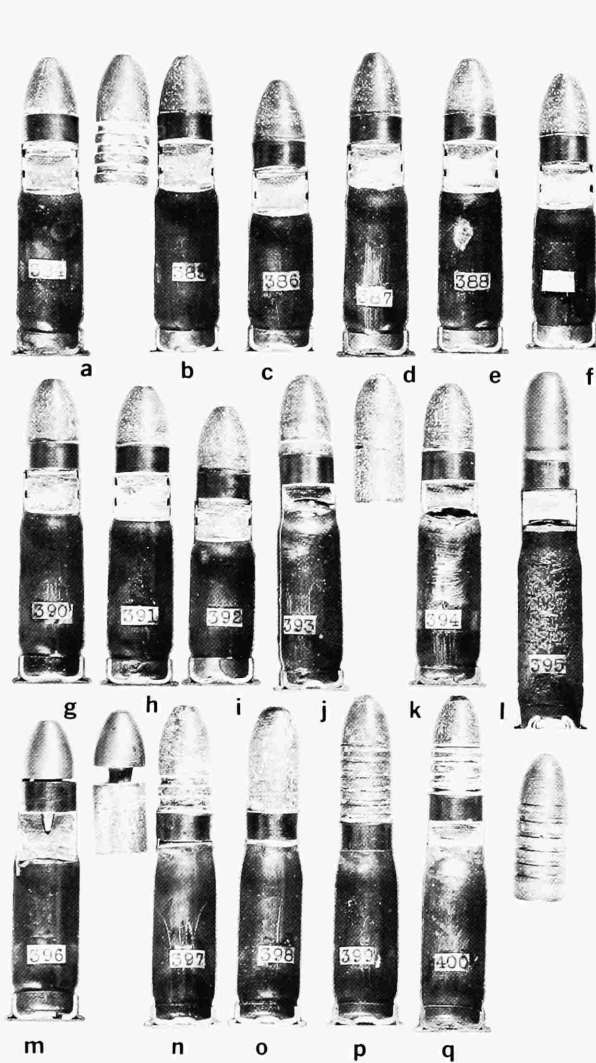

PLATE 40.—Specimens from ninth drawer: *a*, No. 384, bullet to right; *b*, No. 385; *c*, No. 386; *d*, No. 387; *e*, No. 388; *f*, No. 389; *g*, No. 390; *h*, No. 391; *i*, No. 392; *j*, No. 393, bullet to right; *k*, No. 394; *l*, No. 395; *m*, No. 396, bullet to right; *n*, No. 397; *o*, No. 398; *p*, No. 399; *q*, No. 400, bullet to right.

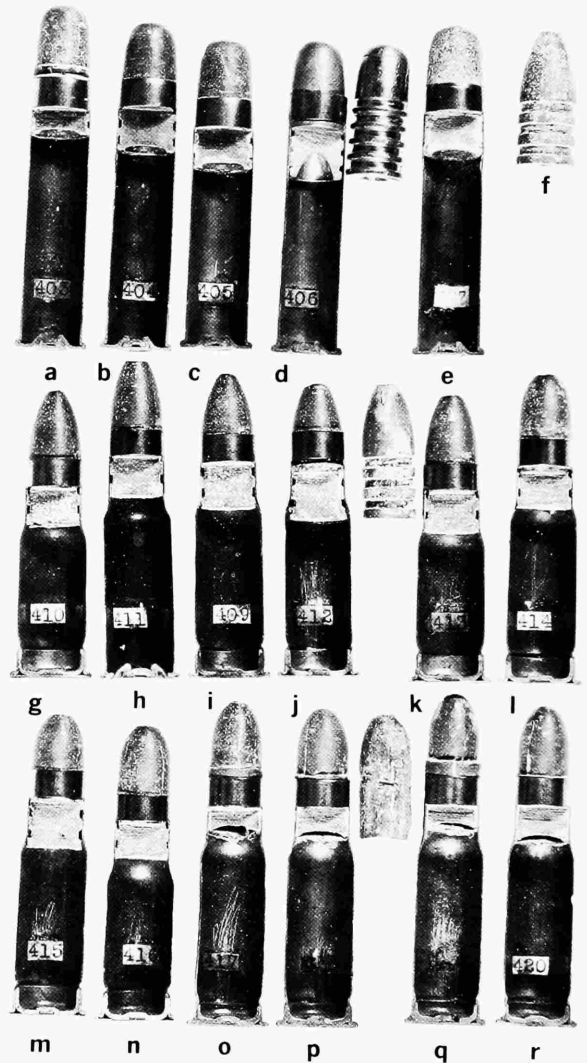

PLATE 41.—Specimens from ninth drawer: *a*, No. 403; *b*, No. 404; *c*, No. 405; *d*, No. 406, bullet to right; *e*, No. 407; *f*, bullet to No. 407; *g*, No. 410; *h*, No. 411; *i*, No. 409; *j*, No. 412, bullet to right; *k*, No. 413; *l*, No. 414; *m*, No. 415; *n*, No. 416; *o*, No. 417; *p*, No. 418, bullet to right; *q*, No. 419; *r*, No. 420.



PLATE 42.—Specimens from ninth drawer: *a*, No. 421, bullet above; *b*, No. 428; *c*, No. 429; *d*, No. 430; *e*, No. 431; *f*, No. 432; *g*, No. 433; *h*, No. 434; *i*, No. 435; *j*, No. 439; *k*, No. 440; *l*, No. 441; *m*, No. 442; *n*, No. 443; *o*, No. 444; *p*, No. 445; *q*, No. 446; *r*, No. 447.

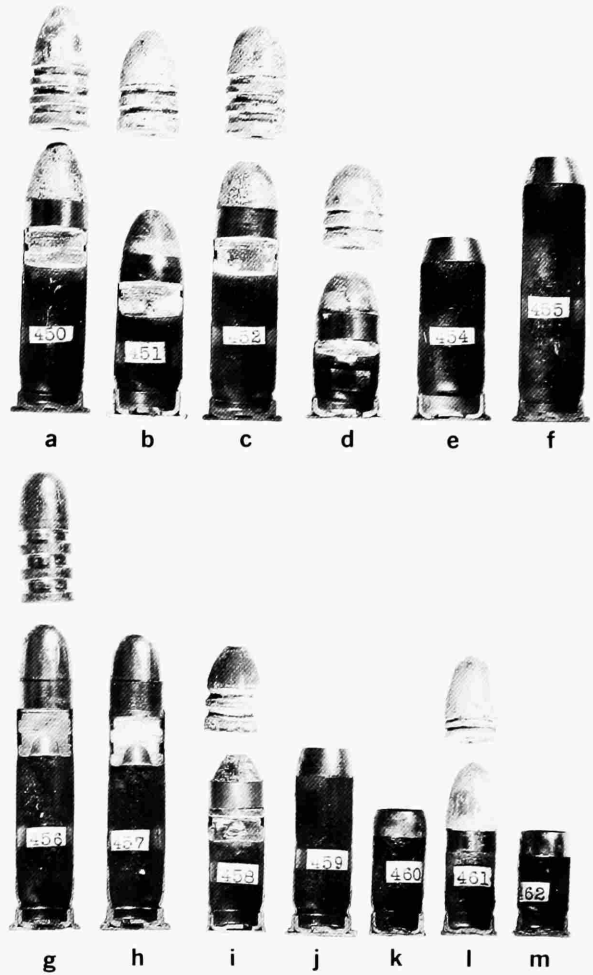

PLATE 43.—Specimens from tenth drawer: *a*, No. 450, bullet above; *b*, No. 451, bullet above; *c*, No. 452, bullet above; *d*, No. 453, bullet above; *e*, No. 454; *f*, No. 455; *g*, No. 456, bullet above; *h*, No. 457; *i*, No. 458, bullet above; *j*, No. 459; *k*, No. 460; *l*, No. 461, bullet above; *m*, No. 462.

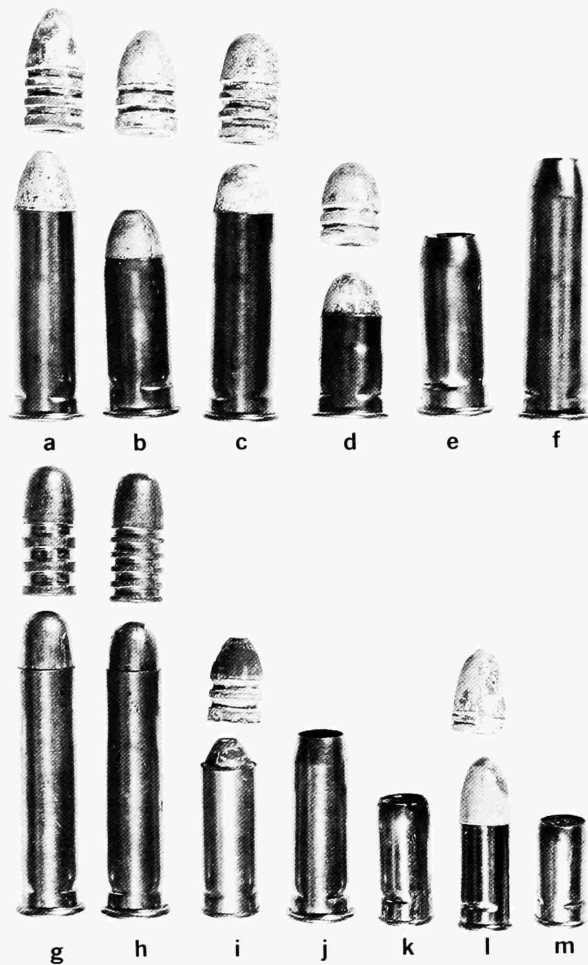

PLATE 44.—Specimens from tenth drawer: *a*, No. 450, bullet above; *b*, No. 451, bullet above; *c*, No. 452, bullet above; *d*, No. 453, bullet above; *e*, No. 454; *f*, No. 455; *g*, No. 456, bullet above; *h*, No. 457, bullet above; *i*, No. 458, bullet above; *j*, No. 459; *k*, No. 460; *l*, No. 461, bullet above; *m*, No. 462.

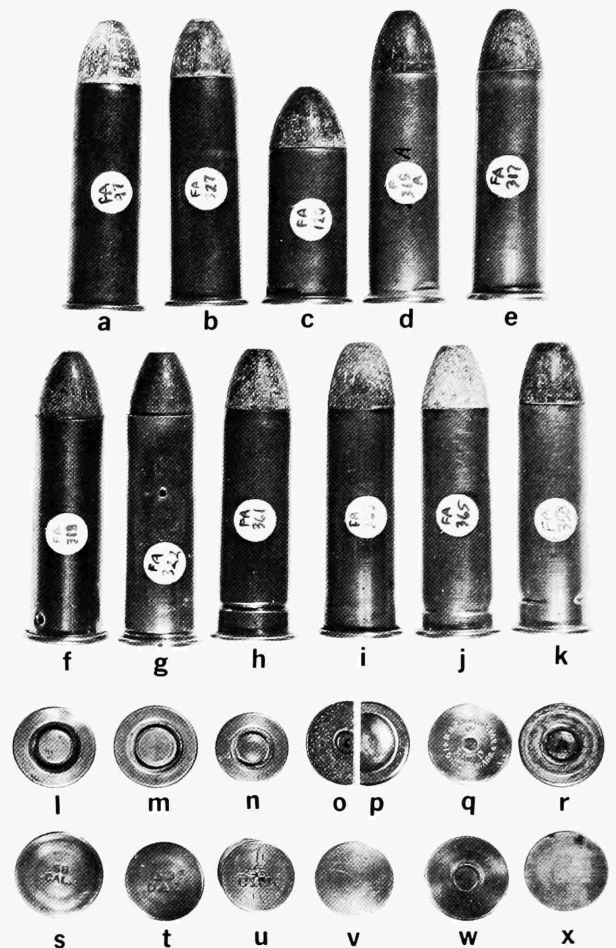

PLATE 45.—Case and head types. Cases: *a*, Remington's Martin-primed with re-entrant fold at head (No. 97); *b*, Springfield Martin-primed with simple fold at head (No. 327); *c*, Bar-primed variant, crimps .092 inch from head (No. 120); *d*, Frankford Arsenal type bar anvil, crimps .110 inch from head (No. 315A); *e*, Wide indents for disk anvil (No. 317); *f*, Stab crimp (No. 318); *g*, Disk anvil, 360-degree crimp (No. 322); *h*, Double crimp (No. 361); *i*, Case reduced above cup anvil (No. 363); *j*, Shallow cup, crimps .197 inch from base (No. 365); *k*, Deep cup, crimps .257 inch from base (No. 358). Heads: *l*, Remington head, Martin primer (No. 97); *m*, Springfield head, Martin primer (No. 327); *n*, Springfield head, Martin primer, cal. 45 (No. 403); *o*, Winchester Millbank's patent primer (No. 99); *p*, Corrugated base (No. 361); *q*, USC Company, Meigs headstamp (No. 100); *r*, Typical Berdan head by UMC Company (No. 104); *s*, Springfield "58 CAL" marking (No. 120); *t*, Springfield "50 CAL" marking (No. 121); *u*, Springfield "45 CAL" marking (No. 122); *v*, Frankford "U.S. CARBINE" marking (No. 457); *w*, USC Company Farrington's patent primer (No. 114); *x*, Winchester Hotchkiss' patent primer (No. 95) [Note line where primer is inserted is barely visible].