

Mason-Willis-Dixon House
Portsmouth Village
Cape Lookout National Seashore

Historic Structure Report



December 2015

for

Cape Lookout National Seashore
Southeast Region, National Park Service

by

JOSEPH K. OPPERMAN-ARCHITECT, P.A.

539 N. Trade Street Winston-Salem, NC 27101

www.jkoa.net | office@jkoa.net | (336)721-1711

Mason-Willis-Dixon House
Portsmouth Village
Cape Lookout National Seashore

Historic Structure Report

December 2015

for

Cape Lookout National Seashore
Southeast Region, National Park Service

by

JOSEPH K. OPPERMANN-ARCHITECT, P.A.

539 N. Trade Street Winston-Salem, NC 27101

www.jkoa.net | office@jkoa.net | (336)721-1711



Cultural Resources, Partnerships,
and Science Division
Southeast Region
National Park Service
100 Alabama St. SW
Atlanta, GA 30303
(404) 507-5847

2015
Historic Structure Report
Mason-Willis-Dixon House
Portsmouth Village
Cape Lookout National Seashore (CALO)

Mason-Willis-Dixon House
LCS #: 012514
CALO ID#: 503
Mason-Willis-Dixon Shed
LSC #: None Associated

The historic structure report presented here exists in two formats. A traditional, printed version is available for study at the park, at the Southeast Regional Office of the NPS (SERO), and at a variety of other repositories. For more widespread access, the historic structure report also exists in digital format through the IRMA Portal, Integrated Resource Management Applications, including the NPS Data Store, accessed at <https://irma.nps.gov/App/Reference/Welcome>, a website of the National Park Service.

Mason-Willis-Dixon House
Portsmouth Village
Cape Lookout National Seashore
Historic Structure Report
2015

Approved by: Pat M. Ky 02/23/16
Superintendent, Cape Lookout National Seashore Date

Recommended by: Acting [Signature] 4/26/16
Chief, Cultural Resources Partnerships & Science Division, Southeast Region Date

Recommended by: [Signature] 4/28/16
ACTING Deputy Regional Director, Southeast Region Date

Approved by: [Signature] 4/28/16
Regional Director, Southeast Region Date

Foreword

We are pleased to make available this Historic Structures Report, part of our ongoing effort to provide comprehensive documentation for the historic structures and cultural landscapes of National Park Service units in the Southeast Region. A number of individuals contributed to the successful completion of this work, but we would particularly like to thank the Project Team who authored the report.

The authors would like to thank the staff at Cape Lookout National Seashore who assisted with the project, especially Patrick Kenney, Superintendent; Jeri L. DeYoung, Chief of Resource Management, who provided helpful comments; and Karen L. Duggan, park ranger, whose research on the people of Portsmouth was used in this report. Dr. Ali Miri, historical architect with the National Park Service's Southeast Regional Office, provided helpful comments as part of his technical review and project oversight. The authors extend special appreciation to the Friends of Portsmouth Island and the many volunteers and descendants who readily provided information and interviews. We hope that this study will prove valuable to park management in ongoing efforts to preserve the house and shed, and other Portsmouth buildings, and to everyone in understanding and interpreting these unique resources.

Dan Scheidt, Chief
Cultural Resources, Partnerships, and Science Division
Southeast Regional Office
2015

Table of Contents

Project Team.....	vii
Management Summary	1
Administrative Data	9

Part I - Developmental History

A. Historical Background and Context.....	13
B. Chronology of Development and Use	25
Timeline	41
C. Physical Description.....	45
General Description	45
Locale	45
The Architecture	48
Construction Characteristics.....	50
Structural Systems.....	50
Exterior Features.....	55
Interior Features.....	64
Room-by-Room Descriptions.....	65
Character-Defining Features.....	79
Summary of Concerns.....	81

Part II - Treatment & Use

A. Ultimate Treatment & Use.....	83
B. Requirements for Treatment.....	85
C. Alternatives for Treatment and Use.....	89
D. Recommendations for Treatment and Use.....	91

Bibliography	97
---------------------------	----

Appendix

Documentation Drawings	
Floor Plan	
North Elevation	
East Elevation	
South Elevation	
West Elevation	
Shed Plan	
Interior Details	

Project Team

National Park Service – Southeast Regional Office

Laurie Chestnut, Contracting Officer

Dr. Ali Miri, Historical Architect and Contracting Officer’s Technical Representative

National Park Service – Cape Lookout National Seashore

Patrick Kenney, Superintendent

Jeri L. DeYoung, Chief of Resource Management

Joseph K. Oppermann–Architect, P.A. (JKOA)

Joseph K. Oppermann, FAIA, Historical Architect

Langdon E. Oppermann, Architectural Historian

Rebecca L. McCormick, AIA

Christopher M. Woollard, Associate AIA

Management Summary

The purpose of this report is to document the development, use, and current condition of the Mason-Willis-Dixon House (Harry and Lida Dixon House) in the Portsmouth Village Historic District at Cape Lookout National Seashore. The National Park Service (NPS) will use this report to inform and guide its stewardship of this historic structure.

The house and its reconstructed shed are part of a group of historic structures that provide what is perhaps the iconic image of Portsmouth. Anchored by the Methodist church, this concentration of residences, outbuildings, community buildings and cemeteries provides visitors a sense of the village in the early twentieth century when it was still a thriving community. Treatment and use of the present house and shed should be predicated on preserving their place in that ensemble of buildings.

The present study first provides historical background and context for Portsmouth Village based on a series of studies, interviews, and reports developed by NPS since the 1970s. Portsmouth's history has been well documented; this Historic Structure Report includes no additional archival research on the larger community, but does include substantial research and historical documentation on the house and its considerable changes over the years.

Determination of the physical evolution of the house is based primarily on early photographs combined with building investigation and extensive dating of building fabric, a process sometimes called "building archaeology."

The report is divided into two major segments, Part I: *Developmental History*, and Part II: *Treatment & Use*. Part I is organized into three sections that address in sequence the historical background and context of Portsmouth; a chronology of development and use of the house specifically, including a timeline; and a physical description of the house's exterior and interior on a room-by-room basis. This last section

includes an assessment of condition and a listing of character-defining features.

Part II presents the recommended "ultimate treatment and use," and also examines alternatives for treatment and use as well as requirements that guide the house's treatment and use. A bibliography follows.

The Appendix contains scaled drawings of floor plans, exterior elevations of the existing building, and selected details.

Historical Overview

Established in 1753 by an act of the colonial legislature of North Carolina, Portsmouth is located on the south side of Ocracoke Inlet, which was the principal access into Pamlico Sound and North Carolina's seaports until a storm opened competing Hatteras Inlet in 1846. The community flourished in the late eighteenth century and by 1800 was the largest on the Outer Banks with a population between 200 and 250. Because Portsmouth was a center of maritime trade, the Federal government established a customs house there in 1806, a marine hospital in 1827, and a post office in 1840. The town reached its peak population in 1860 with more than 600 residents.

Evacuated during the Civil War, Portsmouth recovered neither its population nor its economic vitality, and the customs house was abolished in 1867. As the inlet shoaled up and the population declined, the number of houses in the town dwindled as well, falling from 109 in 1860, to 59 in 1870, and to 44 in 1880. Many buildings must have sat abandoned in the late nineteenth century, including the marine hospital, which burned in 1894. Of those that survived hurricanes and the generally harsh environment, most were dismantled or relocated as the village slowly contracted along with the local economy. After 1883, the shifting sands of the Outer Banks closed Ocracoke Inlet to shipping.

The village got a boost in 1894 when the U. S. Life-Saving Service built a station at Portsmouth. Over the next four decades, a number of Portsmouth residents found employment there. Others made a livelihood in commercial fishing or catering to the wealthy sportsmen who frequented the Outer Banks to hunt and fish.

The island was regularly inundated by tidal surges accompanying tropical storms and hurricanes; these often caused more damage than the wind. In September 1913, for example, a relatively weak hurricane blew across Portsmouth, but the accompanying storm surge destroyed both the Primitive Baptist and Methodist churches, the only buildings of worship on the island. The community was still strong enough, however, to support construction of a new church.

In 1933, a strong hurricane hit the village with sustained winds of 100 mph and torrential rain that flooded most of the island and destroyed many houses. Many residents moved to the mainland.

In 1937, the Coast Guard Station (former Life-Saving Station) was closed, further diminishing the town's vitality, until by 1940 only 42 permanent residents remained, and after another devastating hurricane in 1944, the number dwindled further. By the 1950s, Portsmouth had only fourteen year-round residents.

Several unused buildings were adapted for use by sport fishermen, especially after World War II, including the Coast Guard Station, which was declared surplus property in 1946 and used as a sportsmen's clubhouse. The post office was discontinued in 1959, and by the time the Cape Lookout National Seashore was authorized in 1966, only a handful of permanent residents remained.

With the death of the village's last surviving male resident in 1971, the two remaining residents moved to the mainland. Portsmouth Village became uninhabited, without permanent residents for the first time since the eighteenth century. A number of buildings continued to be occupied seasonally as private residences through an NPS lease program that only recently ended. Other buildings, such as the Methodist Church and Coast Guard Station, are open year-round to the public.

In all but the coldest months Portsmouth Village is a popular destination for day-trippers arriving by small boat from Ocracoke.

The House

The multiple names used for this house can be confusing, and have changed to reflect updated research. Over the years, NPS documents, reports, tourist information, and waysides have used several names for the house, including the Dennis Mason-Dave Willis House (as in the 1978 National Register nomination), the Captain Dave Willis House, the Willis-Dixon House, the Harry Dixon House, and most recently the Lida and Harry Dixon House. The title of this Historic Structure Report reflects the correct chronological sequence of apparent occupants. The State Historic Preservation Office has stated its intent to amend the National Register nomination accordingly.

The scant historical documentation for the earliest period of the house (most in the form of oral interviews) suggests that a house was built on the site of the present structure by 1897. In interviews conducted in the 1980s with former Portsmouth residents, the first dwelling remembered on this site was a small three-room house without a porch, apparently called a "straight" house, one room deep and three wide, consisting of a living room, kitchen and bedroom "all straight across."

An early, but undated, photograph may show this house in the latter years of Willis ownership. It shows a one-story, side-gabled house with front porch. At the west end, set back from the main block, is a lower, one-story gable wing, which physical evidence shows was an early addition to the main block.

Between 1914 and 1918, Harry Dixon (1889-1931) and his wife Lida Woolard Dixon (1888-1961) acquired the property. The son of George Dixon, a fisherman, and his wife Martha "Patsy" Dixon who operated a store, Harry grew up in a house that his parents built along Doctors Creek in 1887. As an adult, Harry worked as a carpenter and joined Jodie Styron and Tom Bragg in constructing the Styron-Bragg House as a hunting and fishing clubhouse. Perhaps inspired by that project, Dixon made major alterations to



Figure 1. Portsmouth Village viewed from Ocracoke Inlet, 2013. (JKOA)

his own residence in 1928 that recast the plain vernacular of the old Willis house into a stylish Craftsman bungalow with a new form from the roof down.

After Harry Dixon's death in 1931, his widow and daughter occupied the house into the 1950s. After Lida's death in 1961, her daughter sold the property to Charles D. and Jeanne Carrington who may have been responsible for replacing most of the Dixons' three-over-one sash with the present six-over-six sash. The property changed hands once more before acquisition by the State of North Carolina in 1969 as part of the early efforts to create a national seashore at the southern end of the Outer Banks.

When the Cape Lookout National Seashore was established in 1976, ownership of the house was transferred to the National Park Service, which used the house as a residence for its chief ranger and, later, for volunteers. The front porch and deck were almost entirely rebuilt in 1979, and the porch and deck flooring was replaced again in 1987. The septic system failed in 1996, after which the house has remained unoccupied.

Statement of Significance

The Portsmouth Historic District was listed in the National Register of Historic Places in 1978 for its significance to the state's early maritime history and as the only remaining village on Core Banks. As the park's Long-Range Interpretive Plan

(2011) points out, "the park contains cultural resources rich in the maritime history of humankind's attempt to survive at the edge of the sea."¹

The 1978 National Register nomination identifies thirty-one historic structures and sites that contribute to the district's historic character, one of which is this house. Unfortunately, several of the thirty-one were already in ruins when the nomination was written, and others have since been lost to storms and decay. No eighteenth-century buildings remain, and only a handful of nineteenth-century buildings have survived into the twenty-first century.

The nomination identifies no period of significance; it was written before these were included in nominations. More recently, the Cultural Landscape Report (2007) has recommended a period of significance ending in 1971, when the island lost its last permanent residents. The authors of this report agree with that recommendation.

The house and its reconstructed shed continue to contribute to the historic character of Portsmouth. They are historically significant for associations with the Mason, Willis and especially the Dixon families, all with roots in Portsmouth that stretch back to the very foundation of the village.

¹ NPS, Cape Lookout National Seashore Long-Range Interpretive Plan (2011), p.11.

The house is architecturally significant as an excellent local interpretation of the Craftsman bungalow, so wildly popular in America in the first decades of the twentieth century. Harry Dixon's stylish and extensive remodeling of an earlier structure, even as Portsmouth was in decline, illustrates the resilience of Portsmouth and its residents.

Methodology

The objectives of this Historic Structure Report (HSR), which complies with the guidelines at NPS-28 (*Cultural Resource Management Guideline*), are to research and prepare a comprehensive and scholarly assessment of the two buildings' histories and fabric, to describe their existing physical conditions, and to recommend treatment for preservation.

The findings and recommendations made in this report rely on the combined research of primary and secondary sources, early photographs, oral histories, and the physical investigation of extant building fabric.

The Scope of Work prescribed by NPS for this HSR specifies "limited" historical research as defined by Director's Order #28: Cultural Resources Management Guidelines. Nevertheless, additional research was necessary for an adequate understanding of the context and history of the house and shed prior to park ownership. Information gathered from that period comes primarily from the park's genealogical research and from careful study of historic photographs and oral histories.

The Scope of Work also specifies "limited" physical investigation of the buildings to determine their evolutionary histories. However, that too was a large component of the work. Investigations involved a close look at architectural features and details such as framing materials and methods; the relationship of finish treatments; and the variety of siding, ghost marks, and nail types. Together these research efforts, both documentary and physical, provide a dual, coordinated approach to determining how the house was used and adapted over the progression of its history.

The firm of Joseph K. Oppermann–Architect, P.A. (JKOA), prepared this HSR. The team for the work

was led by Joseph K. Oppermann, FAIA, historical architect and principal-in-charge; Rebecca L. McCormick, AIA, and Christopher M. Woollard, Associate AIA, assisting architects; and Langdon Edmunds Oppermann, architectural historian. The team conducted the historical research and building investigation, documented the buildings with photography and measured drawings, and authored the HSR. This interdisciplinary approach improves understanding of the buildings' histories and present conditions, both necessary prerequisites for the development of appropriate treatment recommendations.

An initial multi-day visit to the site and the archives was made by the team in September 2013 with follow-up visits in April and October 2014. Measurements were compiled using manual measuring tape, carpenter ruler, digital cameras, and digital recorder, a Leica Disto laser distance meter. Photography was completed for building exteriors and interior spaces. Detailed field drawings were made and used to create digitized AutoCAD drawings of floor plans and elevations. The initial digitized drawings were the base document on which final recordings and assessed conditions were made during the subsequent return trips.

During these subsequent trips, a standard assessment methodology was used for the condition survey of each exterior feature and each interior room, itemizing features and elements and correlating with research findings. Detail photography was conducted. Visual observation of surface conditions, supplemented by a 20-power magnification loupe and Protimeter BLD 2000 moisture meter, was the basis for assessing the physical condition of building materials. In accordance with the NPS Scope of Work, no building system components were tested, and no invasive methods of investigation were employed.

Unique to these field visits was the necessity of wearing hooded net suits while on Portsmouth Island. Present for most of the year, the mosquitoes can be so thick at times that the tour boats cease operation. It is not uncommon for visitors and work crews to don mosquito suits while on the island.

Findings

The present house consists of three discrete structures that material evidence suggests were built at different times in the late 1890s and the first decade of the twentieth century, and significantly redesigned in the 1920s. The structures are balloon framed, but each uses slightly different materials and construction details. By World War I, the components appear to have been joined to create the basic floor plan of the present building.

Around 1928, Harry Dixon remodeled and rebuilt portions of the house as a Craftsman bungalow. He reframed the roof over the main block, maintaining only the ridge line while adding new rafters front and rear to create a longer, wider, lower-pitched, side-gabled roof more typical of the Craftsman style. Also typical of the style, Dixon left rafter ends exposed and added false knee braces in the gables. At the front he added a dormer, although it only lit the unfinished attic, and replaced the attached front porch with an engaged porch supported by tapered box columns, paired on each side of the steps and tripled at the corners, set on brick piers with cast-in-place concrete caps. He surrounded the porch with picket balustrades and built new concrete steps, flanked by stepped brick cheek walls, also with concrete caps.

In front of the west wing, used as the kitchen, Dixon built a large open deck, connected to the front porch and featuring the same brick piers with concrete caps. To complete the Craftsman remodeling, Dixon replaced the window sash on the front and sides of the house (but not the rear) with three-over-one sash. The house was one of the most stylish residences in the village by the time the work was finished.

Existing Conditions

Poor drainage is characteristic of most of Portsmouth, but the natural process of decay of vegetation and generation of new humus has created a bowl-like depression under the house. This traps water and keeps the area damp for extended periods of time, which not only exacerbates rotting of wood posts, but also creates conditions conducive to termites, all conditions that are typical of most of the structures at Portsmouth.

Much of the mortar in the front porch piers dates to 1928 and remains in fair condition. In contrast,

the mortar in the exposed piers on the deck is badly eroded. All but three of the concrete caps on the piers and cheek walls are cracked and broken, with significant material loss in some. The east cheek wall at the steps to the deck leans significantly to the east.

The wood framing appears to be in generally fair condition; ridge lines remain straight and floors level. Insect damage can be observed in some of the sills, and there is likely to be hidden damage elsewhere in the building. The house is, like many others of the period, under-structured by modern standards, especially in terms of spacing between the various framing members, but there is no apparent systemic failure. However, the ferrous nails used in framing have inevitably corroded in the damp, salty environment, making the building more subject to wind damage and other stresses.

The main front door remains in generally good condition, but the front kitchen door has severe damage to the bottom rail. The door at the rear of Room 104 is new but has no exterior hardware and no steps to the ground.

Sash are missing from the windows on the east and north sides of the north wing, but most of the rest are in fair condition. All of the six-over-six sash were installed in the 1960s. Painted finishes are in poor condition with peeling paint and staining from rusting nails. Glazing of windows is in poor condition. Many of the wood-framed screens are missing and those that remain are in poor condition.

The roofing is in fair condition with no apparent leaks. A few shingles are missing or loose.

Most of the house's exterior woodwork is in fair condition. Painted finishes are peeling and bare wood is being exposed at various locations all around the house. Some siding and most of the crown molding in the gables need to be renailed.

The porch is in mostly good condition, since the entire porch, except for the tripled columns at the corners, was completely rebuilt in 1987. The lower parts of the box columns are now deteriorating along with the wooden plinths, and the painted finish on the deck flooring is badly worn.

The lattice on the lower portion of the north wall of the lattice room is badly damaged as is the

painted finish on the entire room. The door steps are missing entirely.

The interior of the house is in fair condition, but most surfaces are soiled or stained and need repainting. There is some deterioration of the ceiling boards at isolated locations where the roof has leaked in the past. Three window sash are missing, and as noted earlier, the exterior glazing on those that remain is in poor condition, which has allowed damage to some interior surfaces.

Wood flooring is in poor condition, primarily from multiple floods, including the terrible hurricane that washed over the Outer Banks in 1933. These events have left much of the flooring cupped and most of the fasteners showing evidence of oxidation.

The shed has lost material integrity, but it remains an important feature in a landscape that has lost many of its small ancillary structures.

General Threats

Barrier islands, such as Portsmouth, will be especially vulnerable to the effects of climate change and sea-level rise, which may negatively affect cultural resources on these islands.

It must be noted that as buildings age, they tend to be less able to stand the stress of constant exposure to the harsh marine environment. The maintenance of a protective exterior paint layer on exterior wood elements is difficult but critical. Unpainted wooden surfaces are eroded by UV sunlight. Termites and wood rot attack and weaken wood framing, and blasts of wind-driven sand abrade exterior surfaces.

More ominous for the historic structure, the nailed connections that hold the house together have been compromised by the inevitable oxidation of nails and other ferrous materials, a condition that may not be readily evident. While wood framing that uses mortise-and-tenon joinery, such as the nearby Washington Roberts House, may withstand high winds and storm surge with minor damage, aging balloon or stick frames with severely corroded nails are less likely to do so. If sea-level rise continues at its present pace, much of Portsmouth Island will be inundated, and the effects of hurricanes and nor'easters will be amplified many times over.

Recommendations for Treatment and Use

The Recommended Ultimate Treatment for the house is Preservation of the exterior as a major feature in the district's cultural landscape and Rehabilitation of the interior to accommodate modern use, if possible.

General Recommendations for Portsmouth Village

- Consult with Janet Cakir PhD, NPS SER Climate Change, Socioeconomics, and Adaptation Coordinator to guide management policies.
- Use results from the climate change study "Identify Cultural Resources Sites Affected by Sea-Level Rise at Cape Hatteras National Seashore" to guide management policies. This study is also applicable to Portsmouth Island.
- Prepare or update a Topographic Survey for the site.
- Prepare a Log of Flood Occurrences. Record at a minimum the dates of occurrences and approximate extent and severity (e.g. depth at specific locations). Correlate recordings with Topographic Survey. Maintain data so that they can be correlated with conditions such as tide, moon phase, etc.
- Evaluate site for flood avoidance potential including the introduction of dams and/or swales to divert or direct flooding waters.
- Evaluate each building, structure, and significant site feature for flood avoidance potential and/or enhancement potential for better withstanding the projected threatening events.
- Identify critical services (fresh water supply, waste disposal, energy sources, etc.), evaluate options, and develop a contingency plan for each.
- Strive to maintain for all buildings a sound structural system and a weather-tight exterior envelope, especially the roof.
- Use maintenance activities as opportunities to enhance the resistive capacities of the buildings and structures whenever feasible.
- Prepare minimum level of record documentation (overall view photographs and text descriptions) for all undocumented cultural resources in the community that are at risk; prepare more extensive documentation (including scaled record

drawings with descriptions) for the more significant resources at risk.

Recommendations for House Site

- Investigate feasibility of partial or complete filling of the depression beneath the house.
- Conduct rigorous annual inspections for termite infestation and treat accordingly.
- Secure clearance from an archaeologist before commencing work that might require ground disturbance.

Recommendations for Foundation Posts

- Replace posts in kind as they fail.
- Preserve distinctive posts and those dating to the house's original construction.
- Install termite shields wherever possible.

Recommendations for Masonry

- Investigate feasibility of righting the sinking cheek wall at the deck.
- Repoint all brickwork.
- Repair concrete caps to a sound condition.
- Consider installing a chimney cap.

Recommendations for Wood Framing

- Conduct regular inspection for the presence of wood-damaging plants and insects; treat accordingly.
- Conduct routine inspections, some during rainstorms, to inspect for evidence of water intrusion and instances of damage.
- Periodically review for evidence of deflection across planes of framing, framing members out of square or plumb, or heightened vibration in framing members.
- Avoid use of ferrous-based fasteners in all construction and repairs.
- If the interior is opened to visitors, provide additional post-and-beam supports for the floor joists if necessary.

Recommendations for Doors

- Ensure all hardware remains operable. Apply lubricant on a regular basis.
- Maintain sound paint finish at all exposed surfaces.
- Reconstruct steps to ground at Room 104.
- Avoid use of ferrous-based fasteners in all construction and repairs.

Recommendations for Windows

- Replace missing sash in Room 105.

- Return all sash to working order, repair glazing, and repaint.
- Repair/replace wood-framed screens.
- Avoid use of ferrous-based fasteners in all construction and repairs.

Recommendations for Roofing

- Routinely inspect for missing or loose shingles and repair or replace as needed.

Recommendations for Siding and Trim

- Repair trim, renailling loose pieces as needed.
- Monitor regularly for open joints, displaced or loose elements, or other evidence of movement; renaill loose pieces.
- Monitor checking, splitting, and instances of rot, and plan remedial actions accordingly.
- Avoid use of ferrous-based fasteners in all construction and repairs.
- Prepare and repaint exterior woodwork to keep a sound exterior surface.

Recommendations for Front Porch

- Prepare and repaint woodwork.

Recommendations for Deck and Portico

- Repair trim, renailling loose pieces as needed.
- Avoid use of ferrous-based fasteners in all construction and repairs.
- Prepare and repaint exterior woodwork.

Recommendations for Lattice Room

- Remove shower from interior.
- Repair lattice and other trim, renailling loose pieces, and replacing if necessary.
- Prepare and repaint exterior woodwork.
- Ensure door is in working order.
- Reconstruct steps to ground.
- Avoid use of ferrous-based fasteners in all construction and repairs.

Recommendations for Flooring

- Avoid aggressive sanding of flooring.
- Do not renew painted or varnished finishes until interior use of the house is determined.

Recommendations for Mechanical and Electrical Systems

- Rehabilitate mechanical and electrical systems to accommodate identified use.
- Maintain present bathroom and kitchen locations.

- Reinstall bathroom lavatory and kitchen sink.
- Continue heating with stoves.

Recommendations for Shed

- Consider adaptive use as an enclosure for a composting toilet.
- Consider elevating the structure if it is necessary to replace the floor.
- Avoid use of ferrous-based fasteners in all construction and repairs.

Administrative Data

Locational Data

<i>Building Name:</i>	Mason-Willis-Dixon House
<i>Location:</i>	Portsmouth Village, Cape Lookout National Seashore
<i>County:</i>	Carteret County
<i>State:</i>	North Carolina

Real Property Information

<i>Acquisition Date:</i>	1976
--------------------------	------

Numbering Information

CALO ID:	503
LCS ID:	012514

Size Information

Mason-Willis-Dixon House

<i>Total Floor Area:</i>	602 square feet ±
<i>Roof Area:</i>	2,100 square feet ±
<i>Number of Stories:</i>	1
<i>Number of Rooms:</i>	6
<i>Number of Bathrooms:</i>	1

Mason-Willis-Dixon Shed

<i>Total Floor Area:</i>	108 square feet ±
<i>Roof Area:</i>	200 square feet ±

Cultural Resource Data

<i>National Register Status:</i>	Contributing structure in Portsmouth Village Historic District, Listed November 29, 1978.
<i>Period of Significance:</i>	No period of significance included in the National Register nomination; it was written before these were included in nominations.

Proposed Treatment

Preservation of the exterior and Rehabilitation of the interior.

Related NPS Studies

Bemisderfer, Tim and Rene Cote. "Portsmouth Village Storm Damage Assessment Report," November 27, 2012.

Cape Lookout National Seashore. *Master Plan, Cape Lookout National Seashore*. Harkers Island NC: Cape Lookout National Seashore, 1971.

Cape Lookout National Seashore. *Final Environmental Impact Statement on General Management Plan / Development Concept Plan*, December 1982.

Cape Lookout National Seashore, *Foundation Document*, October 2012.

Cape Lookout National Seashore, *Long-Range Interpretive Plan*, June 2011.

Cape Lookout National Seashore, "Portsmouth Village, Historic Structures Management Recommendations," August 1984.

Cape Lookout National Seashore. *Resources Management Plan and Environmental Assessment*, 1984.

Cote, Rene. "Narrative Report on the Findings of Historic Structures Examination; Preliminary Test of Historic Structures Survey, Portsmouth Village," 1984.

Denver Service Center. *General Management Plan/Development Concept Plan, Cape Lookout National Seashore*. Finalized 1982, approved 1983.

Ehrenhard, John E. *Cape Lookout National Seashore: Assessment of Archeological and Historical Resources*. SEAC, NPS, 1976.

Holland, F. Ross. *A Survey History of Cape Lookout National Seashore*. Department of History, Office of Archeology and Historic Preservation, NPS, 1968.

Impact Assessment, Inc. *Ethnohistorical Description of the Eight Villages adjoining Cape Hatteras National Seashore and Interpretive Themes of History and Heritage*. Final Technical Report, Vol. 2. Atlanta: National Park Service Southeast Regional Office, November 2005.

Jones, Tommy. *George Dixon House Historic Structure Report*. Atlanta: National Park Service Southeast Regional Office, 2004.

_____. *Wash Roberts House Historic Structure Report*. Atlanta: National Park Service Southeast Regional Office, 2003.

_____. *Portsmouth Life-Saving Station Historic Structure Report*. Atlanta: National Park Service Southeast Regional Office, 2006.

_____. *Ed Styron House Historic Structure Report*. Atlanta: National Park Service Southeast Regional Office, 2004.

Life-Saving Station Logs, excerpted by Tommy Jones, NPS.

National Park Service. "List of Classified Structures Park/Region Report," March 11, 1987.

National Park Service, Office of Policy. "NPS-28: Cultural Resource Management," June 11, 1998.

NPS files including drawings, maps, memos, images and administrative files.

Olson, Sarah. *Historic Resource Study, Portsmouth Village, Cape Lookout National Seashore, North Carolina*. Denver, Colorado: National Park Service, Denver Service Center, March 1982.

Olszewski, George J. *Historic Resource Study for History of Portsmouth Village*, typewritten draft for NPS, September 1970.

VanBeck, Sara L. Cape Lookout National Seashore, Archives and Records Management Review. NPS, 2000.

Whisnant, David E., and Anne Mitchell Whisnant. *Cape Lookout National Seashore Historic Resource Study*, prepared for the Organization of American Historians under Cooperative Agreement with the National Park Service, Draft, January 14, 2010.

Wiss, Janney, Elstner Associates, Inc. *Portsmouth Village, Cultural Resources Report*. Atlanta: National Park Service Southeast Regional Office, 2007.

I.A Historical Background and Context

“Just think, Portsmouth in 1815 or 150 years ago was the largest seaport in North Carolina and now there are just four people who live there year around. Oh! what changes have come about or taken place in 50 years in my lifetime and remembrance. What will happen in the next 50 years? God only knows.”

--Ben B. Salter, 1962²

From the early days of the eighteenth century, North Carolina was dependent on ocean trade

2. Letter to editor, *Carteret News Times*, 1962, printed in Ben B. Salter, *Portsmouth Island: Short Stories & History*, 1972, p. 47.

with other colonies and with the West Indies and Europe, exporting pine products—lumber, tar, pitch—and importing foods and manufactured goods. But access to its ports was not direct; the colony’s coastal geography made shipping difficult. With the single exception of Wilmington, North Carolina’s ports fronted not the ocean but the waters of Pamlico Sound, separated from ocean trade by the long stretch of the Outer Banks.

Several inlets spaced along the Banks allowed seagoing traffic to reach mainland ports, but by the 1730s most of these inlets were unusable as storms



Figure 2. Detail of the 1770 A Compleat Map of North-Carolina from an actual Survey by Capt'n Collet, Governor of Fort Johnston. Engraved by I. Bayly, London. The map shows Portsmouth just south of the winding channel of the inlet.

closed or shoaled them. Ocracoke Inlet remained navigable and was to become the principal ocean passage.³

In 1753, the colonial legislature of North Carolina established Portsmouth Village on the south side of that inlet. The town was a planned community, the act specifying “fifty acres of land on Core Banks, most convenient to the said harbour, adjoining the said Banks, for a town, by the name of Portsmouth, into lots of half an acre each, with convenient streets, as they may think requisite.”⁴ John Tolson bought the first lot in 1756. Buildings were to be substantial; purchasers were required to build a frame or brick house or warehouse, specified to be not less than twenty feet long by sixteen feet wide.⁵

Portsmouth quickly became the largest settlement on the Outer Banks, and was soon the largest English port south of Virginia.⁶ A 1770 Survey Map shows Portsmouth and Ocracoke Inlet with the essential outline of its twisting underwater channel (Fig. 2).

Ocracoke Inlet provided the principal access for shipping trade. However, the underwater geography of the inlet was precarious, with a sandbar at the inlet's entrance and a shoal within. Because the waters were too shallow for large, heavy-laden ships to navigate, cargo was offloaded onto lighters, small boats suited to the shallow waters of the inlet, and taken to Portsmouth's warehouses while the ships passed through the inlet.⁷

This practice, known as lightering, was the reason for Portsmouth's establishment and for its success.

At Portsmouth were built the warehouses, wharves, and boats needed for the lightering business, as well as structures for its residents. The town was home to the many pilots and crew, mariners,

3. Wiss, Janney, Elstner Associates, Inc., *Portsmouth Village, Cultural Resources Report* (Atlanta: National Park Service Southeast Regional Office, 2007), p. 17.

4. David Stick, *The Outer Banks of North Carolina, 1584-1958* (Chapel Hill: The University of North Carolina Press, 1958), p. 40, quotes the act.

5. Sarah Olson, *Historic Resource Study, Portsmouth Village, Cape Lookout National Seashore, North Carolina* (Denver, Colorado: U.S. Department of the Interior, National Park Service, Denver Service Center, March 1982), p. 17, citing State Records of North Carolina, Vol. 25, pp. 252-54.

6. Pat Dula Davis and Kathleen Hill Hamilton, eds., *The Heritage of Carteret County North Carolina, Vol. 1* (Beaufort, NC: Carteret Historical Research Association, 1982), p. 63.

7. Wiss, Janney, Elstner Associates, Inc., *Portsmouth Village, Cultural Resources Report*, p. 17.



Figure 3. A portion of Henry Mouzon's 1775 An Accurate Map of North and South Carolina, showing the lower part of the Outer Banks with Portsmouth on the south side of Ocracoke Inlet. Ships are shown passing through the inlet at Portsmouth. (North Carolina Collection, Wilson Library, UNC-Chapel Hill)

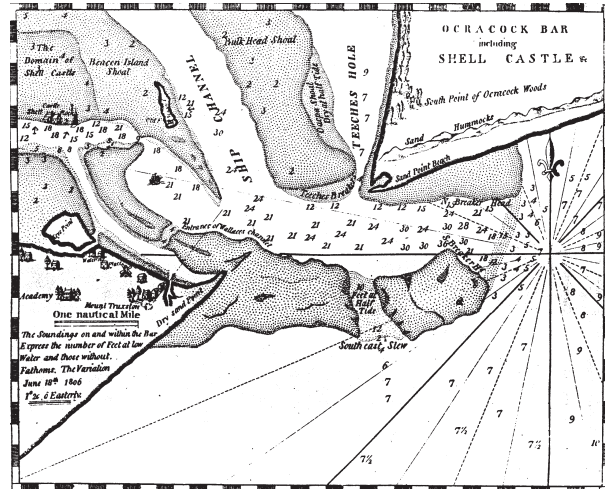

Figure 4. Nautical chart of 1806 shows the inlet's bar and shoals in detail. Skilled local pilots were required to navigate the channel, which changed with tides, time, and storms. "Ocracock [sic] Bar including Shell Castle," A Chart of the coast of North Carolina between Cape Hatteras and Cape Fear from a Survey Taken in the Year 1806, Thomas Coles and Jonathan Price.

channel markers and boat builders. Related businesses developed, in addition to those needed to support a growing population. Five years after Collet, Henry Mouzon's 1775 map of the two Carolinas shows Portsmouth as a developed town with buildings delineated. The inlet is marked as a ship passage (Fig. 3).

Census data give a picture of the village, although the listings for Portsmouth are not precise and

result in differing interpretations. Nevertheless, the figures show the healthy growth of the settlement and the importance of slaves to the enterprise. The white population in 1800 was 165; slaves numbered 98. The total of 25 families gives an indication of the number of houses in the village. By 1810 the white population had increased to 226, the slave population to 121.

As expected, the census reveals that over eighty percent of workers engaged in some aspect of maritime activity.⁸ Portsmouth's life depended on the inlet; residents made their living from trade through the passage, working as pilots, lighter captains, mariners, ship owners. Some were customs agents who sailed out to collect duties. Others had occupations necessary to support the town: teachers, merchants, doctors, and fisherman.

Supporting all were the slaves, whose labor kept the enterprise a success. Slaves were involved in most activities of the village. They loaded and unloaded cargo, but also operated a dolphin fishery and served the critical roles of pilots, who manned all types of vessels.⁹ David Cecelski reports, "At Portsmouth Island, slave crews piloted vessels through Ocracoke inlet, lightered their cargoes, and then guided them to distant seaports of the other side of Albemarle and Pamlico Sounds."¹⁰

Portsmouth continued to grow, with almost 400 people by 1830. Two years earlier, Currituck Inlet farther north had closed, leaving all shipping dependent on Portsmouth's help at Ocracoke Inlet. The community was robust; more than 1,400 vessels passed through the inlet in 1836-37.¹¹ Recognizing Portsmouth's importance to commerce, the federal government established a customs house there in 1806, and in 1827 provided for a marine hospital. A U.S. post office was established in 1840, and in 1842, Congress appropriated funds to buy land and build a new marine hospital, which when completed was the largest structure ever built in Portsmouth.¹²

8. Olson, *Portsmouth HRS*, p. 68.

9. David E. Whisnant and Anne Mitchell Whisnant, *Cape Lookout National Seashore Historic Resource Study* (prepared for the Organization of American Historians under Cooperative Agreement with the National Park Service, Draft, January 14, 2010), pp. 121, 137-138.

10. David Cecelski, *The Waterman's Song: Slavery and Freedom in Maritime North Carolina* (Chapel Hill: University of North Carolina Press, 2001), p. xiii.

11. Wiss, Janney, Elstner Associates, Inc., *Portsmouth Village, Cultural Resources Report*, p. 24, cites Stick, *The Outer Banks*, p. 306.

12. Tommy Jones, *Portsmouth Life-Saving Station Historic Structure Report* (Atlanta: National Park Service Southeast

Portsmouth is considered today remote and isolated, but in the late eighteenth and early nineteenth centuries it was a bustling commercial center with direct contact with European and Atlantic trade and culture, far less isolated than most of North Carolina.¹³ In 1842 the U.S. House Committee on Commerce stated, "Ocracoke Inlet is the outlet for all commerce of the state of North Carolina, from the ports of Newbern [sic], Washington, Plymouth, Edenton, and Elizabeth City. . . more than two thirds of the exports of the State of North Carolina pass out to sea at this point."¹⁴

An event four years later would change the shipping industry in North Carolina. In 1846, a hurricane created an inlet at Hatteras, about twenty miles north of the Ocracoke Inlet. This was the undoing of Portsmouth. Where Ocracoke Inlet was tricky and required lightering, the new Hatteras Inlet was deep and navigable. By 1850, Portsmouth's population reached 463—Hatteras had grown to 661.

Portsmouth depended on its lightering and piloting jobs. The 1850 census recorded 27 pilots, 37 mariners, 7 boat men, 3 fishermen, 5 merchants, 4 carpenters, 2 farmers, and a teacher with 77 students.

Portsmouth, with its facilities well established, grew in the next ten years to more than 600 and the census reported 109 dwellings. This was its peak, not only in population but in importance.

The growth of railroads also affected trade, not only at Portsmouth but on the ports facing the sound, as they strengthened easier north-south travel to the port of Wilmington over the east-west trade to the sound.¹⁵

Portsmouth was still operating as a lightering port in 1860 when, during Edmund Ruffin's visit, he explained,

The village of Portsmouth owes its existence to the fact of its adjoining the nearest water of Pamlico sound, where vessels must anchor and wait for fair winds and tides to cross the shallow and dangerous bar of Ocracoke inlet—and

Regional Office, 2006), p. 17.

13. Whisnant, *Cape Lookout National Seashore Historic Resource Study*, pp. 81-82.

14. Wiss, Janney, Elstner Associates, Inc., *Portsmouth Village, Cultural Resources Report*, p. 25, cites Stick, *Outer Banks*, pp. 87-88.

15. William S. Powell, *North Carolina through Four Centuries* (Chapel Hill: University of North Carolina Press, 1989), pp. 261-63.

after passing outward, as usual but partly laden, to wait to receive the remainder of the cargo, carried across the bar by lighters.¹⁶

Ruffin also described the village:

The occupations of the whole resident population of Portsmouth are connected with the vessels which have to wait here. Pilots, and sailors, or owners of vessels, make up the greater number of the heads of families and adult mails—and the remainder are the few, who as shopkeepers, &c, are necessary to minister to the wants of the others.¹⁷

Ruffin's description then became a forecast:

If Ocracoke inlet should be closed by sand (which is no improbable event) the village of Portsmouth would disappear—or (like Nagshead) [sic] remain only for its other use, as a summer retreat for transient visitors, sought for health and sea-bathing.¹⁸

Ruffin's forecast was timely. The shoals of Ocracoke Inlet were spreading into the inlet, no longer the easiest access to mainland ports. The steady withdrawal of shipping traffic continued and Portsmouth lost its strategic importance. Hatteras with its favored inlet surpassed Portsmouth.¹⁹

The Civil War brought changes to Portsmouth as it did throughout the South. Residents fled for the mainland as the Union Army advanced down the Outer Banks. Many chose not to return; among the former slaves and free blacks, only one family returned to the island. After the war, the town's decline spiraled. By 1870, the number of houses fell from 109 to only 59, and then to 44 in 1880. By 1883, the inlet was no longer navigable for lightering. Many more left, or turned to fishing as occupation.

Other means of livelihood sustained the village. In 1894 the U.S. established a Life-Saving Station in

16. Edmund Ruffin, *Agricultural, Geological, and Descriptive Sketches of Lower North Carolina, and the Similar Adjacent Lands*. (Raleigh: Printed at the Institution for the Deaf & Dumb & the Blind, 1861).

17. *Ibid.*

18. *Ibid.*

19. Impact Assessment, Inc. *Ethnohistorical Description of the Eight Villages adjoining Cape Hatteras National Seashore and Interpretive Themes of History and Heritage*. Final Technical Report, Vol. 2 (Atlanta: National Park Service Southeast Regional Office, November 2005), pp. 408-410. http://www.nps.gov/history/ethnography/research/docs/caha_ethno_v2.pdf.



Figure 5. Duck hunter with live decoys near Portsmouth, December 1915. (CALO Coll. a33)



Figure 6. FDR travelling by oxcart on a visit to the Piletery Club while Assistant Secretary of the Navy. (CALO Coll. a55)

Portsmouth that provided jobs for some residents as cooks, surfmen, or mechanics. Others worked for the several hunting clubs that opened nearby in the late nineteenth and early twentieth centuries. Wealthy northern sportsmen formed clubs near the flocks of water fowl that wintered on the warm waters of Pamlico Sound. One was the Piletery Club, built by wealthy New Yorkers about ten miles from Portsmouth Village and among seven similar gun clubs in Carteret County. Despite its isolation, the elegant club was visited by prominent figures, including Franklin D. Roosevelt while he was Assistant Secretary of the Navy. The clubs provided jobs for both men and women as hunting guides, cooks, maids and laundresses.

Hurricanes were a constant threat to Portsmouth. The "Great Hurricane of August 1899" brought winds that reached 140 miles per hour at Hatteras

before the anemometer blew away, and submerged Portsmouth and Ocracoke under ten feet of water in some places.²⁰ The storm destroyed a Methodist church. Two churches were destroyed in a 1913 storm, though the community was still strong enough to support construction of a new Methodist Church in 1915-16.

Many left Portsmouth after the devastation of another hurricane in 1933. The last general store closed its doors. The force of the hurricane opened a new inlet through the Core Banks south of Portsmouth, creating an island thereafter called Portsmouth Island. Until then, as seen on the old maps, Portsmouth had been a town at the north end of Core Banks, not its own island.²¹

Life on the island in the first half of the twentieth century was far different from its prosperous and bustling earlier years. Older methods of living and housekeeping were rarely updated. Cooking stoves were fueled with kerosene for decades after electricity was common elsewhere. Heat from the stoves dictated summer kitchens, outbuildings more typical of the nineteenth and early twentieth centuries. Refrigeration was not available, either from ice or fuel. Instead, small screened houses, known as dairy houses or milk houses but more akin to a small compartment, were used for short-term storage, sheltering the food from the sun while welcoming ocean breezes. Electricity from generators came late to Portsmouth, after World War II, and only to a few houses.

Drinking water was not taken for granted. There was only one deep freshwater well on the island, and that eventually became brackish. Residents depended on rainwater collected from roofs into cisterns built adjacent to the houses. These were carefully designed and regularly cleaned. Special preparations were made before hurricanes to prevent infiltration of salt water.²²

Years later Ada Roberts Styron visited the island and recalled aspects of life there.

"Usually two of our cows would come up from the range at night, to nourish their penned-up calves and supply us with milk, cream and butter. For them we drew brackish water from a shallow well. We drank rain water from our large juniper cistern. There was only one deep well of good, fresh drinking water on the island. It was on land Up-the-Banks."²³

Essential to the island were provisions from Ocracoke across the inlet, and especially from the mainland. The mailboat *Aleta* served multiple functions. Officially the ferry to Ocracoke across the inlet, it also came out to the inlet to serve Portsmouth. In the 1930s, the *Aleta* made a round trip to the mainland every day, leaving Ocracoke at 6 am for Atlantic, then leaving the mainland at 1 pm for a stop at Cedar Island and a second stop at Portsmouth. A designated resident took a small boat over the shallow waters to meet the mailboat and pick up or deliver items. From the *Aleta* came mail, groceries and provisions from general stores in Atlantic. It also served as a passenger ferry.²⁴



Figure 7. The mailboat *Aleta*. (NPS photo gallery website)

In 1937, the Coast Guard's Life-Saving Station was closed, further diminishing the town's vitality. The population by 1940 dropped to 42 people and continued its rapid decline. There were two students in the school when it closed in 1943 (Fig. 10). Families still lived on the island, but their older children went to school off the island, probably in Ocracoke.²⁵

20. Tommy Jones, *George Dixon House Historic Structure Report* (Atlanta: National Park Service Southeast Regional Office, 2004), p. 10.

21. The inlet later closed, then reopened. Today the sand between Portsmouth and the Core Banks is more often above water than below.

22. Delores Gaskins interview, April 26, 2014 Homecoming (Babb descendant).

23. Ada Roberts Styron recalling 1968 visit to Portsmouth, *Ocracoke Newsletter*, February 21, 2011, <http://www.villagecraftsmen.com/news022111.htm>.

24. Charles S. Killebrew, *Raleigh News & Observer*, February 1, 1948, quoted in "Doctor's Creek Journal," Summer 2015 newsletter of Friends of Portsmouth Island, p. 11.

25. Lynn Salsi and Frances Eubanks, *The Crystal Coast*. (Charleston, SC: Arcadia Publishing, 2000), p. 90.



Figure 8. Carl Dixon taking mail from the mailboat to the Post Office by wheelbarrow, ca 1930. (CALO c29, Aycock Brown Coll.)



Figure 9. Only three people on Portsmouth owned automobiles, among them Walter Styron's 1929 Chevy shown in 1931 on a barge at Portsmouth, heading for Atlantic on the mainland. (CALO a15, Sarah Roberts Styron Coll.)

A year later the Great Atlantic Hurricane of 1944 flooded Portsmouth and caused great damage to buildings, causing yet more residents to relocate to Ocracoke or to the mainland. Families with young children had no choice but to leave.²⁶ The Coast Guard reactivated the station during World War II, but in 1945 closed the station, taking more jobs from the island. The church was next; it ended services in 1956. Thereafter, a minister

26. By 1950 the youngest resident was 28; NPS exhibit at Portsmouth Visitor Center (Dixon-Salter House).



Figure 10. Teacher Mary Dixon with two of her last students. (CALO Coll. b04)

from the mainland visited congregants at their houses once a month. Finally, the mailboat made its last Portsmouth stop in the late 1950s and the Portsmouth Post Office closed in 1959. The former Life-Saving Station (Coast Guard) was used as a lodge by a hunting and fishing club.²⁷

In the 1950s while Portsmouth institutions were closing their doors, individuals began buying abandoned houses for use as summer cottages, and the State of North Carolina began purchasing land on Core Banks, including properties in Portsmouth Village, for the purpose of preserving the natural barrier islands.

When the Cape Lookout National Seashore was authorized in 1966, the State of North Carolina began acquiring buildings in Portsmouth for eventual transfer to the National Park Service. Most owners who used the properties seasonally sold outright, but the remaining residents were granted life estates allowing them to live in their houses until their deaths. The state transferred all

27. Wiss, Janney, Elstner Associates, *Portsmouth Village Cultural Landscape Report*, pp. 43-44.

properties to the Park Service in 1976 when the National Seashore was established.²⁸

Although Portsmouth houses continued in seasonal use, in 1950 only fourteen residents remained, and only four were living year-round on the island in 1962. Soon there were three, a man and two women, all elderly. By the late 1960s, all spent their winters at Ocracoke or on the mainland but the majority of the year at Portsmouth.²⁹ In 1970 the man, Henry Pigott, became ill and moved to Ocracoke to live with a friend.³⁰ After his death in 1971, the women agreed reluctantly to move to Beaufort. Those were the island's last year-round residents. Marian Babb retained a lifetime right to her house and continued to return to Portsmouth in the summers.³¹

In the 1970s, the Park Service was juggling life estates, special use permits, and a court judgment for a 25-year lease.³² It began a successful leasing program for several Portsmouth houses. The long-term agreements, generally twenty years, required leaseholders to maintain and improve the buildings following the Secretary of the Interior's "Standards for Rehabilitation" and specific conditions of the lease, including a requirement for a compost toilet if a flush toilet was not installed.³³ A typical rental amount was about \$5,000 per year.³⁴ Some were leased to fishermen and many to families with a connection to Portsmouth, who used the houses for weekends and summer vacations. The program was successful for many years in putting the houses to use and helping with their maintenance.³⁵

NPS Planning Efforts

The first planning document for the park that addresses Portsmouth is the 1971 Master Plan, compiled from studies carried out from the 1966



Figure 11. View of the village from the Coast Guard tower ca 1928, when wild cattle grazed the island. (CALO c19, Aycock Brown Coll.)

authorization of the park to 1970.³⁶ One of the studies for the plan was a preliminary Historic Resource Study (HRS), produced by NPS historian George Olszewski in a 1970 draft "to satisfy the research needs specified in the Historical Resource Study Proposal CALO-H-1, Historic Resource Study, Portsmouth Village." The area's historic sites were identified, evaluated, and plotted on an historical base map.³⁷ The HRS examined a large number of primary documents not previously researched, and may be the first academic study of the island's history.

The Study recommended the "theme" that should guide the National Seashore's treatment of Portsmouth. The village "should be restored to accent the cultural and economic life of the Bankers. At Portsmouth the story could be told of how the people lived, earned their daily bread, raised their children and adapted to their environment. Economic activity centering around Ocracoke Inlet should be emphasized since it relates so closely to the life of the Portsmouthers."³⁸

28. George J. Olszewski, "Historic Resource Study for History of Portsmouth Village," typewritten draft, September 1970, p. 73.

29. Olszewski, "Historic Resource Study," pp. 70, 72.

30. Rudy and Celestine Carter of Hampton, Virginia, interview, April 26, 2014 Homecoming. Pigott was Rudy Carter's uncle.

31. Salsi and Eubanks, *Crystal Coast*, p. 86.

32. Site map, "Special Use Permits," showing categories of agreements, June 24, 1976.

33. Ellen Fulcher Cloud interview, April 26, 2014 Homecoming.

34. For example, the lease of January 3, 1990 made to Charles Jackson Gilley and Jacob Eli Fisher, Jr. for the Henry Pigott House.

35. Cloud interview, 2014 Homecoming.

36. Cape Lookout National Seashore, *Master Plan, Cape Lookout National Seashore* (Harkers Island NC: Cape Lookout National Seashore, 1971).

37. Olszewski, "Historic Resource Study," p. 1.

38. *Ibid.*, p. 77.



Figure 12. Path through the overgrowth to the church. Undated. (CALO Coll. 04847)

The 1971 Master Plan repeated earlier informal proposals in focusing on the natural environment. It introduces historic resources only generally, loosely stating an intention to “restore the historical scene” at Portsmouth Village.³⁹

The Park Service did address immediate issues at Portsmouth. Vegetation had grown up on the island since the 1950s when the state of North Carolina outlawed free-range grazing on the Outer Banks (*Fig. 11*). In the following years, trees and low vegetation took over much of the open land in the village when only a tiny and elderly population lived on island. In the late 1970s and early 1980s after the Seashore was established, NPS began clearing the trees and overgrown brush and began an as-needed program of repair to buildings.

In response to requirements of the National Parks and Recreation Act of 1978, NPS completed a more comprehensive General Management Plan (GMP) in 1982 (printed in 1983).⁴⁰ The plan reflects additional research on Portsmouth, for which a National Register nomination had been completed. The plan incorporated historic resources planning and introduced interpretive themes for the village,

39. *Master Plan, 1971*, p. 81.

40. *General Management Plan / Development Concept Plan, 1982-83*

mostly taken from Ross Holland’s 1968 Survey History of Cape Lookout National Seashore.

The GMP was preceded by a draft released in August 1978. Work at this time is explained in an undated article:

According to its proposed management plan, released in August of 1978, the National Park Service intends to preserve the exterior of the buildings remaining on Portsmouth. Work has already started on some of the buildings. The Coast Guard Station has been reshingled and both the church and the post office-general store have been painted.

The Park Service hopes to provide transportation to the island for 150 visitors a day. These visitors will receive guided tours during the busy season and may go on self-guided tours in the off-season. Also planned for the village is a dock, water and sanitation facilities, a ranger station, and a maintenance area.

According to Portsmouth district ranger Kevin Kacer, in *The News-Times*, a half-million dollars has been appropriated by Congress for restoration of the buildings over the next five years. However, it will be ten years before restoration is finished.⁴¹

41. Caroline Smith, "Historic Portsmouth," undated article in SHPO files.



Figure 13. The marsh at Doctor's Creek, looking out to the sound. (JKOA, 2013)

The early history of Portsmouth is compelling, and is reflected in planning documents as it supersedes the more recent history of the town. Economics and hurricanes destroyed all eighteenth century and all but two nineteenth-century buildings, yet the documents do not address an interpretive plan for the buildings actually on site.

In 1982 the park finalized the Historic Resource Study on Portsmouth Village, many years in the making. The 1970 draft was delayed by the park's work on the 1976 American Bicentennial. When picked up again it was revised and updated by three other historians before its 1982 publication.⁴²

The park completed a Resources Management Plan and Environmental Assessment in 1984 that more explicitly addresses historic resources. This was the first indication of a systematic look at cultural resources by the park, mainly to comply with Section 106 of the National Historic Preservation Act of 1966. Its emphasis is on preventing deterioration; the plan places historic resources as the park's third priority, behind recreation and natural resources. Recommendations for cultural resources management, focus largely on Portsmouth and the

42. Olson, *Portsmouth HRS*, preface.

Cape Lookout Light Station (because both were listed in the National Register), the park museum, archives, and archaeological sites.⁴³ Portions of this plan apparently were written some years earlier and state in one place that Portsmouth was not yet listed in the National Register, though the listing was effective in 1978.⁴⁴

The Resources Management Plan recommended detailed HSRs, necessary to conduct proper stabilization as well as management of rampant overgrowth around the buildings of the village. At that time, work in the village was unprogrammed and reactive, without benefit of historic research to guide decisions. No interpretive themes were proposed in the plan, but the report recommended hiring a full-time park historian.⁴⁵

In December 1983, NPS staff led by Rene Cote, Southeast Region Historical Architect, inspected the buildings of Portsmouth and prepared a report in January 1984, its purpose "to establish areas of priority which can later be systematically

43. *Resources Management Plan and Environmental Assessment*, (Cape Lookout National Seashore, 1984), pp. 8-9, 115-16; the plan includes a chronology of archaeological work in the park.

44. *Ibid*, Archaeological Data Section.

45. *Ibid*, pp. 162-72, 173-74.

programmed into budget proposals.” The report first recognizes the inalterable geographical conditions of Portsmouth that affect its buildings: the limited natural horizontal drainage, the aggressive marine environment (wind, salt, sun, flooding, humidity), the high water table, and the saline soil.⁴⁶

The geography of the waterways surrounding the island was also noted as a preservation issue, their shallow channels limiting the size of boats and transport of equipment, materials and crews to the buildings. The shoaling that contributed to Portsmouth's economic decline was now affecting its preservation.

After their inspections, Cote and his team addressed factors that could be improved.

- crews (carpenters, painters, roofers) who had conducted repairs and maintenance were not adequately qualified;
- crews were using incompatible paints on structures, applying oil-based primer coat and one latex finish coat;
- water was ponding under and around structures, and sand buildup had caused some structures to sit below grade, leading to moisture deterioration and insect infestation;
- these conditions were causing structural settlement, in turn restricting the operation of windows and doors for interior ventilation.

NPS completed Structure Survey forms in the field to assess conditions at Portsmouth's buildings. These are dated 1984 in CALO files, but are more likely the field notes that Cote's team made in December 1983 to create the January 1984 report cited above.

A management plan completed in 1990 includes brief historical information on Portsmouth. A 1997 plan addresses interpretive themes, not mentioned in the 1984 plan, but a repeat of the “sea” theme in the General Management Plan. The focus for Portsmouth was its early development associated with shipping at Ocracoke Inlet. The plan gave some emphasis to the need for in-depth historical study of Portsmouth's buildings.⁴⁷

In the early and mid-2000s, four Historic Structure Reports (HSRs) were completed by Tommy Jones of the NPS Southeast Regional Office. These in-depth studies of the physical histories of buildings are invaluable to the park's decisions for repair.

The park's first comprehensive study of Portsmouth was not until 2007, when the Cultural Landscape Report provided a lengthy history of the island and specific recommendations. The CLR endorsed the finding of the 1978 National Register nomination that Portsmouth was over 200 years old, and “the only existing village on the Core Banks south of Ocracoke Inlet.” It recommended an extension of the period of significance to the 1971 end of permanent residency.⁴⁸

In 2010, David and Anne Whisnant submitted their excellent draft Historic Resource Study for CALO, which includes a comprehensive history of the lands within the park, including Portsmouth, and recommendations for interpretation.

The Long-Range Interpretive Plan of 2011 addresses the difficulties of providing adequate sanitary facilities for leasing Portsmouth's buildings for residential use. Other daytime, administrative uses might be found, since such facilities for non-residential uses may be feasible. Compost toilets can be housed in the village's outbuildings with minimal impact on historical fabric.

Hurricanes have continued to flood and damage Portsmouth's buildings during NPS ownership. During Hurricane Sandy in October 2012, the village was flooded by storm tides. The Post Office received approximately eight inches of water and the Portsmouth School lost some windows. The Methodist Church was damaged by the heavy winds, losing roof shingles and developing a significant structural tilt.⁴⁹

Documented changes in climate are projected to produce larger and more violent storms. Sea levels are rising as predicted, and the dangers affecting the buildings of Portsmouth Village are expected to increase. Faced with these threats, the National Park Service (NPS) recognized the need to record the buildings of the village. The impact of sea level rise is addressed in the Foundation Document of 2012. Eight properties are extensively documented

46. Rene Cote, “Narrative Report on the Findings of Historic Structures Examination; Preliminary Test of Historic Structures Survey, Portsmouth Village,” 1984.

47. *Resources Management Plan*, pp. 31, 42, 50.

48. Wiss, Janney, Elstner, and John Milner Associates, Inc., *Cultural Landscape Report*, .

49. NPS press release, “Historic Portsmouth Village Methodist Church is Damaged by Hurricane Sandy,” November 16, 2012.

in HSRs; NPS selected thirteen other building complexes to be documented in a new approach to create a permanent visual and descriptive record of the buildings. *The Portsmouth Village Documentation Project* was completed in August 2015, with thirteen stand-alone reports bound in two large volumes.

Portsmouth is celebrated and not forgotten. In 1992 the first Portsmouth Homecoming was held, and has continued to be held in April every other year. In 2000, only nine people were living who were born on Portsmouth; two of them attended the homecoming, including Jesse Lee who was reputedly the last baby born on the island.⁵⁰

The 2014 Homecoming was held on April 26. Over 400 people attended, arriving over several hours in small groups as shallow-draft boats made the rounds from Ocracoke, Core Banks, and Cedar Island. From many states and as far away as California, nineteen Portsmouth families were represented by their descendants, many of whom had spent summers and vacations in Portsmouth houses through NPS leases. The Homecomings are important to the people and beneficial to the village, helping retain an attachment to place. Planning for the 2016 Homecoming is underway.

50. Village Craftsman, *Ocracoke Newsletter*, May 4, 2000.

MAP OF PORTSMOUTH VILLAGE

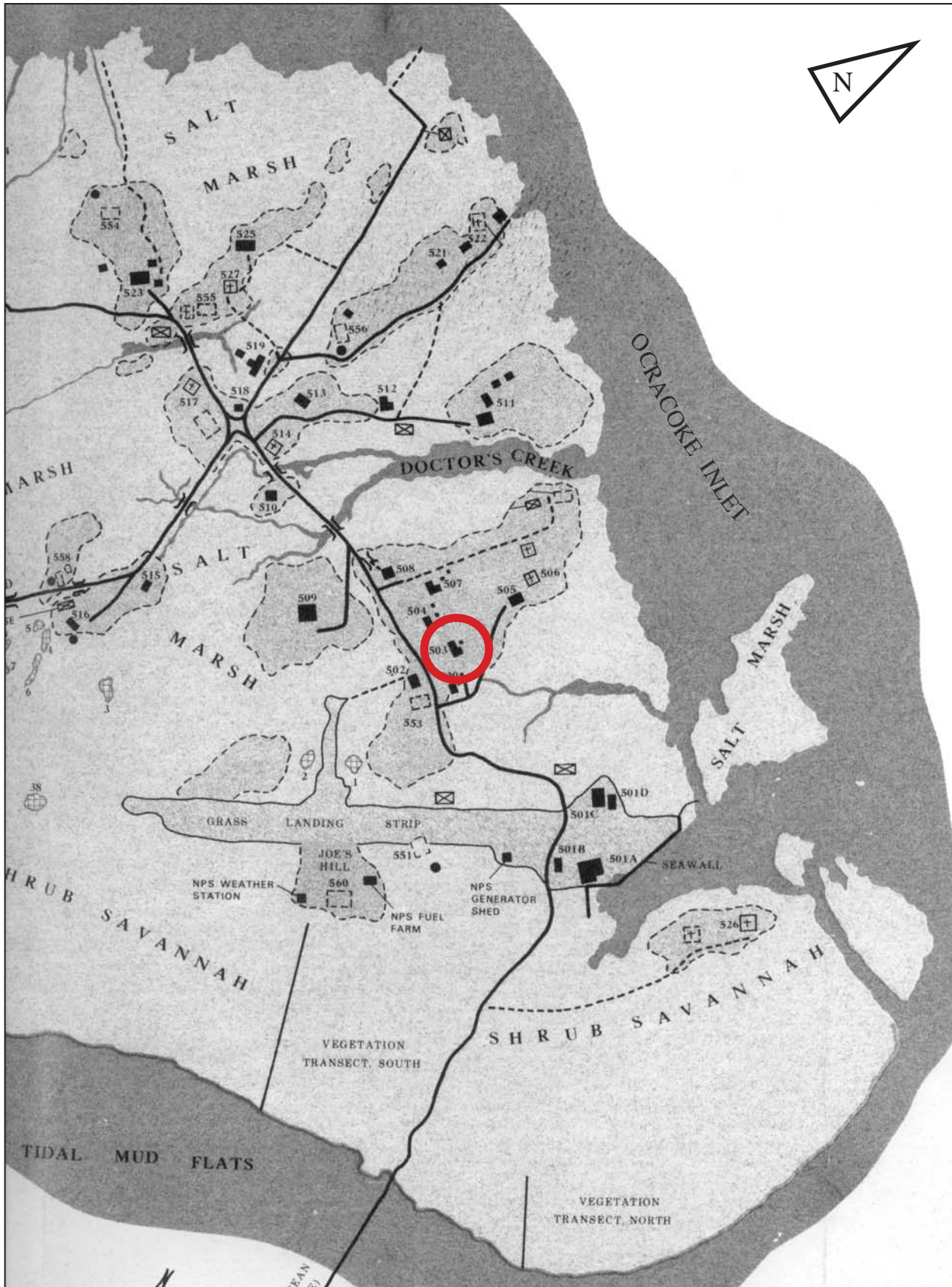

Map of Portsmouth Village showing location of the Mason-Willis-Dixon House. (CALO base map)

I.B Chronology of Development and Use

The multiple names used for this house can be confusing, and have changed to reflect updated research. Over the years, NPS documents, reports, tourist information, and waysides have used several names for the house, including the Dennis Mason-Dave Willis House (as in the 1978 National Register nomination), the Captain Dave Willis House, the Willis-Dixon House, the Harry Dixon House, and most recently the Lida and Harry Dixon House. All refer to the structure discussed in this Historic Structure Report. The title of this report reflects the correct chronological sequence of possible and known occupants. The State Historic Preservation Office has stated its intent to amend the National Register nomination accordingly.

The earliest known transaction thought to be associated with this property was made on November 13, 1894, when Dennis Mason and Joseph W. Robinson bought from Thomas S. Gaskill "a certain piece of land on the lot of Portsmouth Township containing one acre with all improvements."⁵¹ Whether the improvements, meaning one or more structures, included a dwelling is not known. Local tradition generally holds that Mason built a house on the property, though some reports reference his expanding or rebuilding.⁵² Joseph Robinson's role is unclear.

Dennis Mason was from Hunting Quarters, married Jenette in 1892, and by 1894 was living on Portsmouth as a fisherman. Deeds from 1880 to 1916 show that he owned several parcels on the island.⁵³ Whether he and his family lived on this property full time or on another of his holdings is

undocumented, but he sold it in 1897, and by the 1900 census had moved his family back to Hunting Quarters.⁵⁴

The 1897 sale was made by Mason, his wife Jenette, and Joseph W. Robinson, selling the property to Ferdinand G. Terrell.⁵⁵ Terrell was keeper of the Portsmouth Life-Saving Station (LSS), who began there in 1894 when the station was established, but with no crew. A few months later he quickly raised a volunteer crew to go to the rescue of the Richard S. Spofford. Dennis Mason was one of the volunteers and remained to serve as hired crew until 1901. As a surfman, Mason was required when on duty to stay at the station, while his family was living on Cedar Island. This may have precipitated the sale.⁵⁶



Figure 14. Aerial looking south across Portsmouth Village. House is at the left, circled, and shown on map on preceding page. (CALO Coll. c09)

51. Deed book SS/414, recorded 6 July 1895.

52. Lionel Gilgo, interviewed in 1981 and 1982 by Sadie Roberts Styron.

53. Jenette's maiden name unknown. "Portsmouth Village Structure #3, Dennis Mason House/Dave Willis House," research compiled by CALO ranger Karen Duggan, ca. 2006.

54. Duggan research.

55. Deed Book TT/528.

56. Eleanor Lopes Akahloun, *The Magic of Dreams: an American Diplomat's Journey* (Xlibris, 2014). Co-purchaser Joseph W. Robinson is on the 1895 crew list.



Figure 15. Undated photograph showing the house before the changes of the 1920s. An attached porch fronts the main block, and the west wing is in place. Land to the west is vacant where houses would be added in the 1930s. (Dorothy Byrum Bedwell Coll.)

Terrell's purchase of "one acre more or less" was made on February 15, 1897 for \$65. On September 6 of the same year he sold the property to Missouri Willis, also for \$65.⁵⁷ Though the 1897 deeds do not mention improvements, it seems likely a house was there. In an interviews made in the 1980s with former Portsmouth residents, the first dwelling remembered on this site was a small three-room house without a porch, apparently called a "straight" house, one room deep and three wide, consisting of a living room, kitchen and bedroom "all straight across."⁵⁸

An early, though undated photograph provides valuable information about the house on the property in the latter years of Willis ownership (*Fig. 15*). It shows a one-story, side-gabled house with an attached front porch, probably shed-roofed

but possibly hipped. A single window is visible in the west front bay. The location of the front stair railings suggests a central door. At the west gable just behind the ridge is an exterior end chimney with simple corbelling.

Attached at the west and incorporating the chimney is a lower, one-story gable wing, its front set back from the main block. The front of the wing, though small, is three bays wide with a central door flanked by a single window in each bay. The house was said to be red or brownish in color.⁵⁹ In front of the house is a picket fence and perhaps a wire-covered frame. This was the house Harry Dixon was to remake in the 1920s.

The Willis Families

Missouri W. Rollinson Willis (1854-1931) moved to Portsmouth in September 1896 from Hatteras,

57. Deed Book UU/303.

58. Lionel Gilgo and wife Ethel Gilgo, interviewed July 7, 1982 by William Mansfield.

59. Harry Dixon's niece Marian Gray Babb, interviewed July 26, 1978 by Nancy Goodwin.

where her husband Charles Willis (ca. 1848-1921) was a sailor and pilot.⁶⁰ When they moved to this property is not known, but the 1900 census lists the family occupants. In addition to Missouri were her recently married daughter Lena and husband Henry Davis Goodwin (1872-1948) of Cedar Island. Goodwin rented the house from Missouri, then about 45 years old. Boarding in the house was Missouri's son, George Howard, age 20, single and working on board ships. In a rented house next door lived the Willis's 25-year-old son, William Tice Willis, who by 1900 had two young sons and worked as an LSS crew member (he later became LSS keeper). Missouri's husband Charles is not listed on that census, and although Missouri is listed as a widow, Charles apparently did not die until 1921. He may have moved away.⁶¹

Missouri Willis and her household moved away before the 1910 census data was collected, the sons down island to the Drum Inlet area, Lena and her family to Morehead City, and Missouri to an unknown location. Again, Charles Willis is not listed, but his younger brother David is listed and noted as the owner.

How or when David Willis became owner of his sister-in-law's property is unclear; no deed is recorded. Portsmouth was typical of isolated communities, especially coastal and mountain communities, in omitting or delaying the recording of deeds at the county courthouse.

What is known is that David S. Willis (1853-1910) was the son of Thomas Grace Willis and Ellen Willis. In 1875 he married Emma R. Peel (1856-1895), the wedding apparently held in his brother Charles's house in Hatteras.⁶² The couple lived in Hatteras where David was a fisherman; however, after Emma's death in 1895, he moved with his children, daughters Sidney (20) and Mahala (12) and son Milan (17), to a house near Sheep Island just south of Portsmouth Village. Although the 1900 census shows that he owned the Sheep Island house, no deed is recorded for its purchase or for its later disposal when they moved to the village.⁶³

60. Portsmouth online genealogy compiled by Karen Duggan, http://wc.rootsweb.ancestry.com/cgi-bin/igm.cgi?op=SRCH&db=portsmouth_nc&surname.

61. Duggan research, 2006, and Ancestry.com http://records.ancestry.com/lena_wallace_willis_records.ashx?pid=32815656.

62. Portsmouth online genealogy.

63. Duggan research.



Figure 16. Milan Willis, undated. (CALO Coll. b43)

Willis is also known to have owned a freight boat named the *Virginia Dare*. With son Milan serving as mate, he carried freight and occasionally passengers between Portsmouth, Ocracoke and Washington, NC.⁶⁴ He is frequently referred to in 1970s and '80s interviews as Captain Dave or Mr. Dave, and in an interview, was described as "old Mr. Dave Willis, a handsome Hatteras import."⁶⁵

David Willis died in September 1910 a few months after the census was taken. Although no will is recorded, it is likely that the daughters retained the house as neither was yet married. Milan, who had left his father's household after marrying in 1905, may have inherited the *Virginia Dare* (Fig. 16).⁶⁶

Daughter Mahala (also found as Mahaley, Mahalie) married Joseph Roberts in 1913, and by the 1920 census was living in a different house. Sydney never married, dying of typhoid fever in June 1918.

64. Ibid.

65. "1911 Wedding on Portsmouth Island," *Ocracoke Newsletter*, February 21, 2011, www.villagecraftsman.com.

66. Milan married Vera Gilgo in July, and in October bought a house in Portsmouth's "middle community" from his cousin George T. Parsons.



Figure 17. Harry Dixon at about age 18. (CALO Coll. a47)

However, she left the first known record of her father’s ownership: before her death she signed an undated receipt acknowledging \$35.00 paid by Mrs. Harry Dixon for “the house.”⁶⁷ Mrs. Dixon was Lida Woolard, who had married Harry Dixon in June 1914, placing the sale between then and Sydney’s 1918 death.⁶⁸ Lida and Harry would create the house we see today.

Lida Woolard (September 18, 1888-July 26, 1961) was the daughter of Edward Stanly Woolard and Beulah Bragg Woolard. Her mother, who died when Lida was a child, was from Portsmouth, but Lida did not grow up there. She was living in New Bern in 1900, and in Norfolk, Virginia in 1914.⁶⁹ In June 1914 she married Harry Dixon in Portsmouth.

Another family may have lived in the house after Dave Willis’s family and before the Dixons. Ben and Victoria O’Neal are said to have rented the house in the 1910s, though between census years

67. Ben Salter, interviewed January 10, 1978 by unspecified interviewer, and Duggan research. A copy of the receipt is in CALO files. Sydney’s 1918 death may account for the 1917/1918 date reported in some histories for the sale.

68. Although Lida paid \$45 in taxes in 1915, the amount suggests it was for a different property.

69. 1900 census and 1914 marriage certificate.



Figure 18. Vertical-board siding of the exterior of the original main block, covered when the west wing was brought up and attached. Shown is a door cut into the siding to lead from attic of wing to attic of main block. (2014 photograph)

it is difficult to verify their location. Available records and family history show an Isaac Willis O’Neal serving as a Portsmouth surfman from 1911 through 1914, but not Ben O’Neal. However, a Benjamin Gaskill O’Neal served in Ocracoke as a Coast Guard surfman in 1917.⁷⁰

Lida and Harry Dixon

Whether following the Willis family or the O’Neals, the 1920 census shows Harry Dixon, his wife Lida, known as Lydie, and daughter Mildred living in the house. The census lists Harry Dixon as owner, although as indicated above, the payment receipt for the house is in Lida’s name, and no deed from that time is recorded. This situation apparently was recognized and corrected in 1930, when Milan Willis, brother of Sydney and Mahala, recorded a deed to Harry Dixon for \$30.00. This deed finally gives the Dixons clear title to “the same lot or parcel of land owned by the father [David Willis]....

70. Earl W. O’Neal, Jr. “Life Saving Service on Ocracoke Island,” cites records and a family memoir. <http://files.usgwarchives.net/nc/hyde/misc/lifesave.txt>.



Figure 19. Doorway from north wing to added northeast entrance room, now a storage room. Originally an exterior doorway, it retains the Victorian trim found in the wing. (2013 photograph)

at the time of his death.” The reason for the after-the-fact transaction is made clear: “The purpose and intent of this instrument is to vest in the grantee named full and indefeasible title to and in the dwelling house upon described premises ...”⁷¹

By this time the Dixons had not only lived in the house for at least a decade, but had completed a major remodeling.

Harry Needham Dixon (September 10, 1889-September 27, 1931) was the second child of George and Patsy Dixon (*Fig. 17*). He, his brother and three sisters grew up in Portsmouth Village in their parents’ house, and all of their houses still stand in Portsmouth Village.⁷² Both Dixon sons grew up as fishermen, but both were also carpenters, Harry noted for his boat-building ability. A longtime resident remembered Harry as a child:

Harry. . . would take the barrel stays out of a flour barrel, take um and bend um and fix um . . . Then he’d go round the island and bum a old clock from someone. He’d take

the works out of um and put in the stern of that boat. That’s where he leaned to build um. People would come from near and far to watch em play and run up and down the ditch with his boats.⁷³

As an adult Harry Dixon worked as a house carpenter. He helped build the Styron-Bragg House with owners Jodie Styron and Tom Bragg, one of the few two-story houses on the island, a consciously-designed house built in a Craftsman-like style.⁷⁴ That project may have inspired Dixon to update his own residence, for in 1928 he made major alterations to the former Willis family house to create a design new in appearance.

The photograph of the house before Dixon’s remodeling and several taken after completion help to determine the history of the house, but are most valuable when coupled with physical investigation of the building. We know from the early photograph (*Fig. 15*) that the west wing was in place before Dixon’s changes. Measurements and inspection of construction materials and techniques suggest that the wing is an early structure, brought up and attached after the initial main block was built. The method of attachment and the vertical-board siding of the main block’s original exterior are visible in the attic of the wing (*Fig. 18*).

Though not visible in the early photograph, a second wing extending north from the back of the house is also an early structure, of a similar period as the west wing and maybe older. It retains Victorian trim on doors and windows typical of the late nineteenth or very early twentieth century (*Fig. 19*). Structural evidence indicates that it too was attached after the initial main block was built and before Dixon’s project.

Harry Dixon’s changes gave the appearance that the interior of the house was expanded and a second story added, but in fact he added only two small spaces at the back. He retained the existing roofs, but above the main roof he built a new roof structure that extended out beyond the old on all sides. At the front he added a dormer, though it lit only an unfinished attic. He removed the attached

71. Duggan research; deed of June 18, 1930. The nickname Lydie is from a 1985 interview with Elizabeth Howard and Harry’s niece Marian Babb.

72. Duggan research; Jones, *George Dixon House HSR*, 2004; Community Cemetery gravestone.

73. Mattie Daly Gilgo, 1970s interview, in Ellen Fulcher Cloud, *Portsmouth the Way it Was, Island History, Volume III* (Havelock, NC: Print Shop, 1996), p. 151.

74. NPS Portsmouth brochure.



Figure 20. 1979 view showing the rear slope of the Willis roof beneath the higher, longer slope of Harry Dixon's new roof, and the lattice room beneath. The sistered rafters are part of the 1979 repairs. (CALO Polaroid album)

front porch and built in its place an engaged porch, formed by extending the south slope of the roof at the proper angle to cover the porch.

To give the appearance of a symmetrical roof, he built a new, longer back slope above the old, extending it north several feet beyond the existing back wall of the main block. A photograph taken in 1979 during repairs shows the Willis roof visible beneath Dixon's new rear roof (*Fig. 20*). The Willis roof ended at the former rear wall; Dixon's higher roof extended to the back wall of the new lattice room (west) and the new entrance room (east, now the storage room).

The new rear section of roofing created two new corner spaces, one an entrance area, today's storage room, the other the lattice room. The former rear wall of the main block had a central door flanked by single windows. Dixon retained the windows, which no longer opened to the exterior, but overlooked the two new spaces. In the northeast entrance room he created a new outside entrance to the house. Access from that new room



Figure 21. A lattice vegetable house in western North Carolina with exterior door and no access to its associated building.



Figure 22. Undated photograph of Tom Bragg on the steps of the Dixon House, showing the 1928 changes to the front of the house, including the dormer, engaged porch roof, porch posts on piers, railings, paired windows, vertical-glazed doors and sash, west portico and deck, steps and cheek walls. This view of the exterior end chimney illustrates the depth of the newly extended eaves. (CALO f75, Linda Robertson Hudson Coll.)

to the rest of the house was through the existing exterior door to the north wing, which had been the back door to the house.

At the northwest corner, Dixon left the corresponding window in place looking into the lattice room. There is no physical evidence of a doorway from the lattice room to the north wing; it was accessed only by an exterior door, also of lattice. This room may have been built as a vegetable or cooling house, its location in a northern corner shading it from harsh sunlight (*Fig. 21*).

The new eaves at front and rear were deep, in the Craftsman style. Dixon also extended the sides of the new roof to create deep eaves, and added false knee braces to ornament the gable ends. The new eave extension at the chimney is evident in comparison with the early Willis photograph (*Fig. 15*).

Harry Dixon's changes would have been dramatic among the island vernacular of most Portsmouth buildings. The new engaged porch extension of the front roofline was supported by tapered box columns, one at each side of the steps and tripled at the corners, set on brick piers with cast-in-place concrete caps. He surrounded the porch with picket balustrades and built new concrete steps, flanked by stepped brick cheek walls, also with concrete caps (*Figs. 22-23*).

In front of the recessed west wing, used as the kitchen, he built a large open deck, connecting to the porch and extending south to meet its front line (*Figs. 22, 24*). The piers, railings, steps, and cheek walls of the porch were repeated at the front of the deck, centered on the wing's front door. At the doorway he built a one-bay gable-with-arch portico supported by full-height square posts. The deck is called the kitchen porch on the label of a Dixon photograph (*Fig. 24*).



Figure 23. Undated view showing details of the porch. (CALO Coll. b120)



Figure 24. Lida Dixon & Rita Woolard on "kitchen porch," showing the vertical-light sash in the west window of the main block, the new sash and door of the west wing, and the screen door opening to the interior, a distinctive Portsmouth feature. (undated, CALO f74, Linda Robertson Hudson Coll.)

Beneath the front porch, Dixon replaced the earlier single windows flanking the front door with paired windows typical of the Craftsman style, and installed sash of a three-vertical-pane-over-one-light configuration. He also installed a new door with vertical-pane glazing (*Figs. 22-23*). In the wider front windows of the west wing he installed similar sash, but with four vertical panes, and a similar front door. The Dixon photograph shows that the same sash were installed in the west-facing window of the main block (*Fig. 24*). Though undocumented, it is likely that he also replaced the sash of the east side windows of the house, consistent with the extent of his remodeling.

Dixon applied new weatherboard siding directly over the existing vertical-board siding of the house.

The sweeping changes made by Harry Dixon in 1928 help explain later descriptions of the project. Lionel Gilgo remembered in the 1980s that Dixon built a new house "right over the [old house] and then tore the one out of the inside and finished the inside of this one." Dixon did make changes almost all around the house, including roof extensions, windows, porch and ornamentation. Fifty years after the project, Dixon's niece Marian Gray Babb, who was six years old in 1928 when the changes were made, recalled that he added a second story and two more bedrooms, perhaps interpreting the dormer as an upper living space.⁷⁵

⁷⁵ Lionel and Mrs. Gilgo interview, quoted in Duggan research. Marian Gray Babb, interviewed July 26, 1978 by



Figure 25. Undated photograph of the property showing a cool house just west of the kitchen wing and a hipped-roof outbuilding to the east. (CALO Coll. b122)



Figure 26. Young Jakie Robertson with his firetruck, ca. 1947. (CALO Coll. 119)

Harry Dixon was remembered as "all the time fixing up," but enjoyed his new house for only a short time. He died of heart disease on September 25, 1931.⁷⁶

Lida Dixon inherited the house after her husband's death, and she and daughter Mildred continued to live there. In the mid-1930s the house was painted pink after another islander, Henry Pigott, ordered paint from the Sears and Roebuck catalogue only to have pink paint arrive. "He didn't want to ship it back, so he painted his house pink." Lida is said to have used the extra paint for her house.⁷⁷

Mildred married Winford Lee Robertson, a Coast Guardsman stationed in Portsmouth in the late 1930s and early 1940s.⁷⁸ The couple moved to Morehead City. Because they both worked, their son Jakie, born in 1943, lived with his grandmother Lida at Portsmouth until about 1950 when he was seven. Several photographs of Jakie from

Nancy Goodwin.

76. Mattie Gilgo, 1970s interview, in Cloud, *Portsmouth the Way it Was*, Vol. III, pp. 156-58.

77. Frances A. Eubanks and Lynn S. Salsi, *Portsmouth island, Outer Banks Treasure* (Columbia, SC: Montville Press, 2004), p. 102.

78. Obituary of Jakie Douglas Robertson, <http://www.findagrave.com/cgi-bin/fg.cgi?page=gr&GRid=59867204>. Duggan research; Portsmouth online genealogy.



Figure 27. Young Jakie Robertson in front of the house, ca. 1947. (CALO Coll. 121)

this period show the house (*Figs. 26-27*). The Robertsons then moved to Missouri.⁷⁹ Lida Dixon remained in the house until the late 1950s when she moved to a nursing home in Wilson. She died on July 26, 1961.

In the CALO photograph collection is an image of the house perhaps taken in the early 1950s (*Fig. 28*).⁸⁰ Although the photograph is black-and-white, it is clear that the siding is painted a darker color than the white trim, presumably the pink that was used from the 1930s on and remained on the building in 1977. Sash are painted a dark color, and the trellis, foundation lattice, and low fence remain.

The year after her mother's death, Mildred, still living in Missouri, sold the property to attorney Charles D. Carrington and his wife Jeanne B. Carrington of Roanoke, Virginia for use as a vacation residence. The property sold on March 30, 1962 for \$10.00, probably a stand-in amount that does not reflect the actual sale price.⁸¹

79. Jakie Robertson, interviewed July 31, 1985 by Connie Mason, tells of the firetruck given him by his uncle Robert Woolard, Lida's brother, who was the fire chief in Norfolk.

80. The slide is mislabeled October 1984 in the CALO slide index.

81. Duggan research.



Figure 28. Undated photograph, perhaps early 1950s. (CALO acc. 05056)

The Carringtons and Yorks

The Carringtons may have found the house in need of repair. Lida Dixon, living alone since 1950 and sick in the late 1950s, may have been unable to keep up with maintenance, and the house had been through its share of storms. It was vacant before the 1962 sale.

It is likely the Carringtons who, as a part of their repairs, replaced almost all of the 1928 Craftsman windows with six-over-six sash (*Figs. 29-30*). The exceptions are the two pairs of vertical-sash windows at the front and the front door. Their location under cover of the front porch would have left them in better condition than exposed sash, probably explaining their retention. The unprotected front windows of the west wing, as well as its door, were replaced (*Figs. 29, 31*). Of note is the two-over-two window, perhaps original, remaining on the back of the west wing. This was retained both by Harry Dixon in the 1920s and by the Carringtons in the 1960s, and remains today, presumably because it was the back of the house.

In July 1966 the Carringtons sold the property to Harris W. York and her husband Marion Franklin “Frank” York (1932-2010), of Liberty, Randolph County, NC, who also used it as a vacation residence.⁸² The purchase price was \$1,200.00. While the true price of the 1962 transaction is not known, it would seem that the 1966 value would be affected by knowledge that the state was buying properties to include in the recently authorized national seashore, and on January 29, 1969 the State of North Carolina bought the property from the Yorks for \$10.00. Again, this is probably a stand-in amount.

Under the state's leasing program, the property was then leased to a series of individuals for use as a summer or fishing/hunting house. Leaseholders listed in CALO files include Billy Ipoc (Beaufort), Van Landingham (Ocracoke), Elmer Dewey Willis (Williston) and Vaughn Yeoman (Morehead City).⁸³

82. MFY obituary and brother's obituary, Greensboro News and Record, March 18, 2010 and December 1, 2013.

83. Duggan research.



Figure 29. Condition of the house in 1977, also showing the 1960s replacement doors, the 1960s replacement six-over-six sash of the west wing, and the retained Craftsmen-style vertical-pane sash beneath the front porch. (CALO acc. 03355)

National Park Service

In 1976 when the National Seashore was established, the state transferred the acquired properties to the National Park Service, including this house and other buildings in the village. This house was selected to be the district ranger's residence.

A group of photographs taken in 1977 shows the house, still painted pink, before the Park Service began its repairs, a baseline for their future work (*Figs. 29-31*). Most features of the house are unchanged from the photographs taken during the Dixons' time there. It retains its Craftsman form of roofline with deep eaves and front dormer, as well as the piers and posts of the porch and west deck. Railings front the outer bays of both the porch and deck, and a two-section stepped railing is at the west end of the deck, divided by a square capped wood post. The most notable changes from the Dixon photographs are the replacement west door and the six-over-six sash that replaced the vertical

sash in the west wing, all probably installed by the Carringtons in the 1960s.

Work on the house began in 1979. An NPS album of Polaroid photographs shows the features and condition of the house at that time and some of the work underway. Like many in Portsmouth, the house suffered from severe termite damage (*Figs. 32-34*).

In June and July, an NPS crew replaced most wood features of the porch and deck, which suffered from the more extensive rot and termite damage (*Figs. 32-36*). The subframe of both was replaced and new floorboards installed. The rafters of Harry Dixon's engaged roof extension were replaced, and a new ceiling installed. Also replaced were the two center box columns and all arches, which photographs show were severely damaged by termites. The 1928 tripled corner posts were able to be retained, and the posts and portions of the west portico were also replaced. Some railings were reused and most others replaced, and



Figure 30. Condition of roof and porch, missing fascia, 1977. (CALO Coll. f79)



Figure 31. West wing and stepped railing in 1977. (CALO Coll. f80)



Figure 32. Termites in sill, 1979. (CALO Polaroid album)



Figure 33. Preparing to replace kitchen deck, 1979. (blurry in CALO Polaroid album)



Figure 34. Damage in arches, 1979. (CALO Polaroid album)

the two-part west railing was rebuilt as a single section. The railings apparently continued to cause problems, as they are seen down or removed in later photographs, including 1980 and 2002.

General repairs and replacement were necessary in other areas of the house, including rafters mainly at the rear of the house and deteriorated weatherboards, generally the lower boards damaged by splash from roof runoff. The 1928 sash beneath the porch, the two-over-two rear window, and the 1960s sash were all retained, as well as both front doors. The rear board door was replaced.

In August 1979 the roof was replaced, and by December the house, which had remained pink since the mid-1930s, was painted yellow (Fig. 37). Interior work is less documented, but a kitchen was installed in the west wing, and bathroom facilities installed behind the east bedroom.

During this time, architect John L. Thompson produced sketch plans and elevations of this house and others in the village. However, their use is limited as the proportions and several features are inaccurate.

Two outbuildings remained on the site in 1979, when the National Register nomination refers to a “privy and collapsed shed” behind the house (Figs. 38-40).⁸⁴ In July 1980 the board-and-batten gable shed was disassembled and a new structural frame and roof built. Usable early siding was reinstalled, supplemented by new. A louvered vent was introduced into the upper gable end to add ventilation to the building (Figs. 41-43).

In 1981 the house was fully wrapped and fumigated to combat infestation of insects (Fig. 44).

84. National Register nomination, p. 7-2.



Figure 35. Replacing porch roof framing, 1979. (CALO Polaroid album)



Figure 36. Replacing porch roof, arches, posts, 1979. (CALO Polaroid album)



Figure 37. Aerial view of house (circled at upper right) taken August 1979 while reroofing was underway. House retains the Dixons' pink paint. (CALO acc. 00242)



Figure 38. Privy photographed in 1980, no longer extant.



Figure 39. Front and west side of shed before work, 1979. (CALO coll. f289)



Figure 40. East side of shed before work, 1979. (CALO Coll. f290)



Figure 41. Reconstructed frame for rebuilt shed, 1980. (CALO Polaroid album)

Repairs were made over the years as the house continued as the ranger's residence and station. An NPS "Historic Building Survey" of Portsmouth's buildings was made in 1984, with an NPS crew taking notes on the condition of building components. The form for this house identifies its utilities: propane tanks for heat and cooking, a grounded 12-circuit electric panel, septic tank, shallow well and surface water (cistern), and a park radio phone. The survey also identified deterioration to the wood pilings due to dampness, and insects in the foundation sill, though the building was said to benefit from regular use. Most recommendations centered on the need for improved drainage of the site. The porch and deck were replaced in July & August 1987.

In the 1990s the house was used as housing for the Volunteer In Park (VIP) program, taking advantage of its kitchen, bathroom, and two bedrooms. This practice stopped in 1996 due to problems with the septic system at the house, and volunteers were moved to the LSS. Many other Portsmouth houses benefited from the NPS lease program, which was designed in part as a means to maintain the buildings and to continue the life of the village. The ranger quarters was not offered for lease, and



Figure 42. East side rebuilt shed, 1983. (CALO Coll. f294)



Figure 43. Rebuilt shed with louvered vent in gable end, photographed 1983. (CALO Coll. f295)



Figure 44. West wing and deck piers wrapped for fumigation project, July 1981. Ranger station sign in front of house. (CALO acc. 05537)

in 1996 was reported to be “in serious need of a friend.”⁸⁵

In 2005 a NPS crew spent two years of concentrated work repairing the buildings of Portsmouth. The next year an NPS survey assessed the house in good condition. Photographs allow a comparison of the condition in 1977 and thirty years later (*Figs. 45-46*). In contrast, by 2007 the shed was noted in the 2007 Cultural Landscape Report as being dilapidated and in need of repair, with large portions of the siding missing.⁸⁶ Later that year the shed was rebuilt. Ricky Daniels of Cedar Island signed the interior west wall, documenting that he “rebuilt this old shack.”

85. Cloud, *Portsmouth the Way it Was*, Vol. III, preface.
86. Survey for List of Classified Structures (LCS).



Figure 47. The house in use as the ranger station and ranger’s residence with identifying sign in front. It would later serve as housing for the Volunteer in Park (VIP) program. Undated. (CALO Coll. f109)



Figure 45. Front and east elevations in 1977. Privy is visible in the background. (CALO Coll. f83)



Figure 46. Front and east elevations in 2007. (NPS List of Classified Structures [LCS])



Figure 48. Ricky Daniels documented his work on the shed as he “rebuilt this old shack,” August 2007.

Timeline

- 1753 Portsmouth established by bill “appointing and laying out a Town on Core Banks, near Ocacock [*sic*] Inlet, in Carteret County” passes in the North Carolina colonial assembly.
- 1756 First lots in Portsmouth Village are sold.
- 1770s 1770, Collet map of North Carolina shows Portsmouth and winding channel of inlet.
1775, Mouzon map depicts Portsmouth.
- 1800 White population 165, slaves 98.
- 1806 Customs Office established. Coles and Price map shows windmill and two-story “academy” at Portsmouth.
- 1810 White population 226, slaves 121.
- 1820s 1827, Marine Hospital authorized.
1828, Currituck Inlet closes, sending more shipping to Portsmouth.
- 1836-37 1,400 vessels pass through Ocracoke Inlet.
- 1842 U.S. House Committee on Commerce states “Ocracoke Inlet is the outlet for all commerce of the state of North Carolina, from the ports of Newbern [*sic*], Washington, Plymouth, Edenton, and Elizabeth City. . . more than two thirds of the exports of the State of North Carolina pass out to sea at this point.”
- 1842 Congress appropriates funds for new Marine Hospital.
- 1846 Storms create an inlet at Hatteras. The new, deeper inlet draws trade from Ocracoke Inlet and Portsmouth.
- 1850 Portsmouth population is 463; Hatteras has grown to 661.
- 1852 Coast Survey of Ocracoke Inlet shows two churches at Portsmouth.
- 1860 Population is over 600 residents with 109 dwellings.
- 1870 Census records 59 dwellings.
- 1880 Census records 44 dwellings.
- 1883 Ocracoke Inlet no longer navigable for lightering.
- 1894 Portsmouth Life-Saving Station (LSS) is established.
- 1894 Dennis Mason and Joseph W. Robinson purchase the land “with all improvements.”
- 1897 Feb Keeper Ferdinand G. Terrell purchases from crewmember Mason.

- 1897 Sept Missouri Rollinson Willis purchases the property.
- 1899 Great Hurricane of August 1899, the San Ciriaco Hurricane, submerges Portsmouth and destroys many buildings.
- 1900 Missouri Willis lives in the house with her son and her daughter and son-in-law, who is renting from Missouri.
- 1901 New Methodist church is built.
- 1905 Emma Willis, David Willis's wife, dies.
- 1910 Census shows David Willis and two daughters living in the house; he is shown as owner.
- 1910 David Willis dies.
- 1910s O'Neal family possibly rents the house.
- 1913 Hurricane destroys the island's two churches.
- 1914 Harry and Lida Dixon are married.
- 1915-16 Current Methodist church is built.
- 1914-18 Lida Dixon purchases the property from Sydney Willis, daughter of David Willis. Undated receipt.
- 1920 Census shows Harry Dixon and family living in the house.
- 1928 Harry Dixon, wife of Lida, "rebuilds" the house in a popular style.
- 1930 Deed made to Harry Dixon from Milan Willis, son of David Willis. Stated purpose is to document clear title to the property.
- 1931 Harry Dixon dies, leaving house to wife Lida Dixon.
- 1933 Damage from major hurricane causes many families to relocate to the mainland. New inlet opens through Core Banks south of Portsmouth, creating Portsmouth Island.
- 1937-38 Coast Guard Station is deactivated.
- 1940 Census lists 42 residents.
- 1943 School closes.
- 1944 Great Atlantic Hurricane brings major flooding and damage to Portsmouth; many residents leave for the mainland.
- 1946 Coast Guard Station closes.
- 1956 Regular church services are discontinued; 56 permanent residents at Portsmouth, the youngest is 59.
- 1959 Post Office closes.
- 1960 Census lists 14 residents on Portsmouth; only 4 permanent residents reported in 1962. Many buildings now used as vacation houses or hunting and fishing clubs.

- 1961 Lida Dixon dies, leaving house to daughter Mildred R. Robertson.
- 1962 Four permanent residents reported on Portsmouth. Many buildings now used as vacation houses or hunting and fishing clubs. Roanoke attorney Charles D. Carrington and wife Jeanne B. Carrington purchase and repair the Dixon house as vacation residence; likely replace most Craftsman-style sash with 6/6 sash.
- 1966 Cape Lookout National Seashore authorized. State of NC begins purchases.
- 1966 Carringtons sell to Harris W. York and husband M. Franklin York of Liberty, NC for use as vacation residence.
- 1968 Survey History of Cape Lookout National Seashore is prepared.
- 1969 Yorks sell to State of North Carolina for future national seashore. State begins leasing this and other Portsmouth properties to individuals for vacation residences.
- 1970 Draft Historic Resource Study of Portsmouth.
- 1971 One of the three remaining residents dies; the others leave. Portsmouth now houses only seasonal visitors.
- 1971 Master Plan focuses on the natural environment, suggests “restor[ing] the historical scene” at Portsmouth.
- 1970s NPS begins clearing overgrowth.
- 1976 Cape Lookout National Seashore (CALO) is established; state transfers properties including those on Portsmouth.
- 1979 NPS begins renovations of the house for use as district ranger’s residence, finding significant termite damage. June-July, NPS crew replaces most wooden elements of porch and deck.
- 1979 August, roof replaced. By December, house painted yellow.
- 1979 Portsmouth Village Historic District listed in National Register of Historic Places.
- 1979-80 Architect John L. Thompson produces sketch plans and elevations of the house, though with inaccuracies.
- 1980 Privy deteriorated but still standing. Shed is rebuilt, reusing sections of early siding.
- 1981 July, house wrapped and fumigated.
- 1982 Historic Resource Study of Portsmouth is finalized.
- 1982-83 General Management Plan states intent to preserve exterior of all buildings.
- 1983-84 Portsmouth buildings inspected and past work assessed by NPS team.
- 1987 Porch and deck replaced.
- 1989 Friends of Portsmouth Island is organized.
- 1990s House serves as lodging for volunteers with the Volunteer In Park (VIP) program.

- 1990 Management plan repeats the “sea” theme of the 1982 plan. Emphasizes the need for in-depth historical study of Portsmouth buildings.
- 1992 First Homecoming, sponsored by Friends of Portsmouth Island. Seven people born in Portsmouth are present. Homecoming celebrations continue biennially.
- 1996 Failure of the septic system for the house ends VIP housing there; volunteers are instead housed at the Life-Saving Station complex. House remains vacant to the present.
- 1999 Hurricanes Dennis and Floyd flood and damage buildings.
- 2003 & 04 Hurricane Isabel puts water in all buildings; Alex floods island.
- 2005 CALO crew spends two years repairing Portsmouth buildings.
- 2004-06 Historic Structure Reports completed for Life-Saving Station and three Portsmouth houses.
- 2006 NPS survey assesses the house in good condition.
- 2007 Cultural Landscape Report suggests extension of National Register period of significance to 1971; reports shed in dilapidated condition.
- 2010 Cape Lookout National Seashore Historic Resource Study and recommendations is prepared in draft form for the Organization of American Historians under a cooperative agreement with NPS.
- 2011 CALO Long-Range Interpretive Plan.
- 2012 CALO Foundation Document.
- 2014 Over 400 attend eleventh Homecoming celebration.
- 2015 House included in new Portsmouth brochure.
- 2015 Portsmouth Documentation Project documents 28 buildings, including 15 outbuildings, in an effort to create thorough recordation in the face of rising sea levels.
- 2015 Historic Structure Reports completed for Mason-Willis-Dixon House, Portsmouth Methodist Church, Henry Pigott House, and Tom and Lucy Gilgo House.

I.C Physical Description

General Description

Locale

Portsmouth Village is located on the north end of Portsmouth Island. Once separate from the North Core Banks to its south, the island is now attached by sand banks except during times of very high tide. Though its boundaries depend on the tide and currents, the total area is only about 250 acres.

Portsmouth Island and North Core Banks are part of the long chain of narrow sand reefs that fringe

the southern Atlantic coast of the United States. Most are close to the mainland; in contrast, North Carolina's "Outer Banks" jut out into the Atlantic as much as thirty miles to form an eastern barrier to a series of bays and sounds.

Portsmouth Village is on the south shore of Ocracoke Inlet, a two-mile-wide passage connecting the Atlantic Ocean to the broad and shallow Pamlico Sound. Across the inlet to the north is Ocracoke Island with the small community of Ocracoke at its south end.



Figure 49. Looking east across Doctors Creek of the sand road, wooden bridges, Methodist Church and houses near center of Portsmouth Village. Unless otherwise noted, all images in this section are by JKOA, 2013-2014.



Figure 50. Conducting interviews with the local citizenry of nearby Ocracoke in mosquito net suits.

Climate

The climate is temperate and seasonal. Summers are hot and humid with cooler evenings. The warmest month is July with an average high temperature of 85°F and average monthly nighttime lows of 74°F. The hottest temperature on record is 97°F recorded in 1988. The coldest month is January with an average high of 53°F and low of 40°F. The coldest temperature on record is 6°F recorded in 1985.

The wettest seasons are spring and summer, though the annual rainfall of almost 53 inches is fairly evenly divided throughout the year. The maximum average monthly rainfall is 5.43 inches in August. The minimum average monthly rainfall is 3.19 inches in April. The humidity of the salt-laden air is high through the year, typically staying between 80 and 85 percent RH.

Daily breezes range from 10 to 12 mph but wind gusts can reach two or three times that strength. Winter breezes typically come from the north; summer breezes typically are from slightly west of south.

Rising Sea Levels

The land of Portsmouth Village is but two feet above sea level, making the village especially vulnerable to damage from storms. The soil is sandy. The water table is just a few feet below grade. There are no freshwater wells.

From early summer through fall, tropical disturbances are typical, with hurricanes the most powerful, causing damage from both wind and flood. Strong winter storms called Nor'easters are also common. The location of the Outer Banks so



Figure 51. Record of high water marks from storm surge flooding on Theo Salter House shed (NPS 519).

far from the mainland makes it the most hurricane-prone area north of Florida. The buildings of the Outer Banks have suffered repeated devastation from these storms, which with climate change and resultant sea level rise are projected to be more severe and more frequent.

Estimates of sea level rise have been published by a variety of sources. Global estimates from the Intergovernmental Panel on Climate Change, used by several parks in their Foundation Documents, make estimates for 2100; however, projections for the next several decades are more pertinent for current planning and decision making. The National Oceanic and Atmospheric Administration (NOAA) has published sea level rise scenarios for the United States, but these are not readily useful for localized decisions.⁸⁷

The NPS has developed the Climate Change Response Program (CCRP), a cross-disciplinary program to preserve the natural and cultural resources and values under NPS stewardship.⁸⁸ The CCRP has collaborated with the University of Colorado at Boulder to develop scenarios of sea level rise based on local tide gauges and near-term timeframes. UC Boulder scientists used the U.S. Army Corps of Engineers (USACE) Sea-Level Change Curve Calculator to develop high, intermediate, and low scenarios for 2030, 2050, and 2100.

In general, a “high” scenario reflects current rate of increase of greenhouse gases, or “no change.”

87. Part of NOAA'S National Climate Assessment.

88. <http://www.nps.gov/orgs/ccrp/index.htm>

“Intermediate” scenarios reflect a reduction in greenhouse gases through changes in human behavior and choices. “Low” scenarios reflect historic rates of sea level rise, achieved by dramatic changes in human behavior and choices. This level of change is not anticipated in the near future; therefore, the NPS Southeast Region does not recommend the use of “low” scenario predictions for current planning or decision-making. More details about the scenarios can be found at <http://www.corpsclimate.us/ccaceslcurves.cfm>.

The Ocracoke Light Station is vulnerable to sea level rise and storm surge. Scenarios based on the Beaufort NC tide gauge predict, under current rates of increase in greenhouse gas emissions, that Ocracoke will experience a little less than a foot of sea level rise by 2030, approximately 1½ ft. sea level rise by 2050, and about 5¼ ft. of sea level rise by 2100.

If the rate of greenhouse gas emission increase slows, and renewable energy technologies are embraced, it is projected that an intermediate scenario of sea level rise could unfold at the Beaufort tide gauge, the closest point of reference for Ocracoke. With the intermediate scenario applied for all projections, results show about ½ ft. of sea level rise by 2030, approximately ¾ ft. of sea level rise by 2050, and almost 2 ft. sea level rise by 2100. A high, or no-change, scenario shows a rise of 0.86 feet by 2030.

Storm surge is also expected to increase with sea level rise. The CCRP and UC Boulder scientists have modeled storm surge under a low and high tide scenario. In general, tomorrow’s low tide scenario of surge will be similar to today’s high tide scenario.

Their research indicates that the current no-change trajectory or “high” scenario and the high tide scenarios of storm surge are the most realistic for near-term planning, because dramatic changes in global behavior are unlikely in 15 years. In contrast, the intermediate scenario is suggested for 2050 planning.

These figures are projections and the future may or may not unfold according to these estimates, additionally, the science surrounding the projection of climate change and sea level rise is rapidly advancing, and the Climate Change

Response Program is already working to revise and update these figures.

Seismic Zone

The site is close to an active seismic zone located near Charleston, South Carolina. The last major quake, recorded by the light keeper at the Cape Hatteras Lighthouse, was in 1886. Sporadic seismic activity may again affect the coast.

Flora and Fauna

Much of Portsmouth Island is characterized by salt marshes, shrub savannahs, and shrub thickets, with characteristic low, wind-swept stands of loblolly pine, eastern red cedar, wax myrtle, yaupon, other small trees and shrubs. Large open areas of salt-resilient grasses dominate much of the historic district and is the setting for the Mason-Willis-Dixon House.

Raccoons live on the island but there are no deer or ponies as found on some of the other barrier islands. A variety of sea and shore birds also frequent Portsmouth, but the most renowned inhabitants are the mosquitos. They are present most months of the year and can be so thick at times that the tour boats cease operation. Some visitors and work crews typically don hooded net suits while on the island.

The Village

The extant buildings of Portsmouth Village are grouped at the northwest end of the island. Some 21 historic buildings are fairly evenly scattered on both sides of the main road, Village Road, a sand road running roughly east-west. Two of the village’s largest buildings are close to the two ends of this road, forming visual termini. At the east terminus is the two-story Jody Styron (Tom Bragg) House (NPS 523); at the west terminus is the U.S. Life-Saving Station. The Portsmouth Methodist Church is a focal point near the center of the Village.

Doctor’s Creek extends from Ocracoke Inlet southwestward near the center of the Village, bisecting the settlement into east and west sections, with small wooden bridges connecting the two.

Another unpaved road, Haulover Point Road, extends from the ferry dock at the northwest tip of the island southeastward to Portsmouth School, the southernmost building in the Village.

The Architecture

The Mason-Willis-Dixon House faces in a southwesterly direction but for clarity in this report, the house is assumed to face south.

The present house is the result of the complete remodeling of an existing building, reportedly around 1928, according to oral histories, a date that is supported by the character of the design and the materials used.

Situated some 85' off the north side of the road to the Portsmouth Life-Saving Station, the building is a one-story, wood-framed structure that combines a three-room main block (Rooms 101, 102, and 103, and an engaged front porch) with one-room wings (Rooms 105 and 106) on the north and west sides that were extant buildings apparently moved and attached to the main block by 1920.

The house is set on wooden posts and encompasses a footprint measuring about 38'-8" north to south and 39' east to west. The ridge of the main roof is 15'-8" above grade, that of the north wing about 15'-4" above grade, and that of the west wing 12'-11" above grade. The main

block, the lattice room, Room 104, and the full-width front porch are all under a side-gabled roof with a gabled dormer centered on the front shed of the roof.

A few feet behind the west wing is an end-gabled outbuilding around 9' by 14' in plan, which is described at the end of this section. It is largely a 2007 reconstruction of the historic building and very little historic fabric remains intact.

Architectural Style

Prior to 1928, the house was, like many of Portsmouth's buildings, a utilitarian structure devoid of design details. Harry Dixon completely remodeled the exterior of the earlier house to create a stylish Craftsman bungalow, which was one of the most popular styles nationally for middle-class houses throughout the 1920s. The low-pitched roof over the main block, the deep eaves and exposed rafter tails, the box columns on brick piers, the false knee braces in the gables are all characteristic of the style and were all added by Harry Dixon in 1928.



Figure 52. Front elevation.

The House Site

Located about 780' east of the bridge over Doctors Creek, the house sits less than 700' from Ocracoke Inlet and barely a mile from the shoreline of the Atlantic Ocean. Deeds reference a one-acre tract of land but the associated site is ill defined, which is typical of the houses at Portsmouth. The site is



Figure 53. View in an easterly direction from the rear of the house.

almost uniformly level and poorly drained, with areas prone to standing water, including under the house and along the south and west sides. The site is covered with native grasses, which are kept mown, and a scattering of cedar, pine, and myrtle.

The only outbuilding, which is described at the end of this section, is a reconstruction of the historic shed located a few feet behind the house. Adjacent to the west side of the shed is a series of wooden posts that apparently supported the water box or cistern identified by Thompson in 1980. A septic tank is located just east of the house, but it is no longer in use. A privy photographed in 1980 is no longer present, and no driveways or paths are visible on the site.

Problems of Repair

Poor drainage is characteristic of most of Portsmouth, but the natural process of decay of vegetation and generation of new humus has created a bowl-like depression beneath the house, trapping water and keeping the area damp for extended periods of time. This not only contributes to rotting of wood posts but also creates ideal conditions for termite infestation.



Figure 54. Typical site conditions on the west side of the house.

Construction Characteristics

The house occupies a footprint measuring about 38'-8" north to south and 39' east to west. The ridge of the main roof is 15'-8" above grade; that of the north wing about 15'-4" above grade, and that of the west wing 12'-11" above grade. In addition to nails and other hardware, wood, brick, and concrete are the primary building materials.

Structural Systems

Foundation Posts

Except for the porch and deck, the foundation of the house is formed by a series of wooden posts set directly into the ground and raising the building barely two feet above grade. Posts are typically present at all corners with one or two posts for the intermediate spans, which generally range between 5' and 7'.

The majority of posts are sawn, 6" to 8" square, but log posts are present in a few locations. Posts supporting the main block and west wing of the house are typically 8" by 8". In the rear wing what appear to be the oldest (but perhaps not original) posts are 6½" by 6½" with the newer posts slightly smaller at 5½" by 5½".

The original framing has been augmented by the addition of "shake sills," using nominally 4" by 4" lumber run perpendicularly to the joists and resting on 4" by 4" posts set on concrete pads. The flooring and floor framing for the front porch and the deck were replaced in the late twentieth century.



Figure 56. Example foundation post created from salvaged lumber, showing damage characteristic of *Teredo navalis*, or shipworm. The damage must have occurred prior to the lumber's reuse as a foundation post.



Figure 55. Looking north under west side of front porch and main block, showing historic wood posts at left.



Figure 57. Added supports on west side of main block.



Figure 58. Steps to front porch.



Figure 59. L-shaped pier at southeast corner of front porch.

Problems of Repair

Standing water has precipitated rot in most of the wood posts, which are set into the ground, a problem typical of most of the structures at Portsmouth. There are no shields to protect the structure from termite infestation and damage.

Masonry Features

A brick kitchen chimney along with piers and cheek walls at the front of the house are constructed with similar materials. Bricks are medium-red to orange-red in color, typically $2\frac{3}{8}$ " by 8" to $8\frac{1}{8}$ " by $3\frac{5}{8}$ ", and laid in running bond. Mortar is a warm gray with joints $\frac{1}{2}$ " to $\frac{3}{4}$ " thick and raked to a depth of about $\frac{1}{2}$ ". Paint residue in the mortar suggests that they were painted tan at one time.

Across the front of the house is a series of brick piers that support the front edges of the front porch and the deck. The piers on the front porch are around 60" high, those on the deck about 48".

At the corners of the front porch and at the outside corner of the deck, piers are L-shaped, generally 1'-9" by 1'-9" in plan. Square piers on each side of the two sets of front steps are 1'-5" by 1'-4" in plan.

Each pier is capped with a concrete slab about 2" thick, poured in place with a shallow overlap



Figure 60. Chimney at west gable end of main block. Roof of west wing visible at the left.

projecting about 2" beyond the face of the brick pier.

There are two flights of front steps, each with three poured-concrete steps, the lowest in each flight set directly on the ground. As noted earlier, natural processes have raised the grade so that the top of the bottom step is nearly at grade. One flight, 4'-7" wide, is centered on the front door of the main block; the other flight, 4'-3" wide, is centered on the door on the south side of the west wing.

Flanking the steps are stepped brick cheek walls around 8" thick, capped with concrete like the piers. Brick, mortar, and concrete appear contemporaneous.

The house's single chimney rises just behind the ridge of the roof over the main block of the house. Built to serve a wood- or coal-fired kitchen stove and using materials similar to those in the brick piers and cheek walls, the chimney is between 16¾" and 17" square in plan and rises about 27" above the ridge line. Two courses just below the top course are corbelled out from the face of the chimney stack. There is a variety of tooling of

the mortar joints, which have been repointed on several occasions.

Problems of Repair

Much of the mortar in the front porch piers dates to their construction but remains in fair condition. The mortar in the exposed piers on the deck is badly eroded. All but three of the concrete caps on the piers and cheek walls are cracked and broken, with significant material loss in some.



Figure 62. Steps to deck.



Figure 61. Typical materials in brick piers.

Wood Framing

The house is wood-framed using dimensional lumber, at least some of which must have been salvaged from shipwrecks or elsewhere. The main block, west wing, and north wing are framed in a similar fashion but with variations in dimensions of materials. A variety of cut and wire nails were used for framing, but the particulars of most connections could not be observed directly.

Wall plates, or sills, are generally rectilinear in section and are set on edge directly on the wooden foundation posts or, at the front of the house, set into the brick piers. Those on the main block are 6½" by 9½", and those on the rear wing 8½" by 9". On the west wing, the sills are 6" by 6".

Dimensions of floor joists vary between the three sections of the house, but all are lapped over the sill without a rim joist. In the main block, joists are nominally 2" by 6" set on 24" centers, running north to south. In the west wing, joists are 4" by 4" on 28" centers. In the rear wing, joists are salvaged 3" by 10" and 2" by 8" set on centers 28" to 30" apart. Joists in the main block and north wing run east-west; those in the west wing run north-south.



Figure 63. Typical joist/stud/sill/post connections.



Figure 64. Looking north showing floor framing for the front porch in the foreground.

Studs are nominally 2" by 4" in the main block and Room 104, but are likely 2" by 6" in the north and west wings. Window and door openings are framed with 4" by 4" posts. The nature of corner posts could not be observed nor could the connection of studs to sills but, given the period of construction, studs and posts are probably simply toe-nailed to the sills. In any one area, they generally share the same spacing as the joists.

Roofs on the main block and west wing are framed with nominally 2" by 4" rafters with exposed, vertically cut rafter tails. There are no ridge boards or collar ties. Although the rafters of the front porch appear to have been set on centers about 24" apart, rafters on the main block of the house are around 28" on centers. In the rear wing, rafters are slightly larger at 2" by 4½ or 5" and are set on 36" centers.

The exterior of the main block of the house is sheathed with random-width boards, nominally an inch thick and installed vertically beneath the existing weatherboard. The two wings have no sheathing under the siding on the exterior walls.

Problems of Repair

The wood framing appears to be in generally fair condition, and ridge lines remain straight and floors level. Insect damage can be observed in some of the sills, and there is likely to be hidden damage elsewhere in the building. The house is, like many others of the period, under-structured by modern standards, especially in terms of spacing



Figure 66. Typical sill and bottom ends of vertical sheathing on the main block of the house.



Figure 65. Looking west in attic of kitchen wing.

between the various framing members, but there is no apparent systemic failure. However, the nails used in framing have inevitably corroded in the damp, salty environment, making the building more subject to wind damage and other stresses.



Figure 67. Looking from attic over kitchen wing through door to attic over main block. The white batten on the door has painted lettering from a packing crate that may date to the nineteenth century.

Utilities

Waste and supply lines for a bathroom and kitchen remain in place, along with a modern fiberglass shower, a toilet, and a wall-hung lavatory which is detached from the wall. None of the system is in operation since there is no water supply and no septic system.

Wiring for a simple 60-amp electrical system is more or less intact. It consists almost exclusively of branches to wall-mounted receptacles. Most wiring is in armored cable, but there is no electrical service so the system is inoperative. No fire-detection or security systems are present.

Problems of Repair

The electrical and plumbing systems are inoperative and could not be evaluated. Most of the component of these systems were installed in the early 1980s. There are no smoke, fire, or security systems in place, and it appears that the house was always heated with stoves.

Exterior Features

Most of the house's historic exterior finishes remain in place or else have been replaced in kind.



Figure 68. Looking east, showing roof framing and ceiling joists above the main block of the house.

Doors

The house has four exterior doors: two on the front (south) side opening into Rooms 101 and 106, one on the north side opening into Room 104, and one that opens into the lattice room at the rear of the house but which provides no access to the remainder of the interior.

The front door is 1 $\frac{3}{4}$ " by 2'-7" by 6'-7" and probably contemporaneous with the 1920s remodeling. It features a single flat panel below three vertical lights glazed with beveled glass. The door is hung with two, 3 $\frac{1}{2}$ ", ball-pin hinges. The bottom hinge is brass, the other steel. There is an empty mortise for a missing middle hinge. There is a mortise lock with a pair of brown mineral knobs. Interior and exterior escutcheons are Art Nouveau inspired with the exterior one measuring 3" by 12" and the interior one 2 $\frac{1}{2}$ " by 7 $\frac{1}{2}$ ". A 6" galvanized-steel hasp for a padlock is mounted high on the left casing. Exterior jamb casing is 1 $\frac{1}{4}$ " by 3 $\frac{3}{4}$ ", header casing is about an inch wider, and there is a plain, $\frac{1}{2}$ "-thick drip cap. The door sill is nominally 2" by 6".

The front doorway into the kitchen in the west wing has a mid-twentieth-century replacement of the 1920s door. It is 1 $\frac{3}{8}$ " by 2'-5" by 5'-11" and has three, horizontal, flat panels below three horizontal

lights glazed with plain glass. The door is hung with a pair of 3 $\frac{1}{2}$ " ball-pin hinges and has a 6" padlock hasp. Exterior jamb casing is similar to that at the front door, 1 $\frac{1}{4}$ " by 3 $\frac{3}{4}$ ", with header casing about an inch wider, a plain, $\frac{1}{2}$ "-thick drip cap, and door sill nominally 2" by 6".



Figure 70. Front door to kitchen (west) wing.



Figure 69. Front door, opening into Room 101.



Figure 71. Back door, opening to Room 104.

The back doorway, located on the north side of Room 104, is closed with a new but inoperable board door, $\frac{3}{4}$ " by 1'-10" by 5'-8". The boards are V-joint tongue-and-groove, $\frac{7}{8}$ " by 5 $\frac{1}{4}$ ". The door is hung with a pair of five-knuckle, 3" hinges. There is no other exterior hardware present.

Problems of Repair

The front door to Room 101 remains in generally good condition. The door to Room 106 is



Figure 72. Lock set at front door.

deteriorated with severe damage to the bottom rail. The door to Room 104 is new but has no exterior hardware and no steps to the ground.

Windows

The house has 19 window openings that can be sorted into three groups: one with two-over-two vertical-light sash, which may have been the original sash in the house; one with three-over-one sash, along with the three-light casement windows that light the attic, all of which were part of the ca. 1928 remodeling; and the third group with six-over-six sash, which were probably installed in the third quarter of the twentieth century.

As a part of the ca. 1928 remodeling, Craftsman-style sash with three vertical lights became a primary feature on the front of the house, and perhaps on the east side as well. The only Craftsman-style windows that remain are the paired three-over-one windows under the front porch; the double, three-light, casement sash in the dormer and on the east gable; and the single three-light casement sash in the west gable. Each of the three-over-one windows on the front porch is 1'-8 $\frac{1}{2}$ " by 3'-10"; each of the casement sash is 2'-0" by 2'-2".

Two-over-two sash remain in the 2'-7" by 3'-9" single-hung window on the north side of the kitchen. Two vertical-light sash are also present as the lower sash in the 2'-2" by 3'-10" window now covered by the lattice room and in the 2'-4" by 3'-9" window at the north end of the north wing. Both of the upper sash in those windows have been replaced with six-light sash.



Figure 73. Paired three-over-one windows on the front porch.



Figure 74. Casement windows in east gable. Those in the dormer are similar.

The windows on the south side of the kitchen and on the east and west sides of the main block, and on the west side of the north wing are all six-over-six, single-hung windows, 2'-4" by 3'-10" in the kitchen and main block and 2'-4" by 3'-9" in the north wing.

Windows are cased in a fashion similar to the doors. Jamb casing is typically 1¼" by 3¾" on the main block and ¾" by 3¾" on the wings. Windows are finished with a ½" drip cap similar to that used at the doors.

Shutter pintles survive at the windows on the north and west sides of the north wing and on the north side of the kitchen wing. There is no evidence that the house in its current configuration had shutters, which were not typically used on Craftsman-style houses.

All of the windows appear to have been fitted with wood-framed screens. All of those on the east side and on the north end of the north wing are missing along with one of those on the south side of the kitchen.



Figure 75. Two-over-two window on the north side of the kitchen wing, the earliest intact window in the house.

Problems of Repair

Sash are missing from the windows on the east and north sides of the north wing but most of the rest are in fair condition. Painted finishes are in poor condition with peeling paint and staining from rusting nails. Glazing of windows is in poor condition. Many of the wood-framed screens are missing and those that remain are in poor condition.



Figure 76. Typical six-over-six window installed in the 1960s.



Figure 77. Casing and drip cap typical of all windows, and shutter pintle similar to those found at some older window openings.



Figure 78. Typical casing and sill.



Figure 79. Typical detail showing poor condition of many of the windows.



Figure 80. Typical roofing.

Roofing

The roofs have open decks, typical for wood-shingled roofs. Decking is comprised of nominally 1" by 4" boards spaced 6" or 7" apart. That the decking continues across the rear of the main block is the main indication that the main block was originally built without a north wing.

Roofing is sawn cedar shingles, $\frac{3}{8}$ " by 18" in random widths, with the lowest course doubled. Ridges are finished with a conventional lapped course of short shingles. The chimney and the dormer are flashed with lead, probably installed when the roof was last replaced. There are no gutters.

Problem of Repair

The roofing is in fair condition and there are no apparent leaks. A few shingles are missing or loose. As with most of the historic structures at Portsmouth, no gutters or french drains are present.

Siding and Trim

The house is finished with a conventional lap siding around $\frac{5}{8}$ " by 6 $\frac{1}{2}$ " installed with a reveal between 4 $\frac{1}{2}$ " and 5". Most fasteners are cut nails, except where there have been modern repairs.

Skirt boards of varying widths are installed without a drip cap, the first course of siding simply lapping over the skirt. The skirt boards on the house are



Figure 81. Typical exposed rafter tails.

generally $\frac{3}{4}$ " by $10\frac{1}{2}$ " wide, except in the northeast ell at the rear where the skirt is 4" to 5" wide and on the north end of that wing where a 12" board is used. Skirt boards on the front porch, deck, and lattice room are nominally 8" wide and were installed in the 1980s, replacing narrower skirt boards that had been installed when the porch was built.

Corner boards are $1\frac{1}{4}$ " by $3\frac{3}{4}$ " and wrap each outside corner. Siding is butted to these boards.

Eaves are not boxed, leaving exposed vertically cut rafter tails. Plain boards nominally 1" by 3" cover the joint between siding and soffit. Rake boards in the east and west gables are $1\frac{1}{4}$ " by $2\frac{1}{2}$ " and contemporaneous with the Craftsman-style knee braces, which were constructed from the same stock. A $1\frac{3}{4}$ " bed molding, similar to that used as a base cap on the interior, joins the rake board to the roofing.

Doors and windows are cased with $1\frac{1}{4}$ " by $3\frac{3}{4}$ " boards and have a $\frac{1}{2}$ " drip cap. Door and window sills are typically $1\frac{1}{2}$ " to 2" thick.

Problems of Repair

Most of the house's exterior woodwork is in fair condition. Painted finishes are peeling and bare

wood is being exposed at various locations all around the house. Some siding and most of the crown molding in the gables should be railed.



Figure 83. Typical vertical corner boards and the two widths of skirt board found on the house.



Figure 82. East side and north end of the house.



Figure 84. Typical knee brace, rake board, siding and other trim.

Front Porch

Running across the front of the main block is a Craftsman-style porch, 6'-8" deep, that was part of the ca. 1928 design. Floor framing, flooring, columns, and header were reconstructed in 1987. The four brick piers described above support tapered box columns under a series of shallow segmental arches finished with short lengths of 4" double-beaded tongue-and-groove boards.

Double-beaded boards running east-west are used for the ceiling. At the wall, ceiling height is 7'-4" above the floor, which was built with a typical slope away from the house. Flooring, blind nailed and running north-south, is $\frac{7}{8}$ " by $2\frac{1}{2}$ ", tongue-and-groove.

Balustrades are generally 34" high. Bottom rails are $1\frac{1}{2}$ " by 4", set vertically; top rails are $1\frac{1}{2}$ " by 3", set horizontally. Pickets are 1" by 1" on 3" centers.

Problems of Repair

The porch is in mostly good condition, since all but the tripled columns at the corners was completely rebuilt in 1987. The lower parts of the box columns are now deteriorating along with the wooden plinths.



Figure 85. Front (south) elevation.

Deck and Portico

Extending across the front of the west wing, the deck was designed and built to be a continuation of the front porch. The brick piers, cheek walls, and concrete pier caps match those on the front porch and also date to the 1920s. All of the wood framing and flooring for the deck were replaced as part of the work on the front porch in 1987. The present flooring is the same $\frac{7}{8}$ " by $2\frac{1}{2}$ ", tongue-and-groove flooring found on the front porch. Historically balustrades matching those on the front porch were installed along the south and west (but not the east) sides of the deck, but those are now stored inside the house.

The portico is 2'-6" north-south, 3'-7" east-west, and has a roof ridge 9'-0" above the deck floor. Simple 6" by 6" posts supporting the roof are set on 8" by 8" wooden plinths with broadly chamfered edges. Plinths and columns are 1987 replacements of the ca. 1928 features.

The short header beams between the house and the posts appear to be assemblies salvaged from elsewhere and perhaps installed upside down.



Figure 87. View of portico added to west wing as part of the ca. 1928 remodeling.



Figure 86. Deck and piers added by Harry Dixon along with the front porch ca. 1928.



Figure 88. Lattice room at northwest corner.

Problem of Repair

The painted finish on the deck flooring is badly worn as is the paint on the plinths and lower half of the posts.

Lattice Room

This space, which appears to never have had access to the interior of the main house, is 6'-7" east-west and 4'-6" north-south. Four 2" by 4" rafters supported by a boxed header rest on four nominally 2" by 4" posts with a fifth post at the house supporting the side header. Flooring is 1" by 10" and 1" by 12" planks.

A door opens outward on the north side, but the wooden steps that existed historically are missing. The doorway is 2'-0" by 6'-0" and finished with ½" by 2½" lintel-cut casing.

The south and east walls are formed by the weather-boarded walls of the house itself. The west and north walls and the door are wooden lattice, comprised of ⅛" by 1¾" strips installed horizontally and vertically on 3½" centers.



Figure 89. Northwest oblique.

Problems of Repair

The lattice on the lower portion of the north wall is badly damaged as is the painted finish on the entire porch. The door steps are missing entirely.

Interior Features

The house has five rooms: a living room (Room 101), two bedrooms (Rooms 102 and 105), a kitchen (Room 106), a bathroom (Room 103), and a storage room (Room 104). Floor space is around 632 square feet.

Flooring throughout the house is $\frac{3}{4}$ " by $3\frac{1}{2}$ " tongue-and-groove pine, much of it face nailed. Board ceilings in Rooms 101-105 are nominally 1" by 4", double-V-joint, tongue-and-groove set at 7'-1". The ceiling in Room 106 is finished with nominally 1" by 4" double-beaded, tongue-and-groove boards set at 6'-3" above the floor.

Walls are also finished with tongue-and-groove boards, some with a double bead and some with a double V-joint. On some walls, boards are installed horizontally; on others, often in the same room, boards are installed vertically.

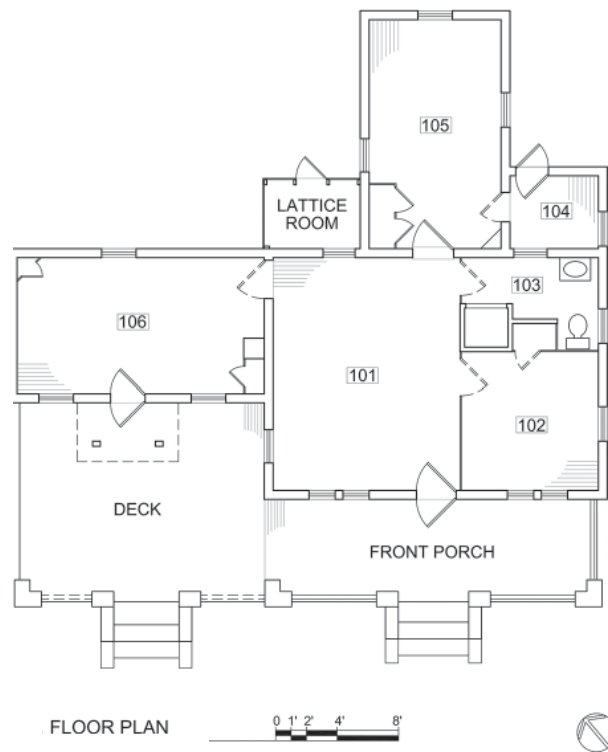

Figure 91. Floor plan of existing building. A larger version of this drawing is in the Appendix.



Figure 90. Southwest oblique, Room 101.

Interior Features Room-by-Room

Room 101 (Living Room)

Measuring 12'-2" east to west and 15'-4" north to south, this room occupies the west side of the main block of the house and is the largest room in the house.

Floor

Typical $\frac{3}{4}$ " by $3\frac{1}{2}$ " tongue-and-groove flooring is installed running east to west. The perimeter of the floor is varnished, but in the center is a large rectangle where the wood is unfinished, probably because it was covered with a linoleum "rug."

Walls

The north, south, and west walls are finished with horizontally installed, double-V-joint, tongue-and-groove boards over a wood frame. The boards on the north wall are 4" wide; those on the south and west walls are 3" wide.

The east wall is comprised of $\frac{3}{4}$ " by $4\frac{1}{2}$ " double-beaded, tongue-and-groove boards installed vertically over a narrow wood frame that is only 3" wide. Its construction is similar to that used in the wall between Rooms 102 and 103.



Figure 92. Mantel and stove flue in Room 101.



Figure 93. Northwest oblique, Room 101.

Ceiling

The ceiling is comprised of 3"-wide, double-V-joint boards running east to west.

Doors

The room has five doorways. The front doorway, which was described earlier, is located on the south wall only a few inches from the southeast corner of the room. It has a screen door that opens to the interior of the house in the distinctive Portsmouth fashion. In addition, a doorway near the north end of the west wall opens to the kitchen. The door itself is missing, but the jamb half of three hinges remains on the north jamb. The opening measures 2'-6" by 6'-2".

Doorways on the east wall open into Rooms 102 and 103. Both doors are missing but parts of the hinges remain on the jamb to Room 103. The doorway into Room 102 is 2'-6" by 6'-6"; the one into Room 103 is 2'-6" by 6"-8".

On the north wall is a doorway into Room 105, which is the north wing. The opening is 2'-8" by 6'-2" and is hung with a 1 $\frac{3}{8}$ " thick door with five horizontal raised panels.

Windows

The room has four windows. A pair of three-over-one windows is located on the south wall.

Each of those windows is 1'-9" by 3'-10". A six-over-six window, 2'-2" by 3'-10", is located on the north wall and another of the same size is on the west wall. All of these windows have brass sash locks but no lifts.

Wood Trim

Windows have $\frac{3}{4}$ " by 3" lintel-cut casing and apron, the apron with a 1" bevel along the lower edge. The front doorway has $\frac{7}{8}$ " by 4" lintel-cut casing. The doorways to Rooms 103, 105, and 106 are cased with $\frac{3}{4}$ " by 3" lintel-cut casing similar to that used on the windows. The doorway to Room 102 is cased with 3" double-V-joint tongue-and-groove planks.



Figure 94. Wall between Rooms 101 and 102.



Figure 95. Northeast oblique, Room 101.



Figure 96. Typical woodwork in Room 101.

Baseboards are $\frac{7}{8}$ " by 5" planks. A $1\frac{1}{2}$ " base cap is used on the south and east walls. The joint between the walls and ceiling is finished with $1\frac{1}{2}$ " bed molding.

Electrical System

Near the center of the ceiling is a $4\frac{1}{2}$ " metal junction box, surface mounted with a keyless porcelain light fixture. Wiring is concealed above the ceiling. A single duplex receptacle is mounted on the north wall at the baseboard.

Mantel

There is no fireplace but there is a 4"-diameter metal flue for a wood- or coal-burning stove near the center of the west wall. A mantel is installed around it with reeded legs set atop the baseboard. The mantel shelf is $\frac{3}{4}$ " by $8\frac{1}{2}$ " by 4'-9" and supported by a pair of scrolled brackets $2\frac{1}{2}$ " by 5" by $11\frac{1}{2}$ ". The shelf is 4'-9" above the floor.

Room 102 (Southeast Bedroom)

This room measures 9'-0" east to west and 9'-9" north to south. It might have been a single space with Room 103 at one time.

Floor

Flooring is typical $\frac{3}{4}$ " by $3\frac{1}{2}$ " tongue-and-groove, installed running east to west, and is a continuation of the flooring in Room 101.

Walls

The south and east walls are finished with horizontally installed, double-V-joint, tongue-and-groove, $\frac{1}{2}$ " by 3" boards. The north wall is finished with horizontally installed, double-V-joint, tongue-and-groove 4" wide.

The west wall is comprised of $\frac{3}{4}$ " by $4\frac{1}{2}$ " double-beaded, tongue-and-groove boards installed vertically over a narrow wood frame that is only 3" thick. The north wall is built in a similar way but with the tongue-and-groove material installed horizontally.

Ceiling

The ceiling is comprised of $\frac{1}{2}$ " by 3", double-V-joint boards running east to west.

Doors

The doorway from Room 101 is 2'-6" by 6'-6", but no door is present. The door that opened to Room 103 was closed to create a small closet and to allow



Figure 97. Southeast oblique, Room 102.

for installation of the present shower in Room 103. The doorway is 1'-8" by 6'-7", but the door itself is missing. The jamb portions of two 3" butt hinges remain in place.

Windows

The room has three windows. A pair of three-over-one windows is located on the south wall. Each of those windows is 1'-9" by 3'-10". A six-over-six window, 2'-2" by 3'-10", is located on the east wall. All of these windows have brass sash locks but no lifts.

Wood Trim

Windows have $\frac{3}{4}$ " by 3" lintel-cut casing and apron, the apron with a 1" bevel along the lower edge. The door to Room 103 is cased with $\frac{3}{4}$ " by 3" lintel-cut casing similar to that used on the windows. The doorway to Room 101 is cased with 3" double-V-joint tongue-and-groove boards.

Baseboards are $\frac{7}{8}$ " by 5" planks, except on the north wall where the baseboard is $\frac{3}{4}$ " by 5 $\frac{1}{2}$ ". The joint between the walls and ceiling is finished with 1 $\frac{1}{2}$ " bed molding, similar to that used in Room 101.

Electrical System

Near the center of the ceiling is a 4 $\frac{1}{2}$ " metal junction box, surface mounted with a keyless

porcelain light fixture. Wiring is concealed above the ceiling. A single duplex receptacle is located on the north wall.

Room 103 (Bathroom)

Located in the northeast corner of the main block of the house, this room measures 9'-0" east to west and 6'-0" north to south.

Floor

Flooring is typical $\frac{3}{4}$ " by 3 $\frac{1}{2}$ " tongue-and-groove, installed running east to west, and is a continuation of the flooring in Room 101.

Walls

The north and east walls are finished with horizontally installed, double-V-joint, tongue-and-groove, $\frac{1}{2}$ " by 3" boards. The south wall is finished with horizontally installed, double-V-joint, tongue-and-groove 4" wide.

The west wall is comprised of $\frac{3}{4}$ " by 4 $\frac{1}{2}$ " double-beaded, tongue-and-groove boards installed vertically over a narrow wood frame that is only 3" thick.

Ceiling

The ceiling is comprised of $\frac{1}{2}$ " by 3", double-V-joint boards running east to west.



Figure 98. Doorway between Rooms 102 and 103, now blocked by the shower in Room 103.



Figure 99. Looking east in Room 103.

Doors

The doorway from Room 101 is 2'-6" by 6'-8", but no door is present, although half of the hinge remains mounted to the jamb.

Windows

The room has two windows, one on the east wall and one on the north wall, both six-over-six, 2'-2" by 3'-10". All of these windows have brass sash locks but no lifts.

Wood Trim

Window and door casing and the window apron use $\frac{3}{4}$ " by 3" lintel-cut planks, the apron with a 1" bevel along the lower edge. There is no baseboard, but the joint between the walls and ceiling is finished with $1\frac{1}{2}$ " bed molding, similar to that used elsewhere in the house.

Electrical System

Near the center of the ceiling is a $4\frac{1}{2}$ " metal junction box, surface mounted with a keyless porcelain light fixture. Wiring is concealed above the ceiling.

Fixtures

There is a medicine cabinet, 2'-0" by 2'-0" by $5\frac{1}{2}$ ", installed near the east end of the north wall.

The wall-hung lavatory beneath it is now missing. A Standard "Compton" toilet is located in the southeast corner of the room. In the northeast corner is a 30" molded fiberglass shower.

Room 104 (Storage Room)

Located on the east side of the house in the ell between the main block and the north wing, this room was noted by Thompson as being a porch that had been enclosed, but there is no physical evidence that it ever existed as a porch. It measures 5'-9" east to west and 6'-6" north to south.

Floor

Flooring is typical $\frac{3}{4}$ " by $3\frac{1}{2}$ " tongue-and-groove, installed running north to south.

Walls

The north wall is finished with vertically installed, double-V-joint, tongue-and-groove boards, $3\frac{1}{2}$ " wide. The same material is used on the east and south walls but it is installed horizontally to a height of about 30" and vertically above that with a 1" by 3" with an eased edge separating the two as a chair rail. The west wall is formed by the original exterior wood siding of the north wing.



Figure 100. Looking west from Room 103 to Room 101.



Figure 101. View looking east in Room 104.

Ceiling

The ceiling is comprised of ½" by 3", double-V-joint boards running east to west.

Doors

The doorway from Room 105 is 1'-10" by 5'-10" with a door with five horizontal panels hung with a pair of 3", five-knuckle butt hinges. The exterior doorway on the north wall is 1'-10" by 5'-8" and is now closed by a fixed panel of vertical boards. The screen door remains in place and opens to the interior of the house in the distinctive Portsmouth fashion.

Windows

The room has two windows, one on the east wall and one on the south wall. Both are six-over-six windows, 2'-2" by 3'-10".

Wood Trim

Windows have ¾" by 3" lintel-cut casing and apron, the apron with a 1" bevel along the lower edge. The doors are cased with similar material. Baseboards are ⅞" by 5" planks. The joint between the walls and ceiling is finished with 1½" bed molding, similar to that used elsewhere in the house. Modern, floor-to-ceiling, wooden shelving has been installed on the north wall.



Figure 103. View of north wall of Room 104.



Figure 102. View from Room 104 into Room 105.



Figure 104. View of interior screen door in Room 104.

Room 105 (Back Bedroom)

This room forms the north wing and is probably the oldest part of the house. The character of its materials suggests that was built late in the nineteenth century or very early in the twentieth. The room measures 8'-8" east to west and 14'-11" north to south.

Floor

Flooring is typical $\frac{3}{4}$ " by $3\frac{1}{2}$ " tongue-and-groove, installed running north to south.

Walls

The north wall is finished with 3" V-joint, tongue-and-groove boards. The south, east, and west walls are finished with 3" V-joint and $3\frac{1}{2}$ " double-V-joint, tongue-and-groove boards. There are a few double-beaded boards above the door to Room 101.

Ceiling

The ceiling is comprised of 3" and 4"-wide, double-beaded boards running north to south.

Doors

In addition to the door from Room 104 on the east wall, described above, a door on the north



Figure 105. North window showing typical casing and corner blocks used at windows and doors in Room 105.



Figure 106. Looking south in Room 105.

wall opens to Room 101. It has two vertical panels above and two vertical raised panels below a single horizontal raised panel. The door measures 1 $\frac{3}{8}$ " by 2"-8" by 6'-1". The door has a rim lock, 4 $\frac{3}{8}$ " by 4 $\frac{3}{8}$ ", mounted to the inside face and a keep mounted to the door casing. Both knobs are missing. A 2'-6" by 6'-1" door with four vertical panels is being stored in this room. Its original location in the house is uncertain.

Windows

The room has windows on the east, north, and west walls. All appear to have been six-over-six, but the lower sash in the east and north windows is missing. Windows are typical 2'-2" by 3'-9", an inch shorter than those in the rest of the house. All of the north window and the lower half of the east window are covered with plywood.

Wood Trim

Window and door casing is deeply molded in a design popular in the late nineteenth and early twentieth centuries. Casing measures $\frac{3}{4}$ " by 4 $\frac{3}{4}$ " and is installed against plain 1" by 4 $\frac{3}{4}$ " by 4 $\frac{3}{4}$ " corner blocks. Window stools are 1 $\frac{1}{4}$ " by 4" with eased edges. Aprons use the same material used as a base cap.



Figure 108. Modern shelving in southeast corner of Room 105.



Figure 107. Looking north in Room 105.



Figure 109. View into Room 101 from Room 105.



Figure 110. Five-panel door between Rooms 101 and 105.



Figure 111. Rim lock on door between Rooms 105 and 101.

Baseboards are $\frac{7}{8}$ " by 4" planks with a $\frac{7}{8}$ " by $1\frac{1}{8}$ " molded cap. Crown molding is typical $1\frac{1}{2}$ " bed molding.

Wardrobe

A wardrobe measuring 1'-10" east to west and 4'-1 $\frac{1}{2}$ " north to south has been built into the southwest corner of the room. Set on 3" by 3" tapered legs that raise the wardrobe nearly 6" above the floor, the wardrobe is plank built and has two large doors above a pair of deep drawers. The front consists of two nominally 1" by 3" vertical planks and one 1" by 5" vertical plank to frame the sides of the door and drawer openings and four 1" by 5" rails. A 1" by 5" board has been scroll-cut and applied as a decorative element on the face of the wardrobe above the doors. The north end of the wardrobe is built with the same 4"-wide, double-V-joint, tongue-and-groove boards on the ceiling, vertically installed. The crown molding used in this room is continued around the top of the wardrobe, and the base cap finishes the lower edge of the piece.

The wardrobe has two doors, each 1'-7 $\frac{1}{2}$ " by 4'-0" and constructed with 1" by 3"-wide molded stiles and top rail, 1" by 4"-wide molded bottom rail, and



Figure 112. Wardrobe in southwest corner of Room 105.

flat plywood panels. Each door is hung with a pair of 3" three-knuckle hinges and is fitted with a small mortised lock set that includes a round knob on the outside and a lever on the inside, but no locking mechanism. A wooden clothes-hanging rod and a 12"-wide shelf run across the upper part of the interior.

The two drawers are also plank built, using 1" by 10" planks for the fronts and 1" by 8" planks for the sides and back. The front of each drawer is 9" by 1'-8" and features a pair of metal clamshell pulls. The drawers slide on 1" by 4" planks laid flat along each side of the opening.

Corner Shelving

Four triangular shelves have been installed in the southeast corner of the room. Constructed of $\frac{3}{8}$ " plywood supported by $1\frac{1}{2}$ " by $1\frac{1}{2}$ " rails, the shelves measure 1'-4" on each side and about 1'-11" along the front edge. These shelves are probably contemporaneous with the shelving installed in Room 104.

Electrical System

Near the center of the ceiling is a $4\frac{1}{2}$ " metal junction box, surface mounted with a keyless porcelain light fixture. Wiring is concealed above the ceiling. Duplex receptacles are located on the north, south, and west walls.



Figure 113. Looking east in Room 106, showing floor-to-ceiling pantry closet.

Room 106 (Kitchen)

Measuring 8'-6" north to south and 16'-1" east to west, this room forms the west wing of the house.

Floor

Flooring is typical $\frac{3}{4}$ " by $3\frac{1}{2}$ " tongue-and-groove, installed running north to south.

Walls

The east wall is finished with $\frac{7}{8}$ " by $5\frac{1}{2}$ " double-beaded, tongue-and-groove boards, installed vertically. The north and west walls are finished with 3" double-beaded tongue-and-groove boards, installed vertically. The south wall has 3" double-beaded boards, too, but 4" center-groove boards are also present.

Ceiling

The ceiling is comprised of 3"-wide, double-beaded, tongue-and-groove boards running east to west.

Doors

The exterior doorway (described earlier) on the south wall includes a wood-framed screen door, $\frac{3}{4}$ " by 2'-2" by 5'-8", mounted on the interior casing. The room can also be entered by the doorway on the east wall from Room 101. The opening is 2'-6" by 6'-2" but no door is hung in the opening. The jamb halves of two hinges remain on the north jamb.

Windows

The room has two six-over-six windows, 2'-2" by 3'-10" on the south wall and one two-over-two window, 2'-4" by 3'-9" on the north wall.



Figure 114. Attic hatch in northeast corner of Room 106.

Wood Trim

The doorway to Room 101 is not cased on the Room 106 side of the opening. The exterior doorway on the south wall is cased with lintel-cut planks, $\frac{3}{4}$ " by $3\frac{1}{2}$ ".

Windows are cased with lintel-cut boards, $\frac{3}{4}$ " by $3\frac{1}{2}$ "; stools 1" by 5"; and aprons $\frac{3}{4}$ " by 3".

Baseboards are $\frac{3}{4}$ " by 3" plank with no cap. Crown molding is typical $1\frac{1}{2}$ " bed molding.

Chimney Flue

The house's only chimney, which also serves the living room stove flue, rises on the east side of this room. It has been boxed in and finished with the same tongue-and-groove boards used at the east end of the room. The flue is terra cotta, 9" in diameter.

Cabinets and Shelving

The paneling of the chimney stack is continued to the south wall in order to create a floor-to-ceiling pantry between the chimney and the south wall. It has two board-and-batten doors that use 3" double-beaded tongue-and-groove boards and $\frac{3}{4}$ " by $2\frac{1}{2}$ " battens. Each door is hung with a pair

of 4" strap hinges and has a $1\frac{1}{8}$ " porcelain knob. Two-inch wooden pivot latches close each door.

In the northwest corner of the room is a built-in cupboard, 1'-7" by 1'-7" and 3'-2" high with its top against the ceiling. The cupboard is built with $\frac{7}{8}$ " by $2\frac{1}{2}$ " planks and has a wood-framed glass door 1'-4" wide. The two shelves on the interior are also built with $\frac{7}{8}$ "-thick boards. A piece of base cap similar to that used in Room 105 finishes the face of the cupboard to the ceiling.



Figure 116. Shelf on north wall of Room 106.



Figure 115. Southwest oblique, Room 106.



Figure 117. Shelf on west wall.

To the right of the cupboard, mounted on the north wall, is a wooden shelf, $\frac{7}{8}$ " by 10" by 3'-6". A length of inverted base cap serves as a rail against the wall, and two 1" by 3" angle braces with chamfered edges support the outside edge. On the west wall is a second shelf, $\frac{7}{8}$ " by 10" by 3'-0". It is supported by a pair of 8" by 12" metal brackets.

Electrical System

There is a 4½" diameter galvanized-metal junction box with a keyless porcelain bulb holder on the west wall and two galvanized-metal duplex receptacles on the north wall. The 60-amp circuit-breaker box for the house's electrical system is located on the bottom shelf of the corner cupboard.

Attic Hatch

At the east end of the ceiling, a hatch provides access to the west wing's attic. From that attic, a wall hatch, which was cut through the original

vertical sheathing on the main block of the house, provides access to the attic in that area. The ceiling hatch is plywood, 1'-5" by 1'-7", and not hinged. It is trimmed with ½" by 2½" wooden strips.

Problems of Repair

The interior of the house is in fair condition, but most surfaces are soiled and stained and need repainting. There is some deterioration of the ceiling boards at isolated locations where the roof has leaked. Three window sash are missing, and as noted earlier, the exterior glazing is in poor condition, which has allowed damage to some interior surfaces.

The flooring is in poor condition, primarily from multiple floods, including the terrible hurricane that washed over the Outer Banks in 1933. These events have left much of the the flooring cupped and most of the fasteners showing evidence of oxidation.



Figure 118. Stove flue and upper door of pantry closet.



Figure 119. Northwest corner cupboard. The electrical circuit breaker is on the bottom shelf of this cabinet.



Figure 120. Wood flooring typical of that found throughout the house.



Figure 121. South elevation of shed.



Figure 122. Gable vent.

Shed

Located just a few yards off the north side of the house's west wing, the shed is the only outbuilding left on the site. It was heavily repaired in 2007, when a substantial amount of the historic materials was replaced and a louvered vent was installed in the gables. Wood-framed with board-and-batten siding, the building is 14'-4" north to south and 9'-0" east to west. The building rises 5'-11" from the flooring to the top of the wall plates.

Wood Frame

Any piers that were present have now disappeared so that the sill and several of the joists are now resting on the ground. All framing material is nominally 2" by 4" except for the sills which are 4" by 4". Three 2" by 4" joists, more or less evenly spaced, run east to west.

Corner posts consist of doubled 2" by 4" lumber and 2" by 4" braces and there are three 2" by 4" studs on each side. A horizontal 2" by 4" member runs between the studs and posts and across the rear (north) end of the structure about midway up the walls. The top plate consists of a single 2" by 4" board.

The building has five rafters, each 2" by 4", including the two end rafters and on centers about 3'-7" apart. Rafters are joined at the top without a ridge board and toe-nailed to the top plate at each stud and corner post. Collar ties are also 2" by 4".

Flooring

The flooring, which is only a few inches above grade, is generally 1¼" by 8" to 8½". A large oil spill coats much of the floor.

Siding and Trim

The building is finished with board-and-batten siding, all of it installed in 2007 except for some of the boards at the north end. Boards are a random mix of widths of 9½", 10", and 11". Battens are 1" by 2½".

Openings

The building has a single door, located at the south end. It is also board-and-batten and measures 2-8½" by 5'-9". It has two vertical boards ¾" by 9¾", one ¾" by 8½", and one ¾" by

4" The door has Z battens, with the top batten 1" by 6", the bottom batten 1" by 6½", and the cross batten 1" by 3". The door is hung with a pair of 3", five-knuckle butt hinges and is closed with a wooden pivot latch.

There is a single window, located in the north end. It is 1'-8" by 2'-4" and has one-over-one sash. Louvered vents are placed at the top of each gable.

Roofing

The rafters have an open deck comprised of nominally 1" by 4" boards. Roofing is random-width ⅜" by 18" wood shingles similar to those used on the house.

Problems of Repair

The parts of the shed that are visible are in good condition. Considering the building's proximity to the ground, deterioration of the sills and floor joists is probably ongoing.



Figure 124. Window at north shed wall.



Figure 123. Southeast oblique.



Figure 125. Looking south inside shed.



Figure 126. Looking north inside shed.



Figure 127. Pivot latch on shed door.

Character-Defining Features

Important character-defining features of the Mason-Willis-Dixon House include:

Distinctive Characteristics of the Site

- The setting at the heart of the historic village of Portsmouth.
- The open grassy site only a few yards from the water.
- Tall grasses and low shrubs surrounding the grassy site with interspersed clumps of wind-bent trees.
- Location of buildings and site features.
- Long vistas across Doctor's Creek of the Church and other buildings on the east bank.
- View of the other buildings on the east side of Doctors Creek, including the Methodist Church, the Washington Roberts House, the Ed Styron House and others.

Distinctive Characteristics of the Building Exterior

- The log posts that form the house's foundation.
- The house's wood-frame construction.
- The Craftsman-style front porch, with its segmentally arched headers, brick piers, box columns, and balustrades.
- The open deck on the south side of the west wing, including the brick piers and cheek walls and their concrete caps.

- The portico at the front door to the west wing.
- The gable roofs, dormer, and Craftsman-style knee braces.
- The wood-shingle roofing.
- The lapped siding and unboxed eaves.
- The brick chimney.
- The wooden front door with its single panel, three vertical lights, and its hinges, mortise lock, and mineral knobs.
- The three-over-one wooden windows at the front of the main block of the house.
- The wood sash with three vertical lights in the dormer and gable windows.
- The two-over-two wooden window on the north side of the kitchen.

Distinctive Characteristics of the Interior

- The floor plan and existing room arrangement.
- The tongue-and-groove flooring.

- The beaded and V-joint walls and ceilings, baseboards, crown molding, and door and window casings.
- The molded casing and corner blocks in Room 105.
- The wood mantel in Room 101.
- The wardrobe in Room 105.
- The corner cupboard, pantry, and shelving in Room 106.
- The wood-framed interior screen doors and exterior window screens.
- Flue openings in Rooms 101 and 106

Distinctive Characteristics of the Shed

- The location and proximity to the house.
- The end-gabled form of the building, with a window in the north end and a door in the south end.
- The wood frame.
- The board-and-batten siding and wood-shingled roof.
- The wooden pivot latch on the door.



Figure 128. Northwest oblique.

Summary of Physical Conditions

Repairs conducted by NPS in the late 1970s, throughout the 1980s, and in the mid-2000s were extensive and addressed major concerns. General upkeep provided by the Friends of Portsmouth Island group over the last several years has addressed many of the building's aesthetic issues. Overall, the house is in good shape, and the outbuildings in good to fair condition.

While most current concerns are aesthetic in nature and represent no threat to the safety of the general public or NPS staff or to the building, a handful of concerns do require attention.

Highest Concern: Immediate Threat to Life/Safety of Occupants or Immediate and Serious Threat to Building

- There are no immediate threats to the building.
- There are no immediate threats to the safety of occupants. The change in floor level from Room 101 to 106 is a distinctive feature of the house, and should be recognized as a potential trip hazard.

High Concern: High Potential for Becoming a Threat to Occupants or Building

- Poor drainage is characteristic of most of Portsmouth, but the natural process of decay of vegetation and generation of new humus has created a bowl-like depression beneath the house. This traps water and keeps the area damp for extended periods of time, which not only exacerbates rotting of wood posts, but also creates conditions conducive to termites, all conditions that are typical of most of the structures at Portsmouth.
- Much of the mortar in the front porch piers dates to their construction but remains in fair condition. The mortar in the exposed piers on the deck is badly eroded. All but three of the concrete caps on the piers and cheek walls are cracked and broken, with significant material loss in some. The east cheek wall at the steps to the deck leans significantly to the east.
- The door to Room 106 is deteriorated with severe damage to the bottom rail. The door

- to Room 104 is new but has no exterior hardware and no steps to the ground.
- Sash are missing from the windows on the east and north sides of the north wing but most of the rest are in fair condition.
- Glazing of windows is in poor condition. Many of the wood-framed screens are missing and those that remain are in poor condition.
- The lattice on the lower portion of the north wall of the lattice room is badly damaged as is the painted finish on the entire room. The door steps are missing entirely.
- Most of the house's exterior woodwork is in fair condition. Painted finishes are peeling and bare wood is being exposed at various locations all around the house.
- Some siding and most of the crown molding in the gables should be rerailed.
- The painted finish on the deck flooring is badly worn as is the paint on the plinths and lower half of the posts.

Medium Concern: Delayed Threat to Occupants or Building

- The interior of the house is in fair condition, but most surfaces are soiled or stained and need repainting. There is some deterioration of the ceiling boards at isolated locations where the roof has leaked. Three window sash are missing, and as noted earlier, the exterior glazing is in poor condition, which has allowed damage to some interior surfaces.
- The flooring is in poor condition, primarily from multiple floods, including the terrible hurricane that washed over the Outer Banks in 1933. These events have left much of the the flooring cupped and most of the fasteners showing evidence of oxidation.
- The wood framing appears to be in generally fair condition, and ridge lines remain straight and floors level. Insect damage can be observed in some of the sills, and there is likely to be hidden damage elsewhere in the building. The house is, like many others of the period, under-structured by modern standards, especially in terms of spacing between the various framing members, but there is no apparent systemic failure. However, the nails used in framing

have inevitably corroded in the damp, salty environment, making the building more subject to wind damage and other stresses.

- The roofing is in fair condition and there are no apparent leaks. A few shingles are missing or loose. The house has no working electrical, plumbing, or HVAC systems.
- The parts of the shed that are visible are in good condition. Considering the building's proximity to the ground, deterioration of the sills and floor joists is probably ongoing.

Low Concern: Aesthetic Concerns Posing No Threat to Occupants or Building

- The finishes of the porch floor decks and exterior woodwork are failing.
- Glazing and painting of window sash are failing.

II.A Ultimate Treatment and Use

The house and its reconstructed shed are part of a group of historic structures that provide what is perhaps the iconic image of Portsmouth. Anchored by the Methodist church, this concentration of residences, outbuildings, community buildings and cemeteries provides visitors a sense of the village in the early twentieth century when it was still a thriving community. Treatment and use of the Mason-Willis-Dixon House and shed should be predicated on preserving their place in that ensemble of buildings.

The house is historically significant for its associations with the Mason, Willis, and especially the Dixon families, all with roots in Portsmouth that stretch back more than two centuries. The house is also architecturally significant as an excellent local interpretation of the Craftsman bungalow, which was wildly popular in the first decades of the twentieth century. Harry Dixon's stylish and extensive remodeling of an earlier house, even as Portsmouth was in decline, illustrates the resilience of Portsmouth and its residents.

In the 1970s NPS began a successful leasing program for several Portsmouth houses. The long-term agreements, generally twenty years, required leaseholders to maintain and improve the buildings following the Secretary of the Interior's "Standards for Rehabilitation" and specific conditions of the lease, including a requirement for a compost toilet if a flush toilet were not installed.⁸⁹

The leasing program at Portsmouth Village, like that at Cape Lookout Village, came to a close as the initial lease period ended. A plan for reuse was developed for the historic buildings at Cape Lookout Village after an unsuccessful challenge to



Figure 129. Mason-Willis-Dixon House seen from Village Road.

the NPS decision not to renew. No similar plan has been developed for Portsmouth.

Reestablishment of the leasing program at Portsmouth seems unlikely given the more stringent code requirements for sanitary facilities now in place. Installing and maintaining sanitary facilities during the initial phase of the leasing program was a constant challenge due to the shallow water table.⁹⁰ In addition, the Long-Range Interpretive Plan notes that leasing may not be "desirable or feasible."

A plan for reuse was developed for the historic buildings at Cape Lookout Village after those

89. Ellen Fulcher Cloud interview, April 26, 2014 Homecoming.

90. Cape Lookout National Seashore, Foundation Document, 2012, p. 29.

leases expired, and there was an unsuccessful challenge to the NPS decision not to simply renew them. There is not yet a similar plan for those at Portsmouth.

Continuing the use for which an historic structure was built is almost always the best option for historic preservation, and so it is for this residence. With its central location and high visibility, the house was a logical location for a ranger station at one time and a popular residence for volunteers after that, all while several nearby houses were leased. The house has two bedrooms, a full bathroom, and kitchen, but there is currently no water, sewer, or electrical service and all utility systems need to be updated. The house remains a sound and viable residence and could probably be readily leased. Unfortunately, as noted in the park's recent Long-Range Interpretive Plan (LRIP), there are obstacles to leased residential use, beginning with major changes to the NPS legal authority for leasing that make the process more cumbersome.

In addition, the LRIP points out that "development of adequate sanitary facilities is not only challenging in the district but is also further complicated by sea level rise"91 Maintaining a potable water supply has always been an issue at Portsmouth, and with a rising and increasingly saline water table, wells may no longer be practical.

The rising water table was a factor in failure of the septic tank and drain field at the house.

The Long-Range Interpretive Plan also notes that leasing may not be "desirable or feasible," and though that may be true, other daytime or administrative uses might be found, since sanitary facilities for non-residential uses may be feasible. A free-standing toilet would be unacceptable within the cultural landscape at the center of Portsmouth, but one might be housed in the reconstructed shed with a minimal impact on historic fabric.

At the very least, the house could be included among the buildings that are routinely opened to the public. Any threat of vandalism would be outweighed by the benefits of "eyes on the building," which can help forestall the inevitable neglect that results when a building is not being used. It is noteworthy that long-time park personnel cannot recall an instance of vandalism, a problem at some parks.

The park's GMP is outdated, and when it is updated, NPS will decide how to manage the residences in the Portsmouth historic district. In the meantime, and in keeping with the park's approach to Portsmouth's other historic structures, *the Recommended Ultimate Treatment for the house is Preservation of the exterior of the house as a major feature in the district's cultural landscape and Rehabilitation of the interior to accommodate modern use, if possible.*

91. Cape Lookout National Seashore, Long-Range Interpretive Plan, pp. 38-39.

II.B Requirements for Treatment

Treatment and use of all historic properties maintained by the National Park Service are guided by a number of Federal laws and regulations, as well as to NPS policy, directives, and functional requirements. In addition to protecting cultural resources, these requirements also address issues of life safety, fire protection, energy conservation, abatement of hazardous materials, and handicapped accessibility.

Some of these requirements may contradict or be at cross purposes with one another if they are rigidly interpreted. Any treatment must be carefully considered with a goal of maximizing the preservation of historic features and materials.

National Historic Preservation Act

The National Historic Preservation Act of 1966 as amended (NHPA) mandates Federal protection of significant cultural resources, including buildings, landscapes, and archeological sites. In implementing the act, a number of laws and authorities have been established that are binding on the NPS.

Section 106

A routine step in the park's planning process for the treatment of cultural resources is compliance with Section 106 of NHPA. This requires that, prior to any undertaking involving National Register or National Register-eligible historic properties, Federal agencies "take into account the effect" of the undertaking on the property and give the Advisory Council on Historic Preservation "a reasonable opportunity to comment with regard to such undertaking."

To satisfy the requirements of Section 106, regulations have been published (36 CFR Part 800, "Protection of Historic Properties") that require, among other things, consultation with local governments, State Historic Preservation

Officers, and Indian tribal representatives. They also establish criteria under which the Advisory Council may comment, but as a practical matter, the vast majority of Federal undertakings do not involve review by the Advisory Council. The purpose of Section 106 review is to ensure that all interested parties have a voice in the preservation of our nation's cultural heritage, and that historic properties are protected.

To expedite the review process, a programmatic agreement (PMOA) has been developed among the Advisory Council on Historic Preservation, the National Council of State Historic Preservation Officers and the NPS to allow for a streamlined Section 106 review process. With certain conditions, routine repairs and maintenance that do not alter the appearance of the historic structure or involve widespread or total replacement of historic features or materials are reviewed by cultural resource specialists within the NPS.

The Secretary's Standards

The *Secretary of the Interior's Standards for the Treatment of Historic Properties* are the Secretary's best advice to everyone on how to protect a wide range of historic properties. They provide a philosophy to underpin historic preservation that is widely understood and almost universally accepted in the United States. They are intended to be applied to a wide variety of resource types, including buildings, sites, structures, objects, and districts. *The Standards*, revised in 1992, are codified as 36 CFR Part 68.

The Standards describe four broad approaches to the treatment and use of historic properties. These are, in hierarchical order:

- Preservation, which places a high premium on the retention of all historic fabric through conservation, maintenance and repair. It reflects a building's continuum over time,

through successive occupancies, and the respectful changes and alterations that are made.

- Rehabilitation, which emphasizes the retention and repair of historic materials, but provides more latitude for replacement because it is assumed the property is more deteriorated prior to work. (Both Preservation and Rehabilitation standards focus attention on the preservation of those materials, features, finishes, spaces, and spatial relationships that, together, give a property its historic character.)
- Restoration, which focuses on the retention of materials from the most significant time in a property's history, while permitting the removal of materials from other periods.
- Reconstruction, which establishes limited opportunities to recreate a non-surviving site, landscape, building, structure, or object in all new materials.

Regardless of treatment approach, the Standards put a high priority on preservation of existing historic materials and features and not just the architectural form and style. The Standards also require that any alterations, additions, or other modifications be reversible, i.e., be designed and constructed in such a way that they can be removed or reversed in the future without the loss of existing historic materials, features, or character.

Americans With Disabilities Act of 1990

The Americans With Disabilities Act of 1990 (ADA) establishes comprehensive civil rights protection for disabled Americans, both in employment and in their right to free, unaided access to public buildings. While people with restricted mobility have most frequently benefited from ADA, protection also extends to those with other disabilities, including those with impaired vision or hearing.

Requirements for full compliance with ADA regulations are extensive and easiest to apply to new construction. Full compliance for historic buildings is more difficult and sometimes would require significant alterations to the historic

character of the property. Where that is the case, ADA authorizes a process for arriving at alternatives to full compliance that can preserve historic character while maximizing a disabled visitor's access to the historic building.

International Building Code

As a matter of policy, the NPS is guided by the International Building Code, which includes this statement regarding code compliance in historic buildings:

3406.1 Historic Buildings. The provisions of this code related to the construction, repair, alteration, addition, restoration and movement of structures, and change of occupancy shall not be mandatory for historic buildings where such buildings are judged by the building official to not constitute a distinct life safety hazard [emphasis added].

Threats to public health and safety should always be eliminated, but because this applies to historic buildings, alternatives to full code compliance are always sought where compliance would needlessly compromise the integrity of historic buildings.

NFPA Code 914

The National Fire Protection Association (NFPA) has promulgated codes for historic buildings, most notably NFPA 909, "Code for the Protection of Cultural Resources Properties - Museums, Libraries, and Places of Worship," and NFPA 914, "Code for Fire Protection of Historic Structures." As a matter of policy, NPS recommends installation of fire-suppression systems in every historic building.

NPS Management Policies

The NPS General Management Policies (2006) guide overall management of historic properties, especially Chapter 5 "Cultural Resource Management." Based upon the authority of some nineteen Acts of Congress and many more Executive orders and regulations, these policies require planning to ensure that management processes for making decisions and setting

priorities integrate information about cultural resources, and provide for consultation and collaboration with outside entities. These policies also support good stewardship to ensure that cultural resources are preserved and protected, receive appropriate treatments (including maintenance), and are made available for public understanding and enjoyment.

Section 5.3.5, “Treatment of Cultural Resources”

This section of the management policies provides specific directives, including a directive that “the preservation of cultural resources in their existing states will always receive first consideration.”

The section also states that “treatments entailing greater intervention will not proceed without the consideration of interpretive alternatives.... Pending treatment decisions reached through the planning process, all resources will be protected and preserved in their existing states. Except for emergencies that threaten irreparable loss without immediate action, no treatment project will be undertaken unless supported by an approved planning document appropriate to the proposed action.”⁹² The present HSR is that approved planning document.

Park Planning

The 1982 General Management Plan (GMP) divided the park into management zones, with a 250-acre “historic zone” identified around Portsmouth where preservation and adaptive use of the historic structures was envisioned. Beyond that, the GMP recommended restoration of Portsmouth “to the turn-of-the-century period, but without the replacement of now-missing buildings” and removal of “later buildings of non-historic character.” Those recommendations were based on a narrow understanding of the history and significance of Portsmouth that has since been broadened by additional research and the numerous studies that have been completed since the turn of the present century. We concur with the recommendations of the recently completed Cultural Landscape Report, which suggests the period of significance be extended to 1971, when the island’s last year-round residents decamped for the mainland.

The GMP envisioned some building interiors used for interpretation, and others “adapted for contemporary administrative functions.”⁹³

Subsequent park planning documents provide no additional direction applicable to the treatment and use of the Mason-Willis-Dixon House beyond maintaining its presence in the village.

92. NPS General Management Policies (2006), p. 50.

93. NPS, Cape Lookout National Seashore General Management Plan, 1982, p. 43.

II.C Alternatives for Treatment and Use

In accordance with NPS policy, other alternatives for treatment and use have also been considered in addition to the Ultimate Treatment and Use described above. While perhaps not recommended under the present circumstances, these alternative approaches nevertheless fulfill the basic park mandate to preserve the historic resources at Portsmouth.

Alternative #1: Mothballing

Having completed basic exterior repairs recommended elsewhere, park management could elect to simply mothball the house, following standards established procedures for that action.⁹⁴ Window and door openings would be secured with wood louvers and no visitor access would be allowed.

This approach would have the following advantages:

- retains maximum flexibility for future decisions by park management regarding treatment and interpretation of Portsmouth;
- minimizes cost to preserve the house.

While this approach might be necessary for a short period of time, it becomes increasingly hard to justify as time goes by. As a result, this approach would have the following disadvantages:

- diminishes the public's educational experience, since mothballing would of necessity severely diminish the house's historic character and prevent public access;
- risks long-term neglect if not carefully monitored;
- violates NPS policy in support of adaptive use of historic buildings;

94. See Sharon C. Parks, *Preservation Brief 31: Mothballing Historic Buildings* (National Park Service Technical Preservation Services, 1993).

- leaves the NPS open to public criticism for its failure to use and properly preserve and interpret the resources in the village.

Alternative #2: Restoration ca. 1920

An interesting alternative might be restoration of the house to its appearance prior to Harry Dixon's remodeling in the 1928. Such an approach could enhance visitors' understanding of the early community and the nature of its built environment in the early twentieth century.



Figure 130. Undated photograph showing the house before the changes of the 1920s. An attached porch fronts the main block, and the west wing is in place. Land to the west is vacant where houses would be added in the 1930s. (Dorothy Byrum Bedwell Coll.)

This approach would include removal of the low-pitched roof over the main block and restoration of the original roof, the rafters of which remain in place, and replacement of nearly all of the window sash with simple two-over-two sash. The front porch would be removed and the simple shed-roofed porch that existed before 1928 would be reconstructed. The deck, too, would be removed, with a simple flight of steps providing access to the front door to the kitchen.

This approach would have the following advantages:

- enhance visitors' understanding of the early community and the nature of its built environment;
- the simplified design would also make long-term maintenance less costly.

It would have the following disadvantages:

- destruction of so much historic fabric would likely be judged an "adverse effect" and trigger protracted Section 106 consultation;
- the proposed restoration would be based on very limited archival documentation;
- additional building archaeology might date construction of the three components of the building, but would likely not show when they were brought together to form a single house, which was before 1928;
- would likely anger the local community by destroying a part of the cultural landscape they have always known.

Alternative #3: House Museum

A third alternative that might be considered is that of house museum, with the interior and exterior restored to their appearance at the end of the period of significance. With appropriate furnishing and decoration, the house could exhibit something of the lifestyle of the Dixons and other residents of the community. Without furnishing and decoration, the house could still be a useful exhibit of itself which, if properly interpreted, could help visitors understand how Portsmouth's architecture differed from that on the mainland and how it did not.

This approach would have the following advantages:

- maximizes public benefit and interpretive opportunity by preserving the house and restoring lost features;
- expands visitor understanding of the role that the Mason, Willis, and Dixon families played in the community.

This approach would have the following disadvantages:

- requires a significant outlay of funds to pursue the necessary research and investigations to accurately recreate the historic interiors;
- increases cost of long-term maintenance ;
- cannot be justified as a realistic goal given present budget and staffing level restraints.

II.D Recommendations for Treatment and Use

The following recommendations are intended to achieve the Ultimate Treatment and Use described above for the Mason-Willis-Dixon House: exterior preservation and possible adaptive use of the interior. Most of what is described below is compatible with a variety of uses and is intended to incorporate routine maintenance of the house as it exists today, repairing and, if necessary, replacing in-kind, as well as conducting routine inspections to minimize and prevent damage to the historic fabric of the building.

HSR recommendations are not intended to provide the specific guidance that architectural/engineering plans and specifications or other specialized professional documents would provide. However, A/E plans and specifications or other professional documents may not be needed for many of the recommended actions. Some of the in-kind repairs and maintenance tasks can be performed by skilled craftsmen, if properly guided by cultural resource specialists.

Portsmouth Village - General

Barrier islands, such as Portsmouth, will be especially vulnerable to the effects of climate change and sea-level rise, which may negatively affect cultural resources on these islands.

General Recommendations for Portsmouth Village

- Consult with Janet Cakir PhD, NPS SER Climate Change, Socioeconomics, and Adaptation Coordinator to guide management policies.
- Use results from the climate change study “Identify Cultural Resources Sites Affected by Sea-Level Rise at Cape Hatteras National Seashore” to guide management policies. This study is also applicable to Portsmouth Island.

- Prepare or update a Topographic Survey for the site.
- Prepare a Log of Flood Occurrences. Record at a minimum the dates of occurrences and approximate extent and severity (e.g. depth at specific locations). Correlate recordings with Topographic Survey. Maintain data so that they can be correlated with conditions such as tide, moon phase, etc.
- Evaluate site for flood avoidance potential including the introduction of dams and/or swales to divert or direct flooding waters.
- Evaluate each building, structure, and significant site feature for flood avoidance potential and/or enhancement potential for better withstanding the projected threatening events.
- Identify critical services (fresh water supply, waste disposal, energy sources, etc.), evaluate options, and develop contingency plan for each.
- Strive to maintain for all buildings a sound structural system and a weather-tight exterior envelope, especially the roof.
- Use maintenance activities as opportunities to enhance the resistive capacities of the buildings and structures whenever feasible.
- Prepare minimum level of record documentation (overall view photographs and text descriptions) for all undocumented cultural resources in the community that are at risk; prepare more extensive documentation (including scaled record drawings with descriptions) for the more significant resources at risk.

The House Site

Portsmouth’s coastal climate with its regularly strong winds, high humidity levels and high

salt content of the air, is especially damaging to many construction materials, especially ferrous-based metals. Left unprotected, such materials deteriorate quickly.

Poor drainage is also characteristic of Portsmouth, but the natural process of decay of vegetation and generation of new humus has created a bowl-like depression under the house. This traps water and keeps the area damp for extended periods of time, which not only exacerbates rotting of wood posts, but also creates conditions conducive to termites.

Typically, the use of gutters and a drainage system to direct water rapidly away from the building would be part of the solution to this problem, but the topography of the site would probably make such an approach of little utility. The depression might be filled with sand, gravel, or shell, but the low elevation of the building's wood frame would make that difficult.

Raising the house, including the masonry features on the south side, and regrading the site to eliminate the depression might eliminate this problem but would likely require replacement of all of the foundation posts, which are character-defining features. The house could be raised less than a foot before the brick and concrete piers, cheek walls, and steps would have to be rebuilt. With rising tides, it might be more efficient to manage the effects with more frequent inspection for termites and other hazards to the building.

General Recommendations

- Avoid use of ferrous-based fasteners in all construction and repairs.

Recommendations for House Site

- Investigate feasibility of partial or complete filling of the depression beneath the house.
- Conduct rigorous annual inspections for termite infestation and treat accordingly.
- Secure clearance from an archaeologist before commencing work that might require ground disturbance.

Structural Systems

Except for the front porch, which is supported by brick piers, the house is set on wood posts. The house is one story and has a conventional wood frame.



Figure 131. Tilted brick cheek wall at steps to front deck.

Foundation Posts

Standing water has precipitated rot in most of the wood posts, which are set directly into the ground, a problem typical of the structures at Portsmouth. No metal shields separate the posts from the house's wood frame to protect the structure from termite infestation and damage.

Posts will have to be replaced eventually, and where that is necessary, posts should be replaced in-kind. Distinctive posts, such as the one using salvaged lumber previously eaten by ship worms, should be preserved.

Recommendations for Foundation Posts

- Replace posts in-kind as they fail.
- Preserve distinctive posts and those dating to the house's original construction.
- Install termite shields wherever possible.

Masonry Features

Much of the mortar in the front porch piers dates to 1928 and remains in fair condition. In contrast, the mortar in the exposed piers on the deck is badly eroded. All but three of the concrete caps on the piers and cheek walls are cracked and broken, with significant material loss in some. The east cheek wall at the steps to the deck leans significantly to the east.

All masonry requires routine repair and repointing. The piers, cheek walls, and chimney should all be inspected and repointed as necessary, matching the historic mortar in composition, appearance, and tooling.

The cheek wall on the east side of the steps to the deck has been undermined and developed a significant outward tilt. The feature is small enough that it might be possible to lift it into a more-vertical position.

The concrete caps play a critical role in preserving the brick masonry by protecting the interior and tops of the pier walls from water penetration. Clean cracks might be repaired *in situ* with grout; others might require temporary removal of the cap so that a more permanent repair can be made. Missing pieces could be recast and integrated into any surviving pieces.

The chimney may never have been capped, but a cap to prevent water from penetrating its interior should be considered.

Recommendations for Masonry

- Investigate feasibility of righting the sinking cheek wall at the deck.
- Repoint all brickwork.
- Repair concrete caps to a sound condition.
- Consider installing a chimney cap.

Wood Framing

The wood framing appears to be in generally fair condition; ridge lines remain straight and floors level. Insect damage can be observed in some of the sills, and hidden damage is likely to be found elsewhere in the building. The house, like many others of the period, is under-structured by modern standards, especially in terms of spacing between the various framing members, but there is no apparent systemic failure. However, the ferrous nails used in framing have inevitably corroded in the damp, salty environment, making the building more subject to wind damage and to other stresses.

Recommendations for Wood Framing

- Conduct regular inspection for the presence of wood-damaging plants and insects; treat accordingly.
- Conduct routine inspections, some during

rainstorms, to inspect for evidence of water intrusion and instances of damage.

- Periodically review for evidence of deflection across planes of framing, framing members out of square or plumb, or heightened vibration in framing members.
- Avoid use of ferrous-based fasteners in all construction and repairs.
- If the interior is opened to visitors, provide additional post-and-beam supports for the floor joists if necessary.

Exterior Features

The house is finished with materials typical of the early twentieth century. The NPS has replaced a significant amount of the material, including virtually all of the wooden elements of the front porch and deck.

Doors

The front door to Room 101 remains in generally good condition. The door to Room 106 is deteriorated with severe damage to the bottom rail. The door at the rear of Room 104 is new but has no exterior hardware and no steps to the ground.

Recommendations for Doors

- Ensure all hardware remains operable. Apply lubricant on a regular basis.
- Maintain sound paint finish at all exposed surfaces.
- Reconstruct steps to ground at Room 104.
- Avoid use of ferrous-based fasteners in all construction and repairs.

Windows

Sash are missing from the windows on the east and north sides of the north wing, but most of the rest are in fair condition. Painted finishes are in poor condition with peeling paint and staining from rusting nails. Glazing of windows is in poor condition. Many of the wood-framed screens are missing and those that remain are in poor condition.

Recommendations for Windows

- Replace missing sash in Room 105.
- Return all sash to working order, repair glazing, and repaint
- Repair/replace wood-framed screens.

- Avoid use of ferrous-based fasteners in all construction and repairs.

Roofing

The roofing is in fair condition with no apparent leaks. A few shingles are missing or loose. As with most of the historic structures at Portsmouth, no gutters or french drains are present.

Recommendations for Roofing

- Routinely inspect for missing or loose shingles and repair or replace as needed.

Siding and Trim

Most of the house's exterior woodwork is in fair condition. Painted finishes are peeling and bare wood is being exposed at various locations all around the house. Some siding and most of the crown molding in the gables should be renailed.

Recommendations for Siding and Trim

- Repair trim, renailling loose pieces as needed.
- Monitor regularly for open joints, displaced or loose elements, or other evidence of movement; renaill loose pieces.
- Monitor checking, splitting, and instances of rot, and plan remedial actions accordingly.
- Avoid use of ferrous-based fasteners in all construction and repairs.
- Prepare and repaint exterior woodwork to keep a sound exterior surface.

Front Porch

The porch is in mostly good condition, since the entire porch, except for the tripled columns at the corners, was completely rebuilt in 1987. The lower parts of the box columns are now deteriorating along with the wooden plinths.

Recommendations for Front Porch

- Prepare and repaint woodwork.

Deck and Portico

The painted finish on the deck flooring is badly worn as is the paint on the plinths and lower half of the posts.

Recommendations for Deck and Portico

- Repair trim, renailling loose pieces as needed.
- Avoid use of ferrous-based fasteners in all construction and repairs.

- Prepare and repaint exterior woodwork.

Lattice Room

The lattice on the lower portion of the north (back) wall is badly damaged as is the painted finish on the entire room. The steps at the door are missing entirely.

Recommendations for Lattice Room

- Remove shower from interior.
- Repair lattice and other trim, renailling loose pieces, and replacing if necessary.
- Prepare and repaint exterior woodwork.
- Ensure door is in working order.
- Reconstruct steps to ground.
- Avoid use of ferrous-based fasteners in all construction and repairs.

Interior Features

The interior of the house is in fair condition, but most surfaces are soiled and stained and need repainting. There is some deterioration of the ceiling boards at isolated locations where the roof has leaked in the past. Three window sash are missing, and as noted earlier, the exterior glazing on those that remain is in poor condition, which has allowed weather to damage some interior surfaces.

The collection of furnishings, decorative objects, and other items should be evaluated for historical significance or utility in maintaining the house. All items identified for preservation should be removed to storage until a plan for use of the house is developed.

Flooring

The flooring is in poor condition, primarily from multiple floods, including the terrible hurricane that washed over the Outer Banks in 1933. These events have left much of the flooring cupped and most of the fasteners showing evidence of oxidation. Heavy sanding to remove the cupping is not recommended, since that would require removal of an unacceptable amount of surface wood.

Recommendations for Flooring

- Avoid aggressive sanding of flooring.
- Do not renew painted or varnished finishes until interior use of the house is determined.

Mechanical and Electrical Systems

The electrical and plumbing systems are inoperative and could not be evaluated. Most of the components of these systems were installed in the early 1980s. There are no smoke, fire, or security systems in place, and it appears that the house was always heated with stoves.

Recommendations for Mechanical and Electrical Systems

- Rehabilitate mechanical and electrical systems to accommodate identified use.
- Maintain present bathroom and kitchen locations.
- Reinstall bathroom lavatory and kitchen sink.
- Continue heating with stoves.

The Shed

The parts of the shed that are visible are in good condition. Considering the building's proximity to the ground, deterioration of the sills and floor joists is probably ongoing.

Recommendations for Shed

- Consider adaptive use as an enclosure for a composting toilet.

- Consider elevating the structure if it is necessary to replace the floor.
- Avoid use of ferrous-based fasteners in all construction and repairs.

Priorities

The highest priorities are the routine actions necessary for the house's continued preservation, which above all means regular inspection, keeping the roofing in good repair, and maintaining all exterior painted finishes.

The park should take the necessary steps to assess the collection of furnishings and decorative objects inside the house for any historical significance, and to consider removal of these items to safe storage. The large wardrobe built into the southwest corner of Room 105 should be preserved in situ, as should the corner cupboard and shelving in the kitchen.

The park can do little to combat rising sea level and the consequential threat to cultural and natural resources. Raising the house should be considered, but as noted earlier, any significant change in elevation could alter the house's character-defining features.

Bibliography

- Atwell, Amy Elizabeth. "Portsmouth Village," unpublished ms., 1991.
- Bemisderfer, Tim and Rene Cote. "Portsmouth Village Storm Damage Assessment Report," November 27, 2012.
- Burke, Kenneth E. "The History of Portsmouth, North Carolina, From Its Founding in 1753 to Its Evacuation in the Face of Federal Forces in 1861." Unpublished undergraduate thesis, University of Richmond, Richmond, Virginia, 1958. Revised 1974, 1976.
- Cape Lookout National Seashore. *Master Plan, Cape Lookout National Seashore*. Harkers Island NC: Cape Lookout National Seashore, 1971.
- Cape Lookout National Seashore. *Final Environmental Impact Statement on General Management Plan / Development Concept Plan*, December 1982.
- Cape Lookout National Seashore, *Foundation Document*, October 2012.
- Cape Lookout National Seashore, *Long-Range Interpretive Plan*, June 2011
- Cape Lookout National Seashore, "Portsmouth Village, Historic Structures Management Recommendations," August 1984.
- Cape Lookout National Seashore. *Resources Management Plan and Environmental Assessment*, 1984.
- Carteret County Deed Books.
- Cecelski, David. *The Waterman's Song: Slavery and Freedom in Maritime North Carolina*. Chapel Hill: University of North Carolina Press, 2001.
- Cloud, Ellen Fulcher. *Portsmouth, The Way It Was*. Print Shop, 1996.
- Core Sound Waterfowl Museum and Heritage Center, <http://coresound.com/our-communities/sea-level/>.
- Cote, Rene. "Narrative Report on the Findings of Historic Structures Examination; Preliminary Test of Historic Structures Survey, Portsmouth Village," 1984.
- Davis, Pat Dula, and Kathleen Hill Hamilton, eds. *The Heritage of Carteret County North Carolina*, Vol. 1. Beaufort, NC: Carteret Historical Research Association, 1982.
- Denver Service Center. *General Management Plan/Development Concept Plan, Cape Lookout National Seashore*. Finalized 1982, approved 1983.
- Ehrenhard, John E. *Cape Lookout National Seashore: Assessment of Archeological and Historical Resources*. SEAC, NPS, 1976.

- Eubanks, Frances A., and Lynn S. Salsi. *Portsmouth Island: Outer Banks Treasure*. Columbia, SC: Montville Press, 2004.
- Friends of Portsmouth Island newsletters and website, <http://friendsofportsmouthisland.org/fopi/>.
- Herrin, Angeli. "Deserted Island Comes Alive for Wedding Celebration," *The [Raleigh] News and Observer*, October 1, 1978. found in survey files, State Historic Preservation Office, Raleigh.
- Holland, F. Ross. *A Survey History of Cape Lookout National Seashore*. Department of History, Office of Archeology and Historic Preservation, NPS, 1968.
- Howard, Philip. "1911 Wedding on Portsmouth Island," Ocracoke Newsletter, February 21, 2011, www.villagecraftsmen.com/news022111.htm
- Impact Assessment, Inc. *Ethnohistorical Description of the Eight Villages adjoining Cape Hatteras National Seashore and Interpretive Themes of History and Heritage*. Final Technical Report, Vol. 2. Atlanta: National Park Service Southeast Regional Office, November 2005.
- Interviews by the authors, 2013 and 2014.
- Jones, Tommy. *George Dixon House Historic Structure Report*. Atlanta: National Park Service Southeast Regional Office, 2004.
- _____. *Wash Roberts House Historic Structure Report*. Atlanta: National Park Service Southeast Regional Office, 2003.
- _____. *Portsmouth Life-Saving Station Historic Structure Report*. Atlanta: National Park Service Southeast Regional Office, 2006.
- _____. *Ed Styron House Historic Structure Report*. Atlanta: National Park Service Southeast Regional Office, 2004.
- Life-Saving Station Logs, excerpted by Tommy Jones, NPS.
- Little, M. Ruth. *A Comprehensive Architectural Survey of Carteret County; North Carolina's Archipelago*, 2012.
- National Park Service. "List of Classified Structures Park/Region Report," March 11, 1987.
- National Park Service, Office of Policy. "NPS-28: Cultural Resource Management," June 11, 1998.
- NPS files including drawings, maps, memos, images and administrative files.
- NOAA, *Storm Tide Frequency Analysis for the Coast of North Carolina, North of Cape Lookout*, 1975, p. 6, http://www.nws.noaa.gov/oh/hdsc/Technical_memoranda/TM27.pdf
- Olson, Sarah. *Historic Resource Study, Portsmouth Village, Cape Lookout National Seashore, North Carolina*. Denver, Colorado: U.S. Department of the Interior, National Park Service, Denver Service Center, March, 1982.
- Olszewski, George J. "Historic Resource Study for History of Portsmouth Village," typewritten draft for NPS, September 1970.

- Powell, William S. *North Carolina through Four Centuries*. Chapel Hill: University of North Carolina Press, 1989.
- _____. *Dictionary of North Carolina Biography*, Vol. 5. Chapel Hill: UNC Press, 1994.
- Ruffin, Edmund. *Agricultural, Geological, and Descriptive Sketches of Lower North Carolina, and the Similar Adjacent Lands*. Raleigh: Printed at the Institution for the Deaf & Dumb & the Blind, 1861.
- Salsi, Lynn, and Frances Eubanks. *The Crystal Coast*. Charleston, SC: Arcadia Publishing, 2000.
- Salter, Ben B. *Portsmouth Island: Short Stories & History*. Portsmouth: Doris S. Willis, 1972.
- Smith, Caroline. "Historic Portsmouth," undated article in SHPO files.
- Stick, David. *The Outer Banks of North Carolina, 1584-1958*. Chapel Hill: The University of North Carolina Press, 1958.
- VanBeck, Sara L. Cape Lookout National Seashore, Archives and Records Management Review. NPS, 2000.
- Whisnant, David E., and Anne Mitchell Whisnant. *Cape Lookout National Seashore Historic Resource Study*, prepared for the Organization of American Historians under Cooperative Agreement with the National Park Service, Draft, January 14, 2010.
- White, James E. *Portsmouth Island: A Walk in the Past*. Trent Woods, NC: Mount Truxton Publishing Company, 2010.
- _____, ed. *School Mom of Portsmouth: Memories of Lucy Beacham Gilgo*. Trent Woods, NC: Mount Truxton Publishing Company, 2011.
- Wiss, Janney, Elstner Associates, Inc. *Portsmouth Village, Cultural Resources Report*. Atlanta: National Park Service Southeast Regional Office, 2007.

Selected Maps

- A Compleat Map of North-Carolina from an actual Survey by Capt'n Collet, Governor of Fort Johnston. 1770. Engraved by I. Bayly, London.
- Mouzon, Henry. *An Accurate Map of North and South Carolina*, 1775.
- Thomas Coles and Jonathan Price, both civilian surveyors employed by the federal government. "A Chart of the Coast of North Carolina between Cape Hatteras and Cape Fear from a Survey taken in the Year 1806." National Archives, Washington, D.C., Records of the Office of Chief of Engineers, RG 77, Map H22.
- US Coast Survey. "Sketch of Ocracoke Inlet," 1852. Chart 418, Record Group 23, Records of the Coast and Geodetic Survey, National Archives.

Appendix A: Documentation Drawings

Sheet 1: Floor Plan

Sheet 2: North Elevation

Sheet 3: East Elevation

Sheet 4: South Elevation

Sheet 5: West Elevation

Sheet 6: Shed Plan

Sheet 7: Details



1

NORTH ELEVATION
SCALE: 1/4" = 1'-0"



JOSEPH K. OPPERMAN - ARCHITECT, P.A.
WINSTON-SALEM, NORTH CAROLINA

MASON-WILLIS-DIXON HOUSE
PORTSMOUTH VILLAGE, NC
UNITED STATES, DEPARTMENT OF THE INTERIOR
NATIONAL PARK SERVICE, SOUTHEAST REGION

RECORDATION
DATE:
09.18.2013

RECORDED BY:
JKO
RLM, CMW

SCALE:
1/4" = 1'0"

HSR
APPENDIX:
SHEET

2



1 EAST ELEVATION
SCALE: 1/4" = 1'-0"

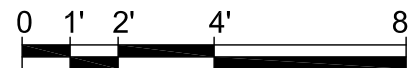

JOSEPH K. OPPERMAN - ARCHITECT, P.A.
WINSTON-SALEM, NORTH CAROLINA

MASON-WILLIS-DIXON HOUSE
PORTSMOUTH VILLAGE, NC
UNITED STATES, DEPARTMENT OF THE INTERIOR
NATIONAL PARK SERVICE, SOUTHEAST REGION

RECORDATION
DATE:
09.18.2013

RECORDED BY:
JKO
RLM, CMW

SCALE:
1/4" = 1'0"

HSR
APPENDIX:
SHEET

3



1

SOUTH ELEVATION
SCALE: 1/4" = 1'-0"



JOSEPH K. OPPERMAN - ARCHITECT, P.A.
WINSTON-SALEM, NORTH CAROLINA

MASON-WILLIS-DIXON HOUSE
PORTSMOUTH VILLAGE, NC
UNITED STATES, DEPARTMENT OF THE INTERIOR
NATIONAL PARK SERVICE, SOUTHEAST REGION

RECORDATION
DATE:
09.18.2013

RECORDED BY:
JKO
RLM, CMW

SCALE:
1/4" = 1'0"

HSR
APPENDIX:
SHEET

4

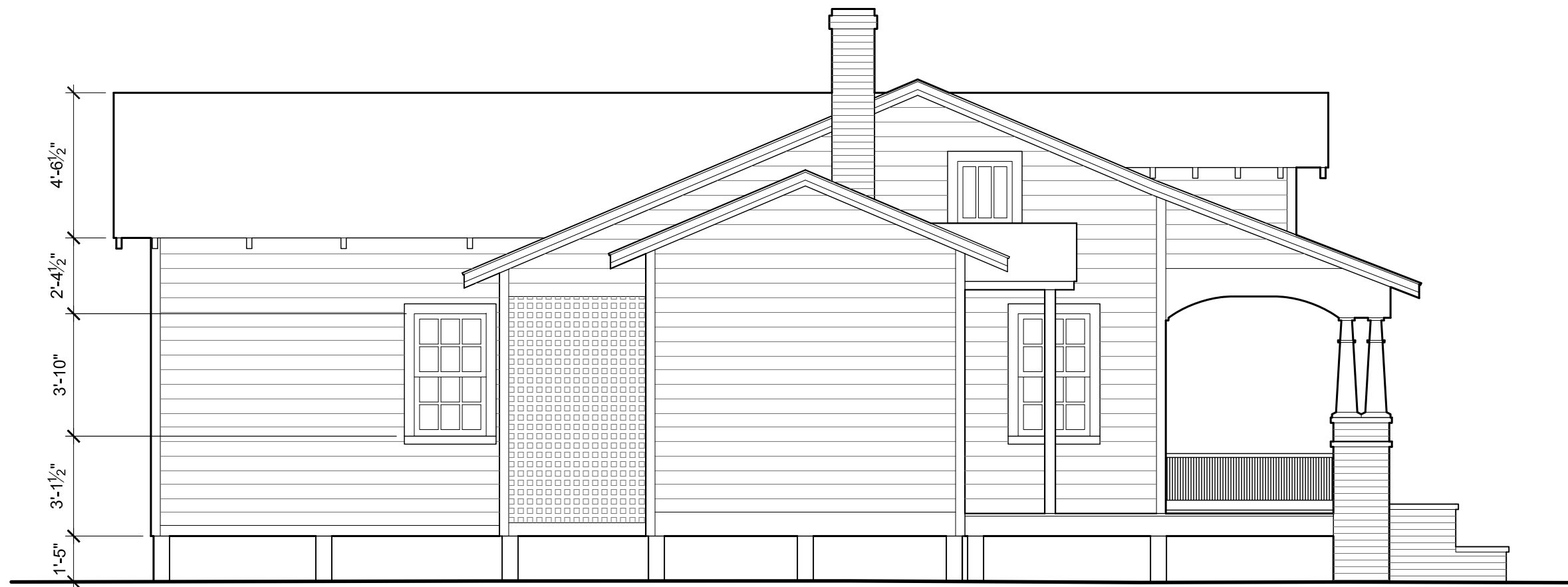

1 WEST ELEVATION
SCALE: 1/4" = 1'-0"

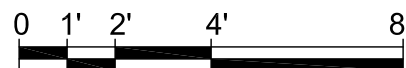

JOSEPH K. OPPERMAN - ARCHITECT, P.A.
WINSTON-SALEM, NORTH CAROLINA

MASON-WILLIS-DIXON HOUSE
PORTSMOUTH VILLAGE, NC
UNITED STATES, DEPARTMENT OF THE INTERIOR
NATIONAL PARK SERVICE, SOUTHEAST REGION

RECORDATION
DATE:
09.18.2013

RECORDED BY:
JKO
RLM, CMW

SCALE:
1/4" = 1'0"

HSR
APPENDIX:
SHEET

5

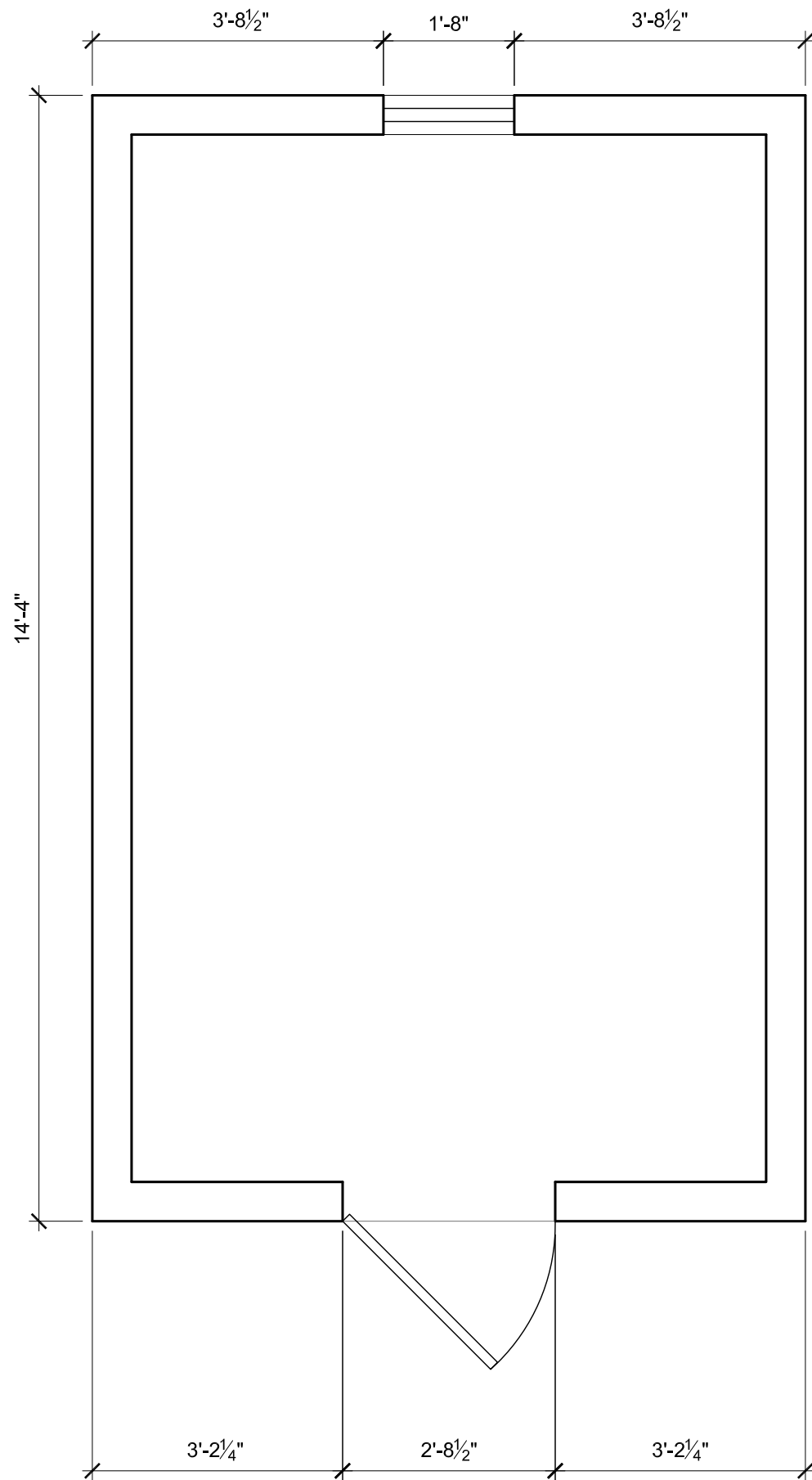

1 SHED PLAN
SCALE: 1/4" = 1'-0"

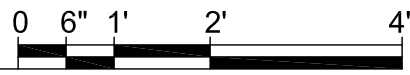

JOSEPH K. OPPERMAN - ARCHITECT, P.A.
WINSTON-SALEM, NORTH CAROLINA

MASON-WILLIS-DIXON HOUSE
PORTSMOUTH VILLAGE, NC
UNITED STATES, DEPARTMENT OF THE INTERIOR
NATIONAL PARK SERVICE, SOUTHEAST REGION

RECORDATION DATE:
09.18.2013

RECORDED BY:
JKO
RLM, CMW

SCALE:
1/4" = 1'0"

HSR APPENDIX:
SHEET

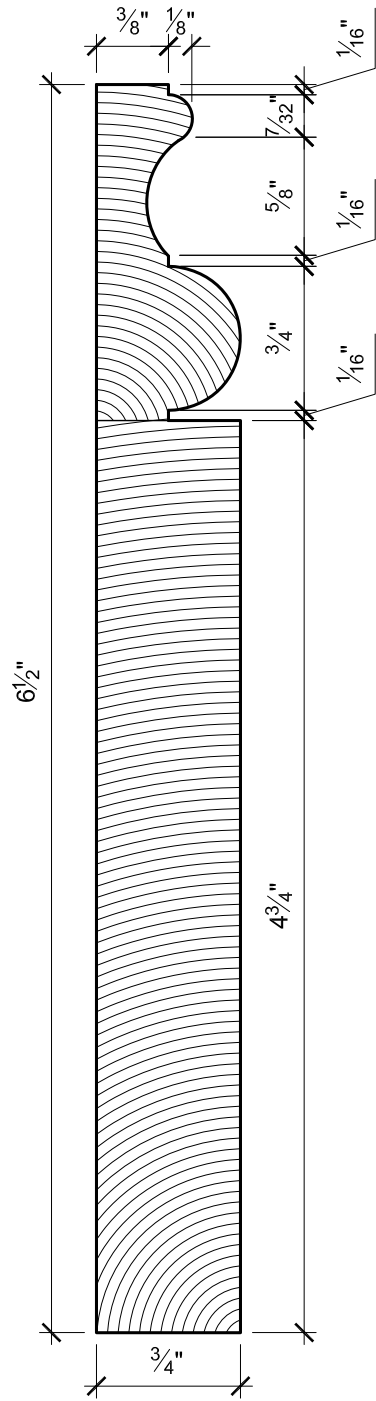

1 TYPICAL BASEBOARD
SCALE: FULL SCALE

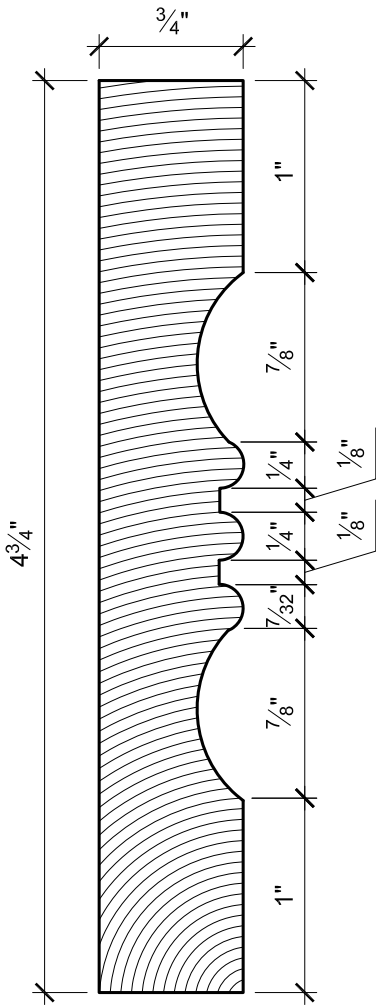

2 TYPICAL CASING
SCALE: FULL SCALE

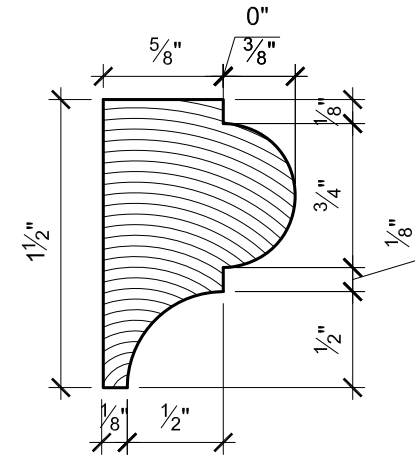

1 TYPICAL CROWN
SCALE: FULL SCALE

JOSEPH K. OPPERMANN - ARCHITECT, P.A.
WINSTON-SALEM, NORTH CAROLINA

MASON-WILLIS-DIXON HOUSE
PORTSMOUTH VILLAGE, NC
UNITED STATES, DEPARTMENT OF THE INTERIOR
NATIONAL PARK SERVICE, SOUTHEAST REGION

RECORDATION
DATE:
09.18.2013

RECORDED BY:
JKO
RLM, CMW

SCALE:
1/4" = 1'0"

HSR
APPENDIX:
SHEET