



# ANALYSIS OF AN INTERVENTION

Larry Wentz and Karen E. Black, Editors

Lessons from US  
Advisory Work in  
Afghanistan's  
Information and  
Communications  
Technology  
Sector



# Analysis of an Intervention



---

# Analysis of an Intervention

Lessons from US Advisory Work in Afghanistan's  
Information and Communications Technology Sector

Larry Wentz and Karen E. Black, Editors

Published for the Defense Information Systems Agency  
by the National Defense University  
May 2017



Opinions, conclusions, and recommendations expressed or implied within are solely those of the contributors and do not necessarily represent the views of the Defense Department or any other agency of the Federal Government. Cleared for public release; distribution unlimited.

Portions of this work may be quoted or reprinted without permission, provided that a standard source credit line is included.

First printing, May 2017

*Cover photo: Commercial cellular towers in Paktika province, Afghanistan, 2011 (Larry Wentz)*

## Dedication

---

In the fog of war, recovery and reconstruction of the affected nation's information and communications technology (ICT) infrastructure is seldom thought of and treated as an essential service and critical infrastructure and a key component of military actions, yet in every conflict in which the United States has been involved, ICT has been key to nation/state security and stabilization. In the 21<sup>st</sup> century, ICT is a key component of reconstruction, underpinning civil security, governance, financial services, information dissemination, and social networking, among many other sectors and services. It is the foundation and engine for recovery and growth.

This book is dedicated to Colonel William Ritchie (US Army, retired), a colleague and close friend who believed that ICT would ensure a promising future for the population of Afghanistan. He was the driving force behind the establishment of the Afghanistan Telecommunications Advisory Team (as well as the Iraq Communications Coordination Element, or ICCE). Colonel Ritchie left us all too soon, but his legacy lives on every time a cellular telephone call is made from Kabul to Kandahar, someone connects to the Internet in Jalalabad, or a student in rural Afghanistan attends a class virtually. Information and communications technology is *the* success story in Afghanistan and has positively affected and will continue to touch millions of lives in Afghanistan (and Iraq) thanks to the vision and efforts of Will.



William D. (Will) Ritchie  
August 5, 1950 – May 21, 2011

*Fred Ruonavar*  
*Chief, Contingency Operations*  
*Defense Information Systems Agency*  
*US Department of Defense*





# Contents

---

<b>FOREWORD .....</b>	<b>LIX</b>
<b>ACKNOWLEDGEMENTS .....</b>	<b>LXI</b>
<b>EXECUTIVE SUMMARY .....</b>	<b>1</b>
<b>INTRODUCTION .....</b>	<b>27</b>
BACKGROUND .....	27
AFGHANISTAN’S ICT SECTOR – A SUCCESS STORY .....	34
US GOVERNMENT ICT POLICY AND DOCTRINE .....	36
ICT-ENABLED INTERVENTION TIMELINE .....	39
SENIOR TELECOMMUNICATIONS ADVISORS – AFGHANISTAN .....	42
INTERVENTION BUSINESS MODEL .....	44
CRITICAL INFRASTRUCTURE PROTECTION .....	48
AFGHANISTAN POST-CONFLICT ICT SECTOR CASE STUDY .....	52
ABOUT THE BOOK .....	54
<b>CHAPTER 1 AFGHANISTAN: THE COUNTRY .....</b>	<b>57</b>
A VERY BRIEF HISTORY .....	57
GEOGRAPHY .....	58
ENVIRONMENT .....	59
DEMOGRAPHICS .....	61
<i>Population</i> .....	61
<i>Literacy</i> .....	63
<i>Refugees</i> .....	64
<i>Poverty</i> .....	64
<i>Ethnic Groups</i> .....	64
GOVERNANCE .....	65
<i>The Emergence of a New Nation-State</i> .....	65
<i>Drafting a New Constitution</i> .....	66
<i>Early Elections</i> .....	66
<i>The National Government</i> .....	67
<i>The Provinces</i> .....	68
<i>Districts and Villages</i> .....	69
<i>The Capital City of Kabul</i> .....	69
<i>Afghanistan’s Flag</i> .....	71
SECURITY .....	72
<i>NATO’s International Security Assistance Force</i> .....	72
<i>Afghanistan National Defense and Security Elements</i> .....	73
<i>Human Safety versus Security</i> .....	74
<i>The Afghan National Security Forces</i> .....	76
ECONOMICS AND SOCIAL DEVELOPMENT .....	78
<i>Economy</i> .....	78
<i>The Black Economy</i> .....	81

<i>Rural-Urban Divide in Afghanistan</i> .....	82
<i>Agriculture</i> .....	83
<i>Education</i> .....	86
<i>Health</i> .....	93
GENDER EQUALITY .....	98
<i>Welfare</i> .....	99
<i>Street Kids</i> .....	99
RELIGION .....	100
CALENDAR AND HOLIDAYS .....	102
CULTURE .....	104
<i>Guidelines</i> .....	105
<i>Art and Music</i> .....	106
<i>Poetry and Proverbs</i> .....	108
<i>Traditional Clothing</i> .....	109
<i>Cuisine and Dining Etiquette</i> .....	110
<i>Government and Business Etiquette</i> .....	112
SPORTS .....	113
FUTURE.....	115
<b>CHAPTER 2 POST-CONFLICT RECONSTRUCTION AND DEVELOPMENT – AFGHANISTAN</b> .....	<b>120</b>
BACKGROUND .....	120
POST-CONFLICT POLICY AND DOCTRINE EVOLUTION.....	131
<i>ICT Policy and Doctrine Shortfalls</i> .....	137
AFGHANISTAN: A HISTORY OF CONFLICT.....	139
IMPACT OF 25 YEARS OF WAR AND THE ROAD TO RECOVERY .....	141
NATIONAL DEVELOPMENT PROJECTS.....	148
THE ROLE AND IMPORTANCE OF ICT .....	149
SHAPING AFGHANISTAN’S ICT SECTOR RECONSTRUCTION AND LONG-TERM DEVELOPMENT.....	159
AD HOC APPROACHES TO RECONSTRUCTION AND DEVELOPMENT.....	166
THE MILITARY AND CIVILIAN SURGE.....	182
THE MILITARY DRAWDOWN AND EXIT PLANS .....	186
FUTURE.....	189
<b>CHAPTER 3 ICT IN AFGHANISTAN</b> .....	<b>195</b>
INTRODUCTION .....	195
A BRIEF HISTORY .....	196
THE MODERN ERA .....	198
<i>Commercial Telephone Services</i> .....	199
<i>Commercial Internet Services</i> .....	208
<i>Voice and Data Services for the Public</i> .....	222
<i>Universal Access and Rural Telecommunications Development</i> .....	226
CIVIL AND MILITARY COMMUNICATIONS.....	228
<i>Early Government Communications</i> .....	228
<i>Second-and Third-Generation Government Networks</i> .....	231
<i>Other ANSF Communications</i> .....	237
ICT IN THE BROADCAST AND MEDIA SECTORS.....	237

<i>Radio and Television</i> .....	237
<i>Transition to Digital Broadcasting</i> .....	238
<i>ICT-Enabling the Media</i> .....	239
ICT INFRASTRUCTURE AND RESOURCES .....	241
<i>Fiber, Satellite, and Spectrum</i> .....	241
<i>Microwave</i> .....	241
<i>ICT Infrastructure Attacks and Shutdowns</i> .....	244
<i>Mobile Service Mitigation</i> .....	246
<i>Infrastructure Protection</i> .....	248
<i>Infrastructure Sharing</i> .....	251
THE SOCIO-ECONOMIC IMPACT OF ICT IN AFGHANISTAN .....	252
CURRENT STATE OF AFGHANISTAN’S ICT SECTOR .....	258
CONCLUSIONS, LESSONS OBSERVED, AND RECOMMENDATIONS .....	261
<i>Commercial ICT Sector</i> .....	261
<i>Civil and Military Communications</i> .....	262
<i>The Future of ICT in Afghanistan</i> .....	264
THE LAST WORD.....	266
<b>CHAPTER 4 ICT INSTITUTIONS AND ICT SECTOR GOVERNANCE .....</b>	<b>268</b>
INTRODUCTION .....	268
HISTORY AND BACKGROUND .....	268
MINISTRY OF COMMUNICATIONS AND INFORMATION TECHNOLOGY.....	269
<i>Vision and Mission</i> .....	269
<i>Organizational Structure</i> .....	271
<i>Priorities and Plans</i> .....	272
<i>Reorganization</i> .....	277
<i>Streamlining Operations</i> .....	278
<i>Budget Execution</i> .....	278
AFGHANISTAN TELECOM REGULATORY AUTHORITY .....	279
<i>Vision and Mission</i> .....	280
<i>Organizational Structure</i> .....	281
<i>Responsibilities</i> .....	281
<i>Licensing Regime</i> .....	282
<i>Telecommunications Development Fund</i> .....	284
NATIONAL ICT COUNCIL OF AFGHANISTAN.....	285
<i>Objectives</i> .....	285
<i>Membership</i> .....	286
<i>Meetings</i> .....	287
CABINET-LEVEL ICT POSITIONS .....	288
TAT ENGAGEMENT WITH AFGHANISTAN’S PUBLIC ICT INSTITUTIONS.....	288
OBSERVATIONS, CONCLUSIONS, LESSONS OBSERVED, AND RECOMMENDATIONS .....	292
<i>Regarding the MCIT and ATRA</i> .....	292
<i>Regarding the TAT’s Engagement</i> .....	295

<b>CHAPTER 5 ICT POLICY AND REGULATORY FRAMEWORK.....</b>	<b>297</b>
INTRODUCTION .....	297
HISTORICAL FOUNDATIONS FOR ICT IN AFGHANISTAN .....	298
TALIBAN ERA TELECOM LAW .....	299
THE NEW MODERN ERA BEGINS .....	300
<i>Practical Considerations for the Creation of Policy in the New Regime</i> .....	302
<i>The Turning Point: How a Statist Strategy Quickly Morphed into a Pragmatic Approach</i> .....	302
THE 2003 TELECOMMUNICATIONS AND INTERNET POLICY AS THE FOUNDATION FOR ALL FUTURE SUCCESSES .....	304
<i>Highlights of the Telecom and Internet Policy</i> .....	305
<i>Licensing by Specific Market Segments Provided Enormous Confidence to Private Investors</i> .....	307
<i>Issues Not Addressed in the 2003 Telecom and Internet Policy That Emerged Later</i> .....	309
POLICY IMPLEMENTATION: FIVE- AND TEN-YEAR PLANS AND ACTION PLANS .....	312
<i>Establishment of the Interim Regulator as a Department of the Ministry of Communications</i> .....	312
FIRST POST-CONFLICT TELECOM LAW .....	313
<i>Building the Regulator in Order to Achieve Promulgation of the Law</i> .....	314
<i>Revised Telecom Law Promulgated by the Parliament in 2009</i> .....	316
<i>Telecom Law is Published in the Official Gazette</i> .....	317
DRAFT ICT LAW TO ADDRESS INTERNET, SOFTWARE INDUSTRY, AND E-COMMERCE .....	318
LESSONS LEARNED.....	320
<i>Learning from What Was Done Right</i> .....	320
<i>Learning from What Could Have Been Done Better</i> .....	321
CONCLUSION .....	322
<b>CHAPTER 6 ICT ORGANIZATIONS AND ASSOCIATIONS .....</b>	<b>325</b>
INTRODUCTION .....	325
<i>International Organizations and Associations</i> .....	326
<i>Regional Organizations and Associations</i> .....	333
<i>National Organizations and Associations</i> .....	338
ATTEMPTED ORGANIZATIONS AND ASSOCIATIONS .....	353
<i>Internet Society</i> .....	353
<i>SAMENA Telecommunications Council</i> .....	353
OBSERVATIONS, LESSONS, CONCLUSIONS, AND RECOMMENDATIONS .....	354
<i>The Current Climate of Afghan Associations</i> .....	354
<i>NICTAA – A Revealing Experience</i> .....	355
<i>Opportunities</i> .....	356
<b>CHAPTER 7 AFGHANISTAN’S FIBER OPTIC INFRASTRUCTURE .....</b>	<b>357</b>
INTRODUCTION .....	357
HISTORY OF THE OPTICAL FIBER CABLE .....	358
CONSTRUCTION OF THE OFC .....	361
INFRASTRUCTURE SHARING – FAILURE .....	363
THE OFC MOVES TO DWDM .....	365
INFRASTRUCTURE SHARING – SUCCESS .....	366
OTHER OPTICAL FIBER PROJECTS TO AUGMENT THE OFC .....	366
<i>World Bank ICT Sector Development Grant</i> .....	366
AFGHANISTAN’S ROLE IN CENTRAL ASIAN FIBER TRANSIT .....	368

<b>CHAPTER 8 SATELLITE COMMUNICATIONS .....</b>	<b>371</b>
INTRODUCTION .....	371
EARLY SATELLITE COMMUNICATIONS PROJECTS.....	371
<i>Restoring Afghanistan’s Earth Station</i> .....	371
<i>Government, District, and Village Communications Networks</i> .....	372
AFGHANISTAN’S SPACE ALLOCATION .....	374
LICENSING AFGHANISTAN’S ORBITAL SATELLITE SLOT .....	375
<i>History and Background</i> .....	375
<i>The Tender Process</i> .....	376
<i>Countdown to Launch</i> .....	379
OBSERVATIONS, CHALLENGES, LESSONS OVSERVED, AND RECOMMENDATIONS.....	380
<b>CHAPTER 9 RADIO SPECTRUM IN POST-CONFLICT ENVIRONMENTS AND STABILITY OPERATIONS - AFGHANISTAN: A CASE STUDY .....</b>	<b>383</b>
INTRODUCTION TO THE RADIO SPECTRUM.....	383
RADIO SPECTRUM IN POST-CONFLICT ENVIRONMENTS AND STABILITY OPERATIONS.....	384
<i>The Importance and Role of the Regulator</i> .....	385
RADIO SPECTRUM IN AFGHANISTAN.....	386
<i>Afghanistan’s Spectrum Region and Frequency Allocations</i> .....	386
<i>Early Spectrum Use and Governance</i> .....	386
<i>Afghanistan’s Spectrum Bands</i> .....	388
WHAT IS RADIO SPECTRUM MANAGEMENT?.....	388
<i>Military Spectrum Management and Coordination</i> .....	389
<i>Civilian Spectrum Management and Coordination</i> .....	390
TRANSITION OF MILITARY SPECTRUM MANAGEMENT FROM ISAF TO GIROA .....	393
<i>Establishing the Ministerial Spectrum Management Office</i> .....	393
<i>Next Steps</i> .....	396
<i>Post-2014 Memoranda of Agreement</i> .....	398
SPECTRUM PROBLEMS IN AFGHANISTAN .....	399
<i>Growth in Radio Spectrum Use and Resultant Interference</i> .....	400
<i>Jamming as a Countermeasure to Improvised Explosive Devices</i> .....	402
THE TAT’S WORK IN SPECTRUM .....	410
<i>Early TAT Support</i> .....	411
<i>Spectrum Management Tools for ATRA</i> .....	413
<i>Spectrum Capacity Development for ATRA</i> .....	415
<i>Spectrum Licensing for Mobile and Wireless Broadband Services</i> .....	416
<i>SIM Box Problems</i> .....	419
<i>Frequency Interference and Jamming Issues</i> .....	420
CONCLUSIONS, LESSONS OBSERVED, AND RECOMMENDATIONS .....	424
<i>Conclusions</i> .....	424
<i>Lessons Observed</i> .....	425
<i>Recommendations</i> .....	426

<b>CHAPTER 10 CYBERSECURITY .....</b>	<b>429</b>
INTRODUCTION AND BACKGROUND .....	429
THE GOOD, THE BAD, AND THE UGLY .....	430
CYBERSECURITY ASSESSMENTS AND RESULTS .....	433
<i>2006 Afghanistan Reconstruction Group Model National Plan (MNP)</i> .....	434
<i>2009 International Telecommunication Union Findings</i> .....	434
<i>2012 Cybersecurity Maturity Assessment</i> .....	437
THE TAT’S POST-ASSESSMENT CYBERSECURITY WORK, PHASE 1 .....	440
<i>Governance</i> .....	440
<i>Legal and Regulatory</i> .....	441
<i>Information and Communication Technology</i> .....	441
<i>Human Capacity</i> .....	443
THE TAT’S CYBERSECURITY WORK, PHASE 2 .....	443
CONCLUSIONS, LESSONS OBSERVED, AND RECOMMENDATIONS .....	445
<b>CHAPTER 11 E-AFGHANISTAN AND E-GOVERNMENT .....</b>	<b>448</b>
E-AFGHANISTAN .....	448
<i>Strengthening of Legal, Regulatory, Policy, and Institutional Frameworks</i> .....	449
<i>Expanding Telecommunication Networks</i> .....	449
<i>E-Government</i> .....	450
<i>M-Government</i> .....	450
<i>Strengthening the Ministry</i> .....	453
<i>Strengthening the Sector</i> .....	454
E-GOVERNMENT .....	455
<i>EGOV.AF Vision and Goals</i> .....	455
<i>E-Government Strategy and Program</i> .....	456
<i>E-Government Directorate and E-Government Resource Center</i> .....	456
<i>E-Government Services</i> .....	456
CONCLUSIONS AND RECOMMENDATIONS .....	461
<b>CHAPTER 12 INFORMATION SHARING IN AFGHANISTAN: THE SYNERGY STRIKE FORCE AND THE JALALABAD PROJECT.....</b>	<b>462</b>
INTRODUCTION .....	462
THE IMPORTANCE OF INFORMATION IN COUNTERINSURGENCY OPERATIONS .....	464
INFORMATION SHARING EXPERIMENTS IN AFGHANISTAN .....	468
SYNERGY STRIKE FORCE .....	470
THE JALALABAD PROJECT .....	470
<i>SMS Crowdsourcing Project</i> .....	474
UNITYNET .....	478
CONCLUSION .....	479
<b>CHAPTER 13 ICT IN FINANCE .....</b>	<b>481</b>
INTRODUCTION .....	481
ICT IN PUBLIC FINANCIAL MANAGEMENT .....	481
SECURE VSAT NETWORK TO MANAGE LIQUIDITY AT BANKS NATIONWIDE .....	483
DIGITAL FINANCIAL SERVICES FOR THE PUBLIC (MOBILE MONEY) .....	486

<i>Roshan Pioneers Mobile Money in Afghanistan in 2007</i> .....	487
<i>Hawala, Remittances, and Trusted Agents</i> .....	489
<i>Roshan’s Commercial Launch in 2008</i> .....	490
<i>US Military Identifies mMoney as “The Way Forward” for ANSF Salary Disbursements</i> .....	491
<i>USAID’s Ground-breaking Efforts to Ignite mMoney</i> .....	492
<i>mMoney Draws Attention of High-level Officials in Washington</i> .....	493
<i>A Focus on Interoperability to Foster a Critical Mass of Digital Financial Services</i> .....	494
<i>COMISAF Acknowledges the Potential for mMoney But Effort Quickly Stalls</i> .....	495
<i>Nationwide Consumer Survey Documents that mMoney is Still Invisible to Most Afghans</i> .....	495
<i>Bulk Payments Offer Some Promise</i> .....	496
<i>Commission Breakthrough</i> .....	498
<i>FAIDA’s Achievements and Plans for the Future</i> .....	498
<i>President Ghani Supports Move to Electronic Payments for All GiRoA Transactions</i> .....	500
<i>Reports of Widespread Fraud Spurs US Military to Revive mMoney for Afghan Local Police</i> .....	501
LESSONS LEARNED.....	502
<i>Learning from What Was Done Right</i> .....	502
<i>Learning from What Could Have Been Done Better</i> .....	503
CONCLUSION.....	503
<b>CHAPTER 14 ICT IN HEALTHCARE: LESSONS LEARNED FROM EASTERN AFGHANISTAN</b> .....	<b>505</b>
INTRODUCTION.....	505
CULTURE AND COLLABORATION.....	506
LOOKING PAST SIMPLE MEDICAL EQUIPMENT DONATION.....	507
MOBILE MEDICAL ICT.....	510
<i>Telephony Applications</i> .....	510
<i>Hardware</i> .....	512
<i>Software</i> .....	514
IMAGING CENTER AND CLINIC ICT.....	515
<i>Infrastructure Assessment</i> .....	515
<i>Selecting a Medical ICT Infrastructure</i> .....	520
OVERVIEW OF ICT STANDARDS FOR HEALTHCARE.....	527
LESSONS LEARNED.....	528
<b>CHAPTER 15 ROSHAN’S TELEMEDICINE PROGRAM: BROADBAND HEALING A NATION</b> .....	<b>532</b>
INTRODUCTION.....	532
ROSHAN’S TELEMEDICINE PROGRAM.....	533
<i>Medical Training via Technology</i> .....	535
LESSONS LEARNED.....	536
CONCLUSION.....	536
<b>CHAPTER 16 USING MOBILE PHONES TO TRACK, REPORT, AND SHARE HEALTH STATISTICS</b> .....	<b>537</b>
INTRODUCTION AND BACKGROUND.....	537
EASTERN REGION DISEASE CONNECTION (ERDC).....	537
MIDWIFE CONNECTION.....	539
IVR4BABY.....	545
CONCLUSION.....	549

<b>CHAPTER 17 ICT FOR GENDER EQUALITY .....</b>	<b>550</b>
INTRODUCTION .....	550
THE IMPORTANCE OF WOMEN’S ACCESS TO INFORMATION .....	550
THE DIGITAL GENDER DIVIDE.....	551
ICT EFFORTS FOR AFGHAN WOMEN .....	554
THE TAT’S GENDER ENGAGEMENTS AND ACCOMPLISHMENTS .....	555
<i>The TAT’s Gender Efforts within ISAF.....</i>	<i>555</i>
<i>Etisalat mHawala Agent Program .....</i>	<i>556</i>
<i>USAID Survey of Afghan Women and Mobile Phones.....</i>	<i>556</i>
<i>ITU Gender Efforts.....</i>	<i>558</i>
<i>Gender Efforts at the MCIT .....</i>	<i>559</i>
<i>USAID Women in Government Internship Program.....</i>	<i>560</i>
<i>TechWomen Afghanistan.....</i>	<i>560</i>
<i>Project Gateway Family Support Hotline .....</i>	<i>561</i>
CONCLUSION, LESSONS OBSERVED, AND RECOMMENDATIONS.....	562
<b>CHAPTER 18 THE ROLE OF SOCIAL MEDIA IN CIVIL DISCOURSE .....</b>	<b>565</b>
INTRODUCTION .....	565
SOCIAL MEDIA BY THE NUMBERS .....	566
EFFECT OF SOCIAL MEDIA ON MAINSTREAM NEWS .....	567
LOW-TECH SOLUTIONS TO THE OFFLINE-ONLINE DIVIDE .....	568
SOCIAL MEDIA AND ELECTIONS: EXCITEMENT AND TRANSPARENCY .....	569
<i>A Turn for the Worse.....</i>	<i>572</i>
<i>Elections Memes: The Amarkhail Calls.....</i>	<i>574</i>
<i>The Final Result .....</i>	<i>576</i>
<i>Supporting Social Media, Supporting Democracy?.....</i>	<i>577</i>
AFGHAN SOCIAL MEDIA SUMMIT .....	578
<i>ASMS2013: Paiwand .....</i>	<i>579</i>
<i>ASMS2014.....</i>	<i>580</i>
<i>ASMS2015 .....</i>	<i>581</i>
AFGHAN SOCIAL MEDIA AWARDS.....	582
PAIWANDGĀH .....	583
SADROZ.AF .....	586
LOOKING FORWARD .....	587
<b>CHAPTER 19 ICT CAPACITY BUILDING IN AFGHANISTAN: GOVERNMENT, DONOR, COMMERCIAL, AND COMMUNITY EFFORTS.....</b>	<b>588</b>
INTRODUCTION .....	588
KEY PLAYERS .....	589
<i>Government Ministries .....</i>	<i>589</i>
<i>Formal Education Institutions .....</i>	<i>593</i>
<i>Donors.....</i>	<i>600</i>
<i>Other ICT Training Entities and Efforts.....</i>	<i>627</i>
CONCLUSIONS, LESSONS OBSERVED, AND RECOMMENDATIONS .....	633



<b>CHAPTER 20 THE TAT’S EFFORTS TO FOSTER ICT CAPACITY DEVELOPMENT .....</b>	<b>639</b>
INTRODUCTION .....	639
TRENDS IN HIGHER EDUCATION .....	640
THE TAT’S WORK TO BUILD ICT CAPACITY .....	642
<i>Facilitate a CIO Culture .....</i>	<i>644</i>
<i>Promote a Professional Workforce .....</i>	<i>648</i>
THE TAT’S ICT CAPACITY BUILDING THROUGH TRAINING AND EDUCATION PROGRAM .....	658
<i>Introduction and Background .....</i>	<i>658</i>
<i>Institutional Context for ICT Training and Education .....</i>	<i>660</i>
<i>Objective and Deliverables.....</i>	<i>662</i>
<i>Description of Activities .....</i>	<i>663</i>
<i>Significant Findings .....</i>	<i>664</i>
<i>Key Recommendations and Progress against Them .....</i>	<i>670</i>
CONCLUSION .....	683
<b>CHAPTER 21 THE TELECOMMUNICATIONS ADVISOR FUNCTION – OPERATIONAL EXAMPLES .....</b>	<b>684</b>
INTRODUCTION .....	684
TELECOMMUNICATIONS ADVISOR FUNCTION .....	691
AD HOC APPROACHES IN IRAQ AND AFGHANISTAN .....	694
SETTING THE STAGE FOR RECONSTRUCTION OF THE AFGHAN ICT SECTOR .....	704
AFGHANISTAN RECONSTRUCTION GROUP AND ITS SENIOR TELECOM ADVISOR .....	708
<i>Establishment of the ARG and Deployment of the First STA.....</i>	<i>708</i>
<i>The ARG/STA and Civil-Military and International Cooperation .....</i>	<i>717</i>
<i>Examples of ARG/STA Efforts and Accomplishments.....</i>	<i>721</i>
<i>The End of the ARG and Associated Reflections.....</i>	<i>724</i>
CHANGING OPERATIONAL ENVIRONMENT .....	727
REESTABLISHING THE SENIOR TELECOM ADVISOR .....	738
<i>Office of the Senior Telecom Advisor to COMISAF – Getting Started.....</i>	<i>746</i>
<i>The ISAF Senior Telecom Advisor and the Telecom Advisory Team .....</i>	<i>759</i>
STA/ARG AND STA/TAT COMPARISON.....	810
FOLLOW-ON SUPPORT ACTIVITIES .....	814
<i>Need for a USG STA-like Advice and Assistance Function Continues .....</i>	<i>816</i>
KEY TAKEAWAYS .....	818
<i>ICT-enabled Intervention Arrangement Framework .....</i>	<i>819</i>
<b>CHAPTER 22 THE STA/ARG AND STA/TAT EXPERIMENTS AND LEARNING EXPERIENCES: LESSONS OBSERVED... 822</b>	<b>822</b>
BACKGROUND .....	822
DIAL STA FOR ICT ADVICE AND ASSISTANCE .....	823
NATURE OF THE ICT CHALLENGES AND OPPORTUNITIES.....	824
INFORMATION AND ICT INTERVENTION STRATEGY CONSIDERATIONS.....	832
DISTRIBUTED AND VIRTUAL TEMPORARY TEAM CHALLENGES .....	835
<i>Lessons Regarding Virtual Distributed Teams and the STA/TAT Reachback Element.....</i>	<i>841</i>
BROAD LESSONS OBSERVED AND OVERARCHING RECOMMENDATIONS .....	845
LESSONS AND RECOMMENDATIONS FROM COUNTERINSURGENCY, STABILITY, RECONSTRUCTION, AND DEVELOPMENT OPERATIONS	847
<i>COIN Lessons.....</i>	<i>848</i>
<i>Lessons and Recommendations from Reconstruction and Development Programs.....</i>	<i>849</i>

<i>Lessons Regarding the Civil-Military Divide</i> .....	853
<i>Lessons Regarding Multinational, Multicultural Interventions</i> .....	855
<i>Money Can't Buy Happiness – Or Failed States</i> .....	856
<i>Intervention Timeline</i> .....	857
<i>A Collection of Lessons</i> .....	858
LESSONS REGARDING THE IMPORTANCE OF ICT IN STABILITY, RECONSTRUCTION, AND DEVELOPMENT OPERATIONS.....	863
LESSONS REGARDING THE US GOVERNMENT’S AND INTERNATIONAL COMMUNITY’S ROLES AND SHORTCOMINGS IN ICT-ENABLED INTERVENTIONS .....	869
<i>Lessons Specific to the US Government</i> .....	871
<i>Examples of US Government Ad Hoc ICT Advisory Capabilities</i> .....	875
LESSONS REGARDING INFORMATION SHARING .....	877
<i>The Synergy Strike Force and the Jalalabad Project: Lessons from Open Information Sharing in Afghanistan</i> .....	881
STA/ARG AND STA/TAT LESSONS.....	884
<i>Lessons Applicable to Both</i> .....	884
<i>Lessons Specific to the STA/ARG</i> .....	887
<i>Lessons Specific to the STA/TAT</i> .....	889
<b>CHAPTER 23 CONCLUSIONS AND RECOMMENDATIONS.....</b>	<b>902</b>
CONCLUSIONS .....	902
WAY AHEAD .....	907
<i>Checklist for Future ICT-Enabled Operations</i> .....	913
<i>Checklist for the Establishment an ICT Advisory Capability</i> .....	920
<i>In Summary</i> .....	931
RECOMMENDATIONS .....	931
<b>APPENDIX A THE AFGHANISTAN ICT TEAM .....</b>	<b>A-1</b>
<i>Leadership - CONUS</i> .....	A-1
<i>Advisory Team – CONUS</i> .....	A-1
<i>OASD-NII/DoD CIO Advisor and Interagency Coordinator – Kabul/CONUS</i> .....	A-1
<i>Leadership – CONUS</i> .....	A-1
<i>Advisory Team – CONUS</i> .....	A-1
<i>Leadership – CONUS</i> .....	A-2
<i>Advisor – CONUS/Kabul</i> .....	A-2
<i>Leadership – CONUS</i> .....	A-2
<i>Advisor – Kabul/CONUS</i> .....	A-2
<i>Advisory Team - CONUS</i> .....	A-2
<i>ICT Advisory Team – Kabul</i> .....	A-2
<i>ICT Advisory Team – CONUS</i> .....	A-2
<i>Economic Growth and Governance Initiative (EGGI) Team – Kabul</i> .....	A-2
<i>Afghan Telecommunications In-Country Support (ATICS) Program – Kabul</i> .....	A-3
<i>IZT Leadership – CONUS</i> .....	A-3
<i>Senior Telecom Advisors/TAT Directors – Kabul</i> .....	A-3
<i>TAT Participants – Kabul</i> .....	A-3
<i>TAT Reachback Team – CONUS</i> .....	A-4

<b>APPENDIX B</b>	<b>AUTHORS, CONTRIBUTORS, AND PEER REVIEWERS</b>	<b>B-1</b>
AUTHORS		B-1
<i>Dr. Maria Beebe</i>		B-1
<i>Karen E. Black</i>		B-1
<i>Oliver Dziggel, MA</i>		B-1
<i>Jennifer Gold</i>		B-2
<i>Eileen Guo</i>		B-2
<i>Shainoor Khoja</i>		B-2
<i>Dr. Peter M. Killcommons</i>		B-3
<i>Robert A. (Bob) Kinn</i>		B-3
<i>Dr. Chi Nche</i>		B-3
<i>Rachel Robb</i>		B-4
<i>Juan Andrés Rodríguez</i>		B-4
<i>Lewis E. Shadle, Sr.</i>		B-4
<i>Larry Wentz</i>		B-4
CONTRIBUTORS		B-5
PEER REVIEWERS		B-5
<b>LIST OF FIGURES</b>		<b>XVIII</b>
<b>LIST OF TABLES</b>		<b>XXI</b>
<b>LIST OF PICTURES</b>		<b>XXII</b>
<b>ABBREVIATIONS, ACRONYMS, AND INITIALISMS</b>		<b>XXIV</b>

## List of Figures

Figure 1: Afghanistan collaboration and information sharing challenges .....	10
Figure 2: ICT for socio-economic development .....	12
Figure 3: ICT-enabled intervention timeline .....	16
Figure 4: STA and support elements construct.....	20
Figure 5: ICT infrastructure 2010-2014.....	21
Figure 6: Afghanistan as a Central Asian ICT hub .....	24
Figure 7: USG ICT policy, doctrine, concepts, and manuals.....	38
Figure 8: ICT-enabled intervention timeline .....	39
Figure 9: Business model for an ICT-enabled intervention.....	45
Figure 10: Taliban attacks on Afghanistan’s cellular network sites .....	48
Figure 11: Map of Afghanistan .....	58
Figure 12: Afghan repatriation, 2002-2013 .....	62
Figure 13: Afghanistan's population by gender and age group .....	63
Figure 14: Afghan ethnic groups.....	65
Figure 15: Afghanistan provinces and provincial capitals.....	68
Figure 16: Flag of Afghanistan .....	71
Figure 17: Afghanistan GDP composition by sector of origin .....	79
Figure 18: Categories of Afghanistan's national priority programs .....	163
Figure 19: ISAF ICT support strategy evolution .....	165
Figure 20: Mobile telephony periodic cost comparison .....	202
Figure 21: Afghan mobile phone subscribers, 2002-2012 .....	202
Figure 22: Market share by mobile network operator, 2012 .....	203
Figure 23: Registered Afghan domains by type, 2013 .....	210
Figure 24: Cellular and VSAT network coverage, 2010 and 2014 .....	211
Figure 25: MTN 3G USB dongle .....	213
Figure 26: Availability of 3G mobile broadband service by province, December 2014.....	216
Figure 27: Afghan Internet users, 2002-2014 .....	218
Figure 28: Afghan Internet prices, 2002-2016.....	219
Figure 29: Inbound Internet traffic to Afghanistan, 2002-2014 .....	220
Figure 30: Original ADSV/VCN network concept .....	224
Figure 31: ANSFnet concept .....	233
Figure 32: GIROANet conceptual network connectivity .....	235
Figure 33: Sources of obtaining news and information, 2013-2015.....	241
Figure 34: Afghanistan microwave and optical fiber networks, 2014 .....	242
Figure 35: Asia Consultancy Group’s microwave network in Afghanistan .....	243
Figure 36: Illustrative nightly cellular tower shutdowns, March 2011 .....	246
Figure 37: ISAF Cellular-Enabled Security and Stability (CESS) concept .....	248
Figure 38: ICT for socio-economic development .....	253
Figure 39: ICT sector revenues in millions (US Dollars), 2002-2012 .....	254
Figure 40: Cumulative investment in ICT sector in millions (US Dollars), 2002-2015.....	255
Figure 41: Afghanistan teledensity versus GDP, 2005 and 2012 .....	256
Figure 42: ICT service coverage by province, 2014.....	259
Figure 43: Afghanitan cellular coverage, September 2014.....	260

Figure 44: DAS-Net and ANSFnet, 2014.....	263
Figure 45: MCIT organizational structure .....	271
Figure 46: MCIT development budget execution in millions (US Dollars), 2006-2013 .....	278
Figure 47: Comparison of budget execution by ministry.....	279
Figure 48: ATRA organizational structure.....	280
Figure 49: Original MCIT OFC project plan .....	359
Figure 50: OFC status, December 2008 .....	361
Figure 51: OFC status, January 2011.....	362
Figure 52: OFC status, January 2012.....	362
Figure 53: OFC status, October 2013.....	363
Figure 54: OFC status, July 2015.....	364
Figure 55: OFC status, September 2014 .....	364
Figure 56: OFC status, April 2016 .....	365
Figure 57: World Bank planned expansion of the OFC.....	367
Figure 58: Possible Central Asian transit routes using Afghanistan’s fiber infrastructure .....	369
Figure 59: Village Communications Network deployment, March 2014.....	373
Figure 60: Representative footprint of Afghanistan's ITU space allocation .....	374
Figure 61: Call for expressions of interest in licensing Afghanistan’s satellite orbital slot.....	377
Figure 62: ITU spectrum regions.....	386
Figure 63: NATO spectrum management coordination process for Afghanistan.....	390
Figure 64: ITU Typical national civil spectrum management system .....	391
Figure 65: Uplink jamming example for the 3G band.....	405
Figure 66: Uplink jamming example for the GSM-900 band .....	405
Figure 67: Example of jammer configuration problems.....	406
Figure 68: Example of jamming a wider bandwidth than the intended target .....	406
Figure 69: Output of CDMA-850 jammer from the Kabul Central Jail.....	409
Figure 70: Output from a Salaam BSC showing continuous external interference .....	410
Figure 71: Sample plot using ICM data to show the direction of external interference .....	423
Figure 72: E-Afghanistan strategy.....	448
Figure 73: Seven components of the E-Afghanistan National Priority Program .....	449
Figure 74: Images of Afghanistan's electronic national identity card.....	457
Figure 75: The MCIT’s vision of an e-government ecosystem .....	461
Figure 76: Three pillars of counterinsurgency .....	465
Figure 77: Iterative counterinsurgency campaign design.....	466
Figure 78: Five components of COIN strategy .....	467
Figure 79: SSF Wi-Fi mesh network diagram .....	473
Figure 80: Sample commodity price list .....	475
Figure 81: SSF Crowdmap indicating the number of agricultural commodity reports .....	476
Figure 82: Color-coded information explained (UnityNet).....	479
Figure 83: Medweb's mobile clinical applications and architecture .....	511
Figure 84: Imaging center equipment and ICT configuration.....	526
Figure 85: Teleradiology cases transferred to AKUH by type .....	533
Figure 86: Number of teleconsultations conducted at Bamyan Provincial Hospital .....	534
Figure 87: Number of teleconsultations conducted at Faizabad Hospital.....	534
Figure 88: Total number of teleradiology consultations .....	535
Figure 89: Example of Midwife Connection supervisory checklist .....	540

Figure 90: SSF Crowdmap indicating the number of midwife reports .....	542
Figure 91: Visual representation of the Midwife Connection program.....	543
Figure 92: Visual representation of IVR4BABY program.....	547
Figure 93: Afghanistan's population by age group and gender, 2015 .....	551
Figure 94: The digital gender divide .....	552
Figure 95: Female Afghan Facebook users compared to other countries.....	554
Figure 96: Screenshot of YouTube video of “official” election rap anthem .....	570
Figure 97: Election Day tweet about a polling center running out of ballots.....	571
Figure 98: Screenshot of Election Day tweet showing ethnic divisions.....	573
Figure 99: Screenshot from YouTube video of the Amarkhail Calls .....	575
Figure 100: Tweet of a photoshopped image of IEC head Amarkhail holding a sheep .....	576
Figure 101: Original design of Paiwandgāh citizen journalism platform .....	584
Figure 102: Projected need for ICT workers in Afghanistan, 2002-2015 .....	589
Figure 103: TVET offerings by category .....	598
Figure 104: Number of ANGeL center completions by quarter.....	608
Figure 105: Clark and Gottfredson’s Learning Mindset Evolution (2009) .....	641
Figure 106: The TAT's Afghanistan ICT Strategy, July 2012 .....	643
Figure 107: US Department of Labor Information Technology Competency Model.....	666
Figure 108: Engman: Lack of clarity about ICT qualifications .....	669
Figure 109: Sample chart of ICT careers and required qualifications.....	670
Figure 110: Spectrum of public-private partnerships.....	672
Figure 111: Systemic reform framework.....	676
Figure 112: CTSA K-12 Computer Science Standards .....	677
Figure 113: Example of ISE lines of engagement.....	698
Figure 114: Afghanistan ICT architecture in the 2006-2007 timeframe.....	706
Figure 115: Projected Senior Telecom Advisor engagement timeline .....	712
Figure 116: STA/ARG I-Team .....	714
Figure 117: NATO Collective Framework.....	718
Figure 118: PGCN and GCN connectivity .....	723
Figure 119: STA orientation battle rhythm.....	749
Figure 120: ISAF strategy .....	754
Figure 121: TAT-1 “get started” strategy and focus (the first 100 days) .....	755
Figure 122: TAT evolution.....	762
Figure 123: ISAF to RSM transition .....	764
Figure 124: TAT-1 four-pillar strategy.....	769
Figure 125: TAT-2 strategy.....	772
Figure 126: TAT-3 strategy.....	774
Figure 127: TAT-4 strategy.....	777
Figure 128: TAT-4 transition status and wins .....	778
Figure 129: Representation of a distributed virtual team .....	789
Figure 130: TAT engagement environment .....	792
Figure 131: Examples of TAT visualization.....	799
Figure 132: Proposed ICT-enabled intervention arrangement framework .....	820
Figure 133: Number of Afghanistan CERP projects by category, FY 2004 - FY 2014 .....	852
Figure 134: Total estimated cost for Afghanistan CERP projects by category, FY 2004 - FY 2014 .....	853
Figure 135: ICT-enabled intervention timeline.....	858

## List of Tables

---

Table 1: Afghanistan country ranking by GDP (PPP) per capita.....	78
Table 2: Education levels in Afghanistan .....	90
Table 3: Subscribers and coverage by mobile network operator (2006 estimates) .....	201
Table 4: Fixed-line telephone switching capacity by city, October 2002.....	206
Table 5: Internet café prices per hour, 2013 .....	226
Table 6: Afghanistan ICT sector statistics, December 2015.....	258
Table 7: ICT sector key performance indicators and targets, 2005-2015 .....	273
Table 8 : National ICT Council of Afghanistan members .....	287
Table 9: ITAA and ITU cybersecurity assessment findings, 2006 and 2009 .....	436
Table 10: Findings of 2012 Cybersecurity Maturity Assessment .....	438
Table 11: Amount transferred via mobile money as of August 15, 2015 .....	500
Table 12: ICTI graduates by year.....	595
Table 13: ICT offerings at Afghan higher education institutions .....	667
Table 14: Documents relative to TAT-2 strategy development.....	771
Table 15: TAT-4 primary areas of engagement .....	776

## List of Pictures

Picture 1: School in Bak, Khost province .....	88
Picture 2: Khost Medical Clinic .....	96
Picture 3: Street kids outside ISAF Headquarters in Kabul .....	100
Picture 4: Traditional blue burqas worn by many Afghan women .....	109
Picture 5: The sport of Buzkashi .....	114
Picture 6: SSF-provided computer lab for school in rural area .....	171
Picture 7: Minister of Communication Stanekzai Receiving ".af" domain from UNDP, 2003 .....	209
Picture 8: Etisalat 3G billboard in Kabul, March 2012 .....	214
Picture 9: Roshan 3G license signing ceremony, September 2012.....	215
Picture 10: Broadband wireless service license signing ceremony, November 2012.....	216
Picture 11: Payphone at the Ministry of Public Health in Kabul.....	225
Picture 12: Codan radio terminal in Khost province.....	228
Picture 13: Switch room at the Afghan Ministry of Foreign Affairs, November 2011 .....	234
Picture 14: A representative from the MCIT presents the DAS-Net concept at ISAF in March 2012 .....	236
Picture 15: MCIT headquarters in Kabul.....	269
Picture 16: Afghanistan's modern-day communications ministers .....	270
Picture 17: MCIT deputy ministers participating in ITU events .....	328
Picture 18: Ceremony for the creation of NICTAA.....	340
Picture 19: ICT Policy consultative session organized by NICTAA, January 2013 .....	341
Picture 20: Inaugural meeting between NISPAA and ATRA.....	344
Picture 21: Mobile Money University Contest award ceremony .....	346
Picture 22: Regional Open Source Conference - Central Asia, March 2013 .....	350
Picture 23: National Open Source Conference of Afghanistan, February 2013 .....	351
Picture 24: World Bank consultation with AfTel.....	366
Picture 25: UNESCAP meeting on increasing fiber connectivity in Central Asia .....	370
Picture 26: Public consultation on licensing Afghanistan's satellite slot .....	377
Picture 27: Signing ceremony for an agreement to launch AfghanSAT1, January 2014 .....	379
Picture 28: Signing of an MoA establishing the Ministerial Spectrum Management Office .....	395
Picture 29: Signing ceremony for an MoA between ATRA and the Afghan MoD regarding post-2014 spectrum management.....	398
Picture 30: TV (Asmai) Hill, Kabul, Afghanistan .....	413
Picture 31: Cybersecurity interview at Afghanistan's central bank, April 2012 .....	437
Picture 32: Depiction of 119 emergency services call .....	459
Picture 33: Hard drive at the Taj.....	471
Picture 34: FabFi RF reflectors and satellite dishes on the roof of the Taj .....	472
Picture 35: Patient outside Nangarhar University Hospital with an IV drip hung in a tree .....	505
Picture 36: Unused donated anesthesia machine .....	508
Picture 37: Examples of basic feature phones.....	512
Picture 38: Low-cost portable ultrasound machine and laptop computer.....	512
Picture 39: Medweb handheld telemedicine kit .....	513
Picture 40: Homemade power conditioner and uninterruptible power supply for an ultrasound machine and clinical computers.....	515
Picture 41: An example of Afghan ingenuity .....	516



Picture 42: Solar panel store in Jalalabad .....	517
Picture 43: Afghan manual patient record system .....	524
Picture 44: Doctors at the French Medical Institute for Children (FMIC) in Kabul using telemedicine to treat patients in Bamyan Hospital .....	535
Picture 45: More FMIC-Bamyan telemedicine sessions .....	536
Picture 46: Measles outbreak in Nuristan province, July 2011 .....	538
Picture 47: The MCIT celebrates the WTISD theme of "Women and Girls in ICT" ... kind of .....	558
Picture 48: Project Gateway call center station .....	561
Picture 49: ICTI graduation ceremony, January 2011 .....	594
Picture 50: Cisco Networking Academy at the American University of Afghanistan's Professional Development Institute .....	597
Picture 51: Afghan beneficiaries of CLDP training .....	615
Picture 52: Sign above the Cisco Networking Academy at the Afghan Ministry of Women's Affairs .....	628
Picture 53: Cisco Networking Academy at Herat University .....	649
Picture 54: Cisco Networking Academy at the ICTI .....	651
Picture 55: TAT meeting at Kabul University, 2012 .....	658
Picture 56: TAT demonstrates e-learning resources to ICTI faculty .....	681
Picture 57: TFBSO Herat facility and incubator .....	701
Picture 58: TAT member's presentation on Afghan ICT to incubator participants at TFBSO Herat facility .....	702
Picture 59: American University of Afghanistan's Professional Development Institute .....	703
Picture 60: Bak DCN node and local school .....	715
Picture 61: Khost girls' school, GCN/CDMA node, and shura meeting .....	716
Picture 62: Khost University Cisco Networking Academy, journalism lab, and computer science lab .....	717
Picture 63: Khost hospital and medical clinic .....	717
Picture 64: Inaugural Afghan National ICT Conference .....	721
Picture 65: Cure International Hospital medical library .....	722
Picture 66: Tangi Saidan Village Community Center .....	722
Picture 67: STA/TAT office at the MCIT .....	748
Picture 68: MCIT building in Kabul .....	748
Picture 69: STA/TAT office at ISAF Headquarters .....	750
Picture 70: TAT members meet with ISAF RC-SW CJ9 .....	757
Picture 71: TAT-1 Director Larry Klooster and team with COMISAF Gen. Petraeus .....	767
Picture 72: ICT Collaboration Conference at ICTI Conference Center .....	768
Picture 73: TAT-2 Director Colonel Beth Bierden and partial team .....	770
Picture 74: TAT-3 Director Colonel Frank Huber and partial team .....	773
Picture 75: TAT-4 Director Dr. Catherine Warner and team .....	775
Picture 76: Casing of the TAT's colors .....	779
Picture 77: Larry Wentz, Bob Kinn, and Lew Shadle, leaders of the TAT's Reachback Team .....	785
Picture 78: SOF VSO COIN initiative .....	787
Picture 79: TAT challenge coin .....	798
Picture 80: TAT patches .....	798

## Abbreviations, Acronyms, and Initialisms

---

2G	Second-generation mobile communications
24x7	Twenty-four hours a day, seven days a week
3D	Three-dimensional
3G	Third-generation mobile communications
4G	Fourth-generation mobile communications
A&L	Administrative and Logistics
A&M	Agriculture and Mechanical
AAA	Afghan Aviation Authority
AACP	Afghan Anti-Crime Police
AAF	Afghan Air Force
AAP-1	Americom Asia-Pacific-1
AB	Azizi Bank
ABADE	Assistance in Building Afghanistan by Developing Enterprises
ABP	Afghan Border Police
ABS	Afghan Broadcasting System
AC	Alternating Current
ACCE	Afghanistan Communications Coordination Element
ACCI	Afghan Chamber of Commerce and Industries
ACDEO	Afghanistan Capacity Development and Educational Organization
ACEM	Afghan Children Education Movement
ACG	Asia Consultancy Group
ACM	Association for Computing Machinery
ACOMET	Afghan Center of Multi-Professional Education and Training
ACP	Afghan Computer Programmers

ACR	American College of Radiology
ACSA	Afghan Computer Science Association
ACSO	Afghanistan Central Statistics Organization
ACSP	Afghanistan Country Stability Picture
ACSS	Afghan Computer Science Society
AD	Anno Domini
ADB	Asian Development Bank
ADSV	Afghan Digital Solar Village
ADT	Agribusiness Development Team
AE	Agricultural Extension
AeLESP	Afghanistan e-Learning English Support Project
AEO	Agriculture Extension Officer
AeQA	Afghan eQuality Alliances
AFCEA	Armed Forces Communications and Electronics Association
AfCERT	Afghanistan Computer, and later Cyber, Emergency Response Team
AfgNIC	Afghanistan Network Information Center
AfgREN	Afghanistan Research and Education Network
AFMIS	Afghanistan Financial Management Information System
AFN	Armed Forces Network
AFP	Agence France-Presse
Afs	Afghanis
AfTel	Afghan Telecom Corporation
AFTS	Automatic Funds Transfer Service
AGCHO	Afghanistan Geodesy and Cartography Head Office
AGE	Anti-government Element
AIA	Afghanistan Interim Administration
AIB	Afghan International Bank

AIMS	Afghanistan Information Management Service
AIRD	Afghanistan Institute for Rural Development
AISA	Afghanistan Investment Support Agency
AKFED	Aga Khan Fund for Economic Development
AKUH	Aga Khan University Hospital
ALP	Afghan Local Police
AMI	Aide Médicale Internationale
AML	Anti-money Laundering
AMMOA	Association of Mobile Money Operators in Afghanistan
AMPS	Advanced Mobile Phone System
ANA	Afghan National Army
ANASOC	Afghan National Army Special Operations Command
ANCOP	Afghan National Civil Order Police
ANDC	Afghanistan National Data Center
ANDMA	Afghanistan National Disaster Management Authority
ANDS	Afghanistan National Development Strategy
ANDSF	Afghanistan National Defense and Security Forces
ANGel	Afghanistan Next Generation eLearning
ANP	Afghan National Police
ANSF	Afghanistan National Security Forces
ANSFnet	Afghanistan National Security Forces Network
AoR	Area of Responsibility
APAN	All Partners Access Network
APDIP	Asia-Pacific Development Information Program
APNIC	Asia-Pacific Network Information Center
APPF	Afghan Public Protection Force
Apps	Applications

APS	Afghan Payments System
APT	Asia-Pacific Telecommunity
ARCA	Afghan Root Certifying Authority
ARCENT	Army Central Command
ARG	Afghanistan Reconstruction Group
ARG/STA	Afghanistan Reconstruction Group/Senior Telecom Advisor
ARO	Afghanistan Reachback Office
ARTF	Afghanistan Reconstruction Trust Fund
AS	Autonomous System
ASD-NII	Assistant Secretary of Defense for Networks and Information Integration
ASDP	Afghanistan Skills Development Project
ASMA	Afghan Social Media Awards
ASMED	Afghanistan Small and Medium Enterprise Development
ASMS	Afghan Social Media Summit
ASN	Autonomous System Number
ASOP	Afghanistan Social Outreach Program
ATA	Afghanistan Transitional Administration
ATICS	Afghan Telecommunications In-Country Support
ATMs	Automated Teller Machine
ATOSA	Afghanistan Telecommunications Operators' Social Association
ATRA	Afghanistan Telecom Regulatory Authority
AUAF	American University of Afghanistan
AUP	Afghan Uniformed Police
AWCC	Afghan Wireless Communications Company
AWDP	Afghanistan Workforce Development Program
AYC	Afghan Youth Connect
BA	Bachelor of Arts

BBC	British Broadcasting Corporation
BBE	Better Business Enterprise
BC	Before Christ
BCE	Before the Common Era
BCT	Brigade Combat Team
BESST	Basic Education Support Systems for Teachers
BG	Brigadier General
BIH	Business Innovation Hub
BMA	Bank-e-Millie Afghan
BPHS	Basic Package of Health Services
BRP	Business Process Re-engineering
BRT	Business Receipts Tax
BSA	Bilateral Security Agreement
BSc	Bachelor of Science
BSS/OSS	Business Support System/Operations Support System
BTA	Business Transformation Agency
BTCA	Better Than Cash Alliance
BTK	Bilgi Teknolojileri Ve İletişim Kurumu (Turkish Information and Communication Authority)
BTS	Base Transceiver Station
BWS	Broadband Wireless Service
C-IED	Counter-Improvised Explosive Device
C2	Command and Control
C2I	Command, Control, and Intelligence
C3	Command, Control, and Communications (US DoD) and Consultation, Command, and Control (NATO)
C4ISR	Command, Control, Communications, Computers, Intelligence, Surveillance, and Reconnaissance

CA	Civil Affairs
CAAT	Counterinsurgency Advisory and Assistance Team
CAC	Common Access Card
CAETE	University of Colorado, Center for Engineering and Advanced Technology Education
CALL	Computer Assisted Language Learning
CAP	Capacity for Afghan Public Services Project
CAREN	Central Asian Research and Education Network
CBA	Cost-Benefit Analysis
CBR	Capacity Building for Results
CCITT	Consultative Committee on International Telephone and Telegraph
CCNA	Cisco Certified Network Associate
CCNP	Cisco Certified Network Professional
CCNs	Cooperating Country Nationals
ccSLD	Country Code Second-Level Domain
CCT	Conditional Cash Transfer
ccTLD	Country Code Top Level Domain
CCTV	Closed Circuit Television
CD-ROM	Compact Disc-Read Only Memory
CD/DVD	Compact Disc/Digital Versatile (or Video) Disc
CDC	Community Development Council
CDDEA	Coordinating Director for Development and Economic Affairs
CDMA	Code Division Multiple Access
CDN	Content Delivery Network
CE	Crisis Establishment
CECOM	Communications-Electronics Command
CENTCOM	Central Command
CENTRIX	Combined Enterprise Regional Information Exchange System

CEO	Chief Executive Officer
CERP	Commander's Emergency Response Program
CERT	Computer Emergency Response Team and Cyber Emergency Response Team
CESP	Committee on Education and Skills Policy
CESS	Cellular Enabled Security and Stability
CEW	Civilian Expeditionary Workforce Program
CFR	Code of Federal Regulations
CFC	Combined Forces Command
CFC-A	Combined Forces Command-Afghanistan
CFSOCC-A	Combined Forces Special Operations Component Command-Afghanistan
CHART	Communication, Heuristic, Analytical, Relational, and Technology
CHW	Community Healthcare Worker
CIA	Central Intelligence Agency
CIDA	Canadian International Development Agency
CIDNE	Combined Information Data Network Exchange
CIIP	Critical Information Infrastructure Protection
CIMIC	Civil-Military Cooperation
CINCEUR	Commander in Chief European Command
CIO	Chief Information Officer
CIP	Critical Infrastructure Protection
CIS	Computer Information Systems, Commonwealth of Independent States, and Communications and Information Systems
CISO	Chief Information Security Officer
CISSP	Certified Information Systems Security Professional
CJ	Combined Joint and Citizen Journalism
CJ1	Combined Joint Manpower and Personnel
CJ6	Combined Joint Communications and Information Systems



CJ8	Combined Joint Finance
CJ9	Combined Joint Civil-Military Operations
CJIOC	Combined Joint Intelligence Operations Center
CJOA	Combined Joint Operational Area
CJTF	Combined Joint Task Force
CLDP	Commercial Law Development Program
CLP	Cisco Learning Partner
CMC	Communications and Media Commission
CMO	Civil-Military Operations
CMOC	Civil-Military Operations Center
CNA	Cisco Networking Academy and Center for Naval Analyses
CNAP	Cisco Networking Academy Program
COIN	Counterinsurgency
COM	Chief of Mission
COMISAF	Commander International Security Assistance Force
COMRS	Commander Resolute Support
COMSAT	Communications Satellite Corporation
COMSATCOM	Commercial Satellite Communications
COMUSFOR-A	Commander United States Forces-Afghanistan
CONOPS	Concept of Operations
CONUS	Continental United States
COO	Chief Operating Officer
COOP	Continuity of Operations
COP	Combat Outpost
CoS	Chief of Staff
COTS	Commercial Off-the-Shelf
COW	Cellular on Wheels

CPA	Coalition Provisional Authority
CPE	Customer Premises Equipment
CPOE	Computerized Provider Order Entry
CRTC	Canadian Radio-Television and Telecommunications Commission
CSC	Civil Service Commission
CSIS	Center for Strategic and International Studies
CSMP	Contingency Support and Migration Planning
CSO	[Bureau of] Conflict and Stabilization Operations
CSR	Corporate Social Responsibility
CSTA	Computer Science Teachers Association
CSTC-A	Combined Security Transition Command-Afghanistan
CSR	Corporate Social Responsibility
CSV	Comma Separated Values
CT	Computerized Tomography
CTAP	Civilian Technical Assistance Program
CTC	Community Technology Center
CTF	Counter-Terrorism Financing
CTI	Computer Technology Institute
CTNSP	Center for Technology and National Security Policy
CTO	Chief Technology Officer and Chief Technical Officer
CTSA	Computer Science Teachers Association
CUG	Closed User Group
DAAD	Deutscher Akademischer Austauschdienst (German Academic Exchange Service)
DAB	Da Afghanistan Bank
DABS	Da Afghanistan Breshna Sherkat
DAI	Development Alternatives, Inc.
DAIL	Afghan Directorate of Agriculture, Irrigation and Livestock

DAS-Net	Da Afghanistan Sterr Network (meaning “the great Afghan network”)
dB	Decibels
dba	Doing Business As
dBm	Decibel-milliwatts
DC	Direct Current and District of Colombia
DCMO	Deputy Chief Management Officer
DCN	District Communications Network
DCOS	Deputy Chief of Staff
DCOS-STAB	Deputy Chief of Staff-Stability
DCOS-STAB-DEV	Deputy Chief of Staff-Stability and Development
DCOS-RES	Deputy Chief of Staff of Resources
DCS	Deputy Chief of Staff
DDR	Disarmament, Demobilization, and Reintegration
DEWS	Disease Early Warning System
DF	Direction Finding
DFAC	Dining Facility
DFID	Department for International Development
DFS	Digital Financial Services
DG	Director General
DHS	Department of Homeland Security
DIA	Defense Intelligence Agency
DICOM	Digital Imaging and Communications in Medicine
DISA	Defense Information Systems Agency
DISA-CENT	Defense Information Systems Agency-Central Field Command
DISA-EUR	Defense Information Systems Agency-Europe Field Command
DISN	Defense Information System Network
DIT	Diploma in Information Technology

DITCO-SWA	Defense Information Technology Contracting Organization-Southwest Asia
DM	Deputy Minister
DMZ	Demilitarized Zone
DoC	Department of Commerce
DoD	Department of Defense
DoDD	Department of Defense Directive
DoDI	Department of Defense Instruction
DoJ	Department of Justice
DoS	Department of State
DOW	Decade of War
DPLC	Domestic Private Leased Circuit
DR	Disaster Recovery and Direct Radiology
DSE-A	DISA Support Element-Afghanistan
DSE-I	DISA Support Element-Iraq
DSL	Digital Subscriber Line
DSO	Defense Spectrum Office
DTH	Direct-to-Home
DTMF	Dual-tone Multi-frequency
DTTV	Digital Terrestrial Television
DTV	Digital Television
DVB-RCS	Digital Video Broadcasting-Return Channel via Satellite (or Return Channel over System)
DWDM	Dense Wavelength-Division Multiplexing
EC	European Commission
ECC	Election Complaints Commission
ECDP	Emergency Communications Development Project
ECM	Electronic Countermeasure

ECON	Economic
EDGE	Enhanced Data GSM Environment
EDMS	Electronic Document Management System
E-Education	Electronic Education
EFA	Education For All
EFL	English as a Foreign Language
EFT	Electronic Funds Transfer
EGA	E-Governance Academy
EGGI	Economic Growth and Governance Initiative
E-GIF	E-Government Interoperability Framework
E-GSM	Extended Global System for Mobile [Communications]
E-gov and E-government	Electronic Government
EGOV.AF	Electronic Government Afghanistan
EGOV-UNU-IIST	E-Government at The United Nations University International Institute for Software Technology
EGRC	E-Government Resource Center
E-Healthcare	Electronic Healthcare
EID	Economic and Infrastructure Development
E-ID	Electronic Identity Card
EIFL	Electronic Information for Libraries
EKG	Electrocardiogram
E-Learning	Electronic Learning
ELCLC	English Language and Computer Learning Center
EMI	Electronic Money Institution
EMIS	Education Management Information System
EMR	Electronic Medical Record
E-NIC	Electronic National Identity Card

E-NID	Electronic National Identification [Card]
Eoi	Expression of Interest
E-Resources	Electronic Resources
ERA	E-Readiness Assessment
ERDC	Eastern Region Disease Connection
ESC	Executive Steering Committee
ESO	Education Support Organization
ESP	English for Specific Purposes
Est.	Estimated
ETSI	European Telecommunications Standards Institute
EU	European Union
EUCOM	European Command
EUPOL	European Police
FAIDA	Financial Access for Investing in the Development of Afghanistan
FAP	Fair Access Policy
FAT	Frequency Allocation Table
FCC	Federal Communications Commission
FCC-IB	Federal Communications Commission-International Bureau
FCI	Femme Comp, Inc.
FDI	Foreign Direct Investment
FEC	Forward Error Correction
FET	Female Engagement Team
FHIR	Fast Healthcare Interoperability Resources
FM	Field Manual
FMB	Frequency Management Board
FMFB-A	First MicroFinance Bank-Afghanistan
FMIC	French Medical Institute for Children

FMIS	Financial Management Information System
FMS	Foreign Military Sales
FOB	Forward Operating Base
FOR	Fiber Optic Ring
FOSS	Free and Open Source Software
FRAGO	Fragmentary Order
FSS	Fixed Satellite Service
FTE	Full Time Equivalent
FUSION	Featured Europe and South Asia Mobility Network
FY	Fiscal Year
G2B	Government-to-Business
G2C	Government-to-Citizen
G2G	Government-to-Government
G2P	Government-to-People or Government-to-Populace
G77	Group of Seventy-Seven
GATS	General Agreement on Trade in Services
GB	Ghazanfar Bank
Gbps	Gigabits per Second
GCCS	Global Command and Control System
GCDS	Global Content Delivery System
GCEP	Global Connection and Exchange Program
GCI	Global Connect Initiative
GCIO	Government Chief Information Officer
GCN	Government Communications Network
GDA	Global Development Alliance
GDP	Gross Domestic Product
GHz	Gigahertz

GIG	Global Information Grid
GIPI	Global Internet Policy Initiative
GIPI-AF	Global Internet Policy Initiative-Afghanistan
GIRoA	Government of The Islamic Republic of Afghanistan
GIRoANet	Government of The Islamic Republic of Afghanistan Network
GIS	Geographic Information Systems
GMPCS	Global Mobile Personal Communications by Satellite
GNI	Gross National Income
GO	General Officer and GIG Operations
GoI	Government of Iraq
GPF	General Purpose Force
GPRS	General Packet Radio Service
GPS	Global Positioning System
GSG6	General Staff Chief of Communications
GSI	Globecomm Systems Inc.
GSM	Global System for Mobile [Communications]
GSMA	GSM Association
GTR	Global Technology Resources
GTZ	German Agency for Technical Cooperation (Gesellschaft für Technische Zusammenarbeit)
HA/DR	Humanitarian Assistance/Disaster Relief
HARMONIEWeb	Humanitarian Assistance Response Monitoring and Operations Network-Internet Enterprise
HCC	Host Country Contracting
HCI	High Commission of Investment
HDI	Human Development Index
HEDP	Higher Education Development Project
HEDSG	Higher Education Donors Steering Group



HEMS	Higher Education Management System
HEP	Higher Education Project
HF	High Frequency
HIMSS	Healthcare Information and Management Systems Society
HISS	Healthcare Information Systems Society
HIV	Human Immunodeficiency Virus
HKIA	Headquarters Kabul International Airport
HL7	Health Level 7
HQE	Highly Qualified Expert
HR	Human Resources
HSPA	High-speed Packet Access
HVAC	Heating, Ventilation, and Air Conditioning
Hz	Hertz
I-Team	Implementation Team
IA	Information Assurance
IANA	Internet Assigned Numbers Authority
IARCSC	Independent Administrative Reform and Civil Service Commission
IBA	Individual Body Armor
ICANN	Internet Cooperation for Assigned Names and Numbers
ICCE	Iraq Communications Coordination Element
ICCRTS	International Command and Control Research and Technology Symposium
ICDL	International Computer Driver's License
ICG	International Contact Group
ICM	Idle Channel Measurement
ICMAG	Integrated Civil-Military Action Group
ICMP	Integrated Civilian-Military Campaign Plan
ICRC	International Committee of the Red Cross

ICT	Information and Communications Technology
ICT4D	Information and Communications Technology for Development
ICTA	Turkish Information and Communication Authority
ICTI	Information and Communication Technology Institute
ICU	Intensive Care Unit
ICWFD	International Commission on Workforce Development
IDA	Institute for Defense Analyses and International Development Association
IDEA-NEW	Incentives Driving Economic Alternatives – North, East, [and] West
IDLG	Independent Directorate of Local Governance
IDLO	International Development Law Organization
IEC	Independent Election Commission
IECC	Independent Electoral Complaints Commission
IED	Improvised Explosive Device
IEEE	Institute of Electrical and Electronics Engineers
IETF	Internet Engineering Task Force
IFC	International Finance Corporation
IFOR	Implementation Force
IGF	Internet Governance Forum
IGO	Inter-Governmental Organization
IHE	Integrating the Healthcare Enterprise
iHub	Innovation Hub
IJC	ISAF Joint Command
IMF	International Monetary Fund
IMPACT	International Multilateral Partnership Against Cyber Threats
IMT	International Mobile Telecommunications
INDURE	International Distributed Unified Reporting Environment
INMARSAT	International Maritime Satellite Organization

INSS	Institute for National Strategic Studies
INSY	International Synergy
INTELSAT	International Telecommunications Satellite Consortium
IOC	Initial Operating Capability
IO	International Organization
IOPT	ISAF Operational Planning Team
IP	Internet Protocol
IPA	Intergovernmental Personnel Act
IPB	Intelligence Preparation of the Battlespace
IPLC	International Private Leased Circuit
IPv6	Internet Protocol Version Six
IQ	Intelligence Quotient
IRC	International Record Carrier and International Red Cross
IRMO	Iraq Reconstruction Management Office
IS	Islamic State
ISAF	International Security Assistance Force
ISD	Information Security Directorate
ISE	Infostructure and Strategic Engagement
ISIS	Islamic State of Iraq and Syria
ISM	Industrial, Scientific, and Medical
ISO	International Standards Organization
ISOC	Internet Society
ISP	Internet Service Provider
ISP-L	Internet Service Provider-Local
ISP-N	Internet Service Provider-National
ISR TF	Intelligence, Surveillance, Reconnaissance Task Force
ISSD	Information Systems Security Directorate

IT	Information Technology
ITA	Information Technology Agreement
ITAA	Information Technology Association of America
ITAO	Iraq Transition Assistance Office
ITIL	[Formerly] Information Technology Infrastructure Library
ITPC	Iraqi Telecommunications and Post Company
ITU	International Telecommunication Union
ITU-D	International Telecommunication Union-Development
ITU-R	International Telecommunication Union-Radiocommunications
ITU-T	International Telecommunication Union-Standardization
IV	Intravenous
IVLP	International Visitor Leadership Program
IVR	Interactive Voice Response
IVR4BABY	Interactive Voice Response for Baby
IXP	Internet Exchange Point
IZT	IZ Technologies
J6	Communications and Information Systems
JCMB	Joint Coordination and Monitoring Board
JIACG	Joint Interagency Coordination Group
JIATF	Joint Interagency Task Force
JICA	Japan International Cooperation Agency
JIDA	Joint Improvised-Threat Defeat Agency
JIEDD TF	Joint Improvised Explosive Device Defeat Task Force
JIEDDO	Joint Improvised Explosive Device Defeat Organization
JIIM	Joint, Interagency, Intergovernmental and Multinational
JMD	Joint Manning Document
JNCC-A	Joint Network Control Center-Afghanistan

JPEG	Joint Photographic Experts Group
JSC	Joint Spectrum Center
kbps	Kilobits Per Second
KFOR	Kosovo Force
kHz	Kilohertz
KIA	Kabul International Airport
KLE	Key Leader Engagement
km	Kilometer(s)
KMIC	Kandahar Media Information Center
KOICA	Korea International Cooperation Agency
KYC	Know Your Customer
LAN	Local Area Network
LARA	Land Reform Agency in Afghanistan
LEADER	Links in Europe and Asia for Engineering, Education, Enterprise and Research
LEADERS	Leading Mobility between Europe and Asia in Developing Engineering Education and Research
LCDR	Lieutenant Commander
LFSP	Local Fixed Service Provider
LLO	Logical Line of Operation
LLP	Limited Liability Partnership
LMC	Legal Main Contact
LOE	Line of Effort and Line of Engagement
LOFTA	Law and Order Trust Fund for Afghanistan
LTE	Long-Term Evolution
MHz	Megahertz
M&E	Monitoring and Evaluation
M2M	Machine-to-Machine

MA	Master of Arts
MAC	Media Access Control
MAIL	Ministry of Agriculture, Irrigation and Livestock
MAMA	Mobile Alliance for Maternal Action
MB	Megabyte
mBanking	Mobile Banking
MBA	Master's [Degree] in Business Administration
MBB	Mobile Broadband
Mbps	Megabits per Second
MCIT	Ministry of Communications and Information Technology
MCP	Management Capacity Program
MCT	Multipurpose Community Telecenter
MD	Medical Doctor
MDB	Multilateral Development Bank
MDG	Millennium Development Goal
MEC	Monitoring and Evaluation Committee
MedFLOSS	Medical Free/Libre and Open Source Software
MEW	Energy and Water
MFI	Microfinance Institution
MG	Major General
MGAP	Mobile Government Applications Platform
mGCI	Mobile Government Consortium International
M-government and M-gov	Mobile Government
M-Learning	Mobile Learning
MIP	Maximum-Intensity Projection
MIS	Management Information System

MISFA	Microfinance Investment Facility for Afghanistan
MIT	Massachusetts Institute of Technology
M-money and mMoney	Mobile Money
MMS	Multimedia Message Service
MNF-I	Multi-National Force-Iraq
MNO	Mobile Network Operator
MNP	Model National Plan
MoA	Memorandum of Agreement
MoC	Ministry of Communications
MoCIT	Ministry of Communications and Information Technology
MoD	Ministry of Defense
MoDA	Ministry of Defense Advisors
MoE	Ministry of Education
MoEc	Ministry of Economy
MoF	Ministry of Finance
MoFA	Ministry of Foreign Affairs
MoHE	Ministry of Higher Education
MoI	Ministry of Interior
MoIC	Ministry of Information and Culture
MoJ	Ministry of Justice
MoLSAMD	Ministry of Labor, Social Affairs, Martyrs and the Disabled
MOOC	Massive Open Online Course
MoPH	Ministry of Public Health
MoPW	Ministry of Public Works
MoRR	Ministry of Refugees and Returns
MOSS	Minimum Operating Security Standards

MoST	Ministry of Science and Technology
MoTCA	Ministry of Transport and Civil Aviation
MoU	Memorandum of Understanding
MOVECON	Movement Control
MoWA	Ministry of Women's Affairs
MP	Member of Parliament
MPEG	Moving Picture Experts Group
mPOS	Mobile Point-of-Sale
MPR	Multi-Planar Reformat
MRI	Magnetic Resonance Imaging
MRRD	Ministry of Rural Rehabilitation and Development
MSF	Mobile Strike Force
MSMO	Ministerial Spectrum Management Office
MTA	Military Technical Agreement
MTN	Mobile Telephone Network
MTS-L	Mobile Telephone Service License-Local
MTS-N	Mobile Telephone Service License-National
mW	Milliwatt
MWC	Mobile World Congress
MWR	Moral, Welfare, and Recreation
NABDP	National Area Based Development Program
NAP	Network Access Point
NASA	National Aeronautics and Space Administration
NAT	Network Address Translation
NATO	North Atlantic Treaty Organizations
NATTF	NATO Afghanistan Transition Task Force
NC3A	NATO Consultation, Command and Control Agency



NCE	National Command Element
NCES	Net-Centric Enterprise Services
NCISS	NATO Communication Information System School
NCSA	National Cybersecurity Strategy of Afghanistan
NCSC	National Cybersecurity Strategy Committee
NDS	National Directorate of Security
NDU	National Defense University
NEC	National Economic Committee
NEMA	National Electronic Manufacturers Association
NESA	Near East South Asia
NEPS	North-East Power System
NESP III	Third National Education Strategic Plan
NFC	Near Field Communication
NG	Next Generation
NGA	National Geospatial-Intelligence Agency
NGO	Non-Governmental Organization
NHESP	National Higher Education Strategic Plan
NIBP	National Institution Building Project
NICTAA	National Information and Communications Technology Association of Afghanistan
NICTCA	National Information and Communications Technology Council of Afghanistan
NID	National Identification [Card]
NIMA	National Institute of Management and Administration
NIRA	National Internet Registry of Afghanistan
NIR	National Internet Registry
NISPAA	National Internet Service Provider Association of Afghanistan
NIST	National Institute of Standards and Technology
NIXA	National Internet Exchange of Afghanistan

NKB	New Kabul Bank
NOSCA	National Open Source Conference of Afghanistan
NOC	Network Operations Center
NPH	Nangarhar Public Hospital
NPP	National Priority Program
NPS	Naval Postgraduate School
NRAP	National Rural Access Program
NRRCI	National-Regional Resource Corridor Initiative
NSC	National Security Council
NSDD	National Security Decision Directive
NSE	National Support Element
NSM-MAG	Non-Security Ministries-Ministerial Advisory Group
NSMS	National Spectrum Management System
NSP	National Solidarity Program
NSPD	National Security Policy Directive
NSR	New Silk Road
NTIA	National Telecommunications and Information Administration
NTM-A	North Atlantic Treaty Organization Training Mission-Afghanistan
NTSC	National Television System Committee
NU	Nangarhar University
NYU	New York University
O&M	Operations and Maintenance
OAP	Open Access Policy
OASD-NII	Office of the Assistant Secretary of Defense-Networks and Information Integration
OB	Obstetrics
OCC	Operations Coordination Center
OCONUS	Outside the Continental United States

OCP	Operation Cyber Pass
OFC	Optical Fiber Cable
Ofcom	Office of Communications
OHDACA	Overseas Humanitarian Disaster and Civic Aid Program
OMC	Office of Military Cooperation
ONSC	Office of the National Security Council
OPGW	Optical Ground Wire
OPLAN	Operations Plan
OPT	Operational Planning Team
OR	Operating Room
ORHA	Office of Reconstruction and Humanitarian Assistance
OSA	Open Source Afghanistan
OSC	Office of Security Cooperation
OSCE	Organization for Security and Cooperation in Europe
OSD	Office of the Secretary of Defense
OSTP	Office of Science and Technology Policy
OTI	Office for Transition Initiatives
OTT	Over-the-Top
OX	Oximeter
P2P	Peer-to-Peer or Person-to-Person
PACC	Pakistan Afghanistan Coordination Cell
PACS	Picture Archiving and Communication System
PAL	Phase Alternating Line
PASA	Participating Agency Service Agreement
PB	Pashtany Bank
PBX	Private Branch Exchange
PC	Personal Computer

PCHA	Personal Connected Health Association
PCII	Protected Critical Infrastructure Information
PCO	Public Call Office
PDA	Personal Digital Assistant
PDD	Presidential Decision Directive
PDI	Professional Development Institute
PEFA	Public Expenditure and Financial Accountability
PEP	Packet Error Probability
PFM	Public Financial Management
PGCN	Provincial Government Communications Network
PGO	Provincial Government Office
PhD	Philosophiæ Doctor (Doctorate of Philosophy)
PHI	Personal Health Information
PICC	Presidential Information and Coordination Center
PICU	Project Implementation and Coordination Unit
PII	Personally Identifiable Information
PIMS	Provincial Information Management System
PIMSS	Provincial Infrastructure Management Support System
PIN	Personal Identification Number
PKI	Public Key Infrastructure
PMI	Project Management Institute
PMP	Performance Management Plan
PMO	Project Management Office
PoP	Point of Presence
POS	Point-of-Sale
PPP	Public-Private Partnership and Purchasing Power Parity
PRT	Provincial Reconstruction Team

PSA	Public Service Announcement
PSC	Private Security Company
PSD	Private Security Detail
PSTN	Public Switched Telephone Network
PTCL	Pakistan Telecommunication Company Ltd.
PTT	Post, Telephone, and Telegraph
PVO	Private Voluntary Organization
PX	Post Exchange
QDDR	Quadrennial Diplomacy and Development Review
QIP	Quick Impact Program
QoS	Quality of Service
RBAP	Regional Bureau for Asia and Pacific
RC	Reserve Component
RCC	Regional Commonwealth in the field of Communications
RCIED	Remote-controlled Improvised Explosive Device
RECCA	Regional Economic Cooperation Conference on Afghanistan
Ret.	Retired
RF	Radio Frequency
RFA	Request for Application
RFP	Request for Proposal
RIR	Regional Internet Registry
RMC	Risk Management Company
ROSCCA	Regional Open Source Conference-Central Asia
RR	Radio Regulation(s)
RS	Resolute Support
RSM	Resolute Support Mission
RTA	Radio Television Afghanistan and Regional Training Academy

RTD	Rural Telecommunications Development
RTWP	Received Total Wideband Power
S/CRS	US State Department's Office of the Coordinator for Reconstruction and Stabilization
SA	Situational Awareness
SACEUR	Supreme Allied Commander Europe
SAMENA	South Asia, Middle East, and North Africa
SATCOM	Satellite Communications
SATRC	South Asian Telecommunication Regulators' Council
SCA	South and Central Asia
SCADA	Supervisory Control and Data Acquisition
SCAD	Savannah College of Art and Design
SCIS	State Company for Internet Services
SCR	Security Council Resolution
SDG	Sustainable Development Goal
SDH	Synchronous Digital Hierarchy
SDN	Service Delivery Node
SDP	Standard Delivery Platform
SES	Senior Executive Service
SFOR	Stabilization Force
SHAPE	Supreme Headquarters Allied Powers Europe
SHEP	Strengthening Higher Education Project
SIA	Satellite Industry Association and Senior ICT Advisor
SIDA	Swedish International Development Cooperation Agency
SIGAR	Special Inspector General for Afghanistan Reconstruction
SILK-A	[Virtual] Silk Highway-Afghanistan
SIM	Subscriber Identity Module
SMADEF XML	Spectrum Management Data Exchange Format Extensible Markup Language

SMART	Specific, Measurable, Achievable, Realistic, and Time-Based and Software, Mobile, Application, Research and Technology
SMARTLINK	South-east-west Mobility for Advanced Research, Learning, Innovation, Network, and Knowledge
SMB	Spectrum Management Bureau
SME	Subject Matter Expert and Small to Medium Enterprise
SMS	Short Message Service
SMS4DC	Spectrum Management System for Developing Countries
SOA	Service Oriented Architecture
SOE	State-owned Enterprise
SOF	Special Operations Forces
SOFA	Status of Forces Agreement
SOP	Standard Operating Procedure and Service-Object Pair
SOUTHCOM	Southern Command
SP	Strategic Partnerships
SPAWAR	Space and Naval Warfare Systems Command
SPS	Science for Peace and Security
SRAP	Special Representatives for Afghanistan and Pakistan
SRID	State Radio Inspection Department
SRS	Software Radio System
SSF	Synergy Strike Force
SSI	Strategic Studies Institute
SSR	Security Sector Reform
SSTR	Stability, Security, Transition, and Reconstruction
STA	Senior Telecommunications Advisor
Stab Ops	Stability Operations
START	Start-up, Training through Association with Remote Teams
STATT	Strategy Analysis Action Transnational Trends

STEP-UP	Strengthening Tertiary Education Project-University Partnerships
SUV	Sport Utility Vehicle
SWEAT-MSO	Sewer, Water, Electrical, Academic, Trash Removal, Medical, Safety and Other
SWIFT	Society for Worldwide Interbank Financial Telecommunication
SXXI	Spectrum Twenty-one
SY	Solar Year
TA	Telecom[munications] Advisor
TAA	Train, Advise, and Assist
TAT	Telecom[munications] Advisory Team
TB	Terabyte
TCC	Transition Coordination Commission
TCN	Troop Contributing Nation
TCP/IP	Transmission Control Protocol/Internet Protocol
TDCA	Telecom Development Company Afghanistan Ltd.
TDF	Telecommunications Development Fund
TDY	Temporary Duty
TEIN-4	Trans-Eurasia Information Network (Fourth Generation)
Telco	Telephone or Telecom Company
Telecom	Telecommunications
TESOL	Teachers of English to Speakers of Other Languages
TF	Task Force
TF-AO	Task Force-Area of Operation
TFBSO	Task Force for Business and Stability Operations
TFMC	Theater Frequency Management Cell
TIC	Telecommunications Infrastructure Company
TICTAC	Telemedicine Infrastructure Clinic for Treatment of Ambulatory Patients
TMM	TellMeMore



TOR	Terms of Reference
TRAA	Telecom Regulatory Authority of Afghanistan
TRAI	Telecommunications Regulatory Authority of India
TRB	Telecom Regulatory Board
TSI	Telephone Systems International, Inc.
TTC	Teacher Training College and Telecommunications Training Center
TTI	Technical (or Telecommunications) Training Institute
TTP	Tactics, Techniques, and Procedures
TTSP	Technical and Technological Solution Provider License
TU	Technical University
TÜBİTAK	Scientific and Technological Research Council of Turkey (Türkiye Bilimsel ve Teknolojik Araştırma Kurumu)
TV	Television
TVET	Technical and Vocational Education and Training
TVI	Technical and Vocational Institute
TWG	Telecom Working Group
UAE	United Arab Emirates
UC Davis	University of California, Davis
UCS	Univention Corporate Server
UK	United Kingdom
UN	United Nations
UNAMA	United Nations Assistance Mission-Afghanistan
UNCITRAL	United Nations Commission on International Trade Law
UNCTAD	United Nations Conference on Trade and Development
UNDP	United Nations Development Programme
UNESCAP	United Nations Economic and Social Commission for Asia and the Pacific
UNESCO	United Nations Educational, Scientific and Cultural Organization

UNGA	United Nations General Assembly
UNHCR	United Nations High Commissioner for Refugees
UNICEF	United Nations International Children’s Emergency Fund
UNOCHA	United Nations Office for the Coordination of Humanitarian Affairs
UNODC	United Nations Office on Drugs and Crime
UNOPS	United Nations Office for Project Services
UNSCR	United Nations Security Council Resolution
UNSPECA	United Nations Special Program for The Economies of Central Asia
UNU/IIST	United Nations University/International Institute for Software Technology
UNU-EGOV	United Nations University Center for Electronic Governance
UNU-IIST	United Nations University International Institute for Software Technology
UPS	Uninterrupted Power Supply
US	United States
US\$	United States Dollar
USA	United States of America and United States Army
USACE	United States Army Corps of Engineers
USAF	United States Air Force
USAID	United States Agency for International Development
USDA	United States Department of Agriculture
USD-I	Under Secretary of Defense-Intelligence
USFOR-A	United States Forces-Afghanistan
USG	United States Government
USIP	United States Institute of Peace
USJFCOM	United States Joint Forces Command
USMC	United States Marine Corps
USSD	Unstructured Supplementary Service Data
USSR	Union of Soviet Socialist Republics

USTDA	United States Trade and Development Agency
USTTI	United States Telecommunications Training Institute
UTM	Unified Threat Management
V	Volt
VAT	Value-Added Tax
VCN	Village Communications Network
VIP	Very Important Persons or People
VoIP	Voice over Internet Protocol
VolVis	Voluntary Visitors
VPN	Virtual Private Network
VSAT	Very Small Aperture Terminal
VSO	Village Stability Operations
VTC	Video Teleconference or Teleconferencing
WAN	Wide-Area Network
WAP	Wireless Access Point
WC	Writer's Companion
WFP	World Food Programme
WG	Working Group
WH	White House
WHO	World Health Organization
WIG	Women In Government
WiMAX	Worldwide Access for Microwave Communications
WISP	Wireless Internet Service Provider
WITSA	Word Information Technology and Services Alliance
WLAN	Wireless Local Area Network
WLL	Wireless Local Loop
WPCO	Women's Public Call Office

WRC	World Radio Conference
WSIS	World Summit on the Information Society
WSU	Washington State University
WTISD	World Telecommunications and Information Society Day
WTO	World Trade Organization
WTSA	World Telecommunication Standardization Assembly
XDS	Cross-Enterprise Document Sharing
Ziik	Das Zentrum für Internationale und Interkulturelle Kommunikation (Center for International and Intercultural Communication)

## Foreword

---

After decades of war and civil strife, Afghanistan's infrastructure had largely been destroyed and the country had virtually no telecommunications services. Most Afghans had to travel to neighboring countries to make phone calls, and data services were essentially non-existent. The ouster of the Taliban at the hands of the US-led NATO Coalition in late 2001 ushered in a new era for Afghanistan. In 2002, the Afghan Government laid the groundwork for the reconstruction of the country by adopting a policy framework that encouraged public and private investment in Afghanistan's rebirth. With the first private company authorized to provide GSM telephone service in April of that year, the information and communications technology (ICT) sector was among the very first post-war sectors to be established. To date, the ICT has attracted over US\$2 billion in private investment, is one of the largest contributors to the Afghan treasury, and is one of Afghanistan's greatest success stories.

Over the past 12 years, the ICT sector has experienced unprecedented and phenomenal growth: Six companies provide mobile telephone service to nearly 22 million subscribers, and over 88 percent of Afghans live in areas with cellular service. The price of SIM cards decreased from over US\$250 in 2002 to under a dollar today, and per-minute call costs have dropped by at least 95 percent and continue to decrease. Five companies offer 3G mobile broadband services in 16 provinces and have achieved a collective 400,000 customers since the introduction of 3G in March of 2012. We are expecting to introduce 4G services as well.

The first Internet service provider was licensed in 2004, and by 2013 over 50 licensed ISPs provided Internet access to 2.4 million users. Internet prices fell from US\$5,000 per Mbps per month in 2002 to US\$67/Mbps in February 2014. The volume of Internet traffic rose from under 250 gigabytes in 2004 to 4,850 gigabytes in 2012. Domestic Internet bandwidth nearly quadrupled from 557 Mbps in 2009 to 1,866 Mbps in 2011, while international bandwidth tripled from 3,175 Mbps to 9,891 Mbps during that same time.

Afghanistan's ambitious 5,000-kilometer national optical fiber ring is already connected to five of our neighbors. As of mid-2014, over half (62 percent) of the fiber ring is operational, and metropolitan area fiber networks are planned for six of Afghanistan's principal cities. Afghanistan's transition from analog to digital broadcasting is well underway, with the May 11, 2014 inauguration of our first commercial satellite, AfghanSAT1. Both endeavors came to fruition in 2014, a pivotal year in this chapter of Afghanistan's history.

It is widely recognized – but little documented – how ICT has underpinned and advanced progress in all other areas in Afghanistan, including security, governance, socio-economic development, education, agriculture, health, business, and women's rights. We are on our way to transforming Afghanistan into an Information Society. This book provides examples of how tremendously impactful ICT has been in Afghanistan and how ICT has made differences – great and small – in the lives and livelihoods of every Afghan. The book also underscores how fundamentally significant ICT is to a peaceful and prosperous future for Afghanistan.

As you will see, the success of the Afghan ICT sector is a synergistic combination of many factors: forward-thinking policy, legislation, and regulation; private investment; international assistance; the transparency and accountability of, and execution by, Afghanistan's public ICT institutions; and, not least of all, overwhelming demand by Afghans eager to join the modern world. The US government's Senior Telecom Advisor and Telecommunications Advisory Team have been instrumental players in the attainment of our accomplishments thus far. The people of Afghanistan and I are extremely grateful for their assistance in working toward my vision of transforming Afghanistan into an information society.



*Amirzai Sangin  
Minister of Communications and Information Technology, 2004-2014  
Kabul, Afghanistan  
April 2014*

## Acknowledgements

---

The experiences and lessons documented herein represent a whole-of-government and unity-of-effort approach that leveraged the collective interests, support, and untiring efforts of senior leadership and members of the United States Government (USG) civilian and military elements represented by the Department of Defense, Department of State, US Agency for International Development (USAID), Department of Commerce, and other USG elements, such as US Forces-Afghanistan (USFOR-A), the US Embassy Kabul, and the USAID Mission in Kabul. NATO and its International Security Assistance Force (ISAF) and Coalition civil-military partners, the International Community, such as the World Bank and the United Nations, think tanks, academia, private industry, and public and private sector counterparts in Afghanistan provided additional support and cooperation.

Particular thanks for establishing the office of Senior Telecommunications (Telecom) Advisor (STA) in Afghanistan go to the early efforts and support of John G. Grimes, Assistant Secretary of Defense for Networks and Information Integration and the Department of Defense Chief Information Officer (ASD-NII/DoD CIO); Cheryl J. Roby, Acting ASD-NII/DoD CIO; Ambassador David A. Gross, Deputy Assistant Secretary of State for International Communications and Information Policy in the Bureau of Economic and Business Affairs and US Coordinator for International Communications and Information Policy; Ambassador (Retired) Philip L. Verveer, Deputy Assistant Secretary of State for International Communications and Information Policy in the Bureau of Economic and Business Affairs and US Coordinator for International Communications and Information Policy; Lieutenant General (Retired) Carroll F. Pollett, US Army (USA), Director, Defense Information Systems Agency (DISA); Lieutenant General (Retired) Ronnie D. Hawkins, Jr., US Air Force (USAF), Director, DISA; Lieutenant General Alan R. Lynn, USA, Director, DISA; Rear Admiral (Retired) David G. Simpson, Vice Director, DISA; Larry Huffman, Senior Executive Service (SES) (retired), Director, Center for Operations, DISA; Lawrence A. (Larry) Klooster, Operations Directorate Executive, DISA; Philip A. La Perla, Division Chief -- Plans, Exercises, and Readiness, DISA; William D. (Will) Ritchie (deceased), Chief Contingency Operations, DISA; Fred Ruonavar, Chief Contingency Operations, DISA; Kevin Wolfe, DISA; Kamhran Zangna, DISA; Brigadier General (BG) (Retired) Steven J. Spano, USAF, Multi-National Force-Iraq (MNF-I), Deputy Chief of Staff for Communications and Information Systems (DCS CIS); BG (Retired) Gregory L. Brundidge, USAF, MNF-I DCS CIS; Dr. Linton (Lin) Wells II, SES (retired), Director, Center for Technology and National Security Policy (CTNSP), National Defense University (NDU); Stan Lumish, DoD Task Force for Business and Stability Operations (TFBSO); Al Johnson, Director Integrated ICT Support Directorate, ASD-NII/DoD CIO; William (Bill) Barlow, Deputy for Information Sharing Information Enterprise, Architecture and Engineering, DoD CIO; BG (Retired) Brian Donahue, USA, CENTCOM J6; Colonel (Col) Peter A. Gallagher (now BG Pete Gallagher, CENTCOM, J6), USA, ISAF CJ6, Commander, DISA-CENT and Deputy Director of the Pakistan Afghanistan Coordination Cell (PACC), Joint Staff; Colonel (Retired) Rosemary Carter, USA, Commander, DISA-CENT; General (Retired) David H. Petraeus, USA, Commander ISAF (2010-2011); Colonel Mark Baxter, USA, ISAF CJ6; Ambassador Tony Wayne, Coordinating Director for Development and Economic Affairs, US Embassy Kabul; Anne W. Benjaminson, US Embassy Kabul, Economic (ECON) section; Carter Wilbur, US Embassy Kabul, ECON; Alex Thier, Assistant to the USAID Administrator for the Office of Afghanistan and Pakistan Affairs (OAPA); Larry Sampler, Deputy Senior Deputy Assistant to the USAID Administrator,

(OAPA) (now Assistant to the USAID Administrator, OAPA); Kathleen (Kay) McGowan, Digital Finance Lead, Digital Development, US Global Development Lab, USAID, OAPA/Afghanistan and a Senior Policy Adviser to the USAID Administrator; and Amirzai Sangin, former Minister, Afghanistan Ministry of Communications and Information Technology (MCIT).

In addition to the early participants noted above, there were others who played important roles in support of the sustainment of the overall activities of the STA/Telecommunications (Telecom) Advisory Team (TAT) and include, but are not limited to, Teri M. Takai, Department of Defense, Chief Information Officer; Terry Halvorsen, Department of Defense, Chief Information Officer; Phillip (Phil) McDonald, Information Sharing Information Enterprise, Architecture and Engineering, DoD CIO; Vice Admiral (Retired) Nancy E. Brown, US Navy (USN), Director, Command, Control, Communications and Computer Systems, Joint Staff; Major General (MG) Michael Shields, USA, Director Pakistan Afghanistan Coordination Cell, J5, Joint Staff; BG Mark Bowman, USA, CENTCOM J6; James (Jim) Bullion, DoD TFBSO; David Scantling, DoD Business Transformation Agency (BTA) and TFBSO; Ambassador Daniel A. Sepulveda, Deputy Assistant Secretary of State and US Coordinator for International Communications and Information Policy, State Department Bureau of Economic and Business Affairs; Charles P. Siner, Deputy Director, Afghanistan Task Force, Department of Commerce (DoC); Daniel C. Hurley Jr. (deceased), Director of the Communications and Information Infrastructure Assurance Program at the National Telecommunications and Information Administration (NTIA), DoC; Joe Richardson, Cybersecurity Advisor, DoC; Dale Wiggins, Afghanistan Task Force, DoC; Joseph L. (Joe) Gattuso, Attorney-Advisor, International, Commercial Law Development Program (CLDP), Office of the General Counsel, DoC; Thomas Sullivan, Chief of Staff, International Bureau, Federal Communications Commission; Ambassador Michael R. Gardner, Chairman, US Telecommunications Training Institute (USTTI); James J. (Jim) O'Connor, Executive Director, USTTI; Dr. Christopher Zember, Director, CTNSP, NDU; Phil Stockdale, Deputy Director, CTNSP, NDU; Lou Elin Dwyer, Research Analyst, CTNSP, NDU; Sebastian Megens-Sedor, Intern, CTNSP, NDU; Dr. Charles (Chuck) Barry, Visiting Senior Research Fellow, CTNSP, NDU; Siddhartha Raja, ICT Policy Specialist (now Senior Specialist for Technology and Jobs), The World Bank Group; Rajendra Singh, Senior Regulatory Specialist, ICT Policy Division, The World Bank Group; Tenzin Norbhu, Lead ICT Policy Specialist, The World Bank Group; Ambassador Richard Olson, Coordinating Director for Development and Economic Affairs, US Embassy Kabul; Ben Yates, US Embassy Kabul, ECON; David Arnold, US Embassy Kabul, ECON; Domingo Villaronga, US Embassy Kabul, ECON; Michael Gunzburger, US Embassy Kabul, ECON; Dr. S. Ken Yamashita, Afghanistan Mission Director, USAID; Susan L. Coleman, Office of Economic Growth (OEG), USAID; Lane Smith, IT and Capacity Building in Higher Education Coordinator, USAID Mission Kabul; Greg Howell, Economic Growth and Governance Initiative (EGGI), USAID; Steven Rynecki, EGGI, USAID; Michelle Parker, Nangarhar Provincial Reconstruction Team (PRT) and COMISAF Development Advisor, USAID; Melissa Sinclair, PRT, USAID; Rick Carbone, USAID Advisor Forward Operating Base (FOB) Sharana; Jordan Sellman, Economic and Trade Advisor, USAID OAPA; MG Kevin Wendel, USA, Commander, Combined Security Transition Command- Afghanistan (CSTC-A); MG Harold J. Greene (deceased), USA, Deputy Commander, CSTC-A; General John R. Allen, US Marine Corps (USMC), Commander ISAF (2011-2013); General Joseph F. Dunford, Jr., USMC, Commander ISAF (2013-2014); General John F. Campbell, USA, Commander ISAF (2014); Ambassador Mark Sedwill, NATO Senior Civilian Representative to Afghanistan; David Gallalee, Deputy Senior Civilian Representative to COMISAF; MG Claudio Mora, Italian Army (ITA), Deputy Chief of



Staff (DCOS) Stability; MG (DEU) Richard Rossmanith, Bundeswehr, ISAF DCOS Stability; MG Frederico Bonato, ITA, DCOS Stability; MG H. R. McMaster, USA, Director CJATF-Shafafiyat; Rear Admiral David Smith, USN, ISAF CJMED; MG Michael J. Kingsley, USAF, ISAF Director, NATO Afghanistan Transformation Task Force and Non-Security Ministries-Ministerial Advisory Group (NSM-MAG); BG Joseph A. Brendler, USA, ISAF CJ6; BG William Scott, USA, ISAF CJ6; Colonel (Retired) Keith June, USA, ISAF and Resolute Support (RS), CJ6; Lieutenant Commander (LCDR) Doug Vanderlip, USN, Lead US Projects, RS CJ6; Dave Warner, MD, PhD, ARCH Synergist, MindTel; Fary Moini, Moini International Consulting, La Jolla Golden Triangle Rotary Club, San Diego/Jalalabad Sister Cities Foundation; Stephen R. Brown, Past Trustee, The Rotary Foundation, La Jolla Golden Triangle Rotary Club, Afghan Youth Connect Program, Jalalabad; Dwight R. Hunsicker, Senior Vice President (SVP) and General Manager, Government Solutions, Globecomm Systems Inc. (GSI); Paul J. Johnson, SVP Strategic Marketing and Corporate Business Development, GSI; Tom O'Neil, Director, Business Development, GSI; James P. (Jim) Craft, Former Senior Telecom Advisor, Afghanistan Reconstruction Group, US Embassy Kabul, now CIO, Joint Improvised-Threat Defeat Agency (JIDA); Farid Abass, IT/Telecom Specialist; Ken Zita, Network Dynamics Associates, LLC; Stephen (Steve) Herrmann, Principal, Deloitte Consulting LLP; Peter Butturini, former Strategic Relationship Manager, Deloitte Consulting LLP; Keith Sontheimer, Senior Manager, Deloitte Consulting LLP; Peter M. (Pete) Cuvillo, Director, Deloitte Consulting LLP (retired); Evin Planto, President and Chief Executive Officer (CEO), IZ Technologies, Inc. (IZT); Lynette Planto, Vice President Business Development, IZT; Dr. Walter Kaffenberger, NATO Programme Manager, Engagement Section, Public Diplomacy Division (retired); Joey V. Mendoza, former Mobile Money and Branchless Banking Leader, USAID/FAIDA; Jeff DePasquale, Gartner, Inc.; Catherine O'Leary, Gartner, Inc.; Amanda Campbell, GardaWorld; Stephen "Parkie" Parkinson, GardaWorld; and Paul Cupples, GardaWorld.

Many Afghan government, academia, and industry counterparts were key players and include, but are not limited to, Wahabuddin Sadaat, Deputy Minister Finance and Administration, MCIT; Engineer (Eng.) Baryalai Hassam, Deputy Minister Technical, MCIT; Aimal Marjan, Deputy Minister Information Technology, MCIT; Wais Payab, Director of Technology and Innovation, MCIT; Mujeeb Mohmand, Director of E-Government, MCIT; Zmarialai Wafa, Director Information Systems Security and PKI Management Authority, MCIT; Eng. Haji Gul Wahaj, Communication Advisor, MCIT; Eng. Abdul Wakil Shergul, Former Chairman, Afghanistan Telecom Regulatory Authority (ATRA); Khair Mohammad Faizi, Former Vice Chairman, ATRA; Abdul Malik Nazari, Board Member, ATRA; Dr. A. Naser Sazish, Board Member, ATRA; Gul Ahmad Rastman, CEO, Afghan Telecom Corporation (AfTel); Ajmal Ayan, VP Wireline, AfTel; Ahmad Saeed, Former Chief Operations Officer (COO) and VP Wireline, AfTel; Khaleeq Ahmad, VP Wireless, AfTel; Jabir Sarfaraz, Acting CIO and Executive Vice President, Wireless (Salaam) AfTel; Abdul Saboor Nasimzada, Chief Technology Officer (CTO) Wireline, AfTel; Mohammad Ismail Bhat, Head of the Project Management Office and Project Director of the World Bank-funded Afghanistan ICT Sector Development Project, MCIT; Mohaymen Sahebzadah, Asia Consultancy Group (ACG); Omar Mansoor Ansari, President, TechNation and founder and former President of the National ICT Association of Afghanistan (NICTAA); Mohammad Rahim Stanikzai, ICT Director, Ministry of Agriculture, Irrigation and Livestock; Dr. C. Michael Smith, President, American University of Afghanistan (AUAF); M. Salim Saay, former Director of Information Technology, Ministry of Higher Education (MoHE), and former Assistant Professor Computer Science (CS) Faculty, Kabul University; Mohammad Tariq Meeran, Assistant Professor, IT Manager CS Department, Kabul

University; Roya Mahboob, President, Afghan Citadel Software Company and CEO, Digital Citizen Fund; Amin Ramin, Managing Director, Afghan Wireless Communication Company (AWCC); Vishal Rattanpal, Director of Business Operations, AWCC; Karim Khoja, CEO, Roshan; Hassan Jaber, CEO, MTN Afghanistan; Roger Merheb, General Manager, Capital Projects, MTN Afghanistan; Dr. Ali Asgharzadeh, Chief Commercial Officer, Etisalat; Mohammad Gul Khulmi, CEO, Wasel Telecom; Fawad Ahmad Muslim, President and CEO, Jahaan Technology Corporation; Sami Hashimi, CEO, AfghanCyber and Past President, National ISP Association of Afghanistan (NISPA); Farshid Ghyasi, Founder and CEO, Netlinks; Nadeem Bhat, Melat Networks; Wais Qadir, Melat Networks; Abdul Ghafoor, Chairman, RANA Technologies; Wahidullah Dosti, RANA Technologies; Mina Ghazanfar, CeReTechs; Nasir Rahimi, CeReTechs; Shakir Stanekzai, NEDA Telecommunications; Paul Shaw, NEDA Telecommunications; Jamal N. Noorzaie, President and CEO, New Dunia Telecom and Past President, NISPA; Omar Popal, Afghan ICT Solution; Fraidoon Saifi, Netzone; and Dr. Mohammad Humayon Qayoumi, Chief Adviser to the President, Infrastructure, Human Capital, and Technology, Presidential Palace, Kabul, Afghanistan.

Thanks to our authors, contributors, and peer reviewers, official and unofficial, named and not.

Thanks to the Senior Telecom Advisors and TAT Directors for your leadership and to all TAT members, visitors, subject matter experts, and contractors. This is your story.

We apologize to anyone we have inadvertently neglected to include.

The editors and authors alone are responsible for any errors of fact, omission, or interpretation. This work is theirs alone and does not purport to represent the assessment, interpretation, or views of the Department of Defense, DoD CIO, Joint Staff, DISA, National Defense University, Department of State, USAID, Department of Commerce, or other US Government elements.

## Executive Summary

---

Larry Wentz and Karen E. Black

For nations emerging from conflict, information and communications technology (ICT) has become a “game changer” in post-conflict security, stability, reconstruction, and development operations. Its importance to mission success now competes with priorities for roads, power, and water as “critical infrastructure” and an “essential service.” However, the US government (USG) and international policy have yet to formally recognize the criticality of ICT and its role, nor have organizations changed their ways of doing business. Approaches for the use of ICT continue to be ad hoc and are generally not well coordinated across participating civil-military elements of the intervening force, international donor participants, the affected nation’s government, and commercial ICT sector counterparts. Additionally, the intervening and responder elements tend to view ICT as a capability that will be there when it is needed and that it is the responsibility of the affected nation and commercial companies to recover the sector in a timely fashion and provide needed services. In reality, however, this is not the case. Planning for early recovery of affected nation ICT sector governance, deployment of temporary infrastructure to help bridge essential communications gaps, and early emphasis on affected nation ICT infrastructure recovery and the provision of emergency communications services need to be part of the overall recovery and reconstruction process from the outset of the intervention and need the help of the interveners. The intervening civil-military elements can help enable early infrastructure recovery efforts by employing techniques such as anchor tenant. For example, the Defense Information Systems Agency (DISA) leased Afghan fiber optic connectivity to support deployed US military units’ command and control needs. Another example is the Swedish company Ericsson, which set up an emergency mobile GSM<sup>1</sup> base station in Kabul to support the United Nations (UN) World Food Programme and other humanitarian organizations as well as important government officials.

ICT is a critical component supporting the intervening civil-military elements’ complex communications, collaboration, and information-sharing needs. Despite advances made in ICT capabilities and information-sharing tools, civil-military coordination and information sharing in post-conflict operations continues to be a challenge – and it is culture and behavior, not a technology issue. ICT has also become a powerful enabler of the affected nation’s security, governance, reconstruction, and socio-economic development and growth. Therefore, ICT needs to be more effectively leveraged by the civil-military elements participating in the intervention both to support their mission needs and to facilitate the affected nation’s post-conflict cross-sector recovery and rehabilitation.

---

<sup>1</sup> Global system for mobile communications, a second generation of protocols for digital cellular networks originally developed by the European Telecommunications Standards Institute (ETSI). GSM is now a trademark owned by the GSM Association.

There are policy and doctrine challenges yet to be effectively addressed by the USG and the International Community regarding ICT in post-conflict environments. They include the role of commercial ICT and the use of civilian ICT professionals to help civil and commercial ICT actions across the civil-military responder elements. ICT experts can assist the affected nation to establish ICT sector governance (policies, regulations, laws) and provide decision makers an informed understanding of international ICT standards and best practices. Civilian ICT experts can engage ICT leadership in the affected nation government, such as the minister of communications, chairman of the ICT regulator, and management of state-owned ICT enterprises, as well as executives of the mobile network operators (MNOs) and Internet service providers (ISPs). Intervening forces and donors need an informed understanding of the affected nation's ICT landscape, including supply chains, business processes, who makes things happen in the ICT sector, and who are the spoilers. These types of activities are generally counter-cultural for the military: it is not something it trains to do, nor does it have adequate policy, doctrine, or tactics, techniques, and procedures (TTPs) to support. Hence the need for civilian professional ICT subject matter expertise to address the civil and commercial ICT sector challenges and opportunities and to facilitate collaboration, harmonization, and information sharing among participating civil-military elements in post-conflict recovery, reconstruction, and development activities.

There is an urgent need to establish new USG policy and doctrine regarding the importance of ICT as an enabler, to develop USG and international response strategies and plans that treat ICT as an essential service and critical infrastructure, and to agree upon and institute cooperative international organization ICT-related planning, implementation, and information-sharing arrangements among responder stakeholders. The civil-military interveners need to know how to work together before the interventions rather than learn during the intervention. Additionally, there is a need to institutionalize a USG approach for providing a "one-stop shop" for professional advice and assistance on civil and commercial ICT. This organization should be the USG voice for all ICT-related matters and have a principal person to deal with the leadership of the intervening forces and governments, and the affected nation. These ICT experts should be facilitators, connectors, and harmonizers, as well as the trusted source of informed situational awareness of ICT matters and efforts among and across USG Interagency and coalition forces, international organizations, and the affected nation.

Today, the amorphous nature of modern security threats – conflict and terrorism – has made it "increasingly difficult to define a uniquely 'military' role and mission."<sup>2</sup> The lines between war and peace have become blurred. Methods of conflict have changed and now include use of political, economic, informational, cyberspace, humanitarian, and other military and non-military measures. As USG budgets and the capacities of civilian agencies stagnated or declined in the 1990s, civilian elements no longer had the resources or capabilities to respond effectively to international crisis operations nor rapidly deploy needed civilian expertise and capabilities. As a result, the military became engaged more and more to

---

<sup>2</sup> Gilsinan, Kathy (2016). "We Have No Idea What War Is." *The Atlantic*, August 10. Accessed September 14, 2016. <http://www.theatlantic.com/international/archive/2016/08/rosa-brooks-war-military/494846/>.

step into the breach, expanding the military's role and sidelining civilian agency participation.<sup>3</sup> The military was not and is still not adequately trained to take on the roles of the civilian agencies in post-conflict recovery, reconstruction, and development actions.<sup>4</sup> Post-conflict operations are also a misnomer today because elements of the various forms of conflict (including, for example, pockets of insurgency and terrorist activities) remain for some time in a landscape churning with political, economic, and security competitions that require constant attention by the intervening and affected nation security forces.<sup>5</sup> In fact, the transition from conflict to peace and prosperity can take years — experience suggests decades — and this is stressing responder nations' political will and donors' willingness to commit for the long haul, especially with the pervasiveness of conflicts around the world today, which is stretching their abilities to respond. The threats now being experienced do not come neatly packaged as "military" versus "civilian" threats. To operate more effectively in the space in between war and peace, the USG will need to explore and implement additional means to bridge the civil-military divide, and integrate and employ improved whole-of-government approaches in future operations.

Modern warfare and related post-conflict operations are complex and almost always multilateral civil-military interventions requiring countries to cooperate as allies or coalition partners.<sup>6</sup> There are also the affected nation, inter-governmental organizations (IGOs), international organizations (IOs), and non-governmental organizations (NGOs) that need to be factored into the cooperation and information-sharing activities of an intervention. The military tends largely to operate in the classified information domain for security reasons, while the IOs, NGOs, aid agencies, and affected nation tend to operate in the unclassified domain for the sake of impartiality, neutrality, and transparency in their dealing with the civil government and local population. Additionally, intervening coalition military elements are accustomed to deploying secure tactical access to their own interoperable global secure communications network designed to facilitate information sharing among themselves, so it is easy for them to overlook the reality that sharing data and information with civilian partners, who generally rely on commercially-available non-secure connectivity and services, may not be as easy. The need for the US military to share information with non-military elements has been recognized by the US Department of Defense (DoD). Relatively recent (2009) DoD instructions, such as DODI 3000.05 (Stability Operations) and DODI 8220.02 (ICT Support for Stability Operations) address policies and systems to facilitate information sharing between the DoD and non-DoD partners and include arrangements for both classified and unclassified information sharing. The USG tends to rely on controlled-access websites or gateways on the open Internet for unclassified information sharing, which introduces access challenges for non-USG participants.

---

<sup>3</sup> Ibid.

<sup>4</sup> Ibid.

<sup>5</sup> Hoffman, Dr. Frank (2016). "The Contemporary Spectrum of Conflict: Protracted, Gray Zone, Ambiguous, and Hybrid Modes of War." *2016 Index of U.S. Military Strength*. The Heritage Foundation. Accessed September 14, 2016. <http://index.heritage.org/military/2016/essays/contemporary-spectrum-of-conflict/>.

<sup>6</sup> Auerswald, David P. and Stephen M. Saideman (2014). *NATO in Afghanistan: Fighting Together, Fighting Alone*. (Princeton: Princeton University Press).

Despite ongoing efforts to improve, multinational (alliance or coalition) and civil-military information sharing continues to be a challenge. Much of the information the military possesses is classified, and the rationale for many of its decisions requires access to classified material. However, the military has a tendency to use classified networks to share unclassified information in an operational environment. Storing unclassified information on classified networks adds to the challenges of civil-military unclassified information sharing. It is difficult and slow to move unclassified information from classified networks or rapidly declassify classified information as authorized so it can be shared with non-DoD, international, and civilian organizations. The delays hinder effective engagement by many military senior leaders and action officers with non-military participants.<sup>7</sup>

During the Afghanistan operation, a number of ad hoc solutions emerged to address civil-military unclassified information-sharing needs. They were generally portals hosted on the open Internet-with access controls. One example is the Humanitarian Assistance Response Monitoring and Operations Network-Internet Enterprise (HARMONIEWeb), a joint venture between the Assistant Secretary of Defense for Networks and Information Integration (ASD-NII, now DoD Chief Information Officer (CIO)) and US Joint Forces Command (USJFCOM, which was dissolved in August 2011) to provide a collaborative toolset for the exchange of unclassified information across the civil-military boundary. Another was the International Distributed Unified Reporting Environment (INDURE), which was scoped and funded by the US Central Command (USCENTCOM) and the Under Secretary of Defense for Intelligence (USD-I). The goal of INDURE was to create a data repository and reporting tools “to provide a standardized way for Non-Governmental Organizations (NGOs), United States Agency for International Development (USAID) and US Department of State (DoS) Provincial Reconstruction Teams (PRTs) to report information on observations and analysis outside of DoD networks, as well as provide releasable DoD information back to those organizations for force protection and planning purposes.”<sup>8</sup> Yet a third solution was DISA’s All Partners Access Network (APAN), a “collection of communities developed to foster information and knowledge sharing [for those] ... who don’t have access to traditionally restricted DOD networks.”<sup>9</sup> Additionally, the North Atlantic Treaty Organization’s International Security Assistance Force (ISAF) Joint Command created Ronna, which means “guiding light” in Dari, an unclassified information sharing website to improve “access [by] and communication with the various organizations and communities in Theater.”<sup>10</sup> Ronna was an online community of interest hosted by APAN.

---

<sup>7</sup> McArthur, James C., William D. Betts, Nelson R. Bregón, Faith M. Chamberlain, George E. Katsos, Mark C. Kelly, E. Craig Levy, Matthew L. Lim, Kimberly K. Mickus, and Paul N. Stockton (2015). “Interorganizational Cooperation Part I of III: The Interagency Perspective.” *Joint Forces Quarterly*, Issue 79, 4<sup>th</sup> Quarter 2015.

<sup>8</sup> Air Force Research Laboratory, Rome Research Site (2010). “International Distributed Unified Reporting Environment (INDURE) Concept of Operations,” V1.1 Internet Draft, 5-6. Accessed September 24, 2016. <http://info.publicintelligence.net/INDUREconops.pdf>.

<sup>9</sup> Defense Information Systems Agency. APAN. Accessed September 14, 2016. <https://www.apan.org/>.

<sup>10</sup> Ronna Overview Brief, updated August 2013. Accessed September 14, 2016. <http://slideplayer.com/slide/715515/>.

In coalition civil-military operations, participants continue to view information as power, and this can influence their willingness to openly share it. In some cases, national policy differences regarding openly sharing information can impact the ability to freely collaborate. DoD instruction changes noted earlier encouraged more open information sharing and created an environment of asking the question, “What can I share?” but trends in using over-classification as a means to restrict information sharing have generated a relook at this issue and suggest that the wrong question is being asked. The question should be: “What can’t I share and why?”<sup>11</sup> There are also sensitivities related to using “.mil” and “.gov” email addresses to exchange information with non-US government organizations. There are organizational, personnel, and cultural differences as well. Multiple languages also add complications. These differences in the way information is viewed, protected, handled, understood, and shared introduce additional challenges in terms of management of the knowledge network supporting an operation and related civil-military collaboration, cooperation, and information sharing.

In October 2011, the Chairman of the Joint Chiefs of Staff issued a task order to capture experiences gained from over the last decade of war (DOW).<sup>12</sup> Four of the DOW themes that emerged were particularly relevant to reinforce the importance of incorporating civilian concerns into military objectives and processes: interagency coordination, understanding the environment, transitions, and adaption. From these findings, it was observed that:

1. Interagency coordination emphasized the difficulty with synchronizing and integrating civilian and military efforts at the national level, particularly during the Interagency planning cycle.
2. Understanding the environment implied assessment of the enemy threat as well as aspects of both the civilian population and friendly forces.
3. Transitions spoke to the importance of looking beyond near-term military goals to account for the factors that will contribute to the enduring success of overarching political objectives.
4. Adaption recognized the fact that regardless of the operational foundation provided by joint doctrine, the realities and conditions on the ground combined with a “thinking enemy” will require adaption.<sup>13</sup>

Real-world multination and civil-military crisis response operations such as those in the Balkans, Iraq, Haiti, and Afghanistan suggest some persistent threads in the challenges experienced and the lessons observed. For example, at the national level, as well as the operational and tactical levels, there continues to be a lack of a shared understanding of the civil-military participants: national governments and their

---

<sup>11</sup> Pomerleau, Mark (2016). “Info-sharing hurdles hinder alliance partnerships.” C4ISRNET, August 7.

<sup>12</sup> Joint and Coalition Operational Analysis (JCOA) Division, Joint Staff (2012). *Decade of War, Volume 1: Enduring Lessons from the Past Decade of Operations*, June 15.

<sup>13</sup> McArthur, James C., Cara Allison Marshall, Dale Erickson, E. Paul Flowers, Michael E. Franco, George H. Hock, George E. Katsos, Luther L. King, William E. Kirby, William M. Mantiplay, Michael E. McWilliams, A. Christopher Munn, Jeffrey K. Padilla, Elmer L. Roman, Raymond E. Vanzwienen, and Jeffrey P. Wissel (2016).

“Interorganizational Cooperation III of III: The Joint Force Perspective.” *Joint Forces Quarterly*, Issue 81, 2<sup>nd</sup> Quarter 2016.

militaries; IGOs, e.g., NATO and the European Union; international organizations (IOs), e.g., the UN, the International Telecommunication Union, and the World Bank; NGOs; and affected nations and their roles, responsibilities, authorities, capabilities, interests, limitations, agendas, and expectations. Participating organizations and people are culture driven. The US government's and the International Community's ICT crisis response actions, including civil-military information-sharing arrangements, remain ad hoc, - and reactive. Further, there is no agreed-upon ICT vision, strategy, or plan for addressing the affected nation's ICT sector governance ICT infrastructure. Nor are there any frameworks for focusing intervention elements' ICT resource allocations (people and money). There is no lead agency, within the USG or internationally, for ICT activities related to post-conflict stability and reconstruction operations, and there is a lack of professional senior civil and commercial ICT thought leadership and strategic thinking to support intervention leadership decision making. Finally, there is no agreed-upon civil-military strategy, plan, or institutionalized ICT-enabled intervention construct within the USG or International Community that addresses the ability to offer informed and professional ICT advice, assistance, and investment guidance related to intervention decision making for full-spectrum ICT support to humanitarian assistance/disaster relief and security, stability and reconstruction operations.<sup>14</sup> In spite of the civil-military community attempts to absorb the lessons, history suggests many will be observed again in the next engagement. The US Army Center for Lessons Learned some years ago made the observation that lessons are learned when behavior changes.

In 2010, ISAF and Coalition military elements were heavily engaged in combat operations, counterinsurgency (COIN), and stability operations activities. In fact, the time period from 2010 to 2012 arguably saw the zenith of COIN and stability operations in Afghanistan. These operations were comprehensive, full spectrum COIN, and certainly had a kinetic or lethal side, but they also had a nonlethal or soft power side, which included COIN development. The NATO/ISAF COIN Campaign Plan sought to address the root causes of the insurgency (e.g., insecurity and political and economic marginalization) through a combination of soft power options such as governance and socio-economic development initiatives and projects, which helped provide basic social services to the Afghan people and thereby add legitimacy to GIROA.<sup>15</sup>

At the 2010 Wilton Park Conference 1022 on winning hearts and minds in Afghanistan, it was noted that although development aid is becoming an increasingly important tool to "win hearts and minds" and promote stability in COIN operations, there is still a surprisingly weak evidence base for the effectiveness of aid in promoting stabilization and security objectives.<sup>16</sup> Some key points that emerged from the conference and were highlighted in its resultant report include:

---

<sup>14</sup> Wentz, Larry (2011). "ICT Support to Crisis Operations." Brief to Center for Technology and National Security Policy, National Defense University. Available at: <http://slideplayer.com/slide/7975298/>.

<sup>15</sup> Barham, Charles (2016). "Stability Operations: Lessons from Afghanistan." *Small Wars Journal*, February 11.

<sup>16</sup> Wilton Park Conference (2010). *Winning 'Hearts and Minds' in Afghanistan: Assessing the Effectiveness of Development Aid in COIN (Counter Insurgency) Operations (WP1022)*. Accessed April 14, 2016. <https://www.wiltonpark.org.uk/wp-content/uploads/wp1022-report.pdf>.



- Current stabilization strategies are based on entrenched and often questionable assumptions. Research findings presented at the conference questioned many of the assumptions underpinning COIN stabilization strategies, including that key drivers of insecurity are poverty, unemployment and/or radical Islam; economic development and modernization are stabilizing; aid projects win hearts and minds and help legitimize the government; extending the reach of the central government leads to stabilization, and development projects are an effective means to extend this reach; and the International Community and the Afghan government have shared objectives when it comes to promoting development, good governance and the rule of law.
- The implementation of COIN doctrine has not adequately addressed political issues. The research findings from Afghanistan highlight that many of the fundamental conflict drivers are inherently political in nature, such as ethnic grievances and inter- and intra-tribal disputes. Indeed, many Afghans believe the main cause of insecurity to be their government, which is perceived to be massively corrupt, predatory, and unjust. A COIN strategy premised on using aid to win the population over to such a negatively perceived government faces an uphill struggle, especially in a competitive environment where the Taliban are perceived by many to be more effective in addressing the people's highest priority needs of security and access to justice. Without "getting the politics right," both military and aid efforts are unlikely to achieve their desired effects.
- Effectively designed and delivered development aid does seem to have some stabilization benefits at a tactical level, but not at a strategic level. Researchers and practitioners described ways in which aid had been used effectively to legitimize interactions between international forces and local communities (i.e., to get a foot in the door), which had proven useful in terms of developing relationships, and gathering atmospheric and intelligence. But these were relatively short-term transactional relationships, and there was little evidence of more strategic level effects of populations being won over to the government as a result of development aid. While there is ample evidence of development programs having clear development benefits, for example the National Solidarity Program (NSP) and the Basic Package of Health Services, there was little evidence of even successful development outcomes having major stabilization benefits. Several critical questions remain. These include: whether aid in itself is unable to stabilize, or whether the current modalities for delivering aid to promote stabilization are inappropriate; and, while development aid may not be effective at addressing the main causes of insurgency in the most insecure regions, whether aid could be effective at helping to consolidate stability in more secure areas.
- Less is often more – too much aid can be destabilizing. There was considerable consensus that Afghanistan cannot effectively absorb the large increases in aid spending earmarked for the insecure regions of the country. Too much aid money spent quickly with little oversight can be delegitimizing and destabilizing in many ways, including by: fueling corruption; creating destabilizing winner-loser dynamics in ethnically and tribally divided societies; supporting a

lucrative war/aid economy that benefits insurgents, corrupt government officials and other malign actors; and creating perverse incentives among key actors to maintain the status quo of insecurity and bad governance. Having to spend large sums of aid money quickly also reduces the opportunities for prioritizing the critically important processes of effective development, and instead focuses attention primarily on generating products. Historical evidence also suggests that the Afghan state's rentier economy has politically destabilizing consequences, as it reduces the government's need to derive legitimacy from, or be accountable to, the citizens of Afghanistan.

- Aid seems to be losing rather than winning hearts and minds in Afghanistan. At a time when more aid money is being spent in Afghanistan than ever before, popular perceptions of aid are overwhelmingly negative. Despite the considerable work that has been done, including the expansion of basic social services, major investments in roads and other infrastructure, and a communications revolution, negative perceptions persist that little has been done, that the wrong things have been done, that what was done is poor quality, that the benefits of aid are spread inequitably, and that much money is lost through corruption and waste. Research findings suggest policymakers should be cautious in assuming that aid projects help create positive perceptions of the deliverers of aid, or that they help legitimize the government.
- Strengthening provincial and district governance systems and fostering effective and transparent Afghan leadership which connects to Kabul are key. Local governance is not a replacement for Kabul's leadership, but constitutes a key component in a social contract between the center and periphery. In practice this means encouraging a more responsive and transparent state, promoting more merit-based appointment mechanisms, building social capacity along the lines of NSP, and addressing abuses of power that look inequitable to the population. Fostering quality Afghan leadership is also critical to a sustainable exit strategy.<sup>17</sup>

At the conference, there was broad recognition of the urgency to appraise the International Community's efforts to implement aid as a tool of COIN in Afghanistan. With the US aid budget in Afghanistan in 2010 set to double in the coming year, growing impatience of taxpayers from troop-contributing countries, the looming "Obama deadline" to cease combat operations and withdraw troops, and general donor fatigue regarding Afghanistan, time was short to produce results that were commensurate with the billions of dollars in assistance that had been and would be channeled to the country. There was also a sense that the International Community was "muddling through" COIN operations, without clearly achieving synergy among the three tracks of security, governance, and development. In research carried out by Tufts University in the most insecure Afghan provinces under investigation, perceptions of aid were universally negative.<sup>18</sup> In response to the negative perception of the development agenda, participants questioned

---

<sup>17</sup> Ibid.

<sup>18</sup> Ibid.

whether the issue was with aid in itself failing to stabilize, or with the current modalities for delivering aid-for-stabilization being misguided. The “deliverers” of aid could be the problem, for in some of the most insecure parts of the country, the delivery mode shifted away from traditional development workers to private contractors and the military, whose core business was not long-term community engagement.<sup>19</sup>

Based on some three years of NATO/ISAF stability operations and COIN experience, there were a few lessons that emerged.

1. Military and political leaders need to commit at the outset to finishing the job, which requires a long-term effort.
2. Stability operations needed to be both a NATO/ISAF and Afghan effort with a transition to the Afghans for the longer term. Afghans did not have a mechanism to support a stability operations organization so the International Community had to fill the longer-term development gap.
3. We should not try to force too much change too fast — the [Afghanistan National Development Strategy](#) outlined the Afghan government’s strategies for security, governance, economic growth, and poverty reduction.<sup>20</sup>

Some of the key drivers of stability that relate to aid can be summarized as ensuring quality of assistance in aid projects; avoiding cultural faux pas; delivering on promises; attending to any harmful influences on the political economy that might provide people with incentives to sustain the conflict; demonstrating the commitment of donors/practitioners over the long-term; genuine consultation, which requires a proper appreciation for local context and culture; transparency and integrity, which requires a demonstration that corruption (abuses of power; waste of resources) is taken seriously; and reducing risk and providing some kind of assurance that people will become more secure due to the international and Government presence over the long-term.<sup>21</sup>

Regardless of improvements to the coordination of the International Community’s efforts, the participation of Afghan people themselves remains the key deciding factor in improving aid’s impact on stabilization. A better understanding of the continuing barriers to Afghan participation, therefore, represents a critically important way forward. The major challenges remain political, which will only be solved with political solutions. Time frames set by politicians will continue to impact aid effectiveness. Operationally, practitioners will have to prioritize how to balance the need for short-term stability gains with longer-term stabilization and development objectives.<sup>22</sup>

---

<sup>19</sup> Ibid.

<sup>20</sup> Barham, 2016.

<sup>21</sup> *WP1022 Report*, 2010.

<sup>22</sup> Ibid.

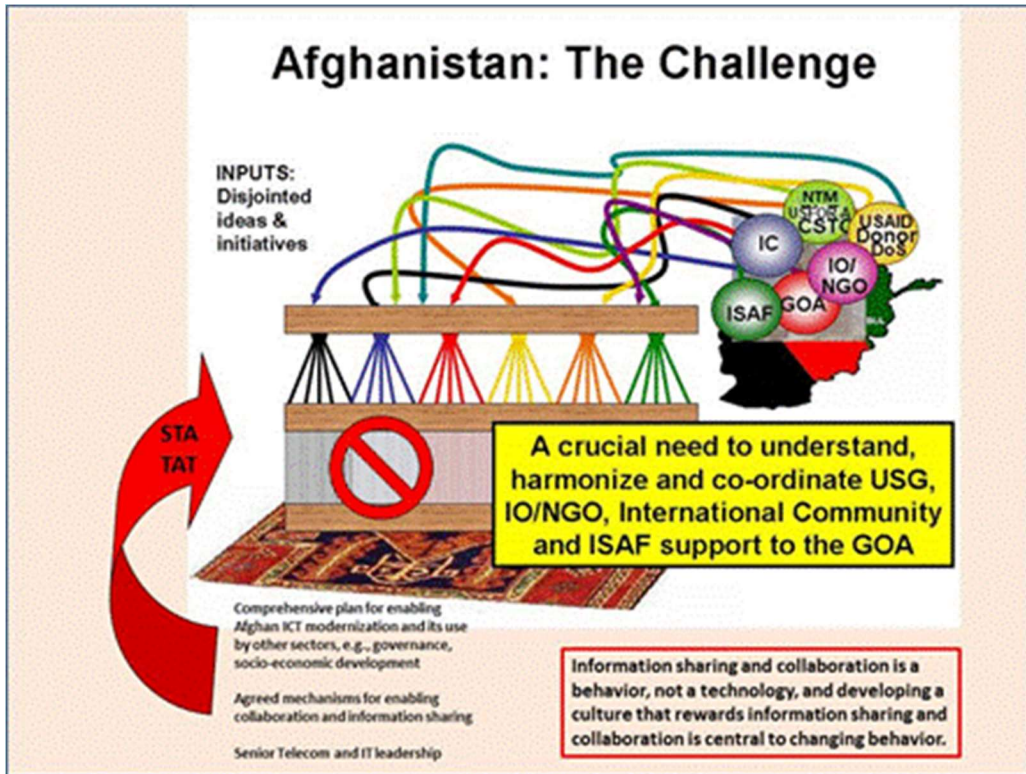

Figure 1: Afghanistan collaboration and information sharing challenges

As noted in earlier discussions on multilateral civil-military collaboration and information-sharing challenges and the 2010 Wilton Park Conference 1022 findings and observations, the Afghanistan experience has made it clear that multilateral civil-military operations and cooperation among Coalition forces and nations, donors, IGOs, IOs, NGOs, and the Government of the Islamic Republic of Afghanistan (GIROA) are neither straightforward nor guaranteed, as illustrated in [Figure 1](#). Adding to these challenges, all the aforementioned groups differ significantly in what they are willing to do and how and where they are willing to do it. On the military side of the operation, some countries refuse to participate in dangerous or offensive missions, others change tactical objectives with each new commander, and some countries defer to their commanders while others hold them to strict accountability for their actions.<sup>23</sup> Countries, IGOs, IOs, and NGOs planning to engage in interventions must enter multinational, multicultural, collaborative arrangements with their eyes wide open.<sup>24</sup> They need to be able to look at opportunities and expectations for improving quality of life through the eyes of those they are trying to help and not shape the options and priorities based solely on their own beliefs, priorities, and life styles. Furthermore, the use of whole-of-government or comprehensive or integrated approaches to achieve unity of civil-military efforts are hard to plan, coordinate, and execute across a complex mix of participating

<sup>23</sup> Auerswald and Saideman, 2014.

<sup>24</sup> Ibid.

international civil-military elements that are likely to have differing skills and operational capabilities, lack of a shared vision, hidden agendas, and resistance to collaboration and open sharing of information.

There is a lack of agreed-upon processes to facilitate and protect the free flow of information whenever and wherever it is needed. One needs to be constantly reminded that information sharing and collaboration is a *behavior*, not a technology. Developing a culture that rewards information sharing and collaboration is central to changing behavior and improving the information-sharing environment.

From a policy perspective, USG and NATO lessons from Afghanistan, as well as from other interventions such as Iraq and the Balkans, suggest that caveats and other “inconvenient” mechanisms of national control of participating military and civilian government contingents are not going to go away and will be inherent in multilateral civil-military efforts for some time to come.<sup>25</sup> Red cards, caveats, phone calls home for behind the scenes national guidance, frequent changes in leadership, restrictive rules of engagement, different operating procedures and strategies, and differing incentives and reward systems add friction to the overall effort, reducing effectiveness and making it harder for an alliance or Coalition to achieve its objectives.<sup>26</sup> Additionally, people and organizational cultural and behavior differences, restrictive military policies on information sharing with non-military elements, differing civil-military expectations, and strained civil-military trust relationships add to the complexity and lack of effectiveness of execution, cooperation, and information sharing in complex operations.<sup>27</sup>

Real-world experiences suggest information (i.e., content) and ICT can help increase the likelihood of success in security, stability, and reconstruction operations if they are engaged as part of an overall strategy that coordinates the actions of outside interveners and focused on generating effective results for the affected nation.<sup>28</sup> As noted earlier, the intervening civil-military elements need to be able and willing to view and shape actions, expectations, and outcomes through the eyes and priorities of those they are trying to help. Properly utilized information and ICT can help create a knowledgeable civil-military intervention, organize complex activities, and integrate stability and reconstruction operations with the affected nation, making stability and reconstruction operations more effective.

---

<sup>25</sup> Ibid.

<sup>26</sup> Ibid.

<sup>27</sup> Wentz, 2011.

<sup>28</sup> Kramer, Franklin D., Larry Wentz, and Stuart Starr (2007). “I-Power: The Information Revolution and Stability Operations.” *Defense Horizons*, Number 55, February 2007. Center for Technology and National Security Policy, National Defense University. Available at: <http://handle.dtic.mil/100.2/ADA466767>.

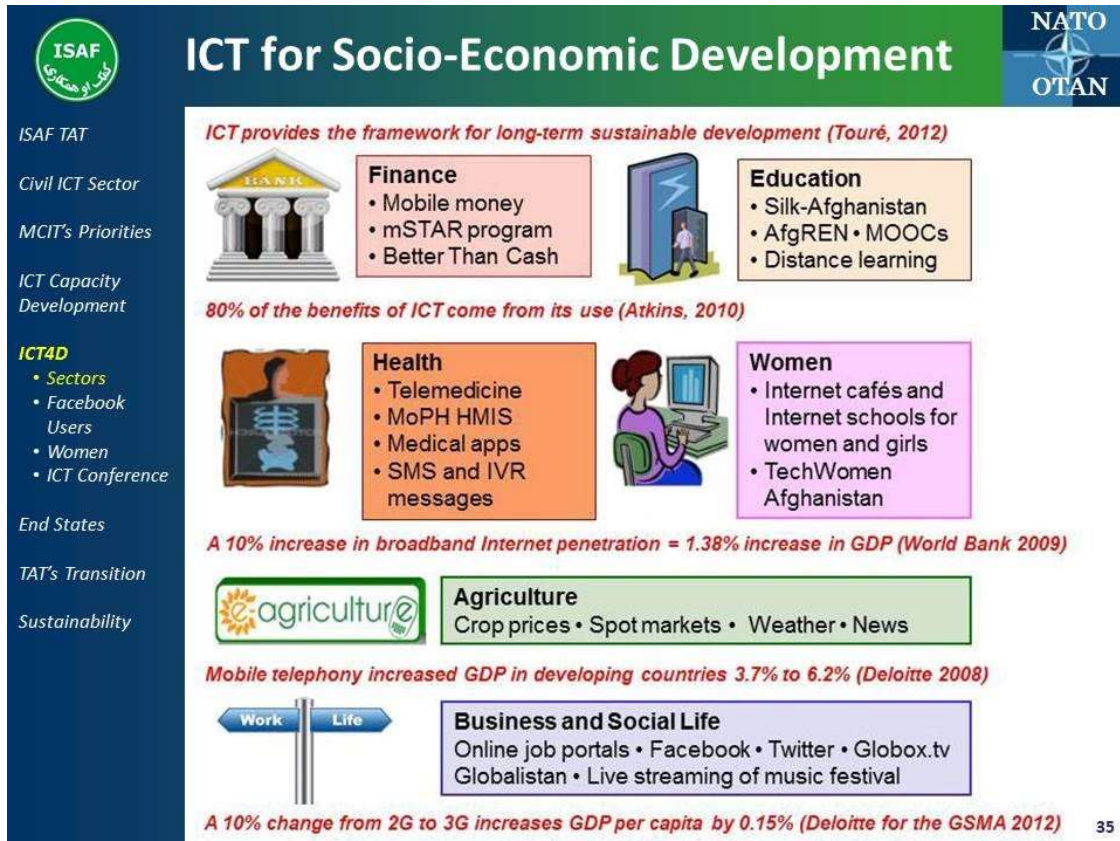

Figure 2: ICT for socio-economic development

The use of capabilities emerging from the information technology revolution has demonstrated the importance of ICT as an enabler of not only security and stability operations, but also of legitimate governance and cross-sector reconstruction operations.<sup>29</sup> Figure 2 illustrates several examples of ICT for cross-sector socio-economic development and growth and related benefits. However, in spite of examples of the successful smart use of ICT demonstrating its role and value as an essential service and critical infrastructure, it has yet to be recognized, treated, and formally agreed upon as such by the intervening USG and international civil-military community involved in post-conflict security, stability, and reconstruction operations. ICT sector recovery typically does not receive the needed coordinated focus of priority investments and allocation of resources.

In today's Information Age, the technological tools — the Internet, mobile phones, social media, and other instruments to collect, store, analyze, and share information digitally — have spread quickly. The digital dividends — the broader development benefits from using these technologies — have, however, lagged behind.<sup>30</sup> A World Bank report on digital dividends suggests that although digital technologies have

<sup>29</sup> Ibid.

<sup>30</sup> World Bank (2016). *World Development Report 2016: Digital Dividends*. World Bank, Washington, DC: World Bank. doi:10.1596/978-1-4648-0671-1. License: Creative Commons Attribution CC BY 3.0 IGO. Accessed September

boosted growth, expanded opportunities, and improved service delivery, their aggregate impact has fallen short and is unevenly distributed. Additionally, the report notes that for digital technologies to benefit everyone everywhere requires closing the remaining digital divide, especially in Internet access.<sup>31</sup>

The Internet remains unavailable, inaccessible, and unaffordable to a majority of the world's population,<sup>32</sup> and Afghanistan is an example of the digital divide between developed and developing countries. By the middle of 2013, reportedly 36 percent of Afghans lived in areas with Internet access,<sup>33</sup> and that figure continues to increase with the proliferation of 3G<sup>34</sup> mobile broadband service. However, terrestrial Internet access and 3G service are predominantly in major population centers, creating a digital divide between urban and rural areas within the country. Also in 2013, Afghanistan was showing a positive trend in the use of online social networking sites such as Facebook. At that time, the number of Facebook users in Afghanistan was growing faster than in most of the other countries in its region — 15 percent over a six-month period versus 3 percent to 6 percent.<sup>35</sup> The ratio of male to female users in most of the countries was around 70 percent to 30 percent,<sup>36</sup> but in Afghanistan only 16 percent of Facebook users were female, an example of Afghanistan's digital gender divide.

Closing the digital divide is a priority for the US government.<sup>37</sup> The Global Connect Initiative (GCI), a new US Department of State (DoS) initiative launched in 2015 has the goal of bringing 1.5 billion new Internet users online by 2020<sup>38</sup> by stimulating the expansion of ICT infrastructure, both in the US and in other countries, to deliver access to the Internet in as many remote locations ("connectivity deserts" in GCI speak) as possible around the world.<sup>39</sup> But greater digital adoption will not be enough. To get the most out of the digital revolution, countries also need to work on the "analog complements" by strengthening regulations that ensure competition among businesses, by adapting workers' skills to the demands of the new economy, and by ensuring that institutions are accountable.<sup>40</sup>

On April 13, 2016, the Institute of Electrical and Electronics Engineers (IEEE) and the World Bank convened 160 of the top connectivity network engineers, regulatory experts, and representatives from government

---

14, 2016. <http://documents.worldbank.org/curated/en/896971468194972881/pdf/102725-PUB-Replacement-PUBLIC.pdf>.

<sup>31</sup> Ibid.

<sup>32</sup> Ibid.

<sup>33</sup> According to the Islamic Republic of Afghanistan Ministry of Communications and Information Technology (MCIT).

<sup>34</sup> Third-generation wireless digital technology based on International Telecommunication Union (ITU) International Mobile Telecommunications (IMT)-2000 specifications.

<sup>35</sup> From Social Bakers, [www.socialbakers.com](http://www.socialbakers.com), as of February 2013.

<sup>36</sup> Ibid.

<sup>37</sup> Global Connect Initiative Interagency Fact Sheet. Accessed September 14, 2106. <https://share.america.gov/wp-content/uploads/2016/04/4.-GCI-Interagency-Factsheet-FINAL.pdf>.

<sup>38</sup> Ibid.

<sup>39</sup> Global Connect Initiative meeting, April 14, 2016, co-hosted by the World Bank and the US Department of State. Accessed September 14, 2016. <https://share.america.gov/globalconnect/>.

<sup>40</sup> World Bank (2016). World Development Report 2016: Digital Dividends.

to develop a plan of action for how to meet the GCI's ambitious goals (e.g., Internet connectivity should be an integral part of all national development strategies and should be made more available, accessible, and affordable around the world, as that helps achieve the United Nation's (UN's) 2030 [Sustainable Development Goals](#)<sup>41</sup>). Experts made available fiber maps, current projects, and potential projects to create situational awareness. They helped create a roadmap that includes detailed, region-specific action plans, including: (1) recommendations for which areas and populations to focus initial efforts on, (2) technical solutions in every region, (3) getting past regulatory and tax barriers, and (4) successful integration of connectivity into multilateral development bank (MDB)<sup>42</sup> and country development plans.<sup>43</sup>

On April 14, 2016, the World Bank and US Department of State co-hosted a high-level event to support the Global Connect Initiative. They were joined by Finance Ministers from all continents, along with technology CEOs, NGO presidents, and heads of the major MDBs.<sup>44</sup> US Secretary of State John Kerry's remarks noted that the GCI initiative has three interrelated goals:<sup>45</sup>

1. To encourage finance ministers to make Internet access central to all development and growth initiatives;
2. To work in cooperation with multilateral development institutions in order to double public and private lending for connectivity and digital technologies; and
3. To harness the knowledge, skills, and resources of the tech community itself to implement solutions for high-speed, affordable broadband access.

In follow-on discussions after the meeting among the White House, the DoS, the Department of Defense Chief Information Officer (DoD CIO), and Afghan government representatives, the participants expressed hope that a timely implementation of Afghanistan's strategy and plans to expand its Internet coverage and penetration could serve to present a showcase example of what could be done in other developing countries that are not further burdened with being a conflict zone. The thought was if Afghanistan can do it with all its problems, then less challenged developing countries should also be able to improve Internet penetration.<sup>46</sup>

All too often, ICT is viewed as a commodity in post-conflict reconstruction, and its recovery is seen as the responsibility of the affected nation and private sector. There are expectations that ICT will be there for

---

<sup>41</sup> Global Connect Principles. Accessed September 14, 2106. <https://share.america.gov/wp-content/uploads/2016/04/1.-GCI-Connectivity-Principles-FINAL.pdf>.

<sup>42</sup> The best-known multilateral development bank is the Word Bank, which extends loans and credits to a plethora of countries. Other popular MDBs include the African Development Bank and the Asian Development Bank.

<sup>43</sup> IEEE Internet Initiative (2016). "Global Connect Stakeholders: Advancing Solutions." April 13. Accessed September 14, 2016. <http://internetinitiative.ieee.org/events/conferences/global-connect-stakeholders-advancing-solutions>.

<sup>44</sup> Global Connect Initiative. Accessed September 14, 2016. <https://share.america.gov/globalconnect/>.

<sup>45</sup> Kerry, John (2016). "Remarks at the Global Connect Initiative Event." Washington, DC, April 14. Accessed September 14, 2016. <http://www.state.gov/secretary/remarks/2016/04/255824.htm>.

<sup>46</sup> Global Connect Initiative meeting, April 14, 2016, as told to co-author Larry Wentz by Robert Kinn, who represented DoD CIO at the meeting.



use by the intervening elements when needed. In reality, ICT most likely will not be available in an operational state capable of meeting early demands of the intervening force. Additionally, the intervening force will not likely have a full complement of ICT expertise and contacts to effectively engage their civil and commercial (private) ICT sector counterparts. In regard to the latter point, there will also be a lack of professional civil and commercial ICT subject matter expertise engaged as senior telecommunications (telecom) or ICT advisors to the intervening civil-military leadership and affected nation. Use of such expertise is necessary to facilitate more informed decision making related to issue resolutions and the allocation of resources to ICT sector governance and infrastructure recovery and reconstruction, not to mention its use as an enabler and accelerator of progress by and in other sectors, such as civil security, governance, rule of law, finance, agriculture, health, education, and gender equality. Coordinated use by civil-military interveners of senior telecom/ICT advisors to work with the affected nation government and the private ICT sector will also be lacking, as will professional civil and commercial ICT thought leadership and strategic thinking to supporting the overall intervention strategy, planning, and implementation efforts related to the ICT sector and its uses to support security, stability, and reconstruction.

Successful approaches to leveraging the role and use of ICT in post-conflict reconstruction need to be rooted in a thorough understanding of the affected nation's national political, legal, economic, social, cultural, and communications contexts.<sup>47</sup> It is important to understand the information and communications culture and the ICT-related business culture, along with ICT processes used by the affected nation government and private sector entities.

The ICT environments of post-conflict countries will also differ markedly. There is no single prescription for ICT-enabled stabilization or the role of ICT in reconstruction that can be applied across the board. Post-conflict societies, nevertheless, share certain common characteristics that are relevant to information and ICT-enabled intervention. Social cohesion will have been disrupted by violence, leaving legacies of hostility, suspicion, and insecurity, which will need to be overcome to avoid reversion to violence. (There is a 44 percent chance that within five years violent conflict will return to a country emerging from civil war.<sup>48</sup>) Economic production and trade will also have been disrupted, resulting in underemployment, underinvestment, and underperformance. Substantial numbers of people will have likely gone into exile, taking skills and capital with them, but also offering the potential that those skills and capital may return.<sup>49</sup> Although there will also be a public lack of trust of the emerging affected nation government, there will be population expectations for improvements in security and government services enabled by the intervening civil-military elements, which is the so-called "golden hour" to make a visible difference before the public mindset shifts from viewing interveners as liberators to occupiers (see [Figure 3](#), ICT-enabled

---

<sup>47</sup> Kelly, Tim and David Souter (2014). *The Role of Information and Communication Technologies in Postconflict Reconstruction*. World Bank Studies. Washington, DC: World Bank. doi:10.1596/978-1-4648-0074-0. License: Creative Commons Attribution CC BY 3.0. Accessed September 7, 2015. <https://issuu.com/world.bank.publications/docs/9781464800740?e=0/6688927>.

<sup>48</sup> Collier, Paul et al. (2003). *Breaking the Conflict Trap: Civil War and Development Policy*. (Washington, DC: The World Bank and Oxford University Press, 2003).

<sup>49</sup> Ibid.

intervention timeline). In fact, improved physical security appears to be the first need to be addressed before the citizenry can find value in higher order needs such as education and economic development.<sup>50</sup> Expectations for improvements in quality of life, security, governance, and socio-economic development and growth will need to be carefully managed — both those of the intervening elements and the affected nation government and population.

## ICT-enabled Intervention Spectrum

### Treat ICT as an Essential Service and Critical Infrastructure

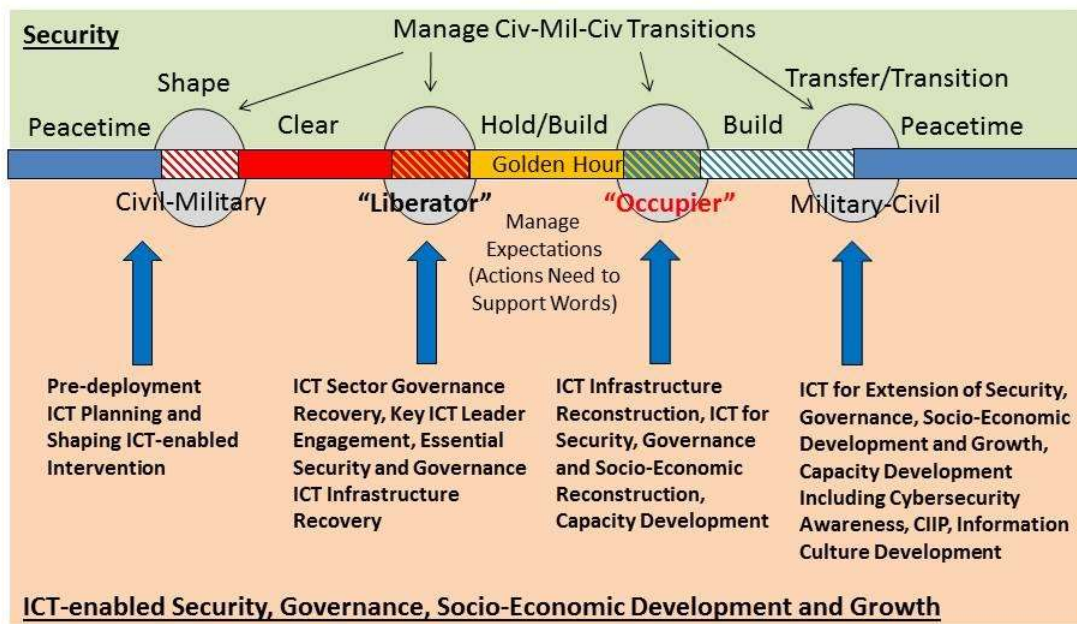

Figure 3: ICT-enabled intervention timeline

There will be a need for public awareness information campaigns to advertise the successes to both the affected nation and the participating nations' populations. As they say in crisis response operations, "You only get one chance to make a first impression, trust is earned over time but easily broken, and actions and outcomes need to support words."

The concept of a Senior Telecommunications (Telecom) Advisor (STA) (or perhaps more appropriately, a Senior ICT Advisor to include information, broader aspects of communications, and technology) in post-conflict reconstruction and stability operations is to have a source to provide strategic thinking, thought leadership, and informed ICT advice and assistance to senior civilian and military leadership and to represent the ICT-related engagement interests of the intervening senior decision-making elements with

<sup>50</sup> WP1022 Report, 2010.

the affected nation's government and the private ICT sector. Such an approach was employed in Afghanistan, but it was not the first time. There is a saying in post-conflict operations that "someone's new idea is likely some else's old idea revisited." For example, there was an Iraq Communications Coordination Element (ICCE) (which was renamed Infostructure and Strategic Engagement, or ISE) supporting the Commander Multi-National Force-Iraq (MNF-I). There were STA equivalents at both the US Embassy Baghdad and on the MNF-I ICCE/ISE teams. Between 2005 and 2008, Afghanistan had an STA as part of the Afghanistan Reconstruction Group (ARG) at the US Embassy Kabul. Several years later, from 2010 to 2014, there was an STA at ISAF who was supported by an on-the-ground Telecommunications (Telecom) Advisory Team (TAT). The STA/TAT closed its ISAF office in October 2014. A team of three contractors that had supported the ISAF STA/TAT continued to support ISAF CJ6<sup>51</sup> and then Resolute Support (RS) CJ6/Train, Advise and Assist (TAA) team until January 2016. The follow-on effort was funded by DISA and then US Forces-Afghanistan (USFOR-A). Although a demand for STA-like advice and assistance continues (from RS CJ6/TAA, the US Embassy Kabul, and the USAID Mission in Afghanistan), the STA function has not been revived by either State or Defense to provide such support.

The TAT was largely staffed through the DoD Civilian Expeditionary Workforce (CEW) program. In addition, a three-person team of civilian contractors funded by the Defense Information Systems Agency (DISA) provided professional civil and commercial ICT expertise to support the STA and the TAT, two of whom worked in country. The contractors lived outside the ISAF compound and had their own private security company (PSC), giving them more flexibility and freedom of movement than personnel who lived on the base. The contractors' arrangement allowed them to embed daily at the Ministry of Communications and Information Technology (MCIT) and interact with its personnel as well those at the Afghanistan Telecom Regulatory Authority (ATRA), which was housed in the same building, and state-owned Afghan Telecom Corporation (AfTel), which was located on the MCIT compound. The contractors were also able to move about the city of Kabul to meet with members of the private ICT sector (e.g., MNOs and ISPs), academia, and other Afghan ministries.

The desired characteristics of the STAs employed in Afghanistan at the US Embassy Kabul and then ISAF emphasized a preference for senior civilian professional ICT subject matter experts (SME) with civil and commercial ICT experience. The supporting TAT element CEW staff was intended to be civil service ICT experts recruited from USG agencies. The STA was to be an experienced senior level person who understood ICT sector governance activities related to telecommunications and information technology policy, regulations, laws, and international standards. This individual also needed to understand technology and future trends as well as ICT-related strategy and planning, architecture development, acquisition, implementation, operations and management, and security (both physical infrastructure protection and cybersecurity, now referred to within the USG as Critical Information Infrastructure Protection, or CIIP) of ICT systems that form the civil and commercial ICT infrastructure and service offerings. An understanding of the dual-use nature of ICT to support both civil and military communications needs was important as well. Key Afghanistan ICT infrastructures in this regard were the

---

<sup>51</sup> Combined Joint Communications and Information Systems

country's fiber, satellite, and microwave networks, and the government and commercial cellular telephone and data networks.

As part of the concept formulation for the STA/TAT in Kabul, the Interagency planners preferred the individual for the position of STA come from the US Government Senior Executive Service (SES) or be hired by the government to fill such a position as a government civilian or government equivalent employee (e.g., DoD Intergovernmental Personnel Act (IPA) or DoD Highly Qualified Expert (HQE) personnel). They wanted the position to be equivalent to the Ambassador and/or General Officer levels in order to have the STA be a visible and active part of the senior USG leadership team. The Interagency also desired for the individual to have some military experience to help bridge the civil-military divide and facilitate cooperation and a shared understanding of the importance of ICT and its role in support of military C4ISR<sup>52</sup> systems and services for combat support operations, related stability operations, supporting COIN activities, and as an enabler of post-conflict reconstruction, security, stability, governance, and socio-economic development of the affected nation.

Additionally, Interagency personnel felt the individual filling the STA position should be proactive and have the personality, social skills, cultural sensitives, and passion to work and help make things happen in a complex multinational, multicultural civil-military war zone and in post-conflict security, stability (including COIN) operations and reconstruction environments. It was also important for that person to be able to develop strategic and trusted partnerships and interact professionally with the USG Interagency and Coalition civil-military elements and with senior leadership of international organizations, NGOs, the Afghan government, and the private ICT sector. The individual also needed to be sensitive to business cultures and processes, as well as politics and relationships within and between GIRoA and the private sector.

The first STA at the ARG was recruited from a senior level position in industry as an SES-equivalent with prior military experience and reported to the US Ambassador as part of the ARG. His replacement was recruited as a GS-15. Recruiting SES candidates to deploy for a year to a war zone proved to be a challenge. The first STA at ISAF was an HQE (SES-equivalent) with prior military experience, and the fourth STA was an SES from the DoD. The other two ISAF STAs were experienced senior US Army Signal Corps Colonels. Two of the ISAF STAs (one of the Colonels and the DoD SES) were female. The ISAF STAs reported to both the Commander of ISAF (COMISAF) and the Deputy Chief of Staff (DCOS) level. (For most of the ISAF TAT's four years of operation, the reporting chain was through DCOS Stability Operations.) The team was frequently recognized by COMISAF and his senior leadership as the "go to" organization for advice and assistance related to ICT in Afghanistan. The team was also recognized by and actively engaged with the US Embassy Kabul, the USAID Mission, the UN, the World Bank, and senior leadership at the MCIT, ATRA, and AfTel, and the private ICT sector as the civil-military organization to work with on Afghan ICT-related activities. The STA was the principal spokesperson for the USG dealings with GIRoA senior ICT leadership,

---

<sup>52</sup> Command, control, communications, computers, intelligence, surveillance, and reconnaissance

i.e., the Minister of Communications and Information Technology, the Chairman of ATRA, and the CEO of AfTel, and others.

Both the STA/ARG and ISAF STA/TAT were supported by a CONUS-based<sup>53</sup> Reachback team. In the case of the ISAF STA/TAT, Reachback was composed of experienced ICT professionals who had spent significant time on the ground in Afghanistan and in other operations such as Iraq, were experienced in military-civil-commercial engagements, and had a passion for and commitment to the modernization of the Afghan ICT sector and its use as an enabler of security, governance and socio-economic development. The Reachback team had extensive contacts and relationships going back over several years' experience in country. Reachback had access to personnel within GIRoA, the Afghan ICT sector, the US Embassy Kabul, USAID, the UN, the ITU, and the World Bank. In the US, Reachback had contacts at and relationships with the headquarters elements of the USG Interagency, academia, think tanks, international organizations, professional associations, and industry. They played important roles as facilitators, coordinators, harmonizers, and connectors both in country on temporary duty (TDY) as SME gap fillers and on special assignments in Kabul and downrange. The Reachback team was a key participant in the overall STA/TAT effort, and the effectiveness of its members was enhanced with frequent visits to Kabul to participate with the STA/TAT on the ground. This was particularly important when new members arrived to join the TAT in Kabul. There was no STA/TAT and Afghan ICT orientation and mentoring program per se for new CEW staff, so visits by Reachback were a way to have an opportunity to build needed trust relationships and develop a shared understanding of the purpose of the STA/TAT and its vision, mission, and strategy. Reachback was the institutional memory and transition continuum for ICT advisory support to ISAF and the Interagency teams both in country and CONUS.

In spite of numerous attempts to conduct an ICT-enabled intervention, there still is no agreed-upon USG or international policy, doctrine, strategy, or approach to guide the implementation of an ICT-enabled intervention capability. The engagements in Iraq and Afghanistan were essentially ad hoc experiments and learning experiences.

---

<sup>53</sup> Continental United States

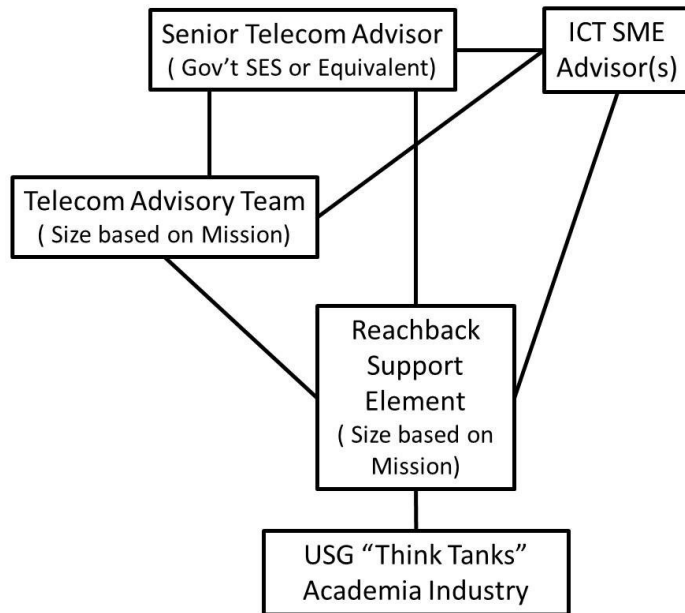

Figure 4: STA and support elements construct

Figure 4 illustrates the STA/TAT and Reachback configuration implemented to support ISAF and to work with the US Embassy Kabul, the USAID Mission in Afghanistan, and other key ICT stakeholders. This construct and lessons from its use in Afghanistan should be explored as a possible framework for shaping future ICT-enabled intervention arrangements.

This book focuses on two success stories emerging from Afghanistan: (1) the dramatic evolution of the Afghan ICT sector and the use of ICT as a cross-sector enabler of reconstruction, security, governance, and socio-economic development, and (2) the use of Senior Telecom Advisors as trusted civil and commercial ICT SME advisors to senior USG leadership, ISAF, and GIRA.

Significant progress has been made in the ICT sector in Afghanistan, and it truly is the success story emerging out of the recovery of a country left dysfunctional from decades of war. Progress towards bridging the digital divide and moving Afghanistan into the twenty-first century Information Age has not been accidental, but was largely due to having the right people at the right time and places with the right visions, energy, passion, and expertise to make informed decisions and take actions to make things happen. MCIT Minister Sangin helped influence the substantial progress in the Afghan ICT sector during his nearly ten years in office (2004 to 2014). For example, the early implementation of good public-private partnerships enabled the provision of ICT services to the fledgling Afghan government. The adoption of policies that favored competition and private (including foreign) investment and the enacting of light-touch legislation and regulation were key to jumpstarting and enabling commercial companies to invest in and implement infrastructure and offer ICT services to the public.

Afghanistan had essentially no ICT infrastructure in 2001. By mid-2014, there were six mobile network operators and over 50 Internet service providers. The 5,626 operational cellular towers supported 21.6

million subscribers with 80 percent penetration and 89 percent population coverage.<sup>54</sup> Commercial MNOs and ISPs provided voice and data services to urban and some rural areas. Eight out of every 10 Afghan women had some access to mobile phones; in 2002 it was zero.<sup>55</sup> The satellite-based Village Communications Network that provides access to phone (and data) service in remote villages had grown to 1,222 terminals serving rural area communications needs. Additionally, there were hundreds of public call offices (PCOs) and community radio systems. There were Internet cafés in major metropolitan areas such as provincial and district centers. Donors, IGOs, and NGOs provided Internet access to schools, universities, hospitals, medical clinics, and agricultural and community centers. Minister Sangin’s vision for all Afghan citizens to have access to telephony services and to transform the country to an information society had largely become a reality.

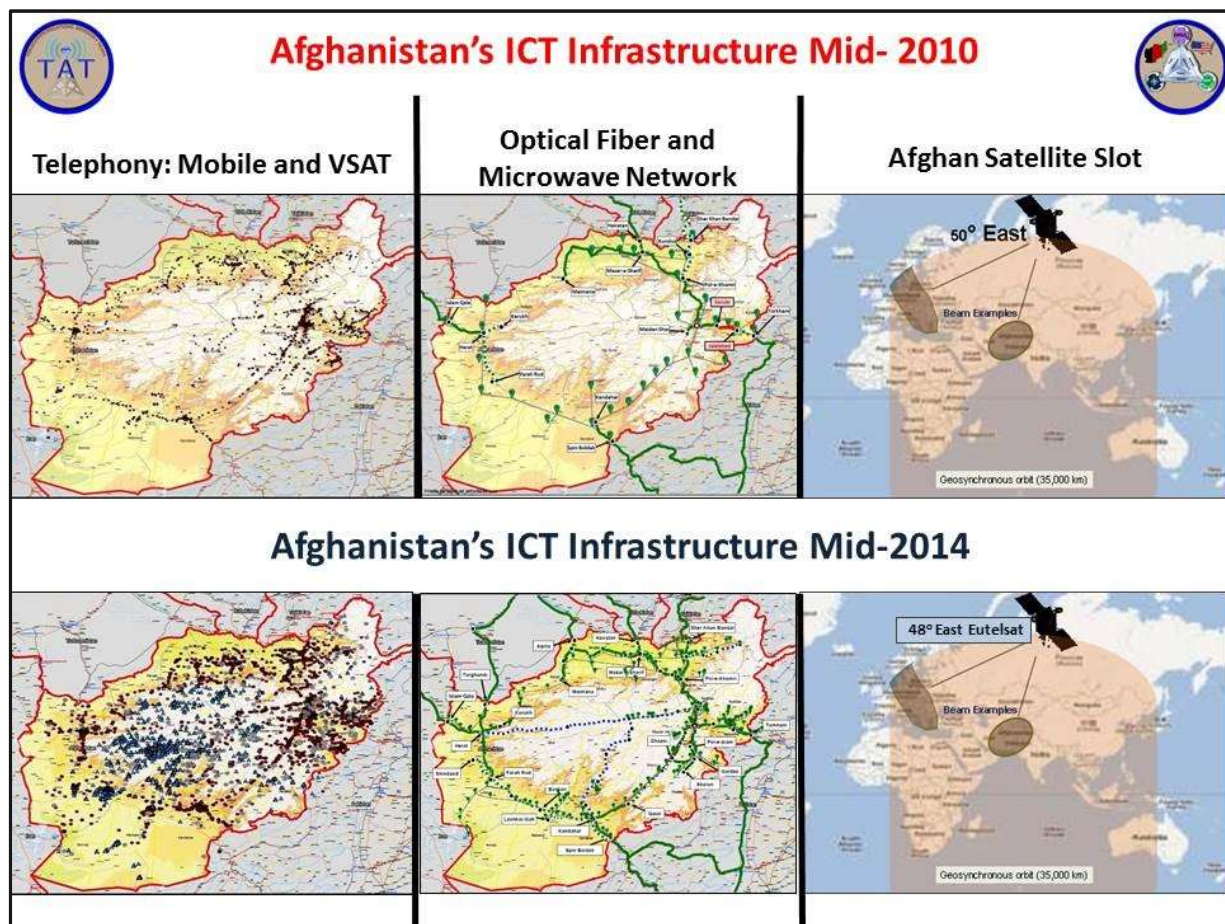

Figure 5: ICT infrastructure 2010-2014

<sup>54</sup> Senior Telecommunications Advisor, Interim Program Review to DISA, May 2014.

<sup>55</sup> MCIT Minister Sangin presentation to the Afghan American Chamber of Commerce conference “Afghanistan as a Hub: The Role of Information & Communications Technologies,” June 2014.

By March 2014, 62 percent of Afghanistan's national optical fiber cable (OFC) network was operational.<sup>56</sup> When complete, Afghanistan will have over 5,000 kilometers of fiber optic cable network connecting all six major cities and many provincial capitals. The OFC connects Afghanistan to five of its six neighbors (all except China), giving it access to key terrestrial and undersea fiber cables. These interconnections have helped to decrease Internet costs in Afghanistan: The price for 1 megabit per second per month (Mbps/month) of Internet access decreased from US\$5,000 in 2002 to US\$7.50 in 2016.<sup>57</sup> The regional interconnections also put Afghanistan in the position potentially to generate millions of dollars in revenue by carrying international transit traffic among Europe, the Middle East, and Asia. However, AfTel still holds a monopoly over Afghanistan's optical fiber infrastructure, at least until a recently-approved policy ending it (see below) is enacted.

Afghanistan's first satellite, AfghanSAT1, launched in partnership with Eutelsat, was inaugurated in May 2014, and digital terrestrial television (DTTV) services began in Kabul in August 2014. [Figure 5](#) illustrates the rapid growth of the cellular and fiber optic network and the introduction of Afghanistan's satellite capability from 2010 to 2014.

In addition to being a socio-economic success story, the ICT sector provided communications for the Afghan National Security Forces (ANSF). For example, the ANSF has access to the fiber optic network and uses fixed and mobile telephone services. They also have an extensive high-frequency tactical radio network. ICT also gave them a method to counter propaganda by insurgents in remote areas through the deployment of the District and Village Communications Networks. The DCN and VCN, respectively, provided government personnel and citizens access to voice and data services.

Bringing Afghanistan out of the digital dark ages also benefits the West. A report by the Pew Research Center shows Muslims outside the US who use the Internet are much more likely than other Muslims to have a favorable opinion of Western culture.<sup>58</sup> In advance of the troop withdrawal at the end of 2014, a *Boston Globe* columnist listed ICT as the second of three reasons to be hopeful about Afghanistan's future, stating: "In Afghan cities, technology has created a cultural shift that could turn out to be more powerful than anybody's militia."<sup>59</sup> This sentiment echoes what former Vice Chairman of the US Joint Chiefs of Staff General James "Hoss" Cartwright, said earlier that year: "As we leave Afghanistan, the thing that will most affect that culture over the long term is leaving behind that network and those cell phones ... and the

---

<sup>56</sup> 2,275 kilometers of 5,086 planned were operational. The planned figure includes the World Bank central and northeast spurs in addition to the main ring. The 62 percent figure was reported by TAT Advisor and fiber SME Lew Shadle to TAT leadership, March 28, 2014. See [Chapter 7](#), Afghanistan's Fiber Optic Infrastructure, for more information.

<sup>57</sup> Per the MCIT, 2016.

<sup>58</sup> Pew Research Center (2013). "Among Muslims, Internet Use Goes Hand-in-Hand With More Open View Toward Western Culture." May 31. Accessed January 6, 2016. <http://www.pewforum.org/2013/05/31/among-muslims-internet-use-goes-hand-in-hand-with-more-open-views-toward-western-culture/>.

<sup>59</sup> Stockman, Farah (2013). "Three reasons for hope in Afghanistan." *Boston Globe*, April 9. Accessed January 6, 2016. <http://www.bostonglobe.com/opinion/2013/04/08/gambling-pomegranates/dekCKppa3xT9QeEKGqEqJ/story.html>.



introduction of that technology is probably far more lasting than anything else ... and far more influential.”<sup>60</sup>

The intent of the ISAF Senior Telecom Advisor and supporting Telecommunications Advisory Team (TAT) from 2010 to 2014 was to establish a “one-stop shop” for ICT advice, assistance, and mentoring for the USG Interagency, Coalition civil-military elements, and Afghan counterparts, and be the provider of informed situational awareness of Afghan ICT sector activities, issues, and operational status. The STA provided professional civil and commercial leadership and subject matter expertise regarding ICT and performed the role of key advisor to GIRoA ICT leadership. The STA/TAT also interacted with the commercial ICT sector and ICT stakeholders and other representatives of international organizations such as the World Bank, the ITU, and the UN. The STA/TAT played important roles as facilitators, coordinators, harmonizers, and connectors, including regarding USG Interagency coordination and information sharing. In October 2012, at his daily morning standup briefing, COMISAF General John Allen, USA, stated TAT’s work with the Ministry of Communications was “one of the most important non-security governmental engagements” ISAF had with the Afghans.

Challenges for the future include a deteriorating security situation (including threats against ICT personnel and facilities); the need to sustain economic and political stability; a lack of reliable electric power; poor spectrum management; and a lack of qualified management, technical, contracting, marketing, and financial personnel. In addition, the new Ghani National Unity Government has introduced ICT sector governance changes. There is a new Minister of Communications and rumored likely internal MCIT management adjustments, a new ATRA Chairman and Board members, and there have been leadership and organizational changes rumored at AfTel as well. Additionally, President Ghani installed a Chief Adviser for Infrastructure, Human Capital, and Technology, whose portfolio includes the ICT sector and oversight of its governance, as well as improvements in ICT infrastructure and services.

The new ICT administration is, collectively, trying to manage the ICT sector governance changes. Needless to say, the leadership and other changes have resulted in disruptions that have impacted timely decision making and actions to move improvements in ICT infrastructure and services forward. It will likely take some time to adjust to the ICT sector governance changes, and there may be more yet to come before things return to a more stable and effective environment. While managing changes in ICT sector governance, efforts continue to try to implement digital services such as mobile money, an electronic national identity card (e-NIC), and other electronic and mobile government services. President Ghani has invigorated the need to employ ICT for Afghan women as well as to promote the inclusion of women in the ICT sector. Managers at the MCIT and ATRA are trying to grow a cybersecurity and information culture and continue to modernize and leverage ICT infrastructure and services, particularly the expansion of 3G

---

<sup>60</sup> Reed, John (2013). “Let freedom ring: Gen. Cartwright says 4G [*sic*] is America’s lasting legacy in Afghanistan (Updated).” *Foreign Policy*, January 24. Accessed January 6, 2016. <http://foreignpolicy.com/2013/01/24/let-freedom-ring-gen-cartwright-says-4g-is-americas-lasting-legacy-in-afghanistan-updated/>.

mobile broadband services and the likely future introduction of 4G/LTE.<sup>61</sup> They continue to try to improve Internet access, coverage, and penetration while reducing the cost of Internet services. Implementation and activation of the national fiber optic network continues, including improvements to its five regional interconnects. In regard to the latter, and as mentioned above, Afghanistan is trying to position itself to become a strategic ICT hub – a Digital Silk Road that would connect South Asia, Central Asia, North East Asia, and the Middle East (see [Figure 6](#)).

## Afghanistan – The ICT Hub of Central Asia *Modern-Day Digital Silk Highway*

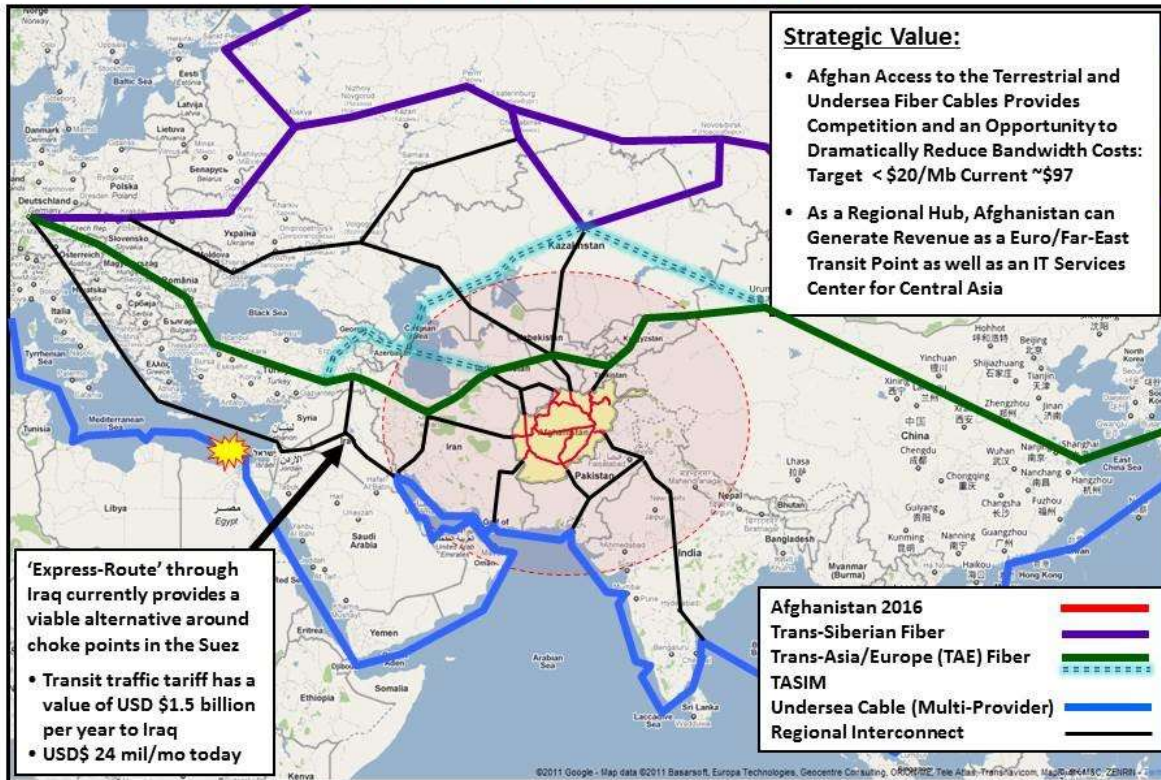

Ishadle\_baseline\_ict\_infra08/2013

11

Figure 6: Afghanistan as a Central Asian ICT hub

All of this activity is occurring while Afghanistan is experiencing mass emigration as Afghans flee the country in droves. The exodus has set off alarm bells among Afghan leaders concerned about the “brain

<sup>61</sup> Fourth-generation wireless digital technology based on International Telecommunication Union (ITU) International Mobile Telecommunications (IMT) Advanced specifications and long-term evolution, a high-speed wireless communications standard developed by the Third Generation Partnership Project (3GPP).

drain” – the departure of some of the country’s best minds.<sup>62</sup> So much so, the Afghan Ministry of Refugees and Repatriations has launched a slick social-media campaign to dissuade Afghans from making the jump to Europe.<sup>63</sup> This trend is particularly troublesome for the ICT sector because it already suffers from a lack of indigenous ICT expertise. The relatively tech-savvy ICT sector workers are among the most employable elsewhere, and many have already left their country.

To ensure future growth in the ICT sector, a new policy was needed to facilitate sustainable development through a private-sector-led fiber optic and broadband market. In August 2016, President Ghani approved the MCIT’s policy of Open Access and Competitive Provisioning for Afghanistan’s Fiber Optic and Broadband Sectors to attract private investment and, in turn, promote a robust ICT marketplace, free of monopolies, which has the potential to provide affordability, ubiquity, and growth in other economic sectors. The Open Access Policy will be the legal framework to offer network operators and service providers access to Afghanistan’s fiber optic and broadband infrastructure at a fair price, as well as providing the right for private businesses to build, own, and operate active and passive infrastructure. This policy will also authorize the Afghan government, in particular the MCIT and ATRA, to establish and implement necessary regulations for attainment of the goals of the policy.

After achieving remarkable growth over the past decade, the Afghan economy has floundered in the past three years as international investors and aid organizations have drastically scaled back operations following the withdrawal of most international troops.<sup>64</sup> For instance, gross domestic product (GDP) growth shrunk to about two percent in 2014 after expanding at a nine percent rate just two years prior.<sup>65</sup> According to the Afghanistan Investment Support Agency, reduced investor confidence in the economy has resulted in foreign direct investments dropping by 30 percent in the first half of 2015. The economic shrinkage has been accompanied by spikes in unemployment and capital flight.<sup>66</sup> Afghanistan’s overall economic environment is being undermined by ongoing political and security challenges, and the inability to deliver basic services on a reliable basis has severely eroded confidence in the government.<sup>67</sup> The economy is also hobbled by insurgency and corruption.<sup>68</sup> On the good news side, on July 29, 2016, Afghanistan became the 164<sup>th</sup> country to join the World Trade Organization (WTO) — twelve years after it first applied for WTO membership in 2004.<sup>69</sup> Afghan officials have said the WTO membership will help

---

<sup>62</sup> Bezhan, Frud (2015). “‘Stay With Me’: Afghan Government Begg Citizens Not to Flee.” *The Atlantic*, September 22. Accessed September 14, 2106. <http://www.theatlantic.com/international/archive/2015/09/afghanistan-brain-drain-migrant-crisis/406708/>.

<sup>63</sup> Ibid.

<sup>64</sup> Shams, Shamil (2016). “Will WTO membership help improve Afghanistan economy?” *Deutsche Welle*, July 29. Accessed September 14, 2016. <http://www.dw.com/en/will-wto-membership-help-improve-afghanistans-economy/a-19437115>.

<sup>65</sup> Ibid.

<sup>66</sup> Ibid.

<sup>67</sup> “2016 Index of Economic Freedom: Afghanistan.” The Heritage Foundation. Accessed September 14, 2016. <http://www.heritage.org/index/country/afghanistan>.

<sup>68</sup> Ibid.

<sup>69</sup> Shams, 2016.

their country "strengthen its rule of law, establish transparency, and lay the foundations for healthy economic growth."<sup>70</sup> Although the WTO membership is expected to confer benefits such as granting access to new markets and global supply chains, it remains unclear how much Afghanistan will be able to benefit from the new opportunities. The economic hardship is in large part due to the continued political deadlock and worsening security situation in the conflict-ridden country. Experts believe that it is essential for Kabul to focus on improving the security situation in order to allow the country to benefit from the increased trading opportunities provided by joining the WTO.<sup>71</sup>

Afghanistan began its "Decade of Transformation" with the confluence of three major transitions – security, governance, and the economy – occurring at the same time. Managing one would be troublesome, but dealing with all three simultaneously is perhaps Afghanistan's greatest challenge for the future. For example, the transfer of security responsibility to Afghan forces and drawdown of Coalition forces has increased uncertainty as the government confronts high levels of insurgent threats, corruption, heavy and persistent drug trafficking, weak institutional capacity, and a severely underdeveloped judicial system.<sup>72</sup> Two years of political and security uncertainty have resulted in reduced economic activity and the emergence of significant fiscal vulnerabilities.<sup>73</sup> The financial sector remains underdeveloped, and scarce access to financing hinders private-sector growth.<sup>74</sup> The new Unity Government finds itself in a complex threat environment, with a mix of the Taliban, al-Qaeda, and ISIS (or Daesh). Further, Afghanistan's political, tribal, and ethnic jungle poses a steep learning curve with complicated interdependencies that will take time to understand and may delay the implementation of changes needed to achieve peace, political stability, security, good governance, social development, and economic growth. Donor fatigue and waning USG and International Community interest are further impacting Afghanistan's overall recovery process. The Afghan and US governments and the International Community need to manage their expectations. The change process will take a long time, maybe decades, and will need continued USG and international support.

---

<sup>70</sup> Ibid.

<sup>71</sup> Ibid.

<sup>72</sup> "2016 Index of Economic Freedom."

<sup>73</sup> Ibid.

<sup>74</sup> Ibid.

# Introduction

---

Larry Wentz

## Background

The role of information and communications technology (ICT) for crisis response interventions (i.e., humanitarian assistance, disaster relief, security and stability operations, and post-conflict recovery, reconstruction, and development) has come a long way since the days of the NATO-led IFOR/SFOR<sup>75</sup> and KFOR<sup>76</sup> interventions in the Balkans in the mid- to late 1990s. The use of commercial ICT during IFOR and the early stages of SFOR and KFOR was largely to provide long-haul access connectivity to the areas of operation and for connectivity between static headquarters and subordinate command posts in these areas. The forces made extensive use of commercial satellite services (both fixed and mobile, e.g., VSAT<sup>77</sup> and INMARSAT<sup>78</sup>), copper cable, fiber optic and microwave networks, as well as satellite phones for dismounted operations and use in disadvantaged and remote areas where commercial voice and data coverage was poor or non-existent.<sup>79</sup>

Civil-military elements made some use of commercial cellular and Internet services where they existed. Countrywide coverage in Bosnia was limited, and there were political opposition challenges with affected nations' governments and regulators that hindered the introduction and expansion of cellular and Internet services that could have been used to support unclassified civil-military communications needs.<sup>80</sup> There were also international military sensitivities to the use of non-secure commercial communications networks to support operations, including disconnects in civil-military collaboration and information sharing.<sup>81</sup> The latter was not a technology issue; it was an organization, personnel, and culture issue with

---

<sup>75</sup> Implementation Force/Stabilization Force. IFOR ran from December 1995 to December 1996 as Operation Joint Endeavor. SFOR succeeded IFOR under Operations Joint Guard (December 1996 to June 1998) and Joint Forge (June 1998 to December 2004).

<sup>76</sup> Kosovo Force, a peacekeeping force in the country from June 1999 to present. As of June 2016, nearly 4,559 KFOR troops remain in Kosovo. Kosovo Force (KFOR) Key Facts and Figures. Accessed September 14, 2016. [http://www.nato.int/nato\\_static\\_fl2014/assets/pdf/pdf\\_2016\\_06/20160610\\_2016-06-KFOR-Placemat.pdf](http://www.nato.int/nato_static_fl2014/assets/pdf/pdf_2016_06/20160610_2016-06-KFOR-Placemat.pdf).

<sup>77</sup> Very small aperture terminal, a two-way satellite ground station with a dish antenna generally smaller than three to four feet.

<sup>78</sup> International Maritime Satellite Organization, a British satellite company that offers voice and data services worldwide via portable terminals that communicate with ground stations through 12 geostationary telecommunications satellites. Per *Wikipedia*. "Inmarsat." Last updated September 8, 2016. <https://en.wikipedia.org/wiki/Inmarsat>.

<sup>79</sup> Wentz, Larry, ed. (1997). *Lessons from Bosnia: The IFOR Experience*. (Washington, DC: National Defense University Press); available at [http://www.dodccrp.org/files/Wentz\\_Bosnia.pdf](http://www.dodccrp.org/files/Wentz_Bosnia.pdf) and Wentz, Larry, ed. (2002). *Lessons from Kosovo: The KFOR Experience* (Washington, DC: Department of Defense Command and Control Research Program (DoD CCRP) Press); available at [http://www.dodccrp.org/files/Wentz\\_Kosovo.pdf](http://www.dodccrp.org/files/Wentz_Kosovo.pdf).

<sup>80</sup> *Ibid.*

<sup>81</sup> *Ibid.*

related behavior challenges – a lack of shared values and expectations and people treating information as power, making them unwilling to share.

In addition to the military networks, during KFOR, Coalition modes of communication came to include face-to-face conversations; the sneakernet;<sup>82</sup> handheld commercial sports radios such as the Motorola TalkAbout; mobile phones on GSM<sup>83</sup> cellular networks; satellite phones; and the Internet. The Internet, in fact, became the Coalition unclassified information-sharing network among KFOR, Coalition national military and civilian elements, the United Nations (UN) Mission in Kosovo, international organizations (IOs), non-governmental organizations (NGOs), and affected-nation civilian and military organizations. Coalition civil and military elements participating in Kosovo, as well as those supporting them, constructed Internet websites that were used to inform and share information. The issue quickly became one of information overload and an inability to easily find information the civil-military elements could use. More powerful information discovery tools were needed.<sup>84</sup>

In support of the sustained military operations in the Balkans, a military strategy referred to as commercialization of the tactical command and control (C2) systems was employed. It used contractors to provide and operate commercial IT<sup>85</sup> and communications capabilities and services to replace the tactical C2 systems of the military elements — a secure military tactical ICT overlay was used to support essential headquarters C2 and intelligence (C2I) needs and to support tactical C2I and maneuver operations.<sup>86</sup>

For the interventions into Afghanistan and Iraq and the disaster relief operation in Haiti, the rapid evolution of ICT capabilities and services offered new opportunities for the civil-military community to use commercial cellular and Internet services and leverage new network applications. Such capabilities and services include text messaging, web-based services, smartphones and related apps, social networking and social media tools, rapidly deployable satellite-based cellular nodes and Internet hot spot capabilities, crowdsourcing and crowdmapping software, virtual reality tools, drones for surveillance and reconnaissance, and big data and cloud storage, among others. These ICT-based services became the drivers of the new way of doing business, with new techniques and applications emerging almost daily. This evolution was part of the move into the “Digital Age” of global connectivity and network access. In his recent book, *The Seventh Sense*, Joshua Ramo argues the Digital Age in which we now live is as transformative as the Industrial Revolution.<sup>87</sup> The spread of networks and constant, ever-faster

---

<sup>82</sup> The term sneakernet refers to the transference of information from person-to-person, often, but not always, meaning via removable electronic media like thumb drives, compact discs, and external hard drives.

<sup>83</sup> Global system for mobile communications, a second generation of protocols for digital cellular networks originally developed by the European Telecommunications Standards Institute (ETSI). GSM is now a trademark owned by the GSM Association.

<sup>84</sup> Wentz, 2002.

<sup>85</sup> Information technology

<sup>86</sup> Wentz, 1997 and Wentz, 2002.

<sup>87</sup> Ramo, Joshua Cooper (2016). *The Seventh Sense: Power, Fortune, and Survival in the Age of Networks*. (New York: Little, Brown and Company).

connections is creating a new kind of order with new sources of strength.<sup>88</sup> Others agree: ICT is more than just a business tool — it is also leading the world into the next Industrial Revolution.<sup>89</sup> ICT broadens the horizon of collaboration's potential, helping different parties and sectors work to a common aim. Power is both more concentrated and more distributed than ever before. Individuals, firms, and nations that can appreciate and master the new order will flourish; those that cannot will flounder.<sup>90</sup>

Other changes that have occurred between the Balkan days and today include more active US government and international organization engagements (which are still stovepiped with varying degrees of coordination and information sharing) regarding the recovery of the affected nation's ICT sector, its administration, and the use of ICT as an enabler of security, governance, and socio-economic development. Additionally, the private sector providers of, for example, satellite and fiber optic connectivity for intervening civil-military elements, have become more engaged with those elements. Furthermore, commercial mobile network operators (MNOs) and Internet service providers (ISPs) have become more willing to invest in areas where security remains a challenge to help recover and expand ICT coverage and services. These changes, relative challenges, and impacts are the subject of discussion in the chapters of this book. There have been both successes and failures, but progress is being made to improve the ability of the civil-military responder community to adjust its behavior and priorities. For example, there is now more willingness to employ shared understandings and approaches and to engage in somewhat more open collaboration, coordination, and information sharing as a new way of doing business in support of ICT-enabled interventions.

The transition to ICT-enabled interventions has created a demand for civil and commercial ICT expertise to be an integral part of the intervening civil-military elements. It is no longer simply a matter of civil-military elements interfacing with the affected nation's ICT sector to lease connectivity and contract voice and data services. ICT has become such an important and essential aspect of interventions that the interveners can no longer take it for granted: they cannot assume that ICT connectivity and services will be available upon arrival in country. Nor can they presume the affected nation emerging from conflict has the ability to rapidly rebuild or establish ICT sector governance and infrastructure or enable the private sector to invest in ICT equipment and services. Civil and commercial ICT subject matter experts (SMEs) are needed to be a part of the intervening civil-military team to work with the affected nation's ICT sector governance structure, such as the minister of communications, the regulator, and any state-owned ICT service providers to help: rebuild public institutional capabilities; develop ICT policies, regulations, and laws; establish public-private-partnerships to enable investments in the ICT sector and its uses; and help develop the affected nation's ICT strategies and plans. The ICT SMEs also need to work with both the

---

<sup>88</sup> Rose, Gideon (2016). Review of *The Seventh Sense: Power, Fortune, and Survival in the Age of Networks* by Joshua Cooper Ramo, *Foreign Affairs*, May/June 2016. Accessed June 17, 2016, <https://www.foreignaffairs.com/reviews/capsule-review/2016-04-14/seventh-sense-power-fortune-and-survival-age-networks>.

<sup>89</sup> Dunne, Niall (2016). "Three truths behind the transformational power of ICT." *BT Let's Talk* (blog), February 1. <https://letstalk.globalservices.bt.com/en/2016/02/three-truths-behind-the-transformational-power-of-ict/>.

<sup>90</sup> Rose, 2016.

public and private ICT sectors to help the affected nation make smart use of ICT to enable security, governance, and socio-economic development and growth. Additionally, ICT capacity development programs focused on building the bench of an ICT-savvy work force and developing the ICT skills and awareness of the government, industry, and the overall population, are needed to leverage the benefits of the Digital Age.

The advances in ICT capabilities and services made over the past ten to 15 years are an important factor influencing major changes in current and future crisis response, conflict, and post-conflict operations. They have progressively reduced the costs of managing information, connecting people and organizations in fixed, disadvantaged, and on-the-move locations. Additionally, they have also developed the ability to provide ready access to and the real-time sharing of information. Broadband, mobility, and the cloud are becoming the pillars that enable the emerging Networked Society.<sup>91</sup> ICT has become an enabler of individuals and organizations to undertake information-related tasks much more efficiently and introduce innovations in products, processes, and organizational structures that, in turn, have generated new ways of working, market development, and livelihood practices. ICT can help provide transparency and the ability to extend governance to help reduce corruption and enhance government legitimacy through the provision of electronic government (e-government or e-gov) services. ICT has become integral to the security, stability, rule of law, governance, and social, political, and economic development of nations emerging from conflict. ICT can also enhance professional and social interactions within and between communities, strengthening the processes of cultural transmission, and contributing to rural development and poverty reduction.

As a motivator to recovering the ICT sector, it is generally understood that ICT can be used to enhance the ability of people to communicate to do whatever they wish to do. Governments can use ICT to improve local security and administration, deliver services, manage information, monitor behavior, and control dissent. Citizens use ICT to access new and different sources of information, share opinions, proliferate cooperation or dissent, and hold their governments accountable. Social networking tools have given rise to crowdsourcing for reporting on incidents and happenings, broadcasting alerts, organizing events and responses, tracking actions, and the emergence of citizen journalism. On the other hand, the Internet and mobile phones are valued and used by insurgents, criminals, and terrorists, and this needs to be factored into the intervention ICT-related strategies and plans as well as the ICT sector recovery, reconstruction, and development strategies and plans of the affected nation. ICT has also become an important enabler of post-conflict stability, recovery, reconstruction, and development, especially with ways in which ICT can be used by the intervening military and civilian elements of governments and donors for rapid deployment of ICT-enabled support to affected nation post-conflict crisis response and to facilitate the transition from conflict to security, stability, and, ultimately, peace and prosperity.

---

<sup>91</sup> Kruse, Erik (2013). "Networked Society." Accessed September 14, 2016.  
<https://www.lith.liu.se/presentation/namnder/dm/D40IT20/fran-konferensen/1.640232/ErikKruse.pdf>.



The importance of ICT to nations emerging from crisis and conflict is evidenced by ICT becoming recognized internationally as an essential service and critical infrastructure. UN efforts such as the 2015 [Millennium Development Goals](#) (MDGs) and now its [Sustainable Development Goals](#) (SDGs), which include commitments to end poverty, protect the planet, promote gender equality, and ensure prosperity for all, include ICT components. The United Nations Development Programme (UNDP) and Educational, Scientific and Cultural Organization (UNESCO) promote ICT education and ICT for development (ICT4D). The UN [World Food Programme](#) (WFP) [Emergency Telecommunications Cluster](#) is a global network of organizations that work together to provide shared communications services in humanitarian emergencies and has employed ICT in its food voucher programs. The International Telecommunication Union (ITU) considers ICT a human right. The World Bank conducts a plethora of research on the use of ICT, issuing reports such as, *The Role of Information and Communication Technologies in Post-Conflict Reconstruction, From Transition to Transformation: The Role of the ICT Sector in Afghanistan*, and *World Development Report 2016: Digital Dividends*. Specific to Afghanistan, the World Bank funded an Emergency Communications Project<sup>92</sup> in 2003 and an Afghanistan ICT Sector Development Project in 2011.<sup>93</sup> The latter is focused on expanding fiber optic network connectivity, mainstreaming the use of mobile applications in strategic sectors in the government, supporting the development of the local IT industry, and ICT capacity development, including establishing an ICT incubator at the ICT Institute in Kabul.

Additionally, efforts of other organizations, such as the [ICT for Peace Foundation](#), aim to facilitate improved, effective, and sustained communication between peoples, communities, and stakeholders involved in conflict prevention, mediation, and peace building through better understanding of and enhanced application of ICT.<sup>94</sup> Academic organizations and think tanks such as the National Defense University, Naval Post-Graduate School, Army War College, RAND Corporation, the Institute for Defense Analyses (IDA), the MITRE Corporation, the Center for Naval Analyses (CNA), the Center for Strategic and International Studies (CSIS), and the Brookings Institution have researched and written extensively on civil-military crisis response activities, lessons learned, and the role of ICT.

On the other hand, US government (USG) policy documents such as the 1997 Presidential Decision Directive 56 (Managing Complex Contingency Operations) and the 2005 National Security Presidential Directive-44 (Management of Interagency Efforts Concerning Reconstruction and Stabilization) aimed to improve coordination, planning, and implementation of stabilization and reconstruction assistance but did not specifically address the role of ICT. Department of Defense (DoD) Instructions 3000.05 (Military Support for Stability, Security, Transition, and Reconstruction) and 8220.02 (ICT Capabilities for Support

---

<sup>92</sup> World Bank (2003). *Afghanistan - Emergency Communications Project*. Washington, DC: World Bank. Accessed March 14, 2016. <http://documents.worldbank.org/curated/en/657161468185398097/Afghanistan-Emergency-Communications-Project>.

<sup>93</sup> World Bank (2011). *Afghanistan - ICT Sector Development Project*. Washington, DC: World Bank. Accessed March 14, 2016. <http://documents.worldbank.org/curated/en/2011/03/13995882/afghanistan-ict-sector-development-project>.

<sup>94</sup> ICT for Peace Foundation. Accessed March 14, 2016. [http://ict4peace.org/?page\\_id=3](http://ict4peace.org/?page_id=3).

of Stabilization and Reconstruction, Disaster Relief, and Humanitarian and Civic Assistance Operations) begin to address the role and uses of ICT and civil-military information sharing, but they do not clearly establish ICT as an essential service and critical infrastructure, its importance as an enabler of security, stability, and reconstruction operations, or the need to institutionalize mechanisms to support ICT-enabled interventions including education, training, and exercises.

Afghanistan actually “got it” in terms of the importance of ICT as an enabler of recovery. The [Afghanistan National Development Strategy \(ANDS\)](#) which served as the vision, strategy, and roadmap for guiding the cross-sector reconstruction of Afghanistan from 2008 to 2013, was based on the Millennium Development Goals. The ANDS was underpinned by the principles, pillars, and benchmarks of the Afghanistan Compact.<sup>95</sup> The pillars of the ANDS were: security; governance, rule of law and human rights; and economic and social development. ICT fell under Economic and Social Development as part of Infrastructure activities. In the 2006-2008 timeframe, the Ministry of Communications and Information Technology (MCIT) provided the strategic leadership to develop an Information and Communications Technology Sector Strategy<sup>96</sup> that provided the policy, vision, and action plan for the way ahead in the ICT sector and the use of ICT by other sectors. This strategy evolved to become the [E-Afghanistan National Priority Program \(NPP\)](#) in 2011, the objective of which was “To make affordable communication services available in every district and village of Afghanistan through [an] enabling market economy, so that all Afghans, men and women alike, can use ICT to expeditiously improve [g]overnment, social services, foster the rebuilding process, increase employment, create a vibrant private sector, reduce poverty and support underprivileged groups and to make Afghanistan a forefront member of the E-global society.”<sup>97</sup> In November 2011, the *E-Afghanistan* program was referenced in Appendix 3 (Information and Communications Technology) to Annex W (Stability Operations) of NATO’s International Security Assistance Force’s (ISAF’s) Operations Plan 38302 Revision 6. The ANDS and *E-Afghanistan NPP* were key reference documents used by ISAF, Coalition civilian and military elements, donors, and international organizations such as the UN, ITU, and the World Bank.

The bottom line: ICT can be an important component for success in post-conflict security, stability, reconstruction, and development operations. To achieve successful results requires that a purposeful strategy be adopted to use these capabilities to achieve the desired end state of building up the affected nation and to develop operational activities that effectively implement its strategies. In complex

---

<sup>95</sup> The Afghanistan Compact was the result of the London Conference on Afghanistan between the Islamic Republic of Afghanistan and the international community, held January 31-February 1, 2006. Accessed March 14, 2016.

[http://www.nato.int/isaf/docu/epub/pdf/afghanistan\\_compact.pdf](http://www.nato.int/isaf/docu/epub/pdf/afghanistan_compact.pdf).

<sup>96</sup> Islamic Republic of Afghanistan Ministry of Communications and Information Technology (MCIT). *Information and Communication (ICT) Sector Strategy 1387-1391 (2007/08-2012/13)*, February 2008. Accessed March 14, 2016. [http://mcit.gov.af/Content/files/ICT%20Sector%20Strategy%20-%20English%20final%20Singed\(2\).pdf](http://mcit.gov.af/Content/files/ICT%20Sector%20Strategy%20-%20English%20final%20Singed(2).pdf).

<sup>97</sup> Islamic Republic of Afghanistan Ministry of Communications and Information Technology (MCIT) (2011). *E-Afghanistan National Priority Program (NPP) Proposal*, May. Accessed March 14, 2016.

<http://mcit.gov.af/Content/files/PSD%20NPP%202%20E%20Afg%20NPP%20Proposal%2023%20May%202011.pdf>

operations, the USG and International Community cannot achieve the social, political, and economic goals for which government personnel, military forces, and civilian elements are committed unless the USG and International Community can engage in comprehensive approaches and work effectively with affected nation governments, local businesses, and members of civil society. This is an enduring truth that has been demonstrated repeatedly in many real-world contingencies.

Unfortunately, in spite of the progress being made regarding the use of ICT in both the public and private sectors, real-world experience suggests recovery and reconstruction of the affected nation's ICT sector will not likely be the first priority [of intervening governments' civilian and military elements or the donor community in post-conflict interventions], though it is likely to be one of the first to bring tangible social and economic benefits<sup>98</sup> and facilitate early restoration of security, governance, and rule of law. In this regard, the USG's and international organizations' policies have yet to formally recognize the new role of ICT for crisis response, nor have either institutionalized needed policy, doctrine, or other mechanisms to support ICT-enabled interventions and related education, training, and exercise program changes to fully leverage the capabilities of the Digital Age. Clearly, for the USG, senior leadership and support is needed to establish appropriate policy that recognizes the importance and priority of ICT as an essential service and critical infrastructure and to shepherd the change process as an Interagency whole-of-government action.

The USG and International Community need to manage expectations and put recent Afghan successes in the context of the environment. Yes, the Afghans understood the importance of ICT (as mentioned above), and post-2001, there were certainly successes in the Afghanistan ICT sector, particularly as compared to other sectors, but the intervention community needs to be reminded that Afghanistan is still a war zone, and sustainment of progress is dependent upon managing the security environment of the country and establishing a government that can lead the Afghans to stability and peace. Success also depends on the International Community and the political will of participating nations and donors, and their appetite for the public interest versus their fatigue from a generation of support. Additionally, ICT has so far failed to be applied to its maximum capability as an enabler of post-conflict reconstruction and socio-economic recovery. Despite the US's global leadership in virtually every aspect of technology – from personal mobility to big data – US policymakers, and the International Community as well, have failed to apply this dominance in the civilian battlespace before, during, and after military engagement. A big part of the reason for this failure in the USG is that ICT continues to lack a “home” in the highly-compartmentalized and competitive realm of USG policymakers, and consequently, there is no single actor that “owns” this agenda, and no mechanism to integrate ICT solutions into the “classic” supply chains of development (for example, roads, power, schools, and healthcare).

---

<sup>98</sup> Kelly, Tim and David Souter (2014). *The Role of Information and Communication Technologies in Postconflict Reconstruction*. World Bank Studies. Washington, DC: World Bank. doi:10.1596/978-1-4648-0074-0. License: Creative Commons Attribution CC BY 3.0. Accessed September 7, 2015. <https://issuu.com/world.bank.publications/docs/9781464800740?e=0/6688927>.

## Afghanistan's ICT Sector – A Success Story

The cessation of conflict often leaves the ICT sector of post-conflict countries in disrepair. The civil and commercial communications infrastructure will likely have been destroyed and ICT sector governance will most likely be dysfunctional. This was certainly the case in Afghanistan at the end of 2001. The good news is significant progress has been made in the Afghan ICT sector, and it truly is *the* success story of the country emerging from decades of war. Progress towards bridging the digital divide (the disparity between technology haves and have nots due to geography, demography, or economic status) and moving Afghanistan into the twenty-first century Information Age has not been accidental, but was largely due to having an enabling environment with the right people at the right places with the right passion to work, along with the vision, energy, and expertise to make reasonable decisions and take actions to make things happen.

During the war years, there was little access to telecommunications services, especially national and international calling capabilities. Afghans had to travel to neighboring countries such as Pakistan and Iran to make and receive phone calls. Because the Taliban had forbidden music, television, and the Internet, these capabilities largely did not exist. The ICT culture and skills had evaporated: most of the population with the necessary expertise left the country during the war years, and technological advancements that proliferated in developed countries largely skipped Afghanistan during its decades of turmoil. Hence, there was a shortage of Afghan leaders, managers, administrators, and technical personnel with twenty-first century ICT-oriented business and technical skills in the civil sector, the private sector, and education institutions. Key skill areas of concern include business management and practices, project management, financial management, telecommunications and IT (both technical and management skills), cybersecurity, critical infrastructure protection, spectrum management, and English language. There was a need to develop across the Government of the Islamic Republic of Afghanistan (GIROA) and the private sector a more informed information culture that recognized the value and utility of information in achieving operational and strategic success, where information forms the basis of organizational decision making, and information technology is readily exploited as an enabler for effective information systems.<sup>99</sup> With the emergence of access to the Internet and related information services, there was a need to develop a “cybersecurity culture” and more informed information security awareness on the part of the providers, operators, and users.

Afghanistan's ICT sector has come a long way since 2001. Mobile services coverage in 2014 was approximately 90 percent with nearly 22 million mobile subscribers and a mobile penetration rate of over 80 percent.<sup>100</sup> Eight out of every ten Afghan women had at least some access to a mobile phone (in 2002

---

<sup>99</sup> Definition of “information culture” from Choo, Chun Wei (2008). “Information Culture and Information Use: An Exploratory Study of Three Organizations.” *Journal of the American Society for Information Science and Technology*, 59(5): 792-804 (March 2008): 793. Accessed August 21, 2105.  
<http://choo.fis.utoronto.ca/FIS/ResPub/JASIST2008.pdf>.

<sup>100</sup> Senior Telecommunications Advisor, Interim Program Review to DISA, May 2014.

it was zero).<sup>101</sup> There are over two million Internet users – maybe more – and the price of one Megabit per second per month (1 Mbps/month) of Internet access has decreased from US\$5,000 in 2002 to US\$67 in 2014 and now, with increased competition, US\$7.50 in 2016.<sup>102</sup> Investment in the ICT sector has exceeded US\$2 billion.<sup>103</sup> Presently, with annual revenue of US\$200 million, the ICT sector is the second-largest source of income for the Afghan government, accounting for ten percent of its total revenues.<sup>104</sup> The ICT sector is one of the largest employers in Afghanistan, providing upwards of 200,000 direct and indirect jobs.<sup>105</sup> The benefits of ICT impact not only improved security, rule of law, and governance but also socio-economic development and growth. It validated its role as a cross-sector enabler in areas such as finance, agriculture, education, healthcare, and gender equality.

Afghanistan's ICT sector success was and continues to be enabled by a number of factors:

- An understanding by GIRoA of the importance of ICT as an engine of economic growth and its role as an enabler of cross-sector reconstruction and development;
- Early establishment by GIRoA of ICT policies, regulations, and laws and an initial spectrum management capability and GIRoA's willingness to take early action to issue an international competitive tender for Afghanistan's first nationwide GSM license;
- A knowledgeable and experienced Minister of Communications and Information Technology with continuity of service over multiple years;
- The MCIT's vision, strategy, and plan for moving Afghanistan ICT into the twenty-first century Information Age being supported at the highest level of government, including by former President Hamid Karzai and current President Ashraf Ghani;
- Establishment of a good public-private partnership that enabled private sector companies to invest in ICT and rapidly grow their networks;
- International community and US government support that placed emphasis on:
  - The development of ICT sector governance, including policies, regulations, and laws; best practices; and education and training.
  - ICT capacity building, including the establishment of related educational institutions and training facilities and the development of information culture and cybersecurity awareness training; and

---

<sup>101</sup> Sangin, Amrizai (2014). "Afghanistan as a Hub: The Role of Information & Communications Technologies." Presentation to the Afghan American Chamber of Commerce conference, June.

<sup>102</sup> Per the MCIT, 2016.

<sup>103</sup> Afghanistan Telecom Regulatory Authority (ATRA). Telecom Statistics (End of December 2015). Accessed January 5, 2016. <http://atra.gov.af/en/page/telecom-statistics-2013>.

<sup>104</sup> Islamic Republic of Afghanistan Ministry of Communications and Information Technology (MCIT) (2014). *The Ministry of Communication and ITs' [sic] activities and achievements report 1381-1393 (2002-2014)*, English version, 32 (not available electronically).

<sup>105</sup> Ibid: 39.

- Creation of a national telecommunications and IT network, particularly the national fiber optic network and its regional interconnections.

Challenges for the future include: a deteriorating security situation (threats against ICT personnel and facilities); the need to sustain economic and political stability; a lack of reliable electric power; poor spectrum management; and a lack of qualified management, technical, contracting, marketing, and financial personnel. With the introduction of the new Ghani administration in 2014, a new Minister of Communications was installed, and related internal management adjustments were proposed or rumored at the deputy minister and other management levels. Additionally, a new Chairman was introduced at the Afghanistan Telecom Regulatory Authority (ATRA), as were new ATRA Board members, and there were proposed and actual leadership and organizational changes at state-owned Afghan Telecom Corporation (AfTel). In 2015, the Office of the Chief Adviser to President Ghani for Infrastructure, Human Capital, and Technology was created, and ICT oversight is part of the position's infrastructure portfolio. Needless to say, the changes in the ICT sector governance leadership created uncertainties and modified the established ways of doing business that will take time to stabilize. As of early 2016, many of the further proposed or rumored changes had yet to occur, and stabilization of the ICT sector governance remained a challenge.

The new ICT administration is engaged in trying to manage its governance changes and business processes while trying to implement digital services such as mobile money, an electronic national identity card (e-NIC), and other electronic and mobile government services. They continue to try to grow a cybersecurity and information culture and to modernize and leverage ICT infrastructure and services, particularly the expansion of 3G<sup>106</sup> mobile broadband services and the possible introduction of 4G/LTE.<sup>107</sup> Efforts continue to improve Internet access while reducing the cost of Internet services and to continue the implementation and activation of the national fiber optic network with its five regional interconnects. President Ghani has invigorated the need to employ ICT for Afghan women.

## US Government ICT Policy and Doctrine

In the Information Age, it should not be surprising that ICT has emerged as an essential service and critical infrastructure supporting complex civil-military operations and related crisis response actions facilitating the recovery of a disaster-stricken nation. With the increase in the power of ICT as an enabler, it has become extremely important for the USG and other responder nation's civil-military elements, inter-governmental organizations (IGOs), international organizations (IOs), non-governmental organizations (NGOs), and donors to step back and review and adjust their concepts, strategies, and plans for the role

---

<sup>106</sup> Third-generation wireless digital technology based on International Telecommunication Union (ITU) International Mobile Telecommunications (IMT)-2000 specifications.

<sup>107</sup> Fourth-generation wireless digital technology based on International Telecommunication Union (ITU) International Mobile Telecommunications (IMT) Advanced specifications and long-term evolution, a high-speed wireless communications standard developed by the Third Generation Partnership Project (3GPP).

and importance and the effective use of ICT in crisis response and post-conflict security, stability, reconstruction, and development operations.

There is a need for the intervening community at large to view and treat affected nation civil and commercial ICT as an essential service and critical infrastructure with a focus, priority, and investment interest equivalent to that of roads, power, and water. In reality, ICT is an enabler of the recovery of these infrastructures. However, one must not overlook the challenges of the lack of reliable commercial power in post-conflict operations and the role of power as an essential companion to ICT operations. Alternative sources of power need to be part of the ICT-enabled intervention capabilities. Options such as diesel generators, solar, wind, and micro-hydro power should be considered for both urban and rural areas. For Afghanistan, solar was an excellent alternative to electric power, especially in rural and disadvantaged areas, not only for cellular sites and terrestrial transmission facilities, but also for deployable VSAT<sup>108</sup> satellite terminals and related IT equipment in extremely remote areas. Additionally, low-power ICT equipment also needs to be considered as an option for establishing voice and data services in remote areas where commercial power is not likely to be available. Frequently in Afghanistan, one would see vehicle batteries used to charge mobile phones as well as solar-powered chargers and even bicycle-powered chargers to power laptops at homes and in bazaars.

Approaches to the smart use of information and ICT in support of civil-military interventions are still ad hoc, and no agreed-upon USG or international policy exists in terms of approaches to be used for ICT-enabled interventions. See [Figure 7](#) on USG policy, doctrine, concepts, and manuals that need to be reviewed and updated to reflect the role and importance of ICT and the use of whole-of-government responses for complex operations. One such document is National Security Policy Directive (NSPD)-44 from 2005 that empowered the Secretary of State to lead and coordinate the US government's response across all involved agencies and to work with the Secretary of Defense to harmonize civilian and military activities. Another is Presidential Decision Directive 23 (PDD 23) in 2013 on US Security Sector Assistance Policy that fostered USG policy coherence and Interagency collaboration. Others are 2009's DoD Instruction 3000.05 (Military Support for Stability, Security, Transition, and Reconstruction) that gave stability operations priority comparable to combat operations and DoD Instruction 8220.02 (ICT Capabilities for Support of Stabilization and Reconstruction, Disaster Relief, and Humanitarian and Civic Assistance Operations) that addressed information-sharing activities and arrangements that facilitate coordination and cooperation between DoD and non-DoD partners.

---

<sup>108</sup> Very small aperture terminal, a two-way satellite ground station with a dish antenna generally smaller than three to four feet.

## Stability and Reconstruction Ops: Policy and Doctrine

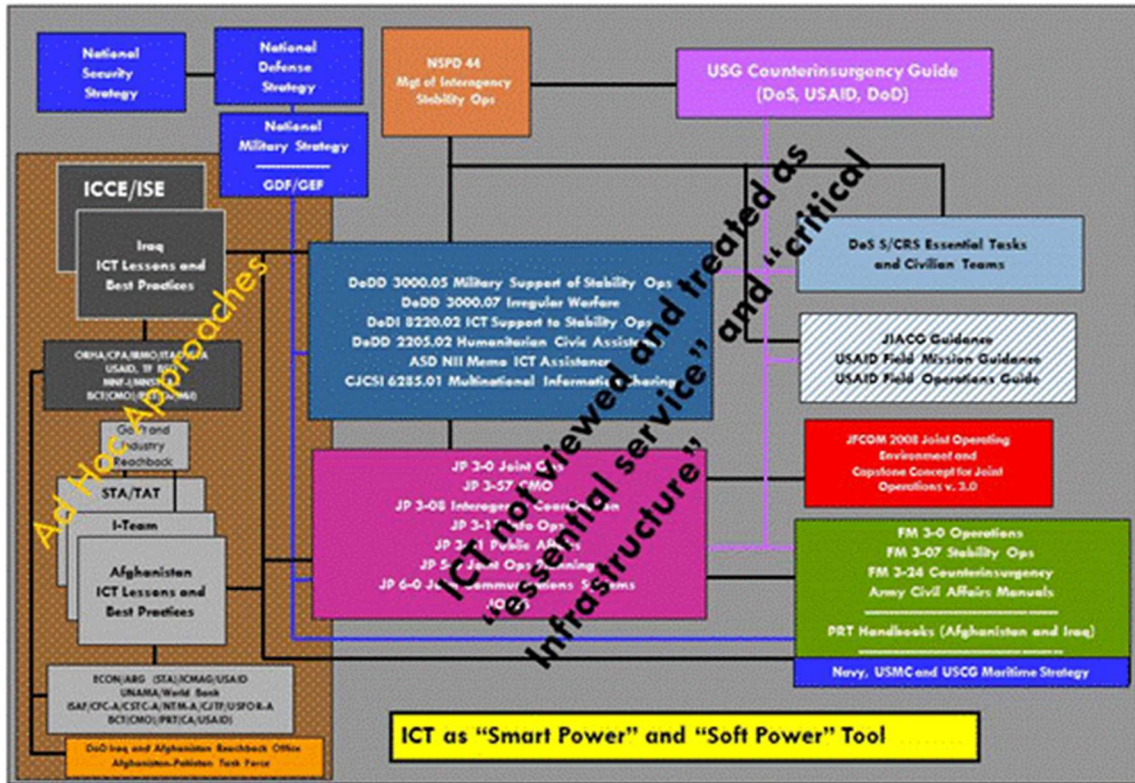

Figure 7: USG ICT policy, doctrine, concepts, and manuals

Although the national-level directives and DoD instructions have started to introduce the importance of ICT in crisis response actions, the USG policy, doctrine, and approaches have yet to address the importance of ICT as a critical infrastructure and an essential service, and agreed civil-military approaches have yet to incorporate ICT-enabled interventions. The value and importance of ICT has not yet been, in some cases, fully understood or appreciated by USG decision makers. Activities related to USG crisis response operations including the value of ICT-enabled intervention approaches — policy, doctrine, procedures, education, exercises, and training — do not yet adequately incorporate the role and importance of civil and commercial ICT as an enabler. Furthermore, the need for an affected nation to have functional ICT sector governance operating early in the intervention to help get infrastructure and services in place and operational may not be fully appreciated as an action the intervening force will likely need to be prepared to help jumpstart. The same can be said for agreed international crisis response concepts, approaches for interventions, and capabilities for post-conflict security, stability, and reconstruction operations.



## ICT-enabled Intervention Timeline

As a nation emerges from conflict and starts the recovery process, careful attention needs to be paid to the fact that ICT infrastructure and its governance will likely have been destroyed or is dysfunctional and that, for recovery purposes, ICT needs to be treated as both a sector and an enabler of cross-sector recovery, reconstruction, and development for the affected nation. There will be a need to recover ICT sector governance early — to have a functioning ministry and regulator and the development and enactment of policies, regulations, and laws. Early emphasis also needs to be placed on ICT support for intervening civil-military responders and for the affected nation’s communications needs for security,

# ICT-enabled Intervention Spectrum

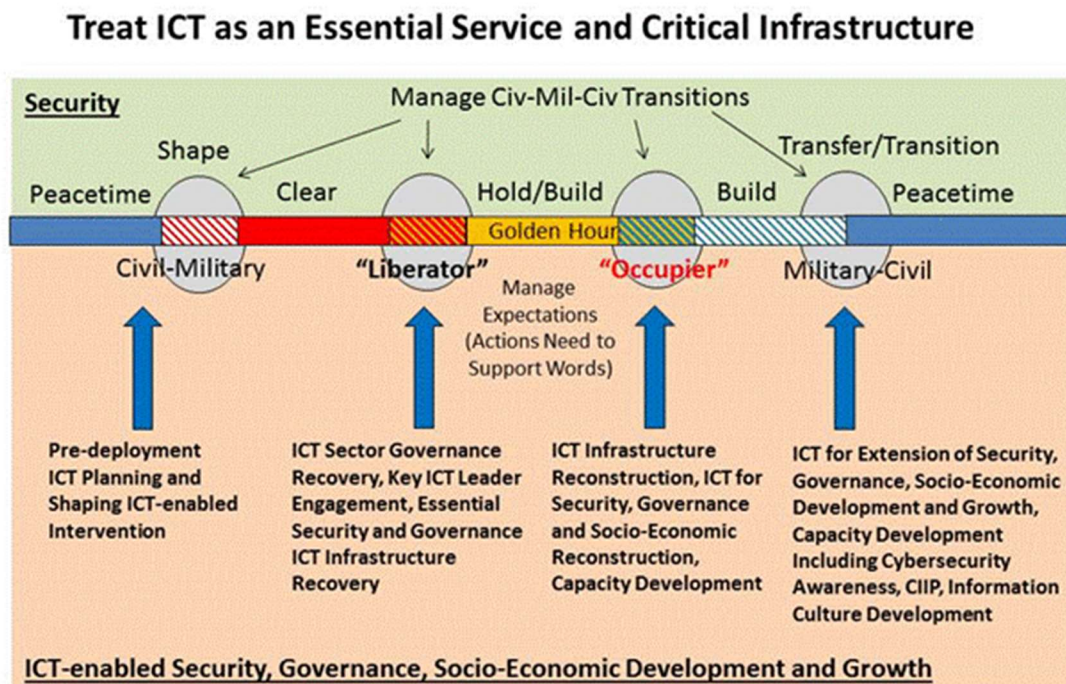

Figure 8: ICT-enabled intervention timeline

defense, and basic governance. Attention needs to be given to developing an ICT strategy and plan for the recovery, reconstruction, and development of civil and commercial ICT infrastructure and services. Consideration should be given to including public-private sector partnerships to jumpstart commercial sector investments to introduce and grow competitive nationwide voice and data networks with access to the global ICT and information environment (see [Figure 8](#)).

As mentioned above, there are no agreed-upon USG or International Community policies, concepts of operations (CONOPS), institutional arrangements, doctrines, or processes for managing a partial or full-spectrum ICT-enabled intervention. International organizations such as the ITU, UN, and the World Bank and national elements such as the US Agency for International Development (USAID), the US Trade and Development Agency (USTDA), the Federal Communications Commission-International Bureau (FCC-IB),

and the Departments of Defense, State, and Commerce (DoC), along with other government elements, can and do address different aspects, but no one element has the role and responsibility for providing an experienced professional team of civil and commercial ICT subject matter expert (SME) advisors on the ground to work on ICT sector governance, infrastructure, and services; the use of ICT to enable security, governance, and socio-economic development and growth; and capacity development to rebuild and train an ICT-savvy workforce. An agreed-upon timeline such as the one illustrated in [Figure 8](#) does not exist to help shape a USG and international unity-of-effort ICT-enabled response capability. There is no policy or doctrine guiding when to intervene, where, and with which capabilities to do what for whom. The early responses to recovery of ICT sector governance have been largely independent and uncoordinated efforts of a number of different USG and international organizations. Ad hoc approaches such as a Senior Telecommunications (Telecom) Advisor (STA) and a Telecommunications Advisory Team (TAT) have been used to experiment with ICT-enabled interventions in support of stability and reconstruction operations. These improvised approaches have been important learning experiences and need to be used to help shape and institutionalize ICT-enabled approaches to be used in future operations.

Early attention needs to be given to recovery of the ICT sector governance (policies, regulations, laws, licenses, contracting, and spectrum management) and organizations and their leadership to provide needed experienced, professional advice to authorities and to facilitate development of an initial strategy and plan for ICT infrastructure recovery and reconstruction. Early reclamation, rehabilitation, or establishment of ICT infrastructure will be needed not only to support the C4ISR<sup>109</sup> connectivity and service needs of the intervening civil-military responders but also to help jumpstart the restoration of the ICT sector of the affected nation. This is imperative to support early essential government communications related to civil security and governance and to allow the population to communicate and begin socio-economic recovery, including job creation. In this regard, early establishment of good public-private partnerships to enable commercial investments in the ICT sector are key. History has shown mobile network operators (MNOs) are willing to take risks in post-conflict zones and know how to rebuild – or build – commercial voice and data networks in stressed environments.

Former Secretary of the Army Martin R. (Marty) Hoffmann observed that after every conflict there is a “golden moment” (also referred to as the “golden hour”) in which recovery and reconstruction is most easily accomplished. This is the moment after significant hostilities have ceased and before opposition to reform has had an opportunity to gel. The intervener’s transformation from liberator to occupier is a well-known challenge and can happen quickly and early in the transformation process. As illustrated in the intervention spectrum graphic in [Figure 8](#), the USG and the International Community all too often intervene with the resources needed for recovery and reconstruction *after* this magical point in time. The USG and the International Community must do better in future operations. ICT-enabled interventions may be the answer to help improve the way the world conducts post-conflict stability and reconstruction operations including related counterinsurgency (COIN) activities at village, district, and provincial levels.

---

<sup>109</sup> Command, control, communications, computers, intelligence, surveillance, and reconnaissance

Post-conflict reconstruction and development can last for years, and a decade or more is not unusual. The transition from conflict to stability operations encompasses not only security, but also the start of recovery, reconstruction, and development and sets the expectations of the local population for a better quality of life. Implementation of post-conflict activities, therefore, needs to be accompanied by an effort to manage expectations of both the interveners and the affected nation's government and population. For example, the "golden moment" may be as short as a few months, during which time the intervener's actions must begin to support their words and promises and start to meet the expectations of the local population regarding improvements in the quality of life, particularly security and government services. This suggests a tight link is needed between the civil-military post-conflict recovery and reconstruction elements and the public affairs and information campaign elements of the intervening force to tell a credible, coherent, and timely story to inform the population and others involved in the intervention of things that are happening. Certainly, an ICT-enabled intervention with effective use of social media can play an important role in helping make this happen, as well as provide the ability for the rapid identification of problems and opportunities that need to be addressed.

The intervening civil-military elements can also help enable early infrastructure recovery efforts by employing techniques such as anchor tenant where they make offers to, for example, guarantee leases of connectivity and procurement of services for a period of time. This incentivizes communications providers to expand coverage and offer services at reasonable prices to meet the needs of the intervening elements and provide capacity to support affected nation security and government activities and help enable early economic growth. The revenues generated by such an arrangement can, in turn, be used to help jumpstart the expansion of critical civil and commercial ICT capabilities such as the fiber optic cable network in Afghanistan. The expanded network services can then be used to support broader civil and commercial needs and generate additional revenues. In the case of Afghanistan, the USG was an anchor tenant for the Afghan national fiber optic network. During the 2010 to 2015 timeframe, leases of fiber optic connectivity by the Defense Information Systems Agency (DISA) to support US military C4ISR needs cost over US\$300 million at an average annual rate of about US\$53 million, making the USG a major contributor of revenue to GIRoA, which it still is today. As a result, the national fiber optic network has expanded, including the establishment of cross-border links to other national networks and onto international cables, further contributing to economic growth opportunities for Afghanistan and creating a competitive environment to reduce costs of voice and data services.

Afghanistan's fiber optic network is an example of dual-use technology that can be employed by both civil and commercial interests as well as military purposes. Hence the interest in early recovery of ICT sector governance to facilitate infrastructure recovery and leasing connectivity such as on Afghanistan's fiber optic network to provide countrywide connectivity and global access. ICT sector governance recovery is also important for civil-military spectrum management. There were challenges coordinating civil and military spectrum management activities and de-conflicting interference in Afghanistan. In 2012, the issue of civil-military coordination was finally addressed by the signing of a Memorandum of Agreement (MoA) among ISAF, ATRA, and the Afghan National Security Forces (ANSF) for military, civil, and commercial spectrum management. The MoA laid the foundation for establishing a Ministerial Spectrum Management Office in 2012 comprised of spectrum managers from the Afghan Ministries of Defense and

Interior, the National Directorate of Security, and ATRA, with support from ISAF and now Resolute Support (RS).

Investment in ICT capacity development to build an ICT-savvy workforce of the affected nation is necessary as well. ICT also needs to be leveraged as an enabler of cross-sector (security, governance, rule of law, agriculture, finance, education, gender equality, and healthcare) recovery, reconstruction and development, including paying early attention to its use as an engine of economic growth. Additionally, ICT is an important source of revenue for the affected nation an engine of job creation within the sector, for businesses supporting the sector, and by other sectors using ICT services. The bottom line is that ICT plays a vital role in restoring affected nation sovereignty and its recovery of national defense and security capabilities. It also serves to facilitate moving the nation into the global information and business environments.

Unfortunately, recent real-world experiences suggest the US government has lost the ability to capitalize on the “golden moment,” which it did so effectively at the end of World War II. This ability will not likely be restored under the current structure of American foreign policy, which lacks an agreed-upon USG international crisis response strategy and plan and an operationally-trained and rapidly-deployable civil-military ICT-enabled element that can plan for and conduct ICT support activities for security, stabilization, reconstruction, and development operations in a timely and effective manner.

## Senior Telecommunications Advisors – Afghanistan

The use of Senior Telecommunications (Telecom) Advisors (STAs) in Afghanistan as civil and commercial ICT subject matter experts to provide advice and assistance to senior USG, ISAF, GIRoA, and commercial ICT sector leadership in Kabul charted new territories of operation. The arrangements were both experiments and learning experiences regarding ICT-enabled interventions. The approaches used were based largely on prior experience in other real-world operations and the professionalism of those who developed the concepts and participated in their implementation. The efforts were largely Kabul-centric with limited attempts to obtain a more countrywide perspective. Travel inside and outside of Kabul was dependent upon the security situation at the time.

The first attempt to use a senior civilian professional civil and commercial ICT advisor was between 2005 and 2008 with the Senior Telecom Advisor (STA) position at the Afghanistan Reconstruction Group (ARG) located at the US Embassy Kabul and reporting to the US Ambassador. The USG, mainly the Departments of Defense and State and the National Security Council (NSC), took an action to consider ways to accelerate the process of Afghan reconstruction post-2002 and elected to provide selected professional SMEs on the ground in Kabul to help. An experimental unit known as the Afghanistan Reconstruction Group, or “ARG,” was organized by former Secretary of the Army Marty Hoffmann (working as an advisor to then Secretary of Defense Donald Rumsfeld) in 2003 when it became obvious that the perceived “business-as-usual” approach to reconstruction was in danger of making Afghanistan another Haiti or Kosovo. One of the SME positions staffed was the STA, who had the lead role to provide advisory support related to all aspects of the emerging Afghan ICT sector. The STA was also to prioritize advisory support issues working directly with the Afghan Minister of Communications and his staff as well as with the regulator, ATRA, the state-owned ICT service provider AfTel, and commercial mobile network operators

and Internet service providers. The STA was also to interface with ISAF, the Combined Forces Command-Afghanistan/Combined Security Transition Command-Afghanistan (CFC-A/CSTC-A), the US Embassy Kabul Economic (ECON) Section, the USAID Mission, the DoC, and other USG Interagency elements as necessary, and with international organizations such as the World Bank and UN.

The second attempt was from 2010 to 2014 with the USG-sponsored (DoD lead and DoS supported) ISAF STA and the supporting Telecommunications (Telecom) Advisory Team (TAT) located at ISAF Headquarters in Kabul and reporting to the Commander of ISAF and US Forces-Afghanistan (USFOR-A) and also working with the US Embassy Kabul and USAID Mission. DISA funded<sup>110</sup> and managed the establishment of the office in July 2010 and operation of the STA/TAT advisory support until October 2014. The STA/TAT mission was to facilitate the development of the Afghan ICT sector and advise and assist GIRoA in employing ICT to enable security, governance, stability, and socio-economic development. This was accomplished by: facilitating and coordinating the US Government's, Coalition forces', and ISAF's strategic interests in ICT in Afghanistan, both in country and CONUS;<sup>111</sup> developing coordinated strategies and synchronizing solutions among GIRoA, the USG Interagency, NGOs, the International Community, and private industry; providing ICT experience and expertise to advise and assist Afghanistan's public ICT institutions; improving harmonization, coordination, and synchronization of ICT policy, services, and infrastructure initiatives across economic sectors; providing leadership, strategic direction, and other assistance as needed to support the private ICT sector; improving performance and developing ICT capacity within GIRoA; and gaining and maintaining informed situational awareness across the Afghan ICT ecosystem to create synergies among the activities and initiatives of various stakeholders. The STA provided civil and commercial professional ICT leadership and subject matter expertise to perform the role of key leader advisor to and primary US government (USG) day-to-day engagement leader with the GIRoA Minister of Communications and Information Technology, the Chairman of ATRA, and the Chief Executive Officer (CEO) of state-owned Afghan Telecom Corporation (AfTel) and their staffs. The STA also interacted with commercial MNOs and ISPs and the ICT representatives of national and international organizations.

Both STA efforts were supported by a CONUS-based reachback element composed of experienced ICT professionals who had spent significant time on the ground in Afghanistan, were experienced in military-civil-commercial engagements, and had a passion for and commitment to the modernization of the Afghan ICT sector and the use of ICT as an enabler of security, governance, and socio-economic development.

The Reachback team had extensive contacts and relationships going back over several years' experience in country. Reachback had access to personnel within GIRoA, the Afghan ICT sector, the US Embassy Kabul, USAID, the UN, the ITU, and the World Bank, among other entities. In the US, Reachback had contacts and relationships with the headquarters elements of the USG Interagency, academia, think tanks,

---

<sup>110</sup> The DoD Task Force for Business and Stability Operations (TFBSO) also provided funding support for the first year of operation.

<sup>111</sup> Continental United States

international organizations, professional associations, and industry. They played important roles as facilitators, coordinators, harmonizers, and connectors both in country and CONUS. Reachback was the institutional memory and transition continuum for ICT advisory support to ISAF and the Interagency teams both in country and CONUS.

In Operation ENDURING FREEDOM in Afghanistan, DISA also deployed a DISA Support Element-Afghanistan (DSE-A) to Kabul in 2009 to coordinate the establishment and operation of Tier 0 DISN<sup>112</sup> entry points to support the military surge C4ISR connectivity needs. The DSE-A office in Afghanistan was closed in November 2014 and moved to Bahrain. Among the other major achievements of DISA in Afghanistan were the development of a common video teleconferencing (VTC) platform to enable the multinational forces in theater to communicate via a secure VTC bridge and assisting US Central Command (CENTCOM) to establish a secure collaboration mission network — CENTRIX-ISAF (Combined Enterprise Regional Information Exchange System-ISAF). Additionally, DISA played a key role in enhancing the overall communications infrastructure to support some 6,000 users of handheld satellite communications through the Afghan Mission Network (AMN). Established in 2010, AMN supported 30 nations and 85,000 users and became the principal Coalition military command-and-control network in Afghanistan. AMN reinforced that commanders operating in complex coalition environments require responsive coalition mission networks for command and control and information sharing in theater.<sup>113</sup>

## Intervention Business Model

An agreed-upon ICT-enabled intervention concept, process, and arrangement for assigning a lead USG agency for ICT and establishing timely professional ICT-focused thought leadership and strategic thinking and advice and assistance to intervening force leadership and the affected nation has yet to be sufficiently reflected in USG or international ICT-related policy and organization arrangements to be institutionalized and used in crisis response operations. The need for such an institutional arrangement to meet the needs of ICT support for security, stability, and reconstruction operations and affected nation recovery, reconstruction, and development is only just beginning to receive USG senior leadership attention and momentum. Approaches for the smart use of ICT in support of interventions are still ad hoc and often suffer from inadequate attention paid to the need to provide professional civil and commercial ICT subject matter experts to advise the intervening civil-military leadership and work with the professional civilian ICT counterparts of the affected nation.

Responder elements, in many cases, have an inadequate understanding of the affected nation's information culture and related ICT business (government and private sectors) culture, including decision-making and ICT supply chains. There is a lack of an informed understanding of the ICT capacity development needs given the skilled workforce has likely left the country during the conflict phase and not yet returned in force in the post-conflict phase. Development of an agreed-upon ICT-enabled strategy

---

<sup>112</sup> The DISN is the Defense Information System Network managed by DISA. Tier 0 is the gateway access to the network.

<sup>113</sup> Defense Information Systems Agency (DISA). Accessed September 7, 2015. <http://disa.mil/About/Our-History>.

and plan for recovery, reconstruction, and development of the ICT sector and its governance continues to be lacking. Responses are largely stovepiped and loosely coordinated. A more informed understanding by the civil-military responder community of the importance of ICT to achieving timely success in an intervention is needed as well. There also exists a need for a more informed and shared understanding of the use of ICT as a game changer and cross-sector enabler. Jumpstarting the recovery of ICT sector governance and reconstruction of ICT infrastructure such as satellite, microwave, and fiber networks needed to support intervening military C4ISR network connectivity and civil-military responder communications and information needs often does not get early attention. Recovery of ICT networks and services is not just a private sector responsibility, and it is not likely the networks will be available when the interveners arrive on the ground. The affected nation and intervening civil-military elements have a shared responsibility and need to engage to help develop effective ICT sector governance and encourage the early implementation of good public-private partnerships to jumpstart and enable the MNOs and other ICT providers to invest in infrastructure, implement services, and expand coverage.

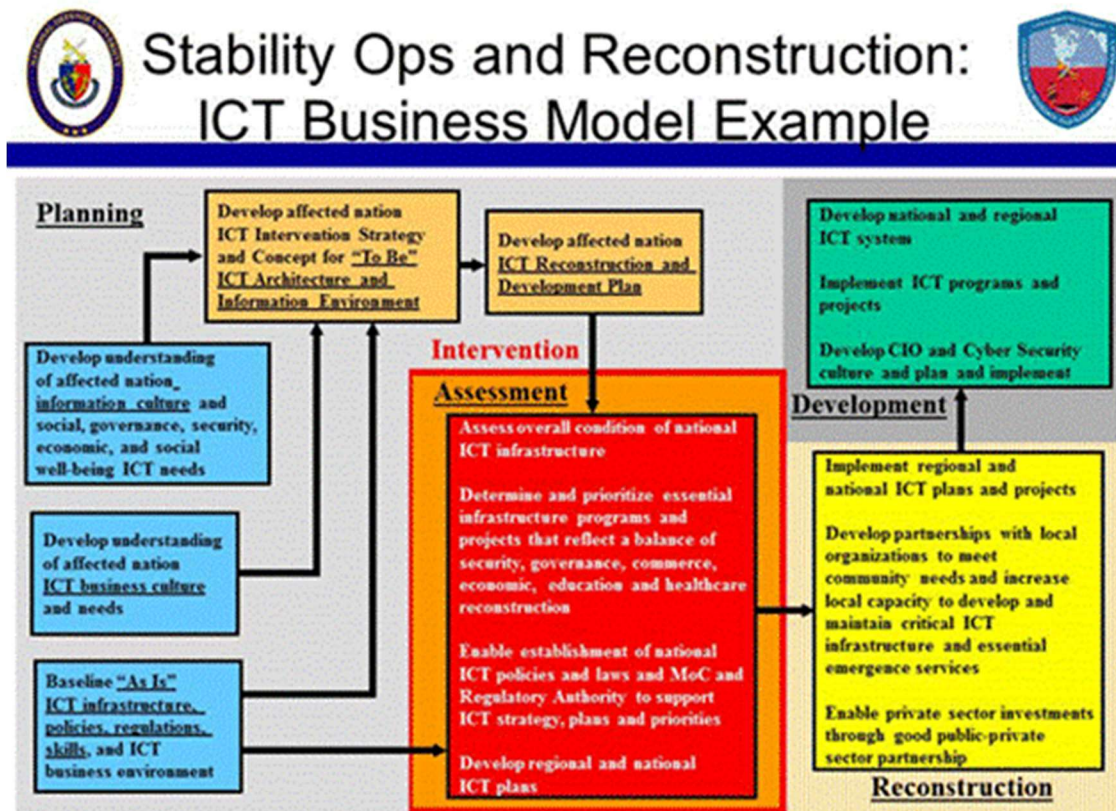

Figure 9: Business model for an ICT-enabled intervention

An informed understanding before an intervention of the affected nation's existing ICT sector governance, key leaders, government and private sector business cultures and processes, and infrastructure and related supply chains tends to be lacking (see example business model in [Figure 9](#)). Additionally, an informed understanding of who makes things happen and who are the spoilers is often missing in advance

of an intervention — there is no equivalent of an intelligence preparation of the battlespace for the ICT sector. Establishing trusted professional partnerships with key leaders before an intervention is important but not always achievable. A key leader engagement strategy tends to be developed on the ground in real time as part of the intervention force’s on-the-job training and does not always include civil and commercial ICT professionals dealing with the development of ICT situational awareness or establishing trusted working relationships with the affected nation’s ICT counterparts.

Civil-military responders’ trust relationships with the affected nation are key to intervention success. Trust is difficult to build, harder to keep, and, once lost, almost impossible to regain.<sup>114</sup> Defined as the “assured reliance on the character, ability, strength, or truth of someone or something,”<sup>115</sup> trust typically emerges as one’s expectations are consistently met over time. It is the consequence of keeping promises. Trust cannot be assumed or passed on to one’s replacement upon redeployment; it must be earned – a reality that highlights a central challenge in effectively conducting multidimensional civil-military operations and the need for multiyear assignments to sustain trust relationships.

Establishing trust is a special challenge in temporary groups, where relative strangers come together for a limited period of time to work on a specific problem or task and often work on highly-complex tasks, with little formal structure to guide coordination and control. Temporary groups depend for their success on a wide variety of individuals with diverse skills, yet lack the time necessary to learn who really knows what. Additionally, they seem to lack the normative structures and institutional safeguards that minimize the likelihood of things going wrong. Moreover, there isn’t time to engage in the usual forms of confidence-building activities that contribute to the development and maintenance of trust in more traditional, enduring forms of organization.<sup>116</sup> This was the case for the ISAF TAT that was staffed, in part, by the DoD Civilian Expeditionary Workforce program that recruited DoD employees from different government organizations to work six- to 12-month assignments in Kabul at ISAF Headquarters as part of the TAT. As a result, the TAT had a very high turnover rate that resulted in almost constant teambuilding challenges. Trust is an important element of building teams, and the TAT would have benefited from the use of techniques for building “swift trust” in such groups.<sup>117</sup> Key factors that facilitate formation of swift trust in temporary groups include professional reputation and membership in a professional group that permits attributions regarding skills and competencies. Additional factors facilitating formation of swift trust are clear role definitions, clarity about tasks, and leaders who display professional competence, reliability, and flexibility. Individual commitment involves greater engagement with one’s tasks and activities, and also with one’s social group. Leaders need to inspire greater commitment in the group and

---

<sup>114</sup> Currall, Steven C. and Marc J. Epstein (2003). “The Fragility of Organizational Trust: Lessons From the Rise and Fall of Enron.” *Organizational Dynamics* 32, no. 2 (2003): 196-197, doi: 10.1016/S0090-2616(03)00018-4.

<sup>115</sup> *Merriam-Webster Dictionary*, s.v. “trust.” Accessed March 5, 2015. <http://www.merriam-webster.com/dictionary/trust>.

<sup>116</sup> Bartone, Paul T. and Albert Sciarretta (2015). “Human Dimension Issues in Distributed and Virtual Teams.” *Small Wars Journal*, January 19. Accessed September 7, 2015. <http://smallwarsjournal.com/jrnl/art/human-dimension-issues-in-distributed-and-virtual-teams>.

<sup>117</sup> *Ibid.*



they also need to create the conditions for greater trust. The leader must be competent, cooperative, and forgiving, but also willing to enforce standards and discipline when needed, to include firing or relieving non-performers.<sup>118</sup>

Trust is not something USG institutions are optimized to engender. Government processes and regulations can limit the ability to share information and create a shroud of intrigue that undermines trust. The military tends to operate in classified environments for security reasons and the non-military in an unclassified environment. This creates problems for the open sharing of information, especially in unclassified operations such as humanitarian assistance and post-conflict reconstruction and development. The layering of biases within and between institutions creates over-burdened processes that bureaucratize US governance and limits the ability to react and accomplish strategic goals. In effect, the USG is partially paralyzed by its own actions, and this paralysis becomes more pronounced as the USG works with partners (both Interagency and international civil-military elements). If, at the institutional level, the DoD cannot create a space of shared understanding with its civil-military teammates, then efforts requiring a “whole of government approach” may or will fail.<sup>119</sup>

Adding to the challenges is the lack of an informed and shared understanding and agreed-upon mapping of civil-military responder stakeholder organizations’ roles, responsibilities, strengths, and weaknesses in international crisis response operations. There are also civil-military policy differences, people and organization cultural differences, as well as myriad languages that add to the challenges. Additionally, approaches to program development, project coordination, information sharing, and implementation for international crisis response operations differ as well. Experience in Iraq and Afghanistan and other recent crisis response operations suggest actions continue to be ad hoc and shared expectations and civil-military coordination and information sharing continue to be problematic. There is no USG and international responder agreed-upon shared vision, strategy, architecture, or plan for affected nation ICT sector governance, infrastructure and services recovery, reconstruction and development, or the use of ICT as a cross-sector enabler.

Additionally, an ICT-oriented coherent and pre-coordinated intervention strategy and plan and agreed coordination and information sharing agreements and mechanisms are not typically developed, trained or exercised, or in place for use by the responding nations and international organizations for supporting affected nation ICT recovery, reconstruction, and development.

Donors and interveners tend not to view ICT adequately as a high-priority need for early focus and investment or its use as an enabler of cross-sector recovery, reconstruction, and development, i.e., security, governance, rule of law, socio-economic development and growth, and ICT capacity development. Most times these actions are viewed to be the responsibility of the affected nation and/or

---

<sup>118</sup> Ibid.

<sup>119</sup> Grigsby Jr., Wayne W., Cheryl Sim, and Matt Dabkowski (2015). “Twelve Lessons from Sixteen Months: Reflections of a CJTF-HOA Commander.” *Small Wars Journal*, May 22. Accessed September 7, 2015. <http://smallwarsjournal.com/jrnl/art/twelve-lessons-from-sixteen-months-reflections-of-a-cjtf-hoa-commander>.

the private sector without sufficient recognition of the importance of civil and commercial ICT. Nor is there ample appreciation for the need for ICT advice and assistance to facilitate early recovery and development of effective ICT sector governance (policies, regulations, and laws) and infrastructure and services including implementing good public-private partnerships to enable investments and growth. This is work in progress for the USG and much remains to be done. Additionally, similar actions need to be initiated within the International Community to develop an agreed-upon international responder vision, strategy, plan, and capabilities for leveraging the role and use of ICT as an enabler of crisis response and affected nation recovery, reconstruction, and development.

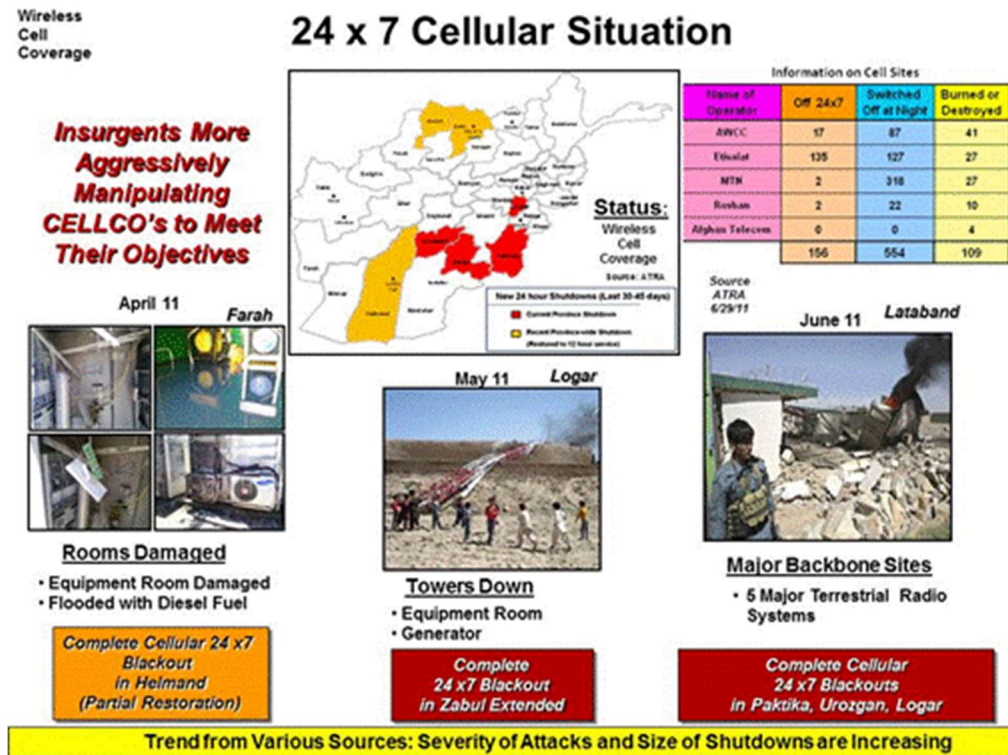

Figure 10: Taliban attacks on Afghanistan's cellular network sites

## Critical Infrastructure Protection

Emerging societies have a growing dependency on information and ICT, which has become essential to national security, economic well-being, and social cohesion for all nations. At the same time, these technologies are globally interconnected, producing global interdependencies, and they contain vulnerabilities and introduce threats to the national systems and to the nation. To maximize societies' benefits from these ICTs, the risks resulting from interdependencies, vulnerabilities and threats must be

managed. Enhancing cybersecurity and improving critical infrastructure protection have become the watchwords for efforts by many nations to address and manage these risks.<sup>120</sup>

ICT has introduced new capabilities and tools that spoilers, criminals, and insurgents can and do use not only to command and control their own operations but for extortion, corruption, disruption of intervening forces' operations, and undermining the security and stability of the affected nation trying to recover and transition to sustainment of peace and security. ICT has become a target in Afghanistan, with the Taliban, insurgents, and criminals forcing MNOs to turn off their cellular towers at night through threats and extortion, physically destroying those facilities, and kidnapping and killing ICT workers and their family members (see [Figure 10](#)). In response to such threats and actions, the Afghan Office of the National Security Council (ONSC) met in April 2011 to develop a security strategy and plan to mitigate threats and attacks against public and private ICT networks and infrastructure, or to minimize them to a level where they cannot disrupt ICT services, depriving Coalition and Afghan militaries, the Afghan police and emergency personnel, and Afghan citizens of the benefit of 24x7 telecommunications services. The Afghan ONSC developed a security strategy and plan, which was built on effective intelligence activities, coordination, and unity of efforts between ANSF and ISAF elements, and the security and technical capacities of GIRoA and private telecommunication companies.<sup>121</sup>

The bad guys also leveraged the power of social networking tools to shape and influence perceptions to support their goals. They used cyber-attacks to deface government websites and disrupt information systems supporting security, governance, rule of law, and economic activities. These destructive and spoiler actions have added a new dimension to conducting security, stability, and reconstruction operations and protecting critical infrastructure of the affected nation. Policies, strategies, capabilities, and capacity development adjustments need to be factored into shaping approaches to be used in future operations as well as for real-time adaptations for ongoing operations such as the one in Afghanistan, where there is an emerging need to more effectively protect, defend, and respond to attacks on critical infrastructure such as ICT networks and power grids. A balance of physical, personal, and cybersecurity protection and increased redundancy in network design coupled with flexible response capabilities will need to be considered to provide resilience to absorb and respond to a wide range of threat vectors from criminals to spoilers to insurgents.

As the intervening community starts to consider ways in which ICT can contribute to post-conflict stability and reconstruction, it should also not forget that, as noted above, ICT can also be used by the insurgents to trigger or prolong conflict. As mentioned above, in Afghanistan the Taliban (and others) attacked and destroyed cellular network equipment sites and forced MNOs to shut off mobile phone service at night. Mitigating threats and treating ICT as a critical infrastructure that needs protection should, therefore, be

---

<sup>120</sup> International Telecommunication Union (ITU) National Cybersecurity/CIIP Self-Assessment Tool, Rev. April 2009. Accessed September 7, 2015. <https://www.itu.int/ITU-D/cyb/cybersecurity/docs/itu-self-assessment-toolkit.pdf>.

<sup>121</sup> Islamic Republic of Afghanistan Office of National Security Council (ONSC) Directorate of Interior Affairs (2011). *Security Strategy for Telecommunication Networks in the Territory of GIRoA*, July 31.

part of post-conflict strategies for ICT as well as maximizing value added.<sup>122</sup> On the other hand, it should also be noted that over time the Taliban became smarter in terms of the value of ICT to its operation, and changed its approach from looking at ICT as a threat that needed to be neutralized to a capability that needed to be exploited to support its cause. This aspect presents an additional set of factors that need to be incorporated into ICT-enabled interventions, post-conflict ICT strategies, counterinsurgency operations, and related Information Operations campaign plans. The Internet and the digital information domain have become battlespaces as well.

There is a need for emerging nations such as Afghanistan to develop not only a Critical Infrastructure Protection (CIP) program but, more importantly, because of general greater reliance on information technology (IT) and its use to control other systems such as the SCADA<sup>123</sup> systems to control power grids, there is also a need to establish a Critical Information Infrastructure Protection (CIIP) program as well. Understanding other key interrelationships and impacts such as IT systems' dependencies on power and backup capabilities for critical data storage systems and disaster recovery plans are also important factors. Key to this is a national cybersecurity strategy and plan, related policies, laws and enforcement, and active implementation of cyber protection, detection, and response capabilities. Another menace emerging from information networks is insider threat. The challenge in this regard is that cybersecurity measures tend to be focused on threats from outside organizations, but this has changed. People with authorized access to government, business, and other networks can cause harm should they choose to do so – and they are doing so. As a result, insider threat programs have become part of national cybersecurity strategies and plans. Natural disasters such as earthquakes, floods, incidents of severe weather, mudslides, and epidemics are also areas needing more attention, especially concerning more effective use of ICT support for humanitarian assistance and disaster relief (HA/DR). The role of ICT support for disease detection, prevention, and response networks is also important. In the case of Afghanistan, these areas of concern have been and continue to be challenges for the Afghan National Disaster Management Authority and public health system.

Cybersecurity/CIIP is a shared responsibility of government, business, other organizations, and individual users who develop, own, provide, manage, service, and use information systems and networks. Managing the inherent risks requires that the participants act cooperatively and in coordination with one another, and that each participant take action to address security appropriate to his or her role. The collective goal of participants is to prevent, prepare for, respond to, and recover from incidents. In this interconnected system and world, the roles and responsibilities of participants for cybersecurity/CIIP are shared and often overlap. Only when all participants share a common vision and understanding of the security objectives and how to achieve them, as well as their individual roles in the effort, can the collective goal be achieved.<sup>124</sup>

---

<sup>122</sup> Kelly and Souter, 2014.

<sup>123</sup> Supervisory control and data acquisition, a system using communications signals for remote monitoring and control.

<sup>124</sup> ITU National Cybersecurity/CIIP Self-Assessment Tool, April 2009.

Only national governments are in positions to lead national efforts involving all relevant national participants to enhance cybersecurity and improve CIIP. The preparation of a national strategy has proven to be a valuable tool for effective, coordinated national action. By establishing a common vision and delineating participant roles and responsibilities, a national strategy provides a guide for managing risks inherent in ICT use and addressing cybersecurity/CIIP. Such a national strategy can also provide valuable support for regional and international cooperation. Only when a nation has organized itself to address cybersecurity/CIIP can it gain requisite experience and capability that will allow it to participate meaningfully in regional and international cooperative security efforts.<sup>125</sup>

Afghanistan needs to improve its focus on CIP, cybersecurity/CIIP, and HA/DR and related strategies, plans, and operational capabilities that address detection, protection, risk management, information sharing, and response challenges. Both the ITU and NATO have CIP and cybersecurity/CIIP programs (as do NATO's partner nations) that could be leveraged by Afghanistan to help it develop an Afghan CIP/CIIP national strategy and plan and implement related protection, risk management, information sharing, and response capabilities. The MCIT published the National Cybersecurity Strategy of Afghanistan in November 2014, though it has yet to be endorsed or codified by the larger government. The USG, through the combined efforts of the Departments of State, Defense, and Commerce, as well as USAID, the National Defense University, the Department of Homeland Security (DHS), the STA initiatives at the US Embassy Kabul and ISAF, as well as personnel from industry and academia, have provided advice and assistance to the MCIT regarding cybersecurity strategy and plans. NATO, the European Union (EU), the ITU, and the UN are actively engaged in ICT for HA/DR and post-conflict operations as are many nations' civil-military elements and NGOs participating in international crisis response activities. Many entities have made offers of assistance to help Afghanistan. For example, in July 2009, Afghanistan participated in a NATO Civil Emergency Planning Committee workshop in Brussels on Civil Support for Afghanistan, and, at that time, NATO and participating member nations made offers to help Afghanistan assess the situation in country and to provide advice and assistance to it on concrete steps for introducing a greater civil support capability. The Afghanistan Reconstruction Group (ARG)/STA and ISAF STA/TAT made offers to help develop a framework for an Afghan National Crisis Response Plan and companion ICT response plan. These offers included help from DHS to advise and assist with approaches for developing a response plan along the lines of the US National Response Plan that addresses responding to national emergencies such as natural disasters and terrorist attacks. Offers of help from the DoS/USAID, the DoC, the FCC-IB, and the DoD on ICT fly-away capability packages and policies and regulations to support ICT for HA/DR were made as well. The US also offered assistance to help develop information systems for disease surveillance, tracking, and medical response, including the use of ICT and related social networking tools and geographic information systems (GIS) tools for data collection, assessment, and visualization. Progress has been slow and much work remains to be done to help GIRoA move forward in these areas.

---

<sup>125</sup> Ibid.

## Afghanistan Post-conflict ICT Sector Case Study

The international civil-military intervener community is not employing a coherent ICT-enabled civil-military approach for the Afghan ICT sector today. There is generally no clear mapping or shared understanding of responding stakeholder organizations' roles and responsibilities and no agreed-upon leadership to guide and coordinate who does what and when in the ICT sector. Program development, project coordination, information sharing, and ICT implementation are largely uncoordinated and non-standard among responder elements. Agreed-upon strategies and business models, architectures, and plans tend to be lacking for affected nation ICT sector governance recovery and ICT infrastructure and services recovery and reconstruction.<sup>126</sup>

While there is little doubt that ICT is an engine of change for security, stabilization, governance, and social and economic development, quantifying its impact is difficult. Evidence remains largely anecdotal, and the link between ICT deployment and reconstruction and development remains vague. Consequently, senior civil-military leadership of the intervening elements lack agreed-upon frameworks and measures to make informed investment decisions, track ICT-related reconstruction and development progress, and assess impacts.

One needs to remember, stabilization concerns the establishment of physical security and governmental institutions in whose integrity and viability both citizens and potential investors have confidence. Stability is therefore an essential prerequisite for both reconstruction and development and requires the rebuilding of political institutions, restoring rule of law, the reintegration of former combatants, the establishment and maintenance of physical security, the restoration of critical economic sectors, the injection of capital into the financial system, the production and distribution of food supplies, and the restoration of health and education services.<sup>127</sup>

The ICT sector is one among many competitors for the attention of policymakers and practitioners in the complex reconstruction context. The evidence suggests that it has an increasingly important part to play in stability and reconstruction, not just as a sector in and of itself, but as an enabler of cross-sector recovery, built around a general-purpose technology, which can contribute to reconstruction across the board. This impact can be felt from early stages in recovery and reconstruction, including stabilization and COIN activities. The sector can also help in generating income from fees paid by investors, from taxation of communications usage and, in the form of foreign exchange, from calls made by relief agencies and those in the diaspora. It merits more attention than it has sometimes been paid.<sup>128</sup>

---

<sup>126</sup> Wentz, Larry, Frank Kramer, and Stuart Starr (2008). *Information and Communication Technologies for Reconstruction and Development: Afghanistan Challenges and Opportunities*. National Defense University, Center for Technology and National Security Policy, *Defense Technology Paper 45*, January 2008. Available at: <http://ctnsp.dodlive.mil/files/2013/07/DTP-045.pdf>.

<sup>127</sup> Kelly and Souter, 2014.

<sup>128</sup> Ibid.

Recent post-conflict security, stability, and reconstruction operations experiences in Iraq and Afghanistan, coupled with the continued rapid advances in ICT, strongly suggest that USG and International Community policy and doctrine needs to be adjusted to address the following considerations aimed at improving the effectiveness of the international civil-military community response through the use of information and ICT-enabled interventions to facilitate a comprehensive approach for enabling timely recovery of a post-conflict nation:

- Treat ICT as critical infrastructure and an essential service as a priority focus area for early resource allocations.
- Improve collaboration and coordination of initial efforts to facilitate:
  - sharing and leveraging donor and other civil-military stakeholders' knowledge of the affected nation's political, economic, social, cultural, and communications factors influencing ICT sector governance and infrastructure recovery and development and the use of ICT by other sectors;
  - early recovery of ICT sector governance (policy, regulations, laws, and government institutional ICT capacity) and initial infrastructure supporting improved security and governance;
  - establishment of a policy and regulatory framework that enables competition, liberalizes the market, implements good public-private partnerships, and offers stability to investors and service providers; and
  - establishment of a framework for longer-term investment and development of ICT infrastructure and services.
- Use of professional senior civil and commercial ICT SMEs such as a Senior Telecom Advisor (STA) and, as appropriate, a supporting Telecom Advisory Team (TAT) to advise and assist leadership of the civil-military intervention community and the affected nation to achieve early restoration of the affected nation's ICT sector governance and to enable timely recovery and reconstruction of ICT sector infrastructure and services.
- Agree on approaches for using information and ICT as an enabler of security, stability, governance, and socio-economic development and growth for the affected nation.
- Implement agreed-upon information-sharing arrangements that facilitate collaboration, coordination, and information sharing among USG and international civil-military partners and affected nation counterparts in complex post-conflict intervention operations.

As mentioned above, approaches to smart use of information and ICT in support of civil-military interventions are still ad hoc and no agreed-upon USG or international policy exists in terms of approaches to be used. Additionally, if an STA and TAT are employed, it remains unclear if the capability should be with a civil or military element, or both. Further, the authority, roles, responsibilities, and relationships of such individuals to provide strategic thinking and thought leadership for ICT-enabled interventions and timely recovery of the ICT sector and the use of ICT as an enabler and game changer also need to be more clearly defined and agreed upon by stakeholders.

Attempts so far to implement an ICT advisory support capability have used ad hoc approaches that were experiments and learning experiences. Lessons have been learned, and follow-on research has been done

regarding approaches to be used in the future, including when to intervene with such a capability, management of transition from civilian lead to military lead and vice versa, and approaches to conducting shared planning and collaborative execution to achieve civil-military unity of effort. Despite endeavors to date, additional work needs to be done to craft and introduce new USG policy (e.g., updates to DODIs 3000.05 and 8220.02, as well as revisiting broader policies such as NSPD-44 and PPD-23) to raise the awareness and treatment of ICT as an essential service and critical infrastructure and enable institutionalization of agreed-upon ICT-enabled approaches as new doctrine. For international crisis response activities, organizations such as the UN, ITU, NATO, EU and others also need to update their ICT policies, strategies, and plans. Participating nations need to adjust their national ICT support strategies and plans such as a USG plan for an ICT role in support of post-conflict reconstruction operations. A shared approach for information sharing in crisis response operations also needs to be agreed upon and implemented.

The ISAF Senior Telecom Advisor/Telecom Advisory Team (STA/TAT) learning experience from 2010 to 2014 can be viewed as a success story, as was the Afghanistan Reconstruction Group/Senior Telecom Advisor (ARG/STA) at the US Embassy Kabul between 2005 and 2008. The construct of a senior civilian telecom (or in today's terminology, ICT) advisor and supporting in-country advisory team with CONUS-based reachback support showed great promise as a model to consider for shaping ICT-enabled approaches in future crisis response operations. The ISAF STA/TAT effort earned the recognition of the USG Interagency, ISAF and Coalition forces, the international responder community, and GIRoA ICT counterparts as the "one-stop shop" for advice and assistance on civil and commercial ICT; as a facilitator, connector, and harmonizer of the USG Interagency, ISAF and Coalition forces, international organizations, and Afghan ICT-related activities; and as the trusted source of informed situational awareness on the Afghan ICT sector and USG, ISAF and Coalition forces, and international organization ICT-related activities. The strategic partnerships established with GIRoA counterparts and the ability of the STA to actively interact with senior USG and ISAF leadership enabled a two-way communications channel to connect senior USG and ISAF leadership with GIRoA counterparts and allowed the STA to play the role of intermediary on important ICT related issues — a benefit to both parties. It also provided a clear USG and ISAF ICT focal point for the Minister of Communications and the regulator to deal with on ICT issues and opportunities.

## About the Book

Afghanistan has long been a battleground for strategic wars by larger external powers. In part, this has been due to its geographic position in the Middle East, Central Asia, and South Asia. In addition, the fragmented and polarized nature of Afghan society, which is made up of many different ethnic groups, has led to its multiple internal struggles, which have gained support from the different external powers.<sup>129</sup> Afghanistan continues its struggle to rebuild itself amidst the ongoing war despite the billions of dollars

---

<sup>129</sup> Peace Direct. "Afghanistan: Conflict Profile." Insight on Conflict. Last updated: February 2015. <https://www.insightonconflict.org/conflicts/afghanistan/conflict-profile/>.



of aid that has been pumped into the country. Unfortunately, there is no immediate end in sight to the Afghanistan conflict, and complex issues related to security, governance and economic growth suggests that new conflicts will likely arise as has been the case over the last three decades. The fatigue of war felt by the Afghan people is strong, along with a yearning for a chance of a more tolerable situation in a country where several generations have only known war.<sup>130</sup>

Formally speaking, NATO/ISAF and US military combat operations did not cease in Afghanistan until the end of December 2014, when combat forces were finally removed and NATO changed its mission to train, advise, and assist under Resolute Support. Hence, references to a “post-conflict” environment throughout the book can be misleading or confusing if taken literally. Post-conflict is a “conflict situation in which open warfare has come to an end. Such situations remain tense for years or decades and can easily relapse into large-scale violence.”<sup>131</sup> Post-conflict, stability operations, peacebuilding, and nation-building have lots of fuzzy overlaps, and all are viewed as attempts to avoid a relapse into violent conflict. In post-conflict areas, there is an absence of war, but not essentially real peace, so elements of conflict remain. Lakhdar Brahimi, former Special Adviser of the Secretary-General of the United Nations, stated that “the end of fighting does propose an opportunity to work towards lasting peace, but that requires the establishment of sustainable institutions, capable of ensuring long-term security.”<sup>132</sup> Prolonged conflict can lead to terrible human loss and physical devastation; it can also lead to the breakdown of the systems and institutions that make a stable society work and these are the very systems that need to be revived.<sup>133</sup> As Krishna Kumar, author and professor of education at Delhi University, pointed out several years ago, “Rebuilding institutional infrastructure shattered during conflict is as important if not more important than physical infrastructure ... yet this is an area which has largely been overlooked by the international community in the past.”<sup>134</sup>

This book focuses on two success stories: (1) the dramatic evolution of the Afghan ICT sector and the use of ICT as a cross-sector enabler, and (2) the deployment of Senior Telecom Advisors as civil and commercial ICT SME advisors to senior USG leadership, ISAF, and Afghan ICT counterparts. The objective was to generate within the civil-military coalition, the international responder community, and Afghanistan an awareness of the importance of ICT as an essential service and critical infrastructure and as a game changer in post-conflict recovery and reconstruction. Another objective was to convey and justify the value of an STA and its recognition as a one-stop shop for advice and assistance on civil and commercial ICT challenges, opportunities, and situational awareness. These objectives were realized.

---

<sup>130</sup> Ibid.

<sup>131</sup> Junne, Gerd and Willemijn Verokren, eds. (2005). *Post-conflict Development: Meeting New Challenges*. (Boulder, CO: Lynne Rienner).

<sup>132</sup> Brahimi, Lakhdar (2007). “State Building in Crisis and Post-conflict Countries.” 7<sup>th</sup> Global Forum on Reinventing Government: Building Trust in Government, June 26-29, 2007. Accessed September 7, 2015. <http://unpan1.un.org/intradoc/groups/public/documents/un/unpan026305.pdf>.

<sup>133</sup> Ibid.

<sup>134</sup> Kumar, Krishna, ed. (1997). *Rebuilding Societies after Civil War: Critical Roles for International Assistance*. (Boulder, CO: Lynne Rienner).

The first part of this book sets the stage by providing an overview of Afghanistan's geography, environment, culture, governance, and other interesting facets. The challenges of post-conflict stability and reconstruction operations and approaches to facilitate recovery of a nation emerging from conflict, including the role of ICT as an enabler and related challenges and opportunities are addressed. An overview of the Afghanistan ICT sector follows, with chapters addressing ICT institutions, ICT sector governance and the associated legal and regulatory framework, and various infrastructures. The book describes the role and importance of Afghanistan's national fiber optic network and the country's opportunity to become a regional ICT hub. It then gives examples of ICT for security, governance, socio-economic development, and gender equality. Experiences from the field on the uses of ICT for agriculture, health, and education are addressed, with specific examples from Jalalabad in Nangarhar province. ICT capacity development follows, with examples of improving computer science and IT curriculum at public Afghan universities, the introduction of cybersecurity and chief information officer (CIO) education and training, introduction of e-learning, improving Internet access for universities and implementing broadband campus networks, the use of incubators and accelerators for ICT business startups, and ICT innovation programs. The book also offers examples of how ICT was employed for information sharing and how social media was used in civil discourse.

The remainder of the book charts the path and documents the experiences of employing two different yet functionally similar ad hoc instances of the use of an STA in Afghanistan — the ARG/STA and the ISAF STA/TAT. Along the way, other ad hoc activities, such as, the DoD Task Force for Business and Stability Operations and ISAF Provincial Reconstruction Team activities in Afghanistan are touched upon. Some references to similar experiences in Iraq related to the Iraq Communications Coordination Element (ICCE) and the follow-on Infostructure and Strategic Engagement (ISE) team are conveyed. The US Embassy Kabul ARG/STA and ISAF STA/TAT experiments and learning experiences have provided unique insights into the challenges and opportunities of deploying STAs. Findings and lessons from these efforts are captured in the book along with thoughts for approaches for future ICT-enabled interventions. Observations and lessons related to the success of the STAs and the overall Afghan ICT sector are also included.

Finally, the editors, authors, and contributors have had direct on-the-ground experience in Afghanistan. They have made every effort to convey the information in this book as accurately as possible. However, as is often the case in Afghanistan, there are competing and conflicting sources of information. Recollections and perspectives differ among the diverse group of professionals that imparted their knowledge and experience to create this collective work. The book is largely both US- and Kabul-centric and is by no means an exhaustive account of the Afghan ICT sector or the work within it. However, it adequately captures the substance and conveys the intended points. It also offers valuable lessons observed and learned as well as recommendations that can and should be considered in planning for future interventions.

## Chapter 1 Afghanistan: The Country

---

Larry Wentz

### A Very Brief History

Afghanistan, which means “land of the Afghans,” has a storied and bloody history, primarily because of its geographic location along historical trade and migratory routes and among the various civilizations and peoples of Asia, the Middle East, the Mediterranean, and the Indian subcontinent.

Afghanistan’s written history can be traced back to around 500 BCE,<sup>135,136</sup> although civilization in the area dates back to between 3000 and 2000 BCE.<sup>137</sup> The modern state of Afghanistan is generally described as being established in 1504, as part of the Mughal Empire under Zahir-ud-din Muhammad Babur, or in 1747, when the assassination of Persian Nadir Shah ended the Afsharids’ rule and Ahmad Shah Durrani came to power. Durrani subsequently united or defeated all the tribes and consolidated all the lands of present-day Afghanistan (and then some).<sup>138</sup> Since Alexander the Great conquered Afghanistan in 330 BCE and Central Asia fell to Genghis Khan and the marauding Mongols in the early 1200s, Afghanistan has been part of or given rise to numerous other empires, including but not limited to the Macedonians, Aryans, and Arabs, as well as the [Kushans](#), [Hephthalites](#), [Samanids](#), [Saffarids](#), [Ghaznavids](#), [Ghorids](#), [Khiljis](#), and [Hotaks](#).

Afghanistan was a pawn between clashing British and Russian empires in the mid-nineteenth century. British involvement in Afghanistan ended in 1919 after two Anglo-Afghan wars (1839-1842 and 1878-1880). However, the Russians invaded Afghanistan again in 1979, ushering in a decade-long conflict (and numerous proxy wars) that ended with a Russian withdrawal in 1989. Two civil wars ensued (1989-1992 and 1992-1996), followed by five years of Taliban rule, which ended in December 2001 as a result of a US-led invasion to find al-Qaeda leader Osama bin Laden, who had been given safe haven by the Talibs. The North Atlantic Treaty Organization’s (NATO’s) International Security Assistance Force (ISAF) occupied Afghanistan from 2001 to 2014, ceasing combat operations and transitioning to a support mission in December 2014.

Afghanistan has been ruled by a monarch, has been a democracy, and has suffered decades of civil war followed by several years of Taliban rule. It is now an Islamic republic. The passing of the presidential reins from Hamid Karzai to Ashraf Ghani in 2014 was the first peaceful transfer of power in Afghanistan’s history.

---

<sup>135</sup> *Wikipedia* (2014). “History of Afghanistan.” Accessed August 14, 2014. [https://en.wikipedia.org/wiki/History\\_of\\_Afghanistan](https://en.wikipedia.org/wiki/History_of_Afghanistan).

<sup>136</sup> Before the common area

<sup>137</sup> *Wikipedia*, 2014. “History of Afghanistan.”

<sup>138</sup> *Ibid*.

Afghanistan's byzantine cultural heritage has been shaped by the myriad and varied influences over the centuries. A legacy of conflict and conquest has produced a fiercely independent and resilient people with an intricate social fabric, strong but ephemeral loyalties, and a unique but often inexplicable ethos.

## Geography

The Islamic Republic of Afghanistan is an area of approximately 652,864 square kilometers (km), which is slightly smaller than the state of Texas. It is a landlocked plateau between Iran and Pakistan that also shares borders with China, Tajikistan, Turkmenistan, and Uzbekistan (see Figure 11). In 1893, Sir Mortimer Durand, a British diplomat and civil servant of British India, and Amir Abdur Rahman Khan, the Afghan amir (king) established a 2,430km (1,510-mile) border between Afghanistan and British India, called the Durand Line, which essentially runs the length of Afghanistan from the northeast all the way to its southern boundary. The Durand Line cuts through the Pashtun tribal areas and further south through the Balochistan region, politically dividing ethnic Pashtuns as well as Baloch and other ethnic groups, who live on both sides of the border. The Durand Line has been an area of contention between Afghanistan and Pakistan since Pakistan's creation (separation from India) in 1947.<sup>139</sup>

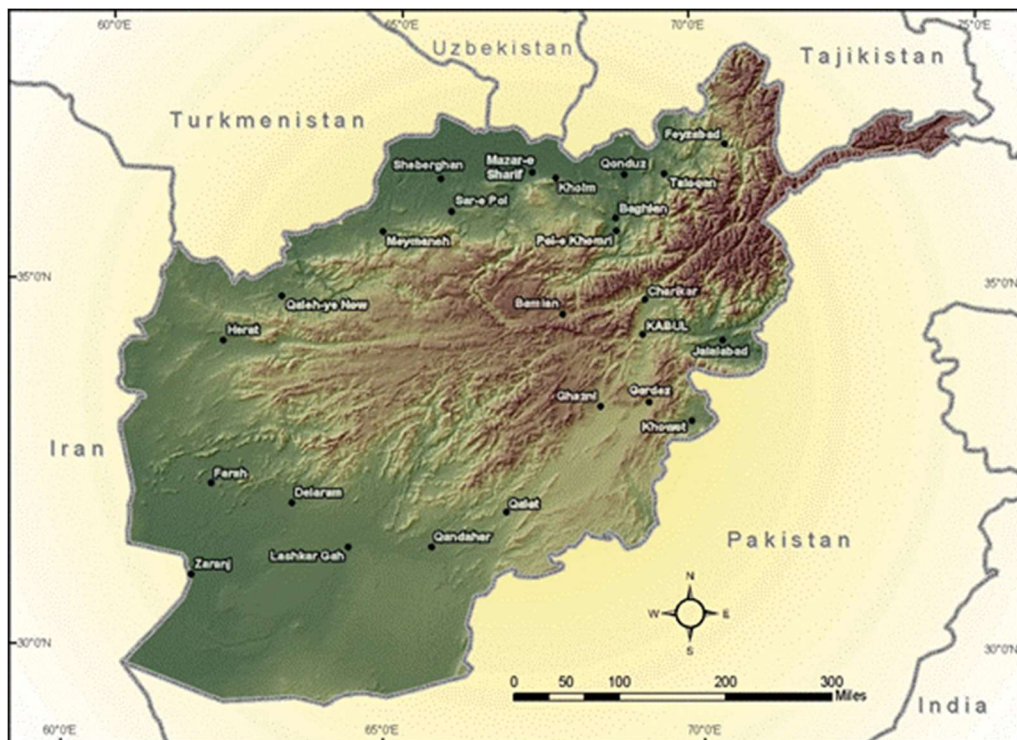

Figure 11: Map of Afghanistan

---

<sup>139</sup> Wikipedia (2016). "Durand Line." Last modified August 9, 2016. [https://en.wikipedia.org/wiki/Durand\\_Line](https://en.wikipedia.org/wiki/Durand_Line).

Tall mountains (part of the Hindu Kush mountain system) cover much of the country and small glaciers and year-round snowfields are common. More than 49 percent of the total land area lies above 2,000 meters' elevation.

Afghanistan has long been known as the crossroads of Asia, which is reflected in the country's ethnic and linguistic diversity. The country sits at an important geostrategic location connecting the Middle East with Central Asia and the Indian subcontinent, which has been home to various peoples through the ages. It was part of the Silk Road, which was not a single "road" but rather a network of trade routes that linked cities, trading posts, hostels, and caravan-watering places. The land has witnessed many military conquests since antiquity, notably by Alexander the Great, Chandragupta Maurya, and Genghis Khan. It also served as a source from which local dynasties such as the Greco-Bactrians, Kushans, Saffarids, Ghaznavids, Ghorids, Timurids, Mughals and many others established their empires.

Afghanistan's rugged mountain terrain and lack of roads and bridges made transporting equipment, people, and supplies into remote areas challenging, especially by vehicle. The geography also made it difficult to develop needed infrastructure. Much of Afghanistan's infrastructure (roads, bridges, communications, and power) either did not exist prior to 2001 or was heavily damaged during the continued warfare, cutting off communities and isolating those in rural areas who needed help the most. Movement in remote and mountainous areas where terrain is rough and proper roads and bridges largely do not exist was difficult to impossible. In some cases, horses and donkeys were – and still are – used as the main means of transportation.

## Environment

Afghanistan is a land of extremes: It has rugged mountains and lush, fertile valleys; high and low plains; wind-swept deserts with shifting dunes; and acres of arable land, each with its own environment.

Afghanistan has clearly defined seasons. Summers are hot and winters can be bitterly cold. The wet season generally runs from winter through early spring. Rain and melting snow can make many roads difficult to traverse. Otherwise, the weather in the spring is generally nice and the country blooms. Spring is also known as the start of the Taliban fighting season, so the security situation can become more dangerous then, particularly in the southern and eastern areas of the country. Autumn, with dry, pleasant weather, is one of the best times to visit Afghanistan. Toward the end of November, winter sets in and snow is common across much of the country.

Afghanistan is, however, a land of marginal environment. Annual distribution of rainfall is that of an essentially arid country. Hence, rivers fed by melting snow and glaciers of the mountains are Afghanistan's main source of water. This is not, however, without its challenges. Because Afghanistan is a landlocked country, there is a natural flow of river water to neighboring countries. Due to historical disputes with these countries, runoff is not well managed.

Climate change has also caused early melting of snow in more recent years, and there is a lack of reservoirs to collect water. Decades of war destroyed most of Afghanistan's water distribution infrastructure

including pumping stations. A 2012 [HydrateLife](#) report on the Afghanistan water crisis estimated that only about 30 to 35 percent of the water coming out of the mountains stays in Afghanistan.<sup>140</sup>

Further, an article in *Weather and Climate Extremes* in 2014 noted that several seasons of drought in recent decades have contributed to the current water crisis in Afghanistan.<sup>141</sup> The country began experiencing unusual droughts in 1995. [Oxfam](#) reported the worst record of drought was in 2011, which struck 14 out of 34 provinces of the country, affecting 2.6 million people. Localized and wide-range droughts are becoming recurrent features. According to an analysis of climate and drought records of the Asia Development Bank (ADB), localized droughts have a periodicity of three to five years, and droughts covering large areas recur every nine to 11 years. The pattern of long droughts, poor harvests, and flash floods has been a growing trend for the people of northern Afghanistan in particular, with experts largely in agreement that the climate is becoming more extreme. A November 2014 United Nations (UN) Intergovernmental Panel on Climate Change report identified Afghanistan as one of 11 countries globally at extreme risk of both climate change and resultant food insecurity.<sup>142</sup>

The Hindu Kush mountain range is a geologically active area where earthquakes frequently occur. They can be deadly and destructive, at times causing landslides and avalanches during the winter. In 1998, an earthquake killed about 8,500 people and destroyed tens of thousands of houses in Takhar and Badakhshan provinces. In 2012, another earthquake incident occurred in northern Baghlan province, triggering a large landslide that crushed mud houses in a remote village killing more than 70 people. In May 2014, there was a pair of mudslides triggered by heavy rains in Argo district of Badakhshan province. The mudslides affected some 300 houses and over 1,000 people. The UN reported there were 350 confirmed dead and that it was unlikely to find more bodies due to the "catastrophic nature" of the mudslide.<sup>143</sup>

Other environmental challenges include:

- A lack of energy options is causing deforestation because wood is used extensively for cooking and heating.
- There is serious air pollution, caused by dust; pervasive use of diesel generators for electric power; and burning wood, plastic, and dung for cooking and heating.
- Open sewers are common while wastewater treatment is not.

---

<sup>140</sup> HydrateLife (2012). *Afghanistan's Water Crisis*. March 28, 2012. Accessed August 14, 2014. <http://www.hydratelife.org/?p=105>.

<sup>141</sup> Miyan, M. Alimullah (Revised 2014). "Droughts in Asian Least Developed Countries: Vulnerability and sustainability." Elsevier *Weather and Climate Extremes* 7 (2015) 8-23. Accessed September 29, 2014. [http://ac.els-cdn.com/S2212094714000632/1-s2.0-S2212094714000632-main.pdf?\\_tid=cb8e1eb0-e44b-11e6-8298-00000aab0f27&acdnat=1485492667\\_723a2f3e0628411965f27103b0f08c38](http://ac.els-cdn.com/S2212094714000632/1-s2.0-S2212094714000632-main.pdf?_tid=cb8e1eb0-e44b-11e6-8298-00000aab0f27&acdnat=1485492667_723a2f3e0628411965f27103b0f08c38).

<sup>142</sup> Dyke, Joe (2014). "Climate change: Afghans on the front line." *IRIN News*, November 14. Accessed January 7, 2015. <http://www.irinnews.org/report/100791/climate-change-afghans-on-the-front-line>.

<sup>143</sup> "Afghanistan landslide 'kills at least 350.'" *BBC News* May 2, 2014. Accessed September 29, 2014. <http://www.bbc.com/news/world-asia-27261783>.

- Water supplies are perpetually polluted, contributing to serious sanitation and public health problems.

The 2014 CIA World Factbook estimated 61 percent of Afghanistan's population has access to clean water, 30 percent has access to electric power, and 28 percent have a flush toilet or latrine.<sup>144</sup>

Finally, the country's natural resources include: coal, copper, iron ore, lithium, uranium, rare earth elements, chromite, gold, zinc, talc, barites, sulfur, lead, marble, precious and semi-precious stones, natural gas, and petroleum, among others. In 2010, US and Afghan government officials estimated that untapped mineral deposits located in 2007 by the US Geological Survey are worth between US\$1 and US\$3 trillion.

## Demographics

### Population

The ability to document the history of Afghanistan's population has been impacted by poor vital-records-keeping, logistical and political challenges, and aborted census efforts due to a heightened lack of security caused by war. Hence, attempts to gauge the population of Afghanistan in 2014 are largely based on estimates. A structured census seems to be some way into the future. It is becoming widely accepted by the International Community, however, that the country has recently surpassed 31 million residents. However, population estimates produced by the Social-demographic Statistics Department of the Afghanistan Central Statistics Organization (ACSO), suggest the 2014 population of the country was about 29 million, with 27.5 million settled inhabitants plus another 1.5 million nomadic,<sup>145</sup> compared to the CIA World Factbook, which estimated the population to be about 31.8 million as of July 2014.<sup>146</sup> Exact figures are difficult to come by, especially with the large number of returning refugees (see [Figure 12](#)<sup>147</sup>).

According to the 2014 CIA World Factbook,<sup>148</sup> Afghanistan has one of the world's largest repatriated populations. Additionally, the 2014 population growth for Afghanistan was estimated to be 3 percent,<sup>149</sup> making it one of the fastest-growing countries in the world.

Based on ACSO statistics, about 13.7 million Afghans are women and 14.4 million are men. The estimates also suggest an urban population of around 6.5 million (23.1 percent) with over 3 million living in Kabul

---

<sup>144</sup> United States Central Intelligence Agency (CIA) (2014). *The World Factbook: Afghanistan*. Accessed December 9, 2014. <https://www.cia.gov/library/publications/the-world-factbook/geos/af.html>.

<sup>145</sup> Islamic Republic of Afghanistan Central Statistics Organization (ACSO). *Afghanistan Statistical Yearbook 2013-14*. Accessed January 5, and August 23, 2016. [http://cso.gov.af/Content/files/Population\(3\).pdf](http://cso.gov.af/Content/files/Population(3).pdf).

<sup>146</sup> CIA, 2014.

<sup>147</sup> ACSO *Statistical Yearbook 2013-14*.

<sup>148</sup> CIA, 2014.

<sup>149</sup> TradingEconomics.com. Accessed December 9, 2014.

<http://www.tradingeconomics.com/afghanistan/population-growth-annual-percent-wb-data.html>.

alone, a rural population of 20.1 million (71.5 percent), and roughly 1.5 million (5.4 percent) fully nomadic Kuchi (Pashtun nomads, from the Persian word *koch*, meaning migration).<sup>150</sup>

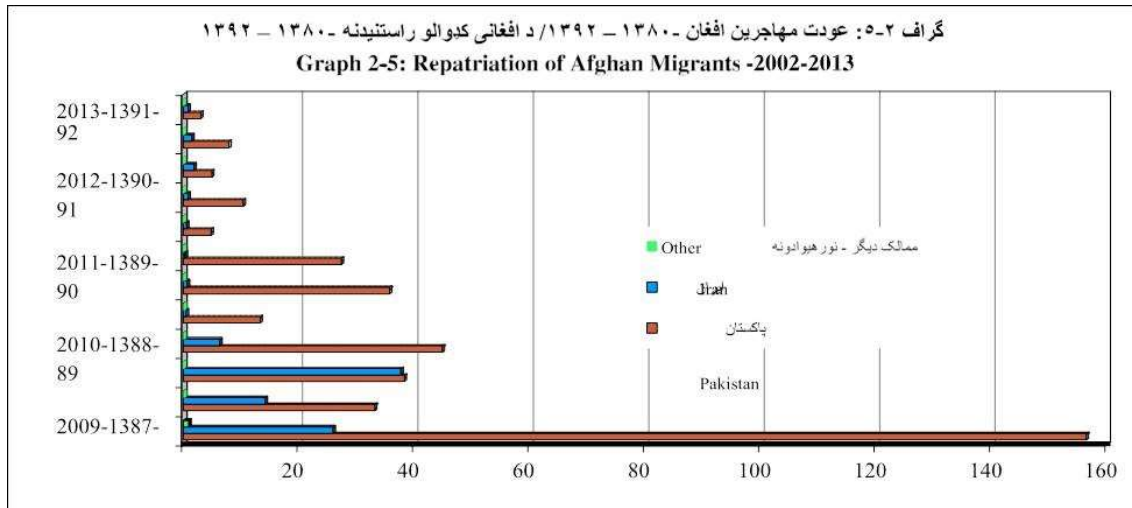

Figure 12: Afghan repatriation, 2002-2013

The 2014 CIA World Factbook<sup>151</sup> suggested 64 percent of the Afghan population was under the age of 25, with 50.7 percent male and 49.3 percent female. Similarly, ACSO data shows 70 percent of Afghans are under the age of 30 with 50.69 percent male and 49.31 percent female.<sup>152</sup> It is also worthwhile to note that 46.11 percent of the population is under the age of 15 (with, again, a nearly even split between male and female; see [Figure 13](#)).<sup>153</sup> They are the next generation and the future of Afghanistan.

<sup>150</sup> ACSO *Statistical Yearbook 2013-14*.

<sup>151</sup> CIA, 2014.

<sup>152</sup> ACSO *Statistical Yearbook 2013-14*.

<sup>153</sup> *Ibid.*



گراف ۱-۲: نفوس مسکون به تفکیک گروه های سن و جنس در سال ۱۳۹۲ / میشت وگری، د عمر د تولیو او جنس په توپیر ۱۳۹۲

Graph 2-1: Settled Population by Sex and Age Groups-2013

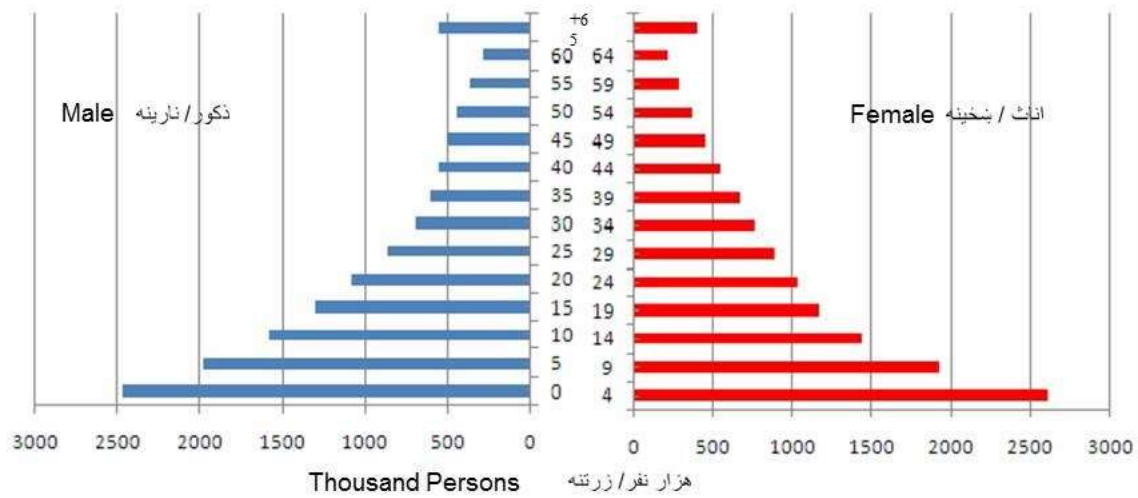

Figure 13: Afghanistan's population by gender and age group

## Literacy

During the reign of Mohammad Zahir Shah (1933–1973), there were efforts to modernize Afghanistan that included free elections, civil rights, women’s rights, and the founding of the first modern university. Despite improvements, in 1979 the [United Nations Educational, Scientific and Cultural Organization](#) (UNESCO) estimated the Afghanistan adult (ages 15 and above) literacy rate to be 18.16 percent (male 30.31 percent and female 4.99 percent).<sup>154</sup>

There are no universal definitions or standards of literacy. Estimates are usually based on “the ability to read and write at age 15 and above.” In 2014, Afghanistan reported new literacy data to the UNESCO Institute for Statistics for the first time in over 30 years. For 2011, it was reported that 32 percent of the adult population of Afghanistan could read and write, compared to 18 percent in 1979.<sup>155</sup> The youth literacy rate increased from 30 percent in 1979 to 47 percent in 2011. Gender disparity remains high in Afghanistan, with only 18 percent of adult women able to read and write, compared to 45 percent of adult men. Among youths between 15 and 24 years, the situation has improved, with a female literacy rate of 32 percent and a male literacy rate of 62 percent in 2011. The lack of literate and skilled workers has been a major economic disadvantage in Afghanistan and is still a challenge.

<sup>154</sup> United Nations Education, Scientific, and Cultural Organization (UNESCO) Institute for Statistics as reported on IndexMundi. “Afghanistan – Literacy rate.” Accessed August 14, 2014. <http://www.indexmundi.com/facts/afghanistan/literacy-rate>.

<sup>155</sup> Ibid.

## Refugees

According to the [United Nations High Commissioner for Refugees \(UNHCR\)](#),<sup>156</sup> there are 2.6 million Afghan refugees worldwide, with up to 92 countries providing safe haven. Nearly all of them (2.5 million) are living in Pakistan and Iran, with 1.5 million registered in Pakistan. There is also an estimated 2 million undocumented Afghans in both countries.

Afghan refugees represent about 20 percent of the world's total refugee population and constitute the largest protracted situation in the world for over three decades. During 2014, Afghanistan was replaced as the largest source country of refugees because of the war in the Syrian Arab Republic.<sup>157</sup>

Afghanistan remains the largest voluntary return operation in UNHCR's history.<sup>158</sup> Almost six million refugees have voluntarily returned home since the Taliban regime was ousted, and the UNHCR estimates just under two million of them still require support. As of September 2014, UNHCR also noted about 700,000 people were registered as internally displaced, most of them in the south and west of the country.

## Poverty

Afghanistan is one of the most impoverished nations in Asia. The proportion of the population of Afghanistan in poverty is estimated at 36 percent, although it varies from a relatively low 29 percent in urban areas such as Kabul to 36 percent in rural areas and 54 percent among the country's nomadic Kuchi population.<sup>159</sup>

The foreign troop withdrawal in 2014 has, however, caused widespread concerns about the country's stability. As security within Afghanistan deteriorates, the number of asylum seekers from Afghanistan has been steadily rising.<sup>160</sup> Most Afghan asylum seekers are headed to Europe via Turkey and Greece.

## Ethnic Groups

According to data from the US Department of State, Afghanistan is composed of a number of ethnic groups: Pashtun (including Kuchis, 42 percent), Tajik (27 percent), Hazara (9 percent), Uzbek (9 percent), Aimaq (4 percent), Turkmen (3 percent), Baloch (2 percent), and other (4 percent).<sup>161</sup> The official languages are Dari (50 percent) and Pashto (35 percent). There are other languages spoken, such as Turkic (Uzbek and Turkmen) at 11 percent each, and some 30 minor languages (primarily Balochi and Pashai) at

---

<sup>156</sup> United Nations High Commissioner for Refugees (UNHCR) (2014). "Regional Bureau for Asia and Pacific (RBAP) Fact Sheet." September. Accessed December 9, 2014. <http://www.unhcr.org/5000139a9.pdf>.

<sup>157</sup> UNHCR (2014). *Global Trends 2014: World at War*. Accessed August 14, 2015. <http://unhcr.org/556725e69.html>.

<sup>158</sup> Ibid.

<sup>159</sup> Kline, Jordan (2015). "Poverty in Afghanistan." *The Borgen Project* (blog), March 21. <http://borgenproject.org/poverty-in-afghanistan/>.

<sup>160</sup> Mirzaei, Elissa Bogos (2014). "Farwell Kabul." November 13. *Al Jazeera*. Accessed August 14, 2015. <http://www.aljazeera.com/programmes/viewfinder/2014/11/2014119122152149511.html>

<sup>161</sup> Civil-Military Fusion Center (2011). *Afghan Ethnic Groups: A Brief Investigation*, August 2011. Accessed December 9, 2014. [http://reliefweb.int/sites/reliefweb.int/files/resources/CFC\\_Afg\\_Monthly\\_Ethnic\\_Groups\\_Aug2011%20v1.pdf](http://reliefweb.int/sites/reliefweb.int/files/resources/CFC_Afg_Monthly_Ethnic_Groups_Aug2011%20v1.pdf).

4 percent. Turkic (Uzbek and Turkmen), Balochi, Pashai, Nuristani, and Pamiri are third official languages in areas in which they are primarily spoken.

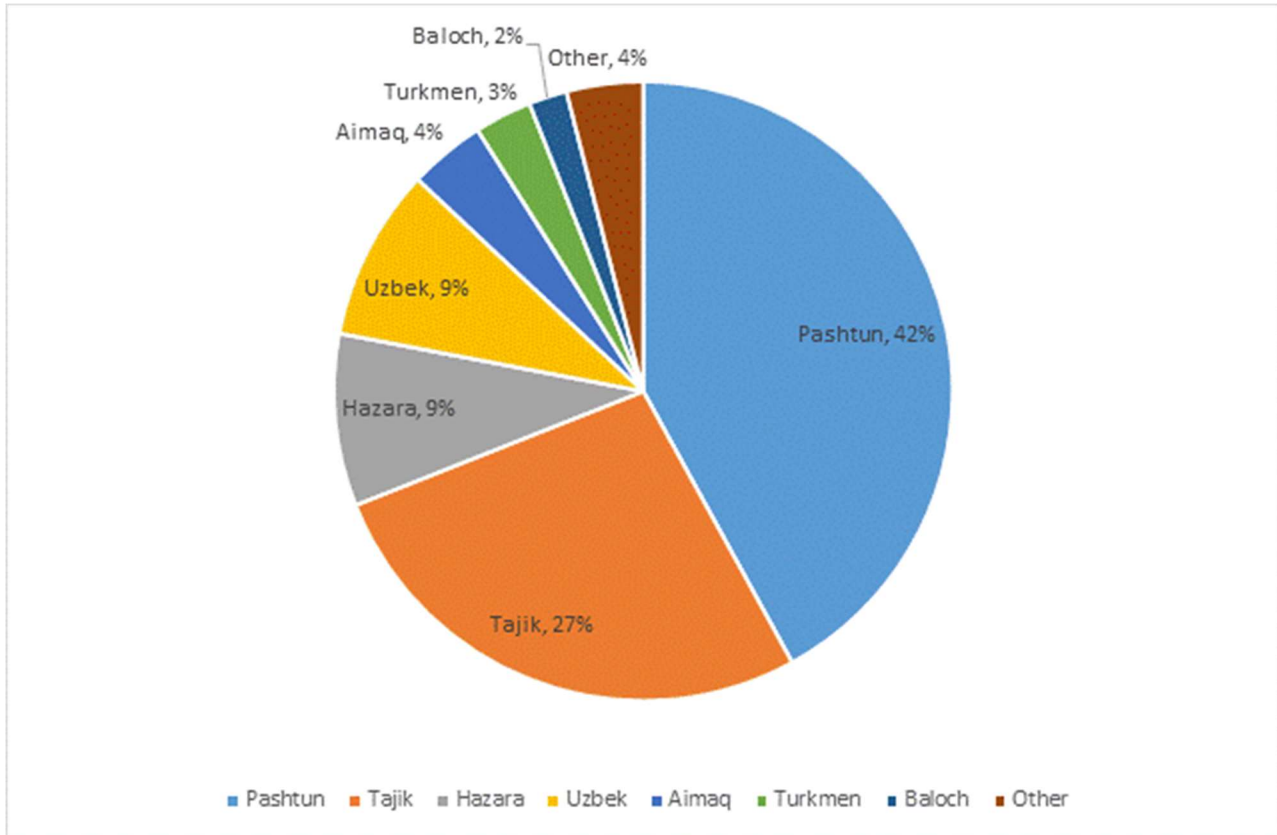

Figure 14: Afghan ethnic groups

## Governance

### The Emergence of a New Nation-State

During November and December 2001, the US, with the help of Coalition partners and Afghan Northern Alliance fighters, ousted the Taliban from power and gained control of much of Afghanistan. The Taliban and al-Qaeda forces did not give up entirely but went into hiding. The absence of law and order in the wake of the rapid victory suggested immediate steps were required to start the Afghan recovery process to move forward in establishing security and a new government. The International Community felt it necessary to have a transition period before a permanent government was established. To accomplish that goal, at least one *Loya Jirga*<sup>162</sup> needed to be convened to agree upon a national government. In

---

<sup>162</sup> Grand assembly of tribal elders

response to this need, the UN sponsored the Bonn Conference,<sup>163</sup> which resulted in the Bonn Agreement<sup>164</sup> on December 5, 2001, to establish a process for political reconstruction of Afghanistan and to establish a UN-mandated international security assistance force to create a secure environment in and around Kabul.

The political process included the adoption of a new constitution and decisions to hold a presidential election in 2004 followed by National Assembly elections in 2005. The Afghan leaders attending the Bonn Conference participated in the process of reconstructing their country by helping set up a new government structure on December 22, 2001, namely the Afghanistan Interim Administration (AIA), under the chairmanship of Hamid Karzai.

Subsequent to establishing the AIA, an emergency Loya Jirga was convened June 11-19, 2002, to elect a new head of state and appoint the Afghanistan Transitional Administration (ATA). The ATA would run the country for a maximum of two years until a "fully representative government" could be chosen through free and fair elections.<sup>165</sup> The election for president of the ATA was held at the Loya Jirga by secret ballot on June 13, 2002. Hamid Karzai was selected by an overwhelming majority of 83 percent, and he stayed in office as President and Chairman of the transitional administration until the 2004 presidential election.

## Drafting a New Constitution

The Bonn Agreement of December 2001 required Afghanistan to draft and adopt a new constitution within two years. In October 2002, interim President Hamid Karzai appointed a nine-member Constitutional Drafting Commission, which, over the following six months, drafted a new constitution, using the 1964 Afghan constitution as a basis. A Loya Jirga consisting of 502 delegates was convened in Kabul December 14, 2003, to consider the proposed new constitution. After much debate and discussion, the assembly finally endorsed the charter January 4, 2004. The new constitution<sup>166</sup> provided for a strong presidency, a two-chamber legislature, and an independent judiciary. It guaranteed freedom of religion while recognizing Islam as the country's official religion. It also recognized that men and women are equal before the law, and it guaranteed language rights of minorities.

## Early Elections

The country held an election for the office of President of Afghanistan October 9, 2004. Hamid Karzai won the election with 55.4 percent of the votes and three times more votes than any other candidate. At a formal ceremony in Kabul, Karzai was sworn in as President of the Islamic Republic of Afghanistan on

---

<sup>163</sup> Officially, the International Conference on Afghanistan, Bonn (2001).

<sup>164</sup> Officially, the "Agreement on Provisional Arrangements in Afghanistan Pending the Re-Establishment of Permanent Government Institutions," the first in a series of international agreements to reestablish the Afghan state after the fall of the Taliban regime.

<sup>165</sup> *Wikipedia* (2016). "Afghan Transitional Administration." Last modified October 19, 2016. [https://en.wikipedia.org/wiki/Afghan\\_Transitional\\_Administration](https://en.wikipedia.org/wiki/Afghan_Transitional_Administration).

<sup>166</sup> The Constitution of the Islamic Republic of Afghanistan, ratified January 26, 2004. Accessed February 9, 2015. <http://www.afghanembassy.com.pl/afg/images/pliki/TheConstitution.pdf>.

December 7, 2004, becoming the first democratically elected president of the country. The National Assembly was inaugurated December 19, 2005. This was a historic occasion that marked the culmination of the political transition process set out in the Bonn Agreement. Among the elected officials for the parliament were warlords, former communists, Taliban defectors, and women's rights activists. Additionally, some of the provincial governors were former warlords. Afghanistan also named its first female provincial governor, Ms. Habiba Surabi, who President Hamid Karzai appointed to govern Bamyan province. President Karzai was re-elected in August 2009 for a second term.

Due to term limitations set by the constitution, President Karzai was not eligible to run for re-election in 2014. There were eleven candidates for the 2014 presidential election held April 5, 2014. No candidate secured more than the 50 percent of the vote, so there was a second-round run-off election on June 14 between the two leading candidates, Dr. Abdullah and Dr. Mohammad Ashraf Ghani Ahmadzai (commonly known as Ashraf Ghani). Preliminary results were expected on July 2 and the final result on July 22. However, due to allegations of widespread fraud, it was announced on July 12 all ballots would be audited under UN supervision. After months of political tensions and a US-brokered power-sharing arrangement, the candidates agreed in principle and signed a shared power agreement on September 21, 2014, after which the Afghan Independent Election Commission (IEC) announced Ghani as the winner of the presidential election. Pursuant to the power-sharing agreement, Ashraf Ghani was named president and Abdullah became chief executive, a position akin to prime minister. On September 29, 2014, Ghani was sworn in as the new president, marking the first peaceful transition of power in Afghanistan in more than 100 years, and the first democratic transfer of power since the Taliban government fell in 2001. President Ghani then swore in Abdullah as chief executive, forming a "National Unity Government."

## The National Government

The Government of the Islamic Republic of Afghanistan (GIROA) has three branches: executive, legislative, and judicial. The executive branch consists of the president, who is head of both state and government. For each of Afghanistan's 34 provinces, the president appoints governors, who are representatives of the central government in Kabul. The legislative branch consists of the National Assembly, with two houses: the *Wolesi Jirga* (House of the People, the lower house) and the *Meshrano Jirga* (House of Elders, the upper house). The Wolesi Jirga is responsible for making and ratifying laws and approving the actions of the president and the upper house, which has an advisory role with veto power. Under the judicial branch are a Supreme Court (*Stera Mahkama*), high courts, appeals courts, and local and district courts. Eligible judges may have training in either Islamic jurisprudence or secular law. The Supreme Court is composed of nine members, including the chief justice, who are appointed by the president for ten-year nonrenewable terms, with the approval of the Wolesi Jirga. The Supreme Court has the power of judicial review.

No laws may be passed that are contrary to the laws of Islam. Law is administered on an intermittent basis according to a mixture of codified law,<sup>167</sup> Shari'a (Islamic law), and local customs. Although the judicial system has historically been corrupt or nonexistent in many parts of Afghanistan, the new Supreme Court appointees offer a glimmer of hope.<sup>168</sup>



Figure 15: Afghanistan provinces and provincial capitals

## The Provinces

Afghanistan is administratively divided into 34 provinces (see [Figure 15](#)), with each province having its own capital and provincial administration. The provincial governors are representatives of the central government in Kabul and are responsible for all administrative and formal issues within their provinces. There are also provincial councils that are elected through direct and general elections,<sup>169</sup> which serve for four years. The functions of provincial councils are to take part in provincial development planning and to

<sup>167</sup> Kramer, Frank, Stuart Starr, and Larry Wentz. n.d. *Information Communications Technology Support to Reconstruction and Development: Some Observations from Afghanistan*. Report presented at the 12<sup>th</sup> International Command and Control Research and Technology Symposium (ICCRTS), Newport, Rhode Island, June 2007. Accessed August 14, 2015. [http://www.dodccrp.org/events/12th\\_ICCRTS/CD/html/papers/106.pdf](http://www.dodccrp.org/events/12th_ICCRTS/CD/html/papers/106.pdf).

<sup>168</sup> International Crisis Group (2006). *Countering Afghanistan's Insurgency: No Quick Fixes*. Asia Report No. 123. November 2, 2006. [https://www.justice.gov/sites/default/files/eoir/legacy/2014/09/29/icg\\_11022006.pdf](https://www.justice.gov/sites/default/files/eoir/legacy/2014/09/29/icg_11022006.pdf). Accessed August 14, 2015.

<sup>169</sup> *Wikipedia* (2015). "Afghanistan." Accessed August 14, 2015. [https://en.wikipedia.org/wiki/Islamic\\_Republic\\_of\\_Afghanistan](https://en.wikipedia.org/wiki/Islamic_Republic_of_Afghanistan).

participate in the monitoring and appraisal of other provincial governance institutions.<sup>170</sup> Each province is represented in the government of Afghanistan by two members of the Meshrano Jirga, or House of Elders. One is elected by the provincial council to a four-year term, while the second is elected by the district councils to a three-year term.<sup>171</sup> Representatives in the Wolesi Jirga, or House of the People, are directly elected from the districts, although in each province, two of the representatives must be women. They are appointed by the president of Afghanistan.<sup>172</sup>

## Districts and Villages

Each province encompasses a number of districts and typically over 1,000 villages. The number of districts in Afghanistan has fluctuated over the years, with new districts being created by splitting or merging parts of others. In 2009, the Afghan Ministry of Interior (MoI) recognized a total of 398 districts.<sup>173</sup> As Afghanistan continues to organize itself, this number may change over time. District governors are selected by the provincial governors. Per Article 141 of the Afghan Constitution,<sup>174</sup> mayors of cities should be elected through free, general, secret, and direct elections. However, this process has never been put into practice. Instead, appointments to these posts have been filled by Afghanistan's interior ministry, subject to presidential approval.<sup>175</sup>

## The Capital City of Kabul

Located in east-central Afghanistan, Kabul, or Kabul City so as not to be confused with the province of the same name, is the capital of Afghanistan. Kabul has served as the country's capital more than once throughout its tumultuous history, and has been the capital continuously since 1776.<sup>176</sup> It is situated at an elevation of about 5,900 feet in a narrow valley, between two steep ranges of the Hindu Kush Mountains along the Kabul River. Kabul is one of the highest capital cities in the world.<sup>177</sup> It is Afghanistan's largest city (by far) and the fifth fastest growing city in the world.<sup>178</sup> With a population of between 3.5 and 5

---

<sup>170</sup> Ibid.

<sup>171</sup> *Wikipedia* (2015). "Provinces of Afghanistan." Accessed August 14, 2015. [https://en.wikipedia.org/wiki/Provinces\\_of\\_Afghanistan](https://en.wikipedia.org/wiki/Provinces_of_Afghanistan).

<sup>172</sup> Ibid.

<sup>173</sup> *Statoids.com*. "Districts of Afghanistan." Last updated November 20, 2010. <http://www.statoids.com/yaf.html>.

<sup>174</sup> 2004 Constitution.

<sup>175</sup> "Afghans Demand Elected Mayors: Municipal election rules have never been implemented." 2015. Institute for War and Peace Reporting. ARR Issue 513, March 21, 2015. Accessed September 13, 2016. <https://iwpr.net/global-voices/afghans-demand-elected-mayors>.

<sup>176</sup> *Encyclopædia Britannica*. "Kabul." Accessed September 13, 2016. <https://www.britannica.com/place/Kabul>.

<sup>177</sup> Ibid.

<sup>178</sup> *City Mayors Statistics*. "The world's fastest growing cities and urban areas from 2006 to 2020." Accessed January 7, 2015. [http://www.citymayors.com/statistics/urban\\_growth1.html](http://www.citymayors.com/statistics/urban_growth1.html).

million in a city designed to support 300,000, Kabul is quite literally “bursting at the seams.”<sup>179</sup> The mayor of Kabul is appointed by the president of Afghanistan.<sup>180</sup>

Facing increased insurgency threats to the city, at the end of 2009, the European Union Police (EUPOL) mission in cooperation with the ANP, Kabul police, and NATO Training Mission-Afghanistan/Combined Security Transition Command-Afghanistan helped establish, fund, and operate a series of fixed and mobile check points operationally manned by EUPOL and Afghan police to create a layer of perimeter security around central Kabul, referred to as the “Ring of Steel.” In January 2013, the Afghan police took over full responsibility for Kabul’s Ring of Steel.<sup>181</sup>

In a 2014 news article in *The Guardian*, it was noted that rapid urbanization had taken a heavy toll on the Afghan capital.<sup>182</sup> The author says that the hope of increased security and economic possibilities enticed many Afghans to move to Kabul: people displaced by fighting in the countryside, refugees returning from Pakistan and Iran, and hordes of laborers simply looking for a better life. What was a ghost town ravaged by civil war became a shabby, bustling metropolis. Yet despite being strained beyond capacity, Kabul seems to have lost none of its attraction to the people flocking there. Many have made long journeys from remote districts in the south of the country, where fighting between insurgents and government forces has uprooted thousands of families. A significant portion of Kabul’s slum-dwellers gave up relatively decent living conditions to move to the city, only to find themselves disillusioned and jobless.<sup>183</sup>

He aptly describes the city as follows: Cars clog the streets, negotiating for space with street vendors and donkey carts. At the fringes, crude houses pepper the hillsides and the valley along the river, spreading far beyond what a short time ago were the edges of the Afghan capital ... Many streets remain unpaved or untended ... High-rise apartment blocks, and glitzy, multi-story wedding halls and modern office buildings poke out of the sprawling traditional single-floor buildings. Modern Western style shopping malls are emerging as well.<sup>184</sup>

He further reports: The city has been unable to keep up with the fast-paced urbanization and seemed incapable of providing jobs and services to sustain all its newcomers. Kabul’s incapacity to absorb such large numbers of migrants was partly due to the former Taliban regime’s disregard for the city during its five-year rule through nearly the end of 2001. However, more recent neglect for Kabul’s informal settlements has compounded its problems, creating fertile ground for crime and perhaps even insurgency.

---

<sup>179</sup> Rasmussen, Sune Engel (2014). “Kabul – the fifth fastest growing city in the world – is bursting at the seams,” December 11. *TheGuardian.com*. Accessed January 7, 2015.

<https://www.theguardian.com/cities/2014/dec/11/kabul-afghanistan-fifth-fastest-growing-city-world-rapid-urbanisation>.

<sup>180</sup> *New World Encyclopedia*. “Kabul.” Last modified May 27, 2014.

<http://www.newworldencyclopedia.org/entry/Kabul>.

<sup>181</sup> European Police (EUOPOL) Afghanistan (2013). “Afghan police take over full responsibility for Kabul’s Ring of Steel,” January. Accessed September 13, 2016. <http://www.eupol-afg.eu/node/224>.

<sup>182</sup> *Ibid.*

<sup>183</sup> *Ibid.*

<sup>184</sup> *Ibid.*



As the foreign troops departed and the attention of international donors waned, they left behind a city beset by criminality and economic malaise.<sup>185</sup>

The author, however, ends on a more positive note: In 2013, after a decade without a plan for urban development, the government of Kabul approved a new 15-year, three-phase roadmap for the city, which estimated the population in that period would grow to 8 million. The plan proposes a series of ring roads to alleviate the gridlock that chokes the city.<sup>186</sup> It also includes building housing, establishing an agriculture economic zone, developing infrastructure (roads, power, water, information and communications technology (ICT), and sewerage), and introducing greenery (plants and parks) to beautify the capital.<sup>187</sup> Referred to as “Kabul New City,” it will be located north of the existing Kabul City between Bagram Airbase and Kabul International Airport and will be about 1.5 times as large as the capital proper.

## Afghanistan’s Flag

The official flag of Afghanistan is shown in [Figure 16](#). The details of the coat-of-arms and flag are regulated in Chapter 1, Article 19 of the Afghan Constitution: “The Afghan flag shall be made up of three equal parts,



Figure 16: Flag of Afghanistan

with black, red, and green colors juxtaposed from left to right perpendicularly. The width of every colored piece is equal to half of its length.”<sup>188</sup> Black represents the occupation of foreigners; red symbolizes the blood of freedom fighters; and green signifies freedom and Islam.

The national emblem of the Islamic Republic of Afghanistan is located in the center of the flag. The emblem is composed of a *mehrab*<sup>189</sup> and pulpit in white with a flag located on either side. In the upper-middle part of the insignia is the sacred phrase, “There is no God but Allah and Mohammad is his Prophet, and Allah is

Great” along with a rising sun. The word “Afghanistan” and the solar year “1298,” which equates to 1919, the year Afghanistan declared independence from Great Britain, are located in the lower part of the insignia. The entire emblem is encircled by two branches of wheat.

---

<sup>185</sup> Ibid.

<sup>186</sup> Ibid.

<sup>187</sup> “Welcome to the Kabul New City Official Website.” Dehsabz-Barikab City Development Authority (DCDA). Accessed September 13, 2016. <http://www.dcd.gov.af/>.

<sup>188</sup> 2004 Constitution

<sup>189</sup> A mehrab, or mihrab, is an ornamental indentation in the wall of a mosque that marks the direction of Mecca.

## Security

### NATO's International Security Assistance Force

To address the immediate security needs created by the absence of law and order following the ousting of the Taliban government, the International Security Assistance Force (ISAF) was established by the United Nations Security Council Resolution (UNSCR) 1386 on December 20, 2001. As envisaged by the Bonn Agreement, ISAF would provide security assistance for the establishment and operation of the Afghan Transitional Authority by creating a secure environment in and around Kabul. The ISAF operation was initially led by and composed of military elements of participating nations. The command was led by a general officer provided on a six-month rotational assignment by different nations starting with the United Kingdom (UK).

On August 11, 2003, NATO assumed leadership of the ISAF operation, ending the six-month national leadership rotations. In October 2003, the United Nations extended ISAF's mandate to cover the whole of Afghanistan (UNSCR 1510) and expand the security assistance mission across the country in support of Afghan recovery and reconstruction activities. The ISAF mission was to support the Afghan government by “conduct[ing] operations in Afghanistan to reduce the capability and will of the insurgency, support the growth in capacity and capability of the Afghan National Security Forces (ANSF),<sup>190</sup> and facilitate improvements in governance and socio-economic development in order to provide a secure environment for sustainable stability that [was] observable to the population.<sup>191</sup>

On December 1, 2009, President Obama announced at a speech at the United States Military Academy at West Point that it was in the United States' vital national interest to send additional US troops and civilian personnel to Afghanistan for approximately 18 months.<sup>192</sup> The purpose was to seize the initiative to bolster the Afghan state “from the bottom up.” The primary military objective was to reverse the Taliban's momentum while building the Afghan security forces capacity to set the conditions to allow for a responsible transition of US forces out of Afghanistan. President Obama authorized a “military surge” of 30,000 military personnel to be deployed as soon as possible, mainly to southern and eastern Afghanistan.

On June 22, 2011, President Obama announced the US's intentions to start to withdraw combat troops from Afghanistan.<sup>193</sup> These troops would be withdrawn slowly until the end of 2014, with a small follow-on force remaining to support training, advising, and assisting the ANSF. On December 5, 2011, ten years

---

<sup>190</sup> At the end of 2014, the ANSF became the Afghan National Defense and Security Forces (ANDSF). The terms are used interchangeably throughout this book.

<sup>191</sup> Beljan, Robert (Maj., Armed Forces of Bosnia and Herzegovina) (n.d.). *What Lessons From ISAF Operations Can Be Drawn for UN PKOs?*, 12. Accessed December 10, 2014. <http://cdn.peaceopstraining.org/theses/beljan.pdf>.

<sup>192</sup> Obama, Barack (2009). “Remarks by the President in Address to the Nation on the Way Forward in Afghanistan and Pakistan,” December 1. The White House Office of the Press Secretary. Accessed December 10, 2014. <http://www.whitehouse.gov/the-press-office/remarks-president-address-nation-way-forward-afghanistan-and-pakistan>.

<sup>193</sup> Obama, Barack (2011). “Remarks by the President on the Way Forward in Afghanistan,” June 22. The White House Office of the Press Secretary. Accessed December 10, 2014. <https://www.whitehouse.gov/the-press-office/2011/06/22/remarks-president-way-forward-afghanistan>.

after the Bonn Conference of 2001, the International Community, composed of 85 countries, 15 international organizations, and the United Nations met in Bonn with Afghanistan leaders to shape the long-term joint engagement and to help advance the political process in the country.

At the May 2012 NATO Summit in Chicago, leaders discussed how to extend the NATO-Afghanistan partnership further. Allies and partners agreed upon a framework of a new NATO mission to train, advise, and assist (TAA) the Afghan forces. Support for the further development of the ANSF would continue under a new, smaller non-combat NATO-led mission, Resolute Support (RS). The Resolute Support Mission (RSM) would consist of an international force of about 12,500 troops, of which 9,800 would be US military. The final handover of responsibility for Afghanistan's security to the Afghan government, which had occurred over time in tranches, took place on June 18, 2013. The completion of the withdrawal of all international combat troops occurred by the end of 2014. The transition of ISAF to RS occurred on December 28, 2014. At the beginning of 2015, Afghan security forces numbered about 350,000 personnel.<sup>194</sup>

## Afghanistan National Defense and Security Elements

There are three Afghan institutions that have primary responsibility for defending and securing the country: the Ministry of Defense (MoD), the Ministry of Interior (MoI), and the National Directorate of Security (NDS). The MoD and MoI are headed by a presidentially appointed, parliamentary-approved minister. The NDS is headed by a director and is also a parliamentary-approved position. These institutions are responsible for providing strong and effective leadership and creating structures, procedures, and plans to build, reform, manage, and sustain Afghanistan's national defense and security.

### *The Ministry of Defense and the Afghan National Defense Forces*

The MoD oversees Afghanistan's military elements. It is responsible for the implementation of defense policies and is the military's strategic-level headquarters providing oversight to the armed defense forces. Its objectives are to defend the nation and its interests, and to defeat the current insurgency. The defense forces consist of the Afghan National Army (ANA), the ANA Special Operations Command (ANASOC), the Mobile Strike Force (MSF), and the Afghan Air Force (AAF). Given Afghanistan is a landlocked country, there is no navy. The MoD also manages contingency planning, defense-related logistics, and routine policy functions of the military. Elements of MoD also develop, refine, and implement strategic policies to achieve national defense objectives. The majority of leaders in the MoD are senior ANA officers.

### *The Ministry of Interior and the Afghan National Police*

The MoI is responsible for law enforcement. It is central to the establishment and maintenance of the rule of law and the development of enduring police forces that are professional and effective. The MoI provides oversight and direction to the Afghan National Police (ANP) pillars: the Afghan Uniformed Police

---

<sup>194</sup> Barakat, Sultan and Brooke Smith-Windsor (2015). *Post-ISAF Afghanistan: The Early Months*, Brookings Institution Policy Dialogue, February 2015. <https://www.brookings.edu/wp-content/uploads/2016/06/bdc-nato-event-report.pdf>. Accessed March 14, 2016.

(AUP), Afghan Border Police (ABP), Afghan National Civil Order Police (ANCOP), and Afghan Anti-Crime Police (AACP). It also provides oversight and direction to two other specially created elements, the Afghan Local Police (ALP) and the Afghan Public Protection Force (APPF). The ALP is a community protection and defense force focused at the district and village levels. The ALP complements counterinsurgency efforts by targeting rural areas with limited to no ANSF presence in order to enable conditions for improved security, governance, and development. The APPF was the result of Presidential Decree 62 (PD62),<sup>195</sup> regarding the dissolution of private security companies (PSCs), which were to be replaced by Afghan-led security supported by risk management companies (RMCs). The APPF was essentially a state-run security enterprise to protect people (largely foreigners), vital infrastructure, construction projects, and convoys. APPF guards do not have a mandate to investigate crimes or arrest suspects. In 2014, directions were given to dissolve the APPF and transition its functions to the ANP.

### *The National Directorate of Security*

The NDS is GIRoA's domestic intelligence agency. It reports directly to the president and has departments and branches across Afghanistan. NDS elements serve in each province and synchronize efforts as appropriate with ANSF elements of the Regional, Provincial, and District Operations Coordination Centers (OCCs). The mission of the OCCs is to plan, integrate, synchronize, and coordinate the efforts of the ANSF and NDS to facilitate a common operational picture and to help coordinate information flow and actions among GIRoA entities and, to a lesser extent, between Coalition forces and GIRoA.

### *Human Safety versus Security*

Human safety and security are closely interrelated concepts that pertain to protection of lives and assets. There is a distinct difference between safety and security that needs to be understood clearly.<sup>196</sup> For example, someone is safe when he is protected against danger or risk, and he is not likely to be harmed or lost.<sup>197</sup> "Human security" is an approach that rejects the traditional prioritization of national security and instead identifies the individual as the primary referent of security. It offers a way of broadening perspective and recognizing that pressing threats to individuals do not [only] come from ... war, but from ... emergencies" that affect people's everyday quality of life, "such as famine, disease, displacement, civil conflict, environmental degradation, and other natural disasters."<sup>198</sup>

Human security is about people living their lives with dignity, and being free from fear and want. To date, there has been a strong tendency to focus on insecurity caused by civil conflict, with less attention on

---

<sup>195</sup> Afghanistan Presidential Decree #62, "About dissolution of Private Security Companies" August 17, 2010. Accessed December 9, 2014.

[http://psm.du.edu/media/documents/national\\_regulations/countries/asia\\_pacific/afghanistan/afghanistan\\_decree\\_number\\_52\\_dissolution\\_psc\\_2010-english.pdf](http://psm.du.edu/media/documents/national_regulations/countries/asia_pacific/afghanistan/afghanistan_decree_number_52_dissolution_psc_2010-english.pdf).

<sup>196</sup> Koshal (2011). "Difference Between Safety and Security." *Difference Between.com*, June 15. Last updated November 20, 2014. <http://www.differencebetween.com/difference-between-safety-and-vs-security/>.

<sup>197</sup> Ibid.

<sup>198</sup> Hobsen, Christopher; Paul Bacon and Robin Cameron (eds.) (2014). *Human Security and Natural Disasters*. (New York: Routledge).

issues to do with environmental security and the threats posed by natural disasters, which represent an increasingly important human security threat to people everywhere and in Afghanistan in particular.<sup>199</sup> Regarding the latter, Afghanistan is prone to a number of natural disasters: earthquakes, flooding, drought, landslides, and avalanches. Earthquakes are relatively frequent (more so in the north and northeast), and often trigger landslides. Floods are common in the spring when snow begins to melt and rainfall is heavy, and they too trigger landslides.

In 2003 Afghanistan, as one of the member states of the UN, developed key policy documents such as the Disaster Management Framework, National Strategy for Disaster Management, and National Disaster Management Plan. The Afghanistan National Disaster Management Authority (ANDMA) is the principal institution at the national level with the mandate to coordinate and manage all aspects related to disaster mitigation, preparedness, and response through its national and provincial offices.<sup>200</sup>

### *The Afghanistan National Disaster Management Authority*

To undertake better and effective disaster management activities, all stakeholders, both government ministries and non-governmental organizations, are under the leadership of the National Emergency Committee and its secretariat, the Afghanistan National Disaster Management Authority (ANDMA), which organizes national disaster management activities from preparedness to response. The ANDMA is under the Office of the President and has the mandate to coordinate and manage post-disaster response activities for the government. Key government ministries provide necessary assistance for disasters in accordance with their mandated roles and responsibilities. Those with important disaster response roles include, but are not limited to, the following ministries: Interior (MoI), Defense (MoD), Information and Culture (MoIC), Public Health (MoPH), Agriculture, Irrigation and Livestock (MAIL), Communications and Information Technology (MCIT), Refugees and Returns (MoRR), Finance (MoF), Transport and Civil Aviation (MoTCA), and Public Works (MoPW). The Department of Meteorology provides weather-related information and early-warning information. The ANDMA and the MoIC work in close coordination with the media and mobile telephone companies in disseminating that information.

Regarding key defense and security ministry support to ANDMA, both the MoI and MoD play important roles. The MoI has established an Office of Disaster Preparedness within the Ministry, which supports the ANDMA disaster response activities. The office performs two important tasks in disaster management: rescue services and firefighting, especially in urban areas. The MoD has an important role providing security, logistics, and, if necessary, assistance in distribution of relief items and the provision of equipment for emergency response in support of the ANDMA. The MoD can provide trained personnel with specialized skills, such as placement of ICT equipment in isolated areas, and can provide specialized transportation systems.

---

<sup>199</sup> Ibid.

<sup>200</sup> Islamic Republic of Afghanistan National Disaster Management Authority. Accessed February 9, 2015. <http://www.andma.gov.af/>.

## The Afghan National Security Forces

The ANSF are comprised of the ANA, ANASOC, MSF, AAF, and ANP and are a growing source of national pride as well as a strong visual symbol of GIRoA's enduring strength. In mid-2014 the ANSF were nearing their official end-strength goal of 352,000 members. The ANSF have shown progress evolving into confident and capable troops. On June 18, 2013, the ANSF assumed lead responsibility for nationwide defense and security from NATO's Coalition forces. However, in both form and substance, the ANSF are still very much a work in progress. They are struggling to hold their ground in an increasingly hostile environment that emerged and increased with the drawdown of Coalition war fighting forces. For example, nearly 80 percent more Afghan security forces were killed in the summer of 2013 compared to 2012. In 2014 around 5,000 members of the Afghan security forces were killed battling the ongoing insurgency. Halfway through the 2015 fighting season 4,100 soldiers and police officers have been killed and about 7,800 wounded, with months of heavy fighting still ahead.<sup>201</sup>

In 2014, the ANSF sustained about a 6.5 percent increase in casualties. In 2013, the Afghan Army experienced a 34 percent attrition rate. Pay disparities and high casualty rates were among the principal causes of attrition.<sup>202</sup> Far from their homes, poorly paid, and discriminated against, every year thousands of ANA soldiers and officers desert the army. Insurgent subversion has also crippled the forces in several ways, including through insider attacks against Afghan forces. These attacks have dropped significantly in number, from 35 in 2012 to less than a dozen in 2013.<sup>203</sup> Yet the insurgency continues to co-opt, coerce, and bribe the defense and security forces long after their recruitment. Taliban forces also have fairly easy access to both military and police uniforms via black markets. The result is a force that might very well have traitors in its midst. Compounding these problems are low rates of literacy, which may be as little as 50 percent of Afghan security personnel. The ANSF also face challenges in many areas including recruiting, leadership, training, logistics, counter-improvised explosive device (C-IED), operations, and procurement. Additionally, the ANA continue to desert, shrink, and be squeezed due to lack of funds and modern weapons needed to defeat Taliban and Islamic State (IS) insurgents. Private criminal militias are in control of 70 percent of the territory of the state and pose a perpetual threat to the existence of the ANA.<sup>204</sup>

Another aspect of security includes attacks on Coalition forces by Afghan forces. The so-called "green-on-blue" insider attacks emerged as a major threat to Coalition forces in Afghanistan. In February 2012, two American officers were shot dead at close range in Afghanistan's Interior Ministry. In May 2012, the Commander of ISAF (COMISAF) said that about half of the green-on-blue attacks had been carried out by Taliban infiltrators. In August 2012, approximately 25 percent were due to Taliban infiltration and coercion

---

<sup>201</sup> Gady, Franz-Stefan (2015). "Is the Afghan Army Losing the War in Afghanistan?" *The Diplomat*, July 22. Accessed September 29, 2015. <http://thediplomat.com/2015/07/is-the-afghan-army-losing-the-war-in-afghanistan/>.

<sup>202</sup> Wilson, John (2014). "The Clock Is Ticking in Afghanistan." *US News and World Report*, April 15. Accessed September 29, 2015. <http://www.usnews.com/opinion/blogs/world-report/2014/04/15/the-afghan-national-security-forces-remain-a-work-in-progress>.

<sup>203</sup> Ibid.

<sup>204</sup> Jalalzai, Musa Khan (2015). "Challenges of the Afghan National Army." *South Asia Monitor*, January 12. Accessed September 29, 2015. <http://southasiamonitor.org/detail.php?type=n&nid=10222>.

of Afghan forces. The insider attacks increased dramatically in 2012 and accounted for 15 percent of Coalition deaths. In 2011 green-on-blue attacks accounted for 6 percent; in 2010 and 2009, 2 percent each; and in 2008, less than 1 percent.<sup>205</sup>

The US military became so concerned with the green-on-blue attacks in 2012 that it ordered units to designate "guardian angels" in each unit whose job it was to provide security for troops working with Afghans. In addition, COMISAF directed all US and NATO troops to carry loaded weapons at all times, even on military bases, where Afghans were employed or had access (such as for deliveries).

Although insider attack levels dropped off after 2012, they continued through 2015. An August 2014 attack killed US Major General Harold J. Greene, who was on a key leader engagement (KLE) visit (military jargon for a high-level meeting) to the Marshal Fahim National Defense University in Kabul. He was the highest-ranking American officer killed in the Afghan war, and he was the highest-ranking service member killed on foreign soil since 1972 during US combat operations in Vietnam.<sup>206</sup>

There is an absence of visible justice in many parts of the country. For years, the ANP have tended to be viewed by the average Afghan in many areas as a source of fear rather than security. The ANP have been accused of improper treatment of the local population and have been ineffective in controlling crime. In the hinterland, local and regional military commanders continue to exercise control, and many times, the military has to respond to incidents due to a lack of police coverage or ability to respond. A contributing factor to the civil policing situation is that many of the fighters demobilized from the militias joined the police, private security firms, or organized crime networks — and some all three. Corruption and the relative level of incompetence of the police force have also been driven by under pay, or not being paid on time, and a lack of real training and basic equipment.

The ANP have, however, made progress, but the challenges are urgent, and critical capabilities remain underdeveloped. Without effective engagement throughout all levels of the community, the ANP lacks the ability to gather information continuously; prevent and discover crimes, including crimes against internal security; address causes of conflict before they escalate into full scale factional and anti-government grievances; and demonstrate that the government can regulate the community and keep public order. Given the ethnic and ideological fault lines that exist across the country, and the limited reach of the central government, it is essential that the ANP be an adaptive and culturally sensitive organization wherever it is present. Helping the ANP shift from a wartime footing to a contextually appropriate community-policing model, and advancing professionalism within the ministry and the

---

<sup>205</sup> Roggio, Bill and Lisa Lundquist (2012). "Green-on-blue attacks in Afghanistan: the data." *The Long War Journal*, August 23. Updated April 2015. Accessed May 5, 2015. <http://www.longwarjournal.org/archives/2012/08/green-on-blue-attack.php>.

<sup>206</sup> *Wikipedia* (2016). "Harold J. Greene." Last modified August 18. [https://en.wikipedia.org/wiki/Harold\\_J.\\_Greene](https://en.wikipedia.org/wiki/Harold_J._Greene).

operating forces, is critical to sustainability. If a national police force is going to succeed, the linkage between policing and governance must be recognized and strengthened.<sup>207</sup>

## Economics and Social Development

### Economy

Afghanistan is an extremely impoverished country and one of the world’s poorest and least developed nations. Its economy is a complex mix of informal, formal, illicit, and aid-sustained elements. Economic statistics for Afghanistan traditionally are inexact, but for the past 20 years, it has routinely ranked among the poorest nations in the world<sup>208</sup> as indicated in [Table 1](#).

Table 1: Afghanistan country ranking by GDP (PPP) per capita

	International Monetary Fund (2013)	World Bank (2011-2013)	US Central Intelligence Agency (1993-2013)
Rank	162	160	181
Number of Countries	187	185	195

For 2015, the World Bank reported Afghanistan’s gross domestic product (GDP) as US\$19.2 billion and its gross national income (GNI) per capita at US\$630, down to less than a third of what it was in 2013: US\$1,960.<sup>209</sup> It indicates an annual GDP growth rate for 2015 of a mere 1.5 percent, down from over 14 percent in 2012.<sup>210</sup>

Afghanistan’s major economic centers are Kabul, Herat, Kandahar, Jalalabad, Khost, Mazar-e-Sharif, and Kunduz. Its economy is comprised primarily of services, followed by agriculture, industry, and construction (see [Figure 17](#)).<sup>211</sup> Afghanistan’s primary agricultural products are opium, wheat, fruits, nuts, wool, mutton, sheepskins, and lambskins.<sup>212</sup> Its primary industries are manufacturing and mining, which together comprise 13 percent of GDP,<sup>213</sup> while there is also small-scale production of bricks, textiles, soap,

<sup>207</sup> Hughes, Michelle (2014). *The Afghan National Police in 2015 and Beyond*. United States Institute of Peace Special Report 346, May 2014. Accessed May 5, 2015.

[http://www.usip.org/sites/default/files/SR346 The Afghan National Police in 2015 and Beyond.pdf](http://www.usip.org/sites/default/files/SR346%20The%20Afghan%20National%20Police%20in%202015%20and%20Beyond.pdf).

<sup>208</sup> *Wikipedia* (2015). “List of countries by GDP (PPP) per capita.” Accessed March 18, 2015.

[http://en.wikipedia.org/wiki/List\\_of\\_countries\\_by\\_GDP\\_\(PPP\)\\_per\\_capita](http://en.wikipedia.org/wiki/List_of_countries_by_GDP_(PPP)_per_capita). PPP stands for purchasing power parity.

<sup>209</sup> World Bank (2016). “World Bank Open Data: Afghanistan.” Accessed August 9, 2016.

<http://data.worldbank.org/country/afghanistan>.

<sup>210</sup> *Ibid*.

<sup>211</sup> TradingEconomics.com. Accessed December 9, 2014. <http://www.tradingeconomics.com/afghanistan/gdp>.

<sup>212</sup> CIA, 2014.

<sup>213</sup> TradingEconomics.com.



furniture, shoes, fertilizer, apparel, food products, non-alcoholic beverages, mineral water, cement, and hand-woven carpets.<sup>214</sup> Customs duties constitute one of the largest sources of domestic revenues since they tend to be easier to administer and collect in developing countries because of fierce border protection. However, collecting domestic taxes in Afghanistan has been problematic, and a tax gap of some 60 percent exists, fueled by a culture of not having paid official taxes for many years.

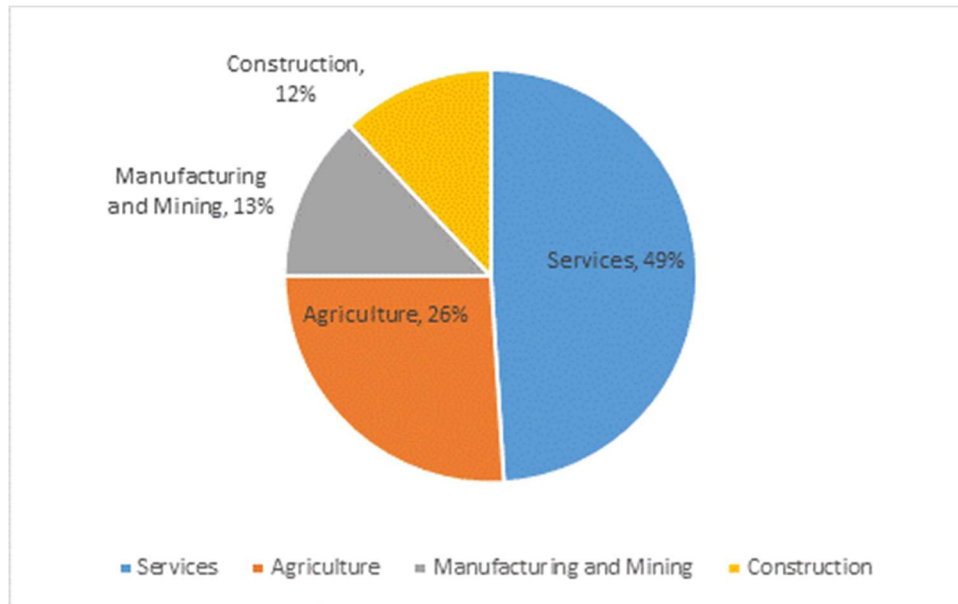

Figure 17: Afghanistan GDP composition by sector of origin

Afghanistan's economy, which always has been heavily agricultural, was shattered by the wars of the 1980s and the 1990s. Industry, much of which depended on agricultural output, suffered as well. After the wars, small-scale trade in urban centers and agriculture in some regions revived quickly. However, damage to the road and agriculture infrastructure would take much longer to repair. Transportation, heavily dependent on the road network, was frayed by the wars. Despite major efforts in the past ten to fifteen years, 85 percent of national roads are in poor shape, and most cannot be used by motor vehicles. Rapid urbanization is creating another strain, although it could also help boost growth over time through the economic benefits of clustering population and commerce.

Since 2002, Afghanistan's economy has been heavily driven by donors. Prior to the end of 2014, the international and academic communities expressed concerns about the possible impact of the drawdown of Coalition forces on the progress Afghanistan had made and sustenance of its economy. They were especially concerned about the potential impact of the diminishment of economic support and deep

---

<sup>214</sup> CIA, 2014.

donor fatigue.<sup>215</sup> This is especially important because Afghanistan had to engage not only in a security transition but also political and economic transitions at the same time. In 2015, the World Bank argued that the political and security transition continued to take a heavy toll on Afghanistan's economy.<sup>216</sup> Economic growth is estimated to have fallen to 2 percent in 2014, down from 3.7 percent in 2013 and an average of 9 percent from 2003-2012. It was further noted that political uncertainty combined with weak progress on reform dealt a further blow in 2014 to investor and consumer confidence, already in a slump from uncertainty, which had been building since 2013. The economy also faces headwinds from the drawdown in aid, affecting growth in non-agricultural sectors (manufacturing, construction, and services). The agricultural harvest in 2014 was strong for the third year in a row, but was up only marginally from the bumper year of 2012. Agriculture benefited from robust cereals production thanks both to well-distributed, timely rainfall and an increase in irrigated area for wheat cultivation.

The ICT sector has been a major contributor to the Afghan economy. An ICT economic impact study conducted by Altai Consulting for USAID in 2014 estimated the gross revenue generated in the ICT sector in 2013 was US\$1.81 billion and the direct contribution to GDP was US \$950 million.<sup>217</sup> Despite the good progress, the view of the World Bank view is the economic growth outlook for 2015 remained weak.

Afghanistan's labor force was estimated at 7.52 million in 2012, with over 78 percent employed in agriculture.<sup>218</sup> Widespread unemployment remains a concern: Afghanistan's unemployment rate was 25 percent in 2014 but increased to 40 percent in 2015,<sup>219</sup> after international troops and organizations largely left the country. Among the most pressing labor problems are the lack of skilled workers and administrators, which could become worse due to an increase in Afghan emigration related to growing security concerns. While head of the Afghan Transition Coordination Commission (TCC) in 2010, Dr. Ashraf Ghani warned about the potential threats Afghanistan might face if significant attention is not paid to Afghanistan's economic and investment conditions.<sup>220</sup> He cited rising youth population, widespread unemployment, and the lack of investment opportunities as the main challenges the government must tackle.

---

<sup>215</sup> Fair, C. Christine (2015). "The Other Drawdown in Afghanistan." *Current History*, April. Accessed September 13, 2016. [https://www.academia.edu/14485386/The\\_Other\\_Drawdown\\_in\\_Afghanistan](https://www.academia.edu/14485386/The_Other_Drawdown_in_Afghanistan).

<sup>216</sup> Raouf Zia, Abdul (2015). *The World Bank Group in Afghanistan: country update*. Kabul, Afghanistan: World Bank Group. <http://documents.worldbank.org/curated/en/528831467995804890/The-World-Bank-Group-in-Afghanistan-country-update>.

<sup>217</sup> Altai Consulting (2014). *ICT Economic Impact Assessment*. July 2014, 7. Accessed December 9, 2014.

<http://www.altaiconsulting.com/docs/ICT%20Economic%20Impact%20Assessment.pdf>.

<sup>218</sup> CIA (2015). *The World Factbook: Afghanistan*. Accessed August 31, 2015.

<https://www.cia.gov/library/publications/the-world-factbook/geos/af.html>.

<sup>219</sup> TradingEconomics.com. Accessed August 31, 2015 and August 17, 2016.

<http://www.tradingeconomics.com/afghanistan/unemployment-rate>.

<sup>220</sup> "Afghanistan's economic issues must be seriously considered – Ahmadzai." *Wadsam.com*, February 15, 2013. Accessed December 9, 2014. <http://wadsam.com/afghan-business-news/afghanistans-economic-issues-must-be-seriously-considered-ahmadzai-989/>.

The World Trade Organization (WTO) began membership negotiations with Afghanistan in 2005. Discussions and adjustments were ongoing in 2008, but membership was not expected for several years. A draft deal was agreed in March 2014, and Afghanistan became the 164<sup>th</sup> WTO member on July 29, 2016.<sup>221</sup>

## The Black Economy

Afghanistan faces a number of serious economic challenges. Much of the Afghan “black economy” comes from poppy cultivation and the production of illicit drugs. Afghanistan produces over 80 percent of the world’s opium. In 2012, the total value of the Afghan opiate economy was estimated at roughly US\$2.4 billion, equivalent to 15 percent of the country’s licit GDP.<sup>222</sup> A 2014 report published by the [United Nations Office on Drugs and Crime](#) (UNODC)<sup>223</sup> found that illicit opium production in Afghanistan not only persists, but has actually increased (from 154,000 hectares in 2012 to 209,000 hectares in 2013). For nearly 14 years, the Afghan government, with the help of the International Community and aid agencies, has worked to eradicate opium production entirely. The UNODC report shows that not only have these efforts been unsuccessful, but that the eradication programs may have pushed farmers to increase their outputs. The report showcases the negative trends of the Afghan opium industry, in which 13 years of consolidated effort to eradicate opium crops, with millions of dollars spent, have been a failure. Compared to the other difficulties the country faces, from an active insurgency to widespread corruption and nepotism, the opium problem was understood to be relatively manageable. Yet the government and International Community have not been able to deal with it.

In October 2014, the US Office of the Special Inspector General for Afghanistan Reconstruction (SIGAR), reported<sup>224</sup> opium production in Afghanistan in 2013 was the highest ever: 209,000 hectares, up 36 percent from 2012. The average yield per hectare rose 11 percent over the preceding year. Potential production was up 49 percent. SIGAR observed that “opium poppy cultivation has far exceeded previous records. Affordable deep-well technology has turned 200,000 hectares of desert in southwestern Afghanistan into arable land over the past decade. Due to relatively high opium prices and the rise of an inexpensive, skilled, and mobile labor force, much of this newly arable land is dedicated to opium cultivation.”<sup>225</sup> SIGAR warned: “With deteriorating security in many parts of rural Afghanistan and low levels of eradication of poppy fields, further increases in cultivation are likely in 2014.” SIGAR also noted,

---

<sup>221</sup> World Trade Organization. Accessed August 17, 2016.

[https://www.wto.org/english/thewto\\_e/acc\\_e/a1\\_afghanistan\\_e.htm](https://www.wto.org/english/thewto_e/acc_e/a1_afghanistan_e.htm).

<sup>222</sup> Quigley-Jones, Jennifer (2012). “The High Costs of Afghanistan’s Opium Economy: Why the World Needs to Pay Attention to This Growing Crises.” Center for American Progress, June 8. Accessed December 9, 2014.

<https://www.americanprogress.org/issues/security/news/2012/06/08/11715/the-high-costs-of-afghanistans-opium-economy/>.

<sup>223</sup> United Nations Office on Drugs and Crime (2014). *World Drug Report 2014*. Accessed January 7, 2015.

<http://www.unodc.org/wdr2014/>.

<sup>224</sup> Special Inspector General for Afghanistan Reconstruction, Office of Special Projects (2014). *SIGAR-15-10-SP Special Report: Poppy Cultivation in Afghanistan 2012-2013*. October. Accessed January 7, 2015.

<https://www.sigar.mil/pdf/Special%20Projects/SIGAR-15-10-SP.pdf>.

<sup>225</sup> Ibid.

“The narcotics trade poisons the Afghan financial sector and undermines the Afghan state’s legitimacy by stoking corruption, sustaining criminal networks, and providing significant financial support for the Taliban and other insurgent groups.”<sup>226</sup>

Smuggling, particularly across the Pakistan border, of people, drugs, weapons, lumber, fertilizer, and other items is also an important part of the “black economy,” which competes with and drains resources from the formal economy. Extortion, taxation, and kidnapping for ransom are other contributors.

## Rural-Urban Divide in Afghanistan

An article published by the Afghan Institute for Strategic Studies in 2014 noted, “Today, there are two Afghanistans ... the haves and the have-nots.”<sup>227</sup> The majority of the population (71.5 percent, as indicated above), which lives in rural areas, is “conservative, traditional and live[s] in or near absolute poverty with a vastly different lifestyle from the Afghan urbanites, whereas, the Afghan urban population is more liberal, connected to modern technology and the world wide web and for the last couple of years, the aid dependent bubble economy has provided them with high rates of disposable income in cash and unaccounted wealth.” The author claims income disparity between the two is at “staggering double digits,” and warns, “If history is any lesson to Afghan statesmen and politicians, successive Afghan regimes have been toppled by a rebellion in the rural areas of Afghanistan because of neglect or rapidly imposed reforms. And more often than not – Afghan politicians, policymakers, and public officials along with their international allies forget this divide and think of Afghanistan in the narrow sense of the six major cities, which is a grave mistake.”<sup>228</sup>

The author goes on to say, “The Afghan government early on understood this issue and tried addressing it, but along the way it lost its focus on a rigorous rural development agenda – the interim administration of Afghanistan led by Hamid Karzai and under the initiative of the then Finance Minister and current President of Afghanistan, Dr. Ashraf Ghani [Ahmadzai], recognized this threat and designed several comprehensive national rural development programs such as the National Solidarity Program (NSP), National Rural Access Program (NRAP), National Area Based Development Program (NABDP), and the Microfinance Investment Facility for Afghanistan (MISFA), among others. Their collective basic objectives are to:

- Provide block grants to self-organized, democratic, and self-governed community councils around the country;
- Fund the priorities identified by them for their own communities;
- Improve their accessibility to urban centers by building rural roads; and

---

<sup>226</sup> Ibid.

<sup>227</sup> Asey, Tamim (2014). “The Price of Inequality: The Dangerous Rural-Urban Divide in Afghanistan – Analysis.” Afghan Institute for Strategic Studies, November 26. Accessed January 7, 2015. <http://www.aiss.af/the-price-of-inequality-the-dangerous-rural-urban-divide-in-afghanistan-analysis/>.

<sup>228</sup> Ibid.

- Provide micro credits for their household and business needs.”<sup>229</sup>

“That said, none of these programs after almost a decade are sustainable and are heavily dependent on foreign aid and management. In addition, these programs were community development projects rather than fundamental productive and growth led projects to provide mass employment and serve as important drivers of the rural economy of Afghanistan. More often than not, they have been important elements of an only subsistence unsustainable rural economy in the country.”<sup>230</sup>

“Afghanistan is fast moving towards an elite monopoly and extractive political and economic institutions where the rule of the few over its wealth, public offices and politics is increasingly marginalizing the vast majority of its population... the rural inhabitants of Afghanistan.”<sup>231</sup> It is suggested that this is a “cause for alarm within the historical context of the country. Regimes changes have often come from rural Afghanistan due to negligence of Afghan statesmen, policy makers, and politicians who often lose touch with the realities of Afghan rural life in the comforts of their villas in the cities.”<sup>232</sup> The Institute suggested, “the new Afghan president [should] make small and medium enterprises (SMEs) the driver of the Afghan economy and break the tight grip of the few families and individuals over its economy and business sector.” It emphasized, “balanced development of the country and equal allocation of financial resources and business opportunities is essential for an inclusive Afghanistan.”<sup>233</sup>

## Agriculture

Agriculture is a vital source of growth, employment, and subsistence, but three decades of conflict have destroyed much of Afghanistan’s farming infrastructure, limiting the sector’s capacity to increase output and contributing to severe food insecurity. Agriculture traditionally has been the foundation of Afghanistan’s economy, employing as much as 80 percent of the workforce and contributing 26 percent<sup>234</sup> of the gross domestic product (GDP). Because of the poor quality of most agricultural land, subsistence agriculture predominates.

Although many Afghan farmers returned to their land in the early 2000s, landmines and the destruction of irrigation systems have made much agricultural land unusable. Livestock, a vital part of the agricultural economy, was similarly affected as grazing land disappeared. The droughts between 1999 and 2002 devastated the rural population and further reduced all types of agricultural output. Many of the nomadic Kuchis were forced to find sedentary occupations.

In the early 2000s, half of Afghanistan’s arable land was uncultivated because of limited water supplies. However, agricultural output increased beginning in 2003 because of increased rainfall, except in the south where the drought persisted into 2004. The cultivated area rose significantly in 2004. It decreased

---

<sup>229</sup> Bullets added for ease of readability.

<sup>230</sup> Asey, 2014.

<sup>231</sup> Ibid.

<sup>232</sup> Ibid.

<sup>233</sup> Ibid.

<sup>234</sup> TradingEconomics.com. Accessed December 9, 2014. <http://www.tradingeconomics.com/afghanistan/gdp>.

by 21 percent in 2005; however, productivity increased. With increased rainfall, output again increased in 2006, but delays in the restoration of irrigation systems hindered further agricultural progress. The primary legal crops were wheat, rice, barley, potatoes, as well as corn and other vegetables, and fruits such as grapes. The main types of livestock were cattle, sheep, and goats; and cow's milk was the most valuable product of livestock. In the winter of 2007–2008, Afghanistan faced a severe grain shortage, in part because wheat was supplanted by poppies in some areas, and also because of intensified violence and reduced grain imports.<sup>235</sup>

United States government policymakers have long focused on rehabilitating the farming sector to provide profitable options other than poppies, which fuel the country's opium trade.<sup>236</sup> The US has touted wheat as an alternative crop in areas such as Helmand and Nangarhar. However, poppy cultivation is three times more lucrative, so it is a difficult sell to farmers to change. In the Herat area, saffron sells well and fetches a good price on the international market and can be grown on otherwise unused fields. However, farmers have had difficulty effectively processing and marketing saffron well enough to be competitive in the international market, but are improving. In general, US eradication efforts have been widely unpopular in Afghanistan and have not discernibly hurt the drug industry.<sup>237</sup> The programs to end poppy cultivation suffered from many factors, including poor regional cooperation, and a lack of compensation to farmers for lost crops. In key areas poppies continued to be more economically viable than alternative crops.

Afghan almonds, pomegranates, pistachios, raisins, and apricots are examples of high-demand products, and wheat production is a traditional agricultural mainstay. Lack of cold storage facilities and poor marketing and transportation networks have been challenges for selling products outside of Afghanistan. Efforts through World Bank funding and by the US Department of Agriculture (USDA) and USAID agriculture advisors and investments, along with US National Guard Agribusiness Development Teams, have served to help start the restoration of the agriculture sector. Washington State University (WSU), the University of California, Davis (UC Davis), and Texas A&M University supported agriculture development activities in Afghanistan under a USAID contract. UC Davis' "[eAfghan Ag](#)" website is a publicly accessible, online information resource center that provides access to technical information, diagnostic tools, subject matter experts for advice, and other agriculturally relevant information. The site was started with USAID funding managed through the USDA. Washington State University's department of International Research and Agricultural Development under the College of Agricultural, Human, and Natural Resource Sciences, along with UC Davis and Texas A&M, has had a physical presence in

---

<sup>235</sup> "Country Profile: Afghanistan." 2008. Library of Congress – Federal Research Division, August: 7. Accessed January 7, 2015. <https://www.loc.gov/rr/frd/cs/profiles/Afghanistan.pdf>.

<sup>236</sup> Peter, Tom A. (2010). "Why Some Afghanistan Opium Farmers Turn from Poppies to Saffron." *Christian Scientist Monitor*, June 1. Accessed December 9, 2014. <https://www.questia.com/newspaper/1P2-32545320/why-some-afghanistan-opium-farmers-turn-from-poppies>.

<sup>237</sup> Dreazen, Yochi J. (2009). "U.S. Seed New Crops to Supplant Afghan Poppies." *The Wall Street Journal*, last updated August 14, 2009. Accessed December 9, 2014. <http://www.wsj.com/articles/SB125021357982431177>.

Afghanistan working with GIRoA assisting in the planning, organization, strengthening, and development of public and private sector agriculture-related institutions in Afghanistan.<sup>238</sup>

In April 2013, the Afghan Investment Support Agency (AISA) reported<sup>239</sup> significant success had been achieved regarding saffron, which is increasingly being grown in Afghanistan. Saffron is regularly cultivated now in more than seven provinces, on a total area of around 250 hectares involving approximately 1,300 farmers. Growing saffron created 67,500 work days, and around 3,000 kg of saffron is the estimate of the crop for 2013 with a value of around US\$3,900,000, calculated according to an average price of US\$1,300/kilogram (kg), in addition to annual 1,406.25 metric tons of livestock fodder produced as a by-product. Countrywide investment so far resulted in 14 private Afghan companies now engaged in processing and marketing saffron, and the interest in buying Afghan saffron from abroad is increasing (including in the US, Europe, and the United Arab Emirates). Estimated total suitable area for saffron production in Afghanistan is about 7,000 to 10,000 hectares. After cultivation of this area, total production will be about 50,000 to 70,000 kg. Saffron is the most expensive and the only agriculture product that is sold by its weight in grams. It has its own importance among agriculture products due to its limited need for water and its ability to be grown on infertile land. Once harvested, it can be stored from five to seven years. It is also easily transported.

A World Bank 2014 country snapshot<sup>240</sup> noted agricultural output in 2013 reached record levels for a second consecutive year because of favorable weather conditions. It estimated cereals production in 2013 at 6.5 million metric tons, an increase of 2.7 percent over the previous year, and the highest level achieved over the past decade. Given favorable precipitation, particularly for the second harvest season in the year, the Ministry of Agriculture, Irrigation and Livestock (MAIL) also estimated very favorable horticulture – particularly fruits – and livestock output in 2013. While the record agriculture output in 2013 helped to counterbalance the overall confidence shock to the economy, it was up only modestly over the bumper harvest of 2012 and was thus not sufficient to fully circumvent the overall slowdown in GDP growth.<sup>241</sup>

Both food security and civil security depend largely on a productive agricultural economy. Clearly, Afghanistan's future is synonymous with agriculture. A strong agricultural sector can be an engine for economic growth by raising incomes both on and off the farm. The agricultural value chain also includes

---

<sup>238</sup> For more information, see WSU's website at <http://ird.wsu.edu/tag/afghanistan/>.

<sup>239</sup> Katawazy, Abdul Samad (2013). *A Comprehensive Study of Afghan Saffron*. Afghanistan Investment Support Agency (AISA), April 2013. Accessed December 9, 2014. [http://www.aisa.org.af/Content/Media/Documents/Paperonsaffronedited\\_Recovered\\_8112014131248124553325\\_325.pdf](http://www.aisa.org.af/Content/Media/Documents/Paperonsaffronedited_Recovered_8112014131248124553325_325.pdf).

<sup>240</sup> World Bank (2014). *Afghanistan - Country snapshot*. October. Washington, DC; World Bank Group. <http://documents.worldbank.org/curated/en/601021467994615876/Afghanistan-Country-snapshot>. Accessed December 9, 2014.

<sup>241</sup> Joya, Omar; Khan, Faruk (2014). *Afghanistan economic update*. Washington DC: World Bank Group. <http://documents.worldbank.org/curated/en/265661467996753469/Afghanistan-economic-update>. Accessed December 9, 2014.

selling inputs, value-added processing, and increasing transportation and other services. A robust agricultural economy will play a major role in helping create both economic and political stability.

## Education

### History

The Afghan government established a modern educational system at the end of the nineteenth century, retaining traditional Islamic learning while introducing a modern curriculum. This secular system emphasized productive skills while effectively limiting Islamic studies to ritual knowledge. The public school curricula included religious subjects, but detailed instruction was left to religious teachers. Traditional religious schools, found in towns and villages, taught children ethics and morals as well as ritual knowledge through the study of the Qur'an, the *hadith*,<sup>242</sup> and other religious texts. Higher-level *madrassas* located in Herat, Kunduz, Ghazni, Kandahar, and Kabul are known as important learning centers. Leading religious leaders also attend famous *madrassas* in India such as the renowned establishment located at Deoband.<sup>243</sup> In 1935, the Afghan government declared education universal, compulsory, and free.<sup>244</sup>

By the 1960s, technical education assumed critical importance because of the surge in development.<sup>245</sup> Additionally, the expanding government apparatus required more bureaucrats: ninety percent of all school graduates were employed by the government, with the result that the educated tended to be seen by villagers as government officials. Graduates of *madrassas* sought careers as religious functionaries or judges.<sup>246</sup>

Beginning in 1979, with the Soviet invasion, a succession of wars and civil unrest virtually destroyed Afghanistan's education system, and many teachers (along with other professionals) left the country. By 1996, there were only about 650 schools still operating. That year, the Taliban regime banned education for females, and the *madrassa* (mosque school) became the main source of primary and secondary education (for boys).<sup>247</sup> Three decades of conflict devastated Afghanistan's education system and resulted in literacy rates plummeting. Violence throughout the country made the existence of primary and secondary schools nearly impossible. Schools still existed during these times, but they had little access to resources or qualified professionals.

Once Hamid Karzai took office as President and Chairman of the Afghanistan Transitional Administration (ATA) in 2002, a major restructuring of the education system began. Since then, the Afghan government

---

<sup>242</sup> Sayings of the Prophet Mohammad.

<sup>243</sup> Darul Uloom Deoband, an Islamic university founded in 1866.

<sup>244</sup> "History of educational system in Afghanistan." ReliefWeb, May 12, 2003. Accessed October 17, 2014.

<http://reliefweb.int/report/afghanistan/history-educational-system-afghanistan>.

<sup>245</sup> Blood, Peter R. ed. (2001). *Afghanistan: A Country Study*. Washington: GPO for the US Library of Congress, 2001. Accessed October 17, 2015. <http://countrystudies.us/afghanistan/71.htm>.

<sup>246</sup> Ibid.

<sup>247</sup> Mongabay. "Afghanistan: SOCIETY." Accessed October 17, 2015.

[http://data.mongabay.com/reference/new\\_profiles/802.html](http://data.mongabay.com/reference/new_profiles/802.html).



and international donors have worked closely to rebuild Afghanistan's education sector. Many organizations, especially USAID, UNESCO/Afghan Children Education Movement (ACEM), the United Nations International Children's Emergency Fund (UNICEF), the World Bank, and the Asia Development Bank, sponsored and organized education initiatives. The government of Afghanistan similarly viewed education as the key to the long-term success of Afghanistan.

### *Governing Bodies*

The governing bodies for the education sector consist of three line ministries. First is the Ministry of Education (MoE), which is responsible for policy formulation and the organization and supervision of primary and secondary schools, as well as of technical and vocational education and training (TVET). Second is the Ministry of Higher Education (MoHE), which is responsible for the advancement of higher education, including undergraduate and graduate degree programs and achieving international education standards, such as by establishing a national university credit system. Third is the Ministry of Rural Rehabilitation and Development (MRRD), which is responsible for training on rural development issues through its Afghanistan Institute for Rural Development (AIRD). The training and education section of AIRD focuses on rural development, including planning and managing it; local governance; and gender studies. The degree education opportunities include an undergraduate program in rural/regional planning and a post-graduate program in rural development.

A fourth government body involved in the education sector is the Independent Administrative Reform and Civil Service Commission (IARCSC). The IARCSC manages and administers a national capacity building initiative that trains at the institutional, organizational, and individual levels, with an ultimate aim to improve service delivery through a responsive, organized, and efficient civil service.<sup>248</sup> The capacity development programs support some of the major national ministries and their provincial organizations such as the ministries of Agriculture, Economy, Rehabilitation and Rural Development, Transportation and Civil Aviation, and Public Health.<sup>249</sup>

### *Rehabilitating the Education Sector*

According to the Afghan Ministry of Education, in 2001, the state of education was bleak. There were:

- Fewer than a million Afghan boys enrolled in 3,400 general schools taught by 20,700 male teachers. Girls did not have access to education.
- Four teacher-training colleges (TTCs) in four (out of 30 at the time) provinces with 190 male students and 50 male lecturers.
- Thirty-eight technical and vocational institutes (TVIs), partially active, with 1,510 male students and 550 instructors.

---

<sup>248</sup> Islamic Republic of Afghanistan Independent Administrative Reform and Civil Service Commission. "IARCSC reiterates its commitment to continued national capacity development efforts." Accessed January 7, 2015. <http://www.afghanexperts.gov.af/?page=home&lang=en>.

<sup>249</sup> Ibid.

- Two thousand literacy courses training 22,000 adult males.

The curriculum was out of date and politicized: several versions of textbooks were in use promoting a culture of violence.<sup>250</sup>

The Afghan Transitional Administration (ATA) inherited a disabled and defunct education system. Most schools were housed in unusable buildings and lacked safe drinking water and sanitation facilities. Many classes were taught outdoors (see [Picture 1](#)). Neither a standard national curriculum nor textbooks existed. Several versions of textbooks in use were promoting a culture of violence. There were 220 unregulated madrassas without any formal curricula.<sup>251</sup>



*Picture 1: School in Bak, Khost province*

*(Photo by Larry Wentz)*

Within a few years, nine provinces had established informal community education programs.<sup>252</sup> The Ministry of Education estimated that in 2006, eight million children were in school, including nearly three million girls.<sup>253</sup> In 2008 about 9,500 schools reportedly were operating, with at least some education

facilities in every province.<sup>254</sup> Despite renewed emphasis on educating girls, in 2008 the ratio of girls to boys in secondary schools was one to three or four, as rural families continued the tradition of educating only males.<sup>255</sup> Additionally, the low percentage of female students was influenced by cultural beliefs that females belong in the home.

The early days of restructuring education were not without challenges. Insurgents burned many schools and murdered teachers, and the Taliban's killing of and death threats to those teaching females undermined efforts to educate girls. In 2007, increased Taliban activity forced the closure of 35 percent

<sup>250</sup> Islamic Republic of Afghanistan Ministry of Education (MoE). "Strategic Plan Executive Summary." Accessed January 7, 2015. <http://moe.gov.af/en/page/2010>.

<sup>251</sup> Islamic Republic of Afghanistan Ministry of Education (MoE). n.d. "Where We Were." Accessed January 7, 2015. <http://moe.gov.af/en/page/2021/>.

<sup>252</sup> Mongabay. "Afghanistan: SOCIETY."

<sup>253</sup> "Country Profile: Afghanistan." 2008.

<sup>254</sup> Ibid.

<sup>255</sup> Ibid.

of the schools in the southern provinces.<sup>256</sup> Schools gradually reopened as the security situation improved over subsequent years. However, in the 2013 to 2014 timeframe, there was a reemergence of insurgent activity as the Coalition began to draw down combat forces and leave the country. This resulted in schoolgirls once again being caught in the crossfire, causing the withdrawal of students and teachers from schools in affected areas.

### *Present Day*

The structure of the Afghan education system consists of three levels of general education from grades 1-12, a parallel system of Islamic education, technical and vocational education and training (TVET), as well as non-formal education. There is also formal teacher training for applicants straight out of higher secondary school and for university graduates. [Table 2](#) summarizes the structure and levels of the Afghan education system.<sup>257</sup> Afghanistan's Ministry of Education has developed a standard curriculum and textbooks, with assistance from donors and international partners. By 2013, Afghanistan had 16,000 schools throughout the country, and approximately 3.6 million girls were enrolled, comprising nearly 40 percent of a total of 9.1 million active pupils.<sup>258</sup> The number of teachers has grown from 20,000 to more than 185,000.<sup>259</sup> Enrollment, including of girls, has improved but remains a serious challenge due to a lack of qualified teachers and suitable school facilities.

In 2013-2014, data indicates the total number of students across public and private higher education institutions was about 205,000, which shows roughly a 27 percent increase compared to the data of the previous year.<sup>260</sup> The number of instructors also showed a 33 percent increase compared to 2012-2013.<sup>261</sup>

### *Challenges*

The quality of education in Afghanistan continues to be low. It is affected by multiple factors including the lack of teachers with a thorough content-based knowledge and an understanding of effective teaching methods; the lack of safe, conducive learning spaces; and the lack of quality teaching and learning materials (including textbooks). There is also a lack of access to computers, the Internet, and online resources and electronic learning (e-learning).

---

<sup>256</sup> Ibid.

<sup>257</sup> United Nations Educational, Scientific and Cultural Organization (UNESCO) and Islamic Republic of Afghanistan Ministry of Education (MoE) (2015). *Education for All 2015 National Review Report: Afghanistan*. Accessed August 17, 2015. <http://unesdoc.unesco.org/images/0023/002327/232702e.pdf>.

<sup>258</sup> World Bank, 2014, *Afghanistan - Country snapshot*.

<sup>259</sup> Ibid.

<sup>260</sup> ACSO (2014). Press Release, June 17. Accessed August 17, 2105. <http://cso.gov.af/en/news/press-release-17-june-2014>.

<sup>261</sup> Ibid.

Table 2: Education levels in Afghanistan

Level	Length	Grades	Ages	Description
Primary	Six (6) years	1-6	7-12	<ul style="list-style-type: none"> <li>Students learn the basics of reading, writing, and arithmetic as well as about their national culture</li> </ul>
Lower Secondary	Three (3) years	7-9	13-15	<ul style="list-style-type: none"> <li>Middle school where basic academic-style education continues</li> <li>Students must pass an exam at the end if they wish to study further</li> </ul>
Higher Secondary	Three (3) years	10-12	16-18	<ul style="list-style-type: none"> <li>During secondary school, students choose between continuing on an academic path that could lead to university or study subjects such as applied agriculture, aeronautics, arts, commerce, or teacher training instead</li> <li>Both paths culminate in a Baccalaureate examination</li> </ul>
TVET	Variable	10-12 And 13-14	16 and over	<ul style="list-style-type: none"> <li>Short-term courses or longer-term training</li> <li>Formal TVET is led by the MoE, whereas non-formal courses and programs are led by MoLSAMD and non-governmental organizations (NGOs)</li> </ul>
Tertiary	Variable	Grade 13 and above	18 and over	<ul style="list-style-type: none"> <li>Teacher education (grades 13-14) is offered at Teacher Training Colleges (TTCs) under the MoE</li> <li>Higher education is led by the MoHE at public (free) or private (for a fee) universities. Acceptance is based on scores on a standard nationwide entrance exam (Konkor).</li> <li>Bachelor's degrees (4 years)</li> <li>Master's degrees (3 years)</li> <li>Doctorate (PhD) degrees (3 years)</li> <li>Islamic seminaries and universities also offer education for grades 13-14</li> </ul>
Non-formal	Variable	Variable	Variable	<ul style="list-style-type: none"> <li>Short TVET courses</li> <li>Literacy courses</li> <li>Adult/continuing education courses</li> <li>Available to private citizens and sometimes organized for, e.g., the ANSF</li> </ul>

The classroom environment and the quality of education are particularly affected by the quality of teaching. Teachers rarely target their teaching to address the specific learning needs of each child in their classes. Efforts are mainly centered on the brighter children, and little attention is given to children who

are experiencing difficulty. Existing classroom-based methods are not effective in teaching students to read and write, nor do they develop the critical thinking and analytical skills of students. Improving the pedagogical skills of teachers as well as their content knowledge is critical to improving the quality of education in Afghanistan. Although there has not been a comprehensive study on violence in classrooms, there are anecdotal reports of physical punishment of students as a classroom management technique. Additionally, long walking distances to school and lack of safe and proper learning environments are major impediments toward female participation in schooling.

There are no female students enrolled in grades 10-12 in nearly 49 percent of Afghanistan's 412 districts (200 out of 412). Nearly 59 percent of the districts (245) do not have a single qualified female teacher. A whopping 90 percent of qualified female teachers are located in the nine major urban centers (Kabul, Herat, Nangarhar, Mazar, Badakhshan, Takhar, Baghlan, Jozjan, and Faryab).<sup>262</sup>

Low salaries for teachers are also a major problem for both the teachers and the education system. In 2007, teachers' salaries ranged between US\$32 per month (for a grade 12 teacher with no experience) to US\$88 per month (for a teacher with a master's degree and 40 years of experience). The average teacher salary was approximately US\$74 per month, which included a US\$32 meal allowance.<sup>263</sup> Additionally, Afghan teachers face work disincentives, and inadequate salaries sometimes drive teachers to focus more on private tutoring, which pays better.

Higher education has had its challenges as well, including the availability of qualified instructors and professors. When Kabul University reopened in 2002, some 24,000 students, male and female, enrolled. In the early 2000s, the rehabilitation of five other universities progressed very slowly. Although seven universities were operating in 2007, only a total of 22,700 students were active in higher education. Today there are 30 government universities and nearly 100 private universities and institutions of higher education and growing.<sup>264</sup> Accreditation and quality assurance are not in sync with the growth, and not all these universities and institutions have been approved by the MoHE. The rapid expansion of university education since 2002 has placed extra demands on an education system much in need of development.

Universities also needed facilities and skills to train future teachers. USAID established the Higher Education Project (HEP)<sup>265</sup> to help address these needs by building sustainable capacity at the tertiary level to deliver high-quality pre-service and in-service teacher education for secondary schools. USAID designed HEP in collaboration with the MoHE, the Academy for Educational Development, Indiana

---

<sup>262</sup> Islamic Republic of Afghanistan Ministry of Education (MoE). n.d. "Vision of the Ministry of Education." Accessed January 7, 2015. <http://moe.gov.af/en/page/2019/>.

<sup>263</sup> Islamic Republic of Afghanistan Ministry of Education (MoE) (2007). *Education Sector Strategy for the Afghanistan National Development Strategy*. Accessed January 7, 2015. [http://planipolis.iiep.unesco.org/upload/Afghanistan/Afghanistan\\_MoE\\_strategy\\_English.pdf](http://planipolis.iiep.unesco.org/upload/Afghanistan/Afghanistan_MoE_strategy_English.pdf).

<sup>264</sup> Islamic Republic of Afghanistan Ministry of Higher Education (MoHE). Accessed January 14, 2015. <http://www.mohe.gov.af/?lang=en&p=private>.

<sup>265</sup> United States Agency for International Development (USAID) Fact Sheet: Higher Education Project. Last updated September 30, 2013. <https://www.usaid.gov/news-information/fact-sheets/higher-education-project-hep>.

University, and the University of Massachusetts. The project worked within the 18 institutions offering four-year teacher education programs in Afghanistan to strengthen planning and faculty skills through training, scholarships, and material support. The project also supported the MoHE in establishing standards in teacher education and promoting a coordinated national strategy for teacher education and certification.

Corruption in the education sector is a challenge as well. Examples include teachers having to pay bribes to their superiors to receive salaries, “ghost” employees who do not come to work but who nonetheless receive salaries, or those who are double-registered and thus receive two salaries for a single day’s work. Further, students pay teachers bribes for grades, and teachers pay bribes for positive competency/performance evaluations. Corrupt practices at higher levels in the public education system include parents or students paying for early distribution of the questions or answers of the Konkori university entrance exam, students buying their way into universities, and then buying their way through their courses, or even buying university degree credentials entirely.

The Afghan government publicly recognized the problem of corruption in education and acknowledged the need to make institutional reforms intended to reduce and prevent its occurrence. The government created several overlapping programs involving multiple ministries, including the MoE, the MoHE, and the Ministry of Finance (MoF). Anti-corruption efforts include Basic Education Support Systems for Teachers (BESST), which addresses management training for principals, creating and administering competency tests for principals and teachers, developing organizational charts and human resource databases and manuals, creating human resource policies and standardizing job descriptions, and developing community involvement via “school improvement councils.” BESST also addresses modernizing the university entrance exam system and creating forgery-proof university diplomas. The MoE developed an Education Management Information System (EMIS) to register employees and monitor education indicators. EMIS is incorporated in the Afghanistan Financial Management Information System (AFMIS) created and implemented by the MoF to track activities such as expenditures on education programs at national and sub-national levels.<sup>266</sup> The MoE also worked to expand EMIS capabilities to the local schoolhouse level to cover student enrollment, exam scores, and student and teacher attendance. The MoHE pushed through legislation on its oversight responsibility for nascent private universities.

Despite the challenges, the education system in Afghanistan is regarded as one of the country’s success stories since the US-led Coalition drove the Taliban from power. In 2001, no girls attended formal schools, and there were fewer than a million boys enrolled. By 2012, the World Bank says there were 7.8 million pupils attending school – including about 2.9 million girls.<sup>267</sup> However, many primary and secondary schools were – and still are – operating from tents and houses, and under trees, especially in rural areas. The World Bank says of 180,000 teachers, only 52 percent met the minimum standards required and the

---

<sup>266</sup> Wirak, Anders et al. (2009). *Identification Report for Danish support to Education (MoE) Afghanistan for the period 2010-2012 (SY 1389-91)*. August. Accessed July 16, 2015. <http://www.doc88.com/p-4184726113044.html>.

<sup>267</sup> “Afghanistan: Before and after the Taliban.” *BBC News*, April 2, 2014. Accessed July 17, 2014. <http://www.bbc.com/news/world-asia-26747712>.

rest were receiving in-service training. Girls' dropout rates are still very high in secondary schools, and the country's adult literacy rate (39 percent over the age of 15 can read and write) is still one of the lowest in the world.<sup>268</sup>

The Asia Foundation found that 74.3 percent of Afghans were satisfied with the availability of education for children in 2014.<sup>269</sup> A strong education system that includes professional teachers and high-quality learning materials and methodologies is essential to Afghan economic growth, democratic development, and stability. Afghanistan has one of the youngest populations in the world, making quality education for rapidly growing numbers of school-aged boys and girls a top national priority. They are the future leaders and key to change in Afghanistan.

The political, social, cultural and security situation have and continue to impact the development of education in Afghanistan. The country is going through a period of security and political reform and social and economic changes which will have a profound impact on the future of the Afghan society and its role in the global information and business environments. The progress of education in Afghanistan will depend on security, good governance, relevant and imaginative strategies, adequate financial resources, and continued support of the International Community. There is a strong and growing demand for modern education and training for boys and girls in Afghanistan.

## Health

As with much of the country, decades of war largely destroyed Afghanistan's health system and healthcare infrastructure. Doctors and nurses fled the country, leaving behind few healthcare workers. For those who remained, medical training was inconsistent or unavailable. "During the 1990s, medical schools were operated according to ethnic and religious rivalry. Consequently, medical students were often admitted through nepotism. A survey by the World Health Organization (WHO) showed 70 percent of nurses, midwives, and laboratory technicians did not meet minimum knowledge and skills standards when they were tested. The Ministry of Public Health [could not] employ those trained by NGOs because they [did] not meet the government's requirements. As a result, there was a shortage of at least 7,000 physicians and 20,000 nurses, midwives, and allied health professionals."<sup>270</sup>

In 2000, Afghanistan had one of the lowest life expectancy rates in the world, at an average of 41 years.<sup>271</sup> Many Afghans did not have access to even the most basic health services, and women were even worse off due to a dearth of female physicians. "In 2002, only 9 percent of Afghans lived within a one-hour walk

---

<sup>268</sup> Ibid.

<sup>269</sup> Hopkins, Nancy, ed. (2014). *Afghanistan in 2014: A Survey of the Afghan People*. (The Asia Foundation, 2014), 9. Accessed July 16, 2015. <https://asiafoundation.org/resources/pdfs/Afghanistanin2014final.pdf>.

<sup>270</sup> Acerra, John R., Kara Iskyan, Zubair A. Qureshi, and Rahul K. Sharma (2009). "Rebuilding the health care system in Afghanistan: an overview of primary care and emergency services." *International Journal of Emergency Medicine* 2:77-82, June. Accessed July 17, 2015. [http://www.ncbi.nlm.nih.gov/pmc/articles/PMC2700223/pdf/12245\\_2009\\_Article\\_106.pdf](http://www.ncbi.nlm.nih.gov/pmc/articles/PMC2700223/pdf/12245_2009_Article_106.pdf).

<sup>271</sup> World Health Organization (WHO) (2015). "Afghanistan: WHO statistical profile." Accessed July 17, 2015. <http://www.who.int/gho/countries/afg.pdf?ua=1>.

of a health facility.”<sup>272</sup> In 2003, Afghanistan had 11 physicians and 18 nurses per 100,000 people, and the per capita health expenditure was US\$28.<sup>273</sup> In 2004, Afghanistan had one medical facility for every 27,000 people, and some centers were responsible for as many as 300,000 people.<sup>274</sup> Despite large-scale international assistance, the WHO did not expect Afghanistan’s health indicators to improve substantially for at least a decade. Afghanistan ranked 173 out of 178 in the United Nations Human Development Index (HDI) in 2004. The HDI is a summary measure of average achievement in key dimensions of human development: a long and healthy life, being knowledgeable, and having a decent standard of living. It was created to emphasize that people and their capabilities should be the ultimate criteria for assessing the development of a country, not economic growth alone.<sup>275</sup>

In 2005, there were 60 infant deaths out of 1,000 live births within the first month after birth, which was the second-highest rate in the world. In rural areas, one in five children (20 percent) died before reaching age five. The maternal death rate of 1,900 per 100,000 live births was one of the world’s highest. At the same time, the physical and psychological effects of war substantially increased the need for medical care. Because of poor sanitation and an insufficient supply of potable water, infectious and parasitic diseases such as malaria and diarrhea were very common. Malnutrition and poor nutrition also were pervasive. It was also estimated there were some 800,000 disabled Afghans.

An estimated one-quarter of the Afghan population still had no access to healthcare in 2007. Neonatal care was especially poor. Maternal, infant and under-five mortality rates remained some of the highest in the world. Reducing child mortality, improving maternal health, combating malaria and other diseases, and reaching Afghanistan’s [Millennium Development Goals](#) (MDGs) were central to Afghanistan’s public health mission. Still, a full 20 percent of children would die before the age of five, mostly of preventable diseases. One in five women died in childbirth or during pregnancy (and only 8 percent of births were attended by trained professionals).

Economic instability continued to be an issue. International organizations provide a large share of medical care. About 95 percent of healthcare spending is from donors, not the government, and comes from outside sources such as the European Commission, the World Bank, USAID, and many other donors. While external funding is important, domestic support of healthcare needs to increase to make the system sustainable. External funding has unpredictable availability, frequent policy shifts, and the potential to end without warning. Improvement in the economy, viable internal funding sources, and more spending by the Afghan government would serve to improve access to and affordability of healthcare.

Health authorities consider Afghanistan a high-risk country for human immunodeficiency virus (HIV) because of the high incidence of intravenous drug use, unsafe blood transfusion procedures, the high

---

<sup>272</sup> USAID. Afghanistan: Health. <https://www.usaid.gov/afghanistan/health>. Last updated August 23, 2016.

<sup>273</sup> “Country Profile: Afghanistan” (2008).

<sup>274</sup> Ibid.

<sup>275</sup> United Nations Development Programme. Human Development Reports: Human Development Index. Accessed July 17, 2015. <http://hdr.undp.org/en/content/human-development-index-hdi>.



number of refugees, poor health facilities, and general illiteracy. In 2012, the World Bank reported reliable data on the prevalence of HIV prevalence in Afghanistan was sparse, but noted 1,250 cases had been reported.<sup>276</sup> However, it claimed the Joint United Nations Programme on HIV and AIDS (UNAIDS) and the WHO estimated that there could be between 2,000 and 3,000 Afghans living with HIV.<sup>277</sup> The World Bank noted the HIV epidemic is concentrated mainly among injecting drug users, and an emerging epidemic is likely to be hinged on a combination of injecting drug use and unsafe paid sex.<sup>278</sup>

Even in 2014, medications for hospitalized patients many times still needed to be purchased from an outside pharmacy by family members and brought to the hospital. This situation is common throughout the country. Additionally, about half of Afghanistan's pharmaceutical imports continue to be smuggled and not subject to quality control, according to a 2014 report<sup>279</sup> by the Independent Joint Anti-Corruption Monitoring and Evaluation Committee (MEC), a watchdog assembled by the International Community and the Afghan government. Corruption and lack of border controls have opened the country up to a flood of substandard drugs and a deadly boom in counterfeit medicine. This situation prevails throughout the country. Medical laboratories also lack supplies and personnel.

The Afghan MoPH contracts with NGOs for the majority of healthcare in Afghanistan.<sup>280</sup> Although the ministry and NGOs have improved communications, lack of coordination on provincial and district levels results in inefficient and, at times, duplicated services. The ANA, ANP, and MoPH have developed separate but redundant healthcare facilities to serve specific segments of the population. Lastly, many Afghans use unregulated private sector healthcare services. Integration and coordination among NGOs, the Ministry of Public Health, and various sectors of the Afghan government is required to create a sustainable healthcare system for the entire country.

In Kabul, state of the art hospitals have opened, and clinics have been built and staffed around the country. There are advanced hospitals located in Kabul, such as the French Medical Institute for Children, CURE International Hospital, and the Jamhuriat Hospital. Also, non-profit organizations, such as Save the Children and Mahboba's Promise (Australian aid organization focused on women and children) assist the governmental facilities with the healthcare. Private sector elements such as Roshan and the Aga Khan Foundation, Cisco, Medweb, PACTEC, and others provide telemedicine, IT services, and portable medical kits for community doctors and nurses. Overall, the highly-populated areas, such as Kabul and other major cities, now have reasonable health facilities.

---

<sup>276</sup> World Bank (2012). "HIV/AIDS in Afghanistan." July 10. Accessed July 17, 2015. <http://www.worldbank.org/en/news/feature/2012/07/10/hiv-aids-afghanistan>.

<sup>277</sup> Ibid.

<sup>278</sup> Ibid.

<sup>279</sup> Independent Joint Anti-Corruption Monitoring and Evaluation Committee (2014). *Vulnerability to Corruption Assessment (VCA) Report on Pharmaceuticals importation process*, October. Accessed July 16, 2015. [http://www.mec.af/files/2014\\_11\\_19\\_Pharmaceutical\\_VCA\\_ENGLISH.pdf](http://www.mec.af/files/2014_11_19_Pharmaceutical_VCA_ENGLISH.pdf).

<sup>280</sup> Acerra et al., 2009.

However, the rural areas continue to lack access to basic healthcare. Healthcare quality and available resources vary widely from urban to rural areas. Hospitals outside of Kabul have a difficult time providing anything more than rudimentary care.<sup>281</sup> There is a lack of basic medical equipment and most healthcare workers are not properly trained to operate or maintain any that exists.<sup>282</sup> Patients' beds and rooms are primitive and unsanitary (see [Picture 2](#)). There is little to no recordkeeping. Electricity is intermittent and running water is usually dirty.<sup>283</sup>

Physicians' salaries are low relative to a reasonable standard of living, forcing many to practice at hospitals or public clinics in the morning and spend the afternoons in private clinics. Additionally, few residency training programs exist, and those that do provide minimal guidance in terms of lectures, clinical practice, or supervision.<sup>284</sup>

Afghanistan has two official languages, making it necessary for courses to be offered in both Dari and Pashto. Upon completion of training programs, few healthcare workers desire to work in rural areas because of the poor living and working conditions, a lack of educational opportunities for their children, security issues, and poor transportation.<sup>285</sup>

Afghan societal norms dictate that only women can provide medical care for women. The Taliban regime forbade women and girls from going to school; thus, virtually no female doctors or nurses were trained during this period. Although the overall number of healthcare workers is improving and women's access



Picture 2: Khost Medical Clinic

(Photo by Larry Wentz)

---

<sup>281</sup> Ibid.

<sup>282</sup> Ibid.

<sup>283</sup> Ibid.

<sup>284</sup> Richards, Tessa (2003). "Afghanistan struggles to build post-conflict health care." *BMJ* 2003;326:1079. Accessed July 16, 2015. <http://www.bmj.com/content/326/7394/837.2>.

<sup>285</sup> World Health Organization (WHO). *Country cooperation strategy for WHO and Afghanistan, 2006–2009*. Formerly available at: [http://www.who.int/countryfocus/cooperation\\_strategy/ccs\\_afg\\_en.pdf](http://www.who.int/countryfocus/cooperation_strategy/ccs_afg_en.pdf) but has been replaced with a more current version (2009-2013). Originally accessed November 7, 2008.

to healthcare is better, there are still many obstacles to overcome to decrease the disparities between men and women. The focus must be on women.<sup>286, 287</sup>

Data on public health indicates there were 2,106 health centers in 2013-2014,<sup>288</sup> including basic and comprehensive health centers and sub-centers. Despite an increase in the number of health centers, still, for every 10,000 people there were five beds and three medical doctors.<sup>289</sup> There were 1,529 people affected by AIDS in 2013-2014, an 11 percent increase compared to the previous year.<sup>290</sup>

Things are not perfect, but progress is being made. There remain, however, many barriers to creating accessible, effective, and sustainable healthcare in Afghanistan. The main challenges to rebuilding Afghanistan's healthcare system include the lack of security, the lack of infrastructure, economic hardship, poor coordination between the government and healthcare providers, the inaccessibility to healthcare facilities (especially in rural areas), unsuitable hospital conditions, and the lack of trained healthcare workers (especially females).

Médecins Sans Frontières (Doctors Without Borders) provided some specific insights on challenges ahead. They expressed concern about the impact of the drawdown of Coalition troops and the closing of Provincial Reconstruction Teams (PRT). As they rightly point out, there are still hostilities in many parts of the country, which create medical and humanitarian needs. There remain obstacles for Afghans to get to healthcare facilities, especially in rural areas. Many of the medical facilities in rural areas, which were funded by PRTs, were found to be understaffed, lacking in supplies, or have ceased operation entirely since the PRTs were closed down. Public health facilities meant to offer free healthcare services were found to charge patients fees to cover food and medicine. They observed donated ambulances but no way to fuel them, as well as high-tech equipment without electricity or generators to run them and no training for personnel to operate and maintain them.

The challenges of establishing a functional healthcare system in Afghanistan include those typically of a developing nation, post-conflict nation, and a combat zone. The long-term goal of quality healthcare for

---

<sup>286</sup> United Nations International Children's Education Fund (UNICEF) (2008). "UNICEF Humanitarian Action Update: Afghanistan," January 17. Originally accessed November 7, 2008 at [http://www.unicef.org/infobycountry/afghanistan\\_31224.html](http://www.unicef.org/infobycountry/afghanistan_31224.html) and September 12, 2016 at [http://www.unicef.org/infobycountry/files/Afghanistan\\_HAU\\_17jan08.pdf](http://www.unicef.org/infobycountry/files/Afghanistan_HAU_17jan08.pdf).

<sup>287</sup> Allison M. "Nationwide survey and assessment of OB/gyn and skilled birth attendant training and graduates in Afghanistan." HOPE Worldwide Afghanistan, Center for Disaster and Humanitarian Assistance Medicine, July 2008, as cited by Acerra, John R., Kara Iskyan, Zubair A. Qureshi, and Rahul K. Sharma (2009). "Rebuilding the health care system in Afghanistan: an overview of primary care and emergency services." *International Journal of Emergency Medicine* 2:77-82, June. Accessed July 17, 2015. [http://www.ncbi.nlm.nih.gov/pmc/articles/PMC2700223/pdf/12245\\_2009\\_Article\\_106.pdf](http://www.ncbi.nlm.nih.gov/pmc/articles/PMC2700223/pdf/12245_2009_Article_106.pdf).

<sup>288</sup> ACSO Press Release, June 17, 2014.

<sup>289</sup> "[Afghanistan] Health sector: the background and current condition" (2016). Center for Strategic & Regional Studies, April 24. Accessed September 14, 2016. <http://csrskabul.com/en/blog/health-sector-the-background-and-current-condition/>.

<sup>290</sup> ACSO Press Release, June 17, 2014.

all citizens will only be met by a combination of specific goal-oriented projects, foreign aid, and domestic responsibility.<sup>291</sup>

According to USAID, Afghanistan's health sector has improved steadily over the past decade or so, as indicated by the following statistics.<sup>292</sup> More than 57 percent of the population now lives within a one-hour walk of a health facility, enabling them to seek medical attention, consult trained staff, and pick up medicine. The under-five mortality rate has decreased from 87 per 1000 live births in 2005 to 55 in 2015. As of 2013, 39 percent of babies were delivered by skilled birth attendants, up from 14 percent in 2010. The World Health Organization reports Afghanistan has made steady progress in recent years combating polio; the number of cases peaked at 80 in 2011, but has since dropped, according to the Global Polio Eradication Initiative, to 20 in 2015. Even with these improvements, many Afghans still lack access to basic health services.

Healthcare services have made progress in the last decade, although Afghan health indicators are still below average for low-income countries. Additionally, the country has one of the world's highest levels of child malnutrition. There is evidence of "improved access to care, enhanced quality of patient care, and more knowledgeable healthcare workers in rural areas. These improvements show the effects of streamlined cooperation between the Afghan military, civilian government, and NGOs. Unfortunately, the country's healthcare system still needs significant improvement before it meets basic and higher-level health care needs. The focus on primary care is appropriate since primary care is the first line of defense and yields large dividends."<sup>293</sup> Time and commitment will ensure a brighter, healthier future for the nation of Afghanistan and its people. However, much work remains to be done.

## Gender Equality

Toward the end of the twentieth century and into the twenty-first, Afghan women were among the worst off in the world: most were illiterate, many had no access to healthcare, and child and forced marriages were common. Traditional Afghan custom, which was revived by the Taliban and other fundamentalist rebel groups, imposed limits on women's activities outside the home. When the Taliban came to power in 1996, it imposed many restrictions on the behavior of women in Afghanistan. Among them, women were prohibited from working outside the home, attending school, being treated by male doctors, wearing perfume, participating in sports, and even leaving their homes without the escort of a male relative. The Taliban also required Afghan women to wear long veils, tent-like garments called *burqas*, which cover them from head to toe and hide their faces behind mesh screens. Wearing the burqa is part of the ancient custom of *pardah*, which requires women to conceal themselves from men outside the home. In Afghanistan, burqa colors vary by region, with light blue the predominant color in Kabul. Burqas in Mazar-e-Sharif tend to be white, while those in Kandahar are generally brown or green. Afghan women are no longer required to wear burqas by law, but some are still made to cover up by their husbands or

---

<sup>291</sup> Acerra et al., 2009.

<sup>292</sup> USAID, Afghanistan: Health.

<sup>293</sup> Acerra et al., 2009.

fathers. More than a decade after American and Coalition forces toppled the Taliban regime, the improvement in the quality of life for Afghan women is unmistakable. Women are now participants and in many cases, leaders in a society that once systematically subjugated them. There are females in government at almost every level, including the Afghan Parliament. There are women in business, including as business owners. Young girls are going to school, young women are in college, and new opportunities for women are cropping up around the country. However, with the recent resurgence of the insurgency, women and girls in affected areas are not going to work or attending school because they are receiving threats. Progress is being made in women's rights but lots remains to be done, and the impact of the insurgency on women needs to be addressed.

## Welfare

Largely because of protracted military conflict, in the early 2000s Afghanistan had the highest proportion of widows and orphans in the world (1 million and 1.6 million in 2005, respectively).<sup>294</sup> Large numbers of disabled individuals and former members of regional militias also lacked means of support. The billions of dollars in aid that flooded Afghanistan after 2001 tended to bifurcate society, as wealth was concentrated in a small group of elite. In 2006 the British Department for International Development (DFID) estimated 70 percent of Afghans were subsisting on less than US\$2 per day.<sup>295</sup> The Afghan government offered very little welfare protection. Most of the welfare benefits in the country have been provided by national and international NGOs, such as the Afghan Health and Development Services, Afghan Women's Education Center, and Humanitarian Assistance for the Women and Children of Afghanistan, and by United Nations' organizations.

## Street Kids

On any given day in the towns and cities of Afghanistan, tens of thousands of children head to the streets to beg and hawk sundries, even during the winter.<sup>296</sup> Life is harsh for Afghanistan's street children. Many resort to sifting through piles of trash to eke out a living or earn a pittance working for shopkeepers.<sup>297</sup> Others sell scarves, bracelets, and other trinkets. On a "good" day, a child can earn 150 Afghanis (about US\$3) that can then be used to purchase enough bread for a family of seven and perhaps have some left over to purchase clothes. According to surveys by the UN children's organization, UNICEF, there are an estimated 60,000 street children in Kabul alone.<sup>298</sup>

---

<sup>294</sup> "Country Profile: Afghanistan." 2008.

<sup>295</sup> Ibid.

<sup>296</sup> Nelson, Soraya Sarhaddi (2008). "Children Try to Make a Living on Afghan Streets." *NPR.org*, January 30. Accessed September 12, 2015. <http://www.npr.org/templates/story/story.php?storyId=18525484>.

<sup>297</sup> Weeks, Chris (2012). "A haven for Afghanistan's street children." World Vision Afghanistan, August 9. Accessed September 12, 2015. <http://www.wvi.org/afghanistan/article/haven-afghanistans-street-children>.

<sup>298</sup> Trust in Education. "Life on the Streets" (n.d.). Accessed August 11, 2015. <http://www.trustededucation.org/why-afghanistan/life-on-the-streets/>.



Picture 3: Street kids outside ISAF Headquarters in Kabul

(Photo by Larry Wentz)

For street children in Kabul (see [Picture 3](#)), life is a daily battle to earn enough money so their families can eat. They leave their meager homes or shelters early in the morning, hoping to sell some cheap items or beg enough to survive. Most have had at least one parent killed in the war, and many are refugees. Since it is so difficult for widows to earn an income, being fatherless puts an even heavier burden on children and may force them to take to the streets as the family's breadwinner.<sup>299</sup>

Each day, street children put themselves in dangerous situations, such as approaching cars hoping for a handout or to sell sticks of gum. Along the way, many are abused. They live in fear of being robbed of their paltry earnings, their freedom, and even their lives. With such low earnings, street children are often hungry and have little access to medical care.<sup>300</sup> Unless they are in special programs, very few attend school, reducing their opportunities to build a decent future.

## Religion

Islam is the official religion of Afghanistan, and it is the basis for a strong common bond among Afghans, with the overwhelming majority of the population being Muslim (about 99 percent).<sup>301</sup> Sunni Muslims comprise 80 to 89 percent of Afghan Muslims, with Shias in the minority at 10 to 19 percent.<sup>302</sup> This mirrors the global Islamic population, which is 85 percent Sunni.<sup>303</sup> Sunni Islam belongs to the Hanafi Islamic law school, while the majority of Shias follow the Twelver branch of Islam with smaller numbers of Ismaili.<sup>304</sup> The remaining 1 percent or less of the population practices other religions. Islamic religious convention

<sup>299</sup> Ibid.

<sup>300</sup> Ibid.

<sup>301</sup> *Wikipedia* (2015). "Culture of Afghanistan." Accessed December 22, 2015. [https://en.wikipedia.org/wiki/Culture\\_of\\_Afghanistan](https://en.wikipedia.org/wiki/Culture_of_Afghanistan).

<sup>302</sup> Ibid.

<sup>303</sup> Harney, John (2016). "How Do Sunni and Shia Islam Differ?" *The New York Times*, January 3. Accessed August 26, 2016. [http://www.nytimes.com/2016/01/04/world/middleeast/q-and-a-how-do-sunni-and-shia-islam-differ.html?\\_r=0](http://www.nytimes.com/2016/01/04/world/middleeast/q-and-a-how-do-sunni-and-shia-islam-differ.html?_r=0).

<sup>304</sup> "Demography of Afghanistan." (2012). *Afghan Citizen* (blog), July 18. <http://afghancitizen.blogspot.com/>.

and codes, together with traditional practices, provide the principal means of controlling personal conduct and settling legal disputes.

Both Sunni and Shia Muslims share the most fundamental Islamic beliefs and articles of faith. The differences between these two main sub-groups within Islam initially stemmed not from spiritual differences, but political ones. Over the centuries, however, these political differences have spawned a number of varying practices and positions, which have come to carry a spiritual significance.<sup>305</sup> Most Muslims do not distinguish themselves by claiming membership in any particular group, but prefer to be called simply "Muslims."

The division between Shia and Sunni began after the death of the Prophet Muhammad and stems from differences in opinion over who should assume leadership of the Muslim faith. The word "Sunni" in Arabic comes from a word meaning "one who follows the traditions of the Prophet."<sup>306</sup> Sunni Muslims believed the new leader should have been chosen by consensus from the eligible constituency. The Arabic word "Shia" has been shortened from the historical "Shia-t-Ali," meaning "the Party of Ali."<sup>307</sup> Fittingly, the Shia thought leadership of the Islamic faith should have remained within Prophet Muhammad's bloodline, believing only his descendants were fit for the job. Upon the prophet's death, the Shia wanted leadership to pass to his cousin and son-in-law, Ali bin Abu Talib. Instead, the prophet's close friend and advisor, Abu Bakr, became the first caliph of the Islamic nation. (Ali eventually assumed the role after two of Abu Bakr's successors were assassinated and he was, himself, intentionally poisoned.)

Throughout history, Shia Muslims have not recognized the authority of elected Muslim leaders, choosing instead to follow a line of Imams which they believe have been appointed by the Prophet Muhammad or God Himself. They are also known as followers of *Ahl-al-Bayt* (people of the household of the Prophet).<sup>308</sup> Sunnis consider Ali, who ruled the Islamic Caliphate from 656 to 661, the fourth and final of the *Rashidun*, while Shias regard him as the first Imam after Muhammad. Shias consider Ali and his descendants the rightful successors to Muhammad, all of whom are members of the *Ahl al-Bayt*. This disagreement split Muslims into the Sunni and Shia branches.<sup>309</sup> Through present day, "Sunnis emphasize God's power in the material world, sometimes including the public and political realm, while Shiites value martyrdom and sacrifice."<sup>310</sup>

Ali's tomb is believed to be located at a fifteenth-century mosque, the Blue Mosque, in Mazar-e Sharif, a Shiite holy city in northern Afghanistan and a leading place of Muslim pilgrimage.<sup>311</sup> Scattered throughout

---

<sup>305</sup> "What's the Difference Between Shia and Sunni Muslims." About.com. Last updated December 1, 2015.

[http://islam.about.com/cs/divisions/f/shia\\_sunni.htm](http://islam.about.com/cs/divisions/f/shia_sunni.htm).

<sup>306</sup> Ibid.

<sup>307</sup> Ibid.

<sup>308</sup> Ibid.

<sup>309</sup> Ibid.

<sup>310</sup> Harney, 2016.

<sup>311</sup> Afghanistan's Web Site. "Religion in Afghanistan" (n.d.). December 15, 2015.

<http://www.afghanistans.com/Information/People/Religion.htm>.

Afghanistan are the flag-covered graves of saint-like people who are revered and petitioned for help in childbearing, settlement of disputes, moral leadership, and in other capacities.<sup>312</sup>

The mullah, a male religious leader or teacher, is an important figure in Muslim life in Afghanistan and elsewhere. Ideally, a trained *mullah* will have studied Islamic traditions (*hadith*) and Islamic law (*fiqh*).<sup>313</sup> They are often *huffaz*, that is, they have memorized the Qur'an. However, uneducated villagers often recognize a literate Muslim with a less than complete Islamic training as their *mullah* ("religious cleric"). *Mullahs* with varying levels of training lead prayers in mosques, deliver religious sermons, and perform religious ceremonies such as birth rites and funeral services. They also often teach in a type of Islamic school known as a *madrassa*. *Mullahs* arbitrate local disputes, based upon Islamic legal principles, and they are also called upon to provide advice and resolution of many other physical, social, and personal problems, including such things as legal and medical advice, local water disputes, and family feuds. In some of the more remote rural areas, the local mullah and the local *khan* ("landlord") dictate what their followers may and may not do.<sup>314</sup>

The *Hajj*, which means "intend to journey," is an annual, week-long pilgrimage by Muslims to the holy city of Mecca, Saudi Arabia, during the twelfth lunar month of year. The Prophet Muhammad was reportedly born in Mecca, and it is there he first revealed the Qur'an. The Hajj is one of the pillars of the Islamic faith, meaning all Muslims are obligated to undertake it at least once in their lifetimes (at least those who are physically and financially able to). Hajj pilgrims perform a series of rituals including walking around the *Kaaba*, standing vigil on Mount Arafat, and taking part in a ritual "Stoning of the Devil." At the end of the Hajj, the three-day festival of Eid al-Adha begins around the world.

## Calendar and Holidays

Chapter 1, Article 18 of the Afghan Constitution<sup>315</sup> stipulates the solar calendar as the official state calendar. Government and other public holidays, such as Independence Day and New Year's Day, are determined according to it. Official Afghan dates are given in solar years (SY) but are often stated according to the Gregorian calendar used by most donor nations. Afghanistan's calendar year runs from March 21 to March 20. Its fiscal year historically matched its calendar year. However, in October 2011, the government changed Afghanistan's fiscal year to begin in January (starting in 2012, and every year thereafter) to align better with donor funding cycles and to improve development budget execution, which was sometimes hindered by delays in the Afghan Parliament's approval of Afghanistan's annual budget.

The lunar calendar, also called the Islamic or *Hirji* calendar, dictates religious holidays in Afghanistan. The dates for religious holidays and Islamic festivals are determined according to religious leaders' observations of the positions or phases of the moon, which means the dates can vary among sects or

---

<sup>312</sup> Ibid.

<sup>313</sup> *Wikipedia* (2016). "Mullah." Last updated July 6, 2016. <https://en.wikipedia.org/wiki/Mullah>.

<sup>314</sup> Ibid.

<sup>315</sup> 2004 Constitution.



tribes. The published, or at least anticipated, dates of religious holidays are approximations, and the date of celebration is not firmed up until very close to the actual day. This makes it difficult to plan, as government offices, banks, shops, and commercial companies close for religious holidays. Additionally, Shias sometimes celebrate religious holidays, like the Birth of the Prophet Muhammad, at different times (five days later) from Sunnis. The dates for national and religious holidays are often announced via the media. During many holidays, Afghans often visit friends and families, prepare lavish meals, and attend special prayers. Some key holidays are as follows.<sup>316</sup>

**Eid al-Fitr** is celebrated on the first day of the month of *Shawwal*, immediately after the conclusion of *Ramadan*, the Islamic holy month of fasting (*sawm*). Eid al-Fitr is also known as the Feast of Breaking the [*Ramadan*] Fast, the Sugar Feast, and the Lesser *Eid*. It is celebrated for one to three days. Themes of Eid al-Fitr are unity, charity, and enhanced piety as demonstrated throughout Ramadan. Many Muslims go to early prayers, often in new clothes, then visit or entertain their families and friends. During Eid al-Fitr, children sometimes receive *Eidi* (small gifts or money), and children who have successfully completed their first Ramadan fast are specially recognized.

**Eid al-Adha** is the tenth day of the twelfth month of the Islamic (*Hijri*) calendar and begins upon the conclusion of the annual Hajj pilgrimage. The three-day Eid al-Adha holiday is also known as the Feast of Sacrifice, commemorating the Prophet Abraham's devotion to God. Abraham was willing to slay his son Ismael as a sacrifice to Allah; however, upon learning of his devotion, Allah instead provided a lamb for the sacrifice. Eid al-Adha is celebrated in the same fashion as Eid al-Fitr, with people visiting family and friends, exchanging gifts, and preparing and eating big, celebratory meals. In some regions of Afghanistan, namely in and around Kabul but also other in areas, Afghans prepare *haft mewa*, a dish of seven fruits in a sweet syrup.

**Ashura**, a day of mourning, is observed on the tenth day of the month *Muharram* in the Islamic calendar. It commemorates the martyrdom of Prophet Muhammad's grandson Hussain and his followers at the battle of Kerbala. Ashura is particularly significant for Shia Muslims, who consider Hussain the rightful successor of Muhammad. In Afghanistan and elsewhere, some Muslims express their sorrow and absolve their sins through self-flagellation, whipping their backs with chains, and letting their blood flow. Others beat their chests with their fists. In more modern times, some Muslims donate blood.

**Mawleed al-Nabi, or Roze-Maulud**, is the twelfth day of the month *Rabi al-Awal* in the Islamic calendar. On this day, people celebrate Prophet Muhammad's birthday. They attend prayers, remember Muhammad, and entertain and visit with friends and family.

**Nowruz**, March 21<sup>st</sup>, is the first day of spring and marks the beginning of the Afghan (and Persian) new year (New Year's Day for the solar calendar). Nearly all Afghans celebrate Nowruz, and a plethora of customs and traditions – dishes, meals, sports, and festivals – abound.

---

<sup>316</sup> Much of the holiday information is excerpted and paraphrased from: Afghanistan Online. "Culture." Accessed August 13, 2015. <http://afghan-web.com/culture/holidays.html>.

**Jeshen**, observed on August 19<sup>th</sup>, is Afghanistan's Independence Day, also known as National Day. Even though Afghanistan was never a British colony, the British did have control of its foreign policy due to an agreement signed by a former Afghan King. The Third Anglo-Afghan War ended this agreement, and the British officially recognized Afghanistan via the Treaty of Rawalpindi.

Some other holidays include:

- Liberation Day (February 15th), commemorating the Soviet withdrawal from Afghanistan in 1989;
- Victory Day (April 28th), which celebrates when mujahedeen rebel forces ended the socialist government (the Democratic Republic of Afghanistan) of Mohammad Najibullah in Afghanistan in 1992;
- Labor Day (May 1st); and
- Remembrance Day for Martyrs and Disabled (May 4th).

## Culture

Afghanistan, which means "land of the Afghans," has a centuries-old civilization. The Afghan culture has been around for over three millennia, tracing records to at least the time of the Achaemenid Empire in 500 BCE.<sup>317</sup>

As mentioned above, Afghanistan is over 70 percent rural, and many Afghan communities are self-sufficient and live in relative isolation. With its tribal origins, which continue into the present day, Afghanistan is culturally and ethnically diverse. Each tribe has its own region, language, influences, and customs. Unfortunately, common to most is a variety of social ills such as poverty, interethnic strife, inequality of women, and widespread thievery, kidnapping, and banditry.<sup>318</sup> Warlords continue to operate and influence local politics and use their militias to maintain power and control.

Pashtuns, which largely populate the southern and eastern parts of the country, as well as along the Afghanistan-Pakistan border, have ruled Afghanistan as the dominant ethno-linguistic group for over 300 years.<sup>319</sup> Often characterized, especially among themselves, as *the* indigenous Afghans, various theories abound as to the origins of the Pashtun people, although modern genetic testing is finally unraveling some of the mystery. All Pashtuns live by *Pashtunwali*, a deeply-rooted tribal code that governs individual and community ethics and conduct. Pillars of the Pashtunwali code include:

- *Melmastia* (hospitality): showing hospitality and profound respect to all visitors, regardless of race, religion, national affiliation, or economic status, and doing so without any hope of remuneration or favor.

---

<sup>317</sup> *Wikipedia* (2015). "Culture of Afghanistan." Accessed October 2, 2015.

[https://en.wikipedia.org/wiki/Culture\\_of\\_Afghanistan](https://en.wikipedia.org/wiki/Culture_of_Afghanistan).

<sup>318</sup> Afghanistan's Website. "Afghanistan Social Problems" (n.d.). Accessed October 2, 2015.

<http://www.afghanistans.com/Information/People/SocialProblems.htm>.

<sup>319</sup> *Wikipedia* (2015). "Pashtuns." Accessed October 2, 2015. <https://en.wikipedia.org/wiki/Pashtuns>.

- *Nanawatai* (asylum): the protection given to a person against his or her enemies. People are protected at all costs. Even those running from the law must be given refuge until the situation can be clarified.
- *Badal* (justice): to seek justice or take revenge against the wrongdoer. No time limit restricts the period in which revenge can be taken. Justice in Pashtun lore suggests even a mere taunt counts as an insult, which usually can only be redressed by shedding the taunter's blood. Blood feuds handed down through generations are legendary, and revenge is regarded as a necessary redress of wrongs.<sup>320</sup>

Western Afghanistan, including the city of Herat, is heavily influenced by Iran and Persian culture, while Afghanistan's northern provinces and people have much in common with their Central Asian neighbors. Many urban Afghans, particularly those living in Kabul, are often influenced to some degree by the Indian culture, at least as experienced through Bollywood films and music, and, more recently, by the Westerners who have lived and worked in the capital city for over a decade.

Despite some differences, the majority of Afghans live by the same Islamic traditions, celebrate the same holidays, dress the same, consume the same food, listen to the same music, and share the same view about the world.<sup>321</sup> Nearly all Afghans speak at least two languages, and many speak several more. Characteristically, the family is the mainstay of Afghan society. Extremely close bonds exist within the family, which consists of the members of several generations. The family is headed by the oldest man, or patriarch, whose word is law for the whole family. Family honor, pride, and respect toward other members are highly prized qualities.<sup>322</sup>

## Guidelines

Some guidelines to follow regarding Afghan culture include, but are not limited to, the following.<sup>323</sup>

- Remove your shoes when entering an Afghan home or if in a gathering of Afghans. Further, learn to sit cross-legged, as Afghan meals are often served on a rug on a floor, with guests sitting on cushions around the food. Sitting cross-legged prevents your feet from touching the food and from showing the bottom of your foot to someone, which is considered an insult.
- Do not use your left hand for physical contact with others, to eat, or to make gestures.

---

<sup>320</sup> Wikipedia (2015). "Pashtunwali." Accessed October 2, 2015. <https://en.wikipedia.org/wiki/Pashtunwali>.

<sup>321</sup> Cox, Katie (2014). "Culture in Afghanistan." Prezi, November 17. Accessed October 2, 2015. <https://prezi.com/uphfyx1meck/culture-in-afghanistan/>.

<sup>322</sup> Kinnison, Caitlin (2013). "Afghanistans [*sic*] way of life." Prezi, March 27. Accessed October 2, 2015. [https://prezi.com/osb4usib0\\_4c/afghanistans-way-of-life/](https://prezi.com/osb4usib0_4c/afghanistans-way-of-life/).

<sup>323</sup> Cultural guidelines are largely excerpted and paraphrased from "Dos & Don'ts in Afghan Culture!" (2014). Language Culture (blog), October 18. Accessed October 2, 2015. <https://langauageculture.wordpress.com/2014/10/18/dos-donts-in-afghan-culture/>.

- Shake hands for greetings and goodbyes, with your right hand only. Extend your hand first to elders, and stand up to do so, as a show of respect. If given, return the gesture of placing your right hand over your heart after shaking hands.
- Do not point, which is extremely rude, or make a “thumbs-up” gesture, as it is an offensive Muslim insult.
- Afghans value personal relationships. Trust and respect are earned, not given. Respect elders.
- Recognize the nature of Afghan hospitality. Try all food offered to acknowledge the hospitality of the host. Give a gift in return for receiving one.
- Use the term “Afghan” when describing people or their ethnicity. Use “Afghani” only as it relates to money.
- Avoid discussions of religion.
- Do not ask men direct questions about their female relatives.
- Do not express emotions in public, particularly anger, which is a sign of weakness.

Expect Afghans to have a different sense of time and punctuality.

- Speak kindly and respectfully to everyone, and be a good listener.
- Plan extra time for meetings and visits to drink tea (*chai*) and socialize before getting to the reason for the appointment.

The list above is by no means exhaustive, as the Afghan culture is complicated. Afghans are generally welcoming and hospitable, and can be quite tolerant of ignorance of their customs and religion, provided it is not accompanied by malice or poor intentions.

## Art and Music

Afghan art has spanned many centuries. In fact, the world's oldest oil painting was found in Afghanistan, in caves behind the ancient giant Buddha statues destroyed by the Taliban in 2001.<sup>324</sup> The [National Museum of Afghanistan](#)'s collection had been one of the most important in Central Asia, with over 100,000 items dating back several millennia.<sup>325</sup> However, during the three decades of war and conflict, much of the art was stolen from Afghanistan and smuggled to Pakistan, Iran, and other neighboring countries. The Taliban destroyed many of the remaining objects, including the Bamyán Buddha statues, as well as many artworks and sculptures from the National Museum. The museum lost about 70 percent its works. After 2002, the new Afghan government put more time and attention into research into and discovery of the heritage and art of Afghanistan. Fortunately, after extensive research, in 2004 the Afghan government succeeded in finding 228 extraordinary artifacts under the Presidential Palace. These ancient artworks spanned 2200 BC to 200 AD and included gold bowls with artistic links to Mesopotamia, bronzes,

---

<sup>324</sup> “World’s Oldest Oil Paintings Found in Afghanistan.” *Fox News*, April 24, 2008. Accessed October 25, 2015. <http://www.foxnews.com/story/2008/04/24/world-oldest-oil-paintings-found-in-afghanistan.html>.

<sup>325</sup> *Wikipedia* (2015). “National Museum of Afghanistan.” Accessed October 25, 2015. [https://en.wikipedia.org/wiki/Afghanistani\\_National\\_Museum](https://en.wikipedia.org/wiki/Afghanistani_National_Museum).

stone sculptures, ivory decorative items, painted glassware imported from Roman and Indian markets, and more than 100 gold ornaments. After announcing the huge discovery of the artworks under the Presidential Palace, the Afghan government put them on a world tour along with some other art found in the country. Since 2007, a number of international organizations have helped to recover over 8,000 artifacts, the most recent being a limestone sculpture from Germany.<sup>326</sup> Approximately 843 artifacts were returned by the United Kingdom in 2012, including the famous first-century Bagram Ivories. The Ministry of Information and Culture has expressed interest in creating online museums for Afghans to access via the Internet to facilitate a greater appreciation for their cultural heritage.

Traditionally, Afghan jewelry has played a role in defining not only identity but also wealth, and there exists a wide variety of styles across the country. In recent times, however, imported gold has come to dominate the market, and locally produced jewelry has tended to be de-valued or sold as antiques. Turkmen jewelry is particularly sought after for its quality workmanship. Among the indigenous materials used in Afghan jewelry are gold, silver, lapis lazuli, rubies, emeralds, sapphires, tourmaline, and black diamonds. The majority of silver and gold has historically been imported. None of the jewelry produced in Afghanistan today can compete with the quality of workmanship and the artistic designs of the archaeological finds that are on display in the Hidden Treasures exhibition from the National Museum currently touring the world. Efforts are being made to raise the standard of craftsmanship to a level that allows for the export of ethnic jewelry rather than just raw materials, an example being [Turquoise Mountain Institute](#), which trains students in traditional designs and encourages them to develop their own.

Traditionally, Afghans have been a very musical people who enjoy singing and playing many types of instruments. Some of the instruments include:

- The harmonium, which is similar to a small piano or accordion;
- The *chang*, a harp-like apparatus;
- The *tabla*, a percussion instrument like bongos;
- The *dhol*, a double-headed barrel drum;
- The *surnai* and wooden flutes; and
- Several stringed instruments such as the *robab*, *settar* (or *sitar*), *dil rubah*, and *tanbur*.

Typically, Afghan music takes the form of folk songs or ballads. Many songs are known by everyone and have been around for generations.

Afghans also enjoy performing the Pashtun folk dance, *attan*, which is the national dance of Afghanistan. The technique behind the *attan* has changed over the centuries, but its base has not changed. It is usually performed in a circle to the beating of a Dhol drum, which has a very deep and low-resonant sound. The circle can range from two to over a hundred people, with men and women dancing separately or together, according to local norms or family restrictions. The performers follow each other going around and around

---

<sup>326</sup> Ibid.

in a circle as the rhythm and beat speed up.<sup>327</sup> There are many different kinds of attan in Afghanistan, reflecting regional differences, such as *Kabuli*, *Wardaki*, *Logari*, *Khosti/Paktia*, *Herati*, *Kochyano/Kuchi*, *Khattak*, and *Nuristani*,<sup>328</sup> which have variations of twists and turns, clapping, steps, spins, head movements, handkerchief waving, and use of swords or weapons by men.

## Poetry and Proverbs

In Afghan culture, poetry is honored and venerated. The history of poetry in Afghanistan predates the Islamic conquest of the country in the seventh through eleventh centuries ... and Pashto poetry dates back to the eighth century.<sup>329</sup> Afghan poetry has long been a cultural tradition and passion. It is mainly in Dari and Pashto languages, although in modern times it is also becoming more recognized in Afghanistan's other languages.<sup>330</sup> Even though many Afghans are illiterate, classic Persian and Pashto poetry plays an important role in the Afghan culture. Poetry has always been one of the major educational pillars in the region, to the level that it has integrated itself into culture.<sup>331</sup>

The *landay*, a form of folk poetry consisting of a single stanza, is particularly popular in Afghanistan. *Landay* means "short, poisonous snake" in Pashto, which may be an allusion to its minimal length and use of sarcasm.<sup>332</sup> Each poem has twenty-two syllables, nine in the first line and 13 in the second, and may or may not rhyme. Landays were originally sung out loud, and are still often recited orally, traditionally by women. Landays are often critical, particularly of gender roles, or reflect profound sadness, anger, disillusionment, and despair. When landays discuss love, it is often in wistful or bittersweet terms. Modern landays are sometimes combined and set to rock, rap, or hip-hop music beats.

An example of a landay written by a young Afghan girl named Lima, likely reflecting restrictive Taliban rule:

You won't allow me to go to school.  
I won't become a doctor. One day you will be sick.

Like poetry, proverbs are valued in Afghan language, both verbal and written. Afghans universally prize wit and cleverness in speech. They use proverbs in their daily conversations far more often than Westerners do, and with far greater effect. An appropriate Afghan proverb inserted at the right time can

---

<sup>327</sup> "Culture Practices: Culture of Afghanistan" (n.d.). Afghanistan Language and Culture Program, Language Acquisition Resource Center, San Diego State University. Accessed October 24, 2014. <https://larc.sdsu.edu/alcp/resources/afghanistan/culture-2/culture/>.

<sup>328</sup> Ibid.

<sup>329</sup> *Wikipedia* (2015). "Poetry of Afghanistan." Accessed October 24, 2015. [https://en.wikipedia.org/wiki/Poetry\\_of\\_Afghanistan](https://en.wikipedia.org/wiki/Poetry_of_Afghanistan).

<sup>330</sup> Cox, 2014.

<sup>331</sup> *Wikipedia*, 2015. "Culture of Afghanistan."

<sup>332</sup> Ibid.

carry the weight of an entire explanation or discussion.<sup>333</sup> Per US Navy Captain Edward Zelle, an expert on Afghan proverbs and the author of several books about them, Afghan proverbs “demonstrate our common humanity and the humanity of Afghans.”<sup>334</sup> An example of a Dari proverb is:

*Qatra, qatra darya mesha.* (Drop by drop, it becomes a river.)

The proper use of Afghan proverbs demonstrates respect and understanding of Afghan culture at a very high level. Their use can lead to deeper personal connections that in turn help bridge very different religions, ethnicities, customs and traditions.<sup>335</sup>

## Traditional Clothing

Traditional Afghan clothing has undergone many variations over the centuries, with fashions rising and waning and rising again, according to the times and, in no small part, the ruling regime. For example, the style of Afghanistan clothing during King Zahir Shah’s reign in the 1950s was much like Western clothing at that time. When it was in fashion in the West, women in the capital city of Kabul were also wearing short-sleeved shirts and miniskirts. Cotton and wool have historically been and remain dominant fabrics, particularly for men’s clothing, and silk is often used for women’s dresses; however, for expensive dresses, silk was also an important raw material.

During the Taliban regime, women had to wear long dresses over trousers and cover themselves with burqas. *Burqas*, the most concealing of Islamic women’s veils, are tent-like like garments with only small mesh screens to allow women to breath and see (at least somewhat). In Afghanistan, burqas are often shorter in front – above the knee – but reach to the ankle in the back. Women were only allowed to wear black shoes, but



Picture 4: Traditional blue burqas worn by many Afghan women

(Photo by Mohamed Somji/Flickr)

---

<sup>333</sup> *Wikipedia* (2015). “Afghan proverbs.” Accessed October 24, 2015.

[https://en.wikipedia.org/wiki/Afghan\\_proverbs](https://en.wikipedia.org/wiki/Afghan_proverbs).

<sup>334</sup> *Ibid*.

<sup>335</sup> *Wikipedia*, 2015. “Culture of Afghanistan.”

never white, which was the same color as the Taliban flag. The belief was if women wore white shoes, they were stepping on the flag and being disrespectful.

Traditional Afghan women's attire is very ornate and elegant, with colorful and beautiful handmade embroidery. Typical women's clothing includes long, colorful dresses and knee-length dresses with a trouser known as *panjabbi*. Today, there are no limitations regarding Afghan women's clothes, as long as they follow Islamic laws of covering one's head, clavicle, wrists, ankles, and backside, and any cultural or familial impositions. Women and girls often mix and match Western styles with Afghan fashions, especially headscarves. There are still women who cover their entire body with burqas, mostly at the insistence of their husbands or fathers, not by choice. Typically, Afghan women wear headscarves outside of their homes. They wear the scarves in several ways, including as *hijabs*, *niqabs*, *al-amiras*, *shaylas*, and *khimars*.

The traditional men's clothing in Afghanistan is called *perahan tunban*, and is a knee-length dress with baggy trousers, typically with a gold- or silver-stitched embroidery waistcoat. *Perahan tunban* (dress and trouser) is also known as *shalwar kameez*. Traditional men's styles became more common during the Taliban regime, which had banned foreign-style clothing such as suits, jeans, and pants. Modern Afghan men wear *shalwar kameez* as well as jeans and suits. Afghan men also wear long-sleeved, calf-length *chapan*s, typically over *perahan tunban*. *Chapan*s are typically made of silk and striped in green and black. A well-made *chapan* can be very expensive, thus, only influential or rich people can afford to wear one.

Men cover their heads with different types of hats, or scarves, often wrapped as turbans, such as the *qarakul* (made from lambskin), *pakool* (made of wool), turban (made of silk or cotton), or regular caps, which mostly come in white and black colors.

Current men's footwear products are mostly Chinese, with a small percent of consumers using Western-made footwear products found in stores and local bazaars. Both men and women normally wear flip-flops or sandals in the summertime, while boots are more common, at least among women, in winter.

## Cuisine and Dining Etiquette

Afghan cuisine is largely based on the country's traditional staples, such as wheat, maize, barley, and rice, along with its native fruits and vegetables.<sup>336</sup> It is a blend of tastes and spices from regions that surround Afghanistan, with influences from India, China, Russia, and Turkey.

*Kabuli palau*, Afghanistan's national dish, is steamed rice pilaf mixed with raisins, carrots, pistachio nuts, and lamb. It is one of the most popular dishes in Afghanistan. *Korma* is a stew or casserole, usually served with *chala*, or parboiled white rice that is then baked with butter or oil and salt. *Mantu* is a meat-stuffed dumpling topped with yogurt that takes its flavor cues from Chinese and Central Asian cuisines. *Aushak* is leek-filled pasta dumplings with a meaty tomato sauce topped with yogurt and dried mint. *Kabobs* also feature prominently in Afghan cuisine. They are most often found in restaurants and outdoor vendor

---

<sup>336</sup> Wikipedia (2015). "Afghan cuisine." Accessed December 6, 2015. [https://en.wikipedia.org/wiki/Afghan\\_cuisine](https://en.wikipedia.org/wiki/Afghan_cuisine).



stalls. *Kofta* consists of balls of minced or ground meat — usually beef or lamb — mixed with spices and onions. Soups made of a variety of items, such as vegetables, noodles, beans, yogurt, and ground meat, are very popular in Afghanistan. These soups are locally known as *shorma*.

Afghan bread, *Naan-e Afghani*, is the national bread of Afghanistan. The bread is oval or rectangular and baked in a *tandoor*, a cylindrical oven that is the primary cooking equipment of the sub-continental region.<sup>337</sup> Bread is a staple of the Afghan diet and is served with most meals, or is even a meal itself among poorer Afghans. Diners share a loaf (or loaves) of bread, pulling off pieces to use to scoop up food from a plate or bowl and transfer it to their mouths.

Afghanistan produces many high-quality fruits, including grapes, apricots, plums, and other stone fruits, pomegranates, melons, and berries, along with some varieties of oranges. Fresh, dried, and pickled or canned fruits are an important component of Afghan fare. Several nuts, including walnuts, almonds, pistachios, and pine nuts are also very popular in the country.<sup>338</sup> Raisins and nuts are served at just about every meeting or gathering.

Afghanistan, like most regions of the world, has its own unique tea culture. Black or green *chai* (tea) is the most popular drink in Afghanistan. It is customary for hosts and hostesses, personal and professional, to serve tea to their guests.

The availability of safe drinking water remains a challenge in Afghanistan, and one needs to be careful consuming local water. It is best for foreigners to drink bottled water. One should also avoid anything with ice, as it may have been made from the tap water. Fresh fruits and vegetables, including salads, may be washed in tap or well water, so one needs to be careful consuming these foods as well.

There are many differences between Afghan and Western dining etiquette. Westerners generally dine seated on chairs at tables, are served individual meals or portions (although some Western meals are served buffet or family style), and use cutlery and other utensils for serving and eating. Afghans, at least in family and social situations, often eat seated in a circle on large colorful cushions called *toshak*. Food is served on cloth, plastic, or vinyl tablecloths (*disterkhan*) spread on the floor or carpet. Afghan food is generally served communally with everyone sharing from the same dish.<sup>339</sup> Afghans usually do not use cutlery. Since food is often eaten directly with the hands, cleanliness is extremely important. A bowl or basin is often provided for hand washing, just prior to meals. The left hand should be used as little as possible and is not to be used in a communal bowl. Food is taken with the right hand, but both hands can be used to eat once food is taken from the communal bowl. Food should be taken only from the portion of the communal plate directly in front of you. Food is usually scooped up into a ball at the tip of the

---

<sup>337</sup> *Wikipedia* (2015). "Afghan bread." Accessed December 6, 2015. [https://en.wikipedia.org/wiki/Afghan\\_bread](https://en.wikipedia.org/wiki/Afghan_bread).

<sup>338</sup> "Food in Afghanistan." BestCountry.com. Accessed December 6, 2015. <http://www.best-country.com/asia/afghanistan/food>.

<sup>339</sup> University of West Florida (UWF). "Afghanistan Course." Accessed October 20, 2015. <http://uwf.edu/atcdev/afghanistan/>.

fingers, or with *naan* (Afghan bread) used as a scoop, and then eaten. When guests are present in Afghan homes, males eat separately and typically prior to females and children.<sup>340</sup>

## Government and Business Etiquette

Business is very personal in Afghanistan. It is conducted based on relationships and established trust, contrary to much Western business, which is based on expertise and authority. Afghans generally believe peoples' needs and the joy surrounding life's positive events are more important than the demands of a time schedule.<sup>341</sup> Afghan time is more fluid, and appointments and events do not necessarily start or end on time (other than prayers). Afghans like to drink tea and establish – or renew – a relationship before starting a meeting, sharing backgrounds and building rapport. It is considered rude to ask a direct question without first asking about a person's well-being.<sup>342</sup> It may take several meetings before anything of substance is discussed.

The Afghan communication style can be rather indirect. It is, therefore, sometimes necessary to read between the lines for an answer rather than expect it to be explicitly stated. For example, if someone is asked if they can complete a job on time, you will rarely get "no" as the answer. It is therefore also important to phrase questions intelligently. Honor and shame should always be considered. Always speak in a way that is not direct or pins blame on someone. Never make accusations or speak down to anyone.<sup>343</sup> The two greatest impediments for Westerners in conducting business in Afghanistan are likely to be the language barrier and the highly complex social structure related to clan and tribal relations. Having an interpreter who understands both the language and the unique Afghan tribal culture is essential to the successful conduct of official business. When possible, interpreters should be of a similar age to the Afghan leaders with whom you are meeting. Rank-appropriate behavior is expected. Leaders should not be too jovial. They should not perform menial tasks (distribution of supplies, food, or other items). Orders should be issued quietly and followed without question. This establishes true leadership in the eyes of Afghans. Anything less undermines the leader's credibility.<sup>344</sup>

Men should wear conservative suits and shoes for meetings. Women should dress modestly and conservatively. The general rule is to show little flesh from the neck downwards. Wearing a headscarf is advisable. Business cards are not widely used in Afghanistan. They therefore carry a sense of importance and prestige. If you are given a business card, take it respectfully and study it so that they see that you are spending time considering their credentials. Comment on it and any qualifications the giver may have.<sup>345</sup>

---

<sup>340</sup> Ibid.

<sup>341</sup> UWF "Afghanistan Course."

<sup>342</sup> Ibid.

<sup>343</sup> Commisceo Global. "Afghanistan Guide." Accessed August 26, 2016. <http://www.commisceo-global.com/country-guides/afghanistan-guide>.

<sup>344</sup> UWF "Afghanistan Course."

<sup>345</sup> GlobalSecurity.org. "Etiquettes of Afghan Culture." Accessed August 20, 2015. <http://www.globalsecurity.org/military/world/afghanistan/etiquette.htm>.

Other factors to consider: Some holidays are determined by the lunar cycle and, therefore, are not announced until just before the holiday is to be observed, causing last-minute disruptions in schedules, postponements, and cancellations. Many Afghans are beholden to bus schedules, so they have to leave at prescribed times. Working Afghan women, similarly, are constrained by daycare hours. Most Afghans equate "business" with "trading" and rely on trusted family or tribe members and are not open to alternatives. In the book *Why Muslim Economies Fail*, the most persuasive observation is that in Muslim culture, business is not business in the Western sense of the word. The transactions we apply to business processes are really a trade and barter system Afghans have relied on for centuries. It is not formalized in operating procedures, regulations, and by-laws. It is codified in honor, reputation, and balance of power or influence. Afghanistan's weak legal framework, regulatory enforcement, and dispute resolution mechanisms make it difficult to resolve business disagreements in the country.<sup>346</sup> Further, corruption creates serious challenges in doing business in Afghanistan, and customs regulations and procedures are neither transparent nor consistent.

## Sports

The Persian word *buzkashi* (goat grabbing) is the basis of the name of Afghanistan's national sport and passion. It is played on horseback, and may have derived from Afghan equestrians hunting mountain goats. A favorite Afghan pastime, *buzkashi* reflects the values of the country: strength, courage, and horsemanship.<sup>347</sup> "The ancient game of buzkashi is part of Afghan life and is offered as a primer to that end. It has little to do with politics but much to do with the spirit of the place."<sup>348</sup>

Traditional buzkashi matches involved two opposing teams on horseback, generally composed of ten members, each of which tries to get control of and transport the headless carcass of a calf or goat into a circle in front of judges or across the goal line (see [Picture 5](#)<sup>349</sup>). Games are often played on Fridays, the Afghan weekend, but may span several days. Rules introduced by the Afghan Olympic Federation, and the modernization of the game in other Central Asian countries, have brought more structure to the sport.

In 2012, the Afghan Film Project produced a 28-minute movie entitled [Buzkashi Boys](#), directed by Sam French and produced by Ariel Nasr. A *Los Angeles Times* article by film critic Betsy Sharkey claimed, "Even boys who seem to have no future have dreams in director Sam French's wrenching portrait of an Afghan street urchin and his best friend, a blacksmith's son. Watching the daring Buzkashi riders race their horses for control of a dead goat in the brutal tribal sport, the two friends begin to question the confines of their lives. French shows exceptional intelligence and sensitivity in capturing the spirit of youth and the weight

---

<sup>346</sup> United States Department of Commerce (DoC) US Commercial Service (2014). *Doing Business in Afghanistan: 2014 Country Commercial Guide for U.S. Companies*. Accessed August 21, 2015. [http://files.export.gov/x\\_965742.pdf](http://files.export.gov/x_965742.pdf).

<sup>347</sup> Kim, Lucia (2002). "Buzkashi – an Afghan tradition thrives." *The Christian Science Monitor*, January 4. Accessed August 21, 2015. <http://www.csmonitor.com/2002/0104/p9s1-wosc.html>.

<sup>348</sup> This quote appears on or in just about every English-language reference to Buzkashi. While rarely referenced, it is likely by Larry B. Lambert, in his book *Buzkashi*.

<sup>349</sup> Photo from <http://questionscritiques.free.fr/Photos/buzkashi2.jpg>. Accessed August 21, 2015.



Picture 5: The sport of Buzkashi

of duty that test the boys. Their intensity and confusion is matched by Kabul's, a dusty, dramatic backdrop for this tale. The young stars, Fawad Mohammadi and Jawanmard Paiz, are exceptional. Together they create a different truth of Afghanistan — impoverished boys with rich imaginations, who dream of horses and heroes not shaped by war. It gets my vote; it won my heart.”<sup>350</sup> *Buzkashi Boys* was nominated for an Oscar in 2013 (Best Live Action Short Film), and won three awards in 2012.<sup>351</sup>

Afghans also play other sports, such as soccer (which they call football)

and basketball. Cricket is also rapidly growing in popularity, picked up by Afghan refugees living in Pakistan. Other sports include rugby, baseball, kite flying, volleyball, golf, handball, boxing, Taekwondo, track and field, bowling, and skateboarding.

For many years in Afghanistan, especially under the former Taliban government, women were not permitted to play outdoor games or sports. However, the recent rise of a national women's soccer team is a sign of change in the country. The players wear black head coverings and black leggings in all their matches to obey the rules of their country's strong Islamic culture. Afghan women and girls are also participating in track and field, basketball, baseball, boxing, and weightlifting. Afghanistan sent two athletes – one male and one female – to the 2016 summer Olympic Games.

Skateboarding has also become a popular co-ed sport in recent years and is used as a tool for empowering youth, to create new opportunities and the potential for change. [Skateistan](#) began as a grassroots “Sport for Development” project on the streets of Kabul in 2007.<sup>352</sup> It emerged as Afghanistan's first skateboarding school, and is dedicated to teaching both male and female students: over 40 percent of its

---

<sup>350</sup> Sharkey, Betsy (2013). “Oscar-nominated short films a mixed and marvelous bag.” *Los Angeles Times*, February 1. Accessed August 16, 2016. <http://articles.latimes.com/2013/feb/01/entertainment/la-et-mn-oscar-shorts-20130201>.

<sup>351</sup> IMDb.com. “Buzkashi Boys.” Accessed August 16, 2016. [http://www.imdb.com/title/tt2133304/awards?ref=tt\\_awd](http://www.imdb.com/title/tt2133304/awards?ref=tt_awd).

<sup>352</sup> Percovich, Oliver. “Skateistan.” Creative Visions. Accessed August 16, 2016. <http://www.creativevisions.org/cap-alumni/skateistan/>.

students are female. The non-profit skateboarding charity has constructed the two largest indoor sport facilities in Afghanistan, and hosts the largest female sporting organization (composed of female skateboarders). Skateistan believes that when youth come together to skateboard and play, they forge bonds that transcend social barriers. Furthermore, through creative education classes the youth are enabled to explore issues that are important to them.<sup>353</sup>

*Gudiparan bazi* (kite flying) is also a national Afghan pastime and outdoor sport. People have been flying kites for more than 100 years in Afghanistan. Banned by the Taliban regime, it is once again a common hobby of many Afghans throughout the country. Afghans typically fly a “fighter kite” made in different sizes using bamboo sticks and colorful thin tissue paper, which gives the Afghan kite a unique look. Fighter kites are always flown using sharp glass coated (cutting) lines. Kite fighting (a male-dominated event) is an outdoor sport undertaken by many young Afghans.

## Future

At the July 2013 Afghanistan: From Transition to Transformation II Senior Officials Meeting,<sup>354</sup> the World Bank presentation noted that although transition has slowly started to impact the economy, Afghanistan’s main challenges go beyond the transition economics. Challenges to development in the post-transition period will be substantial; ranging from stubbornly high poverty and persistent conflict and violence, to increasing labor market pressures and low human capital. The decline in foreign aid and Afghanistan’s growing need for foreign exchange earnings underlines the importance of an appropriate growth strategy.

With the scaling down of international presence and NATO’s ISAF combat mission having ended in December 2014, unless the Afghan government takes concrete steps and makes bold decisions, there is a feeling Afghanistan’s economy is likely headed for severe turbulence with the possibility of collapse. The country possesses massive amounts of natural resources and minerals for which there is high demand, handicrafts such as carpets are exported, and there are manufacturing plants producing cotton textiles, leather goods, and other products. After agriculture, the carpet industry is Afghanistan’s second largest employer. Out of a population of over 27.5 million, around one million Afghans are involved in carpet production, and carpets vie with dried fruit as the country’s most important legal export. (The cultivation of poppies for illicit heroin and opium production remains Afghanistan’s most lucrative economic activity.)

Afghans have long been enthusiastic entrepreneurs. Their location at the crossroads of Asia earned them a reputation as savvy traders across the region, and one reason for Afghan success in the past has, in essence, been communication. Trade depends on communications. The new information and communication technologies (cellular and Internet) that have become available are giving Afghans an opportunity to blossom again in their traditional role, but using new tools. One sees frequent use of mobile phones and Internet by vendors in the local bazaars and Internet cafes and public call offices,

---

<sup>353</sup> “The Girls of Skateistan.” (2015). *Girl’s Gone Child* (blog), April 20. Accessed August 21, 2015.

<http://www.girlsgonechild.net/2015/04/the-girls-of-skateistan.html>.

<sup>354</sup> World Bank (2013). *Afghanistan: From Transition to Transformation*. July 11. Accessed August 21, 2015.

<http://www.worldbank.org/content/dam/Worldbank/document/SAR/afghanistan/SOM-WorldBank-July2013.pdf>.

which in many cases also include an Internet café as well. Carpets, jewelry, agriculture products, and other Afghan products are now marketed on Internet websites, and sales transactions are executed over the Internet and mobile phones, including via mobile money applications.

The Afghan government has the mandate and responsibility to create a transparent business-friendly environment. If it cannot ensure certainty beyond 2014, then the government must at least ensure the private sector, which it claims is the engine of growth, is not choked by the current cumbersome business processes.

Despite the progress of the past few years, Afghanistan is still extremely poor and highly dependent on foreign aid. Much of the population continues to suffer from shortages of housing, clean water, electricity, medical care, and jobs. The World Bank noted the country has made no progress in poverty reduction. Afghan business is dominated by small firms, most of which are younger than four years. Instability, corruption, and access to land, credit, and electricity all rank as serious obstacles to development.

Afghanistan was identified as the worst country for investments in Asia, and the seventh worst in the entire world, per a 2014 economic report published by the World Bank.<sup>355</sup> Economic experts said the World Bank report makes it clear Afghanistan will not be able to attract international investment anytime in the near future unless the government takes the initiative and implements the necessary reforms in accordance with international standards. Addressing Afghanistan's formidable development challenges will require reforms in three areas: restoring fiscal stability, restoring confidence and creating private sector jobs, and strengthening social cohesion and service delivery. Above all, a high level of commitment to tackle corruption and strengthen governance across the board will be critical.

In strengthening its economic growth and private sector investments, Afghanistan will need to overcome many other challenges, including low revenue collection, poor job creation, corruption, increasing government capacity, and poor public infrastructure. Although ongoing international assistance is aimed at supporting longer-term economic development in Afghanistan, there are concerns whether this can be sustained in an increasingly insecure environment.<sup>356</sup>

Based on a 2014 survey conducted by the Afghan Chamber of Commerce and Industries (ACCI), 80 percent of the private sector leaders who were questioned identified worsening security conditions as the single greatest challenge to Afghan businesses.<sup>357</sup> Problems in the current financial and customs systems of Afghanistan were also cited. The study shed light on some key areas for the government to work on if there is any possibility for economic conditions to improve and attract private sector growth in

---

<sup>355</sup> Ibrahimkhil, Shakeela (2014). "World Bank Labels Afghanistan Worst Country for Investment in Asia." *TOLONews.com*, October 31. Accessed December 9, 2014. <http://www.tolonews.com/en/afghanistan/16941-world-bank-labels-afghanistan-worst-country-for-investment-in-asia>.

<sup>356</sup> World Bank (2012). *Afghanistan in Transition: Looking Beyond 2014*, May. Accessed August 21, 2015. <http://www.worldbank.org/en/news/feature/2012/05/09/afghanistan-in-transition-looking-beyond-2014>.

<sup>357</sup> "Insecurity, Infrastructure Cited as Top Problems for Afghan Businesses in Private Sector Survey." *Silk Route E2E Newsletter*, Week 5, Issue 87, February 2, 2015. Accessed August 21, 2015. <http://e2escm.com/sr87/>.

Afghanistan. When private sector leaders were asked about lack of electricity, 92 percent of respondents said it was a major challenge. When asked about infrastructure, 77 percent said they faced major problems. The other issues reported by the businesses were difficulties with customs in Herat and Nangarhar, contract law, bank guarantees, a shortage of financing options and administrative corruption.

A World Bank 2014 Afghanistan country snapshot<sup>358</sup> noted economic performance growth slumped to 3.6 percent in 2013 from 14.4 percent the year before, as consumer and business confidence fell ahead of presidential elections in April 2014, and as NATO-led forces prepared to pull out most of their troops by the end of that year. Company registrations dropped to the lowest level since 2008, offering a proxy for the pullback by investors in the face of mounting uncertainty over the looming political and security transitions. Opium production increased substantially, although the value of the crop remained around 4 percent of GDP, due to lower prices. Inflation stayed under 10 percent in 2013.

Da Afghanistan Bank (DAB),<sup>359</sup> the central bank of Afghanistan, is a monetary institution that upholds international best practices in fostering price stability and a sound financial system conducive to macro-economic stability and broad-based economic growth. It regulates all the banking and money-handling operations in Afghanistan. It issues all notes, executes government loans, and lends money to cities. DAB currently has 47 branches throughout the country, with five of these situated in Kabul, where the headquarters is also based. There are 17 banks in Afghanistan—three state, eight private, and six foreign bank branches. Traditional local “money bazaars” also exist to provide money-lending and foreign exchange conversions. Additionally, there is an informal and largely undocumented money transfer system, called *hawala*, based on a vast network of brokers around the country who move money among people, places, and entities.

The currency of Afghanistan is the Afghani (AFN) and its value in early 2015 was roughly 58 AFN to one US dollar. In 2013, the Afghani depreciated against both the US dollar and the Euro by 8.8 percent and 12.3 percent, respectively.<sup>360</sup> The depreciation was largely in line with expectations and explained by several factors. First, the drawdown of international security forces, which began in 2012 and culminated with the transition of ISAF to the RSM at the end of 2014, can affect capital inflows and thus the exchange rate trend. Second, increased uncertainty surrounding the political and security transition could raise demand for foreign exchange and lead to an increase in the pace of capital flight. Finally, official grants could be affected by slower policy implementation during the transition.

The World Bank in its 2014 economic report noted the Afghan financial sector is still overshadowed by the collapse of Kabul Bank in 2010, and the privatization of New Kabul Bank, the successor institution, had

---

<sup>358</sup> World Bank, 2014. *Afghanistan - Country snapshot*.

<sup>359</sup> *Wikipedia* (2015). “Da Afghanistan Bank.” Accessed August 21, 2015. [https://en.wikipedia.org/wiki/Da\\_Afghanistan\\_Bank](https://en.wikipedia.org/wiki/Da_Afghanistan_Bank).

<sup>360</sup> World Bank (2014). *South Asia Economic Focus*, Spring 2014. Washington, DC: World Bank. Accessed January 7, 2015. <http://www.worldbank.org/content/dam/Worldbank/document/SAR/wb-south-asia-economic-focus-spring-2014.pdf>.

not yet been finalized.<sup>361</sup> The Kabul Bank crisis highlighted serious supervisory shortcomings at Afghanistan's central bank, and regulatory weakness of the financial sector remains a key concern. Upon taking office, President Ghani re-opened investigations into the Kabul Bank debacle, is seeking longer sentences for officials and employees already convicted in relation to the collapse, and is attempting to recover the hundreds of millions of dollars lost by Kabul Bank.

The SIGAR 2014 report on Afghanistan's banking sector<sup>362</sup> expressed concern that it remains fragile and in need of robust regulation by DAB. Further, forensic audits of major commercial banks in Afghanistan have identified systemic weaknesses in many areas of banking governance and operations, including personnel capacity, internal controls, accounting, credit analysis, and compliance with regulations. In the view of SIGAR, DAB's ongoing limitations and inability to conduct robust oversight allow such weaknesses in Afghan banks to remain unchecked, heightening the risk of another banking crisis. In conclusion, SIGAR noted the Afghan banking sector remains unstable and at risk of experiencing another crisis like the near collapse of Kabul Bank.

In a May 2015 International Monetary Fund country report for Afghanistan,<sup>363</sup> it was noted that Afghanistan completed a peaceful transfer of power in September 2014, with the conclusion of the presidential elections and establishment of the national unity government. The new government is resolved to push ahead with economic reforms and improve governance to promote economic growth and development that benefits all Afghans. The International Community and key donors have reaffirmed their partnership and commitment to Afghanistan at the London Conference held in December 2014. They welcomed the new government's commitment to macroeconomic stability and reforms that will promote sustainable and inclusive growth.

At the September 2015 Senior Officials Meeting in Kabul, the World Bank Vice President for South Asia Region gave a presentation on "Future Economic Growth Prospects and Challenges: Emerging from Transition."<sup>364</sup> In the presentation it was noted that although the International community expected the transition period to be difficult, they now see it has affected Afghanistan much more severely than many had anticipated. It was viewed that Afghanistan faces tremendous challenges surrounding growth, employment creation and poverty reduction, and the role of peace and reconciliation in enabling the government's vision for greater self-reliance. The community expected the governance and security

---

<sup>361</sup> World Bank, 2014. *Afghanistan - Country snapshot*.

<sup>362</sup> Special Inspector General for Afghanistan Reconstruction (2014). *Afghanistan's Banking Sector: The Central Bank's Capacity to Regulate Commercial Banks Remains Weak*. SIGAR 14-16-Audit Report/Afghanistan Banking Sector. January 2014. Accessed January 7, 2015. <https://www.sigar.mil/pdf/audits/SIGAR%2014-16-AR.pdf>.

<sup>363</sup> International Monetary Fund (IMF) (2015). IMF Report No. 15/140: *Islamic Republic of Afghanistan Staff-Monitored Program*. May 7, 2015. Accessed January 7, 2015. <https://www.imf.org/external/pubs/ft/scr/2015/cr15140.pdf>.

<sup>364</sup> Dixon, Annette (2015). "Future Economic Growth Prospects and Challenges: Emerging from Transition." Transcript of speech from World Bank Senior Officials Meeting, September 5. Accessed December 3, 2015. <http://www.worldbank.org/en/news/speech/2015/09/06/future-economic-growth-prospects-and-challenges-afghanistan>.



situation to dip momentarily, economic growth to decline and fiscal management to be difficult. The Chicago and Tokyo commitments prepared the community for this but what they did not predict was how long-lasting the impact of the political transition would be and how deeply it would affect the recovery process. It was noted the National Unity Government inherited weak governance institutions and a serious fiscal situation because of the transition. Increased violence and conflict, pervasive corruption and political uncertainty have taken a toll on private investment and employment generation. Over one third of the population lives below the poverty line and over half is vulnerable. The most recent household survey indicates that poverty has increased during the transition process, mainly due to fewer employment opportunities. Even more growth and investment is now needed to bring the country back on a more sustainable growth path.

The World Bank suggested the following areas need urgent attention:

- First, private sector confidence needs to be restored. Closer dialogue in this respect is key to garnering support.
- Second, poverty impact of public expenditure needs to be enhanced. The only way to mitigate poverty in the short-term is to re-program the existing portfolio of development interventions.
- Third, Afghanistan's security strategy and commitments need to be re-visited in light of the changes in the security situation. Achieving greater self-reliance will critically depend on how realistic and affordable the country's security will be in the long-term.
- Fourth, government must deliver on its reform program. Early wins, even when modest, are important building blocks for confidence building and expanding the constituencies for reform and for peace.

The transition of security, governance, and economy at the same time with a new government team in a complex environment has a steep learning curve and complicated interdependencies that will take time to understand, harmonize, synchronize, and implement to have expected impacts on achieving a timely peace, political stability, security, good governance, social development, and economic growth. Both GIRoA and the International Community will need to manage their expectations. The change process will take a long time and will need continued international support.

## Chapter 2 Post-conflict Reconstruction and Development – Afghanistan

---

Larry Wentz

### Background

Post-conflict security, stability, reconstruction and development is a multidimensional complex civil-military operation for which agreed-upon US Government (USG) whole-of-government and international collaborative policies, doctrine, and institutional arrangements for intervention are problematic. Adding to the challenges, these types of operations require not only skills different from those needed for high-intensity combat – skills such as knowledge of foreign cultures and operating in multinational environments – but also a higher degree of maturity, because in these types of missions, the kind of aggressive behavior that accompanies combat operations can backfire.<sup>365</sup> It is difficult to turn combat warriors into goodwill ambassadors and intelligence analysts – both essential missions for engaging in stability and reconstruction work. In the absence of agreed-upon policy and approaches for conducting international post-conflict operations, ad hoc contributing organization arrangements that are siloed or stovepiped with limited coordination, collaboration, or information sharing among the civil-military participants continue to be the means for doing business. Hence, there is an ongoing need to develop new thinking to describe and address the complex interrelationships between and among diplomatic, defense, multinational, and other activities in the field.

Post-conflict is a fragile, unstable environment further challenging the ability to achieve consistency and continuity in maintaining security and stability to allow civil-military intervener elements and the affected nation to conduct appropriate operations to restore civil security and governance and start the return of rule of law, socio-economic recovery, and the reconstruction and development process. Rehabilitation is a long-term process but expectations tend to be high to achieve early visible progress even though reality suggests this is not what happens. Both Iraq and Afghanistan have had multiple relapses in security causing a return to conflict and disrupting reconstruction and development activities. In Afghanistan today (2016), with the emergence of renewed threats and a risk-averse operational environment of the intervening elements, embassies, aid agencies, and the NATO Resolute Support element are essentially in lock down with very limited ability to get out to meet with Afghan counterparts and conduct reconstruction and development activities. Although a less than desirable means of operating, intervener elements need to be adaptable and resilient and find creative ways to deal with restrictive force protection measures. They should attempt to at least continue some level of engagement through meetings at safe houses in secure zones, at embassies, and at the Resolute Support compound even if it

---

<sup>365</sup> Dorn, Dr. A. Walter and Michael Varey (2009). “The Rise and Demise of the ‘Three Block War,’” *Canadian Military Journal*, Vol. 10, No. 1, 2009. Accessed February 7, 2015.  
<http://www.journal.forces.gc.ca/vol10/no1/doc/07-dornvarey-eng.pdf>.

means only having willing Afghans come meet with the interveners on their turf. Information and communications technology (ICT) such as email, telephone, and video teleconferences (VTCs) are other means to communicate but are generally not sufficient. Face-to-face interactions need to continue for the intervener elements to be effective.

The concept of the “Three Block War,”<sup>366</sup> briefly used as a military metaphor by US Marine Corps General Charles C. Krulak at the end of the 20<sup>th</sup> century, can help conceptually to convey, in part, the multidimensional nature of modern military missions in support of post-conflict reconstruction and development operations and explore some of the confusing situations confronted. The core idea was that military forces conduct humanitarian, peacekeeping/stabilization, and combat operations simultaneously on three separate city blocks, or more widely. Colonel John Agoglia, then Director of the US Army Peacekeeping and Stability Operations Institute, suggested that US operations such as those in Iraq and Afghanistan were not characterized by the three blocks, but US forces were in a fourth block of “... governance, reconstruction and economic development,”<sup>367</sup> a mission the military did not necessarily have enough of the right training, skills, experience, and expertise to conduct.

Fitting the Three Block War concept into the US Government’s three pillars of diplomacy, development, and defense, or the whole-of-government approach, remains an unresolved challenge. The two concepts cannot easily be mapped onto each other – the Three Block War only describes the roles of the military, not those of other government organizations. While the metaphor suggested some of the potential situations faced by modern forces, it fell short as a strategic guide. The Three Block War was not incorporated or converted into either US military doctrine or into Department of State/US Agency for International Development (USAID) post-conflict reconstruction and development policies.<sup>368</sup>

With the arrival of the Information Age, ICT has emerged as a game changer in post-conflict reconstruction and development. Its importance to mission success now competes with priorities for roads, power, and water as critical infrastructure and an essential service. However, USG and international policy has yet to formally recognize this new role and change its way of doing business. ICT is both a key player in supporting the intervening civil-military elements communications, collaboration, and information-sharing needs, and an enabler of the affected nation’s recovery of security and governance as well as an engine of socio-economic development and growth. The power of information and ICT as an enabler needs to be more effectively leveraged by the civil-military elements participating in interventions and supporting post-conflict reconstruction and development. A challenge yet to be effectively addressed as policy and doctrine is the role of commercial ICT and use of civilian professional ICT expertise to help work civil and commercial ICT actions, facilitate recovery of the affected nation’s ICT sector governance (policies, regulations, laws), provide an informed understanding of international ICT standards and best practices, and deal with their professional ICT counterparts in government, such as the minister of communications and the chairman of the regulatory authority and with personnel at private sector mobile

---

<sup>366</sup> Ibid.

<sup>367</sup> Ibid.

<sup>368</sup> Ibid.

network operators (MNOs) and Internet service providers (ISPs). Understanding the business processes of the government and industry and who makes things happen in the ICT sector of the affected nation is needed as well. These activities are generally counterculture for military elements and not something they train to do or have policy, doctrine, and tactics, techniques, and procedures (TTPs) to support.

In his book *Team of Teams*, General Stanley McChrystal, US Army (retired), notes that issue resolution in today's rapidly changing world marked by increased speed and dense interdependencies requires sustained organizational adaptability through the establishment of a team of teams.<sup>369</sup> High-speed networks and digital communications mean that collaboration can and must happen in real time. The distributed, decentralized, and web-like architecture of the Internet empowers each individual to be a collaborator. Real-time innovation and problem solving requires integrative and transparent leadership that empowers team members.<sup>370</sup> The new environment allows networked organizations to strike rapidly, reconfigure in real time, and integrate globally dispersed actions.

Management models based on planning and predicting instead of resilient adaptation to changing circumstances are no longer suited to today's challenges. Organizations must be networked, not siloed, in order to succeed. Organization goals must shift from efficiency to sustained organization adaptability. McChrystal noted that agility and adaptability tend to be characteristics of small teams. The traits that make small teams adaptable are trust, common purpose, shared awareness, and empowerment of individual members to act.<sup>371</sup> The conclusion is that there is a need to scale the adaptability and cohesiveness of small teams up to the enterprise level. This involves creating a team of teams to foster cross-silo collaboration so that insights and actions of many teams can be harnessed across the organization and innovation and problem solving become products of teamwork not a single architect. Transparency is required to ensure common understanding and awareness and behavior changes are needed to establish trust and foster collaboration. This implies a change in reward systems as well, since [organizations] need to be able to reward the desired behavior. The role of the leader becomes creating the broader environment instead of command and control micromanaging.<sup>372</sup> Understanding these factors are important as future teams are put together to conduct post-conflict operations.

The book *Why Nations Fail*, co-authored by MIT economist Daron Acemoglu and Harvard political scientist James A. Robinson, argues that the key differentiator between countries is "institutions."<sup>373</sup> The authors purport the most determining factor between rich and poor countries is the effectiveness of their economic and political institutions. They introduce two terms to describe ineffective and effective economic and political (governance) institutions. Extractive institutions "extract incomes and wealth from

---

<sup>369</sup> McChrystal, General Stanley (2015). *Team of Teams: New Rules of Engagement for a Complex World*. (New York: Penguin Publishing Group).

<sup>370</sup> Ibid.

<sup>371</sup> Ibid.

<sup>372</sup> Ibid.

<sup>373</sup> Acemoglu, Daron and James A. Robinson (2012). *Why Nations Fail*. (New York: Crown Business).

one subset of society [the masses] to benefit a different subset [the governing elite].”<sup>374</sup> Examples include forced labor, protected monopolies, and the clientelistic relationships between union bosses and political parties.<sup>375</sup> The antidote to extractive institutions is inclusive institutions, which are designed to create incentives that reward everyone for hard work and innovation. Inclusive economic institutions include the protection of private property rights, predictable enforcement of contracts, regulation to prevent monopolies, access to credit, and opportunities to invest. They argue nations thrive when they develop inclusive political and economic institutions, and they fail when those institutions become extractive and concentrate power and opportunity in the hands of only a few.<sup>376</sup>

The lesson of history, the authors claim, is that countries cannot get their economics right if they do not get their politics right. If sustained economic growth depends on inclusive institutions, giving aid to regimes presiding over extractive institutions cannot be the solution. Many studies estimate that only about 10, or at most 20, percent of aid ever reaches its target. Interestingly, they note that most of the waste resulting from foreign aid is not fraud, just incompetence, or even worse, simply business as usual for aid organizations.<sup>377</sup>

Countries such as Afghanistan are poor because of their extractive institutions – which result in lack of property rights, law and order, or well-functioning legal systems and stifling dominance of national and, more often, local elites of political and economic life.<sup>378</sup> The same institutional problems mean that foreign aid will be ineffective, as it will be plundered and unlikely to be delivered where it is supposed to go.<sup>379</sup> After 2001, the International Community thought that all Afghanistan needed was a large infusion of foreign aid. Not surprising this led to business as usual with a large part of the promised money going to business overhead for offices and operations of the international organizations, donors, NGOs,<sup>380</sup> and implementing partners pursuing their own agendas and hiring English-speaking bureaucrats and teachers to work for the aid community at salaries far exceeding local Afghan salaries—creating false economies.<sup>381</sup> Foreign aid is one of the most popular policies that Western governments, international organizations, and NGOs recommend as a way of combating poverty around the world. And of course, the cycle of failure of foreign aid repeats itself over and over again. The idea that rich Western countries should provide large amounts of development aid in order to solve the problems of poverty is based on an incorrect understanding of the causes of poverty.<sup>382</sup>

Additionally, a growing number of development experts have observed economic development is not a panacea and cannot be divorced from security and governance. The government cannot gain sufficient

---

<sup>374</sup> Ibid.

<sup>375</sup> Ibid.

<sup>376</sup> Ibid.

<sup>377</sup> Ibid.

<sup>378</sup> Ibid.

<sup>379</sup> Ibid.

<sup>380</sup> Non-governmental organizations

<sup>381</sup> Acemoglu and Robinson, 2012.

<sup>382</sup> Ibid.

legitimacy solely by building projects or otherwise infusing money into a local economy.<sup>383</sup> In fact, such development can actually increase instability rather than decrease it.<sup>384</sup> Andrew Wilder and Stuart Gordon conclude from their research in Afghanistan that US and international aid efforts “show little evidence of ... winning hearts and minds or promoting stability.”<sup>385</sup> An Afghan tribal elder summed up the argument this way: “Lack of clinics, schools, and roads are not the problem. The main problem is we don’t have a good government.”<sup>386</sup>

The above finding was echoed by a group of development experts who discussed the topic at the 2010 Wilton Park Conference “Winning ‘Hearts and Minds’ in Afghanistan: Assessing the Effectiveness of Development Aid in COIN<sup>387</sup> Operations.”<sup>388</sup> The end-of-conference report found that “many Afghans believe the main cause of insecurity to be their government, which is perceived to be massively corrupt, predatory and unjust ... Without getting the ‘politics right’ both military and aid efforts are unlikely to achieve their desired effects.”<sup>389</sup>

Research findings presented at the Wilton Park conference also questioned many of the assumptions underpinning COIN stabilization strategies in Afghanistan, including: key drivers of insecurity are poverty, unemployment and/or radical Islam; economic development and modernization are stabilizing; aid projects win hearts and minds and help legitimize the government; extending the reach of the central government leads to stabilization and development projects are an effective means to extend this reach; and the international community and the Afghan government have shared objectives when it comes to promoting development, good governance and the rule of law.<sup>390</sup>

Conference recommendations included: ensure COIN doctrine is evidence-based and priority is given to assessing stabilization effects of projects, rather than assuming impact based on amounts of money spent or the number of projects implemented; development and COIN policies should acknowledge the potentially destabilizing effects of aid and need for greater recognition of the inadvertent role of aid donors (and not just aid recipients) in fueling corruption when they provide money without adequate safeguards and oversight; incentive structures should be created that reward quality and not just quantity, processes and not just products, and impacts rather than just outputs; and donors should avoid setting development aid up to fail by expecting it to deliver on unrealistically ambitious stabilization objectives for which it is not well-suited—differentiate between stabilization funds used for relatively small-scale

---

<sup>383</sup> Fishstein, Paul and Andrew Wilder (2012). *Winning Hearts and Minds? Examining the Relationship Between Aid and Security in Afghanistan*. (Medford, MA: Feinstein International Center, January 2012).

<sup>384</sup> Ibid.

<sup>385</sup> Ibid.

<sup>386</sup> Wilder, Andrew and Stuart Gordon (2009). “Money Can’t Buy America Love.” *Foreign Policy*, December 1.

<sup>387</sup> Counterinsurgency

<sup>388</sup> *WP1022 Report*, 2010.

<sup>389</sup> Ibid.

<sup>390</sup> Ibid.

and short-term projects designed to promote stability effects at a tactical level and larger-scale and longer-term development aid projects designed to promote development objectives.<sup>391</sup>

Two important lessons are: (1) Foreign aid is not a very effective means of dealing with the failure of nations around the world today. Countries need inclusive economic and political institutions to break out of the cycle of poverty. (2) Since the development of inclusive economic and political institutions is key, using the existing flow of foreign aid in part to facilitate such development would be useful. Structuring foreign aid so that its use and administration brings groups and leaders otherwise excluded from power into the decision-making process and empowering a broad segment of population might be a better prospect.<sup>392</sup> An example of an inclusive approach the Afghans used was the National Solidarity Program (NSP), the single largest development program in the country. It was created by the Afghan Ministry of Rural Rehabilitation and Development, or MRRD, in 2003 to develop the ability of Afghan communities to identify, plan, manage, and monitor their own development projects. The NSP promoted a development paradigm whereby communities were empowered to make decisions and manage resources during all stages of the project cycle. The program laid the foundation for a sustainable form of inclusive local governance, rural reconstruction, and poverty alleviation. Communities elected their representatives and leaders to form Community Development Councils or CDCs to implement the development projects.<sup>393</sup>

Post-conflict nation-building encompasses two different types of activities, reconstruction and development, for which the distinction between the two is often blurred.<sup>394</sup> Reconstruction refers to the restoration of war-torn or damaged societies to their pre-conflict situation, whereas development refers to the creation of new institutions and the promotion of sustained economic growth that transforms the society open-endedly into something that it had not been previously. Reconstruction is possible when the underlying political and social infrastructure survives the conflict or crisis. The challenge then becomes a matter of injecting sufficient resources to jumpstart the process in the form of supplying food, roads, buildings, infrastructure, and the like.

Development, however, is much more problematic, both conceptually and as a matter of pragmatic policy.<sup>395</sup> The development function is critical to creating and maintaining self-sustaining indigenous institutions that permit outside powers to formulate an exit strategy. It is an important phase that requires the eventual weaning of local actors and institutions from dependence on outside aid. Although conceptually straightforward, it is extremely difficult to implement in practice because local institutions are rarely strong enough to do the things they need to do and outside nation-builders get into the habit of ruling and making decisions and are reluctant to allow their local protégés to make their own mistakes. Nation builders also lack clarity about their own impact on local populations and fail to understand how

---

<sup>391</sup> Ibid.

<sup>392</sup> Acemoglu and Robinson, 2012.

<sup>393</sup> Ibid.

<sup>394</sup> Fukuyama, Francis, ed. (2006). *Nation-Building: Beyond Afghanistan and Iraq*. (Baltimore, MD: Johns Hopkins University Press).

<sup>395</sup> Ibid.

their continued presence in country tends to weaken those institutions they are trying to help strengthen.<sup>396</sup>

Security is important to the success of governance (institution building) and reconstruction efforts.<sup>397</sup> One must not forget that the host nation is ultimately responsible in the end for maintaining security and establishing viable institutions that meet the people's needs, especially since the host nation will have to do the heavy lifting for itself after US forces leave.<sup>398</sup>

America's most successful reconstruction and development effort occurred at the end of World War II when Europe and Japan were quickly and successfully returned to the world economy and, for the first time in their history, many nations adopted basic human rights and democratic institutions. The occupation of the Axis countries was administered by civilians, most of whom lacked significant development expertise, operating under the direction of the United States Army. They restored and improved healthcare, education, and legal systems in these countries, setting them on the road to becoming democracies.<sup>399</sup>

In his 1972 RAND Corporation study of the failure of US government efforts in Vietnam, Ambassador Robert W. Komer, former Chief of Pacification for the US government in Vietnam, argued that "the typical behavior patterns of . . . US institutions involved in the conflict made it difficult for them to cope with an unfamiliar conflict environment and greatly influenced what they could and could not, or would or would not, do."<sup>400</sup> Both the military and civilian agencies, he claimed, behaved in a bureaucratic manner which proved self-defeating. They behaved in this way because their institutional imperatives prevented them from behaving in any other fashion. Bureaucracies, whose modus operandi was to rely on precedent whether or not it was appropriate to resist change and to block outside interference in their operations, were incapable of readily adjusting to a new environment. He noted several interrelated attributes, common to all bureaucracies:<sup>401</sup>

- A tendency to shoehorn new policies or environments into familiar processes rather than try to learn how to cope with new situations.
- A tendency to define the world around them in terms of their own terms of reference, whether or not those terms have any bearing on reality.

---

<sup>396</sup> Ibid.

<sup>397</sup> Ibid.

<sup>398</sup> "Civil Operations and Revolutionary Development Support (CORDS)/Phoenix Counterinsurgency Lessons from Vietnam for the Future," *Military Review*, March-April 2006.

<sup>399</sup> Berner, Thomas F. "Send in the Amateurs! Recruiting from the Private Sector to Accelerate Nation-Building: The Experience of the Afghanistan Reconstruction Group." Published in Gott, Kendall D. and Michale G. Brooks, eds. (2006). *Security Assistance: US and International Historical Perspectives. The Proceedings of the Combat Studies Institute 2006 Military History Symposium*. (Fort Leavenworth, KS: Combat Studies Institute Press).

<sup>400</sup> Komer, Robert. W. (1972). *Bureaucracy Does Its Thing: Institutional Constraints on US-GVN Performance in Vietnam*. RAND Corporation, August 1972. Accessed October 4, 2015. <http://www.rand.org/pubs/reports/R967.html>.

<sup>401</sup> Ibid.



- A reluctance to change accepted ways of doing things. Bureaucrats prefer to deal with the familiar. To change may be to admit prior error, which is a cardinal bureaucratic sin. Organizations typically shift only slowly in response to changing conditions.
- A lack of institutional memory. Turnover of personnel combined with inadequate lessons learned procedures prevents progress. As Ambassador Komer so aptly stated, “We don’t have twelve years’ experience in Vietnam. We have one year’s experience twelve times over.”<sup>402</sup>

One can argue that crisis operations from Somalia to Haiti, Bosnia, Kosovo, Afghanistan, and Iraq have similar attributes and challenges to those noted above. Each American-led operation was somewhat better organized than its predecessor. Despite continuing coordination and political challenges, [the US] managed to meet their goal of stabilizing fragile post-conflict situations, for example, returning Bosnia and Kosovo to an economic state close to what they had been prior to conflict.<sup>403</sup> There is, however, a tendency to treat each new USG nation-building engagement as if it were the first encounter and send in new teams of people to face old problems. There has also been a reluctance to develop a USG doctrine for conducting such missions and to develop a cadre of experienced personnel who could be deployed to support them. In the absence of an agreed-upon USG international response doctrine and related pre-trained and experienced deployable capability, the use of ad hoc experiments and learning experiences has continued to be the norm for putting a USG and international response capability together.

Former Secretary of the Army Martin R. (Marty) Hoffmann observed that after every conflict there is a “golden moment” in which reconstruction and nation-building is most easily accomplished.<sup>404</sup> This is the moment after significant hostilities have ceased and before opposition to reform has had an opportunity to gel. The intervener transformation from liberator to occupier is a well-known challenge and can happen quickly and early in the transformation process. Nation-building interventions can last for years, and a decade is not unusual. The transition from conflict to stability operations encompasses not only security but also the start of recovery, reconstruction, and development and sets the expectations of the local population for a better quality of life. Implementation of recovery, therefore, needs to be accompanied by managing expectations of both the interveners and the affected nation’s government and population. For example, the golden moment may be as short as few months during which time the intervener actions must begin to support their words and promises and start to meet the expectations of the local population that there will be improvements in the quality of life. Unfortunately, recent real-world experiences suggest the US government has lost the ability to capitalize on the golden moment, which it did so effectively at the end of World War II. This ability will not likely be restored under the current structure of American foreign policy that lacks an agreed USG International Crisis Response Strategy and Plan and an operationally trained and rapidly deployable civil-military element that can plan for and conduct stabilization, reconstruction, and development operations in a timely and effective manner.<sup>405</sup>

---

<sup>402</sup> Komer, 1972.

<sup>403</sup> Berner, 2006.

<sup>404</sup> Ibid.

<sup>405</sup> Ibid.

There were and are additional opportunities to improve the USG's intervention capabilities. For example, the State Department's Office of the Coordinator for Reconstruction and Stabilization (S/CRS) was established in 2004 to lead, coordinate, and institutionalize US Government civilian capacity to prevent or prepare for post-conflict situations, and to help stabilize and reconstruct societies in transition from conflict or civil strife so they can reach a sustainable path toward peace, democracy and a market economy. In response to the recognized need for whole-of-government planning and response to crises abroad such as Iraq and Afghanistan, in 2005 President Bush issued National Security Presidential Directive-44 (Interagency Stability and Reconstruction efforts) to improve coordination, planning, and implementation of stabilization and reconstruction assistance. NSPD-44 empowered the Secretary of State to lead and coordinate the US Government response across all involved agencies and to work with the Secretary of Defense to harmonize civilian and military activities. The S/CRS, now the Bureau of Conflict and Stabilization Operations (CSO), was designated the lead agency to do this. Some progress has been made but there is work still to be done. In 2005, the Department of Defense (DoD) issued Directive 3000.05 (Military Support for Stability, Security, Transition, and Reconstruction) that gave stability operations priority comparable to combat operations and the mandate they be explicitly addressed and integrated across all DoD activities ranging from doctrine to planning and execution. In 2009, it became a DoD instruction DODI 3000.05 (Stability Operations) with additional clarification of US military support to stability operations led by other USG agencies. Also issued in 2009 was DoD Instruction 8220.02 (ICT Capabilities for Support of Stabilization and Reconstruction, Disaster Relief, and Humanitarian and Civic Assistance Operations) that addressed information-sharing activities and arrangements that facilitate coordination and cooperation between DoD and non-DoD partners to enable common understanding of the stabilization and reconstruction, disaster relief, and humanitarian and civic assistance environment; support integrated whole-of-government response capability; and resourcing of ICT capabilities to share spectrum or bandwidth, and to provide associated ICT infrastructure services needed to support civil-military partners in stabilization and reconstruction.

Adding to these opportunities is the role ICT can and has played as an element of power where the power is derived from a combination of people, content, and technical capabilities. The 21<sup>st</sup> century is the Information Age and this power needs to be leveraged. For stability operations, reconstruction, and development, ICT has become strategic to promoting capable government institutions, economic growth, and open societies in post-conflict affected nations. Information, real-time networking, big data, assuring network resilience and sustainability, effective collaboration, real-time situational awareness, cybersecurity, and responsiveness to human and social needs are examples of ICT power elements to be leveraged. ICT is not, however, adequately understood by all responder elements of the USG engaged in reconstruction and development planning, despite it being absolutely strategic to state-building in the new millennium. ICT is not systematically incorporated into US policy and crisis response capabilities today, impacting effective engagement in international crisis response activities – ad hoc arrangements remain the approach of the day. ICT matters to stabilization, reconstruction, and development because it helps ensure free flow of information; it is an engine for economic growth; it helps create effective, self-sustaining institutions; it creates jobs; and it contributes to establishing legitimacy by demonstrating the affected nation can deliver services to its citizens. ICT is an enabler of smart interventions and improved information sharing and collaboration across the civil-military boundaries.

Leveraging the power of information and ICT will require political will and a whole-of-government approach to do so. Policy changes such as elevating the importance of ICT to that of an essential service and critical infrastructure are needed. Additionally, strengthening and operationalizing capabilities such as CSO (formerly S/CRS) and improving USAID focus on ICT and engagement capabilities such as its new Global Development Lab need to be explored. DoD ICT-related roles and responsibilities in stabilization and reconstruction as set forth in DODIs 3000.05 and 8220.02 should be formalized and ad hoc approaches that have been proven to work, such as the Senior Telecom Advisor and Telecom Advisory Team employed in Afghanistan, should be institutionalized. NSPD-44 needs to be revised and DODIs 3000.05 and 8220.02 need to be updated. In addition, the latter two need to incorporate the role of ICT as an enabler of both the intervening civil-military force and the affected nation's recovery.

At the outset of the 2002 reconstruction and development intervention into Afghanistan, the international military Coalition and USG interests and investments in Afghanistan public ICT reconstruction and development were problematic. There appeared to be a general lack of understanding of the Afghan ICT business, information, and ICT cultures. Donors shunned providing telecom reconstruction funds for public services – ICT was best left to the private sector. This view was largely influenced by the so-called “Washington Consensus”<sup>406</sup> championed by the International Monetary Fund, the World Bank, and the US Treasury Department. The USG initially took a largely hands-off approach to underwriting Afghan ICT, despite the obvious need for emergency support following the war. On the other hand, early subject matter expert advisors were funded by the US Trade and Development Agency (USTDA), USAID, the World Bank, and the International Telecommunication Union to assist the Ministry of Communications to address ICT sector governance and development activities – telecommunications policies, laws, and regulations; spectrum allocation and management; organizational arrangements; capacity development; and strategies and plans for ICT infrastructure recovery and growth, particularly the introduction of cellular networks and mobile telephone services and building the national fiber optic network with regional interconnections. Over several years, other USG elements helped with the development of the Afghan national fiber optic network, including leasing connectivity and training Afghan Telecom to maintain and operate the network. The World Bank also funded sections of Afghanistan's optical fiber network.

Foremost among the emerging government of Afghanistan needs was the establishment of a modern national ICT network. The initial challenge was linking provincial and district capitals to each other and with Kabul to extend governance, and ultimately to provide access to the broader worldwide Internet. The World Bank, USAID, and the Coalition forces coordinated efforts with the Government of Afghanistan

---

<sup>406</sup> The “Washington Consensus” is a set of ten relatively specific economic policy prescriptions that is considered to constitute the “standard” reform package promoted for crisis-racked developing countries by Washington, DC-based institutions such as the International Monetary Fund (IMF), the World Bank, and the US Treasury Department. It was coined in 1989 by English economist John Williamson. The prescriptions encompassed policies in such areas as macroeconomic stabilization, economic opening with respect to both trade and investment, and the expansion of market forces within the domestic economy. See *Wikipedia*, “Washington Consensus,” at [https://en.wikipedia.org/wiki/Washington\\_Consensus](https://en.wikipedia.org/wiki/Washington_Consensus).

beginning in 2003 to design and execute several significant projects that, collectively, would build out an ICT network for use by government officials, businesses, and civilians. The initial elements of the network consisted of satellite-based links to connect the provinces (called the Government Communications Network (GCN) and funded by World Bank for US\$14 million) and districts (called the District Communications Network, DCN, funded by USAID for US\$14.2 million) with Kabul, the Kabul fiber loop to connect all Government of the Islamic Republic of Afghanistan (GIROA) institutions, and the repair and restoration of the main Kabul earth station (funded by the World Bank for US\$4.8 million) to link Kabul with the world. This was followed by the Afghan national fiber optic ring to link provinces and districts along the national ring road with each other, Kabul, the five countries surrounding Afghanistan, and through them, on to the rest of the world. As the ICT sector matured, USAID also funded activities such as the establishment of Cisco Networking Academies, the implementation of mobile money services, support for e-government initiatives, cybersecurity, chief information officer (CIO) training, ICT4Agriculture (e.g., an e-Afghan Ag web portal at the University of California – Davis and USAID-Roshan initiative Malomat, a price information system using mobile phone short message service technology), ICT4Health, a Women’s Economic Development Center at the American University of Afghanistan, ICT4Women, Afghan media, ICT4Education, ICT capacity development, professional development centers, ICT for democracy and governance, and ICT advisors to the ministry of communications, the regulator, and state-owned Afghan Telecom Corporation. The US Embassy funded Internet-based computer labs in schools in Jalalabad, a satellite-based map database of Afghanistan’s cultural heritage sites, and training young Afghans in the fields of archaeology and geographic information systems (GIS), as well as other education initiatives such as Fulbright scholarships.

The government of Afghanistan established a policy and regulatory framework, including good public-private partnerships with the mobile network operators (MNOs) that enabled private participation and competition early in the ICT sector reconstruction process. MNOs in past post-conflict environments have shown a pattern of spectacular entrepreneurial initiative in setting up operations as soon as or even before conflict ends, demonstrating that it is possible to achieve commercial success in post-conflict economies.<sup>407</sup> The government framework allowed a number of local and international investors to set up cellular telephone networks and begin providing mobile phone and Internet services, bringing into Afghanistan experience from other developing countries and enabling the establishment of competitive markets for communications. By 2006, there were four MNOs in Afghanistan and several ISPs. The total private investment in the ICT sector since 2001 has exceeded US\$2 billion.

The significant donor presence in Afghanistan has been a factor contributing to growth in ICT. Several entities and agencies, such as the United Nations Development Programme (UNDP), United Nations Assistance Mission in Afghanistan (UNAMA), Afghanistan Information Management Service (AIMS), World Bank, US Embassy, US Agency for International Development (USAID), DoD Task Force for Business and

---

<sup>407</sup> Bray, John (2005). *International Companies and Post-conflict Reconstruction*. World Bank, Conflict Prevention and Reconstruction, Social Development Department, Paper No. 22, February. Accessed February 7, 2015. <http://documents.worldbank.org/curated/en/994031468752728929/pdf/31819.pdf>.

Stability Operations (TFBSO), Swedish International Development Cooperation Agency (SIDA), Japan International Cooperation Agency (JICA), Canadian International Development Agency (CIDA), Department for International Development (DFID), German Agency for Technical Cooperation (GTZ), and Korea International Cooperation Agency (KOICA) over time contributed directly to ICT sector development.<sup>408</sup> Operational staff (including Afghans) working for these and other organizations have also used sophisticated ICT services in their workplaces, inspiring wider interest and use. Kabul today has many private IT skills training businesses. While the quality of these varies greatly, there is no doubt that the large number of students which they attract see IT skills as important in improving their employability.

Recent post-conflict operations, such as those in Iraq and Afghanistan, have demonstrated ICT has become an enabler of national transformations. There is little doubt that ICT is an engine for enabling security and stability, the extension of legitimate governance, and economic growth, and a means to shape the information environment to improve social well-being, including connecting villages, health centers, and educational institutions, and providing community access points to be used for communications and information sharing.

## Post-conflict Policy and Doctrine Evolution

The United States Government has been trying for years to institutionalize foreign aid, reconstruction, and development work and create a professional cadre of civil servants devoted to providing assistance to countries throughout the developing world. Peacekeeping in the Cold War era was typically limited to monitoring ceasefires between two parties and manning buffer zones. Today, however, Western nations have developed an interest in achieving more ambitious goals, including the rebuilding of nations in post-conflict situations. Western nations' goals now include aiding in stabilization, providing humanitarian aid, facilitating post-war reconstruction and development, encouraging economic and social rehabilitation, leading security sector reform and promoting democratization. Real-world experience suggests nation building and its supporting policy development should no longer occur without a careful cost-benefit analysis<sup>409</sup> and more effective use of unity of effort by the USG and international civil-military responder elements. Progress is being made but much remains to be done, especially regarding leveraging the power of ICT as a game changer and enabler of post-conflict reconstruction and development.

In 1997, President Clinton issued Presidential Decision Directive 56 (PDD 56) that governed Interagency management of post-conflict situations. Under PDD 56, an ad hoc Interagency working group called the Executive Committee would be called upon to supervise the day-to-day management of US operations when crises occurred. As noted earlier, the State Department created S/CRS in 2004 as the first formally-mandated office to enhance the nation's institutional capacity to respond to crises involving failing, failed, and post-conflict states and complex emergencies. The core functions of S/CRS consisted of conflict

---

<sup>408</sup> *From Transition to Transformation: The Role of the ICT sector in Afghanistan*. Washington, DC: World Bank. Available at: [https://www.infodev.org/infodev-files/final\\_afghanistan\\_ict\\_role\\_web.pdf](https://www.infodev.org/infodev-files/final_afghanistan_ict_role_web.pdf).

<sup>409</sup> Davids, Christiaan, Sebastian Ritjens, and Joesph Soeters (2010). "Measuring Progress in Reconstructing Afghanistan." *Baltic Security and Defense Review*, Volume 12, Issue 1.

prevention, planning, civilian response operations including a Civilian Response Corps, and strategic communications. In 2005, President Bush issued National Security Presidential Directive-44 (Interagency Stability and Reconstruction efforts) to improve coordination, planning, and implementation of stabilization and reconstruction assistance. NSPD-44 empowered the Secretary of State to lead and coordinate the US Government's response across all involved agencies and to work with the Secretary of Defense to harmonize civilian and military activities. S/CRS was designated the lead agency to do this.

In 2005, the DoD issued Directive 3000.05 (Military Support for Stability, Security, Transition, and Reconstruction) that gave stability operations priority comparable to combat operations and to be explicitly addressed and integrated across all DoD activities ranging from doctrine to planning and execution. In 2009, it became DoD instruction DODI 3000.05 (Stability Operations) with additional clarification of US military support to stability operations, including support to activities of USG Interagency, foreign governments, and international organizations with assistance in areas such as governance, rule of law, and fostering economic stability and growth. The updates to the policy also emphasized integrated civil-military efforts including a unity of effort collaboration with the US Interagency, foreign governments, inter-governmental organizations (IGOs), international organizations (IOs), non-governmental organizations (NGOs), and private sector elements. Additionally, the policy supports use of DoD resources to lead efforts related to restoration of essential services and repair and protection of critical infrastructure until such time as it is feasible to transition responsibilities to other USG agencies, foreign governments and security forces, and IOs.

The US Army leverages a variety of General Purpose Force (GPF) units with military and civilian personnel from the United States Army Corps of Engineers (USACE) to generate capability for restoring sewer, water, electrical, academic, trash removal, medical, safety and other (SWEAT-MSO) essential services.<sup>410</sup> Note that ICT is not explicitly viewed as an essential service, reinforcing the view that there is a need for a USG policy change to establish proper recognition of ICT as an essential service and critical infrastructure and a priority area for resource allocations. The Army most often accomplishes the stability operations mission in coordination with the Joint, Interagency, Intergovernmental, and Multinational (JIIM) community, private voluntary organizations (PVO), and people of the partner nations. Much of the Army's capability to restore or provide essential services is found in the Reserve Component (RC), limiting flexibility. The Army has the capability to repair some critical infrastructure, and Army forces provide the secure environment that facilitates the repair of critical infrastructure. USACE affects indirect efforts to repair complex infrastructure through management of large contracts. Army engineers and Civil Affairs also advise and assist partner nations in repair and maintenance activities. The Army recognizes the need to empower host nation governments to prepare for and respond to emergencies that disable infrastructure.<sup>411</sup> While the Army has the capability to support partner nations in restoring essential

---

<sup>410</sup> Headquarters, Department of the Army, G-35 DAMO-SSO (2011). *Army Stability Operations Self-Assessment Report on Implementation of DODI 3000.05*, March. Accessed November 12, 2014. [https://www.pksoi.org/document\\_repository/doc\\_lib/Army%20Stab%20Ops%20Self-Assessment%20\(FINAL\).pdf](https://www.pksoi.org/document_repository/doc_lib/Army%20Stab%20Ops%20Self-Assessment%20(FINAL).pdf).

<sup>411</sup> Ibid.

services, its ability to provide essential services is limited to small scale, short-term efforts. The Army is neither manned nor equipped to provide large scale, long term essential services without assistance from the JIIM community and host nation support.<sup>412</sup>

Despite increased collaboration between the DoD and other USG agencies, Interagency integration remains challenging for two reasons. First, other USG agencies lack authority, funding, and capacity to identify, train, and deploy large numbers of its permanent workforce. Second, there is no directive assigning responsibilities and authorities for whole-of-government conduct of Stability Operations training. As a result, the Army is challenged to fully integrate non-DoD civilian expertise into planning and execution of Stability Operations.<sup>413</sup> There are also inconsistencies between DoD policy, Joint doctrine, and Army doctrine in describing the interdependency of activities related to Stability Operations. These inconsistencies hinder understanding across the JIIM community and make Unity of Effort difficult to achieve, creating unnecessary obstacles to employing Title 10<sup>414</sup> and Title 22<sup>415</sup> funds in a coordinated manner. Progress is being made but work remains to be done.

Also issued in 2009 was DoD Instruction 8220.02 (ICT Capabilities for Support of Stabilization and Reconstruction, Disaster Relief, and Humanitarian and Civic Assistance Operations) that addressed information-sharing activities and arrangements that facilitate coordination and cooperation between DoD and non-DoD partners to enable common understanding of the stabilization and reconstruction, disaster relief, and humanitarian and civic assistance environment; support integrated whole-of-government response capability; and resourcing of ICT capabilities to share spectrum or bandwidth, and to provide associated ICT infrastructure services needed to support civil-military partners in stabilization and reconstruction. This instruction, to the extent authorized by law, and subject to applicable statutory and regulatory restrictions and limitations, authorizes establishment of information-sharing activities that facilitate coordination and cooperation between DoD and non-DoD partners to enable common understanding of the stabilization and reconstruction, disaster relief, and humanitarian and civic assistance environment; and to support an integrated whole-of-government response capability. Additionally, in response to requirements defined by Combatant Command and validated by Joint Staff, the Department of Defense or Military Department Headquarters may resource ICT capabilities to share spectrum or bandwidth, and to provide associated ICT infrastructure services necessary to support stabilization and reconstruction. Updates to DoD Instruction 8220.02 are needed to reflect lessons from real-world experiences in Iraq and Afghanistan that clearly demonstrated the importance of the role ICT plays as a “game changer” and an enabler of stability and reconstruction operations and the importance of engaging in recovery of the affected nation’s ICT sector governance and infrastructure, especially in the

---

<sup>412</sup> Ibid.

<sup>413</sup> Ibid.

<sup>414</sup> Title 10 of the United States Code outlines the role of armed forces in the United States Code. It provides the legal basis for the roles, missions and organization of each of the services as well as the United States Department of Defense. Each of the five subtitles deals with a separate aspect or component of the armed services.

<sup>415</sup> Title 22 of the United States Code outlines the role of foreign relations and intercourse in the United States Code.

areas of spectrum and dual-use technology such as fiber optic networks, satellite systems and private sector mobile voice and data services. There is also a need to incorporate guidance on approaches, such as an ICT advisor and/or advisory team, to provide professional civil and commercial ICT subject matter expert advice and assistance to USG elements, to help harmonize and coordinate ICT-related activities of USG and non-USG elements of an international coalition response operation, and to engage affected nation ICT counterparts participating in ICT sector recovery and reconstruction.

The US State Department led a Quadrennial Diplomacy and Development Review (QDDR) in 2010 to assess how it and USAID could become more efficient, accountable, and effective in a changing world and to provide a blueprint for elevating State and USAID civilian power. An assessment<sup>416</sup> by the Center for Strategic and International Studies (CSIS) observed that QDDR 2010 had many useful ideas but failed to address the legacy of nearly a decade of failure on the part of the State Department, USAID, and the civil departments of the US government to come to grips with the need to provide effective civilian partners in the wars in Iraq and Afghanistan. In CSIS's view, the QDDR 2010 did not address the failures in the top leadership of USAID and State that left the US military without effective civilian partners for much of the Iraq and Afghan conflicts.<sup>417</sup>

As noted earlier, in 2011 the State Department strengthened its capacity to anticipate and address emerging conflict dynamics by creating the Bureau of Conflict and Stabilization Operations (referred to as CSO), which succeeded S/CRS. Building on the belief that science, technology, innovation, and partnership can accelerate development impact faster, cheaper, and more sustainably, in April 2014, USAID established the US Global Development Lab ("the Lab"), which first began as a recommendation of the 2010 QDDR. A second QDDR was initiated in 2014. The intent of QDDR 2014 was to map a fresh four-year strategy for US foreign policy agencies excluding the Department of Defense.

Additional policy and doctrine actions have been and are being taken by the military to address security and post-conflict civil-military operations' needs. For example, United States policy on Security Sector Assistance is aimed at strengthening the ability of the United States to help allies and partner nations build their own security capacity, consistent with the principles of good governance and rule of law. The United States has long recognized that the diversity and complexity of the threats to our national interest require a collaborative approach, both within the USG and among allies, partners, and multilateral organizations.<sup>418</sup> Presidential Policy Directive 23 (PPD-23), Security Sector Assistance, issued in April 2013, requires a collaborative approach both within the USG and between civilian and other military organizations and is aimed at strengthening the ability of the United States to help allies build their own

---

<sup>416</sup> Cordesman, Anthony H. (2010). *The Quadrennial Diplomacy and Development Review (QDDR): Concepts Are Not Enough*. Center for Strategic and International Studies (CSIS), December 21, 2010. Accessed February 7, 2015. [https://csis-prod.s3.amazonaws.com/s3fs-public/legacy\\_files/files/publication/101221\\_QDDR\\_Review.pdf](https://csis-prod.s3.amazonaws.com/s3fs-public/legacy_files/files/publication/101221_QDDR_Review.pdf).

<sup>417</sup> Ibid.

<sup>418</sup> The White House. "Fact Sheet: U.S. Security Sector Assistance Policy." Office of the Press Secretary. April 5, 2013. Accessed February 7, 2015. <https://www.whitehouse.gov/the-press-office/2013/04/05/fact-sheet-us-security-sector-assistance-policy>.



security capacity. PPD-23 implies unity of effort across the government through participation in interagency strategic planning, assessment, program design, and implementation of security sector assistance. The joint doctrine-specific outcome of the PPD-23 process was the requirement for a Joint Publication (JP) on security cooperation. In this regard, JP 3-20.8 joint doctrine provides interagency, inter-governmental, and treaty-based organizations with an opportunity to better understand the roles, capabilities, and operating procedures used by the Armed Forces. There are joint doctrine solutions that help fill gaps in routine planning, training, and coordinating for cooperation with civilian organizations. Current revision of several Joint Publications (JP 3-0, Joint Operations; JP 3-07, Stability Operations; JP 3-08, Inter-organizational Coordination; and JP 5-0, Joint Planning) highlights the need for improving the degree of institutional-level understanding between the military and civilian organizations. In 2012, the Director of Joint Force Development directed a more aggressive path for counterinsurgency joint doctrine development “to guarantee we capture what we’ve learned about the conduct of counterinsurgency over the last decade and to harmonize joint and service efforts, I’m directing an accelerated development and release of JP 3-24, Counterinsurgency Operations (COIN). This joint publication will address the big ideas of COIN ... providing overarching and enduring guidance, while capturing the means by which the interagency and others contribute to this critical mission.”<sup>419</sup> The revised JP 3-24 was issued November 22, 2013 and:

- Provides an overview of counterinsurgency operations.
- Explains the nature, prerequisites, and objects of an insurgency.
- Presents the fundamentals of counterinsurgency.
- Discusses the operational environment during counterinsurgency operations.
- Covers planning for counterinsurgency operations.
- Describes assessing counterinsurgency operations.
- Addresses supporting operations for counterinsurgency operations.
- Discusses building governance to counterinsurgency operations.

Despite the progress, much work remains to be done, and the USG has yet to experience in recent failed-state interventions the success it enjoyed in post-World War II reconstruction and development. During World War II, the US military’s extensive planning for the occupation of Germany was a major factor in achieving long-term strategic objectives after the war was won. By the time Germany surrendered in May 1945, detailed Allied planning for the occupation of that nation had been ongoing for two years. All staff sections at Supreme Headquarters Allied Expeditionary Forces and Army Group headquarters invested considerable resources in developing what became Operation ECLIPSE. The plan correctly predicted most of the tasks required of the units occupying the defeated country. Within [three] months, those formations had disarmed and demobilized German armed forces, cared for and repatriated four million

---

<sup>419</sup> Flynn, George J. (2012). Memorandum, “Way Forward for the Revision of JP 3-24, *Counter- insurgency Operations*,” June 22.

[prisoners of war] and refugees, restored basic services to many devastated cities, discovered and quashed a potential revolt, created working local governments, and reestablished police and the courts.<sup>420</sup>

As a reminder, it is the view of many scholars of post-conflict operations that the US Government has lost the ability to capitalize on the golden moment which it did so effectively at the end of World War II. This is especially true for third-world countries emerging from conflict. Many argue that the success of European affected nations was supported by a modern culture and work ethic and a population and leadership that had the skills and will to rebuild their nation. These factors were enablers of the recovery process. The ability to rebuild failed states will not be restored under the current structure of American foreign policy, and approaches to post-conflict reconstruction and development. The USG approach needs to more effectively incorporate the views, needs, and capabilities of the country we are trying to help and actions need to be consistent with what the country is capable of doing and needs to do. We also need to be more careful about simply looking at the world through our eyes rather than through the eyes of those we are trying to help and holding and sharing views about what is best for them. We need to shape our support in terms of what makes sense for the affected nation to be able to do and what they need to do to start and sustain recovery, reconstruction, and development.

To be successful, post-conflict operations, such as those experienced in Iraq and Afghanistan, require much detailed Interagency planning, many forces, multi-year civilian and military commitments, and a national dedication to nation building. As noted earlier, recent American experiences with post-conflict operations have generally featured poor planning, problems with relevant military force structures, and difficulties with a handover from military to civilian responsibility. Exit strategies require the establishment of political stability, which has been difficult to achieve given fragmented populations, weak political institutions, and propensity for rule by violence.<sup>421</sup> It is important to look beyond the conflict to the challenges of occupying the country.

Additionally, economic development must be integrated and fully compatible with security and political strategies. As all three mission elements are necessary to generate the requisite legitimacy to defeat the insurgency, great care must be taken not to pursue one at the expense of the other two. This requires thorough intermission planning and an acknowledgment that each component affects the success of the others. To achieve this synergy, planners from all three mission sets, including representatives from the affected government, must work together to develop compatible plans. It may also require appointment of a single decision maker who exercises authority over all three missions.<sup>422</sup>

---

<sup>420</sup> Crane, Conrad C. and W. Andrew Terrill (2003). *Reconstructing Iraq: Insights, Challenges, and Missions for Military Forces in a Post-conflict Scenario*. Strategic Studies Institute, US Army War College, February 2003.

<sup>421</sup> Ibid.

<sup>422</sup> Donley, Colonel Patrick H. Donley, USAF, "Economic Development in Counterinsurgency: Building a Stable Second Pillar." *Joint Forces Quarterly* 81, 2<sup>nd</sup> Quarter 2016.

## ICT Policy and Doctrine Shortfalls

ICT supports the US Government's three pillars of diplomacy, development, and defense, which provide the foundation for promoting and protecting the US's national security interests abroad. As noted earlier, information and ICT are important components for success in security, stability, reconstruction, and development operations. The USG and the International Community do not yet formally view or treat ICT as an essential service, critical infrastructure, or an engine of change for affected nation security, governance, and socio-economic recovery and growth in post-conflict operations. There continues to be a reluctance on the part of the USG and International Community to adjust their policies and doctrines regarding the role ICT plays in the information age as a game changer in post-conflict reconstruction and development and the need for national whole-of-government and international unity of effort comprehensive approaches to provide priority focus, coordination mechanisms, and investment of resources necessary to leverage the power of information and the ICT sector.

NATO introduced the concept of a "comprehensive approach," defined in NATO doctrinal publication AJP-01, for use in international crisis response management situations. The comprehensive approach is a conceptual framework intended to address the need for actors involved in a stabilization mission to work together, from planning to implementation.<sup>423</sup> This approach is sometimes described as a "whole-of-government approach," while in the United Nations' context it is known as an "integrated approach." Again, little attention has yet to be given to the emerging role and importance of ICT as an enabler of security, stabilization, and post-conflict reconstruction operations.

As stated in AJP-01, "Implementing the comprehensive approach requires sensitivity, rapport, respect, trust, patience and tact, as well as determination to collaborate with all actors, military and civilian, at all levels." Interagency coordination among these actors is exceptionally difficult due to incompatible planning, training, and conduct of operations and differences in people and organization cultures. NATO's introduction of the comprehensive approach for its International Security Assistance Force (ISAF) mission in Afghanistan was considered a key to achieving success, since historically an insurgency cannot be defeated by military action alone. There is a need for civilian-related activities as well. The aim of the comprehensive approach at ISAF was to link the military operations with other efforts that were of importance to the population in order to win their support. Security was the main objective for ISAF operations. However, to be fully effective, security needed to be followed by good governance, justice, and the rule of law, and then be reinforced by infrastructure reconstruction and socio-economic development and growth, which cannot be delivered by the military alone. Former NATO Senior Civilian Representative Mark Sedwill characterized ISAF as "a civil-military experiment in real time and under conditions of stress that only combat can deliver."<sup>424</sup> This unique civil-military integration in the difficult security environment of Afghanistan posed serious challenges in the absence of clear doctrinal guidelines

---

<sup>423</sup> Beljan, Robert (2013). "Afghanistan: Lessons Learned from an ISAF Perspective." *Small Wars Journal*, May.

<sup>424</sup> NATO Senior Civilian Representative Report (2010). *A Comprehensive Approach: Lessons Learned in Afghanistan*. July 15, 2010. Accessed September 7, 2015.

<https://nllp.jalrc.nato.int/IKS/Sharing%20Public/SCR%20Report%20Final.pdf>.

on how to conduct joint, combined civil-military efforts, to include security, governance and socio-economic developmental programs.<sup>425</sup>

In Afghanistan, there were also NATO civil-military cooperation challenges with the United Nations (UN) and European Union (EU). Although NATO-UN cooperation was of utmost importance, given that the two organizations were perceived as respective leaders of the military and civilian efforts in Afghanistan, the cooperation between the two organizations was problematic. UN officials were ambivalent about working closely with a military alliance like NATO.<sup>426</sup> Cooperation between the EU and NATO was poor as well. The EU was criticized for not doing enough and for failing to show any serious desire to engage with the problems in Afghanistan.<sup>427</sup> After considerable pressure, the EU created EUPOL (European Police) Afghanistan, a mission to support and train Afghan police. Both NATO and EU ran police training programs but they were not effectively coordinated.<sup>428</sup> Despite optimism for greater coordination, the comprehensive approach only energized into action those that wanted greater civil-military integration and coordination, while leaving those that were more comfortable with the status quo continuing in their settled ways.<sup>429</sup> There was also great reluctance by humanitarian organizations to work closely with the military, both for practical and ideological reasons – they were reluctant to work under military protection, insisting that it compromised their neutrality. Initially hesitant to turn the NATO role in Afghanistan into a coordinator of the international effort, NATO eventually had to shoulder broader leadership. Hesitant also to create civilian capabilities of its own, NATO later saw it as necessary as well. These civil-military challenges illustrate the problems of implementing a strategy on the ground in a conflict where bureaucracies have already entrenched themselves and modus operandi had been developed.<sup>430</sup> NATO, too, discovered if there was progress on the ground, it was largely due to personalities – right people, right place, right time, and right attitude. NATO's objectives in Afghanistan were very ambitious and implementation of the comprehensive approach at the international level proved difficult. Civil-military relationships were constrained by different interests, goals, priorities, and organizational cultures. Lessons have been learned but the comprehensive approach still leaves a lot of room for improvement and work remains to be done to refine the approach for use in future International crisis operations.<sup>431</sup> Some of these lessons are imparted in [Chapter 22](#).

---

<sup>425</sup> Beljan, 2013.

<sup>426</sup> Steinsson, Sverrir (2015). *NATO's Comprehensive Approach in Afghanistan: Origins, Development, and Outcome*, July 26, 2015. Accessed September 7, 2015. <http://www.e-ir.info/2015/07/26/natos-comprehensive-approach-in-afghanistan-origins-development-and-outcome/>.

<sup>427</sup> Ibid.

<sup>428</sup> Ibid.

<sup>429</sup> Ibid.

<sup>430</sup> The NATO comprehensive approach for Afghanistan was launched as a result of the adoption of a new Strategic Concept for crisis management at the Lisbon Summit in 2010 where it was decided to enhance NATO's contribution to a comprehensive approach to crisis management as part of the international community's effort and to improve NATO's ability to deliver stabilization and reconstruction effects, "Lisbon Summit Declaration," November 2010.

<sup>431</sup> Steinsson, 2015.

## Afghanistan: A History of Conflict

Afghanistan's history is as varied as its people. The country has gone through many changes and many rulers. In 328 BC, Alexander the Great entered the territory of present-day Afghanistan, then part of the Persian Empire, to capture Bactria (present-day Balkh). Invasions by the Scythians, White Huns, and Turks followed in succeeding centuries. In AD 642, Arabs invaded the entire region and introduced Islam.

Arab rule gave way to the Persians, who controlled the area until conquered by the Turkic Ghaznavids in 998. Mahmud of Ghazni (998-1030) consolidated the conquests of his predecessors and turned Ghazni into a great cultural center as well as a base for frequent forays into India. Following Mahmud's short-lived dynasty, various princes attempted to rule sections of the country until the Mongol invasion of 1219. The Mongol invasion, led by Genghis Khan, resulted in massive slaughter of the population, destruction of many cities, including Herat, Ghazni, and Balkh, and the despoliation of fertile agricultural areas.

Following Genghis Khan's death in 1227, a succession of petty chiefs and princes struggled for supremacy until late in the 14th century, when one of Khan's descendants, Tamerlane, incorporated Afghanistan into his own vast Asian empire. Babur, a descendant of Tamerlane and the founder of India's Moghul dynasty at the beginning of the 16th century, made Kabul the capital of an Afghan principality.

Ahmad Shah Durrani unified the Pashtun tribes and, in 1747, was the founder of what is now known as Afghanistan. A Pashtun, Durrani was elected king by a tribal council after the assassination of the Persian ruler Nadir Shah at Khabushan in the same year. Throughout his reign, Durrani consolidated chieftainships, petty principalities, and fragmented provinces into one country.

In 1893, the British imposed a 2,430km (1,510-mile) borderline on the Amir of Afghanistan in a bid to strengthen the former's control over the northern parts of India. The agreement was signed between Sir Mortimer Durand, the Indian Foreign Secretary at the time, and Amir Abdur Rahman Khan in Kabul. The line is thus known as the Durand Line,<sup>432</sup> and it runs through Pashtun tribal lands between Afghanistan and then British India, marking their respective spheres of influence. In modern times, it marks the border between Afghanistan and Pakistan.

Afghanistan won independence from notional British control in 1919. A brief experiment in democracy ended in a coup in 1973 and a counter-coup in 1978. With the exception of a nine-month period in 1929, all of Afghanistan's rulers until the 1978 Marxist coup were from Durrani's Pashtun tribal confederation, and all were members of that tribe's Mohammadzai clan after 1818. The Soviet Union invaded in 1979 to support the tottering Afghan communist regime, touching off a long and destructive war. The USSR<sup>433</sup> withdrew in 1989 under relentless pressure by internationally-supported mujahedeen rebels, leaving the Afghan communist government to fend for itself against the mujahedeen and warlords.

---

<sup>432</sup> *Wikipedia* (2016). "Durand Line." Last modified August 9, 2016. [https://en.wikipedia.org/wiki/Durand\\_Line](https://en.wikipedia.org/wiki/Durand_Line).

<sup>433</sup> Union of Soviet Socialist Republics

After several years of civil war, the Afghan government fell in 1992. The civil war continued and the Taliban insurgency emerged in 1994 with the intent to end the country's civil war and anarchy. The word "Talib" means pupil, and the Taliban, is a movement originating from religious schools run by Jamiat Ulema-e-Islam for Afghan refugees in Pakistan. The Taliban continued to gain power and, in 1994, developed enough strength to capture the city of Kandahar from a local warlord and proceeded to expand its control throughout Afghanistan, occupying Kabul in September 1996. In 1997, the Taliban issued an edict renaming the country the Islamic Emirate of Afghanistan and named its leader, Mullah Omar, Head of State and Commander of the Faithful, granting him ultimate authority. This group dedicated itself to removing warlords, providing order, and imposing Islam on the country. It received considerable support from Pakistan. By the end of 1998, the Taliban occupied about 90 percent of the country, limiting the opposition largely to a small, mostly Tajik corner in the northeast and the Panjshir valley.

While in power, the Taliban enforced a strict interpretation of Shari'a, or Islamic law, an interpretation of which leading Muslims have been highly critical. The Taliban were condemned internationally for their brutal treatment of women. Women faced public flogging and execution for violations of the Taliban's laws. The Taliban banned listening to music, watching movies, television and videos, use of the Internet by both ordinary Afghans and foreigners, and imposed many other restrictions on both women and men. The Taliban committed serious atrocities against minority populations, particularly the Shi'a Hazara ethnic group, and killed noncombatants in several well-documented instances. In 2001, as part of a drive against relics of Afghanistan's pre-Islamic past, the Taliban destroyed two large statues of the Buddha outside of the city of Bamyán and announced destruction of all pre-Islamic statues in Afghanistan, including the remaining holdings of the Kabul Museum.

Starting in the mid-1990s, the Taliban provided sanctuary to Osama bin Laden, a Saudi national who had fought with them against the Soviets, and provided a base for his and other terrorist organizations. The UN Security Council repeatedly sanctioned the Taliban for these activities. Bin Laden provided both financial and political support to the Taliban. Bin Laden and his al-Qaeda group were charged with the simultaneous bombings of the US Embassies in Nairobi, Kenya and Dar es Salaam, Tanzania August 7, 1998. Later that month, in retaliation for the bombings, the United States launched a cruise missile attack against bin Laden's terrorist training camps in Afghanistan.

On September 9, 2001, agents working on behalf of the Taliban and believed to be associated with bin Laden's al-Qaeda group assassinated Northern Alliance Defense Minister and chief military commander Ahmed Shah Masood, a hero of the Afghan resistance against the Soviets and the Taliban's principal military opponent.

On the morning of September 11, 2001, 19 Middle Easterners (15 from Saudi Arabia, two from the United Arab Emirates, and one each from Egypt and Lebanon) hijacked four commercial airliners in the United States. They flew two planes into the iconic World Trade Center towers (1 and 2) in lower Manhattan, the third into the Pentagon in Washington, DC, and the fourth crashed into a field near Shanksville, Pennsylvania. The coordinated attacks killed nearly 3,000 people. Although no one claimed responsibility for the attacks, immediately or for several months thereafter, the US Federal Bureau of Investigation (FBI) and National Security Agency (NSA), along with intelligence officials from other countries, connected the hijackers to al-Qaeda. There was broad speculation Osama bin Laden, the founder of al-Qaeda, was

responsible for the attacks, and he was living in Afghanistan at the time. The US Government demanded the Taliban hand over Bin Laden. The Taliban's response was to demand proof of Bin Laden's guilt. In response to the Taliban's repeated refusal to expel bin Laden and his group and end its support for international terrorism, the US and its partners in the anti-terrorist Coalition began a campaign on October 7, 2001, targeting terrorist facilities and various Taliban military and political assets and al-Qaeda elements within Afghanistan. Operation ENDURING FREEDOM was designed to capture or kill Osama bin Laden and al-Qaeda militants as well as replace the Taliban government in Afghanistan with a government friendly to US and international interests.

The US (and others) believed bin Laden was hiding in the Tora Bora mountain area in eastern Afghanistan. Under pressure from US air power, Coalition forces, and anti-Taliban ground forces, the Taliban disintegrated rapidly, and Kabul fell from its grasp on November 13, 2001. By December 17, 2001, the last cave complex in Tora Bora had been taken and their defenders overrun. Osama bin Laden and other key leaders had escaped to Pakistan. Osama bin Laden was eventually tracked down and killed in a raid on his compound northeast of the city center of Abbottabad, Pakistan on 2 May 2011 by US Navy SEAL Team Six.

Following Tora Bora, US and UK forces and their Afghan allies consolidated their positions in the country. In November-December 2001, the US, with the help of Coalition partners and Afghan Northern Alliance fighters, ousted the Taliban from power and gained control of much of the country. The Taliban and al-Qaeda forces did not give up and went into hiding.

In December 2001, an international conference that included 25 prominent Afghans met in Bonn, Germany to decide on a plan for governing the country (commonly referred to as the Bonn Conference). Stakeholders agreed to restore security, stability, and governance to Afghanistan by creating a post-Taliban interim government to manage the country for six months until a *Loya Jirga*<sup>434</sup> could be convened to forge a two-year transitional government to move toward a more permanent, elected government. Hamid Karzai was selected to head the interim government.

## Impact of 25 Years of War and the Road to Recovery

By 2001, Afghanistan had been destroyed by some 25 years of war. There was no functioning central government. Millions of Afghans had died and millions had become displaced and were refugees. The country's economy was reduced to a bare subsistence level with a gross domestic product (GDP) per capita of about US\$180. The human capacity was very low, given the educated class had mostly left the country. Two generations were lost as they grew up in war and could not get a proper education. Women, in particular, had not been allowed to get an education or go to work. Electricity was essentially non-existent, as were communications services – phones, Internet, radio, and TV. An Afghan wanting to make a phone call to relatives abroad had to travel to Pakistan or another neighboring country to make the call. Historical and valuable treasures were looted and destroyed. A UN-sponsored health survey in northern

---

<sup>434</sup> Grand assembly of tribal elders

Afghanistan in January 2002 found alarming levels of malnutrition, especially among women and children, and officials warned that the situation could worsen dramatically.<sup>435</sup>

Most of the population of approximately 25.8 million had been engaged in agriculture.<sup>436</sup> In previous years, opium poppy cultivation was the mainstay of the economy and largely financed the military and criminal operations of various factions. In 1999 and 2000, the country was the world's largest opium producer. After the Coalition forces withdrew from Afghanistan at the end of 2014, more than 90 percent of the world's heroin still came from this war-torn country. The presence of millions of landmines and unexploded ordinances throughout the country restricted areas available for cultivation and slowed the return of refugees needed to rebuild the economy. Trade consisted mainly of opium, fruits, minerals, gems, and carpets as well as the smuggling of goods to Pakistan. Some of the main items smuggled from Afghanistan into Pakistan were drugs (opium, hashish, and heroin), lumber, precious stones, copper, automobiles, and electronics. Another form of smuggling was human trafficking. Formal economic activity remained minimal in most of the country, especially rural areas, and was inhibited by recurrent fighting. The country was dependent on international assistance, and large portions of the population required food aid to survive.<sup>437</sup>

A historically Pashto term, Loya Jirga, translates to “grand council.” It is a unique forum in which tribal elders of each ethnic group convene to discuss and resolve Afghanistan’s affairs. The Loya Jirga is centuries old tradition and a quintessential part of the Afghan government. A decision-making assembly, the jirga refrains from time limitations and continues until decisions are reached through consensus. The jirga addresses a variety of issues, such as foreign policy, military action, or the introduction of new ideas and reforms.

The absence of law and order in the wake of the rapid 2001 victory of American, Coalition, and Afghan Northern Alliance forces, suggested immediate steps were required to start the recovery process to move Afghanistan forward in establishing security and a new government. As noted earlier, stakeholders felt it necessary to have a transition period before establishing a permanent government, which would require at least one Loya Jirga to be convened. In response to this need, the UN sponsored the Bonn Conference, the result of which was participants the Bonn Agreement<sup>438</sup> on December 5, 2001. The Bonn Agreement established a process for the political reconstruction of Afghanistan and a UN-mandated international force to create a secure environment in and around Kabul. An Afghanistan security sector reform (SSR) program was also established in Bonn. Initially, different donor countries took responsibilities, such as the

---

<sup>435</sup> US Department of State Bureau of Democracy, Human Rights, and Labor (2002). *Country Reports on Human Rights Practices: Afghanistan*. Accessed October 15, 2016.

<http://www.state.gov/j/drl/rls/hrrpt/2001/sa/8222.htm>.

<sup>436</sup> Ibid.

<sup>437</sup> Ibid.

<sup>438</sup> Officially, the “Agreement on Provisional Arrangements in Afghanistan Pending the Re-Establishment of Permanent Government Institutions,” the first in a series of international agreements to reestablish the Afghan state after the fall of the Taliban regime.



US leading military reform, Germany planning police reform, the United Kingdom leading counter-narcotics, Italy overseeing judicial reform, and Japan leading disarmament, demobilization, and reintegration of the ex-combatants.<sup>439</sup> The political process included the adoption of a new constitution, a presidential election to be held in 2004, and National Assembly elections in 2005. The Afghan leaders attending the Bonn Conference participated in the process of reconstructing their country by helping set up on December 22, 2001 a new government structure, namely the Afghan Interim Administration (AIA) under the chairmanship of Hamid Karzai.

After establishing the AIA, an emergency Loya Jirga was convened June 11-19, 2002 to elect a new Head of State and appoint an Afghanistan Transitional Administration (ATA) which, in turn, would run the country for a maximum of two more years until a fully representative government could be elected through free and fair elections.<sup>440</sup> The Loya Jirga election for president of the ATA was held by secret ballot on June 13, 2002. Hamid Karzai was chosen with an overwhelming majority of 83 percent and stayed in office as President<sup>441</sup> and Chairman of the transitional administration until the 2004 election. On June 19, 2002, the last day of the Loya Jirga, Karzai announced to the Loya Jirga the names of 14 ministers of the future Afghan transitional administration, including three Vice-Presidents. He also named a Chief Justice.<sup>442</sup> These were agreed by Loya Jirga but additional ministers, national security advisors and vice presidents were added to cabinet installed the end of June 2002.

To address the security needs, the International Security Assistance Force (ISAF) was established by the United Nations Security Council Resolution 1386 on December 20, 2001. As envisaged by the Bonn Agreement, the purpose of ISAF was to provide security assistance for the establishment of the Afghan Transitional Authority. ISAF was initially led by military elements of participating nations, and leadership was based on a six-month rotational assignment by different nations starting with the UK. ISAFs main purpose was to create a secure environment in and around Kabul and support the start of recovery, reconstruction, and development of Afghanistan.

In response to a request from the Transitional Government of Afghanistan for assistance in laying out the foundations for sustainable peace and development, the UN took action to establish the United Nations Assistance Mission in Afghanistan (UNAMA). UNAMA is a political UN mission established on March 28, 2002 by United Nations Security Council Resolution 1401. Its original mandate was to support the Bonn Agreement (December 2001). Reviewed annually, this mandate has been altered over time to reflect the changing needs of the country and was extended for another year on March 15, 2016, by Resolution 2274 (2016).<sup>443</sup> Overall, the resolution calls for UNAMA, led by the Secretary-General's Special Representative,

---

<sup>439</sup> Security Sector Reform (SSR) Resource Centre. Country Snapshot: Afghanistan. Accessed October 15, 2015. <http://www.ssrresourcecentre.org/countries/afghanistan/>.

<sup>440</sup> *Wikipedia* (2016). "Afghan Transitional Administration." Last modified October 19, 2016. [https://en.wikipedia.org/wiki/Afghan\\_Transitional\\_Administration](https://en.wikipedia.org/wiki/Afghan_Transitional_Administration).

<sup>441</sup> *Ibid*.

<sup>442</sup> *Ibid*.

<sup>443</sup> *Wikipedia* (2016) United Nations Assistance Mission in Afghanistan. Last Modified September 28, 2016. [https://en.wikipedia.org/wiki/United\\_Nations\\_Assistance\\_Mission\\_in\\_Afghanistan](https://en.wikipedia.org/wiki/United_Nations_Assistance_Mission_in_Afghanistan).

to continue leading and coordinating international civilian efforts in assisting Afghanistan with its transition – within the mandate and guided by the principle of reinforcing Afghan sovereignty, leadership, and ownership.<sup>444</sup>

The agreements noted above set the conditions to pave the way forward for the creation of a three-way partnership among the ATA, ISAF, and UNAMA to begin the transition of Afghanistan to sustainable peace and development.

A challenge that arises with the intervening forces is meeting expectations of the affected nation's leadership and population, in this case the Afghans. Circumstances on the ground change over time in ways not always anticipated and in significant part in response to the intervention. The transformation from liberator to occupier is a well-known problem for intervening forces<sup>445</sup> and happened in Afghanistan. Interventions generally last for years, and a decade or longer is not unusual,<sup>446</sup> e.g., in Afghanistan it has been more than 15 years. Stability operations encompass not only security but also humanitarian assistance, return of rule of law and governance, and recovery, reconstruction, and development of institutions and infrastructure, all of which take time. In addition to actual changes, managing expectations of both the interveners and the affected nation becomes extremely important.<sup>447</sup> Intervener actions need to support words and begin to support expectations so that the local population experiences improvements in quality of life before they forget what life was like before the intervention. Otherwise, the population's perception of interveners will begin to shift from liberators to keepers of the status quo or, more likely, occupiers. The proper balance between stabilization and long-term development is important to achieving success in the eyes of those the interveners are trying to help. Additionally, actions must address the needs of those to be helped, not necessarily what the interveners believe needs to be done. In other words, interveners must look at the world through the eyes of those they are trying to help. Further, they must keep actions simple and address the expectations, needs, and priorities of those being helped.

On August 11, 2003, NATO assumed leadership of ISAF, ending the six-month national leadership rotations. The Alliance became responsible for the command, coordination, and planning for the force, including the provision of a force commander and headquarters on the ground in Afghanistan.<sup>448</sup> Germany provided the first ISAF commander under NATO leadership. This new arrangement overcame the problem of a continual search to find new nations to lead the mission and the difficulties of setting up a new

---

<sup>444</sup> Ibid.

<sup>445</sup> Wentz, Larry. (n.d.) *Information and Information Communications Technology as an Enabler of Success in Stability and Reconstruction Operations*. Available at: [http://star-tides.net/sites/default/files/documents/files/I-ICT%20in%20Stability%20Ops\\_Wentz.pdf](http://star-tides.net/sites/default/files/documents/files/I-ICT%20in%20Stability%20Ops_Wentz.pdf).

<sup>446</sup> Kramer, Franklin D., Larry Wentz, and Stuart Starr (2007). "I-Power: The Information Revolution and Stability Operations." *Defense Horizons*, Number 55, February 2007. Center for Technology and National Security Policy, National Defense University. Available at: <http://handle.dtic.mil/100.2/ADA466767>.

<sup>447</sup> Ibid.

<sup>448</sup> Australian Contribution to the International Security Assistance Force. Accessed December 20, 2016. <http://peacekeepers.asn.au/operations/OpSLIPPER.htm>.

headquarters every six months in a complex environment. A continuing NATO headquarters also enabled small countries, less likely to take over leadership responsibility, to play a stronger role within a multinational headquarters.<sup>449</sup>

ISAF's mandate was initially limited to providing security in and around Kabul. In October 2003, the United Nations extended ISAF's mandate to cover the whole of Afghanistan (UNSCR 1510), paving the way for an expansion of the mission across the country.<sup>450</sup> The ISAF mission was to support the Afghan government by "conduct[ing] operations in Afghanistan to reduce the capability and will of the insurgency, support the growth in capacity and capability of the Afghan National Security Forces (ANSF),<sup>451</sup> and facilitate improvements in governance and socio-economic development in order to provide a secure environment for sustainable stability that [was] observable to the population."<sup>452</sup> The Bonn Agreement of December 2001 required Afghanistan to draft and adopt a new constitution within two years. In October 2002, interim President Hamid Karzai appointed a nine-member Constitutional Drafting Commission, chaired by then Vice-President Nematullah Shahrani. Over the next six months, this body drafted a new constitution, based largely on the 1964 Afghan constitution.<sup>453</sup> A 502-delegate constitutional Loya Jirga convened in Kabul, Afghanistan, on December 14, 2003, to consider the proposed Afghan Constitution. Originally planned to last ten days, the assembly did not endorse the charter until January 4, 2004.<sup>454</sup> The new constitution provided for a strong presidency, a two-chamber legislature, and an independent judiciary. It guaranteed freedom of religion while recognizing Islam as the country's official religion. It also recognized that men and women are equal before the law, and it guaranteed language rights of minorities.

An election to the office of President of Afghanistan was held on October 9, 2004. Hamid Karzai won the election with 55.4 percent of the votes and three times more votes than any other candidate.<sup>455</sup> At a formal ceremony in Kabul, Karzai was sworn in as President of the Islamic Republic of Afghanistan on December 7, 2004, becoming the country's first democratically elected president. The National Assembly was inaugurated December 19, 2005. This was a historic occasion, marking the culmination of the political transition process set out in the Bonn Agreement. Among the elected officials for the parliament were warlords, former communists, Taliban defectors, and women activists. Additionally, some of the provincial governors were former warlords. President Karzai appointed Afghanistan's first female provincial governor, Ms. Habiba Surabi, of Bamyan province. Karzai was re-elected in August 2009 for a second term.

---

<sup>449</sup> Ibid.

<sup>450</sup> Ibid.

<sup>451</sup> At the end of 2014, the ANSF became the Afghan National Defense and Security Forces (ANDSF). The terms are used interchangeably throughout this book.

<sup>452</sup> Beljan, Robert (Maj., Armed Forces of Bosnia and Herzegovina) (n.d.). *What Lessons From ISAF Operations Can Be Drawn for UN PKOs?*, 12. Accessed December 10, 2014. <http://cdn.peaceopstraining.org/theses/beljan.pdf>.

<sup>453</sup> *Wikipedia* (2016). "2003 loya jirga." Last modified July 23, 2016. [https://en.wikipedia.org/wiki/2003\\_loya\\_jirga](https://en.wikipedia.org/wiki/2003_loya_jirga).

<sup>454</sup> Ibid.

<sup>455</sup> *Wikipedia* (2016). "Afghan presidential election, 2004." Last modified December 16, 2016. [https://en.wikipedia.org/wiki/Afghan\\_presidential\\_election,\\_2004](https://en.wikipedia.org/wiki/Afghan_presidential_election,_2004).

At the NATO Summit in Lisbon in November 2010, Afghanistan's President Hamid Karzai asked German Federal Chancellor Angela Merkel to host a follow-up conference ten years after the 2001 Bonn Conference. In order to prepare for the second Bonn Conference, the Afghan Government worked in collaboration with the International Contact Group (ICG) on Afghanistan.<sup>456</sup> The ICG was established by Richard Holbrooke in February 2009. By 2011 it comprised some 50 countries and international organizations such as the United Nations, NATO, the EU, and the Organization of Islamic Cooperation (OIC). Its members include nations contributing troops in Afghanistan, donor countries, and regional players. The ICG meets roughly three times a year. Most member countries are represented by their Special Representatives for Afghanistan and Pakistan (SRAP), while others are represented by senior officials. Some states have observer status.

Hence, ten years after the Bonn Conference of 2001, the International Community, composed of 85 countries, 15 international organizations and the United Nations, met again in Bonn on December 5, 2011. Together with Afghanistan, the goal was to give concrete shape to the long-term joint engagement and to advance further the political process in the country. Additionally, following the handover of responsibility for Afghanistan's security to the Afghan Government by 2014 and the completion of the withdrawal of all international combat troops by the end of 2014, the aim was to ensure that Afghanistan remained stable and developed economically. "Afghanistan must become stable, a country that is in no way a threat to peace," wrote Guido Westerwelle, German Foreign Minister, in a joint newspaper article with his Afghan Foreign Minister colleague Zalmay Rassoul on December 2, 2011.<sup>457</sup> They further noted Afghanistan will continue to require the assistance of the International Community, especially after the agreed withdrawal of international forces. They concluded by stating, "In Bonn, [they] want[ed] to lay the cornerstone for strong engagement beyond 2014-- an engagement that will mainly show a civilian face."<sup>458</sup>

The Bonn Conference focused on the following three issues involving the conclusion of the Afghan War and the transition of security responsibility to the Afghan Government, scheduled to occur in 2014: the civil aspects of the process of transferring responsibility to the Government of Afghanistan by 2014; the long-term engagement of the international community in Afghanistan after 2014; and the political process that is intended to lead to the long-term stabilization of the country.<sup>459</sup>

At the May 2012 NATO Summit in Chicago, leaders discussed how to further build the NATO-Afghanistan partnership. Allies and partners agreed on the outlines of a new NATO mission to train, advise, and assist Afghan security forces after transition of full security responsibility to the Afghans was completed on or

---

<sup>456</sup> *Wikipedia* (2016). "International Conference on Afghanistan, Bonn (2011)." Last modified December 17, 2016. [https://en.wikipedia.org/wiki/International\\_Conference\\_on\\_Afghanistan,\\_Bonn\\_\(2011\)](https://en.wikipedia.org/wiki/International_Conference_on_Afghanistan,_Bonn_(2011)).

<sup>457</sup> Rassoul, Zalmay and Guido Westerwelle (2011). "Paving the Way to Afghanistan's Future," December 3. Accessed October 4, 2014. <http://mfa.gov.af/en/news/5117>.

<sup>458</sup> *Ibid.*

<sup>459</sup> *Wikipedia*, 2016. "International Conference on Afghanistan, Bonn (2011)."

before the end of 2014.<sup>460</sup> Support for the further development of the Afghan National Security Forces (ANSF) continued under a new, smaller non-combat NATO-led mission (“Resolute Support”). As transition proceeded and ISAF combat forces gradually returned home, insurgents continued to find steadfast, highly capable Afghan forces standing against them, with the [C]oalition’s active support. In addition, by publicly outlining NATO’s plans for future presence, the alliance was being transparent with Afghanistan’s neighbors about its efforts and looked to them to continue to provide critical regional support to Afghanistan.<sup>461</sup> The US, NATO Allies, and ISAF partners announced an agreed-upon vision for the ANSF and committed to providing adequate funding for this force. The plan call[ed] for the ANSF to achieve surge strength of 352,000 by the end of 2013 and remain at that size for two full years, through the end of 2015, to allow continued progress toward a secure environment in Afghanistan.<sup>462</sup> While the NATO Summit focused primarily on security issues, the US and its Allies were equally committed to supporting a sustainable Afghan economy that depends less and less on donor support over time.<sup>463</sup>

Due to term limitations set by the constitution, Afghan President Karzai was not eligible to run for re-election in 2014. There were eleven candidates for the 2014 presidential elections held April 5, 2014. No candidate secured more than the 50 percent of the vote, so there was a second-round run-off on June 14 that consisted of two candidates, Abdullah and Ashraf Ghani Ahmadzai. Preliminary results were expected on July 2 and the final result on July 22. However, due to allegations of widespread fraud, on July 12 it was announced that all ballots would be audited under UN supervision. After months of political tensions and a US-brokered power-sharing arrangement, the candidates agreed in principle and signed a shared power agreement on September 21, 2014 and the Independent Election Commission announced Ghani as the winner of the presidential election. The power-sharing agreement named Ashraf Ghani Ahmadzai as president and his challenger, Abdullah Abdullah, as chief executive. Ghani became the country’s new president on September 29, 2014 and then swore in Abdullah as his chief executive – a position akin to prime minister – forming a “national unity government.”

Afghanistan has historically consisted of “power struggles, bloody coups, and unstable transfers of power.”<sup>464</sup> The 2014 election represented the first democratic transfer of power in Afghanistan’s history and the “first peaceful leadership transition in more than 40 years.”<sup>465</sup> The political transition marked the end of President Hamid Karzai’s nearly 13 years in power.

---

<sup>460</sup> Fact Sheet: Chicago Summit – NATO’s Enduring Presence after 2014.” Accessed October 4, 2014.

<https://www.whitehouse.gov/the-press-office/2012/05/21/fact-sheet-chicago-summit-nato-s-enduring-presence-after-2014>.

<sup>461</sup> Ibid.

<sup>462</sup> Fact Sheet: Chicago Summit - Sufficient and Sustainable ANSF. Accessed October 4, 2014.

<https://kabul.usembassy.gov/fs-ansf.html>.

<sup>463</sup> Fact Sheet: Chicago Summit – NATO’s Enduring Presence after 2014.

<sup>464</sup> AFGHANISTAN - FIN2PAMIR - Google Sites. Accessed October 4, 2014.

<https://sites.google.com/site/fin2pamir/route-planing/countrys-to-visit/afghanis>.

<sup>465</sup> Kerry, John (2014). “Afghanistan’s Triumph of Statesmanship and Compromise.” Op-Ed, *Washington Post*, September 27. Accessed October 4, 2014. <https://www.state.gov/secretary/remarks/2014/09/232231.htm>.

## National Development Projects

Upon assuming power in 2001, the post-Taliban government envisioned the creation of “national” development projects responsible for creating public trust in governance.<sup>466</sup> These programs included a National Emergency Employment Program to provide jobs across the country, a National Health and Education Program to get basic health packages to citizens and get children back in school, a National Transportation Program to make Afghanistan a land bridge for South and Central Asia and the Gulf, a National Telecommunications Program to set up a cell phone network across the country and attract private investment, a National Accountability Program to build good financial management, and finally, a National Solidarity Program (NSP) to carry out rural development, empower citizens in decision-making, and connect them to their government.<sup>467</sup>

The NSP was created in 2003 and became one of the Afghan government’s most successful rural development projects. Under the program, the Afghan Ministry of Rural Rehabilitation and Development (MRRD) disbursed modest grants to village-level elected organizations called Community Development Councils (CDCs), which, in turn, identif[ied] local priorities and implemented small-scale development projects. A limited number of domestic and international non- governmental organizations (NGOs) then assisted the CDCs. Once a CDC agreed on a venture, US\$200 per family (with a ceiling of US\$60,000 per village) was distributed for project execution.<sup>468</sup> Multiple donors funded the NSP through the World Bank’s International Development Association, the Afghan Reconstruction Trust Fund (ARTF) administered by the World Bank, the Japanese Social Development Fund, and bilateral grants. The US was the single largest donor to the NSP. ARTF contributions flowed through the Afghan national budget and provided a means by which the US and other donors could channel development assistance directly through the Afghan government.

Under this model, the NSP built schools for thousands of children, constructed village water pumps that saved many hours of labor, and assembled irrigation networks that enabled far higher agricultural yields. By 2013 nearly 32,000 CDCs were established and more than 30,000 block grants worth US\$1.18 billion provided for the implementation of around 65,000 projects. The NSP was the only government program functioning in all 34 provinces and helped serve as the face of the Government to the rural people. Furthermore, inclusion of women was a mandatory component of the program. It gave women a voice in local governance issues. Finally, it has provided socio-economic development to a population of over 24 million in over 368 districts.<sup>469</sup>

---

<sup>466</sup> Ghani, Ashraf and Claire Lockhart (2008). *Fixing Failed States: A Framework for Rebuilding a Fractured World*. (Oxford: Oxford University Press).

<sup>467</sup> Humayun, Ahmed A., Andrew M. Exum, and John A. Nigel (2009). *A Pathway to Success in Afghanistan: The National Solidarity Program*. March 16, 2009. Accessed October 4, 2014. <https://www.cnas.org/publications/reports/a-pathway-to-success-in-afghanistan-the-national-solidarity-program>.

<sup>468</sup> Ibid.

<sup>469</sup> Yemak, Reza; Fun Gan, Delice Cheng (2013). *Celebrating ten years of the National Solidarity Program (NSP): a glimpse of the rural development story in Afghanistan*. Washington DC; World Bank. Accessed October 4, 2014.

In July 2013, the World Bank reported on its multi-year (2007-2011) randomized impact evaluation of Afghanistan's NSP. The evaluation findings showed that one of the government's flagship programs has improved the villagers' access to basic utilities such as drinking water and electricity. NSP also increased access to education, healthcare, and women's counselling services. The program increased girls' school attendance, but did not impact the school attendance of boys. Doctor visits, prenatal exams, and medical professional attendance in cases of illness or injury were also improved. Finally, NSP raised the proportion of women who had a group or person with whom they could discuss their problems.

The large scale Western-led development projects also accomplished much good in Afghanistan, and they have an important role to play in further reconstruction activities. But much of this conventional development assistance has done little to reinforce the legitimacy of the Afghan government.<sup>470</sup> According to a 2008 Oxfam report,<sup>471</sup> only one-third of all international aid was funneled through the Afghan government. The absence of an Afghan imprimatur on most sizable development projects meant the central government often got little credit when progress was made on the ground.

Additionally, traditional development programs acquired a debilitating stigma in the eyes of many Afghans. A common Afghan complaint was that more funds were expended on the operation of international NGOs and their consultants than on Afghan needs. And even with the best of intentions, conventional assistance projects were often perceived to have been designed with an eye to donor constraints rather than recipient needs, limiting the effectiveness of projects.<sup>472</sup>

## The Role and Importance of ICT

For post-conflict operations, security and stabilization are priorities for setting the conditions for reconstruction and development, and ICT has become a key enabler of both. In support of transition to a post-conflict environment, there will be an urgent need to satisfy immediate communications requirements of the intervening civil-military elements to support security and humanitarian assistance and to help set the conditions for recovery, reconstruction, and development activities. In addition to the responder's deployable ICT capabilities they bring with them, there will be a need to address early the affected nation's ICT recovery and both temporary and longer-term reconstruction. Given the affected nation's ICT infrastructure will likely be in disrepair and the ICT sector governance functions of its ministry of communications and regulator dysfunctional, there will be early responder activities needed to address, in an organized way, the recovery of ICT sector governance and the development of an action plan to drive early ICT sector recovery and longer-term reconstruction and development. Hence, it will be necessary for the responder elements to help establish emergency communications networks to support

---

<http://documents.worldbank.org/curated/en/155731467993744166/Celebrating-ten-years-of-the-National-Solidarity-Program-NSP-a-glimpse-of-the-rural-development-story-in-Afghanistan>.

<sup>470</sup> Waldman, Matt (2008). *Falling Short: Aid Effectiveness in Afghanistan*. Oxfam, March 2008. Accessed October 4, 2014. [https://www.oxfam.org/sites/www.oxfam.org/files/ACBAR\\_aid\\_effectiveness\\_paper\\_0803.pdf](https://www.oxfam.org/sites/www.oxfam.org/files/ACBAR_aid_effectiveness_paper_0803.pdf).

<sup>471</sup> Ibid.

<sup>472</sup> Sturm, Frankie (2008). "Security through Development: Saving the National Solidarity Program in Afghanistan, October 28, as quoted by Humayun, et al. (2009).

both the intervener elements and to help the affected nation's government establish temporary emergency government communications capabilities to facilitate conducting civil security, emergency services, and central government actions. This will require the civil-military intervener elements to plan for the rapid deployment of some basic ICT capabilities to help meet essential communications needs and to explore donor options for early investments to jumpstart ICT sector governance and infrastructure recovery, reconstruction, and development. Deploying basic ICT capabilities offers an opportunity to employ approaches such as anchor tenant to help the affected nation quickly begin ICT infrastructure recovery, infrastructure that can be used by both the affected nation and the interveners – a win-win situation. The affected nation can also use the anchor tenant approach to generate a revenue stream from leases, which it can invest back into further infrastructure recovery. The interveners can be provided early communications connectivity in areas needed to support security and stabilization requirements. The ICT capabilities and services can further be used to support the early communications needs of the affected nation to facilitate recovery of governance, rule of law, and emergency services and to support the early communications needs of responder elements such as NGOs, aid agencies, contractors, international organizations, and others. Early ICT capabilities and services can also help create job opportunities and enable an earlier start of private business sector recovery.

There will be a need for international advisors to assist in helping the affected nation's government restore ICT sector governance. In preparation for ICT sector recovery, reconstruction, and development, once a functioning minister and elements of a ministry of communications (MoC) have been put in place by the affected nation's government, advisors will be needed to help rapidly establish a first cut at ICT policies, regulations, and laws and an early regulatory capability. Organizational arrangements, functions, staffing, and training plans for the MoC and regulator will need to be addressed as well. These activities may also require the use of consultants and advisors to help initially staff key positions and functions with the necessary professional skills until the affected nation can recruit and properly trained staff to do the required jobs. There will also be a need to assemble an early ICT vision, strategy, and plan for guiding recovery and reconstruction of ICT infrastructure and services as a priority in rebuilding national infrastructure and restoring government services. Establishment of an early ICT licensing regime and a framework for public-private-partnerships to enable private investment in the ICT sector is key to the early introduction and growth of nationwide voice and data services. Here again, professional consultants and advisors with commercial ICT skills and an understanding of ICT governance factors, international standards, business processes, and private ICT sector investments can and will need to be employed to help.

A social network of and selected trusted relationships with ICT-savvy interveners and subject matter experts (SMEs) with key ICT players in the affected nation are important considerations as well. These are, however, skills and relationships that should be developed over time *before* an intervention, not as part of the intervention. If prior arrangements do not exist, this should be a priority action for the SME advisory support team. In Afghanistan, the USG (e.g., USTDA and USAID) and other elements of the International Community (e.g., UNDP, ITU, and the World Bank) responded with funding for civil and commercial ICT SMEs to advise the minister of communications on ICT sector governance development activities – telecom policies, laws, regulations, spectrum management, organizational arrangements, capacity development, and strategies and plans for ICT infrastructure recovery and growth, particularly the



introduction of mobile telephone services and building national infrastructure such as microwave and fiber optic networks, and interconnecting these networks with regional partner nations. Introduction of satellite services for access to rural and disadvantaged areas is important as well. The early SME and investment support efforts tended to be independent and uncoordinated activities. A challenge to this independent approach is developing and managing a shared understanding of who is doing what and when and coordination and harmonization of activities. The early SME support for recovery of Afghan ICT sector governance and infrastructure comprised multiple independent advisors with little to no coordination or information sharing among the participants.

For longer-term donor investments in Afghan ICT infrastructure reconstruction and capacity development, there was more willingness to coordinate actions between donors such as USAID and the World Bank. Examples include World Bank funding for the Government Communications Network and international satellite gateway, USAID funding for the District Communications Network, and USG/USAID and World Bank collaborative efforts in the areas of the Afghan national fiber optic network and ICT capacity development at Afghan universities, including program development for chief information officer, cybersecurity, and computer science training. Through a partnership among USAID, UNDP, Cisco Systems, the Ministry of Communications, and the ITU, the Cisco Networking Academy Program was introduced and initiated at Kabul University in 2002. By 2006, the program was expanded to universities in Herat, Mazar-e-Sharif, Khost, Jalalabad, and Kandahar. UNDP, Microsoft, and the MoC supported creating ICT Training Centers in provincial capitals and MoC-sponsored ICT capacity development at the ICT Institute (ICTI) in Kabul. In 2002, the UN Educational, Scientific, and Cultural Organization (UNESCO) sponsored building community multimedia centers with interactive television and Internet technologies across Afghanistan. UNESCO was also engaged in technical and vocational education and training (TVET) and higher education programs, as were USAID, the World Bank and nations such as Japan, Germany, and South Korea.

To promote ICT sector investment and engage the private sector in early ICT recovery activities, the affected nation government needs to take urgent action to remove legal and regulatory barriers to investment and allow the issuing of competitive licenses for communications operators as soon as possible.<sup>473</sup> International mobile network operators (MNOs) have shown that they are prepared to invest in cellular telephone networks very soon after security and stability has been achieved. In Afghanistan, the interim Afghan government established a Ministry of Communications (MoC) in 2002 and gave it authority to issue licenses. The MoC authorized Afghan Wireless Communications Company (AWCC) to provide GSM<sup>474</sup> cellular services on a temporary basis (the MoC awarded AWCC an official GSM license in

---

<sup>473</sup> Kelly, Tim and David Souter (2014). *The Role of Information and Communication Technologies in Postconflict Reconstruction*. World Bank Studies. Washington, DC: World Bank. doi:10.1596/978-1-4648-0074-0. License: Creative Commons Attribution CC BY 3.0. Accessed September 7, 2015. <https://issuu.com/world.bank.publications/docs/9781464800740?e=0/6688927>.

<sup>474</sup> Global system for mobile communications, a second generation of protocols for digital cellular networks originally developed by the European Telecommunications Standards Institute (ETSI). GSM is now a trademark owned by the GSM Association.

2003), so AWCC began building a national cellular network with international gateway access. By 2006 there were four commercial MNOs operating in Afghanistan - AWCC, Roshan, MTN, and Etisalat. Early good public-private-partnerships with the Afghan MoC enabled private sector investment and the proliferation of voice and data coverage and services. Between 2002 and 2006, cellular network coverage grew from basically nothing to over 50 percent of the country; the number of users increased from essentially zero to over two million; and direct foreign investment in ICT exceeded US\$700 million.<sup>475</sup> Today (2016) there are six MNOs (additions were Afghan Telecom and Wasel Telecom), population coverage (by ICT services) exceeds 90 percent, mobile phone users exceed 24 million, and foreign investments exceed US\$2.2 billion.<sup>476</sup>

The rapid reestablishment of communications networks facilitates improvement in security and governance and the extension of governance beyond the central government. It also facilitates social cohesion and helps jumpstart economic recovery. Early ICT investments contribute to providing job opportunities within the ICT sector as well as sectors that support the ICT sector and sectors that use ICT. Significant success in all these areas was observed in Afghanistan.

To improve the USG and International response, shared ICT strategies need to form part of the responder elements and host nation plans for long-term ICT sector reconstruction and development.<sup>477</sup> For Afghanistan, the [Afghanistan National Development Strategy \(ANDS\)](#) and [E-Afghanistan National Priority Program \(NPP\)](#) provided the strategies and plans that donors used to shape their ICT investments. These strategies, plans, and programs helped form the USG (e.g., US Embassy, USAID, USFOR-A,<sup>478</sup> PRTs<sup>479</sup>) and ISAF ICT response activities. They also influenced other donors such as the World Bank and its Afghanistan ICT Sector Development project. The project focused on revising of GIRoA ICT policy; increasing access to the Internet and mobile phone services; developing, implementing, and adopting mobile government (m-government) applications; and training Afghans through an IT skills development program, which includes capacity-building activities for the Ministry of Communications and Information MCIT and ATRA. It is now widely agreed internationally that ICTs contribute substantially to security, governance, and social and economic development. This is supported by wide-ranging experience from developing countries of ICTs increasing value as an enabler in finance, health, education, agriculture, and enterprise development.<sup>480</sup> National strategies [such as the *ANDS* and *E-Afghanistan NPP*] which include infrastructure, access, and applications development, built on a careful understanding of local communications markets and priorities, increase the likelihood that ICTs will enable sustainable developmental gains. [ICT should, therefore,] be included in national civil-military development planning from an early stage.<sup>481</sup> Additionally,

---

<sup>475</sup> Statistics per the Afghanistan Telecom Regulatory Authority (ATRA) and the Afghan Ministry of Communications and Information Technology (MCIT).

<sup>476</sup> Ibid.

<sup>477</sup> Kelly and Souter, 2014.

<sup>478</sup> United States Forces-Afghanistan

<sup>479</sup> Provincial Reconstruction Teams

<sup>480</sup> Kelly and Souter, 2014.

<sup>481</sup> Ibid.

there is a need to put mechanisms in place to facilitate coordination, harmonization, and information sharing among donor and civil-military responder community activities. There were a few such programs in Afghanistan. The first was an initiative by the Afghan Information Management Services (AIMS) called the Provincial Infrastructure Management Support System (PIMSS). The purpose of PIMSS was to introduce appropriate information management systems, infrastructure, and capacity to enable the creation of a “common operating picture” to aid coherent development decision making for all government and development partners in Afghanistan. AIMS implemented a pilot project in Nangarhar province but it never became a national program. ISAF implemented the Afghanistan Country Stability Picture (ACSP) geographic information system database to share reconstruction status situational awareness information with the civil-military community. Examples of attempts at unclassified information sharing among civil-military intervention participants and Afghans also included Internet-based systems such as USCENTCOM’s<sup>482</sup> International Distributed Unified Reporting Environment (INDURE), and ISAF’s Afghan web portal named Ronna.

As noted earlier, ICT has proven to be a basic enabler of informal social and economic discourse, leading to a strengthening of civil society and the promotion of security, internal stability, job creation, social services, and economic solidity in affected nations. It is a demonstrated enabler of national transformations. There is little doubt that ICT is an engine for economic growth, a means to shape the information environment, and a means to improve social well-being,<sup>483</sup> including connecting villages, health centers and educational institutions and providing community access points. Additional arguments as to why ICT and affected nation ICT, in particular, are important include but are not limited to:

- ICT can be used to help create a knowledgeable intervention, organize complex activities, and integrate stability and reconstruction operations with the affected nation.
- The affected nation’s ICT infrastructure provides an alternative source of ICT capacity, coverage, and capabilities for use by USG and coalition partners.
- ICT provides opportunities to shape the environment for Stabilization and Reconstruction Operations.
- ICT is essential for an affected nation to prosper in a globalized economy and establish a knowledge culture and to participate in the global information society and business environments.
- ICT can significantly change key parts of an affected nation’s society, particularly by providing young people access to global knowledge that changes sectarian attitudes and behaviors.
- ICT provides an affected nation transparency and the ability to extend governance to help reduce corruption and enhance government legitimacy.

---

<sup>482</sup> United States Central Command

<sup>483</sup> Saadawi, Tarek and Louis Jordan, Jr., eds. (2011). *Cyber Infrastructure Protection*. Strategic Studies Institute (SSI), US Army War College, May 2011. Accessed October 4, 2015. [https://ia600703.us.archive.org/30/items/CyberInfrastructureProtection\\_112/10-Cyber.pdf](https://ia600703.us.archive.org/30/items/CyberInfrastructureProtection_112/10-Cyber.pdf).

- ICT offers the best way to help every sector at once through realistic and modern e-government services (civil security, governance, distance learning, telemedicine, GIS-based<sup>484</sup> agriculture, finance, power and water management, and e-commerce).
- ICT allows the USG to positively influence attitudes of the leadership and general population of the affected nation.
- ICT has been demonstrated to be one of the best generators of jobs and revenues for affected nations.
- ICT facilitates communication of situational awareness of and for affected nation forces, capabilities, and threats that can save lives.

As noted earlier, the major challenge is that the USG and the International Community have not yet formally recognized nor treated ICT as an essential service and critical infrastructure. Limiting more effective unity of effort response is the fact that a formal and agreed-upon USG and International Community ICT policy and doctrine continues to be lacking. USG and International Community ICT-related response actions continue to be largely reactive and ad hoc. USG ICT-related activities in support of stability operations and as an enabler of reconstruction and development are problematic:

- There is no clear USG lead agency for ICT.
- ICT-based thought leadership and strategic thinking are lacking.
- There is no agreed-upon USG institutional arrangement to meet the needs of ICT support for interveners in security and stability operations or for affected nation recovery, reconstruction, and development.
- Intervention activities suffer from a lack of adequate understanding of the affected nation's information culture and related ICT business (government and private sector) culture.
- There is no clear mapping of responding stakeholder organizations' roles and responsibilities.
- Program development, project coordination, information sharing, and implementation are largely uncoordinated and non-standard.
- There is no agreed-upon vision, strategy, architecture, or plan for enabling affected nation ICT recovery, reconstruction, and development.
- A coherent intervention strategy and plan is not developed for the support of responding nations, international organizations, and non-governmental organizations for the affected nation's ICT recovery, reconstruction, and development needs.
- And, donors and civil-military interveners do not view ICT as a high-priority need to be addressed early and used as an enabler of cross-sector reconstruction and development, i.e., security, governance, and economic and social well-being.

To further the argument of the importance of ICT importance as a dual use technology, an affected nation's commercial (private) ICT sector plays an important role in supporting intervening civil-military

---

<sup>484</sup> Geographic information system

elements needed to connect bases within the affected nation and for access into and out of the country. It supports C4ISR<sup>485</sup> connectivity needs of the military responder elements. The cellular network becomes the lifeline for civil-military elements operating in the field. Internet services support MWR<sup>486</sup> and civil-military element needs for private communications with loved ones at home. The commercial ICT capabilities facilitate communications among coalition civil-military responder elements, donors, NGOs, contractors, international organizations, and the affected nation's government and for conducting business locally, regionally, and internationally.

Hybrid commercial satellite and terrestrial networks have emerged as the way of the future to provide high-performance and resilient broadband fixed and wireless data and voice services in support of civil-military interventions and sustained operations in hostile and disadvantaged environments and to facilitate affected nation security, governance, and socio-economic recovery. Commercial ICT provides critical communication connectivity and information services in support of C4ISR for the civil-military intervention and related combat operations and is an enabler of stabilization and transition operations, all of which have excessive demands for reliable, high-quality performance, and affordable broadband data services. Commercial SATCOM<sup>487</sup> and fiber optic networks play a key role in facilitating the extension of connectivity into disaster areas and within the affected nation to support intervening forces C4ISR broadband service needs including subsequent civilian humanitarian assistance and ICT sector recovery and development and connection with the international voice and information environment.

SATCOM is, however, a limited and costly resource so early attention is needed to move appropriate demand from satellite to terrestrial networks such as fiber optic and microwave. For the affected nation, ICT is an essential service and critical infrastructure that plays a vital role on the road to acquiring its national sovereignty and security, and it serves to facilitate the return of rule of law and governance and as a change agent that enables socio-economic recovery and development and facilitates moving the nation into the global information and business environments. All too often, the international and USG intervening elements do not give adequate attention to planning for the use of terrestrial communications that can be as little as a third of the cost of satellite or to the need for early investments to help restore destroyed networks so that their capabilities will be available not only to support the C4ISR needs but to help jumpstart the restoration of the telecom and IT sectors of the affected nation.

For example, a fiber optic network is a dual-use technology that can serve both military connectivity and civil and commercial needs. An example of a smart intervention was the USG engaging with GfR as an anchor tenant for leasing fiber optic bandwidth to support the US military surge that started in 2010 in Afghanistan. In advance of the deployment of troops, the Defense Information Systems Agency (DISA) negotiated leases of fiber optic connectivity to provide broadband access into and out of the theater of operation and to provide connectivity between and among bases being built in country. The USG's intent was to lease fiber where available, which provided an incentive for GfR, the Ministry of

---

<sup>485</sup> Command, control, communications, computers, intelligence, surveillance, and reconnaissance

<sup>486</sup> Morale, welfare, and recreation

<sup>487</sup> Satellite communications

Communications and Information Technology (MCIT), and state-owned Afghan Telecom Corporation (AfTel), in particular, to re-engage regarding the construction of a national fiber optic network and its interconnection with neighboring countries, providing access to the international information network. Up to this point, work on the fiber optic ring had been stopped for over a year due to a deteriorating security environment. Installed fiber was being cut, and fiber installers were being kidnapped or killed by the Taliban. The US also provided advice and assistance to AfTel to help it develop a responsive operations and maintenance (O&M) element to manage the network and repair damage to cables. This became a win-win situation: the US military leased needed connectivity into and out of country and between bases while US leases generated revenue for the Afghan government and regional interconnections provided Afghanistan access to competitive Internet service providers (ISPs). The latter contributed to AfTel's ability to reduce the price for 1 megabit per second per month (Mbps/month) of Internet access from US\$5,000 in 2002 to US\$7.50 in 2016.<sup>488</sup> The regional interconnections offer Afghanistan the opportunity, over time, to become a hub for regional transit traffic for data services. Regarding the anchor tenant investment: between 2010 and 2015, DISA leased Afghan Telecom fiber optic connectivity to support US military C4ISR needs at a cost over US\$300 million, an average annual rate of about US\$53 million, making the USG AfTel's largest customer. Because of the revenue from the USG (and, of course, other customers), the national fiber optic network has increased in coverage and the number of cross border links to other international networks, contributing to economic growth opportunities for Afghanistan.

As headquarters, forward operating bases, and other facilities grew and were occupied, the US military and other Coalition partners deemed it necessary to provide communications services for personal and business use by the civil-military elements. Many of the initial voice and data networks for US military locations were provided by USG-contracted service providers that established networks directly connected to commercial telephone networks in the US and to ISPs outside Afghanistan. Coalition partners made similar arrangements with service providers in their countries for their installations. As the Afghan commercial ICT networks grew in capacity and coverage services became more readily available through local MNOs and ISPs. Since the outside-contracted ICT services for Coalition facilities competed with local vendors, ISAF and USFOR-A found it necessary (at the urging of the Afghan government) to revisit their contracting arrangements to ensure that, in accordance with Afghan ICT laws and regulations, only authorized and licensed Afghan vendors were used for non-military C2 voice and Internet services on bases in Afghanistan. This was also a concern for donor organizations and contractors, many of which set up their own VSAT<sup>489</sup> access for Internet and other services without appropriate Afghan licenses to do so. There were a lot of unlicensed VSAT networks operating during the Taliban era and into the days of ISAF operations. Once the problem was discovered, ATRA, the ICT regulator, acted to close down unlicensed operations. This is a consideration that needs to be factored into responder ICT support planning that includes deployable capabilities that may not necessarily have landing rights in an affected nation, especially once an ICT law is enacted and enforced. Once the affected nation's ICT governance is restored

---

<sup>488</sup> Per the MCIT, 2016.

<sup>489</sup> Very small aperture terminal, a two-way satellite ground station with a dish antenna generally smaller than three to four feet.

and ICT laws and regulations are enacted, temporary unlicensed operations will be challenged and taken down if not licensed, as happened in Afghanistan. Some of these arrangements included NGO-provided connectivity and services to clinics and schools. International bypass fraud is another area of concern. Nefarious actors often install illegal SIM<sup>490</sup> boxes,<sup>491</sup> which they use to route international calls through a VoIP<sup>492</sup> connection, making the calls appear to the service provider terminating them as local calls. The SIM box owner then pockets the difference between what they charge the customer (for an international call) and what they pay the terminating service provider (for a local call). ATRA has discovered and shut down a number of illegal SIM box operations in Afghanistan over the years.

As noted, information and ICT can significantly increase the likelihood of success in stability operations – if they are engaged as part of an overall strategy that coordinates the actions of outside civil-military interveners and focuses on generating effective results for the affected nation. Properly utilized, ICT can help create a knowledgeable intervention, organize complex activities, and facilitate integration of stability operations with the affected nation recovery, reconstruction, and development, making stability operations more effective.

For the USG, the key to the effective use of ICT as an enabler is a strategy that requires:

1. The USG gives high priority to such an approach and ensures that the effort is a joint civilian-military activity with senior-level support and concomitant senior-level strategic thinking and thought leadership.
2. The USG and the International Community view and treat ICT as an essential service and critical infrastructure and prioritize investments and shape actions accordingly.
3. The military makes commercial ICT part of the planning and execution of stability, reconstruction, and transition operations.
4. Pre-planning and the establishment of ICT partnerships be undertaken with key regular participants in stability and reconstruction operations, such as NATO, the United Nations, the ITU, and the World Bank.
5. The focus of the intervention, including the use of ICT, be on the affected nation, supporting its governmental, societal, and economic recovery and development.
6. Key information technology capabilities be harnessed to support the strategy and to accomplish the mission successfully.

---

<sup>490</sup> Subscriber identity module, a removable smart card for some types of mobile phones that stores identifying information regarding the phone and associated customer account.

<sup>491</sup> SIM boxes – also known as GSM gateways – have valid uses but can be exploited to glean revenue by bypassing official interconnection termination routes. The use of SIM boxes is illegal in Afghanistan.

<sup>492</sup> Voice over Internet Protocol

Implementing the above ICT-enabled strategy should include:

1. the development of an information and ICT strategy and business plan for the affected nation so that ICT is effectively used to support intervention, stabilization, recovery, reconstruction, and development;
2. agreements among interveners regarding information and data sharing and collaboration, and the harmonization and synchronization of ICT-related initiatives;
3. the use of commercial and free and open source (FOSS) tools and platforms to provide and share unclassified information and data; and
4. the establishment of trusted strategic partnerships with stakeholder key leaders and senior government officials and ICT industry counterparts of the affected nation.

Further, establishing a trusted professional civil and commercial ICT advisor capability is an important consideration in the intervention capability package. Ideally, the ICT advisor would work with the affected nation's government and private sector ICT counterparts and advise the military commander on the role and use of commercial ICT to support military C2. The advisor would engage as needed on behalf of the commander and his organization with the affected nation's senior ICT leadership to help command elements such as the CJ6<sup>493</sup> acquire needed communications connectivity and services, facilitate coordination of service restorations as appropriate, help resolve spectrum issues, and help plan the proper use of commercial ICT to support mission needs. There should be planning to provide needed technical support to the advisor as well as a plan for sustaining continuity of advice and assistance over multiple years. An exit strategy is also needed for implementing a smooth transition to the affected nation and accommodating the drawing down of military support arrangements and transitioning as appropriate to peacetime support arrangements. The advisor should also facilitate coordination, harmonization, and information sharing across the civil-military elements participating in the intervention and the related ICT actions. The individual should be the one-stop shop for advice and assistance on civil and commercial ICT actions and be the informed provider of ICT situational awareness to all participants. The advisor should also be responsible for a public information campaign to tell the ICT story in cooperation with the public affairs section of the intervention civil-military elements.

Development agencies [and military responders] should share [their] experience [and lessons learned from the use] of ICTs in post-conflict reconstruction more effectively. There is a growing body of experience in the use of ICTs in post-conflict contexts. While contexts vary, more extensive experience sharing would enable governments and development agencies to make more effective use of ICTs at all stages of post-conflict work, from short-term stabilization to long-term development.<sup>494</sup>

Despite the challenges noted above, ICT has been and continues to be a game changer in Afghanistan. Its impact and related US legacy was eloquently expressed by the former Vice Chairman of the US Joint Chiefs of Staff, General James "Hoss" Cartwright, USMC, during a speech on how information technologies are

---

<sup>493</sup> Combined Joint Communications

<sup>494</sup> Kelly and Souter, 2014.



changing war, which he gave in 2013 at the [Center for Strategic and International Studies](#) in Washington, DC. General Cartwright was quoted as saying, “The longest lasting and perhaps most important legacy of the United States’ war in Afghanistan [is a] cell phone network capable of supporting smartphones.”<sup>495</sup> He further stated, “As we leave Afghanistan, the thing that will most affect that culture over the long term is leaving behind that network and those cell phones because they are talking across mountains and social barriers that heretofore have never been crossed by that culture ... and the introduction of that technology is probably far more lasting than anything else that we’re going to do in Afghanistan and far more influential. ... We don’t yet understand the power of these tools,”<sup>496</sup> he added, pointing out the literally revolutionary power of cell phones and social media tools like Twitter and Facebook.

## Shaping Afghanistan’s ICT Sector Reconstruction and Long-Term Development

The policy and regulatory framework of Afghanistan’s ICT sector is covered in [Chapter 5](#), but there are several other concepts and documents that were pertinent to shaping Afghanistan’s ICT sector reconstruction and long-term development. Among them are the United Nations’ [Millennium Development Goals](#) (MDGs) of 2000, on which, at least in part, the *Afghanistan National Development Strategy (ANDS)* was based. Afghan government efforts, such as the renamed Ministry of Communications and Information Technology’s (MCIT’s) [ICT Sector Strategy](#)<sup>497</sup> and *E-Afghanistan National Priority Program*, are also key stratagems. Further, efforts by ISAF and the USG further helped to lay groundwork and extend vision for a sustainable Afghan ICT sector. These are described in more detail below.

The UN’s MDGs constituted an unprecedented promise by heads of state globally to address social issues such as peace, security, development, human rights, and fundamental freedoms and commit their nations to “a new global partnership to reduce extreme poverty, and set out a series of time-bound targets”<sup>498</sup> before the end of 2015.

The eight Millennium Development Goals (MDGs) set out by UN Secretary General Kofi Annan at the Millennium Summit of September 2000 were to:

- Goal 1: Eradicate extreme poverty and hunger.
- Goal 2: Achieve universal primary education.
- Goal 3: Promote gender equality and empower women.

---

<sup>495</sup> Reed, John (2013). “Let freedom ring: Gen. Cartwright says 4G [sic] is America’s lasting legacy in Afghanistan (Updated).” *Foreign Policy*, January 24. Accessed January 6, 2016. <http://foreignpolicy.com/2013/01/24/let-freedom-ring-gen-cartwright-says-4g-is-americas-lasting-legacy-in-afghanistan-updated/>.

<sup>496</sup> Ibid.

<sup>497</sup> Islamic Republic of Afghanistan Ministry of Communications and Information Technology (MCIT). *Information and Communication (ICT) Sector Strategy 1387-1391 (2007/08-2012/13)*, February 2008, 1. Accessed March 14, 2016. [http://mcit.gov.af/Content/files/ICT%20Sector%20Strategy%20-%20English%20final%20Singed\(2\).pdf](http://mcit.gov.af/Content/files/ICT%20Sector%20Strategy%20-%20English%20final%20Singed(2).pdf).

<sup>498</sup> United Nations Development Programme, “Millennium Development Goals.” Accessed September 7, 2015. [http://www.undp.org/content/undp/en/home/sdgoverview/mdg\\_goals.html](http://www.undp.org/content/undp/en/home/sdgoverview/mdg_goals.html).

- Goal 4: Reduce child mortality.
- Goal 5: Improve maternal health.
- Goal 6: Combat HIV/AIDS, malaria and other diseases.
- Goal 7: Ensure environmental sustainability.
- Goal 8: Develop a Global Partnership for Development.<sup>499</sup>

Although ICT was not a specific MDG, under Goal 8: Develop a Global Partnership for Development, governments state they would, “In cooperation with the private sector, make available the benefits of new technologies – especially information and communications technologies.” Afghanistan achieved its targets of 500 mobile phone subscribers and 200 Internet users per 1,000 population by 2015. The mobile phone goal was achieved in 2010, and by 2015 the number was 830, exceeding even the target of 800 for 2020. Unfortunately, achieving the Internet target was less successful. By 2015 the World Bank and Internet Live Stats<sup>500</sup> estimated 67 versus 200 Internet users per 1,000 population.

The MDGs helped to shape the agenda for development-oriented ICT initiatives, such as those conducted under the International Telecommunication Union World Summit on the Information Society (WSIS) and UN Development Programme (UNDP), both of which promote the ICT4D (Information and Communications Technologies for Development) initiative. ICT4D aims at bridging the digital divide (the disparity between technological "haves" and "have-nots" based on geographic locations or demographic groups) and aiding social and economic development by ensuring equitable access to up-to-date communications technologies. ICT includes any communication device -- encompassing radio, television, mobile phones, computer and network hardware and software, satellite systems, the Internet, and so on, as well as the various services and applications associated with them, such as videoconferencing, social networking, and distance learning.

ICT offers enormous potential to help achieve development goals. There is growing evidence for the macroeconomic benefits of boosting ICT uptake and penetration. At the macroeconomic level, if ICT-driven economic growth translates into growth in individuals’ incomes, then genuine improvements in living standards can be achieved. The opportunities offered by ICT are explicitly recognized in Target 18 under Goal 8, which calls for the benefits of new technologies, especially ICTs, to be made available in cooperation with the private sector. In reality, however, the greatest contribution of ICT towards achieving the MDGs may be in their catalytic role for empowering people and promoting grassroots development to take place, enabling people to learn about their world and take action to find answers to overcome their own challenges.<sup>501</sup>

In February 2007, the Afghan cabinet approved the re-naming of the Ministry of Communications to the Ministry of Communications and Information Technology (MCIT) “as an acknowledgement of the central

---

<sup>499</sup> Ibid.

<sup>500</sup> Based on July 2016 estimated annual profile. [www.InternetLiveStats.com](http://www.InternetLiveStats.com).

<sup>501</sup> World Summit on the Information Society (2015). *Report on the WSIS Stocktaking 2010: Tracking progress*, 7. Accessed March 14, 2016. [http://www.itu.int/dms\\_pub/itu-s/opb/pol/S-POL-WSIS.REP-2010-MSW-E.docx](http://www.itu.int/dms_pub/itu-s/opb/pol/S-POL-WSIS.REP-2010-MSW-E.docx).

role that the ... information and communications technology (ICT) sector would play in accelerating Afghanistan's full participation in the global Information Society."<sup>502</sup> The MCIT is to provide strategic leadership regarding ICT sector development and act as the focal point for all stakeholders to help shape future policies and to promote large-scale projects. The National ICT Council of Afghanistan, commonly referred to as simply the ICT Council, was established by Presidential Decree in May 2007 as the primary forum for all ICT stakeholders. The ICT Council includes representatives (on both permanent and rotational bases) from government; the private sector and business community, including banking and financial sectors; NGO and civil society organizations; academia and other associations and educational institutions; and the ICT user community drawn from civil society organizations and Internet and other user groups. The Vice President of the country chairs the ICT Council and the MCIT administers the functions of its Secretary.

In February 2008, the MCIT submitted an *ICT Sector Strategy* and plan to be incorporated into the *ANDS* as the way ahead to evolve the ICT sector. The *ICT Sector Strategy* vision, which was first stated in May 2003 and presented to the ICT Council, was "[to] make affordable communication services available in every district and village of Afghanistan through [an] enabling market economy, so that all Afghans, men and women alike, can use ICT to expeditiously improve Government, social services, foster the rebuilding process, increase employment, create a vibrant private sector, reduce poverty, and support underprivileged groups."<sup>503</sup>

The *ANDS* was formally approved by President Hamid Karzai on April 21, 2008 and was the document that outlined the Afghan government's strategies for security, governance, economic growth, and poverty reduction. Started as an interim report in 2005, the *ANDS* became the product of intensive consultations among the Afghan government and a wide array of stakeholders including tribal and religious leaders, the private sector, NGOs, and the International Community. The *ANDS* was presented to the International Community at the Paris Donor's Conference on June 12, 2008, during which donor countries pledged more than US\$20 billion to help rebuild Afghanistan.

Called "an Afghan-owned blueprint for the development of Afghanistan in all spheres of human endeavor" by President Karzai, the *ANDS* laid out the following goals for the period starting in 2008 and ending in 2013:

- **Security:** Achieve nationwide stabilization, strengthen law enforcement, and improve personal security for every Afghan.
- **Governance, Rule of Law, and Human Rights:** Strengthen democratic practice and institutions, human rights, the rule of law, delivery of public services and government accountability.

---

<sup>502</sup> MCIT, 2008. *ICT Sector Strategy*.

<sup>503</sup> Ibid.

- **Economic and Social Development:** Reduce poverty, ensure sustainable development through a private sector-led market economy, improve human development indicators, and make significant progress toward the Millennium Development Goals (MDGs).<sup>504</sup>

The *Afghanistan National Development Strategy (ANDS)* aimed to promote growth, generate wealth, and reduce poverty and vulnerability. It is organized into three pillars, security, governance, and social and economic development,<sup>505</sup> with ICT falling under pillar three. Another strategic objective of the *ANDS* was “to enable the private sector to lead Afghanistan’s development within a competitive market-based economy ... and encourage increased private sector investment.”<sup>506</sup> The economic and social development pillar is a core contributor to these wider national objectives.

At the Kabul Conference in July 2010, the Afghan government presented a plan based on the *ANDS* for improving development efforts through sector-specific National Priority Programs (NPPs). Referred to as the Kabul Process, the aim was to support full Afghan leadership and responsibility for the development of Afghanistan over the coming years. The 22 NPPs were grouped together into six clusters to strengthen coordination among government institutions and international organizations with the overall focus of economic development. The six clusters were Security, Governance, Human Resources Development, Infrastructure Development, Private Sector Development, and Agriculture and Rural Development, as illustrated in [Figure 18](#).<sup>507</sup> ICT was originally assigned to the Infrastructure Development cluster but was moved to the Private Sector Development cluster. The Afghan government asked donors to align their programs with the NPPs to coordinate and target development efforts in support of principles of aid effectiveness. The conference also endorsed an Afghan government-led transition plan for responsible governance, stability, and sustainable economic and social development.

The *E-Afghanistan NPP* “provide[d] an opportunity to bridge the communications gap that exist[ed] within the country whilst also creating new systems of data and information management within a model of new public management. To establish greater national unity, it [was] important that in time all districts, major villages, and even remote rural areas [were] able to communicate with Kabul, with one another, and with the rest of the world.”<sup>508</sup> *E-Afghanistan* became the guiding document for shaping ISAF and USG ICT support strategies and plans for Afghanistan reconstruction and development and ICT initiatives to support security, governance, and socio-economic development, as well as related ICT capacity development efforts.

---

<sup>504</sup> Islamic Republic of Afghanistan, *Afghanistan National Development Strategy (ANDS) 1387-1391 (2008/09 - 2012/13)*, Volume One. Accessed March 14, 2016. <http://mfa.gov.af/Content/files/Volume%201%20ENG.pdf>.

<sup>505</sup> Islamic Republic of Afghanistan Ministry of Economy (2014). *Afghanistan National Development Strategy 2008-2013 Executive Summary*, June, 1. Accessed March 14, 2106. <http://mfa.gov.af/Content/files/EXECUTIVE%20SUMMARY%20English%20A5.pdf>.

<sup>506</sup> *ANDS*, Volume One.

<sup>507</sup> Islamic Republic of Afghanistan Ministry of Finance. Accessed March 14, 2016. <http://mof.gov.af/en/page/3976>.

<sup>508</sup> MCIT, 2011. *E-Afghanistan NPP*.



Figure 18: Categories of Afghanistan's national priority programs

The *E-Afghanistan National Priority Program* aimed to fulfill the above vision with a goal “to create a modern and efficient Information and Telecommunications sector and e-government to enhance the effectiveness, efficiency and transparency of the public sector, provide for social services, develop a vibrant private sector, and create a connected and productive society.”<sup>509</sup>

The program is divided into seven components, namely:

1. **Strengthening of Legal, Regulatory, Policy and Institutional Frameworks.** This component aims to create the enabling environment for the working of the ICT Sector.
2. **Expanding Telecommunication Network.** This component aims to provide the physical backbone to the ICT Sector by creating the necessary infrastructure.
3. **E-Government.** This component aims to provide value added service in the government using ICT to increase efficiency, effectiveness, and transparency in Government.
4. **M-Government.** This component aims to provide government services using mobile telephony to increase efficiency and effectiveness of government services.
5. **Postal Sector Modernization.** This component aims to modernize the postal sector to improve its reach and service delivery.

---

<sup>509</sup> Ibid.

6. **Strengthening the Ministry.** This component aims to strengthen the Ministry of Communication and Information Technology so that it can meet the current and future challenges and do its role as a facilitator, regulator, and policymaker efficiently and effectively.
7. **Strengthening the Sector.** This component aims to strengthen the Sector through appropriate interventions.<sup>510</sup>

Concurrent with the NPPs, the Afghan government envisioned a plan for a National-Regional Resource Corridor Initiative (NRRCI), of which ICT was a facet, “to prioritize strategic infrastructure investments around key corridors to maximize returns to growth, revenue and sustainable employment creation.”<sup>511</sup> Its program-level objective was “connecting Afghanistan to the region and the rest of the world.”<sup>512</sup>

Within the context of “connecting Afghanistan,” the specific ISAF ICT support strategy<sup>513</sup> was defined in evolutionary steps (see [Figure 19](#)):

1. Implement terrestrial and wireless core ICT infrastructures;
2. Transition towards e-solutions;
3. Refocus the MCIT on policy and establish an independent regulatory authority; and
4. Increase dependency on the private sector for economic growth and revenue generation.

The USG Senior Telecom Advisor/Telecommunications (Telecom) Advisory Team (STA/TAT) successfully convinced COMISAF<sup>514</sup> and GIRoA to consider ICT as an essential service and critical infrastructure, on par with roads, water, and power. They helped institutionalize ICT as such in ISAF Operations Plan (OPLAN) 38302, Rev. 6 in November 2011 and Rev. 6.2 in September 2012, as Annex W, Appendix 3. The role and mission of the STA/TAT and its ICT strategy and plans were included as well. The STA/TAT was also successful in having ICT recognized as critical infrastructure and an essential service by the Afghan Office of the National Security Council (ONSC), as iterated in its national *Security Strategy for Telecommunication Networks*<sup>515</sup> issued in July 2011.

By mid-2014, the Afghan government and the MCIT continued to focus on future expansion and modernization of the country’s ICT infrastructure and services. Efforts were underway to expand the fiber optic network to all provinces, expand 3G<sup>516</sup> mobile broadband services to all populated areas, and, in the

---

<sup>510</sup> Ibid.

<sup>511</sup> Islamic Republic of Afghanistan (2010). *The Economic and Infrastructure Development (EID) Cluster: National Priority Programs*, July.

<sup>512</sup> Ibid.

<sup>513</sup> Appendix 3 to Annex W to COMISAF OPLAN Revision 5, International Security Assistance Force (ISAF) Operations in Afghanistan, January 25, 2011, pre-approval draft (NATO/ISAF Unclassified).

<sup>514</sup> Commander, International Security Assistance Force

<sup>515</sup> Islamic Republic of Afghanistan Office of National Security Council (ONSC) Directorate of Interior Affairs (2011). *Security Strategy for Telecommunication Networks in the Territory of GIRoA*, July 31.

<sup>516</sup> Third-generation wireless digital technology based on International Telecommunication Union (ITU) International Mobile Telecommunications (IMT)-2000 specifications.

future, introduce 4G/LTE<sup>517</sup> technologies. The MCIT also planned to convert Afghanistan's television broadcasting system from analog to digital, and the MCIT envisioned the full utilization of AfghanSAT1, Afghanistan's first satellite (see [Chapter 8](#), *Satellite Communications*), for ICT and broadcast services. The Afghan government was pursuing the development of a national cybersecurity strategy and plan as it implemented rudimentary cybersecurity capabilities. Increased cybersecurity awareness and development of an information and cybersecurity awareness culture was also at hand. Other efforts to leverage ICT as an enabler of

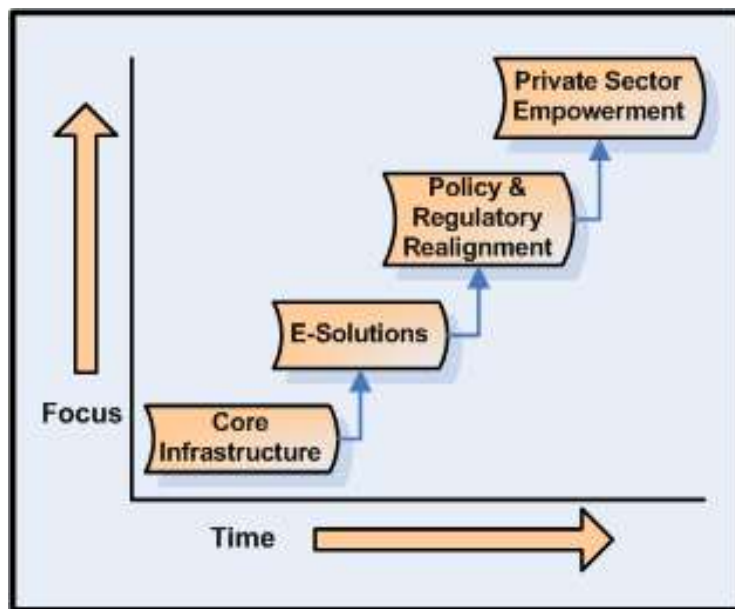

Figure 19: ISAF ICT support strategy evolution

socio-economic development and growth included but were not limited to electronic -government (e-gov) services, including an electronic national identity card (E-NIC), mobile money, online banking, e-commerce, e-agriculture, e-health, and other e-services. The Afghans were also connecting schools, vocational training institutions, and universities to the fiber optic network and improving students' access to the Internet and online learning resources. They were considering improving healthcare services by connecting hospitals, healthcare centers, and medical schools to broadband services and the Internet and exploiting telemedicine to access global health SMEs. The tremendous progress made in the introduction of ICT in Afghanistan since 2001 has opened opportunities to document the history and heritage of Afghanistan on Internet websites and make it readily available to inform and educate the Afghans and the world. Also included in the emerging documentation are websites with e-books on the history of Afghanistan, videos, pictures and other reference material.

One of the challenges for the future was a deteriorating security situation. The Taliban, criminals, and other anti-government elements threatened and attacked GSM operators' personnel and facilities, forcing them to shut down their cell towers at night. In some areas, such as Helmand, cellular services were shut down 24x7. Other challenges included sustaining economic and political stability; a lack of reliable electric power; poor spectrum management; a dearth of qualified management, technical, contracting, marketing, and financial personnel; managing ICT sector governance changes with a new minister; internal MCIT management and business processes adjustments; a new ATRA chairman and board members; and AfTel leadership and organizational changes. Further, the Afghans faced difficulties

<sup>517</sup> Fourth-generation wireless digital technology based on International Telecommunication Union (ITU) International Mobile Telecommunications (IMT) Advanced specifications and long-term evolution, a high-speed wireless communications standard developed by the Third Generation Partnership Project (3GPP).

implementing e-services and sustaining growth of a cybersecurity and information culture. They were not willing nor able to modernize and leverage ICT infrastructure and services, including managing the expansion of wireless and mobile broadband services; improving access to and reducing the cost of Internet services; continued implementation of the national fiber optic network and its regional interconnections; and determining the role and use of Afghanistan's youth and women.

New ICT priorities emerging from the Ghani government include the following top five: Open access (to ICT infrastructure) regulation and implementation, SIM card/user registration, mobile money and e-payments, Internet access and reduced cost of service, and e-government applications like the e-Takzira (electronic national identity card or E-NIC).

## Ad Hoc Approaches to Reconstruction and Development

To help facilitate the extension of security and governance and facilitate reconstruction, US military-led reconstruction teams were originated in early 2002 with a program called Coalition Humanitarian Liaison Cells. These cells were made up of five to ten US Army Civil Affairs officers who manned small outposts in the provinces of Afghanistan where Coalition Forces were present. Their mission was to assess humanitarian needs, implement small-scale reconstruction projects,<sup>518</sup> and establish relations with United Nations Assistance Mission in Afghanistan (UNAMA) and non-governmental organizations (NGO) already in the field. These cells fell under the authority of the Coalition Joint Civil Military Operations Task Force and the Department of Defense funded their operations through the Overseas Humanitarian, Disaster, and Civic Aid Fund. These cells evolved throughout 2002, and by the end of the year, they were expanded to include security forces and representatives of [other elements of] the US Government [and] renamed Provincial Reconstruction Teams (PRT).<sup>519</sup> The first US PRT was established in Gardez in November 2002 and became fully operational in February 2003.

A US PRT included two military components. First, two Army Civil Affairs (CA) teams that consisted of an "A" team responsible for conducting assessments of reconstruction needs and contracting with Afghan firms to build schools, clinics, bridges, and wells,<sup>520</sup> and a "B" team that operated the PRT's Civil-Military Operations Center and coordinated with the UNAMA regional office and international NGOs engaged in providing humanitarian relief and development assistance.<sup>521</sup> Second, a force protection unit that usually consisted of an infantry platoon of National Guard and several small units of military police, intelligence officers, and other specialists. There were also civilian police advisors and civilian representatives of USG elements. A US PRT generally consisted of 50 to 100 staff led by a military officer of the rank of Lt. Colonel or Commander. It was largely a military organization with three to five civilians. Depending on the area

---

<sup>518</sup> "Provincial Reconstruction Teams (PRTs)." Institute for the Study of War. Accessed March 14, 2016.

<http://www.understandingwar.org/provincial-reconstruction-teams-prts>.

<sup>519</sup> Ibid.

<sup>520</sup> Perito, Robert M. (2005). *The U.S. Experience with Provincial Reconstruction Teams in Afghanistan: Lessons Identified*. United States Institute of Peace Special Report 152, October 2005. Accessed March 14, 2016.

<http://www.usip.org/sites/default/files/sr152.pdf>.

<sup>521</sup> Ibid.



and mission, the civilian staff generally included a representative from one or more of the following organizations: USAID, the Department of State, the Department of Agriculture, and the Department of Justice. Not all US PRTs had all these components.

The PRT's mission was to help extend the authority of the Afghan government into the provinces in order to develop a stable and secure environment [and] enable security sector reform and economic and social development.<sup>522</sup> PRTs were located on secure compounds, such as Forward Operating Bases (FOBs) in provincial capitals and used armed convoys for movement in the local areas. The teams "interact[ed] primarily with the governor, provincial level representatives of the central government ministries and elected provincial councils"<sup>523</sup> as well as with personnel from schools, hospitals, health clinics, and agriculture. Their task [was] to help insure that traditionally strong local authorities promoted the aims of the central government and not pursue independent agendas.<sup>524</sup>

Following a discussion of NATO defense ministers at an informal gathering in Colorado Springs in October 2003, and a more specific discussion at that time between the NATO Secretary General, SACEUR/CINCEUR,<sup>525</sup> and the US Secretary of Defense, it was agreed that as part of the planned expansion of the NATO/ISAF mission in Afghanistan, the PRTs (US plus other countries' as they were created) would be placed under the evolving NATO command of ISAF, which would, over time, be the responsible multinational command for Afghan nationwide activities. All the PRTs in Afghanistan finally came under one theater military command (ISAF) on October 5, 2006, when ISAF completed its four-stage geographic expansion throughout the country and assumed responsibility for the five Regional Commands (East, South, West, North, and Capital). Up to this time, there were two separate military commands, the Combined Forces Command-Afghanistan (CFC-A) and ISAF, each commanding PRTs in its own separate areas of operation. Bringing all the PRTs under one theater commander constituted a major step forward in trying to achieve unity of effort and coherence.

As noted earlier, the United States defined the PRT mission as providing security through development and reconstruction and extending the reach and influence of both the Coalition Forces and the Afghan Government.<sup>526</sup> On the other hand, the ISAF PRT mission statement was not solely of military origin. The PRT mission statement was agreed on January 27, 2005, as part of the PRT Terms of Reference by the PRT Executive Steering Committee (ESC) in Kabul (an ambassadorial-level body chaired by the Afghan Minister of Interior). The executive committee set high-level strategic policy for all PRTs in Afghanistan. The PRT mission statement, which was incorporated into the ISAF Operations Plan, was "Provincial Reconstruction Teams (PRTs) will assist The Government of the Islamic Republic of Afghanistan (GIROA) to extend its

---

<sup>522</sup> Perito, Robert (2007). Testimony before the US House of Representatives' Armed Services Subcommittee on Oversight and Investigations, October 18. Accessed March 14, 2016. <http://www.usip.org/publications/2007/10/18/the-us-experience-provincial-reconstruction-teams-in-iraq-and-afghanistan>.

<sup>523</sup> Ibid.

<sup>524</sup> Ibid.

<sup>525</sup> Supreme Allied Commander, Europe/Commander in Chief, European Command

<sup>526</sup> Perito, 2007 testimony.

authority, in order to facilitate the development of a stable and secure environment in the identified area of operations, and enable Security Sector Reform (SSR) and reconstruction efforts.”<sup>527</sup>

The Germans established a PRT in Kunduz in December 2003 that became the first PRT under ISAF command. The US and other nations established PRTs and as noted above, by October 2006 ISAF had control over all PRTs. At the height of PRT activities in the 2010 timeframe, there were 26 PRTs across Afghanistan with 14 lead nations. The US sponsored 12 PRTs.

There were challenges in developing the overall concept of operation, implementing collaboration and information sharing, and establishing coherence of the multinational PRT activities. For example, in 2007, the US Institute of Peace (USIP), based on its experience with and assessment of early PRT activities in Afghanistan, was asked to testify before the US House of Representatives’ Armed Services Subcommittee on Oversight and Investigations. During the testimony, Robert Perito of the USIP noted his assessment suggested that, beyond the mission statement, there was little to no agreement within the US government or between the US and its allies [and NATO/ISAF] on how PRTs should be organized, conduct operations, or what they should accomplish. Actual [PRT] decisions on priorities and programs reflect[ed] local conditions along with national priorities of participating governments. [The] PRTs located in the relatively peaceful north and west of the country conduct[ed] classic peacekeeping operations and emphasized economic development and reconstruction of essential infrastructure. In the south and east along the border with Pakistan, PRTs were engaged in counterinsurgency operations to counter Taliban resurgence.<sup>528</sup>

Perito also pointed out that PRTs differed among the participating ISAF nations. There were generally three models: the US, the UK, and Germany. The US model is described above. The focus of US PRTs was initially on security and quick-impact projects but later shifted to security and security sector reform and reconstruction. The UK PRTs had 70 to 100 personnel and were made up of military (security and security sector reform), political (Foreign and Commonwealth Office) and development (Department for International Development, or DFID) components. The three elements led the PRT jointly with the civilian elements reporting separately to their respective organizations. The US, where appropriate, handed off established PRTs to NATO and Coalition partners, e.g., the Kunduz PRT was originally American and was handed off to the Germans in October 2003. Other nations’ PRTs used variations of these models to meet their mission needs. The result was the proliferation of organizational structures reflecting national policy preferences and bureaucratic configurations.<sup>529</sup>

As an example, the German PRT mission was largely focused on peacekeeping, reconstruction, and development. The Germans had two PRTs, one in Kunduz, and the other in Feyzabad. The PRT in Kunduz was among the largest in the country and consisted of around 270 military and 30 civilian personnel. However, the German government explicitly wanted to keep its military presence as small as possible and

---

<sup>527</sup> International Security Assistance Force Operations Plan 38302 Revision 6 (NATO/ISAF Unclassified).

<sup>528</sup> Ibid.

<sup>529</sup> Ibid.

thus established the only PRT with a shared military and civilian command. The civilians were not under military command and reported to a senior civilian from the Ministry of Foreign Affairs. In addition, the civilians were not part of ISAF and had separate accommodations and offices outside the military camp. Germany was particularly worried about the protection of its forces, and many observers criticize the safety regulations under which the German PRTs had to work, limiting their force effectiveness – the German government resisted military use in combat roles. The Germans’ emphasis on force protection limited its military’s ability to patrol the countryside. They were also very cautious and avoided local unrest. German PRT troops were not allowed to stay overnight outside their camps and so were not able to carry out long-range patrols. Patrols also had to be accompanied by an armored ambulance, which made convoys larger and less flexible. The Germans chose Kunduz as the location for its first PRT because of the area’s safety and stability. Their emphasis on force protection was controversial given the view of many NGOs and other aid workers that military support for reconstruction was driven more by security than developmental considerations. The many restrictions placed upon the German contingent by Berlin prompted German journalist Constanze Stelzenmuller, in a 2004 *Zeit Online* article entitled “Hebammen [Midwives] in Uniform”<sup>530</sup> to comment that the principal enemy facing German soldiers was neither the Taliban nor warlords but the politicians back home.

The US PRTs initially were not well integrated into the larger counterinsurgency strategy and hence experienced persistent USG Interagency differences over funding, staffing, and other issues. It was further noted there was “a lack of unity of command resulting in a lack of unity of effort.”<sup>531</sup> Another impediment was uncertainties regarding specific responsibilities and authorities of various US agencies involved due to the lack of approved Interagency doctrine and formal agreements such as MoUs<sup>532</sup> to govern roles and responsibilities. With no one in overall charge, there were separate stovepipes of authority that led to confusion on civilian and military roles including State and DoD differences about who would provide security, support, and funding. Coordination was largely on an ad hoc basis.

There were also other challenges. The US military often imposed their priorities on civilian reconstruction missions even when State and USAID were the lead agencies for the projects.<sup>533</sup> Difficulties were also encountered in PRT coordination with humanitarian NGOs working in their area of operation. It was not until November 2006 that DoD and DoS adopted a MoU that specified their respective financial and other

---

<sup>530</sup> Stelzenmuller, Constanze (2014). “Hebammen in Uniform.” *Zeit Online*, last edited October 25, 2006. Accessed March 14, 2016. <http://www.zeit.de/2004/39/Afghanistan>.

<sup>531</sup> US House of Representatives Committee on Armed Services, Subcommittee on Oversight & Investigations (2008). *Agency Stovepipes vs Strategic Agility: Lessons We Need to Learn from Provincial Reconstruction Teams in Iraq and Afghanistan*. Committee Print 8, 41-409, April 2008. Accessed March 14, 2016. <http://democrats-armedservices.house.gov/cache/files/2/0/20ca518e-0183-433f-be5a-7e872dbc41b7/3B701FBF89464A360E6688FC3A825A48.prt-report-vf.pdf>.

<sup>532</sup> Memoranda of understanding

<sup>533</sup> Weitz, Dr. Richard (2010). “CORDS and the Whole of Government Approach.” *Small Wars Journal*, Volume 6, Number 1, February 4.

contributions to the PRTs.<sup>534</sup> In the end, PRTs were the forefront of US efforts to apply military and civilian COIN assets in an integrated manner to remote conflict-prone areas.

In the mid-2006 timeframe, ISAF took actions to implement a number of initiatives aimed at improving the coherency of the multinational civil-military response to reconstruction and to improve coordination and information sharing. Two Development Advisor positions (one from the UK, a DFID liaison, and one from the United States, a USAID liaison) were created to advise Commander ISAF (UK military at that time) on reconstruction matters. An ISAF Afghanistan Country Stability Picture (ACSP) GIS database was created and maintained by ISAF to share reconstruction situational awareness status information with the civil-military community. ISAF scheduled a series of PRT conferences in Kabul to build a more informed and shared understanding of ongoing PRT reconstruction-related activities, needs, support opportunities, and activities among ISAF, the PRTs, other Coalition military, national government elements, international organizations (IOs), and NGOs. The US Embassy and ISAF provided briefings at the PRT conferences on the Afghan ICT sector and opportunities to use ICT as an enabler of security, governance, and socio-economic development. The senior telecom advisor at the US Embassy offered assistance to PRTs to help them develop a more informed understanding of how to leverage ICT in their areas of operation. In 2006, one of the members of the ARG/STA<sup>535</sup> team visited the Khost PRT to advise the new commander on ICT opportunities that might be made a part of his quick-impact projects. One of the challenges in general was the lack of planned ICT expertise as an SME element of the PRT teams, limiting their ability to identify and implement ICT-related opportunities. ISAF created a PRT handbook, and its development involved military as well as civilian participants. The PRT Executive Steering Committee, originally formed in 2004 to create a priority list for the establishment of new PRTs, refocused its efforts to provide high-level PRT policy guidance on the kinds of activities PRTs should undertake to support the Afghan government and to extend its authority. Other activities included the establishment of pre-deployment PRT training courses and improving arrival orientation training. ISAF instituted a PRT help desk and a web portal to facilitate its responses to PRT questions and needs.

Perito also articulated several additional findings: US PRT operations were strongly influenced by the personalities of team members and had a bifurcated chain of command with the State Department in charge of political and economic issues and the military responsible for security and movement. Operational priorities often reflected the personal expertise and interests of team members and [could] change with the rotation of personnel. [PRTs] suffered from the inability of US civilian government agencies to recruit provide personnel and relied upon junior officers, retirees or civil servants. Most USAID slots were filled with contract personnel who often [had] only a limited knowledge of their sponsoring agency and government regulations and requirements. PRTs initially focused on quick impact village improvement projects designed to demonstrate goodwill and encourage a favorable local reaction to the presence of foreign military units in rural areas. PRTs [were] part of the security presence in their areas of operation, but they had no offensive capability and their only security function was force protection.

---

<sup>534</sup> Ibid.

<sup>535</sup> Afghan Reconstruction Group/Senior Telecom Advisor

PRTs varied greatly in size, organization and functions, and needed an agreed concept of operations and organizational structure with a single chain of command.<sup>536</sup>

Following the April 2008 NATO Summit in Bucharest, NATO civilian representatives took action to enhance the coherence of ISAF PRT efforts in close coordination and consultation with the Afghan government,



*Picture 6: SSF-provided computer lab for school in rural area*

*(Photo courtesy of Dr. Dave Warner)*

UNAMA, and ISAF. At the March 2010 ISAF PRT conference in Kabul on “The Year Ahead,” the NATO Senior Civilian Representative stressed the key to the success of PRTs and the way ahead was to regain the initiative against the insurgents; rebuild and reinforce Afghan government institutions; and, resolve political grievances that fueled the insurgency. Approaches to improving collaboration, coordination, and information sharing were also explored.

Regardless of improvements to the coordination of the international community’s efforts, the participation of

Afghan people themselves remains the key deciding factor in improving aid’s impact on stabilization. A better understanding of the continuing barriers to Afghan participation, therefore, represents a critically important way forward. For example, what costs do ordinary Afghans bear in terms of increased risk to personal and family security by participating in development programs? How compelling is the value equation of risk versus envisaged benefits to the people, and who are they prepared to constructively engage with in order to make such a transaction? While many say that the Afghan people should play a role or support the government, the people are between a rock and a hard place, they are not safe from the insurgents, and they do not trust the government to provide security.<sup>537</sup>

Although ICT emerged as a key enabler of security, extension of governance, and socio-economic development and growth, ICT skills on PRTs and an ICT focus of project planning were not actively part of PRT activities. ISAF and the US Embassy made numerous attempts with limited success to intentionally populate PRTs with ICT subject matter experts and/or provide assistance to PRTs to explore opportunities to leverage the power of ICT as an agent of change, including for education of the young through computer labs in schools and universities with more pervasive access to Internet, and providing Internet access and IT services at medical clinics and hospitals. There were also some early efforts to have PRTs and CDCs look at prioritizing ICT development under NSPs but nothing came out of these discussions. One area of interest

---

<sup>536</sup> Perito, 2007 testimony.

<sup>537</sup> WP1022 Report, 2010.

that did emerge from discussions with the PRTs was putting cellular towers on FOBs to protect them from physical attacks by the Taliban. ISAF initiated an effort to protect cellular towers in the 46 most dangerous districts in Afghanistan as part of its Cellular Enabled Security and Stability (CESS) program.

On the other hand, a number of NGOs and private volunteers, such as PACTEC, the La Jolla (California) Golden Triangle Rotary Club, the Synergy Strike Force (SSF) in Jalalabad, One Laptop per Child (OPLC)-Afghanistan, the International Committee of the Red Cross (ICRC), and others, worked on initiatives to support ICT for education, healthcare, and agriculture. Also, mobile network operators such as Roshan and AWCC, as part of their corporate social responsibilities, provided computers and Internet access to schools, medical clinics, and hospitals.

In the book *The Good War* by Jack Fairweather,<sup>538</sup> he noted the PRT concept threatened the aid and NGO community, who were asked to provide a supporting role at the outset, which implied to them a military takeover of their reconstruction work in provinces. Additionally, the military in the lead role reopened a long-standing debate about the principles underlying humanitarian work and military motivations in pursuing these activities. The aid agencies and NGOs saw military-sponsored nation building destroying their carefully maintained neutrality that could turn aid workers into targets whether they cooperated in programs or not. NGOs such as [ICRC](#), [CARE](#), and [Médecins Sans Frontières \(Doctors Without Borders\)](#) were quite vocal in their concerns about creating confusion in the minds of those who receive aid and confusion among those who carry out military and humanitarian missions at the same time. There were threats to withdraw staff. NGO staff had concluded that being seen dealing with the PRTs and the military might lead to Afghans associating their aid mission with the military counterterrorism operation. This resulted in NGOs not associating with the military, creating a civil-military gap that showed little signs of closing.

There were also concerns about the risk of PRTs overpowering fragile local governments and, given the sometime corrupt practices of the Afghan officials, there was concern PRTs may be tempted to use money to create a parallel system of reconstruction that might bypass governors they were meant to empower. There were also concerns with US military commander perceptions. Many of the commanders saw the PRTs as souped-up civil affairs teams of the type they were familiar with in past operations, that they used to hand out money to in the form of quick clean up contracts following operations. This meant that reconstruction projects undertaken by PRTs were often viewed through the military prism limiting the scope of the projects and not as in support of a political strategy having appropriate input from the Afghans.

NGOs also felt they were more in tune with the local population's culture and needs, and knew how to get things done. They lived in safe houses and traveled daily without force protection to the towns and villages to work with the local population. They saw the military as being cut off from the local population

---

<sup>538</sup> Fairweather, Jack (2014). *The Good War: Why We Couldn't Win the War or Peace in Afghanistan*. (New York: Basic Books).

by living in heavily protected garrisons and traveling off the bases in armed convoys with heavily armed force protection teams to meet with local leaders and the population.

Evaluations of PRT performance have been mixed at best. One researcher at the [George C. Marshall European Center for Security Studies](http://www.marshallcenter.org/mcpublicweb/mcdocs/files/College/F_Publications/occPapers/occ-paper_16-en.pdf) found in 2008 that PRTs “led to counter-productive results – for instance the empowering of local Power Brokers and ... the weakening of the Afghan government.”<sup>539</sup> President Karzai also started to express concern that PRTs were bad for his country. He saw them as "parallel structures" to his government.<sup>540</sup> On the other hand, governors were fond of their ample cash and quick-fix projects and an overwhelming majority across the country were satisfied with the performance of PRTs in their respective provinces.

At a 2010 Wilton Park Conference on “Winning Hearts and Minds in Afghanistan” it was noted that in the most insecure Afghan provinces under investigation in research carried out by Tufts University, perceptions of aid were universally negative. An Afghan view noted: “the international community still does not understand local culture and politics, as well as insurgents to adjust their policy. In order to win, they have to know the people who they want to deal with them.” Many also argued that to “know the people,” the international community must remedy its lack of understanding of women in Afghanistan (in the household, decision-making, etc.). Only then will it be possible to determine their importance to development initiatives, and their possible role in combating insurgency and violence. Insurgents and militaries are almost entirely male, but half of the Afghan population is female and these women have a role if international donors are trying to win the hearts and minds of the population. It is unclear how many of the ideas presented by men either originate from or were influenced by women.<sup>541</sup>

One of the greatest causes for dissatisfaction was the perception that the Afghan government and PRTs were colluding in elite empowerment and corruption. In a study in Helmand, for example, elite capture of development assistance eclipsed any sense of it being a public good. In response to the negative perception of the development agenda, participants questioned whether the issue was with aid in itself failing to stabilize, or with the current modalities for delivering aid-for-stabilization being misguided. The deliverers of aid could be the problem, for in some of the most insecure parts of the country, the delivery mode shifted away from traditional development workers to private contractors and the military, whose core business was not long-term community engagement.<sup>542</sup>

Donors should also avoid setting development aid up to fail by expecting it to deliver on unrealistically ambitious stabilization objectives for which it is not well-suited. Donors should differentiate between

---

<sup>539</sup> Gauster, Markus (2008). *Provincial Reconstruction Teams in Afghanistan*. George C. Marshall European Center for Security Studies Occasion Paper Series No. 16, January 2008 (ISSN 1863-6039). Accessed March 14, 2016. [http://www.marshallcenter.org/mcpublicweb/mcdocs/files/College/F\\_Publications/occPapers/occ-paper\\_16-en.pdf](http://www.marshallcenter.org/mcpublicweb/mcdocs/files/College/F_Publications/occPapers/occ-paper_16-en.pdf).

<sup>540</sup> Dempsey, Judy (2011). “Karzai Seeks End to NATO Reconstruction Teams.” *The New York Times*, February 6. Accessed March 14, 2016. <http://www.nytimes.com/2011/02/07/world/asia/07munich.html>.

<sup>541</sup> *WP1022 Report*, 2010.

<sup>542</sup> *Ibid.*

stabilization funds, used for relatively small-scale and short-term projects designed to promote stability effects at a tactical level, and larger-scale and longer-term development aid projects designed to promote development objectives. The perceived imbalance in aid spending between insecure and secure provinces could be redressed by spending more development funds in relatively secure regions while continuing to spend stabilization funds in less secure regions.<sup>543</sup>

Additionally, it was noted that a significant finding across the provinces was the central importance of process over the product; how people were engaged was almost more important than the desired end state. Most people's experience of the National Solidarity Programme, for example, had been very positive because communities [felt] that they were benefiting equally through a genuine consultation process. Despite this apparent success, however, there was no clear evidence to suggest that the NSP had direct security benefits.<sup>544</sup>

To an audience of foreign ministers and defense experts attending the annual Munich Security Conference [in February 2011], President Karzai called for the dismantling of NATO-run provincial reconstruction teams<sup>545</sup> since there was no need for them after 2014. Mr. Karzai also repeated his call for allied governments to stop using private security companies, contending that they, along with the civilian-military reconstruction teams, [were] an impediment to the central government's expanding its authority throughout the country.<sup>546</sup> Karzai did not exactly demand that PRTs be instantly disbanded. He was pressing for a responsible and gradual transition of PRT activities from NATO to the Afghan government, which was consistent with ISAF and US drawdown and transition plans. The US started its drawdown of US-sponsored PRTs later in 2011, followed by the gradual drawdown of other ISAF lead nation PRTs. By November 2013, there was one active ISAF PRT in Herat led by the Italians; it closed in February 2014.

In addition to PRTs, there were other USG elements and initiatives supporting civil-military and stability and reconstruction operations with intent to try to achieve improved USG unity of effort. USAID's Afghanistan Social Outreach Program (ASOP) supported the Afghan Independent Directorate of Local Governance (IDLG) to develop district-level community councils (shuras) in the absence of formally elected district councils.<sup>547</sup>

US Army CA elements provided Brigade Combat Teams (BCTs) and division-level organizations the expertise needed to support civil-military operations, including where appropriate civil-military operations centers (CMOCs) for coordinating civil-military activities in an area of operations, and tactical support to military stability and reconstruction activities. The CMOC is the point of interface between US armed forces and indigenous civilian governments and populations, other US government organizations,

---

<sup>543</sup> Ibid.

<sup>544</sup> Ibid.

<sup>545</sup> Dempsey, 2011.

<sup>546</sup> Ibid.

<sup>547</sup> US Agency for International Development. Afghanistan Social Outreach Program (ASOP). Accessed October 4, 2014. <https://www.usaid.gov/node/52026>.



inter-governmental organizations (IGOs), non-government organizations (NGOs), and private volunteer organizations (PVOs).

There were also other Interagency elements such as Joint Interagency Coordination Groups (JIACG), Joint Interagency Task Forces (JIATF), Integrated Civil-Military Action Group (ICMAG) at the US Embassy, and teams from the State Department Office of the Coordinator for Reconstruction and Stabilization (S/CRS) that helped focus on the extension of security, governance, and reconstruction, and counterinsurgency activities.

The US Combined Forces Special Operations Component Command-Afghanistan (CFSOCC-A) engaged in a program referred to as village stability operations, or VSO, that was a bottom-up approach focused on delivering security, stability, and governance in the rural villages and district centers in Afghanistan and working upwards to extend governance to the provincial centers and beyond. Included in this effort was the establishment of the Afghan Local Police (funded by the US) as a local defense force under the Afghan Ministry of Interior.

Army National Guard members drawn from farming communities were used to provide one of the more effective tools in the agriculture sector through the use of Agribusiness Development Teams (ADTs) that included support from US Department of Agriculture, USAID, US Farm Bureaus, and academia.

An Afghanistan Reconstruction Group (ARG), a NSC-sponsored joint DoD and DoS initiative located at the US Embassy, was established in 2004 to provide sector subject matter experts (recruited from the private sector and other expert sources) advisory support to both USG elements and Afghan government ministries. From 2005 to 2008, the ARG had a Senior Telecommunications (Telecom) Advisor (STA) who focused on the civil and commercial ICT sector and GfRoA ICT governance elements (MCIT, ATRA, AfTel and IT elements of the Afghan ministries). “To create a cooperative environment, [the STA] established a US integration team, referred to as the I-Team, which consisted of US ICT representatives from the US Embassy, USAID, and the US military. Over time, the team was expanded to include ISAF, the GCN/DCN contractor [Globecom Systems Inc.] GSI, and BearingPoint experts embedded in the MCIT [and] ATRA,”<sup>548</sup> and AfTel. I-Team meetings were held several times a month to share and coordinate ongoing ICT activities and discuss challenges and approaches to leveraging activities. Meetings were action-oriented and used as a means to inform, coordinate, and develop a shared agreement on initiatives to be pursued.<sup>549</sup> The STA was supported by an Afghanistan Reachback Office (ARO) in the Pentagon as well as two US-based ICT reachback capabilities the STA set up “to build social networks to coordinate and share information on important ICT-related issues and actions and to seek advice, assistance, and best practices. One group supported USG-only activities and included the US I-Team members, ASD-NII,<sup>550</sup> DoS, USAID,

---

<sup>548</sup> Wentz, Larry, Frank Kramer, and Stuart Starr (2008). *Information and Communication Technologies for Reconstruction and Development: Afghanistan Challenges and Opportunities*. National Defense University, Center for Technology and National Security Policy, *Defense Technology Paper 45*, January 2008. Available at: <http://ctnsp.dodlive.mil/files/2013/07/DTP-045.pdf>.

<sup>549</sup> Ibid.

<sup>550</sup> US Assistant Secretary of Defense for Networks and Information Integration

ARO, NDU, Army Corps of Engineers, and other US government elements as appropriate in CONUS. This group held weekly teleconferences. A second group consisted of US industry volunteers with an interest in helping Afghans and Afghan ICT to be successful. They were engaged to seek advice and best practices as well as provide mentoring support for Afghans and related ICT initiatives. This group held a teleconference about once a month and the STA participated as appropriate.”<sup>551</sup>

From late 2008 to early 2010 there was no equivalent of a Senior Telecom Advisor in country. Workarounds included establishment of a Telecom Working Group (TWG) at the US Embassy to facilitate Interagency coordination, information sharing, and ICT strategy and planning; linking the TWG to a DoD Chief Information Officer (CIO) and the National Defense University (NDU) reachback element to provide SME advice and assistance; and establishment of the Integrated Civil-Military Action Group (ICMAG) at the US Embassy. Regarding the latter, ICMAG was formed to achieve a fully-integrated USG effort from Kabul to the village level through joint decision-making, assessment, planning, and action. The group consisted of the US Embassy, USAID Mission, USFOR-A, CJTF-101, CSTC-A, and ISAF. The team focused on Interagency problem solving for COIN initiatives in Regional Command-East (RC-E). The approach used by the team included: integrated plans that captured a unified picture of USG ends, ways, and means at the RC, TF-AO,<sup>552</sup> and provincial levels in support of GIRoA; regional operations assessment briefs that provided USG-wide assessment of the situation on the ground and impact of USG actions across all lines of effort to drive decision-making; Interagency planning staff able to facilitate civilian-military problem solving across organizational cultures; and a venue for capturing and disseminating lessons learned and best practices to current and incoming personnel.

Additionally, a USG Integrated Civilian-Military Campaign Plan (ICMP) for support to Afghanistan was published August 10, 2009, and “provided guidance from the US Chief of Mission and the Commander of US Forces-Afghanistan to US personnel in Afghanistan. The Plan represent[ed] the collaborative effort of all the USG Departments and Agencies operating in Afghanistan and the range of different equities, resources, and approaches. The Plan [was] based on close collaboration with the International Security Assistance Force (ISAF) as well as the United Nations Assistance Mission in Afghanistan (UNAMA) and partner nations to build effective civilian and military mechanisms for integrated assistance. But its most important component [was] a strong partnership with the Government of the Islamic Republic of Afghanistan (GIRoA) that [would] build the capacity needed to provide Afghanistan with a stable future. The ultimate goal [was] for the GIRoA to have full responsibility for its own security and administration as the international community continue[d] to offer economic assistance, training, and other non-combat support for the continued development of the country.”<sup>553</sup> The core principles were:

---

<sup>551</sup> Wentz et al., 2008.

<sup>552</sup> Task Force-Area of Operation

<sup>553</sup> United States Government (2009). *Integrated Civilian – Military Campaign Plan For Support to Afghanistan*. August 10, 2009. Public Intelligence.net. Accessed October 4, 2014. <https://publicintelligence.net/u-s-integrated-civilian-military-campaign-plan-for-support-to-afghanistan/>.

- Afghan leadership, Afghan capacity, Afghan sustainability. Efforts must be designed, at all times, to assist the Afghan government to assume a more effective leadership role.
- Action required at all levels. Invest in critical infrastructure and service delivery systems critical to the development of sustainable national governance and economic growth.
- Unity of Effort comes through true integration. Civil-military teams organize effectively at the district, provincial, and regional levels to implement the COIN mission and reduce “stove-piping.” Additionally, civilian structures reorganize to achieve more coherent civilian-military integration.
- The International Community is a Key Partner. Success depends on close collaboration with allies in ISAF and friends in UNAMA.
- Give guidance, resources, and authority at the right levels. Focus tools and resources at the sub-national level to allow civilian and military teams in the field, working in partnership with the Afghan people, to lead security, reconstruction and governance initiatives. Effort should be directed at restoring peace and security to Afghanistan from the bottom-up.
- Progress must be visible and measurable. It is critical to show tangible progress to the Afghan population and the international community, particularly in the short-term.
- Accountability and transparency. Actions must embody and foster accountability and promote good government. Avoid close association with corrupt officials and institutions in the eyes of the people. Set a standard for transparency.<sup>554</sup>

It was noted in the executive summary that the ICMP was an ambitious agenda for change which required additional resources. It also recognized that the challenges to Afghanistan were complex, the solutions would not be simple, and there was no single formula for success.

“The plan was admirable in intent,” a former senior official, who asked to speak anonymously, said, “but it made heroic assumptions about the US government’s ability and willingness to provide the requisite civilian staff.” Special Representative to Afghanistan and Pakistan Richard Holbrooke “wanted to see something along these lines in part because he remembered the day when USAID had 2000 officers in the field in Vietnam, most of them outside the wire,” the former official said.<sup>555</sup> “Dick Holbrooke was one of them. But the rules were different then. The mantra of force protection had not yet taken hold in Washington. The USG was prepared to let young American civilian provincial reps and district reps die in Vietnam with no greater regret than they felt for young uniformed men who met their end in Indochina. ... Eight years into the Afghan conflict neither USAID nor State had been able to meet the civilian staffing challenge. And the State Department's rules on reducing the risk of civilian deaths limited the deployment of those civilians who had been deployed to working largely inside the wire.” He concluded, “The Civil-

---

<sup>554</sup> Ibid. (paraphrased).

<sup>555</sup> Rozen, Laura (2009). “Primary Sources: US government document lays out Afghanistan strategy.” *Politico*, September 7. Accessed October 4 2014. [http://www.politico.com/blogs/laurarozen/0909/Primary\\_sources\\_US\\_government\\_document\\_lays\\_out\\_Afghanis\\_tan\\_strategy\\_.html](http://www.politico.com/blogs/laurarozen/0909/Primary_sources_US_government_document_lays_out_Afghanis_tan_strategy_.html).

Military Campaign Plan articulated elegantly what USG would do with a qualified civilian team on the ground in Afghanistan, but it did not explain how USG would acquire and deploy this team.”<sup>556</sup>

The Counterinsurgency Advisory and Assistance Team (CAAT) originated in August of 2009 as a result of a request to the US Deputy Secretary of Defense via the CENTCOM Commander and the Chairman of the Joint Chiefs of Staff. The intent of the request was to provide COMISAF with a “directed telescope” that would help him operationalize his intent for the counterinsurgency campaign. The CAAT was renamed COMISAF Advisory and Assistance Team and provided directed observations and reporting to COMISAF on strategic priority areas; identified opportunities to enhance and exploit ISAF initiatives; and advised and assisted across the theater in order to maximize ISAF campaign effects.<sup>557</sup> The CAAT produced a bi-monthly magazine about counterinsurgency entitled *COIN Common Sense*. Each issue concentrated on a specific theme. Past issues covered topics such as “Civil Society and Counterinsurgency,” “Partnering: A Counterinsurgency Imperative,” “Information Operations,” “Reintegration & Reconciliation,” “Socioeconomic Development,” “Developing Governance,” “Neutralizing Malign Influences,” “Enable the ANSF,” “Insider Threat,” “Security Force Assistance,” and “COIN is a Mindset.” The September 2011 Volume 2, Issue 1 of *COIN Common Sense* contained an article on the ISAF Telecom Advisory Team titled, “Behind the Scenes With [sic] the Telecommunications Advisory Team” by Larry Wentz (this chapter’s author), the TAT Reachback team and JP Morgan, CAAT Senior Information Operations Advisor. As part of the military drawdown, the CAAT was disestablished in September 2014.

The office of the Senior Telecom Advisor and its supporting Telecommunications (Telecom) Advisory Team (staffed through the DoD Civilian Expeditionary Workforce program) were established on July 1, 2010, in Kabul at ISAF Headquarters. The group was sponsored through a combined DoD and DoS agreement and led by DISA. An SME support element staffed by a two- to three-person Deloitte (contractor) team was located outside the ISAF wire in a safe house in Kabul with its own private security detail (PSD) and transportation. They were embedded daily at the MCIT, ATRA, and AfTel, where the Minister of Communications and Information Technology had provided office space for them and the ISAF-based STA/TAT members to use. The Deloitte team had freedom of movement around Kabul to visit GIRoA ICT elements and private sector ICT counterparts. A CONUS-based reachback team was also employed and was supported by DISA, DoD CIO, NDU, Gartner, and Deloitte CONUS. The STA/TAT and Reachback element held weekly teleconference calls to coordinate ongoing ICT-related activities and share information. The STA/TAT mandate was to:

- support COMISAF and facilitate in-country USG Interagency coordination and information sharing;
- be a connector and harmonizer of ICT-related activities;
- interface with international organizations such as the World Bank, ITU, UNDP, and UNAMA;

---

<sup>556</sup> Ibid.

<sup>557</sup> Ronna website. Accessed October 14, 2014. <https://ronna.apan.org/CAAT/Pages/Public-Portal.aspx>.

- advise and assist USG elements on civil and commercial ICT and GIRoA's Telecom and IT sector including the Ministry of Communications and Information Technology, the Afghanistan Telecom Regulatory Authority, and the state-owned enterprise (Afghan Telecom), CIO and IT manager elements of the Afghan ministries, and as appropriate, the private ICT sector providers (MNOs and ISPs); and
- provide informed situational awareness on the Afghan ICT sector.

After a little more than four years of operation, as part of the military drawdown in Afghanistan, the STA/TAT ceased operation in October 2014.

Both the ARG and STA/TAT employed CONUS-based reachback support elements that included Reachback member trips to Afghanistan (TDY<sup>558</sup>) not only to support USG elements in Kabul, but also downrange to advise and assist on ICT activities at FOBs, COPS<sup>559</sup>, selected VSO sites, PRTs, NGOs, and the provincial, district, and village levels to develop a more informed understanding of needs and possible uses of ICT to help support outstanding needs such as extension of governance to provincial, district, and village levels; Internet access for schools and universities, hospitals, health clinics, and agriculture; and use of mobile phones and text messaging for education, healthcare, agriculture, and finance, as well as other ICT support for socio-economic development and growth.

Another DoD ad hoc element in Afghanistan was the Task Force for Business and Stability Operations (TFBSO), which was established in 2009 and closed in 2014 as part of the drawdown activities. The TFBSO concentrated on attracting private foreign direct investment, corporate development, procurement, and reform of the banking sector. Its in-country headquarters was in Kabul with a field office in Herat where it established an ICT Incubator in cooperation with the Herat University computer science department. The TFBSO also sponsored ICT (and other) investor visits to Afghanistan. The American University Afghanistan (AUAF) International Center for Afghan Women's Economic Development was funded by the TFBSO and USAID. The center has a business innovation hub that includes an accelerator and incubator program. The accelerator program takes existing small businesses and helps them become more effective. The AUAF Professional Development Institute has a Microsoft Academy and Cisco Networking Academy. The World Bank also invested in an ICT incubator at the MCIT-sponsored ICT Institute in Kabul, which became operational in 2014. The ICT Institute also has a Cisco Networking Academy. Opportunities exist for possible collaboration between ICTI and its World Bank-funded incubator and the AUAF innovation center and its accelerator and incubator programs. The TFBSO also sponsored, in cooperation with DISA, part of the funding for the establishment of the STA/TAT and its first year of operation at ISAF Headquarters in Kabul.

Examples of US sources of reconstruction and development funding included USAID's Development Plan and related Performance Monitoring Plan and Quick Impact Program (QIP), USAID Kabul Grants, DoD's Overseas Humanitarian Disaster and Civic Aid Program (OHDACA), and the Commander's Emergency

---

<sup>558</sup> Temporary duty

<sup>559</sup> Combat outpost

Response Program (CERP), which was established in 2003. CERP was a form of so-called “expeditionary economics,” also referred to as “money as a weapon system.”<sup>560</sup> CERP provided money (US federally appropriated funds) for military commanders to use for conducting rebuilding, reconstruction, and development. The military used the money for the benefit of the Afghan people in agriculture, public roads, schools, and medical clinics or for humanitarian aid such as “food for work” projects. The use of funds and project approval in the field could be authorized by military commanders (CJTF up to US\$2M, BCT up to US\$500K, BN<sup>561</sup> up to US\$25K<sup>562</sup>), but projects needed to be appropriately coordinated with PRTs, USAID, and other reconstruction and development activities. Funds were to be used to benefit the local population until a more formal reconstruction or development project could be initiated. Requests for CERP funding grew from US\$40 million in 2003 to over US\$1 billion in 2010.<sup>563</sup> The challenges of implementing expeditionary economics with CERP funding have proven daunting and additional research is needed to figure out ways to make its implementation more efficient and effective. Other donors included but were not limited to JICA (Japan), CIDA (Canada), DFID (UK), GTZ (Germany), KOICA (Korea), and the World Bank.

In the design of future aid programs, findings suggest greater reflection should be dedicated to understanding exactly how individual CERP funding at the commander’s level relates strategically to broader aid-delivery efforts within Afghanistan. There appeared to be a need for more research into the potentially destabilizing effects of short-term QIPs in feeding corruption and the war economy. Not only does the potential for local government exploitation of such funds present a threat to host nation legitimacy, but it is of concern that allocating funding contracts to local power-holders and contractors with links to the insurgency has formed a back-channel directly in opposition to Coalition interests.<sup>564</sup> Large donor budgets in Afghanistan have also induced a political economy in which the GIRoA has taken on rentier state characteristics, exacerbating official corruption, eroding the accountability of the central government to its own population, and fostering a climate of aid dependency. In light of the distorting impacts on the local Afghan economy, research suggests that the injection of funds has failed to achieve the level of stability desired.<sup>565</sup>

Certainly, many good people were doing good things in Afghanistan, but the degree to which activities were harmonized, coordinated, and leveraged with information shared about their activities remained problematic. This was not a technology issue. It was a combination of people, policy, culture, and

---

<sup>560</sup> “RAND Study: ‘Money as a Weapon’ Works in Afghanistan.” US Institute of Peace event, October 13, 2016. See <http://www.usip.org/events/rand-study-money-weapon-works-in-afghanistan> for more information.

<sup>561</sup> Battalion

<sup>562</sup> US Army Contracting Command Commander’s Emergency Response Program (CERP) Training Template, February 22, 2010.

<sup>563</sup> Johnson, Gregory, Vijaya Ramachandran, and Julie Walz (2012). “CERP in Afghanistan: Refining Military Capabilities in Development Activities.” US National Defense University *PRISM* 3, No. 2, March 2012.

<sup>564</sup> *WP1022 Report*, 2010.

<sup>565</sup> *Ibid.*

organization issues. Technology was an enabler; the international and USG civil-military crisis response community can (and should) do better.

No institutional arrangements or agreed-upon ICT mechanisms and processes (including within USG civil-military elements) were in place for effectively synchronizing and coordinating multinational (and national) actions or information sharing. ICT program development, project coordination, information sharing, and implementation were and continued to be loosely coordinated, ad hoc, and in some cases non-standard, especially across ICT support to Afghan ministries. Harmonization, coordination, and information sharing was largely personality driven – the right people at the right place and the right time with the right attitudes. Since the process was not institutionalized, every time there was a change of command, leadership, or personnel, the process started all over again. This could happen as often as every six months to a year in both the civilian government agencies (US Embassy and USAID) and military elements (PRTs and ISAF). IOs and NGOs also experienced turnover challenges. Continuity of support activities and trust relationships built over time were key to success, and the disruptive approach related to frequent rotation of personnel was not a good way to do business in a multinational complex operational environment such as Afghanistan.

Although limited reconstruction situational awareness information was shared and tracked among participating civil-military elements to begin with, ICT was not one of the categories actively tracked or even recognized as important to track. Coalition civil-military emphasis was mainly on roads and to a lesser extent water and power. In contrast, rural Afghans' needs were water, then roads and power. This suggested some disconnect in the view of what was needed versus what should be provided by Coalition reconstruction efforts. In fact, many locals were of the view that the Coalition's emphasis on roads was driven more by military operational requirements and logistics than the needs of the local community.

The lack of standard formats for data posed significant hurdles to sharing. Free-form text documents made timely roll-up and data-mining efforts nearly impossible. Military data tended to be classified and the declassification process or removal of unclassified products from classified networks was a challenge. The lack of relational database management systems did not make it any easier – the military process tended to be slow and risk averse. When sharing works, it tends to work largely due to the personalities of key personnel on the ground not by institutional policies, procedures, or ICT support capabilities, such as collaborative information environments, shared web portals, common GIS databases, and shared civil-military situational awareness (SA) tools.

There were multiple efforts to develop GIS-based Afghanistan reconstruction SA tools and web portals. For example, the UNDP, USAID, ISAF, US Army Corps of Engineers, and the office of the US Assistant Secretary of Defense for Networks and Information Integration (ASD-NII) were developing tools and web portals. Only the ASD-NII effort was focused specifically on Afghanistan ICT. The STA at the ARG, in cooperation with ASD-NII and US Navy SPAWAR,<sup>566</sup> set up an Afghanistan ICT portal as a way to openly share ICT-related information and inform the community on related policy, technical, operational, and

---

<sup>566</sup> Space and Naval Warfare Systems Command

implementation activities, issues, and opportunities. It was to be a repository for all relevant ICT documentation and serve as an electronic library with links to other key websites, such as the Afghan MCIT, ATRA, USAID, UN, and others. Chat room capabilities were offered to facilitate collaboration and coordination among those in different geographic areas and time zones. Unfortunately, the portal never realized its expectations. Other independent databases, such as the USAID SharePoint reconstruction database, the UNDP AIMS Provincial Infrastructure Management Support System (PIMSS) pilot in Nangarhar discussed earlier, and the ISAF Afghanistan Country Stability Picture (ACSP) GIS database were established, but information was not actively shared on a regular basis and the databases were not electronically linked nor held to common data standards. In early 2006, the US Army Corps of Engineers was tasked by the US Ambassador and a senior US military commander to develop a GIS-based Afghanistan common operational picture for reconstruction. This effort was subsequently rolled into the ISAF ACSP effort. None of the databases mentioned actively tracked ICT activities.

There were several other efforts to bridge the information-sharing gaps using web portals that could be remotely accessed from the Internet. Publications such as the NATO-run Civil-Military Fusion Center (CFC) weekly news reports and special studies could be downloaded from the CFC website. Examples of other websites were the ISAF Combined Information Data Network Exchange (CIDNE), USCENTCOM International Distributed Unified Reporting Environment (INDURE), ISAF Ronna, and the US systems, the Humanitarian Assistance Response Monitoring and Operations Network-Internet Enterprise (HARMONIEWeb) and the All Partners Access Network (APAN). The challenges with these systems were they tended to not be user friendly, requiring registration and password access, and interactions with the websites were often slow contributing to frustrations in retrieving information.

These systems were aimed at trying to address these open information-sharing short falls between and among the military and with non-military GIRA public and private ICT sector elements, aid agencies, NGOs and international organizations working in the Afghan ICT sector but with only some limited success.

## The Military and Civilian Surge

As President Obama took office in early 2009, his administration's new Afghanistan strategy acknowledged that the international community's largely "top-down," heavily centralized approach to governance assistance in the years following 2001 must be complemented by localized approaches more appropriate to Afghanistan's decentralized social makeup and history ... [and] attempt to bolster the Afghan state from the bottom up.<sup>567</sup> [The] primary military objective was to reverse the Taliban's momentum.

A new ISAF commander, US General Stanley McChrystal, was appointed in June 2009. He conducted a detailed review of the USG's and the Coalition's Afghanistan strategy and produced a hard-hitting report. He warned of a critical situation unless there were major changes. In particular, he said there were not

---

<sup>567</sup> Brown, Frances Z. (2012). *The U.S. Surge and Afghan Local Governance*. United States Institute of Peace Special Report 316, September 2012. Accessed May 5, 2015. <http://www.usip.org/sites/default/files/SR316.pdf>.



enough forces to fight the counterinsurgency campaign that was underway. Coalition forces would need to increase, as would the ANSF, along with improving its capabilities. Key would be an ISAF focus on developing the ANSF capability so they could defend their country and participate with the Coalition in a joint fighting effort with a view to transitioning security responsibilities to the Afghans and drawing down Coalition forces. The ANSF also needed to be large enough to facilitate replacement of departing Coalition forces. The emphasis was on increasing the ANSF and government capacity together so that a change in dynamics occurs in the ability of the Afghans to defend and govern Afghanistan. As Gen. McChrystal noted, success will be determined in the minds of the Afghan people. It is not the number of people killed but the number convinced. It is the number that did not get killed, the number of houses that did not get destroyed, and the number of kids that get a chance to go to school. It is giving the Afghan people a chance after 30 years of war to make a choice for the future.<sup>568</sup>

On December 1, 2009, President Obama announced at a speech at the United States Military Academy at West Point that it was in the vital national interest of the US to send additional US troops and civilian personnel to Afghanistan for approximately 18 months.<sup>569</sup> The purpose of augmenting the US force was to seize the initiative while building the Afghan security forces' capacity to set the conditions to allow for a responsible transition of US forces out of Afghanistan. The civilian element of the surge was intended to work with the USG's partners, the World Bank, the United Nations, and the Afghan government and people, to pursue a more effective civilian strategy so that the Afghan government could take advantage of improved security. Part of COMISAF McChrystal's, and later (in July 2010) Gen. David Petraeus's, counterinsurgency "clear-hold-build" strategy was to secure territory by separating the enemy from the population and staying in the area, establish a secure presence to hold on to the area so the new government could connect with the people and tribal and local leaders, and then work with the government to build up institutions of the state (justice, security, governance, and economic development) to inoculate local populations against the Taliban's return and help the people buy into the new government and the services offered. Clear cut objectives were set to refocus on al-Qaeda, to reverse the Taliban's momentum, and train Afghan security forces to defend their own country.<sup>570</sup> President Obama made it clear that our commitment would not be open-ended and that we would likely begin to draw down our military forces in July 2011.

While military forces have a legitimate role in each of the COIN mission elements of "clear-hold-build," their primary expertise lies in providing a secure environment so that political and economic development

---

<sup>568</sup> Paraphrased from Graff, Peter (2009). "McChrystal upbeat on revamped Afghan strategy." Reuters, December 2. Accessed October 4, 2014. <http://www.reuters.com/article/idUSSP412292>.

<sup>569</sup> Obama, Barack (2009). "Remarks by the President in Address to the Nation on the Way Forward in Afghanistan and Pakistan," December 1. The White House Office of the Press Secretary. Accessed December 10, 2014. <https://www.whitehouse.gov/the-press-office/remarks-president-address-nation-way-forward-afghanistan-and-pakistan>.

<sup>570</sup> Obama, Barack (2011). "Remarks by the President on the Way Forward in Afghanistan," June 22. The White House Office of the Press Secretary. Accessed December 10, 2014. <https://www.whitehouse.gov/the-press-office/2011/06/22/remarks-president-way-forward-afghanistan>.

can occur. Since publication of the military COIN guidance, many observers believe the strategy has been expanded to include a preliminary “Shape” phase (intelligence preparation of the battlefield, interagency planning, and so forth) and a concluding “Transfer” phase (bulk U.S. force withdrawal, primary responsibility shifts to the affected nation security forces, and so forth). Whether the military’s “Shape, Clear, Hold, Build, and Transfer” model is correct, it provides a useful framework that political and economic development experts can use to integrate their actions with their security colleagues. To date, however, political and economic developers have not created comparable models to guide their actions or inform their mission partners. Consequently, their efforts appear somewhat reactive and disjointed, and may, as a result, be perceived as being subordinate to the security mission.<sup>571</sup>

President Obama authorized a “military surge” of 30,000 military personnel to be deployed as soon as possible mainly to southern and eastern Afghanistan, in particular to Helmand and Kandahar provinces with emphasis on Helmand as the center of the drug trade – the financial engine of the insurgency. There were also 116 critical districts that the counterinsurgency had to address. The governments of ISAF troop-contributing nations accepted Gen. McChrystal’s stark conclusions and a major increase in forces followed. In addition to the US commitment, other ISAF nations provided a further 10,000 troops. By early 2010, the ISAF strategy was reset. It was a heavy additional burden, but what became known as the “McChrystal Strategy” gave an increased focus and resolve to a military effort that had seemed to be close to stalemate.

The President also launched a “civilian surge” over the next year of personnel from USAID and the Departments of State, Justice, Commerce, and Agriculture, roughly tripling the total US government civilian presence in Afghanistan from 300 to more than 1,100 to oversee additional thousands of contracted civilian implementing partners. The ability to respond to a rapid staffing up for the civilian surge proved to be a monumental challenge due to a lack of capacity of civilian agencies and the Civilian Response Corps (CRS, recruited from federal employees on active duty). The CRS was not adequately staffed to properly respond to the demand and alternatives needed to be explored such as use of Foreign Service nationals who worked at US embassies overseas and retirees from federal service. Furthermore, all-civilian branches of the US government were (and still are) not designed to deploy people rapidly the way the Pentagon can. Elements such as “the State Department must shed the risk-averse culture it adopted in the mid-1980s ... [It] cannot ignore risk, but [organizations] need to be willing to manage risk rather than simply avoid it.”<sup>572</sup> Additionally, it was difficult to recruit the right people willing to deploy into a hostile zone for an extended period of time. Ramping up pre-deployment training was a challenge. There was also a need to provide the government civilians the necessary armed escort force protection to support movement in country, which had to be planned for and was costly. It was also a challenge to be able to put the right people in the right spots – all on tight budgets. Some agencies did not want to “give

---

<sup>571</sup> Donley, 2016.

<sup>572</sup> Transcript of interview of John E. Herbst, Coordinator for Reconstruction and Stabilization, US Department of State, by Greg Bruno, Council on Foreign Relations, March 31, 2010. Accessed October 4, 2014. <http://www.cfr.org/afghanistan/waiting-civilian-surge-afghanistan/p21785>.

up” their most skilled employees for long periods of time and there were few professional incentives for others. As a result, the ad hoc deployments of government employees to missions overseas tended to put the wrong people in critical jobs. To succeed in an operation like Afghanistan, you needed to have a substantial, well-thought-out and well-resourced civilian effort with leadership and participants that have the passion to make a difference. It is not just another duty as assigned.

A major part of the US civilian effort was focused on agriculture, which made up a vast percentage of Afghanistan’s economy. US agronomists taught Afghan farmers how to boost farm output. In this regard, Agribusiness Development Teams (ADT) composed of Army National Guard soldiers with backgrounds and expertise in various sectors of the agribusiness field were formed and deployed to provide training and advice to Afghan universities, provincial ministries, and local farmers.<sup>573</sup> USAID and USDA supported these teams.

At this time, Afghan women were getting paid for a day's work as they learned job skills for future employment. Youth were taking part in local *shuras* (councils) to learn about the workings and responsibility of government.

Because of cultural beliefs and restrictions, Afghan women were not allowed to speak to men outside of their immediate family members. These cultural norms prevented US male soldiers from looking at or talking to women encountered during patrols. To appropriately engage Afghan females, the US Army and Marines established female engagement teams (FETs). The FETs were comprised of volunteer female members of appropriate rank, experience and maturity to develop trust-based and enduring relationships with the Afghan women they encountered on patrols. Having such a team at its disposal gave American forces an added tool in reaching out to the Afghan population ...<sup>574</sup>

The Afghanistan-Pakistan (AFPAK) Hands (APH) Program was launched by the DoD in September 2009 “to fill a need for individuals who knew the culture, language, history, politics, and other aspects of the Afghanistan and Pakistan region. The AFPAK Hands [were] financial managers from the Army, Air Force, Navy, and Marine Corps specifically selected and trained as experts in the Afghan and Pakistani cultures and their financial management processes and systems.”<sup>575</sup>

The Ministry of Defense Advisors (MoDA) was another program initiated in 2009 to create a critical new means of capacity building in Afghanistan security ministries. Prior efforts had focused heavily on improving the tactical proficiency of Afghan security forces but often neglected ministerial capacity building. The MoDA initiative reflected the realization that effective and accountable defense institutions (namely, the Afghan Ministries of Defense and Interior) must sustain hard-won tactical gains. MoDA

---

<sup>573</sup> United States Army (n.d.). Agribusiness Development Team (ADT) Information Paper. Accessed October 4, 2014. [https://www.army.mil/aps/08/information\\_papers/other/ARNG\\_Agribusiness\\_Development\\_Team.html](https://www.army.mil/aps/08/information_papers/other/ARNG_Agribusiness_Development_Team.html).

<sup>574</sup> McCullough, Christopher (Sgt., US Army) (2012). “Female engagement teams: who they are and why they do it.” United States Army, October 2. Accessed October 4, 2014. <https://www.army.mil/article/88366/>.

<sup>575</sup> Lee, Mark W. (Maj., US Army) (2014). The Afghanistan-Pakistan Hands Program. United States Army, February 11. Accessed October 4, 2014. [https://www.army.mil/article/115523/The\\_Afghanistan\\_Pakistan\\_Hands\\_Program/](https://www.army.mil/article/115523/The_Afghanistan_Pakistan_Hands_Program/).

partners DoD civilian experts with Afghan counterparts to build ministerial core competencies such as personnel and readiness, logistics, strategy and policy, and financial management.<sup>576</sup>

In 2009, a Pakistan Afghanistan Coordination Cell (PACC) was stood up at the Pentagon to ensure expertise developed during deployments to Afghanistan [was] channeled directly back into supporting warfighters on the ground ... The staff was selected based on members' expertise in areas ranging from intelligence to policy, plans and operations to logistics and communications.<sup>577</sup>

Provincial Reconstruction Teams were also doing everything from providing security, to conducting reconstruction and development, to improving the government's capacity to deliver services and establish rule of law to the Afghan people. They collaborated with the local Afghan government on key issues affecting the province and worked together to advance Afghan-led solutions. US civilian advisers to the local government often worked out of the provincial governor's office.

## The Military Drawdown and Exit Plans

The total number of ISAF and US forces climbed to 130,000 at the height of the war. The majority belonged to various branches of the United States Armed Forces and were fighting the Taliban insurgency and training the Afghan National Security Forces (military and police). On June 22, 2011, President Obama announced<sup>578</sup> the US's intentions to start the withdrawal of troops with the combat elements scheduled to depart slowly until the end of 2014 with a small follow on international force of around 12,500, of which 9,800 would be US military, to remain into 2015 under the NATO Resolute Support Mission to focus on training, advising and assisting the Afghan National Security Forces. At the beginning of 2015, Afghan security forces numbered about 350,000.<sup>579</sup>

President Obama and President Karzai committed in May 2010 to negotiate and conclude a strategic partnership agreement that would provide a framework for future relationships. On May 1, 2012, the first anniversary of Osama bin Laden's death, President Obama made an unannounced trip to Afghanistan to sign the agreement, to visit American troops, and to address the American nation from Bagram Air Base about his plans to responsibly end the war. Afghan President Hamid Karzai and US President Barack Obama signed the US–Afghanistan Strategic Partnership Agreement, officially titled the *Enduring Strategic Partnership Agreement between the United States of America and the Islamic Republic of Afghanistan*. In his address from Bagram Air Base, Obama committed to pulling 23,000 troops out of the country by the end of summer and sticking to the 2014 deadline to turn security fully over to the Afghan government. He

---

<sup>576</sup> Defense Security Cooperation Agency (n.d.). Ministry of Defense Advisors (MoDA). Accessed September 7, 2015. <http://www.dsca.mil/programs/ministry-defense-advisors>.

<sup>577</sup> Miles, Donna (2009). "Coordination Cell to Provide Focus, Expertise for Afghanistan Mission." American Forces Press Information Service, June 26. Accessed September 7, 2015. <http://www.globalsecurity.org/military/library/news/2009/06/mil-090626-afps02.htm>.

<sup>578</sup> Obama, 2011.

<sup>579</sup> Barakat, Sultan and Brooke Smith-Windsor (2015). "Post-ISAF Afghanistan: The Early Months," Brookings Institution Policy Dialogue, February 2015. <https://www.brookings.edu/wp-content/uploads/2016/06/bdc-nato-event-report.pdf>. Accessed March 14, 2016.

said that NATO would set a goal at its meeting in Chicago in May 2012 for Afghan forces to lead combat operations in the 2013 timeframe.<sup>580</sup>

The strategic partnership agreement is a legally binding executive agreement and went into effect on July 4, 2012. The purpose of the agreement was “to cement an enduring partnership with Afghanistan that strengthens Afghan sovereignty, stability, and prosperity, and contributes to a shared goal of defeating al-Qaeda and its extremist affiliates.”<sup>581</sup> The agreement helped “to promote training of Afghan forces, a reconciliation and reintegration process for Taliban fighters who leave the battlefield, and regional stability with a focus on improving relations with Pakistan.”<sup>582</sup> The ten-year agreement requires the two governments to replace the current status of forces agreement (SOFA) with a bilateral security arrangement (BSA) within a year.

Covered areas under the agreement are military and security issues as well as assistance in building Afghanistan’s economy and its democracy. One of the provisions of the agreement is the designation of Afghanistan as a major non-NATO ally of the United States to provide a long-term framework for security and defense cooperation. Other provisions of the agreement are:

- The United States’ commitment to support Afghanistan’s social and economic development, security, institutions and regional cooperation for 10 years;
- The commitment by Afghanistan to strengthen government accountability, transparency and oversight, and to protect the human rights of all Afghans, both men and women;
- Access to and use of Afghan facilities by US personnel beyond 2014;
- Granting the United States the possibility of keeping forces in Afghanistan after 2014 for purposes of training Afghan forces and targeting al-Qaeda;
- Non-Commitment by the US to any specific troop levels or funding levels in the future; and
- Commitment by the US to seek funding from the US Congress on an annual basis for social and economic assistance for Afghanistan as well as to support the ... ANSF.<sup>583</sup>

On May 21, 2012, the leaders of the NATO-member countries endorsed an exit strategy during the 2012 NATO Summit in Chicago. The NATO-led ISAF Forces would transition command of all combat missions to

---

<sup>580</sup> Obama, Barack (2012). “Remarks by President Obama in Address to the Nation from Afghanistan,” May 1. The White House Office of the Press Secretary. Accessed December 10, 2014. <https://www.whitehouse.gov/the-press-office/2012/05/01/remarks-president-obama-address-nation-afghanistan>.

<sup>581</sup> The White House. “Fact Sheet: The U.S.-Afghanistan Strategic Partnership Agreement.” Office of the Press Secretary. May 1, 2012. Accessed September 7, 2015. <https://www.whitehouse.gov/the-press-office/2012/05/01/fact-sheet-us-afghanistan-strategic-partnership-agreement>.

<sup>582</sup> Sieff, Kevin and Scott Wilson (2012). “Obama makes surprise trip to Afghanistan to sign key pact, mark bin Laden raid.” *The New York Times*, May 2. Accessed September 7, 2015. [https://www.washingtonpost.com/world/obama-makes-surprise-trip-to-afghanistan-to-sign-key-pact-mark-bin-laden-raid/2012/05/01/gIQAvYHduT\\_story.html?utm\\_term=.31018fa3614e](https://www.washingtonpost.com/world/obama-makes-surprise-trip-to-afghanistan-to-sign-key-pact-mark-bin-laden-raid/2012/05/01/gIQAvYHduT_story.html?utm_term=.31018fa3614e).

<sup>583</sup> *Wikipedia* (2016). “U.S.–Afghanistan Strategic Partnership Agreement.” Last modified December 18, 2016. [https://en.wikipedia.org/wiki/U.S.%E2%80%93Afghanistan\\_Strategic\\_Partnership\\_Agreement#cite\\_note-APWP\\_SPA\\_Highlights-43](https://en.wikipedia.org/wiki/U.S.%E2%80%93Afghanistan_Strategic_Partnership_Agreement#cite_note-APWP_SPA_Highlights-43).

Afghan forces by the middle of 2013, while at the same time evolve from combat to a support role of training, advising, and assisting the Afghan security forces. The withdrawal of most of the 130,000 foreign troops would occur by the end of December 2014. On June 18, 2013, the handover of the lead for security from NATO to Afghan forces was completed.

President Karzai called a Loya Jirga, or a grand council, to discuss the draft bilateral security agreement which the US and Afghans had concluded. This involved 2,500 of Afghanistan's influential citizens from throughout the country. After three days of debate, the Loya Jirga [on November 24, 2013] overwhelmingly endorsed the BSA as written and urged President Karzai to sign it before the end of the year.<sup>584</sup> Karzai rejected the final recommendation of the Loya Jirga to promptly sign the BSA with the United States but sent to the Afghan parliament for final ratification. Although the parliament endorsed the BSA in 2013, Afghan President Hamid Karzai continued to refuse to sign it, taking issue with US soldiers conducting night raids on Afghan homes, the USG's peace talks with the Taliban, jurisdiction over US military soldiers, and other matters.

On May 27, 2014, President Barack Obama announced that US combat operations in Afghanistan would end in December 2014<sup>585</sup> and that the troop levels would be reduced to 9,800 troops by this time. He also noted that number would be cut in half by the end of 2015, and by the end of 2016, there would be only a vestigial force to protect the embassy in Kabul and to help the Afghans with military purchases and other security matters.<sup>586</sup>

During another surprise trip to Afghanistan in May 2014 to visit the troops at Bagram Airfield, Obama conveyed his hope the United States would sign the BSA with Afghanistan once Afghanistan swore in a new president to be able to plan for a limited military presence beyond 2014.<sup>587</sup> Both contending presidential candidates, Ashraf Ghani Ahmadzai and Abdullah Abdullah, had publicly stated they would sign the BSA if elected.

Afghanistan held a presidential election on April 5, 2014. No candidate secured more than 50 percent of the vote, so there was a second-round run-off on June 14 between Abdullah and Ghani. However, due to allegations of widespread fraud, on July 12 it was announced that all ballots would be audited under UN supervision. A functioning government in Kabul was lacking during the period of resolving the election

---

<sup>584</sup> Dobbins, James F., Special Representative for Afghanistan and Pakistan (2013). Transcript of opening statement of testimony before the United States House of Representatives Foreign Affairs Committee, December 11. Accessed October 4, 2014. <https://www.state.gov/p/sca/rls/rmks/2013/218660.htm>.

<sup>585</sup> Obama, Barack (2014). "Statement by the President on Aghanistan," May 27. The White House Office of the Press Secretary. Accessed December 10, 2014. <https://www.whitehouse.gov/the-press-office/2014/05/27/statement-president-afghanistan>.

<sup>586</sup> Landler, Mark (2014). "U.S. Troops to Leave Afghanistan by End of 2016." *The New York Times*, May 27. Accessed December 10, 2014. <https://www.nytimes.com/2014/05/28/world/asia/us-to-complete-afghan-pullout-by-end-of-2016-obama-to-say.html? r=0>.

<sup>587</sup> Obama, Barack (2014). "Remarks by the President to the Troops at Bagram Air Base, Aghanistan," May 25. The White House Office of the Press Secretary. Accessed December 10, 2014. <https://www.whitehouse.gov/the-press-office/2014/05/25/remarks-president-troops-bagram-air-base-afghanistan>.

stalemate and fraud dispute. Additionally, there was the threat of abandonment by the West if the BSA was not signed soon. Despite these conditions, the Afghan security forces performed with courage and effectiveness. Election disputes were resolved and Ashraf Ghani was inaugurated on September 29, 2014; and his challenger, Abdullah Abdullah, became chief executive, forming a “national unity government.” On September 30, 2014 as its first major act, the new Afghan government signed the Bilateral Security Agreement<sup>588</sup> with the US, allowing the US military to keep troops in the country and to retain Afghan bases to continue counterterrorism operations. The BSA became effective January 1, 2015 and remains in force “until the end of 2024 and beyond,” unless it is terminated by either side with two years’ notice.<sup>589</sup> Signing the BSA with the US was a precondition for a separate NATO status of forces agreement, which was signed as well, sanctioning 12,000 foreign troops to remain in Afghanistan post-2014 when the NATO-led combat mission ended.

## Future

Security remains the country’s biggest test. The International Community has helped raise and train the ANSF, which numbered around 350,000 at the beginning of 2015. However, since the handover of the lead for security responsibilities from NATO to Afghan forces in June 2013, the Afghan National Army and Police (ANA and ANP, respectively) have seen a dramatic rise in casualties and desertions – raising questions about the sustainability of the Afghan forces. Furthermore, the security forces lack proper warfighting equipment, such as heavy weapons, as well as a proper air force with trained pilots and aircraft.<sup>590</sup>

Increased ground combat between insurgents and government forces contributed to a surge in civilian casualties in 2014. “The twice-yearly United Nations updates on civilian deaths have regularly found the Taliban responsible for roughly three-quarters of civilian casualties, and the [2014] report indicated that the trend held steady through the first six months of 2014. Pro-government forces were responsible for less than 10 percent of the ... civilians killed.”<sup>591</sup>

[Human Rights Watch World Report 2014](#) noted abuses by the Afghan Local Police (ALP) continued to be a serious problem. Designed to operate in areas with limited Afghan police or army presence, the ALP has been plagued from its beginnings in 2010 by structural problems that included poor vetting of recruits, weak command and control structures, and lack of accountability mechanisms.<sup>592</sup> These problems

---

<sup>588</sup> Officially, the “Security and Defense Cooperation Agreement between the United States of America and the Islamic Republic of Afghanistan.”

<sup>589</sup> *Wikipedia* (2016). “U.S. – Afghanistan Strategic Partnership Agreement.” Last modified December 18, 2016.

[https://en.wikipedia.org/wiki/U.S.%E2%80%93Afghanistan\\_Strategic\\_Partnership\\_Agreement](https://en.wikipedia.org/wiki/U.S.%E2%80%93Afghanistan_Strategic_Partnership_Agreement).

<sup>590</sup> Excerpted and paraphrased from “What Kind of Afghanistan will foreign forces leave?” *BBC News*, December 17, 2013. Accessed October 4, 2014. <http://www.bbc.com/news/world-25410582>.

<sup>591</sup> Ahmed, Azam and Matthew Rosenberg (2014). “Ground Battles in Afghanistan Contribute to Surge in Civilian Casualties.” *The New York Times*, July 9. Accessed October 4, 2014. <https://www.nytimes.com/2014/07/10/world/asia/civilian-casualties-surge-in-afghanistan-fighting-un-says.html>.

<sup>592</sup> Human Rights Watch (2014). *World Report 2014: Afghanistan, Events of 2013*. Accessed September 7, 2015. <https://www.hrw.org/world-report/2014/country-chapters/afghanistan>.

persisted, as did allegations of ALP involvement in murder, rape, theft, extortion, and child recruitment. In the recommendation for the UN Security Council on the 2014 UNAMA mandate on human rights violations, it was noted to express concern at the level of abuse committed by members of the ALP and called on the Afghan government to ensure that ALP recruits are more thoroughly vetted, trained, and independently monitored so that any allegations of human rights abuses are transparently investigated and appropriately disciplined and/or prosecuted.

The high cost of maintaining the Afghan security forces and the likelihood the Afghan government would not be able to afford such a force on its own are major challenges,<sup>593</sup> requiring not only continued international financial assistance but possible extension of Coalition forces' mission and level of support to the NATO Resolute Support Mission in 2015. In fact, in November 2014, President Obama authorized the US troops in Afghanistan to carry out missions against militant groups, including the Taliban, that threaten them or the Afghan government, as well as to support combat missions of the Afghan troops using jets, bombers and drones, the *New York Times* reported, citing administration, military and congressional officials.<sup>594</sup> The United States is also preparing to increase the number of its military forces in Afghanistan in 2015. The so-called "bridging solution" envisages providing up to 1,000 extra troops until other countries step forward later in the year.<sup>595</sup>

Corruption, organized crime, and human and drug trafficking remain a widespread and growing problem in Afghan society. "Transparency International, an organization that tracks corruption internationally, ranked Afghanistan at the bottom of its global list in 2013.<sup>596</sup> Each of 177 countries was graded on a scale of 100. Afghanistan received an 8 - the same score as North Korea and Somalia and lower than every other country in the world. The United Nations estimates that the total cost of corruption in Afghanistan has reached \$4 billion and in 2012, half of all people in the nation had to pay a bribe to a public official to receive some kind of basic service."<sup>597</sup> Criminal activity is continuous and widespread. Criminals rarely operate alone, but rather in groups which are prone to use deadly force on victims. It is often difficult to differentiate between politically-motivated criminal behavior, terrorism, and/or traditional illegal activity. While narcotics trafficking accounts for a large portion of Afghanistan's crime problems, the country is challenged by a myriad of criminal terrorist threats, many of which target foreigners. All Westerners and

---

<sup>593</sup> *BBC News*, 2013.

<sup>594</sup> *Sputnik International* (2014). "Obama Extends US Combat Role in Afghanistan." Last updated November 11, 2014. <https://sputniknews.com/military/201411221015023303/>.

<sup>595</sup> "US to increase troops in Afghanistan in 2015." Accessed September 7, 2015. <http://www.ansarpress.com/english/3016>.

<sup>596</sup> Afghanistan ranked 166 out of 168 in 2015. Accessed March 14, 2016. <https://www.transparency.org/country/AFG>.

<sup>597</sup> Swarts, Phillip (2014). "Afghanistan corruption still severe problem, U.S. watchdog says." *The Washington Post*, May 14. Accessed September 7, 2015. <http://www.washingtontimes.com/news/2014/may/14/afghanistan-corruption-still-severe-problem-us-wat/>.



Afghans associated with Westerners are potential targets, to include non-governmental organization (NGO) employees, media, clergy, local medical staff, aid and rehabilitation workers, and others.<sup>598</sup>

Afghanistan is [a] source, transit, and destination country for men, women, and children subjected to trafficking in persons, specifically forced labor and forced prostitution. Trafficking within Afghanistan is more prevalent than transnational trafficking, and the majority of victims are children.<sup>599</sup> Drug production has continued to increase, with Afghanistan now producing some 90 percent of the world's opium production.<sup>600</sup> In fact, opium remains Afghanistan's biggest cash crop and poppy-derived products brought [US]\$3 billion to Afghanistan in 2013, constituting 15 percent of its gross domestic product [GDP].<sup>601</sup> The drug economy continues to fund the insurgency, and the Taliban reportedly has received an estimated US\$100 million annually from taxing poppy farmers and drug traders. The drug trade also fuels organized crime and official corruption and has intensified a domestic addiction crisis in the country, which now has more than a million addicts.<sup>602</sup>

Afghanistan's institutions were destroyed in the two decades of war that preceded the US-led invasion. The process of institution building has had tangible success and the country has functioning institutions in the capital, Kabul, as well as in provinces and most districts. Afghanistan is back on the international stage, with diplomatic missions in some 70 countries and representation in most international organizations. But there are problems with a lack of effective governance or bad governance in many parts of the country ... Rule of law and access to justice remain two of the biggest challenges despite some government efforts to improve the situation.<sup>603</sup>

Despite gains toward building a stable central government, a resurgent Taliban, the emergence of Daesh or ISIS elements in Nangarhar province, and continuing provincial instability particularly in the south and the east remain serious challenges for the Afghan Government. The Taliban have gradually regained control of large parts of Afghanistan as US and NATO withdrew combat force elements from the region and transitioned to a smaller force focused on training, advising, and assisting the Afghan forces. The Taliban say they will keep fighting as long as foreign forces are present in Afghanistan.<sup>604</sup> There is a need to stabilize the borders with Afghanistan's neighbors, especially the 1,600-mile frontier with Pakistan. So long as safe havens exist in Pakistan, the Taliban can continue its insurgency indefinitely. International

---

<sup>598</sup> US Department of State Overseas Security Advisory Council (OSAC). *Afghanistan 2013 Crime and Safety Report*. Accessed October 4, 2014. <https://www.osac.gov/Pages/ContentReportDetails.aspx?cid=13762>.

<sup>599</sup> *Wikipedia* (2016). "Human trafficking in Afghanistan." Last updated July 25, 2016. [https://en.wikipedia.org/wiki/Human\\_trafficking\\_in\\_Afghanistan](https://en.wikipedia.org/wiki/Human_trafficking_in_Afghanistan).

<sup>600</sup> Papaherakles, Pete (2014). "Afghanistan Opium and 'Black Ops.'" *American Free Press*, November 23. Accessed September 7, 2015. <https://americanfreepress.net/afghanistan-opium-and-black-ops/>.

<sup>601</sup> *Ibid.*

<sup>602</sup> *BBC News*, 2013.

<sup>603</sup> *Ibid.*

<sup>604</sup> *Ibid.*

worries also center on the fragility of Ashraf Ghani's and Abdullah Abdullah's national unity government and the challenges it faces.

The reconstruction process of Afghanistan began in 2002. There were more than 14,000 reconstruction projects ... in Afghanistan, such as the Kajaki and the Salma Dams. Many of these projects were supervised initially by the Provincial Reconstruction Teams. [One of t]he World Bank's contribution[s] is the multilateral Afghanistan Reconstruction Trust Fund (ARTF), which was set up in 2002. It was financed by 24 international donor countries and had spent more than US\$1.37 billion as of 2007. Approximately US\$30 billion has been provided by the international community for the reconstruction of Afghanistan, most of it from the United States.<sup>605</sup>

In 2002, the world community allocated US\$4 billion at the Tokyo conference followed by another US\$4 billion in 2004. In February 2006, US\$10.5 billion was committed for Afghanistan at the London Conference and US\$11 billion from the United States was committed in early 2007. Despite these vast investments by the international community, the reconstruction effort's results have been mixed. Implementation of development projects at the district and sub-district level have been frequently marred by lack of coordination, knowledge of local conditions, and sound planning on the side of international donors as well as by corruption and inefficiency on the side of Afghan government officials. On the provincial and national level, projects such as the National Solidarity Program, inter-provincial road construction, and the US-led revamping of rural health services have met with more success.<sup>606</sup>

Despite steady growth over the past decade, Afghanistan's dependency on foreign aid and businesses created by the foreign military presence remains a serious concern, especially with the drawdown of ISAF and US forces. Exports have remained disproportional to the size of imports. Fluctuating weather has also left the harvests unpredictable. Government operating expenditures are growing faster than revenues. Although the mineral sector offers an opportunity for long-term economic sustainability there are doubts as to whether Afghanistan has the capacity to tender and develop the mines. Its landlocked economy is recovering steadily with improvements in agriculture production and significant growth in the ICT sector, which has moved Afghanistan into the Information Age, facilitated foreign investments, and provided an ability for the country to reach out and become a part of the international business community.

On the good news side, Afghanistan's GDP per capita in 2014 had reached US\$687 from US\$180 in 2002. Some eight million children were going to school, of which about 40 percent were girls. This was up significantly from 1 million children in school in 2001 with virtually zero girls. Afghanistan has 17 universities with over 200,000 students and growing. About 85 percent of the country has access to basic healthcare compared to 9 percent under the Taliban, and life expectancy has increased from 42 years to

---

<sup>605</sup> *Wikipedia* (2016). "Reconstruction in Afghanistan." Last updated November 6, 2016. [https://en.wikipedia.org/wiki/Reconstruction\\_in\\_Afghanistan](https://en.wikipedia.org/wiki/Reconstruction_in_Afghanistan).

<sup>606</sup> *Ibid.*

62.<sup>607</sup> Women are an integral part of the new Afghan society with leaders in business and all levels of government. For example, Roya Mahboob, an Afghan entrepreneur and businesswoman who founded Afghan Citadel Software Company received attention for being among the first female IT CEOs in Afghanistan, where it is still relatively rare for women to work outside the home. On April 18, 2013, Roya Mahboob was named to *TIME* Magazine's 100 Most Influential People in the World for 2013. Habiba Sarabi is Governor of Bamyan Province, Afghanistan's first modern-day first female governor, and 28 percent of the members of parliament are women. Afghanistan now has 17 banks and has introduced some limited use of mobile money to pay ANSF elements, teachers, and some government employees. Roads, bridges, dams and power generation and distribution networks have been reconstructed. The ICT sector has been a major success story with the country going from essentially no service in 2002 to over 90 percent of the Afghan population living in areas with cellular service, including 3G mobile broadband service in major urban areas. There was extensive use of text messaging (SMS), and digital financial services such as mobile money were being introduced. Internet use was becoming more pervasive, as was the use of social networking tools such as Facebook, Twitter, and YouTube. Finally, the media sector had grown rapidly. Although the media was tightly controlled under the Taliban government from 1996 to late 2001, the new state media gradually relaxed press restrictions, and private media began growing rapidly in the past decade with extensive coverage in newsprint, radio (including call-in talk shows), television, and the Internet (Afghan as well as international news websites).

Afghanistan has received tens of billions of dollars in aid ... The country has seen a great deal of development, and quality of life has improved for millions of Afghans. Thousands of kilometers of new roads have been built and the health sector has progressed with clinics built in even remote districts. Thousands of new schools have also been built where millions of boys and girls are receiving education ... But Afghanistan is still one of the poorest countries in the world. There are still places in the country which have not felt the benefits of international aid. Many children are still deprived of education and do not have access to basic facilities such as health clinics and clean water. Afghans in general say that a lot of aid money has been wasted and that the international community should have invested in major infrastructure projects such as building dams, housing schemes, and industrial zones. Overall, the Afghan economy is largely dependent on foreign aid and drug income.<sup>608</sup>

As NATO withdrew the remaining ISAF combat troops by the end of 2014, there were concerns related to the Afghan government's ability to sustain the economic and development gains made over the past 12 years and the extent to which the ANSF could sustain the security environment. Concerns were also related to whether the international civilian aid organizations would be able to continue operations or need to refocus their efforts based on lessons learned. Although lessons from history suggest there is plenty of potential within Afghan culture for promoting positive values, Afghans remain skeptical about what will happen next and whether the new government power-sharing deal will really work.

---

<sup>607</sup> United States Central Intelligence Agency (CIA) (2014). *The World Factbook: Afghanistan*. Accessed December 9, 2014. <https://www.cia.gov/library/publications/the-world-factbook/geos/af.html>.

<sup>608</sup> *BBC News*, 2013.

Finally, in the Information Age, it should not be surprising that ICT has emerged as critical infrastructure and an essential service supporting complex civil-military operations and related crisis response actions facilitating the recoveries of disaster-stricken nations. With the increase in the power of ICT as an enabler, it has become extremely important for the USG and other responder nations' civil-military elements, international organizations, non-governmental organizations, and donors to step back and review and adjust their concepts, strategies, and plans for the role and importance of the effective use of ICT as an enabler in crisis response and post-conflict stability, reconstruction and development operations. There is a need for the community to view and treat affected nation civil and commercial ICT recovery, reconstruction, and development with a focus, priority, and investment interest equivalent to those used for crisis response recovery of other disrupted or destroyed essential services such as roads, power, and water. ICT have become an important cross-sector enabler of post-conflict reconstruction and development, especially with ways in which ICTs can be used by governments and donors to support the transition from conflict to stability to peace, and improve the quality of life for those we try to help. The International Community and USG both need an agreed-upon policy, strategy, and plan to use ICT as a post-conflict engine to enable recovery, reconstruction, and development.

Challenges for the future (some of which were iterated earlier in this chapter) include: a deteriorating security situation (including threats against ICT personnel and facilities); sustainment of economic and political stability; a lack of reliable electric power; poor spectrum management; a dearth of qualified management, technical, contracting, marketing and financial personnel; and problems with and within the national unity government.

## Chapter 3 ICT in Afghanistan

---

Karen E. Black (with contributions by Robert Kinn and Lane Smith)

### Introduction

Like much of Afghanistan's history, the narrative describing the development of information and communications technology (ICT) services in Afghanistan is incomplete and inconsistent, due in no small part to the utter decimation of many official sources of information, both physical and human, throughout decades of conflict and turmoil, and the inevitability of elements being lost in translation among multiple languages.

One of the goals of this chapter is to chronicle the establishment of modern commercial, civil, and military and police ICT services in Afghanistan. Another is to describe the country's digital coming-of-age and convey its socio-economic impacts and benefits. The legal and regulatory framework that enabled Afghanistan's modern ICT services is covered in [Chapter 5](#) and the institutions that govern the ICT sector in [Chapter 4](#). Some of the infrastructure underlying Afghanistan's modern ICT sector is included herein, but its optical fiber infrastructure, the licensing and use of its orbital satellite slot, and its electromagnetic spectrum are each covered in separate chapters.

Much of the information in the section below entitled "A Brief History" is excerpted or paraphrased from documents produced by the Afghan Ministry of Communications and Information Technology (MCIT) or its predecessor, the Ministry of Communications (MoC), including but not limited to its [ICT Sector Strategy](#),<sup>609</sup> [E-Afghanistan National Priority Program](#) (NPP),<sup>610</sup> and an official activities and achievements report,<sup>611</sup> as well as from an unpublished "Telecom Book,"<sup>612</sup> which the author assisted personnel at the MCIT to compile and write. The information in the "Modern Era" section is largely from publicly-available documents, although there are often discrepancies between – and even within – various sources of

---

<sup>609</sup> Islamic Republic of Afghanistan Ministry of Communications and Information Technology (MCIT). *Information and Communication (ICT) Sector Strategy 1387-1391 (2007/08-2012/13)*, February 2008. Accessed March 14, 2016. [http://mcit.gov.af/Content/files/ICT%20Sector%20Strategy%20-%20English%20final%20Singed\(2\).pdf](http://mcit.gov.af/Content/files/ICT%20Sector%20Strategy%20-%20English%20final%20Singed(2).pdf).

<sup>610</sup> Islamic Republic of Afghanistan Ministry of Communications and Information Technology (MCIT) (2011). *E-Afghanistan National Priority Program* (NPP) Proposal, May. Accessed March 14, 2016. <http://mcit.gov.af/Content/files/PSD%20NPP%202%20E%20Afgh%20NPP%20Proposal%2023%20May%202011.pdf>.

<sup>611</sup> Islamic Republic of Afghanistan Ministry of Communications and Information Technology (MCIT) (2014). *The Ministry of Communication and ITs' [sic] activities and achievements report 1381-1393 (2002-2014)*, English version (not available electronically).

<sup>612</sup> The "Telecom Book" was a project undertaken by the MCIT between 2011 and 2013 to document the ICT sector from its origins through modern day. The author of this chapter was a collaborator of the MCIT's on the effort and wrote and edited substantial portions of its text. Although it was never released as a book, it formed the basis for the above-referenced activities and achievements reports.

information. The profiles of major service providers are from the companies themselves, from open sources, and from the MCIT and the Afghanistan Telecom Regulatory Authority (ATRA).

The rapid deployment and unprecedented adoption of modern telephone and Internet services in Afghanistan is a compelling story in itself. Further, it is the foundation for Afghanistan's socio-economic developments to date and the impetus of the country's re-emergence as a new nation-state.

## A Brief History

Afghanistan's entry into the world of electronic communications began at the end of the nineteenth century when a rudimentary one-to-one wired telephone was installed at the Arg Palace,<sup>613</sup> an ornate fortress in the Wazir Akbar Khan area of Kabul, which has housed Afghan kings and presidents from the 1880s all the way through to the present day. In 1908, a small 25-line telephone system was installed in the north tower.

Telegraph service was launched in Afghanistan in 1914, and several 50- and 100-line telephone switchboards were installed at the Shahi-Du-Shamshera post office in Kabul in 1919. In 1930, seven short-wave telegraph and telephone machines were installed among Kabul, Herat, Mazar-e-Sharif, Maymana, and Khost. Another higher-powered system was installed at the central telegraph building in Kabul in 1933. Afghanistan became a member of the [International Telegraph \(now Telecommunication\) Union](#) (ITU) on April 12, 1928.<sup>614</sup>

A 1,300-line automated relay telephone switch was installed 1949 and its wiring completed in 1950. In 1953, another switch with 5,000 lines of capacity was installed but was not activated until 1957, when its transmission network was completed. Afghanistan's first Ministry of Communications (MoC) was established in 1955 (although some source documents claim 1855, which is presumed to be an error). In 1959, the MoC installed a 1,500-line telephone switch in Kandahar City and

### THE TALE OF AN AGHAN MAN WHO WANTED TO CALL HIS ONLY SON

There is an oft-told (and frequently embellished) story, perhaps an urban legend of sorts, about a man from Sang-e-Takhat District of Daikundi Province who sent his only son to Iran to work to earn money for the family.

After no news of his son for quite some time, the father decided to travel to Pakistan to call him. After immense difficulty, the father earned the necessary money for travel expenses and began his trip to Pakistan, through Kabul and onto Torkham at the Afghan-Pakistan border. As the father reached Torkham, night fell so he had to remain there, only to find out in the morning the border crossing was closed. While he waited for it to reopen, he fell ill.

The father finally made it into Pakistan and called his son in Iran. After spending around three days in Pakistan, it took the father one month to travel back to his home district, having been away from the rest of his family and his livelihood for the duration of his journey.

Whether the story is true or not, it is representative of the challenges ordinary Afghans faced just to communicate in a fashion we so often take for granted.

---

<sup>613</sup> "Arg" means citadel in Dari and Pashto.

<sup>614</sup> The International Telegraph Union, established in 1865, was renamed the International Telecommunication Union (ITU) in 1932.

inaugurated its connection to Kabul in 1961. Kabul City was also connected to Torkham, a major border crossing on the Durand Line between Afghanistan and Pakistan.

By the early 1960s, Afghanistan enjoyed local telephone service in several areas and domestic long distance across much of the country via a 120-channel network comprised of three- and 12-channel systems and approximately 14,000 route kilometers (km) of analog telephone lines mounted on wooden telephone poles. Afghans were able to make international calls to Iran and Pakistan (and, by some accounts, Turkey). Three international radio transceiver stations were installed in Kabul between 1963 and 1964, connecting the capital by radio to international telephone transit centers in Paris, London, New Delhi, and Moscow. Afghanistan was assigned country code 93, part of World Zone 9 (Middle East and West Asia), by the ITU's Consultative Committee on International Telephone and Telegraph (CCITT).

In the 1960s and '70s, in order to meet rising demand from both the government and citizenry, the Ministry of Communications undertook two major projects to expand telephone service in the capital city. The first project, which ran from 1964 to 1969, added 10,000 new telephone lines in and around Kabul: 3,000 each in the Sher Shah Mena and Shar-e-Naw neighborhoods, 200 in Policharkhi, and 5,000 in the center of the city. The second project, conducted in consultation with the ITU, included the installation of three automated sub-city switches in Shar-e-Naw, Khair Khana, and Macrorayan and the activation of an additional 13,200 new telephone lines.

Afghanistan became a member of the [Asia-Pacific Telecommunity](#) (APT) in 1979, the same year Soviet troops invaded the country. Despite the upheaval, telephone switches were installed in the provincial cities of Jalalabad, Parwan, Polikhomri, Shebarghan, and Kunduz in 1983 and 1984. In 1997, satellite connections and microwave links were established between Kabul and Mazar-e-Sharif, Herat, Kandahar, and Jalalabad. In 1998, the US Central Intelligence Agency (CIA) estimated the number of telephones in use in Afghanistan to be around 29,000.<sup>615</sup>

Unfortunately, years of conflict destroyed most of Afghanistan's physical public service delivery substructures, including its ICT infrastructure. The ensuing years of political instability and civil war, followed by five years of Taliban rule, left most of the country without even basic telephone service. For the millions of Afghans who fled their homeland, reaching those who stayed behind was difficult. Afghans had to travel abroad to make international phone calls and mail letters.

An Afghan Interim Authority, which was established by the Bonn Agreement<sup>616</sup> and included a Department of Communication, commenced in December 2001. While some telephone and Internet service (both

---

<sup>615</sup> Uldal, Siri Birgitte and Muhammad Aimal Marjan (2004). *Information and Communication Technology in Afghanistan*. Norwegian Center for Telemedicine Report #05-2004, February 4, 2004, 11.

<sup>616</sup> Officially, the "Agreement on Provisional Arrangements in Afghanistan Pending the Re-Establishment of Permanent Government Institutions," December 5, 2001, the first in a series of international agreements to reestablish the Afghan state after the fall of the Taliban regime.

generally satellite-based) existed at that time, it was by and large reserved for Afghan elites and personnel from foreign governments and international organizations.

Around that time, only one of every 550 Afghans had access to telephone service.<sup>617</sup> Early policy goals were to increase fixed-line teledensity to 0.43 percent and to increase mobile users from 0.92 per thousand people to 2.52 by solar year (SY) 1382 (March 2003 - March 2004).<sup>618</sup> The private sector took an early lead in the mobile sector, while the government largely developed Afghanistan's terrestrial (fiber and copper) infrastructure. Early military personnel and aid workers were often equipped with satellite phones, and at least one organization had its own private mobile network.<sup>619</sup> For example, in early 2002, the United Nations (UN) World Food Programme (WFP) had a private GSM<sup>620</sup> network serving approximately 200 of its workers in Kabul, donated and installed by Ericsson, a large telecommunications company out of Sweden. The system had capacity for 5,000 users, so the UN allowed personnel from other humanitarian organizations, as well as government officials, to use the network to coordinate efforts in the absence of any other telephone services.<sup>621</sup>

## The Modern Era

In 2003, the Afghan Transitional Administration's (ATA's) stated policy was "to enable the rapid growth of affordable communications to all of our people so they may experience the Digital Age, wherever they are and whoever they may be."<sup>622</sup> Understanding the enormous resources – physical, financial, and human – required and the challenges inherent to building contemporary communications systems essentially from nothing, the Afghan government took a pragmatic approach by deciding quite early to end its monopoly on the ICT sector. It opened the market to private investment, applied minimal regulations, committed to follow international best practices, and provided the required spectrum and support for wireless (cellular) access, backhaul, and national backbone communications networks to facilitate reconstruction and accelerate the provision of modern telephone and Internet services to the Afghan citizenry.

---

<sup>617</sup> Islamic Transitional Government of Afghanistan Ministry of Communications (MoC). Telecommunications and Internet Policy, Final Working Draft, November 2003. Accessed August 19, 2015.

[http://mcit.gov.af/Content/files/AfghanistanTelecomPolicy\\_English29112010235311722.pdf](http://mcit.gov.af/Content/files/AfghanistanTelecomPolicy_English29112010235311722.pdf).

<sup>618</sup> Ibid.

<sup>619</sup> Ericsson had established a private mobile network in Kabul in January 2002 with 200 phones for humanitarian workers and government officials.

<sup>620</sup> Global system for mobile communications, a second generation of protocols for digital cellular networks originally developed by the European Telecommunications Standards Institute (ETSI). GSM is now a trademark owned by the GSM Association.

<sup>621</sup> Herold, Marc W. (2002). "Karzai & Associates' Trickle-Down Reconstruction." *Cursor* (blog), May 12. <http://cursor.org/stories/karzai.htm#27>. Original reference: Rosenbaum, Andrew, "Ericsson Builds Emergency Mobile Net in Kabul," Newsbytes [Amsterdam], January 17, 2002.

<sup>622</sup> Telecommunications and Internet Policy 2003.



## Commercial Telephone Services

### Mobile Cellular Service

#### Afghanistan's Mobile Revolution



Afghanistan's first commercial cellular network, an analog advanced mobile phone system (AMPS), was established by [Afghan Wireless Communications Company](#) (AWCC). Formed in September 1998 by Afghan-American Ehsan Bayat, AWCC was a joint venture with the Ministry of Communications under the Taliban regime, along with Telephone Systems International (TSI) out of New Jersey.<sup>623</sup> The network was very basic and was used predominantly by Taliban commanders, earning the company the nickname "Taliban Tel." However, Afghanistan's modern ICT era is generally agreed to have begun in April 2002 when AWCC launched the country's first commercial mobile GSM network. (AWCC was allowed to continue to operate because the post-Taliban interim government honored AWCC's contract with the previous administration.) AWCC paid US\$1.2 million for the privilege of an interim authorization from the Afghan government to provide GSM services, and was later awarded an official GSM license (in July 2003) for a fee of US\$5 million.<sup>624</sup>

On April 6, 2002, amid great fanfare, Afghanistan's interim leader Hamid Karzai placed the first call to an Afghan émigré in Germany, which "event was heralded as the most significant step to-date in Afghanistan's nascent entry into the modern world."<sup>625</sup> AWCC provided voice and data services for the *Loya Jirga*<sup>626</sup> meeting in June 2002. Although AWCC launched with only four base stations in Kabul, by November 2002, AWCC had installed nine more in the capital city, for a total of 13, and had begun providing service in Herat (August), Mazar-e-Sharif (September), and Kandahar (November). AWCC operated the primary international gateway in the country with a capacity of approximately 250 lines, via satellite service from an international carrier located in Guam, allowing international calls to and from Afghanistan on its network.<sup>627</sup> AWCC also built out a [national microwave network](#) to achieve a "one-hop" architecture to minimize having to use satellite backhaul service (which is described in more detail later in this chapter).

---

<sup>623</sup> AWCC is an operating subsidiary of American company Telephone Systems International, Inc. (TSI). The Afghan Ministry of Communications and Information Technology holds a 20 percent stake in AWCC.

<sup>624</sup> Even though AWCC's official GSM license was awarded six months after Roshan's, AWCC is often cited as the first GSM licensee because of the provisional status it was granted to offer GSM services in 2002.

<sup>625</sup> Telephone Systems International, Inc (2002). *A Nation on the Line: The Story of the Afghan Wireless Communication Company*. Accessed August 19, 2015. <http://www.afghanwireless.com/images/AWCC%20Brochure%20012703.pdf>.

<sup>626</sup> Grand assembly of tribal elders. The emergency Loya Jirga was convened in June 2002 to form a second interim administration for Afghanistan.

<sup>627</sup> Uldal and Marjan, 2004, 18.

In January 2003, [Roshan](#)<sup>628</sup> was awarded the country's first GSM license,<sup>629</sup> also for US\$5 million. Roshan began offering services in July of that year. In August 2003, AWCC's and Roshan's networks were interconnected, allowing the companies' customers to call each other across the two networks. US government civilians, along with other foreign nationals in country, and USFOR-A<sup>630</sup> turned to AWCC's and Roshan's services early on, with tens of thousands of mobile telephone lines in use on a daily basis, jumpstarting MNOs' revenues.



While demand for modern ICT services was also evident among Afghans, the two early GSM operators had to contend with and overcome myriad issues and challenges. Electricity, where it existed, was often intermittent and unreliable. Roads were in poor condition, and inter-city transport was often treacherous, both physically and because of nefarious actors "patrolling" thoroughfares. Spectrum interference was common, there was no national numbering plan, and limited infrastructure existed for backhaul, long distance, and international services. Additionally, the GSM operators had to contend with a lack of skilled ICT workers and a digitally illiterate population. Despite these and other tribulations, both AWCC and Roshan continued to increase their numbers of subscribers, network capacity, and network reach. The two companies enjoyed a three-year duopoly by agreement with the MoC (which was later institutionalized in policy) not to allow another company to provide mobile telephone service until January 2006.



In anticipation of opening the mobile market to further competition, the MoC concluded a public bidding process in September 2005 and awarded GSM licenses to Watan Mobile and Investcom, operating under the name Areeba.<sup>631</sup> The fee for the second round of GSM licenses had risen to US\$40.1 million, more than eight times the US\$5 million paid by both AWCC and Roshan. After commencing services in July 2006, Areeba had an estimated subscribership of 200,000 by the end of that year. Watan withdrew from the market.

In September 2005, [Afghan Telecom Corporation](#) (AfTel) was established by Presidential Decree and with an initial capital investment of US\$2 million from the Afghan treasury. AfTel was issued a Unified Services

---

<sup>628</sup> Roshan means "light" and is the name under which the Telecom Development Company Afghanistan Ltd. (TDCA) operates. TDCA is owned by the Agha Khan Fund for Economic Development (51 percent), Monaco Telecom International (36.75 percent), and TeliaSonera (12.25 percent).

<sup>629</sup> Roshan is often reported as having received the country's second GSM license because AWCC was already providing GSM services through a provisional government authorization. However, its license preceded AWCC's by six months.

<sup>630</sup> United States Forces-Afghanistan

<sup>631</sup> Areeba was a subsidiary of the Lebanon-based firm Investcom in consortium with Alokozai-FZE. Areeba was acquired by South African-based Mobile Telephone Network (MTN) in mid-2007 as part of a US\$5.53 billion global merger between the two companies.

license in April 2006, the only one in the country to date, and began offering CDMA<sup>632</sup> mobile telephone services shortly thereafter. By the end of that year, it reportedly offered CDMA service in all 34 provinces.



In May 2006, the fourth GSM license was awarded to [Etisalat](#),<sup>633</sup> also for US\$40.1 million. Etisalat began offering commercial services in Afghanistan in August 2007. In four short years, Afghanistan had achieved nearly two million mobile subscribers, as indicated in [Table 3](#).<sup>634</sup>

Table 3: Subscribers and coverage by mobile network operator (2006 estimates)

Operator	Subscribers	Coverage
AWCC	700,000	45 cities in 18 provinces
Roshan	1,000,000	150 cities and towns in 27 provinces and along 5 major highways
Afghan Telecom	250,000	144 cities, towns, and districts in all 34 provinces; most government ministries and offices
Areeba	?	4 cities in 4 provinces
Etisalat	Not yet operational	n/a

The sixth and last entrant to Afghanistan’s mobile network market was another CDMA service provider, [Wasel Telecom](#), which also provided fixed-line services as described below. Wasel commenced offering service in several northern Afghan provinces in May 2008.



Between 2006 and 2012, prices of mobile voice services decreased dramatically, with the price of SIM<sup>635</sup> cards declining from US\$250 each to only a dollar (US\$1), and the price-per-minute for both local and international calls decreasing more than six-fold, which you can see in [Figure 20](#).<sup>636</sup>

<sup>632</sup> Code division multiple access, a method used by some radio communications technologies that makes it possible for several transmitters to send information over a single communication channel simultaneously, thereby allowing multiple users to share finite frequency bandwidth without interference.

<sup>633</sup> Etisalat Afghanistan is a wholly-owned subsidiary of Etisalat Telecommunications Corporation in the United Arab Emirates, a multinational company operating in the Middle East, Africa, and Asia.

<sup>634</sup> Adapted from Global Internet Policy Initiative-Afghanistan (GIPI-AF) Team (2006). *Promoting Internet Policy and Regulatory Reform in Afghanistan. Assessment Report*, December 2006, 14.

<sup>635</sup> Subscriber identity module, a removable smart card for some types of mobile phones that stores identifying information regarding the phone and associated customer account.

<sup>636</sup> Adapted from Hamdard, Javid (2012). *The State of Telecommunications and Internet in Afghanistan, Six Years Later (2006-2012)*. March 2012, 12. Accessed October 12, 2015.

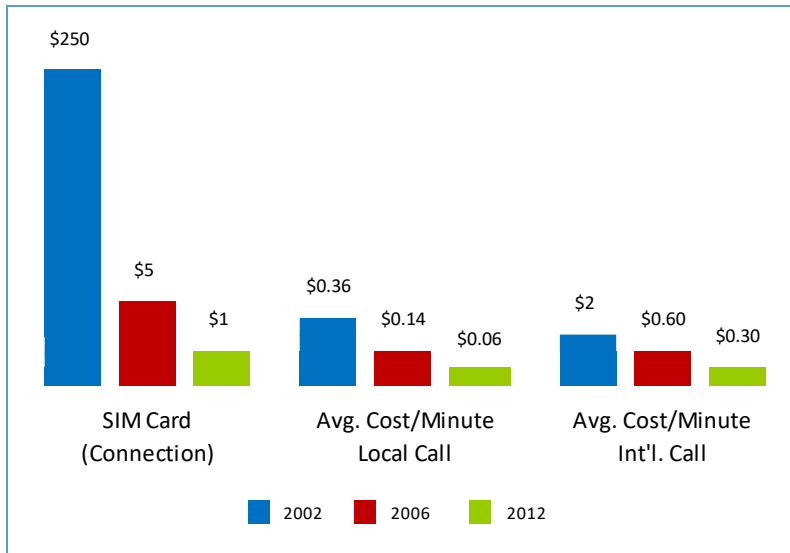

Figure 20: Mobile telephony periodic cost comparison

Mobile voice telephony services continued to expand and flourish throughout Afghanistan, with Roshan reaching the six-million customer mark in June 2012.<sup>637</sup> In ten years, Afghanistan achieved nearly 20 million mobile phone subscribers, as indicated in [Figure 21](#).<sup>638</sup>

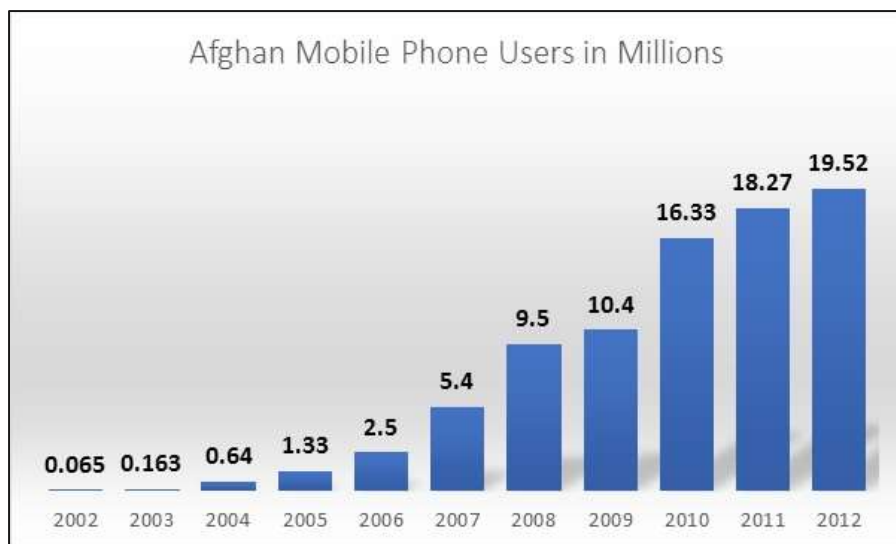

Figure 21: Afghan mobile phone subscribers, 2002-2012

[https://www.usaid.gov/sites/default/files/documents/1871/The%20State%20of%20Telecoms%20and%20Internet%20%20in%20Afghanistan%20\(2006-2012\)%20Low-Res.pdf](https://www.usaid.gov/sites/default/files/documents/1871/The%20State%20of%20Telecoms%20and%20Internet%20%20in%20Afghanistan%20(2006-2012)%20Low-Res.pdf).

<sup>637</sup> Roshan (2012). "Roshan the First Operator to Reach 6 Million Customers in Afghanistan." *PRNewswire*, June 6. Accessed October 12, 2015. <http://www.prnewswire.com/news-releases/roshan-the-first-operator-to-reach-6-million-customers-in-afghanistan-158462185.html>.

<sup>638</sup> Chart provided to the author by the MCIT in mid-2012 as part of the "Telecom Book" project.

At that time (mid-2012), market share by number of subscribers was fairly well-distributed among the four major GSM operators, as indicated in [Figure 22](#).<sup>639</sup>

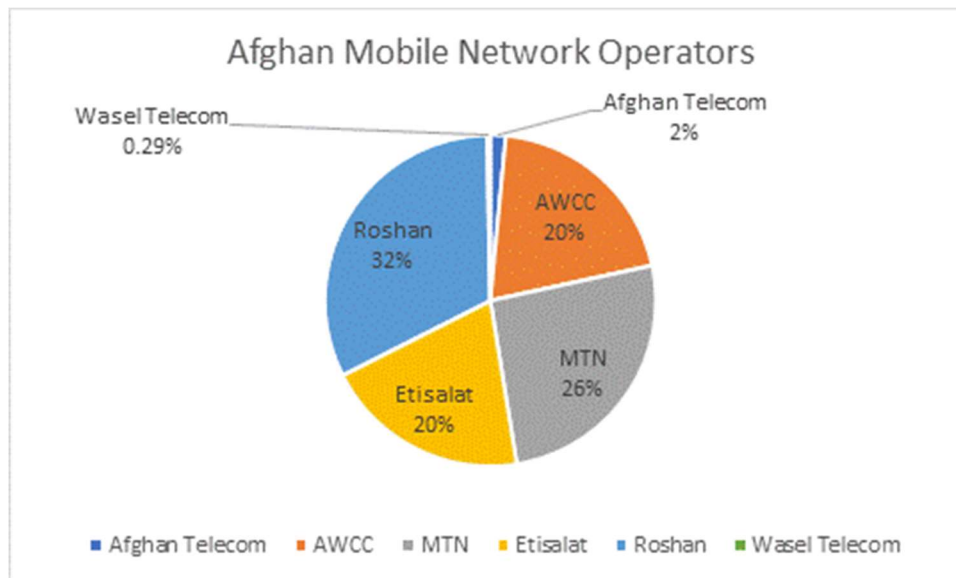

Figure 22: Market share by mobile network operator, 2012

In July 2011, the Afghan Office of the National Security Council issued a directive<sup>640</sup> requiring Afghan Telecom to provide 24x7 mobile telephone service to the government, in no small part to counter the Taliban's and other insurgents' successful efforts to have commercial mobile network operators (MNOs) shut down their cell towers at night. AfTel undertook a lengthy evaluation process<sup>641</sup> to determine whether to keep, upgrade, and expand its existing CDMA network or to implement a new GSM network. In July 2012, the AfTel Board of Directors approved AfTel's decision for the latter. AfTel developed and released an international competitive tender<sup>642</sup> on July 1, 2012 for the construction of a GSM/3G<sup>643</sup> network, the contract for which it awarded to ZTE in October 2012. (ZTE is one of two Chinese companies – the other being Huawei – which are very active in the Afghanistan ICT sector through numerous projects, past and present.) AfTel subsequently released related tenders for a satellite cellular backhaul network

---

<sup>639</sup> Adapted from Hamdard, 2012, 17.

<sup>640</sup> Islamic Republic of Afghanistan Office of National Security Council (ONSC) Directorate of Interior Affairs (2011). *Security Strategy for Telecommunication Networks in the Territory of GIROA*, July 31.

<sup>641</sup> With the assistance of the Telecommunications Advisory Team (TAT) and the Space and Naval Warfare Systems Command (SPAWAR), which was contracted by the US Defense Information Systems Agency (DISA) to assist the TAT.

<sup>642</sup> Again, with the TAT's and SPAWAR's assistance.

<sup>643</sup> Third-generation wireless digital technology based on International Telecommunication Union (ITU) International Mobile Telecommunications (IMT)-2000 specifications.

for its GSM/3G network and for a project management office (PMO) to oversee the network implementation and plan its GSM/3G service launch.<sup>644</sup>

AfTel publicly announced its entry into the GSM/3G market November 20, 2012, claiming its new network would cover the remaining 15 percent of the population without communications services, bridge the gap in areas where the three existing 3G service providers were not already operating, and provide telephone service and Internet access 24 hours a day. AfTel launched GSM services under the brand name “Salaam,” which means “peace,” in Kabul on February 4, 2014<sup>645</sup> and in ten other cities shortly thereafter. It planned to extend GSM/3G service to all 34 provinces within six months. By mid-2014, AfTel had acquired approximately a quarter of a million GSM subscribers.<sup>646</sup>

That figure increased to 650,000 subscribers by September 2014.<sup>647</sup> Such rapid growth, however, was not without consequences. AfTel’s Salaam service was plagued by problems, including weak signal strength, poor quality of service, and slow data speeds. Customer complaints were apparently numerous and severe enough to prompt the Minister of Communications to issue a public statement declaring he was addressing the problems.<sup>648</sup> The MCIT reportedly signed a contract in August 2014 with a company to help AfTel improve its GSM/3G network, but it is unclear with whom or how they were going to provide assistance. The MCIT also pledged to install another 333 cell towers, ostensibly for AfTel, in two phases using money from ATRA’s Telecommunications Development Fund (TDF).<sup>649</sup>

AfTel sold its CDMA network and operation to Wasel Telecom, which allowed Wasel to extend its CDMA mobile service offering nationwide beginning in September 2014.<sup>650</sup>

## Present Day

Since April 2002, when Afghan Wireless first launched mobile telephone service in Kabul, the adoption and use of mobile voice telephony in Afghanistan has been phenomenal: 82.3 percent of Afghan households report owning at least one mobile phone.<sup>651</sup> By the end of December 2015, ATRA showed the six MNOs had installed 6,501 cellular base transceiver stations (BTSs) and accrued over 25 million customers among them. Mobile services coverage was available to 89 percent of the Afghan population

---

<sup>644</sup> The TAT also assisted AfTel with these two tenders.

<sup>645</sup> MCIT (2014). “MCIT/Afghan Telecom inaugurates GSM & 3G Services.” February 9. Accessed October 12, 2015. <http://www.mcit.gov.af/en/news/mcit-afghan-telecom-inaugurates-gsm-3g-services>.

<sup>646</sup> MCIT, 2014. *Activities and achievements report*, 18.

<sup>647</sup> MCIT (2014). “Salaam Network Activities & Challenges.” September 3. Accessed January 6, 2016. <http://mcit.gov.af/en/news/36038>.

<sup>648</sup> Ibid.

<sup>649</sup> Ibid.

<sup>650</sup> Wasel Telecom. Accessed October 12, 2015. [http://www.wasel.af/?page\\_id=1791](http://www.wasel.af/?page_id=1791).

<sup>651</sup> Warren, Zachary and Nancy Hopkins, eds. (2015). *Afghanistan in 2015: A Survey of the Afghan People* (The Asia Foundation), 11. Accessed January 6, 2016. <http://www.asiafoundation.org/resources/pdfs/Afghanistanin2015.pdf>.

(by geographic area),<sup>652</sup> and Afghanistan achieved a mobile penetration rate of 89 percent as well.<sup>653</sup> (Those numbers are not too terribly far from former MCIT Minister Sangin’s goal of one phone for every Afghan.)<sup>654</sup> While the coverage and penetration of mobile telephone service in Afghanistan is extraordinary, the next phase in the country’s mobile revolution – using their phones for a variety of purposes, tasks, and functions as we do in the West – will be even more so.

### *Ten Percent (10%) Telecom Service Fee*

Recognizing the success of the Afghan mobile sector, the National Unity Government under President Ashraf Ghani and Chief Executive Officer Abdullah issued a legislative decree to impose a ten percent tax on telephone subscribers – for every SIM recharge – beginning September 23, 2015. The move, an unabashed bid to increase government revenues from reliable domestic sources, was unanimously rejected by the *Wolesi Jirga* (Lower House) of the Afghan Parliament in October 2015.<sup>655</sup> Interestingly, many Afghan youths took to social media to protest the Parliament’s decision to nix the tax, using the hashtag #IWantToPayTax and supporting the Afghan government’s effort toward self-reliance and a weaning off of donor dollars.<sup>656</sup> The MCIT is responsible for collecting the tax and ensuring the transparency thereof, so it installed a “semi-real-time data management system” to do so.<sup>657</sup> Data from the system reportedly indicated 62 percent of the amount collected in the first couple weeks was from 76 percent of subscribers who topped-up their SIMs for 50 Afs each.<sup>658</sup> By mid-November 2015, the Afghan Ministry of Finance reported having collected 104 million Afs – over US\$1.5 million<sup>659</sup> in tax revenue.

### *Fixed-Line and Wireless Local Loop Services*

As mentioned above, Afghanistan’s ICT infrastructure was essentially annihilated by years of perpetual conflict. However, by October 2002, Afghanistan’s terrestrial telephone switching capacity was reported

---

<sup>652</sup> Afghanistan Telecom Regulatory Authority (ATRA). Telecom Statistics (End of December 2015). Accessed March 16, 2016. <http://atra.gov.af/en/page/telecom-statistics-2013>. ATRA updates this statistics page quarterly or thereabouts, without preserving historical reference to earlier periods on its website.

<sup>653</sup> Using a total population (nomadic and settled) of 28,601,365, per ACSO’s *2013-2014 Statistical Yearbook*, [http://cso.gov.af/Content/files/Population\(3\).pdf](http://cso.gov.af/Content/files/Population(3).pdf), accessed January 5, and August 23, 2016, and 25,375,284 mobile subscribers, per ATRA’s Telecom Statistics (End of December 2015). The number of subscribers can be slightly misleading, as some people have more than one SIM card while others have none.

<sup>654</sup> Sangin, Amirzai (2011), Lecture at American University, Kabul, November 27, 25.

<sup>655</sup> “Parliament rejects decree to impose 10% tax on mobile phone users.” 2015. *Khaama Press*, October 14. Accessed April 3, 2016. <http://www.khaama.com/parliament-rejects-presidential-decree-to-impose-10-tax-on-mobile-users-1625>.

<sup>656</sup> Kumar, Ruchi (2015). “#IWantToPayTax: Why Afghans are protesting against their parliament’s decision to scrap telecom tax.” *DNA India*, October 18. Accessed April 3, 2016. <http://www.dnaindia.com/world/report-iwanttopaytax-why-afghans-are-protesting-against-their-parliament-s-decision-to-scrap-telecom-tax-2136282>.

<sup>657</sup> MCIT (2015). “Collection of 10 percent Telecom Service Fees is secure and transparent.” October 4. Accessed April 3, 2016. <http://mcit.gov.af/en/news/53507>.

<sup>658</sup> Ibid.

<sup>659</sup> Moosakhail, Zabihullah (2015). “10% Telecom Service Tax within commitments to international community,” *Khaama Press*, November 21. Accessed April 3, 2016. <http://www.khaama.com/10-telecom-service-tax-within-commitments-to-international-community-4244>.

to be just over 33,000 active lines,<sup>660</sup> as indicated in [Table 4](#),<sup>661</sup> with plans to add another 56,500. Most fixed-line service was still analog, but Herat had a digital system.

Table 4: Fixed-line telephone switching capacity by city, October 2002

City	Capacity	Active	% Active	Planned Expansion
Kabul	27,000	20,150	75%	38,000
Herat	7,800	7,000	89%	5,000
Kandahar	5,000	n/a	0%	5,000
Mazar-e-Sharif	3,500	3,500	100%	10,000
Kunduz	1,000	1,000	100%	2,500
Jalalabad	1,400	1,400	100%	5,000
Total	45,700	33,050	72%	56,500

The cities in [Table 4](#) were in the first tier of the Ministry of Communications' three-tier plan, with the Tier 2 cities of Pulekhomri, Parwan, Juzjan, Khost, Ghazni, Faryab, Takhar, Helmand, Badakhshan, Paktika, and Farah to receive 1,000 lines each. Tier 3 included only rural areas. Afghanistan reestablished long distance telephone service among Kabul, Mazar-e-Sharif, Herat, and Kandahar via a VSAT<sup>662</sup> backbone transmission network connecting those cities. Jalalabad had a VSAT terminal but did not have a switch to which to connect it.<sup>663</sup>

In July 2003, the Ministry of Communications announced its intention to address the lack of last-mile services by inviting bids for a project to implement CDMA wireless local loop (WLL) services<sup>664</sup> for 35,000 lines: 20,000 for Kabul and 5,000 each for Khost, Kunduz, and Jalalabad.<sup>665</sup> In August 2003, the MoC signed a contract with Huawei and ZTE, both from China, for digital switching equipment for 100,000 fixed telephone lines for the cities of Kabul, Mazar-e-Sharif, Kandahar, Jalalabad, Khost, Kunduz, Pulekhomri, Sheberghan, Ghazni, Faizabad, Lashkargah, and Taloqan.<sup>666</sup> By the end of 2003, several microwave links had been repaired, allowing for a 2 Mbps<sup>667</sup> international connection between Kabul and Pakistan.<sup>668</sup> Two

---

<sup>660</sup> The MCIT's *ICT Sector Strategy* says there were only 15,000 functioning telephone lines in early 2003, equating to a penetration rate of 0.06 percent, one of the lowest in the world.

<sup>661</sup> Uldal and Marjan, 2004, 11.

<sup>662</sup> Very small aperture terminal, a two-way satellite ground station with a dish antenna generally smaller than three to four feet.

<sup>663</sup> Uldal and Marjan, 2004, 11.

<sup>664</sup> Wireless local loop is a generic term for the various technologies and systems that allow for a wireless "last-mile" connection for a service provider to deliver voice and data services to a customer, often, but not only, where terrestrial infrastructure does not exist.

<sup>665</sup> Uldal and Marjan, 2004, 15.

<sup>666</sup> Ibid.

<sup>667</sup> Megabits per second, a measure of data transfer rates.

<sup>668</sup> Paragraph excerpted and paraphrased from Uldal and Marjan, 2004, 11-16.



years after the Taliban regime left Kabul, there were approximately 172,000 telephones among Afghanistan's 25 million citizens.<sup>669</sup>

In January 2004, the MoC invited bids to build an SDH<sup>670</sup> microwave network between Kabul and the eastern provinces, including Jalalabad, Nuristan, Kunar, and Laghman, which was to terminate in Peshawar, Pakistan.<sup>671</sup> By early 2004, Kabul had a digital switch with a capacity of 12,000 lines. While "there [was] no dynamical interconnection between the analogue and the digital network, [there was] an ongoing project to decommission analogue exchanges and transfer the lines to the digital exchanges in Kabul ... to allow communication between GSM [mobile networks] and the older analogue system."<sup>672</sup> On September 15, 2005, the MoC launched a digital switch and CDMA WLL services in 11 provincial capitals with a total of 35,000 lines, funded by the Indian government.<sup>673</sup>

State-owned Afghan Telecom began providing digital fixed-line services in May 2006. Wasel Telecom<sup>674</sup> was awarded the first Local Fixed Service Provider (LFSP) license<sup>675</sup> in May 2006 (also through a competitive bidding process) and commenced offering services one or two years later, depending on the source. Wasel Telecom is the only company besides AfTel authorized to provide fixed-line services, and only regionally.

Between 2007 and 2008, with US\$50.5 million in funds from the Afghan treasury, the MCIT expanded the country's national digital telephone network, installing 152,000 copper telephone lines throughout five provinces.<sup>676</sup> In May 2011, the MCIT reported 200,000 copper telephone lines (along with digital exchanges to support them) had been installed throughout the country over the preceding seven years. It planned to install 30,000 more in ten provincial capital cities in SY1390 (March 2011-March 2012).<sup>677</sup> In November 2012, the MCIT inaugurated a telephone switch in southwest Kabul, the last exchange to be installed with only copper connectivity (future ones would be a combination of copper and fiber),<sup>678</sup> and the culmination of the MCIT's project to install 100,000 landlines throughout Kabul City.<sup>679</sup>

---

<sup>669</sup> Uldal and Marjan, 2004, 1.

<sup>670</sup> Synchronous digital hierarchy, a protocol for digital transmission over optical fiber.

<sup>671</sup> Uldal and Marjan, 2004, 16.

<sup>672</sup> Ibid.

<sup>673</sup> MCIT (n.d.). "Digital Switch and CDMA WLL in 11 Provinces." Accessed January 6, 2016.

<http://mcit.gov.af/Content/Media/Documents/digitalswtich231120106538752.pdf>.

<sup>674</sup> Wasel Telecom is, or at least was in 2006, a joint venture between AG Telecom LLC (the majority shareholder) and Modern Technology International (both based in the United Arab Emirates), and Korean and Afghan entrepreneurs.

<sup>675</sup> LFSP licenses are awarded on a case-by-case basis and at no charge to private companies interested in providing services in underserved and rural areas.

<sup>676</sup> MCIT (n.d.). "Expansion of the National Digital Telephone Network." Accessed January 6, 2016.

<http://mcit.gov.af/Content/Media/Documents/expansion2311201064030179136201175640290553325325.pdf>.

<sup>677</sup> MCIT, 2011. *E-Afghanistan NPP*, 31.

<sup>678</sup> ISAF Telecommunications Advisory Team (TAT) Weekly Report, November 28, 2012.

<sup>679</sup> MCIT (2012). "Digital Phone Project of Kart-e now officially inaugurates." November 27. Accessed January 6, 2016. <http://mcit.gov.af/en/news/15028>.

Installation of fixed-line service continued past 2012 in other parts of the country. The MCIT's website is peppered with stories of inaugurations of digital telephone projects and installations of digital telephone exchanges throughout Afghanistan, such as 5,000 in Umaide Sabz Maina and 19,000 in Ahmad Shahbaba in May 2014.<sup>680</sup> Despite all this activity, and even though having a landline is somewhat of a status symbol among Afghans, ATRA's website claims only 110,000 landline telephones were in use in Afghanistan as of the end of December 2015.<sup>681</sup>

## Commercial Internet Services

As described above, Afghanistan enjoyed relatively modern telephone service before decades of perpetual conflict largely destroyed its ICT infrastructure. However, the Internet had just made it to the country at the turn of the century. In the year 2000, a single, private Internet service provider (ISP) "offer[ed] limited, satellite-based service with low bandwidth to a few international organizations and diplomatic representations."<sup>682</sup> Some in the donor community and international media had reportedly established their own Internet service for private use, also via satellite. However, in July 2001, the Taliban government banned use of the Internet by anyone outside the government.<sup>683</sup> It did so in order "to block access in Afghanistan to anti-Islamic material,"<sup>684</sup> and because it could neither control nor censor in- and outbound communications through Internet network facilities, which were in neighboring Pakistan.

Modern Internet service essentially began in Afghanistan in 2002, after the (interim) Karzai administration replaced the toppled Taliban government in December 2001. Internet access was generally provided via satellite by regional and international ISPs. One non-governmental organization (NGO), PACTEC, was allowed to provide Internet services for other NGOs<sup>685</sup> in the early days. AWCC provided limited 2G<sup>686</sup> mobile broadband service.

The Ministry of Communications had responsibility for the Internet connectivity – the conduit – but regulation of Internet content was assigned to the Ministry of Information and Culture (MoIC). Reportedly, personnel from the MoIC travelled to Dubai to "see" and learn about the Internet they would be policing, since the concept of it was so completely foreign as to be unimaginable.

---

<sup>680</sup> MCIT (2014). "MCIT officially inaugurates Digital phone Projects of Ahmad Shahbaba and Umaide Sabz Maina." May 19. Accessed October 9, 2015. <http://mcit.gov.af/en/news/mcit-officially-inaugurates-digital-phone-projects-of-ahmad-shahbaba-and-umaide-sabz-maina>.

<sup>681</sup> ATRA, Telecom Statistics (End of December 2015).

<sup>682</sup> GIPI-AF, 2006.

<sup>683</sup> By the Taliban Foreign Minister, which was followed by a formal Taliban Decree of August 25, 2001, prohibiting all members of the administration of the Islamic Emirate of Afghanistan, all non-Emirate institutions, all foreign and local NGOs, and all individuals from using the Internet within the territory of the Republic.

<sup>684</sup> "Taleban 'outlaw internet.'" *BBC News*, July 12, 2001. Accessed September 30, 2015. [http://news.bbc.co.uk/2/hi/south\\_asia/1437852.stm](http://news.bbc.co.uk/2/hi/south_asia/1437852.stm).

<sup>685</sup> Uldal and Marjan, 2004, 24.

<sup>686</sup> Second-generation wireless digital technology, which replaced first-generation analog systems.

## Reclaiming Afghanistan's Domain

According to the [Internet Assigned Numbers Authority](#) (IANA), the “.af” country code top level domain (ccTLD) was originally delegated in October 1997 to administrative contact Mr. Abdul Razeeq and technical contact NetNames of London.<sup>687</sup> On December 31, 2001, the [United Nations Development Programme](#) (UNDP), with approval from the Afghan Interim Authority – which had been established only nine days prior – contacted the IANA to assume temporary administration of the .af registry. The UNDP’s role was “to restore DNS service, to build technical and administrative capacity within Afghanistan, and to shift technical operations to a community-based management structure inclusive of multiple sectors within Afghanistan when feasible and appropriate.”<sup>688</sup>



*Picture 7: Minister of Communication Stanekzai Receiving ".af" domain from UNDP, 2003*

*(Photo from Ministry of Communications Telecom and ICT Policy Documents, October 2003)*

In September 2002, the Ministry of Communications, jointly with UNDP as its proposed temporary technical partner, submitted a formal request to the IANA to re-delegate the .af domain to the MoC (see [Picture 7](#)). The IANA approved the MoC’s proposal on January 8, 2003.<sup>689</sup> As part of its responsibilities, the MoC was required to enter into a memorandum of understanding with the [Internet Cooperation for Assigned Names and Numbers](#) (ICANN) and agree to its accountability framework. The MoC and UNDP assumed legal and technical control, respectively, of the .af ccTLD in March 2003.<sup>690</sup> Later that month, the MoC established the Afghan Network Information Center (AfgNIC) as an independent entity responsible for management of the .af ccTLD and domain name registration services for the country. The first websites registered under the re-delegated .af domain<sup>691</sup> were for the Ministry of Communications ([www.moc.gov.af](http://www.moc.gov.af)) and the UNDP Afghan country office ([www.undp.org.af](http://www.undp.org.af)).<sup>692</sup> By September 2003, AfgNIC.af had registered more than 81 second-level country

---

<sup>687</sup> Internet Assigned Numbers Authority (2003) *IANA Report on the Redellegation of the .af Top-Level Domain*. January 8, 2003. Accessed September 30, 2015. <https://www.iana.org/reports/2003/af-report-08jan2003.html>.

<sup>688</sup> Ibid.

<sup>689</sup> Ibid.

<sup>690</sup> Ibid.

<sup>691</sup> UNDP hosted and maintained the main domain name server at its headquarters in New York, NY.

<sup>692</sup> GIPI-AF, 2006, 10-11.

code domains (ccSLDs).<sup>693,694</sup> Three years later, that number had risen to 400,<sup>695</sup> and by mid-2013, it was over 6,500.<sup>696</sup> [Figure 23](#) depicts the distribution of Afghan domains by type.<sup>697</sup>

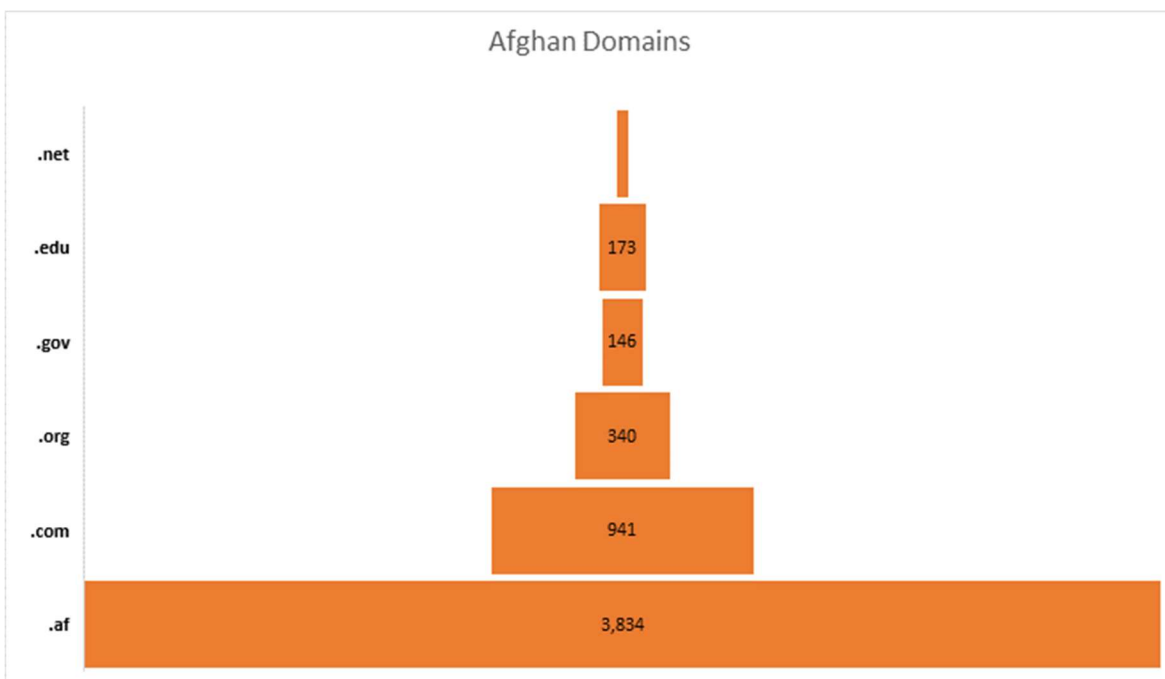

Figure 23: Registered Afghan domains by type, 2013

### Internet Service Providers

Although Internet service was available in 2002 (see section on Internet cafés below), NEDA Telecommunications received Afghanistan’s first official ISP license in November 2004. By the end of that year, the nascent regulator had issued five additional national ISP licenses to companies providing Internet access in the five major cities of the country.<sup>698</sup> By 2006, there were 26 ISPs, including the two GSM operators (AWCC and Roshan) and Afghan Telecom.<sup>699</sup> In 2009, Wasel Telecom was awarded an ISP

---

<sup>693</sup> Second-level domains are directly below top-level domains in the Domain Name System hierarchy and generally refer to the organization that registers the domain name with a domain name registrar. For example, [www.mcit.gov.af](http://www.mcit.gov.af) is a second-level domain registered to the Afghan MCIT.

<sup>694</sup> GIPI-AF, 2006, 31.

<sup>695</sup> Ibid. p. 11.

<sup>696</sup> Per the Afghanistan Network Information Center (AfgNIC), as reported to the Afghan MCIT and this author via email at the time.

<sup>697</sup> Per the MCIT in mid-2012, as part of the “Telecom Book” project.

<sup>698</sup> GIPI-AF, 2006, 11. However, the Afghan MCIT provided information in 2012 that said NEDA received its license in both September and November 2004, with other ISPs licensed thereafter. Earlier MCIT information – supplied by UNDP – supports the January 2003 license date for NEDA.

<sup>699</sup> GIPI-AF, 2006, 14.

license. As of June 2015, ATRA reported a total of 57 licensed ISPs,<sup>700</sup> including three WiMAX<sup>701</sup> providers. AfTel is also authorized to provide WiMAX under its Unified Services license.

Most of Afghanistan's traditional ISPs provide service to their customers via satellite transport networks to points of presence located outside the country, such as Moscow, Hong Kong, London, and Brussels, among others. Additionally, Afghan ISPs do not have domestic interconnect agreements with one another that would permit customers to access content from other ISPs. The lack of domestic interconnectivity results in excess bandwidth consumption over multiple satellite links and multi-hop delays, all of which contribute to excessive costs of operations, which translate to higher prices for Afghan consumers.

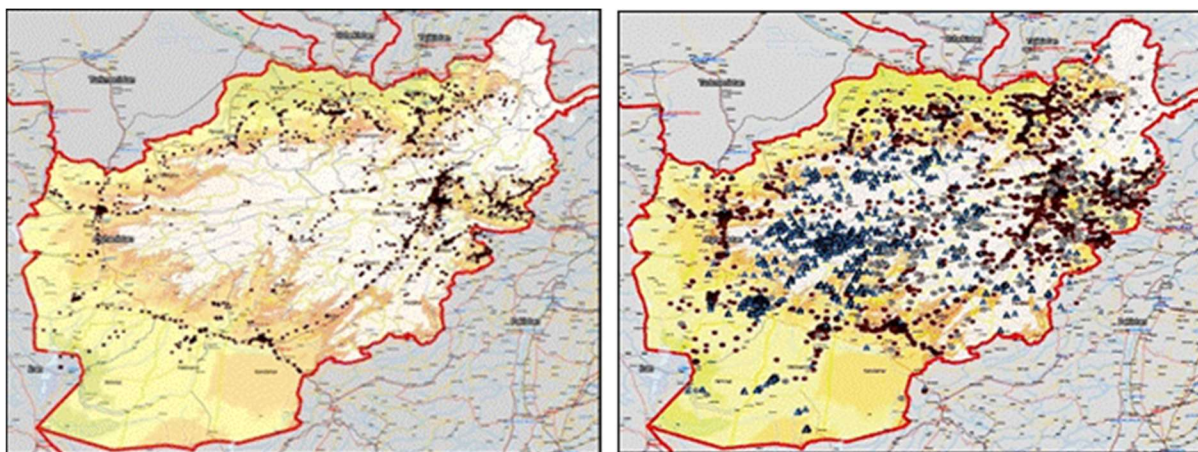

Figure 24: Cellular and VSAT network coverage, 2010 and 2014

(Graphics courtesy of former TAT Senior ICT Advisor Lewis E. (Lew) Shadle, Deloitte Consulting LLP)

Afghan ISPs have not enjoyed the same success and visibility as the country's mobile network operators. ISPs were generally quicker to deploy services upon the fall of the Taliban regime, with VSAT dishes popping up all over the country, while the MNOs were slower to build out their cellular networks (see [Figure 24](#)). However, to some extent, the ISP community had somewhat of a bad reputation within Afghanistan's public ICT institutions. The MCIT, in particular, viewed ISPs as bandits, mom-and-pop operations, and undercapitalized VSAT installers that did not invest in permanent infrastructure, which claims were not without validity. Further, the MCIT seemed to hold it against the ISPs when they did not immediately shift from satellite connectivity to fiber-based services provided by AfTel, which the MCIT owns. However, the MCIT did not seem to take into consideration that AfTel did not distinguish between

---

<sup>700</sup> ATRA, Telecom Statistics (End of June 2015). Accessed October 12, 2015. <http://atra.gov.af/en/page/telecom-statistics-2013>. ATRA updates this statistics page quarterly or thereabouts, without preserving historical reference to earlier periods on its website.

<sup>701</sup> Worldwide Interoperability for Microwave Access, a family of wireless communications standards that enables the delivery of last-mile wireless broadband Internet service.

wholesale and retail prices until mid-2012, nor did it recognize AfTel's notorious and perpetual quality of service (QoS) issues were a major deterrent for the ISPs.

Making matters worse, ISPs faced what they collectively believed to be an unfair tax burden, particularly as compared to the MNOs, claiming to pay roughly 47 percent of their revenues in taxes and fees. Moreover, ISPs are not allowed to provide voice services (voice over Internet Protocol, or VoIP, which is illegal in Afghanistan except among closed-user groups), but the MNOs can provide Internet access and data services. Further, the ISPs face competition from illegal and unlicensed ISPs that do not pay license fees or taxes. They also had to contend with outside Internet services contracted by Coalition forces under the auspices of the Military Technical Agreement (MTA) and by diplomatic missions to which the rules do not apply.

The National ISP Association of Afghanistan (NISPAA), through facilitation by the Telecommunications Advisory Team (TAT), met with ATRA for the first time in November 2011 to address these and other concerns, thus beginning a somewhat constructive dialog on the challenges facing the ISP industry. As a result, ATRA agreed in late November 2011 to meet with the Ministry of Finance (MoF) to discuss decreasing the Business Receipts Tax (BRT) on ISPs to stimulate growth of the sector. However, the issue never got much traction and was ultimately shelved once the MoF initiated broader discussions to replace the BRT with a value-added tax (VAT). The TAT and NISPAA solicited the World Bank to conduct a study on the taxation of ISPs, similar to one they conducted on the telecommunications sector in 2007,<sup>702</sup> but the World Bank declined to do so.

At the urging of NISPAA, and the facilitation of the TAT, both ATRA and NATO's International Security Assistance Force (ISAF) began cracking down on illegally-operating ISPs. ATRA even published and maintained a list of them on its website for a time, though it no longer does. ISAF issued a FRAGO<sup>703</sup> requiring ISPs to have valid licenses from ATRA and the Afghanistan Investment Support Agency (AISA) as part of its contracting process. While ATRA's and ISAF's actions were certainly more than lip service, none had any real effect.

Shortly after his official confirmation in March 2012, the Minister of Communications (Sangin) began publicly stating, "The past five years have been all about voice [services], and the next five will be all about data [services]." The ISPs smelled opportunity. However, the introduction of 3G mobile broadband service a year later (see below) allowed Afghans to access the Internet from their mobile phones over the MNOs' rather than the ISPs' networks. Further deteriorating matters, the MCIT and ATRA were disappointed with the lack of response by the ISP community to its tender for broadband wireless services (BWS, see below). ATRA expected to issue at least five BWS licenses (if not ten), but only two ISPs ponied up the US\$520,000 to meet the winning bid price (for a total of three licensees).

---

<sup>702</sup> World Bank (2007). *Analysis of Taxation of Telecommunication services in Afghanistan*, July 2007.

<sup>703</sup> Fragmentary Order, used to send timely changes of an existing order, without reissuing it in its entirety, to subordinate and supporting commanders while providing notification to higher and adjacent commands.

As mentioned above, Afghanistan’s early ISPs generally deployed VSAT-based Internet services. As the country and ICT sector matured, many more options for Internet access became available. As depicted in [Figure 24](#), the cellular networks proliferated enormously between 2010 and 2014.

## *Options for Internet Access*

### Terrestrial Internet Access

#### *Fiber-Based Internet Access*

Afghan Telecom Corporation (AfTel), the state-owned monopoly fiber service provider, offers fiber-based Internet services around the country on both a retail and wholesale basis. However, poor quality of service, frequent fiber cuts, unscheduled outages, and uncompetitive pricing have hindered their adoption. AfTel struggles to meet the reliability, responsiveness, and availability demands of a commercial carrier. AfTel supposedly adopted a two-tiered – wholesale and retail – pricing structure as of May 2012. However, AfTel often offers wholesale prices to large government, enterprise, and International Community customers, thereby effectively precluding ISPs from competing to offer fiber-based Internet services, at least to the “bigger fish.”

In cases where a network operator’s wholesale customer is also its retail competitor – a model that has worked in many countries around the world for years – it is imperative the underlying operator have fair, transparent, cost-based pricing, which Afghan Telecom lacks. ATRA has called for AfTel to develop cost-based tariffs, though AfTel has not yet produced any. Many ISPs have suggested AfTel exit the retail ISP market and provide only wholesale fiber-based Internet services, which would give the ISPs some space in which to operate and compete.

#### *Dial-up and Digital Subscriber Lines*

Afghan Telecom offers retail dial-up Internet access and digital subscriber line (DSL) service<sup>704</sup> over copper- and fiber-based facilities. AfTel also has joint ventures with other ISPs, both national and international, to complement and broaden its retail dial-up and DSL offerings. By mid-2012, AfTel was providing DSL service in six cities. Wasel Telecom also offers dial-up Internet access in its service area.



Figure 25: MTN 3G USB dongle

### Mobile Broadband and Broadband Wireless Services

The high cost of satellite and terrestrial fiber Internet access hindered the MCIT’s policy objective of increasing Internet penetration and use, so the MCIT embarked upon a two-pronged strategy to deploy 3G mobile broadband (MBB) and broadband wireless service (BWS) in Afghanistan. Mobile broadband allows individuals to access the Internet on feature phones, smartphones, personal digital assistants (PDAs), and tablets through built-in radio transmitters and receivers. It allows other web-

---

<sup>704</sup> Digital subscriber line (DSL) technology allows users to access high-speed Internet access across a telephone networking using “regular” telephone lines, so customers can have both voice (telephone) and data (Internet) services over a single connection.

enabled devices, like laptops and computers, to access the Internet, generally using portable 3G modems, like USB<sup>705</sup> dongles (see [Figure 25](#)). Broadband wireless service provides affordable last-mile access to the Internet for enterprises and institutions over technologies such as WiMAX. Between the two services, which collectively cover individuals and groups of people, the MCIT expected Internet access and use by Afghans to increase substantially, which it did (see [Figure 27](#) and [Figure 29](#) below).

### *Mobile Broadband Service*

In July 2011, the MCIT/ATRA released an international competitive tender for 3G mobile broadband service in the 2100 MHz band.<sup>706,707</sup> ATRA concluded the tender process in December 2011, after disqualifying all three bidders, and subsequently offered the four incumbent GSM operators the opportunity to acquire 3G licenses for the reserve tender price of US\$25 million each.



Picture 8: Etisalat 3G billboard in Kabul, March 2012

(Photo by Karen Black)

On March 18, 2012, Etisalat was awarded Afghanistan's first 3G license.<sup>708</sup> Etisalat began offering 3G mobile broadband services in Kabul nearly immediately and expanded to Jalalabad in mid-June 2012.<sup>709</sup> MTN signed the second 3G license in June 2012,<sup>710</sup> followed by Roshan in September 2012.<sup>711</sup> Afghan Telecom entered the GSM/3G market in February 2014, as per above. Afghan Wireless, the first mobile network operator in the country, was the last to receive its 3G license in March 2014.<sup>712</sup>

---

<sup>705</sup> Universal serial bus, a standard for common port interfaces used to connect computer devices and equipment.

<sup>706</sup> Megahertz

<sup>707</sup> MCIT (2011). "Afghanistan launches international competitive tender for 3G mobile license in 2100 MHz Band." July 19. Accessed October 14, 2015. <http://mcit.gov.af/en/news/2301>.

<sup>708</sup> MCIT (2012). "The First 3G License Issuance to Etisalat Telecommunications Company." March 19. Accessed October 13, 2015. <http://mcit.gov.af/en/news/7980>.

<sup>709</sup> Etisalat (2012). "Etisalat customers to enjoy high speed internet." June 17. Accessed October 13, 2015. <http://www.etisalat.af/about-us/press-releases/217-etisalat-3g-becomes-operational-in-jalalabad>.

<sup>710</sup> MCIT (2012). "MCIT Signs 3G Second License Agreement with MTN." June 23. Accessed October 13, 2015. <http://mcit.gov.af/en/news/10736>.

<sup>711</sup> MCIT (2012). "MCIT Issues 3G License to Roshan Company." September 23. Accessed October 13, 2015. <http://mcit.gov.af/en/news/12954>.

<sup>712</sup> MCIT (2014). "MCIT Issues 3G license to AWCC." March 19. Accessed October 13, 2015. <http://mcit.gov.af/en/news/mcit-issues-3g-license-to-afghan-wireless-communications-company-awcc-2>.



By December 2014, 3G mobile broadband service was available in 28 of Afghanistan's 34 provinces, illustrated on the map in [Figure 26](#).<sup>713</sup>



Picture 9: Roshan 3G license signing ceremony, September 2012

(Photo by Karen Black)

Spurred by media reports<sup>714</sup> in February 2013 that Etisalat had obtained a license for and was testing long-term evolution (LTE) 4G<sup>715</sup> mobile broadband service in Afghanistan and promising speeds of up to 100 Megabits per second (Mbps), ATRA issued a press release “to correct any public misperception that Etisalat may have secured additional rights and be in a position to provide services that other Licensees cannot provide by virtue of having signed an additional license.”<sup>716</sup> ATRA confirmed, however, the licenses “are

technology neutral [and] Licensees are not restricted in their use of technology ... and may use internationally recognized next generation standard in providing services to its customers.”<sup>717</sup> Etisalat launched 3.75G service in June 2012 in Kabul, followed by four other cities (Jalalabad, Mazar-e-Sharif, Herat, and Kunduz) later that summer.<sup>718</sup> In December 2014, AWCC launched 3.75G+ service in Kabul, claiming it was the “first mobile telephony company to bring true mobile broadband services to Afghan consumers.”<sup>719</sup>

As of the end of 2015, there were nearly two million 3G subscribers in Afghanistan,<sup>720</sup> quite an impressive uptake in three-and-a-half years. The importance and impact of the introduction of mobile broadband

---

<sup>713</sup> ATRA. Accessed October 13, 2015.

[http://atra.gov.af/Content/files/3G\\_services\\_Coverage\\_Map%20Q4\\_2014.JPG](http://atra.gov.af/Content/files/3G_services_Coverage_Map%20Q4_2014.JPG).

<sup>714</sup> “Etisalat to launch the first ever 4G service in Afghanistan.” 2013. *Wadsam.com*, February 19. Accessed 13 October 2015. <http://wadsam.com/afghan-business-news/etisalat-to-launch-the-first-ever-4g-service-in-afghanistan-989/>. And “Etisalat Commences Trials on Country's First 4G LTE.” 2013. *Daily Outlook Afghanistan*, February 20. Accessed October 13, 2015. [http://www.outlookafghanistan.net/national\\_detail.php?post\\_id=6679](http://www.outlookafghanistan.net/national_detail.php?post_id=6679).

<sup>715</sup> Fourth-generation wireless digital technology based on International Telecommunication Union (ITU) International Mobile Telecommunications (IMT) Advanced specifications.

<sup>716</sup> ATRA Press Release, February 21, 2013. Accessed October 13, 2015.

[http://mcit.gov.af/Content/files/ATRA\\_PR\\_4G\\_21022013\(1\).pdf](http://mcit.gov.af/Content/files/ATRA_PR_4G_21022013(1).pdf).

<sup>717</sup> Ibid.

<sup>718</sup> Etisalat (2012). Accessed October 14, 2015.

<http://www.etisalat.af/component/finder/search?q=3.75&Itemid=934>.

<sup>719</sup> AWCC (n.d.). “Afghan Wireless Launches 3.75+ Services: First Cellular Telephony Company to Bring True Mobile Broadband To Afghanistan.” Accessed October 14, 2015. <http://afghan-wireless.com/afghan-wireless-launches-3-75g-services/>.

<sup>720</sup> ATRA, Telecom Statistics (End of December 2015).

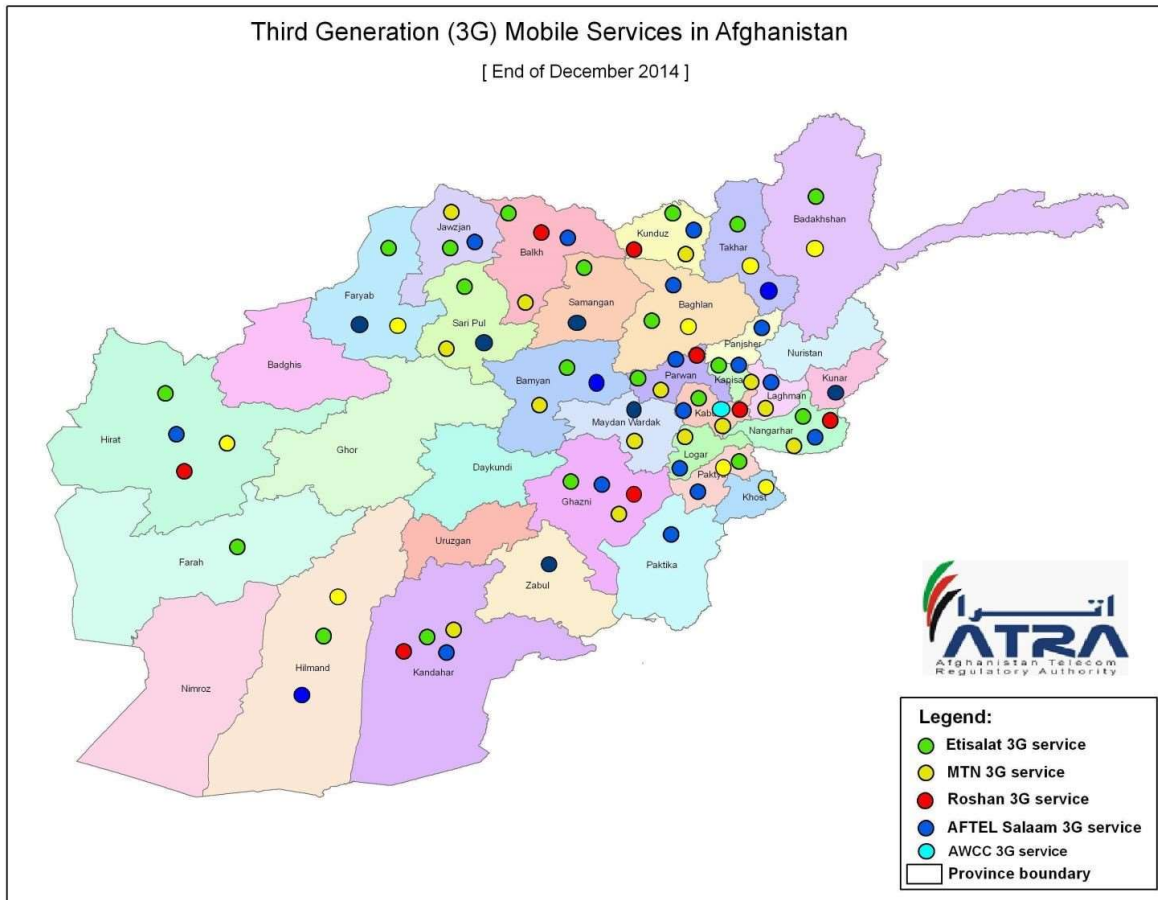

Figure 26: Availability of 3G mobile broadband service by province, December 2014

service in Afghanistan is noteworthy because it allows Afghans to access the Internet via their nearly ubiquitous phones, particularly since terrestrial-based services have not achieved the same levels of deployment or adoption. Additionally, a growing body of research correlates the availability of broadband Internet access – and 3G mobile broadband service specifically – with increases in economic growth, which is described in more detail below.

### Broadband Wireless Service

In May 2012, ATRA issued a competitive national tender open to all Afghan ISPs for up to ten broadband wireless service licenses to allow more affordable last-mile access to the Internet. The new licenses were to supplant the five provisional WiMAX licenses already granted, but were to be technology-neutral spectrum permits so as to accommodate



Picture 10: Broadband wireless service license signing ceremony, November 2012

(Photo by Karen Black)

different and future technologies in accordance with international best practices. On November 18, 2012, ATRA awarded what it called WiMAX licenses to three ISPs, [NEDA Telecommunications](#) (featured in [Picture 10](#)), [IO Global](#), and [Ariana Network Services](#), for US\$520,000 each.<sup>721</sup> Afghan Telecom was also able to continue providing broadband wireless service (it was a provisional WiMAX permit holder) under its Unified Services license. AfTel claimed to have deployed WiMAX technologies in all 34 provinces by early 2010.<sup>722</sup>

## Other Types of Internet Access

### *Broadband Satellite Service*

Two companies, Etisalat and NEDA Telecommunications, are authorized under Global Mobile Personal Communications by Satellite (GMPCS) licenses to resell [YahSat](#) broadband satellite Internet service under the [YahClick](#) name in Afghanistan. YahClick is a cost-effective broadband Internet service offered through a new generation of satellites that leverage higher bandwidth available in the Ka-band and employ low-power antennae. According to YahSat, these high-throughput satellites are based on a multi-spot beam payload and are optimized for delivering broadband services. Because of its high frequency (26.5-40 Gigahertz), the Ka-band allows the same frequency to be re-used numerous times over different geographical areas, much like how GSM cells operate in cellular phone technology. Etisalat launched YahClick in November 2012 and NEDA sometime shortly thereafter. While YahClick has not necessarily been the positive disruptive force in the Afghan Internet market some predicted, it extended Internet services into previously unserved areas.

### *Wireless Internet/Wi-Fi Service*

In August 2015, Afghan Wireless launched high-speed wireless Internet “Super WiFi” service<sup>723</sup> available only to its subscribers in the capital city. Through 350 hotspots around Kabul, AWCC offers “both mobile and fixed base True Broadband High Speed Internet access ... WiFi-Enabled voice calling and texting service ... fast download speeds, [and] video streaming and data services ...”<sup>724</sup>

---

<sup>721</sup> MCIT (2012). “MCIT-Issues WIMAX License to Internet Services Provider Companies.” November 18. Accessed October 13, 2015. <http://mcit.gov.af/en/news/14780>.

<sup>722</sup> Presentation by Engineer Abdul Saboor Nasimzada, [then] Head of Transmission Services of Afghan Telecom Corporation at the Capacity Middle East Conference in Dubai, February 22-23, 2010.

<sup>723</sup> Wi-Fi is a local area wireless computer networking technology that employs radio waves to allow computers, mobile phones, and other devices to connect to the Internet and communicate with one another within a particular area without being physically connected.

<sup>724</sup> AWCC (2015). “Afghan Wireless Launches Super WiFi Services in Kabul City.” August 18. Accessed October 13, 2015. <http://afghan-wireless.com/afghan-wireless-launches-super-wifi-services-in-kabul-city/>.

## Internet Users and Internet Usage

Statistics on Internet users and Internet usage in Afghanistan have historically varied greatly. Actual figures notwithstanding, the growth of both is undeniable. As you can see by the graph in [Figure 27](#), Afghanistan achieved over two million Internet users by 2014, per the MCIT.<sup>725</sup>

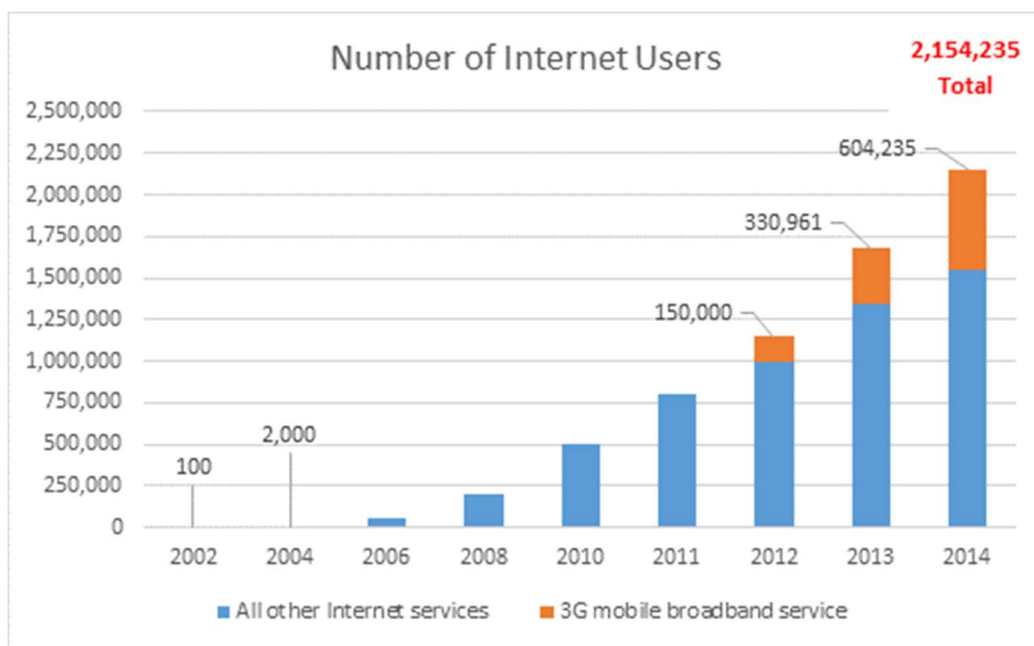

Figure 27: Afghan Internet users, 2002-2014

The growth in the number of Internet users is particularly impressive considering many Afghans had absolutely no concept of the Internet until after the US-led invasion ousted the Taliban government in late 2001. Using data from the World Bank,<sup>726</sup> which estimates Afghanistan's 2014 population at 31.63 million and the number of Afghan Internet users as 6.4 people per 100, the number of Afghan Internet users equals 2,024,320 million, a figure similar to the MCIT's. Internet World Stats claims Afghanistan had over 4 million users in 2015,<sup>727</sup> and some informal estimates place the number of Afghan Internet users as high as five to six million. The higher figures may not be unrealistic, considering ATRA reported nearly two million 3G mobile broadband users alone, as mentioned above, at the end of 2015.<sup>728</sup> In its 2015

<sup>725</sup> Adapted from a chart on MCIT website, <http://mcit.gov.af/Content/images/Eng%20-%20Internet%20Users.png>, and from the MCIT's *MCIT's Achievement & Operational Activities Report 2002-2015*, <http://mcit.gov.af/en/page/11/mcits-achievements-activities-report-2002-2015>, both accessed October 14, 2015.

<sup>726</sup> The World Bank. Accessed January 6, 2016. <http://data.worldbank.org/country/afghanistan> and <http://data.worldbank.org/indicator/IT.NET.USER.P2>.

<sup>727</sup> Internet World Stats. Accessed March 22, 2016. <http://www.internetworldstats.com/asia/af.htm>.

<sup>728</sup> ATRA, Telecom Statistics (End of December 2015).

survey of the Afghan people (an annual and well-respected assessment of many indicators of Afghan life), the Asia Foundation reported just over a fifth – 21 percent – of respondents nationwide claim someone in their household has access to the Internet.<sup>729</sup>

ATRA initiated an effort in 2012 to work with NISPAA and the ISPs to more effectively and accurately gather data on the number of Afghan Internet users. The MNOs have been reporting their subscriber figures to ATRA for years, so the number of 3G mobile broadband service users is likely highly accurate. ATRA would like to emulate that same reporting requirement for Internet users.

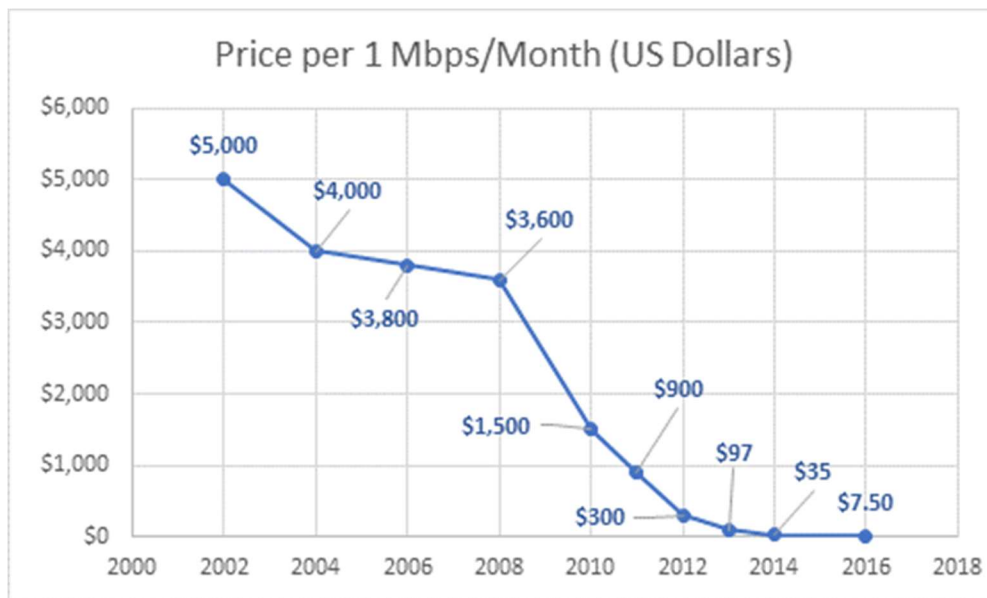

Figure 28: Afghan Internet prices, 2002-2016

Whatever the actual number, the increase in number of Afghan Internet users, which is driven to a great extent by sheer demand, is also inversely proportional to cost decreases for Internet access over the same time period, as the graph in [Figure 28](#) depicts.<sup>730</sup> The decreases are a result of a concerted, prolonged, and ongoing effort by the MCIT, which owns Afghan Telecom, to lower the cost of Internet access – from US\$5,000 to US\$7.50 per megabit per second per month (Mbps/month), a 99.85% decrease. Significantly, concurrent with the Internet price reduction from US\$900 to US\$300 Mbps per month effective May 1, 2012, the MCIT made a historic and much-needed distinction between wholesale and retail prices, which stimulated the market.

As the MCIT completed segments of and increased the capacity on its optical fiber cable (OFC) system, it was able to negotiate better rates from its underlying Internet bandwidth providers (namely Pakistan, Uzbekistan, and Iran). Quite significantly, on May 1, 2012, the MCIT and Afghan Telecom lowered Internet

<sup>729</sup> Warren and Hopkins, 2015.

<sup>730</sup> Adapted from MCIT, 2014. *Activities and achievements report*.

prices from US\$900 to US\$300 per Megabyte (MB) per month. Concurrent with the reduction, they offered a lower rate to service providers (MNOs and ISPs), making a much-needed and significant distinction between wholesale and retail prices for the first time. This two-tiered pricing scheme was an important evolution of Afghanistan’s Internet pricing structure.

Not surprisingly, the combination of more Internet users and lower prices led to an increase in Internet traffic as depicted in the chart in [Figure 29](#).<sup>731</sup> Domestic Internet bandwidth nearly quadrupled from 557

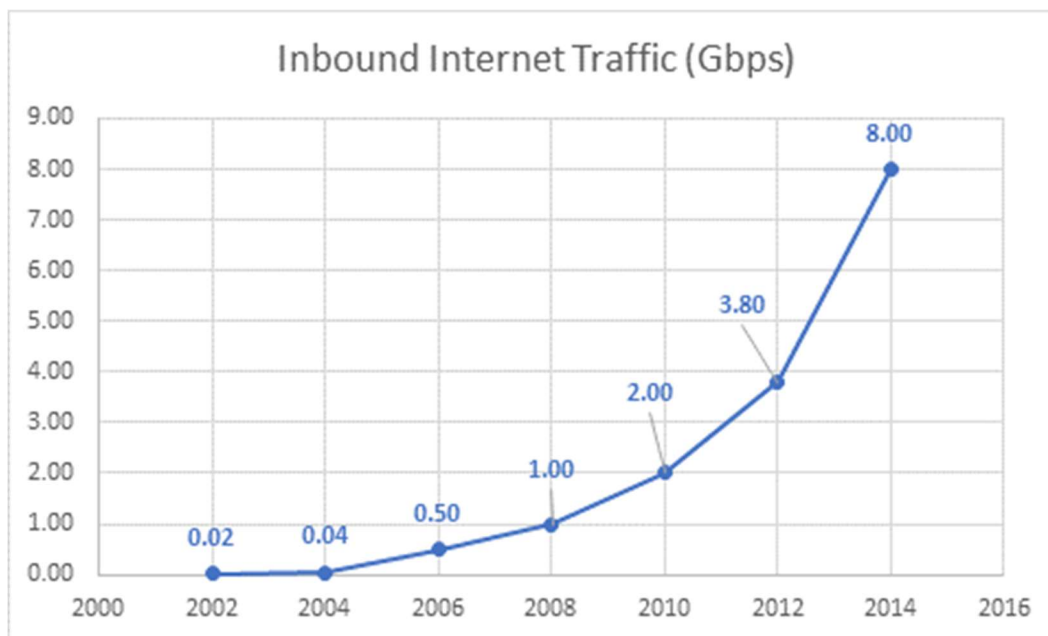

Figure 29: Inbound Internet traffic to Afghanistan, 2002-2014

Mbps in 2009 to 1,866 Mbps in 2011, while international bandwidth tripled from 3,175 Mbps to 9,891 Mbps during that same time.<sup>732</sup> The MCIT estimated bandwidth use at 15,000 Mbps in 2015.

### National Internet Exchange of Afghanistan

The MCIT, to its credit, realized that to support and grow a local Internet economy in Afghanistan, it would need to facilitate the direct exchange of data traffic among ISPs. Such an arrangement is often accomplished through Internet exchange points (IXPs). An Internet exchange point (IXP), sometimes called a network access point (NAP), is a location at and through which ISPs and content delivery networks (CDNs) can physically connect (peer) their networks. IXPs keep local Internet traffic local, thereby reducing costs and improving quality. In its 2011 *E-Afghanistan National Priority Program*, the MCIT called for the

<sup>731</sup> Adapted from chart on MCIT website. Accessed October 14, 2015. <http://mcit.gov.af/Content/images/Eng%20-%20Inbound%20Internet%20Traffic.png.png>.

<sup>732</sup> Information provided to the author by the MCIT for use in the nomination MCIT Minister Sangin to the Internet Society Internet Hall of Fame, February 2013.

establishment of the National Internet Exchange of Afghanistan (NIXA). The MCIT's intended results in establishing NIXA were to spur competition, lower consumer prices, reduce operational costs, improve reliability and redundancy, and create a vast amount of new local Internet bandwidth for sale to consumers.<sup>733</sup> NIXA was to be located on the ground floor of the MCIT's headquarters building in Kabul within the Afghanistan National Data Center (ANDC).

The MCIT began working to implement NIXA, a supposed high-profile initiative and top priority, with assistance from three American organizations. The US Department of Defense Task Force for Stability Operations (DoD TFBSO) connected MCIT personnel with their peers at other IXPs and helped to gather information on different operating models. The TFBSO also contacted Google and Akamai regarding potentially putting cache and content servers, respectively, at NIXA. Contractors to the US Forces-Afghanistan (USFOR-A) physically installed racks and equipment for NIXA at the ANDC. The Telecommunications Advisory Team (TAT) assisted the MCIT to draft various documents, such as a NIXA Member Agreement and NIXA Terms and Conditions, which the MCIT circulated among the ISPs for comment. The TAT also researched and recommended fees and prices (most IXPs operate on a not-for-profit basis but charge nominal fees to cover operations and maintenance costs) to the MCIT and helped it to develop a fee schedule. The MCIT ordered autonomous system numbers (ASNs) for NIXA and even planned an open house in the fall of 2011. After a series of postponements, the MCIT abandoned the open house idea in early 2012.

The original plan was for five ISPs, including AfTel, to connect to NIXA through a single fiber connection from AfTel to NIXA. The fiber connection was installed but was never made operational, at least not for NIXA.<sup>734</sup> The gentleman who was to be the General Manager of NIXA proposed the MCIT request two strands of dark fiber be installed from NIXA to every AfTel PoP in Kabul, which did not occur. There were countless challenges, setbacks, and delays that hindered the establishment of NIXA, including but not limited to:

- Insufficient physical plant (clean and constant power; environmental controls such as air conditioning and humidity; the ability to limit, or at least monitor, access and egress, etc.) at the ANDC;
- Donor contract issues;
- Problems with NIXA equipment orders and shipments;
- The inability of the ISPs to negotiate long-term leases with their landlords so as to have relatively permanent locations to which to run fiber to connect their sites to NIXA;
- A dearth of local content in local languages, coupled with the realization that was not changing, at least not quickly; and
- Other priorities for the MCIT and the ISPs.

---

<sup>733</sup> MCIT, 2011. *E-Afghanistan NPP*.

<sup>734</sup> At some point in 2014 or 2015, the fiber connection between AfTel and the ANDC was co-opted from its original intent for NIXA and used for the mobile government applications platform also installed at the ANDC.

Eventually, the MCIT co-opted NIXA's ASN range to replace its IP<sup>735</sup> addresses that were blocked or blacklisted and tabled NIXA until after it deployed IPv6,<sup>736</sup> which, as of mid-2016, had yet to occur. At one point in recent history (late 2015 or early 2016), the MCIT supposedly issued a tender, or at least a request for information, soliciting assistance to establish NIXA, though the author could no longer locate it on the MCIT's website as of this writing. With the advent of 3G mobile broadband services, and the relatively low numbers of fiber-based Internet users, it may be years before NIXA becomes a priority for the MCIT again, if ever.

## Voice and Data Services for the Public

As the Information Age dawned on Afghanistan, the MoC and others made strident efforts to ensure it was as inclusive as possible. In the early days of introducing ICT, the focus was on providing access to communications services, not on everyone having a mobile phone. There were many early policy proclamations and initiatives to bring modern voice and data services to the Afghan citizenry. Some programs were designed to reach those who could not afford equipment or service fees or lived in areas without coverage or with limited coverage, while others educated the public on how to use phones, computers, and the Internet.

### *Telekiosks and Multipurpose Community Telecenters*

Working in partnership with UNDP and the French government, the Afghan Ministry of Communications, which is also responsible for postal services, opened several (seven to nine) telekiosks as post offices around Kabul in 2003 to offer "affordable prices to use Internet and offer free basic computer training."<sup>737</sup> Each telekiosk was equipped with four computers connected to the Internet via satellite and a printer, and each was staffed by one man and one woman to assist users.<sup>738</sup> The telekiosks were part of the MoC's plan to "to make data services equally accessible to urban and rural communities, [by equipping] 50 percent of Post Offices with Internet terminals and enhanced communication capabilities by the end of 1382 (March 20, 2004)."<sup>739</sup> It is unclear if the MoC ever fulfilled that vision, as there is no mention of telekiosks in any of the MoC/MCIT's official status and achievement reports reviewed by the author, and the telekiosk page on Afghan Post's website says only, "Provided Internet/email services and computer training to the general population, especially for young people who are particularly keen on developing their IT skills, thus speeded up the implementation of new technologies of communications. These kiosks have created a link between Afghans living in Kabul and those who were outside."<sup>740</sup>

---

<sup>735</sup> Internet Protocol

<sup>736</sup> Internet Protocol version 6, the next generation of Internet addressing standards that will replace the IPv4 addresses we use today, the last blocks of which the Internet Assigned Numbers Authority distributed in February 2011.

<sup>737</sup> Uldal and Marjan, 2004, 36.

<sup>738</sup> Ibid.

<sup>739</sup> Telecommunications and Internet Policy 2003.

<sup>740</sup> Islamic Republic of Afghanistan Afghan Post website. Accessed October 12, 2015.  
<http://afghanpost.gov.af/en/page/9249/9251>.



The ITU had plans to implement Multipurpose Community Telecenters (MCTs) to offer basic voice and data services, including email and Internet access, among others. An original fundraising effort, in conjunction with several other organizations, fell substantially short of the US\$50,000 goal, amassing only about US\$12,500.<sup>741</sup> Afghan Post’s website states there are 11 MCTs in eleven provincial capitals and Kabul, offering “access to ICTs and E-mail ...”<sup>742</sup>

### *Village Communications Network*

In the mid-2000s, the Senior Telecommunications Advisor (STA) at the Afghanistan Reconstruction Group (ARG) of the US Embassy Kabul<sup>743</sup> and his team conceived of several new ICT sector initiatives in coordination with the Ministry of Communications and AfTel. One of the ideas was a satellite-based solution powered by renewable energy to bring thin-route communications capabilities to remote and rural areas, which became known as the Afghan Digital Solar Village (ADSV). The STA and others identified [Invenco](#), based in San Francisco, to conduct a pilot project, leveraging its experience doing similar projects in Africa. Unfortunately, unforeseen complications arose in getting Invenco’s equipment through customs at Kabul International Airport, so the project was tabled as the first STA prepared to depart Afghanistan. The Minister of Communications, however, saw the idea’s intrinsic value and the group worked to devise another solution, rebranding the ADSV project as a MoC/AfTel initiative called the Village Communications Network (VCN).

The ADSV/VCN was designed to capitalize on the construction and connectivity of the Afghan government’s District Communications Network (DCN) (described later in this chapter) by using wireless technologies such as Wi-Fi to extend transmission signals to the village level, as depicted in [Figure 30](#).<sup>744</sup> AfTel had unused Hughes VSAT equipment leftover from the DCN sitting in a warehouse in Kabul, so it agreed to reconfigure it for use as VCN network terminals to provide limited voice and data capabilities. The first-phase test terminals were deployed in remote locations but within an acceptable distance from the national Ring Road to allow for relatively easy access by AfTel engineers. Initial tests were successful, so AfTel went onto to deploy VCN nodes across all 34 provinces, achieving over 400 installations by early 2009. At one time, the plan was to deploy 6,000 VCN terminals at a cost of US\$47 million.

---

<sup>741</sup> Uldal and Marjan, 2004, 35.

<sup>742</sup> Afghan Post website.

<sup>743</sup> Mr. James P. (Jim) Craft, who served from September 2005 to October 2006.

<sup>744</sup> Taken from “Afghan Digital Solar Village Demonstration Project Concept Note,” date and author unknown.

VCN kits were installed by AfTel and entrusted to village elders to run. AfTel also sold VCN kits to local entrepreneurs, who would then establish local community calling centers where residents could make and even receive calls for a fee. While the original intent was for the VCN to provide both voice and data services, bandwidth limitations of the equipment made Internet capabilities of the VCN unviable, and most installations were used solely for telephone services. Data provided to the author by the MCIT show approximately 600 VCN installations as of March 30, 2011, and sales of another 700, for a total of 1,300 VCN sites across the country, a number confirmed by AfTel leadership.<sup>745</sup> (There is additional information on VCNs in [Chapter 8, Satellite Communications.](#))

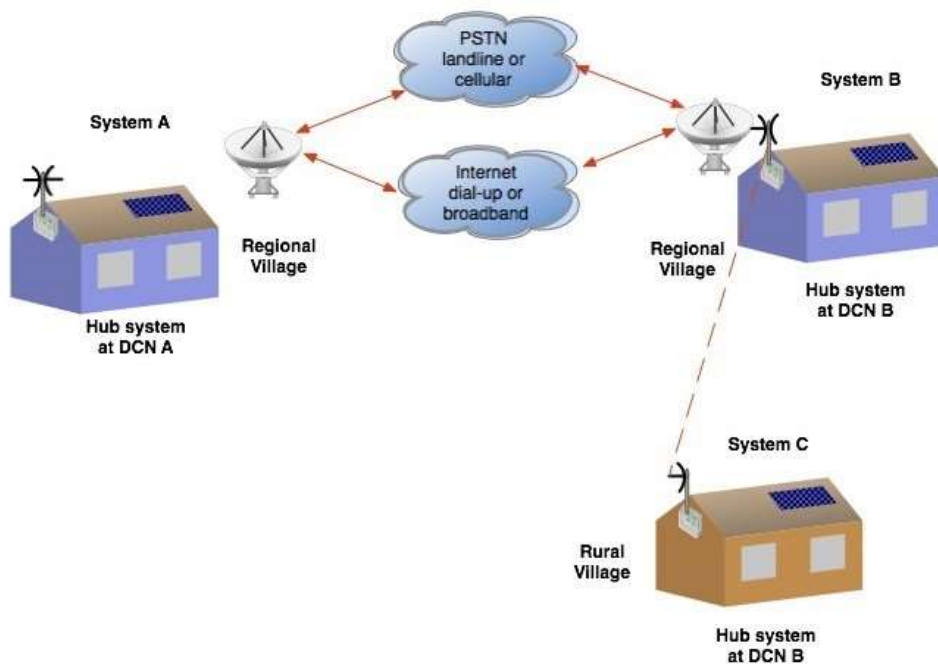

Figure 30: Original ADSV/VCN network concept

### Public Call Offices

Public call offices (PCOs) surfaced to benefit the more remote and less affluent factions of Afghan society. Several mobile network operators, of their own volition, established PCOs throughout the country. PCOs are telephone facilities in public places, basically payphones without booths, which allow Afghans the ability to place and even receive calls. Many PCOs are operated by entrepreneurs or other business owners, which provides income and employment opportunities for Afghan citizens while improving overall access to ICT services. Combining commerce with corporate social responsibility (CSR), Roshan initiated its [Women’s Public Call Offices](#) (WPCO) project whereby Afghan women could get micro-loans

---

<sup>745</sup> Per AfTel’s former Chief Operating Officer and Vice President, Wireline Division, Ahmad Saeed, in an email to the author April 1, 2016.

and enjoy subsidized calling rates to start and run PCOs. In some areas, Roshan (and other MNOs) also offered subsidized rates to former soldiers who ran PCOs.

The Ministry of Communications initiated a Public Call Office Project to install 1,000 community calling centers in 1,000 villages across Afghanistan to provide both telephone and Internet services for the locals. In February 2013, AfTel won the contract to install the PCOs via an award from ATRA's Telecommunications Development Fund (TDF), likely deploying unused DCN/VCN equipment. As of 2014, the project was reportedly 15 percent complete. AfTel reports operating over 700 PCOs throughout the country (many of which preceded the February 2013 award).

### *Payphones*

Afghan Telecom owns and operates a network of approximately 300 public payphones across the cities of Kabul and Herat. Payphones are located along city streets, in markets and shopping districts, in schools, and in many government buildings. Callers must have special prepaid payphone credit cards, sold and rechargeable by AfTel, to use the devices. Calls to AfTel's network are 1 Af and calls to other networks are 2 Afs per minute. Calls can also be made to international destinations, at rates which vary by country.



*Picture 11: Payphone at the Ministry of Public Health in Kabul*

*(Photo by Karen Black)*

### *Internet Cafés*

Internet cafés and other public venues with Internet access played a prominent role in the early days of Afghanistan's introduction to data services, as very few households had computers at the time (and still do not). The Asia Foundation's 2008 survey of the Afghan people stated only 5 percent of Afghans claimed to own computers,<sup>746</sup> the first year for which the author found reliable computer ownership statistics.

In mid-2002, coincident with the Loya Jirga meeting in Kabul, AWCC established Afghanistan's first public Internet café at the Intercontinental Hotel.<sup>747</sup> It was equipped with 11 computers sharing a wireless 128 Kbps<sup>748</sup> link, which was connected to AWCC's GSM network.<sup>749</sup> The USAID also established a ten-seat Internet café in Kabul around the same time.<sup>750</sup> In December 2003, Park Tourism Group opened a 20-seat Internet café next to the Kabul Hotel that was open around the clock and attracted upwards of 50 visitors

---

<sup>746</sup> Rennie, Ruth, Sudhindra Sharma, and Pawan Sen (2008). *Afghanistan in 2008: A Survey of the Afghan People*. The Asia Foundation, 2008, 117. Accessed October 12, 2015.

<http://www.asiafoundation.org/resources/pdfs/Afghanistanin2008.pdf>.

<sup>747</sup> AWCC. Accessed October 10, 2015. <http://www.afghanwireless.com/news/news-31jul.htm>.

<sup>748</sup> Kilobit per second, a measure of the speed of data transfer.

<sup>749</sup> Uldal and Marjan, 2004, 38.

<sup>750</sup> GIPI-AF, 2006, 10.

a day by February 200[4].<sup>751</sup> By early 2004, there were some 80 Internet cafés in the country: approximately 50 in Kabul (one reportedly owned by a female) and ten each in Mazar-e-Sharif, Kandahar, and Herat.<sup>752</sup>

Table 5: Internet café prices per hour, 2013

Location	Price/Hour for Internet Use
Kabul	40 Afs (US\$0.71)
Herat	30 Afs (US\$0.53)
Jalalabad	40 Afs (US\$0.71)
Kandahar	60 Afs (US\$1.06)
Kunduz	40 Afs (US\$0.71)
Mazar-e-Sharif	30 Afs (US\$0.53)
Pul-e-khumri	30 Afs (US\$0.53)

Altai Consulting estimated the number of Internet cafés in Afghanistan quadrupled between 2007 and 2013 to 400: 130 in Kabul, 100 in Herat, nearly 60 in Mazar-e-Sharif, 30 in Kandahar, fewer than 20 in Jalalabad, and another 50 or so throughout the rest of the country.<sup>753</sup> Despite decreases in the cost of Internet bandwidth, Altai reports retail prices at Internet cafés remained fairly consistent between 2007 and 2013 (see [Table 5](#)).<sup>754</sup>

## Universal Access and Rural Telecommunications Development

The MCIT's Universal Access Policy Document [for] Rural Telecommunications Development in Afghanistan,<sup>755</sup> issued in SY 1387 (2008), has three main objectives:

1. To put into place a mechanism that will encourage investment for the development of rural communications networks by providing subsidies for the implementation of Universal Access projects, and will enable the Government of Afghanistan to fulfill its Universal Service/Universal Access obligations by 2015, according to the [ITU] World Summit on the Information Society (WSIS) Goals of 2003 and 2005;
2. To improve socio-economic conditions of rural areas by providing access to ICT facilities; and
3. To fill the access gap in rural areas by subsidizing projects that are commercially viable but need initial financial support, or that are not commercially viable but are desirable because of the Government's obligations.

---

<sup>751</sup> Uldal and Marjan, 2004, 38.

<sup>752</sup> Uldal and Marjan, 2004, 1.

<sup>753</sup> Altai Consulting (2014). *ICT Economic Impact Assessment*. July 2014, 46-47. Accessed July 7, 2016. <http://www.altaiconsulting.com/wp-content/uploads/2016/03/ICT-Economic-Impact-Assessment.pdf>.

<sup>754</sup> Ibid.

<sup>755</sup> ATRA. Accessed August 19, 2015. [http://atra.gov.af/Content/files/UAPolicyDocument-21Oct2008-FinalEd1\\_0.pdf](http://atra.gov.af/Content/files/UAPolicyDocument-21Oct2008-FinalEd1_0.pdf).

The mobile and fixed-line service licenses do not contain stipulations requiring operators to provide service in rural areas. However, the licenses mandate operators pay 2.5 percent of their adjusted gross revenues into the Telecommunications Development Fund (TDF), quarterly in arrears, which is administered by ATRA. ATRA then uses the funds to subsidize the cost of the installation of cellular base transceiver stations (BTSs) in un- and underserved areas (among other projects in accordance with its mandate).

The Universal Access Policy and Telecommunications Development Fund, both based on international standards and best practices, have been instrumental in extending the reach of ICT services throughout Afghanistan and fulfilling the GIRA's policy "to enable the rapid growth of affordable communications to all of our people so they may experience the Digital Age, wherever they are and whoever they may be."<sup>756</sup>

Beginning in 2010 if not earlier, ATRA issued least a dozen rounds of tenders for bids for projects to use TDF monies to expand cellular network service coverage as part of the MCIT's Rural Telecommunications Development (RTD) program. Each tender called for a specific number of cellular towers to be installed in designated geographic areas. According to the MCIT, through 2013, 152 BTSs have been installed and activated in remote areas, with installation of another 323 underway.<sup>757</sup> The TDF had accrued US\$136 million by the end of 2011 or 2012.<sup>758</sup> At that time, approximately US\$32.6 million of the TDF had been expended toward rural telecommunications development to support Afghanistan's universal access efforts.<sup>759</sup>

However, in recent years, the TDF has largely sat unused. Several projects seem to have been abandoned, and ATRA seems unable or unwilling to draw upon the funds to further build out ICT infrastructure in rural areas, often citing a lack of security as the reason. The most recent TDF tender announcement on its website is from 2014.<sup>760</sup> The mobile network operators assert, as of mid-2016, there should be somewhere between US\$150 million and US\$180 million available in the fund, although exact figures are elusive (but should not be). In 2015, the Ministry of Finance reportedly borrowed US\$29 million from the fund, and it is unclear if that will be returned.

Recently, the MCIT announced ATRA had plans to use TDF for Internet cafés and wireless Internet access in buildings, among other projects allowed under the TDF.<sup>761</sup> The new Minister of Communications undertook a review of the TDF's mandate after taking office in April 2015.

---

<sup>756</sup> Telecommunications and Internet Policy 2003.

<sup>757</sup> MCIT, 2014. *Activities and achievements report*, 45.

<sup>758</sup> Per the MCIT in mid-2012, as part of the "Telecom Book" project. The author was never able to adequately clarify the year.

<sup>759</sup> Ibid.

<sup>760</sup> ATRA (2014). Projects Tender Announcement. Accessed August 21, 2016.

<http://atra.gov.af/en/page/6981/6984>.

<sup>761</sup> Ibid.

## Civil and Military Communications

There was a dire need to develop across the Afghan government and within the military a more informed information culture that recognizes the value and utility of information in achieving operational and strategic success, where information forms the basis of organizational decision making, and information technology is readily exploited as an enabler for effective information systems.<sup>762</sup> The Afghan government, with the assistance of international donors, embarked upon the implementation of a series of successively more sophisticated solutions for civil and military communications.

### Early Government Communications

#### *Codan Radio System*

In 2003, USAID's Office for Transition Initiatives (OTI) provided nearly US\$300,000 in funding to assist the Afghan Ministry of Communications to establish a high-fidelity (HF) radio system to allow the new government in Kabul to communicate with provincial officials, so chosen because radios were cost-effective and quick to deploy, and because they did not require infrastructure to operate.<sup>763</sup> The radios were equipped with voice, email, and basic computing capabilities, as well as with rudimentary printers and scanners. Ultimately, the radio system was installed in 30 provinces and reportedly had significant impact. Officials in Faryab province were able to transmit information about periodic factional fighting and receive advice from the Karzai administration as to how to resolve the issue, and Takhar province used the Codan radios to request and receive emergency assistance after severe flooding.<sup>764</sup>



Picture 12: Codan radio terminal in Khost province

(Photo by Larry Wentz)

The [Codan](#) HF radio system enabled immediate intra-government communications and was an important step toward ensuring early security and stability under Afghanistan's first democratically-elected leader. According to a lesson learned by USAID OTI and paraphrased by Codan, "It is important to quickly establish

---

<sup>762</sup> Definition of "information culture" from Choo, Chun Wei (2008). "Information Culture and Information Use: An Exploratory Study of Three Organizations." *Journal of the American Society for Information Science and Technology*, 59(5): 792-804 (March 2008), 793. Accessed August 21, 2015. <http://choo.fis.utoronto.ca/FIS/ResPub/JASIST2008.pdf>.

<sup>763</sup> "USAID/OTI and Codan: Helping to rebuild lives in Afghanistan," author and date unknown. Accessed April 2, 2016. [http://www.codanradio.com/wp-content/uploads/2012/06/afghanistan\\_casestudy.pdf](http://www.codanradio.com/wp-content/uploads/2012/06/afghanistan_casestudy.pdf).

<sup>764</sup> Ibid.

a concrete effect within developing countries so that the local governments and people can see a tangible outcome immediately.”<sup>765</sup>

Perhaps envisioned as only a temporary stop-gap solution, the Codan radio system is still in operation throughout Afghanistan today, with the base stations located within MCIT buildings in provincial capitals.

### *First-Generation Government Networks*

#### **Government Communications Network**

Using World Bank concessional credits totaling US\$14 million,<sup>766</sup> in 2003, GIRoA tendered for the components of an extensive network, dubbed the Government Communications Network (GCN) that would link provincial capitals with Kabul ministries and other GIRoA institutions through a satellite-based telecommunications system with voice, Internet, and video conferencing capabilities. The satellite network consisted of a hub site in Kabul, an international gateway in Europe, and remote provincial stations interconnected in a full-mesh configuration with the Kabul hub.<sup>767</sup> Over the following 18 months, [Globecom Systems Inc.](#) (GSI), the winning contractor, built out the systems, including the landing points in each province. GSI also planned to provide last-mile links to each governor’s office, the international satellite segments, and a landing facility and network operations center (NOC) at the Ministry of Communications’ headquarters in Kabul.

A related GCN component financed the installation of a fiber optic loop in Kabul, connecting all of the ministries, the Supreme Court, the Presidential Palace, and other significant GIRoA institutions through underground conduits. Three ministries located in the Darulaman region of Kabul were too far from central Kabul to be reached by fiber cable and were ultimately connected by microwave. Each ministry and government institution was also provided with a twenty-seat Internet access center.

Once operational, the GCN, and particularly its video conference capability, proved very popular for both ministerial-level and presidential-level political and executive communications. With the reestablishment of the *Meshrano* and *Wolesi Jirgas* (upper and lower houses of Parliament, respectively) in 2005, national politicians also began using the GCN to communicate with constituents and political allies in their home jurisdictions. In addition, nascent Afghan Telecom used the telecommunication capacity of each provincial landing point to support the backhaul of national traffic generated by fixed wireless local loops it had established in several provincial capitals. Moreover, the satellite technology was sophisticated enough to permit single hop calling between provinces, thus facilitating regional communications within Afghanistan as well.

By 2011 the GCN connected over 40 government offices in Kabul and 34 provincial capitals. While in broad terms a success, the GCN experienced some significant shortfalls due to its limited financing. The World

---

<sup>765</sup> Ibid.

<sup>766</sup> Under the World Bank Emergency Communications Project of 2003

<sup>767</sup> Globecom Systems, Inc., reference paper, “Afghanistan Government Communications Network and District Communications Network.”

Bank credit only allowed for the connection of each governor's office to the provincial landing point. It did not include resources or technology for linking the provincial level ministerial offices, courts, or other GIRoA institutions, thus limiting its utility. A second challenge was the high cost and, hence, limited bandwidth available through the international space segment, thus making Internet access expensive and data transfer rates slow. The sporadic and fluctuating supply of electricity in both Kabul and the provinces was a third issue, limiting the availability and reliability of GCN Internet services by government servants. A fourth issue was the lack of computer and Internet literacy on the part of GIRoA civil servants. These four issues, taken as a whole, dramatically reduced the utility of the GCN and the ministry Internet centers.

### Provincial Governors Communications Network

To address some of the issues and shortcomings of the GCN, the US Department of Defense Chief Information Officer (DoD CIO) deployed an ICT subject matter expert (SME) based at the US Embassy Kabul in 2005-2008 to work on a range of Interagency and Coalition ICT activities. The DoD CIO SME worked with the Embassy's Afghanistan Reconstruction Group (ARG) and Combined Forces Command Communications (CFC J6) representatives in meetings with the Ministry of Communications/Afghan Telecom to identify and resolve at least some of the deficiencies in the GCN. The group learned the World Bank's funding for the GCN was reportedly insufficient and, as such, AfTel decided to use the money to deploy earth stations at MoC/AfTel sites in all provincial capital locations, but to forego the installation of last-mile connectivity between those sites and provincial ministerial and governors' offices.

Consequently, it was decided that CFC J6 would obtain funding to create the Provincial Governors Communications Network (PGCN), named by the DoD and agreed to by CFC J6, to complete last-mile connectivity to provincial governors' offices and, where practicable, ministry offices in or near the provincial capitals. The selected solution introduced the first WiMAX networking capability in Afghanistan, via a WiMAX hub at the MoC/AfTel provincial capital building, which was customized for WiMAX line-of-sight delivery to end locations. Initially, the donor-funded PGCN delivered last-mile connectivity to governors' offices in 19 provinces and ultimately to 29 in 2007. The understanding and agreement were that the MoC/AfTel would assume responsibility for connecting the remaining provinces. However, unfortunately, they applied resources to connecting only two more.

### District Communications Network

Extending government communications even further, the District Communications Network (DCN) project sought to strengthen communications between Kabul ministries and 334 (of about 365) district capitals. The DCN was financed by a USAID grant of US\$14.2 million in 2005, using a host country contracting (HCC) mechanism whereby GIRoA designed, tendered, awarded, and oversaw the contract for the DCN system. USAID seldom uses the HCC mechanism – or at least rarely so in Afghanistan at the time – because it requires a high level of management and oversight capability, which were not necessarily available in country. However, the successful implementation of the DCN – 27 sites connected by 2011 – it was a point of significant pride for both USAID and the Afghans. GSI was the winning bidder for the DCN, allowing it to achieve significant economies of scale by using a common (with the GCN) NOC and fielding a single management team for both projects.



The DCN consisted of a more economical Hughes Network Systems satellite system that allocated bandwidth across all of the installed sites based on demand. It was designed to provide communications to the typical GIRoA District Government Center, where all officers are housed in a single building, and also to address the communications needs of Afghan civilians by providing them access to basic voice and data services. The DCN “package” provided ten desk telephone handsets connected to a PBX<sup>768</sup> and four desktop computers, plus a facsimile (fax) machine and printer for use as a public Internet café and public call offices. It also provided one or more diesel generators to power the system during hours of need. The premise behind the DCN design was that the public Internet cafés would be operated by private entrepreneurs, creating jobs and generating revenue sufficient to pay for the generator fuel and other maintenance costs.

However, many DCN nodes were near Afghan National Police (ANP) checkpoints – for security – in un- or poorly marked buildings on the outskirts or on the way out of town, rather than in areas convenient for the people. Locals were not adequately informed about the DCN nodes and capabilities and, thus, did not necessarily use them. As of the end of March 2011, there were still approximately 75 DCN nodes in operation throughout the country.<sup>769</sup>

## Second-and Third-Generation Government Networks

Despite the implementation and use of the GCN and DCN, as preparations began for the eventual transition of national security operations from ISAF to the Afghans, the Coalition recognized a lack of communication between the national and sub-national levels of government – and among Afghanistan’s security entities – as a critical capability gap. The Coalition believed the lack of communication would hinder GIRoA and the Afghan National Security Forces (ANSF) in exercising effective governance and command and control. Resultantly, the Coalition devised concepts for the next generation of government networks, designed to take advantage of developments in ICT infrastructure and the deployment of modern ICT and services in Afghanistan. An original concept paper in February 2011 described a single IP-based enterprise network to which GIRoA ministries, regional headquarters, provinces, and districts [could] connect, together with selected Afghan National Army (ANA) and Afghan National Police (ANP) headquarters.<sup>770</sup> The concept was separated into a network for the Afghan National Security Forces (ANSF), dubbed ANSFnet, and another for the rest of the government, aptly named GIRoANet, with a plan to eventually connect the two.

### *ANSFnet*

In April 2011, the NATO Training Mission-Afghanistan/Combined Security Transition Command-Afghanistan (NTM-A/CSTC-A) called for the creation of Afghan National Security Forces Network Computer Information Systems (CIS) Council for “decision making, information sharing, coordination, and

---

<sup>768</sup> Private branch exchange

<sup>769</sup> Per data provided to the author by the MCIT in mid-2012.

<sup>770</sup> 110220-NUI-GIRoANet Concept Paper v4\_1, Draft.

resolution of issues regarding cross-ministerial communications/CIS capabilities and programs.”<sup>771</sup> The ANSFnet CIS Governance Council consisted of an Executive Management Board, a Senior Steering Committee, and a Technical Working Group.

In July, NTM-A/CSTC-A issued a FRAGO calling for CJ6 to align and integrate stovepiped CIS capabilities within ANSF networks by creating ANSFnet. By August 2011, NTM-A/CSTC-A had released a strategic plan and roadmap for ANSFnet.<sup>772</sup> The vision was to create “a single, scalable and secure information environment, managed and operated by ANSF and its partners (i.e., Coalition Forces), that provides the infrastructure necessary to sustain and enhance an evolving ANSF.”<sup>773</sup> The goal was to address and overcome various communications challenges of the Afghan National Security Forces (ANSF), such as a lack of interoperability, poor network reliability, inconsistent network security, limited network governance and management, duplicate capabilities, and high sustainment costs.<sup>774</sup>

The ANSFnet was to have six focus areas:

1. Governance and sustainment;
2. Computing infrastructure;
3. Network and communications infrastructure;
4. Applications;
5. Information and data; and
6. Security.<sup>775</sup>

The ANSFnet concept network configuration was to connect the Afghan Ministries of Interior and Defense (MoI and MoD, respectively), and include links to the National Directorate of Security (NDS) and the Presidential Information and Coordination Center (PICC) at the Palace as depicted – quite simply – in [Figure 31](#).<sup>776</sup>

---

<sup>771</sup> NTM-A/CSTC-A FRAGO 11-480 – CJ6 Support to ANSF Network (ANSFnet) Computer Information Systems (CIS) Governance Council, July 24, 2011.

<sup>772</sup> NATO Training Mission – Afghanistan (NTM-A)/Combined Security Transition Command – Afghanistan (CSTC-A) Chief Information Officer, “Afghanistan National Security Forces Network (ANSFnet) Strategic Plan and Roadmap,” Pre-decisional Draft, August 2011.

<sup>773</sup> Ibid.

<sup>774</sup> NATO Training Mission – Afghanistan (NTM-A), “Afghan National Security Forces Network (ANSFnet) Executive Management Board Kickoff Brief (UNCLASSIFIED),” September 2011.

<sup>775</sup> NTM-A/CSTC-A ANSFnet Strategic Plan and Roadmap.

<sup>776</sup> Ibid.

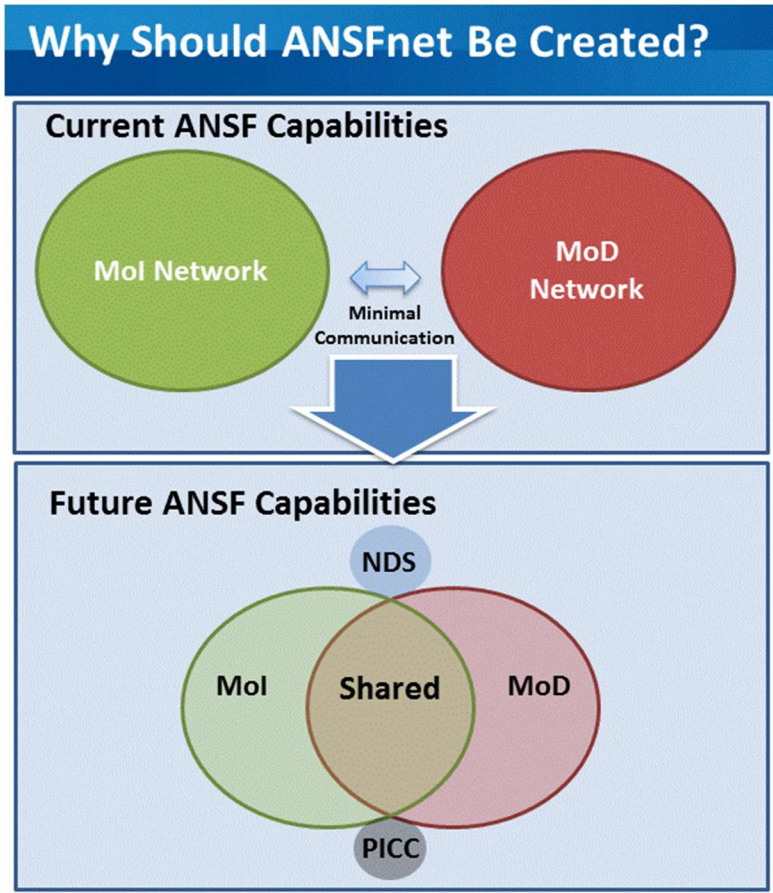

Figure 31: ANSFnet concept

The plan was to utilize strategic shared information technology (IT) resources and applications, tactical communications elements such as radios, and the country’s commercial cellular infrastructure.<sup>777</sup> The desired end-state was to have the MoI and MoD retain their unique and disparate systems while creating joint consolidated computing and communications infrastructure and support systems and integrated and interoperable combat and combat support systems.<sup>778</sup>

Following the signing of an ANSFnet Agreement between the MoI and MoD, formalizing and officially defining the network partnership, NTM-A/CSTC-A and the Afghans began to phase in ANSFnet connectivity and capabilities in late 2011 and early 2012. ANSFnet was designed to provide secure and non-secure voice, data, and Internet services at and among headquarters down to district, brigade, and battalion levels. It includes a mix of fixed and tactical communications capabilities across multiple methods of transmission: optical fiber in Kabul, AWCC’s microwave network for point-to-point

<sup>777</sup> Ibid.

<sup>778</sup> NTM-A/CSTC-A ANSFnet Strategic Plan and Roadmap.

connectivity outside the capital, cellular service and mobile phones, satellite service, and tactical radio systems. ANSFnet also included basic commercial off-the-shelf (COTS) software.

By October 2011, ANSFnet included web hosting and email services, and the MoI and MoD were planning

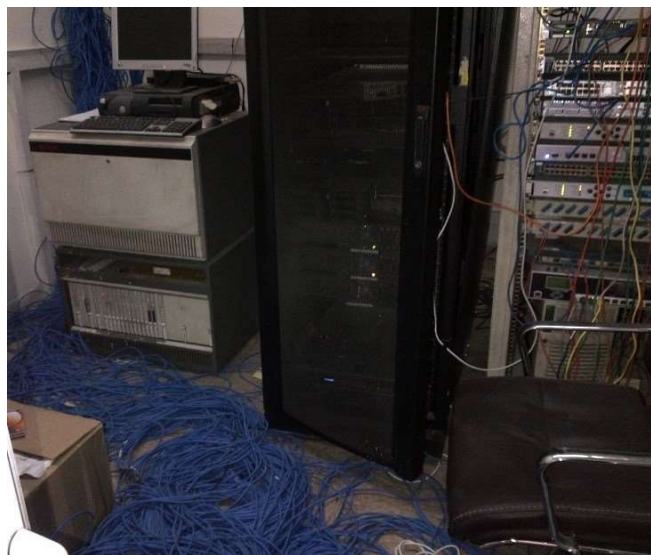

Picture 13: Switch room at the Afghan Ministry of Foreign Affairs, November 2011

(Photo by Karen Black)

to deploy other applications, such as a biometrics database and an electronic document management system (EDMS). NTM-A also planned to extend connectivity to the Afghan National Army (ANA) camps at Kandahar and Mazar-e Sharif as the first two outlying sites connected via the MCIT's optical fiber cable (OFC) network. Another accomplishment was the installation of a routing scheme for ANSFnet, which was critical for C2 (command and control) communication as part of security operations against insurgent activity. The MoI and MoD also decided to install and maintain separate ANSFnet NOCs at their own facilities, though they did not entirely understand nor subscribe to basic tenets of network operations.

Eventually, the Afghan Ministry of Foreign Affairs was connected via the Kabul City Metro Fiber ring to ANSFnet, along with a few other security-related entities in Kabul. Despite its trials and tribulations, the ANSFnet continued to expand and evolve.

In accordance with the aforementioned FRAGO, which also called for the MoD and MoI to develop interaction with the MCIT to create GIRoANet, the ANSFnet CIS Governance Council hosted a meeting in September 2011 to discuss having ANSFnet become the basis for (but still remain a subset of) the larger GIRoANet, described below. Later (in late 2013 and through the end of 2014), the two terms would be used interchangeably by ISAF and the Coalition, albeit erroneously so.

### *GIRoANet/DAS-Net*

In August 2011, the same time NTM-A/CSTC-A released the strategic plan and roadmap for ANSFnet, ISAF CJ6<sup>779</sup> wrote a concept of operations (CONOPS) for GIRoANet. The CONOPS documented the idea to build upon the ANSFnet to establish a GIRoA-wide communications network (see [Figure 32](#)) in accordance with ITU open standards. It made specific mention of the need for good oversight regarding the

---

<sup>779</sup> Combined Joint Communications and Information Systems

interconnection between ANSFnet and GIRoANet to ensure security and prevent the inadvertent release of data to entities outside of the security ministries.”<sup>780</sup>

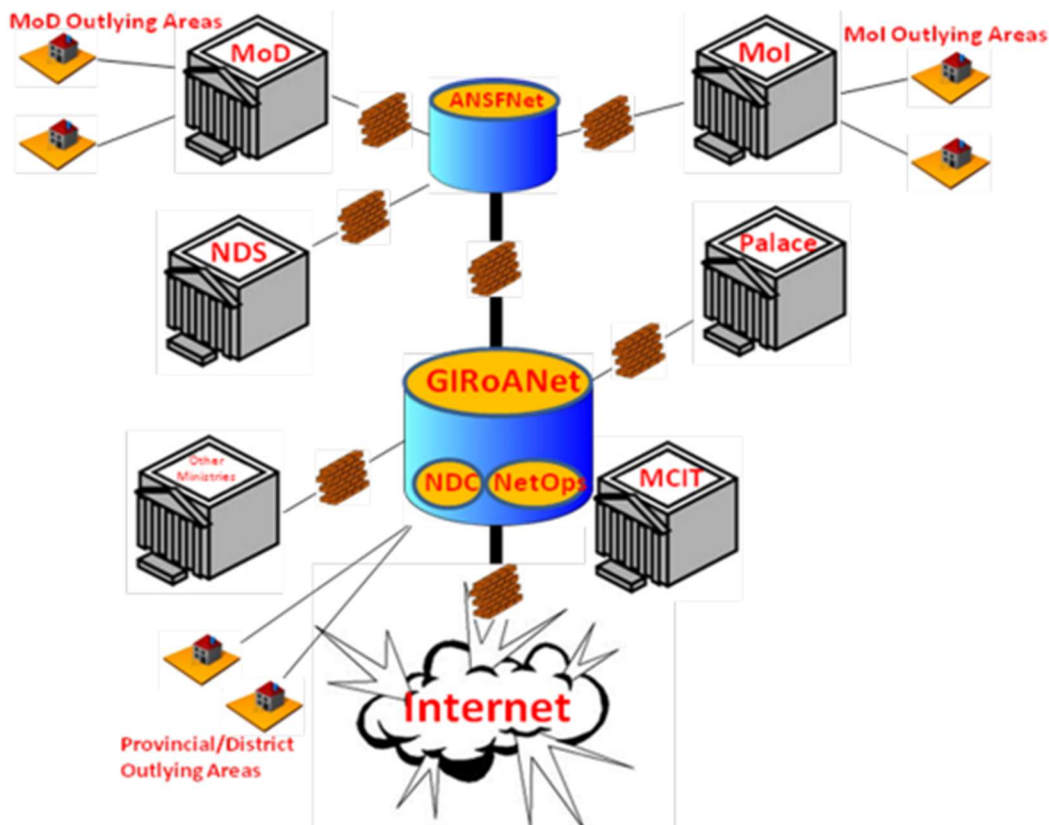

Figure 32: GIRoANet conceptual network connectivity

GIRoANet was planned to be implanted in three phases, with the first being the continued expansion, evolution, and maturation of ANSFnet. Phase 2 would connect ministries and government agencies in Kabul, via optical fiber where available, and Phase 3 would connect regional, provincial, and eventually district government offices. At its end state, GIRoANet was “envisioned to be an interoperable, interconnected, robust and flexible network communication system [that would] allow GIRoA Ministries and organizations an interoperable and interconnected means to communicate with each other from the Central level down to the local level.”<sup>781</sup> The plan was to use the Afghan National Data Center (ANDC) at the MCIT as the central hub for GIRoANet.<sup>782</sup>

<sup>780</sup> ISAF CJ6, “Government of the Islamic Republic of Afghanistan – Network (GIRoANet) Concept of Operations (CONOPS), Version 2.1 Draft, August 2011 (NATO/ISAF UNCLASSIFIED REL GIRoA).

<sup>781</sup> Ibid.

<sup>782</sup> The rest of the GIRoANet section is excerpted verbatim or paraphrased from Bierden, Elizabeth A. (Col., USA) (2012). *ISAF Telecommunications Advisory Team [TAT] Year in Review*, July 1.

As mentioned above, the ANSFnet CIS Governance Council hosted the GIRoANet Senior Steering Group Kickoff Meeting in September 2011, which was attended by the MoI, MoD, MCIT, and the TAT, to discuss implementing GIRoANet. At that meeting, the group agreed to form two working groups, a Technical Working Group and a working group specifically to focus on the sustainability of GIRoANet by Afghans in preparation for transition.

Originally, the concept of GIRoANet seemed to have sufficient interest by the Afghans, and planning for it proceeded that fall. At the Technical Working Group on October 17, 2011, which was also attended by ISAF CJ6 and NTM-A CJ6, the group discussed how to consolidate disparate and finite GIRoA networks and foster inter-ministerial connectivity. At that time, only six ministries were connected to the fiber network in Kabul. The MCIT and prioritized list of the next which they took several some ministries were required of them to also agreed to create standards but, at least to did.

The TAT assumed the lead November 2011, from an of TAT's support to CJ6 on provided GIRoANet the purpose, governance, areas – for the MCIT to

Technical Working Group meeting on November 14, 2011, which, for the first time, included CSTC-A CJ2.<sup>783</sup> At this meeting, the definition of GIRoANet was agreed upon to be, “Both a framework for describing, developing, managing, and maturing the evolution of a network-enabled services environment for the Government of the Islamic Republic of Afghanistan as well as the physical manifestation of this environment through the implementation of an IP-based core network to connect GIRoA ministerial networks.” Later that month, CIOs from about 15 ministries enthusiastically approved the GIRoANet concept.

In addition to working on the physical architecture for GIRoANet, the TAT investigated potential uses of and for it, such as share maps provided by the National Geospatial-Intelligence Agency (NGA) with the Afghan Geodesy and Cartography Head Office (AGCHO) and the Land Reform Agency in Afghanistan (LARA). The TAT also supported the MCIT's efforts to have the Provincial Information Management System (PIMS), a GIS application with 10 Terabytes (TB) of map data under the Afghanistan Information



Picture 14: A representative from the MCIT presents the DAS-Net concept at ISAF in March 2012

(Photo by Karen Black)

AfTel agreed to provide a 26 ministries to connect, months to do. Because confused about what was connect to the fiber, AfTel minimum connection TAT's knowledge, never

for GIRoANet from CJ6 in ISAF perspective, as part civil ICT matters. TAT concept slides – covering requirements, and focus present at the GIRoANet

---

<sup>783</sup> Combined Joint Intelligence

Management Services (AIMS), to move to the ANDC last fall. Unfortunately, all of these efforts stalled and never came to fruition, at least by the time the TAT ceased operations in October 2014.

In a positive sign of ownership of the concept, the Afghans renamed GIRoANet on February 1, 2012 to DAS-Net, short for Da Afghanistan Sterr Net, meaning “the great Afghanistan network.” Unfortunately, the effort seemed to lose steam shortly thereafter, and there has not been any significant progress in establishing an Afghan-wide government network, despite a brief and futile revival of the concept – by the Afghans – in late 2012 or early 2013.

The benefits of DAS-Net are many and include:

- Significant monetary savings by reducing the number of ISP connections from 30 or 40 to one, connected at the Afghan National Data Center at the MCIT;
- Standardization of processes and procedures for network traffic, including email, file transfer, and voice over IP;
- Drastically improving the cybersecurity posture of GIRoA by having the Afghan Cyber Emergency Response Center (AfCERT) interrogate all inbound and outbound traffic;
- And increasing the operational efficiency, transparency, and accountability of ministries, government agencies, and public servants.

## Other ANSF Communications

Largely separate from and in addition to efforts for commercial and civil communications, the Coalition and donor governments undertook efforts to provide modern ICT services for the Afghan National Security Forces (ANSF) to support command and control at the operational and tactical levels. In addition to ANSFnet described above, the ANSF uses fixed and tactical satellites, microwave and cellular networks, fiber optic connections where available, and tactical radios. The goal is to provide connectivity and communications at the national, regional, provincial, and district levels, particularly among the various command and control centers, but all the way down to company and patrol levels. NTM-A/CSTC-A, and their implementing partners, were largely responsible for ensuring the development and deployment of modern ICT services for the ANSF. While the TAT was involved in meetings regarding ANSFnet its focus was on civil and commercial, rather than military and police, communications.

## ICT in the Broadcast and Media Sectors

### Radio and Television

Since 2002, when there were only state-owned national broadcasters, Afghanistan’s broadcast sector has undergone rapid growth, with annual growth of 20 percent in the number of outlets since 2006.<sup>784</sup> Demand for radio and television services continues to increase, and with it, so does the need for spectrum resources. In Kabul alone, there were 30 television stations and 42 radio stations by mid-2013. ATRA had already assigned all available frequencies, and Kabul’s radio spectrum has almost reached complete

---

<sup>784</sup> Per the MCIT in mid-2012, as part of the “Telecom Book” project.

saturation. Other large cities, like Herat and Mazar-e-Sharif, broadcast approximately 10-15 television channels and 20 radio stations, of which 3 and 12 are local, respectively. Smaller provincial capitals typically have one to three local radio stations and one local television station. As of the end of 2015, Afghanistan had 285 FM radio operators with 715 transmitters and nearly 100 TV operators with 316 transmitters among them.<sup>785</sup>

While the Afghan Ministry of Information and Culture (MoIC) issues radio and television (TV) broadcast licenses (and regulates content), ATRA allocates frequencies and permits for radio and television broadcasting. The broadcast sector was liberalized without a clear strategy or plan, which resulted in a fragmented market with poor quality. Complicating matters, some Afghans access direct-to-home (DTH) satellite services from other countries without any regard to local policy. Because of past actions – and inaction – Afghanistan’s rural areas are underserved, while its urban areas are overcrowded.

Drawing on the positive experience of the digitalization of mobile telephone services, Afghanistan chose to migrate from analog to digital terrestrial television services (DTTV) based on actual needs and demands. DTTV has a number of benefits that can help to rectify the issues in Afghanistan’s broadcast sector, including network sharing, the ability to provide free to air and paid services, interactive services, high spectrum efficiency, and reduced broadcast costs. The aims of digitalization are to protect the local culture, develop a new industry in Afghanistan, and provide employment to Afghans. With DTTV, Afghanistan hoped to create approximately 30,000 to 40,000 jobs.

## Transition to Digital Broadcasting

As far back as 2011, the Minister of Communications had plans to transition Afghanistan’s outmoded analog television broadcasting system to DTTV, at which time he directed ATRA (and solicited the TAT’s support) to begin working to clean up Afghanistan’s electromagnetic spectrum resources (see [Chapter 9, Radio Spectrum in Post-Conflict Environments and Stability Operations – Afghanistan: A Case Study](#)).

The MCIT and ATRA issued a tender on April 10, 2013, for one license for the provision of a digital terrestrial broadcast network and multiplexer,<sup>786</sup> with the licensee expected to build and operate a nationwide network for the distribution of DTTV services. The bidding period closed on June 20, 2013, with four companies having submitted offers. On August 21, 2013, the MCIT and ATRA awarded the license and contract to the [Asia Consultancy Group](#) (ACG), a company headquartered in the United States, under the name ARX, with offices in Afghanistan, China, Dubai, and Pakistan. ACG had previously constructed a microwave network of managed towers across the country (see below).

The plan was to have DTTV services available in Kabul within six months of award (January 2014), followed by first-tier provinces within a year, second-tier provinces within two years, and third within three years.

---

<sup>785</sup> ATRA, Telecom Statistics (End of December 2015).

<sup>786</sup> MCIT (2013). “Tender for the License of [the] Provision and Operation of [a] Digital Terrestrial Broadcast Network and Multiplexer.” Afghanistan Telecom Regulatory Authority, Spectrum Management Department, April 10. <http://atra.gov.af/Content/files/RFP%20DTTV%20V8-3-2013.pdf>. Accessed April 2, 2016.



The goal is to have Afghanistan in its entirety transitioned to digital broadcasting within five years. DTTV was officially inaugurated in Afghanistan on August 31, 2014. While behind schedule, and amid some controversy over the awarding of a license to the Afghan Broadcasting Company, the transition from analog to digital broadcasting marks yet another success for the ICT sector and the country.

As Afghanistan's broadcast and media sector continues to grow, it is imperative that the government take proper measures to create a regulatory framework that addresses consumer needs. Because it is spread across satellite, cable, and terrestrial broadcast networks, it needs to be a coordinated effort with sound regulations.

### ICT-Enabling the Media

Article 34 of the Constitution of Afghanistan approved in January 2004 guarantees freedom of expression, the right to express thoughts through speech, writing, and other means, and the right to print and publish without prior submission to or approval by the government. The Mass Media Law of 2009 further guarantees Afghans the right to information and prohibits censorship. The Government of the Islamic Republic of Afghanistan (GIROA) operates the only national broadcast system, Radio Television Afghanistan (RTA), and five private media groups dominate the landscape: [Ariana Television Network](#) (owned by the Ehsanullah Bayat, who owns the majority of AWCC), [Moby Group](#), Saba Media Organization, [Killid Group](#), and Noor Television Network. While neither this chapter nor this book include an in-depth look at modern Afghan media, it is worthwhile to mention that media in post-conflict Afghanistan has proliferated tremendously and to note the compelling and significant role ICT has played in enabling the media.

From early on in post-Taliban Afghanistan, radio and television broadcasters solicited input and feedback from their listeners and viewers via telephone calls and text messages and by conducting surveys employing interactive voice response (IVR) technology. More recently, many have added email messages and digital posts via, e.g., Facebook, Twitter, and Instagram, among other social media platforms. Many news outlets have interactive websites and other online presences, digital versions of publications, news applications (apps) for smartphones, and some even stream live broadcasts.

Perhaps the most powerful role ICT has played regarding the media is the rise of participatory and citizen journalism in Afghanistan. In February 2013, an Innovation Lab sponsored by NGO Internews in Kabul sought to explore and devise examples of how technology and media might reinforce each other. Outcomes of the forum included the following prototypes:<sup>787</sup>

- **Mobile Traffic**, a dynamic system that incorporates IVR and short message service (SMS, or texting) technologies to collect and disseminate traffic data via mobile phones;

---

<sup>787</sup> Excerpted from Maher, Rachel (2013) "Kabul Innovation Lab Report."  
[http://www.internews.org/sites/default/files/resources/Internews\\_AMDEP\\_InnovationLabs\\_2014-01-28.pdf](http://www.internews.org/sites/default/files/resources/Internews_AMDEP_InnovationLabs_2014-01-28.pdf).  
Accessed April 2, 2016.

- **8AM Mobile News**, a mobile application that customizes content from one of Afghanistan’s leading investigative newspapers for distribution on Android mobile devices;
- **1TV Reporting App**, which features moderated content – audio, video, and images – captured and submitted by the Afghan public; and
- **Consultative Bridge**, an interactive site to distribute information on family, health, and legal issues to women and community leaders in Afghanistan’s northern provinces.

Some of the solutions, or similar such ideas, went on to be implemented by participating media agencies or other organizations.

In late 2013 or early 2014, Afghanistan’s first citizen journalism platform, [Paiwandgāh](#), was born, with a mission to feature first-hand accounts of news submitted directly by Afghans and others in the country via telephone, the Internet, SMS, social media, and other digital delivery channels. Paiwandgāh featured prominently in the Afghan presidential election of 2014 and is described further in [Chapter 18. \*Pajhwok Afghan News\*](#) also has a participatory platform.

On November 2013, Paywast, Afghanistan’s first mobile social media platform, launched the country’s first news application for Android and iPhones. The namesake outlet, *Paywast News*, was developed in conjunction with Afghanistan’s largest online newspaper, [Khaama Press](#), and first business news portal, [Wadsam.com](#).

The intersection of ICT and media, particularly citizen journalism, is in its infancy in Afghanistan, but is already having a profound impact on the country. According to the Asia Foundation, whose *A Survey of the Afghan People* in 2015 is the source of the chart in [Figure 33](#), between 2013 and 2015, the number of Afghans who reported using the Internet for news grew from 3.2 percent to 9.6 percent.<sup>788</sup> Mobile phones and the Internet were not even considered – or were statistically insignificant – as sources of news and information in their 2011 and 2012 publications. Moreover, because of the intersection of ICT and media, Afghans are increasingly creating, not just consuming the news, and they are using the digital realm to inform each other and to demand transparency and accountability from their leaders. To that point, “democratic process and civil society ... depend on information sharing and continuous information flow,”<sup>789</sup> which is facilitated and enhanced by ICT.

---

<sup>788</sup> Warren and Hopkins, 2015.

<sup>789</sup> CNI Technical Services, LLC (2011). *Research and Analysis Project for UNCLASSIFIED Information Sharing in Afghanistan: A Model for US Military and Coalition Commanders, the US Intelligence Community, and US Homeland Security*. Prepared for the Center for Technology and National Security Policy (CTNSP) at the National Defense University (NDU) on behalf of the Intelligence, Surveillance, Reconnaissance Task Force (ISR TF), January 28, 2011. Contract # SP4705-10-C-0055.

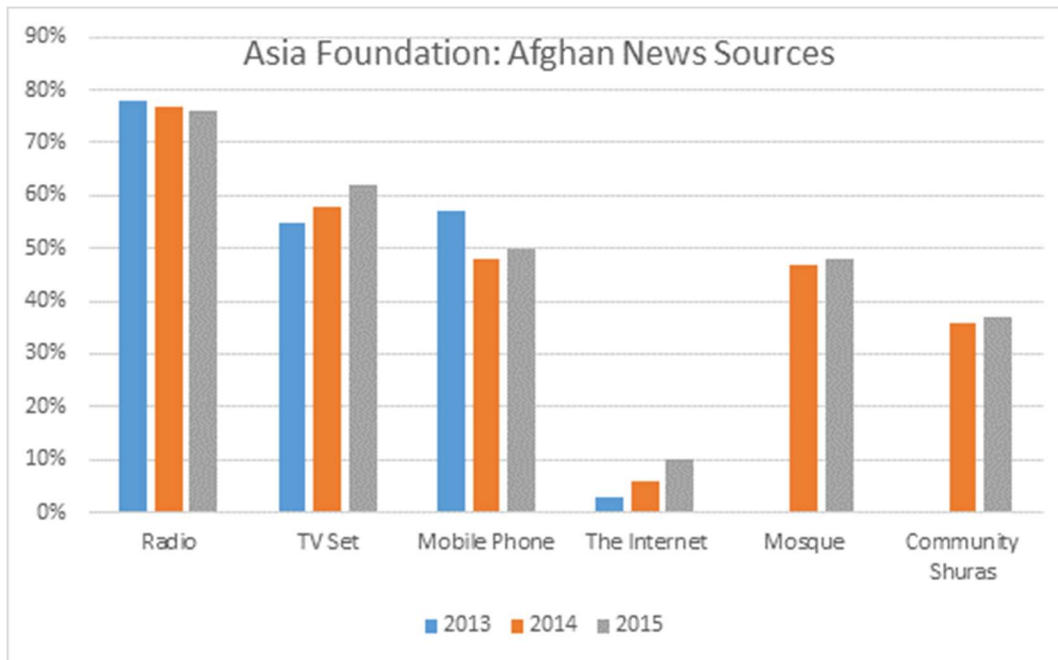

Figure 33: Sources of obtaining news and information, 2013-2015

## ICT Infrastructure and Resources

Afghanistan's public ICT institutions largely created an enabling policy, legal, and regulatory environment (see [Chapter 5, ICT Policy and Regulatory Framework](#)) that allowed for the rapid deployment and provision of the modern ICT services described above. None of them would be possible, however, without a robust underlying physical ICT infrastructure along with satellite and spectrum resources. The overall approach adopted by GIRoA to encourage private investment to accelerate reconstruction of its nation was extended to the ICT sector. Beginning with the first post-war Minister of Communications, the government undertook projects to rehabilitate and rebuild the salvageable elements of its former communications architecture and began devising plans for contemporary ICT infrastructure. The need to protect it – and the opportunity to share it – would become apparent later.

### Fiber, Satellite, and Spectrum

Afghanistan's underlying ICT infrastructure and resources consist of the national optical fiber backbone, its satellite orbital slot, and its assigned electromagnetic spectrum, all of which are described in individual chapters.

### Microwave

Additional infrastructure, funded by private companies, donors, and the Afghan government, consists of microwave networks used for transmission, backhaul, and point-to-point services.

As mentioned above, AWCC built out a high-capacity digital microwave ring for and concurrent with its GSM network. Completed in late 2007, AWCC's microwave network spanned 2,500 kilometers (km) and provided service to 250 towns in 31 provinces, as well along major highways.<sup>790</sup> It had a minimum capacity of STM-1 (155 Mbps). The network boasted one of the world's highest GSM sites (at 3,980 meters at Salang) and one of its longest links (187 km between Charkend and Qarapol).<sup>791</sup> AWCC established microwave connectivity to Uzbekistan and Tajikistan in the north, Pakistan in the south and east, and Iran in the west (see [Figure 34](#)).

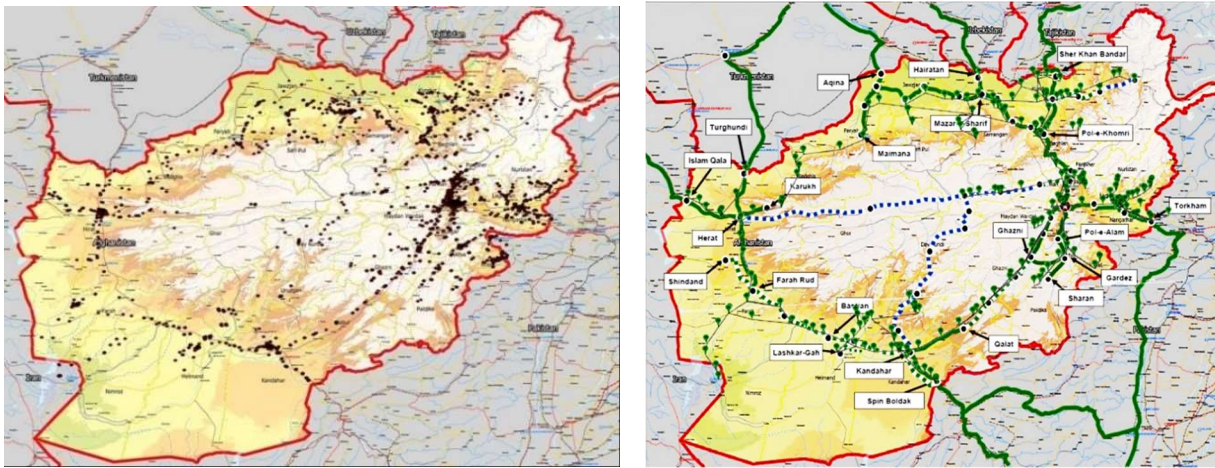

Figure 34: Afghanistan microwave and optical fiber networks, 2014

(Graphics courtesy of Lew Shadle)

Initially, the US government installed its own microwave circuits to deliver data among its numerous civilian and military facilities. However, when in need of a robust microwave circuit between Kabul and Bagram Air Field, USFOR-A accepted a US\$200,000 per year bid from AWCC in lieu of an equivalent USG-owned solution that would cost US\$2 million to construct and US\$1 million per year to operate. AWCC provided domestic private line circuits (DPLCs) over its microwave network to the Coalition and Afghan National Security Forces, which lay within in a "gray area" of legality due to AWCC's existence prior to the establishment of GIRoA-issued licenses. When AfTel, the only company allowed to provide DPLCs, forced the issue, the parties ultimately addressed it by making AWCC a subcontractor to Afghan Telecom.

As mentioned above, in the late 1990s, the Ministry of Communications established microwave links between Kabul and the cities of Mazar-e-Sharif, Herat, Kandahar, and Jalalabad, continuing onto Pakistan.

<sup>790</sup> AWCC (2007). "Afghan Wireless Again Creates History in Afghanistan." *Afghanistan Online*, November 3. Accessed September 13, 2016. [http://www.afghan-web.com/economy/afghan\\_wireless\\_history.html](http://www.afghan-web.com/economy/afghan_wireless_history.html).

<sup>791</sup> Ibid.

Under the World Bank-funded Emergency Communications Project<sup>792</sup> of 2003, US\$2 million was used to repair, reestablish, and expand broadband microwave transmission capacity between Kabul and Nangarhar, Nuristan, Kunar, and Laghman provinces, terminating in Peshawar, Pakistan. Later, Afghan Telecom also constructed a microwave network of its own (or contracted others to do so) to support its CDMA and other services. Its 2010 business plan<sup>793</sup> called for the installation of 81 towers in SY1390 (2011) and the leasing of another 22 STM-1s<sup>794</sup> worth of microwave capacity. AfTel later conducted an international competitive tender for a satellite cellular backhaul network prior to building its GSM network, which it awarded to Insta Telecom in January 2013.

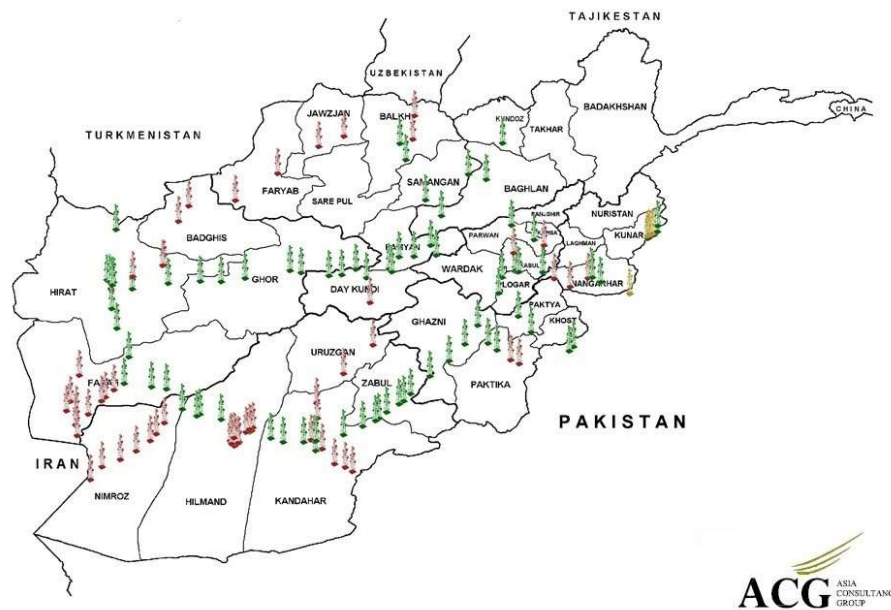

Figure 35: Asia Consultancy Group’s microwave network in Afghanistan

ACG, the company awarded the DTTV license described above, “was founded and is staffed by people who planned and built out the first cellular network in Afghanistan,”<sup>795</sup> and they constructed an impressive ICT infrastructure of managed towers across some of the most rugged and unforgiving terrain in Afghanistan as depicted in [Figure 35](#).

<sup>792</sup> World Bank (2003). *Afghanistan - Emergency Communications Project*. Washington, DC: World Bank. Accessed March 14, 2016. <http://documents.worldbank.org/curated/en/657161468185398097/Afghanistan-Emergency-Communications-Project>.

<sup>793</sup> Afghan Telecom Corporation (2010). *AfTel Five-Year Business Plan and Financial Projections*. June 29.

<sup>794</sup> Synchronous transport (or transfer) module-level 1, a transmission standard for optical fiber networks with a bit rate of 155.52 megabits per second (Mbps).

<sup>795</sup> Asia Consultancy Group Company Presentation, August 2015.

Based on American Tower's business model,<sup>796</sup> ACG essentially acts as an ICT real estate landlord. It operates and maintains the towers and leases space to Afghanistan's MNOs (and other service providers) to hang repeaters (or other hardware) to expand their own microwave networks.

## ICT Infrastructure Attacks and Shutdowns

As ICT infrastructure proliferated across the country, the Taliban and other anti-government elements (AGE) and criminals viewed it, particularly cellular service, as a detriment. They believe the Coalition tracks their movements via mobile phones, and they know Afghans use their phones to call authorities to report insurgent and criminal activity. They also believe the MNOs are "cash cows" in collusion with the US and other foreign governments. As such, these nefarious actors target the MNOs (and to a much lesser extent, the ISPs) with extortion, threatening to damage or destroy ICT infrastructure if they do not pay. They issued orders to Afghanistan's MNOs to shut down their cell towers overnight, threatening to destroy them if the MNOs did not comply. Many a tower was blown up or burnt down over the years, and several were targets of theft and vandalism. Employees of MNOs (and ISPs) were threatened, kidnapped, and even killed. Early attacks on cellular sites were limited to burning fuel tanks and generators, but the aggressions escalated to blowing equipment rooms. In the second half of 2010, insurgents began planting bombs and rockets under the legs of cellular towers, causing the towers to fall and destroying their foundations, rendering the site useless.

In 2008, Roshan's CEO stated, "On any one day we have to switch off between 30 [and] 50 sites at night in the south ... and then switch them on in the morning," or sites get attacked. "Up to 18 Roshan sites have been attacked. It's a loss of revenue. It's also a loss of security."<sup>797</sup> According to the former General Counsel and head of government affairs for Roshan in 2009, "The Afghan government has been unable to provide security, so that leaves us with little choice but to comply with demands."<sup>798</sup>

Tower attacks and shutdowns equated to millions of dollars of lost revenue for the MNOs and the Afghan government. For example, between 2010 and 2011, AWCC lost US\$14 million in revenues from site shutdowns and attacks, which translated into US\$4.5 million in lost tax revenue for GIRoA. AWCC spent a further US\$3.2 million in that same time period to rebuild the attacked sites.<sup>799</sup>

For years, there were no provisions or formal programs within GIRoA or ISAF for the protection of ICT infrastructure, particularly that belonging to private companies. Moreover, Afghanistan's fledgling

---

<sup>796</sup> "American Tower Corporation: An Overview," May 2015. Accessed April 5, 2016.

<http://www.americantower.com/Assets/uploads/files/PDFs/investor-relations/AMT%20Overview%20Presentation.pdf>.

<sup>797</sup> Reuters (2008). "Afghan wireless industry plagued by security issues." *The Globe and Mail*, September 25 (updated March 13, 2009). Accessed April 3, 2016. <http://www.theglobeandmail.com/report-on-business/afghan-wireless-industry-plagued-by-security-issues/article660279/>.

<sup>798</sup> "An Industry on the Line: Telecommunications in Afghanistan." 2009. Knowledge@Wharton, March 26. The Wharton School of the University of Pennsylvania. Accessed April 3, 2016.

<http://knowledge.wharton.upenn.edu/article/an-industry-on-the-line-telecommunications-in-afghanistan/>.

<sup>799</sup> Presentation entitled "Information on Attacks on AWCC Cellphone towers" provided to the author.

security forces are notoriously weak and ineffectual, or at least were in the mid-2000s when the threats and attacks began, so Afghanistan's commercial MNOs were left to make their own security arrangements. Some hired security guards to protect tower locations, while others established relationships with community leaders and enlisted their help and that of local residents, or employed other measures. At one point or another, all the MNOs complied with orders to shut down service, and all had towers destroyed, at an average cost of US\$250,000 each.

According to the Afghan Office of the National Security Council in July 2011:

- There had been full destruction of 132 towers/antennae, with Roshan incurring the most at 60.
- There had been partial destruction of 67 towers/antennae, 33 of them AWCC's.
- Twenty-eight (28) antennae had been burned, all of them Etisalat's.
- There were occasional shutdowns of 432 towers at different times.
- Fifty-five (55) cellular sites were shut down for 24 hours or more.
- A total of 227 towers/antennae were destroyed and another 124 rendered non-functional.<sup>800</sup>

At some juncture, the MNOs began voluntarily shutting down hundreds of cell towers at night in high threat areas, particularly in the south and east of the country. Threats and attacks diminished but did not necessarily stop. There was a backlash from the local population for the loss of cell service, especially in rural areas, as cellular service is a security and emergency lifeline for them. For the Taliban, the service shutdowns – no matter how they came about – were a political victory. For the Coalition forces and ANSF, the shutdowns hindered security and troop operations, which were of great concern to both.

Afghanistan's terrestrial infrastructure was not immune to problems. Fiber installation teams were threatened and attacked; some were kidnapped, and others killed. The national optical fiber cable was frequently cut, both accidentally and intentionally. The latter necessitated the selective use of Coalition forces, the ANSF, local police, and even private security companies to protect fiber installation and repair teams. Fiber cables along the Salang Tunnel in the northeast were frequently severed by trucks and traffic accidents. In some areas, installed fiber was not ducted or buried and simply lay exposed on top of the ground. If it were covered at all, it was only lightly so, making it an easy target. Eventually fiber cables were buried in shallow trenches to make it more difficult to locate and cut. Additionally, locals often dug up copper wire and sold it as scrap or made it into trinkets to sell in markets.

Other issues, such as the lack of reliable electricity, threaten, damage, and destroy ICT infrastructure. The absence of continuous, clean power, including frequent spikes and brown- and blackouts, wreaks havoc on ICT infrastructure, such as microwave radio relay sites, telephone switching centers, satellite ground terminals, and the electronics running the optical fiber network. Further, as Afghanistan's ICT

---

<sup>800</sup> Islamic Republic of Afghanistan Office of National Security Council (ONSC) Directorate of Interior Affairs (2011). *Security Strategy for Telecommunication Networks in the Territory of GIROA*, July 31.

infrastructure and services matured, cyber threats and attacks posed challenges and caused trouble. Cybersecurity is covered in more detail in [Chapter 10](#).

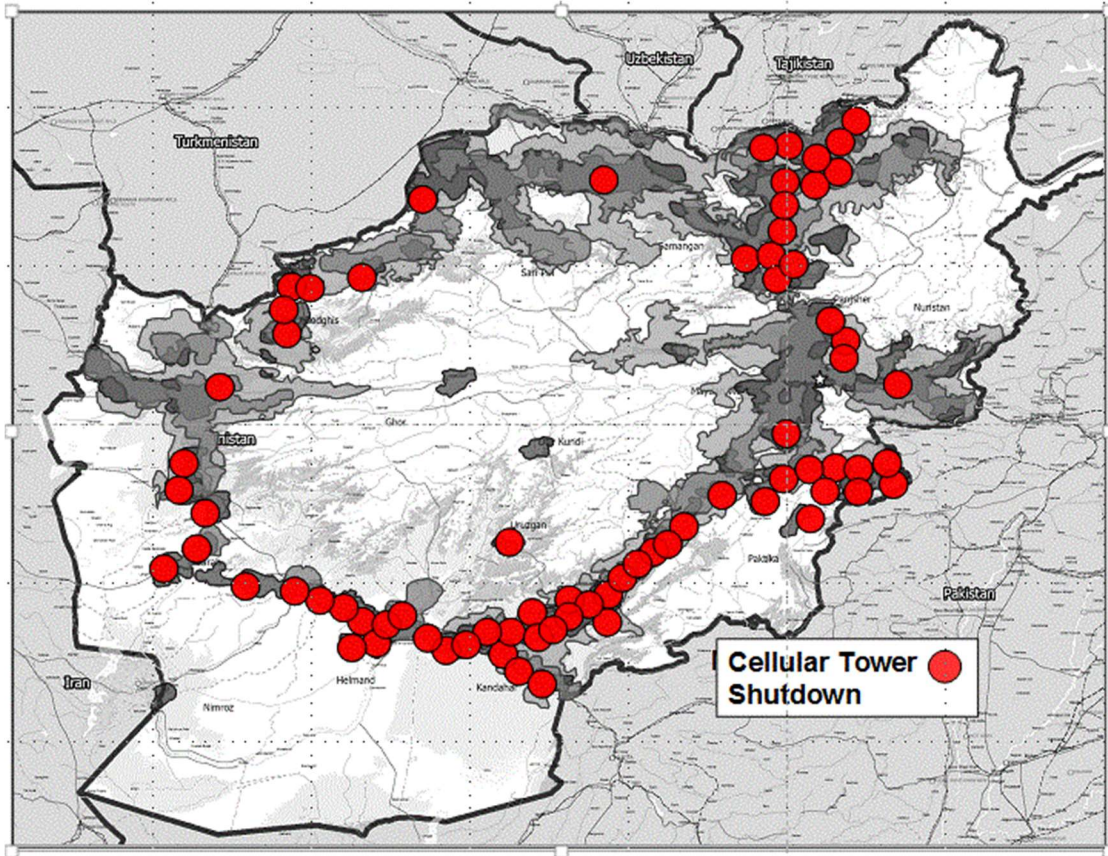

Figure 36: Illustrative nightly cellular tower shutdowns, March 2011

(Graphic courtesy of Lew Shadle)

## Mobile Service Mitigation

### ISAF 24x7 Cellular Service Programs

Because of the operational impact of unreliable cellular service, or the absence of service entirely, ISAF undertook a number of programs to provide, supplement, or restore mobile telephone service whenever and wherever commercial service was unavailable, for whatever reason. These programs included, but certainly were not limited to:

- The installation of “cellular on wheels” (COW) equipment, essentially portable, temporary mobile networks, on forward operating bases (FOBs);
- The Expeditionary Cellular Communications Services (ECCS) program, a US\$68 million contract awarded by the US Army to ManTech International Corporation in November 2010 to provide continuous cellular service to US and Afghan troops. The ManTech contract was canceled by the US DoD in 2012 after an extensive review of the program; and
- The ANSF Cellular Pilot Program, also known as District Emergency Cellular Service, to provide civilian-to-police/emergency responders and police-to-police calling capability during



commercial cellular outages in Kandahar. The program was to employ outdoor solar-powered BTS equipment designed to extend GSM services a few kilometers from the 23 approved (out of the 70 proposed) district government centers and ANSF locations.

Additionally, the US Department of State (DoS) awarded a US\$7.2 million contract to MNM Communications, Inc. to construct six towers across Helmand, Kandahar, and Ghazni provinces. Ostensibly, the towers were to provide cellular network transmission services to the US DoD in cooperation with the ECCS program and to Afghan MNOs. The towers were to provide broadcast services to local Afghan television and radio stations as well. Construction of the extra-tall towers was completed in 2012; however, costs to operate and maintain (O&M) them far exceeded the DoS's estimates, so it never awarded the separate O&M contracts. By then, the DoD has ceased the ECCS project,<sup>801</sup> and the Afghan MNOs had refused to connect to the towers for fear of Taliban reprisals.<sup>802</sup> The US DoS transferred one tower to the DoD for use in Helmand province; however, it became defunct upon base closures as part of the drawdown of combat forces. The DoS attempted to auction off the remaining five but as of October 2014, it still had not done so.<sup>803</sup>

### *Cellular-Enabled Security and Stability*

The above events and other mitigating factors led ISAF to establish a Cellular-Enabled Security and Stability (CESS) Operational Planning Team (OPT) in December 2011. Concurrently, ISAF called for the dissolution of its myriad (and others') 24x7 cellular service programs in favor of support of GIRoA-led efforts. The CESS Working Group focused on assisting and coaching GIRoA stakeholders regarding the implementation of the Afghan ONSC Security Strategy.<sup>804</sup>

In late 2012 and into early 2013, ISAF identified 46 of the most dangerous districts in Afghanistan that did not have 24x7 (or any) mobile phone service, and worked with the TAT, which had assumed the lead for the CESS program by that time, to facilitate the provision of cellular service to those strategically important areas. The TAT explored multiple avenues, including sourcing funds from NTM-A and the use of the TDF, for AfTel to construct the towers. None of the efforts was successful, and the CESS program was eventually terminated during transition activities as ISAF became RSM.

---

<sup>801</sup> Sopko, John F., Special Inspector General for Afghan Reconstruction (2014). Letter to the heads of the US DoS, DoD, CENTCOM, and ISAF, February 25. Accessed March 6, 2016. <https://www.sigar.mil/pdf/special%20projects/SIGAR-14-37-SP.pdf>.

<sup>802</sup> Munoz, Carlos (2014). "SIGAR: State Department may have spent millions on unneeded telecommunications towers." *Stars and Stripes*, September 18. Accessed March 6, 2016. <http://www.stripes.com/news/sigar-state-department-may-have-spent-millions-on-unneeded-telecommunications-towers-1.303742>.

<sup>803</sup> Picolli, Sean (2014). "Journalist: \$6.5M US Tab for Unused Afghan Cell Towers." *Newsmax*, October 16. Accessed March 6, 2016. <http://www.newsmax.com/Newsmax-Tv/afghanistan-unused-cellular-towers/2014/10/16/id/601232/>.

<sup>804</sup> Islamic Republic of Afghanistan Office of National Security Council (ONSC) Directorate of Interior Affairs (2011). *Security Strategy for Telecommunication Networks in the Territory of GIRoA*, July 31.

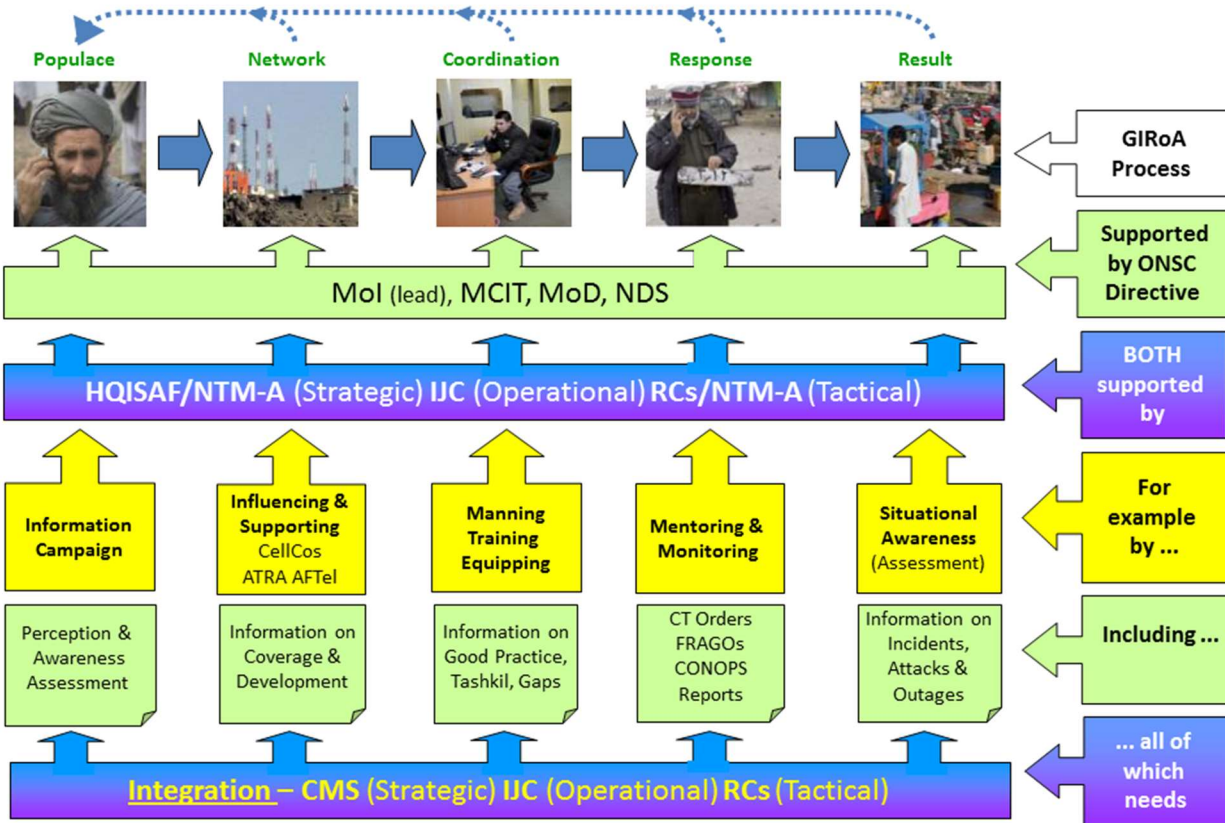

Figure 37: ISAF Cellular-Enabled Security and Stability (CESS) concept

## Infrastructure Protection

As a vital enabler of security, governance, and socio-economic development and growth, it is imperative Afghanistan's ICT infrastructure be properly protected. The continual threats to and attacks on cellular infrastructure finally prompted action. In June of 2011, the Afghan ONSC held a working group meeting about restoring 24x7 mobile service. The action items and responsible parties were:

President Karzai was to promulgate two decrees to clarify authority for implementing actions as follows:<sup>805</sup>

- The Ministry of Interior (MoI) was to make its properties available for placement of mobile towers, including access to these facilities during construction and subsequent maintenance. The MoI was to adopt the price list published by the MCIT for these facilities' leases and conclude all leases within thirty days.

<sup>805</sup> From "Action items from the ONSC Working Group to Restore 24x7 Mobile Service" meeting June 20, 2011.

- The MCIT was to:
  - (a) Expand AfTel's network to provide mobile service to the population and landline connections to GIRoA officials nationwide;
  - (b) Utilize the Telecommunications Development Fund (TDF) for any purpose to restore uninterrupted 24x7 telecommunications service, including reconstruction of damaged infrastructure and to subsidize insurance of network infrastructure; and
  - (c) Establish a national network security office with the authority to collect information on all ICT networks, private and government, and provide up-to-date status reports to the National Security Advisor on the status of 24x7 service and outages.
  
- ATRA was to immediately notify the MNOs in writing of their obligation to provide 24x7 service availability pursuant to their licenses, and to report all planned outages to ATRA and the local (district) governor not less than four (4) hours before shut down. ATRA was also to impose applicable penalties and fines for non-compliance, commencing thirty (30) days from the issuance of ATRA's written notice. For the avoidance of doubt, ATRA was also to amend the existing GSM licenses with clauses included in the Unified Services license that clarifies the obligation of 24x7 service availability once service has become commercially available at a location.
  
- The MNOs were to comply fully with the security plan and the terms of their licenses, such as reporting planned network outages and network security incidents (including threats and attacks) to the MoI. They were also to make greater use of local communities to protect local assets and utilize MoI (and other ANSF) protected facilities to place new towers and consolidate existing towers.

This plan was later formalized as the ONSC's *Security Strategy for Telecommunication Networks*, released in July 2011. However, ongoing intimidation, threats, and attacks on cellular infrastructure caused the MNOs to invoke the "force majeure" clauses in their contracts in October 2011. ATRA responded with a Restoration Order (which the TAT assisted it to write), demanding the MNOs restore service in all provincial capitals within 48 hours or face fines and other regulatory sanctions. ATRA emphatically refuted the MNOs force majeure claims, since all of them had been operating in an active theater of war, knowingly so, since they commenced operations.

Thus, the MNOs began to repair and replace infrastructure and restore cellular service as directed, over the next several months. ATRA put into place procedures for the MNOs to report threats, attacks, and damaged or destroyed infrastructure, though the MNOs did not necessarily comply. The MNOs, the MCIT, and ATRA launched discussions about financial compensation for physical equipment damage and loss. Several ideas were deliberated, including devising a schedule of equipment with fixed replacement costs for specific items. Eventually, the Minister of Communications and Information Technology approved a 50 percent split whereby ATRA would reimburse the MNOs half their actual costs of or destroyed

equipment from the TDF. However, as of March 2013, ATRA had received no requests from MNOs for reimbursement.<sup>806</sup>

The ONSC Strategy called for Afghan Telecom to provide uninterrupted “next generation” mobile services to the Afghan government and military, which precipitated AfTel’s entry into the GSM/3G market, as described earlier in this chapter.

There was a time when the US government provided logistics support to assure the availability of critical mobile phone services. A modest example was placing a Roshan cell tower on the US Embassy grounds in 2005, where reliable electricity and security were available. An example of more strategic support was the placing of cell towers on US FOBs as part of its COIN<sup>807</sup> strategy to overcome insurgent control (threats, attacks) of mobile services. Another was the provision of security otherwise not available in remote locations, enabling the MNOs to adjust their business plans to allow for additional investments for further rural expansion that otherwise would not have otherwise met cost-benefit thresholds.

As mentioned above, Coalition forces, the ANSF, local police, and even private security companies were engaged to protect fiber installation and repair teams. The TAT also facilitated discussions among the MCIT, AfTel, and ISAF regarding the potential for ISAF to provide security, or transportation for ANSF troops and equipment to provide security, for the southeast segment of the OFC, which was the target of frequent and intentional fiber cuts, though the entities never agreed upon any formal arrangements.

For its part, the TAT successfully lobbied ISAF and GIRoA to consider ICT as critical infrastructure and an essential service, on par with roads, water, and power. Further, the TAT institutionalized ICT as critical infrastructure in ISAF Operations Plan (OPLAN) 38302 Revision 6, Annex W, Appendix 3, and successive versions thereof. The TAT was also successful in having ICT recognized as critical infrastructure by the ONSC. In advance of the spring 2012 fighting season, ISAF and the ANSF cooperated to plan Operation *Naweed*, which means “hope.” Zamema 5, the Stability Annex to Operation *Naweed*, included ICT infrastructure – fiber and cellular – and the need to protect it. The MoD launched Operation *Naweed* June 20, 2012, at which time Zamema 5 had yet to be signed, and it is unclear if it ever was.

For a time, threats regarding and attacks on ICT infrastructure seemed to dissipate somewhat, perhaps because the Taliban and AGE realized the value of ICT to further their purposes, however reprehensible. Unfortunately, threats and attacks appear to be on the rise again, picking up after the cessation of Coalition combat operations at the end of 2014. For example, two towers, one each of MTN’s and Etisalat’s, were destroyed in central Logar province in June 2015.<sup>808</sup> In January 2016, news reports began surfacing about a secret meeting in Pakistan in December 2015 where the Taliban demanded a ten percent “protection tax” from at least three Afghan MNOs supposedly in attendance. Apparently motivated by a

---

<sup>806</sup> Meeting between the author and ATRA TDF Manager Mohammad Dauod at ATRA’s offices in Kabul, March 17, 2013.

<sup>807</sup> Counterinsurgency

<sup>808</sup> Azizi, Abdul Maqsood (2015). “Taliban blow up mobile phone towers in Logar.” *Pajhwok Afghan News*, June 21. <http://www.pajhwok.com/en/2015/06/21/taliban-blow-mobile-phone-towers-logar>.

similar tax imposed by the Afghan government on telephone subscribers in September 2015 that amassed around US\$1.14 million within days of its imposition, the Taliban is attempting to extort the MNOs in exchange for leaving their equipment alone and not harming their employees.<sup>809</sup> It is unclear if or how the MNOs responded and, as of this writing, the author can find no further information regarding the Taliban's demands or any repercussions against the MNOs for not meeting them. Expanding beyond ICT infrastructure, in January 2016, the Taliban "sabotaged a major power line in the northern province of Baghlan ... cutting a supply of electricity from Uzbekistan to Kabul ... and exposing a vulnerability in the nation's rickety infrastructure ..."<sup>810</sup>

## Infrastructure Sharing

In response to attacks on their cellular infrastructure as described above, some of Afghanistan's MNOs discussed sharing towers and other equipment in an effort to confuse those threatening and extorting them and to save costs and mitigate damages (and also to comply with the ONSC directive to consolidate their infrastructure when possible). However, there were no formal infrastructure sharing efforts in the country.

Infrastructure sharing was mentioned in a brief to US Ambassador to Afghanistan Zalmay Khalilzad at the US Embassy Kabul in mid-2004 as part of a discussion of the concept of Afghanistan's OFC. The Embassy ICT subject matter expert (SME) briefer recommended that empty ducts be included in the USAID-funded ring road (Highway 1) construction project, noting the highest line-item cost for the ring road project was for the field security detail. By including empty ducts under or alongside the ring road build (which at the time was completed only a small portion of the way from Kabul south towards Kandahar), the eventual fiber installer could more easily feed strands of fiber and repeaters into the ducts at a later time. The Ambassador and Country Team accepted the common-sense logic of the proposal, but came back with a decision to not include the ductwork due to the lack of active program status of the OFC project at that time.

Many years later (in December 2011), the World Bank held an inaugural Infrastructure Sharing Workshop to raise awareness and initiate public discussion of the concept. The idea of infrastructure sharing is to integrate efforts and share resources so as to eliminate or minimize duplication of effort, lower the cost of and accelerate network deployment, increase economies of scale, and even create new sources of revenue. Examples of infrastructure sharing include installing utility and fiber ducts concurrent with road construction and along railways as they are built, utilizing the optical ground wire (OPGW) in the electric grid for communications, and installing base transceiver stations (BTSs) on power towers.

---

<sup>809</sup> "Taliban Want Telecom Infrastructure 'Protection Tax.'" 2016. *Daily Outlook Afghanistan*, January 29. Accessed April 3, 2016. [http://www.outlookafghanistan.net/national\\_detail.php?post\\_id=14211](http://www.outlookafghanistan.net/national_detail.php?post_id=14211).

<sup>810</sup> Jolly, David (2016). "Taliban Sabotage Cuts Major Power Source for Afghanistan Capital." *The New York Times*, January 27. Accessed April 3, 2016. <http://www.nytimes.com/2016/01/28/world/asia/taliban-electricity-afghanistan-uzbekistan-kabul.html>.

Following 18 months of meetings, facilitated by the World Bank and the TAT, among various Afghan ministries and entities, including but not limited to Communications (MCIT), Public Works (MoPW), Energy and Water (MEW), Rural Rehabilitation and Development (MRRD), Finance (MoF), Economy (MoEC), and Kabul Municipality, the Afghans developed a National Infrastructure Sharing Policy. It was approved by the Afghan Cabinet in March 2013 and subsequently distributed by the Ministry of Economy as Economic Council Act #22 in April. According to the World Bank, Afghanistan was the third country in the world to have such a policy.

The Ministry of Economy hosted its first infrastructure sharing meeting May 1, 2013. At that meeting, participants decided to commission a board to create the processes and procedures to implement the new policy. They also agreed to establish a directorate within the MoEC to maintain a national database of all infrastructure projects and plans, complete with a staff to examine projects for potential infrastructure sharing opportunities.

The TAT was instrumental in initiating and mediating the signing of an infrastructure sharing agreement between AfTel and Da Afghanistan Breshna Sherkat (DABS), the state-owned electric company, in March 2013, an effort led by TAT Advisor Lew Shadle. The agreement allows AfTel to utilize surplus optical ground wire (OPGW) in DABS' electric network. This arrangement vastly and quickly extends Afghanistan's fiber network, providing both new capacity as well as redundancy to the national optical fiber cable (OFC).

Unfortunately, other than the AfTel-DABS agreement, little known progress has been made regarding infrastructure sharing in Afghanistan. However, the policy is in place and has the potential to feature prominently in Afghanistan's next phase of reconstruction and development under President Ghani, who formerly worked at the World Bank.

---

*ICTs play a catalytic role in creating opportunities for people in every walk of life, especially for those among us who are vulnerable and disadvantaged, while providing the framework for long-term sustainable development.*

*-- Former ITU Secretary-General Dr. Hamadoun I. Touré, 2012*

---

## The Socio-economic Impact of ICT in Afghanistan

The deployment of advanced ICT infrastructure in Afghanistan and the proliferation of modern ICT services across it is only a small part of the success story of the Afghan ICT sector: 80 percent of the benefits of ICT come from its usage ... only 20 percent from its production."<sup>811</sup> ICT has created a paradigm shift in the country that has benefitted citizens, communities, businesses, industries, and the government.

---

<sup>811</sup> Atkinson, Rob (2010). "ICT and Innovation: Powering National Economic Growth." A presentation at a Boeing Event: Leading and Nurturing a High Tech Enterprise, St. Louis, MO. December 6.

The “use of ICT for new goods and services ... can be transformational,”<sup>812</sup> and it has been in Afghanistan. Mobile phones and the Internet have created more and different ways for Afghans to communicate as well as to source and share information. They have broadened Afghans’ worlds, boosted productivity and economic output, spurred innovation and social change, and improved healthcare and education. “Extending these opportunities is critical to accelerating economic and social growth ... while enabling the transition from a resource-based to a knowledge-based economy.”<sup>813</sup> The success of the ICT sector is an extraordinary accomplishment for Afghanistan. The contribution of ICT to Afghanistan’s reconstruction, security, stability, and transformation cannot be overemphasized. “The degree of ambition of Afghanistan’s technocratic reforms, and to a considerable extent the progress in their implementation, have exceeded expectations, especially for a low-income, conflict-affected country.”<sup>814</sup> As [Figure 33](#) earlier in this chapter illustrates, more Afghans now get their news through their mobile phones than their mosques. Three times as many Afghan use the Internet as a source of news and information than just three years ago. These trends, particularly if they continue, have the potential to be revolutionary for Afghanistan’s future.

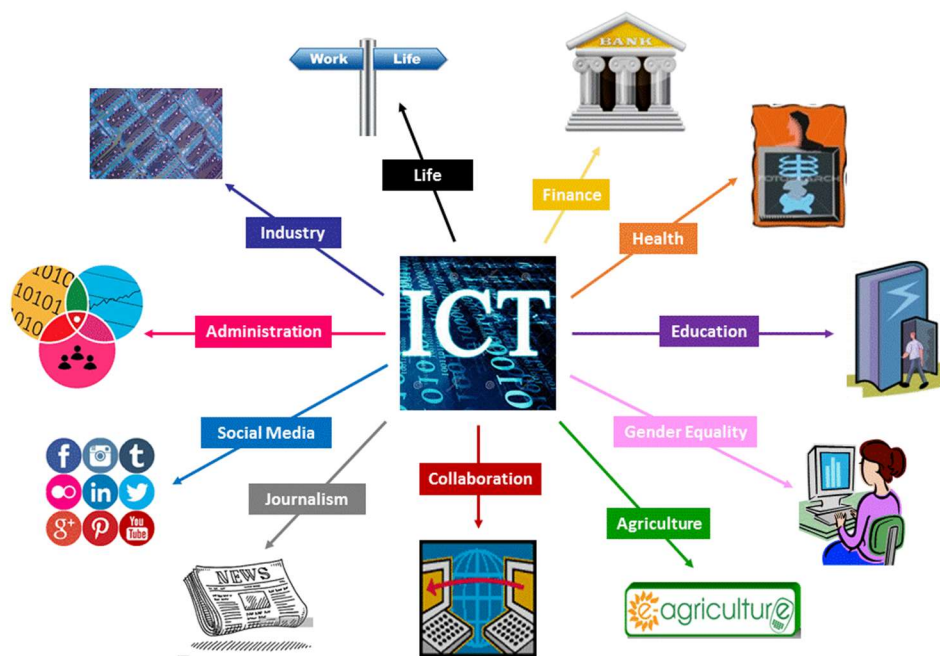

Figure 38: ICT for socio-economic development

<sup>812</sup> Ibid.

<sup>813</sup> Deloitte LLP (2014). *Value of Connectivity: Economic and social benefits of expanding internet access*. March: 4.

<sup>814</sup> Byrd, William A (2016). *Technocratic Reforms in Afghanistan: Benefits and Limitations*. United States Institute of Peace, *PeaceBrief* 209, July 5, 2016. Accessed September 7, 2016.

<http://www.usip.org/publications/2016/07/05/technocratic-reforms-in-afghanistan-benefits-and-limitations>.

As depicted in [Figure 38](#), ICT underpins just about every sector and industry of the Afghan economy and touches many facets of everyday Afghan work and life. ICT, and particularly mobile communications, especially in developing countries, is “pivotal to the global economy, both as an industry in itself and as an enabler for adjacent sectors and services.”<sup>815</sup> Individual chapters or sections in this book are devoted to how ICT has been employed in finance, health, and education. Other chapters describe how ICT enables information sharing and collaboration, promotes gender equality, transforms journalism, and encourages civic engagement and civil discourse. Yet another chapter describes the ability of ICT to improve transparency, increase accountability, and decrease corruption in government and among public officials. It also explains how electronic and mobile government (e- and m-government, respectively) can improve the efficiency and effectiveness of the government to deliver services to its citizenry.

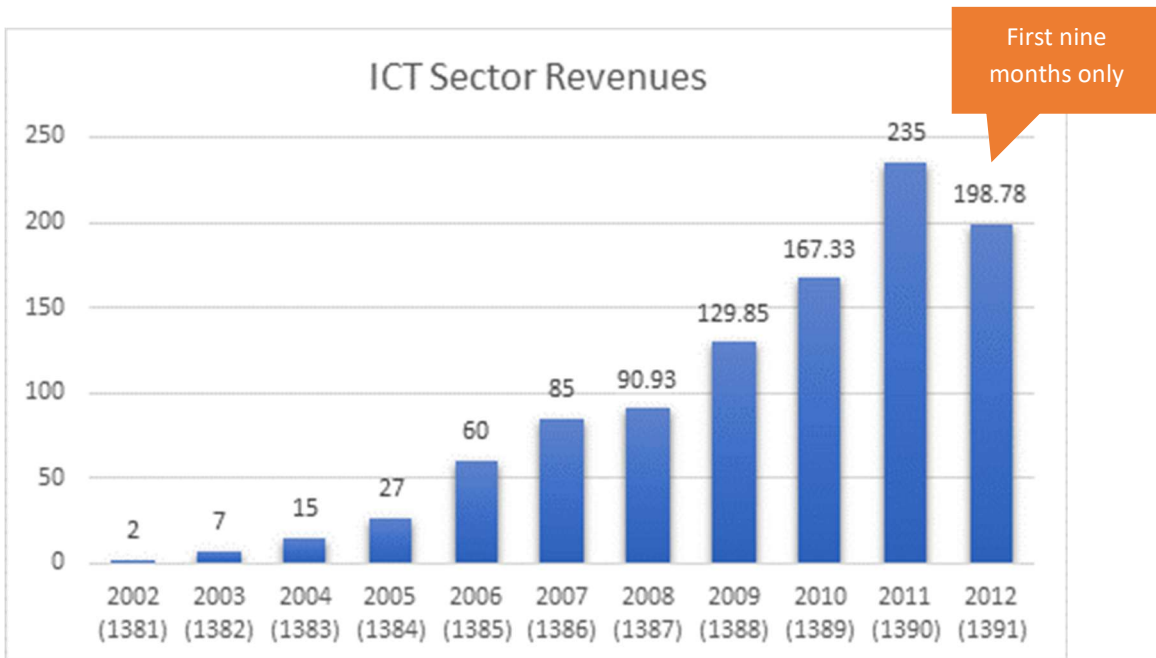

Figure 39: ICT sector revenues in millions (US Dollars), 2002-2012

Quite explicable, the proliferation of ICT services throughout Afghanistan was paralleled by dramatic growth in ICT sector revenue, as illustrated by the graph in

. The Afghan ICT sector is one of the largest revenue-generating areas of the Afghan economy and has often been described as the largest legitimate sector. In the early post-war years (and prior to the establishment of an ICT regulator), the MCIT was among the few government entities that actually generated revenue rather than only accruing expenditures and making disbursements. For the fiscal year

<sup>815</sup> GSM Association (2016). *The Mobile Economy in 2016*. Summary extract. Accessed July 7, 2016. <https://www.gsmaintelligence.com/research/?file=e888862e19a8097c48291a8f66b4ddc5&download/>.



ending March 20, 2007 (SY1385), the ICT sector accounted for 20 percent of all government receipts to the Afghan treasury,<sup>816</sup> largely through taxes and spectrum and license fees. That contribution dropped to 12 percent by 2011, but is still a significant figure.<sup>817</sup> In the second quarter of FY1391 (mid-2012), the MCIT was the third largest contributor to the GiRoA's treasury after the Ministry of Transportation and Civil Aviation and the Ministry of Interior, with revenue from mobile telephone service contributing 445 million Afghanis compared to railway services at 599 million Afs.<sup>818</sup> With annual revenue of US\$200 million, the ICT sector is the second-largest source of revenue for the Afghan government, accounting for ten percent of its total revenues.<sup>819</sup> The ICT sector is one of the largest employers in Afghanistan, providing upwards of 200,000 direct and indirect jobs,<sup>820</sup> and paying some of the highest wages in the country.

Afghanistan embraced private investment as part of its post-war redevelopment. In 2002, the transitional government approved new, liberal investment laws applicable to both domestic and foreign companies. As indicated in

, investment in the ICT sector has exceeded US\$2.4 billion to date.<sup>821</sup>

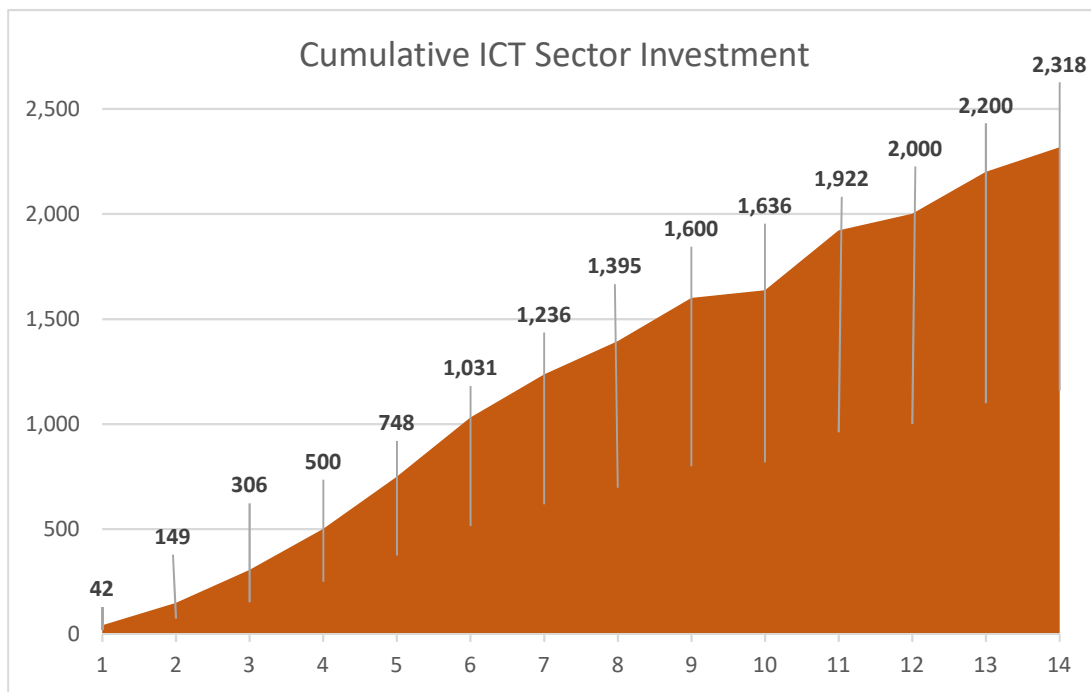

Figure 40: Cumulative investment in ICT sector in millions (US Dollars), 2002-2015

<sup>816</sup> MCIT, 2008. *ICT Sector Strategy*.

<sup>817</sup> Statistic provided by the MCIT to the author in mid-2013, reportedly per the Afghan Ministry of Finance.

<sup>818</sup> Islamic Republic of Afghanistan Ministry of Finance *Quarterly Financial Bulletin*, 2Q1391.

<sup>819</sup> MCIT, 2014. *Activities and achievements report*, 32.

<sup>820</sup> MCIT, 2014. *Activities and achievements report*, 39.

<sup>821</sup> ATRA, Telecom Statistics (End of December 2015).

In 2013, the *total* contribution of the ICT sector to Afghanistan’s GDP was estimated at US\$2 billion, with its *direct* contribution assessed at US\$950 million.<sup>822</sup>

In addition to the impressive statistics in Afghanistan, there is a growing body of evidence globally that correlates increases in the deployment and use of ICT with economic improvements. Various studies have demonstrated economic benefits related to mobile phone penetration. For example:

- In 2005, Vodafone reported a one-percent increase in mobile phone penetration can increase a country’s economic growth by as much as 6.75 percent.<sup>823</sup>
- In a study of six developing countries in 2008, mobile telephony made a positive impact on economic welfare by increasing GDP between 3.7 and 6.2 percent.<sup>824</sup>
- In 2013, the GSM Association reported a 10-percent increase in mobile penetration increases Total Factor Productivity in the long run by 4.2 percentage points.<sup>825</sup>

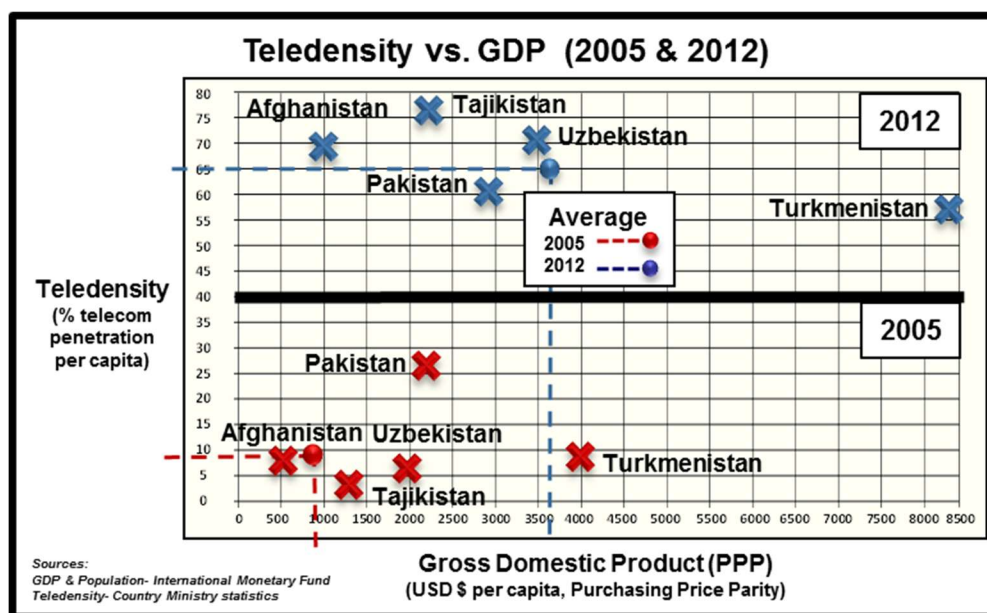

**As teledensity increased by 1%, GDP increased by 3%**

Figure 41: Afghanistan teledensity versus GDP, 2005 and 2012

(Graphic courtesy of Lew Shadle)

<sup>822</sup> Altai Consulting, 2014.

<sup>823</sup> Vodafone (2005). *Africa: The Impact of Mobile Phones*. The Vodafone Policy Paper Series, Number 2, March 2005. Accessed March 4, 2016. <http://www.itu.int/osg/spu/dtis/documents/Papers/vodafonepapers.pdf>.

<sup>824</sup> Deloitte (2008). *Economic Impact of Mobile Communications in Serbia, Ukraine, Malaysia, Thailand, Bangladesh and Pakistan*. January 2008. Accessed June 7, 2014. [https://www.telenor.rs/media/TelenorSrbija/fondacija/economic\\_impact\\_of\\_mobile\\_communications.pdf](https://www.telenor.rs/media/TelenorSrbija/fondacija/economic_impact_of_mobile_communications.pdf).

<sup>825</sup> Deloitte LLP (2012). *What is the impact of mobile telephony on economic growth?*, November 2012. Accessed June 7, 2014. <http://www.gsma.com/publicpolicy/wp-content/uploads/2012/11/gsma-deloitte-impact-mobile-telephony-economic-growth.pdf>.

We have seen similar such encouraging indicators in Afghanistan. Using mobile phone penetration, gross domestic product (GDP), and population data from 2005 and 2012, [Figure 41](#)<sup>826</sup> illustrates the impact of mobile telephony on the overall productive capacity of Afghanistan. As indicated on the chart, a one-percent increase in Afghanistan's teledensity can arguably be correlated to approximately a three-percent increase in GDP. Three percent is significant, considering Afghanistan averaged an annual GDP growth rate of 11.12 percent from 2003 to 2015 and experienced a record low of 2.10 percent in 2015.<sup>827</sup> Additionally, donor funding still accounts for more than 75 percent of Afghanistan's annual budget.<sup>828</sup>

The introduction of 3G (and beyond) mobile broadband service is expected to have even a bigger impact on Afghanistan than regular mobile telephony already has. Research indicates that for any given level of mobile penetration, a 10 percent substitution from 2G to 3G increases GDP per capita growth by 0.15 percent, and a doubling of mobile data use leads to an increase in the GDP per capita growth rate of 0.5 percent.<sup>829</sup> Similar such data abounds regarding overall broadband penetration, as indicated by the statistics below:

- In 2009, the World Economic Forum estimated for every dollar invested in broadband (fixed and wireless), the US economy is expected to see a tenfold return.<sup>830</sup>
- The World Bank reports a 10-percent increase in broadband Internet penetration in developing countries is estimated to correspond to a 1.38 percent increase in GDP.<sup>831</sup>
- Raising broadband penetration in emerging markets to current Western European levels could add US\$300 to US\$420 billion in GDP and create 10 to 14 million new jobs.<sup>832</sup>

As proffered earlier in this chapter, mobile coverage and mobile penetration in Afghanistan are at nearly 90 percent each, but the number of fiber-based and terrestrial Internet users remains very low. Therefore, most of the economic benefit Afghanistan derives from ICT in the immediate future will likely stem from the continued adoption of 3G mobile broadband service. Globally, mobile broadband connections are forecast to increase from 47 percent to 71 percent of total broadband connections by 2020, and data

---

<sup>826</sup> Analysis conducted and chart produced by Lewis E. (Lew) Shadle, former TAT Senior ICT Advisor and Reachback Team member, Deloitte Consulting LLP.

<sup>827</sup> TradingEconomics.com. "Afghanistan GDP Annual Growth Rate." Accessed September 13, 2016. <http://www.tradingeconomics.com/afghanistan/gdp-growth-annual>.

<sup>828</sup> Shevory, Kristina (2016). "Once a Bright Spot, Afghan Telecoms Face Unsustainable Losses." *The New York Times*, April 8. Accessed July 7, 2014. <http://www.nytimes.com/2016/04/09/business/international/once-a-bright-spot-afghan-telecoms-face-unsustainable-losses.html?ref=business&r=0>.

<sup>829</sup> Deloitte LLP (2012).

<sup>830</sup> World Economic Forum (2009). *ICT for Economic Growth: A Dynamic Ecosystem Driving The Global Recovery*. Accessed September 7, 2016. [http://www3.weforum.org/docs/WEF\\_IT\\_DynamicEcosystem\\_Report\\_2009.pdf](http://www3.weforum.org/docs/WEF_IT_DynamicEcosystem_Report_2009.pdf).

<sup>831</sup> World Bank (2009). *Information and Communications for Development: Extending Reach and Increasing Impact*. World Bank. © World Bank. <https://openknowledge.worldbank.org/handle/10986/2636>. License: CC BY 3.0 IGO." Accessed July 7, 2016.

<sup>832</sup> itu4u (2015). "Digital Divide Progress Report: 15 Year Review." *itublog* (blog), August 26. <https://itu4u.wordpress.com/2015/08/26/digital-divide-progress-report-15-year-review/>.

traffic is expected to grow by a compound annual growth rate of 49 percent between 2015 and 2020.<sup>833</sup> The number of smartphone connections around the world is predicted to increase by 2.6 billion by 2020, with 90 percent of that growth coming from developing regions.<sup>834</sup> All of those figures bode well for Afghanistan’s next generation of ICT sector development.

## Current State of Afghanistan’s ICT Sector

Since the introduction of commercial mobile service in mid-2002, Afghanistan has achieved over 25 million mobile subscribers. As reported earlier in this chapter, mobile service coverage and mobile penetration are nearly 90 percent each, both remarkable feats in less than a generation. By the middle of 2013, 36 percent of Afghans reportedly lived in areas with Internet access,<sup>835</sup> and there are at least two million Afghan Internet users – perhaps double that, if not more. Since the introduction of 3G mobile broadband services in 2012, there are nearly two million 3G subscribers, as indicated in [Table 6](#).<sup>836</sup>

Table 6: Afghanistan ICT sector statistics, December 2015

Mobile Network Operators	6
Landline Operators	1
Mobile Base Transceiver Stations	6,501
Mobile Telephone Network Population Coverage	89%
Landline Telephones	110,000
GSM Subscribers	25,080,389
Active GSM Subscribers	19,709,018
CDMA Subscribers	297,895
3G Mobile Broadband Subscribers	1,910,178
Internet Service Providers	54 (including two WiMAX Operators)
ICT Solution Providers	46
Cumulative Investment in ICT Sector (USD)	2,318,809,569

Mobile penetration and coverage has exceeded the MCIT’s goals. However, Internet access and use has lagged behind. MCIT Minister Sangin’s goal in mid-2012 was for 50 percent of Afghans to have access to Internet services in the next two years.<sup>837</sup> In early 2013, the MCIT estimated approximately 36 percent of

<sup>833</sup> The GSM Association (2016). *The Mobile Economy 2016*. Accessed July 7, 2016. <https://www.gsmaintelligence.com/research/?file=97928efe09cdba2864cdcf1ad1a2f58c&download>.

<sup>834</sup> Ibid.

<sup>835</sup> According to the MCIT.

<sup>836</sup> ATRA, Telecom Statistics (End of December 2015).

<sup>837</sup> MCIT Minister Amirzai Sangin, in a speech at the MCIT during the signing ceremony for the issuance of MTN’s 3G license, June 20, 2012.

all Afghan citizens lived in areas with Internet access,<sup>838</sup> so they are not too far off. As mentioned above, Internet statistics vary greatly, and ATRA, the official source for ICT sector statistics does not currently publish them, but the MCIT reported 2.1 million Internet users as of the end of 2014 as depicted in [Figure 27](#) above.

According to the MCIT, several of Afghanistan’s provinces are nearing 100 percent ICT service coverage, nebulous as that descriptor is, as indicated in [Figure 42](#).<sup>839</sup>

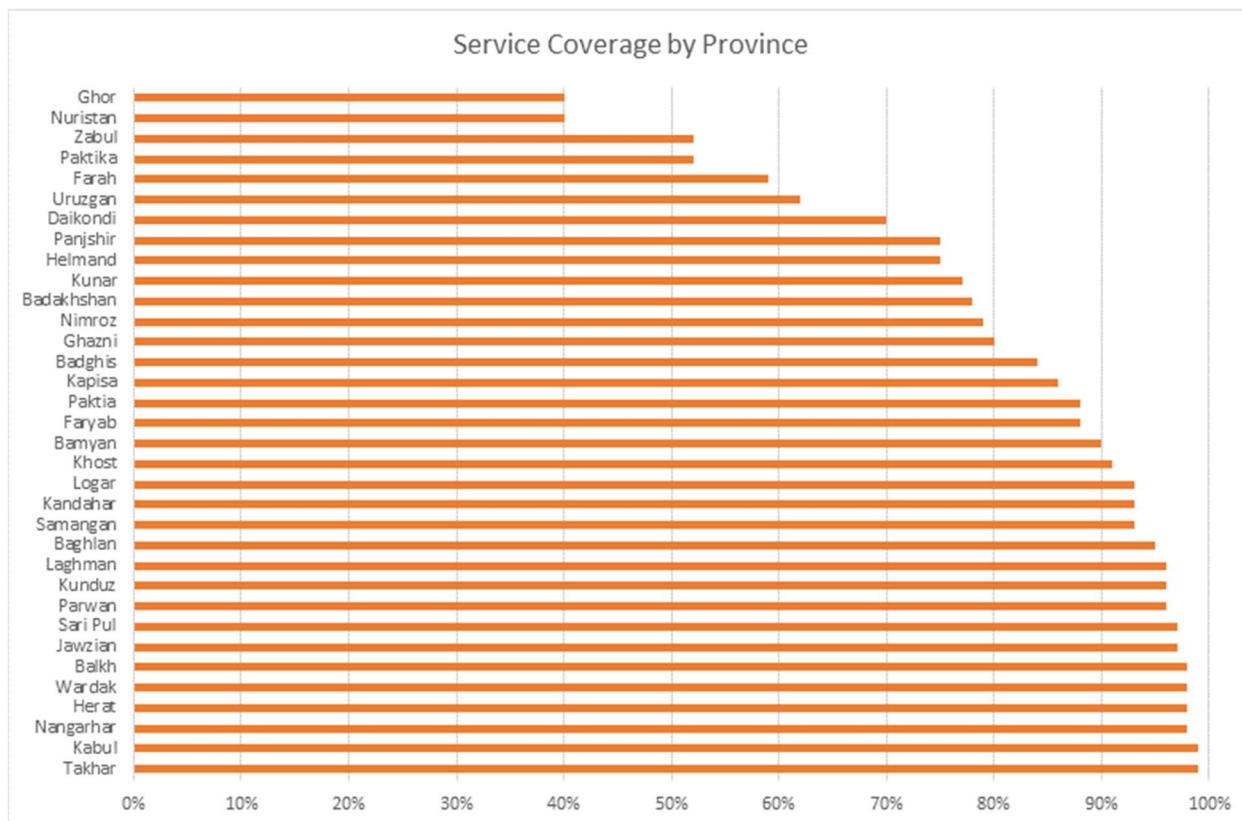

Figure 42: ICT service coverage by province, 2014

Perhaps most representative of the current state of the Afghan ICT sector, as it relates to the availability of cellular telephone service, is [Figure 43](#), which illustrates the combined coverage of the country’s six mobile network operators.

Afghanistan’s ICT sector has long been considered one of the country’s greatest and most visible success stories. In recent months, however, the sector has begun to falter. With the withdrawal of most Coalition troops at the end of 2014 and the concomitant exodus of associated foreign workers, along with half a million Afghans who lost their war-related jobs, the mobile network operators have experienced

<sup>838</sup> Statistic provided by the MCIT to the author in January 2013.

<sup>839</sup> Adapted from a chart in MCIT, 2014. *Activities and achievements report*.

significant declines in their customer bases and resultant revenues.<sup>840</sup> Additionally, over the past decade, the total tax load on telecommunications has climbed to more than 25 percent, even before the government levied a 10-percent tax on mobile phone consumers in September 2015.<sup>841</sup> All of this, and the resurgent extortion of Afghanistan’s mobile network operators by the Taliban, threatens the continued viability of the mobile sector, and may lead to consolidation within the ICT industry and a decline by operators to invest in it further.

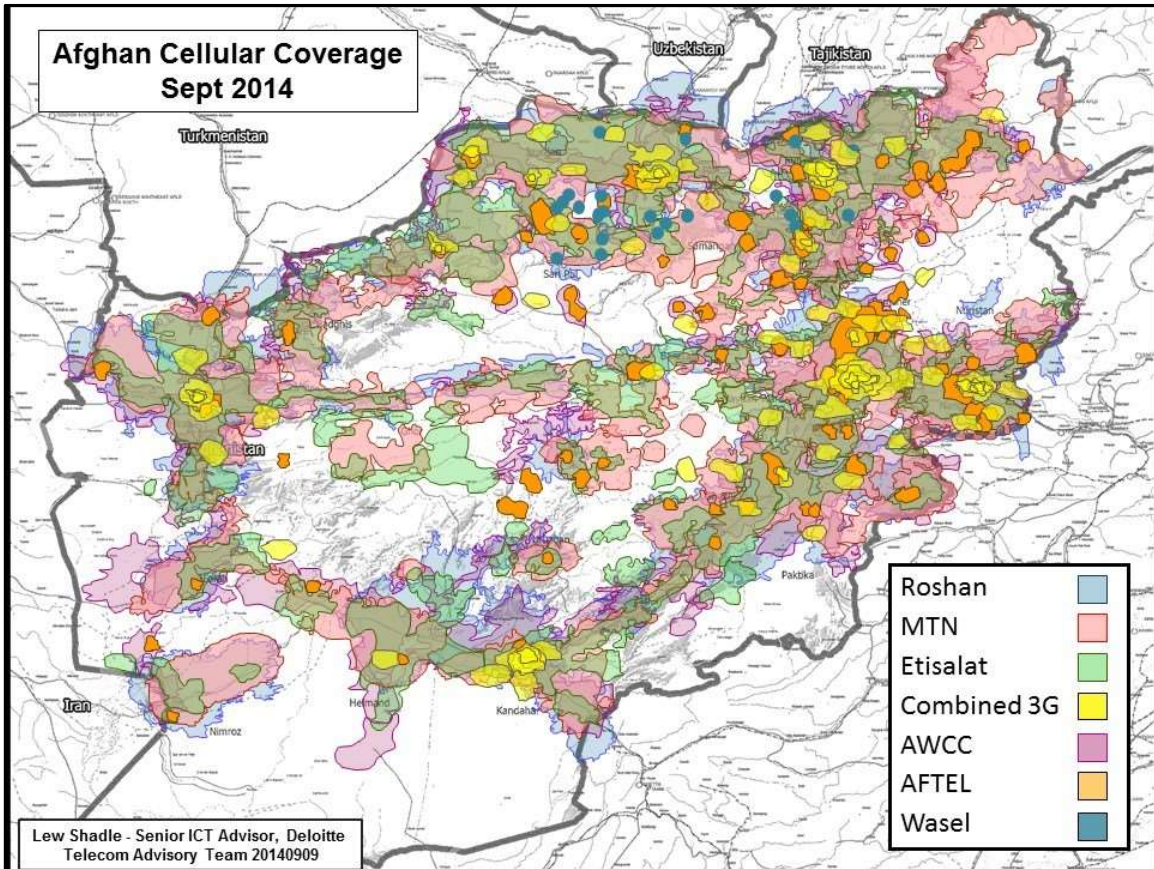

Figure 43: Afghanistan cellular coverage, September 2014

(Graphic courtesy of Lew Shadle)

On a more positive note, President Ghani approved a new Open Access Policy on August 28, 2016, which should be an attractive proposition for Afghanistan’s mobile network operators. The first of its two main provisions makes available ICT infrastructure and facilities, including but not limited to AfTel’s optical fiber, through a transparent process with reasonable prices. The second allows “competitive provisioning,” that is, the ability for the MNOs to build and operate their own fiber networks, including international gateways. Some within the Afghan government have expressed concern that such actions

<sup>840</sup> Shevory, 2016.

<sup>841</sup> Ibid.

could cause the demise of AfTel, so the government is considering how the policy might include some incentives or a directive for companies to build more widely to mitigate the implications if that were to occur.

## Conclusions, Lessons Observed, and Recommendations

### Commercial ICT Sector

The ICT sector in Afghanistan emerged from next-to-nothing in 2002 to become a thriving, revenue-generating, job-creating sector, and one of the most vibrant and exciting fields in the country. ICT has been critical to the reconstruction of Afghanistan and has accelerated progress in all other areas of the Afghan economy. The achievements in Afghanistan's commercial ICT sector, particularly mobile telephony, can arguably be attributed to the following:

- Early recognition – essentially from the beginning of the Afghanistan Transitional Administration (ATA) – of the fundamental importance of ICT to the country's rehabilitation and reconstruction, and its designation as a priority sector for development.
- Willingness by the ATA to honor AWCC's contract with the Taliban government and issue it provisional authority to establish GSM service, along with an Internet café for the Loya Jirga in 2002.
- Early leadership by competent ministers with vision and relevant commercial ICT expertise. The continuity of service (ten years) of the second post-war minister allowed for policies and programs to be carried out absent the upheaval that accompanies changes in administration.
- The establishment of an independent sectoral regulator, at least in theory.
- Forward-thinking policies, strategies, laws, and "light-touch" regulation, which created an enabling environment conducive to private investment.
- An uncomplicated and reasonable administrative process and the adoption of international best practices regarding the licensing of service providers.
- Rapid infrastructure deployment coupled with rapacious demand, particularly by Afghanistan's sizeable young population, leading to unprecedented adoption of ICT services.
- The design and execution of universal access and rural telecommunications development programs, complete with a funding mechanism in the form of the TDF. While not perfect, the combination of the three components has successfully supplemented and complemented the commercial cellular companies' networks to extend ICT services to even the remotest villages.
- The deployment of multiple infrastructures – fiber, cellular, microwave, and satellite.
- A concerted and prolonged effort by the MCIT to reduce international access and transport costs, which have translated into lower costs for service providers and lower prices for consumers.

Nevertheless, the ICT sector has not been free of challenges. Afghanistan's mobile sector has been plagued by frequency interference issues, and ATRA lacks the capacity to appropriately manage and monitor Afghanistan's spectrum resources. ATRA has yet to operate independently of the MCIT, which has been a perpetual conflict of interest because of the ministry's ownership stakes in AfTel and AWCC. The entry of state-owned AfTel into the GSM/3G market in early 2014 created consternation among the

other major mobile network operators, whose “common perception ... is that Afghan Telecom ... will be given preferential treatment by ... [the] MCIT and ATRA ... [and] trust in the regulatory bodies is a critical factor in MNOs continuing to invest in the sub-sector.”<sup>842</sup>

There was no indigenous ICT expertise in Afghanistan as it emerged from conflict, a tremendous void to fill as the country literally fabricated the ICT sector from the ground up. ICT capacity-building efforts widely have fallen short of the mark. Public ICT institutions are unable to compete with the private sector in attracting and retaining talent and expertise. Afghanistan’s citizens have ravenous high-tech appetites, but they are technical neophytes, and general digital illiteracy abounds. None of the US technology-training giants, such as Cisco and Microsoft, elected to engage in the country in any meaningful way. Organized online ICT training has not been adopted at the institutional level.

Afghanistan’s fledgling bureaucracy leaves a lot to be desired. Corruption, nepotism, and patronage networks undermine progress within the government and in every sector, and ICT is no exception. Long-standing tribal affiliations and deeply-rooted rivalries often trump the sector’s – and the country’s – best interests.

The Internet sub-sector and ISPs have not experienced the same commercial success as voice services and the MNOs. The dearth of terrestrial infrastructure and expensive obstructions created a generally uneven playing field, which was later exacerbated by AfTel’s fiber monopoly. NIXA has yet to become a reality, and local Internet content in local languages has been slow to materialize.

While the US has been engaged with the Afghan ICT sector at the aid and advisory levels since the toppling of the Taliban, very few US companies elected to invest in Afghanistan’s digital revolution. China, in particular, has bid on and won extensive infrastructure and equipment contracts in both the public and private sectors, which could prove problematic if its intentions are anything other than economic. Similarly, Afghanistan has struck ICT partnerships with Iran, Russia, and other countries whose interests often run counter to those of the United States.

## Civil and Military Communications

A testament to the success of one of the initial forays into civil and military communications in Afghanistan is that the Codan radio network is still operational and in use today. The results of Afghanistan’s first-generation civil networks – government, provincial government, and district – are a mixed bag, as described within those sections. Despite their deployment beginning as far back as 2003, a lack of communication between the national and sub-national levels of government – and among Afghanistan’s security entities – was still recognized as a critical capability gap in 2012.

ANSFnet has achieved a degree of success, as measured by the extension of connectivity if nothing else. Unfortunately, by March 2012, there were already major problems with ANSFnet, particularly security

---

<sup>842</sup> Altai Consulting, 2014.



issues, “causing users [not to] trust ANSFnet to securely convey communications in their day-to-day operations”<sup>843</sup> and jeopardizing ANSFnet’s future viability. Among the problems were:

- Inadequate institutional security policies, training, and oversight;
- Inconsistency in enforcing compliance measures as well as in the monitoring and accounting of information assurance tasks stated in network security policies;
- Visiting of non-work-related websites by ANSF personnel;
- Frequent virus attacks and outbreaks;
- Suspected intrusions and hijacking or compromising of servers and services; and
- Unavailability of applications, such as Microsoft Exchange, for weeks and even months.<sup>844</sup>

NTM-A/CSTC-A proposed to complete a full assessment of ANSFnet’s security posture to identify all security gaps. Included in its proposed activities were to:

- Re-evaluate and update policies and re-align security responsibilities and personnel, as and where needed;
- Verify and validate security mechanisms;
- Train and certify network users and administrators;
- Modify and update NOC and helpdesk procedures; and
- Develop measures for security effectiveness.

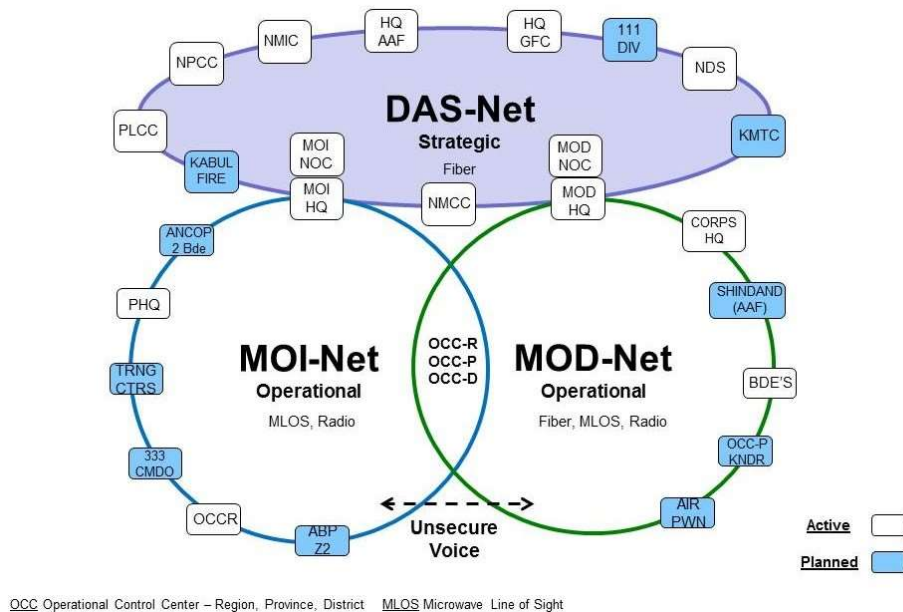

Figure 44: DAS-Net and ANSFnet, 2014

<sup>843</sup> NTM-A ANSFnet Focus Areas Brief.

<sup>844</sup> Ibid.

Just prior to the transition of ISAF to NATO's follow-on Resolute Support Mission (RSM), NTM-A was redesignated as CJ7<sup>845</sup> and became a Staff Element under ISAF. It is unclear whether NTM-A/CSTC-A undertook that assessment or what support, if any, CJ7 continues to provide to ANSFnet. It is unknown to the author how ANSFnet is performing or progressing under Afghan control. It is highly likely the ANSF does not have the ICT skills and expertise to continue to operate and properly maintain the network and its applications because of the overwhelming lack of human ICT capacity in the country. For whatever reason(s), the MCIT has not moved the DAS-Net initiative forward. There was never a tangible plan or network design developed outside of physical Layer 1 connectivity. One glaring reason is the concept itself may be flawed: in the US, we do not have, nor want, a government-wide network. Civil interconnectivity and government interoperability may well be something that has to evolve more organically, based on need rather than unilateral imposition, and from the bottom up rather than the top down. That being said, the Coalition was successful in helping GfRoA achieve some level of integration regarding its civil and military communications, as depicted in [Figure 44](#).

The implementation of modern ICT services for the government and military have introduced an unparalleled, and sometimes unpopular, level of accountability and transparency. These consequential effects have sometimes caused those in power – or at least those with something to hide or lose – to thwart the installation of ICT solutions or undermine the support of technological progress within the civil sector and the ANSF.

## The Future of ICT in Afghanistan

Despite its phenomenal achievements to date, the Afghan ICT sector faces a multitude of risks going forward. The mobile market is crowded, with five national operators (and a sixth regional carrier), and is nearing saturation. However, the focus of the sector has shifted away from vanilla voice services to data, value-added, and over-the-top (OTT) services and content, creating a plethora of new opportunities. Taxation of both operators and consumers must be kept in check, lest it drive down demand, or at least usage, going forward. The entry of state-owned AfTel into the GSM/3G market in early 2014 created consternation among the other major mobile network operators, whose “common perception ... is that Afghan Telecom ... will be given preferential treatment by ... [the] MCIT and ATRA ... [and] trust in the regulatory bodies is a critical factor in MNOs continuing to invest in the sub-sector.”<sup>846</sup>

Afghanistan's optical fiber network is nearly complete. It has yet to be utilized to anything approaching its full potential, but it holds tremendous promise for the country's future. To date, AfTel has enjoyed a monopoly on the fiber, another bone of contention with the MNOs and ISPs, and a detriment to the sector. However, the Afghan High Economic Council approved a new Open Access Policy in April 2016, and President Ghani granted final approval of a more comprehensive version by presidential decree in August 2016. The OAP opens the door to competition in constructing and operating optical fiber networks (and other broadband infrastructure), including international gateways. The Afghan government requires – and

---

<sup>845</sup> Combined Joint Training and Exercises

<sup>846</sup> Altai Consulting, 2014.

is soliciting – expert assistance to develop the appropriate regulations, licensing templates, and pricing regimes in support of the new policy. Implementation of the OAP is expected to begin by November 2016 and be completed by mid-2017. Concurrent with the advent of open access, the MCIT may want to consider (yet again) privatizing Afghan Telecom. Either that, or leave it to its own devices to operate according to open market principles and succeed or fail on its own.

These actions are necessary to further capitalize on the success of Afghanistan’s ICT sector so far, and to take the next steps in its development. The overarching goal is to continue to expand access to broadband services, increase their uptake, and reduce their costs, which will unequivocally benefit Afghanistan’s economy and, ultimately, its citizens. Afghanistan has an auspicious opportunity – which can only increase with open access to the fiber – to become, or at least play a major role in, a Central Asian ICT hub. The country is well-situated to carry international data transit traffic from the Indian Ocean, via Pakistan across Afghanistan and to existing links to its neighbors to the north and on to Europe. Should that come to fruition, it could provide increased revenues to Afghanistan’s operators and, consequently, the government. The World Bank has shown interest in supporting such regional connectivity, and is considering a grant of US\$50 million in late 2016 under its Digital CASA initiative.<sup>847</sup>

While approval of the OAP and the transit hub opportunity are both great news for the Afghan ICT sector writ large, the timing of both is less than ideal. Confidence in the country and its future continue to erode amid a deteriorating security situation, replete with the resurgence of the Taliban and the arrival of Islamic State militants in the country. The consequences of the 10-percent extortion tax imposed on the MNOs by the Taliban in late 2015 have yet to play out, but could be severe and could tip the risk-reward ratio for the private sector into negative territory.

The local Internet economy will continue to be usurped by the MNOs, to the detriment of the ISPs, some of which is natural and is expected as the ICT sector continues to mature. Although terrestrial Internet service has largely failed to launch, there remains opportunity, particularly with the recent approval of the Open Access Policy. The new OAP also includes provisions for private companies, rather than just the government, to establish and operate Internet exchange points (IXPs). IXPs will help keep local Internet traffic local, thereby improving speeds and decreasing costs.

The coincidence of the departure of Coalition troops with the installation of the new Unity Government, and the associated ministerial changeover, have been disruptive to the ICT sector and the country as a whole. The reduction in the number of foreign aid workers, along with the associated decline in Afghan employment and the record-low growth of Afghanistan’s GDP in 2015, create additional challenges for the ICT sector and the country.

Despite the recognition by GIRoA of ICT as critical infrastructure and a five-year-old government strategy to protect it, little of any measurable consequence had been accomplished, and the private sector remains

---

<sup>847</sup> Digital CASA is an endeavor to foster cooperation among the governments of Afghanistan, Kyrgyzstan, and Tajikistan to implement cross-border broadband connectivity in Central Asia and South Asia.

left to its own devices to safeguard its investments. The sector has reached the stage at which the attention of policymakers can be gradually shifted from enabling infrastructure building to securing existing infrastructure.<sup>848</sup> Another menace to Afghanistan's ICT infrastructure and services is not physical, but is no less portentous. Cyber threats and digital crimes have emerged as material and troublesome vexations. Afghanistan's cybersecurity posture – by all measures and in all regards – is wholly insufficient and thoroughly inadequate to deal with the realities of twenty-first century cyberspace. If Afghanistan does not accelerate its efforts, the lack of effective cybersecurity could expose and debilitate the entire ICT sector.

Overall, Afghanistan's policy, legal, and regulatory framework, while initially strong, has not kept pace with the sector. If history is any indication, the pace of technological change will continue to increase. It is imperative ATRA have the capacity to be able to keep up with developments in the ICT sector, the introduction of new technologies, and cybersecurity challenges. It is also paramount for continued sector success that ATRA become – or at the very least be perceived to be – impartial and independent.

Perhaps most importantly, there is an unambiguous scarcity of skilled ICT workers at all levels. In-country ICT training is inadequate, and traveling abroad for instruction gets expensive. Further, there is a palpable paucity of Afghan leaders, managers, administrators, and personnel with ICT-oriented skills across the public and private sectors and within the country's higher education institutions. In addition to technological aptitude, key skill areas of concern include business and financial management, program and project management, software development, systems administration, English language, and, especially, cybersecurity. Additionally, Afghanistan's technology-trained youth – who are highly employable elsewhere – are leaving the country in droves. All of the above, combined with a looming shortage of ICT workers worldwide (there are expected to be two million more ICT jobs than there are professionals to fill them in between 2012 and 2020<sup>849</sup>) could leave Afghanistan's ICT sector in dire straits.

## The Last Word

As mentioned above, Afghanistan's ICT sector is entering its next phase of development, one that will see more advanced ICT services employed in additional and innovative ways across all sectors of the economy, the population, and the government. Afghanistan has birthed its first generation of digital natives, who will bring an entirely different perspective to what it means for Afghanistan to become an information society.

President Ghani has experience fixing failed states (and authored a book by the same name). He is keenly aware of the role ICT can – must – play for Afghanistan to participate fully in today's global business environment and for Afghanistan to wean itself off donor dollars to achieve eventual economic

---

<sup>848</sup> Altai Consulting, 2014.

<sup>849</sup> Tandon, Nidhi (2012). *A Bright Future in ICTs: Opportunities for a New Generation of Women*. Accessed March 16, 2016.

<http://www.itu.int/osg/blog/2012/04/26/NewReportABrightFutureInICTsOpportunitiesForANewGenerationOfWomen.aspx>.

independence. He is a technocrat who recognizes the power of ICT as an agent of change for Afghanistan. As he states, “Telecommunications ... provide immense scope for innovation ... and the creation of value chains that ... create domestic constituencies for global engagement and national transformation.”<sup>850</sup> Ghani claims, “Ordinary Afghans, like citizens around the world, have a deep desire to be participants in an inclusive international order.”<sup>851</sup> Information and communications technology is a powerful vehicle to help Afghanistan’s transform into a productive, self-reliant state and an instrument through which Afghans can become participatory global citizens.

Bringing Afghanistan out of the digital dark ages benefits the West. The Pew Research Center revealed Muslims outside the US who use the Internet are much more likely than other Muslims to have a favorable opinion of Western culture.<sup>852</sup> In advance of the troop withdrawal at the end of 2014, a *Boston Globe* columnist listed ICT as the second of three reasons to be hopeful about Afghanistan’s future, stating, “In Afghan cities, technology has created a cultural shift that could turn out to be more powerful than anybody’s militia.”<sup>853</sup> This sentiment echoes a quote by the former Vice Chairman of the US Joint Chiefs of Staff, General James “Hoss” Cartwright. He said (in 2014), “As we leave Afghanistan, the thing that will most affect that culture over the long term is leaving behind that network and those cell phones ... and the introduction of that technology is probably far more lasting than anything else ... and far more influential.”<sup>854</sup>

---

<sup>850</sup> Ghani, Ashraf and Clare Lockhart (2008). *Fixing Failed States* (Oxford: Oxford University Press).

<sup>851</sup> Ibid.

<sup>852</sup> Pew Research Center (2013). “Among Muslims, Internet Use Goes Hand-in-Hand With More Open View Toward Western Culture.” May 31. Accessed January 6, 2016. <http://www.pewforum.org/2013/05/31/among-muslims-internet-use-goes-hand-in-hand-with-more-open-views-toward-western-culture/>.

<sup>853</sup> Stockman, Farah (2013). “Three reasons for hope in Afghanistan.” *Boston Globe*, April 9. Accessed January 6, 2016. <http://www.bostonglobe.com/opinion/2013/04/08/gambling-pomegranates/dekCKppa3xT9QeEKGqEqJ/story.html>.

<sup>854</sup> Reed, John (2013). “Let freedom ring: Gen. Cartwright says 4G [*sic*] is America’s lasting legacy in Afghanistan (Updated).” *Foreign Policy*, January 24. Accessed January 6, 2016. <http://foreignpolicy.com/2013/01/24/let-freedom-ring-gen-cartwright-says-4g-is-americas-lasting-legacy-in-afghanistan-updated/>.

## Chapter 4 ICT Institutions and ICT Sector Governance

---

Karen E. Black

### Introduction

Essential to the development of any sector are the institutions that govern it and the environment they create. The reconstruction required in Afghanistan was – and still is – enormous. The Afghan government recognized very early on that information and communications technology (ICT) could and should be a crucial component of its rebuilding efforts. It knew ICT would underpin and accelerate development in all sectors as well as enable security, governance, and socio-economic growth. Therefore, the importance of Afghanistan’s ICT sector institutions and ICT sector governance cannot be overstated.

This chapter parallels, rather than duplicates, the chapters on the establishment of the legal and regulatory framework ([Chapter 5](#)) and the development of the Afghan ICT sector ([Chapter 3](#)). It concentrates on and tells the story of the concerted and consistent vision and goals of the Afghan Ministry of Communications (later, the Ministry of Communications and Information Technology, MCIT). It also describes the ATRA, its role, and its relationship with the MCIT. This chapter also covers the Telecommunications Advisory Team (TAT’s) engagement with both entities and the lessons observed from those arrangements.

The charts in this chapter were all provided by the MCIT or ATRA to the author.

### History and Background

The Ministry of Communications (MoC) of Afghanistan was originally established in 1955. Although official ministry documents show a gap in leadership between 1996 and 2002 (essentially during Taliban rule of the Islamic Emirate of Afghanistan until its demise in December 2001), the MoC continued to function and even promulgated legislation during that time (see [Chapter 5](#), *ICT Policy and Regulatory Framework*). The MoC was reestablished under the Afghan Transitional Administration (ATA) in June 2002. The following month, Presidential Decree 4517 gave the MoC the responsibility to develop the ICT sector through the creation and institution of policies, laws, regulations, and procedures, and granted it statutory authority to issue ICT service licenses and spectrum frequency permits. The MoC was institutionalized in the Cabinet of the Islamic Republic of Afghanistan after the presidential election in 2004. At that time and historically, the MoC was a one-stop communications shop, a government-run phone company similar to former incumbent post, telephone, and telegraph (PTT) entities in other countries (e.g., Western Europe prior to liberalization in 1998). However, the Telecommunications (Telecom) and Internet Policy of 2003,<sup>855</sup> called for a separation of powers and duties: an independent regulator and a separate “phone company” were

---

<sup>855</sup> Islamic Transitional Government of Afghanistan Ministry of Communications (MoC). Telecommunications and Internet Policy, Final Working Draft, November 2003. Accessed August 15, 2015. [http://mcit.gov.af/Content/files/AfghanistanTelecomPolicy\\_English29112010235311722.pdf](http://mcit.gov.af/Content/files/AfghanistanTelecomPolicy_English29112010235311722.pdf).

to be established, in an effort to delineate responsibilities among policy, regulation, and service provision. The Ministry of Communications is Afghanistan’s ICT policy entity.

## Ministry of Communications and Information Technology



As mentioned above, the “new” Afghan Ministry of Communications began under the Afghan Transitional Administration (ATA) in June 2002 and continued operations for five years until the Afghan Cabinet approved its name change to the Ministry of Communication and Information Technology (MCIT) in February 2007 “as an acknowledgement of the central role that the ... information and communications technology (ICT) sector will play in accelerating Afghanistan’s full participation in the global Information Society.”<sup>856</sup> For ease of reference, this chapter uses only MCIT, rather than both MoC and MCIT, from here forward, regardless of the year. For ease of reading, the full title of Minister of Communications and Information Technology is often shortened to simply Minister of Communications.

### Vision and Mission

The MoC’s first post-war strategic vision, stated in 2003, was “[t]o make affordable communication services available in every district and village of Afghanistan through [an] enabling market economy, so that all Afghans, men and women alike, can use ICT to expeditiously improve Government, social services, foster the rebuilding process, increase employment, create a vibrant private sector, reduce poverty, and support underprivileged groups.”<sup>857</sup> That vision was basically reiterated in the ICT section of the *Afghanistan National Development Strategy*.<sup>858</sup> Over the years, the MCIT has refined that vision, but has not deviated substantially from it. The MCIT’s overarching objective is to implement the Afghan government’s ICT policy “to enable the rapid growth of affordable communications to all of our people so they may experience the Digital Age, wherever they are and whoever they may be,”<sup>859</sup> and its mandate is “to provide high quality communication, IT and postal



Picture 15: MCIT headquarters in Kabul

(Photo from the MCIT)

---

<sup>856</sup> Islamic Republic of Afghanistan Ministry of Communications and Information Technology (MCIT). *Information and Communication (ICT) Sector Strategy 1387-1391 (2007/08-2012/13)*, February 2008. Accessed March 14, 2016. [http://mcit.gov.af/Content/files/ICT%20Sector%20Strategy%20-%20English%20final%20Singed\(2\).pdf](http://mcit.gov.af/Content/files/ICT%20Sector%20Strategy%20-%20English%20final%20Singed(2).pdf).

<sup>857</sup> Ibid.: 19.

<sup>858</sup> Islamic Republic of Afghanistan, *Afghanistan National Development Strategy (ANDS) 1387-1391 (2008/09 - 2012/13)*, Volume One, 96. Accessed March 14, 2016. <http://mfa.gov.af/Content/files/Volume%201%20ENG.pdf>.

<sup>859</sup> Ministry of Communications (MoC), Transitional Islamic State of Afghanistan (2003). Paraphrased from *Telecom and ICT Policy Documents*, October 2003 (Sumbola 1382), English translation, Part II. “Information and Communication Technology (ICT) Policy, 11. Accessed November 17, 2014. <http://mcit.gov.af/Content/files/Telecom%20and%20ICT%20Policy.pdf>.

services for the Afghan People at affordable prices.”<sup>860</sup> The MCIT’s current vision is to transform Afghanistan into an Information Society,<sup>861</sup> and its current mission is to create a strong foundation and prepare the land for growth and development of the ICT sector in order to increase effectiveness, efficiency, and transparency ... and to create a transparent lawful framework for encouraging private sector investment for the provision of telecommunications and Internet services ... in order to transform Afghanistan into an information and technology community.<sup>862</sup>

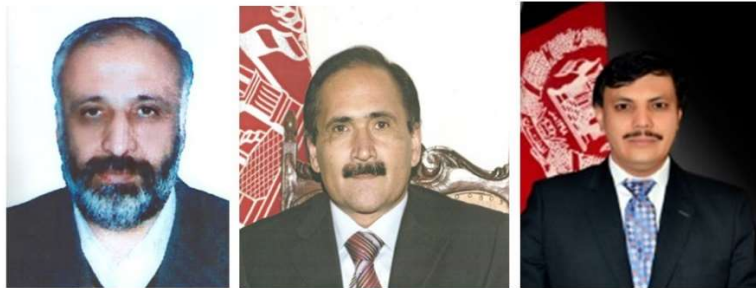

*Picture 16: Afghanistan's modern-day communications ministers*

*(Photos from the MCIT)*

---

*The first post-war Minister of Communications was M. Masoom Stanekzai (left), who was appointed by Interim President Karzai in June 2002, followed by Amirzai Sangin (center) in December 2004. Acting Minister Sangin was originally rejected by the Afghan Parliament in 2010 but ultimately confirmed in March 2012. Deputy Minister Baryalay Hassam (not pictured) briefly assumed the position of Acting Minister upon Minister Sangin’s resignation in November 2014 after President Ghani assumed office in September. On April 21, 2015, Abdul Razaq Vahidi (right) became Afghanistan’s twenty-fifth Minister of Communications.*

---

---

<sup>860</sup> MCIT website. Accessed October 16, 2015. <http://mcit.gov.af/en>.

<sup>861</sup> Ibid.

<sup>862</sup> Paraphrased from the English translation of the “MCIT-100-Days Work Plan,” May 5 – August 6, 2015.



## Organizational Structure

Under the Minister are three deputy ministers: Finance and Administration, Technical, and Information Technology (IT), each of whom oversees several of fifteen directorates that comprise the MCIT. The Deputy Minister – Technical oversees the Policy and Planning Directorate, the General Directorate of IT, and the Information and Communication Technology Institute (ICTI), among others. Under the General Directorate of IT are the subordinate Directorates of E-Government, Information, and Cyber Security (also called the Information Systems Security Directorate), and Technology and Innovation. The responsibilities of the Deputy Minister – Finance and Administration include the Directorates of Finance, Administrative Affairs, and Human Resources, as well as the Directorate of Afghan Post and the Afghan Postal Regulatory Authority, and the 34 Provincial Directorates. The Directorate of Supervision and Evaluation, the Liaison and Documentation Directorate, as well as the MCIT’s Legal Advisor, report directly to the Minister.

The organization chart in [Figure 45](#) was provided by the MCIT in mid-2013, at which time it was current. Some changes may have been made under the new minister.

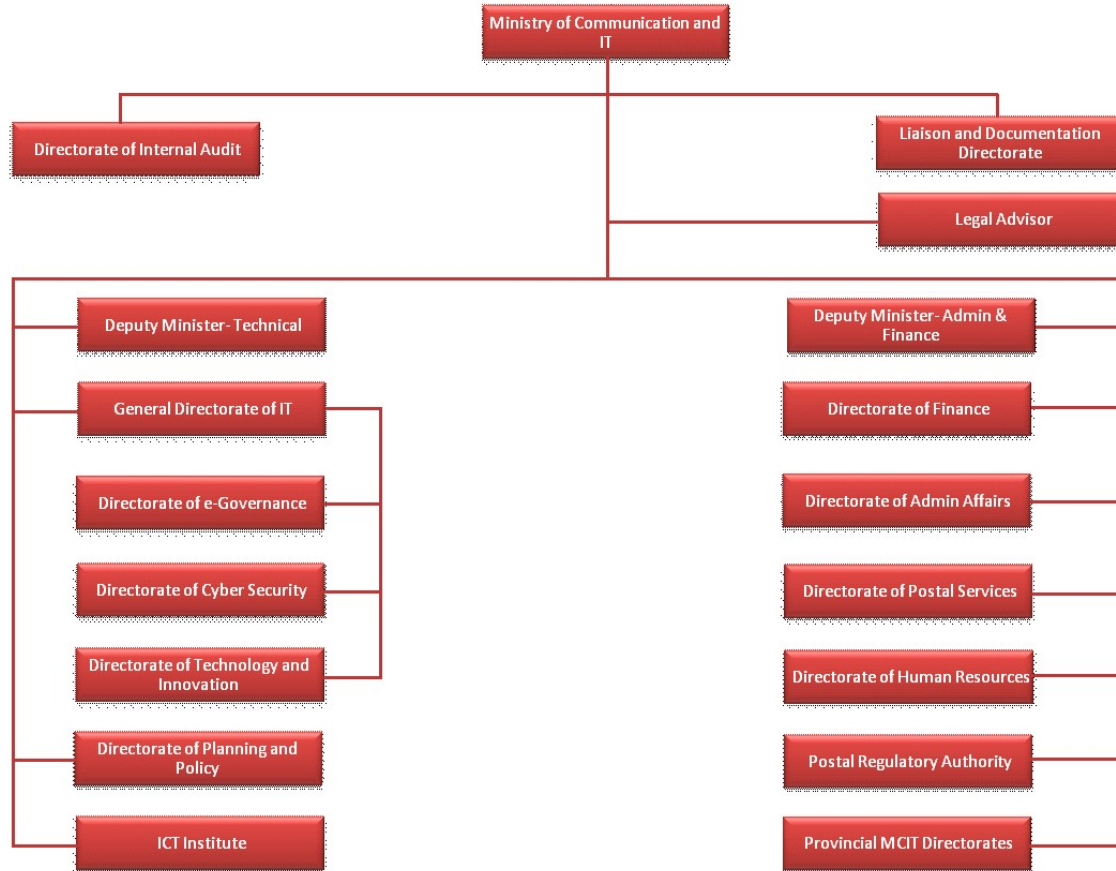

Figure 45: MCIT organizational structure

## Priorities and Plans

To address and overcome the “tyranny of distance” and the “alienation associated with remote geography”<sup>863</sup> faced by Afghan communities, the MCIT set out to create an enabling environment for the rapid reconstruction and modernization of the ICT sector through its policies and legal and regulatory framework, which are covered in another chapter.

While the text below generally describes the MCIT’s published policies, plans, and strategies, it would be negligent not to mention in this section the origins of the plan for Afghanistan’s optical fiber cable (OFC) network (which is covered in detail in [Chapter 7](#)). While it is not mentioned specifically in any plans or priorities below until 2012, the concept for an optical fiber backbone network for Afghanistan originated in 2003. At that time, Minister of Communications Stanekzai, aided by an advisor from the US Agency for International Development (USAID), future minister Amirzai Sangin, asked for US assistance to design a fiber network to parallel Afghanistan’s national ring road. In 2004, Alcatel-Lucent developed a concept paper for the OFC. It was envisioned to be approximately 3,100 kilometers and connect most of Afghanistan’s principal cities. That same year, the US Trade Development Agency (USTDA) conducted a feasibility study and a cost-benefit analysis. When Sangin became Minister of Communications in late 2004, he shortly thereafter issued a tender for the construction of the OFC, using money from the Afghanistan Reconstruction Trust Fund (ARTF) through the government budgeting process.

As you can see, from very early on, the MCIT had grand visions, but it also had clearly-articulated goals and objectives. For example, in its 2003 Telecommunications and Internet Policy, its four broad goals were to:

1. Facilitate social and political integration nationwide;
2. Enhance national and civil security;
3. Provide a macro economic stimulus; and
4. Adopt international best practices.

And the MCIT outlined three main objectives as central to its vision and policies:

1. Universal network access at reasonable cost to promote employment, economic growth, and social well-being.
2. Universal access to information and knowledge, using ICT as the medium.
3. Increasing government and strategic use of ICT in order to broaden ICT applications, modernize and improve operations, and stimulate development and innovation.

Building on success against specific targets set in 2003, the MCIT issued a five-year development plan for solar year (SY) 1384-1389 (2005-2009) that included the following four core activity areas and goals:<sup>864</sup>

---

<sup>863</sup> MCIT, 2008. *ICT Sector Strategy*, 5.

<sup>864</sup> MCIT. “Five-Year Development Plan 1384-1389 (2005-2009),” DRAFT, 1. The fifth core activity area concerned Afghan Post.

1. Regulation – Accelerating the creation of a fully competitive and transparent regulatory and marketing environment, pursuing a strong legislative agenda and an ambitious licensing program.
2. Afghan Telecom – Successfully removing the MCIT from competition in the telecommunications services market by extracting its service operation activities and transferring them into a new national telecommunications carrier (Afghan Telecom).
3. ICT Development – Developing a fully functional Information Society in Afghanistan, supported by model e-government.
4. Capacity Development – Institutional reform and human capacity development at the MCIT.

That was followed by another five-year plan for SY1390-1394 (2011-2015), which kept core activities 3 and 4 above but changed 1 to Rural Coverage (accelerating the penetration of telecommunications services in rural areas) and 2 to the Privatization of Afghan Telecom.<sup>865</sup>

In both plans, the MCIT identified key performance indicators and established targets for each as depicted in [Table 7](#). As you can see, mobile telephone penetration targets were revised upward between the two plans, whereas fixed-line telephone penetration and Internet penetration were both revised downward.

*Table 7: ICT sector key performance indicators and targets, 2005-2015*

Key Performance Indicator	MoC Five-Year Plan 2005-2009			MCIT Five-Year Plan 2011-2015		
	2005	2007	2009	2011	2013	2015
Fixed-line telephone penetration	0.5%	2%	4%	2%	4%	10%
Mobile telephone penetration	3%	8%	16%	50%	80%	95%
Internet penetration	.25%	3%	10%	8%	20%	50%
Number of cities, towns, and villages connected	180	3,000	6,000	4,000	8,000	20,000
Cumulative foreign direct investment (US\$ millions)	500	1,000	2,000	1,276	2,000	3,000
Direct employment (number of jobs)	6,000	10,000	15,000	15,000	30,000	50,000
Indirect employment (number of jobs)	12,000	25,000	35,000	35,000	70,000	100,000

In 2007, the Minister of Communications, supported by the Senior Telecommunications Advisor (STA) at the Afghanistan Reconstruction Group (ARG) at the US Embassy Kabul, was successful in lobbying the

---

<sup>865</sup> Ibid.

leaders of the development of the [Afghanistan National Development Strategy \(ANDS\)](#) to have ICT recognized as a national “priority sector” for investment and development.

In its [ICT Sector Strategy](#) (2008-2013), written and submitted for inclusion in the *Afghanistan National Development Strategy (ANDS)* in February 2008, the MCIT outlined four major objectives, each with several subcomponents:<sup>866</sup>

#### Promotion of ICT development

- Create awareness across the government and the public about the importance of ICT
- Encourage implementation of required ICT solutions and systems in every ministry through the development of a Chief Information Officer (CIO) culture
- Make ICT a cross-cutting tool to support the *ANDS*

#### Coordination of ICT activities

- Create awareness about the existing ICT situation in the country
- Coordinate new activities among ministries and/or donors
- Avoid the duplication and waste of resources

#### Policies and standards for ICT

- Establish policies and procedures
- Establish the legal framework for ICT
- Create ICT standards
- Establish proper procedures for data integrity, security, and access
- Ensure privacy protection
- Create emergency preparedness

#### E-Government initiatives

- Develop a strategic plan for e-government
- Promote e-government to deliver services effectively, reduce bureaucracy, and fight corruption
- Ensure interoperability of systems and solutions, for example: national ID, passport, license, land ownership registry, etc.

In the *ANDS* (2008 to 2013), the key expected outcomes for the ICT sector were listed as:

- An improved enabling environment;
- Improved infrastructure with fiber optic and copper;
- *E-Afghanistan [National Priority Program]* created; and
- Improved ICT literacy.<sup>867</sup>

---

<sup>866</sup> Paraphrased from MCIT, 2008. *ICT Sector Strategy*.

<sup>867</sup> *Afghanistan National Development Strategy*, 100.

The MCIT delivered its proposed [E-Afghanistan National Priority Program](#) (NPP) in May 2011, which was approved by the Joint Coordination and Monitoring Board (JCMB)<sup>868</sup> in October 2011. The seven main components of E-Afghanistan are:

1. Strengthening of legal, regulatory, policy, and institutional frameworks;
2. Expanding telecommunication networks;
3. E-Government;
4. M-Government;
5. Postal sector modernization;
6. Strengthening the ministry (to include ATRA); and
7. Strengthening the ICT sector.

*E-Afghanistan* and e-government are covered in more detail in [Chapter 11](#).

Shortly after his official confirmation by the Afghan Parliament, in April 2012, the minister announced the MCIT's priorities for next three years, all with the stated goal of transforming Afghanistan into an information society:

- To provide cellular network coverage for the remaining 15 percent of the population;
- To further extend the optical fiber cable (OFC);
- To increase broadband Internet services;
- To provide technical assistance to the Ministry of Interior for the electronic national identity cards (e-Tazkira);
- To introduce the concept of electronic government (e-government);
- To convert from analogue to digital broadcasting; and
- To install and use a satellite in orbit.<sup>869</sup>

Minister Sangin made substantial progress against those objectives before leaving office at the end of 2014: At least 86 percent of the Afghan population lived in areas with cellular service.<sup>870</sup> By March 2014, 62 percent of the OFC was operational.<sup>871</sup> Under his administration, the MCIT/ATRA released tenders for mobile broadband service and broadband wireless service, with ATRA granting four 3G and three BWS

---

<sup>868</sup> The Joint Coordination and Monitoring Board was a 28-member body comprised of 21 representatives from the international community and 7 from the Afghan government established "for overall strategic coordination of the implementation of the Afghanistan Compact and the interim Afghanistan National Development Strategy, per its Terms of Reference. Accessed December 15, 2015. [http://www.diplomatie.gouv.fr/en/IMG/pdf/JCMB\\_TOR\\_-\\_English.pdf](http://www.diplomatie.gouv.fr/en/IMG/pdf/JCMB_TOR_-_English.pdf).

<sup>869</sup> As announced by MCIT Minister Amirzai Sangin on April 8, 2012 at the MCIT's Annual Conference of Directors in Kabul, which was attended by the author. The priorities were subsequently published on the MCIT's website.

<sup>870</sup> As of December 2013, the MCIT reported 86% coverage in its 2014 *The Ministry of Communication and ITs' [sic] activities and achievements report 1381-1393 (2002-2014)*, English version (not available electronically), 32.

<sup>871</sup> 2,275 kilometers of 5,086 planned were operational. The "planned" figure includes the World Bank central and northeast spurs in addition to the main ring. 62% figure as reported by TAT Advisor Lew Shadle to TAT leadership, March 28, 2014. See [Chapter 7](#), Afghanistan's Fiber Optic Infrastructure, for more information on the OFC.

licenses between 2012 and 2014. While Afghanistan still awaits the official introduction of its e-Tazkira, the MCIT certainly provided technical assistance to the Ministry of Interior, to the point it was technically – though not politically – ready to launch. The MCIT unveiled its e-government strategy and implementation plan in November 2011 and established a Directorate of E-Governance and an E-Government Resource Center the following year. Afghanistan’s first satellite, AfghanSAT1, launched in partnership with Eutelsat, was inaugurated in May 2014, and digital terrestrial television (DTTV) services began in Kabul in August 2014

Under the new minister, Vahidi, the priorities remained much the same and were published as follows:

- To deliver telecommunications and IT services to remote areas throughout the country;
- To supply high-speed Internet to the people of Afghanistan;
- To design, develop, and deploy the technical platform on the electronic national identity card and provide technical assistance to the Ministry of Interior (Moi) regarding its successful implementation;
- To extend the fiber optic network in the country;
- To replace the existing analogue television broadcasting systems with digital broadcasting and to tighten regulations for the broadcasting companies; and
- To enhance the capacity of the Afghan government by introducing the concept of e-government and encouraging all the ministers to integrate ICT within their operations.<sup>872</sup>

Shortly after assuming office in April 2015, Minister Vahidi outlined his first 100-Day Plan, which includes the following topics:

- Registration of SIM<sup>873</sup> cards;
- Distribution of electronic national identity cards;
- Approval of cybersecurity, electronic signatures, and electronic transactions laws;
- Providing government offices with email service, websites, and video conferencing services;
- Building capacity at ATRA;
- Changing Afghanistan to a regional ICT hub;
- Assessing and promoting the capacity and revenues of Afghanistan’s satellite;
- Improving the technical and financial systems of Afghan Telecom;
- Strengthening the system of electronic governance throughout the country;
- Studying private sector participation in the development of optical fiber (open access policy); and
- Developing the IT industry.<sup>874</sup>

---

<sup>872</sup> Paraphrased from the MCIT website, accessed October 17, 2015. <http://mcit.gov.af/en>.

<sup>873</sup> Subscriber identity module, a removable smart card for some types of mobile phones that stores identifying information regarding the phone and associated customer account.

<sup>874</sup> Paraphrased from the English translation of the “MCIT-100-Days Work Plan,” May 5 – August 6, 2015.

While the plan is more tactical in nature, the initiatives are in keeping with previously established goals, priorities, and plans. The MCIT released a Second 100-Day Plan; however, the author has been unable to obtain an English version of it to date.

## Reorganization

Pursuant to the 2003 Telecom and Internet Policy, the Ministry of Communications retooled its Engineering Department to become the new Telecom Regulatory Board (TRB), which remained under the MCIT's domain. The new entity had six members – the former head of the Engineering Department plus five part-time staff.

In 2005, the Law for the Regulation of Telecommunication Services, commonly known as the “Telecom Law,” explicitly separated ICT sectoral responsibilities into three elements: policy, regulation, and operations. The MCIT was to be responsible for policy, and an independent regulator was to be established for the sector. The creation of an independent legal and regulatory body, which was to be financially autonomous in that its administrative costs would be covered by revenue generated through spectrum, license, and other fees, was critical to continue to facilitate private investment in the sector.

The fledgling TRB actually helped to lobby the Ministry of Justice to pass the Telecom Law (in December of 2005), which codified the responsibilities of the regulator, although it left ultimate responsibility for the ICT sector with the Minister of Communications. The TRB was renamed the Telecom Regulatory Authority of Afghanistan (TRAA), which moniker was short-lived, as its pronunciation was considered offensive in Dari, one of Afghanistan's two official languages. The concept of an independent sectoral regulatory body was largely foreign to Afghans, but the MCIT pressed on toward become a pure policy shop.

The MCIT had begun transitioning out of its service provider operations. The remnants of the Engineering Department and other functions related to network operations were consolidated into a separate business unit. Afghan Telecom Corporation (AfTel) was created by Presidential Decree and with an initial capital investment of US\$2 million from the Afghan treasury in September 2005 to operate infrastructure and provide ICT services, assuming those duties from the MCIT. The MCIT retained ownership of AfTel, but AfTel is required to operate as a fully-independent entity based on open market principles. Although the Telecom and Internet Policy of 2003 specifically calls for the privatization of AfTel, that has yet to be accomplished. The new Vahidi administration has revived the effort, but it is complicated by the fact AfTel is responsible for providing 24x7 GSM<sup>875</sup> service to the Afghan government as directed by the Afghan ONSC in July 2011, among other factors.<sup>876</sup>

---

<sup>875</sup> Global system for mobile communications, a second generation of protocols for digital cellular networks originally developed by the European Telecommunications Standards Institute (ETSI). GSM is now a trademark owned by the GSM Association.

<sup>876</sup> Islamic Republic of Afghanistan Office of National Security Council (ONSC) Directorate of Interior Affairs (2011). *Security Strategy for Telecommunication Networks in the Territory of GIROA*, July 31.

## Streamlining Operations

Between 2006 and 2013, the MCIT reduced its personnel from 5,056 to 2,792, cutting its staff nearly in half. More reductions were made in the provinces than at MCIT headquarters – 1,585 to 1,207 (along with 315 postal personnel) – perhaps reflecting a decrease in scope of duties as ATRA and AfTel assumed those within their areas of responsibility, as well as an increase in operational efficiency. Former Minister of Communications Sangin was committed to shrinking his organization by reducing bloat, culling dead weight, and employing ICT to automate manual tasks, with the eventual goal of having the MCIT become a streamlined policy organization with a small staff.

## Budget Execution

In Afghanistan, ministries and other government agencies generally have operational budgets for ordinary, recurring expenses and development budgets for reconstruction projects and strategic one-time expenses. The ability of an entity to spend its money is known as budget execution, which is historically low in Afghanistan. For example, between SY1384 and SY1389 (March 2005 to March 2011), the Afghan government spent only an average of 44.5 percent of its development budget (with a low of 37 percent in SY1389.)<sup>877</sup> The MCIT, however, generally spends more than 80 percent of its development budget every year, as indicated in the chart in [Figure 46](#).

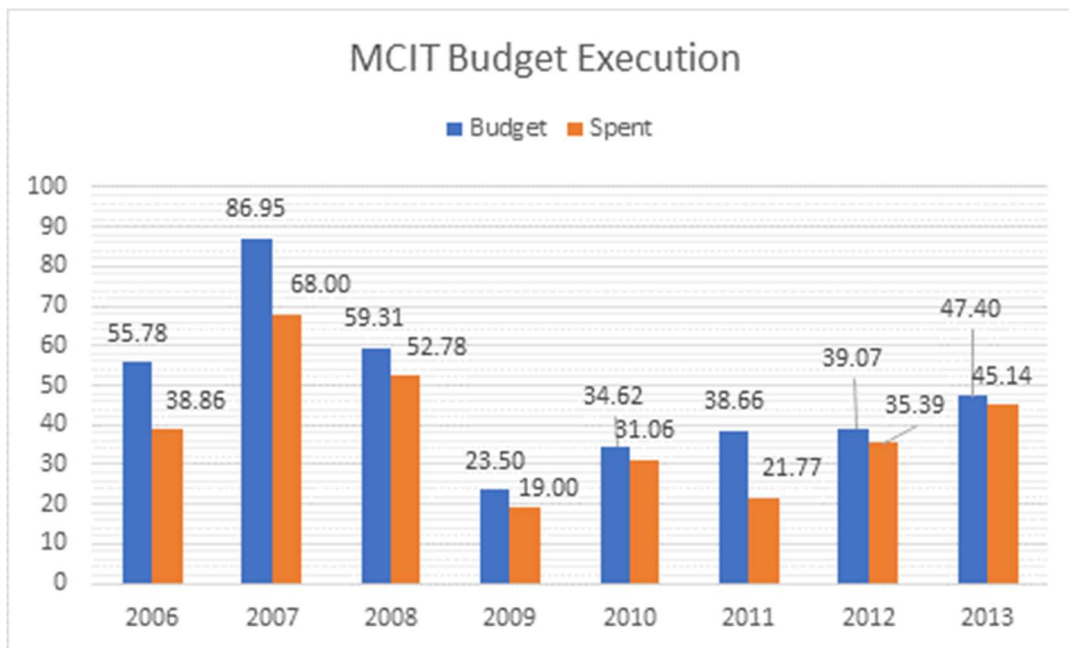

Figure 46: MCIT development budget execution in millions (US Dollars), 2006-2013

---

<sup>877</sup> Zyck, Steven A. (2011). "Use It or Lose It": Budget Execution in Afghanistan. Civil-Military Fusion Centre Monthly Report, April 2011. Accessed 14 December 2015. [http://reliefweb.int/sites/reliefweb.int/files/resources/Full\\_Report\\_220.pdf](http://reliefweb.int/sites/reliefweb.int/files/resources/Full_Report_220.pdf).



Year after year, the MCIT has ranked at or near the top of all Afghan ministries in terms of overall budget execution (as illustrated in [Figure 47](#)), which is tracked by the Afghan Ministry of Finance’s Budget Execution Directorate.

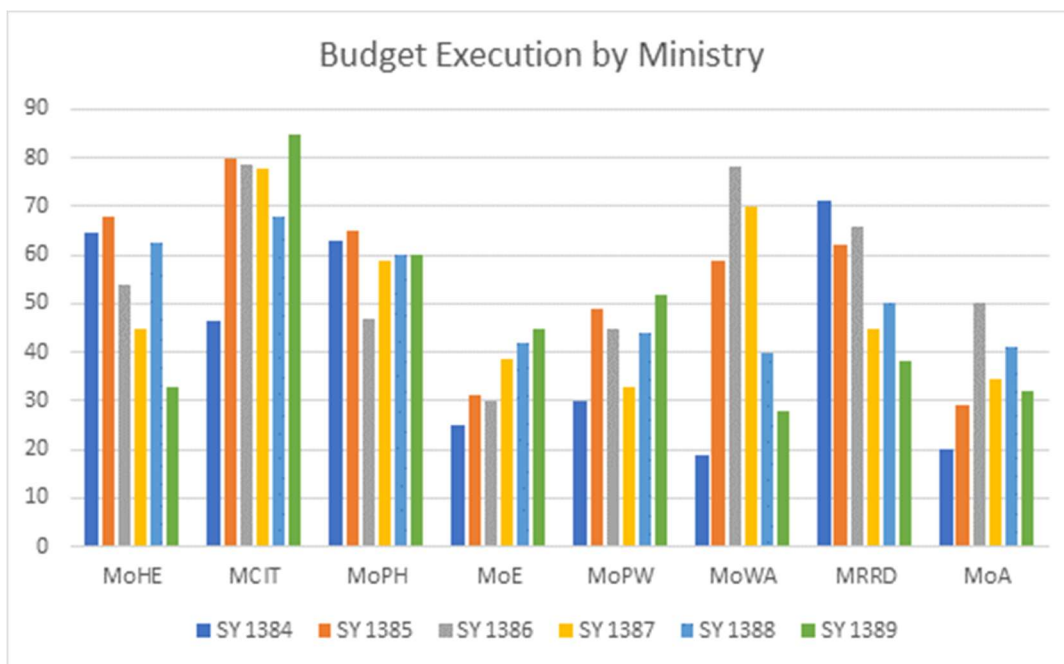

Figure 47: Comparison of budget execution by ministry

As donor funds increasingly move toward “on budget” aid, where monies flow through the Afghan government’s treasury and budgeting and allocation processes, budget execution will become even more important. According to USAID, budget execution system reform in Afghanistan “is critical to achievement of the sustainable socio-economic development and political stabilization goals” of the Afghan government and the International Community and is “a fundamental reform requirement for the successful pursuit of the USG’s foreign policy objectives in Afghanistan.”<sup>878</sup>

## Afghanistan Telecom Regulatory Authority



As described above, the establishment of a separate and independent ICT sector regulator was congruent with Afghan government goals and international best practices, and was important to the success of the ICT sector, particularly with regards to attracting investment. The ATRA was formally established in 2006 by merging the previous interim Telecom Regulatory Board (TRB) with the frequency management functions of State Radio Inspection Department (SRID) of the MCIT,

<sup>878</sup> USAID Afghanistan (2012). *Budget Execution Reform in Afghanistan*. Final Report, September 2012. Accessed December 15, 2015. [http://www.chemonics.com/OurWork/OurProjects/Documents/FS%20Share%20Final%20Report/Links/PIR%202/F%20Share%20Afghanistan%20Budget%20Exec%20Report\\_FINAL.pdf](http://www.chemonics.com/OurWork/OurProjects/Documents/FS%20Share%20Final%20Report/Links/PIR%202/F%20Share%20Afghanistan%20Budget%20Exec%20Report_FINAL.pdf).

pursuant to the Telecom Law of 2005. The first five members of the ATRA Board of Directors were appointed by President Karzai in June 2006.

## Vision and Mission

### Vision

The vision of ATRA is to achieve a competitive ICT market throughout Afghanistan that ensures the wide availability of ICT services at reasonable prices, that facilitates access to government services and resources, that enhances educational and social development, and that links all Afghan citizens to the rest of the world after decades of isolation.<sup>879</sup>

### Mission

ATRA’s mission is to facilitate the rapid development of affordable, high-quality ICT services to the entire population of Afghanistan by providing a transparent, non-discriminatory legal-regulatory framework that encourages innovative private sector participation and accelerates the adoption of “Information Society Services” as soon as possible.<sup>880</sup>

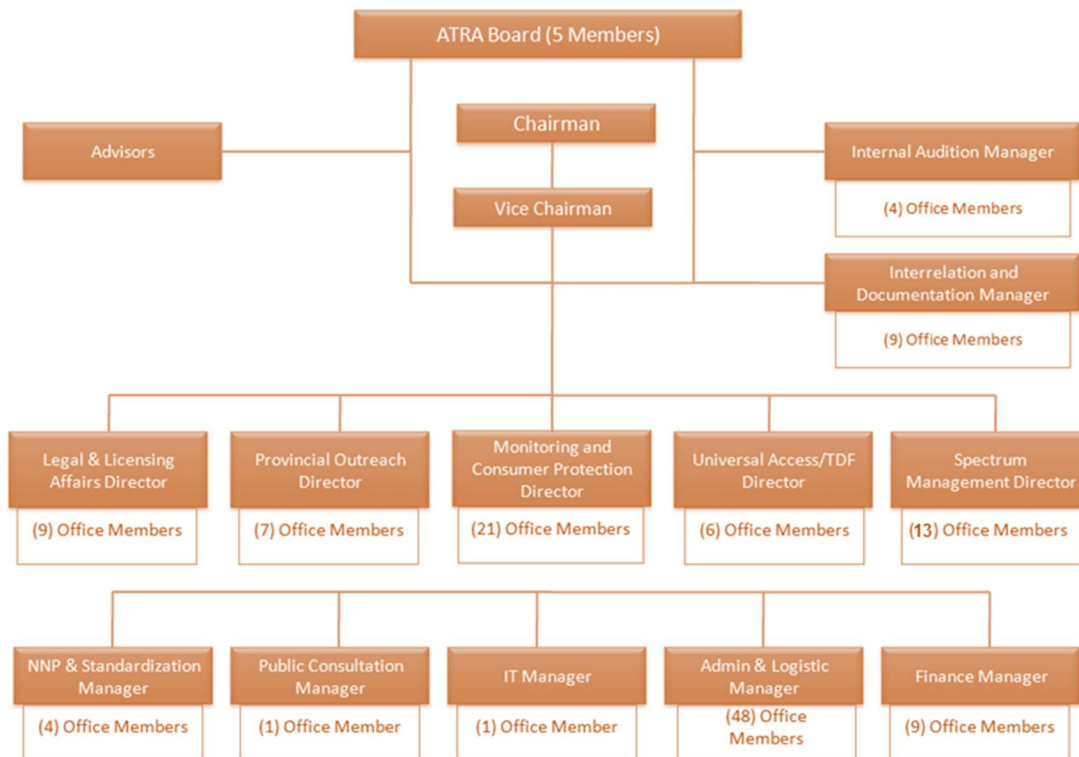

Figure 48: ATRA organizational structure

<sup>879</sup> Paraphrased from Afghanistan Telecom Regulatory Authority (ATRA) website. Accessed 17 October 2015. <http://atra.gov.af/en/page/6903>.

<sup>880</sup> Ibid.

## Organizational Structure

ATRA is governed by a Board of Directors with a Chair, Vice Chair, and three members, all of whom are proposed by the Minister of Communications and approved by the Afghan President. Per the Telecom Law, there is a permanent inter-ministerial committee, comprised of the ministers of Communications and Information Technology, Finance, Commerce and Industries, Economy, and Justice, that assists ATRA to conduct its affairs. There are 12 departments within ATRA, and it supplements its personnel with national and international expert advisors. ATRA provided the organigram in [Figure 48](#) in mid-2013.

Dr. Mohammad Najeeb Azizi took over as the Chairman of the ATRA Board of Directors on July 15, 2015, succeeding Engineer Abdul Wakil Shergul. The organizational structure of ATRA may have changed under the new Chairman.

## Responsibilities

Broadly, ATRA is responsible for regulating the affairs of and related to the Afghan ICT sector and to perform its functions in an independent, open, objective, transparent, and non-discriminatory manner in accordance with international best practices.

There are 38 specific duties and authorities delineated in the Telecom Law of 2005, but the general scope of the ATRA's duties includes, but is not limited to, the following:

- Implementing the national policy of competition and market liberalization and other national ICT policies;
- Issuing licenses for the provision of ICT services and radio spectrum and setting and collecting the fees for such;
- Publishing a framework Interconnection Agreement to be used by licensed operators and setting rules regarding interconnection to ensure it is available on a fair and non-discriminatory basis;
- Regulating tariffs;
- Resolving disputes between and among service providers;
- Protecting consumers and responding to their complaints;
- Setting technical standards for and approving telecommunications network and customer premises equipment;
- Monitoring service quality and adherence to rules, regulations, and license conditions, including conducting inspections;
- Preparing and maintaining a national numbering plan and ensuring non-discrimination in the allocation of numbers;
- Establishing and maintaining relevant registries;
- Collecting and reporting ICT statistics; and
- Any other functions that ensure a fair, transparent, and competitive market environment according to international best practices.

ATRA also makes and issues decisions as necessary in the context of the above. It is supposed to publicly publish all policies, regulations, license conditions, interconnection agreements, public consultation findings, tender qualification and scoring criteria, quality of service reports, and other documentation required for full transparency and to ensure a level playing field for all market participants. However, ATRA's website, though much better than in years past, is notoriously out of date and many of its hyperlinks do not work. ATRA prepares an annual financial report for the Council of Ministers.

## Licensing Regime

Pursuant to the Telecom Law, any person or entity operating and providing ICT systems and services in Afghanistan must be licensed by ATRA. In the course of such, ATRA conducts assessments and public consultations as needed for new licenses, prepares and publishes required forms relating to the issuance of licenses, and administers the entire license process. Following is an overview of licensing requirements for the Afghan ICT sector:

- No person or entity shall offer ICT services unless licensed by ATRA, in accordance with the Telecom Law, with the exception of telecommunications devices operated for private use.
- Licenses issued to the same class of operators or service providers shall not unjustifiably discriminate between licensees.
- Licensees must adhere to all license conditions and applicable laws.
- ATRA shall post all licenses publicly on its website and shall maintain copies of all licenses.
- Except for limitations imposed by the Telecom Law, there shall be no limitation on the number of licenses that may be issued in any class prescribed by ATRA.
- Final approval in regard to issuing, amendment, renewal, suspension, and revocation of licenses is subject to the decision of the inter-ministerial committee; and
- Issuance of licenses shall be conducted through a bidding process for the following services:
  - Telephone and Internet services or new and advanced technologies;
  - Supportive services through the Telecommunications Development Fund (TDF) for universal access; and
  - Such other services that ATRA may deem necessary.

The types of licenses issued by ATRA are:

- Unified services license
- Mobile telephone service license – national (MTS-N)
- Mobile telephone service license – local (MTS-L)
- Local Fixed Service Provider license (LFSP)
- Internet Service Provider license – national (ISP-N)
- Internet Service Provider license - local (ISP-L)
- Technical and technological solution provider license (TTSP)
- 2G and 3G mobile broadband license
- Wireless broadband service license
- Global mobile personal communications by satellite (GMPCS) license

There are no foreign equity limits imposed on the licenses. The original (2G) mobile telephone service licenses and LFSP license are valid for 15 years. Third-generation (3G) mobile broadband service licenses were issued after an international competitive bidding process, and the broadband wireless service licenses after a competitive national tender open to all licensed ISPs but specifically excluding mobile network operators (MNOs) at the time. Further, the mobile broadband and broadband wireless service licenses, the latter of which are currently in use for the provision of WiMAX<sup>881</sup> service, are technology neutral and, therefore, are able to accommodate new technologies such as long-term evolution (LTE) and 4G in the future. Internet and other types of licensing are subject to market demands, law and policy requirements, and regulatory proceedings.

ATRA also manages Afghanistan civil electromagnetic spectrum (see [Chapter 9](#)) and issues permits for frequencies for television and radio broadcasters, although the Ministry of Information and Culture (MoIC) regulates the providers and the content thereof. License and radio frequency (spectrum permit) fees vary depending upon the type of services and networks operating in the country.

### *Licensees*

State-owned Afghan Telecom Corporation holds the only unified services license in the country, and Wasel Telecom holds the only LFSP license. AfTel offers 3G mobile broadband services under its unified license, and Wasel also has a license to provide CDMA mobile telephone services.

ATRA currently lists 54 licensed Internet service providers (ISPs).<sup>882</sup> Three of the ISPs, NEDA Telecommunications, IO Global, and Ariana Network Services, also have broadband wireless service licenses under which they offer WiMAX services. Two companies hold GMPCS licenses, Etisalat and NEDA Telecommunications, both of which are reselling YahSat broadband satellite service under the YahClick brand name.

As of December 2015, ATRA has licensed 96 television (TV) broadcasting companies operating 316 TV transmitters and 285 FM radio operators with 715 transmitters.<sup>883</sup> ATRA has also provided frequency permits for thousands of HF, VHF, UHF,<sup>884</sup> microwave, and satellite station operators to use or provide ICT services throughout the country.

While ATRA issues licenses to broadcast service providers, along with spectrum permits for applicable services, only the license and provision of services are under ATRA's domain. The MoIC, as mentioned above, is responsible for regulating broadcasting providers and censoring their content.

---

<sup>881</sup> Worldwide Interoperability for Microwave Access, a family of wireless communications standards that enables the delivery of last-mile wireless broadband Internet service.

<sup>882</sup> ATRA website. Accessed April 4, 2016. <http://atra.gov.af/en/page/6963/6965/7239>.

<sup>883</sup> ATRA. Telecom Statistics (End of December 2015). Accessed February 2, 2015. <http://atra.gov.af/en/page/telecom-statistics-2013>.

<sup>884</sup> High-frequency, very high-frequency, and ultra-high-frequency, respectively.

## Telecommunications Development Fund

According to the MCIT, in 2007, ten of Afghanistan's 34 provinces had less than half of their populated areas covered by communications services, while a quarter of populated areas were not covered in another 14 provinces. On the opposite end of the spectrum, the remaining ten provinces had more than half of their populated areas covered by communications services, with Kabul, Kunduz, and Herat provinces leading at almost 100 percent coverage.<sup>885</sup> Hence, there was still a significant "digital divide" to address, especially in rural and remote areas.

To fulfill the MCIT's and ATRA's visions to extend affordable communications to the people of Afghanistan, as well as to meet obligations of the 2005 Telecom Law and to work toward meeting international universal service standards, the MCIT issued the Universal Access Policy Document [for] Rural Telecommunications Development in Afghanistan<sup>886</sup> in 2008, which had three main objectives:

- To put into place a mechanism that will encourage investment for the development of rural communications networks by providing subsidies for the implementation of Universal Access projects, and will enable the Government of Afghanistan to fulfill its Universal Service/Universal Access obligations by 2015, according to the [ITU] World Summit on the Information Society Goals of 2003 and 2005;
- To improve socio-economic conditions of rural areas by providing access to ICT facilities; and
- To fill the access gap in rural areas by subsidizing projects that are commercially viable but need initial financial support, or that are not commercially viable but are desirable because of the Government's obligations.

The "mechanism" mentioned in item #1 above was instituted as the Telecommunications Development Fund (TDF).

ATRA oversees and administers the TDF and implements the Universal Access program in Afghanistan according to the Universal Access Program Manual of Operating Procedures,<sup>887</sup> both of which were devised according to international best practices. The TDF accrues cash through contributions by Afghanistan's mobile network operators (MNOs) and fixed service providers, who each pay 2.5 percent of their adjusted gross revenues into the TDF quarterly in arrears, as stipulated in their licenses, without favor or prejudice. The TDF is used for reinvestment in Afghanistan's ICT infrastructure, for projects

---

<sup>885</sup> Per data provided to the author in mid-2012, as part of a project undertaken by the MCIT between 2011 and 2013 to document the ICT sector from its origins through modern day. The "Telecom Book" was never published, but it later became the foundation for the MCIT's *Activities and Achievements Report, 1381-1393 (2002-2014)*. The author of this chapter was a collaborator of the MCIT's on the "Telecom Book" effort and wrote and edited substantial portions of its text.

<sup>886</sup> ATRA website. Accessed August 19, 2015. [http://atra.gov.af/Content/files/UAPolicyDocument-21Oct2008-FinalEd1\\_0.pdf](http://atra.gov.af/Content/files/UAPolicyDocument-21Oct2008-FinalEd1_0.pdf).

<sup>887</sup> *Universal Access Program Manual of Operating Procedures*. Revision 1.1., October 21, 2008, prepared by ASTRO Systems, Inc. as part of Telecommunications Development Fund Technical Assistance.

deemed to be of strategic importance, including for public safety, and to provide ICT services to areas not adequately addressed by licensed operators.

The TDF had accrued US\$136 million by the end of either 2011 or 2012.<sup>888</sup> Around that time, the balance of the TDF drew the attention of GIRoA officials and ATRA came under pressure to start spending the money (or risk losing it in the form of “loans” to the Treasury or other GIRoA entities, was the implication). ATRA earmarked US\$5 million each for ICT projects in education and health, and the MCIT signed memoranda of understanding (MoUs) with the Ministries of Education, Higher Educations, and Public Health in order to implement them.

The new Minister of Communications undertook a review of the TDF’s mandate after taking office in 2015 and subsequently signed new MoUs with the ministries above, ostensibly for new ICT projects for each, using TDF money. ATRA also plans to use TDF for Internet cafés and wireless Internet access in buildings, among other projects allowed under the TDF.<sup>889</sup>

## National ICT Council of Afghanistan

Understanding the importance of the ICT sector to the development of Afghanistan, the MCIT with advice and support from the United National Development Programme (UNDP) and USAID, launched an effort to create the National ICT Council of Afghanistan (NICTCA), generally referred to simply as the “ICT Council.” The goal was to “develop a common understanding among all stakeholders on the nature and implementation of ICTs in Afghanistan in order to enhance the coordination among [them].”<sup>890</sup> The ICT Council was to be multilateral, transparent, and democratic and include the full involvement of government agencies.<sup>891</sup> It was officially established via Presidential Decree in May 2007 and inaugurated the twenty-ninth of that month.<sup>892</sup> The ICT Council, the name by which the NICTCA is commonly referred, is multilateral, transparent, democratic, and participatory, inviting the full involvement of government agencies and stakeholders regarding ICT in Afghanistan.

## Objectives

The objectives of the ICT Council are as follows, and the ICT Council maintains the right to modify any objectives as it deems necessary and suitable for national development:

1. Establish and enforce common standards among all ICT stakeholders and endorse applications and implementations of common international ICT standards in Afghanistan.
2. Provide a platform for coordinating efforts in pursuit of common goals pertaining to ICT policy development.

---

<sup>888</sup> Per the MCIT in mid-2012, as part of the “Telecom Book” project. The author was never able to adequately clarify the year.

<sup>889</sup> Ibid.

<sup>890</sup> United Nations Development Programme (UNDP) Project Document (2005). “National ICT Council Of [sic] Afghanistan.” Version 1.1, November 24, 1.

<sup>891</sup> Ibid.

<sup>892</sup> MCIT. (2007). “Inauguration of the ICT Council of Afghanistan.” May 29 (hard copy given to the author).

3. Advocate efforts in advance of the implementation of new technologies (e-governance, Internet technologies, etc.) across different sectors through consultation with stakeholders.
4. Advocate changes to ICT regulations and laws and liaise with the appropriate boards or relevant committees in order to foster unity in the ICT field in Afghanistan and create an environment for cooperation among members and sectors (public, private, and civil society).
5. Discuss national ICT policies and strategies in the public sector and provide confirmation, assessments, and recommendations to the Government of Afghanistan.
6. Sponsor and coordinate regular ICT conferences at the national, regional, and international levels.
7. Facilitate the creation of healthy and functioning ICT-related industry associations to further the cause of ICT and its use to improve conditions in Afghanistan.
8. Advocate and promote gender balance in the field of ICT in Afghanistan, entailing international feedback and consultation to improve ICT in Afghanistan based on best practices and lessons learned from other countries' experiences.
9. Promote democracy and access to information through ICTs in Afghanistan and envisage government transparency, accessibility, accountability, and efficiency through the implementation of e-Government projects.
10. Coordinate strategic planning and the implementation of ICT initiatives throughout Afghanistan while, upon request by any government agency or any other ICT Council member, providing advisory support.
11. Encourage full-scale development of the ICT industry in Afghanistan and assist the country in gaining a competitive edge in the regional ICT industry.<sup>893</sup>

Acting as a coordinating focal point, the ICT Council is tasked to formulate a national ICT agenda for the development of the sector and the benefit of the country. To verify and document progress as well as to identify bottlenecks and potential issues regarding the implementation of ICT policies and projects, the ICT Council, through the MCIT, is supposed to conduct biennial e-Readiness Assessments (ERAs);<sup>894</sup> however, the author is not aware of any having been conducted (which does not mean they have not been) nor seen the results of any.

## Membership

The ICT Council is self-regulated and its membership is selected through expressions of interest. It consists of representatives from the following groups, on both permanent and rotational bases (see [Table 8](#)).

- Government representatives from the office of the President and the Ministries of Information and Culture, Interior, Foreign Affairs, Defense, Education, Finance, Public Health, Social Welfare, and others as applicable;

---

<sup>893</sup> Paraphrased UNDP, 2005, 2.

<sup>894</sup> Per data provided to the author in mid-2012 as part of "Telecom Book" project.



- The private sector and the business community, particularly, representatives from the banking and financial sectors including investors, IT industry, manufacturing, and retail sectors (with strong interest in e-commerce), private Internet service providers, and service industries (transport, etc.);
- Representatives of accredited non-governmental organizations (NGOs) and civil society organizations;
- Representatives from academia and other associations and educational institutions; and
- The ICT user community drawn from civil society organizations and Internet and other user groups.

*Table 8 : National ICT Council of Afghanistan members*

Organization	Number of Seats	Membership Status
Ministry of Communications and IT	1	Permanent
Ministry of Education	1	Permanent
Ministry of Higher Education	1	Permanent
Ministry of Finance	1	Permanent
Ministry of Economy	1	Permanent
Ministry of Commerce	1	Permanent
Ministry of Interior	1	Permanent
Ministry of Foreign Affairs	1	Permanent
Ministry of Culture	1	Permanent
Ministry of Public Health, Ministry of Justice, and Da Afghanistan Bank (Central Bank)	3	Rotational
Afghanistan Investment Support Agency (AISA)	1	Permanent
National ICT Association of Afghanistan (NICTAA)	1	Permanent
Parliament	1	Permanent
Civil Service Commission of Afghanistan	1	Permanent
Association of Private Media Organizations	1	Permanent
Association of ICT Vendors	1	Permanent
Consumer Advocate	1	Permanent
<b>Total Members</b>	<b>19</b>	

The First Vice President of the country chairs the ICT Council and the MCIT administers the functions of its Secretary (at least it formerly did; see below).

## Meetings

The ICT Council is supposed to meet quarterly, with the first three assemblages each year designated as regular coordination meetings to follow a published agenda. The last meeting each calendar is supposed to be a general meeting at which the organization is supposed to assess its effectiveness and propose ideas to improve efforts the following year. Extraordinary meetings may be convened by petition of a third of the council's members.

After taking office in September 2014, President Ghani moved the ICT Council out from under the MCIT's purview and it now reports directly into his administration.

## Cabinet-Level ICT Positions

In addition to Afghanistan's public ICT institutions, there is a Commission on Transport and Telecommunication in the *Meshrano Jirga* (Upper House) of the Afghan Parliament (or at least there was under the former administration). Former President Karzai appointed a Special Cybersecurity Advisor to the Office of the President. The position was filled by the Director of the MCIT's Information Systems Security Directorate (ISSD), also known as the Cybersecurity Directorate, who served from early 2013 until the end of Karzai's term. New President Ashraf Ghani has a special ICT advisor, Dr. Mohammad (Mo) Qayoumi, formerly the President of San Jose State University in California. In his new position as Special ICT Adviser, Dr. Qayoumi leads a commission on infrastructure, human capital, and technology.

## TAT Engagement with Afghanistan's Public ICT Institutions

As part of its Afghanistan ICT Strategy,<sup>895</sup> one of the major initiatives identified and undertaken by the Telecommunications Advisory Team (TAT) was to help strengthen the country's public ICT institutions. By and large, the TAT enjoyed constructive and productive relationships with the MCIT and ATRA. The affiliations spanned senior leadership – the Minister of Communications and the Chairman of the ATRA Board of Directors – and all levels of personnel throughout the two organizations. The Senior Telecom Advisor/TAT Director held standing weekly meetings with the Minister of Communications, at least through most years of its operation, although the meetings waned during the TAT's fourth year of operation, due at least in part to the International Security Assistance Force's (ISAF's) shift in focus almost entirely to Afghanistan's security ministries prior to transition to Mission Resolute Support at the end of 2014. TAT leadership also began holding standing weekly meetings with the ATRA Board in late 2011, which proved beneficial, particularly in holding ATRA accountable for taking actions and making progress toward its decisions and promised deliverables (even internally).

The foundation for the TAT's successful engagement was laid, in no small part, by two TAT advisors<sup>896</sup> who had previously worked as peers alongside two Afghans, one of whom later became the Minister of Communications and the other, ultimately, a deputy minister.<sup>897</sup> The precedent US government (USG) ICT advisory effort, the Senior Telecommunications Advisor (STA) at the Afghanistan Reconstruction Group (ARG), and the ICT Implementation Team (I-Team) based at the US Embassy Kabul from 2005 to 2008, also paved the way positively for the reincarnated ICT function. Their relationships and the trust and respect they had built were extended, at least somewhat, to TAT leadership, if not necessarily the TAT itself. Two of the TAT's civilian advisors (contractors from Deloitte Consulting LLP) worked in an office at the MCIT headquarters building in Kabul (where ATRA also has offices) until March 2013, allowing for regular visibility, day-to-day interactions, impromptu meetings, and even a slight semblance of comradery. Other

---

<sup>895</sup> Bierden, Elizabeth A. (Col., USA) (2012). *ISAF Telecommunications Advisory Team [TAT] ICT Strategy*, January 16.

<sup>896</sup> Oliver Dziggel and Anthony (Tony) Lodá

<sup>897</sup> Amirzai Sangin and Aimal Marjan, respectively

members of the TAT attempted to build and maintain relationships with their Afghan counterparts within the MCIT and ATRA, with some more successful than others.

That being said, during its just over four years of operation between 2010 and 2014, the TAT was instrumental in several key MCIT and ATRA initiatives, some, but certainly not all, of which are described below.

**Optical Fiber Cable:** The TAT maintained fastidious focus on the installation and operation of Afghanistan's national optical fiber backbone, which is a strategic priority for that country as well as the USG. The TAT helped the Afghans to address issues, solve problems, and communicate effectively with vendors and other stakeholders, and generally facilitated positive progress overall. The TAT became *the* authoritative source on the status of the OFC in theater and CONUS<sup>898</sup> (and of ICT infrastructure in general). As of mid-2014, 62 percent of the OFC, which figure takes into account the planned routes through central Afghanistan in addition to the original main ring, is operational as reported above, and Afghanistan's fiber infrastructure is connected to five neighboring countries. The TAT was actively involved and tremendously influential in perpetuating the vision of Afghanistan as a Central Asian fiber transit hub, which has now progressed past the conceptual stage into one of active discussions with neighboring governments and has been endorsed by the United Nations Special Program for the Economies of Central Asia (UN-SPECA). (See [Chapter 7, Afghanistan's Fiber Optic Infrastructure](#), for more information.)

**24x7 Cellular Service Restoration and Provision:** In response to the Afghan ONSC's issuance of its *Security Strategy for Telecommunication Networks*<sup>899</sup> in July 2011, the TAT assisted ATRA to draft a Restoration Order demanding all MNOs resume providing mobile service in areas where they had shut down service in response to threats by the Taliban and other anti-government elements (AGE) or where their equipment had been damaged or destroyed. It further supported ATRA to develop reporting mechanisms and associated processes and procedures for the mandatory reporting of threats to and outages of (both planned and unplanned) of MNO's infrastructure. The restoration and provision of 24x7 mobile service was of critical importance to GIRoA, ISAF, and the USG to support military operations, extend governance, and maintain security throughout the country.

**3G Mobile Broadband and Broadband Wireless Service:** The TAT assisted ATRA to develop and issue an international competitive tender for 3G mobile broadband service and a national one for and broadband wireless service. Of particular importance was the TAT's successful lobbying of the MCIT and ATRA to make the licenses for both technology-neutral so as to be able to accommodate future evolutions of and advances in technology. As a result, ATRA issued four 3G licenses to Afghanistan's four GSM mobile network operators (plus Afghan Telecom Corporation is authorized to provide 3G services under its unified license). As indicated above, by the end of December 2015, Afghanistan reports having nearly 2 million 3G subscribers. ATRA also issued three licenses for broadband wireless to Afghan ISPs, under which they,

---

<sup>898</sup> Continental United States

<sup>899</sup> ONSC, 2011.

along with AfTel under its unified services license, are offering WiMAX services. Research shows a positive correlation between broadband Internet service penetration and mobile broadband in particular, and economic growth. Undoubtedly, the provision and proliferation of mobile broadband and broadband wireless service throughout the country will have positive effects on the country through Afghanistan's Decade of Transformation.<sup>900</sup>

**ICT Law:** The TAT assisted the MCIT to draft an ICT Law to complement and update previous legislation and prepare Afghanistan for the next phase of ICT sector development. While the law has yet to be approved or promulgated, and pieces of it were turned into separate draft legislation, it should receive the required review in the near future, as it is one of the new Minister of Communication's priorities.

**Satellite Communications:** The TAT was instrumental in ATRA's developing and issuing a tender for the license of its orbital satellite slot (assigned by the International Telecommunication Union, ITU), as well as in evaluating the responses thereto and negotiating with bidders to arrive at a solution. In May 2014, AfghanSAT1 was launched, in partnership with Eutelsat. Afghanistan is attempting to utilize it to extend ICT services into remote and un- and underserved areas, but its commercial success is questionable at present. The TAT also spurred ATRA to work with the ITU to address and resolve encroachment issues within its assigned slot, the result of years of neglect of communication with the ITU. The TAT's SATCOM<sup>901</sup> engagement with the MCIT and ATRA spanned all four years of its operation and is certainly among its notable successes. (See [Chapter 8, Satellite Communications](#), for more information.)

**Spectrum:** The TAT identified spectrum management as a challenge for ATRA shortly after it began operation in country in mid-2010, noting ATRA did not have spectrum management software and was not properly planning for, managing, or monitoring spectrum allocation and use. The TAT, therefore, began working with ATRA to source solutions. In 2011, the Minister of Communications requested the TAT's assistance to conduct a study of Kabul's FM<sup>902</sup> broadcast allocations, de-conflict and re-groom Afghanistan's radio and television broadcast bands, and devise a frequency allocation plan for the provinces, largely but not entirely prompted by his plan to transition Afghanistan from analog to digital television broadcasting. The TAT complied, and went further to introduce the MCIT and ATRA to a Western spectrum expert, who assisted them in-country and out for several years. Of paramount strategic and tactical importance, the TAT was a key player in the establishment of the Ministerial Spectrum Management Office (MSMO) and the transition of military spectrum management from ISAF to GIRA prior to ISAF's cessation in December 2014. And lastly, but certainly not least, the TAT assisted ATRA and Afghanistan's mobile network operators to analyze and resolve frequency interference issues that had plagued the cellular service providers for years. The TAT's spectrum engagement with the MCIT and ATRA is another effort that encompassed the TAT's entire tenure and one that had numerous measurable,

---

<sup>900</sup> 2015-2024, as agreed at the Tokyo Conference on Afghanistan July 8, 2012 and codified in the Tokyo Declaration, "Partnership for Self-Reliance in Afghanistan: From Transition to Transformation."

<sup>901</sup> Satellite communications

<sup>902</sup> Frequency modulation

positive, and lasting effects. (See [Chapter 9](#), *Radio Spectrum in Post-Conflict Environments and Stability Operations – Afghanistan: A Case Study*.)

**Afghan Telecom Corporation:** Although AfTel is not a public ICT institution, it is owned by the MCIT and, as such, the MCIT has a vested interest in its operation and success. As mentioned above, the TAT was indispensable regarding Afghanistan’s fiber optic network, which is managed by AfTel. The TAT, with assistance of Space and Naval Warfare Systems Command (SPAWAR) assisted AfTel to evaluate whether to keep its existing CDMA<sup>903</sup> cellular network or implement a new GSM one. Once the decision to move to GSM/3G was made and approved, the TAT (with SPAWAR) assisted AfTel to develop and issue a tender for a GSM/3G network. The TAT also assisted with related tenders for a cellular satellite backhaul network and a project management office (PMO, at which a TAT advisor worked for a time) for AfTel’s GSM/3G network deployment. The TAT also aided AfTel with tenders for a convergent billing system and other business and operations support systems (BSS/OSS). The installation of the new billing system was anticipated to increase AfTel’s recognized revenue by as much as 50 percent (due to non- and incorrect billing with the previous systems), though the TAT never received confirmation of the improvement. AfTel’s GSM/3G network implementation was also another step toward meeting the ONSC’s security directive of July 2011, in support of strategic GIRoA, ISAF, and USG goals and objectives. In mid-2012, the MCIT and AfTel differentiated between wholesale and retail fiber-based Internet prices for the first time, in which the TAT had a very influential hand. The distinction helped to further stimulate an already hot market, making it even riper for the advent of 3G mobile broadband service (which Etisalat first launched in Afghanistan in March 2012).

**Cybersecurity:** Even the concept of cybersecurity is in an embryonic stage in Afghanistan, which is no surprise for a country relatively new to the digital arena. However, Afghanistan’s nascent cybersecurity posture and efforts are of critical importance going forward. After the ONSC’s website was hacked, the Minister’s iPhone was infected with a virus, DNS and IP<sup>904</sup> addresses assigned to the MCIT were blacklisted, along with a few other high profile cyber events in 2011 and 2012, the Minister of Communications elevated cybersecurity among his priorities and requested the TAT conduct a cybersecurity maturity assessment on the MCIT’s behalf. The TAT did so (with Deloitte Consulting, LLP) and delivered a report of Afghanistan’s dismal cybersecurity state in mid-2012, along with 44 recommendations to consider implementing. The MCIT, with the assistance of the TAT and others, implemented some of them, rejected a few, and has – or at least had – plans to work toward other of the suggestions. The TAT and personnel from the Commercial Law Development Program (CLDP) of the US Department of Commerce assisted the MCIT and GIRoA to develop Afghanistan’s first National Cybersecurity Strategy, which has yet to be formally approved but is a giant – and absolutely imperative – step forward for Afghanistan. (See [Chapter 10](#), *Cybersecurity*, for more information.)

---

<sup>903</sup> Code division multiple access, a method used by some radio communications technologies that makes it possible for several transmitters to send information over a single communication channel simultaneously, thereby allowing multiple users to share finite frequency bandwidth without interference.

<sup>904</sup> Internet Protocol

**Infrastructure Sharing:** The TAT supported and facilitated the World Bank’s efforts to have GIRoA develop and adopt a national infrastructure-sharing policy to accelerate infrastructure deployment and provide much-needed redundancy to Afghanistan’s optical fiber cable. Approved as Economic Council Act #22 in April 2013, Afghanistan was reportedly the third country in the world to have such a policy. The TAT was also instrumental in AfTel signing an infrastructure-sharing agreement with the state-owned electric company, allowing AfTel to utilize surplus fiber in Afghanistan’s electric grid.

**Capacity Development:** Although the situation has improved at both the MCIT and ATRA, particularly in the past few years, both entities, along with GIRoA at large and the private sector, continue to struggle with the lack of digital literacy and human ICT capacity within their organizations and within Afghanistan. In response to government and industry needs, the TAT undertook a comprehensive program for short- and long-term ICT capacity development, complete with ICT curricula reviews and recommendations and the development of a strategy and roadmap to build a cadre and culture of chief information officers (CIOs) across the government, an effort led, at least in part, by the MCIT. (See the two chapters on ICT capacity development, [Chapter 19](#) and [Chapter 20](#), for more information.)

## Observations, Conclusions, Lessons Observed, and Recommendations

*Author’s Note: Some of the observations, conclusions, lessons observed, and recommendations are excerpted or paraphrased from the ISAF Telecommunications Advisory Team Year in Review, released July 1, 2012 by Colonel Elizabeth A. Bierden, USA, Director of the ISAF Telecommunications Advisory Team from 2011 to 2012. The report (which the author helped to write and edited) is a collective record of the TAT’s experience under her year of leadership.*

### Regarding the MCIT and ATRA

Although they continue to improve, the MCIT and ATRA are still relatively immature national ICT policy and regulatory regimes, where ICT policy decisions and ministerial actions are often disconnected from statutory authority. However, having ministers with ICT sector experience and Western ICT business experience was an important element in Afghanistan’s early post-conflict public ICT institutions. The MCIT and ATRA have consistently published well-articulated policies, plans, and goals, many with the assistance of expert foreign advisors and in keeping with international guidelines and industry best practices. Creating an enabling policy, legal, and regulatory framework is paramount for private sector participation and investment.

However, there remain gaps in Afghanistan’s ICT statutes. The existing Telecom Law addresses conduit but not content, and the draft ICT Law has still not been promulgated, though it was originally submitted to the Ministry of Justice at the beginning of SY1389 (March 2011). Related laws, such as those covering digital signatures and cybersecurity/cybercrimes, are not on the books either. The ICT legislative landscape has not kept pace with the sector, which has been problematic in the past – Afghanistan could not prosecute cyber criminals – and will continue to be so.

ATRA is still largely under the MCIT’s thumb and is not a truly independent regulator. The symbiotic nature of the relationship between the MCIT and ATRA worked well for a time, especially because of ATRA’s poor level of skills and experience, but has become counterproductive. Their interconnectedness creates

tension with Afghanistan's private MNOs and causes uncertainty regarding further investment in the sector. As of mid-2016, ATRA's offices are still in the same building as the ministry, and only recently was ATRA able to remove the condition that all its decisions go through the minister. In 2016, ATRA has indicated independence as one of its top priorities.

Along the same lines, the MCIT's ownership of AfTel is a conflict of interest. Despite early (2003) policy calling for AfTel's privatization, that has yet to occur. AfTel is the monopoly fiber provider, although an open access (to the fiber) policy was reportedly approved by the Afghan Economic Council on April 5, 2016. AfTel is also a direct competitor of the private sector companies in the GSM/3G mobile arena, which have shelled out millions for license fees and infrastructure, giving AfTel a doubly unfair competitive advantage. AfTel also competes with ISPs, which are also its customers. The denationalization of AfTel, however, is complicated by the ONSC directive for it to provide 24x7 mobile telephone services to the Afghan government.

Corruption is still an issue throughout the Afghan government, and the MCIT and ATRA are not immune. The country and its institutions, Afghanistan's public ones among them, also still grapple and battle with nepotism, cronyism, and tribalism. However, the situation is slowly improving. Patronage networks are slowly being dismantled, particularly as transparency increases – and with it accountability – in favor of experienced candidates qualified for the positions to which they are elected or appointed, hired or promoted.

Notwithstanding the above, the MCIT and ATRA have managed to guide and steer the development of one of the most successful sectors in Afghanistan's post-war history. Going forward, the MCIT and ATRA may want to consider:

- Seeking legal and regulatory guidance prior to the development and announcement of policy decisions.
- Attending to the passage of pertinent legislation sooner than later.
- Ensuring its policies keep pace with, or better yet precede, developments in the ICT sector and encourage further investment, growth, expansion, and maturation.
- Focusing increased efforts on improving ATRA and developing it into a truly independent body, as ATRA is pivotal to and underlies the success of the overall ICT sector.
- Privatizing AfTel or divesting its ownership in it.
- Implementing pre-hire competency tests.
- Employing ICT to make the MCIT the model of GIROA transparency and accountability.

Despite the success of the ICT sector, there is a critical lack of ICT skills within the MCIT and ATRA and in Afghanistan in general. Afghanistan's work force has not kept pace with the needs of the ICT sector, which gap is becoming more pronounced as technology advances. While the country has youth on its side, with

approximately 70 percent of Afghans under the age of 30 (and nearly half of them female),<sup>905</sup> Afghans are leaving the country in droves as the security situation continues to deteriorate,<sup>906</sup> and digitally-literate, ICT-trained youth are among the most employable elsewhere. As such, the MCIT and ATRA, as well as GIRoA and the private sector, are going to continue to struggle to staff their organizations with competent personnel. ATRA, in particular, lacks capacity in many critical areas, despite years of mentoring by expert advisors and definitive training.

While the MCIT and ATRA have stepped up formal training over the past few years, largely funded by the World Bank and USAID (see [Chapter 19](#)), there is a global high-tech skills shortage looming.<sup>907</sup> To that end, the MCIT and ATRA should consider:

- Continuing efforts to initiate and implement ICT capacity building efforts and ICT skills development programs.
- Drawing the attention of GIRoA and the International Community to the need for ICT workers worldwide, which could adversely affect the country, as Afghans seek employment elsewhere.
- Making a concerted effort to train women and girls in ICT and recruit them to positions at the MCIT and ATRA, particularly since half of Afghanistan's population under 30 is female. This would have the additional benefit of improving the percentage of women employed at Afghanistan's public ICT institutions in line with government and international targets.

The MCIT and ATRA have recently revived or established relationships with regional and international entities, such as the ITU, Asia Pacific Telecommunity, and GSM Association among others, which they should continue to maintain and expand. The MCIT and ATRA have also formed relationships with their counterparts in other countries (India, Turkey, Estonia, and China, to name a few) and many of their neighbors. These associations and affiliations provide Afghanistan's public ICT institutions with networks of their peers, training and capacity-building opportunities, and the potential for service provision (with Afghanistan as both vendor and customer). The MCIT and ATRA would do well to continue such endeavors.

The US government should note that Afghanistan has ICT relationships in some form or fashion with Pakistan, China, and Iran, as well as with many of the former Soviet republics, at the same time there is very little, if any, continuing US involvement or influence in the ICT sector.

---

<sup>905</sup> Islamic Republic of Afghanistan Central Statistics Organization (ACSO). *Afghanistan Statistical Yearbook 2013-14*. Accessed March 16, 2016. [http://cso.gov.af/Content/files/Population\(3\).pdf](http://cso.gov.af/Content/files/Population(3).pdf).

<sup>906</sup> Alikozai, Hasib Danish (2015). "Afghanistan's Other Security Threat: Brain Drain." *Voice of America*, September 7. Accessed March 14, 2016. <http://www.voanews.com/content/afghanistan-other-security-threat-brain-drain/2951915.html>.

<sup>907</sup> Roberts, Dexter (2012). "The Surprising Global Shortage of Skilled Workers." *BloombergBusiness*, May 29. Accessed March 16, 2016. <http://www.bloomberg.com/news/articles/2012-05-29/the-surprising-global-shortage-of-skilled-workers>. Originally published by *Business Week* at <http://www.businessweek.com/articles/2012-05-29/the-surprising-global-shortage-in-skilled-workers> (link no longer available).



## Regarding the TAT's Engagement

As mentioned above, overall the TAT had productive, constructive relationships with the MCIT and ATRA, particularly at senior levels. Several on the team were considered particularly trusted advisors and were highly regarded. Holding weekly meetings between MCIT/ATRA and TAT leadership was a key success factor in maintaining continuity of effort and making progress. However, the change in leadership from a civilian general equivalent in the TAT's first year of operations to military colonels in years 2 and 3 had slight implications on interactions with MCIT and ATRA leadership: Afghan leadership noted TAT's diminished authority and less direct access to ISAF decision makers. Although TAT leadership returned to a civilian general equivalent in year 4, by that time ISAF was winding down non-security ministry engagements and shifting its entire focus to the Afghan National Security Forces.

The TAT was, overall, less successful in making and sustaining connections between and among subject-matter peers at lower levels of the organizations, though there were some notable exceptions. Frequent rotations of TAT members and the resultant changes in areas or levels of expertise hindered efforts at building peer-to-peer relationships. Further, not everyone needs to meet the minister. Originally, only the STA/TAT Director met with the Minister of Communications, sometimes accompanied by a well-regarded TAT advisor or subject matter expert (SME). However, successive TAT Directors often brought new TAT members in to introduce them to MCIT and ATRA leadership, which was somewhat inappropriate – like introducing a random junior officer or GS-12 who works at the Defense Information Systems Agency to DoD Secretary Carter or FCC Chairman Wheeler.<sup>908</sup> It also reinforced the turnover of the TAT and the fleeting nature of its members' engagement. Making matters worse, TAT members sometimes tramped through the MCIT building in full "battle rattle" (bullet-proof vests and helmets) drawing attention to themselves and to the TAT's affiliation with ISAF and foreign military forces, which became increasingly less popular over the years. To some extent, the TAT's relationships with the MCIT and ATRA deteriorated over time because of the points above, and personnel at both entities lost respect for the TAT as a group and as individuals, diminishing its position as trusted advisors.

In future such situations, it would behoove the USG to consider having a few, more permanent, non-military, senior professional commercial advisors to work with ICT leadership, as was the original vision for the organization, rather than what the TAT became. It would also be smart to consider having some people work only behind the scenes, whether in-theater or CONUS, and limit those who get face time with high-ranking government officials.

Having an office at the MCTI's headquarters – which also housed ATRA – helped the TAT to maintain a consistent – and persistent – presence and allowed for ad hoc participation, drop in meetings, etc.

Additional observations, conclusions, lessons observed, and recommendations:

---

<sup>908</sup> US Department of Defense Secretary Ashton (Ash) Carter and Thomas E. (Tom) Wheeler, Chairman of the Federal Communications Commission

- The TAT had to maintain independence and, therefore, not favor any one MNO or ISP over another. The TAT sometimes had to walk a fine line within the ICT sector because of its assistance to AfTel (e.g., GSM/3G network deployment), often to the chagrin of the other companies.
- Having civilian advisors with commercial ICT expertise was key to establishing and maintaining relationships with Afghanistan's private ICT sector.
- ISAF's, the Coalition's, the USG's, and the TAT's priorities were not necessarily GIRoA's.
- Be cognizant of offering Western solutions to Afghan problems and military solutions to civil problems.
- Advisors advise – not dictate or demand.
- There are often underlying motives and politics that drive bureaucratic decision-making. Learning to understand these dynamics and continually “soft-pushing” the issues will generally motivate more decisive actions. Accepting the eventual actions and results as Afghan-owned is also key, even if we do not completely agree with the decisions.
- ISAF transition activities meant the TAT had to focus on only ANSF-related ICT areas, so the TAT had to step back and disengage from other valuable areas of engagement with the MCIT and ATRA.

In October 2012, at his daily morning standup briefing after a presentation on Afghanistan's ICT sector compared to similar countries<sup>909</sup> by TAT Director Colonel Francis (Frank) Huber, former COMISAF<sup>910</sup> General John Allen stated that TAT's work with the Ministry of Communications was "one of the most important non-security governmental engagements" ISAF has with the Afghans. The need for that engagement did not end when combat operations ceased. In fact, it is more important than ever, particularly with Afghan leadership having changed at the executive and ministerial levels, with the heads of the country and of the MCIT and ATRA all having turned over in a single year.

Because ICT is a crucial enabler underpinning security, governance, and socio-economic development and growth in post-conflict and developing countries, key leader engagement in ICT should be considered in future planning.

---

<sup>909</sup> General Allen specifically requested this subject after a general brief on the ICT sector Colonel Huber gave at the morning standup two weeks earlier.

<sup>910</sup> Commander, [NATO's] International Security Assistance Force

## Chapter 5 ICT Policy and Regulatory Framework

---

Oliver Dziggel

### Introduction

Information and communications technology (ICT) infrastructure is capital-intensive. When the World Bank and other donors assessed the ICT situation in Afghanistan in early 2003, it calculated that more than US\$2 billion would be required to construct a national network that was on par with low-income developing countries, based on a then widely-accepted standard established by the International Telecommunication Union (ITU). The estimate was especially high for Afghanistan because its existing network was barely functional, and the terrain over which to provide connectivity is so difficult.

Even if only one-tenth of that amount were available to Afghanistan, either in the form of grants or loans (and it was not), there was a broad consensus among donors that funds were immediately required for much higher priorities, primarily humanitarian assistance (such as food support and refugee shelter), healthcare, and education.<sup>911</sup>

Consequently, Afghan leadership adopted a very pragmatic policy to open the market to private investment, private ownership of infrastructure, and the provision of a wide range of ICT services by private firms. Equally crucial, no attempt was made to handicap the market by retaining any statutory protection for incumbents – neither for the government-owned landline system (operated as a

---

<sup>911</sup> This is not meant to underplay the significant level of international donor support to the ICT sector. For example, the projects below all included substantial support directly to the Ministry of Communications:

- **World Bank:** Emergency Communication Project (US\$22 million, 2003-2008), ICT Sector Development Project (US\$50 million, 2011-2017) – included support for the legal-regulatory framework, network infrastructure, and training.
- **United States Trade and Development Agency (USTDA):** Technical assistance to Ministry of Communications (US\$25,000, 2003); Feasibility Study for National Optical Fiber Network (US\$300,000, 2006).
- **International Telecommunication Union (ITU):** National Spectrum Plan (est. US\$100,000, 2004); Rehabilitation of the ICT Institute (US\$6 million, 2006).
- **United States Agency for International Development (USAID):** Emergency Response (est. US\$250,000, 2003) – mainly Motorola radios; Afghanistan Economic Growth and Private Sector Strengthening (part of US\$100 million, 2003-2009); Economic Growth and Governance Initiative (part of US\$100 million, 2009-2014), Broadcast Media (est. US\$20 million, 2003-2008); Afghanistan Media Development and Empowerment Project (est. US\$20 million, 2011-2014) – included support to Ministry of Communications for broadcast spectrum realignment and migration to digital broadcasting; E-Governance Resource Center, Phases I and II (est. US\$5 million, 2010-2016).
- **United National Development Programme (UNDP):** Technical Assistance to Ministry of Communications (est. US\$150,000, 2004-2006) – preparation of electronic government strategy and action plan.
- **Japan International Cooperation Agency (JICA):** Technical Assistance to Ministry of Communications (est. US\$200,000, 2006) – support for electronic government.

department of the Ministry of Communications (MoC)), nor for the analog advanced mobile phone system (AMPS, a first-generation cellular technology), which was established as a joint venture with the Taliban regime in 1998.<sup>912</sup>

In a country already burdened with so many other shortcomings in a post-war environment, it was crucial for Afghanistan to adopt a legal-regulatory framework that would provide potential private investors with a number of key assurances:

1. Predictability: Reduce the already-significant political risk by publishing a fully-articulated sector policy that addresses all of the major market segments and still embraces opportunities for innovation and creative disruption;
2. Transparency: Establish a sector regulator that is as independent as possible;
3. Reasonable Risk/Profit Ratio: Introduce a phased, incremental exposure to full competition; and
4. Level Playing Field: Avoid measures that protect incumbents from competitive forces or provide new entrants with statutory advantages.

With tailored technical assistance and sustained in-country support from the international donor community, Afghanistan was able to accelerate the adoption and implementation of an enabling environment that maximized private investment and set new standards for the path that a post-conflict country can take from smoldering rubble to the most advanced technologies and services.

## Historical Foundations for ICT in Afghanistan

Throughout most of its history, Afghanistan has provided telecommunications services generally adhering to the norms of its region and the standards set by the ITU. Its first law governing the sector was The Law of Telegraphs (15 Sombula 1317 = 1938)<sup>913</sup>, which was little more than what we might call a “service level agreement” that briefly described the numerous types of telegraph services to be made available, the transmission priority, the delivery obligation, and a simple four-tier price list. This law received a complete overhaul in 1967 with The Telegraph Law, but it was also accompanied by The Telephone Law<sup>20</sup> (Hoot

---

<sup>912</sup> The establishment of “Taliban Tel” is a colorful story, with many twists, turns, allegations and litigations; for a good example, see Eric Ellis’ “Wireless Wars.” Accessed December 15, 2015. <http://198.173.119.27/awcc.htm>. Originally published in *Fortune International (Europe) Magazine*, Volume 150, Issue 8, October 18, 2004.

<sup>913</sup> The laws of Afghanistan were compiled by the United Nations Development Programme (UNDP) in 1975 in paper form; USAID and the International Development Law Organization (IDLO) compiled the laws again in 2004, and they were briefly available in electronic form (online) and presented on CD-ROM to the Ministry of Justice and the US Library of Congress. As of August 2015, they do not appear to be available online any longer at either. Best available online resource: Asian Legal Information Institute. Accessed August 18, 2015. <http://www.asianlii.org/af/legis/laws/>. The Law of Telegraphs is available at: <http://www.asianlii.org/af/legis/laws/lot1938161/>.

1345 = 1967)<sup>914</sup> which made customer premises equipment (CPE)<sup>915</sup> available to the public. This law followed the common practice of the time of establishing a state-owned telecommunications monopoly. Article 2 of the law explicitly provides full statutory authority to the MoC for the importation of all communications equipment, for the operation of all networks (except for defense purposes), and for the provision of all communications services. Yet it provided fairly comprehensive consumer protections. Another noteworthy feature is that Article 9 states the “freedom and secrecy of telephone communications are inviolable” as provided by Article 30 of the Afghan Constitution of that era.<sup>916</sup>

In tandem with technological developments around the world, the legal-regulatory framework was expanded<sup>917</sup> in 1982 with the Wireless Regulation,<sup>918</sup> which dealt primarily with consumer access to equipment to receive broadcasting, and the Telex Regulation<sup>919</sup> which governed the International Record Carrier (IRC)<sup>920</sup> regime and consumer ownership of telex equipment. In 1992, a Telephone Regulation was adopted to address various new services that were made possible by the introduction of new network equipment and CPE. It is unclear whether these rules allowed for private ownership or operation of CPE.

## Taliban Era Telecom Law

During the Taliban regime, there was no “rule of law” as we understand it in the West – and certainly no incorporation of civil or commercial law, because their strict interpretation of sharia<sup>921</sup> essentially prohibited a “civil government.” Furthermore, although its leadership consistently utilized modern

---

<sup>914</sup> Asian Legal Information Institute, August 18, 2015.

<http://www.asianlii.org/af/legis/laws/tl1967ogn75p1967031113451220a383/>.

<sup>915</sup> Customer premises equipment (CPE) is telephone equipment or other hardware that is physically situated at the client’s location rather than on the service provider’s site (or in between the two, such on a network or in a switching or other facility).

<sup>916</sup> The Constitution of Afghanistan 1964. “Constitutions of the Past (1964).” *Afghanistan Online*. Accessed August 21, 2016. <http://www.afghan-web.com/history/const/const1964.html>.

<sup>917</sup> None of the regulations mentioned in this paragraph are available online that the author and editors could find, including from official sources such as the Afghanistan Ministry of Justice (<http://moj.gov.af/en>); the Afghanistan Laws Database (which includes regulations, <http://www.moj-laws.gov.af/>); the Afghan MCIT (<http://mcit.gov.af/en/>); the ATRA (<http://atra.gov.af/en/>); the US Library of Congress (<https://www.loc.gov/>, see footnote 3), or the online resources for Afghan legislation offered by the US Library of Congress ([http://www.loc.gov/law/find/pdfs/2012-007612\\_AF\\_RPT.pdf](http://www.loc.gov/law/find/pdfs/2012-007612_AF_RPT.pdf)). All accessed December 15, 2015 and August 21, 2016.

<sup>918</sup> Officially, the Regulation for the Use of Radio Frequencies and Radio Communications Equipment in Afghanistan. Islamic Republic of Afghanistan from MCIT (n.d.). Regulation for the Use of Radio Frequencies and Radio Communications Equipment in Afghanistan. Accessed December 3, 2015.

[http://mcit.gov.af/Content/files/Radio\\_Frequencies\\_and\\_Radio\\_communication\\_Regulation-Eng.pdf](http://mcit.gov.af/Content/files/Radio_Frequencies_and_Radio_communication_Regulation-Eng.pdf).

<sup>919</sup> Regulation of Telex. Decree No. 709, 15 Asad 1354 (1975). Compilation of Afghanistan Laws. New Zealand Digital Library. Accessed August 21, 2016.

<http://www.nzdl.org/gSDL/collect/areu/Upload/1385/Compilation%20of%20Afghanistan%20laws.pdf>.

<sup>920</sup> An International Record Carrier is “a common carrier engaged in providing overseas telecommunications service [such as] ... telex, private line service and alternate voice data service.” DefinedTerm.com. Accessed August 21, 2016. <https://definedterm.com/a/definition/209053>.

<sup>921</sup> The religious-legal system that governs followers of the Islamic faith.

communications devices, including radios to listen to broadcasting, all such technologies and use of such services were banned for use by the general public.

It is, therefore, surprising that a Law to Regulate Telephone Services was promulgated by the Ministry of Communications in 2000. According to several people who were working at the MoC at the time,<sup>922</sup> the primary purpose of the law was to ensure the regime could tap into a revenue stream with some degree of legitimacy. Underlying this was the reality that international calls were being placed and that some foreign administrations were threatening to block calls from Afghanistan due to the lack of payments by the MoC to the foreign telephone companies for the completed calls. It should also be noted that during the Taliban regime, Afghanistan ceased paying its annual membership dues to the ITU; this resulted in other parties poaching some of its valuable resources, such as its satellite orbital slots.

As with predecessor legislation, Article 2 maintained the exclusive authority of the MoC for all communications services (except for defense). Article 11 dispenses with the need for a court order to “inspect” communications for “solid reasons,” including national security, personal welfare and “economic matters” (undefined). Article 19 states a “royalty fee” (rent) can be collected for enterprises with a private branch exchange (PBX switchboard) – whether or not network service is actually provided.

Section 6 (Articles 26-31) provides for penalties for non-compliance, but unlike the reputation the Taliban have earned for harshness, the section actually reflects a highly-evolved sense of fairness, including the issuance of warnings as the first step and ultimately simply cutting off service for non-payment. The final Article makes it clear that this new law replaces all previously-Gazetted laws on the subject, showing a remarkable adherence to both the form and the substance of the historical Afghan approach to law-making.<sup>923</sup>

## The New Modern Era Begins

The new Afghan Transitional Administration (ATA) addressed the telecommunications sector less than six weeks after the *Loya Jirga*<sup>924</sup> met on June 13, 2002 to appoint Hamid Karzai as the Interim President. Karzai signed Presidential Decree 4517 on July 28, 2002 for the explicit purpose of giving the MoC legal authority to create a licensing regime that would allow private parties to provide telecom services to the public and utilize spectrum resources. Probably the main underlying reason for the urgency of Decree 4517 was that the incumbent AMPS cellular operator (today known as Afghan Wireless Communications Company, AWCC), which had begun offering services in the major urban areas of Afghanistan under the Taliban regime, was now seeking, at a minimum, to prevent the seizure of its network, and on the upside,

---

<sup>922</sup> As intimated to the author, who lived and worked in Kabul on various finance, economic growth, and ICT endeavors between May 2003 and January 2016. All unreferenced observations and assertions in this chapter are based on his direct experience and first- or second-hand knowledge from actually being in country and working with the players.

<sup>923</sup> Laws come into force once published in the Official Gazette (and any further effective date cited therein); see Law of the Official Gazette 1963 (1342).

<sup>924</sup> Grand council of tribal elders

to capitalize on the regime change to become a viable commercial enterprise.<sup>925</sup> During the Taliban regime era, the AMPS network was regarded largely as an “intercom system” for the roughly 2,000 commanders who were its most prominent users (and therefore its protectors); it was designed and implemented on a shoestring budget and had only the most rudimentary system of billing and administration.

But another significant factor was surely that the President’s office was being inundated by countless offers from people and companies seeking authorization to offer telecommunications services in this otherwise virgin market of 25 million consumers. Some of these offers were made by serious parties with legitimate capabilities and capital (notably German enterprises, because it was at the Bonn Conference<sup>926</sup> where the ATA was formed). But many very dubious proposals were being offered on behalf of very suspicious parties. Note that these offers were not made through official channels (such as the international competitive tenders for GSM<sup>927</sup> licenses) but rather through a wide variety of influence peddlers with access to the President’s ear.

The “investment” offers were not just limited to the telecom sector, of course, which is why Decree 4517 explicitly stipulates that “all actions [are] to be endorsed” by the High Commission of Investment (HCI). The HCI was established by a prior Presidential Decree and was largely guided by German national governance principles of industrial policy by which the State actively intervenes in the flow of private investment into the marketplace, ostensibly to squeeze greater value out of each investment for the benefit of society and guide the capital into certain sectors for certain priority objectives. In any event, that was the overt rationale for the HCI.

Meanwhile, Afghan officials and other cynical observers at the time derided the HCI approach as less a check-and-balance than a mechanism to minimize the opportunity for the President or a sole minister to reap the “commissions” on green-lighting a particular investment deal – sort of a *pari-mutuel* graft and corruption control mechanism.

---

<sup>925</sup> As noted earlier, AWCC formed a joint venture with the Taliban regime in 1998 and initially utilized analog mobile technology (AMPS). After the fall of the Taliban, AWCC was allowed to start construction of digital infrastructure in January 2002, which went operational with limited global system for mobile (GSM) service in April 2002. By 2003 AWCC extend service to five cities – Kabul, Herat, Mazar-e-Shairf, Kandahar, and Jalalabad – and reported 150,000 subscribers by mid-2004. Telecom Development Company Afghanistan Ltd. (TDCA, dba Roshan) was awarded a GSM license in January 2003 through an international competitive tender, and AWCC received its GSM license in July 2003. Following a second round of international competitive tenders, MTN was awarded the third GSM license in 2005 and Etisalat the fourth in 2006. Afghan Telecom Corporation was awarded a Unified Service license (including national GSM) in 2005, and Wasel Telecom a regional fixed-CDMA Local Fixed Service Provider (LFSP) license for wireless local loop in 2006. AWCC also established an Internet café in the Intercontinental Hotel in July 2002, although the first ISP licenses were not issued until the end of 2004.

<sup>926</sup> Officially, the International Conference on Afghanistan, Bonn (2001)

<sup>927</sup> Global system for mobile communications, a second generation of protocols for digital cellular networks originally developed by the European Telecommunications Standards Institute (ETSI). GSM is now a trademark owned by the GSM Association.

## Practical Considerations for the Creation of Policy in the New Regime

Once Decree 4517 was promulgated, the question arose of how best to implement it. The Minister of Communications at the time was a highly-trusted confidant to President Karzai, but with very limited experience in the sector, much less in the mobilization of the massive funds now needed to build new ICT infrastructure from the post-war rubble. In addition, his portfolio also included disarmament, demobilization, and reintegration (DDR) which was essentially the donor-funded program to provide cash for work to former Taliban commanders who had agreed to cooperate with (or at least not overtly fight) the ATA.

Fortunately, the ITU provided funding to the MoC and recruited a highly-capable expert as part of its technical assistance to Afghanistan. This individual (who later became Minister) was able to recruit a small team of Afghans to form a policy office adjacent to the Minister's office. At this early phase of Afghanistan's reconstruction, the only electricity in the entire 17-story MoC tower in downtown Kabul was a small generator serving the Minister's third-floor office suite; the remainder of the building was essentially occupied by people who had only the vaguest sense of rule of law or modern ICT and had at best received vocational training at the MoC's Technical Training Institute (TTI), later renamed the Information and Communication Technology Institute (ICTI), more than a decade ago.

## The Turning Point: How a Statist Strategy Quickly Morphed into a Pragmatic Approach

Commencing shortly after the appointment of the Minister of Communications in June 2002, a 16-page "Telecommunications Development Strategy"<sup>928</sup> paper was prepared by an external expert and circulated to the Afghanistan Reconstruction Steering Group's Implementation Group meeting held in Kabul on October 11-12, 2002. This document also contained a snapshot of both the physical infrastructure and human capital that existed at that moment. On the one hand, a remarkable amount of restoration had been achieved in just three months; on the other hand, its main goal appeared to serve as a basis for soliciting donor support for several of the highest-priority communications requirements, namely governmental emergency systems and basic connectivity in support of the humanitarian relief effort (with the winter fast approaching). Consequently, the Strategy concluded with a request to donors for up to US\$120 million in 2003 for 11 projects (briefly described in an Appendix to the Strategy), plus an estimated US\$122 million annually for the subsequent five years.

At this juncture, there was not much of a role explicitly foreseen for the private sector, and to the extent that it was mentioned, it was characterized as a potential joint venture with the government and some element of private equity financing to complement donor funds might be accommodated.

---

<sup>928</sup> Stanekzai, Mohd. Masoom (2002). *Telecommunications Development Strategy, Islamic Transitional Government of Afghanistan*. Accessed August 21, 2016.  
<http://unpan1.un.org/intradoc/groups/public/documents/apcity/unpan016263.pdf>.



As the numerous donor institutions returned to their respective headquarters to ponder these requests, the MoC commenced work on the development of the ICT sector policy. One of the first fundamental questions that required definition and deep reflection was: What is the ICT sector? At that juncture, policymakers around the globe were widely debating the issue of convergence. Indeed, while the European Commission (EC) had recently adopted a legal-regulatory framework that recognized the convergence of conduit and content, the majority of its Member States remained comfortably in the paradigm that had been put in place since the 1930s, namely a strict separation of licensing and service provisioning between the telephone companies (conduit) and the broadcasters (content). In the 2002-2003 timeframe, only the United Kingdom had already combined the two under a single sector regulator (its Office of Communications, or Ofcom) and even that had yet to be operationalized (the British Parliament had adopted the legislation in early 2002, but gave an 18-month window for implementation).

Notwithstanding the appeal of putting in place a “future-proof” policy right from the start, the conclusion was actually reached fairly quickly by the MoC that Afghanistan would continue to keep conduit and content as separate sectors for the foreseeable future. One factor was certainly that there was indeed a Ministry of Information and Culture (MoIC) already empowered in the interim Constitution of the Islamic Transitional Government. But candidly, the prevailing thinking within the MoC was that it was simply better to avoid the potential headache of supervising content – after all, Afghanistan was historically a very conservative nation, and the dust had not yet settled on how conservative the post-conflict nation would be or how it would react to the unfettered access to information and ideas that the Internet, for example, might provide.

Next on the critical path towards forming a policy was the question: How will a newly-formed State pay for anything? Normally, an operational national telephone company is a cash cow for the state coffers; but as noted earlier, the Taliban regime did not implement a civilian government, nor did it nurture or sustain the sector in any dimension. Indeed, the existing telecom infrastructure was so poor, it couldn't even be privatized (something that was considered).

By the time of the October 2002 meeting between the transitional government and international donors, the results of the international competitive tender for the first nationwide GSM license had been evaluated (but not publicly announced) and the winning bidder had offered US\$5 million; this was a remarkable figure at the time, and more than double the amount of the second qualified bidder (US\$2 million). The significance of this outcome cannot be overstated: legitimate private investors were willing not only to make significant investments in ICT infrastructure (the initial business plan committed to around US\$30 million to build the GSM network) but pay substantial license fees as well. In addition to the one-time US\$5 million payment, the GSM license (which was essentially the template provided by the GSM Association) also required a recurring regulatory fee and a “spectrum fee” of 2.5 percent of gross revenues (which was pegged at the same rate as applied in India at the time).

But what about the existing AMPS-based network established under the Taliban regime? It was operating on the relevant ITU-adopted standard frequencies in the 800 megahertz (MHz) band – not the standard GSM-900 MHz band in the international competitive tender. The decision was made to allow the AMPS network operator to migrate to GSM, provided that its management agreed to match the US\$5 million winning bid. And so, logically, it did.

Consequently, by the close of 2002, the MoC was almost the only government institution in the position to *contribute* to the Afghan national treasury. (The other was the Afghanistan Investment Support Agency (AISA), but, unlike the MoC, it is legally entitled to retain its fees!) As this reality set in, two things were evident to Afghan policymakers: (1) Telecommunications licensing could be a lucrative undertaking for the government, and (2) there was essentially no need to utilize the very scarce resources of the government treasury for ICT infrastructure – when there were still millions of displaced and homeless Afghans scattered about, both internally and externally.

Also around this timeframe, the Ministry of Finance (MoF) was formulating its fiscal framework and its own sector policy. Due to the inability of the central government to collect taxes, customs, duties, or essentially any other form of revenue, the MoF decided it would have two budgets working in tandem, an operational budget and a development budget. (Afghanistan had a development budget under the Taliban and previous regimes; however, it had not been executed for many years.<sup>929</sup>) Beginning with preparation of the Solar Year (SY) 1381 budget (March 2002-March 2003), the MoF created a draft development budget and presented it at a major donor meeting in Kabul in October 2002.<sup>930</sup>) The operational budget covered the operating costs of the government itself (mainly salaries, but also expenses such as oil for heat, office equipment, etc.); the development budget, which initially came entirely from donor contributions, was spent mainly on infrastructure projects, such as roads, hospitals, and schools as well as more intangible things like salary “top ups” to entice the Afghan diaspora to return to government service.

So, the US\$10 million from the GSM licenses was clearly government-generated revenue, and just as clearly, part of the standard fiscal regime, meaning it became part of the pool for the operational budget.

## The 2003 Telecommunications and Internet Policy as the Foundation for all Future Successes

The post-conflict successes in the ICT sector in Afghanistan can be traced to the articulation of a thoughtful, concise, and flexible Telecommunications (Telecom) and Internet Policy,<sup>931</sup> which was adopted by the Council of Ministers in July 2003.<sup>932</sup>

The first notable aspect of the Telecom and Internet Policy was that its primary guiding principle was to bring all Afghans to “experience the Digital Age.” This was actually rather bold in that timeframe, especially for a developing country virtually at the bottom of the ITU’s statistical tables for all services,

---

<sup>929</sup> World Bank (2004). Carnahan, Michael, Nick Manning, Richard Bontjer, and Stéphane Guimbert, eds. (2004). *Reforming Fiscal and Economic Management in Afghanistan*, 23. Accessed August 23, 2016. <http://documents.worldbank.org/curated/en/302851468767104925/pdf/296980PAPER0Re10economic0management.pdf>.

<sup>930</sup> Ibid.

<sup>931</sup> Islamic Transitional Government of Afghanistan Ministry of Communications (MoC). Telecommunications and Internet Policy, Final Working Draft, November 2003. Accessed August 19, 2015. [http://mcit.gov.af/Content/files/AfghanistanTelecomPolicy\\_English29112010235311722.pdf](http://mcit.gov.af/Content/files/AfghanistanTelecomPolicy_English29112010235311722.pdf).

<sup>932</sup> Commercial mobile telephone and Internet service commenced in mid-2002, preceding the policy.

and even more so for a war-ravaged country facing a plethora of pressing humanitarian crises. Moreover, in 2003, the governments in many developing countries were still clinging to development policies and sector “master plans” that aspired to very measured, meager progress in digital infrastructure and penetration – much less the wholesale embrace of digital services and the Internet.

Secondly, it was notable that the Telecom and Internet Policy underscored the broader impacts of pervasive, affordable access to communications, stating: “Telecommunications is a basic enabler of informal social and economic discourse necessary in the strengthening of civil society.” After the promulgation of the Policy, the Minister of Communications frequently explained to his government colleagues, other decision-makers, and the public that communications services would be the patch that mended the fabric of Afghan society, which had been so severely worn bare through decades of war and deprivation. (For this sentiment, he ultimately won several prominent awards, including from the GSM Association.)

Finally, and quite significantly, over the course of six months, the new Policy that emerged was now to “[e]ngage private investment to the greatest extent possible.” Consequently, many of the other articulated principles, standards, objectives, goals, and subsequent actions served to buttress this keystone element.

While Afghanistan’s commercial ICT companies, particularly the four large commercial mobile network operators (MNOs), have pumped millions of foreign direct investment (FDI) into the country, the government’s monopoly over its fiber optic network, which is owned by the MoC and managed by state-owned Afghan Telecom Corporation (AfTel), has prevented the MNOs from investing even more. The adoption of an Open Access Policy (see Editors’ Note below) could change their positions.

### Highlights of the Telecom and Internet Policy

Even though accession to the World Trade Organization (WTO) was likely not in the forefront of any Afghan political leader’s mind in 2003, the Minister of Communications nevertheless agreed to reflect the fundamental principles of its General Agreement on Trade in Services (GATS) and Information Technology Agreement (ITA) fully and unambiguously in the Telecom and Internet Policy of Afghanistan.

In the first instance, this meant that there would be a clear segmentation of sector roles between policy, regulation, and the provision of services to the public. The Policy, therefore assigned the policy role to the MoC, and called for the “corporatization and rapid privatization of Afghan Telecom Corporation,” a corporation owned by the MoC, to which the Policy assigned all existing ICT infrastructure. Crucially, the Policy also stipulated that an independent sector regulator would be established by the end of that solar year (by around March 20, 2004).

Secondly, it meant that Afghanistan would give no preferential treatment to Afghan Telecom (AfTel) – there would be open market competition and a “level playing field” for all service providers. In addition, an entire chapter of the Policy was an explicit competition policy. This was a crucial ingredient, because it identified to potential investors exactly how the market would evolve. For example, it made a commitment to retain GSM services as a duopoly only until January 2006 – and this was adhered to with precision. In addition, the Policy provided assurances there would be no preferential treatment for

domestic versus foreign-owned licensees (which could be 100 percent foreign). One missing element was the repatriation of profits, which the subsequent Telecom Law, nevertheless addressed (see below).

Thirdly, the MoC promised complete transparency in its policies and decisions, and the Policy stated that “the MoC will periodically review this policy and publish updates to its official website.” Indeed, even by the time the first draft of the Policy had been circulated, most of these principles had been posted to the MoC website for global scrutiny – and support. A few years later, a regional think tank<sup>933</sup> affiliated with the ITU named Afghanistan as having the best official website for the telecom sector.

Lastly, the Policy addressed two issues that grew massively in significance as the market matured and as it overtook all other economic sectors in post-Taliban Afghanistan:

### *Universal Service*

The Policy called for the creation of a Telecommunications Development Fund (TDF) as a mechanism to ensure the Information Society would indeed reach every Afghan. The TDF would collect funds (specifically, 2.5 percent of gross revenues) from the fixed and mobile service providers and use them to subsidize the construction of facilities in rural, remote, and “un-economical” territories of Afghanistan. The universal service obligation remains a mainstay of telecom policy on a global basis, and just as in many other countries, this benevolent idea essentially became a burden to policymakers as the pace of incoming funds soon far outstripped the government’s ability to put it to intended uses.

Unfortunately, the Policy provided a broader and better scope for the use of TDF than eventually was formalized once the independent regulator was established, stating that it should be used for “infrastructure projects of strategic importance, including for public safety, or to provide basic access services in communities not adequately addressed by licensed operators.” This approach provided the flexibility for independent third-party systems in the remote hinterland, and would have accommodated virtual network operators or pure infrastructure owners (such as American Tower in the USA). The regime ultimately adopted by the ATRA sought to emulate the “reverse auction” approach that was successfully implemented in Latin America, where there were multiple decentralized telephone company (telco) licensees that could more easily incorporate “thin route” service in their network footprint with negligible subsidies. The TDF was further defined by the Universal Access Policy Document [for] Rural Telecommunications Development in Afghanistan,<sup>934</sup> issued in SY 1387 (March 2008-March 2009).

### *Taxation*

Only a single sentence in the Telecom and Internet Policy is devoted to taxes. It was primarily a placeholder because, by July 2003, Afghanistan was struggling to build a functioning MoF and had meager lawful or institutional means to collect revenue. (Total revenue in 1381 (March 2002-March 2003) was US\$70 million; by 1383 (March 2004-March 2005) this had increased to US\$309 million.) The Policy clearly

---

<sup>933</sup> LIRNEasia. Accessed August 28, 2015. <http://lirneasia.net/about/>.

<sup>934</sup> Afghanistan Telecom Regulatory Authority (ATRA) website. Accessed August 19, 2015. [http://atra.gov.af/Content/files/UAPolicyDocument-21Oct2008-FinalEd1\\_0.pdf](http://atra.gov.af/Content/files/UAPolicyDocument-21Oct2008-FinalEd1_0.pdf).

stated that all licensees would be liable to pay all applicable taxes, duties, and fees, but what it did not reflect was the prevalence of “tax holidays” and waivers being approved by the HCI. Both of the initial GSM licensees received tax breaks on the basis of letter-agreements with the MoF; by the time the second wave of GSM licenses were awarded at the end of September 2005 in anticipation of introducing further competition beginning in 2006, all tax breaks had been rescinded by the MoF (at the request of the International Monetary Fund (IMF) and the Afghan Parliament). A World Bank analysis conducted in Afghanistan in 2009<sup>935</sup> concluded that the GSM licensees were being taxed mercilessly by the MoF because they were highly compliant with the nation’s tax regime – whereas virtually every other domestic enterprise was non-compliant.

Relatedly, in September 2015, the Afghan government imposed a 10 percent tax on consumers for mobile “top-ups” (adding funds to existing prepaid mobile services accounts). The government had tried to impose the same tax earlier in the year, but it had been rejected by the *Wolesi Jirga*, the House of the People, or lower house of the Afghanistan Parliament. While the tax has been successful in bringing more revenue to the government, it may be responsible for up to a 10 percent reduction in consumer use of mobile phones, which will negatively affect both company and government revenues, employment, and future investment. Also, there have been news reports that the Taliban has demanded its own 10 percent “tax,”<sup>936</sup> thus doubling the burden on the operators, at least those who comply.

## Licensing by Specific Market Segments Provided Enormous Confidence to Private Investors

Mirroring the typical approach to WTO accession, the Telecom and Internet Policy enumerated a comprehensive list of commitments to market opening, which segmented the market (pursuant to the state of technology at that time) and was designed to provide significant – but unbiased – opportunities to local entrepreneurs to invest in virtually all lucrative businesses.

Rather than analyzing each of the 12 license categories, this chapter will only highlight the key categories with the greatest significance to policy-making.

### *Wireless and Wireline*

The Telecom and Internet Policy articulated a duopoly for the two existing GSM licensees at the time, and envisioned competition from additional wireless and three wireline licensees beginning in 2006. In practice, only Afghan Telecom attempted to provide fixed line services. It was issued a Unified Service License in 2006, which also entitles it to provide mobile services (as well as anything else, including fixed wireless services).

---

<sup>935</sup> Spectrum Strategy Consultants for The World Bank (2009). *Analysis of Taxation of Telecommunications Services in Afghanistan*.

<sup>936</sup> “Taliban Want Telecom Infrastructure ‘Protection Tax.’” 2016. *Daily Outlook Afghanistan*, January 29. Accessed April 3, 2016. [http://www.outlookafghanistan.net/national\\_detail.php?post\\_id=14211](http://www.outlookafghanistan.net/national_detail.php?post_id=14211).

### *International Gateways*

The Policy intended to restrict international gateways to networks which the Ministry of Communications controlled (100 percent of Afghan Telecom, 20 percent of AWCC), noting that once the independent regulator was fully-functioning, this could be relaxed. However, this fine point in policy was fairly quickly set aside, because the first competitive mobile network operator (MNO) license was granted to Telecom Development Company of Afghanistan (TDCA)/Roshan to include international gateways.<sup>937</sup>

Presently, the commercial MNOs operate microwave (and other) gateways, but the Afghan government has prohibited them from constructing or operating fiber gateways (the Policy is neutral as to type of infrastructure or transmission for International Gateway Service licenses). The companies claim that when two of them attempted to build fiber gateways, they were stopped, in one case forcibly by the Afghan military. By mid-2016, this had become a point of contention between the MNOs and AfTel (as well as the regulator), likely because of the economic rewards of operating gateways, not to mention the MNOs forced dependence on AfTel. The commercial companies are seeking a policy statement from the government to let them build gateways.

### *Very Small Aperture Terminals*

Essentially within days of the ouster of the Taliban, VSATs<sup>938</sup> began appearing around Kabul, initially serving the various United Nations entities, peacekeeping forces, and international non-governmental organizations (NGOs), but very soon also their “implementing partners” (contractors) and other private enterprises. The Policy accommodated the work of the “foreign partners” by allowing all “private networks” and disallowing all resale. However, it also required registration of all network equipment (which the Afghan government was ill-prepared to enforce), and it required the assignment of spectrum (which, likewise, was beyond the government’s scope to detect). Initially, the regulator sought to establish an elaborate regime of tiered service provision, first based on local, regional, and international connectivity, but eventually this was abandoned and replaced with an Internet service provider (ISP) licensing regime.

### *Cable Television*

The Policy recognized cable as a broadcast media and, therefore, deferred its regulation to the Ministry of Information and Culture (MoIC), in sharp contrast to the emerging “convergence” approach being implemented by the European Union (EU) and being championed by the ITU at that time.

### *Customer Premises Equipment*

The Policy rejected advice from the ITU and other regional parties to establish a “homologation” regime. Instead, it implicitly authorized the importation and use of all customer premises equipment (CPE),

---

<sup>937</sup> AWCC already operated an international gateway for its original analog mobile network, as well as its GSM network by mid-2002.

<sup>938</sup> Very small aperture terminals, two-way satellite ground stations with dish antennae generally smaller than three to four feet.

provided it had previously received “type approval” by other leading authorities such as the US Federal Communications Commission (FCC), the Canadian Radio-television and Telecommunications Commission (CRTC), the EU, the Institute of Electrical and Electronics Engineers (IEEE), and ITU.

## Issues Not Addressed in the 2003 Telecom and Internet Policy That Emerged Later

### *Mandatory User Registration and National Identity Cards*

One significant oversight in the Policy, and certainly the licenses, was the lack of specificity with regard to what is referred to in the banking regime as “Know Your Customer” (KYC) registration. In truth, there were far higher priorities in the immediate post-conflict and reconstruction phase – and indeed, formal official documentation was an even lower priority under the Taliban. Consequently, very few Afghans would have been able to produce legitimate proof of identity, and so perhaps this was a pragmatic accommodation of the market realities at that time. ATRA finally imposed mandatory user registration in 2009, by which time there were already more than a million users, which made compliance, particularly after-the-fact, both costly and incomplete.

As is a routine business practice, from the start, the mobile network operators required new subscribers to complete some form of registration and distributed a general “terms and conditions” sheet. However, it would have been useful also to require a thumb- or fingerprint and/or a passport snapshot (or later, digital image) to accompany all applications for service. Even after the ATRA SIM registration regulation came into effect, MNOs only collected personal data and biometric information in paper form – with the view toward meeting the minimum requirement.

By 2009, when both the militant insurgency and the narco-criminality were flourishing, the lack of information about mobile users was a glaring national security issue, and so was the lack of a national identity card as the basis for establishing legitimate proof of identity.

In the ensuing years, ATRA made several attempts to implement mandatory SIM card registration. In late 2011, the Ministry of Communications and Information Technology (MCIT)<sup>939</sup> announced a two-week “crack down” on illegal (unregistered) SIM cards.<sup>940</sup> In 2012, ATRA and the MNOs agreed to sell all SIM cards deactivated, which could only be activated upon receipt of proper registration forms. In 2014, the MCIT drafted a SIM card sales policy and procedures, though it was never implemented. By 2015, ATRA had identified SIM card registration as a top priority, and discussed mandatory SIM registration at a coordination meeting with the mobile network operators.<sup>941</sup> In 2016, ATRA stated its intention to use

---

<sup>939</sup> The Ministry of Communications was renamed the Ministry of Communications and Information Technology in February 2007.

<sup>940</sup> “Crackdown on Unregistered SIM Cards Soon.” 2011. *Daily Outlook Afghanistan*, August 25.

<sup>941</sup> ATRA (2015). “ATRA Holds a Coordination Meeting with Telecom Companies.” August 3. Accessed August 22, 2016. <http://atra.gov.af/en/page/7013/7014/atra-holds-coordination-meeting-with-mno-representatives>.

biometrics<sup>942</sup> (most likely fingerprints) for SIM card registration. Experts have pointed out flaws in such systems,<sup>943</sup> including flawed source documents for the biometrics (which might be the case for Afghanistan because of a lack of a national identity card) and gaps in electronic verification systems. There have also been some reports of the Taliban obtaining access to biometric readers, which, when combined with access to databases, could prove to be a security issue.

### *Infrastructure Sharing and Conduits*

The Telecom and Internet Policy was silent on infrastructure sharing and conduits. It would have been very beneficial to either incentivize infrastructure sharing or, in some select cases, perhaps make it mandatory (for example, in the most urban areas and along the most travelled corridors). The MNO licenses were eventually revised to make infrastructure sharing mandatory (not just tower or pole attachment, but also street and premises ducts). In addition, there were numerous discussions between the MoC and the Ministry of Public Works (MoPW) concerning the obvious benefit of placing utility conduits beneath the score of new roads being built by multiple donors (both in cities as well as the national ring road). Unfortunately, many of the main donors in the road construction segment were unwilling to delay projects to incorporate conduits into the design and construction, despite informal analyses that illustrated that ultimately the lease of these conduits would more than pay for itself, and despite the Afghan Economic Council having approved and promulgated an Infrastructure Policy in April 2013. For more information on infrastructure sharing, see [Chapter 3, ICT in Afghanistan](#).

### *Infrastructure Protection*

Initially, network infrastructure was not specifically targeted by the insurgency, and if anything, was threatened mostly for commercial extortion. But starting with US President Obama's troop surge in 2009<sup>944</sup> and increasing thereafter, infrastructure and telco<sup>945</sup> personnel were significant targets of the insurgency (and criminal gangs, for extortions). If the broader parameters of the TDF as set forth in the Policy had remained, or if ATRA had acted with courage to take action, it would have made sense to extend the TDF to rebuild critical infrastructure on a rapid-response basis to preserve continuity of service and as

---

<sup>942</sup> ATRA (2016). "A Meeting in Regards to SIM Registration Held between ATRA Board and Telecom Companies." August 16. Accessed August 22, 2016. <http://atra.gov.af/en/page/7013/7014/a-meeting-in-regards-to-sim-registration-held-between-atra-board-and-telecom-companies>.

<sup>943</sup> Such as the GSM Association. See its November 2013 white paper, *The Mandatory Registration of Prepaid SIM Card Users*. Accessed August 21, 2016. <http://www.gsma.com/publicpolicy/wp-content/uploads/2013/11/GSMA-White-Paper-Mandatory-Registration-of-Prepaid-SIM-Users-32pgWEBv3.pdf>.

<sup>944</sup> On December 1, 2009, in a speech at the US Military Academy at West Point, US President Barack Obama announced he would send an additional 30,000 troops to Afghanistan. Obama, President Barack (2009). "Remarks by the President in Address to the Nation on the Way Forward in Afghanistan and Pakistan," December 1. The White House Office of the Press Secretary. Accessed December 10, 2014. <http://www.whitehouse.gov/the-press-office/remarks-president-address-nation-way-forward-afghanistan-and-pakistan>.

<sup>945</sup> Short for telephone or telecom company



a matter of national security. While a couple avenues for employing the TDF for such were explored, none came to fruition.

### *Literacy*

With a national illiteracy rate exceeding 70 percent,<sup>946</sup> much more could have been done to utilize the communications networks to improve both basic and financial literacy. Again, the TDF could have been utilized to subsidize literacy training on both interactive voice response (IVR) and text message platforms.

### *Censorship*

The Ministry of Communications made an unambiguous decision to focus exclusively on infrastructure, in line with the “conduit versus content” dichotomy that was broadly embraced in international policy fora; policy with respect to content was explicitly deferred to the Ministry of Information and Culture.

### *Gender Mainstreaming*

There was no policy discussion with respect to the role of women, or any remedial actions to increase access to or use of ICT by women.<sup>947</sup>

### *Broadband*

Essentially all discussion was focused on basic communications, meaning voice. In large part, this was simply a reflection of the nascent state of the technology options available at the time, as well as the lack of standards, the lack of a private sector “business case,” and the relatively high cost of consumer handsets.

### *Electronic Government*

There were some comments received from donors (including the ITU and the United Nations Development Programme (UNDP)) to at least include a “placeholder” for electronic government (e-government) initiatives in the Telecom and Internet Policy, but the consensus in 2003 was that it was simply too soon: most government offices lacked electricity, and indeed, many lacked windows, heat, and literate staff.<sup>948</sup>

---

<sup>946</sup> United Nations Educational, Scientific and Cultural Organization (UNESCO) Office in Kabul (n.d.). “Enhancement of Literacy in Afghanistan.” Accessed December 15, 2105.

<http://www.unesco.org/new/en/kabul/education/enhancement-of-literacy-in-afghanistan-ela-program/>.

<sup>947</sup> However, the Minister of Communications proactively instituted a policy of hiring women for positions within his ministry, and at one point, there were women in key positions at the ministry and the regulator. Much later (2015), USAID awarded a US\$40 million contract explicitly to increase employment opportunities for women, both in the government as well as small and medium enterprises (SMEs).

<sup>948</sup> Electronic government was nevertheless a second-tier priority for the Ministry of Communications (MoC), and by 2006, the UNDP and JICA had provided technical advisors to draft an e-government policy and action plan. Furthermore, e-government was highlighted by the MoC in the *Afghanistan National Development Strategy (ANDS)* in 2008 as a strategic cross-cutting capability, and around US\$300 million was requested in the presentation to donors for its implementation.

## Roaming

It was decided that while international roaming would be mandatory (with proof of commercial arrangements required within six months of the issuance of the license), it was acknowledged that domestic roaming would potentially be a disincentive to aggressively building network infrastructure, and potentially lead to collusion or “cherry picking” of denser and wealthier customer districts.

## Policy Implementation: Five- and Ten-Year Plans and Action Plans

In tandem with the finalization of the Telecom and Internet Policy, the Ministry of Communications began drafting a ten-year plan for its implementation, guided by a sector specialist from the World Bank. The initial plan was finalized by July 2003 for circulation to international donors and included key performance indicators to be achieved by 2008 and 2013.

Not surprisingly, the initial plan reflected the biases of government, telephone companies, and donors at the time: for example, it envisioned a rather robust buildout of fixed telephone lines (15 percent by 2013, which never came close) and, conversely, a very conservative estimate of mobile penetration (30 percent by 2013, whereas the actual result was more than double).

The ten-year plan set out a clear list of tasks and timeframes for actions to be taken by the Ministry, which consisted of equal parts enabling environment to accelerate private sector investment, standing up the new institutional bodies (especially the independent regulator and a “corporatized” Afghan Telecom), and public sector investments in core strategic projects, including e-government pilot projects and rural connectivity. Since this initial plan was developed with the donor community in mind, most of the actions were accompanied by cost estimates.

Although not explicitly stated, many of the legal-regulatory actions were timed to be completed by December 2004 so they could be promulgated by Presidential Decree in advance of the first sitting of the Parliament, scheduled for December 18, 2004.

## Establishment of the Interim Regulator as a Department of the Ministry of Communications

To achieve a virtually instantaneous start to the implementation of its Policy and Action Plan, the MoC took the very pragmatic step to “re-task” its existing Engineering Board and used the largely-unfilled staff slots to form the nucleus of the Telecom Regulatory Board (TRB). This approach allowed the MoC to utilize the existing civil service regime and budgetary framework to quickly launch an institutional entity that could act as the focal point for donors, rapidly set policy actions in motion (especially the legislative drafting), and commence recruiting and training new staff to take on purely regulatory roles.

Dismantling the MoC Engineering Department also achieved a secondary objective, which was to get the Ministry out of the telco business: everything else that was related to network operations was henceforth consolidated in the AfTel business unit.

The statutory basis for this action was Presidential Decree 4517, which provided authority to the MoC with respect to licensing and spectrum management. The MoC’s specific administrative structure and

powers were further defined in a Ministerial Decree signed on May 15, 2003, “to regulate, monitor, and supervise all telecom activities provided by the private sector.”

The TRB was initially comprised of the former head of the MoC Engineering Department plus five permanent members with specific and relevant skills including legal, spectrum, and ICT, although their commitment to the TRB was only on a part-time basis. With guidance from the donor community, a more permanent the staff structure was drafted by the end of 2003 and submitted to the Ministry of Finance as part of the standard budget process by early 2004.

## First Post-Conflict Telecom Law

An initial Law on Telecommunications<sup>949</sup> (commonly referred to as the “Telecom Law”) was prepared for discussion and circulated by the World Bank staff on June 28, 2003. This version was essentially a slightly modified version of the “model law” that had been developed and published by the World Bank’s legal department a few years prior.

A revised law was prepared and circulated for discussion on July 25, 2003 by a commercial law firm contracted by the World Bank. This version addressed several additional issues:

- The scope was broadened to all “electronic communications” in keeping with the recent European Union directives; this was also done to make it more explicit that Internet services were covered.
- The division of responsibilities was delineated between the MoC (for policy) and the TRB (renamed the Telecom Regulatory Authority of Afghanistan (TRAA), as independent regulator), and the regulator’s oversight role over all licensees and service providers was codified.
- Licensing was made mandatory only for those with “significant market power,” and all others would simply require formal, but non-discriminatory, authorization by the regulator.
- Spectrum policy was left as a function of the MoC (against the advice of the legal advisors), but assignment was delegated to the TRAA.
- An automatic review was set for three years, in recognition of the fact that much would change in the post-conflict period as the broader legal-regulatory framework matured and as indigenous expertise developed sufficient to administer more advanced concepts and technologies (for example, convergence of media).

In order to solicit substantive inputs from Afghan government and commercial stakeholders, a series of workshops were conducted in Kabul and then Ottawa, Canada (where the World Bank’s legal advisors were based), which identified a number of reservations, primarily reflecting the fact that the notion of an “independent sector regulator” was a wholly-foreign concept at this juncture in Afghanistan. Secondly, it was decided that licenses would be required for all service providers for discrete service categories. Third, it was decided that all spectrum management functions would remain with the MoC, primarily because it

---

<sup>949</sup> Various drafting parties have given different names to the Telecom Law; the final version, as cited in the Official Gazette, is called the Law for the Regulation of Telecommunication Services.

was actually the only MoC institution with competent staff. There were also clearly strong institutional rivalries at play in this decision. Finally, the drafting participants insisted on the establishment of a “Technical Standards Authority” to conduct homologation, on the basis it was purported this was the regionally-prevalent approach.

By September 2003, the inputs from the workshops were incorporated into a revised draft and circulated to both government stakeholders (the Ministries of Justice, Commerce, and Finance) and the private sector (AWCC, TDCA/Roshan, ISPs, and broadcasters) for comment. In October, the final draft was translated into Dari with the hope of obtaining the President’s signature by November.

Unfortunately, no steps were taken to promulgate this version, which was essentially lost or buried. There was never any official reason given, but by April 2004, MoC officials were unable to locate a copy of the finalized draft.

Consequently, in May 2004, a new drafting process was initiated, this time funded by USAID and implemented by consultants who remained in-country (as opposed to relying on periodic visits). The main impetus for the new initiative was pressure from the private investment community: the existing GSM operators required a tangible and “permanent” legal-regulatory framework to secure large-scale loans from legitimate sources, and a number of other potential investors were waiting in the wings to provide a range of other services (mainly Internet access and VSAT-based services). Furthermore, the two GSM licensees sought to strengthen the validity of their licenses. Finally, as was noted earlier, the absence of rule of law created a vacuum that was attracting questionable operators who were essentially providing services without official authorization or oversight.

While there is always a desire to achieve promulgation “as soon as possible,” this time around, the process did have a firm deadline: in order for it to have the force of law with just the President’s signature (as a Decree), the entire process would need to be completed by the seating of the first Parliament (which turned out to be December 2005, a full year later than originally expected). If this deadline had been missed, it is safe to say that promulgation may have taken many more years, not only because the telecom sector requires a highly technical law, but also because it sought to establish an independent sector regulator, an entirely unknown concept in Afghanistan at that time, as mentioned above.

The crucial point is that as much attention needed to be paid to the promulgation process as the drafting process.

### Building the Regulator in Order to Achieve Promulgation of the Law

The fully-redrafted law was completed by the end of June 2004, and, in consultation with the Minister of Communications, it adopted an “international best practices” approach. In sharp contrast with what had become the “last final draft” of 2003, several key features were radically improved:

- The regulator would be independent, based on the following salient qualities:
  - Institutional independence was assured by virtue of its being self-funded on the basis of the regulatory fees that it was empowered to collect and administer. Therefore, neither the Ministers of Communication or Finance, nor the Parliament, could exert policy influence by restricting funding.

- Policy independence was assured, based on the fact that the promulgation of its normative acts was conclusive. Decisions could only be challenged by petitioning an independent administrative law board established by the central bank law<sup>950</sup> (and not overturned outright by the Minister of Communications, for example).
- The regulator would have authority over all operational facets of the sector, including licensing and, importantly, also spectrum policy and assignment.
- There were a number of checks and balances to provide explicit policy oversight. For example, the Afghan Cabinet would have the authority to approve new license categories (a new “Unified Service” license was ultimately awarded to AfTel, covering not only landline but also wireless services). Major licenses (such as GSM/3G<sup>951</sup>) could only be awarded on the basis of international competitive tenders, and the final selection was supervised by an inter-ministerial committee, nominated by the Minister of Communications, and appointed by the President.
- Despite its statutory independence, the regulator was still within the bureaucratic construct of the civil service regime. Thus, its headcount remained within the MoC allotment, its job descriptions were approved by the Civil Service Commission (itself an independent institution), and its Board could be removed (pursuant to due process and only as a consequence of explicitly stated infractions).
- A chapter on investment guarantees was added, including the right to repatriate profits.
- The name of the regulator was changed to the ATRA because the pronunciation of “TRAA” was deemed offensive in Dari.

The first order of business was the establishment of a special committee, headed by the TRB legal advisor, to build a consensus of support for the new draft within the TRB/ATRA as well as within the MoC. The panel included the head of the MoC Spectrum Management Office as well as representatives from ICT Policy and Administration (with an emphasis on budget and personnel).

However, for this new review and buy-in process to be effective, and in order to make the knowledge transfer sustainable, particularly with respect to license compliance, the TRB/ATRA was restructured to emulate the main components of the new draft law. From this point onwards, all recruiting and hiring was done on the basis of the functional requirements articulated in the new draft law. All TRB/ATRA staff was provided with intensive training on the underlying concepts of the law (such as competition); this training was mandatory for all new hires and the heads of the new departments.

The review – and education – process was completed by June 2005, at which time the final draft was submitted to the cabinet for approval. Although the entire draft law was provided to the cabinet (in Dari), it was essentially approved on the basis of a one-page explanatory note presented by the Minister of

---

<sup>950</sup> Da [The] Afghanistan Bank Law, published in the Official Gazette on December 17, 2003.

<sup>951</sup> Third-generation wireless digital technology based on International Telecommunication Union (ITU) International Mobile Telecommunications (IMT)-2000 specifications. The wording of the GSM license is such that 3G and 4G (third- and fourth-generation mobile service) are viewed as extensions of GSM and will accommodate and encompass future mobile technologies defined by GSM Association as they evolve and emerge.

Communications. The paper succinctly enumerated the key reasons a law was required and identified what would change (establishment of an independent regulator, “corporatization” of AfTel) along with what would not change (the Minister of Communications was still ultimately responsible for the development and stewardship of the ICT sector).

The cabinet approved adoption of the law in principle but requested a formal review and approval by the Ministry of Justice, notably its legislative drafting department (called “*Taqnin*”). Reportedly, under the Taliban regime, only the Taqnin was empowered to draft legislation, and even under the new transitional Afghan government, it was felt that the Taqnin was required to review all legislation for compliance with the Afghan Constitution and adherence to sharia (Islamic) legal principles.

At this crucial juncture, the value of training the TRB/ATRA staff on all features of the draft law was rewarded, because none of the staff of the Taqnin spoke English, and it was fully up to the TRB/ATRA staff not only to explain the words (which was already a huge challenge, because many technical terms have no precise equivalent in Dari) but also to impart the philosophy and intent (there was great skepticism about private provision of services and frequent rebuttals of compare/contrast with how things are done in Saudi Arabia or Iran).

Fortunately, the TRB/ATRA staff performed flawlessly and prevailed on almost all substantive matters. The final draft law was approved by the Taqnin with only minor revisions or clarifications, and it was approved by the full cabinet on December 8, 2005. The legislation was signed by President Karzai on December 18, 2005, just prior to the first seating of the Parliament.

### Revised Telecom Law Promulgated by the Parliament in 2009

Although the 2005 Telecom Law had full statutory force, it was widely understood and accepted that once the new Parliament was constituted, it would undertake a review in due course – and most likely conduct its own drafting effort.

The first indication that Parliament wanted to do so came in early 2007, when the Minister of Communications delivered his annual formal summary of accomplishments and defended the recently renamed (in February 2007) Ministry of Communications and Information Technology’s (MCIT’s) budget for the forthcoming solar year (commencing on March 21). Several Members of Parliament expressed dissatisfaction with the fact that the private sector was becoming so successful in the provision of mobile services, whereas AfTel was struggling financially and was barely in the wireless market. (AfTel launched CDMA<sup>952</sup> mobile services in 2006 and had no concrete plans, at the time, to provide GSM services, like the four major private carriers.) The Minister of Communications provided a strong rebuttal, emphasizing that in contrast to virtually every other government institution, the MCIT was a major contributor to the

---

<sup>952</sup> Code division multiple access, a method used by some radio communications technologies that makes it possible for several transmitters to send information over a single communication channel simultaneously, thereby allowing multiple users to share finite frequency bandwidth without interference.

Afghan treasury – as the direct result of license and spectrum fees and corporate taxes paid by licensees – not to mention the biggest generator of well-paying, sustainable jobs.

Following its standard protocol, the Parliament assigned the task of reviewing the Telecom Law to both the newly-formed Telecommunications Committee and the National Economic Committee (NEC). However, not surprisingly, due to an enormous backlog of pending matters, as well as higher priorities, no concrete actions were taken the following year. In addition, it is important to understand that the entire government was stretched to its capacity throughout 2006-2008 in the [Afghanistan National Development Strategy \(ANDS\)](#) process, which the donors meant to be a comprehensive inventory of policy priorities and actions, but which the government understood to be the creation of billion-dollar “wish lists” for continued extravagant funding.

But by the middle of 2008, the Telecom Law had finally been added to the Legislative Calendar, and both the MCIT and ATRA began briefing the Committees and key Members of Parliament on the details of the existing law as well as identifying potential room for improvement.

To support an entire portfolio of critical economic legislation, USAID provided technical consultants to various Parliamentary elements, but mainly with a procedural focus. Nevertheless, the Chair of the NEC specifically requested and received substantive technical assistance, including some measure of support for the Telecom Law. By the end of 2008, the NEC had at least half a dozen USAID-funded advisors, conducting research and preparing topical briefs (for example, telephone penetration and telecom infrastructure spending in each Parliamentary district).

The MCIT and ATRA maintained an ongoing and collegial engagement with the Parliament throughout 2009, and disagreements of policy were very rare. The two Committees approved the draft law mid-year, and the lower house of Parliament (Wolesi Jirga) approved it on October 4, 2009. There were some minor disputes regarding discrepancies between the two official versions (Dari and Pashto) and, to a lesser extent, the unofficial “reference version” in English, so a special Joint Committee was established to iron these out, and a final draft was approved on December 26, 2009.

However, when the draft came to the Wolesi Jirga for a vote in March 2010, two more substantive issues were revisited: the first dealt with the budget (principally, independence, oversight and accountability), and the second with the composition and appointment of ATRA senior leadership. As a result, the revised draft law was remanded back to Committee, where these issues were all clarified or revised. In actuality, the overall quality of the draft law was indeed improved. It was finally adopted by the full Parliament in December 2010.

### Telecom Law is Published in the Official Gazette

The final step in the long promulgation process was achieved on March 3, 2011, once the law was formally published in the Official Gazette (Issue 1031, as a stand-alone document). Once again, there had been some delay owing to the need to synchronize the Dari and Pashto versions (which are equally binding and both appear in the same issue).

## Draft ICT Law to Address Internet, Software Industry, and E-Commerce

At some point early in the Parliamentary review process of the Telecom Law, consideration was given to either appending several new chapters explicitly to address the ICT industry (to promote software) and emerging Internet issues (primarily cybersecurity), or to submit a separate law to address these. It was ultimately decided not to delay any further the existing law and to have ATRA address these issues with regulations and procedures. The extra chapters would potentially add upwards of 70 pages to the existing 35-page Telecom Law – and would drill far deeper into numerous highly-technical topics that the majority of Members of Parliament were ill-prepared to comprehend (for example, public key infrastructure (PKI)<sup>953</sup> – but even the concept of “spam” was a stretch).

Consequently, a draft ICT law was prepared and circulated to all interested parties on March 28, 2008. This law was composed of chapters that adopted the United Nations Conference on Trade and Development (UNCTAD) model legislation on digital signatures and electronic commerce, incorporated the Council of Europe Convention on cybercrime, and established authority for monitoring, enforcement, and the imposition of penalties. This legislative work occurred in tandem with initiatives at the MCIT to develop an electronic government architecture and e-government services, including a new electronic national identity card (e-NIC). The e-NIC was designed to include embedded semiconductor “smartcard” technology that could preserve personal data records (including voter registration, driver’s license, and medical patient files) and could also potentially be used for electronic commerce (e-commerce) transactions, such as conditional cash transfers (CCTs) for benefits and pensions.

Also, there was a strong interest on the part of the MCIT to establish a new department or independent body as the institutional implementer for most of these tasks, as opposed to adding them to the ATRA responsibilities.<sup>954</sup> The MCIT was already performing country code Top Level Domain (ccTLD) functions and Internet domain name administration (essentially, the management of .af), and it was in the process of establishing a state-of-the-art national data center that aspired to host all civil e-government services. Additionally, it planned to establish a Computer Emergency Response Team (CERT)<sup>955</sup> as well as an

---

<sup>953</sup> Public key infrastructure (PKI) refers to the collection of technology, policies, and procedures that collectively create a protective structure (access control, authentication, confidentiality, data integrity, etc.) to allow a group of network users to securely and privately exchange data on an unsecure network (such as the Internet).

<sup>954</sup> At the beginning of SY 1391 (March 2012), the MCIT established three new directorates under the General Directorate of Information Technology (IT): the Information Systems Security Directorate (ISSD), the E-Government Directorate, and the Technology and Innovation Directorate. In December 2013, the General Director of IT was promoted to Deputy Minister, IT.

<sup>955</sup> The MCIT established Afghanistan’s Computer Emergency Response Team (AfCERT) in 2010, later renamed the Cyber Emergency Response Team, which is part of the Information Systems Security Directorate. By the fall of 2013, the AfCERT was actively pursuing and solving cybercrimes; however, Afghanistan had no cybercrime laws to apply, so perpetrators often went unpunished.



Internet exchange point (IXP).<sup>956</sup> The MCIT, therefore, sought statutory authority to house all of these ICT-related functions under one roof, which in turn also meant a budgetary mandate to the Treasury.

The draft version of the Information and Communications Technology (ICT) Law was translated into Dari in February 2010 and circulated to the Ministry of Justice (MoJ) and Parliament. However, the Taqnia rejected the proposed law on March 6, 2012, claiming it was “too long, too technical, and contained elements that could be addressed through future policy and regulation.”<sup>957</sup> The MCIT attempted to revise the ICT Law but did not have the expertise to do so, and was unsuccessful in garnering assistance for several years, so the ICT Law languished. Fortunately, the US Department of Commerce (DoC) offered its support.

The DoC’s Commercial Law Development Program advised the draft ICT Law be separated into several laws, and the MCIT reached the same conclusion. Following a workshop on the issues in Tallinn, Estonia, in 2014 attended by representatives from the MCIT, ATRA, the MoJ, and other Afghan government entities, the text was divided to create two, and possibly more, separate pieces of legislation: a cybercrime bill and an electronic (e-)transactions bill (that included PKI and electronic signatures provisions). The remaining miscellaneous topics including intellectual property, competition, and management of the .af domain would be addressed under one of these or in yet a third bill. It was also agreed that a number of provisions, such as data protection, could be addressed as normative acts by ATRA.

The Council of Europe engaged an attorney to work together with MCIT’s Information Systems Security Directorate (ISSD) on making the draft cybercrime law current and fully consistent with the Budapest Convention.<sup>958</sup> At the same time, a representative from the United National Commission on International Trade Law (UNCITRAL) did the same to make the law consistent with its model law. Concurrent with that, the MCIT’s ISSD convened a working group from within the Afghan government to review the provisions in light of Afghanistan’s needs and legal structure.

Shortly after Abdul Razaq Vahidi was confirmed by the Wolesi Jirga as the new Minister of Communications in April 2015, he submitted a 100-Day Plan to President Ghani that explicitly included the promulgation of the draft ICT Law as one of his top priorities. At a second workshop held in Istanbul, Turkey, in June 2015, representatives of all the stakeholder offices within the Afghan government agreed to support the draft bills. The ISSD continued to work on the bills and, by mid-2016, reported the MoJ decided to move those portions of the cybercrime bill that have to do with criminal offenses to the new draft penal code, but left the processes and international cooperation sections, and that the Ministry of Justice could move the laws towards Parliament by late 2016.

---

<sup>956</sup> The MCIT initiated an effort in 2010 to implement the National Internet Exchange of Afghanistan (NIXA). However, as of mid-2016, the Internet exchange point has not come to fruition.

<sup>957</sup> Bierden, Elizabeth A. (Col., USA) (2012). *ISAF Telecommunications Advisory Team [TAT] Year in Review*, July 1, 46.

<sup>958</sup> Officially, the Convention on Cybercrime, which came into effect in July 2004. It is an international treaty that seeks to address the investigation and prosecution of computer and Internet crimes.

## Lessons Learned

While the ICT policies that were implemented in Afghanistan have received widespread praise, and ultimately achieved superior results in terms of pervasive service availability at affordable and still-falling prices, there are a number of observations that warrant consideration for policy-making in the future.

### Learning from What Was Done Right

**Mobilize the Private Sector:** There is really no excuse for draining government (or donor) resources to provide ICT services to the public. Licensing of services is extremely well understood by private investors, who will pay a premium for the privilege of earning a reasonable rate of return, provided that the legal-regulatory regime is transparent and predictable.

**Create Simple, Yet Comprehensive Statements of Policy:** Avoid master plans and 15-year timetables – technology evolves much too rapidly. The idea is to set beacons that will foster buy-in and illuminate a path to desired results.

**Be Guided by International Best Practices:** The term “international best practices” has become overused to the point of becoming a cliché, but mainly because it is rarely empirically applied. Do not attempt to overlay one country’s policies or institutional construct directly upon another. Rather, take the time to really compare and contrast (and rate and rank), and then don’t be afraid to be driven by ambitious goals. Hint: many developing countries have successfully adopted – and created – best practices precisely because they were unencumbered by the paralysis of layers of special interests and byzantine barriers to change; this is especially true in post-conflict countries.

**Level the Playing Field:** Avoid the nostalgic protection of incumbent interests and, especially, avoid the trap of a national champion. If there is a national telephone company, privatize it.<sup>959</sup> In the interim, at least corporatize it and compel it to obtain a license, with no special conditions. A license that sets transparent performance metrics will benefit the consumer in the near-term and also attract a better offer from a legitimate investor upon its sale.

**Strong Competition Trumps Strong Regulation:** If the service is limited by spectrum (like GSM is), start with a duopoly at a minimum, then expand competition in a calculated manner, on a timetable or with a triggering event (like reaching a specific number of customers). Effective competition can be achieved by setting transparent and easily-verified performance metrics (such as number of towers operating in specific geographic territories) and with the imposition of fines for non-compliance. Competition will also minimize the need for institutional capacity of the regulator, allowing a quick start.

**Build a Human Resource-centric Institution:** The ideal first hire in establishing a new regulator (or other ICT institution) is the Human Resources Manager. The remaining institutional structure should be designed to reflect the statutory requirements of the relevant law(s) (e.g., Telecom and ICT Law), and this,

---

<sup>959</sup> Editors’ Note: In some cases, there may be a compelling security reason(s) for retaining government control of a civil communications element to meet government and military needs.

in turn, will drive job descriptions and performance requirements. Skills testing should be part of the recruitment process to gauge suitability for hire and placement, and a mandatory training program should be administered for advancement.

**Train While Doing:** In a post-conflict country, it is highly likely there will be a severe shortage of the right skills for effective governance – and this will be especially true in the technology sector, where skilled workers may have more easily found employment outside of the conflict zone, and in any event, where technological advances and approaches will not necessarily have penetrated inside the conflict zone. It is, therefore, important that externally-provided technical assistance explicitly integrates the indigenous workforce into all policy initiatives and tasks. For example, while the indigenous staff may have never prepared a license, it is crucial to include them in the development of one so that they will have a basic understanding of it in order to monitor for compliance.

**Conduct International Competitive Tenders:** Global technology standards have made it much easier to attract private investors and suppliers from around the world, and this is especially true for the main ICT service categories like cellular, and infrastructure categories like optical fiber. While the so-called “beauty contest” approach to service licensing was considered, ultimately, a much more transparent and credible tender process produced the best results in Afghanistan. It consisted of two phases: in order to be qualified, a bidder had to prove it had a minimum number of customers in that service category and a minimum amount of revenue under management. Once the due diligence was done to qualify, it was simply the highest financial offer, which left no room for political intervention or misinterpretation of results.

### Learning from What Could Have Been Done Better

**Outsourcing the License Monitoring and Compliance:** Afghanistan’s new regulator had neither the indigenous skills nor the requisite specialized equipment to monitor certain aspects of license compliance – notably, the footprint of cellular signals and the quality of service (QoS) of the calls. It would have been expeditious to hire private firms that specialize in these (and other) regulatory tasks, rather than to require voluminous data from the licensees that the untrained regulator rarely examined properly, and, in some cases, were fraudulently prepared by the licensee.

**Implement E-Government Services from the Start:** One unique characteristic of the ICT licensees in general is that they typically have advanced IT systems embedded in everything they do. The regulator should have been the first test bed for e-government – and even e-commerce – platforms in Afghanistan. Much of the regulatory reporting should have been based on electronic filing and even artificial intelligence evaluation (for example, quick ratios to compare and contrast the results amongst licensees in the same service category and identification of anomalies in performance reporting). Beyond these internal processes, this should also extend to automatically publishing industry results onto the regulator’s official website.

**Keep Signature Authorities Simple:** As the regulator grew as an institution, far too many routine and mundane tasks were subject to the approval of the chairman or the board, often requiring explicit signatures. Written policies and procedures and better delegation of authority would have resulted in

much faster and efficient service, particularly in the issuance of simple authorizations as well as small procurements.

**Use It or Lose It:** The Telecommunications Development Fund (TDF) was intended to subsidize the availability of basic telecom service in rural areas that were deemed uneconomical for the licensees. Reflecting the resounding success of the mobile telephone services market, the TDF accumulated a vast treasury in the millions of dollars and, thus, represented not only a significant opportunity cost (in that it was not used) but also raised the risk of theft, misuse, or abuse. Furthermore, the regulator missed a key opportunity to show its utility to the Afghan Parliament by not instituting a fair but rapid response scheme, whereby funds could be disbursed to Parliamentary districts with low penetration: for example, to deploy VSATs rapidly with mesh cellular capabilities to get entire villages online.

## Conclusion

Rebuilding an economy in a post-conflict environment requires the clearest articulation of sector policy, a very simple roadmap with an accelerated timetable to achieve those stated policy goals, and an unwavering commitment to its execution. The ICT sector is relatively unique because there are ample private investment options to achieve rapid results, so long as the enabling environment is established and the legal-regulatory framework is biased towards achieving results that benefit the consumer, as opposed to protecting incumbent or vested interests (including those of the sponsoring government itself).

Afghanistan was extremely fortunate because the constellation of “founding father” policymakers and advisors was given the latitude and political support from the outset to design and implement an “idyllic” vision of a modern telecom market. Afghanistan also benefited from the timing of its renaissance, because cellular network solutions had evolved to the point where technologies were stable, infrastructure (including handsets) was becoming relatively inexpensive, and there was strong global investor appetite for acquiring cellular licenses.

Policymakers should recognize that ICT is the crucial enabler of economic development in this highly-interconnected global community, where access to information is the competitive edge. The fact that Afghanistan was able to achieve so much in such a short period – with meager indigenous resources and under wobbly internal security conditions – provides a persuasive proof of concept that good policy can produce great results and it is worthwhile getting it right, from the start.

*Editors’ Note: Following are some more recent legal-regulatory developments. As of November 2014, there is a National Cybersecurity Strategy of Afghanistan (NCSA).<sup>960</sup> However, it has only been adopted by the*

---

<sup>960</sup> Wafa, Zmarialai (2014). *National Cybersecurity Strategy of Afghanistan*. November, version 2.0. Islamic Republic of Afghanistan MCIT. Accessed March 21, 2016. <http://mcit.gov.af/Content/files/National%20Cybersecurity%20Strategy%20of%20Afghanistan%20%28November2014%29.pdf>.

MCIT and is not a true national strategy (at least not yet). A Cyber Crime Law<sup>961</sup> and an Electronic Transactions and Electronic Signatures Act<sup>962</sup> have been drafted, but did not receive formal review under the Karzai administration. The relatively new Minister of Communications<sup>963</sup> included action on these two laws among the priorities explicitly listed as part of this “100-Day Plan” presented to President Ghani. It is unknown to the editors if they have been reviewed by mid-2016 or even added to the legislative calendar.

The MCIT also adopted an Open Access Policy<sup>964</sup> (OAP) in July 2012, which was to be implemented over four years (2012-2016) in two stages but was not acted upon. Although purely speculative, many believe the MCIT had no real intention of opening up its fiber optic network to competition because it owns Afghan Telecom, which holds a monopoly on the fiber. The core principles of the OAP were non-discrimination, transparency, and cost-based pricing as it related to fiber-based services. The new Minister of Communications and Information Technology had “policy development for open access to the OFC” among the priorities in his initial 100-Day Plan, and a new policy was, in fact, developed. The new OAP has two parts: the first makes facilities, including but not limited to the MCIT’s optical fiber, available through a transparent process with reasonable prices. A second aspect allows “competitive provisioning,” that is, the ability for operators to build and operate their own fiber networks, including international gateways. Some within the Afghan government have expressed concern that such actions could cause the demise of AfTel, so the government is considering how the policy might include some incentives or a directive for companies to build more widely, should that occur.

The Afghan High Economic Council (HEC) approved the new OAP April 5, 2016. Unfortunately, the April 5, 2016 OAP lacked specific details, instructions, and guidelines as to how an OAP would be executed, and, as a result, it languished. In January 2016, Dr. Mohammad Qayoumi, the Senior Advisor to President Ghani on Infrastructure, visited the US and met with several telecommunications experts. One, in particular, was Lewis Shadle, who had spent several years working in the Afghanistan ICT sector, specifically but not only on the buildout of the country’s fiber optic networks. Mr. Shadle gave recommendations to Dr. Qayoumi that he felt would have the greatest impact on the ICT sector. He explicitly suggested Afghanistan adopt an Open Access Policy to include the ability of ATRA to license private companies to build, own, and operate optical fiber infrastructure, and to enable private companies to own and operate international gateways and Internet exchange points (IXPs). Accordingly, Dr. Qayoumi began working with the US Embassy, Kabul, USAID, and the US Department of Commerce’s Commercial Law Development Program to seek assistance in developing a more detailed policy. Dr. Qayoumi was successful in placing the ensuing presentation on the agenda for the High Economic Council to consider. On August, 28, 2016, Mr. Shadle presented the

---

<sup>961</sup> MCIT Information and Systems Security Directorate (ISSD). Accessed March 21, 2016.  
<http://nic.af/Content/files/Cyber%20Crime%20Law.pdf>.

<sup>962</sup> MCIT. Accessed March 21, 2016.  
[http://nic.af/Content/files/Electronic%20Transactions%20and%20Electronic%20Signatures%20Act%20\(revised-final\)%20\(00000003\).pdf](http://nic.af/Content/files/Electronic%20Transactions%20and%20Electronic%20Signatures%20Act%20(revised-final)%20(00000003).pdf).

<sup>963</sup> Abdul Raziq Wahidi, inaugurated in April 2015.

<sup>964</sup> MCIT. Accessed March 21, 2016.  
[http://mcit.gov.af/Content/files/Open%20Access%20Policy%20of%20the%20Afghanistan\\_2\(1\)\(1\).pdf](http://mcit.gov.af/Content/files/Open%20Access%20Policy%20of%20the%20Afghanistan_2(1)(1).pdf).

*“new” Open Access and Competitive Provisioning Policy for the Fiber Optic and Broadband Sectors to the HEC. President Ghani approved it on the spot and codified his authorization as a presidential decree.*

*The Afghan government requires support to develop the appropriate regulations, licensing templates, and pricing regimes in support of the new policy. The government sought a senior ICT advisor to provide expert policy, legislative, and regulatory guidance to liberalize the broadband communications sector. The Telecom Policy Advisor’s core responsibilities will be to:*

- Provide technical and strategic expertise on the design of the overall legal, regulatory, and institutional framework for the development of a liberalized broadband sector.*
- Provide technical expertise on a range of fiber optic and ICT policy and regulatory issues to promote competition and investment and to protect the public interest including licensing, network interconnection (including termination charges), options for price regulation, and regulatory treatment of new technologies.*
- Advise on strategies for private participation and competition in the ICT sector, including licensing, concessions, tenders, outsourcing, public-private partnerships, and privatization.*
- Provide technical presentations to ministry officials and Members of Parliament.*
- Liaise with local legal experts to develop products that comply with Afghan law.*
- Advise local legal experts on international best practices for broadband-friendly practices and policies.*

*The author of this chapter deployed to Kabul in January 2017 to work on legal, regulatory, and institutional framework of the OAP. Implementation of the OAP is expected to be complete by mid-2017.*

## Chapter 6 ICT Organizations and Associations

---

Karen E. Black

### Introduction

In general, a strong institutional framework includes a constructive relationship with the private sector as well as regional and international collaboration, and that is no different in Afghanistan. By nature, people and organizations tend to gather together – associate – based on common interests and shared goals. Associations offer like-minded people, or at least those with similar objectives, the opportunity to have a collective voice and to derive benefit from strength in numbers. Associations can fill gaps between the public and private sectors by establishing standards that create synergies and promote a common good.

While trade and business associations are technically illegal in Afghanistan, “social associations” are allowed. Various groups have evolved within the Afghan information and communications technology (ICT) sector, some initiated by Afghans and others conceived or introduced by donors, aid agencies, and other outsiders. Additionally, Afghanistan participates in several regional and international ICT organizations.

Afghanistan's historical and byzantine tribal culture creates a bit of a dichotomous effect regarding associations. On one hand, the concept of *qwan*, which can loosely be translated as "solidarity group" and represents the tribal and local (district) structures inherent to the country,<sup>965</sup> means Afghans are accustomed to belonging to social constructs, adhering to their norms and codes of conduct, and contributing to, as well as deriving benefit from, a collective. Afghans regularly form *shuras* (councils), with elected or selected representatives (often elders), who serve for some duration, and hold *jirgas*, which are ad hoc meetings to solve problems or achieve consensus on a specific issue. On the other hand, associating and aligning with people outside one's tribe, *qwan*, other extended faction, or ethnicity, is not innate nor encouraged, and is often discouraged or even expressly prohibited.

However, the introduction of technology to a decimated nation with a relatively young,<sup>966</sup> tech-hungry population and a tremendous need for advanced tools and solutions of all kinds, along with the rapid pace of change in the ICT sector, have converged to create opportunities for cooperation and collaboration that have, at least to some extent, been able to transcend Afghanistan's traditional cultural barriers. As a testament, following are some of the ICT associations to which Afghanistan belongs and that exist within Afghanistan. There are international industry organizations and regional groups, as well as

---

<sup>965</sup> Miakhel, Shahmahmood (2009). “Understanding Afghanistan: The Importance of Tribal Culture and Structure Building in Security and Governance.” Accessed December 8, 2015.

<http://www.pashtoonkhwa.com/files/books/Miakhel-ImportanceOfTribalStructuresInAfghanistan.pdf>.

<sup>966</sup> Approximately 70 percent of Afghans are 30 years old or younger as of 2014, per the Islamic Republic of Afghanistan Central Statistics Organization (ACSO). *Afghanistan Statistical Yearbook 2013-14*. Accessed January 5, 2016. [http://cso.gov.af/Content/files/Population\(3\).pdf](http://cso.gov.af/Content/files/Population(3).pdf).

national and local ensembles, all with varying degrees of participation, influence, and benefit. Collectively, they represent a new age within Afghanistan and a potential avenue of sustainability of the Afghan ICT sector.

## International Organizations and Associations

### *International Telecommunication Union*



The International Telegraph Union was established in Paris, France in 1865. It was renamed the [International Telecommunication Union](#)<sup>967</sup> (ITU) in 1932 and became a specialized United Nations (UN) agency for ICT in 1947. Headquartered in Geneva, Switzerland, the ITU is a public-private partnership (PPP) comprised of 193 countries and over 800 private-sector entities and academic institutions founded on the principle of international cooperation among them. The ITU celebrated its 150<sup>th</sup> anniversary in 2015. It is the oldest of the international organizations under the UN umbrella.

The ITU's responsibilities and activities include allocating global radio spectrum and satellite orbits, creating technical standards, improving access to ICT, especially for the disadvantaged, and supporting people's fundamental right to communicate. The ITU's three main areas of activity are radiocommunications (ITU-R), standardization (ITU-T), and development (ITU-D), and it works in these sectors through conferences, meetings, study and focus groups, seminars, workshops, forums, and the like. Its "key areas of action" are:

- accessibility;
- broadband;
- climate change;
- cybersecurity;
- digital divide;
- emergency telecommunications;
- Internet;
- gender equality; and
- youth and academia.

### Leadership and Governance

The ITU is headed by a secretary-general and deputy and governed by a plenipotentiary conference and an administrative council. The Plenipotentiary Conference is the "supreme organ of the Union ... and the decision-making body which determines the direction of the Union and its activities." It meets every four years, in between which the Administrative Council governs the entity. The ITU has a comprehensive group of "basic texts," documents that include its constitution, various rules and regulations, standards and protocols, decisions, recommendations, and the like.

---

<sup>967</sup> International Telecommunication Union information in this section is from various pages of its website. Accessed December 8-9, 2015. [www.itu.int](http://www.itu.int).



## Membership and Benefits

Organizations may join the ITU but individuals may not. Organizations can be countries (governments), state-owned and commercial service providers, manufacturers, academic and research institutions, and other ICT entities of any size or stature. The ITU prides itself on its membership representing a cross-section of the global ICT sector. ICT sector members account for about two-thirds of participants, while associates and academia comprise 20 percent and 12 percent, respectively. Sector members pay a minimum annual fee (but are free to pay more). Academia and some developing countries are afforded discounts.

Services available to ITU members include:

- practical information on ICT services, including toolkits, templates, and best practices;
- online access to resources regarding budget implementation and human resources;
- letters and notifications;
- access to the ITU library and archives service; and
- a global directory of ITU membership.

Benefits of joining the ITU are:

- the opportunity to network with ICT regulators, policymakers, and experts;
- the ability to contribute to global standards and best practices;
- advice to governments on ICT strategies and technologies;
- participation in study groups on emerging issues in the ICT field;
- sharing of expertise and access to training and specialized seminars;
- engagement in regional and global debates;
- launch of innovative public-private partnerships; and
- access to world-leading ICT statistics and studies.

Each year, the ITU Secretary-General announces a theme, which member states are encouraged to celebrate on World Telecommunications and Information Society Day (WTISD). WTISD is observed May 17 each year to commemorate the anniversary of the signing of the first International Telegraph Convention and the creation of the ITU. The theme for 2016 is ICT entrepreneurship for social impact. Recent past themes include telecommunications and ICTs: drivers of innovation (2015), broadband for sustainable development (2014), ICTs and improving road safety (2013), and women and girls in ICT (2012).

## Afghanistan and the ITU

Afghanistan became a member of the ITU on April 12, 1928. It is in ITU Administrative Region E, which includes Asia and Australia. The Afghan MCIT, the ATRA, and AWCC, a mobile network operator (MNO) of which the MCIT owns 20 percent, are all members. Interestingly, Afghan Telecom (AfTel), a state-owned (by the MCIT) corporation is not a member (although it may technically fall under the MCIT's membership as a wholly-owned entity), nor is Roshan, one of Afghanistan's largest MNOs. Etisalat and MTN, two other

Afghan MNOs, are listed as members in their home countries (the United Arab Emirates and South Africa, respectively).

Both ATRA and the MCIT have departments, or at least personnel, assigned to interact with the ITU (and other associations); however, they have not necessarily been particularly proactive in establishing and maintaining constructive relationships. Consultants under a US Agency for International Development (USAID) project attempted to assist ATRA to engage with the ITU fairly early on and to submit Afghan ICT statistics and an annual country report, but to little avail.

The Telecommunications Advisory Team (TAT), along with other advisors, often recommended to the MCIT and ATRA the value the ITU offers in providing tools, templates, training, and other resources that could assist them in executing their duties. In the tumultuous years of Afghanistan's pre-invasion past, the MCIT neglected to respond to ITU correspondence regarding its satellite orbital slot, which resulted in encroachment, albeit legal, and the resultant diminution of its footprint. The MCIT and ATRA are reportedly now working with the ITU to address and mitigate the encroachment issues.



Picture 17: MCIT deputy ministers participating in ITU events

*On the left: MCIT Deputy Minister (Technical) Engineer Baryalai Hassam at the ITU World Summit on the Information Society (WSIS)+10: Future of the Information Society and Challenges to Address beyond 2015, May 14, 2013, in Geneva (Photo by J.M. Planche). On right: MCIT Deputy Minister (Finance and Administration) Wahabuddin Sadaat, at the MCIT's commemoration of World Telecommunications and Information Society Day (WTISD) at a celebration on May 15, 2013, in Kabul (Photo from the MCIT).*

The former Minister of Communications and Information Technology under President Karzai and members of his staff participated in a number of ITU events over the years, and the former Chairman of the ATRA Board of Directors, as well as ATRA personnel, have attended various ITU events and training sessions. The MCIT typically organizes an event to commemorate WTISD every year. Because radio communications are one of the ITU's three main areas of activity, ATRA, in particular, could likely benefit greatly from ITU resources and training regarding spectrum management.

## GSM Association



The [GSM Association](#)<sup>968</sup> (GSMA) was formed in 1995 as an organization dedicated to global system for mobile (GSM) communications standards and utilization. It is a powerhouse in the mobile communications sector and a well-regarded source of statistics, GSM-related information, and research. The GSMA hosts the Mobile World Congress (MWC) each year, the largest annual event in the mobile communications industry, along with other regional and smaller events. It represents the interests of over 800 GSM network operators from 220 countries, and its membership includes companies in the broader mobile ecosystem, such as handset manufacturers, software suppliers, and application developers. The GSMA is headquartered in London and has eight additional offices around the world.

### Engagement and Advocacy

Among the GSMA's areas of engagement and concentration are:

- spectrum for mobile broadband;
- public policy;
- climate change;
- smarter apps guidelines;
- personal data;
- mobiles for development;
- connected women;
- mobile economy;
- digital commerce;
- network 2020;
- managed services; and
- connected living.

The organization also conducts and publishes research, sponsors contests, and issues awards. The GSMA includes a number of working groups, which it considers the engines of the association. They include: roaming, billing networking, fraud and security, interoperability, and other timely and relevant topics.

### Leadership and Governance

GSMA leadership consists of a chair and deputy chair, although how they obtain the positions and serve is unclear to the author. A 25-person board provides members with a "stronger voice, clearer direction, and faster decision making." The GSMA Organization manages the day-to-day activities of the GSMA and its Director General reports to the board. There are also several standing committees, including ones for finance, public policy, and strategy, among others, as well as groups for spectrum management and regulatory officers. In addition to the topical groups, the GSMA has six regional interest groups representing and serving various regions of the world.

### Membership and Benefits

There are three types of membership in the GSMA as follows:

- Full, which is reserved for licensed mobile network operators using GSM technology

---

<sup>968</sup> GSM Association information in this section is from various pages of its website. Accessed December 9, 2015. [www.gsma.com](http://www.gsma.com).

- Associate, which is open to companies in the broader mobile ecosystem and organizations in various industry sectors (e.g., financial, healthcare, transportation)
- Rapporteur, for non-GSM licensed operators moving to LTE/HSPA<sup>969</sup> or those wishing to roam on GSM networks. Machine-to-machine (M2M) operators that are affiliates of full members may also attain rapporteur membership status

Full members pay fees on a tiered basis according to number of customers and wireless revenue. Associate and rapporteur members pay based on revenue alone.

Benefits vary by type of membership, with some resources offered to associate and rapporteur members at discounted costs. All members are afforded the following:

- InfoCentre<sup>2</sup>, a global community of 25,000+ industry experts
- Participation and networking in GSMA-facilitated programs, projects, groups, seminars, and training as well as global trade events
- Access to key tools, such as white papers, newsletters, and webinars
- Use of GSMA lounges
- Marketing opportunities

## Afghanistan and the GSMA

All five of Afghanistan's GSM mobile network operators – Afghan Telecom Corporation (operating its Salaam GSM brand), Afghan Wireless Communications Company, Etisalat, MTN, and Roshan – are full members of the GSMA. There are several reports, studies, and press releases regarding the Afghan ICT sector on the GSMA's website, a refreshing change from the typical dearth of information on Afghan ICT.

### *Afghan Minister Wins GSMA Government Leadership Award*

On February 15, 2011, the former Minister of Communications and Information Technology under President Karzai, Amirzai Sangin, was presented with the mobile industry's prestigious Government Leadership Award at the Government Mobile Forum, which is part of the Ministerial Program of the GSMA's Mobile World Congress. In presenting the award, Tom Phillips, Chief Regulatory Officer of the GSMA, said, "This award acknowledges the pioneering leadership of the government of Afghanistan and is a testament to the vision, courage, and integrity of its policy makers who are encouraging foreign investment in the country. By reducing the spectrum fees payable by mobile operators and creating a light-touch regulatory environment which does not impose onerous burdens on operators, the government of Afghanistan is building a new economic era and driving trade through the power of mobile communications." Minister Sangin graciously accepted the award on behalf of the Afghan government, thanking the GSMA "for recognizing the efforts of our government for creating policies and a regulatory environment that, together with the efforts of all stakeholders, have resulted, despite the challenges of the ongoing insurgency and war, in the tremendous success of telecommunications and ICT in

---

<sup>969</sup> Long-term evolution/high-speed packet access, two standards for wireless digital communications

Afghanistan.” He also stated his determination “to continue to develop the potential for telecommunications and ICT as an enabler for the socio-economic development of our country.”<sup>970</sup>

## The GSMA Foundation

The GSMA Mobile for Development Foundation, Inc., known simply as the GSMA Foundation, works among commercial mobile network operators, donors, and the international development community to create positive social change through, and demonstrate the impact of, mobile technology. The foundation works in healthcare, agriculture, and gender, among other areas. It is governed by an independent board of directors.

## *Armed Forces Communications and Electronics Association*



The [Armed Forces Communications and Electronics Association](http://www.afcea.org)<sup>971</sup> (AFCEA) is an international not-for-profit organization that provides a forum for military, government, industry, and academia to align technology and strategy to meet the needs of those who serve. Since 1946, AFCEA has offered members the key benefits of being able to engage, serve, associate, influence, transform, learn, collaborate, and save.

The extensive association has 149 chapters, over 32,000 individual members, and more than 1,600 corporate members.

## Afghanistan National Chapter

Seeking to identify, create, and use ICT sector associations to promote ICT professional and social networks in Afghanistan, beginning in 2005 the Senior Telecommunications Advisor (STA) of the Afghanistan Reconstruction Group (ARG) at the US Embassy Kabul and its ICT Implementation Team (I-Team) sought to establish an Afghanistan National Chapter of AFCEA. The original concept was for it to have US leadership, at least the first year, and for key Afghans to join as charter members. The idea was to create concentric rings of trust working their way out from a US/NATO core. The STA and the I-Team recruited ICT personnel across the MCIT, the Afghan security ministries, the presidential palace, and other organizations. They also worked with two US ICT companies, Femme Comp, Inc. (FCI) and Globecomm Systems Inc. (GSI), which sponsored charter memberships for several high-profile recruits. It was hoped the Afghans, perhaps some of the charter members, might eventually take the lead to run the chapter from year two forward.

The Afghan Chapter of AFCEA was established in late 2006 with its headquarters in Kabul. It achieved a minimal number of members and included honorary Afghan members. The chapter was formally activated in early 2007 at a meeting of the Northern Virginia Chapter of AFCEA at AFCEA headquarters. The chapter

---

<sup>970</sup> GSM Association (2011). “The Islamic Republic of Afghanistan Wins GSMA Government Leadership Award.” February 15. Accessed December 9, 2015. <http://www.gsma.com/newsroom/press-release/the-islamic-republic-of-afghanistan-wins-gsma-government-leadership-award/>.

<sup>971</sup> AFCEA information in this section is from various pages from its website. Accessed December 8-9, 2015. [www.afcea.org](http://www.afcea.org).

established bylaws, which articulated its mission “to be the premier information technology, communications, and electronics association for professionals in international government, industry and academia worldwide,” and its mission “to serve[] its members by providing a forum for the ethical exchange of information ... [and] increase[] knowledge through the exploration of issues relevant to its members in information technology, communications, and electronics for the defense, homeland security and intelligence communities, and other government entities with components supporting these missions.”<sup>972</sup>

Though it was initially off to a good start, the fledgling Afghan AFCEA Chapter did not really get off the ground, plagued by a lack of continuity of engagement and a failure to find Western officers to replace those who rotated out. Further, the ARG and I-Team, which were the driving force behind the Afghan AFCEA Chapter, ceased operation in the summer of 2008. The Afghan Chapter eventually became inactive. Efforts were made to reactivate the dormant Afghan Chapter when the office of the STA was reestablished under the US Department of Defense (DoD) at NATO's International Security Assistance Force (ISAF) in 2010, but no one stepped up to take the lead on this activity because the primary focus at that time was on the surge.<sup>973</sup>

In April 2012, a second effort was made to revive the chapter, led by Lieutenant Commander (LCDR, US Navy) Douglas B. Vanderlip, with the support of the TAT. Activities and accomplishments included translating the membership form into Dari and having AFCEA agree to fund individual memberships so joining would be at no cost to the Afghans. A relaunch dinner was planned, complete with a video teleconference back to an AFCEA chapter with a special guest speaker in the United States. However, LCDR Vanderlip redeployed early, after which the reactivation effort lost traction and eventually ceased. In late 2015, a third attempt was made to reactivate the Afghan Chapter of AFCEA, driven again by LCDR Vanderlip, who returned to Kabul for another tour of duty, this time as the Resolute Support (RS) Mission Lead for US Projects under the CJ6.<sup>974</sup> This attempt, too, was unsuccessful, at least by the time LCDR Vanderlip redeployed in March 2016. The Afghan Chapter of AFCEA is still listed on the AFCEA website.<sup>975</sup>

---

<sup>972</sup> Bylaws of the Afghan National Chapter, Armed Forces Communications and Electronics Association (AFCEA).

<sup>973</sup> On December 1, 2009, US President Barack Obama announced his plan to send 30,000 more troops to Afghanistan, which was accompanied by a wave of civilian experts. The former is known as the “military surge” or “troop surge,” and the latter as the “civilian surge.” Collectively, they are known as the “Afghan surge” or simply “the surge.”

<sup>974</sup> Combined Joint Communications

<sup>975</sup> AFCEA website. Accessed December 9, 2015. <http://www.afcea.org/membership/chapters/search.jsp>.

## Regional Organizations and Associations

### *Asia-Pacific Telecommunity*



The [Asia-Pacific Telecommunity](#)<sup>976</sup> (APT) began in Bangkok in 1979 and has evolved into an association of ICT service providers, equipment manufacturers, and research and development organizations. It was founded on the joint initiatives of the United Nations Economic and Social Commission for Asia and the Pacific (UNESCAP) and the ITU. It assists members in preparing for the ITU and other regional and global events.

The APT's goal is to support and facilitate its members in bringing about qualitative and sustainable growth of ICT in the Asia-Pacific region and promote regional harmonization of global ICT programs and activities throughout. The APT boasts a membership of 176, with 38 members, four associate members, and 134 affiliate members. Afghanistan has been a member of the APT since 1979, the year it was founded. Afghan Telecom Corporation and Etisalat, two of Afghanistan's ICT service providers, are affiliate members, having joined in January 2011 and 2012, respectively.

### Objectives and Activities

APT's overarching objective is to foster the development of ICT infrastructure and services in the Asia-Pacific region, with a particular focus on lesser-developed areas. To that end it may:

- promote the expansion of ICT infrastructure and services and maximize the benefits of technology for the welfare of the people in the region;
- develop regional cooperation in areas of common interest, including radio communications and standards development;
- undertake studies relating to developments in ICT technology, policy, and regulation in coordination with other international organizations;
- encourage technology transfer, human resource development, and the exchange of information for the balanced development of ICT infrastructure and services within the region; and
- facilitate coordination within the region with regard to major issues pertaining to ICT infrastructure and services with a view to strengthening the region's international position.

The APT's main areas of work are policy and regulation, radio communications, standardization, human resource development, and ICT development.

The APT is quite an active organization, with a full calendar of events spanning topics and geographic locations. Meetings and programs for 2015 included preparatory groups for World Radio Conference (WRC) and World Telecommunication Standardization Assembly (WTSA) events; workshops on policy and

---

<sup>976</sup> Asia-Pacific Telecommunity information in this section is from various pages of its website. Accessed December 7-8, 2015. [www.apr.int](http://www.apr.int).

disaster management; a conformance and interoperability event; management and council meetings; spectrum and wireless working groups; and cybersecurity and regulatory forums.

The APT has published a yearbook since 1994, which is a comprehensive source of ICT statistics and information for countries in its region. It also published a monthly electronic newsletter, which is available to the public on its website.

## Leadership and Governance

The General Assembly of the APT is its governing entity, and it is composed of all members and associate members. It meets in ordinary session every three years and in extraordinary session when circumstances require. It elects a president and two vice presidents, all of whom serve for three-year terms. The General Assembly also elects a secretary-general and deputy, who conduct the duties established by the General Assembly and the Management Committee.

The APT's Management Committee, also comprised of members and associate members, meets once a year. It pursues the policies and principles of the General Assembly and supervises the Secretariat function, among other responsibilities. The Management Committee elects a chair and two vice-chairs every two years.

The secretary-general and deputy secretary-general, assisted by the other officials of the Secretariat, carry out the duties established by the Management Committee and the General Assembly. The APT Secretariat is composed of the secretary-general, deputy secretary-general, and other officials as approved by the Management Committee.

## Membership

The APT offers full, associate, and affiliate memberships as follows:

- Membership is open to all states in the region that are members of the United Nations Economic and Social Commission for Asia and the Pacific (UNESCAP).
- Associate membership is open to any territory, part, or group of territories within the region that is an associate member of UNESCAP.
- Affiliate membership is open to any enterprise, agency, institute, organization, association or other undertaking, entity or participant, whether private or government-owned, commercial or not-for-profit, active in telecommunication services or information infrastructure with a substantial presence in, and commitment to, the region. Applicants for affiliate membership are nominated by a member or an associate member.

Membership fees are voluntary and discretionary, with members free to decide their contributions between 0.5 to 60 units, with 2015's unit value established at US\$10,280.



### *South Asian Telecommunication Regulators' Council*

The [South Asian Telecommunication Regulators' Council](#)<sup>977</sup> (SATRC) was formed in 1997 by a joint initiative between the APT and the ITU Regulatory Forum for South Asia. SATRC holds annual meetings to discuss issues of importance and address common concerns relating to ICT regulations in South Asia, such as radio frequency coordination, standards, trends and issues, strategy, and international affairs. It also identifies and promotes areas of potential cooperation and facilitates information exchange through seminars, training sessions, and workshops. The SATRC currently has nine member nations: Afghanistan, Bangladesh, Bhutan, India, Islamic Republic of Iran, Maldives, Nepal, Pakistan, and Sri Lanka, as well as affiliate members from those countries.

The SATRC operates according to published Terms of Reference. It develops, adopts, and implements two-year action plans aimed at “addressing the regulatory issues and challenges of common concern to its members that arise due to technological, market dynamic, and innovations and developments ... so as to harness their full potential in a harmonious manner for the benefit of all by utilizing the expertise and financial resources available from within its member countries.”

SATRC Action Plan Phase V for 2014-2016 calls for the establishment of working groups for policy, regulation, and services as well as for spectrum and the creation of a SATRC web portal to collect and share information among regulators.

### *Asia-Pacific Network Information Center*

The [Asia-Pacific Network Information Center](#)<sup>978</sup> (APNIC) is one of five Regional Internet Registries (RIRs) that are collectively responsible for the allocation and registration of Internet numbering resources, such as Internet Protocol (IP) addresses and autonomous system (AS) numbers, throughout the world. In a nutshell, the Internet Assigned Numbers Authority (IANA), which is at the top of the complex global Internet ecosystem, delegates Internet resources to the RIRs, which, in turn, allocate and manage them within their regions. RIRs also provide various other Internet-related services, such as maintaining the Internet routing registry and the “Whois” database<sup>979</sup> for their areas. RIRs sometimes operate through National Internet Registries (NIRs), but are free to work directly with any organization with a requirement for IP addresses.

APNIC is a not-for-profit community that also helps to develop policies for managing and distributing IP addresses and supports Internet-related capacity building and infrastructure projects. APNIC covers 56

---

<sup>977</sup> South Asian Telecommunication Regulators' Council information in this section is from various pages of its website. Accessed December 7-8, 2015. [www.apt.int/APTSATRC#8](http://www.apt.int/APTSATRC#8).

<sup>978</sup> APNIC information in this section is from various pages of its website. Accessed December 9, 2015. [www.apnic.net](http://www.apnic.net).

<sup>979</sup> WHOIS (pronounced “who is”) databases store information regarding the registrants of Internet domain names, Internet protocol (IP) addresses, and autonomous system numbers (ASN). Such information includes administrative and technical names, contact information, and registration and expiration dates. WHOIS is a protocol used to query databases that store registrant information.

economies throughout Asia and Oceania, divided into several regions, with Afghanistan assigned to the Southeast Region. APNIC has approximately 5,000 members and works with seven NIRs in its territory.

## Governance

APNIC is governed by an executive council comprised of elected members who serve two-year terms. Annual elections are held at the APNIC Member Meeting (with non-attending members able to vote online). Council members serve as individuals and not as representatives of their (or any) organizations. APNIC and its executive council operate according to published bylaws and hold regularly-scheduled group and leadership meetings.

## Membership

Membership in APNIC is open to everyone in the Asia-Pacific Internet community – organizations and individuals alike – with various tiers according to the number of IP address resources over which each member has rights. APNIC members include service providers, governments, universities, and other civil and commercial entities. Membership fees are paid annually and are based upon total IP resource holdings, along with an initial one-time setup fee. There are also non-member APNIC account holders, who need Internet resources but cannot or do not become APNIC members.

Benefits of APNIC membership include assistance with network management, Internet registry support, member rates for training (including two free training registrations upon joining), research, advocacy, invitations to technical conferences (with up to four free registrations upon joining), and access to APNIC's online portal.

## Afghanistan and APNIC

Afghanistan's Network Information Center (AfgNIC) is not listed as one of APNIC's National Internet Registries. However, the MCIT, at which AfgNIC is located, is a member of APNIC. There are 36 other Afghan entities listed as APNIC members, including all six voice and mobile service providers and many of Afghanistan's licensed Internet service providers (ISPs).

## *Regional Commonwealth in the field of Communications*



The [Regional Commonwealth in the field of Communications](http://www.en.rcc.org.ru)<sup>980</sup> (RCC<sup>981</sup>) is an assemblage of civil communications leaders, largely from countries in the Commonwealth of Independent States (CIS) and the former Soviet Union. It was established in Moscow in 1991 with the mission of ensuring cooperation among the new states regarding communications matters. Its principal tasks are:

---

<sup>980</sup> RCC information in this section is from various pages of its website. Accessed December 9, 2015.

[www.en.rcc.org.ru](http://www.en.rcc.org.ru).

<sup>981</sup> Although the abbreviation of the name is RCC, the logo depicts PCC.

- the extension of mutually beneficial relations among RCC communications administrations in the course of harmonization of development of communications networks and facilities;
- coordination in the field of scientific and technical policy, radio spectrum management, tariff policies for communication services and settlements, staff training; and
- interaction with the international organizations in the field of communications, informatization, and information interchange.

The RCC's activities are concentrated in telecommunications, radio communications, international cooperation, regulation and legislation, and human resources development, among other areas. Similar to the APT, the RCC holds various events on ICT topics, which are hosted among member countries, and prepares its membership for regional and international events.

The RCC is run by the Board of the Heads of the Communications Administrations, which carries out its responsibilities under the group's published regulations. There is also an executive committee in Moscow and various working groups and commissions. Also similar to the APT, the RCC publishes a statistic yearbook.

### Afghanistan and the RCC

At the Ninth Turkmenistan International Conference and Exhibition in September 2015, the Afghan Minister of Communications and Information Technology discussed the potential for Afghanistan to join the RCC, which initiated official correspondence between the MCIT and the RCC Committee. The Committee received Minister Vahidi in October, and by November 2015, Afghanistan was granted observer status. The MCIT's website claims Afghanistan was approved to join the RCC and Minister Vahidi to join its board in March 2016,<sup>982</sup> which may be the date formal acceptance and full membership is expected to be granted. In any event, observers may:

- participate in meetings of the RCC Board, except meetings related to the issues of implementation of intergovernmental agreements of the CIS countries;
- speak in debates at board meetings to make suggestions and comments on issues discussed and materials in question, present and request information on meeting agendas, and receive reports and decisions concerning them;
- participate in the work of the RCC commissions; and
- participate in joint research projects, seminars, and workshops conducted by the RCC.

According to the same MCIT article, gaining membership into the RCC and other regional and trans-regional organizations is one of the goals of the new leadership of the MCIT in order to improve ICT services in the country. The longer-term objective is to have Afghanistan become an optical fiber ICT transit corridor in Central and South Asia, thereby restoring its historical prominence along a new "Digital

---

<sup>982</sup> MCIT (2015). "Afghanistan obtained membership of the Regional Commonwealth in the Field of Communications (RCC)." November 18. Accessed December 8, 2015. <http://mcit.gov.af/en/news/afghanistan-obtained-membership-of-the-regional-commonwealth-in-the-field-of-communicationsrcc>.

Silk Road.” The concepts of Afghanistan as a Central Asian fiber transit hub and the Digital Silk Road were socialized with the Afghans by the US State Department and the Telecommunications Advisory Team (TAT) for many years.

## National Organizations and Associations

### *National Information and Communications Technology Alliance of Afghanistan*



The National Information and Communications Technology Alliance of Afghanistan<sup>983</sup> (NICTAA) is a consortium of ICT stakeholders throughout the country, and it is considered the umbrella ICT association of Afghanistan, though it was certainly not the first. Founded in 2007 by 11 organizations, known as the Founding Members of the Alliance (see text box), NICTAA is governed by a board of directors comprised of a president, first and second vice-presidents, a treasurer, and seven elected members.

While sometimes confused with the inter-ministerial body, the National ICT Council of Afghanistan (NICTCA), which is better known as simply the ICT Council and is described in [Chapter 4](#). NICTAA holds a permanent seat on NICTCA, representing the civil Afghan ICT sector. NICTAA brings the collective concerns and priorities of its members to the government to ensure they are active partners in the policymaking and legislative processes.

### Introducing a Master Organization

As with the idea of creating an Afghanistan chapter of AFCEA above, NICTAA was conceived by the STA and I-Team with the goal to create an ICT sector association at large, an overarching entity that provided added value to its members through diversity yet was united by overall objectives. The aim was for the commercial ICT sector to be able to speak with one voice in advocacy engagements with the Afghan government to

#### Founding Members of NICTAA

- Afghan Computer Science Association
- Afghan Media International
- South Asia Free Media Association Afghanistan
- National Internet Services Providers Association of Afghanistan
- Afghan Telecom Corporation
- Afghan Wireless Communications Company
- Alcatel-Lucent Afghanistan
- The American University of Afghanistan
- Kardan Higher Education Institute (now Kardan University)
- MTN Afghanistan
- Telecom Development Company of Afghanistan (TDCA)/Roshan

---

<sup>983</sup> Unreferenced information on NICTAA was previously retrieved by the author from its website, [www.nictaa.af](http://www.nictaa.af), which was “temporarily down” (according to former NICTAA President Omar Ansari) in November 2015 when the author attempted to access it, and from a presentation entitled “National ICT Alliance of Afghanistan” by Ehasan Mamundzai, member of NICTAA’s Board of Directors, provided to the author in March 2012 by Mr. Ansari. As of September 2016, NICTAA’s website appears to be defunct.

represent and protect its interests. The STA and I-Team worked with Afghans in 2005 and 2006 to establish NICTAA and was introduced to the man who became its first president by a mutual Afghan ICT colleague. The STA and I-Team also helped to draft NICTAA's charter and approach other ICT associations for potential membership.

## Strategy and Objectives

NICTAA's five strategic themes and related pursuits are:

1. Leadership – Enabling Afghan ICT firms to play a leading role in the sector and the country
2. Education – Promoting ICT education for Afghans and the use of ICT to improve education
3. Policy – Representing and involving Afghan ICT stakeholders in policy and decision-making processes
4. Advocacy – Campaigning for an improved regulatory environment, including self-regulation, policy reform, setting industry standards, and establishing member rights
5. Industries – Developing new ICT-related industries and creating an enabling environment for them

Its objectives are to:

- exchange ideas, views and experiences among members on the development and application of ICT;
- educate the public on ICT issues and capabilities;
- advise on current and progressive curriculum development;
- bridge the digital divide;
- inspire Afghan youth to taking productive and creative approaches to contribute to the redevelopment of Afghanistan;
- support and guide young entrepreneurs to guarantee a sustainable future both them and their country;
- promote gender balance in ICT;
- promote ICT as an enabler in every walk of life;
- promote software development and localization;
- advocate and promote intellectual and copyright laws;
- promote sustainable development and application of efficient, adequate, and cost-effective ICT networks and services throughout Afghanistan;
- ensure that ICT and the ICT sector are given key consideration in national strategic and economic documents;
- coordinate and create, if necessary, strategies in and for the ICT sector;
- coordinate gradual and effective implementation of national strategies in the ICT sector;
- encourage research, innovation, and creativity contributing to local and worldwide ICT development;
- coordinate national and international developmental issues;
- ensure coordination among ICT players, producers, and consumers in Afghanistan;

- promote more direct investment in the ICT sector; and
- prepare and disseminate research on ICT issues for the public, government, or internal (member) use.



*Author's Note: The photograph was taken at a ceremony to sign a memorandum of understanding for the formation of NICTAA and provided to the author by former NICTAA President Omar Ansari, as was the text following. Representing the various "pillars" from left to right are: Nizar Zakka of the World IT and Services Alliance as an observer; Jim Baker of the Afghanistan Reconstruction Group as an observer; Naser Rahimy representing the National ISP Association of Afghanistan; Hadia Ahmadzai of Kardan University, representing academia; Hayat Wahdat of Alcatel-Lucent, representing the private sector; and Aimal Marjan of the Afghan Computer Science Association, representing civil society.*

*Picture 18: Ceremony for the creation of NICTAA*

## Membership

NICTAA's membership includes representatives from three "pillars:" private companies, civil society (experts, individuals, and organizations), and academia. Members include, but are not limited to, private telecommunications companies; Internet service providers (ISPs); ICT solution providers; software development companies; hardware manufacturers and dealers; electronic media and entertainment production companies; associations of professionals; educational institutions and universities; research and development centers; associations of ICT consumers, and non-governmental organizations (NGOs). Members must apply and must:

- be registered with the Afghan government;
- operate in Afghanistan;
- have a vision, mission, objectives, and bylaws that address the needs of the ICT sector;
- be directly involved in developing or utilizing ICT;
- have a minimum of five employees (companies only); and
- have a physical office or address in Afghanistan.

Benefits to members include networking; marketing and promotion; coordination and information sharing with other members and between NICTAA and external entities; policy programs and policy advice; representation to and lobbying of government, regional, and international entities; and business strategy, planning, and development.

## Activities and Engagement

NICTAA holds a Biannual National Congress on ICT and an Annual Public Policy Meeting, plus it hosts various timely subject-specific industry events. NICTAA represents Afghanistan at the regional and international levels and engages in global policy development issues through such entities as the World Information Technology and Services Alliance (WITSA), the World Congress on IT, the Internet Cooperation for Assigned Names and Number (ICANN), the International Telecommunication Union (ITU), the United Nations (UN), the Internet Society (ISOC), the Internet Governance Forum (IGF), and the Tech Forum Central Asia.

Among other endeavors, NICTAA worked to revive the Afghanistan Localization Project, a program active between 2004 and 2008 to translate off-the-shelf software and applications, such as the Microsoft suite of products, to Dari and Pashto, and was an active proponent of the need to develop local Internet content in local languages. NICTAA, along with

Open Source Afghanistan (OSA, a member organization; see below) initiated and hosted the inaugural Regional Open Source Conference – Central Asia (ROSCCA) in October 2011 in Kabul. In March 2012, NICTAA hosted a cybersecurity roundtable to inform a study conducted by the Telecommunications Advisory Team (TAT) as requested by the Minister of Communications. NICTAA was approached by the MCIT in June 2012 about combining forces to pursue cybersecurity and IPv6<sup>984</sup> deployment efforts.



*Picture 19: ICT Policy consultative session organized by NICTAA, January 2013*

*(Photo courtesy of Omar Ansari)*

NICTAA participated in the Afghanistan Country Workshop at the United Nations-sponsored World Summit on the Information Society (WSIS) in 2012 and 2013.

In January 2013, NICTAA hosted a consultation on the Afghan ICT Policy, which the World Bank undertook to update as part of its US\$50 million Afghanistan ICT Sector Development Project. It also helped to promote Safer Internet Day within Afghanistan on February 11, 2014.

## Present Day

For many years, NICTAA seemed to have its finger on the pulse of the Afghan ICT sector, as well as on regional and international ICT trends, initiatives, events, and opportunities. It was very involved in public

---

<sup>984</sup> Internet Protocol version 6, a communications convention that identifies and locates computers on networks using 128-bit addresses, developed by the Internet Engineering Task Force (IETF) to replace IPv4, which uses 32-bit addresses, upon the depletion (assignment) of all IPv4 addresses.

policy as the modern Afghan ICT sector began to take shape. However, NICTAA's activities have subsided somewhat in recent years. Its website was "temporarily down due to issues and for a redesign" in November 2015, according to a NICTAA official, and its Facebook page has not been updated since February 2014.<sup>985</sup>

### *Afghan Computer Science Association*



One of the first ICT-related groups to be established in Afghanistan was the Afghan Computer Science Association (ACSA). ACSA began in 1999 as a national non-profit organization of information technology (IT) professionals who came together to promote the use of computers, increase general awareness of computers and computer science among the public, and to look after the professional interests of IT personnel in the country.

In its early days, ACSA developed software for government entities, businesses, and entertainment. It also worked to create a computer curriculum for high schools and published a bimonthly magazine *The Computer Science*, the first computer magazine published in Dari and Pashto.<sup>986</sup> ACSA was a founding member of NICTAA.

ACSA's original aims and objectives<sup>987</sup> were:

- to facilitate the professional advancement of personnel engaged in Information Technology (IT) and related occupations;
- to promote knowledge of the development and use of IT equipment and related techniques;
- to provide facilities for exchange of information and views of IT equipment and related techniques;
- to foster and encourage high standards of professional ethics and conduct among its members;
- to prescribe professional qualifications and to conduct examinations for members and others in the field of Information Technology;
- to establish the first IT research center in the country;
- to promote Internet and intranet literacy in Afghanistan through countrywide computer education and training programs;
- to promote constructive, healthy, and positive uses of Internet technology amongst the young generation;
- to keep the members posted about the latest revolutions and upcoming permutations of computer technology;

---

<sup>985</sup> NICTAA website, [www.nictaa.af](http://www.nictaa.af) and NICTAA Facebook page, <https://www.facebook.com/nictaa.af/>, both accessed November 2, 2015. As of September 2016, it appears NICTAA's website is defunct.

<sup>986</sup> Uldal, Siri Birgitte and Muhammad Aimal Marjan (2004). *Information and Communication Technology in Afghanistan*. Norwegian Center for Telemedicine Report #05-2004, February 4, 2004, 39.

<sup>987</sup> Unreferenced information on ACSA was previously retrieved by the author from its now-defunct website for use in other projects and documents.



- to issue a bi-monthly magazine, *The Computer Science*, and newsletters to keep the members informed and aware of modern innovations and developments;
- to encourage the trend of software development;
- to illuminate Afghanistan on the Internet; and
- to provide computer/Internet education to children.

ACSA has evolved to be an association of ICT – rather than just IT – professionals with over 2,000 members. Its Facebook page remains active and “discusses the most recent technology advancements, issues and how technologies touch lives.”<sup>988</sup>

### *National ISP Association of Afghanistan*



The National ISP [Internet Service Providers] Association of Afghanistan (NISPAA) was originally founded in March 2006 through a series of meetings and negotiations coordinated by the Global Internet Policy Initiative (GIPI)-Afghanistan. It was registered as a legal entity (social association) in 2010. NISPAA is a non-profit consortium of Internet service providers in Afghanistan, which aims to coordinate and protect the rights of the ISPs, as well as act as a mediating body for resolving disputes among the ISPs. Its founding members included New Dunia Telecom, Afghan Cyber, RANA Technologies, NEDA Telecommunications, NetZone, Afghan Telecom Corporation, AFSAT, PACTEC, IO Global, and MultiNet. The Telecom Advisory Team (TAT) was instrumental in reviving NISPAA in 2010.

### Organizational Structure and Objectives

NISPAA’s organizational structure consists of an elected chairman, a semi-annually elected vice-chairman, and a rotating executive committee of six members. The association holds bi-monthly meetings and is governed by a comprehensive set of bylaws. As of 2012, NISPAA has a membership of 21 major ISPs, each of which pays a mandatory US\$200 monthly membership fee.

NISPAA’s objectives<sup>989</sup> are:

- to deliver the most cost effective and best quality of data services to end users;
- to work with the Ministry of Communications and Information Technology (MCIT), the Afghanistan Telecom Regulatory Authority (ATRA), the Ministry of Finance (MoF), and other public policy makers to create the best environment for growth for the industry;
- to create awareness within our community in order to bring more efficiencies in working environments, the public sector, the educational arena, and medical and research institutions in order to create better accountability and manageable growth; and

---

<sup>988</sup> ASCA Facebook page. Accessed November 2, 2015. <https://www.facebook.com/groups/acsa.af/>.

<sup>989</sup> NISPAA website. Accessed November 2, 2015. <http://www.nispaa.org.af/about-us.html>.

- to unify the above ideas in order to find a solution that will be acceptable to the government, the public, and the private sector and that will result in the healthy growth of the Internet industry in Afghanistan.

## Accomplishments

The TAT facilitated and attended the first-ever meeting between NISPAA and ATRA on November 12, 2011, which allowed the two entities to begin a constructive dialog on several regulatory challenges facing ISPs. Among NISPAA’s objections were: illegal ISPs operating within the country and being contracted by ISAF and Coalition forces, high taxation on ISPs (reportedly approximately 47 percent in total), the lack of wholesale fiber broadband prices for ISPs (and other service providers), and the illegality of Voice over Internet Protocol (VoIP) services.



*Picture 20: Inaugural meeting between NISPAA and ATRA*

*(Photo courtesy of Karen Black)*

Beginning with that first meeting, which was followed by several others with ATRA and even the Minister of Communications, NISPAA leadership successfully lobbied ATRA to crack down on illegal ISPs. ATRA agreed to issue warnings to, impose fines upon, and to blacklist illegal operators, beginning with companies on a list provided by NISPAA. At one time, ATRA even maintained and published a list of illegal ISPs on its website, but no longer does.<sup>990</sup> ATRA sent letters to Afghan ministries and the International Community asking them not to do business with illegal operators. ATRA also sent a letter<sup>991</sup> to NATO's International Security Assistance Force (ISAF) in December 2011, listing the troubles illicit Internet operators were causing Afghanistan, such as the financial loss from uncollected taxes and frequency interferences issues, and asking it to avoid signing contracts with such companies. A list of licensed ISPs accompanied the letter. As a result, ISAF issued a fragmentary order (FRAGO) requiring companies from which it procured Internet services to have valid ISP licenses from ATRA and valid business licenses from the Afghanistan Investment Support Agency (AISA) as part of its contracting process.

To address NISPAA's concerns regarding taxation, ATRA agreed in late November 2011 to meet with the Ministry of Finance (MoF) to discuss decreasing the Business Receipts Tax (BRT) on ISPs from 10 percent to 2 percent – which is in line with what the mobile network operators (MNOs) pay – to stimulate growth of the sector. ATRA, however, gained little traction, so NISPPA began lobbying the MoF directly in January

---

<sup>990</sup> ATRA. Accessed November 2, 2015. <http://www.atra.gov.af>. The author previously saw a list of illegal ISPs on ATRA’s website in 2012.

<sup>991</sup> MCIT, Afghanistan Telecom Regulatory Authority, Legal and Licensing Affairs Department Letter No. 10254 dated SY16/9/90, signed by Engineer Khair Mohammad Faizi, Vice Chairman of the ATRA Board of Directors.

2013, along with AISA. The taxation issue was ultimately shelved when the MoF began investigating the feasibility of replacing the BRT with a value-added tax (VAT) or similar mechanism.

On a positive note, NISPAA and the TAT (via its advisory work with the MCIT and Afghan Telecom) played at least some part in the announcement by MCIT and Afghan Telecom of a two-tiered pricing structure effective May 1, 2012, which afforded ISPs (and MNOs) wholesale fiber broadband prices that were lower than the established retail tariffs, allowing the service providers to profit from the difference. NISPAA also agreed in April 2013 to cooperate with ATRA to better collect, manage, and report statistics on Internet users and Internet usage, estimates for which have varied widely and were notoriously unreliable since the advent of commercial Internet services in the country.

NISPAA's requests to legalize Internet-based voice services, particularly since the MNOs can provide data and Internet services via 3G<sup>992</sup> mobile broadband licenses, fell on deaf ears. VoIP remains illegal for ISPs with licenses (but is allowed in a closed user group (CUG) environment, like between ministerial headquarters and provincial directorates or between public universities).

NISPAA lost steam with the advent of 3G mobile broadband services in 2012, which put several ISPs out of business. NISPAA has not updated its website in some time, and its former Facebook page, established in 2013, appears to be defunct.

### *Afghanistan Telecom Operators' Social Association*



Established in April 2010 by Afghan Telecom Corporation, Afghan Wireless Communications Company, Etisalat, MTN, and Roshan, the Afghanistan Telecom Operators' Social Association (ATOSA) is an informal trade association representing telecommunications operators. ATOSA is registered with the MoJ as a legal entity, and represents the collective interests of telecom operators with the Afghan government, consumers, and other relevant entities. It also resolves inter-operator disagreements and disputes when necessary. The aim of forming ATOSA was to "provide a forum through which operators can constructively raise and address issues of common concern, including security and predictability in the policy environment. In addition, the Association will work to improve relations with other industries and sectors in Afghanistan to encourage a cooperative reconstruction effort."<sup>993</sup> With no official organizational structure or permanent office, ATOSA's monthly meetings are chaired and hosted on a rotational basis by member companies, often in Dubai. Prior to ATOSA becoming an official social association, Afghanistan's four

---

<sup>992</sup> Third-generation wireless digital technology based on International Telecommunication Union (ITU) International Mobile Telecommunications (IMT)-2000 specifications.

<sup>993</sup> *PRNewsire* (2010). "Telecommunication Operators Launch Afghanistan Telecommunication Operators' Association," April 13. Accessed November 2, 2015. <http://www.prnewswire.com/news-releases/telecommunication-operators-launch-afghanistan-telecommunication-operators-association-90766824.html>.

major commercial mobile network operators (MNOs) (all above except Afghan Telecom) met regularly as a loose “GSM group” for years.

### *Association of Mobile Money Operators in Afghanistan*



The Association of Mobile Money Operators in Afghanistan (AMMOA) was established in May 2011, with the assistance of USAID, to help build a mobile money ecosystem in Afghanistan. (Humorously, the group was initially named the Association of Mobile Money Operators but they realized the acronym for such was “AMMO” so they added the “in Afghanistan.”) Mobile money enables Afghans to use their mobile phones to receive, store, and transfer funds, make payments and purchases, send remittances, and receive cash disbursements. AMMOA was reportedly among the first such national groups in the world.

Afghanistan’s four major mobile network operators, Afghan Wireless Communications Company, Etisalat, MTN, and Roshan, were all founding members. The association’s first president, Roshan M-Paisa President Zahir Khoja, said, “Being organized makes it easier for us to come together on regulatory issues and other issues of common concern,”<sup>994</sup> such as platform interoperability and consumer protections.



*In the photo to the left, Deputy USAID Mission Director Brooke Isham (right) presents Kabul University student Hakima (flanked by her parents) with a 250,000 Afs (US\$5,000) award and a plaque for a winning idea to use mobile money in the “Gender” category.*

*Picture 21: Mobile Money University Contest award ceremony*

*(Photo by Frank Petrella, USAID)*

AMMOA and USAID co-sponsored a Mobile Money University Contest, which ran from April 18 through June 17, 2012 and included 33 public and private universities in 18 provinces. The goal of the contest was for students to come up with innovative ideas for how to use mobile money in areas such as agriculture, education, women’s empowerment, government service, and small business

development. The contest culminated in awards to eight Afghan university students of 250,000 Afghani (Afs) each.

AMMOA and USAID also co-sponsored a Mobile Money Fair in July 2013, which was attended by over 300 people representing Afghanistan and the International Community. The three-hour event included mobile money enrollment and training programs and demonstrations of various mobile money transactions.

---

<sup>994</sup> USAID (2011). “Mobile Money Operators Organize.” USAID website, November 4. Accessed November 3, 2015. <https://www.usaid.gov/results-data/success-stories/mobile-money-operators-organize>.

AMMOA also initiated a survey in mid-2013 to gauge Afghans knowledge of, interest in, and any aversions to mobile money, the results of which were to shape a marketing campaign designed to increase the adoption and use of mobile money in Afghanistan.

It is unclear to the author as of this writing if AMMOA is still operating. Its website no longer exists, and Internet searches return no information. It worked in close conjunction with USAID's Financial Access for Investing in the Development of Afghanistan (FAIDA) project, which began in February 2011 and was originally scheduled to end in February 2016.<sup>995</sup> However, a USAID press release<sup>996</sup> from February 22, 2016, reports FAIDA has “teamed up with the Afghan government, mobile network operators, financial institutions, and mobile money service providers to raise awareness” of mobile money and branchless banking.

### *Better Than Cash Alliance*



ALLIANCE | Improving Lives Through Digital Payments

In January 2013, Afghanistan became the fifth member nation – and one of the founders – of the “[Better Than Cash Alliance](#),” which is based at the United Nations, joining the “partnership of governments, companies, and international organizations that accelerates the transition from cash to digital payments in order to reduce poverty and drive inclusive growth.”<sup>997</sup> To join the Better Than Cash Alliance, prospective members must make a commitment to digitize cash payments; agree to the Alliance’s guiding principles; designate a point person to engage with the Alliance; and agree to share lessons learned with other members.

USAID was actively involved in Afghanistan’s bid to join the Better Than Cash Alliance and intended to “promote an industry-led approach to building up the electronic payment ecosystem ... and support close collaboration with the Afghan Government to bring greater transparency and efficiency to the financial system.”<sup>998</sup>

It is possible the Better Than Cash Alliance has supplanted AMMOA as the guiding organization for mobile money and digital financial services in Afghanistan. Several of the activities and accomplishments listed on USAID’s Better Than Cash Fact Sheet,<sup>999</sup> had previously been undertaken or were accomplished by AMMOA.

---

<sup>995</sup> USAID (2015). Fact Sheet: “Financial Access for Investing in the Development of Afghanistan.” Accessed November 3, 2015 and March 8, 2016. <https://www.usaid.gov/news-information/fact-sheets/financial-access-investing-development-afghanistan-faida>.

<sup>996</sup> USAID (2016). “Afghanistan Mobile Money Public Awareness Campaign.” USAID website, February 22. Accessed March 8, 2016. <https://www.usaid.gov/afghanistan/news-information/press-releases/afghanistan-mobile-money-public-awareness-campaign>.

<sup>997</sup> Better Than Cash Alliance. Accessed November 3, 2015. <https://www.betterthancash.org/about>.

<sup>998</sup> USAID (2013). Fact Sheet: “Better Than Cash.” Accessed November 3, 2015. <https://www.usaid.gov/news-information/fact-sheets/better-cash>.

<sup>999</sup> Ibid.

In any event, President Ghani’s government fully supports the implementation of mobile money. He directed representatives from various Afghan ministries to attend an Electronic Money Summit in Kabul, co-sponsored by USAID, at the end of October 2015. President Ghani said “a cash-only system is risky, inefficient, and vulnerable to corruption ... [and has ordered government agencies to use non-cash payments ... whenever practical.”<sup>1000</sup>

### *Innovation Hub (iHub) Afghanistan*



Innovation Hub Afghanistan – or [iHub](#) – is a volunteer, non-profit, non-government open forum that aims to bring together ICT professionals, experts, and students from across Afghanistan to learn, share, innovate, network, and socialize with each other. The goal is for Afghan ICT professionals to be able to contribute to the growth and development of the ICT sector through collaborative facilitation and the development of more relevant and localized ICT solutions and services.<sup>1001</sup> The group's ultimate objective is to foster the wider use of ICT for socio-economic development. Co-founded by a group of Afghan ICT professionals in March 2012, iHub Afghanistan held regular monthly meetings on various topics in Kabul, at least through January 2015. The topics of that meeting were recent cybersecurity incidents in the country, the Internet of Things, and a panel on bridging the gap between university graduates' educations and ICT sector demand. Past topics have included web application development, open source advantages, cybersecurity, responsive web design, and empowering women through ICT. Additionally, there are (or were) iHub groups in Herat, Jalalabad, Kandahar and Mazar-e-Sharif, which meet (or at least met) periodically.

While iHub’s website has not been updated recently, iHub has two Facebook pages,<sup>1002</sup> one centered around the association and the other as an open platform community page for all things ICT-related.

### *TechWomen Afghanistan*



TechWomen Afghanistan officially began May 17, 2012, on the International Telecommunication Union’s World Telecommunications and Information Society Day (WTISD 2012), the theme of which that year was “women and girls in ICT.” It was originally touted as a multi-stakeholder platform by and for women aimed at increasing women's participation in technology, governance, civil society, and business through the use of various ICT disciplines. The goal of

---

<sup>1000</sup> USAID (2015). “Afghan government will strengthen electronic payment system.” USAID website, October 30. Accessed November 3, 2015. <https://www.usaid.gov/afghanistan/news-information/press-releases/afghanistan%E2%80%99s-government-will-strengthen-electronic>.

<sup>1001</sup> Paraphrased from the iHub website. Accessed November 3, 2015. <http://www.ihub.af/>.

<sup>1002</sup> iHub Afghanistan Facebook pages. Accessed November 3, 2015. <https://www.facebook.com/groups/innovation.hub/> and <https://www.facebook.com/IHubAfghanistan/timeline>.

TechWomen has two facets: the first is increasing women's involvement in technology and the second is decreasing the digital divide of a diverse population of stakeholders.

The mission of TechWomen is to empower Afghan women to become global leaders and technology experts in the field of ICT. Through affirming, supporting, and guiding them in all facets of their professional and personal development. TechWomen and its partners are striving to bring together pragmatic and committed women, projects, and organizations to learn and share knowledge. TechWomen is led by women and is comprised of leading female executives, business owners, researchers, academics, software engineers, programmers, administrators, and students in the field of ICT in Afghanistan and throughout the world. TechWomen Afghanistan is part of TechWomen Central Asia.

TechWomen Afghanistan strives to accomplish its mission by:

- increasing the number of women and girls studying ICT by creating massive awareness and engaging women in technology disciplines;
- building long-term and solid livelihoods through entrepreneurship and continued professional development of women;
- developing plans and programs on to address the status of women in the field of ICT; and
- supporting institutions in addressing the unique needs of women.

TechWomen was launched primarily by TechNation, an IT firm aiming to develop Afghanistan as a technology enabled nation, NawPal Communication, a communications and public relations firm, NICTAA, and Open Source Afghanistan. Additional support and expertise were provided by the Ministries of Communication (MCIT), Education (MoE), and Higher Education (MoHE), as well as ATRA and Girl Geek Dinners International.

TechWomen and TechNation organized the TechWomen Summit, which was held in Kabul in early December 2015, with the British Embassy in Kabul as the primary sponsor of the event. “The Summit focuse[d] on ways technology can help Afghan women improve their lives. Leaders and key actors from the technology sector, civil society, industry, and government converge[d] ... to address women's leadership and participation in technology, share latest technology developments, and promote digital literacy among women.”<sup>1003</sup> TechWomen Afghanistan is based at TechDera (see below).



### *Open Source Afghanistan*



Open Source Afghanistan (OSA)<sup>1004</sup> was founded in 2009 and is an association of people, companies, (NGOs, schools, and universities that are united by their interest in Linux and Free and Open Source

<sup>1003</sup> Techwomen Afghanistan. Accessed November 3, 2015. <http://www.summit.techwomen.af/>.

<sup>1004</sup> Description and objectives were paraphrased from Open Source Afghanistan's Facebook page. Accessed November 4, 2015. [https://www.facebook.com/OpenSourceAfghanistan/info/?tab=page\\_info](https://www.facebook.com/OpenSourceAfghanistan/info/?tab=page_info).

Software (FOSS). OSA serves as the country's FOSS user group, bringing together open source users and developers to share knowledge and experience, create awareness, train, advocate, and provide expert advice and technical assistance to various public and private institutions on FOSS.

The objectives of Open Source Afghanistan are to:

1. create awareness of FOSS in Afghanistan;
2. build local knowledge and know-how regarding FOSS;
3. provide technical and advisory assistance to individuals and organizations;
4. facilitate and support research and assessments in the area;
5. assist in developing localized content, tools and applications;
6. advocate for policy reforms; and
7. work with the international organizations and the FOSS community to foster technology transfer that supports the wide use of FOSS in Afghanistan.

Open Source Afghanistan is creating nationwide awareness of the advantages and benefits of open source alternatives to traditional fee-based licensed software, as well as sharing information on such through electronic and print publications, holding meetings and events, hosting online forums, and participating in regional FOSS conferences and events.



*Picture 22: Regional Open Source Conference - Central Asia, March 2013*

*(Photo courtesy of Omar Ansari)*

As mentioned above, OSA, together with NICTAA, of which it is a member, initiated and hosted the first Regional Open Source Conference-Central Asia (ROSCCA) in October 2011 at the Information and Communication Technology Institute (ICTI) in Kabul. Future Afghan president Dr. Ashraf Ghani gave the opening address and was very supportive of the ICT sector, remarking that ICT can be a technical solution to a political problem. ROSCCA 2011 included participation from Nepal, Iran, India, Pakistan, Tajikistan, Kyrgyzstan, Italy, and the United States and aimed to develop a shared understanding of free and open source (FOSS) technologies and their use.<sup>1005</sup>

---

<sup>1005</sup> United Nations Educational, Scientific and Cultural Organization (UNESCO) Office in Kabul (2011). "Afghanistan initiates the first Regional Open Source Software Conference in Kabul," October 23. Accessed November 2, 2015.



The second Regional Open Source Conference – Central Asia (ROSCCA 2013) took place March 25-29, 2013, in Dushanbe, Tajikistan. Mr. Omar Ansari, President of NICTAA (third from left in Picture 22), read the conference declaration and later presented a paper entitled "Policy Recommendations to Member Countries." Approximately 200 people from several different countries attended the conference. ROSCCA went on to host further annual meetings, at least through 2014.<sup>1006</sup>



Picture 23: National Open Source Conference of Afghanistan, February 2013

(Photo courtesy of Omar Ansari)

OSA also originated and hosted Afghanistan's first national gathering on FOSS, the National Open Source Conference of Afghanistan (NOSCA), in February 2013 in Jalalabad. The event, which was attended by over 200 people, included lectures, hands-on training sessions, and thematic breakout sessions.

There is also Open Source Nangarhar, a user group nearly 350 members strong, that promotes FOSS in eastern Afghanistan.<sup>1007</sup>

### TechDera



*Dera* means "gathering place" in Dari, and [TechDera](#) is a multi-purpose community technology center in Kabul that offers ICT training and education, mentoring and counseling, job preparation and internships, access and connectivity, industry networking, gaming, and micro groups centered on technology topics. TechDera's mission is to use ICT "to create[] a new generation of community leaders ... and develop[] technology and management skills of its members and clients" and "allow[] both Afghan men

---

[http://www.unesco.org/new/en/kabul/about-this-office/single-view/news/afghanistan\\_initiates\\_the\\_first\\_regional\\_open\\_source\\_software\\_conference\\_in\\_kabul/#.VjfTvLBRGUk](http://www.unesco.org/new/en/kabul/about-this-office/single-view/news/afghanistan_initiates_the_first_regional_open_source_software_conference_in_kabul/#.VjfTvLBRGUk).

<sup>1006</sup> ROSCCA Facebook page. Accessed November 2, 2015. <https://www.facebook.com/ROSCCA>. ROSCCA's published website appears to be defunct. Accessed November 2, 2015. [www.roscca.org](http://www.roscca.org).

<sup>1007</sup> Open Source Nangarhar Facebook page. Accessed November 4, 2015. <https://www.facebook.com/groups/osn.af/>.

and women access to diverse programs and services that can provide technology support and social and economic benefits.”<sup>1008</sup>

TechDera is also a membership-based club for ICT users, developers, and administrators. Member services and benefits include:<sup>1009</sup>

- access to the facility with 24x7 Wi-Fi<sup>1010</sup> Internet connectivity and open computer lab time;
- monthly member meetings and newsletters keeping members current on technology evolution and event alerts;
- learning and sharing experiences through various TechDera programs such as freelance technology business, authoring books, and launching publications by members;
- help in setting career goals, participating in internship and job training programs, and enrolling in lectures and training courses to enhance technical and professional capacity;
- a professional network of tech users and developers and participation in local, national, regional, and international conferences, awards, and events;
- the ability to host events at TechDera and assistance in acquiring sponsorships;
- the opportunity to create an income stream by developing apps and content and getting products promoted;
- receiving technical support for troubleshooting hardware and software tools and devices;
- the ability to print, scan, photocopy, and record important documents;
- discounts and special offers on products and services; and
- the opportunity to join TechDera Communities.

In addition to basic computer training, TechDera has taught courses in website design, including one class just for Afghan women in 2015, and mobile applications development.

TechDera was founded in 2011, finally coming to fruition after several years of planning. It is affiliated with TechNation, a for-profit Afghan technology firm that “helps develop Afghanistan as a technology enabled nation by promoting ICT as a tool for development ... by skilling up young professionals, building infrastructure, and establishing and supporting community technology centers and call centers to make it possible for Afghans to take advantage of new and hidden opportunities.” TechDera has emerged as a preeminent technology resource and training center, a physical and virtual ICT hub in Kabul.

### *Other Organizations and Associations*

In addition to those described above, various other ICT associations, both formal and informal, have emerged throughout the country. Two examples are Afghan Computer Programmers (ACP), founded in

---

<sup>1008</sup> TechDera. Accessed November 4, 2015. <http://dera.technation.af/>.

<sup>1009</sup> Paraphrased from TechDera.

<sup>1010</sup> Wi-Fi is a local area wireless computer networking technology that employs radio waves to allow computers, mobile phones, and other devices to connect to the Internet and communicate with one another within a particular area without being physically connected.

2011 as a community of coders, and the Afghan Computer Science Society (ACSS), which was begun by a group of computer science and software engineering students in 2012. There are also numerous local and regional ICT-related groups throughout the country.

## Attempted Organizations and Associations

### Internet Society

For several years, various attempts were made to have Afghanistan join the [Internet Society](#) (ISOC). Benefits of membership are:



- **Awareness:** Be informed on Internet policy, and technical and development issues that impact your business and the market at large.
- **Engagement:** Collaborate with key stakeholders to address the critical issues impacting the general welfare and effectiveness of the global Internet.
- **Advantage:** Stay ahead of the new technology trends, and leverage that knowledge to grow your business and your partnership opportunities.
- **Opportunity:** Align yourself with key players in the industry who have committed to expanding the global Internet community.
- **Partnership:** Expand your global network of contacts with respected industry leaders, top-level policy makers, scientists, and engineers, and establish new partnerships and opportunities.<sup>1011</sup>

At different times, the effort was led by the MCIT, NICTAA, and NISPAA, and there was even discussion about the three organizations combining forces in 2012 to pursue ISOC membership. However, to date, Afghanistan has no direct representation within ISOC, which is unfortunate, because ISOC has a wealth of resources and information, not to mention community grants and other opportunities open only to members.

### SAMENA Telecommunications Council

Like the Asia-Pacific Telecommunity (APT) and Regional Commonwealth in the field of Communications (RCC) above, the [SAMENA Telecommunications Council](#)<sup>1012</sup> is a platform for operators,



regulators, and service providers in South Asia, the Middle East, and North Africa regions. SAMENA's vision and mission are to provide a unified voice and a consensus-building platform to enable, shape, and effect changes in policies and regulations and build cooperation among national administrations with regards to ICT.

---

<sup>1011</sup> Internet Society. Accessed November 4, 2015. <http://www.internetsociety.org/get-involved/join-community/organisations-and-corporations>.

<sup>1012</sup> Information in this section is from various pages of the SAMENA Telecommunications Council website. Accessed December 9, 2015. [www.samenacouncil.org](http://www.samenacouncil.org).

Driven by specific needs for mentorship, tutelage, and best practices on a variety of subjects within the MCIT, ATRA, and, in particular, Afghan Telecom Corporation, the TAT suggested pursuing membership in SAMENA several times. The TAT was able to secure a preferential rate from SAMENA leadership, but none of the Afghan entities were willing or able to commit to joining.

With the new MCIT Minister's goal of pursuing regional partnerships, membership in SAMENA may be something Afghanistan considers pursuing in the future.

## Observations, Lessons, Conclusions, and Recommendations

The number and breadth of Afghan ICT associations covered in this chapter are a testament to their importance to the sector at large. Kudos are due to the Afghans for recognizing as far back as 1999, when the Afghan Computer Science Association began, the value in establishing ICT associations, particularly since allegiances to tribes and ethnicities can pose obstacles to forming and joining outside groups, as mentioned above. In Afghanistan, both pre- and post-invasion, the community of people with any ICT knowledge was fairly small. Those working in the sector – generally within the government, the only real users of ICT at the time – were often educated in the same places, such as the Telecommunications Training Center (TTC) in Kabul (now the Information and Communication Technology Institute) or at schools in Pakistan and Iran in areas with large populations of Afghan refugees. Perhaps born of this familiarity or out of sheer necessity due to the dearth of information, experience, and resources, the greater Afghan ICT sector began as quite a small group of people with a common and enduring affiliation, which paved a positive path for future collaboration. That closeness, however, also had some downsides. One was a somewhat incestuous association landscape, as leaders of one association were often officers or founders of another. There is also a deep-seated concept in Afghan ethos of competition and rivalry among equals, so sometimes comparable groups with similar missions cropped up, seemingly in direct competition with each other.

## The Current Climate of Afghan Associations

Several of Afghanistan's official national ICT associations seem to be waning, while less formal groups such as iHub, which is run on a volunteer basis, and other more specialized assemblies – such as the Kabul University Computer Science Association and Afghan Computer Programmers – do not seem to be. There are several possible reasons for this: one explanation is the Afghan ICT sector has matured somewhat, and many early issues have been sorted out, so there are perhaps fewer matters of collective interest at present, although that could change as the sector enters another phase of development. Another is that the ICT sector has largely come to be dominated by four commercial mobile network operators, which now offer Internet and data services as well as voice services, along with a few relatively large and deep-pocketed ISPs, so the number of market players is diminishing, which is typical as an ICT sector matures. NISPAA, for example, seemed to decline after the introduction of 3G mobile broadband services, which ate into ISPs customer bases, causing some to close up shop. NISPAA may have also been discouraged by its lack of success in reducing taxation on ISPs and cracking down on illegal ISPs, two efforts it pursued as a group.

A third reason for the perceived fading of some national ICT associations is the larger ICT ecosystem has grown tremendously within Afghanistan, so some segmentation is natural. For example, there may have

only been a handful of computer science graduates in Khost or Kandahar in years past, whereas now there are fifty, so instead of joining a regional or national group, they form their own relationships and local associations with more narrow commonalities. Or previously, the only way to get assistance with a computer problem was to attend a meeting of computer users, whereas now people can call someone, Google the answer, or visit an online technology forum, including ones in Dari and Pashto (Afghanistan's two official languages).

A fourth explanation for the perceived fading of some of Afghanistan's national ICT associations is the mass migration out of the country due to increasing violence and insecurity. The number of Afghans applying for asylum in Europe in the first six months of 2015 tripled from the same period in 2014, and passport applications increased five-fold in a year, up to 5,000 a day, and it is the younger generation leaving.<sup>1013</sup> Afghanistan's youth, like most places, are the most tech-savvy and the biggest ICT users, and Afghan ICT workers are among the most employable elsewhere.

It is interesting to note the US-backed associations – AFCEA, NICTAA, and AMMOA – are perhaps faring worse than some of the more organically grown, Afghan-initiated efforts like iHub, Open Source Afghanistan, and TechDera. The timing for the establishment of the AFCEA Afghan chapter may have been premature, as far as Afghan readiness and willingness, or unfortunate, with US attention (at least) focused on the surge. Or it may be the Afghans have no real interest in an ICT association related to its security forces, at least at present.

### NICTAA – A Revealing Experience

As far as NICTAA, efforts to establish it proved to be a “revealing experience,” according to some involved at the time. At the outset, several Afghans were looking to include participation by the Afghan civil ICT sector, bringing a “state” mindset to the organization, perhaps stemming from decades of engagement with the Soviets and subsequent leftist rulers, and believing commercial and government elements should work together as a group. The STA and I-Team had to educate the Afghans on the fundamental concepts of a professional association and the natural tension that always exists between government and private sector interests. Over time the Afghans learned public-private sector friction is an inherent and enduring state of affairs, particularly if one is looking to bring a capitalistic/private enterprise approach to growing a productive sector.

While NICTAA did not necessarily effectively establish itself as the planned key umbrella, or master, ICT association in Afghanistan representing commercial ICT interests, it served a valuable purpose as a buffer between the Afghan government and the ICT sector at large, inviting debate and discourse particularly with regards to policy. It was also instrumental in the creation of several other niche associations.

---

<sup>1013</sup> Rahim, Fazul and F. Brinley Bruton (2015). “Afghanistan Exodus: Tens of Thousands Flee Taliban, ISIS Violence.” *NBC News*, September 5. Accessed September 6, 2015. <http://www.nbcnews.com/storyline/europes-border-crisis/afghan-exodus-taliban-isis-driving-tens-thousands-civilians-europe-n420131>.

## Opportunities

Membership and participation in international associations like the ITU and GSMA, as well as the various regional groups, offer Afghanistan's ICT institutions and ICT sector at large the opportunity for long-term assistance and enduring engagement, or "sustainability" in popular post-war-planning vernacular. Most have resources geared specifically to developing countries that could be advantageous, particularly regarding capacity building, as donor dollars and foreign engagement wane. Some of the regional associations, in particular, have an added advantage of allowing Afghans to develop peer-to-peer relationships outside civil ICT entities, which could be beneficial and of great strategic value as Afghanistan tries to position itself as a significant regional ICT player.

Local and national Afghan associations, both industry-facing and user-based, will continue to be an important part of the ICT landscape. Those that arise organically out of necessity or desire are likely to have the greatest chance of success.

## Chapter 7 Afghanistan's Fiber Optic Infrastructure

---

Lewis E. Shadle (with contributions by Lane Smith)

### Introduction

Afghanistan has historically been one of the poorest and least connected countries in the Central Asian region, and it desperately needs to continue to develop its basic infrastructures. For example, the establishment of a robust terrestrial information and communications technology (ICT) infrastructure connecting all 34 provinces holds the promise to be a critical component of Afghanistan's economic prosperity and facilitate its participation in the global information society. To date, deployment of an optical fiber ring around the country, which serves its major population centers, as well as microwave and mobile broadband infrastructures are well underway. The fiber optic ring digitally connects Afghanistan to five of its six neighbors: Pakistan, Uzbekistan, Turkmenistan, Tajikistan, and Iran – all except China. However, even with respect to this substantial progress, additional technical and financial assistance are necessary to extend the country's ICT infrastructures to meet the Government of the Islamic Republic of Afghanistan's (GIROA's) vision of universal service coverage and socio-economic enrichment of the populace.

Afghanistan's strategic geopolitical position as the nexus of a modern-day "Silk Highway," taken with the International Community's efforts to rebuild the country's other critical infrastructures, are themselves compelling rationale for coincidental and greater investment in ICT. Where Afghanistan was historically a major trade and transit terminus of eastern and western civilizations, it too could be a transit route for subsea and transcontinental telecommunications. Afghanistan holds the promise to be, in effect, a Central Asian ICT hub. Complementary efforts to develop Afghanistan's other core infrastructures, such as roads, rail, power lines, water supplies, and gas pipelines, represent a golden opportunity to concurrently deploy fiber conduits more rapidly than building entire fiber infrastructures in the absence of these developments. Burying fiber conduit in the roadbed as a road is built is much less costly and disruptive than trenching along an existing road. It can also be accomplished by the general contracting firm building the road. When performed after the fact by a separate contractor, the chance of destabilization of the existing roadbed as well as the possibility of damage to other conduits and cables (if they exist) will always present a challenge.

The Afghan Ministry of Communications (expanded to Communications and Information Technology in 2007), the government entity charged with overseeing the expansion of ICT infrastructures, has pursued several specific development initiatives designed to provide deeper penetration of network coverage, greater access to ICT services, and lower costs for use. Foremost, and the element of focus of this chapter, is the deployment of fiber optic cables. Not to be overlooked, however, are past efforts by the MCIT to

build and deploy satellite-based VSAT<sup>1014</sup> networks to reach deep into the rural regions of the country and microwave towers to carry both voice and data over the countries' mountainous and challenging terrain. These infrastructures have been successfully deployed by the government and in partnership with the private sector. (See [Chapter 8, Satellite Communications](#) and [Chapter 3, ICT in Afghanistan](#), for more information.)

## History of the Optical Fiber Cable

The linchpin of Afghanistan's national broadband network is the optical fiber cable (OFC) network, largely buried along the right-of-way of the national ring road. As noted earlier, spurs connect the primary fiber ring to fiber optic networks in Iran, Turkmenistan, Uzbekistan, Tajikistan, and Pakistan. The OFC provides orders of magnitude greater bandwidth than satellite links, at much lower costs, and the redundancy of multiple routing options through neighboring countries reduces the potential risks from technical, political, and economic disruptions of terrestrial connectivity through any given country.

The concept underlying the optical fiber ring dates from around 2003. At that time, the Minister of Communications, M. Masoom Stanekzai, aided by an advisor, Amirzai Sangin, from the United States Agency for International Development (USAID), asked for US assistance to design a backbone fiber network. Their vision was for the fiber to be laid alongside the national ring road (Highway 1), which the United States, Japan, Saudi Arabia, and the Asian Development Bank (ADB) were providing assistance to rebuild. The US government contracted Alcatel-Lucent to develop a concept paper for the OFC.

In mid-2004, the US Department of State Under Secretary for Global Issues deployed an ICT subject matter expert to the US Embassy in Kabul, and the USAID Administrator was asked to provide the first brief on the proposed fiber project to then US Ambassador to Afghanistan Khalilzad. The brief noted the largest line item cost for the proposed fiber project was for physical security to be provided to the field teams then beginning reconstruction of the ring road. The brief recommended the field teams constructing the ring road place empty ducts alongside the rights of way, significantly leveraging the security cost across both the road construction and proposed fiber projects. This idea was an early attempt to demonstrate the benefits of infrastructure sharing (see below). A subsequent session with Ambassador Khalilzad noted the proposed strategy made sense, but that the USG could not pre-place the ducts since the fiber project was then only an unbudgeted and proposed concept versus an active and funded project.

By late 2004 the US Trade Development Agency (USTDA) completed a feasibility study that validated the economic, social, and security benefits of this infrastructure, with an estimated cost of US\$60-75 million, a 12- to 18-month construction period, and a payback period, with savings to be realized from reduced satellite costs, of 18 to 24 months. Given the enormous funds expended by NGOs, foreign embassies and their development partners, and the Coalition for satellite connectivity, the payback period for this investment was probably fewer than two years. Also, a competitive tender process could identify and

---

<sup>1014</sup> Very small aperture terminal, a two-way satellite ground station with a dish antenna generally smaller than three to four feet.



contract an operating company to manage the ring, with regulatory oversight to assure that cost-based access to this ring would be available to the burgeoning cell phone operators and ISPs, further reinforcing the positive, pro-competitive telecom policies of the GfRoA.

Both USAID and the US Forces-Afghanistan (USFOR-A) endorsed the concept, after overcoming some resistance based on a fear that any USG traffic transiting Iran would be vulnerable to hacking, and began exploring funding mechanisms. Between 2004 and 2005, the US Department of Defense (DoD) determined the fiber optic ring, “FOR,” as it was titled, would not be used by the warfighter. Consequently, it arranged for briefs by the DoD ICT subject matter expert to the NATO Coalition’s Communications (CJ6) personnel that DoD would not fund or utilize the FOR. This position was later reversed, once transition was underway from post-warfighting stabilization and development to a new phase of warfighting referred to as the “surge.”<sup>1015</sup> At that time, US leases of limited but available fiber bandwidth were negotiated with the state-owned operator Afghan Telecom Corporation (AfTel), which held a monopoly on Afghanistan’s fiber and was the only company authorized to lease it. These negotiations were conducted at a time when the future of AfTel was uncertain, both in terms of its ability to capture revenues and also regarding possible privatization or sale to third-party entities in states that did not share NATO Coalition and USG interests.

USAID initially allocated US\$10 million in the FY 2005 Supplemental Appropriation and US Forces began exploring ways to fund the construction by pre-purchasing up to US\$50 million of capacity on the potential ring for its use upon completion. However, domestic politics intruded. The Afghan-American owner of AWCC, a leading Afghan cellular company, reached into the presidencies of both Afghanistan and the US to complain that USG funding of such an investment would compete unfairly with his company’s effort to build a privately-financed microwave network along the ring road. His entreaties won the day, and potential US funding was shut down. This action led to several consequences.



Figure 49: Original MCIT OFC project plan

By this time (late 2004), former USAID advisor Amirzai Sangin, who had served as the CEO of AfTel for the previous year, became the Minister of Communications. He began to draft a tender based on the concept

---

<sup>1015</sup> On December 1, 2009, US President Barak Obama announced he would send an additional 30,000 troops to Afghanistan. Obama, Barack (2009). “Remarks by the President in Address to the Nation on the Way Forward in Afghanistan and Pakistan,” December 1. The White House Office of the Press Secretary. Accessed December 10, 2014. <http://www.whitehouse.gov/the-press-office/remarks-president-address-nation-way-forward-afghanistan-and-pakistan>.

for the fiber ring developed by Alcatel-Lucent and completed a United States Trade and Development Agency (USTDA) bid package. Minister Sangin proposed to fund the optical fiber ring within the GIROA budget as a component of the Afghan Reconstruction Trust Fund (ARTF). The tender was designated for a project that officially became known as the National Optical Fiber Cable (OFC) Network.

In concept and execution, the OFC network was destined to link virtually all the principal cities of Afghanistan following the route of Highway 1, which makes a large loop around the country. The project envisioned a high-capacity optical fiber ring adjacent to the ring road, around which, when phase one was complete, would be approximately 3,100 km in length. In addition to connecting many of Afghanistan's key cities, this project also called for the construction of points of presence (PoPs) along the route to provide on-and-off ramps to the backbone for all district centers and provinces not directly in the primary path of the fiber. Major spurs off the main optical fiber cable route would connect outlying provinces, and a future-planned central spur would connect the rugged and sparsely populated central regions of the country to the main fiber ring. In planning, the OFC project targeted completion in the 2008 timeframe.

Five companies participated in the tender, with the highest bid of US\$225 million coming from a leading US firm and the eventual winning bid of US\$65 million from the Chinese firm ZTE. The MoC awarded the contract to ZTE only after it initially awarded it to an Indian firm that was subsequently removed from competition due to an undisclosed disqualification. Trenching for the conduit soon began, followed almost immediately by documented complaints from Louis Berger, the contractor responsible for the ongoing maintenance of the ring road. The complaints noted that ZTE's contractors (comprising numerous local firms) were improperly backfilling the trenches and severely compromising the road surface and shoulders. USAID brokered a meeting between the Afghan Ministries of Public Works and Communications to resolve the complaints, but the issues surrounding the impacts on existing infrastructure continued long after.

Ultimately, portions of the fiber ring were lit up (activated) as they were completed, and high-speed terrestrial connectivity became available, which was a momentous occasion. It is worth noting that, as the initial segment of the OFC between Kabul and Bagram Air Base was under construction, the first cross-border link from Herat to Iran was also being completed. (Iran considers western Afghanistan to be in the Iranian sphere of influence, if not a de-facto Iranian territory, much as Afghans consider western Pakistan to be part of Afghanistan, or Pashtunistan, despite the constraints of the nineteenth-century imposition of the Durand Line.<sup>1016</sup>)

One of the biggest customers of Afghanistan's new OFC was USFOR-A. It wound up paying substantially more to Afghan Telecom to lease the fiber than it would have paid if the pre-purchase approach had been viable politically in the context of the changing DoD mission assessments. This was an unintended but real consequence of the decision of the USG to not seed-fund a portion of the project two years earlier.

---

<sup>1016</sup> The Durand Line is the border between Afghanistan and Pakistan, named for British diplomat Sir Mortimer Durand, who established it in 1893.

## Construction of the OFC

Following the 2006 award for the OFC's construction, the contractor began building along portions of the ring road that were already improved, mainly north from Kabul to Bagram, as noted earlier, and then

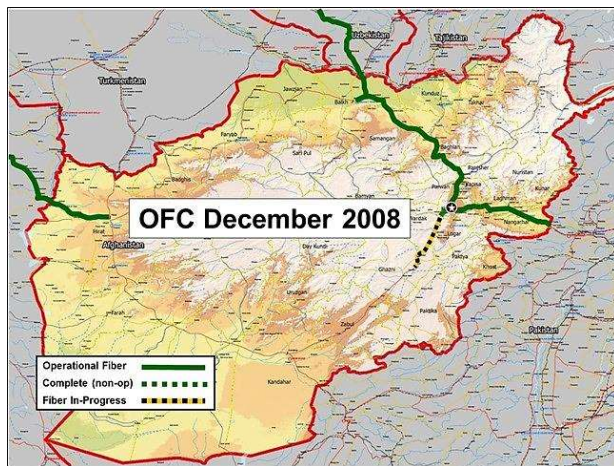

Figure 50: OFC status, December 2008

south of Kabul towards Kandahar. By mid-2007, some 140 kilometers of fiber had been trenched. A continuing series of cuts associated with improvised explosive devices (IEDs) placed along the road by insurgents to attack Coalition convoys, civil works for unrelated projects, and even villager pilfering to extract non-existent copper, continued to plague the project. On the southeast segment of the ring road, fiber had to be re-laid, spliced, and moved several times. The effect of this was a fiber route that was unreliable and unable to be commissioned for service.

The southeast segment remained almost entirely unusable until 2014 – a full six years after the 2008 target completion date for the entire primary OFC ring. Though now commissioned, the southeast route remains a challenge to keep in operation as it is a highly-contested area full of insurgent activity, particularly during the fighting season (April to November).

Continuing north of Bagram toward Mazar-e-Sharif, progress was better and by the end of 2008, the entire northeast segment to Mazar and on to the Afghan/Uzbek border town of Hairatan was installed. It took several more months of testing and continual repairs at the Salang Tunnel for the fiber to be commissioned by AfTel, which would then take over operational responsibilities for the fiber.

In addition to the north route, the contractor built the segment east of Kabul to the Pakistan border at Torkham Gate. This link would be followed by the first international agreement for high-capacity terrestrial Internet traffic with Pakistan Telecommunication Company Ltd. (PTCL), the semi-private incumbent operator in Pakistan. Before this terrestrial connection was made, the bulk of Internet access supplied to Afghanistan was accomplished through very expensive satellite connections. Due to its expense – upwards of US\$3,500 per month per megabit (Mb/mo) of capacity, many of the early Internet service providers (ISPs) would require subscribers to share their access at a contention rate of up to 100:1. Consequently, the user experience was poor and penetration of subscribers remained low.

The agreement with PTCL lowered the cost of raw Internet capacity to approximately US\$300, or roughly one-tenth the rate of satellite bandwidth. A second agreement with Uzbek Telekom for US\$400 Mb/mo provided backup access in the event the primary access route through PTCL was lost. The Telecommunications Infrastructure Company (TIC), the state-owned operator in Iran, also provided Internet access in western Afghanistan at a cost of US\$400/Mb/mo, but it was limited to Herat.

As was noted earlier, AWCC was continuing to build out its microwave network, primarily along the same ring road route. Due to the close relationship AWCC enjoyed with the NATO Coalition and the Afghan security ministries, Defense and Interior, and the National Directorate of Security, AWCC built its own

international connections with PTCL across the border at Torkham and south of Kandahar at Chaman. These connections were used not only by the Coalition and security ministries, but also provided Internet access for moral, welfare, and recreation (MWR) activities at military facilities along its path.

In the summer of 2010, the DoD/DISA Telecommunications Advisory Team (TAT) was established. One of the early activities of the TAT was to develop a knowledge-base of the progress of the OFC with intent to inform the Coalition on availability of commercial fiber that could be used by nearby military facilities for both domestic and international private leased circuits. By the end of 2010, the TAT was ready to publish its first status report, accurately detailing the current state of the fiber, IT capacities, routes, and international connectivity.

The first detailed OFC graphic description by the TAT (as in [Figure 51](#)) was used to document a major fiber cut in what was previously operational fiber in the region of the Soroubi Dam near the city of Jalalabad. In addition to poor construction, this cut was caused by significant runoff and high water near the dam. Tracking repair and assisting AfTel became one of the first priorities for the TAT as an active coordinator and advisor among the MCIT, AfTel, Coalition contracting, and International Security Assistance Force (ISAF) leadership.

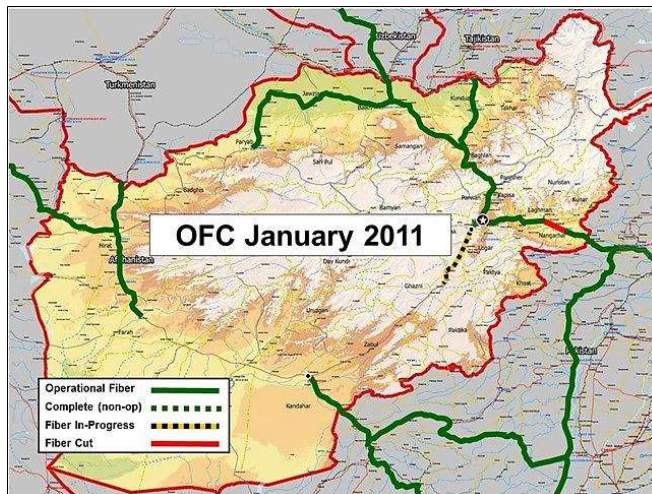

Figure 51: OFC status, January 2011

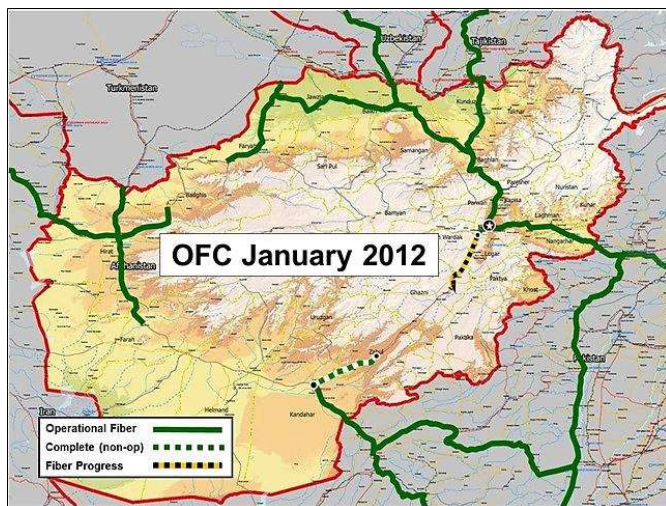

Figure 52: OFC status, January 2012

This cut had an impact on ISAF operations because the fiber provided significant connections among Coalition headquarters in Kabul, operations at Bagram, and the major regional command operations in Kandahar, which was the center of the military surge in Kandahar and Helmand provinces at the time. The cut prompted the Coalition to contract for an alternative route using AWCC’s microwave network to regain capacity and connectivity. Repairing the fiber around Soroubi was not a matter of splicing cables back together. The cable was dangerously exposed along the mountainsides and had become visible to

insurgents, criminals, and villagers. In fact, during a meeting on the status of the OFC with MCIT Minister Sangin, he noted, “Talibs were actually sitting on the cable.” Due to the criticality of this route, the Coalition stepped in to aid AfTel by using a US defense contractor to assist in laying 82 kilometers of new

fiber and offering security assistance to the workers. It took until January of 2012 before the route was operational again (see [Figure 52](#)).

By early 2012, significant progress had been made in building out the OFC, primarily along the southeast segment. Due to a combination of the Coalition providing physical security for the workers (mainly due to military operations in the Wardak and Ghazni areas) and private security companies employed by the Chinese contractor, ZTE was able to install (in some cases, re-install) a significant amount of fiber from Maiden Shar south to Ghazni. ZTE had successfully laid additional fiber from Kandahar north to Qalat. Even with the extra protection, many challenges continued to impact the pace of building along this segment. In one instance, two local laborers were killed and one ZTE contractor was taken hostage by insurgents. Many villagers had been threatened by the Talibs to stop working because their activities were seen as supporting the Central Government, an offense punishable by death. Furthermore, local village residents employed by ZTE would work by day to lay the fiber and at night to destroy it, all in order to remain employed. The final leg of this segment around Ghazni would remain unfinished until late 2013.

## Infrastructure Sharing – Failure

In summer of 2011, the Asian Development Bank (ADB) released a tender through the Ministry of Public Works (MoPW) to build a 233-kilometer segment of the ring road along the northwest quadrant of Afghanistan. The build posed an opportunity to lay utility conduits coincident with the construction through which AfTel would later run fiber. This sort of infrastructure sharing was discussed as far back as 2004 during the conceptual stages of the OFC, but nothing was done at the time. In December 2011, several Afghan ministries – among them Communications (MCIT), Public Works (MoPW), Energy and Water (MEW), Rural Rehabilitation and Development (MRRD), Finance (MoF), Economy (MoEC) – as well as other agencies, began discussing how to share infrastructure. Their efforts culminated in a National Infrastructure Sharing Policy, which was approved by the Afghan Cabinet in March 2013 and codified as Economic Council Act #22 in April. At some point (well before the policy was enacted), the MCIT presented ADB with a proposal to share infrastructure (i.e., have ADB’s road construction contractor install empty ducts for AfTel alongside the road). Unfortunately, ADB balked, saying that it was too late in the process, the design was complete, and that any change to the contracting process would cause unnecessary delays for the road construction. The MCIT Minister attempted several times to intercede, directly with the Minister of MoPW as well as at the Presidential Palace, but was never successful in having ADB’s contractor change the road plans or accepting an offer for the MCIT to co-build (install fiber ducts) with the ADB contractor.

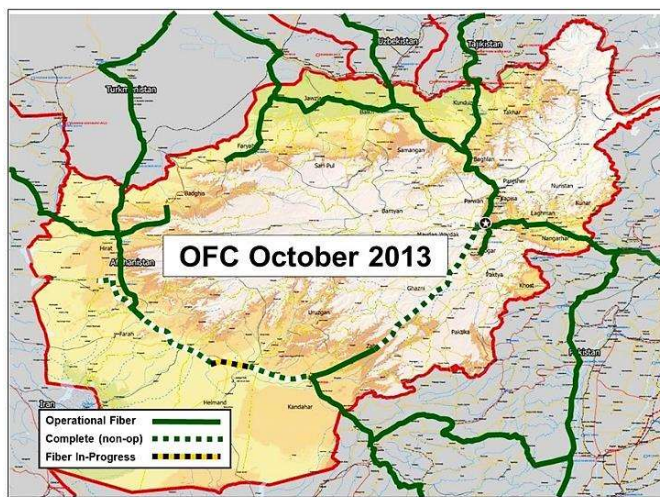

Figure 53: OFC status, October 2013

As result of this reluctance to work together and acknowledgement that going it alone on this segment of the OFC would take approximately 48 months, MCIT Minister Sangin decided to pursue a potential bypass route through Turkmenistan that would provide the necessary closing of connectivity between the eastern OFC and the Herat region (see top left of [Figure 53](#)).

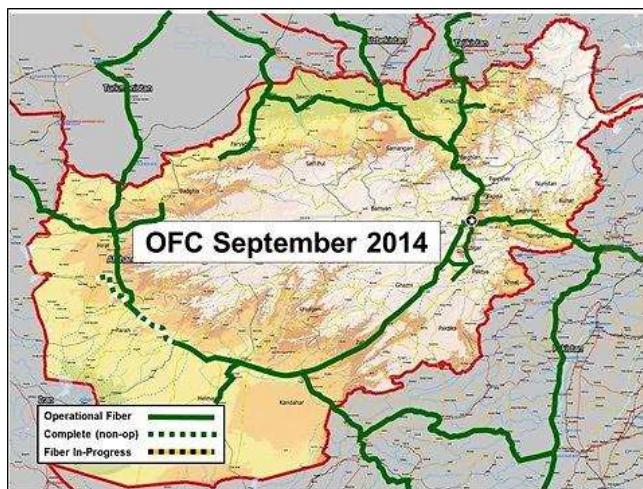

Figure 55: OFC status, September 2014

In late 2012, Minister Sangin, Deputy Minister Hassam, and AfTel’s Head of Transmission traveled to Ashgabat, Turkmenistan to meet with the Turkmen President and head of Turkmen Telekom to discuss using existing Turkmenistan fiber as a route for Afghan traffic around the northwest segment. Turkmenistan had an existing but relatively low-capacity (155 Mbps<sup>1017</sup>) route from Kerki through Turkmenbashi, Mary, and Torkundi. If AfTel could use this route, it would only need to build a 35-kilometer leg from Ankhoy on the main fiber ring to Aqina on the Turkmen/Afghan border. In turn, Turkmen Telekom would build a 60-kilometer leg

from Kerki south to Aqina and complete a segment from Mary south to Torkundi. For AfTel to utilize this route would require Turkmen Telecom to upgrade the fiber’s capacity, as the MCIT and AfTel desired to lease two 622 Mbps circuits on it. In November 2012, AfTel and Turkmen Telekom signed an agreement for AfTel to lease fiber in Turkmenistan. AfTel also lent Turkmen Telekom several higher-capacity optical cross-connect cards for their similar ZTE equipment. The Turkmenistan bypass route was activated in February 2013. To date (mid-2016), this route is the only path completing the OFC from northwest Afghanistan to Herat.

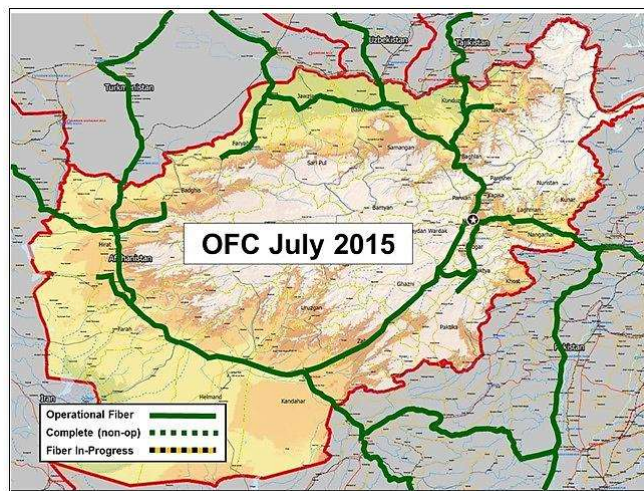

Figure 54: OFC status, July 2015

During 2013 there was significant additional progress made on the southeast and southwest segments of the OFC. By May of 2013, construction and repair on the southeast segment was finally completed and the span was reasonably stable. The leg from Kandahar north to Qalat was commissioned for operation in April and testing began on the remaining section from Qalat to Maiden Shar. A completely new 106-kilometer fiber had been laid from Maiden Shar south to Ghazni

<sup>1017</sup> Megabits per second, a measure of data transfer rates.

in the most troublesome area on that span with the aid of US contractors. It would not be, however, until July of 2014 that the entire southeast segment would become operational, an event so significant that MCIT Minister Sangin held a very public ribbon-cutting ceremony in Ghazni to commemorate the occasion.

The southwest segment also saw significant progress with several sections being built and tested simultaneously. The legs from Kandahar to Gareshk and south to Lashkargah and northwest to Bastion were completed in July 2013. The remaining segments from Bastion west to Delaram and north from Delaram to Shindand were completed in August of that year. Testing began on this segment immediately, and by September 2013 the sections from Kandahar to Lashkargah and Delaram were operational. The remaining leg from Delaram to Shindand would take another six months but was finally operational in March of 2015 (see [Figure 54](#)).

### The OFC Moves to DWDM

During the last phases of commissioning of the OFC, AfTel had begun upgrading completed segments of the fiber with a higher-capacity optical technology known as dense wavelength division multiplexing (DWDM). (See [Figure 56](#), where the DWDM links are depicted in black). The original OFC project envisioned a capacity of 10 Gbps<sup>1018</sup> for the entire ring. However, demand from the Coalition, domestic customers (primarily the cellular network operators), and even new international prospects seeking to offer transit through Afghanistan drove AfTel to begin implementation of capacities greater than 10 Gbps. DWDM technology would offer multiple 10 Gbps circuits, as many as 160 over the same fiber that before only offered one. DWDM also offered more resiliency and lower cost than was envisioned at the beginning of the project. However, higher capacity on the fiber ring would not be sufficient to meet international standards for availability and reliability. For industry-standard key performance metrics to be met, there would need to be more than a single ring operating; there would need to be multiple rings that could be used to back up all primary segments of the ring.

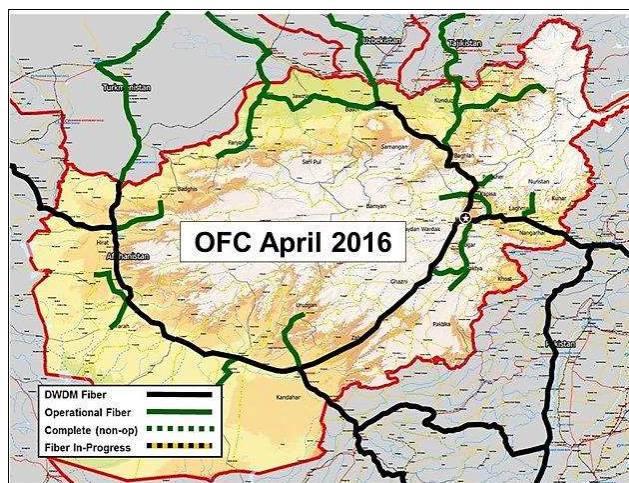

Figure 56: OFC status, April 2016

---

<sup>1018</sup> Gigabits per second, a measure of data transfer rates.

## Infrastructure Sharing – Success

One of the possible solutions to a single-ring segment was to take advantage of additional fiber pairs that existed in Afghanistan’s overhead electricity infrastructure that was being developed to distribute power across the country from domestic power stations and from neighboring countries. The power distribution network was funded by an assortment of international donors: ADB, India, Japan, USAID, and others. The northeast segment was known as the North-East Power System (NEPS) and ran from the Pakistan border



Picture 24: World Bank consultation with AfTel

(Photo by Lew Shadle)

at Torkham through Kabul and north to Mazar-e-Sharif and then on to the Uzbekistan border at Hairatan. The NEPS power system comprised a ground wire along the entire span that contained within the conductor several pairs of fiber known as optical ground wire (OPGW). Members of the Telecommunications Advisory Team met with the USAID design-build contractor, Louis Berger/Black & Veitch, and determined the OPGW was unused and that it held the

potential to be utilized as an aerial backup for the in-ground fiber that followed the same general route. The MCIT, AfTel, and the power company, Da Afghanistan Breshna Sherkat (DABS), held several meetings to negotiate AfTel’s use of the spare fiber as redundancy for the OFC and also to provide a revenue-sharing arrangement between AfTel and DABS that would be mutually beneficial. Today, AfTel is using the OPGW in the power conductors along the entire NEPS route from Torkham to Hairatan. IT serves as a critical backup not only for current domestic traffic but is now being viewed as a viable route for international IP transit from undersea cables at the Port of Karachi to transcontinental terrestrial fiber networks to the north in Central Asia.

## Other Optical Fiber Projects to Augment the OFC

### World Bank ICT Sector Development Grant

The World Bank Afghanistan ICT Sector Development Project is a six-year,<sup>1019</sup> US\$50-million program for the MCIT. It is funded by an emergency recovery grant from the International Development Association (IDA). The project began in May 2011 and is scheduled to close in July 2017. This grant is intended to help

---

<sup>1019</sup> The project was originally scheduled for five years but a decision was taken in June 2015 to extend the project for a year to ensure completion of the World Bank-funded sections of Afghanistan’s optical fiber cable in a volatile security environment.



finance the costs associated with expanding connectivity, mainstreaming the use of mobile applications across the GIRoA, and supporting the development of the local IT industry. Component 1 of the project aims to expand connectivity. Within the context of the OFC, a specific subcomponent – expanding the national backbone network – would build upon the earlier OFC and add additional segments to the ring, particularly the central spur across the center of the country and the northeastern spur, providing fiber connectivity from Kunduz to Faizabad in Badakhshan Province. Both of these spurs would reach deep into some of the most rural districts and provinces in the Afghanistan. The following is (excerpted and paraphrased) from the project description the World Bank Country Team provided to the MCIT in April 2011.

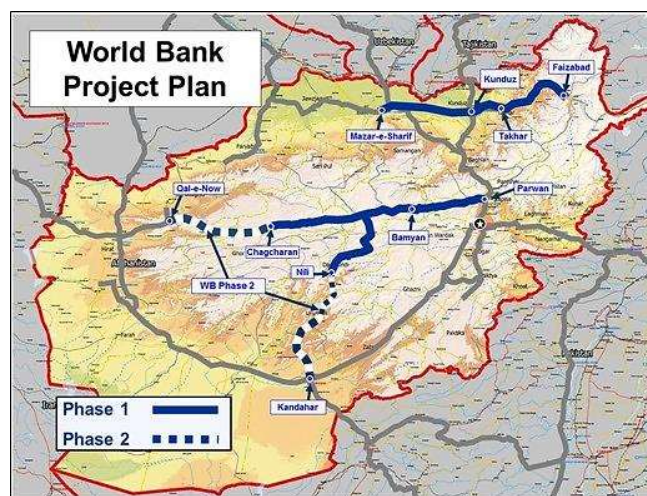

Figure 57: World Bank planned expansion of the OFC

Component 1 will finance the turnkey procurement, installation, and testing of the third phase of Afghanistan’s national backbone network and connect underserved provinces of the country.<sup>1020</sup> The third phase is also planned as a way to create infrastructure that will allow for multiple redundancies on the backbone network.<sup>1021</sup> This will allow Afghanistan to become a regional hub for high-capacity terrestrial traffic, connecting South Asia, Central Asia, and the Middle East, and creating a “Digital Silk Road.” There are significant financial and strategic gains to be made from becoming such a hub, not the least of which is that Afghanistan could establish itself as a key transit point for inter-regional if not global data traffic.

The Project plans to finance three segments:

- Parwan to Bamyán to Chagcharan (in Ghor province), estimated at 660 km;
- Bamyán to Nili (Daikundi), estimated at 150 km; and
- Kunduz-Faizabad (Badakhshan), estimated at 270 km.

<sup>1020</sup> Surveys suggest that this region has the lowest mobile phone ownership in the country (30 percent compared with a 52 percent national average). See <http://asiafoundation.org/resources/pdfs/Afghanistanin2009.pdf> (page 138). And as is evident from one service provider’s coverage map, there is little coverage in the central region. See <http://www.roshan.af/web/coverage-maps/index.htm>.

<sup>1021</sup> Creating multiple routes among points on the network will reduce single points of failure. For example, once the entire network is complete, three routes will link Kabul and Herat through the northern, southern, and central provinces. This reduces the possibility of damage at one point in the network from disrupting connectivity entirely.

A cost-benefit analysis conducted in late 2010 found that the estimated US\$27 million investment in these segments of the backbone network will create an infrastructure that could have an internal rate of return of 7.45 percent up to 2022.

## Afghanistan's Role in Central Asian Fiber Transit

As the OFC neared completion and additional fiber projects got underway, it became apparent that the maturity of the MCIT's fiber infrastructure and its unique location in southwest Asia could be leveraged to make Afghanistan a central participant in IP transit across the region. Afghanistan's strategic geopolitical position presents itself as the nexus of a modern-day "Digital Silk Road." Where Afghanistan was historically a major trade and transit terminus of eastern and western civilizations, it too could be a terminus for subsea and transcontinental telecommunications. (See [Figure 58](#)).

To realize this vision, the region needs to develop new and expand existing commercial optical fiber transit routes through South and Central Asia, thereby increasing access, capacity, and revenues within the region. Commercial optical capacity supporting international carriers between Asia and Europe are heavily dependent on undersea fiber cables routed through the Red Sea and across Egypt. These routes expose a risk from accidental cuts, sabotage, and political instability, and have demonstrated their negative impact time and time again, recently (early 2013) with the purposeful cut of a major cable off the coast of Alexandria, Egypt.

The continued demand from commercial bandwidth providers between the Far East and Europe is driving interest in seeking new and diverse routes between the regions. Transit through Pakistan, Afghanistan, and Central Asia provides viable routes that are attractive to the multinational Tier-1 operators and will generate lower-cost access, increased revenue, and greater domestic penetration as routes through the region are exploited. This three-facet concept – (1) providing alternate routes for multinational operators, (2) enabling diverse, low-cost and high-capacity bandwidth through the region, and (3) offering greater domestic penetration and utilization – holds the promise of benefiting carriers, the nations of Central Asia, and the interests of Afghanistan.

According to several multinational Tier-1 carriers, there are no signs of a looming collapse in demand for long-haul capacity. They note that as broadband, particularly mobile broadband, becomes commonplace around the world, access capacity required by end-users will continue to grow. According to Cisco Systems, monthly global mobile data traffic will surpass 10 Exabytes in 2017. Increased bandwidth at the local level will lead to more demand for long-haul capacity. In fact, TeleGeography's Global Bandwidth Outlook forecasts international capacity demand to grow at a compounded annual rate of 37 percent between 2011 and 2018.

In direct response to this demand, there is currently a growth surge in terrestrial and submarine cable deployments underway. Several new multinational carrier and consortium-funded projects are focused on providing new diverse routes to provide more resilient paths and to lower latency. Other projects are targeting existing routes on which there have been no new cables or capacity increase in nearly a decade. In 2014 alone there were 12 new optical fiber cables slated to launch, and in 2015-2016 another 18 are planned. Collectively, these projects amount to approximately US\$5 billion in fiber infrastructure investment, with Asia seeing the largest number of new projects.

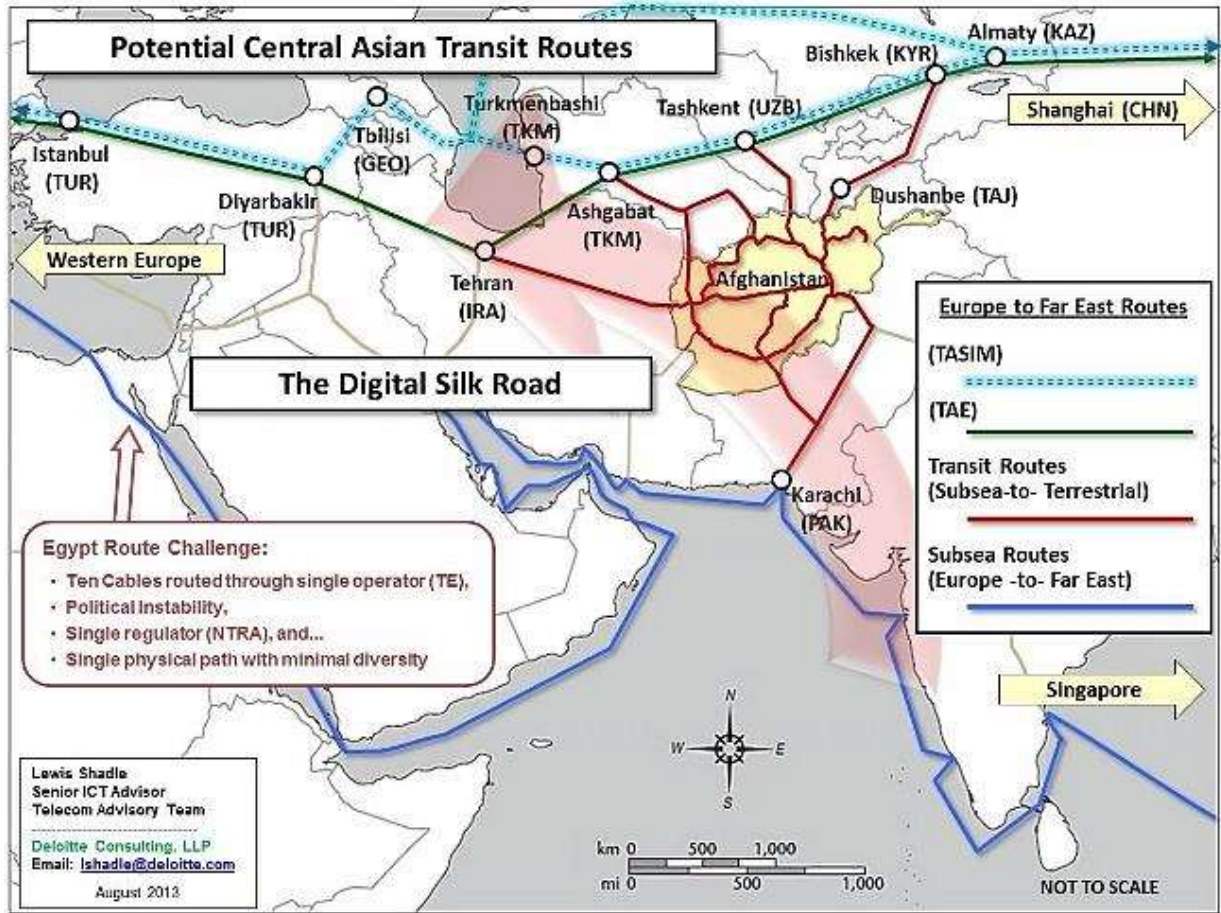

Figure 58: Possible Central Asian transit routes using Afghanistan's fiber infrastructure

Several Tier-1 carriers have indicated they would consider extending their own networks into southwest and central Asian regional hubs in locations such as Kabul and Dushanbe as capacity through the region increases. In lock-step with this capacity would come content-mirroring and caching services as well as content distribution capabilities that are core components of hub nodes on the routes. The economic impact to the southwest and Central Asian region could be significantly and positively altered as broadband penetration increases. The promise of a Central Asian transit route through Afghanistan became a core component of the TAT mission in 2011. TAT members began to collaborate with public and private stakeholders, socializing the benefits to each participating nation, and seeking sponsorship among the International Community, e.g., the World Bank, Aga Khan Fund for Economic Development (AKFED), and USAID, to develop funding and sustainable approaches. In addition, the TAT continued to investigate interest among national, regional, and international operators and carriers to gauge their willingness to invest in Central Asian transit. The TAT also began to lobby MCIT Minister Sangin on the idea of a buyer-consortium among Pakistan, Afghanistan, Uzbekistan, Turkmenistan, Tajikistan, and possibly Kyrgyzstan and Kazakhstan, an effort in which he and Afghanistan could play a pivotal role.

Today the notion of a transit route through Afghanistan is no longer just a concept; in fact it has become a central focal point for the new Afghan administration and the President's Senior Advisor on ICT. Further,



*Picture 25: UNESCAP meeting on increasing fiber connectivity in Central Asia*

*(Photo courtesy of Lew Shadle)*

Afghanistan's technical and functional capacity increases, there is a distinct opportunity for Afghanistan to realize its new role in the region as a modern-day Digital Silk Road and potentially an ICT Hub of Central Asia.

In Afghanistan, only time will tell ...

Pakistan, Uzbekistan, Tajikistan, China, and Kazakhstan have held joint discussions regarding participation and the potential benefit to the region. The United Nations Economic and Social Commission for Asia and the Pacific (UNESCAP) has endorsed the idea and has established formal development decrees with most of the countries whose territories would be involved. [Picture 25](#) shows a meeting UNESCAP hosted in Almaty, Kazakhstan in June 2014 on increasing fiber optic connectivity in Central Asia.

As the OFC and other ICT infrastructures in Afghanistan continue to strengthen, mature, and improve, and as

## Chapter 8 Satellite Communications

---

Karen E. Black (with contributions by Robert Kinn and Lane Smith)

### Introduction

Because decades of war and civil unrest had decimated most of Afghanistan's infrastructure, including telecommunications infrastructure, satellite communications (SATCOM) was the most efficient, though certainly not the most cost-effective, way of reestablishing basic communications. Satellite service was critical to establishing the Afghan government's ability to communicate between and among ministries and agencies in Kabul as well as to and from Kabul to provincial government offices. SATCOM services were also necessary to coordinate Afghanistan's massive emergency reconstruction efforts and immediate development priorities.

After the US-led invasion ousted the Taliban regime in December 2001, the cast of characters that moved into Afghanistan – foreign governments, non-governmental organizations (NGOs), aid organizations, international media outlets, and myriad other entities – generally contracted and utilized their own satellite services for voice and data communications.

Over a decade later, the Government of the Islamic Republic of Afghanistan (GIROA) licensed its orbital satellite slot and contracted a company to jointly launch the country's first satellite.

Presently, Afghanistan is utilizing SATCOM for voice and nominal data services as well as television and radio broadcast services. Through AfghanSAT1, it plans to extend affordable information and communications technology (ICT) services to remote and unserved areas. SATCOM also generates revenue for GIROA from various licenses and services, to the tune of US\$15 million annually.<sup>1022</sup>

### Early Satellite Communications Projects

#### Restoring Afghanistan's Earth Station

One of the earliest satellite projects was the rehabilitation of Afghanistan's telecommunications and television satellite earth station in Kabul, which was badly damaged. This was necessary in order to restore transmission capacity between Afghanistan's capital city and the outside world and to allow the state to resume providing international telephone traffic. The World Bank undertook that effort in late 2003 as part of its Emergency Communications Development Project,<sup>1023</sup> with approximately US\$5 million of the

---

<sup>1022</sup> TOLONews (2014). "First Afghanistan Satellite Launched." *TOLONews.com*, May 10. Accessed April 9, 2016. <http://www.tolonews.com/en/business/14820--first-afghan-satellite-launched>.

<sup>1023</sup> World Bank (2003). Afghanistan – Emergency Communications Development Project. Washington, DC: World Bank. ECDP, September 5, 2003. Accessed November 23, 2015. <http://documents.worldbank.org/curated/en/2003/09/2513113/afghanistan-emergency-communications-development-project>.

US\$22 million project budget, which included replacing the antenna of the satellite dish and upgrading the power supply and other equipment needed to make it fully functional.

### Government, District, and Village Communications Networks

Three other early SATCOM-based projects were the Government, District, and Village Communications networks (GCN, DCN, and VCN, respectively).

Funded by the World Bank in 2003,<sup>1024</sup> the GCN was an extensive network designed to link the central government in Kabul with all Afghanistan's provincial capitals through a satellite-based system with voice, Internet, and video conferencing capabilities. The satellite network consisted of a hub site in Kabul, an international gateway in Europe, and remote provincial stations interconnected in a full-mesh configuration to the hub in Kabul.<sup>1025</sup> [Globecomm Systems Inc.](#) (GSI) built out the GCN, including the landing points in each province, and plans to provide last-mile links to each governor's office, the international satellite segments, and a landing facility and network operations center (NOC) at the Ministry of Communications' headquarters in Kabul.

Following the GCN, an effort for a District Communications Network (DCN) to connect public agencies in the more than 300 legislative districts throughout Afghanistan was funded by the United States Agency for International Development (USAID). The DCN project, also designed and installed by GSI, was a VSAT<sup>1026</sup> network connecting the satellite hub in Kabul to various district centers, government offices, police and fire stations, and other important locations. DCN terminals generally included four voice ports, one facsimile (fax) port, and four Internet ports.

To further extend communications capabilities to sub-national levels, the GCN and DCN were followed by the Village Communications Network (VCN) to connect local government offices throughout the country and to provide ICT services to the populace. VCN kits were installed by Afghan Telecom Corporation (AfTel, a corporation owned by the MCIT) and entrusted to village elders to run. AfTel also sold VCN kits to local entrepreneurs, who would then establish local community calling centers where residents could make and even receive calls for a fee. While the original intent was for the VCN to provide both voice and data services, bandwidth limitations of the equipment made Internet capabilities of the VCN unviable, and most installations were used solely for telephone services. As of late 2015, there were approximately 1,300 VCN sites across the country (see [Figure 59](#)).<sup>1027</sup>

---

<sup>1024</sup> Under its Emergency Communications Development Project.

<sup>1025</sup> Globecomm Systems, Inc. (n.d.). "Afghanistan Government Communications Network and District Communications Network."

<sup>1026</sup> Very small aperture terminal, a two-way satellite ground station with a dish antenna generally smaller than three to four feet.

<sup>1027</sup> Per AfTel's former Chief Operating Officer and Vice President, Wireline Division, Ahmad Saeed, in an email message to the author April 1, 2016.

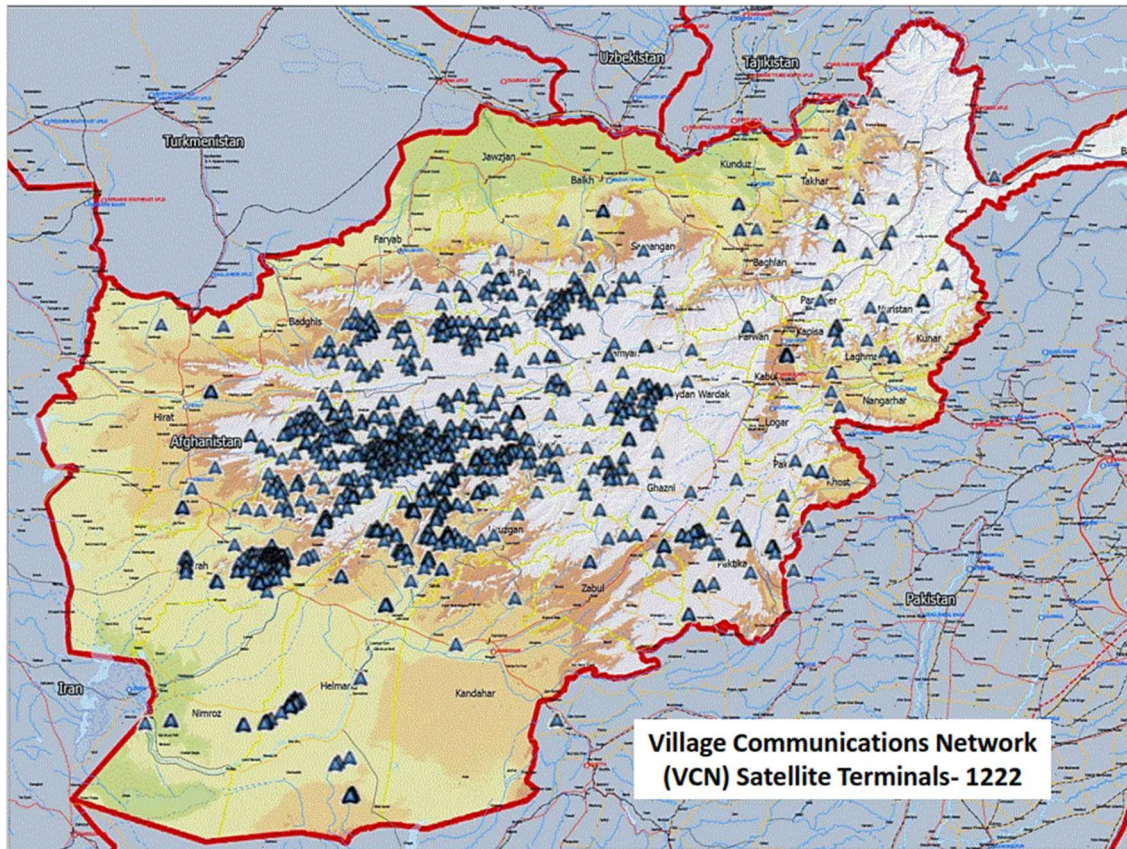

Figure 59: Village Communications Network deployment, March 2014

(Graphics courtesy of former TAT Senior ICT Advisor Lewis E. (Lew) Shadle, Deloitte Consulting LLP)

While the full scope of the three networks was never realized, by 2011 the GCN connected over 40 government offices in Kabul and 34 provincial capitals, and the DCN was on APSTAR 2R<sup>1028</sup> at 36 megahertz (MHz) connecting 27 sites. AfTel planned to implement the VCN on AAP-1<sup>1029</sup> at 19.6 MHz to support approximately 700 sites, which required an upgrade of its existing satellite hub to accommodate an additional 500 terminals. The GCN, DCN, and VCN are described more fully in [Chapter 3, ICT in Afghanistan](#).

<sup>1028</sup> APSTAR 2R was a C- and Ku-band satellite launched in 1997 by Hong Kong-based APT Satellite Company Ltd. at 76.5 degrees east longitude, per the US National Aeronautics and Space Administration (NASA). Accessed March 6, 2016. <http://nssdc.gsfc.nasa.gov/nmc/spacecraftDisplay.do?id=1997-062A>.

<sup>1029</sup> Americom Asia-Pacific-1, a Ku-band satellite that operated at 108.2 degrees east longitude as joint venture of Lockheed Martin and SES AMERICOM, per SES website. Accessed March 6, 2016. <http://www.ses.com/4233325/news/2003/4438489>.

## Afghanistan's Space Allocation

According to ITU allocation plans 30, 30A, and 30B, Afghanistan's space allocation is at 50 degrees east longitude (50°E). The space segment includes spectrum in the C (4-8 gigahertz (GHz)) and Ku (11.7-12.2 GHz) bands. Afghanistan shares its geostationary position with 15 other countries.<sup>1030</sup> In theory, the footprint of a satellite operating from 50°E would be very valuable, as it spans the area from the United Kingdom all the way to western China, allowing access to and from Far Eastern, Central Asian, and

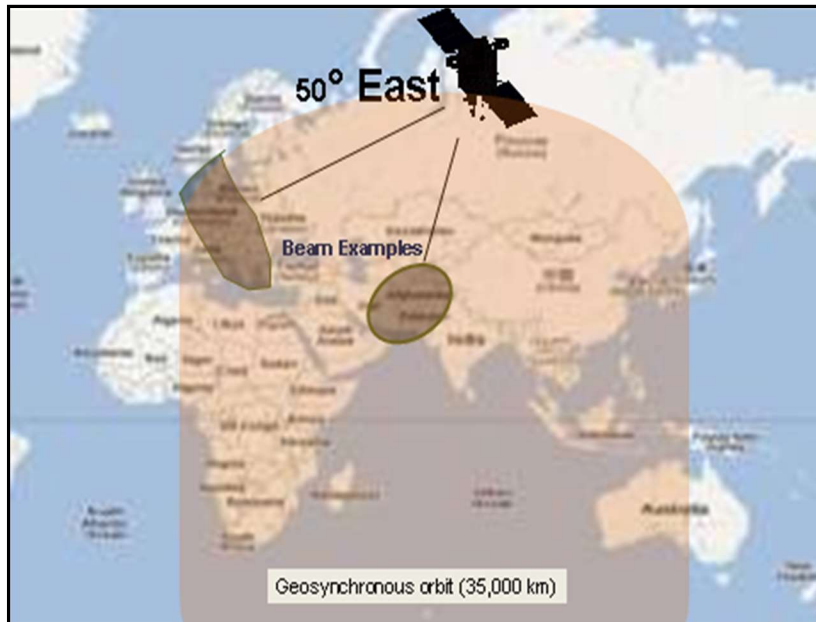

Figure 60: Representative footprint of Afghanistan's ITU space allocation

European markets. In actuality, however, Afghanistan failed to coordinate its assigned frequency as required by the ITU – which was substantial due to the large coverage area – due to the lack of communication between and among the Afghan Embassy in Switzerland, the Ministry of Communications in Kabul, and the ITU. Purportedly, the ITU sent letters to Kabul, which were ignored or neglected due to war and civil unrest, and sent letters to the Afghan Embassy in Geneva that were not answered or forwarded to the appropriate

agency. This miscommunication resulted in other countries encroaching on Afghanistan's assigned orbital satellite slot, making 50°E less attractive as an investment to the types of companies the Ministry of Communications and Information Technology (MCIT) and the Afghanistan Telecom Regulatory Authority (ATRA) hoped to attract. However, the MCIT is now working with the ITU to address the infringements, reclaim its allocation, and enforce its spectrum rights. Also, the US Federal Communications Commission (FCC), via the Telecommunications Advisory Team (TAT), recommended Afghanistan look at the planned fixed satellite services (FSS) band, which Afghanistan has at 48 degrees (48°E), because it was not as heavily utilized and did not have as many encroachment issues.

By December 2011, the ITU had provided to ATRA listings of the filings near Afghanistan's satellite slot. However, the ITU Satellite Bureau had not received any comment from the MCIT or ATRA regarding requests from satellite providers with plans to occupy slots adjacent, near, or in Afghanistan's assignment. The TAT recommended ATRA develop a process to ensure prompt response to ITU requests and filings going forward. The TAT learned Monaco and Luxembourg were the two countries that initiated

---

<sup>1030</sup> Per data provided by the Afghan MCIT to the author during collaboration on an unpublished "Telecom Book."



the ITU coordination process with Afghanistan, but that neither of those filings directly affected Afghanistan's slot.

## Licensing Afghanistan's Orbital Satellite Slot

### History and Background

In 2009, ATRA released an international competitive tender requesting proposals to license the satellite Ku-band frequencies and Afghanistan's satellite slot; however, the offer did not receive any bids. In the following couple years, however, several companies expressed interest in the slot. Also, the Minister of Communications desired to utilize the slot to migrate off the expensive third-party satellite providers supporting the GCN, DCN, and VCN.

Licensing Afghanistan's orbital satellite slot would allow for the provision of fixed satellite-based ICT and broadcast services, including the extension of government services, to rural, and under- and unserved areas of Afghanistan. It would save Afghanistan hundreds of millions of dollars,<sup>1031</sup> and it would also allow GIRoA to generate revenue from the license and from fees and taxes from landing rights and the use of satellite transponder bandwidth by commercial vendors.

In 2010, an ICT subject matter expert (SME) at the Office of the Chief Information Officer of the US Department of Defense (DoD CIO), with prior career experience working at INTELSAT and COMSAT, was contacted by corporate officers of INTELSAT regarding the MCIT's potential interest in using its orbital spectrum allocation by the International Telecommunication Union (ITU), who agreed to connect INTELSAT with the Minister of Communications. The DoD ICT SME coordinated with the Senior Telecommunications Advisor (STA) based at the headquarters of the North Atlantic Treaty Organization's (NATO's) International Security Assistance Force (ISAF) to jointly review the INTELSAT inquiry with the Minister, which triggered a renewed look by the MCIT at a then-dormant consideration of having access to a satellite space segment with footprint(s) covering the Afghan landmass. The Minister shared his desire to identify existing or new space segment transponders to provide satellite based services in Afghanistan, where a solution could be identified that included a number of transponders providing free bandwidth to AfTel to further develop VCN capabilities on a subsidized basis across Afghanistan.

Around the same time (late 2010 or early 2011), AfTel wanted to build a second satellite hub for diversity, and it requested assistance from the TAT, which for several months in 2011 included a SATCOM expert on loan from the US Defense Information Systems Agency (DISA) headquarters,<sup>1032</sup> to further develop GIRoA's SATCOM architecture. That information was to serve as the baseline for developing options for recommendations to the Afghan Ministry of Communications and Information Technology (MCIT) to negotiate reclaiming its assigned orbital satellite slot, which had been encroached upon after decades of Afghanistan's neglecting communications from the ITU about frequency coordination in the slot. The

---

<sup>1031</sup> The Afghan MCIT estimated it pays US\$100 million per year and needs approximately 2,000 megabytes (MB) of capacity per year to provide communications service, per documents provided by the MCIT to the author in 2013.

<sup>1032</sup> Ms. Tania Wilkes, Division Chief, Satellite Gateway Operations (GO6).

Minister of Communications requested the TAT's assistance to help ATRA develop and issue a tender to license the slot.

## The Tender Process

The TAT began working with ATRA in the fall of 2011, with the assistance of DISA support contractor Ralph Puckett from [LinQuest Corporation](#), meeting first with ATRA to discuss the regulatory requirements for Afghanistan to maintain the primary rights to its orbital satellite slot and to assist in the development of a tender for licensing the slot to a satellite provider. The Minister of Communications requested the TAT conduct a public consultation (required by Afghan procurement law) to include other government agencies and the private sector so all were made aware of the SATCOM initiative. He also asked the TAT to write a short paper as the basis for the public consultation, describing the services that could be made available and the potential benefits to the Afghan people.

The TAT assembled a "tender team" comprised of members of the TAT, personnel from DISA GO6<sup>1033</sup> and LinQuest, a member of the ATRA Board of Directors, and the manager of the Afghan National Data Center (ANDC). The team prepared the draft for the public consultation and created a draft timeline for the tender process, both of which were approved by the minister in late October 2011. The consultation document was posted on the MCIT's and ATRA's websites for about a month, with comments originally due November 19, 2011. The tender team also provided the consultation to contacts at various satellite providers and the Global VSAT Forum for dissemination. ATRA originally planned to release the tender in December 2011. However, the comment period was extended through November 30, 2011, and the team learned the tender would be required to undergo a thirty-day legal review prior to release, so the target release date was changed to early February 2012.

ATRA and the MCIT received several inquiries in reference to the SATCOM public consultation, to which ATRA responded, posting the inquiries and answers to its and the MCIT's websites, again as required by Afghan procurement law. The MCIT forwarded several questions regarding co-occupancy to the ITU for clarification.

The TAT assisted ATRA to convene and hold a series of public consultations December 19-20, 2011, regarding the leasing of Afghanistan's orbital satellite slot. The meetings included representatives from the MCIT, ATRA, and AfTel, as well as private-sector mobile network operators (MNOs), Internet service providers (ISPs), and television and radio broadcasting companies. Key discussion topics included:

- the value of the satellite slot to potential vendors based on its footprint and ability to reach European, Middle Eastern, and Asian markets;
- the opportunity for potential revenue and transponder bandwidth by licensing the allotted slot;
- the need for Afghanistan to mature its relationship with the ITU, and to ensure communication and coordination regarding ITU requests, queries, and filings; and

---

<sup>1033</sup> Global Information Grid Operations, or GIG Ops

- the demand for capacity from commercial market segments in Afghanistan.

The TAT further assisted the MCIT and ATRA to develop a questionnaire that ATRA sent to the MNOs, ISPs, and broadcasters as a follow up to the public consultations. The responses helped the TAT to complete the draft tender.

Beginning in January 2012, the TAT assisted the MCIT to develop several important documents: a more comprehensive project timeline, a letter of intent, and a request for expressions of interest (EoI) in Afghanistan’s satellite slot. The purpose of the letter of intent was to notify the SATCOM industry of Afghanistan’s intent to license its ITU-

allotted slot at 50°E. Bureaucratic delays within the MCIT and ATRA, inclement weather in Kabul, and movement restrictions due to an adverse security situation delayed the finalization and release of the EoI until February 18, 2012, at which time it was posted on the MCIT’s and ATRA’s websites with responses



Picture 26: Public consultation on licensing Afghanistan’s satellite slot

(Photo courtesy of Mike Nichols)

due back March 18<sup>th</sup>. The EoI generated little interest and only a couple of questions: one from AsiaSat, a satellite operator based in Hong Kong that owns and operates a fleet of four in-orbit satellites, and the second from *TelecomFinance* magazine about the announcement, not about licensing the slot.

During the Minister of Communication’s confirmation hearing by Parliament on March 5, 2012, he mentioned the MCIT’s and ATRA’s SATCOM efforts, after which he was told Afghanistan’s orbital satellite slot is considered a national resource and, as such, any licensing or leasing of it must be vetted through the Office of the President prior to tender activities commencing, which meant the call for expressions of interest would have to be rescinded and re-announced upon official GIRoA approval. ATRA coordinated with the required offices to obtain the approval necessary to proceed, which was finally granted in mid-April 2012.

During the delay, the TAT assisted the MCIT and ATRA to meet ITU registration and “bring into use” requirements and to communicate with the ITU Asia-

**REQUEST FOR EXPRESSIONS OF INTEREST**

**License of Afghanistan's Allotted Satellite Slot at 50 Degrees East**

Afghanistan has launched an international competitive tender for a single license for the unrestricted use of its satellite orbital slot at 50 degrees east.

The Ministry of Communications and Information Technology (MCIT) is responsible for Information Communication Technology (ICT) development throughout Afghanistan. In order to facilitate rural ICT development and improve access to telecommunications services, MCIT has taken a decision to license its ITU-allotted satellite slot at 50 degrees east longitude, by virtue of an international competitive tender that will be conducted by the Afghanistan Telecom Regulatory Authority (ATRA). ATRA's intention is to make this slot available via license agreement to support both private and public telecommunications services. Furthermore, the scope of this initiative is to provide only the space segment and associated control segment. Provisioning of earth terminals and associated terrestrial infrastructure (i.e., the ground segment) is not within the scope of this requirement.

A wealth of information on the Afghan market, including demographics, the legal-regulatory framework and complete announcement and call for EOI, can be found, free of charge at: [www.atra.gov.af](http://www.atra.gov.af) and [www.mcit.gov.af](http://www.mcit.gov.af).

Figure 61: Call for expressions of interest in licensing Afghanistan’s satellite orbital slot

Pacific regional office in Bangkok. Meanwhile, DISA GO6, Lieutenant Colonel Jeffrey O'Donnell tried to reinstitute support for Afghan SATCOM efforts. Personnel from DISA also contacted satellite vendors to find out why they did not respond to ATRA's call for expressions of interest and to encourage them to respond when it reissued the EoI.

The second call for expressions of interest was posted to the MCIT's and ATRA's websites on or about April 28, 2012. It was also announced in the London edition of the *Financial Times* and the global print edition and online versions of the *Wall Street Journal* (see [Figure 61](#)). ATRA received inquiries from China, India, Turkey, and Sri Lanka, and ultimately received responses on or before the deadline of May 25, 2012, from APT, SuperNet, Eutelsat, AfghanSat, and SuperSat. However, the MCIT and ATRA claimed only three were official expressions of interest. A meeting the TAT facilitated for the Minister of Communications with the Satellite Industry Association (SIA) in Washington, DC in late June 2012 resulted in interest by a sixth company, NewSat. After conclusion of the evaluation period, ATRA notified qualified vendors with an offer to purchase the official satellite tender.

---

*A story initially published by Afghanistan's TOLONews on April 8, 2012, entitled, "Afghanistan to Launch Its First Space Satellite," erroneously stated the Minister of Communications planned to launch a satellite into space. This mischaracterization of the Minister's intent created quite a stir, which amused the minister, and may have indirectly increased interest in ATRA's efforts to license Afghanistan's orbital satellite slot.*

---

In mid-2012, ATRA sent a formal request to the Defense Information Systems Agency (DISA, one of the sponsors of the TAT) for an in-country SATCOM SME. Honoring ATRA's request, DISA contracted with LinQuest to provide in-country satellite expertise. Mr. Ralph Puckett made several trips to Afghanistan throughout the tender process.

The TAT provided ATRA with a copy of the proposed draft tender on May 9, 2012. According to the original timeline, ATRA was to have released the procurement notice in late June 2012 with responses due August 25, 2012, and the winning bidder announced October 1, 2012. However, ATRA did not release the tender<sup>1034</sup> until October 9, 2012 (and published it on its website October 10), with bids due December 9, 2012. The winner was expected to be announced and the license issued February 10, 2013. The TAT assisted ATRA to develop a license template, which it delivered to ATRA on November 16, 2012.

The MCIT/ATRA ultimately received proposals from three companies. The TAT forwarded the proposals to DISA GO6 for technical evaluation and recommendations. DISA GO6 developed a proposal/offer evaluation sheet and assembled a team to assess the merit of each proposal according to the requirements delineated in the procurement documents. ATRA took its time evaluating the proposals

---

<sup>1034</sup> MCIT, ATRA Legal and Licensing Affairs Department (2012). "Tender for the License of Satellite Communications Links Under Afghanistan Registration in Accordance with the International Radio Regulations." Afghan MCIT website, October 10, 2016. Accessed November 23, 2015. <http://mcit.gov.af/en/tender/13604>.

(with the TAT's, DISA's, and LinQuest's assistance). The Minister of Communications ended up negotiating with two of the three companies, each of which was offering a very different solution. Altogether, proposal evaluation and negotiation took over two years.



Picture 27: Signing ceremony for an agreement to launch AfghanSAT1, January 2014

## Countdown to Launch

On January 29, 2014, MCIT Minister Sangin (on right in [Picture 27](#)) signed a Memorandum of Understanding (MoU) with [Eutelsat](#) Chairman and Chief Executive Officer (CEO) Michel de Rosen (on left) for the deployment of Afghanistan's first satellite, AfghanSAT1 at 48° east longitude. According to Minister Sangin, the agreement allows Afghanistan to use six transponders carrying 54 MHz each, four of which are at no cost to the MCIT, and two of which are at an annual cost of US\$2 million each. The duration of the agreement is seven years, during which time the MCIT hopes to reclaim Afghanistan's orbital satellite slot at 50°E.

The footprint of AfghanSAT1 is extensive and covers large areas of the Middle East and neighboring Asian countries, which, it was thought, would be particularly attractive for Afghan television broadcasters. The MCIT expected to generate US\$15 million per year in revenue from mobile telephone, Internet, and broadcast services. The announcement of Eutelsat as the winning bidder concludes ATRA's international competitive tender process for the commercial lease of the slot.

At that time at least, the Minister intended to assign the responsibility for managing and reselling satellite bandwidth to a new division or subsidiary of AfTel, which was to be created in the near future. The author does not know if that ever happened, and those plans may have changed under the new Minister of Communications (Abdul Razaq Vahidi, who assumed office in April 2015). Eutelsat planned to move an existing satellite to the AfghanSAT1 orbital station within a month, and initiated plans to procure and install an earth station and other equipment required for the MCIT and AfTel to exploit its new national resource. Until then, Eutelsat has a Cyprus-based earth station on a six-month lease.

## *Blastoff and Blowback*

Finally, five years after ATRA issued the original tender to license its Ku-band frequencies, and two and a half years after the second tender, AfghanSAT1 (Eutelsat48D) was launched into orbit at 48° east longitude. It was officially inaugurated by the First Vice President of Afghanistan, Mohammad Yunus Qanooni, and MCIT Minister Sangin at a ceremony on May 10, 2014.<sup>1035</sup> AfghanSAT1 has a capacity of twelve transponders and an expected life of eight years (it was seven years old at launch). The MCIT claims it pays US\$4 million for AfghanSAT1 while generating US\$15 million in income from it.<sup>1036</sup> Reportedly, upon launch, ten television stations were broadcast via AfghanSAT1.<sup>1037</sup>

Not even a month after AfghanSAT1 made it to space, members of the Afghan Parliament (MPs) criticized the MCIT and ATRA for signing a contract for the satellite with the Afghan Broadcasting System (ABS) without going through the proper bidding process, claiming “Afghan media companies were not given the opportunity to gain from the launch of the satellite.”<sup>1038</sup> Afghan Broadcasting System is a new company, apparently with some relationship to [Asia Consultancy Group](#), because it is “a startup enterprise licensed by the government of the Islamic Republic of Afghanistan to build and operate the country’s only ... [digital terrestrial television] DTTV ... network.”<sup>1039</sup> The DTTV license was awarded to Asia Consultancy Group (ACG) in August 2013. Evidently, the MPs and media were worried about censorship,<sup>1040</sup> with ABS having broadcast rights via DTTV and AfghanSAT1. ATRA responded, defending itself and providing details of the DTTV procurement process (which are a matter of public record).<sup>1041</sup>

## Observations, Challenges, Lessons Observed, and Recommendations

The MCIT and ATRA can certainly add the launch of AfghanSAT1 to the list of their accomplishments and GIRA’s national resources. However, reports are that AfghanSAT1 has not achieved the commercial success the MCIT originally envisioned. In addition, the author is not clear if or how AfghanSAT1 is being used to extend ICT services into un- and underserved areas of the country (largely due to a lack of visibility into sector activities, particularly post-TAT).

The work the TAT did in SATCOM was born out of TAT’s having a satellite SME on its staff on loan from DISA for six months in 2011, in the person of Tania Wilkes, Chief of DISA’s Satellite and Gateway Operations, who deserves credit for recognizing Afghanistan’s satellite opportunities and reviving its

---

<sup>1035</sup> MCIT (2014). “Ministry Communications & IT Officially Opens Afghan Sat 1.” MCIT website, May 11. Accessed November 29, 2015. <http://mcit.gov.af/en/news/ministry-communications-it-officially-opens-afghan-sat-1>.

<sup>1036</sup> TOLONews (2014). “First Afghan Satellite Launched.”

<sup>1037</sup> Ibid.

<sup>1038</sup> Majidi, Syed Tariq (2014). “MPs Blast MoCI Over Satellite Contract.” *TOLONews.com*, November 4. Accessed March 6, 2016. <http://www.tolonews.com/en/afghanistan/16999-mps-blast-moci-over-satellite-contract>.

<sup>1039</sup> Afghanistan Broadcasting System (2016). Accessed March 6, 2016. <http://absglobalfzc.com/component/content/?view=featured>.

<sup>1040</sup> Ibid.

<sup>1041</sup> MCIT (2014). “MCIT rejects the News posted by Tolo TV about Digital Television Network.” MCIT website, November 5. Accessed March 6, 2016. <http://mcit.gov.af/en/news/mcit--rejects-the-news-posted-by-tolo-tv-about-digital-television-network>.

efforts. However, upon Ms. Wilke's departure, the TAT had to rely more on Reachback and contract SME resources for ongoing SATCOM technical support. While the solutions were workable and successful, the TAT had to learn how best to employ their assistance and how to integrate and validate their input. Using DISA Satellite Operations and commercial satellite communications (COMSATCOM) resources, as well as finding an SME who was familiar with the ITU processes, were examples of the TAT's flexibility and responsiveness to the MCIT's and ATRA's needs in Afghanistan.

The initial information provided by numerous resources on the number of operational satellites and the number of filings for satellites to be made operational in the +/-50°E orbital slot was not entirely accurate, causing the TAT to have to backtrack to obtain all the facts. Coordination between ATRA and the ITU has historically been poor, perhaps due, at least in part, to ITU correspondence going to the Afghan Embassy in Switzerland and not being forwarded to the MCIT or ATRA. The TAT stressed to ATRA the importance of communication with the ITU going forward. ATRA now has some dialogue with the ITU, but the relationship needs to continue to be nurtured.

Identifying to whom in the satellite industry the TAT could speak to understand what the industry thought of this opportunity and its value was another initial challenge. The TAT worked through this, reaching out to the ITU, the Satellite Industry Association (SIA), and the VSAT Forum. The TAT also expanded its resources to a wider group, including but not limited to DISA Satellite Operations, the Defense Spectrum Office (DSO), the ITU Asia-Pacific office in Thailand, and the ITU headquarters in Geneva. The TAT also interviewed vendors to include Intelsat, SES, AsiaSat, and Eutelsat. Utilizing DISA Satellite Operations reachback resources to connect to satellite industry, government, and relevant NGOs at a much earlier stage would have been beneficial.

Leveraging responses and information from satellite vendors was key in TAT's being able to communicate to ATRA that sound business processes, competitive pricing, and committing to and meeting milestone deadlines is what would be attractive to potential companies. Prospective satellite vendors were not going to invest the time and work required to respond to the calls for expressions of interest and resultant tender if they did not see ATRA's offering as a legitimate and lucrative opportunity. The TAT recommended the MCIT or ATRA hire a SATCOM consulting firm to assist with the establishment of regulatory policies as well as the development of management and sales strategies. Further, TAT advised ATRA members to discuss satellite regulatory activities, policy, and management when they travel abroad to meet with their counterparts in other countries and other regulatory agencies.

ATRA's lack of any templates for expressions of interest, tenders, and licenses caused significant delays, as ATRA had to identify legal, financial, and regulatory statements and agree on the format of documents. Much time and coordination could be saved if ATRA were to create and maintain templates for regulatory and business requirements.

While ATRA's engagement was consistent, the MCIT's engagement was very limited. The MCIT's involvement was necessary to define requirements as far as where to extend SATCOM services, what the bandwidth requirements were, to establish a satellite project management office (PMO), and to work ground segment requirements. Typically, SATCOM providers prefer to have anchor customers prior to

launch. Having the requirements and possible commitments earlier in the process may have facilitated the development of the tender.

While “Afghanistan time” is different – much slower – than Western time, the tender process was educational for both the TAT and ATRA on the Afghan procurement law. The SATCOM solution negotiations were a good learning experience for the Afghans, particularly since the three official offers were all quite different. The provisioning of earth terminals was not included as a requirement in the tender issued by ATRA, so they will likely need to issue another tender for those services, if they haven’t already.

Ultimately, the TAT’s SATCOM efforts in Afghanistan spanned all four years of its tenure and was a good example of continuity of TAT operations. It helped the TAT to build and maintain credibility with ATRA and the MCIT. They were also a good example of the use of reachback resources and SMEs on short-term in-country assignments.



## Chapter 9 Radio Spectrum in Post-Conflict Environments and Stability Operations - Afghanistan: A Case Study

---

Dr. Chi Nche and Karen E. Black

*Editors' Note: Some of the verbiage in this chapter is taken or paraphrased from the technical sections of a tender released by the Afghan Ministry of Communications and Information Technology (MCIT),<sup>1042</sup> which were written by Dr. Chi Nche, co-author of this chapter, and, thus, are not referenced.*

### Introduction to the Radio Spectrum

The radio spectrum is the part of the electromagnetic spectrum from 1 hertz (Hz) to 3,000 gigahertz (GHz), allocated for different radio communication services according to *Radio Regulations* (RR) of the International Telecommunication Union (ITU).<sup>1043</sup> Radio waves are a form of electromagnetic radiation. They are similar to visible or infrared light and make up a portion of the entire electromagnetic spectrum, which also includes gamma rays and x-rays. Unlike visible light, radio waves cannot be perceived by human eyes or ears, hence highly specialized test and measurement equipment is required to view and analyze these waves. Radio waves can pass through solid objects and travel long distances and are, therefore, very useful for wireless communication services such as mobile telephony, broadcast (television and radio), and satellite applications, just to name a few. It is generally understood that different parts of the radio spectrum are allocated for different radio transmission technologies and applications, as per the ITU. In most cases, parts of the radio spectrum are sold or licensed to operators of private radio transmission services (for example, cellular telephone network operators or broadcast television stations).

The radio frequency (RF) spectrum is a limited natural and national resource. The use of wireless communication systems in Afghanistan and globally is rapidly increasing, which has led to the continuous introduction of new and more complex communications technologies. Effective management of the radio spectrum is essential to prevent these systems from interfering with each other and also to maximize its use. Any form of interference limits the usability and efficiency of the radio spectrum in providing the communication services for which it was designed. The transmission, emission, and/or reception of radio waves for specific wireless communication purposes should be strictly regulated by the national administration and should be closely coordinated with military forces, both local and occupying. Close collaboration ensures military, government, and commercial communications systems can function efficiently in an interference-free environment.

---

<sup>1042</sup> MCIT (2015). "Tender for Comprehensive Spectrum Management System and Capacity Building (Training) Services for ATRA." Afghanistan Telecom Regulatory Authority (ATRA) website, January 10. Accessed February 11, 2016.

[http://atra.gov.af/Content/files/SPECTRUM\\_MANAGEMENT\\_TENDER\\_DRAFT\\_Date\\_24\\_2\\_2015\\_Modified\\_final.pdf](http://atra.gov.af/Content/files/SPECTRUM_MANAGEMENT_TENDER_DRAFT_Date_24_2_2015_Modified_final.pdf).

<sup>1043</sup> International Telecommunication Union (ITU) *Radio Regulations Articles*, Edition 2012.

Effective spectrum management can spur significant growth in all sectors of the economy, through the provision of efficient and reliable information and communication technology (ICT) services. In addition, governments all over the world use the radio spectrum as a source of considerable revenue. Income can be generated through special auctions to sell parts of the radio spectrum for commercial use (e.g., mobile phones), through licensing fees, and from yearly spectrum fees. These are in addition to the corporate taxes that are generally levied on the licensees. It is important to note there exists the possibility of negatively impacting a country's commercial ICT sector if spectrum fees are exorbitant. Rather than stifling development and growth at the outset by levying heavy licensing (and other) fees, governments can reap second-order income from ongoing usage-based taxes.

In Afghanistan, where very few landlines existed prior to the US-led invasion, and where the remaining terrestrial infrastructure was damaged, the use of wireless communication systems became – and still is – the most efficient method of providing voice, data, Internet, and broadcast services to foreign and local forces, the government, and the general population. Afghanistan, like many more recently-developed and developing countries, generally skipped over the deployment of large-scale copper infrastructure in favor of optical fiber and wireless technologies,<sup>1044</sup> with mobile phone penetration reaching 70 percent within ten years of the introduction of cellular service.<sup>1045</sup> The importance of wireless communications and the requisite spectrum management required for it should, therefore, be recognized and supported at the onset of all interventions and post-conflict and stability operations planning.

## Radio Spectrum in Post-Conflict Environments and Stability Operations

In post-conflict environments and stability operations, where modern communications systems did not previously exist or were damaged, or where effective management of the radio spectrum was never in place or is lacking, the spectrum situation can be complicated. This ecosystem is further obfuscated because the military uses some of the radio spectrum for C4ISR,<sup>1046</sup> and tries to deny communications services on specific frequencies for security purposes, which is called jamming. The most simplistic definition of a jammer is a device that is used to disrupt, deny, or prevent communication via the radio frequency spectrum by transmitting signals within the operational bandwidth of the system. In Afghanistan, the missions of foreign governments and international organizations, among others, also employed jamming at their compounds. Further, Afghan citizens employed inexpensive and readily-available jamming systems for personal protection. Jammers are even available for purchase by the public

---

<sup>1044</sup> State-owned Afghan Telecom Corporation has installed several hundred thousand copper telephone lines, used for both voice and low-speed data services, which are considered to be a status symbol by many Afghans.

<sup>1045</sup> Per the Afghanistan Telecom Regulatory Authority in data provided to one of the authors and published publicly at that time.

<sup>1046</sup> Command, control, communications, computers, intelligence, surveillance, and reconnaissance.

in local markets.<sup>1047</sup> The deliberate jamming of portions of the radio spectrum, therefore, adds a level of complexity that is not normally present in stable environments.

In typical post-conflict environments and stability operations, there is an influx of a multitude of different nations, embassies, United Nations (UN) agencies, commercial companies, military forces, etc., all with different equipment for wireless communication systems, some with regional standards that are not necessarily locally applicable, and even some highly-specialized equipment. This was definitely the case in Afghanistan. Some commercially available equipment is only approved for use in certain ITU regions, but was brought into Afghanistan. Without a cohesive plan to manage the use of the radio spectrum, the situation can become intractable.

### The Importance and Role of the Regulator

It is, therefore, important to consider the role of an independent national ICT regulator from the onset to manage, regulate, and coordinate all transmission and reception systems within the country. This regulator should be supported from the beginning to be technically capable as well as understand the importance of developing best practices and spectrum policies for the sector. A significant portion of this support should include legal guidance and governance advice. Apart from the obvious benefits of wireless communication systems operating in an interference-free environment, the national regulator can create an ICT sector environment that attracts local and foreign direct investment through the creation of ICT sector policies and regulations based on recognized best practices.

In post-conflict environments and stability operations, where military activities and security are paramount, the military usually has priority and control over the use of the spectrum (generally through host-nation agreements). However, the local government, the general population, businesses, and many other entities also need to use the spectrum for day-to-day communications. As such, a separate, recognized, experienced, and qualified team of experts is required. This team of experts should initially provide informed risk-management decisions for and later provide oversight to military frequency usage and jamming, provide a good framework for the management and control of what is designated as civilian spectrum (for both government and commercial use), as well as coordinate spectrum requirements with all stakeholders (military, donors, local government, foreign governments, UN agencies, etc.). This is a very important aspect that should not be overlooked. Appropriate coordination across these entities will create a more cohesive environment, as well leverage individual projects being implemented by them. This does not take away the importance of the role of an independent national regulator. The main objective is to have a team that is capable of coordinating all spectrum issues across all the various agencies within the area of responsibility (AoR) and to develop the affected nation's capacity to coordinate all spectrums.

---

<sup>1047</sup> At meeting in June 2013, an ATRA Board Member told the TAT he had purchased a jammer for the protection of his family, anticipating an increase in bombings and violence leading up to the Afghan presidential election in 2014. He said it was common practice and jammers were readily available.

## Radio Spectrum in Afghanistan

### Afghanistan's Spectrum Region and Frequency Allocations

Afghanistan is situated in ITU Radio Region 3, as depicted on the map in Figure 62, and is assigned frequencies between 3 kilohertz (kHz) and 300 gigahertz (GHz), along with some “special allocations.” It follows the ITU radio-frequency band allocation standard.<sup>1048</sup>

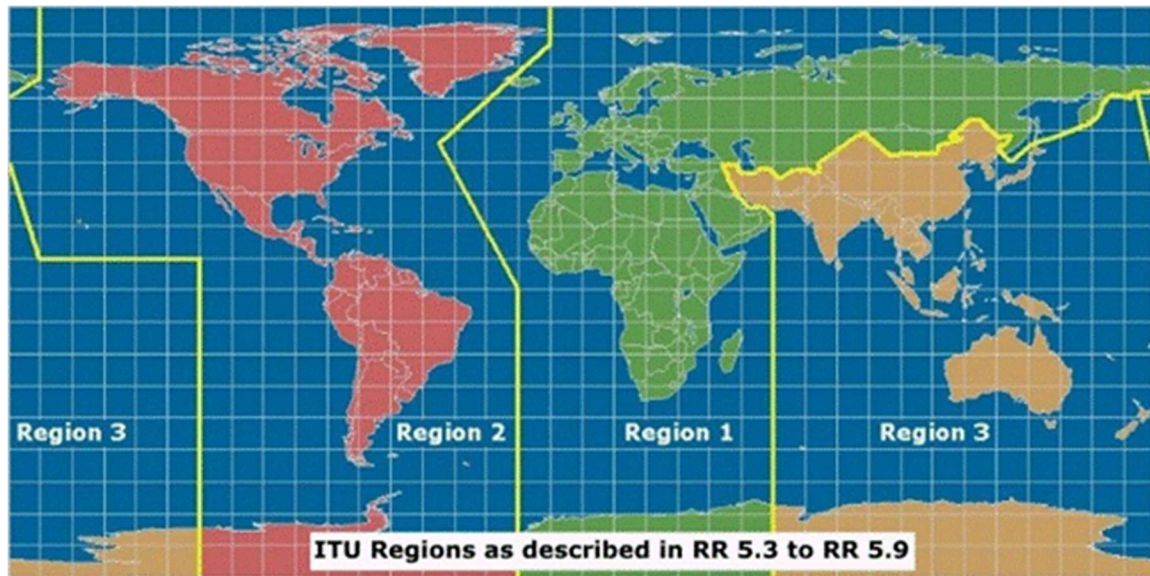

Figure 62: ITU spectrum regions

Afghanistan has a national frequency allocation table (FAT), which it calls its Radio Frequency Spectrum Allocations chart, originally published in 2003 by the Ministry of Communications (MoC) State Radio Inspection Department, as a separate telecommunications regulator was not formally established until later. (See Chapter 4, *ICT Institutions and ICT Sector Governance*, and Chapter 5, *ICT Policy and Regulatory Framework*, for more information.)

### Early Spectrum Use and Governance

Afghanistan's State Radio Monitoring Board at the Ministry of Communications established a “Regulation for the Use of Radio Frequencies and Radio Communications Equipment in Afghanistan” in 1982,<sup>1049</sup> which gave it the authority to devise specifications and grant licenses for the use of radio frequencies as well as

---

<sup>1048</sup> There are other standards, such as the Institute of Electrical and Electronics Engineers (IEEE) radar-frequency bands and the European Union, NATO, and US Electronic Countermeasure (ECM) designations.

<sup>1049</sup> MCIT (n.d.). Regulation for the Use of Radio Frequencies and Radio Communications Equipment in Afghanistan. Accessed December 3, 2015.

[http://mcit.gov.af/Content/files/Radio\\_Frequencies\\_and\\_Radio\\_communication\\_Regulation-Eng.pdf](http://mcit.gov.af/Content/files/Radio_Frequencies_and_Radio_communication_Regulation-Eng.pdf).

monitor its use and investigate interference complaints relating thereto. It also specifies fees for VSAT<sup>1050</sup> and other satellite terminals, according to number, size, and capacity, but not spectrum use.

Satellite Internet service over VSAT began almost immediately after the toppling of the Taliban government by the US-led Coalition in December 2001, which preceded any practical formal authority over Afghanistan's electromagnetic spectrum, but not for long. Article IV, item five of the Military Technical Agreement (MTA) between ISAF and the Interim Administration of Afghanistan, signed January 4, 2002, states, "The ISAF will have the right to utilise such means and services as required to ensure its full ability to communicate and will have the right to the unrestricted use of all of the electromagnetic spectrum, free of charge, for this purpose. In implementing this right, the ISAF will make every reasonable effort to coordinate with and take into account the needs and requirements of the Interim Administration."<sup>1051</sup>

Commercial cellular telephone service was introduced to Afghanistan in April 2002 by AWCC, shortly before Interim President Hamid Karzai signed Presidential Decree 4517 in July of the same year, giving the Ministry of Communications (MoC) of the Afghan Transitional Administration (ATA) legal authority to create a licensing regime that would allow private companies to use spectrum to provide ICT services to the public. As ICT services exploded in post-war Afghanistan, particularly mobile telephony, it was imperative radio spectrum management keep pace with developments in the sector.

The MoC's Telecommunications and Internet Policy of 2003 listed as a target to "maximize the use and value of radio frequency spectrum." It addressed both licensed and unlicensed spectrum and introduced the concept of spectrum licenses and spectrum fees. Afghanistan's Telecommunications Services Regulation Act of 2005 (commonly known as the "Telecom Law") gave its nascent regulator, then the Telecom Regulatory Board (TRB) and later the ATRA, responsibility over all operational facets of spectrum, including policy, licensing, and assignment.

By the end of 2006, six companies were licensed to offer commercial cellular telephone services, there were more than 25 Internet service providers (ISPs),<sup>1052</sup> and radio stations had proliferated around the country, all of which were utilizing spectral resources. With the explosion of ICT services in Afghanistan, particularly mobile telephony, effective spectrum management was crucial. For more information, see [Chapter 5, ICT Policy and Regulatory Framework](#), and [Chapter 3, ICT in Afghanistan](#).

---

<sup>1050</sup> Very small aperture terminal, a two-way satellite ground station with a dish antenna generally smaller than three to four feet.

<sup>1051</sup> Military Technical Agreement Between the International Security Assistance Force (ISAF) and the Interim Administration of Afghanistan ("Interim Administration") (n.d.). Accessed August 3, 2016. <http://webarchive.nationalarchives.gov.uk/+http://www.operations.mod.uk/isafmta.pdf>.

<sup>1052</sup> Adapted from Global Internet Policy Initiative-Afghanistan (GIPI-AF) Team (2006). *Promoting Internet Policy and Regulatory Reform in Afghanistan. Assessment Report*, December 2006, 14.

## Afghanistan's Spectrum Bands

As mentioned above, the MTA of 2002 gave ISAF the authority to manage all of Afghanistan's spectrum, including the Coalition Forces' and Afghan National Security Forces' (ANSF's)<sup>1053</sup> frequencies. Further, all Afghan government and commercial spectrum use was required to be de-conflicted through ISAF. A 2009 Memorandum of Agreement (MoA) between ISAF and ATRA, the telecommunications regulator, gave ATRA the responsibility to manage the civil and commercial spectrum band while the ISAF Theater Frequency Management Cell (TFMC) retained the authority to manage all military spectrum bands. The MoA also created a third, shared band and called for the TFMC and ATRA to coordinate collectively on the assignment of all spectrum within the shared band.

The addition of the shared band was an ad hoc, temporary solution, which deviated from ITU Radio Region 3 standards, thus complicating matters. It was necessary because the NATO Nations are in ITU Radio Regions 1 and 2, and the military allocations in those regions conflict with the civil/commercial bands organic to Region 3, to which Afghanistan is assigned.

The shared band was eliminated at the end of 2014 upon the transition of military spectrum management from ISAF to the Government of the Islamic Republic of Afghanistan (GIROA), as described below. It should be noted that although eliminating the shared band was a brilliant idea, it required tremendous planning and close coordination between ATRA and NATO. This process was not optimally managed, resulting in some operational problems. For example, some frequencies that were within the shared band and allocated for government or commercial use are now within the military band are not accounted for in the military database.

## What is Radio Spectrum Management?

Radio spectrum management is the overall process of administering and regulating the use of the radio frequency spectrum with the sole purpose of maximizing the efficient use of this resource for radio communications services through a combination of administrative, regulatory, and technical procedures. The radio spectrum is a finite resource and its use is limited by noise sources, both natural and manmade. The latter includes problems caused by poor equipment configurations, non-standard collocation of equipment, co-channel interference, inter-system interference, equipment compatibilities, and even deliberate interference introduced for jamming and service denial. Good spectrum management encompasses and addresses all these challenges.

The basic principle of spectrum management starts with the creation of a national frequency allocation table (FAT), which, in most cases, is governed by ITU rules and regulations. The ITU rules and regulations

---

<sup>1053</sup> Afghan National Security Forces (ANSF) is a collective term for all military and police forces in Afghanistan. The ANSF includes the Ministry of Interior (MoI) and the Afghan National Police, Afghan Local Police, and Afghan Border Police under it; the Ministry of Defense (MoD) and the Afghan Armed Forces under it; and the National Directorate of Security (NDS). After 2014, the end of which signified the transition of NATO's International Security Assistance Force mission to its Resolute Support mission, it is often referred to as the ANDSF, the Afghan National Defense and Security Forces.

clearly designate different portions of the radio spectrum for civilian, military, or shared use and the type(s) of radio service to be deployed within the different frequency bands. The FAT for each nation differs slightly, depending on its ITU region designation. The national government then delegates spectral resources internally within the country. Generally, in post-conflict environments and stability operations, military bands are managed by the military, and its spectrum-management cell is responsible for assigning frequencies to the various military units within its area of responsibility. Civilian spectrum is normally managed by a national ICT regulator or similar such body, and should adhere to the general norms provided by the ITU.<sup>1054</sup> Military and civilian spectrum managers have significantly different objectives for what is considered effective and efficient management of the radio spectrum. In addition, the military generally includes spectrum-related resources in its budget, whereas the civil sector relies on other sources of funding, such as spectrum license and use fees.

### Military Spectrum Management and Coordination

Generally, military forces use more advanced and specialized equipment for command and control as well as for intelligence, surveillance, and reconnaissance. Its goal is to limit the interference generated across the spectrum so that deployed systems can function as designed. For a multitude of security reasons, military forces and law enforcement may try to deny wireless communications services through deliberate radio frequency jamming. Military forces generally have a spectrum manager in theater, who is responsible for all spectrum management activities.

Military spectrum management is relatively easier than civilian/commercial spectrum management, as it requires management of frequencies for its operational and security needs and there is no need to manage billing or enact complicated rules and policies to manage hundreds of private operators. Some coordination is required with the civil frequency managers, but the military does not have to deal with private requests for spectrum allocation. In addition, the military is not bogged down with license fees, license renewals, or ensuring entities meet requirements set forth in licenses, nor for any emission policies. This makes the process simpler and more dependent on spectrum engineering for frequency deconfliction and to avoid interference among the military's various systems deployed in theater.

In times of conflict, military spectrum management is complicated by the need of local forces to use frequencies too. The coordination process between local and foreign forces is not flawless, which can lead to serious interference problems. Such is the case in Afghanistan, where interference problems are generally caused by the lack of spectrum knowledge within the ANSF. The complexity increases where

---

<sup>1054</sup> In the United States (and some other countries), military spectrum bands are governed by a non-military entity. In the US, the National Telecommunications and Information Administration (NTIA), an agency of the Department of Commerce (DoC), assigns and regulates frequencies for all federal entities, including the military, and the Federal Communications Commission (FCC), has authority and control over the commercial spectrum. In other countries, civil authorities control all spectra, and military entities must negotiate to have access to and maintain their spectrum resources.

joint forces from different branches of the military and even from different nations, such as the NATO and Troop Contributing Nations (TCNs) in Afghanistan, are utilized.

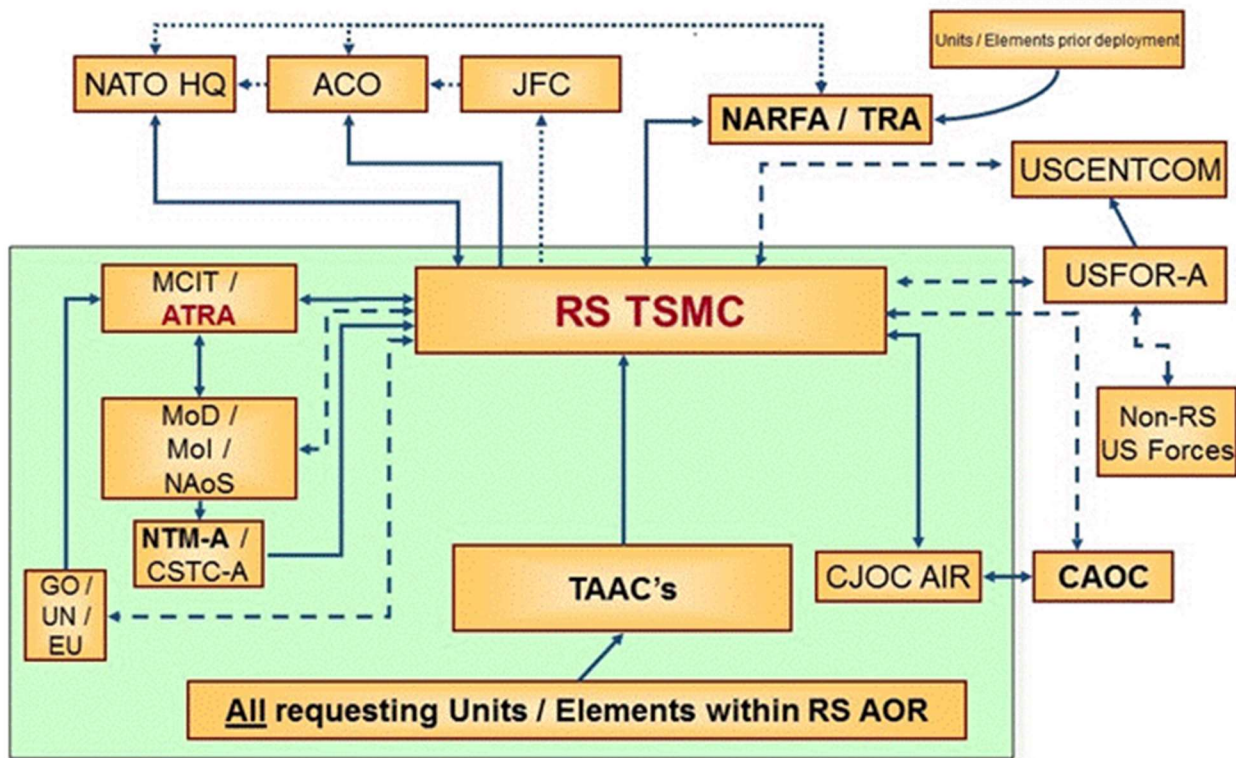

Figure 63: NATO spectrum management coordination process for Afghanistan

Figure 63 shows the military spectrum management coordination chart that primarily focuses on fulfilling military requirements, but it also clearly shows the level of coordination required between civilian and military entities. With the complete transition of military spectrum management to GIRoA at the end of 2014, continuous coordination is enabled through the Ministerial Spectrum Management Office (MSMO), which is comprised of spectrum managers from the Afghan Ministries of Defense and Interior (MoD and MoI, respectively), the National Directorate of Security (NDS), and ATRA with support from NATO’s Resolute Support (RS) Mission. The MSMO is described in more detail below.

### Civilian Spectrum Management and Coordination

Per general best practices, the regulator or agency responsible for civilian radio spectrum management should be independent, transparent, and capable of developing policies and regulations that create an ICT environment that encourages competition, spurs private investment, and allows for the introduction of new technologies and applications. It should understand how the ICT sector can generate government revenue, boost the economy, and provide communications services for its people, as well as be used for national security.



The main objectives of civilian spectrum management are to use the radio frequency spectrum effectively and efficiently in an interference-free manner, provide guidelines for the use of transmission and reception devices, generate government revenue, and, most importantly, create policies and regulations to create an environment to drive the ICT objectives of the government. Coordination is also required with the military frequency managers to avoid interference and to utilize the radio spectrum efficiently. In Afghanistan, there are instances when the civilian spectrum manager may need to use frequencies within designated military bands and vice versa. Close coordination through a defined process of the MSMO is required to eliminate any potential conflicts.

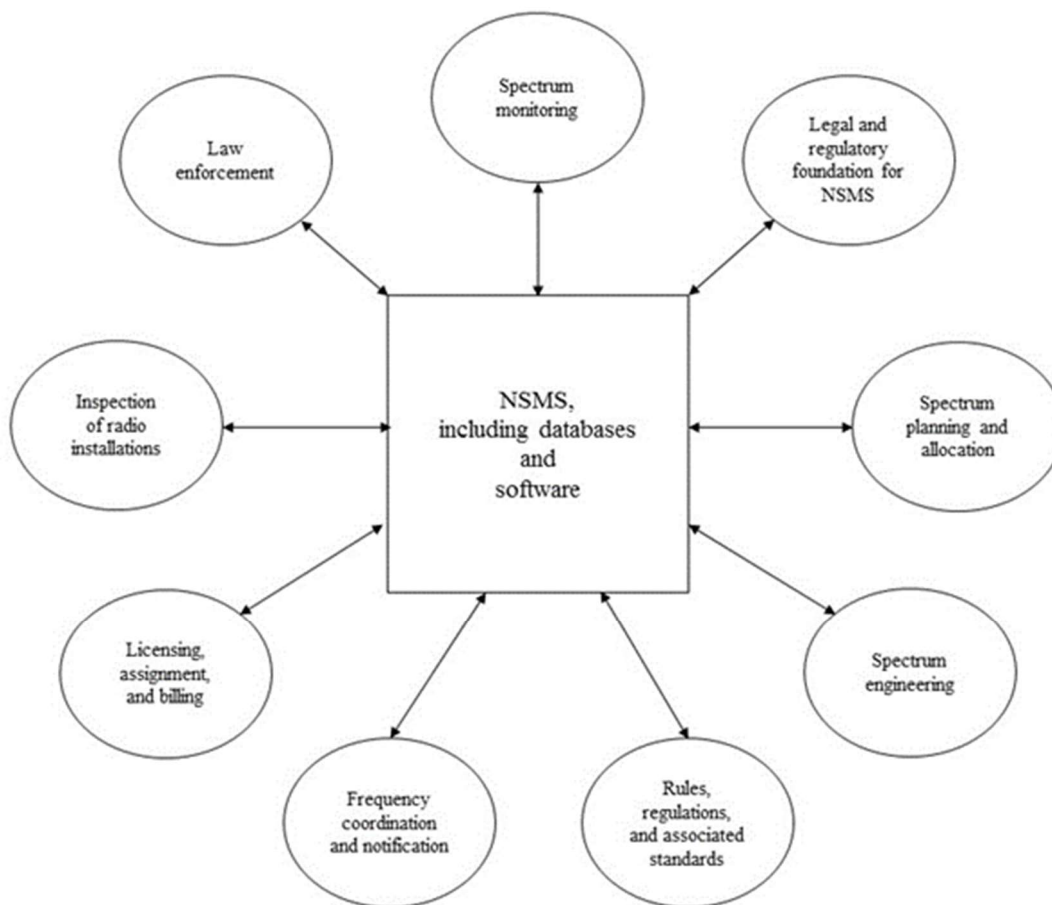

Figure 64: ITU Typical national civil spectrum management system

[Figure 64](#), from the ITU Spectrum Monitoring Handbook,<sup>1055</sup> depicts a typical civil national spectrum management system. This figure clearly shows the various elements that must be developed and implemented to ensure an efficient and effective national spectrum management system. A

---

<sup>1055</sup> International Telecommunication Union (ITU) *Radiocommunication Bureau Handbook, Spectrum Monitoring*, Edition 2011.

comprehensive spectrum management system will benefit the state economically, as it enables the provision of reliable ICT services to its people.

In Afghanistan, ATRA is tasked with national civil spectrum management as well as coordination with the security entities through the MSMO as depicted in [Figure 63](#). ATRA is currently performing all the functions shown in [Figure 64](#). However, gaps exist in many areas due to lack of technical, rules, procedural, and policy knowledge, as well as the lack of equipment and software. Some areas with significant deficiencies follow:

- Spectrum monitoring
- Quality of Service (QoS) monitoring
- Spectrum planning and allocation
- Spectrum engineering
- Frequency coordination and notification
- Frequency conflict mediation processes and procedures
- Inspection of radio installations
- Software, including databases
- Development and implementation of policies and rules
- Understanding the functions of a regulator

As indicated in [Figure 64](#), a comprehensive civil spectrum management system encompasses technical, financial, and regulatory functions, among others. However, ATRA often conflated these functions, rather than delegating, e.g., technical functions to technical people and accounting functions to financial people, to their detriment. In addition, the availability of qualified and well-trained staff is a major problem. Qualified staff should be continuously trained and retained to meet the spectrum management needs, as new technologies are continuously being introduced.

It should also be noted, due to Afghanistan's relatively recent introduction into the Information Age, ATRA remains fairly closely attached to and controlled by the Ministry of Communications and Information Technology (MCIT). Although this relationship was useful at a certain point in time, primarily because the MCIT had more qualified staff, including a minister with an ICT background, the general perception is that ATRA is not as independent as it should be. This presents a major trust issue for the private sector that is exacerbated by the fact that the MCIT owns Afghan Telecom Corporation (AfTel) and 20 percent of AWCC, both of which offer 3G<sup>1056</sup> mobile broadband service in direct competition with all other mobile network operators (MNOs). Further, AfTel is the monopoly optical fiber supplier in the country (although that may change soon when the MCIT and the Afghan government promulgate its Open Access Policy; see [Chapter 5, ICT Policy and Regulatory Framework](#)).

---

<sup>1056</sup> Third-generation wireless digital technology based on International Telecommunication Union (ITU) International Mobile Telecommunications (IMT)-2000 specifications.

## Transition of Military Spectrum Management from ISAF to GIRoA

By agreement at the Lisbon Summit in 2010, the United States and other ISAF nations committed to transition full responsibility for security and other military functions from Coalition forces to the Afghans by the end of 2014. As such, GIRoA was to assume full responsibility from ISAF for the management of all RF spectrum used by the Afghan military and police (then the ANSF, now the ANDSF as indicated above), by December 31, 2014. Additionally, the ANSF had to assume responsibility for jointly managing shared military-civil spectrum in cooperation with ATRA, which manages Afghanistan's civil spectrum.

Beginning in mid-2011, the Telecommunications Advisory Team (TAT) played an instrumental role as liaison among ISAF, the NATO Training Mission-Afghanistan (NTM-A), and ATRA, regarding the transition of military spectrum management responsibilities. The TAT socialized with ATRA and the Minister of Communications the concept of establishing a separate entity tasked specifically with military spectrum management and walked them through how such an arrangement would work.

In the spring of 2012, the Spectrum Transition Working Group, consisting of representatives from the ISAF Spectrum Management Bureau (SMB), ISAF Joint Command (IJC), NTM-A, and the TAT (and later other organizations, such as the Afghan Ministries of Defense and the Interior, the NDS, and the US Agency for International Development (USAID)), was established and began meeting weekly to plan for and synchronize all matters, including training, required to prepare the Afghans for the responsibility of managing their electromagnetic spectrum.

### Establishing the Ministerial Spectrum Management Office

In March 2012, ATRA and the MCIT formally approved the establishment of a new Ministerial Spectrum Management Office (MSMO) at ATRA, which was to be responsible for inter-ministerial collaboration on spectrum use. The MSMO was to define policy and guidance for military and police spectrum and coordinate with ATRA on the use of shared frequency bands. The MSMO was to be jointly staffed by personnel from ATRA and the ANSF. However, ATRA's *tashkeel* (essentially the human resource allocations) for the MSMO was not approved, nor was ATRA able to identify an appropriate line of funding for spectrum management tools for the MSMO. In the absence of an approved *tashkeel* for the MSMO for SY<sup>1057</sup>1391 (March 2012 to March 2013), ATRA agreed to lend two of its personnel to the organization temporarily.

Challenges notwithstanding, ATRA began drafting a memorandum of agreement (MoA) among itself, ISAF, and the ANSF to establish all relevant agencies' roles and responsibilities with regards to the MSMO and to ensure the MSMO would be operated in a manner consistent with spectrum policy and relevant laws.

In late 2011, stakeholders were already discussing Spectrum XXI (SXXI) as the spectrum management platform of choice for the MSMO. The acquisition process for 40 client and two service systems, ostensibly began in February 2012 but it was not until late July 2012 that it was agreed the procurement process

---

<sup>1057</sup> Solar year

would be led by NTM-A (rather than the Defense Spectrum Office, DSO) and proceed under the Foreign Military Sales (FMS) Program.<sup>1058</sup> In the fall of 2012, the NTM-A Council of Colonels earmarked US\$1M for SXXI software, servers, desktop computers, and training, the release of which was contingent upon the signing of a memorandum of understanding (MoU) among the three security ministries detailing the management responsibilities and processes of the MSMO (which was different and separate from the aforementioned MoA), as well as charter for the new entity. NTM-A's funding, however, covered only the MoI and MoD, not the NDS, which would be required to purchase its own software licenses and hardware (or find funding for such). The TAT worked with NTM-A, ISAF CJ6,<sup>1059</sup> and the security ministries on the development of the MoU.

---

*In June 2012, TAT Director Colonel Elizabeth A. (Beth) Bierden, USA, briefed General John Allen, USMC, Commander of ISAF, on the ICT sector and the TAT's work in it. General Allen commented on how important military spectrum management was for ISAF's command and control and indicated his support for the TAT's efforts regarding the Afghanistan Telecom Regulatory Authority (ATRA) and the Ministerial Spectrum Management Office (MSMO).*

---

In July 2012, the TAT proposed to the Spectrum Transition Working Group and ATRA's Spectrum Director two recommendations: (1) The ANSF establish a spectrum management bureau, similar to the ISAF SMB, to manage military and police spectrum requirements; and (2) ATRA assign specific military bands to the ANSF and delegate authority to the ANSF for their allocation and management.<sup>1060</sup> More specifically, the latter recommendation was to attempt to push the ANSF to use the military bands already designated in the ITU Radio Region 3 allocation. However, this was complicated by the fact the Afghans were procuring spectrum monitoring and managing equipment from nations outside of Region 3, which was produced to operate on the military ranges of the country where they were developed, which ranges did not always line up with Region 3. This incongruence implies Afghanistan may have to develop a new national frequency allocation table.

The TAT's recommended approach eliminated the need for ANSF personnel to be physically located at ATRA (where the new MSMO was to be established) and the need for a common software platform, allowing ATRA to proceed with Spectrum Management System for Developing Countries (SMS4DC) while the ANSF adopted SXXI. The SXXI software and associated hardware would only be fielded to the ANSF under the direct mentorship of NTM-A. ATRA embraced the idea, and after the requisite approvals within ATRA and the MCIT, amended the MoA – still in draft, and under circulation and review within GIRoA at the time – to reflect it.

---

<sup>1058</sup> ISAF Telecommunications Advisory Team (TAT) Weekly Reports, February 2 and August 8, 2012.

<sup>1059</sup> Combined Joint Communications and Information Systems

<sup>1060</sup> ISAF TAT summary of meeting among representatives from the TAT, ISAF SMB, ISAF CJ6, and ATRA, July 2, 2012 and TAT Weekly Report, July 5, 2012.

The TAT distributed the MoA, which had been vetted and approved by the relevant GIRoA agencies, at a meeting of the ISAF Frequency Management Board (FMB) September 18, 2012 and requested comment by October 15. ATRA agreed to provide a second MoU to NTM-A and ISAF CJ6 regarding ATRA's intention to release military spectrum to the ANSF. The parties agreed the goal was for the MSMO to be operational no later than March 2013 so ISAF CJ6 and NTM-A would have time to train and mentor the ANSF.



*Picture 28: Signing of an MoA establishing the Ministerial Spectrum Management Office*

*(Photo courtesy of Brice Hall)*

Beginning in September 2012, the TAT, NTM-A, and ISAF CJ6 began drafting a proposed charter for the MSMO. The focus of the charter was on the frequency allocation table, the composition of the MSMO (personnel from the Afghan security institutions and ATRA), and the process for transition of frequency from ISAF to the MSMO. It also included the spectrum assignment process, assignment authority within the MSMO, as well as the specific roles of each of the security entities.<sup>1061</sup> Key stakeholders within both the Coalition and GIRoA supported having the Afghan MoD act as the lead assignment authority for the MoD, MoI, and NDS, at least at the operational level, and reiterated the need for a separate MoU reflecting such.<sup>1062</sup> The TAT and NTM-A worked with GIRoA officials to determine if an agreement to give MoD full assignment authority over the military spectrum needed to be codified into law, as there was concern that inter-ministerial agreements may not be strong enough to stand the test of time.<sup>1063</sup>

---

<sup>1061</sup> TAT Weekly Report, October 3, 2012.

<sup>1062</sup> TAT Weekly Reports, August 8 and September 9, 2012.

<sup>1063</sup> TAT Weekly Report, August 16, 2012.

On November 20, 2012, Brigadier General (BG) William Scott, Director of ISAF CJ6, attended the ISAF FMB meeting, the purpose of which was to finalize the MoA among the security ministries. BG Scott stated the importance of the MoA and offered his and ISAF's full support. The following week, the FMB convened a special meeting with representatives from ATRA and the MoD, Mol, and NDS to secure concurrence among the three security entities on the final version of the MoA establishing the MSMO as the official entity for security- and defense-related electromagnetic spectrum. The representatives agreed to the MoA and formally agreed the MoD would be the lead organization managing the MSMO. ATRA agreed to allocate portions of the spectrum and assignment authority for it to the MSMO.<sup>1064</sup>

On December 19, 2012, ISAF hosted a ceremony at which representatives from ISAF, ATRA, and the Afghan security institutions signed the MoA officially establishing the Ministerial Spectrum Management Office. Signatories were BG Scott (in the center at the table in [Picture 28](#)); Engineer Abdul Wakil Shergul, Chairman of the ATRA Board of Directors (on right); Major General (MG) Iqbal Ali of the Afghan MoD; BG Haidar Samim of the Afghan Mol; and MG Massoud Andarabi of the Afghan NDS.

## Next Steps

Immediately after the accomplishment of establishing the MSMO on paper, efforts turned toward logistics and tactical issues, namely equipping, staffing, and training the MSMO. Stakeholders were pushing to have the MSMO charter ready for signature by February 5, 2013 so NTM-A could release the funds to purchase SXXI spectrum management software and related hardware. Discussion ensued regarding the need for a tool to bridge the gap until the MSMO obtained SXXI. ISAF CJ6 recommended the ANSF utilize Mercury, a spectrum coordination application developed by the US Department of Defense (DoD) in response to a capability gap: the need to coordinate spectrum use with host nations during humanitarian and disaster relief (HADR) operations. While Mercury is not a spectrum management tool, it offers some basic spectrum management functions and allows users to request and receive frequency assignments via an unclassified web-based environment.<sup>1065</sup>

Training the ANSF was the NTM-A's concern, but the TAT worked to identify training opportunities, both immediate and sustainable, for ATRA. The TAT suggested spectrum training at the US Telecommunications Training Institute (USTTI) and also proposed exchange and partnership programs with other countries; ATRA ultimately agreed on Turkey as a good candidate. The TAT leveraged Turkish military associates at ISAF to arrange meetings with the Turkish Information and Communication Authority (ICTA), or Bilgi Teknolojileri ve İletişim Kurumu (BTK) in Turkish. ICTA has partnerships with 16 countries and was interested in working with Afghanistan. The chairman of ICTA issued invitations to the MCIT Minister, ATRA Chairman, and two additional Afghans (which were ATRA's Director of Spectrum Management, and another ATRA spectrum employee), to host them – with lodging and some meals paid but not

---

<sup>1064</sup> TAT Weekly Reports, November 21 and 28, 2012.

<sup>1065</sup> Meccia, Major Tom (2012). Defense Information System Agency (DISA) Joint Spectrum Center (JSC) presentation. Accessed December 7, 2015.  
[http://energy.gov/sites/prod/files/Tuesday\\_Cedars\\_1545\\_Meccia\\_JSC%20Brief%20DOE%20CONF2012V2.pdf](http://energy.gov/sites/prod/files/Tuesday_Cedars_1545_Meccia_JSC%20Brief%20DOE%20CONF2012V2.pdf).

transportation to and from Istanbul – to attend a series of ICT/regulatory conferences in May 2013, one at which a speaker from the ITU was slated to discuss spectrum regulation issues.

The TAT also connected ATRA with the Turkish equivalent of the MSMO, the Scientific and Technological Research Council of Turkey, also known in Turkey as the TÜBİTAK, which is responsible for Turkish military spectrum management. While in Turkey for the conferences, ATRA received a demonstration of MARSsys, TÜBİTAK's spectrum management software, which is utilized by over a dozen countries. MARSsys conforms to NATO and ITU standards, but is not compatible with SXXI. However, ATRA considered MARSsys as a potential tool for civil and shared spectrum management.

In March 2013, NTM-A announced it would officially fund the purchase of SXXI software and related hardware, as well as training for the MoD and MoI. The US Defense Information Systems Agency's (DISA's) Joint Spectrum Center (JSC) planned to configure and ship the SXXI server by August 2013, and planned to send at least one server technician to Kabul to install and configure the server at the MoD network operations center (NOC) with the intention of connecting it to the other security entities via ANSFnet, a wide-area network (WAN) linking Afghanistan's security institutions. Prior to installation, the NATO Spectrum School was to provide a three-week training course that covers advanced spectrum management theory and SXXI usage to personnel at the Afghan MSMO, during which ATRA was to provide a one-day course covering host nation rules and regulations. For various reasons, implementation of the SXXI hardware and software was delayed for many months. One such reason was that site surveys of locations at which equipment was to be deployed were not completed until September 2013 (although there were many others).

Between June 8 and 26, 2013, the NATO Communication Information System School (NCISS) in Latina, Italy conducted spectrum training for the MoD. The instructors had to bring the spectrum training software with them, since the MSMO's had yet to be installed, and erased it after the course. The first group of 15 students focused on basic spectrum management, while the second, consisting of seven students, focused on gaining a basic understanding and operational baseline of the Spectrum XXI software. All 22 trainees were expected to begin work at the MSMO upon the completion of training. NCISS conducted further training in December 2013. A third, advanced training course for MSMO personnel who completed December's training took place between February 12 and March 12, 2014. Eight trainees (two each from the MoD, MoI, and NDS, as well as two from the Afghan National Army) completed the four-week course on Spectrum XXI software. The MSMO desired two additional month-long training sessions be held during 2014 that would include live operations on SXXI once it was installed. At some point, ATRA personnel participated in Spectrum XXI training. The Spectrum Director later admitted to the TAT the software was too complicated for ATRA's current spectrum managers to learn and use.

In February 2014, the TAT arranged for the DISA Support Element in Kandahar to install SXXI servers at ISAF and the MoD, connect them to the ANSFnet fiber, and train personnel on the Help Desk Utilities software. Finally, on March 12, 2014, the MSMO, which had relocated from ATRA to MoD headquarters at some point, had an installed and working SXXI server and was able to share frequency files with ISAF via ANSFnet. This marked the initial operating capability (IOC) of the MSMO and was a critical step towards the Coalition handing off management of military spectrum to the Afghans.

NTM-A conducted another training session in February 2015 for SXXI and spectrum analyzers with over 20 students from the MoD, the MoI, the NDS, and ATRA graduating. Another six-week training session was scheduled for January 2016. This course covered spectrum management, spectrum analyzers, and SXXI.

### Post-2014 Memoranda of Agreement

The final steps in transitioning military spectrum management from ISAF to GIRoA involved GIRoA determining how to handle future spectrum coordination with foreign forces and the drafting of two additional memorandums of agreement regarding spectrum-related operations after transition (post-2014): one between the MoD and ATRA, and another between ISAF and the ANSF (referred to above as MoUs, as they were called that at the time).

### Future Coordination with Foreign Forces

ATRA and the MSMO worked with the Afghan Ministry of Foreign Affairs (MoFA) to develop and sign a coordination letter(s) that outlined the basis for future spectrum agreements with foreign forces.



*Picture 29: Signing ceremony for an MoA between ATRA and the Afghan MoD regarding post-2014 spectrum management*

*(Photo courtesy of the MCIT)*

### MoA between the MoD and ATRA

Beginning in June 2013, the TAT, ISAF SMB, and the MoD discussed the drafting of an MoA between the MoD, as managing entity of the MSMO, and ATRA for post-2014 operations to assuage the MoD's concerns regarding the allocation of future spectrum, particularly since some of its equipment requires permanent assignments, and because of the general – and projected – increase in use of Afghanistan's electromagnetic spectrum. The SMB delivered a proposed draft MoA to the MoD by the end of June. The document was reviewed and negotiated for several months, approved by ATRA in November, and finally signed on December 5, 2013 by ATRA Vice Chairman Engineer Khair Mohammad Faizi (on right in [Picture 29](#)) and Major General Ali (in uniform in center foreground), the Ministry of Defense General Staff Chief



of Communications (GSG6). The MoA outlined the terms and conditions for post-2014 spectrum allocation, coordination, and utilization and established responsibilities of and the relationship between the MoD and ATRA.

### *MoA between ISAF and the ANSF*

Prior to finalizing the transition of military spectrum management from ISAF to GIRoA, the Coalition needed to secure a spectrum allocation for NATO's Resolute Support Mission, which was scheduled to begin January 1, 2015 immediately upon the completion of its ISAF Mission on December 31, 2014. Because outgoing President Karzai refused to sign the Bilateral Security Agreement (BSA)<sup>1066</sup> with the US and the NATO Status of Forces Agreement (SOFA), which delayed the subsequent Spectrum Management Implementing Arrangement, the TAT drafted an MoA as a workaround to be signed by ISAF CJ6, the MoD, and ATRA. The agreement delineated an allocation of frequencies for ISAF and its follow-on Resolute Support Mission (RSM) until such time as the BSA was signed. The MoA was projected to be signed in mid to late September 2014. The BSA between the United States and Afghanistan, finally signed September 30, 2014 under the new Ghani Unity Government, asserts the "recognition of Afghan ownership and allocation of frequencies within Afghanistan," and states, "[Afghanistan] shall allocate Afghan-owned frequencies [to US forces] based on relevant Afghan regulations."

On December 16, 2014, ISAF and GIRoA signed the final documents allowing ISAF to transition all frequency management to the MSMO. This was a major achievement for ISAF CJ6 and the TAT because of the problems leading up to the agreement. At one point, ISAF wanted ATRA to sign the final document and to agree on the new FAT, something that ATRA was refusing to do. The TAT was able to convince ISAF that ATRA no longer needed to sign based on the MoA of 2012. The TAT also assisted in making the FAT acceptable to the MSMO, ATRA, and ISAF. One of the major changes in the new FAT was the elimination of shared bands.

Throughout the spectrum management transition process, the TAT advised and mentored ATRA and fostered communication, cooperation, and collaboration among all key stakeholders regarding this important strategic initiative.

## Spectrum Problems in Afghanistan

After the US-led invasion of Afghanistan in 2001, wireless communication systems were deployed for both military and civilian use. In the early days, interference problems and other general spectrum issues were negligible, mainly because spectrum usage was not widespread, with only a handful of users and operators of wireless communication systems. In addition, jamming was limited, as it targeted mainly

---

<sup>1066</sup> Officially named the "Security and Defense Cooperation Agreement between the United States of America and the Islamic Republic of Afghanistan." Quotations are from Article 12, Paragraphs 2 and 3, of the Pre-Decisional Document as of November 2013, from the Afghan Ministry of Foreign Affairs website. Accessed December 4, 2014. <http://mfa.gov.af/en/news/bsa>.

enemy systems to prevent the adversary from using wireless communication systems for its own command and control.

With the fall of the Taliban regime, the US and Coalition partners began a program for the stabilization and reconstruction of Afghanistan. This led to the influx of more foreign nationals and more business entities trying to take part in reconstruction opportunities and activities. In addition, GIRoA also encouraged private investment (foreign and local) in different sectors, with ICT as a priority sector. As mentioned above, mobile telephony proliferated quickly throughout the country, with six mobile network operators (MNOs) serving approximately 25 million subscribers and nearly 90 percent of the population living in areas with cellular network service by the end of June 2015.<sup>1067</sup> As Operation ENDURING FREEDOM continued under ISAF, two important issues developed, which have had a lasting impact on radio spectrum usage in Afghanistan. These are:

- The growth and more extensive use of the radio spectrum for civilian use and military use, which, coupled with poor spectrum knowledge and management, caused perpetual interference problems.
- The use of improvised explosive devices (IED) by insurgents, notably remote-controlled IEDs (RCIEDs), which use radio signals as trigger mechanisms, causing jamming to increase as a countermeasure.

### Growth in Radio Spectrum Use and Resultant Interference

Regarding the first issue, more use of the radio spectrum was necessitated to meet communications needs of the foreign and local militaries, the government, the Afghan people, and Afghan businesses, and, therefore, proper management of this resource was a major requirement.

With the introduction of new complex technologies in Afghanistan, ATRA and the MNOs had to understand not just the technologies being deployed, but also the spectral requirements to mitigate the various forms of interference that ultimately allow coexistence of multiple wireless communication systems in the same geographical area. From the regulator's point of view, guidelines and conditions must be issued with spectrum licenses based on best practices, mainly from the ITU. The regulator also has to be in a position to monitor and enforce the guidelines and conditions. Implementing the above requires tools and associated software for radio frequency design and monitoring, as well as trained qualified technical staff at ATRA. For the MNOs, understanding the wireless technology, adhering to license conditions, as well as understanding the importance of good engineering practices is required. Coordination and cooperation between the public and private sectors is also important. Unfortunately, all of these are severely limited in Afghanistan, resulting in many interference issues that could have been avoided. Myriad problems emerged and persisted with no sound method of identifying their root causes, including:

---

<sup>1067</sup> ATRA. Telecom Statistics (End of June 2015). Accessed November 30, 2015. <http://atra.gov.af/en/page/telecom-statistics-2013>.

- poor site construction and lack of proper electrical grounding for the electronic equipment and the coaxial cables;
- use of cordless phones from different regions that operate on different frequencies;
- poor colocation of sites (not following basic engineering colocation principles to ensure adequate RF isolation between systems);
- use of RF repeaters by both the MNOs and the general public without technical understanding of the implementation requirements;
- lack of basic maintenance of the radio systems;
- bad RF network designs resulting in overshooting and co-channel interference;<sup>1068</sup>
- intermodulation<sup>1069,1070</sup> problems caused by inadequate RF isolation;
- assignment of frequencies without adequate frequency separation and without the necessary technical guidelines for adequate RF isolation (e.g., CDMA-850<sup>1071</sup> and GSM-900<sup>1072</sup>);
- lack of spectrum monitoring and inspection of communications facilities resulting in operators changing design coordinates for their towers;
- assignment of multiple microwave frequencies without required engineering analysis;
- MNOs and other service providers trying to use the radio spectrum illegally or using more bandwidth than allowed in their licenses;
- graft within ATRA whereby personnel resold already-licensed frequencies and pocketed the money;
- faulty or improperly installed Coalition jammers;
- rough jammers installed on taxis and private vehicles;
- myriad jammers at the compounds of missions of foreign governments and international organizations;
- jammers used for personal protection by Afghans; and
- unwanted out-of-band emissions from jammers.

---

<sup>1068</sup> Overshooting occurs when a broadcast signal exceeds its target; co-channel interference is crosstalk from different radio transmitters using the same frequency.

<sup>1069</sup> Intermodulation interference is the undesired combining of several frequencies in a nonlinear device, producing new, unwanted frequencies, which can cause interference to other systems if these newly created frequencies fall within operating bands of other systems.

<sup>1070</sup> To assist with the evaluation of inter-modulation problems, DISA approved the purchase of a basic software for intermodulation calculations.

<sup>1071</sup> Code division multiple access, a method used by some radio communications technologies that makes it possible for several transmitters to send information over a single communication channel simultaneously, thereby allowing multiple users to share finite frequency bandwidth without interference.

<sup>1072</sup> Global system for mobile communications, a second generation of protocols for digital cellular networks originally developed by the European Telecommunications Standards Institute (ETSI). GSM is now a trademark owned by the GSM Association.

## Jamming as a Countermeasure to Improvised Explosive Devices

Regarding the second issue, the use of IEDs to target Coalition and Afghan forces as well as the general population began to increase around 2005. These low-technology devices, some of which were triggered using a radio frequency such as a mobile phone signal (referred to as RCIEDs), became weapons of choice for the insurgents, who used them in a variety of ways with deadly consequences.

With the casualty rate increasing from IEDs, the US government invested US\$20 billion on IED countermeasures, plus another US\$45 billion<sup>1073</sup> on mine-resistant vehicles. This led to the creation of the Joint IED Defeat Organization (JIEDDO),<sup>1074</sup> which spent a lot of time on counter-IED (C-IED) training and the development of IED countermeasures, which were different depending on the trigger mechanisms of the IEDs. The insurgents often had the ability to vary their IED tactics whenever a countermeasure was deployed.

For wireless communications-based trigger devices, one of the main countermeasures, which is still being used today, is radio frequency jamming. Radio frequency jamming for service denial is an effective tool to combat RF-based trigger mechanisms for IEDs and is also often used to deny or prevent enemy communications. In order to prevent the use of RF signals to trigger explosive devices, the US military increased its jamming: it was deployed on bases and tactical vehicles, and even in areas where a lot of people gathered. As a result, jammers were used all over the country, sometimes incorrectly and sometimes without proper regard as to which signals should be jammed. (Incorrect frequencies may have been jammed due to poor intelligence or a change in IED tactics or for other reasons). The less specific the target range being jammed is, the less effective jamming will be.

A form of RF jamming was even used as a technique to prematurely detonate IEDs from aircraft by transmitting high power signals within suspicious target areas and along convoy routes. The insurgents also constantly changed tactics, always trying to find other wireless devices to be weaponized. In addition to mobile phones, insurgents have been known to use wireless garage door openers, wireless key fobs, cordless phones, and many other types of devices that operate on radio frequencies. This meant jammers had to be adapted quickly when a new threat was detected. The implication of this is that jamming, in and of itself, became a very complex issue that required a good understanding of deployed systems as well as the need to limit the impact of jamming on the communication services of the military and civilians.

Also concerned with IED-caused casualties, Afghan President Karzai tasked the MCIT to come up with a “means to prevent the use of mobile phones in terrorist attacks” via Presidential Decree 45 (PD45),<sup>1075</sup>

---

<sup>1073</sup> Robson, Seth (2012). “Casualties down but IED attacks continue with cheap materials.” *Stars and Stripes*, November 23. Accessed December 14, 2015. <http://www.stripes.com/news/pacific/casualties-down-but-ied-attacks-continue-with-cheap-materials-1.198145>.

<sup>1074</sup> JIEDDO grew out of the Army and the Joint Improvised Explosive Device Defeat Task Forces (JIEDD TF). The JIEDD TF became JIEDDO in February 2006, and was renamed the Joint Improvised-Threat Defeat Agency (JIDA) in March 2015, per JIDA’s website, accessed November 27, 2015. <https://www.jieddo.mil/about.htm>.

<sup>1075</sup> Karzai, Hamid (2012). Full text of Presidential Decree 45 (PD45): “The Office of the President of Islamic Republic of Afghanistan Decree On the execution of content of the historical speech of June 21, 2012 in the special session

issued in June 2012. ATRA held weekly meetings to discuss measures to reduce the use of mobile phones for explosive detonations but lamented such an effort takes time and money, not to mention expertise. Ultimately, ATRA was instructed by the Afghan ONSC to implement dual-tone multi-frequency (DTMF) blocking on mobile-to-mobile communications. DTMF is a technique to instruct a telephone switching system of the telephone number to be dialed, or to issue commands to switching systems or related telephony equipment. DTMF tones, generally referred to as touch tones, were exploited to trigger denotation devices by simply dialing a combination of numbers from the keypad of a mobile phone. Simplified, DTMF blocking on mobile-to-mobile calls prevents callers from sending touch tones once a call is connected, so someone would not be able to, for example, “press one for English,” or enter a voice mailbox password. Some of the MNOs spent a lot of money to implement DTMF blocking with the hope of completely eliminating C-IED jamming. However, this turned out not to be the case, in part because not all the MNOs implemented DTMF blocking, and because insurgents had other methods and techniques to counter it. The outcome was, therefore, general dissatisfaction among the MNOs and ATRA. ATRA claimed it was wrongly advised to implement DTMF blocking, which never resulted in the elimination of C-IED jamming.

### *The Jamming Environment in Afghanistan – An Ecosystem of Mistrust*

A fundamental principle of jamming is to limit the unintended consequences of jamming. For jamming to be highly effective, meaning cause the least disruption of wireless communication services to other users, including the users of jammers, a good understanding of the RF spectrum and the wireless communication technologies being used are of utmost importance. With the increasing use of jammers in Afghanistan, sometimes without due consideration to others or basic explanations of the jamming process, a climate of distrust developed between the MNOs and ISAF and persisted for an extended period of time. The commercial MNOs attributed virtually all perceived wireless communications problems to ISAF jamming and blamed ISAF for many wireless communications problems. The main reasons for the distrust are six-fold:

- The MNOs lacked the skillsets and tools to conduct interference investigations on their systems. The regulator (ATRA) also lacked the skillsets and tools to conduct interference investigations.
- Military jamming was focused on threats, with equipment deployed hastily, even with known potential interference problems.<sup>1076</sup>

---

of National Assembly” June 21. Islamic Republic of Afghanistan Permanent Mission of Afghanistan to the United Nations in New York website. Accessed November 27, 2015. [http://www.afghanistan-un.org/2012/07/the-office-of-the-president-of-islamic-republic-of-afghanistan-decree-on-the-execution-of-content-of-the-historical-speech-of-june-21-2012-in-the-special-session-of-national-assembly/?utm\\_source=feedburner&utm\\_medium=feed&utm\\_campaign=Feed%3A+PermanentMissionOfAfghanistanToTheUnInNewYork+%28Permanent+Mission+of+Afghanistan+to+the+UN+in+New+York%29bestth#sthash.j5umHd9P.dpuf](http://www.afghanistan-un.org/2012/07/the-office-of-the-president-of-islamic-republic-of-afghanistan-decree-on-the-execution-of-content-of-the-historical-speech-of-june-21-2012-in-the-special-session-of-national-assembly/?utm_source=feedburner&utm_medium=feed&utm_campaign=Feed%3A+PermanentMissionOfAfghanistanToTheUnInNewYork+%28Permanent+Mission+of+Afghanistan+to+the+UN+in+New+York%29bestth#sthash.j5umHd9P.dpuf).

<sup>1076</sup> “Military” referring here more generally to local and foreign forces. Per a US spectrum expert, US military operators would be loath to introduce mission risk, which could compromise life and gear, by hastily deploying equipment, which is repeatedly tested and exercised prior to use.

- With no common jammer specifications, NATO's Coalition forces and Troop-Contributing Nations deployed different jammers.
- Private entities, embassies, other organizations, and even citizens, deployed jammers.
- Lack of understanding of what effective jamming is, and in some cases what portions of the RF spectrum should be jammed.
- For a multitude of security reasons, ISAF could not clearly explain the nature of jamming or react to questions regarding jamming. (The MNOs conceded some ISAF jamming was necessary and strategic when employed by NATO to deny communications to the insurgency.)

As noted above, the MNOs' misperception about the implementation of DTMF blocking also greatly contributed to this ecosystem of mistrust.

These problems were created mainly by a general lack of spectrum knowledge, which in some cases is as basic as knowing which frequencies to jam. In cellular telephone networks, communications between the serving sector (tower) and a mobile handset is via two frequency bands, referred to as the uplink (mobile to tower) and downlink (tower to mobile). Jammers were sometimes configured to jam the uplink bands of the mobile networks, rather than the downlink bands. For localized jamming, where an RF-free bubble is created to protect a physical area or a moving convoy, jamming the downlink is more efficient and effective, as the network (tower receivers) will not perceive the jamming signals, and, therefore, it does not affect the performance of the cell tower serving other nearby areas. When the uplink is jammed, the cell towers perceive the jammer signal as interference (high noise level) and the performance of the cell site is affected for the entire area it serves, which is not the desired effect when employing RF jamming as a countermeasure for IEDs. Jamming the uplink is more applicable for denying wireless communication service in a wide area.

Examples of jamming problems are illustrated in Figures 65 through 68. Noting that the 3G frequency band in Afghanistan is from 1920 to 1980 megahertz (MHz) (uplink) and 2110 to 2170 MHz (downlink), [Figure 65](#) shows the entire 3G band being jammed. [Figure 66](#) shows a similar case for the GSM-900 MHz band, noting that the GSM-900 MHz band in Afghanistan is from 880 MHz to 915 MHz (uplink) and 925 MHz to 960 MHz (downlink). In [Figure 67](#), the effects of a poorly configured jammer are obvious, illustrating partially jamming the uplink between 900 MHz and 915 MHz.

Radio frequency jamming is only one method of service denial, and various RF jamming techniques can be deployed in order to minimize unwanted interference into the bands that are not within the targeted bands. Examples of different RF jamming techniques include:

- reactive jamming, where the jammer monitors the RF channels and only starts jamming when it perceives an increase of RF power or activity within the channel;
- passive jamming, where the jammer is on continuously; and
- barrage jamming covering a large bandwidth, sometimes with multiple jammers.

Denial of mobile service can also be accomplished by using cell site simulators that mimic cell towers. Such systems are often used in jails, as they allow jammer operators to decide which calls can be allowed to go through.

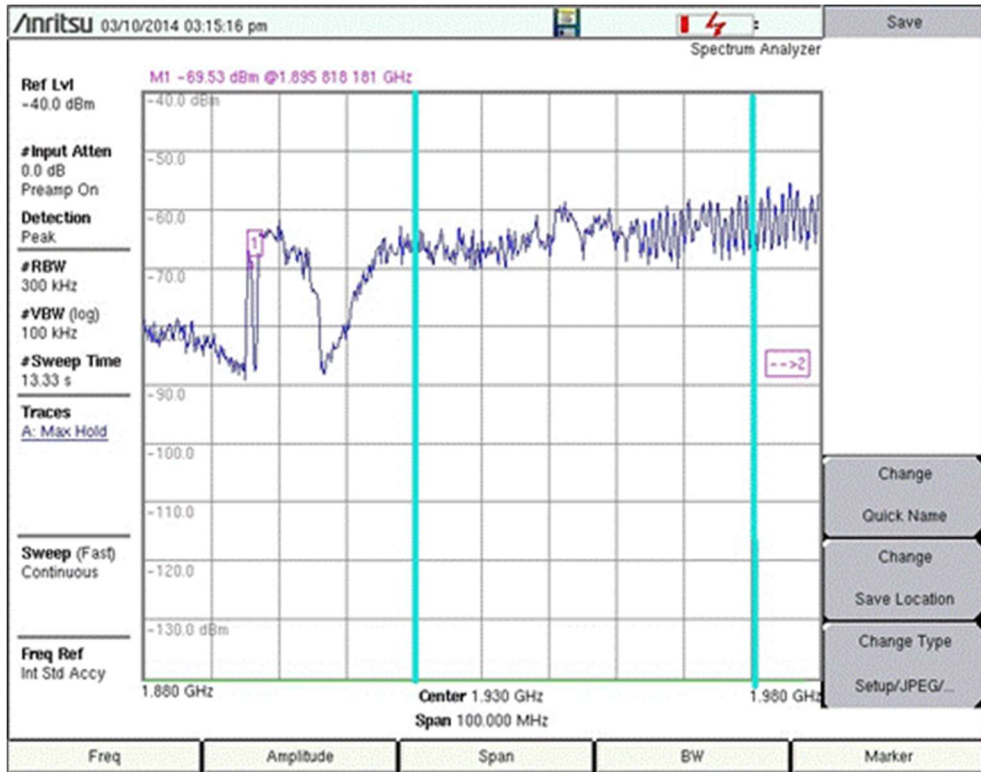

Figure 65: Uplink jamming example for the 3G band



Figure 66: Uplink jamming example for the GSM-900 band



Figure 67: Example of jammer configuration problems

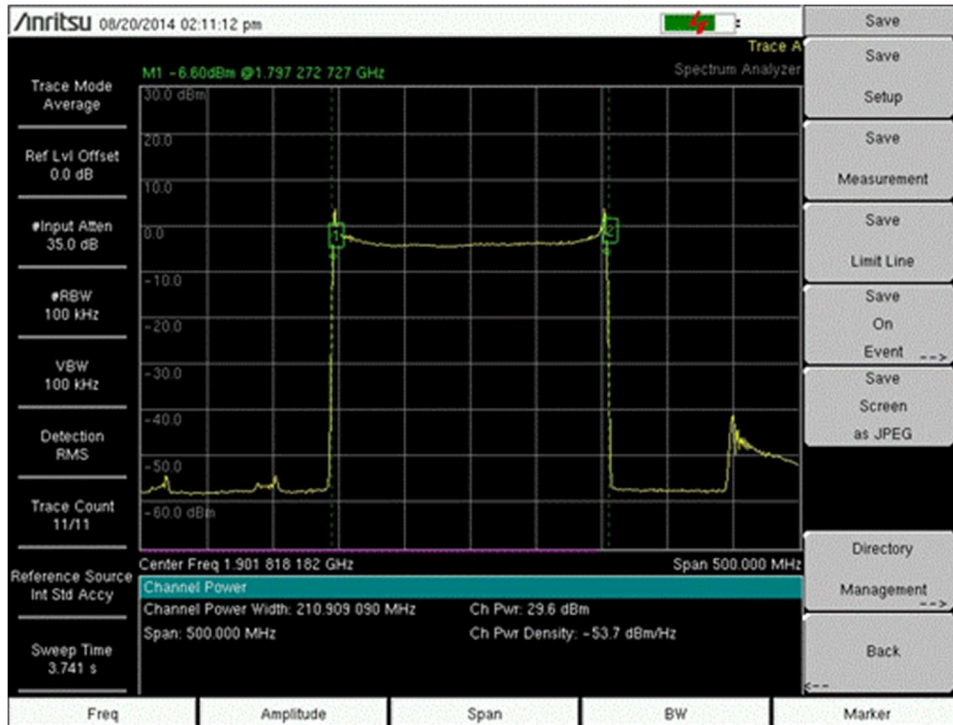

Figure 68: Example of jamming a wider bandwidth than the intended target



An example of knowing what frequency bands to jam was illustrated after the supply of portable jammers to the Afghan National Police (ANP). In this case, three mobile phone uplink bands were the intended targets, the GSM-900 band, the GSM-1800 band, and the 3G band. Although the intended jamming was acceptable within two of the bands, [Figure 68](#) shows a problem with the jamming module for the GSM-1800 MHz band. In [Figure 68](#), the intended target is the GSM-1800 uplink (1805 to 1875 MHz). However, the module jams up to 2100 MHz covering the entire uplink band of the 3G networks (1920 to 1980 MHz). Although the output powers of these portable devices were relatively low, deploying thousands of them within a city could have wreaked havoc on the 3G cellular telephone networks. Because of the close collaboration between the TAT and the Electronic Counter Measures (ECM) team, the TAT, was able to intervene and the design specifications of the portable jammers were altered, against the manufacturer's will.

Other detected and identified jammer problems included:

- jammers with jamming fills<sup>1077</sup> that resulted in jamming outside the required bands;
- faulty jammers that were not repaired; and
- jammers with poor out-of-band emissions, high harmonics, etc., causing interference in the other bands.

Most of these problems could have been resolved easily with the use of specialized RF bandpass filters, timely repairs, and better knowledge of the jammer environment. Also, better coordination between military and civilian entities would have resulted in quicker clarifications and/or resolutions.

Another major deficiency was the fact that most of the Coalition military jammer operators did not understand the technical requirements of jamming and were often more concerned about ensuring the jammers were on, regardless of their effectiveness. To make matters even more complicated, there is a lot of secrecy surrounding military-grade jammers, making the sharing of facts and general information more challenging.

At the request of the TAT, NATO agreed to work with the TAT to evaluate some of the jammers installed on the NATO bases. The intent was to look at the targeted bands and, most importantly, the out-of-band emissions of the jammers, as this is part of what may have been causing the interference in the uplink bands. After a series of tests in October 2014, it was concluded that the out-of-band emissions could create problems, especially for GSM-900 MHz sectors that are directed towards these jammers. At same time the TAT was working on having ISAF issue a FRAGO<sup>1078</sup> that would provide better guidance as to the use and maintenance of jammers. As the draft FRAGO was circulating within ISAF, somehow it was decided

---

<sup>1077</sup> A jamming fill is a combination of parameters that define how a target band is to be jammed (bandwidth, power, etc.).

<sup>1078</sup> Fragmentary Order, used to send timely changes of an existing order, without reissuing it in its entirety, to subordinate and supporting commanders while providing notification to higher and adjacent commands.

to follow the guidance in the FRAGO, without actually using it. Following the results of the tests, the TAT recommended the use of external bandpass filters as a quick method to resolve some of the issues.

### *GIRoA Jamming*

As noted, jamming is not restricted only to the Coalition forces, embassies, and security agencies. In fact, GIRoA also uses jammers. Some of these jammers are provided by the Coalition to GIRoA. In one case, GIRoA requested jammers to be installed in one of the jails on the outskirts of Kabul. Through an agreement between the MoI and ATRA, six sets of jammers were installed around the facility on 20 meter towers. Each of these had two sets of panel antennas pointing towards the main prison buildings where service was to be denied. Over a period of time, all operators felt that part of the GSM band, especially the newly introduced E-GSM<sup>1079</sup> band, was not clean. However, no technical study was done to verify the problem. The obvious answer, according to the MNOs, was interference from military jammers. As spectrum usage increased, the E-GSM band was licensed resulting in the reallocation of frequencies. Etisalat was very pleased to move away from the lower half of the GSM-900 band and it reported very low interference after the move. However, overall the interference complaints did not subside. In 2014, Afghan Telecom, through its Salaam subsidiary and brand, began providing GSM services within the E-GSM band. After deploying GSM base stations in Kabul, Salaam started complaining to the regulator about severe external interference in the eastern part of the city. As was the case, ATRA forwarded the complaint to the TAT for further investigation.

The TAT's starting point in the investigation was to ask ATRA if GIRoA operates any jammers. The answer was a resounding no. After many tests and site visits using a spectrum analyzer and a combination of tests with Afghan Telecom/Salaam (its 3G/GSM network division and brand name) and its 3G/GSM equipment venter Huawei, the source of the interference was traced to the jail. After a few days of negotiations for access, the TAT entered the prison complex and found the jammers. When confronted, ATRA said the jail jammers were a secret!

Basically, the TAT observed each jammer was configured to jam the uplink bands of CDMA-850, GSM-900, and GSM-1800. Unfortunately, the CDMA-850 jamming module had a bandwidth that extended about 20 MHz into the GSM-900 unlik band, which was the problem causing the interference complaints from three of the major MNOs whose unlik bands where being jammed. To further demonstrate the impact of these jammers, the TAT arranged and turned off all of the CDMA-850 jammers for one hour. The interference experienced by the three MNOs dropped to zero. Unfortunately, these jammers are still on! [Figure 69](#) shows the output of the CDMA-850 jamming module, noting that the CDMA-850 band in Afghanistan is 815 to 850 (uplink) and 851 to 880 MHz (downlink). [Figure 69](#) also shows the module jamming from 840 MHz to 900MHz, which includes 20 MHz of the GSM-900 MHz band.

---

<sup>1079</sup> Extended GSM, an extension of the GSM-900 frequency range.



Figure 69: Output of CDMA-850 jammer from the Kabul Central Jail

Figure 70 shows the results of the Salaam switch – high continuous external interference – when all the CDMA-850 MHz jammers were temporarily turned off. The average interference perception dropped dramatically from a high of 40 percent to five percent.<sup>1080</sup>

After the discovery of these jammers, the TAT also learned and noted a few other issues, summarized below:

- The prison wardens did not want the jammers, as they dealt a blow to the business of charging prisoners for cell phone calls.
- The towers on which the jammers were installed were not secured, potentially allowing corrupt individuals to ascend them and turn off the jammers.
- The main panel for the power supply to each tower is located at the base of the tower and was not always locked, making it easy to turn off jammers.
- Some modules of the jammers were not working at all, and some jammers were completely unplugged from their electrical outlets.

<sup>1080</sup> Generally in GSM networks, there is a network parameter that measures the signal strength in the idle GSM channels and provides a good indication of what is deemed as external interference, by binning the results into five interference bands. This is the idle channel measurement (ICM), and when this parameter returns values in ICM bands 4 and 5, there is a strong probability that this is caused by external interference.

- There was no repair, monitoring, or maintenance plan in place and no spare parts.
- There was a lack of technical knowledge about the jammers.

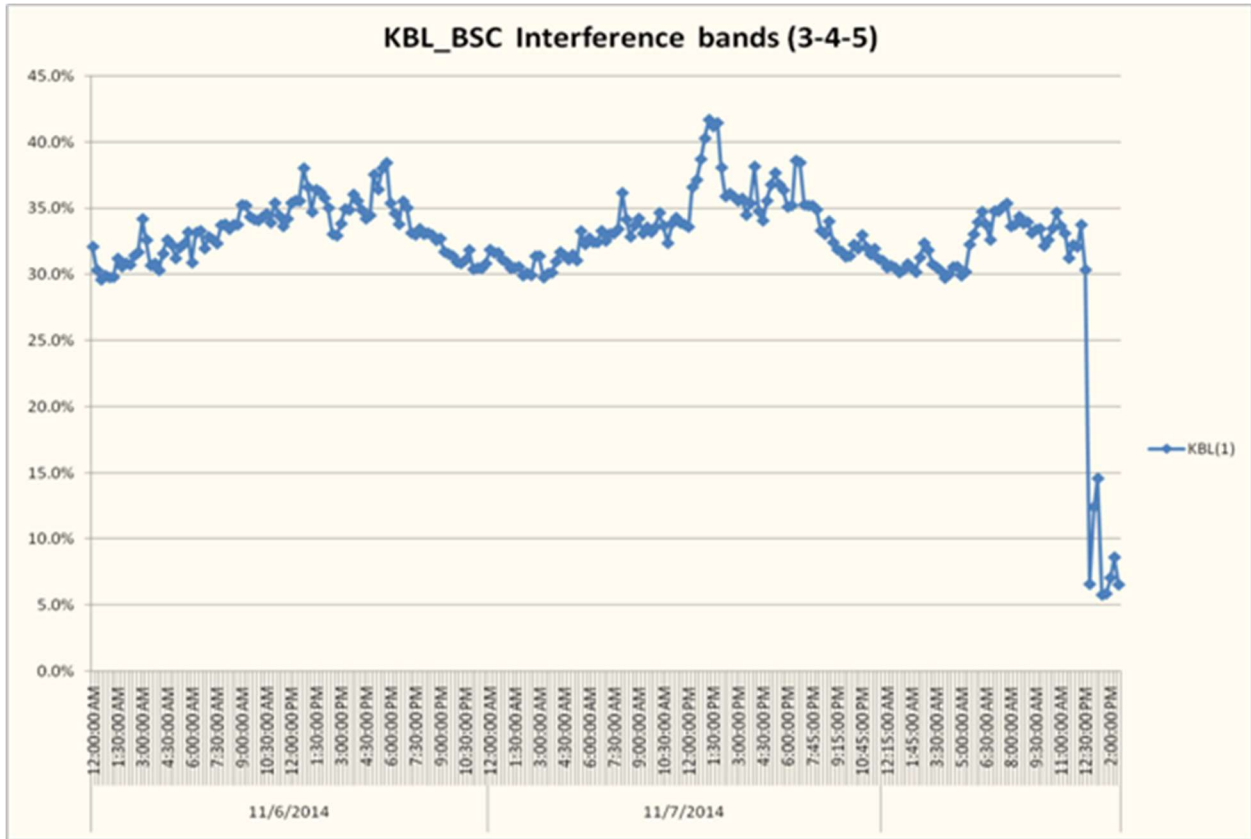

Figure 70: Output from a Salaam BSC showing continuous external interference

The interference dropped drastically (as you can see on the right) at 12:30 after turning off the jammers.

As is sometimes the case, when one is technically challenged to provide answers to the root cause of a problem, somebody else is blamed. This is exactly what ATRA and the MNOs did. Without the technical expertise, equipment, and software to investigate and isolate network-related problems, they passed all the blame to the Coalition forces and the US Embassy. On the other hand, these foreign users of the spectrum could not explain or demonstrate that their systems were not to be blamed. This is not to say the various jamming systems did not cause interference. In fact, for the reasons listed above, these systems caused some level of interference, at but not to the extent the MNOs perceived.

### The TAT's Work in Spectrum

Afghanistan's electromagnetic spectrum is considered a national resource and is a military, civil, and commercial asset. It was and remains a critical component of the US government's and US military's communications infrastructure in the Afghanistan AoR. Spectrum was of paramount importance to ISAF's combat and security operations and continues to be of great significance to NATO's Resolute Support

Mission. The TAT advised and assisted GIRoA to help effectively manage and monitor its electromagnetic spectrum throughout all four years of its operations in country, some of which was described above and more of which is iterated below, and assisted ISAF to transfer military spectrum management from the Coalition to the GIRoA, which was covered earlier in this chapter. The Afghan Telecommunications In-Country Support (ATICS) Program, the successor organization to the TAT, continued working on spectrum until its contract ended and its personnel redeployed in January 2015.

As mentioned above, the Military Technical Agreement of 2002 gave ISAF unrestricted use and overall management of Afghanistan's spectrum until 2009, when ISAF and ATRA agreed ISAF would manage all military spectrum and ATRA would manage the civil and commercial bands. To do so, ATRA had to establish appropriately staffed entities with properly trained personnel equipped with suitable tools, as well as have an effective policy and regulatory framework and standard operating procedures. It also meant ATRA is responsible for ensuring the Afghan government and commercial ICT service providers and broadcasters have adequate and uncongested clean frequencies on which to operate their equipment and provide their services. ATRA's spectrum management responsibilities grew to include managing the frequency on which Afghanistan's satellite operates and managing spectrum assignment and frequency allocation for Afghanistan's nascent digital broadcasting system.

### Early TAT Support

In its current-state assessment report,<sup>1081</sup> the intent of which was to provide an informed and comprehensive understanding of ICT situational awareness by documenting programs, initiatives, efforts, and needs in the Afghan ICT sector, the TAT identified spectrum management as an issue within its first 30-45 days on the ground in mid-2010. The TAT reported ATRA did not have spectrum management software and was not properly planning for, managing, or monitoring spectrum allocation and use, resulting in frequency interference and a host of other problems. As such, the TAT immediately undertook an effort to assist ATRA with its spectrum-related responsibilities. Initial endeavors, working in conjunction with USAID, included connecting ATRA to contacts at the ITU to purchase SMS4DC and investigating spectrum training for Afghans via the ITU in country and at the USTTI in Washington, DC. It is unclear when ATRA purchased a license for SMS4DC, but it eventually did. (It used its own funds to do so.)

Several events throughout 2011 brought to the forefront the need for ATRA to be able to effectively manage and monitor spectrum. ISAF wanted GIRoA to assume responsibility for the management of the Cospas-Sarsat Program, which provides distress alert and location data to assist search and rescue authorities. Also, the Afghan Minister of Communications requested the TAT's assistance to conduct a study of the Kabul FM<sup>1082</sup> broadcast allocations, de-conflict and re-groom Afghanistan's radio and

---

<sup>1081</sup> ISAF Telecommunications Advisory Team (TAT) (2010). *Afghanistan ICT Current-State Assessment: ICT Strategy Project, Rev. 3.0*, 10 October, 2010.

<sup>1082</sup> Frequency modulation, a method of encoding information in a sound [or other type of] wave by varying the rate of occurrence. This contrasts with amplitude modulation (AM), in which the size of the wave varies.

television broadcast bands, and devise a frequency allocation plan for the provinces. He also requested the TAT assist ATRA with basic principles for current and future spectrum allocations. An assessment of ATRA by Internews, a non-governmental organization (NGO) and implementing partner for USAID, identified many shortcomings in ATRA's spectrum management department, including the lack of a written spectrum policy, a lack of transparency in issuing spectrum permits, and an apparent aversion to using software and other automated tools ATRA had purchased.<sup>1083</sup>

---

*The TAT and the spectrum support team it assembled helped ATRA to address various frequency interference issues in Kabul's broadcast bands. One such instance involved the US Armed Forces Network (AFN) and NAI radio stations, which was ultimately resolved by ISAF agreeing to move AFN from FM 94.1 to FM 107.3.*

---

In response, the TAT assembled and spearheaded a loose "spectrum support team," which included personnel from ISAF CJ6, the US DSO and the JSC, the NTIA, USAID and its implementing partner Internews, the FCC, and the World Bank, and provided a proposal to all parties outlining recommended areas in which to assist ATRA with its spectrum management and monitoring responsibilities and capabilities. Among the main areas the TAT identified were: (1) management of shared frequency bands between ISAF and the ANSF; (2) spectrum assignment procedures, interference cases, and engineering processes for frequency assignment; (3) policy development; (4) spectrum training and human capacity building; and (5) developing a frequency plan and policies to allow for the introduction of new ICT services and digital broadcasting in the future.

Internews agreed to, and did, provide:

- training and guidance regarding spectrum monitoring and enforcement, both in-country and abroad;
- assistance in developing recommendations for a national broadcast allocation table;
- expertise in and recommendations for broadcast rules and regulations with respect to spectrum management and monitoring; and
- two sets of mobile spectrum monitoring equipment.

---

<sup>1083</sup> TAT Weekly Report, September 23, 2011.

The DSO/JSC agreed to provide support for interference resolution for TV (Asmai) Hill in Kabul, including a survey team and survey equipment to allow remote monitoring, as well as training on interference resolution. It agreed to allow ISAF, ATRA, and other relevant parties to test its self-developed software

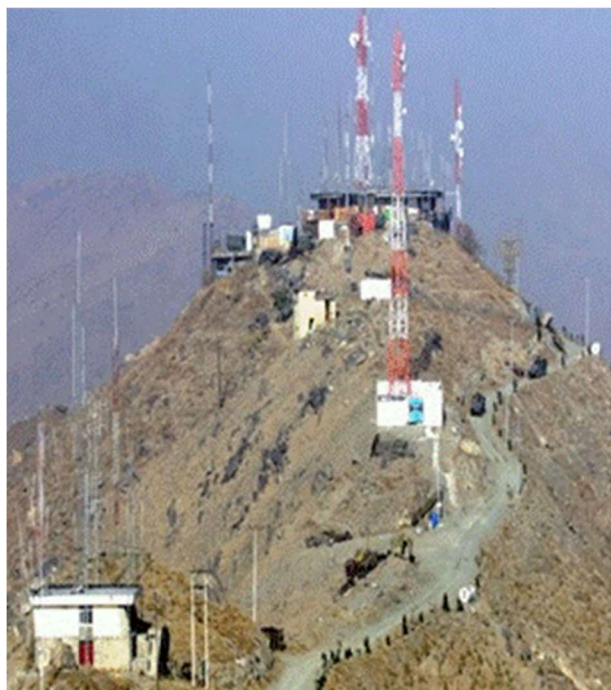

Picture 30: TV (Asmai) Hill, Kabul, Afghanistan

(Photo courtesy of the MCIT)

in military and shared bands. In late October 2011, the ATRA Board approved ISAF's proposal to have GIRoA assume management of Cospas-Sarsat and began working on how to propose it to the Afghan Aviation Authority (AAA). The TAT supported ISAF CJ6 as it prepared a plan to transition the management of military spectrum management to GIRoA. Toward the end of 2011, ATRA hired a new, and reportedly more experienced, spectrum manager, to whom ISAF CJ6 presented its initial plan for transition of military spectrum management from ISAF to GIRoA in December 2011, as described above in the section "Transition."

### Spectrum Management Tools for ATRA

ATRA knew – or at least was advised – it needed tools with which to manage spectrum, and, as mentioned above, it had agreed to procure (or had already procured) a license for SMS4DC. However, once ISAF began planning for the transition of military spectrum management to GIRoA, key stakeholders agreed a separate cell should be established for that purpose and discussion on spectrum management tools then broadened to include the Afghan Ministries of Defense and the Interior. The idea was for all entities to have a common tool to help ensure cooperation and transparency among the parties. In September 2011, ATRA, ISAF CJ6, and the TAT all agreed on SMS4DC as that common platform. To facilitate the implementation and use of SMS4DC, ISAF CJ6 offered to include ATRA personnel in future SMS4DC

tool, Mercury, for the coordination of frequencies, and to make minor modifications, if necessary, so GIRoA could use it. The DSO also offered to help with the development of policies as they pertain to security agencies, to review policies developed by other entities, and to coordinate with the NTIA and FCC for assistance with policy development, policy-related training, and policy analysis as needed. The TAT also facilitated a two-week visit by the DSO/JSC in January 2012 to conduct a spectrum survey of the FM broadcast frequencies in Kabul. The ATRA Chairman, the ATRA Board, and ATRA's Spectrum Manager generally accepted the recommendations from the survey results the TAT presented to them in February 2012.

The TAT routinely attended meetings of ISAF's SMB and FMB, as well as the Spectrum Management Working Group. The TAT also served as a liaison between and among ISAF, ISAF IJC, NTM-A, and ATRA, particularly regarding frequency assignments

training courses for the MoD and Mol.<sup>1084</sup> However, the following month, the ISAF FMB said SMS4DC did not meet the needs of the ANSF, so the ISAF SMB proposed to explore other tools that would meet the needs of all entities.<sup>1085</sup> In November 2011, Spectrum XXI was discussed among ATRA and its Internews advisor, the TAT, and ISAF CJ6 as the common spectrum management platform. Spectrum XXI is a Windows-based client/server software system, which is the standard throughout the US DoD, is used by the NTIA for processing frequency records for US federal agencies, and was used by all NATO ISAF spectrum elements in the Afghan AoR.<sup>1086</sup> In February 2012, discussions began among the TAT, ISAF CJ6, ATRA, the DSO, CSTC-A,<sup>1087</sup> and CECOM<sup>1088</sup> regarding how to initiate the procurement process for Spectrum XXI and various avenues of approach for such.

As late as June 2012, there were collective apprehensions about ATRA's use of Spectrum XXI because of the aptitude required to operate it and due to assertions by some that it is mainly a military spectrum management application. Thus, ATRA planned to proceed with implementing SMS4DC, which it preferred anyway because of the software's ability to generate invoices for spectrum licenses. It is unclear as to when ATRA actually deployed SMS4DC, but ATRA continued to use a basic spreadsheet to manage frequency assignments well into 2013 and claimed it would begin transitioning to SMS4DC in May of that year.<sup>1089</sup> Spectrum XXI was eventually procured and installed at the MSMO located at ATRA, which is described earlier in this chapter in the section on transitioning spectrum responsibilities from ISAF to GIRoA.

In early 2013, ATRA also considered purchasing MARsys, a program developed by and used at the Scientific and Technological Research Council of Turkey (known as TÜBİTAK), which focuses on Turkish military spectrum management and electronic countermeasures. MARsys is based on an off-the-shelf platform, but was significantly modified to fit the needs and requirements of the Turkish military, and conforms to NATO SMADEF XML<sup>1090</sup> and ITU standards. It is not, however, compatible with the Spectrum XXI. As late as June 2013, ATRA was reportedly still considering purchasing MARsys or using SMS4DC.<sup>1091</sup> It was not until December 2013 ATRA finally began investing in training on SMS4DC, which it deemed to be sufficient in the immediate term, with a plan to fully migrate to it by March 2014.

In 2014, with the introduction of a spectrum expert within the TAT, the TAT re-evaluated the various software options being considered for use by ATRA. Although ATRA had a copy of SMS4DC and was

---

<sup>1084</sup> TAT Weekly Report, September 30, 2011.

<sup>1085</sup> TAT Weekly Report, October 28, 2011.

<sup>1086</sup> Defense Information System Agency (DISA) website. Accessed 29 November 2015.

<http://www.disa.mil/Mission-Support/Spectrum/Spectrum-XXI>.

<sup>1087</sup> Combined Security Transition Command-Afghanistan, a multinational military organization tasked with training the Afghan National Security Forces. The CSTC-A commander is also the commander of the NATO Training Mission-Afghanistan (NTM-A).

<sup>1088</sup> Communications-Electronics Command of the US Army.

<sup>1089</sup> TAT Weekly Report, April 27, 2013.

<sup>1090</sup> NATO spectrum management data exchange format extensible markup language.

<sup>1091</sup> TAT Weekly Report, June 26, 2013.



attempting to make it operational with the help of the consultant from Internews, a fully operational version of the SMS4DC was never completed. With the re-evaluation, the TAT noted SMS4DC was not going to work for ATRA. Firstly, it was very difficult to install and customize to the needs of ATRA and it also lacked some modules needed by a regulator. The TAT advised ATRA to purchase a complete commercial spectrum management software as the others being considered focused only on the engineering aspects of spectrum management.

In April 2014, the TAT contacted three potential spectrum management vendors (ATDI in Australia, LST in Germany, and WARP in Sweden) to assist ATRA to fill the gaps in its spectrum management capabilities. In July, the TAT recommended ATRA consider outsourcing spectrum management, monitoring, and training and presented ATRA with a statement of work it can use in the tender for such services when it is ready.

The TAT began assisting ATRA with a tender for spectrum management software and monitoring equipment in June 2014. In January 2015, the Ministry of Communications issued an international competitive tender for a “comprehensive spectrum management system and capacity building (training)” for ATRA,<sup>1092</sup> with bids due at the end of February. There were five bidders with substantially different prices, leading the TAT to advise ATRA to send out more questions for clarifications. The evaluation has been completed but ATRA has not yet decided on the winner.

### Spectrum Capacity Development for ATRA

While the paragraph below is by no means an exhaustive list of ATRA’s spectrum capacity development activities, it is illustrative of the TAT’s and others’ efforts to that end.

In 2004, the Office of Assistant Secretary of Defense for Networks and Information Integration (OASD-NII, now the DoD Chief Information Officer (DoD CIO), provided spectrum training for several Afghans at the TRB, ATRA’s predecessor. The TRB’s Director of Spectrum Management attended spectrum management training at the USTTI in Washington, DC in 2002 and 2006 (all of which predated the TAT). As mentioned above, in 2010, the TAT connected ATRA to appropriate personnel at the USTTI and ITU for potential spectrum management training. Unfortunately, largely due to either visa or funding issues, ATRA spectrum personnel were unable to receive training from USTTI, but ATRA spectrum personnel did receive assistance, if not definitive training, from the ITU. As also mentioned, the TAT assembled a “spectrum support team” to assist ATRA in executing its spectrum management responsibilities and to develop the skills and knowledge to do so. By way of introduction, the TAT helped to facilitate a contract between ATRA and Internews’ for on-site mentoring of spectrum personnel and further training in Bosnia.

---

<sup>1092</sup> MCIT (2015). “Tender for Comprehensive Spectrum Management System and Capacity Building (Training) Services for Afghanistan Telecom Regulatory Authority (ATRA).” ATRA website, January 10. Accessed February 11, 2016.  
[http://atra.gov.af/Content/files/SPECTRUM\\_MANAGEMENT\\_TENDER\\_DRAFT\\_Date\\_24\\_2\\_2015\\_Modified\\_final.pdf](http://atra.gov.af/Content/files/SPECTRUM_MANAGEMENT_TENDER_DRAFT_Date_24_2_2015_Modified_final.pdf).

The TAT (along with the World Bank) regularly encouraged ATRA to work with other regulators, and the TAT was instrumental in ATRA's connecting with and being trained on spectrum-related subjects, among other topics, by regulators in India and Turkey. The NATO Spectrum Management School trained Afghans at various government agencies, including ATRA, on Spectrum XXI software. The TAT facilitated a visit by the chairman of the ATRA board of directors to the US FCC, which trip did not ultimately occur, but the TAT assisted ATRA in obtaining best practices from the FCC and NTIA. As part of the US DoC's Commercial Law Development Program (CLDP), ATRA received spectrum training via videoconference from a spectrum expert from the DoC NTIA in a series of seminars held in Kabul beginning in 2013. The TAT's spectrum expert, Dr. Chi Nche, co-author of this chapter, also personally trained ATRA spectrum personnel on a variety of subjects.

In May 2014, the TAT visited the Information and Communication Technology Institute (ICTI) and the American University Afghanistan (AUAF) in Kabul to learn more about their ICT curricula and the potential for them to supply interns to help ATRA in the near term. The TAT also engaged the Ministry of Finance's Civil Technical Assistance Program (CTAP) to help design a program for ATRA to be able to retain highly qualified personnel.

### Spectrum Licensing for Mobile and Wireless Broadband Services

The TAT was instrumental in ATRA's releasing tenders for mobile and wireless broadband services, which resulted in ATRA's issuing spectrum licenses and assigning frequencies to the winning bidders and other parties that matched the reserve tender price in the case of mobile broadband, or the financial offer of the winning bidder for wireless broadband.

#### *3G Mobile Broadband Service*

In August 2011, ATRA released an international competitive tender<sup>1093</sup> for one license to provide and operate nationwide broadband mobile (3G) services in one paired block of 2 x 10 MHz (20 MHz total), in the 2.1 GHz band, with frequency band 1920-1980 MHz specified for uplink and 2110-2170 MHz for downlink. The reserve price was established as US\$25 million, which was based on independent valuations of spectrum, with due consideration given to Afghanistan's requirements and market conditions. ATRA concluded the bid process in December 2011 after disqualifying all bidders, but subsequently offered the four incumbent GSM mobile network operators, which were explicitly excluded from bidding originally, along with the two CDMA MNOs, the opportunity to purchase 3G licenses<sup>1094</sup> at the reserve tender price. Etisalat was awarded the first 3G license in March 2012, followed by MTN in June, and Roshan in September. (Afghan Telecom entered the 3G market – through its subsidiary Salaam – in February 2014, and AWCC was awarded a 3G license in March 2014.)

---

<sup>1093</sup> ATRA, MCIT (2011). "Invitation to Tender and Tender Instructions to the Applicant for a License for the Provision and Operation of Broadband Mobile Service (3G) Within Afghanistan," August 1.

<sup>1094</sup> The tender actually stated the licenses would be technology neutral and any technology platform could be used, not just 3G.

### *Preemptive Planning for 4G Frequencies*

In July 2014, the TAT completed a study for ATRA regarding which frequency blocks should be used for 4G<sup>1095</sup> mobile broadband service in the future. The TAT recommended the Asia-Pacific Telecommunity (APT) 700 band,<sup>1096</sup> most prevalent in the Asia-Pacific region, because Afghanistan's conversion to digital broadcasting frees up frequencies in that band used by analog television channels.

### *Wireless Broadband Service*

In May 2012, ATRA released a national competitive tender<sup>1097</sup> open to all licensed Internet service providers (ISPs) to bid for up to ten Wireless Broadband Licenses, in blocks of 10 or 20 MHz (Categories 1 and 2, respectively) with a reserve fee of US\$50,000 per MHz. The GSM network operators and Mobile Telecommunications Services licensees which also held ISP licenses were precluded from bidding. ATRA planned to assign frequencies for the broadband wireless service in the following band: 2.3 - 2.4 GHz, 2.5 - 2.6 GHz, and 3.4 - 3.6 GHz, with the majority of assignments expected to be made in the latter band. The TAT reminded ATRA of its decision in 2007 to assign 2.3, 2.4, 5.3, and 5.7 GHz to Wi-Fi<sup>1098</sup> services and suggested they clarify the tender with a written letter, which ATRA did not do (to the TAT's knowledge), but in September 2012, ATRA stated all broadband wireless service licensees would be assigned frequencies in the 3.4 - 3.6 GHz band. ATRA accepted the TAT's recommendation to make it a technology-neutral spectrum auction, rather than explicitly for WiMAX<sup>1099</sup> service as it had planned to do, in order to accommodate other and future technologies. Upon award, all previously-issued provisional WiMAX licenses, except Afghan Telecom's, became null and void. Licensees would be required to remit spectrum fees according to regulations<sup>1100</sup> and prices established by ATRA's Spectrum Management Office and an annual administrative fee of US\$40,000.

Bids were due two months later, but it took ATRA many more months to successfully conclude the tender, finally awarding Wireless Broadband Service licenses to three ISPs in November 2012 for the price of US\$520,000 per MHz.

---

<sup>1095</sup> Fourth-generation wireless digital technology based on International Telecommunication Union (ITU) International Mobile Telecommunications (IMT) Advanced specifications.

<sup>1096</sup> The Asia-Pacific Telecommunity (APT) band is a segmentation of the 698-906 MHz band, usually referred to as the 700 MHz band; it was formalized by the APT and specially configured for the deployment of mobile broadband technologies. It is commonly referred to as the Digital Dividend.

<sup>1097</sup> ATRA (2012). "Invitation to Tender and Applicant Instructions, Wireless Broadband Services," May 16.

<sup>1098</sup> Wi-Fi is a local area wireless computer networking technology that employs radio waves to allow computers, mobile phones, and other devices to connect to the Internet and communicate with one another within a particular area without being physically connected.

<sup>1099</sup> Worldwide Interoperability for Microwave Access, a family of wireless communications standards that enables the delivery of last-mile wireless broadband Internet service.

<sup>1100</sup> The radio regulations on the MCIT's website, "Regulation for the Use of Radio Frequencies and Radio Communications Equipment in Afghanistan," are from 1982. They refer to the State Radio Monitoring Department at the MCIT as the responsible body and they say nothing about spectrum fees for mobile or wireless broadband.

### *Lack of Coordination and Conflicting Spectrum Assignments*

In April 2013, the TAT brought to ATRA's attention some of the frequencies assigned to the MNOs for 3G mobile broadband service were in the 2120-2160 MHz band, which is a shared band.<sup>1101</sup> According to the ISAF, which message the TAT related to ATRA, there was no coordination of the shared band frequencies prior to their being licensed. ATRA admitted it notified ISAF of the 3G licensures, but only after the contracts were signed. ATRA also affirmed it understood it was required by the Memorandum of Agreement between ISAF and ATRA of 2009 to coordinate with ISAF regarding frequencies in the shared band *before* they are assigned. To make matters worse, two MNOs were assigned frequencies and bandwidth that overlapped, which was not officially recognized by ATRA until March 2014, once frequency interference issues and the resultant complaints had reached a crescendo.

Similarly, some of the frequencies assigned to the ISPs for wireless broadband services were in the shared band and others were in the military band. None had been coordinated with ISAF prior to their assignment. Once again, ATRA admitted it informed ISAF only after the wireless broadband contracts were signed.

Further, some of the frequencies assigned to ISPs conflicted with the industrial, scientific, and medical (ISM) radio bands defined by the ITU Radio Regulations. ISM frequencies are reserved for use other than telecommunications and include applications such as cordless phones, amateur radio, microwave ovens, and medical machines. Some ISM bands are worldwide, while others are subject to local acceptance or have some exceptions. The TAT had brought potential conflicts with ISM bands to ATRA's attention a year prior (April 2012), as provisional WiMAX licensees were already utilizing 2.4 GHz, a global ISM frequency, at that time and the broadband wireless tender actually included the 2.4 GHz band, according to the draft the TAT reviewed and commented on prior to release.

ATRA had no explanation as to why it licensed frequencies in the shared and military bands without prior coordination with ISAF, nor why it licensed frequencies in conflict with ITU ISM bands. ATRA said it understood conflicts were likely to result and it would be its responsibility to address and resolve them.

In 2015, ATRA was taken by surprise when it learned of AWCC's deployment of "Super Wi-Fi." AWCC accepted the term "Super Wi-Fi" was simply a marketing gimmick and was not referring to the use of the TV white spaces for wireless broadband. Basically, AWCC deployed an 802.11n Wi-Fi-based network in Kabul consisting of 350 hotspots collocated on existing 2G<sup>1102</sup> and 3G sites. The equipment is fully compliant to all FCC regulations: 47 CFR § 15.247 (Operation within the bands 2400-2483.5 MHz and 5725-5850 MHz) and 47 CFR. § 15.249 (Operation within the bands 2400-2483.5 MHz and 5725 - 5875 MHz). The main problem is that these frequency bands, especially the 5.8 GHz band, are not clearly defined by ATRA.

---

<sup>1101</sup> ISAF Telecommunications Advisory Team meeting summary regarding meeting between the TAT and ATRA on April 27, 2013.

<sup>1102</sup> Second-generation wireless digital technology, which replaced first-generation analog systems.

In the FAT for Afghanistan, the 5.8 GHz band is designated as a military band, and ATRA should have coordinated its use with RS through the MSMO. ATRA has given a conditional acceptance to this network and as of late 2014 was working to finalize any license changes.

Frequency coordination requires all stakeholders to adhere to the license conditions. Due to the problems and confusion initiated by the AWCC “Super-Wi-Fi” concept, the chairman of ATRA requested for frequency band verification of some of the frequency bands. It was observed that some of the WiMAX operators at 3.4 GHz simply changed their frequencies contrary to what is in the license.

### SIM Box Problems

Subscriber identity module (SIM) boxes ultimately create what can be perceived as a spectrum problem because their use causes network quality of service problems (dropped calls, poor voice quality, network congestion, etc.). The use of SIM boxes is illegal in Afghanistan. SIM boxes – also known as GSM gateways – have valid uses but can be exploited to glean revenue by bypassing official interconnection termination routes and pocketing the difference between the costs and prices of calls. In a nutshell, SIM boxes have phones on different networks, rigged such that incoming calls on one network are routed out on another, making it appear as if calls originate and terminate on operators’ networks so no interconnect fee is payable. Widespread use of these devices results in a loss of revenue for the MNOs and the government, and poor call quality, and can even pose major security issues. SIM box owners can record the data for further processing in order to view the messages being transmitted through the system. In addition, calls that go through SIM boxes are more difficult to detect for surveillance purposes, and even the basic encryption of signals can be compromised, as these illegal operators want to provide the cheapest service possible. The only beneficiary of nefarious SIM box use is the operators of these devices, who ultimately obtain and retain all the lost revenues.

A number of SIM boxes have been located and confiscated in Afghanistan; however, their detection is often difficult because they are often installed in homes or garages, and specialized equipment is needed to pinpoint the devices. In one case the TAT was informed ISAF was possibly operating an illegal SIM box on one of its bases. After some discussions with ATRA and the MNO, the TAT worked with the MNO and another company (with the required specialized equipment) to try to locate the SIM box. After a few attempts, the SIM box was located within the camp in one of the equipment shelters. This was, of course, a major embarrassment for ISAF and initiated the need to find the perpetrator. The SIM box was collocated with an MNO’s cell site equipment, and Internet service was supplied to the SIM box from the base station equipment. With the help of the garrison commander, power was disconnected from the SIM box and the locks were changed on the fence. The hope was the SIM box operator would come for repairs and would be arrested. After a few weeks, the TAT went back to check and the SIM box was gone. The TAT checked with the garrison commander, but he had no knowledge of its removal. The TAT checked the

CCTV<sup>1103</sup> footage, which was scanning the area, but, unfortunately, the scan area did not include the area in question.

## Frequency Interference and Jamming Issues

At the request of the Afghan Minister of Communications, the TAT began assisting ATRA to evaluate, isolate, and mitigate frequency interference issues beginning in 2011, some of which were described earlier, and continued to do so until it ceased operations in October 2014. The Afghan Telecommunications In-Country Support Team (ATICS), the follow-on organization to the TAT, continued to work frequency interference under USFOR-A/RSM CJ6<sup>1104</sup> through the end of January 2015.

The TAT spent a lot of time working with ATRA and ISAF regarding the shared military-civil spectrum band, which was sloppy and often inaccurate, causing unnecessary interference. The TAT helped ATRA to validate its data and improve its accuracy and recommended ATRA make permanent military or civil assignments to reduce the shared spectrum frequency allocation table. The TAT also worked with ATRA and ISAF to improve communication and coordination between the entities.

The TAT also became involved in frequency interference and jamming issues experienced by the MNOs and ISPs, and even the Civil Aviation Administration, generally acting as neutral third party and an unofficial mediator of sorts between and among them, ATRA, and ISAF. All those entities, as well as the Minister of Communications, requested the TAT's assistance at one point or another. The MNOs' complaints generally stemmed from two causes, at least in perception if not always in fact: poor frequency management by ATRA and jamming by ISAF. ATRA had, in fact, assigned military and shared frequencies for commercial operations, with some of the conflicts ultimately resolved by spectrum reallocation. After some negotiations, ATRA and ISAF agreed to convert "tainted" shared or military bands to civil bands in exchange for the conversion of equal civil frequencies to military or shared, an even "swap," which was confirmed by both parties in writing in June 2013.

Initial investigations into the impact of ISAF jammers were ultimately determined to be mainly limited to the areas around military bases as a force protection issue, so the jamming issue was considered moot for a time. Further issues and testing most often resulted in findings of others' jamming (e.g., UN agencies and Afghan security entities), and for more than a year (throughout 2012 and well into 2013) not a single investigated incident indicted ISAF as the culprit.

The MNOs are required by license to meet certain quality of service (QoS) standards, with fines levied by ATRA if they do not. The MNOs were reluctant – or refused – to pay the fines because of their position. Many QoS issues were caused by poor frequency management by ATRA, which was true, and jamming, which was also true, but was not necessarily done by ISAF. The issue reached a head in May 2013, when the Vice Chairman of ATRA was summoned to the Afghan Parliament to address the plethora of GSM QoS

---

<sup>1103</sup> Closed-circuit television, a technology used in video surveillance.

<sup>1104</sup> United States Forces-Afghanistan/[NATO's] Resolute Support Mission [United States Department of Defense] Combined Joint Communications.

complaints from consumers and to answer as to why ATRA had not collected the monies due from the MNOs for QoS fines (among other ICT issues such as consumer complaints of overbilling and the lack of SIM card registration). The Parliament tasked the MCIT and ATRA with outlining their solutions and accelerating and documenting collection efforts.<sup>1105</sup>

ISAF worked to mitigate some jamming issues, but the TAT pointed out to ATRA how the frequency interference issues and jamming problems demonstrated the need for it to conduct proper spectrum management and coordination and to have a proper regulatory framework with monitoring capabilities and enforcement mechanisms where ATRA could identify unauthorized emitters and legally order them to cease operations or suffer consequences. The TAT also reminded ATRA it had done little to render mobile phones less effective for triggering IEDs, which would reduce the need for jammers.

In fact, the ISAF Chief of Staff issued a draft letter to ATRA, delivered by the TAT, which stated ISAF would no longer address jamming issues until ATRA develops a spectrum regulatory framework that outlines and regulates the use of jammers. ATRA consulted with the security entities and they determined ATRA and the MoI would be responsible for enforcement of jammer regulations, which would take six to 12 months to work through the legislative approvals process.

Things got worse before they got better, with three of the major MNOs requesting “clean” frequencies in June 2013. ATRA agreed to have Roshan temporarily move to frequencies reserved for Afghan Telecom’s 3G/GSM services, which reduced interference and congestion by about 20 percent. In July 2013, ATRA requested, via the TAT, ISAF involvement in high-level joint meetings to address and resolve frequency interference issues once and for all. The subject seemed to take on more urgency all around, due to AfTel’s imminent 3G/GSM Salaam service launch (originally planned for October 2013) and the looming transition of military spectrum management from the Coalition to the Afghans. After a few ad hoc meetings among affected and interested parties, the Minister of Communications requested the Senior Telecom Advisor (STA)/TAT Director chair a multilateral, permanent ensemble that met on a regular basis, and the Spectrum Interference Working Group was born. Throughout late 2013 and into 2014, ATRA (through consultants), the MNOs, ISAF, and the TAT all conducted independent analyses and discussed possible origins of the interference, and various solutions. The TAT offered a strategy to assist ATRA with cleaning up congestion in the unused 1970-1980 MHz 3G band, which could then be an operationally acceptable reallocation to Roshan.

Through the end of 2013, the TAT held detailed discussions with the MNOs, US electronic warfare teams, commercial spectrum tool vendors, and members of the ISAF community to develop a way ahead to resolve Afghanistan’s spectrum issues in light of security and regulatory concerns. After years of confusion, blame games, and frustration, the US DoD, through DISA, brought on Dr. Chi Nche, this chapter’s co-author, as a subject matter expert in spectrum with a mission to hunt down interference in Afghanistan. His story is below.

---

<sup>1105</sup> TAT Weekly Report, May 15, 2013.

## *Interference Hunting in Afghanistan – A Spectrum Expert’s Odyssey*

I joined the TAT in January 2014, having been recruited as a civilian spectrum expert. Following an introductory meeting, I started discussing spectrum monitoring capabilities with ATRA, and accompanied ATRA personnel in their mobile monitoring van to take measurements throughout Kabul. I had been told ATRA’s instrumentation van was state-of-the-art with excellent spectrum equipment. The only other piece of equipment that resembled something for spectrum analysis was an old piece of direction finding (DF) equipment capable of operating up to a few hundred megahertz. There was also a computer-based spectrum analyzer that could barely measure any RF signal not higher than -90 dBm,<sup>1106</sup> not to mention its frequency selectivity and scanning rate. I had been informed, based on a few reports and verbally, that interference was present everywhere in Afghanistan.

I was introduced to the highly-priced monitoring van, apparently purchased by the World Bank on the advice of a previous advisor. After inspection of the van, which has an extendible mask and a large dome-shaped antenna, two problems were obvious to me:

- Given the security situation in Afghanistan, this van looks very suspicious, even to the eyes of all the local and foreign forces. Even ATRA did not permit this van to be driven outside of Kabul for fear of insurgent attacks.
- The equipment was more suitable for general spectrum monitoring activities for frequencies up to 3 GHz. It was perfect for broadcast and obviously not portable.

The equipment in the van had problems. One of the local oscillators was faulty. Luckily, another oscillator was available and I spent a day trying to replace it.

For the next few weeks, our team spent a lot of time visiting the areas where interference was supposed to be prevalent. Unfortunately, no such widespread interference was detected, even with the mask extended. The only noticeable observation of interference was when a vehicle with a jammer went by, which is perfectly understandable. The first report I presented to the TAT basically concluded that the interference was not present, as nothing could be found. At the onset, I had requested portable spectrum equipment, which would have allowed the teams to go closer to the cell site antennae where the interference source could be determined, based on the azimuth of the sector antenna.

With the partial conclusion from the report, more tests were needed and I started looking for a portable spectrum analyzer. For interference hunting, the starting point should be close to the cell sites. In fact, the recommendation was to connect a spectrum analyzer directly to the receive-only diversity antenna of the sector. This would allow us to view what the antenna was picking up and subsequently being

---

<sup>1106</sup> Per *Wikipedia*, dBm is an abbreviation for decibel-milliwatts, expressing the power ratio in decibels (dB) of the measured power referenced to one milliwatt (mW). It is used in communications networks as a convenient measure of absolute power because of its capability to express both very large and very small values in short form. Accessed February 11, 2016. <https://en.wikipedia.org/wiki/DBm>.



demodulated. While working with the TAT and ISAF to get a spectrum analyzer, it was mentioned that one or two of these devices were owned by Huawei, Roshan, and Etisalat.

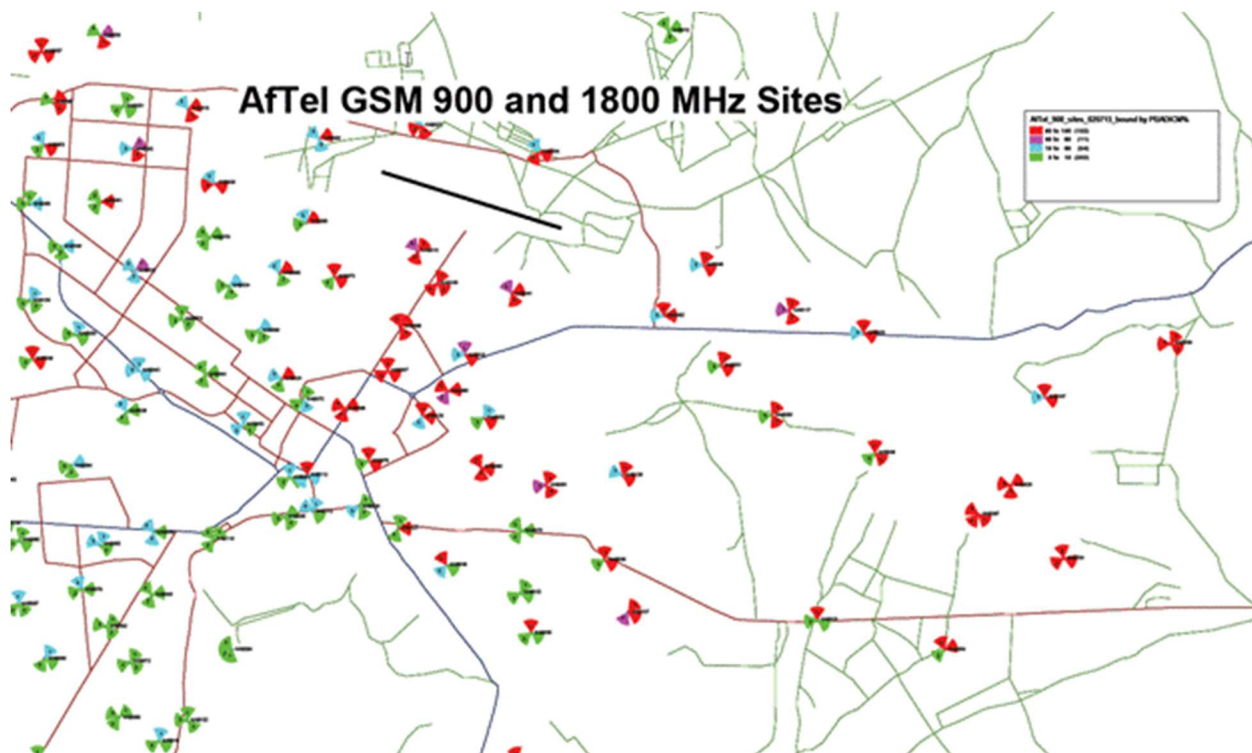

Figure 71: Sample plot using ICM data to show the direction of external interference

The TAT arranged a meeting with the MNOs and ATRA where I set out to explain the interference hunting process, starting with the basic understanding of the different types of interference, test and measurement equipment, and how we can utilize network data to identify sources of interference. After about a month, the TAT secured a monitoring receiver from ISAF and shortly thereafter a spectrum analyzer from the ISAF C-IED team. I also arranged for some tunable bandpass filters<sup>1107</sup> as well as cables and connectors and started the tests again. With this new setup we were able to identify interference and understand the signature of the interference, and suggested mitigation techniques. We found poorly installed repeaters, uplink jamming, inter-modulation, and a host of other interference issues that were internal problems to the MNOs. It was now possible to identify the interference problems attributed to jammers versus interference that was either internally generated or other interference sources such as repeaters.

---

<sup>1107</sup> Tunable bandpass filters, antennae, and connectors were paid for by DISA. When the shipment arrived from the US, ATRA did not want to pay the custom duty of about US\$500, which created a delay of three weeks. Ultimately DISA paid for the custom duty.

As the TAT proceeded with this process, visiting sites and taking measurements, I suggested the use of network data to help speed up the process. Generally in GSM networks, there is a network parameter that measures the signal strength in the idle GSM channels and provides a good indication of what is deemed as external interference, by binning the results into five interference bands. This is the idle channel measurement (ICM), and when this parameter returns values in ICM bands 4 and 5, there is a strong probability this is caused by external interference. A similar parameter exists for 3G systems. This is the received total wideband power (RTWP), which is utilized to identify areas of high external interference. When such data is plotted according to sectors, it is possible to visualize the impact of interference and potentially isolate the location of the interference.

[Figure 71](#) shows a typical plot obtained from AfTel's Salaam network showing sectors that are affected by external interference using the ICM parameter, with red indicating extremely high levels. It can clearly be seen that interference was high in the eastern part of the city (coming from the central jail), the airport area (close to the HKIA<sup>1108</sup> NATO camp), and south of the airport (close to camp RS headquarters and other embassies). Similar plots were created for all the MNOs in the various cities.

## Conclusions, Lessons Observed, and Recommendations

### Conclusions

In the 20 years between when Afghanistan's State Radio Monitoring Board issued its first radio frequency regulations in 1982 and ISAF assumed unrestricted use of and control over Afghanistan's electromagnetic spectrum in 2002, RF use was nominal, and spectrum management was likely not a principal concern of the succession of regimes that lorded over the turbulent nation. However, the US-led Coalition that invaded the country in search of Osama Bin Laden and his al-Qaeda hosts paved the way for reconstruction of the war-torn nation. The Afghans were eager to join the modern world, and ICT became a national priority. Despite early recognition of the need to create a licensing regime to allow private companies to use Afghanistan's spectrum to provide ICT services, and President Karzai's granting the legal authority for such, civil spectrum management did not appear to acquire any primacy within GIRoA. In all fairness, few predicted such precipitous adoption of ICT services, particularly mobile telephony. The surfeit of demand for spectrum taxed a weak, underdeveloped, and vulnerable system, and radio-controlled detonation devices further complicated spectrum matters.

Very early in its existence, the TAT recognized an utter dearth of spectrum knowledge within GIRoA, inefficacious spectrum allocation, management, and monitoring, and the absence of the necessary tools with which to do so, along with myriad frequency interference issues across communications and broadcast services. Of its own volition, and shortly thereafter by request of the Minister of Communications, the TAT began to assist ATRA with its spectrum-related duties, an effort it continued through all four years of operation, and which was important enough to be carried on by ATICS. All too soon after the TAT began advising and assisting ATRA in spectrum matters, ISAF sounded the transition

---

<sup>1108</sup> Headquarters Kabul International Airport

siren, and routine capacity and resource building gave way to the logistics and mechanics of transferring functional control of spectrum management from the Coalition to the Afghans.

In addition to the TAT's and others' assistance, ATRA was [re-]introduced to regional and global spectrum resources and had several short- and long-term in-country experts. Despite this, and despite reasonable cooperation among various entities, agencies, and donors, ATRA's spectrum capabilities improved sluggishly at best, and it is still struggling to acquire and implement suitable spectrum management software. In the short term, spectrum management by ATRA may best be accomplished by outsourcing it to a private spectrum management firm, while the long-term solution should include local capacity development and should be a combination of training existing employees and hiring personnel with appropriate and relevant technical skills. Hiring and developing local talent in Afghanistan may be easier said than done, given the present security situation and the massive migration it is experiencing, especially of its ICT-savvy youth.

## Lessons Observed

The Afghans did not necessarily – and perhaps still do not – fully understand the scope and significance of effective spectrum allocation, management, monitoring, compliance, and enforcement. The total transition of spectrum management responsibilities from the Coalition to GIRoA was overwhelming, as the country had not managed radio frequency use of any sophistication or particular consequence prior to the US-led invasion and had done managed civil spectrum well during the occupation. Further, the cooperation required among the various Afghan entities and agencies (ATRA, the Ministries of Interior and Defense, etc.) was unusual and uncomfortable, and the government structures, rules, and processes were not set up to accommodate such arrangements.

That being said, the Ministerial Spectrum Management Office is a good example of several organizations (ISAF CJ6, IJC, NTM-A, USAID, ATRA, and the TAT, among others) all working together to transition spectrum management functions to GIRoA. At ISAF's and ATRA's request, the TAT agreed to assign a person specifically to aid in spectrum transition, a single point of contact to synchronize and synergize all spectrum transition efforts. Identifying and developing a team of key Coalition stakeholders was also paramount to spectrum transition success. The TAT's weekly meetings with ATRA, which commenced in February 2012 and covered a variety of subjects, not just spectrum, and weekly Spectrum Transition Working Group meetings at ISAF helped to keep everyone on the same page and moving forward at the same rate.

Similarly, efforts by early TAT advisors to organize an interagency "spectrum support team" were generally effective and produced positive results, such as a multi-year contract with an in-country Internews spectrum expert for ATRA and broad reachback resources for the in-country team. Working with regional resources, such as regulators in India and Turkey, seemed to appeal more to the Afghans than working with entities such as the ITU and APT.

ATRA's relationship with and dependence on the MCIT was problematic for at least some companies in the private sector, particularly since the MCIT owns Afghan Telecom and 20 percent of AWCC. The regulator really needs to be a completely independent and self-funding entity. ATRA does not necessarily grasp nor comprehend the overall functions of a regulator and its role in the sector, although it continues

to improve. The regulator should be capable of issuing and should issue guidelines and conditions with spectrum (and other) licenses based on international best practices, or at least regional standards. ATRA must be able to monitor and enforce all license guidelines and conditions, which ability has been elusive at best and outright corrupt at worst. Coordination and cooperation between the public and private sectors is also important.

In the private sector, on the technical side, one cannot assume that commercial mobile network operators sufficiently understand wireless technologies, particularly as rapidly as they change and advance, nor that they follow good network construction and sound engineering practices. Nor can one assume licensees voluntarily adhere to all license conditions and restrictions. In the case of Afghanistan, the MNOs were sometimes the tail wagging the regulator dog.

Establishing specifications for wireless communication equipment is an important part of effective RF management.

Poorly executed jamming causes unnecessary frequency interference issues.

The ubiquity of demand for communications services cannot and should not be underestimated, even in the poorest and most devastated countries. Service growth in Afghanistan far outpaced the ability of GIRoA to manage, monitor, and regulate it.

## Recommendations

### *Broad Recommendations*

A robust ICT infrastructure benefits a country's people, its government, and the occupying forces because it connects people together, generates revenue, spurs economic growth, and, most importantly, can be used to communicate security threats, meet C4ISR requirements. In addition, value-added services, such as mobile money (mMoney), electronic funds transfer (EFT), biometric-based user registrations, electronic identity cards (E-IDs), etc., can be used to improve the lives of the people, reduce corruption, and increase accountability. The radio spectrum and the wireless communication services it underpins and enables is a major element of a country's ICT infrastructure. Effective management of the radio spectrum is imperative, and, therefore, should be recognized as such, planned for, and supported in all future interventions and post-conflict and stability operations planning.

Radio frequency use and management, however, should not be addressed in a vacuum. In today's world, basic telecommunications services (voice, fax, SMS<sup>1109</sup>), have been superseded by the need for broadband for Internet (data) services and other broadband applications. As such, spectrum should be considered as an integral component part of an overarching comprehensive ICT plan that also includes a national fiber-based broadband plan. With the huge financial investments and time required to design and provision optical fiber networks, it is important to have an expert support team that looks at the broad requirements of the ICT sector so as to be able to create good, synergistic regulatory policies. Fiber optic networks

---

<sup>1109</sup> Short message service, or texting

provide backhaul for individual cellular networks, support mobile and wireless broadband technologies, and provide for aggregate national and international data transport. The objective of such a comprehensive ICT plan is to provide a cohesive and enabling ICT environment, where the private sector, the local government, the occupying forces, and donors are able to coordinate to ensure the development of a robust ICT infrastructure to achieve, or at least make progress toward, sustainable stabilization.

Further, as part of a comprehensive, full-scope ICT plan, countries should consider adopting and promoting infrastructure sharing to leverage various rebuilding projects. This would ensure an ICT component is included in the planning. Examples of such projects are installing utility ducts and fiber conduits concurrent with road construction, utilizing excess optical ground wire (OPGW) in electric power transmission lines for communications services, and installing base transceiver stations (BTS) on electric transmission towers.

The RF spectrum is a limited natural and national resource and a military, civil, and commercial asset. Its significance should be recognized, and planning and support for it should be elevated among the US government's priorities in all future interventions.

### *Specific Recommendations*

It is important to continue to have a senior telecommunications advisor (STA) or similar position, held by a person with relevant technical experience, who is able to coordinate all ICT-related issues across all the various factions, agencies, governments, and other stakeholders. This coordination ideally would facilitate the creation of general ICT policies, including spectrum policies that attract private investment and enable the effectual deployment and management of ICT infrastructure and resources.

The national ICT regulator needs modern equipment and software for spectrum management and monitoring. Efforts to equip the regulator with such should, therefore, be encouraged or supported to obtain the necessary equipment at the outset.

Spectrum management training of local staff from all the relevant agencies, military and civil, should be considered at the beginning of an intervention. Training should be provided only to individuals with the required basic knowledge. Training should also be ongoing, as the ICT sector is constantly evolving and requires up-to-date technical knowledge.

Relatedly, putting in place an experienced spectrum management team to handle civil and commercial spectrum from the beginning would allow for a gradual transfer of responsibilities (as personnel are trained) based on host-nation competency, rather than spending so much time and energy correcting spectrum management mistakes.

Official jamming must be managed and controlled to the extent possible so as to minimize frequency interference. Official jammer operators must be trained and have well-functioning equipment appropriate to the jamming need. All other jamming, if any, should be subject to policy, law, and regulation. The open sharing of at least some jammer-related information by security forces, both foreign and local, would be advantageous to mitigating a negative environment.

The TAT refrained from adding a spectrum management specialist to its staff until its fourth year of operation because ATRA had an international expert on contract, and frequency interference issues only really escalated upon the proliferation of 3G mobile broadband services beginning in 2012. However, spectrum expertise should at least be considered as a potential core competency for similar future in-country advisory teams.

## Chapter 10 Cybersecurity

---

Karen E. Black (with contributions by William B. (Brad) Howard, Robert Kinn, and Larry Wentz)

*Author's Note: Some of the text in this chapter has been taken verbatim or paraphrased from the report resulting from the Cybersecurity Maturity Assessment, which the Telecommunications Advisory Team (TAT) conducted in 2012 (referenced below), portions of which the author helped to write and edit. The primary author of that report was Arne Brinck from Deloitte Consulting LLP, who was contracted to DISA in 2012 to assist the TAT.*

### Introduction and Background

The dawn of Afghanistan's digital age is a remarkable success story, with over 3,000 kilometers of operational optical fiber, 6,500 cellular base transceiver stations (BTSs), hundreds of microwave towers, 25 million mobile phone users, and at least two million Internet users, if not four or five.<sup>1110</sup> Voice and data services abound in all 34 of Afghanistan's provinces. Even the Taliban uses Twitter.

It is a universal requirement for all countries to embrace cybersecurity as a means to ensure the well-being of its citizens, protect their infrastructure and information, engender the trust of other nations, and create an environment conducive to cross-border commerce. Cybersecurity in Afghanistan is in its infancy but is a recognized need as Afghanistan moves further into the digital realm and along the

journey to fulfill its vision to become an information and technology community.<sup>1111</sup> The rapid adoption of new technologies, particularly by a very digitally-illiterate populace, and the ever-increasing networked environment present new and complex risks, ones Afghanistan is ill-equipped to face.

---

*In 2007, rumors circulated around Afghanistan that a deadly virus was spreading through mobile phones and that anyone answering calls from affected numbers would contract a fatal illness, bleed from the mouth, nose, and ears, and then die!*

*Another story circulating was that upon finding out their mobile phones were infected with viruses, some Afghans buried them in the ground like they did other diseased animals and items, believing them to be contagious.*

---

---

<sup>1110</sup> Afghanistan Telecom Regulatory Authority (ATRA). Telecom Statistics (End of December 2015). Accessed January 5, 2016. <http://atra.gov.af/en/page/telecom-statistics-2013>.

<sup>1111</sup> Paraphrased from the English translation of the "MCIT-100 Days Work Plan," May 5 – August 6, 2015.

Unfortunately – or fortunately – several high-profile cyber incidents in 2011 and 2012 elevated cybersecurity among the priorities of the Afghan Minister of Communications and Information Technology and the Government of the Islamic Republic of Afghanistan (GIRoA). They include, but are not limited to:

- a couple of costly and embarrassing financial cyber thefts from Afghan banks;
- the hacking of the websites of the Afghan ONSC and the Afghanistan Telecom Regulatory Authority (ATRA);
- the blacklisting of DNS and IP<sup>1112</sup> addresses assigned to the MCIT, rendering its email server useless; and
- the infection of the Minister’s iPhone with a virus.

Fast forward a couple years: At the end of December 2014, the Afghan Ministry of Communications and Information Technology’s (MCIT’s) centralized data network was compromised. An attacker – purportedly from China – injected a script into the MCIT’s JavaScript library, ostensibly to use .gov.af websites as proxies for external attacks.<sup>1113</sup> The intrusion was supposedly reported to the media by ThreatConnect, a commercial threat intelligence platform, although the MCIT claims to have been aware of the issue before it was made public. The MCIT also claims the Afghan National Data Center (ANDC), where Afghanistan’s .af domain is hosted, has been under “various failed attacks” over the past four or five years. It further stated it has been able to “overcome” (notably, it did not say “detect”) them “without any damage to its systems.”<sup>1114</sup>

The cybersecurity culture in Afghanistan, if one can call it that, remains stuck, much as it did in the US 15 years ago, with the issue only slowly gaining the attention of senior government officials. The MCIT, for its part, recognizes the criticality of cybersecurity. For that reason, and because it arguably has the most tech-savvy workforce within the Afghan government (although that is not saying much), it is the best place to start to transition from having essentially no cybersecurity to an environment with safe networks and secure information repositories. As of mid-2013, reportedly, only one Certified Information Systems Security Professional (CISSP) lived and worked in the country – the Director of the ISSD. While there certainly may be others, and Cisco’s CISSP is not the only certification, those are not good odds.

## The Good, the Bad, and the Ugly

### *The Good: Institutional Cybersecurity Constructs*

While it has a long way to go, the MCIT and GIRoA have begun to implement at least some cybersecurity organisms.

---

<sup>1112</sup> Internet Protocol

<sup>1113</sup> MCIT, “Information Regarding the Potential Cyber-Attack on the .GOV.AF Websites.” Accessed March 11, 2016. <http://mcit.gov.af/en/news/information-regarding-the-potential-cyber-attack-on-the-govaf-websites>.

<sup>1114</sup> Ibid.



## Information Systems Security Directorate and AfCERT

The MCIT established a Cyber Emergency Response Team (CERT) in 2009, officially named AfCERT, with a mandate to fight cyber threats and crimes and provide awareness of and solutions regarding cybersecurity to the government and private sector alike.<sup>1115</sup> The AfCERT also investigates cybercrimes. The MCIT established three new directorates in March 2012, among them an Information Security Directorate (ISD), which was later renamed the Information Systems Security Directorate (ISSD), and is sometimes called the Cybersecurity Directorate. The AfCERT moved under it. Also under the ISSD are Afghanistan's Network Information Center (AfgNIC) and Public Key Infrastructure (PKI), which includes cryptography, digital signatures, and an Electronic Certification Authority (ECA). AfgNIC has been in operation for several years, but the PKI and ECA are relatively new (only a couple years old as of early 2016, if that).

The AfCERT's mission is "to establish and achieve a safe, secure, and resilient cyber space for the government, businesses, and citizens of Afghanistan." Its mission is "to protect and assure data, information and IT infrastructure security in Afghanistan's cyberspace, enhance capacities to prevent and respond to cyber threats, protect the children and youth of Afghanistan in cyberspace, mitigate the risk of vulnerability [and] damage from cyber threats and incidents through a variety of standardized institutional structures, policies, procedures, people, technologies and administrative processes."<sup>1116</sup> The AfCERT is responsible for identifying and investigating cyber threats and crimes, including performing digital forensics, promoting cyber awareness, and conducting cyber audits. The AfCERT has been investigating cyber breaches and cybercrimes for many years now. It refers perpetrators to the Attorney General's office (and even reported one case to Interpol). However, Afghanistan has no laws under which to prosecute cybercrimes.

The MCIT planned to establish a network operations center (NOC) for the AfCERT, which was supposedly already underway in March 2012, and to connect it to the IMPACT<sup>1117</sup> Global Response Center in Cyberjaya, Malaysia. The Director of the ISSD and AfCERT described a rudimentary alert system using email to make cyber threats and vulnerabilities known to public and private entities. The goal, in 2012, was to have the AfCERT become an independent body within three to five years.<sup>1118</sup> To the author's knowledge, that had not happened as of late 2015.

## Special Cybersecurity Advisor to the Office of the President

As described in [Chapter 4, ICT Institutions and ICT Sector Governance](#), former President Karzai appointed a Special Cybersecurity Advisor to the Office of the President. The Director of the MCIT's Information Systems Security Directorate (ISSD) (also known as the Cybersecurity Directorate) who also oversees the

---

<sup>1115</sup> MCIT Information Systems Security Directorate. Accessed January 18, 2016. <http://nic.af/en/page/about-us/history>.

<sup>1116</sup> Ibid.

<sup>1117</sup> International Multilateral Partnership Against Cyber Threats, the operational home of the ITU's Global Response Center (GRC)

<sup>1118</sup> Per a meeting between the author and the Director of the MCIT ISSD and AfCERT Zmarialai Wafa (and others), March 28, 2012 at the MCIT in Kabul.

AfCERT and AfgNIC, served as the Special Cybersecurity Advisor from early 2013 until the end of Karzai's term. New President Ashraf Ghani has a special ICT advisor, Dr. Mohammad (Mo) Qayoumi, formerly the President of San Jose State University in California. In his new position as Special ICT Advisor, Dr. Qayoumi leads a commission on infrastructure, human capital, and technology. The author does not know if his portfolio includes cybersecurity or not, or if cybersecurity is on the Ghani administration's radar. President Ghani is presumably very aware of cyber dangers because he was educated and lived in the West for many years and is technologically savvy. However, the author does not know if President Ghani fully understands the dismal state of Afghanistan's cyber defenses.

### National Cybersecurity Strategy of Afghanistan

In response to one of the observations and recommendations of a Cybersecurity Maturity Assessment conducted in 2012 (see below), the Director of the ISSD led an effort to have the MCIT convene a committee to establish a national cybersecurity strategy. Using the National ICT Council of Afghanistan, an inter-ministerial body of government ICT stakeholders, the Director was successful in assembling a group of government officials, industry professionals, and representatives from academia into a National Cybersecurity Strategy Committee (NCSC), which he chaired. In September 2012, the US Department of Commerce funded (at least in part), and the TAT helped to facilitate, a four-day workshop in Kabul to raise awareness of cybersecurity within GIRoA and lay the foundation to draft a national cybersecurity strategy. The group studied and analyzed various cybersecurity strategies from different countries. Over the next 20 months or so, the NCSC met several times and eventually finalized National Cybersecurity Strategy for Afghanistan (NCSA) (something the United States government has been able to do for years). In July 2014 the committee submitted the initial draft strategy to the MCIT and the ICT Council to review.

As of November 2014, there exists a National Cybersecurity Strategy of Afghanistan (NCSA).<sup>1119</sup> However, it has only been adopted by the MCIT and is not a truly a national strategy (at least not yet). A Cyber Crime Law<sup>1120</sup> and an Electronic Transactions and Electronic Signatures Act<sup>1121</sup> have been drafted, but did not receive formal review under the Karzai administration. The relatively new Minister of Communications<sup>1122</sup> included action on these two laws among the priorities explicitly listed as part of this "100-Day Plan" presented to President Ghani. As of mid-2016, it is unknown to the author if either has been reviewed or added to the legislative calendar.

---

<sup>1119</sup> Wafa, Zmarialai (2014). *National Cybersecurity Strategy of Afghanistan*. November, version 2.0. Islamic Republic of Afghanistan MCIT. Accessed March 21, 2016.  
<http://mcit.gov.af/Content/files/National%20Cybersecurity%20Strategy%20of%20Afghanistan%20%28November2014%29.pdf>.

<sup>1120</sup> MCIT Information and Systems Security Directorate (ISSD). Accessed March 21, 2016.  
<http://nic.af/Content/files/Cyber%20Crime%20Law.pdf>.

<sup>1121</sup> MCIT. Accessed March 21, 2016.  
[http://nic.af/Content/files/Electronic%20Transactions%20and%20Electronic%20Signatures%20Act%20\(revised-final\)%20\(00000003\).pdf](http://nic.af/Content/files/Electronic%20Transactions%20and%20Electronic%20Signatures%20Act%20(revised-final)%20(00000003).pdf).

<sup>1122</sup> Abdul Raziq Wahidi, inaugurated in April 2015.

### *The Bad: Challenge upon Challenge*

There are many challenges to developing a cybersecurity culture in Afghanistan. Among them are tribal differences and political pitfalls, an overwhelming lack of awareness – let alone understanding – of cyber dangers and cybersecurity, a near-total vacuum of cybersecurity skills, a population of networked neophytes, and the colossally slow pace of progress and change within both the government and the country. Afghanistan suffers from a bit of separatist mentality (except when it comes to uniting against outsiders), and traditional factions often oppose each other simply because of history (or ethnicity or tribal affiliation). It is often difficult to rally and unite Afghans behind anything (except foreign invaders). That mindset will need to be overcome to have a united cyber front. Before an interview about cybersecurity as part of the TAT's Cybersecurity Maturity Assessment, a CIO of an Afghan ministry googled the term to see what it meant in preparation for the meeting. And he was among the more tech-savvy CIOs!

Some feel that cybersecurity is not important for GIRoA to bother with at present because “who would want to hack Afghanistan?” This position underscores the lack of awareness and understanding of cybersecurity and the threat to Afghanistan's optical fiber, microwave, and satellite networks and about 25 million mobile devices vulnerable to exploitation. For example, a hacker could manipulate vulnerabilities within GIRoA networks to launch attacks on other networks while making it appear the attacks were from the government itself (similar to the attack on the .gov.af domain in December 2014). In addition to causing other problems, such a stunt could undermine public confidence in government. The theft of commercially- or personally-sensitive information on unclassified GIRoA networks could further erode Afghan's trust in public institutions.

### *The Ugly: It's Even Worse than It Looks*

Detailed assessments of the MCIT's technology and network architecture performed in 2012 and 2013 revealed several serious shortcomings that could be summed up as follows: There were effectually no cybersecurity measures or capabilities within the MCIT at all. The MCIT neither observed nor implemented virtually any tenets of current Western cybersecurity and information assurance (IA) standards. This void was not due to malfeasance on the part of the MCIT, but rather to deficits of awareness and capabilities, of not knowing what to do or how to make a solid cybersecurity state.

Assuming the MCIT has among the most IT-savvy personnel, as conventional wisdom and practical experience indicate, one might surmise the other Afghan ministries are even worse off. Perhaps many are not even aware that cybersecurity is a critical management competency in today's day and age. There was one exception: The Ministry of Interior (MoI), which outsources its network operations and security to a private contractor (but has some ICT-skilled Afghans among its staff).

## Cybersecurity Assessments and Results

Though it is sometimes hard to tell, the concept of cybersecurity is not entirely new to Afghanistan. Three organizations have conducted cybersecurity assessments. The Information Technology Association of America (ITAA) and the International Telecommunication Union (ITU) conducted the first two in 2006 and 2009, respectively. Minimal progress was made between 2006 and 2009 against the ITAA's recommended actions. Some progress, though not significant, was made between 2009 and 2012, when the Minister of

Communications requested a third study, an assessment of the country's cyber maturity, particularly within, but not limited to, the Afghan government.

There are a number of conceivable reasons for Afghanistan and the MCIT not to have implemented nor sustained any measured cybersecurity efforts:

1. Initial actions described in 2006 were vague and therefore difficult to implement by a nation unprepared to address cybersecurity concerns.
2. Afghanistan was overwhelmed with conflict and other pressing matters. Cybersecurity was not identified as a priority.
3. No individual or organization was granted authority to execute cybersecurity responsibilities. Therefore, no one was held accountable either.
4. The ability of Afghanistan to implement, operate, and sustain recommendations was not given due consideration.

Highlights of these two assessments and resultant follow-on actions are described below.

### 2006 Afghanistan Reconstruction Group Model National Plan (MNP)

In 2005, the Afghan Minister of Communications asked for US assistance in developing a cybersecurity regime. Beginning in 2006, Senior Telecommunications Advisor (STA) James (Jim) Craft, part of the Afghanistan Reconstruction Group (ARG) based at the US Embassy Kabul, conducted a series of meetings with Afghan leadership to develop a Model National Plan (MNP) for cybersecurity and critical infrastructure information protection on behalf of the ITAA. The intentions of the MNP were threefold: provide comprehensive guidance on cybersecurity strategy in terms of offering resources; put forward a vision of what an effective cybersecurity posture for Afghanistan could be in practice; and serve as an institution-building roadmap for national policymakers.

The MNP outlined policy objectives for five overarching areas identified based on previous US experience developing cyber infrastructures, programs, and procedures. The five areas are national policy development; legal and regulatory development; incident response watch and warning; industry-government partnership; and dialogue to develop a "culture of security." At the time, the MNP delineated eleven actions to which Afghan leadership committed.<sup>1123</sup> [Table 9](#) lists them, along any progress made against them as measured by the ITU in 2009.<sup>1124</sup>

### 2009 International Telecommunication Union Findings

Towards the end of 2009, the ITU offered a readiness assessment pertaining to the third theme of the Model National Plan, incident response, entitled "Readiness Assessment for the Establishment of AfCERT

---

<sup>1123</sup> Jim Craft (2006). *Model National Plan (MNP) for Cyber Security and Critical Information Infrastructure Protection (CIIP)*. For the ITAA, April 13, 2006

<sup>1124</sup> Deloitte Consulting LLP (2012). *Afghanistan National Cybersecurity Strategy Maturity Assessment Report*. May 31, 2012.

for Afghanistan.”<sup>1125</sup> Two ITU experts planned to perform a two-week assessment that lasted only five days, being cut short by security threats. They also sought to define an incident response framework and undercover critical information about the state of Afghan cybersecurity more generally. A few examples drawn from the report show the fragility of cybersecurity efforts in Afghanistan. In the original report noted (with the text cleaned up slightly by the author):

1. There is a need to pass, implement, and continuously improve cybercrime legislation.
2. There is no mechanism to identify or deter cyber threats within the government sector.
3. Some agencies claim they have never experienced any sort of cyber-attacks. There could only be two main reasons for this. Either they do not want to share the attack information or they do not know that they are being or have been attacked.
4. The network of the country is dispersed and, thus, the detection of cyber incidents is very difficult.
5. Cybersecurity and cybercrime laws are severely lacking in Afghanistan.
6. Threats from external and internal sources are high. The government’s top secret and secret data are kept on servers that are not connected to the Internet but inside risks should also be taken into consideration.
7. Few government agencies or departments have any information on security- or cybersecurity-related policies nor any procedures in place.
8. The government agencies and ministries are not aware of the type of cybersecurity standards that are available to be adopted to increase the security level of their agencies.
9. There is no awareness of common standards or regulatory frameworks.
10. Stakeholders are not willing to share information and fear reporting incidents.
11. Stakeholders do not have human resources that are capable of handling cybersecurity incidents, and most do not have basic knowledge of cybersecurity.

The 2009 ITU findings demonstrate Afghans made minimal progress against the 2006 ITAA recommendations.

---

<sup>1125</sup> Subramaniam, Sivanathan and Jagdish Singh (2009). *Readiness Assessment for Establishment of AfCERT for Afghanistan*, December 4, 2009.

Table 9: ITAA and ITU cybersecurity assessment findings, 2006 and 2009

2006 ITAA Noted Action	Action Completed?	Relevant 2009 ITU Finding
(1) Assign information security officers in writing	No	<ul style="list-style-type: none"> <li>Few government agencies or departments have any information on security or cybersecurity related policies and procedures in place.</li> </ul>
(2) Begin training and awareness programs	No	<ul style="list-style-type: none"> <li>Knowledge of ICT lacks in the general public as the public must travel outside of Afghanistan to obtain ICT knowledge and skillsets.</li> </ul>
(3) MoC should establish Afghan CERT within a National Cybersecurity Management Structure	Yes*	<ul style="list-style-type: none"> <li>AfCERT premise is not fit to host AfCERT due to its lack of security controls.</li> <li>Location of AfCERT servers is without the standard requirements of security.</li> <li>AfCERT offices not conducive and too cramped for AfCERT staff to carry our daily activities.</li> </ul>
(4) Adopt integrated cybersecurity laws, regulations, standards, and policies	No	<ul style="list-style-type: none"> <li>Cybersecurity and cyber-crime laws are severely lacking in Afghanistan.</li> <li>There is a need for passing, implementing and continuously improving cyber-crime legislation.</li> </ul>
(5) Define cybersecurity organizations	No	
(6) Implement cybersecurity plans	No	<ul style="list-style-type: none"> <li>Few government agencies or departments have any information on security or cybersecurity related policies and procedures in place.</li> </ul>
(7) Adopt a prioritized, defense-in-depth strategy at every level within organization	No	
(8) Implement high priority elements of defense-in-depth nationwide, e.g., training and awareness, anti-virus software, readiness assessments	No	
(9) Create and use mechanisms that facilitate collaboration, e.g., portals, conferences, and professional associations	No	<ul style="list-style-type: none"> <li>Stakeholders are not willing to share information and fear reporting incidents.</li> </ul>

2006 ITAA Noted Action	Action Completed?	Relevant 2009 ITU Finding
(10) Begin budgeting process for cybersecurity – use low cost/free resources	Yes	<ul style="list-style-type: none"> <li>A budget proposal for the establishment of AfCERT has been submitted to the Ministry of Finance of Afghanistan.</li> </ul>
(11) Adopt a national program of assessments and process improvement	No	<ul style="list-style-type: none"> <li>No awareness of common standards or regulatory frameworks.</li> </ul>

*\*Afghanistan had established an AfCERT within the MCIT; however, its capacity and capabilities were deemed marginal at the time of the report.*

### 2012 Cybersecurity Maturity Assessment

As previously stated, several high-profile cyber incidents in 2011 and 2012 elevated cybersecurity among the Afghan Minister of Communications and Information Technology's priorities. He requested the Telecommunications Advisory Team (TAT) conduct an appraisal of Afghanistan's national cybersecurity governance structure, primarily, but not only, within Afghan's public institutions. The goal was to identify cyber capabilities already in place along with areas that should be improved to meet the cyber threat environment Afghanistan faced. On behalf of the TAT, the Defense Information Systems Agency (DISA) contracted a cybersecurity expert from Deloitte Consulting LLP to undertake the exercise. The TAT considered the work and the findings of the ITAA and ITU studies to establish a baseline.



*Picture 31: Cybersecurity interview at Afghanistan's central bank, April 2012*

The TAT conducted the assessment over eight weeks in early 2012. The result of the Cybersecurity Maturity Assessment was a menu of recommendations for establishing foundations for Afghanistan's national cybersecurity strategy. Those recommendations emerged from four areas of data collection and analysis (listed below) based on observations, stakeholder interviews, site visits, and documentation review.

- **Governance** – the leadership, management, and control structure responsible for leading and implementing cybersecurity programs in support of the strategy.
- **Legal/Regulatory** – the legal and regulatory environment as it relates to cybersecurity, to include laws, regulations, policies, and enforcement and compliance mechanisms.
- **Information and Communications Technology (ICT)** – ICT infrastructure that may introduce risk and the ability of Afghanistan to protect and defend its infrastructure, networks, systems, and data.
- **Human Capacity** – the ability of Afghanistan as a society of people to develop, implement, manage, and promote a national cybersecurity strategy.

[Table 10](#)<sup>1126</sup> lists all the recommendations derived from the assessment – which are really just observations – and their associated risk ratings. Not all of these findings were accepted or endorsed by the MCIT, nor are they meant to be interpreted as such. Following the delivery of the report to the Minister of Communications and Information Technology in June 2012, and his general endorsement of it, the TAT worked with the MCIT to turn the observations in [Table 10](#) into recommended courses of action and an implementation plan.

*Table 10: Findings of 2012 Cybersecurity Maturity Assessment*

Reference	Recommendation	Risk Rating
<b>Governance</b>		
1	No national cybersecurity strategy	High
2	No GIRoA level cybersecurity organization structure	High
3	No GIRoA cybersecurity specific roles and responsibilities	High
4	No public - private cybersecurity partnerships	Medium
5	No categorization scheme for data and ICT infrastructure (confidentiality, integrity, availability)	Medium
6	No distinction between PII, PHI, PCI <sup>1127</sup> or other specific data types	Medium
7	Little to no use of cybersecurity standards, policies, or procedures	Medium
8	No definition of critical infrastructure	Medium

<sup>1126</sup> Ibid.

<sup>1127</sup> Personally identifiable information, personal health information, and protected critical infrastructure information



Legal and Regulatory		
9	No cybersecurity or cyber-crime laws	High
10	No cybersecurity requirements within ICT tenders or contracts	High
11	No cybersecurity or cyber-crime arm within ATRA	Medium
12	No cybersecurity policies or standards requirements for ISP, ICT or other private sector companies	Medium
13	No public-private partnerships or structured communication	Medium
14	Little to no understanding of the legal/regulatory environment by public and private organizations	Medium
Information and Communications Technology		
15	No ICT risk management program or framework	High
16	Unsecured email environment	High
17	Unsecured DNS environment – DNS blacklist	High
18	Little to no use of data encryption	Medium
19	Little to no use of transmission security	Medium
20	Little to no use of identity and access management	Medium
21	Few to no cybersecurity policies or procedures	Medium
22	No cybersecurity considerations within ICT acquisition strategy	High
23	National fiber ring dependent on foreign connections	High
24	Unsecured satellite communications	Medium
25	Fiber / transmission monitoring relegated to physical security and availability	Medium
26	No cybersecurity standards leveraged for ICT development	Medium
27	Firewall and other security appliance misconfiguration concerns	High
28	No cyber threat and vulnerability information sharing	High
29	No incident handling and response processes or procedures	High
30	Many ad hoc solutions (mail, web, storage, hosting, etc.) deployed throughout GIRoA; no common architecture	Low
31	ANDC unprepared for National Payment Switch	High
32	NOCs have limited capability and are often not fully functioning, if at all operational	High
33	Minimal continuity of operations (COOP) and disaster recovery (DR) measures in place	Medium
34	No segregation of duties	Medium

Human Capacity		
35	Afghanistan does not have the native cybersecurity talent required to operate, maintain and defend its networks and systems	High
36	Cybersecurity not significantly addressed within the public education system, to include higher education	Medium
37	Cybersecurity education that is offered is not standardized and has little success	Medium
38	Minimal efforts to mitigate the insider threat	High
39	Government salaries not competitive with private sector	Medium
40	No cybersecurity historical or corporate knowledge	Medium
41	University students use and connect personal devices	Medium
42	Language is sometimes a barrier	Medium
43	Lack of accountability, focus	High
44	Little to no cybersecurity awareness – no awareness campaigns or outreach	Medium

## The TAT's Post-assessment Cybersecurity Work, Phase 1

Following the Minister's general endorsement of the findings and recommendations of the TAT's Cybersecurity Maturity Assessment, he directed his staff to cooperate with the TAT to develop an implementation plan. In late 2012 and through part of 2013, the TAT and its cybersecurity subject matter experts (SMEs) in-country and CONUS,<sup>1128</sup> to develop an actionable plan according to the four overarching categories of governance, legal and regulatory, ICT, and human capacity.

### Governance

Of the four categories listed above, governance was the top priority to address first. Developing a national cybersecurity strategy for Afghanistan was the first order of business under governance and would lay the foundation for a lot of future work (once it was approved): defining critical infrastructure, developing and implementing standards, and executing a public awareness campaign. The strategy would also feed the legal and regulatory requirements, the second category. The TAT recommended GIRoA establish a cybersecurity governance board to direct the categorization of sensitive data, mandate cybersecurity actions across GIRoA, and define and enforce cybersecurity measures across all sectors. The TAT worked with the US Department of Commerce CONUS regarding adapting to Afghanistan a public awareness campaign it had executed in another country, but nothing tangible came to fruition from those discussions.

---

<sup>1128</sup> Continental United States

## Legal and Regulatory

Regarding the legal and regulatory component, the TAT assisted the MCIT to source legal experts with cybersecurity, or at least ICT, knowledge. It also facilitated a relationship with the US Department of Commerce, which assisted the MCIT to redraft a new ICT Law, a Cyber Crime Law, and a law that addresses digital signatures and electronic (e-)commerce transactions, none of which have undergone legislative review to date. Developing cybersecurity requirements and standards are also included in this category, as are cybersecurity regulations, policy, enforcement, and compliance. One cannot enforce what is not written, approved, or promulgated across the government.

## Information and Communication Technology

As mentioned above, an assessment of the MCIT's cyber posture, or lack thereof, exposed devastating weaknesses and vulnerabilities at the strategic and tactical levels and revealed at least fifteen areas that required attention. One of the top items in the implementation plan in this category was the development of a risk-management framework. That TAT recommended the MCIT adopt something like the US National Institute of Standards and Technology (NIST) SP 800-37. It has identified a disciplined and structured process for categorizing the information system, selection of a set of baseline controls to minimize risk, implementation of the controls, assessment (continually or periodically) of the controls, and authorization of the information system to connect to the overall network. Lastly, monitoring of the controls and information system helps identify deficiencies as technologies evolve. The ICT component of the action plan has the most "nuts and bolts" to consider for security. Examples are encryption of data and network traffic, backup strategies, configuration of the DMZ<sup>1129</sup> that connects to the outside Internet, and security monitoring.

The TAT worked with the MCIT on elements in the ICT category like those above while waiting for the cybersecurity strategy to gain traction. The TAT met regularly with MCIT technical staff and the Minister to update him on progress. Some of the technical staff at the MCIT were well-versed in network operations and even the basic concepts of cybersecurity but had not been able to clearly articulate to their management the step-by-step procedures needed. The TAT discussed with the technical staff the need to first understand what the MCIT network looked like in order to improve security. The old adage "you can't defend what you don't know" held true at the MCIT, as the IT staff did not know what the MCIT's network comprised, or what devices were connected to it, and did not perform standard network discovery functions.

Apparently, the MCIT could not perform network scanning without Cabinet-level approval (!) so using commercial software tools such as SolarWinds or free tools such as NMap, OpenAudit, and Spiceworks were not possible. This was a show stopper in identifying the MCIT's network topology. Additionally, the MCIT was not operating Microsoft Active Directory, which meant that enterprise-level pushes of software updates and anti-virus patches were not possible. For updates and patches to be installed, they would

---

<sup>1129</sup> Demilitarized zone, which in computer lingo is a physical or logical barrier that separates internal networks from external networks and services.

have to be manually applied to each network segment and each network device, an immense resource issue. Further complicating matters, many staff brought their own laptops and used personnel email addresses for official government business (in part because of the issue described in the next paragraph).

The MCIT network and its associated IPv4 addresses were consistently blacklisted by DNS servers. This was because of the infected information systems and servers within the MCIT that were spewing spam and other malicious code. In short, being on a blacklist prevents traffic to and from the range of blacklisted IP addresses, effectively isolating the network(s). Absent an Active Directory environment, there was no viable action the MCIT could take to quarantine and clean infected systems effectively. The work-around was to simply apply an unused IP address from the few that had timed out long enough to become “clean” again to DNS blacklist servers. It did not take very long to have these IP addresses added to blacklists, and thus the cycle began anew. The MCIT also co-opted all the IPv4 addresses it procured for the National Internet Exchange of Afghanistan (NIXA), as it was not yet operational (and has yet to come to fruition).

The problem with this approach, besides being wrong, was the National Internet Registry of Afghanistan (NIRA), also under the ISSD umbrella, was running out of IPv4 addresses. No additional IPv4 resources were available because the Internet Assigned Numbers Authority (IANA) exhausted its inventory in April 2011. The MCIT decided the solution was to migrate to IPv6. The migration to IPv6 would solve the immediate issue of the lack of IPV4 addresses but *would not* prevent the MCIT’s IP addresses from continuing to be blacklisted because the MCIT was not solving the root problem. It was quickly evident that migration to a directory service such as Microsoft Active Directory was the only feasible long-term solution. However, no one at the MCIT had Active Directory skills so it would need to contract with an outside support service, an undertaking in and of itself. Remember, though, there was no way to run a discovery of the network without Cabinet approval, so another serious problem remained. (The required Cabinet approval is misguided, as it was based on the belief that scanning a network for discovery and topological reasons would expose email and file content, which goes against privacy protections of the Afghan Constitution, but is untrue.)

It is important to note the MCIT hosts two diverse networks. One belongs to the MCIT and the other, while being managed and maintained by MCIT, serves the Afghan National Data Center (ANDC). Neither network had visibility into the other, and the missions of each are different. The MCIT network provides computer and network support to the employees of the ministry, while the ANDC’s was operated as a service to other ministries (and commercial companies) to host web pages, provide backup and storage functions, and to offer redundancy. The ANDC was to host the data for the Afghanistan’s electronic national identity card, at least at that time and until a data center could be built at the Ministry of Interior (see [Chapter 11, E-Afghanistan and E-Government](#)).

The challenges that existed within the MCIT’s network were also evident in the ANDC’s. In fact, it was during an analysis session between the TAT and ANDC personnel that the issue of legal software licenses arose. Essentially, there was not a single legal license for any type of software in the ANDC (or the MCIT, for that matter), except, perhaps, the occasional program contributed by donors: for an operating system, anti-virus application, or network devices. The TAT asked for a copy of the network topology, at least a high-level one that showed the DMZ and security network devices. The TAT reviewed the documents but was not allowed to make and take copies. The TAT saw there were single points of connectivity failure

and that the border routers had some time ago reached an end-of-support lifecycle. Additionally, there were serious problems with HVAC<sup>1130</sup> to keep the server rooms cool, to the point where excessive heat was causing hardware failures. Also, there were no reliable uninterrupted power supplies (UPSs), even though power to the building often failed. The TAT assisted the ANDC to draft several separate tenders to address most of the above issues, replacing the single tender the MCIT had previously issued that combined ill-joined components, like air conditioning and software.

## Human Capacity

Human capacity, the fourth component, needs to be addressed at the macro and micro levels. At the macro level, the TAT had (separate from its cybersecurity efforts) undertaken a major “ICT Capacity Development Through Training and Education” project, which included cybersecurity-related elements. The project included ICT curricula review and recommendations for reform. One of the recommendations suggested by the TAT (and others, who peer-reviewed the curricula) was adding degree programs or at least major or minor fields of study in information assurance and cybersecurity. Another recommendation was for Afghanistan to look at and consider adopting something like the K-12 Computer Science Standards,<sup>1131</sup> which were established by the Computer Science Teachers Association (CSTA) and the Association for Computing Machinery (ACM) in order to strengthen computer science competency beginning in primary school. Also as part of the ICT capacity development project, the TAT created a CIO strategy and roadmap for GIRoA to develop a cadre of qualified CIOs across the Afghan government. See [Chapter 20, \*The TAT’s Efforts to Foster ICT Capacity Development\*](#), for more information.

At the micro level, the TAT recommended and introduced the concept of computer user (and other) agreements and annual IA training and tests for all government employees, similar to those the US government requires its employees and contractors to take. A computer user agreement is an important methodology toward increasing awareness by directing proper behavior and identifying and punishing unacceptable behavior of users of information systems. Annual IA training not only serves as a refresher and reminder, but it supports modifying the training to introduce new threats and vulnerabilities as they arise. Annual training for all GIRoA employees (and immediate training for new hires) that includes new threat vectors is a must for changing the cultural views of cybersecurity in Afghanistan. Right now, the Afghans don’t know what they don’t know, and they need to learn that what they don’t know could hurt them. Incorporating human cybersecurity capacity into the Afghan workforce, especially in the public sector, will require consistent, persistent, unified efforts across the government and the country.

## The TAT’s Cybersecurity Work, Phase 2

When the TAT’s cybersecurity SME redeployed and was replaced in early 2013, the focus of ISAF was changing to a Train, Advise, and Assist (TAA) mission, which influenced the direction of the TAT’s future cybersecurity support activities. The TAT’s cybersecurity efforts changed, and the new TAT SME elected

---

<sup>1130</sup> Heating, ventilation, and air conditioning

<sup>1131</sup> Computer Science Teachers Association (CTSA). CTSA K-12 Computer Science Standards. Accessed January 30, 2016. <https://csta.acm.org/Curriculum/sub/K12Standards.html>.

to take a somewhat different approach. He basically discarded the endorsed recommendations of the Cybersecurity Maturity Assessment and the associated implementation plan, which the TAT and the MCIT had devised and the MCIT was in the process of working through. He was, however, successful in drafting and having the Director of the MCIT ISSD approve an “MCIT Cybersecurity Acceptable Use Policy Statement” and an “MCIT Cybersecurity Acceptable Use Policy” (AUP) in July 2013. The TAT also supported the MCIT to develop a PKI tender. The TAT’s other cybersecurity efforts included supporting the MCIT regarding asset management software, online vulnerability management, developing an incident management strategy for the AfCERT, devising a cybersecurity awareness concept and campaign, provisioning forensic tools, and information assurance certification for the MCIT ISSD staff.

The TAT tried to help the MCIT, particularly the ISSD, identify and source relevant cybersecurity training. The SME re-introduced the International Commission on Workforce Development’s eSkills360 program to the MCIT (see [Chapter 20](#)) as a potentially quick, easy, and inexpensive (if not free) way to improve its human cybersecurity capacity. Other efforts included helping arrange ITU training for the AfCERT manager and facilitating Afghan participation in the US State Department’s Voluntary Visitors (VolVis) program, part of its International Visitor Leadership Program (IVLP), in June 2014. The Reachback element of the TAT assisted in arranging a VolVis trip that focused on cybersecurity awareness for the Afghans. The DoS sponsored ten Afghan ministry CIOs and IT managers to visit the US for a week to:

- obtain a better understanding of the cyber policy development process and observe best practices for implementing such a policy that could be applied and enforced within Afghanistan;
- examine how the US attempts to safeguard its infrastructure through technology, law enforcement, and legal parameters; and
- observe best practices and methods to foster cooperation.

Visits included US government agencies such as the Departments of State, Defense, Commerce, Justice, and Homeland Security, the Federal Communications Commission, the National Cybersecurity Center of Excellence, and others. The trip also included visits to academia at the National Defense University eCollege and meetings with industry professionals at Cisco in Silicon Valley. The Afghan participants comprised the Ministries of Communication, Finance, Foreign Affairs, Defense, Interior, Agriculture, Public Health, and Justice, as well as the National Directorate of Security.

As part of the support to the MCIT ISSD, the TAT cybersecurity SME conducted fact-finding visits to the ITU cybersecurity executing arm of the United Nations’ IMPACT Global Response Center in Malaysia; to NATO<sup>1132</sup> Headquarters in Brussels to visit the cybersecurity division to discuss cybersecurity policies and strategies; to the NATO Computer Incident Response Capability in Mons, Belgium; and to the NATO Cooperative Cyber Defense Centre of Excellence in Estonia.

---

<sup>1132</sup> North Atlantic Treaty Organization

## Conclusions, Lessons Observed, and Recommendations

The subject of cybersecurity is staggeringly complicated, and so is Afghanistan. Its byzantine tribal culture with deeply-ingrained values, norms, and customs, is nearly impossible for outsiders to understand. Combining the two is a formidable task. The Afghan ethos is not one of inclusion. Historically, Afghanistan's myriad factions have operated autonomously and only come together, in loose and fleeting alliances, for short-term shared purposes. Cooperation and information sharing do not necessarily come naturally to Afghans; rather, suspicion and distrust prevail. Afghans are a proud people, and saving face is huge. They do not like to admit, at least not publicly, of any wrongdoing or to be called out for mistakes, even in the context, for example, of divulging cyber vulnerabilities or attacks for the collective good.

Cybersecurity assistance by the US government to Afghanistan began more than a decade ago to jumpstart Afghans' awareness of cyber threats and the need for senior decision makers to take actions to develop policies, laws, and a national cybersecurity strategy and plan. Early efforts were introduced when Afghanistan was still a voice-based society, and transition to a data-driven information society had not yet begun. While well-intended, they may have been premature; hence, little progress was made for a number of years. Afghanistan has now truly entered the Information Age, but progress in cyber matters continues to move slowly. The Afghans are on a steep learning curve regarding the cyber challenges they face and what to do about them. They desperately need help from the International Community.

The TAT's and others' recommendations and assistance ran the gamut from being too lofty to being imprudently tactical. For example, it is difficult to expect Afghans to include cybersecurity considerations within their ICT acquisition strategies (Cybersecurity Maturity Assessment finding #22 above) if (1) they do not know what they should be considering, and (2) they do not have ICT acquisition strategies. (As mentioned above, the MCIT sought a single vendor to provide air conditioning and software.) Similarly, suggesting the MCIT put "Afghan Government Property: For Official Use Only" stickers on computers at its headquarters (which the TAT did, paraphrasing the wording) was somewhat absurd, particularly since there are many more pressing problems, and because many MCIT employees use their personal laptops at work. Furthermore, expecting Afghans in 2006 to "define cybersecurity organizations" (ITAA noted action #5) is unrealistic if Afghans did not comprehend what cybersecurity entailed or what cybersecurity organizations should do. While asking Afghans to "assign information security officers in writing" (ITAA noted action #1) sounds simple enough, it is rather futile if no one knows what an information security officer's responsibilities are.

Trying to grasp and improve Afghanistan's cyber stance is a daunting proposition. It is akin to being dropped into the middle of a jungle in the dark and having to figure out where one is, where one needs to go, and how to get there, with no compass or tools. There is an overwhelming amount of work to be done in multiple areas across many organizations and countless layers of physical infrastructure by people who, for the most part, do not even begin to comprehend the subject at hand. Cybersecurity most assuredly must be addressed at the strategic level. Be that as it may, assisting GIRoA to understand and implement small, effective, tactical, sustainable cybersecurity solutions would have immediate benefits, be much more impactful and lasting, and give the government some necessary breathing room to address the bigger picture.

In the specific case of the MCIT, it really needs cybersecurity people working in the weeds to help it have the basics: functioning computers, virus-free software, a firewall that protects its network, and a server that can send and receive email. The MCIT should be the shining cybersecurity example for the rest of Afghan government. Its personnel are relatively more technically-sophisticated than most of the rest of GIROA's, yet they are, for the most part, cyber-ignorant. While they are eager for assistance, they do not necessarily know enough about cybersecurity to know where to start, to ask the right questions, or to push back on those who give them advice.

That being said, the MCIT did not take advantage of relatively inexpensive – and even free – online training when offered the opportunity. Afghans have a general dislike for online training, plus it precludes them from traveling to India, Dubai, or other places to take in-person classes. Cyber education and training are imperative at all levels within the Afghan government, in the private sector, and for the populace.

The Afghan bureaucracy can be an obstacle to performing general ICT management and cyber functions, as the latter operates in real time and nanoseconds, while the former in months and years. While state salaries may be adequate for workers at the Ministry of Martyrs and the Disabled, they are not sufficient for the Ministry of Communications and Information Technology. And, after assigning an information security officer in writing, an organization should not have to wait until the beginning of the next fiscal year to have the officer's *tashkeel* (human resource slot and budgetary allocation) approved. As the government matures, it will have to move away from the one-size-fits-all approach that allowed the country to establish governance structures quickly in the immediate post-Taliban era and toward sector-specific, or at least more flexible, approaches that can accommodate Afghanistan's high-tech future.

Like many developing countries and emerging nations, Afghanistan is in relatively dire cyber straits. This fact should be of great concern to the US government, as well as to other foreign governments and the rest of the connected world. Cybersecurity is a shared responsibility among government, industry, academia, and individual users who provide, manage, service, and use information systems and networks. Managing the inherent risks of such use requires that the participants act cooperatively and in coordination with one another and that each participant takes action to address security appropriate to its role. The collective goal of participants is to prevent, prepare for, respond to, and recover from incidents. In our interconnected world, the cybersecurity roles and responsibilities of participants often overlap. Only when all participants share a common vision and understanding of the security objectives and how to achieve them, as well as their individual roles in the effort, can the collective goal be achieved.<sup>1133</sup>

While the Afghan government made policy, legal, and regulatory decisions that enabled the rapid deployment of ICT networks and services, it did so without sufficient consideration for establishing an appropriate and adequate cybersecurity posture or preventative cyber-threat-detection measures. One

---

<sup>1133</sup> International Telecommunication Union (ITU) National Cybersecurity/CIIP Self-Assessment Tool, Rev. April 2009. Accessed September 7, 2015. <https://www.itu.int/ITU-D/cyb/cybersecurity/docs/itu-self-assessment-toolkit.pdf>.



should not be surprised by this lack of attention because most nations entering the Information Age leave cybersecurity as an afterthought. The consequences of this oversight have yet to be felt, at least in any catastrophic way. If timely actions are not taken to secure Afghanistan's networks and infrastructure, problems will ensue – it is only a matter of when. Afghanistan, like many other nations, has let the Trojan horse out of the barn, and it will take a concerted, steadfast effort to corral it, one that requires extraordinary systemic, seismic change at all levels of government and within the population.

To complicate matters, at least potentially, China is extraordinarily active in Afghanistan's ICT sector. Chinese companies installed, for example, much of Afghanistan's optical fiber cable (OFC) network and Afghan Telecom Corporation's GSM/3G<sup>1134</sup> network and convergent billing system. The MCIT also contracted an Iranian company to install a segment of the OFC. Further, the MCIT has initiated ICT relationships with Russia and other countries whose interests often run counter to those of the United States.

Afghanistan has produced its first generation of digital natives. Like young people everywhere, they have tremendous technology appetites. As Afghanistan's indigenous ICT-literate population grows, they pose both a risk and an opportunity as they and the ICT sector mature.

The TAT's (and others') cybersecurity efforts, while important and constructive to at least some small extent, were just a drop in the bucket of what needs to be done. Real cyber change will have to encompass everything from policy at the executive level, to requirements, standards, enforcement mechanisms, and punitive actions at the ministerial level, to public awareness campaigns, and cyber education and the development of responsible digital citizenship for and among the population starting from an early age. With NATO's focus on building Afghanistan's National Security Forces during its Resolute Support Mission, it may want to consider adding cyber defenses to its mandate.

Once decisive executive or ministerial actions are taken, Afghanistan may want to consider free and open source software (FOSS) solutions, both to replace its abundant illegal software and to employ as cyber defense weaponry. On a positive note, the MCIT has engaged the government of Estonia, which has developed a robust cybersecurity posture, albeit reactively after the notorious cyberattacks it suffered in 2007. Afghanistan will need prolonged and enduring assistance – like from the Estonians and others – to secure its ICT assets and protect its cyber future.

---

<sup>1134</sup> Global system for mobile communications, a second generation of protocols for digital cellular networks originally developed by the European Telecommunications Standards Institute (ETSI). GSM is now a trademark owned by the GSM Association. Third-generation wireless digital technology based on International Telecommunication Union (ITU) International Mobile Telecommunications (IMT)-2000 specifications.

## Chapter 11 E-Afghanistan and E-Government

Karen E. Black

### E-Afghanistan

*E-Afghanistan*, the title of which is meant to convey a plan for the digitization of the country, is one of 23 National Priority Programs (NPPs) for Afghanistan. It is part of the Private Development Sector Cluster and is coordinated under Pillar Three – Economic and Social Development – of the *Afghanistan National Development Strategy (ANDS)*. The goal of *E-Afghanistan* is “to create a modern and efficient information and telecommunications sector and e-government to enhance the effectiveness, efficiency, and transparency of the public sector, provide for social services, develop a vibrant private sector, and create a connected and productive society.”<sup>1135</sup> The *E-Afghanistan NPP* was endorsed by the Joint Coordination and Monitoring Board (JCMB)<sup>1136</sup> in October 2011.

The *E-Afghanistan* strategy includes the following four elements:

- Building on the successes of the past ten years to meet the challenges of the future;
- Building the capacity of government organizations and public sector institutions, the private sector, and the education streams feeding both;
- Provisioning the latest and value-added services; and
- Creating a productive and efficient government and Afghan citizenry.<sup>1137</sup>



Figure 72: E-Afghanistan strategy

<sup>1135</sup> Islamic Republic of Afghanistan Ministry of Communications and Information Technology (MCIT) (2011). *E-Afghanistan National Priority Program (NPP) Proposal*, May. Accessed March 14, 2016. <http://mcit.gov.af/Content/files/PSD%20NPP%202%20E%20Afgh%20NPP%20Proposal%2023%20May%202011.pdf>

<sup>1136</sup> The Joint Coordination and Monitoring Board was a 28-member body comprised of 21 representatives from the international community and 7 from the Afghan government established “for overall strategic coordination of the implementation of the Afghanistan Compact and the interim Afghanistan National Development Strategy, per its Terms of Reference. Accessed December 15, 2015. [http://www.diplomatie.gouv.fr/en/IMG/pdf/JCMB\\_TOR\\_-\\_English.pdf](http://www.diplomatie.gouv.fr/en/IMG/pdf/JCMB_TOR_-_English.pdf).

<sup>1137</sup> Paraphrased from MCIT *E-Afghanistan NPP*. Graphic depicting the strategy elements was copied verbatim.

The *E-Afghanistan* program is comprised of the seven components depicted in [Figure 73](#).

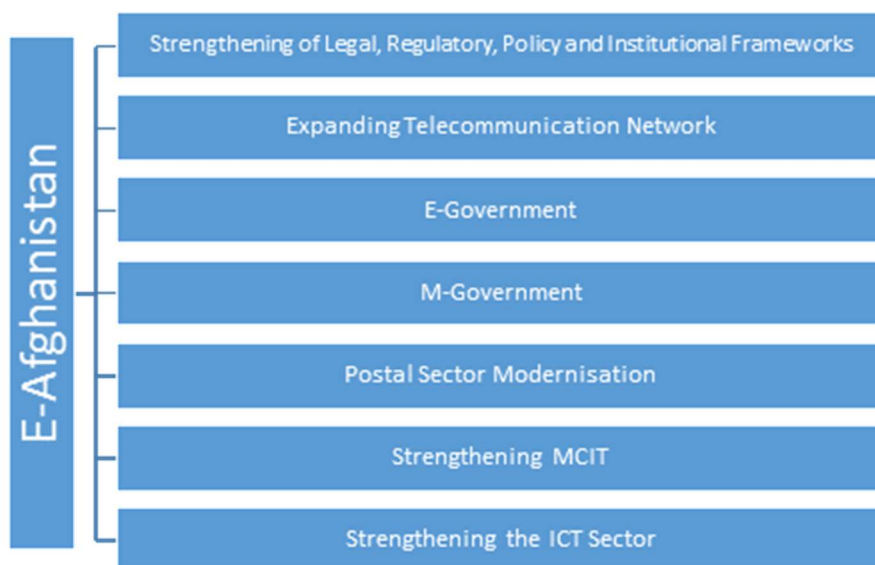

Figure 73: Seven components of the *E-Afghanistan National Priority Program*

Each of the seven components has myriad subcomponents, which are too many to list here. This chapter discusses some, though not all, of them. This chapter does not cover component five, Postal Sector Modernization.

### Strengthening of Legal, Regulatory, Policy, and Institutional Frameworks

The aim of this component is to create – or continue to, as it were – an enabling environment for the Afghan ICT Sector by establishing constructive and conducive legal, regulatory, and institutional frameworks and developing appropriate policies. Regarding progress against this component, the 2005 Telecom Law is in place and was updated in 2010. A new ICT Law and a Digital Signatures Law have been drafted and are reportedly soon to be slated for legislative review. An Open Access Policy, which will end Afghan Telecom Corporation’s monopoly control over the MCIT’s optical fiber network, was approved by the Afghan High Economic Council in April 2016 and by Afghan President Ghani in August 2016. The National Cybersecurity Strategy of Afghanistan was completed in 2014, though it has not been officially accepted outside the MCIT.

To maintain the ICT sector and create conditions for sustainable growth, it is necessary to continue to enhance and update the policy, legal, and regulatory, framework, using international best practices and models as guides. There has already been significant progress in this regard but there is much more to be done in the future. (See [Chapter 5](#), *ICT Policy and Regulatory Framework*, for more information.)

### Expanding Telecommunication Networks

Prior to and since the adoption of the *E-Afghanistan NPP*, the MCIT, ATRA, and AfTel, along with the private sector, have expanded information and communications technology (ICT) infrastructure, networks, and services. Approximately 2,900 kilometers (km) of the national optical fiber cable (OFC)

network has been installed to date, accounting for 87 percent completion of the main fiber ring of 3,100 km, with 2,275 km operational as of March 2014. (This does not include the additional ~2,000 km comprising the central and northeastern spurs. See [Chapter 7, Afghanistan's Fiber Optic Infrastructure](#), for more information.) As of the end of December 2015, over 6,500 mobile base transceiver stations (BTSs) have been installed throughout the country, with 89 percent of Afghans living in areas with mobile telephone service.<sup>1138</sup> Additionally, there are over 100,000 landlines in use.<sup>1139</sup> Over eight rounds of awards have been made by the Afghan Telecom Regulatory Authority (ATRA's) Telecommunications Development Fund (TDF) for rural telecommunications development (RTD) in support of Afghanistan's universal access/universal service objectives. Additionally, Afghanistan's first satellite, AfghanSAT1, was launched in May 2014, adding to Afghanistan's ICT infrastructure, resources, and networks. For more information on Afghanistan's ICT development, see [Chapter 3, ICT in Afghanistan](#).

Two elements that have not yet been accomplished are establishing the National Internet Exchange of Afghanistan (NIXA) (also covered in [Chapter 3](#)) and establishing an "ICT Village." The intent behind the ICT Village, also known as the Kabul IT<sup>1140</sup> Park, is to create a "High-tech Center of Excellence" with "state-of-the-art infrastructure" in which established and emerging members of Afghanistan's ICT business sector can operate, expand, collaborate, and thrive.<sup>1141</sup>

## E-Government

The third component of *E-Afghanistan*, electronic or e-government (e-gov), is covered in a separate section below.

## M-Government

One of the goals of *E-Afghanistan's* mobile or m-government (m-gov) component is to take advantage of the "widely available platform" of the over 25 million Afghan mobile phone subscribers to "support the mainstreaming of mobile applications across [the] Government for public service delivery" and "offer an opportunity for 'anytime, anywhere' service delivery in social sectors in support of the range of programs implemented by various ministries (e.g. in health, education, agriculture, rural development)."<sup>1142</sup> It is further intended for m-gov applications to "support the management of geographically distributed staff and resources across the country, improving monitoring and evaluation, and strengthening delivery systems."<sup>1143</sup>

To accomplish this, the MCIT's approach was, at its heart, two-fold: (1) seek m-gov advisory services to develop m-gov regulations and train government of the Islamic Republic of Afghanistan (GIROA) personnel

---

<sup>1138</sup> Afghanistan Telecom Regulatory Authority (ATRA). Telecom Statistics (End of December 2015). Accessed March 14, 2016. <http://atra.gov.af/en/page/telecom-statistics-2013>.

<sup>1139</sup> Ibid.

<sup>1140</sup> Information technology

<sup>1141</sup> MCIT, 2011. *E-Afghanistan NPP*, 41.

<sup>1142</sup> MCIT, 2011. *E-Afghanistan NPP*, 45.

<sup>1143</sup> Ibid.

on the basics of m-gov, and (2) install a common m-gov application service delivery platform and develop 30 apps for it.

### *Mobile Government Advisory Services*

The MCIT, through funding from the World Bank's Afghanistan ICT Sector Development Project,<sup>1144</sup> awarded a US\$536,000 contract<sup>1145</sup> to the Mobile Government Consortium International (mGCI) (with local Afghan partner Netlinks), in June 2012, with the following summary objectives and expected outcomes:

#### **Summary Objectives**

- **Strategy Formulation:** Designing a mobile government strategy and a roadmap in order to prepare the transformation of various government organizations and agencies so that they can effectively use m-government applications and services within their organizations, and in offering services to the businesses and citizens.
- **Regulatory Framework (Procedural and Capacity Strengthening):** Examining and suggesting improvements to the existing legal and regulatory framework and aligned policies, which will facilitate developments related to mainstreaming mobile government applications and services.
- **Capacity Building for Government Officials:** Designing and performing capacity building training programs for key government officials by bringing know-how from developing and other nations that show success in m-government.
- **Training for International Know-How:** Train 40 CIOs/Heads of IT Departments/Officials of the Afghan government in Turkey.
- **Training for Internal Strength:** Train 100 professionals from provinces in Kabul on mobile government, who can then train respective officials/representatives in provinces so as to enable mechanisms for central and local mobile government applications and services to spread widely around the country.

#### **Expected Outcomes**

1. Design of a sound strategy and action plans for mainstreaming mobile government in Afghanistan, which can be used as a roadmap or series of actions by the government officials.
2. Based on the strategy formulation suggestions for a sound regulatory framework relevant to m-government for accelerating and facilitating activities in mobile sector and government's operations related to the mobile government.

---

<sup>1144</sup> World Bank (2011). *Afghanistan - ICT Sector Development Project*. Washington, DC: World Bank. <http://documents.worldbank.org/curated/en/2011/03/13995882/afghanistan-ict-sector-development-project>, accessed 14 March 2016.

<sup>1145</sup> MCIT (n.d.). Mobile Governance and Capacity Building Initiatives. Accessed March 14, 2016. <http://mcit.gov.af/Content/files/Press%20Release%20on%20WB%20funded%20Mobile%20Platform-Innovation%20Support-IT%20Training%20Projects%20of%20MCIT-03%20Dec%202012.pdf>.

3. Identification of priority areas for mobile government implementation to enable at least 10 government units to use mobile government within their organizations and /or offer services to the citizens.
4. Enabling 40 high-level government officials to have the knowledge of international mobile government implementations and ability to lead deployment of appropriate m-government services in Afghanistan.
5. Enabling 100 government staff to have strong knowledge of mobile government especially in terms of technical aspects so that they can train others around the country to support widespread use of mobile government in the country.
6. Creating a base for transformation of government organizations to use mobile technologies for themselves and offering services to citizens.
7. Creating a base for understanding citizens' needs and ways of responding to these needs and demands.

As of May 2013, the mobile government strategy was at an “advanced stage” but mGCI’s consultancy with the World Bank “closed prior to completion of all the deliverable per the client’s needs” and the World Bank was “discussing alternative arrangements.”<sup>1146</sup> The statuses of both the m-gov strategy regulatory framework are unknown to the author. mGCI successfully trained 40 Afghan CIOs/Heads of IT Departments and 82 IT professionals in Kabul on mobile government at a series of sessions in Turkey.

### *Standard Delivery Platform for Mobile Government Applications*

The idea behind establishing a standard delivery platform (SDP) for mobile government applications was to consolidate efforts into a single, common dais and reduce the duplication, fragmentation, and costs of stand-alone and proprietary systems while increasing coordination, conserving resources, and improving overall service delivery to support mainstreaming m-government applications across Afghanistan. The MCIT thought a single platform would support the “rapid design, development, testing, deployment, and maintenance of mGov applications ... and speed up ‘time-to-market.’”<sup>1147</sup> Unfortunately, the opposite was true.

Again with funds from the World Bank ICT Sector Development Project, the MCIT awarded a US\$3.3 million contract<sup>1148</sup> in late 2012 for the implementation of a Mobile Government Applications Platform (MGAP) and the development and implementation of 30 m-government apps within two years. The contract was awarded to USTronics from America and was implemented by its Afghan subsidiary, Paywast. The anticipated go-live date was originally set for December 2013. The MGAP was installed at the Afghan National Data Center (ANDC) at the MCIT in early 2013, with testing expected to commence in May.

---

<sup>1146</sup> Raja, Siddhartha; (2013). *Afghanistan - Afghanistan ICT Sector Development Project: P121755 - Implementation Status Results Report: Sequence 04*. Washington, DC: World Bank Group. Accessed March 14, 2016. <http://documents.worldbank.org/curated/en/2013/05/17752866/afghanistan-afghanistan-ict-sector-development-project-p121755-implementation-status-results-report-sequence-04>.

<sup>1147</sup> MCIT, 2011. *E-Afghanistan NPP*, 46.

<sup>1148</sup> MCIT, n.d.

Paywast secured several hundred short codes<sup>1149</sup> from ATRA for use on the platform (the idea being that each m-gov app would have its own short code). By August, the MGAP was “mostly functional” but was powered down most of the time because of ongoing power problems at the ANDC, hindering Paywast’s ability to test the first m-gov app, which was due in September 2013.<sup>1150</sup> Paywast and the MCIT had difficulty achieving agreement with Afghanistan’s mobile network operators (MNOs) regarding the implementation of m-gov apps. The former wanted a master agreement to simplify and expedite app testing and deployment, but at least a couple of the MNOs took issue with the agreement or the process, which contributed to the delays in launching the platform.

In February 2016, the World Bank reported Paywast had soft-launched the MGAP on Afghan Telecom Corporation’s (AfTel’s) network and was expected to be connected to “relevant government agencies” (presumably those with m-gov apps) in March 2016.<sup>1151</sup> The MGAP is connected to AfTel via the fiber optic connection originally installed at the ANDC for the National Internet Exchange of Afghanistan (NIXA).

## Strengthening the Ministry

Under its “Strengthening the Ministry” component, the MCIT aimed to ensure the MCIT could meet the current and future challenges of the ICT sector and the country and perform its role efficiently and effectively. The subcomponents of strengthening the MCIT included:

- restructuring the Ministry;
- establishing a cybersecurity center;
- building the human capacity of the MCIT and other ministries;
- developing a Chief Information Officer (CIO) cadre across the government;
- creating a resource center to mainstream ICT in government/e-government; and
- improving the Information and Communication Technology Institute (ICTI).

There are no further details in the plan about how and why to restructure the MCIT. As far as establishing a cybersecurity center, the MCIT established the Afghanistan Cyber Readiness Team (AfCERT) in 2009, (see [Chapter 10, Cybersecurity](#), for more information). The MCIT’s (and other’s) efforts toward building human capacity, developing a CIO cadre, and improving the ICTI are covered in detail in the two chapters on ICT Capacity Development ([Chapter 19](#) and [Chapter 20](#)). The MCIT successfully established an E-Government Resource Center, which is described below.

---

<sup>1149</sup> Short codes are like 911 and 411 in the US and 999 in the UK.

<sup>1150</sup> Per Jes Kaliebe Peterson of Paywast in a meeting with the author, August 8, 2013, in Washington, DC.

<sup>1151</sup> Singh, Rajendra-000312761; (2016). *Afghanistan - Afghanistan ICT Sector Development Project: P121755 - Implementation Status Results Report: Sequence 09*. Washington, DC: World Bank Group. Accessed March 14, 2106. <http://documents.worldbank.org/curated/en/2016/02/25910981/afghanistan-afghanistan-ict-sector-development-project-p121755-implementation-status-results-report-sequence-09>.

## Strengthening the Sector

By “Strengthening the Sector,” the MCIT planned, with the support of the World Bank, to “develop the capacity of the public sector to integrate IT further in its programs, while also accelerating the development of the private IT sector.”<sup>1152</sup> The elements of this component include:

- Establishing a National Internet Registry of Afghanistan (NIRA), a non-profit department of the MCIT to manage, allocate, and supervise Afghanistan’s autonomous system number (ASN) and related Internet resources;
- Implementing an IT incubator to develop the local IT sector and stimulate creation of IT solutions; and
- Design and implement a multi-faceted skills development program to develop much-needed ICT/IT skills in the country.

Although the author does not know the date, NIRA was established under the Afghanistan Network Information Center (AfgNIC) and was operating by late 2011.

After years of delays, the MCIT awarded a contract to local Afghan company TechNation to lead the implementation and manage a technology startup business incubator, dubbed “*Ibtikaar*,” which means “innovation.” Ibtikaar was inaugurated in November 2014 “to support innovative entrepreneurs in the ICT sector by providing ... physical office space, training, business [advice], and support with market, funding access and networking opportunities to technology startups in Afghanistan.”<sup>1153</sup> Ibtikaar was originally envisioned to be a focal point of the ICT Village, but since that has yet to be built, the incubator is located on the campus of the ICTI. Ibtikaar’s programs are two years long. It is on its second round of companies, having called for applications in July 2014 and July 2015.

The MCIT, with support and funds from the World Bank, implemented an “ICT Skills Development Program” (also known as the “Bridging Program”), a US\$2 million pilot project to train up to 1,500 Afghans, largely but not entirely from the public sector, by 2016. The first round of training commenced October 1, 2012. According to a recent project status report, the MCIT and World Bank met their goal of training 1,500 Afghans by 2016.<sup>1154</sup> Further, the original program has been extended, with another 500 people (200 of them women) expected to be trained by June 2016.<sup>1155</sup> By many accounts the ICT Skills Development Program has been successful. It is described in detail in [Chapter 19](#).

---

<sup>1152</sup> MCIT, 2011. *E-Afghanistan NPP*, 60.

<sup>1153</sup> MCIT, n.d.

<sup>1154</sup> Singh, Rajendra-000312761; (2016). *Afghanistan - Afghanistan ICT Sector Development Project: P121755 - Implementation Status Results Report: Sequence 09*. Washington, DC: World Bank Group. Accessed March 14, 2016. <http://documents.worldbank.org/curated/en/2016/02/25910981/afghanistan-afghanistan-ict-sector-development-project-p121755-implementation-status-results-report-sequence-09>.

<sup>1155</sup> Ibid.



## E-Government



Electronic government (e-government or e-gov) is often defined as e-administration plus e-services. It is a framework for redesigning work processes to incorporate technology to make government more effective and efficient, not to mention transparent and accountable. Afghanistan's capitalized on its robust ICT infrastructure to provide government-to-government (G2G), government-to-business (G2B), and government-to-citizen (G2C) services.

As far back as 2005, if not earlier, the MCIT began laying the groundwork to transform Afghanistan into an information society supported by model e-government services. As part of the *E-Afghanistan NPP*, in 2008, the MCIT began developing an E-Government Strategy. The program methodology was developed by the United Nations University/International Institute for Software Technology (UNU/IIST).

The goal of the project was to define a conceptual strategy and a concerted implementation plan towards the development of Electronic Governance in Afghanistan (EGOV.AF). The specific objectives of the project are below.

- **Readiness Assessment:** Identify the state-of-practice and state-of-readiness for Electronic Governance in Afghanistan, including existing initiatives and studies.
- **Research:** Identify relevant international best practices and adapt them to the conditions in Afghanistan, taking into account the results of the Readiness Assessment.
- **Strategy Development:** Agree on the vision for the future of Electronic Governance in Afghanistan and define a set of goals, strategies, and targets to realize this vision, taking into account the results of the Readiness Assessment and Research activities.
- **Program Development:** Define a concrete government program through which the goals and strategies defined during Strategy Development can be implemented.
- **Human Capacity Development:** Raise the capacity of the public workforce in Afghanistan, covering a range of leadership, management, and technical skills, to be able to lead, implement, and benefit from the EGOV.AF Program.
- **Organizational Capacity Development:** Raise the organizational capacity of the MCIT to play the role of central coordinator of Electronic Governance in Afghanistan and particularly the EGOV.AF Program.

### EGOV.AF Vision and Goals

The vision for the EGOV.AF Program is that most people of Afghanistan will benefit from the equitable access to quality public information and services of high priority with equal opportunities for men and women in a balanced manner across urban and rural areas, reduced corruption, and improved security and stability and participation in governance with everyone motivated and enabled to contribute. EGOV.AF has three major strategic, albeit preliminary, goals: To improve public information services, particularly in health, education, and agriculture; to modernize the Afghan public sector through innovation, collaboration, and technology, within the appropriate policy environment; and to improve public participation in government that fosters transparency and, as a result, public confidence.

## E-Government Strategy and Program

The United Nations University/International Institute for Software Technology's (UNU/IIST's) Center for Electronic Governance developed (in collaboration with the MCIT) and delivered (in 2011) comprehensive e-government strategy and e-government program implementation documents<sup>1156</sup> to help guide the MCIT in its e-government efforts. While the MCIT and GIRoA now have strategic and tactical roadmaps, they need to ensure they have the legal, physical, institutional, and security constructs in place to accommodate the provision of e-government services across the country.

## E-Government Directorate and E-Government Resource Center

Per the *E-Afghanistan NPP*, the MCIT planned to implement an E-Government Directorate within the MCIT and an E-Government Resource Center (EGRC) at the MCIT. Both were established in March 2012, with the former responsible for e-government coordination and standardization, as well as e-government capacity building and audits. The latter is to provide advice, training, and support to other GIRoA ministries and agencies regarding the implementation of e-government and ICT services within their ministries and for their constituents. The US Agency for International Development has committed nearly US\$5 million across two projects (EGRC-I and EGRC-II) that began in 2009 and are expected to run through 2016.

## E-Government Services

### *Electronic National Identity Card*

There are reportedly between 60 and 100 e-government projects across GIRoA, too many to detail here, but one of the most prominent is the electronic national identify card (E-NIC, or e-Tazkira).

The strategic impetus behind the e-NIC is to replace the slow, cumbersome, issue-riddled paper *tazkira* (identification) system with, at least in theory, a reliable, unified, and efficient national system. In addition to basic identification, the goal is eventually to allow Afghan citizens to have multiple services on a single E-NIC, to include *tazkira* (identification), driver's license, vehicle registration, and, eventually, perhaps voter registration with e-voting. The e-NIC could also be a platform for future e-government (G2C) services, such as taxes, passports, land registration, health, and agriculture, and may even be able to be used for financial transactions. For the Afghan government, the e-NIC provides a database of national statistics and may help to implement an addressing scheme for districts, villages, and Afghan cadastral services.

The e-NIC is a smart card with a chip similar to the Common Access Cards (CACs) used by the US Department of Defense (DoD). The card was designed by an Afghan artist and all of the elements have historical or cultural significance. The images in [Figure 74](#) were current as of mid-2013, but may have changed, as the physical appearance of the card has gone through several iterations.

---

<sup>1156</sup> Dzhusupova, Zamira et al. (2011). *E-Government Strategy Draft for Afghanistan*. January 24, 2011 and Shareef, Mohamed et al. (2011). *Electronic Government Program Draft for Afghanistan*. March 30, 2011.



Figure 74: Images of Afghanistan's electronic national identity card

The front of the card is on the left.

The original memorandum of understanding (MoU) for cooperation between the MCIT and the Ministry of Interior (MoI) regarding the development and implementation of the e-NIC was signed on January 10, 2009, designating the MoI as the lead entity with the MCIT providing technical support. The e-NIC implementation contract was awarded to Afghan company Global Technology Resources (GTR) on 19 September 2010 (after a formal procurement and tender process) and was approved by the Afghan Ministry of Finance in November 2010. GTR subcontracted important e-NIC elements to industry experts, such as IRIS Corporation Malaysia, which is the pioneer of the smart card business, Hyundai IT Korea, which specializes in biometric identification systems and holds 17 patents in this area, Dongdo System Korea, which has 28 years of system integration experience, and Entrust Security System USA, which is the lead public key infrastructure – or PKI - provider globally. Afghanistan's PKI network is in place and the PKI Authority and Afghan Root Certifying Authority – or ARCA – have been established at the MCIT.

The e-NIC was originally expected to be implemented in three phases, with Kabul being first, followed by 15 provinces in Phase 2 and the remaining 18 provinces in Phase 3. The original rollout schedule was to be completed within 36 months of contract signing. There were myriad issues, some propagated by NATO's International Security Assistance Force (ISAF), which hindered the original e-NIC effort and left a bad taste in the Afghans' mouths.<sup>1157</sup> The Afghans still had plenty of work to do on their side prior to the implementation of the e-NIC.

On March 25, 2012, MCIT Minister Sangin and MoI Minister Bismillah Mohammadi signed another MoU for cooperation regarding e-NIC, which replaced the original 2009 document. The plan at that time was

<sup>1157</sup> MCIT Minister Sangin indicated to the TAT that he and other Afghans had lingering ill feelings because of past actions by ISAF to use the e-NIC as an excuse to collect unauthorized biometric data, which tainted previous attempts to implement the e-NIC.

that the e-NIC would be available on July 1, 2012 but that date was pushed out to 1 January 2013. Two reasons for the delay were that the Afghan National Data Center (ANDC) at which the e-NIC servers and data were to be housed until the MoI built out its own data center, continued to have power and other problems, and the MoI had not yet established a network operations center or a printing facility.

After years of delays, the MoI began enrollment for the e-NIC, on April 17, 2013, with the goal to have 14 million cards issued prior to the 2014 presidential elections to be used for voter identification. However, enrollment was halted almost immediately, pending the Afghan Parliament resolving an outstanding issue regarding tribal affiliation – whether to print it on the actual card – and the passing of a related population registry law. The *Wolesi Jirga* (Lower House) voted to pass the Population Registration Act in July 2013; the *Meshrano Jirga* (Upper House) in December 2013 or January 2014. E-Tazkira enrollment was expected to resume sometime in early 2014, after the Population Registration Act is translated into both Dari and Pashto and before it is signed by the Afghan president.

As of this writing, enrollment for the e-NIC has not yet resumed, although President Ghani is calling for implementation of the e-NIC sooner rather than later. In September 2015, the Presidential Palace said Ghani would soon issue a decree to start the process of distributing e-NICs, but as of January 2016 that had not yet happened.

### *119 Emergency Calling Centers*

Established in February 2008 by a resolution from the Afghan Office of the National Security Council (ONSC), the 119<sup>1158</sup> National Call Center's mission was to receive complaints from the public concerning emergencies and police corruption and misbehavior. The ONSC directed the MCIT to create an emergency services network for the Ministry of Interior (MoI) with the executive authority vested in the MoI Deputy Minister for Security. The original mission has evolved to include the following three major areas:

#### 1. Anti-corruption

- Operate a National Corruption Reporting and Response Center to receive and process reports of police corruption and wrongdoing.
- Provide an immediate response and investigative capability for corruption incidents of a critical and immediate threatening nature.
- Process and transfer corruption incidents to the appropriate agency as required. Maintain an official record of all reported cases. Track and review the findings of all cases to ensure proper resolution and report findings directly to the Minister of the Interior.

---

<sup>1158</sup> Like 911 in the US and 999 in the UK.

## 2. Emergencies

- Receive and process requests for emergency police, fire, and medical services to the appropriate organization in a timely manner. Provide oversight and management for Regional Emergency Service Call Centers.

## 3. Counterinsurgency

- Provide a means for the public to report insurgent activity, with the goal to invoke an immediate response and provide investigative capability.

The call center operator takes the call, gathers basic information, validates the call, and then notifies the closest police, fire, or emergency medical service – or other relevant authority – to provide assistance. Call volume can be as high as 4,000 calls a day. The program was designed to be nationally directed, regionally aligned, and locally responsive, with the end state of having a nationwide emergency services call center system that is managed and sustainable by GIRoA.



Picture 32: Depiction of 119 emergency services call

The MoI established the Kabul National Emergency Center in 2009, which was staffed 24 hours per day. The Kandahar Call Center was established in 2011 by the MoI with assistance from UNDP as an emergency service tip-line. The Lashkargah Call Center was established in 2009 as a “crime stoppers” line.

The MoI, with support from the NTM-A, UNDP, and the European Police (EUPOL) worked to revamp the existing three and establish three new (for a total of six) regional 119 emergency call centers. The revamped call center in Kabul was the first to go live followed by the call centers in Kandahar and Lashkargah, which were operational by mid-2013. A new call center was also established in Herat by that time. The Jalalabad/Nangarhar call center opened September 15, 2013, and the sixth call center in Mazar-e-Sharif was inaugurated in early November 2013. Phase II was to include call centers in Paktia and Kunduz in the summer of 2014. Eventually, it is planned to have a 119 call center in each province, preferably collocated with the provincial chiefs of police.<sup>1159</sup> The establishment of emergency calling services and

---

<sup>1159</sup> Information in “Emergency Calling Services” section above is from an Unclassified brief entitled “119 Emergency Call Centers” by Craig C. Lebamoff, Senior Advisor/Counsel ISAF/CSTC-A MoI MAG, dated February 20, 2014 and provided to the TAT.

centers is in direct support of an ISAF FRAGO to implement the ONSC's *Security Strategy for Telecommunication Networks*<sup>1160</sup> so as to increase access by Afghan citizens to the police and to improve the confidence of the populace in the ANSF and GIRoA, all with the aim of bolstering security and stability.

Initially, as an advisor to ISAF's Cellular Enabled Security and Stability (CESS) program led by the Office of the Deputy Chief of Staff of Stability (DCOS-STAB), the Telecommunications Advisory Team (TAT) played a supporting role in the establishment of emergency calling services. The TAT functioned as a liaison among the Mol, ATRA, and the mobile network operators (MNOs). The TAT facilitated cooperation among Afghan stakeholders in addressing and resolving issues related to correctly routing calls to the appropriate call centers. By mid-2013, routing was at 95 percent accuracy.<sup>1161</sup> The call centers were plagued by prank and nuisance calls, which were exponentially greater than actual distress calls. For example, of the 47,850 calls to the 119 emergency number in a month, only 480 were legitimate.<sup>1162</sup> After much debate, in February 2012, ATRA decided to impose a 3 Afs charge for all calls to short code 119 to reverse the troublesome trend.<sup>1163</sup> Because of the backlash ATRA and the mobile network operators experienced from the Afghan citizenry, ATRA decreased the charge to 1.5 Afs in June 2012.

The TAT also worked with ATRA regarding the potential use of the Telecommunications Development Fund (TDF) to finance further call center expansion and to assist the Mol in investigating the implementation of a fixed charge for every mobile subscriber to help fund operations and maintenance (O&M) of the 119 call centers going forward. Using the TDF in such ways, at least at the time, was outside its mandate.

The 119 emergency call centers connect the Afghan population to government services and at the same time provide the ANSF with situational awareness of any suspicious activities. Some of the benefits of 119 emergency services follow.

- There is increased perception of security by Afghan citizens and increased trust in the ANSF to protect them.
- Afghan officials are increasingly deterred from engaging in illegal and corrupt activities.
- The call centers directly connect the Afghan population to their government.

### *Afghanistan Portal*

The MCIT planned to launch an "Afghanistan Portal" in October 2013, which was to be a collective of GIRoA websites that can be used by Afghan citizens to interact with government entities. However, as of early November 2013, many ministry websites were still in the planning phases of development and the MCIT delayed the launch of the portal until more web pages are ready so as not to risk or undermine the

---

<sup>1160</sup> Islamic Republic of Afghanistan Office of National Security Council (ONSC) Directorate of Interior Affairs (2011). *Security Strategy for Telecommunication Networks in the Territory of GIRoA*, July 31.

<sup>1161</sup> Per a legal advisor to CSTC-A to the TAT.

<sup>1162</sup> As told to the author by an advisor to the ANP at and ISAF Gender Coordination Group Meeting November 15, 2012, during a discussion about where female members of the ANP could turn for help.

<sup>1163</sup> ATRA Decision & Order of the Board On 119 Call Center for Emergency Response. ATRA-D-2012-Feb-20-1.

value of the portal. The portal was, at one time, supposedly 30 percent complete with the main portal page being tested for live implementation followed by individual ministry portal pages. However, to the author’s knowledge, the portal never came to fruition.

## Conclusions and Recommendations

Afghanistan’s well-designed, well-executed *E-Afghanistan National Priority Program* has been very successful overall, with the MCIT having achieved many of its stated objectives. The implementation of e-government, on the other hand, particularly the e-NIC, has not been as successful. That may be a blessing in disguise because Afghanistan needs to improve its cybersecurity posture and cyber defenses (see [Chapter 10, Cybersecurity](#)) in advance of any widespread e-government efforts.

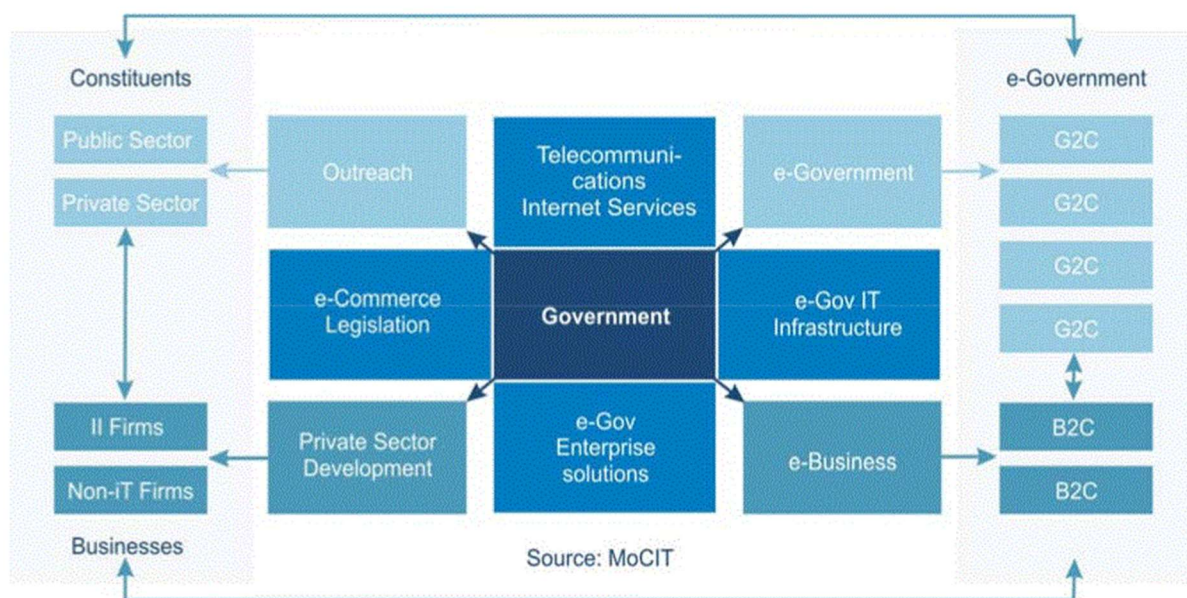

Figure 75: The MCIT’s vision of an e-government ecosystem

Figure 75<sup>1164</sup> illustrates the aspirations of the MCIT to develop a comprehensive e-government ecosystem. Understanding the desire and need to advance e-government with Afghanistan, it would be prudent for the MCIT to delay broad-scale introduction of G2C e-government services unless and until it is supremely confident in its ability to execute them nearly flawlessly, or better than “Afghan good enough.” Rolling out sub-standard or non-working solutions will undermine citizens’ confidence in e-government and perhaps hinder adoption of future such services. The country also needs to embark on a concerted digital literacy training campaign for its public sector personnel and citizenry in order to reap the full benefits of e-government.

<sup>1164</sup> Islamic Republic of Afghanistan Ministry of Communications and Information Technology (MCIT). *Information and Communication (ICT) Sector Strategy 1387-1391 (2007/08-2012/13)*, February 2008. Accessed March 14, 2016. [http://mcit.gov.af/Content/files/ICT%20Sector%20Strategy%20-%20English%20final%20Singed\(2\).pdf](http://mcit.gov.af/Content/files/ICT%20Sector%20Strategy%20-%20English%20final%20Singed(2).pdf).

## Chapter 12 Information Sharing in Afghanistan: The Synergy Strike Force and the Jalalabad Project

---

Karen E. Black, Jenn Gold, Rachel Robb, and Juan Andrés Rodríguez

### Introduction

The importance of information sharing in complex operations, such as military interventions, crises responses, and humanitarian assistance and disaster relief (HA/DR) operations, “has been repeatedly demonstrated in recent years,” according to the Center for Technology and National Security Policy (CTNSP) at the US National Defense University (NDU).<sup>1165</sup> The CTNSP “takes on topics that bridge the gap between technical and policy-making communities, supporting the Office of the Secretary of Defense, the Services, and Congress”<sup>1166</sup> and has spent years researching how to “foster UNCLASSIFIED information sharing in the field in post-conflict, post-disaster and development environments.”<sup>1167</sup> It contends, “if U.S. or coalition forces cannot communicate, collaborate, or exchange information with the population they seek to influence, they cannot achieve the social, political, and economic goals for which the forces were committed.”<sup>1168</sup> The CTNSP further asserts that “incentivized information sharing is vital to complex operations and that creating environments conducive to information sharing benefits U.S. military and U.S. government objectives while also helping coalition partners, international organizations, non-governmental organizations (NGOs) and the local community.”<sup>1169</sup> The CTNSP also insists “democratic process and civil society ... depend on information sharing and continuous information flow.”<sup>1170</sup>

In 2005, the Office of the Assistant Secretary of Defense for Networks and Information Integration (ASD-NII, now the [Department of Defense Chief Information Officer](#), DoD CIO) “supported an effort aimed at developing a strategy to better connect the disparate players involved in post-conflict work ...”<sup>1171</sup> Also in 2005, US Department of Defense Directive (DoDD) 3000.05, which was subsequently reissued as DoD Instruction (DoDI) 3000.05 in 2009, made stability operations<sup>1172</sup> a core US military mission the DoD should

---

<sup>1165</sup> CNI Technical Services, LLC (2011). *Research and Analysis Project for UNCLASSIFIED Information Sharing in Afghanistan: A Model for US Military and Coalition Commanders, the US Intelligence Community, and US Homeland Security*. Prepared for the Center for Technology and National Security Policy (CTNSP) at the National Defense University (NDU) on behalf of the Intelligence, Surveillance, Reconnaissance Task Force (ISR TF), January 28, 2011. Contract # SP4705-10-C-0055.

<sup>1166</sup> United States National Defense University (NDU) Center for Technology and National Security Policy (CTNSP) Accessed October 27, 2015. <http://ctnsp.dodlive.mil/>.

<sup>1167</sup> CNI Technical Services, 2011.

<sup>1168</sup> Ibid.

<sup>1169</sup> Ibid.

<sup>1170</sup> Ibid.

<sup>1171</sup> Ibid.

<sup>1172</sup> DoDI 3000.05 defines stability operations as “an overarching term encompassing various military missions, tasks, and activities conducted outside the United States in coordination with other instruments of national power to maintain or reestablish a safe and secure environment, provide essential governmental services, emergency



conduct “with proficiency equivalent to combat operations.”<sup>1173</sup> The directive also requires the US military to collaborate with other relevant entities – US government agencies, foreign governments and security forces, international governmental organizations and partners, NGOs, and the private sector – in planning, preparing for, and conducting stability operations. ASD-NII and the Chief Information Officer of the DoD (DoD CIO) were tasked with establishing “policies and standards for technical information exchange and communications” among the DoD and other entities, “developing policies, plans, and processes to provide information and communication technology [ICT] strategies, infrastructure, and equipment necessary to support the conduct of stability operations,” and “identifying and developing strategies for the use of ICT capabilities to enable civil-military interaction, information sharing, and accelerating stability and reconstruction activities.”<sup>1174</sup>

The DoD faced numerous internal challenges related to implementing DODI 3000.05, which were very pronounced in the mountains and deserts of Afghanistan. They included, but were certainly not limited to: an inculcated culture of restricting information; storing unclassified data on classified systems; constraints prohibiting field personnel from sharing data housed on unclassified networks, and restricted or blocked access to the public Internet at DoD facilities (which could be used to share unclassified data); few relationships with locals in the communities where they were based; and fortified compounds that were inaccessible – albeit by design – to non-military personnel and Afghans. Additionally, the US military has not traditionally understood the value in gathering, let alone sharing, “soft data” about the local populace – their needs and wants, especially regarding security, political, and economic conditions; their allegiances, dynamics, and tensions; and their perceptions of and attitudes towards the troops and other actors and development activities in their cities, towns, and villages.

The DoD faced external challenges as well, primarily the sheer number of organizations, both formal and informal, involved in Afghan reconstruction, each with their own internal bureaucracies and information-sharing issues. By virtue of the number of players, at least some of their interests, goals, and agendas were invariably incompatible, while others were similar or complementary. However, a lack of information sharing often led to conflict on one hand, or duplication of effort and waste of resources on the other.

In addition to these challenges, the CTNSP declares, “Experience has proven the primary obstacles to [information] sharing are ... social. The human beings on the ground are the ones who must implement policy and strategy, collaborate and share information, and respond to rapidly changing circumstances and conditions.”<sup>1175</sup>

---

infrastructure reconstruction, and humanitarian relief.” Accessed July 8, 2014.

<http://dtic.mil/whs/directives/corres/pdf/300005p.pdf>.

<sup>1173</sup> DoDI 3000.05.

<sup>1174</sup> Ibid.

<sup>1175</sup> CNI Technical Services, 2011.

## The Importance of Information in Counterinsurgency Operations

After several years of fighting increasingly unconventional and asymmetrical wars in both Iraq and Afghanistan, the centuries-old doctrine of counterinsurgency (COIN) was revived and applied to both fronts. Some of the more prominent COIN publications in recent history including the documents named below. Dr. David J. Kilcullen, while serving as the Chief Strategist of the Office of the Coordinator for Counterterrorism of the US State Department, penned the “Twenty-Eight Articles: Fundamentals of Company-level Counterinsurgency,” which was published in the *Small Wars Journal* in March 2006.<sup>1176</sup> In September of that year, he offered the “Three Pillars of Counterinsurgency” at a conference in Washington, DC.<sup>1177</sup> In December 2006, the US Department of the Army, jointly with the Marine Corps, released *Counterinsurgency*, often referred to as *Field Manual (FM) 3-24*<sup>1178</sup> (in which Kilcullen’s 28 articles were eventually formalized as Appendix A<sup>1179</sup>). Those were followed by the *US Government Counterinsurgency Guide*<sup>1180</sup> in January 2009 (which was a product of the US Interagency Counterinsurgency Initiative, in keeping with the Whole-of-Government approach).

Common to all three (and other such) texts is the importance of information to COIN operations. Dr. Kilcullen’s three pillars of interagency cooperation – security, political, and economic – are based on information, and support the overarching goal of control (see [Figure 76](#)). *FM 3-24* describes information operations as one of the key logical lines of operation (LLOs), encompassing and underlying all others, in effective iterative COIN planning and design (see [Figure 77](#)).<sup>1181</sup> The *Counterinsurgency Guide* imparts a COIN model with five main functional components: political strategy, economic development, security, information, and control,<sup>1182</sup> with information described as the “base component for all other activities, providing the linkages that allow discrete functional elements to cooperate as an integrated whole.” (See [Figure 78](#).)<sup>1183</sup>

---

<sup>1176</sup> Kilcullen, Dr. David (2006). “Twenty-Eight Articles: Fundamentals of Company-level Counterinsurgency,” *Small Wars Journal*, Edition 1, March. Accessed December 10, 2014.

<http://smallwarsjournal.com/documents/28articles.pdf>.

<sup>1177</sup> Kilcullen, Dr. David J (2006). “Three Pillars of Counterinsurgency.” Remarks delivered at the US Government Counterinsurgency Conference, Washington DC, September 28. Accessed December 10, 2014.

[http://www.au.af.mil/au/awc/awcgate/uscoin/3pillars\\_of\\_counterinsurgency.pdf](http://www.au.af.mil/au/awc/awcgate/uscoin/3pillars_of_counterinsurgency.pdf).

<sup>1178</sup> While Commander, US Combined Arms Center, Lieutenant General (US) Petraeus along with Lieutenant General (US) Mattis, USMC, CG Marine Corps Combat Development Command, led the development of *FM 3-24*.

<sup>1179</sup> *Wikipedia*. “David Kilcullen.” Accessed December 10, 2014.

[http://en.wikipedia.org/wiki/David\\_Kilcullen#cite\\_note-23](http://en.wikipedia.org/wiki/David_Kilcullen#cite_note-23).

<sup>1180</sup> Headquarters, Department of the Army (2006). *US Army Field Manual 3-24, Counterinsurgency*; MCWP 3-33.5, December. Accessed December 10, 2014. <http://usacac.army.mil/cac2/Repository/Materials/COIN-FM3-24.pdf>.

<sup>1181</sup> US Army *FM 3-24*.

<sup>1182</sup> US Department of State Bureau of Political-Military Affairs (2009). *US Government Counterinsurgency Guide*, January 13. Accessed December 10, 2014. <http://www.state.gov/documents/organization/119629.pdf>.

<sup>1183</sup> *Ibid*.

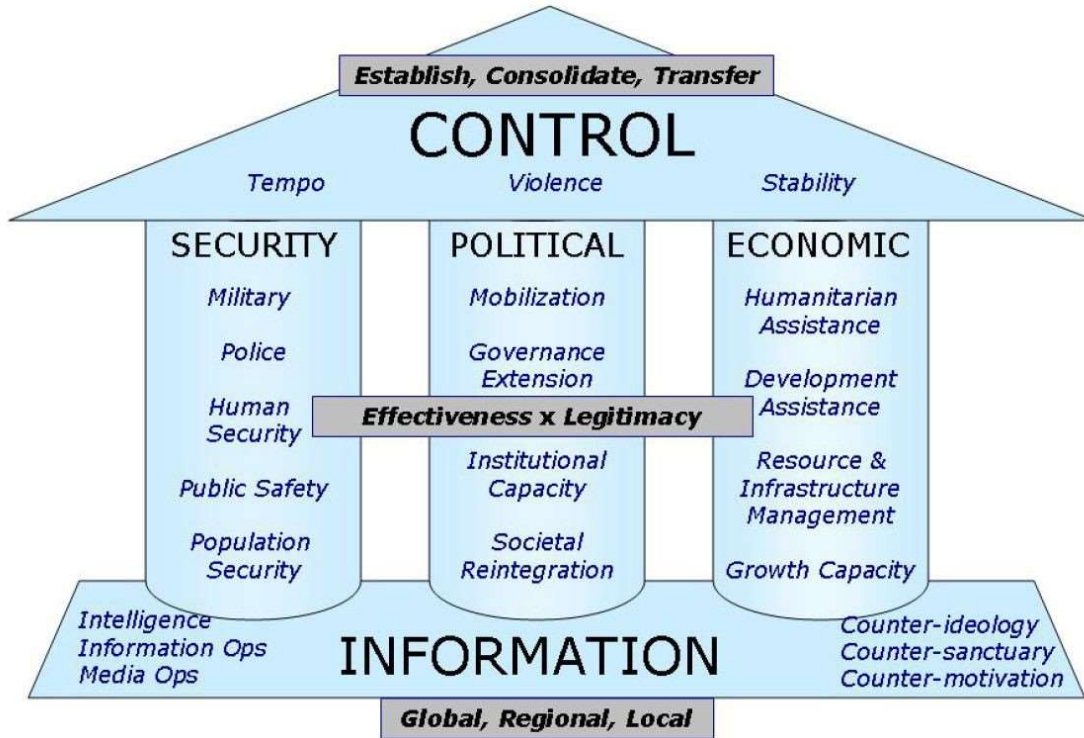

Figure 76: Three pillars of counterinsurgency

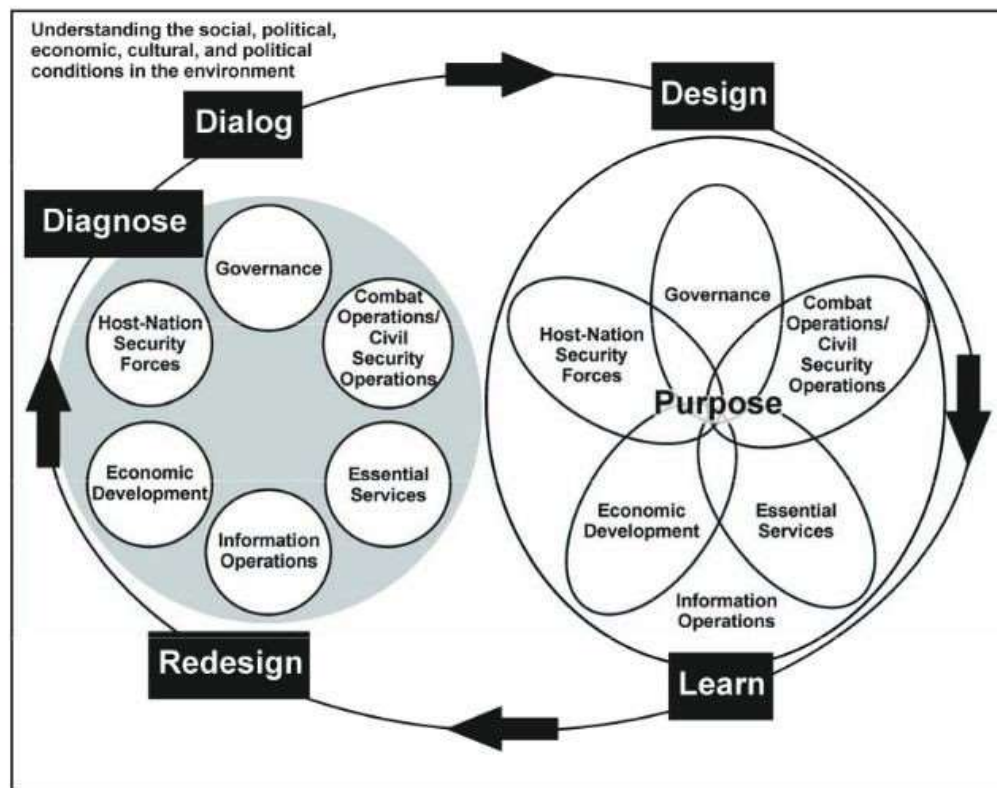
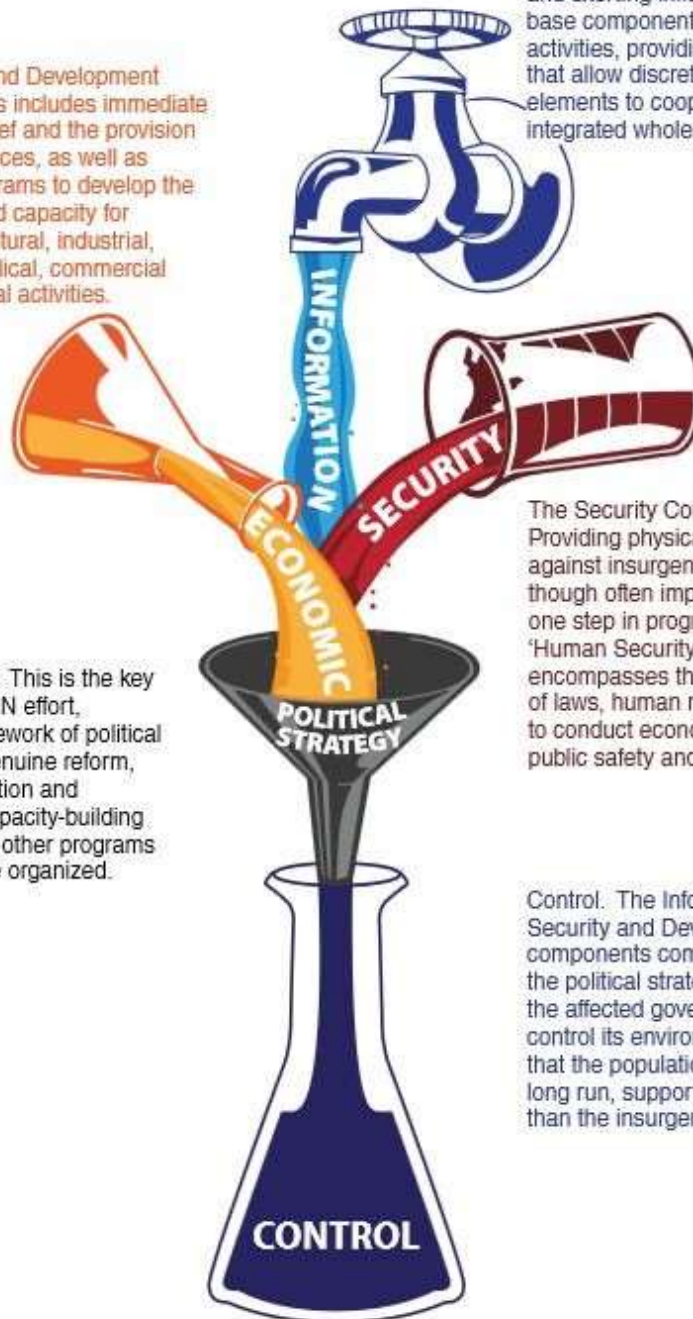

Figure 77: Iterative counterinsurgency campaign design

## Comprehensive Approach to Counterinsurgency

The Economic and Development Component. This includes immediate humanitarian relief and the provision of essential services, as well as longer-term programs to develop the infrastructure and capacity for legitimate agricultural, industrial, educational, medical, commercial and governmental activities.

Political strategy. This is the key function in a COIN effort, providing a framework of political reconciliation, genuine reform, popular mobilization and governmental capacity-building around which all other programs and activities are organized.



The Information Component. Information (acquiring knowledge and exerting influence) is the base component for all other activities, providing the linkages that allow discrete functional elements to cooperate as an integrated whole.

The Security Component. Providing physical security against insurgent violence, though often imperative, is only one step in progressing towards 'Human Security' which also encompasses the maintenance of laws, human rights, freedom to conduct economic activity, public safety and health.

Control. The Information, Security and Development components combine within the political strategy to enable the affected government to control its environment, such that the population will, in the long run, support it rather than the insurgents.

Figure 78: Five components of COIN strategy

General (US) Stanley A. McChrystal assumed command of the North Atlantic Treaty Organization's (NATO's) International Security Assistance Force (ISAF) and United States Forces – Afghanistan (USFOR-A) on June 15, 2009. In his "Commander's Initial Assessment," dated August 30, 2009, he said NATO "require[d] a new strategy," one that is "properly-resourced and executed through an integrated civilian-military counterinsurgency campaign." He went on to say, "Major insurgent groups outperform GIRA<sup>1184</sup> and ISAF at information operations."<sup>1185</sup> In a speech at West Point on December 1, 2009, President Obama announced a "surge" of 30,000 additional troops to be deployed to Afghanistan beginning in January 2010<sup>1186</sup> (at which time he also announced American troops would begin withdrawing from Afghanistan in June 2011). The troop surge was followed by a civilian surge, "a wave of civilian experts meant to bolster the parallel military surge."<sup>1187</sup> According to former US Ambassador to Afghanistan Karl W. Eikenberry in 2013, "counterinsurgency (COIN) doctrine [was] at the heart of the Afghan surge."

General (US) David H. Petraeus took over as COMISAF<sup>1188</sup> on July 4, 2010, following General McChrystal's resignation after the publication of the infamous [Rolling Stone article](#)<sup>1189</sup> and Lieutenant General (UK) Sir Nick Parker's interim stint as theater commander. Bringing with him lessons learned from Iraq and the US Army *Field Manual 3-24 on Counterinsurgency* he co-authored, on July 27, 2010, General Petraeus issued COMISAF's [Counterinsurgency Guidance](#)<sup>1190</sup> to the troops under his command. Many of "the 24 points [were] largely plucked from *Field Manual 3-24* and David Kilcullen's 28 COIN principles albeit with an Afghan flavor."<sup>1191</sup> Among his directions were: "Be first with the truth," which included getting accurate

---

<sup>1184</sup> Government of the Islamic Republic of Afghanistan

<sup>1185</sup> Stanley A. McChrystal, General, US Army, Commander, US Forces – Afghanistan/International Security Assistance Force, Afghanistan (2009). "Commander's Initial Assessment." August 30, 1-1 and 2-7. Accessed December 10, 2014. [http://www2.gwu.edu/~nsarchiv/NSAEBB/NSAEBB292/Assessment\\_Redacted\\_092109.pdf](http://www2.gwu.edu/~nsarchiv/NSAEBB/NSAEBB292/Assessment_Redacted_092109.pdf).

<sup>1186</sup> Obama, President Barack (2009). "Remarks by the President in Address to the Nation on the Way Forward in Afghanistan and Pakistan," December 1. The White House Office of the Press Secretary. Accessed December 10, 2014.

<http://www.whitehouse.gov/the-press-office/remarks-president-address-nation-way-forward-afghanistan-and-pakistan>.

<sup>1187</sup> Wendle, John (2011). "Whatever Happened to the Civilian Surge in Afghanistan?" *TIME* magazine, August 8. Accessed December 10, 2014. <http://content.time.com/time/world/article/0,8599,2087066,00.html>.

<sup>1188</sup> Commander of the International Security Assistance Force

<sup>1189</sup> Hastings, Michael (2010). "The Runaway General," *Rolling Stone*, June 22. Accessed December 17, 2014. <http://www.rollingstone.com/politics/news/the-runaway-general-20100622>.

<sup>1190</sup> Memo from General David H. Petraeus, COMISAF/CDR USFOR-A, to The Soldiers, Sailors, Airmen, Marines, Civilians of NATO ISAF and US Forces-Afghanistan, Subject: COMISAF's Counterinsurgency Guidance, July 27, 2010. Accessed December 10, 2014. [http://images.defensetech.org/wp-content/uploads/2010/07/COMISAF\\_COIN\\_Guidance\\_Jul\\_2010.pdf](http://images.defensetech.org/wp-content/uploads/2010/07/COMISAF_COIN_Guidance_Jul_2010.pdf).

<sup>1191</sup> Grant, Greg (2010). "Petraeus Issues New COIN Guidance for Afghan Theater." *DefenseTech*, July 28. Accessed December 22, 2014. <http://defensetech.org/2010/07/28/petraeus-issues-new-coin-guidance-for-afghan-theater/>.

information to the chain of command, to Afghan leaders, and to the people; and “Fight the information war aggressively.”<sup>1192</sup>

Given the above, there seems to be general agreement that information underpins effective COIN operations. (In fact, Information Operations became military doctrine as far back as 1996 with the publication of US Army *Field Manual 100-6*.<sup>1193</sup>) However, accurate, valid, and timely information, particularly regarding the attitudes and perceptions of citizens, is often difficult to amass, analyze, and disseminate in conflict zones. In Afghanistan, in particular, traditional methods of gauging the effectiveness of on-the-ground efforts (surveys, interviews, and polls) were impractical, if not impossible, due to language barriers, low literacy rates, harsh terrain in and difficulty reaching remote areas, instability, distrust by Afghans, and myriad other reasons.

## Information Sharing Experiments in Afghanistan

The issuance of DoDD 3000.05 coupled with the recognition by the ASD-NII that the US military “did not have an effective means of communicating with the wide array of international players and citizens”<sup>1194</sup> in Afghanistan, led to the formation of a pilot project, called the “Hub,” to test theories regarding information sharing and the use of the Internet as a “disruptive force” for good,<sup>1195</sup> as well as to connect the various factions performing stability, security, transition, and reconstruction (SSTR) activities. The premise of the effort was that “connections increase situational awareness, access to expertise, and support U.S. military and USG objectives.”<sup>1196</sup> The endeavor called for a neutral site to be equipped with accessible technology and connectivity and staffed by non-military personnel who could move relatively freely among the local population.

The city of Jalalabad, Afghanistan was initially identified as a potential area of operations (AOR) where concurrent SSTR-related activities were being conducted by multiple, separate but interrelated entities across the US DoD, other US agencies, foreign governments and security forces, the International Community, NGOs, and the private sector, among others. Jalalabad was also found to have a favorable set of sustained, well-established, multi-domain, social networks actively engaged in numerous and various efforts. The La Jolla [California] Golden Triangle Rotary Club and the Sister Cities Foundation, which paired San Diego and Jalalabad, were among the prominent actors in the region. A United Nations Office for Project Services (UNOPS) guesthouse in Jalalabad city, which was compliant with minimum operating security standards (MOSS), was identified as a potential “neutral site” at which to base the Hub. A team of civil engineers from Australia and New Zealand were living there while they worked on road construction projects in the area. The Aussies and Kiwis installed a pool and tiki bar and made the Taj Mahal guesthouse, or “Taj” for short, into a gathering place on Thursday nights – the start of the Afghan

---

<sup>1192</sup> Petraeus memo, July 27, 2010.

<sup>1193</sup> Headquarters, Department of the Army. 1996. *US Army Field Manual 100-6, Information Operations*, August 27. Accessed December 22, 2014. <http://www.emilitarymanuals.com/pdf/BlackOps/FM100-6.pdf>.

<sup>1194</sup> CNI Technical Services, 2011.

<sup>1195</sup> Ibid.

<sup>1196</sup> Ibid.

weekend – for expatriates (expats) working in the area to relax, enjoy a friendly social environment, and meet and socialize with other contractors and development personnel.

Separate from and independent of the DoD, the La Jolla Rotarians began working in Afghanistan in 2002, undertaking various projects in education, gender equality, agriculture, and health. Among other endeavors, they built a ten-station computer lab with Internet access at the Rotary School of Jalalabad, which they had constructed using funds from the club’s non-profit foundation, and established a telemedicine network connecting doctors in Jalalabad to their counterparts in San Diego.<sup>1197</sup>

Dave Warner, MD, PhD, a medical doctor and technocrat, traveled to Kabul in late 2004 to conduct an assessment of medical capabilities. During the trip, it became clear to him there were opportunities to improve the efficiency of US government efforts in the region on many fronts. In late 2005, it was brought to his attention ASD-NII was developing an information sharing resource called the “Hub” to support SSTR information exchange and communications requirements. As part of the initial implementation phase of the Hub, ASD-NII required direct onsite interaction with potential users of the Hub to assess its viability in a complex, real-world, SSTR operation. In 2006, Dr. Warner again traveled to Afghanistan, this time to Jalalabad, on an assessment mission with the Rotarians to help evaluate how to expand its various programs within Nangarhar province. Dr. Warner had previously worked with the ASD-NII on ICT for crisis and information sharing in real-world HA/DR events, so his trip was dual-purposed, also to conduct an assessment of Jalalabad in support of ASD-NII’s cross-domain information sharing efforts in the context of DoD Directive 3000.05. The objective of the Jalalabad evaluation was to identify specific opportunities where the Hub (collaboration environment) might be used to tangibly and meaningfully facilitate information sharing within and among entities in such a way as to better optimize SSTR operations.

During that excursion, Dr. Warner spent his last night in country (a Thursday) at the Taj, where he interacted with multiple people from a myriad of diverse organizations. He was able to gather a tremendous amount of (unclassified) information on a variety of subjects and projects, giving him a much fuller and clearer picture of what was really going on in Nangarhar province, both the good and the bad. He learned more in that single evening than he had in all the official meetings during his trip. He realized the dearth of bandwidth left the numerous entities operating in the area – local, national, and international – with few ways to communicate, particularly given the volatility of the region, which often precluded travel. He also realized a lack of high-resolution satellite imagery was hindering civil works projects, which were being planned with close-range images in an area of great topographical variations. From that evening on, Dr. Warner, a longtime proponent of the principle of “radical inclusion,”<sup>1198</sup> was

---

<sup>1197</sup> Brown, Stephen R., *Rotary’s Projects in Afghanistan, 2002-2012*. Accessed October 29, 2015. [http://www.ligtrotaryclubfoundation.org/uploads/2/2/1/0/22104606/pamphlet\\_with\\_sports\\_program\\_added\\_fe\\_b\\_18\\_2013.pdf](http://www.ligtrotaryclubfoundation.org/uploads/2/2/1/0/22104606/pamphlet_with_sports_program_added_fe_b_18_2013.pdf).

<sup>1198</sup> The principle of “Radical Inclusion” states: “Anyone may be a part of Burning Man. We welcome and respect the stranger. No prerequisites exist for participation in our community.” The Burning Man Project. Accessed December 16, 2014. <http://burningman.org/culture/philosophical-center/10-principles/>.

determined to use ICT to improve communication, coordination, and information sharing in eastern Afghanistan.

Enter Synergy Strike Force (SSF), led by Dr. Warner, a self-proclaimed Synergist.<sup>1199</sup> SSF arrived in Jalalabad in 2006, specifically to gather and share information within and from the remote and dangerous eastern Nangarhar province.

## Synergy Strike Force

SSF is an eclectic group of individuals with a wide array of talents who volunteer to support humanitarian relief and stabilization efforts in disaster-affected and post-conflict environments. Individuals are invited to participate based on their life experiences, operational or technical knowledge, and demonstrated social skills in austere environments. With several people resident on the ground and more than 30 traveling back and forth to Afghanistan over a number of years, SSF became a primary player in a loose alliance of American civilians and local Afghans who cooperated in a stabilization mission in eastern Afghanistan. Dr. Warner and his team were and engaging in information sharing across the various and disparate organizations involved in key reconstruction sectors, such as health, education, agriculture, and gender equality, all with the goal of creating peaceful prosperity. The modus operandi of the SSF is to spend considerable time with the local population to learn about their culture directly from them. With this insight, the SSF team can pull together skills from its pool of people with expertise in different backgrounds, and then offer guidance depending on local needs instead of imposing solutions that are not culturally appropriate and, therefore, unsustainable. A significant attribute of SSF was its long-term commitment to and involvement in Nangarhar province, which allowed SSF members to develop a vast social network of trusted – and trusting – Afghan partners.



## The Jalalabad Project

In 2006, Dr. Warner and the SSF began an experiment to test theories regarding effective unclassified information sharing and to demonstrate the effectiveness of enhanced connectivity. Dubbed the Jalalabad Project, “the intent was to establish relationships and provide connectivity for actors on the ground, incentivize information sharing, and act as a catalyst for increased coordination, connectivity, and collaboration.”<sup>1200</sup> The aim was to prove that opening channels for information sharing helps to establish relationships and, as a result, increases synergy among different social actors for more effective humanitarian relief, development, and security.

---

<sup>1199</sup> Synergists are those who bridge the gaps among systems, organizations, and individuals and engage in problem-solving with local stakeholders.

<sup>1200</sup> CNI Technical Services, 2011.



SSF's activities included accruing, processing, and hosting sharable imagery; acquiring and sharing unclassified data from multiple partners and sources in stability operations across the spectrum; developing a database of on-the-ground activities; and iteratively refining methods and techniques to provide synergistic support to the various contributing factions in an active theater of war. The aim of the Jalalabad Project was to help improve situational awareness for the US government and US military, in support of stabilization operations and socio-economic development and growth. SSF planned to accomplish this aim by connecting people – physically and technologically – in order to source and share information from and among them as well as to share it with other interested parties and engaged organizations. In a 2013 interview for *Pacific Standard* magazine,<sup>1201</sup> Dr. Warner was reported as saying, “The most valuable information in a conflict or disaster zone ... was information that could be shared with everybody.”



Picture 33: Hard drive at the Taj

Photo courtesy of Dr. Dave Warner

SSF established a neutral base of operations at the Taj guesthouse. With a partner, Dr. Warner assumed the lease for the Taj in 2007, and eventually took it over himself in 2008. SSF maintained security at the Taj in such a way, using local Afghans as security guards, so as to keep the volunteers and guests safe but accessible and so as not to exclude or greatly limit access by local Afghans. With a tiki bar and free Wi-Fi<sup>1202</sup> Internet access, the Taj was a physical and virtual hub, a non-threatening environment where people from all over eastern Afghanistan, expats and locals alike, gathered, socialized, strategized – and shared information. In what was known as the “Beer for Data” program, SSF offered an

## WHAT IS A FAB LAB?

A fab lab is a “high tech workshop where ordinary people design machines and conduct science to improve the quality of their lives.” There are currently 40 or so interconnected fab labs in more than ten countries. The Jalalabad Fab Lab, originally housed on the same compound as the Taj, was implemented in May 2008 via a US National Science Foundation Grant to “investigate post-war and disaster recovery applications of [local] digital fabrication.” As part of a program run by MIT’s Center for Bits and Atoms (CBA), fab labs are established to become community resources. MIT has identified applications in ICT, civil engineering, and healthcare to be particularly beneficial in distressed situations.

<sup>1201</sup> Calvert, Brian (2013). “The Merry Pranksters Who Hacked the Afghan War.” *Pacific Standard*, July 1. Accessed July 9, 2014. <http://www.psmag.com/navigation/politics-and-law/the-merry-pranksters-who-hacked-the-afghan-war-60873/>.

<sup>1202</sup> Wi-Fi is a local area wireless computer networking technology that employs radio waves to allow computers, mobile phones, and other devices to connect to the Internet and communicate with one another within a particular area without being physically connected.

environment conducive to sharing, where free beer, although illegal, was available to anyone willing to impart information in the form of reports and other documents, photos, contacts, etc. Those who shared information populated a hard drive with photographs, maps, engineering plans for civil works and construction projects, geographic coordinates of various public and private facilities, names of citizens and businesspeople, curricula from schools, agricultural information, white papers, and other facts, figures, and documents relative to the free and open collection of information on reconstruction and development activities in the area. Dr. Warner and the SSF compiled a vast repository of information – over 1 Terabyte (TB) – which they openly shared with the US government, the US military, the International Community, NGOs, and trusted Afghans.

Outside the Taj, Dr. Warner realized the lack of access to the Internet and insufficient bandwidth to support its use in and around Jalalabad hindered communication and, therefore, collaboration and cooperation, and was inhibiting meaningful progress. SSF wanted to foster the connection and use of the Internet to facilitate information sharing and to help enable the Afghan people to transcend their isolation from the rest of the world and participate in the greater global dialog. So, from the Taj, SSF established a public satellite Internet network in 2008 that served as a technical hub for several projects across eastern Afghanistan.

Leveraging the relationships SSF had established with Afghans at the Nangarhar Public Health Hospital and the Computer Science Faculty at Nangarhar University, and the trust garnered by being a relatively unaffiliated neutral third party wanting to help Afghans, Dr. Warner was able to connect the medical and educational facilities using “FabFi” nodes and long-range Wi-Fi mesh networks and Wi-Fi spokes originating from the Taj hub.



*Picture 34: FabFi RF reflectors and satellite dishes on the roof of the Taj*

FabFi is an open source wireless mesh networking system that evolved out the Massachusetts Institute of Technology’s (MIT’s) [Fab Lab](#) (see sidebar<sup>1203</sup>). FabFi nodes are made out of everyday items – in many

---

<sup>1203</sup> Sun, Amy (2009). *NSF Annual Report: Jalalabad Fab Lab*. CCF-0832234, April 2009.

cases scrap – and employ commercial wireless routers mounted on wood frames covered with metal mesh, thereby creating a radio frequency (RF) reflector. The reflector shapes the signal from the router, generating the equivalent of a directed Wi-Fi link between end points (other RF reflectors), which create an ad hoc network, essentially a collection of FabFi nodes interconnected by the directed Wi-Fi links provided by the RF reflectors. This meshed network is able to transmit wireless Ethernet signals up to several miles and allows users to interact locally and share digital resources, thereby offering accessibility at a relatively low cost. The FabFi node at the Taj was also connected to the public Internet via satellite, which provided users the ability to join the global online community.

The homegrown FabFi network bypassed local Internet infrastructure, which means users were not subject to government censorship of websites and were free to search the public Internet without obstruction. The configuration was technically illegal, as it was essentially Internet resale, although SSF provided the service free of charge to end users. Since SSF was relaying Internet traffic into and out of the country, it should have held an International Transit Internet Service Provider (ISP) license issued by the Afghanistan Telecom Regulatory Authority (ATRA). However, since it did not have a license, it was not subject to the restrictions and requirements of such.

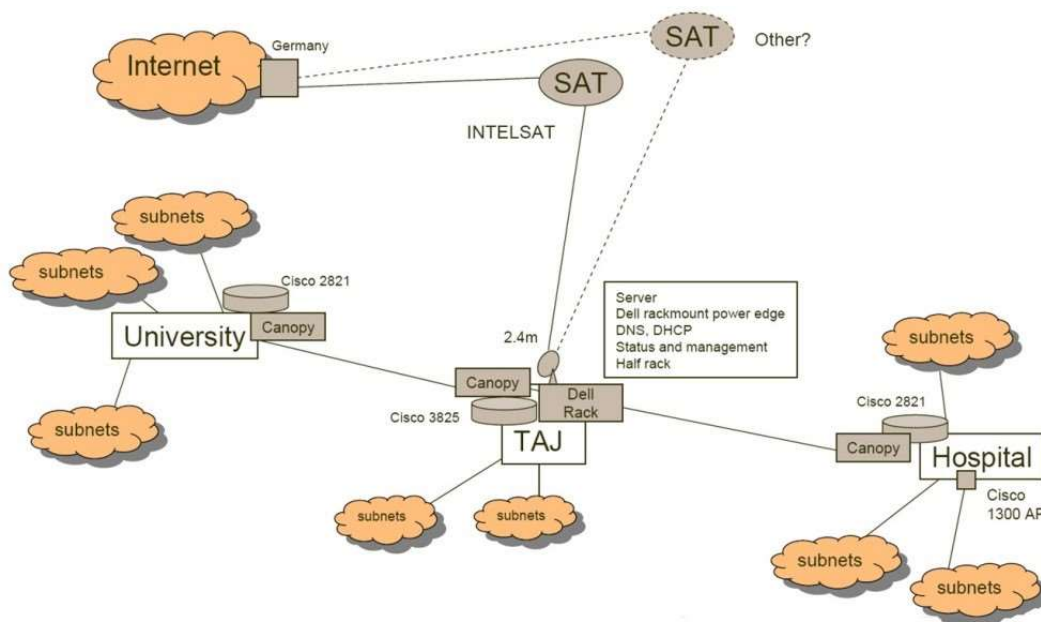

Figure 79: SSF Wi-Fi mesh network diagram

MIT originally established the FabFi network at the Taj, but Dr. Warner and the SSF assumed responsibility for it when MIT left Jalalabad. The FabFi node with its Internet connection and directed Wi-Fi links to end user locations allowed the network to be used to support collaboration between the hospital and the college, as well as allowing personnel at both to conduct research using Internet. The collaboration led the hospital to build a database of public health information, which it was able to share with NGOs and others working in the health sector in eastern Afghanistan. Additionally, there were links from the Taj to various Nangarhar University facilities around Jalalabad, including to the library at the main campus, the teaching hospital, and the medical school.

With the public Internet connection it had established at the Taj, SSF, in partnership with the US National Defense University's [STAR-TIDES](#) program and [Small World News'](#) "Alive in Afghanistan" project, monitored the 2009 Afghan presidential election. They provided officials with overall better data and were able to collect and map incidents of election fraud and violence using [Ushahidi](#), an open source map platform that allows users to crowdsource information via short message service (SMS, or texting) and other ICT tools. SSF and Small World News teamed up again in 2010 to monitor the Afghan parliamentary election, though that was before the authors' time in country.

## SMS Crowdsourcing Project

SSF's initial foray into crowdsourcing in the Afghan elections prompted Dr. Warner began exploring feasible ways to crowdsource information from Afghans. He understood the information collected could be shared back with the wider local populace. He decided on a relatively low-tech approach: SSF enlisted a local radio station to broadcast questions to its listeners and ask them to respond via text messages. The queries began with arbitrary-interest questions like "Who is your favorite cricket player?" and other such innocuous queries in order to discern if Afghans would participate.

Once SSF established that listeners would, in fact, text answers in response to the broadcasted questions, SSF shifted the questions to solicit more valuable information, such as, "What is the price of mutton, gas, and milk in your village?," or "Where is the cheapest grain sold?" Listeners continued to respond in increasing numbers – up to 3,500 messages in less than a month – to the broadcasted queries, and SSF felt confident in applying the crowdsourcing concept to other areas, such as agriculture and health. As a result, SSF developed the following projects, among others. Additionally, SSF utilized technology for several projects in the health sector, which are described elsewhere in this book.

While SSF realized Afghans were willing to share information and interact with the radio stations via SMS, the number of correctly formatted – and, therefore, usable – messages was very low. Afghans also started asking questions themselves, instead of just providing answers.

SSF decided to refine the process so that they could implement greater controls. From the initial experimentation, they knew there was interest in receiving information on crop prices, so they opted to pursue another avenue to collect information based on the crowdsourcing techniques. SSF decided to try to leverage the Agriculture Extension officers (AEs) from the Afghan Directorate of Agriculture, Irrigation, and Livestock (DAIL), who were already gathering crop price data in the area, and aggregate it for broadcast by radio stations and publication on the Internet. That is how the SMS Crowdsourcing Project was born.

The SMS Crowdsourcing Project was developed to provide technical support to the Afghan Ministry of Agriculture, Irrigation, and Livestock (MAIL), which is responsible for supporting agricultural livelihoods and productivity throughout the country. The MAIL had undertaken an effort to improve the collection and publication of weekly agriculture data informing agriculture awareness, ongoing local service provision, and preparedness for potential future government interventions in the agriculture sector. The overarching goal was to implement a faster, safer, more reliable, and cost-effective mechanism by which the MAIL could collect and disseminate price information garnered from its district offices. The primary aim of SSF's project was to enhance the ability of the MAIL to collect, monitor, and report data on

commodity prices through SMS technology. A secondary aim was to use local radios stations to air weekly prices directly to the community.

In January 2011, SSF approached the Nangarhar Directorate of Agriculture, Irrigation, and Livestock (DAIL) office in the city of Jalalabad, a provincial-level subsidiary of the MAIL, with an idea to use technology to improve connectivity and coordination among DAIL personnel, particularly district-level Agricultural Extension (AE) officers responsible for the provision of agricultural support to local communities.

Weekly retail market price

District (1-22)

Nangarhar



Price (Afg)

Local wheat (Kg)	<input type="text"/>	مخلى نغيم (كيلو)
Imported wheat flour (Kg)	<input type="text"/>	وارد شوى اوږه (كيلو)
Local Rice (Kg)	<input type="text"/>	مخلى وړجى (كيلو)
Rice imported (Kg)	<input type="text"/>	وارد شوى وړجى (كيلو)
Maize (Kg)	<input type="text"/>	جوار (كيلو)
Mungbeans (Kg)	<input type="text"/>	بسيه (كيلو)
Pea (Kg)	<input type="text"/>	نخود (كيلو)
Potato (Kg)	<input type="text"/>	الوټان (كيلو)
Vegetable Oil (Litre)	<input type="text"/>	نباتي عوښي (ليتر)
Milk (Litre)	<input type="text"/>	شيدى (ليتر)
Veal (Kg)	<input type="text"/>	د خوسى عوښه (كيلو)
Beef (Kg)	<input type="text"/>	د غوايي عوښه (كيلو)
Mutton (Kg)	<input type="text"/>	د پسته عوښه (كيلو)
Chicken Imported (Kg)	<input type="text"/>	وارد شوى د چرگ عوښه (كيلو)
Imported Urea (Kg)	<input type="text"/>	وارد شوى كيمياوى سره (كيلو)
Local Urea (Kg)	<input type="text"/>	مخلى كيمياوى سره (كيلو)
DAP, Best quality (Kg)	<input type="text"/>	ډى اى پى سره (كيلو)
Agriculture labour (excl, food cost) (Day)	<input type="text"/>	د زراعت كارگر مزد (د ورځې)
Pair of oxen hiring (excl, food cost) (Day)	<input type="text"/>	د يوې جوړې قليمه بانوگرايه (د ورځې)
Water pump charge (incl, fuel cost) (Hour)	<input type="text"/>	د واټر پمپ كرايه (څو ساعت د تيلو سره)
Tractor hiring charge (incl, fuel cost) (Hour)	<input type="text"/>	د ټراكتور كرايه (څو ساعت د تيلو سره)
Diesel (Litre)	<input type="text"/>	ډيزل (ليتر)
Liquid gas (Kg)	<input type="text"/>	مايچ گاز (كيلو)
Petrol (Litre)	<input type="text"/>	پترول (ليتر)

Figure 80: Sample commodity price list

Prior to the project start, AE officers traveled daily to local markets in their districts where they manually collected and documented – with paper and pencil – the weekly prices of 25 agricultural commodities ranging from grains and meats to fertilizer, diesel fuel, and labor (see [Figure 80](#)). Every week, the AE officers recorded the price of each commodity in standard units of consumption on a formatted document and brought their documents to the DAIL central offices in Jalalabad. Eventually, the paper documents made their way to MAIL’s headquarters in Kabul. There were no routine schedules, either for the AE officers to submit their weekly reports to the DAIL or for DAIL personnel to transport the reports to the MAIL. Instead, the DAIL sent documents when it was able to or

when it was convenient, which, in many cases resulted in significant delays in reporting. In Kabul, personnel at the MAIL digitized the documents and archived them for internal use. None of the collected information was shared.

SSF designed a program whereby all AE officers received new mobile feature phones and enough minutes to last for six months of SMS reporting. From April to October 2011, SSF held a series of three workshops in Jalalabad city to train Nangarhar’s cohort of AE officers in the use of SMS technology to perform their weekly price reporting duties. The officers received laminated forms with 25 different commodities listed on which they recorded prices with washable markers as they walked through the markets. Once they finished, they would send an SMS with each price (just the number) separated by a comma in the same order as the form from top to bottom. The text messages with comma separated values (CSVs) were

received by SSF's modems at the Taj, and that information would then be made automatically accessible on SSF's website and also aired by radios stations. By publishing the price information online, SSF and the DAIL were able create situational awareness on local market prices, and the local radio station could share the commodities' prices to even the most remote villages. Thus, farmers and others who made their livings in the agriculture ecosystem were able to receive important and timely data allowing them to make informed decisions: producers could sell their crops at the best prices and buyers could shop for the lowest prices or at least know if prices were fair. Local SSF staff would also collect incoming data from the AE officers via their own iSMS modem and publish the number of reports per location online to a Crowdmap<sup>1204</sup> deployment (see [Figure 81](#)).

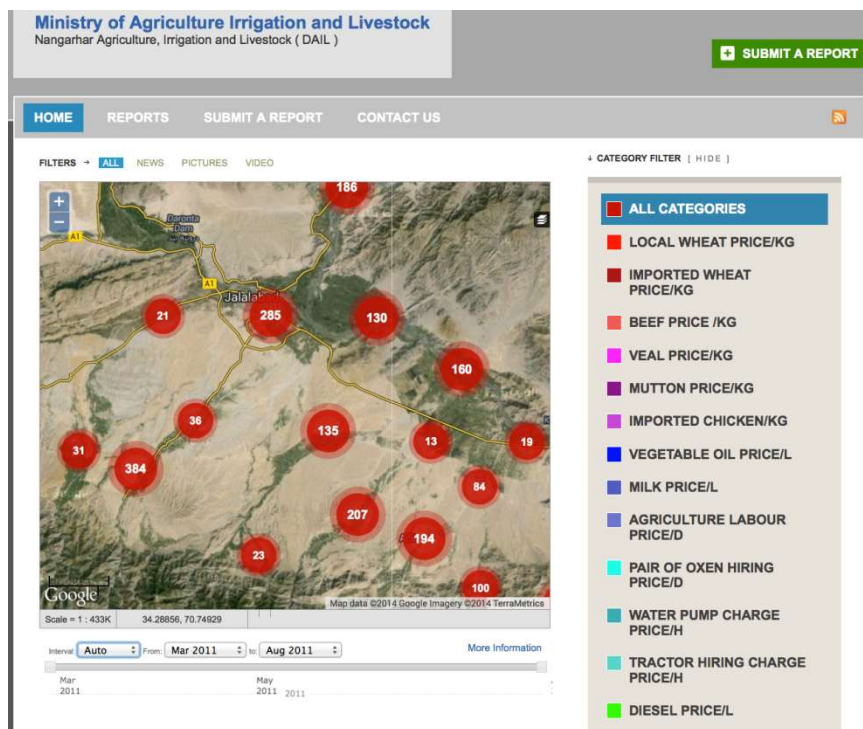

Figure 81: SSF Crowdmap indicating the number of agricultural commodity reports

The SSF team's objective in Jalalabad was to establish long-term relationships with actors on the ground ranging from the education, medical, agricultural, and military spheres and facilitate information sharing amongst and between these groups in order to ultimately improve the lives of local Afghan people. Greater efficiency in collecting, transmitting, and disseminating of information in the field is essential for successful development, humanitarian relief, and security initiatives. Through the implementation of pilot projects such as this, SSF found that by teaching local Afghan partners to use and become empowered by ICT, the information-sharing process became more efficient, relevant and ultimately successful.

<sup>1204</sup> Crowdmap is an online geospatial information-mapping tool. See [www.crowdmap.com](http://www.crowdmap.com).

## *Challenges and Lessons Learned*

The SMS Crowdsourcing [pilot] Project lasted a total of six months and was rated as highly successful by the Nangarhar DAIL, the local radio stations, and SSF. The DAIL regarded the project both as a more effective mechanism by which to gather agricultural commodity price data, and as a comparatively inexpensive and convenient means of managing data requests, public service, and outreach efforts. Weekly price data submitted in real time by the district AE officers and aggregated digitally was published and made available at a rate faster than the traditional paper-based method by orders of magnitude. Moreover, the digital recording of the data allowed the MAIL to have quick access to a spreadsheet downloadable from SSF's website with real-time information on locations and prices of agricultural goods. In addition, the map (see [Figure 81](#)) was created to show a more interactive version of the information but was deemed less useful to the MAIL in comparison to the spreadsheets, as it did not include price information, only the number of reports by location. The map turned out to be a great tool for another reason: the "shock and awe" of showing an interactive map populating information right then and there was good for getting people on board. They had never seen anything like it before, so it was great to watch their expressions. They refreshed the map all day! Unfortunately, the pilot project did not run long enough to allow SSF to add price data to the map, nor were they able to gather and analyze sufficient data to see trends or any economic or social effects.

The group training sessions coupled with individual feedback were among the most important aspects of this project. SSF employees would call AE officers if they incorrectly formatted messages to make on-the-spot corrections and to help prevent future mistakes. The only way to ensure the AE officers understood the process was through continuous training, monitoring of their progress, and constructive feedback.

The greatest challenge SSF experienced during the SMS Crowdsourcing Project was working with the AE officers, for several different reasons. Men from districts where security threats were high were not eager to travel to training sessions because of safety concerns and were much harder to contact to validate price information due to a lack of connectivity in their areas. For instance, the AE officer from Sherzad district participated in the project for only one week; he stopped for unspecified security reasons, which could have been he was threatened for working with the Afghan government or Americans, or because the roads were too dangerous to traverse, but that is just speculation. Apart from this, the education level and digital aptitude of the AEs was significantly low, causing SSF personnel to have to verify incorrectly formatted messages constantly. While the use of SMS was status quo for Afghan youths, it was foreign to the older males. (Imagine trying to explain to your grandma how to send a text message.) And while they could follow directions during face-to-face interactions, some would quickly forget once they got back home, even despite the training materials we provided them.

Another challenge was finding incentives for AE officers to maintain participation. Although the rapid receipt of information directly benefited the DAIL director, the AE officers never saw the results of their efforts. Consequently, in order to keep the AE officers motivated, SSF had to reimburse them every two weeks for charges they incurred sending the SMS reports.

Recommendations to mitigate some of these challenges and to improve such an effort in the future are to encourage the MAIL to adopt the use of SMS data collection and transmission as standard operating

procedure (SOP) and to implement short codes (similar to how 911 and 411 work in the US) specifically to do so for the different provincial offices. If it were SOP, the AE officers would be required to participate – their jobs would be to collect and text information – and incentives would no longer be required. Providing recognition and awards, or other appropriate motivators, to the farmers and AE officers with the most accurate and consistent reporting would be a bonus. Further, developing an interactive voice response (IVR) service the AE officers (and others) could use to hear competing market prices announced would be a useful tool and would let the AEs see – or hear, as it were – the results of their work.

Ideally, the DAIL director from Nangarhar would have taken the digital data collection model to the MAIL to implement countrywide but he did not, for reasons unclear, and SSF did not have funding to remain in Afghanistan and continue the project. There was a similar effort initiated by the United States Agency for International Development (USAID) under its Incentives Driving Economic Alternatives – North East, West (IDEA-NEW) project,<sup>1205</sup> called Malomat, which ran from July 2010 to May 2011. Malomat is a price information system that provides farmers, input suppliers, traders, wholesalers and other stakeholders with access to commodity information in 15 wholesale markets throughout Afghanistan and abroad, using mobile phones with IVR and SMS technology. On a positive note, Malomat is now independently run by Roshan, one of Afghanistan’s mobile network operators. However, it is unfortunate SSF’s work in Nangarhar was not able to become part of the Malomat program, largely due to programmatic reasons, which is symbolic of an oft-repeated travesty across the development arena where bureaucracy trumps common sense, results, and the greater good.

Despite the challenges and the lack of expansion, the SMS Crowdsourcing Project was a successful proof-of-concept pilot, and SSF was able to achieve having undereducated, digitally illiterate Afghans employ technology to collect, transmit, display, and broadcast timely agricultural data that was accessible to and useful for both the Afghan government and citizenry.

## UnityNet

The Jalalabad Project became the basis for an idea named UnityNet, which was conceived as a “globally deployable sensor for ‘white’ information.”<sup>1206</sup> The UnityNet model provides “an ISR<sup>1207</sup> platform that ‘senses’ population-centric atmospheric and information critical to COIN and stability operations”<sup>1208</sup> and “enables host-nation, open-information sharing environments in areas ... of interest to the United

---

<sup>1205</sup> USAID (2015). Accessed October 26. <https://www.usaid.gov/news-information/fact-sheets/incentives-driving-economic-alternatives-%E2%80%93-north-east-west-idea-new>.

<sup>1206</sup> Thompson, Gary H. and David W. Meunch (2010). *UnityNet: A Global Deployable Sensor for White Information*. Defense Intelligence Agency (DIA), May 5 2010. Accessed December 17, 2014. [http://www.oss.net/dynamaster/file\\_archive/100529/e757154e3b4532aeeed75f6d5b5955f6/UnityNet\\_White\\_Paper\\_FINAL%20%285%20May%202010%29%282%29%5b1%5d.pdf](http://www.oss.net/dynamaster/file_archive/100529/e757154e3b4532aeeed75f6d5b5955f6/UnityNet_White_Paper_FINAL%20%285%20May%202010%29%282%29%5b1%5d.pdf).

<sup>1207</sup> Intelligence, surveillance, and reconnaissance

<sup>1208</sup> Thompson and Meunch, 2010.



States.”<sup>1209</sup> The UnityNet concept “bridges the gap” among military, government, and civilian operations and provides a platform for a unified information collection and dissemination effort.

Per US counterinsurgency doctrine, “effective COIN programs address all aspects of the local populace’s concerns.”<sup>1210</sup> However, garnering, collating, analyzing, and understanding the innumerable factors and dynamics that shape a population’s collective mindset is no easy feat. This information includes, but is by no means limited to, cultural norms, social practices, and religious customs; inter-personal, inter-family, and inter-group relationships; political affiliations; perceptions and experiences of government effectiveness or lack thereof; socio-economic indicators; levels of education; access to and knowledge and understanding of independent information; and degree to which basic needs are met. The data is generally classified into three categories: population-centric, or “white” information; government-centric, or “green” information; and malign actor, or “red” information (see [Figure 82](#)).<sup>1211</sup>

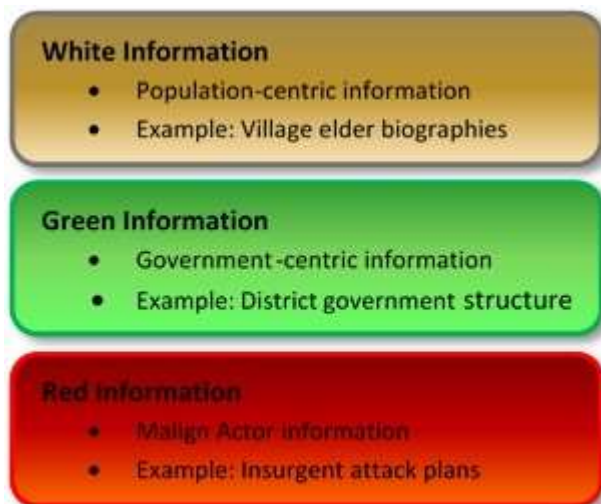

Figure 82: Color-coded information explained (UnityNet)

In conflict environments, most of the data gathered by the military is red information, and any white information amassed is often incidental and anecdotal and within the context of kinetic operations. Civil groups and NGOs also collect white information, but it is often for their use for specific purposes and is not often or routinely shared outside their organizations.

SSF successfully accumulated vast amounts of data from a multitude of sources, including crowdsourcing white information from local Afghans (as described above), and shared it via free and open source (FOSS) tools. Such an approach allowed the data to be used, updated, modified as needed, and improved upon by a cadre of military, government, and civilian personnel. According to the authors of the UnityNet white paper, “The Jalalabad experience of bringing people and technology together in an open-source process model ... evolved into a force that ... brought significant change to Nangarhar province. It is this experience [they] propose to emulate in the future form of UnityNet.”<sup>1212</sup>

## Conclusion

Affordable, reliable, robust, proliferate, and sustainable information and communications technologies – such as mobile phones, Internet access, and accessible hardware and networks – allow indigenous and

---

<sup>1209</sup> Ibid.

<sup>1210</sup> US Army *FM 3-24*.

<sup>1211</sup> Thompson and Meunch, 2010.

<sup>1212</sup> Ibid.

foreign populations to work together and collaborate more efficiently and effectively in creating and sustaining a secure and stable environment and facilitate information sharing. The importance of information sharing in complex operations and for stability, security, transition, and reconstruction (SSTR) activities is well understood, but information-sharing operations are generally not well-designed or executed. As a result of the Synergy Strike Force's work in Jalalabad, now, at least, there are some observations, conclusions, principles, and tools to guide future information-sharing efforts. However, work remains to be done at high levels to create the conditions conducive to effective information-sharing operations.

While DODI 3000.05 and 8220.02 provide policy on information sharing and the use of ICT to enable it, the directives still need to be translated into doctrine. Further, there is no US government policy designating ICT as critical infrastructure and an essential service, on par with water, roads, and electricity, nor any doctrine regarding ICT-enabled interventions. The proffered template for information-sharing operations and the UnityNet concept and platform are steps forward indeed, but they remain ad hoc approaches yet to be tested and operationalized. To move toward being able to implement and support effective information-sharing operations, priorities must be established and clearly articulated. New, creative, and progressive models of engagement must be built. Capabilities need to be defined and tactics, techniques, and procedures (TTP) developed. Existing rules and regulations must be examined for applicability, or new ones must be devised. Socialization, education, and training must be conducted, and attitudes and cultures must change. All of this requires fresh, bold, decisive leadership and sustained action.

The role of ICT as an enabler should be recognized and codified strategically and tactically in future interventions. The free flow of unclassified information is paramount in complex operations and will only become more important in our increasingly interconnected world. Further, "democratic process and civil society ... depend on information sharing and continuous information flow."<sup>1213</sup> Therefore, the US government and its partners must be willing and able to embrace and facilitate information sharing within, among, and outside their constructs, as well as with and for the people with whom they engage.

---

<sup>1213</sup> CNI Technical Services, 2011.

## Chapter 13 ICT in Finance

---

Oliver Dziggel

### Introduction

A significant effort with a considerable amount of money was spent to attempt to integrate information and communications technology (ICT) into the financial sector of Afghanistan, but with very limited results. This chapter will examine three prominent initiatives: the Ministry of Finance's deployment of ICT in support of its Public Financial Management (PFM) mandate, the central bank's nationwide secure private VSAT<sup>1214</sup> network to manage cash operations, and the launch of public mobile money (mMoney) services by several mobile network operators (MNOs).

In the case of the government systems, it is important to keep in mind that a fundamental barrier to success is the widespread unavailability of electricity. Even the diesel-powered generators, which were deemed as a quick-start and temporary solution, often failed to provide reliable power, due to lack of diesel re-supply or because of equipment failures due to lack of preventative maintenance and unauthorized diversion of power to other purposes. A second barrier was the total lack of indigenous information technology (IT) skills; this was overcome initially via a surge of donor technical assistance, but it has proven to become a growing problem as donor assistance has receded over time. Finally, it was quickly realized by the Afghan decision makers that ICT would potentially uncover endemic corruption and multiple layers of cash-siphoning, so foot-dragging and sabotage often hobbled the valiant attempts by numerous donors to institute transparency and accountability through automation.<sup>1215</sup>

### ICT in Public Financial Management

Between 2002 and 2012, 33 international donors contributed more than US\$7 billion in direct support of the Afghan national budget, channeled to the Ministry of Finance (MoF) treasury through the World Bank-administered Afghanistan Reconstruction Trust Fund (ARTF). The international donor community demanded strict accountability of those funds, and since the Taliban regime had only the most rudimentary recordkeeping of its mainly cash-based governmental operations, it was immediately decided to implement a green-field financial management information system (FMIS).

In early 2003, the United States Agency for International Development (USAID) awarded a contract for technical assistance to the MoF for the implementation of a treasury system which came to be called the Afghan Financial Management Information System (AFMIS). By 2013, more than 99 percent of the

---

<sup>1214</sup> Very small aperture terminal, a two-way satellite ground station with a dish antenna generally smaller than three to four feet.

<sup>1215</sup> Editors' Note: Gaps still exist between technology and institutions, and the lack of appropriate governance can result in technology being used to control, rather than to enable and empower.

Government of the Islamic Republic of Afghanistan (GIROA) budget execution was conducted by AFMIS, which is managed by roughly 260 specially-trained Afghans.

According to FreeBalance, the Canadian software house that was selected to provide the core of AFMIS, its "Accountability Suite" treasury system offers a broad range of PFM capabilities to GIROA decision makers, and by extension, to international donors:

- Visibility throughout the budget cycle where every step can be audited, to increase the chances of discovering corrupt practices;
- Segregation of duties to prevent the same individual from approving purchase orders, receiving those goods, and approving payment;
- Use of budget and approval controls to reduce the opportunity for corrupt practices;
- Avoiding cash as much as possible via electronic funds transfers; and
- Standardized reports and automated processes to improve efficiency.

AFMIS has two distinct dimensions, which were implemented in phases as the respective governance institutions were established. The initial focus was the automation of the central government: the approximately 29 ministries and agencies based in Kabul. The second phase, referred to as sub-national, was extending AFMIS outside Kabul, first to the central government's outposts in the provinces, and then also to the provincial and municipal governments.

Beyond the lack of electricity, there were two additional infrastructure barriers that impeded the success of AFMIS. First, AFMIS can only achieve the promise of real-time PFM if all budgetary units are connected to the primary server, which is based at the MoF headquarters in Kabul. Second, the buildings in which the various government offices were housed were in very poor physical condition, often without windows and perimeter security (computers, peripherals, and supplies were often stolen).

An assessment by the World Bank and the United Kingdom's (UK's) Department for International Development (DFID) in June 2008 (the Public Financial Management Performance Assessment<sup>1216</sup>) rated Afghanistan better than the average of a sample of other low-income countries. Interestingly, on some criteria, Afghanistan's ratings were even better than the average of a sample of middle-income countries.

Notwithstanding this glowing official appraisal, in practice, the majority of GIROA institutions were rather uncooperative when it came to actually utilizing FMIS, including the ICT assets that were deployed to operate it. Eventually, two factors changed the dynamics: (1) a massive amount of training was provided, starting with fundamentals (such as financial literacy, basic budget principles, and accounting); and (2) FMIS was made mandatory. In retrospect, it would have been more effective to have made FMIS mandatory from the start: For the first year, either require representatives from the line ministries to be seconded to the MoF to learn the ropes in the budget and treasury functions, or vice versa, deploy

---

<sup>1216</sup> World Bank (2008). *Afghanistan: Public Financial Management Performance Assessment*. Washington, DC. © World Bank. <https://openknowledge.worldbank.org/handle/10986/8062> License: CC BY 3.0 Unported. Accessed November 8, 2015.

adequately-trained FMIS specialists to become embedded at the line ministries to facilitate uptake. (The latter is probably a non-starter, as the MoF delegates would most likely have been branded as “spies” lurking inside those institutions.) A second improvement would have been to impose mandatory accountancy training for one (or more) budget analysts in the year prior to physically deploying the FMIS assets to the line ministries. It needs to be emphasized that there were essentially no chartered accountants in Afghanistan until 2010, at the earliest (when Da Afghanistan Bank, DAB, sponsored a national accounting standard and established a training institution).

## Secure VSAT Network to Manage Liquidity at Banks Nationwide

During the Taliban regime, the predominant currency in circulation in Afghanistan was the Pakistan rupee, and to a much lesser extent, the Iranian rial (mainly in the western territories). There were also a variety of currencies from the Central Asian Republics (along the northern border areas). In addition, many of the regional warlords and commanders issued their own currencies within their spheres of influence.

In October 2002, soon after the establishment of the transitional government in Kabul, the national bank (DAB) was reconstituted, and a new currency (the afghani) was introduced. The physical currency was printed in the UK, flown to Kabul, and slipped quietly under cover of night into DAB’s main headquarters, where it had to be moved by wheelbarrows into the vaults. At this stage, DAB was still functioning as a commercial retail bank, which meant it would have to distribute the physical cash on to its branch offices countrywide. The initial cash diffusion was achieved using military and donor assets (helicopters and charter planes), but stakeholders sought a more secure and permanent solution.

Consequently, USAID provided a three-year US\$4 million contract to establish a nationwide private VSAT network for DAB, which also included the upgrade of physical facilities at all branches (including diesel generators) and a core banking system (software) to manage all cash operations. The initial phase, which focused on Kabul plus the top six commercial centers,<sup>1217</sup> commenced on September 12, 2004 and ran through September 12, 2007.

The USAID contract provided assistance in these key areas:

1. **Infrastructure Rehabilitation:** Facility assessments were conducted of all DAB offices, a rehabilitation plan was prepared, and the head office and the main regional offices (the hubs) were brought to a state of modernization befitting a central bank.
2. **Information Technology:** Procurement and installation of computers, servers, the information security equipment to protect core DAB systems, and the kilometers of cabling and wiring necessary for connectivity.
3. **Communications:** A proprietary communications system was installed at the head office in Kabul connected to the regional hubs via a VSAT network that provided dedicated bandwidth unavailable from any other option.

---

<sup>1217</sup> Kandahar, Herat, Mazar-e-Sharif, Kunduz, Jalalabad, and Khost

4. **Power Generation:** The core requirement for a modern bank is clean and consistent power. A dedicated line from Kabul's sub-station that had the most capacity was installed. Also installed were two generators with a total of 1.1-megawatt capacity and a fifteen-thousand-liter tank providing a week's worth of capacity to run the projected needs of the DAB. Further, the entire power distribution system of the DAB headquarters (and most branch offices) was rewired.
5. **Accounting Processes and Software:**<sup>1218</sup> The primitive legacy system was replaced with a modern accounting system that eliminates imbalances, ensures controlled entries and audit trail, supports transaction processing of all DAB products and services, and permits a structured regime of financial reporting for informed decision making and compliance with DAB financial reporting under the newly-enacted Bank Law.<sup>1219</sup>
6. **Training and Institutional Capacity Development:** In the first phase, essentially all non-construction tasks were performed by expat contractors; then, Afghans were recruited and trained (and their premium salaries paid using donor funds). Finally, after new job descriptions and a pay scale were adopted, all operations were migrated to full local control.

The impact of the delivered infrastructure and attendant training cannot be overstated. DAB was furnished with the necessary environment to become a modern institution in a location where this is still a rarity. The furnishing of clean, consistent power was a first step toward installing technology, but the immediate impact was on the staff. No longer was the central bank of Afghanistan left in the cold and the dark. The installation of a communications and network system meant that the institution could communicate among its offices, bringing unification to an institution that had been parsed by war into remote unconnected and uncoordinated fiefdoms. Next, the installation of an accounting and banking system brought a level of consistency and control unavailable to all but a few entities in Afghanistan. The DAB began to manage its affairs as a single unit with a vastly improved ability to understand its financial positions, take proactive measures to improve and make more efficient the business of the GIRoA, and to timely access information to make informed decisions in support of monetary policy, economic development, and financial sector growth and stability – all factors that support the development of an emerging economy.

By late 2007, DAB operated a VSAT communication system in its head office and six regional hub office locations. Substantial effort went into training activities aimed at ensuring DAB's ability to administer and manage this system. Other training topics included user operations, troubleshooting and maintenance, and creating value from the variety of features such a system has, including video conferencing, VoIP<sup>1220</sup> telephony, internal and external surveillance monitoring, and shared networking accessible across the country to connected locations. The system has been adopted rather well by head office and the regional

---

<sup>1218</sup> USAID stipulated a contractual requirement to support the connection to the Society for Worldwide Interbank Financial Telecommunication (SWIFT).

<sup>1219</sup> The Law of Banking, which went into effect in September 2003. It was followed by the Law of Da Afghanistan Bank, enacted in February 2004.

<sup>1220</sup> Voice over Internet Protocol

hubs, and DAB management now understands the benefits of their new system. After some reluctance, DAB has engaged a bandwidth and system support provider and, overall, has met its obligations with respect to monthly service fees, appointment of dedicated IT personnel for system administration, and in insisting that departments and connected branches utilize the VSAT tools to conduct the work of the bank. The items procured and deployed during this period (as specified in the inventory turnover documents) included:

- Seven VSAT earth station systems (one each at headquarters and six regional hub branches);
- Supporting servers and IT security applications;
- Critical backup power supply systems for all units;
- VoIP telephony systems;
- Dedicated, reliable, high-speed data and Internet bandwidth; and
- Core network redundancy servers and backup applications.

Once the core network was functional, a full complement of branch equipment, services, and security enhancements were also provided, including:

- Two hundred (200) computers deployed across the headquarters and regional branch network;
- Seventy-five (75) printers and scanning equipment;
- E-mail service under the DAB domain for all offices (“branch”@centralbank.gov.af);
- Networking gear and server equipment to support local area networking;
- Substantial training in computer systems and DAB core applications: Automatic Funds Transfer Service (AFTS), Branch Accounting System, e-mail and management information system (MIS) reporting;
- Armored vehicles for secure cash transport;
- Banknote processing and counterfeit identification equipment; and
- Security assessments, plans, and implementation support for treasury vault protection, human entry/exit control, intrusion alert systems, and personnel security protocols.

There was also a rudimentary network operations center (NOC) to manage the local area network (LAN) and overall network operations. It took roughly one year for this initial ICT environment to run smoothly and to achieve seamless integration between headquarters and the six regional centers, even with a massive amount of training. It must be emphasized that the biggest challenges were a prevalent bias against information sharing and strong resistance to the adoption of modern business processes (such as transparency, accountability, and merit-based hiring and promotions<sup>1221</sup>).

Beginning in late 2008, the VSAT network and branch modernization project was eventually extended to the remaining DAB branches, ultimately achieving the goal of having at least one DAB branch operating in

---

<sup>1221</sup> There were no human resources (HR) under this contract. An aspect of a later contract explicitly expressed HR but provided no IT component for it.

each of the 34 provinces of Afghanistan. This goal was on the critical path of helping GIRoA to establish a truly national footprint, because each bank branch effectively served as a local beacon for economic growth and legitimate governance. Note, however, that by this stage DAB was no longer allowed to provide retail banking services – this was now the exclusive domain of the approximately 16 commercial banks (licensed and supervised by DAB). However, DAB was allowed to service GIRoA accounts; for example, the disbursement of government salaries and the depositing of funds collected at the *Mustafiats* (Directorates of Finance, mainly customs and other duties). Meanwhile, redundant DAB branches were privatized, and commercial banks were incentivized to establish branch offices outside of Kabul and the major urban centers, in exchange for getting a piece of the GIRoA payroll disbursement business.

## Digital Financial Services for the Public (Mobile Money)

In emerging markets, virtually all mobile telephone services are provided on a prepaid basis (as opposed to postpaid in industrial countries). There are a number of reasons for this, but the main ones are that these economies typically function on purely cash bases (no credit), and the majority of people are poor (arguably not “creditworthy” in the traditional commercial banking sense). All prepaid users are therefore familiar and comfortable with periodically purchasing “scratch cards” with a coded value that gets “loaded” to the users’ mobile accounts, and, therefore, already have a practical understanding of conducting financial transactions electronically.

When mobile network operators (MNOs) in Africa in the early 2000s made it possible to transfer airtime value *on their own networks* from one prepaid user to another, it quickly followed that these credits could, in turn, be converted back into cash/currency – provided that somebody was willing to do so (initially as an “unofficial” reseller). According to a seminal research paper funded by DFID,<sup>1222</sup> people in Uganda, Botswana, and Ghana began using the mobile phone credit-transfer process as a proxy to commercial money transfer services (like Western Union and MoneyGram) on a widespread basis by 2002. The chief attraction was avoiding the high cost of the money transfer services (including hawala<sup>1223</sup>), but a close second was the ubiquity of the coverage – anywhere mobile network services were available.

The DFID paper speculated that, if formalized, the “mobile money” mechanism could have a profound impact on poverty reduction and economic growth. As such, DFID provided a grant to Vodafone (the largest MNO in the world at the time) to operationalize this concept in a commercial context, and a pilot project was launched in Kenya in 2005. Safaricom, with close to 70 percent market share in Kenya, developed software to offer mobile money as a stand-alone service (branded as M-Pesa), and the initial target was to allow microfinance borrowers to repay their loans via mobile money. A concurrent

---

<sup>1222</sup> McKemey, Kevin Dr. Scott, Nigel Dr. Souter, David et al. (2003). *Innovative Demand Models for Telecommunications Services*. Final Technical Report (R8069). September 2003, 55. Accessed November 8, 2015. [http://r4d.dfid.gov.uk/pdf/outputs/ICT/2936\\_R8069\\_FinalReport.pdf](http://r4d.dfid.gov.uk/pdf/outputs/ICT/2936_R8069_FinalReport.pdf).

<sup>1223</sup> Hawala is an ancient informal, honor-based money or value transfer system employing networks of human brokers traditionally used in, but not limited to, the Muslim world.



commercial banking crisis in Kenya quickly propelled this service to widespread use for domestic remittances by 2007.

And thus, consumers in emerging markets leapfrogged into person-to-person (P2P<sup>1224</sup>) digital financial services (DFS) long before comparable “mobile wallet” services finally became available in the industrialized world.

### Roshan Pioneers Mobile Money in Afghanistan in 2007

By early 2007, as the mobile money (mMoney) phenomenon was grabbing headlines as a minor miracle in the mobile industry in Africa, Roshan was beginning to implement plans to launch its own variant of the digital finance service, which it branded as “M-Paisa,” in Afghanistan (with “m” signifying “mobile” and “paisa” meaning “cash in Dari and Pashto). Roshan had a corporate vision and a high degree of confidence that it could make mMoney work in Afghanistan, to some degree because its sister enterprise under the Agha Khan Development Network ownership umbrella was a microfinance institution (MFI), called the First MicroFinance Bank of Afghanistan, FMFB-A.<sup>1225</sup> Further confidence came from the fact that Roshan had recruited its M-Paisa senior management team directly from Safaricom’s mPesa operation in Kenya.

Roshan entered the Afghan DFS market carefully on a pilot project basis. Since there was neither a legal-regulatory framework nor an institutional oversight capability in place at the central bank (DAB), it was agreed that DAB would furnish a letter of authorization, provided that the telecommunications regulator (ATRA) also submitted a letter of “no objection” prior to the launch of any money transfer services, to create an official record that there was no regulatory conflict. The ATRA Board was wholly unfamiliar with the notion of mMoney and intensely debated whether it was even an allowable service within the scope of the mobile network operators’ GSM<sup>1226</sup> licenses, or would require a completely new license category under the Telecom Law.<sup>1227</sup> If it were determined to fall under the latter, it would require approval by the Afghan Cabinet and potentially even an international competitive tender to be compliant. Ultimately, however, it was clarified that M-Paisa was integral to the GSM service umbrella (as articulated by the GSM license and confirmed by the GSM Association). Therefore, following a public consultation, ATRA provided its “no objection” to DAB.

Roshan’s motivations for offering mMoney were certainly sound, based on the nascent status of Afghanistan’s financial sector and the market demographics, including:

---

<sup>1224</sup> Also peer-to-peer

<sup>1225</sup> The First MicroFinance Bank of Afghanistan, established by the Agha Khan Development Network, was one of the first financial institutions under post-Taliban banking laws.

<sup>1226</sup> Global system for mobile communications, a second generation of protocols for digital cellular networks originally developed by the European Telecommunications Standards Institute (ETSI). GSM is now a trademark owned by the GSM Association.

<sup>1227</sup> Officially the Law for the Regulation of Telecommunication Services of 2005.

- Fewer than 2 percent of Afghans had bank accounts, which had risen to 10 percent in 2014.<sup>1228</sup>
- Thirty-five percent of Afghans owned one or more SIM<sup>1229</sup> cards, now up to at least 86 percent.<sup>1230</sup>
- Fifty percent of Afghans had mobile phone access, which had risen to nearly 90 percent by late 2015.<sup>1231</sup>

In addition, by this point, Roshan had developed an extensive agent network for the retail distribution and sales of its airtime top-up cards, which could also serve as mMoney cash points.

On the GIROA side, there was little to no awareness of or interest in DFS or mMoney, despite an effort by the regulators to include other relevant institutions in the public consultations conducted in March and April 2007. Later, however, in a series of briefings leading up to the drafting of the Electronic Money Institution's (EMI's) Regulation,<sup>1232</sup> there was a stronger effort to articulate the potential public policy and social benefits of mMoney, including, for example:

- The ability to track money flows and illicit behavior.
- The provision of a nationwide mobile banking platform would provide a traceable alternative to cash payments; it is costly to transport cash physically, especially over longer distances.
- Facilitating stability and improving governance.
- Modern financial services for the Afghan unbanked, a large, rural population working mostly in agriculture and small-scale enterprises whose size and profile are typically of little interest to the commercial banking sector, leaving the microfinance and informal lending sectors as the only resources available to most of them.

Not surprisingly, over time, the most intensive interest and support came from the elements within GIROA that were actively engaged in the realm of Anti-Money Laundering (AML) and Counter-Terrorism Financing (CTF). Also, the MoF was initially intrigued because it was at that time expanding the tax base by attempting to collect various taxes, duties, and fees from small- and medium-sized taxpayers (because the pool of large taxpayers was under two dozen firms).

What was missing from the internal and external dialogue was any discussion of the economic or financial impacts: a cost-benefit study should have been undertaken. Even more so with respect to the clear-use cases: disbursement of GIROA military and civilian payrolls.

---

<sup>1228</sup> World Bank (2014). Global Findex Financial Inclusion Data Afghanistan. Accessed March 22, 2016.

<http://datatopics.worldbank.org/financialinclusion/country/afghanistan>.

<sup>1229</sup> Subscriber identity module, a removable smart card for some types of mobile phones that stores identifying information regarding the phone and associated account.

<sup>1230</sup> MCIT (2015). Telecom Statistics (End of September 2015). Accessed March 22, 2016. <http://mcit.gov.af/en>.

<sup>1231</sup> Ibid.

<sup>1232</sup> The Supreme Council of Da Afghanistan Bank approved the Electronic Money Institution's Regulation on July 26, 2011. They formally codified it as an amendment to the Regulation on Money Service Providers, which was originally introduced in 2006 and updated in 2009.

As the dialogue expanded, it was also acknowledged that there were also enormous barriers to the broad adoption of DFS/mMoney:

1. Low level of literacy (reading, writing and numeracy);
2. Trust (failure of Kabul Bank<sup>1233</sup> and a general and pervasive distrust of formal financial instruments);
3. Afghans prefer the established informal remittance channels (see more on the hawala industry, below);
4. Lack of reliable national identity cards made it hard to meet DAB registration rules – widely known in the financial sector as “Know Your Customer” (KYC);
5. Spotty network footprint (M-Paisa service limited to Roshan SIMs and subscribers);
6. Lack of interoperability among MNOs;
7. Lack of liquidity in the mMoney ecosystem, which requires pervasive cash-in/cash-out locations (agents or dealers); and
8. Few places at which to spend mMoney (virtually none exist).

Further, most existing Roshan point-of-sale (POS) vendors were simply selling low-denomination top-up cards for airtime.

In order to launch its M-Paisa service, Roshan deployed a version of Vodafone’s network software mMoney platform (which is based on a menu-driven Unstructured Supplementary Service Data, USSD) and initially focused on meeting the repayment needs of microfinance clients of the First MicroFinance Bank Afghanistan (FMFB-A). It also recruited a handful of the top mPesa executives from Safaricom to spearhead its Afghan mMoney operation. Roshan offered mMoney services under a Money Service Provider license beginning in 2008, which was supplanted by an Electronic Money Institution license in mid-2011.

## Hawala, Remittances, and Trusted Agents

The hawala system of money transfer is well-established throughout Afghanistan (and surrounding countries) and, indeed, DAB, as an early priority, adopted regulations to govern this “primitive” financial service arrangement (as of 2010, there were 152 hawaladars licensed by DAB<sup>1234</sup>). The word hawala comes from Arabic and means “transfer.” The concept is fairly simple: a customer hands a “trusted agent” some money in his community, who signals to a cohort in a distant location (now made simple via phone), who in turn disburses the funds, minus a significant commission – reportedly close to 20 percent.

---

<sup>1233</sup> Kabul Bank, originally established in 2004, collapsed in September 2010, resulting in nearly US\$1 billion in losses and great public scandal.

<sup>1234</sup> Fakiri, Katrin (2016). *Building a Gateway to Digital Payments in Afghanistan: The World Food Programme’s E-Voucher Initiative*. Better Than Cash Alliance Case Study, May 2016, 9. Accessed June 21, 2016. [https://btca-prod.s3.amazonaws.com/documents/185/english\\_attachments/Afghanistan\\_Case\\_Study\\_May2016.pdf?1463507198](https://btca-prod.s3.amazonaws.com/documents/185/english_attachments/Afghanistan_Case_Study_May2016.pdf?1463507198).

A related service, which is known to most Westerners, is provided by international remittance providers such as Western Union, MoneyGram, and Ria Financial Services. But to be clear, unlike these publicly-traded, globally-branded institutions with robust networks of bricks-and-mortar storefronts and vast electronic paper trails (and reporting), hawaladars are arguably “mom and pop shops” based more on close personal relationships, using simple voice calls, and having relatively little regulatory oversight. (It must be noted that for Afghan consumers, the lack of paper trail also means no exposure to the tax man in Kabul.)

However, the Taliban regime had dismantled the entire commercial banking industry in Afghanistan, and by 2003, more than 5,000 hawaladars plied their services in Kabul alone, according to an International Monetary Fund (IMF) estimate.<sup>1235</sup>

After the collapse of Taliban rule, the international donor community quickly installed the legal-regulatory framework for modern banking, starting with the establishment of an independent regulator (DAB) and a licensing regime for commercial banks (and other typical financial services). It is no surprise, however, that the majority of the commercial banks that were initially authorized were simply “clusters” of hawaladars, including Kabul Bank (which failed spectacularly by 2010 with approximately US\$900 billion in illegally diverted funds).

The “community clout” of the hawaladars was demonstrated in the rapid growth of deposits: between 2004 and 2009, total assets in the commercial banking sector grew from US\$262 million to US\$3 billion.<sup>1236</sup>

Attempts to assess “financial inclusion” in Afghanistan tend to discount the pervasiveness and the market power of the hawala system – mainly reflecting an analytical bias that discounts remittances versus financial products such as dividends on deposit, loans, and insurance – but the reality is that most Afghans still trust and rely upon their community-based hawaladar to meet their admittedly undeveloped financial needs. Mobile money has so far been unable to displace the hawala system.

## Roshan’s Commercial Launch in 2008

In February 2007, Roshan and its sister institution, the First Microfinance Bank of Afghanistan (FMFB-A), began a pilot of Vodafone’s M-Pesa service, which it branded M-Paisa, with a small number of clients in Kabul. FMFB-A clients who choose to use M-Paisa signed up with their loan officer, who is trained in M-Paisa and able to register them from the bank branch using a special handset employing a master subscriber identity module (SIM) card. Client take-up is low, however, for several reasons, according to reports by USAID. First, Roshan’s agent network is not located in enough areas to meet FMFB-A’s needs.

---

<sup>1235</sup> Bennett, A. de Schaetzen, B. van Rooden, R. et al. (2003). *Islamic State of Afghanistan: Rebuilding a Macroeconomic Framework for Reconstruction and Growth*. International Monetary Fund Country Report No. 03/299. September 5, 2003, 119. Accessed November 8, 2015. <https://www.imf.org/external/pubs/ft/scr/2003/cr03299.pdf>.

<sup>1236</sup> Deloitte Consulting LLP (2010). *Afghanistan Economic Growth & Private Sector Strengthening (EGPSS) Project Completion Report* (prepared for the US Agency for International Development). October 2010, 5. Accessed March 21, 2016. [http://pdf.usaid.gov/pdf\\_docs/Pdacs874.pdf](http://pdf.usaid.gov/pdf_docs/Pdacs874.pdf).

Also, not all clients have mobile phones; those who do may get cellular service from a provider other than Roshan that does not offer the M-Paisa system and do not want to change SIM cards or providers. Furthermore, about 20 percent of FMFB-A's clients preferred to receive their loans in US dollars, but the M-Paisa system works only in afghani.

While Roshan continues to work with FMFB-A and other MFIs on offering M-Paisa loan disbursement and repayment services, the overall M-Paisa service continues to grow. After a period of retrenchment in early 2009, when Roshan tightened its agent audit procedures and decertified many non-performing or fraudulent agents, the service grew to 150,000 registered users by 2012, of which about 10,000 were deemed active (used the service monthly).<sup>1237</sup> By 2012, there were approximately 500 agents nationwide, including 90 located at bank branches with bank partners Azizi Bank, Afghan International Bank (AIB), and Bakhtar Bank.<sup>1238</sup>

*Editors' Note: By May 2015, Roshan reportedly has over 1.2 million mobile money subscribers, although the number of active users is lower than that figure.*<sup>1239</sup>

## US Military Identifies mMoney as “The Way Forward” for ANSF Salary Disbursements

In March 2009, as the Coalition forces were accelerating the winding-down of operations in Iraq, US Central Command (CENTCOM) hosted a workshop in Kuwait for its “theater financial officers” (CJ8<sup>1240</sup>) with the explicit theme of “getting cash off the battlespace.” In particular, leaders hoped to apply “lessons learned” in Iraq to operations in Afghanistan, since personnel levels in the latter were about to “surge” (in terms of both Coalition as well as Afghan National Security Forces (ANSF) numbers). At this workshop, the representatives from Afghanistan astounded their counterparts from Iraq by describing the relatively progressive state of the enabling environment for advanced financial services, including the fact that mMoney was already commercially available and in use (mainly for loan repayment and bulk disbursement of salaries).

Soon thereafter, the Afghan CJ8 sponsored the first pilot project to demonstrate mMoney for ANSF payments. Planning began in April 2009, and the demonstration pilot was launched in June with approximately 50 rural Afghan National Police (ANP) officers attached to the police academy in Wardak province (just west of Kabul).

The pilot project was initially acclaimed as a great success, because the process worked exactly as promised: recipients received their pay on time (on the declared payday as opposed to months later, as frequently happens, especially for remote outposts) and there was no longer a reason for payees to go

---

<sup>1237</sup> Data provided by Roshan to the author while he was working in Kabul.

<sup>1238</sup> Ibid.

<sup>1239</sup> Blumenstock, Joshua E., Michael Callen, Tarek Ghani, and Lucas Koepke (2015). *Promises and Pitfalls of Mobile Money in Afghanistan: Evidence from a Randomized Control Trial*. Accessed August 6, 2016. [http://www.jblumenstock.com/files/papers/jblumenstock\\_ictd2015.pdf](http://www.jblumenstock.com/files/papers/jblumenstock_ictd2015.pdf).

<sup>1240</sup> Combined Joint Finance

AWOL<sup>1241</sup> because they could send remittances to family and friends elsewhere in Afghanistan without taking days to travel to their physical locations. Another shocking reality was also exposed: many recipients reportedly believed they had received a 30 percent raise – because their superiors had not skimmed anything off the top.

There were glitches early on, however, particularly involving literacy. Roshan discovered that many of the officers could not read the text messages informing them that their salaries had been deposited into their accounts, and that many did not fully understand how to make transactions. Roshan then implemented a monthly automated call to inform officers of their salary payment, plus an interactive voice response (IVR) system in English, Dari, and Pashto to allow them to make transactions manually over the phone in the language of their choice.

The primary problems with the pilot were caused by politics and corruption within the ANP. Commanders were outraged at losing the ability to distribute cash to their staff (and take a cut for themselves), and tried many ways to circumvent the system. One commander collected every officer's SIM card and demanded that an M-Paisa agent give him all the salary payments, which he said he would distribute to the officers. The agent refused, closed his shop, and went home until it was deemed safe. There was also a great deal of opposition at Kabul Bank, which had been responsible for ANP salary accounts up to that point and did not want to see its business jeopardized. (One reason then-Minister of Interior Hanif Atmar wanted to use M-Paisa was the high number of ANP "ghost accounts" on the books at Kabul Bank.)

The ANP salary payment initiative expanded up to 250 officers (at other locations), and plans were announced to expand it nationally in the summer of 2010, but they were put on hold when Kabul Bank informed the Ministry of the Interior that it would offer the identical service for free. A few months after making this offer, DAB took control of Kabul Bank, citing irregularities. Around the same time, Minister Atmar, who had been supportive of M-Paisa, quit his post. So, nothing ever materialized from Kabul Bank, and mMoney quickly faded from the agenda.

*Editors' Note: By May 2014, approximately 1,100 ANP were being paid via M-Paisa, accounting for less than 1 percent of the police force (compared to 18 percent paid via "trusted agent"). The Law and Order Trust Fund of Afghanistan (LOFTA), which administers salary payments to the ANP, hoped to pay 3,200 ANP via M-Paisa by the end of SY1393 (March 20, 2015).<sup>1242</sup>*

## USAID's Ground-breaking Efforts to Ignite mMoney

In February 2011, USAID launched a five-year US\$108 million<sup>1243</sup> program called Financial Access for Investing in the Development of Afghanistan (FAIDA), which included an explicit work stream to accelerate the adoption of mMoney (estimated US\$10 million component).

---

<sup>1241</sup> Absent without leave

<sup>1242</sup> Combined Security Transition Command-Afghanistan (CSTC-A) (2014). CSTC-A Response [letter] to SIGAR 14-50-SP, "ANP Mobile Money Pilot Program." May 3, 2014.

<sup>1243</sup> Initially funded at US\$43 million

Contractor Chemonics' primary focus for the expansion of mMoney hinged on providing US\$2.1 million in grants to the four<sup>1244</sup> GSM MNOs:

- AWCC developed custom "Know Your Customer" electronic registration mobile point-of-sale (mPOS) devices, which include biometric capture and a near field communication (NFC) transaction interface, which it deployed to 400 merchants. AWCC migrated 2,000 of its employees to mMoney, disbursing over US\$5.7 million in salaries (September 2012 to August 2014).
- Etisalat: Integrated its mMoney platform software with the commercial banks and the DABS billing system, which made it possible for 2,147 electric customers to pay US\$459,599 in bills via mobile phones (December 2011 to August 2014).
- MTN planned to pay the salaries of 100,000 teachers via mMoney.<sup>1245</sup>
- Roshan utilized mMoney for the repayment of 10,000 microfinance loans (mostly to women), which resulted in US\$334,233 in loan repayments during the term of the grant (November 2011 to March 2013).

FAIDA also implemented a small grant program to spur innovations, through its Mobile Money University Contest, which ran from mid-April to mid-June 2012 and included 33 Afghan universities. Students were encouraged to come up with innovative ideas for how to use mobile money in areas such as agriculture, education, women's efforts, and government service. From over 5,000 entries, a panel consisting of representatives from the four GSM companies and USAID chose 27 finalists and eight winners. (There were two female winners among the eight.) Winners received 250,000 Afs (approximately US\$5,000) each, and decorative plaques. The winners' schools also received five computers each along with free Internet access for a year. FAIDA also provided a grant to spur the development of a national payments switch for interoperability amongst MNOs and commercial banks (April 2013 to October 2015).

FAIDA was not directly involved with the ANSF salary disbursement activities. However, AWCC's grant was used to deploy a new handheld "biometrics capture kit" which has subsequently become part of the NTM-A/CSTC-A<sup>1246</sup> police salary payment scheme (see further below).

### mMoney Draws Attention of High-level Officials in Washington

The FAIDA mMoney component had great ambitions and was strongly encouraged and supported by USAID headquarters, which led to a visit by the head of USAID, Rajiv Shah, to Kabul in August 2011 and his written instruction to all USAID Missions worldwide to include mMoney in all financial operations whenever practical. Administrator Shah's keynote appearance at the mMoney Forum in Kabul on 24 August 2011 drew numerous ministers, ambassadors, over 100 VIPs,<sup>1247</sup> and the international media.

---

<sup>1244</sup> Afghan Telecom Corporation had a CDMA network at that time and launched mobile GSM service after the FAIDA mobile money grant program. At that time (February 2014), had no plans to offer mMoney.

<sup>1245</sup> MTN ultimately abandoned its mMoney aspirations, and no grant was issued.

<sup>1246</sup> NATO Training Mission-Afghanistan/Combined Security Transition Command-Afghanistan

<sup>1247</sup> Very important persons

Deputy Minister (Finance and Administration) Sadaat also announced the Ministry of Communications and Information Technology's (MCIT's) commitment to:

- Use mMoney for paying MCIT personnel salaries in Helmand, Ghazni, and Paktika; and
- Upgrade Afghan Post offices in these provinces, and potentially many more, to become mMoney cash points and also offer additional electronic government services (in all 465 post offices nationwide).

USAID also identified the following opportunities to help scale the uptake and use of mobile money through:

- Pricing (fees) that allows for rural inclusion;
- Interoperability among banks, mobile operators, and merchants;
- New branchless banking laws to help mobile money flourish;
- Better understanding consumer preferences for informal money transfers (hawala);
- Strategies to ensure rural market liquidity (enough cash in the till for payouts);
- Business models for mobile network operators and agents to ensure their sustainability, as well as to surmount challenges on agent recruitment and management; and
- Increasing caps on mobile money transactions for customs duty payments and government salaries.

### A Focus on Interoperability to Foster a Critical Mass of Digital Financial Services

In 2010, the Task Force for Business and Stability Operations (TFBSO) took a strong interest in a variety of ICT initiatives in Afghanistan, including mMoney. The TFBSO was a unit of the US Department of Defense established to accelerate private sector solutions as a counterinsurgency and village stability initiative in Iraq, which migrated to Afghanistan as activities in Iraq wound down.

The TFBSO concluded that the lack of interoperability among the existing and potential providers of digital financial services (including commercial banks and MNOs) was a major impediment to achieving national scale, and its solution was the establishment of a "national payments switch" that would be self-sustaining on the basis of interchange fees. The TFBSO concept progressed to the point of the creation of the Afghan Payments System (APS) consortium, but the entire initiative collapsed by June 2011, due to lack of financial support or enthusiasm from the expected members.

The TFBSO ultimately handed the project over to the Central Bank of Afghanistan (DAB), which then was able to obtain US\$ 5.5 million in World Bank funding for a national payments switch.<sup>1248</sup> In 2013, DAB selected a vendor and a team to install the system; it was expected to go live by the end of 2015.

---

<sup>1248</sup> World Bank (2011). *Afghanistan - Financial Sector Rapid Response Project*. Washington, DC: World Bank. Accessed August 6, 2016. <http://documents.worldbank.org/curated/en/525981467989986286/Afghanistan-Financial-Sector-Rapid-Response-Project>.



As of November 2015, the APS has four core members, which contributed US\$150,000 each:

- Pashtany Bank (PB) – state-owned;
- Bank-e-Millie (BMA) – state-owned;
- Ghazanfar Bank (GB) – privately-owned; and
- Azizi Bank (AB) – privately-owned.

The MNOs have been invited to join APS. According to FAIDA, AWCC will reportedly join soon, and Roshan has informally expressed interest. In addition, third-party credit card processors have already been signed up (Visa, MasterCard, etc.); credit card clearing will be done by a Lebanese bank.

*Editors' Note: The Afghanistan Payments System platform was officially inaugurated April 26, 2016, with five banks. Two additional banks and a mobile network operator were in discussions to join the platform as of June 2016.*<sup>1249</sup>

### COMISAF Acknowledges the Potential for mMoney But Effort Quickly Stalls

In early 2011, the Commander of NATO's International Security Assistance Force (COMISAF) General David Petraeus offered some encouragement for mMoney as the approach to getting cash off the battlespace in Afghanistan, and several scenarios for pilot projects were explored, primarily ANSF salary payments and Commander's Emergency Response Program (CERP) payments to contractors under US\$5,000. However, by July 2011, the COMISAF mantle had been passed to his successor, General John Allen, who announced his mandate was to ensure that all ISAF projects would be completed by the end of 2012, and, therefore, no new initiatives would be approved for funding or technical support.

### Nationwide Consumer Survey Documents that mMoney is Still Invisible to Most Afghans

Despite being commercially available for more than five years, a statistically-reliable nationwide consumer survey, sponsored by USAID and conducted by Altai Consulting, found that mobile money was a concept still completely unknown to most Afghans.<sup>1250</sup>

As of mid-2013, only 5 percent of SIM owners had subscribed to mMoney, and only two-thirds of these subscribers actually perform transactions, with most services essentially unused. Moreover, these

---

<sup>1249</sup> Rostom, Ahmed Mohamed Tawfick; Rostom, Ahmed Mohamed Tawfick (2016). *Afghanistan - Financial Sector Rapid Response Project: P119047 - Implementation Status Results Report: Sequence 08*. Washington, D.C.: World Bank. Accessed August 6, 2016. <http://documents.worldbank.org/curated/en/623281469552333018/Afghanistan-Financial-Sector-Rapid-Response-Project-P119047-Implementation-Status-Results-Report-Sequence-08>.

<sup>1250</sup> Altai Consulting (2013). *Market Research on Mobile Money in Afghanistan*. November: 3. Accessed November 8, 2015. <http://www.altaiconsulting.com/application/views/images/media/pdf/Altai%20MR%20Mobile%20Money%20FINA.L.pdf>.

mMoney users predominantly received (as opposed to transmitted) funds, and most were forced by their employers to receive their salaries via mMoney and reported they would prefer to be paid in cash.<sup>1251</sup>

Altai reported, “56 percent of mMoney non-users state that they would consider subscribing to mMoney, but they have a general lack of awareness of the service and of its benefits. Business owners are also skeptical of mMoney.”<sup>1252</sup>

Two years later, FAIDA looked back upon four years of various efforts to reach the “tipping point” for widespread adoption of mMoney and found the results relatively sobering. As a general matter, few Afghans had even heard of mMoney – and even fewer actually utilized mMoney with any regularity.

FAIDA’s mMoney manager attributed the failure to reach national scale on two primary factors:

- **Lack of Demand for Cash Alternative:** Afghans still prefer cash, and mMoney has not made a strong “use case” (except for when mandatory by employers); and
- **Lack of Awareness:** Most Afghans have no awareness about any alternatives to cash and have no exposure to mMoney – and most are rural and overwhelmingly illiterate.

In response, FAIDA stated it intends to launch a million-dollar nationwide public relations campaign, including radio and TV programming (short skit dramas), posters, and billboards.

### Bulk Payments Offer Some Promise

By 2014, FAIDA recognized its various efforts to indirectly influence market players was not achieving appreciable results, so it began exploring bulk payments being made by international non-governmental organizations (NGOs), such as conditional cash transfers (CCT) by United Nations (UN) organizations such as the [World Food Programme](#) (WFP) and UNICEF.<sup>1253</sup>

The WFP has historically distributed food to refugees and internally displaced persons, mainly post-disaster or post-conflict. Due to the logistical challenges of physically moving food to rural and remote locations in Afghanistan, as well as studies that concluded that locally-produced-and-sold food has a greater sustainable economic impact, WFP then moved to paper vouchers.

Each paper voucher has a unique barcode, which is readable by special point-of-sale (POS) devices that were distributed by WFP to commercial banks in Afghanistan. New Kabul Bank (NKB) is the primary partner for this particular CCT program. Each WFP beneficiary receives a voucher (with 2,000 Afs value), and merchants in villages accept the vouchers in exchange for a predetermined “basket” of staple foodstuffs (rice, flour, milk, etc.). However, these paper vouchers are easily duplicated on xerographic copiers, so when merchants attempted to redeem them at commercial banks, the banks rejected the duplicates – and the merchants experienced huge losses.

---

<sup>1251</sup> Ibid.

<sup>1252</sup> Ibid.

<sup>1253</sup> United Nations International Children’s Emergency Fund

In early 2015, FAIDA was finally able to convince the WFP to utilize mMoney on a pilot basis, after a year of persuasion. FAIDA arranged for the MNOs to demonstrate their capabilities, and WFP selected AWCC. The main reason was AWCC's use of NFC as a back-up (or alternative) to the network menu. At enrollment for the WFP program and mMoney service, each beneficiary receives an NFC-enabled sticker that can be adhered to the mobile phone or onto the WFP-issued identity card.

The first WFP mMoney pilot included 600 beneficiaries in 15 communities in metropolitan Kabul. To enroll, the beneficiary was required to bring his tazkira,<sup>1254</sup> and then one digital portrait was taken at the time of the application with the mPOS device. The WFP/AWCC team enrolled all 600 beneficiaries within two days (in May 2014). The WFP/AWCC team also recruited and trained beneficiaries, merchants, and agents. AWCC provided each merchant in the pilot with its mPOS terminal, which is specially designed to do the mobile user registrations required by ATRA (to meet the Mandatory SIM Registration requirement) as well as the Know Your Customer (KYC) elements required by the central bank for mMoney services. The mPOS approach was developed utilizing USAID's grant under the FAIDA program (as mentioned above). Beneficiaries can transact in the "traditional" mMoney approach (using MNO network access via USSD) or NFC. The vast majority utilized NFC (satisfaction surveys were done and will be provided by FAIDA). Merchants provide a receipt of the transaction via the AWCC mPOS terminal. There is no "cash out" in this WFP CCT – this is entirely for the acquisition of goods from the merchant.

The second WFP pilot concluded its second monthly disbursement in July 2015 and employs several innovations learned from the first pilot. For example, instead of being required to accept the full amount of 2000 Afs in goods at one time, the beneficiary can now purchase in increments (e.g., four purchases at 500 Afs each).

Consumer satisfaction surveys have found that 90 percent of beneficiaries and 100 percent of merchants are fully satisfied. USAID is reportedly very pleased with the results so far. The WFP has more than 200,000 beneficiaries in Afghanistan, and the expectation is that they will all be enrolled to the eVoucher disbursement mechanism. As of August 2015, AWCC transacted US\$407,354 to 10,556 WFP beneficiaries via mMoney. The program is being expanded to three additional provinces: Bamyan, Badghis, and Ghor. There is new management at the WFP, and FAIDA hopes to introduce the capabilities of the other MNOs for the future rollouts.

As with the WFP, most of UNICEF's beneficiaries and workforce are in rural and remote locations throughout Afghanistan. FAIDA assisted UNICEF with a pilot project in 1Q2015: salary payments in six provinces. AWCC is currently the mMoney provider, and it also performs a branchless banking function, in that it opens an account for each beneficiary (although the commercial banks are responsible for their own KYC). FAIDA has had some preliminary discussions with UNICEF to facilitate mMoney for additional salary, stipend, and CCT disbursements.

---

<sup>1254</sup> Identity paper

## Commission Breakthrough

One of the notable barriers to the establishment of a viable mMoney ecosystem is the merchant or agent in the local community to conduct the transactions (cash-in, cash-out, and purchases). In the past, the MoF has rejected mMoney for G2P<sup>1255</sup> disbursements in part because it said it lacked the funds in the budget to pay for the mMoney transaction fees. For the ALP salary disbursement initiative (at least in this pilot phase, see below), CSTC-A has agreed to cover the one-time mMoney processing fee to AWCC:

- 150 Afs to cover the one-time registration fee per ANSF employee, and
- 3,500 Afs to cover the cash-out fee (unlimited number of times).

Note that AWCC normally charges 1 percent of the transfer amount as cash-out fee, but has agreed to waive this tariff schedule for GIROA employees.

## FAIDA's Achievements and Plans for the Future

According to USAID, FAIDA's accomplishments up to June 2015<sup>1256</sup> included:

- Creating 5,428 full-time equivalent (FTE) jobs.
- Providing financial assistance to 35,464 families.
- Supporting 13,330 businesses, of which 11,655 were women-owned.
- Helping 5,161 micro-, small- and medium-sized enterprises (SMEs) to receive US\$45.6 million in commercial loans. Another US\$18 million in loan applications is also in process.
- Conducting microfinance and commercial banking training for 2,410 financial sector employees.
- Holding 22 business and gender workshops for 1,200 businesswomen from all 34 provinces.
- Helping 575 businesswomen to obtain US\$1.86 million in loans for start-ups or business expansion.
- Working with banks to develop 33 culturally-appropriate and Islamic finance products.
- Providing assistance to OXUS microfinance institutions<sup>1257</sup> to simplify the loan application process for SMEs, resulting in loans to 1,840 clients (544 women), the creation of 1,849 jobs, and the profitability of OXUS.
- Supporting the World Food Programme's (WFP) implementation of mobile money eVouchers through mobile service provider AWCC, enabling the provision of vouchers to buy goods from authorized AWCC merchants to Afghan beneficiaries.
- Helping to implement the registration of 135 Independent Directorate of Local Governance (IDLG) employees with AWCC mobile money service to receive a portion of their salaries linked to their bank accounts.

---

<sup>1255</sup> Government-to-people or government-to-populace

<sup>1256</sup> FAIDA briefing paper, "Mobile Money in Afghanistan." August 2015, provided to the author during a meeting on August 25, 2015 in Kabul. Similar and updated statistics can be found on USAID's website:

<https://www.usaid.gov/news-information/fact-sheets/financial-access-investing-development-afghanistan-faida>.

<sup>1257</sup> The OXUS Group. Accessed November 8, 2015. <http://www.oxusnetwork.org/en/about-us/welcome-to-oxus>.

- Tailored assistance, which has generated 22 loan applications to date, totaling more than US\$625,000.

In the remaining contract period of performance, FAIDA intends to explore several more innovations and activities, including those listed below:

**eKiosk:** FAIDA is exploring support for automated teller machines (ATMs) and other mechanisms to diversify the mMoney ecosystem. FAIDA plans to set up 100 kiosks in Kabul to facilitate DABS electric bill payments and loan repayments for all MFIs. For example, one MFI has recently deployed its own kiosks in Kabul that offer electronic top-up of mobile phones and MFI loan repayments (they accept cash via NFC from AWCC mWallet).

**Branding:** FAIDA will be launching a special logo for the entire range of mMoney services, so that consumers will know from a distance that the merchant/agent accepts mMoney (similar to the way Western Union signs are displayed).

**Cost-Benefit Analysis (CBA):** FAIDA acknowledged that its discussions with the MoF regarding mMoney have failed to identify and quantify the true “end-to-end” costs of salary and CCT disbursements, which should include, for example, the cost of physically moving cash, the security to protect cash (and losses) and the time (hours or days) away from official posts when workers travel to commercial banks in urban areas to conduct business. FAIDA may conduct a comprehensive analysis, under its Better Than Cash Alliance (BTCA)<sup>1258</sup> support work stream.

**mWallets and mBanking:** While mMoney is characterized as a DFS that transacts entirely within the MNO’s network and platform, mWallets are explicitly tied to accounts with commercial banks (or comparable regulated financial institutions). AWCC is the first to link its service with a bank (New Kabul Bank, NKB), and, therefore, can be said to be facilitating mBanking. This is a further innovation and breakthrough, because this means it overcomes the main objection that the MoF had to the use of mMoney, namely the purported statutory requirement (in the Public Financial Management Law<sup>1259</sup>) for GIRoA salaries to only be disbursed through commercial bank channels.

**Branchless Banking:** One of the most distinguishing innovations that have made DFS extremely successful in Pakistan (and elsewhere) is the widespread embrace of agnostic agents and branchless banking. Branchless banking is defined as the delivery of financial services outside conventional bank branches using ICT and nonbank retail agents.<sup>1260</sup> The underlying proposition is that by piggy-backing on existing facilities (e.g., general store, pharmacy) and utilizing devices already owned by customers and retailers

---

<sup>1258</sup> Better Than Cash Alliance. Accessed November 8, 2015. <https://www.betterthancash.org/>.

<sup>1259</sup> Officially, the Public Finance and Expenditure Management Law of 2005.

<sup>1260</sup> Lyman, Timothy R., Mark Pickens, David Porteous (2008). *Regulating Transformational Branchless Banking: Mobile Phones and Other Technology to Increase Access to Finance*. Consultative Group to Assist the Poor (CGAP) Focus Note 43, January 2008. Accessed November 8, 2015. <http://www.cgap.org/sites/default/files/CGAP-Focus-Note-Regulating-Transformational-Branchless-Banking-Mobile-Phones-and-Other-Technology-to-Increase-Access-to-Finance-Jan-2008.pdf>.

(e.g., mobile phones), banks and microfinance institutions can extend access to their financial products via simple transactional services without having to build physical outlets. Branchless banking has the potential to lower the cost of delivering financial services and expand the formal financial system to previously unreached areas and population. As for consumer acceptance of such solutions, though literacy remains low at 28 percent,<sup>1261</sup> the relative youth of the Afghan population and the rapid growth of the mobile communications sector are positive indicators of the current and future levels of technological literacy.

Table 11: Amount transferred via mobile money as of August 15, 2015

Amount Transferred via mMoney with FAIDA Support (as of August 15, 2015)			
Project	MNO	Customers	Value (US\$)
DABS	Etisalat	5,707	829,532
WFP	AWCC	13,556	2,321,760
UNICEF	AWCC	72	77,462
AWCC & ATN employees	AWCC	2,000	1,126,316
MFI (Mutahid DMFI)	Roshan	3,528	1,034,233
Interns	AWCC	560	217,555
Top Vision	White-label	9,147	15,215
NUG	AWCC	650	180,000
<b>Total</b>		<b>35,220</b>	<b>5,802,072</b>

## President Ghani Supports Move to Electronic Payments for All GIRoA Transactions

President Ghani has publicly stated his support for mMoney and mobile banking (mBanking)<sup>1262</sup> and has established an “eBoard” to accelerate the migration of GIRoA services to ICT, mainly to increase transparency and reduce corruption. Ghani has a number of advisors supporting these priority initiatives:

- eVoting;
- eTazkira; and
- Additional functionality on the eTazkira smartcard (including making tax payments and receiving CCTs).

<sup>1261</sup> United States Central Intelligence Agency (CIA) (2014). *The World Factbook: Afghanistan*. Accessed December 9, 2014. <https://www.cia.gov/library/publications/the-world-factbook/geos/af.html>.

<sup>1262</sup> USAID (2015). “Afghanistan’s Government Will Strengthen Electronic Payment System.” October 26. Accessed November 8, 2015. <https://www.usaid.gov/afghanistan/news-information/press-releases/afghanistan%E2%80%99s-government-will-strengthen-electronic>.

In a November 2015 letter, the President requested cooperation and support of the “government mobile salary payments initiative” and “in reaching agreement on a national financial inclusion strategy for the country.”<sup>1263</sup>

## Reports of Widespread Fraud Spurs US Military to Revive mMoney for Afghan Local Police

The mandate for ISAF expired on December 28, 2014 and marked the official end to combat operations. However, all of the pre-existing activities of NTM-A/CSTC-A to stand-up the ANSF were continued on January 1, 2015 under the successor mandate of the Resolute Support Mission’s (RSM’s) “Train, Advise, Assist” (TAA) rubric. This change of command and restructuring was accompanied by a number of reports of financial irregularity – and in the case of the Afghan Local Police (ALP), an apparently systemic fraud including ghost employees, massive corruption, and patronage.<sup>1264</sup> To address the findings of the lack of transparency, accountability, and a reliable paper trail, RSM again revived the idea of using mMoney to pay ALP salaries.

In April 2015, RSM CJ8 was tasked to launch a mMoney pilot project, and after exploring the capabilities of the three MNOs offering a mMoney, selected AWCC (with New Kabul Bank as its commercial banking partner). AWCC was competitively selected because it offered a superior approach, which includes mobile point-of-sale (mPOS) devices to meet the central bank’s (DAB’s) “Know Your Customer” requirements of registration (and includes biometric registration and near field communication (NFC) to process transactions). The pilot project was developed to include roughly 800 ALP in Kapisa (selected because all ALP were being paid in cash), but by September, the RSM leadership had decided to accelerate the rollout to six provinces (16,000 ALP) by the end of 2015 and 100 percent coverage by the end of 2016.

Reduction of corruption is one of the main drivers behind the move to mMoney. For example, in Kapisa Province, over 800 ALP were on the official *tashkeel* (on the GIROA budget eligible for salary payments), but after the requisite biometric enrollment, ultimately only 555 were found. This suggests that 30 percent of the ALP roster were “ghost employees.”

RSM CJ8 negotiated a superior fee schedule with NKB/AWCC, which is roughly one one-hundredth percent (0.01%) of the salary being disbursed. This is vastly cheaper than even direct deposit (electronic funds transfer, or EFT) and also much cheaper than Roshan’s commercial mMoney fees. Fortunately, Roshan has also recently adopted the mPOS equipment and agreed to meet the low AWCC mMoney fee, so it will also participate in the forthcoming nationwide rollout.

---

<sup>1263</sup> Letter from Afghan President Mohammad Ashraf Ghani to Partners, dated November 21, 2015, a copy of which was provided to the author.

<sup>1264</sup> US Department of Defense Inspector General (DODIG) (2014). *Government of the Islamic Republic of Afghanistan Needs to Provide Better Accountability and Transparency Over Direct Contributions*, Report No. DODIG-2014-102, August 29. Accessed November 8, 2015. <http://www.dodig.mil/pubs/documents/DODIG-2014-102.pdf>.

The mPOS devices, but more importantly the biometric enrollment, are the significant breakthroughs in this latest iteration of the mMoney salary disbursement effort because it eliminates duplicate enrollment, and provides absolute confidence that the payment is received by the payee; equally important, biometrics are also used by the mPOS when cashing out – thereby removing the barrier to serving illiterate or semi-literate customers. Actually, thanks to the biometric feature at the mPOS, no phone is even required for cash-out.

In addition, this initiative will bring ALP salary disbursements to 100 percent EFT: 40 percent were already receiving direct deposits, but the remaining police were using “trusted agents” because there were not commercial bank branches or ATMs in reasonable proximity. Under the AWCC/NKB approach, salaries are actually deposited to the bank account of the recipient, who is then able to access the account via mobile phone and conduct a variety of transactions (cash-out, transfer remittances to other parties, or purchase goods and services at merchants with the mPOS device).

The Afghan banking system has a liquidity problem at the retail level, which will still be a challenge that even mMoney will not solve (until a more robust “ecosystem” emerges, so mMoney users can use funds in their mWallets for purchases of goods and services, and not just “cash out” the entire salary on the spot).

## Lessons Learned

In the context of military occupation or post-conflict peacekeeping, some degree of nation-building will certainly be an integral part of the mission. The immediate deployment of ICT in all financial operations will significantly increase transparency and accountability, and ultimately reduce corruption, fraud, waste, and abuse. The “golden moment” is immediately after the dust settles, because this is when the embracement of new approaches will be most genuine – soon thereafter, the maleficent impulses return and corruption and “gaming the system” will begin to dominate.

On the civilian side of the reconstruction effort, donor funds will flow mainly through the host government’s ministry of finance and treasury, and therefore the immediate deployment of ICT systems is critical to ensure transparency and potentially increased efficiency. In terms of government operations, the place to begin is with an electronic treasury system that automates revenue collection, spending, and reporting. In addition, the central bank is the mechanism through which the broader financial system will be restarted, and therefore ICT is needed to provide domestic liquidity and to transact with the rest of the world.

On the military side, at a minimum, the foreign forces will have an ongoing requirement to pay for local goods and services – and more than likely, the foreign forces will also pay the salaries of the security forces as they are rebuilt. Cash transactions should be avoided at all costs, and mMoney (or, more accurately, mBanking) has now been proven to be a viable complement to more traditional electronic funds transfer (direct deposit).

## Learning from What Was Done Right

ICT in Public Financial Management (PFM):



- Donors demanded automated PFM systems at the MoF from the start.

#### ICT in Commercial Banking:

- The central bank facilitated nationwide liquidity for commercial banks by deploying a secure VSAT network to manage its core banking system.
- Automated bank supervision was introduced by the central bank (but apparently never properly analyzed by bank supervisors).

#### ICT in Digital Financial Services:

- It has taken a relatively long time, but mBanking has finally been introduced; this is defined as transactions tied to a commercial bank account, done via mobile phone. As smartphones become less expensive, this will become the dominant approach to mMoney.
- To address the high proportion of illiterate customers, one of the MNOs introduced interactive voice response (IVR) systems to complete transactions.

## Learning from What Could Have Been Done Better

#### ICT in PFM:

- The MoF was allowed to operate "two sets of books" for far too long, and a single set was not made mandatory.
- Virtually nobody at the MoF or the other GIRoA institutions has financial literacy; donors should have provided initial training on simple accounting packages (like QuickBooks) instead of assuming GIRoA "finance managers" actually had an understanding of accounting and budgets.

#### ICT in Commercial Banking:

- Literacy is extremely low and financial literacy is even lower; much more should have been done to educate the public about the benefits of electronic transactions.

#### ICT in Digital Financial Services:

- All military payments should have been mandatory EFT – either direct deposits to commercial bank accounts or via mMoney (below reasonable thresholds for each).
- The MCIT's roughly 350 post offices were never utilized as mMoney transaction points (this would have required construction to upgrade security, plus electricity, and train employees).

## Conclusion

Afghanistan benefited from mobile phone technology, which had reached a level of technical maturity and affordability that made it possible to provide wireless coverage to nearly 90 percent of the population in just over a decade. Today, smartphones have virtually replaced the basic Nokia handset that was the entry point for most consumers – although most citizens in Afghanistan have had no exposure to mobile services beyond basic voice calling. There was a moment in time when the MCIT had just awarded the

first 3G<sup>1265</sup> licenses to mobile network operators and Google had offered to donate one million “entry level” smartphones to Afghanistan that could have provided a quantum jump forward, particularly if GIRoA (with donor assistance) simultaneously launched a clever portfolio of applications, including, for example, literacy, financial literacy, and electronic government. The bottleneck at that critical moment was the lack of reliable and affordable bandwidth; however, even that could have been solved by the establishment of Internet Wi-Fi<sup>1266</sup> hotspots subsidized by the Telecommunications Development Fund (TDF) (free for limited duration, such as is available at most airports around the world these days).

Furthermore, one of the best functional apps that should have been preloaded to all smartphones is mBanking – with mandatory commercial accounts for every citizen receiving salaries, CCTs, or any small payments from GIRoA, the military, and all international donors. Together with mandatory biometric enrollment of each user SIM, this would have put Afghanistan immediately on the trajectory of achieving the full potential of the Information Age.

---

<sup>1265</sup> Third-generation wireless digital technology based on International Telecommunication Union (ITU) International Mobile Telecommunications (IMT)-2000 specifications.

<sup>1266</sup> Wi-Fi is a local area wireless computer networking technology that employs radio waves to allow computers, mobile phones, and other devices to connect to the Internet and communicate with one another within a particular area without being physically connected.

## Chapter 14 ICT in Healthcare: Lessons Learned from Eastern Afghanistan

---

Dr. Peter M. Killcommons

### Introduction

As founder and CEO of [Medweb™](#), a medical technology solutions company, and longtime philanthropist, I have leveraged my medical background to aid individuals in other countries around the world. To date, I have visited remote villages and military outposts in Afghanistan, Peru, Iraq, and Kuwait on charitable missions and medical care trips. Most recently, I assisted the [La Jolla \(California\) Golden Triangle Rotary Club](#) and [Rotary International](#) as part of the San Diego-Jalalabad [Sister Cities International](#) program in installing medical equipment and training doctors at hospitals in Jalalabad and Kabul, Afghanistan. As part of these activities, I visited ACOMET<sup>1267</sup> Family Hospital and Afshar Hospital in Kabul, as well as the Nangarhar University Jalalabad Hospital, the Nangarhar Public Health Hospital, and the Mogul Khan Memorial Hospital in Jalalabad to provide such services. This chapter presents some of my experiences in using information and communications technology (ICT) as an enabler in the healthcare sector.



*Picture 35: Patient outside Nangarhar University Hospital with an IV drip hung in a tree*

Afghanistan has been involved in conflict for over 35 years. With an average life expectancy of around 44 years<sup>1268</sup> (in 2009 when I began working there), this means that many people alive in Afghanistan do not know what it is like to live without war. The electricity grid and infrastructure are also in great disrepair. Even urban areas have to survive with spotty electricity, while rural areas (where over 70 percent of Afghans live<sup>1269</sup>) have no electricity at all. With this backdrop of war and startling infrastructure shortages, this chapter discusses the healthcare ICT technologies we deployed in equipping an imaging center and some hospitals in Jalalabad during the most recent conflict.

---

<sup>1267</sup> Afghan Centre of Multi-Professional Education and Training

<sup>1268</sup> Infoplease. "Life Expectancy for Countries, 2009." Accessed October 5, 2015. <http://www.infoplease.com/world/statistics/life-expectancy-country-2009.html>.

<sup>1269</sup> Islamic Republic of Afghanistan Central Statistics Organization (ACSO). *Afghanistan Statistical Yearbook 2013-14*. Accessed January 5, 2016. [http://cso.gov.af/Content/files/Population\(3\).pdf](http://cso.gov.af/Content/files/Population(3).pdf).

As a physician and entrepreneur with 20 years of experience developing hardware and software solutions for teleradiology, telemedicine, and electronic or e-health, I was excited to be invited to work with my Afghan medical colleagues from 2009 to 2011 to evolve a healthcare ICT architecture for several hospitals and a medical imaging center in Jalalabad. I worked in collaboration with the La Jolla Golden Triangle and Jalalabad Rotary Clubs. At the end of the day, my goals were to assist Afghans in achieving a higher quality of healthcare. I accomplished this in two ways: first, by building a collegial partnership between medical professionals in Jalalabad and California, in the spirit of the Rotarian Sister Cities project, and for that matter, with Rotary International as a whole, sharing experiences and in the context of what was needed and what might work in the Afghan culture; and second, by giving them some of the tools and technologies that we are fortunate to have in the USA.

Described below are some of the unique perspectives and challenges I encountered and addressed during the process of selecting technologies and ICT solutions that would have the greatest positive impact. This chapter shares some of the technologies we used, the experiences and lessons we learned from the project, as well as several technologies and tools to consider for future efforts based on our experiences. The goal is to provide some insight into which tools were helpful in Afghanistan and which tools to avoid when working in similar environments.

## Culture and Collaboration

First, my Rotary colleagues and I made sure to establish a good rapport with our Afghan medical colleagues. We immediately sought out the IT<sup>1270</sup> person (if there was one), so we could determine what they did and did not need. Afghan doctors I encountered had mostly received their medical educations from neighboring countries as well as from the local medical school in Jalalabad. They were very professional and eager to get more modern equipment to improve their practices. In all cases, they looked forward to having better access to ICT resources for medical education, collaboration, and improved diagnostic capabilities.

By taking time to understand and respect the local culture of our Afghan colleagues, we were able to see what worked for them and what they were interested in supplementing or modifying to improve their clinical workflow. For example, our Afghan colleagues lacked clinical training in modalities like computerized tomography (CT) and ultrasound; those who did have that knowledge had acquired it from training outside Afghanistan. Therefore, an area of great interest was the imaging center, and efforts revolved around providing tools to allow Afghan doctors to request consultations with a remote physicians or assistance in reviewing various CT or ultrasound findings.

A substantial difference in the practice of medicine in Afghanistan is that, because of cultural differences and the lack of emergency services, it is quite common for patients to delay their arrivals to hospitals or emergency rooms until their illnesses have progressed well beyond the stage of survival. In particular, Afghan women are not permitted to travel independently without being accompanied by males (generally

---

<sup>1270</sup> Information technology

family members). For these and other reasons, Afghanistan's perinatal/maternal mortality rate is one of the highest in the world. According to *The State of the World's Children* report,<sup>1271</sup> Afghanistan's under-five mortality rate of 257 deaths per 1,000 live births (in 2008) was the third highest in the world, surpassed only by the rates for Angola and Sierra Leone. Most of these deaths occur because of the lack of access to basic medical care surrounding pregnancy. As opposed to the USA, where most childbirths occur in hospitals, Afghan women generally give birth at home, usually with another female or midwife attending. Given this situation, mobile ICT healthcare solutions that can be used in rural villages have a great impact on improving the lives of women and children. As mentioned above, Afghan women who arrive for medical imaging exams are typically accompanied by their husbands or other male family members. When our male Afghan colleague performed an ultrasound exam on a female, the patient's husband would hold up a sheet between the patient (his wife) and the doctor, and then the doctor would reach under the sheet with the ultrasound probe to perform the exam. While workable, the lack of visibility is not ideal.

## Looking Past Simple Medical Equipment Donation

Unlike US hospitals, any equipment donated to an Afghan hospital becomes the responsibility of an individual rather than the institution. That person will be held accountable for any damage that occurs to the equipment. Imagine that, as an employee, your boss assigned you personal financial responsibility for a million dollar CT machine given to the hospital as a gift. If someone broke it, you would be personally responsible for the cost of replacing it. Now also imagine your monthly salary is between US\$100 to US\$300.

That is pretty much the scenario for the hapless employees of Afghan hospitals assigned to care for the expensive equipment as it arrives. For that reason, it was not uncommon to see computer labs with a dozen workstations that were only open for an hour or two per week when the person tasked with their care was able to supervise their use personally.

Given this reality, approaches that allow clinicians to use their personal laptops or tablets to interface with a medical facility's ICT infrastructure are more practical and useful. That way, donors can give the solution directly to the physician, while giving the hospital the hardware and equipment – Wi-Fi<sup>1272</sup> routers, web servers, and switches – that can (should) be kept in a secure room with a reliable source of electricity and accessed wirelessly.

---

<sup>1271</sup> UNICEF. *The State of the World's Children, Special Edition*. Accessed October 5, 2015.

[http://www.unicef.org/rightsite/sowc/pdfs/statistics/SOWC\\_Spec\\_Ed\\_CRC\\_TABLE%201.%20BASIC%20INDICATOR\\_S\\_EN\\_111309.pdf](http://www.unicef.org/rightsite/sowc/pdfs/statistics/SOWC_Spec_Ed_CRC_TABLE%201.%20BASIC%20INDICATOR_S_EN_111309.pdf).

<sup>1272</sup> Wi-Fi is a local area wireless computer networking technology that employs radio waves to allow computers, mobile phones, and other devices to connect to the Internet and communicate with one another within a particular area without being physically connected.



*Picture 36: Unused donated anesthesia machine*

Another important consideration is how the setting and the needs of a rural clinic, hospital, or imaging center in Afghanistan differ from those in the USA. There are many examples of well-meaning organizations whose donated medical equipment has been left unused for a variety of reasons. Examples we encountered were an anesthesia machine that was given to a hospital without training or supplies (see [Picture 36](#)); critical care monitors for the intensive care unit (ICU) left turned off (and with dust covers on, no less) to prevent damage from power spikes; and a set of flexible colonoscopes with color Polaroid printers for a university hospital operating room that were unused due to a lack of training, anesthesia, printer supplies, and the lack of a suitable method for sterilization.

In the case of the ICU monitors, the power coming to the hospital from the local power grid was exceptionally unreliable, with regular spikes well above the rated voltage, which would cripple sensitive electronic equipment. For that reason, the staff of the hospital was reluctant even to plug in the ICU monitors except when there was a dire emergency, or when a visiting dignitary came through. The same occurred with most medical imaging equipment and computers.

In the case of the flexible colonoscopy system with video printer, although an exceedingly useful tool in the US and a generous contribution, the local hospital did not have the supporting surgical infrastructure and training to use the system safely, nor did it have a local source for the printer paper. Sterilization of the scopes was also a problem. The hospital had more fundamental needs, such as basic surgical equipment, like a reliable autoclave,<sup>1273</sup> adequate sterile drapes, surgical gloves, antiseptic, a functioning water heater, etc.

Typically, clinics operated by non-governmental organizations (NGOs) and hospitals had working sterilization equipment and autoclaves because they supported visiting doctors from other countries. However, in the Nangarhar Public and University Hospitals, it was common to see sterilization using whatever was available and functional. At the University Hospital, sterilization was done using a common pressure cooker sitting on a hot plate plugged into an outlet by stripping the ends of the wire and jamming them into the slots for the plug. The power grid fluctuations routinely damaged the regular autoclave equipment there.

Another basic problem was that sterile drapes, sponges, and towels were not generally available. On the shelf in the operating room (OR), the “sterilized” surgical kits were often wrapped in torn and blood-stained towels. Endoscopes use in these conditions presented an even greater risk because, if the bowel was punctured, there were generally inadequate antibiotics, surgical supplies, and intravenous (IV) fluids to perform the abdominal surgery needed to repair the rupture. Most of the doctors would have gladly traded the colonoscopy equipment for a basic autoclave. However, since local laws prohibited them from selling any equipment, it was left unused and taking up space in a closet.

Further challenges with equipment donations included getting equipment through customs and over poor roads. There were also numerous other Afghan transportation challenges, like reliability, weather, checkpoints, insurgent patrols, and layers of graft.

Medical waste disposal was also an ongoing problem. Several years earlier, in response to a report of medical waste being dumped directly outside the hospital in an open pit, the University Hospital received a brand new medical waste incinerator in a nice new building. When I asked why they continued to dispose of medical waste in an open pit, they informed me that while the incinerator worked, there was no budget for fuel to run the incinerator. The alternative was to dump the medical waste, and once every few weeks or so they would hire a local truck to pick it up and dump it somewhere outside of the city.

With some of these challenges in mind, the following section discusses using portable and mobile telephone-based solutions along with solar-powered technologies wherever possible to minimize the risk of equipment damage (not to mention employing power filters and surge protectors whenever possible).

---

<sup>1273</sup> An autoclave is a pressure chamber, similar to a pressure cooker, used to sterilize medical instruments and other equipment. It employs steam to kill germs, bacteria, and spores that boiling water does not. Autoclaves are standard equipment in Western medical facilities.

## Mobile Medical ICT

As discussed above, given the limited availability of transportation and power, Medweb focused on what ICT solutions for healthcare we could deliver using mobile phones, portable computers, local area networks (LANs), and access to the Internet. Because of our experience in country, we better understand the challenges the Afghans faced in establishing and using an electronic hospital record system using desktop computers when electrical power (even to hospitals with backup generators) was highly erratic. Ironically, the hospitals with backup generators did not have budgeted funds or another consistent money supply for diesel fuel to operate the generators.

In order to meet some of the challenges, while also recognizing the lack of suitable patient transportation, we decided first to focus on mobile healthcare applications (apps) that could be used in the community, thus negating the need for doctor or patient to travel. Two of the apps we developed for the local population are described briefly below and more fully in [Chapter 16, \*ICT in Healthcare: Lessons Learned from Eastern Afghanistan\*](#).

## Telephony Applications

### *IVR4BABY*

IVR4BABY is an interactive voice response (IVR) and dial-back system implemented in Pashto, Dari, and English. The application would call a registered patient's (pregnant mother's) mobile phone weekly and provide a short verbal message about the current stage of her pregnancy (based on her previously-provided estimated date of conception) and what the mother-to-be should expect as routine events for that week of her pregnancy. It also provided advice on diet and other things the mother should know or parameters to follow for a healthy pregnancy. IVR4BABY provided a contact number the mother (or caregiver) could call if she experienced a problem with her pregnancy. The server for this was developed to run on a Linux<sup>1274</sup> platform so that it could be used with a PC<sup>1275</sup> and connected to a cellular network using standard SIM<sup>1276</sup> card and Android mobile phone connected to the server via a USB<sup>1277</sup> cable. This app was fully developed and is available for free from Medweb. Scalable versions allow the use of multi-SIM USB interface boxes as a cost-effective way to interface to the local cellular network without setting up a full SS7<sup>1278</sup> interoperability platform to use the cellular provider's backbone signaling network.

---

<sup>1274</sup> Linux is a free and open source computer operating system.

<sup>1275</sup> Personal computer

<sup>1276</sup> Subscriber identity module, a removable smart card for some types of mobile phones that stores identifying information regarding the phone and associated customer account.

<sup>1277</sup> Universal serial bus, a standard for common port interfaces used to connect computer devices and equipment.

<sup>1278</sup> Signaling system number 7, an international standard or architecture for out-of-band signaling that defines how network elements in a public switched telephone network (PSTN) exchange information over a digital network.



## Midwives Connect

A second app, Midwives Connect, was developed for midwives that allowed them to report in on a daily basis to the Obstetrics Department at the Public Hospital about what births had occurred. It also provided a mechanism to allow the midwives to report if they encountered a woman with a difficult pregnancy. This capability was in addition to the basic process of equipping the midwives with mobile phones for simple verbal reporting. The reason for this was to try and maintain an ongoing relationship and communications with the midwives deployed in regional and rural areas, and to help further reduce maternal mortality. Previously, when midwives completed their training at the Public Hospital, they were expected to go return to their villages and regions to work. The midwives worked autonomously, with no follow up at all, no reporting capabilities to track activities, and no online capabilities for access to physical or subject matter expert (SME) support.

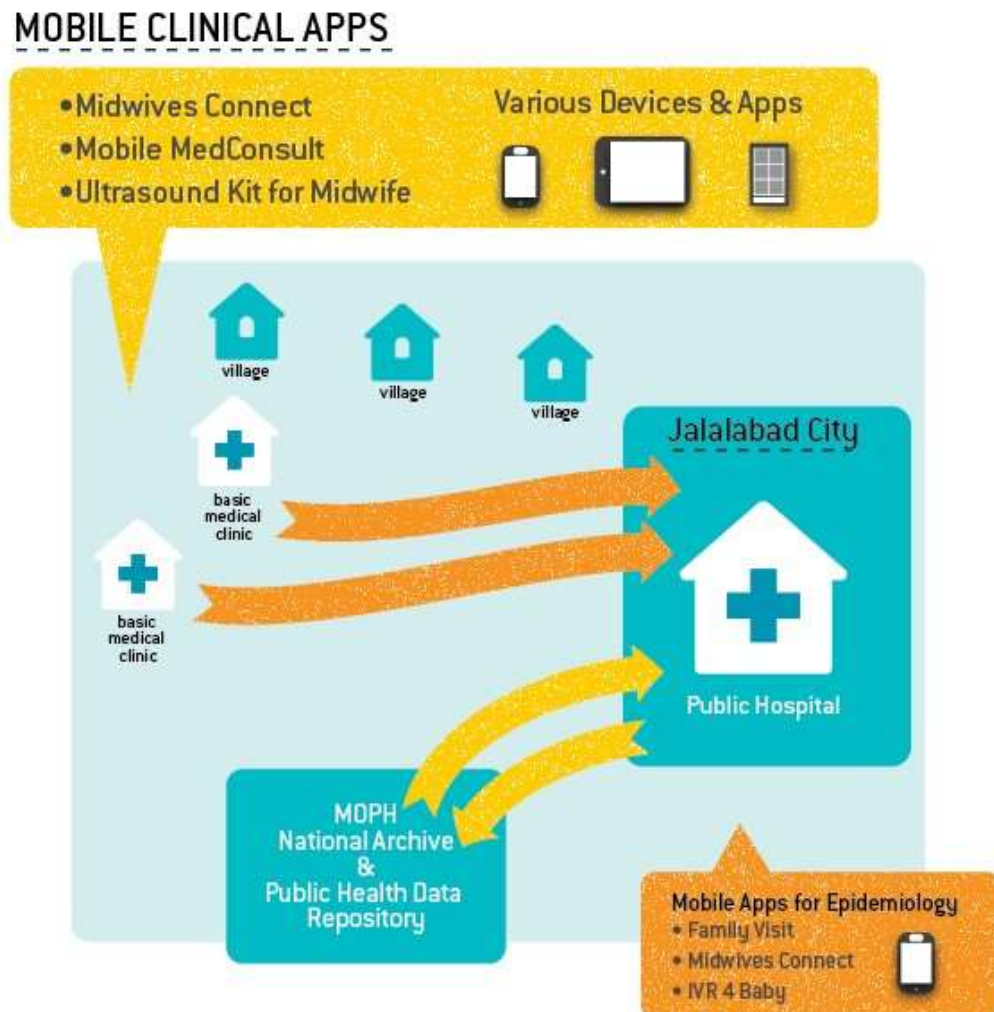

Figure 83: Medweb's mobile clinical applications and architecture

## 2G versus 3G

While the above apps were developed and used to some degree in Afghanistan, they were designed for 2G<sup>1279</sup> networks using basic feature phones because, when they were developed, 3G<sup>1280</sup> technology was not yet available except in limited parts of Kabul. The use of feature phones was also politically expedient, because in the early period of our work, people who had smartphones were assumed to be collaborating with Coalition forces and were threatened for such.



Picture 37: Examples of basic feature phones

Over the past several years, from March 2012 onwards, we began to see 3G network services in the larger cities, which expanded to rural areas over the ensuing years. 3G mobile broadband service opened up new opportunities to use smartphones to create a larger medical ICT infrastructure that extended into even the smallest villages.

## Hardware

### Portable Ultrasound



Picture 38: Low-cost portable ultrasound machine and laptop computer

Probably the most powerful and convenient diagnostic tool that can be used in the unpredictable environments of the developing world are portable ultrasound machines (see [Picture 38](#)). These devices can be used for prenatal evaluation, tumor locating, cardiac assessment, and evaluating blood flow in the carotids or limbs. They are inexpensive, transportable, and relatively easy to interpret and use. We combined a simple abdominal ultrasound (powered over a USB interface) with a laptop computer. In the future, a foldable solar panel could be added to keep the system charged in the absence of electricity. Medweb donated several portable ultrasound machines to hospitals in Jalalabad and Kabul.

Perinatal mortality is one of the greatest challenges in the developing world. While the numbers vary slightly, approximately 20 percent of pregnancies will result in death.<sup>1281</sup> Many such outcomes can easily be prevented with the proper diagnostic tools to detect

---

<sup>1279</sup> Second-generation wireless digital technology, which replaced first-generation analog systems.

<sup>1280</sup> Third-generation wireless digital technology based on International Telecommunication Union (ITU) International Mobile Telecommunications (IMT)-2000 specifications.

<sup>1281</sup> According to *Wikipedia*, perinatal mortality rates “vary widely and may be below 10 [percent] for certain developed countries and more than 10 times higher in developing countries. The [World Health Organization] has

complications, like breach delivery or other issues, before they become critical. Having a clinician or midwife perform a prenatal ultrasound exam can have a remarkably positive impact on perinatal survival rates.

### *Handheld Telemedicine Kit*

Another useful tool for rural environments and small clinics is a handheld telemedicine kit like Medweb's in [Picture 39](#). There are several versions of these kits that we customized for different types of care. For example, the Obstetrics (OB) Kit might include a portable ultrasound, fetal monitor, glucometer, etc., while a Cardiac Kit would include an EKG,<sup>1282</sup> stethoscope, blood pressure monitor, weight scale, and pulse oximeter. The kit in the photo is more of a general purpose kit that includes a mix of these tools, including an ultrasound, EKG, pulse oximeter, ophthalmoscope, otoscope, dermoscope, general exam camera, and glucometer.



Picture 39: Medweb handheld telemedicine kit

### *Vitals Plus Kit*

Medweb's Vitals Plus Kit uses a smartphone tool to bring in data from diagnostic devices, such as those mentioned above, into a centralized server and medical record, or to submit a consultation request to a

---

not published contemporary data. "Perinatal mortality." Last modified September 6, 2016.  
[https://en.wikipedia.org/wiki/Perinatal\\_mortality](https://en.wikipedia.org/wiki/Perinatal_mortality).

<sup>1282</sup> Electrocardiogram, a test of the function of the heart.

clinician. The smartphone app connects to a variety of inexpensive wireless devices. Examples are listed below, along with their method of connecting (Bluetooth, wireless, or infrared).

- Pulse OX Fingertip pulse oximeter (Bluetooth)
  - Ihealthlabs (Fingertip oxygen sensor for phones)
  - Nonin (Fingertip oxygen sensor for computers)
- Blood pressure cuff (Bluetooth)
  - Ihealthlabs (Wireless battery-powered blood pressure cuff)
- Weight scale (Bluetooth)
  - Ihealthlabs (Wireless battery-powered weight scale)
- Temperature (Infrared)
  - Welch Allyn Caretemp non-contact forehead thermometer
  - Extech IR200 non-contact forehead infrared thermometer

## Software

Medweb employed open-source software or other freely available software applications to store, distribute, and display (non-sensitive) medical data and to communicate with medical personnel and other stakeholders, such as the programs listed below.

### *FrontlineSMS.com*

[Frontline](#) created a structured menu system that can be used to do medical reporting via SMS (short messaging service), or texting. The software collects SMS messages and organizes them into a web-based user interface that can be used to track and respond to requests from nurses or clinicians who are linked only with smartphones.

### *Ushahidi.com*

[Ushahidi](#) is a geography-based collaboration and social networking tool for data collection and visualization. The Ushahidi information management platform allows one to collect information easily via text messages, email, Twitter, and web forms and then display it in a map format. However, the “CrisisNet” portion of this platform is designed for disaster response and has been enhanced to address the needs of medical response by several vendors including Medweb. Ushahidi is distributed at no cost. Following are some useful components of Ushahidi.

- Crowdmapper allows teams to collaborate in real time around geo-located information, building maps together.
- SMSsync creates a two-way SMS gateway with an Android phone and a local SIM anywhere in the world.
- CrisisNET finds, formats, and exposes crisis data in a simple, intuitive structure that’s accessible anywhere.

## Imaging Center and Clinic ICT

Following is a list of the specific challenges encountered when setting up ICT resources for an imaging center in Jalalabad. The issues are illustrative of what one would need for a clinic or hospital as well. The imaging center added another wrinkle because of the power requirements for the CT scanner.

### Infrastructure Assessment

First we created a list of what resources were already there and they were configured. In the case of the imaging center, we looked at power, security, communications, and existing ICT equipment.

#### Power

The clinic received power from two sources: it had a connection to city power, which was very irregular, and it also had two generators on the roof of the building. One was an old 110-volt (V), 5 kilowatt (KW) generator, and the second was a much larger 220V generator that appeared to be less than ten years old. Both generators ran on diesel fuel and were started manually when needed.

Lighting and fans were run using city power, and the generators were only started when the CT scanner,



*Picture 40: Homemade power conditioner and uninterruptible power supply for an ultrasound machine and clinical computers*

ultrasound, or x-ray machines were needed, after which they would be turned off to conserve fuel. Computers, and to some extent the ultrasound machine, were operated from city power most of the time, with a rather ingenious home-grown uninterruptible power supply (UPS) and power conditioner system (see [Picture 40](#)). As the first phase, a power conditioner connected sequentially to a battery charger for a bank of car batteries, and from there to an inverter which provided 110V AC<sup>1283</sup> to the ultrasound machine and the physician's desktop computer.

This arrangement, while clever and resourceful, suffered from two issues:

the city power would routinely go out for hours at a time and would often fluctuate from 70 volts to 400+ volts throughout the day. This type of power fluctuation would cause the power supply of any computer system to fail. Indeed, over the course of several years of working with the imaging center, we saw them

---

<sup>1283</sup> Alternating current, where the flow of electricity periodically reverses direction, as opposed to direct current (DC), in which power flows in only one direction.

replace power supplies for the CT as well as get a new ultrasound machine after it was also damaged (despite the elaborate power conditioner system).

The second issue was the lack of fuel for the generator. Fuel was expensive and frequently in limited quantity, which led to the clinic to take risks. The clinic would sometimes run its medical equipment on city power when it lacked fuel but had an urgent case. Besides the lack of fuel, sometimes generator maintenance was an issue, since replacement and spare parts were also in short supply. [Picture 41](#) is another example of Afghan ingenuity: they kept a generator cool using a fan, garden hose, salad bowl, and a brick to help the leaky radiator maintain the engine temperature.



*Picture 41: An example of Afghan ingenuity*

## Solar Power

Solar power, in the form of readily available photovoltaic panels, has begun to show up in local Afghan markets (see [Picture 42](#)). Several different quality and price levels are available, imported from China and other countries. Prices run the gamut and are relative to their likely reliability based on manufacturer. Solar charge controllers available in the market in Jalalabad were of the older variety and were not adequate to handle the needs of an imaging center. The important point is that solar power is rapidly being deployed and adopted as an alternative to electricity, an acceptable and viable one at that.

## *Internet Access/Internet Services*

There was no Internet connection to the clinic when we first visited, and the only method for publishing output from the CT and ultrasound machines was to push video to a film printer, which printed the images onto conventional x-ray films. This type of set up preceded digital imaging systems and was a transition technology from traditional x-ray film.



*Picture 42: Solar panel store in Jalalabad*

We worked with Afghan Telecom Corporation (AfTel), Rotary International, and a local wireless Internet service provider (WISP) to establish a 256 Kbps<sup>1284</sup> link to the clinic using inexpensive WiMAX<sup>1285</sup> connectivity. All of these facilities shared a 2 Mbps<sup>1286</sup> microwave connection back to AfTel in Kabul. The connection worked well at certain times of the day, but was subject to massive over-subscription at other times. There were no controls to prioritize bandwidth by use or a “fair access policy” algorithm to restrict bandwidth access. Also, when school was in session at the university, the link would routinely be saturated with student-generated traffic during the day.

Volunteer Rotarian doctors in San Diego, California (truly amazing people) had agreed to assist their Afghan colleagues with reading complex cases and sending their interpretations back to the Afghan radiologist.

---

<sup>1284</sup> Kilobits per second, a measure of data transfer rates.

<sup>1285</sup> Worldwide Interoperability for Microwave Access, a family of wireless communications standards that enables the delivery of last-mile wireless broadband Internet service.

<sup>1286</sup> Megabits per second, a measure of data transfer rates.

We took advantage of the “time-of-day caching” feature in the Medweb server to hold medical imaging studies until the evening before sending them to a server in New York and onto the radiologists in San Diego. The radiologists in California would then submit their reading results back to Medweb, and we would upload them to the clinic’s Medweb server in Jalalabad before the next working day.

## Internet Issues to Consider

There are several important considerations when deciding what type of Internet connection to use and how to structure it that differ from conventional Internet connections in the USA. In Jalalabad, the Rotarians provided an Internet network through a local Internet service provider (ISP) that connected medical and educational facilities to each other directly on the same regional WiMAX network, which then connected to Afghan Telecom. Before that, Internet service in the area was most commonly delivered through multiple satellite Internet connections.

### *Satellite versus Terrestrial*

Due to the initial lack of ICT infrastructure, Internet connections to medical facilities, the university, clinics, hospitals, businesses, and guesthouses in Jalalabad were mostly over KU-band or C-band satellite links. These links came from a variety of providers around the globe. Our guesthouse had Internet service from a commercial satellite ISP in the United Kingdom. One of the hospitals was connected via satellite to a provider in Pakistan, and another medical facility connected via satellite to a provider in Dubai.

Using satellite-based Internet service adds tens of thousands of miles the data has to travel to arrive at its intended destination. This distance adds significant delays – up to several seconds to send a packet of data – referred to as latency. However, even more problematic, when sending data packets using the standard Internet TCP/IP<sup>1287</sup> protocol for typical file transfer, every packet of data requires an acknowledgement packet to be returned. Normally these packets are returned in a few thousandths of a second. However, latency can increase to several seconds over a single-hop satellite connection, slowing transmission speeds down even more.

In scenario described above, where the facilities involved are using satellite-based Internet service from multiple providers, sending an x-ray from the imaging center to the hospital half a mile away could add a delay of several seconds per packet. The data bounces from the roof antenna of the imaging center to a satellite in space to an earth station in Dubai. It then travels over terrestrial optical fiber to a satellite hub in Pakistan. It again bounces off a (different) satellite to arrive at the antenna at the hospital! Since the typical approach to file transfer is a serial stream,<sup>1288</sup> this convoluted route delays the file transfer by many hours, regardless of the available bandwidth on the link. For example, a 3 Mbps connection may “max out” at an effective file transfer rate of just 200 Kbps rate simply because the mechanism for sending the file is delayed waiting for acknowledgement packets.

---

<sup>1287</sup> Transmission Control Protocol/Internet Protocol, a set of rules governing communications and how devices connect on the Internet or within private networks.

<sup>1288</sup> In a serial data stream, data bits are transmitted over a communication channel one at a time sequentially.



In order to compensate for this type of delay, the ICT medical imaging and telemedicine appliance we used had a combination of several technologies designed to overcome the inherent delay.

- First, the medical ICT appliance compresses the medical imaging files to be transferred using lossy<sup>1289</sup> JPEG 2000<sup>1290</sup> compression to achieve ratios typically of 20:1 compression. The compression varied depending on quality metrics for the type of medical modality.
- Second, it increases the size of the standard TCP/IP data transfer packet by ten-fold, thus reducing the number of required acknowledgement packets.
- Third, it broke up the data into parallel streams to better utilize the available bandwidth, which was otherwise mitigated by acknowledgement packet delay.
- Fourth, it used a technology referred to as packet error probability (PEP), or forward error correction (FEC), for error correction. The simplest implementation of this converts the data packet stream to a serial push without acknowledgement packets. Then, at the other end of the satellite link, the serial stream is converted back into a conventional packet architecture when delivered to the receiving computer. (Equipment manufacturers often build this last component into satellite modems, and the effectiveness varies greatly by brand.)

The Medweb appliance used in our clinic combines these technologies into a single software module called a Venturi Accelerator. It allows much greater speeds in the delivery of medical data than can be achieved using just a conventional satellite PEP/FEC modem, or a raw satellite link by itself. In my experience, it is always better to use the hardware PEP/FEC function of the satellite modem, combined with the other technologies of the Venturi Accelerator, to achieve optimum performance. Of course, the preferred approach for local Internet traffic – as in traveling across the city from the imaging center to the hospital in Jalalabad – is to have both facilities use the same local Internet service provider. Another idea is to establish a peering point, or local Internet exchange point (IXP), where ISPs can physically connect to each other to exchange traffic, thereby avoiding having to route local traffic over satellite links.

Conquest and Osiris picture archiving and communication system (PACS), described below, are designed only to operate on a conventional TCP/IP LAN, so they are less effective for this type of imaging transfer.

### *Wired versus Wireless*

A wireless Internet service provider (WISP) is just that – it provides non-terrestrial Internet access through the air. While large WISPs typically use microwave towers and technologies, the advent of extremely low-

---

<sup>1289</sup> Lossy, versus lossless, compression permanently deletes certain information, particularly redundant or unnecessary information (like white space), from a file so as to reduce its size before transmission. With lossy compression, when the file is uncompressed only some but not all of the original data remains, though it is likely unnoticeable to the receiver of the data. With lossless compression, all data remains and can be recovered while a file is uncompressed.

<sup>1290</sup> A state-of-the-art image compression technique and coding system using wavelet technology developed by the Joint Photographic Experts Group in the year 2000 to supersede the original standard from 1992.

cost, high-speed modems using WiMAX, a variant from conventional 802.11b<sup>1291</sup> wireless routers and access points, has allowed ISPs to install wireless links that work up to a distance of 30 miles per hop with ease. In our case, the Rotarian-sponsored Internet network was implemented using this type of wireless architecture to achieve the connections among the hospital, imaging center, and university facilities. This configuration provided a fast and inexpensive local network that completely eliminated the latency issues suffered with satellite Internet connections.

However, there is another issue that must also be considered when using WiMAX technology. WiMAX Internet routers, just like wireless Internet access points, typically use the 2.4 GHz<sup>1292</sup> and 5 GHz frequency bands to communicate. Unfortunately, many mobile network operators use several bands in those same frequency ranges. I noticed that the hospitals, which were located on the main road through Jalalabad, would experience network outages every time a military or United Nations convoy passed. Improvised explosive device (IED) jammers mounted on the vehicles in the convoys caused the outages. The IED jammers are designed to interfere with cellular signals on certain frequencies to prevent terrorists from setting off roadside IEDs via mobile phone as the convoy passes. The outages increased in frequency as more NGO organizations, taxis, and others employed IED jamming capabilities on their vehicles.

## Selecting a Medical ICT Infrastructure

To meet the basic needs of the imaging center, we elected to install Internet access, a basic firewall, Wi-Fi, and then we used Ethernet<sup>1293</sup> (wired) cable to connect the various medical imaging devices.

### *IP Firewall*

We used a basic IP router as a simple Wi-Fi firewall router. The external interface had a public IP address, and the internal interface was set up to do network address translation (NAT) and port forwarding for only the external interface of the Medweb server. This configuration allowed the medical imaging devices to stay inside the protected private network, with only the SSL-encrypted<sup>1294</sup> web interface of the Medweb server facing the public Internet. We used an off-the-shelf US\$99 router from a local electronics store in Jalalabad.

If you are pre-staging equipment, another option worth considering is to use a combination of [Ubiquiti Networks'](#) (UBNT's) NanoBridge or PowerBeam hardware, with a copy of [Untangle](#) running on a Linux computer. Untangle is a free unified threat management (UTM) system for Internet networks. Untangle's Bandwidth Control software product provides tools to manage bandwidth consumption on a network better, including controlling and visualizing the use of the network at a fine-grained level. Bandwidth

---

<sup>1291</sup> An Institute of Electrical and Electronics Engineers (IEEE) wireless networking specification. An amendment to 802.11, 802.11b allows throughput up to 11 Mbps in the 2.4 GHz band.

<sup>1292</sup> Gigahertz

<sup>1293</sup> Ethernet is a brand name for a family of computer networking technologies, originally based on the IEEE 802.3 standard, generally used in local, wide, and metropolitan area networks (LANs, WANs, and MANs).

<sup>1294</sup> Secure socket layer, the standard security technology for establishing an encrypted link between a web server and a browser, ensuring data passing over the link is secure and private.

Control delivers increased network visibility and management and allows for the prioritization of web traffic to business-critical services while deprioritizing tasks such as Dropbox or Windows Update. Bandwidth Control can even penalize torrent downloaders.

Another of Untangle's software products, Next Generation (NG) Firewall Free, is a basic UTM that combines all of Untangle's free applications with its NG Firewall platform. It can also be used for web filtering, virus blocking, spam blocking, and network performance management. In fact, one could probably load Untangle onto the Medweb PACS/telemedicine appliance. Doing so would solve many of the virus and other problems that we encountered as detailed later in this chapter.

### *Medical Imaging Devices and Electronic Medical Records*

The CT scanner we used was a single-slice CT with a proprietary analog coaxial video output and separate sync cable, as was the ultrasound machine. (As comparison, contemporary CT scanners provide a digital output over Ethernet.) The x-ray machine had no digital or video sensor and relied on plain x-ray film processing. Therefore, we needed to convert the analog video output of the machines to a DICOM<sup>1295</sup> 3.0-compliant network interface and then provide a telemedicine/teleradiology appliance that could provide a digital archive, encryption, routing, display, and reporting. We elected to use a [Medweb](#) Unified Teleradiology and Telemedicine appliance to achieve this task, along with a [TIMS Medical](#) analog video-to-digital DICOM converter.

### CT and Ultrasound Connectivity

The CT and ultrasound machine we found at the clinic were extremely old but were the best equipment available in the area at the time. To capture the images from them, we used an automated video capture box from [Foresight Imaging](#). The box, a TIMS, is a very nice device for handling the complex and proprietary video frequency and resolutions that are typical of medical devices. Unlike the world of television, which until recently was limited to NTSC and PAL<sup>1296</sup> standards, the medical imaging industry evolved many different video delivery protocols.

The TIMS box has an automated software tool that can analyze the incoming video signal and automatically configure itself to perfectly capture the video information as still images or MPEG<sup>1297</sup> movies. It then can deliver that information formatted as a DICOM study to the Medweb PACS/telemedicine appliance, or to any DICOM destination. Foresight Imaging's TIMS 2000 video and image capture system allows the capture of DICOM images and video from any computer screen and sends them to PACS or a DICOM CD/DVD.<sup>1298</sup>

---

<sup>1295</sup> Digital Imaging and Communications in Medicine, the global standard for transmitting medical imaging over any type of IP LAN.

<sup>1296</sup> National Television System Committee and Phase Alternating Line (PAL), two color encoding systems for video delivery in analog television broadcasting.

<sup>1297</sup> A video file format often used for creating videos and movies distributed over the Internet, named after the Moving Picture Experts Group, which developed it.

<sup>1298</sup> Compact disc/digital versatile (or video) disc, both optical disc storage formats.

It is worth mentioning the video delivery protocol was developed for use in intramural networks, and so the Medweb appliance encrypted and compressed the image data when sending between devices over a wide area network. Encryption and compression are other functions of the appliance that we used to deliver images to a server in the USA so that radiologists in San Diego could review the studies.

To capture the video from the CT scanner, we also used a powered video splitter device. It allowed us to take a secondary video feed from the CT scanner without changing the amplitude of the video, which would have changed the quality of the image coming out of the printer. The video splitter maintained the video amplitude and quality without requiring us to make changes to the settings of the other devices. We also added a momentary push-button foot pedal next to the CT scanner console, which was used to capture the video frames the CT technician selected on the console. The trigger signal, along with the video, were brought back to the TIMS box and connected to the trigger and coax video inputs.

We did the same thing with the analog ultrasound machine used by the physician. By automatically configuring the inputs to support the respective proprietary video feeds, we were able to get the images into the TIMS. The TIMS uses the Windows operating system, and the application allows one to enter patient name and demographic data at the start of each study, capturing images until the series is complete, and labeling each group of images into their respective series before sending the study to the PACS/Telemedicine Server. From there we delivered the images to a web interface on the server, and also sent a copy of every study to a remotely-hosted Medweb server in the USA so that volunteer Rotarian doctors could easily access the studies and work with their Afghan colleagues as noted above.

### **PACS and Telemedicine: Using a Unified Healthcare ICT Appliance**

The Medweb Linux-based PACS (picture archiving and communication system) and Telemedicine appliance combine a number of components: a basic firewall, a PACS, a digital storage archive for images, reports, as well as email, a web-based clinical user interface with integrated radiology viewer, and VPN<sup>1299</sup> software. The server appliance also had a mail server, DNS, patient registration, electronic health record, and radiology information system, all of which we elected not to use because they were overly complex for the working environment. The physician was happy with his paper accounting system and was primarily interested in the ability to transmit his images to colleagues in San Diego.

Having all these capabilities in one server greatly simplified the time and effort for installation as well as the maintenance required to keep it running. Typical USA-based imaging centers might spread this sort of technology over a dozen different servers and vendors. A key part of our successful strategy was to place a local webserver in the clinic that provided all of the interactive routing, collection, display, and archiving of all medical imaging, as well as other clinical services, teleconsultation, scheduling, and patient

---

<sup>1299</sup> Virtual private network, a collection of encryption technologies and security mechanisms that allow authorized users to communicate securely in their own sub-network (such as a company's internal network) over the Internet or another public network.

registration. This configuration means the webserver can (should) be in a locked room with suitable UPS, environmental controls, and reliable power.

The server appliance was also designed to work in warm failover pairs, so that if any hardware component fails, the secondary server will take over where the primary left off at the same IP address. This redundancy leaves the facility fully functional and provides a service window for remote repair or installation of a replacement appliance with no down time. We connected the server to both the private wired clinic network, as well as a Wi-Fi router. The Medweb server also has a full stateful inspection firewall that safeguards the local devices from the larger Internet. The external interface was set up to face the public Internet connection. Setting up this firewalled appliance protected the other sensitive medical devices and computers substantially from hacking. Here are some of the features of the Medweb PACS/Telemedicine webserver appliance:

- Combines functions of a medical image server;
- Accepts DICOM imaging from multiple devices;
- Provides detailed visualization tools including MPR, MIP, 3D<sup>1300</sup> views, automatic segmentation, and virtual fly through;
- Supports input of EKG with interpretation;
- Offers a radiology information system to track and provide patient registration, exams, procedure codes, and reporting;
- Supports telemedicine workflow and structured telemedicine consultations;
- Has an integrated web videoconferencing server;
- Has an integrated streaming device server;
- Has a shared radiology viewer, allowing over-the-shoulder radiology consultations;
- Generates statistics, reports, and links to wide area networks with a sophisticated bandwidth saving communications protocol that includes application-layer priority for stat exams over conventional imaging; and
- Has time-of-day routing, compression, encryption, and forward error detection.

Medweb's solutions are an example of how to implement these various technologies in a universal health ICT architecture that can be remotely managed. As a company, Medweb, has a generous philanthropic program dedicated to improving healthcare around the world, so it provides its Universal Health ICT Server Appliance at a reduced cost, or even free, depending on a user's resources.

## PACS and FOSS

As comparison, another route we could have taken would have been to supply just the PACS system, which could then be integrated with any of several free and open source (FOSS) software packages. Both [OsiriX](#) PACS and [Conquest](#) PACS are freeware picture archiving and communications systems that accept

---

<sup>1300</sup> Multi-planar reformat, maximum-intensity projection, and three-dimensional, respectively, three common reformation techniques used in tomographic imaging.

DICOM from multiple devices, provide detailed visualization tools including MPR, MIP, 3D views, and automatic segmentation; and archive studies to a storage device.

### *Patient Records Management, Film Management, and Reporting*

Patient registration in Afghanistan currently consists of a bound, paper logbook into which a clinician records (handwrites) a patient's name, referring doctor, the required procedure, along with payment information and status (see [Picture 43](#)).

The existing IT infrastructure at the imaging center consisted of a single computer the physician used to generate and print reports he gave to patients after their exams, along with the films so they could give them to the referring doctors. The doctor kept digital copies of the reports on the computer. However, there was no backup system for the hard disk, leaving the stored reports vulnerable.

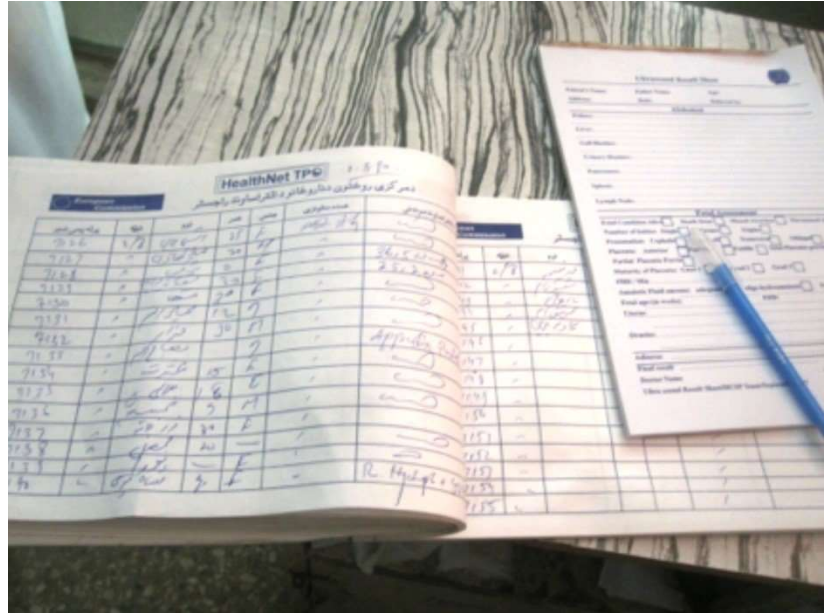

*Picture 43: Afghan manual patient record system*

There was no electronic medical record (EMR) system or billing system, and no method for electronically capturing, storing, or displaying the medical images or laboratory results. This problem is not unique to imaging centers, but is a general approach to administrative operation across all the medical institutions that I visited in Afghanistan. The exception was ACOMET Family Hospital in Kabul, which used an EMR system from England.

There is a basic medical clinic administrative workflow built into the Medweb server that could have been used for this purpose. However, the clinician was content with the existing system and did not see a need to complicate further the workflow or accounting mechanism.

If we were to have installed an EMR system, we could have used a Medweb server and Telemedicine Infrastructure Clinic for Treatment of Ambulatory patients (TICTAC) program which is actually written as a basic triage clinic, but includes features such as:

- Patient registration;
- Consumables tracking;
- Device integration;
- Interactive training;
- Clinical monitoring;
- Medication tracking and management;
- Computerized provider order entry (CPOE); and
- Triage records and transport tracking;
- Resource management.

Other FOSS options for EMR include:

- [OpenEMR](#), a FOSS electronic health records and medical practice management application that runs on Windows, Linux, and Mac OS X.
- [OpenClinic GA](#), an open source clinic workflow architecture and integrated hospital information system for low resource environments. It was developed at the University of Brussels and is used in Sub-Saharan Africa.
- [GNUHealth](#), a portal of medical workflow apps that fall under the GNU General Public License.<sup>1301</sup>

Another free product, Vesuvius from [Sahana Software Foundation](#), can also handle hospital triage management. Vesuvius provides tools to assist in local and remote hospital triage management, including photo capture and electronic notifications of patient intake records to hospitals and the person locator registry.

While these solutions work on regular PCs running Linux or Windows, they require their own setup, configuration, and maintenance, and they do not include many of the other functional components that would be required to bring a clinic online.

Following is a diagram (see [Figure 84](#)) that shows how we configured the resultant system at the imaging center in Jalalabad.

## Additional Freeware and Medical Information Resources

Below are some additional freeware and medical information resources.

[Medical Free/Libre and Open Source Software](#) (MedFLOSS) is an organization that lists some 300+ FOSS healthcare software projects of various stages of completion and implementation that can be used to radically lower costs and increase adoption of ICT for healthcare solutions in low-resource settings around the world.

There is a host of online medical resources, not the least of which are [PubMed](#)<sup>1302</sup> and MEDLINE.<sup>1303</sup> These online resources are often free for developing countries like Afghanistan. There are also online medical school curricula available, which are developed by larger medical institutions, typically in Europe and North America. The Afghan Ministry of Public Health (MoPH) compiled a novel set of medical books and

---

<sup>1301</sup> A free software license that guarantees its users the right to run, study, share, and modify the software.

<sup>1302</sup> Published by the US National Center for Biotechnology Information at the US National Library of Medicine, part of the National Institutes of Health. Accessed January 8, 2016. <http://www.ncbi.nlm.nih.gov/pubmed>.

<sup>1303</sup> MEDLINE is a component of PubMed and is an expansive indexed database at the US National Library of Medicine containing life sciences journal articles with a concentration on biomedicine.

lectures in Pashto and Dari and put them on CDs and DVDs, which the MoPH distributed to all medical students in Afghanistan during one of my visits to Jalalabad.

## IMAGING CENTER

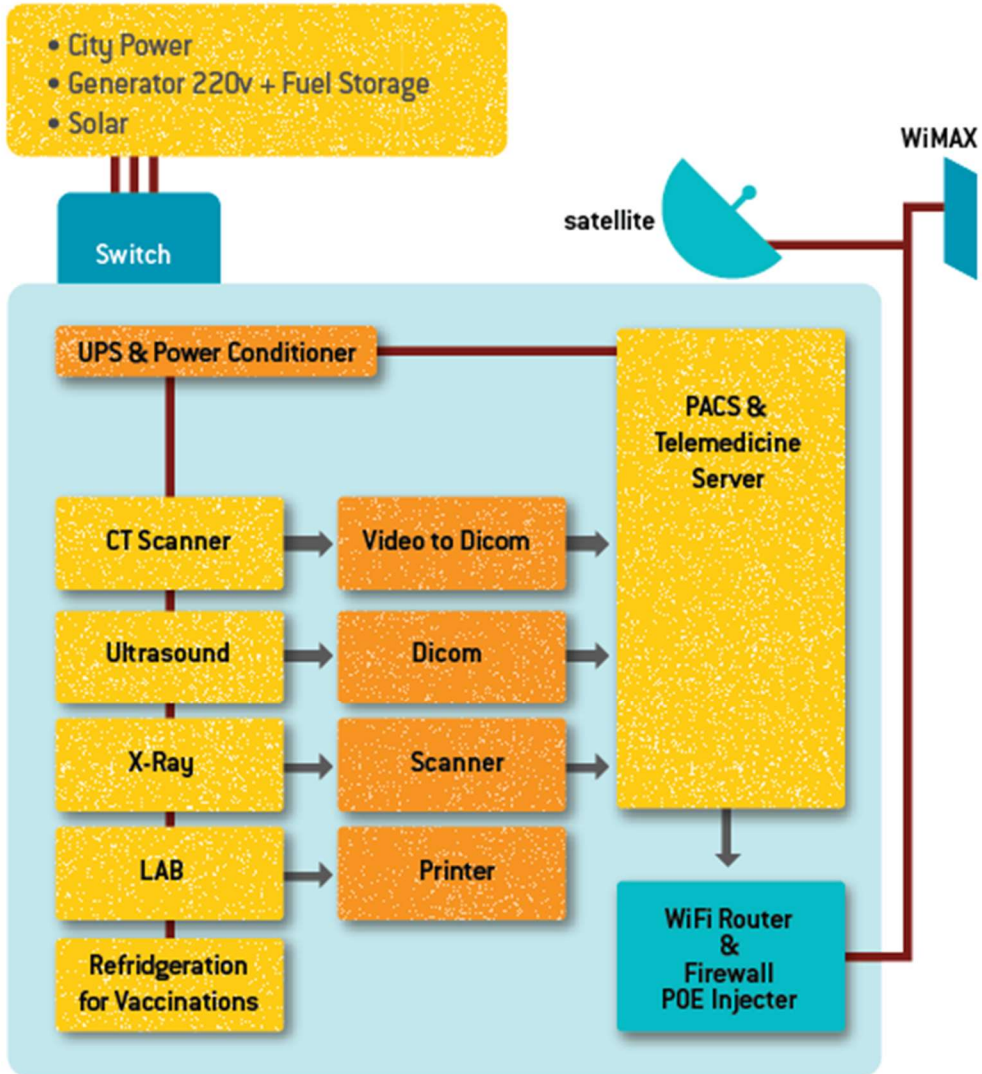

Figure 84: Imaging center equipment and ICT configuration

### Mobile Solutions

There is a rapidly-expanding list of mobile medical record resources that utilize smartphones and tablets. However, in Eastern Afghanistan, smartphones were not very common, especially before the introduction



of 3G mobile broadband services in March 2012, which took a while to expand to rural areas. Therefore, mobile apps were, for the most part, limited 2.5G<sup>1304</sup> technology on feature phones.

### *Using a Remote Hosted Server for Consultations and Optimized Bandwidth Utilization*

When we initially set up the server at the clinic in Jalalabad, we were able to access the server remotely through the Internet. However, the browser interface download speed from Afghanistan to California was very slow and tedious. US radiologists expect as standard that any electronic PACS or DICOM server should display a radiology study within two seconds of clicking the study request link in the user interface. (This standard requirement was first developed by the US Army and spread rapidly across the commercial marketplace.) US doctors are also accustomed to fast and reliable Internet connections. To accommodate their expectations, we placed another server in the US, and we configured the server in Jalalabad to do a timed forwarding of studies in the middle of the night when Internet usage was minimal on the shared Jalalabad Rotary network.

With the addition of the second server in the US, the studies always appeared instantaneously in the US radiologists' browsers, and they were able to do their over-reads very efficiently. The doctors dictated their reports, which then uploaded automatically from their PCs to the US-based server. From there, the reports would traverse cyberspace back to the server in Jalalabad for review by their Afghan colleagues.

This type of remote hosting provides several advantages. Besides (perceived) speed and efficiency, it also provided a backup archive of patient data for the clinician in Afghanistan. The power and highly-variable congestion of the oversubscribed Internet links in Afghanistan made reliable access to the server much more problematic. By transferring studies in off hours, we were able to meet the performance requirements needed to keep the radiologists engaged on both sides of the network connection. The two-server system described above has been in use since 2011. Since that time, we have replaced the server in Jalalabad once due to damage caused by power surges.

## Overview of ICT Standards for Healthcare

The world of healthcare comprises individual treatment, but the success of individual treatment benefits greatly from the analysis of population health and the ability to share successful methodologies across the medical community. That requires the establishment of standardized nomenclature to describe disease, tests, and treatments as implemented, and then systems that provide simple and intelligible methods for the sharing of that information across languages and communities. Various international standards bodies around the world have done considerable work in this area. Some of the most prominent are:

- The National Electronic Manufacturers Association (NEMA);

---

<sup>1304</sup> Second-and-a-half generation wireless digital technology between 2G and 3G, reflecting the addition of packet-switching (to circuit-switching), generally associated with general packet radio service (GPRS) data service.

- The Healthcare Information and Management Systems Society (HIMSS), which created the international Health Level 7 (HL7) set of standards;
- The Integrating the Healthcare Enterprise (IHE) standards;
- The Personal Connected Health Association (PCHA);
- Continua, the standards organization for connected medical devices; and
- The American College of Radiology (ACR), which created the DICOM standard.

Following are brief descriptions of some of those standards.

[Health Level 7 \(HL7\) International](#) provides a standard messaging and workflow protocol and language that offers standardized text messages, orders, reports, lab results, billing, and procedure messages and communications among all information systems in a hospital setting.

[Fast Healthcare Interoperability Resources](#) (FHIR) is a next-generation standards framework created by HL7 that improves on HL7 while creating a common structure for mobile devices and connected health devices in the community.

[Digital Imaging and Communications in Medicine](#) (DICOM) is a standard for the acquisition, transmission, storage, and display of all imaging, waveform, and non-text messaging and results that are part of that system.

[Integrating the Healthcare Enterprise](#) (IHE) takes a variety of healthcare communication standards like Oasis, HL7, and DICOM and defines how each of them is used to complete all the tasks of a particular functional role in the hospital or among hospitals, clinics, and providers. These functional workflows or pathways are called actors.

[Cross-Enterprise Document Sharing](#) (XDS) is an extension of IHE that incorporates messages between unrelated hospitals, clinics, or healthcare providers in a manner that guarantees the unique identification of patient data despite variations in medical record number or identification of the same patient when s/he is treated at multiple facilities.

## Lessons Learned

Based on our experience providing a selection of fixed and mobile ICT for healthcare solutions for medical facilities in Eastern Afghanistan, we offer the following lessons learned.

1. Power is unreliable, and fuel for generators is expensive, so it is best to design ICT systems to run on solar panels, which can be mounted inconspicuously on the roof of the facility. Solar power should be used only for essential servers and communications gear, whether satellite, WiMAX, or wired.
2. Local societal and customs and religious beliefs preclude women from easily reaching medical care (at least in Afghanistan), so outreach is a very important part of any health initiative. For this reason, strongly consider using mobile applications wherever possible.
3. Wireless networks are a critical component of a successful implementation in a hospital clinic or imaging center. They allow the clinician to carry a laptop, tablet, or smartphone, which s/he can use to access the servers that used for labs, imaging, telemedicine, and hospital administration

and workflow. This inexpensive approach, combined with solar-powered server systems, makes for a stable and sustainable system.

4. Wireless networks, while the easiest and most effective way to deploy ICT for healthcare, are also the most vulnerable, as most are at 2.4 GHz and operate at the same frequency as the IED jamming devices used on passing convoys. If possible, it may be useful to consider a hard-wired Ethernet network for critical components like medical imaging device networks. Wi-Fi networks can also operate at 5 GHz, which might be worth trying since that is a shorter wavelength (than 2.4 GHz) and, therefore, travels less distance. We did not get to try this in Afghanistan, so further research would have to be done to see if that would be a workable frequency, or if it would also be affected by IED jamming devices.
5. Mobile ultrasound machines with a laptop and solar charger can be very effective and inexpensive with profound positive results for pregnant women's health and that of their unborn babies.
6. The use of an integrated appliance for telemedicine, teleradiology, unified threat management, video conferencing, and electronic medical records greatly simplified the speed and ease of setting up a telemedicine network, while reducing the cost and infrastructure burden as well as the need for IT staff at the hospital.
7. Equipment donation is not assistance. The public hospitals have a requirement to keep track of all equipment delivered and keep it on the premises of the hospital for auditing purposes. We saw equipment that was lying idle because there were either no instructions for use or no training, no supply chain or budget to provide whatever consumables the machine needed, or the device was too fragile (i.e., any computer) to hook up to hospital power. The donated equipment was kept neatly under dust covers and was used only on rare occasions, if ever.
8. Bandwidth is unfettered, so it is not uncommon for enterprising students to sit on the steps outside a medical facility with their laptops and download music videos or bootleg movies to record to CD and sell. This type of usage impacts the available bandwidth for medical workflows. A free tool like Untangle can go a long way by creating a media access control (MAC) layer and a fair access policy (FAP) for general Internet users, as well as providing a tunneled priority for specific medical devices and/or medical teleconsultations using web video.
9. Doctors in Afghanistan, like everyone else, find the Internet a fascinating place to explore. However, none of them have antivirus software on their computers, so it is a good idea to restrict Internet web access to only critical medical computers, and/or provide an antivirus gateway like Untangle that will prompt the user to download and install antivirus software on his or her computer before gaining access to the Internet. The sheer volume of viruses we found on laptops and desktops was staggering and was a frequent cause of slow performance and corrupted applications.
10. Collaborate, and remember the doctors you are working with are dedicated professionals and colleagues who risk their lives every day to work where they do. That mutual respect will go a long way when working with the local medical community.
11. There are no Radio Shacks in Afghanistan (and, sadly, now there are few in the USA), so you need to plan your equipment purchases in advance down to every connector and network device.

12. Sustainability is the key to success. When visiting the Public Hospital in Jalalabad, I saw half a dozen different KU-band satellite systems on the roofs of various buildings. However, only one of them worked. The issue is that various international donors funded many programs for 12 to 24 months, but there were no sustainability plans or budgets for ongoing service, upkeep, or training. All programs should be designed with a budget and a plan to support the program going forward. Alternative, donors should work with the local medical facility and clinicians to figure out a way programs can continue to support themselves.
13. Routine training is imperative. Local web video libraries can be updated and reviewed over a local area network to provide a mechanism for bi-annual review, or to initiate a structured training program that is sustainable and available 24x7.
14. Staff turnover is inevitable, so all devices, programs, and IT infrastructure should be designed to be robust, but also provide a simple user interface so that a system administrator with limited technical knowledge can log into a web page and add or delete users for mail, web, and clinical imaging access. Where possible, instructional videos can be uploaded to the telemedicine appliance server or other webserver so that a single, fast archive is available on site for clinicians to review basic operations or various devices, as well as expanding their library to include common operating and emergency room and nursing procedures, etc.
15. Portable x-ray units exist that make use of direct radiology (DR) plates instead of conventional x-ray film. While costs were prohibitive just five or six years ago, prices have now come down so far that they are a much more sustainable alternative to plain film in places like Afghanistan, where getting chemical reagents and x-ray film can be difficult to impossible. Medweb has experience marketing a portable x-ray system that is compatible with the Medweb telemedicine appliance. Like all devices, it uses standards to communicate with the telemedicine appliance. In this case, it supports DICOM Worklist SOP<sup>1305</sup> class, as well as simple and compressed DICOM storage class, to transfer images to the storage appliance. Using a portable x-ray and DR plate system eliminates the need to have a supply chain for x-ray film and x-ray film processing chemicals.
16. Portable x-ray equipment can use Monoblock x-ray heads, which combine the x-ray tube and electronics into the head of the x-ray machine and have low-enough energy consumption that they can be operated on a rechargeable battery pack and solar array. Again, this eliminates the cost and supply chain complexities that are so expensive in rural areas.
17. Unified health ICT appliances like the Medweb server provide a layperson-friendly, but secure, health ICT architecture that allows facile installation, management, and triage. They also provide tracking of healthcare patients, events, human resources, medications, and epidemiological information in a rational and well-thought-out manner that is easily scalable to enterprise and nationwide networks that are consistent with contemporary health ICT interoperability standards.

---

<sup>1305</sup> Service-object pair

18. Using a consolidated compression IP accelerator scheme in the telemedicine/teleradiology server will greatly improve effective throughput on satellite Internet links.
19. Try to use local Internet exchange points, and WiMAX technology when moving medical traffic between local facilities.
20. Creating a local wireless Internet service provider (WISP) and then linking that local group of connections to a single satellite backhaul network will make better use of network resources and improve effective speeds when connecting to the larger Internet.
21. Jamming devices may negatively impact your local hospital network. Take that into consideration when selecting hardware in your wireless network design. More robust and more densely-placed wireless access points in the hospital will overcome the effects of the passing IED jammers on nearby roads.

# Chapter 15 Roshan’s Telemedicine Program: Broadband Healing a Nation

---

Shainoor Khoja

## Introduction

More than three decades of war have crippled Afghanistan’s healthcare system, making it one of the least developed in the world. And despite significant improvements in some health indicators and access to healthcare since 2001, the World Health Organization (WHO) currently estimates that only 4.8 doctors, nurses, and health workers are available per 10,000 people in Afghanistan, while 23 are needed to ensure basic delivery of healthcare.<sup>1306</sup>

The need for effective healthcare facilities is abundantly clear. However, other challenges persist – Afghanistan’s rugged terrain and remote villages, spread across almost 252,000 square miles of land, make it extremely difficult and costly for citizens in rural areas to travel to receive proper treatment. The lack of reliable power sources can mean hospitals have to cope without electricity for days at a time.

For some, access to the right medical knowledge and technology is the difference between life and death.

As the leading telecommunications company in Afghanistan, [Roshan](#) has been a catalyst in expanding coverage and making telephone services accessible to Afghans across the country. In 2003, fewer than 100,000 people had phones. Today, it is estimated that almost 90 percent of the population has a phone.<sup>1307</sup> By investing over US\$600 million in Afghanistan’s infrastructure, Roshan has installed state-of-the-art equipment to supply even the most rural areas of the country with 3G<sup>1308</sup> mobile voice and Internet service.

Roshan, which is owned 51 percent by [the Aga Khan Fund for Economic Development](#) (AKFED), is not only a telecommunications company but also a social enterprise. Since its inception in 2003, Roshan has been leveraging technology to support the rebuilding of Afghanistan. Through Roshan Community, the

---

<sup>1306</sup> Maranto, Rachel (2013). *Investing in Healthworkers to Save Children’s Lives*. Save the Children, 4. Accessed November 4, 2015. [http://healthworkers.savethechildren.net/wp-content/uploads/2013/11/AFG\\_Health\\_Worker\\_Briefing.pdf](http://healthworkers.savethechildren.net/wp-content/uploads/2013/11/AFG_Health_Worker_Briefing.pdf).

<sup>1307</sup> Using a total population figure of 28,601,365 (27,101,365 settled and another 1,500,000 nomadic) from the ACSO. “Estimated Settled Population by Civil Division, Urban, Rural and Sex 2015-16.” Accessed August 30, 2016 (<http://cso.gov.af/en/page/demography-and-socile-statistics/demograph-statistics/3897111>) and the total number of mobile phone subscribers of 25,378,284 (25,080,389 GSM and 297,895 CDMA) from the Afghanistan Telecom Regulatory Authority (ATRA). Telecom Statistics (End of December 2015). Accessed January 5, 2016. (<http://atra.gov.af/en/page/telecom-statistics-2013>). Calculations with the above figures show a mobile penetration rate of 89%.

<sup>1308</sup> Third-generation wireless digital technology based on International Telecommunication Union (ITU) International Mobile Telecommunications (IMT)-2000 specifications.

Corporate Social Responsibility (CSR) arm of the company, Roshan has implemented many projects to empower communities. It has also looked at ways to leverage telecommunications infrastructure to expand access to technology. These projects include building ten schools, 186 water wells, 29 playgrounds, and 35 e-learning<sup>1309</sup> centers, and many other projects to empower communities, improve social and health indicators, and provide better access to technology across the country.

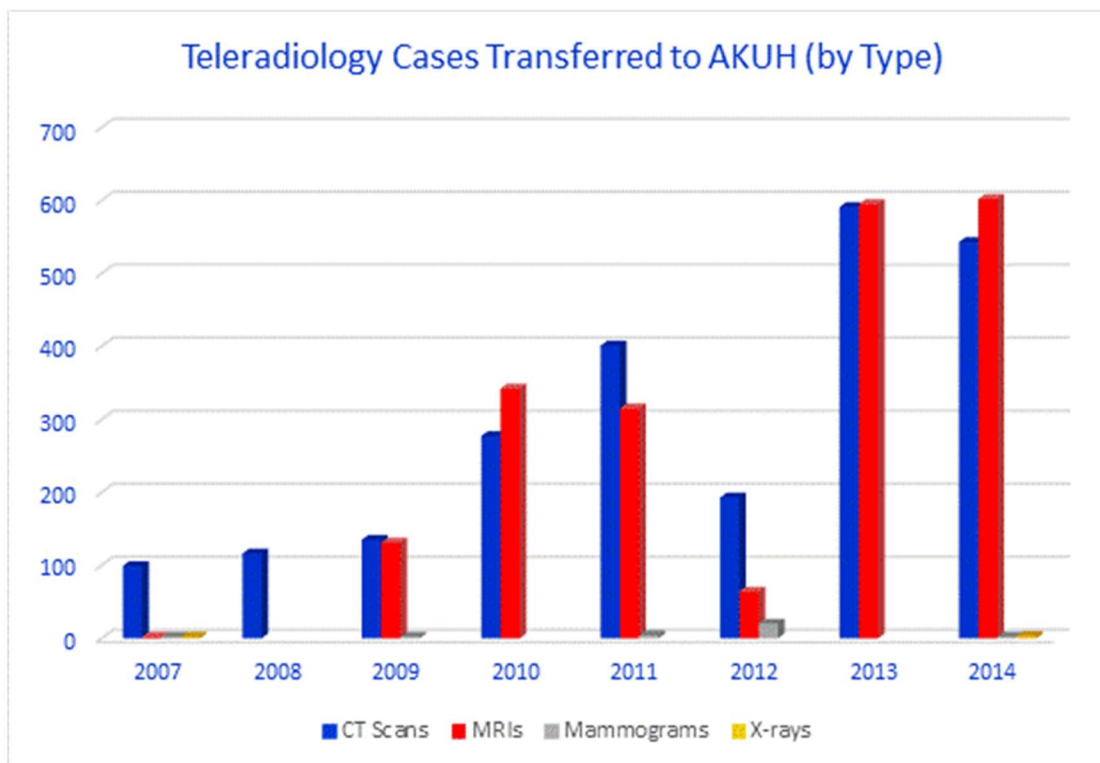

Figure 85: Teleradiology cases transferred to AKUH by type

## Roshan's Telemedicine Program

Launched in 2007, the Telemedicine Program is one of Roshan's signature CSR projects to improve access to healthcare. Through the Telemedicine Program, Roshan leveraged its nationwide telecommunications infrastructure and reliable network to connect Bamyan Hospital in the central highlands of Afghanistan, Faizabad Hospital in Badakhshan province in the northeast, and Mirwais Hospital in Kandahar province to the French Medical Institute for Children (FMIC) in Kabul. Roshan connected all four of those hospitals to one of the most modern and best-equipped medical institutes in the region: the Aga Khan University Hospital (AKUH) in Karachi, Pakistan, the center of excellence.

<sup>1309</sup> Short for electronic learning, meaning learning conducted via electronic media, typically, though not only, online via the Internet.

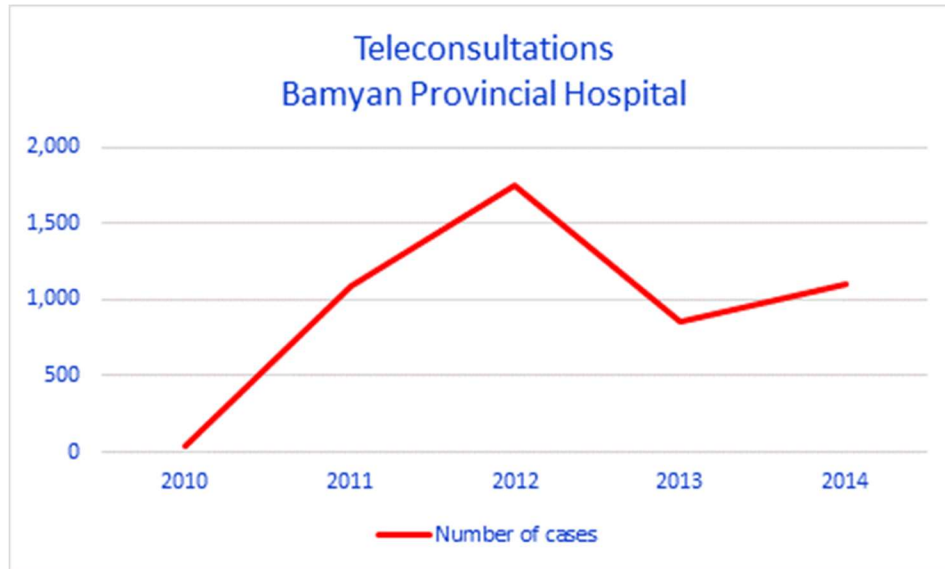

Figure 86: Number of teleconsultations conducted at Bamyán Provincial Hospital

With high-speed broadband data connectivity, Afghan doctors can communicate with one another in real time and have direct diagnostic supervision so international medical experts can be present in a surgical ward, even if they are physically thousands of miles away. Telemedicine is set up for a variety of specialties, from medical and nursing education to teleradiology, telepathology, and hospital management. Telemedicine has eliminated lengthy trips to specialists who practice only in major cities, saving patients an average of US\$125 and five working days for travel – resources that most Afghans do not have.

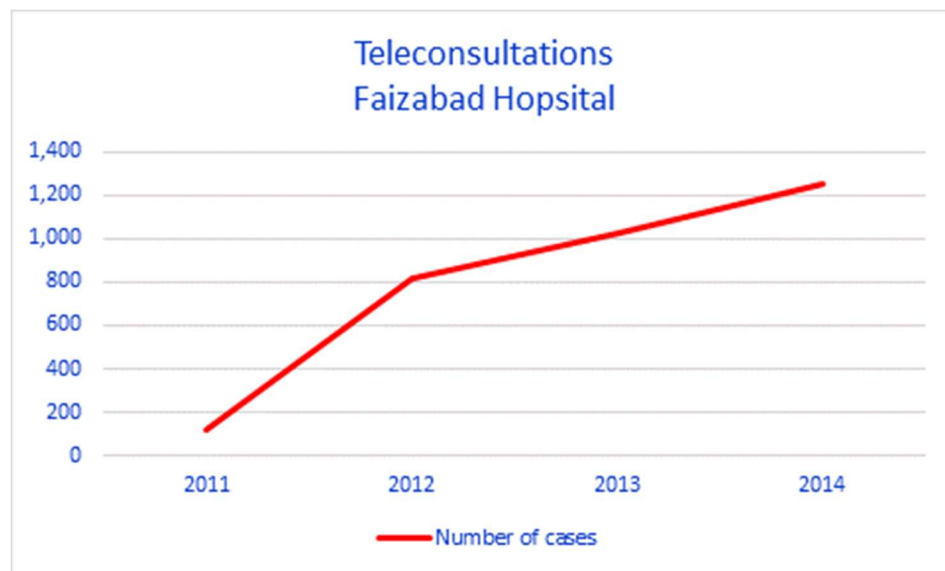

Figure 87: Number of teleconsultations conducted at Faizabad Hospital

Since 2007, Roshan’s Telemedicine Program has treated and diagnosed more than 14,000 Afghan patients, providing nearly 6,000 teleconsultations and teleradiology sessions. As a result of Roshan’s comprehensive wireless network and high-speed service, critical medical imaging such as the CT scan,



MRI,<sup>1310</sup> x-ray, and ultrasound can be transferred and assessed immediately. Also, by sharing video, data, and voice transmission capabilities, patient consultations are enhanced. Additionally, all medical services can be paid for remotely and instantaneously with Roshan’s mobile payment system, M-Paisa. (See [Chapter 13](#), *ICT in Finance*, for more about M-Paisa and mobile money.)

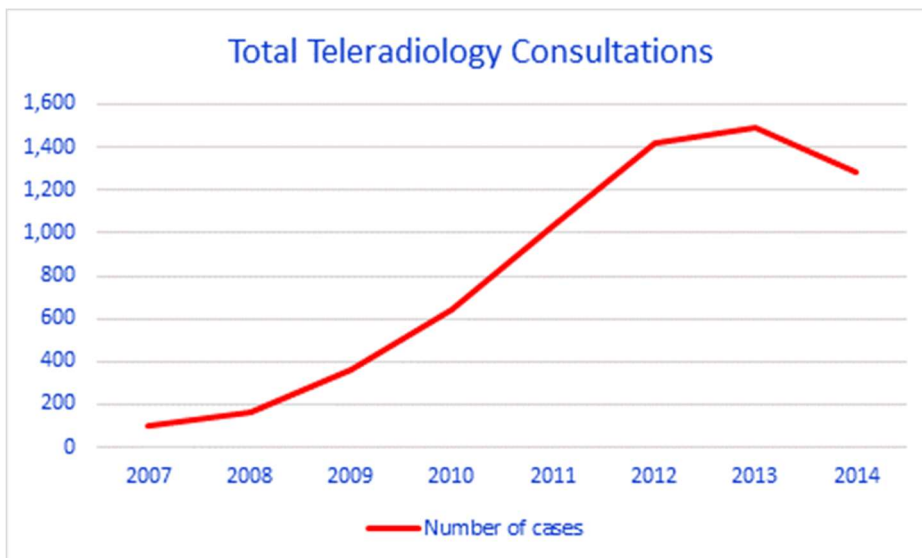
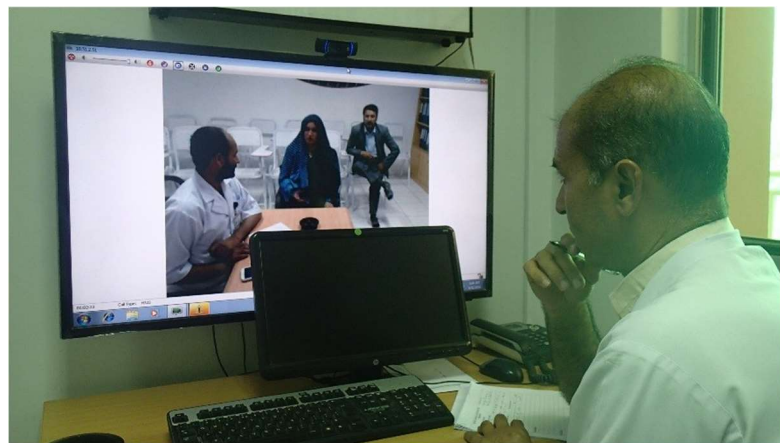

Figure 88: Total number of teleradiology consultations

## Medical Training via Technology

Roshan also used the telemedicine network it established to offer long-distance medical training in Afghanistan. More than 4,000 healthcare providers nationwide have received training, setting the groundwork for growth in Afghanistan’s own medical community. Now, doctors can listen and watch



Picture 44: Doctors at the French Medical Institute for Children (FMIC) in Kabul using telemedicine to treat patients in Bamyan Hospital

lectures and training sessions from some of the best physicians in the world, and caregivers are bringing health services to villages using technologically-equipped mobile ambulances. An entire Afghan e-health curriculum has been developed and is being continually expanded, with peers educating peers and knowledge being shared across borders and geographic barriers. The result is a long-term program that develops professional medical

---

<sup>1310</sup> Computerized tomography and magnetic resonance imaging, both of which are medical imaging techniques employed in radiology to “see” inside a body without cutting into it.

expertise in Afghanistan and connects the best healthcare professionals to the most desperate in need of them.



Picture 45: More FMIC-Bamyan telemedicine sessions

## Lessons Learned

In countries like Afghanistan, telemedicine is not only expanding the frontier of access to quality healthcare for impoverished and remote communities, but it is also a life-saving technology. This fact was demonstrated in the recent case of Afghan surgeons successfully [separating conjoined twins](#), Ayesha and Seddiqa, saving their lives and making history. The twins' parents hail from Badakhshan, one of the most remote provinces of Afghanistan. Fifteen days after they were born, Ayesha and Seddiqa's parents brought them to Faizabad Hospital, which is connected via Roshan's telemedicine link to the French Medical Institute for Children (FMIC) in Kabul. Using this connectivity, doctors in Kabul were able to examine the twins and determine an operation to separate them could be possible. The operation was indeed successful, and the rest is history.

Telemedicine has also proved to be a cost-saving technology, enabling the poor and needy to seek treatment and gain access to the best healthcare professionals without travelling long distances or paying enormous amounts of money. This aspect of the technology is especially important in the context of Afghanistan where rugged terrain dominates the country's geography, and roads are often non-existent or unsafe.

## Conclusion

Telemedicine is not just a model of technological advancement. It is also an example of how technology, when combined with communities, doctors, and governments, can improve healthcare access and medical care in even the least developed countries.

# Chapter 16 Using Mobile Phones to Track, Report, and Share Health Statistics

---

Jenn Gold, Rachel Robb, and Juan Andrés Rodríguez

## Introduction and Background

International Synergy (INSY) Group, a non-governmental organization (NGO), was founded by three Synergy Strike Force (SSF) members: Rachel Robb, Jennifer Gold, and Juan Andrés Rodríguez in 2011 (see [Chapter 12](#)). Based on the principles of SSF, the goal of INSY Group was to identify additional funding opportunities and continue to implement ICT4D<sup>1311</sup> projects in Afghanistan that would empower Afghan communities through the use of information and communications technology (ICT) infrastructure and open information sharing.

In partnership with Medweb, INSY Group was a finalist in the Bill and Melinda Gates Foundation’s [Saving Lives at Birth](#) Grand Challenge in 2012. Simultaneously, international funding for development projects in Afghanistan began to decrease, and access to large project grants in the ICT4D sector diminished. Prior to this, INSY Group established a professional relationship with Medweb by collaborating with their philanthropic work in Afghanistan. It was a natural pathway to partnership and, after the increased security threat following the Qur’an burnings at Bagram Air Base in February 2012,<sup>1312</sup> INSY Group temporarily left Afghanistan and began working with Medweb to expand its mobile health projects.

Medweb’s founder and Chief Executive Officer (CEO), Dr. Pete Killcommons, contracted the INSY Group team to lead the further development of INSY’s various m- and e-health<sup>1313</sup> applications (amongst others) and integrate them into Medweb’s telemedicine solutions offered to governments and health institutions worldwide. Some of those projects are described below.

## Eastern Region Disease Connection (ERDC)

SSF provided technical and operational support to the Nangarhar Public Hospital (NPH) beginning in 2005. In 2011, SSF initiated a new project with NPH’s Disease Early Warning System (DEWS) Office, the director of which had requested an ICT platform to accelerate and enhance local-level reporting of epidemiological outbreaks in remote areas throughout Nangarhar province. Thus, the Eastern



---

<sup>1311</sup> Information and communication technology for development

<sup>1312</sup> See “Koran Burning in NATO Error Incites Afghans” by Sangar Rahimi and Alissa J. Rubin, *The New York Times*, February 21, 2012. [http://www.nytimes.com/2012/02/22/world/asia/nato-commander-apologizes-for-koran-disposal-in-afghanistan.html?\\_r=0](http://www.nytimes.com/2012/02/22/world/asia/nato-commander-apologizes-for-koran-disposal-in-afghanistan.html?_r=0). Accessed August 29, 2016.

<sup>1313</sup> Mobile health and electronic health. Mobile health refers to the practice of medicine using mobile devices, such as portable computers, laptops, tablets, personal digital assistants (PDAs), and, most commonly, mobile phones. Electronic health is a collective term for medical and healthcare conducted using automated electric or digital processing.

Region Disease Connection (ERDC) project was born. The goal of the ERDC was to create a repository of real-time health information collected from eight Ministry of Public Health (MoPH) doctors throughout Afghanistan's eastern region: Laghman, Nangarhar, Kunar, and Nuristan provinces. At the outset of the project, it was hoped ERDC would evolve into an early warning monitoring and prevention system for disease outbreaks. The plan was for local radio stations to cooperate in airing public health messages along with questions and answers relating to disease outbreaks and broadcast a phone number for listeners to call and report symptoms or outbreaks of diseases observed in their villages.



Real-time-photograph  
Mon, Jul 18, 2011 at 2:26 PM

Measles outbreak Wagal, Nouristan  
LAT 35.19064 LON 70.98987

*Picture 46: Measles outbreak in Nuristan province, July 2011*

SSF designed a method to synergize local radio stations, short message service (SMS, or texting) technology, and online data visualization software to collect, track, and display information on local epidemiological outbreaks based on crowdsourced information provided by MoPH doctors working in rural clinics. SSF distributed GPS<sup>1314</sup>-enabled smartphones and held two training sessions with DEWS officers. Under the guidelines of the program, each week the participating doctors were to report on the number of five-year-old children in their hospitals and clinics diagnosed with any symptoms of cough and

---

<sup>1314</sup> Global positioning system

cold, pneumonia, diarrhea, dehydration, measles, malaria, and typhoid. The doctors transmitted reports via SMS messages directly to an iSMS modem<sup>1315</sup> SSF had installed and maintained. SSF then uploaded the data onto an online geospatial information-mapping tool ([Crowdmap](#)), verifying information on a weekly basis directly with the DEWS officers via phone to ensure accuracy and validity.

Socio-cultural realities and political concerns at the MoPH as well as continuing technical challenges, constrained project implementation. With regards to the first challenge, although SSF had originally agreed to implement a publicly-accessible ICT platform for reviewing the inputs, after a preliminary review of the results, DEWS officials requested the Crowdmap deployment not be publicly available due to the privacy concerns the MoPH had in revealing national public health data. As a result, SSF had to decentralize the project and implement it exclusively with the DEWS director within Nangarhar. With regards to the political environment, at implementation mid-point, MoPH officials began expressing apprehension that real-time epidemiological data collection could cause a conflict of interest with major donors because the statistics SSF collected were different than the ones officially recorded. Also, higher figures would create public health service expectations among local communities to which the MoPH lacked the capacity to respond. With regards to technical challenges, the sporadic and daily loss of electricity in the public hospital posed a major challenge for doctors to access the Crowdmap; if they were unable to access the Internet, the information was not available.

## Midwife Connection

The Afghan Ministry of Public Health (MoPH) conducts a national midwife training program to support improved maternal and child health outcomes in rural villages. Under the program, young women are selected by tribal elders and sent to clinics, where they receive training from MoPH doctors and nurses. Upon graduation from the program, the girls return home and for women and children in their villages. Midwives are continuously supervised by provincial-level MoPH directors, complete monthly monitoring and child health statistics and submit them to the MoPH headquarters in Kabul. In reality, midwives often



board for two years at district level in infant and maternal healthcare. Upon graduation from the program, they act as primary healthcare providers in their villages. In theory, these rural midwives are supervised and supported by provincial-level MoPH directors, who are, in turn, required to submit evaluation reports on maternal and child health statistics and submit them to the MoPH headquarters in Kabul. In reality, midwives often

lack the technical and physical ability to transmit and receive potentially life-saving medical information to and from their provincial MoPH directors quickly due to physical distance and a lack of ICT infrastructure and access, which also impedes local oversight at the ministry level. Further, rural midwives are generally barely sixteen years old, and they are most often the only individuals with any medical training in their villages. In extreme

---

<sup>1315</sup> An iSMS modem acts as a “text server” of sorts and lets one send and receive text messages en masse relatively inexpensively.

cases, these midwives become the primary caregivers for their entire villages, not just for mothers and babies.

Supervisory Checklist for Midwives			
Province: <input type="radio"/> =Nangarhar <input checked="" type="radio"/> =Laghman <input type="radio"/> =Kunar <input type="radio"/> =Nuristan			
Type of health facility:			
<input type="radio"/> =Regional Hospital	<input type="radio"/> =Provincial Hospital		
<input type="radio"/> =Cluster Hospital	<input type="radio"/> =CHC Plus		
<input type="radio"/> =CHC	<input type="radio"/> =BHC		
<input type="radio"/> =SHC	<input type="radio"/> =Health Post		
Midwife Supervisor: <input type="radio"/> =Mobile1 <input type="radio"/> =Mobile2			
Date of Midwife Employment: DDMMYY			
Date of Midwife Graduation: DDMMYY			
Does the midwife practice the following activities:			
<input type="checkbox"/> =anteatal care	<input type="checkbox"/> =Intra partum care		
<input type="checkbox"/> =Postnatal care	<input type="checkbox"/> =Newborn care		
<input type="checkbox"/> =FP services	<input type="checkbox"/> =STIs management (OPD)		
<input type="checkbox"/> =Female OPD	<input type="checkbox"/> =Registration		
<input type="checkbox"/> =Growth Monitoring	<input type="checkbox"/> =Immunization		
<input type="checkbox"/> =TB	<input type="checkbox"/> =Other		
From your observations, how do you feel that she is coping?			
<input type="radio"/> =Excellent	<input type="radio"/> =Good		
<input type="radio"/> =Fair	<input type="radio"/> =Poor		
Is she able to make decisions as a (newly qualified) midwife?			
<input type="radio"/> =Always	<input type="radio"/> =Sometimes		
<input type="radio"/> =Never			
If sometimes and always, please give some examples:			
<input type="checkbox"/> =PPH	<input type="checkbox"/> =Mal Presentation		
<input type="checkbox"/> =Cord Presentation	<input type="checkbox"/> =Shoulder dystocia		
<input type="checkbox"/> =Asphyxia	<input type="checkbox"/> =Sick Newborn		
<input type="checkbox"/> =Post Partum Infection	<input type="checkbox"/> =Prolong labour		
<input type="checkbox"/> =Other			
Did she conduct any clinic deliveries, since last visit date?			
<input type="radio"/> =YES	<input type="radio"/> =NO.		
If yes - how many were conducted alone?			
Enter the amount.			
If yes - how many were conducted with a co-person health provider present?			
Enter the amount.			
If yes - how many were conducted with a relative?			
Enter the amount.			
If no - did she conduct any home deliveries since the last date?			
<input type="radio"/> = YES	<input type="radio"/> =NO.		
If yes - how many were conducted alone?			
Enter the amount.			
If yes - how many were conducted with a co-person health provider present?			
Enter the amount.			
If yes - how many were conducted with a relative?			
Enter the amount.			
If yes - how many were conducted with a TBA?			
Enter the amount.			
Since last visit, any problems faced during delivery (Home and HF)?			
<input type="radio"/> =YES	<input type="radio"/> =NO		
If yes - what were the complications?			
<input type="checkbox"/> =PPH	<input type="checkbox"/> =Prolong labour		
<input type="checkbox"/> =Mal presentation	<input type="checkbox"/> =Cord Presentation:		
<input type="checkbox"/> =Shoulder dystocia	<input type="checkbox"/> =Asphyxia		
<input type="checkbox"/> =Post partum infection	<input type="checkbox"/> =sick newborn		
Total Number of normal deliveries at home:			
Enter the amount.			
Total Number of normal deliveries at health facility:			
Enter the amount.			
Does she use the partograph?			
<input type="radio"/> =YES	<input type="radio"/> =NO.		
Does she have her learning resource material in clinical site?			
<input type="radio"/> =YES	<input type="radio"/> =NO		
If yes, which ones? Does she still work according to these?			
Phase 1	<input type="radio"/> =YES	<input type="radio"/> =NO	<input type="radio"/> =N/A
Phase 2	<input type="radio"/> =YES	<input type="radio"/> =NO	<input type="radio"/> =N/A
Phase 3	<input type="radio"/> =YES	<input type="radio"/> =NO	<input type="radio"/> =N/A
MNP	<input type="radio"/> =YES	<input type="radio"/> =NO	<input type="radio"/> =N/A
IMPAC	<input type="radio"/> =YES	<input type="radio"/> =NO	<input type="radio"/> =N/A
BMNC	<input type="radio"/> =YES	<input type="radio"/> =NO	<input type="radio"/> =N/A
Is the clinic staff aware of the constant and purpose of LRM?			
<input type="radio"/> = YES	<input type="radio"/> = NO.		
If yes, are they using it in their work with the midwife?			
<input type="radio"/> =YES	<input type="radio"/> =NO.		
Is the midwife Involved in record keeping (HMIS)			
<input type="radio"/> =YES	<input type="radio"/> =NO.		
Any main material/equipment for the midwife's room still missing?			
<input type="radio"/> =YES	<input type="radio"/> =NO.		
Send all messages to: (+93 778 505 714)			

Figure 89: Example of Midwife Connection supervisory checklist

In Nangarhar province, a pair of supervisory midwives physically travels to each district-level clinic once a month (there are 22 districts in Nangarhar, with basic health services available in all but one district). Each month, the supervisory midwife team records changes in local health statistics provided by local midwives on standardized paper-based checklists (see Figure 89). After the team circulates to each of the districts, it returns to the city and submits the hardcopy documents to the midwife director. The length and

duration of travel largely depend on the method of transportation used and the weather. Typically, a male family member drives the midwife team to each clinic; however, alternate modes of transportation have been used when necessary, such as bus and even walking.

The midwife director, who is employed by the MoPH, is required to provide monthly evaluation reports to his various funding operations based on the information gathered by the supervisory midwife team. To improve upon this method using real-time connectivity, SSF converted the standard MoPH checklist into an SMS-compatible format and provided mobile phones, SIM<sup>1316</sup> cards, and prepaid minutes to the supervisory midwives. The midwives were then able to text information into a previously installed (by SSF) iSMS modem, which received the data and uploaded it to the Internet, where the midwife director could review it.

SSF held training sessions with the supervisory midwife team on how to format the SMS reports and text them to the modem and with the midwife director on how to access the messages over the Internet. Lastly, SSF linked the modem with a Crowdmap deployment (see [Figure 90](#)) to allow for real-time data visualization and

## AFGHANISTAN'S BASIC PACKAGE OF HEALTH SERVICES (BPHS)

Initiated by the World Health Organization (WHO) in March 2002 (Solar Year 1381), the Afghan Ministry of Health (MoH) (as it was then named) began a process to determine its major priorities and discern which health services were necessary and important to address Afghanistan's greatest health problems. The MoH decided to call these crucial services a Basic Package of Health Services (BPHS). The key elements of the BPHS were:

- (1) Those services that would have the greatest impact on the major health problems;
- (2) Services that were cost-effective in addressing the problems faced by many people; and
- (3) Services that could be delivered to give equal access to both rural and urban populations.

The overarching components of the BPHS are:

- Maternal and newborn health;
- Child health and immunization;
- Public nutrition;
- Communicable diseases;
- Mental health;
- Disability; and
- Supply of essential drugs.

The BPHS further provided standard names and descriptions for the key types of facilities of Afghanistan's provincial health system: Health Post, Basic Health Center, Comprehensive Health Center, and District Hospital.

The BPHS, originally published by the Transitional Islamic Government of Afghanistan in March 2003 (SY 1382), was a collaborative effort that represented a broad consensus among health stakeholders. The BPHS was revised in 2005 by the Ministry of Public Health.

---

<sup>1316</sup> Subscriber identity module, a removable smart card for some types mobile phones that stores identifying information regarding the phone and associated customer account.

trend monitoring of maternal and infant health data.

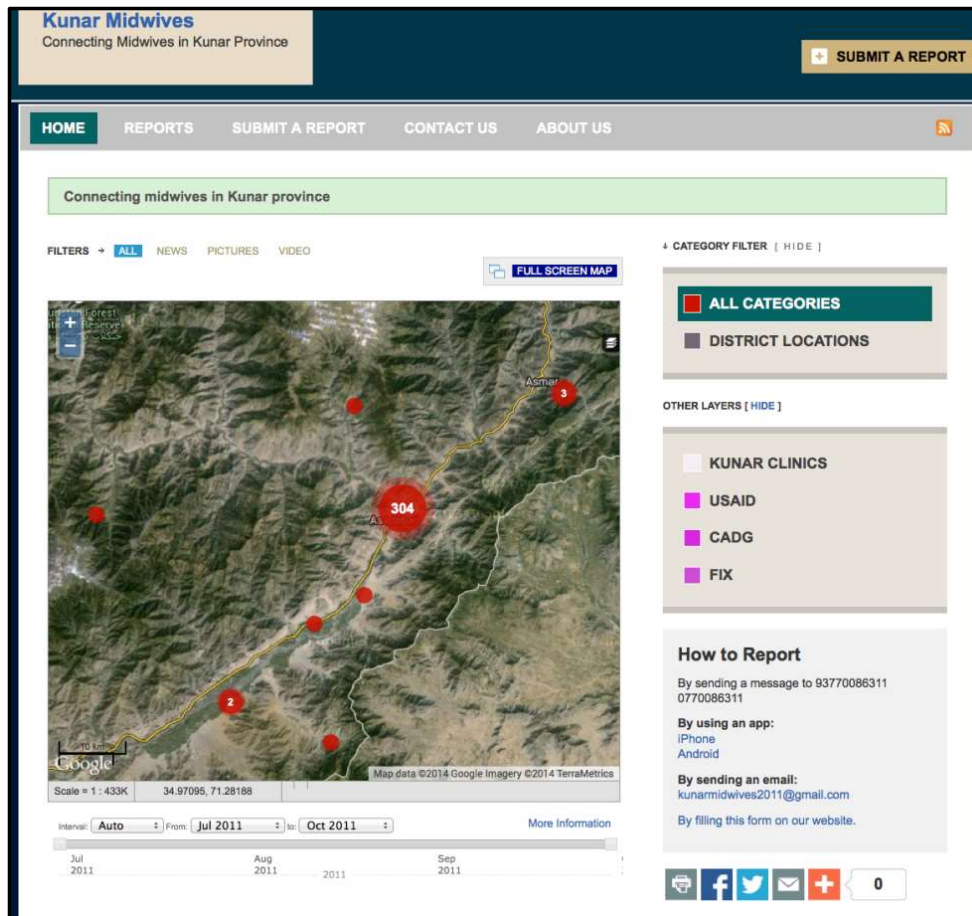

Figure 90: SSF Crowdmap indicating the number of midwife reports

In Kunar province, the Aide Médicale Internationale (AMI) launched a program to establish the Basic Package of Health Services (BPHS)<sup>1317</sup> for the MoPH (see sidebar), which includes maternal and newborn health. Because of this arrangement, the midwifery department in Kunar province is not required to submit monthly reports to the MoPH in Kabul. Consequently, the MoPH does not make use of a midwife supervisory team; thus, there is little communication between the midwives in Kunar and the health ministry. To improve communications, SSF and the Kunar midwife director created a list of questions for the midwives to answer on a weekly basis, and SSF converted the list into an SMS-compatible format. Due to physical distance and security concerns, SSF trained the Kunar midwife director in his hometown,

<sup>1317</sup> Transitional Islamic Republic of Afghanistan Ministry of Public Health. *A Basic Package of Health Services for Afghanistan, 2003/1382*. March, 10, 2003. Accessed December 11, 2014. <http://unpan1.un.org/intradoc/groups/public/documents/APCITY/UNPAN018852.pdf#search=%22basic%20package%20of%20health%20services%20afghanistan%22>.



Jalalabad city, on all steps of the process, which was to be similar to that described for Nangarhar province above. SSF also provided him with mobile phones, SIM cards, and prepaid minutes for distribution to the 24 newly-graduated midwives upon his return to the province, whom he then trained in SSF’s data collection and reporting methods.

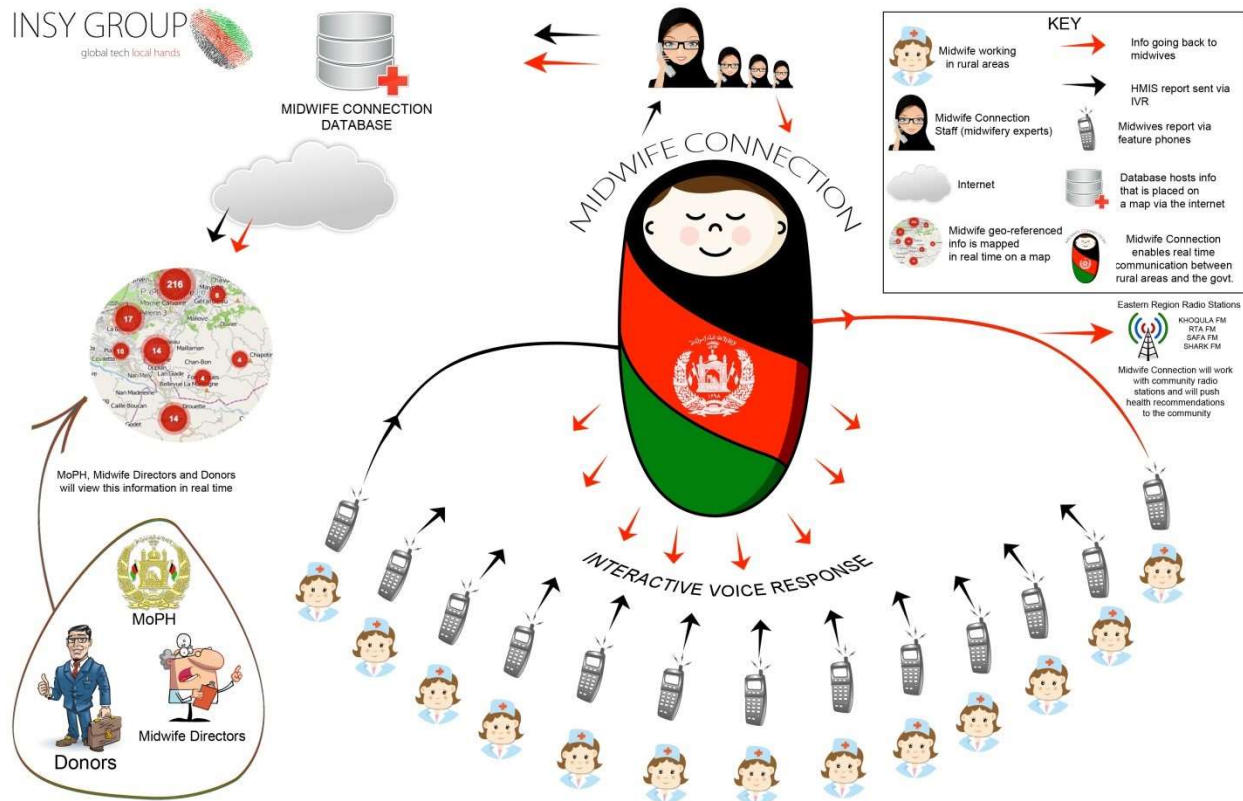

Figure 91: Visual representation of the Midwife Connection program

As is to be expected when introducing new information and communications technologies in a local Afghan context, the first month of implementation in both Nangarhar and Kunar provinces was marked by slow and inconsistent outputs from midwives. After three months in Nangarhar province, SSF conducted a mid-point feedback session where the supervisory midwives explained the SMS codes were too difficult and repetitive to format correctly when submitting their checklists via text. Also, the MoPH checklist included several questions that required narrative responses, which proved difficult to integrate into the SMS template and, therefore, resulted in a number of incomplete or incorrectly formatted submissions. Another socio-cultural perception and security concern was highlighted in the Nangarhar supervisory midwives’ fears about carrying GPS-enabled mobile phones into the more remote villages through which they circulated. These midwives carried basic Nokia feature phones that lacked advanced features. However, they stated the use of GPS technology would indicate they were working with Americans and could get them into trouble. They were fearful that geo-locating or “tagging” the coordinates of the clinics they visited, which was used to mark locations for input into the geospatial visualization tool, would indicate their locations and activities, which could allow for insurgents to track their movements and attack their vehicles.

In Kunar province, two weeks after implementation, local SSF staff traveled to the city of Asad Abad to speak with the 24 participating midwives, where they determined most of them still struggled to understand fully the SMS format and lacked incentives to make regular use of the technology. Together, SSF and the midwives agreed to streamline and simplify the SMS format down to four basic pieces of information: (1) the number of weekly infant deaths; (2) the number of weekly maternal deaths; (3) the number of weekly infant births; and (4) specific drugs and medical supplies needed at each clinic. To provide enhanced communication and oversight to the program, SSF assigned a local (Afghan) female employee to lead the project and act as a focal point for the midwives. SSF tasked her with calling each of the midwives daily to coordinate and ensure their SMS outputs included correctly formatted and complete data. The project lead checked the iSMS modem every day, aggregated the SMS data onto a spreadsheet, and uploaded the information onto a Crowdmap deployment for monitoring by the midwife directors to visualize infant and maternal health statistics. She also conducted interviews with every midwife to assess the needs of each local clinic, employing a questionnaire to determine access to critical services such as water and electricity, if the clinic was accessible by roads, and the degree of security presence and government support. Also, if the midwives did not send in messages or if their information needed to be verified, the project lead would call them.

Three months later, at the culmination of the project, the project lead had received over 230 messages from the midwives in Kunar province and conducted interviews with ten of the 24 participants. She compiled these interviews into short stories that detail the midwives' experiences working in rural clinics.

SSF established that with monitoring and training provided by the project lead, the Kunar midwives were willing to and capable of communicating in-depth information on public health situations in local communities via their mobile phones. They sent SMSs and left voicemail messages to share information with the project lead. They were willing to share details about their clinics, working conditions, and the conditions of their villages. The bond the project lead and the midwives established was most astonishing: the girls trusted the SSF project lead and were eager to share stories with her on a daily basis.

Unfortunately, once SSF received the text messages from the midwives, there was little it could do with the information. The support of the donors and the Ministry of Public Health was minimal to non-existent due to the fact that the Midwife Connection project was initially envisioned as a research project with no sustainable financial incentives attached to its implementation.<sup>1318</sup> Without this support, neither Kunar nor Nangarhar midwives received any recognition, compensation, or follow-up actions to assist them with their communities' local public health needs. On a number of occasions, the midwives reported infant deaths; in several of the situations, their deaths were preventable. In one particular instance, a midwife from Asad Abad reported a death caused by poor road construction – the pregnant mother was unable to get to the hospital in time for medical attention due to the shoddy roads, and, consequently, her baby was stillborn. In another situation, a midwife reported an infant death due to a lack of calcium: the mother

---

<sup>1318</sup> Despite repeated and valiant attempts, INSY Group was never able to source donor funding or grants for the Midwife Connection program. As such, it tried to make the effort more of a grass-roots campaign where the midwives and midwife directors would push the MoPH for its implementation, but that did not happen.

was malnourished, and her calcium intake was poor, causing a miscarriage, another easily preventable death.

For this pilot project to have succeeded, a top-down directive needed to be established. Recognition of and reaction to the midwives' reports needed to be timely and public for rural midwives to feel their work is relevant; otherwise, they had no real incentive to participate. Ultimately, while the timeliness of the monthly checklist submissions demonstrably improved, when compared to the earlier paper-based method, it proved exceedingly difficult for SSF and the midwife director to convert the data into immediately actionable information via the online mapping tool. When the MoPH came out with a longer and more extensive evaluation checklist, SSF suspended the project pending further review and enhancement.

However, the insight into rural midwives SSF gained from this project was important to understanding the reality of rural healthcare conditions in eastern Afghanistan. Understanding their routines, challenges, and reporting processes provided foundational knowledge critical to establishing and expanding upon the process by which maternal and infant mortality statistics are tracked and reported. The speed at which information moves from the midwives' clinics to the MoPH is anything but immediate. The combination of the lack of electricity and Internet access hinders the possibility of information exchange in a timely manner. The same holds true for community healthcare workers (CHWs), who volunteer their time to visit households and collect health and sanitation information. SSF observed that local healthcare providers in Afghanistan are severely under-resourced relative to the challenges they face and the critical support they provide to rural communities. Given the ongoing lack of basic human resources – the number of midwives and CHWs – and the availability of ICT connectivity at the MoPH, along with Afghanistan's persistently high infant and maternal mortality statistics, it is SSF's view that any potential future endeavors to increase the quality and speed of information exchange among local health workers and their MoPH counterparts should be viewed as relatively low-cost, high-return investments.

## IVR4BABY

The concept behind the Interactive Voice Response for Baby (IVR4BABY) project was to give customized knowledge on pregnancy and childbirth directly to expectant Afghan mothers in rural communities every week. Women living in rural areas of Afghanistan have limited access to healthcare due to geography and a lack of skilled midwives in their proximities, among other reasons. Further, literacy rates are particularly low among rural Afghan women. The IVR4BABY pilot project took the knowledge of Afghan midwives and provided it to expectant mothers using voice-based software and mobile phones.

Despite foundational gains since the ouster of the Taliban regime in 2001, Afghanistan's maternal health situation remains abysmal. Afghanistan has one of the highest maternal mortality rates in the world: 327 out of every 100,000 women who give birth die during labor.<sup>1319</sup> Over half of Afghan women who die

---

<sup>1319</sup> Islamic Republic of Afghanistan Ministry of Public Health Afghan Public Health Institute (2011). *Afghanistan Mortality Survey 2010*. November 2011, 128. Accessed December 15, 2015. <http://dhsprogram.com/pubs/pdf/FR248/FR248.pdf>.

during childbearing years die from pregnancy-related causes, most of which are preventable. Further, over 75 percent of Afghans live in isolated, low-resource communities, often hours or days away from the nearest public health facility. Lack of access to even basic maternal health information and care is most severe in tribal areas, where it has been reported that mothers feed newborns sugar water instead of breast milk due to an ingrained cultural perception of colostrum as unsanitary.

Nationwide community healthcare worker and midwifery training programs have made admirable strides in extending basic maternal health information and services to rural women, but the programs require years of lead time and remain structurally under-resourced and fragmented. The access-to-care situation is often further complicated by cultural perceptions of male and female household elders, who are resistant to the idea of institutional deliveries and have strong preferences to have women seen and treated only by other women. In 2011, the nationwide midwife-to-population ratio stood at around 1 to 10,000, even as fertility rates hovered at six to seven children per mother. Further, there are an estimated two midwives for every 1,000 deliveries, there are fewer than 100 obstetric care facilities for over 1.2 billion births every year, and 80 percent of Afghan mothers lack access to vital prenatal health information and skilled care.

IVR4BABY is a mobile health application that utilizes interactive voice response technology to deliver information to expectant Afghan women via mobile phones. The program was designed to work as follows: Women would be alerted to the program through public service announcements (PSAs) broadcasted by local and national radio stations (these stations also aired maternal health education programs in conjunction with the PSAs). Women would register on the IVR system using mobile phones, generally belonging to their husbands or households, by dialing a four-digit short code<sup>1320</sup> linked to the IVR system server. The IVR server was to be installed and hosted at the project implementation site, SSF's headquarters, in Jalalabad. Once a mobile number was registered, IVR4BABY would automatically call the individual registrant back and ask her a quick series of questions to capture and record her district of residence, estimated date of conception, and preferred method of receiving pregnancy information (either via SMS or recorded voice messages in Dari or Pashto). IVR4BABY would then send information to the pregnant woman via the mobile phone – free of charge – three times per week. Messages contained culturally-sensitive information giving families a sense of what to expect throughout pregnancy as it progresses (physiological changes, indications of complications, etc.), preventive care advice (such as proper hygiene and nutrition), and encouragement to adopt healthy lifestyle choices (e.g., encouraging breastfeeding and skin-to-skin contact once children are born). Most importantly, IVR4BABY messages encouraged registrants to call into or visit the closest district medical facility or seek service from a midwife or community health worker upon experiencing any adverse symptoms explicated in the messages.

---

<sup>1320</sup> A short code is a series of digits shorter than regular telephone numbers used for phone calls or messaging for specific purposes. Examples include dialing short code 411 to reach directory services and 911 to reach emergency services in the US. Another example is, "Text 'traffic' to 1234 for traffic updates."

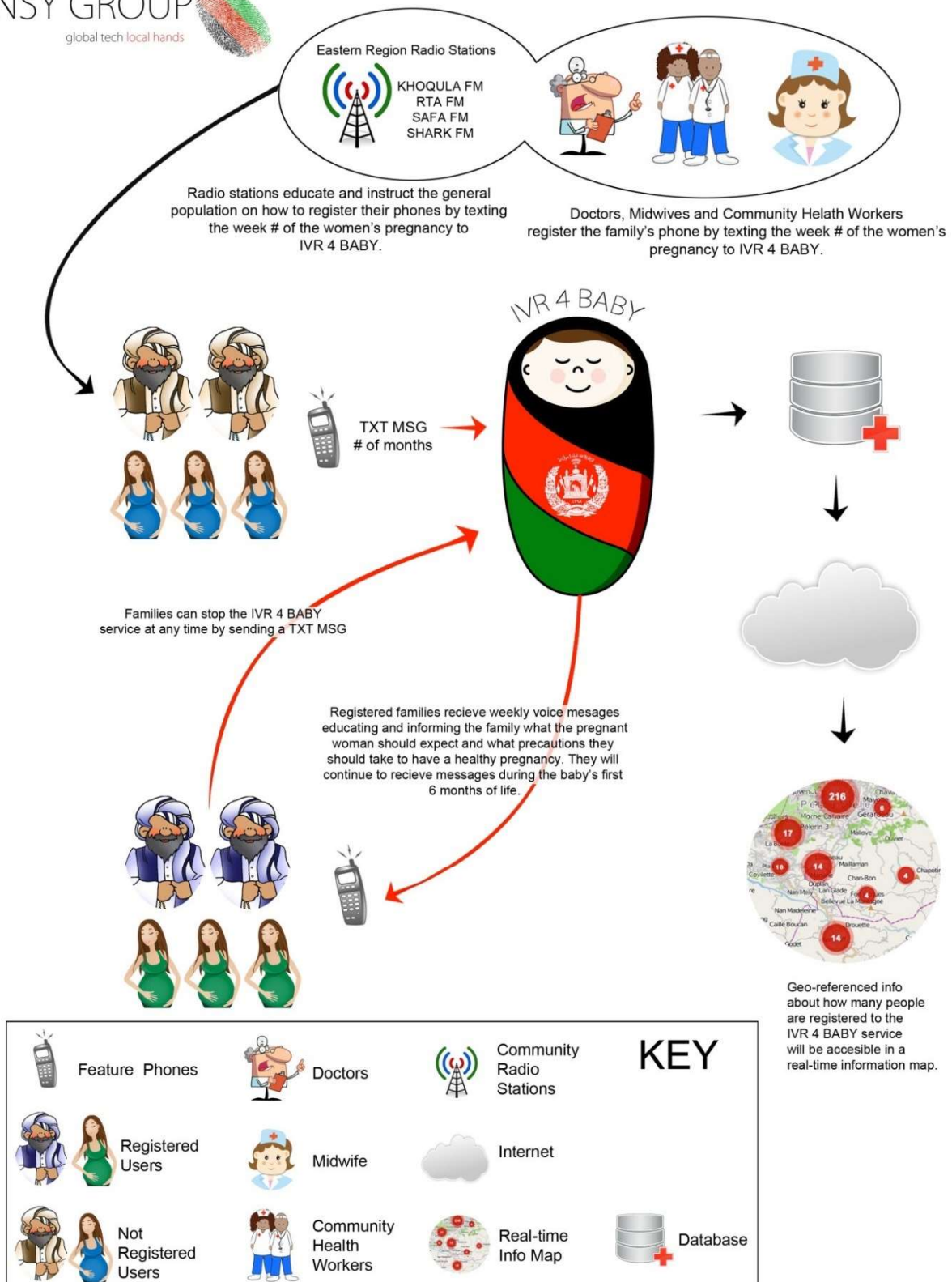

Figure 92: Visual representation of IVR4BABY program

SSF designed IVR4BABY in direct consultation with local Afghan mothers, midwife students, doctors, and hospital directors. The Nangarhar Department of Public Health, which had prioritized mobile phone-based solutions as the primary means of closing gaps in rural citizens' access to basic health information and services, granted preliminary buy in. The IVR system was in alignment with the Ministry of Public Health's national health connectivity strategy. According to The Asia Foundation's *A Survey of the Afghan People* in 2012, 94 percent of urban Afghans and 63 percent of rural villagers owned and used mobile phones.<sup>1321</sup> The United States Agency for International Development (USAID) reported as of late 2012, 80 percent of Afghan women had access to mobile phones (48 percent owned and 32 percent borrowed when needed).<sup>1322</sup> In rural areas, 44 percent of women reported owning mobile phones (compared to 49 percent of urban women). With respect to gender and cultural sensitivities, although household decision-making remains firmly with the eldest males, who could prohibit women in their families from using mobile phones, SSF's field observations strongly indicated that even men with deeply conservative views recognized and appreciated the centrality of maternal health to family survival and wanted women in their families to have access to pre- and neonatal healthcare information.

The IVR system was coded using open source non-proprietary Asterisk software and was to be housed and operated by a local company in Kabul that had similar technology already in use. The weekly recordings were translated into Dari and Pashto by a young man and woman, both of whom also provided great insight into the interpretation of the messages by both men and women listeners. The messages were adapted from content provided by the Mobile Alliance for Maternal Action (MAMA) Baby Center, an organization with a mission "to deliver vital health information to new and expectant mothers through mobile phones."<sup>1323</sup>

SSF was successful in having the directors of public health in Nangarhar and Kunar provinces sign memorandums of agreement to implement IVR4BABY. Unfortunately, however, SSF was never able to bring IVR4BABY to fruition or test it in real time, primarily for two reasons: To obtain a short code from the ATRA involved six months' to one year's wait time, and SSF was never able to secure adequate funding for the project. SSF did, however, enter IVR4BABY into the [Bill and Melinda Gates Foundation's Saving Lives at Birth Grand Challenge competition in 2012](#). While IVR4BABY made it past the first round, it was not among the projects selected for funding.

IVR4BABY is essentially a low-cost technology transfer grounded in local culture, knowledge, and existing behavior patterns. It does not require value shifts, institutional changes, or cultural adjustments. IVR platforms are already in use by the Afghan government, radio and television networks, and others. The

---

<sup>1321</sup> Hopkins, Nancy, ed. (2012). *Afghanistan in 2012: A Survey of the Afghan People* (The Asia Foundation, 2012), 11. Accessed December 16, 2015. <https://asiafoundation.org/resources/pdfs/Surveybook2012web1.pdf>.

<sup>1322</sup> USAID (2013). *Connecting to Opportunity: A Survey of Afghan Women's Access to Mobile Technology*, May 22, 2013, 3. Accessed December 16, 2015. [https://www.usaid.gov/sites/default/files/documents/1871/survey\\_afghan\\_women\\_mobile.pdf](https://www.usaid.gov/sites/default/files/documents/1871/survey_afghan_women_mobile.pdf).

<sup>1323</sup> Mobile Alliance for Maternal Action. Accessed December 16, 2015. <http://mobilemamaalliance.org/who-we-are>.

IVR4BABY project simply applied existing technology to the health sector to address an important – even dire – need.

## Conclusion

For INSY Group, these research pilot projects provided a unique understanding of the Afghan public health infrastructure and daily operations. Working closely with the DEWS officials and the midwife directors, INSY Group members witnessed the strengths, weaknesses, enthusiasm, and fears of local Afghans in employing and utilizing ICT for development programs. While the ability to establish sustainable efforts and prioritize needs were two of the greatest cultural challenges faced in each project, the eagerness to learn and compassion exhibited by every Afghan in wanting to help their fellow citizens was universal.

## Chapter 17 ICT for Gender Equality

---

Karen E. Black

*Author's Note: Some of the text below is excerpted directly or paraphrased from documents previously written by the author.*

### Introduction

Although they are far better off today than under the repressive Taliban regime from 1996 to 2001, Afghan women are undeniably still among the most disadvantaged in the entire world. As recently as 2011, Afghanistan was ranked as the most dangerous place in the world for women,<sup>1324</sup> and violence against Afghan women peaked in 2013.<sup>1325</sup> Only a quarter of Afghan women are literate, compared to 52 percent of men.<sup>1326</sup> Thirty-five percent of Afghan girls were enrolled in secondary school in 2014 and nearly two percent in university. Comparatively, 61.5 percent of Afghan boys attended high school and 5.5 attended college.<sup>1327</sup> Although the Afghan Constitution affords women equal rights, they do not necessarily enjoy these rights in practice. Half of Afghanistan's population is female,<sup>1328</sup> mirroring the population of the rest of the world. As Cherie Blair, founder of the [Cherie Blair Foundation for Women](#), so clearly stated, "We can't afford to ignore half the population."<sup>1329</sup> And that is true in Afghanistan ... particularly if it wants to become a stable, peaceful, and prosperous society.

### The Importance of Women's Access to Information

Access to information is **critical** to the empowerment of women. Studies of developing countries show that gender equality is not only a human right and morally just, "it is a socio-economic imperative."<sup>1330</sup> There is a plethora of empirical evidence that "links gender equality to increased prosperity and

---

<sup>1324</sup> Anderson, Lisa (2011). "TRUSTLAW POLL – Afghanistan is most dangerous country for women." *Thomson Reuters Foundation News*, June 15. Accessed September 7, 2016. <http://news.trust.org/item/?map=trustlaw-poll-afghanistan-is-most-dangerous-country-for-women/>.

<sup>1325</sup> Mashru, Ram (2014). "Violence Against Women in Afghanistan Peaked in 2013." *The Diplomat*, January 14. Accessed September 7, 2016. <http://thediplomat.com/2014/01/violence-against-women-in-afghanistan-peaked-in-2013/>.

<sup>1326</sup> United States Central Intelligence Agency (CIA) (2015). *The World Factbook: Afghanistan*. Accessed September 7, 2016. <https://www.cia.gov/library/publications/the-world-factbook/geos/af.html>.

<sup>1327</sup> The World Bank Gender Data Portal: Afghanistan. Accessed September 7, 2016. <http://datatopics.worldbank.org/gender/country/afghanistan>.

<sup>1328</sup> Islamic Republic of Afghanistan Central Statistics Organization (ACSO). Accessed March 9, 2015. <http://cso.gov.af/Content/files/2-1.pdf>.

<sup>1329</sup> Blair, Cherie (2012). "We Can't Afford to Ignore Half the Population." *HuffPost Lifestyle* (blog), September 27, (updated November 26, 2012). Accessed March 2, 2016. [http://www.huffingtonpost.co.uk/cherie-blair/we-cant-afford-to-ignore-half-the-population\\_b\\_1918302.html](http://www.huffingtonpost.co.uk/cherie-blair/we-cant-afford-to-ignore-half-the-population_b_1918302.html).

<sup>1330</sup> United Nations Secretary-General Ban Ki-moon (2010). "More than Basic Human Right, Equality is Social, Economic Imperative, Secretary-General Says in Statement on Creation of 'UN Women.'" United Nations, July 2. Accessed March 2, 2016. <http://www.un.org/press/en/2010/sgsm12991.doc.htm>.



security.”<sup>1331</sup> The International Telecommunication Union (ITU) recognizes that information and communications technologies (ICTs) are “tools through which gender equality and women’s empowerment can be advanced.”<sup>1332</sup> In order for women to become a power base for stability, peace, and prosperity in Afghanistan, Afghan women need information and communications technology. ICT allows women insight into issues that directly affect them *without censorship or distortion*. ICT broadens women’s perspectives and gives them a greater understanding of their situations and how to overcome them. ICT decreases the isolation of marginalized women and offers interaction with and inclusion into society. ICT allows women to communicate freely and, quite literally, gives them a voice.

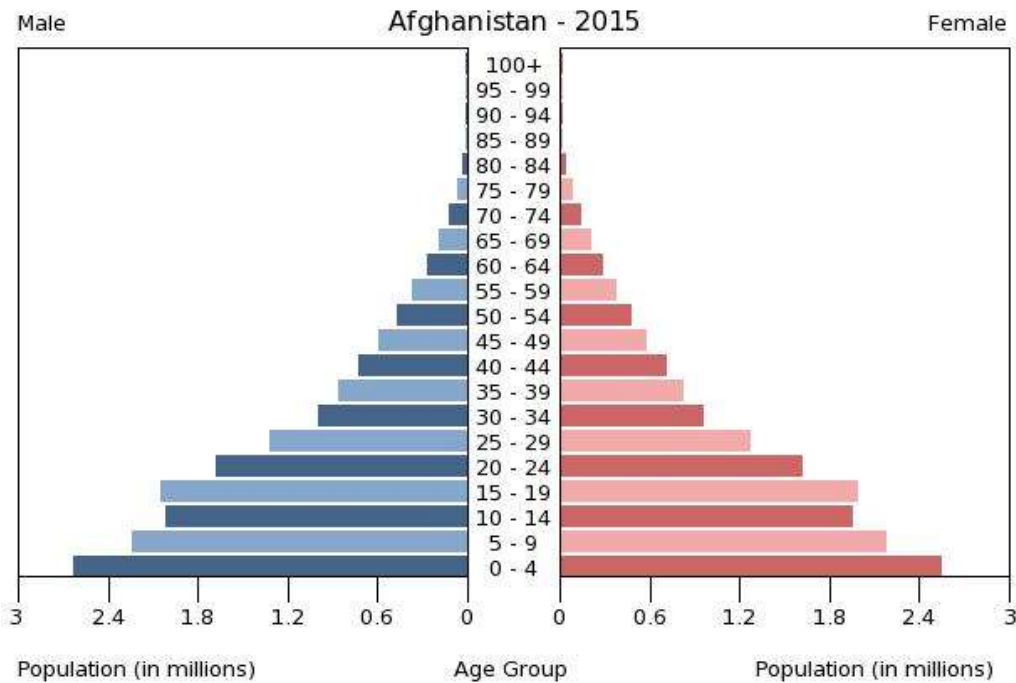

Figure 93: Afghanistan's population by age group and gender, 2015

## The Digital Gender Divide

ICT opens up whole new worlds for women and girls and affords them opportunities like never before. Studies show ICT can be particularly transforming – and even transcendent – for women, extending their worlds beyond the limits of ordinary experience. However, empirical studies show women in the

<sup>1331</sup> Clinton, Hillary Rodham (2010). “Remarks on Evidence and Impact: Closing the Gender Gap.” Gallup, Washington, DC, July 19. Accessed March 2, 2016.

<http://www.state.gov/secretary/20092013clinton/rm/2012/07/195244.htm>.

<sup>1332</sup> “Gender equality and the empowerment of women and girls through ICT.” International Telecommunication Union. Accessed September 17, 2016. <http://www.itu.int/en/action/gender-equality/Pages/default.aspx>.

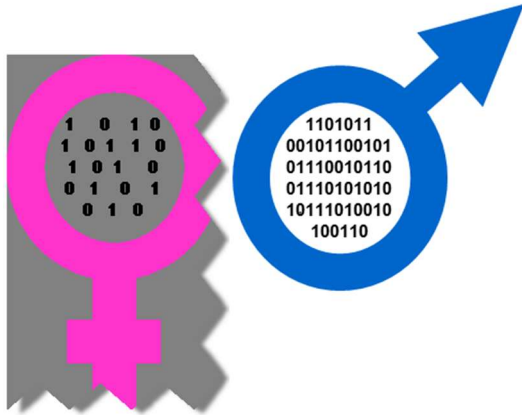

Figure 94: The digital gender divide

developing world have significantly lower technology participation rates than men,<sup>1333</sup> a “digital gender divide.” The digital gender divide is the difference in women’s and girls’ access to and use of information and communications technologies, as well as the lack of relevant ICT content for them, and a skills gap in using them.

Typical barriers for women and girls regarding the use of ICT, but are certainly not limited to:

- Social attitudes and norms;
- A lack of dedicated (female only), or at least culturally-acceptable, facilities, such as retail phone shops, public call offices (PCOs), computer labs, and Internet cafés;
- Low literacy and education levels;
- An inability to travel to ICT centers (because they are not allowed, travel is unsafe, they have no transportation, they prohibited from driving, etc.);
- Household responsibilities and family obligations (or prohibitions);
- No time or opportunity to learn to use technology; and
- Cost.

Unless the digital gender divide is specifically addressed, ICT may actually *exacerbate* existing inequalities and even create new ones.<sup>1334</sup> ICT can actually *reinforce* and *reproduce* patterns of gender segregation unless women and girls enjoy digital inclusion. To quote one study, “The gender divide is one of the most significant inequalities to be *amplified* by the digital revolution.”<sup>1335</sup>

It is not enough to have separate gender and ICT policies. ICT policy must be *specific to women* and *ensure women benefit from ICT*. Unfortunately, however, “women are under-represented in all decision-making structures in the ICT sector,”<sup>1336</sup> in developing as well as developed countries. For Afghan women to benefit from ICT for social and economic empowerment, they must have affordable access to ICT and

<sup>1333</sup> Antonio, Amy and David Tuffley (2014). Review of “The Gender Digital Divide in Developing Countries.” *Future Internet*, September 2 (revised October 16). 6(4), 673-687; doi:10.3390/fi6040673. Accessed September 17, 2016. <http://www.mdpi.com/1999-5903/6/4/673/htm>.

<sup>1334</sup> United Nations Division for the Advancement of Women, Department of Economic and Social Affairs (2005). *Gender equality and empowerment of women through ICT*. United Nations, September 2005, 3. Accessed March 2, 2016. <http://www.un.org/womenwatch/daw/public/w2000-09.05-ict-e.pdf>.

<sup>1335</sup> Primo, Natasha (2003). *Gender Issues in the Information Society*. UNESCO Publications for the World Summit on the Information Society. Accessed March 2, 2016. [http://portal.unesco.org/ci/en/file\\_download.php/250561f24133814c18284feedc30bb5egender\\_issues.pdf](http://portal.unesco.org/ci/en/file_download.php/250561f24133814c18284feedc30bb5egender_issues.pdf).

<sup>1336</sup> Nicol, Chris (2003). *ICT Policy: A Beginner’s Handbook*. The Association for Progressive Communications, December.

considerable training on it, and there must be content and applications that are relevant to women's wants and needs. That's a tall order, considering Afghanistan has little of any of the above.

Over half of all Internet users worldwide (53.2 percent) are between the ages of 15 and 34.<sup>1337</sup> As of 2013, 1.5 billion of the world's Internet users were male, while only 1.3 billion were female,<sup>1338</sup> and "the gap between male and female online users widens rapidly in the developing world ..."<sup>1339</sup> Women are estimated to comprise 25 percent or less of Internet users in Africa, 22 percent in Asia, 38 percent in Latin America, and a mere 6 percent in the Middle East.<sup>1340</sup> Four times as many Afghan men as women use a computer and the Internet.<sup>1341</sup>

Globally, females are, on average, 21 percent less likely to own mobile phones, representing a gender gap of 300 million.<sup>1342</sup> In Afghanistan, 48 percent of women reported owning mobile phones.<sup>1343</sup> While the percentage surprised some, women still lag well behind Afghan males.

A comparison of female Afghan Facebook users to female Facebook users in neighboring and similarly poor countries<sup>1344</sup> showed Afghan females ranked well below their sisters in both as indicated in [Figure 95](#).

---

<sup>1337</sup> "Distribution of internet users worldwide as of November 2014, by age group." Statista. Accessed March 2, 2016. <http://www.statista.com/statistics/272365/age-distribution-of-internet-users-worldwide/>.

<sup>1338</sup> "Male Internet users outnumbered female: United Nations report." (2013). *Indo-Asian News Service*, September 23. Accessed March 2, 2016. <http://gadgets.ndtv.com/internet/news/male-internet-users-outnumber-female-united-nations-report-422381>.

<sup>1339</sup> Ibid.

<sup>1340</sup> Antonio and Tuffley, 2014.

<sup>1341</sup> Hopkins, Nancy ed (2013). *Afghanistan in 2013: A Survey of the Afghan People*. (The Asia Foundation), 12. Accessed March 2, 2016. <https://asiafoundation.org/resources/pdfs/2013AfghanSurvey.pdf>.

<sup>1342</sup> Ibid.

<sup>1343</sup> USAID (2013). *Connecting to Opportunity: A Survey of Afghan Women's Access to Mobile Technology*. May 22, 2013, 3. Accessed March 2, 2016. [https://www.usaid.gov/sites/default/files/documents/1871/survey\\_afghan\\_women\\_mobile.pdf](https://www.usaid.gov/sites/default/files/documents/1871/survey_afghan_women_mobile.pdf).

<sup>1344</sup> Using data current as of February 2013 from *Socialbakers.com* and the World Bank's poorest countries as of May 2012.

### Regional Countries

	<u>Pakistan</u>	<u>Uzbekistan</u>	<u>Afghanistan</u>	<u>Turkmenistan</u>	<u>Tajikistan</u>
Total Facebook users	8,055,680	160,920	421,300	10,900	41,880
% Change in past six months	5.76%	2.59%	15.79%	18.53%	2.10%
Position in the list	28	136	110	195	169
Penetration of population	4.37%	0.58%	1.45%	0.22%	0.56%
Penetration of online population	27.66%	2.93%	33.53%	9.83%	4.14%
Male	70%	64%	84%	70%	70%
Female	30%	36%	16%	30%	30%
Largest age group	18-24	18-24	18-24	25-34	18-24

### World Bank's Poorest Countries

	<u>Togo</u>	<u>Madagascar</u>	<u>Afghanistan</u>	<u>Guinea</u>	<u>Mozambique</u>
Rank on poorest countries list	10	11	12	13	14
Total Facebook users	114,420	284,400	421,300	69,560	330,720
% Change in past six months	6.53%	3.30%	15.79%	13.77%	-7.55%
Position in the list	144	119	110	159	115
Penetration of population	1.85%	1.34%	1.45%	0.67%	1.50%
Penetration of online population	37.48%	80.76%	33.53%	69.69%	33.91%
Male	74%	57%	84%	71%	68%
Female	26%	43%	16%	29%	32%
Largest age group	18-24	18-24	18-24	18-24	18-24

Figure 95: Female Afghan Facebook users compared to other countries

## ICT Efforts for Afghan Women

There *are* some ICT efforts specifically for women in Afghanistan. Through its corporate social responsibility (CSR) arm, Afghan mobile network operator Roshan began a [Women's Public Call Offices \(WPCO\)](#) project whereby Afghan women can get micro-loans and enjoy subsidized calling rates to start and run call shops. The female CEO of an Afghan IT company and her Digital Citizen Fund foundation have installed a dozen or so "Internet schools" for Afghan women and girls in Kabul and Herat. There was a pilot project to train 200 Afghan National Policewomen to read and write through level 3 (essentially our third grade) using basic feature phones and a free content authoring platform from [Ustad Mobile](#), an education technology company whose CEO spent seven years in Afghanistan. (Incidentally, Ustad Mobile means "mobile teacher" in Dari). A relatively new organization, TechWomen Afghanistan, encourages young Afghan women to study ICT and work in the field and is attempting to develop leadership among women already in the sector (see [Chapter 6, ICT Organizations and Associations](#)).

The American University of Afghanistan (AUAF) houses a state-of-the-art [International Center for Afghan Women's Economic Empowerment](#) "dedicated to advancing the role of women in Afghanistan's economy. The center ... incubate[s] female-led small and medium-sized businesses, provide[s] business training to female entrepreneurs, funnel[s] investment capital to promising women-run businesses, and provide[s] women access to all the business and information technology (IT) assets at [AUAF]. These assets include a [Professional Development Institute](#), which offers myriad ICT courses, and a [Business Innovation Hub](#).

## The TAT's Gender Engagements and Accomplishments

As part of its major line of effort to employ ICT as an enabler of stability by underpinning socio-economic development and growth, the ISAF Telecommunications Advisory Team (TAT) worked with and in support of several programs regarding ICT for gender equality. (See [Chapter 21](#) and [Chapter 22](#) for more information on the TAT). Reportedly, there are more NGOs for women than for any other sector, group, or cause in Afghanistan. However, very few of them involve ICT, except as it relates to basic computer training. The TAT's gender work streams fell into two overarching categories: promoting women in ICT and using ICT to empower women.

Throughout its ICT for gender equality efforts, the TAT engaged with numerous organizations, including but not limited to the International Security Assistance Force (ISAF) gender advisors, the Deputy Chief of Staff of Stability and Development (DCOS-STAB-DEV) Gender Advisors; the the US Ambassador-at-Large for Global Women's Issues and the US Department of State (DoS) [Office of Global Women's Issues](#); the Cultural Affairs Office and Public Affairs Section of the [US Embassy Kabul](#); the United States Agency for International Development (USAID), which has [gender equality and women's empowerment](#) as a global focus area; the US Department of Defense's (DoD's) Task Force for Business and Stability Operations' (TFBSO's) Director of Women's Economic Advancement Initiatives; gender advisors and other representative from various donor governments, non-government organizations (NGOs) and the private sector; the Afghan [Ministry of Women's Affairs](#) (MoWA); and gender advisors at the headquarters of the North Atlantic Treaty Organization (NATO) the Supreme Headquarters Allied Powers Europe (SHAPE).

With regards to women in ICT, the TAT mentored the CEO of an Afghan-woman-owned software development and IT services company, Roya Mahboob, who was one of *TIME* magazine's 2013 most influential people in the world.<sup>1345</sup> The TAT introduced women in ICT to representatives at [Checci and Company Consulting](#) and [Development Alternatives, Inc.](#) (DAI), both USAID contractors, who were conducting research in 2012 on how better to include gender mainstreaming in ICT efforts and how to improve future gender and economic engagement programming for women in ICT, respectively.

### The TAT's Gender Efforts within ISAF

The TAT helped to plan and facilitate speakers at and participants for ISAF's "Afghan First Policy Workshop" for women in December 2011, at which a TAT advisor moderated a panel on challenges faced by Afghan women in ICT. In late December that year, ISAF released a FRAGO<sup>1346</sup> with the aim of increasing participation by women in its contracting processes, which the TAT reviewed. ISAF hosted several events for [International Women's Day](#) on March 8, 2012, and ISAF Joint Command (IJC) held the first National Women's Shura in Kabul on April 23, 2012, though neither of the events had an ICT component.

---

<sup>1345</sup> Sandberg, Sheryl (2013). "Roya Mahboob." "The 2013 TIME 100." *TIME* magazine, April 18. Accessed March 2, 2016. <http://time100.time.com/2013/04/18/time-100/slide/roya-mahboob/>.

<sup>1346</sup> Fragmentary Order, used to send timely changes of an existing order, without reissuing it in its entirety, to subordinate and supporting commanders while providing notification to higher and adjacent commands.

The TAT regularly participated in the weekly ISAF Gender Working Group, which included gender advisors from ISAF, IJC, the NATO Training Mission-Afghanistan (NTM-A), the US Embassy Kabul, and other entities, and attended weekly Gender Coordination Meetings. The TAT worked with the ISAF gender advisors to institutionalize the need to address Afghanistan’s digital gender divide in ISAF Operations Plan (OPLAN) 38302 Revision 6.2.

A TAT advisor represented the ISAF gender community as a presenter and an Afghan panelist at a NATO Building Integrity Conference on “Women’s Role in reducing the Risk of Corruption, and Promoting Good Practices in the Defence and Security Sector” at NATO headquarters in Brussels in March 2013. The TAT briefed the Commander of ISAF using ICT for gender equality and to achieve stability in October 2012, and the TAT shared the same brief with officials from SHAPE in March 2013.

### Etisalat mHawala Agent Program

With regards to using ICT to empower women, the TAT supported the efforts by mobile network operator [Etisalat](#) beginning in the fall of 2011 to create an agent program for women in conjunction with the Afghan Ministry of Women’s Affairs (MoWA) and USAID’s Financial Access for Investing in the Development of Afghanistan (FAIDA) program, which was to include business, English, and technical training, microloans (to be paid back through mobile money), discounted equipment and airtime, and other resources for women, such as daycare and health and legal advice. Etisalat and MoWA signed a memorandum of understanding on March 8, 2012, International Women’s Day. However, the program did not get off the ground for many years. Once it launched, Etisalat planned to create 1,500 Afghan businesswomen by the first quarter of 2014,<sup>1347</sup> though it is unclear if they accomplished that goal.

### USAID Survey of Afghan Women and Mobile Phones

In March 2012, USAID released its [Gender Equality and Female Empowerment Policy](#), in which “harness[ing] science, technology, and innovation to reduce gender gaps and empower women and girls” is one of its seven guiding principles. The TAT worked with USAID’s Senior Afghanistan Policy Advisor in Washington, DC and in-country USAID gender contacts to support USAID’s efforts with regards to ICT for women per its new policy.

Also in March 2012, the GSMA’s [mWomen Program](#), a public-private partnership between the worldwide mobile industry and the international development community, released a [report](#) about how mobile technologies could be used to benefit women. The goal of the mWomen program, launched in 2010, was “to reduce the mobile phone gender gap by 50 percent by 2014, bringing mobile connectivity and services to more than 150 million women in emerging markets.”<sup>1348</sup> A previous [report](#) indicated that, worldwide,

---

<sup>1347</sup> Etisalat. Accessed September 17, 2016. <http://www.etisalat.af/women-empowerment>.

<sup>1348</sup> GSMA mWomen (2011). *Striving and Surviving: Exploring the Lives of Women at the Base of the Pyramid*. March 8, 2011. Accessed March 2, 2016. <http://www.mwomen.org/Research/striving-surviving-exploring-the-lives-of-women-at-the-base-of-the-pyramid>.

300 million fewer women than men own mobile phones and that in Afghanistan, a woman is 78 percent less likely to own a mobile phone than a man, the largest mobile gender gap in the world.<sup>1349</sup>

Consequently, USAID funded a survey of Afghan women's mobile phone ownership and use in the fall of 2012 that involved 2,000 women, 60 percent urban, 40 percent rural. The resultant report<sup>1350</sup> indicated, encouragingly so, that 80 percent of Afghan women surveyed have phones or access to one. Nearly all the respondents claim not to fear technology, and 88 percent of women without phones say they would acquire them if cultural and cost barriers were removed.<sup>1351</sup> While the results were better than many people – this author included – expected them to be, Afghan men are still three times more likely to own phones than their female counterparts, and just over a quarter of Afghan women have SIMs<sup>1352</sup> registered in their names. Cultural and institutional inhibitors and cost continue to be the biggest obstacles for Afghan women.<sup>1353</sup>

Key findings of USAID's survey of Afghan women's mobile phone ownership include the following.

- 48 percent of Afghan women reported owning a mobile device.
- 32 percent of Afghan women said they could borrow phones when needed.
- 67 percent of Afghan women who own mobile phones acquired them in the two years prior to the survey.
- Social norms (53 percent) and cost (49 percent) are the two greatest barriers to access to mobile phones for Afghan women.
- 94 percent of Afghan women surveyed say they do not fear technology.
- 88 percent say if social and cost barriers were removed, they would acquire mobile phones.
- 30 percent of the women surveyed can read text messages.
- 25 percent of Afghan women use their phones to access social and commercial services.<sup>1354</sup>

A TAT advisor sat on the Steering Committee for the survey, met with the company doing the actual surveys, reviewed the report pre-publication, and helped to plan an event to launch the findings.

---

<sup>1349</sup> GSMA mWomen (2009). *Women & Mobile: A Global Opportunity: A study on the mobile phone gender gap in low and middle-income countries*. Accessed March 2, 2016. [http://www.gsma.com/mobilefordevelopment/wp-content/uploads/2013/01/GSMA\\_Women\\_and\\_Mobile-A\\_Global\\_Opportunity.pdf](http://www.gsma.com/mobilefordevelopment/wp-content/uploads/2013/01/GSMA_Women_and_Mobile-A_Global_Opportunity.pdf).

<sup>1350</sup> USAID (2013). *Connecting to Opportunity: A Survey of Afghan Women's Access to Mobile Technology*, May 22, 2013, 3. Accessed December 16, 2015.

[https://www.usaid.gov/sites/default/files/documents/1871/survey\\_afghan\\_women\\_mobile.pdf](https://www.usaid.gov/sites/default/files/documents/1871/survey_afghan_women_mobile.pdf).

<sup>1351</sup> Ibid.

<sup>1352</sup> Subscriber identity module, a removable smart card for some mobile phones that stores identifying information regarding the phone and associated customer account.

<sup>1353</sup> Ibid.

<sup>1354</sup> Ibid.

## ITU Gender Efforts



On April 25, 2012, the ITU launched a “Tech Needs Girls” campaign in an effort to “attract greater participation of girls in the technology sector ... [and] ... achieve greater empowerment, equality, education and employment for girls through greater access to opportunities in the world of information and communication technologies (ICTs).”<sup>1355</sup> In conjunction with its global [Girls in Tech](#) program, the ITU also immortalized April 26<sup>th</sup> as “Girls in Tech Day” going forward. As ITU Secretary-General, Dr. Hamadoun Touré stated, “Over the coming decade, there are expected to be two million more ICT jobs than there are professionals to fill them. This is an extraordinary opportunity for girls and young women ...”<sup>1356</sup> Since Afghanistan is already struggling to meet its demand for skilled ICT workers (see [Chapter 19](#) and [Chapter 20](#) about ICT capacity building in Afghanistan), the TAT embarked upon a concerted effort to increase participation by women and girls in ICT.

The ITU Council launched the year of “Women and Girls in ICT” on World Telecommunications and Information Society Day (WTISD), May 17, 2012. ITU Secretary-General Dr. Hamadoun Touré stated the ITU would “focus our efforts [that] year on women and girls, using the power of ICTs to provide new digital opportunities to end discrimination and empower women and girls to achieve their rightful place as equals in the world. This effort with ICTs must begin not only from the cradle, but from antenatal health care,



Picture 47: The MCIT celebrates the WTISD theme of “Women and Girls in ICT’ ... kind of

<sup>1355</sup> International Telecommunication Union (ITU) (2012). “Tech Needs Girls: World leaders draw up roadmap for female tech education and careers push.” April 26. Accessed March 2, 2016. [http://www.itu.int/net/pressoffice/press\\_releases/2012/21.aspx](http://www.itu.int/net/pressoffice/press_releases/2012/21.aspx).

<sup>1356</sup> Ibid.



reaching out to the remotest communities through telemedicine and other means — with every mother, every girl, and every woman guaranteed her birthright.”<sup>1357</sup>

## Gender Efforts at the MCIT

The Ministry of Communications and Information Technology’s (MCIT’s) celebration of World Telecommunications and Information Society Day (WTISD), held on May 16, 2012, was supposed to promote the theme of “Women and Girls in ICT” (see [Picture 47](#)). The TAT suggested several female participants, whom the MCIT invited. Unfortunately, there was little mention of women and girls at the event, and the only female panelist was not even in the ICT sector. However, the MCIT said it would donate seventy percent (70 percent) of the proceeds from the event (garnered through sponsorships from the private sector) toward establishing a computer lab at a location of the Ministry of Women’s Affairs choosing. Despite valient efforts, the author could not confirm with either the MCIT or MoWA this actually happened.

In 2003, the Afghan Transitional Administration’s (ATA’s) stated policy was “to enable the rapid growth of affordable communications to all of our people so they may experience the Digital Age, wherever they are and whoever they may be.”<sup>1358</sup> As such, the TAT approached the MCIT about increasing participation by women in girls in ICT throughout Afghanistan. The TAT proposed the idea of potentially using money from the Telecommunications Development Fund (TDF) to create and implement programs employing ICT for gender equality and women’s empowerment. The TDF, also known as a Universal Service Fund, is a pool of money fed by quarterly contributions from Afghanistan’s service providers (2.5 percent of their adjusted gross revenues) and administered by the Afghanistan Telecom Regulatory Authority (ATRA). It is used to fund Afghanistan’s Rural Telecommunications Development program, among other endeavors included in its mandate. One of the TDF’s objectives is to enable the Afghan government to fulfill its international universal access/universal service obligations, of which access by women and girls is a component. ATRA had recently earmarked US\$5 million each for ICT projects in education and health, and the MCIT signed memoranda of understanding with the Ministries of Education, Higher Education, and Public Health to implement them. The MCIT and ATRA, however, were unwilling to do the same regarding ICT for gender equality, despite evidence the TAT produced of similar such TDF-funded programs in other countries such as in India and across the African continent. The MCIT was largely a Pashto organization, and the Pashtuns, Afghanistan’s largest ethnic tribe and generally considered the “original” Afghans, are very conservative in their views of women, which may have been among the reasons.

---

<sup>1357</sup> Message from ITU Secretary General Touré. Accessed March 2, 2016.

<http://www.itu.int/en/wtisd/2012/Pages/toure.aspx>.

<sup>1358</sup> Islamic Transitional Government of Afghanistan Ministry of Communications (MoC). Telecommunications and Internet Policy, Final Working Draft, November 2003. Accessed August 19, 2015.

[http://mcit.gov.af/Content/files/AfghanistanTelecomPolicy\\_English29112010235311722.pdf](http://mcit.gov.af/Content/files/AfghanistanTelecomPolicy_English29112010235311722.pdf).

## USAID Women in Government Internship Program

According to USAID, only 20 percent of the Afghan government’s 333,000 employees are female.<sup>1359</sup> USAID originally launched its Women In [sic] Government (WIG) program in February 2010 to increase Afghan women’s ability “to participate fully in Afghan society by providing internships to recent female university graduates with the goal of transitioning them into full-time positions in the public and private sectors.”<sup>1360</sup> As described in [Chapter 19](#) and [Chapter 20](#), the WIG program placed female college graduates in six-month paid (by USAID) internships in government. USAID provided training and equipment (laptops, mobile Internet access). Recipient entities were asked to provide workspace, relevant on-the-job training, and, if possible, transportation and meals, which may be either free or available for a fee (to be paid by the interns).

The TAT introduced the WIG program to leadership at the MCIT, ATRA, and state-owned Afghan Telecom Corporation (AfTel) but only got traction at AfTel. AfTel hired eight interns in late 2012. Four of the women were staffed in AfTel’s procurement department and the others were in various non-technical positions, reportedly only because of AfTel’s immediate needs. AfTel’s COO was exceptionally pleased with the interns’ performance and planned to bring an additional dozen or so on board in early 2013. He also stated he was open to hiring interns into technical positions in the future should AfTel have positions available and the WIG program have qualified candidates. (WIG’s activities and interns were predominantly geared toward the finance sector). The COO expected most, if not all, of the interns would be hired into permanent positions; however, it is unclear if that occurred, or if any additional interns were hired.

## TechWomen Afghanistan

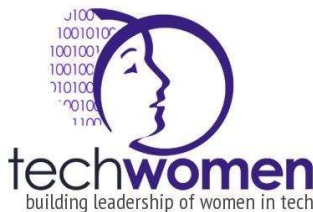

TechWomen Afghanistan is “a multi-stakeholder platform for women aimed at increasing women’s participation in technology, governance, civil society and business through the use of various information communication technology (ICT) disciplines”<sup>1361</sup> with the goal of increasing leadership in technology among young Afghan women. TechWomen was launched in September 2012 and boasts

150 members – all women in technology. The TechWomen Summit 2015, held in Kabul in December 2015, included 300 professional women representing a broad swath of Afghan society. Speaking at the event, Shabana Mansoor, one of the group’s founders, said, “Incorporating women into this process of technological advancement will be crucial for sustainability and genuine progress.”<sup>1362</sup>

---

<sup>1359</sup> USAID. Women In Government (WIG) Factsheet. Accessed January 7, 2015. <http://www.usaid.gov/news-information/fact-sheets/women-government-internship-program>.

<sup>1360</sup> Ibid.

<sup>1361</sup> From TechWomen Afghanistan’s former website, previously retrieved by the author.

<sup>1362</sup> “Kabul Summit Promotes Women’s Involvement in Technology.” 2015. United Nations Assistance Mission in Afghanistan (UNAMA), December 17. Accessed September 7, 2016. <http://unama.unmissions.org/kabul-summit-promotes-women%E2%80%99s-involvement-technology>.

Among the benefits TechWomen Afghanistan offers its members are:

- Awareness of the latest technologies;
- Training on critical topics, including ICT, leadership, management, entrepreneurship, and finance;
- Career guidance and mentoring;
- Internship opportunities with various government institutions and private sector companies;
- Scholarship and fellowship opportunities in ICT; and
- Networking with peers.

Furthermore, TechWomen Afghanistan develop plans and programs to improve the participation of women in ICT and support institutions in addressing the special needs of women and ICT.

### Project Gateway Family Support Hotline

On January 30, 2013, [Strategy Analysis Action Transnational Trends \(STATT\)](#) and [Afghanistan Capacity Development and Educational Organization \(ACDEO\)](#) launched Project Gateway, which was originally funded by the Canadian Embassy, had the support of the Afghan Ministry of Women's Affairs, and was monitored by the [Afghan Women's Network](#). Project Gateway is a toll-free family support hotline staffed



Picture 48: Project Gateway call center station

(Photo courtesy of Karen Black)

by a team of advisors educated in law, social work, and counseling. The program was conceived and designed to overcome barriers to reaching families in need, particularly those that are physically and culturally isolated. It was geared toward women, but was named a “family” line specifically to disassociate it from “women’s issues” and the negativity and potential threats surrounding such.

By dialing short code<sup>1363</sup> 6464, callers reach a call center where they can get legal advice and counseling, ask questions about religion and what the Q’uran really says, and be referred to services and resources offered by the Afghan government, non-governmental

organizations, and other entities. As testament to the value and promise of this program, in the days leading up to the official launch during which advisors were taking calls in preparation to go live, a father called the hotline on behalf of his daughter, who was having marital difficulties because of an abusive husband. The daughter then spoke to an advisor herself, who referred her to an association of attorneys.

---

<sup>1363</sup> Short codes are like 911 and 411 in the US and 999 in the UK.

At the launch ceremony, that recorded call was played as an example, and a representative from the Attorney General's office who was in attendance confirmed the young lady had already filed for divorce. The project organizers were having difficulty obtaining the short code, so the TAT interceded with ATRA on their behalf and were able to have ATRA expedite the approval processes.

According to STATT:

- In its first seven weeks of operation, the hotline responded to more than 2,300 callers. The hotline served just over 19,000 people in its first year.
- The hotline was piloted and began outreach for its services in the Eastern region and quickly received calls from all 34 provinces, without advertising anywhere else.
- A slight majority of callers are men and the reasons cited for calls are very similar, irrespective of whether the caller is male or female.
- At least 25 percent of callers have called back to say thank you for the service provided and many are repeat callers. Some of the cases have resulted in legal action.<sup>1364</sup>

## Conclusion, Lessons Observed, and Recommendations

As a developing nation emerging from decades of conflict and strife, Afghanistan must take advantage of every opportunity to accelerate its reconstruction and transformation and improve its economic situation. Recent research indicates that “getting women into the workforce correlates with higher growth ... and can yield far better growth than conventional market reforms.”<sup>1365</sup> A recent in Dubai argued that putting “two million of the Gulf region's women into paid work would boost the GDP of the Gulf countries by 30 percent - or US\$363 billion.”<sup>1366</sup> Women who are empowered become solutions to poverty, poor health, and vulnerability for their families and within their communities.<sup>1367</sup>

The Afghan ICT sector is thriving, with mobile services coverage and mobile penetration at nearly 90 percent each.<sup>1368,1369</sup> Thirty-six percent of Afghans reportedly live in areas with Internet access.<sup>1370</sup> There

---

<sup>1364</sup> Hayes, Ceri (n.d.). “Tackling Gender-Based Violence with Technology.” Accessed March 2, 2016.

[http://www.genderit.org/sites/default/upload/statt\\_tackling\\_gbv\\_with\\_technology.pdf](http://www.genderit.org/sites/default/upload/statt_tackling_gbv_with_technology.pdf).

<sup>1365</sup> Power, Carla (2012). “The Price of Sexism” *TIME* magazine, June 4.

<sup>1366</sup> Ibid.

<sup>1367</sup> “Great courage and PCI are Empowering Women.” Accessed September 17, 2016.

[https://www.pciglobal.org/empowering-women/?gclid=Cj0KEQjw9vi-BRCx1\\_GZgN7N4voBEiQAaACKVpulKkd6lP4Rn9WI4Vw-Kzx5g4ND28LmBq2SvCeOyssaAm088P8HAQ/](https://www.pciglobal.org/empowering-women/?gclid=Cj0KEQjw9vi-BRCx1_GZgN7N4voBEiQAaACKVpulKkd6lP4Rn9WI4Vw-Kzx5g4ND28LmBq2SvCeOyssaAm088P8HAQ/).

<sup>1368</sup> Afghanistan Telecom Regulatory Authority (ATRA). Telecom Statistics (End of December 2015). Accessed March 16, 2016. <http://atra.gov.af/en/page/telecom-statistics-2013>. ATRA updates this statistics page quarterly or thereabouts, without preserving historical reference to earlier periods on its website.

<sup>1369</sup> Using a total population (nomadic and settled) of 28,601,365, per ACSO's 2013-2014 Statistical Yearbook, accessed January 5 and August 23, 2016, [http://cso.gov.af/Content/files/Population\(3\).pdf](http://cso.gov.af/Content/files/Population(3).pdf), and 25,375,284 mobile subscribers, per ATRA's Telecom Statistics (End of December 2015). The number of subscribers can be slightly misleading, as some people have more than one SIM card while others have none.

<sup>1370</sup> Per the MCIT.

are at least two million Afghan Internet users<sup>1371</sup> and nearly two million 3G<sup>1372</sup> mobile broadband subscribers.<sup>1373</sup> As indicated earlier, fewer than 50 percent of Afghan women own basic feature phones, and even fewer have smartphones, which precludes them from experiencing the benefits of Afghanistan's 3G mobile broadband revolution. Significantly, and of particularly relevance here, Deloitte reported a 10 percent change from 2G<sup>1374</sup> to 3G increased GDP<sup>1375</sup> per capita by 0.15 percent.<sup>1376</sup> Afghanistan REALLY CAN'T AFFORD to ignore half its population.

According to the Asia Foundation, only 12 percent of Afghan households report owning computers as of 2012,<sup>1377</sup> the last year it included computer ownership in its survey of household assets. In its 2015 *Survey of the Afghan People*, the Asia Foundation reported just over a fifth – 21 percent – of respondents nationwide claim someone in their household has access to the Internet.<sup>1378</sup> Many Afghan women and girls are confined to their homes, so very few have a means to go online.

Rumors have circulated among the Afghan ICT expatriate community that President Ghani is looking for ways to get mobile phones into the hand of Afghan women on a massive scale. If he is able to do so, Afghanistan should consider employing [Ustad Mobile's](#) free content authoring platform to teach women and girls basic Dari and Pashto (reading and writing) – and anything else – on their phones, since three quarters of Afghan women are illiterate<sup>1379</sup> and only a third are enrolled in secondary school. (The Dari and Pashto literacy courses follow the Afghan Ministry of Education's curriculum and are free.)

There are vast donor dollars spent on a plethora of programs for Afghan women, but there are very few, if any, that are specifically designed to bridge the digital gender divide. Afghan women deserve the same digital opportunities as their male counterparts and the social inclusion they offer. There is certainly no lack of desire on their part. Every effort should be made specifically to increase access to and the use of ICT by Afghan women and girls.

---

<sup>1371</sup> Islamic Republic of Afghanistan Ministry of Communications and Information Technology (MCIT) (2014). *The Ministry of Communication and ITS' [sic] activities and achievements report 1381-1393 (2002-2014)*, English version, 32 (not available electronically).

<sup>1372</sup> Third-generation wireless digital technology based on International Telecommunication Union (ITU) International Mobile Telecommunications (IMT)-2000 specifications.

<sup>1373</sup> ATRA, Telecom Statistics (End of December 2015).

<sup>1374</sup> Second-generation wireless digital technology, which replaced first-generation analog systems.

<sup>1375</sup> Gross domestic product

<sup>1376</sup> Deloitte LLP (2012). *What is the impact of mobile telephony on economic growth?*. November 2012. Accessed June 7, 2014. <http://www.gsma.com/publicpolicy/wp-content/uploads/2012/11/gsma-deloitte-impact-mobile-telephony-economic-growth.pdf>.

<sup>1377</sup> Hopkins, Nancy, ed (2012). *Afghanistan in 2012: A Survey of the Afghan People*. (The Asia Foundation), 11. Accessed March 2, 2016. <https://asiafoundation.org/resources/pdfs/Surveybook2012web1.pdf>.

<sup>1378</sup> Warren, Zachary and Nancy Hopkins, eds. (2015). *Afghanistan in 2015: A Survey of the Afghan People* (The Asia Foundation), 11. Accessed January 6, 2016. <http://www.asiafoundation.org/resources/pdfs/Afghanistanin2015.pdf>.

<sup>1379</sup> 2015 estimate, CIA, 2015.

To that end, US Government and International Community planning for and execution of all future interventions should include adherence to United Nations Security Council Resolution (UNSCR) 1325, which “reaffirms the important role of women in the prevention and resolution of conflicts, peace negotiations, peace-building, peacekeeping, humanitarian response and in post-conflict reconstruction and stresses the importance of their equal participation and full involvement in all efforts for the maintenance and promotion of peace and security.” That planning and execution should include addressing, mitigating, and closing the digital gender divide. As proffered above, ICT is a “tool[] through which gender equality and women’s empowerment can be advanced.”<sup>1380</sup> The MCIT and ATRA should allow the Telecommunications Development Fund to be used for ICT programs to promote gender equality and empower Afghan women.

Afghanistan should also:

- Explicitly include women and girls amongst the beneficiaries of the ICT revolution.
- Include a gender perspective in all ICT initiatives.
- Promote gender-aware training and content development.
- Provide safe and secure online spaces for women and girls.
- Develop content applicable to and for women.
- Promote the global knowledge commons as part of a poverty reduction strategy.
- Include women in ICT decision-making.
- Promote science and technology education for women.
- Support women as ICT entrepreneurs.<sup>1381</sup>

ICT is the most expeditious and effective way to empower Afghan women and girls and allow them to become a power base for stability, peace, and prosperity in Afghanistan. The US Government and the International Community must acknowledge and accommodate this untapped potential by recognizing the importance of ICT for gender equality and expending resources to bridge the digital gender divide.

---

<sup>1380</sup> “Gender equality and the empowerment of women and girls through ICT.” International Telecommunication Union. Accessed September 17, 2016. <http://www.itu.int/en/action/gender-equality/Pages/default.aspx>.

<sup>1381</sup> From the Association for Progressive Communications’ Women’s Networking Support Programme. Accessed October 14, 2015. <http://www.apc.org/en/about/programmes/womens-networking-support-programme-apc-wnsp>.

## Chapter 18 The Role of Social Media in Civil Discourse

---

Eileen Guo

### Introduction

It is high summer in Herat, just after a delicious lunch prepared in honor of one of the family's adult sons, who has returned to visit from the United States. The dishes and the plastic "tablecloth," upon which Afghan meals are typically served, have been cleared, and the men have left the room.

Almost in slow motion, headscarves come off, bodies comfortably stuffed with food stretch out in the extra space, and some of the women start napping. Someone brings out glasses and pitchers of cool water. There is intermittent conversation among the younger women – the unmarried cousins, the sisters, the young wives, and myself, the foreign guest. Sometimes there is no conversation at all, just smiles and quiet, interrupted occasionally by a click as someone scrolls through her feature phone, or a ding as another receives a Facebook or email notification.

I watch with interest as one of the cousins, still in high school, motions to a sister-in-law to come join her. She shows her images on her iPhone, and they giggle and talk in hushed voices. I join them; the cousin scrolls through her photos: school friends – always female – posing in front of flowers, in parks on picnic blankets, or with arms around each other in the schoolyard.

The number of photos is limited, and when she is done, she points at mine, and I open my own photos. Together, we go through the pictures I have taken of Herat, of life in Kabul, and of my family and friends outside of Afghanistan. I have many photos, and it takes us some time to go through them, but when we do, the cousin asks me if I have Facebook, and then, navigating through my account, deftly adds herself to my friends list.

In my nearly three years of living in Afghanistan and visiting with a number of Afghan families, it is a scene that has often repeated itself. Sometimes with the men present, but more often in their absence, women and children spend many moments of their leisure time pulling out phones – their own, those of husbands or brothers, or the communal one of the family – and sharing their contents.

At first, I thought it was because I was a foreigner and my phone and its contents, in particular, were a curiosity. But as these visits continued, I saw that the social sharing was not just an exchange between the women and me, but between and among the various women and the children as well.

It was a reflection of the growing significance of social media in Afghanistan. Those photos, videos, and games (the latter of which were preferred by the children) represented an important way for Afghans to discover and interact with the outside world. With social mores as well as continued insecurity limiting the ability for most Afghans, especially Afghan women, to physically explore outside their immediate worlds, curious Afghans were turning to technology, and social media especially, as an alternative.

## Social Media by the Numbers

Accurate statistics on social media use in Afghanistan are hard to come by. Population figures from the ACSO estimate that the overall Afghan population for 2013-2014 was approximately 27.5 million people (plus another 1.5 million nomads).<sup>1382</sup> Within that 29 million are reportedly over 20 million active mobile subscribers,<sup>1383</sup> 5-6 million Internet users,<sup>1384</sup> between 1.2-1.8 million social media users, and between 800,000-900,000 Facebook users.<sup>1385</sup>

These users are found all over Afghanistan, and not just limited to the large cities, as a back-end examination of Facebook page analytics shows. Social media users are *not* simply coming en masse from the largest population centers, such as Kabul, Herat, and Kandahar, but also lesser urban centers such as Kunduz, Khost, Ghazni City, Kunar, Lashkargah in Helmand, Maimana in Farah, and Gardez in Paktia, among others.

Another misperception is that social media in Afghanistan is dominated by educated, Westernized elites. While it may be true the first Afghans to use social media in the country were young, typically male, English-speaking Afghans exposed to Facebook and other social networks through their work interactions with Western colleagues, this has long since shifted.

Today, Dari- and Pashto-language websites, group blogs, and Facebook groups are common, though largely invisible to Western eyes due to the language barriers. These include [Pashto Landay](#),<sup>1386</sup> a Facebook page that celebrates the *landay*, a traditional form of poetry, [Gap-e-Jawan](#),<sup>1387</sup> an online group blogging website affiliated with the Afghan Youth Voices Festival and supported by the non-governmental organization (NGO) Internews, as well as "[The Republic of Silence](#),"<sup>1388</sup> a Farsi-language news and opinion website.

Even Twitter, which has been much less popular than its more visually based rival, Facebook, has been increasing in its usage numbers. According to a Twitter representative, as of 2014 there were about 40,000 registered accounts in Afghanistan, and this number is increasing, due in part to the efforts of the [Afghan Social Media Summit](#), related training programs, television advertisements for stations' Facebook and Twitter channels, as well as the growing phenomenon of "live-tweeting" of popular events ranging from 2012's Consultative *Loya Jirga* to the live debates on TOLONews leading up to the presidential election.

---

<sup>1382</sup> Islamic Republic of Afghanistan Central Statistics Organization (ACSO). *Afghanistan Statistical Yearbook 2013-14*. Accessed January 5, 2016. [http://cso.gov.af/Content/files/Population\(3\).pdf](http://cso.gov.af/Content/files/Population(3).pdf).

<sup>1383</sup> Afghanistan Telecom Regulatory Authority (ATRA) website, Telecom Statistics (End of December 2015). Accessed January 5, 2016. <http://atra.gov.af/en/page/telecom-statistics-2013>.

<sup>1384</sup> Email message from Javid Hamdard, Afghan ICT expert, June 15, 2014.

<sup>1385</sup> Bezhan, Frud (2014). "Afghan Election: Antisocial Networking Prompts Call for Twitter, Facebook Ban." *Radio Free Europe Radio Liberty*, June 23. Accessed July 9, 2014. <http://www.rferl.org/content/afghanistan-election-social-media-ban/25432485.html>.

<sup>1386</sup> Pashto Landay Facebook page. Accessed June 20, 2014. <https://www.facebook.com/pashtolanday?fref=ts>.

<sup>1387</sup> Gap-e-Jawan website. Accessed June 20, 2014. <http://gapejawan.com/>.

<sup>1388</sup> The Republic of Silence website. Accessed June 20, 2014. <http://urozgan.org>.



Other relevant statistics regarding social media use in Afghanistan include the number of males using social media – or at least the number of social media users registered as men – which remains much higher than females. According to Social Bakers data from February 2013, 84 percent of social media users from Afghanistan are male versus 16 percent female. This is especially significant considering that demographic estimates of the Afghan population suggest that the number of women – 51 percent – is slightly higher than that of men – at 49 percent. This number is high even considering comparable countries – those that are in the region or that are at a similar stage in terms of economic development – in which the split is almost universally 70 to 30 percent men to women.

This reality exists for a number of reasons. First, families restrict access to the Internet and social media for women at a much higher rate than for men. Secondly, many women are themselves cautious about the very real dangers of online harassment. And finally, as a result of all these factors, a large number of women use social media pseudonymously.

## Effect of Social Media on Mainstream News

The statistics and figures do not accurately reflect the true reach of social media in Afghanistan, as the flow of information between traditional and social media and between mobile-based content and social media, is porous. Thus, while Facebook, Twitter, and YouTube are certainly important distribution platforms for news, increasingly they have also become the *source* of news themselves.

As a result, content that is posted online first is often cited in news bulletins on television, the role of social media is discussed on talk shows, and television channels run advertisements on screen for their own online pages. All of this contributes to a context in which the average Afghan media consumer is *reached* by social media content, even if he or she has not signed up for his or her own account.

One example of this is the recent trend of videos shot on mobile devices and shared on YouTube and Facebook of altercations between Afghan traffic police and the guards of strongmen, who traditionally receive de facto impunity for any and all actions. Journalist Matthieu Aikins wrote about this phenomenon in a post for *The New York Times* entitled “Viral Justice.” “Every week now it seems, I see on my Facebook news feed that some poor Afghan cop has been beat up. It’s a sign of progress.”<sup>1389</sup> Aikins goes on to explain that rather than letting this incident go quietly, as might have occurred in the past, the viral reach of social media has meant the videos made their way onto TOLONews, the largest and most popular news channel in country, forcing action, usually in the form of a public apology from the strongmen involved. Aikins continues, “[T]he increasing availability of camera phones and mobile Internet access is chipping away at a culture of impunity for the most powerful ... Once the news attracts a critical mass of viewers on Facebook, private channels can no longer ignore it, and they no longer fear that they’d be sticking their necks out by reporting it alone.”<sup>1390</sup>

---

<sup>1389</sup> Aikins, Matthieu (2013), “Viral Justice.” *The New York Times*, *Latitude* (blog), June 28. Accessed July 9, 2014. <http://latitude.blogs.nytimes.com/2013/06/28/viral-justice/>.

<sup>1390</sup> Ibid.

The apology is only a first step towards true accountability, but it is nevertheless an important one. Also significant is the indubitable role social media played in facilitating the “viral justice.”

## Low-Tech Solutions to the Offline-Online Divide

In addition to the two-way information flows between the news media and social media, there is also an important peer-to-peer exchange connecting the online and offline worlds that occurs using low-tech mobile technology.

All around Kabul and other major cities, entrepreneurial individuals have created micro-enterprises around impromptu “content kiosks.” Set up within retail mobile phone shops, or sometimes as stand-alones on the side of a road, these micro-enterprises are startlingly simple. They can consist of merely a laptop filled with videos, ringtones, mobile phone backgrounds, and other content, along with a USB cable, through which the proprietors load the content onto customers’ mobile phones for a small fee.

From there, the content continues to spread offline, thanks to Bluetooth technology. Bluetooth, which allows mobile phones to connect directly to each other without an Internet connection, is available on most basic feature phones, which proliferate across Afghanistan and other developing countries. Bluetooth has connected rural-to-urban and online-to-offline (and vice versa) Afghanistan in a novel, if not entirely new, way. It allows for the two-way peer-to-peer flow of information, which differs significantly from the media’s one-to-many model of information flow.

This low-tech solution to social sharing has been leveraged effectively by the Taliban, though it has yet to be used to similar effect by either the International Community or the Afghan government. As *The Wall Street Journal* reported in 2011, the Taliban “now has some 40 singers ‘with their beautiful and attractive voices,’ each of whom produces on average of 12-song album a month.”<sup>1391</sup> These get converted into ringtones, which are sold for US\$2 each at roadside kiosks. (It is worth noting, however, the same article described Afghan travelers purchasing these ringtones for the sole purpose of getting through Taliban-established checkpoints, and it is unclear how popular they actually are in influencing their “users.”)

Bluetooth-based social media – defined in this case as, quite literally, media that is shared socially – has untapped potential in the Afghan media market. The retail content outlets require virtually no technology infrastructure, are fast and easy to establish, and allow for reach into even the most remote corners of Afghanistan. On the other hand, they are virtually invisible to the uninitiated, much harder to track, and also typically slower regarding speed of dissemination due to the one-to-one nature of most Bluetooth shares.

But even so, it is a folly to ignore this medium, as the International Community has thus far done. After all, mobile phones are the most individualized and personalized messaging platform. While other communications mediums – broadcast, print, street-based, online – certainly impact public opinion, these

---

<sup>1391</sup> Nissenbaum, Dion and Habib Khan Totakhil (2011). “For Safety, Afghan Travelers Tune in to Taliban Ringtones.” *The Wall Street Journal*, December 28. Accessed July 9, 2014. <http://online.wsj.com/news/articles/SB10001424052970203733304577102093405583640>.

are, by design, intended for a mass audience, rather than the individual. They are shared at specific times or locations, and thus cannot compete with the ringtone or image that can be consumed and shared at will. By not even communicating on the same platforms as the Taliban, in this case, the International Community has essentially given the Taliban uncontested access, as well as an undisputed narrative, to an audience of potentially millions.

The potential of peer-to-peer sharing using Bluetooth connectivity is not, of course, limited to countering Taliban messaging, nor does it need to be restricted to one-to-one sharing. Analyzing trends in the Bluetooth content market reveals insights about the public opinions and preferences of its users. For example, one seller, who has a kiosk in the Pul-e-bagh area of Kabul, shared that while Taliban songs had a large audience when he started his business a year ago, they are no longer as popular.

Meanwhile, Bluetooth routers that can distribute content to up to 30 cell phones within range are in use in other parts of the world, and could be put to a variety of different uses, from broadcasting voting instructions within a certain radius of a polling center or providing health information within a hospital. Ultimately, the potential use of Bluetooth as another social media platform is limited only to the creativity of a program designer.

## Social Media and Elections: Excitement and Transparency

Perhaps nowhere has the influence of social media in Afghanistan been more obvious than in the 2014 presidential election, during which everyone from the candidates to the Independent Election Commission (IEC) to individual Afghan citizens, used social media as the most effective way of both finding and sharing information.

With nearly two-thirds of the Afghan population under 25,<sup>1392</sup> this comes as no surprise. In the 2014 election cycle, there were a variety of initiatives aimed at reaching this demographic. In addition to the active social media campaigning by the candidates, there were MTV-style get-out-the-vote drives featuring election anthems contests and rap music, as well as numerous programs (including one run by my organization, Impassion Afghanistan) to encourage active participation, online and off, by young Afghans. In addition to encouraging voter participation, social media also played a role in fostering transparency by providing a platform for observations and irregularities to be shared from across the country. [Figure 96](#) shows a screenshot of a YouTube video of one of the two “official” rap anthems created for the elections to encourage the Afghan youth vote.

---

<sup>1392</sup> Wendle, John (2014). “Afghanistan elections: Youth voters ‘vital’.” Al Jazeera, April 4. Accessed July 9, 2014. <http://www.aljazeera.com/indepth/features/2014/04/afghanistan-elections-youth-voters-vital-20144483111685242.html>.



Figure 96: Screenshot of YouTube video of “official” election rap anthem

(Official Election Anthem by Sonia with Subtitles can be found at [https://www.youtube.com/watch?v=2-2\\_az9I5MQ](https://www.youtube.com/watch?v=2-2_az9I5MQ).)

Social media’s importance became even more important due to the unavailability of certain other communications channels. In a surprise and unprecedented move, the Ministry of Communications and Information Technology (MCIT), suspended all short message service (SMS, or text messaging) nationwide at the last minute – and without warning – on Election Day. Though never officially explained, the two most commonly posited reasons given were to prevent Taliban intimidation of voters, especially in rural areas, as well as to prevent candidates from continuing their last-minute campaigns. Sattar Sadat, the chief of the Election Complaints Commission (ECC), criticized the move, saying “such actions could prevent a transparent election process and monitoring process,” leading to further confusion as to the MCIT’s motives.<sup>1393</sup>

---

<sup>1393</sup> Bezhani, Frud (2014). “Afghanistan Blocks Election Day Texting.” *Radio Free Europe Radio Liberty*, April 5. Accessed July 9, 2014. <http://www.rferl.org/content/afghanistan-election-texting-ban/25322351.html>.

Despite the MCIT's controversial move and the ECC's warning, the Paiwandgāh citizen journalism (CJ) social media platform (see below) still received nearly 600 polling-station reports from 27 of the country's 34 provinces during the first round of elections. In the absence of the ability to text, many of these reports came in via social media, e-mail, and phone calls. The combination of mobile phones and the Internet may have made the April 5, 2014 vote the country's most transparent ever.

In some cases, the citizen journalists' reports led to immediate responses from the appropriate government entities. During the run-off held June 14, 2014, for example, a tweeted report from Paiwandgāh that a polling center in Ayno Mina in Kandahar province had run out of ballot papers (see [Figure 97](#)) prompted an almost immediate response from the Kandahar Media Information Center's (KMIC's) official Twitter account. @KandaharMedia immediately responded, "@Paiwandgah: IEC says the ballot papers will be replaced soon, it won't be delayed."<sup>1394</sup>

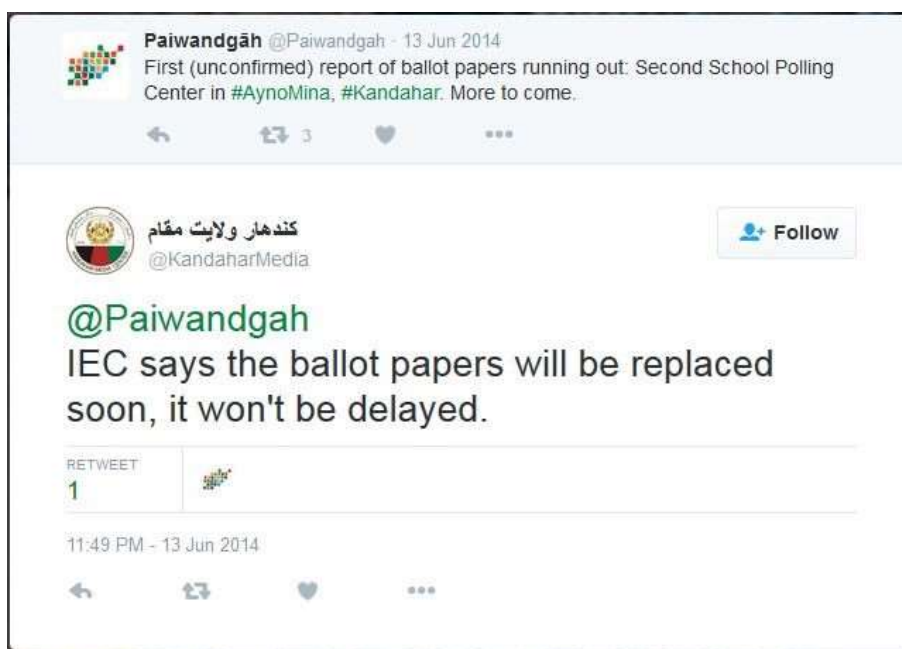

Figure 97: Election Day tweet about a polling center running out of ballots

Even when the reports were not immediately sent onwards to government entities, all reports of irregularities and/or fraud were forwarded to the Independent Electoral Complaints Commission (IECC).

Also despite the SMS ban, photos of smiling Afghans with inked fingers popped up all over the country's social media. These "voter selfies" were some of the many signs that social media had become a key platform of both self-expression and civic participation in Afghanistan. Despite the very real security

---

<sup>1394</sup> Tweet from @KandaharMedia, June 13, 2014. Accessed July 9, 2014. <https://twitter.com/KandaharMedia/status/477704299662041088>.

threats these inked fingers represented, given the Taliban's penchant for cutting off inked fingers,<sup>1395</sup> these visible marks of voting became the ultimate status symbol in the age of short and pithy Facebook status updates.

The jubilant social sharing on the day of the elections, as well as commitment to exposing fraud and irregularities, seemed aimed at showing the world Afghanistan is no longer merely a stereotype of perpetual warfare, chronic poverty, and oppressed women – in much the same way that the elections themselves became a symbol of resistance against threats of insecurity.

## A Turn for the Worse

The jubilation of the first round of voting, however, quickly turned to tension and frustration in the aftermath of the second round,<sup>1396</sup> during which frontrunner Dr. Abdullah Abdullah accused his opponent, Dr. Ashraf Ghani, as well as Ziaulhaq Amarkhail, the head of the Independent Election Commission (IEC), of “industrial-scale” fraud. As a result, Abdullah boycotted the IEC, demanding an immediate stop to vote-counting while an investigation into fraud was carried out.

As the country was pushed into a political deadlock, the tensions played out in a battle of words and images on the country's most popular social media platforms. Four days after the second round, the “Anti-Fraud Movement” had emerged on Facebook and Twitter, calling hundreds to the streets of Kabul to protest. During the protests, some demonstrators carried signs reading, “We will defend our vote to the last drop of blood!” and shouted “Death to Amarkhail!” These sentiments were echoed by some and condemned by others on social media, reflecting the divisions in how Afghans felt about the elections.

The numbers of demonstrators grew on Saturday and spread to other cities, with photos emerging on social media of voters in Herat, in western Afghanistan, burning their voter registration cards in protest. Despite fears these demonstrations would spiral out of control, they largely remained peaceful.

However, additional, larger protests took place on Friday (the Afghan weekend day), June 27, 2014, with an estimated 15,000 people taking to the streets of Kabul. The protesters were joined, this time, by their leaders, including Dr. Abdullah, his vice-presidential candidate Mohammad Mohaqeq, as well as President Karzai's brother Mahmoud Karzai, and political leader and former chief of the National Directorate of Security, Amrullah Saleh. As with previous protests, these were also partially organized on social media and the topic of much more conversation therein.

The demonstrations in the streets reflected a climate of polarization in election-related discourse, especially online, where supporters of both candidates have adopted partisan and divisive language to discredit and attack the opposition. Powerful northern governor Atta Mohammad Noor, a prominent supporter of Abdullah, was the most notable example. On June 18, 2014, he posted a photo and message

---

<sup>1395</sup> Roussinos, Aris (2014). “In Photos: The Taliban Cut Off the Fingers of Afghan Voters.” *VICE News*, June 16. Accessed July 9, 2014. <https://news.vice.com/article/in-photos-the-taliban-cut-off-the-fingers-of-afghan-voters>.

<sup>1396</sup> Neither of the two leading candidates secured more than 50 percent of the vote, so there was a second round of voting on June 14, 2014.

on his Facebook page, since removed, hinting at a “second generation of jihad” if allegations of fraud were not addressed.<sup>1397</sup>

The ethnic jibes were echoed by ordinary Afghans as well. @Muzesi1453, tweeting apparently from Turkey, wrote on June 20, “Abdullah is a Tajik and successor of Masood, whose polity is based on ethnicity & divisiveness. Why’d Pashtoons vote for him??”<sup>1398</sup>

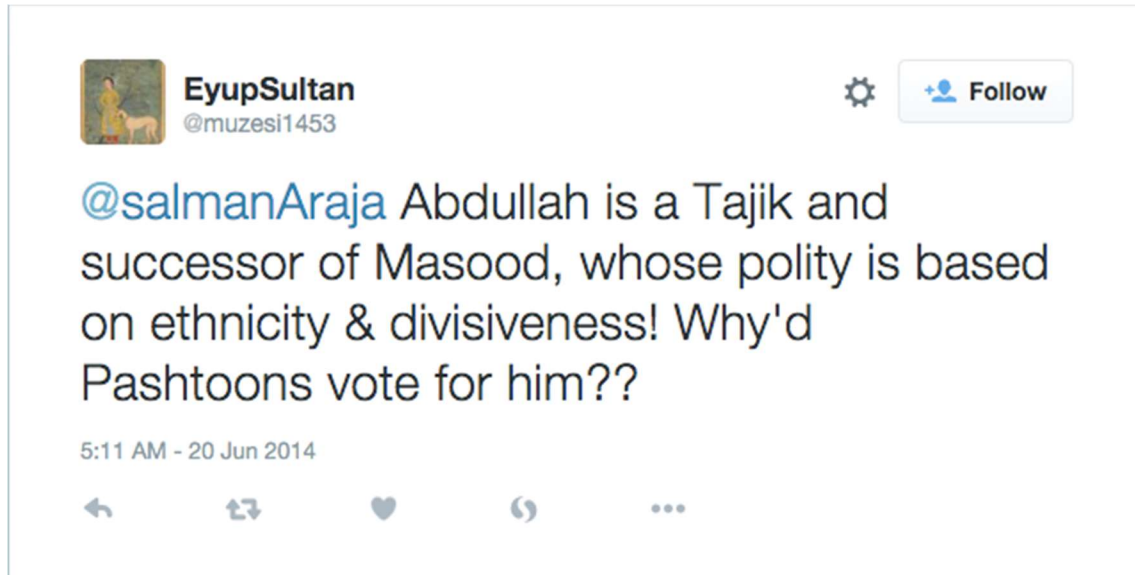

Figure 98: Screenshot of Election Day tweet showing ethnic divisions

In a tweet that has since been deleted, @Fedalibrahimzada, from Mazar-e-Sharif, wrote on June 21 that “til we get rid of Pashtun we will fight.”<sup>1399</sup> Not everyone, however, took part in the ethnic attacks. @AttaNasib, based in Washington DC, observed on June 24 (later deleting this tweet as well): “New Gen. Afghans falling victims to same old ethnic schisms. War of words is disconcerting regarding #AfghanElections #Afgelections #fraud.”<sup>1400</sup>

While the ethnic rallying and personal attacks did occur during the first round, they increased significantly in number in the run-off and the aftermath of the fraud allegations. Examples include unverified composite images and grainy videos that claim to show bad and sometimes illegal behavior; name-calling and jeers based on ethnicity and tribal affiliations; and online calls to action to fight against the fraudulent process. The more extreme of these echoed the ethnic divisions that marked Afghanistan’s civil wars.

---

<sup>1397</sup> Bezhan, 2014. “Afghan Election: Antisocial Networking Prompts Call for Twitter, Facebook Ban.”

<sup>1398</sup> Tweet from @salmanAraja, June 20, 2014. Accessed July 9, 2014.

<https://twitter.com/muzesi1453/status/479914348354080768>.

<sup>1399</sup> Tweet from @Fedalibrahimzada, June 21, 2014, Accessed June 21, 2014.

<https://twitter.com/fedaibrahimzada/status/480255023927296000>.

<sup>1400</sup> Tweet from @AttaNasib, June 24, 2014. Accessed June 24, 2016.

<https://twitter.com/attanasib/status/481148532737335296>.

In a country only a generation removed from the most recent civil war that pitted many of today's political leaders and their militias against each other, such words are not to be taken lightly. Indeed, on June 22, 2014, the United Nations released a statement urging all parties to "refrain from inflammatory statements, hate speech, or statements which promote divisive ethnic mobilization."<sup>1401</sup> Meanwhile, a group of Afghan senators called for a nationwide ban of Facebook to prevent the potential of incitement to violence, a step that the government ultimately did not take.<sup>1402</sup>

### Elections Memes: The Amarkhail Calls

On June 22, 2014, Abdullah's team released recordings of alleged phone calls between Ziaulhaq Amarkhail, the head of the IEC; members of Ashraf Ghani's campaign team; as well as provincial IEC officials, implicating all of these parties in "industrial-scale" fraud. In the calls, a voice allegedly belonging to Amarkhail gives his co-conspirators directions on how to "stuff sheep," the code phrase he reportedly used to indicate the "stuffing of ballot boxes."

The Amarkhail Calls were released on social media as a video featuring voice-overs of three calls paired with photos of the men allegedly involved, as well as English-language subtitles. [Figure 99](#) shows a screenshot from a YouTube video of the Amarkhail Calls. Because the video version was released simultaneously by numerous accounts directly onto Facebook, an accurate count of views and reach is hard to come by, though anecdotal evidence suggests there are very few Afghans have not seen the tapes.

---

<sup>1401</sup> United Nations Assistance Mission in Afghanistan (UNAMA) (2014). "UNAMA Urges Responsible Use of Social Media on Elections Issues," June 22. Accessed June 22, 2014.

<http://unama.unmissions.org/Default.aspx?ctl=Details&tabid=12254&mid=15756&ItemID=38076>.

<sup>1402</sup> Ghanizada (2014). "Afghan senators asks [sic] government to block Facebook website." *Khaama Press*, June 22. Accessed July 9, 2014. <http://www.khaama.com/afghan-senators-asks-government-to-block-facebook-website-6233>.



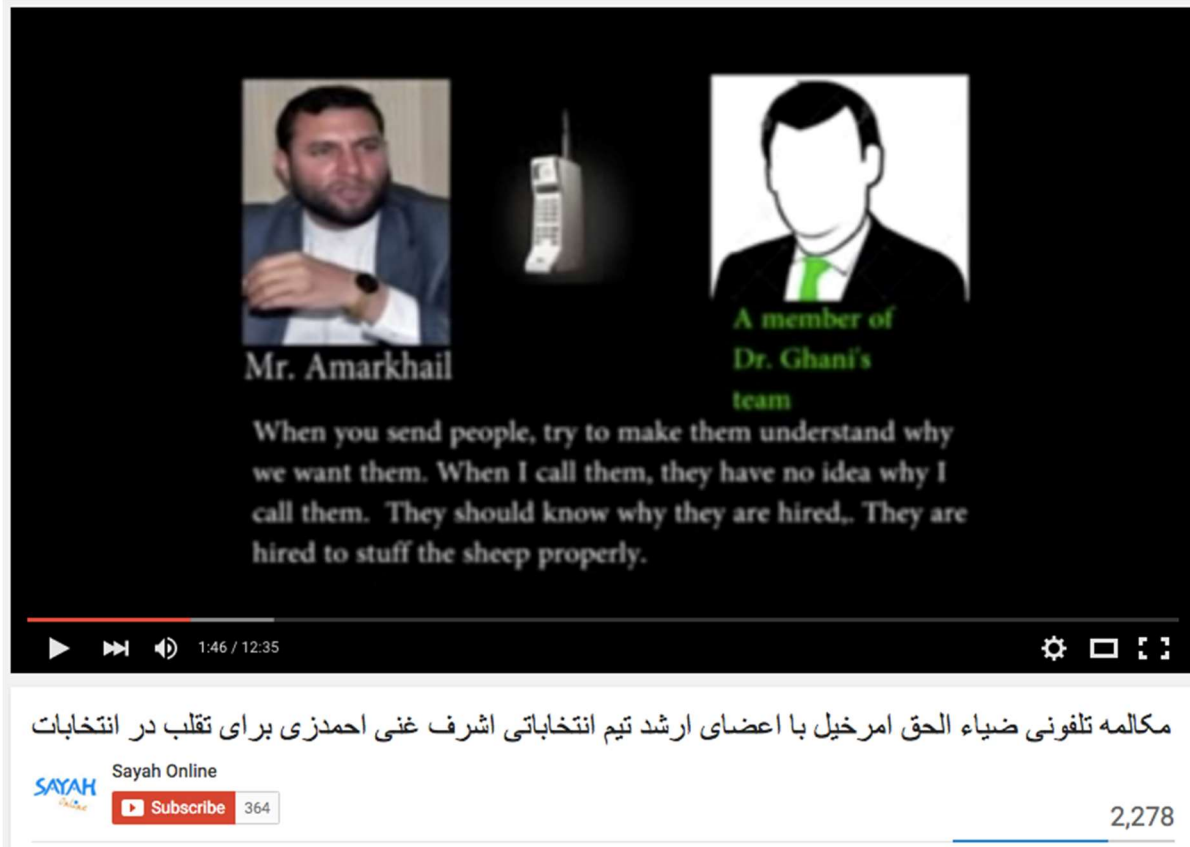

Figure 99: Screenshot from YouTube video of the Amarkhail Calls

(The YouTube post on the Amarkhail calls mentioned above can be found at [https://www.youtube.com/watch?v=m8p63WF\\_j4M](https://www.youtube.com/watch?v=m8p63WF_j4M).)

To some, these tapes became a “game-changer,” moving Abdullah’s position from that of a “sore loser,” as some social media users have called him, to a once-again credible player with legitimate claims. To others, however, the tapes prove nothing, since there has not been independent verification of the tapes’ authenticity. Rather, they have raised serious questions and concerns about the legality (or lack thereof) of the methods by which the tape was obtained.

For still others, the tape provided a source of dark humor in an otherwise fraught time. Numerous jokes about sheep-stuffing circulated among Afghan Facebook users. In one video, a man off-camera initiates a call-and-response to a flock of sheep, who *bah* back in unison. The caption that accompanies the video reads, “Sheep Protest Amarkhail and Ashraf Ghani Team...for using their name in fraud!”



Figure 100: Tweet of a photoshopped image of IEC head Amarkhail holding a sheep

Playing off a common sight on the roads of Afghanistan, impossible combinations of humans and animals on motorcycles and in the backs of vehicles, the photo-shopped image of Amarkhail holding a sheep (see [Figure 100](#)) made its rounds on social media.<sup>1403</sup>

On June 23, 2014, Amarkhail resigned from his post as the Head of the IEC Secretariat, citing “the sake of the process and national interests.” As of June 29<sup>th</sup>, however, the Abdullah team had not yet returned to the official elections process, leading to continued speculation as to how the elections crisis would be resolved. Meanwhile, hashtags #ElectionCrisis and #RiggedElections joined the more neutral #AfghanElections as popular conversation markers.

## The Final Result

On July 7, 2014, the Independent Election Commission announced the preliminary results of the contested elections, with Dr. Ashraf Ghani the winner with 56.44 percent of the vote. These results were widely contested by Dr. Abdullah Abdullah’s supporters, however, and led to a lengthy and oft-delayed audit process during which all eight million votes cast in the run-off<sup>1404</sup> were recounted.

<sup>1403</sup> Tweet by @eileenguo, June 27, 2014. Accessed July 9, 2014.

<https://twitter.com/eileenguo/status/482445168792977409>.

<sup>1404</sup> The figure of eight million votes cast during the run-off elections was itself highly contested, since only 6.6 million were cast during the first round, which was widely considered to have had much higher voter turnout. See

Meanwhile, the candidates continued their negotiations to form a National Unity Government, which was not confirmed until September 19, 2014, when the IEC released the final results, declaring Ghani the winner. As part of their agreements, hours later, Ghani and Abdullah signed a power-sharing agreement cementing Ghani's role as president and Abdullah's as chief executive, a created position similar to prime minister. As part of that deal, however, the final vote tallies and audit results would not be publicly released,<sup>1405</sup> a controversial end to a fraught electoral process.

The presidential elections of 2014, however troubled, in many ways represented a coming-of-age for social media in Afghanistan. They showed more clearly than ever before not only the potential and power of social media as a way to open doors, but also its means as a rapid distribution channel for rumors, which ran rampant throughout the elections, as well as its dangers as a potentially divisive medium. The elections taught Afghan social media users that, ultimately, social media is just a tool, and its use for good or ill is ultimately dependent on the people using it.

### Supporting Social Media, Supporting Democracy?

Afghanistan's 2014 election drama raises interesting questions about how influential social media ultimately was in affecting the election's outcomes. After all, while important conversations were taking place online and off, ultimately, the outcome was resolved as political disputes have been resolved for centuries: in back-room negotiations out of the public eye.

Elections, however, are important to democratic societies not just for their outcomes, but also as signifiers of the political process. More than any other aspect of governance, elections serve as the largest and most direct point of interaction between citizens and their government. And in that way, social media and mobile technology in Afghanistan have played a hugely significant role in informing and shaping public dialogue and opinion in Afghan culture, society, and politics.

Clay Shirky, a professor at New York University's (NYU's) Interactive Telecommunications Program, and one of the most recognized writers on the social and economic effects of the Internet, is perhaps the strongest advocate for this point of view. According to Shirky, social media has played a key role in effecting and demanding political and social change around the world. As Shirky wrote for *Foreign Affairs* magazine:

---

Thomas Scherer's article, "Why the Afghan election still isn't over." *The Washington Post*, August 12, 2014. Accessed February 9, 2015. <http://www.washingtonpost.com/blogs/monkey-cage/wp/2014/08/12/why-the-afghan-election-still-isnt-over/>.

<sup>1405</sup> Apparently, they later were, with Dr. Ashraf Ghani garnering 55.27 percent of the vote to Dr. Abdullah Abdullah's 44.73 percent. Islamic Republic of Afghanistan Independent Election Commission (2014). "Runoff Presidential Election Final Certified Results." Accessed August 24, 2016. [http://www.iec.org.af/results/en/final\\_runoff](http://www.iec.org.af/results/en/final_runoff).

“[T]he networked population is gaining greater access to information, more opportunities to engage in public speech, and an enhanced ability to undertake collective action. In the political arena... these increased freedoms can help loosely coordinated publics demand change.”<sup>1406</sup>

While social media does not itself topple regimes or lead naturally to democracy, it does provide a new platform for conversations to take place that was not previously available. In the aftermath of the Afghan elections, public feeling shifted significantly from hope, excitement, and engagement with the political process, to uncertainty, disappointment, and disenchantment. This illuminates the need to engage the Afghan public in conversation and undertake initiatives that increase their sense in the importance of their own voices and to effect change. And giving them a place to vent is even more important than ever.

As I found in my visits with Afghan women in their homes, social media provides access to new conversations with a greater audience, as well as an important window into outside perspectives. This represents a huge reason as to why a free and open Internet and an educated social media public should be supported.

To date, a number of governments have supported social media in Afghanistan. These have included funding for wider efforts including free speech, youth engagement, an open and independent media, as well as targeted funding for the Internet and social media specifically. A selection of these initiatives follows.

## Afghan Social Media Summit

The [Afghan Social Media Summit](#) (ASMS) is an annual event that brings together both new and experienced Afghan social media users with technology experts, public figures, and thought leaders from both inside and outside of Afghanistan to network, build community, and for mutual learning. ASMS actually consists of two sets of events: the summit itself, typically held in Kabul, as well as provincial trainings.

As of mid-2016, three summits have been organized. The first, called “*Paiwand*” or Dari for “connection,” was held September 21-22, 2013, with follow-on provincial trainings for new users conducted in five provinces. The second, rebranded to “Afghan Social Media Summit,” took place from October 19-21, 2014, with provincial trainings for both new and intermediate users of social media in ten provinces across Afghanistan. The third was held October 18-20, 2015, with provincial trainings expanded to 15 provinces to take place in 2016. Twenty fifteen (2015) also saw the launch of the first-ever Afghan Social Media Awards, which recognized social media achievements and excellence in ten categories (see below).

ASMS is organized by Impassion Afghanistan, the country’s first digital media agency (and, for full disclosure, my company). It was first organized in response to a request for proposals by the US Embassy in Kabul. The event was one of several US Embassy “Get out the Vote” initiatives that used new media to

---

<sup>1406</sup> Shirky, Clay (2011). “The Political Power of Social Media: Technology, the Public Sphere, and Political Change.” *Foreign Affairs*, January/February 2011. Accessed February 6, 2015. <http://www.foreignaffairs.com/articles/67038/clay-shirky/the-political-power-of-social-media>.

promote youth participation and engagement in the 2014 elections. Similar projects funded during this time include “[Baztab](#),” a social network designed for young Afghans to discuss the elections, as well as the “2014 Elections Anthem” competition produced by [Sound Central Festival](#), Afghanistan’s only rock festival.

### ASMS2013: Paiwand

Paiwand, the first year’s event, brought together 260+ participants from 24 provinces, and 25 speakers (including five that joined from abroad via videoconference). Over 35 journalists covered the event for a variety of publications, ranging from official media partner 1TV to *The Guardian UK* to the Agence France-Presse (AFP).

The event sessions all fell under the general topic of using social media for social good, but its focus was on social media and civic engagement. The agenda consisted of short TED-style talks,<sup>1407</sup> panel discussions, as well as small-group interactive workshops. These were split into several over-arching themes:

- “Why Are We Here? (The Importance of Social Media in Afghanistan);”
- Innovation, Mobile, and Emerging Technologies;
- New Media, New Afghanistan;
- Skills-Building Workshops and Participant Roundtables;
- Digital Diplomacy;
- Social Media and the Elections; and
- Social Media for Development (sponsored by the United Nations Development Programme as part of the global Social Good Summit).

After the conclusion of Paiwand, the Impassion team conducted day-long introductory workshops on social media in five provinces: Bamyan, Mazar-e-Sharif, Herat, Nangarhar, and Kandahar. Thus, in addition to the 262 attendees, an additional 242 Afghans were trained in basic social media.

The summit was successful by all measures, raising the profile of social media and the technology sector both in Afghanistan and abroad. In addition to the live coverage of the event on 1TV, Afghanistan’s second largest television network, it also played an important role in shifting the global conversation about Afghanistan, albeit temporarily.

Paiwand was the official in-country partner of the global Social Good Summit, an annual event held simultaneously in over 70 countries, celebrating the use of social media for social good and organized in conjunction with the United Nations Foundation and the United Nations Development Programme.

Additionally, Paiwand and, as a result, Internet use in Afghanistan, was covered by a number of international media organizations, including those that do not typically cover the country, such as VICE

---

<sup>1407</sup> Originally, TED stood for the convergence of technology, entertainment, and design. Now, “TED Talks” are short (18 minutes or less) presentations on a variety of topics, delivered by experts and laypeople alike, in cities around the world.

Media and *Fast Company* magazine, in addition to Fox News, *The Guardian UK*, the British Broadcasting Corporation (BBC), and various newswires.

## ASMS2014

Following the success of the first social media summit, the US Embassy decided to extend the original grant for an additional two years, providing funding for ASMS2014 and ASMS2015.

ASMS2014 was designed to be larger than the first iteration in a number of ways: a longer duration, a more diverse set of topics, more speakers, as well as a larger audience. Thus, the event was to be held over three days instead of two, a small budget allowed for international speakers to attend the event, and the event was designed to accommodate three times as many attendees as the previous year.

The ASMS2014 agenda included:

- Hashtag activism;
- Workshops;
- Technology and innovation;
- #AfghanElections;
- Civic technology;
- Privacy, rights, and cybersecurity;
- Movie screenings;
- The changing face of news; and
- Online advocacy for women's rights.

Some of the standout sessions were the panel discussion on privacy, rights, and cybersecurity, featuring former Google engineer Matt Stephenson, who spoke about privacy and cybersecurity from the user perspective; Javid Hamdard, one of Afghanistan's leading technology experts; Zmarialai Wafa, the Director of the Information Systems Security Directorate (ISSD) at the MCIT; with me as the moderator.

The interactive discussion, with a lively question-and-answer session with the audience, simultaneously revealed how new the issues were to Afghan social media users, and yet how important they already were.

Meanwhile, the concept of citizen journalism was also widely discussed at the event. The film *#ChicagoGirl*, about the efforts of a Syrian-American and a group of citizen journalists in the Syrian conflict, was screened for the first time in Afghanistan, showing attendees a poignant case study of just how powerful citizen journalism could be. Aziz Koshan, the lead researcher behind SadRoz (see below), discussed how citizen journalism and monitoring of government could be used to keep government accountable; Javid Faisal, the program manager of a peace reporting project in Kandahar, meanwhile, discussed the power of citizen journalism in promoting buy-in to peace in Kandahar province; and Moksh Juneja of the Wikimedia Foundation India discussed citizen contributions to Wikipedia.

Overall, more than 700 participants attended ASMS2014 over the course of the three days (including 60 women, who were present for the entirety of the event), representing 22 provinces. They were joined by 43 speakers from eight countries, two of whom flew into Kabul just for the event.

The reach of the social media summit went beyond the number of physical attendees, however. Media partnerships with TOLO TV, the largest television channel in Afghanistan, and Arman FM, its radio station, provided coverage of the event as well as pre-event advertising in all 34 provinces in Afghanistan. Additionally, because of the nature of the event, social media also played a key role. There were 962 Twitter users who chimed into the conversation using the hashtag #asms2014, 2,030 unique users who interacted with our live updates posted on Facebook, and 3,858 minutes of our livestream on YouTube watched 689 times during the days of the event itself.

As with the first iteration, provincial trainings followed the summit itself and, again, as with the summit, these increased in size and complexity of content. Whereas previous trainings were held in the five major cities and provinces of Afghanistan, after ASMS2014, they included five new provinces that heretofore had been considered secondary in terms of both social media use as well as in receiving development and aid assistance.

The provinces where trainings occurred were:

- Balkh
- Bamyan
- Ghazni
- Herat
- Jowzjan
- Kandahar
- Kapisa
- Khost
- Kunduz
- Nangarhar

In addition, whereas the earlier trainings were day-long in length and focused on an introduction to social media, the trainings following ASMS2014 were three days in length and brought participants up from the basics of digital literacy to social Media and, finally, to citizen journalism.

## ASMS2015

In a symbolic merging of tradition and modernity, the third annual Afghan Social Media Summit was held in the historic grounds of the Queen's Palace in Babur Gardens.

As with the previous event, ASMS2015 was designed to be larger than both the first and second iterations of the summit, with more opportunities for participants to engage with each other and with social media in novel ways. In addition to the speeches and workshops, ASMS2015 featured a "selfie station," art and photography exhibits, and even a live demonstration from Kabul Boys Parkourm, a self-taught musical group that learned all of its technique from YouTube.

The ASMS2015 agenda was also redesigned to reflect a number of content streams such as journalism and citizen journalism, technology entrepreneurship, civil society and activism, and arts and culture, to better reflect both the diverse interests of the participants as well as the ways in which social media and new technologies have affected every aspect of Afghan culture. Some of the topics discussed included:

- Social media for entrepreneurs and SMEs;<sup>1408</sup>
- Civic technology;
- Privacy, rights, and cybersecurity;
- Journalistic ethics in an age of social media;
- Positive messages from the arts: New dynamics through social media;
- Countering violent extremism; and
- Movie screenings: #ChicagoGirl and Voice of a Nation.

Over 1,200 participants attended ASMS2015 during the three days, with the highest percentage of female participants yet, at 30 percent.

The reach of the social media summit went beyond the number of physical attendees, however. Media partnerships with TOLO TV and Shamshad TV provided coverage of the event as well as pre-event advertising in all 34 provinces in Afghanistan. In addition to the television audiences, social media again played a key role, with 892,637 impressions on Twitter; 1,384,769 on Facebook; and over 56,000 visits to the website during the month of the event.

To build on the social media summit, Impassion plans to expand the provincial trainings to fifteen provinces in the spring of 2016.

## Afghan Social Media Awards

In 2015, ASMS also played host to Afghanistan's inaugural Afghan Social Media Awards (ASMA), which were designed to encourage the development of technology, innovation, and social media in Afghanistan by rewarding the best and most innovative uses of each in country.

The first-ever ASMA was broadcast on Shamshad TV, and was also covered extensively on other Afghan media channels. The event had ten award categories:

1. Twitter Power User
2. Best Instagrammer
3. Best Blogger
4. YouTube Star
5. Facebook Star
6. Citizen Journalist of the Year
7. Best Social Media Campaign
8. Best Use of Social Media for Civic Engagement
9. Best Use of Social Media for Journalism
10. Best Use of Social Media to Inspire Offline Action

---

<sup>1408</sup> Small- and medium-sized enterprises



There was a public nomination and voting period, with the top four finalists moving to the final round, which was judged by an Afghan-international jury. The Afghan jury members were selected based on their nuanced understanding of the effect of social media on Afghan culture and society (and vice versa), while the international jury members were selected based on their deep expertise in social media itself. The jury members were:

- Aimal Marjan, Deputy Minister, Information Technology, Ministry of Information and Communications Technology (MCIT)
- Massoud Hussaini, Pulitzer Prize-winning photojournalist
- Ahmad Shuja, Co-founder of Impassion Afghanistan
- Malalai Shinwari, Former BBC journalist and Member of Parliament
- Dawn Barbar, Co-founder of New York Tech Meetup and original Producer of Shorty Awards
- Xavier Damman, Creator of Storify
- Jean MacKenzie, Executive Editor, Paiwandgāh

The winners of the awards were:

1. Radio Free Europe Journalist Malali Bashir – Twitter Power User
2. Afghanistan\_You\_Never\_See – Best Instagrammer
3. Omid Haqbin, Norband.com – Best Blogger
4. Snr Bros Entertainment – YouTube Star
5. Naim Atarud – Facebook Star
6. Wais Barakzai – Citizen Journalist of the Year
7. Safi Airways – Best Social Media Campaign
8. Delawar Faizan – Best Use of Social Media for Civic Engagement
9. BBC Farsi Journalist Kawoon Khamoosh – Best Use of Social Media for Journalism
10. Civil Society Activist Omaid Sharifi – Best Use of Social Media to Inspire Offline Action

## Paiwandgāh

[Paiwandgāh](#), which is Dari for “a place of connection,” is a social media and mobile technology-based platform that allows Afghans all over the country to connect and contribute to the national dialogue about the most important issues facing the nation. Using Paiwandgāh, all citizens are able to send in stories, opinions, and personal experiences through calls, SMS, and social media.

Paiwandgāh is a project of Impassion Afghanistan, the country’s first and only digital media agency. It evolved out of the massive success of Paiwand, Afghanistan’s first Social Media Summit. After the summit and the associated provincial trainings, there was a clear desire for continued engagement, as well as genuine interest in participating in the national conversation around the elections. Meanwhile, the grant agreement with the US Embassy required that follow-on social media engagement occur. The question was, what form would this engagement take?

One of the key takeaways from the first social media summit was that there were far more impassioned youths interested in speaking up than actual social media users in the country. Additionally, one of our core beliefs at Impassion is that social media should mean more than simply the online channels. Thus,

Impassion decided the best way to engage its new cadre of social media enthusiasts would be to create a platform where all Afghans – whether or not they had stable Internet connections – could speak up.

And so Paiwandgāh was born. Originally designed to mirror the “crisis mapping” of [Ushahidi](#), Paiwandgāh is a citizen journalism platform that receives, aggregates, and displays content from Afghan citizen journalists all over the country.

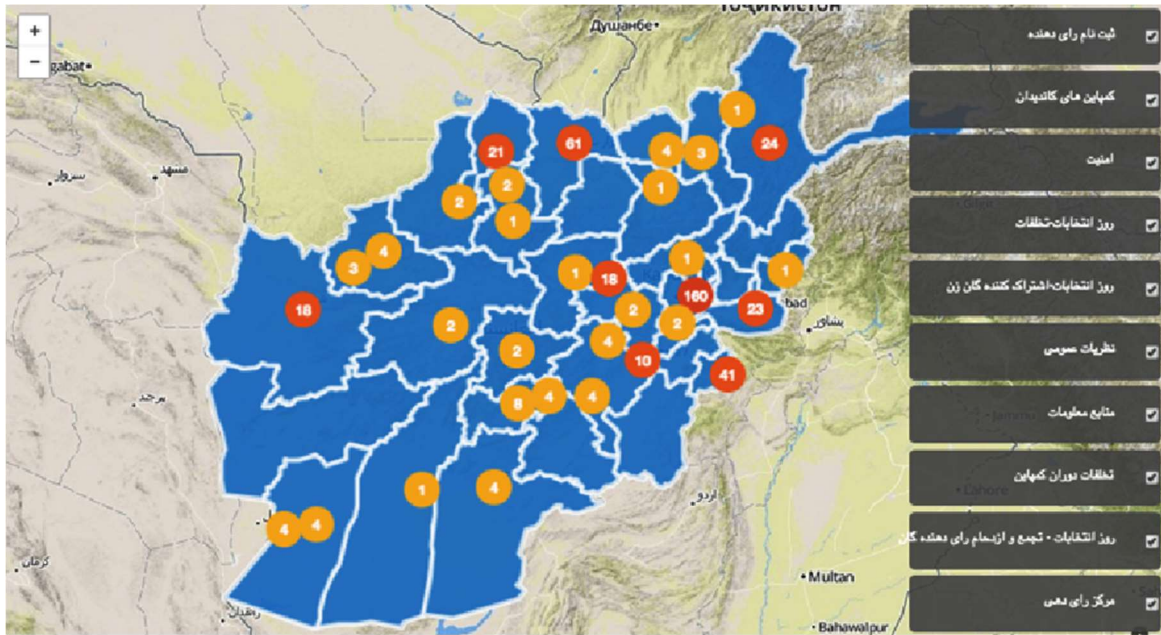

Figure 101: Original design of Paiwandgāh citizen journalism platform

The first iteration of Paiwandgāh was focused on the elections and, despite a last-minute ban on SMS around the country on April 7, 2014, Paiwandgāh received approximately 578 reports on Election Day via phone calls, the Internet, Twitter, and Facebook and, when the ban ended around 5:00 pm, SMS. They came from 27 provinces, including some remote and restive areas that surprised even our team, as we had previously not had strong presences in those locations.

Categories of reports received included the following:

- Voter registration;
- Candidate campaigns;
- Security;
- Election day – irregularities;
- Election day – women's participation;
- Public opinion;
- Sources of information;
- Campaign Irregularities;
- Election day - voter turnout;
- Polling center; and
- Voter fraud.

Reports ranged from excited ones saying little more than, "We're so excited to be voting, and everything is going well!" to significant cases of voter fraud, some of which were sent on to the Independent Elections Complaint Commission (IECC). Some of the reports of fraud received include the following:

- [Scarves for votes](#); and
- [Happy and hopeful voters in Herat](#).

Paiwandgāh continued to cover the elections throughout the second round of voting, as well as the uncertainty that followed. On the second round of elections, June 14, 2014, the platform received 473 reports from 29 provinces, adding Nimroz and Farah to the list of represented provinces.

Many citizen journalists reported lower voter turnout in the second round of elections than in the first, including in Nili, Jawzjan, and Kunduz. One contact, however, mentioned higher voter turnout in Loya Paktiya, though this was secondhand information and he was not able to corroborate those reports personally. The citizen journalists also had different perspectives on this phenomenon, with one from Jawzjan explaining that low turnout was due to the lesser number of candidates up for election in this round, and another from Kunduz explaining that voters were happy with the lack of congestion that lower turnout meant.

Impassion was already using social media as one of its primary distribution platforms, using the hashtag #afgelect2014, which became one of the two most followed and used hashtags relating to the Afghan elections. (The other was simply #afghanelections.)

Paiwandgāh's election-related coverage was widely shared and followed by a number of different organizations, including research organizations such as the [Afghan Analysts Network](#), news organizations, and campaign teams that viewed our reports as more neutral and therefore more trustworthy than other sources. In fact, the growing impact of Paiwandgāh's reporting was demonstrated by BBC Farsi, which used several Paiwandgāh citizen journalists to serve as stringers and sources for their elections live-blog in areas where they did not already have reporters.

After the elections, Paiwandgāh shifted and expanded its coverage. As of the end of 2015, it was the largest citizen journalism platform in Afghanistan, with a total of 320 registered citizen journalists from 28 provinces, an average of 60 citizen journalists reporting every month, and an average of 12 stories per month.

Many of these citizen journalists were not active social media users, beyond Facebook and perhaps YouTube, before joining and working with Paiwandgāh but, due to the prominence of Twitter in Paiwandgāh's distribution strategy, have now also joined that platform.

But Paiwandgāh and the other citizen journalism programs in Afghanistan, such as that of newswire [Pajhwok Afghan News](#),<sup>1409</sup> do not just promote more widespread adoption of social media platforms for reporting. Rather, they help shift online behavior of Afghan social media users from that of an online content-consuming culture to a content-producing culture in which netizens realize the power of their own voices. This mirrors the empowering factor of social media overall, which democratizes content production.

## SadRoz.af

In addition to the Afghan Social Media Summits and Paiwandgāh, another major social media for peace and democracy project that Impassion Afghanistan implemented is “Sad Roz,” which translates from Dari to “one hundred days.”

[SadRoz.af](#) was a collaborative tool to enable Afghans from around the country to monitor the government's progress on its campaign promises. SadRoz.af was an independent, non-political monitoring platform and did not take a position on the issues it tracked. SadRoz.af aimed to foster accountability and transparency in electoral democracy in Afghanistan by providing voters a monitoring tool and offering an information clearinghouse for activists and civil society on the government's progress.

Launched on September 3, 2014, this participatory technology project tracked the first 100 days of the National Unity Government, led by President Ashraf Ghani with Chief Executive Abdullah, comparing it to their (especially the president's) campaign promises. Every ten days, SadRoz.af sent out a report card on the government's performance to 400 subscribers. All of the content was also shared on social media platforms to maximize SadRoz.af's reach.

SadRoz.af was available in both of Afghanistan's national languages and in English. It differed from other presidential trackers in one key way: its participatory nature, which was key to its success. While, initially, campaign promises were compiled after extensive research into both main presidential contenders' campaigns as well as via focus groups with civil society organizations, such as women's rights and human rights groups, who were themselves tracking promises and policies, once SadRoz.af was launched, visitors were also invited to contribute.

In fact, this was incentivized and rewarded with the public “leaderboard,” which displayed the top contributors to the site. Viewers submitted 28 missing promises, of which ten met the requirements of SadRoz.af and were published on the site.

SadRoz.af was the first time that an Afghan government was held accountable for its actions and its promises by its citizens in real time. The impact was immediate, with over 200,000 Facebook interactions,

---

<sup>1409</sup> However, there is no separate site for citizen journalism on Pajhwok. Guidelines for its citizen journalism program for the 2014 election can be found at <http://www.elections.pajhwok.com/en/content/guidelines-citizen-journalists>. Accessed February 9, 2015.

features and interviews on all of Afghanistan’s major news channels as well as with foreign press, and, perhaps most significantly, attention by the Presidential Palace itself.

The Media Directorate at the Presidential Palace studied SadRoz.af and shared its feedback, suggesting 20 progress updates for inclusion in SadRoz.af. After proper vetting by the SadRoz.af team, five of these updates were judged applicable and incorporated into SadRoz.af. SadRoz.af invited, and President Ghani's team agreed, to send a 500-word response for inclusion in the final report of SadRoz.af. (As of writing, this report has not been received.)

In many ways, SadRoz.af served as a proof of concept that citizens did still want to engage politically, even after the flawed elections of 2014. Thus, the website’s success in terms of website and social media visitors, media coverage and discussions sparked, and attention and willingness to engage by the Presidential Palace, showed the power of social media in civic engagement.

And while the first one hundred days of the new government has concluded, and with it the SadRoz.af project, the concepts of public accountability, participatory media, and social media for democracy will live on. In late 2015, the SadRoz.af team was in discussions with one of Afghanistan’s largest media organizations to create a permanent media project on government accountability.

## Looking Forward

Social Media in Afghanistan has grown by leaps and bounds since the Internet arrived in country after the fall of the Taliban regime,<sup>1410</sup> and is now a proven, though still nascent, tool for advocacy, transparency, accountability, and citizen journalism.

However, the gains in Afghan Internet use are, as with the gains in Afghanistan overall, fragile. A truly self-sustaining ecosystem of social media users, bloggers, and an Afghan Internet public has yet to truly develop. Without that full ecosystem, the community of Internet users in Afghanistan will remain sensitive to disruption.

Thus, for social media to stand on its own two feet, the community of Internet users in country and the community of Afghans in country must become one and the same. Especially as the Afghan public continues to discover some of the uglier sides of the social media – its unregulated nature, its vast reach, and the very speed in spreading information (both true and untrue) – it will be up to everyone to fight for an open and free Internet. After all, the true power of social media lies not in the medium itself, but in how it is used. This, perhaps, will require some continued, gentle reminding on the part of the International Community that has invested so much in supporting social media in country.

---

<sup>1410</sup> OpenNet Initiative (2007). “Afghanistan.” May 8. Accessed June 27, 2014. <https://opennet.net/research/profiles/afghanistan>.

## Chapter 19 ICT Capacity Building in Afghanistan: Government, Donor, Commercial, and Community Efforts

---

Karen E. Black and Dr. Maria Beebe

### Introduction

According to the World Bank, “It is clear that mismatch between the demand and supply of skilled labor [in Afghanistan] is a result of inadequate institutional response to policy needs which otherwise might have led the government to address this weak link at this initial critical stage of the country development.”<sup>1411</sup> This disparity is particularly pronounced in the information and communications technology (ICT) sector, which did not exist in any modern sense in Afghanistan, until the beginning of the 21st century. Consequently, there was – and still is – a dearth of indigenous ICT skills.

The Afghan Ministry of Communications and Information Technology (MCIT) recognized “the developments [of the ICT sector] cannot be sustained unless the sector has capacity to support the initiatives and make best use of the facilities created,”<sup>1412</sup> and stated, “Academia, [the] private sector, and [other] ministries have to build their capacity to meet the challenges in IT [Information Technology] and Telecom sectors.”<sup>1413</sup>

To document this phenomenon, the World Bank funded a consultancy to conduct an analysis of ICT skills in Afghanistan to assess the gap between industry needs and available skillsets and to outline a training program with recommended courses. Released in July 2011, the report on the findings indicates a ratio of ICT technology growth to human resources growth of three to one (3:1), “showing a sharp shortage of skilled and semi skilled [*sic*] labour force in the ICT sector, [which] will widen in the coming years,”<sup>1414</sup> as depicted in [Figure 102](#).

---

<sup>1411</sup> World Bank (2013). *Afghanistan - Second Skills Development Project*. Washington, DC: World Bank. Accessed November 17, 2014. <http://documents.worldbank.org/curated/en/2013/03/17425687/afghanistan-second-skills-development-project>.

<sup>1412</sup> Islamic Republic of Afghanistan Ministry of Communications and Information Technology (MCIT) (2011). *E-Afghanistan National Priority Program (NPP) Proposal*, May, 14. Accessed March 14, 2016. <http://mcit.gov.af/Content/files/PSD%20NPP%202%20E%20Afgh%20NPP%20Proposal%2023%20May%202011.pdf>

<sup>1413</sup> *Ibid.*: 1.

<sup>1414</sup> Waiss, Dr. Ahmed (2011). “Skills Development in Information and Communication Technology (ICT).” July, 4-5.

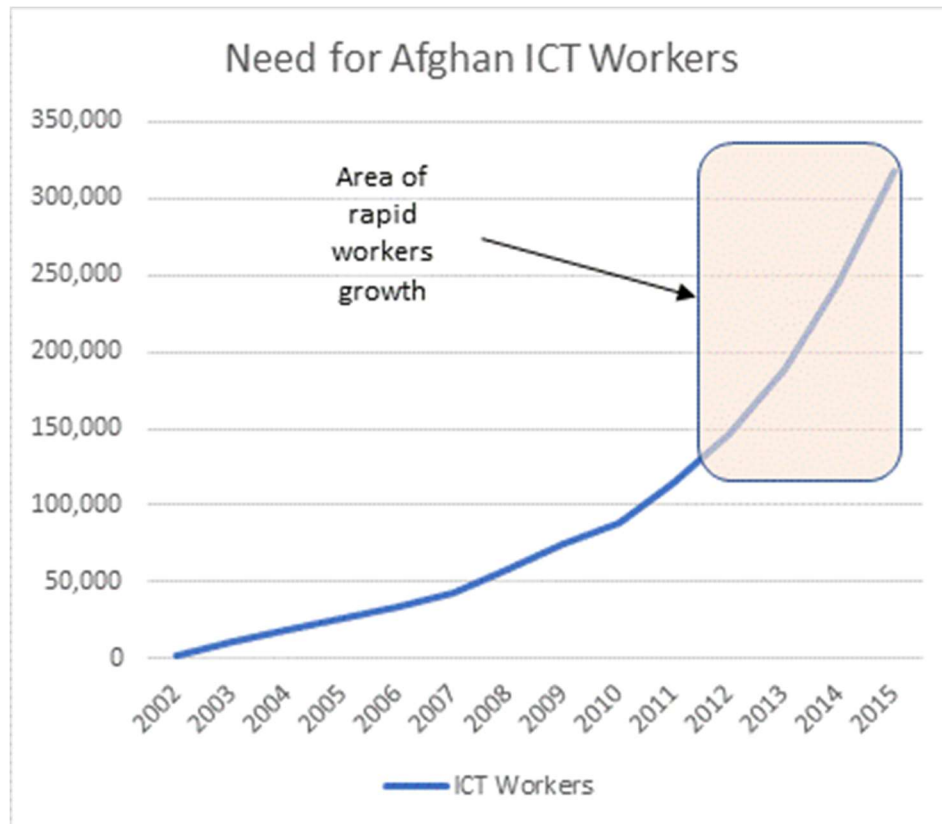

Figure 102: Projected need for ICT workers in Afghanistan, 2002-2015

In addition to sustaining the ICT sector, developing ICT capacity is vital across the board in Afghanistan. ICT skills at all levels, for users and administrators alike, are needed and must be developed within the government as well as in all other sectors of economy. In addition, the general population must be afforded the opportunity to learn basic ICT skills required in our modern, digital world. Developing a skillset – and a highly specialized one at that – essentially from scratch is an enormous undertaking and requires the participation of multiple entities, both formal and informal.

## Key Players

There are many entities involved in ICT capacity building in Afghanistan, but several of the principal players include the Afghan ministries of communication and education; universities, both public and private, as well as technical and vocation institutions; donors; non-governmental organizations (NGOs); and commercial, non-profit, and community ICT training centers.

## Government Ministries

The three key ministries involved in ICT capacity building in Afghanistan are the Ministry of Communications and Information Technology (MCIT), with its focus on fostering an environment for the deployment and use of ICT; the Ministry of Higher Education (MoHE), with its focus on degree-related education; and the Ministry of Education (MoE), with its focus on ICT in primary education and technical and vocational education and training (TVET). These three ministries, to varying degrees, have professed commitment to the use of ICT in numerous policy statements.

The Ministry of Finance (MoF) also has a role, as it manages and administers Afghanistan's budget and allocates money to the various line ministries. It has been generally challenging for the MoE and MoHE to convince the MoF to fund ICT projects and training for their staffs. The MoF also runs the Civilian Technical Assistance Program (CTAP), which is "a National Capacity Development program of the government of Afghanistan, designed to strengthen the capacity of Tashkeel<sup>1415</sup> staff and key ministries within the Government of the Islamic Republic of Afghanistan, whereby assisting public agencies to effectively deliver services to the public while supporting towards the successful implementation of the [Afghanistan National Development Strategy \(ANDS\)](#) and their prioritized programs."<sup>1416</sup> The MCIT participates in CTAP and has two advisors assigned specifically to capacity building within the ministry.

### *Ministry of Communications and Information Technology*

In November 2003, the Ministry of Communications (MoC)<sup>1417</sup> released an ICT Policy that emphasized the use of ICT in educational efforts so that Afghanistan could "leapfrog" some stages of development and be better prepared to enter the global economy of the twenty-first century. The ICT Policy states the MoC, in collaboration with the MoE, MoHE, and associated institutions, would take steps to:

- Develop ICT curricula and teacher training materials at both the secondary and tertiary levels in ICT related courses, such as, computer science, multimedia, communications, and engineering.
- Invite prestigious foreign universities to collaborate with Afghan universities to establish ICT research and development programs, including PhD programs in ICT.
- Create opportunities, such as mobile Internet units, networking academies, and telecenters for students in remote locations, to be exposed to technology.
- Support opportunities for distance education, including access to international online courses.
- Establish partnerships with the private sector to develop and provide ICT training for the workforce.
- Coordinate the training of civil servants in ICT skills and applications.<sup>1418</sup>

The MCIT and MoHE also mention the use of ICT in and for education in their National Priority Programs (NPPs). The NPPs recognize the need to focus national priorities and align them with Afghanistan's National Development Strategy, given the limited resources and capabilities available. The NPPs articulated three-year implementation plans, with costing and budgets, and identified likely constraints and approaches to mitigate them. Of most relevance here are the 2011 MCIT NPP, [E-Afghanistan](#), the 2011 MoHE NPP, *Expanding Opportunities for Higher Education*, and the 2011 MoE NPP, *Education for All*.

---

<sup>1415</sup> Essentially, an organization's official, approved staffing plan.

<sup>1416</sup> Islamic Republic of Afghanistan Ministry of Finance (MoF) Civilian Technical Assistance Program (CTAP). Accessed 31 March 2015. <http://www.ctapafghanistan.org/> (now <http://www.ctap.gov.af/>).

<sup>1417</sup> The Ministry of Communications was renamed the Ministry of Communications and Information Technology in February 2007.

<sup>1418</sup> Ministry of Communications (MoC), Transitional Islamic State of Afghanistan (2003). Paraphrased from *Telecom and ICT Policy Documents*, October 2003 (Sumbola 1382), English translation, Part II. "Information and Communication Technology (ICT) Policy, 11. Accessed November 17, 2014. <http://mcit.gov.af/Content/files/Telecom%20and%20ICT%20Policy.pdf>.



Two of the main components of the MCIT's *E-Afghanistan NPP* are "Strengthening the Ministry" and "Strengthening the [ICT] Sector," which, the MCIT understood, included developing capacity for its staff and for the larger ICT workforce in both the public and private sectors. Two of *E-Afghanistan's* subcomponents are "Improving ICT Training and Digital Literacy" and a "Skills Development Program for Universities and Private Institutions," both of which it approached by identifying the need for three different types of skills as follows:

- CHART skills (Communication, Heuristic, Analytical, Relational and Technology): focused on foundational skills needed in the ICT sector;
- SMART Skills (Software, Mobile, Application, Research and Technology): focused on the IT industry; and
- START Skills (Start-up, Training through Association with Remote Teams): focused on entrepreneurship and cutting edge technologies.<sup>1419</sup>

The MCIT also identified the need to update and revise its aforementioned ICT Policy to "address challenges in the areas of development of local ICT human resources [and] ICT enabled *[sic]* curriculum both for primary and higher education."<sup>1420</sup> Another subcomponent of *E-Afghanistan* is the need to build a chief information officer (CIO) cadre within and across the government, which is briefly mentioned below and covered more extensively in the following chapter.

## Exchange Programs

The MCIT recently began to take advantage of ICT capacity building through exchange programs with communications ministries and regulators of other countries. For example, in early 2013, the Telecommunications Advisory Team (TAT) facilitated an introduction between personnel at the MCIT and the ATRA to the Turkish Information and Communication Authority (ICTA) and the Scientific and Technological Research Council of Turkey, also known as the TÜBİTAK, to facilitate cooperation and training specifically regarding spectrum management. The Turks invited their Afghan colleagues to a series of ICT/regulatory conferences in May 2013, and the hope was the two states would continue to broaden and sustain the relationship.

Shortly thereafter, the MCIT Minister went to Estonia in May 2013, during which visit an ambassador issued a formal invitation<sup>1421</sup> to the Minister for Afghans to visit its e-Governance Academy (EGA). The MCIT sent a delegation of representatives to Tallinn for a week-long workshop about electronic transactions and cybercrime in August 2014. The event was organized through cooperation with the EGA,

---

<sup>1419</sup> Islamic Republic of Afghanistan Ministry of Communications and Information Technology (MCIT) (2011). *E-Afghanistan National Priority Program* (NPP) Proposal, May, 44 and 62. Accessed November 17, 2104. <http://mcit.gov.af/Content/files/PSD%20NPP%202%20E%20Afgh%20NPP%20Proposal%2023%20May%202011.pdf>

<sup>1420</sup> Ibid.: 30.

<sup>1421</sup> MCIT (2013). "H.E. Amirzai Sangin Minister of Communications & IT Visits Republic of Estonia," May 25. Accessed February 9, 2015. <http://mcit.gov.af/en/news/20607>.

the Estonian Ministry of Foreign Affairs, the United States Department of Commerce (DoC) Commercial Law Development Program (CLDP, more on it below), and the United States Agency for International Development (USAID).<sup>1422</sup> Similarly, in December 2015, the CLDP organized a four-day training tour in New Delhi where personnel from the MCIT and ATRA, worked with their peers from the Telecommunications Regulatory Authority of India (TRAI) on a host of topics.<sup>1423</sup>

In November 2015, the MCIT sent 20 employees, selected through a merit-based process, to China to attend a nearly three-week training course on “Telecom Operation and Planning.” The training included sessions on fiber optics, networking, and ICT equipment. China has pledged continued support regarding capacity development for MCIT staff, including workshops, seminars, long-term scholarships, and academic partnerships.<sup>1424</sup> Similarly, in February 2016, the Minister of Communications led a delegation of representatives from the MCIT, ATRA, state-owned Afghan Telecom Corporation (AfTel), and other entities to Almaty Kazakhstan, where the Afghans met with their counterparts as part of a World Bank-sponsored Digital Development Conference.<sup>1425</sup>

### *Ministry of Higher Education*

In contrast to the comprehensive vision of the MCIT, the MoHE mentions ICT only once in its NPP. It does, however, include the need for technology curricula and training in two of its twelve expected outcomes. In its 2005 Strategic Development Plan, the MoHE states only the need to “explore and develop the possibilities of distance education within the country, connecting internationally and partnering with overseas institutions of higher education.”<sup>1426</sup> With regard to distance learning, Kabul University’s 2005 plan<sup>1427</sup> states, “The rapid development of online courses suggests that Kabul University can address the national need for a better-educated workforce by building the capacity to offer academic and training programs – whether belonging to Kabul University or any other university – throughout Afghanistan.” The strategy states the “university will, therefore, work with national and international partners to create a network that can be used to offer a wide variety of online courses throughout the nation.” However, despite positive policy pronouncements with regard to distance education and distance learning, it is important to note that key Afghan stakeholders continue to have major reservations about distance

---

<sup>1422</sup> Estonia e-Governance Academy (2014). “Afghanistan parliament and government representatives visiting Estonia,” August 14. Accessed February 9, 2015. <http://ega.ee/news/afghanistan-parliament-and-government-representatives-visiting-estonia/>.

<sup>1423</sup> United States Department of Commerce (DoC) Commercial Law Development Program (CLDP) Office of General Counsel (2015). “CLDP Conducts Training Seminar for Afghan Telecom Officials,” December 7-10, 2015. Accessed January 15, 2016. <http://cldp.doc.gov/programs/cldp-in-action/details/1518>.

<sup>1424</sup> MCIT (2015). “China supports MCIT towards Technical Capacity Building,” November 24. Accessed January 15, 2016. <http://mcit.gov.af/en/news/china-supports-mcit-towards-technical-capacity-building>.

<sup>1425</sup> MCIT (2016). “Minister of MCIT participates in Digital Development Conference in Kazakhstan,” February 21. Accessed March 8, 2016. <http://mcit.gov.af/en/news/china-supports-mcit-towards-technical-capacity-building>.

<sup>1426</sup> Islamic Republic of Afghanistan Ministry of Higher Education (MoHE). *Strategic Development Plan 2005*. Accessed November 17, 2014.

[http://planipolis.iiep.unesco.org/upload/Afghanistan/Afghanistan\\_MoHE\\_strategic\\_plan.pdf](http://planipolis.iiep.unesco.org/upload/Afghanistan/Afghanistan_MoHE_strategic_plan.pdf).

<sup>1427</sup> *Kabul University 2005 Strategic Plan*.

education or newer versions of such. In fact, the MoHE's "National Higher Education Strategic Plan: 2010-2014" (NHESP) says, "...it will be important to consider the possibility of ... distance education" in the future but that "movement in this direction should be slow with pilot offerings before major expansion is undertaken."<sup>1428</sup>

The NHESP also barely mentions ICT. It does, however, claim there are "persistent gaps in demand and supply of science and technology trained manpower" and "solutions will require ... well-coordinated science and technology structures." It also states, "During the last eight years following the election of a democratic government, much progress has been made in rehabilitating the higher education system including upgrading infrastructure [and] improving information and communications technology (ICT) ..." Further, it outlines the need to develop a community college program, which did not exist in Afghanistan in 2013, which will provide "specialized post-secondary education" including both short courses and mid-level training in computer science as well as "highly technical training geared to specific industries ..."<sup>1429</sup>

### *Ministry of Education*

Interestingly, the MoE's NPP<sup>1430</sup> mentions ICT many times. It incorporates ICT facilities and laboratories as part of its infrastructure improvement and general construction plans, along with drinking water, sanitary toilets, tables, chairs, and sports facilities. It also includes ICT in its proposed curriculum reform to improve access to and quality of Islamic education, expand job opportunities, and reduce the pool of recruits for insurgency. One of the MoE's NPP deliverables is to improve ICT systems, applications, and training. The MoE's NPP even states ICT training for relevant staff is part of improving the management and administration of its schools.

The MoE's third "National Education Strategic Plan 2015-2020 (Draft)" (generally referred to as NESP III) calls for using ICT as one of its strategies to improve general literacy<sup>1431</sup> (one of the MoE's priority programs), which will have a secondary effect of simultaneously improving digital literacy. Also, one of the MoE's goals is to train 550 employees in IT by the year 2020.<sup>1432</sup>

## **Formal Education Institutions**

### *Public Universities*

There are approximately 30 public institutions of higher learning throughout Afghanistan, ranging from the Panjsher Higher Education Institute to Kabul Medical, Education, and Polytechnic Universities. The

---

<sup>1428</sup> Islamic Republic of Afghanistan Ministry of Higher Education (MoHE). *National Higher Education Strategic Plan (NHESP): 2010-2014*. Accessed December 20, 2016. <http://www.mohe.gov.af/policy1/en>.

<sup>1429</sup> Ibid.

<sup>1430</sup> Islamic Republic of Afghanistan Ministry of Education (MoE) National Priority Program. *Education For All*. Accessed January 15, 2015. <http://thekabulprocess.gov.af/images/npps/hrd/2-Education%20for%20all.pdf>.

<sup>1431</sup> MoE. *National Education Strategic Plan (2015-2020)* (Draft), 49. Accessed February 9, 2015. <http://moe.gov.af/Content/files/NESP%20III%20Draft-June%2022%2c%202014%20%28English%29%281%29.pdf>.

<sup>1432</sup> Ibid. 53.

number and type of ICT resources, including basic Internet connectivity, varies widely among them, as do the academic offerings in ICT.

Article 43 of the Constitution of Afghanistan states that “Education is the right of all citizens of Afghanistan...” and it “...shall be offered up to the B.A. level in the state educational institutions free of charge by the state.”<sup>1433</sup> According to the MoHE Strategic Plan, “the total budget allocated to the 22 universities in 2009 was [US]\$35 million, averaging about [US]\$1.5 million per institution. No university can provide quality higher education with such limited resource provisions.”<sup>1434</sup> Despite these limited resources, the MoHE has made progress in improving the quality of computer science education. Several Afghan universities offer Bachelor of Science degrees in computer science, and Kabul University now offers master’s degrees in computer science.

A purported recent law will allow Afghanistan’s public institutions of higher learning to take funding from sources other than the government, such as endowments, which will likely help to improve the quality of education in at least some universities.

### *Information and Communication Technology Institute*



The Information and Communication Technology Institute (ICTI) is a four-year institution of higher learning that specializes in ICT training. It is considered a directorate under the MCIT, with funding provided by the MCIT, ATRA, and state-owned AfTel, but follows the rules and

basic curriculum of the MoHE. Bachelor’s degrees from the ICTI are conferred by Kabul University. The ICTI is the reincarnation of the Telecommunications Training Center (TTC), which was established in 1964 by cooperation between the International Telecommunication Union (ITU) and the United Nations Development Programme (UNDP). The TTC was originally a vocational school under the MoE to train telecommunications technicians, the only school of its kind in Afghanistan at the time.



Picture 49: ICTI graduation ceremony, January 2011

(Photo by Neil Sleevi)

By 1971, the TTC had expanded its curriculum to include radio,

<sup>1433</sup> The Constitution of the Islamic Republic of Afghanistan, ratified January 26, 2004. Accessed February 9, 2015. <http://www.afghanembassy.com.pl/afg/images/pliki/TheConstitution.pdf>.

<sup>1434</sup> MoHE, *NHESP: 2010-2014*.

television, outside plant, microwave, telex, and other areas and achieved junior college status.

Table 12: ICTI graduates by year

Number of ICTI Graduates by Year	
Class of 2010	34 (1 female)
Class of 2011	62 (2 females)
Class of 2012	49 (4 females)
Class of 2013	49 (2 females)
Class of 2014	39 (4 females)
Class of 2015	39 (2 females)

Recognizing the need for a skilled Afghan ICT workforce, and with a US\$4 million grant from the Iranian government, officials from the MCIT and MoHE cooperated to upgrade the TTC and reopen it with a more modern program (e.g., digital and Internet Protocol (IP)-based systems) as the ICTI in 2007, offering four-year degrees. Each year, 50 students are admitted to the ICTI, depending on their scores on the Konkor exam, the national university entrance test.

In April 2012, the ICTI submitted a three-year project proposal to ATRA to use the Telecommunications Development Fund (TDF) for costs such as incentives for staff, stationary, printers, computers, software, lab equipment, Internet fees, and books for a project in support of the MCIT. However, such expenses are outside the TDF's mandate, so the ICTI's application was not approved. On a more positive note, the MCIT planned a four-year educational assistance project<sup>1435</sup> to further strengthen the ICTI, the main objective of which is to build capacity among its lecturers and technical instructors. The plan includes providing:

- A two-year master's degree course for lecturers and instructors;
- Non-degree fellowships; and
- New and additional courses at the ICTI by international instructors.

Additionally, the ICTI recently joined several partnerships funded by the European Commission under its Erasmus+ Programme<sup>1436</sup> (formerly the Erasmus Mundus project). Erasmus+ is a European Union program that runs from 2014 to 2020 to create socio-economic change through education, training, and sports for youth, with components for interaction between Europe and Asia and partnerships with developing countries. The former Erasmus Mundus project was usurped by Erasmus+ beginning in 2015. The ICTI is involved in the following:

- FUSION (Featured Europe and South Asia Mobility Network), the key objective of which is "to enhance the capacity for international cooperation between universities in the Asian and EU countries by facilitating transfer of people, know-how, culture and best practice in training the next generation of researchers and academic staff."<sup>1437</sup>
- SMARTLINK, which stands for the South-east-west Mobility for Advanced Research, Learning, Innovation, Network, and Knowledge, "aims to mobilize [exchange] 160 students, researchers

<sup>1435</sup> MCIT (2013). *Information and Communications Sector Development and Progress, 2003-2013*. August (unpublished but provided to co-author Karen Black).

<sup>1436</sup> European Commission (2015). *Erasmus+ Programme Guide*. Accessed February 9, 2015. [http://ec.europa.eu/programmes/erasmus-plus/documents/erasmus-plus-programme-guide\\_en.pdf](http://ec.europa.eu/programmes/erasmus-plus/documents/erasmus-plus-programme-guide_en.pdf).

<sup>1437</sup> FUSION website. Accessed February 9, 2015. <http://fusion-edu.eu/FUSION/>.

and staff ... between Asia and Europe ... with a focus on research and training in Smart [sic] technologies.”<sup>1438</sup>

- The LEADER Project (Links in Europe and Asia for engineering, education, Enterprise, and Research) at the University of Sannio in Italy, which provides scholarships for students, researchers, and staff from target countries to study, research, train, or teach at host universities in Europe.<sup>1439</sup>
- LEADERS (Leading Mobility between Europe and Asia in Developing Engineering Education and Research), which is a scholarship and exchange program for students and researchers with a focus on various types of engineering, ICT, photonics, energy, and other high-tech areas of study.<sup>1440</sup>

According to Professor Mohammad Shafi Sharifi,<sup>1441</sup> Director of the ICTI, the institute will benefit from five types of mobility (exchange), with undergraduates through to post-doctoral students and administrative staff eligible for different programs of different lengths, generally between two and 12 months. In February 2015, Professor Sharifi indicated the ICTI was in the process of developing separate curricula for its Telecommunications/Engineering and ICT Departments in time for the start of the March 2016 academic year.

### *Private Universities*

According to the MoHE,<sup>1442</sup> there are nearly 100 private universities and institutions of higher learning in Afghanistan, of various sizes and statures. Twenty-eight of them offer degrees in Computer Science, and one, Bakhtar University, even offers a Master’s. Enrollment numbers seem to indicate the private sector educates just over half as many Afghans as the public universities: 52,119 versus 99,530 in 2012.<sup>1443</sup> The private sector has the ability to charge tuition and fees whereas the public universities cannot. The quality of at least some of the private universities is far superior to public education. Two private institutions that are considered exemplary, particularly with regards to ICT capacity building, are:

---

<sup>1438</sup> SMARTLINK website. Accessed February 9, 2015. <http://smartlink-edu.eu/>.

<sup>1439</sup> LEADER Project website. Accessed February 9, 2015. <http://www.leader.unisannio.it/>.

<sup>1440</sup> LEADERS Project website. Accessed February 9, 2015. <http://www.emleaders.eu/index.asp>.

<sup>1441</sup> Email message from Professor Mohammad Shafi Sharifi to co-author Karen Black, February 5, 2015.

<sup>1442</sup> MoE. Accessed January 14, 2015. <http://www.mohe.gov.af/?lang=en&p=private>.

<sup>1443</sup> MoHE chart (2013), referenced in Aturupane, Harsha, 2013. *Higher education in Afghanistan: an emerging mountainscape*. Washington DC; World Bank. Accessed November 17, 2014. <http://documents.worldbank.org/curated/en/2013/08/18197239/higher-education-afghanistan-higher-education-afghanistan-emerging-mountainscape>.

- The American University of Afghanistan (AUAF): AUAF operates a Professional Development Institute (PDI) that offers education and training programs to private businesses, NGO's, government agencies, and individuals. Per its website,<sup>1444</sup> AUAF's PDI also offers custom-tailored courses in Information Technology, including Cisco, Comp TIA, International Computer Driver's License (ICDL), Microsoft, Oracle, Red Hat, and others.
- Kardan University: Kardan is one of the implementing institutions for the World Bank-funded Bridging Program (see below). Kardan University is also implementing the Afghanistan Workforce Development Program (AWDP) funded by USAID (see below). As one of the leaders of an association of private universities, Kardan has expressed interest in public-private partnerships.



Picture 50: Cisco Networking Academy at the American University of Afghanistan's Professional Development Institute

(Photo by Larry Wentz)

### *Technical and Vocational Institutes*

The Afghan Committee on Education and Skills Policy (CESP) published an overview of technical and vocational education and training (TVET) in Afghanistan in 2010, the goal of which was “to provide relevant and quality technical and vocational educational opportunities for post basic education.”<sup>1445</sup> In order to inform and in advance of implementing its Afghanistan Workforce Development Program (AWDP) as described above, USAID commissioned a consultancy to conduct an inventory of TVET providers in 2011.<sup>1446</sup> Common to both reports is an acknowledgement of a severe shortage of skilled and semi-skilled workers, a labor force that does not meet market demands, fragmented TVET policy and administration (several ministries are involved), the lack of cohesive oversight and consistent standards, and the relatively poor quality of TEVT instruction and provision, among other points. Both reports also identify ICT as a target sector for TVET.

---

<sup>1444</sup> American University of Afghanistan (AUAF). Accessed January 14, 2015.

<http://auaf.edu.af/academics/professional-development-institute/>.

<sup>1445</sup> Afghan Committee on Education and Skills Policy (CESP) (2010). *Technical – Vocational Education and Training in Afghanistan, An Overview*, 1. Accessed January 14, 2015.

[http://cesp.gov.af/anqa/Documents/TVET\\_Overview.pdf](http://cesp.gov.af/anqa/Documents/TVET_Overview.pdf).

<sup>1446</sup> Development Alternatives, Inc. (DAI) (2011). *Afghanistan Technical and Vocational Education Training (TVET) Providers Inventory*, November 2011. Prepared for USAID under the Afghanistan Small and Medium Enterprise Development (ASMED) Project, contract number 306-C-00-07-00503-00. Accessed January 14, 2015.

[http://pdf.usaid.gov/pdf\\_docs/pnaea952.pdf](http://pdf.usaid.gov/pdf_docs/pnaea952.pdf).

Of the over 400 technical and vocational institutes (TVIs) interviewed for USAID’s report (177 of which were in Kabul), nearly 19 percent (18.65%) claim to provide training in ICT and/or computers as depicted in [Figure 103](#).<sup>1447</sup>

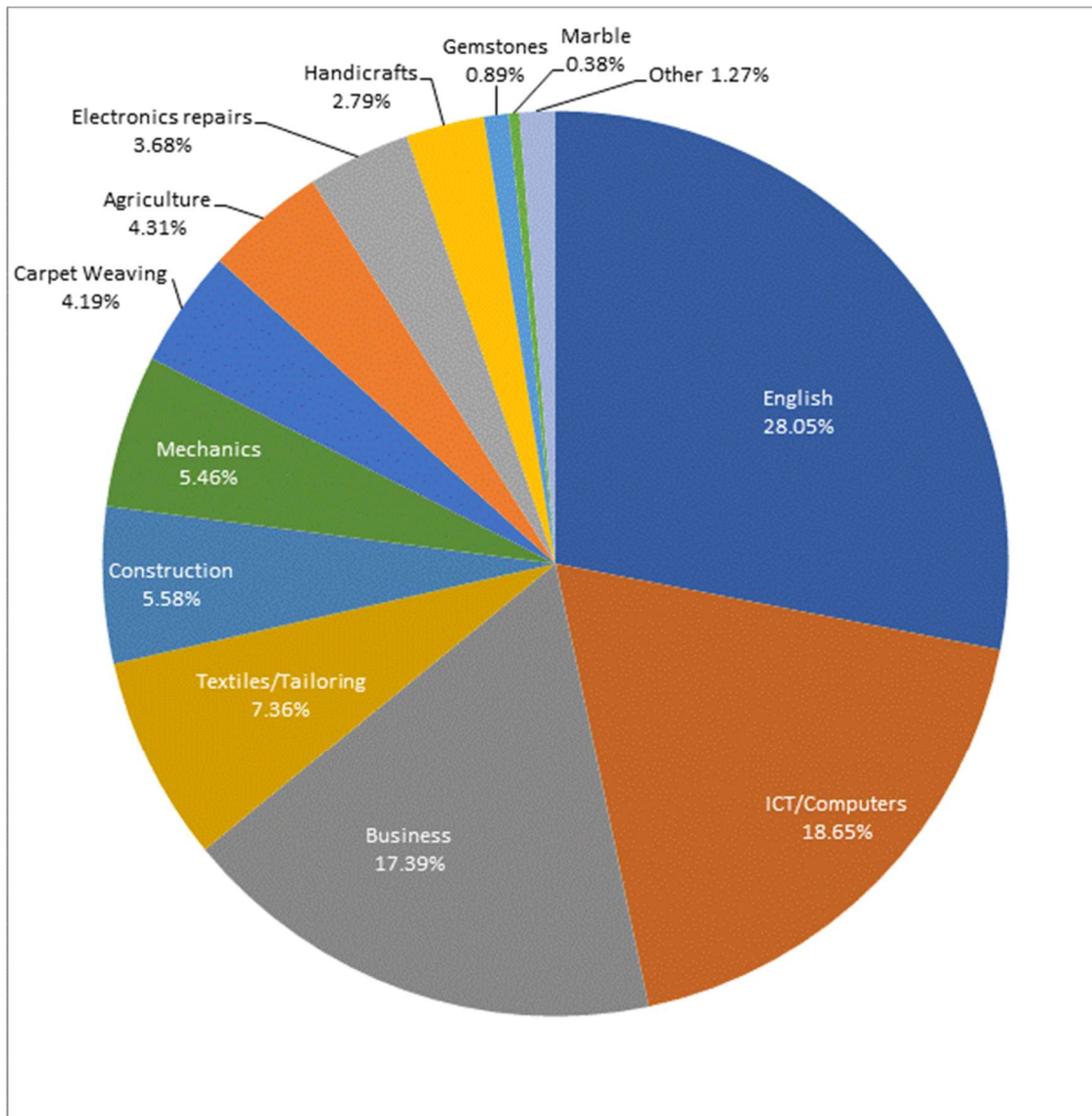

Figure 103: TVET offerings by category

The USAID report notes Khurasan and Bakhtar Institute of Higher Education have continuing education programs in very specific technical competencies. They also mention ICT courses at AUAF’s Professional Development Institute, as per above. Interestingly, the researchers for the USAID report noted, “Under-utilization of on-line resources is a major development hindrance for TVET development. While Internet

<sup>1447</sup> DAI, 2011. *TVET Providers Inventory*, 15.



access is acknowledged as a challenge in most areas, support to expand ‘virtual learning’ is a more efficient approach than erecting new buildings. Well-over 50 of TVET survey respondents claim to utilize Internet, yet only one reported using on-line resources in developing curricula. Lack of in-country expertise and the enormous challenge of physical movement in Afghanistan implores TVET providers to increase use of distance learning and on-line resources.”<sup>1448</sup>

The World Bank’s first Afghanistan Skills Development Project (ASDP I, which ran from 2008 to 2014<sup>1449</sup>) included a component to improve the relevance, quality, and efficiency of TVET programs in general, and a subcomponent called for the establishment of a new TVI, the National Institute of Management and Administration (NIMA), which is be dedicated to training Afghans in highly-skilled, in-demand areas, including information technology. NIMA offers two-year diplomas in ICT, one of its three disciplines (the other two being management and accounting). According to the World Bank, 75 percent of NIMA graduates (not all of whom studied IT) were employed six months after completing training.<sup>1450</sup>

Additionally, the Computer Technology Institute (CTI) in Kabul offers a Diploma in Computer Applications, the only TVI to do so to date to the authors’ knowledge. The CTI has 800 day students and 500 night students, with more than fifty percent female enrollment. CTI estimates that 50 to 90 percent of its graduates become employed. Those who obtain jobs in state-owned institutions request a special certification from CTI, but CTI does not have a formal follow-up process for graduates who get jobs in the private sector (hence the fifty percent estimate).

In 2014, the Afghan Ministries of Education (MoE) and Labor, Social Affairs, Martyrs, and Disabled (MoLSAMD), jointly with the United Nations Education, Science and Cultural Organization (UNESCO) and other organizations, unveiled Afghanistan’s first ever sector-wide “National TVET Strategy.”<sup>1451</sup> It provides a national framework as well as a common platform for TVET for the following five years and aims to coordinate efforts among government, civil society, and donors. The Ministry of Communications and Information Technology is not one of the 13 ministries with representatives on the TVET Board. However, the plan calls for the introduction of modern ICT to TVET delivery and assessment, the equipping of TVET institutions with ICT, and training of TVET teachers on new learning technologies.<sup>1452</sup>

---

<sup>1448</sup> Ibid.: 2.

<sup>1449</sup> Per the World Bank, “The closing date of February 28, 2013 was extended for a period of 16 months to June 30, 2014. The extension was granted to provide time to complete construction activities; to facilitate and develop a new implementing partner for the National Institute on Management and Administration (NIMA); and to allow for two additional graduation cohorts from Institute.” World Bank Independent Evaluation Group ICR Review report # ICRR14732, World Bank (2015). *Afghanistan - Skills Development Project*. Washington, D.C.: World Bank Group. Accessed August 22, 2015. <http://documents.worldbank.org/curated/en/2015/08/24915897/afghanistan-skills-development-project>.

<sup>1450</sup> World Bank, 2015. *Afghanistan - Skills Development Project*.

<sup>1451</sup> Islamic Republic of Afghanistan (n.d.). *National TVET Strategy*. Accessed August 22, 2015. <http://www.unesco.org/new/fileadmin/MULTIMEDIA/FIELD/Kabul/pdf/NationalTVetStrategyEnglish.pdf>.

<sup>1452</sup> Ibid.: 49.

## Donors

As in other sectors, there are myriad donors in the ICT capacity building space. Three of the most prominent are the World Bank, the USAID, and the North Atlantic Treaty Organization (NATO). India, Japan, Norway, Turkey, and South Korea, among many other donor governments, were or still are also active in the ICT capacity building space, as were/are various UN organizations in Afghanistan.

### *The World Bank*

From 2002 through 2014 or mid-2015, the World Bank Group committed over US\$3.07 billion to the development of Afghanistan.<sup>1453</sup> Several World Bank projects and programs include higher education and capacity building in general, and many specifically include ICT capacity development. Some of those projects are described below.

### Emergency Communications Development Project

In September 2003, the World Bank International Development Association (IDA) issued a US\$22 million credit for an Emergency Communications Development Project (ECDP) to the Transitional Islamic State of Afghanistan “to support activities designed to improve delivery of communications services to the Government and the people of Afghanistan.”<sup>1454</sup> Second only to actually expanding the Government Communications Network (GCN)<sup>1455</sup> was “providing urgently needed policy ... capacity building to the MoC ...”<sup>1456</sup> Capacity building under the ECDP, which ran through March 2007, included specific training for MoC staff to be able to operate and maintain the GCN, as well as overall MoC institutional capacity building in several areas, including but not limited to policy and regulation, project management, and spectrum, among others.

### Afghanistan ICT Sector Development Project

The World Bank’s US\$50 million ICT Sector Development Project, in support of the MCIT’s *E-Afghanistan NPP*, “recogniz[ed] a gap between skills demanded by the IT industry ... and the level of skills among Afghan graduates.”<sup>1457</sup> Two of the four components of the ICT Sector Development Project are “IT industry

---

<sup>1453</sup> Raouf Zia, Abdul (2015). *The World Bank Group in Afghanistan: Country Update*. Kabul, Afghanistan World Bank Group. Accessed October 9, 2015. <http://documents.worldbank.org/curated/en/2015/04/24381192/world-bank-group-afghanistan-country-update>.

<sup>1454</sup> World Bank (2003). *Afghanistan - Emergency Communications Development Project*. Washington, DC: World Bank. Accessed October 9, 2015. <http://documents.worldbank.org/curated/en/2003/09/2513113/afghanistan-emergency-communications-development-project>.

<sup>1455</sup> See [Chapter 8](#), Satellite Communications, and [Chapter 3](#), ICT in Afghanistan, for more information about the GCN.

<sup>1456</sup> Ibid.

<sup>1457</sup> World Bank (2011). *Afghanistan - ICT Sector Development Project*, 28. Washington, DC: World Bank. Accessed August 22, 2015. <http://documents.worldbank.org/curated/en/2011/03/13995882/afghanistan-ict-sector-development-project>.

development” and “project management support,” both of which include funding for capacity building activities within the MCIT.

### *ICT Skills Development Program*

As part of the IT industry development component, the World Bank’s Afghanistan ICT Sector Development project includes financing for a “skills development program aimed at developing a pool of skilled and qualified IT professionals as a key building block of IT sector development in Afghanistan.”<sup>1458</sup> Among the 15 potential programs the report proffered as part of comprehensive ICT training strategy is a “bridging program” for selected graduates to enhance their skills to meet market demand. Accordingly, the World Bank, in conjunction with the MCIT, implemented an ICT Skills Development Program (also known as the “ICT Skills Bridging Program”), a US\$2 million pilot project to train up to 1,500 Afghans, largely but not entirely from the public sector, by 2016. Through a competitive bid process, Kardan University and Rana Technologies, both based in Kabul, and InfoTech Global Limited from Singapore, were selected to implement the initial phase of the bridging program (InfoTech dropped out after the first round of instruction), with each awarded about US\$200,000. Trainees were to be given pre-tests and post-tests to measure gains made during the training. Subject to improvements in the skill level of trainees, institutions that show success were to be given an opportunity to train an additional number of students.<sup>1459</sup>

Target trainees include (1) final year students or recent graduates of engineering and technology programs; (2) teachers in ICT programs; and (3) IT staff of the Afghan Government identified by MCIT. Moreover, trainers from these institutions are also to be trained under the program as part of a train-the-trainers program. Trainees who register for the program are expected to pay a nominal fee for the training program with the fees to be refunded upon satisfactory completion of the program. Also upon satisfactory completion of the training, job-seeking trainees are to be matched with firms that are hiring. A career fair was to be part of the training process.

The bridging program curriculum is delivered in about 150 hours over three months and includes the following themes:

- Software skills, including database (such as Oracle) development and maintenance, data recovery, and mobile applications;
- Hardware skills, including networking and related certifications; computer assembly and maintenance; trouble shooting, and repairs;
- Internet technology skills, including website development, e-portals and services, cybersecurity, and network monitoring; and

---

<sup>1458</sup> Ibid.

<sup>1459</sup> In-person communication between co-author Maria Beebe and Mohammad Ismail Bhat, Head of the Project Management Office and Project Director of the World Bank-funded ICT Sector Development Project of Afghanistan, MCIT.

- Soft skills, including communication, interpersonal relations, business, and entrepreneurial skills.

Trainees are able to specialize in a theme of their choosing, or gain skills across multiple themes.

Training commenced October 1, 2012.<sup>1460</sup> After feedback from the initial group of students, the World Bank restructured the bridging program to provide fewer lectures and more hands-on training. By early 2013, each of the three institutions had trained 150 trainees. The World Bank reported a total of 1,500 Afghans were trained by early 2016, with another 500 (including 200 women) to be trained by June 2016.<sup>1461</sup>

A complementary objective of the Bridging Program was to encourage competition between certified and high-quality academic institutions and training centers in Afghanistan to deliver high-quality and industry-relevant IT/ICT training.

### *ICT Skills, Project Management, and Fiber Optics Training*

Using funds from the Afghanistan ICT Sector Development Project, the MCIT issued seven separate requests for proposals<sup>1462</sup> for training between July 2014 and July 2015.<sup>1463</sup> Two requests were for a total of 140 MCIT staff to be trained in either project management or results-based project management, while a third is for spectrum management for ATRA personnel. One of the tenders is specifically and only for 200 female IT professionals in Kabul to be trained in job-oriented ICT skills (awarded to Rana University), while another is for a mixed group (males and females) of 200 in five provinces (awarded to Bakhtar University). Two tenders are for *advanced* job-oriented ICT skills, one for 100 IT professionals in Kabul, with 20 additional personnel to be trained abroad (awarded to Aptech Afghanistan) and the other for 100 government CIOs (GCIOs) and technical managers. The training for GCIOs and technical managers includes an e-government component.

In March 2016, the MCIT issued a request for expressions of interest and terms of reference for a four-week training course on “Fiber Technologies and Systems,” also using funds from the ICT Sector Development Project.<sup>1464</sup> The main topics include principles of synchronous digital hierarchy (SDH),

---

<sup>1460</sup> Norbhu, Tenzin Dolma (2012). *Afghanistan - Afghanistan ICT Sector Development Project: P121755 - Implementation Status Results Report: Sequence 03*. Washington, D.C.: World Bank Group. Accessed August 22, 2015. <http://documents.worldbank.org/curated/en/2012/10/16887904/afghanistan-afghanistan-ict-sector-development-project-p121755-implementation-status-results-report-sequence-03>.

<sup>1461</sup> Singh, Rajendra-000312761; 2016. *Afghanistan - Afghanistan ICT Sector Development Project: P121755 - Implementation Status Results Report: Sequence 09*. Washington, D.C.: World Bank Group. Accessed March 14, 2016. <http://documents.worldbank.org/curated/en/2016/02/25910981/afghanistan-afghanistan-ict-sector-development-project-p121755-implementation-status-results-report-sequence-09>.

<sup>1462</sup> Or similar such documents.

<sup>1463</sup> MCIT. Accessed September 9, 2015. <http://mcit.gov.af/en/tender?page=1>.

<sup>1464</sup> MCIT (2016). “Request for Expressions of Interest (REOI) and the Terms of Reference (TOR) for the Post of ‘Trainer on Fiber Technologies and Systems.’” March 5. Accessed March 16, 2016.

network configurations and operations, and inside and outside plant installation, commissioning, and safety.

### *Incentive Payment Program*

The MCIT's Project Implementation and Coordination Unit (PICU), of which the World Bank Project Management Office (PMO) at the MCIT is a part, proposed an incentive payment program in early 2012 for its project management capacity building efforts. Falling under the project management support component of the World Bank's Afghanistan ICT Sector Development Project, the intent of the US\$400,000 program (US\$100,000 per year for each of the remaining project years, or approximately US\$8,000 per month) was to make supplemental salary payments available to approximately 25 MCIT staff (three to eight employees of specific departments) who provide dedicated support to the implementation of the World Bank project. According to the World Bank, "The limited capacity of the mid-level staffers of MCIT was identified as a concern during Project preparation, and hence this capacity development arrangement is proposed as a means to ensure successful Project implementation. The incentive payments will enable high-performing staff to maximize their contribution to the Project by allowing them to seek new training and take on an increased workload."<sup>1465</sup> The types of additional training sought included "topics such as English language skills, accounting procedures, administration, management, computer operation, and project management."<sup>1466</sup>

Unfortunately, the World Bank reported in December 2013, it closed the capacity building incentive program "due to non-activity since the start of the project"<sup>1467</sup> and redirected the US\$400,000 in funds to be used for other training for the MCIT staff and for operating costs. However, in June 2014, the World Bank reported the MCIT was "defining a robust results framework for the [project management] training program,"<sup>1468</sup> which would be overseen by the MCIT Deputy Minister – Technical and Administration and coordinated with the Capacity Building for Results program (see below), which was being used in the PMO.

---

<http://mcit.gov.af/en/tender/request-for-expressions-of-interest-reoi-and-the-terms-of-reference-tor-for-the-post-of-trainer-on-fiber-technologies-and-systems>.

<sup>1465</sup> World Bank (2012). *Afghanistan - ICT Sector Development Project: restructuring*, 5. Washington, DC: World Bank Group. Accessed September 9, 2015.

<http://documents.worldbank.org/curated/en/2012/02/23989632/afghanistan-ict-sector-development-project-restructuring>.

<sup>1466</sup> Ibid.: 4.

<sup>1467</sup> Raja, Siddhartha (2013). *Afghanistan - Afghanistan ICT Sector Development Project: P121755 - Implementation Status Results Report: Sequence 05*. Washington, DC: World Bank Group. Accessed September 9, 2015.

<http://documents.worldbank.org/curated/en/2013/12/18708318/afghanistan-afghanistan-ict-sector-development-project-p121755-implementation-status-results-report-sequence-05>.

<sup>1468</sup> Raja, Siddhartha (2014). *Afghanistan - Afghanistan ICT Sector Development Project: P121755 - Implementation Status Results Report: Sequence 06*. Washington, DC: World Bank Group. Accessed September 9, 2015.

<http://documents.worldbank.org/curated/en/2014/06/19711733/afghanistan-afghanistan-ict-sector-development-project-p121755-implementation-status-results-report-sequence-06>.

### Chief Information Officer Training

As part of Component 2 of its ICT Sector Development Project, Mainstreaming Mobile Applications, the World Bank included CIO training as part of its overall ICT capacity building efforts focused on mobile government (m-government or m-gov), government-to-citizen (G2C) applications, and the strategic use of mobile applications. Through a contract with Mobile Government Consortium International (mGCI) of the United Kingdom, the World Bank trained 40 CIOs/Heads of IT Departments in Government of the Islamic Republic of Afghanistan (GIROA) ministries and other agencies in Kabul, and then took them to Turkey in October 2012 for further training on m-government and G2C applications. The contract also included training of 100 other IT professionals in Kabul on m-government. As of June 2015, the World Bank reported having trained 140 CIOs,<sup>1469</sup> exceeding its original goal.

### Capacity Building for Results Facility

The World Bank's Capacity Building for Results (CBR) Facility is a US\$350 million grant to the Afghan Ministry of Finance (MoF) through the Afghanistan Reconstruction Trust Fund (ARTF, a pooled donor funding mechanism), under the Afghan national budget, for a program that runs from 2012 to 2017. Its objective is "to assist the government in improving the capacity and performance of select line ministries in carrying out their mandates and delivering services to the Afghan people ... to be achieved through the implementation of specific capacity and institution building programs ..." <sup>1470</sup> The project consists of four components:

1. Technical assistance facility for preparation and implementation of line ministry capacity building programs;
2. Building human resources;
3. Civil service training; and
4. Project management, monitoring, and evaluation.

The anticipated key outcomes are measured using development budget execution rates, business process improvements, and service delivery improvements as key indicators.

The underlying impetus behind CBR is to address GIROA's severe capacity constraint and uncompetitive pay at line ministries and agencies, particularly since civil service reform has been slow, and to do so in advance of transition from NATO's International Security Assistance Force (ISAF) mission to Mission Resolute Support, which occurred at the end of 2014. According to the World Bank, "... [T]he proposed

---

<sup>1469</sup> 0000A8056; 0000A8056 (2015). *Afghanistan - Afghanistan ICT Sector Development Project: P121755 - Implementation Status Results Report: Sequence 08*. Washington, DC: World Bank Group. Accessed August 22, 2015. <http://documents.worldbank.org/curated/en/2015/06/24725706/afghanistan-afghanistan-ict-sector-development-project-p121755-implementation-status-results-report-sequence-08>.

<sup>1470</sup> World Bank (2011). *Afghanistan - Capacity Building for Results Facility Project: Emergency Project Paper*. Washington, DC: World Bank. Accessed August 22, 2015. <http://documents.worldbank.org/curated/en/2011/12/15653518/afghanistan-capacity-building-results-facility-project-emergency-project-paper>.

salary levels for the senior civil servants under the government’s new pay and grading reform are well below the levels being paid by donors to staff and consultants on comparable posts”<sup>1471</sup> and by the private sector. Further, “As donors begin to reduce their funds for technical assistance and project support, the government will face an increasing responsibility for delivery of services in the context of a shrinking envelope of support. Government must have the skilled staff at the central and sub-national levels ... [and] the task of building more sustainable, strategic and longer term capacity is therefore more urgent than ever.”<sup>1472</sup>

The assistance provided by the CBR Facility and program is based on a ministry’s specific needs and existing capacity according to its approved CBR plan. All ministries began at the Tier 3 (lowest) level and must strengthen their basic functional departments and implement various outlined public administration reforms prior to applying for more comprehensive levels (Tier 2 and Tier 1) of support. The CBR can include supplemental pay so that GIROA can offer competitive salaries in order to recruit and retain qualified staff in key positions. Attracting and keeping staff at Afghanistan’s public ICT institutions is particularly challenging because of disparity in pay and opportunities – such as training, travel, and advancement – afforded by the private ICT sector. The TAT encouraged the MCIT to use the CBR program for qualifying positions as an incentive for recruiting and retaining key staff and managers, including but not limited to cybersecurity personnel, which were – and still are – exceptionally scarce in Afghanistan, and to staff its Information Systems Security Directorate (ISSD).

The MCIT began the CBR proposal and application in mid-2012 and was accepted by March of 2013. (AfTel, however, was unable to take advantage of the program because of its status as a state-owned corporation rather than a government entity.) The implementation of CBR at the MCIT, which is at Tier 3, was in the “initial stages” by mid-2014.<sup>1473</sup> On January 13, 2015, the MCIT and the MoF signed an agreement to implement CBR at the MCIT, which will allow the MCIT to recruit 300 people over two years. The MCIT will be allocated US\$15-20 million of the total \$350 million CBR facility.<sup>1474</sup> Afghan President Ashraf Ghani called the CBR a “strategic priority” for GIROA and “a key instrument for realizing a new dynamic public sector.”<sup>1475</sup>

---

<sup>1471</sup> Ibid.

<sup>1472</sup> Ibid.

<sup>1473</sup> Raja, Siddhartha (2014). *Afghanistan - Afghanistan ICT Sector Development Project: P121755 - Implementation Status Results Report: Sequence 06*. Washington, DC: World Bank Group. Accessed March 5, 2015.

<http://documents.worldbank.org/curated/en/2014/06/19711733/afghanistan-afghanistan-ict-sector-development-project-p121755-implementation-status-results-report-sequence-06>.

<sup>1474</sup> MoF General Budget Directorate Capacity Building for Results (CBR) Program (2015). “CBR Program launched in the Ministry of Communications and IT.” January 13. Accessed March 5, 2015. <http://cbr.gov.af/en/news/cbr-program-launched-in-the-ministry-of-communication-and-it>.

<sup>1475</sup> MoF CBR Program (2015). “CBR is a Strategic Priority for Afghan Government’ H.E. Mohammad Ashraf Ghani.” March 1. Accessed March 5, 2015. <http://cbr.gov.af/en/news/cbr-is-a-strategic-priority-for-afghan-government-he-mohammad-ashraf-ghani>.

## Afghanistan Second Skills Development Project

The World Bank provided the Afghan Government, with the Ministry of Education as the responsible agency, with an emergency grant of US\$55 million for the Second Skills Development Project (also known as Afghanistan Skills Development II, or ASDP II), which runs from 2014 to 2018. The grant focuses on building systems and institutions in the formal sector to impart technical and vocational skills in diverse job streams. The grant assists Afghan youth to advance their skills and competencies, including in ICT. The objective of ASDP II is “to increase the potential for employment and higher earnings of graduates from Technical and Vocational Education and Training (TVET) schools and institutes through improvements in the skills delivery system,”<sup>1476</sup> and its four components are:

1. Strengthening of the TVET institutional system;
2. Improving performance of TVET schools and institutes;
3. Improving teacher competencies; and
4. Project management, monitoring and evaluation, and public awareness.

ICT is one of the project’s five “focus sectors” for curricular reform (identified based on “perceived market needs”), with the others being management and administration, accounting and banking, basic engineering skills (such construction related trades, metal work, and mechanical repairs), and agriculture and related sub-sectors.

A precedent TVET-focused World Bank program, the Afghan Skills Development Project (ASDP I), which was funded by a US\$20 million grant from the International Development Association (IDA) through the ARTF provided funding to establish NIMA, as mentioned above.

## Higher Education Development Project

The World Bank’s Strengthening Higher Education Program (SHEP) is being followed by the Higher Education Development Project (HEDP),<sup>1477</sup> designed to provide assistance to higher education in Afghanistan in general. ICT is not specifically mentioned in the HEDP Project Information Document, at least not the only one available on the World Bank’s website at the time of writing, which is from the appraisal stage. However, according to the February 5, 2016 *Implementation Status and Results Report*, one of HEDP’s goals is to have 12 public Afghan universities equipped with functional ICT centers for ICT-based higher education by 2019.<sup>1478</sup>

---

<sup>1476</sup> World Bank (2013). *Afghanistan - Second Skills Development Project*. Washington DC: The World Bank. Accessed March 5, 2015. <http://documents.worldbank.org/curated/en/2013/02/17292238/afghanistan-afghanistan-second-skills-development-project>.

<sup>1477</sup> 0000A8056; 0000A8056 (2015). *Project Information Document (Appraisal Stage) - Higher Education Development Project - P146184*. Washington, DC: World Bank Group. Accessed March 14, 2015. <http://documents.worldbank.org/curated/en/2015/06/24592311/project-information-document-appraisal-stage-higher-education-development-project-p146184>.

<sup>1478</sup> Aturupane, Harsha (2016). *Afghanistan - Higher Education Development Project: P146184 - Implementation Status Results Report: Sequence 01*. Washington, DC: World Bank Group. Accessed 14 March 2016.



## *The United States Government*

### United States Telecommunications Training Institute

The United States Telecommunications Training Institute (USTTI) is a non-profit 501(c)3 corporation funded by the US government, private companies, and various industry groups. It provides “tuition-free training for qualified communications professionals, regulators, and entrepreneurs from the developing world.”<sup>1479</sup> Over 85 courses in subjects such as spectrum monitoring and management, policy and regulation, broadcasting, and cybersecurity, are offered in several locations across the US and are taught by government officials and volunteer industry experts. The USTTI also offers scholarships for travel costs, from monies and in-kind donations from companies and government agencies, such as the US Department of State (DoS) and its USAID subsidiary.

In 2002 and 2006, Mr. Nadershah Arian, then a Board Member of the Afghan regulator, participated in USTTI spectrum management training. Additionally, during 2005, the USTTI honored Ms. Ogai Ahmadi and Ms. Malalai Hiela Safi as the 7,000<sup>th</sup> and 7,001<sup>st</sup> graduates upon completion of their three-week hands-on training course with Cisco.<sup>1480</sup> In September 2009, Ambassador Michael R. Gardner, Chairman of the USTTI, sent then MCIT Acting Minister, Amirzai Sangin, a letter, offering priority acceptance to Afghan officials for ICT capacity building and training, which was significant because of the USTTI’s ten-to-one ratio (10:1) of applicants to training slots at that time. The letter was hand-delivered to Minister Sangin by Major General Mark S. Bowman, Office of the Chief Information Officer/G-6, US Army (and formerly US Central Command J6), following a request from the office of the US Assistant Secretary of Defense for Networks & Information Integration/Department of Defense Chief Information Officer (ASD-NII/DoD CIO). Ambassador Gardner never received a reply.

Afghans can apply directly to USTTI through its website, but the USTTI vets and qualifies all applicants and approves or denies them. Between 2008 and 2014, over 100 Afghans applied to USTTI, several from the MCIT, ATRA, and AfTel (on their own rather than part of any sanctioned program), but also from donor organizations, NGOs, and private companies. Unfortunately, only a handful were actual able to attend, largely due to funding or visa issues.

### United States Agency for International Development

The USAID, another substantial donor in Afghanistan, has education among its eleven priority sectors.<sup>1481</sup> Its education strategy “focuses on addressing urgent needs and strengthening Afghan processes and

---

<http://documents.worldbank.org/curated/en/2016/02/25879279/afghanistan-higher-education-development-project-p146184-implementation-status-results-report-sequence-01>.

<sup>1479</sup> United States Telecommunications Training Institute (USTTI). Accessed January 14, 2015.

<http://ustti.org/about/index.php>.

<sup>1480</sup> Paraphrased from a letter dated September 3, 2009 from Ambassador Michael R. Gardner, Chairman of the United States Telecommunications Training Institute (USTTI), to Acting Minister Amirzai Sangin, Afghan MCIT, provided by Mr. James J. (Jim) O’Connor, Executive Director, USTTI, to co-author Karen Black.

<sup>1481</sup> USAID. Accessed January 21, 2015. <https://www.usaid.gov/what-we-do>.

institutions to build a national educational system that can sustain itself in the long term”<sup>1482</sup> and includes primary, tertiary, and vocational education. For example, USAID, among other donors, assisted the MoE with its National Education Strategic Plan III (2014-2020), which includes science and technology as one of its five main program areas. Among many other higher education projects, USAID funded the Strengthening Tertiary Education Project-University Partnerships (STEP-UP) in Afghanistan, as a follow-on to the Higher Education Project (HEP), implemented by the University of Massachusetts. Under HEP, USAID funded the development of a concept for and subsequent establishment of an Information Technology Community College at Kabul Polytechnic University and helped to develop Afghanistan’s first IT associate’s degree. As part of the procurement process for STEP-UP, USAID requested interested parties to review and comment on the draft concept paper. The activity is valued at more than US\$92 million over a five-year period. The USAID Global Development Alliance (GDA) released its Annual Program Statement for public-private alliances, including higher education institutions, with a call for concept papers that closed January 31, 2014. USAID also supports the AUAF, which has ICT/IT training at its Professional Development Institute, as mentioned above, along with degrees in computer science.

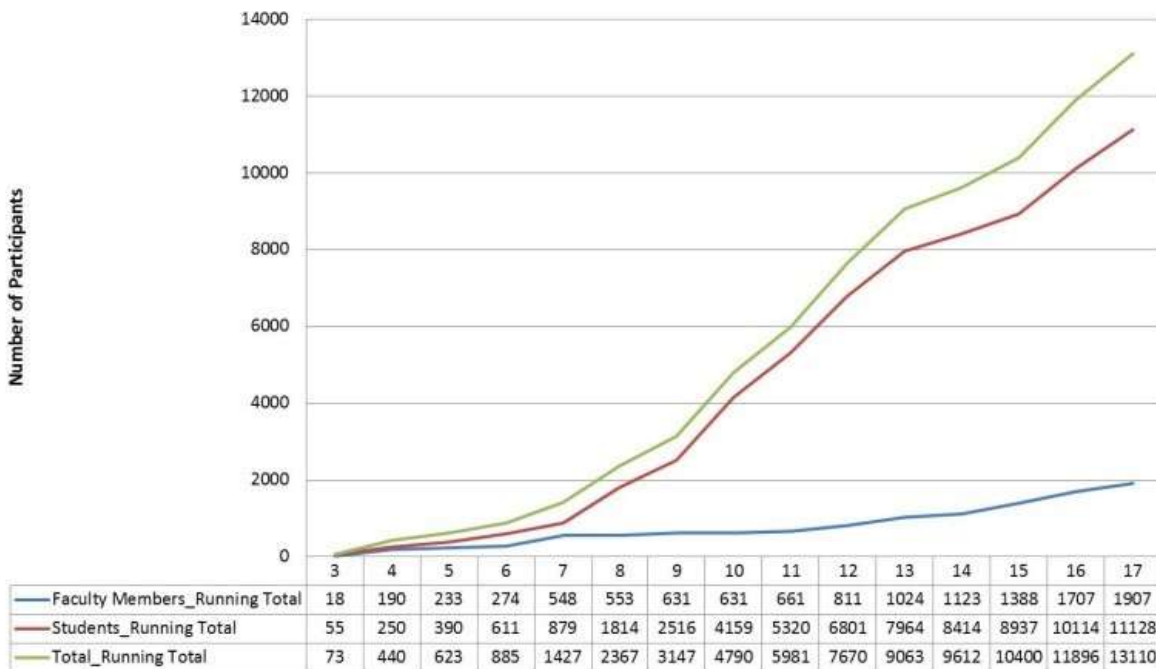

Figure 104: Number of ANGeL center completions by quarter

(Includes participants who completed more than one training in the fiscal year)

In addition to its work in the formal education sector, USAID has funded several projects in the past and continues to fund others designed to develop capacity in specific areas, ICT being one of them.

<sup>1482</sup> USAID. Accessed January 21, 2015. <https://usaid.gov/afghanistan/education>.

Descriptions of four of these programs are below, all of which fall under USAID's Economic Growth, rather than Education, sector. Additionally, USAID funded advisors to the MCIT and Afghan Telecom Corporation.

### *Afghan eQuality Alliances*

Beginning in 2006 and running through the end of 2010, USAID, in partnership with the MoE and Washington State University (WSU) in the US, ran the US\$12.3 million Afghan eQuality Alliances (AeQA) project to build capacity in Afghanistan's higher education institutions. Among its activities, AeQA established Afghan Next Generation eLearning (ANGeL) resource centers in major Afghan universities and a digital library (in conjunction with the University of Arizona). It also aimed to improve the quality of instruction in priority academic disciplines, like computer science, through partnerships among universities in the United States, Afghanistan, and other third-world universities, and it established 35 such partnerships.<sup>1483</sup> For example, lecturers from the Kabul University Computer Science Faculty attended the University of Western Cape in South Africa to complete research masters' degrees in computer science.

AeQA trained 1,500 faculty members (30 percent of the entire higher education staff) and 10,000 students in basic and intermediate IT skills at its ANGeL centers. Courses included the International Computer Driver's License (ICDL), server management, web design and development, and several others.<sup>1484</sup>

### *Afghanistan Workforce Development Program*

Another USAID program is the Afghanistan Workforce Development Program (AWDP), the goal of which is "to increase job placements and wages for 25,000 Afghans – twenty-five percent (25%) of them women – through increased access to quality technical and business education and training, job placement and support services. A wider goal is to increase highly-qualified, demand-driven labor in the Afghan work force in key economic sectors,"<sup>1485</sup> ICT being one of them. The four-year (beginning in 2012), US\$72 million program aims to address "the scarcity of technically-skilled Afghan labor and trained business managers."<sup>1486</sup>

Two of the AWDP's processes are (1) to develop and adapt curricula and (2) to support the creation of competency-based training. Several of their opportunities have included requests for applications (RFAs) for grants for ICT training, but the one issued October 8, 2012,<sup>1487</sup> specifically excluded the participation

---

<sup>1483</sup> Washington State University (2011). Afghan eQuality Alliances Project presentation. January 25.

<sup>1484</sup> Ibid.

<sup>1485</sup> USAID. "Afghanistan Workforce Development Program (AWDP) Overview." Accessed January 13, 2015. <https://www.usaid.gov/news-information/fact-sheets/afghanistan-workforce-development-program-awdp>.

<sup>1486</sup> Ibid.

<sup>1487</sup> Creative Associates International project website (2012). "Request for Applications (RFA) for Afghanistan Workforce Development Program (AWDP), October 8, 2012. Accessed January 21, 2015. [http://www.crea-awdp.com/wp-content/uploads/2012/09/AWDP\\_RFA-Communication\\_and\\_Employability\\_Skills-October\\_08.pdf](http://www.crea-awdp.com/wp-content/uploads/2012/09/AWDP_RFA-Communication_and_Employability_Skills-October_08.pdf).

of public sector entities (despite USAID’s AWDP “briefer” document<sup>1488</sup> including them). The scope of work for ICT training for that particular RFA included the following tasks:

1. Adapt and/or develop ICT sector training curricula so that they are modular, competency-based and demand-driven;
2. Design a training approach for the curricula;
3. Recruit qualified candidates for short- and medium-term training programs for mid-level ICT sector occupations;
4. Provide primarily short-but also medium-term modular competency-based ICT skills training courses; and
5. Place training graduates into private and public sector employment opportunities in the ICT sector.

The AWDP announced another RFA in February 2013 to facilitate access to employment in the ICT sector through improved training. The scope of work for this RFA included the following tasks:

1. Identification of the market needs for international certified ICT-training programs, including network security;
2. Design of a training program for the implementation of curricula that provide internationally certified training for mid-level ICT sector occupations;
3. Delivery of internationally certified training course/s that provide official certification; and
4. Placement of graduates of short-term ICT training programs into private and public sector employment opportunities in the ICT sector.

The scope of work for an ICT RFA released by the AWDP on January 15, 2015, which also excluded public sector entities, calls for “specific demand driven ICT training for job seekers and employees of private sector companies,” with encouragement to include “the use of specific/relevant technology such as software applications, web-based programs ... and the use of social/professional media such as Facebook, LinkedIn, Yahoo Groups, etc.”<sup>1489</sup> The AWDP has released several other RFAs in Kabul and other cities.

The AWDP has been updated to use a four-step process to determine what skilled labor is needed and how to create it:

1. **Labor market demand assessment:** Economic sector assessments determine what skills the private sector needs. The focus is on the mid-career/semi-professional level.
2. **Curriculum development or adaptation:** Curricula is designed or adapted with Afghan training providers to meet skills for a proven labor market demand from private sector employers.

---

<sup>1488</sup> Afghanistan Workforce Development Program (AWDP) Briefer, May 4, 2012, provided to co-author Karen Black by AWDP.

<sup>1489</sup> Creative Associates International project website. “Request for Applications (RFA) for Afghanistan Workforce Development Program (AWDP), January 20, 2015. Accessed January 21, 2015. <http://www.crea-awdp.com/wp-content/uploads/2012/09/RFA-for-Marketing-008-2015.pdf>.

3. **Competency-based training:** Grants are provided to help local organizations deliver training in specific areas that businesses need.
4. **Employment placement services:** Pre-employment training, job-placement services, and follow-up services are provided to trainees to help them find jobs.<sup>1490</sup>

As of November 4, 2015, USAID claims to have achieved the following through the AWDP:

- Completed 43 short-term labor market-driven training programs, with another 24 grants and 11 contracts in progress for more training programs.
- Provided 21,646 mid-career/semi-professional employees and job seekers – 36 percent are female – with technical and business management skills, including how to use financial management software, web design and electrician skills.
- Found jobs or got promotions with salary increases for 13,439 training program participants, 36 percent of which were women.
- Helped to establish four profitable job training and placement service companies, based on a model developed with AWDP support.<sup>1491</sup>

### *Women In Government Internship Program*

As one of the components of its Economic Growth and Governance Initiative (EGGI), which ran from 2009 to 2013, USAID implemented the Women In *[sic]* Government (WIG) internship program to help GIRoA increase participation by women in government to 30 percent in accordance with the UN's [Millennium Development Goals](#) (MDGs) and pursuant to the *Afghanistan National Development Strategy (ANDS)*. According to USAID, only 20 percent of GIRoA's 333,000 employees are female.<sup>1492</sup> USAID originally launched WIG in February 2010 to increase Afghan women's ability "to participate fully in Afghan society by providing internships to recent female university graduates with the goal of transitioning them into full-time positions in the public and private sectors."<sup>1493</sup>

The WIG program took female Afghan college graduates, selected via an application and interview process, and placed them in six-month paid internships (approximately US\$230 per month, funded by USAID), primarily, but not only, in government positions, where the young women had the potential to be hired into full-time jobs, or at least to gain real job experience. As part of the WIG program, USAID's implementing partner for the program provided capacity building workshops and weekly training for interns, mostly on Thursday afternoons when government offices were generally closed, "to build the interns' skills and enable them to succeed in their positions."<sup>1494</sup> The training covered subjects such as interviewing; office skills; business and financial management; leadership and governance; ethics and

---

<sup>1490</sup> USAID. "AWDP Overview."

<sup>1491</sup> Ibid.

<sup>1492</sup> USAID. "Women in Government Overview." Accessed August 28, 2015. <https://www.usaid.gov/news-information/fact-sheets/women-government-internship-program>.

<sup>1493</sup> Ibid. Accessed January 7, 2015.

<sup>1494</sup> Ibid.

accountability, computer and presentation skills; and other topics relevant for job success. Further, all interns went through an orientation to learn how government entities work. Interns received laptops with mobile broadband service (paid by USAID), which they used at their assigned locations.

USAID was able to expand WIG outside of Kabul, into Balkh, Herat, and Nangarhar provinces. It provided internship opportunities to 446 interns and achieved a job placement rate (retention after the internship) of 70 percent.<sup>1495</sup>

### *E-Government Resource Center Projects I and II*

USAID committed US\$4.9 million over five years for two E-Government Resource Center (EGRC) projects in Afghanistan, both of which included capacity development components. One of the primary purposes of EGRC I, which ran from 2009 to 2011, was to address identified skills gaps at the MCIT and across the Afghan government, one of which was a lack of chief information officers. Therefore, EGRC I included a program to create and train CIOs in ministries and government institutions.

The CIO training was contracted to Grail Consulting Services out of India. Grail trained nearly 30 GIRoA CIOs/IT Managers/ICT Managers in New Delhi for three weeks in March and April 2010. The CIO course “broadly covered” the following subjects:<sup>1496</sup>

1. Background of IT and its application in public sector management;
2. Content and knowledge management;
3. E-Governance basic concepts and e-government developments in Afghanistan;
4. E-Government interoperability framework (e-GIF);
5. IT standards;
6. Service oriented architecture (SOA);
7. IT governance (COBIT Framework);
8. IT project management (Prince2 Framework);
9. IT service management (ITIL<sup>1497</sup> Framework); and
10. IT security management.

Grail’s report gives only factual information – number and names of trainees, logistics, and curriculum – and offers no indication as to the Afghans’ grasp or understanding of the material covered. Some of the topics may have been too advanced for at least some of the audience, but the training may have laid a foundation for the future.

---

<sup>1495</sup> Ibid.

<sup>1496</sup> Grail Consulting Services (2010). *Completion Report: Chief Information Officer’s (CIO) Training*. April 10. Submitted to the Ministry of Communication and Information Technology, Government of the Islamic Republic of Afghanistan.

<sup>1497</sup> Formerly, Information Technology Infrastructure Library (acronym now defunct), a set of standards and certifications for information technology service and management.

The follow-on project, EGRC Phase II (EGRC II), began in August 2013 and was expected to continue through August 2016. EGRC II “include[d] a major training component on ICT utilization and implementation, promoting the overall capacity of the civil service and key [MCIT] staff.”<sup>1498</sup> According to USAID, a “key function” of the EGRC [the Afghan organization, not the project] is to “carry out a robust program of human resource [ICT] capacity building.”<sup>1499</sup> EGRC II also included funding to establish a “cadre of trainers to continue the government-wide skills development program at the conclusion of the project.”<sup>1500</sup>

Specifically, EGRC II called for training of:

- 400 senior government managers on the basics of e-government;
- 1,000 civil servants on e-government technical and managerial subjects; and
- 300 trainers to be staffed at the EGRC for future training throughout GIRoA.

Accordingly, in June 2015, the MCIT solicited bids for two separate e-government training programs as follows.

The “E-Government Trainings for Government Ministries and Agencies”<sup>1501</sup> project calls for training of 400 employees from 30 government ministries in 16 classes consisting of 25 trainees each to have been conducted between July and December 2015. The courses were to run for ten working days and were geared toward government directors, heads of departments, managers, and officers. The main topics include:

1. E-Governance concepts;
2. Change, project, and technology management;
3. Business process re-engineering (BRP);
4. Writing requests for expressions of interest, proposals, and quotes;
5. Establishing and managing IT infrastructure and e-Government;
6. Technology management; and
7. Information resources strategy and planning.

---

<sup>1498</sup> USAID (2012). Project Authorization Document (PAD) E-Government Resource Center 2 (EGRC 2). October 15: 2.

<sup>1499</sup> Ibid.: 5.

<sup>1500</sup> Ibid.: 2.

<sup>1501</sup> MCIT (n.d.). “Request for Proposals (RFP) for E-Government Trainings for Government Ministries and Agencies.” Accessed September 9, 2015.

[http://mcit.gov.af/Content/Post/Attachment/RFP%20of%20EGRC%20II%20trainings%20e-Governance\\_v162cedfd2-65f7-46d2-b073-22a25acc3373.pdf](http://mcit.gov.af/Content/Post/Attachment/RFP%20of%20EGRC%20II%20trainings%20e-Governance_v162cedfd2-65f7-46d2-b073-22a25acc3373.pdf).

The terms of reference (TOR) for a separate project<sup>1502</sup> outline required training for 300 senior managers within the Afghan government and ten government CIOs in Kabul as well as ten EGRC staff abroad. The training for the senior managers is identical in length and subject matter as that for directors and heads of departments above. The CIO training is similar in length, duration, and subject matter but includes leadership and human capital management.

Additionally, ten EGRC personnel are to be trained for two weeks each, divided according to area of focus and location, essentially deeper dives into some of the overarching themes above with an emphasis on be able to train on those subjects. The TOR request three people be trained in Korea on E-Governance Concepts and four in Turkey on project human resources, and financial management, along with developing training teams. The remaining three are to undergo training specifically regarding writing, managing, and evaluating proposals and other such procurement-related documents.

Also under the EGRC II project and also in June 2015, the MCIT solicited bids for cybersecurity training for 180 staff of 30 government ministries and agencies between July and December 2015. The TOR<sup>1503</sup> call for the training to be conducted in Kabul with nine classes of 20 trainees each over four-and-a-half months, for a total of 90 working days and 563 hours of training. The MCIT expects the cybersecurity training to include the following modules:

1. Network security;
2. Compliance and operational security;
3. Threats and vulnerabilities (application, data, and host security);
4. Access control and identity management; and
5. Cryptography.

Participants in all training above are to be tested at the conclusion of their courses, and those scoring 70 percent or more on exams administered will receive official certificates. Quite ironically, the MCIT did not accept proposals sent by electronic means (email or fax) for any of their training requests above.

As of December 2015, EGRC II claims to have begun cybersecurity training for 180 government employees and e-governance training for 400 employees.<sup>1504</sup>

---

<sup>1502</sup> MCIT (n.d.). "Terms of Reference for Training for Chief Information Officers (CIOs), E-Government training and training for 10 ECRC staff abroad." Accessed September 9, 2015. <http://mcit.gov.af/en/tender/request-for-proposal-rfp-by-mcit-training-of-cios-e-government-in-kabul-and-training-for-10-egrc-staff-abroad>.

<sup>1503</sup> MCIT (n.d.). "Terms of Reference (TOR) ... for Cyber Security training for government ministries and agencies for 180 trainees in Kabul." Accessed August 26, 2015. <http://mcit.gov.af/Content/Post/Attachment/TOR%20Cyber%20Securitydfb9664c-4539-405c-b1e4-44162b33e643.pdf>.

<sup>1504</sup> USAID. "Electronic Government Resource Center Phase II Overview." Accessed March 14, 2016. <https://www.usaid.gov/news-information/fact-sheets/e-government-resource-center-phase-ii>.



## US Department of Commerce

### *Commercial Law Development Program*

The Commercial Law Development Program (CLDP), part of the US Department of Commerce (DoC), helps the United States achieve foreign policy goals in developing and post-conflict countries through technical assistance focused on commercial law reforms. As a division of Commerce's Office of the General Counsel, CLDP has a mandate to improve the legal environment for doing business in the countries that benefit from its technical assistance, in order to foster greater political stability and economic opportunity for local entrepreneurs and US companies alike. CLDP accomplishes its mission through multi-year programs structured around capacity building events for foreign officials (lawmakers, regulators, judges, and lawyers) or others, including and educators and students. CLDP draws upon highly-experienced volunteer experts – regulators, judges, policymakers, business leaders, and attorneys from both the public and private sectors to share their expertise throughout CLDP programs.

CLDP's programs support the US government's efforts to assist foreign countries' economic development and to promote an environment that encourages free-market based reforms. In Afghanistan, CLDP is engaged in a multi-pronged approach to support private sector growth and economic stability through relationships with several Afghan ministries, independent government agencies, and trade associations. Major areas of focus in Afghanistan are investment promotion, commercial law implementation, alternative dispute resolution, and commercial law education. USAID funds CLDP's activities program under an interagency agreement.

Afghanistan's ICT sector has stood out as a success story, with several competing mobile carriers and Internet service providers, and a strong legal foundation that supports competition and the greater deployment of services. Nevertheless, maintaining that success is a key challenge for the Afghan government as well as an opportunity to encourage growth and investment in the private sector market. ATRA is largely responsible for regulation of the sector, along with the MCIT.



*Picture 51: Afghan beneficiaries of CLDP training*

*(Photo by John Horn)*

CLDP has, since 2013, undertaken several lines of activity in the Afghan ICT sector:

**Legislative Assistance:** CLDP has been assisting the MCIT with drafting legislation on several issues, primarily cybercrime legislation and the law of electronic transactions, including electronic and digital signatures. The MCIT had, prior to 2008, developed an omnibus bill under the name “ICT Law” that included provisions on these topics as well as many more. CLDP recommended that the “ICT Law” be revised as two separate bills. With the assistance of the Council of Europe for the cybercrime law and of the United Nations Commission on International Trade Law (UNCITRAL) for the electronic transactions law, CLDP provided support to the MCIT and to several other stakeholder offices and ministries drafting the laws. As of November 2015, these two laws were under review at Afghanistan’s Ministry of Justice. CLDP plans to continue its support of this legislation as it is considered by the Afghan Parliament and, once it is passed, CLDP will provide training for judges and others on implementation of the laws.

**Skills and Issues Training:** As successful as Afghanistan’s ICT sector has been, the country’s primary ICT regulatory organizations, the MCIT and ATRA,<sup>1505</sup> have few staff members skilled in developing the policies, processes, and procedures required for successful regulatory oversight of the sector. CLDP’ goal is to strengthen these institutions by developing the capacity of the mid-level officials who have the responsibility to implement relevant policies and regulations. CLDP, in 2013, coordinated with the Department of Defense advisors of the Telecommunications Advisory Team (TAT), and with MCIT and ATRA, to identify a standing group of nearly 20 mid-level officials from MCIT and ATRA who would participate in a series of training programs. CLDP staff interviewed all the candidates to evaluate their current duties, experience, and English proficiency.

The goal of the training program is to expose these trainees to increasingly detailed training, so that there is a progression and accumulation of knowledge, both to increase the trainees’ competency and to put them in a position to train their colleagues. As part of the training program, CLDP has organized several seminars in Kabul, as well as video conferences from the United States, as follows:

- **Introductory review:** a two-day interactive discussion of the role of regulatory institutions in a competitive environment, administrative procedures, and basic regulatory functions, which both set a baseline for the students and identified areas of interest and need for future sessions.
- **Participation by subsets of the group at the 2012 and 2014 United Nations Internet Governance Forums (IGF)** (with World Bank training funds supporting the 2012 travel expenses). The IGF is a unique gathering of key stakeholders in the ICT field and an unusual opportunity to discuss issues such as connectivity and cybersecurity, among many others, with a multi-stakeholder audience.
- **Videoconference on the basics of telecommunications technology,** taught by a leading expert from the University of Colorado.

---

<sup>1505</sup> ATRA is the official ICT sector regulator. However, it is not [yet] fully independent of the MCIT.

- Videoconference on spectrum management, taught by a spectrum expert from the Commerce Department's National Telecommunications and Information Administration (NTIA).
- Seminar in Kabul, taught in conjunction with a private sector advisor, on topics including the pros and cons of privatization and on comparisons with the Federal Communications Commission (FCC).
- Seminar in Kabul, taught with the help of two experts, one from the FCC and one from the private sector, on issues including quality of service (QoS), pricing, and the transition to digital television (DTV).
- Law Student Internships: As part of a larger program with Kabul University law students to expose them to relevant work environments, CLDP placed several law students within ATRA, MCIT, and Roshan.

**Connectivity initiatives:** CLDP supported Afghan participation in IGF 2015, held in Brazil in November 2015, but altered the program from training of mid-level officials to engagement of higher-level officials as part of a larger effort to increase connectivity. CLDP sponsored attendance by a Deputy Minister from MCIT, the ATRA Chairman, an executive from AfTel, and an Afghan NGO representative. CLDP plans to develop further programming to assist Afghanistan with the structuring of its markets to promote competition and investment.

**Social media:** CLDP has coordinated with the US Department of State on related issues, including preventing the harassment of women through Facebook using fake accounts and posting of threatening comments.

**Future plans:** As of this writing, CLDP plans to continue providing assistance with the cybercrime and e-transactions legislation and to continue, as well, its capacity building for ATRA and the MCIT. CLDP planned to hold additional seminars and site visits in third countries, starting with India in December 2015. In India, the Afghan participants were to spend a minimum of one week at seminars and meetings with experts from the US FCC, India's government agencies, and from private industry. CLDP is also planning to support future Afghan participation at IGFs for high level decision-makers able to develop post-forum action plans.

*Editors' Note: Per CLDP's website, from December 7-10, 2015, CLDP conducted a training seminar for mid-level managers from ATRA and the MCIT, hosted, at least in part, by the Telecommunications Regulatory Authority of India (TRAI) in New Delhi. Topics included best practices, regulatory procedures, spectrum management, broadband licensing, consumer affairs, and enforcement.<sup>1506</sup>*

---

<sup>1506</sup> CLDP, 2015.

## US Department of State

### *Afghanistan E-Learning English Support Project and English Language and Computer Learning Centers*

Between 2011 and 2013, the US Embassy funded two programs<sup>1507</sup> to enhance English language and computer/IT skills, both of which were implemented by a local NGO, the Educational Support Organization (ESO). The first, the Afghanistan e-Learning English Support Project (AeLESP), was a successor to USAID's Afghan e-Quality Alliances (AeQA) program described above, which ended December 31, 2010. AeLESP picked up where AeQA left off and ran through January 31, 2011.<sup>1508</sup> The follow-on English Language and Computer Learning Centers (ELCLC) project ran from February 1, 2012 through January 31, 2013. The goals of the two projects were to help students and faculty members learn English, computer, and basic IT skills to be able to participate in the global world. ELCLC was active in seven public universities around the country.<sup>1509</sup> The courses, which included English as a Foreign Language (EFL), ICT, and English for Specific Purposes (ESP), were offered completely free of cost and through "research- proven methodologies ... [in] computer labs [with] high-speed wireless Internet access, up-to-date Computer Assisted Language Learning (CALL) technologies, and comprehensive English course curricula developed by Washington State University."<sup>1510</sup> The ELCLCs used computer applications, such as TellMeMore (TMM) and Writer's Companion (WC), which allowed students to learn technology as they learned English. ELCLC certification required taking and passing tests in the following seven modules:

- ICT concepts;
- Using the computer and managing files;
- Word processing;
- Using spreadsheets;
- Using databases;
- Presentations; and
- Web browsing and communication.

The seven ELCLCs also offered the International Computer Driver's License (ICDL) course and were approved certification test centers for such.

### *Voluntary Visitors Program*

The Voluntary Visitors (VolVis) Division of the US State Department creates professional programs for important overseas mission contacts. The program is designed to advance the objective of promoting

---

<sup>1507</sup> Nangarhar University (n.d.). "English Language and Computer Learning Center (ELCLC)." Accessed January 15, 2016. <http://nu.edu.af/en/page/7155/english-language-and-computer-learning-center-elclc>.

<sup>1508</sup> This program *may* have run through the end of January 2012 rather than 2011.

<sup>1509</sup> Kabul, Kabul Polytechnic, Balkh, Herat, Kandahar, Nangarhar, and Sheikh Zayed Universities

<sup>1510</sup> Nangarhar University, ELCLC.

democracy abroad and to enhance mutual understanding of the social, economic, legal, technical, cultural, and political climates of the participants' countries and the US.

From June 16-26, 2014, the US State Department sponsored an International Visitor Leadership Program (IVLP) for Central Asia and Afghanistan entitled "Cyber Security: A Project for Afghanistan." Ten IT Managers representing various entities and agencies of the Afghan Government (the Ministries of Communication and Information Technology, Defense, Interior, Agriculture, Finance, Foreign Affairs, and Justice, along with the National Directorate of Security) were invited to travel to the United States to meet and confer with their professional counterparts in government, industry, and academia. Through these encounters, the intent was for them to gain a greater understanding of the technical, legal, cultural, and political influences in US society and enjoy a firsthand experience of the United States, its people, and its culture. This was all facilitated through visits to federal, state and local government agencies, commercial companies, and academic organizations as well as by social and cultural tours of Washington, DC, San Francisco, and Silicon Valley.

The main goal of the program was to help the visitors explore and seek a broad and balanced range of perspectives of the policy, technical, operational, legal, and education and training aspects of the cybersecurity sector and its role in supporting national security. To this end, the interactions included a variety of appointments with subject matter experts (SMEs) and representatives of government, industry, and academic organizations. The visitors had the opportunity to meet with leaders, managers, and technical experts to:

- Observe, discuss, and develop a more informed understanding of the cyber policy development process and best practices for implementing policy and protective actions that could be applied and enforced within Afghanistan;
- Examine how the US attempts to safeguard its cybersecurity challenges through technology, law enforcement, and legal parameters; and
- As chief information, technical, or security officers within their organizations, observe best practices, lessons learned, and methods to foster improved cybersecurity practices, capabilities, and cooperation that could be applied to their organizations and programs.

The agenda included visits with SMEs and cybersecurity-related elements of organizations such as the US Departments of State, Commerce, Justice, Treasury, and Homeland Security along with the Federal Communications and Trade Commissions; international organizations such as the Organization of American States; state and local government elements such as San Jose Office of Economic Development and Chamber of Commerce; centers of excellence such as the National Cybersecurity Center of Excellence and Chesapeake Innovation Center; industry elements such as the corporate headquarters of OSISoft, Glimmerglass, and Cisco; and academic institutions such as the National Defense University iCollege and San Jose State University. The visitors also met with the US Ambassador to Afghanistan at the Afghan Embassy in Washington, DC.

Overall, the program was successful and mainly achieved its goals, both professional and non-professional. The program gave the Afghan visitors an opportunity to exchange views and to gain valuable knowledge and a unique understanding of the US approach to cybersecurity. They met with many people

during their trip and took with them a wealth of newly-acquired professional knowledge, as well as a new perception of the diversity of America's culture and lifestyle. The visitors made important professional contacts for follow-on activities related to best practices, lessons learned, partnerships with innovation centers and centers of excellence, access to US SMEs, and professional development opportunities available through the NDU iCollege, the Department of Homeland Security training programs, the US Telecom Training Institute, and industry, such as Cisco Networking Academy. Many opportunities were identified for cooperative efforts to help further develop the Afghan National Cybersecurity Strategy and Plan, possible cooperative efforts, and opportunities for furthering cybersecurity capacity development. Unfortunately, there did not seem to be a process nor organization accountability identified for developing an action plan to manage and track implementation of follow-on USG-Afghan action opportunities.

## Other

### *United States Trade and Development Agency*

The United States Trade and Development Agency (USTDA) provided early support to the Ministry of Communications, in the form of on-site project officers and advisors, in developing policy, and in conducting a feasibility study for a national optical fiber network.

### *Federal Communications Commission International Bureau*

Several times throughout the years of the occupation of Afghanistan, the International Bureau of the Federal Communications Commission (FCC) offered to train Afghan ICT regulators; however, such training never came to fruition.

### *Center for International and Intercultural Communication of the Technical University of Berlin*

Following the Bonn Agreement of 2001,<sup>1511</sup> the Technical University (TU) of Berlin, specifically, the Center for International and Intercultural Communication (ZiiK) began working to establish and support "academic structures in the field of IT and computer science."<sup>1512</sup> ZiiK worked with the MoHE in Kabul and directly with several Afghan universities. The effort was led by Dr. Nazir Peroz, and funding was provided by the German Federal Foreign Office under the Stability Pact for Afghanistan, the German Academic Exchange Service (DAAD), and the World Bank.

---

<sup>1511</sup> Officially, the "Agreement on Provisional Arrangements in Afghanistan Pending the Re-Establishment of Permanent Government Institutions," December 5, 2001, the first in a series of international agreements to reestablish the Afghan state after the fall of the Taliban regime.

<sup>1512</sup> Peroz, Dr. Nazir, ed (2014). *IT Structures for Higher Education in Afghanistan: Project Overview, 2001-2014*, ZiiK-Report Nr. 36, November 2014, xiii. Accessed December 11, 2015. [http://www.ziik.tu-berlin.de/fileadmin/fg53/Ziik/Ziik\\_Reports/Ziik\\_Report\\_Nr.36.pdf](http://www.ziik.tu-berlin.de/fileadmin/fg53/Ziik/Ziik_Reports/Ziik_Report_Nr.36.pdf).

Beginning in 2002, the ZiiK team developed an IT strategy plan<sup>1513</sup> to build an “IT supply system” for Afghan universities and provided technical, organizational, and advisory assistance to bring it to fruition. The plan, which is based on the four themes of IT infrastructure, IT education, IT security, and modernization of administrative structures, included:

- Establishing a stable power supply;
- Providing secure access to the Internet;
- Interconnection of university buildings on campuses;
- Purchasing and installing computer workstations;
- Constructing IT centers at the bigger universities;
- Basic and advanced IT training for university members on-site and at TU Berlin;
- Training IT technicians and administrators on-site and at TU Berlin;
- Creating the foundation for computer science faculties (departments) at particular universities;
- Providing academic educations for bachelor's, master's and PhD students;
- Developing a standard computer science curriculum;
- Establishing computer science libraries;
- Creating and implementing exchange programs for students and lecturers; and
- Awarding scholarships to Afghan students.

### Ministry of Higher Education

Beginning in November 2004, ZiiK assisted the MoHE to establish an IT Department to coordinate and supervise national and international IT projects in higher education. In keeping with ZiiK’s overarching themes, the IT Department has three sections: IT infrastructure, IT education, and IT management. It holds annual IT conferences, develops strategic IT plans, and provides IT education for personnel from other Afghan universities. The latter is accomplished through the IT Training Center ZiiK helped the MoHE to install in January 2009. The center offers specialized IT training to affiliates of the MoHE and staff from other Afghan universities and serves as a videoconference facility (for administrative purposes and distance-learning lectures).

From June through November 2009, several (nine or ten) MoHE employees were trained at TU Berlin for six months to prepare them to serve as IT administrators at the MoHE. The training focused on system and network administration of Linux-based environments.

### Kabul University

ZiiK established an IT Center at Kabul University in March 2003 with 90 computers, two servers, networking equipment, power generators, and voltage regulators. The center has trained 2,500 people and now (since 2012) serves as a national IT education center for Afghanistan. (NATO funded satellite

---

<sup>1513</sup> Information in this section is excerpted and paraphrased from Peroz, 2014. ZiiK-Report Nr. 36.

Internet connectivity to this facility beginning in 2005 under its SILK-Afghanistan project, which was later replaced by fiber-based Internet access as part of the Afghanistan Research and Education Network (AfgREN) under the follow-on SILK-Afghanistan 2.0 project.) ZiiK funded and installed facilities as follows:

- February 2005: A 20-station computer lab for the German Department at Kabul University with work stations, Internet access, and specialized German-language software.
- October 2007: Because there were no computer technicians, ZiiK helped Kabul University to establish a central “PC<sup>1514</sup> Workshop” to teach the staff how to repair, restore, recycle, and responsibly dispose of computer hardware.
- December 2010: A sixty-station computer lab for the Computer Science Department and another fifty-station computer lab for the Department of Economics, both with server hardware, uninterruptible power supplies (UPSs), projectors, printers, and even spare parts.

ZiiK also funded, purchased, and shipped nearly 1,000 modern international computer science books and furnished the equipment (shelves, tables, chairs, etc.) to establish a Computer Science Library at Kabul University in February 2005. Students, with assistance from ZiiK, created a cataloging and lending system for the library. The library was expanded, both physically and in terms of references materials, in December 2010 when the Computer Science Department moved to another building.

## Herat University

Prior to 2004 and the engagement of Dr. Peroz and ZiiK, Herat University had no computer science education. In August of that year, ZiiK began an assessment of the IT environment at Herat University, then dispatched a six-person team in November to provide basic computer science training and education to the faculty and select students. To jumpstart its efforts, ZiiK began installing a computer lab for the newly-formed Computer Science Department in November 2005 with 40 stations, Internet access, and network services for its faculty members and students. The hardware was pre-configured in Germany then shipped to Herat. The facility opened in June 2005.

Between November 2004 and March 2010, ZiiK claims to have trained 450 Herat University students, via a specially-developed computer science curriculum created specifically for Afghanistan. It also offered master’s degrees in computer science, with training conducting at TU Berlin, for several students, the first of whom graduated in 2010 and returned to teach bachelor-level computer courses at Herat University.

Similar to Kabul University, ZiiK also established an IT Center, a Computer Science Library (May 2005), and a PC Workshop (October 2011) at Herat University. The IT Center, which opened in June 2010, has 160 computers,<sup>1515</sup> four servers, network equipment, and voltage regulators. The hope is to expand the IT Center into a regional training center able to accommodate students and faculty from neighboring provinces.

---

<sup>1514</sup> Personal computer

<sup>1515</sup> Paid for by NATO



## Balkh, Nangarhar, and Kandahar Universities

Following the same model, ZiiK continued its work in the provinces, beginning in Balkh in 2005, Nangarhar in 2010, and Kandahar in 2012. At each of the namesake universities, ZiiK installed IT Centers as follows. Balkh University's opened in the spring of 2013 with 60 computer workstations and six servers, along with network and supplementary equipment. Nangarhar University's has 90 workstations and three servers and was inaugurated in December 2011. In February 2014, a 75-workstation, four-server IT Center opened at Kandahar University. The hope, as per above, is for all three to expand in the future to offer IT training for neighboring provinces.

In Balkh, the Germans also installed a 25-seat computer lab in December 2009 and a PC Workshop in October 2013. ZiiK provided IT Administrator training for seven Balkh lecturers and employees at TU Berlin between June and November 2009. Following that, Balkh University hosted employees from Nangarhar to train with its own staff (12 people total between the two schools) for two months in late 2011 to become administrators of the IT Centers at their respective universities.

At each of the three universities, ZiiK was instrumental in developing and implementing computer science curricula. NATO contributed hardware at all three sites, as well as the provision of Internet access, with each campus having received a Network Infrastructure Grant (NIG) of between €200,000 and €275,000 from NATO.

## IT Administrator Training

Between July and December 2014, 18 employees from the five aforementioned IT Centers attended training at TU Berlin to enable them to independently operate and maintain – and even expand – the IT infrastructure and resources at their colleges. According to a report by ZiiK, “The training focuses on systems and network administration under a particular Linux-based system (Univention Corporate Server, UCS) which is to be rolled out at all of the five IT Centers to replace the existing installations. Such a unified system setup and a comprehensive education of the administrators will allow consistent server infrastructures at the Afghan universities and a better exchange between the IT centers, improved interoperability as well as better support.”<sup>1516</sup>

## Academic Programs

### *Master's Program in Computer Science*

TU Berlin created a special program for Afghan lecturers to study for and receive Master's Degrees in Computer Science in Germany to address the lack of trained teachers. Now in its third generation, the program, which began in 2007 and runs through 2016, has graduated nearly 50 students from nine universities,<sup>1517</sup> with another 25 currently studying. Participants are nominated by their home institutions

---

<sup>1516</sup> Peroz, 2014. ZiiK-Report Nr. 36, xiii.

<sup>1517</sup> Kabul University, Kabul Polytechnic University, Kabul Education University, and the Universities of Herat, Nangarhar, Kandahar, Balkh, Khost, and Kunar

and selected via a competitive process, which includes exams in computer science, mathematics, and English as well as a personal interview.

The program consists of two semesters of preparatory courses, followed by four semesters of degree-related coursework. The first four semesters (two preparatory and two discipline-related instruction) are held at TU Berlin. The fifth semester is spent at students' home universities in Afghanistan, where they conduct field research to prepare their theses, which they write during the sixth semester back in Germany. Thesis topics are to be relevant to IT in Afghanistan.

The program graduated its first group of master's students (24 total) in March 2010, the second in September 2013 (22 total), and the third will graduate in 2016. Further, TU Berlin provided financial support for students from the first two graduating classes to implement their thesis projects in Afghanistan. Among them were administration, information, and accounting systems; dormitory and hospital management systems; campus network planning; quality assurance and accreditation programs; and a scholarship database.

### *Doctoral Programs in Computer Science*

Four graduates of TU Berlin's Master's in Computer Science program, two each employed by Kabul and Herat Universities, were invited to return to TU Berlin, complete with scholarships provided by the German Academic Exchange Service, as candidates for doctorate degrees (PhDs) in computer science. The plan is for them to return to Afghanistan and develop master's-level study courses for their schools.

### *Summer and Winter Academies*

Between 2002 and 2009, TU Berlin hosted 105 lecturers, staff, and students from Afghan universities for one- to seven-month summer and winter academies. Attendees received basic training in computer science, system and network administration, IT security, and other technology, academic, and business topics. The goal was to teach them so they could return to their home schools to execute their IT-related duties and transfer the knowledge they gained. A secondary aim was to foster cultural exchange and understanding.

### *Conferences and Meetings*

In the past fifteen years, the Germans have facilitated and funded various IT-related meetings, workshops, and symposia in Afghanistan and Germany, including an annual (from 2005 to 2013) Information Technology for Higher Education in Afghanistan conference held at the MoHE in Kabul. Averaging 150 or so participants each year, the conferences had unique and timely themes, such as, "Information Technology for Higher Education in Afghanistan," (2005); "IT Security" (2009); and "An Assessment of IT in Higher Education in Afghanistan and its Effects on Society," (2011). Other assemblages include "IT Security," a workshop hosted by Balkh University in November 2005; "Sustainable and Secure IT Supply for the Area of Higher Education in Afghanistan," a symposium held at TU Berlin in August 2008; and "Afghanistan – Vision and Action," a seminar held in Berlin in November 2011.

## *The North Atlantic Treaty Organization*

In addition to leading the ISAF mission in Afghanistan from 2003 to 2014, the North Atlantic Treaty Organization (NATO) has been heavily involved in non-military activities and initiatives in several sectors and was a major donor to ICT-related activities and ICT capacity building. Some of NATO's ICT capacity building efforts are described below.

### **Cybersecurity Training**

SILK-Afghanistan was part of NATO's Virtual Silk Highway Project (SILK), named after the historic Silk Road trading route that linked Europe and Asia. The SILK project connected academic and scientific communities across the South Caucasus and Central Asia to each other and to the Internet, originally via satellite. SILK-Afghanistan (SILK-A) began at Kabul University in 2006. The second phase of the project, SILK-Afghanistan 2.0, officially launched 29 May 2013, replaced satellite Internet access with optical fiber, which is the underlying infrastructure for the Afghan Research and Education Network (AfgREN). Both have been instrumental in ICT capacity development.

According to NATO, "Apart from improving higher education in Afghanistan, the SILK-Afghanistan Programme helps develop Afghan capacity especially in information and communication technology, a vital component of any growing economy."<sup>1518</sup> In addition to connectivity, NATO provided extra funding to train IT/ICT staff at the universities so they were/are able to operate and maintain the infrastructure and equipment, including cybersecurity training, and continued to include training in its funding for such topics as optical fiber networking and IPv6,<sup>1519</sup> as SILK-A 2.0 and AfgREN were rolled out.

In early 2010, NATO's Public Diplomacy Division, under its Science for Peace and Security (SPS) Programme, funded a cybersecurity training course in Istanbul, Turkey for 18 Afghans. The main categories covered were introductions to Microsoft and Unix/Linux security; perimeter protection; and system security auditing. Topics within those categories included web, email, and network services; topologies and firewalls; security, filtering, and auditing tools; service and kernel configurations; and vulnerabilities and threats, among others.<sup>1520</sup>

Two and a half years later in mid-2012 (May 21<sup>st</sup> to June 1<sup>st</sup>) NATO's SPS Programme funded a hands-on cyber defense training course in Ankara, Turkey for 16 Afghan system and network administrators.<sup>1521</sup> The

---

<sup>1518</sup> North Atlantic Treaty Organization (NATO) (2010). "Expansion of SILK-Afghanistan connects additional 9000 students to global information highway." October 19 (last updated October 22, 2010). Accessed November 20, 2014. [http://www.nato.int/cps/en/natolive/news\\_67108.htm](http://www.nato.int/cps/en/natolive/news_67108.htm).

<sup>1519</sup> Internet Protocol version six, the most recent level of the global system that provides a numbering system (for identification and routing) for computers connected to and traffic traversing the Internet.

<sup>1520</sup> *NATO Advanced Training Course #984204 General Report*.

<sup>1521</sup> The TAT was able to facilitate agreement among NATO and the Ministries of Higher Education and Communications for two representatives from the Afghanistan National Data Center (ANDC) at the MCIT to attend the training.

course was developed in close cooperation between NATO and the country of Georgia and was comprised of 60 training hours over ten days on the following subjects:<sup>1522</sup>

- Awareness of cybersecurity;
- Scrutinizing e-mail messages;
- Identifying system vulnerabilities;
- Auditing user and system activities;
- Introduction to incident handling;
- Authenticating access to computer systems;
- Hardening system configurations;
- Security web portals and servers;
- Introduction to cryptography;
- Tracing Internet access of users;
- Monitoring network traffic; and
- Information security architecture design and analysis.

Ambassador Grigol Mgaloblishvili, Head of the Georgian Mission to NATO and co-director of the Advanced Training Course, said, "Our motives are our continued contribution to the Alliance engagement in Afghanistan beyond 2014 through capacity-building and training of Afghan experts."<sup>1523</sup>

According to workshop organizers, trainees acknowledged (via evaluation forms) the course enhanced their awareness and knowledge of and competence in cybersecurity. However, organizers also noted varying levels of proficiency among the trainees as well as a lack of experience in basic security concepts. They also indicated poor English skills among the trainees were problematic.<sup>1524</sup>

### IT Training Center at Kabul University

In November 2011, NATO approved a grant to provide an IT training center at Kabul University's Computer Science Faculty (Department), the plan for which was to train the staff and students of 15 departments as well personnel within GIRoA ministries in order to have qualified IT professionals to ensure the sustainability of SILK-Afghanistan and to administer other ICT projects.

### *Other International Organizations and Donor Governments*

Many other international organizations and donor governments provided support to the Ministry of Communications, ATRA, and AfTel. Among them are the International Telecommunication Union (ITU), which provided policy guidance and expert advisors, and the United Nations Development Programme (UNDP), which funded the Cisco Networking Academies (in concert with USAID) and assisted with Afghanistan's e-government strategy, among other endeavors. The governments of India and the Islamic Republic of Iran provided emergency network restoration and rehabilitation of the ICTI, respectively. The Japanese and Koreans assisted the MCIT in the areas of e-government and advanced networking training for the Afghanistan Research and Education Network (AfgREN), correspondingly. The University of Brighton's (England) School of Computing, Engineering, and Mathematics established several partnerships

---

<sup>1522</sup> NATO Advanced Training Course #984449 General Report.

<sup>1523</sup> NATO (2012). "Afghan managers train in cyber defence." May 23. Accessed February 2, 2015. [http://www.nato.int/cps/en/SID-BA1C773B-B21F099F/natolive/news\\_86990.htm](http://www.nato.int/cps/en/SID-BA1C773B-B21F099F/natolive/news_86990.htm).

<sup>1524</sup> NATO Advanced Training Course #984449 General Report.

with Kabul University, Kabul Polytechnic University, and the ICTI beginning around 2006 and continuing at least through 2012, if not longer, for graduate level ICT training.

## Other ICT Training Entities and Efforts

### *MCIT Provincial IT Training Centers*

The MCIT established several Provincial IT Training Centers in 2007 to promote awareness of and provide education in the IT sector. The training programs teach basic computer knowledge, such as navigating an operating system, using office automation applications such as word processing, spreadsheets, databases, and presentation software, and how to use the Internet. The admission fee for the provincial ICT training program is 400 Afs, approximately US\$4.00, 30 percent of which is subsidized by the MCIT for government employees. GIROA personnel are admitted to the program with confirmation letters from their organizations, while private citizens are required to have graduated from high school and must pay the admission fee in full.

The Provincial IT Training Centers graduate approximately 290 government employees and more than 2,200 public students each year. The MCIT reports the training programs positively impact the performance of GIROA officials and public service delivery at the provincial, district, and community levels.<sup>1525</sup>

The MCIT reported ATRA approved the budget for procurement of new equipment for the Provincial IT Training Centers in 2014 or 2015.<sup>1526</sup>

### *Cisco Networking Academies*

The Cisco Networking Academy Program (CNAP) provides “a comprehensive 21<sup>st</sup> century learning experience to help students develop the foundational ICT skills needed to design, build, and manage networks, along with career skills such as problem solving, collaboration, and critical thinking. Students complete hands-on learning activities and network simulations to develop practical skills ...”<sup>1527</sup> Through a partnership among Cisco, the UNDP, the ITU, and the MCIT, CNAP was initiated at Kabul University’s Faculty of Computer Science and the MCIT’s Telecommunications Training Center (TTC, now the ICTI), and the Ministry of Women’s Affairs (MoWA) in October 2002. Because of the program’s initial success, USAID joined the partnership in 2004 to expand the program to other provinces, update and broaden the curriculum, and develop a sustainability strategy. The MCIT assumed responsibility for the Cisco Academies upon conclusion of the original UNDP project.

---

<sup>1525</sup> MCIT, 2013.

<sup>1526</sup> Islamic Republic of Afghanistan Ministry of Communications and Information Technology (MCIT) (2014). *The Ministry of Communication and ITs’ [sic] activities and achievements report 1381-1393 (2002-2014)*, English version, 57 (not available electronically).

<sup>1527</sup> Cisco. “Cisco Networking Academy: About Us.” Accessed February 24, 2015. <https://www.netacad.com/web/about-us/about-networking-academy>.

By 2010, Afghanistan had one Cisco Regional Training Academy (RTA) at Kabul University and nine local Cisco Networking Academies (CNAs) hosted at:

- Balkh University
- Bamyan University
- Herat University
- Kabul Education University
- Kabul Polytechnic University
- Kabul University
- Ministry of Women's Affairs
- Nangarhar University
- Skeikh Zayed University at Khost
- Information and Communications Training Institute (ICTI)

As of August 2013, over 1,500 students had passed through the various Cisco Network Academies throughout the country, over 30 percent of which were female.<sup>1528</sup>

Since Afghans can attend public universities at no charge – and, by extension, the Cisco Networking Academies housed therein – there is no direct source of funding to operate, maintain, and continually update the academies, nor to train instructors for them. Non-university students can pay to attend CNAs in the evenings; however, evening classes have not gained much traction in Afghanistan for cultural and logistical reasons. Additionally, all funds generated by the CNAs revert to the MoHE's general fund and cannot be retained by or used specifically for the academies. Unfortunately, neither the universities nor the MoHE adequately incorporate funds for the Cisco Networking Academies into their budgets. Consequently, most of the facilities have fallen into disrepair, have outdated or non-functioning equipment, and lacked qualified instructors.



Picture 52: Sign above the Cisco Networking Academy at the Afghan Ministry of Women's Affairs

(Photo by Karen Black)

Cisco Networking Academies are discussed further in [Chapter 20](#).

### *Commercial, Non-Profit, and Community ICT Training Centers*

#### **Commercial ICT Training**

#### *For-Profit ICT Training Centers and Institutes*

For-profit ICT/IT training centers abound in Kabul, with signs for various skills training and certification programs peppering the cityscape. Many of the smaller entities are geared toward basic computer and

---

<sup>1528</sup> MCIT, 2013.

mobile phones skills for the general populace or slightly more advanced training for job seekers. Some, such as Cresco Solution Afghanistan and Kaweyan Business Development Services, have arisen in response to donor programs with ICT training components in order to receive funds and fill specialized training needs (as identified by donors). Others, such as Rana Technologies and some of the mobile network operators, have developed full-fledged in-house training facilities and programs for their own employees – out of necessity – with some branching out to provide training via donor contracts and to the public for a fee. In fact, Rana Technologies created its own training arm, Rana University. Aptech Afghanistan Ltd. is affiliated with Aptech Computer Education out of India. Jahaan Technology Corporation found a niche early on, training civil servants and civilians alike on basic computer skills and office software applications.

According to Altai Consulting, there were 250 IT training centers in Afghanistan in 2014, approximately 100 in Kabul, 100 among Kandahar, Mazar-e-Sharif, Herat, and Jalalabad, and fifty throughout the rest of the country.<sup>1529</sup> Altai differentiates between training centers, which is defines as having short-term courses on the basics of IT, and training institutes, which it says are two- to five-year programs with more advanced courses and a diploma.<sup>1530</sup>

Subjects of ICT training range from the very basic “how to use a computer” to web design and mobile application development, to networking basics to wireless technologies and database administration. Afghanistan ICT Solution<sup>1531</sup> claims to be a Microsoft Gold Certified Partner and the only Kaspersky [Security Solutions] Partner operating in Afghanistan. Internetwork-Path offers Cisco and Microsoft training, along with Linux and Oracle courses, and a host of other topics. It claims to be a Pearson VUE® Authorized Test Center and a Prometric Test Center.<sup>1532</sup> Aptech Afghanistan, which is affiliated with Aptech, an Indian ISO-certified IT training company, offers courses in computer education, software development, hardware and networking, as well as English. It claims to have alliances with Microsoft, Oracle, and Red Hat and offer official industry certifications, with all exams taken online.<sup>1533</sup> Aptech also offers its own Aptech certifications.

The above are just a few examples of commercial ICT training centers. While both the need and opportunity for ICT training is plentiful, very few companies have or offer “official” certifications. Since many employers do not know what, for example, a Cisco certification looks like or entails, any piece of paper suffices. There is a thriving black market for ICT skills certifications in the country.

---

<sup>1529</sup> Altai Consulting (2014). *ICT Economic Impact Assessment*. July 2014. Accessed September 15, 2015. <http://www.altaiconsulting.com/wp-content/uploads/2016/03/ICT-Economic-Impact-Assessment.pdf>.

<sup>1530</sup> Official diplomas must be sanctioned by the Ministry of Education or Higher Education.

<sup>1531</sup> Afghanistan ICT Solution. Accessed August 27, 2015.

[http://www.afghanictsolution.com/sp\\_gc.php?sp=about\\_us](http://www.afghanictsolution.com/sp_gc.php?sp=about_us).

<sup>1532</sup> Internetwork-Path. Accessed August 28, 2015. [http://internetwork-path.com/index.php?option=com\\_content&view=article&id=54&Itemid=63](http://internetwork-path.com/index.php?option=com_content&view=article&id=54&Itemid=63).

<sup>1533</sup> Aptech Afghanistan Ltd. Accessed August 28, 2015. <http://aptech.edu.af/industry-alliances/>.

## *In-House Training*

More out of sheer necessity than any sort of ICT capacity development mandate, many Afghan ICT service providers offer in-house, on-the-job training programs. Employers interviewed as part of a technical and vocational education survey,<sup>1534</sup> including three mobile network operators (MNOs), reported graduates from Afghan institutes of higher education require three to six months of training upon hire, which is costly for employers.

As mentioned above, Rana Technologies, an ISP, developed its own training company, Rana University, which provides in-house as well as out-sourced (for profit) training. Several of the MNOs have developed comprehensive in-house training programs for their employees. Etisalat, an MNO, sends some of its employees to its headquarters in Dubai for training. Roshan, which conducts its own training, contracted with at least one training firm out of Dubai<sup>1535</sup> for 3G mobile broadband training for its personnel.

## *Non-Profit ICT Training*

### *Internet Training Centers for Girls*

Afghan IT businesswoman Roya Mahboob, the first CEO of an Afghan technology company (Afghan Citadel Software Company) and one of *Time* magazine's "100 Most Influential People" in 2013, set on a mission to create a safe learning environment to improve the digital literacy of Afghan girls. Ms. Mahboob created 13 technology centers in Herat and Kabul, many connected to girls' schools, where Afghan females can learn how to use computers and the Internet, and even learn programming and other advanced digital skills. Reportedly, that effort has connected 55,000 Afghan females to the World Wide Web.

### *International Commission on Workforce Development*

Based in California, the founders of the International Commission on Workforce Development (ICWFD) recognized the need for ICT skills training in developing countries and the challenges inherent therein. The ICWFD's self-imposed mandate is to "recommend[ing] policies, strategies and solutions that enable the workforce of G77<sup>1536</sup> Developing Countries and marginalized sectors of all countries to compete in the current and future global economy."<sup>1537</sup> A survey the ICWFD conducted in seven developing countries found a lack of subject matter experts; ineffective educational policies; little or no accountability or quality assurance; inconsistent curricula, standards, metrics, and mechanisms; an inability to authenticate teacher training or qualifications; and that specialized ICT instruction and courses are generally unaffordable; among other findings,<sup>1538</sup> all of which were true in Afghanistan.

---

<sup>1534</sup> DAI, 2011. *TVET Providers Inventory*, 7.

<sup>1535</sup> TLT Academy, a division of Teralight Networks Ltd., per a Teralight executive in 2013 to co-author Karen Black.

<sup>1536</sup> The Group of 77 (G-77) was originally a group of 77 low-income/developing countries of the United Nations, which number has increased to 134, although they retained the original name. Accessed January 15, 2015. <http://www.g77.org/doc/>.

<sup>1537</sup> International Commission on Workforce Development (ICWFD). Accessed January 14, 2015. <http://www.icwfd.org/whyhow.cfm>.

<sup>1538</sup> Paraphrased from ICWFD website.



The ICWFD further realized electronic learning (e-learning) was more feasible than sending experts to developing countries. However, it found three key barriers to e-learning:

1. Expert (certification level with audio, video, and instructional competency) content is very expensive for local students;
2. Piracy abounds; and
3. Low Internet bandwidth speeds create bad end-user experiences.<sup>1539</sup>

Again, all of those proved true in Afghanistan.

To address the issues above, the ICWFD launched the “e-skills360” program and portal,<sup>1540</sup> through which it offers over 3,000 technical, business, and professional development courses, everything from programming, networking, cybersecurity, and software development to instruction on the Microsoft Office suite of products and other common commercial applications to sales, customer service, effective listening, and project management. Many of the technical courses are from leading ICT industry “brand” names such as Cisco, CompTIA, Oracle, and others.

The ICWFD’s model is to offer courses free to individuals in developing countries through sponsorships, partnerships, philanthropy, and corporate social responsibility (CSR) programs. Essentially, donors – which can be commercial or government entities, educational institutions, groups or associations, and even individuals – purchase courses for nominal rates, as low as US\$10 each. The ICWFD then provides the courses at no charge to the “underprivileged masses” via personal identification numbers (PINs), which act as users’ passwords when they log into the e-skills360 portal. Generally, the ICWFD prints PINs on scratch cards with the purchasers’ logos on them, which are then distributed to eligible students. PINs can also be disseminated by short message service (SMS, also known as texting) or email without actually printing scratch cards. Courses can be downloaded rather than having to be done online, which is advantageous for those without continual or reliable Internet access, as is often the case in Afghanistan. Course completers receive printed confirmation of completion at the end of each course. While actual certifications are not available, the ICWFD partners with local testing centers where students can take proctored certification exams upon completion of the online coursework.

Unfortunately, the ICWFD’s e-skills360 program did not gain any traction in Afghanistan, despite having achieved great success in Egypt, Malaysia, India, and Jordan, among other countries.

## Community ICT Training

### *TechNation/TechDera*

TechNation bills itself as a “first class technology firm” that provides a range of ICT products and services, from hardware and software installation to network design and setup to IT maintenance and security. It also offers strategy, legislative, and policy development, branding and marketing, and ICT training. It has

---

<sup>1539</sup> Ibid.

<sup>1540</sup> E-Skills 360 E-Learning Portal. Accessed January 14, 2015. <http://eskills360.icwfd.org/Index.cfm>.

implemented projects, such as Ibtikaar, an incubation project; iLabs in 2015 in Kabul, Jalalabad, Herat and Mazar-e-Sharif; and building mobile application applications (apps) for the youth, in partnership with UNESCO.

In addition to its commercial ICT training, TechNation offers community technology and skills building through its Community Technology Centers (CTCs). Through the CTCs, TechNation provides “technical skills training, career guidance and development opportunities and resources ... to create social and economic opportunities that can help change people’s lives and transform communities.”<sup>1541</sup>

One such center is Tech Dera. Dera means “gathering place” in Dari, and TechDera is a multi-purpose community technology center in Kabul, supported by TechNation, that offers ICT training and education; mentoring and counseling; job preparation and internships; access and connectivity; industry networking; gaming; and micro groups centered on technology topics. TechDera’s mission is to use ICT “to create[s] a new generation of community leaders ... and develop[s] technology and management skills of its members and clients” and “allow[ing] both Afghan men and women access to diverse programs and services that can provide technology support and social and economic benefits.”<sup>1542</sup>

TechDera is also a membership-based club for ICT users, developers, and administrators. Member services and benefits include:<sup>1543</sup>

- Access to the facility with 24x7 Wi-Fi Internet connectivity and open computer lab time;
- Monthly member meetings and newsletters keeping members current on technology evolution and event alerts;
- Learning and sharing experiences through various TechDera programs such as freelance technology business, authoring books, and launching publications by members;
- Help in setting career goals, participating in internship and job training programs, and enrolling in lectures and training courses to enhance technical and professional capacity;
- A professional network of tech users and developers and participation in local, national, regional, and international conferences, awards, and events;
- The ability to host events at TechDera and assistance in acquiring sponsorships;
- The opportunity to create an income stream by developing apps and content and getting your products promoted;
- Receiving technical support for troubleshooting your hardware and software tools and devices;
- The ability to print, scan, photocopy, and record your important documents;
- Discounts and special offers on products and services; and
- The opportunity to join TechDera Communities.

---

<sup>1541</sup> TechNation. Accessed August 28, 2015. <http://technation.af/services.html>.

<sup>1542</sup> TechDera. Accessed November 4, 2015. <http://dera.technation.af/>.

<sup>1543</sup> Paraphrased from TechDera.

In addition to basic computer training, TechDera has taught courses in website design, including one class just for Afghan women in 2015, various programming languages, and mobile applications development.

TechDera was founded in 2011, finally coming to fruition after several years of planning, and has emerged as a preeminent technology resource and training center, a physical and virtual ICT hub in Kabul.

### *Operation Cyber Pass*

The Khyber Pass is a mountain pass through the Spin Ghar Mountains on the road connecting Jalalabad, Afghanistan to Peshawar, Pakistan. Historically, it was an important part of the ancient Silk Road trade route and, more recently, it was a major resupply route for NATO forces in Afghanistan for many years. Dr. Dave Warner, MD, PhD, who has worked in Afghanistan since 2006 in the medical and technology fields and as the head of the Synergy Strike Force (SSF, see [Chapter 12](#)), had the idea for the “Khyber Pass to meet the Cyber Pass” by initiating Operation Cyber Pass (OCP), an experiment to achieve peace and stability by employing ICT or, as Dr. Warner says, “overwhelming communications.” The objective was to establish a series of self-contained, independently-operated, sustainably-powered, Internet-enabled computer training centers along the Afghanistan-Pakistan border one of the most dangerous areas of the country, and one generally neglected by the Afghan government and the donor community.

Through Operation Cyber Pass, SSF installed over 30 stand-alone, self-contained, solar-powered, Internet-enabled computer training centers, also called “cyber nodes,” in Nangarhar and Kunar provinces (mostly Nangarhar), seven of which are in remote district sites. Although each implementation is different, the general plan is for all locations to have sustainably-powered computer hardware and associated software and peripherals, Internet access, school supplies (tents, blackboards, notebooks, pens, and locally-acceptable teaching materials), and access to fresh water (hand-pump wells and pipelines to local springs).

SSF has identified over 50 more potential sites along the Khyber Pass where it currently has strong, well-established social networks and where new computer training centers could be established if it is able to source funding.

## Conclusions, Lessons Observed, and Recommendations

The above accounting of ICT capacity development in Afghanistan is by no means exhaustive. Even with a partial list as such (and a very Kabul-centric one at that), the plethora of players and programs involved in ICT – and other – capacity building, only some of which are described here, can be dizzying. While all of the entities and actors involved generally had or have the same ultimate goal – to build capacity in and for the ICT sector, Afghanistan’s public institutions, and its citizenry – each had/has its own agenda, objectives, rules, modus operandi, and the like. Some of the programs and opportunities are/were complementary, while others are/were redundant or even competed with each other. Neither of those two phenomena is specific to ICT capacity development or to Afghanistan, but they are larger issues that continue to confound the international development community.

While ICT was recognized as a priority sector for Afghan reconstruction very early on, the near-total dearth of indigenous ICT skills was not, or at least not formally. The Telecommunications and Internet Policy of

2003<sup>1544</sup> calls for universal network access for Afghan citizens and the resultant access to information and knowledge, as well as the widespread implementation of e-government services. But who was going to work in the sector to provide those services and who was going to use them? Afghanistan was reasonably cosmopolitan and modern, and even somewhat secular, at least in its urban areas, with relatively advanced communications services from the 1950s through 1980s. However, its descent into decades of war and turmoil, including successive governments and the suppressive Taliban regime, largely destroyed its ICT infrastructure. This prolonged upheaval left the Afghans behind the technology times and with an ultra-conservative, fundamentalist view of contemporary communications. Not only did the Afghans have to essentially start from scratch, they had to – and still have to – overcome cultural and religious barrier to technology: computers are sometimes referred to as “devil’s boxes.” The shift from a sixth century mentality to a twenty-first century way of thinking and conducting business – official, commercial, and social – was enormous and requires a tremendous amount of training.

Commercial ICT training centers were among the first to offer ICT training in-country. However, some training centers offered bogus certifications or simply sold credentials while other programs offered no certifications at all. There was no oversight – there still is not – and no standardization for or among them. Neither Cisco nor Microsoft would allow its employees into Afghanistan (Microsoft, ever, and Cisco at least by 2010) which precluded their engagement in a direct and more impactful way. Public-private partnerships should be explored to bring globally recognized ICT industry training and certifications to commercial and civil institutions alike with classes available to the public and public servants.

The German government and the Technical University of Berlin engaged in Afghan ICT capacity development very early on, and have a slate of accomplishments to show for their efforts. Among the keys to ZiiK’s success were conducting on-the-ground advanced assessments, tailoring its solutions to the Afghan environment, and designing sustainability into its programs, such as training the trainers, establishing PC [repair] Workshops, and funding the implementation of IT projects from its master’s program graduates. However, while ZiiK worked with the MoHE and the World Bank, much of its work was conducted in a silo, although, to be fair, it made a concerted effort to be inclusive and cooperative with its annual IT for Higher Education conferences, among other engagements.

There were a few other early donor efforts to address the issue of ICT capacity development, such as the Cisco Networking Academies. However, they were doomed to fail because of the lack of a viable sustainment plan. Other than the revamping of the Telecommunications Training Center (TTC), reopened as the Information and Communication Technology Institute (ICTI), there were scarce institutional endeavors to train Afghans in ICT in the early days. The ICTI itself fell short, as did other public Afghan universities, but the ICTI appears to be on a good forward trajectory with the partnership programs it has undertaken, and the Ministry of Higher Education is making progress with its ICT-related curricula and degree programs. The Ministry of Education shows a lot of promise in incorporating ICT into its facilities and curricula and teaching ICT skills to young Afghans. The new TVET strategy includes ICT as an enabler

---

<sup>1544</sup> Paraphrased from MoC, 2003. *Telecom and ICT Policy Documents*.

but not as a subject area, at least not expressly, even though it was found by more than one study to be target sector and is the second most widely-taught subject at TVET institutions, after English.

Other working and impactful solutions, such as Operation Cyber Pass (OCP), were basically ignored. OCP was largely self-funded and operated outside of the constructs and constraints of (both US and Afghan) government and bureaucracy, allowing it to achieve greater results with less money and effort and be sustainable by engaging locals throughout the process. Unfortunately, OCP never achieved widespread recognition or critical mass. Other programs, such as the ICWFD's e-skills360 program, were not implemented – even though its abundant list of available courses met at least some of the training and capacity development needs expressly articulated by the MCIT, ATRA, and AfTel. The addition of the e-skills360 program to the MCIT's Provincial IT Training Centers seemed like a natural fit, yet it gained no traction whatsoever. In the case of the e-skills360 program, part of why it may never have been duly considered is a general disinclination of Afghans toward online and distance learning. Plus, e-learning offerings precluded them from traveling to Dubai, India, Turkey, or elsewhere for similar such classes. Another detriment of the e-skills360 program was its lack of formal certifications at the time, although that has changed.

In several instances, the MCIT (to include ATRA and AfTel here) seemed not to want to help itself. For example, it did not or would not engage with the Afghan Civil Service Commission (CSC) for training it said it needed and the CSC offered (see [Chapter 20](#)). The World Bank ceased its Incentive Payment Program due to “non-activity” by the MCIT. The MCIT never managed to produce a list of potential candidates for training at the USTTI, despite being guaranteed priority consideration and acceptance for its staff. Nor did the MCIT engage with the US FCC for regulatory training it offered for ATRA. Some training programs that targeted GIRoA personnel were unavailable to AfTel since it was legally a corporation, albeit a state-owned one, and not a government agency. On a positive note, the MCIT has recently begun to take greater advantage of training offered by the International Telecommunication Union and Asia-Pacific Telecommunity (APT) and by various regional other governments (China among them).

Some training classes for GIRoA personnel were too complex or at too high a level to be effective, or the range in knowledge of students was too broad for a course to achieve useful results. For example, CIO training, by definition, is for chief information officers. However, GIRoA CIOs are not necessarily of the generally-accepted caliber or level of industry-standard CIOs, and, in some cases, were glorified IT managers or system administrators, were among the few in the ministry who knew how to use computers, or were nepotistic appointees.

On a positive note, the MCIT's Provincial IT Training Centers graduate nearly 300 GIRoA employees and more than 2,200 public students each year, and ATRA recently budgeted for the procurement of new equipment for them. The new Minister of Communications and Information Technology, who took office in April 2015, listed among the priorities in his “100-Day Plan” to analyze the “education and teaching” at the ICTI, connect 15 schools and five universities with broadband Internet access, and connect five universities to the Trans-Eurasia Information Network (TEIN4) via the Afghanistan Research and Education Network (AfgREN).

It wasn't until the mid- to late-2000s the need for ICT training seemed to come to light in any sort of appreciable way, and many ICT capacity development donor projects commenced in that timeframe. As with all donor endeavors, some were more productive than others. There is often, however, a mismatch between donor-devised programs and actual needs, although in the case of ICT capacity development, training in just about every subject at every skill level is needed. For many years, there was also a misalliance between the Afghan fiscal year and donors' budget and programmatic years, but Afghanistan changed to a Gregorian calendar-year fiscal year in 2012, thereby alleviating some of those issues.

Quite noteworthy, the Afghan eQuality Alliances (AeQA) program trained 30 percent of the entire higher education staff along with 10,000 students all across the country in basic and intermediate IT skills, and established partnerships with 35 universities to continue such training. Its successor programs, the Afghanistan e-Learning English Support Project (AeLESP) and the English Language and Computer Learning Centers (ELCLC), combined learning English and technology, and the ELCLC, had quite a robust ICT curriculum with test administered after each training module.

The World Bank's ICT Skills Development project seems to have achieved a reasonable degree of success and, as such, was expanded. It was preceded by a study of needed ICT skills, the curricula then thoughtfully designed, and it was reasonably well-executed using a combination of local and foreign training resources. The training was conducted in batches, with feedback and observations of what worked and did not incorporated into the next round of sessions. Classes were relatively small and included pre- and post-test training to assess course and teacher effectiveness. Keep in mind, though, the ICT Skills Development project was a "bridging program" to address the gaps between university-educated Afghans and the skills needed within government and the ICT sector. The program also trained GIRoA personnel who needed to be proficient, or at least reasonably competent, in ICT to perform their duties. While short-term, gap-filling efforts such as the World Bank's were certainly needed and produced viable results by many accounts, true ICT capacity development will require systemic reform at many levels within the government and academia in Afghanistan.

The Afghan Workforce Development Project, too, has trained quite a few Afghans, especially young women, in ICT. Requests for applications were issued for specific skills and segments so as to be able to more closely manage the content and intended recipients, with successful courses duplicated and new needs and targets identified and addressed in future RFAs. The AWDP, along with the World Bank's ICT Skills Development project, had the secondary effect – a positive unintended consequence – of Afghans establishing new ICT training centers, such as Cresco Solution Afghanistan and Rana University. One of the World Bank's lesser objectives with regards to ICT capacity development in Afghanistan, which seems to have come to at least some measure of fruition, was to generate competition among training facilities to deliver high-quality, industry-relevant training.

In the absence of third-party monitoring and evaluation of ICT capacity building efforts, both individual and collective, it is difficult to assess the success of any of the endeavors. The number of people trained is only one indicator – and not a particularly valuable measure at that – of the success of any ICT capacity building program, yet that is often one of the only statistics reported or the only gauge of achievement ... not what was taught, learned, retained, applied, and passed on. The World Bank ICT Skills Development Project includes pre- and post-training testing specifically for that reason – to gauge what students

actually learned. By many accounts, it seems to have been successful not only in terms of the number of people trained, but also in skills learned and resultant jobs/promotions/pay increases attained by trainees.

There appears to be a flurry of training activity in Afghanistan, as evidenced by the plethora of requests for proposals (RFPs) issued by the MCIT and ATRA between 2014 and to date in 2016. This is likely due in part to the ICT sector having matured to a certain extent and entering a new phase, coupled with the drying up of donor dollars and the exodus of both expatriates and Afghans alike. The “brain drain” of young, technology-savvy youth – who are among the most employable abroad – is particularly acute and alarming, and will pull the collective Afghan ICT IQ<sup>1545</sup> down ever further. Unfortunately, much of the requested training seems too little, too late, akin to rearranging deck chairs on the *Titanic*. Also, several RFPs call for the trainers to be Afghan nationals or an Afghan company and for the training to occur in country. Even with the crop of new training companies described above, few, if any, are qualified to offer some of the advanced training requested. As a double whammy, fewer outside companies and foreigners are likely willing to travel to Kabul as the security situation continues to deteriorate.

The Afghan government and the donor community missed the boat regarding recognizing early on the criticality of the need for indigenous ICT skills at all levels within public institutions, the private sector, and the populace. For post-conflict and developing nations to join the information society, the need to understand and manage the gap between ICT skills needed by government and industry and ICT skills training available is crucial. It is of **paramount** importance to adequately train the ICT policymaking and regulatory bodies, as ICT underpins and accelerates development in all sectors of the economy. It is also essential to build an ICT-literate cadre of government professionals so as to be able to conduct official business in the digital realm, thereby improving efficiency, transparency, and accountability.

Governments and the donor community alike would do well to develop a concerted, sustained (and sustainable) ICT capacity development campaign in the planning for or, at the very least, at the onset of, any intervention into post-conflict, emerging nations, and digitally-illiterate nations. They should look to the various established international (ITU, UN) and regional bodies (APT, ICT for Africa) for immediate assistance and look for existing programs rather than re-inventing wheels. They should also look at establishing public-private partnerships to make available a wide array of globally-recognized ICT industry certifications. The ICT capacity development models that seemed to work well in Afghanistan were those with specific skills criteria and target trainees, conducted in several rounds over a period of time, incorporating feedback and improving on successive endeavors.

A recent study on global workforce needs indicated a “key issue was a lack of such hard skills as IT knowledge.”<sup>1546</sup> According to another report, “the [global] ICT sector will be looking to hire at least 1.7

---

<sup>1545</sup> Intelligence quotient

<sup>1546</sup> Roberts, Dexter (2012). “The Surprising Global Shortage of Skilled Workers,” *BloombergBusiness*, May 29.

Accessed March 16, 2016. <http://www.bloomberg.com/news/articles/2012-05-29/the-surprising-global-shortage->

million people in the coming years.”<sup>1547</sup> Further, the ITU Secretary-General stated in May 2012, “Over the coming decade, there are expected to be two million more ICT jobs than there are professionals to fill them.”<sup>1548</sup> Unless Afghanistan is able to develop and sustain its own local ICT workforce, within both the government and the private sector, it may have trouble competing with the rest of the world for high-tech workers<sup>1549</sup> during its Decade of Transformation (2015-2024).

---

[of-skilled-workers](http://www.businessweek.com/articles/2012-05-29/the-surprising-global-shortage-in-skilled-workers). (Originally published by Business Week at <http://www.businessweek.com/articles/2012-05-29/the-surprising-global-shortage-in-skilled-workers>; link no longer available.)

<sup>1547</sup> Tandon, Nidhi (2012). *A Bright Future in ICTs: Opportunities for a New Generation of Women*. Accessed March 16, 2016.

<http://www.itu.int/osg/blog/2012/04/26/NewReportABrightFutureInICTsOpportunitiesForANewGenerationOfWomen.aspx>.

<sup>1548</sup> Ibid.

<sup>1549</sup> Bierden, Elizabeth A. (Col., USA) (2012). *ISAF Telecommunications Advisory Team [TAT] Year in Review*, July 1, 64.



## Chapter 20 The TAT's Efforts to Foster ICT Capacity Development

---

Dr. Maria Beebe and Karen E. Black

*Editors' Note: Some of the material in this chapter, particularly regarding the TAT's ICT Capacity Building Through [sic] Training and Education program, is excerpted, adapted, or paraphrased from various reports and other documents written by Dr. Maria Beebe, who was contracted to the TAT as an ICT education expert and is the co-author of this chapter, and, thus, are not referenced.*

### Introduction

Information and communications technology (ICT) is critical for socio-economic development in Afghanistan. Econometric analysis conducted by the World Bank estimated a ten percent increase in high-speed Internet connections in developing countries correlates to annual gross domestic product (GDP) growth of 1.38 percentage points (1.38%).<sup>1550</sup> The International Telecommunication Union's (ITU's) 2009 analysis using ICT household data revealed a positive relationship between better educational performance and greater household Internet access and between the proportion of households with Internet access and female labor force participation.<sup>1551</sup> These worldwide findings suggest significant benefits could be achieved from the use of ICT in Afghanistan, but only if Afghanistan builds the required human and institutional ICT capacity.

In Afghanistan, the annual revenue from the ICT sector is now over US\$200 million per year, accounting for ten percent of all revenues of the Government of the Islamic Republic of Afghanistan (GIROA).<sup>1552</sup> For the ICT sector to realize its full potential will require a population that is not only ICT literate but also ICT fluent. Capacity building is important, not only to maintain, upgrade, and advance Afghanistan's physical ICT infrastructure, but also to integrate ICT into the daily lives of Afghans, allowing them to build virtual connections with and within local, national, regional, and global communities.

In 2005, when the Computer Science Faculty (Department) at Kabul University held its first workshop to upgrade its curriculum, there were 1.33 million mobile phone users, or approximately five users out of

---

<sup>1550</sup> World Bank (2009). *Information and Communications for Development: Extending Reach and Increasing Impact*. World Bank. © World Bank. <https://openknowledge.worldbank.org/handle/10986/2636>. License: CC BY 3.0 IGO." Accessed October 24, 2014.

<sup>1551</sup> International Telecommunication Union (ITU) (2009). *Measuring the Information Society – The ICT Development Index 2009*. Accessed March 4, 2016. <http://www.itu.int/pub/D-IND-ICTOI-2009/en>.

<sup>1552</sup> Islamic Republic of Afghanistan Ministry of Communications and Information Technology (MCIT) (2014). *The Ministry of Communication and ITs' [sic] activities and achievements report 1381-1393 (2002-2014)*, English version, 325 (not available electronically).

100 inhabitants.<sup>1553</sup> As of the end of 2015, there were more than 20 million active mobile phone users.<sup>1554</sup> The percent of Internet users increased from about one percent in 2005 to five percent in 2011 and over six percent (6.4% in 2014, which would equate to over two million (using the World Bank’s Afghanistan population figure of 31.63 million for the same year).<sup>1555</sup> Unofficial estimates put the number as high as five million Afghan Internet users in 2015. With the increase in use of ICT comes the need for capacity building in the ICT sector.

## Trends in Higher Education

Education ministries and institutions around the world are under pressure to:

- Provide education to more people to maintain competitiveness in the knowledge-based global economy;
- Meet the increasing demand for education;
- Modernize educational systems and practices that may have been adequate for the twentieth century;
- Deliver more for less under difficult economic circumstances; and
- Tackle problems of dropping out, underachievement, exclusion, and un(der)employment.<sup>1556</sup>

Complicating the pressure on education ministries and institutions, learning is evolving from permanent, one-time learning to continuous learning to dynamic learning.<sup>1557</sup> Continuous education is needed for ongoing and changing qualifications and dynamic learning for rapid, adaptive, collaborative, and self-directed study, as depicted in [Figure 105](#).

---

<sup>1553</sup> Per the Islamic Republic of Afghanistan Ministry of Communications (MoC), published and garnered by co-author Maria Beebe at the time.

<sup>1554</sup> Afghanistan Telecom Regulatory Authority (ATRA). Telecom Statistics (End of December 2015). Accessed March 16, 2016. <http://atra.gov.af/en/page/telecom-statistics-2013>. ATRA updates this statistics page quarterly or thereabouts, without preserving historical reference to earlier periods on its website.

<sup>1555</sup> The World Bank. “Internet users (per 100 people).” Accessed January 5, 2016.

<http://data.worldbank.org/indicator/IT.NET.USER.P2>.

<sup>1556</sup> GSM Association (2012). GSMA Connected Living Programme: mEducation. *New Business Models: Innovation in Practice*. October 2012. Accessed January 14, 2015. [http://www.gsma.com/connectedliving/wp-content/uploads/2012/10/GSMA\\_NewBusinessModels\\_10\\_12.pdf](http://www.gsma.com/connectedliving/wp-content/uploads/2012/10/GSMA_NewBusinessModels_10_12.pdf).

<sup>1557</sup> Clark, Timothy R. and Conrad A. Gottfredson (2009). “Agile Learning: Thriving in the New Normal.” December. Accessed November 17, 2014. <http://www.cedma-europe.org/newsletter%20articles/Clomedia/Agile%20Learning%20-%20Thriving%20in%20the%20New%20Normal%20%28Dec%2009%29.pdf>.

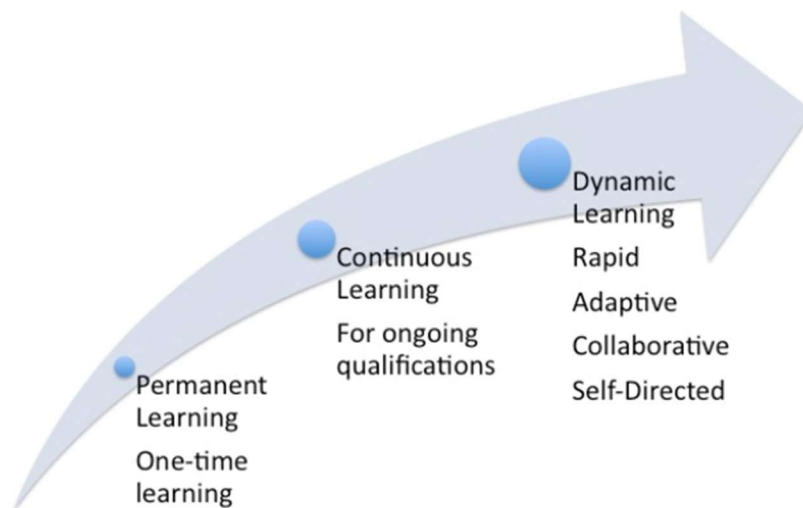

Figure 105: Clark and Gottfredson's Learning Mindset Evolution (2009)

The push to deliver results and the progressive evolution of learning from permanent to continuous propelled the use and integration of ICT in learning. Electronic, or e-education, and mobile learning (m-learning) provide the essential elements for ICT capacity building. McKinsey and Company noted the conditions for e-education success are similar to the success factors in traditional education.<sup>1558</sup> These conditions include:

- Assembling relevant content and activities needed to achieve the desired learning objectives;
- Structured delivery of learning materials and activities;
- Interaction between teachers and learners and among learners;
- Formative evaluation to provide learners feedback while learning is in progress; and,
- Summative evaluation to ascertain relative proficiency against established standards.

Massive open online courses (MOOCs), m-learning, and other online technologies, coupled with pedagogical shifts and localized content creation, have the potential to increase access, reduce costs, and deliver quality education.<sup>1559</sup> However, because of a general disinclination for distance learning by many Afghans (despite pronouncements to the contrary) there is a need to think of ways to make some of the resources and benefits of online teaching and learning available to them without their having to adopt all the features. Important characteristics that need attention include:

---

<sup>1558</sup> Pandit, Vivek, Jean-Christophe Lebraud, and Ramdoss Seetharaman (2012). *Transforming Learning through mEducation*. McKinsey&Company, April 5, 2012. Accessed January 14, 2015. <http://mckinseysociety.com/transforming-learning-through-meducation/>.

<sup>1559</sup> Beebe, Maria A. (2013). "FOSS Principles, MOOCs, m-learning and other online resources: Implications for capacity building." Presentation at the International Telecommunication Union's (ITU'S) World Summit on the Information Society (WSIS), Geneva, Switzerland, May 14.

- **Open source and open content, along with notions of transparency and easy access to data and information.** For example, [Ustad Mobile](#), an m-learning solution, was built using open source software, and the content-authoring platform is available for free as a resource for educators and innovators from Afghanistan and elsewhere to build m-learning courses.
- **Multiple models of education replacing traditional single models.** Alternative paradigms include online learning, hybrid learning, and collaborative models. MOOCs and m-learning need to be explored as complimentary to traditional university courses. Subject to disclaimers, copyright statements, and written permissions, it is possible for Afghans to re-purpose and increase the local relevance of these learning materials to the Afghan situation while taking advantage of an up-to-date and world-class knowledge base.
- **College graduates who are entering the workforce require skills that are acquired not only from formal but also from informal learning experiences.** The Afghan higher education institutions can design informal learning activities, including internships, fellowships, mentorships, and service learning programs to augment formal curricula.
- **The vast resources that are accessible to students via the Internet are changing the role of educators.** In some cases, the educator becomes more of a content guide. Afghan educators can help students become critical consumers of e-resources and add their own creations to the knowledge base.

The challenge for everyone who is interested in ICT capacity building is to scale up pockets of innovation and transform dependence on grants and pilot projects to commercial sustainability. Part of the solution is to engender partnerships and collaboration.

## The TAT's Work to Build ICT Capacity

Recognizing all of the above, the Telecommunications Advisory Team's (TAT's) "ICT Strategy" for Afghanistan, released in January 2012, included a work stream to foster ICT capacity development. It was part of the TAT's line of effort to sustain the ICT sector because such sustainment "is dependent upon a consistent, knowledgeable, competent ICT workforce."<sup>1560</sup> The TAT also recognized, "While there are several ICT programs at Afghanistan's public and private universities as well as other ICT skills development programs, there is a widely-acknowledged gap between the ICT education students receive and the actual skills required to work in the sector, an issue that is certainly not limited to, but is perhaps more pronounced, in Afghanistan."<sup>1561</sup>

The TAT's work to foster ICT capacity development was two-pronged: First, it aimed to facilitate a chief information officer (CIO) culture to support the Ministry of Communications and Information Technology's (MCIT's) goal of developing a CIO cadre within the MCIT as part of its "Strengthening the

---

<sup>1560</sup> Bierden, Elizabeth A. (Col., USA) (2012). *ISAF Telecommunications Advisory Team [TAT] ICT Strategy*, January 16.

<sup>1561</sup> Ibid.

Ministry” component of its *E-Afghanistan National Priority Program* (NPP),<sup>1562</sup> as well as across the Afghan government. Second, the TAT aimed to promote a professional workforce by assisting the Ministry of Higher Education (MoHE) and others to revitalize older and perhaps install additional Cisco Networking Academies (CNAs) throughout Afghanistan and also by advising and assist the MoHE with revamping ICT curricula at Afghan schools and universities, including the MCIT’s Information and Communication Technology Institute (ICTI), in order to bring formal ICT education in line with industry needs. The TAT began working on both overarching efforts immediately upon the release of its strategy, rolling existing related work into those two categories.

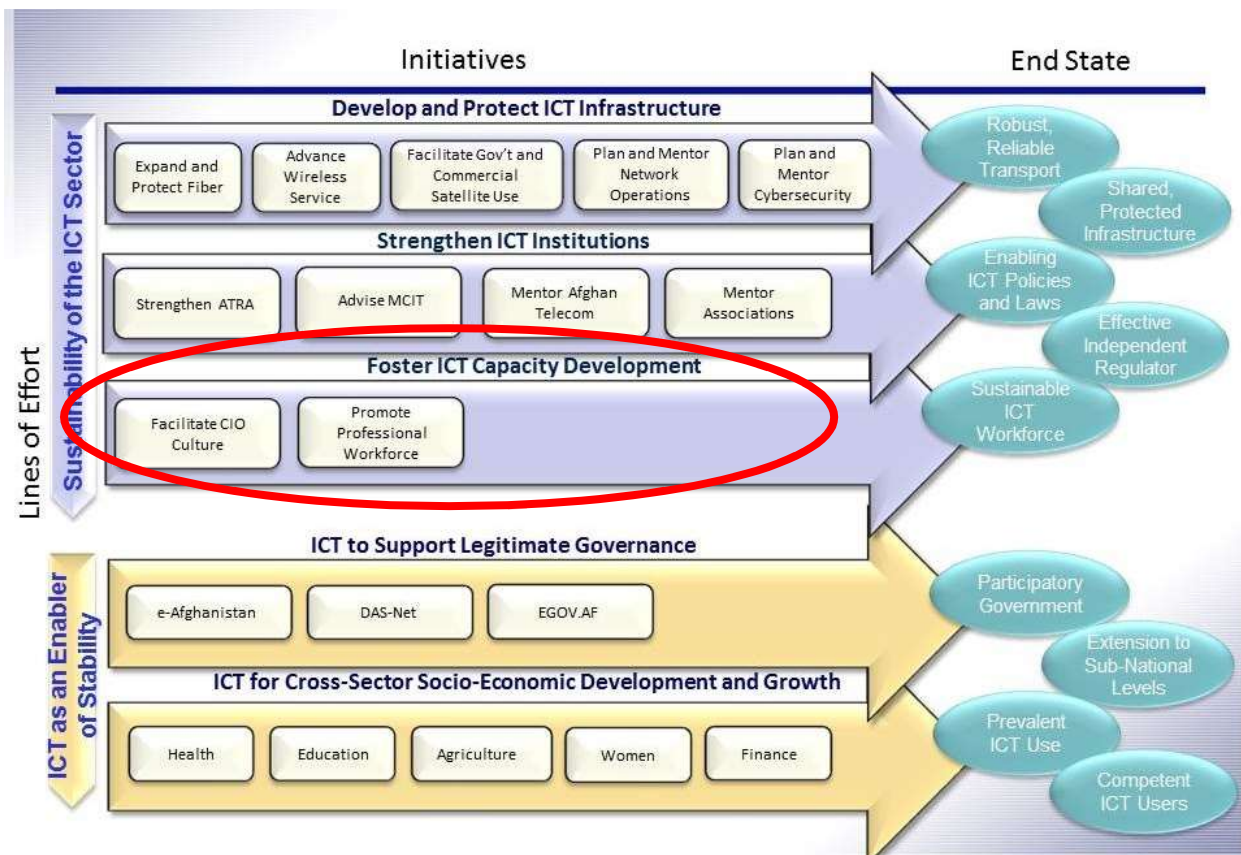

Figure 106: The TAT's Afghanistan ICT Strategy, July 2012

In mid-2012, the TAT enlisted outside expert assistance with its ICT capacity development efforts and initiated its “ICT Capacity Building Through Training and Education” project, which encompassed and appropriated activities to facilitate a CIO culture and promote a professional workforce. Parts of that effort are interspersed in the sections below, and the program is described in detail later in this chapter.

<sup>1562</sup> Islamic Republic of Afghanistan Ministry of Communications and Information Technology (MCIT) (2011). *E-Afghanistan National Priority Program* (NPP) Proposal, May. Accessed January 14, 2015. <http://mcit.gov.af/Content/files/PSD%20NPP%202%20E%20Afgh%20NPP%20Proposal%203%20May%202011.pdf>

## Facilitate a CIO Culture

Immediately upon the release of its strategy, the TAT began its initiative to facilitate a CIO culture by researching what CIO training, if any, was occurring in or planned for Afghanistan, and by learning more about Afghanistan's Government CIO Council concept. The goal was to help GIRoA establish a CIO framework within ministries and agencies by providing advice on recruiting, motivating, and retaining CIOs; devising career development program guidelines for CIOs; and reinforcing GIRoA's strategic information technology (IT) plan development and associated metrics. Further into the effort, the Defense Information Systems Agency (DISA), the sponsor of and on behalf of the TAT, contracted the US National Defense University (NDU) to create a CIO professional development strategy and roadmap as part of a larger ICT education and training assessment.

### *CIO Training*

To promote institutional ICT capacity development within GIRoA and facilitate a CIO culture, which was a major focus of the MCIT prior to implementing its e-government strategy (EGOV.AF), in February 2012, the TAT began contacting various organizations to better understand what resources were committed, funded, or planned that were intended to or could be used for CIO development, including the following:

- The International Telecommunication Union (ITU),
- The North Atlantic Treaty Organization (NATO),
- The United Nations Development Programme (UNDP),
- The United Nations Assistance Mission-Afghanistan (UNAMA),
- The World Bank (via its Project Implementation and Coordination Unit – PICU – at the MCIT in Kabul),
- The US Department of State (DoS),
- The US Agency for International Development (USAID),
- The US Telecommunications Training Institute (USTTI),
- The US Department of Defense (DoD) Task Force for Business and Stability Operations (TFBSO),
- US Forces-Afghanistan (USFOR-A), and
- The Combined Security Transition Command-Afghanistan (CSTC-A).

The TAT also contacted various donor governments (Germany, India, Turkey, Iran, South Korea, and Japan) and government development agencies – the Australian Agency for International Development (AUSAID), the Canadian International Development Agency (CIDA), the United Kingdom's Department for International Development (DFID), and Japan International Cooperation Agency (JICA) – along with several non-governmental organizations (NGOs).

The TAT met with representatives from the US Telecommunications Training Institute (USTTI) in May 2012 to discuss regional approaches to delivering training to government CIOs. For example, the USTTI said it may be able to provide a set of core courses (e.g., in cybersecurity, spectrum, policy and regulation, e-government, etc.) that could be taught to select personnel from various Afghan ministries. The group discussed including a train-the-trainers component so the Afghans could bring the training home with them and offer it more widely.

As part of the CIO strategy and roadmap (see below), Idea Sciences recommended and organized, with the assistance of George Washington University in the US, a short course for ten GIRoA CIOs to be taught by former US government CIOs in partnership with a Turkish university in the summer of 2012. However, GIRoA could not, or at least did not, proffer a slate of candidates nor could it source funding for the Afghans to travel to Turkey. The short course in Turkey was designed to address CIO culture, CIO leadership competencies, and model e-government strategy dimensions. The curriculum was to address strategic, operational, and tactical dimensions of the role of the government CIO.

The TAT also reviewed documentation about a CIO Capstone Workshop NDU conducted for government CIOs in Iraq in 2008, with a follow-on training class in Washington, DC. The TAT attempted to source funding from the US DoS for similar training for the Afghans but was unable to garner commitment from the DoS, nor could GIRoA offer a suitable slate of candidates with sufficient knowledge and skills to be approved by NDU.

### *Government CIO Council*

As another facet of its effort to facilitate a CIO culture, the TAT assisted GIRoA with its fledgling Afghan Government Chief Information Officers (GCIO) Council. The GCIO, as it is known, is composed of GIRoA CIOs and IT Directors and is intended to be a coordinating body with a mandate “to ensure that [Afghanistan’s electronic government, or EGOV] development across ... ministries and agencies is progressing harmoniously [and] in line with ... EGOV strategy.”<sup>1563</sup> GIRoA and the MCIT formally established the GCIO March 21, 2012 (the beginning of solar year 1391), with the MCIT’s Director of E-Government spearheading the effort. The GCIO was to be chaired by the head of the MCIT’s E-Government Directorate and be under the E-Government Resource Center. It was to operate according to standards and guidelines [to be] established by the National ICT Council of Afghanistan (NICTCA). The GCIO had no idea how it would begin to establish formal CIO qualifications, job responsibilities, or the like and welcomed assistance from the TAT.

The TAT consulted with DISA to discuss ideas on how the TAT might advise GIRoA toward developing a CIO culture. DISA’s CIO, Mr. Henry J. Sienkiewicz, SES,<sup>1564</sup> suggested soliciting assistance from the CIO Council of *CIO Magazine* and the Maryland Air National Guard, which had relevant capacity development experience in Eastern Europe. The TAT also consulted with Gartner, Inc., under its contract with DISA, along with NDU, regarding how to help GIRoA establish a CIO framework and recruit, motivate, measure the performance of, reward, and retain CIOs. Ultimately, DISA contracted NDU to develop a CIO strategy and roadmap to present to the MCIT and GIRoA. The TAT supplied the GCIO with a Gartner report on public sector CIO definition and organization structure, which included a checklist to consider for the roles and responsibilities of government CIOs. The TAT offered to assist the GCIO to shape the material to meet Afghan needs.

---

<sup>1563</sup> Mohmand, Abdul Mujeeb, Aimal Marjan, and the Center of E-Government at the United Nations University-International Institute for Software Technology (EGOV-UNU-IIST) (n.d.). “Current e-Government in Afghanistan.”

<sup>1564</sup> Senior Executive Service

The MCIT Director General for ICT indicated he was extremely grateful for the work TAT had done to guide its GCIO effort and new E-government Resource Center (EGRC) in the CIO area and requested further TAT assistance in the areas of CIO leadership development, above and beyond and to complement that being provided by the World Bank.<sup>1565</sup>

TAT Senior ICT Education Advisor Dr. Maria Beebe, this chapter's co-author, visited the United Nations University International Institute for Software Technology (UNU-IIST) in Macau in mid-2012 to learn more about its PhD program in ICT for Sustainable Development. She also investigated its Center for Electronic Governance (UNU-EGOV), which was organizing a week of executive-level training on "Foundations of Government Information Leadership." The TAT passed along relevant training opportunities provided by UNU to the MCIT GCIO. Toward the end of 2012 and into 2013, the TAT worked with the Director General of E-Government at the MCIT, who was developing an ambitious three-year plan to enhance the MCIT's institutional training and certification processes while simultaneously developing employee incentives to retain a qualified CIO work force with viable career progression. At the TAT's suggestion, he planned to present his training proposal to the United Nations in early 2013 for potential funding but it is unclear if he did and, if so, to what end.

### *CIO Professional Development Strategy and Roadmap*

From October 2012 to September 2013, NDU subcontractor Idea Sciences worked closely with the TAT to develop a comprehensive CIO professional development strategy and roadmap for Afghanistan. The broader exercise included reviewing assessments of existing CIO resources and training available, generating senior leadership awareness of the need and importance of a qualified cadre of government CIOs, proposing approaches to implementing a CIO framework, offering best practices to assist Afghanistan in creating a skilled CIO workforce, and suggesting capacity development, certifications, and professional degree programs for CIOs.

Idea Sciences delivered the CIO strategy to NDU and the TAT in September 2013. The document includes an overview of organization development at each stage of the entity's lifecycle, with GIRoA operating in the first phase, where the organization "'invents' itself ... [and needs CIOs with] high energy to drive change, excellent communication skills to capture the imagination of Afghan senior leaders and a keen awareness of the needs of Afghan citizens."<sup>1566</sup> It also includes capacity building at each stage of the employee lifecycle, covering such subtopics as recruiting candidates and orienting, educating, and training those hired, along with best practice curricula. The CIO strategy describes characteristics of a CIO culture, offers a CIO roadmap, and suggests a way forward for GIRoA, complete with recommendations, an action plan, and a recognition and reward system. Appendices to the document include a sample learning plan,

---

<sup>1565</sup> MCIT Director General Aimal Marjan to outgoing TAT Director Colonel Elizabeth A. (Beth) Bierden, USA, incoming TAT Director Colonel Francis J. (Frank) Huber, USA, and TAT Deputy Director John Horn during a meeting at the MCIT on June 26, 2012.

<sup>1566</sup> Idea Sciences (2013). "2013 CIO Roadmap." September, 17. Prepared for the [US] National Defense University.



an IT readiness survey, a capability maturity model for information security, and skills surveys for CIO candidates, among other practical and useful tools for GIRoA CIOs.

The TAT provided the CIO Strategy to the Director of the E-Government Directorate of the MCIT, who was also spearheading the GCIO effort, in September 2013. Despite being received with great appreciation, little was done, to the TAT's knowledge, toward implementing the strategy and roadmap, at least by the time the TAT ceased operations in October 2014. As with many other things, it may be some time before the MCIT and GIRoA are in the position to move forward, and doing so will likely require a confluence of need, leadership, and funding.

### *CIO Certification Program*

In partnership with NDU and Idea Sciences, the TAT shared examples of a CIO certification program developed by the Federal CIO Council in the United States. The key features of the certification program include: alignment to US law (the Information Technology Management Reform Act of 1996, also known as the Clinger-Cohen Act of 1996); collaboration in defining the core competencies that define the workforce requirements and their revisions every two years; definition of learning objectives used as the foundation for IT course and curriculum development; and design of courses consistent with the competencies by universities, such as NDU and Carnegie Mellon.

The US program identified twelve sets of competencies for CIOs:

- Policy and organization;
- Leadership and human capital management
- Process and change management;
- Information resources strategy and planning
- IT performance assessment: models and methods;
- IT project and program management;
- Capital planning and investment control;
- Acquisition;
- Information and knowledge management;
- Cybersecurity/information assurance;
- Enterprise architecture; and
- Technology management and assessment.<sup>1567</sup>

For each competency, sub-competencies were identified. For each sub-competency, learning outcomes were listed, which then became the basis for IT course and curriculum development.

The document was shared with the MCIT Director of e-Government, who indicated he had shared the information with the Planning Directorate and suggested the adaptation of the framework to his donors. The TAT requested the Director carefully assess the core competencies and decide which ones were

---

<sup>1567</sup> United States CIO Council (2012). "2012 Clinger-Cohen Core Competencies & Learning Objectives." December. Accessed November 17, 2014. <https://cio.gov/wp-content/uploads/downloads/2013/02/2012-Learning-Objectives-Final.pdf>.

relevant for Afghan government CIOs now, or may be in the future. The Director's assessment was supposed to help NDU and Idea Sciences articulate a set of courses, modules, and training programs for government CIOs, but that follow-on work never materialized, largely due to security conditions at the time, precluding advisors' travel and limiting their time in country, and the turnover of TAT personnel and leadership. However, the TAT did, at the MCIT Director's request, revise the alignment of the CIO certification from US law toward Afghan law.

## Promote a Professional Workforce

The other major work stream under the TAT's initiative to foster ICT capacity development was to promote a professional ICT workforce, one comprised of indigenous Afghan workers at all levels, from technicians to middle management to cybersecurity experts, which was able to be replenished and that could be sustained indefinitely. The TAT's activities under this broad effort included helping to revitalize Afghanistan's Cisco Networking Academies; participating in the Higher Education Donors Steering Group (HEDSG), primarily to coordinate Cisco-related actions; engendering attendance at the United States Telecommunications Training Institute (USTTI) by personnel from Afghanistan's public ICT institutions; introducing USAID's Women In Government (WIG) internship program to the MCIT, the ATRA, and state-owned Afghan Telecom Corporation (AfTel); and investigating and advocating the International Commission on Workforce Development's (ICWFD's) e-skills360 program for potential use in Afghanistan.

Beginning in late 2010, the TAT worked with the MoHE, MCIT, the World Bank, and others to try to revitalize the existing Cisco Networking Academies (CNAs) in Afghanistan. The World Bank was willing to participate in discussions, but declined to provide funding, as the money under its US\$50 million Afghanistan ICT Sector Development Project was already committed, albeit it in part for its ICT Skills Development Program (see [Chapter 19](#)). However, the World Bank was willing to entertain the idea of perhaps training Cisco instructors under it.

At the TAT's suggestion, the MoHE conducted an assessment of the nine academies to get a status of each to determine needs, identify gaps, and establish priorities for potential funding. The survey, which was carried out by the IT Director of the MoHE and the Legal Main Contact (LMC) from the regional Cisco academy in Kabul, was intended to ascertain the:

- Training capacity (number of seats);
- Number of students at each academy and per program;
- Number and types of programs offered;
- Number of instructors;
- State of facilities and inventory of equipment;
- Availability of lab bundles for each curriculum taught and requirements for equipment upgrades;
- Internet connectivity (type, speed, cost, provider, and donor/funder, if applicable);
- Viability and sustainability; and
- Desired/needs for future program offerings and capacity building plans.

The MoHE delivered the results of its assessment to the TAT at the end of October 2011. Key among the findings was that none of the sites had been upgraded since 2002 or 2003, which essentially meant never, and the equipment in the CNAs was not compatible with current versions of Cisco products. The MoHE estimated the cost for equipment upgrades to be US\$500 million, which seemed an exorbitant amount. Some of the centers had not offered training since 2008, and only three of the eight Cisco certification courses were offered in Afghanistan. Further, the MoHE wanted to increase the capacity of the CNAs from 60 to 120 students and expand the curriculum to include training courses in wireless technologies and network security. The regional academy at Kabul University also wanted to include Cisco Certified Network Associate (CCNA) and Cisco Certified Network Professional (CCNP) courses and certifications.



*Picture 53: Cisco Networking Academy at Herat University*

*(Photo by Larry Wentz)*

The TAT, as well as the MCIT's Director General of ICT, discussed with the MoHE in great detail the importance of a viable sustainability strategy for the Cisco Networking Academies. Because most of the academies – all expect one – are within public Afghan universities, they are not allowed to charge any money for Cisco training for university students, as free public education through college is guaranteed to all Afghan citizens by the Afghan Constitution.<sup>1568</sup> The group discussed developing a marketing plan to increase enrollment in the evening programs, for which they could charge fees, in order to produce much-needed revenue. However, the MoHE later reported that it was unable to retain any money generated from the Cisco Academies for the facilities because, by law or regulation, all monies generated were required to go back into a larger pool of funds for the university in general or to the MoHE. The group also deliberated the potential and merit of applying to ATRA for a grant from the Telecommunications Development Fund (TDF), but ATRA claimed the request was outside of the mandate of the TDF.

In December 2011, the MoHE requested the TAT fund or help to find funding to upgrade and expand Afghanistan's CNAs. The TAT reviewed the list of requested equipment for accuracy, applicability,

---

<sup>1568</sup> The Constitution of the Islamic Republic of Afghanistan, ratified January 26, 2004. Accessed February 9, 2015. <http://www.afghanembassy.com.pl/afg/images/pliki/TheConstitution.pdf>.

## COMMANDER'S EMERGENCY RESPONSE PROGRAM (CERP)

The National Defense Authorization Act of 2012 describes the Commander's Emergency Response Program (CERP) as "the program that (1) authorizes the United States military commanders in Afghanistan to carry out small-scale projects designed to meet urgent humanitarian relief ... or reconstruction requirements within their area of responsibility; and (2) provides an immediate and direct benefit to the people of Afghanistan."

For projects to be selected for CERP funding, they should:

- Provide immediate and measurable benefit to the local population.
- Be completed quickly.
- Promote local national employment.
- Be highly visible to the local populace.
- Be sustained by the host national after turnover.
- Incorporate host nation entities throughout the life of the project, from inception turnover.
- [Be] accepted as beneficial by the local population.

*(Per US Army Techniques Publication (ATP) No. 1-06.2, "The Commander's Emergency Response Program," April 2013, p. 1-1.)*

CERP began in Iraq, using funds seized during the US invasion, as a non-lethal weapon to assist commanders on the ground and later was funded by the US Department of Defense with Federally appropriated monies.

completeness, and relevancy and attempted to source funding from the Commander's Emergency Response Program (CERP, see sidebar), the US Embassy in Kabul, USAID, and others. However, the glaring lack of a feasible sustainability strategy discouraged many potential donors.

Also in the fall of 2011, the TAT met with the CNA Regional Lead in Dubai, where he explained how Cisco was revamping its training: Cisco was moving away from its operational tree and engagement model to a flatter configuration so that all CNAs could interact with each other and deal directly with Cisco rather than only through their assigned regional academies. The changes were expected to be implemented in Afghanistan in January 2012. It is unknown to the authors if they were. Cisco asked for the TAT's assistance in having the MCIT assign a part-time person to oversee the Cisco Academies in Afghanistan (different from the LMC position) and ensure their compliance with Cisco training and reporting requirements, which the MCIT eventually did approximately six months later. Since Cisco's corporate policy did not allow its employees to travel to Afghanistan at the time, the single point of contact was especially important to them. The Cisco Regional Lead explained a recent initiative where Roshan, an Afghan mobile network operator, donated US\$100,000 for Cisco training, an effort that dwindled due to the lack of oversight in country. The TAT and Cisco also discussed the possibility of Cisco conducting instructor training courses for Afghans so as to increase the number of qualified teachers and perhaps implementing additional CNAs through Afghanistan's Technical and Vocational Education and Training (TVET) program, at a cost of approximately US\$2,000 each. Despite repeated follow up by the TAT, neither idea went any further.

From late 2010 through late 2011, the TAT worked with the American University of Afghanistan (AUAF) to try to establish a Cisco Networking Academy with capacity for 20 students at its Professional Development Institute (PDI). The plan was initially to support Cisco certifications in Discovery and IT Essentials. On behalf of the AUAF, the TAT submitted a CERP application to fund the initial equipment for the Cisco Networking Academy at the PDI. Unlike the public

universities, the PDI could charge students for Cisco training, which money it would then put back into the academy to sustain it. (A requirement for CERP funds was projects must be sustainable by the Afghans). Ultimately, it was determined AUAF did not qualify for CERP funds, but it found money elsewhere to establish a Cisco Networking Academy at its PDI.



*Picture 54: Cisco Networking Academy at the ICTI*

*(Photo by Larry Wentz)*

There was very little activity or progress toward revitalizing Afghanistan’s Cisco Networking Academies between the end of 2011 and mid-2012, primarily because no donor – at least none the TAT could find – was willing to fund the effort without a feasible way to operate and maintain the CNAs going forward. However, in the fall of 2012, the TAT attempted to address the lack of qualified CNA instructors, particularly for the “hands on” training components, and create opportunities for Cisco instructors, such as peer development, mentoring, and the sharing of best practices sharing. The TAT met with the Higher Colleges of Technology at Dubai Men’s College to discuss the possibility of their offering train-the-trainer courses for Afghan Cisco instructors and advanced Cisco training for qualified Afghans. However, nothing materialized from those discussions.

The TAT also investigated the Cisco Learning Partner (CLP) initiative and how it might be employed to offer private-sector Cisco training capabilities in Afghanistan. Cisco Learning Partners “focus primarily on core technology training and preparing IT professionals for career certification by delivering best-in-class Cisco Authorized curriculum.”<sup>1569</sup> Cisco confirmed there were no private Cisco-certified learning centers in Afghanistan, but there was a “gray market” of what Cisco viewed as unauthorized training centers. The TAT researched grant opportunities available from the donor community, including USAID, the World

---

<sup>1569</sup> Cisco. “Learning Partner Overview.” Accessed January 16, 2015.  
[http://www.cisco.com/web/learning/wwlpc/clp\\_associate.html](http://www.cisco.com/web/learning/wwlpc/clp_associate.html).

Bank and the United Nations Educational, Scientific and Cultural Organization (UNESCO), for start-up equipment to establish Afghanistan's first Cisco-authorized CLP, but to no avail.

Beginning in mid-2012, under its ICT Capacity Building Through Training and Education program (described in detail later in this chapter), the TAT initiated discussions among a broad group of stakeholders to consider transforming at least some of Afghanistan's CNAs into "ICT Smart Hubs" that would offer a variety of recognized ICT industry courses and certifications, not just Cisco, which, the TAT suggested, could be funded and sustained through public-private partnership (PPPs).

### *Higher Education Donors Steering Group*

In the fall of 2011, the program directors for USAID's Higher Education Project (HEP) and NATO's SILK-Afghanistan programs proposed holding meetings to coordinate donors working in the ICT space in higher education, with the idea to include representatives from the USAID, NATO, the International Security Assistance Force (ISAF) Deputy Chief of Staff of Stability (DCOS-STAB), the MoHE, the US DoS, the World Bank, and the TAT. Potential areas of mutual interest and coordination were ICT infrastructure, the Higher Education Management System (HEMS), digital libraries, web support, Cisco Networking Academies, and ICT capacity building. The TAT attended the inaugural Higher Education Donors Steering Group (HEDSG) meeting in October 2011 and agreed to assume the role of coordinating Cisco Networking Academy requirements and related work.

The second HEDSG meeting, which was run and led by Afghans, occurred in November 2011 and was chaired by a Deputy Minister from the MoHE. The Deputy Minister listed three priorities:

1. Promote ICT capacity building within academic institutions and for faculty members;
2. Ensure ICT infrastructure supports higher education in terms of accessibility and sustainment after the withdrawal of Coalition forces at the end of 2014; and
3. Build and maintain the appropriate governance of ICT in higher education.

The group attempted to meet after November 2011. However, the momentum was disrupted by the Western holiday season, a cold and snowy winter that made travel difficult or impossible, and the murder of two ISAF mentors at the Afghan Ministry of Interior in February 2012, which dramatically restricted travel for ISAF personnel for months afterward. The TAT has no record of attending any further meetings, or if they even occurred; however, the spirit of the original intent of the meetings – to coordinate among donors – remained.

### *The United States Telecommunications Training Institute*

As part of its effort to develop ICT capacity through education, the TAT worked with the US Embassy in Kabul, with funding provided by the US State Department's Bureau of South and Central Asian Affairs (SCA), to facilitate trips for personnel from the MCIT, ATRA, and AfTel to the United States Telecommunications Training Institute (USTTI) in Washington, DC. The State Department money, which was available to train participants from Pakistan, Kyrgyzstan, and Tajikistan, as well as Afghanistan, was awarded in 2010. The USTTI began training officials in July of that year and did so until the money was depleted in 2012. Through the DoS grant, the USTTI was able to train 37 officials from the region. However,

only four were from Afghanistan.<sup>1570</sup> Of the four Afghan attendees, one each was from the MCIT, ATRA, and AfTel, plus there was a senior IT person/financial database officer from the Ministry of Rural Rehabilitation and Development (MRRD). A fifth Afghan from the MCIT also attended the USTTI, outside of the TAT-State Department initiative and with different funding, by combining USTTI training with a trip to the US for a meeting of the Internet Corporation for Assigned Names and Numbers (ICANN).

Unfortunately, the USTTI faced several impediments in attempting to train more officials from Afghanistan. Per James J. (Jim) O'Connor, Executive Director of the USTTI, the enormous amount of time required for the background checks and security clearances necessary for obtaining US visas for the Afghans became very difficult, which was compounded by frequent personnel rotations at the US Embassy in Kabul.<sup>1571</sup> Mr. O'Connor also said that working with the Afghans and getting nominations from their side proved futile. In all of his experiences working with countries around the world, he has never had such a lack of response from a country as the one he experienced with the leaders from Afghanistan. On numerous occasions dating back to 2007 (before the State SCA grant was awarded), the USTTI gave assurances to Afghan officials their nominees would be given priority acceptance and placement in USTTI courses. The USTTI never received a list of nominees from any Afghan official. In contrast, the response USTTI received from Pakistan and Kyrgyzstan for candidates to potentially use the grant was overwhelming. As a result, those two countries were able to train senior officials at both their regulators and establish strong relationships with each other and the USTTI that continue today.

USTTI Founder and Chairman Ambassador Michael R. Gardner and the State Department desired to have participants from nations in the same region attend courses at the same time as a means to build trust relationships and professional networks. For example, having regulators from Afghanistan and Pakistan train together would allow them to meet each other and learn what challenges they had in common and how they could help each other. This did not seem to interest the Afghans.

As of early 2015, the USTTI was still willing to provide priority acceptance for Afghan officials. However, they were not receiving Afghan nominations from any of the entities with which they work. Further, without funding available, it is rare any Afghans who applied and were accepted would be able to travel to the USTTI for training.

The TAT, too, observed difficulties and delays in the larger application and approval process. Because of the various organizations involved, and the bureaucracies inherent to both Afghan and US government agencies, shepherding candidates from identification and assessment through course selection, applications, and approvals (including from their internal organizations and USTTI, as well as for visas) and on to funding and travel arrangements made for quite a few moving parts scattered among several departments at multiple entities over relatively long periods of time. There is no mechanism in place to

---

<sup>1570</sup> Excerpted and paraphrased from an email message from Mr. James J. (Jim) O'Connor, Executive Director, United States Telecommunications Training Institute (USTTI) to co-editors Larry Wentz and Karen Black, February 23, 2015.

<sup>1571</sup> Ibid.

manage the entire process and monitor progress, nor is there a single person or entity with overall responsibility. The TAT and USTTI, among others, can and did help facilitate the disparate parts, but the Afghans were ultimately obliged to make things happen and they either could not or did not want to do so.

Visas are known to be the “long pole in the tent” and it is the Afghans’ responsibility to take action to obtain them. On the US side, the local Consular Office is responsible for issuing visas, which cannot be expedited unless the applicant is a senior member of government, such as a minister. The MCIT’s interaction with the US Embassy was typically through the Economic (ECON) Section, as ICT fell into one of its portfolios, but ECON cannot intervene to expedite the visa process. The Afghans know visa issuance takes a long time, so they need to learn to plan accordingly. Funding for training and associated travel expenses is also an Afghan responsibility. There are grants and other mechanisms they can try to tap for support, but it is up to them to obtain funding, even if there is a program in place such as the DoS SCA money when it was available.

The TAT initiated an effort to have the MCIT put together an approved list of internal candidates from that would potentially qualify for USTTI training. The MCIT also had responsibility to work with the other Afghan ministries to identify their candidates but did not perform this role very well. Such a list was started but never finalized, approved, or provided to the TAT, the US Embassy, or USTTI.

### *ICT Curricula Review and Reform*

Prior to the advent of its ICT Capacity Building Through Training and Education project, the TAT had begun (in January 2012) advising the ICTI regarding revamping its curriculum with the goal of having a redesigned program of study in time for the entering class of solar year (SY) 1392 (March 2013). That effort was subsequently rolled into the larger project where the TAT reviewed and assessed the computer science curriculum at Kabul University and the Bachelor of Science (BSc) in Computer Science curriculum at the ICTI.<sup>1572</sup> The goal was to examine ICT worker educational needs in view of the ICT market, labor, industry, and technical and professional demands, and to identify gaps and overlaps in the programs of study. The appraisal also included reviewing learning materials, teaching methods and tools, teacher qualifications, and instruments and means of evaluation.

The curriculum for the BSc in Computer Science was initially developed in 2005 with participants from the University of Maryland, Colgate University, Washington State University, the Technical University of Berlin, Herat University, Nangarhar University, the UNDP, USAID, the MCIT, and Afghanistan Information Management Service (AIMS). The stakeholder process was convened by Kabul University and funded by USAID under the Afghan eQuality Alliances Project. In 2007, the curriculum was reviewed by Delhi University with funding provided by the World Bank under its Strengthening Higher Education Project (SHEP). Moreover, curricula of other universities were reviewed during study abroad and official visits from 2007 onwards to the University of the Western Cape (South Africa), Delhi (India), Purdue (US), and

---

<sup>1572</sup> Degrees earned at the ICTI are conferred by Kabul University.



Peshawar and Jenah (Pakistan). During 2012, the MoHE conducted a curriculum revision process, following the 2012 MoHE curriculum revision and development guidelines. In its overview, the MoHE indicated the incorporation of current market requirements using feedback, information, survey outcomes through official and unofficial methods from computer science graduates and post-graduate students at various universities, Internet service and telecommunications service providers, as well as results from surveys conducted by the MCIT in March 2012.

### *Women In Government Internship Program*

A frequent lament of management at the MCIT, ATRA, and AfTel was they had difficulty recruiting and retaining staff, even for entry-level positions. While some Afghans are drawn to civil service, either out of a sense of duty or by obligations imposed by families or tribes, working for GIRoA does not have – at least officially – many of the perks or benefits of civil service in the United States. Moreover, the pay is less, often substantially so, than from jobs with donor organizations, NGOs, and the private sector. In an effort to help mitigate at least some of those recruitment and retention issues, the TAT introduced USAID’s Women In Government (WIG) internship program to the MCIT, ATRA, and AfTel.

As described in the previous chapter, the WIG program placed female college graduates in six-month paid (by USAID) internships in government (and in some cases, hard-to-fill private sector) positions. USAID provided training and equipment (namely laptops and mobile Internet access). Recipient entities were asked to provide workspace, relevant on-the-job training, and, if possible, transportation and meals, which may be either free or available for a fee (to be paid by the interns).

A member of the TAT was introduced to the WIG program in late winter of 2012, and the TAT tried to encourage the MCIT, ATRA, and AfTel to sponsor interns through the WIG program. The timing was fortuitous, as the theme of the International Telecommunication Union’s (ITU’s) annual World Telecommunications and Information Society Day (WTISD) (May 17, 2012) that year was “Women and Girls in ICT.” ITU members – of which Afghanistan is one – are encouraged to celebrate WTISD according to each year’s theme. The TAT hoped the MCIT would embrace the WIG internship program and announce it as part of its commemoration of WTISD, which it held on May 16, 2012. Unfortunately, it did not.

The TAT introduced WIG to the Director General of Policy and Planning and the Gender Manager of the MCIT, both of whom were receptive and even enthusiastic, although the reaction by Acting MCIT Minister Sangin was polite but noncommittal. The Chairman of the ATRA Board of Directors, Engineer Abdul Wakil Shergul, was interested in learning more about the program. Unfortunately, despite repeated attempts by the TAT to engage the MCIT and ATRA further, including working with the Gender Affairs Coordinator at the MCIT, neither organization adopted the program.

AfTel was originally lukewarm about the WIG program, but the Chief Operating Officer (COO) and the head of Human Resources met with the WIG Program Manager and Program Lead in mid-2012 and eventually hired eight interns in late 2012. Four of the women were staffed in AfTel’s procurement department and the others were in various non-technical positions, reportedly only because of AfTel’s immediate needs. AfTel’s COO was exceptionally pleased with the interns’ performance and planned to bring an additional dozen or so on board in early 2013. He also stated he was open to hiring interns into technical positions in the future should AfTel have positions available and the WIG program have qualified

candidates. (WIG's activities and interns were predominantly geared toward the finance sector). The COO expected most, if not all, of the interns would be hired into permanent positions; however, it is unclear if that occurred, or if any additional interns were hired.

### *International Commission on Workforce Development*

The TAT investigated another non-profit organization, the International Commission on Workforce Development (ICWFD), described in the [Chapter 19](#), as part of its ICT capacity building efforts.

The TAT introduced the ICWFD's "e-skills360" program to management at the MCIT, ATRA, and AfTel. The e-skills360 program offers over 3,000 technical, business, and professional development courses – generic and industry-branded – via PIN<sup>1573</sup>-code access. The TAT provided the three entities with a number of test PINs, courtesy of the ICWFD, so they were able to try several courses. Although many of the available courses met training needs *explicitly expressed* by all three organizations, the program went nowhere. Some of the reasons may have included the following: Afghans are not terribly keen on online education, partly because of the lack of available and reliable Internet connectivity (although e-skills360 courses could be done offline), partly because they prefer in-class instruction with certificates (not necessarily certifications) awarded at the end, and partly because it could preclude their being able to travel to Dubai, India, Turkey, or elsewhere to take the same classes. The lack of certifications may have dampened individual enthusiasm, though not necessarily for the program as a whole.<sup>1574</sup> The ICWFD was willing to entertain working with local entities to proxy certification exams and was looking to do so program-wide. By August 2013, the ICWFD accomplished offering official certifications by seven industry entities, including the internationally-renowned Project Management Institute (PMI), the ScrumAlliance, and ITIL (formerly known as the Information Technology Infrastructure Library).

The TAT member who oversaw TAT's ICT capacity building efforts did not embrace the e-skills360 program, which may have accounted for some of the inertia, and TAT leadership did not want to spend time fundraising (finding potential donors) for it. The e-skills360 program was very successful in several other countries, such as Nigeria, India, Malaysia, Egypt, Bangladesh, and Jordan. The countries employed various methods of funding, including "bidding wars" among large corporations like Coca-Cola and Pepsi, public (government) monies, and donor funding.

Primarily for the reasons above, e-skills360 was never formally briefed to MCIT Minister Sangin or ICT-interested donors, who may have seen its potential, particularly for use in the MCIT's Provincial IT Training Centers around the country. It was particularly regrettable given the commission's director kindly offered a matching grant of up to US\$500,000, more than once, whereby the ICWFD would offer Afghans a dollar amount of courses for free equal to the money they paid for the program (so if Afghanistan put US\$500,000 toward the program – from GIRoA or donors or both – it would receive US\$1 million in courses).

---

<sup>1573</sup> Personal identification number

<sup>1574</sup> The ICWFD now offers various industry certifications, though it did not during that timeframe.

The TAT included the ICWFD's e-skills360 program in its proposal to transform select Cisco Networking Academies into ICT Smart Hubs, introduced it to the founders of TechDera, which does ICT training, along with a couple other providers of ICT training, and even briefly explored having public universities offer the e-skills360 courses at night to the public when their computer labs were not in use, but nothing materialized from any of those endeavors.

### *Other*

The TAT investigated several other ICT training opportunities and mechanisms as part of its efforts to promote a professional workforce, some of which are listed below.

### **Afghan Civil Service Commission**

The TAT suggested the MCIT look at the Afghan Civil Service Commission (CSC) for institutional capacity development, particularly its IT and English training courses. Nothing ever materialized from this idea, perhaps due to political reasons or inter-ministerial rivalries, perhaps because of simple inaction or inertia, or maybe the MCIT needed a little handholding. In addition to individual training courses, the CSC administers and oversees several institutional capacity development programs, including the:

1. Management Capacity Program (MCP);
2. National Institution Building Project (NIBP); and
3. Capacity for Afghan Public Services Project (CAP).<sup>1575</sup>

In addition to the English language and IT courses, it is likely the MCIT could have benefitted from one or more of the programs above.

### **Information and Communication Technology Institute**

In early 2012, the TAT worked with ISAF Advisors to the MoHE and NATO to investigate the possibility of using the Information and Communication Technology Institute (ICTI) for on-site and distance learning courses during evenings and scheduled breaks – whenever classes were not in session – with the aim of providing ICT courses, seminars, and workshops for public ICT professionals. The ICTI had not ever been utilized in that way, but was open to discussing the opportunity. Ultimately, the GIRoA bureaucracy proved to be too much of an obstacle to bring anything to fruition. Similar such discussions materialized with post-TAT ICT advisors in 2015, but again to no avail.

### **MCIT Provincial IT Training Centers**

As iterated in [Chapter 19](#), the MCIT established several Provincial IT Training Centers in 2007 to promote awareness of and provide education in the IT sector. The training programs teach basic computer knowledge, such as navigating an operating system, using office automation applications such as word processing, spreadsheets, databases, and presentation software, and how to use the Internet. The

---

<sup>1575</sup> Islamic Republic of Afghanistan Independent Administrative Reform and Civil Service Commission. Accessed January 15, 2015. <http://www.afghanexperts.gov.af/?page=AboutUs&lang=en>.

admission fee for the provincial ICT training program is 400 Afs, approximately US\$4.00, 30 percent of which is subsidized by the MCIT for government employees. Government employees are admitted to the program with confirmation letters from their organizations, while private citizens are required to have graduated from high school and must pay the admission fee in full.

The Provincial IT Training Centers graduate approximately 290 government employees and more than 2,200 public students each year. The MCIT reports the training programs positively impact the performance of GIRA officials and public service delivery at the provincial, district, and community levels.<sup>1576</sup> The MCIT reported ATRA approved the budget for procurement of new equipment for the Provincial IT Training Centers in 2014 or 2015.<sup>1577</sup>

The TAT suggested the IT Training Centers implement the International Commission on Workforce Development's (ICWFD's) e-skills360 training program – with its PIN-coded courses available for free to the Afghans with a cost to the sponsor(s) of US\$10 each – but unsuccessfully so.

## The TAT's ICT Capacity Building Through Training and Education Program

In order to further its work stream to foster ICT capacity development, which was a major priority of both the Afghan government and industry, the TAT designed and implemented a multi-faceted ICT Capacity Building Through *[sic]* Training and Education program between March 2012 and May 2013. DISA, on behalf of the TAT, contracted with NDU and Deloitte Consulting, LLP to engage ICT education experts for this effort, one of whom is the co-author of this chapter (Dr. Maria Beebe). Following are background and context for ICT capacity building, in general as well as in Afghanistan, a description of the TAT's activities under the program, as well significant findings and key recommendations.

### Introduction and Background

Often, the focus of a country's training and education systems is aligned to its social and economic goals. Thus, capacity building in ICT, from the use of computers and their applications to the deployment, management, and maintenance of ICT equipment, software, and systems to the specialized business and industry uses of ICT, contributes to economic and social development and, by extension, to national and international security.



*Picture 55: TAT meeting at Kabul University, 2012*

*Pictured are Senior ICT Education Advisor Dr. Maria Beebe (right) and Kabul Education University Chancellor Dr. A. Hamidzai in 2012  
(Photo courtesy of Maria Beebe)*

---

<sup>1576</sup> MCIT (2013). "Information and Communications Sector Development and Progress, 2003-2013." August (unpublished but provided to co-author Karen Black).

<sup>1577</sup> MCIT, 2014. *Activities and achievements report*, 57.

Capacity building includes a range of training and education activities. Training is viewed as learning to work, learning how to perform a task, the “know how,” whereas education is viewed as learning to understand why certain actions are taken, learning how to think through how to perform a task, the “know why.” As used below, “training” refers to short-term technical, industry-related courses and certifications, professional development, and continuing education programs that do not lead to a degree. “Education” refers to courses and modules that lead to an associate’s, bachelor’s, or master’s degree. Sometimes, training programs are integrated into modules and courses that are taken for credit as part of a degree program.

Given the diverse set of technological tools and resources that are used to communicate and inform, ICT capacity building requires the consideration not only of the physical telecommunications systems and networks and the services that utilize them (voice, data, and broadcast services) and the hardware and software of information storage, processing, and presentation but also the associated management, financial, and regulatory practices to ensure the technologies work seamlessly.

The diversity, complexity, fast changing nature, new vocabulary, and many applications of ICT bring many meanings to ICT capacity building, particularly, in terms of specifying capacity building in what ICT competencies by whom and for what purpose. As stated above, the intent of the ICT Capacity Building Through Training and Education project was to make recommendations to improve how Afghan institutions train and educate for the ICT workforce. In this regard, it might be useful to recognize the several tiers of the ICT workforce, along with the basic competency requirements. The different ICT workers include:

- **ICT workers with skills for office productivity:** To be good workers in the twenty-first century, nearly everyone needs a basic understanding of ICT and how to make productive use of it. An important role of ICT training and education is to teach students how to be competent users of ICT technologies and how apply ICT to demonstrate higher-order problem solving and critical thinking skills in order to succeed in both their academic and work careers.
- **ICT workers with competence in ICT infrastructure and support:** In addition to workers with basic ICT skills for office productivity, Afghanistan also needs more knowledgeable and capable technical people to deploy, manage, and maintain ICT equipment and systems for users. Across sectors and industries, ICT professionals are needed to manage computer and communications hardware, software, applications, networks, digital storage and sharing tools, and electronic processing tools for use of the equipment and systems.
- **ICT workers with competence in specialized business and industry uses of ICT:** Afghanistan needs a competent workforce that understands not only the relevant ICT equipment and applications, but also understands the specialized business and industry uses of ICT. Almost all businesses and industries, including small- and medium-sized enterprises (SMEs), including ICT-specific and telecommunications industries, make strategic use of ICT. Industries have developed specialized systems and uses of ICT with specialized legal and regulatory

requirements, quality control systems, integrations with production and research equipment and systems, security requirements, and software applications. For example:

- Banks and other financial services use ICT to maintain customer financial records, conduct business, perform financial reporting, ensure the security of proprietary information, and comply with regulations.
  - Health services make use of ICT applications including consumer informatics, medical and clinical informatics, and bio informatics, as well as remote diagnostics and telemedicine.
  - Property management operations (facilities management and maintenance) use ICT to network and control heating, cooling, and lighting of buildings, as well as to control and secure access to buildings.
  - National energy programs use ICT to monitor and manage electricity distribution and load balancing, smart metering systems, and customer billing.
  - Telecommunications, cable television, and other entertainment industries use ICT to store and deliver services and content and manage and interact with their customers.
- **ICT research and development scientists:** ICT fields require constant evolution and improvement. Afghanistan needs research and development scientists who deeply understand the science and technologies that underlie ICT and who can work to advance the ICT fields and apply and adapt technologies to their country.
  - **ICT trainers and educators:** To prepare all the above ICT workers, Afghanistan needs trainers and educators who can teach the many dimensions of ICT, not only from a purely computer science or telecommunications perspective, but also paying attention to the accompanying soft skills and management and leadership competencies, especially as the ICT workers move to higher levels, including becoming government chief information officers (CIOs).

## Institutional Context for ICT Training and Education

The institutional context in which ICT capacity building takes place in Afghanistan includes:

- Training and education policy and planning;
- Infrastructure;
- Language and other socio-political factors; and
- Financing.

These contextual areas are contested political spaces where ICT capacity building can be facilitated or constrained.

Regarding the first two bullets, the policy and planning entities involved in ICT capacity development were described in [Chapter 19](#), and ICT infrastructure is covered elsewhere in this book. It is pertinent to note here, however, that the North Atlantic Treaty Organization (NATO), under its Science for Peace and Security (SPS) Program, provided satellite-based Internet connectivity to various Afghan universities, a project it called SILK-Afghanistan. Later, NATO worked with the US Embassy and the ATRA to provide

additional funding to install fiber optic connections to universities to form the basis for the Afghanistan Research and Education Network (AfgREN) and to connect to international bandwidth and other research and education networks.

### *Language and Other Socio-political Factors*

Language diversity and other socio-political factors form part of the institutional context in which ICT capacity building takes place in Afghanistan. These contextual factors could either facilitate or hinder training and education in ICT.

**Language:** The Afghans are diverse ethnically and linguistically, speaking Dari and Pashto (the two official languages), as well as Tajiki, Uzbeki, Turkic, and other languages. Although the Pashtuns make up the largest ethnic group, more Afghans speak Dari, a language more closely related to Persian/Farsi than Pashto. For teaching at the tertiary level, the language policy under consideration as of 2009 was to shift to all teaching to English. In practice, most lectures are done primarily in Dari, with most of the textbooks in English. Language is an issue as far as ICT capacity building, since English is the language of technology and many e-resources are in English. Kabul University students, more than anything else, wanted “to connect to globalization and take advantage of information and opportunity and [that] students in the Islamic Law School wanted to learn English and be computer literate.”<sup>1578</sup> When asked about their Internet use, Kabul University students indicated they are more likely to search Iranian sites because of the language issue.

**Geography:** Afghanistan is a land-locked country that shares borders with Tajikistan, Uzbekistan, and Turkmenistan (three countries that gained independence from the USSR<sup>1579</sup> in 1991); Iran; Pakistan; and China. Afghanistan consists of extremely rugged mountains, plains in the north and southwest, and sandy deserts along the southern border. This diverse geography explains at least some of the difficulty faced by government and development workers in building infrastructure, including ICT infrastructure, and in building capacity. However, it has also been pointed out by both Afghans and external observers that the geographic challenge is one ICT can bridge.

**Power Struggles:** Afghanistan has a long history of internal strife and external invasions and pressures, resulting in alternating fusion and fission.<sup>1580</sup> The external invasions have contributed to Afghanistan’s heritage including Buddhism followed by Islam. In 1979, a rebellion by the mujahedeen, Islamic fighters, against the Marxist government led to an invasion by the Soviet Union. The mujahedeen, with covert aid from the US, fought the Soviets and in 1989, the USSR pulled out. Power sharing among the mujahedeen disintegrated in 1994, and they turned their guns on each other. Different warlords, with support from various external interests, governed different parts of Afghanistan. Disillusioned mujahedeen fighters, mostly Pashtuns, then formed the Taliban movement. In 1996, the Taliban seized control of Kabul. After

---

<sup>1578</sup> Ghani, Ashraf and Claire Lockhart (2008). *Fixing Failed States: A Framework for Rebuilding a Fractured World*. (Oxford: Oxford University Press).

<sup>1579</sup> Union of Soviet Socialist Republics

<sup>1580</sup> Dupree, Louis K. 1973. *Afghanistan*. (Princeton: Princeton University Press).

the terrorist attacks of September 11<sup>th</sup> (2001), the US invaded Afghanistan as part of its war on terror. Hamid Karzai became transitional president and served as President from 2001 to 2014, when he was succeeded by Ashraf Ghani in a highly-contested election that resulted in a power-sharing “Unity Government,” with candidate Abdullah serving as the country’s Chief Executive Officer. These internal power struggles continue to bedevil the Afghan government. A challenge is how to use ICT to diminish power struggles, for example, by broadening perspectives and by fostering the ability to appreciate differences as normal, legitimate, non-threatening, negotiable, and even complimentary. One potential area is to build capacity of Afghans to develop e-content as well as mobile applications that will minimize power struggles.

**Islam:** The Constitution adopted in 2004 defines Afghanistan as an Islamic Republic. Thus, legislation is based on Islamic laws and values, which clearly support women’s education, but individual ideologies in the government have complicated the decision-making process for higher education, particularly with regards to the education of women. Several articles of the Constitution make explicit the link between Islam and education, including articles that indicate education is to be based on Islam. The stricter interpretations of Islam sometimes mean less freedom of movement for women, making ICT an ideal vehicle for women and girls to access knowledge and information.

**Human Development Indicators:** Afghanistan continues to rank at or near the bottom of the United Nation’s Human Development Index (HDI) year after year. The HDI is a “summary measure of average achievement in key dimensions of human development: a long and healthy life, being knowledgeable, and having a decent standard of living.”<sup>1581</sup> Such low scores indicate low levels of capacity to fully utilize ICT for personal growth or as levers for economic growth. However, as mobile phone use continues to proliferate across the country (nearly ninety percent (90%) of Afghans live in areas with cellular service as of December 2015<sup>1582</sup>), one can imagine the possibilities to use ICT to improve the human development indicators.

### *Financing*

Donor funds from the World Bank, USAID, NATO, etc. are potentially useful for kick-starting ICT capacity building through training and education. Most countries fund their ICT capacity building, including ICT related equipment, through a mix of sources and mechanisms, both internal and external. Moreover, there is a need for sustainment plans for maintenance, lifecycle replacements, spare parts, upgrades, and retiring physical ICT systems while balancing emerging requirements and budget constraints.

### **Objective and Deliverables**

The objective of the TAT’s multi-faceted ICT Capacity Building Through Training and Education program was to engage stakeholders in the process of making recommendations for improvements to Afghan ICT

---

<sup>1581</sup> United Nations Development Programme, Human Development Reports, Human Development Index (HDI). Accessed January 30, 2016. <http://hdr.undp.org/en/content/human-development-index-hdi>.

<sup>1582</sup> ATRA. Telecom Statistics (End of September 2015).



training and education systems with a focus on identifying and meeting skills needed by government and industry. The results were to include findings, actionable recommendations, and a notional implementation timeline for Afghanistan’s education system at the vocational (two-year),<sup>1583</sup> bachelor’s (four-year), and master’s (six-year) levels, with the goal of their supplying a skilled ICT workforce prepared for employment in either the public and private sectors, based upon identified needs and projected demand. Recommendations were to include specific changes to curricula, as well as broader certification, programmatic, and resourcing issues. The results were to be socialized with the Ministries of Communication and Information Technology (MCIT), Education (MoE), and Higher Education (MoHE) for their review, input, and approval.

## Description of Activities

Under its ICT Capacity Building Through Training and Education project, the TAT and its ICT education experts undertook a number of activities, including but not limited to:

- A current-state assessment of ICT education and training;
- An assessment of general education, including business, management, and “soft skills” such as literacy, critical thinking, problem solving, numeric skills, and effective communications;
- An assessment of faculty qualifications and career development;
- Review and assessment of educational policies, planning, and financing;
- Review and assessment of ICT infrastructure for education;
- Review and assessment of ICT curricula and training materials, including evaluation tools;
- Identifying responsible entities and current processes for curricula reform;
- Recommending changes to ICT curricula;
- Researching ICT training and certification programs, opportunities, and available funding;
- Assessing the role and efficacy of Cisco Networking Academies; and
- Interviews of key stakeholders, including GIRoA entities, private companies, donors, academics, associations, and individuals.

Individual course reviews were explored through five lines of questioning:

1. What ICT courses are taught? Is course content current, relevant, and taught at the level allowing students to achieve expected proficiencies with program outcomes?
2. How are ICT courses taught? What teaching methods are used? What is the balance between acquiring and applying knowledge? What learning resources and opportunities are available? What is the level of integration into the curriculum? Is the syllabus comprehensive? Is student workload appropriate?
3. When is it taught? Are course prerequisites appropriate? Is the course offered in the best semester or professional year?

---

<sup>1583</sup> At present, Afghanistan does not have a community college program but does have a few two-year “associate” programs, largely through technical and vocational education institutes.

4. What measures are used to determine if students achieved desired learning outcomes? How are students assessed? Are these assessments aligned with course objectives, program outcomes, and government and industry ICT work force needs?
5. What gaps and overlaps exist at the vocational, undergraduate, and graduate levels in ICT education and what additional curriculum should be introduced to address those gaps?

## Significant Findings

### *ICT Workplace: Demand for ICT Competency*

The responses from a limited number of industry stakeholders seem to indicate that there is a sufficient number of ICT graduates (those who finish Bachelor's in Computer Science degrees) to meet present workplace requirements, but these same industry stakeholders are not satisfied with the quality of graduates. Although entry-level skills are taught by training providers in Afghanistan, employers have expressed dissatisfaction about the quality of their new hires. Almost all new hires are sent to Dubai, India, or Turkey for training with the cost of training absorbed by company or the Afghan Government. Employers interviewed as part of a technical and vocational education survey,<sup>1584</sup> including three mobile network operators (MNOs), reported graduates from Afghan institutes of higher education require three to six months of training upon hire, which is costly for employers. Representatives from many ICT companies made similar such statements to members of the TAT quite often, lamenting the additional training required for their Afghan personnel.

Interviews with Afghan stakeholders revealed that:

1. Industry cares about quantity and quality of ICT workers.
2. Interviewees in both the public and private sectors expressed satisfaction with the quantity of ICT workers, but not the quality. Quality issues include lack of hands-on experience, inability to understand basic ICT terms, and inability to do basic mathematics.
3. Interviewee comments regarding the lack of quality of their new ICT hires is consistent with the World Bank indicators that suggest that the quality of education in Afghanistan is poor. The World Bank indicated that critical areas for improvement include literacy and numeric skills, as well as skills in problem solving, team building, critical thinking, and effective communications.<sup>1585</sup> These concerns about quality do not revolve around what are considered

---

<sup>1584</sup> Development Alternatives, Inc. (DAI) (2011). *Afghanistan Technical and Vocational Education Training (TVET) Providers Inventory*, November 2011. Prepared for the USAID under the Afghanistan Small and Medium Enterprise Development (ASMED) Project, contract number 306-C-00-07-00503-00. Accessed January 14, 2015. [http://pdf.usaid.gov/pdf\\_docs/pnaea952.pdf](http://pdf.usaid.gov/pdf_docs/pnaea952.pdf).

<sup>1585</sup> World Bank (2011). *L'éducation en Afghanistan - Réussir malgré la difficulté du contexte*. Results Profile. Washington, DC: World Bank Group. Originally accessed July 30, 2012. <http://documents.worldbank.org/curated/en/2015/11/25462109/education-afghanistan-achieving-results-difficult-environment-l'éducation-en-afghanistan-réussir-malgré-la-difficulté-du-contexte>.

strictly technical competencies – these are general workplace competencies, such as problem solving and decision-making; or academic foundational competencies, such as math and science; or personal effectiveness competencies, such as dependability and reliability that accompany technical competence. (See Tiers 1-3 of the competency pyramid below.)

4. ICT technical training is related to mostly industry-related certifications: Cisco certifications, data center certifications, security certifications; Microsoft Server Administration certification; and Oracle and MySQL certifications for database management.
5. Interviewees indicated that, for the longer term, government agencies will need better- educated staff with degrees from universities. Along with short-term industry certification, there is a need to develop long-term academic programs that will graduate competent engineers, database managers, security experts, programmers, managers, contract negotiators, and more. (See Tier 4 of the competency pyramid.)
6. Industry itself is not always able to articulate necessary job competencies. For example, one interviewee stated, “I need IT persons who are able to do communications.” Upon further questioning, the interviewee suggested the need for telecommunications line installers who have the competency to “install, setup, rearrange, or remove switching, distribution, routing, and dialing equipment used in central offices.” Or “ICT workers able to service or repair telephone, cable television, Internet, and other communications equipment on customers' property,” or “install communications equipment of communications wiring in buildings.”

## LACK OF QUALITY IN HIGHER EDUCATION

A typical 33-year-old in 2012 was born in 1979 when the Russians invaded Afghanistan. *He* would have gone through secondary and tertiary schooling during the Mujahedeen and Taliban periods. *She* would not have been allowed to go to school during the Taliban period. The hypothetical 33-year old could be an instructor at a university in 2012. A typical 40-year old Afghan would have a similar experience as the 33-year old with a faulty educational system. The knowledge of a 50-year old instructor would have been frozen in time because of lack of interaction with the outside world.

The pyramid in [Figure 107](#) is useful in looking at the Afghan demands for competencies of the ICT workforce.<sup>1586</sup> It has been updated slightly since 2012 when the TAT originally employed it in its ICT capacity development work. For example, “Databases and Applications” was formerly “Information Management;” “Visualization” was added to “Digital Media;” “Risk Management, Security, and

---

<sup>1586</sup> United States Department of Labor, Employment and Training Administration Competency Model Clearinghouse. Accessed January 30, 2016. <http://www.careeronestop.org/competencymodel/competency-models/information-technology.aspx>.

Information Assurance” replaced “Security and Data Integrity;” and “Basic Computer Skills” was broadened to become “Fundamental IT User Skills.”

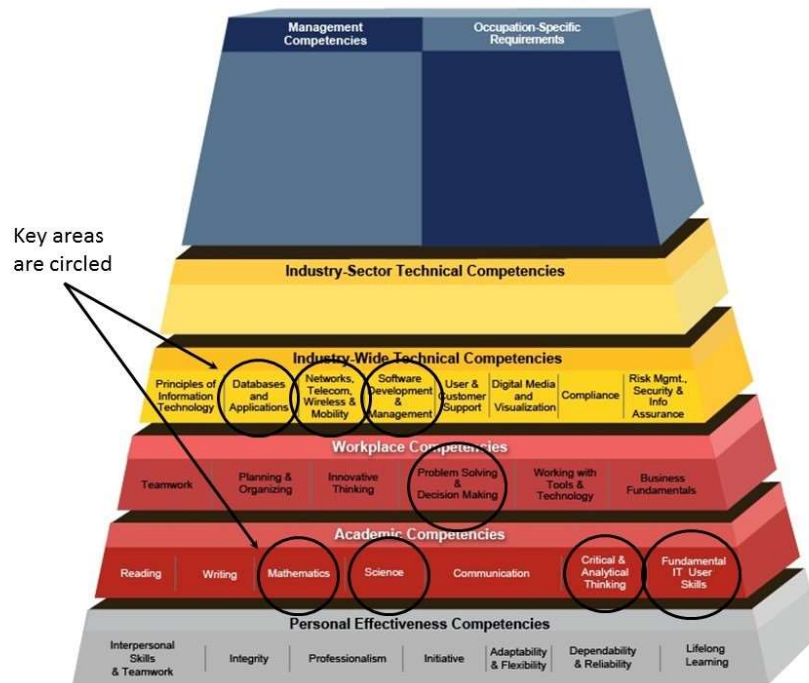

Figure 107: US Department of Labor Information Technology Competency Model

The model shows foundational competencies at three levels. The first three tiers (from the bottom up) consist of competencies that are required regardless of the industry: Personal Effectiveness Competencies, [Basic] Academic Competencies, and Workplace Competencies. The next two tiers are industry-related competencies. The top level in addition to the ICT occupation-specific requirements (not listed on the model), also highlights management competencies, including staffing, informing, delegating, monitoring work, supporting others, strategic planning, preparation and evaluation of budgets, team building, visioning, monitoring and controlling resources. These management competencies show up as requirements for potential CIOs.

### *ICT Providers: Supply of Training and Education*

While Afghanistan has made tremendous effort in reviving and revitalizing its higher education system, there continue to be constraints on educational quality. The litany of complaints from university administrators, lecturers, and students includes outdated course catalogs and syllabi, course content, and textbooks. Moreover, most lecturers are locked in the traditional mode of lecturing which means that students are passive listeners. There are very few opportunities for student development through industry internships and service learning programs. The lack of quality across higher education is rooted in history (see sidebar).

Improving the quality of instruction, research, and services provided by institutions of higher education is one of the MoHE’s strategic goals, as articulated in its NPP, *Expanding Opportunities for Higher Education*. As part of its quality assurance efforts, the MoHE released its *By-Laws for Quality Assurance and Accreditation* in 2011 and a *Curriculum Revision and Development Final Report* in 2012. In the latter, there is recognition that “rapid technological development creates new facilities and paves the way for new knowledge. At the same time, accessibility to these technologies is very important.”

[Table 13](#) summarizes Afghan institutions and their offerings with regards to ICT education and training as of late 2012, including whether they have Cisco Networking Academies. There is also a CNA at the Ministry of Women’s Affairs (MoWA).

Kabul University began offering a master’s degree in Computer Science in 2014, with the first class graduating in 2016. Faculty from Estonia’s Tallinn University are teaching the graduate courses. Additionally, seven Afghans are currently doing their PhDs at Tallinn University and will then return to Afghanistan to teach the master’s-level courses. There are five more PhD candidates studying computer science: two at the Technical University of Berlin, two with scholarships provided by the US, and one provided by Italy.

Table 13: ICT offerings at Afghan higher education institutions

ICT Offerings at Afghan Higher Education Institutions			
Institution	Undergraduate	Graduate	Presence of CNA
American University of Afghanistan	BSc Computer Science BSc Information Technology	Master’s in Business Administration (MBA)	Cisco Networking Academy
Baghlan University	Department of Computer Science	--	--
Balkh University	BSc Computer Science	--	Cisco Networking Academy
Bamyan University	--	--	Cisco Networking Academy
Ghazni University	Department of Computer Science	--	--
Herat University	BSc Computer Science	--	Cisco Networking Academy
Information and Communication Technology Institute	BSc Computer Science	--	Cisco Networking Academy

Kabul Education University	Faculty of Natural Science with Department of Computer Science	Master's in Education Master's in TESOL <sup>1587</sup>	Cisco Networking Academy
Kabul Polytechnic University	BSc Computer Science	--	--
Kabul University	Faculty of Computer Science with three departments: Information Technology Information Systems Software Engineering	MA in Public Administration	Cisco Regional Academy
Kardan University <sup>1588</sup>	Department of Computer Science BSc Computer Science Diploma in Information Technology (DIT)		
Kunduz University	Department of Computer Science		
Nangarhar University	Faculty of Engineering Department of Computer Science		Cisco Networking Academy
Parwan University	Department of Computer Science		
Sheikh Zayed University (Khost)	Faculty of Education with Department of Computer Science Bsc Computer Science		Cisco Networking Academy

### *ICT Capacity Building Needs*

The ICT Capacity Building Through Training and Education project placed Afghan ICT capacity building needs into two categories: short-term training needs and longer-term educational needs that lead to an

---

<sup>1587</sup> Teachers of English to Speakers of Other Languages

<sup>1588</sup> Formerly the Kardan Institute of Higher Learning

associate's, bachelor's, or master's degree. In the aggregate, however, the following needs were identified:

1. Improved technical competencies, from entry level through professional and expert levels;
2. More diversified industry certifications;
3. More diversified technical knowledge and skills, particularly in the areas of information assurance (IA), computer and network security, and telecommunications engineering;
4. A better balance of technical competencies and cognitive, analytical skills, sometimes referred to as "soft skills," including problem solving, management, and customer care; and,
5. Better preparation for jobs of the future, including those meeting specialized business and industry uses of ICT, government CIOs, and the use of ICT in other sectors, such as e-health and e-education services.

These needs cannot be addressed strictly through short-term "fixes." A long-term solution requires building the academic programs of universities in Afghanistan. These programs are weighed down by curricula that have not been responsive to industry requirements, instructors that require pedagogical training and refresher courses, out-of-date infrastructure, standards that are based on multiple-choice tests and not on competency measures, and student learning with limited hands-on, practical experience. Alongside curricula development, there is the need for systemic reform, for sustainment planning, and for national, regional, and global partnerships that show long-term commitment, shared responsibility, reciprocal obligation, equality, mutuality, and balance of power.

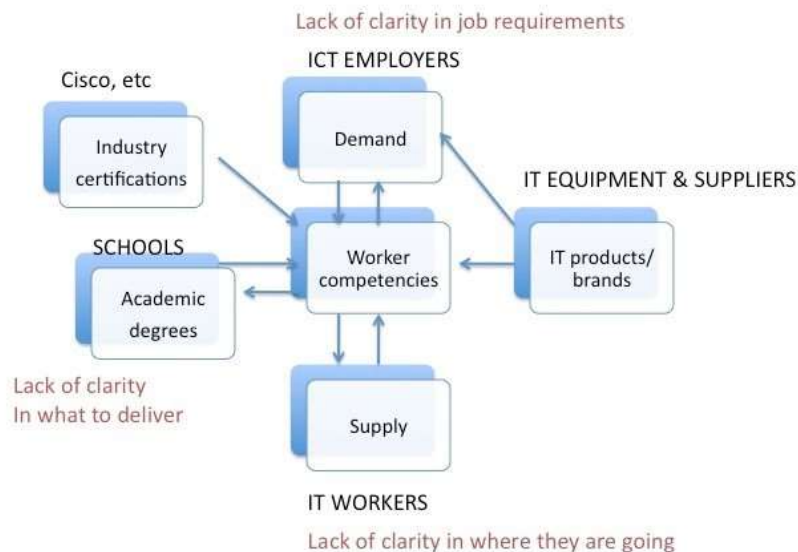

Figure 108: Engman: Lack of clarity about ICT qualifications

## Lack of Clarity among Stakeholders Regarding ICT Qualifications

The lack of clarity about job requirements and the lack of clarity in what content to deliver are not surprising considering the complexity of the ICT competencies. The ICT/IT workers also face a problem when they state their qualifications without knowing which competencies belong to which job category (see [Figure 108](#)<sup>1589</sup>) and without considering the different levels of expertise.

The chart in [Figure 109](#) is based on the CompTIA IT Certification Roadmap<sup>1590</sup> illustrates the complexity of the ICT workforce. ICT careers (top row) include ICT Skills for Office Productivity, Database and Network Administration, Security, and the like. Each career path (first column on the left) starts at a beginner level and advances through to expert level. The road is not always straight, and some skill areas converge. In Afghanistan, the delineation of qualifications and the choice of a career path are made more difficult and more uncertain because of a fairly nascent ICT industry.

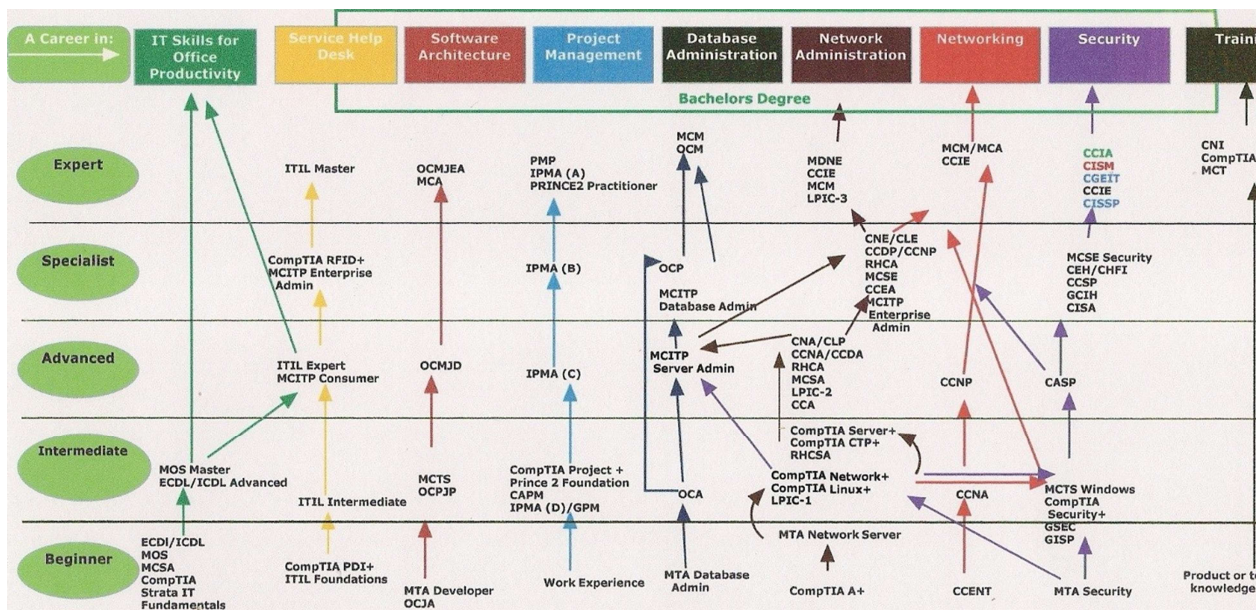

Figure 109: Sample chart of ICT careers and required qualifications

## Key Recommendations and Progress against Them

Given the scope of ICT competencies, knowledge, and skills needed in Afghanistan, the recommendations below emphasize a broad and deep action plan geared to build ICT capacity through training and education. The recommendations are categorized into five interrelated lines of effort (LOE):

- LOE 1: Sustainment strategies, including public-private partnerships (PPPs);

<sup>1589</sup> Engman, John (2003). CompTIA, "Skills Standards, Certification and Assessment for Technicians in the Information & Communications Technology (ICT) Industries."

<sup>1590</sup> CompTia IT Certification Roadmap. Accessed March 6, 2016. <https://certification.comptia.org/docs/default-source/downloadablefiles/it-certification-roadmap.pdf?sfvrsn=2>.



- LOE 2: Expansion of short-term ICT training in technical, professional, and continuing education;
- LOE 3: The revision of ICT-related curricula;
- LOE 4: Systemic changes to the broader educational system; and
- LOE 5: Partnerships and engagement with regional and global academic and industry stakeholders.

Altogether, there were twenty specific recommendations for the five LOEs.

### *LOE 1: Sustainment*

The TAT recommended adapting several mechanisms for the sustainment of ICT capacity development as follows:

- Include ICT services in the government budget.
- Request for a portion of the revenues generated by the telecommunications sector as a set aside not only for physical infrastructure but also for human resources development.
- Establish either a university foundation for each university or one university foundation that will serve all the Afghan public universities.
- Set up public-private partnerships as a sustainment strategy to operate and maintain ICT Smart Hubs. And,
- Train the trainers from public institutions to build the ICT bench.

### Progress

The lack of a sustainment strategy has been a continuing challenge for ICT projects and training facilities that provide infrastructure, networks, and computers with no thought for ongoing operating expenses. It is also difficult for Afghanistan’s institutions of higher learning – and primary and secondary schools – to keep pace with the rapid rate of change of technology. To address these challenges, the TAT spearheaded an effort to draft a framework for PPPs, providing a unique opportunity for public universities to partner with the private sector. The draft PPP agreement was socialized with the MoHE, the MCIT, the Director of the ICTI, several private universities, and the National ICT Alliance of Afghanistan (NICTAA), the “master” ICT association.

While PPPs are not prevalent in Afghanistan, there are several successful ones already, such as the collaboration between the Ministry of Public Health (MoPH) and private hospitals in the national immunization and tuberculosis control programs; the Friends for Justice Reform in Afghanistan Scholarship Program, and the non-governmental organization (NGO) Education Support Organization (ESO) managing the seven English Language and Computer Learning Centers (ELCLCs, described in [Chapter 19](#)) at seven public universities.

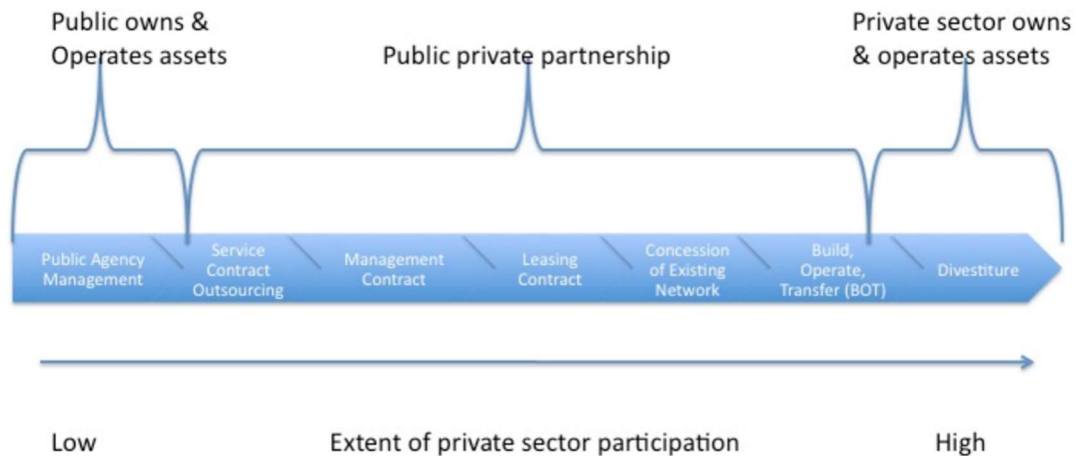

Figure 110: Spectrum of public-private partnerships

The TAT drafted and provided key stakeholders with a discussion document to show the range and different types of partnerships between the public and private sectors and an illustrative PPP agreement.

Kardan University and an association of private sector universities requested assistance in convening a high-level stakeholder discussion to develop a strategic framework for PPPs in higher education using lessons learned from existing Afghan PPPs and cases from other countries.

### *LOE 2: Expansion of Short-term ICT Training*

The TAT recommended restructuring the existing Cisco Networking Academies into ICT Smart Hubs to provide a range of short-term training that contributes to long-term educational services and provides better preparation for jobs in the future, including specialized business and industry uses of ICT, preparing government CIOs, and developing Afghan-specific applications for e-government services, e-health and e-education services. The specific recommendations for short-term ICT training in technical, professional, and continuing education were to:

1. Restructure select Cisco Networking Academies into ICT Smart Hubs.
2. Expand short-term training offerings to include cybersecurity.
3. Launch professional development training programs up to the CIO level.

### Progress

As part of its general ICT capacity development work and under its Capacity Building Through Training and Education program, the TAT responded to MoHE requests for assistance with regard to upgrading Afghanistan's existing Cisco Networking Academies. To respond to this challenge and to ensure sustainability, the TAT developed and delivered a concept paper for ICT Smart Hubs to be operated as PPPs. The plan was for the ICT Smart Hubs to be the premier venues for excellence in building Afghan ICT capabilities and from where other ICT capacity building activities will radiate. The TAT's ICT Smart Hub

concept is consistent with the MCIT's three-pronged approach to ICT capacity development<sup>1591</sup> and rolls everything into one holistic plan:

- CHART skills (Communication, Heuristic, Analytical, Relational and Technology): focused on foundational skills needed in the ICT sector;
- SMART Skills (Software, Mobile, Application, Research and Technology): focused on the IT industry; and
- START Skills (Start-up, Training through Association with Remote Teams): focused on entrepreneurship and cutting edge technologies.<sup>1592</sup>

The TAT socialized the ICT Smart Hubs concept with key stakeholders from the MCIT, MoHE, Kabul University, ICTI, Kardan University, several other private sector providers of higher education, and NICTAA. To illustrate the feasibility of the concept, the TAT drafted several documents, such as a business plan, including programs and services, sample financial projections (profit and loss statement, cash flow, balance sheet, breakeven analysis, and financial templates and spreadsheets), facility configurations, and content for curriculum.

The TAT also attempted to source funding and/or PPPs for ICT Smart Hubs with NATO, the World Bank, and USAID, but was unsuccessful in doing so. As such, the TAT provided the following recommended next steps:

1. Identify funding for ICT Smart Hubs to include (a) updated computer equipment, virtual labs and e-textbooks, (b) training of trainers on how to teach the new curriculum using specialized computer equipment, virtual laboratories, and e-textbooks, and (c) design and implementation of a digital library linked to an e-learning management system.
2. Once funding for the equipment is identified and secured: (a) Finalize the Smart Hub equipment configuration, (b) Finalize the draft PPP agreement to indicate areas of responsibility between the public and private higher education institutions, including responsibility for inviting external global and regional partners; (c) Issue a request for expressions of interest to operate ICT Smart Hubs as PPPs. The expression of interest will be in the form of a business plan with financial projections; and (d) Plan training of trainers that may primarily be provided online, via video conferencing or Skype.
3. Once funding for the training of trainers is identified and secured: (a) Request partners to finalize a short-term and long-term training plan for the potential trainers. (b) Implement training of trainers on new content areas in advanced networking, cybersecurity, telecommunications, and CIO competencies that will combine in person instruction as well as online learning.

---

<sup>1591</sup> MCIT, 2011. *E-Afghanistan NPP*, 44 and 62.

<sup>1592</sup> Ibid.

### *LOE 3: Curriculum Revision and Development*

The TAT recommendations for computer science and other ICT related curriculum revision were aligned with the MoHE curriculum revision and curriculum development guidelines issued in 2012. The guidelines identify six steps:

1. Needs assessment at the country level (identifying the country workforce requirements);
2. Learning needs assessment that balance international standards with the needs of the country and that identify conditions that need to be in place (for example, faculty members, laboratories, technicians, teaching materials);
3. Objectives and goals of the curriculum;
4. Educational strategy, methodologies or pedagogies (lecture, discovery, study tour, site visit, lab, problem solving);
5. Implementation (access to resources, political and financial support, administration); and
6. Assessment of the planned objective and goals.

The specific recommendations with regards to curricula revision and development were to:

1. Augment existing resources in order to implement the existing MoHE Computer Science curriculum that is focused on Information Technology, Information Systems, and Software Engineering.
2. Support the Information and Communication Technology Institute's (ICTI) plans for curriculum revision, including greater differentiation between bachelor's degrees in computer science and telecommunications.
3. Improve the learning experience for ICT learners at the bottom of the pyramid.
4. Socialize and locate funds for the proposed new areas of study to fill the gaps in the current plans of the MoHE, including the ICTI, and to address industry priority requirements and jobs for the future. The recommended new areas of study include Information Assurance, Advanced Networking, Telecommunications, and Chief Information Officer (CIO).

### **Progress**

Kabul University revised the curriculum for its BSc in Computer Science, which has three majors – Information Technology, Information Systems, and Software Development – and provided it to the TAT. The TAT suggested considering additional majors or minors or professional degree courses in information assurance (cybersecurity) and CIO development. The TAT helped the MoHE to revive old relationships with the University of Colorado, the University of Maryland, Colgate University, and Delhi University. Faculty members who were part of the external stakeholders who helped with the curriculum development in Kabul in 2005 willingly donated their time and expertise. Reviewers stated the curriculum met international standards, but expressed concern over lecturers' abilities as well as the lack of access to current textbooks. These concerns are further addressed in the Systemic Reform LOE below.

The TAT also received ICTI's revised curriculum for its BSc in Computer Science, which separates the computer science from the telecommunications track, and also sent it for peer review. The comments

were similar to those given to Kabul University. Kabul University and the ICTI have both begun to integrate the Association for Computing Machinery (ACM) guidelines into their revised curricula.

The TAT facilitated initial discussions between Kabul University, ICTI and the University of Colorado, Center for Engineering and Advanced Technology Education (CAETE) that offers a dual master's degree in computer science and telecommunications. The dual-degree could serve as a model for the ICT for more clearly-defined computer science and telecommunications tracks.

As for graduate-level education, Kabul University drafted a curriculum for a master's degree in computer science with a focus on information technology. The curriculum was an outcome of a visit by the Vice Chancellor at Kabul University and the IT Manager at the MoHE to the University of Tallinn in Estonia. At Kabul University's request, the TAT provided sample syllabi and examples of relevant master's degree programs from various universities to assist it in its planning. Kabul University now offers a Masters in Computer Science.

As part of ICT curriculum reform, the TAT recommended the Afghans add cybersecurity/information assurance and CIO capacity development to at least some ICT-related courses. The TAT provided various industry models and standards for both, such as model programs from Cyberwatch<sup>1593</sup> and the 12 Clinger-Cohen CIO competencies. (See [Facilitate a CIO Culture](#) section above).

The next steps the TAT recommended were as follows:

1. For the existing BSc curriculum with majors in Information Systems, Information Technology, and Software Development: Continue to assess and review e-textbooks and courses with a complete set of program descriptions, syllabi for each course, learning objectives and outcomes, readings, and student activities; have these e-resources available as links on a website that is Afghan-led and Afghan-owned.
2. For the cybersecurity/information assurance and CIO curricula: Continue to assist the Afghans to develop a set of competencies and sub-competencies, aligned to a program with a set of training programs or courses, syllabi for each training program or course, learning objectives and outcomes, readings, and student activities that are reviewed by Afghan stakeholders for relevance in the Afghan context.

#### *LOE 4: Systemic Reform*

To succeed in the implementation of the suggested new curricula, the TAT recommended systemic reforms such as standards development; faculty, staff, and student development; and infrastructure development. All these recommendations can be implemented simultaneously or phased in.

---

<sup>1593</sup> Cyberwatch is a consortium of 45 universities and 50 community colleges in the US plus 40+ partners from business, government agencies, and professional associations. The TAT encouraged the Afghans to engage with Cyberwatch online if nothing else and, perhaps, for student and faculty exchange programs.

1. Develop standards to demonstrate individual competence and to ensure quality of ICT services provided by ICT workers at their workplaces.
2. Support faculty development through a mix of master’s and doctoral degree scholarships and refresher courses through study abroad, online coursework, and visiting lecturers.
3. Support infrastructure development to upgrade computer labs and modernize equipment and to increase access to international bandwidth.
4. Support student development through internships, virtual internships, and service learning.

The MoHE 2012 “Curriculum Revision and Development Guidelines” underscore the importance of curriculum development and revision to quality higher education. Moreover, the MoHE is cognizant that the success of implementing a revised or new curriculum is dependent on faculty development, staff and student development, along with infrastructure development and standards development. [Figure 111](#) shows that the focus of higher education is the student. The formal environment requires not only revised and new curriculum but also trained faculty, up-to-date computer laboratories, and standards. In addition, various informal activities that are beneficial to student development include internships with industry, mentorships (including online relationships), service learning programs where students teach their local communities, and participation in local, regional, and international competitions.

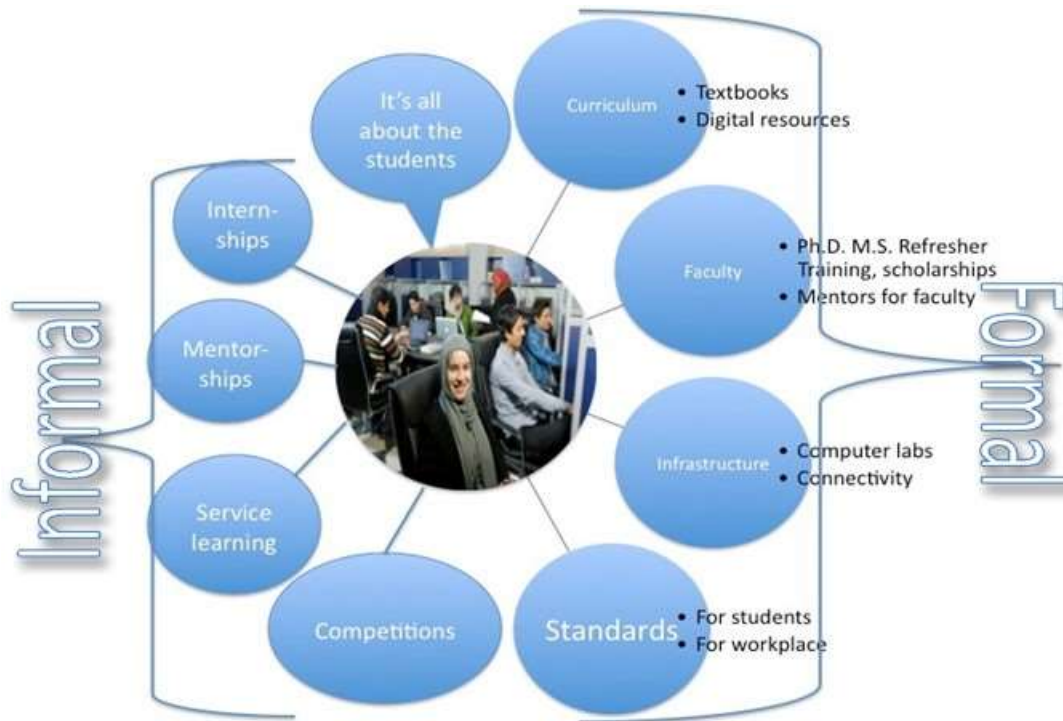

Figure 111: Systemic reform framework

## Details and Progress

### Standards Development

The TAT suggested the need for Afghanistan to develop standards to demonstrate individual competence in ICT practice. The goal is for graduate students to be knowledgeable users and critics as well as designers,

builders, and innovators of computer applications that can affect every aspect of life. Considering the Afghan context where English is a second language and where computer science is presently introduced in tertiary schooling, and is at its infancy in primary and secondary schooling, the K-12 Computer Science Standards might be relevant for individual core competencies.<sup>1594</sup> The Computer Science standards were set forth by the Computer Science Teachers Association (CSTA) and the Association for Computing Machinery (ACM) in order to strengthen computer science competency beginning in primary school.

The Computer Science Standards map five Computer Science strands to three levels as depicted in [Figure 112](#). For each intersection of strand and level, learning standards are articulated. For example, computation thinking is further divided into problem solving, algorithms, data representation, modeling and simulation, abstraction, and connections to other fields. The standards could serve as a roadmap for Afghan computer science education from the primary through the tertiary level. For those already in tertiary education, the timeframe for getting from Level 1 to Level 3 will be very much compressed.

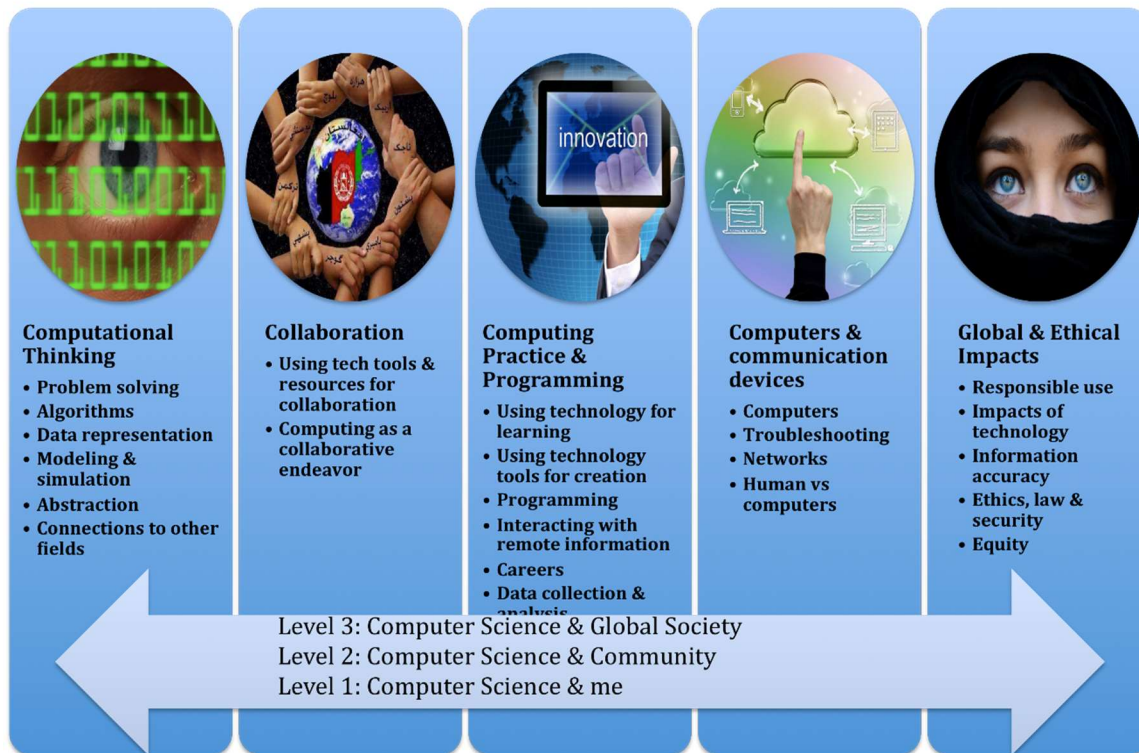

Figure 112: CSTA K-12 Computer Science Standards

<sup>1594</sup> Computer Science Teachers Association (CSTA). CSTA K-12 Computer Science Standards. Accessed January 30, 2016. <https://csta.acm.org/Curriculum/sub/K12Standards.html>.

## *Faculty Development*

A concern raised about the implementation of new and additional curricula is faculty preparedness. While it is true that there were no Computer Science faculty members with master's degrees when the initial curriculum was designed, the situation has changed. At least eight faculty members from Kabul University completed their Master's of Science in Computer Science from the University of Western Cape in South Africa with funding provided by USAID through the Afghan eQuality Alliances project. In addition, the German Academic Exchange Service (DAAD) funded nearly 50 lecturers to do their master's at the Technical University of Berlin (TU Berlin). Two classes (2010 and 2013) are now back at their home universities. However, given the speed of ICT innovation, these faculty members still require refresher courses to update their knowledge, particularly on the intersection among technology, pedagogy, and relevant content. And, with the Afghans having started an ICT-related master's program, there is a need for faculty members with doctoral degrees. The MoHE has voiced the need for a two-pronged approach for faculty development support: Invite visiting lecturers with PhDs from partner universities to teach master's-level courses for three to four years while Afghan faculty members complete their doctoral studies. TU Berlin, with funding from DAAD, has invited four Afghan who completed their master's degrees in computer science there to return as candidates for their PhDs.

To address this need, a faculty-to-faculty exchange program, involving Afghan lecturers visiting potential US partners and vice-versa was envisioned. The exchange would help inform the vision of Afghanistan's higher education through cooperation in ICT curriculum development, as well as exposure to modern teaching methodologies and the use of online courses, virtual laboratories, digital libraries, and other e-learning and m-learning resources. Meanwhile, several opportunities arose that could fill the need. These included the following:

For short-term capacity-building, the US State Department announced a Junior Faculty Development Program for citizens of Afghanistan to participate in a two-month professional development program in the United States. The program is open to ICT faculty members with only a bachelor's degree and/or limited experience as a lecturer at an Afghan public or private university. The TAT shared the announcement on social media and emailed to several Afghan stakeholders. It might be possible to discuss with the State Department the possibility of an ICT development program for a team of faculty members to visit with US universities, including those who have peer reviewed the Computer Science curriculum.

The US Embassy Kabul announced a Fulbright Doctoral (PhD) Fellowship Program for citizens of Afghanistan to pursue a fully-funded doctoral degree in the United States. The first announcement was for 2014-2015, which was followed by another opportunity for 2015-2016.

The Estonian government provided funding for Afghan faculty members to visit the University of Tallinn to meet with their counterparts and develop a master's degree program in computer science. The funding included support for Estonian faculty to help teach master's level courses at Kabul University.

## *Student Development*

A student-centered education includes various formal and informal learning experiences. Organizations, like the National ICT Association of Afghanistan (NICTAA) -- a multi-stakeholder body that is dedicated to



the support of ICT development efforts in Afghanistan through synergies among private companies, civil society, and academia – could play a facilitative role. NICTAA indicated it could assume a leadership role in the following Afghan student development activities:

- **ICT Internships:** NICTAA internships would provide practical experience for beginners in ICT jobs or professions. An ICT internship is on-the-job training in an ICT related field that the student or young worker wants to learn more about. While employment is not guaranteed at the end of an internship, many employers use internships as a way to train and evaluate future employees. NICTAA could lean on its private sector members to accept interns who pass a nomination and selection process. The plan was to do a three-month pre-internship intensive training program and then a three-month internship within an ICT industry-related field.
- **ICT Service Learning:** Service learning, as practiced in the US, is a teaching and learning strategy that integrates community service with instruction, encourages reflection, teaches civic engagement, and strengthens communities. The intent of a service-learning activity is to change both the student and the beneficiary of the service; on the part of the student – self-reflection and self-discovery, and on the part of the individual or community beneficiary – the acquisition and comprehension of values, skills, and knowledge content. NICTAA planned to leverage its civil society members to identify community service programs that students can undertake. This might take the form of training community members, including police and army personnel, on IT office skills for productivity or teaching literacy through m- learning.
- **ICT Competitions:** Competitions allow students to show their specific skills to specific people. Competing is one of the best ways to learn. By competing, students can learn to differentiate themselves from others. Competitions are fun, free, and fast becoming a key way employers recruit fresh talent in the Western world. In partnership with academia, NICTAA planned to seek mentors and local sponsors to donate prizes. An initial effort that was discussed but was shelved was participation in the Digital Forensics Challenge provided by the US DoD Cyber Crime Center (DC3).

To raise funds to support these student development activities, NICTAA leaders planned to foster the establishment of a Friends of NICTAA to serve as a development and communications center for United States and other international donors. The organization will be a non-profit corporation and be recognized by the IRS as a tax-exempt public charity under Sections 501(c)(3) and 170(b)(1)(A)(vi) of the Internal Revenue Code, if registered in the US.

However, NICTAA’s level of activity has declined substantially in the past couple years (see [Chapter 6, ICT Organizations and Associations](#)), and very few, if any, of these recommendations have moved forward.

### *Infrastructure Development*

As indicated earlier, the NATO-funded SILK-Afghanistan project largely shifted away from satellite-based connectivity to fiber optic communications for high-speed Internet access to Afghan universities and some governmental institutions. As more and more of the primary, secondary, and tertiary institutions make

use of ICT for improving the quality of education, an infrastructure upgrade will be required. In addition, many of Afghanistan's computer laboratories, in particular the Cisco Academies, were established as early as 2004. Most are in dire need of upgrades to be able to run some of the recent versions of online training materials and virtual laboratories.

Fortunately, the new Minister of Communications listed among the MCIT's priorities in his "100-Day Plan" to analyze the "education and teaching" at the ICTI, connect 15 schools and five universities with broadband Internet access, and connect five universities to the Trans-Eurasia Information Network (TEIN4) via the Afghanistan Research and Education Network (AfgREN), as mentioned in [Chapter 19](#). The first 100 days is long past, and the status of all of those priorities is unclear. (The MCIT released a Second 100-Day Plan, but the authors have been unable to obtain an English translation of it.) In fact, several Afghan universities had their broadband fiber service cease when Afghan Telecom Corporation, the state-owned fiber management monopoly, turned off circuits for non-payment by the Afghanistan Telecom Regulatory Authority (ATRA). Per agreement among the MCIT, ATRA, and NATO, ATRA had been funding the connectivity through its Telecommunications Development Fund (TDF) but discontinued doing so mid-to late 2015, claiming it was reviewing the TDF's mandate.

On a positive note, the MCIT signed memorandums of understanding (MoUs) with both the MoHE and MoE in August 2015 "to include ICT in the process of education" by bringing Internet access and dynamic resources into the classroom to enhance the quality and effectiveness of instruction, improve the delivery of education, and have students benefit from online opportunities.<sup>1595</sup> While it does not say the TDF will be used to do so, the announcement follows the above-mentioned review of the TDF, and previous (2012) MoUs between the MCIT and MoHE and the MCIT and MoE provided US\$5 million each from the TDF to be used for ICT in education efforts.

### Digital Libraries

Consistent with the notion that textbooks are integral to developing and revising curriculum, ICTI requested a list of computer science textbooks that would have cost about US\$250,000 according to its Director. Along with a request by the MoHE for the TAT to download e-textbooks, which it could not do because of bandwidth constraints it became apparent to the TAT that a discussion on the usefulness of a digital library needed to be revived and revisited.

To understand whether Afghans would be interested in e-textbooks or e-resources, the TAT held a working session on the use of e-textbooks and e-resources to ICTI faculty members in March 2013. The ICTI Director and six lecturers were given hands-on experience with [MIT's Open Courseware](#)<sup>1596</sup> to assess the relevance of the courses in science, especially physics, and mathematics. Drilling down from the syllabus to problem sets created added excitement rather than just reading the learning outcomes. The

---

<sup>1595</sup> MCIT (2015). "MCIT signs Memorandum of understanding with MoHE and Ministry of Education." August 15. Accessed March 22, 2016. <http://mcit.gov.af/en/news/51080>.

<sup>1596</sup> Massachusetts Institute of Technology, MIT Open Courseware. Accessed October 24, 2014. <http://ocw.mit.edu/index.htm>.

lecturers, some of whom brought their own laptops, also liked [Saylor Academy](#),<sup>1597</sup> which has a complete curriculum in mathematics and computer science with downloadable readings.



Picture 56: TAT demonstrates e-learning resources to ICTI faculty

(Photo courtesy of Maria Beebe)

Several developments suggest that the Afghans might be ready for digital libraries. Three examples of digital libraries that have been developed with Afghans in mind are:

- The [Afghan Digital Libraries](#)<sup>1598</sup> initiated by the University of Arizona and funded by USAID.
- The [Darakht – Danesh Library](#),<sup>1599</sup> a project of Canadian Women for Women in Afghanistan.
- The [Afghanistan Digital Library](#),<sup>1600</sup> which was developed by New York University (NYU) to retrieve and restore works published in Afghanistan between 1870 and 1930. The long-term objective is to collect, catalogue, digitize, and provide access to as many of this period's publications as possible.

Another positive development is that the MoHE IT Director indicated that two of his staff would be assigned to transition ownership of the digital library developed by the University of Arizona. The MCIT Director General of IT, now Deputy Minister, indicated the MoE has requested a digital library. The President of NICTAA initiated discussions with [Electronic Information for Libraries](#)<sup>1601</sup> (EIFL) on the

---

<sup>1597</sup> Saylor Academy. Accessed October 24, 2014. [www.saylor.org](http://www.saylor.org).

<sup>1598</sup> Afghanistan Digital Libraries. Accessed October 24, 2014. [www.afghandigitallibraries.org](http://www.afghandigitallibraries.org).

<sup>1599</sup> Darakht-e Danesh. Accessed October 24, 2014. [www.darakhtdanesh.org](http://www.darakhtdanesh.org).

<sup>1600</sup> Afghanistan Digital Library. Accessed October 24, 2014. <http://afghanistandl.nyu.edu/>.

<sup>1601</sup> Electronic Information for Libraries. Accessed October 24, 2014. <http://www EIFL.net>.

possibility of their supporting Afghan attempts to integrate the various digital library efforts. (EIFL won a 2013 World Summit on the Information Society prize for capacity building.)

The Afghanistan Research and Education Network (AfgREN) would be an ideal lead for integrating these various disparate efforts; however, the network is still in its infancy. The digital librarians will require capacity building to implement, maintain, and sustain the libraries.

Systemic reform requires balancing curriculum development with faculty, staff, and student development along with developing computer science standards, maintaining and upgrading computer laboratories and Internet connectivity, and accessing virtual labs, e-textbooks, and other digital resources. A systemic reform process requires sustained engagement with Afghan stakeholders to assess and adapt computer science and other relevant standards for Afghan realities; funding faculty, staff, and student development that is demand driven; and fostering sustainment of infrastructure through local or global public private partnerships or development alliances.

### *LOE 5: Partnerships and Engagement*

The MoHE is cognizant that by itself it cannot meet the demand for higher education by Afghans in its entirety. The MoHE has started to coordinate with registered private higher education institutions around accreditation and a quality assurance process. The MoHE also recognizes that the private sector is a major employer in Afghanistan and has started to work with private sector and industry to make sure programs meet their needs. The MoHE has also achieved better coordination with the MoE regarding technical vocational education and training (TVET) and the establishment of community colleges, quality assurance, monitoring and evaluation, and other areas; the Ministry of Women Affairs (MoWA) on the implementation of gender equality; the Ministry of Labor, Social Affairs, Martyrs, and Disabled (MoLSAMD) on the assessment of labor requirements. The MoHE has also started to collaborate with the MCIT on infrastructure issues and long-term academic programs. Finally, the MoHE is desirous of regional and global partnerships with training providers, academic institutions, and industry that are beneficial to Afghanistan's Decade of Transformation.<sup>1602</sup> The specific recommendations were to:

1. Explore MoHE-industry collaborations on the development of an ICT sector competency framework, industry certifications, student internships, and industry sponsorship of research.
2. Deepen MoHE/MOE/MCIT collaboration to develop, among other things, an ICT Masterplan for Education.
3. Facilitate regional and global partnerships with academic institutions that are willing to engage in public-private partnerships or global development alliances, not only to train the trainers but also to foster student-to-student engagements.
4. Facilitate partnerships and engagement between Afghan academic institutions and regional and global industry.

---

<sup>1602</sup> 2015-2024, as agreed up at the Tokyo Conference on Afghanistan July 8, 2012 and codified in the Tokyo Declaration, "Partnership for Self-Reliance in Afghanistan: From Transition to Transformation."

Both the MoHE and MCIT recognize that engagement with global partners is beneficial towards gaining international recognition and contributing to Afghanistan’s Decade of Transformation, but that funding these global partnerships is problematic for both parties.

The short- to mid-term goals for partnerships engagement include:

1. Expansion of person-to-person networks through identifying resources for faculty and staff exchanges.
2. Better coordination of resources and current efforts to avoid redundancy, maximize leveraging from individual initiatives, and provide the greatest possible benefit from those limited resources.
3. Enhancing English language capacity of faculty, staff, and students as part of faculty development preparation to be able to reach an acceptable TOEFL<sup>1603</sup> score required for US scholarships.
4. Deepening of collaboration among the Ministries of Communication, Higher Education, and Education to develop, among other things, an ICT Masterplan for Education.
5. Facilitation of regional and global partnerships with academic institutions that are willing to engage in public private partnerships or global development alliances not only to train the trainers but also to foster student-to-student engagements, albeit virtually.
6. Continue to facilitate engagements between Afghan academic institutions and regional and global industry.

As evidence of progress, the MCIT has published its intent to install broadband fiber optic connectivity to 15 schools and five universities, as mentioned above. Additionally, the ICTI has established multiple regional and international partnerships, under the European Commission’s Erasmus+ Program, as described in [Chapter 19](#). Further, there are 12 PhD candidates (two from Herat University and ten from Kabul University) studying for doctorate degrees in computer science abroad through partnerships with universities in the US, Estonia, Germany, and Italy.

## Conclusion

ICT capacity development is a complex and comprehensive undertaking, one for which the archaic, cumbersome Afghan bureaucracy is not the best-suited or particularly well-equipped to undertake. However, it is an absolutely necessary endeavor in order for Afghanistan to maintain and protect the significant gains it has made in deploying ICT infrastructure and services and to keep pace with the evolution of technology into the future. Complicating matters is the “brain drain” of educated tech-savvy Afghan youth, coincident with the drying up of donor dollars and the deteriorating security situation. The government of Afghanistan needs to prioritize the use of Telecommunication Development Funds for investment in ICT capacity development across all levels. ICT capacity development will likely continue to challenge and bedevil the country for years to come.

---

<sup>1603</sup> Test of English as a Foreign Language

## Chapter 21 The Telecommunications Advisor Function – Operational Examples

---

Larry Wentz and Bob Kinn

### Introduction

The amorphous natures of modern security threats – conflict and terrorism, but also things like climate change and financial collapse – have made it “increasingly difficult to define a uniquely ‘military’ role and mission.”<sup>1604</sup> The lines between war and peace have become blurred. The adversaries are using a spectrum of unconventional warfare means such as those attributed to multidimensional activities of gray zone, ambiguous, irregular, and hybrid modes of conflict that are just below the threshold of aggressive use of military force.<sup>1605</sup> Methods of conflict have changed and now include use of political, economic, informational, cyberspace, humanitarian, and other non-military measures. The more traditional conventional instruments of military power are used as well. Revolutionary technology changes have reduced the salience of state borders and physical territory and increased the lethality and disruptive capabilities of non-state actors.<sup>1606</sup> Post-conflict operations are a misnomer today. The absence of high levels of conflict does not mean there is essentially real peace everywhere in the affected nation and that no methods of disruption are being employed. For example, there will be insurgency activities that continue, albeit at lower levels, that need to be controlled by the security forces. Elements of the various forms of conflict now being experienced remain for some time in a landscape churning with political, economic, and security competitions that require constant attention.<sup>1607</sup> The institution of an effective affected nation government and security force is necessary to facilitate transition to peace, but this takes a long time to achieve, probably decades. The realities of transitioning from conflict to peace are not clear-cut and are much more complex than anticipated, as has been experienced in Iraq and Afghanistan.

The US government (USG) drawdown of civilian workforce and cut backs in funding of the State Department, USAID,<sup>1608</sup> US Information Agency, and other civilian agencies in the 90s reduced the ability to effectively engage, assist, and communicate globally with “soft power” capabilities.<sup>1609</sup> As budgets and capacities of civilian agencies stagnated or declined, the civilian elements no longer had the resources and

---

<sup>1604</sup> Gilsinan, Kathy (2016). “We Have No Idea What War Is.” *The Atlantic*, August 10. Accessed September 14, 2016. <http://www.theatlantic.com/international/archive/2016/08/rosa-brooks-war-military/494846/>.

<sup>1605</sup> Hoffman, Dr. Frank (2016). “The Contemporary Spectrum of Conflict: Protracted, Gray Zone, Ambiguous, and Hybrid Modes of War.” 2016 Index of U.S. Military Strength. The Heritage Foundation. Accessed September 14, 2016. <http://index.heritage.org/military/2016/essays/contemporary-spectrum-of-conflict/>.

<sup>1606</sup> Brooks, Rosa (2016). *How Everything Became War and the Military Became Everything*. (New York: Simon and Schuster).

<sup>1607</sup> Hoffman, 2016.

<sup>1608</sup> United States Agency for International Development

<sup>1609</sup> Brooks, 2016.

capacity to effectively respond and rapidly deploy needed civilian expertise and capabilities. As a result, the military became engaged more and more to step into the breach, expanding the military's role and sidelining civilian agency participation.<sup>1610</sup> The military was not, and is still not, adequately trained to take on the roles of the civilian agencies in post-conflict recovery, reconstruction, and development actions. On the other hand, they have the resources and capability to step into the job to make things happen. Experience suggests, however, the military construction and economic development are not likely to be as cost-effective as civilian engagements due to stricter adherence to US and international standards.<sup>1611</sup>

The threats being experienced today do not come neatly packaged as "military" versus "civilian" threats. To operate more effectively in the space in between, the USG will need to explore and implement additional means to bridge the civil-military divide and integrate and employ improved whole-of-government approaches in future operations. Attempts are being made to expand civilian capacity and "rebalance" civilian and military roles. Examples of such include the establishment of the State Department as the lead for stability and reconstruction activities and its related civilian response corps; the use of Provincial Reconstruction Teams (PRTs) in operational areas; increased funding for non-military activities; the institution of civil-military training programs; and presidential policy directives and Department of Defense (DoD) directives/instructions to improve integration of civil-military activities as a whole-of-government and unity-of-effort response capability. Despite progress, there is still a tendency when a crisis hits for senior USG leadership to dial 1-800-MILITARY to have it take the lead role to respond.

As a result, the military as an institution may become demoralized and less effective because the USG is trying to force one institution to do too many things.<sup>1612</sup> Likewise, State Department, aid agencies, and NGOs<sup>1613</sup> have expressed concerns and resentment<sup>1614</sup> about the militarization of aid and the shrinking of the humanitarian space.<sup>1614</sup> There are also organization and people-culture differences that contribute to a lack of trust among members of the civil-military community, which impact their willingness to collaborate and share information. The civilian agencies are more risk-averse in their operations. A core tenet of most aid agencies and NGOs is neutrality, hence not taking sides in conflicts, and thus they are concerned that with more military engagement in aid-like activities, the aid they provide could become an instrument of war, and they could become targets.<sup>1615</sup> Herein lay some examples of the civil-military differences that need to be managed operationally, as well as part of the change process, and institutionalizing new ways to conduct intervention operations. Information and communications technology (ICT) can be an enabler not only of the change process to bridge the civil-military divide, but also an enabler of smart interventions to facilitate the early recovery of failed states and their eventual return to peace and prosperity.

---

<sup>1610</sup> Ibid

<sup>1611</sup> Ibid.

<sup>1612</sup> Gilsinan, 2016.

<sup>1613</sup> Non-governmental organizations

<sup>1614</sup> Brooks, 2016.

<sup>1615</sup> Ibid.

The USG possesses more information than ever before and has vastly greater processing power, but the accelerated pace of global change has far exceeded [its] collective ability to understand much less change<sup>1616</sup> and to more effectively leverage the power of ICT to enable smart interventions and facilitate recovery of nations emerging from conflict. ICT, including information content and social networking tools, have become an important enabler of post-conflict security, stability, reconstruction, and development, especially with ways in which ICT can be used by governments emerging from conflict, interveners, and donors to support the transition from conflict to stability and ultimately a lasting peace, improved quality of life, and economic growth for the affected nation. The reality is, however, the ICT sector is not recognized or treated as a priority sector and is simply viewed as one among many competitors for the attention of policymakers and practitioners. Based on past and current real-world operations, the ICT sector most likely will not be the first priority of governments and donors in post-conflict stability and reconstruction operations.<sup>1617</sup>

On the other hand, the intervening military elements will have an interest in the affected nation's ICT sector governance and civil and commercial ICT infrastructure and service capabilities to support civil-military spectrum management, access to in-country and out-of-area connectivity for C4ISR,<sup>1618</sup> ICT for stability operations and counterinsurgency (COIN) activities related to extension of security and governance, rule of law, and socio-economic development. Also, other service needs such as cellular telephone and Internet services to support civil-military coordination and information sharing and morale, welfare, and recreation needs will be of interest. Civilian government and international interveners will also have a need for ICT services to support their operations and to communicate with the military elements and the affected nation and its population.

The military can facilitate early ICT infrastructure and service recovery efforts by employing techniques such as anchor tenant where they make offers to, for example, guarantee leases of connectivity and procurement of services for a period of time. This incentivizes communications providers to expand coverage and capacity and offer services at reasonable prices to meet the needs of the intervening military elements as well as to support the affected nation's initial security and government recovery activities and to help enable economic growth. Technologies such as the Afghan fiber optic network are dual-use and of value to civil, commercial, and military users. For example, the Defense Information Systems Agency (DISA) was (and still is) an anchor tenant of Afghanistan's fiber optic network and leases connectivity to support US C4ISR needs within the country and to access global connectivity in the region. The fiber optic network is also a major enabler of security, governance and socio-economic development and growth for Afghanistan.

---

<sup>1616</sup> Ibid.

<sup>1617</sup> Kelly, Tim and David Souter (2014). *The Role of Information and Communication Technologies in Postconflict Reconstruction*. World Bank Studies. Washington, DC: World Bank. doi:10.1596/978-1-4648-0074-0. License: Creative Commons Attribution CC BY 3.0. Accessed September 7, 2015. <https://issuu.com/world.bank.publications/docs/9781464800740?e=0/6688927>.

<sup>1618</sup> Command, control, communications, computers, intelligence, surveillance, and reconnaissance



Different countries emerging from violence pose different challenges and different opportunities. Post-conflict countries differ markedly from one another in size and level of economic development, in social structures, the causes of conflict, the ways in which conflicts end, and the legacies left behind.<sup>1619</sup> The ICT environments of post-conflict countries will also differ markedly. There is no “one size fits all” approach for ICT-enabled interventions. Successful approaches to the use of ICT in stability and reconstruction are rooted in a thorough understanding of national political, economic, social, cultural, and communications contexts.<sup>1620</sup> An informed understanding of the affected nation’s ICT sector governance, infrastructure, and services and the related government and business cultures and processes are important to success, as is as an understanding of the affected nation’s information culture.

In the Digital Age the USG and international crisis responders need to take actions to more effectively leverage the Internet, mobile phones, wireless communications, and other ICT tools and services. There is an urgent need for the responder community to focus on ICT-enabled interventions including where, when, how, and with which capabilities. Today, there is no agreed-upon policy or guidance on when during the lifecycle of peace to conflict to security to post-conflict stability to peace operations that an ICT-enabled intervention needs to be made by whom, the mission to be addressed, who has the lead to support whom with what types of capabilities, to do what, and for how long. Attempts to date have been ad hoc and reactive versus preplanned and exercised as a professional unity of effort response capability. It is largely good organizations with good people with good intentions trying to do good things to help make a difference in complex and many times dangerous environments. However, the process lacks unity of effort including inadequate civil-military collaboration and information sharing as well as a lack of shared vision, strategy, and plan to shape and manage the response activities.

The USG use of Senior Telecom[munications] Advisors (STAs) in Afghanistan included both State Department and Defense Department arrangements and charted new territories of operation. The approaches used were based largely on prior experience in other real-world operations and the professionalism of those who developed the concepts and participated in their implementation. The efforts were largely Kabul-centric with some attempts to obtain more countrywide perspectives and engagements through visits downrange to meet with forwarded-deployed civil and military elements such as ISAF<sup>1621</sup> PRTs and Forward Operating Bases (FOBs) and visits to Afghan provincial, district, and village government personnel, businesses, schools, medical facilities, and local activities. The first STA was a senior executive recruited from industry for an SES<sup>1622</sup>-equivalent position at the Afghanistan Reconstruction Group (ARG), a combined DoS and DoD element at the US Embassy Kabul. His replacement was a senior civilian recruited from industry for GS-15<sup>1623</sup> equivalent position. Later instances of DoD-sponsored STAs were senior ICT professionals, both civilian SES or equivalents, and US military colonels,

---

<sup>1619</sup> Kelly and Souter, 2014.

<sup>1620</sup> Ibid.

<sup>1621</sup> International Security Assistance Force

<sup>1622</sup> Senior Executive Service

<sup>1623</sup> General Schedule, referring to the pay scale for most government civilians

most of whom had significant ICT experience. These DoD-led instances were located at ISAF Headquarters in Kabul. STA assignments were for one year each versus multiyear assignments, which would have helped facilitate continuity in operations on the ground and sustainment of trust relationships with the Afghan ICT counterparts. The efforts were basically experiments and learning experiences that had senior DoD and DoS (US Ambassador and ISAF commander) top cover to support the attempt to conduct an ICT intervention to facilitate ICT sector recovery and the use of ICT as a cross-sector enabler. The ICT sector was, in fact, one of a few economic reconstruction success stories emerging from Afghanistan. The STA was a major factor in the success of the ICT sector. This also was a success story of innovation in government and will be discussed in more detail later in this chapter.

There were a number of challenges that influenced the ability to shape economic reconstruction. For example, the STA quickly assessed that freedom of movement to engage and even embed with Afghan ICT counterparts to work with them as part of their team was critical to success. As the security situation deteriorated risk-averse security policies and actions started to limit the ability to effectively conduct the operational mission. This was the case in Afghanistan where in the early days of the ARG/STA and then ISAF STA/TAT the security situation was not as high a threat, and, perhaps more importantly, the risk tolerance of senior leadership was much higher, which allowed freedom of movement and the ability to embed daily with the Afghans. As the security situation began to deteriorate, it became necessary to travel in armed convoys with IBA<sup>1624</sup> and weapons. This introduced changes (decreases) in the number of trips outside the wire, the times of departure and return, duration of visits, the ability to embed daily or as needed at Afghan facilities, and freedom of movement within facilities. Additionally, the higher visibility of security measures had an increasing damping effect of the Afghans' willingness to partner with US personnel on a professional basis. Some of the Afghans the STA/TAT regularly dealt with received threats from the Taliban because they were engaging with US personnel.

After "green-on-blue" attacks<sup>1625</sup> began to increase in 2011, ISAF force protection requirements changed in early 2012 to requiring ISAF personnel to carry weapons at all times and have a guardian angel while visiting the Afghans at their facilities. This added challenges to movements to and within the Afghan facilities, conducting private meetings with senior Afghans, and even gaining access to facilities in some cases. For example, Afghan universities did not allow guns on campus, and some government facilities would not allow open carrying of weapons during visits. The deterioration of the security situation eventually resulted in lock down on the US Embassy and military compounds, making it very difficult to go out and meet with Afghan counterparts. The strict restrictions on local travel essentially shut down operations, limiting communications with Afghan counterparts to phone calls and emails or having the Afghans visit the US Embassy or ISAF compounds. This, too, had restrictions on the Afghans and their willingness to come to the US Embassy and ISAF compounds. There needs to be a better way to balance

---

<sup>1624</sup> Individual body armor

<sup>1625</sup> Attacks by Afghan forces on Coalition forces

force protection and conducting operations to support stability and reconstruction missions in changing threat environments.

In addition to the security challenges, improving collaboration and information sharing among the USG and international participants including the affected nation was important. This was not a technology issue, it was a behavior issue driven by people and organization culture issues and reluctance to share or collaborate. One of the roles of the STA was to facilitate harmonization, collaboration, and information sharing, and focused efforts in this area proved very effective. The first STA did not have a dedicated budget or support staff but was still able to significantly help the Afghans achieve dramatic improvements in the ICT sector by focusing on harmonization, collaboration, and information sharing initiatives between and amongst the Afghans, the US, and its global partners.

Other challenges influencing the ability to change behavior included responder community reluctance to treat ICT as “critical infrastructure” and an “essential service” and resistance to prioritizing investments to more effectively use ICT as a “game changer” and an enabler of security, governance and socio-economic development and growth. Again, this was an area in which the STA’s skills were of value. For example, the STAs in Iraq and Afghanistan actually achieved recognition as the “go to organizations” for ICT advice, assistance, and ICT sector situational awareness and were the major spokespersons for raising the awareness to the USG Interagency, Coalition military (e.g., Multi-National Force-Iraq and International Security Assistance Force-Afghanistan), and International Community of the value of ICT in post-conflict stability and reconstruction operations.

Early attention to the restoration of Afghan ICT sector governance and recovery of critical ICT infrastructure to support governance and emergency services were important considerations. As Afghanistan emerged from conflict, the ICT sector was destroyed and needed rapid attention to recover. There was no STA at this time, but the USG and International Community responded to try to help. Their responses tended to be stovepiped efforts with little collaboration or information sharing among the various responder elements, e.g., USAID, the US Trade and Development Agency (USTDA), the International Telecommunication Union (ITU), the United Nations (UN), the World Bank and others.

In order to fix shortfalls in the current situation, the USG and International Community need to make policy adjustments to set the priorities for resource allocations and investments, develop an agreed-upon strategy and approach to include ICT as a key element of intervention and post-conflict stability and reconstruction activities, and introduce policies and capabilities to facilitate collaboration and information sharing. It is necessary for both to have the “political will” to change, which is a key ingredient to improving the way they do business in the future and improving their success in post-conflict stability and reconstruction operations.

Post-conflict societies share certain common characteristics that are relevant to ICT-enabled interventions. Social cohesion has been disrupted by violence, leaving legacies of hostility, suspicion, and insecurity which need to be overcome if countries are not to follow the experience of many and revert to violence. Economic production and trade will also have been disrupted, resulting in underemployment, underinvestment, and underperformance. Substantial numbers of people are likely to have gone into exile, taking skills and capital with them, but also offering the potential that those skills and capital will

return. Infrastructure, including information and communications infrastructure, is likely to have been destroyed but can be restored.<sup>1626</sup>

Stabilization requires the rebuilding of political institutions, the reintegration of former combatants, the establishment and maintenance of physical security, the restoration of critical economic sectors such as mineral extraction, the injection of capital into the financial system, the production and distribution of food supplies, and the restoration of health and education services.<sup>1627</sup> Regarding the ICT sector, this involves reestablishing ICT sector governance, including a ministry of communications and a regulator, developing and implementing ICT policies, laws, and regulations, rehabilitating or privatizing state-owned ICT enterprises, and forming early public-private-partnerships to enable private investment in the ICT sector.

The purpose of this chapter is to chart the path and document the experience of employing two different yet functionally similar ad hoc instances of the use STAs in Afghanistan. The first was the STA at the Afghanistan Reconstruction Group (ARG) at the US Embassy Kabul in the 2005-2008 timeframe. The ARG was sponsored by the US National Security Council (NSC) and the Departments of State (DoS) and Defense (DoD). The second was an STA and supporting Telecom Advisory Team in the 2010-2014 timeframe at ISAF Headquarters in Kabul. It was led by the DoD with DISA as the designated sponsor and supported in concept by the DoS/USAID. Both efforts were supported by a CONUS<sup>1628</sup>-based Reachback element and were attempts to provide professional civil and commercial ICT advice and assistance in support of post-conflict civil-military stability and reconstruction operations. The STA/ARG and STA/TAT, with their reachback elements, were distributed virtual teams. Not surprisingly, they experienced the challenges of a lack of a shared identity – team members unable to collectively identify with a common goal or purpose irrespective of their geographic proximity.<sup>1629</sup> There were other unintended consequences of separated teams, which included not being able to develop sufficient trust and team members unable to communicate as easily as physically co-located team elements. Regarding communications, this was often difficult due to technological limitations, time zone differences, and competing priorities.<sup>1630</sup>

Interestingly, for the first incarnation of the STA/TAT, referred to as TAT-1, team building was less of a problem than for the following three. The STA and Reachback (which consisted of personnel from the office of the Assistant Secretary of Defense for Networks and Information Integration [ASD-NII/DoD Chief Information Officer \(CIO\)](#), the [National Defense University](#) (NDU), [Deloitte Consulting](#) LLP, [Gartner, Inc.](#), and [DISA](#)) worked as a team before deploying personnel to Kabul, and when the STA deployed, he was

---

<sup>1626</sup> Kelly and Souter, 2014.

<sup>1627</sup> Ibid.

<sup>1628</sup> Continental United States

<sup>1629</sup> Huang, Laura. (2012). *Mitigating the Negative Effects of Geographically Dispersed Teams*. Research Translations. University of California-Irvine, Paul Merage School of Business, Center for Global Leadership. Available at:

[http://merage.uci.edu/ResearchAndCenters/CLTD/Resources/Documents/Huang\\_Laura\\_Mitigating%20the%20Negative%20Effects%20of%20Geographically%20Dispersed%20Teams\\_2012.pdf](http://merage.uci.edu/ResearchAndCenters/CLTD/Resources/Documents/Huang_Laura_Mitigating%20the%20Negative%20Effects%20of%20Geographically%20Dispersed%20Teams_2012.pdf).

<sup>1630</sup> Ibid.

accompanied by the NDU advisor to help set up the office. The NDU and ASD-NII members of Reachback rotated through Kabul roughly once a month to keep a Reachback member on the ground as much as possible for the first year. The Deloitte advisor deployed shortly after the office was established in Kabul as part of on-the-ground Deloitte advisory team to the STA/TAT. The STA and the NDU, ASD-NII, and Deloitte advisors worked together to help build an integrated STA-led TAT-1 team. The TAT was staffed by volunteers through the DoD Civilian Expeditionary Workforce (CEW) program. The STA and his advisors conducted mentoring, facilitated the development of a shared understanding of a vision, strategy, and plan for TAT-1, and conducted continuous team build activities as the CEW members arrived over a six-month period. This approach broke down many of the barriers to building distributed virtual teams and created a trust environment that was not replicated by follow on teams, referred to as TAT-2, TAT-3, and TAT-4. Later versions of the TAT did not have the same degree of interactions with Reachback through regular visits or real-time integration and trust-building on the ground. Although these teams were effective in different ways, they were not able to fully leverage the value of a more proactive interaction with all the players. With the ISAF surge and then drawdown, billeting became a major challenge, limiting the ability for Reachback to travel more frequently to Kabul. The ability to have a great deal of mentoring and face-to-face time with new members of the TAT-1 team was the tiebreaker in the ability to sustain a high degree of trust and a shared understanding of everyone's roles and the actions to be taken. In later phases of the TAT, such proactive interactions were very limited on the ground, and conference calls and emails became the norm for communicating. The teams tended to be driven more by individuals or small groups and had less of an overall team effort.

Other ad hoc activities, such as the DoD Task Force for Business and Stability Operations (TFBSO) and ISAF Provincial Reconstruction Teams in Afghanistan are touched upon in this chapter. There are also some references to Iraq experiences related to Coalition Provisional Authority telecommunications advisors, the Multi-National Force–Iraq and its Iraq Communications Coordination Element (ICCE) and the follow-on Infostructure and Strategic Engagement (ISE) team.

The STA/ARG and STA/TAT experiments and learning experiences have provided unique insights into their challenges and opportunities. Some findings and lessons from these efforts are captured in this chapter along with thoughts for approaches for future ICT-enabled interventions. Others are in [Chapter 22](#). Some observations related to the success of the Afghan ICT sector are included as well but are also covered in more detail in other parts of the book.

## Telecommunications Advisor Function

The Telecom Advisor (TA) function provides professional civil and commercial advice and assistance on ICT for post-conflict reconstruction and development strategies, operational concepts, system architectures, technical designs, programs, acquisitions, implementations, operations, and capacity development. This includes appropriate coordination with the military as necessary to meet related command and control, intelligence, logistics, morale and welfare, and other communications and information service needs. Civil and commercial ICT includes dual-use technologies such as fiber optic cables, satellite connectivity, and cellular telephone and Internet services, including social networking tools. Military success in C4ISR (at the lowest cost) is highly dependent on a mature or maturing civil and commercial ICT sector that is shaped to allow the greatest access of the military to its connectivity,

information, capabilities, and services. This is where the abilities of the TA function come to bear – to help shape the ICT environment for the success of the US national strategy and the affected nation’s strategy.

The TA function provides ICT-focused “thought leadership” and “strategic thinking” to senior military and civilian leadership and their organizations working ICT initiatives and issues as well as to the affected nation’s government and private sector counterparts as appropriate. Informed understanding of international standards and best practices, current awareness of ICT technology trends, and experience and understanding of ICT sector governance, policy, regulations, laws, business processes, education, and training are all part of a robust portfolio of skills needed. The TA function also offers experienced-based insights on IT management, chief information officer (CIO) and chief information security officer (CISO) concepts and roles, network operations, cybersecurity, and critical infrastructure protection.

Important to execution of the function is mentoring, harmonization, coordination, informed situational awareness, and connector services and support to US Government Interagency elements (such as the US Embassy, USAID Mission, Department of Commerce (DoC), and others), Coalition civil-military elements (such as, NATO’s ISAF and its troop contributing nations), international organizations (such as the UN, ITU, and World Bank), NGOs, and the affected nation’s ICT counterparts working the development of the public and private ICT sectors. An informed understanding of the use of ICT capabilities as an enabler of other sectors such as security, governance, rule of law, agriculture, finance, health, and education and ICT as an engine of economic growth and for empowering women are important as well.

The TA function provides ICT-based professional leadership and subject matter expertise to perform the role of key leader advisor to and primary US government day-to-day engagement leader with the affected nation’s minister of communications, the chairman of the regulator, and the leadership of any state-owned telecom and IT enterprises and their staffs. The TA function advises the military commander on ICT-related issues and uses to meet C4ISR operational mission and other objectives and advises the senior civilian representative on ICT-related policy, legal, financial, investment and other issues and activities of interest to the USG in the affected nation. Additionally, the TA function provides the expertise to proactively interact with various other ICT personnel within the public and private ICT sectors and academia, such as other ministry’s IT managers, CIOs, and CISOs; public and private universities and vocational training centers providing ICT education and training; professional ICT associations; commercial service providers – in particular, the chief executive officers (CEOs) of the mobile network operators (MNOs) and Internet service providers (ISPs). Although private sector MNOs and ISPs do not need a lot of advice from a TA, they are part of the ICT ecosystem, and maintaining strategic partnerships with them is part of the role of the TA, especially as a harmonizer, coordinator, and connector. This is generally not the case for the civil sector state-owned ICT enterprises, which will likely need help in developing their networks and network operations, business processes, and human capacity in order to be able to meet expected international performance standards for quality of service.

There are no current USG or international policy, doctrine, or institutional arrangements, mechanisms, or processes that provide guidance for implementing the TA function. Implementations to date have been based largely on prior operational experience of organizations and individuals assigned the responsibility to establish a TA capability. Approaches have included filling a preassigned position that has been designated as the TA function, establishing an ad hoc arrangement within an organization, and taking on

the function as another duty as assigned within an established organization such as the military command, US Embassy, or USAID Mission. Experience suggests the means to realize and implement the TA function has been a function of USG Interagency willingness to execute establishment of the function, the prior experiences and existing business practices of the organization assigned lead responsibility, and the ability of the lead organization to resource both in terms of needed expertise and funding to operate.

Ideally, the TA function supporting a military or combined civil-military operation should be performed by a senior civilian ICT professional. However, for a military-only mission, the TA could also be military. The role of STA may, however, be outside the military's training and core capabilities, making execution a little more challenging and possibly less effective. There are also potential cultural and social barriers for a military leader engaging with an affected nation's civil authorities and business leaders. Members of the National Guard or Reserves, such as US Army Civil Affairs, may have an advantage over regular military personnel because of their civilian experience. For a senior civilian as an STA, it would therefore be desirable for this individual to have some military leadership experience or experience working with the military to help bridge the civil-military divide – as noted earlier, there are organizational and people cultural differences and trust relationships that need to be managed.

Depending on the operational need, the STA can be complimented with an organization such as a Telecom Advisory Team (TAT) that would be composed of a collection of ICT professionals from different US government agencies with varying degrees of expertise in the ICT sector and its uses. In Afghanistan, these personnel rotated every six to 12 months and were led by the STA who rotated annually. As a result, the deployed teams experienced frequent turnover of staff and leadership, resulting in a constantly fluctuating group that had not worked together before and this can and does disrupt teaming arrangements and trust relationships. Establishing trust is a special challenge in temporary groups, where relative strangers come together for a limited period of time to work on a specific problem or task, which was the case for the STA/TAT in Afghanistan. An additional challenge for the STA/TAT was connecting with Reachback in the States and using means other than virtual connections to do team building. For example, Reachback should travel to Kabul frequently to participate as members of the team on the ground, which proved to be hard to do during the surge and drawdown phases of operations.

The TA function could be implemented in a portfolio of sector-specific interests of an existing organizational arrangement such as a US Embassy Economic (ECON) section. Experience suggests ICT would likely be one of a number of areas of interest for the ECON officer but not necessarily a priority focus area. The TA function could also be set up as an ad hoc element within the military command, US Embassy, or USAID Mission. In fact, there could be a TA function supporting the US Embassy and a separate TA function supporting the military. Under this arrangement, there would be a need for close cooperation and information sharing between the two TA functions and an agreed-upon understanding of roles and responsibilities and information sharing arrangements.

Individuals and organizations implementing the TA function need to have the social and business skills to interface with high-level officials and the professional expertise and experience to operate in dynamic, complex, multinational, and multicultural environments. In many cases, hostile wartime environments require movement in armored vehicles, wearing personal protection equipment during travel, and being prepared to use government-issued weapons for self-defense.

## Ad Hoc Approaches in Iraq and Afghanistan

In the absence of adequate ICT-related policy guidance, ad hoc approaches continue to be the means to an end to try to improve ICT-related operations and actions on the ground in support of security, stability, and reconstruction. On the good news side, the ad hoc approaches, or what some might refer to as learning experiences or experiments, are now starting to address ICT needs, but none reflect approved policy or doctrine guidance or agreements to institutionalize approaches tried. There were numerous initiatives related to USG and international engagements in the ICT sector in Iraq and Afghanistan, but they were not that well-coordinated or leveraged across the USG participating elements or with the affected nations and international participants. Additionally, many of them did not leverage the private sector in a systematic way. These shortfalls were a motivator for introducing ad hoc approaches such as the ICCE/ISE in Iraq and STA/ARG and STA/TAT in Afghanistan. The goal was to have them be trusted and informed ICT professional advisors to help harmonize, leverage, be a good connector, and share information on ICT sector activities and to work more effectively providing unity of effort among the USG Interagency and international responders and with the affected nation's public and private ICT sector counterparts.

Before the intervention into Iraq, there were several separate DoS, DoD, and USAID planning efforts for post-invasion recovery and reconstruction. One was a DoS-sponsored study that worked with Iraqis who knew Iraqi institutions first-hand to help plan what should follow regime removal in Iraq – the effort became known as “The Future of Iraq Project.” Another was an OSD-Policy<sup>1631</sup> task to the NDU Institute of National Strategic Studies (INSS) to conduct an Iraq regime replacement workshop and publish a report. Yet a third was a Department of the Army Deputy Chief of Staff/G-3 task to the Army War College Strategic Studies Institute (SSI) to conduct a workshop on post-invasion planning for Iraq and publish as an SSI monograph. There was also a USAID-led working group that put a plan together for humanitarian assistance and basic reconstruction activities.<sup>1632</sup> The workshops included USG Interagency participation but there was a lack of coordination among the plans. The plan prepared for Iraq by the OSD-Policy and its Office of Special Plans along with US Central Command and others was coordinated with the DoS and included references to drawing on the Interagency work that had already been accomplished. However, it is not clear the other plan recommendations were actually used that effectively in this regard. There were interactions with DoS members who objected to DoD plans to initially set up a US Embassy element in Iraq subordinate to the DoD that would assist in establishing a new Iraqi regime. The plan was sent by the Secretary of Defense (SecDef) to the White House as NSPD-24<sup>1633</sup> (Iraq Post-War Planning Office) for the President's signature, and it NSPD-24 was signed on January 20, 2003.<sup>1634</sup> The directive provided the Pentagon the basis for standing up an Interagency post-war planning office with a broader focus on regime change than initially anticipated, resulting in greatly reducing the enthusiasm of other USG agencies to

---

<sup>1631</sup> Office of the Secretary of Defense

<sup>1632</sup> Rudd, Gordon W. (2011). *Reconstructing Iraq: Regime Change, Jay Garner and the ORHA Story*. (Lawrence, KS: University Press of Kansas).

<sup>1633</sup> National Security Presidential Directive

<sup>1634</sup> Rudd, 2011.



participate in effort. The office was also to be responsible for building links to international organizations, such as the UN, NGOs, and other members of the International Community as appropriate. The post-war planning office received policy guidance and direction from the NSC-chaired Interagency executive committee, deputies committee, and principals committee as appropriate.<sup>1635</sup>

The DoD established the Office of Reconstruction and Humanitarian Assistance (ORHA) on January 20, 2003, two months before the 2003 invasion of Iraq, and established an operational headquarters in Baghdad on April 21, 2003. As its name indicated, ORHA was set up to focus on providing humanitarian and reconstruction assistance. No one in the US Government ever envisioned that ORHA would become the headquarters of an occupying power with the responsibilities inherent in that term as defined in The Hague and Geneva Conventions. ORHA and its mission had several serious flaws. It was simply too small and lacked sufficient resources.<sup>1636</sup> It was composed of a mix of US government personnel, contractors, and retired military. There was a lack of Interagency planning behind the ORHA effort. For various policy reasons, e.g., USG decision not to establish a DoS/USAID team or the UN as the lead agent for humanitarian assistance, it was not able to effectively partner with the US State Department, USAID, Department of Agriculture, or the Treasury Department and United Nations.<sup>1637</sup> The chain of command was unclear.<sup>1638</sup> A unified mission plan for post hostilities in Iraq was developed with four pillars to guide ORHA's work: reconstruction, humanitarian affairs, civil administration, and an expeditionary staff to handle logistics and security.<sup>1639</sup> Among the key recommendations were: the need for an integrated civil-military approach; the importance of quickly setting up an interim government; and the necessity of "internationalizing" the reconstruction period. Retired US Army Lieutenant General Jay Garner led ORHA and noted in the introduction of the ORHA plan, "History will judge the war against Iraq not by the brilliance of its military execution, but by the effectiveness of the post-hostilities activities."<sup>1640</sup>

Twenty-two days after its establishment, the DoD replaced ORHA on May 12, 2003, with the Coalition Provisional Authority (CPA) led by former Ambassador L. Paul Bremer III who arrived with much greater authority than what Garner had at ORHA and a much different mandate for the future of Iraq. Creation of the CPA signaled to the world that the United States was going to assume responsibility as an occupying power over Iraq under The Hague and Geneva Conventions until a new government could be formed. "The CPA's stated mission was to 'restore conditions of safety and stability, to create conditions in which the Iraqi people can safely determine their own political future, and facilitate economic recovery,

---

<sup>1635</sup> The White House (2003). National Security Presidential Directive/NSPD-24, January 20 (declassified August 25, 2011). Accessed September 7, 2015. <https://fas.org/irp/offdocs/nspd/nspd-24.pdf>.

<sup>1636</sup> Rudd, 2011.

<sup>1637</sup> Taylor, Richard (2007), "Humanitarian Assistance and Network Governance: The ORHA Case." *The Cornwallis Group XII: Analysis for Multi-Agency Support*, April 2007.

<sup>1638</sup> Rudd, 2011.

<sup>1639</sup> Ibid

<sup>1640</sup> Wright, Dr. Donald P. and Colonel Timothy R. Reese (2008). *ON POINT II: Transition to the New Campaign: The United States Army in Operation IRAQI FREEDOM May 2003-January 2005*. (Fort Leavenworth, Kansas, US Army Combined Arms Center: Combat Studies Institute Press). Accessed September 7, 2015. <http://usacac.army.mil/cac2/cgsc/carl/download/csipubs/OnPointII.pdf>.

sustainable reconstruction, and development.’ The US government never issued a formal order dissolving the ORHA. Some of its staff members joined the CPA, and Garner returned to civilian life.<sup>1641</sup>

The CPA was a division of the DoD, and Bremer reported directly to the Secretary of Defense and the President. CPA’s late creation, small size, short-term staff rotations, and fragmented arrival into Iraq meant that Bremer did not have the capacity he needed to function as the headquarters of an occupying power. One result of its late creation and lack of planning capacity was that rather than arriving in Baghdad with the equivalent of a campaign plan, Bremer and his staff took over a month to create a vision statement that contained the broad outlines and objectives of the CPA mission. The informal culture and lack of formal staffing processes within the CPA also clashed directly with the disciplined military decision-making process of the Army.<sup>1642</sup> On June 28, 2004, CPA transferred limited sovereignty of Iraqi territory to the Iraqi Interim Government. CPA closed down its operations and Bremer departed Iraq.

Both ORHA and CPA had a point of contact or advisor for telecommunications. For example, the CPA created the Iraq Program Management Office (PMO) with six sector PMOs, of which one was Transportation and Communications. The CPA maintained a senior advisor to each of the Iraqi ministries, and a civilian advisor was provided to the Iraqi Ministry of Communications.<sup>1643</sup> On March 20, 2004, CPA Order Number 65 established the Iraqi Communications and Media Commission ("the Commission") as an independent and non-profit-making administrative institution. The Commission was and still is solely responsible for licensing and regulating telecommunications, broadcasting, information services, and other media in Iraq and is committed to the principles of objectivity, transparency, non-discrimination, proportionality, and due process in carrying out its duties.<sup>1644</sup>

The USAID Mission had an ICT-focused element in the early phases that addressed restoration of telephone exchanges in Baghdad, restoration of countrywide telephone service, restoration of emergency services networks, installation of an international satellite gateway, restoration of the fiber optic backbone, cybersecurity, and Iraqi ICT capacity development. Independent private sector GSM<sup>1645</sup> and other wireless networks emerged in the absence of a national backbone infrastructure. Exchange of information between networks had to be done by transiting through out-of-country gateways, limiting the ability to enable effective business use of ICT capabilities and ICT for economic growth.

---

<sup>1641</sup> Ibid.

<sup>1642</sup> Ibid.

<sup>1643</sup> Astor, Linda Gossack (2004). "Iraq Reconstruction – Telecommunications." Last revised April 29, 2014. [http://web.ita.doc.gov/ITI/itiHome.nsf/9b2cb14bda00318585256cc40068ca69/b26ea9118c1f755685256e8900763389/\\$FILE/ATTRLZ00/IraqTelecom.pdf](http://web.ita.doc.gov/ITI/itiHome.nsf/9b2cb14bda00318585256cc40068ca69/b26ea9118c1f755685256e8900763389/$FILE/ATTRLZ00/IraqTelecom.pdf).

<sup>1644</sup> Arabiae, Lex. "The Communication and Media Commission in Iraq." Meyer-Reumann & Partners (blog), n.d. Accessed September 7, 2015. <http://lexarabiae.meyer-reumann.com/issues/2015-2/lex-arabiae-vol-xix-1st-issue/the-communication-and-media-commission-in-iraq-cmc/>.

<sup>1645</sup> Global system for mobile communications, a second generation of protocols for digital cellular networks originally developed by the European Telecommunications Standards Institute (ETSI). GSM is now a trademark owned by the GSM Association.

Coalition military focus was more directed at ICT at the Ministries of Defense and Interior, MoD and MoI respectively, for C2 networks such as the Iraq C2 Network, Iraq Defense Private Network, and Iraq Defense Network. Later, USAID engaged in building public-private partnerships in the ICT sector through the Iraqi ICT Alliance initiative that was devoted to promoting the development of ICT in Iraq. Areas of its work included training programs focused on women and youth; improved computer curriculum at universities; e-government; ICT investments and economic growth; Internet access for schools, community centers, and health networks; and ICT training for Iraqi government civilian and military personnel.

In May 2004, the US Embassy Iraq established the Iraq Reconstruction Management Office (IRMO), and the DoD established the Project Contracting Office, which replaced the PMO. IRMO was the primary liaison with the Iraq interim government. In May 2007, the Iraq Transition Assistance Office (ITAO) was established and assumed the remaining functions of IRMO. The US Embassy had senior consultants who provided management and technical advice to the Iraq Ministry of Communications on areas such as professional management development, network and services development, and technical education. The advisors performed STA-like roles and were civilian professional executives with international ICT experience – living and working in Iraq.<sup>1646</sup> The advisor support to ITAO ended in October 2008. USAID interests in ICT became less at this time as well. There was a US Embassy-led Telecom Working Group to facilitate Interagency coordination and subsequently a Strategic Framework Agreement Telecom Working Group.

Early in the Iraq intervention operation, DISA deployed a DISA Support Element-Iraq (DSE-I) to coordinate operation of the Tier 0 DISN<sup>1647</sup> entry points. The Multi-National Force-Iraq (MNF-I) Deputy Chief of Staff (DCS) for Communications and Information Systems (CIS) worked non-military activities with Government of Iraq (GoI) ICT elements and private sector ICT counterparts up to the 2006 timeframe when the emphasis shifted to military needs to support the rollout of infrastructure to support the surge in 2007. The DoD Business Transformation Agency (BTA) and DISA engaged and deployed an ICT Team in 2006-2007 to work with the GoI and private sector ICT counterparts to baseline Iraq's ICT sector infrastructure and governance and to develop an architecture, strategy, and plan to reconstruct an ICT sector that would have significant benefits to the GoI and to Coalition forces (recommendations were both technical and business-related).

To provide renewed focus on Iraq ICT sector governance and infrastructure reconstruction and facilitate improved coordination and information sharing of ICT sector activities and interactions with GoI counterparts, starting in February 2008, MNF-I DCS CIS reengaged with the GoI through the establishment of the Iraq Communications Coordination Element (ICCE). A year later ICCE was renamed Infostructure

---

<sup>1646</sup> Fonow, Robert (Bob), Senior Advisor at US Embassy Baghdad Iraq Transition and Assistance Office (2008). Presentation at Iraq Development Program conference, Dubai, UAE, February 17.

<sup>1647</sup> The DISN is the Defense Information System Network managed by DISA. Tier 0 is the gateway access to the network.

and Strategic Engagement (ISE) to support Iraq ICT sector governance and civil and commercial infrastructure recovery and reconstruction.

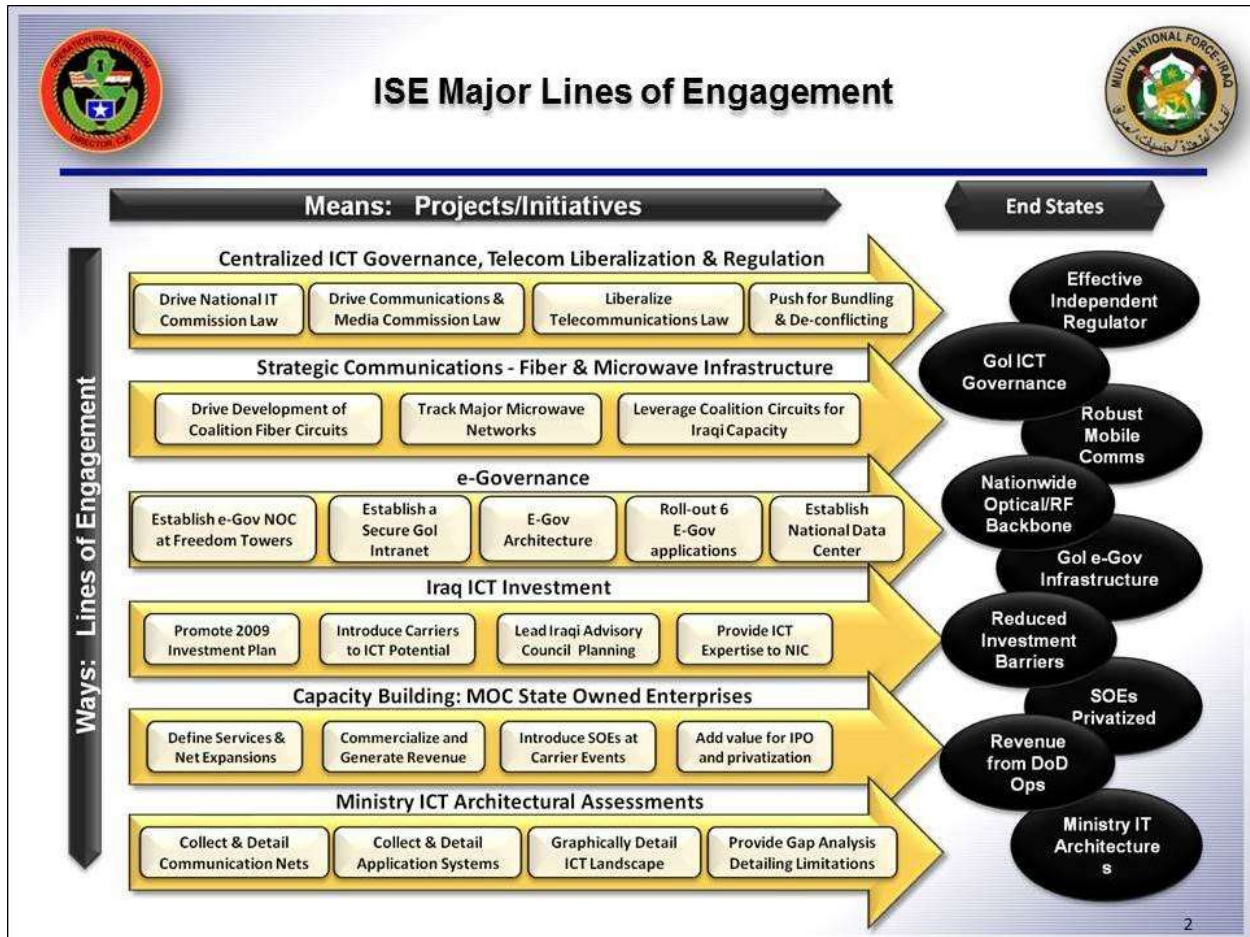

Figure 113: Example of ISE lines of engagement

The ICCE/ISE team was led by a colonel and consisted of a mix of US Government civilian, military, and contractor personnel reporting to the MNF-I DCS CIS, a US brigadier general. A translator/interpreter with telecom and IT experience was also part of the team. The team included a small reachback support element at ASD-NII (now DoD CIO) and NDU CTNSP.<sup>1648</sup> A February 2008 MNF-I FRAGO<sup>1649</sup> formally established the ICCE within the MNF-I command arrangements with an initial operational capability for ICCE on February 27, 2008 and full operational capability on April 1, 2008. The ICCE established MoUs<sup>1650</sup> with Gol counterparts (e.g., the Ministries of Communications, Defense, Interior, and Science and

<sup>1648</sup> Assistant Secretary of Defense-Networks and Information Integration, Department of Defense Chief Information Officer, and National Defense University Center for Technology and National Security Policy

<sup>1649</sup> Fragmentary Order, used to send timely changes of an existing order, without reissuing it in its entirety, to subordinate and supporting commanders while providing notification to higher and adjacent commands.

<sup>1650</sup> Memoranda of understanding

Technology (MoST), the National Security Council, and the Prime Minister, Information Technology) and coordinated with the US Embassy Iraq through its Telecom Working Group (TWG). Oversight was provided by an ICT Senior Steering Group of executive/flag officer-level representatives. The MNF-I DCS CIS and ICCE Director met weekly with the minister of communications. The purpose of the ICCE/ISE was to assist the GoI in developing Iraqi communications infrastructure and policies and to improve the delivery of services. ICCE/ISE also worked to develop capacity within the related GoI organizations to improve institutional systems, processes, and human skills and to improve ICT sector governance in general (see illustration of lines of engagement (LOEs) in [Figure 113.](#))

In 2008, the DoD and DoS sponsored a CIO capstone workshop for the CIOs of Iraqi ministries, which was conducted by the NDU Information Resource Management College (now the iCollege). An NDU team went to Erbil, Iraq in August 2008 to conduct a two-week training program that addressed a range of topics such as the role of the CIO, governance, strategic thinking, enterprise architectures, information assurance, and IT acquisition and program management. A second phase of the training was a one-week training program held in Washington, DC at NDU. This effort included additional lectures on subjects such as IT project management, information assurance, and e-government, but, more importantly, a large portion of the program was a series of visits with government CIOs and industry CEOs/CIOs who shared experiences, challenges, and lessons.

In January 2010, the MNF-I Joint Campaign Plan was updated to reflect the Obama Administration's decision to move aggressively from security/stabilization to a "mentor and train" transition phase. In support of that decision, the ISE Team began a reassessment of each LOE with a focus on sustainability and Iraq ownership. Over the following months, many of the individual initiatives within the LOEs were curtailed because they either were not in scope of the mentor and train mission or their objectives could not be met within the window of active operations in Iraq.

In September 2011, the ISE Team, in conjunction with a drawdown of US combat forces, was transferred administratively to the US Embassy, with continued funding from the DoD. On December 19, 2011, with the final pullout of all combat forces in Iraq, the ISE Team was shut down. There remains no dedicated effort to continue ICT development in Iraq led by the DoD today.

In Afghanistan, the USAID Mission supported ICT sector governance and infrastructure and services recovery and reconstruction initiatives related to ICT for governance and for socio-economic (e.g., agriculture, health, education and finance) development and growth as well as capacity development. The USAID-funded Economic Growth and Governance Initiative (EGGI) focused on ICT sector governance by providing support to the Ministry of Communications and Information Technology (MCIT), the Afghanistan Telecom Regulatory Authority (ATRA), and Afghan Telecom Corporation (AfTel). USAID also funded two projects for an E-Government Resource Center (EGRC) (Phases I and II) focused on improving Afghan government websites, strengthening and upgrading the methods of inter-ministerial communications, training for government IT managers and CIOs, and supporting the institutionalization of established policies, guidelines, and technical standards for public bodies. Phase II focused on the establishment of the E-Government Resource Center within the MCIT to serve as the central source of technical expertise, skills, and guidance "to improve government operations, increase transparency, and promote efficient service delivery" and "to help the Afghan government implement streamlined, modern,

and effective electronic services.”<sup>1651</sup> Other related USAID initiatives addressed cybersecurity plans, laws, and training; CIO recruitment and training for ten ministries; and e-gov applications and database development, and e-gov training and education for managers and staff. USAID also invested in ICT areas such as the VSAT-based<sup>1652</sup> District Communications Network (DCN) that provided voice and Internet access to the general public through telekiosks established at District centers on a fee-for-service basis; ICT for agriculture (e.g., Malomat, an SMS-based product pricing system and the University of California, Davis [eAfghan Ag](http://eAfghanAg.com) website); ICT for healthcare and education; and mobile money. For its part, the MCIT made important changes, including the establishment of Deputy Minister of Information Technology, to whom the heads of the E-Government Directorate, Information System Security Directorate, and Technology and Innovation Directorate report.

In the 2005-2008 timeframes, ICT activities were also channeled through the Afghanistan Reconstruction Group (ARG) that provided a Senior Telecom Advisor (STA). The Afghan Reachback Office (ARO) at the Pentagon supported the STA/ARG. An ASD-NII/NDU reachback support element provided assistance to both the STA/ARG and ARO. Following the departure of the STA/ARG in 2008, the US Embassy Kabul established an ambassador-level Telecom Working Group (TWG) to coordinate Interagency ICT-related activities in country and with CONUS-based Interagency elements. DISA deployed a DISA Support Element-Afghanistan (DSE-A) to Kabul in 2009 to coordinate establishment and operation of Tier 0 DISN entry points to support the military C4ISR surge connectivity needs.<sup>1653</sup> The DSE-A office in Afghanistan was closed in November 2014 and moved to Bahrain.

The US Embassy Kabul also supported ICT through its Public Affairs section for media and education opportunities such as scholarships. The ECON section supported ICT for governance and investment actions as one of many items in its portfolio of responsibilities. “In 2008 the La Jolla Golden Triangle Rotary Club Foundation received a grant from the US Department of State’s Bureau of Educational and Cultural Affairs to establish a Global Connection and Exchange Program (GCEP) via Internet-based computer labs in schools in Jalalabad. GCEP’s primary goals were to develop information technology (IT) skills in Afghan students, and to use technology to connect Afghan students with their peers in the United States, while promoting good citizenship skills.”<sup>1654</sup> The Department of Commerce also engaged in ICT investment activities, regulator training, telecom and cybersecurity law reviews, and development of the National Cybersecurity Strategy of Afghanistan. A number of USAID and World Bank programs focused on ICT capacity development at Afghan universities and vocational training centers. The World Bank also funded

---

<sup>1651</sup> USAID (2016). “Electronic Government Resource Center Phase II,” October. Accessed December 20, 2016. <https://www.usaid.gov/sites/default/files/documents/1871/Electronic%20Government%20Resource%20Center%20Phase%20II%20%28EGRC%20II%29.pdf>.

<sup>1652</sup> Very small aperture terminal, a two-way satellite ground station with a dish antenna generally smaller than three to four feet.

<sup>1653</sup> Defense Information Systems Agency (DISA). Accessed February 7, 2015. <https://www.disa.mil/About/Our-History/2010s>.

<sup>1654</sup> Brown, Stephen R. and Meltem Çelik (2015). *Seven Years of Dynamic Outcomes*, January 30. Accessed October 4, 2014. <http://sistercities.org/sites/default/files/AYC%20Final%20Report.pdf>.

the development of the VSAT-based Government Communications Network (GCN) that provided voice, video teleconference (VTC), and Internet services connecting the national government in Kabul with the 34 provincial governors, expansions of Afghanistan’s fiber optic network, implementation of a mobile government service platform and m-gov services, and an ICT incubator at the ICT Institute.

In early 2010, the DoD Task Force for Business and Stability Operations (TFBSO)<sup>1655</sup> established offices in Afghanistan. Its office in Kabul was located outside of the ISAF compound in its own safe house with contracted security protection. (A second office in Herat is described below.) The TFBSO had its own armored vehicles with PSD<sup>1656</sup> that gave them on-the-ground mobility and highly-flexible freedom of movement. The TFBSO was headquartered at the Pentagon and personnel there supported on-the-ground efforts in Afghanistan and participated in regular rotation of staff into Afghanistan to participate in activities with Afghan counterparts. The staffing model relied on the energy and enthusiasm of a predominately junior professional staff rather than seasoned professionals, recognizing there was also a need for mid-career professionals familiar with USG processes and technical expertise. Success was uncommonly reliant on the efficacy of its senior leaders in coordinating with stakeholders inside and outside of government and personal engagement in identify and recruiting the right personnel for the job. The TFBSO had its own contracting staff. The TFBSO mandate from SecDef was to focus on the “development of economic opportunities, including private investment, industrial development, banking and finance system development, agriculture diversification and revitalization, and energy development.”<sup>1657</sup> The Afghanistan focus was on three lines of effort: extractives, investments, and indigenous industries.



Picture 57: TFBSO Herat facility and incubator

The TFBSO’s Investment work in Afghanistan included ICT, such as sponsoring ICT investor visits to Afghanistan. The TFBSO office in Herat included an ICT incubator established in 2011 to support the

---

<sup>1655</sup> The TFBSO became embroiled in controversy for its operations in both Iraq and Afghanistan, with claims its mission was in violation of the authority of the Department of Defense, among other allegations and criticisms. Although now defunct, the TFBSO is under investigation by the Special Inspector General for Afghanistan Reconstruction (SIGAR).

<sup>1656</sup> Private security detail

<sup>1657</sup> Gates, Robert M., US Secretary of Defense (2010). “Continuation of Task Force for Business and Stability Operations.” Memorandum, March 25.

development of private industry. The Herat office was located at an industrial park near the airport on a secure compound that had a small multistory hotel-like facility to accommodate staff and visitors and office areas for them. One building served as a conference center and another housed the incubator (see [Picture 57](#)). The incubator was largely used by students from Herat University who were bussed daily from the university to the TFBSO Herat compound and back.

In 2010, DISA with financial support from the TFBSO, established the ISAF STA/TAT to provide subject matter expert (SME) support to Afghan ICT sector governance and infrastructure reconstruction for security, stability, governance and socio-economic development and growth. Efforts also addressed capacity development for Government of the Islamic Republic of Afghanistan (GIROA) ICT elements, including the Ministry of Higher Education modernizing the public universities' computer science and cybersecurity curricula and Cisco Networking Academies at several universities and vocational training centers. The STA/TAT interacted with TFBSO headquarters and the field offices in Kabul and Herat. See [Picture 58](#) of the NDU advisor to STA/TAT giving a lecture on Afghan ICT to Herat University students participating in the ICT incubator at the TFBSO Herat facility. (The establishment and evolution of the STA/TAT operation is covered in much more detail later in this chapter.)



*Picture 58: TAT member's presentation on Afghan ICT to incubator participants at TFBSO Herat facility*

By 2012, the ICT incubator was not meeting expectations to bring together entrepreneurs with ideas for technology businesses, and this “led to a gradual shift of the model to one that became called an ‘accelerator,’ which focused on taking local companies with track records of success across a range of sectors and helping them grow significantly.”<sup>1658</sup>

---

<sup>1658</sup> Zimmerman, Sarah Rebecca, Daniel Egel, and Ilana Blum (2016). *Task Force for Business and Stability Operations: Lessons from Afghanistan*. RAND Corporation. Accessed October 4, 2016. [http://www.rand.org/pubs/research\\_reports/RR1243.html](http://www.rand.org/pubs/research_reports/RR1243.html).



In 2013, the TFBSO and USAID invested in the establishment of the [International Center for Afghan Women’s Economic Development](#) at the [American University of Afghanistan](#) (AUAF) in Kabul. The center includes a [Business Innovation Hub](#) (BIH) which is a business accelerator similar to the ultimate TFBSO model in Herat. The BIH provides a variety of business and transaction advisory services designed to help Afghan businesses in all sectors to reach their full potential. It is staffed by a team of Afghan and international consultants with extensive local and international business experience.

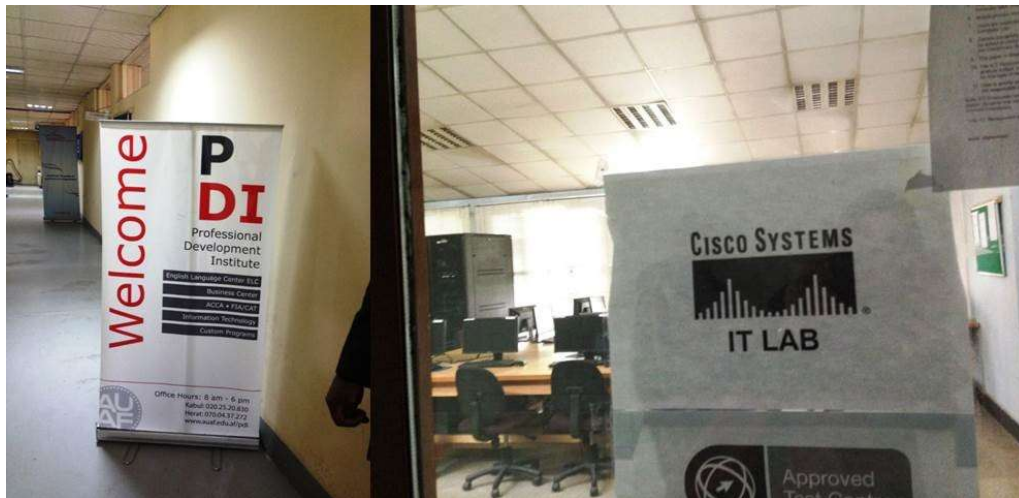

*Picture 59: American University of Afghanistan’s Professional Development Institute*

USAID also invested in other AUAF initiatives including its [Professional Development Institute](#) (PDI). The PDI Information Technology (IT) program offers a variety of technology training: Cisco, Comp TIA, ICDL,<sup>1659</sup> Microsoft, Oracle, and Redhat, among others (see [Picture 59](#)). The institute provides a range of flexible options to tailor training and certification programs to meet various customers’ needs such as the Afghan National Security Forces (ANSF) and industry IT training. PDI’s IT programs have several advantages for students. First, training is authorized by the respective vendors (there are many unauthorized IT training centers in the country), and, second, PDI’s testing center provides students with the opportunity to certify their training with internationally-recognized certifications. USAID also facilitated the development of a bachelor of arts and law degree with Stanford Law School to cultivate a professional class of lawyers ready to navigate Afghanistan’s unique and challenging legal landscape. AUAF established a VTC classroom to link it with Stanford University as well as the London School of Economics to accommodate a distance learning classroom environment.

Donors such as the World Bank and USAID also provided resources for ICT skills bridging programs and short-term training programs. The bridging program (which included subjects such as hardware, software, the Internet, and soft skills such as communication, interpersonal relations, business and entrepreneurial skills) was funded by the World Bank. USAID funded the Afghanistan Workforce Development Program (AWDP) and Assistance in Building Afghanistan by Developing Enterprises (ABADE), which were premised

---

<sup>1659</sup> International Computer Driver’s License

on short-term training programs with a short-term view of capacity building (fill in the ICT skill gaps now). There were also longer-term focused programs such as the World Bank Strengthening Higher Education Program (SHEP) and USAID Higher Education Program (HEP). The USG also made use of the Washington, DC-based US Telecommunications Training Institute (USTTI) to conduct specialized training for personnel of Afghan civil agencies. The DoC conducted regulator training at ATRA and the Federal Communications Bureau-International Bureau (FCC-IB) offered to provide regulator orientation training for the ATRA chairman and to conduct VTC training for ATRA regulators and staff. (See [Chapter 19](#) and [Chapter 20](#) for more information on ICT capacity building in Afghanistan.)

In the case of both Iraq and Afghanistan, the ad hoc efforts served to improve the ability of the USG to advise and assist GoI and GIROA ICT counterparts so that significant benefits would be provided to them and to Coalition forces. The efforts also helped facilitate trust building, information sharing, harmonization of activities, connecting providers with customers, and synchronization of ICT civil-military actions. This helped to create an affected nation government, Coalition military, US Interagency, and international organization environment of collaboration, cooperation, and informed information sharing to improve civil-military planning, implementation, and shared situational awareness and focus for developing strategic partnerships and coordinating key leader engagements with affected nation ICT counterparts. The approaches also served to improve the ability to better inform and advise the ambassadors and their staffs, USAID, and the US military commanders and their staffs on the value of ICT as a game changer and enabler of success and provider of informed and timely advice related to resolving challenges that emerged.

## Setting the Stage for Reconstruction of the Afghan ICT Sector

The Ministry of Communications (MoC) of Afghanistan was originally established in the year 1955. The first post-conflict era Minister of Communications was His Excellency Mohammed Masoom Stanekzai, who was appointed by Interim President Karzai in June 2002. Telecom was seen by the Interim government as essential to stimulating economic activity in all sectors, promoting democracy and civil security, and restoring administrative control.<sup>1660</sup> By virtue of Presidential Decree No. 4517 signed by Interim President Karzai in July 2002, the MoC was granted the statutory authority to issue ICT licenses and spectrum frequency permits and was given the responsibility to lead the ICT sector to rapid implementation, development, and growth through the establishment of organization elements, policies, laws, regulations, procedures and an ICT strategy and plan for the way ahead. Afghanistan was committed to following international best practices in telecommunications sector reform and embraced a market regime based on aggressive market liberalization, transparent regulation, fair competition, and private sector participation.<sup>1661</sup>

---

<sup>1660</sup> Zita, Ken, Network Dynamics Associates LLC. "Afghanistan Telecom Brief," USTDA South Asia Communications Infrastructure Conference, New Delhi, India – April 21-23, 2004.

<sup>1661</sup> Ibid.

In support of the establishment of a new post-conflict government and direction given by the interim government to give ICT recovery and development priority emphasis, the International Community started its response activities in 2002, first by providing subject matter expert consultants and then by funding support to ICT sector governance recovery and development and ICT infrastructure recovery, reconstruction, development, and modernization. Organizations that engaged early included the US Trade and Development Agency (USTDA), the Department of State including USAID, the International Telecommunication Union (ITU), the United Nations Development Programme (UNDP), the Asian Development Bank (ADB), and the World Bank. Over time, international sources of ICT-related support and assistance in kind included countries such as Germany, China, Iran, India, Korea, Japan and others. Industry giants such as Microsoft and Cisco also provided early assistance from outside the country. Later in the recovery and reconstruction process, the Department of Defense (DISA and the National Defense University), the Department of Commerce, the Federal Communications Commission-International Bureau, NATO, and others engaged in ICT sector activities.

Responder activities were, however, largely independent initiatives with participating nations and organizations all having good intentions to help make things happen, but it was not a coherent approach. The responder elements lacked top-down leadership, coordination, information sharing, and a framework for supporting informed decision-making. As the recovery and reconstruction process moved forward, there was a need to improve coordination and harmonization of the multitude of activities to help the Afghans restore governance of the ICT sector, to put policies, strategies, and plans together, and to help fund reconstruction of the ICT sector.

The MoC also took actions early in the recovery process to set the conditions for implementing a good public-private partnership to enable private sector ICT investments and growth. The growth of the mobile network operators (MNOs) and introduction of Internet service providers (ISPs) and access to Internet were important to making significant advances in the ICT sector and its related success. Improving the ability for the government and security forces to communicate and the general public to communicate was particularly important to improving security, governance, and public safety in the early phases of recovery as well as to the successes of the longer-term phases of ICT sector reconstruction and development.

In October 2002, the MoC created a Telecommunications Development Strategy and also made available a National Telecommunication Policy Paper and a draft Information and Communication Technologies (ICT) Policy Paper. The drafts came after a workshop organized and hosted by Asia-Pacific Development Information Program (APDIP) UNDP.<sup>1662</sup> A delegation of high officials from the government and ICT professionals took part in the workshop. In July 2003, the MoC finished an updated version of the policy document by the Telecommunications and Internet Policy Final Working Draft and Information and Communication Technologies (ICTs) Policy (draft).<sup>1663</sup> After devising and implementing the

---

<sup>1662</sup> Uldal, Siri Birgitte and Muhammad Aimal Marjan (2004). *Information and Communication Technology in Afghanistan*. Norwegian Center for Telemedicine Report #05-2004, February 4, 2004.

<sup>1663</sup> Ibid.

Telecommunications and Internet Policy in 2003, the MoC established the Telecom Regulatory Board (TRB) as an interim entity to assume responsibility for the issuance, monitoring, and enforcement of licensing and spectrum management functions.

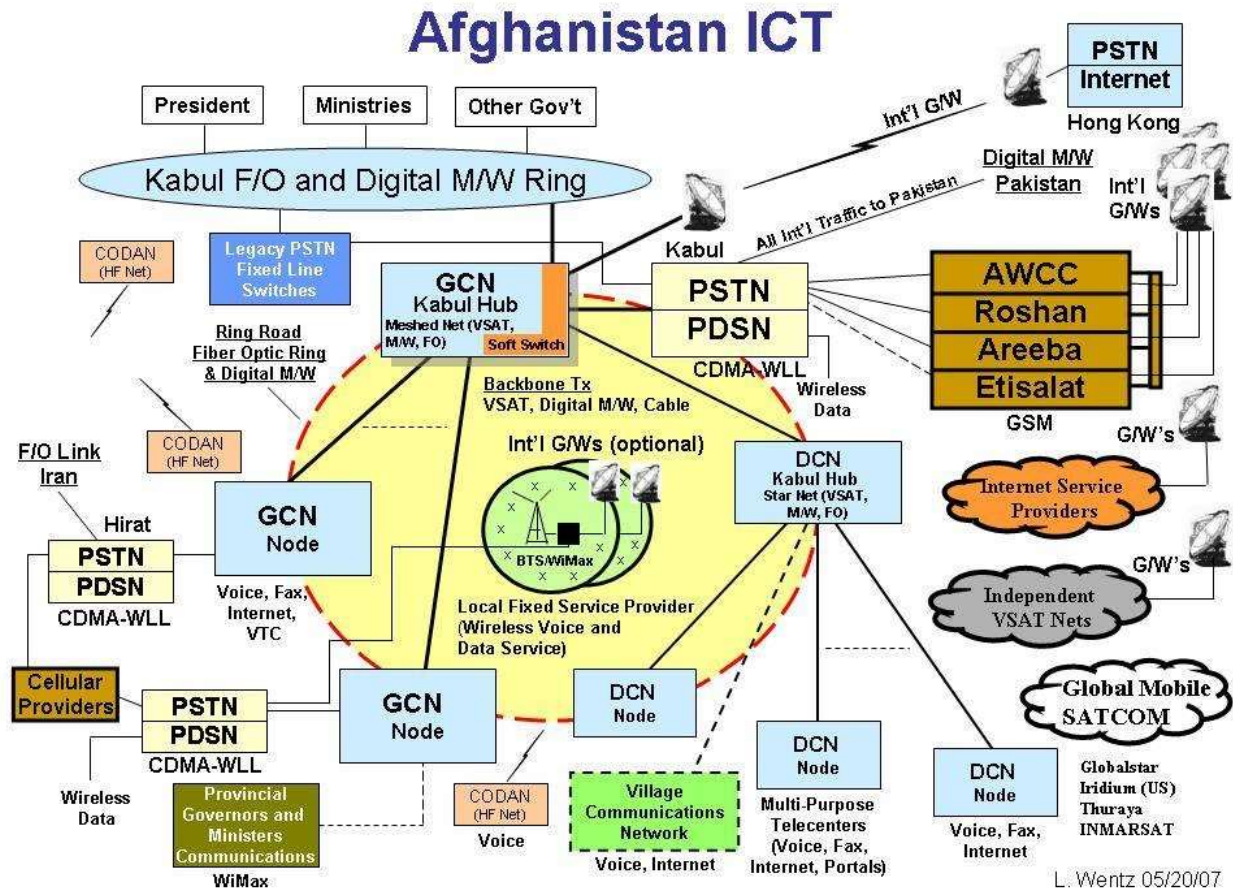

Figure 114: Afghanistan ICT architecture in the 2006-2007 timeframe

Following the 2004 recognition of ICT by GIRoA as a priority sector for investment, additional policy steps were implemented to ensure the ICT sector would become an even more driving force in the development of the country and that ICTs would advance appropriately throughout Afghanistan in the years following. A state-owned enterprise, Afghan Telecom Corporation, was established in September 2005 to implement, maintain, and operate a nationwide fiber optic network, provide cellular network services (initially CDMA<sup>1664</sup> and then later replaced with GSM technology), fixed line services, Internet services, a

<sup>1664</sup> Code division multiple access, a method used by some radio communications technologies that makes it possible for several transmitters to send information over a single communication channel simultaneously, thereby allowing multiple users to share finite frequency bandwidth without interference.

Kabul-provincial government HF<sup>1665</sup> radio network for security communications, satellite-based networks comprising the GCN, DCN, and VCN,<sup>1666</sup> and the possibility of other satellite-based services that became a reality in 2014 with the launch of AfghanSAT1. Amirzai Sangin was appointed Minister of Communications by President Karzai in December 2004 and remained in this position until late 2014 when he stepped down with the election of the new Afghan President, Ashraf Ghani. The Afghanistan civil ICT network architecture for the 2006-2007 timeframe is illustrated in [Figure 114](#) along with the four mobile commercial network operators (Afghan Wireless Communications Company, Roshan, Areeba now MTN, and Etisalat), the ISPs, independent VSAT networks, and mobile SATCOM<sup>1667</sup> phones.

The continuity, vision, and leadership of the MoC (later the MCIT; see below) for over some 13 years has been supported by a consistent strategy and plan to reconstruct and modernize Afghan ICT that has, in turn, led to the ICT sector being a major success story for Afghanistan. The fact that ICT was designated a priority sector by the government in 2002 and then a critical sector as part of the [ICT Sector Strategy](#) development for input to the [Afghanistan National Development Strategy](#) in the 2006 to 2008 timeframe, coupled with the ministry being designated as the leading government entity for ICT, were all key factors for success. To reflect this new government emphasis, the designation of the MoC changed to Ministry of Communication and Information Technology (MCIT) in February 2007. The Afghanistan Telecom Regulatory Authority (ATRA) was formally established in 2006 by merging the previous interim Telecom Regulatory Board (TRB) with the frequency management functions of State Radio Inspection Department (SRID) of the MoC. This approach to ICT sector recovery and reconstruction has been supported by a business-friendly institutional framework within the MoC/MCIT as well as within ATRA. As noted, a succession of technically-aware ministers, supported by technocrats, has established a consistent, forward-looking vision of sector development, which has engaged the private sector in spite of the volatile security and investment environments. While there was [and still is] a shortage of skilled personnel at lower levels, the growth and competition oriented approach of MCIT and, increasingly, ATRA has contributed significantly to the growth of the ICT sector despite security and governance concerns.<sup>1668</sup>

There are, however, challenges to be overcome to ensure the success of the sector continues. With the change in the Afghan government the end of 2014, a new MCIT minister was appointed in April 2015, Abdul Razaq Vahidi. A new ATRA Chairmen was also appointed, Dr. Mohammad Najeeb Azizi, and the ATRA board members were replaced as well. Needless to say, the governance of the ICT sector has undergone major changes. Changes to AfTel management and personnel were proposed – and some have come to fruition as of 2016 – as well changes to MCIT deputy ministers and other senior staff and managers. A new ICT advisor to the President was also added to provide high-level oversight of the sector. The impact of the changes and implied changes have yet to fully emerge and to be understood, but clearly

---

<sup>1665</sup> High-frequency

<sup>1666</sup> Government Communications Network, District Communications Network, and Village Communications Network.

<sup>1667</sup> Satellite communications

<sup>1668</sup> Kelly and Souter, 2014.

the uncertainty introduced by the key leadership changes and rumored possibilities of other important management changes has significantly reduced the operational effectiveness of executing ICT sector governance and related decision making process.

## Afghanistan Reconstruction Group and its Senior Telecom Advisor

### Establishment of the ARG and Deployment of the First STA

Problems and delays in the USG-led Afghan reconstruction program began almost immediately after the program was initiated in 2002, leading the USG, and the National Security Council (NSC) in particular, to consider ways to accelerate the process and provide selected professional SMEs on the ground in Kabul to help. An experimental unit known as the Afghanistan Reconstruction Group or “ARG” was organized by former Secretary of the Army Martin R. (Marty) Hoffmann (working as an advisor to then Secretary of Defense Donald Rumsfeld) in 2003 when it became obvious that the perceived “business-as-usual” approach to reconstruction was in danger of making Afghanistan another Haiti or Kosovo. With the assistance of Hernando De Soto, the leading expert on private enterprise in the developing world, Secretary Hoffmann conceived of the idea of a small group of advisors, recruited from both the private and the public sectors, and reporting directly to the ambassador. After lengthy DoD consultations with the NSC, DoS, and USAID, the ARG was authorized as a special group on the State Department payroll to be located in Kabul on the US Embassy compound. It did not have its own budget and relied on the embassy for security, transportation, and logistics.<sup>1669</sup>

The ARG was created to assist with the Afghanistan reconstruction effort without creating an additional bureaucratic overlay to the ongoing process,<sup>1670</sup> and was tasked with the mission of accelerating reconstruction. By late 2003, the vanguard of the ARGonauts, as they came to call themselves, started setting up operations at the US Embassy Kabul. The areas and sectors covered by the ARG included transportation/infrastructure, aviation, water, energy, telecom, finance, privatization, private sector development, mines and industry, agriculture, rule of law, health, education, elections, gender programs, and public affairs. There was also a companion support office set up in the Pentagon called the Afghanistan Reachback Office (ARO). Supporting the ARO in the telecom area were SMEs from ASD-NII (now DoD CIO) and National Defense University Center for Technology and National Security Policy (NDU CTNSP).

One of the first challenges encountered was ARG members faced long delays in obtaining the necessary approvals from the State Department to deploy to Kabul. The Public Affairs Advisor arrived first with two assistants and shared office space with the State Department’s Public Affairs Office. The next group to arrive, in January 2004, were two people seconded from other government agencies (the Senior Economic

---

<sup>1669</sup> Berner, Thomas F. “Send in the Amateurs! Recruiting from the Private Sector to Accelerate Nation-Building: The Experience of the Afghanistan Reconstruction Group.” Published in Gott, Kendall D. and Michale G. Brooks, eds. (2006). *Security Assistance: US and International Historical Perspectives. The Proceedings of the Combat Studies Institute 2006 Military History Symposium*. (Fort Leavenworth, KS: Combat Studies Institute Press).

<sup>1670</sup> Ibid.

Advisor from the Department of the Treasury and the Senior Natural Resources Advisor from the US Geological Survey) and the Chief of Staff (CoS) along with ARG's executive assistant. The CoS had had a varied and successful career in the private sector, including as a consultant on turnarounds of distressed corporations. In February 2004, the Senior Legal Advisor and the Senior Healthcare Advisor arrived. Over the next several months, advisors on elections and education arrived, as well as the Deputy Chief of Staff (DCOS, who also supervised election work). The DCOS was a sitting judge in the State of Florida with nation-building experience in Panama, Haiti, and Bosnia. Still later arrivals included experts in agriculture, private investment, privatization, aviation, water, and infrastructure. As the group got larger, it split into two parts: DCOS ARG became the Deputy Chief of Staff for social reconstruction (education, agriculture, healthcare, law, and elections), and a second senior person was assigned as Deputy Chief of Staff for economic reconstruction (economy, private investment, privatization, aviation, and infrastructure).<sup>1671</sup>

Each advisor developed an individualized approach to his/her sector that depended on the number of agencies working in that field, the advisor's assessment of the most effective way to work with his or her colleagues, and the most serious problems that needed to be addressed. The approaches fell into one of three categories:

1. **Filling the Gap.** In areas where other agencies did not have significant projects, ARG members were able to focus on providing advice to the ministries in their field and initiate projects of their own.
2. **Coordinators.** Some sectors, such as economics and law, had a plethora of agencies involved, each running their own projects. The ARG members in these areas attempted to coordinate activities, or at least let the left hand know what the right hand was doing. A good example of the need for coordination was reported by an ARG member: "On one occasion one Afghan ministry had been given funds to construct a rather expensive wall around a facility. The next week another ministry contracted to tear down a part of the wall to widen a road under another US funded project."
3. **One-on-One.** Where the number of entities affecting a particular sector was small, the ARG members would focus their energies on providing advice to those entities.<sup>1672</sup>

It was perhaps inevitable that there would be friction between the ARG and the rest of the embassy. There were a number of reasons for this:

- There was the perception that ARG was an affront to the Embassy's efforts. As one career State Department officer put it, "I think the ARG could have been more effective if . . . the traditional governmental entities could have overcome a sense of mistrust based on what ... was a false impression that the ARG's existence somehow suggested that they themselves were not fully trusted to accomplish the goals of the Mission."

---

<sup>1671</sup> Excerpted and paraphrased from Berner, 2006.

<sup>1672</sup> Ibid.

- ARG being a Department of State entity hired by the Department of Defense, the traditional interdepartmental rivalry between State and Defense flared up. As one respondent from USAID put it, “There were times when US political biases, particularly the tension between State and DoD, was introduced in an unnecessary and counterproductive manner by the ARG.” An ARG advisor believed that “ARG lost most of its chance to be effective for a variety of factors. First and foremost was the decision to have ARG staff recruited and reporting to DoD while being State employees. State saw ARG as competitors rather than as the resource [it] should have been.”
- The nature of ARG’s mission, to “accelerate reconstruction,” without a budget for [its] own projects required ARG to become involved in the projects of other agencies. No matter how tactfully this was done, it still brought ARG into conflict with existing agencies.<sup>1673</sup>

The initial ICT engagement between the Pentagon (ASD-NII, now DoD CIO, and later the Sec Def’s ARO) and local commands in Afghanistan began in 2004 before the arrival of the ARG Senior Telecom Advisor (STA) in 2005. ASD-NII approved a trip to Afghanistan for the Deputy Director of Contingency Support and Migration Planning (CMSP) to take a small team from Washington, DC to meet with the Combined Forces Command (CFC) J6<sup>1674</sup> and the Office of Military Cooperation (OMC). (The OMC was later renamed the Office of Security Cooperation – OSC – when the cooperative mission expanded from Afghan National Army (ANA) support to also include Afghan National Police (ANP) support, with the combined ANA/ANP referred to as ANSF, or Afghan National Security Forces). While the primary purpose of the trip was to focus on support to the ANSF regarding spectrum issues, the trip also included a review of broader ICT civil-military issues and opportunities. These included work to establish a baseline for future engagement by ASD-NII/DoD CIO in coordination with CFC, and also broader coordination with the US Embassy Kabul, as ICT work expanded from primarily military ICT issues to also include engagement with Afghan civil sector ICT organizations and initiatives.

While ASD-NII worked in 2004 with the TRB, which reported to the Ministry of Communications, in 2005 the civil-military coordination expanded to include the MoC and Afghan Telecom. ASD-NII/ trips to Kabul continued through 2005 when it moved its in-country base of operations from CFC at Kabul Compound (later renamed Camp Eggers) to the US Embassy Kabul. The OSC was renamed the Combined Security Transition Command-Afghanistan (CSTC-A) in mid-2006 to continue working plans and programs and implementing reform of the ANSF, with goals including counterterrorism, stabilization of Afghanistan, and strengthening of the rule of law.

In 2005, ASD-NII began to work ICT issues from a new basing arrangement at the embassy to leverage embassy relationships developed by a new ICT SME member of the ASD-NII CSMP team who, prior to joining ASD-NII, had been based at the embassy in 2004 to work with key stakeholders across both State and USAID offices with ICT work focused primarily on civil sector ICT issues.

---

<sup>1673</sup> Berner, 2006.

<sup>1674</sup> Communications



The importance of ICT was recognized by the USG and DoD, in particular. The position of STA was created at the outset within the ARG transportation and infrastructure coordinator functional area. The STA position did not, however, get filled until the latter part of 2005. In fact, the STA arrived at the US Embassy Kabul in September 2005 with no pre-deployment training, but with several weeks of briefings and Washington, DC-based meetings across the Interagency, academia, and with industry prior to becoming a government employee. These meetings were initiated by the first STA based on his own engagement strategy developed in the absence of any strategy advanced by government organizations. The ICT Reachback team (ASD-NII and NDU) pulled together informally and helped organize and participated in most of the pre-deployment engagements. It was felt the time would be well spent to have face-to-face meetings with key players in the government Interagency and the private sector that could help once the STA was in Afghanistan, and this, in fact, was the case. The STA took the initiative upfront to develop the right government and industry “reachback” groups that would be focused on ICT in Afghanistan and provide him assistance, since it appeared no one was looking at a broad team approach to reconstruction. Based on his initial assessment of the problem and his industry experience, he knew that he could not do the job alone. Others in government seemed to assume that once someone was “in the STA billet” the problem would be solved, not realizing the complex cultural, political, economic, and technical problems that had to be overcome to ensure rapid development of the ICT sector in a way to support Afghan and US national strategic goals.

The STA set up two reachback groups, one public sector and one private sector, before deploying to Kabul. The effort to build the two reachback groups before leaving the United States became one of the most critical success factors. The key was finding people and organizations with passion and capability then continually engaging to keep them working together well to accomplish tangible results. The Reachback Team members from ASD-NII and NDU worked tirelessly to keep the public sector reachback group engaged and to facilitate coordination of the two group’s activities. The private sector reachback group consisted of companies, NGOs, and universities.

It was quickly discovered that ad hoc distributed virtual team building is difficult but can be done effectively. Challenges included communications that were at times difficult due to technological limitations, time zone differences, and competing priorities.<sup>1675</sup> Weekly and sometimes almost daily teleconference calls were used to stay connected. Dispersed team members can often lack clear and agreed upon goals and objectives, but a shared understanding of goals and objectives was established as part of the informal predeployment discussions and support activities. Establishing trust can be particularly challenging especially in temporary groups, where relative strangers come together for a limited period of time to work on a specific problem or task.<sup>1676</sup> There were early and longer term trust-building measures between the STA and Reachback that included the joint participation in pre-

---

<sup>1675</sup> Bartone, Paul T. and Albert Sciarretta (2015). “Human Dimension Issues in Distributed and Virtual Teams.” *Small Wars Journal*, January 19. Accessed September 7, 2015. <http://smallwarsjournal.com/jrnl/art/human-dimension-issues-in-distributed-and-virtual-teams>.

<sup>1676</sup> Ibid.

deployment discussions, visits, and brainstorming, plus follow-on Reachback visits to Kabul to help the STA develop strategic partnerships with the US Embassy, USAID Mission, military elements, and Afghan counterparts and to help develop and execute a USG ICT strategy and plan. All of these efforts helped overcome many of the challenges in building a distributed virtual team. Complex leadership issues coupled with the need for timely and effective Reachback support and effective team building measures takes recurring tending once a crisis response operation starts. It was a proactive and continuing process during the period of time the first STA was on the ground in Kabul.

ASD-NII’s cultivation of embassy relationships was, in turn, applied to introducing the first STA to a range of embassy contacts when the STA arrived in September 2005 – significantly expediting the STA’s ability to shorten the learning curve to begin substantive work with the embassy social network, as directly or indirectly related to issues pertinent to the development of the Afghan ICT sector.

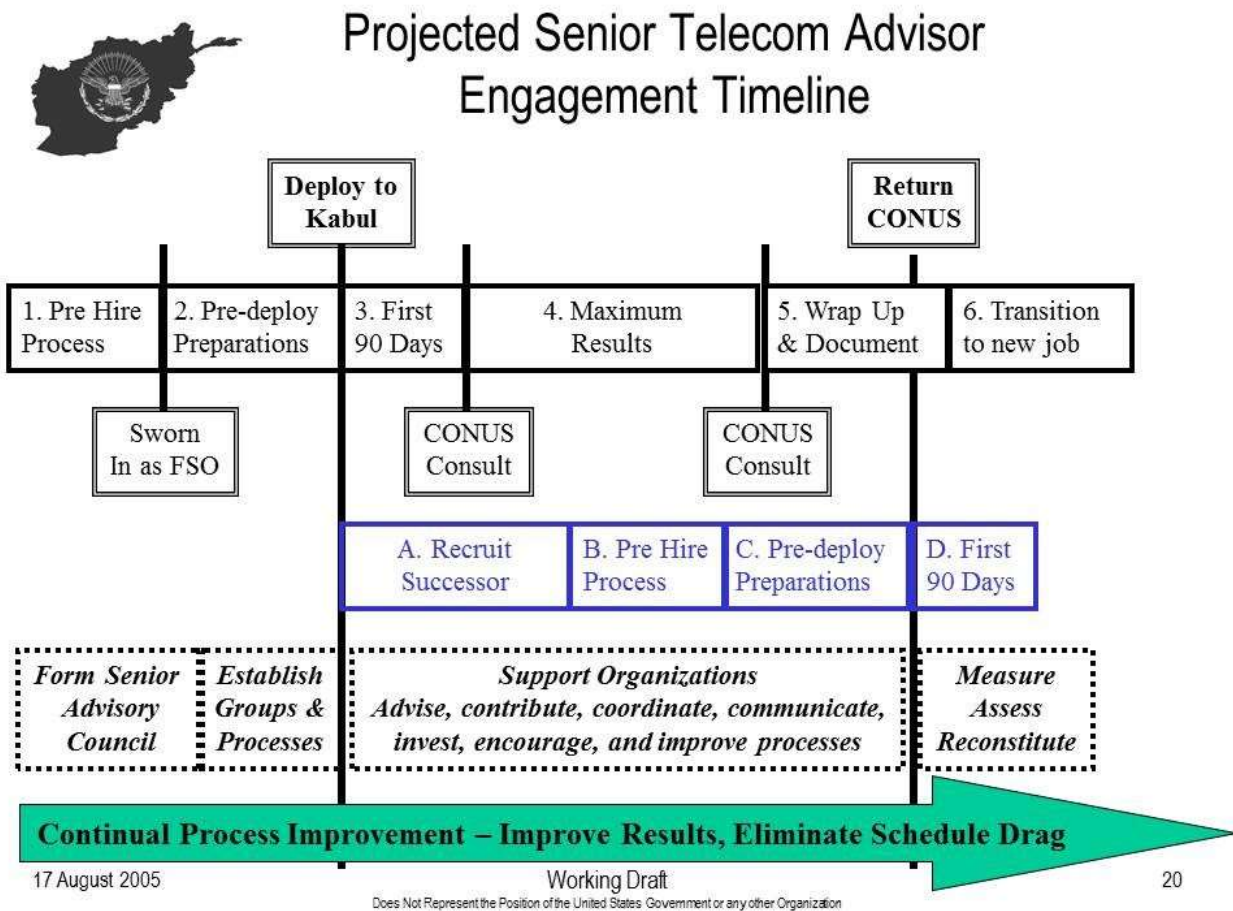

Figure 115: Projected Senior Telecom Advisor engagement timeline

There were three overarching considerations upon the STA’s arrival in Kabul: 1) the STA had to be prepared to serve as a shadow Chief Information Officer (CIO) for US efforts and, most importantly, foster

CIO skills in the Afghans; 2) success in the ICT sector would depend on leveraging global and national market forces and industry capabilities; and, 3) that if the USG could help Afghanistan create a digital society, it would be easier to deal with terrorists. Even in 2005, security appeared to be the primary issue in Afghanistan that influenced all others.<sup>1677</sup> The STA had a very rough strategic plan on how the first STA should engage and what early objectives could be. That strategy, which would evolve over time, was organized into specific objectives and actions to be done across a six-phase engagement plan (see [Figure 115](#)) that included starting the process to recruit his replacement and prepare him for deployment.

The primary stakeholder offices at the US Embassy Kabul were ARG, State ECON, and the USAID Mission Director and staff. The ARG operated as an independent senior organization, reporting directly to the Chief of Mission Ambassador, outside of and beyond “normal” embassy arrangements and reporting relationships. The ARG was responsive to ICT-related engagement, as the ARG Chief of Staff knew that in late 2005 the ARG would have a Senior Advisor added to his staff of a dozen or so other sector advisors, with the new Senior Advisor to provide advisory support to the Afghan ICT sector as the Embassy’s “STA.” The State ECON section was responsive, as it knew in Washington there was an existing ICT reachback capability providing ongoing Interagency coordination between the Department of State and the Pentagon’s ARO and ASD-NII. ECON was also aware that earlier work conducted by ASD-NII trips to the embassy provided information inputs useful for drafting cables back to Main State.<sup>1678</sup> The USAID Mission Director was responsive, as the ASD-NII ICT SME had worked directly with the USAID Mission Director at the embassy in 2004 when he had demonstrated interest in ICT issues and projects and coordinated with the USAID mission director on recruiting USAID Mission’s first position to take USAID lead in working Afghan ICT sector development issues. The 2005 period was also interesting in that a number of key players at the embassy remained in place beyond the normal rotation in the summer of 2005 to continue work into the new rotation year of 2005-2006, providing continuity for ICT engagements across both ASD-NII and the new STA. These actions illustrate the importance of establishing in advance a more informed understanding of the added value of an STA on the ground as part of the embassy support team and providing a proactive orientation program to prepare the STA for a more informed understanding of the operational environment, key players, sector issues and opportunities, and to help shape civil-military relationship building and the focus of the ICT work program to be implemented.

The first embassy-based STA began immediately to implement a pre-deployment plan and timeline to define USG engagement with the Afghan ICT sector. The STA strategy emphasized the USG need to apply its investments, resources, and expertise in a coordinated fashion to:

1. Help the Afghan government shape and implement an effective national ICT strategy that would generate prosperity, promote security and national unity, and help the people of Afghanistan reap the full benefits of the Information Age;

---

<sup>1677</sup> The life and death importance of the ARG work was highlighted when three ARG advisors were seriously injured when their armored Toyota Land Cruiser was hit by an improvised explosive device.

<sup>1678</sup> Informal term for the US Department of State headquarters in Washington, DC.

2. Foster private sector investment and engagement through a transparent free-market, a comprehensive legal and regulatory framework, follow-through on GIROA contracts and commitments, and collaborative mechanisms between the government and the private sector that increased communications and mutual trust;
3. Encourage cooperation between the US and Afghanistan to identify and achieve common goals in international ICT treaties and initiatives; and
4. Identify or provide opportunities and assistance for US firms to fairly compete in Afghanistan.

Figure 116 illustrates the establishment of two I-Teams, one that was US-centric and the other Afghan-centric. The lead roles of primary advisor, liaison advisor, and coordination/training are illustrated as well. Note the STA was the primary advisor to the Ministry of Communications.

## ICT Coordination Relationships Afghanistan: June 2006

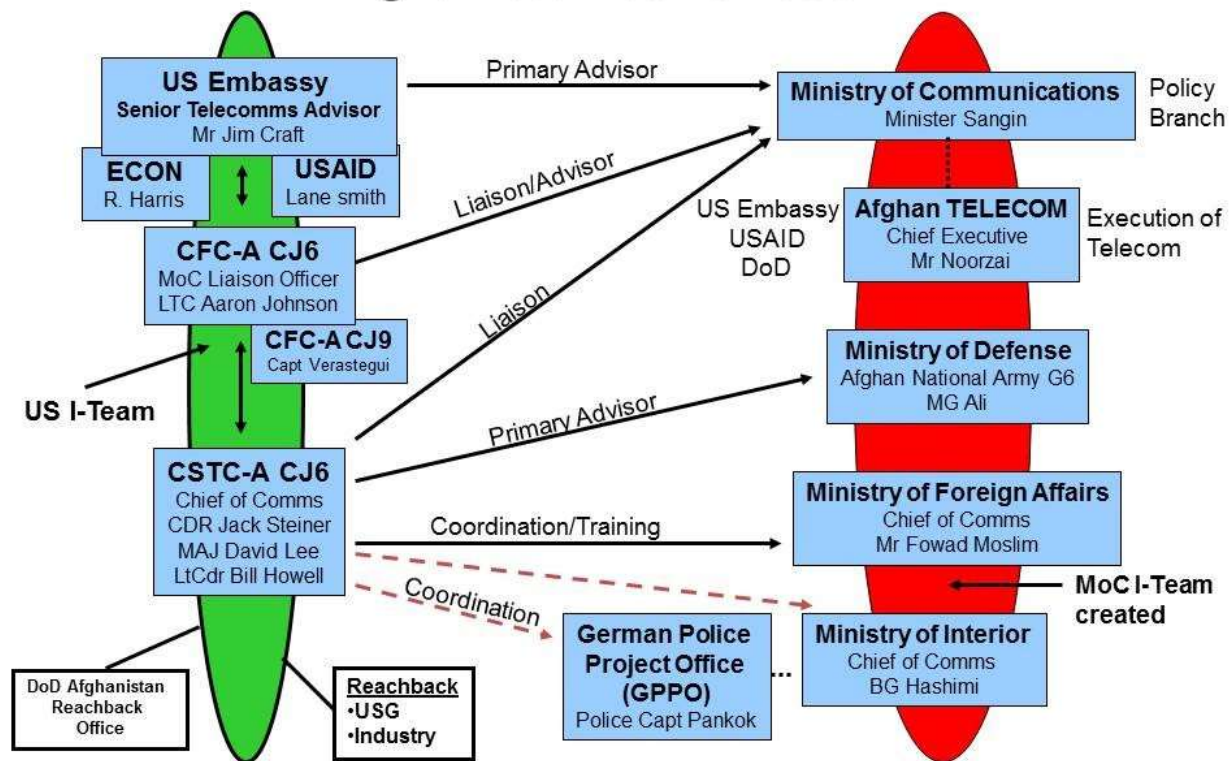

Figure 116: STA/ARG I-Team

One of the key elements of the engagement plan was to create and recruit interested civil-military organization members working ICT initiatives to join an ICT "I-Team," or Integration Team, to set the foundation for an STA approach to providing coordinated advisory support to key Afghan counterparts working in the public and private sectors, as well as those operating in the military elements of the Afghan ICT sector. In practice, the I-Team concept was simple and effective, developing concentric rings working outwards from a core capability, to integrate USG, Coalition, Afghan, and other interest groups to

cohesively engage in information sharing and coordination to work various aspects of the emerging Afghan ICT sector the use of ICT by other sectors. The inner core group comprised the STA, ICT Reachback, and ARG/ARO support. The second outward ring layer was defined by STA efforts, along with ICT Reachback support, to identify and recruit USG Interagency personnel, across US commands and State/USAID offices at the embassy, where participants had interests related to the development and success of the emerging Afghan ICT sector. The third outward ring layer was composed of key Afghans working in the public sector (e.g., at the MoC, TRB, and AfTel), as well as key personnel working in the private sector such as MNOs, ISPs, systems integrators, vendors and other Afghan ICT counterparts. The fourth ring layer consisted of other players with interest in the sector (e.g., personnel at the World Bank, UN, International Monetary Fund (IMF), ITU, and existing and planned professional ICT associations across Afghanistan).



*Picture 60: Bak DCN node and local school*

The mission of the STA was to provide advisory support related to all aspects of the emerging Afghan ICT sector and to prioritize advisory support issues working directly with the Afghan Minister of Communications and organizational elements within the ministry as well as with the TRB AfTel, the MNOs, ISPs, ISAF, CFC-A/CSTC-A,<sup>1679</sup> the USG Interagency, and international organizations. As noted earlier, the ASD-NII set up an office to support the STA and ARO activities that included placing ASD-NII staff in country for selected short term assignments in support of the STA and as acting STA to fill gaps in continuity of support when the position was vacant due to the rotation of the STA and when the STA was on leave. A NDU CTNSP senior research member engaged with ASD-NII as part of the ARO activities and in support of the STA in Kabul including a visit in 2006 to help the STA develop an ICT strategy and plan. His trip also included participating in a fact-finding visit to the Provincial Reconstruction Team (PRT) in Khost at Camp Chapman and visits with Civil-Military Operations (CMO) elements at FOB Salerno. The Khost visit included providing advice to the PRT commander, the Civil Affairs Team, and USAID representative on how to use ICT to support Internet access for healthcare centers, hospitals, schools, and Khost University. At the time of the visit, PRTs did not have civil and commercial ICT skill sets specifically assigned as part of the teams, and ICT was not typically a focus area. The intent of the trip to the Khost PRT was to develop a more informed understanding of PRT challenges and opportunities and to share thoughts on how ICT might be leveraged as part of the PRT strategy for some quick wins and to help shape longer-term initiative

---

<sup>1679</sup> Combined Forces Command-Afghanistan/Combined Security Transition Command-Afghanistan

opportunities. At the time of the visit, the *Afghanistan National Development Strategy (ANDS)* was the basis for shaping PRT initiatives, and although ICT was a key element of the *ANDS*, it was generally not included in PRT plans and skills staffing.

While visiting the Khost PRT, the NDU advisor made a trip to meet with the Bak district governor and visit the Bak District Communications Network (DCN) node and a local school where classes were taught outside under the trees (see [Picture 60](#)). The intent of the of the DCN node was to provide a telekiosk capability in the district town center to make access to voice and Internet services simple and close to the population for easy access. Due to security problems, the DCN node was not located in the center of town but was put on an ANP compound outside of the town that housed the district governor's office and the Afghan national police contingent. Needless to say, few locals walked outside of town to use the facility that was some distance away from the center of the town. Additionally, there were no advertisements on the local radio broadcasts or signs to identify the capability existed and was available for use by the public on a fee-for-service basis. The DCN was also available for use by the district governor as a way to extend governance communications to the district level. During discussions with the Bak governor, the NDU advisor realized he was not aware this capability was available for his use.



*Picture 61: Khost girls' school, GCN/CDMA node, and shura meeting*

In Khost, the NDU advisor made visits (see [Picture 61](#)) to the ANSF Provincial Coordination Center, Department of Communications Center (included HF node, CDMA base station, and Government Communications Network node), Khost University (included a radio station, journalism lab, computer science lab, and Cisco Networking Academy), a local girl's school, a medical clinic, and a hospital. He also made visits to a local public call office (PCO), an Internet café, and a computer supplies and repair shop. He also attended a local shura meeting to review CMO and PRT activities in the area. During the visit to the Khost University, the NDU advisor noted that separate VSAT access for Internet services was provided by different donors for the Cisco Networking Academy and the journalism lab but no Internet access was provided for the computer science lab.

The computer science lab had computers but no power, local area network (LAN), or Internet access (as mentioned above). The lab was on the other side of the wall of the journalism lab. As an interim solution, the NDU advisor suggested that the PRT explore funding for power, a LAN, and a possible sharing arrangement using existing VSAT-based Internet access at the journalism lab by extending it through the wall to the computer science lab. It would have also been possible for the computer science lab to access the Cisco Networking Academy network.



Picture 62: Khost University Cisco Networking Academy, journalism lab, and computer science lab



Picture 63: Khost hospital and medical clinic

## The ARG/STA and Civil-Military and International Cooperation

In the early days of the PRTs, activities were not well integrated into the larger counterinsurgency strategy and they experienced persistent Interagency differences over funding, staffing, and other issues.<sup>1680</sup> There was a need for better alignment of each agency’s mission (DoD, State, USAID and others such as USDA, DOJ<sup>1681</sup>) in the PRTs and allocation of resources (qualified skills and funding) to get the job done.<sup>1682</sup> Observers of Afghanistan PRT operations noted “a lack of unity of command resulting in a lack of unity of effort.”<sup>1683</sup> Another impediment was uncertainties regarding specific responsibilities and authorities of

---

<sup>1680</sup> Weitz, Dr. Richard (2010). “CORDS and the Whole of Government Approach.” *Small Wars Journal*, Volume 6, Number 1, February 4.

<sup>1681</sup> United States Department of Agriculture and Department of Justice

<sup>1682</sup> Parker, Michelle (2007). “The Role of the Department of Defense in Provincial Reconstruction Teams.” Testimony before the US House of Representatives’ Armed Services Subcommittee on Oversight and Investigations, September 5. Accessed March 14, 2016. <https://www.gpo.gov/fdsys/pkg/CHRG-110hhrg37731/html/CHRG-110hhrg37731.htm>.

<sup>1683</sup> US House of Representatives Committee on Armed Services, Subcommittee on Oversight & Investigations (2008). *Agency Stovepipes vs Strategic Agility: Lessons We Need to Learn from Provincial Reconstruction Teams in*

various U.S agencies involved due to the lack of clarity of USG policy on delivery of assistance<sup>1684</sup> and lack of approved Interagency doctrine and formal agreements such as MoUs/MoAs to govern roles and responsibilities. With no one in overall charge there were separate “stovepipes” of authority that led to confusion on civilian and military roles including State and DoD differences about who would provide security, support, and funding.<sup>1685</sup> Early stages of PRT coordination and information sharing were largely on an ad hoc basis.

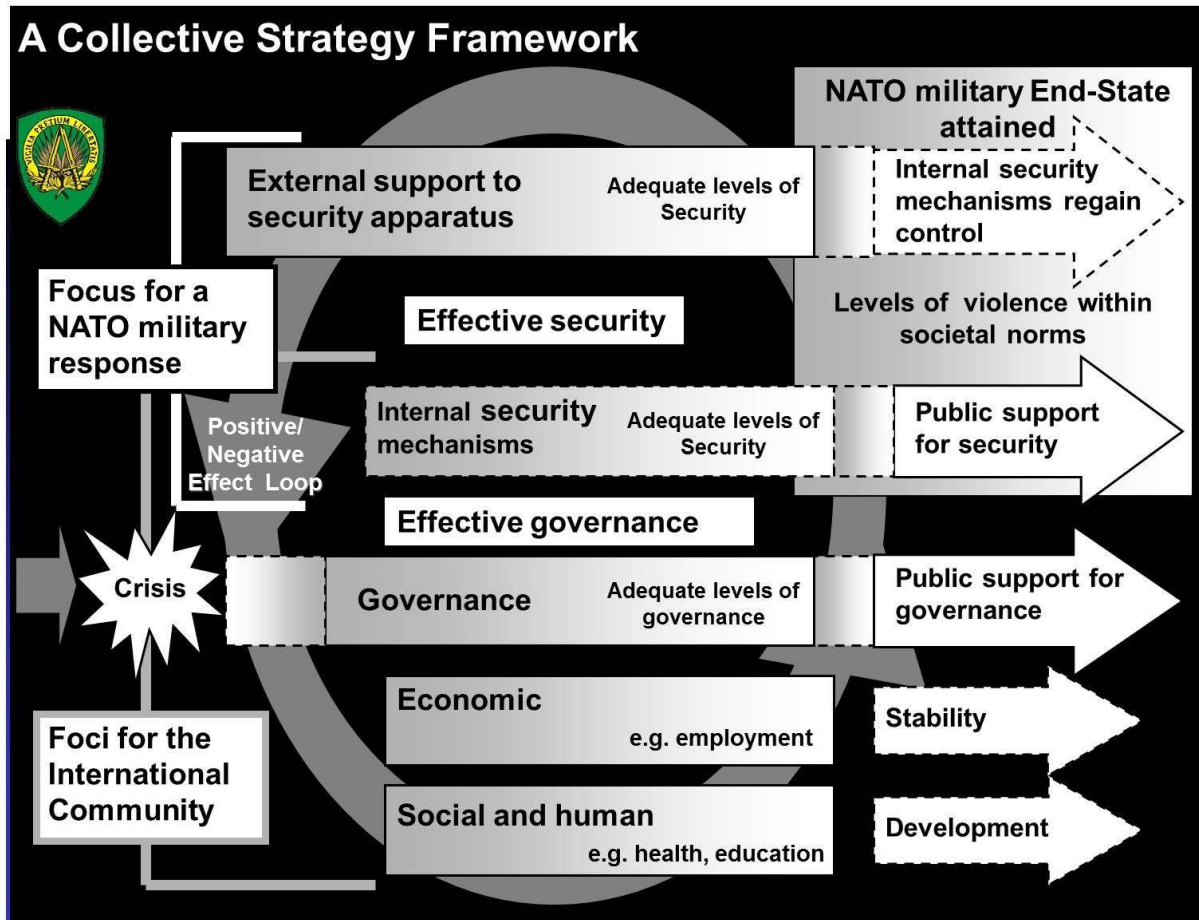

Figure 117: NATO Collective Framework

In the 2006 timeframe, NATO-led ISAF 9 implemented several initiatives to improve the civil-military response to reconstruction and development and to improve coordination and information sharing. Two Development Advisor positions [one from the UK (DFID liaison) and one from the United States (USAID

*Iraq and Afghanistan*. Committee Print 8, 41-409, April 2008. Accessed March 14, 2016. <http://democrats-armedservices.house.gov/cache/files/2/0/20ca518e-0183-433f-be5a-7e872dbc41b7/3B701FBF89464A360E6688FC3A825A48.prt-report-vf.pdf>.

<sup>1684</sup> Parker, 2007.

<sup>1685</sup> Weitz, 2010.



liaison)] were created to advise COMISAF (General David Richards, British Army) on reconstruction and development matters. The motivator was the general had a political advisor and military advisors but no development advisors and he was a strong proponent of the NATO comprehensive or whole-of-government approach of diplomacy, defense, and development in support of post-conflict reconstruction operations.<sup>1686,1687</sup> The NATO collective strategy used a framework<sup>1688</sup> (see [Figure 117](#)) to comprehend the interdependencies of the security, governance, economic, social and human societal domains and to chart the long-term action agreed by the key stakeholders; local governance and the International Community. Such an approach was seen as the most likely to stabilize and create a self-sustaining secure environment by providing a broad framework for consultation, cooperation, and coordination.

At this time, a crucial need existed to understand, harmonize and co-ordinate international community and ISAF support to the [Afghan government]. The interaction between NATO [Coalition] forces and the civil environment (both governmental and non-governmental) in which they operated was crucial to the success of operations. The NATO/SHAPE collective strategy framework above illustrated the recognition that a security, governance, economic, social and human “positive/negative effect” loop exists and was an important factor to be considered in operational planning and execution. Without an adequate level of security, a society will fail to achieve key national goals for economic stability, political normalization, national reconciliation, reconstruction, and social development. However, reducing societal violence and attaining a minimal level of security may only be possible if there are improvements in the economic and political domains, in other words they are interdependent and can positively or negatively affect each other. With this comprehension, NATO planners and operators were equipped to create the operational designs that analyzed the stabilization or peace support requirement be it at the strategic, operational or tactical level. In other words, to help them understand what was happening around them in civil society and to provide a basis for discussion with other representatives of the international community.<sup>1689</sup> It is important to remember that when NATO became responsible for the ISAF mission in Afghanistan, there was no collective strategy or multi-year plan for the reconstruction of Afghanistan.

There was also a lack of a shared civil-military picture of the status of reconstruction and coordination of related activities. To address this civil-military cooperation (CIMIC) shortfall, ISAF led the development and maintained the software tool called the Afghanistan Country Stability Picture (ACSP). ACSP was a comprehensive geographic database of reconstruction and development activities across Afghanistan and held information about different *Afghanistan National Development Strategy* sectors such as education, good governance, health, agriculture and rural development, infrastructure (there was no focus on ICT, a cross-sector enabler) and natural resources, private sector development, security, and social protection. The data held in the ACSP came from several sources: GIRoA, ISAF, PRTs, national elements, and international, governmental and non-governmental organizations, which, along with NATO could use it

---

<sup>1686</sup> Wentz et al, 2008.

<sup>1687</sup> Parker, 2007.

<sup>1688</sup> SHAPE and JFC HQ Brunssum (2005). *NATO Collective Strategy and Experiences from Afghanistan*.

<sup>1689</sup> Ibid.

for optimization and monitoring of reconstruction efforts. To provide efficient access to the ACSP data, the NATO C3<sup>1690</sup> Agency developed a web map service. The ACSP website was used to consult and query the ACSP database over the Internet.

Several other actions were taken to further improve ISAF and PRT situational awareness, coordination, and management of the reconstruction process. ISAF scheduled a series of PRT conferences in Kabul to build a more informed and shared understanding of ongoing PRT reconstruction-related activities, needs, support opportunities, and activities among ISAF, the PRTs, other Coalition military, national government elements, international organizations, and NGOs. The STA/ARG participated in some of these activities and discussed opportunities to leverage ICT as a cross-sector enabler. A PRT Handbook<sup>1691</sup> was created by ISAF and its development involved military as well as civilian elements. Additionally, a PRT Executive Steering Committee was established to provide PRT policy guidance and pre- deployment PRT training courses were established. Improved arrival orientation training was also provided and an ISAF PRT help desk and portal were created to facilitate ISAF response to PRT questions and needs. These were representative of ISAF actions taken to improve PRT coherence.

There were other challenges. The military often imposed their priorities on civilian reconstruction missions even when State and USAID were the lead agencies for the projects.<sup>1692</sup> Difficulties were also encountered in PRT coordination with humanitarian NGOs working in their area of operation. It was not until November 2006 that DoD and DoS adopted an MoU that specified their respective financial and other contributions to the PRTs.<sup>1693</sup> In the end, PRTs were the forefront of US efforts to apply military and civilian COIN assets in an integrated manner to remote areas in conflict-prone areas. Unfortunately, at this time, ICT was not a key element of PRT activities.

Engagement of STA/ARG with ISAF was largely done through weekly meetings at the US Embassy in the ambassador's conference room, where embassy seniors and project leaders met to update progress across a broad range of stabilization and development activities, including regular participation from designated representatives across ISAF and US commands. The first substantive ICT engagement with ISAF was work across ISAF, US Commands, and the embassy on activity and effectiveness updates concerning PRTs, as managed by US and NATO ISAF Coalition commands. PRT teams gathered in Kabul semi-annually for meetings across ISAF (for Coalition-led PRTs) and the embassy (for US-led PRTs), as well as common meetings across combined Coalition and US PRTs. Such meetings provided opportunity for two-way discussions between PRT members and Kabul-based civil-military organizations, identifying the range of current activities underway and providing opportunity to discuss possible future projects across sectors, including the ICT sector. Embassy-based personnel, including the STA and ASD-NII and NDU support on ICT Reachback TDYs,<sup>1694</sup> along with some participation across State ECON and USAID, were able to meet

---

<sup>1690</sup> Consultation, command, and control

<sup>1691</sup> ISAF *PRT Handbook*, Edition 4, March 2009.

<sup>1692</sup> Weitz, 2010.

<sup>1693</sup> Ibid.

<sup>1694</sup> Temporary duty(ies)

with individual PRT representatives across provinces to suggest PRT inclusion of ICT capabilities in future planning for PRT work in their areas of responsibility (AORs). Some PRTs were receptive to considering ICT projects in longer-term planning, and other PRT representatives shared that they viewed ICT capabilities in the category of “luxury” development activities, while the PRTs were still busy with basic development impacting ability to access roads, bridges, shelter, water, etc. After several years of such engagement by the STA and related embassy reps, some PRT members indicated more willingness to consider ICT projects. One PRT representative expressed interest in placing cellular towers at FOBs as a way to extend cellular coverage to more remote locations by removing security costs from the business plans of MNOs having interest in such expansion.

## Examples of ARG/STA Efforts and Accomplishments

In 2006, the STA supported the planning for and participated in Afghanistan’s first ever National ICT



Picture 64: Inaugural Afghan National ICT Conference

Conference (see [Picture 64](#), jointly organized by the Ministry of Communications and the UNDP. Hundreds of participants attended the conference on April 25-26, 2006 at the Kabul *Loya Jirga* tent. More than 30 national and international companies, UNDP projects, and others exhibited their products and services to celebrate Afghanistan’s communications successes. The two-day forum showcased investment opportunities and promoted ICT awareness within the country. It also provided an opportunity to look at some of the leading development efforts in the field of ICT in the

country and opportunities for the public and private sectors to work together in Afghanistan. The Ministry of Communications elaborated on the ICT goals and achievement plan for Afghanistan. In addition, MoC Minister Sangin talked about the relationship of ICT and the UN [Millennium Development Goals](#) (MDGs) and support of Afghanistan’s ICT development plans as articulated in the MCIT *ICT Sector Strategy* input<sup>1695</sup> to the *ANDS* for promoting growth, generating wealth, and reducing poverty and vulnerability in Afghanistan. There were a number of side conferences which focused on expert skills development, gender and ICT, ICT and education, e-governance and e-commerce. The conference was designed to be interactive to gather as much interest and input as possible. During the conference, the .af country code online registration was launched, the formation of the National ICT Council of Afghanistan was announced, and the National Internet Registry Authority of Afghanistan (NIRA) was introduced.

---

<sup>1695</sup> Islamic Republic of Afghanistan Ministry of Communications and Information Technology (MCIT) (2008). *Information and Communication (ICT) Sector Strategy 1387-1391 (2007/08-2012/13)*, February. Accessed March 14, 2016. [http://mcit.gov.af/Content/files/ICT%20Sector%20Strategy%20-%20English%20final%20Singed\(2\).pdf](http://mcit.gov.af/Content/files/ICT%20Sector%20Strategy%20-%20English%20final%20Singed(2).pdf).

The STA engaged in ICT for health and education efforts and tracked NGO and USAID activities such as Partners in Technology International's (PACTEC's) implementation of a VSAT link, associated LAN, and workstations throughout the Cure International Hospital in Kabul. These services and equipment provided doctors, nurses, and other medical staff Internet access for research and reference material and provided an information network to support an online patient record system. They also facilitated lab work such as remote tissue analysis, supported reachback to subject matter



Picture 65: Cure International Hospital medical library

experts outside of Afghanistan for consultation, and provided other e-healthcare) uses. The medical library at the time consisted of medical books on a table with a cable strung through them and locked to table so they could not be removed (see [Picture 65](#)). The hope was to introduce an electronic library and provide access to online medical libraries and experts using the Internet.

The ARG/STA and NDU advisor made visits to other activities such as Tangi Saidan Village Community Center, built by the NGO Morning Star Development, which had a medical clinic serving Afghan families in a rural area 40 miles south of Kabul. Part of the facility was a FM radio station that served 39 surrounding villages. It also had facilities to support education, literacy, and agriculture programs and had an Internet café and meeting room for use by the local women (see [Picture 66](#)).



Picture 66: Tangi Saidan Village Community Center

The STA also participated with USAID and the World Bank in ICT capacity development activities at Kabul University, implementation of Internet access and campus networks for universities, and the making available of distance learning capabilities such as Afghan's Next Generation e-Learning (ANGel) project. Assisting the MoC with the development of an ICT architecture and plan was also an area of focus for the ARG STA, including some STA-led training for development of ICT architectures, strategies, and plans.

In 2005, MCIT Minister Sangin undertook an effort to develop a cybersecurity regime for Afghanistan and asked the STA for US assistance. In 2006, the STA conducted a series of meetings with Afghan leadership for the development of a Model National Plan (MNP) for cybersecurity and critical infrastructure information protection (now referred to as Critical Information and Infrastructure Protection or CIIP). The ARG/STA and USG's cybersecurity effort is described in detail in [Chapter 10](#).

In terms of ICT for governance, the STA/ARG and ASD-NII SME worked with CFC-A J6 to develop the concept for and the CFC-A J6 found funding to acquire and implement the Provincial Governor's Communication Network (PGCN). The PGCN provided a WiMAX-based<sup>1696</sup> wireless capability package to extend the Government Communications Network (GCN) voice, VTC, and Internet services from the MoC building in the provincial capital to the governor's residence and also accommodated, as appropriate, access by other local government administrative offices. The GCN connected the 34 provincial governors and the president and national government organization elements in Kabul with voice, Internet, and VTC services and was used to extend governance to the provincial level. As the security conditions were deteriorating in the 2006 timeframe, the PGCN allowed the governor to communicate from his residence instead of driving through hostile areas to the provincial center to access the GCN services.

Extend  
Legitimate  
Governance

## Provincial Government Connectivity Government Communications Network(GCN)

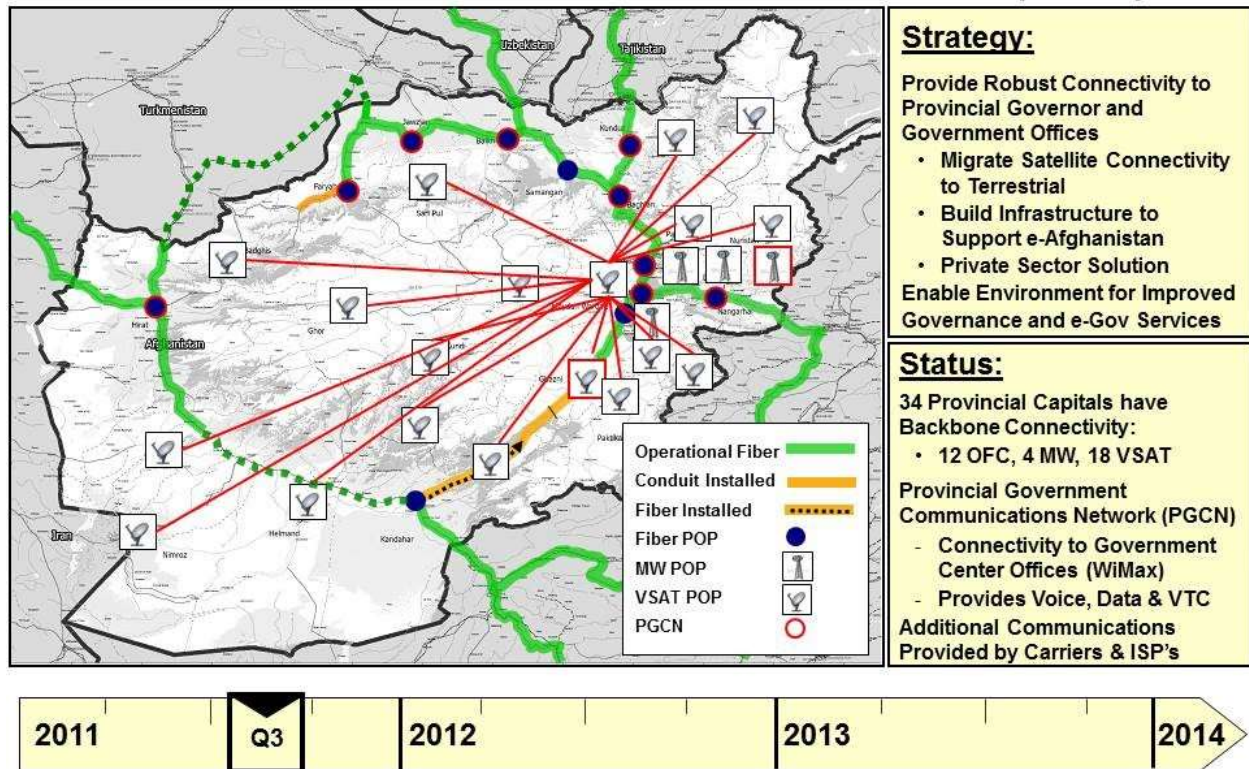

Figure 118: PGCN and GCN connectivity

Figure 118 illustrates the status of the GCN in the 2011 timeframe. It shows where PGCN access had been implemented, the status of the fiber optic network, and the status of migrating GCN connectivity from

<sup>1696</sup> Worldwide Interoperability for Microwave Access, a family of wireless communications standards that enables the delivery of last-mile wireless broadband Internet service.

the satellite to terrestrial capabilities such as the fiber optic network where available and microwave connectivity.

The PGCN was followed by the District Communications Network (DCN, funded by USAID) and later the Village Communications Network (VCN), thereby extending ICT services further and further. The VCN was based on a concept developed by the STA/ARG referred to as the Afghan Digital Solar Village (ADSV). The ADSV concept intended to capitalize on the DCN satellite backbone system by using Wi-Fi and other wireless connectivity options. All these networks (GCN, PGCN, DCN, and VCN), which occurred or began during the ARG/STA tenure, are covered in detail in [Chapter 3, \*ICT in Afghanistan\*](#).

In mid-2006, the STA/ARG, with help from the I-Team and Reachback, set in motion the actions needed to establish an Afghanistan chapter of the Armed Forces Communications and Electronics Association (AFCEA). The chapter was established in late 2006 with its headquarters in Kabul. It achieved a minimal number of members and included honorary Afghan members. The chapter was formally activated in early 2007; however, it never really got off the ground. The STA/ARG's initiative to establish an Afghan chapter of AFCEA, along with subsequent efforts by others to revive it, is described in [Chapter 6, \*ICT Organizations and Associations\*](#).

## The End of the ARG and Associated Reflections

The ARG was closed in mid-2008 timeframe, and with it the STA function that was part of it – a collateral unintended consequence. While the ARG was targeted for shutdown, there was DoD and DoS agreement that the STA position was not specifically targeted, and that the dedicated focus this position and related TA function brought to the Afghan ICT sector served a valuable purpose and should be reestablished in Kabul. The STA/ARG ICT sector responsibilities returned to the ECON section of the US Embassy as one of a number of portfolio areas covered, reducing the level of USG engagement with the Minister of Communications and USG resources focused on the challenges and opportunities in the ICT sector and the use of ICT by other sectors.

It is worth noting that in the 2006-2007 timeframe, the STA worked with Ambassador (AMB) Ronald E. Neumann to separate the Telecom Advisor function from the ARG and position it in a new ambassador-level led organization element that included the US Embassy ECON section, but when AMB William Braucher Wood arrived in 2007, this agreed-in-principle solution for an STA was abandoned. Ironically, a structure that could have accommodated an STA was created later under the Coordinating Director for Development and Economic Affairs (CDDEA) ambassador position, first filled by AMB Early Anthony (Tony) Wayne, then AMB Richard G. Olson, followed by AMB Hilda Arellano, who was then replaced in mid-2013 by the USAID Mission Director in Kabul, Dr. S. Ken Yamashita. With the arrival of AMB Wayne as the CDDEA, instead of reviving the STA position, he established a Telecom Working Group (TWG) to serve as a forum for ongoing Interagency ICT engagement across Kabul and with Washington, DC counterparts.

The various criticisms of ARG by others – a lack of strategic direction, an inadequate task of responsibilities, a lack of expertise, etc. – and the criticisms by ARG of others – a lack of cooperation, bureaucratic red tape, and the like – should not obscure the fact that there was a general consensus that the mission of ARG was an important one, that ARG had been at least partially successful, and that an entity similar to the ARG is necessary. The various STAs worked hard to avoid being drawn into the ARG-

related food fights with limited success. There were fewer consensus as to what form that the ARG-function should take. As noted earlier, very few people believed the ARG to be a failure and in fact, the vast majority thought that it was a useful model for future reformation, although many, both outside and inside ARG, believed that significant structural changes were necessary before it could become a model for future nation building.<sup>1697</sup> In the end, an important value of the ARG was the “people versus institution/policy” issues. Additionally, a key attribute of the ARG was that it was created and reported to senior USG leaders such as the Secretary of Defense, NSC Director, and the Secretary of Defense’s key senior advisor at Pentagon ARO. As was well known then and now, there is no policy prescription for an ARG-like construct, and, therefore, approaches continue to be ad hoc.

Although issues focused on ARG’s relationship with USAID, the bureaucratic flaws of USAID were not unique to it. For example, Ambassador Komer in his RAND Corporation report on lessons from Vietnam indicated that bureaucratic features are a natural tendency in any institution. He argued that “the typical behavior patterns of . . . U.S. institutions involved in the conflict made it difficult for them to cope with an unfamiliar conflict environment and greatly influenced what they could and could not, or would or would not, do.”<sup>1698</sup> Both the military and civilian agencies, he argued, behaved in a bureaucratic manner which proved self-defeating. They behaved in this way because their institutional imperatives prevented them from behaving in any other fashion. Bureaucracies, whose modus operandi was to rely on precedent whether it was appropriate to resist change or not and to block outside interference in their operations, were incapable of readily adjusting to a new environment. They are characteristics inherent to a greater or lesser degree in the behavior patterns of large hierarchically organized institutions – private or public, civilian or military, American or foreign.”<sup>1699</sup>

Some STA/ARG observations addressing what went right and what went wrong and “dos and don’ts” for future operations are offered by James P. (Jim) Craft, the first STA at the ARG from 2005 to 2006. He was one of the senior USG leaders who tried to keep the Telecom Advisor function alive after it was shut down the end of 2008 and was also one of the architects of the movement that led to the establishment of the STA at COMISAF in 2010. His observations as to what worked and what did not follow, and his “dos and don’ts” (lessons observed) are in [Chapter 22](#).

What went right:

- Building mentoring relationships with Afghans
- I-team coordinating Afghans, US Interagency, UN, and private sector efforts
- The focused reachback groups, especially the private sector group
- Having a competent Afghan Minister of Communications
- Personal support from the ASD-NII/DoD CIO

---

<sup>1697</sup> Berner, 2006.

<sup>1698</sup> Komer, Robert. W. (1972). *Bureaucracy Does Its Thing: Institutional Constraints on US-GVN Performance in Vietnam*. RAND Corporation, August. Accessed October 4, 2015. [www.rand.org/pubs/reports/R967](http://www.rand.org/pubs/reports/R967).

<sup>1699</sup> Ibid.

- Turning failing US ICT projects around for success
- Specific, widespread sector results
  - Drafting of a new Telecom Law
  - Starting a national cybersecurity program
  - Launching the national emergency call center (like US 911)
  - Expanding the ICT environment to include the majority of the Afghan population
  - Issuing of new tenders for additional mobile network operator licenses
  - Expanding mobile telephone service to the common Afghan on the street (for which Afghanistan won several awards from international ICT associations.)
  - Establishing ICT professional and trade associations
  - Creating an ICT education and training infrastructure
  - Creating ICT jobs and investments
  - Adding over US\$120 million into the Ministry of Communications budget from license fees
  - Building technical and professional capabilities in the Afghan Ministry of Communications
  - Fostering partnerships for the Afghans with global ICT firms
  - Rapid, countrywide spread of private sector ISPs

#### What went wrong:

- Lack of STA supporting staff and budget, especially seed money for innovation opportunities
- Lack of clearly defined authority or role of the STA within the embassy structure
- Failure to quickly identify corruption in some ICT projects (minor issue)
- Lack of passion for the mission or needed professional skills by many “volunteers” in Afghanistan (many were there to run away from problems at home or to just to get the extra money or “high three” for retirement.
- Lack of STA preparation time for job and long, problematic process to hire for the job, then a rush to get the STA into place
- Failure to get the right successor or have commitment to maintain the function, which was a victim of the initial effort’s great success. (The USG only funds problems.)
- Inability to get the US country team to focus on fostering US business. (There was more career benefit in the Foreign Service in getting diplomatic agreements from foreign countries by helping them get business than helping American firms get the business. On the ground business engagement of US firms gives the US much more influence in pursuing strategic goals.)
- Lack of STA continuity – inability to replace the first STA with an SES-level civilian with equivalent experience and skills
- Later shifting the STA away from supporting the civil sector to focus almost solely on military interests (Security operations depend on a healthy civil infrastructure.)



## Changing Operational Environment

The Afghanistan security situation started to deteriorate significantly in 2007 as the Taliban regrouped, reorganized, and finessed its insurgency strategy against ISAF and the ANSF. In October 2008, the top American general in Afghanistan, COMISAF General David McKiernan, USA, warned that the situation in Afghanistan could get a lot worse. The international forces within Afghanistan had not been able to hold territory they cleared because of a lack of troops. For this reason, the general called for an extra three combat brigades (roughly 20,000 troops). Without this urgent rush of troops, the Taliban would be able to get back into the communities that were once cleared by international troops. The general went on to say that things could get a lot worse before they get better.

ASD-NII/DoD CIO and DISA ICT-related engagement with USFOR-A<sup>1700</sup> began in mid-2008, initially in meetings at Pentagon with CENTCOM J6 representatives, as USFOR-A prepared for activating the J6 in Kabul in the fall of 2008. ASD-NII/DoD CIO was requested by CENTCOM during meetings at the Pentagon to participate in a Site Survey Team TDY, deploying to Afghanistan in November of 2008 – notably a few months following the shutdown of the ARG at the US Embassy Kabul and ending work done at embassy by sector senior advisors, including the STA. ASD-NII participation with the Site Survey Team focused on introducing the USFOR-A J6 colonel and staff to key Afghans operating in both the civil and commercial elements of the ICT sector, providing context and opportunity for continuity regarding various ICT activities underway for several years prior to the arrival of USFOR-A J6.

Following from the Site Survey Team TDY, ASD-NII maintained regular contact with key members of the USFORA J6, to provide DoD-internal reachback support from the Pentagon and directly to USFOR-A when in Kabul, regarding their interest in maintaining a stable Afghan Telecom Corporation (AfTel) to protect the security of DoD leases negotiated with AfTel during the Site Survey Team TDY, and enabling USFOR-A access to AfTel’s broadband fiber network still under construction.

As President Obama took office in early 2009, his administration’s new Afghanistan strategy acknowledged that the International Community’s largely “top-down,” heavily centralized approach to governance assistance in the years following 2001 must be complemented by localized approaches more appropriate to Afghanistan’s decentralized social makeup and history – attempt to bolster the Afghan state “from the bottom up.”<sup>1701</sup> The primary military objective was to reverse the Taliban’s momentum. A new ISAF commander, US General Stanley McChrystal, USA, was appointed in June 2009. He conducted a detailed review of the strategy and produced a hard-hitting report. He warned of a critical situation unless there were major changes. In particular, he said there were not enough forces to fight the counterinsurgency campaign that was underway. Coalition forces would need to increase, as would the ANSF, along with improving its warfighting skills and capabilities.

---

<sup>1700</sup> United States Forces-Afghanistan

<sup>1701</sup> Brown, Frances Z. (2012). *The U.S. Surge and Afghan Local Governance*. United States Institute of Peace Special Report 316, September 2012. Accessed May 5, 2015. <http://www.usip.org/sites/default/files/SR316.pdf>.

On December 1, 2009, in a speech at the US Military Academy at West Point, President Obama announced it was in the US vital national interest to send additional US troops and civilian personnel to Afghanistan for approximately 18 months.<sup>1702</sup> The purpose of the surge was to seize the initiative while building the Afghan security forces capacity to set the conditions to allow for a responsible transition of US forces out of Afghanistan. The civilian element of the surge was intended to work with our Coalition partners, the World Bank, the United Nations, the Afghan government, and others to pursue a more effective civilian strategy so that the Afghan government could take advantage of improved security. Part of COMISAF McChrystal's, and later (in July 2010) General David Petraeus's, USA, counterinsurgency "clear-hold-build" strategy was to secure territory by separating the enemy from the population and staying in the area, establish a secure presence to hold on to the area so the new government could connect with the people and tribal and local leaders, and then work with the government to build up institutions of the state (justice, security, governance, and socio-economic development) to inoculate local populations against the Taliban's return and help the people buy into the new government and the services offered. Clear cut objectives were set to refocus on al-Qaeda, reverse the Taliban's momentum, and train Afghan security forces to defend their own country.<sup>1703</sup> President Obama made it clear that our commitment would not be open-ended and that we would likely begin to draw down our military forces in July 2011.

President Obama authorized a "military surge" of 30,000 military personnel to be deployed as soon as possible mainly to southern and eastern Afghanistan, in particular to Helmand and Kandahar provinces with emphasis on Helmand as the center of the drug trade – the financial engine of the insurgency. There were also 116 critical districts that the counterinsurgency had to address. The governments of ISAF troop-contributing nations accepted Gen. McChrystal's stark conclusions and a major increase in forces followed. In addition to the US commitment, other ISAF nations provided a further 10,000 troops. By early 2010, the ISAF strategy was reset. It was a heavy additional burden, but what became known as the "McChrystal Strategy" gave an increased focus and resolve to a military effort that had seemed to be close to stalemate.

The President also launched a "civilian surge" over the next year of personnel from USAID and the Departments of State, Justice, Commerce, and Agriculture, roughly tripling the total US government civilian presence in Afghanistan from 300 to more than 1,100 to oversee additional thousands of contracted civilian implementing partners. The ability to respond to a rapid staffing up for the civilian surge proved to be a monumental challenge due to a lack of capacity of civilian agencies and the Civilian Response Corps (CRS, recruited from federal employees on active duty). The CRS was not adequately staffed to properly respond to the demand and alternatives needed to be explored such as use of Foreign

---

<sup>1702</sup> Obama, Barack (2009). "Remarks by the President in Address to the Nation on the Way Forward in Afghanistan and Pakistan," December 1. The White House Office of the Press Secretary. Accessed December 10, 2014. <http://www.whitehouse.gov/the-press-office/remarks-president-address-nation-way-forward-afghanistan-and-pakistan>.

<sup>1703</sup> Obama, Barack (2011). "Remarks by the President on the Way Forward in Afghanistan," June 22. The White House Office of the Press Secretary. Accessed December 10, 2014. <https://www.whitehouse.gov/the-press-office/2011/06/22/remarks-president-way-forward-afghanistan>.

Service nationals who worked at US embassies overseas and retirees from federal service. Furthermore, all-civilian branches of the US government were (and still are) not designed to deploy people rapidly the way the Pentagon can. Elements such as “the State Department must shed the risk-averse culture it adopted in the mid-1980s ... [It] cannot ignore risk, but [organizations] need to be willing to manage risk rather than simply avoid it.”<sup>1704</sup> Additionally, it was difficult to recruit the right people willing to deploy into a hostile zone for an extended period of time. Ramping up pre-deployment training was a challenge. There was also a need to provide the government civilians the necessary armed escort force protection to support movement in country, which had to be planned for and was costly. It was also a challenge to be able to put the right people in the right spots – all on tight budgets. Some agencies did not want to “give up” their most skilled employees for long periods of time and there were few professional incentives for others. As a result, the ad hoc deployments of government employees to missions overseas tended to put the wrong people in critical jobs. To succeed in an operation like Afghanistan, you needed to have a substantial, well-thought-out and well-resourced civilian effort.

With the above as a backdrop of the on-the-ground situation and surge-related actions to be taken, it should not be surprising there were numerous response actions started in anticipation of needs emerging from a new operational environment that turned out to be driven by combat, COIN, stability, diplomacy, reconstruction, and development – a major full spectrum, whole of government challenge, as well as integrated multinational response challenge. During full spectrum operations, offensive, defensive, and stability actions are conducted simultaneously in some areas, and asymmetrically in others.

The 2008 departure of the STA from the US Embassy Kabul resulted in the return of ICT responsibilities to an understaffed US Embassy ECON section that had other higher priorities to be addressed by a small staff. The US Embassy also seemed to want to return to so-called “normal operations.” A lack of ICT subject matter expertise and a belief that the Afghan ICT sector was succeeding so the embassy could shift its focus elsewhere were important factors as well, in spite of increasing security concerns. This created a vacuum in a senior civilian focal point for advice and assistance in civil and commercial ICT and a professional ICT SME to work key leader engagements with the MCIT, ATRA, and Afghan Telecom. Additionally, USAID’s activities in the areas of ICT and telecom/IT capacity building were limited in the 2008 timeframe. Generally, ISAF showed minimal interest in civil and commercial ICT projects. However, with the new USFOR-A being set up, there was some interest in ICT and in dealing with the MCIT, ATRA, and AfTel, especially in the areas of the fiber optic network and spectrum. The PRTs also were beginning to express interest in exploring ICT-related projects, but they generally did not have ICT expertise on their teams. There were important ICT project opportunities that could be part of the PRT portfolio of projects in support of COIN initiatives, such as ICT support to local community healthcare and education, ICT support for provincial and district level governance, and extension of cellular service to rural areas.

---

<sup>1704</sup> Transcript of interview of John E. Herbst, Coordinator for Reconstruction and Stabilization, US Department of State, by Greg Bruno, Council on Foreign Relations, March 31, 2010. Accessed October 4, 2014. <http://www.cfr.org/afghanistan/waiting-civilian-surge-afghanistan/p21785>.

The 101<sup>st</sup> Airborne Division assumed its role as the CJTF-101 in Afghanistan in 2008. At this time, the ICT sector in the country lacked coordination among USG element, with ISAF and with Afghan ICT public and private sector elements.<sup>1705</sup> None of the operations or campaign plans contained information on the ICT infrastructure, the ICT sector, tasks to define and develop it, or indications of how to utilize ICT in productive ways in support of the national or international objectives. It seemed that leaders at the highest levels did not consider the ICT sector of any real importance, nor did they show an understanding of how much commercialization of the ICT tactical infrastructure could benefit the overall operation. There was no designated lead agency (lack of unity of command) to identify, plan, coordinate, or interact with the MCIT or other stakeholders in the ICT sector. Many projects were not synchronized (lack of unity of effort), which led to duplication of effort and a waste of resources. The CJTF-101 CJ6 identified a significant lack of coordination among the ICT sector stakeholders and the civil-military organizations operating within the AOR.

The burden once again fell upon the military to be the principle spokesperson for ICT with Afghan counterparts, and in the 2008-2009 timeframe the CJTF-101 CJ6 staff took on this responsibility.<sup>1706</sup> The CJ6 staff, however, lacked adequate civil and commercial ICT system assessment, planning, and engineering resources and expertise to meet the emerging demands to develop programs to use commercial ICT to support military C2 and COIN initiatives. To help, a civilian Senior C4<sup>1707</sup> Advisor was assigned to work with the CJ6 staff – largely in the area of Afghan fiber optic network implementation and use of the fiber network by the US military. The CJTF-101 CJ6 staff tried to monitor the progress of numerous Afghan and US military ICT projects and explore cross-ministry ICT projects. It also attempted to assess impacts of ICT in other sectors such as healthcare and education. However, they lacked a baseline of ICT systems in Afghanistan and there were no mechanisms for monitoring and tracking the ICT activities of the MCIT, ATRA, Afghan Telecom, the US, or private sector initiatives. They also lacked metrics for assessing progress and effects (outcomes versus outputs) of ICT initiatives. As noted, the CJTF-101 CJ6 had limited resources to meet ICT-related mission support activities. There was active collaboration, coordination, and information sharing activities with the ASD-NII and NDU reachback element to leverage institutional memory and in-country contacts to help address civil-military projects of interest and to facilitate coordination and help from USG ICT-related organization elements in CONUS.

The CJTF-101 CJ6 had been in discussions with the MCIT, ATRA, and Afghan Telecom on activities such as extension of the fiber optic ring to US operating bases and placement of communications towers on or nearby FOBs in high-threat areas. There was also interest in moving capacity from satellites to terrestrial commercial networks. CJTF-101 CJ6 had been in discussions with the MCIT on expanding cellular roaming capabilities and emergency response number planning and implementation on cellular networks. There

---

<sup>1705</sup> Smith, Charles D. (2010). Thesis paper “ICT in Full Spectrum Operations: A Case Study of CJTF-101 in Afghanistan.” Master of Military Art and Science, US Army Command and General Staff College, Ft Leavenworth, Kansas.

<sup>1706</sup> Ibid.

<sup>1707</sup> Command, control, communications, and computers

was also interest in improving oversight of the MCIT's and Afghan Telecom's activities such as the fiber ring implementation and operation, the connectivity between major civil and commercial ICT hubs such as Kabul and Kandahar, Afghan ICT coverage mapping, implementation of a national data center, putting ICT into schools and healthcare centers, and other activities such as ICT for agriculture. Capacity building for the ICT workforce and the Afghan population in general was being explored, including training and mentoring for ministry CIOs. Use of NDU to train Afghan CIOs had been offered for consideration to the MCIT minister but no actions were taken to make something happen – although the MCIT minister had expressed an interest. The offer had been worked by the US Senior Telecom Advisor before his departure but the initiative was put on hold since there was no senior ICT spokesperson on the ground to pursue making it happen. Finally, there was US military interest in the use of ICT to support governance, security, healthcare, and education as part of COIN related initiatives.

As for additional challenges, the CJTF-101 CJ6 staff was located on Bagram, Air Base, which is over 50 kilometers from Kabul, and because of force protection measures, traveling to Kabul for meetings was a challenge, and, therefore, limited the ability to have frequent face-to-face meetings with Afghan counterparts. Adding additional limitations to proactive interactions on ICT matters was the fact that there was no longer a US ICT team presence in Kabul to work with daily or as needed with the MCIT, ATRA, Afghan Telecom, CSTC-A, USAID, Embassy ECON section, ISAF, UN, the World Bank, the ITU, and others in the Kabul area. To the extent coordination and information sharing took place, it was done by phone and email with limited face-to-face interactions. Also, there were no good ICT arrangements (e.g., collaborative information environment or interactive web portals) for civil-military collaboration and information sharing among USG stakeholders and with other ICT related stakeholders, including Afghan ICT counterparts. There was limited active ICT project monitoring and shared situational awareness and reporting, including reports from the MCIT, ATRA and Afghan Telecom and private sector ICT providers. In the past (during the ARG/STA tenure) there had been frequent reports from the MCIT and Afghan Telecom on the status of ICT activities and network operations, especially related to the implementation and operation of the fiber optic network. There were also interactions with private sector which became problematic.

In the 2008-2009 timeframe, CJTF-101 had execution responsibility for all Title 10,<sup>1708</sup> US Code responsibilities and served as the National Command Element (NCE) and National Support Element (NSE) for all US forces in the Combined Joint Operational Area (CJOA). Designated with the mission to train and support the Afghanistan National Security Forces (ANSF), CSTC-A executed the responsibilities under Title 22,<sup>1709</sup> US Code.

---

<sup>1708</sup> Title 10 of the United States Code outlines the role of armed forces in the United States Code. It provides the legal basis for the roles, missions, and organization of each of the services as well as the United States Department of Defense. Each of the five subtitles deals with a separate aspect or component of the armed services.

<sup>1709</sup> Title 22 of the United States Code outlines the role of foreign relations and intercourse in the United States Code.

Under this construct, the Commander, CJTF provided all command and support functions for all US national forces in the CJOA. Also dual-hatted as the ISAF Commander, Regional Command-East, the CJTF commander and staff were required to support missions throughout the CJOA including coordination with the Pakistani military and in all other ISAF Regional Commands.

In early 2009, due to the increase in operational forces and the establishment of new bases throughout the CJOA, operational needs outgrew CJTF capabilities. Under General McKiernan's direction, as the US Senior National Representative (US SNR), an "informational" staff was designated to support the role of the US SNR and to assist in the coordination and execution of ISAF/OEF<sup>1710</sup> missions throughout the CJOA.

With the new presidential administration promising more troops in Afghanistan, the mission quickly grew into a national command requirement. USFOR-A was approved for implementation and personnel requests, many of them by-name-requests for the best and brightest, which flowed from Afghanistan to bring USFOR-A to full operational capability. To support CJOA-wide requirements, planners wrote a Joint Urgent Operational Needs Statement for a Signal Brigade to assume the role of Joint Network Control Center-Afghanistan (JNCC-A). In May 2009, the 7<sup>th</sup> Signal Brigade was designated and began deployment into the CJOA to serve as the JNCC-A. This construct, initially created in Iraq, provided one single organization responsible to coordinate and synchronize communications requirements for all US forces under Title 10, and the entire requirement for ANSF development under Title 22. This new JNCC-A was established at Bagram Air Base. During this transition, the CJTF- 101 CJ6 staff served as the conduit for all interaction with the MCIT. No record of the ISAF J6 meeting with MCIT personnel prior to this point could be found. However, it was noted that the ISAF Joint Spectrum Manager did meet with ATRA and attended some of the frequency coordination meetings.

USCENTCOM<sup>1711</sup> J6's visible role in Afghanistan was evident upon the arrival of the USCENTCOM J6 and his direct interaction with COMISAF and the MCIT. Prior to this point, no Annex K (Command, Control, and Communications System) existed for the USCENTCOM Theater Campaign Plan. Shortly after the arrival of the J6, a communications planner was deployed to Bagram and collocated with the CJTF-101 CJ6. While deployed, the communications planner wrote Annex K for the campaign plan, while planning the arrival and transition of 7<sup>th</sup> Signal Brigade as the JNCC-A.

Additionally, the USCENTCOM Deputy J6 was designated as the USFOR-A J6 and deployed to Kabul. Upon the arrival of the USFOR-A J6, the CJTF-101 staff began transitioning designated CJOA-wide responsibilities to USFOR-A J6 and his limited staff. One of these tasks was the coordination and synchronization of ICT sector development at the national level. By assuming this responsibility, USFOR-A became the lead-agent for meeting and synchronizing efforts with the MCIT. However, due to the enormous responsibility of this new position and with a very limited staff, much of the actual coordination with the MCIT remained with CJTF-101 J6. During this same period, DISA conducted site surveys in Bagram, Kabul, and Kandahar to

---

<sup>1710</sup> Operation ENDURING FREEDOM

<sup>1711</sup> United States Central Command

determine the capability to provide DISA-level communications infrastructure that would directly improve access to the global information grid and limit the number of separate connections throughout the CJOA.

Towards the end of 2008, there were a number of ICT-related actions initiated by ASD-NII/DoD CIO, CENTCOM, DISA, NDU and others including DoS/USAID related to Afghanistan. In the absence of having a Telecom Advisor function on the ground in Afghanistan, in the latter part of 2008, two initiatives were proposed by ASD-NII to State and USAID. First was the creation of a Telecom Working Group (TWG) to serve as a forum for ongoing Interagency ICT engagement across Kabul and with Washington, DC. With the arrival in 2009 of the first Coordinating Director for Development and Economic Affairs (CDDEA) AMB Tony Wayne, the TWG was established for this purpose and still exists today – although it is not as active. The second was the initiation of a proactive Interagency advocacy effort in Washington, DC aimed at reactivating the Telecom Advisor function in Kabul.

In January 2009, the first STA at the ARG, ASD-NII, NDU, and two other SMEs with in-country experience met at the US Marine Corps Code Talker Hall in Quantico, Virginia and developed an Afghan ICT way ahead strategy and plan that was made available to senior leaders and stakeholders at DoD, DISA, the Joint Staff, CENTCOM, DoS, USAID and other USG elements. The purpose was to try to create an awareness and more informed understanding of the need to recognize the importance of the Afghan ICT sector to US and Afghan strategic interests for security, governance, stabilization, and socio-economic development; to reestablish US STA-like ICT train, advise, and assist functions in Afghanistan; and to recommend key strategic changes in the US engagement of the Afghan ICT sector based on operational experience and results that would lead to reestablishing US leadership in the Afghan ICT sector. Key bumper sticker-level recommendations included: view and treat Afghan ICT as critical infrastructure and an essential service; reestablish US leadership in support of Afghan ICT; and develop and implement a US ICT strategy and plan to support Afghan ICT. Also included in the strategy and plan were assessments of ICT challenges and short falls and recommendations for near, mid- and long-term actions to engage Afghan ICT sector governance and infrastructure improvements. Further included was the use of ICT to support ISAF and US military C4ISR and counterinsurgency activities and US civilian and military morale and welfare needs. The strategy and plan also addressed communications needs to deal with Afghans and personal security communications while on movement around cities and rural areas. On the ground experience validated mobile phones are, in many cases, a lifeline in a crisis situation so it is important to keep it charged, topped up with minutes, and on one's person.

As noted earlier, in December 2008 DISA-CENT,<sup>1712</sup> DITCO-SWA,<sup>1713</sup> and ASD-NII conducted a site survey in Kabul and Bagram 1) to establish the business processes to formally lease telecommunications transport services from GIRoA's national fiber optic network and work with its state-owned enterprise, AfTel, and 2) to coordinate with USFOR-A J6 and CJTF-101 CJ6 for the establishment of the DISA Support Element-Afghanistan (DSE-A) in January 2009 to support establishing needed connectivity for emerging

---

<sup>1712</sup> DISA Central Field Command

<sup>1713</sup> DISA's Defense Information Technology Contracting Organization-Southwest Asia

C4ISR needs. Key DSE-A support tasks included: interfacing with AfTel to secure additional national and international transport services; (upon approval) coordinate the establishment of Tier 0 DISN subscriber site(s); provide additional coordination for DISA program support within theater (i.e., GCCS, NCES, GCDS, CENTRIX, DVB-RCS, etc.<sup>1714</sup>); and advise on theater NETOPS<sup>1715</sup> policies and procedures. A DSE-A team was viewed to be composed of an officer in charge (OIC), Deputy/DISA Program point of contact and project officer, DISA field engineer (with background in DISN transport), and an on-call DITCO-SWA representative. The DSE-A was established in January 2009 and with the drawdown of US combat forces moved to Bahrain in November 2014.

Despite ongoing activities, by the end of 2009, it was the view of CJTF-101 CJ6 that ICT was not being managed as critical infrastructure or an essential service nor reported on as such. There was a NATO Allied Command Transformation fusion cell supporting ISAF that provided weekly unclassified high-level reports on Afghanistan reconstruction activities, which included some reports on ICT infrastructure activities, but this was not a proactive ICT project monitoring, assessing, and reporting activity. CJTF-101 CJ6 staff was trying to track ICT activities but it had too small a staff to meet the demands of increased interest in ICT project planning, implementation, and monitoring. As noted earlier, but is an important point to re-emphasize, there was a lack of senior USG ICT presence (spokesperson or team) in Kabul to liaise with key stakeholders and to proactively work with the MCIT, ATRA, Afghan Telecom, US Embassy ECON section, USAID, CSTC-A, ISAF, the UN, the World Bank, the ITU and others as needed and appropriate. It was felt this would likely change when USFOR-A and its J6 were established in the Kabul area. It would, however, be important to quickly establish and clarify the roles, relationships, and needs of USFOR-A J6, CJTF-101 CJ6, ISAF CJ6 and other elements such as US Embassy ECON and USAID and dealing with other key civil-military ICT stakeholders including the Afghan ICT counterparts.

DISA recognizing the priority of ongoing combat operations in Afghanistan and, from 2008 through 2010, worked directly with the Commander, USCENTCOM, his J6, and the DISA-CENT support element to design and implement a high-capacity strategic communication network into an active theater of operations, ensuring reliable communications for intra-theater mission partners and to national leadership. Prior to this installation, the Coalition forces in Afghanistan were dependent on satellite communications and tactical microwave links, which had limited bandwidth capacity and induced significant delay. The core service deliver nodes (SDNs) connected Bagram, Kabul, and Kandahar providing high-capacity, diverse network connectivity. In addition to the core sites, DISA leased hundreds of circuits to support remote locations and provided inter-theater DISN connections to the United Kingdom, Germany, Japan, and Bahrain. This core network also increased the IP capability of the theater elements. Among some of the other major achievements of DISA in Afghanistan beyond 2010 include the development of a common video teleconferencing (VTC) platform to enable the multinational forces in theater to communicate by a

---

<sup>1714</sup> Global Command and Control System, Net-Centric Enterprise Services, Global Content Delivery System, Combined Enterprise Regional Information Exchange, and Digital Video Broadcasting-Return Channel via Satellite (or Return Channel over System)

<sup>1715</sup> Network Operations



secure VTC bridge and providing assistance to USCENTCOM to establish a secure, collaboration mission network – CENTRIX-ISAF (Combined Enterprise Regional Information Exchange System-ISAF).<sup>1716</sup> DISA also sent SMEs TDY to help ISAF and USFOR-A and the MCIT and ATRA in the areas of spectrum and fiber optic and satellite communications. It also funded two special studies conducted by Deloitte for the ISAF Telecom Advisory Team (also sponsored by DISA) in the areas of ICT capacity development at Afghan universities in support of the Ministries of Communications and Information Technology, Education, and Higher Education and a Cybersecurity Maturity Assessment in support of the minister of the MCIT's request for assistance.

From the end of 2008 and into 2010, a team composed of DISA, NDU, and ASD-NII investigated the possible use of not only a Senior Telecom Advisor but also the possible introduction of a communications coordination element similar to the Iraq Communications Coordination Element (initially called ICCE then renamed Infostructure and Strategic Engagement or ISE) established by MNF-I DCS CIS<sup>1717</sup> in Iraq as per above. The thinking was being driven by Iraq experiences and lessons and team members with Afghan ICT-related in-country experience. Additionally, there were ICT requirements emerging from ISAF and command elements such as CJTF-101 for advice and assistance in working with the MCIT, ATRA, AfTel, and the four MNOs on Afghan ICT sector issues, support for coordination of ICT-related activities among the US Embassy, USAID, ISAF, and US military elements including PRTs and others as appropriate, and strategic thinking and thought leadership on the use of ICT for security, governance, and socio-economic development and growth as part of emerging counterinsurgency actions.

There was clearly a demand signal emerging from the US military elements in theater for a senior level spokesperson (preferably a senior civilian telecoms and IT expert) for ICT to deal with key civil-military ICT stakeholders and to engage with Afghan ICT counterparts. Ideally, this would be a DoS-led initiative, but that was not likely to happen under the political circumstances at the time and because of their perceived lack of willingness to put a STA back in Kabul. Hence, the responsibility would no doubt fall upon the military to fulfill. There was a need to develop a USG, or at least a US military, strategy and plan for the use of commercial ICT to support C2 and COIN mission needs including an ICT strategy and plan to leverage and support PRT initiatives. There was also a need to implement more effective arrangements for collaboration, coordination, and information sharing among the civil-military ICT stakeholders including Afghan counterparts.

There was also a need to strengthen the relationship between, collaborate with, and share information among the US military elements (e.g., CSTC-A and other elements in US chain of command),; ISAF and its PRTs; the MCIT, ATRA, and Afghan Telecom; the private sector ICT providers; and other international elements such as UNDP/UNAMA, the ITU, and the World Bank, as well as with other USG stakeholders (e.g., the US Embassy, USAID, and civilian elements such as DoC, DOJ, USDA, and US PRTs).

---

<sup>1716</sup> DISA. Accessed February 7, 2015. <https://www.disa.mil/About/Our-History/2010s>.

<sup>1717</sup> Deputy Chief of Staff for Communications and Information Systems

ICT needed to be treated as critical infrastructure and an essential service and monitored and reported on as such. In this age of network-centric warfare, the network is considered part of the weapon system, and commanders and leaders expect that communications will be available everywhere and at all times without exception, but they may not be if not properly planned, implemented, and managed. There needed to be metrics to assess the impact of ICT initiatives on sector reconstruction, a means to monitor and report progress on ICT activities, and a means to visualize and rapidly share situational awareness. There also needed to be a presence of US ICT professionals in Kabul to liaise and work with key civil-military stakeholders working ICT-related activities. Additionally, there was a need to strengthen the ability to reach back to CONUS for various ICT support activities and ICT professionals for advice and assistance, including access to DISA and its breadth and depth of capabilities, ASD-NII, NDU, and other USG elements, academia, think tanks, and industry as appropriate.

Finally, there was a need to raise the awareness of senior military leadership of the importance of the use of ICT to support C4ISR and as an enabler of COIN related activities. ICT can be a powerful enabler of reconstruction and development goals that have COIN related payoffs. It is both a sector and an enabler of cross-sector reconstruction and development. As a sector, ICT supports national capacity building and export-market focus and plays a critical role in reestablishing basic economic linkages by relieving communication bottlenecks from financial, governmental, and cultural information flows. It is an engine of economic growth and creator of jobs both within and in support of the sector. As an enabler, it supports global positioning focus and adoption of cross-sector strategies that can be used to harness the uniqueness of ICT to accelerate a wider reconstruction and development process.<sup>1718</sup> It is also an essential enabler for boosting productivity by helping to establish a climate for job creation, investment, and sustainable growth. The use of e-government can help reduce corruption and enhance transparency in governance and thus offers an opportunity to positively influence attitudes of the leadership and general population. ICT extends the influence of the central government and can serve to revolutionize economic and social development, especially in rural areas. ICT can facilitate the improvement of healthcare delivery by allowing access to remote consultation and diagnosis, medical databases and libraries, epidemic alerts, and treatment. Distance learning can be employed for higher level education as well as technical and vocational training, while primary and secondary education can access educational material, collaborate, and explore interactive learning techniques. Alliances can be formed between learning institutions within the affected nations as well as with off-shore institutions to facilitate capacity building. The real benefits lie not in the provision of technology per se, but rather in promoting creation of powerful social and economic networks by dramatically improving communications and the exchange of information.<sup>1719</sup>

---

<sup>1718</sup> Hameed, Tahir (2006) "ICT as an Enabler of Socio-Economic Development." Presentation for the International Telecommunication Union. Available at: <http://www.itu.int/osg/spu/digitalbridges/materials/hameed-ppt.pdf>.

<sup>1719</sup> Wentz, Larry, Frank Kramer, and Stuart Starr (2008). *Information and Communication Technologies for Reconstruction and Development: Afghanistan Challenges and Opportunities*. National Defense University, Center for Technology and National Security Policy, *Defense Technology Paper 45*, January 2008. Available at: <http://ctnsp.dodlive.mil/files/2013/07/DTP-045.pdf>.

At the US national strategic level the ASD-NII/DoD CIO, the Honorable John Grimes, and the US Joint Chiefs of Staff J6, Vice Admiral Nancy Brown, met with MCIT Minister Sangin at his office in Kabul in August 2009. This meeting set the conditions and perceptions that some US national strategic interest remained in developing the ICT sector of Afghanistan. However, at the ISAF and US military theater strategic and operational levels, the condition of Afghanistan ICT infrastructure and its capabilities seemed to be less well understood and less of a priority. GIRoA continually faced challenges of protecting, monitoring, and developing ICT both as a sector and as a service. Cellular towers were being attacked by the Taliban, criminals, and other anti-government elements. They either destroyed the towers or forced MNOs to turn them off during evening hours, and even some more permanently, with threats of destruction and harm to employees. Likewise, work on building the national fiber optic network was delayed by disruptive Taliban activities such as cutting cables and attacking the workforce laying the cables.

During the 2008-2009 timeframe, there were a number of Washington, DC Interagency advocacy meetings that resulted in a “summit” session at Main State in December 2009 to review how the DoD and DoS might work together to reactivate the STA and its Telecom Advisor (TA) function. The idea of creating two STA positions was reviewed, one at the US Embassy Kabul and one at ISAF, to enable civil-military coordination and integration of USG ICT interests in Afghanistan. Due to crowding and a significant increase in ambassador-level positions at the embassy in this period associated with the civilian surge, State recommended a single STA position be reactivated but placed at ISAF, and that the STA position should work closely with the embassy and USAID mission, primarily through the TWG and the CDDEA. The DoD agreed to take the lead to make it happen. DoD-CIO tasked DISA to sponsor establishing the office of the Senior Telecom Advisor at ISAF and to recruit a senior civilian (preferably at the SES-equivalent level) with professional civil and commercial ICT experience to be the STA. The TFBSO offered to provide funding to help support the first year of operation. It was envisioned that the STA would also have access to senior experienced ICT professionals to help execute the mission. The December 2009 agreement in principle resulted in active planning on the part of DoD elements for a July 1, 2010, establishment of the office of the Senior Telecom Advisor (STA) to COMISAF at ISAF Headquarters in Kabul. As will be covered later, planning for the office included socializing the concept with DoD, DoS, USAID, DoC, CENTCOM J6, NATO, EUCOM<sup>1720</sup> J6, ISAF CJ6, and other USG elements in advance of deployment, including obtaining COMISAF support and approval.

The office of the STA was to be a US-funded and staffed element to be collocated at ISAF Headquarters in Kabul. There were no formal mechanisms put in place to establish the STA office other than deployment orders. ISAF CJ6 took care of initial arrangements such as staff billeting, ISAF reporting, introductions to key ISAF, USFOR-A and US Embassy staffs and Afghan ICT sector governance counterparts, and related office (e.g., space, desks, computers, telecom and IT network access), and staff life support needs. This was unlike the formal agreements for the establishment of the ICCE in Iraq and the ARG at the US Embassy Kabul. For ICCE, there was a FRAGO establishing it formally as a part of MNF-I and there was an MoU with the Iraqi government on its roles and relationship with elements such as the Ministry of Communications

---

<sup>1720</sup> European Command

(MoC), the Communications and Media Commission (CMC, the regulator), state-owned enterprises such as the Iraqi Telecommunications and Post Company (ITPC) and the State Company for Internet Services (SCIS) and other ministries such as Science and Technology, Defense, and Interior. There were also arrangements for MNF-I DCS CIS interactions with the US Embassy and USAID. For the ARG, there was a formal agreement among NSC, DoD, and DoS/USAID and Ambassador Zalmay Khalilzad at the US Embassy on the ARG's role and responsibilities and placement at the US Embassy for life support and being staffed by DoD with senior professionals carefully recruited from industry and government. The lack of formal MoUs/MoAs became problematic for the STA/TAT in the 2012 timeframe when ISAF orders to draw down elements that included the STA/TAT were issued and transfers to US Embassy were explored as an alternative home for the STA/TAT. In this case, the STA/TAT success was viewed as an ISAF success blurring the fact it was still a US element on ISAF, not a NATO element. NATO was now directing the STA/TAT future at the ISAF compound. Agreements were obtained between ISAF and the US Embassy Kabul to delay draw down to allow time for the USG to explore alternative options. Staffing the STA support team through the Civilian Expeditionary Workforce program also created some challenges in matching strategic versus tactical tasks to workforce skills made available through the CEW program. Both ICCE/ISE and ARG recruiting targeted senior experienced professionals. CEW processes needed to be adjusted to accommodate selective targeting and recruiting for specialized skill sets. These challenges will be covered later.

## Reestablishing the Senior Telecom Advisor

The management of the transition of the Telecom Advisor function from DoS to DoD to set up the STA at ISAF was discussed in conceptual terms. It was agreed in principle that DoD would take the lead and the proposed approach would be coordinated with DoS and others as appropriate when it became clearer what would be executed. DISA planning for possibly implementing some version of a Telecom Advisor function in Afghanistan started in the latter part of 2008 following the departure of the ARG and its STA from Kabul. With the surfacing of an interest in planning for ICT connectivity to support a military surge in Afghanistan, the thinking about both a Telecom Advisor and implementing a DSE-A began. Around this same time, there was a CENTCOM J6 meeting with DISA and others to explore possible options for establishing broadband connectivity into and within Afghanistan to support US Forces' C4ISR and related connectivity with higher-level headquarters and between in-country headquarters and regional command elements and with new FOBs, fire bases, airfields, and other elements to be forward deployed as part of the surge. There were also in-country efforts underway to commercialize existing tactical networks, and these efforts were exploring the role and use of Afghan ICT to help meet demands for connectivity and services.

A concern that emerged at the CENTCOM meeting was that the ongoing operation in Iraq was already using the available regional satellite capacity, to which the Afghanistan deployment would also need some access to support increasing connectivity needs to be generated by a surge and expansion of the military C4ISR network in country. The satellite capabilities at that time were not adequate to simultaneously accommodate needs in both theaters of operation so an alternative to help load balance the demand for access was needed. The Afghan national fiber network emerged as an option to be explored. Interestingly, up to this point in time, DoD elements and commands had zero interest in planning for use of the Afghan

national fiber optic network so there was no US demand signal or incentive to the Afghans that there may be USG interest in leasing fiber optic connectivity. Furthermore, most of the systems in use in Afghanistan by the US military at that time were tactical communications. There was reliance on Afghan private sector cellular networks (this was the primary way of contacting Afghans) and selected ISPs for MWR Internet access. The private sector backbone microwave network was also used to support some US military command and control as well as administrative and logistic networks connectivity needs.

Implementation of the Afghan fiber ring was also progressing slowly, and much needed to be done to jumpstart the effort to build out the fiber ring and interconnect it regionally with the global fiber optic network to meet Afghan demands and possible emerging US military C2 demands as well. Realizing that something needed to be done quickly, a CENTCOM and ASD-NII site survey team was sent to Afghanistan to establish the business processes to formally start actions to lease telecommunications transport services on the Afghan fiber network and to work with the state-owned enterprise, AfTel, to provide and manage the services. Interactions with MNOs were also a consideration as well for local microwave and other connectivity for FOBs, airbases, and other needs. Establishment of a DSE-A was discussed with USFOR-A J6 as well and was agreed to be set up in early 2009. The site survey triggered some behind-the-scenes actions to explore how the USG might help jumpstart the process to accelerate expansion of the fiber optic network and to provide some expertise to AfTel to help them prepare to manage services at an expected level of performance needed to meet US military connectivity and performance needs. Subsequently, it was discovered that there were significant delays in Afghan fiber ring implementation activities in 2009 due to increased security threats. In July 2010, MCIT Minister Sangin sent a letter to the US Ambassador to Afghanistan requesting additional US financial assistance to help them with implementation of the fiber optic project.

DISA and NDU along with ASD-NII/DoD CIO were already thinking about the possibility of implementing an Afghanistan Communications Coordination Element (ACCE) to provide needed ICT advise and assist expertise and to possibly also be used to support the DSE-A engineering service needs in country. The thinking was being driven by the DISA Iraq experiences with the DSE-I, the DoD Business Transformation Agency, and the DISA Iraqi ICT Task Force, as well as follow-on DISA support to the MNF-I DCS CIS ICCE/ISE team. The DISA, NDU, and ASD-NII/DoD CIO experiences with Iraq ICT efforts and on-the-ground experience with the STA activities of the ARG in Afghanistan helped shape the thinking as well. Inputs from ASD-NII and NDU Reachback support to the CJTF-101 CJ6 at Bagram Air Base at that time were also identifying demand signals for ICT expert help in country. ASD-NII and NDU participants had prior on the ground experience in Afghanistan including contacts and established trusted relationships with key GIRoA elements such as the Minister of Communications, Chairman of the Telecom Regulatory Board, Deputy Ministers and Directors at the MCIT, the CEO of AfTel, as well as CEOs of the private sector MNOs and some of the ISPs. There were also established contacts with the US Embassy Kabul, USAID Mission, UN, World Bank, US industry in-country, and other Afghan contacts. The contacts of the ASD-NII member who participated in the CENTCOM site survey were, in fact, found to be most valuable to the survey team that visited USFOR-A and GIRoA elements the end of 2008.

In 2009, COMISAF General McKiernan invited the NDU Director of the Center for Technology and National Security Policy (CTNSP) to visit Afghanistan. The CTNSP Director spent time in Kabul and visited Jalalabad

to meet with the Nangarhar PRT. The unifying theme of the visit was the importance of ICT and distributed energy to Afghan reconstruction and the counterinsurgency campaign. An NDU staff member also made a visit to Iraq to research the challenges, opportunities, successes, and lessons of the ICCE/ISE team supporting MNF-I. Findings from both visits were used to help shape the thinking about a DoD focus and approach to providing ICT-related advice and assistance in Afghanistan.

There were several models the DISA, NDU, and DoD CIO team reviewed to help think through possible arrangements for a communications coordination element in Afghanistan. The models examined would naturally need to be tailored to the ICT and business needs and environment unique to Afghanistan at the time of a possible deployment. The models examined included but were not limited to:

- The MNF-I DCS CIS ICCE/ISE team led by a colonel (or GS-15) and reporting to brigadier general responsible to the multinational force commander for communications and information systems. An MNF-I FRAGO established the team, CONOPS,<sup>1721</sup> roles and responsibilities, and rules of engagement. The team was composed of ICT SMEs that were a mix of US Government civilians, military personnel, and contractors. The general officer was designated as the MNF-I key leader to engage with GoI and industry ICT counterparts. Movement inside the “green zone” was by vehicles driven by team members with no IBA or PSD required and outside the “green zone” by US military convoy with IBA and PSD. There was a reachback to NDU and DoD CIO that facilitated access to USG elements, academia, think tanks, and industry for advice and assistance. The team focus was on commercialization of fixed military ICT arrangements, modernizing military network control centers, building knowledge management systems, and improving assistance to the Iraqi government to help them rebuild the country’s ICT in terms of policy, infrastructure, and services. Staff was billeted at US-provided facilities and had access to DFACs.<sup>1722</sup>
- The Afghanistan ARG STA supported by an I-Team coordination arrangement that was sanctioned by the US Ambassador in Kabul and US military commanders to facilitate collaboration and information sharing among civil-military ICT stakeholders and with GIROA and private sector ICT counterparts. The team in Kabul was a mix of government civilian and military personnel. The civilians were DoS employees recruited from industry and other government organizations by the DoD, which also provided oversight of their activities. The team was billeted on the US Embassy and USAID Mission compounds and used US Embassy and USAID dining facilities. Use of ISAF DFAC was by invitation. An Afghan reachback office (ARO), which was a mix of US Government civilian, military, and contractor personnel, was established in the Pentagon in OSD at the SecDef level to provide access to USG elements, academia, think tanks, and industry for advice and assistance. Movement off the US Embassy compound around Kabul was by embassy-provided vehicle and driver (usually an Afghan) with no IBA or PSD. Travel

---

<sup>1721</sup> Concept of operations

<sup>1722</sup> Dining facility(ies)

outside of Kabul was by armed convoy with IBA and PSD. A DoD CIO and NDU reachback element supported both the STA and ARO, and its members rotated on TDY assignments to Kabul as acting STA gap filler and special study assignments. The reachback element was also the continuity across multiple years of operation since its staff did not rotate. The STA was designated by the US ambassador to be the lead for ICT key leader engagement with GIRoA and private sector ICT counterparts, such as the minister of the MCIT, the chairman of ATRA, the CEO of AfTel, international ICT organizations such as World Bank and UNDP, and CEOs of private sector MNOs and ISPs. The focus of the STA and I-Team was to help the US Government focus more attention on ICT to help GIRoA implement a national ICT strategy, foster private sector investment and engagement, encourage US and Afghanistan cooperation on international ICT treaties, and provide assistance for US firms to fairly compete in Afghanistan.

- Establish an Afghanistan Communications Coordination Element (ACCE) that was patterned after the ICCE team in Iraq and previous STA/ARG I-Team in Afghanistan and adjusted to Afghan needs and to support USFOR-A J6 planning for use of Afghanistan ICT, interactions with civil-military ICT stakeholders, and engagements with Afghanistan ICT counterparts and located in Kabul. Establish a DISA Support Element Afghanistan (DSE-A) and use it to also assist ACCE in ICT system assessments, planning, and engineering and engagements with Afghanistan ICT counterparts. Level of effort was suggested to be something like a military (officer and NCO), a GS civilian, and one or two contractors. ACCE/DSE-A focus areas would be to coordinate and share information among key civil and military (including ISAF and PRTs) ICT stakeholders and engage Afghan ICT counterparts on initiatives; formulate US military ICT strategy, plan, and projects for use of Afghan ICT to support C2 and COIN initiatives; develop an enterprise architecture including use of Afghan ICT; develop a baseline of ICT systems in Afghanistan and a mechanism for monitoring and tracking MCIT, US, and other ICT actions; develop metrics for assessing progress and effects including visualization of a common operating picture for ICT project activities; and establish a civil-military collaborative information environment to facilitate collaboration and information sharing among appropriate ICT stakeholders, using the Internet and web portals and other tools to the maximum extent possible.
- Use of a small footprint arrangement forward that would be a senior civilian (SES level) with civil and commercial ICT expertise as a Senior Telecom Advisor to COMISAF. It would be desirable for the STA to have some military experience to help bridge the civil-military divide. The STA would use ISAF movement with PSD for trips outside of the ISAF compound. It was envisioned the STA would be supported by a small contractor ICT SME team located off the ISAF compound in its own safe house, with its own PSD and armored vehicles for transportation. This would give the contractors freedom of movement to meet with GIRoA, private sector, and international organization key ICT leaders. It was also envisioned that a small reachback element in CONUS would provide access to USG elements, academia, think tanks, and industry for advice and assistance. The reachback members would be used for TDY assignments to Kabul as acting STA gap filler and special study assignments. The reachback element would also be the continuity across multiple years of operation. The STA would be assigned by COMISAF as the ISAF lead for

ICT key leader engagement with GIRoA ICT counterparts such as minister of the MCIT, chairman of ATRA, CEO of AfTel, and personnel at international ICT organizations and private sector MNOs and ISPs. The focus of the STA would be to facilitate and coordinate the US government, Coalition forces, and ISAF strategic interests in ICT in Afghanistan and provision of ICT support for military C2 needs; to help grow the ICT economic sector and assist the Afghan government to accelerate the benefits of ICT as an enabler to extend governance and spur socio-economic development and growth for stabilization; developing stabilization solutions working with Interagency and international organizations; recommending ICT strategic engagement initiatives that have benefit across all sectors; improving performance by and developing ICT capacity within GIRoA; and improving harmonization, coordination, and synchronization of ICT policy, infrastructure, and services initiatives across the security, governance, and socio-economic sectors. It was also envisioned the STA would become the “one-stop shop” for advice and assistance on ICT and the provider of informed situational awareness of Afghan ICT sector activities.

The Haiti earthquake in January 2010 diverted some of the attention of DISA, NDU, and DoD CIO to support the initial USG response to the Haiti disaster, which included the NDU member deploying briefly to Haiti to assist civil-military responders and document ICT experiences and lessons. Assistance included ICT-related activities supporting both the USG responder connectivity and information sharing needs and the recovery of the Haitian ICT sector governance and ICT infrastructure that had been destroyed. Roles and interactions of USG civil-military elements such as State, USAID, FCC-IB, Coast Guard, SOUTHCOM,<sup>1723</sup> and other US Task Force military elements and international responders such as UNOCHA<sup>1724</sup> and the ITU, as well as NGOs were examined and documented in an NDU lessons learned report.

As noted earlier, at the end of 2009, DISA had been given the responsibility by a DoD and DoS agreement to sponsor the establishment of an Office of the Senior Telecom Advisor to COMISAF in the 2010 timeframe, with DoD taking the lead to do so and DoS supporting in principle that the STA would have the lead USG role to facilitate harmonization of ICT activities across the civil-military elements in Afghanistan. DISA and TFBSO were to be the primary sponsors for the first year of the STA and DISA would sponsor in subsequent years. In early 2010, DISA, NDU, DoD CIO, and TFBSO revisited Afghanistan needs and started the planning for putting an STA at ISAF Headquarters by July 2010. DISA, in coordination with CENTCOM J6, DISA-CENT, and ISAF CJ6, started the planning for setting up an initial capability. Early shaping of the STA arrangement focused on the development of a concept and plan to put a small footprint on the ground in Kabul. Included was the development of a job description for recruiting an SES or equivalent level civilian (e.g., a Highly Qualified Expert or HQE) with civil and commercial ICT expertise and experience to fill the position. If the candidate had military experience, that was a positive attribute since this would help with bridging any civil-military divides that may be encountered. Efforts also included exploring possible special arrangements to be deployed such as a small contractor team on the ground in Kabul and

---

<sup>1723</sup> Southern Command

<sup>1724</sup> United Nations Office for the Coordination of Humanitarian Affairs



CONUS-based reachback capability to support the deployed elements including possible rotation of Reachback members to Kabul to work with the STA on special assignments and be an “acting STA” gap filler if need occurred. It was envisioned the STA would be located on ISAF compound and be provided billeting, PX,<sup>1725</sup> DFAC, and other appropriate privileges. Movement would rely on ISAF MOVECON.<sup>1726</sup> The small contractor ICT SME team would be located off the ISAF compound in its own safe house, with its own PSD and armored vehicles for transportation. The contractor team would embed member(s) at the MCIT and occupy a desk at the STA office on the ISAF compound.

As for reporting chains, for the USG, the STA would report to the DISA Director of Global Information Grid (GIG) Operations, an SES, and at the ISAF command group level in country. The Deloitte ICT advisors in Kabul would report to the STA. The CONUS-based Reachback team reported to DISA with a link to DoD CIO for USG Interagency coordination and the STA for in-country ICT activities. The DoD CIO was the USG lead for ICT Interagency coordination. The DoD CIO member of the Reachback team was the point of contact for conducting ICT-related Interagency coordination activities relative to the Afghanistan ICT sector.

The DoD crafted a concept, strategy, and plan for setting up the Office of the Senior Telecom Advisor to COMISAF. The plan envisioned the need to cover several years and that, at some point, it would likely be necessary for the DoD lead for the STA to be transitioned to DoS/USAID or some other USG civilian element. The end state and exit strategy for the DoD-sponsored STA was not fully thought out as part of the initial planning process. Although transition of the STA lead from DoD back to DoS was recognized, the details of what was to be transitioned to whom and when were to be determined later (though most felt it was a DoS/US Embassy responsibility to pick up the Telecom Advisor function). The reality was there was no shared agreement or detailed discussion between DoD and DoS on what this really meant. There were different views expressed in general terms about what it meant but none were discussed in any detail. It was recognized that the transition would be driven by available resources and skills and organization business cultures at the DoD and DoS, as well as by responsibilities, views of the job, and the availability of professional ICT SMEs. DoD and DoS are different, so such a transfer is not a simple body or task handover. During the initial planning discussions for deployment of an STA at ISAF, the DoS made it clear it was not prepared to make an offer to take back the lead in the near future. Further action on this was deferred until a later point in time.

In fact, one of the concerns expressed during the DoD-DoS negotiations was that the DoD would set up the operation and then after a year or so hand over the function to the US Embassy as was done in Iraq with the drawdown of military forces and the disposition of the ICCE/ISE team functions. Interestingly, the DoD to DoS transition issues were in fact addressed two years later (at the end of 2011) when President Obama announced the withdrawal of all combat forces and it became clear the STA would become part of the transition and drawdown actions.

---

<sup>1725</sup> Post exchange

<sup>1726</sup> Movement control

The approach for setting up the ISAF STA and its role and mission was socialized in advance of deployment to Kabul with DoD, DoS/USAID, and DoC Washington, DC headquarters elements, CENTCOM, NATO, EUCOM, and with in-country elements such as US Embassy, USAID Mission, ISAF, and USFOR-A and with the GIRoA minister of Communications and IT. At the time, it was felt to be extremely important to be transparent with intent and to allay concerns in advance of deployment that the STA was to replace or compete with ongoing US Embassy and USAID Mission ICT-related activities and existing civil-military organization responsibilities in country. It was also noted that it was important for the STA to be a good listener initially and start to build trust relationships as soon as possible once on the ground in country.

Demand signals from the field identified need for an ICT SME support element for advising military activities related to commercialization of the military tactical systems and expansion of networks to support surge and related bases and airfield connectivity needs – mainly the role and availability of the Afghan national fiber optic network to support C4ISR broadband connectivity needs both within and for access to and from the Afghan theater of operation. There were also requests for advice on how to protect the private sector cell towers and services from Taliban (and other) attacks and forced shut downs, e.g., place cell towers on FOBs. There were also requests for assistance to deal with telecom regulator regarding military-civil spectrum de-confliction and fire, police, and medical emergency response numbers and call centers for citizen reporting and safety communications. Further, advice on the use of ICT for extension of governance to provincial and district levels and for socio-economic development and growth as part of stabilization and counterinsurgency operations was requested. There were also concerns expressed about the need for better civil-military coordination and information sharing of ICT-related activities. The topics of ICT for military MWR (there were concerns that local ISPs were not able to provide reliable service) and survivable private sector cellular service for civil-military emergency use were raised as well. Given these types of demands, it was decided the STA arrangement for implementation should be a senior professional ICT SME with experience in dealing with senior USG civil and military leaders, multinational Coalition and international elements, and should be able to interact with high-level Afghan government and private sector ICT personnel. It was important s/he be familiar with telecom and IT policies, regulations, laws, international ICT standards and best practices, and ICT technology trends.

Given there was a civilian surge competing for billeting and office space, it was decided a small footprint forward would be best. It was also felt the STA needed to be senior enough to operate in direct support of COMISAF and his staff and to work with senior level US Embassy and USAID Mission leadership. The approach proposed and approved was to provide a DISA-sponsored SES or equivalent civil and commercial ICT SME to train, advise, and assist ISAF, USG Interagency, and GIRoA elements and to be a coordinator, harmonizer, and connector of ICT-related activities. The intent was for the STA to become the one-stop shop for advice and assistance on civil and commercial ICT and the provider of informed situational awareness of Afghan ICT sector activities and their status. The STA would be located at ISAF Headquarters and supported on the ground by a two-person contractor team (Deloitte Consulting became the contractor) housed outside of the ISAF compound with its own life support and safe house and with armored vehicles and PSD to allow freedom of movement around Kabul and to embed as appropriate with the Afghans at the MCIT, ATRA and AfTel. A CONUS-based reachback element consisting of DISA, DoD CIO, and NDU would serve as the initial core Washington, DC team. Before deployment of the STA, DISA also placed Gartner on a consulting contract to provide the STA access to its ICT SME advisory pool

and vast research database for advice and assistance. Gartner would become a virtual member of the reachback element. Deloitte in Washington, DC would become a member of the reachback element as well. ISAF CJ6 would temporarily provide administrative assistance in Kabul and DISA GIG Ops would provide longer-term administration and other assistance as needed to support the STA. DISA would also be the go to element because of its broad range of engineering, contracting, and operations expertise and services. DISA would fund the STA, Deloitte, NDU, Gartner, and other special needs. The plan was for Reachback to meet on a weekly basis and have frequent teleconferences with the STA as required to meet work demands for advice and assistance and share ICT situational awareness.

The STA was recruited from industry and brought on board by DISA as an HQE (SES equivalent). He was a retired colonel with several years of relevant civil and commercial ICT experience. DISA, ASD-NII/DoD CIO, NDU, and the first STA based at the ARG engaged in a mentoring program to bring the STA up to speed regarding Afghan ICT sector challenges and opportunities, business culture, and ICT sector contacts within the public and private sectors. Mentoring for dealing with Interagency elements and culture such as DoS/USAID, US Embassy, USAID Mission, and international organizations were provided as well. Pre-deployment visits were made to the State Department, USAID, FCC-IB, Joint Staff Pakistan Afghanistan Coordination Cell (JS PACC), Department of Commerce Afghan ICT elements, and the World Bank for the STA to develop a more informed understanding of the players and ICT-related activities and to socialize the STA approach to be implemented. The STA and NDU advisor met with CENTCOM J6 and DISA-CENT to review the actions to set up the Office of the STA at ISAF. The DISA commander, CENTCOM J6, and DISA-CENT discussed the proposed approach with ISAF and USFOR-A in advance of deployment of the STA and obtained COMISAF approval of concept.

As the planning for the STA was progressing, DISA, DoD CIO, and NDU became aware of a briefing ISAF CJ6 presented at the April 2010 TWG meeting in Kabul. The presentation shared their thoughts on a proposal to establish a Telecom Advisory Team (TAT) at ISAF CJ6 to bring coherence amongst all various ICT programs and projects to provide effective sustainable progress allowing telecommunications to become the critical enabler in Afghanistan. The TAT would provide the expertise and serve as a liaison to holistically focus telecommunications initiatives and resources in support of Communications and Information Systems (CIS) stakeholders and the socio-economic development of Afghanistan within a "Telecommunications Super-Highway" context. It was recommended the TAT be led by a Senior Telecom Advisor and have a staff of 12 personnel consisting of a senior Afghan commercial advisor, a telecom infrastructure technical expert, three budget specialists, two telecom policy and regulation advisors, a civil engineering infrastructure liaison officer (LNO), a telecom/frequency LNO, and two administrative (admin) and coordination support personnel. It was proposed the TAT would be ISAF's telecom advisor to the MCIT. It would form and lead the Telecom Advisory Working Group, provide collective oversight and coordination of telecom activities, influence application of International Community investment, and other activities. Needless to say, this created some concern and confusion on the part of the US Embassy and USAID Mission personnel as well as the DISA, DoD CIO and NDU team, since they were all aware of the agreement between State and Defense to establish a DoD-sponsored Senior Telecom Advisor at ISAF to perform essentially the same functions laid out in the ISAF CJ6 proposal. To be fair, at the time of the ISAF CJ6 pitch to the TWG, it was only a proposal recommending the establishment of a TAT-like element at ISAF CJ6.

Following the pre-deployment mentoring and socializing of the STA approach with the USG Interagency in Washington, DC and CENTCOM in Tampa, Florida, the STA and his NDU advisor departed at the end of June 2010 for Brussels where they met with the NATO C3 Agency and the US Mission to NATO to share the concept to establish an STA at ISAF. In the meeting with the Deputy Director General NC3A,<sup>1727</sup> it was proposed that a collaborative arrangement be explored with the NC3A team already working in Afghanistan and it was agreed this made sense to do. Subsequent discussions with NC3A in Kabul included a request for funding from them (they were a fee-for-service organization) to support a collaborative effort that led the STA to take the position of wait and see what might make sense to do in the future. From Brussels, the STA and NDU advisor traveled to Stuttgart to meet with EUCOM J6 and DISA-EUR<sup>1728</sup> and then headed to Afghanistan.

### Office of the Senior Telecom Advisor to COMISAF – Getting Started

In preparation for the arrival of the STA, the ISAF CJ6 had taken the following actions: put together a smart book on ISAF, Interagency players, and the Afghan ICT sector; assigned a liaison officer to work with the STA upon arrival to help get things started; arranged billeting for the STA and NDU advisor; started the paper work for ISAF/USFOR-A in-processing for billeting, DFAC access, and badging; conducted preliminary discussions with ISAF on where the STA would best fit into organization (either report to the Deputy Chief of Staff (DCOS) Strategic Partnership or DCOS Stability Operations, also referred to below as Stab Ops or STAB), secured STA office space in the CJ6 area and initiated the process to get furniture, phones, and computer support; organized an orientation program; scheduled visits with key personnel from various organizations; and performed numerous other actions needed to set the conditions for creating the Office of the Senior Telecom Advisor to COMISAF and getting the operation up and running.

Upon an early-morning arrival at Kabul International Airport on July 1, 2010, the STA and NDU advisor were met by the ISAF CJ6 liaison officer and taken to ISAF Headquarters to meet the CJ6 and formally start ISAF in-processing and setting up the office of the STA. It was at this meeting the STA learned that the ISAF CJ6 Telecom Advisory Team (TAT) proposal briefed to the US Embassy Telecom Working Group had gone beyond the proposal stage to implementation. Concurrent with the planning for the establishment of the office of the STA at ISAF Headquarters, the ISAF CJ6, with support from CENTCOM, continued its efforts to formalize the proposal for establishing an ISAF CJ6 TAT ICT cell to be staffed with personnel from the DoD Civilian Expeditionary Workforce (CEW) program. As noted earlier, the plan was to recruit an STA to lead the CJ6 TAT and staff team with telecom experts and advisors (commercial, policy, regulatory, technical, frequency), and budget specialists, civil engineers (infrastructure), and administrative support.

The ISAF CJ6 advised the STA and NDU advisor that he would provide the STA use of eight Civilian Expeditionary Workforce (CEW) positions that he had created to augment CJ6 with commercial ICT experts in accordance with his proposed TAT arrangement presented at the TWG in April 2010. The CJ6 felt the CEW team would fit better in the Office of the STA to COMISAF. It was also learned that the CEW positions

---

<sup>1727</sup> NATO Consultation, Command and Control Agency

<sup>1728</sup> Defense Information Systems Agency-Europe Field Command

had been formally established and posted on the CEW website, recruiting for candidates through the CEW program had started, and some candidates had already been selected and were being processed to deploy to ISAF. The details of whom with what skills and when they would arrive was yet to be determined as was who would do the in-processing, mentoring, administrative, and creature comfort support arrangements for the arriving team members. This was the first of a number of surprises to be encountered in the evolution of the STA operation at ISAF.

The CEW element formed the basis for eventually creating the Telecommunications (Telecom) Advisory Team (TAT) that the ISAF STA would direct. It took over six months for all the CEW team members to arrive, with a new member arriving about once a month. The CEW positions were eventually formally transferred to USFOR-A (the US military command in Kabul) under the direction of the ISAF STA whose billet was also made a part of the transfer to USFOR-A. This action made the CEW element formally an integral part of the team working for the STA and gave the STA/TAT legal US status for being in country.

Needless to say, the addition of the CEW elements introduced the need for a real-time adjustment of the STA strategy and plans guiding the creation of the Office of the Senior Telecom Advisor to COMISAF and created a steep learning curve for receiving and conducting the NATO/ISAF and USFOR-A in-processing for new members of the team and establishing related support requirements. ISAF in-processing was not part of the STA staff expertise and had to be learned on the job. The TAT eventually received an admin person removing the burden from the technical staff to do this job. A related challenge was the lack of an STA/TAT orientation and mentoring program at ISAF and the fact that the pre-deployment training did not address the role, mission, and operational environment of the STA/TAT and its reachback element. It also did not address working in a senior-level multinational multicultural environment at ISAF and with international organizations, interacting daily with senior civilian and military personnel, and working daily in an Afghan professional business and government organization environment that differed from the way the US does business. Also, for most of the CEW members, it was their first time in Afghanistan and deploying into a war zone. This was not the case for the Deloitte and Reachback team members (DoD CIO and NDU) who had prior ICT experience in Afghanistan or Iraq or both.

The CEW resources provided access to a mix of administrative, contracting, and ICT skills. The addition of the CEW-staffed TAT meant one of the early tasks for the STA was to review and rethink the initial strategy and plans and how to reshape the work program to accommodate a larger team and likely diverse skill sets to be determined when staff arrived. Since it was unclear at the time who was coming, this became an exercise in shaping the tasks to fit the skills that arrived over the next several months versus recruiting the skills needed to execute the strategy and planned work program. As they say in Afghanistan, things are not always as they seem to be.

The Deloitte two-person team, who were to be direct ICT SME advisors to the STA, was scheduled to arrive after the STA, one later in July and the other in September 2010. The role and use of the Deloitte advisors and participation of Reachback, including selected team member TDYs to provide on the ground support to the STA, also had to be reviewed given the new CEW team arrangements and need for some level of mentoring for CEW elements and the need to match work program with skills available. The Deloitte team was to be housed in a guesthouse in Kabul and have its own PSD and vehicles. For work purposes, one

team member was to be collocated with the STA at the ISAF office and the other embedded at the MCIT facility in downtown Kabul.

The STA, CEW, and Reachback TDY members were billeted on ISAF. In later phases of the TAT, this proved to be a challenge due to lack of transit billeting space caused by increased movement of in-country personnel, causing demand to exceed space available to meet surge requirements and, several years later, to meet force drawdown and transit relocation needs. This was particularly a challenge for those TDY since billeting priority was given to arrivals that would be part of the surge staff with six- to 12-month assignments and in-country movement activities. There were no arrangements or processes to pre-reserve a billeting space for sole use by the STA/TAT for TDY support even though this was part of the CONOPS. It was necessary to compete with other demands for billeting space, both for long-term assignment and short term TDYs.



Picture 67: STA/TAT office at the MCIT

On the good news side, it turned out the MCIT Minister, in anticipation of receiving more focused ICT advice and assistance through the office of the STA, made a room available at the MCIT headquarters

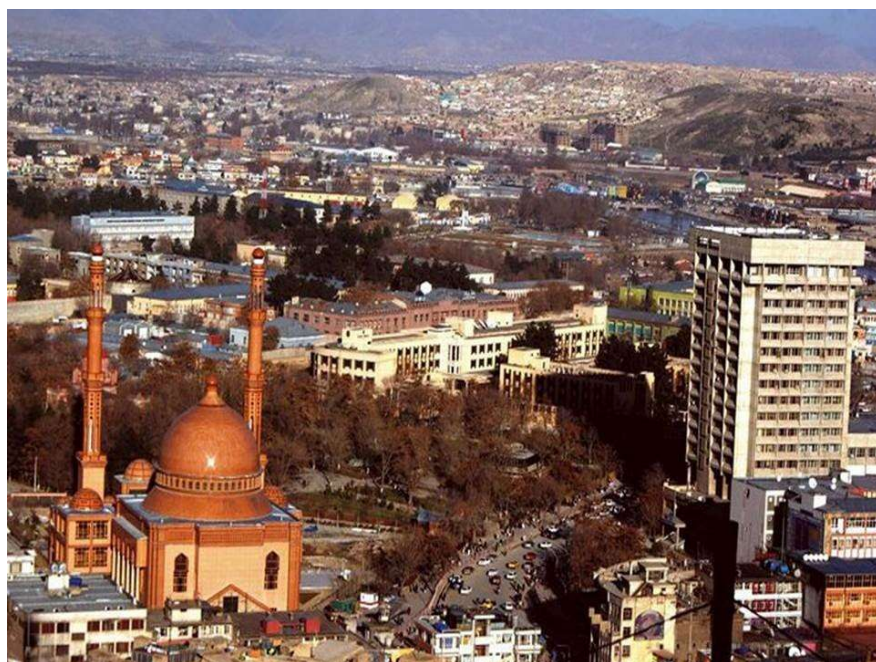

Picture 68: MCIT building in Kabul

building (see [Picture 67](#)) for the sole use by the STA/TAT team. He wanted to develop a close working relationship with the team and was pleased finally to have a single senior USG civilian point of contact (with links to COMISAF and the Ambassador) to deal with on ICT-related matters and to have part of the ICT SME team resident at the MCIT. The minister was also pleased because he knew the Deloitte advisor to be embedded at the MCIT, who had worked with and for him

in the past and with whom he had a trusted professional relationship. The STA/TAT office was located one floor below the minister's office. Over time, other TAT members also used the office space to work with various MCIT, ATRA, and AfTel counterparts. In fact, AfTel after a few months, also provided an office for

TAT use in its building next to the MCIT building in downtown Kabul (MCIT headquarters is the tall building on right in [Picture 68](#)).

The CONUS-based reachback element was already up and running before the STA deployed. A schedule of TDYs for Reachback team members (one from ASD-NII and the other NDU) had been established so they could participate in setting up the office and connecting the STA with key US Embassy, USAID Mission, World Bank, and Afghan counterparts. The plan for the first year was to rotate Reachback team members into Kabul to maintain experienced, near-continuous on-the-ground support and to gap fill for the STA in the event he needed to be out of country. Gap filling for the STA in fact became a real need in the early phase of the TAT when the STA had a personal issue that required him to return to the US for several weeks. The NDU advisor and Deloitte SME provided backfill for him during this period.

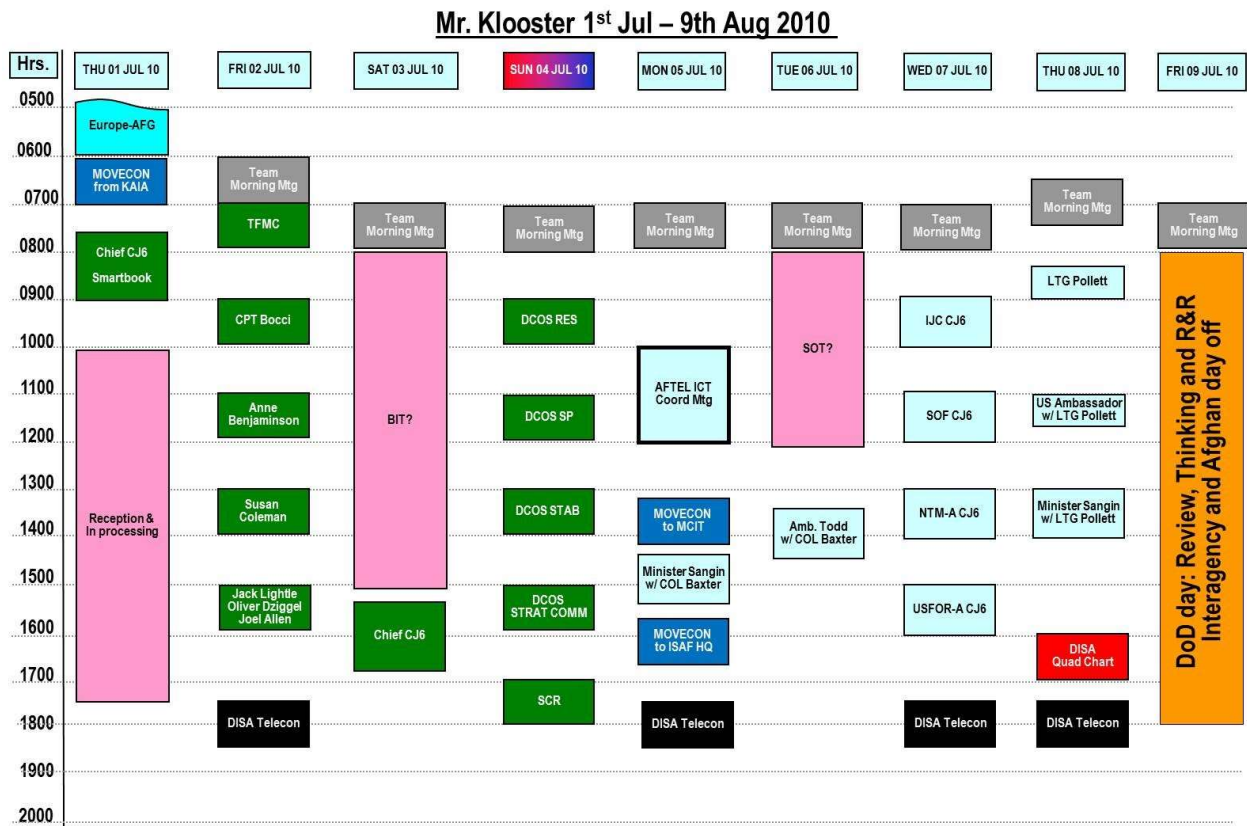

Figure 119: STA orientation battle rhythm

Establishing the STA/TAT office was pretty intense. ISAF CJ6 had arranged an action packed two-week orientation program (see [Figure 119](#)) for the STA to meet with personnel from ISAF: the senior civilian representative (SCR), the Deputy Chiefs of Staff (DCOSs), ISAF Joint Command (IJC), Special Operations Forces (SOF), and the NATO Training Mission-Afghanistan (NTM-A). There were USFOR-A orientation briefings that had to be accommodated as well. ISAF CJ6 also arranged meetings with USFOR-A, the US

Embassy Kabul, the USAID Mission, and key leaders at the MCIT, ATRA, and AfTel. In the middle of the STA orientation, in-processing, and setting up the office, the DISA Director, Lieutenant General Carroll Pollett, USA, and Director of DISA GIG Ops, Mr. Larry Huffman, arrived on July 9, 2010 to visit the STA to see how things were progressing and to make office calls with ISAF, the US Embassy, and with MCIT Minister Sangin.

A particularly useful introduction was to the USAID-funded Economic Growth and Governance Initiative (EGGI) project, which was staffed by another Deloitte team. The EGGI team had Deloitte staff embedded at the MCIT, ATRA, and AfTel and was an important element of ICT SME ecosystem supporting Afghan ICT sector activities. It was important for the STA to develop a trusted collaborative relationship with the EGGI team since there were overlaps in areas of interest and a need to avoid duplication of effort and leverage expertise in place. EGGI Deloitte team support ended in February 2011.

As noted earlier, additional duties assigned were helping the arriving CEW staff to in-process, support some level of mentoring and team building, and help new members transition into their TAT job assignments. In the beginning, the STA/TAT had no admin support other than the initial help offered by the CJ6 to get the STA in-processed and established, so other members of the TAT had to step in and help with new staff in-processing and related support needs. As mentioned, the CJ6 had initiated actions to recruit CEW staff, but the STA did not know what skills would be arriving or when – he just knew some CEWers were on their way. The staffing of the office took several months. Needless to say, the early months were consumed with constant team building as new members arrived each month and real-time reshaping of the work program. In fact, rotation of CEW members became a contributor to near-constant team building throughout the life of the organization.



*Picture 69: STA/TAT office at ISAF Headquarters*

By December 2010, there were ten staff on the ground (the STA, two Deloitte advisors, six CEWs, and one Reachback member on TDY). This emerging Kabul-based operation became known as the Telecom Advisory Team (TAT), TAT-1 for the purposes of this book. The STA wore two hats, one as the STA to COMISAF and the other as the Director of the TAT.

The STA and NDU and Deloitte advisors attended the bi-weekly US Embassy Telecom Working Group (TWG) and Afghan Telecom ICT Coordination Working Group (WG) to familiarize themselves with their activities and introduce the STA and his role. The working groups met on alternate weeks. The US Embassy ECON section chaired the TWG that brought together USG elements working ICT initiatives at the US Embassy, USAID Mission, USFOR-A, DSE-A, ISAF, and other USG elements as appropriate. The purpose of the TWG was to facilitate coordination, cooperation, and information sharing among USG elements working ICT initiatives and to develop an ICT-based social network of USG players working in the Afghan ICT sector. The AfTel ICT Coordination WG brought together elements actively engaged in Afghan ICT projects. The CEO of AfTel chaired the working group, and the Deloitte EGGI team advisor to AfTel



(sponsored by USAID) organized meeting activities. Participants included the AfTel CIO and his senior managers, ISAF (STA/TAT, CJ6, Stability Ops, CJIOC,<sup>1729</sup> and Task Force (TF) 41), USFOR-A, DSE-A, USAID, US Embassy, World Bank, and others as appropriate. The focus of the WG was to provide updates on AfTel ICT networks and coordinate actions to resolve problems. A major interest area was the national fiber optic network. The WG also served to develop social networks and trust relationships among the participants, which helped make things happen on a day-to-day basis. The STA also attended the daily ISAF Commander's Update Briefings.

The STA/TAT-1 offices on the ISAF compound were physically located in the ISAF CJ6 area of operation, affectionately referred to as "Circuit City" (see [Picture 69](#)). The CJ6 provided the STA/TAT office space, computers, printers, and access to official US and NATO Classified and Unclassified IT network services and other office support needs. Circuit City was a Class-V security area, which meant no personal computers or active mobile phones were allowed in the area. This was particularly challenging for Deloitte advisors and Reachback TDY personnel, who used their organizations' laptops and email servers as their primary work devices and methods of communication. The nature of the TAT work program was largely unclassified and focused on working with Afghan counterparts, the USG Interagency, international organizations, and NGOs. It was challenging working unclassified in a classified environment, including not having unrestricted access to the open Internet. There was no so-called "dirty Internet" service either. As a result, access to a number of websites used for unclassified research and information sharing were blocked by the military unclassified systems (both ISAF and US). There was, however, Internet access available at MWR facilities and at other wireless hot spots at coffee shops on the ISAF compound, which could be used with personal laptops for accessing personal email accounts and surfing websites in general.

Transportation and PSD for trips off the ISAF compound by the STA/TAT and Reachback were initially provided by ISAF Headquarters' MOVECON. In the early days, IBA was required for trips from ISAF to government, industry, and academic facilities. Once at the facility, the IBA could be taken off and staff had freedom of movement around the facilities in business attire. In fact, TAT members would be dropped off at a facility and left to conduct business and then picked up later at a pre-arranged time. Sometimes the MOVECON would wait if it was to be a short meeting. Later in the first year of operation, the TAT purchased its own armored SUVs<sup>1730</sup> and also used ISAF Stability Operations' MOVECON.

The STA, a DoD SES/HQE, did not report to the CJ6, a US Army Colonel. Instead, based on early CJ6 discussions with ISAF, it was decided that the STA/TAT should initially be assigned to ISAF DCOS Strategic Partnerships (SP) because of the STA's role as the formally-designated ISAF engagement leader with the MCIT. In this case, as a US-funded office located at ISAF, the STA/TAT worked with DCOS SP but had US access to COMISAF/COMUSFOR-A<sup>1731</sup> and a separate chain of US command to the Director of DISA and the DoD CIO. The STA had weekly calls with DISA Director of GIG Ops and almost daily calls with DISA GIG Ops contingency operations branch chief on a range of STA/TAT staffing, funding, travel, and other

---

<sup>1729</sup> Combined Joint Intelligence Operations Center

<sup>1730</sup> Sport utility vehicles

<sup>1731</sup> Commander of United States Forces-Afghanistan

support issues. The branch chief was the designated DISA focal point for supporting the STA/TAT. After several months of operation, it became clear the STA/TAT lines of operation aligned better with ISAF DCOS Stability Operations (Stab Ops), so action was taken to realign the STA/TAT with Stab Ops. Here too, under the senior USG civilian STA leadership role the STA/TAT worked with the DCOS Stab Ops. Additionally, as an SES and general officer (GO) equivalent, the STA became a member of the GO social network on the ISAF compound, which served to help develop key networking relationships and opportunities to interact with COMISAF and to be a visible part of his senior staff.

The STA had his first one-on-one meeting with COMISAF, General Petraeus, on August 12, 2010, to provide an overview of his mission and STA/TAT task focus. General Petraeus had been informed of the intention to establish the Office of Senior Telecom Advisor and was supportive of the action. He was familiar with the Iraq ICCE team in Baghdad and its work and value to the ICT sector, the USG, and MNF-I, and, therefore, had a feel for the value of the use of a similar capability in Afghanistan. The STA had frequent interactions with COMISAF on STA/TAT ICT-related activities, which included ICT situational awareness and issue briefings at least once a month (and sometimes more often) at the COMISAF morning briefing, email exchanges on subjects such as the Afghan electronic national identity card (e-NID), and several one-on-one meetings.

The TAT-1 strategy at the outset focused on developing a more informed understanding of the ICT-related activities and roles and responsibilities of organizations such as ISAF, ISAF IJC, CSTC-A, NTM-A, the US Embassy and USAID Mission, among others. The STA/TAT adopted the approach first to be a good listener and second to make courtesy calls with key leaders to start to build trusted relationships and a shared understanding of how to be able to effectively work together and help each other. This required multiple meetings and cups of tea with Afghan counterparts to set the conditions to start to determine how to best work together. It was also useful to develop a shared understanding of challenges and opportunities and where the STA/TAT might engage and participate to add value.

The STA/TAT began to put together a framework for developing a team battle rhythm, plans of action and task assignments. A 100-day plan was put together, for which a key task was to conduct a current-state assessment of ongoing stakeholder ICT strategies and activities. The team also explored approaches for developing networking arrangements and collaborative environments such as participating in the US Embassy Telecom Working Group (over time STA/TAT became the co-chair) and the Afghan Telecom coordination working group and assigning a TAT staff member as the TAT liaison to ISAF CJ6 to attend its daily morning meeting and support requests for assistance as appropriate. TAT staff also participated in monitoring the Tanberg VTC coverage of the COMISAF morning stand-up briefing so that the team had a shared situational awareness of ongoing operations. The TAT-1 also identified approaches to documenting visits and meetings and sharing situational awareness through meeting flash summaries, weekly and monthly reports, and regular teleconference calls with the Reachback team in CONUS. The STA/TAT also planned for an outreach initiative with an initial focus on trying to gain some awareness of the team's

activities through articles in AFCEA's<sup>1732</sup> *Signal* magazine, participation in Afghan-American Chamber of Commerce Business Matchmaking events, and participation in appropriate Afghanistan reconstruction-related workshops and conferences.

When the STA/TAT set up its operation in July 2010, the high-level ISAF campaign strategy was focused on:

- protecting the [Afghan] population by prioritizing efforts in high-density population areas where insurgent groups operated primarily with disaffected Pashtun populations and need to reduce civilian casualties;
- enabling the Afghan National Security Forces by accelerating and expanding indigenous security force capacity and capability and partnering at every echelon;
- neutralizing malign influence by identifying and reporting corruption and forging responsible and accountable governance;
- supporting extension of governance by gaining active support of the population through empowering legitimate sub-national leaders with effective population security measures; and,
- supporting socio-economic development by gaining active support of the population through creating security conditions that provide space for community-based development opportunities and connecting economic corridors.<sup>1733</sup>

Of particular interest to the STA/TAT was the role ICT could play as an enabler of security, governance, and socio-economic development and growth, including job creation and the introduction of transparency to help reduce corruption. A challenge was helping the civil-military decision makers become more aware of the benefits of ICT and how to make ICT a more visible part of security, stability, and reconstruction focus and actions.

The ISAF high-level lines of operation and ways and means driving TAT-1 ICT activities are illustrated in [Figure 120](#).<sup>1734</sup>

The risks to the campaign strategy were viewed to be: a failure by GIRoA to provide accountable, legitimate, and responsive governance; a lack of capacity within the ANSF due to poor recruiting and retention along with high attrition and failure to develop operationally-effective COIN forces; international community failure to effectively unify governance and development efforts including its lack of flexibility to reconfigure and create strategic effects; and NATO and Troop Contributing Nations' inability/unwillingness to conduct an effective ISAF COIN campaign and reluctance to sustain long-term commitment and resources.<sup>1735</sup>

---

<sup>1732</sup> Armed Forces Communications and Electronic Association

<sup>1733</sup> BG Berger (France) and Colonel Mario Luppia (Italy), ISAF unclassified briefings at the Afghanistan Reconstruction Summit, Istanbul, Turkey, January 20-21, 2010.

<sup>1734</sup> Ibid.

<sup>1735</sup> Ibid.

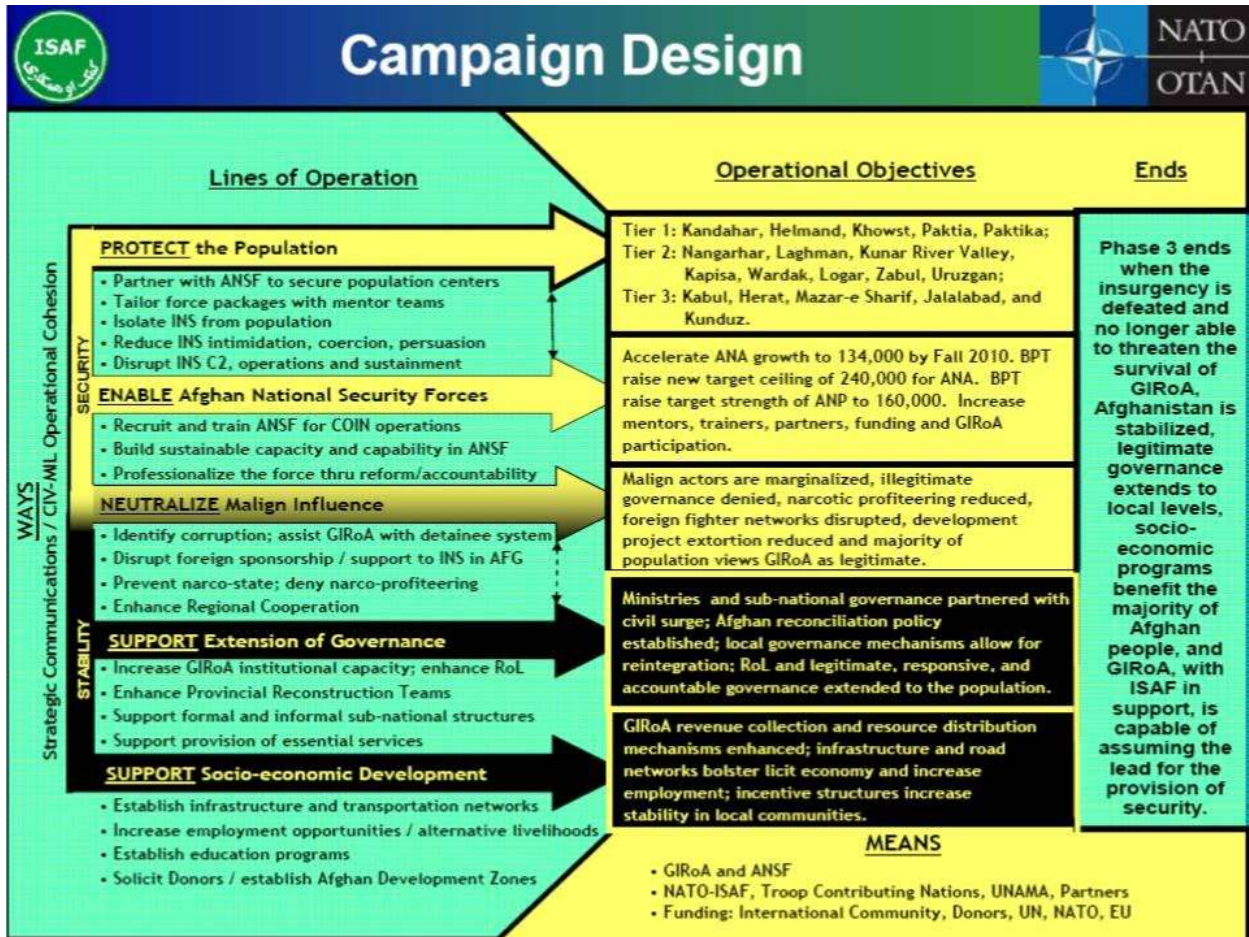

Figure 120: ISAF strategy

During the first 30-45 days of TAT-1 operation (see [Figure 121](#)), the primary task of the team was to discover and document the current Afghan ICT strategy environment and ongoing programs and initiatives. Hence, one of the first tasks of TAT-1 was to try to capture a more informed understanding of the overall ISAF campaign strategy and ICT strategies being pursued by the various civil-military participants in order to develop a shared view of where strategies were consistent and supportive and to identify areas where strategies differed and may need to be appropriately harmonized and synchronized to achieve a more comprehensive ICT strategy and action plan for Afghanistan. Additionally, the intent was also to try to capture and document programs and initiatives being implemented or planned to be implemented to support the strategies identified and try to develop a more informed understanding of where programs appeared to be complementary to achieve shared objectives or appear to be duplicative or overlapping and to identify possible candidates for improved harmonization and synchronization or other adjustments.

The TAT also conducted a survey of GIRoA (including but not limited to the MCIT), US Department of State, US Embassy Kabul, USAID, other US government entities, international organizations (UNDP, UNAMA, World Bank, IMF, etc.), and commercial and private Sector documents related to ICT strategies for Afghanistan. This included a first-cut identification of related programs and initiatives supporting

implementation of the implied or articulated strategies. Documents the TAT reviewed included the [Afghanistan National Development Strategy \(ANDS\)](#), the MCIT's [ICT Sector Strategy](#) for the ANDS, the Economic and Infrastructure Development (EID) cluster report on *E-Afghanistan*,<sup>1736</sup> the ISAF Campaign Strategy and Operations Plan (OPLAN) 38302, ISAF CJ6 ICT plans, IJC J6 ICT plans, NTM-A/CSTC-A J6 ICT plans, the proposed World Bank ICT Sector Development Project, and US Embassy and USAID ICT plans. Additionally, the TAT interviewed key leaders of the organizations surveyed to develop additional insights and identify areas for future investigation. The STA/TAT held discussions with senior leadership at the US Embassy and USAID, ISAF including COMISAF, DCOSs and J6 elements, and Afghan counterparts at the MCIT, ATRA, and AfTel, other Afghan ministries, the mobile network operators (AWCC, Roshan, Etisalat, and MTN) and other ICT companies such as Asia Consultancy Group and selected ISPs.

## Developed Telecom Advisory Team (TAT) ICT Stabilization Roadmap

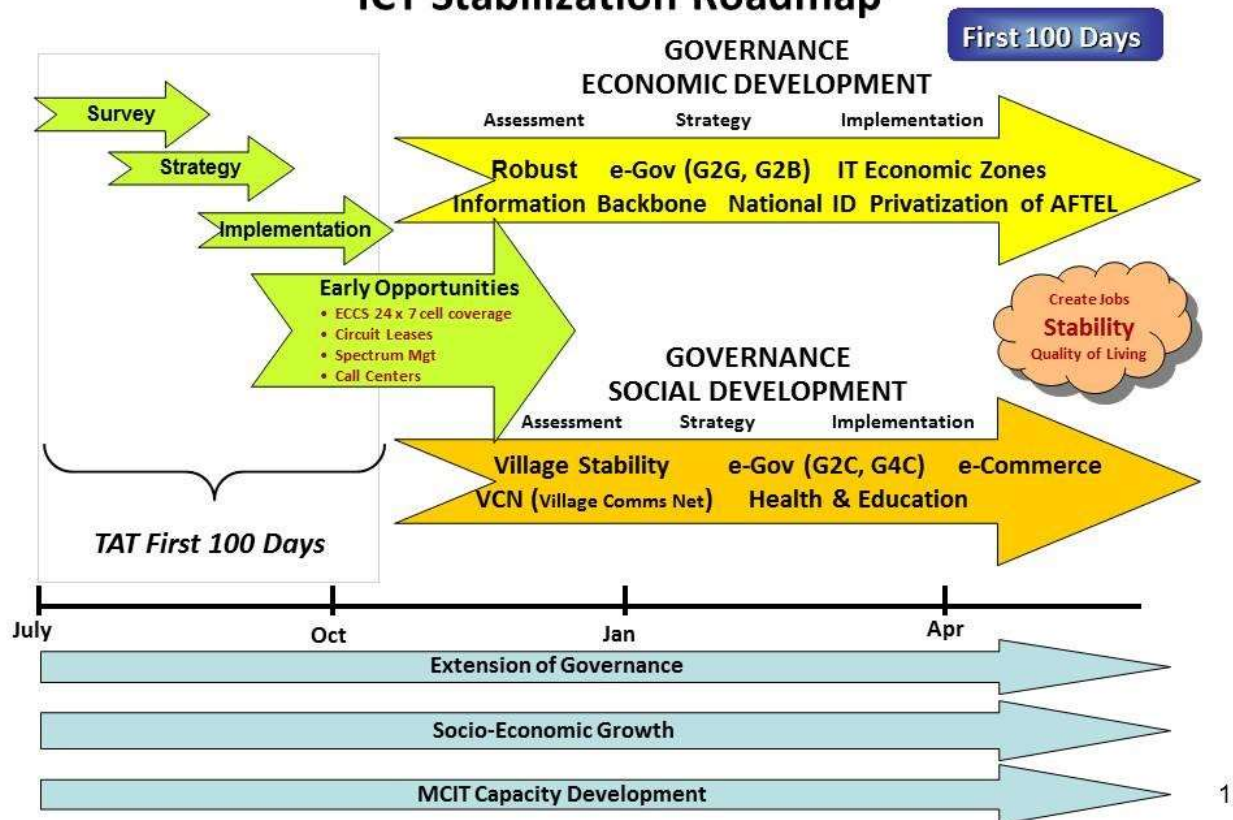

Figure 121: TAT-1 “get started” strategy and focus (the first 100 days)

<sup>1736</sup> Islamic Republic of Afghanistan (2010). The Economic and Infrastructure Development (EID) Cluster: National Priority Programs, July.

Not surprising, the initial findings suggested there were similarities in approaches but also differences. For example, the MCIT *ICT Sector Strategy* and EID cluster report stated supported the *ANDS*. The US Embassy ECON section's and the USAID EGGI project's implied strategies also had clear links to the *ANDS*. However, regarding the ISAF campaign strategy lines of operation (e.g., extension of governance and socio-economic development) and emerging Afghan-related ICT implied sub-strategies, there was a need for further clarification in order to formalize the connections with the *ANDS*. Certainly ISAF and other civil-military responders and donors viewed the *ANDS* as important, but linking ICT strategies and actions were not so obvious in the military plans except with regards to ICT for the ANSF. On the other hand, donors' ICT-related strategies, such as those of USAID and the World Bank could be linked to the *ANDS* and the MCIT *ICT Sector Strategy* of the *ANDS*.

In general, the civil-military and Afghan strategies the TAT reviewed broadly supported the use of ICT as an enabler of Afghan security, socio-economic development, and extension of governance. However, actions did not necessarily support words in the military plans except regarding support for the fiber optic network that was a dual-use technology providing connectivity for ISAF and Coalition forces C4ISR networks and ANSF measures to protect cellular networks from being attacked and turned off at night by the Taliban (and others) in the more hostile areas of Afghanistan, disallowing the local population to contact police and the ANSF to connect with home. There appeared to be strong agreement to emphasize extension of affordable ICT services to every district and village; to use ICT to improve government and offer social services through communications and e-solutions; to reduce poverty and corruption; to create jobs through a vibrant private sector; to bridge the digital divide; and to become a member of the global information society. The challenge was to formalize the implied strategies and harmonize them with stated strategies to develop a comprehensive view of the way ahead.

Some other observations that emerged from the quick look assessment suggested that:

- The success of Afghanistan's ICT economic sector can be attributed to a long-standing ICT experienced minister of communications and information technology who understood the importance of the ICT sector, leveraged the advice of subject matter experts on his team, and developed and implemented a strategy utilizing a strong industry governmental partnership.
- The *Afghanistan National Development Strategy (ANDS)* had in fact provided the framework for ICT strategies and initiatives being articulated and implemented by the various independent civilian and military organizations.
- The associated research and initial assessments identified opportunities for harmonization and synchronization of ICT activities.
- Due to the exceptional progress made in the Afghan ICT sector some of the original strategies, plans, and programs including those of the MCIT needed to be revised. Appropriate adjustments would require additional assessments of options for the way ahead.

- The assessment effort served to set the conditions and focus necessary to develop an informed and comprehensive strategy and plan for the way ahead in the ICT sector modernization and service enhancements and its use by other sectors.<sup>1737</sup>

The remainder of the first year of TAT-1 involved building the team, developing an informed situational awareness of Afghan ICT sector activities, building strategic partnerships with US Embassy, USAID, World Bank, MCIT, ATRA, AfTel and private sector MNOs and ISPs and others, and constantly adjusting the work program to meet the priorities of the USG, ISAF, and MCIT minister and consistent with skills of the staff on hand at the TAT and those that could be provided by Reachback. The STA met weekly with MCIT Minister Sangin to review challenges, opportunities, and priorities. There were also frequent meetings with MCIT deputy ministers and directors and with AfTel management and key staff, especially regarding



Picture 70: TAT members meet with ISAF RC-SW CJ9

the fiber optic network. The STA and TAT also met with the chairman of ATRA and his board members. Less frequent meetings were held with the MNOs and ISPs and international organizations. The TAT-1 became recognized as a key member of the stabilization team at ISAF, the US Embassy, USAID, and the Afghan civil development team at the MCIT, ATRA, and AfTel. The TAT-1 was viewed as the one-stop shop for ICT advice and assistance and an informed source of Afghan ICT situational awareness.

During the first year of operation, the NDU advisor to the STA/TAT provided assistance in Kabul and also conducted numerous missions outside of the ISAF wire to gain ICT situational awareness, advise and assist regarding ICT strategies, opportunities, and activities, and advance the use of ICT for counterinsurgency and stability operations. The trips downrange to Nangarhar, Paktika, Kandahar, Helmand, and Herat provinces also included ICT capacity development activities. For example, the NDU advisor made visits to FOB Sharana in Paktika province to meet with the USAID representative at TF Currahee and the Sharana PRT and to Camp Leatherneck in Helmand province to meet with ISAF Regional Command-Southwest Civil-Military Operations (CMO) and CJ9<sup>1738</sup> representatives see (see [Picture 70](#)). He also visited the following: the CMO element at FOB Fenty, Nangarhar University and local boys' and girls' schools, hospitals, and the NGO, Synergy Strike Force, at its safe house affectionately referred to as the "Taj" in Jalalabad in Nangarhar province; the Kandahar PRT USAID representative at

<sup>1737</sup> ISAF Telecommunications Advisory Team (TAT) (2010). *Afghanistan ICT Current-State Assessment: ICT Strategy Project, Rev. 3.0*, 10 October, 2010.

<sup>1738</sup> Combined Joint Civil-Military Operations

Kandahar Air Base, and a Village Stability Operations (VSO) site at Khakrez in Kandahar province; and the TFBSO office complex and ICT incubator located on an industrial park near Herat airport, Herat University, and the MCIT ICT Training Center in Herat province.

The various visits offered the NDU advisor the ability to explore opportunities such as ICT for security, governance, finance (mobile money), education, health, and agriculture and ICT capacity development. The information learned was valuable toward further shaping the TAT-1's work.

The TAT-1 obtained formal recognition by ISAF of ICT as critical infrastructure and an essential service by incorporating the role and importance of ICT in Appendix 3 (Information and Communications Technology) to Annex W (Stability Operations) to COMISAF OPLAN 38302 Rev. 6, which it initially drafted in January 2011 and which was ultimately approved in November 2011. The TAT's input to the OPLAN included a description of role of ICT as an enabler and the role, mission, and activities of the STA/TAT. This was a first-time event to obtain such recognition for the role of ICT in post-conflict stability and reconstruction operations, including as a horizontal enabler. Appendix 3 also provided formal recognition of the role of the STA/TAT and their associated ICT work plan as an example of an ICT-enabled intervention capability.

In addition to the above, other STA/TAT accomplishments for the first year include but are not limited to the following:

- STA/TAT were recognized as key members of the ISAF stabilization, US Embassy, and Afghan Teams
  - COMISAF – Primary ICT advisor across his staff; provided regular monthly updates to him
  - USAID - Viewed as ICT experts and advisors and the “go to” organization for ICT advice and assistance
  - US Embassy – Co-chaired the Telecom Working Group; served as ICT advisors to ECON Section
  - MCIT – STA was the ISAF senior strategic partner and held weekly meetings with the minister
  - ATRA – STA was the ISAF senior strategic partner and met monthly with the chairman
  - AfTel – STA was the ISAF lead; TAT attended The Afghan ICT Coordination Working Group
  - MCIT, ATRA, and AfTel – TAT staff was embedded daily

Once the Office of the STA to COMISAF and its supporting Telecom Advisory Team and Reachback element were established and underway, the collective group got down to business. Based on its surveys, document reviews, and interviews as described above, along with its current-state assessment and overarching USG and ISAF mission guidance, TAT-1 devised a strategy to guide its work in the Afghan ICT sector. While it was never formalized, it nonetheless provided a framework in which to operate and set the stage for later teams. TAT-1 also drafted the STA/TAT's mission statement, iterated in the next section, which guided the team through the rest of the effort.



The security situation in Kabul was not a significant inhibitor of TAT-1 freedom of movement around Kabul or elsewhere. Visits downrange required additional security protection due to a higher threat environment but were still relatively easy to accomplish – fixed- and rotary-wing military air and embassy air were available for use by TAT members. Security was a managed concern and proper precautions needed to be taken. In Kabul, there were no strict requirements for civilians to carry weapons, though military personnel had to carry weapons at all times. Neither was there a need for guardian angel protection while visiting Afghans. TAT staff could be dropped off at Afghan facilities and picked up hours later. Active daily embedding of staff at the MCIT, ATRA and AfTel was the norm. Freedom of movement and the ability to actively engage and work with the Afghans were key to the successes of TAT-1. Transit billeting on ISAF was not a significant issue for Reachback members on TDY. One could have business lunches and dinners at ISAF and US Embassy dining facilities and at ISAF/USFOR-A security and US Embassy Regional Security Office (RSO) approved local restaurants.

Things changed significantly in later phases of the TAT when security threats increased in Kabul (and elsewhere in the country). There more IEDs and suicide bombers, and green-on-blue attacks increased against advisors. New ISAF security procedures required civilians to carry weapons at all times, movement was by armed convoys, and everyone had to wear their IBA. Guardian angel escorts were required while on Afghan facilities and civilians also had to carry weapons, both of which made embedding more difficult to do. Visits to Afghan facilities were much shorter – an hour or so but not all day. Availability of transit billeting on the ISAF compound became a serious problem for Reachback TDYs when military drawdown, base closings, and realignment of command elements created a significant demand for temporary lodging in the Kabul area. The increase in security threats and actions in Kabul and excessive demands for transit billeting had a major impact on Reachback TDYs to Kabul during TATs 2 through 4. Reachback was allowed only a couple of trips a year and, by the middle of TAT-4, Reachback TDYs and active engagements were essentially shut down. The last Reachback visit to TAT-4 was in May of 2014, its only trip that year. The TAT office closed in October 2014.

More about the TAT's work and the evolution of the TAT through its four years of operation are in the following sections.

## The ISAF Senior Telecom Advisor and the Telecom Advisory Team

### *ISAF and the TAT's Evolutions in Brief*

To set the stage and provide context for the next section describing each of the four TAT's strategies, work, and accomplishments, it is important to relate what was happening within the USG, at ISAF, in Kabul, and in Afghanistan in general. Thus, this section offers a brief overview of the ISAF's and TAT's evolutions between 2010 and 2014 and the operating environment during those years.

In 2010 ISAF and the Coalition military elements were heavily engaged in combat operations, counterinsurgency (COIN) and Stability Operations activities. In fact, the period from 2010 to 2012 arguably saw the zenith of COIN and Stability Operations in Afghanistan. These operations were comprehensive, full spectrum COIN, and certainly had a kinetic or lethal side, but they also had a nonlethal

or soft power side which included COIN development.<sup>1739</sup> The NATO/ISAF COIN Campaign Plan sought to address the root causes of the insurgency (e.g., insecurity, political marginalization, and economic marginalization) through a combination of soft power options such as governance and socio-economic development initiatives and projects which helped provide basic social services to the Afghan people and thereby add legitimacy to GIRoA. Collectively these governance and socioeconomic development activities were known as Stability Operations.<sup>1740</sup> Based on some three years of NATO/ISAF Stability Operations and COIN experience there were a few lessons that emerged: need a commitment at outset to finish the job – it's a long-term effort; it needed to be both a NATO/ISAF and Afghan effort with a transition to the Afghans for the longer term – Afghans did not have a mechanism to standup a Stability Operations organization so International Community had to fill the longer term development gap; and, do not try to force too much change too fast – the *Afghanistan National Development Strategy* outlined the Government of Afghanistan's strategies for security, governance, economic growth and poverty reduction.<sup>1741</sup>

The USG combat support and ISAF COIN and related stability operations missions influenced the early shaping of the TAT-1 activities and subsequently the follow-on TAT-2 (strategy development) and TAT-3 (strategy implementation) strategies and plans, although to a lesser degree. Initially, the TAT-1 focus was on infrastructure (e.g., fiber optic network and wireless networks) to support the communications needs of the USG, ISAF, and the militaries and governments of all its Troop Contributing Nations (TCNs) as well as the Afghan National Security Forces (ANSF). ICT was critical to the US DoD to support the C4ISR requirements of its combat and COIN operations and the warfighters in theater – a key responsibility of DISA's combat support agency mission. The DoD needed to have access to readily-available, high-capacity, and low-cost communications assets among its Regional Commands and to multiple international gateways to provide robust theater access to US Forces C4ISR assets globally. ICT was also essential to the command and control operations of the ANSF. For the TAT-1, work program shaping activities related to ICT for civil security, governance, and socio-economic development and ICT capacity development.

The ISAF organization responsible for developing and managing the stability operations portion of the campaign plan was the office of the Deputy Chief of Staff for Stability Operations (Stab Ops), which is the element that STA/TAT aligned with at ISAF after a short stint supporting DCOS Strategic Partnerships. The TAT expanded its focus beyond MCIT and ATRA interactions to include providing ICT-related advice and assistance support to DCOS Stab Ops. The high-level focus of ISAF DCOS Stab Ops and STA/TAT activities was on governance and strategic level socio-economic development projects. Both worked with members of the International Community to advocate for the execution of projects with the greatest positive COIN and stabilization effects.

The TATs 1 through 3 supported DCOS Stability Operations, but during TAT-2 the support started to move away from COIN per se and more to advise and assist on ICT for security, governance, and socio-economic

---

<sup>1739</sup> ISAF TAT, 2010.

<sup>1740</sup> Ibid.

<sup>1741</sup> Ibid.

development and ICT capacity development. Shortly after the arrival of the second TAT Director, word around ISAF was that “COIN was dead.” With the 2011 US Presidential announcement of military drawdown and transition of security to the Afghans in 2013, preparation for the possible transition of the TAT from ISAF to the US Embassy became a focus of TAT-2 and later TAT-3. Both TAT-2 and TAT-3 also became more engaged in ISAF task transition planning, which carried into TAT-4. Transition is discussed in more detail later in this chapter.

Beginning in late 2011 (during TAT-2), the security situation started to deteriorate with more frequent incidents of insider attacks.<sup>1742</sup> This resulted in significant increases in force protection measures and restrictions on movement, which impacted the STA/TAT’s ability to interact in person with their Afghan counterparts to support the TAT mission. In March of 2013 (during TAT-3), the Deloitte team was recalled by corporate headquarters and its operation in Kabul terminated. Deloitte took this action in response to the Afghan government not granting Deloitte, as a DoD contractor, an exemption to use a private security company (PSC) for the Deloitte team in country. Afghan Presidential Decree 62 (PD62)<sup>1743</sup> mandated the dissolution of PSCs (although the DoD was exempt for a time) and the required use of the Afghan Public Protection Force (APPF) to provide security. With the continued deterioration in conditions on the ground, Deloitte felt the security risk was too high to go with the APPF option (plus it did not want to put the fates of its employees into the Afghan government’s hands) and ordered the team (the TAT ICT advisors and others) out of country and closed the office.

To back fill for the Deloitte team, DISA contracted with IZ Technologies (IZT) to provide three ICT SMEs in Kabul to provide support to the STA/TAT. The contract started in October 2013 with an end date of March 2015. This created a little over a six-month gap in on-the-ground contractor ICT SME support to TAT. By this time, the new Director for TAT-4, Dr. Catherine Warner, had arrived and the IZT team reported to her. The IZT team worked out of the TAT office at the MCIT and supported activities at the MCIT, ATRA, and AfTel.

The security situation continued to deteriorate into TAT-4. Although insider attacks dropped off, they continued through 2014, including an August 2014 attack that killed US Major General Harold J. Greene, Deputy Commander CSTC-A – an officer the TAT-4 worked with closely. He was on a key leader engagement visit to the Marshal Fahim National Defense University in Kabul. The general was the highest-

---

<sup>1742</sup> Per the *Long War Journal*, between 2011 and 2013, insider attacks accounted for 15 percent of Coalition deaths. See “Green-on-blue attacks in Afghanistan: the data” available at:

[http://www.longwarjournal.org/archives/2012/08/green-on-blue\\_attack.php](http://www.longwarjournal.org/archives/2012/08/green-on-blue_attack.php).

<sup>1743</sup> Afghanistan Presidential Decree #62, “About dissolution of Private Security Companies,” August 17, 2010. Accessed December 9, 2014.

[http://psm.du.edu/media/documents/national\\_regulations/countries/asia\\_pacific/afghanistan/afghanistan\\_decree\\_number\\_52\\_dissolution\\_psc\\_2010-english.pdf](http://psm.du.edu/media/documents/national_regulations/countries/asia_pacific/afghanistan/afghanistan_decree_number_52_dissolution_psc_2010-english.pdf).

ranking American officer to be killed in the Afghan war and on foreign soil since 1972 in US combat operations in Vietnam.<sup>1744</sup>

During TAT-4, ISAF’s mission moved away from non-security activities and focused more on the security ministries and the ANSF. Later, TAT-4’s focus was on the drawdown and closing of the TAT and supporting preparation for ISAF to transition to the Resolute Support mission of train, advise, and assist the ANSF. The TAT-4 supported the Non-Security Ministries-Ministerial Advisory Group (NSM-MAG) when it replaced DCOS Stability Operations and then the Enterprise Advisory Group under the Combined Security Transition Command-Afghanistan (CSTC-A) for helping set up the CJ6 ICT Train, Advise and Assist Element to be part of Mission Resolute Support.

## TAT Evolution: TAT 1.0 – 4.0

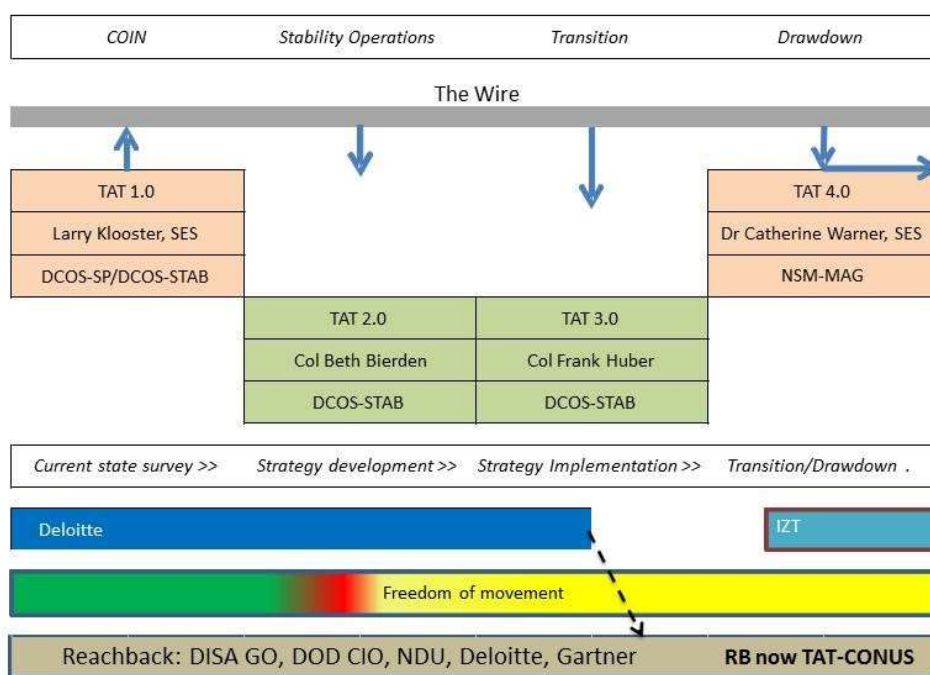

Figure 122: TAT evolution

The evolution of the TAT is illustrated [Figure 122](#). The TAT-1 was focused on ICT infrastructure and COIN and Stability Ops. It forged strategic partnerships with ISAF and USG Interagency elements and Afghan

<sup>1744</sup> *Wikipedia* (2016). "Harold J. Greene." Last modified August 18. [https://en.wikipedia.org/wiki/Harold\\_J.\\_Greene](https://en.wikipedia.org/wiki/Harold_J._Greene).

GIRoA and private sector ICT counterparts. It was outward-looking, and even allowed a few TAT staff to travel downrange to other provinces to assess ICT needs at provincial, district, and village levels and to meet with regional command elements working COIN, Village Stability Operations, and socio-economic development efforts as described above. The remaining years of TAT were more inward and Kabul-centric, with TAT working ISAF mission needs related to ICT infrastructure and stability operations; ISAF/TAT transition activities; training, advising, and assisting the ANSF; and interacting with GIRoA counterparts in Kabul with some limited trips downrange. TATs 2 and 3 continued building and sustaining strategic partnerships as part of DCOS Stab Ops team. They developed (TAT-2) and implemented (TAT-2 and TAT-3) an Afghan ICT strategy.

The STA/TAT remained operational until October 2014 when it was closed as part of ISAF and USG drawdown activities. The closing of the STA/TAT at ISAF was an unintended consequence resulting from a military combat force drawdown action. Following the shutdown of the STA/TAT in October 2014, the TA function moved to the US Embassy Kabul ECON section as another item in its portfolio of activities and the IZT support team was transitioned to the ISAF CJ6/Train, Advise and Assist (TAA) element.

In general, all four phases of the TAT engaged in efforts such as focusing on informing ISAF and USG on the role of ICT as an enabler of security, governance, and socio-economic development and advising ISAF, the USG, international organizations, and GIRoA elements on specific ICT opportunities to be pursued. The TAT also employed its harmonization, coordination, and connector skills to help deconflict and leverage ICT initiatives. They also provided open source informed ICT situational awareness on ICT sector activities.

## The Beginning of the End

In June 2011, President Obama announced starting in July 2011 there would be a rapid drawdown of the “surge” forces to be completed by the summer of 2012. After this time there would be a steady reduction of US forces to continue through 2013 and 2014 until only a small residual force was left by the end of 2014. The combat mission would transition to security support and then train, advise, and assist post-2014. Needless to say, this announcement and subsequent actions shifted the emphasis at ISAF and US Mission to drawdown and transition. Consequently, with the departure of COMISAF General Petraeus in July 2011 and the arrival of General John Allen, USMC, ISAF started planning for the drawdown of counterinsurgency and stability operations and the shift to security force assistance and transition. By the end of 2011 many of the members of the Coalition were tired of the war and were no longer interested in either fighting COIN (although COIN had only been underway for two years), to include its Stability component, or to continue to resource development projects in general. The rush was on for “Transition.”<sup>1745</sup> The intent was to transition the lead for security operations to GIRoA, in five tranches – the fight in Afghanistan was being turned over to the Afghans.

---

<sup>1745</sup> Barham, Charles (2016). “Stability Operations: Lessons from Afghanistan.” *Small Wars Journal*, February 11.

As a result, “ISAF and USG Interagency planning was initiated to support the new guidance and to shape the transition and draw down actions. Included ... was an examination of TAT’s future with regards to the best placement of TAT in support of transition and TAT’s mission beyond 2014. After a series of discussions among TAT, ISAF, and the US Embassy in Kabul, and Reachback with the DC-based Interagency, it was decided that planning should begin to transition TAT to the US Embassy or USAID in the 2013 timeframe and to assess the TAT’s mission and support arrangements beyond 2014.”<sup>1746</sup> As a result, TAT-2 and TAT-3 became heavily engaged in transition planning activities with consideration given to transferring the TAT to US Embassy or USAID Mission, to USFOR-A, to CJ6 or shutting down the TAT. TAT-4 continued with transition planning, but by this time the action was drawing down the TAT versus transitioning and closing operation by the end of 2014 or sooner.

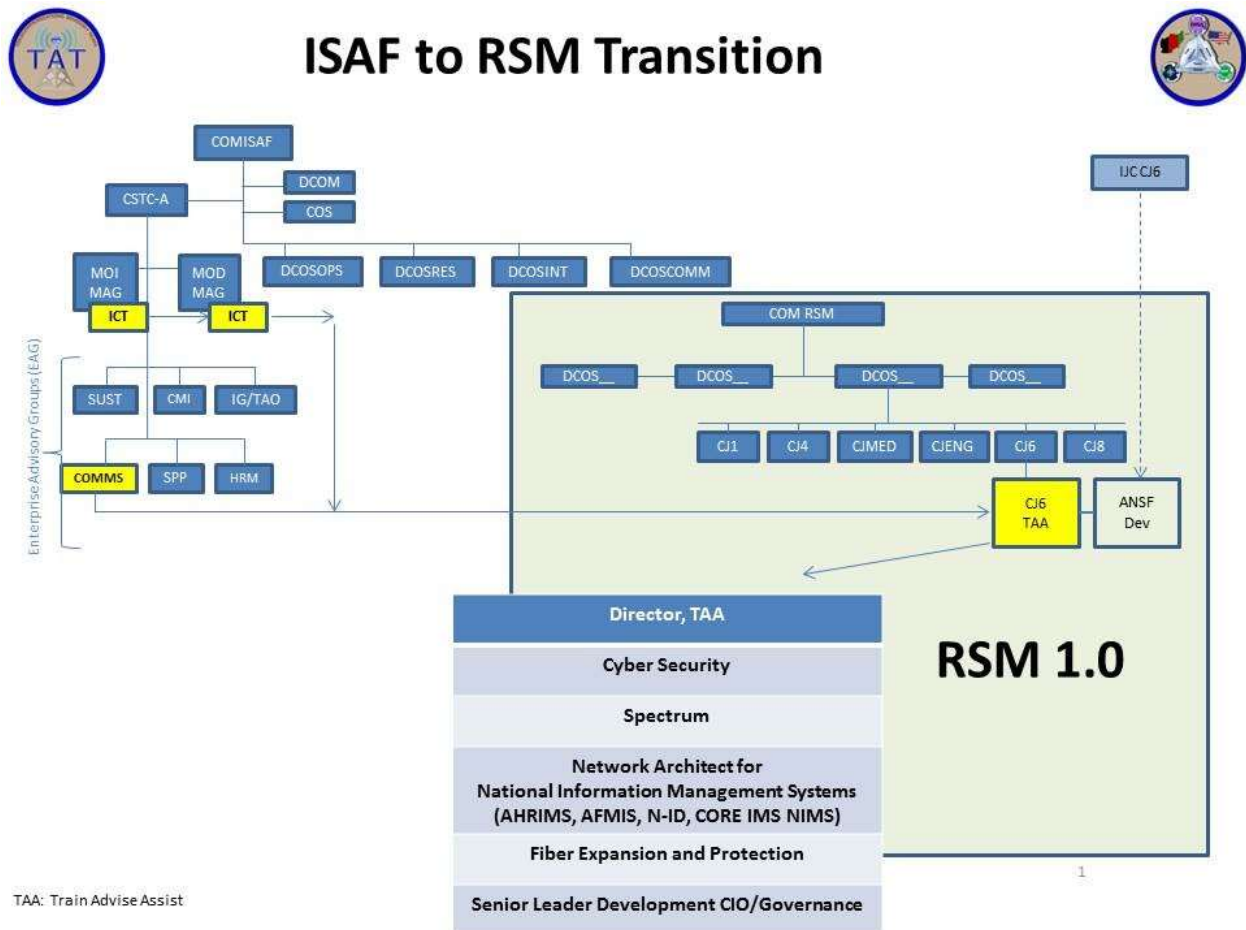

Figure 123: ISAF to RSM transition

Upon the arrival of COMISAF General Joseph Dunford, USMC, in February 2013, ISAF’s focus was on transition of security to the Afghans, the drawdown combat forces, and transition of ISAF to the NATO

<sup>1746</sup> Ibid.

Resolute Support (RS) mission, all of which were to occur at the end of 2014. RS's post-2014 role is to train, advise, and assist the ANSF, in particular the MoD and MoI. The handover of lead responsibility for Afghanistan's security from ISAF and the Coalition to the Afghan government and the ANSF occurred on June 18, 2013.

It has been argued that the USG and NATO/ISAF rushed to a security transition before the insurgency was defeated. They stated the Afghans were prepared to continue the fight in the lead (although one might argue that they were not ready). Additionally, there was no provision for a corresponding transition of stability operations. The Afghans would now lead the fight, and a large part of the international community was still executing development projects, but there was no mechanism to stand up a Deputy Chief of Staff for Stability Operations "like" organization within the Afghan Ministry of Defense or anywhere else in GIRoA. Therefore, the critical task of coordinating and synchronizing development projects with security operations melted away. As the Afghans continued to conduct clear and hold operations, there was no build. There was no flow of basic social services, or the infrastructure to support it. Therefore, the Afghans found themselves clearing and trying to hold the same Districts over and over again.<sup>1747</sup>

General John Campbell, USA, arrived in August 2014 as the final COMISAF and his focus continued to be on the drawdown of combat forces and the transition of ISAF to RS mission. (See [Figure 123](#) for an illustration.) The withdrawal of all international combat troops from Afghanistan was completed by the end of 2014. On December 28, 2014, thirteen years after its creation through the signing of the Bonn Agreement<sup>1748</sup> in Germany, ISAF concluded operations in an event transitioning the operation to the new NATO-led Resolute Support (RS) mission. General Campbell became the first Commander of Resolute Support (COMRS). Despite the transition, IZT support continued (funded by DISA until March 2015 and then by USFOR-A) under RS CJ6/TAA until January 25, 2016 when its support ended. There was - and still is - a need for a USG-sponsored Telecom Advisor function, or now, perhaps more appropriately, an ICT Advisor, at either the US Embassy/USAID Mission or RS/USFOR-A or both.

### *The TAT's Mission and Purpose*

As a USG entity housed at ISAF Headquarters, the STA/TAT was subject to the strategic priorities and missions of both. Within that context and over time, the TAT developed its own mission statement: "To facilitate the further development of the information and communications technology (ICT) sector and assist the Government of the Islamic Republic of Afghanistan (GIRoA) in employing ICT to enable governance, stability, and socio-economic development."<sup>1749</sup> The TAT-1 originally crafted the mission

---

<sup>1747</sup> Ibid.

<sup>1748</sup> Officially, the "Agreement on Provisional Arrangements in Afghanistan Pending the Re-Establishment of Permanent Government Institutions," the first in a series of international agreements to reestablish the Afghan state after the fall of the Taliban regime.

<sup>1749</sup> ISAF Telecommunications Advisory Team

statement. TAT-2 refined it slightly, and it remained in place through the beginning of TAT-4, when it was narrowed a bit. The TAT’s purpose was to:

- Facilitate and coordinate the US Government’s, Coalition forces, and ISAF’s strategic interests in ICT in Afghanistan, both in country and CONUS;
- Provide ICT experience and expertise to advise and assist Afghanistan’s public ICT institutions;
- Provide leadership, strategic direction, and other assistance as needed to support the private ICT sector; and
- Gain and maintain informed situational awareness across the Afghan ICT ecosystem to create synergies among activities and initiatives of various stakeholders.<sup>1750</sup>

This was accomplished by developing coordinated strategies and synchronizing solutions among ISAF, GIRoA, the USG Interagency, NGOs, the International Community, private industry; and academia; improving harmonization, coordination, and synchronization of ICT policy, infrastructure initiatives, and the provision of services across economic sectors; and helping GIRoA to improve its performance and develop ICT capacity and expertise.<sup>1751</sup>

The TAT’s efforts supported the ISAF Campaign Plan line of operation “Enable sustainable economic growth and a population with sustainable access to basic social services.” To that end, support focused on ICT for social infrastructure ... and economic infrastructure – enough to support sustainable economic growth as well as creating within GIRoA the legal, regulatory and policy conditions for sustainable economic growth.<sup>1752</sup> While the TAT’s strategies and work evolved and changed according to USG and ISAF policy and direction, conditions on the ground, available resources and skillsets, and GIRoA needs and priorities, the TAT’s mission and purpose and methods of accomplishing them remained relatively constant over its four years of operations.

## *TATs 1-4: Strategies and Accomplishments*

### TAT-1

The TAT-1 (2010-2011), see [Picture 71](#), was led by Lawrence A. (Larry) Klooster (second from left above), a DoD civilian Highly Qualified Expert or HQE (SES-equivalent). The TAT-1 mission briefed to COMISAF General Petraeus in August 2010 focused on advising ISAF, USFOR-A, and the USG Interagency on Afghan ICT issues and opportunities and assisting the Afghan government to accelerate the benefits of ICT as an essential service enabler by:

- Using ICT to extend governance and enable socio-economic development for stabilization
  - Identifying opportunities and leveraging dual-use technologies

---

<sup>1750</sup> Ibid.

<sup>1751</sup> Ibid.

<sup>1752</sup> Barham, 2016.



- Harmonizing and synchronizing activities across participants (e.g., ISAF/DoD, US Interagency, Afghan government and industry)
- Making information available and pushing to Afghan ICT counterparts in GIRoA and the private sector as appropriate
- Improving coordination of ICT policy, infrastructure initiatives, and services across economic sectors
- Shaping and influencing the building of an Afghan national information infrastructure
- Improving performance and developing capacity for GIRoA.

The strategy was based on executing a 100-days plan focused on establishing operational presence for TAT-1; building strategic partnerships with ISAF, US Embassy, USAID, and Afghan counterparts; documenting ICT activities and creating a baseline (common operational picture of ICT programs across participating donor organizations) and conducting a current-state assessment of ICT initiatives to identify opportunities for harmonization and synchronization; identifying and recommending dual-use ICT opportunities across all sectors (e.g., military and civil/commercial use of fiber optic network, cellular, and ISP networks); advising on quick starts and priority interest areas: 24x7 cellular service, call centers, circuit leasing, national fiber backbone and regional interconnects, national ID, *E-Afghanistan*, and spectrum management; and developing an ICT strategy and plan to enable extension of governance and socio-economic growth, development of Afghan ICT professionalism, enhancement of MCIT capacity development, extension of ICT to rural areas, and the creation of jobs and improvement in Afghans' quality of living.



*Picture 71: TAT-1 Director Larry Klooster and team with COMISAF Gen. Petraeus*

*(Mr. Klooster is second from left.)*

The TAT-1 also helped facilitate an ICT Collaboration Conference held at the ICT Institute conference center in Kabul (see [Picture 72](#)) on July 13, 2011, and sponsored by ISAF, the MCIT, and the National ISP

Association of Afghanistan (NISPAA). The conference focused on enhancing the role of the private sector through enabling policies and legislation including public-private partnerships; the stand up and operation of an Internet exchange point; the state of GIROAnet and the Afghan National Data Center; e-government; and business opportunities for Afghans, including how to do business with ISAF.



*Picture 72: ICT Collaboration Conference at ICTI Conference Center*

As TAT-1 matured, it revised its mission to focus on growing the ICT economic sector and assisting the Afghan government to accelerate the benefits of ICT as an essential service enabler by:

- Extending governance and enable socio-economic development for stabilization;
- Developing stabilization solutions working with the US Interagency and international organizations;
- Recommending ICT strategic engagement initiatives that had benefit across all sectors;
- Improving performance and develop ICT capacity for the GIROA; and
- Improving harmonization, coordination, and synchronization of ICT policy, infrastructure, and services initiatives across economic sectors.

The TAT achieved its first year's goals to become recognized as a key member of the USG, ISAF, and Afghan stabilization teams; obtained USG, ISAF and Afghan community recognition that that ICT is critical infrastructure and an essential service; and focused on and leveraged infrastructure and services such as the national fiber optic network and wireless services. Based on the first year of experience, the TAT-1 established the four-pillar strategy (see [Figure 124](#)), which set the focus for conducting activities in TAT-2 and TAT-3.

# Telecom Advisory Team Strategic Pillars

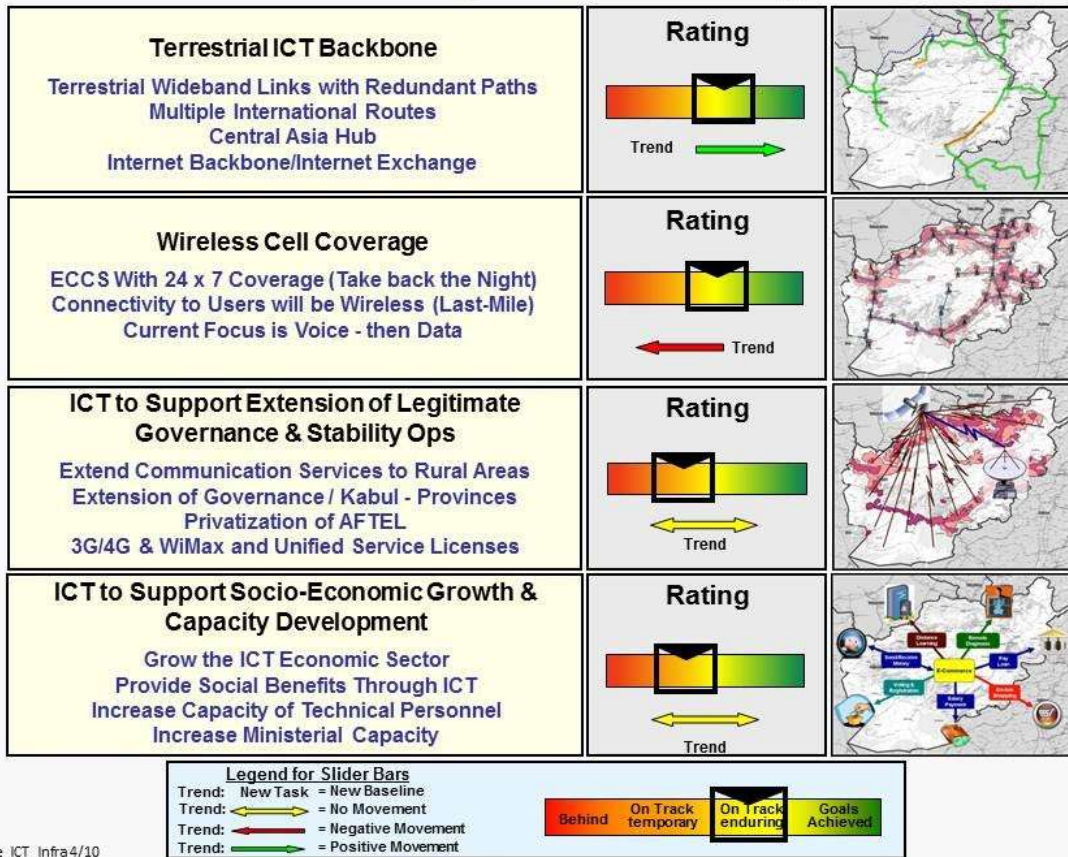

LS\_Baseline\_ICT\_Infra4/10

1

Figure 124: TAT-1 four-pillar strategy

## TAT-2

The TAT-2 (2011-2012) was led by Colonel Elizabeth A. (Beth) Bierden, USA, (second from left in [Picture 73](#)). The TAT's second year of operation started out with a bang, literally, with its first few months marked by several high-profile incidents of violence, such as the attacks on the British [Embassy and then the] American Embassy [and ISAF] on August 19 and September 13, 2011, respectively, and the assassination of Former Afghan President and head of the High Peace Council Burhanuddin Rabbani one week later<sup>1753</sup> at his residence near the US Embassy. The TAT-2 also began operations shortly after President Obama's announcement to drawdown surge forces by the summer of 2012 and combat forces by the end of 2014. On the positive side, TAT-1 had laid a solid foundation for TAT-2 to hit the ground running.



*Picture 73: TAT-2 Director Colonel Beth Bierden (second from left) and partial team*

*(Col. Bierden is second from left.)*

On October 31, 2011, General John Allen approved ISAF's revised campaign plan, "where ISAF's mission changed from [being in] the lead to supporting the Afghans to lead themselves and ISAF redirected its efforts toward transition and stability operations."<sup>1754</sup> As mentioned earlier, TAT-1 had institutionalized the recognition of ICT as critical infrastructure and an essential service and the Telecom Advisor function in its drafting of Appendix 3 (Information and Communications Technology) to Annex W (Stability

---

<sup>1753</sup> Bierden, Elizabeth A. (Col., USA) (2012). *ISAF Telecommunications Advisory Team [TAT] Year in Review*, July 1.

<sup>1754</sup> *Ibid.*

Operations) to ISAF OPLAN 38302 in January 2011. The TAT-2 revised Appendix 3 in October 2011, at the direction of Colonel Bierden and based on feedback and guidance from DCOS Stab Ops and others. TAT-2 submitted the revised document to DCOS Stab Ops in October 2011. Appendix 3 was approved in November 2011 and incorporated into COMISAF OPLAN 38302 Revision 6.

Building on Appendix 3 and TAT-1’s original “four pillars of operation” strategy, TAT-2 developed and published its Afghanistan ICT strategy in January 2012. In a concerted effort to “complement and support rather than duplicate others’ initiatives,”<sup>1755</sup> The TAT-2 reviewed relevant strategies of others as indicated in [Table 14](#).<sup>1756</sup>

Table 14: Documents relative to TAT-2 strategy development

Organization	Strategic Plan	Notes
US Government	Integrated Civilian-Military Campaign Plan for Support to Afghanistan	Updated 10 August 2009
ISAF/DCOS-STAB	ISAF Operations Plan 38302 Revision 6, particularly Appendix 3 to Annex W	Base plan published 31 October 2011; most annexes approved 15 November 2011
GIRoA/MCIT	E-Afghanistan National Priority Program (NPP); EGOV.AF Strategy (AeGS) and Implementation Plan	E-Afghanistan endorsed by JCMB on 19 October 2011; AeGS unveiled in November 2011
USAID	US Foreign Assistance for Afghanistan Post Performance Management Plan 2011-2015	Updated 2 October 2010
US Dept. of State/ US Embassy Kabul	Afghanistan Pakistan Regional Stabilization Strategy	Updated 24 February 2010
The World Bank	Afghanistan ICT Sector Development Project	Project duration is 31 May 31 2011 to 20 June 2016

The TAT-2’s strategy was built around two primary lines of effort: sustainability of the ICT sector and ICT as an enabler of stability. TAT-2 focused on three key areas to cultivate sustainability of the ICT sector: developing and protecting ICT infrastructure, strengthening ICT institutions, and fostering ICT capacity development. TAT’s second major line of effort, ICT as an enabler of stability, focused on employing ICT for legitimate governance and using ICT to promote cross-sector socio-economic development and growth (see [Figure 125](#)).

<sup>1755</sup> Bierden, Elizabeth A. (Col., USA) (2012). *ISAF Telecommunications Advisory Team [TAT] ICT Strategy*, January 16.

<sup>1756</sup> Ibid.

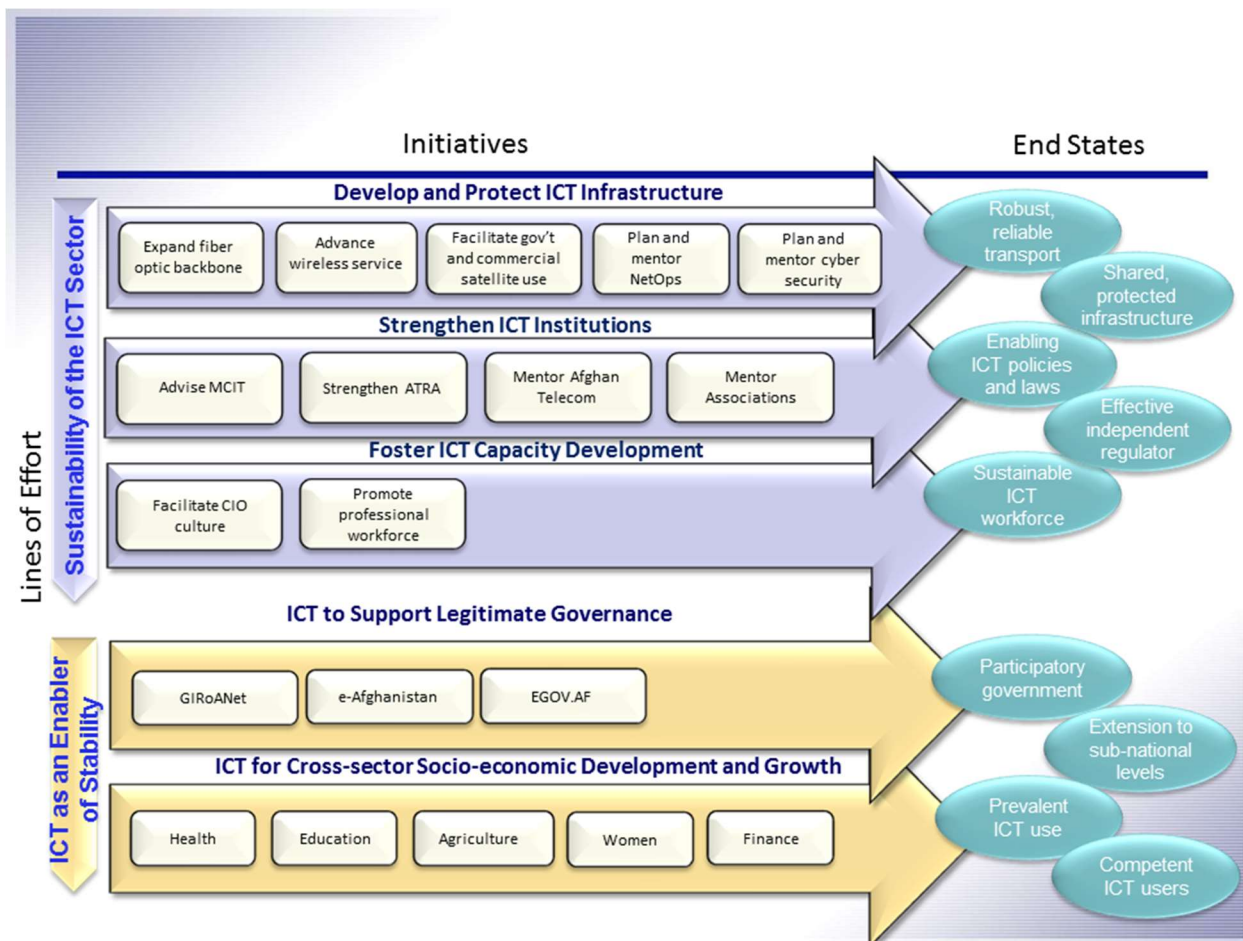

Figure 125: TAT-2 strategy

Several important activities during TAT-2 were the development of the Afghan ICT Strategy that set the direction for TAT-2 and TAT-3, a cybersecurity maturity assessment and report with 44 recommendations conducted by Deloitte at the request of the MCIT Minister to the TAT Director, initiation of an ICT Capacity Building Through [sic] Training and Education program, also conducted largely by Deloitte, which was finished during TAT-3, and a *Year in Review* report that summarized the challenges, opportunities, and lessons of the TAT-2 experience, which Deloitte also helped to prepare. The TAT-2 also engaged with ATRA on: a satellite tender (DISA provided satellite expertise TDY to help); MBB (mobile broadband) and BWS (broadband wireless service) tenders and licenses (a key was that the MCIT and ATRA agreed to make them technology-neutral spectrum permits that accommodate different and future technologies), and it facilitated a relationship with NISPAA and the first-ever meeting between ATRA and NISPAA). The TAT-2 was instrumental in AfTel differentiating between wholesale and retail prices for the first time (with the Internet price reduction in May 2012); instrumental in helping the DoC Commercial Law Development Program (CLDP) getting into the MCIT, ATRA, and AfTel for training, to help with a workshop to develop a national cybersecurity strategy, and drafting ICT legislation. The TAT-2 assisted AfTel to prepare a business

case regarding whether it should upgrade its CDMA<sup>1757</sup> network or install a new GSM<sup>1758</sup> network; tenders for a GSM network and its associated satellite cellular backhaul network; a tender for a convergent billing system; and it assessed the impact of the drawdown of Coalition forces on AfTel. The TAT-2 was also actively engaged in the ISAF's Cellular Enabled Security and Stability program and provided assistance to the MoI, the MCIT, and ATRA. The TAT-2 participated in NATO's efforts to establish the Afghanistan Research and Education network (AfgREN), specifically but not only by helping get NATO, ATRA, and AfTel together which resulted in the Telecommunications Development Fund (TDF) funding the installation of fiber optic connectivity for universities to replace their satellite connections. The TAT-2 helped codify the need to address the digital gender divide in ISAF OPLAN Rev 6.2. The TAT-2 also facilitated MCIT Minister Sangin's visit to US in June 2012 where he spoke about Afghanistan ICT successes at the Center for Strategic and International Studies (CSIS), Federal Communications Commission (FCC), Intelligent Community Forum, and other events.



*Picture 74: TAT-3 Director Colonel Frank Huber and partial team*

*(Col. Huber is in uniform on right.)*

---

<sup>1757</sup> Code division multiple access, a method used by some radio communications technologies that makes it possible for several transmitters to send information over a single communication channel simultaneously, thereby allowing multiple users to share finite frequency bandwidth without interference.

<sup>1758</sup> Global system for mobile communications, a second generation of protocols for digital cellular networks originally developed by the European Telecommunications Standards Institute (ETSI). GSM is now a trademark owned by the GSM Association.

### TAT-3

The TAT-3 (2012-2013) led by Colonel Francis J. (Frank) Huber, USA (front row center in uniform, [Picture 74](#)), had to carefully develop the TAT's priorities and scope of work and evolve TAT's strategy to align its efforts with ISAF's shift from counterinsurgency (COIN) operations to transition, transformation, and sustainment efforts in preparation for the Security Forces Assistance Mission.

The TAT-3's strategy was very similar to TAT-2's (see [Figure 126](#)), with some adjustments to reflect changes in strategic priorities and objectives and the current operating environment

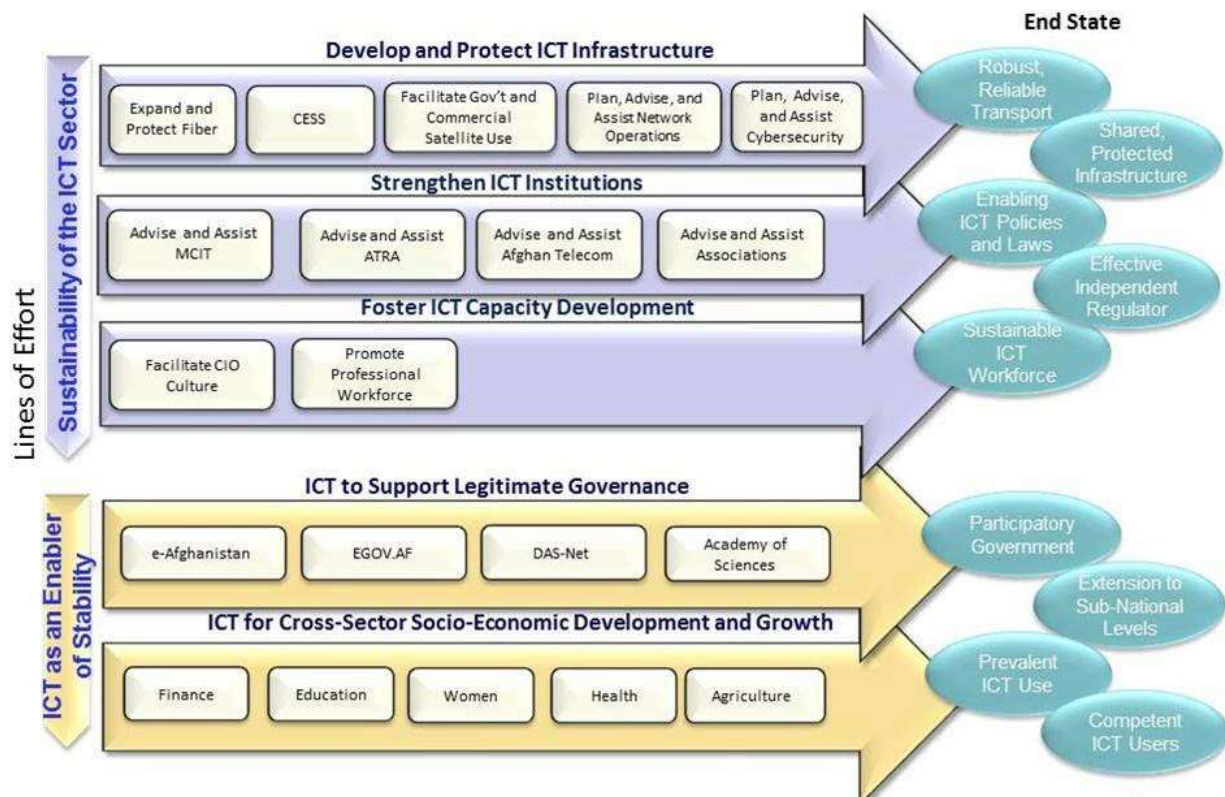

Figure 126: TAT-3 strategy

The TAT-3 also supported ISAF DCOS Outreach and ISAF CJ6. TAT-3 worked with and acted as a liaison among the NTM-A, the MoI, and Afghan Telecom to install cellular towers and provide 24x7 mobile service in ISAF's 46 most dangerous districts in support of the DCOS Outreach's Cellular Enabled Security and Stability – or CESS - program. TAT-3 also worked with ATRA, NTM-A, and the MoI on the six regional 119 emergency call centers the MoI had contracted to be installed in each of the major cities. Three existing call centers were being upgraded and three new ones were being built. The call centers in Kandahar, Lashkargah, and Herat all went operational in 2013. TAT-3 primarily helped work with ATRA and the mobile network operators to resolve issues with call charging and call routing. This work was in direct



support of the ISAF FRAGO to implement the Afghan National Security Council's *Security Strategy for Telecommunication Networks* so as to increase access by Afghan citizens to the police and to improve the confidence of the populace in the ANSF and GIRoA, all with the aim of improving security and stability. The TAT-3 also acted as a liaison among ISAF CJ6, ATRA, and the Afghan defense ministries regarding the transition of military spectrum management from the Coalition to GIRoA. The TAT-3 helped to draft the Memorandum of Agreement (MoA) that was signed by those parties on December 19, 2012, and helped to finalize the charter for the new Ministerial Spectrum Management Office at ATRA. TAT-3 helped to resolve ongoing frequency interference issues that were caused by ATRA's licensing shared and military spectrum bands to the mobile companies and ISPs. ATRA agreed to swap the already-assigned frequencies with available frequencies so the military and shared bands retained the same amount of available spectrum. Finally, TAT-3 focused on ensuring the ICT sector could support the communications requirements of DISA, the Resolute Support Mission, the remaining Coalition troops and ISR elements, and the Afghan National Security Forces after the planned December 2014 draw down of combat forces and that ICT could also continue to be employed to support legitimate governance and socio-economic development, and, therefore, stability and security.



*Picture 75: TAT-4 Director Dr. Catherine Warner (center with scarf) and team*

*(Dr. Warner is in the center with the scarf. Also pictured are DISA Commander Lt. Gen. Ronnie Hawkins to Dr. Warner's left, DISA Director GIG Ops Mr. Larry Huffman to Gen. Hawkins' left and DSE-A Mr. Chris Knight, at end.)*

## TAT-4

The TAT-4 (2013-2014) led by Dr. Catherine Warner (center with scarf in [Picture 75](#)), a DoD SES. She entered during the ISAF transition to Mission Resolute Support and the drawdown phases of combat forces. The STA/TAT reported to the Non-Security Ministries-Ministerial Advisory Group and, later with the focus on transition, Dr. Warner became Director of the Train, Advise and Assist transition element under the Enterprise Advisory Group at ISAF.

At the start of TAT-4, its primary areas of engagement were as shown in [Table 15](#).

Table 15: TAT-4 primary areas of engagement

The TAT's Primary Areas of Engagement (2013-2014)	
Optical fiber infrastructure	General capacity development
Cybersecurity	MCIT capacity development
Spectrum management	Support to the Independent Directorate of Local Government (IDLG)
ANSF Communications	Mobile network operator support
DAS-Net (GIROA intranet) implementation	Mobile money
Electronic government	Emergency calling services
Private sector development (regional and national)	Infrastructure sharing

The near-term priorities of TAT-4 included: AfTel's 3G<sup>1759</sup> GSM network and service launch (prompted, at least in part, by a 2011 GIROA mandate that required MCIT to provide 24x7 communications because insurgents forced private companies to turn off their cellular towers at night); Afghanistan's commercial satellite launch (to, among other purposes, enhance connectivity between telecommunications exchanges and the Village Communications Network and offer bandwidth to television broadcast companies); complete the optical fiber cable (OFC) ring (which involved security for installation and maintenance teams, an upgrade to DWDM,<sup>1760</sup> and improving its quality of service (QoS)); support for the implementation of the electronic national identity card (e-Tazkira), which including assisting the MCIT with the development of the technical platform and assisting the MoI on the enrollment of the population and printing the cards; upgrading AfTel's copper cable infrastructure in select cities; and transition to digital television broadcasting per ITU guidelines.

During TAT-4, the mission started to move away from most non-security activities. With the dissolution of DCOS Stability Ops, TAT-4 initially supported the Non-Security Ministries-Ministry Advisory Group (NSM-MAG, which replaced DCOS Stability Ops) and then transitioned to the CSTC-A Enterprise Advisory Group. There its efforts started to shift away from the TAT's traditional interactions with its Afghan counterparts at the MCIT, ATRA, and AfTel to focusing on the TAT drawdown and on CJ6 ICT-related train, advise, and assist to security ministries, in particular the MoD and MoI. Some engagement remained with MCIT, ATRA, and AfTel: the TAT continued to help ATRA with spectrum management and AfTel with fiber optic network expansion, circuit leasing, and network management.

---

<sup>1759</sup> Third-generation wireless digital technology based on International Telecommunication Union (ITU) International Mobile Telecommunications (IMT)-2000 specifications.

<sup>1760</sup> Dense wavelength division multiplexing

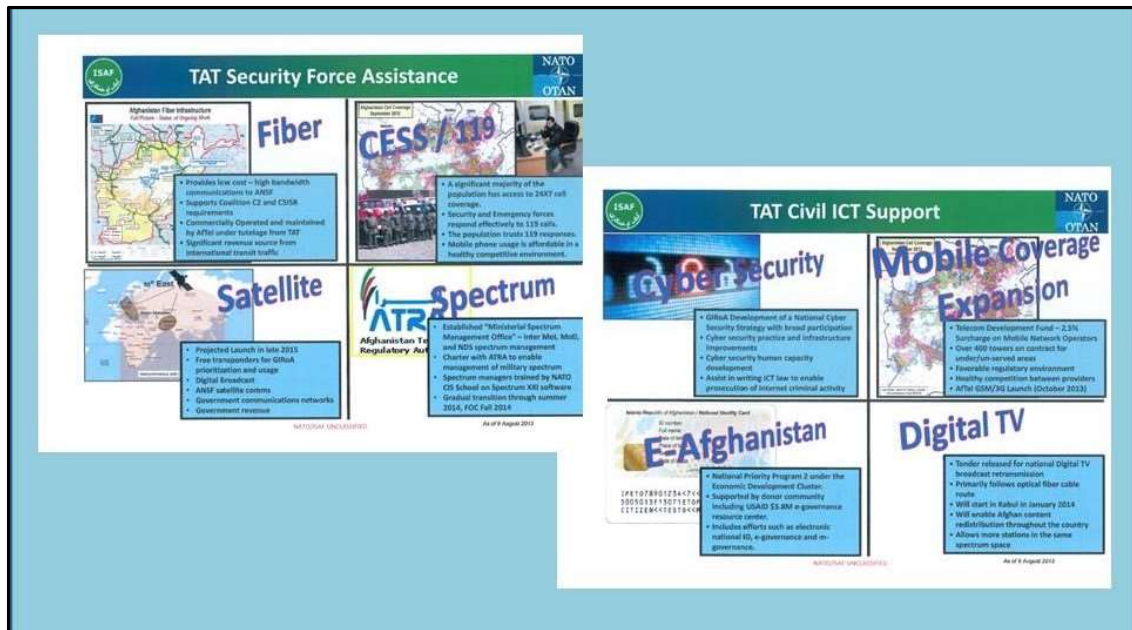

Figure 127: TAT-4 strategy

The TAT-4 reshaped its strategy (see [Figure 127](#)) narrowed down the mission to focus on security force assistance and civil ICT support. Efforts addressed included: ANSF ICT train, advise, and assist (TAA); providing ICT experience and expertise to advise and assist Afghanistan’s public ICT institutions (the MCIT, ATRA, and AfTel); ensuring Afghan ICT infrastructure could support C4ISR requirements of remaining Coalition troops and the ANSF post-2014; supporting CJ6 as liaison to ATRA for spectrum transition; and advising GfRoA on cybersecurity strategy, implementation, and legislation. Some other activities related to cybersecurity included developing cyber risk management framework guidelines, CERT<sup>1761</sup> incident management capabilities, and a cybersecurity awareness campaign for the MCIT Information Systems Security Directorate (ISSD). As part of TAT-4’s support to the MCIT ISSD, TAT members conducted fact-finding visits to the ITU cybersecurity executing arm of the United Nations’ IMPACT (International Multilateral Partnership Against Cyber Threats) headquarters in Malaysia (IMPACT is responsibility for providing cybersecurity assistance and support to the ITU’s 193 member states and also to other organizations within the UN system); to NATO Headquarters in Brussels to visit the cybersecurity division to discuss cybersecurity strategies and a visit to the NATO Computer Incident Response Capability in Mons; and a visit to the NATO Cooperative Cyber Defense Centre of Excellence in Estonia. The TAT-4 was also actively engaged in spectrum training for ATRA staff and analysis of spectrum interference issues. The TAT-4 also provided support to AfTel on technical evaluation of DWDM bids for the fiber optic network;

<sup>1761</sup> Cyber Emergency Response Team

to the Afghan National Army and AfTel MoA for OFC connectivity; for a statement of work for the Kabul metro fiber ring and other network plans such as Mazar-e-Sharif metro area networks.



## TAT Transition - TAT Focus Areas



### TAT Wins

<p><b>Fiber Optic Network</b>  <i>“Improve reliability, capacity, technology in support of economic development and ANSF C2”</i></p> <ul style="list-style-type: none"> <li>- Progress on stalled installation, repair, and O&amp;M of SE, SW and central segments of OFC</li> <li>- Tender drafted for Tech Refresh of OFC</li> <li>- Aftel and DABS (electric company) fiber lease arrangements for redundant paths</li> <li>- Regional IP Transit bandwidth offers facilitated and wholesale IP bandwidth prices reduced 30%</li> <li>- Analysis of commercial market</li> </ul>	<p><b>Cyber Security</b>  <i>“Protect the confidentiality, integrity and availability of critical systems and information”</i></p> <ul style="list-style-type: none"> <li>- Acceptable Use Policy developed and installed</li> <li>- Asset Management Software online</li> <li>- Vulnerability Management online</li> <li>- IA Certifications for 60% Staff</li> <li>- PKI tender drafted –currently in acquisition</li> <li>- Provided qualifications for Forensic Manager</li> <li>- AfCERT Manager training with ITU (IMPACT)</li> </ul>
<p><b>Spectrum</b>  <i>“Develop domestic capability to manage critical national resource”</i></p> <ul style="list-style-type: none"> <li>- Ministerial Spectrum Management Office (MSMO) for ANSF: DSE-A installed servers, connected to DAS-net and trained helpdesk</li> <li>- Civil Spectrum Working Group: TAT hired commercial spectrum expert to collect data during ISAF allotted test period (Roshan, ATRA, TAT) with coalition provided equipment;</li> <li>- Obtained wireless mapping data from JIEDDO</li> </ul>	<p><b>ANSF COMMS</b>  <i>“Provide ANSF robust C2; increase ability of government to provide security”</i></p> <ul style="list-style-type: none"> <li>- Secure calling solutions and security camera feeds in support of elections</li> <li>- Anti-cyber crime and protection of ICT infrastructure part of National Police Strategy</li> <li>- GSG6 Professional Development</li> <li>- ANSF Cyber Security Strategy and CONOPs</li> <li>- Emergency call centers and C-IED reporting tools</li> <li>- Championed Mobile-Money for salary payments</li> <li>- Literacy apps for policewomen</li> </ul>

Figure 128: TAT-4 transition status and wins

As ISAF and TAT-4 drew down, TAT-4 chose to focus on the four key areas of fiber, cyber, spectrum, and ANSF communications (see [Figure 128](#)).

In the end, TAT-4 had the responsibility to turn off the lights for the STA/TAT. The casing of the TAT colors (see [Picture 76](#)) took place at ISAF Headquarters on September 25, 2014, and the departure of the STA and remaining TAT personnel occurred in early October 2014.

Throughout its four years of operation, the STA/TAT had to deal with an extremely fluid environment, internally and externally. The near-constant turnover of personnel created continuity of effort and team-building challenges. Other factors included but were not limited to: multiple changes in ISAF commanders and their understanding of and interest in, or lack thereof, of the STA/TAT and its roles and mission; multiple changes in TAT reporting arrangements within the ISAF command arrangements; and the constantly changing mission of ISAF from security to stability/COIN to combat forces draw down and security force assistance to train/advise/assist. All these impacted the TAT’s lines of operation and work efforts, and, ultimately, its sustainability.



Picture 76: Casing of the TAT's colors

### *Staffing and Augmenting the TAT*

As described earlier in this chapter, DISA's original plan to establish the Office of the Senior Telecom Advisor to COMISAF included a small footprint on the ground in Kabul: a civilian SES or equivalent and a small contractor team of civilian ICT SME senior advisors. As mentioned above, when the first STA arrived at ISAF Headquarters in July 2010, he inherited eight CEW positions from the CJ6 it had planned to use to augment the CJ6 with commercial ICT experts, the recruiting for which had already begun. The CEW personnel became the Telecom Advisory Team (TAT). Occasionally throughout its four-year tenure, the STA/TAT required expertise it did not have on the ground or for special projects. The STA/TAT was able to supplement its workforce with personnel with SMEs on short-term assignments, both volunteers and DISA-funded contractors. DISA planned to continue to maintain the CONUS-based reachback capability, which was in place before the STA arrived, to support the forward-deployed elements. It was envisioned Reachback members would rotate regularly through Kabul to offer the STA/TAT experienced, near-continuous on-the-ground support and be integral members of the effort. The contractors – Deloitte and IZ Technologies – and their arrangements were described above. The CEW program and the STA/TAT's experiences with it are described below, as are some short-term assignments and the STA/TAT's Reachback Team.

### **The Civilian Expeditionary Workforce**

Established by DoD Directive 1404.10 issued in January 2009, the Civilian Expeditionary Workforce (CEW) is "a subset of the DoD civilian workforce [that is] pre-identified to be organized, trained, and equipped in a manner that facilitates the use of their capabilities for operational requirements ... [particularly to be]

ready to deploy in support of combat operations”<sup>1762</sup> and other emergency situations. After some initial challenges to be shared below,<sup>1763</sup> the CEW program, over time, proved to be more flexible and adaptable in helping the TAT to meet its staffing needs than anticipated. In later stages of the TAT’s operation, if needed skill sets did not exist within the CEW talent pool, the TAT was able to delay filling open positions until people with the necessary skills were identified and recruited into the CEW program. The TAT employed this approach in recruiting for several positions. CEW staff members who did not work out were sent home, and CEW staff who needed to return home for personal reasons, or whose sponsoring organization recalled them, were allowed to redeploy. With experience in using the CEW process, improvements were made to make it more responsive in searching for and recruiting candidates, particularly when the TAT provided key words to help clarify its skills of interest. In some cases, the TAT was able to recruit candidates to apply for a CEW position. The TAT was also able to adjust CEW position descriptions to better meet new demands, such as the need for an administrative position and the need for cybersecurity expertise. Over time, and once the TAT figured out better ways to recruit candidates, adjust job descriptions, and leverage the CEW system, the process worked better to shape TAT staff based on skill needs. The TAT’s experience with the CEW program paid dividends, as it allowed TAT to increase the focus and depth of its engagement within the Afghan ICT sector.

### *Challenges with the CEW*

The CEW recruiting process had limitations with regards to staffing positions to meet TAT expertise requirements, as just described. Many candidates who submitted applications for TAT-advertised positions were more tactical than strategic in experience and some lacked the interpersonal skills needed to deal with senior military and civilian leadership, operate in an international and multicultural work environment, and work effectively with the Afghan workforce and its related culture.

Fewer than expected CEW candidates applied for positions specifically at the TAT. The CEW process searched within a pool of candidates interested in the CEW program in general (as opposed to candidates specifically interested in the TAT) and then offered prospects to the TAT for consideration. The recruiting and screening process tended to be conducted by phone calls or through third-party recommendations versus a more rigorous face-to-face interview by the STA or a TAT or Reachback member. There were varying reasons motivating volunteers through the CEW; they ranged from genuine interest in trying to help make a difference in the ICT sector or Afghanistan to those who came for the financial benefits and/or to get away from personal problems or simply for the experience. Additionally, there were challenges in attracting proactive high-demand senior experienced individuals to come work in a war zone and, in some cases, parent organizations were reluctant to let their valuable employees take a year away from their jobs. These points were not a new phenomenon but a reality of a volunteer process for staffing civilian positions in a war zone. Additionally, assignments in hardship areas require a “passion” element that,

---

<sup>1762</sup> Department of Defense Directive Number 1404.10, DoD Civilian Expeditionary Workforce, January 23, 2009. Accessed December 20, 2016. <http://www.dtic.mil/whs/directives/corres/pdf/140410p.pdf>.

<sup>1763</sup> Much of this Civilian Expeditionary Workforce section is excerpted verbatim or paraphrased from Bierden, 2012. *TAT Year in Review*.

unfortunately, was not often found in those volunteering. Experience suggests that passion is a real tiebreaker for effective execution in a complex operational environment.

Overall, the CEW candidate interview process had limitations, and this is an area where the TAT's Reachback team could have been engaged to help, both with the recruiting and screening of possible candidates. This, unfortunately, never happened. There was a need to be able to better advertise, recruit, and influence more interest in candidates to apply for TAT ICT positions and to be able to identify and attract candidates with ICT systems thinking, strategic experience, and with the passion, skills, and experience necessary to operate in a multinational, multicultural, complex, and dynamic environment within a war zone. The TAT made some progress in improving the recruiting of candidates, but this required a focused and interactive effort by TAT leadership, DISA, Reachback, the Civilian Personnel Advisory Center, and USFOR-A CJ1<sup>1764</sup> elements to work the system to find and recruit the appropriate staff.

There was also a shortfall in orientation and mentoring CEW volunteers, especially for the TAT mission and operating environment. The CEW process did not include Afghan ICT orientation training or TAT orientation in terms of mission, nature of the work program, expectations, and the working and creature comfort support environment. Additionally, there were no TAT-focused orientation and mentoring programs aimed at helping the CEW member's transition into their new assignment in country. Overlap of replacements with their predecessors on the job was rare or just long enough to be able to do some left seat, right seat driving before the successor took the lead role for a project. There were some limited team building and integration processes employed but no formal program. The approach was more just putting people into jobs and letting them determine how they might best help.

The lack of orientation and mentoring programs never received the needed attention to fix the deficit properly from one phase of the TAT to the next. Some attempts were made to introduce training programs but none was ever put in place or sustained as part of the TAT business process. There was no TAT playbook, smart book, or standard operating procedures that new CEW members could refer to for developing a more informed understanding of the mission, ongoing activities, key players, and other insights and guidance regarding the operation of the TAT and its work program and environment.

Some attempts to team build on the ground in Kabul included but were not limited to having a movie night in the office on the large screen display with popcorn and pizza to get the team together to socialize, but some CEWers did not want to participate in socializing and were therefore reluctant to participate. There were daily "once around the table" meetings and weekly reviews of events and activities that were used with some success to develop shared understandings of ongoing activities. Going to the firing range as a team with some competition events was employed in TAT-4 with some better success in team building. These were not, however, all-inclusive team building exercises to get TAT members with Reachback support to work as a team to develop and execute a shared vision, strategy, and plan and have a common passion to make a difference by leveraging the skills sets available and willingness to help each

---

<sup>1764</sup> Combined Joint Manpower and Personnel

other to make the team a success versus individual contributions. Here again there were culture and attitude issues with some CEW members who were only interested in what they were working on and were not interested in what others were doing or the future beyond their tour of duty. They were narrowly focused on the near term versus the big picture and long-term strategies and plans to achieve agreed outcomes. The issue was a need for behavior and culture change that takes more time than the duty tour of six to 12 months.

The TAT was a strategic, operational, and tactical focused activity that required professional ICT experts with not only technical experience but operational experience in conflict zones, a passion to make a difference, and a willingness to participate multiple years. This was an important difference between the TAT and Reachback cultures that contributed to disconnects rather than more effectively leveraging the skills, experience, and continuity of the Reachback team. Here again this was a missed opportunity to not only engage the Reachback but also the Deloitte team on the ground in Kabul to help with “strategic thinking” and “thought leadership” and strategic planning and with orientation training and mentoring. Additionally, there should have also been a process put in place at the TAT to facilitate mentoring and additional orientation training that could have leveraged these resources including Reachback TDYs to Kabul to help.

Frequent turnover of CEW personnel was also a management challenge since it caused the TAT to be in a continuous state of flux and team building mode of operation, which, at times, had some impact on the overall effectiveness of the team and continuity of operation. For example, during TAT-2, the team experienced 20 staff turnovers, which placed an unusually large burden on managing the change process, team building, and continuity of support efforts. Not all rotations that year were CEWers. There were other government players such as AFPAK Hands.<sup>1765</sup>

Given the CEW is largely volunteer, skill sets varied with each rotation. This resulted in TAT having to adjust its initiatives and work streams to match staff-on-hand capabilities versus TAT being able to consistently and proactively recruit the skills it needed. Integration of CEW staff was a continuous challenge in that skills of new staff did not always match needed requirements or those of the staff they replaced. These were the realities facing an ad hoc organization operating in a war zone without institutionalized arrangements, formally agreed-upon roles and responsibilities, and employing mature business processes.

Although CEW candidates receive some culture awareness training, there was little effort made to prepare candidates for their assignments or help them to become familiar with the TAT operating environment, both inside and outside the wire. There was no training for how to be a professional advisor working with senior civilians, and the culture at the US Embassy and USAID Mission, with senior military personnel at ISAF and USFOR-A, and with senior ICT professionals and at GIRoA and within the Afghan ICT industry. The TAT’s Reachback Team could have been more effectively employed to help prepare candidates to assume

---

<sup>1765</sup> Afghanistan-Pakistan (AFPAK) Hands (APH) Program, a DoD program initiated in 2009 that trained US Armed Services finance personnel (and others) in the languages and cultures of Afghanistan and Pakistan.



their roles within the TAT and to explain their expected interactions with folks on the ground. TAT-2 implemented an integration period where new team members were given one to two weeks of specialized attention and training aimed at acclimating, orientating, and integrating them into the team, the MCIT, and the environment. It also offered an opportunity for TAT leadership to assess new arrivals for strengths and weaknesses, to confirm or adjust assignments, as well as to consider them to potentially assume additional responsibilities beyond those for which they were hired. The process helped but was never institutionalized as a way of doing business.

From an administrative perspective, initial entry into the CEW program was generally sufficiently organized but in the view of some CEWers could have been better. TAT members experienced inefficiencies such as completing and submitting documents to CEW, only to have to complete them again upon in-processing at the pre-deployment training center at Camp Atterbury in Indiana because CEW failed to forward them to Atterbury. The use of online modules for required training was useful and the content was good, but some links found in CEW documentation or on CEW's and Atterbury's websites did not work, creating a scramble to find correct links or alternative solutions. For non-DoD new hires, completing training modules prior to being issued a DoD common access card (CAC) was difficult, and CEW provided little assistance in facilitating solutions.

TAT members who entered CEW from other government agencies had mixed results. One member struggled getting a written guarantee for return rights (an MoU between the DoD and the member's parent organization), while others reported their efforts as being fully-supported by their parent organization and CEW from a smooth deployment preparation perspective. There were cases of miscommunication and reports of a lack of coordination. Some TAT members reported CEW to be disconnected and dysfunctional and that it provided inaccurate information. The CEW program was very poor with regards to coordinating with multiple organizations for the transitioning of pay, benefits, accounting, and other similar issues.

Camp Atterbury offered two options for pre-deployment training: a one-week "executive" course and a two-week course for those with little to no military experience. The only problematic area of the actual deployment phase at Atterbury was that TAT CEW personnel were deploying into theater without weapons. Though cumbersome, arduous, and lengthy, the TAT resolved the problem of in-country issuance of weapons to the team. All CEW personnel, who qualify, were authorized a weapon once proper documentation was submitted and approved. There were, however, some other important training needs that were not offered. For example, there was no STA/TAT + Reachback orientation training including the multinational, multicultural senior civil-military leader work and organization culture environments of the various entities mentioned earlier. The senior advisor role at TAT was not another duty as assigned. This was a professional ICT subject matter expert position and not all the CEW staff met these criteria. There was no specialized training to prepare TAT members to perform as senior advisors in country. For

example, the DoD Ministry of Defense Advisors (MoDA) program<sup>1766</sup> had an extensive training program to shape the skills to meet senior advisor performance expectations for operating in a complex environment.

Based on TAT's experience, CEW training has some problems, which may improve or disappear as CEW matures as a way of doing business. However, it did not appear to TAT personnel that the technical and operational level employees or leaders who support the CEW program at either the Office of the Secretary of Defense (OSD) or Army Central Command (ARCENT) were totally committed to improving the program. Most seem to approach their jobs as additional duties rather than core functions. While this meets the mission, it really equates to people doing just enough to get by. Engagement at ARCENT was better than at OSD, but neither agency, to include the senior CEW staff at Camp Atterbury, demonstrated it was looking at the strategic picture or pulling loose ends together to eliminate redundancy and ill- purposed actions. Attempts by the TAT to have CEW fix its inoperability failed because of perceived disinterest by personnel to do more than what was outlined in their duty descriptions, a work ethic not unique to these organizations. Overall, however, CEW was a usable and generally successful program that directly supports DoD and its service members in a deployed status.

Training and deployment preparation at Camp Atterbury seemed to be improving with each class, and the TAT predicted that each aspect would become more refined as time passed and more people rotated through Camp Atterbury. Deployment of civilians also takes place at Fort Benning, Georgia; however, TAT's experience with Fort Benning was limited. TAT contractors have also deployed out of the USACE<sup>1767</sup> deployment center in Winchester, Virginia. The CEW program should consider shadow the weapons approval process employed by ACPAK Hands. A vast majority, if not all ACPAK Hands, deploy from Camp Atterbury with weapons and the same should occur with CEW personnel qualifying. The CEW program should also explore special training needs for assignments such as TAT-like advisors operating in a specialized senior multinational, multicultural civil-military environment. Such training may need to be done by organizations other than CEW before deployment.

### Subject Matter Experts and Short-term Assignments

In direct response to identified needs, the TAT was able to augment its staff with subject matter experts (SMEs), such as for satellite and spectrum, loaned from DISA headquarters for short-term assignments.<sup>1768</sup> TAT employed additional resources in the form of contractor SMEs for GSM/3G and satellite and funded by DISA. The TAT also embraced assistance and resources offered by the Satellite Industry Association (SIA), the Federal Communications Commission-International Bureau (FCC-IB), DISA COMSATCOM,<sup>1769</sup> and

---

<sup>1766</sup> The Ministry of Defense Advisors (MoDA) program "partners DoD civilian experts with foreign counterparts to build ministerial core competencies such as personnel and readiness, logistics, strategy and policy, and financial management." It is administered by the Defense Security Cooperation Agency (DCSA). DCSA website. Accessed March 14, 2016. <http://www.dsca.mil/programs/ministry-defense-advisors>.

<sup>1767</sup> United States Army Corps of Engineers

<sup>1768</sup> Much of this Subject Matter Experts and Short-term Assignments section is excerpted verbatim or paraphrased from Bierden, 2012. *TAT Year in Review*.

<sup>1769</sup> Commercial Satellite Communications

others. Additionally, DISA GIG Ops, on behalf of the TAT, contracted a satellite SME from LinQuest to assist the TAT and ATRA to develop a tender for leasing Afghanistan’s satellite orbital slot. DISA GIG Ops also contracted Deloitte and funded NDU to conduct assessments and provide reports and recommendations in the areas of cybersecurity and ICT capacity development. NDU was funded by DISA to support the Deloitte capacity development study and, in this role, contracted with [Idea Sciences](#) to develop a CIO roadmap to be a part of the capacity development study and an input to the Afghan MCIT CIO and e-government activities. Further, the TAT also tasked NDU support funded by DISA with creating an implementation plan for the cybersecurity recommendations put forth as a result of Deloitte’s study. These arrangements involved a combination of in-country and CONUS work and were of limited duration with very specific deliverables. Additionally, the TAT brought Reachback Team members to Afghanistan on TDY to cover advisor absences and for specific projects or efforts. Overall, the TAT found the above arrangements to be quite beneficial, both to TAT and its Afghan colleagues. Supplementing the TAT’s existing skill sets with temporary expertise proved to be very valuable.

### Reachback Team

The CONUS-based Reachback Team was supported by DISA, ASD-NII/DoD CO, NDU, Gartner, and Deloitte in the States. In the case of NDU, there were two forms of support funded by DISA: an advisor to the STA/TAT who traveled to Afghanistan several times as part of his support and a small ICT support team at NDU that worked cybersecurity and ICT capacity development, which included a contract with Idea Sciences to work closely with the TAT to develop a comprehensive CIO professional development strategy and roadmap for the Afghan government. The STA/TAT and Reachback held weekly teleconference calls to coordinate ongoing ICT-related activities and share information.



*Picture 77: Larry Wentz, Bob Kinn, and Lew Shadle, leaders of the TAT’s Reachback Team*

*-- affectionately known as the “Graybeards”*

The TAT’s Reachback Team was composed of experienced ICT and USG professionals who had spent significant time on the ground in Afghanistan, were experienced in military-civil-commercial engagements, and had a passion for and commitment to the TAT’s mission. [Picture 77](#) shows the “Three Amigos” leaders of the Reachback Team, who were affectionately known as the “Graybeards” by the

STA/TAT, DISA, and USG Interagency. They were the strategic thinkers and thought leaders who provided valuable institutional memory and continuity of operations. They also kept abreast of current events and issues that may have impacted the TAT or the Afghan ICT sector.

Reachback played an important role in harmonizing activities across the US Interagency and telling the TAT's story in and around Washington, DC and elsewhere. Reachback worked TAT and broader USG areas of interest and engaged in activities with Afghans and other relevant parties and stakeholders in country and CONUS. The Reachback Team had extensive contacts and relationships going back several years before the TAT. In Afghanistan, it had access to GIRoA elements, the International Community, the Afghan private sector, the US Embassy and USAID, and in CONUS, the USG Interagency, academia, think tanks, international organizations, professional associations, and industry. Reachback played important facilitator, coordinator, harmonizer and connector roles both in country and CONUS. They were the institutional memory and transition continuum for the TAT. Reachback also had a DISA GO element that could facilitate access to the broad range of systems engineering, contracting, and operations advice and assistance offered by DISA and was a link to government research labs and other government ICT policy, technical, and services organizations.<sup>1770</sup>

The ASD-NII/DoD CIO representative of the Reachback Team organized a monthly (and sometimes more often) meeting on Afghanistan ICT in Washington, DC as well as meetings with World Bank ICT personnel working in Afghanistan and in CONUS. He also facilitated meetings with US industry and associations such as the Afghan American Chamber of Commerce (AACC), for which he chaired an Afghan ICT panel at one of its annual conferences in Washington, DC. On trips to Kabul, he facilitated meetings with the US Embassy, USAID Mission, Afghan ICT counterparts, ICT associations, and other interactions as appropriate.

During TATs 1 and 2, the NDU advisor participated with the US and ISAF in some early IT installation activities in Kabul, Khakrez, Arghandab, and Shindand related to an experiment supporting a Special Operations Forces (SOF) Village Stability Operations (VSO) COIN initiative. The experiment was based on the concept referred to as "UnityNet," which was conceived as a "globally deployable sensor for 'white' information."<sup>1771</sup> The UnityNet model provided "an ISR<sup>1772</sup> platform that 'senses' population-centric atmospheric and information critical to COIN and stability operations"<sup>1773</sup> and "enables host-nation, open-information sharing environments in areas ... of interest to the United States."<sup>1774</sup> The UnityNet concept "bridges the gap" among military, government, and civilian operations and provides a platform for a unified information collection, sharing, and dissemination effort. The intent was to demonstrate the

---

<sup>1770</sup> Much of the text in this paragraph is excerpted verbatim or paraphrased from Bierden, 2012. *TAT Year in Review*.

<sup>1771</sup> Thompson, Gary H. and David W. Meunch (2010). *UnityNet: A Global Deployable Sensor for White Information*. Defense Intelligence Agency (DIA), May 5. Accessed December 17, 2014. [http://www.oss.net/dynamaster/file\\_archive/100529/e757154e3b4532aeeed75f6d5b5955f6/UnityNet\\_White\\_Paper\\_FINAL%20%285%20May%202010%29%282%29%5b1%5d.pdf](http://www.oss.net/dynamaster/file_archive/100529/e757154e3b4532aeeed75f6d5b5955f6/UnityNet_White_Paper_FINAL%20%285%20May%202010%29%282%29%5b1%5d.pdf).

<sup>1772</sup> Intelligence, surveillance, and reconnaissance

<sup>1773</sup> Thompson and Meunch, 2010.

<sup>1774</sup> Ibid.

importance of information sharing in complex operations. The free flow of unclassified information is paramount in complex operations and will only become more important in our increasingly interconnected world. The “democratic process and civil society ... depends on information sharing and continuous information flow.”<sup>1775</sup>



Picture 78: SOF VSO COIN initiative

The VSO experiment used commercial off-the-shelf IT hardware, solar power, and commercial satellite (VSAT<sup>1776</sup>) capabilities to provide collaborative information sharing environments and Internet access at the district level to link the Afghan National Army and Police, the National Directorate of Security (NDS), the district governor, and, as appropriate, local medical clinics and schools. The system could also be used

---

<sup>1775</sup> CNI Technical Services, LLC (2011). *Research and Analysis Project for UNCLASSIFIED Information Sharing in Afghanistan: A Model for US Military and Coalition Commanders, the US Intelligence Community, and US Homeland Security*. Prepared for the Center for Technology and National Security Policy (CTNSP) at the National Defense University (NDU) on behalf of the Intelligence, Surveillance, Reconnaissance Task Force (ISR TF), January 28, 2011. Contract # SP4705-10-C-0055.

<sup>1776</sup> Very small aperture terminal, a two-way satellite ground station with a dish antenna generally smaller than three to four feet.

by the Afghan National Security Forces (ANSF) to communicate with higher levels of command and the district governor to communicate with the provincial governor, and all had access to the Internet. Local health clinics were connected to allow access to the Internet for medical and healthcare information. Some local schools and other facilities were connected as well. For example, in Shindand it was planned to connect the Teachers Training Institute and Women's Training and Computer Learning Center near the district center. Due to Taliban threats, it was not possible to visit these training facilities, but equipment had been provided to a trusted local Afghan to install computer labs and Wi-Fi<sup>1777</sup> hotspots and to establish a wireless link to provide Internet access from the hub at the Shindand District Center. The experiment consisted of an IT hub-and-spoke arrangement that was established at a local district SO site. (See [Picture 78](#)). The Shindand District Center VSAT is in the upper left picture. The upper right shows directed Wi-Fi links on the district center at Arghandab. The photos in the lower left and right are computer terminals at the Khakrez site). The hub used a VSAT to access the Internet, a server to support information sharing and management, open source software, Wi-Fi hot spots, and directed Wi-Fi links as spokes to connect the local ANSF compounds, the NDS, the governor's office and residence, and health clinics. The end users were provided computers (with VoIP and VTC<sup>1778</sup> capabilities), monitors, printers, wireless access points, and wireless access to hub. The effort included a training initiative to teach the end users how to use the capabilities. VSO sites that participated included Shindand in Herat province and Arghandab and Khakrez in Kandahar province. During TAT-2, the NDU advisor participated in an assessment of the VSO IT experiment with visits to sites in Kabul, Khakrez, Arghandab, and Shindand.

### *Reachback's Challenges*

At times there were disconnects in a shared understanding among TAT members and the Reachback Team. During the first year of the TAT, the Reachback Team had a member on the ground every month who acted as an integral member of the TAT in Kabul. This proactive interaction served to build shared understandings and trusted relationships and a team approach. Subsequent years of the TAT, for different reasons, made less use of or were unable to use Reachback members TDY to Kabul. This had unintended consequences and resulted in misperceptions and misunderstanding of roles, relationships, capabilities, priorities, and accountability. More importantly, it was difficult for Reachback to establish credibility and build the necessary trust and team relationships with TAT personnel in Kabul for all to work effectively as a distributed virtual team (see [Figure 129](#)).

It became clear over time that it takes more than weekly conference calls and email exchanges to develop the needed working relationships, shared understandings, and teaming arrangements. After the first year, TAT-2 to TAT-4 members and Reachback Team members did not get to know each other fully on a professional level in a timely manner and, in some cases, at all. Hence it was a constant challenge to develop common ground regarding mission, priorities, tasks, skills, and the situation on the ground. It was

---

<sup>1777</sup> Wi-Fi is a local area wireless computer networking technology that employs radio waves to allow computers, mobile phones, and other devices to connect to the Internet and communicate with one another within a particular area without being physically connected.

<sup>1778</sup> Voice over Internet Protocol and video teleconference, respectively

not until team members were able to meet in person in Kabul or in Washington, DC or at conferences that relationships tended to improve. The face-to-face contact and on-the-ground participation were key to building the team, getting to know each other, and developing and maintaining a shared understanding and respect.

## STA/TAT+Reachback: A Distributed Virtual Team

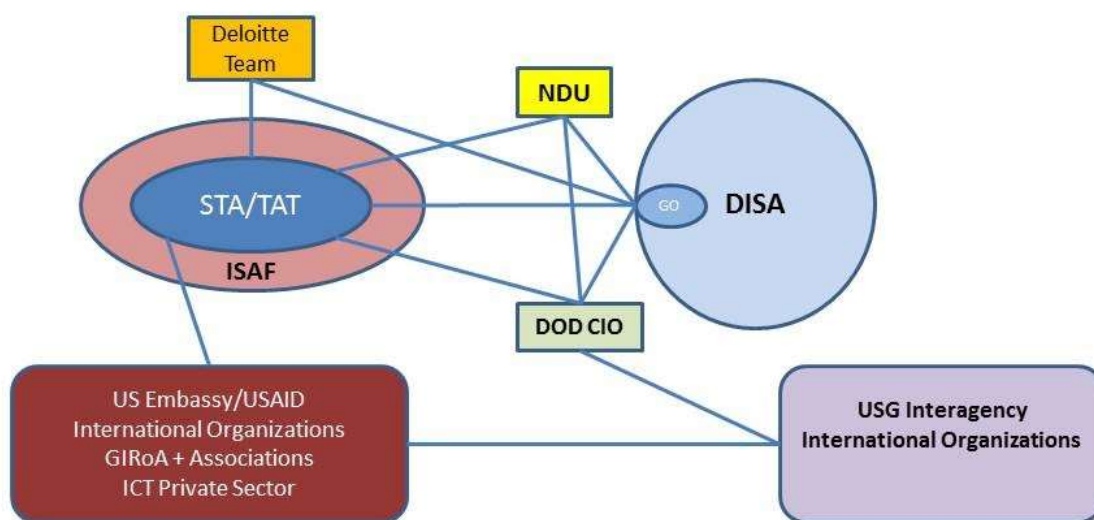

Figure 129: Representation of a distributed virtual team

During the post-TAT-1 era, some of the in-country TAT staff felt the Reachback Team should have had more direct involvement in and accountability for deliverables from afar regarding the day-to-day work being conducted to further TAT’s initiatives and lines of effort. There were shortfalls in communication and information sharing between Kabul and Washington, DC, and knowledge management limitations contributed to this situation. There was no shared web portal to facilitate information sharing, no remote access to the TAT’s shared network drive at ISAF where TAT documentation was stored and archived, and unclassified work at ISAF was often done and stored on high-side (secret) networks, making it difficult to share remotely or be downloaded to CDs for use by Reachback.

Additionally, some TAT members felt Reachback Team members were not explicitly assigned to support specific strategic initiatives, which was perceived to reduce Reachback’s sense of responsibility for regular contact and involvement with the initiative lead in country. This perceived disconnect in understanding of Reachback’s role with respect to particular initiatives at times decreased the extent to which TAT included

Reachback in activities. Reachback responses to requests for information from in-country TAT members sometimes did not meet TAT member expectations, thereby straining relationships at times.

The TAT-Reachback operational experience also reflected many of the challenges of building and sustaining an effective distributed virtual team. The team on the ground had a small footprint with a dynamic turnover of personnel and leadership and a near-term perspective of its work program – what can we accomplish within the timeframe of a year or less. The team in Kabul experienced frequent tasking with quick-delivery priorities. Their current situational awareness was not always effectively shared among the team or with Reachback. They had expectations that Reachback operated in a similar manner and would be more responsive to requests for assistance. The team in the rear had on-the-ground experience in Afghanistan and provided longer-term continuity of operation and institutional memory. Reachback also had a long-term perspective of purpose, the broader stakeholder interest areas, and USG strategy considerations and issue areas. They had access to a broader range of professional expertise to engage to help solve problems versus firefighting issues and dealing with the local civil-military bureaucratic tasking that frequently occurs at higher headquarters levels, which can consume a lot of time and energy to produce “shelfware.” The Reachback team had limited means in place to maintain currency of on-the-ground situational awareness and, from afar, had a different set of organizations and issue areas competing for their time to assist. The view of priorities, urgency, and expectations to help work on-the-ground tasking and priorities differed as well. There were disconnects in shared understanding of roles, relationships, responsibilities, accountability, and urgency to respond that were not adequately addressed through orientation, mentoring, in-country engagement, and management attention to work together to sort out differences.

The challenge in future operations is how to implement and manage the right balance and a shared understanding of roles, relationships, lead and support responsibilities, and expectations for product delivery that helps meet priorities and demands of those on the ground. It is also important to manage perceptions and misperceptions. The original intent when planning for the STA to COMISAF was to have a small team forward with a larger footprint in the rear that was supported by dynamic interaction between the forward and rear elements, including appropriate rotation of Reachback personnel to Afghanistan to work on-the-ground tasks, to help achieve common goals and outcomes to produce timely deliverables, and to be viewed and operated as one team. Some in-country TAT members held perceptions that those not on the ground day-to-day were not really part of the TAT. Another was Reachback did not operate with the same urgency, response priorities, and accountability to meet demands and priorities of the team on the ground. This was a disconnect that largely occurred after TAT-1 and continued until the office was closed in 2014.

Analysis of TAT-1 through TAT-4 operations and challenges suggests a major difference between TAT-1 and TATs 2 through 4 was that the Reachback team was an integral part of TAT-1’s development and helped to shape and mature the team from the outset in 2010 to the end of TAT-1 in 2011. Reachback and STA/TAT-1 engagement started with an active orientation and mentoring program for the STA with proactive Reachback involvement before and after deployment of the STA. It also included active participation of Reachback members TDY to Kabul to help form the STA/TAT mission, strategy, and lines of operation; to facilitate strategic partnership-building between STA/TAT and ISAF/USFOR-A, the US



Embassy and USAID Mission, GIRoA counterparts, and international organizations; and to facilitate CEW team member mentoring and integration into the complex multicultural, multinational civil-military work environment.

The TAT's use of Gartner as part of the Reachback Team also proved to have its challenges. There were disconnects in the TAT's more tactical thinking versus Gartner's more strategic thinking. TAT members were not quite sure how to leverage the capabilities and services offered by Gartner. There was a perceived lack of appreciation and understanding by TAT in Kabul of what Gartner offered in terms of access to senior global professional ICT experts and access to internationally-recognized, high-quality, professional ICT research. It took a bit of time to forge an efficient and effective modus operandi, but even then, the TAT was not able to effectively leverage the DISA-funded contractual relationship with Gartner that gave them access to Gartner resources and databases. The TAT and Gartner came to an arrangement whereby TAT was able to ask specific questions or for assistance in specific areas. Gartner responded by harnessing its network of global SMEs for single or multiple teleconferences with relevant – and interested – TAT personnel. TAT and Gartner leadership also engaged in short bi-weekly calls to exchange status on outstanding issues and make each other aware of upcoming areas of engagement and other significant events. Over time, the TAT became a little more effective in engaging Gartner with regards to e-government, mobile telephony, and ICT for gender issues, along with CIO resources, cybersecurity specialists, and a host of other ICT-related subjects. Over time, Gartner support became less connected with the TAT and it was eventually terminated in 2014.

Lessons about virtual distributed teams in general, as well as specific lessons observed from the STA/ARG and STA/TAT are described in [Chapter 22](#).

### *Strategic Engagements with ICT Stakeholders*

Strategic engagements are intentional processes to mobilize the energy of interested stakeholder groups around a common challenge of success for all. For the STA/TAT, strategic engagements involved developing partnerships and trusted relationships with and among organizational elements that were key to helping the STA/TAT meet their objectives to be informed providers of situational awareness and effective harmonizers, synchronizers, advisors, mentors, and connectors. These trusted relationships were earned over time and were based upon professionalism, integrity, trust, dedication to common goals, and a shared understanding of each other's expectations and values. Active networking was a key element of the process. In dealing with Afghan counterparts, some understanding of Dari and/or Pashtu was useful as well as understanding and respecting Afghan culture and business practices.

As in many conflict-ridden and developing nations, there were a profusion of rehabilitation and reconstruction efforts in Afghanistan. While [Figure 130](#) indicates TAT's primary strategic engagements, it is by no means a complete representation of the myriad participants in the Afghan ICT ecosystem or the full component of organizations with which TAT interact[ed]. TAT function[ed] in a complex environment across a broad spectrum of operations with representatives from many different countries in government, military, and civilian roles. TAT interact[ed] with these stakeholders in order to support the US government's priorities and ISAF's mission, as well as to support the Government of the Islamic Republic

of Afghanistan in their sustainable reconstruction and development efforts and to advance the private ICT sector.<sup>1779</sup>

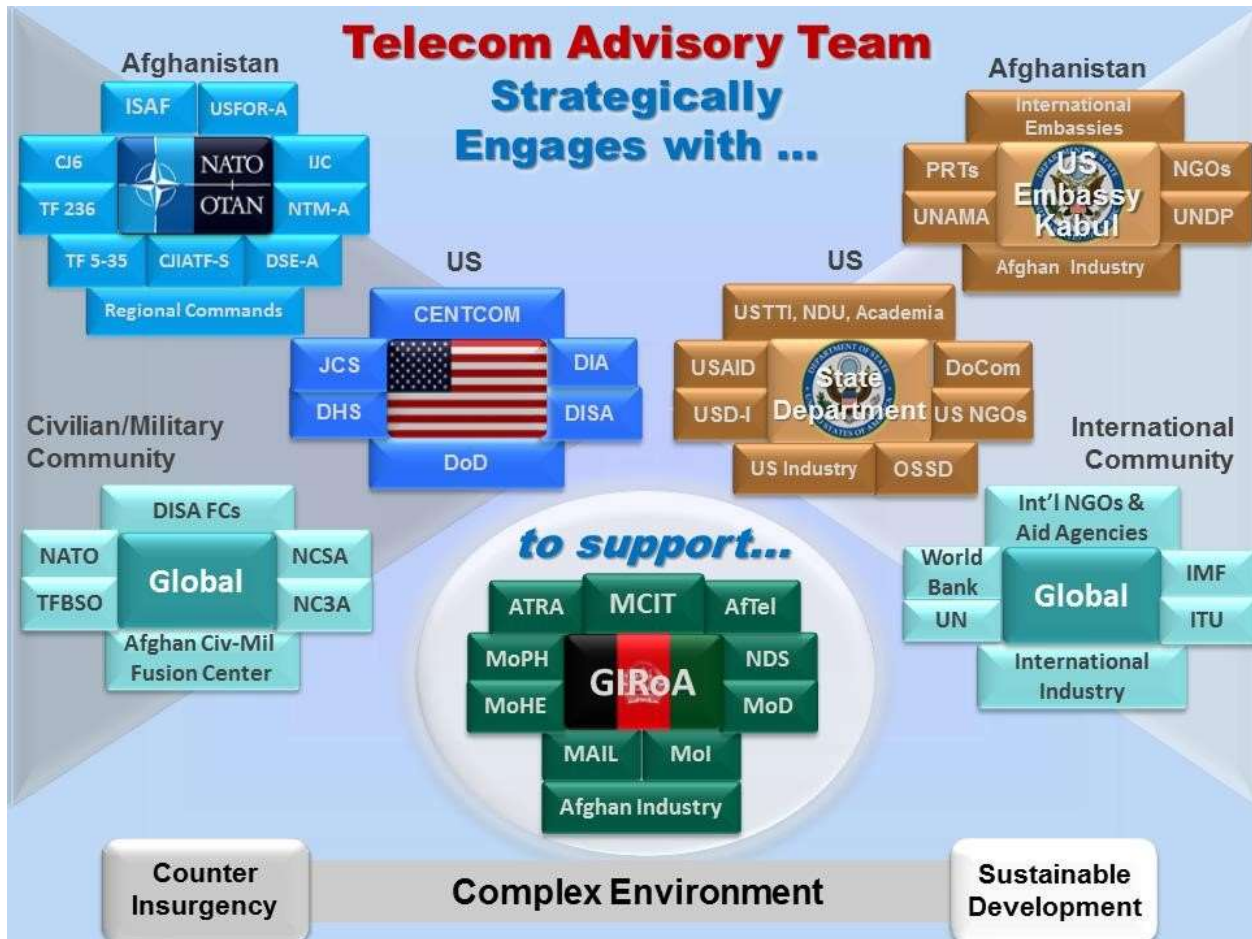

Figure 130: TAT engagement environment

(Graphic courtesy of former TAT Senior ICT Advisor Lewis E. (Lew) Shadle, Deloitte Consulting LLP)

Techniques employed included but were not limited to active participation in the US Embassy-sponsored Telecom Working Group, Afghan Telecom ICT Coordination Working Group, GIRoANet Working Group and other ICT related working groups as appropriate. TAT members were embedded in MCIT, ATRA and AfTel and worked closely with Afghan counterparts. Regular meetings were held with the Minister of MCIT and his senior managers, Chairman of ATRA and board members, senior management of AfTel, the CEOs and CTOs of the MNOs, senior managers of ISPs and CIO and IT managers of other Ministries. TAT participated in meetings with professional associations such as NISPAA and NICTAA and facilitated conferences and workshops such as the Afghan ICT Conferences. TAT actively participated in ISAF meetings and meetings

<sup>1779</sup> Bierden, 2012. *TAT ICT Strategy*.

with senior ISAF leaders such as COMISAF, DCOS Stability Operations and other elements. Regular meetings were held with the US Embassy ECON section and with key USAID elements. The Reachback Team actively engaged DoD, DoS, USAID, USDA, DoC, FCC-International Bureau, and other USG elements and international organizations such as World Bank on TAT and Afghan ICT related activities as well as with think tanks such as MITRE, RAND Corporation, and the Center for Strategic and International Studies (CSIS), government research centers, and academic institutions such as US Telecom Training Institute, Universities, and NDU.

The Deloitte TAT support contract and subsequent IZT support contract were specifically tailored to billet the teams off the ISAF compound and, in the case of Deloitte, provide them with their own PSD to offer a higher degree of freedom to move around Kabul to proactively interact with senior GIRoA and private sector ICT counterparts and to interact daily with the MCIT, ATRA, and AfTel, and other elements as appropriate. One of the reasons behind this freedom of movement was to be able to gain and maintain strategic engagements.

TAT made a number of ICT-related engagements with ISAF and ANSF elements outside of Kabul, including but not limited to ISAF Regional Commands, PRTs, Forward Operating Bases, and Firebases; Afghan ANA, ANP, and NDS district-level bases and operations such as coordination centers and call centers. It also engaged with USAID and NGOs downrange. Provinces visited included Nangarhar, Kandahar, Balkh, Helmand, Paktika, and Herat with visits to selected Provincial and District Centers; universities, boys' and girls' schools; Cisco Networking Academies; call centers; ICT Training Centers; hospitals and healthcare centers; and agriculture centers to gain a more informed understanding of ICT needs and opportunities at the local levels.

### *USG Interagency and International Engagements*

The DoD CIO has worked USG Interagency (e.g., DoS, USAID, DoC, FCC-IB and others) and international organizations' (e.g., World Bank) issues and interests for ICT and other areas going back to 2004. It also worked as the DoD lead for Interagency and international organizations' engagements on ICT issues from that time until present, as driven by CIO management interest and subsequently by inclusion of ICT responsibilities in the DoD CIO charter. At both the global and Afghan levels, Interagency and international organizations' relationships are challenging and require persistent engagement with counterparts at both to fully embrace respective responsibilities and opportunities to progress USG ICT interests.

In the case of work with Interagency and international organization counterparts at the US Embassy Kabul and elsewhere, the ASD-NII/DoD CIO learned the optimal approach was for the DoD to maintain the lead for active dedicated ICT engagement with Afghan counterparts, while inviting its USG Interagency counterparts to participate as often as possible in meetings and activities with Afghan representatives. While the STA was based at the embassy (2005-2008), ASD-NII and NDU reps participated on a dual-hatted basis as core members of the STA Reachback Team (when based at the Pentagon in Washington, DC) and core members of the ICT I-Team (when based in Kabul). In both locations, the Reachback/ I-Team core members engaged with Interagency and international organization counterparts to promote continued efforts to form an effective USG ICT social network.

The DoD regularly provided updates to USG Interagency partners on ICT activities and milestones for sector engagement. The Department of State appreciated receiving such updates, as they could be incorporated into cable traffic between the US Embassy Kabul and Main State. USAID and the Department of Commerce also appreciated the efforts to bring holistic engagements as part of the broader goals of developing a USG ICT community of interest.

USG Interagency counterparts have not been able to apply resources on a dedicated basis to ICT sector issues, as more often than not they have managed their respective engagements within or relating to the ICT sector as one of some 20 or more items in a diversified portfolio, particularly as managed by a State ECON action officer at the embassy in Kabul.

Once trust could be established with USG Interagency counterparts that the DoD's ICT engagement could and would be shared for Interagency situational awareness, the Interagency came to recognize that the DoD's dedicating resources (sometimes as needed on a 24x7 basis between efforts across Kabul and Washington, DC) to the ICT sector proved to be a useful capability for information sharing across the Interagency.

Following the departure of the STA from the US Embassy Kabul, and the resultant loss of the ability to work daily elbow-to-elbow with USG Interagency counterparts there, the recognition of the importance of the TA function became an increasing challenge to maintain, particularly when further complicated through the inevitable rotation of successive personnel as part of annual embassy transitions.

The ASD-NII/DoD CIO and the Reachback Team considered the loss of the STA as a dedicated ICT point of contact (POC) as an important shortfall in executing the USG mission in Afghanistan and approached then Ambassador for Development Tony Wayne at the US Embassy Kabul with the concept of creating a Telecom Working Group to enable continued ICT interaction between Interagency POCs across Washington, DC and the embassy. Ambassador Wayne agreed with the TWG concept and regular monthly teleconferences were initiated, with ongoing participation across the embassy ECON desk, Main State's South Central Asia Bureau, and the DC-based ICT Reachback Team. The TWG monitored ICT events and developments as they occurred in Kabul, and provided a forum for Interagency review and discussion of how Kabul Embassy might engage on selected ICT issue areas.

While there was no STA active in Kabul from mid-2008 to mid-2010, members of the ICT Reachback Team had opportunity to work TDYs in Kabul across interest groups located at the US Embassy Kabul and NATO's ISAF Headquarters. In the fall of 2008, a few months following the deactivation of the STA at the embassy, ASD-NII sent a Reachback Team member to Kabul to assist the new USFOR-A J6 command with introductions to key ICT players across USG, GIROA and the commercial element of the Afghan ICT sector. This TDY allowed for reconnection to Foreign Service officers working ICT issues at the embassy, new connections with the USFOR-A command, as well as time with Afghan counterparts across the MCIT, ATRA, AfTel, and senior management representatives from Afghan MNOs and ISPs. The fall 2008 TDY also included time with the MCIT and AfTel dedicated to the negotiation of leases using the emerging fiber ring network, marking a change in DoD policy regarding access to broadband service offerings from Afghan networks.

The STA at ISAF, along with the TAT support organization, had potential capabilities for continued and varied engagement with USG colleagues on the ground across ISAF and the embassy, as well as with Afghan colleagues inside and outside GIRoA. ASD-NII/DoD CIO and the ICT Reachback Team continued Interagency engagement as well across Kabul and DC, as per the ICT authorization in the ASD-NII/DoD CIO charter. As the number and nature of ICT-related projects and tasks grew at the ISAF TAT, the ICT Reachback Team worked with key representatives across State, USAID, Commerce, and the FCC to improve ICT issues messaging across the Interagency. A key strategy approach was to identify areas of interest to other members of the USG Interagency, and work back from those areas to connections where improvements in ICT capabilities also could deliver improvements in cross-sector interest areas, such as ICT for health, education, governance, etc. A key example was Reachback engagement with the Interagency in monthly meetings hosted by Main State for the New Silk Road Working Group (NSR WG). The NSR WG has primary interest in identifying ways in which infrastructure and process developments in Afghanistan and its South Central Asian regional neighbors could provide value-added integration to broader global trade development objectives such as linking regional trade corridors to transcontinental trade corridors. It is in this context that the NSR WG looks at infrastructure and related development in Afghanistan. Accordingly, the ASD-NII/DoD CIO has provided regular updates on the potential of regional fiber and broader connectivity to support these larger goals, as have colleagues looking at power infrastructure, transportation, and cold storage capabilities, etc. Maintaining Interagency awareness of the utility of ICT infrastructure and services serves to keep ICT identified as a critical infrastructure serving varied needs. The work of the NSR WG also has carried over to the Regional Economic Cooperation Conference on Afghanistan (RECCA) proceedings where the Afghan fiber optic network has been recognized as a key national and regional infrastructure, contributing to development, stabilization, and security for Afghanistan and the region.

As part of its Interagency coordination role, the ASD-NII/DoD CIO representative facilitated regular meetings with his Washington, DC-based ICT counterparts at DoS, USAID, DoC, DoD PACC,<sup>1780</sup> and FCC-IB as well as with the World Bank to discuss Afghan ICT sector challenges and opportunities and to share updates on STA/TAT activities and findings from Reachback visits to Kabul. ASD-NII/DoD CIO also facilitated Interagency meeting for the STA during visits to the Washington, DC area to provide Afghan ICT updates and discuss specific ICT challenges and opportunities. In the early days of the STA/ARG and STA/TAT, the DoD CIO along with the DoS, facilitated coordination of visits by the Afghan Minister of Communications and Information Technology to Washington, DC. A DoS policy change in 2014 shifted the visit coordination role to the Afghan Embassy in Washington, DC.

As part of pre-deployment orientation for the new STAs deploying to ISAF TAT, the ASD-NII representative facilitated introductory meetings with the key Interagency players prior to the STAs' departure to Kabul. There were also attempts to conduct pre-deployment STA/TAT orientation training for CEW staff, but time between DoD pre-deployment training and actual deployment did not allow time for diversion of staff through the Washington, DC area for such orientation. A few CEW staff did have opportunity to meet with

---

<sup>1780</sup> Pakistan Afghanistan Coordination Cell

Reachback members before deployment but did not have opportunity to meet with DISA, DoD, DoS, USAID, DoC, World Bank, or others.

### *Information Sharing and Knowledge Management*

Unclassified information sharing and the coordination and harmonization of activities among civil-military elements, with international organizations and NGOs, and with Afghans in the government, the private sector, and the local population proved to be a challenge. This should not be surprising since civil-military information sharing is a people and organization culture issue, not a technology issue. The following are some examples of approaches tried by the STA/TAT and within the Afghan ICT sector to improve collaboration, cooperation, and information sharing and the challenges encountered.

### **Working Groups**

The US Embassy Telecom Working Group (TWG) and the AfTel ICT Coordination Working Group mentioned earlier are two examples of efforts to bring participants together. In the first case, the TWG brought USG elements working Afghan ICT sector initiatives together to coordinate and share information. In the second case USG, Afghan, and international organization personnel working ICT activities related to the Afghan civil ICT sector met to coordinate activities, share information, and facilitate support to AfTel, the state-owned enterprise responsible for civil ICT sector project implementation and network operations.

The TWG had been ongoing prior to the STA/TAT being established at ISAF. The TAT co-chaired the TWG during TAT-1 and TAT-2 and during TAT-3 (beginning July 1, 2012) it chaired the TWG. The initial focus of the TWG was on the USG Interagency, with some outsiders invited to give special briefings on selected ICT topics. One such presentation was by Wateen in January 2011 about its fiber optic network, IP-based backbone network, wireless networks, and e-government and e-business services in Pakistan as well as the regional interconnections of AfTel's and Wateen's fiber networks. The TWG for the first year of TAT was pretty active with meetings occurring every other week. However, over time participation began to wane and less frequent meetings occurred, changing to once a month. During the latter part of TAT-2 and into TAT-3, in an effort to revive interest, the focus was shifted to bringing in participants from outside of the USG, generally Afghans from the civil and commercial sectors. It was still a challenge to keep people engaged and retain participation, and the TWG met less frequently, eventually only on as-needed basis to address particular issues. During TAT-4, the TWG chair reverted to the US Embassy ECON section but there were few meetings. Contributing to the attendance challenge was competition with transition and drawdown working group activities, USG personnel leaving and not being replaced, and the fact there was less interest in ICT sector activities with the shift in ISAF's mission to the transition of security to the Afghans and on MoD and Mol train, advise, and assist activities.

The AfTel ICT Coordination WG lasted until October 2011 when meetings stopped. There were several attempts to revive interest and after seven months, meetings resumed in May 2012. However, there were only a few meetings before the effort ceased again. Here, too, ISAF transition and drawdown activities had an impact on maintaining interest in WG activities, but it also lost its usefulness. In regard to the latter point, and more positively, a number of more focused relationships emerged to work issues related to fiber, cellular networks and other specific activities, reducing the need for the larger group of participants

to get together. Also, the deterioration in the security situation made it more difficult for USG participants, including the STA/TAT, to travel to AfTel on a regular basis to attend the meetings.

The challenge with such working groups is sustaining topics of interest that attract participation. All too often, once the participants have a shared understanding of what is going on and are not learning anything new, they stop participating. One of the benefits of the working groups is building social networks that are, in turn, used to work actions directly rather than through the larger working group. Also, members need to manage their time and there are lots of working groups competing for their time so it is necessary to prioritize. On the good news side, in their early phases of existence, both working groups were very effective in improving collaboration, cooperation, and information sharing.

### Meetings, Reports, Briefings, and Other Efforts

TAT members often wrote summaries of key meetings with Interagency, international organization, and Afghan counterparts, many of which were stored on a NATO unclassified shared drive set up for STA/TAT use and were also shared by email with STA/TAT and Reachback members. A Deloitte advisor originated the practice of writing what he called “flash summaries,” which was adopted somewhat by the larger TAT, informally at first and formally at one point. However, not all TAT members wrote meeting summaries, even when there was specific guidance from leadership to do so. Further, some of the TAT members’ meeting summaries were not particularly accurate or useful.

In year two, the TAT implemented daily group “huddles” to share information within the team, which was valuable to some extent. However, some members believed the topics of discussion were often not of relevance and interest to the larger group – a reflection of the lack of a culture of information sharing and strategic thinking. Also, Reachback was not part of these group discussions unless present on the ground during TDYs. TAT-2 also employed initially weekly and then biweekly “Strategic Initiative Review” teleconferences to improve collaboration and information sharing among team members and between the TAT in Kabul and Reachback, which were generally deemed to be successful and valuable.<sup>1781</sup>

The TAT, through most of its four years of operation, compiled weekly unclassified reports on its activities and items of relevance in the Afghan ICT sector and regional and international ICT ecosystems, which it shared by email with a wide range of personnel in the DoD, DoS, and DoC, as well as with USAID, NATO, other international organizations, NGOs, ICT entities operating in Afghanistan, and others interested in tracking such activities. Midway through TAT-4, the reports decreased to monthly and the recipients were very limited. The weekly reports were an effective outreach tool that provided shared situational awareness of the TAT’s and others’ ICT sector activities, and global ICT items of relevance, to the larger USG, ISAF, and international communities of interest. TAT-4 produced challenge coins and badges, which they handed out as a way to increase the TAT’s visibility as part of an information campaign to raise awareness of the TAT, its mission, and its efforts (see [Picture 79](#) and [Picture 80](#)).

---

<sup>1781</sup> Portions of this paragraph are excerpted verbatim or paraphrased from Bierden, 2102. *TAT Year in Review*.



Picture 79: TAT challenge coin



Picture 80: TAT patches

Through most of its four years, the TAT compiled and kept current a standard general brief, which it gave to arriving leadership of various ISAF organizations, at fora such as the annual CIS<sup>1782</sup> Conference, and to other organizations as required or requested.

The STA/TAT Director gave twice-yearly unclassified Interim Program Reviews (IPRs) for DISA GIG Ops at Fort Meade, which were attended by interested personnel from the DoD, DoS, USAID, and other USG entities. The IPR and other briefs were generally stored on the shared unclassified network drive at ISAF.

Numerous times over the years, the STA/TAT was requested to brief at COMISAF's daily morning briefings. Topics for these "standups" included the Afghan ICT sector and TAT's work in it, mobile money, Afghanistan's proposed electronic national identity card (e-NIC), ICT for gender equality, cellular telephone service in Afghanistan and threats to it, and a comparison of Afghan ICT to other countries in the region and to similarly poor countries. After a TAT brief in October 2012, COMISAF General Allen stated the TAT's work with the Ministry of Communications was "one of the most important non-security governmental engagements" ISAF had with the Afghans and publicly thanked the TAT for its important work. The TAT also introduced a new standard for visualizing the status of the national fiber optic network and cellular network coverage maps and other illustrations of ICT for governance and socio-economic development (see examples in [Figure 131](#)). The charts were in great demand.

---

<sup>1782</sup> Computer and information systems



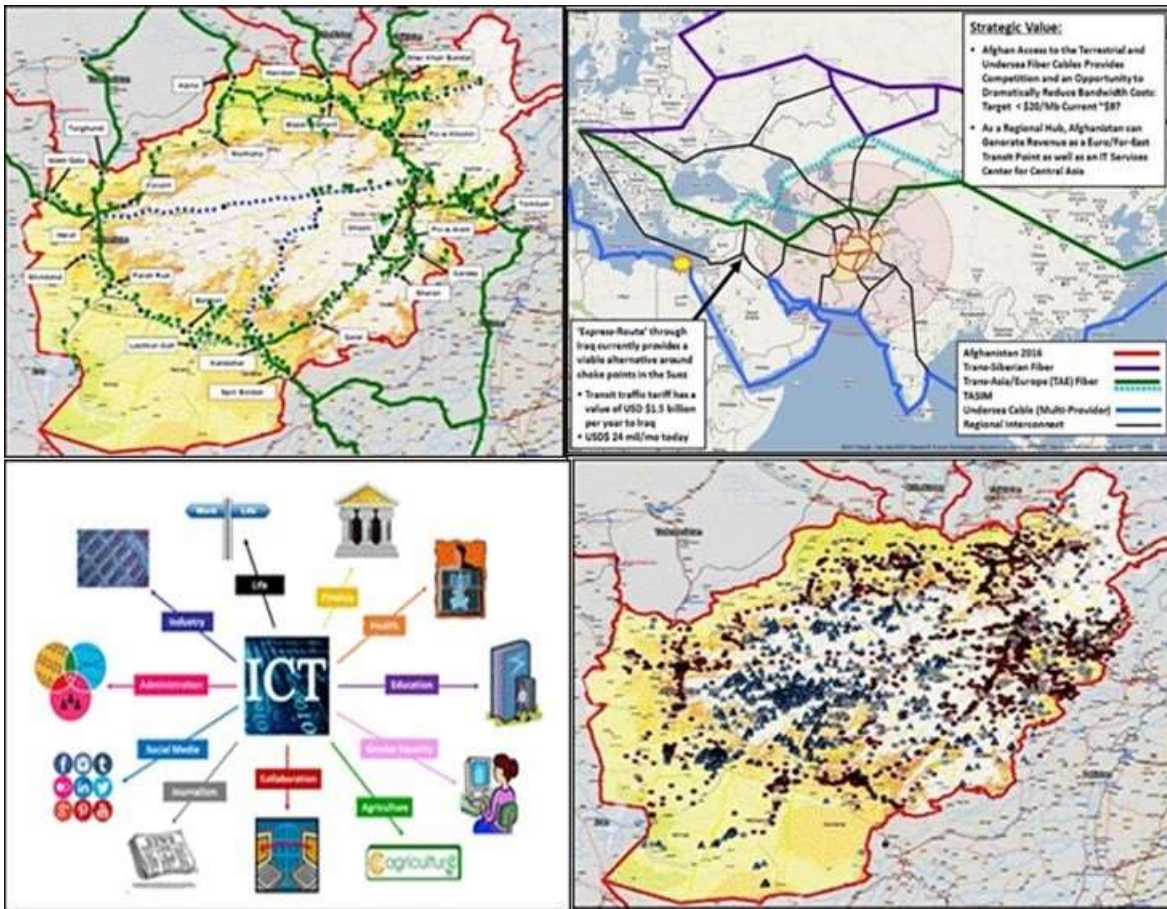

Figure 131: Examples of TAT visualization

The TAT was featured on DISA Dateline several times, a page on DISA’s intranet that showcases efforts of its various factions. The TAT raised and shared awareness through articles in AFCEA’s *Signal* magazine, the Counterinsurgency Advisory and Assistance Team’s (CAAT’s) *COIN Common Sense* magazine, and other publications. STA/TAT Director Dr. Warner was interviewed by Afghan and international press through ISAF’s Public Affairs office. Members of the TAT and Reachback participated in Afghan-American Chamber of Commerce events CONUS and the American Chamber of Commerce in Kabul. TAT members attended and participated in and various Afghanistan reconstruction-related and national and international ICT workshops and conferences in and out of the country, such as the Afghan Ministry of Higher Education’s annual IT symposium, the UN’s annual ICT conference in Kabul, the ITU World Summit on the Information Society in Geneva, and a NATO conference in Brussels, among others. Deloitte’s work with the TAT in Afghanistan was twice recognized as a finalist for the Association of Management Consulting Firm’s annual awards (2012 and 2013).

There were a number of efforts to bridge larger information sharing gaps using web portals, some of which could be accessed through the Internet. Publications such as those by the [NATO Allied Command Transformation’s](#) Civil-Military Fusion Center (CFC) – weekly news reports and special studies – could be downloaded from the CFC website (now defunct). Examples of other websites and web portals were USCENTCOM’s International Distributed Unified Reporting Environment (INDURE), ISAF Ronna, and the

US systems HARMONIEWeb and APAN,<sup>1783</sup> all of which were unclassified. The challenges with these systems were they tended not to be user friendly and required registration and password access. Often interactions with the websites were slow, contributing to frustrations in retrieving information, especially when accessed from the US. There was also the ISAF Combined Information Data Network Exchange (CIDNE), which was classified and, therefore, could only be accessed in theater by personnel with appropriate clearances.

### Challenges with Information Sharing and Knowledge Management

Information sharing within the TAT and between TAT and Reachback had its challenges. The reality of the TAT's mix of participants from different organizations with different information sharing behaviors and experiences did not guarantee a culture of sharing was consistently achieved among members over the life cycle of the TAT. There was a need to reward the desired behavior to achieve a culture of sharing but this was not the case. The TAT-Reachback interactions were a mixed culture of information sharing with those who were strong proponents to those who did not believe it was necessary at all or were not interested in doing it. The high rate of turnover of TAT personnel did not help. Open information sharing among TAT members in Kabul and with the Reachback team in CONUS was key to success but there was no reward system in place to encourage sharing as a desired behavior to achieve a consistent culture of sharing at the TAT.

Adding to the challenges that needed to be considered, the TAT's activities were largely unclassified but the TAT office was in a classified area. This created challenges working unclassified activities in a classified environment where most reports and data were developed and stored on the classified systems, making it difficult to share unclassified information outside of the classified work area. Use of unclassified military networks to access the Internet for research and information sharing had limitations related to the denial of access to social networking tools and to numerous unclassified websites of interest, which were often blocked by the military systems for security reasons. The TAT had to use other means of Internet access, such as Wi-Fi hotspots outside of the classified area in coffee shops, billeting, and MWR facilities on base and other available capabilities for open access to the Internet.

The desks in the TAT office in Circuit City had terminals to access "mission systems" such as US NIPRNet and SIPRNet<sup>1784</sup> and the NATO unclassified and ISAF secret networks. While TAT leadership assigned a primary "mission system" out of the four USG and ISAF information networks, there was limited access to mission systems by TAT personnel, particularly support contractors, as there was not a one-to-one allocation of terminals to people needing access, making it necessary to share terminals. This was due to US and NATO policies and physical space and equipment limitations. Most TAT members had additional assigned "home organization" systems and personal email accounts they needed to be able to access not only from the unclassified mission networks but through the Internet outside of the classified area for

---

<sup>1783</sup> Humanitarian Assistance Response Monitoring and Operations Network-Internet Enterprise and All Partners Access Network, respectively.

<sup>1784</sup> Non-classified Internet Protocol Router Network and Secret Internet Protocol Router Network, respectively.

personal reasons such as for calls home and to attend to personal business. Internet access at the MWR centers and cafes had performance limitations due to demand exceeding network capacity, as it was frequently used for streaming video, and due to limits on the number of simultaneous users allowed to access the system.

Data stored on ISAF networks (unclassified and classified) was not readily available for remote access by off-site government and contractor personnel or the Reachback Team in CONUS. The use of shared network drives within ISAF was well-intentioned but ill-executed. Repeated reorganizations of data and system failures resulted in data loss. There were disconnects and disagreements regarding who was or should have responsible for posting what, when, and where, which contributed to the lack of effectiveness of using shared ISAF drives as a TAT document repository and archive. Attempts to use broader open systems such as HARMONIEWeb and APAN helped some but proved not to be effective ways to collaborate and share information either. Complications with unfriendly user interfaces, poor network connectivity, network performance and latency, and classification and release-ability of documents were challenging as well.<sup>1785</sup> There was no formal process in place to maintain an STA/TAT + Reachback historical database of correspondence and documents. Several times, the shared network drives used for storing documents on various systems were corrupted or wiped out and never fully recovered, if at all, so no valid library exists for STA/TAT research. Various members of the TAT saved some files on CDs, but those are just bits and pieces, many of which were never shared. Ultimately, there is no compiled STA/TAT + Reachback repository or TAT history database.

Procedures for sharing information were different among [TAT] members, with some documenting activities routinely and others not at all. There was no agreed-upon TAT policy, SOP, or database manager for creating, populating, managing, and maintaining an archive of TAT documents and correspondence, including emails. Valuable information [was] missed by team members who were not direct participants in undocumented activities. The process of uploading documents to shared drives [was] often time consuming and logistically challenging with no clear benefit [in the view of some members]. Likewise, downloading unclassified files to CDs for use elsewhere proved to be time consuming. An ISAF copy facility was established to control and move files from mission systems to CDs, which could not be used on the US or ISAF equipment and networks. Team members routinely relied on email to share information and here too there was no saved record. Without an agreed-upon policy for saving documentation and creating a library, nor processes to accomplish such in place, team members often were unable to find documents that were known to have been stored. The return on the time invested to download and upload information to shared drives or sharable media often did not seem to those on the ground to benefit or further the advancement of initiatives but in the end would have been useful for after action assessments and documenting lessons learned.<sup>1786</sup>

---

<sup>1785</sup> Portions of this paragraph are excerpted verbatim or paraphrased from Bierden, 2012. *TAT Year in Review*.

<sup>1786</sup> Ibid.

As stated above, information sharing in this environment was difficult and it was easy to become somewhat stovepiped. Some team members collaborated and shared better than others. Also as noted earlier, there were no formal STA/TAT policies or procedures on information sharing and recordkeeping as part of documenting the history of TAT activities. Neither was there processes to capture experiences and lessons learned nor a database or other place to store them for future assessment activities. Several TAT members indicated that emphasis needed to be placed on making collaboration and information sharing more a part of the TAT's activities and that haring information should be rewarded by recognition. The TAT should have considered employing expertise specific to knowledge management or assigning a specific person the responsibility for storing and organizing information.<sup>1787</sup>

Bridging the Kabul-CONUS divide was not easy. The Internet was a way of exchanging information but much of the information needed was resident on ISAF classified systems that could not be accessed remotely. Moving unclassified information from classified systems proved to be a challenge as well. The STA/TAT published flash summaries on meetings and activity reports on its work program and activities of the ICT sector as a means to share situational awareness with a broader community of interest. Frequent team teleconference calls and Internet social networking tools were used to facilitate unclassified coordination, collaboration, and information sharing. Reachback TDYs to Kabul and other areas of the Afghanistan were used to gap fill SME needs, to conduct special studies, to facilitate team building, to maintain strategic partnership arrangements with Afghan counterparts, to develop a more informed understanding of ICT needs in Kabul as well as at the provincial, district, and village levels, and to update personal and team situational awareness.

In general, institutional arrangements and agreed-upon mechanisms and processes (including within USG civil-military elements) were not in place to facilitate harmonizing, synchronizing, and coordinating national and multinational actions and information sharing, including with non-military GIRoA public and private ICT sector elements, aid agencies, NGOs and international organizations working the Afghan ICT sector. It was largely a manual process.

Unless the US and Coalition forces and civilian elements can share information and collaborate with the populations and organizations they need to work with and influence in complex civil-military operations, they will not be able to achieve the goals for which they were committed. It is important to remember that information sharing and collaboration is a behavior not a technology, and developing a culture that rewards information sharing and collaboration is central to changing behavior.

### *Administrative and Logistics Support and Transportation*

Because [the] TAT originally began with only the STA/TAT Director with two resident contractors who, upon arrival in Kabul, inherited six previously approved CEW positions from ISAF CJ6, the importance of and need for Administrative and Logistics (A&L) support was not immediately apparent nor planned for.<sup>1788</sup> However, into its second year of operation, due in no small part to the substantial turnover that

---

<sup>1787</sup> Ibid.

<sup>1788</sup> Ibid.

TAT experienced, it was recognized there was a requirement to have a full-time A&L resource. As such, TAT adjusted the job description for one of its CEW positions in order to bring on a person dedicated to A&L. Prior to the arrival of A&L support, responsibilities for A&L activities such as in- and out-processing, billeting, meal cards, badging, coordination of movement, and force protection during movement and inside Afghan facilities, accounting, reporting, computer information systems (CIS) connectivity, office supplies, leaves/TDY processing, evaluations, awards, and other administrative functions were either distributed throughout the team or coordinated and supported by other organizations, initially ISAF CJ6 and later a combination of DCOS-STAB, CJ6, and the TAT admin person.

Initially TAT relied on ISAF movement control (MOVECON) but with the surge and limited ISAF capability to accommodate increased movement requests, it became increasingly difficult to obtain ISAF MOVECON support needed to meet the TAT's daily mission needs. The TAT purchased three vehicles in its first year to do its own MOVECON. Once TAT transitioned to DCOS-STAB, TAT used DCOS-STAB's MOVECON as its primary mover, but used its vehicles sparingly in addition to supporting ISAF CJ6's movements. TAT had to put a process in place to have new team members trained on how to get around Kabul and to obtain drivers' licenses. With increased security concerns, ISAF changed its security rules to require two weapons in every vehicle, including a long rifle. This was a problem in the early stages since few TAT members were authorized to carry weapons and had to get shooters from ISAF CJ6 or DCOS-STAB. The TAT changed its procedures and required all eligible team members to obtain drivers' licenses and be issued weapons to maximize its flexibility and movement options. This became even more critical and a challenge when new force protection rules triggered by increases in green-on-blue shootings required personnel visiting Afghan government officials to be armed and to have "guardian angels" accompany them on visits to Afghan facilities. Movement became manpower intensive and introduced challenges within GIRoA facilities and with Afghans, at least some of whom did not want weapons openly visible when visiting. With increased threat levels, trips outside the wire required authorized personnel to be armed and everyone had to wear individual body armor (IBA). Also, additional ISAF paperwork was required to obtain permission to travel outside the wire, adding to administrative support needs since the TAT traveled multiple times every day and frequently to the commercial and military sides of the Kabul airport to drop off and pick up personnel.

Administrative and logistics support was an important element critical to the efficient and effective operation of TAT, particularly in the environment in which TAT operated. A&L support should be considered up front and arrangements should be made to provide continual A&L support. Transportation is also a factor that needs to be consideration at the outset including the need for either separate PSD or staff to perform this function including requirements to use IBA and personnel be armed. Spare IBA for personnel TDY also became a need.

In addition to administrative support, it was also determined quickly that the SES-level STA in a war time environment and operating at the GO level at the headquarters level needed a military aide to handle military protocol, schedules, local movements, travel, security, and other activities required to support the SES. DISA provided the military aide, a USMC or USAF captain.

### *STA/TAT Transition and Drawdown*

In late 2011, ISAF formally announced it would transition combat forces in mid-FY13 to a security force assistance role and begin Coalition troop withdrawal in FY14. Thus, ISAF and USG Interagency planning was initiated to support the new guidance and to shape transition and drawdown actions. ISAF established the ISAF Operational Planning Team (IOPT) to kick off transition efforts, which was succeeded by the NATO Afghanistan Transition Task Force (NATTF). The US Embassy Kabul established a transition task force as well. Early discussions about the drawdown at ISAF included some ISAF elements questioning the need for the STA/TAT, generally by those who may not have understood the STA/TAT was a US-funded activity located at ISAF, not an ISAF-funded activity. Included in transition planning was an examination of the TAT's future, with regards to where it would best be placed and what its mission would be beyond 2014. However, these discussions were largely focused on a very tactical transition — people and tasks — versus transitioning the Telecom Advisor function back to the DoS, as was originally envisioned.<sup>1789</sup>

After a series of discussions among the TAT, ISAF, and the US Embassy in Kabul, and Reachback with the DC- based Interagency, it was decided that planning should begin to explore the transition of the Telecom Advisor function and elements of the TAT, including the STA position, to the US Embassy or USAID in the 2013 timeframe and to assess TAT's mission and support arrangements beyond 2014. There was also consideration given to transitioning some elements of the TAT to ISAF CJ6. In January 2012, a proposed strategy suggested exploring sending five TAT members to US Embassy to include the STA, ICT policy advisor, telecom advisor, IT manager (socio-economic), and a contractor ICT SME. The proposal also included sending two TAT members to DCOS-RES CJ6,<sup>1790</sup> telecom advisors for spectrum and civil ICT development. It was proffered that this transition would occur sometime in mid-2013 and include drawing down the size of the TAT from roughly 14 staff that included two Deloitte contractors to six staff and one Deloitte ICT SME.<sup>1791</sup>

It is important to note that while TAT was nested under DCOS Stability Operations, it was not a NATO asset and did not formally exist in DCOS-STAB's organizational construct. The TAT was not properly documented on the NATO Crisis Establishment (CE), the document that authorizes positions at ISAF, but it was listed on a NATO/EUCOM Joint Manning Document (JMD) through FY13.<sup>1792</sup> Regardless, the ISAF Chief of Staff (three-star level) instructed the TAT would continue to exist under DCOS-STAB until its transition to the US Embassy. From a logistics and support perspective, this arrangement at times caused some friction within ISAF because TAT members were not on the NATO CE but often required the support and resources organic to DCOS-STAB. The TAT-2 Director and DCOS-STAB attempted to have TAT added to the NATO CE but were not successful.

---

<sup>1789</sup> Ibid.

<sup>1790</sup> Deputy Chief of Staff of Resources, Combined Joint Communications

<sup>1791</sup> Portions of this paragraph are paraphrased from Bierden, 2012. *TAT Year in Review*.

<sup>1792</sup> CEW billets were paid for by ARCENT and functionally transferred to ISAF CJ6 JMD in 2010. The TAT originally had a total of nine total billets.

The situation changed significantly in March 2012 when the ISAF Chief of Staff (CoS) advised the Director of the TAT that he decided not to include the TAT on the CE in light of troop drawdowns. The transition planning suddenly shifted from planning for the TAT's transition to the survival of TAT personnel and tasks. Discussion with the US Embassy Kabul and others focused on how to keep TAT alive to support a 2013 transition to the US Embassy. As a result of the discussions, the US Embassy Coordinating Director for Development and Economic Affairs (CDDEA), Ambassador Olson, expressed his concern in an April 2012 letter to the ISAF CoS and offered his support for TAT's work and the relevance of its mission. Furthermore, the US Embassy offered to move the TAT to the Embassy. However, due to space constraints, the Embassy indicated it could not do so until 2014. The Embassy's letter requested that ISAF continue to support TAT through 2014. The ISAF CoS replied to the US Embassy in April 2012, indicating ISAF would provide the necessary support for TAT to continue operations within ISAF until 2014 when it would be able to transition its operations, tasks, and personnel to the US Embassy.

In May 2012, an MoU between ISAF and the US Embassy Kabul was drafted, covering administrative, logistic, and operational support regarding the TAT. It had three phases: In Phase One (July 2012 to July 2013), the TAT would reduce to seven CEW civilians at ISAF; in Phase Two (July 2013 to October 2014), two CEW positions would move to CJ6 CE billets and four CEW civilians would remain at the TAT; and in Phase Three (October 2014) the four remaining TAT civilian positions would transition to the US Embassy. Beginning July 1, 2012, the US Embassy was to provide a desk space in its ECON section and an access badge for one member of the TAT, who would work on the embassy compound and chair the Telecom Working Group. The TAT member, who it was planned would occupy the desk before September 2012, would coordinate priorities with the embassy to ensure coverage of ICT sector priorities and attend appropriate CDDEA meetings. This arrangement set the stage to move the presence of the TA function to the DoS and close down the TAT at ISAF. It was not clear if the US Embassy's responsibilities, business processes, priorities, expectations, deliverables, support arrangements, and culture were discussed in detail or fully understood as part of the transition approach proposed. The assessment and planning appeared to be more people- and task-driven with not enough attention given to what it really meant for the US Embassy to take on the Telecom Advisory function. There was certainly a shared view that the mission the TAT was supporting and related to activities being worked by the US Embassy and were important to try to keep in operation. However, the MoU was never signed. USAID also made an offer to provide a desk(s) for one or two TAT-3 persons to work with them on ICT-related tasks at the USAID Mission compound but no action was taken to make it happen.

There were several key avenues for obtaining final approval for the transition of the TAT to the US Embassy Kabul, all of which TAT was willing to pursue: local agreements, theater external agreements, a possible Participating Agency Service (Interagency) Agreement (PASA), obtaining approval through the National Security Decision Directive (NSDD)-38 that gives the Chief of Mission control of the size, composition, and mandate of overseas full-time mission staffing for all USG agencies, among other options. The recommended completion date for the move was by October 2014. The NSDD process should have begun by October 2012 at the latest, given the TAT's authorization ended in October 2013 and the

DoD would continue to fund the effort even after transition.<sup>1793</sup> There was, however, no formally agreed-upon end state that the DoD and DoS were working to achieve transition of the Telecom Advisor function. It was more moving staff based on current tasks TAT was working and the tasks US Embassy would be willing to accept versus the role they would play at the US Embassy as the Telecom Advisor. There also was no agreed-upon process to manage the military-to-civilian transition to provide, for example, the NSDD-38 process the rationale to authorize additional staff positions at the US Embassy. The US Embassy was also facing cutbacks that were factored into the decision process.

The decision to send a TAT member to occupy the desk at the US Embassy ECON section (including possibly sending TAT members to the USAID Mission) was delayed, since some, including the Deputy TAT Director, felt the move should wait until the new CDDEA arrived. Others felt and argued it would be better to start the process, establish a presence, earn trust, and build relationships and become a part of the US Embassy team – and have a functioning capability in place when the new CDDEA arrived. An issue at the time was the lack of a TAT CEW person with the right skills to work the US Embassy environment. The position needed to be filled by a government civilian on the TAT, and none of the CEW staff at the time had the required skills. There were also continuing discussions about the number of people who would move from the TAT to the US Embassy. It was rumored that discussions went from a person moving to occupy the desk at the ECON section to moving the entire team, which raised concerns on the part of the US Embassy. The Embassy was not prepared or willing to absorb the whole team in terms of office space, billeting, and related support arrangements. Adding to the challenges of the decision process was the fact that there was a couple months' delay between the Director of TAT-2's departure and the arrival of the new Director for TAT-3, leaving the decision making to the Deputy TAT Director. The ECON person who was ICT PoC started to raise some concerns about moving a TAT person before the new CDDEA and other new players arrived. As the uncertainties grew within the Embassy, the Deputy TAT Director decided to wait for the new TAT Director to arrive and for arrival of the new CCDEA.

The new CDDEA, Ambassador Arellano, put the US Embassy's actions to move forward with moving the TAT to the embassy on hold and even added to the list of actions to be reviewed as part of embassy transition planning. The delay resulted in additional ongoing discussions between the TAT and the embassy that appeared to have generated misperceptions of what was actually being planned, and this contributed to generating additional uncertainties. Thus, the opportunity to begin the process of transitioning the Telecom Advisor function back to the US Embassy, which could have included shared responsibility between the DoD and DoS to provide resources to facilitate the transition and a learning experience on how to conduct the transfer of the TA lead from the military (DoD/ISAF/USFOR-A) to civilian (DoS/US Embassy) was lost. TAT leadership reached out to and briefed Ambassador Arellano, who was supportive of TAT's ICT efforts. However, she also held the position that TAT had to be part of a bigger picture of functions moving to the US Embassy in order to commit to taking the TAT. In the same conversation, the head of the US Embassy Economic Section said that USAID had previously ceded its ICT efforts to the TAT. TAT leadership also met the new US Embassy Communications and Public Diplomacy

---

<sup>1793</sup> Birden, 2012. *TAT Year in Review*.



Director, Eileen O'Connor, who was similarly supportive of TAT's role and mission. Since the Embassy Management Counselor was responsible for all facility decisions, TAT needed to reach out to the new person when s/he arrived the summer of 2012. TAT recommended continued and regular communication with new embassy leadership to establish relationships and relate TAT's value.<sup>1794</sup>

In November 2012, MCIT Minister Sangin sent a letter to US Ambassador James Cunningham, expressing his appreciation for USG and STA/TAT support and his desire for continued engagement. In January 2013, Ambassador Phillip Verveer, US Coordinator for International Communications and Information Policy at the Department of State, also send a letter to Ambassador Cunningham expressing his support of TAT and desire to see it continue.

On May 2, 2013, Ambassador Arellano expressed regrets in a letter to the ISAF CoS that, due to limitations on Chief of Mission staffing in Afghanistan, the US Embassy Kabul would not be able to accommodate the TAT as a component of the embassy. These issues – manning limitations, office space, billeting, other support arrangements, business processes, and embassy priorities – were also discussed as part of the ISAF “transfer of tasks” exercise. Ambassador Arellano noted the Embassy continued to view further development of Afghanistan's ICT sector as important to the country's overall development, but it had to make difficult decisions on priorities and staffing. The Embassy transition team informed the NATO Afghanistan Transition Task Force (NATTF), the STA, and others at ISAF of this action. An issue here was the TAT was a USG-funded initiative, not an ISAF one, but this seemed to have gotten lost in the fog of transition discussions. Ambassador Arellano's letter triggered TAT planning to shift from transition to drawdown and close out of STA/TAT operations by the end of 2014.

The TAT began transition planning under the guidance of the IOPT and later the NATTF. The TAT identified the following areas of engagement as essential to transition:

- optical fiber infrastructure,
- cybersecurity,
- spectrum management,
- communications support to the Afghan National Security Forces,
- electronic government,
- national, regional, and international cooperation,
- general ICT capacity development,
- MCIT and ATRA capacity development,
- Independent Directorate of Local Governance (IDLG),
- ATRA development,
- mobile network operator (MNO) support,
- mobile money,
- emergency calling services, and

---

<sup>1794</sup> Ibid.

- infrastructure sharing.

The TAT's efforts to transition the Telecom Advisor function and some of the TAT tasks were overcome by the ISAF drawdown and task transition actions. The TAT continued working closely with the Transition Working Group at the US Embassy Kabul regarding potentially transitioning the Telecom Advisor function to the US Embassy and possibly some TAT tasks to USAID. The TAT also worked with ISAF CJ6 on possible TAT task transitions in support of its train, advise, and assist mission and transition to the Resolute Support Mission the end of 2014. With an ISAF command reorganization that eliminated DCOS Stability Operations, the STA/TAT reported to the Non-Security Ministries-Ministerial Advisory Group (NSM-MAG) and then, with the increasing focus on transition, became part of the ISAF/CSTC-A Enterprise Advisory Group, the leadership of which STA and TAT-4 Director Dr. Warner assumed. Consequently, the TAT's work program started to shift away from the non-security ministries to MoD and MoI and support to CJ6 to help establish the Train, Advise and Assist element to be part of the Resolute Support CJ6 mission.

In early 2014, the Director of DISA directed the TAT to begin transitioning July 31, 2014, and be completed by October 1, 2014, subject to concurrence of COMISAF. The STA was directed to remain in theater until early October 2014 to ensure a successful conclusion of the mission and provide USG oversight of the transition.

MCIT Minister Sangin sent another letter to Ambassador Cunningham in August 2014, once again expressing appreciation for USG and STA/TAT support and requesting extension of a TAT-like capability possibly through the U Embassy Kabul or USAID.

The TAT office officially closed on October 1, 2014, as ordered by the Director of DISA. The STA and Deputy Director TAT did not depart Afghanistan until October 6, 2014. At that time, the IZT support to the TAT was transitioned to the ISAF CJ6/Train, Advise and Assist (TAA) element. As part of the drawdown, the Director of DISA offered the IZT team's assistance – and its reachback capabilities as required – to the US Embassy in addition to ISAF CJ6/TAA. This support arrangement continued with the transfer of ISAF to Mission Resolute Support (RS) at the end of 2014 and ended in March 2015 when the DISA contract with IZT ended. RS CJ6/TAA then established its own contract with IZT through USFOR-A, allowing IZT support to continue. With the departure of the rest of TAT-4, the US Embassy absorbed the role of Telecom Advisor into the ECON section. , The IZT team provided support to the MCIT, ATRA, AfTel, the US Embassy ECON section, and the USAID Mission until January 2016 when IZT's contract with USFOR-A ended.

An unintended consequence of the direction to draw down military forces was the ISAF/USFOR-A action to close the TAT and transition its tasks and people – versus the Telecom Advisor (TA) function – to the US Embassy. Transition plans had to be created on the fly and negotiated at the last minute. The end result was the US Embassy ECON section was given the responsibility for the TA function with no resources to execute it other than as another duty as assigned, and it had to compete with higher-priority embassy initiatives: ICT was not one of the top interest areas. A lesson here is that it is very important to make sure efforts such as the TA function and STA/TAT have an agreed-upon end state and exit strategy as part of the negotiated civil-military agreement when the office is established, have a process in place to facilitate the transition from a military to a civilian lead and the means to resource, and have the proper

authorizations and documentation in place (FRAGO, MoUs/MoAs, formal manning documents, etc.) to justify their existence and the need to support such an effort in country.

### *Implications of Civilian Versus Military Leadership*

Following the departure of the senior civilian STA from TAT-1 in mid-2011, the next two years of operation (TAT-2 and TAT-3) saw two successive US Army colonels assigned to replace the civilian STA as the Director of the TAT. The actions to recruit colonels were taken because attempts to recruit senior civilians (SES level) were unsuccessful. The introduction of the colonels as the TAT Directors resulted in the office being realigned within the ISAF DCOS-Stability Operations command arrangements and aligned with the associated military chain of command – the TAT became a subordinate element of DCOS Stab Ops. Additionally, during TAT-2, the ISAF CJ6 colonel was replaced by a US brigadier general, and during TAT-3 the CJ6 position continued as a brigadier general. These actions resulted in placing the TAT leadership and activities rank ordering under both ISAF and US general officers for support and reporting rather than operating at and with the general officer level, a subtle but important change in the authority, reporting structure, and visibility of the TAT. The TAT-4 was once again led by a civilian SES and operated at the DCOS and GO level. During TAT-4, the ISAF CJ6 brigadier general was replaced by a colonel. A high turnover of TAT staff and leadership and related changes in areas and levels of expertise hindered efforts in team building and developing peer-to-peer relationships with Afghan partners and maintaining the proper mix of skills and performance levels to meet the mission needs.

In the government and business cultures of countries such as Afghanistan, incumbent leadership's perceptions of a senior advisor's value is extremely important. As such, this needs to be understood and factored into the recruitment and training of advisors at all levels. Factors to be considered, based on field experience, are as follows:

- Civilian organizations, such as non-security ministries agencies, tend to prefer civilian professionals to military personnel.
- Advisors and leadership should have professional civil and commercial ICT skills equivalent – or superior – to senior ICT counterparts in the affected nation's government and industry.
- Social and cultural sensitivity are necessary to operate effectively.
- The authority, responsibilities, influence, and access to senior decision makers of advisory leadership – or at least the perceptions of such – matter, as does the ability of senior advisory leadership to make things happen.

These factors are important in building trust relationships and strategic partnerships and make a significant difference in the value to senior government and business leadership of the affected nation and their willingness to work with advisors and their leadership. Respect and trust must be earned, so behavior becomes an important consideration as well. The professionalism of the advisory staff is extremely important. The change in leadership from a professional senior civilian (SES or general officer equivalent) with civil and commercial ICT expertise in the TAT's first year of operations to military colonels in years 2 and 3 had some implied unintended consequences related to interactions with the Afghan MCIT and ATRA leadership. For example, exit interviews with Afghan counterparts suggested Afghan leadership perceived TAT's authority diminished when the GO-level SES was replaced by a lower-ranking official who

had less direct access to ISAF decision makers. Interviewees also suggested the high turnover of TAT staff caused an ever-changing mix of skillsets and levels of support. In their view, some TAT members did not cut muster, and this shortfall sometimes resulted in less than desirable interactions.

Although TAT leadership returned to a senior civilian (SES) in year 4, by that time ISAF was winding down non-security ministry engagements and shifting its entire focus to the Afghan National Security Forces. To some extent, because of the points noted above, the TAT's relationships with the MCIT, ATRA, AfTel, and other Afghan organizations as well as the private sector weakened over time, reducing the effectiveness of the team and its position as trusted advisors. Teams such as the STA/TAT need to be able to maintain a consistently high level of professionalism and social and cultural sensitivities when operating in complex multinational multicultural, and at times high-stress, environments. Organizational and cultural differences also existed between the STA/TAT and the US Embassy, USAID Mission, ISAF, the World Bank, and the UN. Such differences need to be factored into working relationships and ways of doing business. Pre-deployment training does not address business environment differences and how to cope with these differences. There were certainly excellent professional staff and leadership at the STA/TAT, but there were also some TAT members that did not meet the level of professionalism and cultural sensitivity needed for such an operation.

In future operations, the USG needs to consider approaches such as having a few, more permanent, non-military, senior professional commercial advisors to work with ICT leadership, as was the original vision for the organization, rather than what the TAT became. It would also be useful to consider having some people work only behind the scenes, whether in-theater or CONUS, and limit those who get face time with high-ranking government officials. Not everyone needs to deal at the minister level.

## STA/ARG and STA/TAT Comparison

The Senior Telecom Advisor at the Afghanistan Reconstruction Group (STA/ARG) at the US Embassy Kabul during 2005-2008 and the Senior Telecom Advisor and Telecom Advisory Team (STA/TAT) at ISAF during 2010-2014 were experiments and learning experiences that addressed the use of professional civil and commercial ICT expertise to support post-conflict ICT sector recovery, infrastructure reconstruction, and the development and provision of services. They also dealt with the smart use of commercial ICT to address the needs of intervening civil-military stakeholders and forces and to facilitate and harmonize ICT activities related to the rehabilitation and development of GIRoA ICT sector governance the use of ICT as an enabler of security, governance, and socio-economic development and growth for Afghanistan and its citizens.

The US Embassy STA/ARG + Reachback and DoD/ISAF STA/TAT + Reachback models were experiments and learning experiences. As George E. P. Box, one of the great statistical minds of the 20th century, famously said, "Essentially, all models are wrong, but some are useful."<sup>1795</sup> Although the quote was

---

<sup>1795</sup> AZ Quotes. "George E. P. Box Quotes." Accessed June 11, 2014. [http://www.azquotes.com/author/22390-George\\_E\\_P\\_Box](http://www.azquotes.com/author/22390-George_E_P_Box).

originally applied to statistical models, one could argue it could be applicable to describing the ad hoc arrangements and experiments tried in Afghanistan and elsewhere for ICT-smart interventions. The Afghan models were useful and had a number of similar challenges and opportunities.

The STA/ARG was a US-funded team located at the US Embassy compound that operated under US Embassy rules. The ARG senior advisors, including the STA, worked with their counterparts at the embassy across State and USAID and reported through the Chief of Staff ARG directly to the Ambassador. This allowed for senior access at the ambassador level for review of issues and operations independent of State and USAID reporting arrangements. The STA/ARG interacted with the CFC CJ6 and CSTC-A CJ6 and had some limited interactions with ISAF elements.

The STA/TAT was a US-funded team collocated at the ISAF compound and operated under USFOR-A and NATO/ISAF rules. The STA/TAT had varying access to COMISAF, depending on the rank of the STA/TAT Director at the time and the styles and missions of the different commanders, in the form of briefings at morning standups and limited one-on-one meetings. The STA/TAT reported to COMISAF through a Deputy Chief of Staff, mainly DCOS Stability Operations for most of the duration of the STA/TAT. There were also US chain of command options through USFOR-A and USCENTCOM. The STA/TAT's interfaces with the US Embassy Kabul were mainly through the Economic Section but the STA/TAT had access to other elements such as the Coordinating Director for Development and Economic Affairs, Political-Military Section, and Public Affairs Section. For the USAID Mission, the STA/TAT's interactions were largely at levels below the Mission Director, working with personnel in areas such as Democracy and Governance, Economic Growth, Education, Health, Agriculture, Gender, and Infrastructure.

The STA/ARG had its own offices and billeting arrangements. The embassy provided IT and transportation services. As employees of the State Department, ARG staff carried State IDs. The STA/TAT relied on office space and IT provided by ISAF CJ6, relied on ISAF MOVECON until it was able to get its own vehicles, and relied on NATO/ISAF billeting arrangements. The STA/TAT had to compete with other nations and ISAF elements for MOVECON and billeting, which impacted freedom of movement and billeting for TDYs for Reachback and other special support arrangements. STA/TAT staff carried ISAF IDs and DoD CACs,<sup>1796</sup> and this, at times, limited the ability for the STA/TAT to move freely between the ISAF compound and the US Embassy and USAID compounds without DoS escorts.

The STA/ARG was a civilian organization and viewed as such by the USG Interagency and Afghan and international organization counterparts. The STA/TAT, although staffed largely by civilians, was viewed as part of a military organization with a military chain of command and mission focus on combat support activities, not on civil and commercial ICT reconstruction activities. The STA/TAT was officially a US DoD-funded organization with DoS/USAID support and served as the USG Interagency ICT activity coordinator. However, the STA/TAT's identity became blurred when its reporting chain of command was embedded at lower levels in the ISAF DCOS as described in more detail below. During those two years, the STA/TAT was not viewed as operating at the COMISAF level – because it did not – and was also viewed as an ISAF

---

<sup>1796</sup> Common access card

element not a USG construct. Maintaining independence became more difficult for the STA/TAT with directions coming from ISAF versus the USG. The STA/ARG culture was more aligned with working with the US Embassy and USAID Mission than was the STA/TAT's. Some of this had to do with the STA/TAT's inability to adequately bridge the civil-military divide. Another issue was with the STA/TAT's lack of understanding of the US Embassy/USAID culture and the lack of appropriate TAT staff personalities and skills needed to deal in this environment.

The STAs were the principal spokespersons for the USG in its dealings with Afghan government ICT officials and senior leadership of the GIROA ICT governance sector, i.e., the Minister of the MCIT and the Chairman of ATRA. The STAs also represented the USG to private sector ICT counterparts, such as the CEOs of the mobile network operators (MNOs) and Internet service providers (ISPs). In the case of the STA/TAT, the STA/TAT Director was also the ISAF key leader engagement representative for the MCIT.

Both the STA/ARG and STA/TAT had access to a CONUS-based reachback support team. The Reachback Teams provided access to ICT expertise in government agencies and labs, think tanks, academia, and industry and were the continuity and institutional memory across the multiple years of operation of the teams on the ground in Kabul. The STA/ARG relied on its reachback support elements for TDYs to Kabul, their access to the private sector, and for the ad hoc I-Team in Kabul. Between 2008 and 2010 when there was no STA in Kabul, a ASD-NII and NDU Reachback Team provided from CONUS an STA-like advice and assistance support arrangement to the US Embassy, USAID Mission, and US military elements in Afghanistan and worked with the Interagency in CONUS to help build consensus to reactivate an STA capability in Kabul. The interactions between the STA/ARG and Reachback were more team-based and collaborative than those of the STA/TAT with its reachback element. The STA/ARG and Reachback worked as a team and knew each other from experiences on the ground in Kabul and through Reachback support activities.

During the first year of the STA/TAT, there were proactive interactions between STA/TAT and Reachback with weekly teleconference calls and regular TDYs of Reachback staff to Kabul to work as part of the team. In subsequent years of the STA/TAT, the degree of interactions with Reachback decreased as new leadership and CEW team members rotated through the office in Kabul. The group became less of a distributed virtual team, since members did not get a chance to know each other and there were misperceptions of roles and relationships that were not properly addressed. Part of the challenge related to team building and the lack of an orientation program for new TAT members. There were no terms of reference for the STA/TAT, which had an unintended consequence of creating among the new members of STA/TAT and Reachback a lack of a shared understanding and awareness of the STA/TAT+ Reachback mission, Reachback member skills and experience, and roles and relationships of all team members in Kabul and CONUS. Clearly there was a need for face-to-face time on the ground to earn respect and credibility to rebuild the team as members and leaders turned over.

The STA/TAT had a small contractor support element housed outside the ISAF compound with its own lodging, transportation, and PSD, allowing it freedom of movement around Kabul to meet with Afghan ICT counterparts in both GIROA and the private sector and to embed staff on a daily basis at the MCIT, ATRA and AfTel. The STA/TAT was also given an office in the MCIT building by the minister. The STA/ARG did not have these arrangements. The STA/ARG had more freedom of movement than the non-contractor

STA/TAT members because it was able to use US Embassy/USAID Mission transportation resources to meet with Afghan ICT counterparts in Kabul on an as- and when needed basis. The STA/ARG could get out and about regularly in Kabul and have meetings with Afghans in local restaurants as a way to build relationships and conduct business. The security situation in Kabul during the time of the STA/ARG was less severe than it was when the STA/TAT was incarnated at ISAF in 2010. With the civil-military surge, increased green-on-blue attacks and insurgent use of IEDs, and the drawdown of combat forces, the security situation deteriorated resulting in much stricter force protection measures that severely limited the STA/TAT's freedom of movement. In 2015, the security situation was such that convoy movement around Kabul essentially was stopped and helicopters were used to move personnel around to the various remaining military bases and to the airport. Meetings with Afghan counterparts were conducted by having the Afghans visit the US Embassy and Resolute Support compounds.

The two STA approaches had similar missions to provide professional civil and commercial ICT subject matter expert advice and assistance to the US Embassy, USAID Mission, US and Coalition forces, international organizations, and to facilitate collaboration and harmonization of ICT activities across the participating organizations. The STA/ARG created an ad hoc I-Team to facilitate coordination among the US Embassy, USAID Mission, and US military elements. The STA/TAT co-chaired the US Embassy ECON section Telecom Working Group that had a similar mission to facilitate coordination and information sharing among the USG Interagency elements in Kabul. The STA/TAT published and distributed a weekly report of its activities and pertinent information regarding the Afghan ICT sector and the larger regional and international ICT communities, which provided informed situational awareness of ICT to a broad range of recipients in Afghanistan and in CONUS. Towards the end of the STA/TAT operation (midway through TAT-4) the report was generated and distributed only monthly and to a greatly-diminished audience. The STA/TAT also documented important meetings, such as the weekly meeting with the minister of MCIT and other key engagements, in the form of meeting summaries that were distributed among the team, shared with Reachback, forwarded to ISAF leadership as required, and shared with interested parties. The STA/ARG did not produce or distribute similar reports, but it provided ICT sector update reports to the ARG Chief of Staff only, not to a broader USG Interagency or interested ICT community.

There were other elements of implementation of the two STAs that were slightly different. The STA/ARG reported to the US ambassador and was sponsored by US NSC, DoS, and DoD. The STA/TAT reported to COMISAF and was sponsored by the DoD with a DoS/USAID agreement to support the STA/TAT as the Interagency coordinator and spokesperson for ICT. The STA/ARG interfaced regularly with the US ambassador and operated independently as an organization. The STA/TAT initially interfaced at the ISAF Deputy Chief of Staff level (Strategic Partnership then Stability Operations) with COMISAF visibility and met with senior US Embassy and USAID leadership on a somewhat regular basis. The TAT-1 had more independence in its operation than subsequent years, but when the first STA redeployed, who was an SES, he was replaced by a US Army colonel, and the STA/TAT became part of the military chain of command and rules of engagement and was embedded within lower levels of the ISAF organization even though it was a US-funded activity. Neither the STA/ARG or the STA/TAT had its own budget, but both were tasked missions to help accelerate ICT sector reconstruction. The staff of the STA/ARG reported to the State Department but was recruited from both the private sector and other areas of government by the

Department of Defense. For the STA/TAT, staff comprised mainly DoD civilian volunteers recruited through the CEW program with some additional contractor support as-needed and use of AFPAK hands and DISA volunteers. The STA for the ARG was an SES and GS-15 equivalent over a three-year period, and for the TAT it was two SESs and two Colonels over a four-year period. Both the STA/ARG and the STA/TAT encountered high turnover of staff, adding to the challenges of team building and maintaining continuity of an appropriate professional and culturally-sensitive level of support. The efforts of the STAs, along with the efforts of the US Embassy and USAID Mission, helped to recover ICT sector governance in Afghanistan and develop and modernize Afghan ICT infrastructure and services which, in turn, allowed the country to use ICT to facilitate the extension of governance to provincial, district, and village levels; improve government and social services for the populace; facilitate ICT capacity development; help create jobs; empower women; and move Afghanistan into the global information and business environments to accelerate economic growth. Both the STA/ARG and the STA/TAT were recognized as the “go to” organizations for ICT advice and assistance and as harmonizers, collaborators, connectors, and sources of informed situational awareness regarding ongoing Afghan ICT sector activities, challenges, and opportunities.

## Follow-on Support Activities

Deloitte Consulting made a corporate decision to remove its personnel from Afghanistan due to the unfavorable security situation and the decision by then President Karzai to disallow private security companies, which would leave its employees without their security detail, so the Kabul-based Deloitte ICT SME support to the STA/TAT departed the country in March 2013. The Deloitte team returned to CONUS and became part of the Reachback team. In order to continue on-the-ground ICT SME support, DISA contracted with IZ Technologies (IZT) to provide a three-person ICT SME team in Kabul. The DISA-funded IZT support to the STA/TAT began in October 2013. Following the shutdown of the STA/TAT in October 2014, the IZT support was transitioned to the ISAF CJ6/Train, Advise and Assist (TAA) element, which became RS CJ6/TAA upon the change of ISAF to Mission Resolute Support (RS) at the end of 2014. IZT's support continued with the RS CJ6/TAA element until March 2015 when the DISA contract ended. At that time, USFOR-A picked up the responsibility to contract with IZT to continue the support to RS CJ6/TAA from March 2015 through the end of January 2016. The IZT team lived outside the wire in downtown Kabul at the Serena Hotel, used vetted Afghan taxi services for movement, and embedded daily at the MCIT, ATRA, and AfTel.

Towards the end of 2015, due to the deteriorating security situation in Kabul, movement off the RS compound essentially stopped. Thus, IZT's interactions with their Afghan counterparts were essentially limited to email exchanges, phone calls. There were some infrequent meetings at a safe house used by the US Embassy or on the US Embassy and RS compounds, for which the Afghans made the trip through Kabul to meet with USG elements. IZT's meetings with Afghans were primarily with the new GIRoA ICT governance team (those in the Ghani administration) that consisted of the ICT advisor to President Ghani, Mohammad (Mo) Qayoumi, MCIT Minister Abdul Vahidi, and ATRA Chairman Mohammad Azizi. There were also a few meetings with the MCIT Deputy Minister of IT and AfTel leadership and with MNO leadership. The IZT team's focus areas included but were not limited to MCIT policies, ATRA regulations, MNO activities, AfTel fiber optic network, ATRA spectrum issues, MCIT implementation of the E-



*Afghanistan National Priority Program (NPP)*, and various ICT-related strategies, programs, and policy issue areas. Additionally, demand signals for civil and commercial ICT SME train, advise, and assist support to RS CJ6/TAA activities were mainly in areas of spectrum management, the fiber optic network, and network management.

On the US Embassy and USAID Mission side, there was interest in ICT activities but ICT was competing with other priorities such as turnover of military airfields to civilian use. The broader USG Interagency recognized the need for a TA function in a role other than as another duty as assigned to the ECON section at US Embassy, but a special activity such as establishing another STA under current priorities is not likely to happen.

With the advent of the Afghan National Unity Government, changes were made to Afghanistan's ICT sector governance as mentioned above. There have been additional changes at the MCIT and AfTel, the implications which are yet to be understood. For certain, the changes have caused and will continue to cause uncertainties and disruptions that will need to be carefully managed. Mo Qayoumi has assumed a leadership role to try to help manage the ICT sector governance change process and focus priorities to improve ICT services and performance of the ICT sector. Some Afghan-driven ICT priorities for the near future include open access (to infrastructure) regulations and implementation, SIM<sup>1797</sup> card/user registration, mobile money and e-payments, increased Internet access and reduced cost of service, and e-government applications, including but not limited to e-Takzira (electronic national identity card or E-NIC).

One of the challenges for the future is a security situation that continues to decline, amid reemergence of the Taliban and the rise of Daesh, as ISIS is called in Afghanistan. The Taliban, criminals, and other anti-government elements continue to extort and threaten MNO personnel and attack their facilities, forcing them to shut off cellular network services at night and, in some districts such as Helmand, shutting down cell services 24x7. Other challenges include sustaining economic and political stability; a lack of reliable electric power; poor spectrum management; and a dearth of qualified management, technical, contracting, marketing, and financial personnel. The Afghans have and will continue to face difficulties implementing e-services such as mobile money, electronic and mobile government applications and sustaining growth of cybersecurity awareness and the development of an information culture. There is not necessarily the willingness or ability for GIRoA or the private sector to modernize and further leverage Afghanistan's ICT infrastructure and services given the current uncertainties and projected further instability. Approximately 70 percent of Afghanistan's population is 30 years old or younger, and half of its citizens are female, so the country going forward will need to include plans for its youth and women and girls. The above GIRoA ICT priorities and these challenges will continue to drive a need for a professional STA-like advise and assist support role.

---

<sup>1797</sup> Subscriber identity module, a removable smart card for some types of mobile phones that stores identifying information regarding the phone and associated customer account.

The IZT team departed Kabul on January 25, 2016 ending a decade of ICT support to the USG Interagency in Kabul, the Coalition at ISAF/RS, GIROA, the private Afghan ICT sector, and in-country international organizations such as the UN and World Bank. Needless to say, the demands for an STA/ARG or STA/TAT ICT SME support construct remains. ICT activities are now worked with less priority than when there was active, dedicated ICT support, given the US Embassy ECON and RS CJ6/TAA must compete with other higher-demand priorities. However, some ICT actions are being worked somewhat independently by US Embassy ECON, USAID, and RS CJ6/TAA elements. The US Embassy TWG and calls to the CONUS ICT reachback element, as well as the open sharing of ICT situational awareness with the USG Interagency community tracking Afghan ICT activities, dropped off significantly by the end of 2014 and eventually in 2016 had essentially stopped.

### Need for a USG STA-like Advice and Assistance Function Continues

In Spring 2015, the White House (WH) Chief Technology Officer (CTO) team comprised of representatives from WH CTO, the National Security Council (NSC), and the Office of Science and Technology Policy (OSTP), explained to DoD CIO their interest in continuing to learn as much as possible about the Afghan ICT sector, as it would be important to a new WH CTO program being prepared for launch within the USG, called the Global Connect Initiative (GCI). The GCI has the goal of bringing the world's next 1.5 billion additional people online by 2020<sup>1798</sup> by stimulating the expansion of ICT infrastructure, both in the US and in other countries, to deliver access to the Internet in as many remote locations – or “connectivity deserts” in GCI language – as possible around the world.

The WH CTO team, based upon the DoD CIO's Afghan ICT briefs received in the February-March 2015 period leading up to President Ghani's visit to the US, had increasing interest in focusing on Afghan ICT capabilities that could be leveraged for the GCI program. The intent was to assess the ability to present Afghanistan as a “showcase” example of a war-torn and traumatized developing country that nonetheless was able to develop a strong ICT sector, where the showcase example could be shared and compared with other developing countries' efforts to strengthen their ICT sectors.

The WH CTO team worked with Main State's Economic Bureau in mid-2015 to create a new Interagency working group, the USG GCI WG, where the USG Interagency and invited external entities, such as the World Bank and significant funding foundations, could meet monthly to further define the scope and processes to support the launch of the GCI program.

The USG GCI was announced in September 2015 in New York at meetings associated with the UN General Assembly (UNGA), with intent through international outreach at UNGA fora to attract as many countries as possible to begin consideration of participation in the international component of the GCI program. The USG strategy was to include significant foundations as potential funding sources to assist developing countries with participation in the GCI program. Funds could be directed to creating or improving a country's ICT infrastructure, to enable a participating country's networks to be extended via expanded ICT

---

<sup>1798</sup> Global Connect Initiative. Accessed March 14, 2016. <https://share.america.gov/globalconnect/>.

infrastructure to reach new remote regions (connectivity deserts), and to maximize access to the Internet for the country's general population.

DoD CIO worked with the WH CTO team and the USG Interagency to establish and develop the USG GCI Working Group, which is managed on behalf of the WH CTO by Main State's Economic Bureau. DoD CIO has actively participated in GCI WG meetings hosted at Main State, providing inputs derived from more than 12 years of experience working ICT issues in the Afghan ICT sector -- to date the longest ICT engagement by DoD and USG with a host country.

DoD CIO shared with key representatives from WH CTO and State ECON Bureau its intent to complete a review and update to a DoD CIO policy document, DODI 8220.02,<sup>1799</sup> which governs ICT engagement by DoD in OCONUS<sup>1800</sup> activities. DoD CIO has worked with GCI key representatives, in and outside of the GCI WG forum, to attempt to create a similar document at the White House and/or State level, with the intent to declare as USG policy the recognition and elevation of ICT as "critical infrastructure" and an "essential service" for USG OCONUS activities (complementing an existing regime managed by the Department of Homeland Security (DHS) for elevation of ICT in CONUS activities). Recognition of ICT as summarized above would also confirm the importance of leveraging ICT infrastructure as the underlying engine to realize the GCI goal of expanding access to the Internet in remote connectivity deserts around the world.

DoD CIO has also worked for several years with the USG Interagency through the New Silk Road (NSR) Initiative Working Group, also hosted for the Interagency at Main State. State has begun efforts to coordinate information between the NSR and GCI Working Groups, and DoD CIO has joined efforts with State and the Interagency to ensure that ICT infrastructure issues reviewed in the NSR WG are shared with the GCI WG.

Given the WH CTO team's GCI interest to provide incentive for developing countries to improve ICT infrastructure builds to remote connectivity deserts, DoD CIO, at the White House's request, arranged meetings with other ICT SMEs working in Afghanistan to identify programs and solutions to further improve the standing of Afghanistan as a showcase country where ICT improvements could directly relate to efforts to improve access to the Internet. The additional Afghan ICT SME meetings organized by DoD CIO provided the WH CTO team with information on how minimal additional expenditures could be leveraged to realize significant additional new coverage to connectivity deserts and other locations to increase a population's access to the Internet.

Based on the WH CTO team's interest in Afghanistan as a potential significant player in the GCI international program, DoD CIO has continued its engagement with Afghan seniors on ICT programs, projects, and networks that can be pertinent to the ability of Afghanistan to meet the WH CTO team's GCI

---

<sup>1799</sup> Department of Defense Instruction. DoDI 8220.02 can be found at <http://www.dtic.mil/whs/directives/corres/pdf/822002p.pdf>.

<sup>1800</sup> Outside the continental United States

expectations to have it featured as an example for other developing countries participating in the GCI program.

DoD CIO continues to work with USG Interagency counterparts to organize meetings and maintain communications with key senior Afghans across GIRoA (e.g., President Ghani’s cabinet-level ICT Special Advisor, the Afghan Ambassador to the US, the MCIT Minister, the Chairman of ATRA, and key staff at Afghan Telecom), as well as with other key Afghans outside GIRoA who have direct or indirect interest in the continued success of the Afghan ICT sector, to enable DoD CIO to track challenges and improvements in the sector. While the DoD CIO meetings and communications are primarily focused on information pertinent to Afghan capabilities for the GCI, they also play an important role in keeping the door open to maintaining ongoing contact with key Afghans, which may also serve as an enduring foundation to set the stage for continued USG engagement that could result in a future USG decision to field a third-generation ICT advisory capability in Afghanistan.

## Key Takeaways

Information and ICT can significantly increase the likelihood of success in security, stability, and reconstruction operations – if they are engaged as part of an overall strategy that coordinates the actions of outside civil-military interveners and focuses on generating effective results for the affected nation. Properly utilized, ICT can help create a knowledgeable intervention, organize complex activities, and facilitate integration of stability operations with the affected nation recovery, reconstruction and development, making stability operations more effective.<sup>1801</sup> There is, however, no single prescription for ICT-enabled intervention or for the role of ICTs in stability and reconstruction that can be applied across the board.<sup>1802</sup> There are many ad hoc experiences being accumulated, but they are not necessarily being turned into lessons learned consistently, nor institutionalized in changes in the way the USG does business.

Successful approaches to the use of ICT in stability and reconstruction are rooted in a thorough understanding of the affected nation’s political, economic, social, cultural, and communications contexts.<sup>1803</sup> An informed understanding of the affected nation’s ICT sector governance, infrastructure, and services, key personnel (both those that make things happen and those who are impediments to progress or spoilers), and the related government and business cultures and processes, are important to success, as is an understanding of the affected nation’s information culture.

Stabilization is the most important priority in the immediate aftermath of conflict. Emphasis on early ICT-enabled interventions to facilitate recovery of ICT sector governance, establish public-private partnerships and licensing capabilities to jumpstart private ICT sector investments, and emergency ICT capability

---

<sup>1801</sup> Kramer, Franklin D., Larry Wentz, and Stuart Starr (2007). “I-Power: The Information Revolution and Stability Operations.” *Defense Horizons*, Number 55, February 2007. Center for Technology and National Security Policy, National Defense University. Available at: <http://handle.dtic.mil/100.2/ADA466767>.

<sup>1802</sup> Kelly and Souter, 2014.

<sup>1803</sup> Ibid.

packages to support early security and government communications needs are key to success. Without security and stability, it will be impossible to rebuild infrastructure and establish social services and lasting economic recovery. Military security and civil-military humanitarian and development agencies should plan ahead for the possible rapid deployment of emergency ICT networks that will facilitate stabilization. The UNOCHA, WFP, ITU, UNDP,<sup>1804</sup> national crisis response civil-military elements, and others including industry, can and do provide emergency ICT response capabilities to enable early recovery of civil security and essential government functions. For example, in 2002, Ericsson set up an emergency mobile GSM base station in Kabul to support the UN [World Food Programme](#) and other humanitarian organizations and important Afghan government officials.

The value of ICT-enabled interventions in support of post-conflict stability and reconstruction operations through the use of a Senior Telecom Advisor to provide professional civil and commercial ICT advice and assistance to USG civil-military decision-makers and to facilitate harmonization, collaboration, and information sharing among the USG Interagency, multinational coalition forces, international responder elements, and affected nation counterparts was validated by the use of STAs in Afghanistan. The STA/TAT at ISAF was a success story as was the STA/ARG. The STA/TAT effort earned the recognition of the USG Interagency, ISAF and Coalition forces, the international organization responder community, and GIRoA ICT counterparts as the “one-stop shop” for advice and assistance on civil and commercial ICT; as a facilitator, connector, and harmonizer of Interagency, ISAF and Coalition forces, international organization, and Afghan ICT-related activities, and the trusted source of informed situational awareness on the Afghan ICT sector. The strategic partnerships established with the GIRoA counterparts and the ability of the STA to interact actively and regularly with senior USG and ISAF leadership enabled a two-way communications channel to link senior USG and ISAF leadership with GIRoA and allowed the STA to play the role of intermediary on important ICT related issues – a benefit to all parties. The STA also provided a clear ICT focal point for the minister to deal with.

In October 2012, at his daily morning standup briefing, COMISAF General John Allen, USA, stated the TAT’s work with the Ministry of Communications was “one of the most important non-security governmental engagements” ISAF had with the Afghans. The need for that engagement did not end when combat operations ceased. In fact, it is more important than ever, particularly with Afghan leadership having changed at the executive and ministerial levels, with leadership of the country, of the MCIT, and of ATRA all having turned over in a single year.

### ICT-enabled Intervention Arrangement Framework

There is a need to focus on the development of a construct to help shape an ICT-enabled intervention response arrangement, to institutionalize possible response arrangements, and to use them for training as well as operational deployments. Clearly there is a need for senior (SES or equivalent) civilian ICT professional STA (similar to the concept of a senior civilian national representative or political advisor to

---

<sup>1804</sup> United Nations Office for the Coordination of Humanitarian Affairs, World Food Program, International Telecommunication Union, and United Nations Development Programme, respectively.

the military commander) who operates at senior leadership levels – both military and civilian –with appropriate responsibilities and authority. The STA could be located at either the military headquarters or the US Embassy, or maybe both depending on the situation. If there is a single STA in country, then s/he should represent USG interests across the civil-military spectrum. If there are two STAs, then a process will need to be agreed upon to facilitate collaboration and information sharing between the civil-military STAs and there will need to be an agreed-upon vision and focus of ICT efforts. The STA needs the political and operational support, or top cover, of DoD and DoS leadership and the in-country senior civil-military leadership at the ambassador and military commander levels. A possible framework for determining the type of response capability is illustrated in [Figure 132](#).

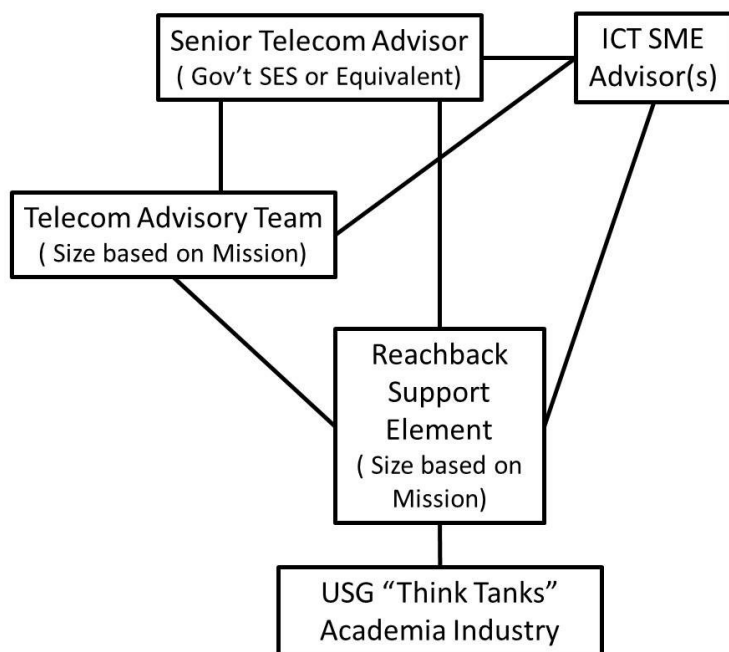

*Figure 132: Proposed ICT-enabled intervention arrangement framework*

This model reflects ad hoc approaches used by both the DoD and DoS in Iraq and Afghanistan. The suggested approach assumes a small footprint forward in conflict areas with a larger foot-print in the rear supporting the STA and the team on the ground. Freedom of movement in conflict zones is a critical factor, including the ability to move when needed outside the wire and embed when necessary with affected nation counterparts. To achieve operational flexibility and freedom of movement, it is desirable to have the STA and support team live off the military compound in a safe house with their own transportation and PSD. As an alternative, consideration should be given to employing or contracting ICT SME advisors to the STA who live off the military compound with appropriate and, as necessary, security protection.

The footprint in the rear needs to be led by a senior civilian with the authority and responsibility to establish a reachback team and to engage across USG agencies for SME support, to interact with academia, think tanks, and industry, and have funding to support special studies and hiring ICT SME

consultants to work in country or in support of Reachback as appropriate. The reachback team will also become the de facto continuity of operation and institutional memory, since this team is likely to comprise the same staff for the duration of the operation. The ICT SMEs on the reachback team provide support to the STA from CONUS as well as in country on regular trips. Reachback members can be used to fill in for the STA when needed, temporarily fill SME gaps in on-the-ground capabilities, and for special study assignments.

There may also be a need to establish a team in country to support the STA and work with USG and Coalition forces elements, international organizations, and affected nation counterparts. The size of the team will depend on phase of operation and demands for ICT SME advice and assistance, among other factors. The challenge is recruiting the right staff and leadership to meet the demands of the mission.

Finally, there is a growing body of civil-military experience in the use of ICTs in post-conflict security, stability and reconstruction operations. There is, however, a gap in leveraging this experience and developing shared strategies, plans and capabilities to conduct more effective unity of effort and improve collaboration and information sharing among the USG and International responder elements. A more extensive experience sharing would enable governments, international organizations, and development agencies to make more effective use of ICTs at all stages of post-conflict work, from short-term stabilization to long-term development.<sup>1805</sup>

---

<sup>1805</sup> Kelly and Souter, 2014.

## Chapter 22 The STA/ARG and STA/TAT Experiments and Learning Experiences: Lessons Observed

---

Larry Wentz and Karen E. Black

### Background

The US government (USG) and international civil-military crisis response community learn about lessons – become aware of them – from a number of sources such as first-hand personal experience, by reading and analyzing case studies such as those in this book, through after-action reports, by attending conferences and workshops, through participating in academic education and training programs (e.g., National Defense University, Naval Postgraduate School, and Army War College), by participating in civil-military exercises, as members of professional societies, through activities of international organizations such as the United Nations (UN), International Telecommunication Union (ITU), and the World Bank, and via various other forms of education and training, documented research, and investigative reporting. Most report findings usually cite “lessons learned,” which often really means “lessons observed.” From personal experiences in operational engagements, one would expect lessons may be more likely to be learned, especially from failures, which provide the real learning opportunities. The reality is, however, we often do not learn from others’ mistakes or even from the ones we make ourselves.<sup>1806</sup>

Approaches such as education, training, exercises, operational experience, group sharing of experiences with “experts,” and other means to learn from one another can be used to improve the ability to achieve a shared understanding of “lessons learned.” Regarding the latter point, the World Bank argues in its report, *The Role of Information and Communication Technology (ICT) in Postconflict Reconstruction*, “there is a growing body of experience in the use of ICTs in post-conflict contexts. While contexts vary, more extensive experience-sharing among the community of practitioners would serve to enable governments and development agencies to make more effective use of ICTs at all stages of post-conflict intervention work.”<sup>1807</sup> Lessons from Afghanistan and Iraq are largely lessons observed or encountered, and many have yet to become lessons learned. The Center for Army Lessons Learned observes that lessons are learned when behavior changes.<sup>1808</sup> Opportunities for making behavior change continue to be challenging, especially those behaviors related to understanding the importance and role of the ICT sector

---

<sup>1806</sup> Holdman, Eric (2010). “The Difference Between Lessons Observed and Lessons Learned.” Emergency Management, January 11. Accessed March 14, 2016. <http://www.emergencymgmt.com/training/Lessons-Observed-and-Lessons-Learned.html>.

<sup>1807</sup> Kelly, Tim and David Souter (2014). *The Role of Information and Communication Technologies in Postconflict Reconstruction*. World Bank Studies. Washington, DC: World Bank. doi:10.1596/978-1-4648-0074-0. License: Creative Commons Attribution CC BY 3.0. Accessed September 7, 2015. <https://issuu.com/world.bank.publications/docs/9781464800740?e=0/6688927>.

<sup>1808</sup> United States Army Center for Army Lessons Learned (2011) Handbook 11-33: *Establishing a Lessons Learned Program* June. Accessed March 14, 2016. <http://usacac.army.mil/sites/default/files/publications/11-33.pdf>.



to support ICT-enabled interventions and the timely recovery and reconstruction of the affected nation's ICT sector governance, infrastructure, and services to be able to employ ICT as an enabler of cross-sector recovery and reconstruction. The intent of this chapter is to share insights into the ICT-related "lessons observed" emerging from Afghanistan's post-conflict ICT sector reconstruction and development and the Senior Telecom Advisor learning experiences discussed in [Chapter 21](#). The Senior Telecom Advisor within the Afghanistan Reconstruction Group (STA/ARG) at the US Embassy Kabul from 2005 to 2008 and the Senior Telecom Advisor and Telecom Advisory Team (STA/TAT) at ISAF from 2010 to 2014 were experiments and learning experiences. Both employed the use of professional civil and commercial ICT expertise to support post-conflict ICT sector recovery. This included recovery of Afghanistan's ICT sector governance, infrastructure [re]construction, and the provision of services, along with the smart use of commercial ICT to address the needs of intervening civil-military stakeholders and forces. It also involved facilitating and harmonizing ICT activities and facilitating the use of ICT as a cross-sector enabler of security, governance, and socio-economic development and growth.

## Dial STA for ICT Advice and Assistance

As mentioned above, there were two different but similar approaches employed by the USG in Afghanistan to provide ICT advice and assistance, the STA/ARG and the STA/TAT. The former was a NSC/DoS/DoD-sponsored<sup>1809</sup> US-funded team located at the US Embassy Kabul compound and operated under US Embassy rules. The latter was a DoD-sponsored and DoS/USAID-supported<sup>1810</sup> US-funded team collocated at the headquarters of NATO's International Security Assistance Force (ISAF) next to the embassy and operated under USFOR-A and NATO/ISAF rules. The STA/ARG was a civilian organization and viewed as such, whereas the STA/TAT, although staffed mostly with civilians, was regarded more as part of a military organization with a military chain of command and mission focus. [Chapter 21](#) describes both the STA/ARG and the STA/TAT in detail and compares the two, and briefly explains another ad hoc ICT advisory capability in Iraq.

The efforts of the STAs, along with the efforts of the US Embassy and its USAID Mission, ISAF, and the Telecom Advisory Team, helped recover Afghanistan's ICT sector governance and develop and modernize its ICT infrastructure, deploy services, and facilitate the use of ICT for the extension of governance to provincial, district, and village levels; to improve government and social service to the populace, to help create jobs; to empower women; and to move Afghanistan into the global information and business environments to facilitate economic growth.

The two STA approaches had similar mandates to provide professional civil and commercial ICT subject matter expert advice and assistance to the US Embassy, USAID Mission, US and Coalition forces, international organizations, non-governmental organizations (NGOs), and the Government of the Islamic Republic of Afghanistan (GIROA), and to facilitate collaboration and harmonization of ICT activities across the participating organizations. The STA/ARG and STA/TAT became known as the "one-stop shops" for

---

<sup>1809</sup> National Security Council/Department of Defense/Department of State

<sup>1810</sup> United States Agency for International Development

informed situational awareness regarding the Afghan ICT sector. While the STA/TAT was in operation at ISAF, the US Embassy Kabul and USAID Mission deferred ICT actions to it. The STA/ARG and STA/TAT experiments and learning experiences have provided some unique and useful insights into STA challenges and opportunities. Findings and lessons from these efforts are captured in this chapter along with thoughts for approaches for future ICT-enabled interventions. Some observations related to the success of the Afghan ICT sector are included as well.

## Nature of the ICT Challenges and Opportunities

ICT is the convergence of telecommunications and information technology. It encompasses the range of technologies for gathering, storing, retrieving, processing, analyzing, and transmitting information that are essential to prospering in a globalized economy<sup>1811</sup> and establishing a knowledge culture. ICT also includes policies, processes, infrastructure, systems, services, education, and people. Most importantly, discussions of ICT also need to consider associated information and messaging activities and their impacts on the society and its functions. Advances in ICT have progressively reduced the costs of managing information, enabling individuals and organizations to undertake information-related tasks much more efficiently, and introducing innovations in products, processes, and organizational structures.<sup>1812</sup> Over time, ICT has proven to become a basic enabler of informal social and economic discourse, leading to a strengthening of civil society and the promotion of security, internal stability, job creation, social services, and economic solidity in affected nations.<sup>1813</sup> It has become a demonstrated enabler of national transformations but not necessarily always for the better. For example, ongoing research of the impact of ICT and social media (e.g., Twitter, Facebook, etc.) in post-Arab spring conflict environments suggests the creation of new mobile technology networks substantially increases collective violence within the (typically developing) country such as Afghanistan.<sup>1814</sup> It is noted that these negative effects can also spill over to other countries if they are bound together by dense communication ties. While the Arab spring experience has fired imaginations about the powerful (potentially destabilizing) effects of social media, evidence in the research to date suggests that such optimism is likely misplaced.<sup>1815</sup> Although uncertainty still exists about how ICT might generate these effects among political leaders, protest groups and

---

<sup>1811</sup> Wentz, Larry, Frank Kramer, and Stuart Starr (2008). *Information and Communication Technologies for Reconstruction and Development: Afghanistan Challenges and Opportunities*. National Defense University, Center for Technology and National Security Policy, *Defense Technology Paper 45*, January 2008. Available at: <http://ctnsp.dodlive.mil/files/2013/07/DTP-045.pdf>.

<sup>1812</sup> Odufuwa, S. (2006). "Information and Communication Technology (ICT) as a research tool in libraries." *Nigerbiblios* 17.

<sup>1813</sup> Saadawi, Tarek and Louis Jordan, Jr., eds. (2011). *Cyber Infrastructure Protection*. Strategic Studies Institute (SSI), US Army War College, May 2011. Accessed October 4, 2015. Accessed September 7, 2015. [https://ia600703.us.archive.org/30/items/CyberInfrastructureProtection\\_112/10-Cyber.pdf](https://ia600703.us.archive.org/30/items/CyberInfrastructureProtection_112/10-Cyber.pdf).

<sup>1814</sup> Lyall, Jason, Nils B. Weidmann, and Allan Dafoe (2015). "Dial ICT for conflict?: Four lessons on conflict and contention in the info age." *The Washington Post*, February 23.

<sup>1815</sup> Ibid.

insurgent organizations, research suggests it is likely that social media platforms like Twitter and Facebook are intensifying, if not driving, political conflict in locations as diverse as Egypt, Syria, and elsewhere.<sup>1816</sup>

On the good-news side, there is little doubt that ICT is an “engine” for the extension of legitimate governance and economic growth, a means to shape the information environment, and a means to improve social well-being including by connecting villages, health centers, and educational institutions, and providing community access points. Additional arguments as to why ICT and affected nation ICT is important include but are not limited to:

1. ICT can be used to help create a knowledgeable intervention, organize complex activities, and integrate Stability and Reconstruction Operations with the affected nation.
2. The affected nation’s ICT infrastructure provides an alternative source of ICT capacity, coverage, and capabilities for use by USG and coalition partners.
3. ICT provides opportunities to shape the environment for Stabilization and Reconstruction Operations.
4. ICT is essential for an affected nation to prosper in a globalized economy and establish a knowledge culture and to participate in the global information society and business environments.
5. ICT can significantly change key parts of an affected nation’s society, particularly by providing young people access to global knowledge that changes sectarian attitudes and behaviors.
6. ICT provides an affected nation transparency and the ability to extend governance to help reduce corruption and enhance government legitimacy.
7. ICT offers the best way to help every sector at once through realistic and modern e-government services (civil security, governance, distance learning, telemedicine, GIS-based<sup>1817</sup> agriculture, finance, power and water management, and e-commerce).
8. ICT allows the USG to positively influence attitudes of the leadership and general population of the affected nation.
9. ICT has been demonstrated to be one of the best generators of jobs and revenues for affected nations.
10. ICT facilitates communication of situational awareness of and for affected nation forces, capabilities, and threats that can save lives.

Like essential services such as roads, power, and water, ICT is both a sector and an enabler of cross-sector recovery, reconstruction, and development. As a sector, ICT supports national capacity building and export-market focus and plays a critical role in re-establishing basic security, governance, and economic linkages by relieving communication bottlenecks from financial, governmental, and cultural information flows. As an enabler, it supports global positioning of the affected nation’s economy and adoption of cross-sector strategies that can be used to harness the uniqueness of ICT to accelerate a wider

---

<sup>1816</sup> Ibid.

<sup>1817</sup> Geographic information system

reconstruction and development process.<sup>1818</sup> Therefore, on the positive side, ICT has emerged as “critical infrastructure” and an “essential service,” while on the negative side, it may not always be for the better as post-Arab Spring research results suggest.<sup>1819</sup> For example, development agencies such as the World Bank and the USAID invest millions of dollars into programs designed to create national telecommunications networks in developing countries such as Afghanistan but these programs do not typically track violence as a potential unintended consequence and conduct assessments of possible impacts of investments in the ICT sector.<sup>1820</sup> Post-Arab Spring research studies suggest that increased violence is a possible, if unintended, consequence of such programming, undercutting broader development and security goals in these countries.<sup>1821</sup> Therefore, it is extremely important the USG and International Community not only view and treat ICT as critical infrastructure and an essential service and as a positive influence, but that they also factor in the potential negative and unintended consequences of a connected society as part of their investment strategies and assessments as well. The potential for unintended consequences and what they might be needs to be mitigated as part of their intervention strategies, investments, and ongoing assessments of the impacts of ICT-related reconstruction and development actions. In this regard, social media permits the collection of fine-grained data on patterns of war and insurgency violence that need to be incorporated into the development of strategies and action plans.<sup>1822</sup>

ICT needs to be leveraged as an enabler of cross-sector reconstruction and development. Using ICT, governments can improve the quality and responsiveness of their organizations as well as the services they provide to citizens by expanding [their] reach and accessibility. The importance the United Nations (UN) attaches to ICT[s] as [an] enabler[s] of economic, governance, security, education, healthcare, and social well-being [in] reconstruction and development is evident in the International Telecommunications Union (ITU) sponsorship of two international summits, the 2003 and 2005 World Summit on the Information Society (WSIS). These summits documented steps on how to establish and organize the Information Society, and their reports referenced the importance of ICT by frequently citing the phrase, “ICT as a tool for social and economic development.”<sup>1823</sup> As noted earlier, ICT is critical infrastructure and an essential service and needs to be treated as such. The relevance of ICT for achieving national stability and reconstruction is unarguable based on historical facts in today’s Information Age.

While there is little doubt that ICT [is] an engine for social and economic development and generator of cultural and political change, quantifying their impact is difficult. Research is becoming more prevalent and conclusive, and there are some reports on the positive impact of ICT on economic growth and job creation. For example, Vodafone in a 2005 report on the impact of mobile phones in Africa found that

---

<sup>1818</sup> Hameed, Tahir (2006) “ICT as an Enabler of Socio-Economic Development.” Presentation for the International Telecommunication Union. Available at: <http://www.itu.int/osg/spu/digitalbridges/materials/hameed-ppt.pdf>.

<sup>1819</sup> Lyall et al., 2015.

<sup>1820</sup> Ibid.

<sup>1821</sup> Ibid.

<sup>1822</sup> Ibid.

<sup>1823</sup> Wentz, et al., 2008.

increasing mobile phone penetration by 1 percent can increase economic growth by as much as 6.75 percent.<sup>1824</sup> A 2005 case study from India for the GSM Association suggested the Indian mobile services industry contributions led to the creation of 3.6 million jobs and some billions of dollars per year in import duties, licenses and spectrum fees, and taxation revenues.<sup>1825</sup> A 2007 study in the Kerala state of India found that the use of mobile phones among fisherman allowed them to arbitrage over price information from potential buyers, which resulted in increased incomes for the fisherman.<sup>1826</sup> Since the introduction of mobile phones [in Kerala], there has been a noticeable reduction in price volatility, which ensured price stability for the consumer.<sup>1827</sup> A Deloitte 2008 report noted mobile telephony increased gross domestic product (GDP) in developing countries 3.7 percent to 6.2 percent.<sup>1828</sup> The World Bank reported in 2009 that a 10 percent increase in broadband Internet penetration is estimated to correspond to a 1.38 percent increase in GDP.<sup>1829</sup> In a report for the GSM Association in 2012, Deloitte noted a 10 percent change from 2G to 3G<sup>1830</sup> increased GDP per capita by 0.15 percent.<sup>1831</sup>

Over the past 30 years, the information revolution has had an important impact on the conduct of military warfighting operations. In the United States, it has produced what is often called “net-centric warfare” or “net-centric operations” – the combination of shared communications, key data, analytic capabilities, and people schooled in using those capacities. That has enabled enhanced joint activities, integrated distributed capabilities, much greater speed, [and] more effective maneuver, [and improved accuracy of weapons systems]. The result has been that the United States and its allies have been able to conduct very effective combat operations under a range of conditions, including quick insertion (Panama),

---

<sup>1824</sup> Vodafone (2005). *Africa: The Impact of Mobile Phones*. The Vodafone Policy Paper Series, Number 2, March 2005. Accessed March 4, 2016. <http://www.itu.int/osg/spu/dtis/documents/Papers/vodafonepapers.pdf>.

<sup>1825</sup> Lewin, David and Susan Sweet (2005). *The economic benefits of mobile services in India*. Ovum, January 26, 2005. Accessed June 7, 2014. [http://www.kiwanja.net/database/document/report\\_economic\\_india.pdf](http://www.kiwanja.net/database/document/report_economic_india.pdf).

<sup>1826</sup> Jensen, Robert (2007). “The Digital Provide: Information (Technology), Market Performance, and Welfare in the South Indian Fisheries Sector.” *The Quarterly Journal of Economics*, 122 (3): 879-924. doi: 10.1162/qjec.122.2.879.

<sup>1827</sup> Steyn, Jacques (2016). “A Critique of the Claims About Mobile Phones and Kerala Fishermen. The Importance of the Context of Complex Social Systems.” *The Electronic Journal of Information Systems in Developing Countries*, Volume 74. Accessed December 20, 2016. <http://www.ejisd.org/ojs2/index.php/ejisd/article/view/1687>.

<sup>1828</sup> Deloitte (2008). *Economic Impact of Mobile Communications in Serbia, Ukraine, Malaysia, Thailand, Bangladesh and Pakistan*. January 2008. Accessed June 7, 2014. [https://www.telenor.rs/media/TelenorSrbija/fondacija/economic\\_impact\\_of\\_mobile\\_communications.pdf](https://www.telenor.rs/media/TelenorSrbija/fondacija/economic_impact_of_mobile_communications.pdf).

<sup>1829</sup> World Bank (2009). *Information and Communications for Development: Extending Reach and Increasing Impact*. World Bank. © World Bank. <https://openknowledge.worldbank.org/handle/10986/2636>. License: CC BY 3.0 IGO. “Accessed July 7, 2016.

<sup>1830</sup> Second-generation wireless digital technology, which replaced first-generation analog systems and Third-generation wireless digital technology based on International Telecommunication Union (ITU) International Mobile Telecommunications (IMT)-2000 specifications.

<sup>1831</sup> Deloitte LLP (2012). *What is the impact of mobile telephony on economic growth?*. November 2012. Accessed June 7, 2014. <http://www.gsma.com/publicpolicy/wp-content/uploads/2012/11/gsma-deloitte-impact-mobile-telephony-economic-growth.pdf>.

maneuver warfare (major combat operations in Iraq), an all-air campaign (Kosovo), and a Special Forces–led effort (Afghanistan).<sup>1832</sup>

At the same time that major combat operations have proceeded so successfully, the United States and its allies have also undertaken a variety of humanitarian assistance/disaster relief (HA/DR), security, stability, and reconstruction operations in Somalia, Haiti, Bosnia, Kosovo, Liberia and several other African countries, Iraq, and Afghanistan. These operations generally have included humanitarian assistance and economic and governance (political) reconstruction and development and have spanned the full spectrum from nonviolent HA/DR to peacekeeping to war fighting and counterinsurgency (COIN). The operations, however, have not in many cases been as effective as combat operations<sup>1833</sup> in leveraging the power of information and ICT. A likely contributing factor may be that ICT has not played as integral role in post-conflict Stability Ops and COIN and related civil-military operations since there is yet to be an agreed-upon USG or international strategy and approach for a “net-centric”-like capability for whole-of-government, unity-of-effort civil-military operations.

Utilizing the fruits of the information revolution for effective security, stability and reconstruction operations requires a prior understanding of what makes these operations effective. For example, stability operations have security, economic, and governance recovery, reconstruction and development elements. Yet while it is widely recognized that stability operations go far beyond purely military actions – encompassing civil security, humanitarian, economic, and governance/rule of law issues – no one has set forth an actual strategic or operational doctrine that leverages the power of the information revolution as a means to achieve success in stability operations. As a World Bank staff report put it, “The Bank, like other international partners, is still learning what works in fragile-states contexts.”<sup>1834, 1835</sup>

The challenges of stability operations are evident. To begin with, no two circumstances are the same. To say that Haiti is different than Somalia is different than Bosnia is different than Iraq is different than Afghanistan is only to hint at the depth and breadth of the complexities. These include the causes of the crisis that occasioned the intervention, the host-nation culture or cultures, the language or languages, the nature of the economies antebellum, the influence of neighbors, and a multitude of other factors.<sup>1836</sup>

By definition, the state structure has collapsed or is severely impaired. Often there has been significant violence. Internal groups have been factionalized and frequently have each other’s blood on their hands.

---

<sup>1832</sup> Wentz, Larry. (n.d.). *Information and Information Communications Technology as an Enabler of Success in Stability and Reconstruction Operations*. Available at: [http://star-tides.net/sites/default/files/documents/files/l-ICT%20in%20Stability%20Ops\\_Wentz.pdf](http://star-tides.net/sites/default/files/documents/files/l-ICT%20in%20Stability%20Ops_Wentz.pdf).

<sup>1833</sup> Paraphrased from Wentz, n.d.

<sup>1834</sup> Ibid.

<sup>1835</sup> World Bank (2005). *Fragile States—Good Practices in Country Assistance Strategies*. Washington, DC: World Bank. Accessed March 14, 2016. <http://documents.worldbank.org/curated/en/907971468327613700/Fragile-states-good-practice-in-country-assistance-strategies>.

<sup>1836</sup> Wentz, n.d.

Economies are in disarray. Social mechanisms have broken down. Information is lacking, and communications mechanisms are limited.<sup>1837</sup>

There is a need for formal USG and international ICT policies and doctrines and agreed-upon frameworks and plans for ICT in international crisis response. In the absence of such to address post-conflict ICT reconstruction, approaches to date have tended to be ad hoc and not well coordinated, and most lacked a strategy and plan for intervention actions and assessment of the affected nation ICT sector and infrastructure recovery, reconstruction, and development needs. Post-conflict ICT reconstruction needs to address ICT sector governance recovery and development as well as ICT infrastructure reconstruction and services development. There needs to be a functional ministry of communications and regulator along with ICT policy, regulations, and laws to issue licenses and start infrastructure reconstruction and service offerings. There is no USG professional civil and commercial ICT SME<sup>1838</sup> organization to turn to for advice and assistance on how to put the pieces back together. Elements of the USG such as US Trade Development Agency (USTDA), Department of State (DoS)/USAID, Department of Commerce (DoC), FCC-International Bureau (FCC-IB), and Department of Defense (DoD) had pieces of the ICT storyboard but no whole-of-government, unity-of-effort approach or understanding of the ICT sector existed. Additionally, there was a lack of informed understanding of the roles and activities of international organizations such as the ITU, UN, and World Bank and their likely engagement on the ground that would need to be harmonized. There was no equivalent of an intelligence preparation of the ICT and related information battlespace.

In order to implement an ICT-enabled intervention, it is necessary to develop an informed understanding of the affected nation's ICT governance structure and business processes and an understanding of the ICT policies, regulations, and laws. It is also necessary to baseline the ICT infrastructure before an intervention as well as to identify the logistics pipelines for ICT equipment in country (who is the manufacturer, who should one deal with for replacement parts and maintenance). Further, it is necessary to identify the key players in the government and private sector with whom the intervening force needs to deal – who makes things happen and who are the spoilers. An early assessment of the status of key people and infrastructure in the ICT sector once deployment of responders takes place needs to be part of the intervention actions. Essentially, an ICT equivalent of a battle damage assessment needs to be done.

In Iraq, although the Coalition Provisional Authority engaged in the ICT sector, it was not until the DoD Business Transformation Agency (BTA) and the Defense Information Systems Agency (DISA) deployed an Iraq ICT Team in 2006-2007 to work with the Government of Iraq (GoI) and private sector ICT counterparts that a baseline for the Iraq ICT sector and governance was developed as along with an architecture, strategy, and plan to recover ICT sector governance and reconstruct ICT infrastructure.

In Afghanistan, things were a little better in that a ministry of communications and regulator were established in 2002 by the interim government, and ICT policies, regulations, and laws were addressed

---

<sup>1837</sup> Ibid.

<sup>1838</sup> Subject matter expert

early on by competent ministers of communications and their staffs. The Afghan government issued interim authorization to Afghan Wireless Communications Company (AWCC) in 2002 to establish cellular telephone service in several key cities as well as international telephony access into and out of the country. The International Community also responded from the outset to provide subject matter expert consultants and funding support to the minister of communications to help develop strategies and plans for the recovery and development of ICT sector governance and reconstruction and modernization of ICT infrastructure.

At the beginning of Afghan reconstruction efforts in 2002, organizations engaged included the USDA, DoS/USAID, DoD/DISA/National Defense University (NDU), DoC, FCC-IB, ITU, UN Development Programme (UNDP), Asian Development Bank (ADB), NATO, the World Bank and others. For example, international sources of ICT-related support included Germany, China, Iran, India, Korea, Japan, and others. Companies from industry, such as Microsoft and Cisco, also provided early assistance. Responder activities were, however, largely independent initiatives with participating organizations all having good intentions to help make things happen. Top down leadership, coordination, and information sharing were all lacking until the establishment of a Senior Telecom Advisor (STA) at the US Embassy Afghanistan Reconstruction Group in 2005, which position remained until 2008. There were a couple years' gap without an STA in Afghanistan until the DoD took action to reestablish the Senior Telecom Advisor at ISAF from 2010 to 2014. Both STAs engaged with the minister of communications (now the minister of communications and information technology), regulator, and other Afghan ICT counterparts including the private sector to advise, assist, and harmonize ICT activities.

In the example for Afghan ICT sector noted above, the civil and commercial ICT infrastructure was decimated, local ability to restore capabilities non-existent, and the environment too hostile for the international ICT industry to lead efforts to quickly restore or rebuild nationwide and international ICT services. Governance of the ICT sector was non-existent, and there was no functioning ministry of communications or telecommunications (telecom) regulator. Further, there was a lack of approved telecom/ICT policies, regulations, and laws, an absence of public and/or private national ICT operators, and an absence of ICT trained leaders, managers, and technical personnel. The intervening force had an inadequate understanding of the Afghan ICT sector, its governance structure, the associated business environment, and the status of ICT infrastructure, including its supply chain, to facilitate recovery. Additionally, the intervening force structure did not include recognized civilian professional subject matter experts, such as, a senior civilian telecom advisor, to interact with public and private ICT sector counterparts to foster ICT sector governance and public-private sector partnerships, enable restoration and modernization of in-country and international services, and facilitate development of the ICT sector and the use of ICT for job creation and cross-sector development.

Commercial SATCOM<sup>1839</sup> played a key role in facilitating the extension of connectivity into and within the Afghanistan to support intervening forces command, control, communications, computers, intelligence,

---

<sup>1839</sup> Satellite communications



surveillance, and reconnaissance (C4ISR), and subsequent civilian humanitarian assistance and reconstruction and development operations. Reliance on broadband terrestrial communications was an early requirement but lacked upfront planning, and timely donor and affected nation (which eventually becomes the host nation when sovereign) investment actions needed to provide such a capability early into the intervention. Fiber optic connectivity with regional access was in high demand but essentially non-existent. It took several years to develop Afghanistan's terrestrial connectivity and achieve regional interconnections to gain access to the global information and business environments.

Both Iraq and Afghanistan are in strategic geographic locations to become ICT hubs in their regions and vital links between the East and the West, which has the potential to generate large revenue streams for both countries. This can only happen if the fiber optic cable infrastructure is completed, operated and maintained consistent with international performance standards, and connected with regional networks. Both Iraq and Afghanistan are now starting to reap the benefits of their fiber networks and position themselves as regional ICT hubs.

Prior to almost all interventions, the International Community will already have significant presence in the form of international organizations, nongovernmental organizations, businesses, bilateral governmental activities, and many more avenues. Once there is a major international intervention, complexity increases greatly. Regardless of the initial number of international actors, the number and diversity of participants increase. More importantly, their relative importance increases for such functionality as exists or is created in the affected nation. Additionally, before the intervention, development often had priority, now there are simultaneous challenges in the security, humanitarian, economic, and governance arenas, and if social needs may be separated from the foregoing, in the social arena as well. Because of the expanded requirements, there are numerous players. Personnel and equipment stream in from civilian and military components of the governments of the United States and other nations, international organizations such as the United Nations (UN) and its many agencies, the North Atlantic Treaty Organization (NATO), the Organization for Security and Cooperation in Europe (OSCE), the World Bank, and others. Nongovernmental organizations also are involved, many of them in the humanitarian arena, as well as numerous others that participate in myriad aspects of reconstruction and development including the ICT sector and its uses. Many businesses also get involved, either as contractors to national and international organizations or as participants in private ventures.<sup>1840</sup>

A very important aspect of the complexity is that dealing with the affected nation has become more difficult. Governmental functions are broken and the government is seen as illegitimate by many and not

---

<sup>1840</sup> Paragraph excerpted and paraphrased from Kramer, Franklin D., Larry Wentz, and Stuart Starr (2007). "I-Power: The Information Revolution and Stability Operations." *Defense Horizons*, Number 55, February 2007. Center for Technology and National Security Policy, National Defense University. Available at: <http://handle.dtic.mil/100.2/ADA466767>.

representative of all the people. Its reach is generally limited and it is ineffective in mobilizing domestic human and other resources.<sup>1841</sup>

A further complicating factor is that circumstances on the ground change over time in significant part as a response to the intervention. The transformation from liberator to occupier is a well-known problem for intervening forces. Interventions generally last for years and a decade is not unusual. Stability operations encompass not only security but also reconstruction and development that take time. In addition to actual changes, managing expectations of both the interveners and the affected nation becomes extremely important. For example, there is a so called “golden moment,” the time during which intervener actions must support expectations of the host government and local population and the local population must experience improvements in quality of life.<sup>1842</sup>

On the good news side, the ad hoc ICT advise and assist approaches tried in Iraq and Afghanistan have clearly demonstrated the benefit of providing strategic thinking and thought leadership to the ICT sector and the use of ICT and the benefits of developing professional strategic partnerships and trusted relationships with senior affected nation ICT counterparts. The minister of communications in Afghanistan was quite pleased to have a professional ICT focal point with authority to deal with him on ICT-related matters. These efforts served to improve the ability of the USG to facilitate harmonization and synchronization of ICT actions and create an Interagency and international environment of collaboration, information sharing, and shared situational awareness. The constructs of both a senior civilian telecom advisor (STA) as part of the Afghanistan Reconstruction Group and its Afghan Reachback Office in Pentagon and the STA and supporting the ISAF telecom advisory team (TAT) with CONUS-based reachback support showed high promise as models to consider institutionalizing for use in future intervention operations.

As part of the assessment process is the need to capture the core capabilities of the approaches used by the US Embassy STA at the ARG and the DoD STA and TAT at ISAF in Afghanistan. Additional experiences from other interventions such as the MNF-I DCS CIS ICCE/ISE<sup>1843</sup> and DoD Business Transformation Agency (BTA)/DISA ICT teams in Iraq need to be assessed in terms of the core capabilities and options in order to provide a menu of things that work that can then be used to shape the capabilities for future operations. This will need additional research and related policy and doctrine changes to develop possible approaches to be institutionalized. The approaches will then need to be tested and exercised and the capabilities and procedures tested before their use in operational deployments.

## Information and ICT Intervention Strategy Considerations

USG and international ICT-related response actions tend to be reactive and ad hoc. USG ICT-related activities in support of stability (including COIN) and reconstruction operations are problematic: there is

---

<sup>1841</sup> Kramer, et al., 2007.

<sup>1842</sup> Paragraph excerpted and paraphrased from Kramer, et al., 2007.

<sup>1843</sup> Multi-National Force-Iraq Deputy Chief of Staff Communications and Information Systems Iraq Communications Coordination Element/Infostructure and Strategic Engagement

no clear USG lead agency for ICT or an agreed-upon USG sponsor for an STA capability and institutional arrangement to meet the needs of ICT support for security and stability operations and affected nation ICT recovery, reconstruction, and development. Intervention activities suffer from a lack of adequate understanding of the affected nation's information and ICT business cultures. Program development and prioritization, project coordination, information sharing, and implementation are largely uncoordinated and non-standard. There is no agreed-upon vision, strategy, architecture, or plan for the affected nation's ICT sector recovery, reconstruction, and development. Responding nations, international organizations, and NGOs do not develop coherent intervention strategies and plans for support to the affected nation for ICT recovery, reconstruction, and development. Donors and interveners do not adequately view ICT sector governance and infrastructure recovery as high-priority needs to be addressed early and used as an enabler of cross-sector reconstruction and development.

All too often the international and USG civil-military intervening elements do not give adequate attention to planning for the use of civil and commercial terrestrial communications that can be as much as a third of the cost of satellite and, if properly used, a "game changer" for achieving early recovery. Additionally, there is a lack of attention to the need for early investments to help restore the affected nation's destroyed networks (it is not just a private sector responsibility) so that these capabilities are available not only to support the C4ISR connectivity needs of the intervening forces but to help jump start the restoration of the ICT sector of the affected nation and its connection with the international information and business environments to facilitate economic growth and socio-economic development. The view that the private sector has the responsibility to take the lead has largely been influenced by the so-called "Washington Consensus."<sup>1844</sup> USG civil-military policies, strategies, and approaches need to be adjusted to emphasize early consideration of the role and use of civil and commercial ICT as an enabler of the intervention, both for helping satisfy the intervening civil-military elements communications and information needs and for early recovery of the affected nation's ICT sector governance and ICT infrastructure and services. Assistance should include ICT SME advice and assistance to the affected government's ICT sector governance elements (ministry of communications and regulator) as well as early investments to help the affected nation jumpstart the recovery of essential civil and commercial terrestrial and wireless communications.

Hybrid commercial satellite-terrestrial networks have emerged as the way of the future to provide high performance and resilient broadband fixed and wireless data and voice services in support of civil-military interventions and sustained operations in hostile and disadvantaged environments and to facilitate the affected nation's security, governance, and socio-economic recovery. Commercial ICT provides critical

---

<sup>1844</sup> The "Washington Consensus" is a set of ten relatively specific economic policy prescriptions that is considered to constitute the "standard" reform package promoted for crisis-racked developing countries by Washington, DC-based institutions such as the International Monetary Fund (IMF), the World Bank, and the US Treasury Department. It was coined in 1989 by English economist John Williamson. The prescriptions encompassed policies in such areas as macroeconomic stabilization, economic opening with respect to both trade and investment, and the expansion of market forces within the domestic economy. See *Wikipedia*, "Washington Consensus," at [https://en.wikipedia.org/wiki/Washington\\_Consensus](https://en.wikipedia.org/wiki/Washington_Consensus).

communications connectivity and information services in support of C4ISR for the civil-military intervention and related combat support operations and is an enabler of stabilization and transition operations, all of which have excessive demands for reliable, high-quality performance and affordable voice and broadband data services. Mobile phones become the lifeline for civil-military responders in the field and the means for interacting with affected nation counterparts.

Commercial SATCOM plays a key role in facilitating the extension of connectivity into disaster areas and within the affected country to support intervening forces C4ISR and subsequent civilian humanitarian assistance and ICT sector recovery and development and connection with the international information environment. SATCOM also facilitates access to disadvantaged populations such as those in remote villages in rural areas. SATCOM is, however, a limited and costly resource, so early attention is needed to move capacity and connectivity demands from satellite to more cost-effective options, such as fiber optic and microwave networks and wireless broadband services. Hence, it is important that alternative means exist or early investments are made to develop needed communications capabilities. These services are or can be provided by the affected nation's private sector (e.g., mobile network operators (MNOs) and Internet service providers (ISPs)) and state-owned enterprises. In early stages of affected nation recovery and reconstruction, donors and intervening military elements may need to employ creative means to obtain the communications services they need. . One such method is to become an anchor tenant to help jump-start infrastructure repair and development. This approach was used by DISA to lease C2<sup>1845</sup> fiber optic connectivity for deployed US military elements. It is a win-win approach. Coalition forces get coverage and services in their areas of interest and the affected nation is able to invest in further infrastructure growth. Early public-private partnerships and government-provided security protection can be used to facilitate private sector investment. This approach was used to jumpstart cellular networks and services and to protect against Taliban attacks on cell towers and installation crews of Afghanistan's national fiber cable. In the end, with an appropriate enabling environment, the private sector will take risks, make investments in, and lead the recovery and growth of private sector network coverage and services.

For the affected nation, ICT is critical infrastructure and an essential service that plays a vital role on the road to regaining its national sovereignty and security. ICT facilitates the return of rule of law and governance and is a "change agent" that enables socio-economic development and growth. ICT also offers transparency in communications, a means to help reduce corruption. It also facilitates moving the affected nation into the global information and business environments, leading to improving literacy and facilitating economic growth and job creation.

Information and ICT can significantly increase the likelihood of success in stability and reconstruction operations if they are engaged as part of an overall strategy that coordinates the actions of outside civil-military interveners and focuses on generating effective results for the affected nation. Properly utilized, ICT can help create a knowledgeable intervention, organize complex activities, and facilitate integration

---

<sup>1845</sup> Command and control

of stability operations with the affected nation recovery, reconstruction and development, making stability operations more effective.

Key to these results is a strategy that requires:

1. The USG gives high priority to such an approach and ensures that the effort is a joint civilian-military activity with senior level support and concomitant senior level “strategic thinking” and “thought leadership;”
2. The USG and International Community view and treat ICT as critical infrastructure and an essential service and prioritize investments and shape actions accordingly;
3. The military makes ICT part of the planning and execution of stability operations, including COIN campaigns;
4. Preplanning and the establishment of ICT partnerships are undertaken with key regular participants in stability operations such as NATO, the United Nations, and the World Bank;
5. The focus of the intervention, including the use of ICT, is on the affected nation and supporting its governmental, societal, and economic recovery and development; and
6. Key information technology capabilities are harnessed to support the strategy.<sup>1846</sup>

Implementing the strategy should include:

1. Development of an information and ICT strategy and business plan for the affected nation so that ICT is effectively used to support security, stabilization, recovery, reconstruction, and development;
2. Agreements among interveners on information and data sharing and collaboration, harmonization, and synchronization of ICT-related initiatives;
3. Use of commercial IT tools and information and data provided on an unclassified basis;
4. Establishment of trusted strategic partnerships with stakeholder key leaders and affected nation senior government and industry ICT counterparts;
5. Engagement of a professional civil and commercial ICT SME to provide strategic thinking and thought leadership and be the USG ICT spokesperson on the ground supporting the intervention leadership.<sup>1847</sup>

## Distributed and Virtual Temporary Team Challenges

Most if not all ad hoc approaches to date (e.g., MNF-I DCS CIS ICCE/ISE in Iraq and US Embassy STA/ARG and ISAF STA/TAT in Afghanistan) to provide in-country professional, civil and commercial ICT advise and assist capabilities for affected nation ICT governance recovery and post-conflict ICT infrastructure and services reconstruction and development employed a mix of distributed and virtual teaming arrangements. There was little to no opportunity to train as a team before deployment and all suffered from the need to continuously team build on the job as a result of the perpetual turnover of civilian and

---

<sup>1846</sup> Kramer et al, 2007.

<sup>1847</sup> Ibid.

military staff and team leadership. Continuity was largely provided by contractor support on the ground and Reachback. These teams had physical and geographic distribution with elements in different areas within the country and with reachback support capabilities in CONUS. They used virtual means to collaborate, communicate, and share information. Additionally, obtaining qualified staff with the passion, skills, and willingness to work in a multinational, multicultural complex civil-military environment in a war zone was difficult. Collaboration and information sharing presented challenges, including the effectiveness of ICT tools, or lack thereof, used to conduct day-to-day operations.

A January 2015 *Small Wars Journal* article on “Human Dimension Issues in Distributed and Virtual Teams” by Paul T. Bartone and Albert Sciarretta<sup>1848</sup> from the Center for Technology and National Security Policy at the National Defense University is a good lead in for framing the challenges faced by and lessons observed from the establishment of the STA/ARG at the US Embassy Kabul and the ISAF STA/TAT at ISAF Headquarters in Afghanistan. Both the STA/ARG and STA/TAT were created to provide a “one-stop shop” for advice and assistance on civil and commercial ICT, the Afghan ICT sector evolution (or some might say revolution), and ICT use as an enabler of security, stability, rule of law, governance, and socio-economic development and growth. The teams also had the roles of facilitators, connectors, harmonizers, and providers of situational awareness on Afghan ICT sector activities. They worked with and advised ISAF, the US Embassy Kabul and its USAID Mission, international organizations NGOs, GIRoA, and other Afghan ICT counterparts (e.g., MNOs and ISPs) on matters related to the Afghanistan ICT sector and the use of ICT.

The ISAF STA/TAT will be used as an example of a distributed virtual team to illustrate some of the challenges encountered during its over four years of existence (July 2010 to October 2014). The Telecom Advisor function was filled by both Senior Executive Service civilians (years 1 and 4, considered Senior Telecom Advisors to the Commander of ISAF and TAT Directors) and US Army Colonels (years 2 and 3, who were TAT Directors only). The TAT comprised a widely diverse staff, with most personnel provided through the DoD Civilian Expeditionary Workforce (CEW) program. There were also TAT members on temporary assignments from the DoD AFPAK Hands<sup>1849</sup> program, short-term volunteers from DISA, and some DISA-sponsored, task-focused support contractors. The TAT also included a two-person Deloitte contractor support team of ICT SMEs in country. The contractors lived outside of the ISAF compound in their own safe house and had their own vehicles and private security detail (PSD). During the first year of the TAT, one member of the Deloitte team had a desk at the TAT office on ISAF and the other was embedded in an office at the Ministry of Communications and Information Technology in downtown Kabul. In subsequent years of the Deloitte team being in country, they spent most of their time leveraging their freedom of movement to embed at the MCIT and meet with ATRA and AfTel and other public and private sector Afghan ICT counterparts in Kabul. The Deloitte in-country team was replaced by a team from IZ

---

<sup>1848</sup> Bartone, Paul T. and Albert Sciarretta (2015). “Human Dimension Issues in Distributed and Virtual Teams.” *Small Wars Journal*, January 19. Accessed September 7, 2015. <http://smallwarsjournal.com/jrnl/art/human-dimension-issues-in-distributed-and-virtual-teams>.

<sup>1849</sup> Afghanistan-Pakistan (AFPAK) Hands (APH) Program, a DoD program initiated in 2009 that trained US Armed Services finance personnel (and others) in the languages and cultures of Afghanistan and Pakistan.

Technologies (IZT) in 2013,<sup>1850</sup> the advisors for which were embedded at the MCIT, ATRA and AfTel. Finally, there was a CONUS-based reachback element that consisted of ASD-NII,<sup>1851</sup> DISA, NDU, Deloitte, and Gartner. This CONUS-based team provided TAT staff access to experienced civil-military ICT SMEs who had prior on the ground Afghan ICT experience and access to other government agencies and labs, academia, think tanks, and US ICT industry experts. The team also provided continuity and institutional memory across the duration of the existence of the STA/TAT and also participated on a TDY<sup>1852</sup> basis in country as SME gap-fillers and to conduct or support special studies. These various and sundry factions that together made up the STA/TAT did not have the opportunity to train together before deployment or over the life of the STA/TAT operation. There was no formal recruiting, orientation, and mentoring process or team build activities up front or ongoing.

There was one important exception to the staffing and teaming arrangements noted above, and that was the initial STA/TAT element referred to as TAT-1. In this case the STA, Reachback, and the Deloitte team spent several weeks together in Washington, DC to conduct pre-deployment training and strategy development and to do some relationship building together and with the DoD, DISA, DoS, USAID, DoC, FCC-IB, Joint Staff Pakistan Afghanistan Coordination Cell, CENTCOM,<sup>1853</sup> the World Bank, and others working Afghanistan ICT issues. The NDU member of Reachback accompanied the STA on visits to CENTCOM and then NATO, EUCOM and DISA-EUR<sup>1854</sup> on their way to Afghanistan to set up the STA office at ISAF. The Deloitte lead arrived in Kabul a few weeks after the office was established and provided on-the-ground civil and commercial ICT support to the STA as well as advice on how to set up the TAT operation based on his experience as a senior member of the MNF-I DCS CIS ICCE/ISE team in Iraq. During the first year of TAT-1, Reachback conducted TDYs and rotated the NDU and ASD-NII members on a monthly basis to provide near continuous presence on the ground at the ISAF office to help develop the STA/TAT ICT strategy and plan, facilitate introductions to ISAF, USFOR-A,<sup>1855</sup> DSE-A,<sup>1856</sup> US Embassy, USAID Mission, international organizations, GIRoA personnel at the Ministry of Communications and Information Technology (MCIT), the Afghanistan Telecom Regulatory Authority (ATRA), and Afghan Telecom Corporation (AfTel), as well as other Afghans working in ICT. The NDU member made several fact-finding trips downrange to Nangarhar, Kandahar, Paktika, Helmand, and Herat provinces. Reachback and Deloitte team members also helped mentor the incoming CEW staff. The STA, Deloitte element, CEW staff, and Reachback developed a unique teaming arrangement (which, unfortunately, was not duplicated after TAT-1) that helped build the necessary trust relationships and a shared understanding of the STA/TAT's mission, objectives, tasks, roles, responsibilities, and relationships to operate effectively as a distributed virtual team. Reachback also helped to spread the word of TAT activities with the USG Interagency in

---

<sup>1850</sup> A directive from President Karzai abolished private security companies, causing Deloitte to pull its advisors.

<sup>1851</sup> Assistant Secretary of Defense for Networks and Information Integration

<sup>1852</sup> Temporary duty

<sup>1853</sup> Central Command

<sup>1854</sup> North Atlantic Treaty Organizations, European Command, and DISA-Europe Field Command, respectively

<sup>1855</sup> United States Forces-Afghanistan

<sup>1856</sup> DISA Support Element-Afghanistan

Washington, DC and with the World Bank and facilitated coordination and information sharing among CONUS-based elements working and interested in Afghanistan ICT. Reachback also facilitated visits by STA and TAT members to Washington, DC to meet with USG Interagency elements working Afghan ICT and support for interim program reviews (IPRs) at DISA.

There was annual turnover of TAT leadership (the STA/TAT Director) and frequent turnover of TAT staff, creating an almost constant team-building environment. The STA/TAT was truly an ad hoc distributed and virtual temporary team. After TAT-1, Reachback had only a limited ability to provide some orientation for the incoming TAT leadership as rotations occurred, and virtually no ability to provide orientation for CEW or other staff. Relationship building between new TAT members and Reachback was done by phone and email, and this had extreme limitations in terms of effectiveness.

The time difference between Kabul and Washington, DC also complicated communications (eight and a half or nine and a half hours, depending on the time of year). Experience from real-world operations suggests the operating hours of the dining facilities (DFACs) often drives the battle rhythm of office operations. In Afghanistan, coordination calls between TAT and Reachback had to be scheduled around the dinner hour at the DFAC — evening in Kabul was morning in Washington, DC. Communications at ISAF to support teleconference calls with Reachback in CONUS was often problematic. The communications systems supporting TAT conference calls frequently had problems establishing connections and the quality of call connections was poor at times.

Reachback visits to Kabul with personal interactions on the ground served to significantly improve the “getting to know you” interactions and relationship building, but these were less frequent after TAT-1. Weekly teleconference calls and day-to-day email exchanges were the primary modes of interacting. As noted, during the first year of the STA/TAT there were frequent Reachback staff visits to Kabul and other areas in Afghanistan, but this dropped off significantly for future phases of the operation. The unavailability of billeting at ISAF for visitors inhibited Reachback’s travel to Kabul in TAT years 2 through 4, especially once the drawdown of Coalition forces began.

The aforementioned article on “Human Dimension Issues in Distributed and Virtual Teams”<sup>1857</sup> includes a section on why geographically dispersed teams fail and captures in general terms many of the challenges and experiences of the STA/TAT. The article notes, “There is now fairly extensive literature on the special challenges of geographically dispersed and virtual teams.”<sup>1858</sup> “In general, the available research shows

---

<sup>1857</sup> Bartone and Sciarretta, 2015.

<sup>1858</sup> Bowman, Elizabeth K. (2007). *Measuring team collaboration in a distributed coalition network*. Report presented at the 12<sup>th</sup> International Command and Control Research and Technology Symposium (ICCRTS), Newport, Rhode Island, June. DTIC Accession Number ADA481312. Accessed June 11, 2014. <http://www.dtic.mil/cgi-bin/GetTRDoc?Location=U2&doc=GetTRDoc.pdf&AD=ADA481312>.



that geographically distributed teams perform less effectively than teams that are co-located, especially on tasks that require innovation.”<sup>1859</sup>

Communication within distributed virtual teams is often difficult due to technological limitations, time zone differences, and competing priorities – and it was a challenge for the STA/TAT and Reachback. Also, as experienced by STA/TAT and Reachback, dispersed team members often lacked clear, agreed-upon goals and objectives, and some held to different values. These shortfalls may lead to additional problems for distributed teams such as more task and interpersonal conflict than co-located ones. These negative effects can be mitigated to some degree by a shared sense of identity and by more frequent spontaneous communications as was done during TAT-1. Face-to-face time on the ground also served to help develop more informed shared understandings and build trust relationships.

For virtual teams, research has identified poor leader communications, uncertainty regarding roles and responsibilities, and lack of trust in relationships as factors impeding successful performance.<sup>1860</sup> Many other studies have identified lack of trust as a destructive factor in geographically distributed teams.<sup>1861</sup> Research also identified trustworthiness and perceived reliability to follow through as key factors in the success or failure of geographically distributed teams.<sup>1862</sup>

Finally, multiple studies pointed to the importance of leaders finding the right balance among structure, including clear goals, responsibilities and lines of authority, and openness or lack of structure. Research has found that teams with an informal but hierarchical organizational structure performed better than teams with more flat network structures. Studies of co-located teams are also relevant here.<sup>1863</sup> Additionally, it was found that while cooperative, democratic structures and systems can work well in

---

<sup>1859</sup> Huang, Laura (2012). *Mitigating the effects of geographically dispersed teams*. Research Translations. University of California-Irvine, Paul Merage School of Business, Center for Global Leadership. Available at: [http://merage.uci.edu/ResearchAndCenters/CLTD/Resources/Documents/Huang\\_Laura\\_Mitigating%20the%20Negative%20Effects%20of%20Geographically%20Dispersed%20Teams\\_2012.pdf](http://merage.uci.edu/ResearchAndCenters/CLTD/Resources/Documents/Huang_Laura_Mitigating%20the%20Negative%20Effects%20of%20Geographically%20Dispersed%20Teams_2012.pdf).

<sup>1860</sup> Frank M. Horwitz, Desmond Bravington, and Ulrik Silvis (2006). “The promise of virtual teams: identifying key factors in effectiveness and failure,” *Journal of European Industrial Training*, Volume 30, Issue 6, 472 – 494. <http://dx.doi.org/10.1108/03090590610688843>.

<sup>1861</sup> Govindarajan, Vijay and Anil K. Gupta (2001). “Building an Effective Global Business Team.” *MIT Sloan Management Review*, 42, July 15, 63-71. Available at: <http://sloanreview.mit.edu/article/building-an-effective-global-business-team/>.

<sup>1862</sup> Zolin, Roxanne, Pamela J. Hinds, Renate Fruchter, and Raymond E. Levitt (2004). “Interpersonal trust in cross-functional, geographically distributed work: A longitudinal study.” *Information and Organization*, 14, 1-26. Available at: <http://www.sciencedirect.com/science/article/pii/S1471772703000356>.

<sup>1863</sup> Hinds, Pamela and Cathleen McGrath (2006). “Structures that work: Social structure, work structure and coordination ease in geographically distributed teams.” *Proceedings of the 2006 20<sup>th</sup> Anniversary Conference on Computer Supported Cooperative Work*, New York, 343-352. Accessed June 11, 2014. <http://dl.acm.org/citation.cfm?id=1180928>.

relatively small organizations, teams working within larger organizations require more structure and systems to facilitate communication and coordination of work activities.<sup>1864</sup>

Research also suggests that multinational teams, although co-located, communicate primarily through electronic systems. Results showed that while these groups establish trust and cohesion, some do not assign clear roles and responsibilities. This leads to confusion as to the overall objective and resulting frustration. In addition, large groups show more frustration and worse performance.<sup>1865</sup>

Temporary teams are generally comprised of strangers who have not worked together in the past and are not aligned in day-to-day operations by organizational requirements but are joined together for a specific purpose (e.g., STA/TAT like team). In civil-military operations, these temporary teams will increasingly be multi-agency, including members from DoD, Department of State (DoS), and other departments, as well as international and allied partners and non-governmental organizations (NGOs). Agility and adaptability are key team characteristics to strive to accomplish. The traits that make teams adaptable are trust, common purpose, shared awareness, and empowerment of individual members to act.<sup>1866</sup> Trust is earned and transparency is required to ensure common understanding and awareness. Behavior changes are needed to establish trust and foster collaboration. In the end, it is largely the right people, in the right place, at the right time and with the right attitude and passion for the mission that make teams work. This was particularly challenging for the STA/TAT, which experienced high turnover of team leadership and staff, lacked an orientation and mentoring program for new members, was a distributed virtual team with the challenges noted above, and only had limited influence over selection of new team members. The STA/TAT was essentially in a continuous and challenged team building mode of operation and was constantly reshaping its work program to accommodate and leverage the capabilities and expertise of staff on hand. Staff experience and expertise often did not match the skills necessary to interact with senior military and civilian leaders of the Coalition forces (ISAF) and civilian government (US Embassy and USAID) and international organizations, with the Afghan government and private sector professional ICT counterparts, or to operate in a multicultural and multinational environment with the stresses of a war zone. Pre-deployment training did not address the skills needed to be a senior advisor as described.

The STA/ARG and STA/TAT were experiments and learning experiences. As the famous quote of George E. P. Box, one of the great statistical minds of the 20th century, said: “Essentially, all models are wrong, but some are useful.”<sup>1867</sup> Although the quote was originally applied to statistical models, it could be argued it is applicable to describing ad hoc arrangements such as the distributed and virtual temporary teams of the STA/ARG and STA/TAT in Afghanistan. Despite the challenges they faced, the STA/ARG and STA/TAT

---

<sup>1864</sup> Hackman, J. Richard (1998). “Why teams don’t work.” In R. Scott Tindale et al. (eds.), *Theory and Research on Small Groups* (245-267). New York: Plenum Press.

<sup>1865</sup> Bowman, 2007.

<sup>1866</sup> McChrystal, General Stanley (2015). *Team of Teams: New Rules of Engagement for a Complex World*. (New York: Penguin Publishing Group).

<sup>1867</sup> AZ Quotes. “George E. P. Box Quotes.” Accessed June 11, 2014. [http://www.azquotes.com/author/22390-George\\_E\\_P\\_Box](http://www.azquotes.com/author/22390-George_E_P_Box).

experiments and learning experiences, in general, were a success, and a wealth of information has been learned and observed from both that can be applied to future interventions. As history constantly reminds us, there will be future interventions, and the USG needs to do better in leveraging the power of information and ICT in post-conflict stability and COIN operations and to facilitate the recovery and reconstruction of the ICT sector and the use of ICT as an enabler of security, governance, and socio-economic development and growth.

The STA/ARG and STA/TAT lessons observed range from broad lessons for future interventions to observations specific to Afghanistan. The STA/ARG and STA/TAT experiences can be used to help shape recommended courses of action, or at least serve as considerations for core capabilities and approaches – what works and what does not.

## Lessons Regarding Virtual Distributed Teams and the STA/TAT Reachback Element

From the outset of installing both the Senior Telecom Advisor at the Afghanistan Reconstruction Group (STA/ARG) at the US Embassy Kabul and the Senior Telecom Advisor and what came to be the Telecom Advisory Team (STA/TAT) at ISAF Headquarters in Kabul, reachback capabilities were established and, in fact, preceded the forward-deployed teams. For both the STA/ARG and STA/TAT, Reachback conducted pre-deployment orientations and facilitated introductions to the US Interagency, socializing the mission and goals. Reachback also facilitated introductions for the STAs to various Afghan stakeholder and players, both in CONUS and in country.

For the STA/ARG, the Afghanistan Reachback Office (ARO) was established at the Pentagon with ICT subject matter experts (SMEs) from ASD-NII (now DoD CIO) and the National Defense University Center for Technology and National Security Policy (NDU CTNSP). When the ARG was dissolved in 2008, with the STA a resultant casualty, the Reachback Team CONUS remained. Reachback was instrumental in the discussions and negotiations to reestablish the Telecom Advisor function in Afghanistan in 2010.

For the STA/TAT, DISA decided to put a small footprint forward, comprised of professional civilian ICT SMEs, with a larger foot-print in the rear. This configuration changed when the STA inherited the CEW billets from ISAF CJ6, which became the Telecom Advisory Team, thus shifting the balance of manpower from CONUS to Kabul and forever altering the dynamics between the two. Reachback was actively engaged with the TAT-1 at ISAF, with members traveling to Kabul regularly and even serving as acting STA during the first year. Reachback's trips to Kabul and participation on the ground diminished over the four years of the STA/TAT (for various reasons), giving rise – at least in part – to disconnects between the forward and rear elements and amplifying the challenges of being a virtual distributed team as described above and in [Chapter 21](#).

In retrospect, one should not be surprised by the challenges and behavior patterns of the different instances of the STA/TAT and Reachback teaming arrangements. Research suggests the overwhelming reason why geographically dispersed and virtual teams such as the STA/TAT and Reachback are likely to perform more poorly is because team members do not have a shared understanding of the goals and do not have clarity regarding overall objectives for the team – a weakness experienced by TATs 2 through 4.

A Small Wars Journal article<sup>1868</sup> on distributed and virtual teams and why they fail captures many of the challenges and experiences the STA/TAT and Reachback relationship experienced. The article notes, there is now fairly extensive literature on the special challenges of geographically dispersed and virtual teams. In general, the available research shows that geographically distributed teams perform less effectively than teams that are co-located, especially on tasks that require innovation. Many of the activities of the STA/TAT and Reachback needed innovative strategic thinking and thought leadership that takes time to execute, but the tactical and operational environment on the ground in Kabul was driven by looking for answers right away.

The article also noted communication is often difficult due to technological limitations, time zone differences, and competing priorities. Also, dispersed team members often lack clear, agreed upon goals and objectives, and may hold to different values. These shortfalls lead to additional problems for distributed teams. For example, geographically distributed teams experienced more task and interpersonal conflict than co-located ones. Research suggests these negative effects are mitigated to some degree by a shared sense of identity, and by more frequent spontaneous communications.<sup>1869</sup> For many TAT challenges, face-to-face meetings through Reachback TDYs to Kabul or trips by TAT members to CONUS helped bridge differences. Often it was a matter of getting to know each other better and managing mutual expectations.

Looking at virtual teams, the article identified poor leader communications, uncertainty regarding roles and responsibilities, and lack of trust in relationships as factors impeding successful performance.<sup>1870</sup> Many other studies have identified lack of trust as a destructive factor in geographically distributed teams. For example, the article noted that trustworthiness and perceived reliability to follow through were key factors in the success or failure of geographically distributed teams.<sup>1871</sup>

Multiple studies point to the importance of leaders finding the right balance among structure, including clear goals, responsibilities, and lines of authority, and openness or lack of structure. For example, geographically distributed research and development teams found that teams with an informal but hierarchical organizational structure performed better than teams with more flat, network structures. Studies of co-located teams are also relevant here. In an extensive series of team studies, it was found that while cooperative, democratic structures and systems can work well in relatively small organizations; teams working within larger organizations require more structure and systems to facilitate communication and coordination of work activities.<sup>1872</sup>

More specifically, the STA/ARG and STA/TAT and their Reachback teams observed the following lessons from their experiences in Afghanistan:

---

<sup>1868</sup> Bartone and Sciarretta, 2015.

<sup>1869</sup> Ibid.

<sup>1870</sup> Ibid.

<sup>1871</sup> Ibid.

<sup>1872</sup> Ibid.

1. Reachback provides thought leadership and strategic thinking for the forward-deployed team. It understands the broader strategies and goals of the USG as well as the interests and issues areas of the myriad stakeholders. Leadership must understand, endorse, and communicate the importance of these responsibilities.
2. Reachback provides a long-term perspective of purpose and serves as the institutional memory and continuity of operations for the forward-deployed team. Leadership must understand, endorse, and communicate this value.
3. All team members, regardless of location, should have a common purpose, shared situational awareness, and a mutual understanding of the mission, goals, challenges, opportunities, and efforts.
4. The forward-deployed and CONUS elements should have a shared understanding of roles, relationships, and responsibilities, including lead and support designations. The team needs to be flexible, adaptable, and agile.
5. Trust and respect between the forward and rear teams must be established and maintained. In-person interactions such as face-to-face meetings and on-the-ground participation are key to getting to know each other, teambuilding, and developing and maintaining trust and respect.
6. Reachback needs to be utilized more effectively and considered an integral part of the team, such as STA/TAT + Reachback, TAT CONUS, or simply just members of the TAT in the rear. The teams forward and rear must develop a partnership mentality and corresponding mode of operation.
7. All team members, regardless of location, should have shared expectations, accountability, and urgency for deliverables. They must work together to meet the priorities and demands of those on the ground and the overarching direction and guidance CONUS. It is important leadership manage perceptions and misperceptions, identify and address disconnects, and sort out differences.
8. The in-country and CONUS teams need to have processes and capabilities to collaborate and communicate effectively and often and to share and manage information and knowledge. it takes more than weekly conference calls and email exchanges, no matter how frequent, to develop the needed working relationships and teaming arrangements.
9. In any team, but especially in distributed and virtual teams, transparency is required to ensure common understanding. Leadership must create the broader, enabling environment and reward desired behaviors.<sup>1873</sup>

---

<sup>1873</sup> McChrystal, 2015.

10. Reachback had access to a wide range of professional expertise willing and able to engage to help find solutions and solve problems, to conduct and provide research, and to work in specialized areas, on projects, and for short-term assignments, both in country and CONUS. This arrangement and capabilities were utilized and proved valuable.
11. Reachback had the ability to gain agreement and run interference at headquarters and senior leadership levels, which was often more effective than the STA/TAT firefighting issues and dealing with the complex civil-military bureaucratic structures on the ground.

Behavior must be shaped to ensure transparency and to establish trust and foster collaboration. This implies a change in reward systems as well, since [organizations] need to be able to reward the desired behavior. The role of the leader becomes creating the broader environment instead of command and control micromanaging.<sup>1874</sup>

In addition to the above, the following additional observations, lessons, and recommendations were offered by former TAT and Reachback members and TAT leadership on the role and use of Reachback. Reachback:

- Is best-suited for Interagency and international organization coordination and information sharing in CONUS. Synchronization and harmonization with USG and non-USG stakeholders and relationship management should remain an activity led and managed by Reachback.
- Should support establishing coordination arrangements in country with the US Embassy, USAID Missions, international organizations, and affected nation ICT sector governance personnel and private sector ICT counterparts.
- Should be used for in-country gap fill during periods of extended absence and personnel transition. Reachback should also be used as staff augmentation for specialized efforts with follow-on mentoring as appropriate.
- Should conduct special research, studies, and SME support activities for the in-country team.
- Should develop (or help to) strategic communications and information campaigns and participate in their implementation. It should conduct outreach, particularly through publications, workshops, conferences, and the like.
- Should help to shape the STA's strategy and work program and assess the impact of STA activities.
- Should be engaged in all planning activities throughout the duration of the engagement, including for transition or shut down.
- Should participate in the collection, documentation, assessment, and dissemination of lessons observed and recommendations.<sup>1875</sup>

---

<sup>1874</sup> Bartone and Sciarretta, 2015.

<sup>1875</sup> Some of the bullets are excerpted or paraphrased from Bierden, Elizabeth A. (Col., USA) (2012). *ISAF Telecommunications Advisory Team [TAT] Year in Review*, July 1, 64.

Specifically regarding staffing the Telecom Advisor function and any in-country support team like the Telecom Advisory Team, Reachback should:

- Assist in identifying skills needed and experience required.
- Support the recruitment processes for the TA and staff.
- Vet candidates prior to hire.
- Provide pre-deployment orientation and preparation for and socialize new hires prior to their departure to theater.
- Mentor new personnel.<sup>1876</sup>

Distributed virtual teams certainly have more and different challenges that collocated ones. However, real-world experience using STA + CEW + SMEs + Reachback in Afghanistan have proven they can and do work, provided the collective team is managed well and that effective policies, procedures, and means of communication are in place to facilitate a shared understanding of mission, roles, and responsibilities and support collaboration and information sharing. Reachback is an important part of the overall effort and should be considered as such. In active conflict areas, putting small teams forward supported by larger elements in the rear will likely continue to be the model, so it is important planners consider the challenges and benefits of distributed virtual teams going forward.

## Broad Lessons Observed and Overarching Recommendations

As noted earlier, there continues to be a lack of USG policy and doctrine with regards to the role of civil and commercial ICT for interventions like Operation ENDURING FREEDOM and there is no agreed-upon coherent strategy. ICT efforts tend to be driven by individuals and are largely focused on the short-term efforts rather than longer-term goals and outcomes. While some concerted strategies exist, others are vague or implied and only become apparent through work accomplished or funding assigned. Plus, they are often driven by the organizations engaged and the leadership, passion, experience, and actions of those experts employed.<sup>1877</sup>

On the good news side, as noted above, the STA/ARG and STA/TAT concepts were successful and effective in addressing the civil and commercial ICT aspects of the intervention in Afghanistan. The focus of activities included use of ICT to support ISAF, Coalition forces, and civilian government organizations such as the US Embassy and USAID, international organizations and NGOs. Both teams engaged the GIRoA ICT governance elements at MCIT, ATRA, and SOE (AfTel) to help address ICT policy, regulations, laws, strategy, and plans for modernization of the ICT infrastructure and services. The teams also engaged with the development of the national fiber optic network, spectrum management, broadband services, critical ICT infrastructure protection such as cell towers on FOBs, [E-Afghanistan National Priority Program](#) (NPP) (e.g., mMoney, e-NIC, and e-gov), ICT capacity development within GIRoA ministries and at the

---

<sup>1876</sup> Ibid.

<sup>1877</sup> Ibid.

Universities, cybersecurity, and many other ICT areas including CIIP program and attempts to work with the Afghan National Disaster Management Authority. The teams established trusted strategic partnerships with key GIRoA leaders such as the Minister of Communications and Information Technology and the chairman of the Afghan Telecom Regulator as well as CEOs of the private sector counterparts, i.e., the MNOs and ISPs. The STA/TAT in particular became the “one-stop shop” for advice and assistance on civil and commercial ICT; a facilitator, connector, and harmonizer of USG Interagency, ISAF and Coalition forces, international organizations, and Afghan ICT related activities; and the trusted source of informed situational awareness on the Afghan ICT sector and USG, Coalition forces, and international organization ICT-related activities. The STA in both cases was the go to person for the MCIT minister and in the case of the STA/TAT, the minister provided open access to him and his senior staff and in addition provided a room at the MCIT for sole use by the STA/TAT team members to embed on a daily basis to work with him and the senior leaders at MCIT, ATRA, and AfTel. The Afghan ICT sector is one of the key success stories emerging from the recovery of the war-torn country. The STA/ARG and STA/TAT both played key and important roles in support of the USG, ISAF, and GIRoA ICT-related activities.

To address these continuing shortfalls, the USG should consider:

11. Developing a USG Policy and doctrine that views and treats ICT as “critical infrastructure” and an “essential service” on par with roads, power, and water.<sup>1878</sup>
12. Developing a USG ICT Support Strategy focused on delivering an ICT vision, strategy, and plan for foreign intervention.
13. Providing a roadmap for ICT assistance by a Senior Telecom Advisor (STA).
14. Providing a baseline for doctrinal and policy components of ICT resourcing.
15. Establishing a US Reachback capability to focus and coordinate government and private sector support of the USG ICT Support Strategy.
16. Providing language and cultural awareness training for operating at the affected nation’s senior levels, e.g., minister’s and deputy minister’s level.<sup>1879</sup>

There are differing organizational goals and “stovepiped” end states. Most support agencies’ goals are driven by internal organizational missions and their goals are not always adequately harmonized to a broader set of national or international goals (such as in this case, the Afghan National Priority Programs, the [Afghanistan National Development Strategy](#), and the [Millennium Development Goals](#)). STA/TAT specifically and conscientiously researched, reviewed, and assessed the applicable strategic plans of the USG, ISAF, GIRoA (particularly the MCIT), USAID, the DoS, and the World Bank, among others, prior to

---

<sup>1878</sup> Based on author discussions with DoD CIO personnel, throughout 2015-16, the DOD CIO worked with the White House CTO and Main State EB/CIP on efforts, in conjunction with the National Security Council, to draft an Executive Order for the Global Connect Initiative (GCI) Program, including specific language to recognize ICT as elevated to essential service and critical infrastructure protection status for USG OCONUS activities. This effort was ultimately displaced by a subsequent draft for the GCI program that was signed by President Obama in June 2016, but lacked the specific ICT language referenced above.

<sup>1879</sup> Bierden, 2012. *TAT Year in Review*.



developing its Afghanistan ICT Strategy to complement and support, rather than duplicate others' efforts.<sup>1880</sup> TAT encouraged and tried to help harmonize other supporting organizations activities and to consider:

- Viewing their goals within, or in relation to, overarching national and international goals, and others' goals.
- Targeting specific end states that will result from continued development and evolution of ICT infrastructures as well as stability, governance, capacity and socio-economic development.
- Focusing on elements necessary to ensure long-term sustainability, especially for leave behind capabilities as well.
- Providing historical context and a basis for establishing sustained institutional knowledge.<sup>1881</sup>

## Lessons and Recommendations from Counterinsurgency, Stability, Reconstruction, and Development Operations

Operation ENDURING FREEDOM (OEF) in Afghanistan, American's longest, is part of a complex, multinational, multicultural, civil-military environment, which is difficult to work in under any circumstances but especially so given the country's perpetual volatility and the resultant instability. Former NATO Senior Civilian Representative Mark Sedwill characterized NATO's International Security Assistance Force (ISAF) as "a civil-military experiment in real time and under conditions of stress that only combat can deliver."<sup>1882</sup> This unique civil-military integration in the difficult security environment of Afghanistan posed serious challenges in the absence of clear doctrinal guidelines on how to conduct joint, combined civil-military efforts, to include security, governance and socio-economic developmental programs.<sup>1883</sup>

NATO introduced the concept of a "comprehensive approach," defined in NATO doctrinal publication AJP-01, for use in international crisis response management situations. The comprehensive approach is a conceptual framework intended to address the need for actors involved in a stabilization mission to work together, from planning to implementation.<sup>1884</sup> This approach is sometimes described as a "whole-of-government approach," while in the United Nations' context it is known as an "integrated approach."

As stated in AJP-01, "Implementing the comprehensive approach requires sensitivity, rapport, respect, trust, patience and tact, as well as determination to collaborate with all actors, military and civilian, at all levels." Interagency coordination among these actors is exceptionally difficult due to incompatible planning, training, and conduct of operations and differences in people and organization cultures. NATO's

---

<sup>1880</sup> Ibid.

<sup>1881</sup> Ibid.

<sup>1882</sup> NATO Senior Civilian Representative Report (2010). *A Comprehensive Approach: Lessons Learned in Afghanistan*, July 15. Accessed September 7, 2015.

<https://nllp.jallic.nato.int/IKS/Sharing%20Public/SCR%20Report%20Final.pdf>.

<sup>1883</sup> Beljan, Robert (2013). "Afghanistan: Lessons Learned from an ISAF Perspective." *Small Wars Journal*, May.

<sup>1884</sup> Ibid.

introduction of the comprehensive approach for its ISAF mission in Afghanistan was considered a key to achieving success, since historically an insurgency cannot be defeated by military action alone. There is a need for civilian-related activities as well.

Volumes have been written about the intervention, as well as about civil-military operations and cooperation; counterinsurgency (COIN) strategies and experiences; and stability, reconstruction, and development operations in Afghanistan and lessons learned (or at least observed) from them. Some relevant lessons observed and imparted by others are related below. Further, the Senior Telecom Advisor at the Afghanistan Reconstruction Group (STA/ARG, 2005-2008) and the STA and the Telecom Advisory Team at NATO's International Security Assistance Force (ISAF) Headquarters (STA/TAT, 2010-2014) observed lessons and formed recommendations based on its years on the ground as part of the US Government's and Coalition's efforts.

### COIN Lessons

A [key] lesson to be taken from the USG and ISAF COIN effort in Afghanistan is the lack of commitment to finish the job.<sup>1885</sup> COIN, to include stability operations, takes time. A publication by the US Joint Staff cites studies that indicate the estimated average time for an insurgency to end successfully is 12 years.<sup>1886</sup> Leaders, both military and political, need to be prepared from the outset to commit to supporting the COIN and stability ops activities in some form or fashion for the long-term.<sup>1887</sup> Leaders planning future COIN development operations might also consider focusing on fewer projects or groupings of projects that the population really needs and can eventually operate and maintain on their own, and then actually delivering it. By studying the population and its needs, COIN and stability ops development should attempt to align the right project at the right place and at the right time, usually in coordination with a military or security operation, in order to add legitimacy to the Host Nation Government in the eyes of the population and to marginalize the insurgency.<sup>1888</sup>

As per the previous paragraph, COIN and stability operations are long-term efforts themselves, and reconstruction activities often take much longer. All three need to be joint efforts: in the case of Afghanistan, this means between NATO/ISAF and the Afghans. Stability and reconstruction activities should be planned with sustainability in mind and, ultimately, transition to the affected nation. In Afghanistan, the Afghans did not have a mechanism or capabilities to standup a stability operations organization, so the International Community had to fill the longer-term development gap and continues to do so.

---

<sup>1885</sup> Barham, Charles (2016). "Stability Operations: Lessons from Afghanistan." *Small Wars Journal*, February 11.

<sup>1886</sup> Headquarters, Department of the Army (2006). *US Army Field Manual 3-24, Counterinsurgency*; MCWP 3-33.5, December. Accessed December 10, 2014. <http://usacac.army.mil/cac2/Repository/Materials/COIN-FM3-24.pdf>.

<sup>1887</sup> Barham, 2016.

<sup>1888</sup> Ibid.

At a 2010 conference on “Winning ‘Hearts and Minds’ in Afghanistan: Assessing the Effectiveness of Development Aid in COIN Operations,” research findings questioned many of the assumptions underpinning COIN stabilization strategies in Afghanistan.

- Key drivers of insecurity are poverty, unemployment and/or radical Islam.
- Economic development and modernization are stabilizing.
- Aid projects win hearts and minds and help legitimize the government.
- Extending the reach of the central government leads to stabilization and development projects are an effective means to extend this reach
- The international community and the Afghan government have shared objectives when it comes to promoting development, good governance and the rule of law.<sup>1889</sup>

Their recommendations for improving COIN operations include the following:

- Ensure COIN doctrine is evidence-based and priority is given to assessing stabilization effects of projects, rather than assuming impact based on amounts of money spent or the number of projects implemented.
- Development and COIN policies should acknowledge the potentially destabilizing effects of aid and need for greater recognition of the inadvertent role of aid donors (and not just aid recipients) in fueling corruption when they provide money without adequate safeguards and oversight.
- Incentive structures should be created that reward quality and not just quantity, processes and not just products, and impacts rather than just outputs.
- Donors should avoid setting development aid up to fail by expecting it to deliver on unrealistically ambitious stabilization objectives for which it is not well-suited — differentiate between stabilization funds used for relatively small-scale and short-term projects designed to promote stability effects at a tactical level and larger-scale and longer-term development aid projects designed to promote development objectives.<sup>1890</sup>

## Lessons and Recommendations from Reconstruction and Development Programs

As with many post-conflict countries, there were and still are innumerable development programs and projects in Afghanistan. Three of them – the National Solidarity Program, the Afghan First program, and the Commander’s Emergency Response Program – are described below, all for different reasons.

An example of an inclusive approach for development the Afghans used was the National Solidarity Program (NSP), the largest development program in the country. It is funded by the World Bank and other donors and is implemented by the Afghan Ministry of Rural Rehabilitation and Development, or MRRD, in

---

<sup>1889</sup> Wilton Park Conference (2010). *Winning ‘Hearts and Minds’ in Afghanistan: Assessing the Effectiveness of Development Aid in COIN (Counter Insurgency) Operations (WP1022)*. Accessed April 14, 2016. <https://www.wiltonpark.org.uk/wp-content/uploads/wp1022-report.pdf>.

<sup>1890</sup> Ibid.

2003 to develop the ability of Afghan communities to identify, plan, manage, and monitor their own development projects. The NSP promoted a development paradigm whereby communities were empowered to make decisions and manage resources during all stages of the project cycle. The program laid the foundation for a sustainable form of inclusive local governance, rural reconstruction, and poverty alleviation. Communities elected their representatives and leaders to form Community Development Councils or CDCs to implement the development projects.<sup>1891</sup> Projects financed by the NSP generally fall into one of six categories: transport; water and sanitation; irrigation; power; literacy and vocational training; and other.<sup>1892</sup>

Overall, despite some areas of limited performance, the community-driven development (CDD) approach of the NSP was considered successful. It increased access by Afghan citizens to utilities and services, including government services, but NSP infrastructure projects were less successful. NSP-funded projects improved the basic literacy and computation skills of both male and female villagers and had positive impacts on gender outcomes.<sup>1893</sup> The author has found no evidence of any ICT projects conducted via the NSP, which is a lesson of omission: ICT is not one of the overarching categories of projects funded by the NSP, though certain endeavors certainly could have fallen under infrastructure or vocational training. However, since the driver behind the NSP is that projects are based on a community's priorities, that may be a lesson in and of itself: Communities may have had access to ICT services already through commercial companies, they did not know enough about ICT to make it a priority, or ICT was not among their priorities. Nevertheless, the NSP may be a useful platform and vehicle to fund ICT training programs for both users and workers going forward, in Afghanistan and elsewhere. The relative success of the NSP, largely attributed to rooting its foundation in community-driven development, should be noted by policymakers, planners, and program designers and considered as an approach for future operations. ICT should be included as a broad category for project funding.

Another guiding policy effort and program was "Afghanistan First," or "Afghan First," a socio-economic program to develop long-term skills and build capacity by giving incentives to Afghan companies and contractors that used local labor to fulfill work contracts.<sup>1894</sup> It also encouraged the Coalition and donors to award contracts to Afghan companies (with certain dollar-value restrictions). The intent of the program was to provide Afghan business owners and workers with a viable source of income while improving their

---

<sup>1891</sup> Acemoglu and Robinson, 2012.

<sup>1892</sup> Beath, Andrew, Fotini Christia, and Ruben Enikolopov (2015). *The National Solidarity Program: Assessing the Effects of Community-Driven Development in Afghanistan*. Policy Research Working Paper No. 7415. World Bank, Washington, DC. © World Bank. <https://openknowledge.worldbank.org/handle/10986/22653> License: CC BY 3.0 IGO.

<sup>1893</sup> Ibid.

<sup>1894</sup> Doscher, Staff Sergeant (USAF) Thomas J. (2007). "'Afghanistan First' Program Shifts Focus to Training," March 14. United States Army website. Accessed September 4, 2014. <https://www.army.mil/article/2262/afghanistan-first-program-shifts-focus-to-training/>.

skills and provide[s] revenue for the burgeoning economy of Afghanistan.<sup>1895</sup> However, some argued the program would more aptly be called Afghan Last.<sup>1896</sup> Some of the issues encountered and lessons learned were:

- There was a lack of qualified Afghan companies to bid on large projects.
- Afghan companies could not meet the high requirements of many projects.
- There was too much bureaucratic red tape in the contracting process.
- Payment by the US Government (and other governments) was “woefully slow,” and Afghan companies could not float the receivables.
- Afghans lacked access to Coalition bases to meet with information and contracting/financing officers (although there was one off base office outside ISAF Headquarters, the Afghanistan Enterprise Development and Advisory program office).
- Afghans encountered obstacles obtaining visas to attend important meetings in the United States and elsewhere outside the country.
- Language barriers were problematic.<sup>1897</sup>

There were some attempts to employ Afghan First with regards to ICT-related activities, by the STA/TAT and other organizations, to little avail. Unfortunately, very few Afghans were qualified to work in the information and communications technology (ICT) sector, though some contracted and subcontracted local labor was employed to trench for the installation of Afghanistan’s national fiber optic cable (OFC) and to protect it and other ICT infrastructure.

The Commander’s Emergency Response Program (CERP) was established by the Iraqi Coalition Provisional Authority in 2003 to enable military commanders to respond to urgent humanitarian relief requirements in Iraq. CERP projects were intended to address urgent, small-scale, humanitarian relief, reconstruction projects and services that immediately assisted the indigenous population and that the local population or government could sustain.<sup>1898</sup> CERP funds were also made available in Afghanistan. Telecommunications was one of the 20 broad categories of assistance eligible for CERP funds.<sup>1899</sup>

---

<sup>1895</sup> Tate, David (2010). “When Afghan First Means Afghan Last.” Regarding War (blog), October 22. Accessed September 4, 2014. <http://www.pbs.org/pov/regardingwar/conversations/blog-1/when-afghan-first-means-afghan-last.php/>.

<sup>1896</sup> Ibid.

<sup>1897</sup> Paraphrased from Tate, 2010.

<sup>1898</sup> Security Assistance Monitor (n.d.). Commander’s Emergency Response Program. Accessed September 4, 2014. <http://securityassistance.org/content/commanders-emergency-response-program>.

<sup>1899</sup> US Department of Defense (2009). Financial Management Regulation 7000.14-R, Volume 12, Chapter 27, *Commander’s Emergency Response Program*, Annex A, January, A-1 – A-5.

However, telecommunications projects comprised a small fraction – in both number and dollar amount – of all CERP-funded projects in Afghanistan, as indicated in [Figure 133](#) and [Figure 134](#) below.<sup>1900</sup>

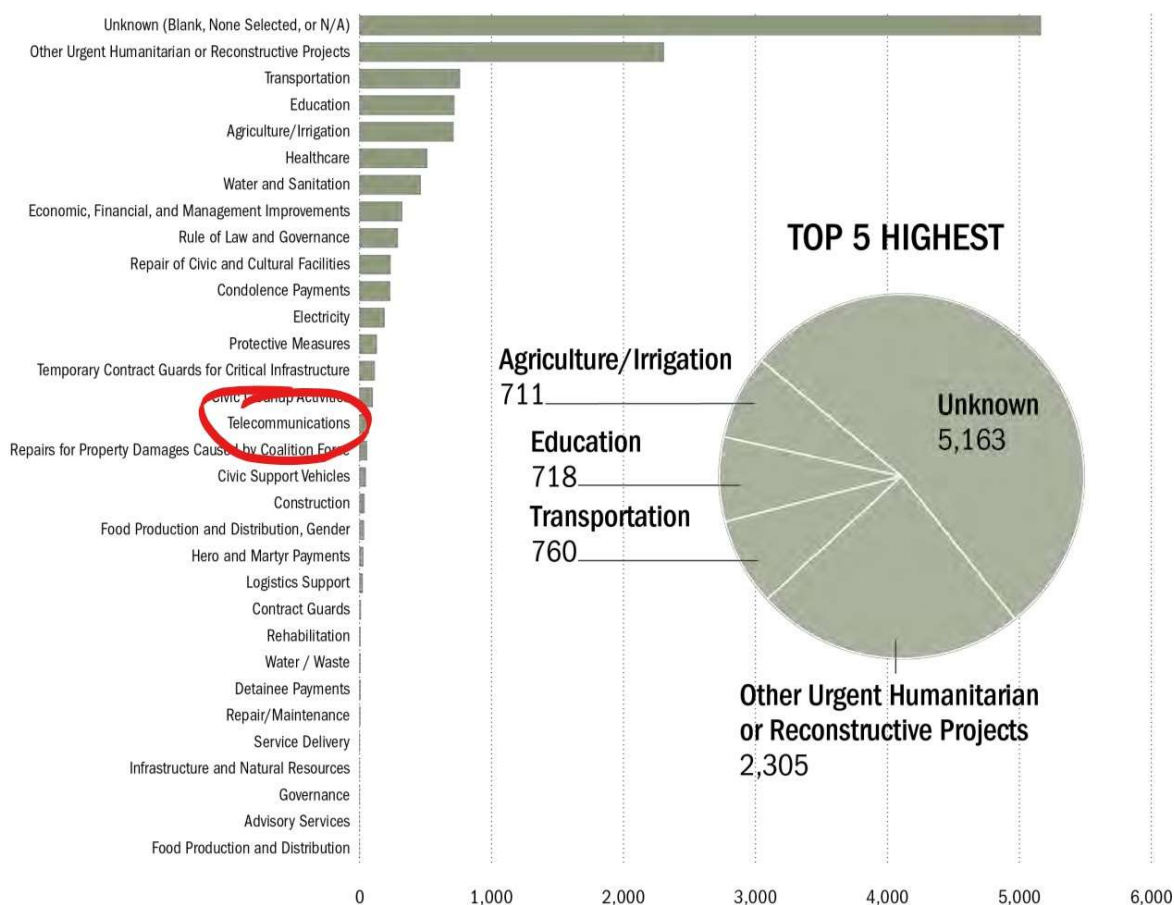

Figure 133: Number of Afghanistan CERP projects by category, FY 2004 - FY 2014

The STA/TAT attempted more than once to help organizations apply for CERP funds for ICT-related projects that fell within CERP’s authorized uses, such as implementing a Cisco Networking Academy at the American University of Afghanistan’s Professional Development Institute, expanding successful ICT-for-health pilot projects, and conducting ICT training for Afghan women and girls. Unfortunately, the TAT was only successful in helping the Afghan Ministry of Communications and Information Technology, which oversees Afghan Post, procure nine new mail delivery trucks, which were delivered in November 2011.

<sup>1900</sup> US Special Inspector General for Afghanistan Reconstruction (SIGAR) (2015). “Fact Sheet: CERP Priorities and Spending in Afghanistan FY 2004 – 2014. SIGAR-14-49-SP.” Available at: <https://www.sigar.mil/pdf/special%20projects/SIGAR-15-49-SP.pdf>.

The TAT and the organizations it attempted to assist in applying for CERP funding found the paperwork and process arduous and the many of the personnel administering the program less than helpful.

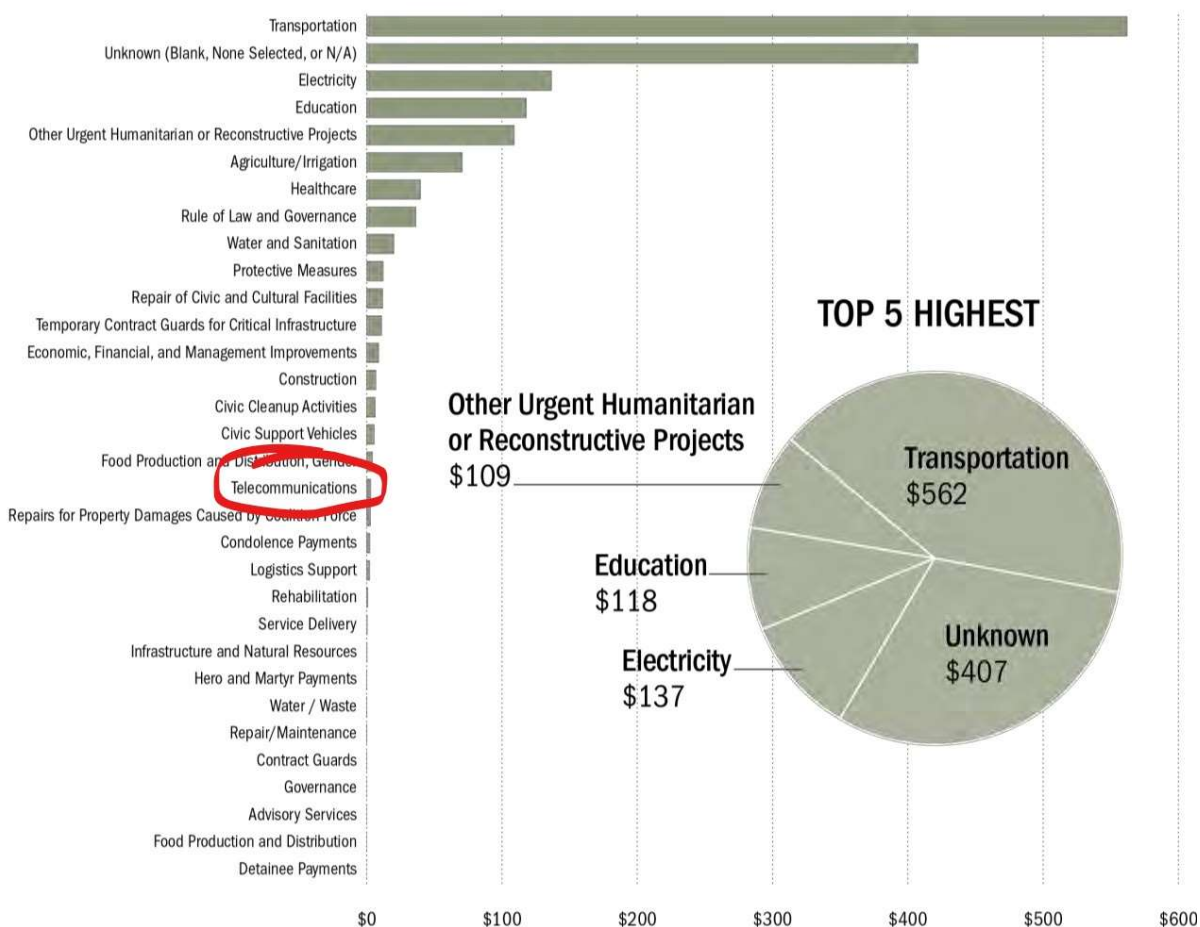

Figure 134: Total estimated cost for Afghanistan CERP projects by category, FY 2004 - FY 2014

### Lessons Regarding the Civil-Military Divide

With CERP, the US military [became] substantially engaged in the development and stabilization space and will likely continue to operate in this space for some time to come ... [causing] tensions ... between the development community and the US military in Afghanistan. There is no clear line that can be drawn down the middle dividing stabilization from development activities. The reality is that both the US Military and USAID are often operating in the same space.<sup>1901</sup> While sometimes problematic, both types of organizations have their strengths and weaknesses and can complement each other's work with effective

<sup>1901</sup> Johnson, Gregory, Vijaya Ramachandran, and Julie Walz (2011). *The Commander's Emergency Response Program in Afghanistan: Refining U.S. Military Capabilities in Stability and In-Conflict Development Activities*, September 2011. Accessed March 20, 2016. <http://www.dtic.mil/dtic/tr/fulltext/u2/a557341.pdf>.

collaboration and with changes in the military's doctrines, education, training, manuals, and understanding to reflect the development operating environment.<sup>1902</sup>

There are often disconnects in or a lack of a shared understanding of the roles, relationships, and business cultures of civil-military participants in post-conflict reconstruction and development. Lessons observed are:

- Military interveners need to understand the business cultures of the US Embassy and USAID Mission and international organizations and how to deal with their personnel appropriately.
- Likewise, civilian organizations need to understand with the military culture and command structure, and how to deal with it effectively.
- This can and should be addressed through improved education and training programs on civil-military culture, roles, and relationships and exercises that involve both military and civilian participation.
- Managing expectations of all participants – civil-military interveners and the affected nation – is extremely important.

In a RAND Corporation report on lessons from Vietnam, Ambassador Robert W. Komer, former Chief of Pacification for the US government in Vietnam, indicated that bureaucratic features are a natural tendency in any institution. He argued that “the typical behavior patterns of . . . U.S. institutions involved in the conflict made it difficult for them to cope with an unfamiliar conflict environment and greatly influenced what they could and could not, or would or would not, do.”<sup>1903</sup> Both the military and civilian agencies, he argued, behaved in a bureaucratic manner which proved self-defeating. They behaved in this way because their institutional imperatives prevented them from behaving in any other fashion. Bureaucracies, whose modus operandi was to rely on precedent whether it was appropriate to resist change or not and to block outside interference in their operations, were incapable of readily adjusting to a new environment. They are characteristics inherent to a greater or lesser degree in the behavior patterns of large hierarchically organized institutions – private or public, civilian or military, American or foreign.”<sup>1904</sup> Unfortunately, the bureaucratic tendencies and characteristics were observed in Afghanistan.

NATO's objectives in Afghanistan were very ambitious and implementation of the comprehensive approach at the international level proved difficult. Civil-military relationships were constrained by different interests, goals, priorities, and organizational cultures. Lessons learned from NATO operations show that addressing crisis situations calls for a comprehensive approach combining political, civilian and military instruments.<sup>1905</sup>

---

<sup>1902</sup> Paraphrased from Johnson et al., 2011.

<sup>1903</sup> Komer, Robert. W. (1972). *Bureaucracy Does Its Thing: Institutional Constraints on US-GVN Performance in Vietnam*. RAND Corporation, August. Accessed October 4, 2015. [www.rand.org/pubs/reports/R967](http://www.rand.org/pubs/reports/R967).

<sup>1904</sup> Ibid.

<sup>1905</sup> North Atlantic Treaty Organization (NATO). “A ‘comprehensive approach’ to crises.” Last updated June 21, 2016. [http://www.nato.int/cps/en/natohq/topics\\_51633.htm?selectedLocale=en](http://www.nato.int/cps/en/natohq/topics_51633.htm?selectedLocale=en).



- Different actors contribute to a comprehensive approach based on a shared sense of responsibility, openness, and determination, taking into account their respective strengths, mandates and roles, as well as their decision-making autonomy.
- Applying a comprehensive approach means a change of mindset. The Alliance is therefore emphasizing joint training of civilian and military personnel. This promotes the sharing of lessons learned and also helps build trust and confidence.<sup>1906</sup>

### Lessons Regarding Multinational, Multicultural Interventions

Similarly, there is a lack of a shared understanding of the purposes, roles, mandates, goals, and capabilities of inter-governmental, international, and non-governmental organizations (NGOs).

- Participants should be educated on the various big players typically involved in post-conflict and crises response operations (e.g., the United Nations, [World Food Programme](#), World Bank, International Development Association, Asian Development Bank, etc.).
- Participants should develop a database of and maintain a network of contacts from inter-governmental, international, and non-governmental organizations operating in the same space.
- It is important to build a more informed shared understanding of each other and establish trust relationships before having to work together in a real post-conflict or crisis response activity.
- Participants need to be careful not to over expect what the various elements can and cannot do and understand the purposes and capabilities the different players bring.
- Participants need access to cultural advisors, interpreters, language trainers, and translators. Staff should have some basic vocabulary and phrases they can use when interacting with the affected nation's personnel and population. Simple greetings and salutations – hello and goodbye – and other phrases like “thank you” spoken in local languages go a long way.

Multinational operations, by definition, involve myriad cultures, including the affected nation's. Cultural differences and language barriers are often problematic. Some of the broader lessons learned by ISAF regarding cultural awareness in planning and conducting military operations (which applies equally to the civilian sphere) include the following. Cultural awareness:

- helps in overall situational awareness and effective decision making;
- provides a better understanding of how the planned military actions will affect both the population and insurgents;
- can assist in predicting how the population and individuals will behave;
- can lead to increased communication and prevent unnecessary tensions; and
- helps in force protection.<sup>1907</sup>

---

<sup>1906</sup> Ibid.

<sup>1907</sup> Beljan, 2013.

Furthermore, cultural mistakes or culturally inappropriate actions and behavior in an operation can easily escalate into bigger problems and lay the groundwork for increased risk in future operations.<sup>1908</sup> Information and ICT are important enablers of improved understanding, sharing, and leveraging the use of cultural awareness.

## Money Can't Buy Happiness – Or Failed States

The plethora of inter-governmental, international, and NGOs and donor governments in post-conflict generally mean well. However, billions of dollars have been spent in Afghanistan with relatively little to show for it. In *Why Nations Fail*, the authors argue nations thrive when they develop inclusive political and economic institutions, and they fail when those institutions become extractive and concentrate power and opportunity in the hands of only a few. If sustained economic growth depends on inclusive institutions, giving aid to regimes presiding over extractive institutions cannot be the solution. Many studies estimate that only about 10, or at most 20, percent of aid ever reaches its target. Interestingly, they note that most of the waste resulting from foreign aid is not fraud, just incompetence, or even worse, simply business as usual for aid organizations.<sup>1909</sup>

Countries such as Afghanistan are poor because of their extractive institutions ... The same institutional problems mean that foreign aid will be ineffective, as it will be plundered and unlikely to be delivered where it is supposed to go.<sup>1910</sup> After 2001, the International Community thought that all Afghanistan needed was a large infusion of foreign aid. Not surprising, this led to business as usual with a large part of the promised money going to business overhead for offices and operations of the international organizations, donors, NGOs, and implementing partners pursuing their own agendas and hiring English-speaking bureaucrats and teachers to work for the aid community at salaries far exceeding local Afghan salaries—creating false economies.<sup>1911</sup> Foreign aid is one of the most popular policies that Western governments, international organizations, and NGOs recommend as a way of combating poverty around the world. And of course, the cycle of failure of foreign aid repeats itself over and over again. The idea that rich Western countries should provide large amounts of development aid in order to solve the problems of poverty is based on an incorrect understanding of the causes of poverty.<sup>1912</sup>

Additionally, a growing number of development experts have observed economic development is not a panacea and cannot be divorced from security and governance. The government cannot gain sufficient legitimacy solely by building projects or otherwise infusing money into a local economy.<sup>1913</sup> In fact, such development can actually increase instability rather than decrease it.<sup>1914</sup> Andrew Wilder and Stuart

---

<sup>1908</sup> Ibid.

<sup>1909</sup> Acemoglu and Robinson, 2012.

<sup>1910</sup> Ibid.

<sup>1911</sup> Ibid.

<sup>1912</sup> Ibid.

<sup>1913</sup> Fishstein, Paul and Andrew Wilder (2012). *Winning Hearts and Minds? Examining the Relationship Between Aid and Security in Afghanistan*. (Medford, MA: Feinstein International Center, January 2012).

<sup>1914</sup> Ibid.

Gordon conclude from their research in Afghanistan that US and international aid efforts “show little evidence of ... winning hearts and minds or promoting stability.”<sup>1915</sup> An Afghan tribal elder summed up the argument this way: “Lack of clinics, schools, and roads are not the problem. The main problem is we don’t have a good government.”<sup>1916</sup>

The above finding was echoed by a group of development experts who discussed the topic at the 2010 Wilton Park Conference “Winning ‘Hearts and Minds’ in Afghanistan: Assessing the Effectiveness of Development Aid in COIN Operations.”<sup>1917</sup> The end-of-conference report found that “many Afghans believe the main cause of insecurity to be their government, which is perceived to be massively corrupt, predatory and unjust ... Without getting the ‘politics right’ both military and aid efforts are unlikely to achieve their desired effects.”<sup>1918</sup>

Two important lessons are:

1. Foreign aid is not a very effective means of dealing with the failure of nations around the world today. Countries need inclusive economic and political institutions to break out of the cycle of poverty.
2. Since the development of inclusive economic and political institutions is key, using the existing flow of foreign aid in part to facilitate such development would be useful. Structuring foreign aid so that its use and administration brings groups and leaders otherwise excluded from power into the decision-making process and empowering a broad segment of population might be a better prospect.<sup>1919</sup>

## Intervention Timeline

Just as important as what organizations do in post-conflict operations and how they do it is *when* they do it. Former Secretary of the Army Martin R. (Marty) Hoffmann observed that after every conflict there is a “golden moment” in which reconstruction and nation-building is most easily accomplished.<sup>1920</sup> This is the moment after significant hostilities have ceased and before opposition to reform has had an opportunity to gel. The intervener transformation from liberator to occupier is a well-known challenge and can happen quickly and early in the transformation process. As illustrated in the intervention spectrum graphic in [Figure 135](#), the USG and the International Community all too often intervene with the resources needed for recovery and reconstruction after this magical point in time. The USG and the International Community must do better in future operations. ICT-enabled interventions may be the answer to help improve the

---

<sup>1915</sup> Ibid.

<sup>1916</sup> Wilder, Andrew and Stuart Gordon (2009). “Money Can’t Buy America Love,” *Foreign Policy*, December 1.

<sup>1917</sup> *WP1022 Report*, 2010.

<sup>1918</sup> Ibid.

<sup>1919</sup> Acemoglu and Robinson, 2012.

<sup>1920</sup> Berner, Thomas F. “Send in the Amateurs! Recruiting from the Private Sector to Accelerate Nation-Building: The Experience of the Afghanistan Reconstruction Group.” Published in Gott, Kendall D. and Michale G. Brooks, eds. (2006). *Security Assistance: US and International Historical Perspectives. The Proceedings of the Combat Studies Institute 2006 Military History Symposium*. (Fort Leavenworth, KS: Combat Studies Institute Press).

way the world conducts post-conflict stability and reconstruction operations including related COIN activities at village, district, and provincial levels.

# ICT-enabled Intervention Spectrum

## Treat ICT as an Essential Service and Critical Infrastructure

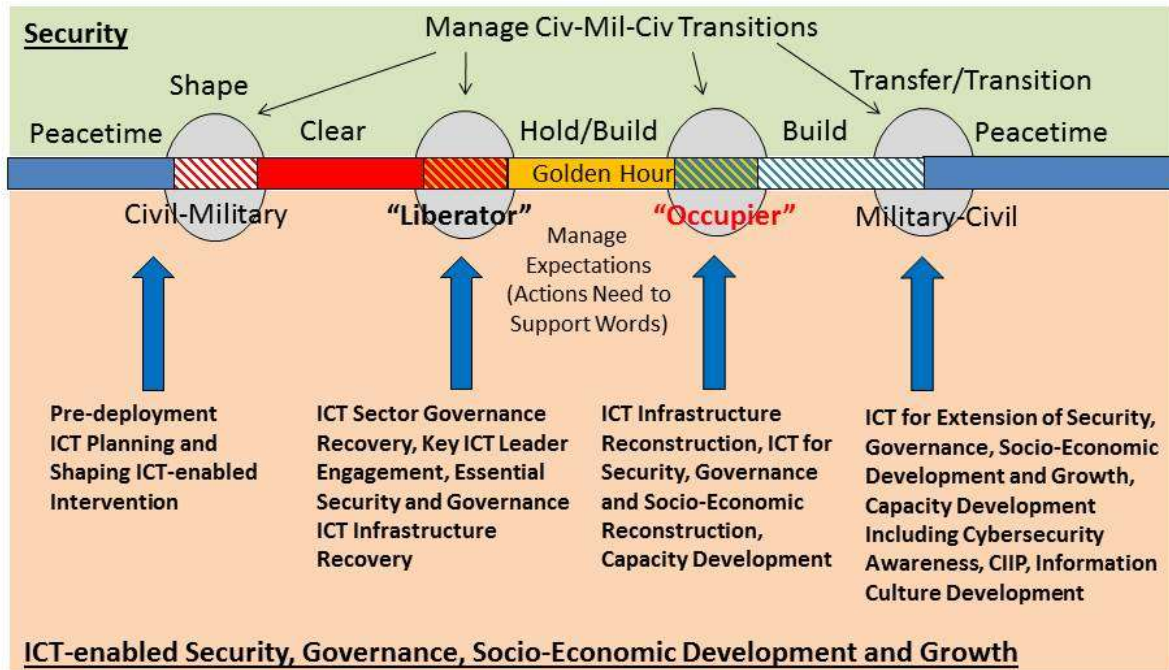

Figure 135: ICT-enabled intervention timeline

## A Collection of Lessons

As mentioned above, there has been a tremendous volume of information written about counterinsurgency, stability, reconstruction, and development operations and lessons observed from them, particularly from Afghanistan. Following is a collection of three of them.

### Ten Lessons for Nation Building

Former US Ambassador to Afghanistan and Iraq Zalmay Khalilzad identified ten lessons for nation building as follows:

1. Any effort to build the post-war order must be based on a fundamental understanding of the aspirations or political center of gravity of a newly liberated society and must be implemented by civilian and military leaders who know how to align the United States with those goals.
2. If US military forces are used to effect regime change or are deployed to stabilize a country after a regime has been toppled by internal forces, it is vital for the United States to position itself as

an ally, not a conqueror or occupier, and to ensure that indigenous leaders take ownership of the new order.

3. Intensive political and diplomatic engagement with national leaders is needed to craft a national compact among competing groups and to form a partnership to execute a mutually agreed strategy for reconstruction.
4. The United States must size and configure its footprint to avoid creating unnecessary friction or over-reliance on any one instrument of policy.
5. Post-conflict reconstruction involves the reconstitution of a country's political elite. Success depends on the emergence of an elite that has roots in the society and the vision and capability to build a new and better political order.
6. Effective communication is vital to the success of any reconstruction program.
7. In post-conflict settings, the United States should utilize a flexible, multilateral model backed up by an energetic and robust American policy and program.
8. If neighboring countries can help or harm our effort, the United States should engage them and shape their conduct to the extent possible, even if we have deep differences with those countries.
9. A closely integrated civil-military structure and set of policies and programs comprise the best way to achieve success.
10. Success requires the US government to provide adequate resources and to find more efficient ways to operate.<sup>1921</sup>

### *The Nine Principles of Reconstruction and Development*

The “Nine Principles of Reconstruction and Development” are a formalization of customary USAID operating procedures developed by Andrew S. Natios, a former Administrator of USAID. They reflect key institutional principles that most seasoned aid agencies incorporate in all their work, from ensuring local ownership and sustainability of a health clinic to flexibly adjusting a rural development program to counteract poppy cultivation.<sup>1922</sup>

The following principles guide US development and reconstruction assistance. They are fundamental to the success of assistance as an instrument of US foreign policy and national security. The principles are not a checklist, but a summary of the characteristics of successful assistance to achieve development objectives including economic growth, democracy and governance, and social transition.<sup>1923</sup>

1. **Ownership:** Build on the leadership, participation, and commitment of a country and its people.
2. **Capacity-Building:** Strengthen local institutions, transfer technical skills, and promote appropriate policies.

---

<sup>1921</sup> Khalilzad, Zalmay (2005). “Ten Lessons for Nation Building.” *The National Interest*, July 18.

<sup>1922</sup> Natios, Andrew S. (Administrator of USAID under President Bush). “The Nine Principles of Reconstruction and Development.” *Parameters*, Autumn 2005.

<sup>1923</sup> Ibid.

3. **Sustainability:** Design programs to ensure their impact endures.
4. **Selectivity:** Allocate resources based on need, local commitment, and foreign policy interests.
5. **Assessment:** Conduct careful research, adapt best practices, and design for local conditions.
6. **Results:** Focus resources to achieve clearly defined, measurable, and strategically-focused objectives.
7. **Partnership:** Collaborate closely with governments, communities, donors, NGOs, the private sector, international organizations, and universities.
8. **Flexibility:** Adjust to changing conditions, take advantage of opportunities, and maximize efficiency.
9. **Accountability:** Design accountability and transparency into systems and build effective checks and balances to guard against corruption.

Natios notes in his conclusion, “It is important to bear in mind two notions regarding the Nine Principles of Reconstruction and Development. First, the Nine Principles significantly overlap with military doctrinal principles comprehensive approach still leaves a lot of room for improvement and work remains to be done to refine the approach for use in future International crisis operations.”<sup>1924</sup>

The continued development of the military’s stabilization operations platform and the increasing frequency of civil-military collaborations mean this convergence is here to stay. Second, effective reconstruction and development work cannot afford to overlook the Nine Principles. Quite simply, reconstruction is not effective when the local population does not feel a sense of ownership toward donor programs. Likewise, if donors ignore the accountability principle, not only does this set a poor example for the local population, but the legitimacy of the donor’s overall involvement is brought into question. The development discipline will continue to evolve as will our understanding of it; the Nine Principles are an important part of this continuing effort.”<sup>1925</sup>

### *Five Lessons We Should Have Learned in Afghanistan*

The apparent USG view of the nature of the challenges in post-2014 Afghanistan became one of maintenance rather than outright victory – managing the risk posed by a continued Taliban insurgency rather than defeating the insurgency (and now ISIS,<sup>1926</sup> or Daesh, as the Afghans – and others – call the group as well) through military victory. As the transition in Afghanistan moved forward, it was important to step back and reflect on some of the broader lessons others have learned from the past 14 years of conflict. An American Security Project article by Joshua Foust on strategic issues in policy planning, titled [“Five Lessons We Should Have Learned in Afghanistan,”](#) provides some interesting perspectives on US foreign policy strategic effects. The article attempted to identify some of the lessons that policymakers need to learn about Afghanistan and apply to future operations. It was meant to establish a framework

---

<sup>1924</sup> Steinsson, Sverrir (2015). “NATO’s Comprehensive Approach in Afghanistan: Origins, Development, and Outcome, July 26, 2015. Accessed September 7, 2015. <http://www.e-ir.info/2015/07/26/natos-comprehensive-approach-in-afghanistan-origins-development-and-outcome/>.

<sup>1925</sup> Ibid.

<sup>1926</sup> Islamic State of Iraq and Syria

for understanding why the Afghanistan war was in the state it was in, and how policymakers can avoid making similar missteps in the future. The five lessons identified below encapsulate Foust's examples of policy failures, strategic shortsightedness, and flawed reasoning that contributed, in his view, to the status of the Afghanistan war in the 2012 timeframe. Following are those five lessons.

1. **The danger of magical thinking.** Magical thinking is causal reasoning that assumes a correlation between acts or utterances and certain outcomes. A rain dance is a very basic example: the belief that dancing in a particular pattern will cause rain clouds to appear. Magical thinking confuses coincidence with causality – assuming actions are related to an outcome when they are not. Magical thinking is based in human nature: assuming patterns and seeing connections between events and actions enabled humans to evolve. “Survival requires recognizing patterns – night follows day; berries that color will make you ill.” The US government has engaged in significant magical thinking in Afghanistan. For the last ten years, military and civilian leaders have promised that if something was built, or a certain area of the country was “cleared” of militants, or if some other singular event like a presidential election took place, the war would be won. It was the political equivalent of a rain dance – rather than understanding the complex reasons why bad things happened in Afghanistan, policymakers chose to assume that simple fixes could produce victory. The result was expensive – not just in lives, but in money. For example, the Kajaki Dam in Helmand and road construction.
2. **Understand the environment.** Counterinsurgency advocates have insisted for years on the importance of understanding the enemy and the population where you're working. It is a lesson the US Army is trying to internalize. Colonel Thomas Roe, then director of the US Army's Center for Lessons Learned, said in an interview that troops need to adopt a more cultural approach to fight effectively in places like Afghanistan: “That goes very deep in the sense that one village may be different culturally from the next one.”<sup>1927</sup> However, this understanding has most often taken the form of crash courses in “culture” during pre-deployment training for some soldiers. Tens of thousands of other civilians have also served in Afghanistan, but one would be hard pressed to identify where increased cultural understanding has become practice. The US government's approach to understanding Afghanistan is based on superficial assumptions and does not account for what Afghans already know.
3. **The war is a political conflict.** If one thing has been missing from US policy in Afghanistan, it is Afghan politics. US officials routinely complained about the behavior of Afghan President Hamid Karzai. These complaints became widespread enough that one general was relieved of his

---

<sup>1927</sup> Wollan, Malia (2012). “Duplicating Afghanistan From the Ground Up,” *The New York Times*, April 14. <http://www.nytimes.com/2012/04/15/us/duplicating-afghanistan-from-the-ground-up.html>.

command for speaking them too freely.<sup>1928</sup> US officials complained about Hamid Karzai because they did not understand Afghan politics. Karzai's domestic political context makes his behavior understandable, even predictable. Understanding why Afghanistan's political leaders behave the way they do is critical to creating policies and plans that will work most effectively with them.

4. **A failure to plan.** The US war in Afghanistan suffered from a failure to enact plans that make sense to regular Afghans. This failing took many forms: by building schools, roads, and hospitals but not providing any way to sustainably maintain them; by creating a cash economy but not devising a system of accountability to limit corruption; and by sending outsiders to administer communities they did not understand. The US has focused much of its effort on infrastructure development. This was most clearly articulated by Rory Stewart, then running a small NGO in Afghanistan and now a British Member of Parliament. In 2007, he made a bold suggestion for how to approach Afghanistan: "To win [Afghans] over we should focus on large, highly visible infrastructure to which Afghans will be able to point in 50 years – just as they point to the great dam built by the United States in the 1960s." It was a startling argument, especially considering the essay argued forcefully for limiting Western ambitions in Afghanistan. The US-led reconstruction of Afghanistan has focused on visible, easily measured construction projects but has neglected what effect those projects have had: do more people drink clean water, have electricity, access medical care, and learn to read?
  
5. **Real success only matters over the long term.** If the US government had planned in 2001 on staying in Afghanistan through 2014, it would have made very different plans for the country than what has happened in the years since. The old cliché about Vietnam – it was not a ten-year war but a one-year war fought ten times – applies to Afghanistan as well. Planning cycles rarely accounted for events more than 12 months into the future, which means the long-term consequences of any given policy were largely ignored. As soldiers arrived on the battlefields of Afghanistan, they faced enormous expectations to show "progress." It was an impossible situation: the military's counterinsurgency strategy required, by all accounts, years to implement and even longer to succeed. Yet officers were pressured, both by political considerations in Washington and command expectations in Kabul, to accomplish big objectives in very short timeframes. Because it is rare for a tour of duty to last more than 12 months, commanders were severely constrained in what choices they could make. It is difficult to be slow and deliberate when one must show progress, right now, in time for a Congressional

---

<sup>1928</sup> MacAskill, Ewan and Declan Walsh (2011). "Hamid Karzai claims on TV his country 'will side with Pakistan if US attacks,'" *The Guardian*, October 23. Accessed September 7, 2015.  
<http://www.guardian.co.uk/world/2011/oct/23/hamid-karzai-us-pakistan-afghanistan>.



hearing or a strategic review. These pressures constrained incentives and shaped day-to-day decision making.<sup>1929</sup>

None of the assumptions policymakers employed in planning for the war matched the reality of the war. As a result, the Afghan war lurched from policy to policy without any strategic plan to ensure long-term success ... In designing a proper strategy, one must start with the desired end state and work backward from there to develop the means by which you arrive at that end state.<sup>1930</sup>

Perhaps the most important lesson – and a theme of this book – is that little attention has been given to the role and importance of ICT as an enabler of COIN, stability, reconstruction, and development operations, which is covered in the next subsection.

## Lessons Regarding the Importance of ICT in Stability, Reconstruction, and Development Operations

With the arrival of the Information Age, ICT has emerged as a game changer in post-conflict stability, reconstruction, and development operations. Its importance to mission success competes with – or is lesser than – priorities for roads, power, and water. ICT is both a key player in supporting the intervening civil-military elements communications, collaboration, and information-sharing needs and an enabler of the affected nation’s recovery of security and governance. ICT underpins and accelerates development in all other sectors, generates income for the affected nation (from spectrum auctions, license fees, and tax revenues), and creates well-paying jobs. Overarching points are numbered for organization and readability, but the bulleted information below the numbered points is equally important.

1. ICT has become the most dynamic growth sector in the world economy over the past twenty years. Converging elements instrumental in the growth of what has become known as the Information Society include:
  - The increased sophistication of “computing” is transforming administration and business practices throughout the industrial world.
    - This has enabled new kinds of administration, different relationships between governments and citizens, and new ways of producing and distributing goods and services.
  - The Internet and the World Wide Web add enormously to the impact of computing by making it cheap and easy to share information between computer users anywhere in the world.
    - Social networking (e.g., Twitter and Facebook) and Web 2.0 and beyond services enabling any user to publish online and make it far easier for social, political,

---

<sup>1929</sup> Foust, Joshua (2012). “Five Lessons We Should Have Learned In Afghanistan,” American Security Project Perspective, July. Accessed September 7, 2015.

<https://americansecurityproject.org/ASP%20Reports/Ref%200066%20-%20Five%20Lessons%20We%20Should%20Have%20Learnt%20In%20Afghanistan.pdf>.

<sup>1930</sup> Ibid.

- and other groups to organize activities including participation in governance (and protests against governments).
  - Mobile phones are pervasive and increasingly complex devices, offering users many complementary services as well as telephony.
    - They are the primary mode of Internet access and of access to social networking for many people in developing countries.
    - They enable people to communicate at will with one another, transforming their ability to access resources and to coordinate with one another.
  - Changes in ICT are accelerating, but it needs to be recognized that ICT improvements have not necessarily been matched by productivity enhancements in the private sector, so technology alone is not enough.<sup>1931</sup>
2. Underlying requirements for ICT make positive contributions to reconstruction and development.
- Leveraging developmental value from communications requires infrastructure, including backbone and access infrastructure in-country and connectivity to international networks:
    - The importance of access to fiber optic cable, rather than reliance on satellites for international connectivity, has become clear from recent experiences.
    - Broadband infrastructure is now regarded as the necessary standard for future international competitiveness.
  - Growth in network deployment, access, and services are best secured through an enabling environment that encourages private sector investment.
    - International communications businesses have become keen to invest in developing markets and have invested in post-conflict markets more quickly than those in other infrastructure sectors.
    - It is important to recognize the potential for rapid returns on investment and be willing to respond to high levels of demand for communication services, especially among diaspora and refugee communities.
    - Propensity to invest is increased by legal frameworks that encourage competition and by regulatory regimes that afford predictability and reduced regulatory risk.
  - The capacity of developing countries, including post-conflict countries, to take advantage of communications opportunities depends substantially on underlying social and economic factors.

---

<sup>1931</sup> Kelly and Souter, 2014 (with minor grammatical and other small changes for consistency and ease of readability).

- ICT alone cannot compensate for shortages of skills, from literacy to computer maintenance; for lack of capital to start and develop businesses, or for lack of confidence in security and prospects for the future.
      - The increasing role of ICT can exacerbate the impact of shortages and weaknesses on national development, increasing rather than reducing divides within society.
    - There is a need for the ICT sector to be integrated into government-wide strategic approaches to social and economic development, poverty reduction, and/or post-conflict reconstruction:
      - Governments in many countries have developed national ICT strategies: some have been aspirational and [have not] always been well integrated with other government or donor agendas.
      - Institutional frameworks for implementation [are] often weak: the underlying communications environment – the adoption and use of ICT by citizens – uncertain.<sup>1932</sup>
3. In stability, reconstruction, and development operations, there is a need to ensure the affected nation can recover or build an ICT-savvy workforce with a depth and breadth of both professional and technical knowledge.
- Skills needed include but are not limited to:
    - Hardware, including computer assembly and maintenance; troubleshooting and repair; and networking.
    - Software, such as database development and maintenance; data protection and recovery; and mobile applications development.
    - Internet technologies, including website development; online portal management; electronic (e-)services and e-commerce;
    - Network management and cybersecurity acumen, such as performance and network monitoring; incident handling and response; public key infrastructure; and cyber defenses.
    - Social media, including online safety, privacy, and rights as well as digital diplomacy;
    - Innovation and entrepreneurship;
    - “Soft skills,” like communication; business writing; management; interpersonal relations; critical thinking; project and program management; financial management; and English language skills.
    - Internationally recognized certifications.
  - Early recovery of ICT capacity development in both academic and vocation education and training is critical.

---

<sup>1932</sup> Ibid.

- If needed (as was the case in Afghanistan), ICT training for citizens should be developed and provided at no or low cost.
  - It is important to recover or build a CIO cadre and culture within the affected nation's government.
  - Consider using diaspora skills such as the [Society of Afghan Engineers](#) and expertise – ICT and other - that has left country but is willing to return to help.
4. There is a need for emerging nations such as Afghanistan to develop not only a Critical Infrastructure Protection (CIP) program for the ICT sector, but, more importantly, because of greater reliance on IT systems and their use to control other systems – such as the use of SCADA<sup>1933</sup> systems to control the power grid, management information systems for an affected nation's treasury and financial institutions, and IT-based emergency services and overall national governance systems – there is a need to establish a Critical Information Infrastructure Protection (CIIP) program as well.
- Countries need to protect ICT networks and services from natural hazards, technology hazards, and terrorist attacks. Further, they need to:
    - treat ICT as a critical national infrastructure that supports their national security and the country's economic, political, and social life.
    - develop a critical ICT infrastructure protection strategy and plan.
    - include a national cybersecurity strategy and a cyber defense program.
  - Countries need to manage risks – physical and otherwise – resulting from globally interconnected networks and related interdependences, vulnerabilities, and threats.
    - Insurgents can and do use ICT to command and control their own operations but also for extortion, corruption, disruption of intervening forces' operations, and undermining the security and stability of the affected nation trying to recover and transition to sustainment of peace and security.
    - Insurgents can and do leverage the power of social networking tools to shape and influence perceptions to support their goals.
    - It is important to manage the impacts of use of Arab Spring-like social media (Twitter, Facebook, etc.) actions to shape conflict and political violence within and across countries.
  - Countries need to develop an ICT support strategy and plan for emergency response command and control, to include:
    - incident command centers and supporting communications and information systems.
    - a national response plan like that of the USG, along with a supporting ICT strategy, plan, and capabilities.

---

<sup>1933</sup> Supervisory control and data acquisition, a system using communications signals for remote monitoring and control.

- deployable ICT capability packages – fly away ICT kits – for both the public and private sectors.
  - civil emergency training and exercise program and capabilities.
5. There is a growing body of evidence of the economic impact of ICT in developing countries. For example:
- A 2005 Vodafone report found that increasing mobile phone penetration in Africa by 1 percent can increase economic growth by as much as 6.75 percent.<sup>1934</sup>
  - A 2005 case study from India suggested the Indian mobile services industry contributions led to the creation of 3.6 million jobs and some billions of dollars per year in import duties, licenses and spectrum fees, and taxation revenues.<sup>1935</sup>
  - A 2007 study in the Kerala state of India found that the use of mobile phones among fisherman ... resulted in increased incomes for the fisherman.<sup>1936</sup>
  - A Deloitte 2008 report noted mobile telephony increased gross domestic product (GDP) in developing countries 3.7 percent to 6.2 percent.<sup>1937</sup>
  - In 2009, the World Economic Forum estimated for every dollar invested in broadband (fixed and wireless), the US economy was expected to see a tenfold return.<sup>1938</sup>
  - In 2012, Deloitte reported a 10 percent change from second- to third-generation mobile broadband service (2G to 3G) increased GDP per capita by 0.15 percent.<sup>1939</sup>
  - The World Bank reports a 10-percent increase in broadband Internet penetration in developing countries is estimated to correspond to a 1.38 percent increase in GDP.<sup>1940</sup>

---

<sup>1934</sup> Vodafone (2005). *Africa: The Impact of Mobile Phones*. The Vodafone Policy Paper Series, Number 2, March 2005. Accessed March 4, 2016. <http://www.itu.int/osg/spu/dtis/documents/Papers/vodafonepapers.pdf>.

<sup>1934</sup> Deloitte (2008). *Economic Impact of Mobile Communications in Serbia, Ukraine, Malaysia, Thailand, Bangladesh and Pakistan*. January 2008.

<sup>1935</sup> Lewin, David and Susan Sweet (2005). *The economic benefits of mobile services in India*. Ovum, January 26. Accessed June 7, 2014. [http://www.kiwanja.net/database/document/report\\_economic\\_india.pdf](http://www.kiwanja.net/database/document/report_economic_india.pdf).

<sup>1936</sup> Jensen, Robert (2007). "The Digital Provide: Information (Technology), Market Performance, and Welfare in the South Indian Fisheries Sector." *The Quarterly Journal of Economics*, 122 (3): 879-924. doi: 10.1162/qjec.122.2.879.

<sup>1937</sup> Deloitte (2008). *Economic Impact of Mobile Communications in Serbia, Ukraine, Malaysia, Thailand, Bangladesh and Pakistan*. January 2008. Accessed June 7, 2014.

[https://www.telenor.rs/media/TelenorSrbija/fondacija/economic\\_impact\\_of\\_mobile\\_communications.pdf](https://www.telenor.rs/media/TelenorSrbija/fondacija/economic_impact_of_mobile_communications.pdf).

<sup>1938</sup> World Economic Forum (2009). *ICT for Economic Growth: A Dynamic Ecosystem Driving The Global Recovery*. Accessed September 7, 2016. [http://www3.weforum.org/docs/WEF\\_IT\\_DynamicEcosystem\\_Report\\_2009.pdf](http://www3.weforum.org/docs/WEF_IT_DynamicEcosystem_Report_2009.pdf).

<sup>1939</sup> Deloitte LLP (2012). *What is the impact of mobile telephony on economic growth?*, November 2012. Accessed June 7, 2014. <http://www.gsma.com/publicpolicy/wp-content/uploads/2012/11/gsma-deloitte-impact-mobile-telephony-economic-growth.pdf>.

<sup>1940</sup> World Bank (2009). *Information and Communications for Development: Extending Reach and Increasing Impact*. World Bank. © World Bank. <https://openknowledge.worldbank.org/handle/10986/2636>. License: CC BY 3.0 IGO." Accessed July 7, 2016.

- Raising broadband penetration in emerging markets to current Western European levels could add US\$300 to US\$420 billion in GDP and create 10 to 14 million new jobs.<sup>1941</sup>

Quantifying the impact of ICT on stability, reconstruction, and development operations can be difficult. Measures for assessing it are lacking and inconsistent. Evidence remains largely anecdotal, and the link between ICT deployment and reconstruction and development remains vague, though increasingly less so. However, there is no doubt ICT supports governance, increases transparency and accountability, improves service delivery, fosters inclusiveness, and accelerates economic growth.

In Afghanistan, the ICT sector, with annual revenue of US\$200 million, is the second-largest source of revenue for the Afghan government, accounting for ten percent of its total revenues.<sup>1942</sup> The ICT sector is also one of the largest employers in Afghanistan, providing upwards of 200,000 direct and indirect jobs,<sup>1943</sup> and paying some of the highest wages in the country. In Afghanistan, a one-percent increase in teledensity can arguably be correlated to approximately a three-percent increase in GDP, which is since significant donor funding still accounts for more than 75 percent of Afghanistan's annual budget.<sup>1944</sup> According to William Byrd, in a report for the United States Institute for Peace, "The degree of ambition of Afghanistan's technocratic reforms, and to a considerable extent the progress in their implementation, have exceeded expectations, especially for a low-income, conflict-affected country."<sup>1945</sup> Former Vice Chairman of the US Joint Chiefs of Staff General James "Hoss" Cartwright went even further, stating in 2013, "As we leave Afghanistan, the thing that will most affect that culture over the long term is leaving behind that network and those cell phones ... and the introduction of that technology is probably far more lasting than anything else ... and far more influential."<sup>1946</sup>

---

<sup>1941</sup> itu4u (2015). "Digital Divide Progress Report: 15 Year Review." *itublog* (blog), August 26.

<https://itu4u.wordpress.com/2015/08/26/digital-divide-progress-report-15-year-review/>.

<sup>1942</sup> Islamic Republic of Afghanistan Ministry of Communications and Information Technology (MCIT) (2014). *The Ministry of Communication and ITs' [sic] activities and achievements report 1381-1393 (2002-2014)*, English version, 32 (not available electronically).

<sup>1943</sup> *Ibid.*: 39.

<sup>1944</sup> Shevory, Kristina (2016). "Once a Bright Spot, Afghan Telecoms Face Unustainable Losses." *The New York Times*, April 8. Accessed July 7, 2014. <http://www.nytimes.com/2016/04/09/business/international/once-a-bright-spot-afghan-telecoms-face-unsustainable-losses.html?ref=business&r=0>.

<sup>1945</sup> Byrd, William A (2016). *Technocratic Reforms in Afghanistan: Benefits and Limitations*. United States Institute of Peace, *PeaceBrief* 209, July 5, 2016. Accessed September 7, 2016.

<http://www.usip.org/publications/2016/07/05/technocratic-reforms-in-afghanistan-benefits-and-limitations>.

<sup>1946</sup> Reed, John (2013). "Let freedom ring: Gen. Cartwright says 4G [sic] is America's lasting legacy in Afghanistan (Updated)." *Foreign Policy*, January 24. Accessed January 6, 2016. <http://foreignpolicy.com/2013/01/24/let-freedom-ring-gen-cartwright-says-4g-is-americas-lasting-legacy-in-afghanistan-updated/>.

## Lessons Regarding the US Government's and International Community's Roles and Shortcomings in ICT-Enabled Interventions

The power ICT needs to be more effectively leveraged by the civil-military elements participating in interventions and supporting post-conflict stability, reconstruction, and development. Despite the importance of ICT in post-conflict stability, reconstruction, and development operations and the demonstrated economic impact of ICT (see previous subsection), US Government (USG) and international policy have yet to formally recognize the role and importance of ICT, and neither have changed their ways of doing business to incorporate ICT into intervention planning or operations. This section imparts examples of lessons observed in real-world operations, by others and by the Senior Telecom Advisor and Telecom Advisory Team (STA/TAT), regarding the US Government's and International Community's roles and short-comings in ICT-enabled interventions.

1. The USG and International Community do not formally view or treat ICT as “critical infrastructure” and an “essential service.” Its importance to mission success competes with – or is lesser than – priorities for roads, power, and water.
  - The STA/TAT were successful in having NATO's International Security Assistance Force (ISAF) recognize ICT as critical infrastructure and an essential service as codified in ISAF Operations Plan 38032 Revisions 6 and 6.2.
  - The STA/TAT was also successful in having the Afghan government consider ICT critical infrastructure and an essential service, as evidenced by the Afghan National Security Council's July 2011 directive<sup>1947</sup> to the Ministry of Communications and Information Technology to:
    - protect ICT infrastructure.
    - report to the government all damaged and out-of-service infrastructure and require all ICT license holders to comply;
    - provide and restore uninterrupted 24x7 telecommunications service; and
    - provide landline telephone connections to all Afghan government personnel nationwide.
  
2. The USG and International Community do not view or treat ICT as an enabler of affected nation governance, meaning the allocation and management of resources to respond to collective problems characterized by the principles of participation, transparency, accountability, rule of law, effectiveness, equity, and strategic vision,<sup>1948</sup>

---

<sup>1947</sup> Islamic Republic of Afghanistan Office of National Security Council (ONSC) Directorate of Interior Affairs (2011). *Security Strategy for Telecommunication Networks in the Territory of GIRoA*, July 31.

<sup>1948</sup> Wentz, Larry and Lew Shadle (2012). “Information and Communications Technology (ICT) Support to Stability Operations.” Draft (version 3) white paper for the Defense Information Systems Agency (DISA), May 2.

3. The USG and International Community do not view or treat ICT as an engine of socio-economic development and growth or as a facilitator of progress in other sectors such as agriculture, finance, education, healthcare, and gender equality (as relayed elsewhere in this book).
4. The USG and International Community do not give the appropriate attention to nor leverage ICT as an enabler of information sharing, which is vital to complex operations.
5. The USG and International Community lack formal post-conflict ICT policies, doctrines, and response plans.
  - There is no agreed-upon USG and/or International Community ICT strategy, architecture, or plan for enabling affected-nation ICT sector reconstruction and the use of ICT infrastructure and services to support civil and military mission needs.
  - USG and international ICT-related response actions tend to be ad hoc and reactive, are stovepiped, and are driven by organization and personnel cultures.
  - There is no clear mapping of responding stakeholder organizations' roles and responsibilities.
  - Program development, project coordination, information sharing, and implementation are largely uncoordinated and non-standard.
  - Donors and civil-military interveners do not view ICT as a high priority that should be addressed early and used as an enabler of cross-sector reconstruction and development.
6. The USG and International response community have not systematically leveraged commercial industry and international organizations such as the United Nations, International Telecommunication Union and the World Bank, which have processes and best practices for recovering an affected nation's ICT sector and using ICT as an enabler of cross-sector reconstruction and development.
7. The USG and International Community do not categorically or systemically include ICT as a component in their overarching stability, reconstruction, and development operations or as a priority area of their programs and projects (e.g., the Afghan National Solidarity Program, Commander's Emergency Response Program, ISAF and USG Provincial Reconstruction Teams, etc.).
8. Intervention activities suffer from a lack of adequate understanding by the USG and International Community of the affected nation's information culture and related ICT business (government and private sector) culture.
9. There is not an agreed-upon ICT-related strategic communications initiative to inform the affected nation of ICT services and benefits and things that have been done to improve local quality of life through the implementation of ICT and the provision of ICT and e-services.



## Lessons Specific to the US Government

Despite laudable efforts by many within the USG<sup>1949</sup> to facilitate the transformation of policy, doctrine, and actions supporting the importance and power of information and ICT in stability, reconstruction, and development operations, ad hoc solutions continue to be the norm. Additionally, not enough senior-level attention has been given to the importance of civil and commercial ICT as a provider of services for civil-military mission support and as an enabler of affected nation recovery.

1. The USG has not developed formal ICT policies, doctrines, directives, or response plans for post-conflict interventions. The USG has limited institutionalized civil-military operations arrangements to meet needs of ICT support for post-conflict and crises operations. In the absence of such:
  - actions are largely reactive versus having a proactive unity of effort.
  - actions tend to be driven by senior political leaders who resort to dialing 1-800-Military.
  
2. The USG lacks a comprehensive “smart power” strategy that employs ICT as a key enabler in post-conflict stability, reconstruction, and development operations.
  - There is a lack of USG senior-level ICT “thought leadership” and “strategic thinking” to support ICT-enabled intervention leadership and to develop strategic partnerships and trust relationships with key ICT leadership counterparts of affected nations.
  - Basic stability operations concepts and constructs for leveraging ICT vary significantly between various DoD/Joint/COCOM/Service/Coalition organizations and civilian organization counterparts.
  - Service schools, research centers, think tanks, and universities need to be engaged to provide strategic thinking, concept development, and education prior to interventions and to assess and document lessons observed during and after them.
  
3. There is no long-term USG sponsor or designated lead agency for ICT.
  - Players include the DoD, DISA, COCOMs,<sup>1950</sup> DoS/USAID, DoC, USTDA, FCC-IB, DHS, and others but who has the lead role and when? The DoS, USAID, and the DoC have been reluctant to take the lead to sponsor and manage a Telecom Advisor function for post-conflict interventions.
  - The DoS and DoD led ad hoc, temporary Telecom Advisor function activities in Iraq and Afghanistan.

---

<sup>1949</sup> NSPD-44, S/CRS now CSO, DODIs 3000.05 and 8220.02, MNF-I DCS CIS ICCE/ISE, BTA/DISA Iraq ICT Team, US Embassy STA/ARG and ARO at the Pentagon, and ISAF STA/TAT and Reachback in CONUS, all of which have been described in this book.

<sup>1950</sup> Combatant commands

- In Iraq, the US Embassy and USAID Mission had senior consultants on their staffs providing ad hoc Telecom Advisor-like functions and the MNF-I ICCE/ISE teams provided Telecom Advisor like functions as well.
  - In Afghanistan, the DoS, as part of an ad hoc agreement among the NSC, DoS, and DoD established the Afghanistan Reconstruction Group (ARG) that included a Telecom Advisor function at the US Embassy. The DoD with the support of DoS/USAID sponsored the establishment of the STA/TAT at ISAF Headquarters.
4. Policy and doctrine are non-existent with regards to ICT-enabled interventions.
- Doctrinal policy outlined in policy documents such as NSPD-44 and DODIs 3000.05 and 8220.02<sup>1951</sup> have not been fully codified into DoD/Joint doctrine, directives, planning guidance, capabilities, education, training, and exercises, or updated to reflect the importance of treating ICT as critical infrastructure and an essential service and the role and importance of ICT in post-conflict stability, reconstruction, and development operations.
  - Doctrine does not yet address or institutionalize intervention arrangements to include ICT advice and assistance.
  - No doctrinal baseline exists for COCOMS or JTF Commanders to tailor Stability Operations civil and commercial ICT activities, resources, and desired outcomes to diverse operational environments.
5. The USG needs to develop ICT profiles for affected nations and countries into which it plans to intervene, to include but not be limited to:
- ICT organizations and key go to leaders in both the public and private sectors;
  - ICT policies, regulations, and laws;
  - ICT architectures, strategies, and plans;
  - ICT business culture;
  - ICT infrastructure and services baseline; and
  - ICT suppliers and points of contact.
6. The USG needs to establish trust relationships within the ICT sector in advance of an intervention, to include:
- key government ICT leaders (e.g., the minister of communications and the head of the regulator);
  - leaders of any state-owned ICT service providers;
  - key government personnel in other sectors; and

---

<sup>1951</sup> Based on author discussions with DoD CIO personnel, DoD is working on revisions to DODI 8220.02 to better address ICT as an essential service and critical infrastructure protection for USG OCONUS activities.

- contacts at commercial ICT companies.

Knowing the right people can be a major advantage to facilitate support to the ICT sector.

7. There is a need for USG civilian commercial ICT professionals to deal with affected nation ICT sector counterparts. Military and civil service communications and IT staff generally lack the skills and experience to perform the specialized functions needed to provide civil and commercial ICT advice to affected nations and deal with senior people in both the public and private sectors.
  - Civilian organizations, such as non-security ministries agencies, tend to prefer civilian professionals to military personnel.
  - The ICT skills of advisors and leaders should be equivalent – or superior – to those of their ICT counterparts in the affected nation’s government and industry.
  - Social and cultural sensitivity are necessary to operate effectively.
  - The authority, responsibilities, influence, and access to senior decision makers of advisory leadership – or at least the perceptions of such – matter, as does the ability of senior advisory leadership to make things happen.
  - Advisors and their leaders should be familiar with, or at least cognizant of, international ICT standards, best practices, and resources (such as those of the ITU and from international and regional associations).
  - Understanding the business processes of the affected nation’s government and industry and who makes things happen – or stops them from happening – in the ICT sector is needed as well.
  - Advisors and their leaders need access to cultural advisors, interpreters, language trainers and translators. Staff should have some basic vocabulary and phrases they can use when interacting with the affected nation’s government employees and the population in general.

These activities are generally counterculture for military elements and not something they train to do or have policy, doctrine, and tactics, techniques, and procedures (TTPs) to support.

8. The USG’s efforts regarding ICT for post-conflict stability, reconstruction, and development operations and approaches for a Telecom Advisor (TA) capability to date have been ad hoc and reactive (see below). They have been afterthoughts rather than part of the deliberate planning process.
  - There is no designated USG spokesperson for ICT-related issues and activities nor a single ICT point of contact for the leadership of affected nations.
  - There is no designated lead to harmonize and coordinate USG ICT strategies, goals, and activities.
  - ICT and TAs have not been considered part of the military mission or training.
  - ICT and TAs are generally not included in its activities or among DoS personnel, except perhaps, as part of a larger portfolio or as tactical, project-based efforts.

- Depending on the intervention, there may be a need for more than one TA – one on the civilian side and one on the military side.
  - Transition of the TA function from a civilian lead to a military lead to a civilian lead (or vice versa) needs a concerted intervention plan and process to manage execution, withdrawal, and transition actions including who has lead roles when.
  - The successful approaches used in real-world experience have not been agreed upon nor institutionalized.
  - There is a need for ICT-related civil-military operations doctrine, training, and exercises.
  - Resourcing both people and capital investment in post-conflict interventions has been ad hoc and generally inadequate for the ICT sector and its uses.
9. There is a lack of shared situational awareness and Interagency governance for ICT initiatives.
- There are no frameworks for managing ICT initiatives and there is a lack of metrics for monitoring progress of ICT activities and measuring their outcomes and impact (not just output).
  - There is a general lack of awareness of who is doing what, where, when, why, how, and for how much in the ICT sector and for ICT support to enable other sectors.
10. Telecom Advisor operations were based in Kabul and were, thus, Kabul- and national-government-centric (in Iraq they were in Baghdad). Future interventions should include personnel in other locations outside the capital city.
- There is a need to meet with provincial, district, village, and rural leadership.
  - There is a need to work with people in other sectors that use ICT such as governance, civil security, finance, agriculture, education, healthcare, and gender equality outside of the capital city and major metropolitan areas.
  - There is a need to meet with business and industry leaders in other areas.
  - There is a need to meet the people and population they are there to help.
11. There is a need to balance risk management and force protection measures to allow TAs and ICT advisors to conduct their work in ICT for stability, reconstruction, and development operations.
- Restricted freedom of movement impacted regular interactions with affected nation ICT public and private sector counterparts:
  - Getting out of bases, FOBs, and protected enclaves to meet with affected nation elements was a challenge as the security environment deteriorated.
    - Meetings, visits, and activities in Kabul decreased or were curtailed.
    - Visits downrange ceased.
  - Having to carry weapons, wear IBA, and have guardian angels impacted the ability to deal effectively with non-security ministries and institutions such as universities.
12. The USG is not effectively mitigating international ICT competitors from other countries, particularly those who have interests counter to America's (e.g., China, Pakistan, Iran, and India).

- Other nations are filling gaps left by the lack of USG attention and the unwillingness or inability of US companies to engage.
- China is a major player in the ICT sectors in both Iraq and Afghanistan.
  - Afghanistan and China recently expanded their ICT sector cooperation agreement, which includes<sup>1952</sup>
    - ICT innovation and technology transfer.
    - Improved regional connectivity (fiber optic network).
    - ICT capacity building.
  - Two prominent Chinese companies in Afghanistan are ZTE (fiber optic network, cellular network equipment and services, etc.) and Huawei (wireless networking equipment and services, routers, LANs, etc.).
- Pakistan
  - provides the bulk of Afghanistan’s Internet services.
  - trained many Afghans working in the ICT sector, both public and private.
- Iran is very influential, especially in western Afghanistan.
  - Iran provides Internet services and cross-border connectivity.
  - An Iranian company was awarded a contract to install part of Afghanistan’s national optical fiber network.
  - Iran funded the rehabilitation and reconstruction of the MCIT’s ICT Institute in Kabul.
- The government of India financed digital telephone and wireless local loop equipment in more than ten provinces.

## Examples of US Government Ad Hoc ICT Advisory Capabilities

Following are examples of USG ad hoc approaches used in recent stability, reconstruction, and development operations to focus on the ICT sector and to harmonize and coordinate USG activities.

- Iraq
  - Office of Reconstruction and Humanitarian Assistance
  - Coalition Provisional Authority
  - US Embassy Senior Telecom Advisor (ended 2008)
  - US Embassy ECON section:
    - Telecom Working Group
    - Strategic Framework Agreement Telecom Working Group
  - Business Transformation Agency/DISA Iraq TF ICT
  - Iraq Reconstruction Management Office
  - Iraq Transition Assistance Office

---

<sup>1952</sup> MCIT (2016) “Afghanistan and China Expands [sic] cooperation in ICT sector,” June 28. Accessed July 11, 2016. <http://mcit.gov.af/en/news/58050>.

- Iraq MNF-I DCS CIS organization elements:
  - Iraq Communications Coordination Element (ICCE, created by BG Spano)
  - Infostructure and Strategic Engagement (ICCE-like continued by BG Brundidge and Admiral Simpson)
- Afghanistan
  - Afghanistan Reconstruction Group (ARG)
    - US Embassy Senior Telecom Advisors (ended 2008)
    - Key leader engagement lead for MoC/MCIT, TRB/ATRA, AfTel and private sector (MNOs and ISPs)
    - I-Team
      - Interagency and ISAF/Combined Forces Command-Afghanistan ICT coordination
    - Reachback at Pentagon and ASD-NII/DoD CIO and NDU support element
  - US Embassy Integrated Civil-Military Action Group
  - ISAF Senior Telecom Advisor and Telecom Advisory Team (STA/TAT)
    - Key leader engagement lead for MCIT, ATRA, AfTel, and private sector (MNOs and ISPs)
    - Reachback element in CONUS
  - US Embassy ECON section Telecom Working Group
  - US Embassy Public Affairs section
  - US Embassy Political-Military (Pol-Mil) section
  - US Embassy Transition Working Group

ICT is indisputably crucial to USG and international civil-military mission success, yet its stature – or lack thereof – is not commensurate in USG or international policy, doctrine, planning, training, or execution. The power ICT needs to be more effectively leveraged by the civil-military elements participating in interventions and supporting post-conflict stability, reconstruction, and development operations. Approaches need to be comprehensive and collaborative and be agreed-upon, formalized and codified by the USG and International Community.

The STA/ARG, MNF-I ICCE/ISO, and STA/TAT were good concepts and their implementations and execution helped to achieve successes for the US Government's (USG's) missions and the stability, reconstruction, and development of Iraq and Afghanistan. The concept of a Telecom Advisor capability needs additional work to define the function and its mission, formalize approaches to consider, and establish official participation, command, and support arrangements. The USG needs to identify core capabilities and organization alignment to enable a TA to be a trusted advisor and provide professional civil and commercial ICT-related advice and assistance for USG mission needs and for affected nation ICT sector recovery and reconstruction. This will require policy to set the conditions, doctrine to establish how to do it, and institutionalization of the approach to establish the capability, including organizing, equipping, and exercising, as well as training both leadership and team to execute in a real-world event.

## Lessons Regarding Information Sharing

The importance of information sharing in complex operations “has been repeatedly demonstrated in recent years,” according to the Center for Technology and National Security Policy (CTNSP) at the US National Defense University (NDU).<sup>1953</sup> The CTNSP has spent years researching how to “foster UNCLASSIFIED information sharing in the field in post-conflict, post-disaster and development environments.”<sup>1954</sup> It contends, “if U.S. or coalition forces cannot communicate, collaborate, or exchange information with the population they seek to influence, they cannot achieve the social, political, and economic goals for which the forces were committed.”<sup>1955</sup> The CTNSP further asserts that “incentivized information sharing is vital to complex operations and that creating environments conducive to information sharing benefits U.S. military and U.S. government objectives while also helping coalition partners, international organizations, non-governmental organizations (NGOs) and the local community.”<sup>1956</sup> The CTNSP also insists “democratic process and civil society ... depend on information sharing and continuous information flow.”<sup>1957</sup>

Examples of information sharing approaches implemented for use in Afghanistan include:

- The **Combined Information Data Network Exchange (CIDNE)** was a classified platform provided by USCENTCOM/ISAF for organizing knowledge to be able to answer fundamental questions about the environment in which the Coalition operated. CIDNE was core to the ISAF Headquarters and ISAF Joint Command information environments.
- The **International Distributed Unified Reporting Environment (INDURE)** was provided by USCENTCOM/ISAF as a standardized way for NGOs, USAID, DoS, and PRTs to report on observations and analysis outside of DoD networks as well as to provide releasable DoD information back to those organizations for force protection and planning purposes.
- **Ronna**, which means “guiding light” in Dari, was a USCENTCOM/ISAF Internet web portal to enable collaboration and information sharing among the full-spectrum of partners working to build a peaceful, prosperous, and democratic state in Afghanistan. Ronna was used to bridge the information gap that existed among the many governmental and non-governmental organizations, as well as for Afghan partners working in and for Afghanistan toward a common goal. Ronna was hosted by All Partners Access Network (APAN).

---

<sup>1953</sup> CNI Technical Services, LLC (2011). Research and Analysis Project for UNCLASSIFIED Information Sharing in Afghanistan: A Model for US Military and Coalition Commanders, the US Intelligence Community, and US Homeland Security. Prepared for the Center for Technology and National Security Policy (CTNSP) at the National Defense University (NDU) on behalf of the Intelligence, Surveillance, Reconnaissance Task Force (ISR TF), January 28, 2011. Contract # SP4705-10-C-0055.

<sup>1954</sup> Ibid.

<sup>1955</sup> Ibid.

<sup>1956</sup> Ibid.

<sup>1957</sup> Ibid.

- The **Afghanistan Country Stability Picture (ACSP)** GIS database was initially a US Embassy, CFC-A/CSTC-A and US Army Corps of Engineers initiative in 2006 that was transferred to ISAF to manage to provide countrywide information and visibility on reconstruction and development projects. It was eventually migrated to INDURE.
- The **Humanitarian Assistance Response Monitoring and Operations Network-Internet Enterprise (HARMONIEWeb)**, originally developed for HA/DR operations, was a DoD and USJFCOM initiative that provided an Internet-accessible environment for the exchange of unclassified information across the civil-government boundary associated with stability, security, transition, and reconstruction operations.<sup>1958</sup>
- **USAID's website**, specifically the [Afghanistan page](#), provides information on reconstruction projects they sponsor and fund. Also, the USAID Performance Management Plan (PMP) program established a systematic process to: monitor and evaluate the achievements of assistance programs, collect and analyze performance information to track progress toward planned results, use performance information and evaluations to influence decision-making and resource allocation, and communicate results achieved or not attained.<sup>1959</sup>

All the systems above had their issues and limitations, and none effectively encompassed or addressed the Afghan ICT sector and related reconstruction activities. There is a need to incorporate ICT as a key element to be tracked and reported.

The sharing of information in complex civil-military operations is important, yet actors rarely do it well.<sup>1960</sup> Experience from stability operations in Afghanistan and Iraq, numerous humanitarian assistance/disaster relief missions, and efforts to build the capacity of foreign partners suggest that effective information sharing is much harder than might be expected.<sup>1961</sup> Key points are:

- Unless US and Coalition forces can share information with the populations they seek to influence in complex civil-military operations, they cannot achieve the goals for which they were committed.
- Information, communications, and related support structures influence all aspects of complex operations and need to be treated as critical infrastructures and essential services but rarely are.

---

<sup>1958</sup> Originally from HARMONIEWeb's website (now defunct) but found in the United States Joint Forces Command Joint Enabling Capabilities Command Newsletter, Vol. 2, Iss. 1, February 2009. Accessed March 10, 2016.

[http://www.jecc.mil/Portals/21/Documents/JECC\\_Newsletter\\_2009FEB-Web.pdf](http://www.jecc.mil/Portals/21/Documents/JECC_Newsletter_2009FEB-Web.pdf).

<sup>1959</sup> US Agency for International Development (2011). *USAID Evaluation Policy*, January.

<sup>1960</sup> Wells, Bosworth, Crowley, and Blachy (2013). "Sharing to Succeed: Lessons from Open Information-sharing Projects in Afghanistan." *Defense Horizons*, NDU INSS. July.

<sup>1961</sup> Ibid.



- Open information-sharing projects require sustained leadership interest plus shared and stable priorities among many parties. Absent this emphasis, changes in personnel, mission priorities, and funding levels will make it hard to develop, transition, and sustain any such effort.
- International organizations, NGOs and sometimes even Coalition partners complain that open information provided to government military sources often gets posted quickly to classified networks making it hard to retrieve and share unclassified information with non-military elements.<sup>1962</sup>

Lessons observed from Afghanistan include the following:

1. The USG lacks agreed-upon ICT leadership and mechanisms at the Departmental level to facilitate civil-military collaboration and information sharing among stakeholders including the affected nation.
2. Key to success and relationship building among civil-military individuals and organizations lies in understanding the roles, relationships, capabilities, motivations, and information sharing needs in complex environments:
  - It is important to manage expectations and to ensure that actions support words and meets shared expectations.
  - Need to get to know each other as individuals.<sup>1963</sup>
3. Conducting unclassified operations in a classified environment creates challenges.
  - The use of classified networks to document unclassified activities and store unclassified data requires the use of cumbersome and time-consuming processes to take unclassified information off classified networks to be able to share it in unclassified environment.
  - Mobile phones and personal computers (meaning non-USG or non-NATO/ISAF) are not allowed in some classified areas (e.g., the CJ6 “Circuit City” area at ISAF Headquarters), making it difficult to communicate with counterparts on unclassified networks and to use personal computers to conduct unclassified work.
    - This was the case for the STA/TAT offices in Circuit City. Nearly all the TAT’s work stream activities were unclassified.
    - The STA/TAT’s civilian ICT SME contractors conducted most of their work on company-issued laptops, which they could not use in the TAT’s offices.
    - The STA/TAT had to have data moved by ISAF to CDs to share information.

---

<sup>1962</sup> Ibid.

<sup>1963</sup> Paraphrased from Wentz, Larry (2006). “An ICT Primer: Information and Communication Technologies for Civil-Military Coordination in Disaster Relief and Stabilization and Reconstruction,” July. Available at <http://oai.dtic.mil/oai/oai?verb=getRecord&metadataPrefix=html&identifier=ADA454071>.



- Diplomacy, Defense and Development.
- Enable “Affected Nation” not do it for them.
- View ICT as an “Essential Service.”<sup>1965</sup>

## The Synergy Strike Force and the Jalalabad Project: Lessons from Open Information Sharing in Afghanistan

The Jalalabad [Open Information Sharing Pilot] Project was an experiment conducted by the Synergy Strike Force (SSF; see [Chapter 12](#)) to test theories regarding effective unclassified information sharing and to demonstrate the effectiveness of enhanced connectivity. “The intent was to establish relationships and provide connectivity for actors on the ground, incentivize information sharing, and act as a catalyst for increased coordination, connectivity, and collaboration.”<sup>1966</sup> The aim was to prove that opening channels for information sharing helps to establish relationships and, as a result, increases synergy among different social actors for more effective humanitarian relief, development, and security.

For the Jalalabad Project, the Synergy Strike Force chose a guesthouse near Jalalabad as a “neutral space” where social, cultural, and bureaucratic barriers could be reduced and a technological infrastructure for information sharing could bring significant value. Initially, guesthouse had satellite-based Internet connections and employed wireless technologies to proliferate access. The pilot identified the following basic findings about effective information-sharing:

- People are more important than technology to bridge social and cultural divides, such as those between Coalition forces and the Afghans.
- Open Internet connectivity itself can facilitate social collaboration and knowledge creation. Many DoD and NGO personnel did not have access to the open Internet in their work environments because they could not afford wideband connectivity in the field or for policy reasons could not access the open Internet. Providing bandwidth, strengthening local computing power, working with available technologies even if only mobile phones, and providing stable power supplies helped reinforce personal relationships that facilitated further sharing.
- Incentives are important. The combination of maps, imagery, an open-hosting platform (computer), and bandwidth, as well as food, drink, and a neutral social space brought together a diverse set of actors who then shared information across their organizational boundaries.
- The project demonstrated that more parties find constructive uses for information and network access than destructive uses.
- Incentivized responsible sharing of open information is a core element in building sustainable socio-economic capacity in partner nations, whether in contested or uncontested environments.

---

<sup>1965</sup> Ibid.

<sup>1966</sup> CNI Technical Services, 2011.

Further, based on its experience in the field, SSF proffered the following broad lessons it learned with regards to information sharing. They are excerpted, paraphrased, and summarized from a report<sup>1967</sup> about the Jalalabad Project and various documents shared by the SSF.

### *The Jalalabad Project*

1. Synergists, who are individuals that bridge gaps among systems, organizations, and individuals and engage in problem solving with local stakeholders, are critical to success and must be neutral, come from, and operate outside all bureaucratic systems.
2. Facilitators are equally important. They create the necessary operational space and provide the resources for synergists to engage in creative problem solving, and provide top cover in dealing with large institutions.
3. Mobility and freedom of movement, providing the ability to share information face-to-face, are key enablers of successful operations.
4. The “battle space” for synergy operations includes neutral space, like the Taj, where people can meet, build relationships, share information, and collaborate as well as sufficient operational space, free from bureaucratic constraints. The model should be similar to special operations work where teams are given cover to perform a mission and allowed individual judgment as to how conduct it.
5. Provide incentives for sharing information. In complex operations in which collaboration is essential, protecting institutional turf undermines the overall mission.
6. Connectivity is not an end-state in and of itself, but open Internet is a crucial enabling tool. Providing bandwidth to a community of locals and internationals, and building relationships among them, are preconditions for sharing data and information and creating an environment where sharing is socially viable.
7. Connectivity is value-neutral but its benefits outweigh its risks.
8. Tagging information with metadata (who, what, where, and when) improves its accessibility and usability, which synergists can encourage. However, it is important to be flexible and accept unstructured and imperfect data. Various tools exist to assist in tagging and structuring data, both at and after submission.
9. Synergy operations require direct funds designated for the operational and recurring costs for Internet-reliant efforts to circumvent the constraints and delays bureaucratic acquisition policies.
10. New metrics are needed to analyze how information flows through social networks, focusing on the existence and rate of relationships and the interactions between them, not just quantitative measurements.

---

<sup>1967</sup> Ibid.

Todd Huffman, one of the participants in the Jalalabad Project, who also has extensive collaboration experience across various environments, formulated the following three principles of information sharing as reported by the US National Defense University:

1. Create immediate value for anyone contributing data; contributors should get an immediate return for their efforts.
2. Return contributors' data to them with improvements; any data that goes in should be available to be downloaded back out again; furthermore, any data should come back better than it went in.
3. Share derivative works such as analyses, spreadsheets, charts, and reports with the data-sharing community; urge users who create derivative works from shared data to contribute their products back to the group.<sup>1968</sup>

Effective information sharing creates a positive and perpetual feedback loop among parties that continues to improve in terms of accuracy and credibility, while ineffective and non-reciprocated information sharing has the opposite effect and can be corrosive to and undermine relationships.

### *Template for Future Information Sharing Operations*

Based on those, the CTNSP created a template for future information sharing, which was designed to adaptable to local circumstances and iterative to incorporate future lessons learned. The five major elements of the template are personnel, neutral sites, partners, connectivity, and iterative project cycles, described below.<sup>1969</sup>

- **Personnel.** Information-sharing operations require both an external synergist and one or more government facilitators to address issues at senior (strategic) and field (tactical) levels.
- **Neutral sites.** Effective site selection must consider (1) a need that can be met by information-sharing; (2) mobility (freedom of movement by all parties); and (3) a social fabric open to accepting such collaboration.
- **Partners.** Successful information-sharing operations should be as inclusive as possible; however, the majority of effort should be directed toward willing and able participants rather than on persuasion of those more reluctant.
- **Connectivity.** Effective connectivity is twofold: It means having or installing the appropriate ICT infrastructure to enable communication as well as having people, policies, practices, and the relationships to facilitate and encourage the flow of information across it and between and among typical stovepipes.

---

<sup>1968</sup> Linton Wells II, James Bosworth, John Crowley, and Rebecca Linder Blachly, "Sharing to Succeed: Lessons from Open Information-sharing Projects in Afghanistan," National Defense University *Defense Horizons*, July 2013.

<sup>1969</sup> Ibid.

- **Iterative project cycles.** Information-sharing operations must be flexible to accommodate the ever-shifting dynamics of complex operations yet iterative so as to be able to continually build on relationships, successful collaborations, and mutual objectives to make measurable progress.

The ideal way to use the template is on an initial 90-day project setup where relationship-building efforts are conducted in parallel with the installation of the enabling technology is installed. Effective information-sharing operations, further, should be designed with the expectation of high staff turnover, which makes building an accessible collective institutional memory and sustaining relationships and maintaining networks imperative.

Dr. Dave Warner, MD, PhD and head of the Synergy Strike Force, summed up the criticality in a 2013 interview for *Pacific Standard* magazine in which he stated, “The most valuable information in a conflict or disaster zone ... was information that could be shared with everybody.”<sup>1970</sup> The USG and International Community must improve their information sharing attitudes and efforts to successfully achieve mission objectives. The USG, in particular, must share information to create whole-of-government and unity-of-effort interventions.

## STA/ARG and STA/TAT Lessons

The Senior Telecom Advisor at the Afghanistan Reconstruction Group (STA/ARG) and the Senior Telecom Advisor and its supporting Telecom Advisory Team (STA/TAT) were parallel entities that arose from agreements among the US National Security Council (NSC) and the Departments of Defense (DoD) and State (DoS), which operated at different points of time during the USG’s Operation ENDURING FREEDOM (OEF) and NATO’s International Security Assistance Force (ISAF) and follow-on Resolute Support Missions in Afghanistan (the STA/ARG from 2005 to 2008 and the STA/TAT from 2010 to 2014). The STA/ARG was implemented within the construct of the US Embassy Kabul under the Department of State and the STA/TAT as a USG entity sponsored by the DoD (with the support of the DoS) and located at ISAF Headquarters in Kabul. Because of their commonalities and despite their differences (see “STA/ARG and STA/TAT Comparison” in [Chapter 21](#)), there are some lessons observed by or applicable to both.

### Lessons Applicable to Both

1. The STA/ARG and STA/TAT were good concepts that were reasonably well-implemented as ad hoc experiments and learning experiences.
2. The STA/ARG’s and STA/TAT’s planning and execution of work in the Afghan ICT sector helped to achieve USG mission successes.
  - They helped USG Interagency elements understand the role of civil and commercial ICT and how to leverage it to achieve operational mission outcomes.

---

<sup>1970</sup> Calvert, Brian (2013). “The Merry Pranksters Who Hacked the Afghan War.” *Pacific Standard*, July 1. Accessed July 9, 2014. <http://www.psmag.com/navigation/politics-and-law/the-merry-pranksters-who-hacked-the-afghan-war-60873/>.

- They were trusted sources of informed situational awareness of initiatives, activities, and key players in the Afghan ICT sector.
  - They effectively coordinated with ICT stakeholders of international, regional, and national organizations and associations, particularly the United Nations and World Bank but encompassing myriad others.
3. The STA/ARG and the STA/TAT were able to demonstrate their value as facilitators and supporters of the development of the Afghan ICT sector and the use of ICT to facilitate Afghanistan’s stability, reconstruction, and growth.
- They had the commercial ICT expertise and experience to work as equals with key Afghan ICT counterparts and leadership in both the public and private sectors.
    - They were effective with and appreciated as senior advisors to the Afghan minister of communications and information technology, the chairman of the regulator, and the CEO of state-owned Afghan Telecom Corporation (AfTel) and their staffs as well ICT personnel of other government ministries and agencies.
    - They were appreciated, at least to a great extent, by the private Afghan ICT sector – particularly mobile network operators (MNOs) and Internet service providers (ISPs) – as independent experts who assist them to find their collective voices, were unbiased and did not play favorites, and were effective liaisons between them and Afghan ICT sector governance.
4. Within the USG, it is imperative the STA/TAT have top cover at the NSC, DoS, and DoD levels.
5. The STA must a visible part of the leadership or command element to be effective – s/he needs a seat at the decision-making table.
- If at the US Embassy, the STA should report to the ambassador.
  - If at the USAID Mission, the STA should report to the mission director.
  - If within a military construct, the STA should report to mission commander.
  - The STA should be a civilian from the Senior Executive Service or of an equivalent level to be able to operate in senior leadership circles.
6. The STA should be the “one-stop shop” for advice and assistance on civil and commercial ICT, a facilitator, connector, and harmonizer of Interagency, coalition forces, and affected nation ICT-related activities, and the trusted source of informed ICT situational awareness.
7. In the hierarchical, patriarchal government and business cultures of countries such as Afghanistan, incumbent leadership’s perceptions of a senior advisor’s value is extremely important.
- The authority, responsibilities, influence, and access to senior decision makers of advisory leadership – or at least the perceptions of such – matter, particularly in hierarchical cultures such as Afghanistan, as does the ability of senior advisory leadership to make things happen.

8. Team composition, personnel traits, and behavior should be substantive considerations because they can have material impacts, both positive and negative.
  - Personnel need to be able to maintain a high level of professionalism and exhibit social and cultural sensitivities when operating in complex multinational, multicultural, and high-stress environments.
  - People need to be good listeners.
  - Having civilian advisors with civil and commercial ICT expertise was important to establishing and maintaining relationships within Afghanistan’s public and private ICT sectors.
    - Advisors’ and leadership’s skills should be equivalent – or superior – to senior ICT counterparts in the affected nation’s government and industry.
    - Civilian organizations, such as non-security ministries agencies, tend to prefer civilian professionals to military personnel.
  - It is imperative to maintain independence – e.g., not favor any one MNO or ISP (or any other company, entity, or faction) over another. That means sometimes walking a fine line when state-owned institutions are involved.
  - There was sometimes a lack of passion for the mission or a poor work ethic exhibited by “volunteers” in Afghanistan. Some were there to run away from problems in their organizations or at home, just to earn extra money, or to get their “high three” for retirement.
9. The STA needs a budget (funds) to support on-site operational mission needs.
10. The need for a Telecom Advisor function did not go away with the dissolution of the ARG or the drawdown of Coalition combat forces at ISAF.

Factors observed that influenced the success of the STA/TAT and STA/ARG include:

- They had the freedom to think beyond the confines of established programs and missions.
- They employed experts able to innovate and imagine novel solutions.
- They brought entrepreneurial and economic skillsets needed for the generation of ideas and the creation of a market economy.
- They had the passion, vision, and strategies to make things happen.
- They developed strategic partnerships and made things work in a complex civilian government and business culture and military operational environment.
- They had experience working with USG Interagency and international organizations.
- They were sensitive to and willing to listen and try to understand Afghan social and ICT business cultures and develop tailored approaches.
- They had the support of senior USG leadership both at headquarters in the States and in country.



## Lessons Specific to the STA/ARG

Some STA/ARG observations regarding “dos and don’ts” for future operations are offered by James P. (Jim) Craft, the first STA at the ARG from 2005 to 2006. His lessons are as follows, noting that every situation will be different with its own nuances.

### Dos:

- Focus on the people (relationships and culture) first, processes second, and technology third.
- Make maximum effort to leverage the private sector in a collaborative manner with two-way information exchange and a win/win approach.
- Apply simple, basic professional disciplines, and technical and non-technical skills, such as program management to all aspects of the work, and teach these skills to as many affected nation personnel as possible.
- Know when to show trust and take risks to show the affected nation that you personally have “skin in the game.” Know when to go alone and unarmed into their homes but always, always keep security in mind. Know when to cut and run.
- Assume that every word you speak and everything you do will be seen by all – continually message that you are there to make the affected nation successful.
- Use a balanced portfolio management approach to all projects and investments of your time.
- Organize the engagement period and its activities by phases
  - Pre-hire process
  - Pre-deployment preparations
  - First 90 days
  - Maximum results
  - Wrap up and document
  - Transition to new job
- After the first 90 days, give continual focus to locating the right successor and processing him/her so there is an overlap for transition, especially with relationships.
- Start with the end in mind all the time.
- Foster a passion for the mission in everyone you can.
- Get out of the bunker.
- Know when to go low profile.
- Empower the success of others, especially affected nation personnel.
- Be clear who you are as an American but don’t try to make the affected nation another America.

### Don’ts:

- Assume that you have the answers – you need to get help from many others.
- Forget that even the most remote applications of ICT are part of a global ecosystem.
- Forget the total lifecycle cost of any technology we encourage. Is what we give sustainable?
- Stay inside the wire or develop a bunker mentality.
- Take the credit or brag. The STA’s success was due to the success of others.

- Go for personal gain, even in little ways. Even the gift of a nice rug may have more strings attached than you see. You can accept presents but need to ensure that you observed ethics rules without offending others.
- Forget the ultimate mission or strategic goals in the “tyranny of the urgent.”
- Forget to take care of yourself – healthy food, sleep, exercise, medical care, etc. You can’t take care of others if you don’t take care of yourself.
- Flaunt wealth. What we consider normal is great wealth in other countries. That makes you a target and creates envy.
- Create bureaucracy. There is more than enough to go around already.
- Forget basic hospitality and courtesy to all individuals you meet.
- Forget that you are an American with American values.
- Forget the basics of the affected nation’s culture.
- Forget the different agendas of the many players, including your own country team.
- Forget to say “thank you” regularly.

Additional lessons regarding the STA/ARG include:<sup>1971</sup>

1. The ARG was not a typical embassy section and its existence threatened some. There was some friction and distrust between ARG personnel and those of the US Embassy Kabul.
2. The role and authority of the STA within the embassy structure were not clearly defined and the STA lacked a support staff.
3. The arrangement of the ARG as a DoS entity whose personnel were hired by the DoD fueled interdepartmental rivalry.
4. The ARG did not have its own budget to accomplish its mission of accelerating reconstruction or to use as seed money for innovation opportunities.
5. The US country team was not focused on fostering US business.
  - There was more career benefit in the Foreign Service in getting diplomatic agreements from foreign countries by helping them get business than helping American firms get the business.
  - On-the-ground business engagement by US firms gives the US much more influence in pursuing strategic goals.
6. There were several issues regarding the STA position, which included:
  - a long and problematic hiring process followed by a rush to deploy, making for insufficient pre-deployment preparation;
  - a failure to commit to maintain the STA function; and
  - the inability to find the right successor, causing a gap in STA continuity.

---

<sup>1971</sup> Lessons specific to the STA/ARG are paraphrased from Berner, 2006 and former ARG/STA James P. (Jim) Craft’s lists of what went right and wrong as iterated in [Chapter 21](#).

## Lessons Specific to the STA/TAT

### *General Lessons*

1. The STA/TAT demonstrated its value to the military commanders of US Forces-Afghanistan (USFOR-A) and ISAF as well as to the in-country USG Interagency.
  - They were trusted advisors to COMISAF and his international staff (CJ6<sup>1972</sup> and DCOS Stability Ops, in particular).
  - They were the “go to” organization for ICT matters by ISAF, USFOR-A, the US Embassy and USAID.
  - However, turnovers in command leadership and DoS personnel came with differing perceptions of the STA/TAT and its mission and significance, causing the STA/TAT to have to prove its value over and over again.
  
2. The STA/TAT was a USG entity housed at ISAF, which became a distinction without a difference and often proved problematic.
  - The STA/TAT’s mission did not fit well into ISAF’s primarily military mission.
    - Frequent ISAF mission changes during the STA/TAT’s tenure (COIN the first year to stability operations and “advise and assist” the second to transition planning in year three followed by security force assistance; “train, advise, and assist,” and drawdown the fourth year) meant the STA/TAT had to make real-time adjustments to its strategy, plans, and modus operandi.
  - The STA/TAT was moved among several different ISAF organization elements.
  - ISAF did not seem to fully recognize the importance and role of ICT in its broader mission (e.g., as an underpinner and facilitator of security, COIN, and stability operations, which became even more pronounced as ISAF’s mission shifted to security force assistance and training, advising, and assisting the Afghan National Security Forces (ANSF).
  - Since STA/TAT did not have its own money (after the first year), its strength was its expertise, which concept was often outside the strengths of the DoD and the Coalition.
  - The STA/TAT was never officially a part of NATO Crisis Establishment or US Joint Manning Document (JMD), making justifying its existence and getting support at ISAF and USFOR-A challenging:
    - A special effort was needed after the office was up and running to get STA/TAT on the EUCOM<sup>1973</sup> JMD.
    - Without proper documentation, getting support took longer since it was necessary to convince ISAF they needed to support the STA/TAT.

---

<sup>1972</sup> Combined Joint Communications

<sup>1973</sup> European Command

- A lot of time and effort was spent justifying the STA/TAT’s existence, purpose, and mission, as well as imparting its effectiveness and accomplishments.
    - The STA/TAT had to recruit an administrative person to handle support needs and develop a more informed understanding of the NATO process used by ISAF.
  - The STA/TAT became caught up in ISAF transition activities (more on transition below).
    - The STA/TAT was required to shift away from supporting the civil and commercial ICT sector to focus almost solely on military interests, even though security operations depend on healthy civil and commercial infrastructures.
    - The STA/TAT ultimately became a casualty of transition.
  - ISAF was viewed as more temporary and the US Embassy more permanent, arguing it may have been better to have placed the STA/TAT at the US Embassy, as with the STA/ARG approach.
  - On the positive side, there was little overlap between the STA/TAT and ISAF CJ6 since their activities supported different objectives, networks, and people. (The one area of significant overlap was spectrum, on which the STA/TAT and ISAF CJ6 collaborated.)
- 3. The STA/TAT did not have any official documentation – USG or ISAF orders, memoranda of understanding, or memoranda of agreement – establishing its legitimacy, assigning command or organization arrangements, and articulating roles, relationships and responsibilities with regards to the USG and the Coalition.
- 4. The STA/TAT had no official, overarching terms of reference or a concept of operations to avoid misunderstandings on its role, mission, reporting arrangement, and to avoid “mission creep.” Either or both would have helped to guide its efforts and provide continuity from year to year as it endured through multiple rotations of leadership and staff (internal and external) and changing phases of its supported missions.
- 5. The ISAF compound and Kabul are not Afghanistan.
  - It was extremely important to go outside the wire to meet Afghans at their offices and elsewhere.
  - It was even more important to be able to go downrange to get a more informed understanding of ICT needs of the Afghan government, business and industry, and the people at the provincial, district, and village levels. However, the TAT operated in and from Kabul, with only a couple of trips by leadership, team members, and Reachback outside the city over its entire tenure.
  - Future such endeavors should consider stationing personnel throughout the country.

### *Lessons Regarding DISA Sponsorship*

Sponsorship by the Defense Information Systems Agency (DISA) had advantages and disadvantages.

1. DISA willingly and successfully provided reachback support and subject matter experts (SMEs) in CONUS for several initiatives and efforts. The designated entry point for access to DISA skills was

DISA GO.<sup>1974</sup> There was, however, no formal process to facilitate a timely reach into DISA for support. Hence, there was limited ability for DISA to support the STA/TAT to engage and leverage the breadth and depth of DISA operational, engineering, and analysis expertise. However, there was no designated entry point or mechanism to allow the STA/TAT to better engage and leverage the breadth and depth of DISA operational, engineering, and analysis expertise.

2. DISA volunteers – on loan and for short-term assignments – supplemented the TAT’s expertise on the ground.
3. DISA willingly and successfully funded ICT SME contractors for special projects in country when requested.
4. DISA is AfTel’s largest customer. It was an anchor tenant for the Afghan national optical fiber cable, which provided AfTel with early revenue and operating capital.
  - Although DISA managed its own leased capacity, it had “skin in the game” and, therefore, a vested interest in the viability of the Afghan ICT sector, which reinforced the TAT’s mission and purpose (though that was not always recognized).
5. The STA/TAT was able to leverage its contacts in and relationships with Afghan ICT counterparts in both the public and private sectors to assist and support the DISA Support Element-Afghanistan (DSE-A).
6. As a Combat Support Agency (CSA), DISA’s focus was to support military activities for intervention and other mission and Coalition partners across the full spectrum of military operations.
  - The STA/TAT had to compete with higher headquarters priorities for resource allocation.
  - DISA’s ability to adjust its support activities across the overlapping mission spectrum was limited for efforts such as:
    - working with non-security ministries (MCIT and others) and
    - the use of ICT for governance and socio-economic development, even though the activities indirectly supported stability operations (including COIN) and other mission needs.
7. There needs to be mechanism to make headquarters staff more aware of field support needs.

---

<sup>1974</sup> Global Information Grid (GIG) Operations

## *Tactical and Operational Lessons*

The original planning for ICT advisory support to COMISAF was to implement a small footprint in country – an STA and two contracted senior civilian commercial ICT advisors – with reachback to a larger support base in CONUS. Reachback would rotate advisors in country on a regular basis as well as provide support from the rear. This all changed with the arrival of the STA at ISAF Headquarters on July 1, 2010. The ISAF CJ6<sup>1975</sup> had begun recruiting for a six- to eight-person commercial ICT support team through the Civilian Expeditionary Workforce (CEW). Upon the STA's arrival in Kabul, the CJ6 gave the CEW positions to him for his use. Therefore, the first lesson learned – not just observed – was:

1. It is necessary to be agile and flexible in accommodating unanticipated changes.
  - The STA immediately had to revise his vision, mission, strategy, and plans to establish and accommodate the Telecom Advisory Team he would lead.
  - The STA had to make adjustments to accommodate CEW staff who arrived versus recruiting the staff needed to meet mission objectives (initially and until halfway through TAT-2; more on the CEW below).

Additional tactical and operation lessons follow.

2. Initial on-the-ground efforts proved successful and set the stage for successive years of STA/TAT operations.
  - Conducting a current-state assessment gave the STA/TAT a baseline from which to work.
  - Interviewing and gathering information was a non-threatening way to meet other ICT stakeholders.
  - Developing a 100-day plan established credibility and shaped the STA/TAT's initial strategy and action plan for the way ahead.
  - The TAT effectively socialized its engagement strategy and established early partnerships with the US Embassy and USAID Mission, ISAF Deputy Chiefs of Staff, select Afghan ministries, and public and private sector ICT counterparts.
3. The STA/TAT's strategy<sup>1976</sup> published in year 2 was well-received in country and in CONUS. It served as a blueprint and steered the STA/TAT's work through years 3 and 4 (until it was significantly pared down in year 4 to accommodate ISAF's mission change and directive to support Afghanistan's security ministries only).
4. Embedding civilian ICT advisors at the Ministry of Communications and Information Technology (MCIT), the Afghanistan Telecom Regulatory Authority (ATRA), and AfTel allowed for typical day-to-day office interactions, drop-in meetings, and more inclusive, collaborative relationships.

---

<sup>1975</sup> Combined Joint Communications

<sup>1976</sup> Bierden, Elizabeth A. (Col., USA) (2012). *ISAF Telecommunications Advisory Team [TAT] ICT Strategy*, January 16.

5. Having its own vehicles gave the STA/TAT freedom of movement and alleviated dependence on ISAF MOVECON,<sup>1977</sup> though it was not always willing or able to use them.
6. There is a need to balance risk management and force protection measures.
  - Restricted freedom of movement impacted regular interactions with public and private sector ICT counterparts.
  - Having to carry weapons, wear IBA, and have guardian angels impacted the ability to deal effectively with non-security ministries and institutions such as universities.<sup>1978</sup>
7. The STA/TAT was not able to effectively leverage CERP or CSTC-A funds, or help others to do so, for worthwhile Afghan ICT projects and activities.

### *Office Operations and Battle Rhythm Lessons*

Other lessons observed relate to office operations and battle rhythm. On a somewhat more humorous side of complex operations, in today's Information Age, it has become standard practice to have TVs running news channels 24x7. This can be of benefit but can also become a significant distraction, especially if the news is replaced by movies or other shows. It was not unusual to observe some TAT staff (and other ISAF personnel) spending more time watching TV than working. Experience in real-world operations also strongly suggests the operating hours of the dining facilities (DFACs) drives the battle rhythm of office operations. This can have unintended impacts on operational effectiveness.

- Distractions in offices such as TVs running during business hours impact the conduct of business and the effectiveness of team activities.
- DFAC operating hours can and do affect office operations and battle rhythm.

The TAT's office operations and battle rhythm changed with each change in leadership.

The STA/TAT's offices were in a Class-V security area, which meant no personal computers or active mobile phones were allowed in the area. This was particularly challenging for contractors, visiting Reachback personnel, and short-term SMEs, all of whom used their organizations' laptops and email servers as their primary work devices and methods of communication. Further, the USG and NATO/ISAF restricted access to certain sites on the Internet and certain applications, which hindered STA/TAT research and information sharing capabilities.

The STA/TAT offices were cramped (six desks in the main office), meaning no one had any privacy. Even the STA shared an office. Working together 12 hours a day, seven days a week, as was required by ISAF,

---

<sup>1977</sup> Movement control

<sup>1978</sup> ISAF implemented new force protection measures in early 2012, during the STA/TAT's second year of operation, after two of its advisors were killed at the Ministry of Interior in a green-on-blue attack in February.

sometimes caused tempers to flare and other tensions. The demanding operational hours diminished rather than increased productivity.

### *Information Sharing and Knowledge Management Lessons*

Lessons regarding information sharing in a larger civil-military context are imparted earlier in this chapter. Lessons below are specific to STA/TAT operations.

There were numerous mission systems, such as the USG's NIPRNet and SIPRNet<sup>1979</sup> and the NATO unclassified and ISAF secret networks. The STA/TAT's primary "mission system" was the NATO unclassified network (as designated by TAT leadership). However, there were fewer NATO unclassified terminals than there were TAT members (due to NATO policies and equipment limitations), making it necessary to share, which was inconvenient at best and untenable at worst.

An overwhelming majority of the STA/TAT's work efforts and products were unclassified, yet at ISAF Headquarters there was substantial use of classified networks to document unclassified activities and share and store unclassified data (in part because of the aforementioned NATO policy and limitations). Conducting unclassified operations in a classified environment created challenges and required the use of cumbersome and time-consuming processes to have authorized personnel move unclassified information from classified networks and provide to STA/TAT staff to be able to share it in unclassified environment, including with Reachback, outside organizations, and Afghans. Additionally, the shared network drives at ISAF Headquarters were susceptible to crashes that resulted in loss of current and historical data on the TAT's activities and other important documents.

There were varying efforts by TAT leadership to implement and enforce rules and processes regarding the documenting, sharing, storing, and archiving of the TAT's work. While some were better than others, overall, the STA/TAT did not effectively employ measures to record and save its efforts. There were few simple, concise descriptions of work streams, including ongoing endeavors under them, mitigating factors to them, challenges encountered regarding them, or expected outcomes for them. Writing summaries of meetings and other events was sporadic and subjective, rather than instituted as policy. All this was problematic for many reasons, not the least of which was handing off responsibilities for work streams to different or new team members. The STA/TAT, however, had a few instances of successful knowledge management and information sharing, each of which includes lessons observed.

- **Weekly report:** From the outset, the STA/TAT produced and distributed an unclassified weekly report of its and others' activities in the Afghan ICT sector, ISAF's and the USG's ICT-related activities, and pertinent information from the larger regional and international ICT arenas.
  - The report was distributed to a wide audience in country and CONUS and was an effective outreach tool that provided shared situational awareness to the larger USG, ISAF, and local communities of interest in country and CONUS.

---

<sup>1979</sup> Non-classified Internet Protocol Router Network and Secret Internet Protocol Router Network, respectively.



- The report created opportunities for the STA/TAT to collaborate, synchronize and synergize efforts, and advise and assist others with their ICT-related activities.
- Toward the end of TAT-4, leadership chose to issue the report only monthly and to a much more limited audience, which severely diminished visibility of its and others' activities and situational awareness of the Afghan ICT sector.

The weekly report was a very effective tool for sharing information externally, particularly since it endured nearly the entire tenure of the STA/TAT. There were frequent requests to be added to the distribution list. The catalog of reports is the only repository of the STA/TAT's work over the entirety of its operation.

- **ICT support strategy:** TAT-1 developed and documented an ICT support strategy for Afghanistan. Although the full document was never formalized or published, it provided four main "pillars" of focus and served as the basis for the next iteration of strategy development by TAT-2. TAT-2 created and published a formal strategy with two main lines of effort, based on the previous four pillars, which was well-received by the USG and ISAF. TAT-3 amended the strategy slightly, and TAT-4 pared it down significantly, with the changes driven largely by ISAF's evolving mission.
  - The TAT's strategy earned it credibility, guided decisions and operations, at times served to justify the STA/TAT's existence at ISAF, documented goals and expected outcomes, and served as a benchmark by which its work could be measured.
  - In the absence of TOR and a CONOPS, the strategy provided at least some structure and continuity for STA/TAT efforts and operations.
  
- **Initiative sheets:** During TAT-2, leadership instilled the use of standard "initiative sheets" to document the various work streams and efforts under the strategy.
  - Each initiative sheet included:
    - a description of the initiative, including when it would be considered complete, what the expected results were, and what impact it was believed it would have.
    - What was the source, amount, and status of funding (if any).
    - milestones to achieve and future or accomplished dates.
    - current actions.
    - internal points of contact and external organizations and roles.
    - parallel or related efforts and dependencies.
    - additional information, including risks and their mitigation.
    - Author, date created or updated, and file location.
  - While the intent was good, the execution was somewhat less so, especially after the initial push to document all initiatives was completed. Keeping them current decreased over time and future TAT leadership discontinued the practice.
  - Nevertheless, the initiative sheets were often the only holistic physical record of a specific effort in a nutshell.

- **Strategic initiative reviews:** Also during TAT-2, leadership began a program to have team members present their initiatives and work on them during weekly teleconferences with Reachback. Topics were scheduled in advance, and the team member responsible prepared and gave a short (15-20 minute) presentation on her/his work. The strategic initiative reviews increased information sharing, especially with Reachback, and invited collaboration and teamwork while they lasted (which was well into year three).
- **Briefings:**
  - General briefs: Through most of its four plus years, the STA/TAT compiled and kept current a standard general brief, which it gave to arriving leadership of various ISAF organizations and other interested parties as required or requested.
  - Topic- or audience-specific briefs: The STA and TAT members developed and gave briefings at events such as COMISAF's daily standup meeting, the annual CIS<sup>1980</sup> Conference, the Pakistan Afghanistan Coordination Cell, visitors from NATO and SHAPE headquarters, and to other organizations and individuals as required or requested.
  - Interim program reviews (IPRs): The STA/TAT Director gave twice-yearly unclassified IPRs for DISA GIG Ops at Fort Meade, which were attended by interested personnel from the DoD, DoS, USAID, and other USG entities.

Overall, briefings were a very effective way of disseminating and sharing information, though there was limited opportunity to employ them. Generally, the STA/TAT's briefs were well-received.

- **TAT Year in Review:** The TAT-2 director produced and published a chronicle of its years' work, which was a collective effort with input from all team members.<sup>1981</sup> It included opportunities, challenges, progress, and lessons learned, as well as a snapshot of the operating environment at the time. It is the only single, comprehensive source of documented TAT history, and only for a certain period of time. The TAT-3 Director attempted to continue the practice but met significant resistance from team members who refused to contribute or comply.
- **Articles and interviews:** The STA/TAT effectively raised and shared awareness through articles in AFCEA's *Signal* magazine, the Counterinsurgency Advisory and Assistance Team's (CAAT's) *COIN Common Sense* magazine, and other publications. One STA was interviewed by Afghan and international press through ISAF public affairs. There was, however, no concerted strategic information awareness campaign.

---

<sup>1980</sup> Computer and information systems

<sup>1981</sup> Bierden, 2012. *TAT Year in Review*.

- **Conferences and events:** The STA/TAT and Reachback helped to organize, participated in, served on panels at, and gave presentations at various conferences and events in country and CONUS.
  - They were effective ways to disseminate and gather information and situational awareness.
  - They afforded opportunities to meet and network with ICT and other stakeholders.

The STA/TAT never implemented a formal process for capturing and documenting lessons observed, though at various points DISA directed the STA/TAT to contribute lessons to the Joint Lessons Learned Program. One of the main purposes of this book is to impart lessons observed from the USG's advisory work in Afghanistan's ICT sector.

Additional lessons observed include:

- A tremendous amount of work is conducted via email, with messages being substitutes for more formal documentation, yet there is little effort made to store and archive important messages.
- The STA/TAT should have (through TOR, CONOPS, directive, or mandate) or devise and implement a system and procedures for:
  - documenting, storing, and archiving work product and communication (important emails).
  - sharing information among the team, with Reachback, with the USG Interagency, coalition mission leadership, affected nation counterparts, and other interested parties.
  - an ongoing strategic information campaign.
- The STA/TAT have (through TOR, CONOPS, directive, or mandate) or devise and implement a process for capturing and documenting lessons observed at the outset and do so for the duration of effort.

### *Lessons Regarding Staffing and Augmenting the TAT*

#### **Staff**

As mentioned above, the first ISAF STA inherited the CJ6 CEW staff upon his arrival, which became the TAT and dramatically changed the original plan to have a small team of senior civilian commercial ICT professionals. The team came with challenges managing and staffing it and a plethora of lessons.

1. The CEW program was not conducive to staffing a specialty organization like the TAT.
  - Many candidates tended to be more tactical than strategic in experience.
  - Some lacked the professionalism and social and cultural sensitivities necessary to operate in a complex, dynamic, multinational, multicultural war zone.
  - Few candidates applied for positions specifically at TAT.
  - The STA/TAT needed to be able to more effectively identify and attract candidates with ICT systems thinking and strategic experience.
  - The candidate interview process was limited. Reachback c/should have been employed to meet with and evaluate prospects.
  - Skills of new staff did not always match requirements.

- Volunteers had a lack of insight into their purpose regarding joining the TAT.
  - There was no advisor-focused training similar to what is done for Ministry of Defense Advisors and AFPAC Hands programs.
2. Upon arrival of CEWers, there was little effort made to prepare new staff for their assignments or help them to become familiar with the operating environment.
    - The STA/TAT had no orientation or mentoring program.
    - There was little – and sometimes no – overlap between arrivals and their predecessors.
  3. Frequent rotations CEW personnel caused continual reorganizing, regrouping, and restarting, which:
    - wasted valuable time, disrupted continuity of operations, and made teambuilding – or at least the need for it – perpetual.
    - resulted in an ever-changing mix of skillsets and levels of support.
    - caused negative reactions in Afghan ICT counterparts, particularly when they perceived new arrivals did not cut muster.
    - resulted in relationships with Afghan ICT counterparts to deteriorate and become less productive over time.

The STA/TAT could also have:

4. Utilized Reachback more effectively as gap and SME fillers.
5. Hired cooperating country nationals (CCNs) – Afghans – who would have brought language skills to help interpret and translate for the team, adding cultural awareness and understanding, and providing the ability for uninhibited movement, including being placed in fixed or roaming positions as needed.

Additional lessons regarding staffing and augmenting the TAT include:

6. Members of ad hoc organizations like the STA/TAT bring their own expectations and work habits with them.
7. Be willing to accept “boots on the ground” gaps to obtain the right expertise.
8. Trust relationships cannot be transferred.
9. Some personnel should be in designated behind-the-scenes support roles only, not outward facing.
10. Limit those who get face time with high-ranking government officials of the affected nation. Not everyone needs to deal at the minister level.

Observations from the earlier STA/ARG experiment apply to the STA/TAT as well. Based on the ARG experience, it was noted there are three crucial elements in the character of anyone who is going to be useful in post-conflict nation-building: “[Some people] have the right qualities: a genuine desire to help the Afghans succeed; common sense; and a sense of what was practical and realistic, given the environment in which [they] operated. Some others had none of these qualities, whereas others had the

desire untampered by reality.”<sup>1982</sup> It would be wise for everyone involved in such missions to recognize that no organization has a monopoly on such qualities. In the end, it is having the right people in the right place at the right time and with the right attitudes and passion to try to help make a difference.

In future operations, the USG should consider approaches such as having a few, more permanent, non-military, senior professional commercial advisors to work with ICT leadership and the USG Interagency and the ICT stakeholders of other organizations, as was the original vision for the organization.

## Leadership

STA/TAT Directors changed over roughly annually. Each new leader brought her/his own leadership and management style and method of operation. This introduced changes in team battle rhythm, dynamics, behavior, and focus of efforts. While understandable, it was not conducive to continuity of operations or accomplishing the STA/TAT’s mission. Most changes in leadership had very little time for a proper handoff, and in one case there was a several-month gap between directors. The Deputy TAT Director assumed the interim directorship.

As mentioned in other areas of the book, the original civilian SES STA was replaced by two active duty Army Signal Corps colonels in years two and three. (The actions to recruit colonels were taken because attempts to recruit senior civilians (SES level) were unsuccessful.) This resulted in the “militarization” of the TAT to a certain extent. At the same time, in both years two and three, ISAF CJ6 leadership was elevated from colonels to brigadier generals. This unfortunate confluence of circumstances meant the TAT was realigned to a subordinate element within the associated military chain of command. Previously, the STA operated at the general officer level as part of COMISAF’s staff, providing the STA/TAT visibility at the command group level. These actions resulted in placing the TAT leadership and activities rank ordering under both ISAF and US general officers for support and reporting rather than operating at and with the general officer level, a subtle but important change in the authority, reporting structure, and visibility of the TAT. In the fourth year, leadership returned to a civilian SES-equivalent.

Lessons for future operations:

1. Leaders should be civilians at the SES or equivalent level.
2. Leadership assignments should be for more than one year, ideally for multiple years.
3. Leadership rotations should include overlap for a proper handover, a minimum of two weeks and a month is ideal.
4. Gaps in leadership should be avoided at all costs.
5. Commercial ICT experience is imperative.
6. Adequate time, effort, and resources must be expended in the recruiting process for leadership to find qualified candidates.

---

<sup>1982</sup> Berner, 2006.

## *Lessons About Stability, Reconstruction, and Development Operations*

Based on the STA/TAT's more than four years' experience in Afghanistan, a few general lessons emerged about working in stability, reconstruction, and development operations.

- ISAF's, the Coalition's, and TAT's priorities are not necessarily the Afghans'.
- Advisors should advise – not dictate or demand.
- Be cognizant of offering Western solutions to Afghan problems and military solutions to civil problems.
- We expected things of the Afghans that the USG and other Western countries have not done or will not do.
- There are often underlying motives and politics that drive bureaucratic decision-making. Learning to understand these dynamics and continually “soft-pushing” the issues will generally motivate more decisive actions. Accepting the eventual actions and results as Afghan-owned is also key, even if we do not completely agree with the decisions.
- Manage expectations carefully to ensure success in a complex civil-military and multinational, multicultural environment.
- Balance longer-term strategic efforts and goals with short-term, immediate-impact projects and deliverables.
- Make no assumptions.
- Many things have been tried before.
- There is often more to the story.
- Afghans figured out the International Community donor system and often understand it better than Westerners.
- Avoid multiple and repeated requests for same information (this was exacerbated by frequent turnover of personnel).
- Resist the temptation to do for the Afghans what they can do for themselves. Remain in a mentorship role and assist them in the deliberation and decision-making processes.
- Borrowing T.E. Lawrence's phrase from “27 articles” about the Arab revolt, “Better the [Afghans] do things [themselves] tolerably than for [us] to do them perfectly.”<sup>1983</sup>
- Do not give the Afghans an airplane when all they need is a bicycle (this per an Afghan).<sup>1984</sup>
- Do not try to force too much change too fast.<sup>1985</sup>

---

<sup>1983</sup> Knigge, Michael (2009). “Lawrence of Arabia offers lessons for Afghanistan.” Interview with John Hulsman for Deutsche Welle, December 12. Accessed July 17, 2015. <http://www.dw.com/en/lawrence-of-arabia-offers-lessons-for-afghanistan/a-5001974>.

<sup>1984</sup> Bullets to reference are paraphrased from Bierden, 2012. *TAT Year in Review*.

<sup>1985</sup> Barham, 2016.

### *Others' Observations about the STA/TAT and the Importance of ICT*

Former Commander of ISAF, General John Allen, USMC, made the following observations about the STA/TAT.<sup>1986</sup>

- After a brief by TAT Director Colonel Beth Bierden in June 2012, General Allen commented on how important military spectrum management was for ISAF's command and control. He stated he supported the TAT's spectrum efforts with the Afghanistan Telecom Regulatory Authority (ATRA) and the Ministerial Spectrum Management Office.
- After a brief by TAT Director Colonel Frank Huber, General Allen stated the TAT's work with the Ministry of Communications [and Information Technology] was "one of the most important non-security governmental engagements" ISAF has with the Afghans.

---

<sup>1986</sup> One of this chapter's co-authors heard both comments while she was a Senior ICT Advisor to the STA/TAT in Kabul.

## Chapter 23 Conclusions and Recommendations

---

Larry Wentz

---

*Elevate the importance of **Information and Communications Technology** to be formally recognized in US government and international policy and doctrine and treated in complex operations as “**Critical Infrastructure**” and an “**Essential Service.**”*

---

### Conclusions

A grand strategy for employing whole-of-government, unity-of-multinational-effort, and improved cooperation and information sharing among civil-military participants in complex operations such as post-conflict security, stability, reconstruction, and development support to nations emerging from conflict has for many years been the subject of research, policy changes, strategy options, ad hoc intervention experiments and learning experiences, and related education and training. Despite the importance the US Government (USG) has placed on security, stability, and reconstruction operations and the need to achieve synergy among the tracks of security, governance, and development, real-world operations such as those in Iraq and Afghanistan suggest that, although progress has been made to improve the situation, much remains to be done to overcome cultural barriers and other planning, execution, cooperation, and information sharing challenges experienced by USG participation in multinational intervention operations. This is particularly true regarding information and information and communications technology (ICT). The USG and multinational civil-military response elements have been unable to use information and ICT capabilities effectively to improve cooperation and share information. More importantly, in the Digital Age, they have not been able to more effectively leverage the power of information and ICT as a “game changer” and an enabler of post-conflict security, stability, governance, and socio-economic development. Reinforcing the latter point on the role of ICT, the World Bank, in its *World Development Report 2016: Digital Dividends* report, suggests that digital technologies have had a profound impact on social and economic development in the past decade. It concludes that the full benefits of ICT transformation will not be realized unless countries continue to improve their business climate, invest in people’s education and health, and promote good governance.<sup>1987</sup> Experience suggests there is an urgent need to explore how to more effectively incorporate the concept of an ICT-enabled intervention into USG and international crisis response policies, doctrine, strategies, and capabilities.

---

<sup>1987</sup> World Bank (2016). *World Development Report 2016: Digital Dividends*. World Bank, Washington, DC: World Bank. doi: 10.1596/978-1-4648-0671-1. License: Creative Commons Attribution CC BY 3.0 IGO. Accessed September 14, 2016. <http://documents.worldbank.org/curated/en/896971468194972881/pdf/102725-PUB-Replacement-PUBLIC.pdf>.



The smart use of ICT has demonstrated in both Iraq and Afghanistan that it can be a game changer in post-conflict recovery, reconstruction, and development, provided it is part of an overall strategy that engages the ICT counterparts of the affected nation's government, international players, and public and private ICT sector participants. Additionally, ICT actions need to be focused on delivering effective results for the affected nation. In this context, ICT's importance to mission success competes with priorities for roads, power, and water as "critical infrastructure" and "essential services." Unfortunately, USG and international policy has yet to formally recognize this new role or change their ways of doing business. Approaches for assisting in the recovery and development of the civil and commercial ICT sectors and the use of ICT to enable security, governance, and socio-economic development continue to be ad hoc and are generally not well-coordinated across intervening civil-military forces and international donors or with the affected nation's government and industry ICT counterparts.

ICT has proven to be a basic enabler of informal social and economic discourse, leading to a strengthening of civil society and the promotion of security, internal stability, job creation, social services, and economic solidity in affected nations. It [has become] a demonstrated enabler of national transformations,<sup>1988</sup> but not necessarily always for the better. For example, ongoing research of the impact of ICT and social media (e.g., Twitter and Facebook) in post-Arab Spring conflict environments suggests the creation of new mobile technology networks substantially increases collective violence within the (typically developing) country such as Afghanistan.<sup>1989</sup> It is noted that these negative effects can also spill over to other countries if they are bound together by dense communication ties. While the Arab Spring experience has fired imaginations about the powerful (and destabilizing) effects of social media, evidence in the research to date suggests that such optimism may likely be misplaced. Although uncertainty still exists about how ICT might generate these effects among political leaders, protest groups, and insurgent organizations, research suggests it is likely that social media platforms like Twitter and Facebook are intensifying, if not driving, political conflict in locations as diverse as Egypt, Syria, and elsewhere.<sup>1990</sup>

The use of Senior Telecom Advisors (STAs) as part of the Afghanistan Reconstruction Group (ARG) and at NATO's International Security Assistance Force (ISAF) Headquarters in Afghanistan and the Multi-National Force-Iraq CIS-led<sup>1991</sup> Iraq Communications Coordination Element/Infostructure and Strategic Engagement (ICCE/ISE) teams in Iraq were ad hoc approaches to experiment and learn from employing an ICT-enabled element to support the senior USG civil-military and coalition leadership and to work with international donors and advise and assist the affected nations' government ICT counterparts. These ICT-

---

<sup>1988</sup> Saadawi, Tarek and Louis Jordan, Jr., eds. (2011). *Cyber Infrastructure Protection*. Strategic Studies Institute (SSI), US Army War College, May 2011. Accessed October 4, 2015.

[https://ia600703.us.archive.org/30/items/CyberInfrastructureProtection\\_112/10-Cyber.pdf](https://ia600703.us.archive.org/30/items/CyberInfrastructureProtection_112/10-Cyber.pdf)

<sup>1989</sup> Lyall, Jason, Nils B. Weidemann, and Allan Dafoe (2015). "Dial ICT for conflict?: Four lessons on conflict and contention in the info age." *The Washington Post*, February 23. Accessed September 7, 2015.

<https://www.washingtonpost.com/blogs/monkey-cage/wp/2015/02/23/dial-ict-for-conflict-four-lessons-on-conflict-and-contention-in-the-info-age/>.

<sup>1990</sup> Ibid.

<sup>1991</sup> Communication and Information Systems

focused support elements were inserted into the ICT sector recovery and reconstruction process during the stability and COIN phases of the Afghan and Iraq post-conflict operations.

There were early responder efforts to help the Afghan ICT sector recover, but these were independent and not well coordinated. For example, at the outset of the intervention, there were ad hoc independent USG and international subject matter expert (SME) consultants funded by United States Trade and Development Agency (USTDA), the United States Agency for International Development (USAID), the World Bank, and the International Telecommunication Union (ITU) to support the recovery of Afghan ICT sector governance and infrastructure. These consultants helped develop ICT policies, laws, and regulations; advised on public-private partnerships to support early investments; helped develop limited spectrum management capabilities; advised on early licensing of commercial cellular providers to jumpstart recovery of national-level services; and helped develop a first-cut version of a national Afghanistan ICT strategy and plan to shape investments and priorities in the recovery and reconstruction of ICT infrastructure and the provision of services, including the use of ICT as a cross-sector enabler of the recovery of other sectors such as security, governance, finance, agriculture, health and education.

There were intervening civil-military, international, and private sector efforts to help enable early infrastructure and service recovery by employing techniques such as anchor tenant and early emergency ICT capabilities. For example, the Defense Information Systems Agency (DISA) leased Afghan fiber optic connectivity to support deployed US military units' command and control needs. Another example was the Swedish company Ericsson, which set up an emergency mobile GSM<sup>1992</sup> base station with international access in Kabul to support the United Nations (UN) World Food Programme and other humanitarian organizations as well as important government officials.

USAID funded a high-frequency (HF) radio network to connect the central government in Kabul with provincial capitals to provide limited voice and data services. Afghan Wireless Communications Company (AWCC) obtained early interim authorization to continue cellular telephone service in Kabul (it had a small network under the previous Taliban government), complete with an international gateway for calling into and out of the country, and expand to other urban areas. AWCC also established an early Internet café in the Intercontinental Hotel in Kabul. The UN, USAID, and Cisco set up computer labs in the larger cities, and established some early Cisco Networking Academies at several public universities. Non-governmental organizations (NGOs) set up VSAT<sup>1993</sup> hubs with voice and Internet services to support hospitals and other needs. These were all good efforts to do good things quickly, but none were part of an overall ICT-enabled intervention strategy or plan, nor were they well-coordinated among the intervention participants.

---

<sup>1992</sup> Global system for mobile communications, a second generation of protocols for digital cellular networks originally developed by the European Telecommunications Standards Institute (ETSI). GSM is now a trademark owned by the GSM Association.

<sup>1993</sup> Very small aperture terminal, a two-way satellite ground station with a dish antenna generally smaller than three to four feet.

Both Afghanistan and Iraq were important experiments and learning experiences in furthering the concept of ICT-enabled interventions and employing the use of professional civil and commercial ICT experts, referred to as Senior Telecom Advisors or STAs, to advise and assist senior USG Interagency leadership and related organizations, such as the US Embassy Kabul and USAID Mission in Afghanistan. Additionally, the STA constructs with their supporting Telecommunications (Telecom) Advisory Team (TAT) and CONUS-based<sup>1994</sup> reachback elements facilitated access to civil and commercial ICT sector SMEs. They also harmonized, coordinated, and shared information regarding ICT-related activities among the USG Interagency, coalition elements such as ISAF and participating nations, and the International Community such as the World Bank, ITU, and UN ICT stakeholders. An additional important function assigned to the STAs (or their equivalents) was to be the USG and coalition military point of contact for key leader engagements with Afghan (and Iraqi) ICT counterparts such as the minister of communications, the regulator, state-owned ICT enterprises, and chief executive officers (CEOs) of the private sector mobile network operators (MNOs) and Internet service providers (ISPs). The ad hoc constructs were “one-stop shops” for informed civil and commercial ICT advice and assistance and informed situational awareness of ICT sector activities in both Afghanistan and Iraq. They were successful learning experiences from which lessons need to be leveraged to shape ICT-enabled interventions in the future.

Affected nation ICT is also a crucial component supporting the intervening civil-military elements’ communications, collaboration, and information sharing needs as well as an enabler of the affected nation’s security and governance recovery and socio-economic development and growth. All too often, however, ICT is viewed as a commodity in post-conflict reconstruction, and its recovery is seen to be the responsibilities of the affected nation and private sector. In fact, there are expectations that ICT will be there for use by the intervening elements when needed. In reality, it most likely will not be there in an operational state capable of meeting early demands of the intervening forces. Information and ICT can be incredibly powerful enablers, but it will take time to overcome cultural and generational resistance to achieve the full benefits of their capabilities, and policymakers need to take this into account. Furthermore, the full scope of digital dividends will not be delivered immediately either.

There are policy and doctrine challenges yet to be effectively addressed by the USG and International Community. They include elevating the role of commercial ICT and including the use of professional civilian ICT expertise to help work civil and commercial ICT actions across the civil-military responder elements, facilitate recovery of the affected nation ICT sector governance (policies, regulations, laws), provide an informed understanding of international ICT standards and best practices, and deal with affected nation government and private sector ICT counterparts.

Significant progress has been made in the ICT sector in Afghanistan, and it has truly been “the” success story emerging out of the recovery of a country left dysfunctional from decades of war. Progress towards bridging the digital divide and moving Afghanistan into the twenty-first century Information Age has not been accidental, but was largely due to having the right people at the right time and places with the right

---

<sup>1994</sup> Continental United States

visions, energy, passion, and expertise to make informed decisions and take actions to make things happen, including leveraging the capabilities of the private ICT sector.

An enabling factor to the success was top cover for the ICT sector at the highest level of government. Although former President Karzai was not an ICT-savvy person per se, he had sufficient understanding of its importance such that he provided presidential-level support for the ICT sector evolution and the use of ICT as an enabler. Support continued with the Ghani-Abdullah National Unity Government. The current President, Ashraf Ghani, is ICT savvy and understands the importance of ICT as “an agent of change” and its key to the future of Afghanistan’s security, governance, and economic transition, including Afghanistan’s role in the global information and business environments. President Ghani has taken personal interest in the modernization of the ICT sector and its governance including assignment of a Chief Adviser for Infrastructure, Human Capital, and Technology, reporting directly to him. His portfolio includes the ICT sector and oversight of its governance as well as improvements in ICT infrastructure and services. He also appointed a new Minister of Communications and Information Technology, a new Chairman of the Afghanistan Telecom Regulatory Authority (ATRA), and new ATRA Board members.

Challenges for the future include: a deteriorating security situation (threats against ICT personnel and facilities); the need to sustain economic and political stability; a lack of reliable electric power; poor spectrum management; and a lack of qualified management, technical, contracting, marketing, and financial personnel. Relatively new ICT governance leaders are attempting to manage ICT sector governance amid their own internal organizational changes, including actual and rumored personnel changes at state-owned (by the Ministry of Communications and Information Technology, MCIT) Afghan Telecom Corporation (AfTel), all while trying to implement digital services such as mobile money, an electronic national identity card (e-NIC), mobile government applications, and other electronic services. Other challenges include sustaining growth of a fledgling cybersecurity and information culture; the willingness and ability to modernize and leverage ICT infrastructure and services, including the expansion of mobile broadband services; improving access to and reducing the cost of Internet service; updating and expanding the fiber optic network and regional interconnections; and increasing access to and use of ICT by the young, women, and those outside major urban areas.

A word of caution, however: Although the ICT sector in Afghanistan has been a success and has operated reasonably well over its first decade and a half with various “advise and assist” support arrangements, there may be a desire on the part of the International Community, Coalition military, and the USG to shift support to other sectors that have not been as successful. Such a shift, without careful consideration of not only first-order but second- and third-order effects, could have significant unintended consequences, especially if the ICT sector is not yet prepared truly to sustain operations on its own without the support and attention of the International Community. Consideration of such a shift in international and USG support needs to be carefully assessed, monitored, and managed over time to ensure informed choices and decisions are made and that progress continues to bridge the digital divide and move Afghanistan into the Information Society of the twenty-first century.

Unfortunately, such a shift has already begun with the drawdown of US forces at the end of 2014 and the related drawdown and termination of the Department of Defense’s (DoD’s) ICT support to non-security-related government elements provided by the STA/TAT. Due to a deteriorating security environment,

other USG non-DoD elements and donor assistance and engagement have decreased as well. Additionally, the relatively tech-savvy ICT sector workers are among the most employable elsewhere, and many have already left Afghanistan. This trend is particularly troublesome for the ICT sector because it already suffers from a lack of indigenous ICT expertise. Not surprisingly, Afghans continue to request USG help regarding ICT advice and assistance, but at the moment there is no USG Interagency agreed-upon strategy or plan for such an arrangement for the Afghan ICT sector. Currently, requests for help are handled through the US Embassy Kabul Economic (ECON) section with limited support from the USAID Mission Afghanistan and CONUS-based State Department Special Representative for Afghanistan and Pakistan and Office of Afghanistan Affairs, the USAID Office of Afghanistan and Pakistan Affairs, USAID's Global Development Lab, and the Department of Commerce's Commercial Law Development Program.

As noted earlier, adding to the challenges, the new Ghani-Abdullah National Unity Government has introduced ICT sector governance changes. The new ICT administration is, collectively, trying to manage the ICT sector governance changes. Needless to say, the leadership and other changes have resulted in disruptions that have impacted timely decision making and actions to move improvements in ICT infrastructure and services forward. It will likely take some time to adjust to new ICT sector leaders and staff, and there may be more fluctuations yet to come before things return to a more stable and effective environment.

## Way Ahead

It is crucial at the outset of and during conducting an ICT-enabled intervention to have an informed understanding of the context and potential for the use of ICT in the affected nation. Experience cannot simply be transferred from one conflict-affected country to another. Of course, there are similarities and some insights from past efforts may have value in helping shape and execute ICT-enabled interventions in other fragile and conflict-affected states. Some USG and international insights include:

- Employ civil and commercial professional ICT SME advisors to help create, as soon as possible, an affected nation ICT sector governance capability and a policy, legal, and regulatory framework that enables early public-private sector partnerships and competition, liberalizes the market, and provides a stable security environment for private sector investors and service providers – the private sector is key to success.
- Focus on the development of an initial pool of ICT-savvy talent drawn from government civil-military elements, think tanks, universities, and other sources of ICT SMEs, and leverage the skills and experience of any affected nation ICT-savvy diaspora or emigrant networks.
- Look for sources of demand that could quickly create non-reversible gains in the sector, e.g. anchor tenant leasing arrangements for intervening elements, expanding mobile telephone services, and actions that anchor other developments (e.g. ICT skills development, mobile applications, expansion of infrastructure and applications).
- Draw on local strengths and concepts to create a vision for the sector, positioning the country in a global information environment context and providing a framework to create buy-in among citizens and other stakeholders.

- Ensure that public agencies build their human and institutional capacities both to undertake the needed technological transformation, but also to respond to the increased demand for services from an ICT-savvy population.
- Support from donors is needed early on in the creation or recovery of the ICT sector governance policy, legal, and regulatory environments and to help attract key talent through lateral entry and capacity-building efforts.
- The [a]ffected nation’s ability to maintain and operate ICT networks and services, sufficient ICT sector resilience to adapt to changing conditions and withstand and rapidly recover from disruption due to acts of insurgents, terrorism and natural disasters, and ability to sustain the operation of donor funded ICT capabilities and services implemented as part of the recovery, reconstruction and development are extremely important.<sup>1995</sup>

USG findings and experiences from the Afghanistan and Iraq ad hoc experiments and lessons observed from them (discussed in chapters 21 and 22, as well as throughout this book) suggest the following high-level policy and doctrine actions need to be considered to ensure ICT-enabled interventions are properly incorporated into USG and international response strategies, plans, capabilities, and funding for post-conflict stability, reconstruction, and development operations. This includes actions to establish a Telecom Advisor function (or maybe more appropriately, an ICT Advisor now days) and supporting team to advise and assist senior civil-military leadership and decision makers for an ICT-enabled intervention.

- Formally designate as USG policy ICT is critical infrastructure and an essential service with crisis response resourcing (people and money) priorities equivalent to roads, power, and water.
- Establish an agreed-upon USG strategy and plan for ICT-enabled interventions and incorporate them into the USG International Crisis Response Strategy and Plan for Stability and Reconstruction Operations.
- Designate USG civil-military elements roles and responsibilities for ICT-enabled interventions and who has ICT leadership role(s) when—could be civilian, military, or both.
- Develop and institutionalize a process for professional pre-deployment ICT assessments and planning for ICT-enabled interventions, including timelines for interventions and agreed-upon processes to manage civil-military responsibility and leadership transitions (related to intervening and withdrawing) and establishing collaboration and information sharing environments.
- Develop timelines for types of ICT-enabled interventions and guidance for approaches to be considered for implementation.

---

<sup>1995</sup> *From Transition to Transformation: The Role of the ICT sector in Afghanistan*. Washington, DC: World Bank. Available at: [https://www.infodev.org/infodev-files/final\\_afghanistan\\_ict\\_role\\_web.pdf](https://www.infodev.org/infodev-files/final_afghanistan_ict_role_web.pdf).

- Develop an exit strategy (ies) as part of the intervention strategy and planning as well as a process for managing transitions from civilian to military lead and military to civilian lead for the Telecom Advisor function.
- Develop processes for managing a lead ICT role and support from civilian to military to civilian organizations over the intervention spectrum.
- Consider responsibilities, business processes, priorities, expectations, deliverables, support arrangements, and culture as factors influencing military to civilian transition. Transitioning involves more than simply rehoming people and tasks.
- Conduct the equivalent of an Intelligence Preparation of the Battlespace (IPB) for the ICT sector for military, civil, and commercial ICT systems, and their governance, as well as the related government and industry business processes and key players, both the ones who can make things happen and the spoilers.
- Leverage the experience and intellectual capacity of service schools and institutions such as the National Defense University Institute for National Strategic Studies, the Naval Postgraduate School Cebrowski Institute for Innovation and Information Superiority, and the US Army War College Peacekeeping and Stability Operations Institute and Strategic Studies Institute.
- Establish a core senior civilian professional ICT response team, with the appropriate mix of resources, capable of on-demand deployments in support of international ICT-enabled crisis response interventions, including access to government, academia, think tanks, and industry sources of professional ICT expertise.
- Educate, train, exercise, and certify senior ICT professionals to participate in ICT-enabled international crisis response interventions with topics to include leadership, advisor skills, social and cultural sensitivities, business processes, trusted relationship building, and language skills.
- Develop ICT fly-away capability packages that can be used to facilitate early recovery of basic ICT services to support security, stability, and restoration of essential government services of the affected nation.
- Provide agreed-upon USG mechanisms and processes to facilitate civil-military collaboration and information sharing including with international organizations and affected nation stakeholders and ICT counterparts.

More specific considerations regarding staffing a STA capability include:

- Recruit senior USG senior civilians (SES equivalents) as STAs and assign them for multiple years to ensure visibility and engagement at senior decision maker levels and continuity of mission and operations, including sustainment of trusted partnerships with affected nation counterparts.
- Staff any supporting team with qualified senior civilian professional civil and commercial ICT SMEs with international crisis response experience, including operating in civil-military and multinational, multicultural environments. Candidates' passion for the job should be a recruiting tiebreaker for selecting personnel.

- Issue the appropriate official documentation necessary to establish the legitimacy of the STA and any supporting team, assign command or organization arrangements, and articulates mission, roles, relationships, and responsibilities.
- Consider employing senior professional ICT contractors with experience to support the STA. Key contacts and insights into the affected nation’s culture will be paramount toward building and sustaining strategic partnerships and trust relationships with ICT counterparts and commercial sector ICT leadership.
- Understand USG volunteer programs such as CEW are not organized to recruit professional ICT SMEs or provide them specialized training to prepare them to work in a complex multinational, multicultural civil-military senior leadership environment in a professional advisory capacity in a war zone. In the event the CEW or other volunteer USG program is used to staff a supporting team, there is a need for ICT SME advisor training programs tailored along the lines of the training for Ministry of Defense Advisors (MoDA)<sup>1996</sup> and AFPAC Hands.<sup>1997</sup>
- To the extent possible, embed experienced professional ICT SMEs with ICT sector governance organizations of the affected nation (e.g., ministry of communications, regulator, and state-owned ICT service providers).
- Create orientation and mentoring programs for ICT-enabled interventions and the Telecom Advisor function to communicate the shared civil-military vision, strategy, and plan to ensure continuity of operations and sustainment of strategic partnerships with affected nation counterparts.
- In the event there is a team to support the TA function, facilitate team building and a shared understanding of the mission and the roles of participants. Create open information sharing arrangements between those forward and those in the rear as an integral business process.
- Share information among the USG, coalition forces, and civilian elements including international organizations and affected nation counterparts and collaborate with them to achieve the goals for which they are committed. Collaborate, coordinate, harmonize, and synergize rather than duplicate efforts.
- Conduct continuous strategic communications and information campaigns to tell the story and keep stakeholders, affected nation officials, and the population informed.

It is also important, from the outset of an intervention, to develop and provide an agreed-upon process to facilitate the collection and sharing of experiences and lessons from USG and international crisis response activities and the leadership to make it happen. Additionally, there is a need to establish agreements to collectively update national and international policies, strategies, plans, and capabilities

---

<sup>1996</sup> The Ministry of Defense Advisors (MoDA) program “partners DoD civilian experts with foreign counterparts to build ministerial core competencies such as personnel and readiness, logistics, strategy and policy, and financial management.” It is administered by the Defense Security Cooperation Agency (DCSA). DCSA website. Accessed March 14, 2016. <http://www.dcsa.mil/programs/ministry-defense-advisors>.

<sup>1997</sup> Afghanistan-Pakistan (AFPAC) Hands (APH) Program, a DoD program initiated in 2009 that trained US Armed Services finance personnel (and others) in the languages and cultures of Afghanistan and Pakistan.



for ICT-enabled crisis response interventions in support of post-conflict stability, reconstruction, and development operations. A more detailed summary of lessons and recommendations from the Afghanistan STA experiences can be found in [Chapter 22, \*The STA/ARG and STA/TAT Experiments and Learning Experiences: Lessons Observed\*](#). Lessons related to specific subjects and efforts are also captured and documented in other chapters of the book.

As noted, the current use of ad hoc approaches tailored to fill real-world operational gaps needs restructuring to include the USG and International Community engaging in comprehensive approaches and working effectively with affected nation governments, local businesses, and members of civil society. Important in this regard is the use of whole-of-government, Interagency, civil-military team methodologies for future operations. Additionally, there must be proactive governance of the affected nation's ICT policy, infrastructure, services, integration, standards, and processes among all stakeholders.

To move the transformation forward, there are a number of efforts that must be executed to define and implement the policy, doctrine, and skillset changes necessary to ensure ICT is viewed and treated as an essential service and a "smart power" enabler of future stability operations and that ICT is employed as an integral part of the intellectual strategic thinking, policy, and doctrine for planning and executing them. Interagency actions need to address cross-functional integration and synchronization across all sectors to prevent the ad hoc and stovepiped solutions that are currently the default way of doing business today.

Information and ICT can be important components for success in stability, reconstruction, and development operations. To achieve successful results requires that a purposeful strategy be adopted to use these capabilities to the desired end of building up the affected nation and to conduct operational activities that effectively implement the strategy. Clear USG senior leadership and support is needed to shepherd the change process.

A strategic approach to smart and better-informed interventions means coalition and Interagency participants will need to undertake five key activities:

1. Conduct pre-event activities with partners.
2. Implement improved collaboration and information sharing.
3. Ensure improved data usability.
4. Develop an information toolbox that maintains lists of:
  - a. Key information partners, including businesses with technical capabilities.
  - b. Information and data management tools.
  - c. Other key tools, such as for collaboration and translation. (Commercial or open source tools are preferred because government-generated tools often will not be available to important partners, especially non-military elements.)
5. Create a forward field information office that provides ICT thought leadership and strategic thinking, a one-stop shop for ICT advice and assistance, and a trusted source of informed

situational awareness to the intervention force senior civil-military leadership and key staff elements.<sup>1998</sup>

Also, creating an overall focus to generate an effective affected-nation information business plan consists of four actionable items:

1. Assess affected-nation information capacity.
2. Build an affected-nation information goal.
3. Create immediate, medium, and long-term information capacities.
4. Analyze information needs and develop methods to fulfill those needs.<sup>1999</sup>

Opportunities to change the USG and international intervener communities' behavior and approaches to ICT stability, reconstruction, and development remain. Progress requires support at the highest levels of governments and the organization and political will to make things happen. Some key areas where changes need to be made are as follows:

- **Policy actions:**

- Designate ICT as critical infrastructure and an essential service.
- Recognize ICT as an engine of governance and socio-economic development.
- Agree on the importance of ICT as an enabler of cross-sector reconstruction and development.
- Elevate ICT investment priorities to be equivalent to roads, power, and water.
- Ensure there is the political will to coordinate and share civil-military ICT-related stability, reconstruction, and development information.
- Establish a USG framework for international crisis response ICT visions, strategies, plans, and business processes.
- Designate agency lead and support roles.

- **Strategies and plans:**

- Improve understanding of affected nation information and related ICT business cultures.
- Develop and agree on coherent community strategies and plans for supporting and enabling affected nation ICT reconstruction and development strategies and plans.
- Improve management of the risks of protecting civilian and military elements and implementing stability and reconstruction initiatives in hostile environments (balance risk management and force protection).
- Institutionalize an arrangement to provide civilian senior leadership and supporting team capabilities to focus on public and private ICT sector recovery, reconstruction, and

---

<sup>1998</sup> Kramer, Franklin D., Larry Wentz, and Stuart Starr (2007). "I-Power: The Information Revolution and Stability Operations." *Defense Horizons*, Number 55, February 2007. Center for Technology and National Security Policy, National Defense University. Available at: <http://handle.dtic.mil/100.2/ADA466767>.

<sup>1999</sup> Ibid.

development; the use of ICT as a cross-sector enabler of security, governance, and socio-economic development; and focus on affected nation ICT capacity development. The leaders should be from the USG Senior Executive Service (SES) or of equivalent stature.

- Establish a USG focal point for ICT thought leadership and strategic thinking.
  - Be the USG ICT spokesperson to work with affected nation ICT counterparts.
  - Advise and mentor USG civilian and military elements regarding ICT matters.
  - Establish early strategic and professional partnerships and trust relationships with key affected nation ICT counterparts and international organizations.
  - Focus on Interagency, inter-governmental organizations (IGOs), non-governmental organizations (NGOs), and affected nation ICT activities, plans, goals, needs, etc.
  - Build on lessons from the Afghanistan Reconstruction Group Senior Telecom Advisor and ISAF Senior Telecom Advisor and Telecom Advisory Team experience in Afghanistan and ICCE/ISE experience in Iraq.
- **Collaboration and information sharing:**
  - Agree on mechanisms to facilitate coordination and information sharing, including situational awareness of stability operations ICT-related recovery, reconstruction, and development activities.
  - Agree on and institutionalize processes for collaboration and information sharing.
  - Develop a concept of operations (CONOPS) for collaboration and information sharing, including common terminology.
  - Agree to implement shared ICT platforms, tools, and capability packages that enable and facilitate collaboration and information sharing.

These activities and items can generate an environment in which the information revolution can help create success in security, stability, reconstruction, and development operations. The next two subsections provide check lists of success factors for affected nation ICT sector recovery and related ICT-enabled civil-military interventions and establishment of an STA/TAT support arrangement.

### Checklist for Future ICT-Enabled Operations

A checklist of policy and strategy success factors to be considered for achieving affected nation ICT sector recovery and the use of ICT to enable security, stability, reconstruction, and development follows and includes factors to be considered regarding ICT-enabled civil-military interventions.

#### *Conditions for ICT Successes for Affected Nations*

1. Have or develop a coherent national ICT vision and strategy for the country.
  - It shapes development of policy, legal, and regulatory frameworks for government, the private sector, and society.
2. Have or appoint a qualified minister of communications who focuses on policy and has:

- key qualified staff;
  - ICT vision, strategies, and plans for the affected nation and its role in the global information environment;
  - understanding of and the ability to leverage the power of ICT as an engine of social and economic development and growth;
  - the ability to leverage wireless services, e-solutions, and advances in ICT technology and related applications to improve government and social services; and
  - ICT capacity building programs and career progressions for managerial and technical staff.
3. Have or create a functional, independent, self-funding regulator.
  4. Have or draft and promulgate ICT laws and regulations and investment laws that create an enabling environment for private investment and competition.
  5. Have or develop an ICT investment plan with funding and the ability to spend, implement, operate, and provide and sustain services.
  6. Be willing to privatize state-owned ICT enterprises.
  7. Focus early on ICT for governance and cross-sector reconstruction by implementing e-services and e-solutions.
  8. Focus on the provision of ICT services to rural areas and disadvantaged populations – build from the bottom up as well as from the top down.
  9. Establish good public-private partnerships, including an industry advisory council and ICT associations.
  10. Have or create an active ICT education and training programs for government personnel and citizens.
  11. Participate in the global information environment through, for example:
    - international organizations such as the UN, ITU, World Bank;
    - professional societies such as the Internet Governance Forum, Association for Computing Machinery (ACM), Institute of Electrical and Electronics Engineers (IEEE), and the Internet Society; and
    - international and regional associations, like the GSM Association.
  12. Track, collect, publish, and share ICT sector statistics.
  13. Participate in local, national, regional, and international ICT conferences and workshops.

14. Publish ICT success stories, best practices, and lessons learned in professional publications and trade journals.
  - Tell the ICT story, advertise successes, and market the value-added benefits of ICT.

### *Conditions for Successes for Intervening Civil-military Responders*

1. USG organizations (e.g., the Departments of Defense, State – to include USAID – and Commerce, the US Trade and Development Agency, and others) work together and support each other as part of a whole-of-government, unity-of-effort approach.
  - USG stakeholders agree on roles and relationships before, or at the very least at the outset of, the intervention.
  - Establish an agreed-upon framework and concept of operations to clarify roles, responsibilities, relationships, capabilities, and limitations among the civilian and military stakeholders.
    - Have an informed understanding of who can and will do what, when, and where.
  - Plan and organize civil-military stakeholder activities.
  - Provide guidance for interactions.
  - Identify organization lead roles.
    - The military may need to take the lead during security and stabilization operations then transfer to a civilian agency longer term.
  - Identify transition point or conditions to transfer lead from military to civilian and vice versa.
  - Enable transition management.
2. Establish formal approved policy and doctrine and an agreed-upon framework and approach for the role of ICT in international crisis response beyond humanitarian assistance/disaster relief (for which USAID has the lead role), to include post-conflict operations.
  - Ensure the role and importance of ICT is understood by and has the attention of both the senior civilian leader and the military commander.
3. Designate a lead agency for ICT.
4. Designate, view, and treat ICT as critical infrastructure and an essential service.
  - Give ICT the same priority and funding as roads, power, and water.
  - Encourage and assist the affected nation to do the same.
  - Assist the affected nation to develop Critical Infrastructure Protection (CIP) and Critical Information Infrastructure Protection (CIIP) programs.
5. Examine past ICT advisory capability models, such as the ICCE/ISE, the STA/ARG, and the STA/TAT, for applicability and develop a model(s) for an ICT advisory capability for interventions.

- The type of model should be driven by the situation and tailored to the needs of the operation.
  - There is likely to be more than just a Senior ICT Advisor (i.e., an ICT support team) during stabilization and reconstruction operations.
  - Efforts demand atypical specialties, tenure, and range of skills, such as:
    - international ICT policy, legal, and regulatory expertise;
    - knowledge of international best practices, standards, templates, toolkits, and business processes;
    - commercial ICT state of practice (CIO and cybersecurity cultures);
    - the ability to deal with the private sector and other senior ICT disciplines.
6. Examine past implementations of ICT advisory capabilities for best practices and lessons to be codified and incorporated into policy, doctrine, concepts of operation (CONOPS), and TTPs.
7. Explore other ad hoc models for lessons, including but not limited to:
- the Iraq Reconstruction Management Office (IRMO) and the Iraq Transition and Assistance Office (ITAO);
  - the Task Force for Business and Stability Operations (TFBSO) in Iraq and Afghanistan;
  - the Afghanistan Reconstruction Group (ARG) and Integrated Civil-Military Action Group (ICMAG) in Afghanistan;
  - reachback elements such as the Assistant Secretary of Defense for Networks and Information Integration (ASD-NII) Iraq and Afghanistan support element, DoD Iraq and Afghanistan Reach Back Office, Pakistan Afghanistan Coordination Cell (PACC), the US Army Corps of Engineer (USACE) Reach Back Operations Center, and others emerging to support real world operations.
8. Provide in-country senior commercial ICT leadership (see [next section](#) for a checklist to stand up an ICT advisory capability) to provide:
- commercial ICT advisory services for deployed USG (DoD, DoS, USAID, DoC, etc.) civilian and military elements.
  - advice on the use of affected nation ICT infrastructure and services to support C4<sup>2000</sup> and enable counterinsurgency actions.
  - advise and work with affected nation ICT counterparts – strategic engagement.
  - advise on ICT governance; policies, laws, and regulations; and the privatization of state-owned ICT enterprises.
  - provide a knowledge repository of commercial and international best practices, business processes, and performance standards.

---

<sup>2000</sup> Command, control, communications, and computers

- enable or assist the affected nation to work toward and meet the conditions for its ICT successes as per above.
9. Agree on USG ICT strategies and plans for facilitating the affected nation’s ICT sector recovery and its provision and use of ICT services.
- Enable or assist the affected nation to recover or establish ICT sector leadership and governance.
  - Use past STA/TAT and ICCE/ISE-like constructs and lines of operation as a useful framework for engaging affected nation counterparts.
  - Baseline the affected nation’s infrastructure, technologies, capabilities, services, and plans.
  - Place early emphasis on enabling or assisting the affected nation to implement ICT capacity building programs and leverage the ICT industry’s ability to do so.
  - Embed key personnel at the ministry of communications, the regulator, and at state-owned ICT enterprises.
  - Facilitate public-private partnerships and private investment opportunities.
  - Use sophisticated business methods to drive strategic ICT effects.
10. Build professional networks and trust relationships with the affected nation’s key ICT counterparts in both government and the private sector.
- Develop a clear understanding of the environment and players.
    - Learn the ICT governance structure.
    - Learn the ICT information and business cultures of both government and industry.
    - Profile key leaders and create influence network diagrams.
  - Conduct purposeful, mutually-beneficial strategic engagements and meet regularly with affected nation ICT counterparts.
    - USG civilian and military elements need to understand how to deal with affected nation government and private sectors.
    - Professionals need to deal with professionals:
      - Military elements will deal best with the affected nation’s military.
      - Civilian elements will deal best with the affected nation’s government and private sector counterparts.
      - Contractors offer access to a unique set of industry and private sector experiences and contacts.
  - Recognize the role of and harness social media to engage and foster professional relationships and networks.
11. Have or develop a strategy and plan for counterinsurgency use of ICT as a “smart power” tool.
- Enable or assist the affected nation to employ ICT as a cross-sector enabler in, e.g., agriculture, finance, education, and healthcare.

- Focus on and address the ICT needs and initiatives of rural areas and disadvantaged populations.
  - Agree on and assign stakeholder roles (military, civilian, USAID, PRTs, etc.) and appropriately synchronize strategies and plans.
  - Understand technology rarely empowers only one side in a conflict, so strategies and plans need to include both positive impacts as well as countermeasures to address and mitigate negative influences and effects.
  - Recognize the potential and power of social media.
    - Leverage the positive benefits but understand that spoilers and insurgents also use it for their own purposes, e.g., to foment violence, manipulate the population, and influence outcomes.
12. Attempt to use the affected nation's ICT infrastructure and services as much as possible.
- Ensure US military planning deliberately focuses on the early rebuilding or implementation of the affected nation's ICT infrastructure.
  - Enable or assist the affected nation to recover and/or expand its ICT infrastructure to accommodate USG needs for capacity, coverage, and diversity and regional and international access.
  - Help jumpstart the ICT sector with targeted investments such as anchor tenant leasing of services and "leave behind" infrastructure investments.
  - Avoid the installation of US-only ICT enclaves that compete with the affected nation's capabilities.
    - Use local providers for non-C4ISR ICT services, such as MWR<sup>2001</sup> Internet access.
    - Use local cellular network services versus installing US reach back cell sites on forward operating bases.
13. Balance risk management and force protection measures so deployed ICT elements can interact regularly with affected nation ICT counterparts within and outside their areas of operation and accomplish their missions. Allow for reasonable travel downrange if security situation is tenable.
14. Get off bases and out of other protected enclaves to meet with affected nation elements as conditions allow:
- National, provincial, district, village, and rural leadership.
  - People in other sectors that use ICT such as governance, civil security, finance, agriculture, education, healthcare, and gender equality.
  - Business and industry leaders and influencers.
  - The people and population you are trying to help.

---

<sup>2001</sup> Morale, welfare, and recreation



15. Actively participate in the larger ICT ecosystem.
  - Attend local, national, regional, and international ICT conferences and workshops.
  - Network with ICT counterparts at organizations such as the UN, ITU, World Bank, and other donor governments and aid agencies.
  - Join professional ICT societies, associations, and organizations.
  
16. Encourage, facilitate, and set the conditions for collaboration and information sharing.
  - Develop, agree upon, and implement a strategy for collaboration and information sharing among the USG civil-military stakeholders and with the affected nation.
  - Provide mechanisms, platforms, and tools to facilitate collaboration and information sharing.
    - Web portals, chat rooms, video teleconferencing, email attachments, etc.
    - More open use of social networking tools such as blogging, Twitter, Facebook, YouTube, etc.
  - Keep unclassified information in unclassified repositories and on unclassified networks.
  
17. Implement strategic communications and public information campaigns for outreach to coalition partners, inter-governmental and international organizations, NGOs, and the affected nation.
  - Develop a strategy and process for getting the right ICT messages to the right audience at the right time.
  - Publish ICT success stories, best practices, and lessons learned in professional publications and trade journals.
  - Leverage the media, including social media, to tell the ICT story.
  - Advertise successes, and market the value-added benefits of ICT.
  - Make sure actions support words.
  
18. Establish processes to document, collect, store, and share a history file of documents (including emails) and activities related to experiences and lessons. Incentivize or enforce participation and compliance as appropriate.
  
19. Enable the affected nation – do not do it for them.
  - Remember that there is a fine line between assisting and intruding.
  
20. Be a good listener.
  
21. View the world through the eyes of the affected nation and understand their needs, wants, priorities, capabilities, and limitations.
  
22. Manage expectations – ours and theirs.

## Checklist for the Establishment an ICT Advisory Capability

If an STA/TAT-like support arrangement is to be employed in a future ICT-enabled intervention, following is a checklist of success factors to be considered to help shape and implement a forward-deployed ICT advise and assist response capability (hereinafter, Senior ICT Advisor (SIA) and ICT Team for ease of reading). Subcategories have been added for reference and organization.

### *USG Actions*

1. Determine among the NSC, DoS, and DoD which entity is best-suited to sponsor a Senior ICT Advisor and supporting ICT Team for post-conflict operations.
  - The general consensus is it should be institutionalized as a DoS/USAID-led activity.
  - However, the DoS/USAID has been reluctant to step up to the challenge, particularly to take on operational field engagement activities outside the wire as security allows.
  
2. Establish policy and doctrine and institutionalize the Senior ICT Advisor/ICT Team approach to be employed, by whom, and when.
  - Have a high-level sponsor CONUS and DoD and DoS leadership provide political and operational support, or top cover.
  - Ensure in-country support from the ambassador and his direct report, the USAID mission director, and the military commander.
  
3. Determine if the ICT advisory capability will be a single position advising both the civil-military elements or if there will be two advisors, one for the civil agencies and one for the military. Also determine if the ICT Team will be based in a single location or have members situated at various sites across the affected nation.
  - If there is a single SIA in country, then s/he should represent USG interests across the civil-military spectrum. If there are two SIAs, then ensure there
    - are clearly defined roles, relationships and responsibilities and an agreed-upon vision and focus of ICT efforts.
    - is an agreed-upon process to facilitate collaboration and information sharing between the civil-military SIAs.
    - is a shared understanding of who has lead role when and where.
      - The military may need to take the lead role of SIA during stabilization operations and then transfer it to the US embassy for longer term engagement.
  - If lead is DoS position at the US embassy,
    - position the SIA at a senior level such as Coordinating Director for Development and Economic Affairs (e.g., Coordinating Director for ICT Activities).
    - hire from industry for the appropriate duration to perform function.
  - If lead is a DoD position,
    - position the SIA at appropriate level of command organization.
    - hire a government civilian or equivalent from industry or contractor.

- For in-country multinational operations, a stronger title than Senior ICT Advisor – such as Senior ICT Director or Administrator – may be necessary to provide the position the appropriate stature to operate in the USG and international environment and to deal with senior affected nation counterparts such as the minister of communications, parliamentarians, and even the president.
4. Develop a CONOPS and Terms of Reference (TOR) that:
    - provide high-level policy and procedures for the establishment of the Senior ICT Advisor and ICT Team and impart their mandate and mission.
    - lay out the vision; strategy; goals; roles and relationships; organization and reporting arrangements; responsibilities and limitations; authority and accountability; reporting requirements; and high-level expectations.
    - communicate guidelines, rules, processes, and procedures for conducting day-to-day operations, including but not limited to pre- and post-deployment activities and obligations; decision making; recruiting, staffing, and performance assessments; orientation and mentoring programs; information sharing; and the collection and storing of documentation and lessons.
    - designates a single point of contact, at least per focus area, to facilitate communication; decrease the likelihood of misunderstandings; fast-track requests and decisions; and maintain accurate messaging related to activities, issues, and resolutions.
    - establish a budget for the Senior ICT Advisor to manage to support on-site operational mission needs.
  5. Issue as appropriate FRAGOs<sup>2002</sup> or their equivalent and institute memoranda of understanding and agreement (MoUs and MoAs) or other official documentation necessary to establish the legitimacy of the Senior ICT Advisor and ICT Team, assign command or organization arrangements, and articulate roles, relationships, and responsibilities within the intervention and among its participating elements.

### *Assembling and Staffing an ICT Advisory Capability*

An ICT advisory capability should be organized, staffed, and managed largely as a civilian team (with military support as appropriate) of professional civil and commercial ICT experts. Similar such capabilities tend to have a small footprint forward and a larger footprint in rear that is actively engaged in day-to-day operations and can moved easily between CONUS and the affected nation as needed. Preferably, the Senior ICT Advisor and at least some key ICT Team members should be continuous, multiyear assignments.

6. An in-country ICT advisory capability should have an appropriate mix of government personnel to represent USG interests and professional commercial ICT contractors to interface with

---

<sup>2002</sup> Fragmentary Order, used to send timely changes of an existing order, without reissuing it in its entirety, to subordinate and supporting commanders while providing notification to higher and adjacent commands.

affected nation ICT officials. The ICT advisory function can be supported by a collective set of ICT SME advisors from government and industry, as was done during the ISAF STA/TAT, which used contractors to interface with government counterparts.

7. For the Senior ICT Advisor (team leader), recruit a senior government civilian (SES, GS-15 or their equivalents) with ICT experience, commercial business skills, and an understanding of military operations and culture to help bridge the civil-military divide.
8. For the ICT Team,
  - contract commercial professional ICT SMEs to be ICT advisors who:
    - have their own off-base life support arrangements, including lodging, transportation, and security protection to allow them flexibility and relative freedom of movement.
    - have the expertise, contacts, and credibility needed to establish initial relationships with ICT counterparts and help build strategic partnerships and trust relationships.
    - can easily embed at affected nation institutions.
  - use the DoD Civilian Expeditionary Workforce (CEW) program to recruit and assign (for not more than two years) volunteer DoD civilian employees to DoD global national security mission positions.
9. Develop a strategy, plan, and process for recruiting to obtain the professional skills needed to serve as ICT Advisor and to staff the ICT Team, to be able to operate in complex multinational and multicultural high-stress environments, and provide continuity over multiple years of operation.
10. Expend the necessary resources (time and money) to cast a wide net to attract qualified candidates.
  - Recruiting and hiring approaches that should be considered include the following.
    - Consider the use of a standby reserve of private sector senior advisors who could fill the position of Senior ICT Advisor and specialized staff positions for the ICT Team.
    - Recruit from government organizations such as DISA, USAID, and agencies specializing in ICT.
    - Recruit from industry and hire a subject matter expert to become a government employee to work as the Senior ICT Advisor.
    - Use the Intergovernmental Personnel Act (IPA) Mobility Program to temporarily assign personnel between the Federal Government, colleges and universities, federally funded research and development centers, and other eligible organizations to fill ICT advisor positions.
    - Engage the DoD Civilian Personnel Management System Highly Qualified Experts (HQEs) program to hire from outside the civil service and uniformed services

and use as appropriate the secretaries of the military departments and heads of defense agencies and DoD field activities with independent appointing authority to authorize assignment of personnel to ICT advisors.

- Other USG sources of possible civil and commercial ICT SME candidates include but are not limited to the DoD AFPAK Hands and Ministry of Defense Advisor (MoDA) programs, US Army Civil Affairs, the Federal Communications Commission-International Bureau, the DoC Commercial Law Development Program, and the DoS Bureau of Conflict and Stabilization Operations (CSO) Civilian Response Corps.
- Create an interview board comprised of the USG Interagency, ICT SMEs, and personnel with experience in past ICT-enabled intervention experiments.

11. Establish a CONUS-based reachback capability to:

- provide strategic thinking and thought leadership.
- serve as the institutional memory and continuity of operations.
- be an active remote element of the forward-deployed team with duties and time split between the States and the affected nation.
- have access to and maintain relationships with key USG Interagency and other ICT stakeholders.
- assist with recruiting, interviewing, and orientation and mentoring of new personnel.
- be used as a ready reserve to gap-fill for the ICT Advisor; in the event of personnel or skills shortages; and for special assignments.
- facilitate developing and sustaining trusted strategic partnerships with affected nation civilian government ICT leadership and with private sector ICT counterparts (where applicable, as those who were previously deployed or spent considerable time on the ground).

See more about utilizing a reachback capability effectively and managing distributed virtual teams [below](#).

### *Pre-deployment Actions*

12. Solicit and obtain agreements with senior leadership at USG Interagency headquarters (DoS, USAID, DoD, and others), develop shared expectations, and ask for their support up front before deploying the ICT Advisor and ICT Team.
13. Create opportunities for the ICT Advisor, ICT Team, and Reachback to meet, socialize, and team-build prior to deployment and to interact with other ICT stakeholders at, e.g., NATO, the UN, ITU, and World Bank.

14. Develop and execute a training program on civil-military culture, roles, and relationships to help bridge the civil-military divide.
  - Military personnel need to understand how to deal with the people and business cultures of the US embassy, USAID mission, and international organizations.
  - Likewise, the civilian organizations need to understand how to deal with the military culture.
15. Develop an ICT profile of the affected nation with key points of contact.

### *Deploying the ICT Advisory Capability*

16. Deploy the ICT advisory capability before or during the “golden hour.”
  - This is the moment after significant hostilities have ceased and before opposition to reform has had an opportunity to gel when there is a chance to make a visible difference before the public mindset shifts from viewing interveners as liberators to occupiers, which is a well-known challenge and can happen quickly and early in the transformation process.
17. Over-estimate the support required.
  - Deploy with the ability to be completely self-sufficient initially with regards to communications, automation, and life support, or pre-arrange to be part of a unit that will provide life support and have the needed agreements to accommodate such in place before deploying.

### *Facilities and Logistics*

18. Establish office space and IT and communications arrangements.
  - Consider IT and communications needs of contractors and visitors (who use company-provided laptops rather than mission terminals).
  - Implement access to “dirty” Internet for unclassified coordination and information exchange in country.
19. Establish administrative and logistics support, including transportation and security arrangements.
20. Research US embassy or military compound organizations and their offerings and hours of operation for both work-related and support services (e.g., badging center, copy facility, IT help desk, clinics, post office, dining facilities, shops, and MWR facilities).
21. Dedicate a person to focus on administrative and logistics functions, e.g., in-processing, billeting, badging, handling visitors, overseeing administrative support with rear, and other activities as needed.

### *Strategic Positioning/Initial Engagement*

The goal of the ICT Advisor and ICT Team is to have them be the one-stop shop for advice and assistance on civil and commercial ICT matters; be facilitators, connectors, and harmonizers of USG Interagency, Coalition forces', and affected nation ICT-related activities; and be the trusted source of informed situational awareness on the ICT sector and others' activities within and regarding it. To that end, the ICT Advisor should:

22. Act quickly and decisively to position the ICT Advisor as the single authority on communicating non-warfighter, ICT-related information to in-theater military and civilian leadership and staffs.
23. Socialize the ICT Advisor/ICT Team engagement strategy to be implemented with the Interagency, the International Community, and affected nation counterparts up front and continuously throughout the operation.
24. Assert responsibility for Interagency facilitation and the coordination of ICT activities.
25. Establish and chair (or co-chair) an Interagency ICT Working Group to ensure a primary and pivotal role.
26. Develop a strategy and approach for becoming visible to senior civilian and military leadership.
  - If located at the US embassy:
    - Become a part of the ambassador's key staff.
    - Participate in the ambassador's staff meetings.
    - Represent the US embassy on activities related to ICT.
  - If located at the USAID Mission:
    - Become a part of the mission director's staff.
    - Participate in mission director staff meetings.
    - Represent USAID on activities related to ICT.
  - If located at military command headquarters:
    - Become a part of commander's key advisory staff.
    - Participate in commander's staff meetings.
    - Brief SIA/ICT Team actions at commander's daily update briefing.
    - Represent military on activities related to ICT.
  - Regularly visit the ambassador and key staff, USAID mission director and key staff, and military commander and senior staff.
  - Become recognized as the civil-military "go to" person for ICT advice and assistance.
  - Proactively participate in special studies and brief US embassy, USAID mission, and military organizations on ICT activities, issues, and successes.
  - Become the key leader to engage with affected nation senior leader ICT counterparts and international organizations working the ICT sector.
27. Begin developing professional ICT and other strategic relationships.

## *Getting Down to Work*

28. Develop and implement an outreach strategy.
  - Develop a clear understanding of the environment.
    - Learn the ICT governance structure.
    - Learn the ICT information and business cultures of both government and industry.
  - Map ICT governance organizations and key private sector ICT companies.
    - Identify and profile key leaders and create influence network diagrams.
    - Collect and document background information on ICT stakeholders and participants.
    - Build an informed understanding of the roles, relationships, capabilities, and limitations of organizations.
  - Create and implement a plan to develop strategic partnerships and for key leader engagement.
    - Hold introductory meetings with senior ICT governance officials and private ICT sector leaders and arrange regular meetings.
  - Develop an informed understanding of ICT priorities, challenges, and opportunities.
  - Embed staff with key organizations such as the ministry of communications, regulator, and state-own ICT enterprises.
  - Identify and start participating in affected nation professional ICT associations.
  - Use past STA/TAT and ICCE/ISE-like constructs and lines of operation as a useful framework for engaging affected nation counterparts.
29. Conduct initial assessments to develop informed situational awareness of the current state of affected nation's ICT sector and what is happening in it.
  - Review and evaluate ICT sector governance, infrastructure, technologies, capabilities, and services and develop a baseline of the "as is" situation.
  - Investigate and assess ICT-related activities and identify who is doing what, where, why, how, for whom, for how long, with whose money, and with what expected outcomes and impacts.
  - Be a good listener.
  - Use the assessments to meet people, broaden professional networks, and socialize the engagement strategy.
  - Create a 100-day plan to establish credibility and shape the way ahead.
30. Develop a strategy and action plan to employ and leverage ICT to support the USG's and coalition partners' civil-military missions.



31. Develop a comprehensive ICT strategy and action plan to facilitate the affected nation's ICT sector recovery and to leverage ICT services to enable security, stability, governance, and socio-economic development and growth. Enable or assist affected nation ICT officials to:
- develop a coherent national ICT vision and strategy for the country (if one does not exist).
  - recover or establish and develop ICT sector governance, including:
    - a policy environment that encourages and facilitates private investment and competition;
    - an independent and transparent regulator; and
    - a legal-regulatory framework that creates an enabling environment.
  - rehabilitate or install new and expand ICT infrastructure.
  - proliferate ICT services, particularly to rural areas and disadvantaged populations.
  - develop e-solutions to improve government and social service delivery to citizens and increase their confidence in the government's abilities.
  - develop and implement ICT capacity building programs for government personnel and citizens.
  - facilitate public-private partnerships and private investment opportunities.
  - work toward and meet the conditions for its ICT successes as per above and accomplish other priorities and goals.
  - identify and mitigate risks.
  - clearly understand, articulate, and communicate expected outcomes and impact.
32. Actively participate in the larger ICT ecosystem.
- Attend local, national, regional, and international ICT conferences and workshops.
  - Network with ICT counterparts at organizations such as the UN, ITU, World Bank, and other donor governments and aid agencies.
  - Join and participate in professional ICT societies, associations, and organizations.
    - Suggest potential associations (e.g., establishing a national AFCEA<sup>2003</sup> chapter).

### *Managing Office Operations*

33. Assign ICT Team members to areas of responsibility and work streams to accomplish the ICT support strategies and action plans.
- Identify priorities, areas of emphasis, relationships and interdependencies, and tasks.
34. Develop a battle rhythm and program of actions.
- Institute policies, procedures, rules, and codes of conduct for office operations.
  - Establish routines, schedules, and calendars.

---

<sup>2003</sup> Armed Forces Communications and Electronics Association

- Assign action officers or responsible parties for key tasks.
  - Identify important meetings to attend.
    - Assess their purposes relative to support strategies and action plans.
    - Designate attendees and backups.
    - Balance meeting attendance with other working time.
  - Schedule regular conference calls with sponsoring agency, appropriate USG elements, and Reachback CONUS.
35. Create orientation and mentoring programs and a briefing book for new personnel, to include but not be limited to:
- an overview of the purpose, mission, vision, strategies, and plans of the ICT Advisor and ICT Team;
  - key USG and coalition leaders and organization elements;
  - key affected nation ICT leader, stakeholder, and important player profiles (including photos, if possible) and contact information;
  - biographies of team members and a contact roster;
  - background reading material;
  - accomplishments, ongoing actions, and current challenges and opportunities;
  - important information on the culture and customs of the affected nation; and
  - facilities, logistics, and office operations information.
36. Develop and implement a knowledge management framework.
- Establish a process and repository to record, collect, and store work product (meeting summaries, memos, documents, reports, emails, etc.).
  - Create a history file to capture actions and the overall experience.
  - Keep unclassified information in unclassified repositories and on unclassified networks.
  - Incentivize or enforce participation and compliance as appropriate.
37. Establish collaboration and information sharing arrangements and procedures, including the use of websites, social media, and other tools and approaches to facilitate civil-military, USG Interagency, and affected nation collaboration, coordination, and information sharing.
38. Outline a process for capturing and documenting lessons learned at the outset and do so for the duration of effort.

### *Additional Things to Do*

39. Balance risk management and force protection measures so deployed ICT elements can interact regularly with affected nation ICT counterparts within and outside their areas of operation and accomplish their missions. Allow for reasonable travel downrange if security situation is tenable.
40. Get off bases and out of other protected enclaves to meet with affected nation elements as conditions allow:

- National, provincial, district, village, and rural leadership.
- People in other sectors that use ICT such as governance, civil security, finance, agriculture, education, healthcare, and gender equality.
- Business and industry leaders and influencers.
- The people and population you are trying to help.

### *Tell the Story*

41. Implement a vehicle to regularly communicate with the larger ICT community and other interested parties in country and CONUS.
  - Consider compiling and distributing weekly reports detailing ICT Advisor and ICT Team work; others' ICT activities; and relevant ICT news.
  - Consider publishing a monthly newsletter.
  - Create and keep current a standard brief(s) to be able to tell the story on demand.
  
42. Implement strategic communications and public information campaigns for outreach to coalition partners, inter-governmental and international organizations, NGOs, and the affected nation.
  - Develop a strategy and process for getting the right ICT messages to the right audience at the right time.
  - Build a relationship with command Public Affairs to create opportunities for interviews and articles (press for early article in *SIGNAL* magazine).
  - Publish ICT success stories, best practices, and lessons learned in professional publications and trade journals.
  - Write white papers and information papers.
  - Leverage the media, including social media, to tell the ICT story.
  - Advertise successes, and market the value-added benefits of ICT.
  - Make sure actions support words.

### *Managing a Distributed Virtual Team*

A Senior ICT Advisor and ICT Team comprised of members in different locations and/or a supporting CONUS-based reachback element creates a distributed virtual team. Experience has demonstrated such teams are difficult to build and manage and sustain effective operations. Factors to consider follow.

- Teams need to be adaptable and agile.
  - Traits that make teams adaptable are:
    - trust, common purpose, shared awareness, and empowerment of individual members to act, and
    - integrative and transparent leadership that empowers team members.
  - Some principles of agile include:
    - Apply the 80/20 rule – 80 percent of results are likely to come from 20 percent of the team.

- Close cooperation and collaboration between all team members.
  - Make decisions and make them on a timely basis.
- Establish, articulate, and maintain a shared vision and clear and agreed-upon understanding of goals and objectives.
- Implement and manage a shared understanding of lead and support roles, responsibilities, relationships, and expectations.
- Treat all team members, regardless of location, as essential and equal participants.
- Implement early and ongoing trust- and team-building activities.
- Proactively manage perceptions and address misperceptions.
- Mitigate the impact of turnover of team members.
  - Properly orient and assimilate new arrivals.
  - Remember trust and respect are earned and cannot be transferred from departing to arriving personnel.
- Develop processes and capabilities to collaborate and communicate effectively among in-country teams and with CONUS team.
  - Consider technological limitations, time zone differences, holidays and working hours, and competing priorities.

### How to Effective Utilize Reachback Support

- View and treat Reachback as an integral part of overall effort that supports, supplements, and complements the forward team.
- Recognize Reachback serves as the institutional memory and provides continuity of operations.
- Recognize Reachback provides strategic thinking and thought leadership to help shape strategy and plans.
- Create opportunities for face time whenever possible.
  - Have new team members meet with Reachback prior to deployment.
  - Rotate Reachback team members into the country regularly to work as part of team on the ground.
  - Attend work-related meetings, conferences, workshops, and events together.
- Specific ways in which Reachback can be used include:
  - to assist with recruiting and interviewing new personnel.
  - to conduct pre-deployment and ongoing mentoring.
  - to gap-fill for personnel or skills shortages and for special and short-term assignments.
  - to sustain continuity of situational awareness and relationships with key affected nation ICT leaders in government and the private sector.
  - to conduct special research, studies, and SME support activities.
  - to facilitate access to government agencies and labs, Interagency leadership and activities, international organization headquarters elements, academia, think tanks and the US ICT industry.

- to support Interagency and international organization coordination and information sharing in CONUS.
- to support as appropriate establishing coordination arrangements in country with the US embassy, USAID, other USG agencies, and international organizations.
- to support the collection, documentation, and analysis of lessons observed and learned.
- to support strategic communications and information campaigns and help tell the story and promote value and success of the operation.

## In Summary

Findings from the use of ad hoc constructs of a senior telecom advisor and supporting telecom advisory team with CONUS-based reachback support in Iraq and Afghanistan have demonstrated the value of such approaches. The STA/TAT approach, in particular, has shown great promise as a model to consider for institutionalizing ICT-enabled interventions for future operations. Lessons from the Iraq MNF-I DCS CIS<sup>2004</sup> ICCE/ISE and Afghanistan US Embassy STA/ARG and ISAF STA/TAT have provided both useful insights into things that make sense to do and things that should be avoided. These ad hoc experiments and learning experiences, need to be further researched along with other insights and lessons observed. Concepts need to be developed with the help of academic institutions such as the Naval Postgraduate School, National Defense University, Army War College, the State Department Bureau of Conflict and Stabilization Operations (CSO), USAID Office of Civilian Military Cooperation, Army Training and Doctrine Center, and think tanks such as the Center for Strategic and International Studies (CSIS), the Brookings Institution, RAND Corporation, the Center for Naval Analyses (CNA), MITRE, and others working civil-military operations.

Additionally, leveraging the experience and intellectual capacity of military service schools and institutions such as the National Defense University National War College, Near East South Asia Center and Institute for National Strategic Studies (INSS), and its Center for Complex Operations and Center for Technology and National Security Policy; the Naval Postgraduate School Cebrowski Institute for Innovation and Information Superiority; and the US Army War College Peacekeeping and Stability Operations Institute and Strategic Studies Institute to assess real-world operational experiences, develop lessons learned, and teach electives on the subject of ICT-enabled interventions that leverage ICT as an enabler of security, stability, reconstruction, and socio-economic development and growth. These institutions can also play an important role by refining concepts and developing approaches to be approved and institutionalized for using constructs such as the STA/TAT and its Reachback distributed virtual team to advise and assist senior civil-military leadership, international civil-military partners, and the affected nation.

## Recommendations

The value of ICT as a “game changer” in security, stability, reconstruction, and development operations is no longer a myth or folklore. Its significance as an enabler of an affected nation’s recovery and return to

---

<sup>2004</sup> Multi-National Forces-Iraq Deputy Chief of Staff for Communications and Information Systems

peace and prosperity has been clearly demonstrated in recent real-world operations such as those in Afghanistan and Iraq. Its importance to mission success now competes with priorities for roads, power, and water as critical infrastructure and an essential service, yet the USG and International Community have not formally recognized the criticality of ICT and its role, nor have intervention organizations substantially changed their ways of doing business. Ad hoc approaches continue to be the norm for doing business. In spite of international interveners operating in the Information Age, approaches for the use of an ICT-enabled civil-military intervention continue to be ad hoc. What efforts there are to employ ICT to facilitate recovery of an affected nation generally are not well coordinated across participating civil-military elements of the intervening force, international donors, or the affected nation's government, commercial ICT sector counterparts, and population. There is no agreed-upon or formalized ICT-driven civil-military strategy, plan, or institutionalized ICT-enabled intervention construct within the USG or International Community that addresses the ability to offer unity of effort and informed and professional ICT advice, assistance, and investment guidance related to intervention decision making for full-spectrum ICT support to humanitarian assistance/disaster relief and security, stability, and reconstruction operations. Bottom line: the United States cannot effectively achieve the security, political, and socio-economic goals for which its military forces and civilian aid agencies are committed unless it can engage effectively with the affected nation's government and the population it is trying to help. The time is now to change USG and international policies, processes, and capabilities to engage in and leverage ICT-enabled unity-of-effort ways of conducting operations in the future that serve to create a knowledgeable intervention, organize related complex activities, and integrate crisis response operations with the affected nation, making security, stability, and reconstruction operations more effective and increasing the likelihood of their success.

Given the global revolution and transformation being experienced because of Information Age technology, senior USG and International Community decision makers need to urgently revisit the establishment and/or revision of civil-military intervention policy, doctrine, strategies, and approaches to treat ICT as critical infrastructure and an essential service. They also need to address how to leverage more effectively the power of information and ICT to facilitate USG and multinational civil-military cooperation and information sharing to conduct whole-of-government and unity-of-effort ICT-enabled interventions for post-conflict security, stability, counterinsurgency (COIN), and development operations. To do this, there is a need to investigate, validate, and implement means to more effectively leverage ICT's role as an enabler of security, governance, and socio-economic development and growth. Furthermore, there is a need to leverage the intellectual power and operational experience of students and faculty at the DoD service schools and colleges to research options, test alternatives, recommend approaches for implementation, and suggest ways to incorporate ICT-enabled interventions into the educational curriculum and training programs of institutions such as such as the National Defense University Institute for National Strategic Studies and National War College, the Naval Postgraduate School Cebrowski Institute for Innovation and Information Superiority, the US Army War College Peacekeeping and Stability Operations Institute and Strategic Studies Institute, and other appropriate research and analysis organizations and accredited education and certified training institutions.

There is a need to clarify and institutionalize USG Interagency ICT leadership roles and responsibilities and create an ICT-enabled concept and intervention process and an ICT advisory arrangement to:

- provide ICT “thought leadership” and “strategic thinking” to senior civil-military leaders.
- be a “one-stop shop” for professional advice and assistance on civil and commercial ICT.
- be the USG spokesperson for ICT and principal person dealing with senior leadership of the civil-military interveners and the affected nation’s ICT sector .
- be a facilitator, connector, and harmonizer of ICT-related activities among the USG Interagency, coalition forces, inter-governmental and international organizations, and the affected nation.
- be the trusted source of informed situational awareness of the affected nation’s ICT sector and USG, coalition forces, donors, and international organization ICT-related activities.

To illustrate the importance of such an action, the ad hoc approaches used in Iraq and Afghanistan to address civil and commercial ICT recovery and reconstruction have made many positive contributions, but more enduring results probably could have been achieved with formally-approved policy guidance and systematic approaches that were institutionalized as the way of doing business. The need, however, is not only USG-oriented. There is also a need for a similar international policy on ICT-enabled interventions and shared and agreed-upon approaches and capabilities to conduct ICT-enabled interventions including improved cooperation and information sharing.

As part of ICT-enabled interventions, a timeline needs to be established to better understand what types of “advise and assist” capabilities are needed when and who assumes the lead role – a civilian agency, the military, or both. Additionally, the process for managing the transition of the lead role from a civilian agency to the military and back to a civilian agency needs to be developed and include the transition of responsibilities to the affected nation as well as possible continuing roles for ICT advice and assistance beyond the civil-military intervention phase of operation. Further, for ICT-enabled interventions, a lead agency needs to be clarified to conduct pre-deployment ICT planning. In Iraq and Afghanistan, there were overlaps and conflicts in the civil-military planning for the recovery and reconstruction of the nations’ ICT sector governance and infrastructure and post-conflict ICT support for security, governance, and socio-economic development. Developing a shared civil-military understanding of the ICT players and their roles, responsibilities, capabilities, limitations, business cultures, and expectations is important as well. For the intervening elements, it is essential to identify upfront who has the lead responsibility for dealing with the affected nation’s ICT sector counterparts and for harmonization and coordination of ICT-related activities of the intervening force, donors, international organizations, and NGOs. If there are both civilian and military leads identified for the ICT sector, then there needs to be processes to develop a mutual understanding of roles and relationships and the sharing of information across the civil-military boundary.

Successful approaches to leveraging the role and use of ICT in post-conflict reconstruction also need to be rooted in a thorough understanding of the affected nation’s national political, legal, economic, social, cultural, and communications contexts. It is important to understand the information and communications culture and the ICT-related business culture, along with ICT processes used by the affected nation’s government and private sector entities. Knowledge before the intervention of the affected nation’s existing ICT sector governance, key leaders, and infrastructure and related supply chains are important. Additionally, knowing who makes things happen and who are the spoilers needs to be included as part of the portfolio of capabilities to support ICT-enabled interventions.

These civil and commercial ICT-related activities are generally counterculture for militaries and are not something they train to do, nor do they have adequate policy, doctrine, or tactics, technics, or procedures (TTPs) to support actions in the field. Hence the need for civilian professional ICT subject matter expertise to address civil and commercial ICT sector challenges and opportunities and to facilitate collaboration, harmonization, and information sharing among the civil-military elements participating in the intervention and related ICT sector post-conflict reconstruction and development activities.

There is an urgent need to establish new USG and international policy and doctrine on the role and importance of ICT as an enabler, to develop USG and international response strategies and plans that treat ICT as critical infrastructure and an essential service, and to agree upon and institute cooperative ICT-related planning, implementation, and information sharing arrangements among responding stakeholders. Participants in complex operations need to know how to work together before an intervention, not learn how during the intervention, which is currently the norm.

To maximize the affected nation's society's benefits from ICT, the risks resulting from interdependences, vulnerabilities, and threats must be managed. Enhancing cybersecurity and improving critical ICT infrastructure protection have become the watchwords for efforts by both intervening forces and affected nations to collaboratively address and manage risks. ICT introduces new capabilities and tools that spoilers, criminals, and insurgents can and do use not only to command and control their own operations but for extortion, corruption, disruption of intervening forces' operations, and to undermine the security and stability of the affected nation trying to recover and transition to security and peace. The bad guys also leverage the power of social networking tools to shape and influence perceptions to support their goals. They use cyber-attacks to deface government websites and disrupt information systems supporting security, governance, rule of law, and economic activities. These destructive actions have added a new dimension to conducting security, stability, and reconstruction operations and protecting critical infrastructure of the affected nation.

There is a need for affected nations emerging from conflict to develop not only a Critical Infrastructure Protection (CIP) program but, more importantly, because of general greater reliance on Information Technology (IT) and its use to control other systems such as the SCADA<sup>2005</sup> systems to control power grids, there is also a need to establish a Critical Information Infrastructure Protection (CIIP) program as well. Understanding other key interrelationships and impacts such as IT systems' dependencies on power and backup capabilities for critical data storage systems and disaster recovery plans are also important factors. Key to this is a national cybersecurity strategy and plan, related policies, laws and enforcement, and active implementation of cyber protection, detection, and response capabilities. Hence, policies, strategies, capabilities, and capacity development adjustments need to be factored into shaping intervention approaches to be used in future operations. There are major IT, cybersecurity, and critical infrastructure protection education and training components that need to be addressed.

---

<sup>2005</sup> Supervisory control and data acquisition, a system using communications signals for remote monitoring and control.



Moving forward, USG ICT policy and doctrine changes need to include guidance for institutionalizing USG civil-military approaches for providing an ICT advisory function to perform the functions described above. Much work remains to be done to identify and verify needs across the peace-to-crisis response-to-peace spectrum and map lessons to them to create an effective USG civil-military ICT-enabled rapid and sustainable response capability to support complex operations. USG policy, such as the National Security Policy Directive (NSPD)-44 from 2005 that empowered the secretary of state to lead and coordinate the US Government's response across all involved agencies and to work with the secretary of defense to harmonize civilian and military activities and Presidential Decision Directive 23 (PDD 23) in 2013 on US Security Sector Assistance Policy that fostered USG policy coherence and Interagency collaboration, are candidates to be reviewed, revised, and reissued. Others that also need to be updated are DoD instructions (DoDI) 3000.05 (Stability Operations) and DoDI 8220.02 (ICT Support for Stability Operations). Additionally, there is a growing body of USG and international civil-military experience in the use of ICT in post-conflict operations that needs to be leveraged as part of the new way of doing business and shaping the way ahead. More proactive and continuous sharing of real-world operational experiences between and among the communities of participants would serve to enable not only USG but international government and development agencies to make more effective use of ICT at all stages of post-conflict operations, from short- to medium-term security, stabilization, and reconstruction, to long-term development.

In summary, ICT can significantly increase the likelihood of success in security, stability and reconstruction operations if it is engaged as part of an overall strategy that coordinates the actions of outside intervenors and focuses on generating effective results for the affected nation using ICT as an enabler and game changer for recovery and return to peace and prosperity.<sup>2006</sup> Properly utilized, ICT can help create a knowledgeable intervention, organize complex activities, and integrate crisis response operations with the affected nation, making security, stability and reconstruction operations more effective. Key to these results is a strategy that requires the following:

1. The USG take a leadership role in conducting and promoting ICT-enabled interventions, give high priority to such an approach, and ensure they are whole-of-government, unity-of-effort civilian-military activities.
2. Military and civilian aid agencies make ICT a formal part of their planning and execution of crisis response operations.
3. The USG establishes ICT-related partnerships with key regular participants in crisis response operations, such as coalition partners' civil-military elements, NATO, the United Nations, and the World Bank, and works with them to plan ICT-enabled interventions. .

---

<sup>2006</sup> Kramer et al., 2007.

4. The focus of the intervention, including the use of ICT, is on the affected nation, and supports its security, governmental, societal, and economic development.
5. Key ICT capabilities are harnessed to support the strategy.

Implementing an ICT-enabled strategy will include enabling or assisting the affected nation to develop strategies and plans to use ICT effectively to support security, stabilization, and reconstruction; agreements among interveners on information sharing and collaboration. Information sharing and collaboration arrangements should include agreements to keep unclassified data in accessible repositories and on unclassified networks; share data on a differentiated basis; and implement common ICT platforms, tools, and capabilities.

ICT can be an important component for success in intervention operations. Successful results require that a purposeful strategy be adopted to use ICT-enabled capabilities to achieve the desired recovery of the affected nation and to develop operational activities that effectively implement the strategy. An ICT-enabled approach can generate an environment in which the power of the information revolution can be harnessed and applied to help create success.

## Appendix A The Afghanistan ICT Team

---

The Office of the Senior Telecom Advisor (STA) and the Telecommunications Advisory Team (TAT) was a US government (USG) initiative from 2010 to 2014, sponsored and funded by the Department of Defense (DoD). The Department of State (DoS) and the United States Agency for International Development (USAID) supported the STA/TAT as the USG Interagency lead for ICT key leader engagement with Afghan ICT counterparts, and acted as harmonizer for all ICT activities. The Office of the Assistant Secretary of Defense for Networks and Information Integration (OASD-NII) which later became the Department of Defense Chief Information Officer (DoD CIO) designated the Defense Information Systems Agency (DISA) as the lead agency responsible for the STA/TAT. The DoD Task Force for Business and Stability Operations (TFBSO) helped fund the first year of the STA/TAT's operation, while the remaining three years were funded by DISA. The STA/TAT was a DoD element collocated with NATO's International Security Assistance Force (ISAF) in Kabul, Afghanistan.

While this book generally mentions only the STA/TAT, there was an extensive cast of characters supporting the STA/TAT in various capacities. The broader Afghanistan ICT Team comprised the following organizations and personnel. Participants are generally listed in alphabetical order, not by rank or position, except the STA/TAT Directors, which are listed chronologically in order of service. Some people functioned in multiple capacities simultaneously or over the course of STA/TAT (and follow on) operations.

### Office of the Assistant Secretary of Defense-Networks and Information Integration/Department of Defense Chief Information Officer (OASD-NII/DoD CIO)

#### Leadership - CONUS

- John Grimes
- Terry Halvorsen
- Cheryl Roby (Acting)
- Teri M. Takai

#### Advisory Team – CONUS

- William (Bill) Barlow
- Robert A. (Bob) Kinn
- Phillip (Phil) McDonald

#### OASD-NII/DoD CIO Advisor and Interagency Coordinator – Kabul/CONUS

- Robert A. (Bob) Kinn

### Defense Information Systems Agency (DISA)

#### Leadership – CONUS

- LTG Ronnie D. Hawkins, Jr., USAF
- Larry Huffman, SES
- LTG Alan R. Lynn, USA
- LTG Carroll F. Pollett, USA

#### Advisory Team – CONUS

- Kelly J. Chott
- Will Ritchie (Deceased)
- Fred Ruonavar
- William J. Schmitt

## Department of Defense Task Force for Business and Stability Operations (DoD TFBSO)

### Leadership – CONUS

- Stan Lumish

### Advisor – CONUS/Kabul

- Karen E. Black

## National Defense University (NDU)

### Leadership – CONUS

- Dr. Linton (Lin) Wells II

### Advisor – Kabul/CONUS

- Larry Wentz

### Advisory Team - CONUS

- Dr. Charles (Chuck) Barry
- Mary Crannell (Idea Sciences)
- Michael Landrum (Idea Sciences)
- Dr. Traci Swanson
- Larry Wentz

## Deloitte Consulting LLP

### ICT Advisory Team – Kabul

- Dr. Maria Beebe (SME)
- Karen E. Black
- Arne Brinck (SME)
- Oliver Dziggel
- Antonio (Tony) Lodà
- Lewis E. (Lew) Shadle

### ICT Advisory Team – CONUS

- Peter Butturini
- Peter M. (Pete) CuvIELLO
- Stephen (Steve) Herrmann
- Keith Sontheimer

The Deloitte ICT Advisory Team was funded by the DoD/DISA. Deloitte consultants were deployed to Kabul from July 2010 to March 2013. A designation of SME indicates subject matter expert advisors brought in for short projects so as to distinguish those who deployed to Kabul on a longer-term basis.

### Economic Growth and Governance Initiative (EGGI) Team – Kabul

- Joel M. Allen
- Oliver Dziggel
- Jack Lightle (Deceased)

The Deloitte EGGI Team was funded by USAID. The advisors listed above worked in the Afghan ICT sector and cooperated with and supported the TAT and vice versa.

## IZ Technologies, Inc. (IZT)

### Afghan Telecommunications In-Country Support (ATICS) Program – Kabul

- Nelson Cuñado
- Oliver Dziggel
- Antonio (Tony) Lodà
- Dr. Chi Nche

IZT consultants were deployed to Kabul from October 2013 to January 2016. ATICS was initially funded by DISA (October 2013 to March 2015) and later by USFOR-A (April 2015 to January 2016). When the TAT ceased operations in October 2014, ATICS moved under the CJ6 at NATO's Resolute Support Mission.

### IZT Leadership – CONUS

- Evin Planto
- Lynette Planto

## Telecommunications Advisory Team (TAT)

### Senior Telecom Advisors/TAT Directors – Kabul

- Lawrence W. (Larry) Klooster (2010-2011)
- Col Elizabeth A. (Beth) Bierden, USA (2011-2012)
- Col Francis J. (Frank) Huber, USA (2012-2013)
- Dr. Catherine Warner (2013-2014)

### TAT Participants – Kabul

The following list includes TAT members and visitors who spent time on the ground in Kabul. TAT personnel largely came from within the US government and military (including volunteers from DISA), through the Civilian Expeditionary Workforce (CEW), or courtesy of the Afghanistan-Pakistan (AFPAK) Hands and Ministry of Defense Advisors programs. The TAT was able to supplement its expertise with visiting contractors and short-stay subject matter experts. A letter vee (V) after a name below indicates a visitor, so as to distinguish those who deployed to Kabul on a longer-term basis.

- Farid S. Abass
- Captain Patrick (Pat) Akers, USAF
- CW2 Gregory (Greg) Amentt, USA
- James Babatunde
- Kevin Bell
- Larry Brewer (V)
- Kyle M. Chase
- Ronald (Ron) Coleman
- Ken Collette (V)
- Jose Cruz
- Dr. Gregory (Greg) Edwards\*
- Colonel Andrew Gale, USAF
- Robin Gibson
- Brice Hall
- Mark Hinton
- John M. Horn, Sr.\*
- William B. (Brad) Howard
- Ronald (Ron) Jones

- Robert (Bob) Kinn (V)
- Christopher (Chris) Miller\*
- Michael (Mike) Nichols
- Oliver Parsons
- Ramon Perez
- Michel (Mike) Pettit
- Michael (Mike) Piatkowski (V)
- Ralph Puckett (V)
- James (Jim) Rickard
- Ted Ryon, Jr.
- Captain Trevor M. Sayer, USMC
- Maj John Myers, USAF
- Donald (Don) Norton
- Neil F. Sleevei
- Dr. Traci Swanson (V)
- James (Jim) Valentine
- Captain Nathan I. (Nate) Waters, USMC
- Larry Wentz (V)
- Tania M. Wilkes
- Captain (now Major) Scott Wilson, USAF

\* Served as Deputy Director TAT

### TAT Reachback Team – CONUS

- Karen E. Black, Deloitte Consulting LLP
- Kelly J. Chott, DISA
- James P. (Jim) Craft, Joint Improvised Explosive Device Defeat Organization (JIEDDO)
- Jeff DePasquale, Gartner, Inc.
- Oliver Dziggel, Deloitte Consulting LLP
- Robert (Bob) Kinn, OASD-NII/DoD CIO (FCI)
- Tenzin Norbhu, The World Bank
- Catherine O'Leary, Garter, Inc.
- Siddhartha Raja, The World Bank
- Will Ritchie (Deceased), DISA
- Fred Ruonavar, DISA
- William J. Schmitt, DISA
- Lewis E. (Lew) Shadle, Deloitte Consulting LLP
- Rajendra Singh, The World Bank
- Keith Sontheimer, Deloitte Consulting LLP
- Larry Wentz, National Defense University

## Appendix B Authors, Contributors, and Peer Reviewers

---

### Authors

#### Dr. Maria Beebe

Dr. Maria Beebe is an applied sociolinguist whose research interests include critical discourse analysis, women's leadership, and information and communications technology (ICT) for development. Dr. Beebe has over twenty years' experience in global development in a wide range of sectors, including higher education and telecommunications. She served as Chief of Party for Afghanistan eQuality Alliances, a Washington State University project funded by the United States Agency for International Development (USAID). She co-edited [AfricaDotEdu](#) to share sustainable development lessons around the use of ICT to create networks for capacity building among higher education institutions in Africa.

#### Karen E. Black

Karen E. Black has over 25 years' experience in international information and communications technology (ICT) in the private and public sectors. She has held executive and senior management positions at various commercial international service providers and twice served as a Senior ICT Advisor to the US Department of Defense. Ms. Black has devoted her career to breaking down technological, political, and social barriers to promote competition and increase access to and the use of ICT. She has lived and worked in Europe, Asia, and the Middle East. From 2010 to 2015, Ms. Black worked in the Afghan ICT sector, where she advised the Ministry of Communications and Information Technology, the Afghanistan Telecom Regulatory Authority, and state-owned Afghan Telecom Corporation. She also facilitated the use of ICT for effective governance and socio-economic development and growth. In Afghanistan, Ms. Black served as an international advisor to TechWomen Afghanistan and as a NATO Country Co-director for the Afghan Research and Education Network (AfgREN) and the Afghan Academy of Sciences. Ms. Black is currently a principal at [Alaurus](#), a boutique international technology consulting firm. She holds Bachelor of Science degrees in Communication Systems Management and Interpersonal Communication from Ohio University.

#### Oliver Dziggel, MA

Oliver Dziggel has more than 36 years of experience and is widely recognized as a highly-effective manager of large-scale, complex, multi-million dollar projects. In Afghanistan (2003-2016) for Deloitte Consulting LLP and others, Oliver led two of the country's largest economic development projects, with 25 discrete work streams in diverse sectors that established entire industries from the ground up, including banking, finance, trade, and information and communications technology (ICT). As a long-standing trusted advisor to the numerous senior Afghan officials, he was appointed and served as a member of the Telecom Regulatory Board (TRB), the first independent regulatory body in the country and an institution he helped to create. More recently, Oliver has been advising governments and institutions to accelerate electronic government, especially digital financial services (electronic and mobile payments) to reduce corruption and increase transaction efficiency. In addition to ICT, Mr. Dziggel has experience in a variety of other sectors including banking, public financial management (PFM), healthcare, energy, mining,

manufacturing, and investment promotion. He has worked extensively in Europe, the former Soviet Union, Latin America, Africa, and Asia. Oliver holds an MA in International Affairs from The George Washington University and a BA in Political Science from Towson State University.

## Jennifer Gold

Jennifer Gold graduated from James Madison University in 2007 with a Bachelor of Science degree in Justice Studies and a concentration in Criminal Justice. Ms. Gold commissioned into the US Army National Guard as a Military Intelligence officer and served in Iraq from 2009 to 2010. Shortly thereafter, she traveled to Nangarhar, Afghanistan as a Cultural Analyst, where she lived from 2010 to 2012. Jennifer co-founded International Synergy Group and assisted in implementing various information and communications technology (ICT) programs for agricultural development, healthcare, and education. In 2012, Jennifer began working with Medweb, a telemedicine company, on its mobile health programs for humanitarian assistance and disaster relief operations. With the support of her family and friends, Ms. Gold decided to pursue a degree in nursing and recently graduated from the Johns Hopkins University School of Nursing in Baltimore, Maryland.

## Eileen Guo

Eileen Guo is a serial social entrepreneur working to empower communities in transitioning environments by connecting local talent with global audiences and opportunities mostly through technology and social media. As the Founder of [Impassion Afghanistan](#), she is leading the company's various information and communications technology (ICT) initiatives, including creating and curating the Afghan Social Media Summit, designing [Paiwandgāh](#), a citizen journalism platform, and advising and training media organizations, embassies, and the Afghan government on social media and mobile technology adoption. A World Economic Forum Global Shaper and one of Diplomatic Courier's "99 Young Professionals in Foreign Policy Under 33," Eileen is currently consulting for the MIT Press *Innovations Journal*. Eileen holds a Bachelor of Arts from Tufts University in Anthropology and International Security, and a Certificate in Humanitarian Field Practices from the Harvard Humanitarian Initiative. She is fluent in Spanish, Mandarin Chinese, and English, and is proficient in Farsi (Dari).

## Shainoor Khoja

Shainoor Khoja operates [Better Business Enterprise](#) (BBE), a consultancy identifying new opportunities in emerging markets and the developed world for businesses to address the needs of base of the pyramid populations, to explore commercial opportunities using technology and to develop innovative business practices. Before BBE, she held the position of Managing Director Roshan Community, at Afghanistan's #1 mobile operator, [Roshan](#), an Aga Khan Fund for Economic Development Company, since 2004 and concluded her fulltime role in 2012. Apart from her daily operational role, Shainoor had been an integral part of the fundraising cycles for Roshan that has raised in excess of US\$180 million for the company. Shainoor's contribution has been focused around innovative strategies that bring strategic value to the growth and development of the group companies. This has entailed incubating initiatives and evolving them into viable commercial products that go to market. Her focus has further been to address lenders requirements for social and economic development increasingly being termed impact investing.



## Dr. Peter M. Killcommons

A respected physician, Dr. Peter M. Killcommons serves as Chief Executive Officer of [Medweb](#), a San Francisco-based medical imaging company he founded in 1992. Medweb's innovative telemedicine platforms are designed for areas with unreliable power or communications systems and are in use in some of the world's most remote locations. A longtime philanthropist, Pete has leveraged his medical background to aid individuals in other countries around the world. To date, he has visited remote villages and military outposts in Afghanistan, Peru, Iraq, and Kuwait on charitable missions and medical care trips. Most recently, he assisted [Rotary International](#) in installing medical equipment and training doctors at hospitals in Jalalabad and Kabul, Afghanistan. He continues to devote time to many philanthropic medical missions, such as the USNS Comfort hospital ship, the American Red Cross, the World Cares Center, and Pens for Peace. Pete attended the City College of New York, where he was in the Sophie Davis Accelerated BS-MD program, after which he attended New York Medical College.

## Robert A. (Bob) Kinn

Robert Kinn has worked in and on Afghanistan since 2004, in positions supporting US government information and communications technology (ICT) interests at the US Department of State, the US Agency for International Development, and the US Department of Defense. In Kabul he worked across the US Embassy Kabul and DoD commands and NATO's International Security Assistance Force (ISAF), as well as with the White House Chief Technology Officer on Global and Afghan ICT issues. In Afghanistan, Mr. Kinn worked primarily on ICT and cross-sector programs and issues. Mr. Kinn served as Acting Senior Telecommunications Advisor (STA) in Kabul on multiple occasions across 2006-2007. He played a lead role in the creation of the Telecom Working Group at the US Embassy Kabul, the National ICT Association of Afghanistan, and the Afghanistan National Chapter of the Armed Forces Communications and Electronics Association (AFCEA), serving as Charter Officer, Vice President, and North America Liaison for the chapter. Bob is currently an FCI Senior Information Analyst, Information Sharing, DoD CIO Information Enterprise, Architecture, and Engineering (IEAE)

## Dr. Chi Nche

Dr. Chi Nche is a senior spectrum management expert with over 20 years' experience in the telecommunications industry. His career includes wireless research and development, wireless network design, network deployment and operations, detecting and mitigating interference issues, and spectrum policies and regulations. He has worked extensively in the US and in many international locations, including Mexico, Latin and South America, and the Middle East. Recently, Dr. Nche supported the Defense Information Systems Agency and US Forces-Afghanistan as an advisor to the Afghan Ministry of Communications and Information Technology and the Afghanistan Telecom Regulatory Agency, helping them to better manage, monitor and regulate wireless spectrum. Dr. Nche graduated from the University of Liverpool in the United Kingdom with a Bachelor's in Engineering. He completed his post-graduate research in the same university to earn his doctorate, specializing in the characterization of the wireless communication channel.

## Rachel Robb

From 2008 to 2010, Rachel Robb worked on the Drug Policy and Andes Region Program at the [Washington Office on Latin America](#). She was the International Representative for the [National Indigenous Congress of Colombia](#) in 2010. Shortly thereafter, Ms. Robb traveled to Afghanistan as a Cultural Analyst, where she lived for two years, designing and implementing ICT for development projects with local communities, including Nangarhar's public health and education sectors. Since 2012, Rachel has managed marketing and international philanthropy projects for the telemedicine company Medweb. She completed post-graduate studies in Anthropology and a Master's in Applied Anthropology with a focus on human rights at the American University in Washington, DC.

## Juan Andrés Rodríguez

In 2010, Juan Andrés Rodríguez worked throughout eastern Afghanistan implementing projects using open source technology and data mapping/visualization and cross domain information sharing. In 2012, Mr. Rodríguez co-founded International Synergy Group, a technology company based in Afghanistan dedicated to developing mobile applications and communications strategies designed specifically to solve local social issues. In 2015, Juan founded an online platform specialized in sourcing tropical perishable goods and he is currently managing the business. He graduated from The Savannah College of Art and Design (SCAD) in Georgia and received a Master's in Product Design Management at the Javeriana University in Bogota, Colombia in 2012.

## Lewis E. Shadle, Sr.

Lewis E. Shadle, Sr. is a successful business leader and infrastructure developer with more than 40 years of commercial experience in information and communications technology (ICT). He is uniquely adept in laying the foundations for "greenfield" ICT supporting US and foreign national government socio-economic development and core information-based services with national and international scope. For eight years as a Senior ICT Advisor, on behalf of US government and international development entities, Lew provided strategic consultation, mentoring, and technical capacity development services to the governments of Iraq and Afghanistan. He is currently the principal of his own firm, advising the Defense Information Systems Agency in global undersea cable systems as a cohort of the Contingency Operations and Critical Infrastructure Program Team.

## Larry Wentz

Larry Wentz is a Visiting Research Fellow at the National Defense University, Center for Technology and National Security Policy. Since 2010, he has been a Senior Advisor to the Department of Defense Chief Information Officer (DoD CIO) and the Defense Information Systems Agency (DISA). From 2010 to 2014, he advised the Senior Telecom Advisor (STA) and supporting Telecommunications Advisory Team (TAT) in Kabul, Afghanistan, spending considerable time on the ground with Afghan public and private sector information and communications technology (ICT) counterparts. Larry also spent time in the field in Khost, Nangarhar, Paktika, Helmand, Kandahar, and Herat provinces researching ICT in support of security, governance, and socio-economic development. In 2006, Larry visited Afghanistan to research ICT sector reconstruction, at which time he also provided support to the STA at the Afghanistan Reconstruction

Group (ARG) at the US Embassy Kabul. Larry has been involved in other global crisis operations in Bosnia, Kosovo, Iraq, and Haiti.

## Contributors

- Joseph L. Gattuso, Attorney-Advisor, International, Commercial Law Development Program (CLDP), US Department of Commerce
- William B. (Brad) Howard, LMI Government Consulting
- Robert A. (Bob) Kinn, FCI Senior Information Analyst; Information Sharing, DoD CIO Information Enterprise, Architecture and Engineering (IEAE)
- Fary Moini, Moini International Consulting
- Lane Smith, International Development Specialist

## Peer Reviewers

- Farid Abass, Information Technology/Telecom Specialist
- CW3 Gregory P. Amentt, US Army Cyber Protection Brigade, Ft Gordon, GA
- James P. (Jim) Craft, Chief Information Officer, Joint Improvised-threat Defeat Agency (JIDA) and former Senior Telecom Advisor at the Afghanistan Reconstruction Group
- Oliver Dziggel, MA, Principal, Digital Financial Services Authority
- Joseph L. Gattuso, Attorney-Advisor, International, Commercial Law Development Program (CLDP), US Department of Commerce
- Bill Gillis, District Grants Coordinator, Community Colleges of Spokane
- Brice Hall, Telecom Program Analyst, Office of Emergency Communications, US Department of Homeland Security
- Greg Hearne, Director/Co-Founder, A Connected Planet Foundation
- Dr. Walter Kaffenberger, NATO Programme Manager, Engagement Section, Public Diplomacy Division (ret.)
- Robert A. (Bob) Kinn, FCI Senior Information Analyst; Information Sharing, DoD CIO Information Enterprise, Architecture and Engineering (IEAE)
- Stan Lumish, Chief Operating Officer, Velankani Communications Technology, Inc.
- Joey V. Mendoza, Independent Senior Consultant, Digital Financial Services
- Steinunn Pieper, Former ISAF Gender Advisor, Icelandic Crisis Response Unit
- Jan M. Sarro, Executive Vice President, Marketing and Business Development, Fusion Telecommunications International, Inc.
- Lewis E. Shadle, Sr., LESA, LLC
- Brian Shniderman, Principal, US Payments Practice Leader, Deloitte Consulting LLP
- Dr. Linton (Lin) Wells II, Managing Partner, Wells Analytics, LLC
- Tania M. Wilkes, Director, Defense Enterprise Computing Centers (DECC) Montgomery, Defense Information Systems Agency
- Major Scott N. Wilson, USAF, Commander, Detachment 1, 53 Computer Systems Squadron (CSS)

**DISA**

