

NTIA Report 99-358

Delivered Audio Quality Measurements on Project 25 Land Mobile Radios

John M. Vanderau



U.S. DEPARTMENT OF COMMERCE
William M. Daley, Secretary

Larry Irving, Assistant Secretary
for Communications and Information

November 1998

This Page Intentionally Left Blank

This Page Intentionally Left Blank

PRODUCT DISCLAIMER

Certain commercial equipment, components, and software are identified in this report to adequately present the underlying premises of this report. In no case does such identification imply recommendation or endorsement by the National Telecommunications and Information Administration, nor does it imply that the equipment, components, or software identified is the best available for the particular applications or uses.

ACKNOWLEDGEMENTS

The Institute for Telecommunication Sciences wishes to thank Union Pacific Railroad's Wireless Engineering Group, located in Omaha, Nebraska, for making Project 25-compliant radios available to the Institute to perform this investigation.

CONTENTS

PRODUCT DISCLAIMER.....	iii
ACKNOWLEDGEMENTS	iv
COMPACT DISK	vi
1. INTRODUCTION.....	1
2. GOALS	2
3. MEASURED PERFORMANCE IN A NONINTERFERENCE ENVIRONMENT.....	2
3.1 SINAD vs. Receiver Sensitivity.....	2
3.2 BER vs. Receiver Sensitivity	3
3.3 Measured Receiver Reference Sensitivity Levels.....	4
3.4 Delivered Audio Quality Recordings.....	5
3.5 Delivered Audio Quality Assessment.....	7
4. MEASURED PERFORMANCE IN CO-CHANNEL AND ADJACENT-CHANNEL ENVIRONMENTS.....	9
4.1 Desired Digital Signal with Unwanted Digital Interferer	9
4.2 Desired Digital Signal with Unwanted Analog Interferer.....	10
4.3 Desired Analog Signal with Unwanted Analog Interferer.....	11
4.4 Desired Analog Signal with Unwanted Digital Interferer.....	12
4.5 Adjacent-Channel and Co-Channel Performance Characteristics	14
4.6 Delivered Audio Quality Recordings.....	15
4.7 Delivered Audio Quality Assessment.....	18
5. CONCLUSION	20
6. REFERENCES.....	21

COMPACT DISK

If a compact disk containing the speech samples discussed in this report is not included with this report, the speech samples may be accessed / obtained at the U.S. Dept. of Commerce's Institute for Telecommunication Science's internet site, <http://flattop.its.bldrdoc.gov/spectrum/P25>

DELIVERED AUDIO QUALITY MEASUREMENTS ON PROJECT 25 LAND MOBILE RADIOS

John M. Vanderau^{*}

Minimum acceptable speech intelligibility of land mobile radios is influenced by a number of factors. These factors include the method of modulation, transmission bandwidth, channel spacing, received signal strength, and the ability of a radio receiver to capture a desired signal in the presence of interfering signals and noise. The Institute for Telecommunication Sciences has compared the speech quality performance of the new generation of Project 25 land mobile radios to analog FM systems.

Keywords: adjacent-channel interference, BER, C/I, co-channel interference, delivered audio quality, land mobile radio, Project 25, reference sensitivity level, SINAD

1. INTRODUCTION

The Public Safety Wireless Advisory Committee's final report [1] promotes the concept of system interoperability between public safety land mobile radio communities. Industry has responded to this need by developing equipment that complies with the Telecommunications Industry Association (TIA) Project 25 (P25) suite of performance standards. P25-compliant radios are digital, use C4FM modulation, and are backward-compatible with traditional analog FM radios.

With P25 equipment now emerging on the marketplace, the Institute for Telecommunication Sciences (ITS) initiated an effort to objectively categorize the intelligibility of received speech under different signal-to-noise and signal-to-interference environments. Audio recordings of speech samples, as received by P25 radio equipment, were made at a number of signal-to-noise and signal-to-interference conditions. These recordings are available[†] to assist communications systems planners in determining system parameters such as minimum acceptable channel spacing and frequency reuse, as a function of their users' minimum acceptable perceived quality of received speech.

^{*} The author is with the Institute for Telecommunication Sciences, National Telecommunications and Information Administration, U.S. Department of Commerce, 325 Broadway, Boulder, CO 80303.

[†] The Institute for Telecommunication Sciences, "Delivered Audio Quality Measurements on Project 25 Land Mobile Radios," <http://flattop.its.bldrdoc.gov/spectrum/P25>, November 1998.

2. GOALS

The goals of this effort were to:

- (1) measure typical values of P25 receiver sensitivity over a wide range of *SINAD* and *BER* values,
- (2) measure typical P25 receiver adjacent-channel and co-channel performance in both analog FM and P25 digital C4FM modes for various channel spacing and interference (e.g. digital signal interfering with digital signal, analog signal interfering with digital signal, etc.) configurations,
- (3) create audio recordings of received speech samples under various conditions of received signal strength in noninterfering, adjacent-channel interference, and co-channel interference environments, and
- (4) determine the intelligibility of the speech samples in a quantitative manner.

It was not, nor is it now, the intent of this task to evaluate the specific performance of, to perform acceptance testing on, or to compare to a competitor's offerings, any particular manufacturer's P25 equipment. Motorola Astro™ P25 radios were utilized during the accomplishment of this task because this particular brand of equipment had been made available to ITS by a third party to support this measurement task. Neither ITS nor the third party has a pecuniary interest in Motorola or any of its P25 competitors. The *only* intent of this task was to categorize received speech quality of a *typical* P25 radio operated in a wide variety of received signal strength, adjacent-channel and co-channel environments.

3. MEASURED PERFORMANCE IN A NONINTERFERENCE ENVIRONMENT

3.1 SINAD vs. Receiver Sensitivity

The signal-plus-noise-plus-distortion-to-noise-plus-distortion (SINAD) ratio gives an indication of the audio quality of a demodulated received analog signal. An RF signal received at some particular power level will yield a unique SINAD ratio at the audio output of the radio receiver under test. Typically, manufacturers specify 12 dB SINAD (dBS) as a minimum performance level. The procedure involves measuring a radio receiver's audio output signal in response to an incident RF signal. The RF signal is modulated by a 1-kHz audio test tone that has been adjusted to deviate the RF carrier to 60% of the maximum frequency deviation permitted for the RF channel. Usually, the maximum permissible frequency deviation for a land mobile radio channel is 5 kHz for earlier generation analog equipment, and 2.5 kHz for newer narrowband equipment. The radio receiver's audio volume is typically adjusted to provide the *rated audio output level* specified by the manufacturer. Then, the power level of the incident RF signal is adjusted to achieve a 12 dB at the receiver's audio output. The SINAD ratio measurement procedure is described in the TIA's land mobile radio equipment measurement procedures [2].

In addition to measuring the 12-dBS sensitivity level of a typical P25 radio operated in the analog FM mode, ITS measured several other sensitivity levels, encompassing a range of

SINAD ratios spanning 6 to 35 dB. The received power sensitivity levels so measured were used later to adjust the output power level of an RF signal that had been modulated by pre-recorded speech samples. This permitted a means of relating a specific SINAD value to the *delivered audio quality* (DAQ) value of a specific received speech recording.

Figure 1 depicts a block diagram of the equipment configuration used to perform a SINAD measurement. The components are a Motorola XTS-3000 portable radio, a Motorola RTX-4005 audio breakout box, and a Motorola R-2670 communications system analyzer. The R-2670 generates an RF signal modulated by a 1-kHz audio tone. The demodulated received audio signal is fed back to the R-2670 via the audio breakout box. The R-2670 then determines the SINAD.

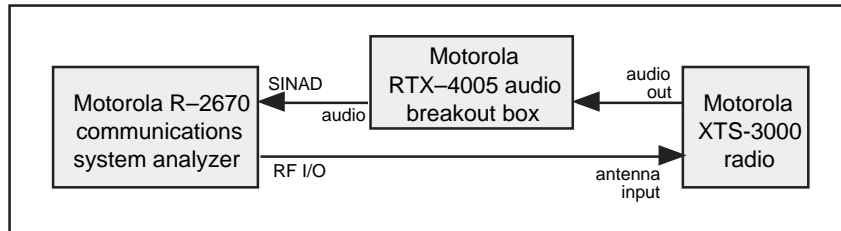

Figure 1. Equipment configuration to perform SINAD measurement.

3.2 BER vs. Receiver Sensitivity

For radios modulated by digital signals, bit error ratio (BER) is analogous to the analog FM radio's SINAD ratio discussed in the preceding section. Typically, P25 manufacturers specify 5% BER as a minimum performance level. The BER measurement procedure is described in the TIA's digital transceiver measurement procedures [3]. The procedure essentially mimics that given by [2] for the analog FM case.

In addition to measuring the 5% BER sensitivity level, ITS measured several other sensitivity levels, encompassing a range of BERs spanning 0.25% to 12.5%. The received power sensitivity levels so measured were used later to adjust the output power level of an RF signal that had been digitally modulated by pre-recorded speech samples. This permitted a means of relating a specific BER value to the DAQ value of a specific received speech recording.

Figure 2 depicts a block diagram of the equipment configuration used to perform a BER measurement. The components are a Motorola Radio Service Software (RSS), a Motorola Radio Interface Box (RIB), a Motorola XTS-3000 portable radio, and a Motorola R-2670 communications system analyzer. The R-2670 generates an RF signal modulated by a specific bit pattern. The radio receiver synchronizes to the incoming signal and outputs the received demodulated bit pattern to the RSS via the RIB. The RSS compares the demodulated received bit pattern to an *a-priori* known copy of the originally transmitted bit pattern and determines the BER.

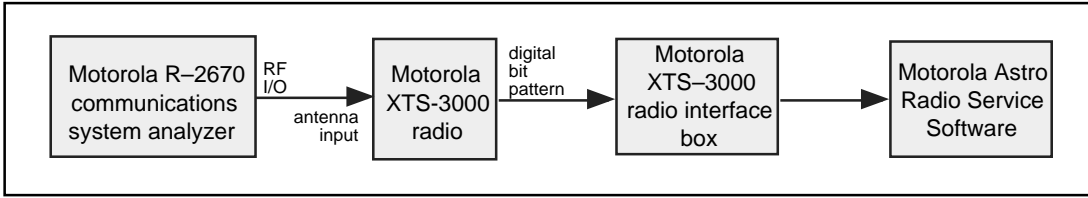

Figure 2. Equipment configuration to perform BER measurement.

3.3 Measured Receiver Reference Sensitivity Levels

Table 1 summarizes the measured receiver's reference sensitivity levels for the SINAD and BER values given. The data presented in Table 1 is plotted in Figure 3.

Table 1. Typical receiver reference sensitivity levels vs. SINAD[†] and BER.

SINAD (dBS)	2.5-kHz deviation Analog FM Receiver Reference Sensitivity Level (dBm)	BER (%)	P25 Digital Receiver Reference Sensitivity Level (dBm)
35.0	-87.0	0.25	-115.1
30.0	-103.0	0.50	-116.0
25.0	-109.5	1.00	-117.6
22.3	-111.0	1.40	-118.2
20.0	-113.5	2.00	-119.0
17.0	-116.5	2.60	-119.6
15.3	-118.2	3.20	-120.1
13.5	-119.9	4.20	-120.8
12.0	-120.5	5.00	-121.4
10.0	-121.5	6.40	-121.9
		8.50	-123.1
		10.50	-123.9
6.0	-123.5	12.50	-124.7

[†] Values given are for narrowband (2.5-kHz) maximum carrier frequency deviation f . For larger (wideband) frequency deviations, sensitivity will improve by as much as $20 \log (f_{wb} / f_{nb})$ dB.

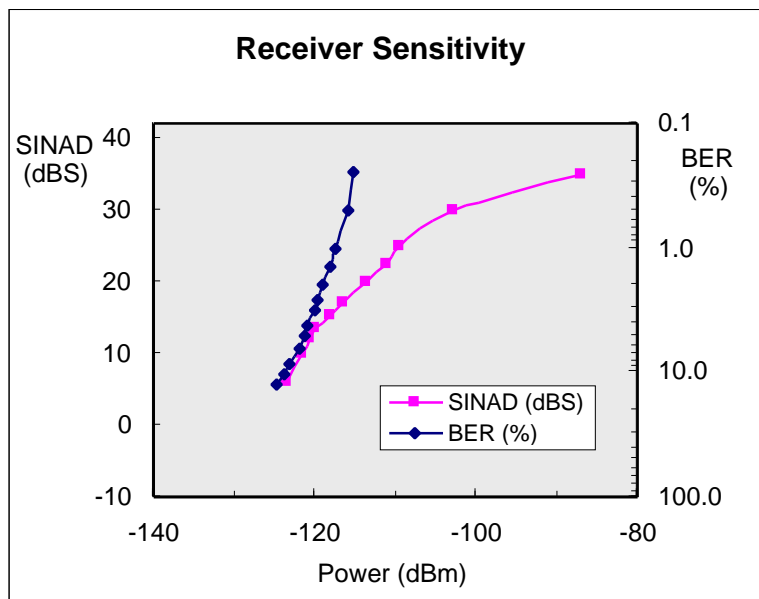

Figure 3. Typical receiver reference sensitivity levels vs. SINAD[†] or BER.

3.4 Delivered Audio Quality Recordings

Figure 4 shows the equipment configuration used to record the audio output of the P25 radio. This configuration is applicable for both analog FM and digital C4FM modes. The inclusion of a Tascom Porta03 Mk II 4-track studio-grade analog cassette player and a Tascom DA-P1 digital audio tape (DAT) recorder is the only significant change to the earlier configurations depicted in Figures 1 and 2.

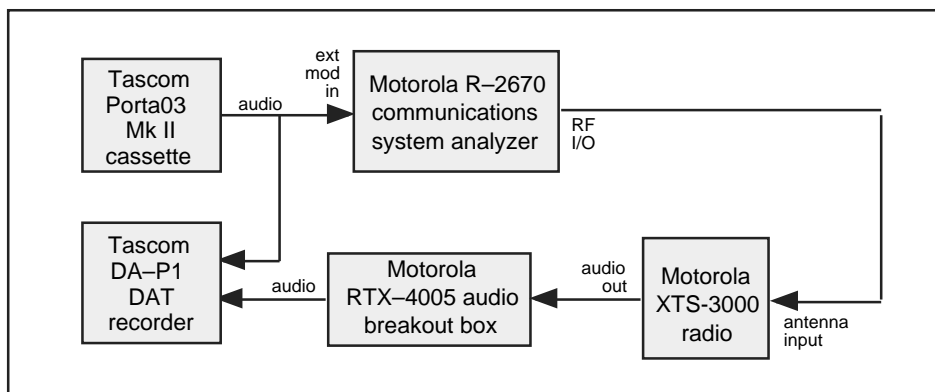

Figure 4. Equipment configuration to record speech.

[†] See Table 1 footnote.

The source audio speech sample from the Tascom Porta03 Mk II analog cassette player was composed of multiple copies of two male and two female speakers each saying four sentences. The sentences were selected from a cataloged list of *phonetically balanced* sentences [4]. These sentences are phonetically balanced in the sense that the number of occurrences of English-language speech *phonemes* is more or less uniformly distributed. The total length of time of the sixteen sentences was approximately 63 seconds. This collection of sixteen sentences was repeated many times over on two tracks of the Tascom analog cassette player, with identical volume and time phase relationship between the two tracks. There was approximately a 9-second pause between each identical group of sixteen sentences. The volume level remained unchanged between sequential groups of sentences.

One audio track from the analog cassette player modulated the RF signal generated by the R-2670 communications system analyzer. The other audio track was recorded directly to one channel of the DAT recorder. This second audio track acted as the “pristine” speech reference, against which the demodulated speech from the radio receiver would later be compared.

Output volume from the Tascom analog cassette player was carefully adjusted to ensure that the R-2670 modulator would not distort the signal, while providing ample audio input voltage to the modulator. This was done by maximizing the R-2670’s audio input voltage level without introducing distortion to the audio signal (i.e., *flat-topping* or *clipping*), as viewed on the R-2670 oscilloscope display and as perceived aurally through the sound speaker, throughout the duration of the sixteen sentences.

Earlier, it was mentioned that a pristine speech reference was recorded on one channel of the DAT recorder. Demodulated speech from the P25 radio receiver was recorded on the DAT recorder’s other channel. Under good signal conditions, the input levels of both channels were individually adjusted to ensure that the input stages of the DAT recorder would neither be overdriven nor underdriven, thereby preventing the occurrence of any undue distortion or noise. The DAT recorder has a peak level meter, permitting both input levels to be carefully adjusted to provide an input signal amplitude margin (ITS chose to use a 6-dB margin) before the DAT recorder’s inputs would be overdriven.

The TIA’s report on methods for evaluating system performance [5] relates power levels corresponding to various SINAD or BER operating points to a DAQ metric of a speech signal[†]. That is, a larger SINAD (analog FM case) or smaller BER (digital C4FM case) yields a higher quality speech signal. These results were based upon extensive subjective listening experiments utilizing listening panels (groups of individuals convened to subjectively assess perceived speech quality). According to the TIA, the DAQ of a 12-dBS

[†] Delivered Audio Quality Metrics:

- DAQ 1 Unusable. Speech present but not understandable.
- DAQ 2 Speech understandable with considerable effort. Requires frequent repetition due to noise/distortion.
- DAQ 3 Speech understandable with slight effort. Requires occasional repetition due to noise/distortion.
- DAQ 3.4 Speech understandable without repetition. Some noise/distortion present.
- DAQ 4 Speech easily understood. Occasional noise/distortion present.

analog FM signal should be equivalent to a 5% BER digital C4FM signal. Similarly, 25-dBS and 1% BER signals should yield equivalent DAQs.

ITS has developed a computer-driven automated technique to measure the *auditory distance* between two signals [6]. Auditory distance is a measure of the perceived difference between two speech signals. When one speech signal is a “perfect” reference signal, and the other speech signal is a distorted signal (e.g. radio output), auditory distance corresponds to the perceived quality of that distorted signal relative to the reference signal. When two speech signals are identical, the auditory distance between them is zero. As the perceived differences between the two signals increase, auditory distance increases as well.

Prior to this effort, ITS had empirically derived a “mapping function” to relate the objectively measured auditory distances to DAQ values that were reported in seven subjective listening tests. DAQ values range from 1 (bad) to 5 (excellent). This mapping function permits an objective means to estimate perceived speech quality, as determined by the auditory distance algorithm, on a quality rating scale used in subjective listening tests.

3.5 Delivered Audio Quality Assessment

Table 2 and Figure 5 present the results of ITS’ objective DAQ scoring. The DAQ results as reported by TIA are also shown.

Table 2. DAQ vs. SINAD[†] and BER.

SINAD (dBS)	2.5-kHz deviation Analog FM Receiver Reference Sensitivity Level (dBm)	Objective DAQ Score (analog FM)	TIA-reported DAQ Scores (analog FM)	BER (%)	P25 Digital Receiver Reference Sensitivity Level (dBm)	Objective DAQ Score (digital C4FM)	TIA-reported DAQ Scores (digital C4FM)
35.0	-87.0	4.4		0.25	-115.1	3.6	
30.0	-103.0	3.8		0.50	-116.0	3.7	
25.0	-109.5	3.1	4.0	1.00	-117.6	3.6	4.0
22.3	-111.0	2.6		1.40	-118.2	3.7	
20.0	-113.5	2.3	3.4	2.00	-119.0	3.6	3.4
17.0	-116.5	2.0	3.0	2.60	-119.6	3.6	3.0
15.3	-118.2	1.8		3.20	-120.1	3.5	
13.5	-119.9	1.6		4.20	-120.8	3.2	
12.0	-120.5	1.6	2.0	5.00	-121.4	3.1	2.0
				6.40	-121.9	2.7	
10.0	-121.5	1.4		8.50	-123.1	1.7	
				10.50	-123.9	1.3	
6.0	-123.5	1.3		12.50	-124.7		

[†] See Table 1 footnote.

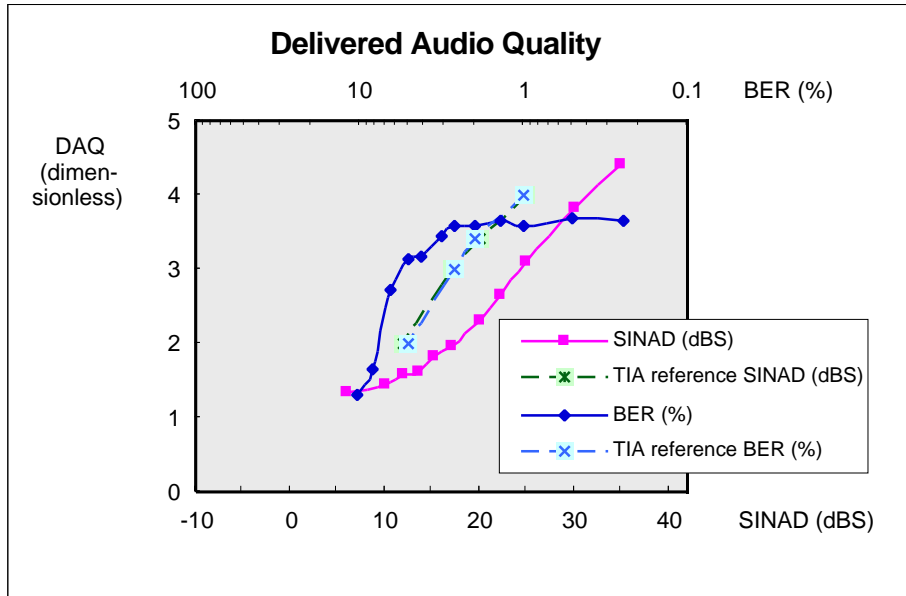

Figure 5. DAQ vs. SINAD[†] and BER.

A threshold effect is apparent in the ITS digital DAQ plot, above which the DAQ remains relatively constant versus BER. This demonstrates the error-correcting capability of the P25 vocoder. At operating points below this threshold (greater BER), the DAQ deteriorates rapidly. But even in this region, the perceived speech quality of the digital signal still exceeds that of an analog signal.

ITS' measurements indicate better digital-mode DAQ performance compared to those reported by TIA. The ITS analog-mode DAQ measurements show somewhat worse performance than has been reported by TIA.

Possible causes for the discrepancies between the ITS and TIA measurements include:

- (1) The inherent high variability in readings when measuring SINAD or BER, particularly since the data collection of SINAD and BER values was not automated. Instead, while measuring SINAD and BER, the displayed values were "averaged" by visual observation. Measurements taken on different days under purportedly identical SINAD and BER conditions exhibited as much as a 10% variation.
- (2) The empirical mapping function relating auditory distance to DAQ value. This function had been previously determined utilizing different speech material under different additive noise and distortion properties.
- (3) The context of TIA's subjective listening tests and composition of the listening panels. Listeners with prior land-mobile radio operating experience may score speech intelligibility higher than naive listeners might. The number of tests conducted, the number of listening panels employed, the types of questions asked, the speech material

[†] See Table 1 footnote.

used, the signal distortion techniques employed, and the land-mobile radio backgrounds of the listening panels would all affect the outcome of a subjective scoring of speech intelligibility.

(4) ITS' audio quality scoring algorithm only provides an *estimate* of speech intelligibility.

To facilitate a direct comparison between the DAQ performance of the analog FM and digital C4FM operating modes, the SINAD and BER axes in Figure 5 were scaled and aligned to point-match TIA's reported analog FM and digital C4FM DAQ values, at both the DAQ = 2 and DAQ = 4 operating points. Using these horizontal-axis scales, TIA's analog and digital mode DAQ operating points are observed to essentially coincide at both DAQ = 3 and DAQ = 3.4.

Comparing ITS' measured DAQ data given by Figure 5 to the receiver sensitivity data plotted in Figure 3, one can generalize that at comparable received signal strengths, digital C4FM yields better received audio performance than does analog FM. For example, Figure 5 shows that a 22 dBS analog signal and a 6.5% BER digital signal both yield a DAQ of about 2.8. From Figure 3, the RF sensitivities of a 22 dBS analog signal and a 6.5% BER digital signal are about -115 dBm and -123 dBm, respectively. Therefore, a weaker digital signal will deliver the same speech quality as will a stronger analog signal.

4. MEASURED PERFORMANCE IN CO-CHANNEL AND ADJACENT- CHANNEL ENVIRONMENTS

Because P25 radios are dual mode (digital C4FM or analog FM), there are four *interference modes* that must be categorized when evaluating adjacent-channel and co-channel performance. These interference modes are described in the following sections.

4.1 Desired Digital Signal with Unwanted Digital Interferer

The procedure to measure the adjacent-channel and co-channel interference rejection ratio of a digital C4FM radio in the presence of a digital C4FM interfering signal is described in the TIA's digital transceiver measurement procedures [3]. Figure 6 shows the equipment configuration.

In the absence of the interfering signal, the 5% BER operating point of the radio receiver was established. As explained in Section 3.2, the RF signal was modulated by a digital bit pattern that, when converted to baseband audio by the radio's vocoder, represents a 1011-Hz audio tone. The desired signal's RF power was then increased by 3 dB (this improved the BER). Then, an adjacent-channel or co-channel interfering signal, modulated by a pseudorandom bit pattern, was introduced and its power level increased to degrade the desired signal's BER back to its original 5%. The difference between the power level of the interfering signal and the 5% BER reference sensitivity level (in the absence of the interferer) is the adjacent-channel or co-channel rejection ratio.

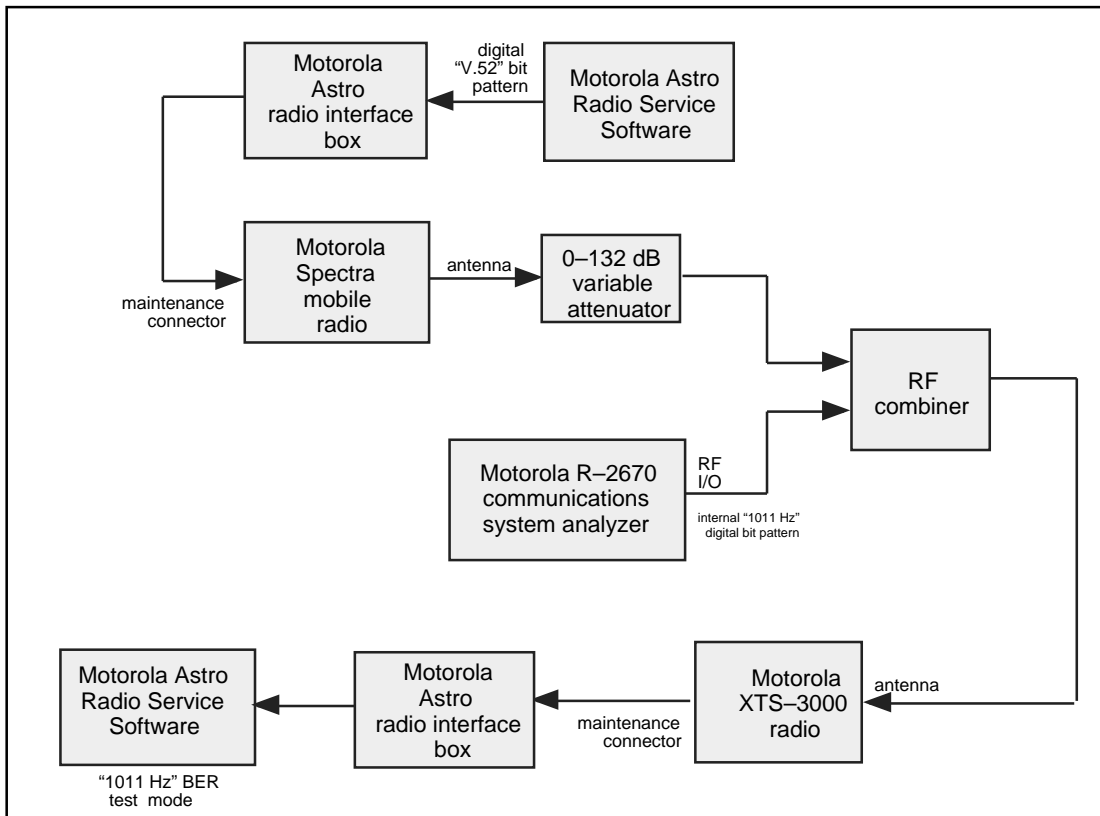

Figure 6. Equipment configuration to measure adjacent-channel and co-channel rejection of desired digital C4FM channel and unwanted digital C4FM signal.

For this interference mode, ITS performed adjacent-channel and co-channel rejection ratio measurements on a typical P25 radio at a number of different channel spacings. Section 4.5 tabulates the measurement results in Table 3 and graphically presents several important cases of interest in Figure 10.

4.2 Desired Digital Signal with Unwanted Analog Interferer

The procedure to measure the adjacent-channel and co-channel interference rejection ratio of a digital C4FM radio in the presence of an analog FM interfering signal is also described in the TIA's digital transceiver measurement procedures [3]. Figure 7 shows the equipment configuration.

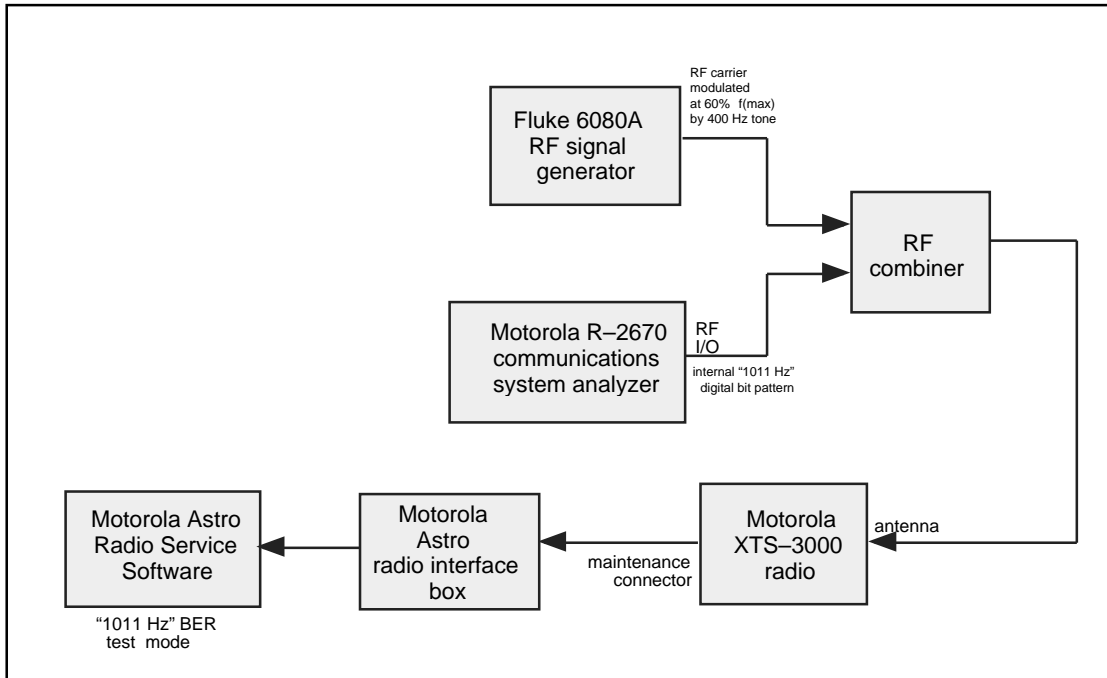

Figure 7. Equipment configuration to measure adjacent-channel and co-channel rejection of desired digital C4FM channel and unwanted analog FM signal.

In the absence of the interfering signal, the 5% BER operating point of the radio receiver was established. As explained in Section 3.2, the RF signal was modulated by a digital bit pattern that, when converted to baseband audio by the radio's vocoder, represents a 1011-Hz audio tone. The desired signal's RF power was then increased by 3 dB (this improved the BER). Then, a frequency-modulated adjacent-channel or co-channel interfering signal was introduced and its power level increased to degrade the desired signal's BER back to its original 5%. The difference between the power level of the interfering signal and the 5% BER reference sensitivity level (in the absence of the interferer) is the adjacent-channel or co-channel rejection ratio.

For this interference mode, ITS performed adjacent-channel and co-channel rejection ratio measurements on a typical P25 radio at a number of channel spacing and (analog interferer's) frequency deviation combinations. Section 4.5 tabulates the results in Table 3 and graphically presents several important cases of interest in Figure 10.

4.3 Desired Analog Signal with Unwanted Analog Interferer

The procedure to measure the adjacent-channel and co-channel interference rejection ratio of an analog FM radio in the presence of an analog FM interfering signal is described in the TIA's land mobile radio equipment measurement procedures [2]. Figure 8 shows the equipment configuration.

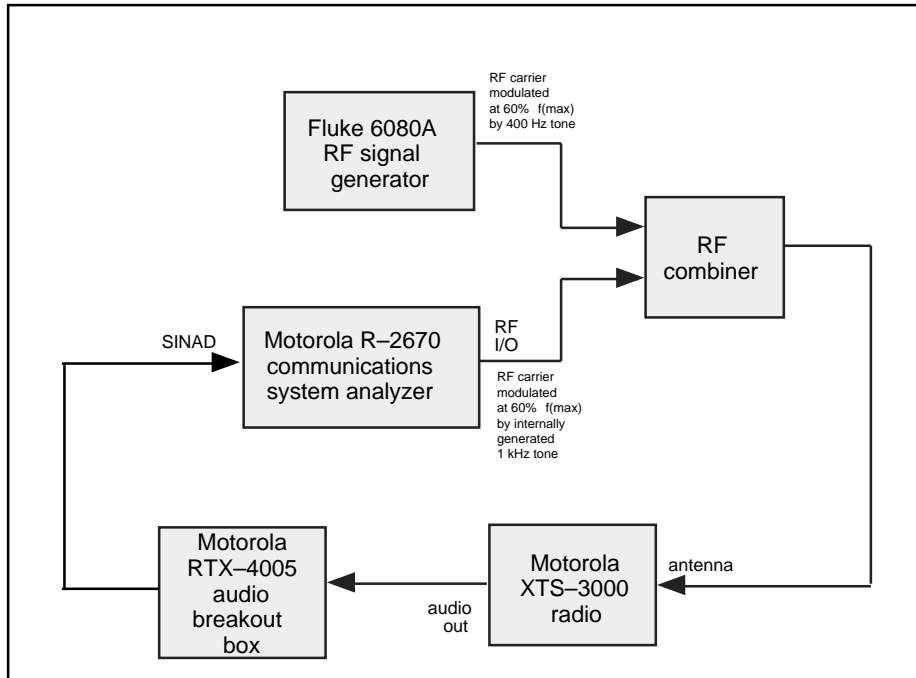

Figure 8. Equipment configuration to measure adjacent-channel and co-channel rejection of desired analog FM channel and unwanted analog FM signal.

In the absence of the interfering signal, the 12-dBS operating point of the radio receiver was established. As explained in Section 3.1, with the radio receiver’s audio volume set to deliver the rated audio output power (per the radio manufacturer’s design specification), the RF signal was modulated by a 1-kHz audio tone at a frequency deviation equal to 60% of the maximum deviation permitted for the RF channel. The desired signal’s RF power was then increased by 3 dB (this improved the SINAD ratio). Then, a frequency-modulated adjacent-channel or co-channel interfering signal was introduced and its power level was increased to degrade the desired signal’s SINAD ratio back to its original 12 dBs. The difference between the power level of the interfering signal and the 12-dBS reference sensitivity level (in the absence of the interferer) is the adjacent-channel or co-channel rejection ratio.

For this interference mode, ITS performed adjacent-channel and co-channel rejection ratio measurements on a typical P25 radio at a number of channel spacing and frequency deviation combinations. Section 4.5 tabulates the results in Table 3 and graphically presents several important cases of interest in Figure 10.

4.4 Desired Analog Signal with Unwanted Digital Interferer

Neither the TIA’s land mobile radio equipment measurement procedures [2] nor the TIA’s digital transceiver measurement procedures [3] describe how to measure the adjacent-

channel and co-channel interference rejection ratios of an analog FM radio in the presence of a digitally modulated interfering signal. However, using a “hybrid” approach based on the applicable procedures described in [2] and [3], ITS measured the interference rejection ratio for this case. Figure 9 shows the equipment configuration.

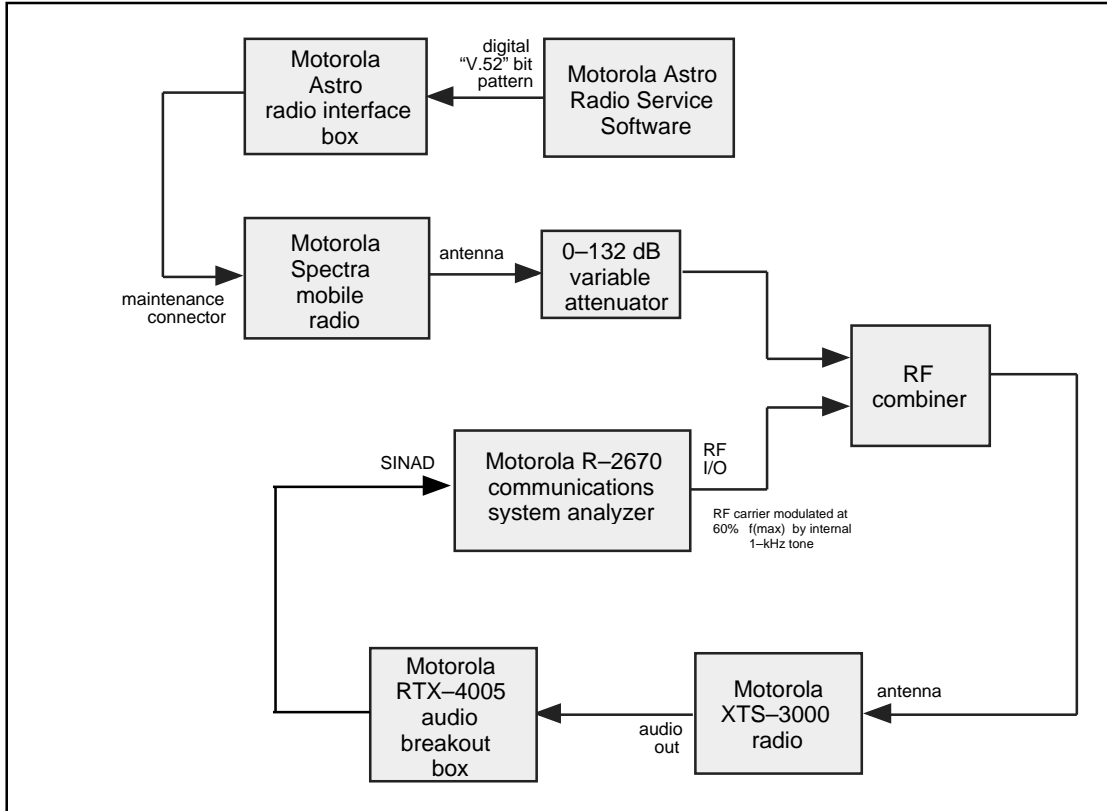

Figure 9. Equipment configuration to measure adjacent-channel and co-channel rejection of desired analog FM channel and unwanted digital C4FM signal.

In the absence of the interfering signal, the 12-dBS operating point of the radio receiver was established. As explained in Section 3.1, with the radio receiver’s audio volume set to deliver the rated audio output power (per the radio’s design specification), the RF signal was modulated by a 1-kHz audio tone at a frequency deviation of 60% of the maximum deviation permitted for the RF channel. The desired signal’s RF power was then increased by 3 dB (this improved the SINAD ratio). Then, an adjacent-channel or co-channel interfering signal, modulated by a pseudorandom bit pattern, was introduced and its power level increased to degrade the desired signal’s SINAD ratio back to its original 12 dBs. The difference between the power level of the interfering signal and the 12-dBS reference sensitivity level (in the absence of the interferer) is the adjacent-channel or co-channel rejection ratio.

For this interference mode, ITS performed adjacent-channel and co-channel rejection ratio measurements on a typical P25 radio at a number of channel spacings and analog frequency deviations. Section 4.5 tabulates the results in Table 3 and graphically presents several important cases of interest in Figure 10.

4.5 Adjacent-Channel and Co-Channel Performance Characteristics

Table 3 tabulates the results of the adjacent-channel and co-channel interference rejection ratio measurements described in the previous four sections. The four interference modes represented in the table are:

- (1) a digitally modulated signal causing interference to a desired digital channel (d/D),
- (2) an analog FM signal causing interference to a desired digital channel (a/D),
- (3) an analog FM signal causing interference to a desired analog FM channel (a/A), and
- (4) a digitally modulated signal causing interference to a desired analog FM channel (d/A).

Table 3. Adjacent-Channel and Co-Channel Performance Characteristics

Interference Mode	Analog Deviation (kHz)		Interference Rejection Ratio, $P_{\text{interferer}} - P_{\text{sensitivity(desired)}}$, (dB)			
			Co-Channel	Adjacent Channel Spacing (kHz)		
	Unwanted Interferer	Desired Signal		7.5	12.5	15
d/D			-14.8	14.5	49.4	58.5
a/D	2.5		-7.9	58.5	65.7	72.0
	4.0		-7.9	40.2	67.9	71.5
	5.0		-7.9	25.8	67.3	71.5
a/A	2.5	2.5	-2.5	40.1	70.5	73.5
	4.0	2.5	-2.5	19.4	68.5	73.5
	5.0	2.5	-2.5	10.3	68.5	73.5
	2.5	4.0	-1.7	9.4	66.5	67.7
	4.0	4.0	-2.0	2.5	66.5	68.0
	5.0	4.0	-1.5	1.3	65.5	69.2
	2.5	5.0	-1.7	10.2	67.1	68.2
	4.0	5.0	-1.7	4.0	67.1	68.8
d/A		2.5	-17.7	-4.7	32.1	51.9
		4.0	-20.2	-14.7	21.3	43.3
		5.0	-20.2	-11.7	23.3	43.3

The frequency deviation of the digital C4FM signals generated by the R-2670 was chosen to be the default deviation setting of the R-2670's digital P25 operating mode. When the R-2670 communications system analyzer or the 6080A signal generator was operated in the traditional analog FM signal generator mode, three values for frequency deviation were used: 2.5, 4, and 5 kHz. Adjacent-channel interferers were offset 7.5 kHz, 12.5 kHz, and 15 kHz in frequency from the desired channel. Of course, co-channel interferers were at the same carrier frequency as the desired channel.

Figure 10 graphically presents several cases tabulated in Table 3. Interference modes (and the maximum frequency deviations of the applicable analog FM signals) are identified in Figure 10's legend. For example, the lowercase "a2.5" means that the unwanted interferer is an analog FM signal with a maximum frequency deviation of 2.5 kHz. Similarly, the uppercase "A5" means that the desired signal is an analog FM signal with a maximum frequency deviation of 5 kHz.

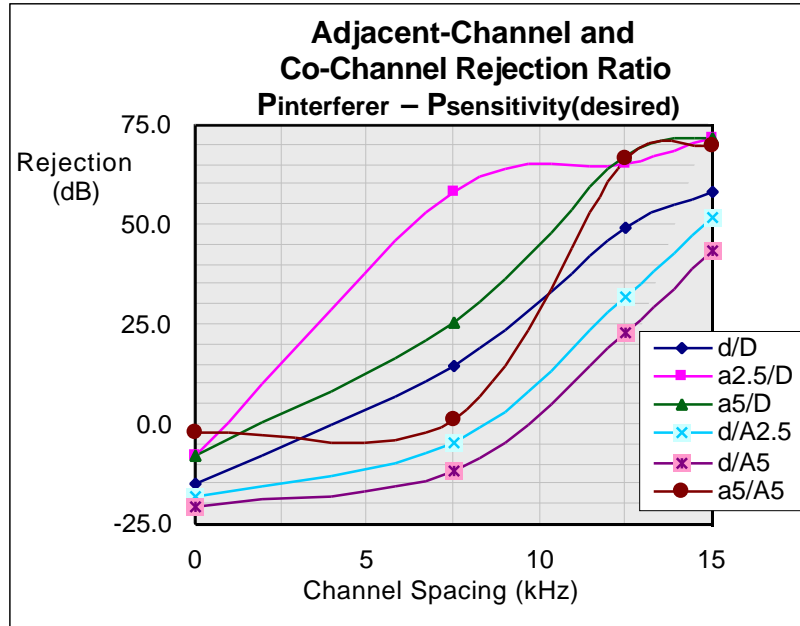

Figure 10. Adjacent-Channel and Co-Channel Performance Characteristics.

The data show that, in general, digital modulation provides better interference protection than analog modulation.

4.6 Delivered Audio Quality Recordings

To provide examples of a desired speech signal in the presence of an interfering signal, a procedure somewhat different from that used for adjacent-channel and co-channel rejection measurements was developed. ITS approached the problem of categorizing perceived speech quality in different carrier-to-interference (C/I) ratio environments by establishing a "baseline" C/I ratio; then the interfering power level was varied while holding the desired signal power constant.

First, the received signal strength of the desired signal was adjusted to invoke, in the absence of an interfering signal, a 35 dBs or 0.25% BER[†]. These SINAD and BER values

[†] These two values were chosen by extrapolating Figure 5's TIA analog and digital mode DAQ plots to the DAQ = 5 operating points of 35 dBs and 0.25% BER.

correspond to high-quality DAQ values. Then, a *degraded reference sensitivity level* was established by introducing an adjacent-channel or co-channel interfering signal. The degraded reference sensitivity level is defined here as “the C/I operating point where a desired 35-dBS analog signal or 0.25% BER digital signal has been degraded to 30 dBS or 0.5% BER, respectively, by an unwanted interfering signal.”[†]

Next, the desired RF signal was modulated by phonetically balanced speech, as depicted in Figures 11 and 12. The same precautions that were observed in Section 3.4 were observed here when adjusting the amplitude level of the modulating speech.

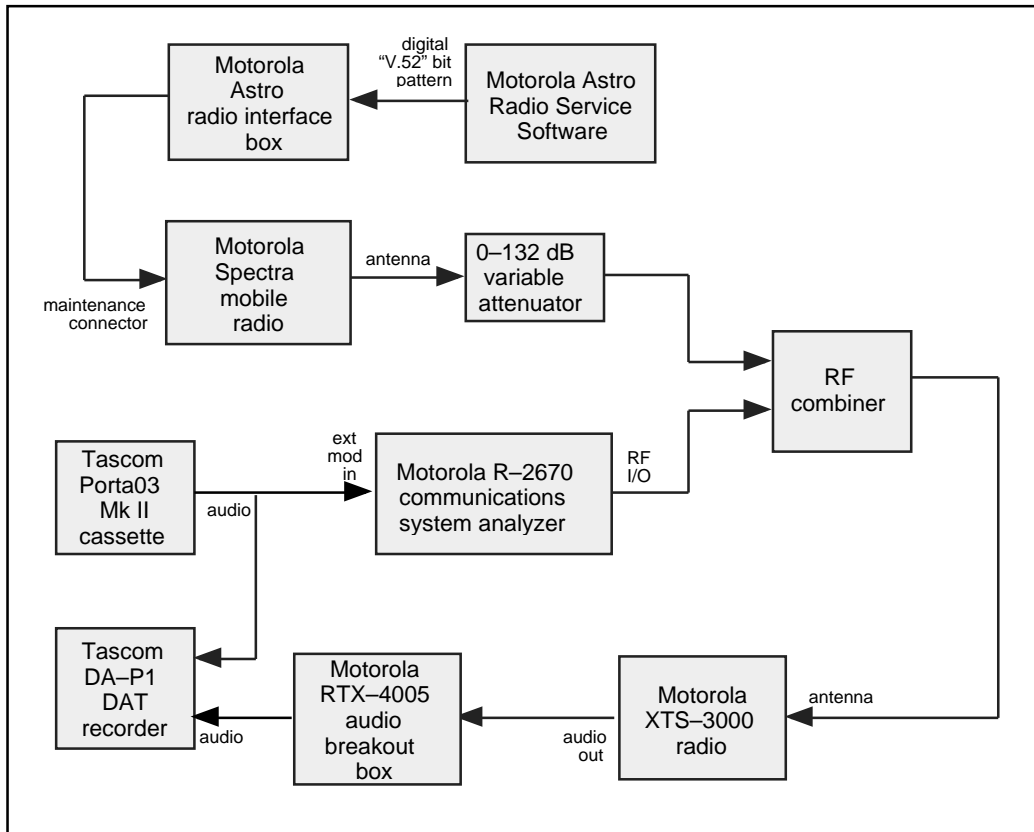

Figure 11. Equipment configuration to record speech for DAQ evaluation, analog FM or digital C4FM desired channel, with unwanted digital interferer.

At this degraded reference sensitivity level, the demodulated speech from the radio was recorded on one track of a DAT recorder and the “pristine” speech reference signal was recorded on the other track, as was done previously in the noninterference cases. The power level of the unwanted interfering signal was increased several times and, at each new C/I

[†] Using Figure 5’s TIA curves, these two values correspond to DAQ = 4 operating points.

ratio, received speech samples were recorded. The unwanted interferer's power was adjusted over a range of 0 to 13 dB above that necessary to establish the degraded reference sensitivity level, while the desired signal's power was unchanged. This yielded a relatively smooth degradation in speech quality from very good to very poor, providing several speech recordings at several C/I ratios. This permitted a means of relating a specific C/I value to a specific received speech recording and its associated DAQ value, for a specific interference mode.

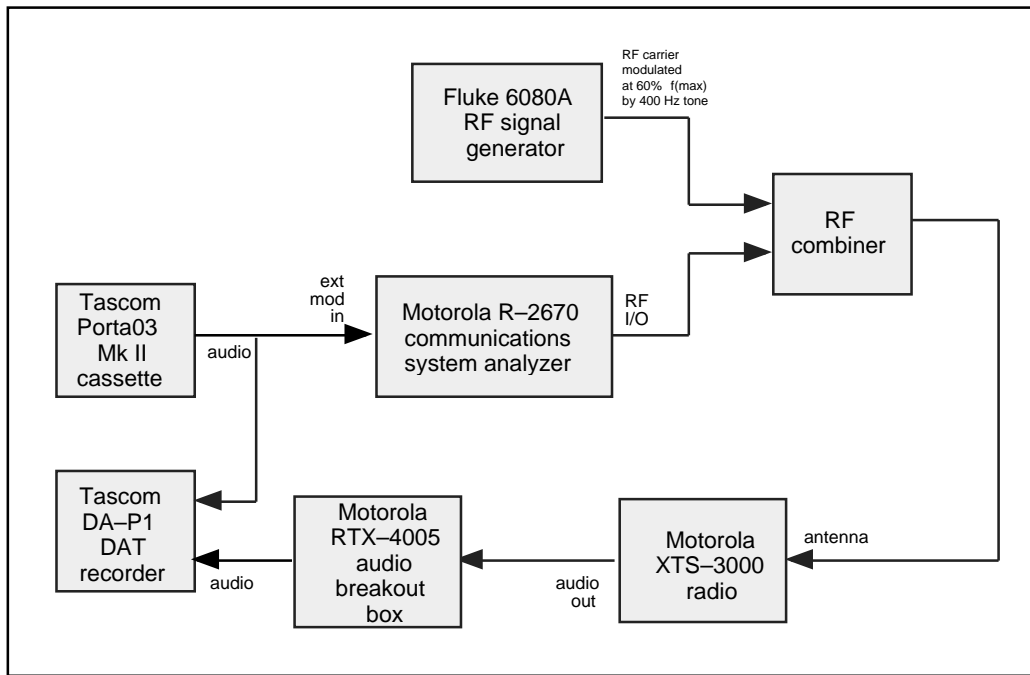

Figure 12. Equipment configuration to record speech for DAQ evaluation, analog FM or digital C4FM desired channel, with unwanted analog interferer.

One might argue that the interfering signal should have been modulated with a different collection of speech samples, but the availability of equipment assets prevented this (another studio-quality cassette player would have been required to modulate the interferer). For example, consider the case of an analog FM signal interfering with a wanted analog FM signal. One might argue that the ability of a listener to aurally “notch out” an interfering audio tone may artificially inflate a subjectively scored perceived speech quality rating, as opposed to the case of distinguishing speech in an environment where there are two competing speech signals. ITS concluded that since its objective measurement technique bases its results on the auditory distance between two signals, the resulting DAQ value will not be artificially inflated, because the algorithm cannot “notch out” the interfering audio tone as a listener might.

4.7 Delivered Audio Quality Assessment

Table 4 and Figure 13 present DAQ values for the different interference modes at various channel spacings. Table 4 values that appear as light-colored text on a dark background correspond to the degraded reference sensitivity levels for each interference mode.

Table 4. DAQ Characteristics in Adjacent-Channel and Co-Channel Environments

Interference Mode	Analog Deviation (kHz)		Co-Channel		Adjacent Channel Spacing (kHz)					
			0		7.5		12.5		15	
	Unwanted Interferer	Desired Signal	-C/I (dB)	DAQ	-C/I (dB)	DAQ	-C/I (dB)	DAQ	-C/I (dB)	DAQ
d/D			-19.7	3.8	6.4	3.5	43.4	4.0	47.0	4.0
			-16.7	3.8	9.4	3.4	46.4	4.0	50.0	4.0
			-13.7	3.8	12.4	2.6	49.4	3.1	53.0	3.9
			-11.7	3.7	13.4	1.7			55.0	4.0
			-9.7	3.7					57.0	3.7
			-8.7	3.1					58.0	3.4
			-7.7	2.6					59.0	2.5
			-6.7	1.9					60.0	1.4
a/D	5		-17.5	2.5	51.0	3.6	61.5	3.5	63.7	3.5
			-14.5	2.6	54.0	3.5	64.5	3.5	66.7	3.5
			-11.5	2.6	57.0	3.4	67.5	3.5	69.7	3.5
			-9.5	2.5	59.0	3.4	69.5	3.3	71.7	3.4
			-7.5	2.2	61.0	2.6	71.5	2.6	73.7	2.8
			-6.5	2.2	62.0	1.8	72.5	1.9	74.7	2.1
			-5.5	1.7	63.0	1.2	73.5	2.0	75.7	1.3
			-4.5	1.2						
a/A	5	5	-18.0	3.0					57.0	3.2
			-15.0	2.6					60.0	2.8
			-12.0	2.3					63.0	2.4
			-9.0	1.9					65.0	1.7
									66.0	1.4
d/A		5							42.9	3.8
									45.9	3.5
									48.9	3.0
									51.9	2.2
									54.9	1.6
									55.9	1.5

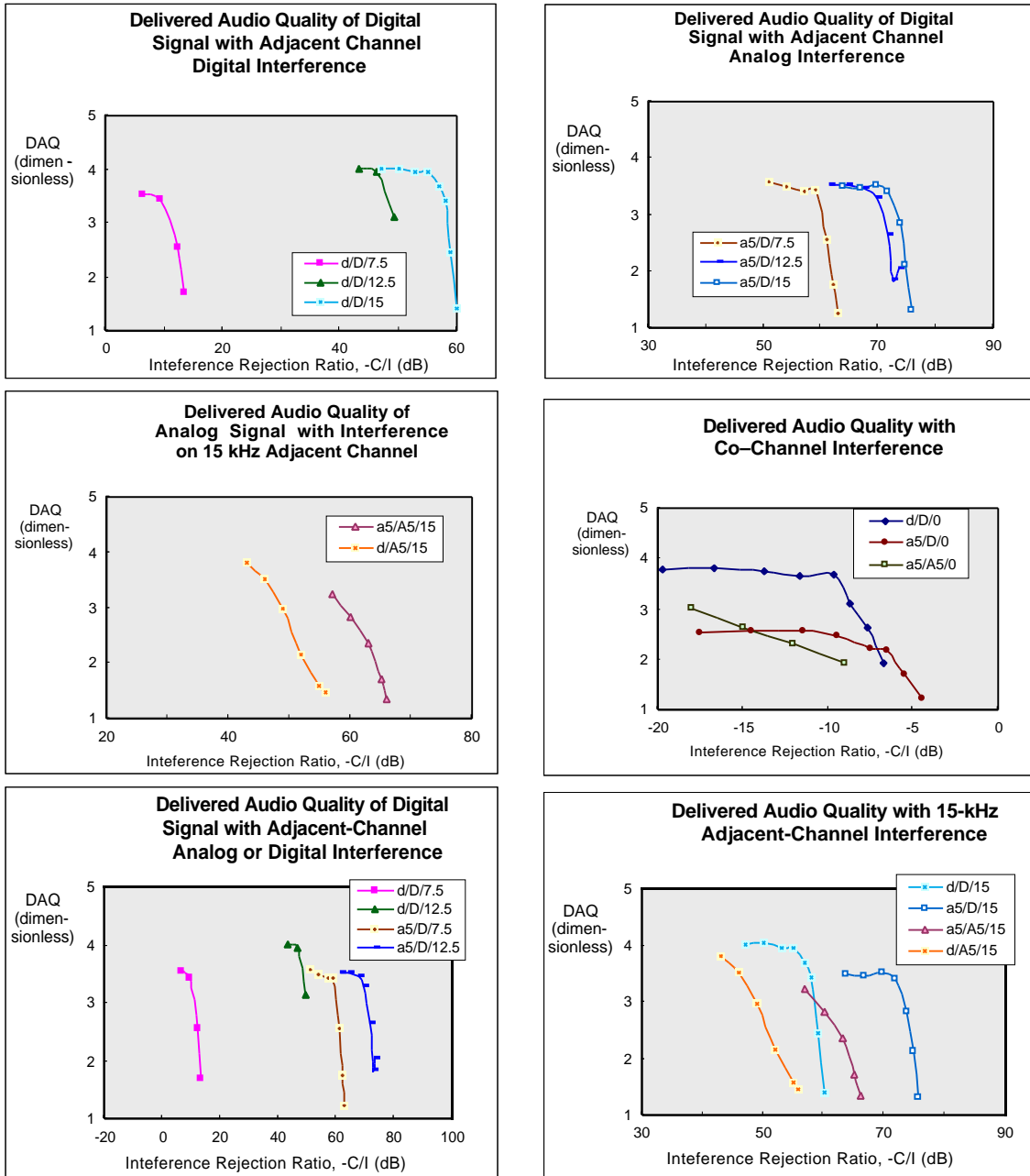

Figure 13. DAQ performance in adjacent-channel and co-channel environments: unwanted digital signal interfering with intended digital signal (d/D), unwanted analog signal interfering with intended digital signal (a5/D), unwanted analog signal interfering with intended analog signal (a5/A5), and unwanted digital signal interfering with intended analog signal (d/A5). All analog FM signals at 5-kHz deviation (a5 or A5). Adjacent-channel frequency offsets are 7.5, 12.5, and 15 kHz.

The various interference environments depicted in Figure 13 show that less spectral overlap between desired and unwanted signals results in greater protection against interfering signals. Generally speaking, digital signals are more immune to interference than are analog signals. All digital signals exhibit a threshold effect in DAQ as a function of the ratio of received interfering power to received desired power. The degradation of a desired analog signal with interference was more linear throughout the analog signal's useful range.

One exception to the above generalities is the case of spectrally overlapping digital signals (7.5-kHz channel spacing, 12.5-kHz bandwidth). This interference mode exhibited the worst interference rejection capability of all *adjacent-channel* interference modes investigated. When the received signal strength of an interfering P25 signal offset 7.5 kHz in frequency exceeded the on-frequency received signal strength of the wanted signal by roughly 10 dB or so, the DAQ of the intended signal was degraded to unusable levels. Larger channel spacings greatly improved interference rejection by an additional 40 to 60 dB or more.

5. CONCLUSION

P25 land mobile radios provide a significant improvement in perceived speech quality in comparison to the traditional analog FM radios. For equal perceptions in speech quality, the P25 radio has a better sensitivity than the analog FM radio.

To assist the land mobile radio user communities and system planners in evaluating the efficacy of P25 radio systems, ITS created speech recordings of received radio transmissions. These recordings provide examples of speech quality as a function of operating mode (conventional analog FM or P25 digital C4FM) at various SINAD ratios, BERs, and C/I ratios. They are available for on-line review or as a computer CD-ROM disk image file that can be downloaded over the internet[†].

[†] The Institute for Telecommunication Sciences, "Delivered Audio Quality Measurements on Project 25 Land Mobile Radios," <http://flatop.its.blrdoc.gov/spectrum/P25>, November 1998.

6. REFERENCES

- [1] Public Safety Wireless Advisory Committee, “Final Report of the Public Safety Wireless Advisory Committee to the Federal Communications Commission,” September 11th 1996.
- [2] Telecommunications Industry Association, “Land Mobile FM or PM Communications Equipment Measurement and Performance Standards,” TIA/EIA-603, February 1993.
- [3] Telecommunications Industry Association, “Digital C4FM/CQPSK Transceiver Measurement Methods,” TIA/EIA IS-102.CAAA, May 1997.
- [4] Institute of Electrical and Electronics Engineers, “IEEE Recommended Practice for Speech Quality Measurements,” *IEEE Trans. on Audio and Electroacoustics AU-17*, No. 3, pp. 225-246, September 1969.
- [5] Telecommunications Industry Association, “Wireless Communications Systems - Performance in Noise and Interference-Limited Situations – Recommended Methods for Technology-Independent Modeling, Simulation and Verification,” TIA/EIA Technical Service Bulletin TSB-88, January 1998.
- [6] S. Voran, “Objective Estimation of Perceived Speech Quality Using Measuring Normalizing Blocks,” NTIA Report 98-347, April 1998.