



NBSIR 85-3118

7th Joint Panel Meeting of the UJNR Panel on Fire Research and Safety

N. H. Jason
K. Davis

U.S. DEPARTMENT OF COMMERCE
National Bureau of Standards
Center for Fire Research
Gaithersburg, MD 20899

March 1985



**U.S. DEPARTMENT OF COMMERCE
NATIONAL BUREAU OF STANDARDS**

Ref. - Circ

OC100

U36

NO. 85-3118

1985

NBSIR 85-3118

**7TH JOINT PANEL MEETING OF THE
UJNR PANEL ON FIRE RESEARCH AND
SAFETY**

N. H. Jason
K. Davis

U.S. DEPARTMENT OF COMMERCE
National Bureau of Standards
Center for Fire Research
Gaithersburg, MD 20899

March 1985

U.S. DEPARTMENT OF COMMERCE, Malcolm Baldrige, *Secretary*
NATIONAL BUREAU OF STANDARDS, Ernest Ambler, *Director*

SEVENTH JOINT PANEL MEETING
OF THE UJNR PANEL ON
FIRE RESEARCH AND SAFETY

Joint with Combustion Toxicity and 2nd Expert Meeting of the
U.S.-Japan-Canada Cooperative Research Group on Toxicity of Combustion
Products from Building Materials and Interior Goods

October 24-28, 1983
National Bureau of Standards
Gaithersburg, Maryland

TABLE OF CONTENTS

	<u>Page</u>
Agenda.....	vii
List of Members (Japan).....	xi
List of Members (U.S.).....	xiv
List of Combustion Toxicity Participants.....	xvi
Group Photograph.....	xviii
 OPENING SESSION.....	 1
 FIRE HAZARD/RISK MANAGEMENT METHODS.....	 5
Progress Reports:	
Progress Report to 7th UJNR Panel on Fire.....	7
The Recent Japanese Progress Report on Fire Risk Analysis Method..	13
Methods of Designing and Evaluating Facilities for Fire Safety.....	17
Discussion.....	29
Development of Design System for Building Fire Safety.....	31
Discussion.....	39
Human Reactions During Residential Fires: Establishing a Data Bank..	41
Discussion.....	51
A Study on Fire Risk Analysis Method for Multi-Use Buildings.....	53
Discussion.....	77
Fire Safety Evaluation Method.....	79
Discussion.....	87
General Discussion.....	89
 FIRE GROWTH PREDICTION.....	 93
Progress Reports:	
Fire Spread Research in the United States.....	95
Recent Progress in Fire Growth Modeling in Japan.....	109
An Assessment of Fire Induced Flows in Compartments.....	121
Discussion.....	151
Pre-Flashover and Flashover Behavior in Compartment Fires.....	153
Discussion.....	177
Preliminary Report on a Model to Describe the Flow in the Ceiling Layer of a Two Layer Fire Model.....	179
Discussion.....	189
The Models to be Developed in Fire Safety Design Project.....	191
A Model for the Transport of Fire, Smoke, and Toxic Gases (FAST).....	209
Discussion.....	271
Smoke Movement as a Density Current.....	273
Discussion.....	285
General Discussion.....	287
 MATERIALS FIRE PROPERTIES AND TEST METHODS.....	 291
Progress Reports:	
Materials Fire Properties and Test Methods.....	293
Discussion.....	299
Recent Advances in Materials Fire Properties and Test Methods.....	301
Discussion.....	309

	<u>Page</u>
Identification of Fire Properties Relevant to the Prediction of Fire Growth.....	311
Discussion.....	323
Concepts on Flame Spread Testing.....	325
A Methodology of the Sensitivity Analysis of Building Properties on the Occurrence of Flashover.....	341
Discussion.....	367
Fire Engineering Test Development: Bench-Scale Tests to Predict Full-Scale Behavior.....	369
Discussion.....	391
Materials Fire Properties and Test Methods to be Developed.....	393
Discussion.....	399
General Discussion.....	401
COMBUSTION TOXICITY AND 2ND EXPERT MEETING OF THE COOPERATIVE RESEARCH GROUP ON TOXICITY OF COMBUSTION PRODUCTS FROM BUILDING MATERIALS AND INTERIOR GOODS.....	403
Progress Reports:	
Progress Report on Combustion Toxicity Research In the U.S.....	405
Discussion.....	411
U.S.A.-Canada-Japan Cooperative Research on Evaluation of Combustion Gas Toxicity.....	413
Studies on Determination of Burning Condition for the Toxicity Test..	419
Discussion.....	445
Conditions Conducive to the Generation of Hydrogen Cyanide from Flexible Polyurethane Foam.....	447
Discussion.....	469
Development of Laboratory Test Apparatus for Evaluation of Toxicity of Combustion Products of Materials in Fire.....	471
Discussion.....	487
Evaluation of a Method for Acute Toxicity of Smoke from Polymeric Materials.....	489
Discussion.....	503
Support Paper:	
Closed-type Burning Testing Apparatus for Plastic Materials.....	505
MEASUREMENT METHODS.....	521
Progress Reports:	
Current U.S. Advances in Fire Research Techniques.....	523
Discussion.....	535
Various Measurement Methods on Fire Research.....	537
Discussion.....	545
New Developments in Fire Protection - Evolution to the Systems Approach.....	547
A Measurement of Doorway Flow Induced by Propane Fire.....	565
Discussion.....	583
Flammability Testing: State-of-the-Art.....	585
Discussion.....	607

	<u>Page</u>
COMBUSTION TOXICITY (CONT.).....	609
Discussion After Progress Report on Canadian Activities.....	611
Study on Evaluation of Toxicity By Gas Using Pure Gas.....	613
Discussion.....	623
General Discussion.....	625
 OPEN TECHNICAL SESSION.....	 627
Analysis of the Fire Protection Cost Index.....	629
Discussion.....	641
An Example of Human Behavior in a Hotel Fire.....	643
Discussion.....	655
Panel Discussion on Capabilities of Fire Growth Prediction.....	657
 CLOSING SESSION.....	 661
Chairmen's Reports on Technical Sessions	
Fire Hazard/Risk Management Methods.....	663
Fire Growth Prediction.....	665
Materials Fire Properties and Test Methods.....	667
Combustion Toxicity and 2nd Expert Meeting of the US-Japan-Canada Cooperative Research Group on Toxicity of Combustion Products from Building Materials and Interior Goods.....	669
Measurement Methods.....	671
Resolutions.....	673
Closing Addresses.....	675
Participant's Index.....	677

AGENDA

Seventh Joint Meeting
of the
U.S.-Japan Panel on Fire Research and Safety
October 24-28, 1983
at the
National Bureau of Standards

Monday, October 24

OPENING SESSION - 10th Floor Conference Room, Administration Bldg.

8:30 Bus leaves Sheraton for NBS

9:00 Call to order by Dr. Richard G. Gann, Coordinator, 7th Panel Meeting
Remarks by Dr. John W. Lyons, Acting Deputy Director, National
Bureau of Standards
Remarks by Mr. Hiroto Ishida, Science Counselor, Embassy of Japan
Remarks and Introduction of U.S. Panel members by Dr. Jack E. Snell,
Director, Center for Fire Research
Remarks and Introduction of Japanese Panel members by
Dr. Katsuro Kamimura, Director General, Building Research Institute

9:40 Election of Officers
Approval of Proceedings of the 6th Panel Meeting
Approval of Agenda for the 7th Panel Meeting
Election of Session Chairmen
Appointment of Resolution Committee
Other Business

9:50 Group Photograph - Red Auditorium Steps

10:00 Break - Outside Lecture Room D

FIRE HAZARD/RISK MANAGEMENT METHODS - Lecture Room D

10:20 Progress Reports:
Progress Report to 7th UJNR Panel on Fire H. Nelson
The Recent Japanese Progress Report on
Fire Risk Analysis Method K. Kishitani/T. Jin

10:50 Methods of Designing and Evaluating
Facilities for Fire Safety L. Cooper

11:40 Formal Lunch - Employees Lounge

1:10 Development of Design System for Building
Fire Safety T. Wakamatsu

2:00 Human Reactions During Residential Fires:
Establishing a Data Bank J. Keating

2:50 A Study on Fire Risk Analysis Method
of Multi-Use Buildings A. Sekizawa/T. Jin

3:40 Break

4:00 Fire Safety Evaluation Method Tokyo Fire Department
(Speaker: T. Jin)

4:50 General Discussion

5:30 Adjourn

5:40 Bus leaves for Sheraton Potomac Inn

7:00 Bus leaves hotel for reception at home of Dr. Jack E. Snell

9:30 Bus returns to Sheraton

Tuesday, October 25

FIRE GROWTH PREDICTION - Lecture Room D

8:30 Bus leaves Sheraton for NBS

9:00 Progress Reports:
Fire Spread Research in the United States H. Emmons
Recent Progress in Fire Growth Modeling
in Japan T. Wakamatsu

9:30 An Assessment of Fire Induced Flows in
Compartments J. Quintiere

10:20 Pre-Flashover and Flashover Behavior
in Compartment Fires H. Takeda

11:10 Break

11:30 Preliminary Report on a Model to Describe
the Flow in the Ceiling Layer of a Two
Layer Fire Model E. Zukoski

12:20 Break

12:30 Buffet Lunch - Senior Lunch Club

1:30 The Models to be Developed in Fire Safety
Design Project T. Tanaka

2:20 A Model for the Transport of Fire, Smoke,
and Toxic Gases (FAST) W. Jones

3:10 Break

3:40 Smoke Movement as a Density Current M. Tsujimoto

4:30 General Discussion

5:00 Adjourn

5:10 Bus leaves for Sheraton

6:45 Bus leaves hotel for Cracked Claw Restaurant

Wednesday, October 26

MATERIALS FIRE PROPERTIES AND TEST METHODS - Lecture Room D

8:30 Bus leaves Sheraton for NBS

9:00 Progress Reports:
Materials Fire Properties and Test Methods P. Pagni
Recent Advances in Materials Fire
Properties and Test Methods H. Suzuki

9:30 Identification of Fire Properties Relevant
to the Prediction of Fire Growth A. Tewarson

10:20 Concepts on Flame Spread Testing T. Hirano

11:10 Break

11:30 A Methodology of the Sensitivity Analysis
of Building Properties on the Occurrence
of Flashover Y. Hasemi

12:20 Break

12:30 Buffet Lunch - Senior Lunch Club

1:30 Tour of Building 205

3:00 Break

3:20 Fire Engineering Test Development:
Bench-Scale Tests to Predict Full-Scale
Behavior V. Babrauskas

4:10 Materials Fire Properties and Test
Methods to be Developed H. Suzuki

5:00 General Discussion
5:30 Adjourn
5:40 Bus leaves for Sheraton

Thursday, October 27

Parallel Sessions

1. COMBUSTION TOXICITY and 2ND EXPERT MEETING OF THE U.S.-JAPAN-CANADA COOPERATIVE RESEARCH GROUP ON TOXICITY OF COMBUSTION PRODUCTS FROM BUILDING MATERIALS AND INTERIOR GOODS - Lecture Room D

8:30 Bus leaves Sheraton for NBS
9:00 Progress Reports:
Progress Report on Combustion Toxicity Research in the U.S. R. Gann
U.S.A.-Canada-Japan Cooperative Research on Evaluation of Combustion Gas Toxicity F. Saito
9:45 Studies on Determination of Burning Condition for the Toxicity Test T. Tanaka
10:35 Break
10:50 Conditions Conducive to the Generation of Hydrogen Cyanide from Flexible Polyurethane Foam B. Levin
11:40 Development of Laboratory Test Apparatus for Evaluation of Toxicity of Combustion Products of Materials in Fire S. Yusa
12:30 Buffet Lunch - Senior Lunch Club
1:40 Evaluation of a Method for Acute Toxicity of Smoke from Polymeric Materials Y. Alarie
2:30 Tour of Building 224
4:30 Bus leaves for Sheraton
6:45 Depart for Blackie's House of Beef, Washington, D.C.

2. MEASUREMENT METHODS - Polymer Building, Room B-119

9:00 Progress Reports:
Current U.S. Advances in Fire Research Techniques R. Friedman
Various Measurement Methods on Fire Research T. Jin/S. Yamashika
9:30 New Developments in Fire Protection - Evolution to the Systems Approach J. Beyreis
10:20 Break
10:50 A Measurement of Doorway Flow Induced by Propane Fire T. Tanaka
1:40 Flammability Testing State-of-the-Art J. de Ris
2:30 Buffet Lunch - Senior Lunch Club
2:30 Tour of Building 224
4:30 Bus leaves for Sheraton
6:45 Depart for Blackie's House of Beef, Washington, D.C.

Friday, October 28

Parallel Sessions

1. COMBUSTION TOXICITY (Continued) - Lecture Room D

8:30 Bus leaves Sheraton for NBS
9:00 Progress Report on Canadian Activities Y. Tsuchiya
9:50 Study on Evaluation of Toxicity by Gas
Using Pure Gas Y. Nishimaru
10:40 Break
11:00 General Discussion
11:30 Formal Lunch - Employees Lounge

2. OPEN SESSION - Polymer Building, Room B-119

9:00 Analysis of the Fire Protection Cost Index H. Nakamura
9:50 An Example of Human Behavior in a Hotel
Fire S. Okishio/T. Handa/
K. Kawagoe
10:40 Break
11:00 Panel Discussion on Capabilities of Fire
Growth Prediction Moderator: J. Quintiere
Panelists: H. Emmons, T. Hirano, P. Pagni
T. Tanaka
11:30 Formal Lunch - Employees Lounge

CLOSING SESSION - 10th Floor Conference Room

1:45 Closing Session, Chairman
1:50 Chairmen's Reports on Technical Sessions
2:50 Resolutions
3:30 Closing Addresses: U.S., Japan
3:50 Adjourn
4:00 Bus leaves for Sheraton

LIST OF MEMBERS (JAPAN)

Panel Members

Dr. Katsuro Kamimura (Japanese Chairman)
Director General
Building Research Institute
Ministry of Construction

Dr. Takao Wakamatsu
Director, Environment, Design, & Fire Department
Building Research Institute
Ministry of construction

Dr. Tadahisa Jin
Chief, Life Safety Section, The 3rd Research Division
Fire Research Institute
Fire Defense Agency
Ministry of Home Affairs

Dr. Ai Sekizawa
Research Member, Fire Physics Section
The 1st Research Division
Fire Research Institute
Fire Defense Agency
Ministry of Home Affairs

Dr. Hiroaki Suzuki
Head, Smoke Control Division
Environment, Design, & Fire Department
Building Research Institute
Ministry of Construction

Dr. Takeyoshi Tanaka
Chief Research Member
Testing and Evaluation Department
Building Research Institute
Ministry of Construction

Dr. Shyuitsu Yusa
Research Member, Organic Materials Division
Material Department
Building Research Institute
Ministry of Construction

Mr. Masazo Furuya
Research Institute for Polymer and Textile
Agency of Industrial Science and Technology
Ministry of International Trade and Industry

Dr. Yuji Hasemi
Research Member, Smoke Control Division
Environment, Design, & Fire Department
Building Research Institute
Ministry of Construction

Associate Members

Professor Koichi Kishitani
Department of Architecture
Faculty of Engineering
University of Tokyo

Dr. Fumiharu Saito
Head, Test Division
Testing Laboratory of Center for Better Living

Professor Kunio Kawagoe
Dean of Faculty of Science and Technology
Science University of Tokyo

Professor Makoto Tsujimoto
Department of Architecture
Faculty of Engineering
University of Nagoya

Professor Yoichi Nishimaru
Dean, School of Medicine
Yokohama City University

Professor Takashi Handa
Department of Applied Chemistry
Faculty of Science
Science University of Tokyo

Professor Toshisuke Hirano
Engineering Research Institute
Faculty of Engineering
University of Tokyo

Observers

Mr. Tomoyuki Mizuno
Department of Architecture
Faculty of Science and Technology
Science University of Tokyo

Mr. Hiroyuki Nakamura
Planning Division
The Research Institute of Shimizu Construction Co., Ltd.

Dr. Hisahiro Takeda
Department of Reaction Chemistry
Faculty of Engineering
University of Tokyo

Dr. Toshimi Hirata
Forestry Research Institute
Ministry of Agriculture, Forestry, and Fishery

Dr. Masahiro Morita
Department of Applied Mathematics
Faculty of Science
Science University of Tokyo

LIST OF MEMBERS (U.S.)

Panel Members

Dr. Jack Snell (U.S. Chairman)
Director, Center for Fire Research
National Bureau of Standards

Professor John Bryan
Chairman, Department of Fire Protection
University of Maryland

Professor Howard Emmons
Division of Applied Science
Harvard University

Dr. Raymond Friedman
Vice President for Research
Factory Mutual Research Corporation

Mr. Harold Nelson
Chief, Facility Fire Safety Performance
Center for Fire Research
National Bureau of Standards

Professor Patrick Pagni
Mechanical Engineering Dept.
University of California

Dr. Takashi Kashiwagi (Secretary)
Exploratory Fire Research
Center for Fire Research
National Bureau of Standards

Speakers

Professor Yves Alarie
Chairman, Department of Industrial
Environmental Health Sciences
Graduate School of Public Health

Dr. John de Ris
Factory Mutual Research Corporation

Professor Edward Zukoski
California Institute of Technology

Dr. Archibald Tewarson
Factory Mutual Research Corporation

Professor John P. Keating
Department of Psychology
University of Washington

Dr. Gordon Hartzell
Southwest Research Institute

Mr. James Beyreis
Underwriters Laboratories, Inc.

Dr. Leonard Cooper
Facility Fire Safety Performance
Center for Fire Research
National Bureau of Standards

Dr. Walter Jones
Smoke & Toxic Gases
Center for Fire Research
National Bureau of Standards

Dr. James Quintiere
Head, Fire Growth Processes
Center for Fire Research
National Bureau of Standards

Dr. Vytenis Babrauskas
Head, Materials Fire Properties
Center for Fire Research
National Bureau of Standards

Dr. Barbara Levin
Head, Fire Toxicology
Center for Fire Research
National Bureau of Standards

Dr. Richard Gann
Chief, Fire Measurement and Research Division
Center for Fire Research
National Bureau of Standards

Combustion Toxicity Participants

Dr. Yoshi Tsuchiya
Division of Building Research
National Research Council of Canada

Dr. K. Sumi
Division of Building Research
National Research Council of Canada

Mr. Yasuo Kuchinomachi
Industrial Products Research Institute



7th Joint Panel Meeting

UJNR Panel on Fire Research and Safety

National Bureau of Standards
October 24-28, 1983

Names of Participants
(Reading left to right, from the bottom row)

Richard Gann	Masazo Furuya
Jack Snell	Takao Wakamatsu
Sam Kramer	Barbara Levin
Hiroto Ishida	Yoichi Nishimaru
Katsuro Kamimura	Hiroaki Suzuki
Kunio Kawagoe	Fumiharu Saito
Takashi Kashiwagi	Hisahiro Takeda
Shyuitsu Yusa	Yuji Hasemi
Tadahisa Jin	Ai Sekizawa
Howard Emmons	Tomoyuki Mizuno
Edward Zukoski	Leonard Cooper
Takeyoshi Tanaka	Makoto Tsujimoto
Takashi Handa	James Quintiere
Koichi Kishitani	Harold Nelson
Toshisuke Hirano	Raymond Friedman
Hiroyuki Nakamura	John Bryan

OPENING SESSION

Opening Session

Dr. Richard Gann, Coordinator for the 7th UJNR Panel Meeting, opened the joint session by welcoming the delegation to the National Bureau of Standards (NBS). He then introduced Dr. John Lyons, Acting Deputy Director of NBS (and former Chairman of the UJNR U.S. delegation) and Mr. Hiroto Ishida, Science Counselor, Embassy of Japan. Opening remarks were made both by Dr. Lyons and Mr. Ishida. Dr. Jack Snell, Director, Center for Fire Research, and Dr. Katsuro Kamimura, Director General, Building Research Institute, introduced the United States and Japanese panel members.

The Combustion Toxicity and 2nd Expert Meeting of the U.S.-Japan-Canada Cooperative Research Group on Toxicity of Combustion Products from Building Materials and Interior Goods was held in conjunction with the 7th UJNR Panel Meeting. The Combustion meeting took place on Thursday and Friday, October 27 and 28, 1983.

Selection of the Chairmen for the sessions was made. The Panel voted unanimously to make the following individuals session chairmen:

Fire Hazard/Risk Management Methods	K. Kawagoe	J. Bryan
Fire Growth Prediction	R. Friedman	T. Hirano
Materials Fire Properties and Test Methods	T. Handa	H. Nelson
Combustion Toxicity Meeting	R. Gann	K. Kishitani
	F. Saito	
Measurement Methods	P. Pagni	
Open Technical Session	T. Wakamatsu	

The minutes of the Sixth Joint Panel Meeting in Tokyo were approved and will be printed in the Proceedings to be published by the Japanese delegation.

The agenda for the week was reviewed and approved. Procedural details for the sessions were discussed.

The opening session adjourned after the above-mentioned discussions were completed. The group photograph was taken.

FIRE HAZARD/RISK MANAGEMENT METHODS

Kunio Kawagoe and John Bryan
Session Chairmen

Progress Report to 7th UJNR Panel on Fire

Facility Fire Safety and Risk Analysis Methods
H.E. Nelson, National Bureau of Standards, USA

This report covers progress on the development and delivery of quantitative procedures for fire safety analysis and fire risk analysis in facilities.

Fire safety analysis methods concern measurement of facility performance in a stipulated fire. The stipulated fire may be a "design stress" (envisioned as a potential method of classifying occupancies) or a specific stipulated fire of particular interest. The object is to determine the capability of a specific facility or design given a potential fire stress.

Fire risk analysis involves a measurement of the intergrated risk imposed upon the occupants and/or monetary values in a facility considering the spectrum of potential fire scenarios and the likihood of occurrence of each scenario.

Fire science and related modeling developments have matured over the past several decades. It is now possible to make at least primitive analytical models of many situations from the point of ignition to the final determination of impact. Current analysis methods build on fire growth models and empirical data and analytical calculations.

Figure 1 is a schematic outline of this approach. To date this approach has been applied to fire safety analysis rather than risk analysis. The fire safety analysis approach starts with emperically derived rates of heat release and rates of other products produced. This input is obtained from rate of heat release tests. Given this stress, the development of threat is modeled as an energy producing process that evolves an energy bearing fluid (smoke and gases.) The building and the fire safety systems present react to this stress by absorbing it, removing it, or undergoing some types of change in response to the stress. The type, level of intensity, location, and time of occurrence of change are determined. Concurrently the capability of occupants to avoid undesirable conditions by escape or relocation is modeled.

Currently there exists varying degrees of capability to analytically model each of the system elements in Figure 1 except for the effectiveness of extinguishing agents and the prediction of the decision made by individuals receiving an alarm or other fire cue. The level of capability however varies widely from very primitive estimates to advanced models with a significant degree of confidence.

Verification testing to establish the level confidence to be placed in these methods is essential. Two large scale verification testing programs will be initiated in the coming year. One will be conducted entirely at the National Bureau of Standards. The other will be jointly undertaken by the National Bureau of Standards and Factory Mutual Research Corporation.

Human Behavior Elements

Modeling efforts related to emergency movement were reported at the 6th Joint Panel meeting. The development of the Escape and Rescue Model (1) and the EVACNET+ model (2) are continuing. These models are approaching useability by the practicing profession. Both, however, suffer from the parsity of data on specific human performance variables.

Two items relative to the necessary variables can be reported. The work of J.L. Pauls, National Research Council of Canada, on the effective width model and the relevance of stairway dimensions (also reported on at the 6th Joint Panel meeting) is receiving increased recognition and acceptance. His model and related variables is currently undergoing public comment review as part of a proposal from the Committee on Safety to Life of the National Fire Protection Association (3) for inclusion in the next edition of the Life Safety Code.

In a separate vein Pearson and his colleagues at the University of North Carolina (4) have completed and issued a report on their studies of the time involved in the initial actions involved in escaping a residential fire. Pearson's work involved both young adults (college students) and elderly persons a number of whom suffer from arthritis. The time differentials found by Pearson appear to be less than expected.

Work on development of the underlining data on human behavior cause relationships continues slowly. The principal investigators in this area are Dr. John Keating, University of Washington and Dr. John Bryan, University of Maryland. Bryan's most recent work is covered under the heading of investigations. Keating has been working on the development of improved interviewing techniques. He is seeking better and more reliable data on behavior initiating conditions and rationale involved, and the actual results as related to the expectations. Keating is also attempting to develop relationships and commonalities that may lead to future modeling. Currently Keating has trained emergency response personnel of the New York City chapter of the American Red Cross in his technique. These persons respond to every significant fire that harms or displaces persons. It is expected that this project will produce a massive increase in the data base.

Investigations

On the fire investigation front, the future of the National Fire Incident Reporting System (NFIRS) remains uncertain, due to federal reorganizations and budget cuts. Decisions regarding NFIRS development and growth are expected to be made shortly. On a more positive note, the NBS Fire Investigation Handbook (5) continues to be widely used - over 5000 copies have been sold. In addition, several new projects in the investigative area have begun at NBS. One is the analysis of detailed electrical

fire investigations to determine the sequence of events and failure modes which led to ignition. Special investigations were conducted for over one hundred cases in ten cities, and are being studied in this project. Another ongoing project is the NBS sponsored interlaboratory evaluation program, involving the recovery and analysis of accelerants. The purpose of this project is to develop a consensus standard for use by forensic laboratories in the investigation of suspected arson fires. Also, two projects are underway which are attempting to develop methods of detecting the presence of accelerants on soot. One is using gas chromatography, while the second approach uses a mass spectrometer.

Dr. John Bryan, University of Maryland has continued investigation of human behavior through questionnaires sent to survivors of fires. He has provided the following summaries on two such activities.

The questionnaire utilized in the study of participants in the MGM Grand Hotel Fire, and reported on at the 6th UJNR Panel on Fire Research and Safety in Tokyo was modified slightly for a human behavior study of the Westchase Hilton Hotel fire. The fire occurred in Houston, Texas on 6, March, 1982. The study of the behavior of the participants in this fire incident was based on 42 written questionnaires, returned from the 130 questionnaires mailed out for a response rate of approximately 32 per cent. In addition, behavioral data was obtained from the transcripts of 13 interviews conducted by Houston Fire Department personnel. Thus, a total participant population of 55 persons was obtained from the approximately 200 persons believed to be in the hotel at the time of the fire. This incident occurred on March 6, 1982 at approximately 2:25 a.m. The questionnaires were initially mailed out 34 days after the fire incident, with a follow up mailing on June 7, 1982. The last questionnaire used in the study was received August 7, 1982.

The questionnaire were in a similar format to the MGM Study (6) and consisted of four pages with a total of 27 check off, completion and fill in items. The last item contained a diagram of the floor plan of the twelve story hotel for the guests to indicate their movements within the building and their egress route from the building. The study elicited the first five actions of the guests, their means of awareness of the fire, and their evacuation or refuge actions in the fire incident. The analysis of the study examined the guest's age, being alone or with others, their previous training, previous fire experience, convergence cluster formation, and reentry of the building.

The questionnaire used in the MGM Grand Hotel fire study (6) and the Westchase Hilton Hotel fire study (7) was sent to the Fort Worth, Texas Fire Department, two days after the 14, June, 1983 fire at the Ramada Inn. The questionnaire was duplicated and mailed out to 65 of the occupants registered in the hotel at the time of the fire incident. The questionnaire was mailed out the week after the fire. As of August 12, 1983, 40 questionnaires had been returned. The data is being initially analyzed by the Fort Worth Fire Department. Copies of the questionnaire responses will be sent to both the National Fire Protection Association and the University of Maryland for addition to their data bases and further analysis.

A significant need exists for advancement of fire modeling and similar capabilities to allow rational recreation of the thermodynamics and human behavioral actions that occurred in actual fires. The potential exists using the knowledge of physics of fire to fill the gaps between data and reconstruct the actual course of a fire event. A prime example of the potential of such was demonstrated by Emmons in his article, "The Analysis of a Tragedy" recently published in Fire Technology (8).

Smoke Control

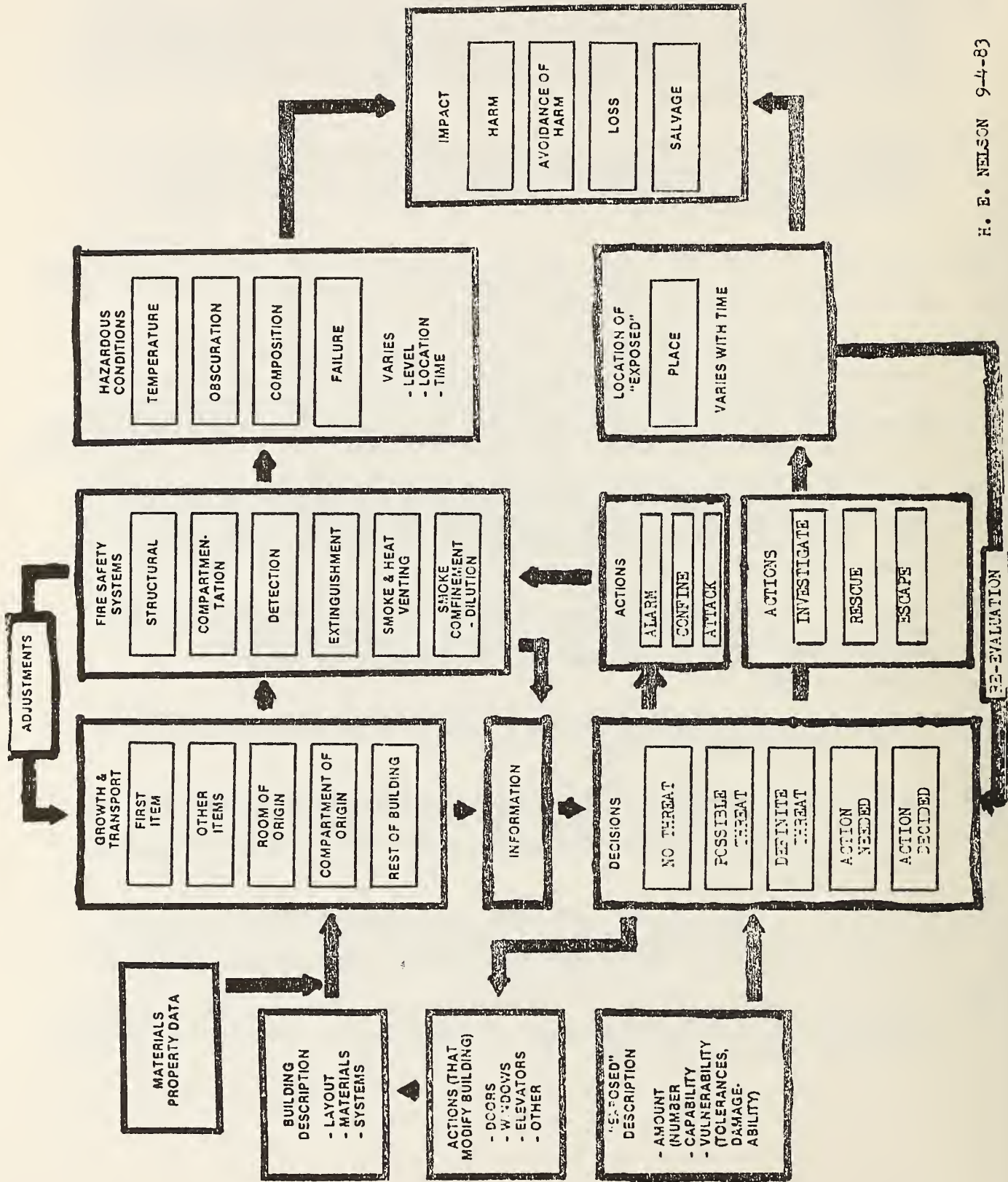
To help engineers design smoke control systems, Klote, J.H. and Fothergill, J.W., have developed a manual entitled "Design of Smoke Control Systems for buildings" (9). This manual is being simultaneously published by both NBS and the American Society of Heating, Refrigerating and Air Conditioning Engineers.

Automatic Sprinklers

Methods have been developed over the past year by Evans (10) and by Heskestad and Delichatsios (11) to adapt calculations of sprinkler response time to fires in single density ambients to the problem of rooms containing two layers. The response time of ceiling pendent sprinklers can be calculated for room sizes found in residential dwellings. Computer codes based on two zone room fire models require the user to specify only the room geometry, properties of the construction materials, and a heat release rate history for the fire. Quasistudy flow approximations are employed to calculate unsteady fires. Some Validation studies have been completed in idealized axisymmetric enclosures. Additional data will be collected in rooms with realistic geometry to assess the accuracy and limitations of the calculation.

REFERENCES

- (1) Alvord, Daniel M., "Status Report of Escape and Rescue Model", Washington, D.C. National Bureau of Standards, 1983, Report No. NBS-GCR-83-432.
- (2) Francis, R.L. and Chalmet, L.G., "Network Models for Building Evacuation; A Prototype Primer, " Washington, D.C. National Bureau of Standards, 1982, Report No. NBS-GCR-81-316 (Kisko, T.M. and Francis, R.L. "EVACNET+ Users Guide," Industrial and Systems Engineering Department, University of Florida, Gainesville, Florida, May 1983)
- (3) Report of Committee on Safety to Life, Proposal 101-678; Appendix D Alternate Calculation for Stair Widths; 1984 Annual Meeting Technical Committee Reports, pp. 502-506; National Fire Protection Association, Quincy, Massachusetts, 1984.
- (4) Pearson, R.G., and Joost, M.G., Egress Behavior Response Times of Handicapped and Elderly Subject to Simulated Residential Fire Situation, Washington D.C., National Bureau of Standards, 1983, Report No. NBS-GCR-83-429.
- (5) Fire Investigation Handbook, U.S. Dept. of Commerce, National Bureau of Standards, Handbook 134, Brannigan, Francis L., Editor, Univ. of Maryland Rescue Institute, Adjunct Staff, College Park, Md., 20742, Bright, Richard G. and Jason, Nora H., Editors Center for Fire Research, National Engineering Laboratory, National Bureau of Standards, Washington, D.C., 20234, August, 1980.
- (6) Bryan, John L., An Examination and Analysis of the Dynamics of the Human Behavior in the MGM Grand Hotel Fire, Clark County, Nevada, November 21, 1980. Quincy: National Fire Protection Association, Revised Edition, August, 1983.
- (7) Bryan, John L., An Examination and Analysis of the Dynamics of the Human Behavior in the Westchase Hilton Hotel Fire, Houston, Texas on March 6, 1982. Quincy: National Fire Protection Association, September, 1983.
- (8) "The Analysis of a Tragedy", Howard W. Emmons, Fire Technology, Vol. 19, No. 2 (May 1983) pp. 115-124.
- (9) Klote, J.H. and Fothergill, J.W., Design of Smoke Control Systems for Buildings, National Bureau of Standards (U.S.), NBS Handbook 141, and American Society of Heating, Refrigerating and Air-Conditioning Engineers, Atlanta, Georgia, 1983.
- (10) Evans, D.D., "Plume Flow in a Two-Layer Environment," HTD Vol. 25, Book No. H00269, Fire Dynamics and Heat Transfer, American Society of Mechanical Engineers, N.Y., N.Y1, Proceedings 1983 NHTC held in Seattle, Washington.
- (11) Heskestad, G. and Delichatsios, M., "The Initial Convective Flow in Fire," Seventeenth Symposium (International) on Combustion, The Combustion Institute, Pittsburgh, Pennsylvania, 1978.



THE RECENT JAPANESE PROGRESS REPORT
ON FIRE RISK ANALYSIS METHOD

by

Koichi KISHITANI

Faculty of Engineering
Department of Architecture
University of Tokyo

Tadahisa JIN

Fire Research Institute
Fire Defence Agency
Ministry of Home Affairs

Seventh Joint Meeting
U.S. Japan Panel on Fire Research and Safety
UJNR, Washington, D.C. Oct.24-28,1983

THE RECENT JAPANESE PROGRESS REPORT
ON FIRE RISK ANALYSIS METHOD

Koichi KISHITANI and Tadahisa JIN

The research programs relating to "the Fire Risk Analysis Method" have been conducted under 3 project groups in Japan. One of the projects is conducted at Tokyo Fire Department and now in the improvement stage for practical use. The other two studies started simultaneously in April 1982 at Fire Defence Agency, Ministry of Home Affairs and Ministry of Construction.

The main purpose of "the Evaluation Method" developed at Tokyo Fire Department is to diagnose fire safety of the specified buildings with scoring system to make the problems clear and to advise building managers or owners of the adequate methods for improvement of fire safety. To make the long story short, this method is a systematic methodology for evaluation of human life safety estimated by summing up scores of 34 fire safety countermeasure-ment items. These 34 items were selected from 134 fire case study as the most important influential factors to human life safety. The distinctive feature of this estimate method is such quantitative scoring system that rates building fire safety by not only total scores of 34 items which involve certain categories in each fire stage, but also scores of indispensable items depending on the occupancies of buildings. Recently in Japan, buildings are getting higher and/or larger, and furthermore, buildings for mixed various occupancies are increasing. As a result, different types of problems are observed in view of fire safety, such as management system or fire separation by occupancies in a building. Subsequently Fire Defence Agency, Ministry of Home Affairs has started the study of "the Risk Analysis Method of Multi-Occupancy Building Fire Safety" intended to establish the assessment of fire

risks of a multi-occupancy building.

On the other hand, the study of "the Development of Design System for Building Fire Safety" has been initiated by Ministry of Construction as a national project to re-examine the current policies re building fire safety, then to re-establish fire safety and promote new technology through development of rational fire safety systems.

Although there exist laws and regulations for protection of human lives and properties from fire in Japan, i.e., Building Standard Law or Fire Service Law, etc., most of them simply touch upon technical specifications. As mentioned earlier, however, the characteristics of buildings have recently so changed that the administrative application of these current laws does not always give the rational fire safety system, and new technologies and knowledge of fire safety system have been developed and accumulated in past decades. Under these circumstances the study related to such "Fire Risk Analysis Method" and its surrounding themes has recently become an important subject of discussions among researchers and administrators. The goal of this study is taking fire safety of buildings as a system design, to establish an overall safety design method with assessments of initial fire, spread fire, smoke behavior and escape of human beings.

I myself don't mention the details of above 3 studies now but mention the current status of these studies. Tokyo Fire Department has a plan to distribute 10,000 pamphlets re fire risk evaluation which include self check lists for building owners to make them diagnose their own buildings. The studies at Fire Defence Agency, Ministry of Home Affairs and Ministry of Construction are now proceeding and I am convinced of the concrete notable results to be obtained and reported in the next UJNR meeting.

REFERENCES

- 1) Tokyo Fire Department, "Fire Safety Evaluation Method", May 1983
- 2) Fire Defence Agency, Ministry of Home Affairs, "Risk Analysis Method of Multi-Occupancy Building Fire Safety", March 1983
- 3) Ministry of Construction, "The Development of Design System for Building Fire Safety", March 1983

METHODS OF DESIGNING AND EVALUATING FACILITIES FOR FIRE SAFETY

Leonard Y. Cooper

1. INTRODUCTION

One paper at the 1982 UJNR Meeting on Fire Research and Safety presented a broad, long-term framework for research and development with a view toward the rational design and evaluation of fire safety[1]¹. The present paper will outline some of the ongoing types of activities which are consistent with that framework, and which are being carried out at the National Bureau of Standards' (NBS) Center for Fire Research(CFR), and at other fire research institutions throughout the world.

The focus of attention will be on recent fire-safety-practitioner-oriented research activities which focus attention on the development of design and evaluation methods of fire safety. The general and long-term goal of such activities is to build on past progress in the fire sciences and to develop a rational, broad-based technology of fire safety. This technology would be built on the more basic fire research products of CFR and similar institutions. Another paper presented at this meeting[2] provides a report on the overall status of this emerging technology for fire safety.

2. CATEGORIES OF ACTIVITIES

The activities which directly lead to a technology for fire safety can be classified into three categories.

The first of these categories has to do with heightening the awareness of the general fire safety community on the existence, utility, and potential of methods of rational fire safe design. The second category has to do with actually carrying out the work of development and verification of design/evaluation methods. The final category of activities involves the identification and tractable formulation of the most significant problems or barriers to fire safe design and, when possible, to the generation of practical, near-term solutions. Having identified these problems, they are referred to basic fire researchers for indepth study and solution.

3. HEIGHTENING THE AWARENESS OF THE FIRE SAFETY COMMUNITY

To heighten the awareness of applied fire research products there are three aspects to the message that must be delivered to the fire safety

¹Numbers in brackets refer to the list of references at the end of this paper.

safety community on a regular basis, and in a convincing manner. The first part of this message is that it is now beginning to be possible to design fire safe facilities by means of traditional, rational and reliable engineering methodologies. The second aspect of the message is that there are groups of scientist/engineers throughout the international fire research community (such as the Facility Fire Safety Performance group of CFR) which are particularly responsive to the needs of the fire safety community, and which are devoted to the development of such design methodologies. This aspect is related to a form of confidence building--confidence that a bridging of the gap between the needs of practitioners of fire safety, on the one hand, and the capabilities and professional interests of researchers of fire science and technology, on the other is not only possible, but is actually in place. The final aspect of the message that must be delivered involves the actual transfer of technology. Here, reference is made to the delivery of applied research products in the form of practical design methods which are attractive and "friendly" enough as to allow the fire safety community to appreciate their utility.

The message is being delivered to the fire safety community by both talks and published works. Within the U.S., these include presentations at regular scheduled conferences of the National Fire Protection Association (NFPA), the American Society for Testing and Materials (ASTM), and the American Society of Heating, Refrigerating, and Air Conditioning Engineers (ASHRAE). For example, the 1982 NFPA Winter Conference included a series of talks which were presented by the Society for Fire Protection Engineers (SFPE) on the topics "Engineering Tools for the FPE (Fire Protection Engineer)" and "From Science to Engineering." Besides seminars at NFPA conferences, the SFPE also sponsors other symposia on a regular basis. The most recent of these was the 1983 SFPE Symposium entitled "Smoke: Its Chemistry, Physics, and Control Through Engineering." Another link to the fire safety community has also been recently established with the appearance of the First Annual 1983 Fire Engineering Conference of the Manhattan College Fire Engineering Institute. Some of the talks presented at the above-referenced conferences and symposia were accompanied with full manuscripts which are available, and which have been or will be published in the open literature.

A comprehensive review of fire science and technology, written for use as a text in the basic education of the fire protection engineer has recently appeared [3]. In a similar vein, the text of a series of lectures which were presented at CFR during the summer of 1983 is also available [4]. Reference [5] presents a qualitative description of the basic gas dynamic phenomena which occur in developing enclosure fire scenarios, and it should prove to be useful as an introduction to the subject. Several aspects of fire safety technology are included in a recent, attractive book on fire safety design [6]. As the fire safety technology continues to grow, more of this kind of fire-science-based material will hopefully be presented in subsequent editions of this latter book and in similar volumes which are written for the use of the fire safety practitioner.

By delivering "the message" to the fire safety community on a regular basis it will hopefully be ready, indeed anxious to use elements of the emerging fire safety technology as they become available. This will lead to the ultimate objective of all fire research, namely enhanced fire safety.

4. DEVELOPMENT AND VERIFICATION OF METHODS OF DESIGN FOR FIRE SAFETY

4.1 Varied Problems--Varied Solutions

Activities of applied fire research groups focus on the actual development and verification of fire safety design tools or methodologies. Taken together, these tools will make up the emerging fire safety technology.

The character of the problems of the fire safety practitioner are varied, and it is no surprise that tools for their solution will be similarly diverse. These tools have ranged and will likely continue to range from simple charts or graphs, which are suitable for self contained guides and standards, to comprehensive, user-friendly computer codes.

4.2 Design Guides and Standards

A few recent examples of the self-contained design guide or standard which is based on advances in fire science and technology include a NFPA recommended method of calculating smoke levels in a smoke-removal-equipped prison cell block [8], a Detection Institute guide for spacing of heat detectors [9], and an ASHRAE guide for designing building smoke control systems [10]. Each of these practical tools for firesafe design are based on sound engineering practices, and they take into account both analytic considerations and experimental data.

4.3 Developing Analytic Methods of Analysis for Design

As in the past, self-contained, fire-science-based design guides and standards of the future are likely to be built on analytic methods (supported by experimental data) which predict limited aspects of fire-generated environments. Such methods tend to be particularly useful in design when they can be understood and simply implemented by the fire safety practitioner, while at the same time holding up to careful scientific scrutiny. Many such analytic methods, which do not tie the user to a sophisticated computation capability, have recently appeared. Some examples of these include engineering relations for fire plumes [11], a method for predicting temperatures in a vented room fire [12], a method for estimating room flashover potential [13], and a method for obtaining general quantitative descriptions of dynamic, fire-generated environments in enclosed spaces under growing, fire-threat conditions [14].

With an eye toward linking the above kind of methodologies together into somewhat more comprehensive design guides for facility fire safety, much can be learned from a prototype fire model which was developed to assess complex forest fire situations in the field [15]. This model was assembled from a series of relatively simple algorithms which predict different aspects of the forest fire scenario. The model with user's guide is designed to be exercised on a hand-held calculator (with a specially designed Fire Behavior Chip) [16].

One final, unique example of a self-contained tool for fire safe design is another method for predicting flashover in certain classes of single, vented enclosures [17]. In a sense which is different from the aforemen-

tioned method of forest fire analysis, this method can also serve as a prototype for future advances in fire safety technology. The method allows one to make predictions of flashover with the use of graphs and tables which are provided in the reference document. The unique aspect of this work is that the graphs and tables were generated by perhaps the most sophisticated computer enclosure fire model in existence today, namely, the Harvard model [18]. Thus, while this kind of prototype design tool is self-contained, it allows the fire safety practitioner to take advantage of a tool of analysis which, for a variety of reasons, would otherwise be totally beyond his reach.

4.4 User-Friendly Computer Aided Design Tools

It is, and will continue to be most effective to determine many aspects of fire safe facility design by using single or even systems of several simple algorithms. Yet, if facility designs are to be optimized, fire safety practitioners will eventually require direct access to relatively sophisticated computer aided design tools. Moreover, the heart of these design tools will be detailed, computer-driven, mathematical models which simulate both fire-generated environments, and the response to these environments of people and of detection and intervention hardware. Direct accessibility here refers to well-documented, "user-friendly" computer software, and to commonly available and relatively inexpensive computer hardware.

Examples of user-friendly computer programs which have been made available recently with user's manuals include programs designed to analyze pressurized stairwells [19], smoke spread in multi-level coal mines [20], and developing fire environments in fully enclosed spaces [21]. The latter program has been named ASET (Available Safe Egress Time) since it uses the predicted environments to estimate the time available for safe egress of occupants from the threatened spaces. Except for the apparent lack of user's manuals and published program listings, it appears that the recently described programs of references [22] and [23] were also developed to be user-friendly. These latter programs predict developing fire environments in a door or window-vented enclosure, and in a fully enclosed or ceiling-vented space, respectively.

The above referenced computer programs can be considered as prototypes of the kind of first generation, user-friendly, applied research products which will likely be developed and made available to the fire safety community in the future. Over the next several years it will be possible to enhance these programs with a variety of important capabilities. These would include, for example, the modeling of fusible link response (e.g., for the simulation of sprinkler activation); and improved phenomenological modeling of detector simulation, heat transfer to enclosure surfaces, wall flow effects, and the onset of hazardous conditions.

One general scheme for the development of future, fire safety, computer aided design programs will involve the addition of user-friendly input and output software to detailed and sophisticated research fire growth models which have been enhanced with fire detection, fire intervention

and human response algorithms. (For now, the "unenanced" research fire growth models referred to could include, for example, the above referenced Harvard model [18], and the two room and multiroom/multilevel models of references [24] and [25], respectively.) If such a scheme is to be invoked with maximum efficiency, it is evident that to every possible extent, the fire modeling activities of applied and basic fire researchers should be carefully planned to complement one another.

4.5 Verification

Up to now the discussion of this section has concentrated on the development of methods for fire safe design. It is evident that all such development must be carried out in concert with experimental programs which lead to verification of the validity and limitations of these design methods.

Since successful fire safe design requires some knowledge of the fire-generated environment, one main area of verification must focus on the mathematical models which provide predictions of key parameters of such environments. Reports of several experimental programs which are useful for the verification of such models have recently appeared. Examples of these include reports of full scale fire tests in a fully enclosed space with leakage from below [26] and with forced ventilation [27], in a single space with door vent [28], and in multi-room enclosures [29, 30, 31].

The verification of models is an important anticipated result of a new and recently initiated CFR project involving a full-scale, multiroom test program. The project is entitled "Validation of Fire Models." Verification of methods of analysis based on fire models is also a major objective of the full-scale test program of reference [28], which is being continued at CFR with the support of the National Park Service of the U.S. Department of the Interior. Another such full-scale test program being planned over the next three years will involve a joint effort between CFR and the Factory Mutual Research Corporation (FMRC), and it will be supported by the U.S. Department of Health and Human Services.

While this section provided a glimpse of the kind of advances in fire safe design methodology that can be anticipated over the next several years, a view of the growth of fire safety technology over the long term is discussed in the reference [1] document.

5. IDENTIFICATION AND FORMULATION OF PROBLEMS

In the course of observing fire tests and constructing compatible, practical engineering models of hazard development, a variety of important problems have been identified. Reference here is made to problems which manifest themselves as apparent barriers to the successful development of methods of fire safe design. As such, these problems are of particular and pressing interest. The situation typically involves physical phenomena which occur during the course of developing enclosure fire environments. These are phenomena which can have a significant impact on fire safety, and which are not, as yet, taken account of in either the simpler of the mathematical fire models or, the more sophisticated computer fire models which are under development in the fire research community.

As the technology for fire safety emerges, a sensitivity to the existence of such problems, which are often masked by conventional wisdom of

the existing fire technology, is required. Having identified them, the task is to formulate the problems in a concise and tractable manner. As appropriate, the problems are then referred to the more basic research groups for indepth study and solution. When possible, practical, near-term solutions must be developed so that, even during the often lengthy period of indepth study, the barriers to fire safety which have been identified can be overcome on a rational basis. Brief descriptions of two past examples, with which the author is most familiar, will illustrate the problem identification and formulation aspects of applied fire research.

The first example has to do with predicting the time-varying temperature of the upper smoke layer and of exposed surfaces in an enclosure fire environment. Up to and somewhat beyond the onset of a life-threatening environment (which would, for example, be characterized by only relatively moderate increases in temperature, the order of a few hundred degrees K), it would appear that convective heat transfer along with radiative heat transfer plays a key role in the establishment of these temperatures increases. Yet, only a few years ago, algorithms for an adequate accounting of the convective heat transfer were not available, and even today additional advances are required in this regard. Since onset of a life-threatening condition must be predicted with reasonable accuracy by fire-safe-design fire models, such algorithms are mandatory. In the context of the generic, two-layer, enclosure fire environment, Figure 1 depicts the plume flow, ceiling jet flow and ceiling heat transfer phenomena which must be analytically described if the required algorithms are to be developed.

Over the last few years the above problem was highlighted, and a practical system of solution elements was developed. This work was communicated to the fire safety community and to the applied and basic fire research community through a series of talks and published papers [32-36]. Hopefully, these communications 1) will heighten the sensitivity of fire safety practitioners to the problem, 2) lead to the near-term development of mathematical enclosure fire models capable of reliable temperature predictions, and 3) stimulate fire researchers to seek the most effective and optimum long-term solutions.

The second example of problem identification has to do with a wall flow phenomenon which is generic to enclosure-fire-generated environments. In real fire events, the phenomenon, which is not taken account of in any existing two-layer zone fire model, can lead to significant deviations in the environment which would be predicted by such models. The effect to which reference is made is the wall flow which draws product-of-combustion-laden upper layer gases down into the (relatively) uncontaminated lower layer. The potentially deleterious effect of such wall flows on life safety, for example, is evident. The phenomenon is illustrated in Figure 2.

The wall flow, which seems to have been observed in numerous experiments (see, for example, references [19], [26] and [31]), is the result of the near-wall, elevated temperature, upper-gas layer being cooled (i.e., increased in density) by the relatively low temperature, upper-wall surfaces. The significance of the wall effect has been quantified in a study on a relatively general class of enclosure fire scenarios [37]. The results of the analytic study have been brought to the attention of the fire technology community. They indicate that the wall effect will be significant in many practical fires.

The results clearly suggest that the wall effect should be studied in greater depth, and that it should be taken account of when developing methods for fire safe design.

6. CHALLENGES FOR THE FUTURE

There are three key challenges associated with the task of developing an effective fire safety technology. First, it is necessary to make judicious selections of readily available components and systems of components, and to assemble them into useable and credible working tools and methods for rational fire safe design. Next, it is necessary to critically evaluate and, where possible, validate these tools. This must be done with an eye toward both determining their strengths and revealing their shortcomings. Finally, it is necessary to initiate research programs which are directed toward the elimination of these shortcomings.

The kinds of activities described in this paper are designed to meet these challenges. By continuing to follow the indicated direction it is hoped that enhanced levels of fire safety, not otherwise likely, will be attained.

7. REFERENCES

- [1] Cooper, L.Y., and Nelson, H.E., Life Safety Through Designed Safe Egress-- A Framework for Research Development and Implementation, 6th Meeting of the UJNR Panel on Fire Research and Safety, Tokyo, JAPAN.
- [2] Nelson, H.E., Facility Fire Safety and Risk Analysis Methods, 7th Meeting of the UJNR Panel on Fire Research and Safety, Wash., D.C.
- [3] Drysdale, D.D., Fire Dynamics: An Introductory Course (Second-Draft, Jan., 1983), Worcester Polytechnic Inst. Center for Firesafety Studies, Worcester, MA.
- [4] Kanury, A.M., Combustion for Fire Scientists, Dept. of Aero. and Mech. Eng., Univ. of Notre Dame, Notre Dame, IN, 1983.
- [5] Cooper, L.Y., Smoke Movement in Rooms of Fire Involvement and Adjacent Spaces, NBSIR 83-2748, NBS, Wash., D.C., 1983, and to appear in Fire Safety Journal.
- [6] Butcher, E.G., and Parnell, A.C., Designing for Fire Safety, John Wiley and Sons, 1983.
- [7] Guide for Smoke and Heat Venting, NFPA 204M, NFPA, Quincy, MA, 1982.
- [8] A Recommended Method of Calculating Expected Level of Smoke in a Smoke Removal Equipped Cell Block, Section A-15-3.1.3 of NFPA Life Safety Code, NFPA, Quincy, MA, 1981.
- [9] Benjamin, I., Heskestad, G., Bright, and R., Hayes, T., An Analysis of the Report on Environments of Fire Detectors, Fire Detection Institute, 1979.

- [10] Klote, J.H., and Fothergill, J.W., Design of Smoke Control Systems for Buildings, ASHRAE, Atlanta, GA, 1983.
- [11] Heskestad, G., Engineering Relations for Fire Plumes, Tech. Rpt. 82-8, SFPE, Boston, MA, 1982.
- [12] McCaffrey, B.J., Quintiere, J.G., and Harkleroad, M.F., Estimating Room Temperatures and the Likelihood of Flashover Using Fire Test Data Correlations, Fire Technology, 17, p. 98, 1981.
- [13] Babrauskas, V., Estimating Room Flashover Potential, Fire Technology, 16, p. 94, 1980.
- [14] Cooper, L.Y., The Development of Hazardous Conditions in Enclosures with Growing Fires, NBSIR, 82-2622, NBS, Wash., D.C., 1982 and to appear in Comb. Sci. and Tech.
- [15] Rothermel, R.C., Fire Behavior Systems for Fire Management, Proc. Sixth Conf. on Fire and Forest Meteorology, Seattle, Amer. Soc. of Forestry, Wash., D.C., 1980.
- [16] Burgan, R.E., Fire Danger/Fire Behavior Computations with the Texas Instruments TI-59 Calculator: User's Manual, USDA Forest Service General Tech. Rpt. INT-61, Intermt. For and Range Exp. Stn., Ogden, UT, 1979.
- [17] Peacock, R.D., and Breese, J.N., Computer Fire Modeling for the Prediction of Flashover, NBSIR 81-2516, NBS, Wash., D.C., 1981.
- [18] Mitler, H.E., and Emmons, H.W., Documentation for CFCV, Home Fire Proj. Tech. Rpt. 45, Harvard Univ., Cambridge, MA, 1981.
- [19] Klote, J.H., A Computer Program for Analysis of Smoke Control Systems, NBSIR 82-2512, NBS, Wash., D.C., 1982.
- [20] Edwards, J.C., and Greuer, R.E., Real-Time Calculation of Product-of-Combustion Spread in Multilevel Mine, Information Circular 8901, Pittsburgh, PA, 1982.
- [21] Cooper, L.Y., and Stroup, D.W., Calculating Available Safe Egress Time (ASET) - A Computer Program and User's Guide, NBSIR 82-2578, NBS, Wash., D.C., 1982.
- [22] Hagglund, B., A Room Fire Simulation Model, FOA Rpt. C 20501-D6, Nat. Defense Res. Inst., Stockholm, SWEDEN, 1983.
- [23] Hagglund, B., Simulating the Smoke Filling in Single Enclosures, to appear as FOA Rpt., Nat. Defense Res. Inst., Stockholm, SWEDEN.
- [24] Zukoski, E.E., and Kubota, T., Two-Layer Modeling of Smoke Movement in Building Fires, Fire and Materials, 4, 1, p. 17, 1980.
- [25] Tanaka, T., A Model of Multiroom Fire Spread, NBSIR 83-2718, NBS Wash., D.C., 1983.

- [26] Muholland, G., Handa, T., Sugawa, O., Yamamoto, H., Smoke Filling in an Enclosure, *Fire Sci. and Tech.*, 1, 1, p. 1, 1981.
- [27] Alvares, N.J., Foote, K.L., and Pagni, P.J., Characteristics of Fire in a Forced Ventilation Enclosure, to appear in *Comb. Sci. and Tech.*
- [28] Lee, B.T., Effect of Wall and Room Surfaces on the Rates of Heat, Smoke, and Carbon Monoxide Production in a Park Lodging Bedroom Fire, to appear as NBSIR, NBS, Wash., D.C.
- [29] Handa, T., Morita, M., Rockett, J.A., Sugawa, O., and Hayashi, K., Some Examples of Application of Harvard V Fire Computer Code to Fire Investigation, *Fire Sci. and Tech.*, 3, 1, p. 63, 1983.
- [30] Cooper, L.Y., Harkelroad, M., Quintiere, J., Rinkinen, W., An Experimental Study of Upper Hot Layer Stratification in Full-Scale, Multiroom, Fire Scenarios, *Journal of Heat Transfer*, 104, p. 741, 1982.
- [31] Smoke Movement in Corridors, BRE News, 60, Building Res. Establishment, Garston, ENGLAND, 1983.
- [32] Cooper, L.Y., A Concept for Estimating Available Safe Egress Time in Fires, *Fire Safety Journal*, 5, p. 135, 1983.
- [33] Cooper, L.Y., A Mathematical Model for Estimating Available Safe Egress Time in Fires, *Fire and Materials*, 6, p. 135, 1982.
- [34] Cooper, L.Y., Heat Transfer from a Buoyant Plume to an Unconfined Ceiling, *Journal of Heat Transfer*, 104, 1982.
- [35] Cooper, L.Y., Convective Heat Transfer to Ceilings Above Enclosure Fires, *Proc. of 19th Inter. Symp. on Combustion*, Comb. Inst., p. 933, 1982.
- [36] Cooper, L.Y., A Buoyant Source in the Lower of Two, Homogeneous, Stably Stratified Layers--A Problem of Fire in an Enclosure, paper 83-WA/FE-4 of 1983 Winter Annual Mtg. of ASME, Amer. Soc. Mech. Eng., New York, NY, 1983, and to appear in *Proc. of 1983 Mtg. of East. Sect. of Comb. Inst.*
- [37] Cooper, L.Y., On the Significance of a Wall Effect in Enclosures with Growing Fires, 1983 Nat. Heat Trans. Conf., Fire Dynamics and Heat Transfer, ASME HTD 25, p. 97, Amer. Soc. Mech. Eng., New York, NY and to appear in *Comb. Sci. and Tech.*

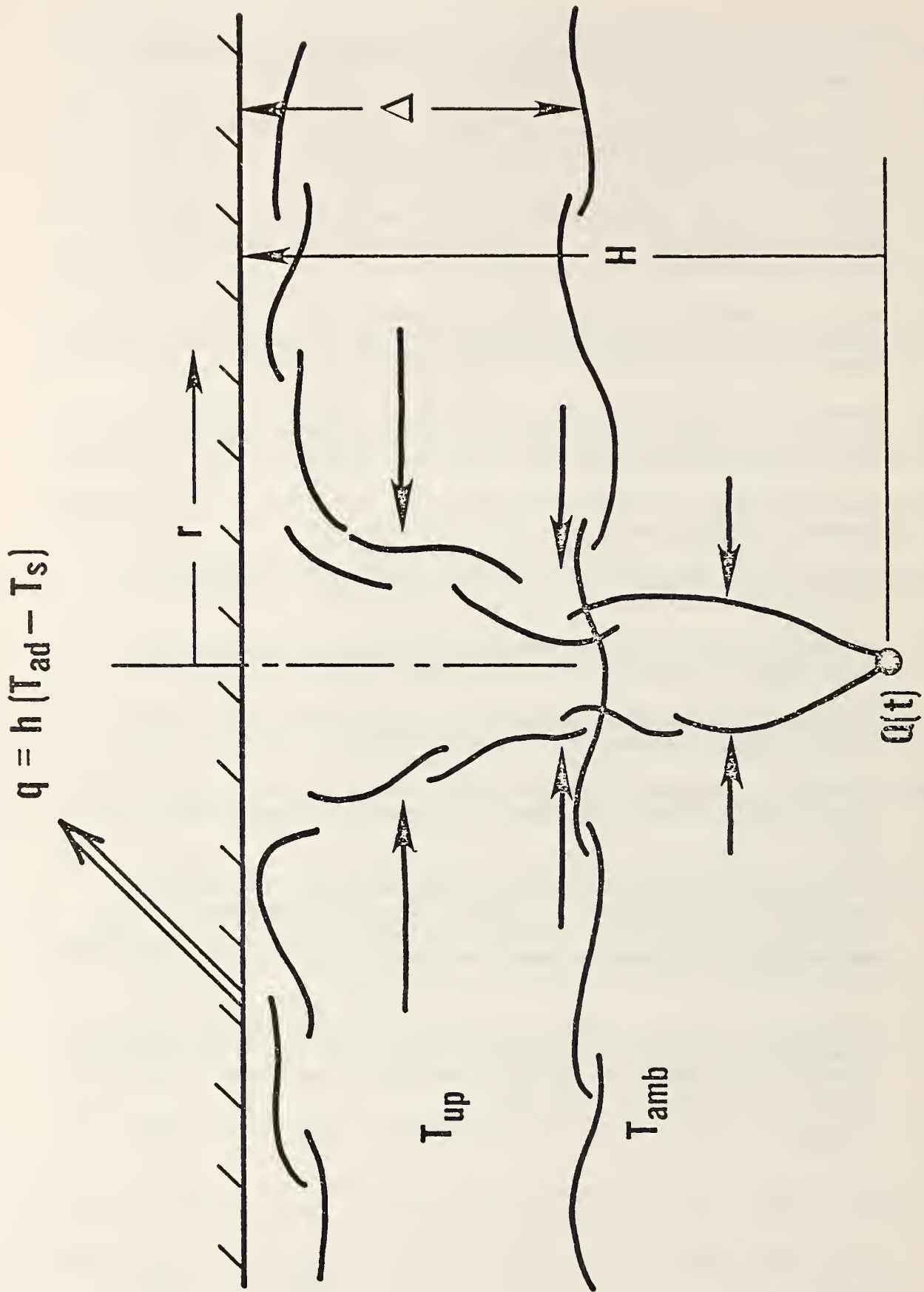


Figure 1. An illustration of the plume flow, ceiling jet flow, and ceiling heat transfer in a generic, two-layer, enclosure fire scenario.

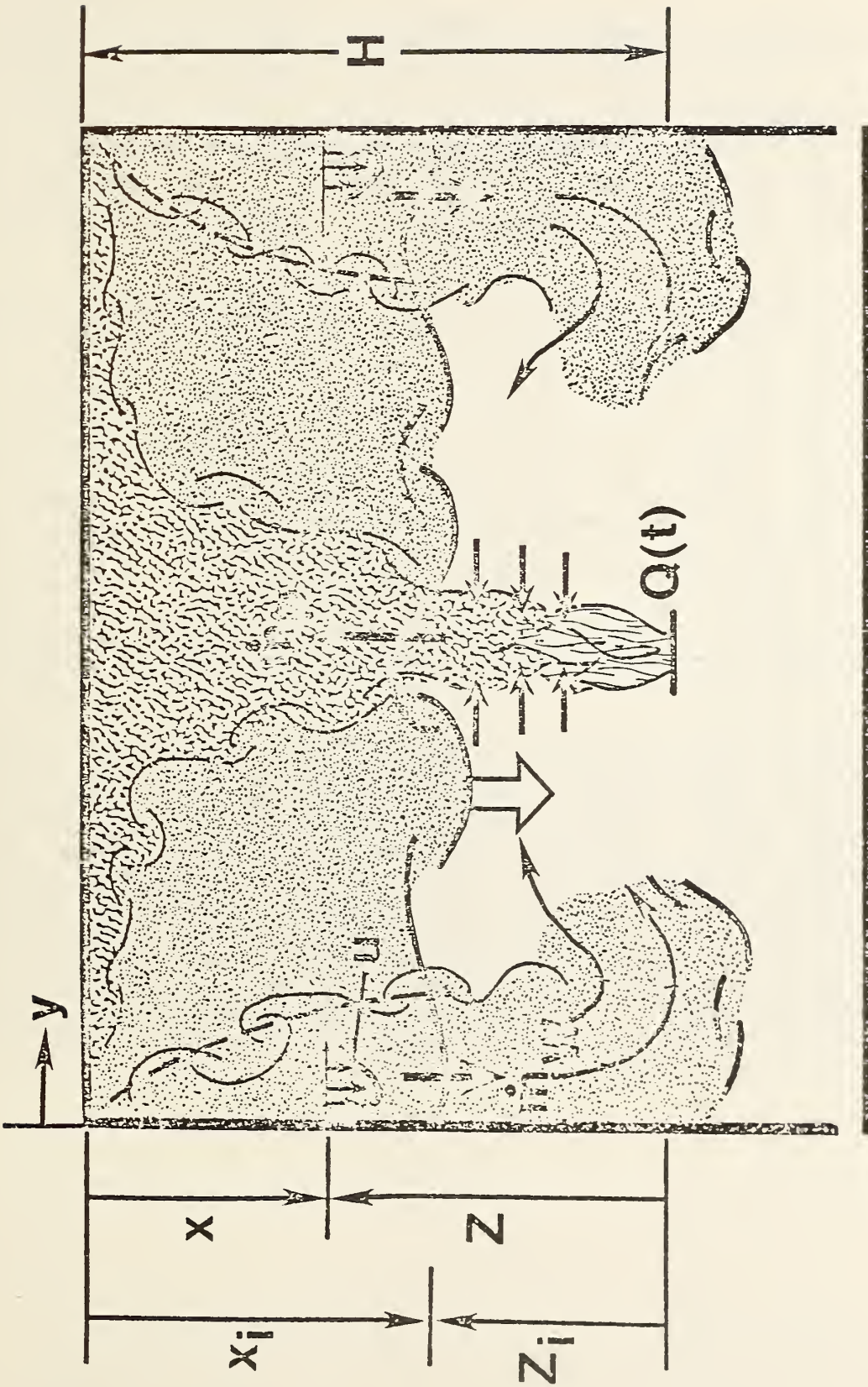


Figure 2. An illustration of wall flows which can have significant effects on enclosure fire environments.

Discussion After L. Cooper's Report on METHODS OF DESIGNING AND EVALUATING FACILITIES FOR FIRE SAFETY:

WAKAMATSU: I'm sure it is very important to analyze or to project a phenomena. When we engage in the analysis of ordinary prediction of phenomena, and if we know the complete factor or element of the phenomena, it's easy to input those elements in a computer, for example. On the other hand, when we look at the actual fire, there are many unpredictable elements which influence the conditions of fire, including how much the windows are opened, or how the fire started, or the weather at the time. So, my question is, how do you predict these unpredictable, uncertain elements when you predict fire phenomena?

COOPER: One of the statements I made was that there are various problems requiring varied solutions and so it is in regard to this question. I'll give you two examples of real classes of problems and possible solutions. The first has to do with the question of opened windows or opened doors, or closed windows or closed doors. One can reasonably argue that for developing fire conditions in an enclosed space, the completely closed enclosure will yield the most quickly developing hazardous conditions providing, of course, the fire develops as it would in open space, which we can assume that it does. So, as a first approximation, I would recommend evaluating the development of conditions in a state assuming that it was enclosed. With regard to the variation in occupancy in a building, I would recommend the development of fuel assemblies which are characteristic of a given occupancy. Hospitals would have beds and bureaus as a characteristic of fuel assembly, warehouses would have characteristic fuel assemblies involving rack storage of special design. One would evaluate the environment as it developed from one of these characteristic fuel assemblies, assuming that the fire developed as it would in a free burn situation.

EMMONS: Dr. Wakamatsu asked what seems to me the most critical question that could be asked relative to fire models. The approach that I think is necessary is that we will continue through the years to develop better and better models to be able to answer more and more precise questions. As we use these models, we will acquire experience with what in a building is critical and what in a building is important but not critical. Each building that is analyzed would be burned on the computer a number of times. Those items in a building which are critical would have to be given special attention. For example, if a certain door was essential to be closed to prevent serious fire spread, the law would have to require that that door be spring loaded, never held open. In other words, I believe we would learn what features of a building are essential to control and to control the most important one by legal requirements.

Development of Design System for Building Fire Safety

- by Ministry of Construction's Promotion of
Cooperative and Total Development Project -

by Takao Wakamatsu
Yasaburo Morishita

Fire Safety Research Group
Building Research Institute

I. Progress

A Research Project "Development of Design System for Building Fire Safety" was initiated in Japan from April, 1982 as a five-year project sponsored by Ministry of Construction's Promotion of Cooperative Research and Total Development Project. The purpose of this project is to develop a rational and total design system for building fire safety by systematizing the knowledges gotten so far in the field of fire research. By the accomplishment of this project, such problems as the restriction of flexibility of building design by fire regulations, the unclearness of the effects and interactions of various fire countermeasures are solved and the fire countermeasures are expected to come to be provided logically and economically from the view point of total fire safety performance of a building.

In 1982 fiscal year, the following items were studied.

- 1) Review of the concerned researches conducted so far.
- 2) Examination of the conditions to be provided in Design System for Building Fire Safety.
- 3) Examination of the framework of Design System for Building Fire Safety.
- 4) Preliminary survey on the actual situations of fire countermeasures and fire damages.
- 5) Survey on Fire Load taken into buildings.
- 6) Examination of the fire resistive performance of a steel structure frame by theoretical thermal strength calculation with computer model.
- 7) Examination of the framework of fire safety diagnosis system as the application of the design system for exist buildings.

II. Framework on Design System for Building Fire Safety

Among these items, the parts concerning the framework on Design System for Building Fire Safety are considered so important in order to have a view on the direction of future development of this project, that the details of the examination on the framework are mentioned below.

- 1) Objectives of the Design System
 - a) To give logically clear bases and interactions of fire countermeasures.
 - b) To evaluate quantitatively the effects of fire countermeasures.
 - c) To give the alternative countermeasures satisfying a standard

safety level.

Further, if these objectives are achieved in the Design System, it will be possible to select an economical countermeasure the effect of which is highest for a given budget by making the Cost-Effectiveness Analysis.

2) Items to be examined in the process of making the Design System

- a) Controlableness of the elements consisting of the Design System.
- b) Possibility of getting objective data on the effects of elements.
- c) Possibility of estimating the situation of elements from the gotten data.
- d) Clarification of the conditions to be provided in the Design System (subject elements and countermeasures to be evaluated, applicable scope of the Design System, etc.)
- e) The goals of the Design System should be described as policies corresponding to the types of buildings.
- f) Expert Judgement should be treated logically and clearly in the determining process of the evaluation method.

3) Constitution of the Design System

- a) The Design System is composed of the goals described as policies and the evaluation method (including quantitative standard) to check if they are satisfied.
- b) The goals are plural, and the combination rules would exist.
- c) The goals and their combination rule would be determined corresponding to the types of building.
- d) Evaluation method is largely decomposed into 4 subsystems, i) Outbreak and Growth of Fire, ii) Smoke Control, iii) Evacuation, iv) Fire Resistance of Structure.
- e) Evaluation is conducted on the respective subsystems and the total system.
- f) Economical Performance is desirable possibly to be evaluated in the last stage of the Design System.

4) Framework of the Design System (Draft)

Fig.1 shows the framework of the Design System for Building Fire Safety (Draft). The items mentioned above are reflected in the constitution of this framework.

On this figure, the present situation of fire safety design is also shown. Many of the buildings designed nowadays are just checked on the accordances with codes at the last stage of design as are shown at "conventional type". Concerning large buildings (ig. the height of which exceeds 31m) which may cause large evacuation risk, the designers of of such buildings are guided to make the documents on fire safety planning, which are examined and modified by the experts on fire safety at the evaluation committee instituted in Building Center of Japan. This evaluation system started in July 1981 by the guidance of Ministry of Construction.

Fig.2 - Fig.5 show the design(evaluation) method for respective subsystems.

III. Current Studies

- 1) Development of Systematic Design Methods for Total Fire Safety
 - * Confirm the Framework of Design System for Building Fire Safety.
 - * Classification of unit spaces composing of a building. - A building can be considered as a network of various unit spaces having different qualities. Consequently, buildings should be classified corresponding to the types of combinations of unit spaces.
 - * Preliminary study on the actual effects of fire countermeasures estimated as reliability (by using fire statistics).
 - * Actual state of provision of fire countermeasures and their costs.
 - * Examination of the evaluation framework for residential fire safety performance.

- 2) Development of Design Methods for Prevention of Outbreak and Growth of Fire
 - * Confirm the Framework of Design Methods for Prevention of Fire Outbreak and Growth.
 - * Development of Fire Growth Model in a room of fire origin.
 - * Trial making of the measuring instrument for combustion properties of materials.

- 3) Development of Design Methods for Smoke Control and Escape Planning
 - * Confirm the Framework of Design Methods for Smoke Control.
 - * Confirm the Framework of Design Methods for Evacuation.
 - * Making of "Menu" of various Smoke Control Methods.
 - * Survey of air infiltration characteristics through crevices of doors, windows, walls etc. in exist buildings.
 - * Survey of characteristics of occupants in buildings (Hospital, Department store)

- 4) Development of Design Methods for Fire Protection of Building Structures
 - * Confirm the Framework of Design Methods for Fire Protection of Building Structures.
 - * Heating experiment of full scale structure.
 - * Survey of Fire Load and actual state of structure in exist buildings.
 - * Experiment for characteristics of materials used for fire protection in high temperature.

- 5) Development of Methods and Techniques for Diagnosis & Improvement of Fire Safety of Exist Buildings
 - * Examination of the Framework of Methods for Improvement of Fire Safety Performance of Exist Buildings.
 - * Survey of actual improvement cases for fire safety in exist buildings(Department Store, Theater, etc.).
 - * Preliminary survey of actual states of maintenances of fire countermeasures.

FIG.1 Framework of Design System for Building Fire Safety (Draft)

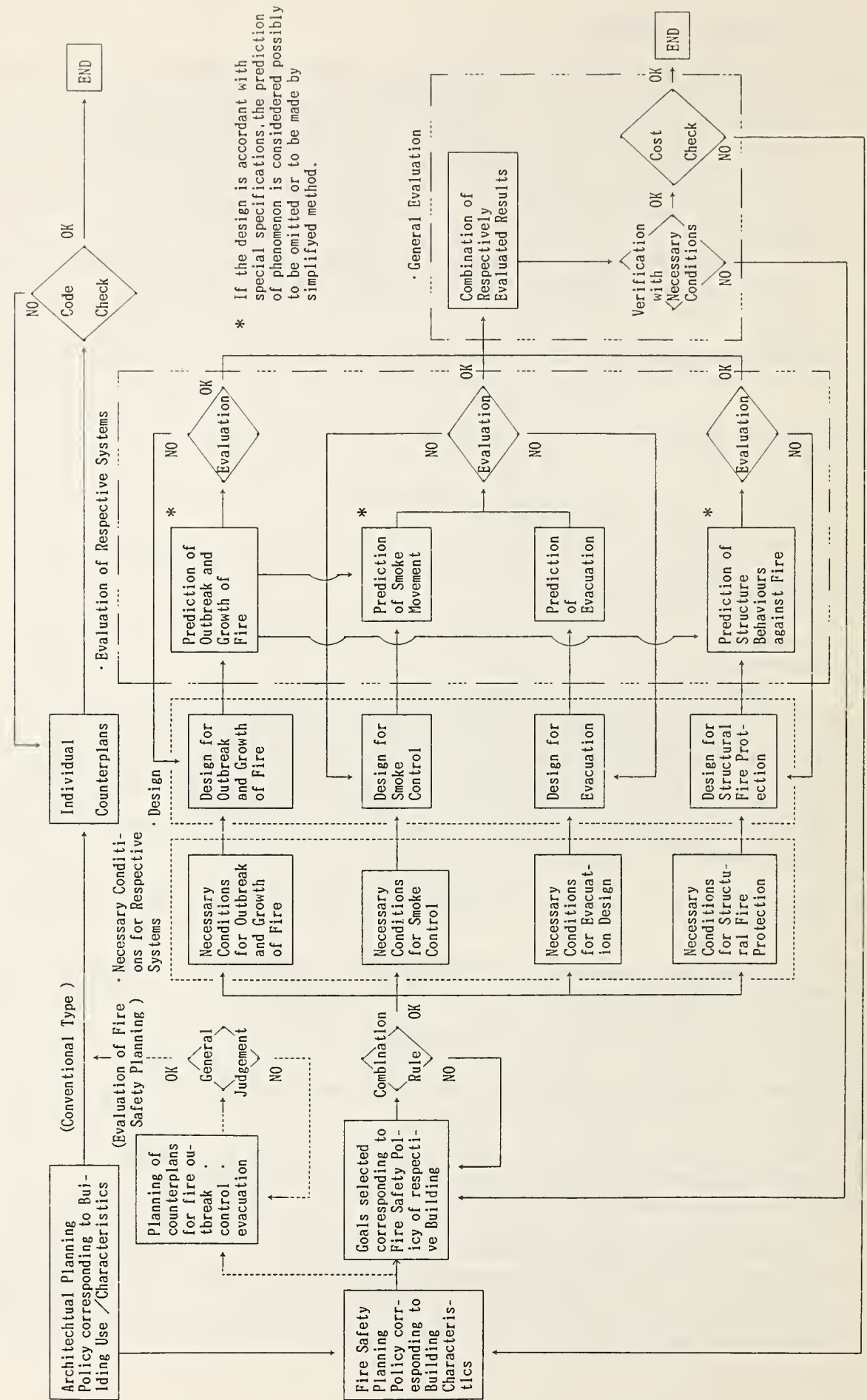
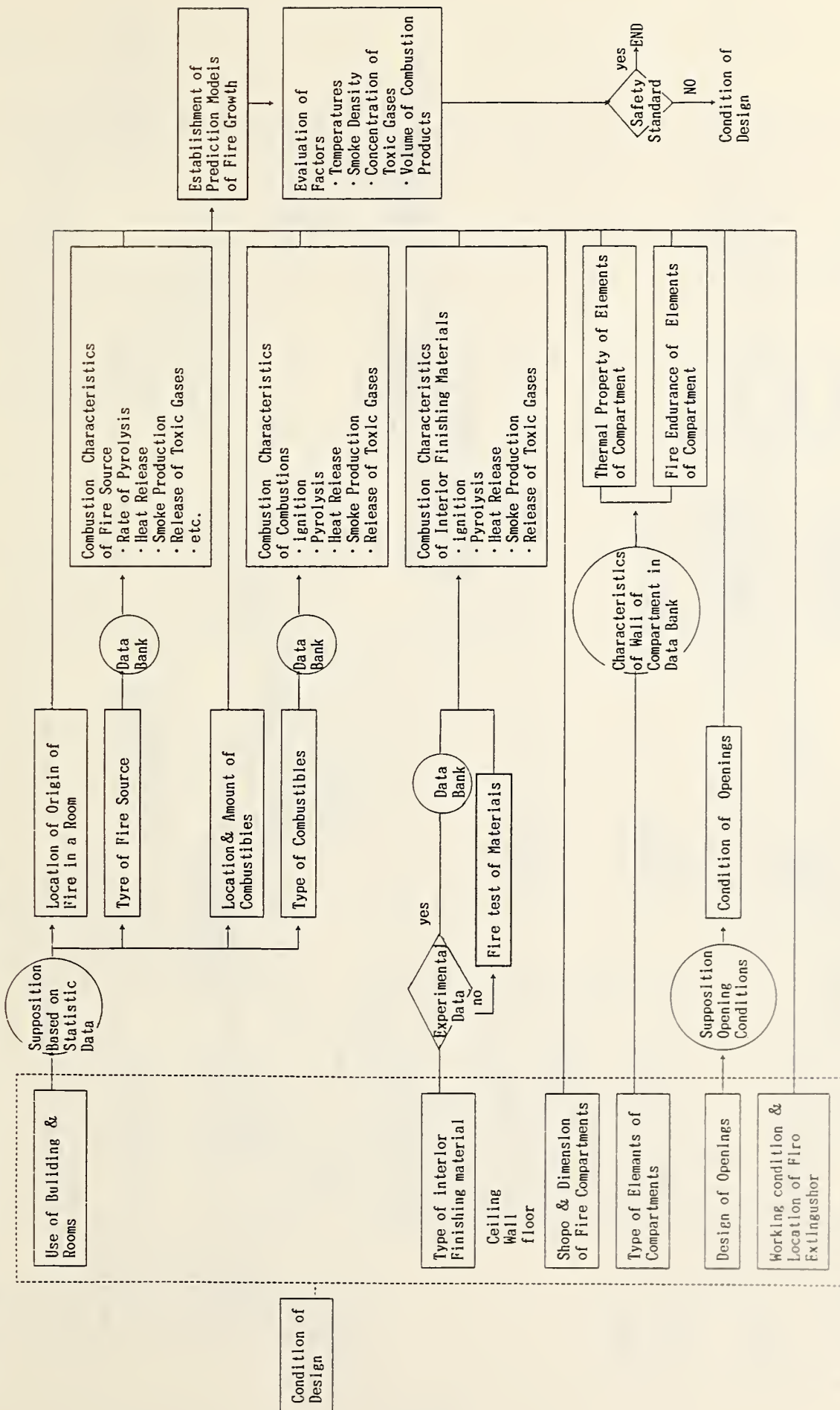
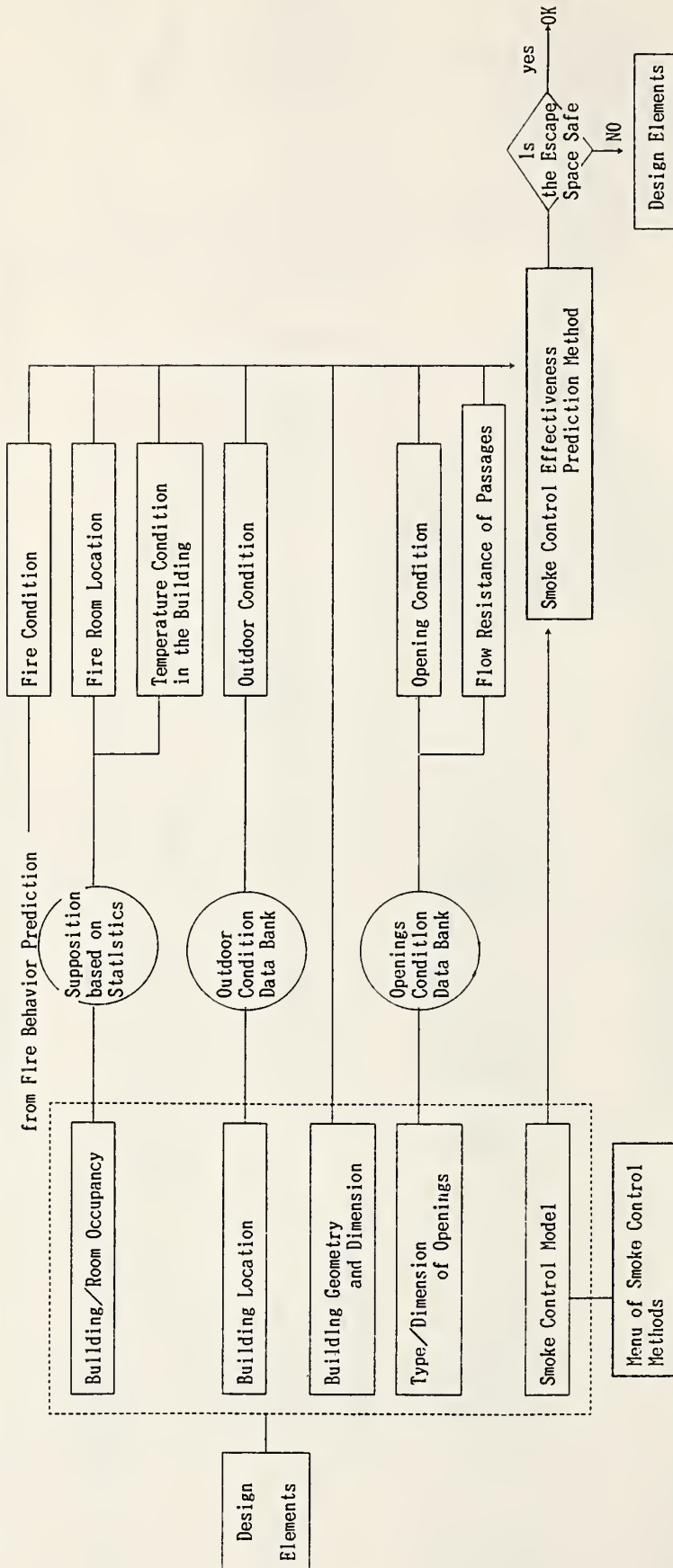


FIG. 2 Framework of Design Methods for Prevention on Outbreak and Growth of Fire



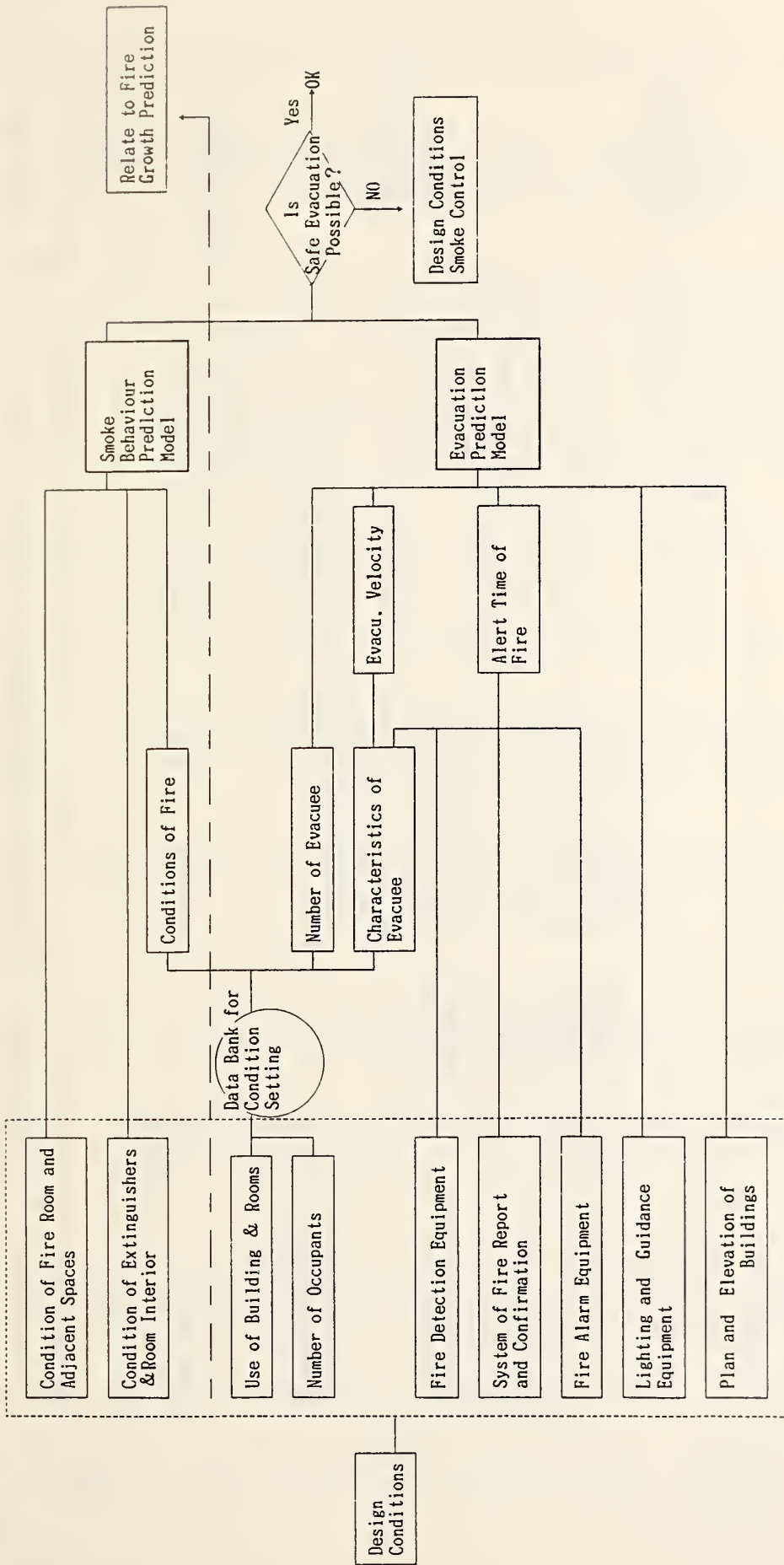
Note : 1) This diagram shows the summary of evaluation systems for fire growth in a compartment, and fire spread through inner & outer parts of buildings. There are some differences between these fire growth models in details.
 2) Concerning the data used for evaluating condition of design, almost only the data of the room are concerned for the fire growth in a room of fire origin. On the other hand, both the data of the room of fire origin and the vicinity are to be considered for the fire spread among rooms.

FIG. 3 Framework of Design Methods for Smoke Control



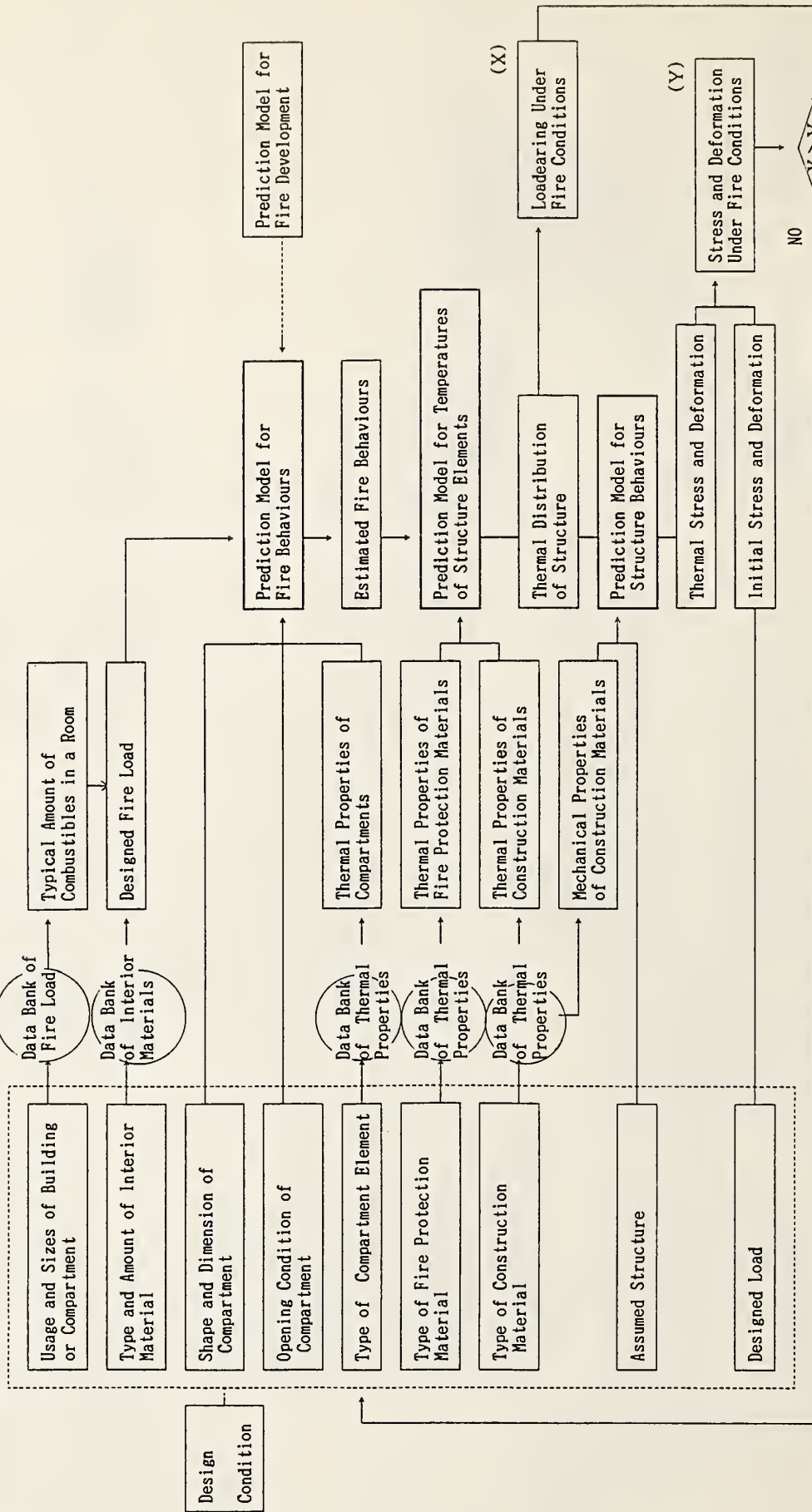
Type of Evacuation	Main Escape Route	Duration to be Ensured	Postulated Fire Stage	Significance of Temperature Condition	Note
Fire Room Evacuation	Room of Origin	Until Egress Completion of Room of Origin	Initial	Not Significant	Important in case of Auditorium, Department Store, etc.
Fire Floor Evacuation	Escape Routes on Fire Floor	Until Egress Completion of Fire Floor	Initial and Developing	(?)	
Whole Building Evacuation	Escape Stairwell	Until Egress Completion of Whole Building	Developed	Significant	
Stay in Protected Refuge	Protected Refuge	Until the Fire Extinguishment	Developed	Significant	Important in Case of Highrise Bldg., Disabled Occupancy, etc.

FIG. 4 Framework of Design Methods for Evacuation



Meaning of terms Category of Evacuation	Related Spaces	Number of Evacuee	Fire Condition	Smoke Behaviour Prediction Model	Evacuation Prediction Model	Is Evacuation Possible?
Evacuation from Fire Room	Fire Room	Occupants of Fire Room	Initial Stage of Fire	Smoke Filling	Evacuation From Fire Room	From Fire Room
Evacuation from floor of Original Fire	Fire Room & Rooms Used as Escape Route	Occupants of Fire Floor	"	Smoke Behaviour in Escape Route	Escape From Fire Floor	From Fire Floor
Evacuation from Building	Fire Room & Escape Stairways	Occupants of Building	Fully Developed Fire	Smoke Behaviour in Escape Stairways	Escape From Building	From Building

FIG. 5 Framework of Design Methods for Fire Protection of Building Structures



(Note)

An example of typical design system is shown in this chart. It is available to replace prediction model for Fire Behaviours by required Fire Endurance

Time or prediction models for Structural Behaviours and Temperatures of Structural Elements by Standard Fire Endurance Test which are specified in regulations.

Discussion After T. Wakamatsu's Report on DEVELOPMENT OF DESIGN SYSTEM FOR BUILDING FIRE SAFETY

NELSON: In Figure 1, you indicated, I believe, that you plan to set a goal for each of the four subsystems and a total goal. That would seem to be very constraining. Couldn't you just set a total goal and thereby allow trade offs between the subsystems?

WAKAMATSU: Yes, we are going to establish a goal for four different subsystems and also one goal for a total system. The purpose of setting up different goals will be explained by quoting an example. We are planning to set a goal for a smoke control. In doing so, we will set how much smoke will be allowed from a burning room and how many minutes smoke should be allowed in a certain stairway; for example, stairway A, and then we might decide that a smoke is not allowed, for example, in stairway B. Our philosophy is to set up different goals for smoke control, for example, or for ignition, or for escape, and by combining these goals, hopefully, we can come up with a complete policy.

If my answer was not very clear, I'm sure that Dr. Tanaka's talk tomorrow will clarify any questions you may have.

NELSON: Your item 2F on Expert Judgement, have you developed any concept of how to logically and clearly treat expert judgement?

WAKAMATSU: We have not decided completely how we will treat expert judgement logically and clearly, but one example is to use the Delphi method. At this stage we do not know at which point or how we are going to incorporate expert judgement.

NELSON: Your work plan for this year, III, item 3, is very close to the items that are on our agenda, and it would be very worthwhile if we coordinated it.

WAKAMATSU: I concur with your comment and hopefully we can pursue our research together.

GANN: On Figure 1, you have three diamonds for evaluation of the prediction models. How do you plan to do the evaluation and what criteria will you use to determine the accuracy of the prediction methods for specific buildings?

WAKAMATSU: This evaluation is not for the evaluation of accuracy or prediction methods of a specific building, but this evaluation will be conducted for established purposes. In other words, this evaluation is to evaluate whether or not a goal is met.

GANN: Sandy Davis is working with Dr. Jones on prediction of validation of predictive models for smoke movement and has worked with the American Iron and Steel Institute on testing prediction methods for steel structures. These results may be of interest to you, and we can talk about them later.

WAKAMATSU: What part of the smoke prediction model were they engaged in?

GANN: It's smoke filling of a corridor. In our tour on Wednesday, you will see the facility and a video tape of one test. Dr. Jones is right here for any further details.

WAKAMATSU: Yes, I would be very much interested in knowing the results you have obtained so far.

KAWAGOE: This problem is tackled in the structure of Fire Safety Division which exists in CIB W14 CIP, and our philosophy is to reduce risks rather than to concern ourselves with safety. In other words, we set up some figures for ignition, flashover, and failure, and the rate of these, I think, must be below a certain established figure. I feel that our method is quite an easy one and quite easy to understand. This subject is mentioned in an article by a workshop published in "Fire and Materials."

Human Reaction During Residential Fires:
Establishing a Data Base

John P. Keating, Ph.D.

Department of Psychology N1-25
University of Washington
Seattle, Washington 98195

U.S. - Japan Panel on Fire
Research and Safety VII

National Bureau of Standards
Gaithersburg, Maryland

October 24, 1983

Human Reaction During Residential Fires: Establishing a Data Base

An opportunity to apply psychological principles to fire egress problems was provided us in 1974, when we were asked by the General Services Administration to design the wording for the vocal evacuation system for the Seattle Federal Building. This building was developed by the federal government to provide a prototype of a high-rise structure which incorporated a total fire safety system concept. The basic hardware of the safety system was designed, and several important decisions concerning the personnel evacuation were made before our involvement. The most significant innovation of the system was the incorporation of a public address component capable of broadcasting prerecorded directions to communicate with building occupants who might be affected by a fire. While a vocal alarm was the egress system recommended by several fire safety conferences for high-rises, systematic development of the wording to be used in such a system was not attempted until our efforts (Keating and Loftus, 1977)

Our specific work with message development for fire evacuations demanded that attention be focused on specific answers to immediate questions within absolute time constraints. As we became familiar with the whole field of human behavior in fires (e.g. Canter, 1980), we became increasingly aware of how little was documented about human response during fire emergencies, especially residential fires. Models of human reactions had been developed (e.g., Bickman et al., 1978 Stahl, 1977), but mainly depended on accumulated anecdotes and limited data to define parameters for computerized projections of damages for specified fire-scenarios. Effective warning systems, emergency signage, and awareness by architects of principles of safe design, could all be enhanced if natural responses to fires could be systematically studied.

Only the survivors really experience how they escape from a fire. Much of what they experienced is forgotten or distorted by natural psychological processes stimulated by threatening traumatic memories. Consequently, we developed an interview instrument for administration to fire victims which relied on the script theory of cognitive processing (Schank and Abelson, 1977) for its format. The technique was designed for general use by investigators during post-fire interviews, and possessed at least five desired characteristics. Such a technique should:

- 1) Incorporate pertinent findings from research on the validity and power of various interview techniques.
- 2) Be directly relevant to the types of accounts expected from fire scenarios.
- 3) Provide data which could be computerized and subjected to comparative analyses across fires.
- 4) Be easy to administer and capable of use by fire investigators after minimal training.
- 5) Have the capability to accommodate data banks large enough to provide sufficient analytic power for appropriate statistical probes.

Interview Techniques: Based on a review of research related to existing interview techniques, an interview approach which could incorporate both the narrative and interrogatory modes into its method seemed optimal. In order to provide such incorporation of both approaches, our procedure involves two phases.

In the first phase of the interview, the witness is invited to recount his or her story of the fire, free from interference or questions by the interviewer (narrative mode). During the second phase of the interview, the respondent and interviewer, using a standardized format, cooperatively generate a comprehensive account of the respondent's behavior during the fire (interrogatory mode). The narrative account or free recall phase is administered prior to the more structured mode to capitalize on research findings (e.g., Whitely and McGeoch, 1927) which demonstrated more accuracy and completeness when this sequence of methods is employed. Additionally, this sequence of interviewing avoids the bias that can be created in the interrogatory phase by use of specific questions and language by the interviewer (cf. Loftus and Palmer, 1974, Loftus, 1979) which may distort accurate recall.

During the initial phase, the interviewer imposes a minimum of structure on the respondent's narrative account. The respondent is simply asked to recount all of his or her behaviors during the fire incident in the sequence they occurred. The interviewer briefly notes details of the account which seem sketchy or incomplete and may need additional probing. Questions are asked only if there seems to be obvious, unaccountable gaps in the narration.

After the narrative is completed, the interviewer initiates the second phase. This phase is a cooperative effort between the interviewer and respondent to convert information presented during the initial narration into a series of statements, each of which describes a single behavioral episode. Each of these statements is designed to include information about what the person did and why, on response to what cognitive or external cue.

Behavioral Episodes. It is obvious that a post-fire interview technique should be tailored to the types of accounts which could be expected from survivors of fires. A conceptualization of how fire events can be sequenced, developed by Lars Lerup (1977), an architect at the University of California at Berkeley, was used to organize the sequencing of behavior by witnesses in their accounts of the fire.

During phase two of the interview, the respondent orders, in the sequence they happened, each of his or her behaviors during the fire. Each discrete behavior is called a "behavioral episode" which was defined as Lerup as:

An individual is involved in a continuous stream of behavior, but this stream has discrete units called episodes, defined at start and end by decision points. An episode, for example, could be a nurse rescuing patients, defined at start by decision point "decision to rescue" and defined at finish by decision point "decision to stop rescue because of smoke density." (p. 29)

The respondent and interviewer attempt to include each appropriate element in the statements. In order to facilitate coding the statements, a form is supplied. A hypothetical example of a sequence of behavior follows:

Situational Cue	Behavioral Response	Reason Why
I smelled smoke	So I ran down the hall	To find where the smoke was coming from
I saw smoke pouring under Mr. Jones' door	So I opened the door	To see how serious the fire was
When I saw Mr. Jones unconscious by the door	I dragged him down the hall to the elevators	To remove him from the smoke and flames
I looked back and saw that I hadn't shut the door	So I ran back to Mr. Jones' room	To shut the door
The smoke was so intense that I couldn't get to the door	So I ran back down the hall	To pull the alarm box next to the elevator
N/A	I sounded the general alarm	So that everyone in the building would be alerted

The resultant data from phase two of the interview is a complete, sequential account of an individual's behavior during a fire, ordered

into discrete behavioral acts, or "episodes." If the interviewer notices gaps in the sequence, the respondent is encouraged to provide the missing information. Such gaps, easily recognized, are indicative of deficiencies in remembering the event, or areas the witness is unwilling to discuss.

Once the interviewer and respondent have described the episodes using behavioral statements, the information is in an easily categorized form. The statements can be categorized as units, and the discrete elements of the statements can be separately categorized as well. The format presents the information in discrete units, thereby avoiding much of the time-consuming effort required to code narrative accounts.

The system for categorizing and coding the statements and elements can be derived through analyses of the content itself, or categories from already existing models of fire behavior can be effectively employed. Once the data is categorized and coded, it can be analyzed to provide various types of information. Simple frequencies and tables can provide a valuable census of behaviors. Researchers could inquire about the percentage of fire victims that attempt to extinguish fires in their homes before calling the fire department, or under what circumstances nursing personnel deviate from prescribed routines, and with what results. Demographic descriptions can be used to scrutinize the data to determine similarly occurring patterns of behavior by sub-groups. Further, elements of the statements can be analyzed separately. Questions could be answered concerning what cues first alert victims in homes as opposed to apartments. The "why" element can be examined to reveal the intentions that underlie selected behaviors suggesting corrective strategies for fire safety educators.

Results of Interviews. Contingency analyses, where inferences are based on the concurrence of elements within the same statements can provide a powerful analytic technique to determine commonly recurring patterns of responses (Breux, 1977). For example, researchers could determine what actions victims take when they cannot see through smoke to a safe escape route. It would be possible to discover the reasons that victims stay in a room while escape is still possible. Such analyses and the ensuing generalizations about human behavior provide potentially valuable information to fire-fighters, building designers, and fire education specialists in their attempts to eliminate erroneous human reactions during fires.

Examples of such analyses can be seen in figures 1 and 2. Figure 1 depicts the behavior of 118 victims of 90 residential fires in Seattle; figure 2 shows the patterns of behavior reported by 239 victims of New York residential fires.

The numbers linking the behavior in these figures is the q coefficient which is a measure of strength of association between two variables. If there is no association at all, the q coefficient will

equal zero. The higher the positive value of q , the more likely a given variable is to follow another one. With large samples the q approaches the chi square distribution.

To compute the q coefficient linking two variables, a transition frequency matrix was set up, so that both row and column headings were identical and consisted of all the acts which appeared in the behavioral sequences. Each row corresponded to a specified variable (act), and each column corresponded to the act which followed a variable in a given row. The cells of the matrix contain the frequencies with which a variable in a column follows a variable in a row. To use the entire matrix, all row totals and column totals (marginals) are calculated, as well as the sum of the rows and columns, to yield the total number of acts which follow another act. The formula for the q is:

$$\frac{f_o - f_e}{f_e}$$

where f_o = frequency observed in the cell of interest in the transition matrix, and f_e = frequency expected by chance in the cell. f_e is computed by multiplying the row total for the specified variable by the column total of the variable of interest that followed the specified variable. This product is then divided by the total number of acts in the matrix. Thus, from the formula the measure of association is actually a measure of the degree of deviation indicated by a given cell in a transition frequency matrix.

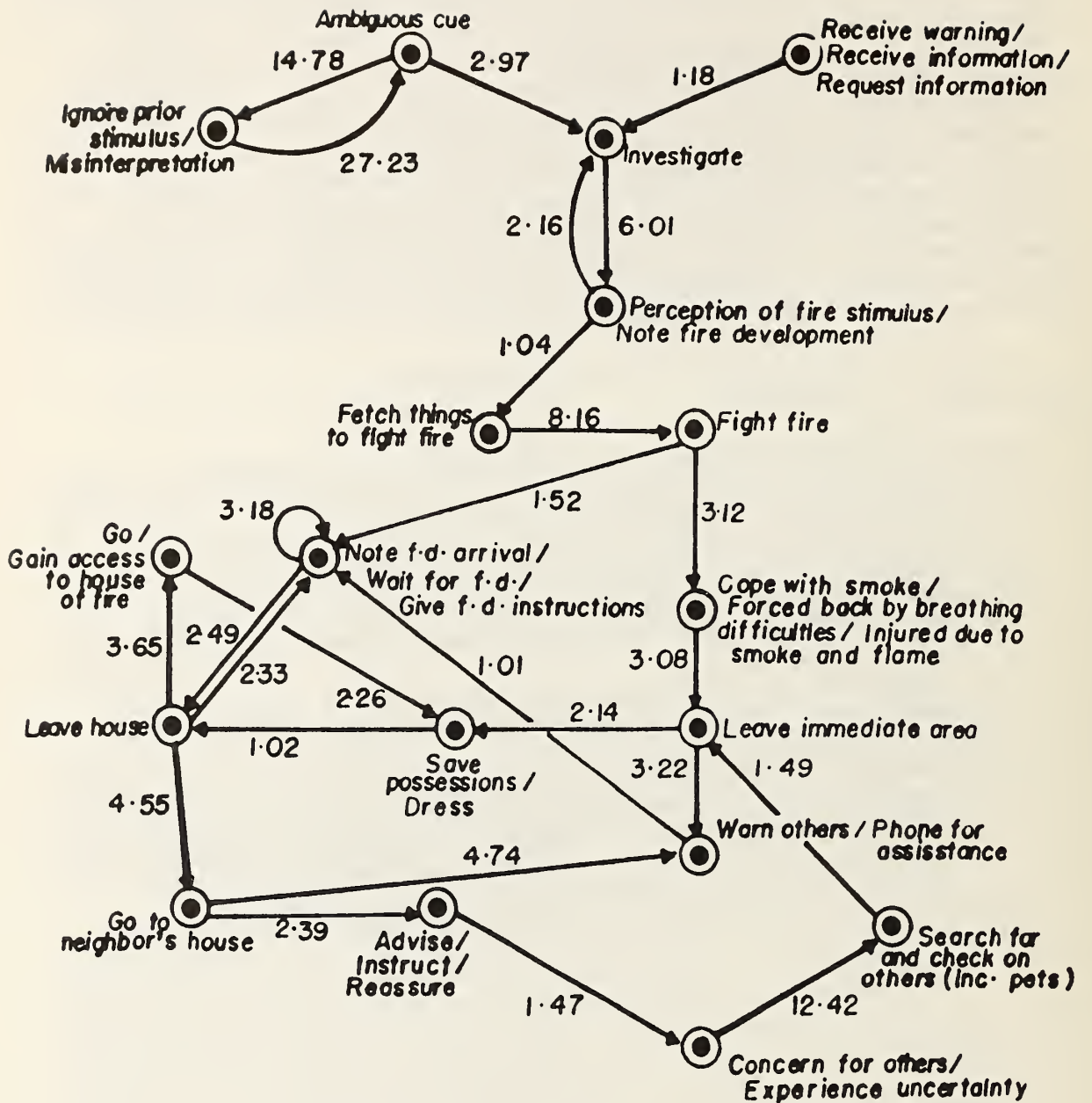
In our case, we used a truncated matrix of the 18 most frequently occurring acts and computed the q values on the matrix in the manner described above. The entire matrix was originally thought to be unwieldy (it was a 30 x 30 matrix, many cells with zero frequencies), but as sample size increases, this total transition frequency matrix will become increasingly useful.

Discussion and Future Research. The behavioral episode interview format satisfies the five criteria listed above as essential to gather usable data about human responses during fires. It incorporates pertinent research findings derived from cognitive processing investigations, tailored to accommodate accounts expected from fire scenarios. Virtually no victim in the study sample had difficulty responding to the interviewer's directions. It can be used to provide comparative analyses across fires as is depicted in figures 1 and 2. It is easy to administer with minimal training. For example, the New York sample was interviewed by twelve members of the emergency response staff of the New York Red Cross, after the staff members were trained by videotape and instruction during one three-hour period; minimal training for a major data gathering effort. (We are indebted to the disaster experts of the Red Cross in NYC for their enthusiastic cooperation in the project.) Finally, the technique has the capability to accommodate a large data bank of virtually unlimited size.

While it is still premature to provide definitive answers to how people tend to respond during a fire emergency, some tentative conclusions can be made from this initial effort. Men are more likely than women to move toward and fight the fire; women tend to warn others and call for help. Similar findings were reported previously by Wood (1972) and Bryan (1977). This is especially true in single dwelling residences (Seattle), but not as obvious for dwellers in multiple occupancies (New York). People have difficulty determining whether a fire is actually present and frequently misinterpret initial cues (signified by the circular start depicted in the figures). Similarly, people return to the house to recall the fire department, not confident that the initial call was successful. The above findings have already proven helpful to fire education specialists.

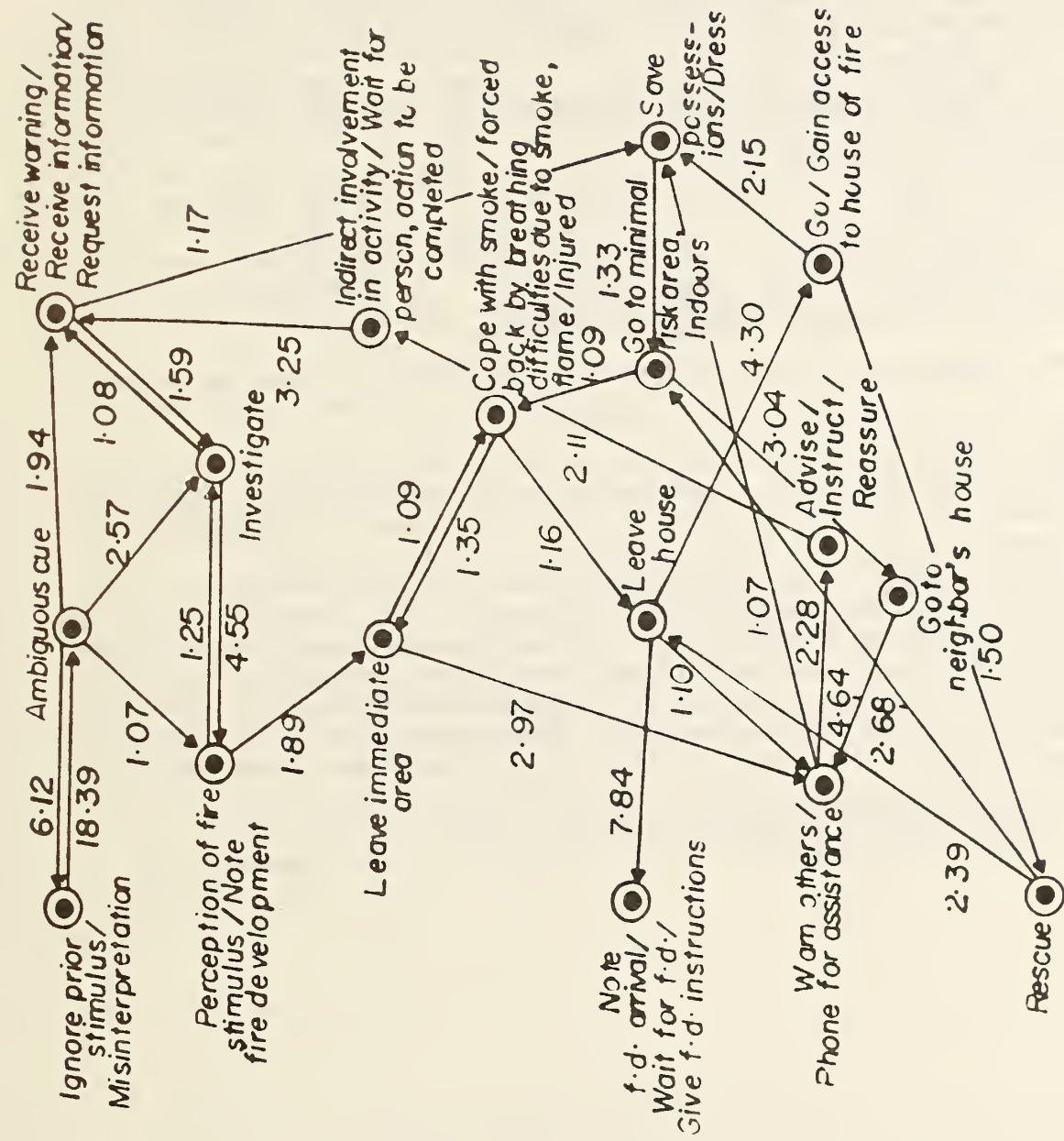
But the major benefits of this research effort are still to come and entail the following:

- 1) Increased expansion of the data-bank by encouraging use of the interview method by post-fire investigators.
- 2) Incorporation of accounts by burn victims into the sample to determine if maladaptive decisions have contributed to their unsuccessful escape compared to the non-burned sample.
- 3) The sequential lag analysis technique is able to link up to four behaviors in sequence, expanding the heuristic power of the analysis.
- 4) Development of powerful probability models of human response based on the contingencies determined by the systematic reports and analyses, and
- 5) Finally, development of an increased data bank will provide confidence that probabilities of behavior generated from the interviewed sample will accurately reflect human response tendencies during fires. Such results should increase the mundane realism of current computerized fire models.



Sequence of behavior during
90 residential fires in Seattle
N=118
Seattle 1979-1982

Figure 1



Sequence of behavior in New York Residential Fires (N= 240)

Figure 2

References

- Bickman, L., Edelman, P. and McDaniel M. A Model of Human Behavior in a Fire Emergency. Center for Fire Research, National Bureau of Standards (NBS-GRC-78-120), Washington, D.C., 1977.
- Breaux, J.J. Analyzing Complex Data: The Description and Analysis of Dynamic Behavior in Fire Situations. British Psychological Society, Exeter, 1977.
- Bryan, J.L. Smoke as a Determinant of Human Behavior in Fire Situations (Project People) College Park: Fire Protection Curriculum, University of Maryland, 1977.
- Canter, David (Ed.) Fire and Human Behavior. London: John Wiley and Sons, 1980.
- Keating, J.P. and Loftus, E.F. Vocal alarm systems for high-rise buildings---a case study. Mass Emergencies: International Journal of Theory, Planning and Practices, 1977, 2, 25-34
- Lerup, L. People in fires: a manual for mapping. Center for Fire Research National Bureau of Standards (NBS-GCR-77-106), Washington, D.C., 1977.
- Loftus, E.F. Eyewitness Testimony. Cambridge: Harvard University Press, 1979.
- Loftus, E.F., and Palmer, J.C. Reconstruction of automobile destruction: An example of interaction between language and memory. Journal of Verbal Learning and Verbal Behavior, 1974, 13, 585-589
- Schank, R. and Abelson, R. Scripts, Plans, Goals and Understanding. Hillsdale, NJ: Lawrence Erlbaum, 1977.
- Stahl, F.I. Simulating human behavior in high-rise building fires: modeling occupant movement through a fire-floor from initial alert to safe egress. Center for Fire Research, National Bureau of Standards (NBS-GCR-77-92). Washington, D.C., 1977.
- Whitely and McGeoch. The effect of one form of report upon another. American Journal of Psychology, 1927, 38, 280.
- Wood, P.G. The Behavior of People in Fires, London: British Joint Fire Research Organization. Fire Research Note 953, November, 1972.

Discussion After J. Keating's Report on HUMAN REACTION DURING RESIDENTIAL FIRES: ESTABLISHING A DATA BASE

JIN: We also have been conducting studies of fire survivors which involved 40 senior citizens in Japan three years ago. We're trying to define the behavior of survivors. The survivors are senior citizens; they are old people. It's very difficult to ask them to answer questions. So, we listen to their stories of what happened during the course of the fire sequence. We did not interrupt their stories. Whenever they strayed from the questions, we would interrupt and ask questions. As a result, because older people did not respond well to our questions, I conducted interviews with my colleague, Dr. Sekizawa. We could only interview one or two people a day. However, we interviewed twenty survivors of a fire and, as a result, we could figure out the behaviors of eighty survivors of the fire. At the most, maybe one or two minutes of difference in time, we could reproduce the behavior. For the problem areas we face, we made a scenario. The scenarios were not consistent with each other. Some of them contradicted each other. We interviewed survivors three times on different days and three times we interviewed the same respondent. Still, we found some gaps. However, we tried to analyze all of the answers from the respondents to see why they behaved in a particular manner.

I think you might encounter similar difficulties in interviewing. My question is: How did you overcome this problem in your interviews?

KEATING: Virtually no member of the sample was not able to respond to the interviewer's directions; our sample was pre-screened for several important characteristics.

First of all, the ability to follow directions, which meant that if they were highly intoxicated, they frequently couldn't report and we had instances pertaining to that. Secondly, we had no instance where the total population consisted of senior citizens, even though there were several senior citizens in our sample. I understand this method was recently used to interview at least the personnel in an adult retarded facility in a recent fire in Georgia, by my colleague Dr. Norman Groner.



A STUDY ON FIRE RISK ANALYSIS METHOD
OF MULTI-USE BUILDINGS

by

Ai SEKIZAWA and Tadahisa JIN

Fire Defence Agency
Ministry of Home Affairs

Seventh Joint Meeting
U.S.-Japan Panel on Fire Research and Safety
UJNR, Washington, D.C. Oct.24-28,1983

1. INTRODUCTION

Recently in Japan, the multi-use buildings have been increased as the buildings are getting higher and/or larger. In these multi-use buildings, there are some problems concerning fire safety, i.e., the existence of plural subjects for building fire safety management and the difference on the planning or the structure between different kinds of occupancies.

Against this circumstance, Fire Defence Agency (FDA) , Ministry of Home Affairs has started the study of "Fire Risk Analysis Method of Multi-use Buildings". The purpose of this project is to prepare the assessment manual for fire service which makes it easy for firemen to diagnose the fire risk of multi-use buildings as well as to advise the building managers or owners the adequate methods to improve fire safety.

This paper gives an outline of the FDA project which started in 1982 and will continue till 1986.

2. OVERALL PROGRAM OF THE PROJECT

The overall program of the FDA project is as follows: (see Fig. 1)

- (1) Fundamental studies on the contents of the fire risk in multi-use buildings and the purposes of practical application of Fire Risk Analysis Method.
- (2) Studies on other evaluation methods of building fire safety.
- (3) Studies on the framework of the total system and subsystems of Fire Risk Analysis Method.
- (4) Studies on the elements and the construction of each system with theories of fire research and statistical data of actual fires.
- (5) Improvement of Fire Risk Analysis Method through its tentative application to some multi-use buildings.
- (6) Preparation of the fire risk assessment manual for fire service.

- (7) Development of Fire Risk Analysis Method to be used for a new multi-use building design at the stage of planning.

The committee for the FDA project (Chairman: Prof. K. KISHITANI), which consists of fire researchers, building designers and administrators, has studied (1) - (3) of the above-mentioned items during 1982. Regarding the item (4), the committee made out the data-base of building fires and also conducted some investigations to learn the actual condition in multi-use buildings. (refer to Appendix I, II)

3. STUDIES ON THE PRACTICAL APPLICATION OF FIRE RISK ANALYSIS METHOD BY FIRE SERVICE

3.1. Purposes for applying the fire risk analysis method

- (1) Extracting among many multi-use buildings those which have much fire risk.
- (2) Direction of the improvement for fire safety and/or the suspension of use in certain case to the building managers or owners.
- (3) Presentation of varieties of fire safety countermeasurements and their effects when the improvement for fire safety is needed.

3.2. Classification of the stage of fire risk analysis

There are so many multi-use buildings in a big city that it is difficult for fire service to apply the Fire Risk Analysis Method to all of these buildings. Therefore, it is needed to classify the fire safety evaluation of multi-use buildings into the following three stages.

- (1) 1st stage: Extract by rough data and using a simple method, those multi-use buildings which have much fire risk.
- (2) 2nd stage: Diagnose the fire risk of those buildings extracted in the 1st stage of evaluation by more detailed data and method.

(3) 3rd stage: Grasp the factors of fire risk and the grade of their risk clearly by some necessary investigations of the buildings which are especially dangerous. And find out adequate countermeasurements of fire safety.

4. PRELIMINARY STUDIES ON THE FRAMEWORK OF FIRE RISK ANALYSIS METHOD

There are three aspects such as fire outbreak, fire spread and evacuation difficulty in the evaluation of building fire risk. Therefore, it is comprehensible and useful that the evaluation method of fire risk is divided into the following subsystems corresponding to the three aspects.

- (1) The evaluation method of the fire outbreak probability
- (2) The evaluation method of the fire spread risk
- (3) The evaluation method of the evacuation difficulty

Each evaluation method of these three has naturally a respective different construction and also gives the results of evaluation in a different way. But the final outputs from these evaluation methods should be a graded value so that we can compare or integrate them.

On the other hand, life safety and property risk are considered as two main indexes of the level of building fire safety. The evaluation for these indexes is achieved by using the results of the three evaluation methods.

The reciprocal relation among the indexes and the methods of fire risk evaluation is shown in Fig. 2.

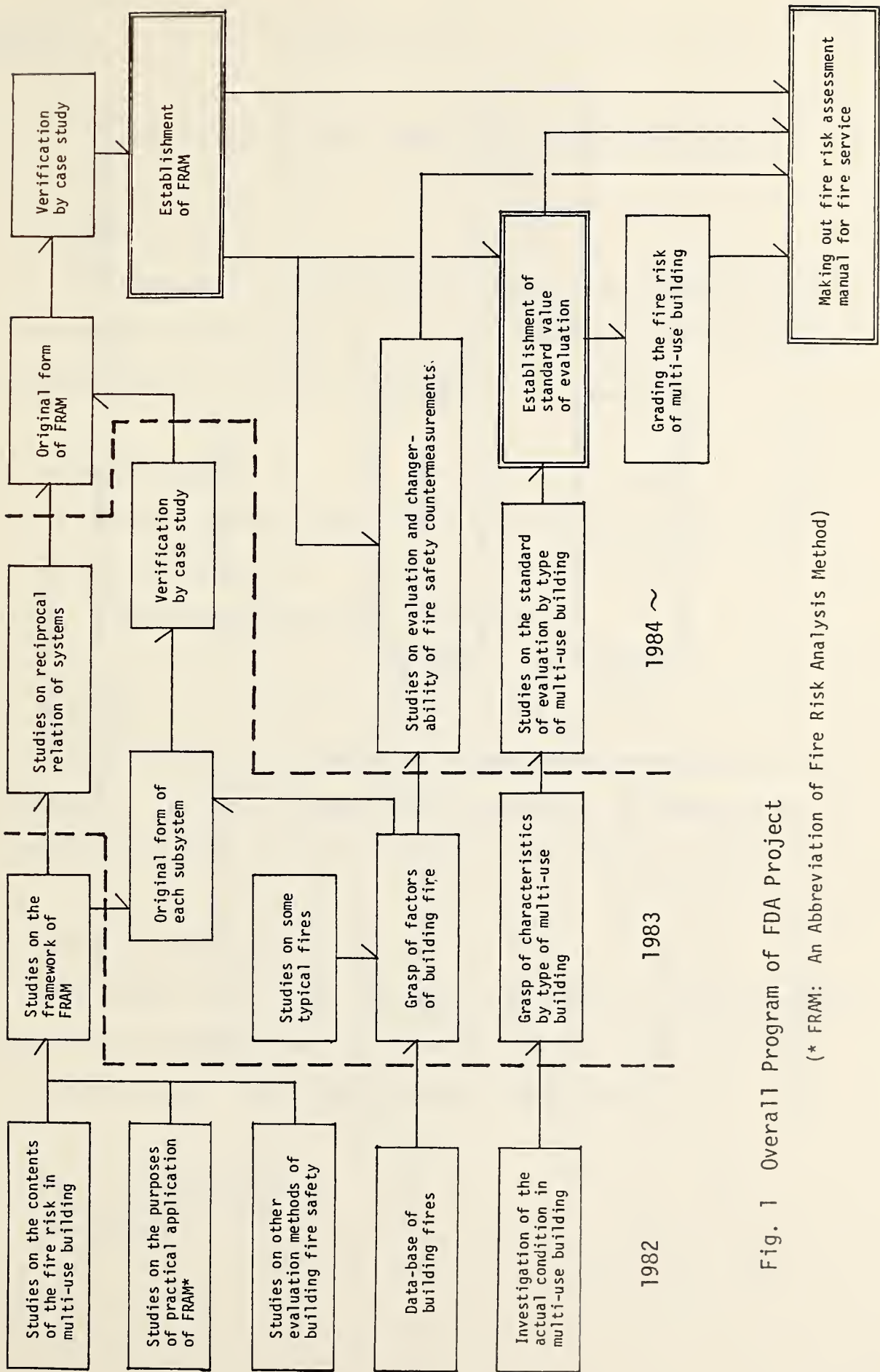


Fig. 1 Overall Program of FDA Project

(* FRAM: An Abbreviation of Fire Risk Analysis Method)

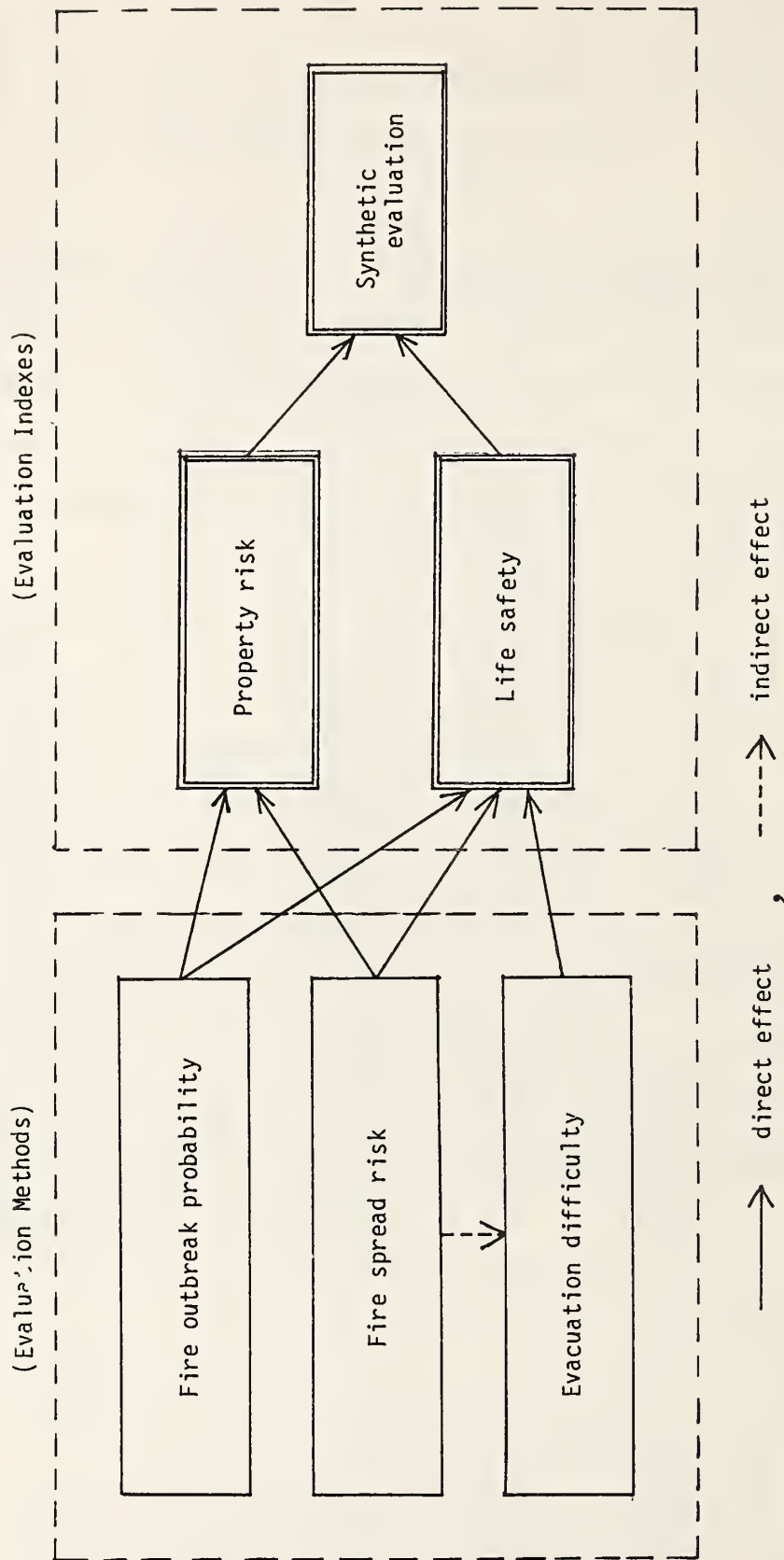


Fig. 2 The reciprocal relation among the indexes and the methods of fire risk evaluation

INVESTIGATION OF ACTUAL CONDITIONS IN MULTI-USE BUILDING

1. Purpose

The purpose of the investigation is to know actual conditions and characteristics concretely as to planning, various equipments, occupants, management and etc. in multi-use buildings.

2. Subject building

- (a) Building with more than 3 stories and besides more than 300 m² as total floor area.
- (b) Building for mixed various occupancies.

3. Sampling

In the beginning, we selected main large cities (49 cities) all over the country. Then we selected 531 buildings totally by extracting about 12 samples from among multi-use buildings in each city above-mentioned.

4. Method of investigation

The firemen of local fire department office reply to the questionnaire according to documentary data of inspection and their daily impressions. If necessary, they conduct a supplementary investigation.

5. Items of investigation

See Table 1.

Table 1. The Items of the Investigation of Multi-use Buildings

Classification	Item
(1) Name of building	1. Name of building
(2) Possessor	2. Classification of possessor 3. Form of possession
(3) Outline of building	4. Total floor area (m ²) 5. Building area (m ²) 6. Lot area (m ²) 7. Number of floors: a) Surface b) Basement 8. Structure 9. Occupancy: a) Main occupancy b) Other occupancies
(4) History of building	10. Time of application for confirmation 11. Time of completion 12. Frequency of extension or reconstruction 13. Initial total floor area 14. Past fires in the building: a) Frequency b) Damage of the most damaged fire
(5) Location and form of building	15. Number of roads facing the lot 16. Width of frontal road 17. Connection with underground arcade 18. Buildings connected: a) Number of buildings connected b) Form of connection c) Floor of connection 19. Characteristics of windows of external wall facing frontal road 20. Balcony 21. Fire escape floor: a) Number of fire escape floors b) Number of entrances on fire escape floor

Table 1. The Items of the Investigation of Multi-use Buildings
(continued)

Classification	Item
(6) Setting situation of fire protection equipment	22. Extinguishing equipment: <ul style="list-style-type: none"> a) Extinguisher b) Sprinkler c) Drencher d) Wall hydrant e) Outdoor hydrant f) Halogenated fire extinguisher g) Fire department connection h) Fire department water source 23. Fire alarm and information equipment: <ul style="list-style-type: none"> a) Automatic fire alarm system b) Gas-leak alarm system c) Electric leakage detection d) Fire information system to fire station e) Emergency communication system 24. Escape equipment: <ul style="list-style-type: none"> a) Fire escapes b) Emergency exit lighting and sign 25. Smoke exhaust equipment
(7) Situation of use	26. Use situation of each floor (detailed investigation by other sheets) 27. Occupant load factor 28. Total number of occupants par day 29. Number of occupants at the peak time 30. Business hours: <ul style="list-style-type: none"> a) Main occupancy b) Other occupancies 31. Situation of use at night 32. Number of tenants: <ul style="list-style-type: none"> a) Business offices b) Residences
(8) Management form of building	33. Whether management by owner's office or management on commission 34. Contents of management on commission <ul style="list-style-type: none"> a) General management b) Fire prevention management c) Crime prevention management
(9) Building safety center	35. Number of building safety centers 36. Location of building safety center 37. Number of workers at building safety center
(10) Fire protection management system	38. Whether there is a plan of self-protective fire defense or not 39. Self-protective fire defense organization <ul style="list-style-type: none"> a) Number of members in daytime b) Number of members at night 40. Number of fire protection managers 41. Evacuation drill

Appendix II

DATA-BASE OF BUILDING FIRES

1. Purpose of fire data-base

The purpose of fire data-base is to grasp the characteristics and the factors of fire risk in a multi-use building.

2. Outline of data-base

All of fires in Japan are reported to Fire Defence Agency (FDA), Ministry of Home Affairs in an unified form. And FDA makes out the data-base of them every year.

From the data-base, we selected such fires that occur in the buildings controlled by Fire Service Law as fire prevention property, and made a new data-base.

There are data of 11,150 building fires from 1979 to 1981 in this data-base.

3. Items of fire report centered at FDA

See Table 2.

Table 2. The Items of Fire Report Centered at FDA

Notes; Extracting only the items concerning a building fire

Classification	Item	Entering Form*
(1) Discrimination of fire	1. Name of municipality 2. Fire number in the municipality	code fig.
(2) Outline of the building of fire origin	3. Name 4. Location 5. Main occupancy 6. Structure 7. Building area 8. Total floor area 9. Number of floors 10. Distance from the nearest fire station	code code fig. (m ²) fig. (m ²) fig. fig. (100m)
(3) Fire origin	11. Position of fire origin in the building 12. Business condition of the zone of fire origin	code code
(4) Time record	13. The time when the fire broke out 14. The time when the fire was informed to fire station 15. The time when fire brigades started water discharge 16. The time when fire brigades repressed the fire spread 17. The time when fire brigades extinguished the fire	fig. fig. fig. fig. fig.
(5) Cause of fire outbreak	18. Origin of fire 19. Opportunity of fire outbreak 20. Ignited material	code code code
(6) Weather conditions	21. Weather 22. Direction of wind 23. Velocity of wind 24. Temperature 25. Relative humidity 26. Snow coverage 27. Whether there was fire warning or not	code code fig. (m/sec) fig. (°C) fig. (%) fig. (cm) yes or no

* Explanatory notes of entering form

code: code value
fig.: figure
(blank): description

Table 2. The Items of Fire Report Centered at FDA
(continued)

Classification	Item	Entering form
(7) Extinguishment	28. Method of fire information to fire station	code
	29. Extinguishing equipment in early stage	code
	30. Number of fire engines which discharged water	fig.
	31. Number of personnel sent out:	fig.
	a) Total	fig.
	b) Firemen	fig.
(8) Fire-damage	31. Number of personnel sent out:	fig.
	c) Volunteer fire corp members	fig.
	32. Main water supply	code
	33. Damage degree of burnt building	code
	34. Burnt building area	fig. (m ²)
	35. Number of burnt buildings	fig.
	36. Number of suffered households	fig.
	37. Number of suffered people	fig.
	38. Number of Fatalities	fig.
	39. Number of Injuries	fig.
	40. Fire loss	
	a) Total	fig.(1000 yen)
	b) Building loss	fig.(1000 yen)
	c) Property loss	fig.(1000 yen)

A STUDY ON FIRE RISK ANALYSIS METHOD
OF MULTI-USE BUILDINGS

(DATA)

by

Ai SEKIZAWA and Tadahisa JIN

Fire Defence Agency
Ministry of Home Affairs

Seventh Joint Meeting
U.S.-Japan Panel on Fire Research and Safety
UJNR, Washington, D.C. Oct.24-28,1983

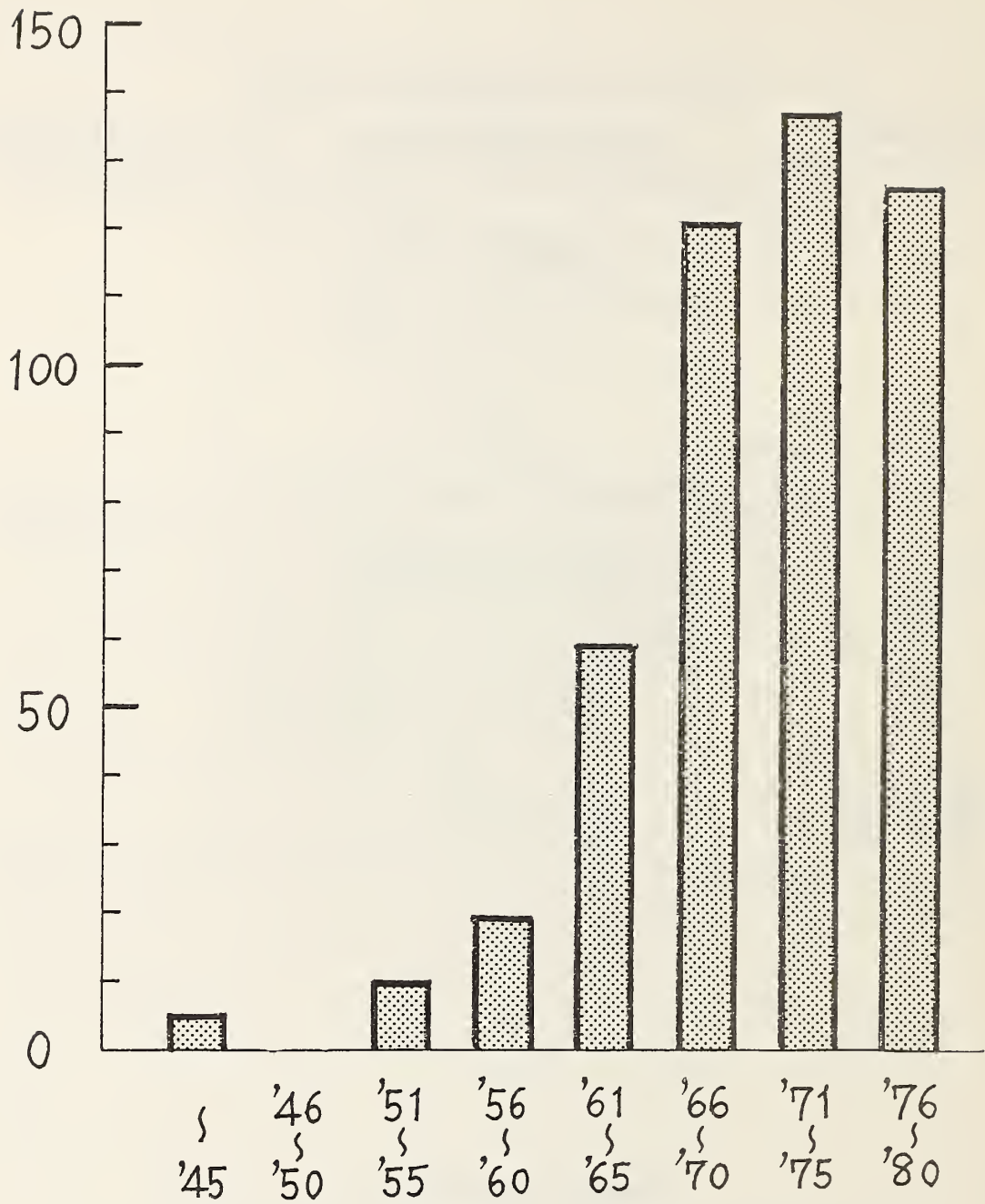


Fig.1-1 Number of multi-use buildings by year of completion

Table 1.1 Main occupancies of multi-use buildings

1. Department stores	108 (20.3 %)
2. Hotels	74 (13.9)
3. Apartment houses	72 (13.6)
4. Restaurants	36 (6.8)
5. Theater	34 (6.4)
6. Public hall	32 (6.0)
7. Hospitals	15 (2.8)
8. Others	160 (30.1)
Total	531 (100.0)

Table 1-2 Frequency of past fires in multi-use buildings

0	449 (84.5 %)
1	61 (11.5)
2	11 (2.0)
3	5 (1.0)
4	1 (0.2)
5	2 (0.4)
6 ~	2 (0.4)
Total	531 (100.0)

Table1.3 Existence of sprinklers

Yes	217 (40.9 %)
No	314 (59.1)
Total	531 (100.0)

Table1.4 Existence of smoke exhaust equipment

Yes	86 (16.2 %)
No	445 (83.8)
Total	531 (100.0)

Table1.5 Existence of emergency communication system

Yes	333 (62.7 %)
No	198 (37.3)
Total	531 (100.0)

Table 1-6 Frequency of evacuation drills in 1981

0	168 (31.6 %)
1	106 (20.0)
2	212 (39.9)
3	16 (3.0)
4	7 (1.3)
5	4 (0.8)
6	2 (0.4)
7 ~	16 (3.0)
Total	531 (100.0)

Table 2.1 Number of fires by type of building

1. Apartment houses	4,077	(36.6 %)
2. Multi-use buildings	3,655	(32.8)
3. Schools	691	(6.2)
4. Offices	566	(5.1)
5. Factories	565	(5.1)
6. Department stores	346	(3.1)
7. Restaurants	293	(2.6)
8. Hotels	240	(2.2)
9. Hospitals	206	(1.8)
10. Others	511	(4.5)
Total	11,150	(100.0)

Table 2.2 Number of arsons by type of building

1. Multi-use buildings	655	(36.0 %)
2. Apartment houses	525	(28.9)
3. Schools	242	(13.3)
4. Department stores	106	(5.8)
5. Offices	89	(4.9)
6. Hospitals	47	(2.6)
7. Hotels	33	(1.8)
8. Restaurants	31	(1.7)
9. Factories	16	(0.9)
10. Others	75	(4.1)
Total	1,819	(100.0)

Table 2.3 Occupancies of fire origin of multi-use building fires

1. Shops	658	(18.0 %)
2. Restaurants	504	(13.8)
3. Offices	252	(6.9)
4. Dwellings	146	(4.0)
5. Factories	116	(3.2)
6. Department stores	78	(2.1)
7. Warehouses	72	(2.0)
8. Others	1,829	(50.0)
Total	3,655	(100.0)

Table 2.4 Causes of multi-use building fires

1. Arsons	655 (17.9 %)
2. Cooking furnaces	627 (17.2)
3. Tabacco	609 (16.7)
4. Electric apparatus	354 (9.7)
5. Playing with a fire	188 (5.1)
6. Stoves	177 (4.8)
7. Bath heaters	95 (2.6)
8. Matches & Lighters	94 (2.6)
9. Others	597 (16.3)
10. Unknown	259 (7.1)
Total	3,655 (100.0)

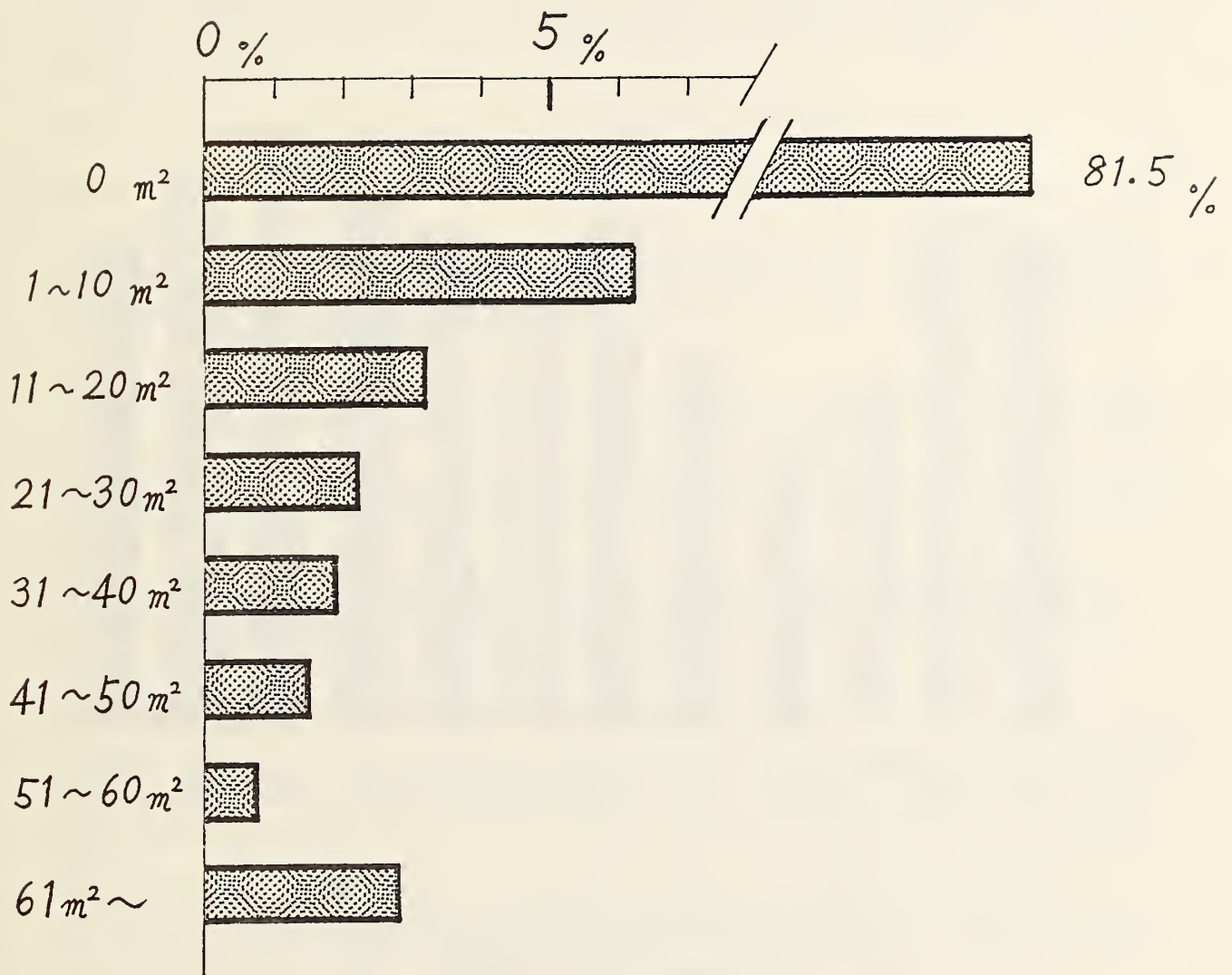


Fig.2.1 Frequency of multi-use building fires by rank of burnt building area

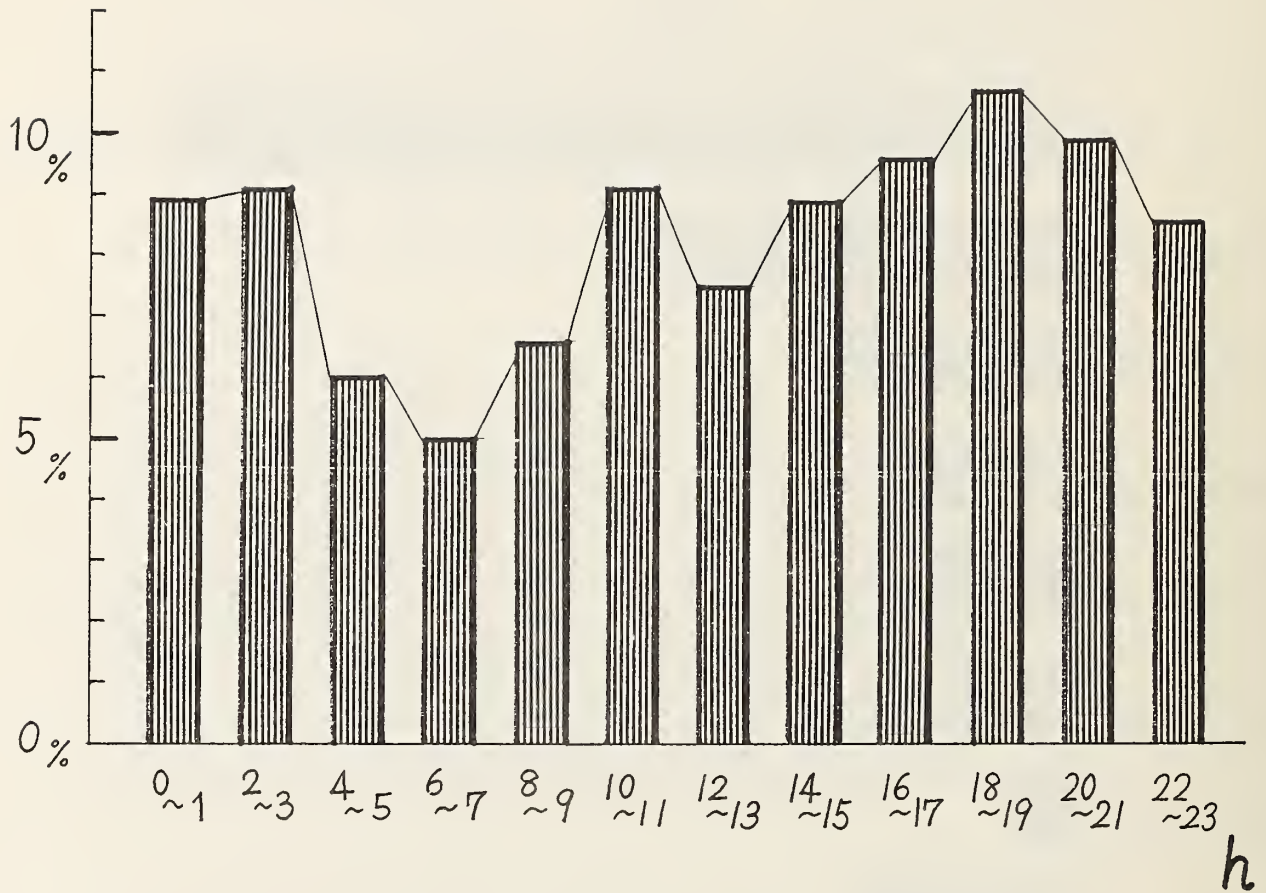


Fig.2.2 Frequency of multi-use building fires by time of fire outbreak

Discussion After A. Sekizawa's Report on A STUDY ON FIRE RISK ANALYSIS METHOD OF MULTI-USE BUILDINGS

PAGNI: On Table 1, sections 3, 4, and 5, you don't mention smoke detectors. Is that in the appendix, page 4?

SEKIZAWA: Even though smoke detectors are not included in this table, that doesn't mean we are not investigating the use of smoke detectors. We do have data on smoke detectors; it happened to be excluded from this table.

PAGNI: In Table 2, what time period is that 11,000 fires occurring in?. Secondly, also in Table 2, on arson, you show approximately 35 percent of school fires as arson and 30 percent of department store fires as arson. Are these typical figures in other years and would they be representative of world-wide averages as well?

SEKIZAWA: Where did you get the 35 percent for schools?

PAGNI: 242 divided by 691.

SEKIZAWA: We have not compared this figure with figures from other cities or the typical figures worldwide. So, we do not have the answer to that particular question. But I'm sure that we can get an answer to your question after we analyze our fire data base.

PAGNI: In Table 2, what time period does that cover? How long did it take to accrue 11,113 fires? Where is that data; is that all in Japan or just Tokyo?

SEKIZAWA: That answer is given in Appendix 2, page 9. In other words, this figure was collected during a three-year period from '79 to '81, from all over Japan.

NELSON: On Figure 1, you have two blocks labeled "verification by case study," one of which should occur this year. Have you got an operational plan? How will you make that verification?

SEKIZAWA: What do you mean by operational plan.

NELSON: Figure 1. Overall program shows a box labeled "Verification by case studies in 1983" and another box "Later in the project in 1984" and I only wondered if they have a plan on how they are going to make the verification?

SEKIZAWA: Yes, we do have an operational plan for verification of the subsystem. In here, we mean the verification study of the subsystem. And, in this case, we are going to use multiple-use buildings from a certain area, particularly from Tokyo. Typically, we are going to select ten cases.

NELSON: How will you decide that it verifies...by judgement, by other models, or by fire histories?

SEKIZAWA: We have not decided exactly how we are going to do it. Mainly, we are going to depend on judgement. Secondly, if we can obtain a fire data base from the past data case, then we would like to compare our studies with the past data.

FIRE SAFETY EVALUATION METHOD

Tokyo Fire Department

Seventh Joint Meeting
U.S. Japan Panel on Fire Research and Safety
UJNR, Washington, D.C. Oct.24-28,1983

FIRE SAFETY EVALUATION METHOD

Tokyo Fire Department

1. Purpose of the Evaluation Method

1)
The main purpose of "the Evaluation Method" is to diagnose fire safety of the specified building with scoring system to make the problems clear and to advise building managers or owners of the adequate methods for improvement of fire safety.

2. Idea of the Evaluation Method

- (1) Employ total score system and establish maximum score at each item and component.
- (2) Select indispensable items for each occupancy which must be cleared.
- (3) Establish standard score to evaluate the grade of life safety. (see Fig. 1)

3. Establish 34 items and their score

- (1) Establish 34 items and 102 components from case study of 60 small fires, 41 partially damage fires and of 33 spread fires. (see Table 1)
- (2) Weight of each items and indispensable items were gained from matrix analysis and event tree analysis of 134 fires.
- (3) Establish score to each items depending on its grade, i.e., 50, 40, 30, 20 and distribute the score to each component depending on the percentage contribution.
- (4) Classify 34 safety items into following 3 countermeasure categories and establish their maximum score

(categories)	(maximum score)
a. fire prevention fire outbreak control fire growth control	420
b. fire spread control	365
c. evacuation and escape	535

(5) Select indispensable items depending on the occupancy of building

(occupancy)	(items)
Department store and supermarket	15
Hotel and Japanese inn	15
Hospital	15
Multi-use building	16

(6) The evaluation is classified into 5 ranks, i.e., S, A, B, C and D. The rank is determined by "Total Score" and "Final Evaluation Value" which consists of countermeasure score and indispensable score.

4. Process to use the Evaluation Method

(1) Total score

Work sheet which consists of 102 components prepare and fill them out after observation, total score is summing up score of 102 component.

(2) Final evaluation score

- a Classify 34 items into 3 countermeasure categories and establish their score.
- b Select indispensable items and establish their score.

(3) Fire Safety Evaluation

Evaluation is classified into 5 ranks from Table 2.

REFERENCE

- 1) Tokyo Fire Department, "Fire Safety Evaluation Method", May 1983

Table 1. 34 Fire Safety Countermeasurements' Items

(I) Consciousness . Organization . Execution of Fire Prevention.	
(A)	Management of Fire Safety
	1. organization . system . competence 2. training . fire safety plan 3. management & inspection of fire protective equipments 4. management of fire control 5. management of general purpose equipments
(B)	Employee
	6. consciousness of fire prevention 7. execution . behavior
(C)	Visitor
	8. behavior . the degrees of consciousness 9. visitors' physical states 10. attribute of personnel
(II) Relation between Man and Facilities . Equipments	
(A)	Location
	11. location of fire
(B)	Alarm & Extinguishment
	12. practical use of fire alarm & automatic alarm system 13. practical use of emergency announcement system 14. practical use of extinguishing equipment
(C)	Evacuation
	15. practical use of evacuation facilities 16. practical use of evacuation equipments 17. operation of smoke control & air conditioning system
(D)	Compartmentation
	18. opening & closing of fire resistive door

(III) State of the Fire Prevent Facilities & Equipments

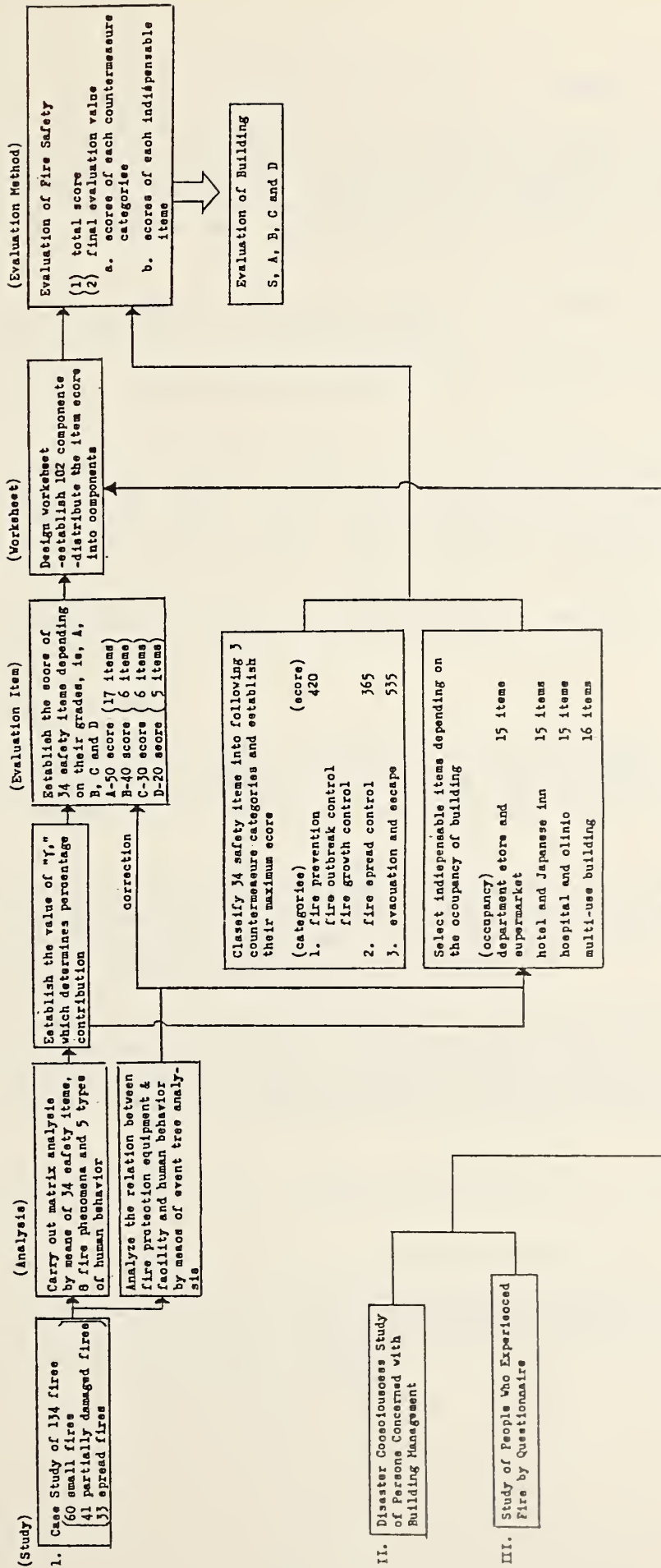
(A)	Fire Room
	19. fire load 20. equipments using fire 21. interior finishing
(B)	Structure
	22. principal structural parts 23. characteristics of interior space 24. outside wall & openings
(C)	Compartmentation
	25. compartmentation of plan 26. compartmentation of stairwell 27. fire resistive door
(D)	Evacuation
	28. facilities for evacuation 29. equipments for evacuation 30. smoke control system
(E)	Extinguishing Equipment
	31. fire alarm bell system 32. fire extinguishing equipment 33. facilities for fire fighting 34. sprinkler system

Table 2. FIRE SAFETY EVALUATION DECISION TABLE

Evaluation Rank	Total Score	Countermeasure Score	Final Evaluation
S (excellent)	900 or more (maximum 1,320)	<ol style="list-style-type: none"> 1. fire prevention and fire outbreak and growth control 340 or more 2. fire spread control 280 or more 3. evacuation and escape. 400 or more 	<p>Indispensable Item Score</p> <p>The countermeasure scores of 1, 2 and 3 should be 203, 184 and 162 or more respectively for department store. The countermeasure scores of 1, 2 and 3 should be 184, 203 and 162 or more respectively for hotel. The countermeasure scores of 1, 2 and 3 should be 184, 184 and 158 or more respectively for hospital. The countermeasure scores of 1, 2 and 3 should be 203, 218 and 158 or more respectively for multi-use building. And the score of each indispensable item should be 50% or more of its maximum score.</p>
A (good)	800 or more	<ol style="list-style-type: none"> 1. fire prevention and fire outbreak and growth control 225 or more 2. fire spread control 210 or more 3. evacuation and escape 300 or more 	<p>The countermeasure scores of 1, 2 and 3 should be 162, 147 and 129 or more respectively for department store. The countermeasure scores of 1, 2 and 3 should be 147, 162 and 129 or more respectively for hotel. The countermeasure scores of 1, 2 and 3 should be 147, 147 and 126 or more respectively for hospital. The countermeasure scores of 1, 2 and 3 should be 162, 174 and 126 or more respectively for multi-use building. And the score of each indispensable item should be 50% or more of its maximum score.</p>
B (acceptable)	600 or more	<ol style="list-style-type: none"> 1. fire prevention and fire outbreak and growth control 170 or more 2. fire spread control 140 or more 3. evacuation and escape 200 or more 	<p>The countermeasure scores of 1, 2 and 3 should be 135, 123 and 108 or more respectively for department store. The countermeasure scores of 1, 2 and 3 should be 123, 135 and 108 or more respectively for hotel. The countermeasure scores of 1, 2 and 3 should be 123, 123 and 105 or more respectively for hospital. The countermeasure scores of 1, 2 and 3 should be 135, 145 and 105 or more respectively for multi-use building.</p>
C	300 or more	<ol style="list-style-type: none"> 1. fire prevention and fire outbreak and growth control 85 or more 2. fire spread control 70 or more 3. evacuation and escape 100 or more 	<p>The countermeasure scores of 1, 2 and 3 should be 81, 74 and 65 or more respectively for department store. The countermeasure scores of 1, 2 and 3 should be 74, 81 and 65 or more respectively for hotel. The countermeasure scores of 1, 2 and 3 should be 74, 74 and 63 or more respectively for hospital. The countermeasure scores of 1, 2 and 3 should be 81, 87 and 63 or more respectively for multi-use building.</p>
D (definitely unacceptable)			<p>neither S, A, B nor C</p>

The evaluation is classified into 5 ranks, ie, S, A, B, C and D. The rank is determined by "Total Score" and "Final Evaluation Value" which consists of countermeasure score and indispensable score. The final evaluation value is determined by the lower rank of them.

Fig.1 FLOW CHART OF "FIRE SAFETY EVALUATION METHOD"



Discussion After T. Jin's Report on FIRE SAFETY EVALUATION METHOD

GANN: I have two questions. The first is, are there any items in your list of 34 that are weighed so heavily that if a building rates extremely well, that it get a high rating regardless of how the building rates with the other 33? For instance, if a building is very well sprinklered, would that give it a high rating?

JIN: As I showed in the slides, the highest number is 50 points and the worst is 20 points. So the difference is only 30 points.

GANN: So, there must be several strong features in a building to get a high rating?

JIN: For example, with the sprinklers, you could get the highest points for this category. However, you have to take into consideration that if this sprinkler were out of order. This is more dangerous for the spread of fire. What kind of counter measures were taken? The sprinkler is but one item; you have to take it all into consideration. Escape is also an important item.

GANN: My second question is, strictly for clarification, would you redefine what the indispensable items are?

JIN: I will explain it later.

KEATING: Would you give some examples and explain why you accepted expert judgement over your empirical generation of the rankings of some of these items?

JIN: The figures we got out of the data is sometimes very far apart from experience.

PAGNI: What motivation does the building owner have to use your pamphlet? Here in the United States, I suspect that the only owners who will use the pamphlet would be the ones that felt their buildings would score well. How do you motivate those whose buildings they think will score low?

JIN: Our fire department has a lot of authority; no one has reported a problem to me. Our fire law is very strict, and, if the owner of a building has tried to cheat, the fire department would know. Another purpose of this brochure is to get them to evaluate their own building before the fire department does their inspection.

NELSON: How accurate do you feel the ratings that you get are relative to the true fire hazard involved?

JIN: We took twenty-one cases and we got twenty-one verifications.

NELSON: Our experience has been that very bad facilities rate very bad and very good facilities rate very good on any rating system. It's the ones that are in the middle ground that are difficult to rate.

JIN: I think our results are the same.

GENERAL DISCUSSION

GANN: Prof. Keating, I have a question. In the interview works that you've done, you do that soon after the fire. Some of the survivors have been through extensive smoke exposure and may, in fact, suffer ill effects much later on. Do you have any scheme at this point for following up on that?

KEATING: There are several parts in your question, Dr. Gann. The first one is that the times after the fire that we interview the victims vary widely. We do not get there as fast as we would like to in all instances. Secondly, the current sample that I talked about today contains no "victims of fires," anyone who was hospitalized for any reason. So, we presume that excessive smoke inhalation during the time of fire is not that prevalent in the sample I talked about today. Thirdly, in the current grant that the National Bureau of Standards has funded, we intend, this year, to interview only victims; namely, hospitalized patients of fires, and obtain during those interviews from the medical staff the level of smoke intoxication as well as alcohol blood levels during the time of admission.

GANN: The reason for my question is that if a person involved in a fire is hospitalized immediately after the fire, that person is counted in the national statistics for injuries. If the person leaves the fire scene and enters a hospital two days later or a week later, even if the injury is related to the fire, the hospital has no way to know this. We need data on that.

KEATING: The only indirect answer I can give you is that at the Northwest Burn Center, we are going to pursue all outpatients of the Burn Unit as well as the Center. I'm not certain at this time that any even approximations of percentages, for instance, can speak to your question.

GANN: Is there Japanese experience in this area?

HANDA: Since I've engaged in the evaluation of fire, I have experience of various stages of people that suffer from fire.

NELSON: Can you tell us anything about it?

HANDA: Most of the records are investigation records by the police of the district. Sometimes we construct tables and we also take a record of people whose behavior were unclear. These records also include dead bodies.

NELSON: It's very hard to get interviews from the dead victims. It does leave a serious void in our data.

EMMONS: Dr. Wakamatsu, in your design you indicate that the occupants of the building are determined in the statistical data. Clearly the number of people who are in the building at any one time is a statistical matter, but it is the best one could do unless you had someone at the door counting. However, in the design, do we not have to design for the worst case rather than a statistical measure?

WAKAMATSU: There are a great many number of conditions that we have to take into consideration when we design this type of research. Of these conditions that we take into consideration, many of them are uncertain conditions. If we take worst cases for every condition, the outcome would be very unrealistic. Therefore, I feel that we cannot avoid taking the probability way of thinking. I don't think that we should take the worst case for every condition we take into consideration.

NELSON: What level of probability are you thinking?

WAKAMATSU: Could you elaborate your question a bit?

NELSON: 90 percentile, 95 percentile?

WAKAMATSU: I think the probability percentile will differ depending on the conditions you are talking about. I think that the answer will differ depending on the philosophy or way of thinking about the conditions you use in the design. Let me give you one example. One condition can be the direction of wind. A certain building will be more severely affected by a certain direction of the wind and also the behavior of smoke affected by the direction of the wind. So, we can get the data based on the weather, what the probability was of a certain direction of wind affecting that building. Then, we can figure out the percentile of wind direction in this case.

NELSON: It seems to me that what Dr. Wakamatsu is talking about, as we said earlier, is one of the most serious questions, and there should be efforts in both of our countries to develop the design stress that will be used for the design conditions. I expect that while they will not be the true worst case, they will have to be a pretty severe case if we were going to certify buildings on the basis of analytical calculations.

WAKAMATSU: It may be necessary to think about the true worst case at the stage of designing but, if that the true worst case will probably not occur, then I think it is not appropriate to use the true worst case probability in designing or in diagnosis.

NELSON: Oh, I agree, the true worst case is what has been shutting down nuclear generating stations in this country. If you design by the true worst case, you'll never be able to build; it will be too severe. But I would find in this country in the case that Dr. Emmon's raised, if you design based on a statistical number of persons, our local fire authority would post a sign on that building not allowing any more than that number of persons in the building.

WAKAMATSU: I think that depending on the conditions we are thinking about, we should depend on the worst possible case, or, in other cases, we should depend on statistical data. When you talk about the number of people to be admitted into a building, maybe we should consider the true worst case.

COOPER: Dr. Wakamatsu, are there any specific examples where analytic methods of predicting fire growth have been used to actually establish Japanese standards, codes, or regulations?

WAKAMATSU: Standards for individual residences, not the buildings, are made on the basis of analytical methods.

COOPER: Is it possible to be more specific?

WAKAMATSU: This particular standard I'm talking about is the one to be applied to wooden homes.

KISHITANI: I take it that Dr. Jin was not quite satisfied with the answer given to your question concerning sprinklers, so I would like to elaborate on that point. One should not be satisfied simply because there are sprinklers attached to the ceiling, because I know of a complete case in California where sprinkler heads are attached but there are no pipes. Needless to say, that the sprinklers will not extinguish fires up above the ceiling, that is the other side of the ceiling and the sprinkler cannot put out the fire if the fire occurs where sprinklers cannot reach. This is common sense but, you know, these have to be taken into consideration. When the local fire department scores the sprinkler, we take into consideration three to four subitems for the one item of sprinkler. In other words, we examine whether or not the sprinklers are being taken care of or being examined regularly and also whether or not the sprinkler system is working. In my personal view, concrete walls are 100 percent fireproof; on the other hand, sprinklers have only 97 percent probability. I feel that this is a very important difference because when we look at a residential fire, the probability of burning the residences is 1/10,000. A 3 percent difference is very important and meaningful when you think about residential fires.

NELSON: What is the probability that the doors in that concrete wall will be closed?

KISHITANI: I don't know.

NELSON: I just meant that everything has a failure mode - sprinklers, fire resistance, compartmentation or any other thing we use.

SEKIZAWA: My question can be answered by either Mr. Nelson or Dr. Cooper. I would like to know how the results of a design system for fire safety research conducted by the Center for Fire Research will be ultimately used. In other words, in my presentation I pointed out that our results will be ultimately used for the development of a manual. I would like to know how the results of your research will be utilized?

NELSON: The work which Dr. Cooper presented is directed towards practicing design engineers as you might find working in consort with an architect in the design of a building. Other work that we've done, as presented at previous meetings, was meant for the plan examiner or other regulatory subprofessionals, such as a fire marshal or fire inspector. We have occasionally done work aimed at training or educating people on emergency evacuation or similar emergency actions, but we have not attempted to develop systems whereby a person without professional qualifications could grade the fire safety of a building.

FIRE GROWTH PREDICTION

Raymond Friedman and Toshisuke Hirano
Session Chairmen

Fire Spread Research in the United States

H. W. Emmons 1983

The quantitative understanding of the rate of fire spread under a wide variety of circumstances of geometry, materials, external radiation, and ambient atmospheric vitiation is necessary for the successful development of predictive fire models. The energy feedback by radiation, gas convection, and solid conduction reacting with the pyrolysis, ignition and combustion of the material is the well established mechanism of fire spread in all cases. The complexity of these processes has prevented generally valid theoretical solutions or empirical data correlations.

Some progress is being made with several problems:

Boundary Layer Fire Spread

J. Tien, Case Western Reserve, is studying the flame spread over a vertical fuel surface both upward (wind assisted) and downward (wind opposed). Although both theoretical and experimental work is intended only theoretical work has been done to date. Laminar flow with finite rate kinetics are being used. Also a two step chemical process is considered, carbon to CO then CO to CO₂. This prevents the simplification of the Shvab-Zeldovich transformation. This is an extension of work he did some years ago solving the steady boundary layer flame with finite kinetics. This work showed the experimentally observed bulbous flame leading edge and resulted in extinction conditions. Presumably similar results will be forthcoming for the vertical flame spread problem now under study.

Wind Aided Fire Spread

A few years ago G. F. Carrier, Harvard University and F. Fendel of Thompson, Ramo, Wooldrige Corporation, analytically developed a solution for the laminar wind aided flame spread along a flat plate. The formulation assumed constant properties and a Shvab-Zeldovich transformation with infinite kinetics. The final steps of the solution were numerical but it was otherwise an exact solution. This solution is now being generalized by including in an equally exact way both distributed flame radiation by soot production and the charring of the solid pyrolysing fuel. These solutions when available will be sufficiently general for detailed comparison with experiments thus confirming (or refuting) the physical model as it is presently understood.

In the meantime progress is being made with experimental data on wind aided flame spread. C. Fernandez-Pello, University of California Berkeley, has obtained PMMA data which shows an excellent correlation of the rate of spread of the pyrolysis front, S , with the wind velocity U

$$S \propto U \left(\frac{T_{\text{surface}} - T_{\text{ambient}}}{T_{\text{flame}} - T_{\text{surface}}} \right)^2$$

Fire Spread on Horizontal Wood Surfaces

A. Atreya, Michigan State University, has just completed his Ph.D. thesis at Harvard University. He experimentally and theoretically studied the rate of fire growth on horizontal surfaces of wood with an external radiant field. The surfaces were 2 feet square and the exter-

nal radiation was uniform to 5% but was limited to 1 w/cm^2 maximum. Uniform grain wood was selected because knots and resinous spots cause irregular spread. Even without obvious irregularities the fire does not spread equally fast in all directions. The burning area is approximately elliptical with one focus at the ignition point. When boards are made, the saw is approximately parallel to the grain. When the grain is cut at a small angle, it serves to jet the pyrolysis gases in the direction of their surface openings thus enhancing or detracting from the fire spread.

Ten different woods and cellulose were tested. For each wood data was obtained as illustrated for maple.

	<u>Char Yield</u>	<u>Formula</u>	<u>C</u>	<u>H</u>	<u>O</u>	<u>Lower ΔH Combustion kw/gm</u>
Maple	.35	$C_{1.62}H_{2.30}O$.515	.061	.424	18.60
Char		$C_{9.68}H_{2.53}O$.752	.034	.214	27.93
Volatiles		$C_{.96}H_{2.26}O$.387	.076	.537	13.57

Values for all of the quantities listed in table 3.3 were measured.

A typical surface temperature variation is as shown in Fig. 3.5.

A considerable study was made of pyrolysis and ignition. A new apparatus was used as shown in Fig. 5.1. This gives quite reproducible surface temperatures and ignition temperatures, Fig. 4.6.

Theoretical models for pyrolysis and flame spread were developed. For pyrolysis, rate equations must be used for both moisture desorption and chemical degradation. For flame spread, pyrolysis must be coupled

with the various feedback mechanisms. The results are shown in Figs. 6.6, 6.7, and 6.8.

Flame Spread on Cellular Plastics

Chuan Tan, Singapore, Ph.D. thesis at Harvard University, has studied the spread of fire on horizontal surfaces of cellular plastics using the same apparatus as for the above study with wood. Cellular plastics are closed pore if rigid or open pore if flexible. The open pore material has random openings and does not have the systematic pore gas ejection properties of wood. Hence the burning in a symmetrical apparatus with uniform external radiation is quite symmetrical.

Cellular plastics burn in three modes, Table VI. Some do not melt. They char and spread rapidly compared to burning in depth. Thus the center initially ignited region soon goes out leaving a ring of fire. Some pyrolyse sufficiently rapidly that the central region does become deeper, the burn surface taking the shape of a bowl. Finally some cellular plastics melt below their ignition temperature. On ignition the melt moves downward to the bottom of the sample (the samples were 3 inches thick) producing a cylindrical hole only a few centimeters in diameter, Fig. 30a. The subsequent pyrolysis takes place from the inside surface of the expanding cylindrical hole while the flame is attached to the upper rim. A simple theory was developed for each of these modes of burning. Essentially the theories are for radiation feedback and check in a general way with the data, Fig. 32b, which shows considerable scatter.

TABLE 3.3a: PHYSICAL VARIABLES

Graph #	SYMBOL	DEFINITION	DESCRIPTION
01	R	(measured)	Equivalent radius of the burning area (mm)
02	\dot{R}	dR/dt	Radial spread rate (mm/sec)
03	\dot{m}''	(dm/dt)/-R ²	Mass flux (mg/cm ² sec)
04	\ddot{m}''	"	" "
05	E _C	[see Append. A]	Convective energy release rate (Watts)
06	E _R	[see Append. A]	Radiative energy release rate (Watts)
07	X _C	E _C /(E _R + E _C)	Convective fraction
08	X _R	E _R /(E _C + E _R)	Radiative fraction
09	X _A	(E _R + E _C)/ \dot{m} · ΔH _v	Combustion efficiency
10	d _f	(measured)	Final char depth (mm) (measured at the end of the test)
11	k _f	(derived from radiation measurements)	Grey flame absorption coeff. (1/m)
12	k _f	"	Grey flame absorption coefficient (optically thin) (1/m)
13	k _f / \dot{m}''	k _f / \dot{m}'' (correlation)	Grey flame absorption coeff. correlation

TABLE 3.3b: CHEMICAL VARIABLES

GRAPH #	SYMBOL	DEFINITION	DESCRIPTION
14	Y_{O_2}	\dot{m}_{O_2}/\dot{m}	Instantaneous mass fraction of O_2
15	Y_{CO_2}	\dot{m}_{CO_2}/\dot{m}	Instantaneous mass fraction of CO_2
16	Y_{H_2O}	\dot{m}_{H_2O}/\dot{m}	Instantaneous mass fraction of H_2O
17	Y_{CO}	\dot{m}_{CO}/\dot{m}	Instantaneous mass fraction of CO
18	Y_{THC}	\dot{m}_{THC}/\dot{m}	Instantaneous mass fraction of THC
19	Y_{sootC}	[see Append. D]	Instantaneous mass fraction of soot from carbon balance
20	Y_{sootP}	[see Append. D]	Instantaneous mass fraction of soot from physical energy balance
21	Y_{charC}	[see Append. D]	Instantaneous mass fraction of char from carbon balance
22	Y_{charP}	[see Append. D]	Instantaneous mass fraction of char from physical energy balance
23	χ_{O_2}	(derived from O_2)	Combustion efficiency based on O_2 consumption
24	$\chi_{CO_2,CO}$	(derived from CO_2 , CO)	Combustion efficiency based on CO_2 , CO production
25	ΔH	[see Append. D]	Heat of combustion (KJ/gm)
26	Y_{sootM}	[see Append. D]	Instantaneous mass fraction of soot obtained from conservation of mass

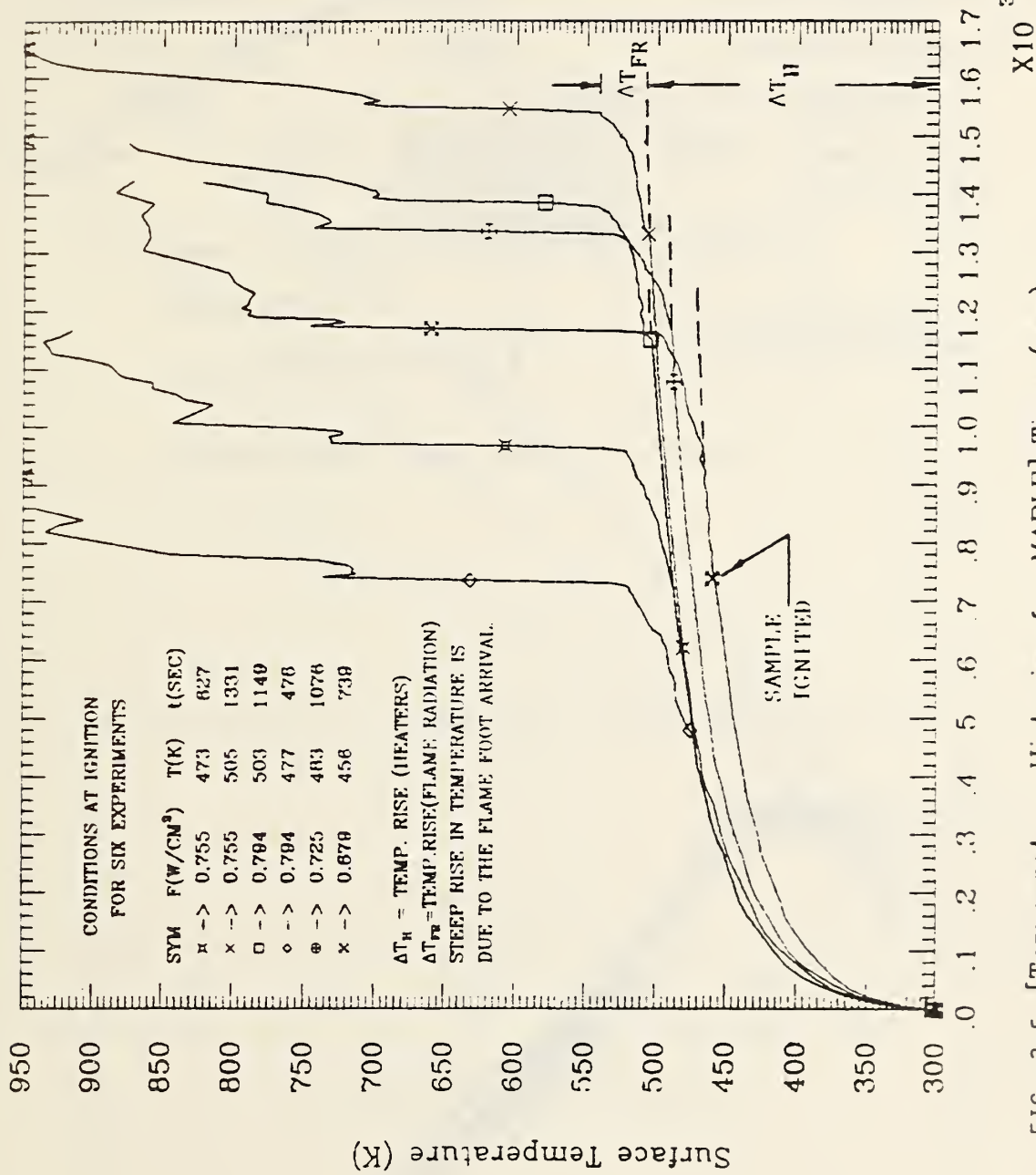


FIG. 3.5 [Temperature Histories for MAPLE] Time (sec)

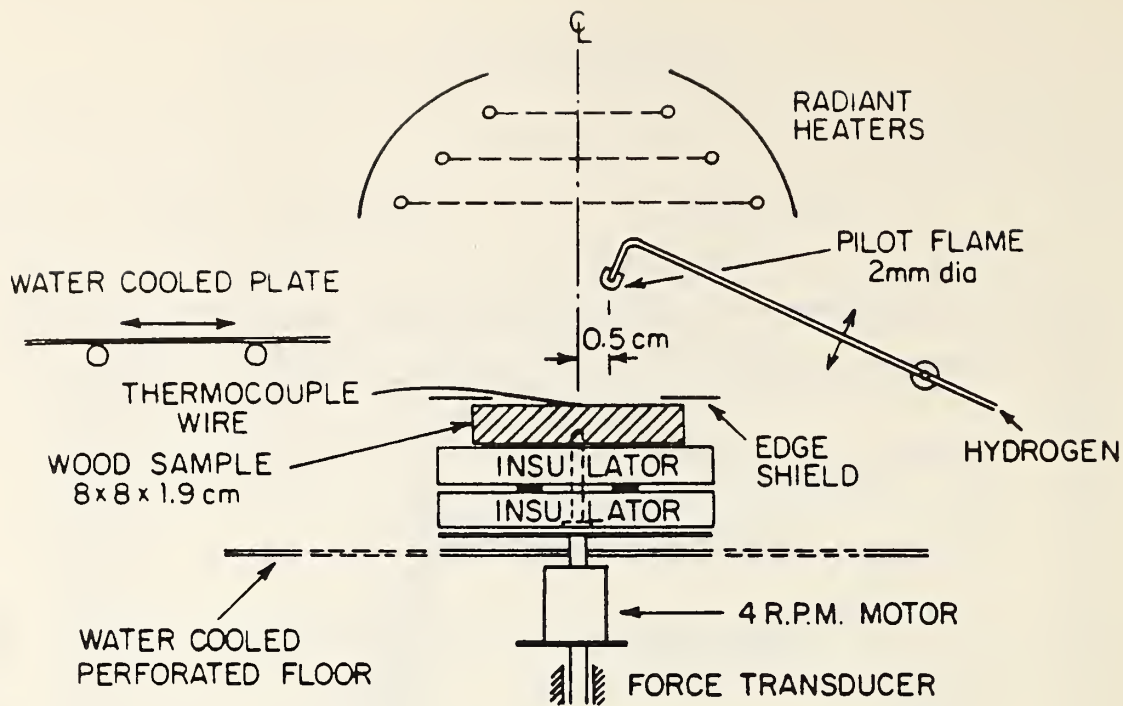


FIG. 5.1 FLASH POINT-FIRE POINT APPARATUS

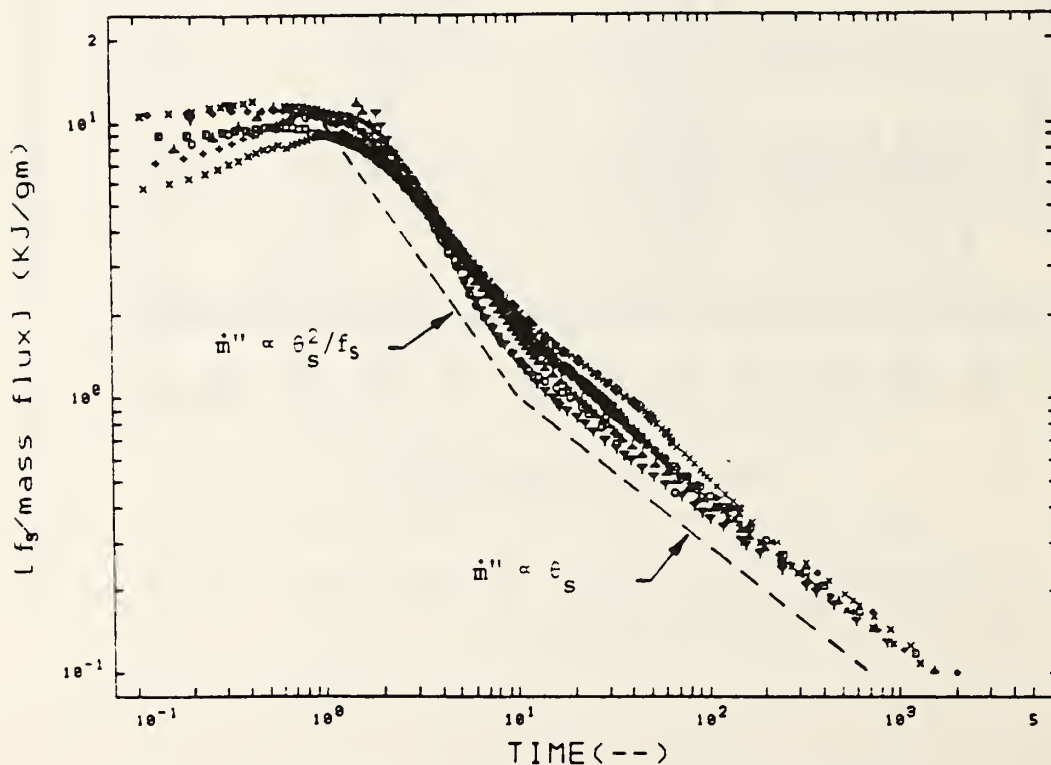


Fig. 4.6 APPARENT LATENT HEAT FOR MAPLE.

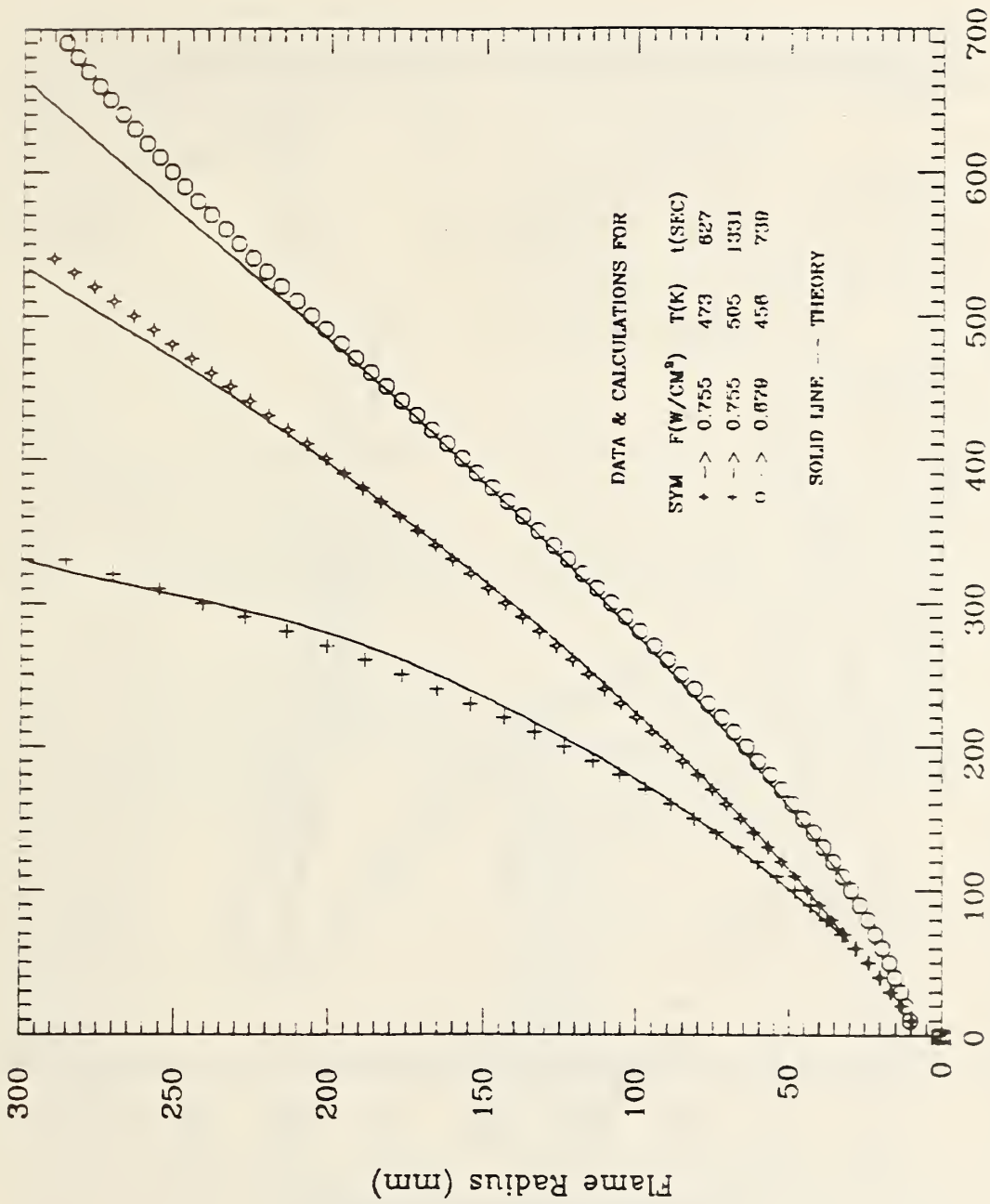


FIG. 6.6 [Flame spread calculation for MAPLE] Time (sec)

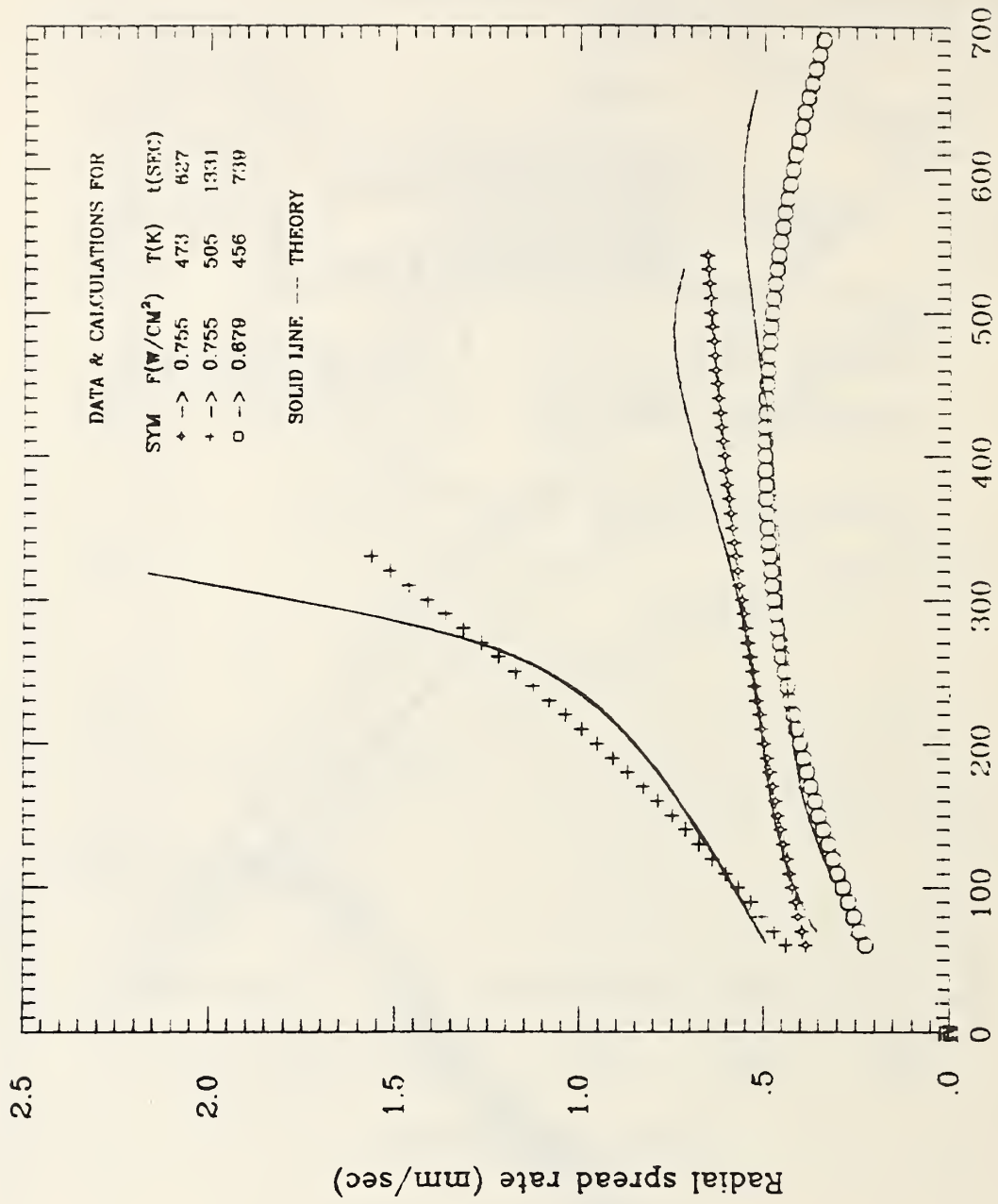


FIG. 6.7 [Spread rate calculation for MAPI.F] Time (sec)

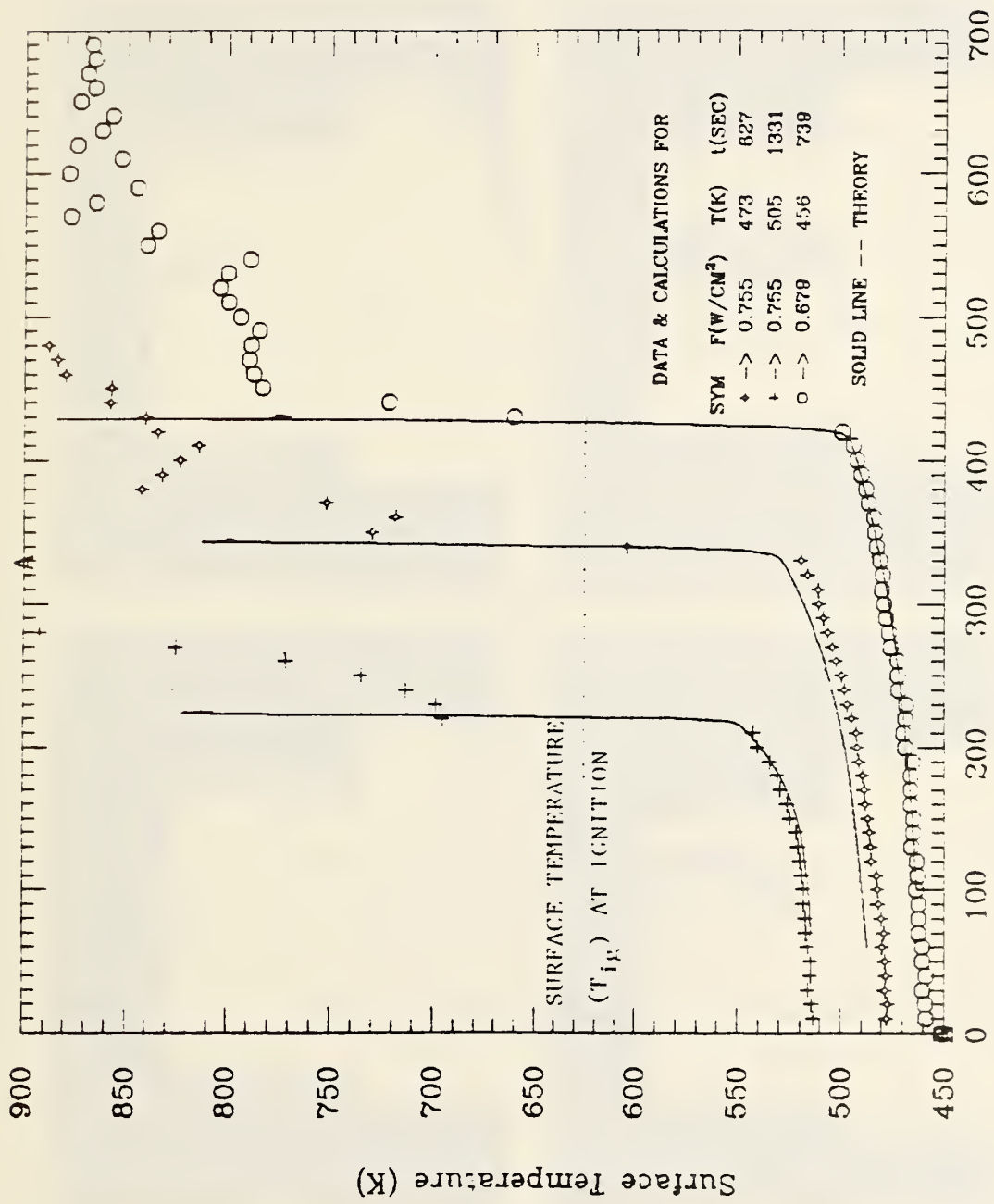


FIG. 6.8 [Surface Temp. Calculation, & data MAPLE] Time (sec)

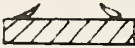
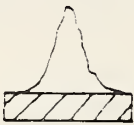

<p>CATEGORY A</p> 	<p>GM32 GM42</p>
<p>CATEGORY B</p> 	<p>7004 GM22 GM24</p>
<p>CATEGORY C</p> 	<p>GM26 GM28 GM48</p>

TABLE VI Classification of foams tested in study.

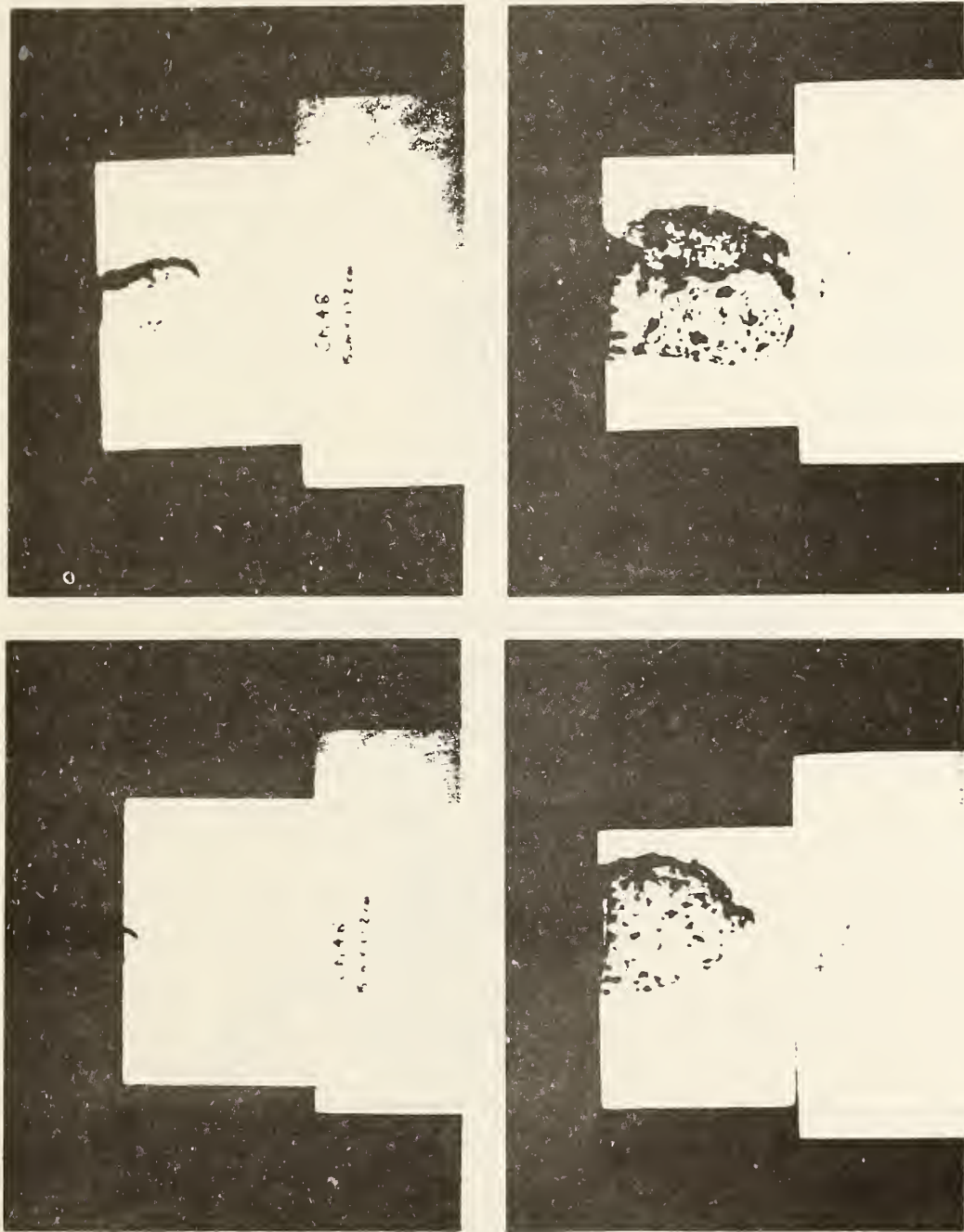
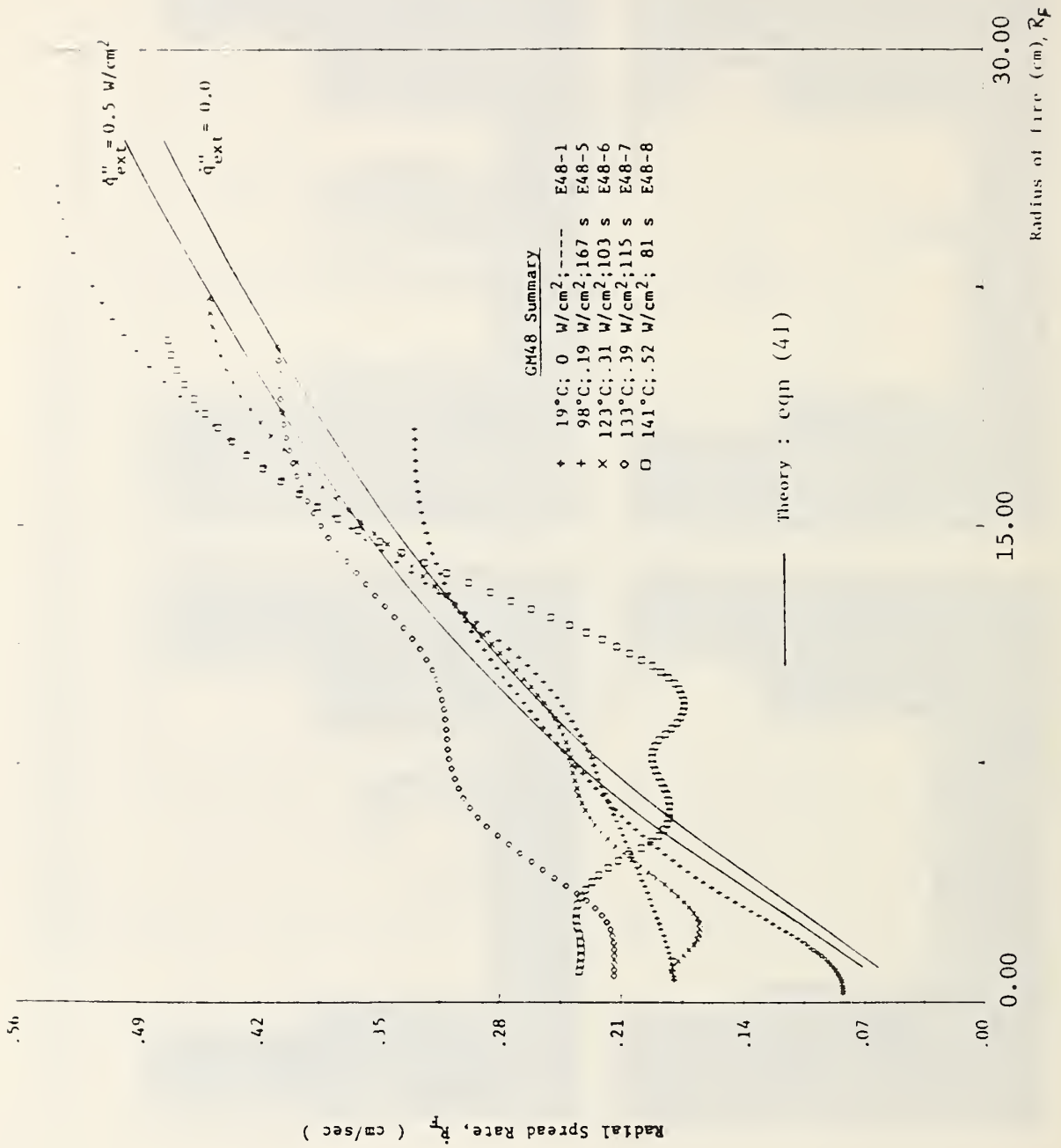


Fig 30A Sequence of photographs showing the progress at the flame front into GM48 foam during the early stages of fire spread.



Graph 32B Experimental and Theoretical Results for Radial Spread Rate, R_f , over GM48, under the effect of external radiation.

RECENT PROGRESS IN FIRE GROWTH MODELING IN JAPAN

by

Takao Wakamatsu and Takeyoshi Tanaka

Building Research Institute

Ministry of Construction

Japan

INTRODUCTION

In this progress report, we intend to present brief outline of some of the primary studies associated with fire growth prediction that have recently been conducted in Japan. The topics here were selected according to the authors' interest, and consequently there may be some other important works that we failed to refer to. Also, the scope of this review is limited to the subjects that directly address building fire problems, although there seemed to be some more interesting works when we look at fire research in general.

FIRE SPREAD OVER MATERIALS

Terai(1) created a theoretical model for predicting the burning propagation over horizontal materials, in an attempt to contribute to qualitative understanding on how a fire spreads at initial stage, where enclosure effect is insignificant. In this model, an initial fire source put on the surface of semi-infinite material, forms a fire column, and propagates axi-symmetrically over the material surface. The model incorporates heat conduction within the material, pyrolysis and gasification of the material, mixing of the gasified fuel with air, and energy feedback from the flame to the material surface. The conduction of heat within the material was formulated into an integral equation and solved using weighting function for the temperature within the material. Sample calculations were carried out for PMMA, whose properties are fairly well known. A couple of the calculation results are given in Figure 1.

Hamada, Sugawara and Kishitani(2) conducted a laboratory experiment to study the basic nature of flame spread over a vertical material. The vertically held PMMA boards with 65cm height, 10cm width and a couple of different thicknesses were ignited at its bottom using nichrome wire, and from the flame length and the pyrolysis front position that were photographed at a given time interval, the upward flame spreads velocities were reduced. It was found, as one of the results, that the

propagation velocity of pyrolysis front(V_p cm/s) is given as a function of pyrolysis position(X_p cm from the bottom) as follows:

$$V_p = 0.039 + 0.00126X_p$$

BURNING BEHAVIOR IN COMPARTMENT FIRE

Takeda(3) conducted the experiments to investigate the fire behavior at pre-flashover period using a cubic small scale compartment, whose size is 50cm x 50cm x 50cm. The PMMA pieces, which were 15cm x 15cm x 6cm of size and placed on the center of the floor as the fuel, were ignited along the edge near the opening of the model compartment using alcohol saturated cotton. It was observed that as the fire grows from fuel control to ventilation control stage, an oscillatory phenomenon appeared in the transient period in between. The oscillation was fairly regular and its interval was a little less than 1.0 second for almost every case. The starting time and the duration of the oscillation varied depending on the size of the compartment opening.

Another series of reduced scale experiments were carried out by Nitta(4) using also PMMA as the fuel. These experiments also aim at investigating the phenomena that lie in the transient region between fuel control and ventilation control regions. The experiments were conducted for the different opening widths of the model compartment, whose size is 60cm x 120cm x 60cm. The measurement was made of the hydrocarbon concentration in the room as well as of other ordinary measurement items, and it was found that the fires undergo transition from fuel control to ventilation control where the ventilation factor $WH^{3/2}$ is about 1,000 $cm^{3/2}$ for this specific setup of the experiments(W and H stand for the the width and the height of the opening, respectively). In Figure 2, the maximum values of the various quantities are plotted versus opening factor, and a sharp peak can be seen on the line of the maximum hydrocarbon concentration where $WH^{3/2}$ is around 1,000.

In compartment fire experiments, in particular in case of small scale ones, there are many evidences that oscillatory phenomena can take place under some conditions, and they are often attributed to the oscillation of the combustion in the room due to some unclarified complex interactions among ventilation, heat transfer and fuel pyrolysis. On the other hand, Satoh, Matsubara and Kumano(5) challenged this explanation by conducting some model room experiments in which there is only an electric

heater as shown in Figure 3, and the field model computations using code UNDSAFE(6). It is revealed, both from the measured room temperature in the model experiments and the predicted effluent enthalpy through the opening, that oscillatory phenomena can take place despite there is no combustion at all in the room of origin. It is also found that, both in the predictions and the experiments, the oscillation frequency was proportional to $Q_0^{1/3}$, where Q_0 is the heat release rate.

DOORWAY FLOW

As we look into compartment fire phenomena more extensively and closely, it is increasingly important to reasonably estimate the rates of in- and outflow through the compartment opening, which is driven by the fire induced buoyancy. And for this purpose, it is almost indispensable to have some equations to correlate the rate of opening flow with some easily and quickly measurable quantities such as room temperatures and a couple of flow pressures at the opening, since otherwise we have virtually no practical mean to obtain the rate of flow at our disposal, especially when we deal with unsteady state fire. BRI felt that it is very important to get this kind of correlation to carry out the experiments concerning to the trilateral cooperative toxicity study project, and conducted a series of experiments for the doorway flow rate with the consultation by Steckler of NBS, who were invited to Japan during the period of the experiments. The test data were reduced using the same procedure given by Steckler(13). The part of the result will be presented in the measurement session of this 7th UJNR meeting.

Matsushita and Terai(8), considering hot gas effluent flow as an upside down weir flow and applying the similar technique as that used in the analysis of weir flow, suggested that there is a possibility that hot gas effluent flow has hyperbolic velocity profile instead of parabolic one as is shown in Figure 4.

PREDICTION OF SMOKE MOVEMENT IN BUILDINGS

Tsujimoto, in an attempt to predict stratified smoke layer movement along corridors and in stair wells in buildings, conducted a series of experiments for smoke flow behavior under a horizontal and an inclined ceiling. The experimental results were compared with the predictions by the theoretical model that were derived based on the theory given by Ellison and Turner(10) for liquid. The comparison between the test

results and the model predictions in the temperature and the velocity of the smoke layer shows good agreement. This work has been presented to this UJNR meeting as a technical paper(9)

Terai and Matsushita(11) predicted the flows throughout an existing underground building to find out the best method to control smoke for that building. The calculations were conducted for several conditions, in each of which one of the candidate smoke control measures to vestibules was employed. The equations were solved for 103 unknown pressures using Newton-Raphson method. A sample of the results is shown in Figure 5. The room of origin is located on the 4th basement. It was predicted that any of the candidate measures will not assure perfect safety for the evacuees in that building.

SMOKE FILLING MODEL

A smoke filling model was used to estimate the time available for safe egress of spectators in Shin-Kokugi-kan(New National Smo-wrestling Arena), which was designed and also is to be constructed by Kajima Kensetsu, one of the most leading construction companies in Japan(12). The available egress time thus estimated was compared with the time also predicted to be necessary for the evacuation of prospected 11,500 spectators. Direct incentive of this prediction was to obtain the authorization for the fire safety design of the building, which is to be given by the evaluation committee, but the importance of this is that this is almost the first time that a smoke filling model is applied to a real problem. Although Shin-Kokugi-kan is somewhat special in its size and shape, it will be desirable if this example encourages other attempts to use this kind of engineering means to evaluate the fire safety performance of buildings. Figure 6 gives the schematic of Shin-Kokugi-Kan and the predicted results of the smoke filling.

CONCLUDINGS

Recent works in Japan that are associated with the prediction of fire in buildings were introduced. Unfortunately, most of the source materials are written in Japanese as can be seen in the reference list, although a few are available in English. This review is by no means sufficient to describe ongoing works in Japan, we would encourage the readers to make direct contact with the authors of the paper in which they are interested.

REFERENCES

- (1) Terai, T.: On The Axisymmetrical Burning Spread Over Horizontal Semi-Infinite Solid, Annual Meeting of The Architectural Institute of Japan, 1982.10 (in Japanese)
- (2) Hamada, K., Sugawara, S. and Kishitani, K.: Experimental Study on Wall Fire (Upward Flame Spread Velocity), Annual Meeting of The Architectural Institute of Japan, 1983.9 (in Japanese)
- (3) Takeda, H.: Pre-flashover Behavior in The Small Scale Compartment, Bulletin of Japanese Association of Fire Science and Engineering, Vol.33. No.1, 1983. (in Japanese)
- (4) Nitta, K.: Experimental Study on Properties of Outflowing Smoke from A Small Scale Enclosure in Fire, Annual Meeting of The Architectural Institute of Japan, 1983.9 (in Japanese)
- (5) Satoh, A., Matsubara, Y. and Kumano, Y.: A Study on Oscillatory Phenomena of The Flow in Compartment Fire, Japanese Association of Fire Science and Engineering, 1983.5 (in Japanese)
- (6) Liu, V.K. and Yang, K.T.: UND Report, TR-79002-78-3, 1978.
- (7) Nakaya, I., Tanaka, T. and Yoshida, M.: A Measurement of Doorway Flow Induced by Propane Fire, to be presented at 7th UJNR meeting, 1983.
- (8) Matsushita, T. and Terai, T.: The Flow of Smoke and Air Through Opening as Two Stratified Layer, Annual Meeting of The Architectural Institute of Japan, 1981.9 (in Japanese)
- (9) Tsujimoto, M.: Smoke Movement as A Density Flow, to be presented at 7th UJNR joint panel meeting, 1983.10
- (10) Ellison, T.H. and Turner, J.S.: Turbulent Entrainment in Stratified Flows, J. Fluid Mech. 6, pp423-448, 1959.
- (11) Terai, T. and Matsushita, T.: On The Comparison Among the Various Methods for Air Supply To and Smoke Exhaustion From The Vestibules of The Evacuation Stair Wells, Annual Meeting of The Architectural Institute of Japan, 1982.10 (in Japanese)
- (12) Sato, H.: Application of A Total Fire Safety System to Shinkokugikan Project - Japanese Sumo Wrestling Stadium, Kajima Institute of Construction Technology, 1983.9.
- (13) Steckler, K.D.: Flow Induced by Fire in A Compartment, NBSIR 82-2520, 1982.

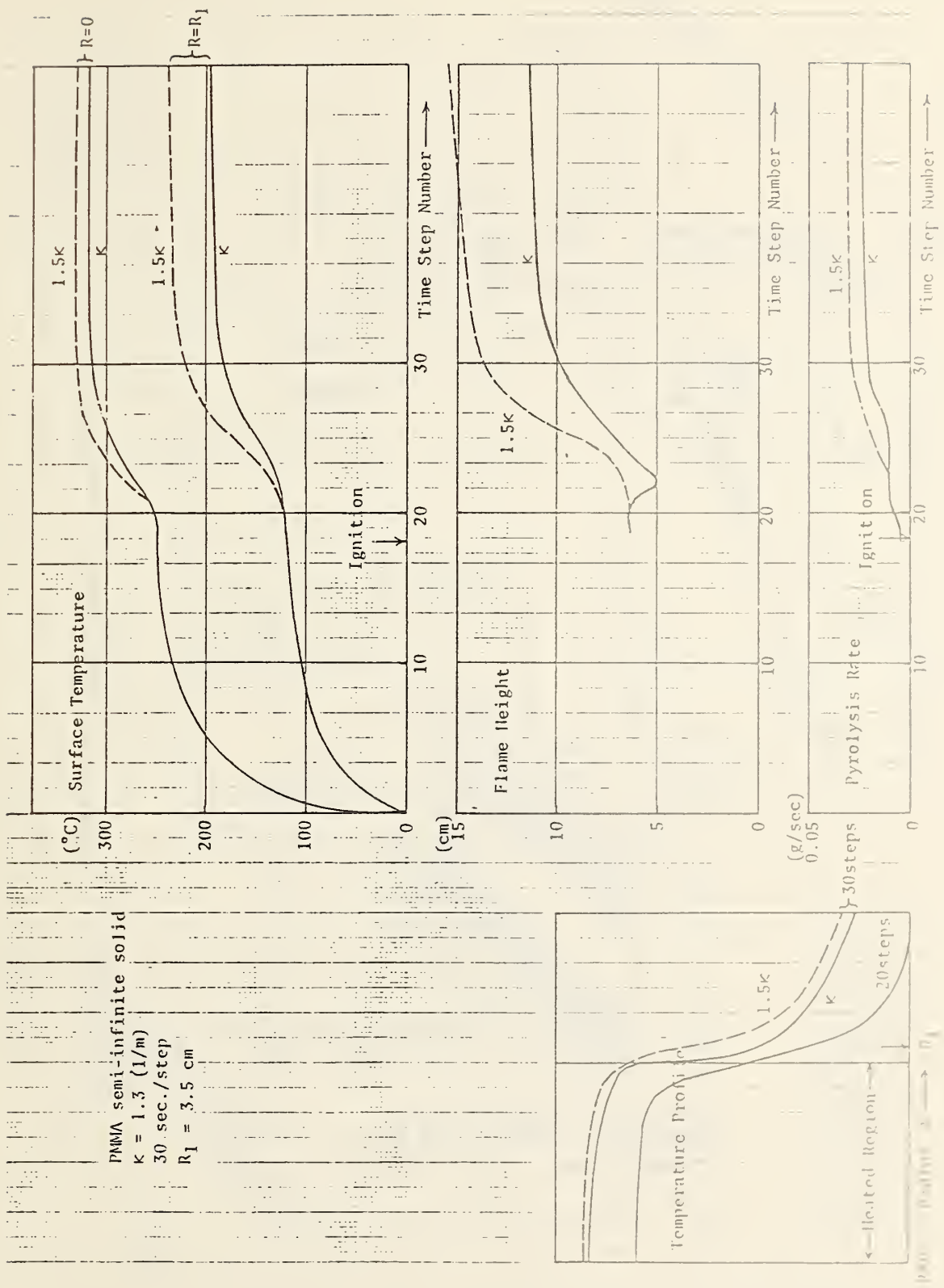


Figure 1. Some of the calculation results by Terai's fire propagation model

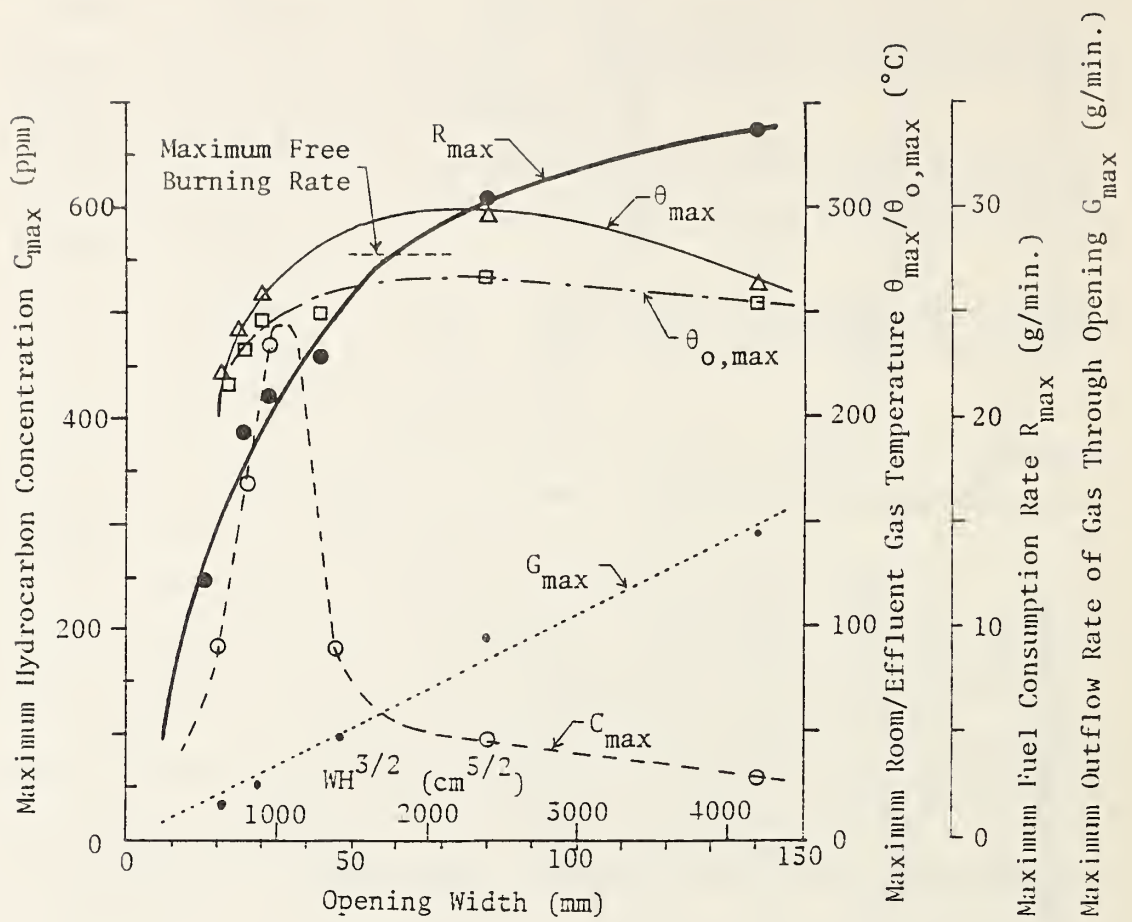
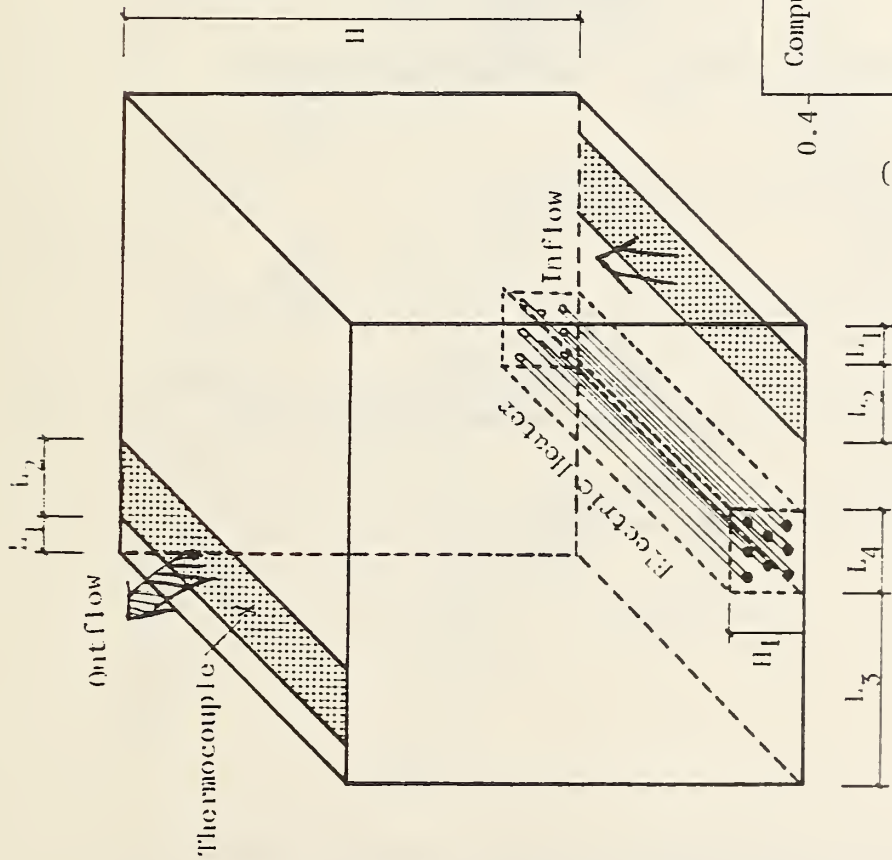


Figure 2. Some of the results of Nitta's experiments

Opening height : 450 mm
 PMMA size : 198x198x20 mm
 Temperature : relative to 19 $^{\circ}C$



Test and Calculation Conditions		
	Test	Calculation
II	0.6 m	2.4 m
L ₁	0.05 m	0.2 m
L ₂	0.15 m	0.6 m
L ₃	0.3 m	1.2 m
L ₄	0.2 m	0.6 m
H ₁	0.2 m	0.2 m
Q ₀	0.5 - 8 kW	50 - 500 kW

Q₀ : Heat Release Rate

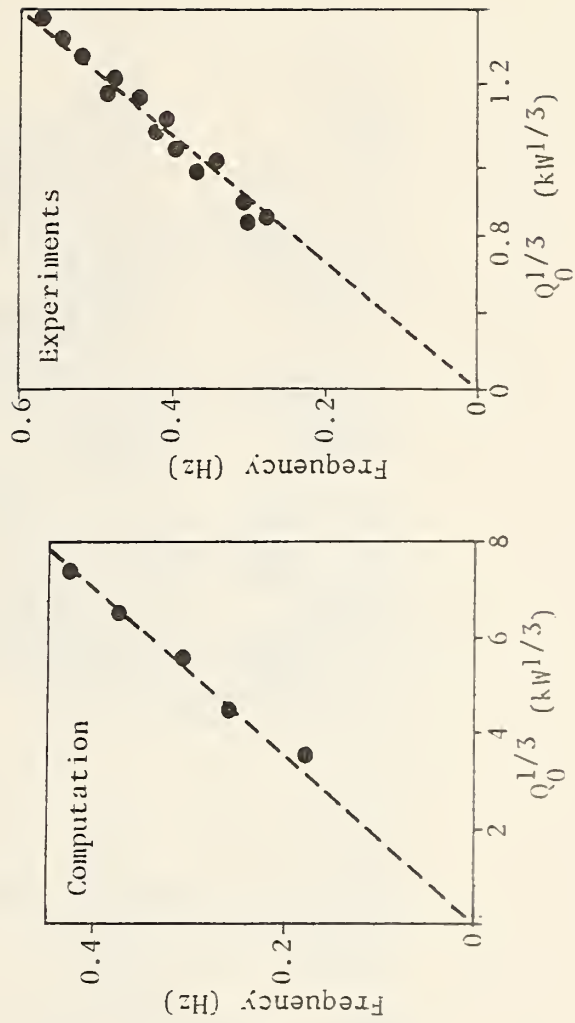
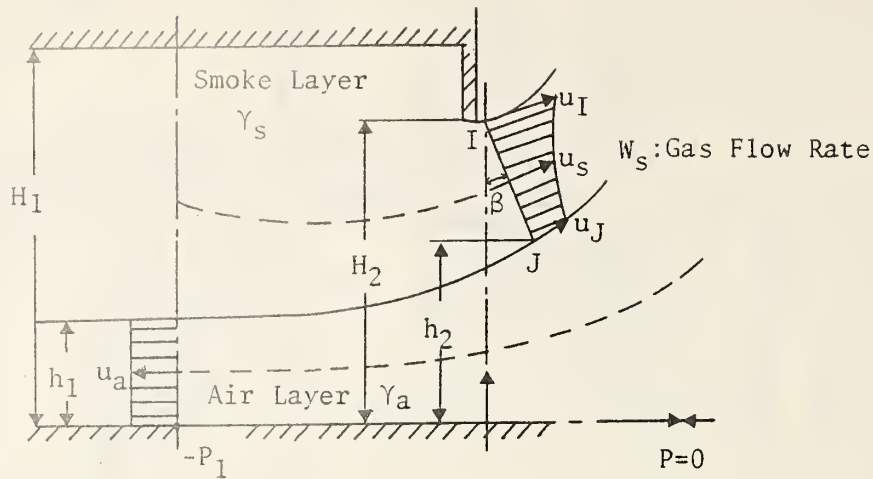


Figure 3. The experimental setup and the relationship between the oscillation frequency and the heat release rate



Effluent Gas Flow Rate Given by The Weir Flow Assumption

$$W_S = C \alpha_s b (H_2 - X)^{3/2}$$

where $C = \frac{k(1+k)}{\cos\beta} \ln \frac{1}{k} / (2g\gamma_S(\gamma_A - \gamma_S))$

$$X = P_1 / (\gamma_A - \gamma_S) + h_1$$

$$k = u_J / u_I = 0.4685$$

β ; Angle between the section IJ and average stream line of the smoke flow. Since generally $\beta < 30$, $\cos\beta = 1$.

Discontinuity Height at The Section IJ

$$h_2 = H_2 - \left(1 - \frac{P_1}{(\gamma_A - \gamma_S)(H_2 - h_1)}\right) (1 - k^2) (H_2 - h_1)$$

Figure 4. The doorway flow seen as an upside down weir flow

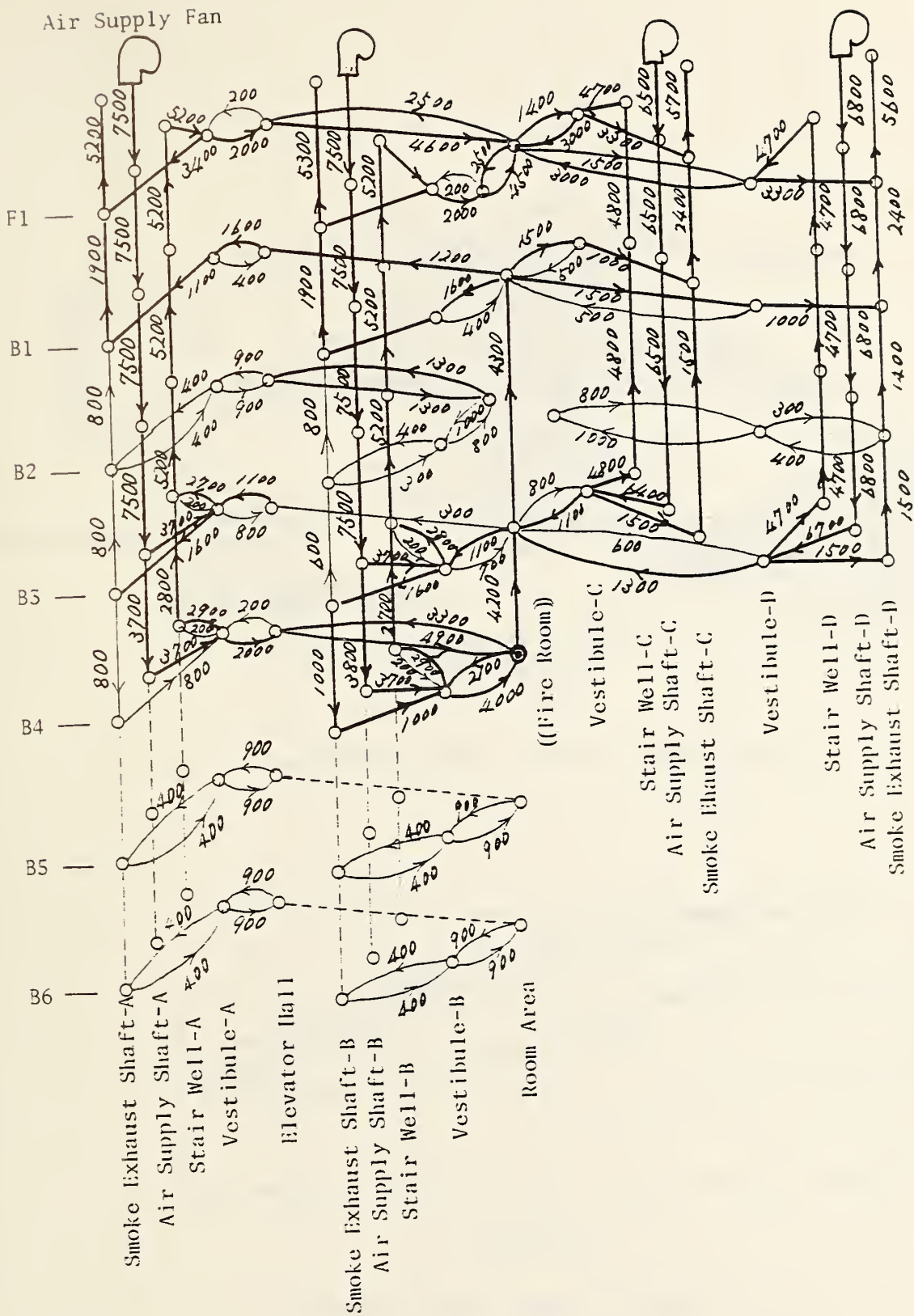
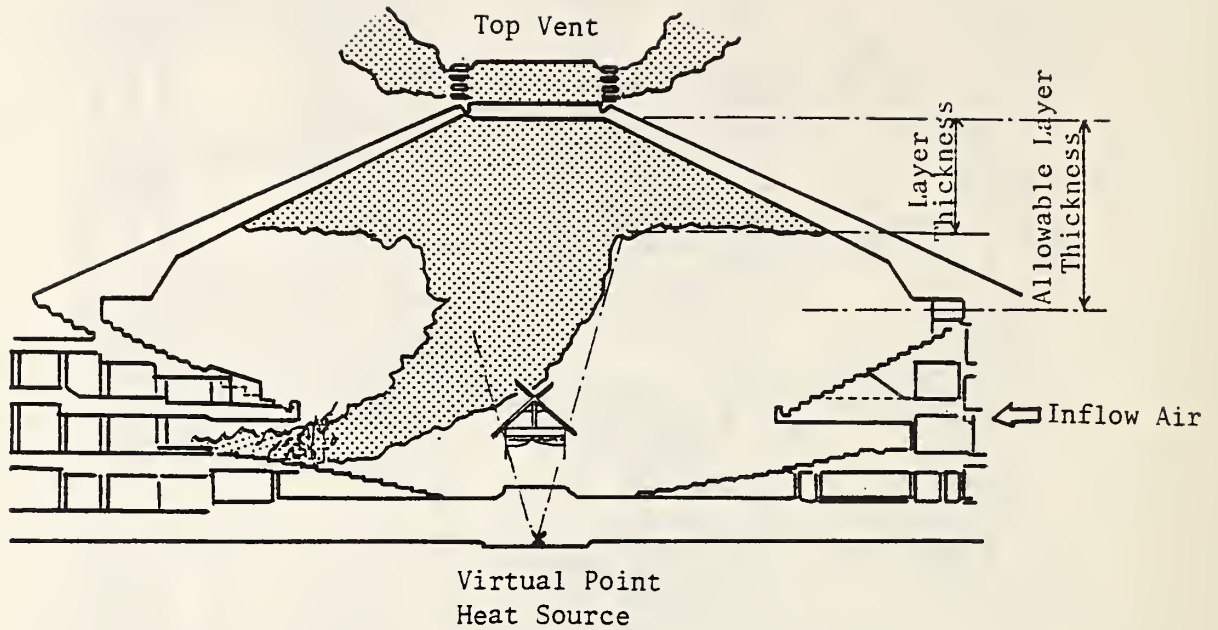
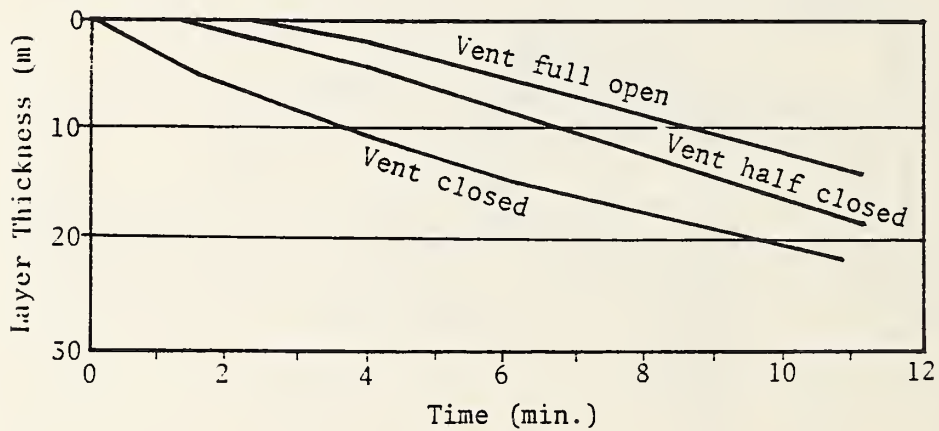


Figure 5. A result of smoke flow prediction for an underground structure (The numbers on the branches represent the flow rates in m^3/h)



(a) Schematic of Fire in Shin-Kokugi-Kan



(b) Predicted Smoke Layer Thickness

Figure 6. The concept and the predicted result of smoke filling in Shin-Kokugi-Kan

An Assessment of Fire Induced Flows in Compartments

by

J.G. Quintiere, K. Steckler, and D. Corley

Center for Fire Research
National Bureau of Standards
Department of Commerce
Washington, DC

September 1983

NOMENCLATURE

a	vertical distance, floor to window
A	area
b	constant, Eq. (18)
c_p	specific heat at constant pressure
C	vent flow coefficient
E_0	entrainment constants, Eq. (13)
F_m	Froude number, Eq. (13)
g	gravitational acceleration
h	convective heat transfer coefficient
H	geometric height, room height
m	mass
M	dimensionless mass flow rate, Eq. (17a), or momentum
Pr	Prandtl number
\dot{Q}	energy release rate
Ri	Richardson number, Eq. (17)
T	temperature
W	width, length of line fire
x	vertical coordinate measured from lower edge of vent
y	normalized coordinate, x/H_0
z	vertical coordinate
β	coefficient of expansion, $1/T_a$
Δ	difference
ν	kinematic viscosity coefficient
ρ	density
ψ	$(T_{g,u} - T_a)/T_a$
δ	dimensionless parameter, Eq. (17c)

Subscripts

a	ambient air
e	vent mixing
f	floor
g	gas
l	lower
p	fire plume
o	vent
w	wall flow or wall

Superscripts

([°])	per unit time
(['])	per unit length
(^{''})	per unit area

INTRODUCTION

The prediction of flow through doors or windows due to compartment fires is important for two reasons. First, it bears on the accuracy of compartment fire growth models. Secondly, it is important in order to predict the effluent rate of combustion products and flames to the surroundings. Since most mathematical fire growth models are approximate it is necessary to evaluate their accuracy and consistency with experimental data. Here the fluid dynamic models and concepts will be examined without concern for the energy transport models. Thus, an assessment of the fluid dynamics is made only.

The problem being addressed is the flow due to natural convection through wall vents and the internal flows associated with a fire within a compartment. Kawagoe [1] assumed a uniform temperature in the compartment for fully developed fires, and computed the vent flow based stagnant hot and cold gas reservoirs on either side of the vent. Later Rockett [2] extended this concept by considering the gas in the room to be composed of a hot upper and cold (ambient) lower layer. Cold air is entrained by the fire up to this thermal interface. Only the fire plume mass flux crosses this interface. Emmons and Mitler [3], Tanaka [4] and others extended these concepts to include the transient case and a complete range of thermal conditions on either side of the vent. It is this "simple" model (hot upper layer, ambient lower layer, plume entrainment) that we wish to assess.

It is recognized that entrainment rate predictions for free fire plumes (e.g., Cetegen, Zukoski, and Kubota [5]) yield good results, but effects of walls and room drafts disturb fire plumes within rooms. Hence, departures from the free plume predictions can be expected [6,7]. In the present study, a line fire along a wall is considered. It is expected that a theoretical entrainment rate, derived from a line-source turbulent wall plume solution [8], is sufficiently accurate for this analysis. Yet no specific entrainment rate checks have been made for wall plumes.

Three factors will influence the accuracy of the "simple" flow model under examination. They include: mixing of hot fluid into the incoming flow at the vent; transport of fluid along the walls due to local buoyancy forces; and the resultant increase of the gas temperature in the lower layer due to these factors and convection from heated surfaces. McCaffrey and Quintiere [9] have shown that the ratio of vent mixing to inflow rate increases as the vent size decreases; and the ratio can exceed 1 for very small doors. Zukoski [10] is attempting to develop a general prediction of vent mixing, and has suggested a correlation in terms of Richardson number (Ri). The wall flows present a complicated problem because of their three-dimensional nature and imprecise free-stream boundary conditions. Nevertheless, Jaluria [11] has presented methods for estimating these flows. The extent of their net transport across an idealized thermal interface is still somewhat ambiguous.

Therefore, this still will present new data (over 100 steady-state experiments) of vent flow rates for various vent geometries and wall-line fires. Those results will then be analyzed to assess the extent of lower layer heating, vent mixing and wall flows. These all represent departures

from our simple concept of fire induced flows in compartments. Finally, theoretical computations based on the "simple" flow model will be presented and compared appropriately to the experimental results.

EXPERIMENTAL APPROACH

A schematic of the full-scale flow facility in which the experiments were conducted is shown in Figure 1. More detailed information on the facility is described elsewhere [7]. The line burner against the rear wall consists of four contiguous sand burners to which methane was supplied. The flow rate of the methane was controlled such that fires of 30 to 120 kW could be specified. The length of the line burner (W) was varied by supplying gas to one, two, three or four burners. The vent, centered on the front wall, can be described in terms of the geometric parameters: W_0 , H_0 and a . The distance $a+H_0$ was kept fixed at 1.8 m, the width W_0 ranged from 0.24 to 0.99 m, and a/H_0 ranged from 0 to 3.

Velocity and temperature measurements were made at the vent and gas temperatures were measured at the right-front corner of the room on a 11.4 cm spacing [7]. In addition, wall surface temperatures were measured on a 22.9 cm vertical spacing near the right-front corner. Following steady-state conditions, these measurements were used to compute the vent flow and other flows of interest. The flow of methane is negligible, so that conservation of mass requires the in and out mass flow rates at the vent to be equal.

A significant feature of this study is the method used to compute the vent flows. Previously [7] this was done by an extensive velocity and temperature traverse over the vent. Under natural convection conditions it has been shown that the mass flow rates could be accurately computed from vertical temperature distributions in the room and vent together with information on the zero pressure gradient (neutral plane, x_2) location. Thus, only center-line velocity and temperature distributions were required at the vent. The formulae to compute the flows are given elsewhere [7]. The approximate method used flow coefficients of 0.73 and 0.68 for the out and in flows, respectively. This method serves as the basis of computation for all the experiments of this study.

EXPERIMENTAL ANALYSIS

Accuracy of Vent Flow Computation

Initially eight experiments were conducted to assess the approximate vent flow rate computational method. Although this had been done for an arbitrarily located circular burner [7], it had not been checked for a line fire. A comparison (Figure 2) of the results based on velocity data is made with the approximate results derived primarily from temperature data. Since the agreement was good, the approximate procedure was applied to the remainder of the experiments. A measure of its overall accuracy is given by Figure 3 in which the mass inflow rate is compared with the outflow rate. High flow rates relate to large openings where horizontal temperature differences occurring at the lower region of the vent are small. Hence, lack of accuracy and precision in these temperature measurements decrease the accuracy of the inflow rates.

In contrast, low flow rates relate to small vents for which these temperature differences are greater and more accurately measured. These factors explain the discrepancies between the two flows. For practical purposes in this study, their arithmetic average was used as the vent mass flow rate (\dot{m}).

Description of Thermal Layers

Numerous data exist from these experiments describing the vertical temperature distribution in the room for a variety of fire and vent conditions. A sample of results are shown in Figure 4a, b, c and d. There, the wall and gas temperatures are shown for two door (a,b) and window (c,d) vent cases. It is obvious from an examination of these data that they can be characterized approximately by two thermal layers of uniform temperatures. Indeed, this representation was done systematically. Although somewhat arbitrary, that process is described as follows:

1. An arithmetic average was used to fit the upper temperatures. The temperature data included points from the top down until the data significantly departed from the average fit.
2. Two integral identities were then used to compute the interface height (x_1) and the lower layer temperatures ($T_{g,\ell}$ and $T_{w,\ell}$). For both the wall and gas temperatures the integrals are

$$\int_0^H \left(\frac{1}{T}\right) dx = [H - (x_1 + a)]/T_u + (x_1 + a)/T_\ell \quad (1)$$

and

$$\int_0^H T dx = [H - (x_1 + a)] T_u + (x_1 + a) T_l \quad (2)$$

Equation (1) constitutes mass equivalency while eq. (2) has no physical significance.

The results of these curve fits are also shown in the examples of Figure 4. It is interesting to note, that under these steady-state fire conditions, a significant rise in the lower region gas and wall temperatures occurs. Also the location of interface (labeled ZD in Figure 4) is nearly coincident with the position where the buoyancy force at the wall changes sign: positive from the floor up and negative from the ceiling down in correspondence to the wall-gas temperature difference.

Correlations for Layer Temperatures

The temperature is a significant variable controlling the flow rates; however, it is a dependent variable in these experiments. In contrast, the fire energy release rate (\dot{Q}) is an independent variable in these experiments. Thus a correlation for temperature in terms of \dot{Q} could be useful. Following the successful correlation by McCaffrey et al. [12] a dimensionless temperature is given as

$$\psi \equiv \frac{T - T_a}{T_a} = 1.6 \left(\frac{\dot{Q}}{\rho_a C_p T_a \sqrt{g} W_o H_o^{3/2}} \right)^{2/3} \left(\frac{h_k A}{\rho_a C_p \sqrt{g} W_o H_o^{3/2}} \right)^{-1/3} \quad (3)$$

The heat loss parameter h_k was taken as $0.014 \text{ kW/m}^2\text{-K}$ for these experimental conditions, and A is the room interior surface area in m^2 . A comparison of the measured upper layer dimensionless temperature with ψ computed from eq.

(3) is shown in Figure 5. The scatter about the line may suggest the lack of a complete correlation. Indeed, the same correlation applied to the lower layer temperature is shown in Figure 6. There, most of the data lie below 0.3ψ as given by eq. (3) and indicated by the straight line. The data above correspond to the small windows ($a/H_0=3$) which display a tendency to seek uniform temperature conditions within the compartment.

Estimation of Wall Flows

The idea here is, within the context of a two layer characterization of the room, to estimate the boundary layer flows that cross the thermal interface (x_1). For this we resort to analyses by Jaluria [11] who made such estimates based solely on the assumptions of two-dimensional natural convection with the wall and free-stream conditions of the boundary layer described by the temperature distributions given in Figure 4. The primary issue is how to decide the net transport rate across the thermal interface ignoring issues of momentum effects and three-dimensional effects. In all our experiments the local buoyancy force in the wall boundary layer produces an upward flow from the floor and a downward flow from the ceiling. These meet and stabilize in a neutrally buoyant region. A portion of that region may lie on both sides of the thermal interface as defined in Figure 4. Thus, the very nature of this flow distorts the concept of a two-layer model.

Jaluria [11] suggests the following procedure to estimate the wall flows and the net transfer rate (positive to the upper layer):

1. At the interface (x_1), calculate the momentum of the upper and of the lower wall boundary layer flows. Use the mean of the laminar and fully turbulent solutions, since this tends to account for transition effects. Precise transition to turbulent flow can not be accurately computed. The formula for laminar flow is

$$M' = \rho v^2 \left(Pr + \frac{20}{21} \right)^{-3/4} Pr^{-1/2} \left(\frac{g\beta\Delta T}{v^2} \right)^{3/4} z^{5/4} \quad (4)$$

and for turbulent flow is

$$M' = 0.04149 \rho v^2 \left(1 + 0.494 Pr^{2/3} \right)^{-0.9} Pr^{-8/15} \left(\frac{g\beta\Delta T}{v^2} \right)^{0.9} z^{1.7} \quad (5)$$

where properties are evaluated at ambient air conditions, ΔT is the absolute value of the layer gas to wall temperature difference, and Z is the distance from the ceiling or floor to the thermal interface.

2. The larger momentum determines the direction of the wall boundary layer flow across x_1 . Once the direction is established it is assumed that all of that boundary layer flow is transported across x_1 . Again, the mean of the laminar and turbulent solutions for mass flow rate (per unit) perimeter constitutes the flow rate. The laminar solution is

$$\dot{m}' = 1.69 \rho v \left(Pr + \frac{20}{21} \right)^{-1/4} Pr^{-1/2} \left(\frac{g\beta\Delta T}{v^2} \right)^{1/4} z^{3/4} \quad (6)$$

and for turbulent flow,

$$\dot{m}' = 0.09795 \rho v (1 + 0.494 Pr^{2/3})^{-0.4} Pr^{-8/15} \left(\frac{g\beta\Delta T}{\nu}\right)^{0.4} Z^{1.2} \quad (7)$$

with the same variable definitions in eqns. (4) and (5). The perimeter is the perimeter of the room minus the burner and vent widths.

The results of wall flow calculations for all the tests indicate predominately upward wall flow, so that there is a net exchange from the lower layer to the upper layer. In about 20 percent of the experiments the flow was estimated as down. Most of the window cases show this preponderance essentially due to a decrease in Z and ΔT in the lower layer. The magnitude of the total wall flow rate (\dot{m}_w), taken to be positive for up or down, is plotted against x in Figure 7. Most of the upward flow rates range from 10 to 50 percent of the vent flow rate, but the net downward wall flow rates nearly equalled the vent flow rates. This estimation procedure does not track the wall flows after separation from the wall. Hence the estimates can be high.

Estimation of Vent Mixing

As the cold ambient flow enters the vent and plunges to the floor of the room, it entrains hot fluid from above. Zukoski [10] has a controlled experiment in which to measure these flows, and a preliminary correlation is given below:

$$\frac{\dot{m}_e}{\dot{m}_o + \dot{m}_e} = b/\sqrt{Ri} \quad (8a)$$

$$Ri = \frac{\Delta\rho g(x_1 + a)}{\rho_a u^2} \quad (8b)$$

$$u = \dot{m}_o / [\rho_a W_o(x_1 + a)] \quad (8c)$$

$$\Delta\rho = \rho_a (1 - T_a/T_{g,u}) \quad (8d)$$

The constant b was taken as 0.17 in these computations. Before discussing those results, an alternative derivation of the vent mixing rates will be considered.

Case 1. Wall Flow to the Upper Layer:

Consider a control volume including the lower layer (over height $x_1 + a$), but excluding the fire plume and wall boundary layers. For a nonabsorbing gas with constant c_p , an energy balance can be written as follows:

$$\dot{m}_w c_p (T_{g,l} - T_a) + \dot{m}_p c_p (T_{g,l} - T_a) - \dot{m}_e c_p (T_{g,u} - T_a) \quad (9)$$

$$- \dot{m}_o c_p (T_a - T_a) = h_f A_f (T_f - T_{g,l})$$

where \dot{m}_p is the fire plume entrainment rate,

h_f is the floor heat transfer coefficient,

$$\left(h_f = 0.14 k Pr^{1/3} \left(\frac{g(T_f - T_{g,u})}{v^2 T_a} \right)^{1/3} \right)$$

A_f is the floor area,

and T_f is the floor surface temperature.

From the mass balance,

$$\dot{m}_p + \dot{m}_w = \dot{m}_o + \dot{m}_e \quad (10)$$

it can be shown that

$$\dot{m}_e = \dot{m}_o (T_{g,l} - T_a) / (T_{g,u} - T_{g,l}) - \frac{h_f A_f}{c_p} (T_f - T_{g,l}) / (T_{g,u} - T_{g,l}) \quad (11)$$

This allows us to estimate \dot{m}_e from the experimental measurements. It should be noted that for this case the result is independent of the wall flow rate. The floor temperature (T_f) was measured for a limited data set and estimated for the remaining experiments from measured lower room temperatures.

Case 2. Wall Flow to the Lower Layer:

In this case, let \dot{m}_w be positive to the control volume enclosing the entire lower layer gas except the flame. A mass and energy balance yield

$$\begin{aligned} \dot{m}_e = \dot{m}_o (T_{g,l} - T_a) / (T_{g,u} - T_{g,l}) - \dot{m}_w \\ - (h_f A_f / c_p) (T_f - T_{g,l}) / (T_{g,u} - T_{g,l}) \\ - (h_w A_{w,l} / c_p) (T_{w,l} - T_{g,l}) / (T_{g,u} - T_{g,l}) \end{aligned} \quad (12)$$

where $A_{w,l}$ is the lower wall area,

and h_w is the convective heat transfer coefficient taken as turbulent natural convection.

The results of these computations are shown in Figure 8 only for Case 1. Eq. (12) gave negative results, suggesting an inconsistency in the analysis probably due to over-estimates for \dot{m}_w . For Case 1, the energy balance results are somewhat more than three times those predicted by eq. (8). For this range of experimental conditions, this corresponds to 10 to 30 percent of the vent flow rate.

SIMPLE FLOW MODEL

As stated earlier, most of the fire growth models (eq. (3,4)) use a flow model which is based on the vent flows and fire plume entrainment. This assumes an ambient lower layer, and no wall or vent mixing effects. As an exercise in assessing the accuracy of such a model, its predictions will be compared to the experimental results for \dot{m}_o , x_1 , and x_2 . The entrainment rate is taken from Grella and Faeth [8] as follows:

$$\dot{m}'_p = E_o F_m^{2/3} \rho_a \left(\frac{g \dot{Q}'}{c_p T_a} \right)^{1/3} (x_1 + a) \quad (13)$$

with the entrainment constant, $E_o = 0.067$ and the local Froude number, $F_m = 5.71$. Here, \dot{m}'_p is approximated as \dot{m}_o . Hence, the three governing equations in dimensionless form are given below:

$$M_o = [\psi / (1 + \psi)]^{1/2} (y_2 - y_1)^{1/2} (y_2 + y_1 / 2) \quad (14)$$

$$M_o = [\psi^{1/2} / (1 + \psi)] (1 - y_2)^{3/2} \quad (15)$$

$$M_o = \bar{\alpha} (y_1 + a/H_o) \quad (16)$$

If $y_1 < 0$, then y_1 should be set equal to zero in eq. (14).

The dimensionless variables are

$$M_o = \dot{m}_o / (2/3 C \rho_a \sqrt{2g} W_o H_o^{3/2}), \quad (17a)$$

$$y_{1,2} = x_{1,2} / H_o, \quad (17b)$$

$$\bar{a} = \left(\frac{3}{2\sqrt{2}C} \right) \left(\frac{W}{W_o} \right)^{2/3} \left(\frac{\dot{Q}}{\rho_a c_p T_a \sqrt{g} W_o H_o^{3/2}} \right). \quad (17c)$$

These equations were solved numerically with ψ given by eq. (3). It should be noted that the dimensionless variables are a function of the parameters ψ and \bar{a} which in principle give the flow solution in terms of fire size and vent geometry. The flow coefficient, C , was taken as 0.70. The experimental and numerical results are compared in Figures 9, 10 and 11 for M_o , y_1 and y_2 , respectively. As y_1 falls below zero, the vent experiences a fairly uniform compartment temperature. For these cases y_2 decreases, dropping below 0.5. These cases yield the best agreement for y_2 and M_o . In contrast, the entrainment height, $(a/H_o + y_1)$, is under-predicted by the model. It might be noted that in Figure 10, the experimental values of y_1 from -1.0 to 0 correspond to $a/H_o = 3$; 0 to 0.4, $a/H_o = 1$; and 0.4 to 0.9, $a/H_o = 0.3$ and 0. Overall, the theoretical M_o is at most 50 percent less than the experimental values; y_1 is much less than the small window experimental values; and y_2 is over-estimated by 50 percent at most.

CONCLUSIONS

The simple flow model consisting of a hot upper layer and ambient cold lower layer gives vent flow rates and layer positions to within 50 percent accuracy. Although the vertical temperature distributions within the room can be approximated well by a two layer thermal model, the lower layer can be significantly hotter than ambient temperature. For these experiments, this is predominately due to vent mixing which is estimated for these data to range from 10 to 30 percent of the vent flow rate. The wall boundary layer flows are suspected to be over-estimated in this analysis, and for the most part was indicated as a net transfer from the lower layer to the upper layer.

REFERENCES

1. Kawagoe, K., "Fire Behavior in Rooms", Rept. No. 27, Building Research Institute, Japan, Sept. 1958.
2. Rockett, J.A., "Fire Induced Gas Flow in an Enclosure", Comb. Sci. & Technol., 12, 165, 1976.
3. Mitler, H.E. and Emmons, H.W., "Documentation for CFR V, The Fifth Harvard Computer Code", Home Fire Project Tech. Rept. No. 45, Div. Appl. Sci, Harvard U., Oct. 1981.
4. Tanaka, T., "A Model of Multiroom Fire Spread", NBSIR 83-2718, Nat. Bur. Stand., Washington, DC, August 1983.
5. Cetegen, B.M., Zukoski, E.E. and Kubota, T., "Entrainment and Flame Geometry of Fire Plumes", Dep. Comm. Grant No. G8-9014, Cal. Inst. Technol., August 1982.
6. Quintiere, J.G., Rinkinen, W.J. and Jones, W.W., "The Effect of Room Openings on Fire Plume Entrainment", Comb. Sci. & Technol., 26, 193, 1981.
7. Steckler, K.D., Quintiere, J.G. and Rinkinen, W.J., "Flow Induced by Fire in a Compartment", 19th Symp. (Int.) on Comb., The Comb. Inst., 913, 1982.

8. Grella, J. and Faeth, G.M., "Measurements in a Two-Dimensional Thermal Plume Along a Vertical Adiabatic Wall", J. Fluid Mech., 71, 701, 1975.
9. McCaffrey, B.J. and Quintiere, J.G., "Buoyancy Driven Counter-Current Flows Generated by a Fire Source", In Spalding, D.B. and Afgan, N. (Eds.) Heat Transfer and Turbulent Buoyant Convection, Hemisphere Pub. Corp., Washington, DC, 1976.
10. Zukoski, E.E., Private Communications, Progress Report, Grant No. G8-9014, April 1983.
11. Jaluria, Y., "Buoyancy-Induced Wall Flow Due to Fire in a Room", NBSIR (to be published), Nat. Bur. Stand., Washington, DC.
12. McCaffrey, B.J., Quintiere, J.G. and Harkleroad, M., "Estimating Room Temperatures and the Likelihood of Flashover Using Fire Test Data Correlations", Fire Technol., 17, 98, May 1981.

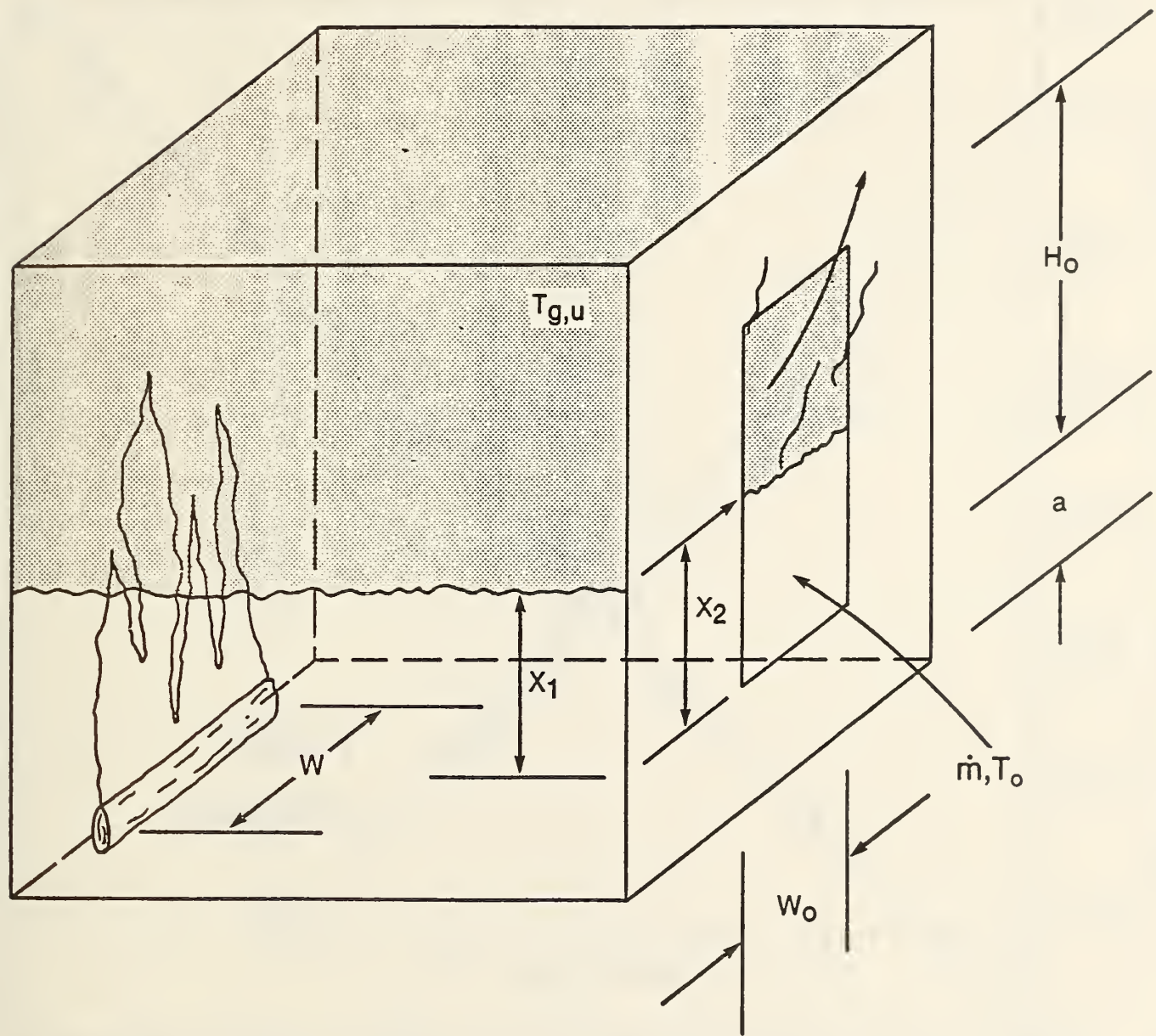


Figure 1. Schematic of experiment

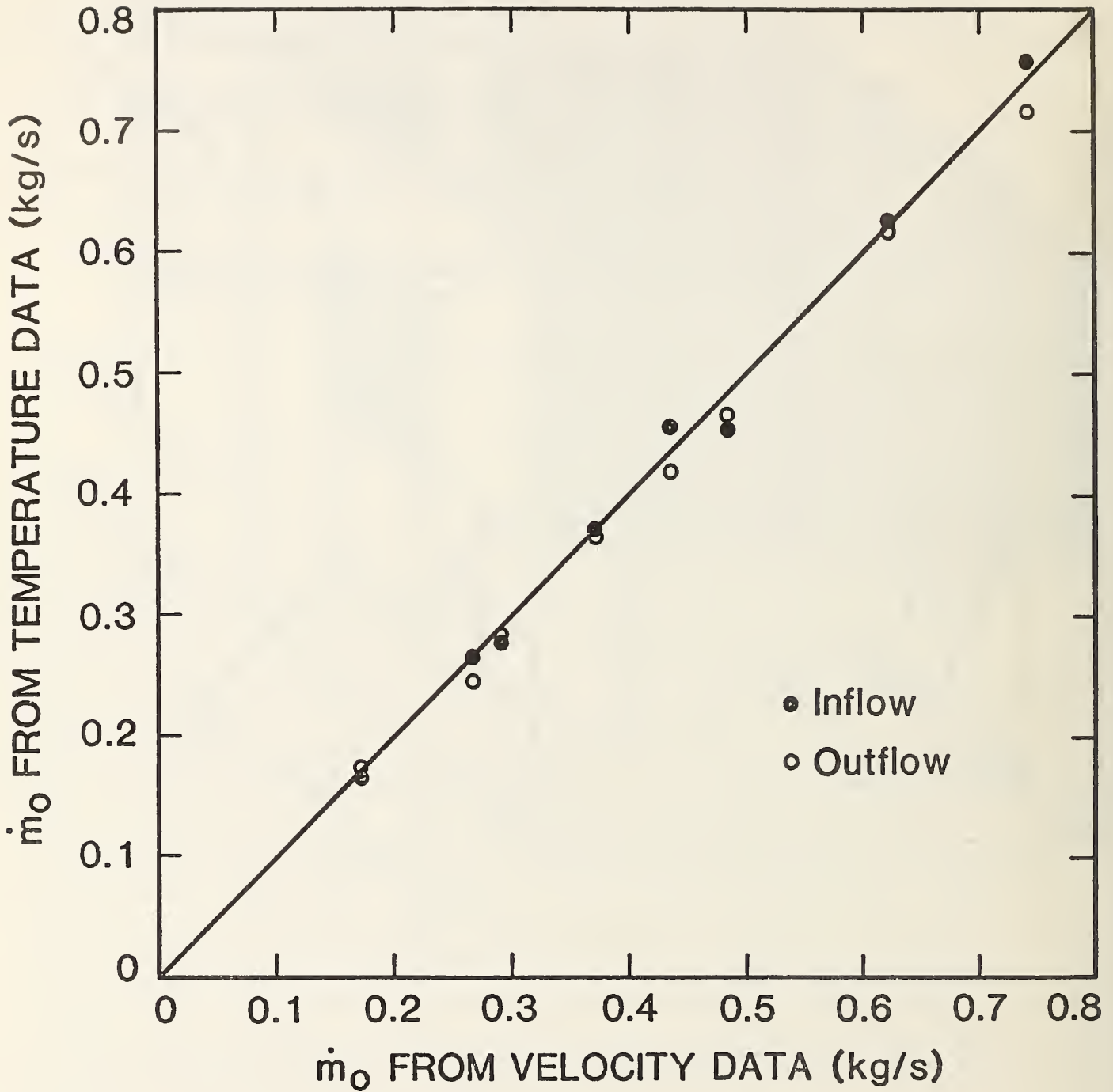


Figure 2. Comparison of approximate to direct method for vent flows

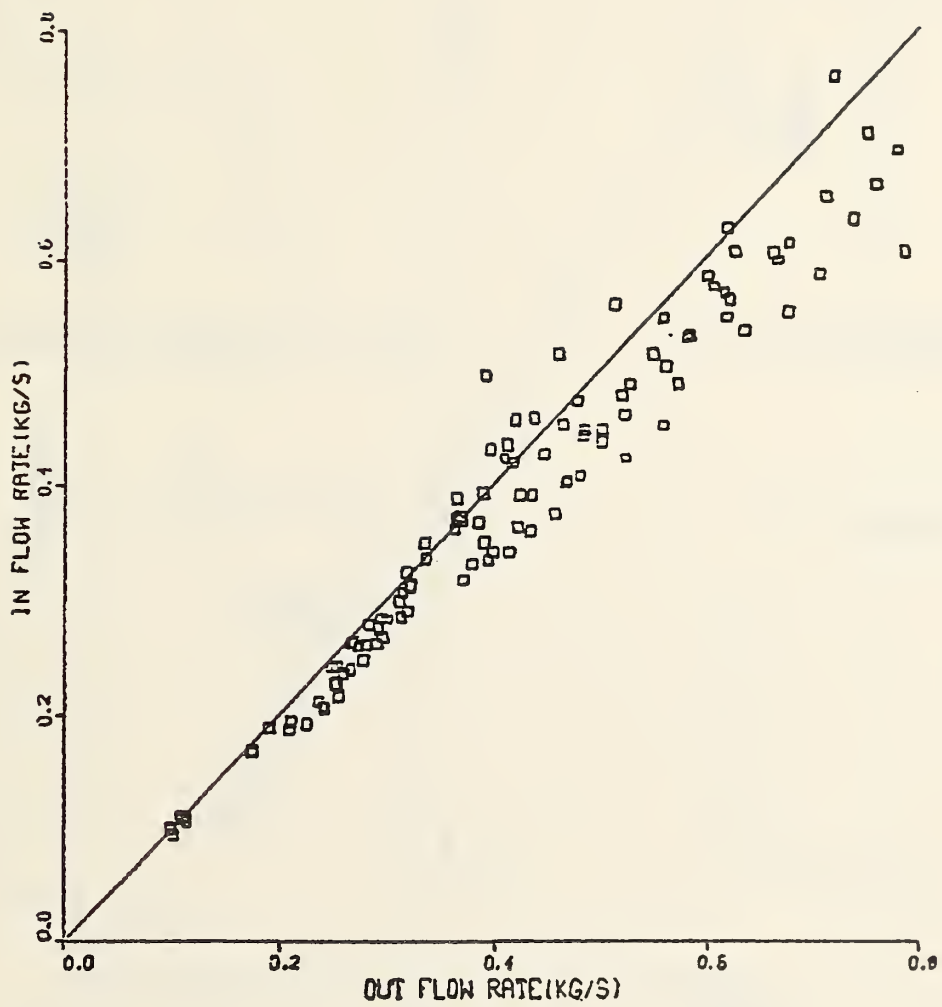
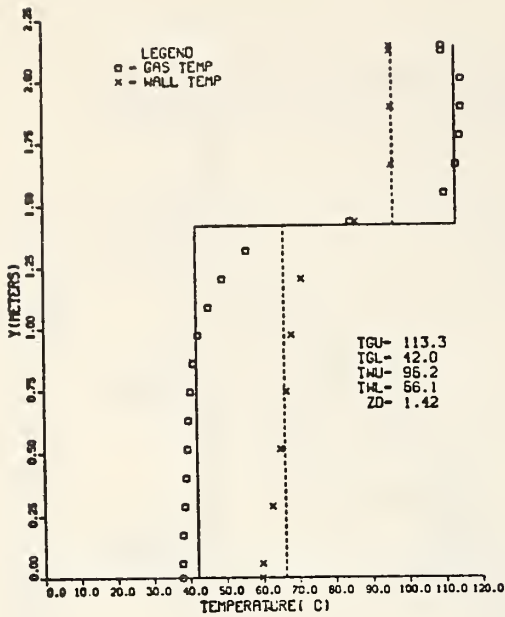


Figure 3. Comparison of inflow and outflow rates by approximate methods

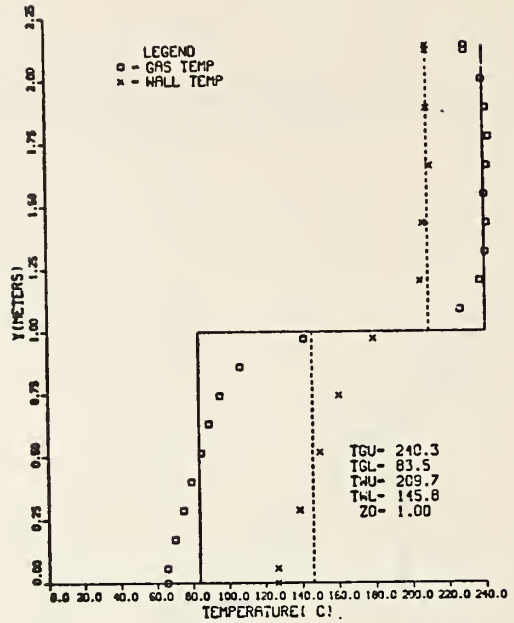
a

ROOM TEMPERATURES VS. HEIGHT
TEST TEC300



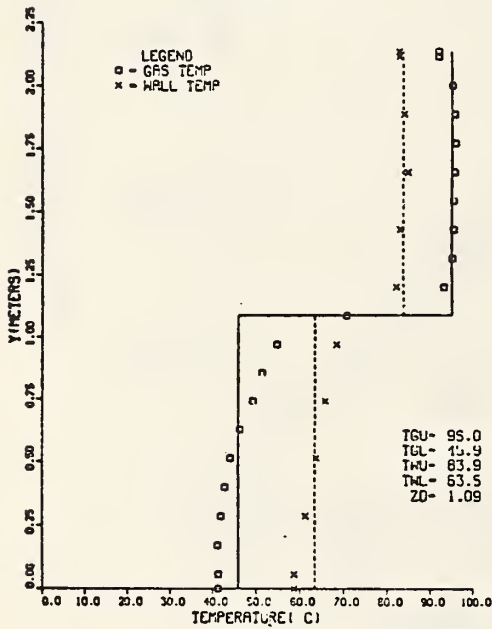
b

ROOM TEMPERATURES VS. HEIGHT
TEST TEC305



c

ROOM TEMPERATURES VS. HEIGHT
TEST TEC443



d

ROOM TEMPERATURES VS. HEIGHT
TEST TEC458

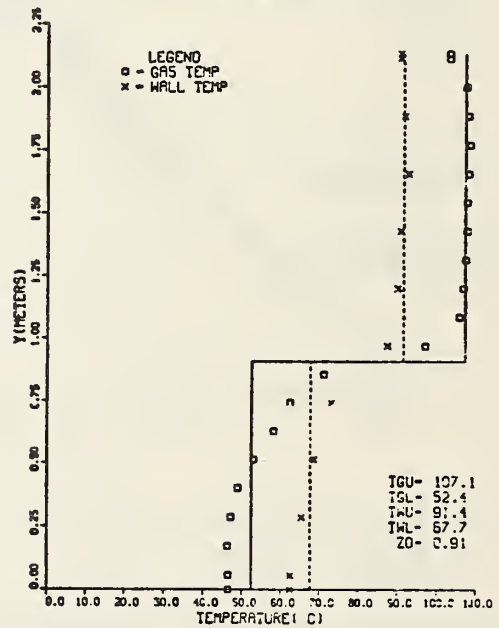


Figure 4. Typical room temperature profiles

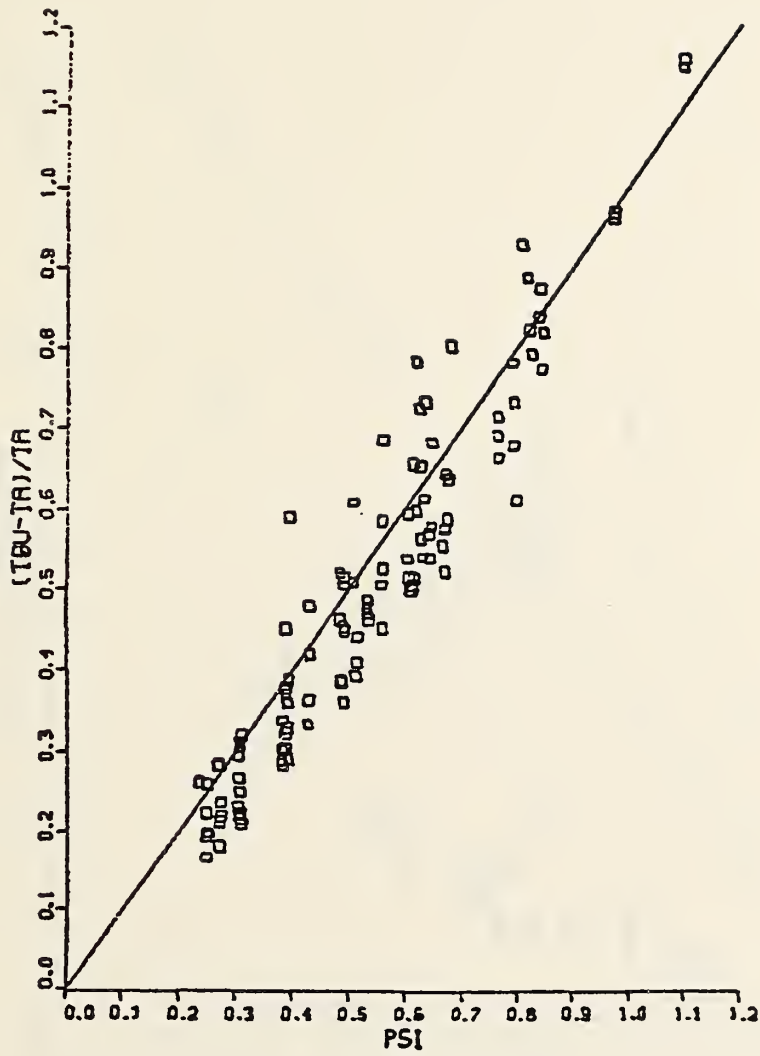


Figure 5. Dimensionless upper layer temperature correlation



Figure 6. Dimensionless lower layer temperatures with ψ

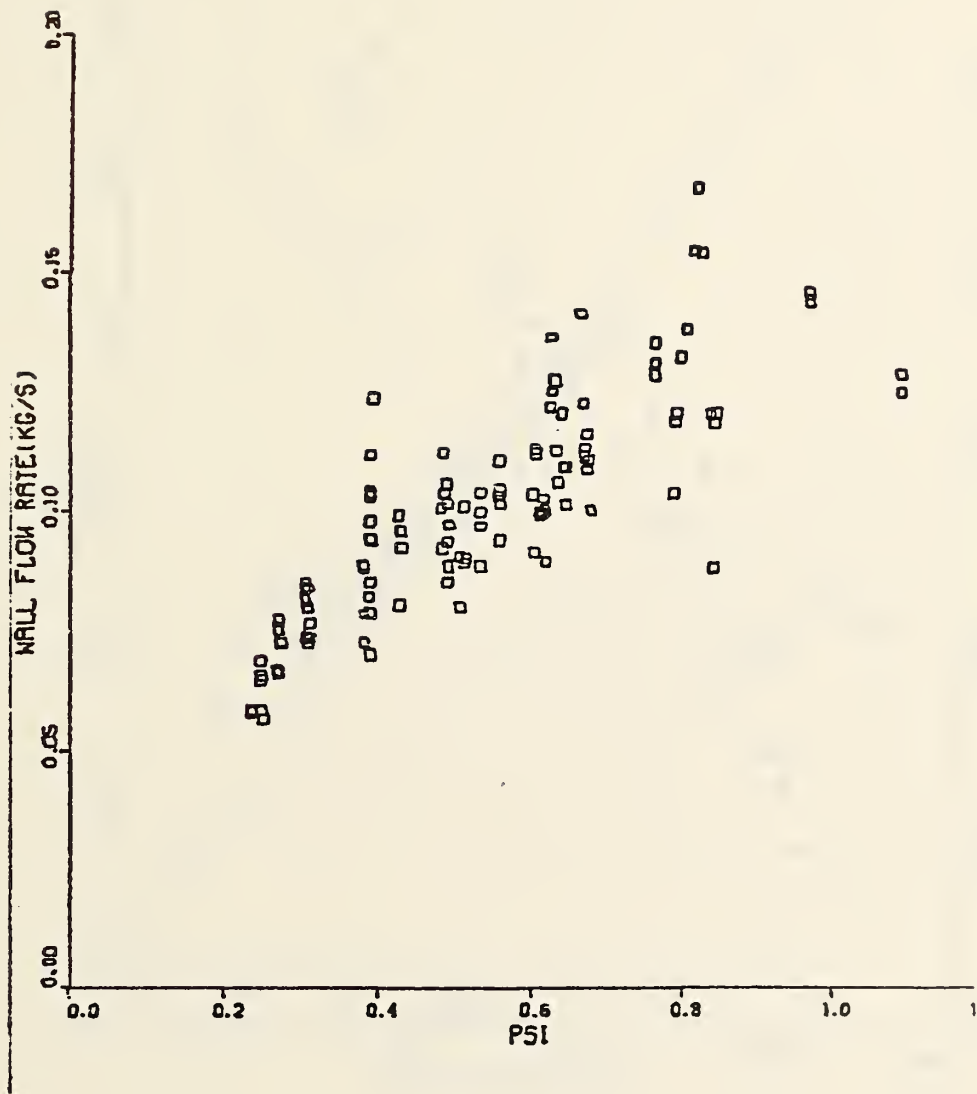


Figure 7. Wall boundary layer flow rates with ψ



Figure 8. Comparison of vent mixing flow rates by two methods



Figure 9. Comparison of dimensionless vent flow rate, experiment with theory



Figure 10. Comparison of dimensionless layer position, experiment with theory

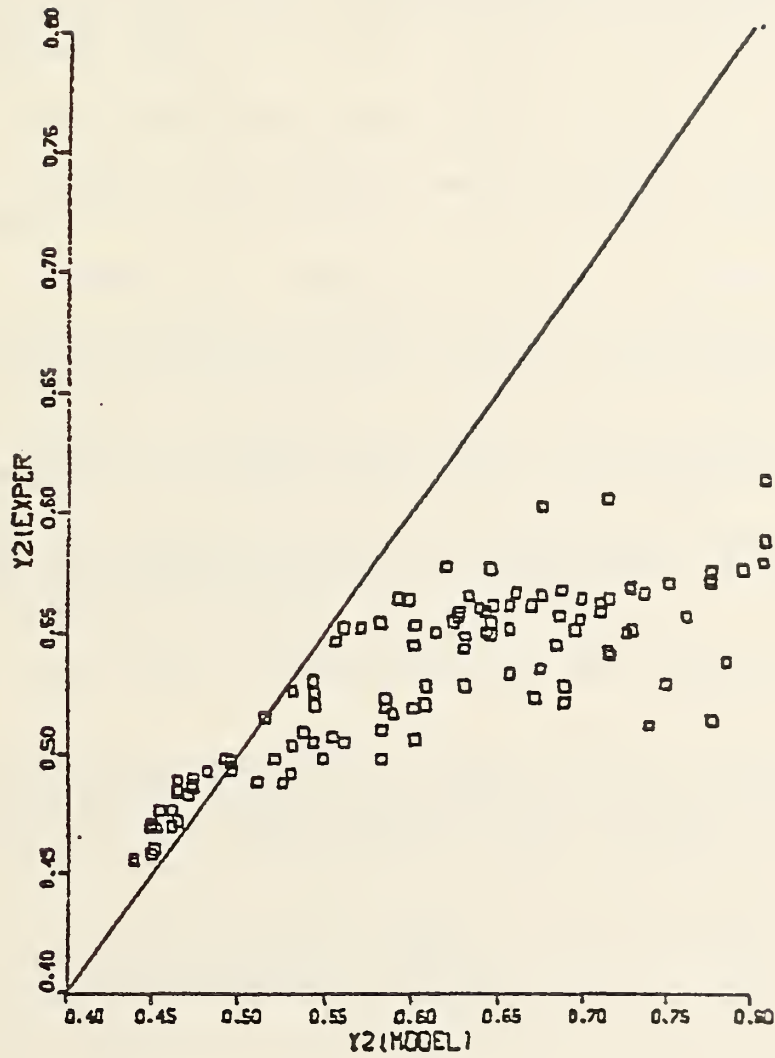


Figure 11. Comparison of dimensionless neutral plane, experiment with theory

Discussion After J. Quintiere's Report on AN ASSESSMENT OF FIRE INDUCED FLOWS IN COMPARTMENTS

MITLER: In the last slide you showed, you used the theoretical model and Jerry Faeth's expression for entrainment.

QUINTIERE: Yes.

MITLER: That could be the reason for the failure of the accuracy.

QUINTIERE: It is possible, as I said, but it is also possible that there are other flows that impact the calculation and will perturb it. In any case, even if the other flows were contained in the model, the model would still be approximate. If one can predict the temperatures within the compartment, the vent flow rate should be able to be done with great accuracy. The entrainment by the fire plume, then, really bears on the prediction of the height of the layer within the room.

ZUKOSKI: Are the actual flames above the interface?

QUINTIERE: I think in all cases they were comparable, maybe Dr. Steckler would care to comment.

STECKLER: In general, yes, flames were above the interface.

ZUKOSKI: I don't believe that Faeth's model is very good for that case and as you get down lower, it may account for some of your problem there.

QUINTIERE: This is the only result we have. We are hopeful that someone else that has the ability to measure entrainment will measure it for this fire.

ZUKOSKI: In the previous slide, the entrainment by the door jet that was formed, when the interface was below the window sill, did the extra entrainment by the door jet have an effect?

QUINTIERE: That is not in this calculation. So it may be if we put that into it.

LEVINE: Dr. Wakamatsu told us of one case where the architects used mathematical modeling to design the smoke protection in their building. I wonder if there are any other cases like this in Japan. We have been developing mathematical models and they have not yet been used by the building community.

WAKAMATSU: We are not only using them for small building but also we are using mathematical models for high rise buildings. We are trying to predict the smoke movement in high rise buildings, particularly smoke movement in doorways.

LEVINE: What methods do you use to teach the building designers how to use the models?

WAKAMATSU: The designers depend on professionals who can compute. However, young building engineers now can compute.

PRE-FLASHOVER AND FLASHOVER BEHAVIOR

IN COMPARTMENT FIRES

HISAHIRO TAKEDA

University of Tokyo*

*present address : Center for Fire Research, National Bureau of Standards, U.S. Department of Commerce, Washington, D.C., 20234

ABSTRACT

New dimensionless variables and parameters which were satisfied with the scaling effect were introduced into the simple one zone model of compartment fires. The solutions of the new dimensionless model were divided into three kinds of types in response to the "F" number, which was defined as the ratio of the fuel surface area to the floor surface area. When the F number was more than 0.107, no critical phenomena appeared in the diagram of the burning rate and the ventilation parameter. While for $F < 0.107$, the critical phenomena which included the discontinuous jump appeared in this diagram. But the flashover as a transient phenomenon was not always correspondent to this discontinuous jump. In this paper the possibility of the occurrence of flashover was discussed using the the theoretical analysis and some experimental approaches. From this the flashover was expected to occur in the region of $F > 0.107$, and even in the region of $0.0388 < F < 0.107$ when $A\sqrt{H}/L^2 < 0.13$.

INTRODUCTION

Liquid or thermoplastic pool fires in compartments have been investigated in recent years. Quintiere et al.[1] reported the quasi-steady state analysis of small scale compartment fires in which they investigated the energy and mass conservation equations in the two zone model to obtain the multi-valued results and discussed the problem of flashover. Also Thomas[2,3] and Thomas et al.[4] presented a qualitative discussion of the problem of flashover. They thought the discontinuous jump from one equilibrium state to another was a kind of flashover. The existence of such discontinuous jump was demonstrated experimentally in the liquid fuel compartment fires by Takeda et al.[5,6]. They, at the same time, showed the scale effect of compartment size. Figure 1 displays their experimental results of the methanol compartment fires in terms of the mass burning rate of methanol R and the ventilation parameter $A\sqrt{H}$ for various size compartments with constant fuel surface area $A_V (=15\text{cm} \times 15\text{cm})$. Where L is the compartment size and R_f is the free burning rate (without compartment). The discontinuous jump appeared in the 0.4 and 0.5m compartment experiments, but did not appear in the other experiments. Clearly this jump phenomenon depends on the correlation between the compartment size and the fuel size.

According to Takeda et al.[7], the most important parameter for the prediction of fire behavior may be the ratio of the fuel surface area A_V to the floor surface area L^2 . They called it "F" number, that is $F=A_V/L^2$. In case of PMMA compartment fires the discontinuous jump appeared in the region of $0.0388 < F < 0.107$ from their theoretical prediction[7], which

agreed well with the experimental results[7]. In this paper, dimensionless variables and parameters were introduced into the one zone model to make a more general fire model with some discussions.

[Pre-flashover fire behavior]

Figure 2 shows the gas temperature-time histories within the compartment for the PMMA wall fire experiments using a small scale enclosure (1.0m × 0.9m × 0.75m height). The number ① ~ ⑥ in this figure indicates the thermocouple position located vertically from ceiling to floor ; ① was located 0.045m just under the ceiling, ⑥ was located 0.045m just above the floor, and ② to ⑤ were located between ① and ⑥ at regular intervals. The hot gas layer rapidly came down at about 1400 sec, and ⑤ and ⑥ thermocouples indicated the characteristic temperature jump. The flashover may be decided to occur at the time of the jump of ⑥ thermocouple. In this case the flashover time t_f was 1426sec.

Figure 3 shows the time dependent temperature profiles in the compartment. The boundary between the upper hot gas layer and the lower cold gas layer could be easily obtained in this figure. If the discontinuous plane is decided as the inflection point of each curve, we can obtain the growth behavior of the upper hot gas layer. Figure 4 displays the behavior of the upper hot gas layer. The flashover occurred at 1426sec and then the gas temperature within the compartment became almost uniform (see Fig.3). So the one zone model may be valid for the post flashover fire model.

[Simple one zone model]

As previously reported [7], the simple one zone model including the mixing controlling step presented the whole aspect of post flashover fire behavior. The theoretical prediction from this model agreed well with the

experimental results[7].

The basic equations of this model are as follows

$$Q_c = Q_v + Q_w + Q_R + Q_o \quad (1)$$

The heat release rate Q_c is as follows:

$$Q_c = \begin{cases} \Delta H_c m_a \mu & \text{for } m_a \gamma < R \\ & \text{(ventilation control)} \\ \Delta H_c R \mu / \gamma & \text{for } m_a \gamma > R \\ & \text{(fuel control)} \end{cases} \quad (2)$$

Q_v is the heat loss rate by ventilation and may be written as:

$$Q_v = C_p \{m_a (T - T_o) + R (T - T_l)\} \quad (3)$$

Q_w is the heat loss rate by wall conduction and may be approximately written as :

$$Q_w = A_w h (T - T_o) \quad (4)$$

Q_R is the feed back energy to the condensed fuel:

$$Q_R = \Delta H_v R \quad (5)$$

Q_o is the radiation heat loss through the ventilation opening:

$$Q_o = A\sigma \{\epsilon T^4 + (1-\epsilon)T_w^4 - T_o^4\} \quad (5)$$

The inflow rate of air by ventilation may be evaluated by the following:

$$m_a = 0.55A\sqrt{H} \quad (6)$$

The burning rate may be described as:

$$R = R_f + \Delta R \quad (7)$$

R_f is the free burning rate and ΔR is the enhancement of the burning rate

by the compartment effect:

$$\Delta R = A_v [\sigma \{ \epsilon T^4 + (1-\epsilon) T_w^4 - T_o^4 \} + h_f (T - T_o)] / \Delta H_v \quad (8)$$

And ϵ is the gas emissivity:

$$\epsilon = 1 - \exp(-kL) \quad (9)$$

[Dimensionless transformation]

Introducing new dimensionless variables and parameters, we must take care of the scaling law. Table I expresses the upper and lower limits of the discontinuous jump appeared in the $R-A\sqrt{H}$ relation, where we can see the oxygen concentration, the combustion efficiency μ , the average gas temperature T and F number are almost constant. So the dimensionless temperature can be defined as $\theta \equiv T/T_o$ (T_o : ambient temperature). The normalized burning rate R/L^2 and ventilation parameter $A\sqrt{H}/L^2$ are also nearly constant. As F is nearly constant as shown in Table I,

$$L^2 \sim A_v \quad (10)$$

and if the following relationship is assumed,

$$R_f \sim A_v \quad (11)$$

we can obtain the following:

$$R_f \sim L^2 \quad (12)$$

So the dimensionless burning rate can be defined as follows:

$$\chi \equiv R/R_f \quad (13)$$

Similarly the dimensionless mass flow rate of inflow air by ventilation ψ can be obtained as follows:

$$\psi \equiv m_a/R_f \quad (14)$$

Also the following dimensionless parameters are introduced,

$$\eta_R \equiv \frac{A_w \sigma T_o^4}{(\Delta H_c R_f)} \quad (\text{dimensionless radiative heat transfer coefficient}) \quad (15)$$

$$\eta_c \equiv \frac{A_w h T_o}{(\Delta H_c R_f)} \quad (\text{dimensionless convective heat transfer coefficient}) \quad (16)$$

$$\alpha_o \equiv A/A_w, \quad \alpha_v \equiv A_v/A_w$$

$$\nu \equiv \Delta H_v / \Delta H_c, \quad \delta \equiv C_p T_o / \Delta H_c$$

Using these variables and parameters, we can obtain the dimensionless equations of fire model.

$$\delta\{\psi(\theta-1)+\chi(\theta-\theta_{\infty})\} + \eta_c(\theta-1) + \nu\chi + \eta_R\alpha_o\{\epsilon\theta^4+(1-\epsilon)\theta_w^4-1\} = \begin{bmatrix} \psi\mu \\ \gamma\chi\mu \end{bmatrix} \quad (17)$$

$$\chi = 1 + (\alpha_v/\nu)[\eta_R\{\epsilon\theta^4+(1-\epsilon)\theta_w^4-1\}+\eta_c(\theta-1)] \quad (18)$$

RESULTS AND DISCUSSION

The calculated results were divided into three kinds of types in response to F as shown in Fig.5. The type I has no critical phenomena, while the types II and III have some characteristic behavior. The type I corresponds to the experimental results of $L=0.15$ and 0.25m in Fig.1, the type II corresponds to 0.4 and 0.5m , and the type III corresponds to 0.7m except for the isolated island. Figure 6 displays these results in terms of the dimensional variables R and m_a .

The jump phenomenon such as type II in Fig.7 has been already observed in the work of the liquid fuel compartment fire experiments[5], but the isolated island appeared in the type III solution has not yet been observed experimentally. Probably this isolated island may not be realized under the ordinary experimental condition. Thomas[2,3] showed the similar prediction in his theoretical prediction, but his approach was not so simple.

The flashover as a transient phenomenon will occur in the regions of type I and II. It must be noted that the discontinuous jump appeared in the $R-A\sqrt{H}$ relationship is different from the flashover as a transient phenomenon. Figure 2 shows the occurrence of flashover in the region of type I.

We can say the flashover will not occur in the region of type III, that is to say, $F < 0.0388$, and even in the region of type II we have no flashover when $A\sqrt{H}/L^2 > 0.13 \text{ m}^{1/2}$. But in the region of type I ($F > 0.107$) we should think about the possibility of flashover. Figure 8 presents an example to show the possibility of flashover for any values of $A\sqrt{H}$, where the upper figure denotes the steady state relationship between R and $A\sqrt{H}$ and the lower figure denotes the R -time histories. From this figure the curves "d", "e" and "f" clearly

show the occurrence of flashover, while the others don't so clearly but we can't eliminate the possibility of flashover. Because the weak flashover may be expected in the curves "a", "b" and "c". The above discussion was summarized in Table II.

SUMMARY

Some aspects of the pre-flashover and flashover fire behaviors were investigated using the small scale experiments and the simple theoretical analysis. The gas temperature in the compartment has a wide distribution in the pre-flashover period, but on the contrary it becomes almost uniform after flashover. So the one zone model is valid to investigate the post-flashover fire behavior. New dimensionless variables and parameters were introduced into the simple one zone model to be satisfied with the scaling effect. The solutions from this model were divided into three kinds of types in response to F number. And the possibility of flashover was discussed from this theoretical prediction. From this result we must consider the possibility of flashover in the region of $F > 0.107$, and even in the region of $0.0388 < F < 0.107$ when $A\sqrt{H}/L^2 < 0.13$. On the contrary, the flashover will not occur in the region of $F < 0.0388$, and in the region of $0.0388 < F < 0.107$ when $A\sqrt{H}/L^2 > 0.13$.

NOMENCLATURE

A	opening area
A_v	fuel surface area
A_w	wall surface area of compartment
$A\sqrt{H}$	ventilation parameter
C_p	specific heat of gas
F	F number ($=A_v/L^2$)
H	opening height
h	wall heat transfer coefficient
h_f	fuel heat transfer coefficient
k	absorption coefficient
L	compartment size
m_a	inflow rate of air by ventilation
Q	rate of heat flow
R	mass burning rate of fuel
T	gas temperature
T_w	wall temperature
ΔH_c	heat of combustion
ΔH_v	latent heat of gasfication

Greek Symbols

γ	fuel to air mass ratio
ϵ	gas emissivity
σ	Stefan-Boltzman constant
μ	combustion efficiency

REFERENCES

- 1 Quintiere, J.G., McCaffrey, B.J. and DenBraven, K., Seventeenth Symposium (International) on Combustion, p1139, The Combustion Institute, 1979.
- 2 Thomas, P.H., Eighteenth Symposium (International) on Combustion, p503, The Combustion Institute.
- 3 Thomas, P.H., Fire Safety Journal, 3, 67, 1980/81.
- 4 Thomas, P.H., Bullen, M.L., Quintiere, J.G. and McCaffrey, B.J., Combust. Flame, 38, 159, 1980.
- 5 Takeda, H. and Akita, K., Eighteenth Symposium (International) on Combustion, p519, The Combustion Institute, 1981.
- 6 Takeda, H., Kawaguchi, K. and Akita, K., Bulletin of Japanese Association of Fire Science and Engineering, 31(2), 19, 1981.
- 7 Takeda, H. and Akita, K., Nineteenth Symposium (International) on Combustion, p897, The Combustion Institute, 1983.

A LIST OF FIGURE CAPTIONS

- Fig.1 Mass burning rate of methanol R as a function of $A\sqrt{H}$ for various size compartments (L : compartment size) with constant fuel surface area($=0.15\text{m} \times 0.15\text{m}$).
- Fig.2 Gas temperature-time histories within the compartment for the PMMA wall fire experiments using a small scale enclosure ($1.0\text{m} \times 0.9\text{m} \times 0.75\text{m}$ height). The number ① ~ ⑥ indicates the thermocouple position located vertically from ceiling to floor.
- Fig.3 Time dependent temperature profile in the compartment.
- Fig.4 Growth of the upper hot gas layer.
- Fig.5 Solutions of the dimensionless equations of compartment fires.
- Fig.6 Theoretical results of the mass burning rate R as a function of $A\sqrt{H}$.
- Fig.7 Behavior of the discontinuous jump in the types II and III.
- Fig.8 Experimental results of PMMA compartment fires in case of 0.4m enclosure with $0.15\text{m} \times 0.15\text{m}$ PMMA floor. The upper figure corresponds to the steady state mass burning rate as a function of $A\sqrt{H}$, and the lower corresponds to the time dependent burning rate. Where a: $A\sqrt{H}=0.00365\text{m}^{5/2}$, b: $A\sqrt{H}=0.625\text{m}^{5/2}$, c: $A\sqrt{H}=0.007\text{m}^{5/2}$, d: $A\sqrt{H}=0.0116\text{m}^{5/2}$, e: $A\sqrt{H}=0.0157\text{m}^{5/2}$, f: $A\sqrt{H}=0.019\text{m}^{5/2}$, g: $A\sqrt{H}=0.0216\text{m}^{5/2}$, h: $A\sqrt{H}=0.0242\text{m}^{5/2}$.

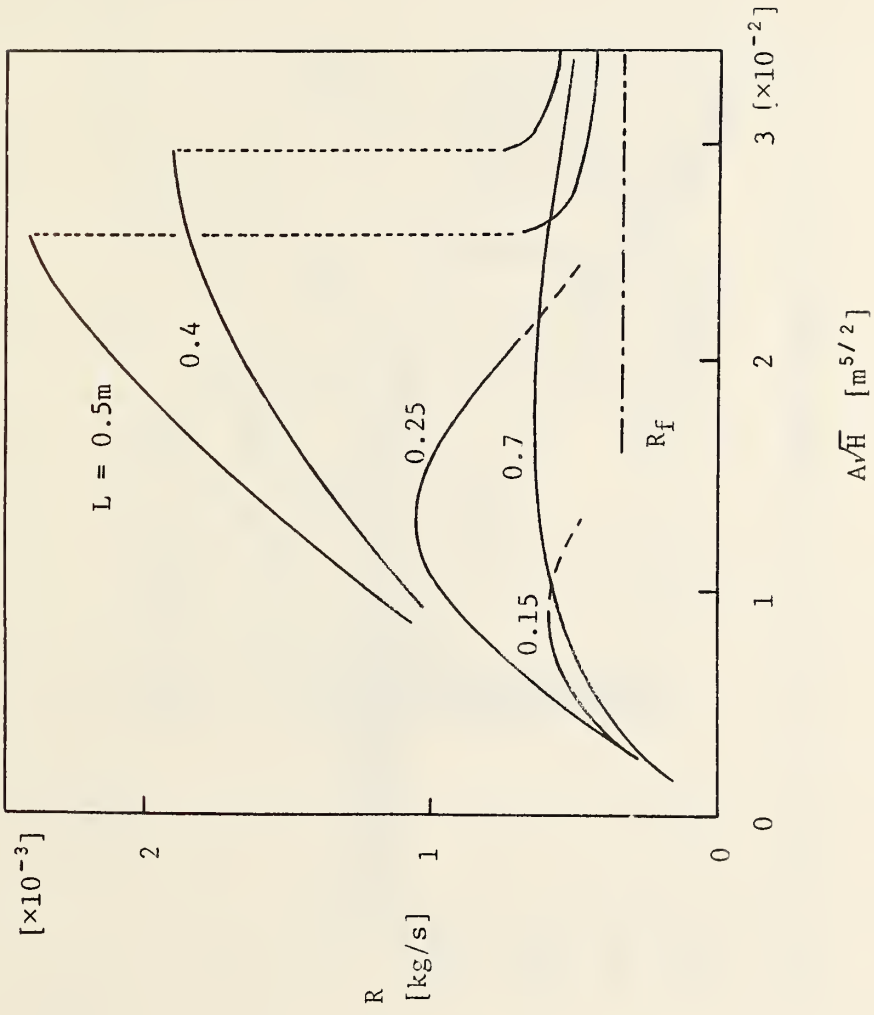


Fig. 1

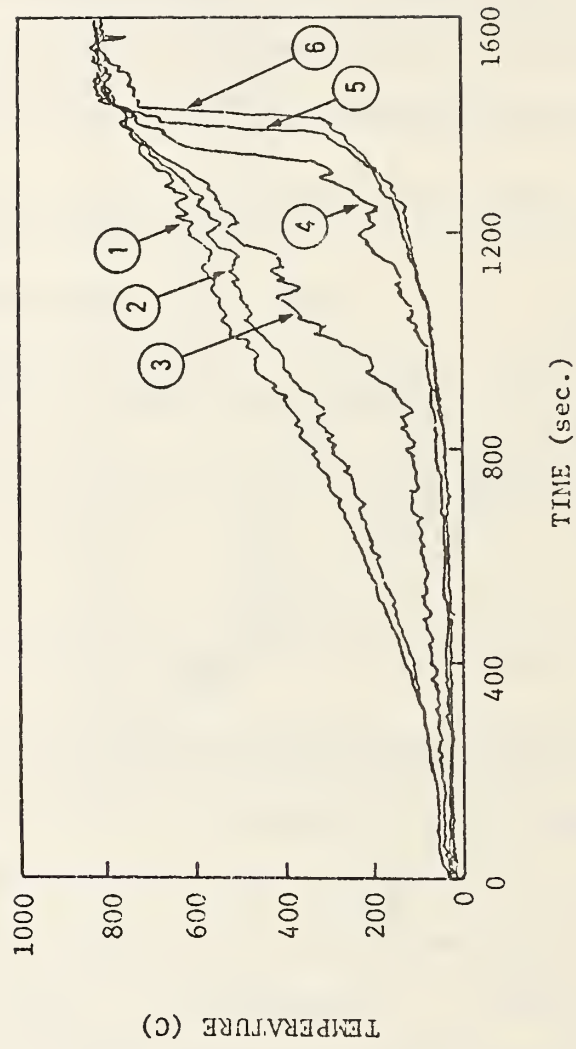


Fig. 2

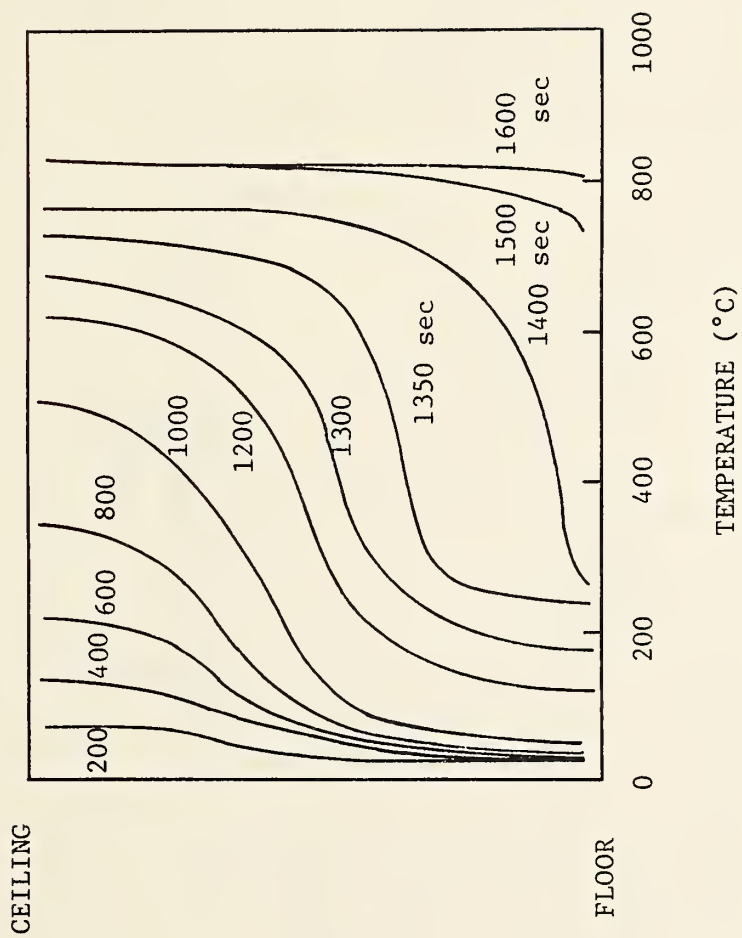


Fig. 3

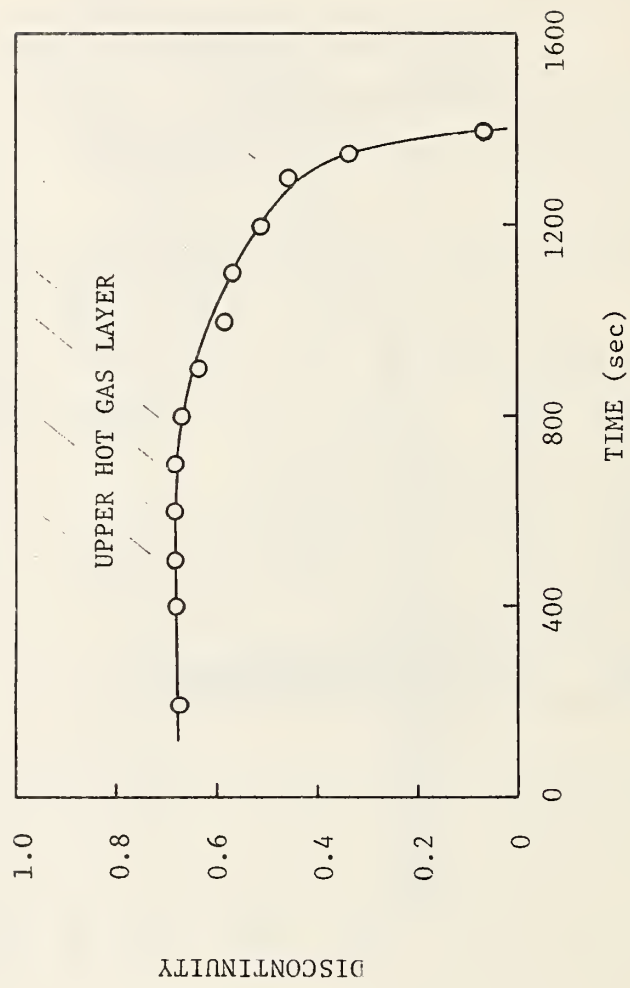
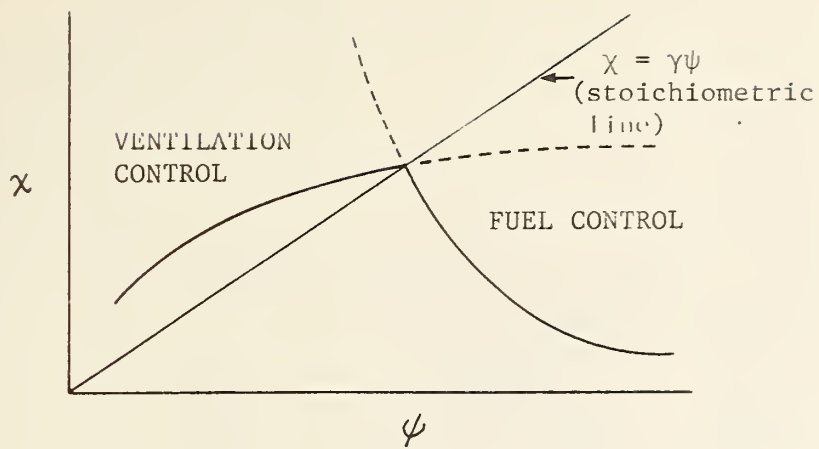
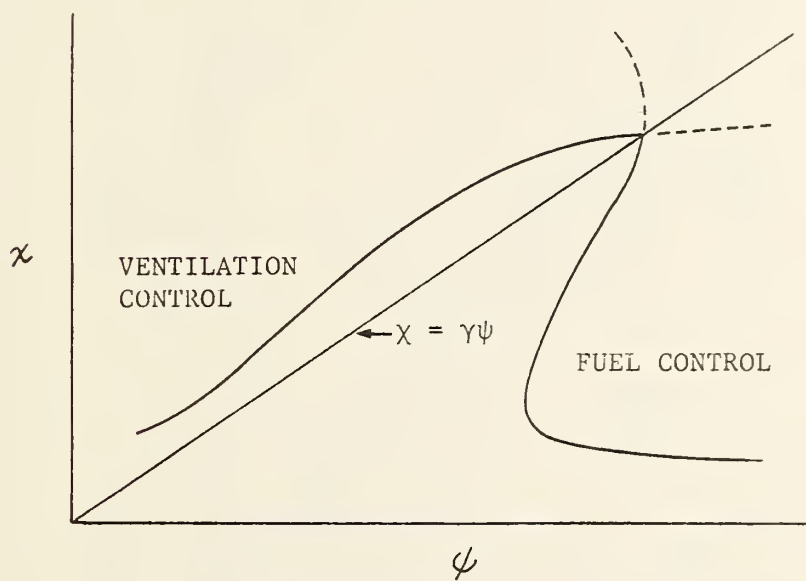


Fig. 4

[I]



[II]



[III]

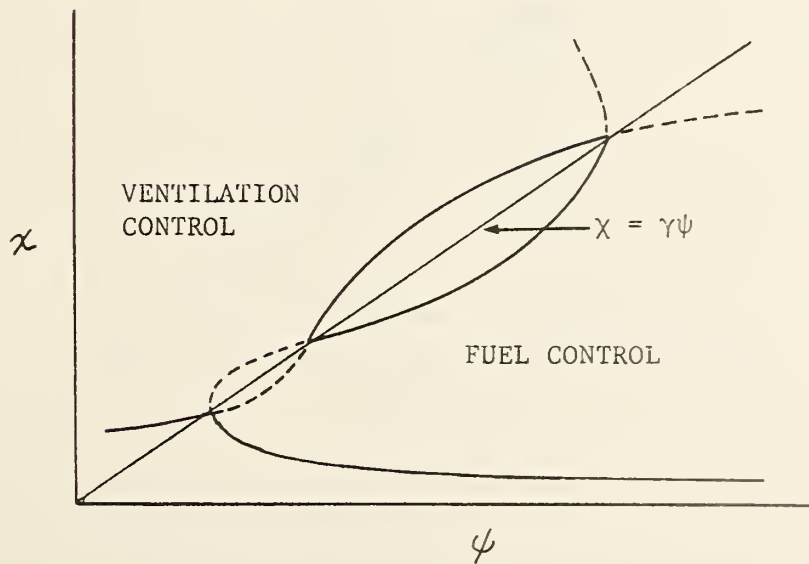


Fig. 5

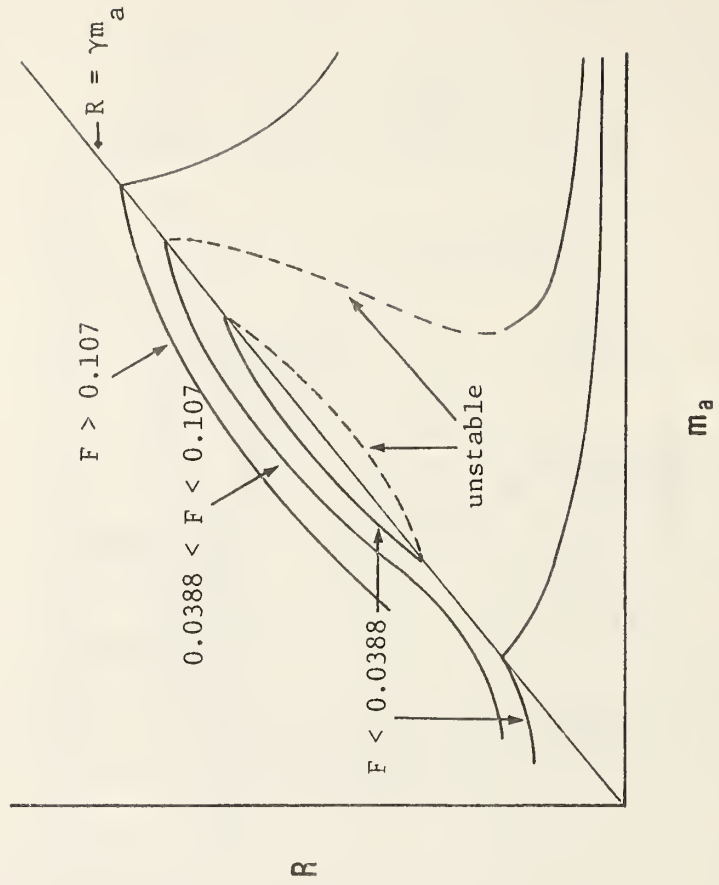
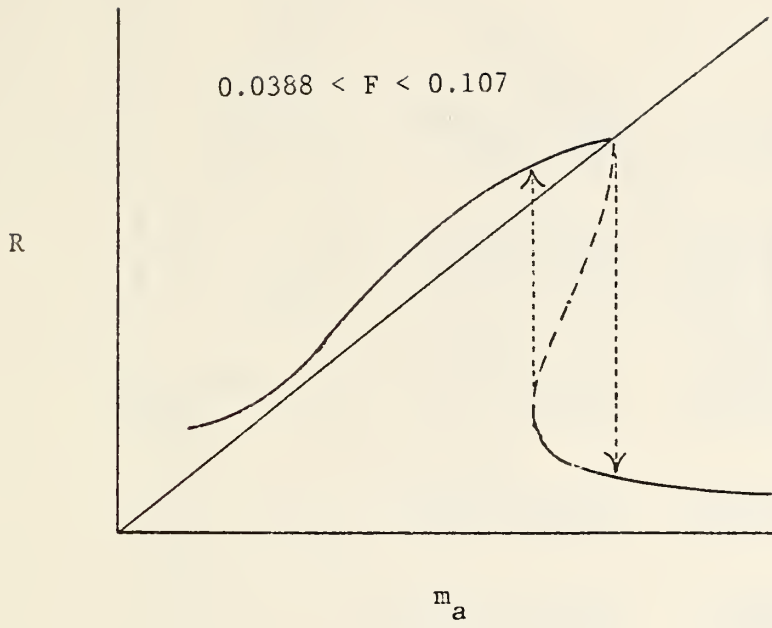


Fig. 6

[II]



[III]

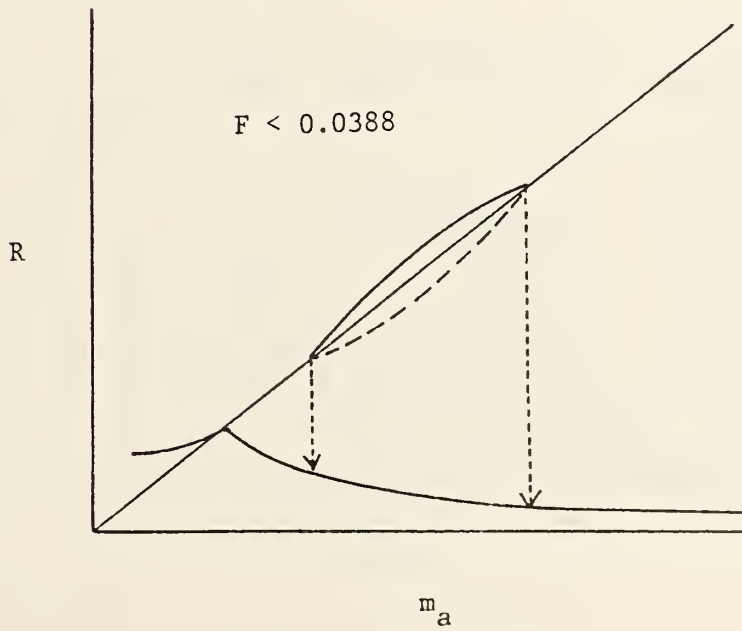


Fig. 7

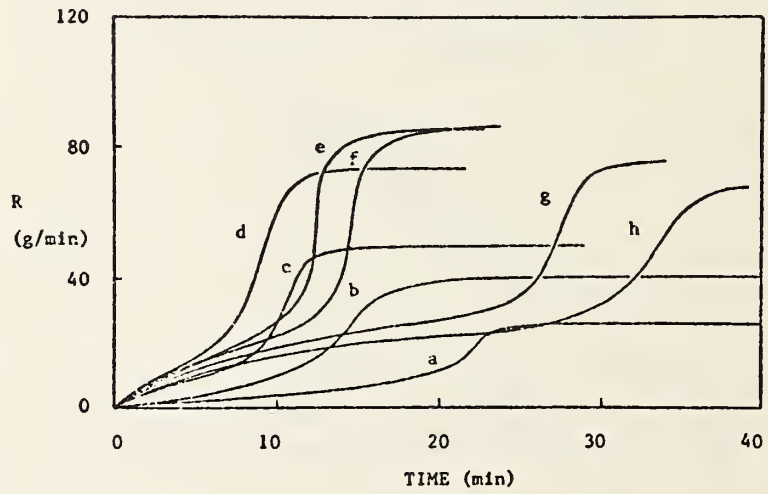
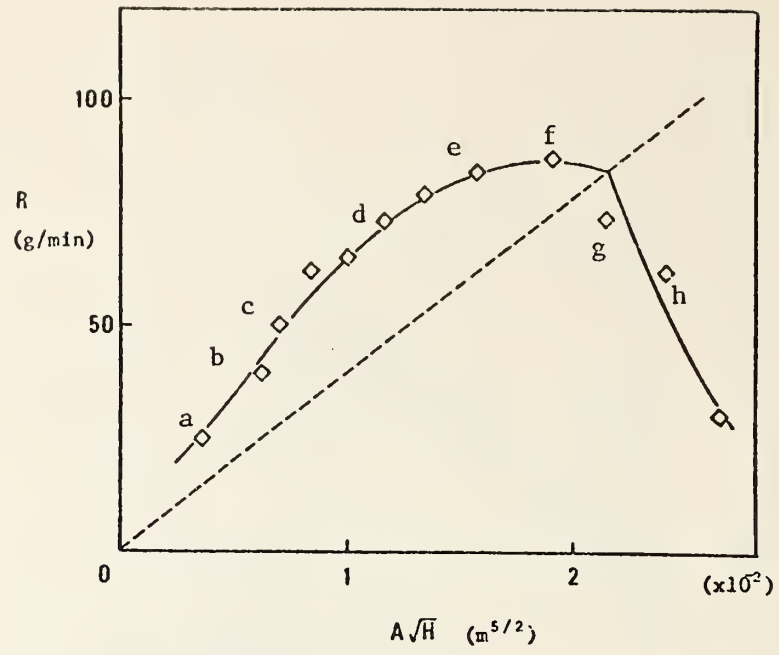


Fig.8

TABLE I

The upper and lower limits of the discontinuous jump

L (m)	Δv (m ²)	R (kg/s)	$A\sqrt{H}$ (m ^{5/2})	O_2 (%)	μ	T (K)	F	R/HL^2 (kg/s m ²)	$A\sqrt{H}/L^2$ (m ^{1/2})
<i>Upper limit</i>									
0.25	0.0067	0.000545	0.008	9.9	0.517	1060	0.1072	0.00872	0.128
0.30	0.0096	0.000792	0.0113	9.9	0.515	1060	0.1067	0.0088	0.126
0.40	0.0171	0.00144	0.0213	10.1	0.508	1060	0.1069	0.009	0.133
0.50	0.0267	0.00228	0.0341	10.2	0.504	1060	0.1068	0.00912	0.136
0.70	0.0524	0.00445	0.0542	10.1	0.507	1060	0.1069	0.00908	0.131
1.00	0.1071	0.00922	0.134	10.2	0.502	1060	0.1071	0.00922	0.134
1.50	0.2409	0.02085	0.303	10.2	0.501	1060	0.1071	0.00927	0.135
2.00	0.4288	0.03717	0.541	10.2	0.501	1060	0.1072	0.00929	0.135
3.00	0.967	0.08385	1.222	10.2	0.500	1060	0.1074	0.00932	0.136
<i>Lower limit</i>									
0.40	0.0062	0.000147	0.00219	0.03	1.0	650	0.0388	0.00092	0.137
0.50	0.0096	0.000228	0.00342	0.025	0.999	650	0.0384	0.00091	0.137
0.70	0.0187	0.000450	0.00670	0.024	0.999	650	0.0382	0.00092	0.137
1.00	0.038	0.000917	0.0137	0.023	0.999	650	0.0380	0.00092	0.137
2.00	0.151	0.00366	0.0347	0.022	0.999	650	0.0378	0.00092	0.137
3.00	0.340	0.00823	0.123	0.0213	0.999	650	0.0378	0.00092	0.137

TABLE II

<p>TYPE I ($F > 0.107$)</p>		FLASHOVER
<p>TYPE II ($0.0388 < F < 0.107$)</p>	<p>$A\sqrt{H}/L^2 < 0.13$</p> <p>$A\sqrt{H}/L^2 > 0.13$</p>	<p>FLASHOVER</p> <p>NO FLASHOVER</p>
<p>TYPE III ($F < 0.0388$)</p>		NO FLASHOVER

Discussion After H. Takeda's Report on PRE-FLASHOVER AND FLASHOVER BEHAVIOR IN COMPARTMENT FIRES

PAGNI: I'm interested in the choice of L^2 in your F number. Does that constrict you too much to the choice of the shape of the compartment? Why not use the ratio of the fuel surface area to the entire compartment surface area?

TAKEDA: I don't think your suggestion will change the results greatly; but, if we adopt your suggestion, then compartment shape factor will not come into the computation. In this case, the shape factor is not incorporated in here. But, I feel it's better if we incorporate a shape factor into our formula in the future. In other words, I feel that the introduction of the compartment shape factor somehow should be incorporated in the future. At this stage, however, a shape factor is not incorporated. As long as the shape of the compartment is closer or similar to a cubic one, we feel that the floor area can be used interchangeably here.

PRELIMINARY REPORT ON A MODEL TO DESCRIBE THE
FLOW IN THE CEILING LAYER OF A TWO LAYER FIRE MODEL

E. E. ZUKOSKI and T. KUBOTA
CALIFORNIA INSTITUTE OF TECHNOLOGY

OCTOBER, 1983

I. INTRODUCTION

This paper is a preliminary report on a project in which we are developing the ability to describe the flow field produced within a room by a fire. Our aim is to describe the flow with sufficient detail that we can make estimates of the heat transfer to the walls of the room and to objects within the room due to forced convection and radiation. In this report we will briefly describe some elements of a model we are developing to predict the flow produced by a fire plume within the ceiling layer.

To illustrate the problems which concern us consider Figure 1 which is a schematic of the flow produced by a fire within a room. To make the flow as simple as possible for this first example, we have picked a configuration which is axisymmetric and have assumed that the region of flaming combustion, i.e., the flame, lies below the interface between the hot and cold layers.

Heat is added to the fire plume in the region of flaming combustion and above the top of the flame, a purely buoyant plume develops in which the enthalpy flux related to the ambient fluid is constant. This plume penetrates the density discontinuity at the interface and then impinges on the ceiling. The plume flow is turned by the impingement process and spreads out along the ceiling to form a wall-jet. This jet impinges on the side walls and is turned downward. As it moves down the vertical side walls, it must be turned again to satisfy the entrainment needs of the plume and wall-jet, and the flow through the openings.

Negative buoyancy forces resulting from the development of cool boundary layers on the side walls will augment the downward momentum of this flow and the resulting wall-jets may produce mixing between the ceiling layer gas and the fresh air in the lower layer. Similar mixing may be produced by the inflowing stream of cool air induced by the pressure difference across the opening.

A strong return flow is required to feed the flow entrainment into the plume and wall-jet flows. Some idea of the size of these flows is given in Figure 1. In this example, we have assumed that the ceiling layer lies half way between the ceiling and the floor, that the ceiling layer temperature is relatively cool because of heat transfer to the walls and that the room has a diameter equal to twice the ceiling height. If we define m as the flow in the plume

at the interface, then the flow in the plume at the ceiling level would be about 3m and the flow in the wall-jet at a radius equal to the room height would be about 9m. If we consider a steady state flow and ignore the entrainment in the flow along the side walls, then the flow out of the opening must be equal to the plume flow m and consequently the total return flow will be about 8m. This large return flow is responsible for keeping the ceiling layer well mixed and consequently at a more or less uniform temperature and composition.

The wall-jet flow and the return flow for this example are complex enough but they have been greatly simplified by the assumption that the flow is axisymmetric. When the room-fire geometry is not axisymmetric, the treatment of the wall-jet and the return flow will be more complex and will require an understanding of the processes which occur when the wall-jet on the ceiling impinges on the side walls at the wall-ceiling corner.

A number of physical processes arise here which must be understood and modeled before a rational description of the whole process can be developed. Because of space limitations, we will be able to mention here only a few of the process which we are attempting to model at present and have restricted ourselves to processes involved with the plume. We also present a more detailed description of the plume calculations to give a better picture of the type of model we are developing.

II. FLAME REGION

At present, the only feature of the flame or the heat addition region which can be described quantitatively is the height of the top of the flame. Flame heights can be estimated from correlations based on extensive set of data and the estimates are probably reliable to within 15% for flames burning in undisturbed ambient air. (See the correlation given in Equations 4.) When the flame is immersed in hot, vitiated air or is blown over by a horizontal current of air, our knowledge of its height or other characteristics is less reliable.

A detailed analytic description of the heat addition process for a large diffusion flame is not possible at present. In addition, we do not have a quantitative measure of the influence on the characteristics of the plume of the buoyancy jump at the interface between hot and cold fluid or the effect of the ceiling when the flame is long enough to impinge on the ceiling.

III. PLUME CALCULATIONS

The flow produced by a turbulent, buoyant plume can be described in terms of a simple algebraic model with some accuracy for a range of conditions. Calculations of this type are described here and will be used to give the initial conditions for the IMPINGEMENT REGION.

1. POINT-SOURCE PLUME

We are interested here in the buoyant plume rising from a point source of buoyancy into a constant density atmosphere. The recipe for the Far Field Plume model can be conveniently given in terms of a dimensionless heat release parameter called Q^* :

$$Q^* = Q^*(Z) = Q/\rho^*C_p^*T^*\sqrt{gZ} Z^2 \quad (1)$$

where, ρ , C_p , and T are the density, specific heat and temperature of the ambient gas around the plume, g is the gravitational constant and Z is the elevation above the point source.

When we assume that the profiles for velocity and temperature difference are Gaussian, then the temperature difference ΔT_m and velocity V_m on the centerline of the plume, the Gaussian half width of the velocity profile b , and the ratio of the velocity and thermal profile half widths s can be expressed as functions of the Q^* parameter, and elevation Z as:

$$\begin{aligned} \Delta T_m &= 9.12*(Q^*)^{2/3} & , & & b &= 0.13*Z \\ V_m &= 3.87*(Q^*)^{1/3} & , & & s &= 0.91 \end{aligned} \quad (2)$$

This formulation is in the standard form with the exception that some of the constants may differ slightly from those proposed by Morton(1954) and other authors and the use of the Q^* parameter gives a particularly simple representation.

The plume mass flow rate can also be given in terms of the parameters used here and is:

$$m(Z) = 0.21*\rho\sqrt{gZ} Z^2 *(Q^*) \quad (3)$$

2. FREE FIRE-PLUME CALCULATIONS

The buoyant plume which develops above a diffusion flame and rises through a constant density atmosphere is called a free fire-plume. Its properties can be calculated with the aid of the point-source model presented above and the introduction of a number of empirical factors derived from different experiments. Our approach will be to replace the fire plume with an equivalent point-source plume for which we have the simple algebraic representations given above.

This calculation is made more complicated in the room fire context by the presence of three length scales, the flame height Z_f , the height of the interface between the hot and cold layers Z_i , and the height of the room Z_c . In room fires, the flame height Z_f can take on any value and can be larger than the ceiling height.

In this report, we will consider the plume calculations for conditions in which the flame length is much less than the interface height; the more complex flows for which $Z_f > Z_i$ will be discussed in a later paper. We will also ignore the effects of disturbances arising in the ambient fluid which can have a large effect on the flame and plume. (E.g., Zukoski et al, 1980)

We assume that the simple buoyant plume starts at the top of the visible flame (i.e., at Z_f) where the heat release rate due to chemical reactions is negligible. Thus, the source of this plume is characterized by a finite diameter and by finite values of mass and momentum fluxes. Given these fluxes and the diameter of the plume at the top of the flame, we can calculate the development of the plume at higher elevations by using the same set of differential equations used by Morton in their original calculations for the point source problem.

However, given our desire for a simple algebraic representation for the plume, we have found it more convenient to find an equivalent point-source plume which has the same heat release rate and the same far field characteristics as the finite-source plume. Thus by adjusting the origin for the vertical or Z axis, we can then use the simple point-source model to estimate the characteristics of the far field for the fire plume.

Because we do not yet have good measurements for the momentum flux and diameter of the plume at the top of the flame, we must use another type of empirical data. These data were obtained by measuring the mass flow rates in plumes formed above fires and finding the location of the source for a point source plume which had the same heat release rate and which gave the best match between the mass flow rates in the real and theoretical plumes.

Mass flow data presented in a form which makes the location of the source particularly easy is shown in Figures 2. The data have been replotted such that a function of the mass flow rate, see Equation 2, is linearly dependent on the elevation Z . Then extrapolation of this line to the origin of the mass flow parameter will give the desired location of the origin of the equivalent point-source plume.

The data suggest that the point-source should be located within a few fire diameters of the base of the flame at a distance close to Z_f below the finite source point. We have defined an offset distance, Z_o , such that if Z is measured from the plane of the base of the flame, the point-source lies at an elevation of $(-Z_o)$. Thus, a positive value for Z_o means that the origin of the equivalent point-source plume lay below the burner.

Values of offset distances are given in Figure 3 as a function of the ratio of flame height to fire diameter for data obtained at Caltech by Cetegen et al (1982). We also show our interpretation of offset data for large fires presented by Heskestad (1981). For large fires, values of Z_f/D are usually small, and consequently the offset distance will be a small fraction of the diameter of the fire.

Also note that the correlation given in this Figure depends on the geometry of the fire-room geometry. When a floor surrounded the fire and was at the same elevation as the fire, values of Z_o were about $0.3 \cdot D$ larger than when the fire was supported on a cylindrical burner several burner diameters above the floor.

To calculate the properties of the fire plume by the scheme outlined above, we must first find the flame length Z_f and then the offset for origin of the equivalent point source plume Z_o . Flame length correlations, see for example Cetegen et al (1982), can be expressed as:

$$Z_f/D = \begin{cases} 3.3*(Q^*D)^{2/3} & \text{when } Q^*D < 1.0 \\ 3.3*(Q^*D)^{2/5} & \text{when } Q^*D > 1.0 \end{cases} \quad (4)$$

where D is the diameter of the base of the fire and Q^*D is the parameter defined in Equation (1) with the elevation Z replaced with fire diameter D .

Also, the offset distance correlations are:

$$Z_o/D = \begin{cases} 0.5 - 0.33*(Z_f/D) & \text{without floor} \\ 0.8 - 0.33*(Z_f/D) & \text{with floor} \end{cases} \quad (5)$$

Plume calculations can now be carried out using the equations for the point-source plume listed above as Equations (2) and (3). However, we must now replace Z with the distance above the effective plume source to the point in question, called Z_e . Thus, the vertical dimension is adjusted for the offset Z_o , and, consequently:

$$Z_e = (Z + Z_o)$$

Note that for large values of Z_f/D , Z_o has a negative value and thus the offset origin of the equivalent plume lies below the source of the fire.

IV. IMPINGEMENT

There is some data available which describes the flow produced by a buoyant plume when it impinges on a horizontal ceiling and considerably more for isothermal jets. This data allows us to make reasonable estimates of the velocity and temperature profiles which result from the turning or impingement processes.

V. WALL-JET

The isothermal wall-jet can be treated with some confidence given our understanding of boundary layer like flows and a large body of experimental data. Three problems arise in making a model for the buoyant wall-jet: First, variations of buoyancy due to the development of a cold boundary layer next to the ceiling may effect the developement of the flow within the wall jet in an unknown manner. Second, the entrainment rate of the wall-jet depends strongly on its buoyancy and we are not confident that the models in use now are satisfactory. Third, if the wall temperature is

below that of the ceiling layer, the wall-jet can develop a negative buoyancy which would act to remove the jet from the wall. At present, we do not know how to treat the flow that will result when this happens.

Finally, the geometrical complexities described above lead to problems in treating the development of the wall-jet region.

VI. RETURN FLOW

A strong return flow is required to supply the fluid entrained by the plume and the wall jet. The calculation of the return flow may be complicated but the basic processes involved are straight forward. At present we are developing a simple two-dimensional flow model.

VII. CONCLUDING COMMENTS

In conclusion, we are developing a model for flow in the ceiling layer which may be a useful design tool. In addition, in the process of formulating this model, we are developing a better understanding of the processes which require further experimental investigation.

REFERENCES:

B. CETEGEN, E.E. ZUKOSKI AND T. KUBOTA, Entrainment and Flame Geometry of Fire Plumes, Report, Daniel and Florence Guggenheim Jet Propulsion Center, California Institute of Technology, Pasadena (1982)

G. HESKESTAD, Personal Communication

B.R. Morton, G.I. Taylor and J.S. Turner, Turbulent Gravitational Convection from Maintained and Instantaneous Sources, Proc. Roy. Soc., A 234, 1-23, (1956)

E.E. ZUKOSKI, T. KUBOTA and B. CETEGEN, Entrainment In Fire Plumes, Fire Safety Journal, 3(1980-81)

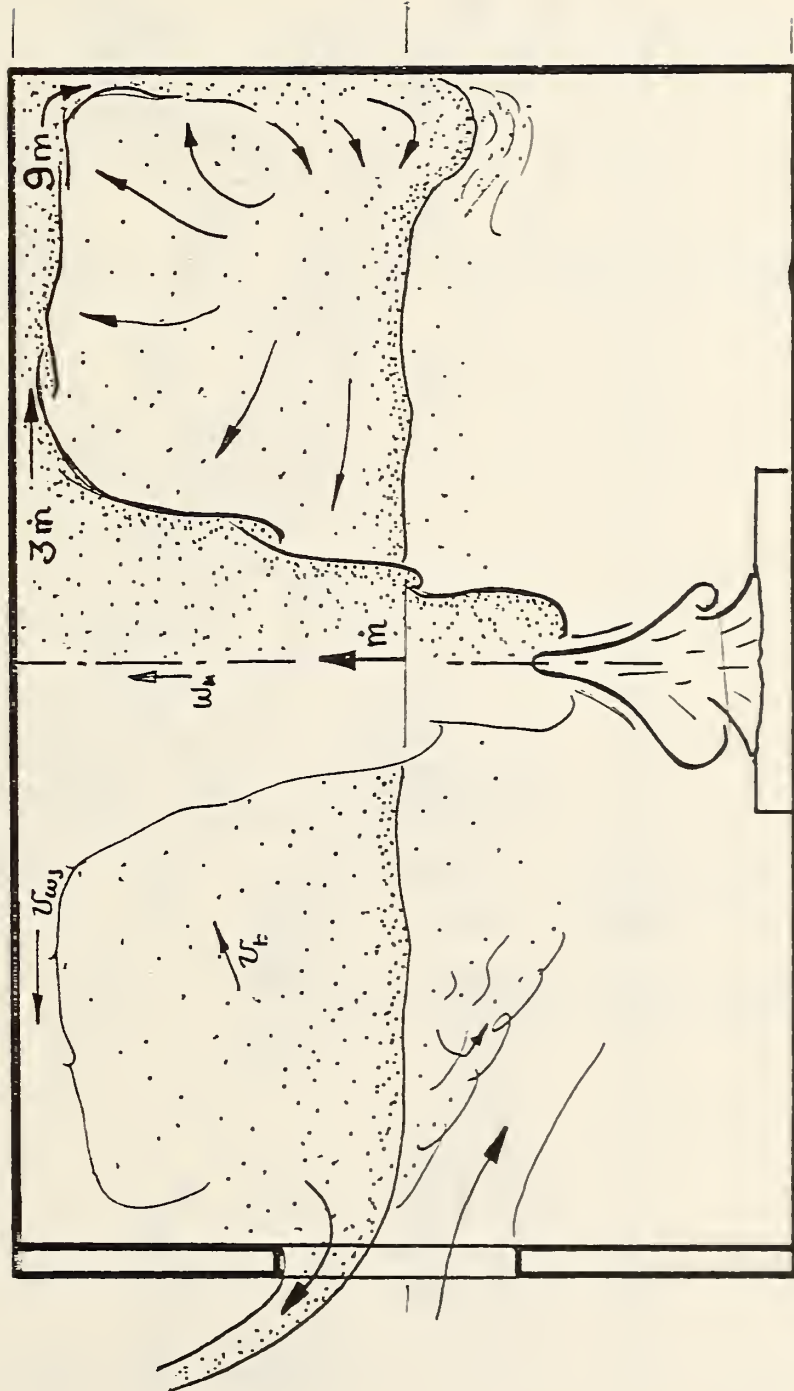


Figure 1. Axisymmetric Room-Fire

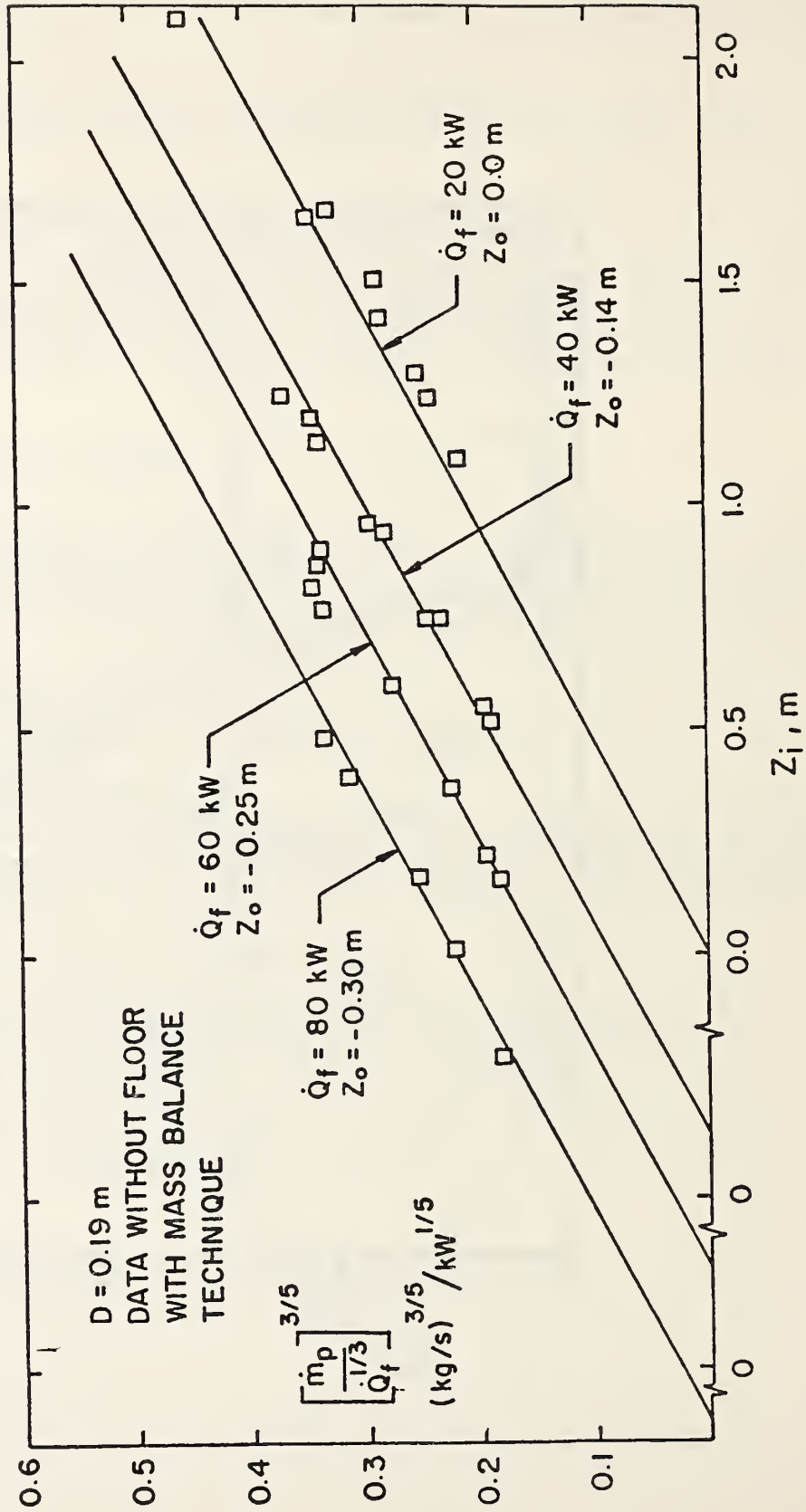


Figure (2) Offset measurement examples for the 0.19 m. dia. burner for far field data obtained without floor. Lines have a slope corresponding to $C_m = 0.21$.

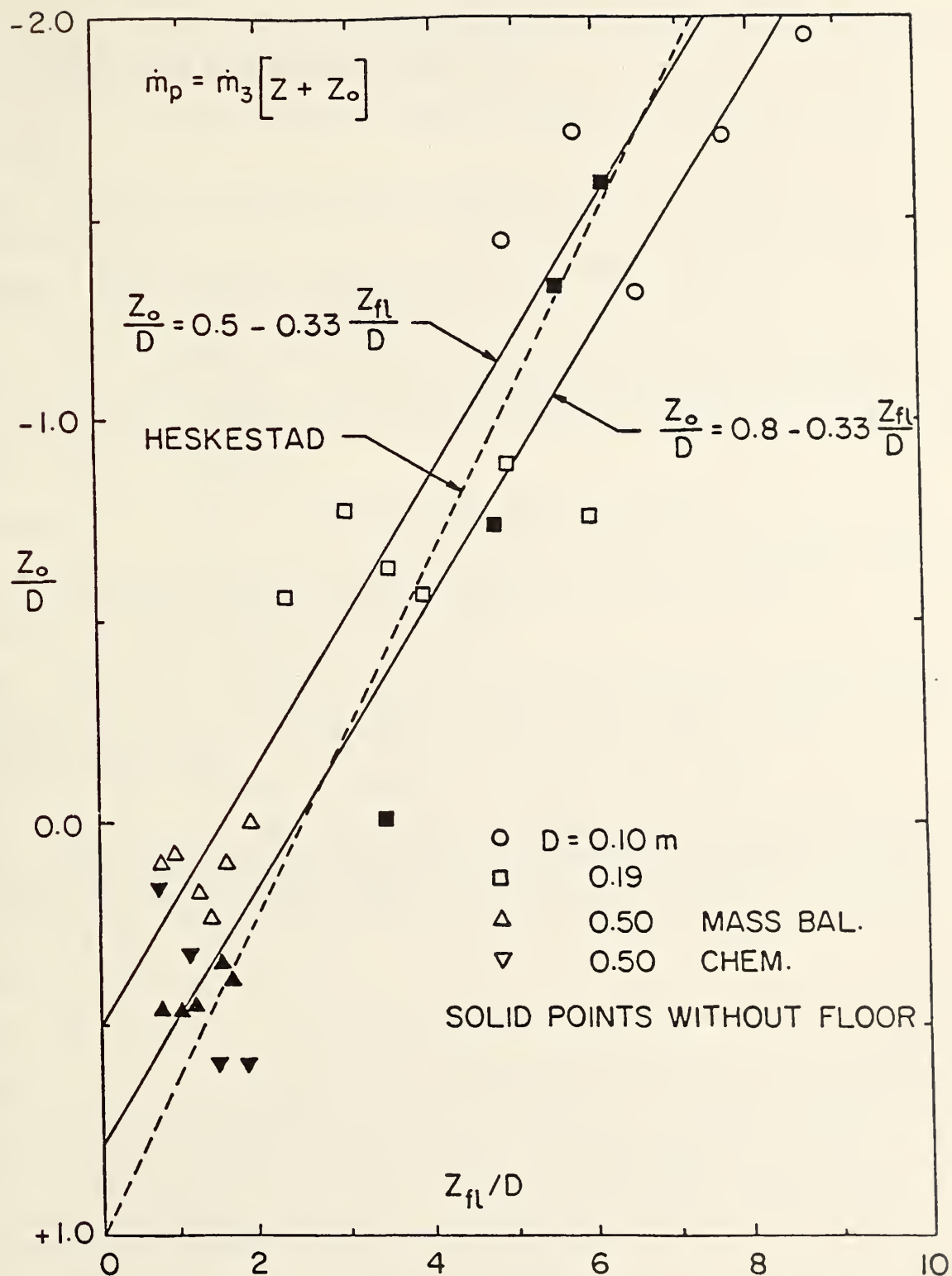


Figure 3. Correlation for Offset

Discussion After E. Zukoski's Preliminary Report on A MODEL TO DESCRIBE THE FLOW IN THE CEILING LAYER OF A TWO LAYER FIRE MODEL

QUINTIERE: In the last slide, what does the flame look like as it impinges on your hood?

ZUKOSKI: Up until the time the flame impinges on the hood, it looks like it's a prediffusion flame.

QUINTIERE: Could you give us some idea of the flame volume over the range of the v value compared to the hood size?

ZUKOSKI: Yes, somewhere in here it's getting up to the top of the hood, but I'd have to go back and check. I don't believe this is due to the impingement of the hood because the flame height has been changed by 2/10ths of a meter with respect to the top of the hood. I think if that were the case, it would show up in more scatter of the data.

QUINTIERE: In no case does the flame splash over the hood.

ZUKOSKI: No, it may hit the top but it doesn't come all the way down and go out. The residence times in the hood are thirty to hundred seconds. The velocities are a few centimeters per second.

EMMONS: As you know, methane in a free burn burns essentially completely whereas other fuels do not. So, similarly in your apparatus you have complete combustion when there's enough oxygen; whereas, with some other fuels, this would not be the case.

ZUKOSKI: I have mentioned the formation of soot and so forth.

PAGNI: Two questions, one referring to your last slide and the other to the previous one. These numbers look similar to those that Professor Sibulkin presented for boundary layer flames in our meeting in August. Is it possible that the details of the diffusion flame itself will lead to these values?

ZUKOSKI: I think it is, yes.

PAGNI: What we need is the flame temperature rather than some mean temperature.

ZUKOSKI: We have added excess fuel to this area here and we are just doing this. As far as we can tell the fuel does not burn. So, you have oxygen in the ceiling layer, you add methane gas that is mixed up, it goes through the flame time after time, and there doesn't seem to be much combustion going on. Well, this is a preliminary feeling. But I think you're right. What's going on in the flame is where the chemistry is occurring. So that's what we have to understand, which makes it even more complicated.

PAGNI: You talked about putting a rich oxygen layer in the containers and then putting a rich fuel jet into that.

ZUKOSKI: Yes.

PAGNI: Why would you be surprised if it burned vigorously?

ZUKOSKI: Because we don't see any effect of the inert gas on the combustion here. Therefore, I don't know that the oxygen that's being entrained would get aired out to their region where the combustion is going on to have any effect. If the inert gas has no effect, the oxygen may not have any effect.

ROCKETT: You have added nitrogen to your fuel in some of these experiments. Does that diluent which presumably would change the flame temperature effect carbon monoxide curve?

ZUKOSKI: We have not done that here. But to get back to the previous point, if you take a small fuel jet and put it up into this can and light it, it sits there and burns. When you get about 50 percent of stoichiometric, the oxygen mole fraction gets to 12 percent and that little fire goes out. The main fire continues to run all the way down to the place where the oxygen mole fraction is 2 percent. So it is affected with entraining fresh air, mixing it right and letting it burn as it goes out.

PAGNI: But if you make the container rich with oxygen, I would expect it to burn tremendously.

LEVINE: Professor Jerry Faeth at Penn State has looked at this problem and has been able to reproduce his results based on a Spalding type model and instantaneous limit mixtures in the plume.

THE MODELS TO BE DEVELOPED IN FIRE SAFETY DESIGN PROJECT

Takeyoshi TANAKA

Testing and Evaluation Division
Building Research Institute
Ministry of Construction

I. INTRODUCTION

It will take a little more time until "Fire Safety Design Method" is framed up into the final form. Nevertheless, one of the salient features of the design method can be already observed in that it attempts to include fire models as a part of the system. These models are to serve rational evaluation for fire safety performance of buildings and are supposed to be included in each of the subsystems of the design method. At present, discussions are underway in each task group to identify the requirements for the models, the functions to be implemented in the models etc.

In a few years, which is the period that our project continues, it is not probable that our understandings on fire reaches the stage where we can solve, without difficulty, any problems of our concern. But of course, this does not necessarily mean that using fire models in a problem like assessment for fire safety is premature. We must keep it in mind that the design of the model should be determined in conjunction with the way the models are used and the feasibility of its development. So far we do not have fair techniques to predict how a cigarette fire in a waste basket grows to a fully involved room fire. However, our knowledge on fire is not considered so insufficient when we study the impact of fire on structural frame. The functions and the level of accuracy required to fire models are not independent on the purpose of the model or the way the model is used.

In "Fire Safety Design Method", the fire models are considered more as a tool for an engineering purpose than as a tool for pure scientific study of the fire behavior. In this sense, the model does not have to be totally scientific if it needs to be based on science. In the following, we will describe how the models are going to be used in the subsystems of "Fire Safety Design Method" and refer to what kind of features should be included in the models.

II. EVACUATION/SMOKE CONTROL DESIGN METHOD

The differences in occupancy, configuration etc. of buildings, which will have significant effects in emergent situation, do not seem to be sufficiently reflected in the subscribed provisions for evacuation or smoke control, at least as long as current Japanese Building Standard Law is

concerned. This would be all right if there were such a versatile evacuation/smoke control system that always works effectively for any conceivable case so we don't have to worry about the difference, but unfortunately we have found none such by now. Since the effectiveness of an evacuation/smoke control system critically depends on the conditions associated with occupants, building construction etc., a designer will have to find out optimum solution for the specific case taking many concerning factors into consideration. The flowchart shown in Figure 1 illustrates the design procedure proposed in this design system, in which the models for evacuees' behavior and smoke control effect play important parts.

II-1. PROCEDURES OF SAFE EVACUATION PLANNING

(0) Premises

This system for safe evacuation planning is based on the following premises:

- (a): Evacuation must be conducted only through smoke free spaces.
- (b): Evacuation plan must be made for all the occupants.
- (c): Smoke control is a backup system for evacuation, so it must be designed to conform to the evacuation system.

Premise (a) is introduced since we have no reliable data on people behavior in the presence of smoke of fire, nor good chances to obtain such data in near future, and accordingly expect significant difficulty to reasonably predict the people movement in seriously emergent condition. In this design system, a designer is supposed to implement some measures to keep the prospected escape routes free from smoke during the time needed so that unpredictable situation can be avoided as best as possible. Some interpretation will have to be made, however, on the meaning of "smoke free" since in some cases, for example in case of evacuation in the room of origin, it is impossible to escape only through literally "smoke free" spaces. Premise (b) does not imply that all the occupants have to be evacuated to out of a building but means that all the occupants must be taken into consideration in the evacuation plan whether they are to escape to the ground or to stay in some protected refuge.

(1) Selection of Basic Strategy for Safe Evacuation Planning.

The design procedure begin with selecting a basic strategy for the safe evacuation of the specific building in concern.

It is considered that Table 1 covers virtually all the practical basic strategies that can be employed in the event of fire, so a designer can choose a basic strategy for evacuating the occupants of his building from Table 1. More than one strategies can be applied to each group of the occupants of the same building corresponding to their different conditions in respect of physical or mental ability, location in the building etc.

Once a specific strategy is adopted, every requirement associated with the strategy, listed in Table 1, must be satisfied.

(2) Elaboration of Concrete Evacuation Planning

According to the basic strategy chosen, more detailed evacuation and smoke control plans must be worked out. Since smoke control is considered to be a backup system for safe evacuation, evacuation plan should be planned prior to smoke control planning. Concrete evacuation planning consists of an evacuation guiding plan and a design of evacuation support system.

(3) Evacuation Guiding Plan

This is a plan regarding where and how to evacuate the occupants. This plan includes determining the type of evacuation e.g. whether it is a total simultaneous one or a selective sequential one. Also special consideration must be paid for the evacuees who have special problems and need appropriate assistance in case of evacuation, as in the case of the evacuation of hospital patients.

Evacuees' population and distributions are given, in principle, as an initial condition for the planning.

(4) Evacuation Support System

This is a system to help materialize the planned evacuation, and includes: properly designed escape route, fire detection system, emergency alarming, announcement and communication system, evacuation guiding by the staffs, emergency lightening system, maintenance of fire equipments etc.

Escape routes must be properly designed so that evacuees can make their way without difficulty according to the evacuation guiding plan. Fire detection system includes searching and locating the place of origin by fire guard, which will affects the initiation time of the evacuation since usually emergency announcements are delivered after the fire is confirmed. Emergency announcement must be persuasive enough to alert the occupants

well for evacuation but must not cause panic. The contents and the timing of the announcement must vary depending on the type of evacuation.

In case of hotels, hospitals, schools etc. where evacuation guiding by the staff is considered to be important, allocation of roles to the staffs must be well organized.

Some proper inspection system may have to be introduced to check, at every certain time interval, whether the disaster prevention and evacuation guiding systems are maintained as is expected by the plan.

(5) Consistency Between Evacuation Guiding Plan and Support System

The design of the evacuation support system must be logically consistent with the evacuation guiding plan and also adequate with respect to its reliability, capability etc. to materialize the evacuation guiding plan.

(6) Prediction of Evacuation Behavior

Based on the evacuation guiding plan, evacuees' movement is predicted throughout the building. In the prediction, it is assumed that evacuees behave basically ordinary way as in non-emergent condition since smoke is not allowed, by the premise, to enter into escape routes. However, some consideration will have to be paid on the possible panic in the event of evacuation in the room of origin, where the presence of smoke is inevitable.

Prediction gives the information of the doors that are being opened due to the evacuation movement as well as the evacuees' distribution in the building at any given moment.

(7) Elaboration of Concrete Smoke Control Planning

The smoke control planning consists of the designs of smoke control method and smoke control support system.

Smoke control method must be so designed that, in principle, it never allows smoke to enter the spaces where and when the evacuees are predicted to be present.

(8) Planning of Smoke Control Method

This is a plan to deal with when and how to protect the necessary spaces against smoke infiltration. Smoke control method includes smoke confinement by the use of physical barriers such as smokeproof door and

danper, natural or mechanical ventilation method and the combination of both the physical barriers and ventilation.

Of course, smoke control design must not be contradictory to the evacuation planning. A door cannot be assumed closed in smoke control planning during the period of evacuation if it is on the escape route.

(9) Smoke Control Support System

In smoke control support system, various systems such as those for fire detection, fan activation and vent control will be included.

Some checking system may be needed to assure the support system is maintained at the condition assumed in the design.

(10) Consistency between Smoke Control Method and the Support System

Smoke control support system must be logically consistent with the smoke control method and also must be adequate in its reliability, capability etc. to materialize the planned smoke control method.

(11) Prediction of Smoke Control Effect

Prediction of smoke control effect is to check if and how well the requirements regarding smoke, which are given in Table 1 corresponding to the selected basic strategy, are satisfied by the planned smoke prevention system. The doors that are predicted as being left open during certain time of evacuation, are assumed as open in this smoke control effect prediction as well.

(12) Examination of Smoke Control Requirements

Based on the prediction of smoke control effect, whether the smoke control requirements are satisfied or not is examined.

(13) Fire Spread Prediction

The prediction for fire spread is given using the models that are supposed to be developed in Fire Spread Prevention Design subsystem. The input conditions to the prediction will be given from the fire spread prevention design of the building.

(14) Examination of The Requirement for Fire Spread Prevention

Based on the fire spread prediction, an examination is made on whether or not the requirements for fire spread prevention listed in Table 1 are satisfied. Since what is concerned in evacuation problem is threat to

human body, fire spread to a space can be judged by occurrence of the condition that is untenable for the evacuees in the space.

(15) Prediction of Fire Resistant Behavior of the Structure

Considering the fire spread prevention performance and fire resistant performance of the structure, the structural response to fire is predicted.

(16) Examination of The Requirements for Structural Integrity

Whether or not the requirements for structural integrity against fire, which are given in Table 1, is satisfied is examined based on the prediction.

II-2. THE MODELS TO BE DEVELOPED

It will be obvious that the design system described above needs at least two models, i.e. one for people movement prediction and the other for smoke control effect. These models need not necessarily be constructed of brand new theories or techniques etc. Rather, what is more important for the models is to fit into the design system. Here are some of the basic concepts of the models to be developed in the project.

II-2-1. Evacuation Model

Since smoke free condition is imposed on the evacuation/smoke control design system, the model will be developed basically based on the findings and data on people movement obtained in non-emergent condition. In other words, the prediction given by this model will be valid only when the circumstance for evacuation is not very hazardous. When the circumstance is serious, we have no means to quantitatively predict human behavior any way. The followings are what should be addressed more earnestly in developing the models rather than trying to predict human behavior in genuine emergency, which is next to impossible.

a) The model shall be able to deal with various types of evacuation that are possible to be proposed by designers, e.g. concurrent total evacuation, selective sequential evacuation, assisted evacuation etc.

b) The model shall be able to deal with the evacuation plans for the evacuees of different physical or mental ability.

c) The model shall be able to assess the time needed prior to onset of evacuation due to the different scenarios on fire detection, locating the place of origin by fire guard, emergency announcement system etc.

d) The model shall be able to give the evacuees distribution throughout the building at any time during the evacuation.

e) The model shall be able to give the information on whether a specific door is left open or not due to the evacuation.

II-2-2 Smoke Control Effect Prediction Model

The basic techniques for predicting smoke control effect have been developed, based on preceding calculation method for building ventilation, and well established by now. The next step will be how to incorporate the technique into the smoke prevention design system. Not only various types of mechanical ventilation method, but also physical smoke barrier methods or natural ventilation methods can be proposed by designers, and sometime the latters may be more reliable if many factors such as maintenance of equipments, are taken into consideration. In such cases, this model will be used as a mean to predict buoyancy driven smoke movement in buildings, and hence need to be able to take care of transient temperature change of the spaces in buildings. The followings are some of the model needs:

a) The model shall be able to deal with any possible mean for smoke control, whether it may use physical smoke barriers or ventilation mechanism.

b) The model shall be able to predict transient change in temperature of the spaces that have significant effects on smoke movement in the building.

c) The model shall be the one that needs only the data that have been experimentally established or can be obtained without extreme difficulty.

d) The numeric for the model shall be stable, and the computation time shall be within the reasonable limit.

III. FIRE SPREAD PREVENTION DESIGN.

III-1. THE ROLES AND MEANS OF FIRE SPREAD PREVENTION

Fire spread within buildings can be classified into the following three for the sake of convenience in discussion.

- 1) Fire spread in the room of origin(A)
- 2) Fire spread outside the room of origin --- Spread to other rooms(B)
-- Spread to upper floor(C)

Although a fire itself is a continuous phenomenon, this kind of classification is often useful because the effective measures to prevent fire spread differ from one to another among these three. Prevention of fire spread contributes both to life safety and property protection, but if aside from the matter of property for simplicity, the role of fire spread prevention is still significant. The first role is that it partially takes part in the evacuation/smoke control design system as described above, that is to remove or mitigate the threat of untenable heat to reach the evacuees. The second role lies in that fire spread prevention is one of the redundant subsystems for fire protection of buildings. The fire spread prevention measures help the other subsystems, such as evacuation, smoke control, fire extinguishment and structural fire resistance to work more effectively by reducing heat load or threat.

The role of fire spread prevention is important, however, the measures that can be practically employed for this purpose are quite limited as shown in the following:

(A) For prevention of fire spread in the room of origin

It can be said that the almost only practical measures to prevent fire spread in the room of origin are a) fire retardation of interior lining, and b) automatic fire extinguisher. The latter is not as promising as the former, but there are still many buildings that must depend on the latter because installation of automatic extinguisher is costly and needs continuous maintenance.

(B) For prevention of fire spread to other room

The measures for this purpose may include fire retardation of interior finish in the sense that it indirectly contributes the prevention of fire spread to other rooms by suppressing fire vigor in the room of origin, but more straightforward measures are: a) fire proof wall, door, danper etc., b) fire resistant buffer spaces (fire prevention zone), and c) fire containment using ventilation method. Of these measures, the most classical and most popular is a). Measure b) is an idea worth being considered when the room to be protected is apart from the room of origin. Measure c) may have a chance to be used in relation with smoke control system.

(C) For prevention of fire spread to upper floor

This type of fire can also be said as the spread through exterior openings, and the measures for preventing this are: a) spandrel, canopy etc., which prevent window flame from touching the windows on the upper floor, and b) wired window panes, which protects window from being broken by flame touching.

III-2. FIRE SPREAD MODEL TO BE DEVELOPED

Although fire is quite a complicated phenomenon that needs a lot of effort to obtain fair prediction, the practical measures to prevent the fire spread are disappointingly limited. In order to develop a practical model, it will be relevant to focus on these measures to prevent fire spread and address a model that can assess the efficiency of those measures.

The mode of fire spread were classified into the three types as stated above, however, since the actual fire is continuous and hence each of the classified modes (A)-(C) is just an aspect of the same phenomenon, a comprehensive model would be desirable if such one can be developed. But it should be kept in mind that our understanding is not ample, in particular, with respect to the combustion of materials in fire. If we deal with whole the process of fire with one model, the error due to the deficiency in our knowledge in the material combustion may be enlarged in the prediction of the later stages of fire. Also, such a comprehensive model may be too broad in scope of study as well. So, at this moment, we try to develop one model for each type of fire spread.

(A) Model for Fire Spread in the Room of Origin

(i) The objects of assessment

The important measures to prevent fire spread in the room of origin are, as mentioned above, fire retardation of interior finish and automatic extinguisher. Since sprinkler has good records on extinguishing performance, it will probably be reasonable to assume that it never fails to extinguish fire once it is activated. So the target of our model turns out to be to assess the performance of interior lining. This must be always kept in mind in working on this model.

(ii) Model Configuration

The model considered here is a single room, to which so-called two layer zone model concept is applied. Each layer is not transparent for radiative heat transfer, and the temperature of lower layer is not necessarily the same as ambient temperature. It could be possible to consider a multiroom model. However, considering current state of our understandings and techniques on fire, it is expected that great deal of our effort must be concentrated on predicting burning behavior of interior lining in implementing the model, so it will be better to eliminate as many factors as possible as long as their effects are not significant.

(iii) Fire Source

The fire sources thus referred to here are not ignition sources such as matches and lighters, but so-called ignited articles such as a waste basket or a sofa. In building spaces, numerous kinds of things can be fire sources in this sense, but the total heat release or burning rates of those article must fall in some finite range, and the larger the heat release of an article, the less the frequency of its emergence as a fire source must be. A model fire source is specified for each of the rooms of different occupancy based on fire incident statistic and furniture burning tests.

The fire source location is specified to either of center, wall side and corner in the room of origin. In prediction of fire spread, source location is set, as a rule, at the corner as long as it is not inadequate. And only for the cases where setting fire source location at the corner is irrelevant, the other locations will be specified.

(iv) Heat Transfer to Internal Lining

The heat transfer to ceilings, floors and walls are calculated as the sum of the three kinds of heat transfer, which are fire source radiation, room layers radiation and room layer convection. Introducing heat transfer from a fire source unavoidably brings about non-homogeneity to heat transfer along interior walls in the model, and hence to the temperature of the internal walls. This must cause radiation exchange between the parts of the walls, but we neglect this to avoid too much complexity in modeling the heat transfer.

(v) Thermal Pyrolysis of Materials

Where a material gets heating that exceeds the critical heating of ignition, it is assumed that the material pyrolyzes at the rate of

$$\dot{m}'' = Q'' / L$$

where L : Latent heat of thermal pyrolysis for steady burning(kJ/kg)

Q'': Incident heat flux(kw/m)

\dot{m}'' : Mass loss rate per unit area(kg/m s)

The pyrolysis of materials below the heating level of ignition criterion is neglected.

(vi) Combustion of the gasified fuel

It is assumed that gasified fuel that emerges from pyrolyzed material burns in room the layers. The combustion of the fuel will be affected by the condition in the layer. The location of the flame formed due to the combustion of the interior lining material is not chased. This may make the heat transfer in the model more homogeneous than the case of real fire, but it will be too complicated to include the effect of radiation exchange between the flames on different positions.

(vii) Combustion of combustibile furniture

The condition of furniture in a room may vary greatly from one room to another, however, since the our goal is not to predict fire growth in general but to assess the performance of the interior lining design, it will be possible to assume some average condition for furnishing based on some statistical data. The layout should be selected as simple as possible so that it does not make the heat transfer calculation too difficult.

(B) Model for Fire Spread to Other Rooms

(i) Objects of the assessment

It is required by the evacuation/smoke control design method that this model must be able to examine whether or not hazardous thermal condition is expected to the refugees in protected shelters or escape routes in the event of fire. The room of origin and the spaces in which evacuees are present may be separated by partitions, fire doors, fire proof buffer spaces or ventilated spaces, so the model needs to be able to assess the fire spread prevention performance by these means.

(ii) Model Configuration

Model includes the room of origin, the room to which fire spread is our concern and the spaces between the two rooms. In any of the spaces involved, two layers are assumed as is the case of a single room.

(iii) Fire room condition

To avoid that the errors involved in the prediction of internal lining combustion is enlarged in the prediction of the later stage of fire, the fire condition in the room of origin is so specified as is not affected exceedingly by the difference in internal lining condition. Some fire source that is large enough to cause ordinary combustibles in the room of origin to ignite and bring about a fully-developed fire but still not large enough to become a controlling factor of fire behavior once the combustibles in the room starts to burn will be chosen as an initial source. The burning rate of the furnishing materials in the room will be assumed as proportional to the incident heat flux to the materials.

(iv) Fire spread of lining material in other than the room of origin.

Basically the same method as that in (A) is used for the prediction of the fire spread on the lining of the rooms. In this case, door jet, in which combustion may be involved, takes the place of fire plume in case of the room of origin.

(v) Heat transfer of partition, door etc.

Not only walls but floor, ceiling and door are included in what is called partition here. Heat transfer to these partition is calculated using average quantity of fire room gas, in other words, the effect of initial fire source is neglected.

If the structure of a partition is simple and the thermal properties of its elements are known, the heat transmission through the wall can be predicted by carrying out the calculations for thermal conduction within the walls, and hence the possibility of the occurrence of the thermally untenable condition to evacuees can be assessed. Unfortunately, the partitions in real world are not always so simplistic and their thermal properties have been rarely known. So some test method must be introduced to produce data on heat transmission properties of various partitions, together with some relevant correlation theory that enable the test results to apply to different heating conditions.

(C) Model for Upper Floor Fire Spread Prediction

(i) Object of assessment

This model is to assess the performance of spandrel, canopy and wired window pane when seen as means to prevent fire spread to upper floors.

(ii) Condition of the room of origin

This is determined in the same way as in (B).

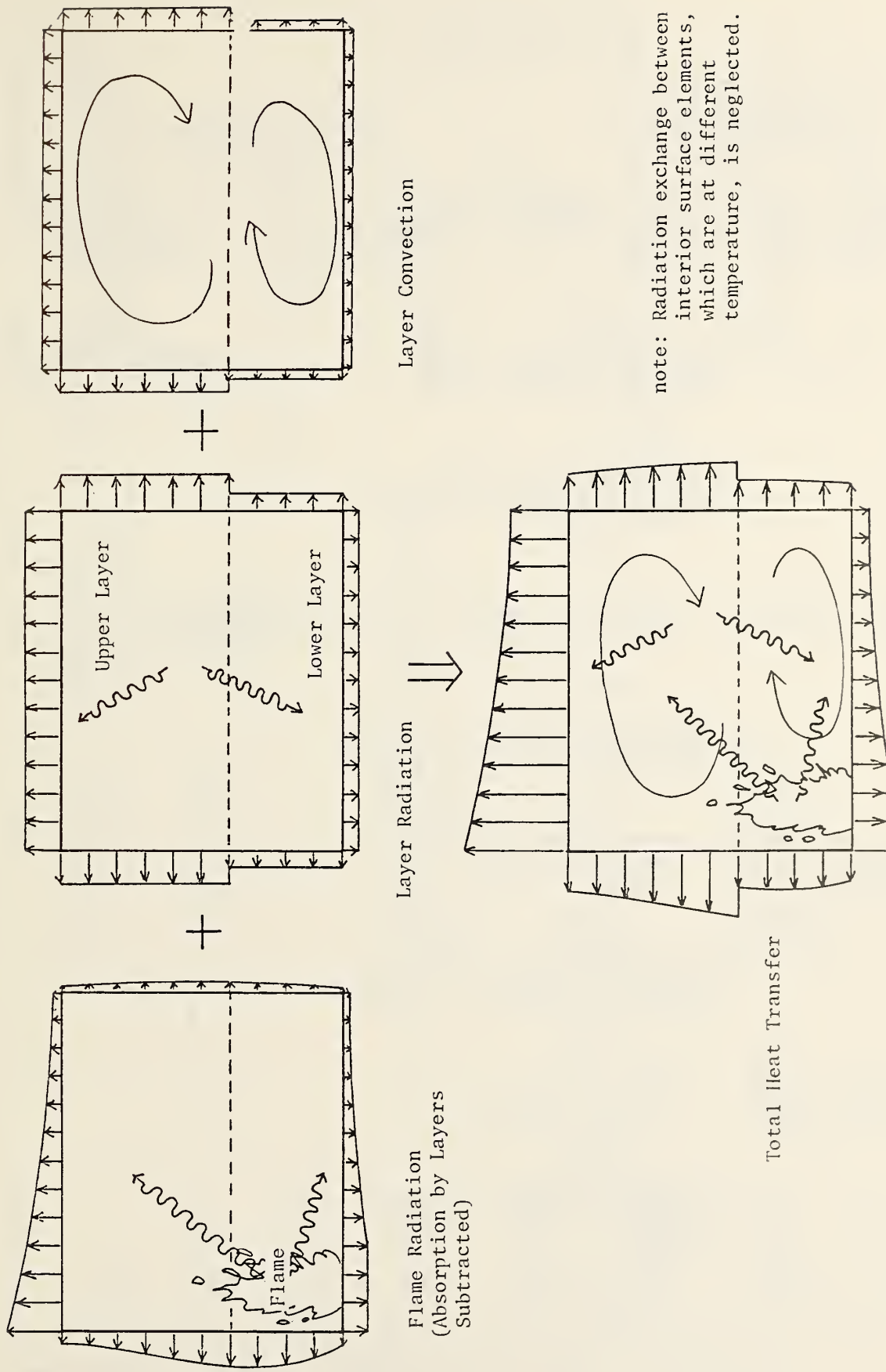
(iii) Fire spread through upper floor window

In implementing a prediction method for fire spread to upper floor through window, the method presented by Yokoi will be a base to begin with, although it is probably more desirable to strive some effort for reasonable prediction on window jet behavior when it contains excess fuel combustion.

CONCLUDING

It is important to use fire models in the fire safety design of buildings for rationally evaluating various fire protection measures. In the fire safety design method, a couple of fire models are supposed to be included in each of the design subsystems. Some consideration were made on how the models are going to be used in the "Fire Safety Design Method", and what kind of features should be implemented in the models in conjunction of the needs from the design method.

Incidentally, the models to be included in the subsystems for fire resistant structural design were not discussed because they are beyond the scope of this paper.



note: Radiation exchange between interior surface elements, which are at different temperature, is neglected.

Figure 2. Schematic of The Heat Transfer Model

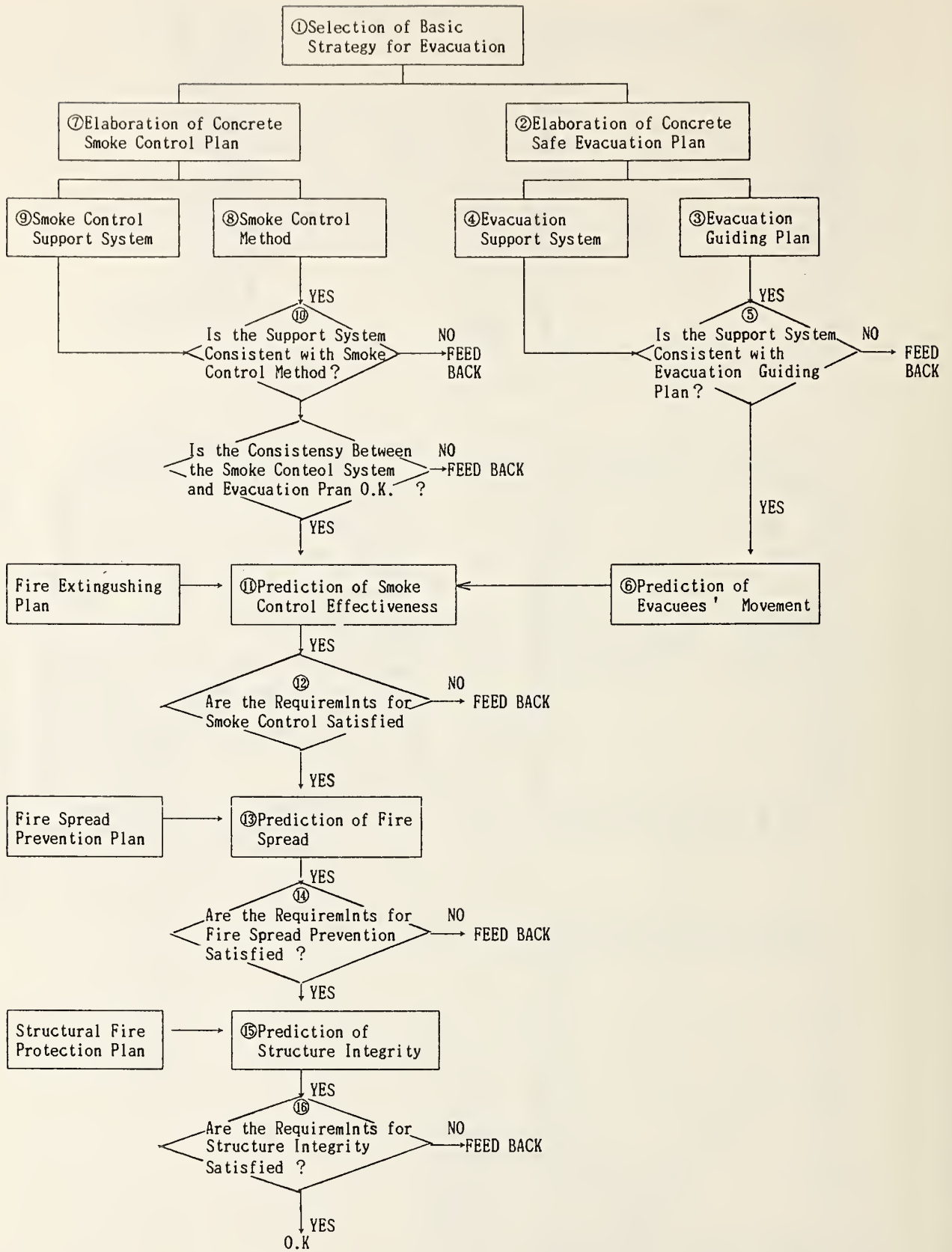


Figure 1 SAFE EVACUATION PLANNING IN FIRE

Table 1 Minimum Requirements for Evacuation

Final Place of Refuge	Items to be Checked		Structural Integrity	Living Spaces		Protected Refuge		Escape Route		Available Evacuation Time	
	Type of Refuge			Fire Spread Prevention	Smoke infiltration Prevention	Fire Spread Prevention	Smoke infiltration Prevention	Fire Spread Prevention	Smoke infiltration Prevention	For Fire Resistant Buildings	For Non-Fire Resistant Buildings
Living Spaces	(1) Stay till fire extinguishment		Till Extinguishment	Till Extinguishment		—	—	—	—	—	—
Protected Refuge	(2) Escape through Fire and Smoke Proof Route		Till Extinguishment					Till Extinguishment	Till Extinguishment	Infinite	
	(3) Escape through Non-Fire Proof but Smoke Proof Route		Till Extinguishment	Till Completion of Evacuation from Living Spaces			Till Extinguishment	Till Fire Spread to Escape Route	Till Fire Spread to Escape Route	Till Fire Spread to Escape Route	—
Outdoor	(4) Escape through Non-Smoke Proof Route		Till Extinguishment								
	(5) Escape through Fire and Smoke Proof Route		Till Completion of Evacuation to Outdoor						Till Extinguishment	Till Extinguishment	Infinite
	(6) Escape through Non-Fire Proof but Smoke Proof Route		Till Completion of Evacuation to Outdoor	Till Completion of Evacuation from Living Spaces					Till Fire Spread to Escape Route	Till Fire Spread to Escape Route	Till the earlier of Fire Spread to Escape Route and Collapse
	(7) Escape through Non-Smoke Proof Route										Till the earlier of Smoke Infiltration and Collapse

NBSIR

A MODEL FOR THE TRANSPORT OF FIRE,
SMOKE AND TOXIC GASES (FAST)

Walter W. Jones

Center for Fire Research
National Engineering Laboratory
National Bureau of Standards
Washington, DC 20234

July 1984

U.S. DEPARTMENT OF COMMERCE, Malcolm Baldrige, Secretary
NATIONAL BUREAU OF STANDARDS, Ernest Ambler, Director

TABLE OF CONTENTS

	<u>Page</u>
LIST OF FIGURES	iv
1. INTRODUCTION	1
2. STRUCTURE OF THE MODEL	2
3. DERIVATION OF THE CONSERVATION EQUATIONS	8
3.1 Fluid Transport	9
4. SOURCE TERMS	11
4.1 Source Terms: Radiation	12
4.2 Source Terms: Convective Heating	16
4.3 Source Terms: Plumes	17
4.4 Source Terms: Door Jets	19
4.5 Source Terms: Fire	21
4.6 Source Terms: Conduction	22
5. NUMERICAL INTEGRATION	25
6. COMPARISON WITH EXPERIMENTAL DATA	29
7. STABILITY AND COMPLETENESS	31
8. CONCLUSIONS	32
9. ACKNOWLEDGMENTS	33
10. REFERENCES	33
APPENDIX A: Notation	35
APPENDIX B: Input/Output Format	38
APPENDIX C: BUILD	41
APPENDIX D: FASTPLOT	44

LIST OF FIGURES

	<u>Page</u>
Figure 1. A schematic of one compartment in the zone model concept. Two layers (1,2) and a single vent are shown	50
Figure 2. Radiation transport scheme. Shown is the view factor calculation of surface "i" as seen by surface "j", transmitted through both layers	51
Figure 3. Possible upper/lower mixing mechanisms which occur at vent jets	52
Figure 4. Comparison of experimental and calculated temperature profiles for the upper layer in the burn room and corridor in the "Nike Site" experiments (Table I)	53
Figure 5. Comparison of experimental and calculated interface height in the corridor of the "Nike Site" experiments (Table I). See ref. Quintiere <u>et al.</u> (1984) and Cooper <u>et al.</u> (1981) for an explanation of the criteria (10%, 20%) used to determine the experimental interface height	54
Figure 6. Comparison of experimental and calculated upper layer temperature in the corridor of "B205" experiments (Table I)	55
Figure 7. Comparison of experimental and calculated interface height in the "B205" experiment (Table I)	56
Figure 8. An example of the upper layer separation which occurs in actual flows	57
Figure 9. An example of fire size specification through mass loss data	58
Figure 10. Sample output from "FASTPLOT". Shown is one of the 100 kW calculations for the "B205" experiments in the three compartment configurations	59

1. INTRODUCTION

In recent years there has been considerable research in the area of the spread of fire and smoke from a room of fire origin to connected compartments. The work is motivated by a need to understand and be able to predict the environmental conditions which occur as a fire develops and spreads. Much of the attention has focused on the development of numerical models which are able to make a reasonably accurate assessment of the environment from ignition. The motivation is two-fold. Being able to correlate laboratory scale experiments with full-scale tests is desirable from a cost standpoint. More important, however, from a life-safety and operational standpoint, the ability to make accurate predictions of the spread of fire, smoke and toxic gases opens up many possibilities for combating these problems, as well as taking effective preventive measures. The ability to prevent the hazards from developing becomes especially important as new and exotic materials become available.

This paper describes a model which allows one to predict the evolution of a fire in a room and the subsequent transport of the smoke and toxic gases which evolve from this fire. The numerical implementation improves on previous work, for a review see Jones (1983), in particular by retaining the conservation laws in their full differential form and solving them as a set of coupled ordinary differential equations (ODE's). Such a formulation takes advantage of the effort which has gone into solving such systems of equations. The result is a numerical scheme which is considerably faster and much more "rugged" than previous models.

The model is assumed to be in a world of uniform temperature T_a and reference pressure P_a , with the outside of a wall at T_e which may not be the same as the ambient. The discussion is broken down into the basic structure and fundamental assumptions which go into the model, followed by a derivation of the predictive equations, a discussion of the source terms, the numerical implementation and some calculations and comparisons with experimental data. The notation is given in Appendix A. The numerical implementation of the model is modular and straightforward. It is designed to be transportable.

2. STRUCTURE OF THE MODEL

The primary element of the model is a compartment. The primary interest lies in the composition of the gas layers in each of these compartments. As such, the model is structured around fluid transport phenomena. In this context, the predictive equations for the gas layers in each compartment result from conservation of mass, momentum and energy together with an equation-of-state for each compartment. The actual physical phenomena which drive the transport are then couched as source terms. Such a formulation allows the greatest flexibility in adding, modifying or deleting terms which are appropriate to the problem being solved.

Each compartment is subdivided into one or more "control volumes." These control volumes will be of sufficient size that we will require only a few to describe any system of interest. The choice is based on the premise that the details which occur within such a volume do not concern us (at present), but their mutual interaction does. Each of these control volumes is called a zone. The rationale for such a choice arises from the experimental observa-

tion that when a fire spreads, the gas layers in the compartments actually stratify into two distinct zones. This is a compromise between a network model and a finite difference model. The former is computationally fast but yields no information on the internal structure whereas the latter yields a great deal of information but requires more computational resources than is warranted. The two zones are referred to as "upper" and "lower", respectively. The basic equations describe the mass, momentum and energy transfer from zone to zone in a fire driven environment. A schematic is shown in figure 1.

In considering dynamic systems, it is necessary to solve a problem self-consistently. If such is not done, then some of the dynamics may be obscured or even lost. In particular, discussion of movement of the zone interfaces must be consistent.

The conservation equations for mass and energy can be written in the form

$$\frac{dm}{dt} = \sum_i \dot{m}_i \quad (1)$$

for mass and from the first law of thermodynamics we have

$$\frac{d}{dt} (EV) + p \frac{dV}{dt} = \dot{Q} + \dot{h} \quad (2)$$

together with an equation of state

$$P = \rho RT \quad (3)$$

which closes the set of equations, and with the definitions

$$\Sigma = c_v \rho (T - T_R)$$

$$\dot{n} = c_p \sum_i \dot{m}_{i,in} (T - T_R) - c_p \sum_i \dot{m}_{i,out} (T - T_R) + \sum_i \dot{h}_{i,o} (T_R)$$

$$\dot{Q} = \dot{Q}_f + \dot{Q}_R + \dot{Q}_c = \text{net energy input}$$

i = index of other compartments ($i \neq$ volume of interest).

The term $h_{i,o}(T_R)$ is relative to the temperature from which this mass parcel, $\dot{m}dt$, came. It includes enthalpy of formation. The equation of state for an ideal gas is usually used for closure of the system. More correctly it should be written

$$P = P(\rho, T, \{i\}), \{i\} \equiv \text{set of species} \quad (4)$$

especially for applications to fire problems which are not ideal gas problems. However, for the case of an ideal gas, the derivations and discussion are simplified, and generalizations can be discussed later. The sign convention is that positive fluxes on the right hand side of an equation will increase the quantity being calculated on the left hand side, that is, transfer into a volume is indicated by a positive flux on the right hand side.

The general form of the model is to divide each compartment into two zones: an upper zone which contains a hot layer, and a lower layer which is relatively cool. There may exist one or more fires and plumes in each compartment and these can usually be considered to be part of the upper zone. Mass and energy transfer between the zones is provided by the plumes, mixing

at the vents, radiation between layers and flow along the walls. In general a plume, once created, simply transfers mass and energy from one zone to another. Another set of equations could be written for the plume, but as long as it is in quasi-steady equilibrium, considering it to be part of the upper zone is sufficient. Another way of looking at the plume is to consider it so small in mass, energy content and volume that it can be ignored except as a transfer mechanism. For some problems, however, the plume must be considered a separate zone along with the concomitant conservation equations. An example would be when the rise time of the plume is of interest or when the actual size and composition of the plume is important.

Since the conservation equations are written in terms of the volumes of these entities, a relationship between the height and the volume is needed, such as

$$V_u = \int_{Z_\ell}^{H_R} ZA(Z) dz \quad (5)$$

to calculate the layer depths. This removes the usual restriction that the compartments be rectangular parallelepipeds, and allows calculations for circular crosssections (aircraft) and trapezoids (atria).

The radiation transport scheme used is fairly simple and derives from the work of Siegel and Howell [1981]. The view factors which are used in the calculation of solid angles are concomitant with surfaces which are planes or discs. The relationship is shown schematically in figure 2. The simplification used here and discussed in more detail by Jones (1983) is retained, but the actual areas are used, and the exact view factors are used wherever

possible, Kusada (1976). For example, in calculating the area of the upper wall, allowance is made for any vents which exist by subtracting their area from the total wall area. In addition, ceiling and upper wall, lower wall and floor are treated separately (as pairs). This is necessitated by the possible use of different materials for the respective surfaces which may have different radiative properties, as well as the different types of convective flow which occur over each of these surfaces. More correctly, we should consider three surfaces, ceiling, wall and floor. This is under development. A problem arises in treating vertical convection as the layer depth tends to zero.

Actual closure of the model is obtained by assuming that the size of the compartment is fixed so that

$$V = V_u + V_l \quad (6)$$

and that there is a single reference pressure

$$P_u = P_l \quad (7)$$

at the boundary (interface) of the zones.

The set of equations which is necessary to describe fully such a physical system can be reduced by considering the physical impact of some of the terms. In particular, the pressure should be a general function of position, $P(X,Y,Z)$, in the compartment, which would require us to include a differential equation for the conservation of momentum explicitly. A general form for the perturbed pressure might be

$$\bar{P}(x,y,t) = P(t) - \int_0^Z \rho(t) dz + \delta P(X,Y,Z,t) \quad (8)$$

where P is a reference pressure and is usually the pressure at the base of the compartment. In the spirit of the "control volume" formulation

$$\delta P \rightarrow 0.$$

This implies that acoustic waves are filtered out and that internal momentum need not be calculated. The hydrostatic term is small in absolute value in comparison with the reference pressure, so it is not necessary to carry this calculation through the equation of state. Finally, the time dependent portion of the hydrostatic term deals with the movement of the interface, and thus can be ignored if we limit ourselves to problems where the momentum associated with the discontinuity (alternatively the velocity) is not significant. Dropping the momentum equation for internal waves increases the computational time step a great deal since we are not limited by the Courant time step criterion (time step \propto grid size/speed of sound). This prohibits us from considering problems such as deflagration waves and explosions. With these considerations in mind, we will assume

$$P_u = P_l = P. \quad (9)$$

The pressure in eqn. (9) is the reference pressure at the floor. This simplification is carried through the conservation equations and greatly simplifies the resulting predictive equations. However, it is necessary to retain the hydrostatic term for the flow field calculations at vents. As we are considering only small changes in the absolute pressure, differences of these terms will be comparable to the hydrostatic pressure change, eqn. (8).

For example, for eqn. (22)

$$\delta P \sim 1 - 1000 \text{ pa}$$

whereas

$$\int (\rho_1 T_1 - \rho_2 T_2) dz \sim 100 \text{ pa}$$

where the integration is over a vent opening. So the flow can be dominated by the hydrostatic term whereas the $\delta P/P < 1\%$.

3. DERIVATION OF THE CONSERVATION EQUATIONS

A zone model describes a physical situation in terms of integrals of extensive physical quantities. Thus we deal with total mass rather than mass density, total energy rather than energy density but temperature is used as before (an intensive quantity). The integrals are volume integrals whose boundary surfaces enclose the Euclidean space of interest. The space with which we are concerned usually is a compartment with zones including a hot upper gas, a cool (relatively) lower layer, objects, plumes and fires. The connections occur at the boundary of these zones. Examples of possible connections are the vents connecting compartments, the radiation from a fire to the compartment walls, etc. With this basis we can mold the conservation equations into a form which describes a fire in terms of the quantities which are appropriate to the control volume approach, intuitively understandable and lend themselves to measurement.

3.1 Fluid Transport

The conservation equations for each compartment of a two layer model are

$$\frac{dm_u}{dt} = \sum_i \dot{m}_{u,i} \rightarrow \dot{m}_u \quad (10)$$

$$\frac{dm_l}{dt} = \sum_i \dot{m}_{l,i} \rightarrow \dot{m}_l \quad (11)$$

$$\frac{d}{dt} \{c_v m_u (T_u - T_R)\} - v_u \frac{dP_u}{dt} = \dot{Q}_u + \dot{h}_u \quad (12)$$

$$\frac{d}{dt} \{c_v m_l (T_l - T_R)\} - v_l \frac{dP_l}{dt} = \dot{Q}_l + \dot{h}_l \quad (13)$$

In writing these equations, we will make two assumptions. First, that the fire will not feed mass directly into the lower layer. Second, we will write the upper layer equation as if there is only one fire. If more than one fire exists, then a sum over such sources is necessary and if none are present, then this term vanishes. The source term \dot{Q} includes all energy transfers due to radiation and convection and \dot{h} includes the enthalpy flow. We can rewrite the energy conservation equations as predictive equations for temperature, in which case they become

$$m_u c_p \frac{dT_u}{dt} - v_u \frac{dP_u}{dt} = \dot{Q}_u + \dot{h}_u - c_p T_u \frac{dm_u}{dt} + c_v T_R \frac{dm_u}{dt} \rightarrow \dot{E}_u \quad (14)$$

and

$$m_l c_p \frac{dT_l}{dt} - v_l \frac{dP_l}{dt} = \dot{Q}_l + \dot{h}_l - c_p T_l \frac{dm_l}{dt} + c_v T_R \frac{dm_l}{dt} \rightarrow \dot{E}_l \quad (15)$$

The right hand side of eqn. (14, 15) can be rewritten in a simpler form. The reference temperature (T_1) is chosen arbitrarily. If the only phase change occurs in pyrolysis of the fuel, then we can set the reference pressure to zero and include the pyrolysis energy as a sink term in the energy release rate. As $T_R \rightarrow 0$ we obtain

$$\begin{aligned} \dot{E}_u = & \dot{Q}_f(u) + \dot{Q}_R(u) + \dot{Q}_c(u) - Q_p \dot{m}_f + c_p \dot{m}_p (T_v - T_u) \\ & + c_p \sum_i \dot{m}_{i,u} (T_i - T_u) \end{aligned} \quad (16)$$

and

$$\dot{E}_\ell = \dot{Q}_f(\ell) + \dot{Q}_R(\ell) + \dot{Q}_c(\ell) + c_p \sum_i \dot{m}_{i,\ell} (T_i - T_\ell). \quad (17)$$

The equations and assumptions necessary to close this set are

$$P = \rho RT \quad (18)$$

$$\rho_u RT_u = \rho_\ell RT_\ell \quad (19)$$

with

$$m = \rho V \quad (20)$$

$$\text{and } V = V_u + V_\ell = \text{constant}. \quad (21)$$

The energy source terms $\{\dot{E}_\ell, \dot{E}_u\}$ are shown schematically in eqns. (16, 17) but can be much more complex and depend upon the configuration. Combining eqns. (10-11) and (14-17), together with the closure relations, we obtain

$$\frac{dP}{dt} = \frac{\dot{s}}{(\beta-1)V} \quad (22)$$

$$\frac{dT_u}{dt} = \frac{1}{\beta} \left(\frac{T_u}{PV_u} \right) \left(\dot{E}_u + \frac{V_u}{(\beta-1)V} \dot{s} \right) \quad (23)$$

$$\frac{dT_\ell}{dt} = \frac{1}{\beta} \left(\frac{T_\ell}{PV_\ell} \right) \left(\dot{E}_\ell + \frac{V_\ell}{(\beta-1)V} \dot{s} \right) \quad (24)$$

$$\frac{dV_u}{dt} = \frac{1}{P\beta} \left(c_p \dot{m}_u T_u + \dot{E}_u - \frac{V_u}{V} \dot{s} \right) \quad (25)$$

where

$$\dot{s} = c_p \dot{m}_u T_u + c_p \dot{m}_\ell T_\ell + \dot{E}_u + \dot{E}_\ell \quad (26)$$

$$\text{and } \beta = c_p/R = \gamma/(\gamma-1) \quad (27)$$

It should be pointed out that the equations are written in this form for the sake of clarity and simplicity. In a numerical implementation there are better ways to express the source terms which minimize the problem of the small difference of large numbers.

4. SOURCE TERMS

Equations (22-25) are written so that physical phenomena which affect the environment are source terms and appear on the right-hand-side. Sources which appear directly are:

1. radiation between the gas layers and walls, fires and other objects,
2. convective heating,
3. flow in plumes,
4. flow in vent jets,
5. mixing at vents.

Phenomena which are included but do not show up explicitly are:

1. radiation between objects,
2. conduction through walls and objects.

4.1 Source Terms: Radiation

In order to calculate the radiation absorbed in a zone, a heat balance must be done which includes all objects which radiate to the zone. Clearly, in order for this calculation to be done in a time comensurate with the other sources, some approximations are necessary.

The terms which contribute heat to an absorbing layer are the same (in form) for all layers. Essentially we assume that all zones in these models are similar, so we can discuss them in terms of a general layer contribution.

Radiation can leave a layer by going to another layer, to the walls, exiting through a vent, heating up an object or changing the pyrolysis rate of the fuel source. Similarly a layer can be heated by absorption of radiation from these surfaces and objects as well as from the fire itself. The formalism which we will employ for the geometry is that used by Siegel and

Howell (1981) and is shown in figure 2. The radiative transfer can be done with a great deal of generality; however, as with most models we assume that zones and surfaces radiate and absorb like a grey-body with some constant emissivity ($\epsilon \leq 1$).

A further assumption consonant with the stratified zone assumption is that emission and absorption are constant throughout a gas layer. In application to a growing fire, a further assumption is made that the lower layer is mostly diathermous. Although not a necessary assumption, this reduces the computation time for this term by 50%. For smoke propagation some distance from the fire(s) such an assumption will not be valid, but the temperature will be so low that radiation will not be the dominant mechanism for heat loss. Flames, plumes, fires, objects and bounding surfaces have some average shape from which the view factors can be calculated. The walls of compartments are usually flat and rectangular. The gas layers are spheres with an equivalent radius of

$$L = 4V/A \quad (28)$$

and an effective emissivity of

$$\epsilon_g = 1 - \exp(-\alpha L). \quad (29)$$

The terms which contribute to heating of a layer are:

1. fires and plumes,
2. walls,
3. other layers,
4. vents (radiation from other compartments),
5. nonburning objects.

The radiation balance of items 2-5 can be dealt with using the following notation:

F_{jk} - geometrical view factor of surface (j) by surface (k)

σ - Stephen-Boltzman constant = 5.67×10^{-8} W/m²K⁴

α - absorption coefficient of the upper gas layer m⁻¹

L - mean beam length of the equivalent sphere (m), defined in eqn. (28)

$\epsilon_{u,\ell}$ - emissivity of the upper/lower walls

ϵ_g - emissivity of the upper gas layer

Using the formalism of Siegal and Howell (1981) we have

$$D = \{1 - (1-\epsilon_u)(1-\epsilon_g)F_{uu}\} \{1 - (1-\epsilon_\ell)F_{\ell\ell}\} - \{(1-\epsilon_u)(1-\epsilon_\ell)(1-\epsilon_g)^2 F_{u\ell}F_{\ell u}\} \quad (30a)$$

$$\begin{aligned} \Pi_u = & \{ \{1 - (1-\epsilon_g)F_{uu}\} \{1 - (1-\epsilon_\ell)F_{\ell\ell}\} \\ & - \{(1-\epsilon_\ell)(1-\epsilon_g)^2 F_{u\ell}F_{\ell u}\} \} \sigma T_{uw}^4 \\ & - (1-\epsilon_g)F_{u\ell}\epsilon_\ell\sigma T_{\ell w}^4 - [1 + (1-\epsilon_\ell)\{(1-\epsilon_g)F_{u\ell}F_{\ell u} - F_{\ell\ell}\}] \epsilon_g\sigma T_g^4 \end{aligned} \quad (30b)$$

$$\begin{aligned}
\Pi_{\ell} = & \left[\left\{ 1 - (1-\epsilon_u)(1-\epsilon_g)F_{uu} \right\} (1-F_{\ell\ell}) - (1-\epsilon_u)(1-\epsilon_g)^2 F_{u\ell}F_{\ell u} \right] \sigma T_{\ell w}^4 \\
& - (1-\epsilon_g)F_{\ell u} \epsilon_u \sigma T_{uw}^4 \\
& - \left[\left\{ 1 - (1-\epsilon_u)(1-\epsilon_g)F_{uu}F_{\ell u} + (1-\epsilon_u)(1-\epsilon_g)F_{\ell u} \right\} \epsilon_g \sigma T_g^4 \right]
\end{aligned} \tag{30c}$$

Finally,

$$\dot{Q}(\text{upper}) = A_u \epsilon_u \Pi_u / D$$

$$\dot{Q}(\text{lower}) = A_{\ell} \epsilon_{\ell} \Pi_{\ell} / D.$$

To this must be added the energy radiated by the fire. A heat transfer balance with the fire is not necessary simply because the amount of heat radiated by the fire is usually much greater than that absorbed by the fire. In order to investigate flashover, however, this calculation must be generalized to include the fire and lower layer absorption in the radiative heat balance equation rather than relying on the postulate that superposition of the terms is sufficient.

A simple example of the results can be given for the case

$$\epsilon_u = \epsilon_{\ell} = 1,$$

for which we have

$$\dot{Q}_g = -\sigma \left[\epsilon_g T_u^4 A + (1-\epsilon_g) T_{uw}^4 (A_u + A_{uv}) - T_{uw}^4 A_u - \epsilon_g T_{\ell w}^4 A_d - T_a^4 A_{uv} \right] + F_f \dot{Q}_f \tag{31}$$

where A_d = area of the upper/lower layer discontinuity

A_{uv} = area of vents which the gas layer "sees"

A_u = area of the upper wall (including ceiling)

F_f = fraction of the fire which radiates times its view factor for
the gas layer.

$$A = A_u + A_d$$

4.2 Source Terms: Convective Heating

Convection is the mechanism by which the gas layers lose (or gain) energy to walls or other objects. Conduction is a process which is intimately associated with convection but as it does not show up directly as a term for heat gain or loss, it will be discussed here.

Convective heat flow is energy transfer across a thin boundary layer. The thickness of this layer is determined by the relative temperature between the gas zone and the wall or object surface, Schlichting (1955) and Turner (1973). We can write the heat flux term as

$$\dot{Q}_c = h_c (T_g - T_w) A_w \quad (32)$$

where the transfer coefficient can be written as

$$h_c = \frac{k}{l} C_v (Gr \cdot Pr)^{1/3}.$$

The terms are:

A_w = area of wall(s) in contact with the zone

Gr = Grashoff number = $gk^3 |T_g - T_w| / \nu^2 T_g$

Pr = Prandtl number ≈ 0.7

k = thermal conductivity of the gas = $2.7 \times 10^{-7} \left(\frac{T_g + T_w}{2} \right)^{4/5}$

ℓ = length scale = $\sqrt{A_w}$

C_v = coefficient which depends on orientation, Turner (1973)

N_u = Nusselt number

$\nu = 7.18 \times 10^{-10} \left(\frac{T_g + T_w}{2} \right)^{7/4}$

For the cases of interest

<u>Orientation</u>	<u>Coefficient</u>	<u>Condition</u>
Vertical	0.130	$Gr \times Pr > 10^8$
Horizontal	0.210	$T_g > T_w$
Horizontal	0.012	$T_g < T_w$

The coefficients for horizontal surfaces apply to a slab over the zone. For the inverse of this situation the coefficients should be reversed.

4.3 Source Terms: Plumes

A fire generates a plume which transports mass and energy from the fire into the upper layer. In addition, the plume entrains mass from the lower layer and transports it into the upper layer. The former generally increases the upper zone internal energy whereas the latter will have a cooling effect. For a fire which is consuming mass at a rate \dot{m}_f , heat addition will be

$$\dot{Q} \approx \chi_e \dot{m}_f \cdot H_c$$

Some fraction, χ_R , will exit the fire as radiation and the remainder will be left to drive the plume. We can empirically divide the heat transfer into actual combustion and simple gasification. The former, denoted by χ_c , is the relative fraction of pyrolysate which participates in the combustion. Also, once combustion occurs, a fraction of the energy leaves the fire as radiation ($\chi_R \dot{Q}$) and convective energy ($(1-\chi_R)\dot{Q}$). The former is a function of such external effects as radiation, e.g., other fires, and vitiation. The latter efficiencies relate to sootiness and Froude number. The mass flow in a plume comes from a correlation of experimental data given by McCaffrey (1983). This correlation divides the flame/plume into three regions:

$$\begin{array}{ll}
 \text{flaming:} & \dot{m}_p = 0.011 Q (z/Q^{2/5})^{0.566} \quad z/Q^{2/5} < 0.08 \\
 \text{intermittent:} & \dot{m}_p = 0.026 Q (z/Q^{2/5})^{0.909} \quad 0.08 \leq z/Q^{2/5} < 0.20 \\
 \text{plume:} & \dot{m}_p = 0.124 Q (z/Q^{2/5})^{1.895} \quad 0.20 \leq z/Q^{2/5}
 \end{array} \quad (33)$$

Entrainment in the intermittent region agrees with the work of Cetegen et al. (1982) but yields greater entrainment in the other two regimes. This difference is particularly important for the initial fire as the upper layer is far removed from the fire. In this formulation, the total mass flow in the plume is given by the above correlation and the fuel pyrolysis is related to it by

$$\dot{m}_p + \dot{m}_v = f(mz, Q) \quad (34)$$

given above.

4.4 Source Terms: Door Jets

Flow at vents is governed by the pressure difference across a vent. In the control volume approximation the general momentum equation for the zones is not solved. Instead, the momentum transfer at the zone boundaries is included by using Bernoulli's solution for forced flow. This solution is augmented for restricted openings by using "flow coefficients." The modification deals with the problem of constriction of velocity streamlines at an orifice.

There are two cases which apply to these models. The first, and most usually thought of in fire problems, is for air or smoke which is driven from a compartment by buoyancy. The second type of flow is due to a piston effect which is particularly important in the early stages of a fire. Rather than depending on density difference between two gases, the flow is forced, for example, by volumetric expansion when combustion occurs.

The results used for this model are those of Bodart and Jones (1984) and will not be duplicated here. The notation used is:

S = smoke

A = air

ij = flow from compartment (i) to (j)

P = floor pressure (reference)

The order of the letters indicate the type of atmosphere from which the fluid is coming and to which it is going. As many as three neutral planes can exist for such flows. Two mixing phenomena which occur at vents are similar to entrainment by plumes. For the case when hot gas leaves a compartment and is driven by buoyancy into the upper layer of a second compartment, a door jet exists which is analogous to a normal plume. Mixing of this type occurs for flow

$$SA_{ij} > 0$$

and is discussed in detail by Zukoski (1982) and Tanaka (1980). The other is much like an inverse plume and causes contamination of the lower layer as cold gas from a compartment flows through a hot layer in a second compartment and is driven by buoyancy (negative) into the lower layer. Quintiere et al. (1981) discuss this phenomena for the case of crib fires in a single room and deduce the relation

$$SA_{i(u \rightarrow \ell)} / AS_{ji} = 0.5 \left(\frac{T_{\ell j}}{T_{ui}} \right) \left(\frac{N - Z_i}{N} \right). \quad (36)$$

This term is predicated on the Kelvin-Helmholz shear flow instability and requires shear flow between two separate fluids. The instability is enhanced if the fluids are of different density since the equilibration distance is proportional to $\nabla \rho$. A schematic of this type of flow is shown in figure 3. As can be seen, mixing into the lower layer of a room occurs under the same conditions for which the "door-jet" mixing to the upper layer occurs.

4.5 Source Terms: Fire

Currently we can deal with two types of fires. The first is a specified fire. Then the mass pyrolysis rate is specified and the heat release rate becomes

$$\dot{Q}_f = h_c \dot{m}_f - c_p (T_u - T_f) \dot{m}_f - Q_p \dot{m}_f \quad (37)$$

whereas the mass loss rate, \dot{m}_v , is related to the pyrolysis rate by

$$\dot{m}_v - \dot{m}_f = (1 - \chi_f) \dot{m}_v.$$

As the burning efficiency becomes 100%, all of the volatiles are burned, and nothing remains for sooting. The heat release goes into radiation and enthalpy flux

$$\dot{Q}_R(\text{fire}) = \chi_R \dot{Q}_f$$

$$\dot{Q}_C(\text{fire}) = (1 - \chi_R) \dot{Q}_f.$$

The term $\dot{Q}_C(\text{fire})$ then becomes the driving term in the plume flow equation (see eqns. (33, 34)).

This approach is extended for a pool fire. A pool fire is basically the same except that it is driven self-consistently by reradiation from the compartment and the flame itself. From Rockett (1983) we have

$$\dot{Q}_f = \dot{Q}_R(\text{ext}) + \dot{Q}_{\text{flame}} - \dot{Q}_{\text{RR}} + \dot{Q}_{\text{conv}} - \dot{Q}_{\text{cond}} \quad (38)$$

where

- \dot{Q}_R = external radiation to the fuel source
- \dot{Q}_{flame} = radiation from the flame back to the fuel
- \dot{Q}_{RR} = fuel surface reradiation
- \dot{Q}_{conv} = enthalpy flux away from the fire
- \dot{Q}_{cond} = conductive heat loss from the fuel to the surroundings

4.6 Source Terms: Conduction

Conduction of heat through solids is not a source term in the sense mentioned earlier. That is, loss or gain of energy from solids occurs by convective heating, which in turn is influenced by subsequent gain or loss through the solids. However, as much of the net heat loss from a compartment occurs through loss to the walls, as well as heating of interior objects, the form of heat propagation in solids will be discussed here.

The equation which governs the heat transfer in solids is

$$\frac{\partial T}{\partial t} = \frac{k}{\rho c} \nabla^2 T \quad (39)$$

and is a linear parabolic equation. As such, it must be solved by a different technique than is used for the ordinary differential equations which describe mass and enthalpy flux. In order to couple these systems in a reasonable way, we appeal to the principle of time splitting. Simply stated, we have two systems of equations which are decoupled as long as the time step used is short compared to the characteristic time scale for either set of equations.

Wall temperatures change and the characteristic time for energy flux through a solid is characteristically on the order of minutes. By using a time step of no more than one second the applicability of time splitting is assured.

Currently the model assumes two walls, the upper wall (and ceiling) which is in contact with the upper layer, and the lower wall (and floor) which is in contact with the lower layer. A refinement will be to separate the ceiling and upper wall, and the lower wall and floor. This will be useful since walls are generally constructed of materials whose thermal properties are different than the ceiling and floor. A further assumption is that conduction is one dimensional only. That is, the heat equation is

$$\frac{\partial T}{\partial t} = \frac{k}{\rho c} \frac{\partial^2 T}{\partial x^2} \quad (40)$$

and the solid behaves as an infinite slab in the other two space dimensions. A corollary to this is that the wall in contact with the gas layer changes temperature instantaneously as the layer interface moves up and down. Such a formulation is not entirely satisfactory as there is a finite equilibration time for the solid. An additional refinement will be to extend this equation to two dimensions to track the layer as it moves up and down. So far, the only zone model to attempt to include this effect is discussed by Jones (1983) and Mitler and Emmons (1981). Even in this case the attempt was made only to include heat loss from the upper layer as it moves down and comes in contact with cool lower walls. However, the phenomenon is important, as is discussed by Quintiere et al (1983), especially as the thermocline in the wall will influence the direction in which the wall boundary flow propagates.

Conduction through solids occurs in two places: the compartment walls and interior objects. The technique used is the same in both cases, although the boundary conditions on the equation may be different. Generally a slab is cut into N intermediate slices (N+1 nodes). Then eqn. (40) is solved for each slice. The actual finite difference used is a time centered, implicit scheme which is symmetric about the nodes. For the interior nodes we have

$$T'_i[1+\eta] = \frac{\eta}{2} [T'_{i+1} + T'_{i-1}] + \left\{ T_i + \frac{\eta}{2} [T_{i+1} - 2T_i + T_{i-1}] \right\} \quad (41a)$$

where

$$\eta = \frac{\Delta t}{\Delta x} \frac{k}{\rho c}$$

and for the edge nodes

$$T'_i \left[1 + \frac{\eta}{2} \right] = \frac{\eta}{2} \left[T'_{i+1} \pm \frac{\dot{Q}_c}{k} \right] + \left\{ T_i + \frac{\eta}{2} \left[T_{i+1} - T_i \pm \frac{\dot{Q}_c}{k} \right] \right\} \quad (41b)$$

The temperature at the starting time at node "i" is T_i and at time $t+\delta t$ it is T'_i . The number of nodes is chosen to reduce the residual error to some reasonable value, say less than 1%. Use of $N > 20$ will improve precision with no concomitant increase in accuracy. This technique would allow one to use different constituents for each slab, although such is not done in the current implementation. Each time step requires both an initial condition and one boundary condition. We start with the internal temperatures in each case, and the flux on the "hot" side. The usual scheme is to set the far side boundary condition to zero heat flux (which allows heat build up in the interior) or to approximate the far side exterior as a constant temperature bath. Either

technique is satisfactory unless this far side happens to be the interior boundary for another compartment.

5. NUMERICAL INTEGRATION

The problem of the spread of fire, smoke, etc. has been formulated as a set of differential equations. These equations are derived from the conservation of mass and energy. As a result, most of the equations are non-linear and first order ordinary differential equations (ODE). The exception to this rule is the heat conduction equation which is a linear parabolic equation, in one or two dimensions. The former can be solved using implicit predictor-corrector methods, Conte (1965), and the latter successive over-relaxation (SOR), Mitchell and Griffiths (1980).

In the numerical implementation, we have relied on the validity of a technique called time splitting. Simply stated, we have decoupled equations which have greatly differing relaxation times, that is

$$\frac{1}{n} \frac{dn}{dt} = L_n$$

where L_n varies by more than an order of magnitude for each process. Except for the driving program which invokes the hydrodynamics, species transport and thermal conductivity, the various modules which incorporate the physical processes are exercised separately and interact as source terms. This splitting technique is standard but the inherent assumptions should be checked when implementing a new numerical model. In addition, a check should be made at each time step to insure that the relevant stability criterion (similar to a Courant condition for fluid flow) is not violated.

For both types of equations the solution at each time step is found by an implicit scheme. The implicit method allows us to implement the numerical solution as a time centered algorithm. This insures reversibility in the physical phenomenon, at least for non-diffusive systems. A test of this assertion is to exclude thermal conduction, integrate from an initial condition to some final time, and subsequently, by changing the sign of the time step, we should be able to return to the starting position. A time reversal calculation is an important step in assuring ourselves that the integration scheme itself is not dissipative and thus will not relax to an incorrect final state. This is a real property in non-dissipative physical systems and should be mirrored as closely as possible in a numerical model. When conductivity is included, such reversibility ceases to be strictly valid, of course.

An additional virtue of the time centered scheme is avoiding the bifurcation which can occur in pure leapfrog schemes. The disadvantage is the one additional source calculation required at each time step. This time appears to be short, however, in comparison with the "corrector" phase of the implicit scheme.

The order of the integrations is as follows:

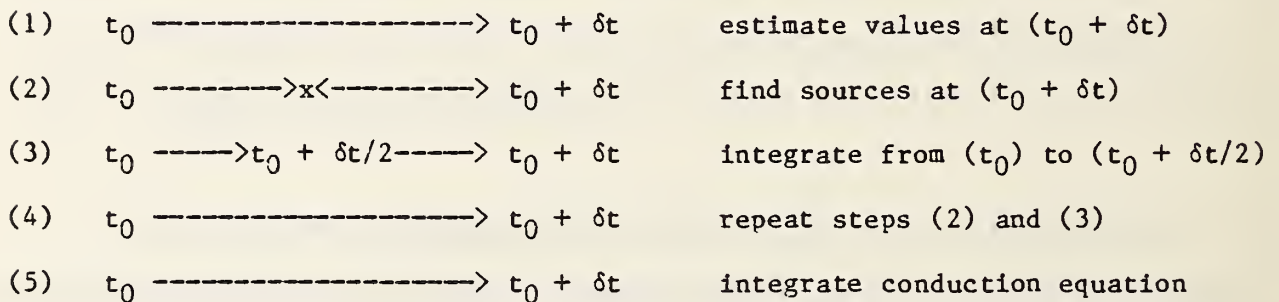
- (1) Estimate the values for pressure, etc. at $t_0 + \delta t$.
- (2) Find the source terms for eqns. (22-25) based on the time centered values ($t_0 + 1/2 \delta t$).

(3) Integrate eqns. (22-25) using the source terms defined at the time centered positions.

(4) Repeat steps (2) and (3) until convergence is reached.

(5) Integrate the conduction equation using the SOR technique.

The following illustration shows where each of these time-step points is, in relation to steps (1-5):



Since each step is of at least second order accuracy, the overall scheme will also be second order accurate ($O(\delta t^3)$). The relative error allowed at each time step is $\sim 10^{-3}$. Thus the precision is greater than the precision of the computer being used (at least as long as these calculations are being done in single precision).

As for the integration scheme itself, it is derived from an Adam-Bashford backwards difference scheme, Conte (1965), of order $k=1$. This yields a single step predictor and second order corrector, $O(\delta t^3)$. These equations become "stiff" if the individual source terms are large, which leads to a short time step, yet the total source function may be tightly coupled if the solution is

being approached asymptotically. Another possibility is that the source terms for the various equations differ by more than an order of magnitude. In either case, the usual time step criterion would require a time step which is prohibitively short. It is possible to modify the Taylor expansion used in obtaining the predictor-corrector scheme to use the asymptotic nature of the equations to enhance the speed of the solver, Young and Boris (1977).

The general form of an equation is

$$\frac{dn}{dt} = q - \ell n \equiv f.$$

Using the notation $n(0)$, $q(0)$, $\ell(0)$, $f(0)$ are the initial values at time (t_0) , and $n(1)$, $q(1)$, $\ell(1)$, and $f(1)$ are the values at the new time $(t_0 + \delta t)$, we obtain first for the normal equations

$$\text{predictor } n(1) = n(0) + \frac{\delta t}{2} f(0) \quad (42a)$$

$$\text{corrector } n(1) = n(0) + \frac{\delta t}{2} (f(0) + f(1)) \quad (42b)$$

and for the stiff equations

$$\text{predictor } n(1) = n(0) + \frac{\delta t}{1 + \delta t \ell(0)} f(0) \quad (43a)$$

$$\text{corrector } n(1) = n(0) + \frac{2 \delta t}{1 + \delta t \{\ell(0) + \ell(1)\}} \{f(0) + q(1) - \ell(1)n(0)\}. \quad (43b)$$

The corrector must be iterated until some specified error criterion is reached. If the specified error can not be reached in a small number of iterations, say two or three, then the time step must be reduced. It turns out to be advantageous to half the time step for each instance that a reduction is required, and increase it by only 10% for each subinterval that the error criterion is satisfied.

6. COMPARISON WITH EXPERIMENTAL DATA

The series of tests which serve as a data-base for this analysis are based on a two-room fire scenario by Cooper et al. (1981) and an ongoing series of full scale validation tests at the National Bureau of Standards. The former was a two-room configuration, consisting of a burn (or fire) room and a corridor. It is referred to as the "Nike Site" in later discussions. The latter is a three room configuration with the additional room being a target room for testing high density occupancy, referred to as "Building 205." The geometry of each of these configurations is shown in Table I.

Comparisons between the model and experimental data are for fires of 100 kW. Figures 4 and 5 show the comparison for the Nike Site tests for the upper layer temperatures in the burn room and corridor, and the interface height in the corridor. Figures 6 and 7 show a similar comparison to the current experiments in B205, a full scale facility at NBS. It is apparent from a comparison of Fig. 4-7 that plume entrainment is estimated very well but that the door jet entrainment is underestimated. We can see this from the good agreement between experiment and theory in any compartment which contains a primary plume whereas in other compartments the predicted temperature is too

high and the layer depth too small in comparison with experimental values. This underestimation occurs in the regions which McCaffrey (1983) calls the flaming and far field regions. In the intermittent region, where the results of McCaffrey (1983) and Cetegen et al. (1982) agree, the entrainment rate appears to be correct.

Another factor which gives rise to disparity between theory and experiment is the assumption, in the model, of known and uniform wall materials. In the experiments, walls consist of several materials in a composite such as calcium-silicate board over gypsum. Allowing for these factors, the agreement seems quite good. As research continues, these discrepancies will be resolved.

Table I.

	Burn	Vent	Corridor	Vent		
Nike Site	Depth ²	4.3	-	11.1-20.2	-	
	Width	3.3	1.07	2.4	0.95	
	Height	2.3	2.00	2.3	0.15	
	Area	14.2	2.14	26.6-48.4	0.14	
	Volume	32.2	-	61.2-112.3	-	
	Burn	Vent	Corridor	Vent ¹	Target	
Bldg. 205	Depth	2.3	-	12.2	-	2.3
	Width	2.3	1.0	2.4	1.0/1.0	2.3
	Height	2.2	1.9	2.4	1.9/2.0	2.2
	Area	5.5	1.9	29.7	1.9/2.0	5.5
	Volume	11.8	-	72.6	-	11.8

Note 1: V1/V2: V1 is from corridor to target room and V2 is from corridor to the ambient.

Note 2: Lengths are in meters, areas in square meters and volumes in cubic meters.

7. STABILITY AND COMPLETENESS

There are a number of phenomena which are either not included or need additional work. They are:

1. Wall effect - two dimensional, unsteady heat flow
2. Separation of flow - vents
3. Ceiling jet - transit time

The first refers to the finite thermal inertia of the wall as the hot layer moves down (or possibly up). There will be a two dimensional thermo-cline in the wall which differs from that in the compartment. Although this has only a small direct effect, it can lead to flow along the walls which can subsequently contribute to contamination of the lower layer. Such effects become particularly important as the smoke travels further from the fire source and temperature differentials become small.

The second problem is quite important for asymptotic predictions, especially near the room of fire origin. Currently we assume that hot gas mixes with hot gas or cold with cold gas as it traverses a vent. This was a reasonable approximation while the lower layer was assumed to be ambient. Now that we calculate the lower layer temperature, we find that the recirculating gas may have a temperature on the order of the lower layer of the room into which it enters. A particular example will demonstrate the effect. In a two compartment calculation, Jones and Quintiere (1983) found that the layer outside of the burn room is lower than that in the compartment of fire origin. As there is no source of heat in this second compartment and cooling occurs

due to mixing, the upper layer in this adjacent space is cool relative to the upper layer in the fire room, and even comparable in temperature with the lower layer. Currently we assume all of the hot gas in the adjacent room, which flows into the fire room, will be deposited in the fire room upper layer. As can be seen in figure 8, Evans (1983) this assumption leads to discrepancies in prediction versus experiment. A better approach is to divide the incoming flow into two components: for flow into compartment (i) from compartment (j), we have a component into the upper layer = $\left(\frac{T_{uj} - T_{li}}{T_{ui} - T_{li}} \right) \dot{m}_{j \rightarrow i}$, with the remainder going into the lower layer. This occurs only after an interface discontinuity has been established.

The third problem will only be important for very long corridors (20 m) or very tall compartments or shafts. Also, it is only a transient phenomenon. For purposes of siting smoke detectors, for example, this transient may be important.

8. CONCLUSIONS

The fire and smoke transport model, as described in this paper, is quite detailed and complete as far as our current understanding of fire phenomenology is concerned. It draws on a great deal of the research into fires which have occurred over the past ten years, pulling together much of the best work which has been done in the field. The numerical implementation is of particular interest because it is extremely durable. The problems discussed in the section "Stability and Completeness" need to be addressed if we are to carry this work further, such as to fires in high rise hotels or on aircraft carriers.

9. ACKNOWLEDGMENTS

Two NBS cooperative students, Alicia Fadell and Charles DeWitt have contributed to this effort. Ms. Fadell was instrumental in implementating the "BUILD" program which generates the configuration and description files for the "FAST" model. Mr. DeWitt is responsible for "FASTPLOT", a routine which enables one to analyze rather easily the extensive output available from "FAST."

10. REFERENCES

- Carslaw, H.S. and Jaeger, J.C., Conduction of Heat in Solids, Oxford University Press, London (1959).
- Cooper, L.Y., Harkleroad, M., Quintiere, J. and Rinkinen, W. (1981), An Experimental Study of Hot Layer Stratification in Full Scale Multiroom Fire Scenarios, ASME 81-HT-9, Milwaukee.
- Cetegen, B.M., Zukoski, E.E. and Kubota, T., Entrainment and Flame Geometry of Fire Plumes, Ph.D. Thesis of Cetegen, Cal. Tech. (1982).
- Conte, S.D., Elementary Numerical Analysis, McGraw-Hill, New York (1965).
- Evans, D., private communication (1983).
- Jones, W.W., A Review of Compartment Fire Models, National Bureau of Standards (USA) IR 83-2684 (1983).
- Jones, W.W. and Fadell, A., A Device Independent Graphics Kernal, to be published as an NBSIR.
- Jones, W.W. and Quintiere, J.G., Prediction of Corridor Smoke Filling by Zone Models, Comb. Sci and Tech 11, 111 (1983).
- Kusada, T., NBSLD, The Computer Program for Heating and Cooling Loads in Buildings, National Bureau of Standards (USA) BSS 69 (1976).
- McCaffrey, B.J., Momentum Implications for Buoyant Diffusion Flames, Comb. and Flame 52, 149 (1983).
- Mitchell, A.R. and Griffiths, P.F., The Finite Difference Method in Partial Differential Equations, J. Wiley & Sons, New York (1980).

- Mitler, H.E. and Emmons, H.W., Documentation for CFC V, The Fifth Harvard Computer Fire Code, Home Fire Project Tech. Rep. #45, Harvard University (1981).
- Quintiere, J.G., Steckler, K. and Corley, D., An Assessment of Fire Induced Flows in a Compartment, submitted for publication in Fire Science and Technology (1984).
- Quintiere, J.G., Steckler, K. and McCaffrey, B.J., A Model to Predict the Conditions in a Room Subject to Crib Fires, First Specialists Meeting (International) of the Combustion Institute, Talence, France (1981).
- Rockett, J.A., Experimental Determination of the Heat Flux to a Burning Surface, to be published in Fire Science and Technology.
- Schlichting, H., Boundary Layer Theory, Pergammon Press, New York (1955), translated by Kestin, J.
- Siegel, R. and Howell, J.R., Thermal Radiation Heat Transfer, McGraw Hill Book Co., New York (1981).
- Steckler, K.D., Quintiere, J.G. and Rinkinen, W.J., Flow Induced by Fire in a Compartment, Nineteenth Symposium (International) on Combustion (1982).
- Tanaka, T., A Model of Multiroom Fire Spread, National Bureau of Standards (USA) IR 83-2718 (1983).
- Tanaka, T., A Model of Fire Spread in Small Scale Buildings, Building Research Institute (Japan) RP #84 (1980).
- Turner, J.S., Buoyancy Effects in Fluids, Cambridge University Press (1973).
- Yokoi, S., Study on the Prevention of Fire Spread Caused by Hot Upward Currents, Kenchiku Hokoku No. 34 (1960).
- Young, T.R. and Boris, J.P., A Numerical Technique for Solving Stiff Ordinary Differential Equations Associated with the Chemical Kinetics of Reactive Flow Problems, J. Phys. Chem. 81, 2424 (1977).

Appendix A - Notation

- A area (m^2); A_u , A_l , A_d are the upper and lower compartment surface areas in contact with the upper and lower gas layer, fig. (1), respectively. A_d is the interface area between the upper and lower layers. In section 4.4, "A" is used as a variable in the flow equations to indicate air.
- B width of a vent (m)
- C, C' flow coefficient $\approx 0.6-0.7$ for both smoke and air
- c specific heat - c_p , c_v (J/kg/K)
- \dot{E} energy release rate (J/s)
- E internal energy of the gases - see eqn. (2)
- F_{ij} view factor - relative area of "i" as seen by "j" (dimensionless)
- g acceleration of gravity (9.8 m/s^2)
- H height (m), H_u , H_l , are the upper and lower limits of a vent - fig. (1)
- h enthalpy (J/kg/K)
- h_c heat of combustion - theoretical (J/kg)
- i, j compartment indices
- k thermal conductivity (J/s/K)
- L mean beam length (m) equivalent opaque sphere
- m mass (kg)
- \dot{m} mass flow (kg/s):
 \dot{m}_v - rate of release of volatiles
 \dot{m}_e - entrained into a plume
 \dot{m}_f - fuel burning rate = $\chi_e \dot{m}_v$
 \dot{m}_{ij} - mass entering room "i" from room "j"
 \dot{m}_p - flow rate in plume ($\dot{m}_p = \dot{m}_v + \dot{m}_e$)
- N height of the neutral plane (m)
- P pressure (pa): $\bar{P} \rightarrow P$ - floor reference pressure
 P_a - outside ambient pressure

- \dot{Q} rate heat is added or lost (J/s):
- \dot{Q}_u, \dot{Q}_l - upper, lower zones, respectively
 - \dot{Q}_f - fire ($h_c \dot{m}_v$)
 - \dot{Q}_o - objects
 - \dot{Q}_R - radiation
 - \dot{Q}_c - convection by walls
 - \dot{Q}_g - radiation added to upper gas layer
 - \dot{Q}_k - radiation from surface "k"
 - \dot{Q}_p - combustion energy lost by formation of volatiles
- R gas constant for specific mixture
- S smoke - section 4.4
- t time (s)
- T temperature (k):
- T_a - ambient
 - T_c - external wall
 - T_u - upper wall
 - T_l - lower wall
 - T_R - reference temperature for enthalphy flow
 - T_g - upper zone temperature
 - T_v - pyrolysis temperature
- V volume (m^3)
- Z layer thickness (m) - Z_i = interface height in compartment (i)
- α absorption coefficient of upper gas layer (m^{-1}), thermal diffusivity (m^2/s)
- γ ratio of specific heat (c_p/c_v)

ϵ emissivity (dimensionless): ϵ_i - surface "i"
 ϵ_g - upper gas layer
 ϵ_u - upper compartment surface
 ϵ_l - lower compartment surface
 ρ_{ui} - density of the lower layer in
compartment (i)

ρ mass density (kg/m^3)

κ thermal conductivity (j/msK)

δ_{ij} Kronecker delta = 0 $i \neq j$
= 1 $i = j$

Δt time step (s)

Δx spatial discretization

Subscripts - In general "u" and "l" indicate upper and lower gas layer, respectively. For area and emissivity variables, reference is to the compartment itself.

Appendix B

Shown in Table II is a sample input for FAST. The organization is that control is at the beginning, followed by component information, connections, wall properties, a description of the fire, species generation information and finally file descriptors for graphics and the dump file.

In general, the first word in each line is a key word and must be included. The explanation of this file will be by example:

<u>Line</u>	<u>Meaning</u>
1	version and title
2	time step information 600 → number of seconds for the calculation 120 → print interval 120 → dump interval (requires files) 1 → graphics interval (requires files) 0 → hard copy counter
3	Number of floors - not used with this version, but retained for compatibility
4	Total number of compartments
5	Maximum number of openings between compartments (<4)
6	ambient temperature,
7-10	compartment geometry, W x L x H x Floor (1 → NROOM)
11-16	connection configuration (outside is compartment NROOM + 1)
17	number of walls used in the calculation ¹
18-27	thermophysical properties of the upper and lower walls respectively (units are SI except energy (kJ) and power (kW)).
28	which compartment the fire is in
29	type of fire (currently only a gas burner is allowed)
30	number of intervals for production rate ²
31	interior position of the fire to establish entrainment rate (1 → center)
32	fuel properties necessary for partial combustion 1.0 → fraction of pyrolysis which burns 0.0 → fraction of water in the fuel 0.750 → fraction of carbon in fuel by weight 0.25 → fraction of hydrogen in fuel by weight 0.00 → fraction of oxygen in fuel by weight 49758 heat release rate (kJ/kg) 300. fuel inlet temperature 0.0 fraction of heat which exits the fire plume in the lower layer as radiation

¹Currently an upper and lower wall are used. This will change shortly to four walls to reflect the physical difference among the ceiling, walls and floor.

²Figure 9 shows a sample fire production curve.

33 mass loss rate at each end point (kg/s),
LFMAX + 1_e
34 area of the fire at each end point (m²)
35 height of the base of the flame (m)
36 duration of each time interval (LFMAX)
37-40 fractional production rate of species 3, 7, 9 & 10³
first number is species (1 → 12)
second number is a conversion factor
third through LFMAX + 3 are fractional production
rates⁴
41 termination label (required)
42-44 file descriptors
DISFG = plan view⁵
CONFG = layer information⁵
DUMPR = dump file for FASTPLOT

There are two primary output files for the model. The first is binary (UNIT = 9) and is used by the routine "FASTPLOT" described in appendix D. The other is an ASCII file (UNIT = 6) and usually is displayed on the printer. Units are SI (MKS) except for energy which is in kJ. The meanings of the symbols, in the order which they appear, are:

Initial	- reiterate the input parameter, generally in the order of input
Timestep Output	-
TIME	- simulated time (s)
U. TEMP	- upper layer temperature (K)
L. TEMP	- lower layer temperature (K)
U. VOLUM	- upper layer volume (m ³)
U. DEPTH	- vertical thickness of the upper layer (m)
C. TEMP	- ceiling temperature at the surface (K)
F. TEMP	- floor temperature (K)
EMS	- flow into the upper layer from the plume (kg/s)
EMP	- pyrolysis rate (kg/s)
ADS	- area of the fire (m ²)
QF	- enthalpy release rate of the fire (kW) to the upper and lower layer
QR	- total radiant energy to the upper and lower layers (kW)
QC	- total convective heating of the upper and lower layers (kW)
Pres	- floor reference pressure (pa)
mass	- vent flow from i → j (kg/s) - sec (section 4.4)

³Species 1-12 are N₂, O₂, CO₂, CO, HCN, HCL, ThHC, H₂O, smoke density, total % L_{C50}, smoke number density and HCL number density.

⁴Fraction of the mass burning rate at the corresponding endpoint (see line 33 and figure 9).

⁵Format for the graphics files is given in the NBSIR by Jones and Fadell.

Species concentrations listed by species:

- mass - total mass of that species in the layer (kg)
- M/V - mass per unit volume multiplied by the conversion factor shown in line 37-40 of the input fuel. Unity leaves this value in (kg/m³).⁶
- PPM - parts per million of the total molecules present
- PPM-M - dosage which is an integral of (PPM) over time (PPM - minutes)

Table II

1 - VERSION 15	Toxic hazard evaluation								
2 - Timesteps	600	120	120	1	0				
3 - NFLOR	1 NUMBER OF FLOORS IN THE CALCULATION								
4 - NROOM	5 TOTAL NUMBER OF ROOMS								
5 - NMXOP	1								
6 - TAMS	300.								
7 - HI/F	0.0	0.0	0.0	0.0	0.0				
8 - WIDTH	3.3	2.4	2.9	2.4	3.3				
9 - DEPTH	4.3	18.8	9.9	9.9	4.3				
10 - HEIGHT	2.3	2.3	2.3	2.3	2.3				
11 - HVENT	1	2		1.07	2.0	0.0			
12 - HVENT	2	3		1.07	2.0	0.0			
13 - HVENT	3	6		0.95	.15	0.0			
14 - HVENT	2	4		1.07	2.0	0.0			
15 - HVENT	4	6		.95	.10	0.0			
16 - HVENT	2	5		1.07	2.0	0.0			
17 - WALLS	2								
18 - COND	.0012	.0012		.0012	.0012	.0012			
19 - SPHT	.840	.840		.840	.840	.840			
20 - DNSTY	2000.	2000.		2000.	2000.	2000.			
21 - THICK	0.50	0.50		0.50	0.50	0.50			
22 - EMISS	0.8	0.8		0.8	0.8	0.8			
23 - COND	.0012	.0012		.0012	.0012	.0012			
24 - SPHT	.840	.840		.840	.840	.840			
25 - DNSTY	2000.	2000.		2000.	2000.	2000.			
26 - THICK	0.50	0.50		0.50	0.50	0.50			
27 - EMISS	0.8	0.8		0.8	0.8	0.8			
28 - LFBO	1 ROOM OF FIRE ORIGIN								
29 - LFBT	1 TYPE OF FIRE (GAS BURNER)								
30 - LFMAX	6 NUMBER OF INTERVALS FOR FIRE GROWTH								
31 - LFPOS	1 POSITION OF THE FIRE (CENTER)								
32	1.0	0.0	.750	.250	.00	49758	300.	.0	
33 - FMASS	.002	.002	.002	.002	.002	.002	.002	.002	
34 - FAREA	.5	.5	.5	.5	.5	.5	.5	.5	
35 - FHIGH	.0	.0	.0	.0	.0	.0	.0	.0	
36 - FTIME	60.	60.	60.	60.	60.	60.	60.	60.	
37 - SPECI 3	1.0	1.0	1.0	1.0	1.0	1.0	1.0	1.0	1.0
38 - SPECI 7	1.0	.025	.025	.025	.025	.025	.025	.025	.025
39 - SPECI 9	3500.	.02	.02	.02	.02	.02	.02	.02	.02
40 - SPECI 10	31.2	1.0	1.0	1.0	1.0	1.0	1.0	1.0	1.0
41 - ENDSP									
42 - DISFG	NIKE13A.DAT								
43 - CONFG	NIKE13B.DAT								
44 - DUMPR	TOXIC.DMP								

⁶This conversion factor allows the user to convert this output to an optical density, LC₅₀ or whatever.

Appendix C

The program BUILD is used to construct data files for configuration display. These files can then be used by FAST to display a decision tree either interactively or as a graphics streaming file. Both the configuration file for display as well as information on position and type of display for the decision tree are built by this program. The commands are:

ADD [VERTEX, EDGE, POLYGON] (default = VERTEX)

- add vertex - create vertices by specifying three (x, y, z) coordinates; add vertices to the work file
- add edge - create edges by specifying two vertices; add edges to work file
- add polygon - create polygons by connecting vertices. A minimum of three vertices are required to define a polygon, and there is an internal maximum specified by NPVERT.

DELETE [VERTEX, EDGE, POLYGON] (default = VERTEX)

- delete vertex - delete vertices and any edges or polygons which are connected to the deleted vertices
- delete edge - delete edges
- delete polygon - delete polygons

DISPLAY [ALL, VERTEX, EDGE, POLYGON] (default = ALL)

- display all - display all edges and polygons in graphics mode
- display vertex - display all vertices and their line numbers in graphics mode .
- display edge - display all edges in graphics mode
- display polygon - display all polygons in graphics mode

DUPLICATE

Duplicate a polygon at another location - asks for a displacement vector.

END

End the program.

ERASE

Erase the display screen.

GET [filename] (default = INFILE)

Open an existing file and assign the filename to INFILE; the elements of this file make up the new work file.

HELP

List all the BUILD commands, their corresponding options, and the default values.

LIST [VERTEX, EDGE, POLYGON] (default = VERTEX)

list vertex - list the world coordinates, window coordinates, and the vertices of the work file on the display screen

list edge - list the edges of the work file on the display

list polygon - screen list work file's polygons on the display screen

MOVE [VERTEX, POLYGON] (default = VERTEX)

move vertex - move a vertex from its present location to a new location - asks for a displacement vector

move polygon - move a polygon from its present location to a new location - asks for a displacement vector

PRINT [ALL, VERTEX, EDGE, POLYGON] (default = ALL)

print all - list the work file's world and window coordinates, vertices, edges, and polygons on the printer

print vertex - list the world coordinates, window coordinates, and vertices of the work file on the printer

print edge - list the work file's edges on the printer

print polygon - list the polygons of the work file on the printer

SAVE [filename] (default = OUTFILE)

Save the current file under the specified filename; assign the filename to OUTFILE.

STATUS

List the filenames stored in INFILE and OUTFILE; indicate the current number of vertices, edges, and polygons and the maximum number of each element allowed.

WINDOW

Create the work file's window space by specifying minimum and maximum x and y coordinates for display. Defaults to WORLD.

WORLD

Create the work file's three-dimensional world space by specifying x, y, and z coordinates. All structures must be contained in this cartesian coordinate system.

Appendix D

FASTPLOT is a data analysis program which runs in conjunction with "FAST." The results for "FAST" are dumped to a data file after each prescribed desired time step. FASTPLOT has the capability to form a list of variables, read in their values at each time interval, list out the values in tabular form, graph the values (hard copy or screen), and save the variables in a file for future reference.

The FAST model models a fire in one of several compartments, or rooms, and follows smoke and toxic gases from one compartment to another. We are concerned with variables in both the upper and lower layers.

The list of variables presently available through FASTPLOT are:

AREA burning area of the fire (m^2)

CONCENTRATION species density in parts per million

CONVECTIVE heat loss from layer to solid surface due to convection (kw/m^2)

DOORJET bouyant mass flow through a vent (kg/sec)

DOSE species concentration integrated over time (ppm-min)

ENTRAINED mass entrained by a plume (from lower layer to the upper layer)

INTERFACE height of the two-zone discontinuity (m)

MASS mass density in a layer (kg/m^3)

MDOTFIRE mass loss rate of the fire source (kg/sec)

NEUTRAL 1)
NEUTRAL 2 } neutral planes (maximum of three) for each vent
NEUTRAL 3 }

PLUME total mass flow into the plume (kg/sec)

PRESSURE reference pressure at the floor of the compartment (pa)

QC total convective heat gain by a layer

QF total enthalpy increase from the fire source

QR total radiative heat gain by a layer

RADIATION heat loss from layer due to radiation (kw/m^2)

TEMPERATURE temperature of the layer (C)

VENTFLOW mass flow through a vent (kg/sec) -
bidirectional

VOLUME volume of the upper zone (m³)

WALLTEMP temperature of the wall (C)

The CONCENTRATION, DOSE, and MASS also have associated with them a species number.

The main control of the program is carried out in the subroutine WHICHONE. It does the actual building of a list and the processing of the options. The possible options available to the user are:

ADD
CHANGE
CLEAR
DEFAULT
DELETE
END
HELP
LIST
PLOT
REVIEW
SAVE

Upon running the program, the first input encountered will be that of the dump file generated by FAST. Most of them will be of the form:

filename.DMP

Next, the user will be asked to input the option which he wishes to have performed. The following is a description of each of the options available. They are in the order that they usually will be encountered. However, some may be executed before the others without any problems. The minimum number of characters required to recognize an option is enclosed in the parenthesis at the beginning of each word.

1. (DE)FAULT

This enables the user to set his own default parameters for the following:

COMPARTMENT #
VENTFLOW DESTINATION
LAYER
SPECIES #
CHARACTER SET FOR PLOTTING

This option may be done at any time and if it is not done the defaults are set to "1, 2, upper, 9, and 4", respectively. The purpose of this option is to change the defaults available for other commands and data input.

2. (VA)RIABLES

The purpose of this option is to allow the user to recall the possible variables that are available for use. They will be listed on the screen.

3. (AD)D

This command is used to build a list of variables. When an option is requested ADD may be entered by itself or together with a list of variables that are to be added. If it is entered alone a message will be printed asking for the variables that are to be added to the list. For example:

```
> ADD
- INPUT VARIABLES TO BE ADDED >
      or
> ADD TEMP, PRES, .....
```

For each variable selected there is a series of questions that will be asked as to the type of that variable wanted. Questions asked about all variables are:

```
WHICH COMPARTMENT? ->
WHICH LAYER? ->
```

If VENTFLOW is chosen the compartment origin and destination will be requested; if CONCENTRATION, MASS, or DOSE are selected the species number of each will be requested.

The maximum number of variables allowed on the list at any one time is 25. If the list is full or the variable is presently on the list the addition will be disallowed and another option requested.

4. (DEL)ETE

When this option is entered the present list of variables will be printed out to the screen and the user will be asked to input the variables to delete by the number associated with them on the list. They must be entered on a single line separated by commas or blanks.

If the variable number that is input does not correspond to one that is currently on the list it will be skipped. After the deletions have been processed a new list is presented and another option requested. If the list is presently empty then that fact will be stated in an error message.

5. (HE)LP

This command may be input at any time that the user is asked for an option. It's purpose is to simply list out to the console a list of the available commands and a brief explanation after which another option will be asked for.

6. (RE)VIEW

At times the user may wish to see what is presently on his list before entering a command. This may be done with the REVIEW command. It will print out the current list along with the compartment number, species, and layer of each of the variables. After the printing of the entire list the option request is again displayed.

7. (LI)ST

After variables have been added to the list and their data values read in, the user may list out the values of any of the variables on the list to either the printer or the console. The user will input the device number (5 = CONSOLE, 6 = PRINTER), and the list of variables presently on the list will be displayed. He will then be asked to input the corresponding number(s) of the variable(s) to be listed out. They must be entered on a single line separated by commas or blanks. The maximum number of variables able to be listed at one time is 8 for the printer and 5 for the console.

8. (PL)OT

This option is central to the data analysis. After entering this command the current list of variables will be displayed along with their numbers. The user will be asked to input the number of the variable(s) to be plotted from the list. They should be entered in a string separated by a comma or a blank space. For example:

```
ENTER VARIABLES TO BE PLOTTED -> 1,2,3,4
                                or
ENTER VARIABLES TO BE PLOTTED -> 1 2 3 4
```

After entering the variable numbers, the number of the device which the graph is to be plotted on will be asked for.

The possible devices are:

1. CALCOMP
2. PRINTER
3. LEXIDATA
4. SCREEN

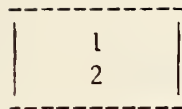
The maximum number of plots per call to PLOT is limited to 4. They will be printed in the following order on the device depending on the number of graphs per page:

1	2
3	4

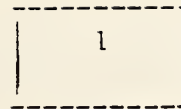
FOUR

1	2
3	

THREE



TWO



ONE

If more than 4 variables are input only the first four will be accepted and the remaining ones disregarded. If a variable number not on the list is entered, an error message will appear, the list will be reprinted and the input will be asked for again. This will continue until all variables entered are currently on the list.

Before the graphing is done the user is given the opportunity to change the range of the X and Y axes. The maximum and minimum values of the X and Y axes will be displayed, followed by a request for a change in each, which will be of the form:

CHANGE (X or Y) AXIS TO? ->

If no change is desired simply enter a <RETURN> and the next axis change will be displayed. If a change is made the value will be entered and the same change request will be made again. This will be repeated until a <RETURN> is entered.

When all the changes have been made, if any, the graph of that particular variable will be plotted. After it has been completed the next variable's maximum and minimum will appear and their changes input as before.

After the final graph has been completed the option request will be displayed and a new option may be entered.

9. (SA)VE

This option allows the user to save the values of the variables on the list in a file. The format used will make the data compatible with an experimental data processing program designed for handling of data in the Center for Fire Research.

The user will be asked for the name to be used for the file. A check will be made to see whether that file presently exists or not. If it does the user will be asked if he wants to write over the old file with this new data. If his answer is NO, nothing will be placed in the file and another option requested. If, however, he does want the file rewritten, or the file does not already exist, the new file will be created and the data stored in it.

Each variable on the list will be dumped with the following format at the beginning of each block of data:

I6,I6,A6, * ----- COMMENT -----

The first I6 will be for the number of data points for that variable, the next I6 is for the number given to that variable on the list, and the A6 is for the actual variable name. Everything after the * is a comment block and will be filled with information relevant to that particular variable, such

things as species number, compartment number, layer, etc. The actual numerical data will be dumped using the format 7E11.5.

10. (CL)EAR

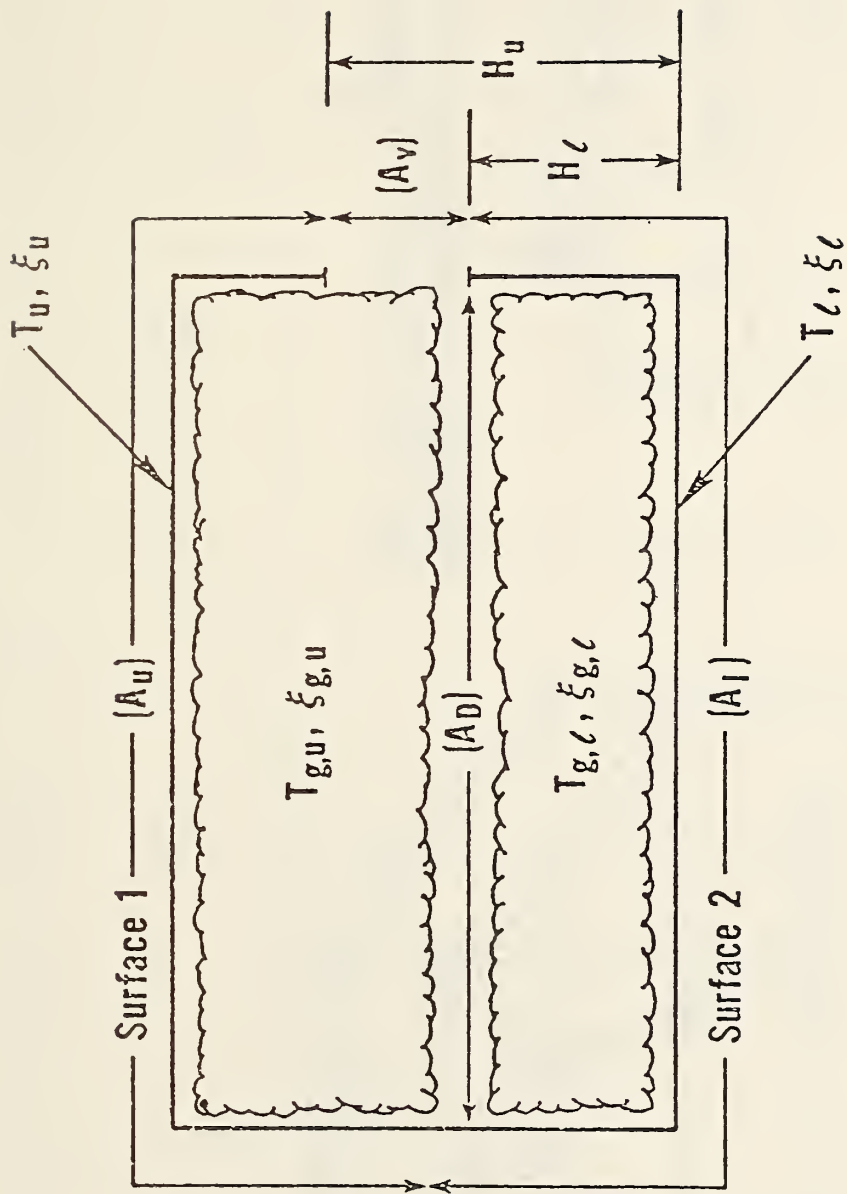
The input of this command empties the variable list.

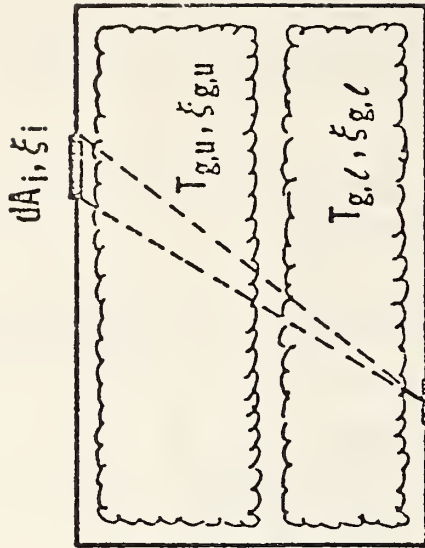
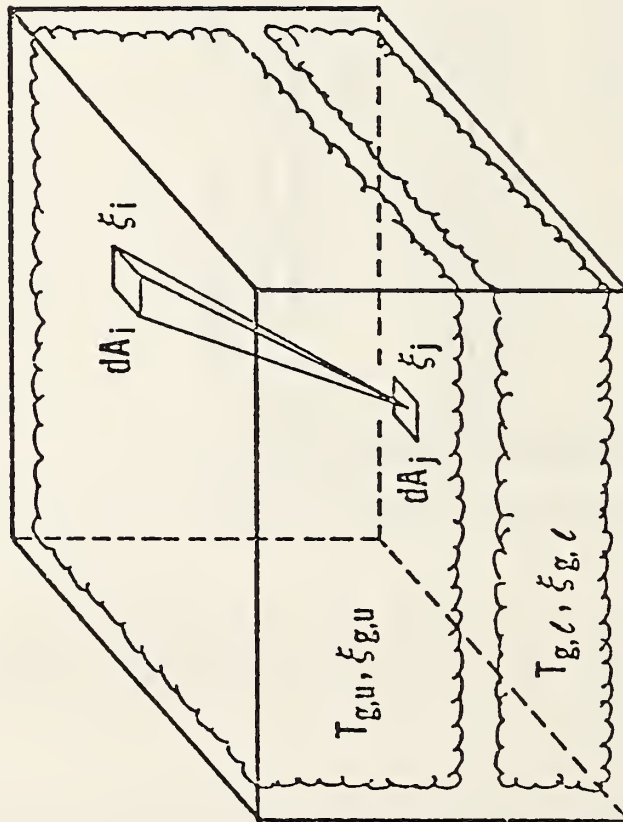
11. (CH)ANGE

This option restarts the program by asking for a new file and resetting all variable lists.

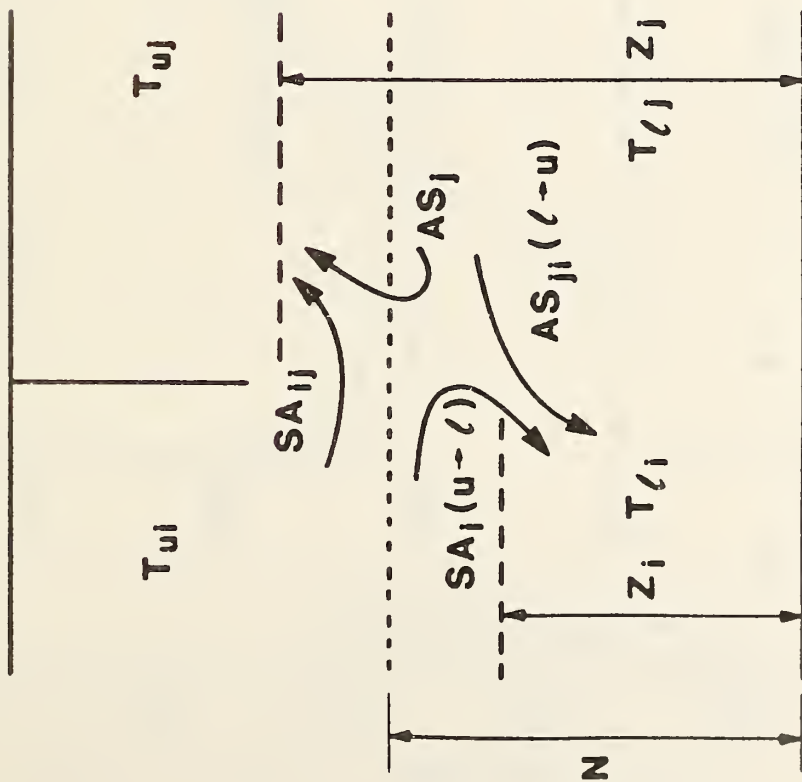
12. (EN)D

This function terminates the execution of the FASTPLOT program.

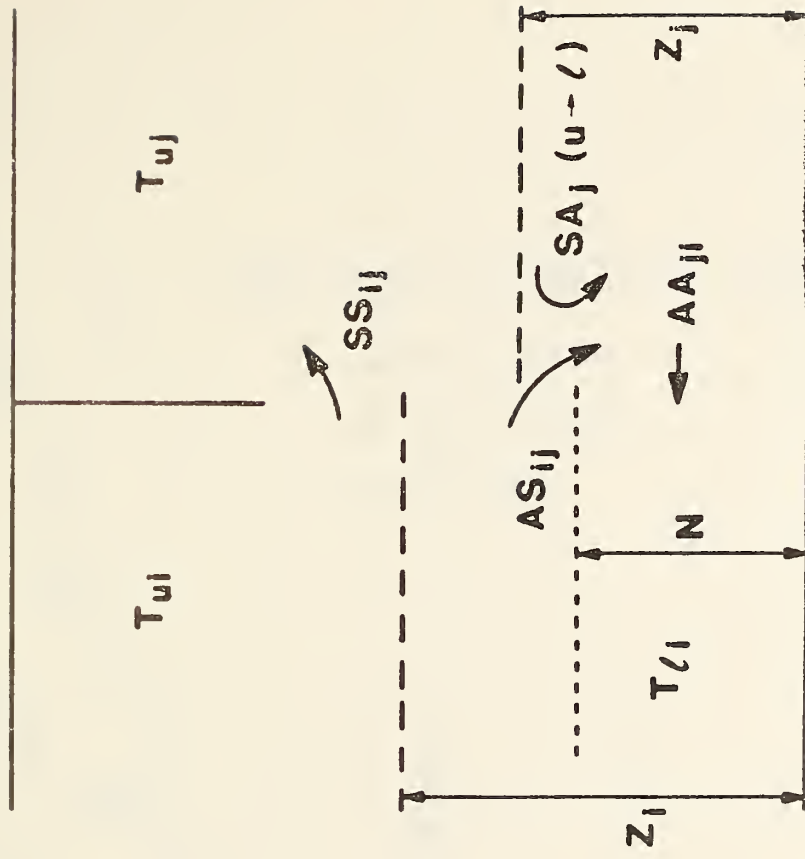




RADIATION PATH BETWEEN TWO SURFACES
WITH TWO ISOTHERMAL LAYERS BETWEEN THEM



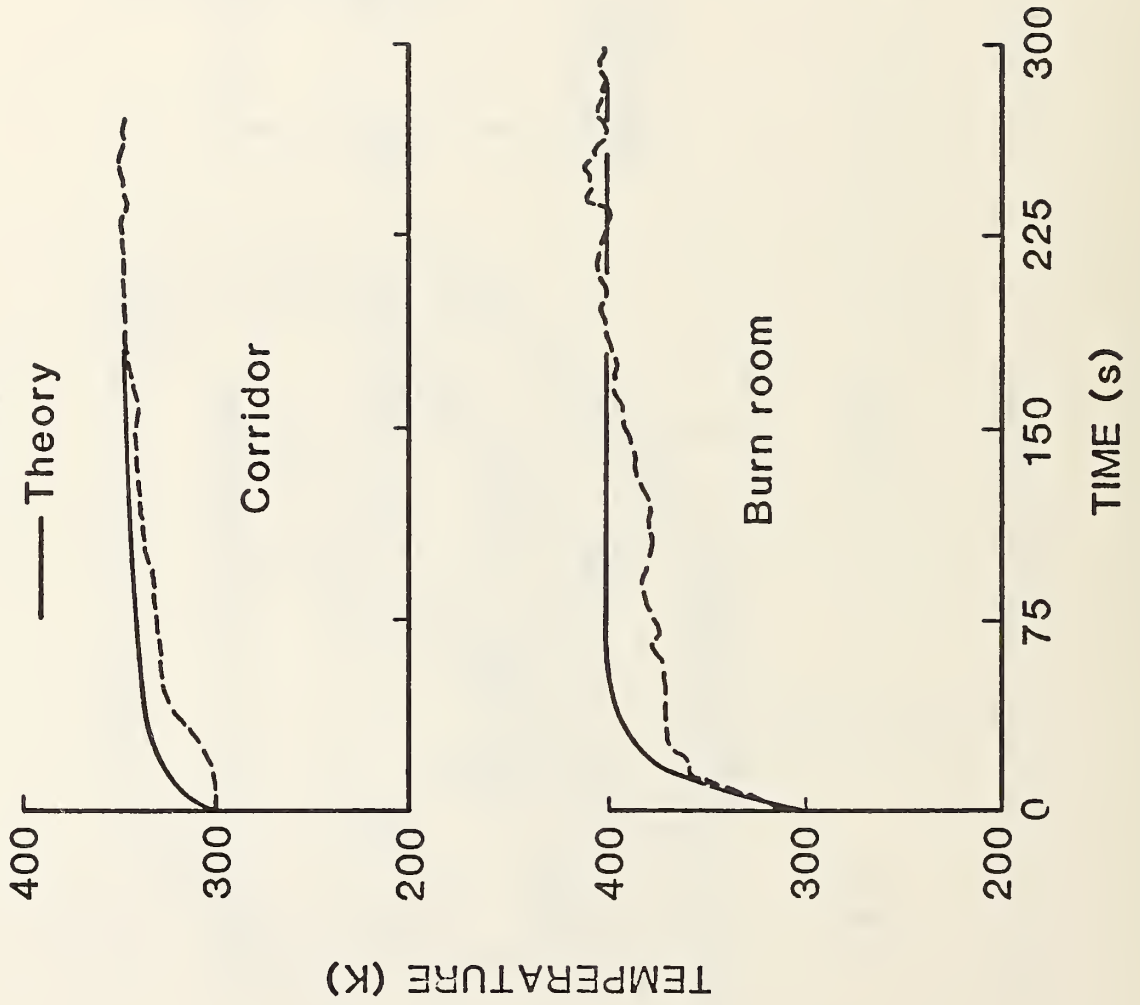
a

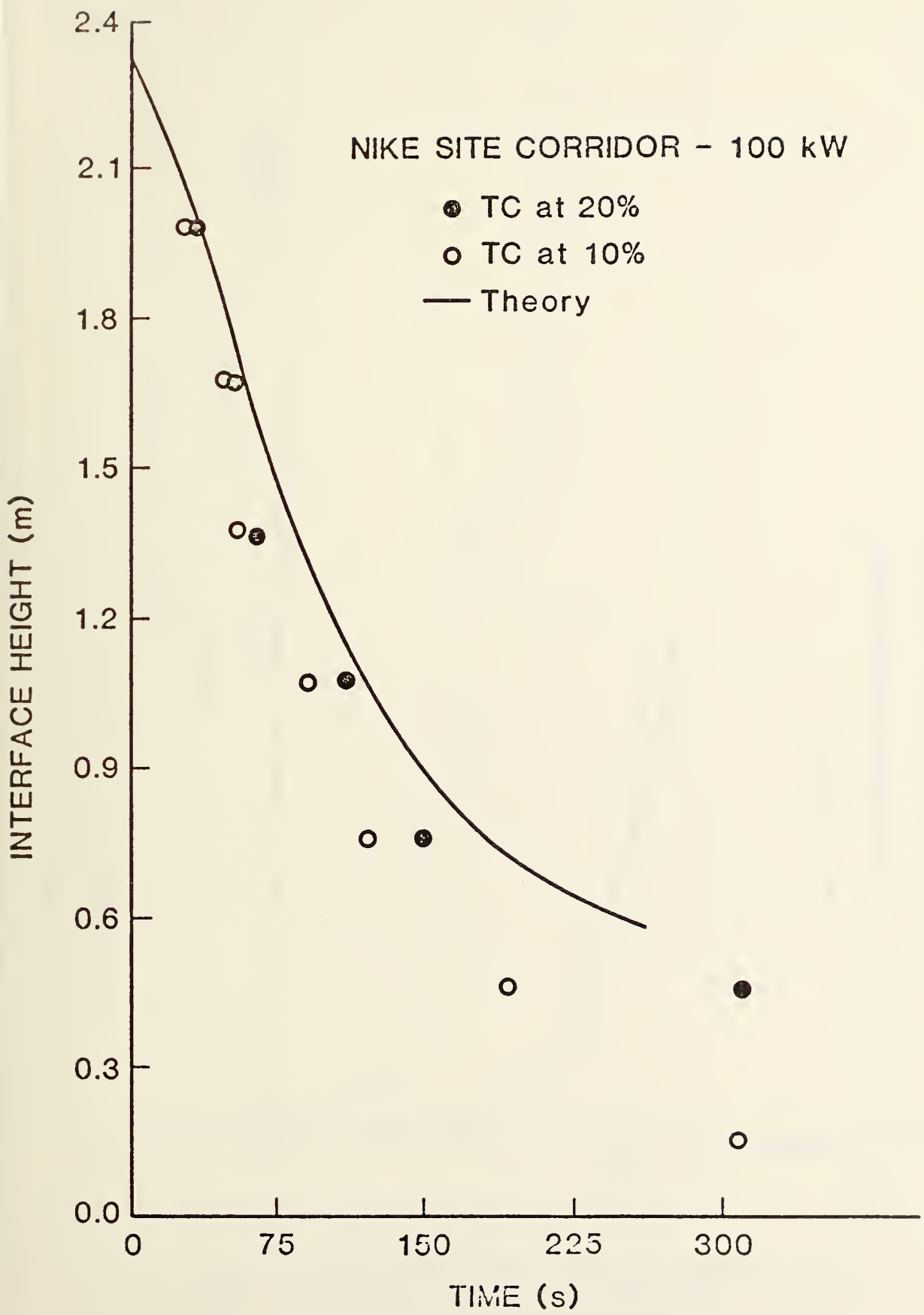


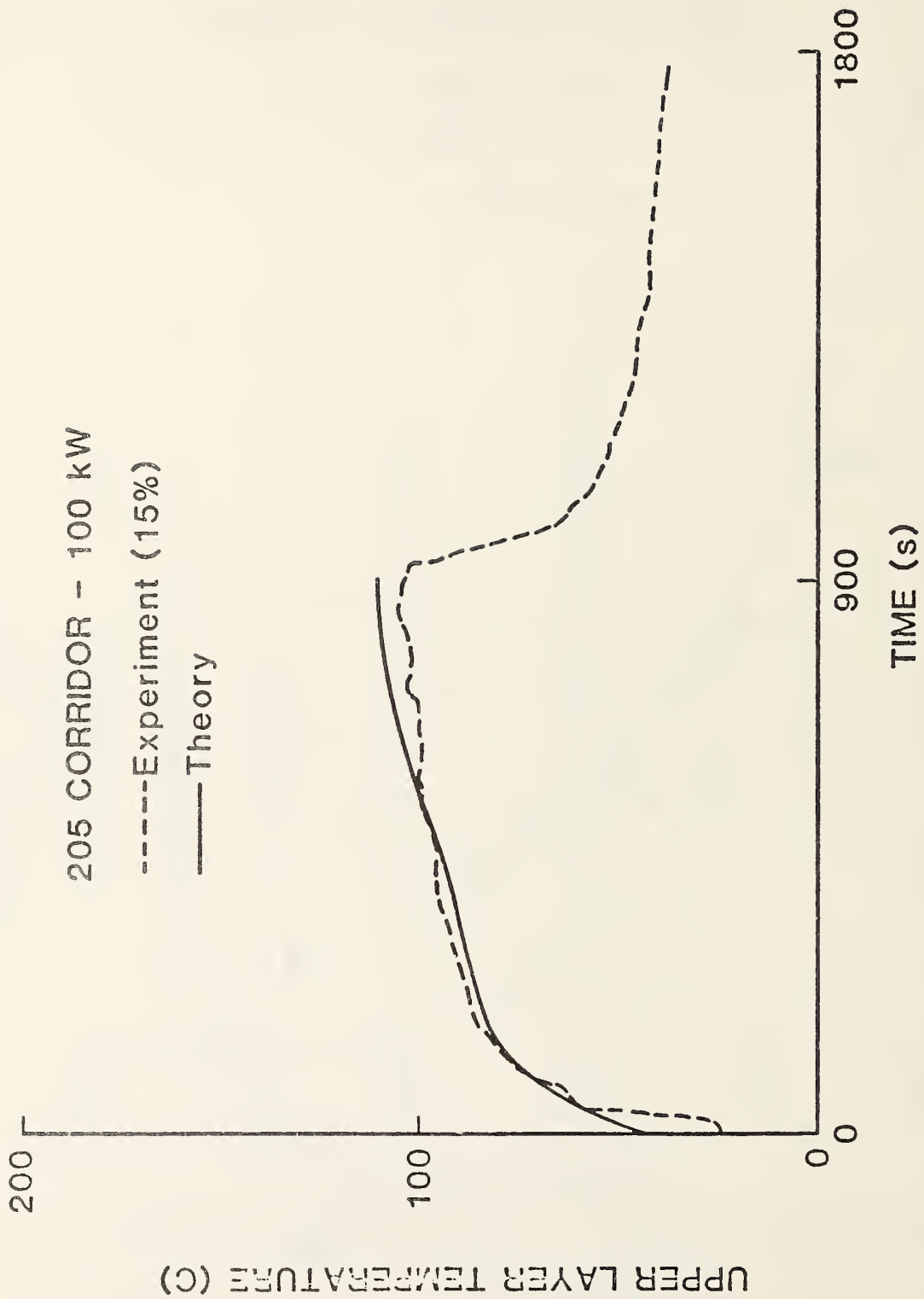
b

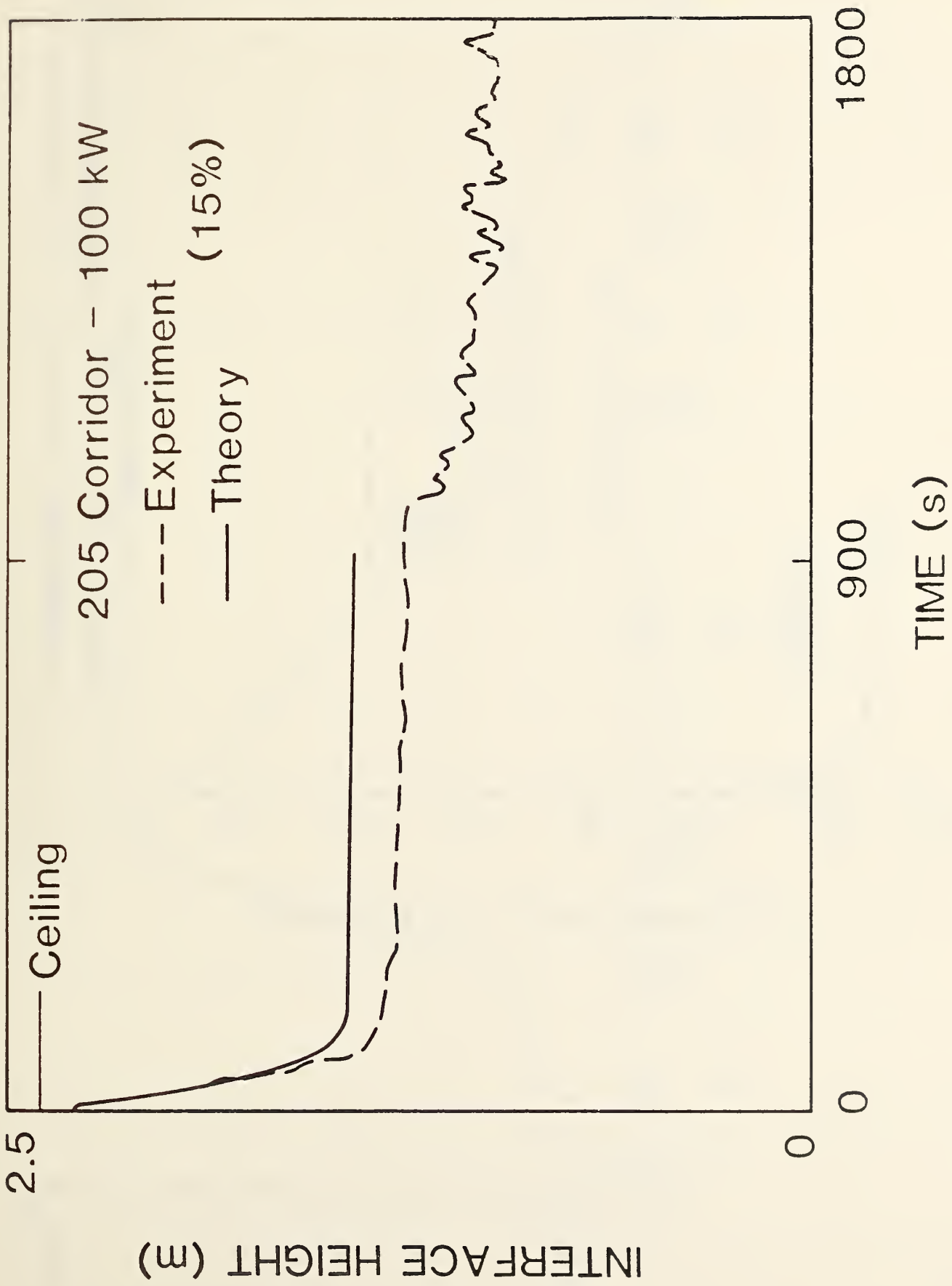
NIKE SITE - 100 kW

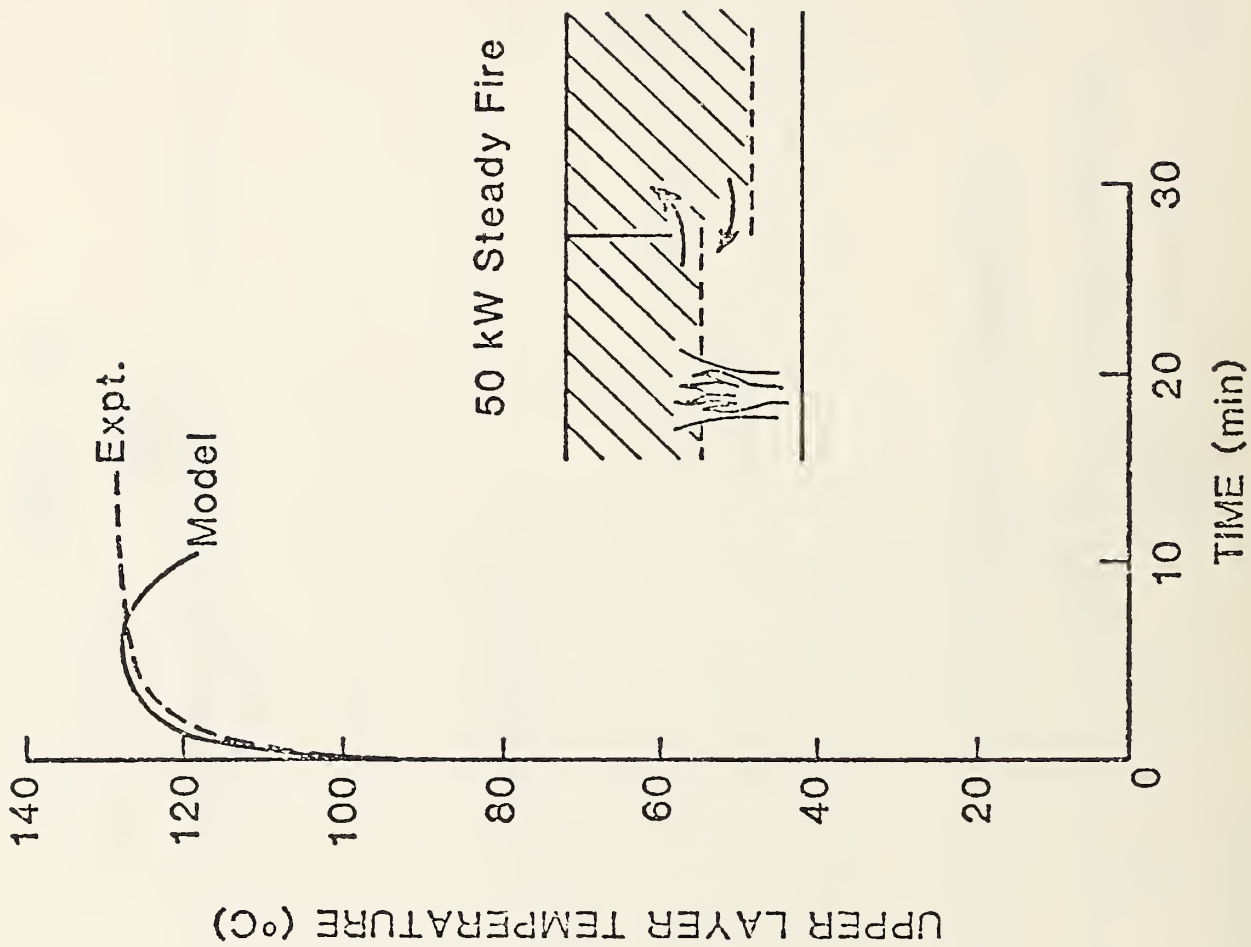
----- Top TC
—— Theory



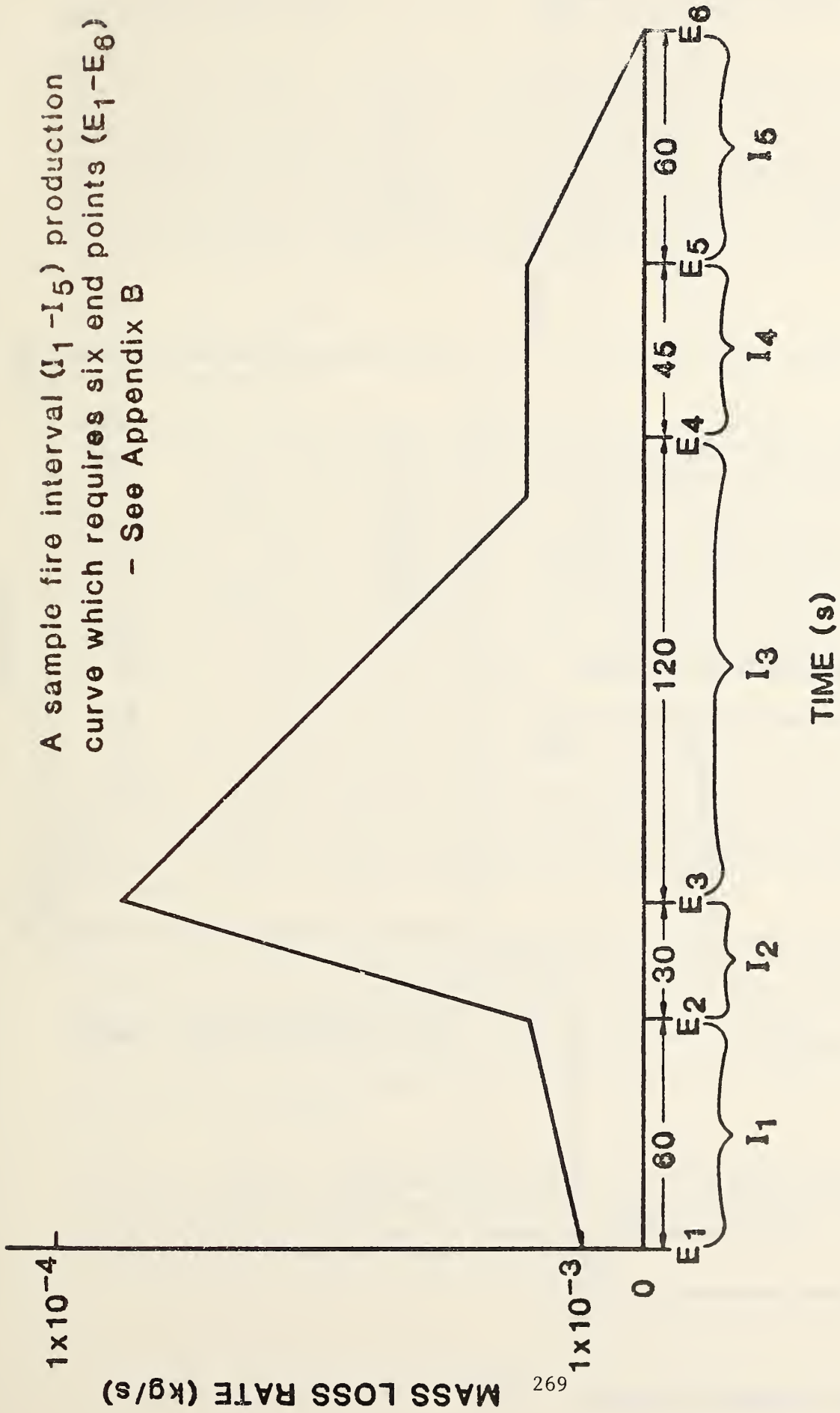


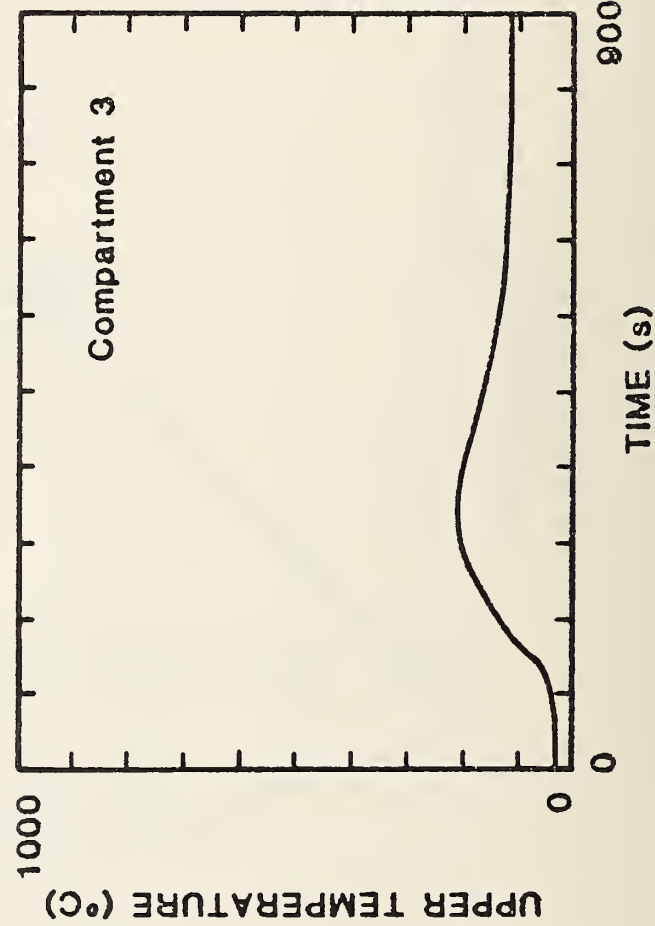
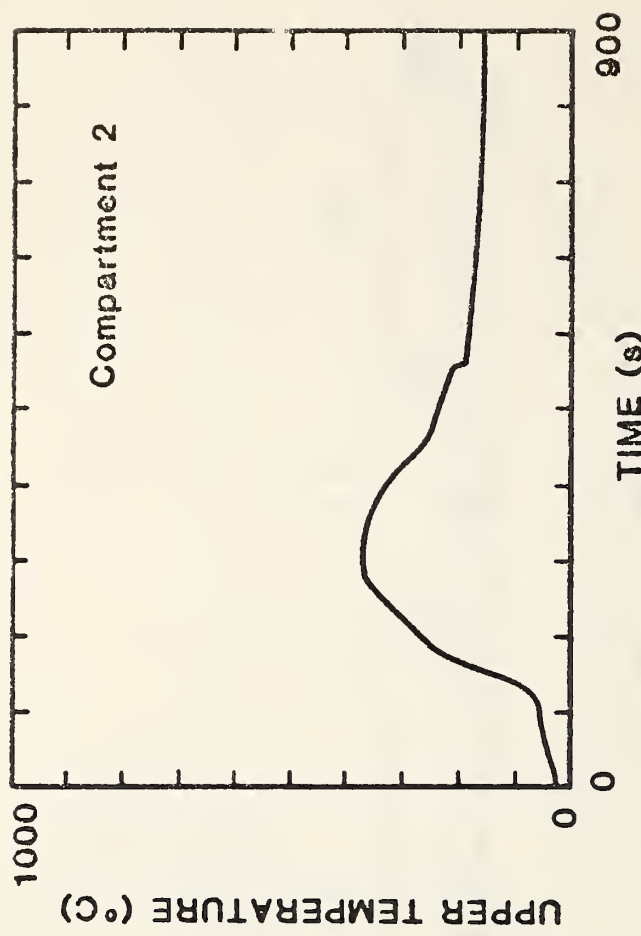
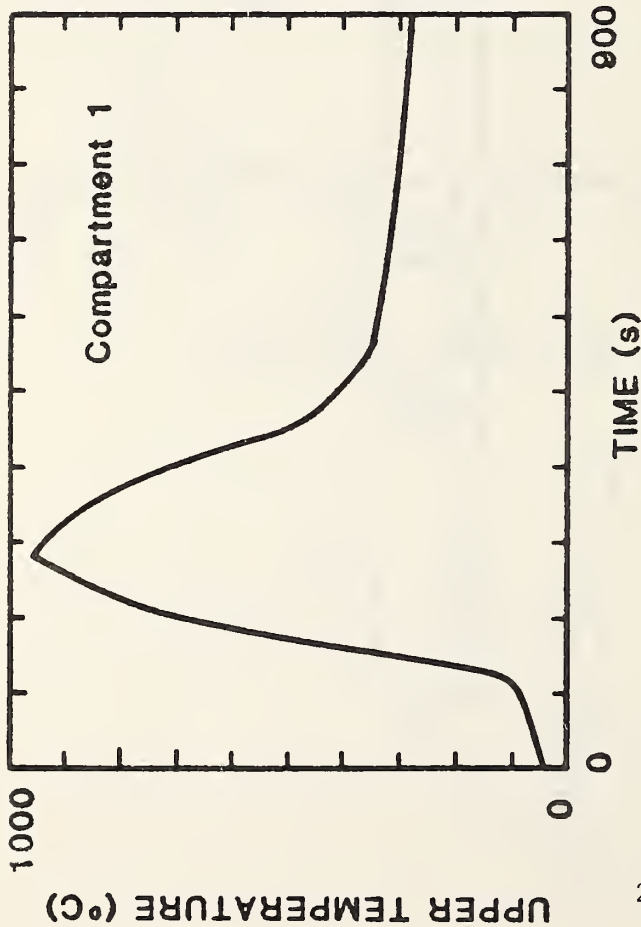






A sample fire interval ($I_1 - I_5$) production curve which requires six end points ($E_1 - E_6$)
 - See Appendix B





Discussion After W. Jones' Report on A MODEL FOR THE TRANSPORT OF FIRE, SMOKE, AND TOXIC GASES (FAST)

ZUKOSKI: I'd like to comment on that last slide that you have. It seems to me that in a real case if you have a recurrent flow going from the second room into the back of the fire room that, in reality, is going to form a third layer. You have to make your mind up which is the worst alternative. If you're worried about toxic materials flowing into the lower layer of the fire room then I would put it all in the ceiling layer. It forms a third layer, an intermediate layer. At least in the experiments we've done, it tends to form an intermediate layer and you have to make your mind up whether you want to treat that as a part of the ceiling or as part of the floor layer.

JONES: You're correct.

ZUKOSKI: If you treat it as part of the ceiling layer you underestimate the ceiling temperature.

EMMONS: It is correct that the third layer would be formed. However, the compensational time required to solve problems with additional layers is quite large. I suspect the best kind of a compromise might be to divide the inflow between the upper and lower layers dependent upon the temperature of the inflow gas, the temperature of the upper layer and the temperature of the lower layer in proportion. This same idea may be important in other respects. With a simple two layer model one can present flashover by igniting another small fire. The model does this because a small heat source carries a considerable volume of lower layer air up into the upper layer and decreases it's temperature and hence it's radiation. Thus, again we either need a third layer, or more, or we divide the material between the upper and lower layer in some reasonable way.

JONES: Your proposed solution to partitioning is what I favor, otherwise we tend to defeat the whole point of going to the simplified single zone models.

QUINTIERE: I think on these so-called partitioned flows for fire growth, they may not be very important, but for hazard to humans, particularly in terms of multi-room models, it could be very important in deciding the hazard condition. So, for human hazard evaluation, one may want to look more seriously at these flows.

PAGNI: With regard to the high temperatures far from the source in your ship calculations, three possible causes suggest themselves. I would like you to comment on whether all three are important, or if you think one dominates. Our intuition can be fooled by a vertical stacking and that may be an important effect. Also, the ship construction is not what we're familiar with, the material properties of the steel are different from most walls. Lastly, the fire strength is rather large, and I assume that it was turned on as a step function at one megawatt.

JONES: To answer the last statement, that's the way the fire started in this particular scenario, experimentally as well as in the model. I point out that vertical passages in ships are a very small cross section and, in general, the walls are actually quite well insulated and seldom uncovered. Finally, the temperature in an absolute sense is not high.

MORITA: When you mentioned the instability of computation, are you talking about the technical mathematical sense of instability or are you talking about the phenomenal sense? Are you using the word "instantaneous" in a sense of phenomena, and when you think about flashover, I'm sure that there is both instability in both senses.

JONES: Yes, that is correct. I was referring in particular to the numerical instability which has plagued many of the zones models to date. There exists also the actual phenomenological instability associated with fractional differentiation. One has to be very careful including a self-consistent fire model in order to make correct predictions in that regime. However, we will have to do more experimental work to uncover the kinetic effects which become very important in that regime.

MITLER: Did you confirm experimentally, at the Nike site, the results that you show the calculations for?

JONES: Not in that last calculation, no. There are two projects under way, one here to hopefully confirm that as part of the validation study which Sandy Davis is undertaking, and the Coast Guard is performing ship fire tests against which we hope can validate this model for shipboard fire validations.

SMOKE MOVEMENT AS A DENSITY CURRENT

Makoto Tsujimoto

Fucalty of Engineering
Nagoya University
Furo-cho, Chikusa-ku
NAGOYA 464

SMOKE MOVEMENT AS A DENSITY CURRENT

Makoto Tsujimoto

1. INTRODUCTION

It is evident that the driving force of smoke movement is the heat generated by combustion in the fire room. But it is not clear what kind of flow the heat makes after blowing out from the fire room.

Considering corridors and staircases as a sort of stream tubes, the smoke movement in the buildings must be classified into two large groups, a pipe flow and an open channel flow. It is considered that the expansion as a result of excess heating in a fire room produces the pressure gradient and forms the pipe flow like Fig 1-a, while the buoyancy of smoke itself forms an open channel flow below the ceiling like Fig 1-b.

In the real scale fire experiment¹⁾, it is observed as follows.

" In a corridor facing to a fire room, smoke moved almost horizontally in a clearly stratified layer along the total length of corridor. And after flash over, the thickness of the smoke layer increased quickly and the smoke came down near to the floor. ----- After the moment, the thickness of the smoke layer decreased and the counter flow of fresh air appeared. "

In view of this, it is not so long that the smoke behaves like a pipe flow, so it is significant to investigate the property of smoke movement as an open channel flow. In case of an open channel flow, the buoyancy of the smoke itself, which is (thickness of smoke) \times (difference of density), is the driving force of the smoke. Such a flow like this is also called " density current ".

At present, many models for the analysis of smoke movement in the building, for example Wakamatsu's²⁾, adopt the equation of air movement through the opening between two rooms with different temperatures. This method is not proper to explain the smoke movement along the long corridor without partitions.

In case behaviour of smoke movement as a density current is revealed, it will be able to solve the smoke movement as an unsteady density current in horizontal and inclined direction.

According to the studies concerned to the head movement of density current³⁾, it is only obtained the relation between velocity, thickness and density difference of the head by the experimental data. So it is impossible to calculate the head velocity in unsteady state provided that the smoke flow rate and the temperature from the fire room are given as a boundary condition.

This report is concerned only with the smoke movement in steady state as a density current, and compares the calculated values used the equations introduced by Ellison & Turner⁴⁾ with the experimental data about the smoke movement below the horizontal and inclined ceiling.

2. THEORY

2.1 Governing Equations

Ellison & Turner⁴⁾ considered the steady state of a layer moving up a ceiling over a stationary ambient fluid like Fig.1. They showed the momentum equation as follows, which represents the momentum balance of the fluid contained in the elementary volume of unit width by $x, x+dx, y=0, y=\infty$,

$$\frac{d(VH^2)}{dx} = -C_d V^2 - \frac{d}{dx} (S_1 \hat{g} H^2 \cos \alpha) + S_2 \hat{g} H \sin \alpha \quad \text{----- (1)}$$

where

$$VH = \int_0^\infty v \, dy$$

$$V^2 H = \int_0^\infty v^2 \, dy$$

$$VH \hat{g} = \int_0^\infty (\rho_a - \rho / \rho_a) g v \, dy$$

$$S_1 H^2 \hat{g} = \int_0^\infty (\rho_a - \rho / \rho_a) g y \, dy$$

$$S_2 H \hat{g} = \int_0^\infty (\rho_a - \rho / \rho_a) g \, dy$$

v : flow velocity along a ceiling

ρ : density of flow

ρ_a : density of ambient fluid

α : slope angle of a ceiling

C_d : drag coefficient

S_1, S_2 : dimensionless coefficients depend on profiles of velocity and density difference

And they considered that heat loss to the ambient is negligible, and showed the equations for continuity of mass deficiency and for entrainment as follows.

$$\int_0^\infty (\rho_a - \rho / \rho_a) g v \, dy = VH \hat{g} = \text{const} \quad \text{----- (2)}$$

$$d(VH)/dx = VE \quad \text{----- (3)}$$

E : entrainment factor, a function of Ri

From the examination of the experimental data in Section 3 for the flow below the inclined ceiling, heat loss is negligible because of the shortness of stream. So Eqs. (1),(2),(3) can be used.

While for the horizontal flow the heat loss can't be neglected, and within the extent of the experiments in 3.1, it is confirmed from the measured values that there is no increase of flow rate by entrainment. So the following equations, which represent the over all heat loss and the conservation of mass, may be used instead of Eqs. (2),(3).

$$\frac{d}{dx}(VH\hat{g})/V\hat{g} = -K \quad \text{-----(4)}$$

$$\frac{d}{dx} \int_0^{\infty} v \rho g \, dy = 0 \quad \text{----} \rightarrow \quad \frac{d}{dx}(VH(g-\hat{g})) = 0 \quad \text{-----(5)}$$

where K:coefficient equivalent to heat transfer coefficient

2.2 Boundary Condition

In treating the open channel flow, it is necessary to examine whether the flow is tranquil(subcritical) flow or shooting(supercritical) flow. According to Ri numbers, which were determined by measured values of the experiments in Section 3, it is confirmed that the flow below the horizontal ceiling is tranquil flow and the flow below the inclined ceiling shooting flow. In the case of tranquil flow, the condition of the end of corridor is important because the disturbance of downstream propagates upstream.

In the case of 3.1.2, the flow is opened to the atmosphere at the end of corridor. So it is considered that the flow turns from tranquil to shooting there. And this is used as the boundary condition. The detailed discussion is found later.

3. EXPERIMENT

3.1 Smoke Movement below the Horizontal Ceiling

3.1.1 Measurement

The corridor in which the experiments were made is shown schematically in Fig 3. The experimental conditions were provided by varying the area of alcohol pool in the fire room and the length of corridor. Each temperature in the corridor was measured by C-A thermo-couple. The profile of velocity was measured by smoke wire and the absolute value of one typical point of this was obtained by measuring the dynamic pressure of flow.

The examples of measured temperature and velocity are shown in Fig.4. The temperature and velocity profiles made into dimensionless form by the each maximum value and the thickness of smoke layer (distance from ceiling face to the point $v=0$) are shown in Fig 5. According to these results, it is considered that profiles are conserved throughout the flow. The value of $S1=0.58$ is obtained by these profiles using the transform equations in Eq.(1).

3.1.2 Comparison with Theory

Introducing the equation $Ri = H\hat{g}\cos\alpha/V^2$ (5-2) and arranging Eqs.(1),(4),(5) under the condition $\alpha=0$.

$$\frac{dRi}{dx} = \{Cd + (1 + S_1 Ri) \left(-K \frac{\hat{g}}{g} - \frac{K}{3}\right)\} 3Ri / (1 - 2S_1 Ri) H \quad \text{-----}(6)$$

$$\frac{dH}{dx} = \{Cd + (2 - S_1 Ri) \left(-K \frac{\hat{g}}{g}\right) - S_1 K Ri\} / (1 - 2S_1 Ri) \quad \text{-----}(7)$$

By the Eqs.(6),(7), it is considered that $Ri=1/2S_1$ is the turning point of flow, and the flow is tranquil flow on $Ri>1/2S_1$ and shooting flow on $Ri<1/2S_1$. This is identical with the flow below the inclined ceiling in paragraph 3.2.2.

By the observational result that the smoke rises at the end of corridor like a water fall upside down, it can be made a decision that the flow turns from tranquil flow to shooting flow at this position.

Therefore as the condition of the end

$$Ri_e = 1/2S_{1_e} = H_e \hat{g}_e / V_e^2 \quad \text{-----}(8)$$

from equation (5)

$$V_e H_e (g - \hat{g}_e) = M \quad \text{-----}(9)$$

where M: mass flow rate across the section, obtained by measured values
Subscript e means the end of corridor

If it is given one of three values (\hat{g}_e, H_e, V_e) in an arbitrary manner, the others are determined by Eqs.(8),(9). And substituting these values into Eqs.(6),(7) as the boundary condition at the end of corridor, the values in upstream (\hat{g}, H, V) can be calculated. Then, in order to determine three values at all points, H_e is varied so that the calculated value (for example \hat{g}) in the most upstream point may be approached to the measured value (\hat{g}) in the same point by repeating approximation.

Then in Eqs.(6) and (7), Cd and K are not determined and remained as an experimental constant. These can be obtained by temperature and velocity profiles at the face of walls if they are measured exactly. But the measurement is not so accurate that the values of Cd, K are determined in the way that the calculated values reconcile to the measured value within the extent that can be estimated by the profiles. Providing $Cd=0.017$, $K=0.9$, the calculated values correspond to the measured values are shown in Fig 6. The difference of calculated values by varying the value of Cd is shown in Fig 6-a. As a result of this, in the case that the flow of smoke is steady tranquil flow, it is appeared that the values of V, H, \hat{g} can be calculated numerically from the turning point of downstream, if mass flow rate and temperature of smoke at the most upstream point of corridor are provided.

3.2 Smoke Movement below the Inclined Ceiling

3.2.1 Measurement

The slope for the experiments is shown schematically in Fig.7. Because of the scale limit of the room for experiments, the length of the slope is not enough. The experimental conditions were provided by varying the inclination angle, power of the heater, and r.p.m. of fan. The conditions for the experiments are showed in the table 1.

The method to measure temperature and velocity are same as 3.1.1, except the absolute value of velocity. The anemometer with temperature correction was used for it. The example of measured temperature and velocity is shown in Fig.8. It is evident that the velocity is accelerated by the bouyancy of the flow even in a short distance.

The temperature and velocity profiles in dimensionless form is shown in Fig.9 like Fig.5. Though the variation of dimensionless profiles is more considerable than that of the horizontal flows, it is ignored in this paper.

The values of $S_1=0.36$ and $S_2=1.09$ are obtained by profile.

3.3.2 Comparison with Theory

Arranging the equations (1),(2),(3) using (5),

$$\frac{dRi}{dx} = \frac{3Ri}{H} \frac{(2-S_1Ri)E-S_2Ri \tan \alpha + Cd}{1-2S_1Ri} \text{ ----- (10)}$$

$$\frac{dH}{dx} = \frac{(1+S_1Ri)E-S_2Ri \tan \alpha + Cd}{1-2S_1Ri} \text{ ----- (11)}$$

In calculation of (10),(11), $Cd=0.017$ obtained in 3.1.1 is used.

For E, Alpert⁵⁾ deduced Eq. $E=0.075 \exp(-3.9Ri)$ from the experimental data by Ellison and Turner

In this paper, E in each experiment is obtained by Eq.(12) from the experimental values.

$$E_{x=1.5} = \frac{(VH)_{x=3.0} - (VH)_{x=1.5}}{3.0-1.5} / V_{x=1.5} \text{ ----- (12)}$$

Results are shown in Fig.10 and Eq.(13) is derived from it,

$$E=0.29 \exp(-3.6Ri) \text{ ----- (13)}$$

The result of calculation using Eqs.(10),(11),(13) are shown in Fig.11. The boundary condition of calculation is the measured values in $X=1.5m$. And according to Fig.11 it is clear that calculated values agree with the observed values on the tendency which H and V increase along the flow.

4 CONCLUSION

- 1) The method to express the smoke movement as a density current in term of the equations by Ellison and Turner is shown.
- 2) In the case that the flow of smoke is tranquil flow in steady state, and that the flow turns from tranquil to shooting at the end, the properties of flow (V, H, \hat{g}) can be calculated numerically if mass flow rate and temperature of smoke at the most upstream point are provided.
- 3) In case of smoke movement along the inclined ceiling, it is observed that the flow is shooting under the condition that the inclination angle is more than 5° .

ACKNOWLEDGMENTS

The author is indebted to Dr. Tokiyoshi Yamada, Mr. Shigeaki Matsumoto, and Mr. Ikuo Watanabe who assisted in data collection and analysis. Also, the encouragement and suggestions of Dr. Heizo Saito and Dr. Osami Sugawa were greatly appreciated.

REFERENCES

- 1) Tetsudo-Kenchiku-Kyokai, Chuotetsudobyoin-Kasai-Jikken-Hokokusho, (Jul. 1968) (in Japanese)
- 2) Wakamatsu, T., Calculation Methods for Predicting Smoke Movement in Building Fires and Designing Smoke Control System, ASTM-NBS Symposium , Washington, D.C. (Mar. 1976)
- 3) for example:
Keulegan, G.H., The motion of saline fronts in still water, 12th progress report on model laws for density current, U.S. Nat. Bur. Standards, No. 5831, (1958)
Simpson, J.E., A comparison between laboratory and atmospheric density currents, Quart. J. R. Met. Soc. 95, pp 758-765, (1969)
- 4) Ellison, T.H., Turner J.S., Turbulent entrainment in stratified flows, J. Fluid Mech. 6, pp 423-448, (1959)
- 5) Alpert, R.L., Turbulent ceiling-jet induced by large-scale fires, Technical Report No. 22357-2, Factory Mutual Research (Sep. 1974)

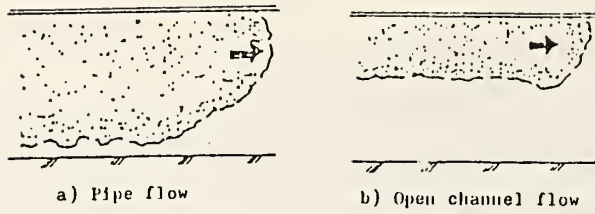


Fig 1 Two types of smoke movement

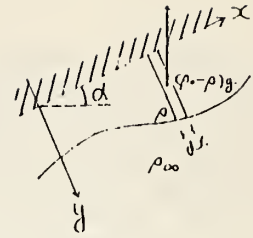


Fig 2 Diagram of flow below the inclined ceiling

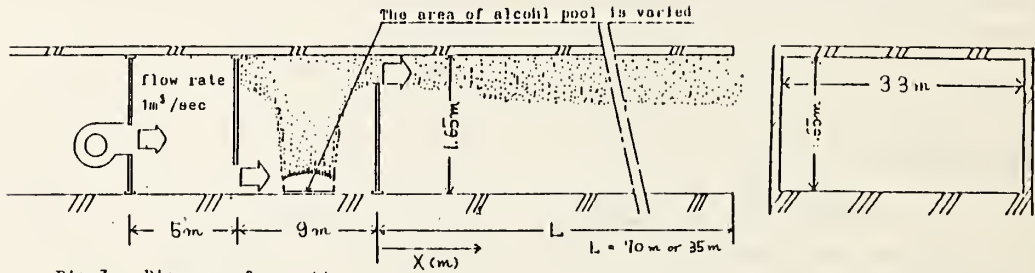


Fig 3 Diagram of corridor

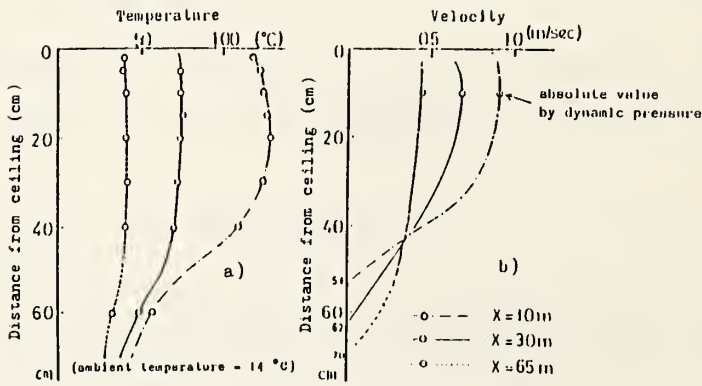


Fig 4 Typical profiles of (a) temperature, and (b) velocity in horizontal ceiling

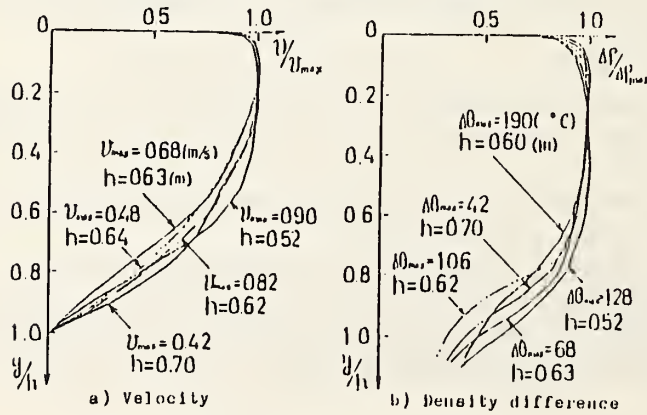


Fig 5 Profiles of velocity and density difference in normalized form

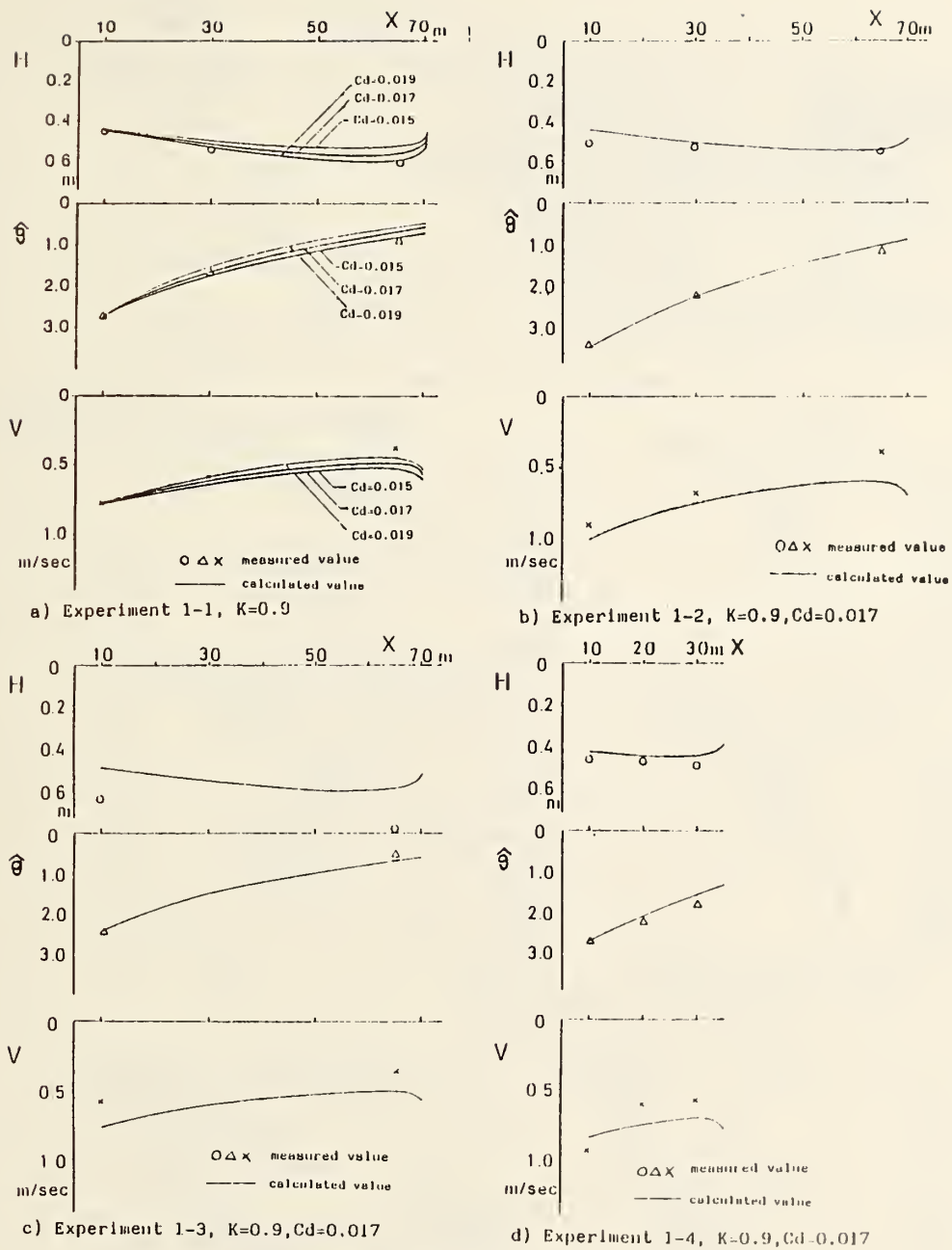


Fig 6 Measured values of experiments and calculated values by Eqs.(10),(11)

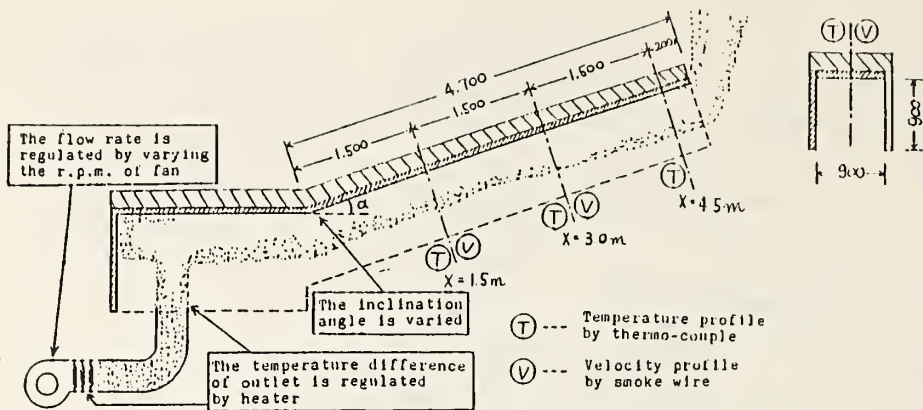


Fig7 Diagram of inclined ceiling

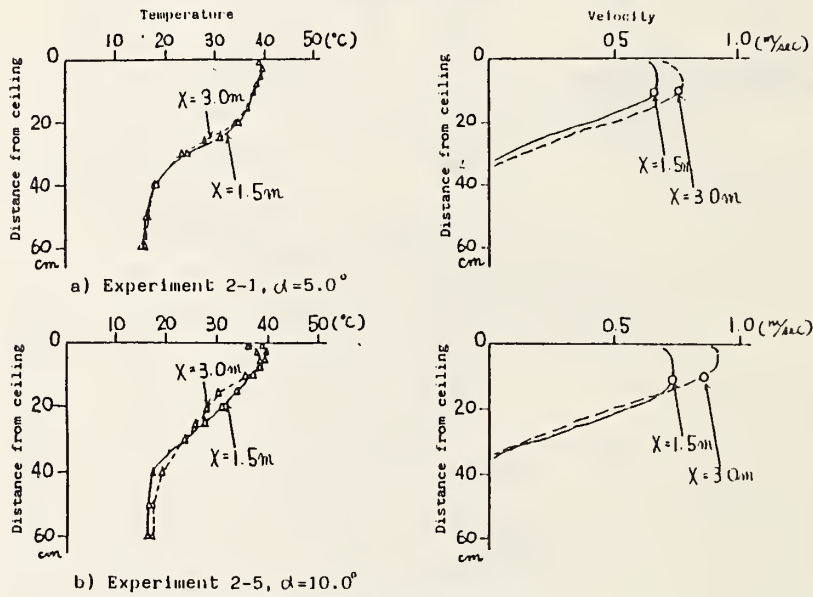


Fig 8 Typical profiles of temperature and velocity in inclined ceiling

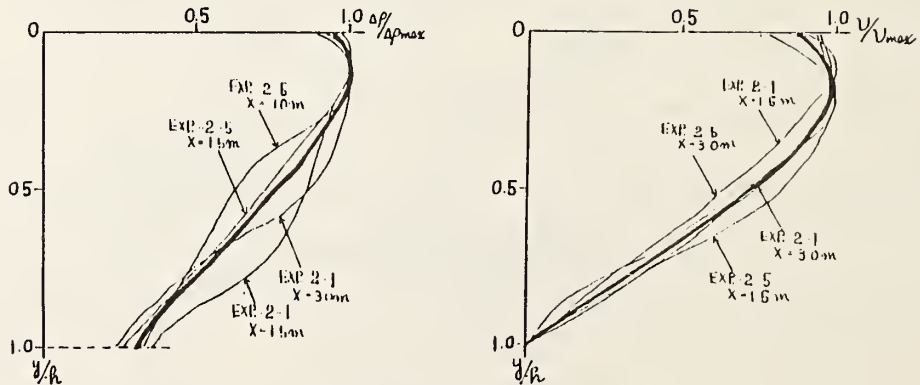


Fig 9 Profiles of velocity and density difference in normalized form

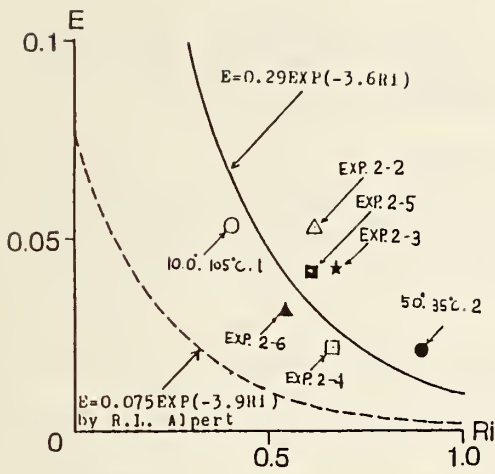


Table 1 Condition of measurement

EXP-NO. terms	2-1	2-2	2-3	2-4	2-5
inclination angle	5.0°	7.5°	7.5°	7.5°	10.0°
temperature difference of outlet	75°C	75°C	35°C	35°C	75°C
flow rate *	1	1	1	2	1

* flow rate 2 is almost a half of flow rate 1

Fig 10 The values of E measured in experiments

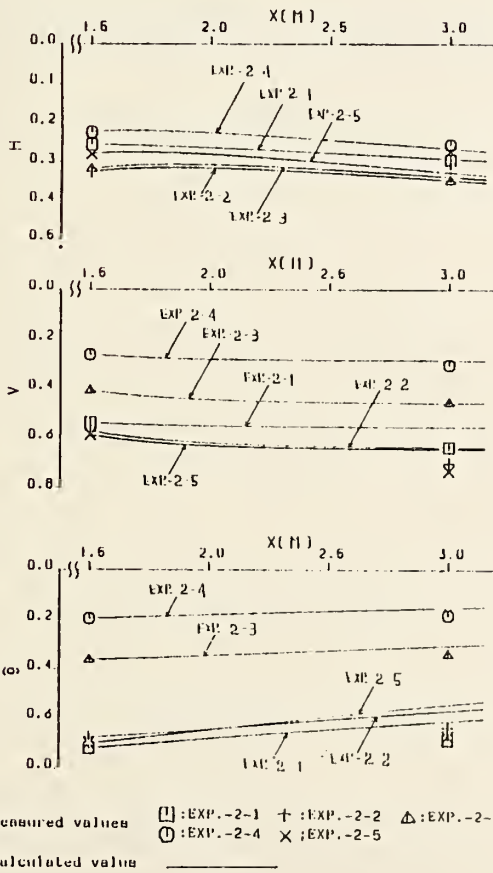


Fig 11 Measured values of experiments and calculated values by Eqs.(10),(11)

Discussion After M. Tsujimoto's Report on SMOKE MOVEMENT AS A DENSITY CURRENT

EMMONS: You have added some interesting and useful data on the steady ceiling jet. Are you also going to study the non-steady ceiling jet? The non-steady ceiling jet is very important in fire development as the fire comes out of one room and travels at some speed down a corridor.

TSUJIMOTO: On page 1, about 10 lines from the bottom of my report, I discuss this. The velocity of smoke is the same, for example, as the velocity of water flow. I have not yet completed my studies.

ZUKOSKI: In Figure 10, there's a discrepancy between what you used for the entrainment and the products of Ellison and Turner as determined by Ellison. We agreed that the experiments of Ellison and Turner, although they're the only experiments in the field, have to be looked at very hard.

TSUJIMOTO: On entrainment, we have performed some studies, but we agreed that we have to do more precise measurements.

PAGNI: What is the smoke layer?

TSUJIMOTO: We use nichrome wire coated with paraffin heated electrically.

QUINTIERE: Do you plan to study the effect of a partition at the end of a corridor on the smoke layer predictions?

TSUJIMOTO: We are not planning to do it.

GENERAL DISCUSSION

PAGNI: I think the Japanese work presented earlier by Tanaka is very important in that it couples the physics of the smoke movement well with the human behavior part of the escape and evacuation procedure. We need more of that kind of coupling.

HIRANO: Since it seems there are no other comments, we would like to show two video tapes as I promised earlier. Dr. Quintiere will comment on the first tape and Dr. Takeda will comment on the second video tape.

QUINTIERE: This tape was shown to me by Dr. Saito. So, someone from the Japanese delegation more familiar with material being burned may wish to comment on this material. I will only say that this is a small-scale experiment with steel foil over plywood, I believe. You will observe a peculiar fire phenomena, the walls and ceiling. The ignition source is a crib fire. I believe it will occur again.

EMMONS: How large is the test chamber?

TANAKA: Approximately one meter by one meter by two meters.

QUINTIERE: This kind of a fire experiment with wall and ceiling lining has gone on in many countries for many years. New materials create serious problems because test methods do not predict this fire phenomena. Now Dr. Takeda will show you another fire phenomena that is unusual.

NELSON: Anybody have any phenomenological explanation or hypothesis?

QUINTIERE: This is a steel foil, not aluminum foil, so perhaps you do not burn through the foil, you simply cook the pyrolysis products through steam and then you reach a flammable mixture.

NELSON: In the days of the steel-clad wood core fire door, we had to vent the fire doors by cutting a hole in the steel to prevent destruction of the door from the distillate. Maybe if it were vented, the problem would disappear.

QUINTIERE: It's vented into the room.

NELSON: No, we cut a hole to vent directly into the wood.

EMMONS: Experiments performed by Alex Robertson at NBS about twenty years ago in a one path meter non-flammable chamber with a small crib showed oscillatory smoke ejection. It did not go poof.

QUINTIERE: Would you like to see it one more time.

HIRANO: Yes.

MITLER: Did I understand correctly that this is a vertical panel of plywood covered by a vertical foil of steel?

QUINTIERE: Dr. Tanaka, would you describe the material.

TANAKA: I am not quite sure, but I understand that the surface is covered with thin laminated iron plates with the exception of a seam in the front plane, a small lining was used.

GANN: This is the same building with the same material?

QUINTIERE: This is different material. Just fire wood, I think.

ZUKOSKI: It also shows how big the room is there.

TAKEDA: This is not a unique phenomena, but under ordinary circumstances this type of experiment extinguished itself.

ROCKETT: Did you weigh the PMMA while it was burning?

TAKEDA: We did not weigh it.

EMMONS: How much was left?

TAKEDA: Eighty percent of the original PMMA was left. The mechanism of extinction is that because of a too high concentration of gas or there was another reason. It isn't clear that extinction was probably due to the too highly concentrated gas, but as for the effect of fluid dynamics, we have to conduct further experiments to find the answer.

EMMONS: Was the vent 16 centimeters high in the middle of the wall or was it a door?

TAKEDA: Center.

QUINTIERE: Sixteen by what?

TAKEDA: Sixteen by 11.

ROCKETT: Do I gather from what you said that you measured the oxygen concentration in the room?

TAKEDA: No, we didn't, but we would like to.

MITLER: Was the fire ventilation limited, as far as you can tell?

TAKEDA: I believe so.

KAWAGOE: Did you measure the temperature inside?

TAKEDA: Yes, we did. We did not observe an unordinary temperature increase. The temperature went up drawing the ordinary curve, perhaps it was higher than the usual, but the temperature dropped abruptly.

WAKAMATSU: Do you feel that you can reproduce the same test?

TAKEDA: Even though we conducted this particular test once, several years ago we conducted a great number of similar tests using alcohol. At that time we repeatedly observed the oscillatory phenomena and also we observed phenomena of abrupt extinction. So, I feel that there is a high degree of reproducibility of this particular test.

ZUKOSKI: It would be interesting to find out the behavior with a pilot flame in the box. We've done similar experiments which were ventilation limited at the bottom of a large cylinder with a flame in the bottom of a large cylinder. The fire goes out but we had an ignition source that would reignite.

EMMONS: In fact, if you had a charring fuel, I believe it would not have gone out because the char would have reignited it. PMMA has only a gas flame. If you go poof, it goes out.

ROCKETT: Several years ago Stanley conducted experiments in a room approximately the same size, with a door and a simulated sprinkler mounted directly outside the door. The spray produced quite fine droplets. Both gas flames and PMMA fires on the floor were extinguished by application of the water outside the door. Extinguishment occurs when the measured oxygen concentration in the room had been lowered by steam generated from the sprinkler to approximately 14 to 15 percent oxygen. Relative to Prof. Emmons' comment, when the PMMA was surrounded with aluminum foil on the side and bottom, extinguishment did not always occur because a small flame remained between the aluminum foil and the side of the PMMA. In this case, as the temperature of the room dropped and the efficiency of conversion of water into steam decreased, the fire would reestablish at a reduced size.

COOPER: You have assembled a lot of data on quasi-steady conditions that ultimately lead to flashover or oscillations or extinguishment. The dimensions of your apparatus are fairly small but it seems that it may be useful to try to model these, to use the existing models, and to compare them with your data. Since you have so many different sets of conditions, it is reasonable to model them. Have you thought of doing this?

TAKEDA: As for the comparison of the model and the result of the experiments, I presented a talk on that subject in the International Combustion Symposium last year in Haifa, Israel.

COOPER: Does this include modeling of the early times of fire?

TAKEDA: That particular comparison did not include early time.

COOPER: This is the calculation that I'm wondering about...an early time comparison, the quasi-steady early time.

TAKEDA: You are asking about early time, when oscillation or flashover will take place, is that correct?

COOPER: I'm talking about times before flashover, prior to times when temperatures exceed, let's say, 300 or 400°C.

TAKEDA: At the current time, I do not have models which will include those early times.

MATERIALS FIRE PROPERTIES AND TEST METHODS

Takashi Handa and Harold Nelson
Session Chairmen

Materials Fire Properties and Test Methods

by

Patrick J. Pagni

Mechanical Engineering Department

University of California

Berkeley, CA. 94720

Introduction

Per the resolutions of the Sixth Meeting of the UJNR Panel on Fire Safety and Research, this introductory progress report will address identification of material fire-related properties necessary to serve as inputs to a performance fire code. The concern here is with definition. The question of the appropriateness of existing fire test methods, which have been reviewed in the literature [1-5], will not be considered. Recent developments in test methods and suggestions for new test methods [6-8] will also be delayed until a consensus has been reached on which properties must be quantified. With this goal in mind the material properties required by current compartment fire computer codes are examined. The amount and geometry of each material present, the compartment geometry and acceptable protocols for determining convective and radiative transfer coefficients are assumed to be known.

Properties

Consider a division of these properties into three phenomenological categories: 1) heat transfer, 2) steady combustion, and 3) fire spread.

The first category is dominated, as noted by Rockett at the recent Emmons Conference [9], by the properties: k , the thermal conductivity, defined as

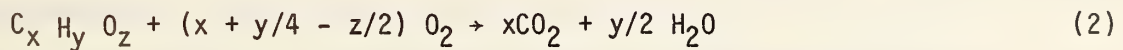
the ratio of that portion of the local heat flux due to molecular motion to the negative of the local temperature gradient; ρ , the density, defined as the mass per unit volume and c , the specific heat capacity, defined as the specific enthalpy increase required to raise the local temperature one degree. It concur that these three properties must be known for all materials in every habitable structure. In the walls, both bearing and non-bearing, and in the interior and exterior surface finishings these properties dictate the heat loss from the compartment at early times and can have a critical influence on the probability of flashover as discussed by Thomas et al. in the analogy between flashover and thermal ignition [10-12]. In the contents of the room, these properties also play an important role as the thermal inertia, $k\rho c$, which strongly influences characteristic temperatures and as the thermal diffusivity, $k/\rho c$, which determines the characteristic times for unsteady behavior.

The properties which dominate steady combustion are those [13,14] included in the definitions of the mass transfer number, $B \equiv (Q_p Y_{O_\infty} - h_s)/L$ and the mass consumption number, $r \equiv Y_{O_\infty} \nu_f M_f / Y_{f_s} \nu_o M_o$. These are: L , the effective latent heat of pyrolysis; Q_p , the enthalpy (heat) release per mass of oxygen consumed; h_s , the surface enthalpy (temperature) in the gas phase; $\nu_f M_f / \nu_o M_o$, the stoichiometric fuel to oxygen mass ratio, assuming complete combustion to CO_2 and H_2O , and Y_{f_s} the surface fuel mass fraction which is known from $Y_{f_s} = (B Y_{f_t} - Y_{O_\infty} \nu_f M_f / \nu_o M_o) / (1 + B)$ if Y_{f_t} , the fuel mass fraction in the pyrolysing material, is known. The quasi-steady, local, compartment oxygen mass fraction, Y_{O_∞} , will be known from computer calculation. The effective latent heat of pyrolysis consists of the pyrolysis enthalpy plus the specific enthalpy required to bring a unit mass of fuel from ambient tem-

perature to the surface temperature plus the radiative emission on an unusual per mass basis minus the radiative influx on that same basis, i.e.,

$$L = \Delta h_p + c (T_s - T_\infty) + (\dot{q}''_s - \dot{q}''_{in})/\dot{m}'' \quad (1)$$

where Δh_p , c , T_s and $\dot{q}''_s = \epsilon_s \sigma T_s^4$ are material properties, but \dot{q}''_{in} and thus \dot{m}'' depend on the environment and therefore must be separately specified [15]. The heat release, when expressed per mass of oxygen consumed, is practically an universal constant, 13 ± 1 kJ/gm O_2 . The activation energies for surface pyrolysis are sufficiently high that surface temperatures do not change significantly over a wide range of pyrolysis rates. The chemical composition of the pyrolyzed material determines the stoichiometry, i.e.,



and therefore,

$$\frac{v_f M_f}{v_o M_o} = \frac{12x + y + 16z}{32x + 8y - 16z} \quad (3)$$

is known, assuming the pyrolyzate's net chemistry is the same as the chemical composition of the original material. Refinements necessary to include time varying properties as might be found in material with significant char can be discussed in the next meeting's material fire properties progress report. For now a start can be made here.

The final problem is to determine material properties required to predict unsteady fire growth. The correlations in Figs. 10-13 of Ref. 16 suggest two essential non-dimensional groups: a Peclet No.,

$$\bar{V} \equiv \frac{k_s \rho_s c_s V (T_s - T_\infty)^2}{k_g \rho_g c_g U_\infty (T_{fl} - T_s)^2} \quad (4)$$

and a Damköhler No.,

$$\bar{D} \equiv \frac{k_g P^2 Y_{O_\infty} Y_{fs} A_g}{c_g \rho_g^2 U_\infty^2} \exp(-E_g/RT_{fl}) \quad (5)$$

Three new material properties are introduced: T_{fl} , the flame temperature; A_g , a global gas phase reaction rate pre-exponential; and E_g , a global gas phase reaction rate activation energy. P , the pressure, and U_∞ , the gas velocity, are compartment parameters. In addition for most fire growth problems, flame radiation plays a crucial role. The radiant heat flux from a flame depends on T_{fl} , on the flame geometry specified by a flame height, x_{fl} , and shape or, at the least, by a quasi-steady mean beam length, $\ell_{fl} \approx 4V/a$ where V is the flame volume and a is the total flame surface area and on the average soot volume fraction in the flame, f_v , [18,19].

Conclusions

Improvements will be required [20] since this property list is based on many assumptions of limited validity which cannot be discussed in detail in the space permitted here. In summary, the following are the fire-related material properties to be determined for all contents and components of habited structures (with units indicated in parenthesis):

k	thermal conductivity (E/LTt)
ρ	density (M/L ³)
c	specific heat capacity (E/MT)

L	effective latent heat of pyrolysis (E/M)
Q_p	heat release/mass of oxygen consumed (E/M)
$C_x H_y O_z$	pyrolyzate net chemical composition
Y_{ft}	pyrolyzate fuel mass fraction
T_s	fuel surface temperature (T)
T_{fl}	flame temperature (T)
f_v	flame average soot volume fraction
l_{fl}	flame mean beam length (L)
x_{fl}	flame height (L)
A_g	global reaction rate pre-exponential ($M/L^3 t P^2$)
E_g	global reaction rate activation energy (E/mole)

It might be concluded that these fire-related material properties are simply engineering material properties and that, while there may be unique fire-related needs, there may not need to be unique fire-related test methods.

References

1. American Society for Testing and Materials, "Symposium on Fire Test Methods," A.S.T.M. Special Technical Publication, Philadelphia, PA., 1962.
2. National Fire Protection Association, "Fire Protection Handbook," 15th Edition, N.F.P.A., Boston, MA., 1981.
3. American Society for Testing and Materials, "Annual Book of ASTM Standards; Part 18: Thermal Insulation; Building Seals and Sealants; Fire Standards; Building Construction; Environmental Accoustics," 1694 p., Philadephia, 1982.
4. International Conference of Building Officials, "Uniform Building Code," 1982 ed; Whittier, CA., 1982.
5. National Research Council of Canada, Associate Committee on the National Building Code, "National Fire Code of Canada," 180 p., Ottawa, 1980.
6. J. de Ris, "Flammability Testing State-of-the-Art," Technical Report J.1.OHOJ2.BU, Factory Mutual Research Corporation, Norwood, MA., June 1983.

7. Tewarson, A. and Pion, R.F., "A Laboratory-Scale Test Method for the Measurement of Flammability Parameters," Technical Report No. 22524, F.M.R.C., Norwood, MA., October 1977.
8. V. Babrauskas, "Heat Release Rate Measurements with the Cone Calorimeter," Emmons Conference on Fire Research, August 23-25, 1983, N.B.S., Gaithersburg, MD.
9. J. Rockett, "Data for Room Fire Models," Emmons Conference on Fire Research, August 23-25, 1983, N.B.S., Gaithersburg, MD.
10. P.H. Thomas, "Fires and Flashover in Rooms - A Simplified Theory," Fire Safety Journal, 3, 67-76, 1983.
11. P.H. Thomas, M.L. Bullen, J.G. Quintiere and B.J. McCaffrey, "Flashover and Instabilities in Fire Behavior," Combustion and Flame, 38, 159-171, 1980.
12. Y. Hasemi, "Thermal Instability in Transient Compartment Fire," Proceedings of the Sixth Meeting of the UJNR Panel on Fire Safety and Research, pp. 452-461, Tsukuba, Japan, 1982.
13. P.J. Pagni, "Diffusion Flame Analyses," Fire Safety Journal, 3, 273-285, 1980.
14. L. Orloff and J. de Ris, "Froude Modeling of Pool Fires," Nineteenth Symposium (International) on Combustion, pp. 885-895, The Combustion Institute, 1982.
15. A. Tewarson, "Heat Release Rate in Fires," Fire and Materials, 4, 185-191, 1980.
16. A.C. Fernandez-Pello and T. Hirano, "Controlling Mechanisms of Flame Spread," Combustion Science and Technology, 32, 1-32, 1983.
17. J. Quintiere, M. Harkleroad and D. Walton, "Measurement of Material Flame Spread Properties," Combustion Science and Technology, 32, 67-90, 1983.
18. S. Bard and P.J. Pagni, "Carbon Particulate in Small Pool Fire Flames," ASME Journal of Heat Transfer, 103, 357-362, 1981.
19. R.A. Beier and P.J. Pagni, "Soot Volume Fraction Profiles in Forced-Combusting Boundary Layers," ASME Journal of Heat Transfer, 105, 159-165, 1983.
20. H.W. Emmons, "A View of Fire Safety from the Twenty-Third Century," Emmons Conference on Fire Research, August 23-25, 1983, N.B.S. Gaithersburg, MD.

ZUKOSKI: Do you have any comments concerning the treatment of composite materials, such as the foams you talked about which have gas pockets?

PAGNI: I think for that kind of foam we could treat the composite with an average property for that material. But for other kinds of composites where they are non-homogeneous and there are layers and threads connecting different fabric, we would need the properties of each part.

EMMONS: It seems to be that we also need, in addition to the suggestion which you have for individual materials, the corresponding "cost" of the corresponding list for furniture items and other built items. The difficulty of having a fundamental treatment of a manner of fire spread on a large chair, given the information on the individual material, will probably be so complex as not to be a reliable method.

PAGNI: Based on past experience, you are probably correct.

QUINTIERE: Do you see the place for phenomenological type parameters, other than just material properties, such as heat transfer type coefficient parameters? We have had some success with this in dealing with flame spread.

PAGNI: Yes, I think that's a very useful contribution to be determined in this analysis, if the radiative and convective transfer coefficients, as well as the geometry, are known.

QUINTIERE: I do not mean that we should define the heat transfer coefficient. I mean we should define parameters like heat transfer coefficients.

PAGNI: There are many phenomena which are so imprecisely known that such coefficients are not only a good idea, they are also necessary. But, I think it might be a mistake to use those when we have the more fundamental alternatives.

RECENT ADVANCES IN MATERIALS FIRE PROPERTIES
AND TEST METHODS

Hiroaki SUZUKI

Building Research Institute
Ministry of Construction

Seventh Joint Meeting
UJNR Panel on Fire Research and Safety
Washington, U.S.A., October 24-28, 1983

Recent Advances in Materials Fire
Properties and Test Methods

H. Suzuki

This report deal with studies on fire properties of materials and some test methods which have been developed in these years in order to grasp the fire behavior of materials and/or to classify materials by their fire performance.

1. Fire Properties of Materials

Flame spread over materials is one of factors for prediction of fire growth in a room. Inducement of a proper formula which will be commonly applied to more materials is an important theme. Many scientific studies for flame spread and their application to practical use have been pursued. No common fomulae, however, have been introduced to be applied to many materials with different properties.

The formula " $X_f = \alpha X_p^n$ " which wasintroduced by the researchers¹⁾ of Factory Mutual at the 15th Combustion Symposium in Tokyo in 1974, has still been used as a typical equasion. Efforts for improvement of this equasion changing flow rate of atmosphere, inclination angles, materials etc. have been made in order to apply practical use.

The other method for study of mechanism of flame propagation has been pursued with changing dynamic environmental conditions. Hirano et al.^{2),3)}, for example, have studied the difference of flame propagation by changes of flow rate of environment. This may become an effective method to predict the spread of fire in a dynamic atmosphere in a room, in the future.

K. Kishitani et al.⁴⁾ have measured flame spread of PMMA at the vertical position and get a relationship between the height of flame (X_f) and the position of the melting front (X_p). That is $X_f = \alpha X_p^n$, where $\alpha = 4.68$ and $n = 0.7$ for PMMA of 0.5cm in the thickness.

K. Akita et al.⁵⁾ have pursued a theoretical study of combustion of PMMA under the natural convection. They deal with effects of different Schmidt number and heat loss from the surface of the materials which due to diffusion coefficients of the pyrolysis products and oxygen.

The theoretical result meet the experimental one in the region of 0.75-2.5 of Schmidt number when a bigger number than that of oxygen for the pyrolysis products is taken.

T. Mikado et al.⁶⁾ and K. Uchida et al.⁷⁾ have studied on electric wire coated with polyvinyl chloride. K. Uchida et al. have conducted a relationship between the damaged length of electric wire coated with polyvinyl chloride using a vertical test method. The relationship is written as follows

$$L_e = -l_0 \ln(x - X_m) + l_1$$

where l_0, l_1 and X_m are constant, L_e is the damaged length, x oxygen index of atmosphere.

On the other hand, weight loss, heat release and smoke production from building materials and furniture have been continued by F. Saito et al.,⁸⁾ S. Fujikawa⁹⁾ and K. Kawagoe et al.¹⁰⁾

K. Kawagoe et al. have obtained 35,000 Kcal/m²h of irradiation heat release flux from flame which was calculated from the data at the distance of 1.5m, 2.0, 2.5, 3.0m from the center of burning cribs. A camera with a fish eye lens was used for the measurement of the shape effect of the flame.

2. Fire Test Methods and Classification of Materials

A box model test method¹¹⁾ is going to be applied as a new test method for evaluation of fire resisting composite materials of foamed plastics covered with thin inorganic materials, in addition to the current fire tests executed by the ordinance of Ministry of Construction, Japan.

A box shaped specimen of 0.84 x 0.84 x 1.68 (W x H x D in meters, without the floor and a wall for opening) is to be located in a bigger box made of asbestos-cement-parlite board (0.3 x 0.67 in meters for openings on one of two smaller walls). About 2 Kgs of cribs are to be used for the fire source in addition to the specimen. Combustion products are collected into a hood with a duct where temperatures, velocity of the flow, and combustion gases (CO, CO₂, O₂) are measured. Heat released rate is calculated by the method which has been developed by W.G. Parker, et al.¹²⁾

A test method for ignitability has been developed at the committee ISO/TC 92/SC 1¹³⁾ for these years and round robin tests have been carried

out among some laboratories in some countries.

An ad hoc committee for the ignitability was organized in the Architectural Institute of Japan and has followed the ISO test method.¹⁴⁾

The purpose of the ad hoc committee is to do testing of ignitability of materials, and to do comparison of six different types of radiometers, used in some countries.

Some plastics burn to blow off flames from openings of buildings whose interior materials of foamed plastics catch fire. Some fire retarded foam plastics show a peculiar phenomenon which is based on the balance between heat release rate and cooling effect by draft when burn. This phenomenon occurred in foamed plastics with stable tissue without being melt when heated.

For an evaluation of fire retarded foamed plastics, especially polyisocyanurate which has self-extinguishing property, in order to classify these foamed plastics which used in warehouses, a fire test method has been developed with 0.5ml of ethy alcohol in a small cup for the the heat source.¹⁵⁾

The classification is made by the area calculated from temperature-time curve which measured in the vent. This test method is only valid for construct among industries.

H. Suzuki¹⁶⁾ and H. Miyazawa¹⁷⁾ have tested the flame spread of building materials by 25 feet tunnel test method and ISO fire spread of flame test method, respectively.

References

- 1) L. Orloff et al, Fifteenth Symposium (International) on Combustion, P37, Aug (1974).
- 2) Hirano, T., Sato, K., and Minami, H., "Response of Flame Spread Phenomena to Ambient Air Stream Velocity Changes," Proceedings of the 6th Joint Panel Meeting UJNR Panel on Fire Research & Safety, 597-615(1982).
- 3) Sato, K., Miki, K., and Hirano, T., "Flame Spread over Paper in an Air Stream with a Velocity Change," in Fire Dynamics and Heat Transfer, ASME HTD-Vol. 25, 9-15(1983).
- 4) K. Kishitani, S. Sugawara and K. Hamada : Annual Conference of Architecture, Field of Fire, P.2809, Sep. 1983.
- 5) K. Akita, T. Hirano and H. Ohtani : Annual Conference on Fire Research, Japanese Association of Fire Science and Engineering, P.73 May 1983.
- 6) Mikado, T. and Akita, K., "Burning Characteristics of Grouped PVC Cables," J. Fire & Flammability, 13, 24-32(1982).
- 7) K. Uchida and T. Hayashi ; Annual Conference on Fire Research, Japanese Association of Fire Science and Engineering, P.31, May 1982.
- 8) F. Saito and M. Yoshida ; ibid, P.2805, Sep. 1983.
- 9) S. Fujikawa ; ibid, P.2803, Sep. 1983.
- 10) K. Kawagoe, T. Mizuno and K. Shinoda : ibid, P.2803, Sep. 1983.
- 11) F. Saito ; Unpublished.
- 12) W.G. Parker : NBSIR 81-2427-1, March, 1982.
- 13) ISO/TC 92/SC 1 : Technical Report TR 5657-Fire Tests-Reaction to Fire-Ignitability of Building Products, N36, June, 1981.

- 14) Report of the Ignitability Test Method ; Technical Repot of Ad Hoc
Committee of Ignitability Test, Architectual Institute of Japan, 1982.
- 15) Nihon Kagaku Bohka Kyokai ; Technical Report of Ad Hoc Committee for
Insulation Materials for Warehouses, March, 1979.
- 16) H. Suzuki ; Annual Conference of Architecture, Field of Fire, P.2813,
Sep. 1983.
- 17) H. Miyazawa ; ibid, P.2815, 1983.

Discussion After H. Suzuki's Report on RECENT ADVANCES IN MATERIALS FIRE
PROPERTIES AND TEST METHODS

GANN: This test method that is to be proposed, do you have some idea of the physical form? What will the test method be like?

SUZUKI: We showed a videotape yesterday. We used a box approximately one meter by one meter by two meters. This is a box model test method.

IDENTIFICATION OF FIRE PROPERTIES RELEVANT
TO THE PREDICTION OF FIRE GROWTH

Archibald Tewarson
Factory Mutual Research Corporation
Norwood, Massachusetts 02062 U.S.A.

(For Seventh U.S.-Japan Natural Resources Panel Meeting
On Fire Research And Safety, National Bureau of Standards,
Washington, D.C.)

September 1983

SCOPE

In this paper, fire properties of materials relevant to the prediction of fire growth are identified and techniques and apparatus for quantification are described.

1. IDENTIFICATION OF FIRE PROPERTIES OF MATERIALS

The fire properties of materials relevant to the prediction of fire growth are:

1.1 Properties Associated With Fire Initiation And Spread

1) Critical heat flux (\dot{q}_{cr}'') below which fire cannot be initiated. Fire initiation can be defined as the onset of fuel vapor generation, piloted ignition or autoignition.

2) Energy (E) required to reach the critical heat flux. Energy is related to the thermophysical properties of the materials and configuration (1).

$$\frac{1}{E} = \left(\frac{p\alpha}{k\Delta T_i} \right)^2 \left[1 - \frac{\dot{q}_l''}{\dot{q}_e''} \right]^2 \dot{q}_e'' \quad (1)$$

where, p = constant; α = thermal diffusivity; k = thermal conductivity; ΔT_i = temperature required for fire initiation above ambient temperature; \dot{q}_l'' = heat losses; and \dot{q}_e'' = heat flux applied to the material.

3) Flame spread rate coefficient (C), expressed as (2),

$$C = \frac{1}{2} (\pi/a\delta_f \dot{q}_{fl}'')^{1/2} \quad (2)$$

where, $a = \alpha(h/k)^2$; δ_f = flame heat transfer distance; \dot{q}_{fl}'' = flame heat flux; and h = heat transfer coefficient. C is related to the thermophysical properties and configuration of the materials.

The flame spread rate coefficient, the critical heat flux and the associated model developed by Quintiere (2) or other models can be used to predict the generation rate of fuel vapors in growing fires.

1.2 Properties Associated With Fire Hazard

The hazard contributed by a fire is expressed in terms of generation of heat and various compounds ("smoke," toxic and corrosive products), all of which depend on the generation rate of fuel vapors and availability of oxygen. The fire properties relevant to the prediction of growth rates of heat and various compounds, ("smoke," toxic and corrosive products) are:

1) Heat of combustion (H_i) which is defined as the ratio of heat release rate (\dot{Q}_i) to the generation rate of fuel vapors (\dot{G}_f)

$$H_i = \dot{Q}_i / \dot{G}_f \quad (3)$$

Heat release rate in fires is defined as the actual heat release rate (\dot{Q}_A) and has a convective and a radiative component, respectively, defined as convective heat release rate (\dot{Q}_C) and radiative heat release rate (\dot{Q}_R). In a similar fashion, actual, convective and radiative heat of combustion, H_A , H_C and H_R respectively, can be defined. The ratio of actual heat of combustion to the

heat of complete combustion of the material is defined as combustion efficiency (χ_A), and its convective and radiative components, χ_C and χ_R , respectively. The product of heat of combustion and predicted generation rate of fuel vapors is equal to the predicted heat release rate in a growing fire.

2) Yields of various compounds ("smoke," toxic and corrosive products) (Y_j) which is defined as the ratio of the mass generation rate of a compound j (\dot{G}_j) to the generation rate of fuel vapors (\dot{G}_f),

$$Y_j = \dot{G}_j / \dot{G}_f \quad . \quad (4)$$

The products of the yield of the compounds and predicted generation rate of fuel vapors are equal to the predicted generation rates of the compounds in growing fires.

3) Mass attenuation coefficient of "smoke" (σ) which is defined as the ratio of the optical density of "smoke" per unit path length (D) to the generation rate of fuel vapors (\dot{G}_f) per unit volumetric flow rate of the mixture of air and fire products (\dot{V}_T),

$$\sigma = D / (\dot{G}_f / \dot{V}_T) \quad . \quad (5)$$

The product of mass attenuation coefficient and the predicted generation rate of fuel vapors and volumetric flow rate is equal to the optical density in growing fires.

4) Suggested corrosivity parameter (C_r), which may be defined as the ratio of rate of corrosion of a metal (\dot{m}) to the generation rate of fuel vapors (\dot{G}_f), where vapors are bubbled through a fixed volume of water,

$$C_r = \dot{m} / \dot{G}_f \quad . \quad (6)$$

This parameter has been developed recently⁽³⁾, and needs to be examined further so that it may become useful for the prediction of corrosivity of the compounds generated in growing fires.

5) Toxicity parameter (T_x), which may be defined (by modifying the conventional definition used in the fire field) as the ratio of the generation rate of fuel vapors (\dot{G}_f) to the total volumetric flow rate of well mixed air and fire products (\dot{V}_T), required to achieve a toxicological end point (incapacitation, death, etc.):

$$T_x = \dot{G}_f / \dot{V}_T \quad . \quad (7)$$

T_x may be modified further, as follows:

$$T_x = (1 - x) \dot{G}_f / \dot{V}_T \quad , \quad (8)$$

where x is the mass fraction of fuel vapors converted to nontoxic compounds such as CO_2 and H_2O .

6) Ventilation parameter (ϕ), which is defined as the ratio of mass flow rate of oxygen (\dot{m}_{O_2}) to the generation rate of fuel vapors (\dot{G}_f) and stoichiometric mass oxygen to fuel ratio (k_{O_2})⁽⁴⁾

$$\phi = \dot{m}_{O_2} / \dot{G}_f k_{O_2} \quad . \quad (9)$$

When $\phi > 1$, fire is defined as overventilated and when $\phi < 1$, fire is defined as underventilated.

1.3 Properties Associated With Fire Detection And Extinguishment

Fires can be detected through heat or compounds generated in fires; thus, the fire properties identified as relevant in Section 1.2 would also be relevant for fire detection.

Fires can be extinguished through interference in the combustion chemistry by 1) reducing oxygen concentration by agents such as N_2 , CO_2 , foams, etc., and 2) interacting with flame chemistry by agents such as Halons, dry powders, etc. Fires can also be extinguished by cooling the flame and the burning materials. In either case the heat release rate, flame heat flux, generation of various compounds, and the generation of fuel vapors must be reduced below some critical values for the extinguishment of the fire. Since extinguishment is the reverse process of ignition, the critical values for various fire properties associated with extinguishment by N_2 , CO_2 , foams, Halons, dry powders, water, etc. may be very similar to the fire properties associated with ignition. For example, the generation rate of fuel vapors for polymethylmethacrylate at or below which piloted ignition cannot be achieved is very similar to the value of the generation rate of fuel vapors where flame is extinguished by water spray and by reducing the oxygen concentration. Thus, the extinguishment parameter (Ex) relevant to the prediction of growing fires may be suggested as ⁽⁷⁾

$$Ex = \Delta P/P \quad , \quad (10)$$

where ΔP is the change in a fire property as a result of application of a known amount of the extinguishment agent, and P is the property in the absence of the extinguishment agent. P can be any one of the fire properties associated with heat release rate, generation rate of an individual compound, or generation rate of fuel vapors.

2. QUANTIFICATION OF FIRE PROPERTIES RELEVANT TO THE PREDICTION OF FIRE GROWTH

2.1 Apparatus

For the quantification of fire properties, the most suitable apparatus that have recently been developed are: 1) the National Bureau of Standards Cone Calorimeter developed by Babrauskas ⁽⁵⁾; 2) the Ohio State University Heat Release Rate Apparatus ⁽⁶⁾; and 3) the Factory Mutual Combustibility Apparatus ⁽⁷⁾. At Factory Mutual, three combustibility apparatus are used ⁽⁷⁾:

- 1) Small-scale apparatus for samples ~10 cm x 10 cm x 10 cm high;
- 2) Intermediate-scale apparatus for samples ~30 cm x 30 cm x 30 cm high; and
- 3) Large-scale apparatus for samples ~300 cm x 300 cm x 300 cm high.

All apparatus operate under very similar principles. In the small-scale and intermediate-scale apparatus radiant heaters are used as external heat sources. In the small-scale apparatus both forced and natural air flow are used where air can be heated and contaminated by various compounds. In the intermediate- and large-scale apparatus, only natural air flow is used.

In all three apparatus, all the products generated in the fire are captured along with ambient air in long sampling ducts where measurements are made for total flow rate of the mixture of air and fire products, gas temperature, concentration of various compounds, and optical transmission. In addition, measurements are made for piloted and autoignition, and generation rate of fuel vapors. The mass flow rate and oxygen concentration in the inlet air in the small-scale apparatus are also measured.

2.2 Measurements

2.2.1 Fire Initiation

The critical heat flux (\dot{q}_{cr}'') and energy (E) are quantified by measuring time to ignition as a function of external heat flux. E is then equal to time to ignition x external heat flux. Figure 1 is a plot of $1/E_{ig}$ as a function of external heat flux (\dot{q}'') for the piloted ignition of various polyolefin cables. The intercept on the \dot{q}'' -axis is defined as the critical heat flux (\dot{q}_{cr}''). From eq (1) and the slopes in Figure 1, $\rho\alpha/k\Delta T_i$ can be calculated for conditions where $\dot{q}_l'' \ll \dot{q}_e''$.

Quintiere⁽²⁾ has developed a model and has described the technique for the quantification of flame spread rate coefficient, (C), in eq (2). Currently we are using Quintiere's model for flame spread rate for vertical cables about 60 cm in length, exposed to external heat flux at the lower end.

2.2.2 Heat Of Combustion

For the quantification of heat of combustion (H_c) using eq (3), the ratio of heat release rate and generation rate of fuel vapors is determined as a function of time under various experimental conditions. The actual heat release rate is calculated from the generation rates of CO and CO₂ and occasionally verified by using the oxygen depletion technique of Huggett⁽⁸⁾. The convective heat release rate is calculated from gas temperature, total mass flow rate of the mixture and the specific heat of air at the gas temperature. The radiative heat release rate is calculated from the difference between actual and convective heat release rate, because losses are negligibly small in our apparatus.

Table 1 lists data for some selected materials for overventilated fire conditions. For simple materials for overventilated fires, the heat of combustion is found to be independent of the fire size and shape of the materials and fire stages (growth and steady state).

2.2.3 Yields Of Various Compounds

For the quantification of the yields of various compounds (Y_i), using eq (4), the ratio of the generation rate of compounds and fuel vapors are determined as functions of time under various experimental conditions. The generation rates of the compounds are calculated from the concentrations of the compounds and total volumetric flow rate of the mixture of air and fire products.

Table 2 lists data for some selected materials for overventilated fire conditions. For simple materials for overventilated conditions, the yields of major compounds are found to be independent of the fire size and shape of the material and fire stages (growth and fully developed).

2.2.4 Mass Attenuation Coefficient Of "Smoke"

For the quantification of the mass attenuation coefficient of "smoke" (σ) using eq (5), the ratio of optical density per unit path length at three wavelengths of light to the generation rate of fuel vapors per unit volumetric flow rate of the mixture of air and fire products is determined as a function of time under various experimental conditions. Table 3 lists data for some selected materials for overventilated fires. For simple materials for overventilated conditions, σ is found to be independent of fire size and shape of the material and fire stages (growth and fully developed).

2.2.5 Suggested Corrosivity Parameter

For the quantification of the suggested corrosivity parameter⁽³⁾, fuel vapors are bubbled through a fixed volume of distilled water (100 ml). A mild steel probe is immersed in the solution and its resistance is measured as a function of time. The resistance changes because of loss of metal due to corrosion. From the measurements, the rate of corrosion of the metal is determined and is divided by the generation rate of fuel vapors. Data for some selected materials are listed in Table 4.

The suggested corrosivity parameter needs further refinement so that it may become useful for the prediction of corrosion potential of compounds generated in a growing fire.

2.2.6 Ventilation Parameter (ϕ)

The ventilation parameter, ϕ , is calculated using eq (9) from the ratio of total mass flow rate of inlet oxygen to the generation rate of fuel vapors per unit stoichiometric oxygen to fuel ratio.

The ventilation parameter, ϕ , is found to be a function of Pagni's normalized flame height, $X_{f\ell}$ ^(10,11). For polymethylmethacrylate (PMMA), cellulose and polyvinyl chloride (PVC) in our apparatus⁽⁴⁾,

$$X_{f\ell} \approx 34/\phi^{1.5} \quad . \quad (11)$$

As ϕ decreases, $X_{f\ell}$ increases, i.e., increase in "excess pyrolyzate" i.e., fuel vapors which are not consumed in the flame which produced them^(10,11). The combustion efficiency and generation efficiencies of products of complete combustion decrease and the generation efficiencies of products of incomplete combustion increase with increase in the "excess pyrolyzate" for PMMA, cellulose and PVC in our experiments using the small-scale combustibility apparatus⁽⁴⁾.

The "excess pyrolyzate" concept is applicable to the prediction of fire growth (see Reference 10 and comments on the paper). We have been examining this concept for enclosure fires of PMMA reported by Quintiere *et al*⁽¹²⁾ in conjunction with PMMA data obtained in our small-scale apparatus⁽⁴⁾.

Quintiere *et al*⁽¹²⁾ have reported the values of induced air flow rate, generation rate of fuel vapors, and gas temperature for steady-state enclosure fires of PMMA pools for several ventilation openings and pool areas. If we assume that the oxygen concentration in air entering the fire is either normal or close to the normal value, then the value of ϕ can be calculated from eq (9) for enclosure fires of PMMA pools. Since the sum of the induced air flow rate plus the generation rate of fuel vapors is equal to the total mass flow rate of the mixture of air and fire products, \dot{m}_g , leaving the enclosure, the convective fraction of the combustion efficiency (χ_c) can be calculated as follows,

$$\chi_c = \dot{m}_g c_p \Delta T / \dot{G}_f H_T \quad , \quad (12)$$

where c_p is assumed to be the specific heat of air at the gas temperature; $\Delta T = \text{gas temperature above ambient in the enclosure}$; and $H_T = \text{net heat of complete combustion of PMMA (25 kJ/g)}$. The calculated data on the basis of the above mentioned assumptions are shown in Figure 2 by open circles. The data from the FM small-scale apparatus taken from Reference 4 are also included in the figure by dark circles. A reasonable agreement between the two sets of data can be noted, considering that: 1) heat losses in enclosure fires, even at the steady state, are expected to be higher than in the FM small-scale

apparatus; and 2) mixing and entrainment processes are expected to be somewhat different in the enclosure and in the small-scale apparatus.

The relationship between Pagni's normalized flame height ($X_{f\ell}$) and ventilation parameter (ϕ) is shown in Figure 3, taken from Reference 4. As ϕ decreases $X_{f\ell}$ increases and thus "excess pyrolyzate" is expected to burn outside the compartment and contribute to fire growth.

2.2.7 Suggested Extinguishment Parameter

The extinguishment parameter (Ex) is quantified by applying known amounts of water from a nozzle, by reducing the total air flow entering the apparatus or by adding N_2 or CO_2 into the inlet air. The generation rates of fuel vapors, heat and various chemical compounds are determined in the presence and absence of the extinguishment agents and Ex calculated from eq (10).

Table 5 lists some selected values of Ex determined experimentally for PMMA fires with various water application rates at different external heat flux values in our small-scale apparatus⁽⁷⁾.

3. SUMMARY

Pertinent fire properties of materials for the prediction of fire growth have been identified and techniques and apparatus for their quantification are described. The most suitable apparatus are the NBS Cone Calorimeter, the Ohio State Heat Release Rate Apparatus and the FM Combustibility Apparatus. It is suggested that for the quantification of fire properties in these apparatus the following concepts be considered: 1) "excess pyrolyzate" developed by Pagni^(10,11); 2) flame spread developed by Quintiere⁽²⁾; 3) induced air flow rate for compartment fires developed by Quintiere et al⁽¹²⁾ and examined further by Stickler et al⁽¹³⁾; and 4) ignition, combustion and product generation efficiencies developed by Tewarson⁽⁹⁾. It is also suggested that these apparatus be considered for the quantification of corrosivity, toxicity and fire extinguishment parameters in a fashion which is useful for the prediction of hazard and fire extinguishment for growing fires.

Acknowledgement

This work is supported by a grant No. NB83NADA4021 from the U.S. National Bureau of Standards, Center for Fire Research, which is deeply appreciated.

REFERENCES

1. Tewarson, A, Ignition of Electric Wires And Cables (under preparation).
2. Quintiere, J., Fire And Materials 5, 52, 1981.
3. Tewarson, A., Khan, M.M., and Steciak, J., "Combustibility of Electrical Wire and Cable for Rail Rapid Transit Systems, Volume I. Flammability," Technical Report July 1982, Contract DTRS-57-80-C-00073, Agency Code DTS-852, Transportation Systems Center, Cambridge, MA.
4. Tewarson, A., and Steciak, J., Combustion And Flame (in press).
5. Babrauskas, V., "Development of the Cone Calorimeter - A Bench-Scale Heat Release Rate Apparatus Based on Oxygen Consumption," National Bureau of Standards, Washington, D.C., Technical Report NBS1R82-2611, November 1982.
6. Smith, E.E., "Heat Release Rate of Building Materials" Ignition, Heat Release and Noncombustibility of Materials, ASTM STP 502, American Society for Testing and Materials, Philadelphia, PA, 1972, p. 119.
7. Tewarson, A., "Quantification of Fire Properties of Fuels and Interaction With Fire Environment," U.S. National Bureau of Standards, Washington, D.C., Technical Report FMRC J.I. OEON6.RC, April 1982.
8. Huggett, C., Fire And Materials, 4, 61, 1980.
9. Tewarson, A., "Physico-Chemical And Combustion/Pyrolysis Properties of Polymeric Materials," (paper in preparation).
10. Pagni, P.J. and Shih, T.M., 16th Symposium (International) On Combustion, The Combustion Institute, Pittsburgh, PA, 1976, p. 1329.
11. Pagni, P.J., Fire Safety Journal 3, 273, (1980/81).
12. Quintiere, J.G., McCaffrey, B.J., and Den Braven, K., 17th Symposium (International) On Combustion, The Combustion Institute, Pittsburgh, PA, 1978, p. 1125.
13. Stickler, K.S., Quintiere, J.G. and Rininen, W.J., 19th Symposium (International) On Combustion, The Combustion Insitute, Pittsburgh, PA, 1982, p. 913.

TABLE 1

HEAT OF COMBUSTION OF SOME SELECTED MATERIALS FOR VARIOUS
POOL SIZES FOR OVERVENTILATED CONDITIONS^a

Material	Apparatus	Pool Area (m ²)	Heat of Combustion (kJ/g)		
			Actual	Convective	Radiative
Rigid Polyurethane Foam	Large	~7	16.4	10.8	5.6
	Small	0.008	15.8	6.5	9.3
Methanol	Large	4.68	18.7	15.6	3.1
	Small	0.008	19.4	17.1	2.3
PMMA	Large	2.37	24.2	15.8	8.4
	Intermediate	0.073	23.8	14.9	8.9
	Small	0.008	24.4	17.9	6.5
Hydrocarbon Transformer Fluid	Large	2.37	35.6	23.8	11.8
	Small	0.008	38.2	25.1	13.1
Heptane	Large	0.93	41.2	26.8	14.4
	Small	0.008	37.7	19.9	17.8

^aTaken from Reference 7

TABLE 2

YIELDS OF MAJOR COMPOUNDS FOR SOME SELECTED
MATERIALS FOR OVERVENTILATED POOL FIRES^a

Material	Pool Area (m ²)	CO ₂	CO	HCN	"Smoke"
Methanol	4.68 ^b	1.29	<0.001	-	-
	2.32 ^b	1.30	<0.001	-	-
	0.008 ^d	1.32	<0.001	-	-
PMMA	2.37 ^b	2.11	0.008	-	-
	0.073 ^c	2.10	0.010	-	-
	0.008 ^d	2.15	0.011	-	0.022
Heptane	0.93 ^b	2.83	0.015	-	-
	0.008 ^d	2.80	0.034	-	-
Rigid Polyurethane Foam	~7 ^b	1.50	0.027	0.010	-
	0.008 ^d	1.51	0.036	0.012	-
Polyvinylchloride	0.008 ^d	0.40	0.057	-	-
Polystyrene	0.008 ^d	2.2	0.071	-	0.15
Polypropylene	0.008 ^d	2.9	0.025	-	0.077

^aTaken from References 7 and 9^bFrom large-scale combustibility apparatus^cFrom intermediate-scale combustibility apparatus^dFrom small-scale combustibility apparatus

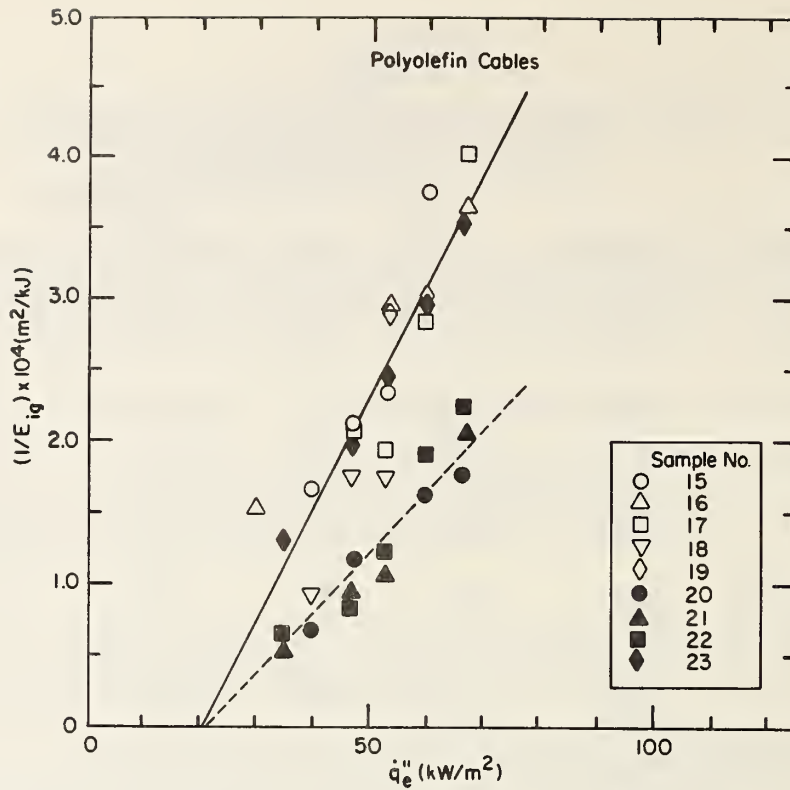


Figure 1 Inverse of piloted ignition energy as a function of external heat flux (taken from ref. 1)

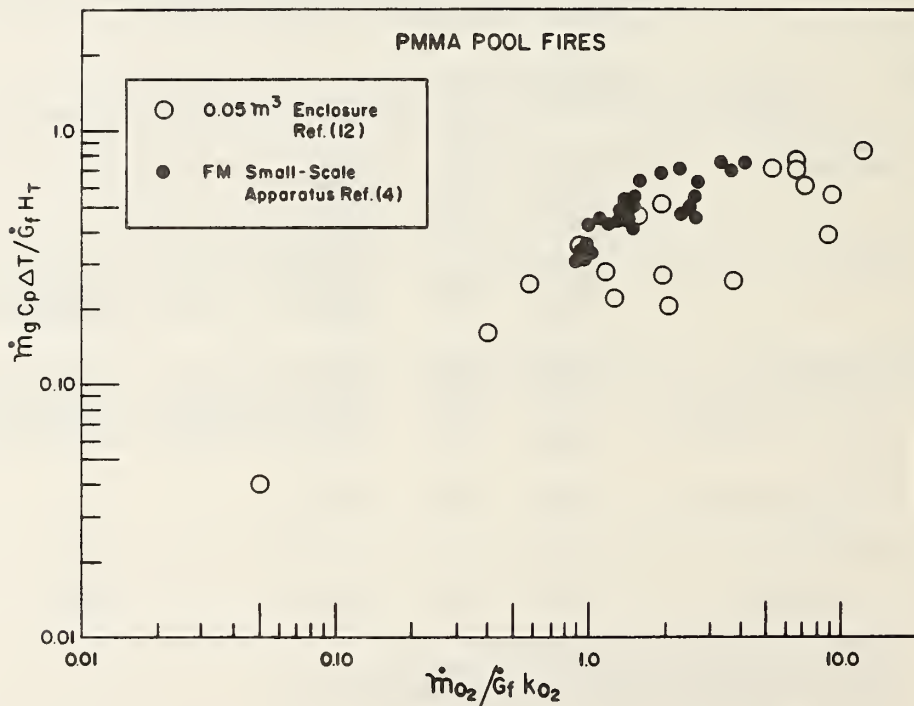


Figure 2 Convective fraction of the combustion efficiency as a function of the ventilation parameter

TABLE 3

MASS ATTENUATION COEFFICIENT OF "SMOKE"
FOR OVERVENTILATED FIRES^a

Material	Mass Attenuation Coefficient of "Smoke" (m ² /g)
Red Oak	0.113
Polymethylmethacrylate	0.161
Polypropylene	0.224
Polystyrene	0.730

^aTaken from Reference 9

TABLE 4

CORROSIVITY PARAMETER FOR OVERVENTILATED FIRES^a

Material	Micrometer of Corrosion of Steel/g of Fuel Vapors
Polyvinylchloride polymer	3.0 ^b
Polyolefin cable	3.8
Ethylene propylene/polyolefin cable	1.6
Silicone/polyolefin cable	1.7
Teflon cable	8.0 ^b

^aUsing 100 ml of distilled water; data taken from Reference 3

^bUnder nonflaming conditions

TABLE 5

EXTINGUISHMENT PARAMETER (Ex) FOR PMMA FIRES USING WATER SPRAYS^a

External Heat Flux (kW/m ²)	Water Application Rate (g/m ² s)	Extinguishment Parameter Calculated From		
		Fuel Generation	Actual Heat Release Rate	Generation Rate of CO
0	1	0.17 ^b	0.14 ^b	0.06 ^b
10	1	0.07	0.09	-
15	1	0.02	0.08 ^b	-
15	2	0.13 ^b	0.16 ^b	0.13 ^b

^aData taken from Reference 7

^bClose to flame extinguishment

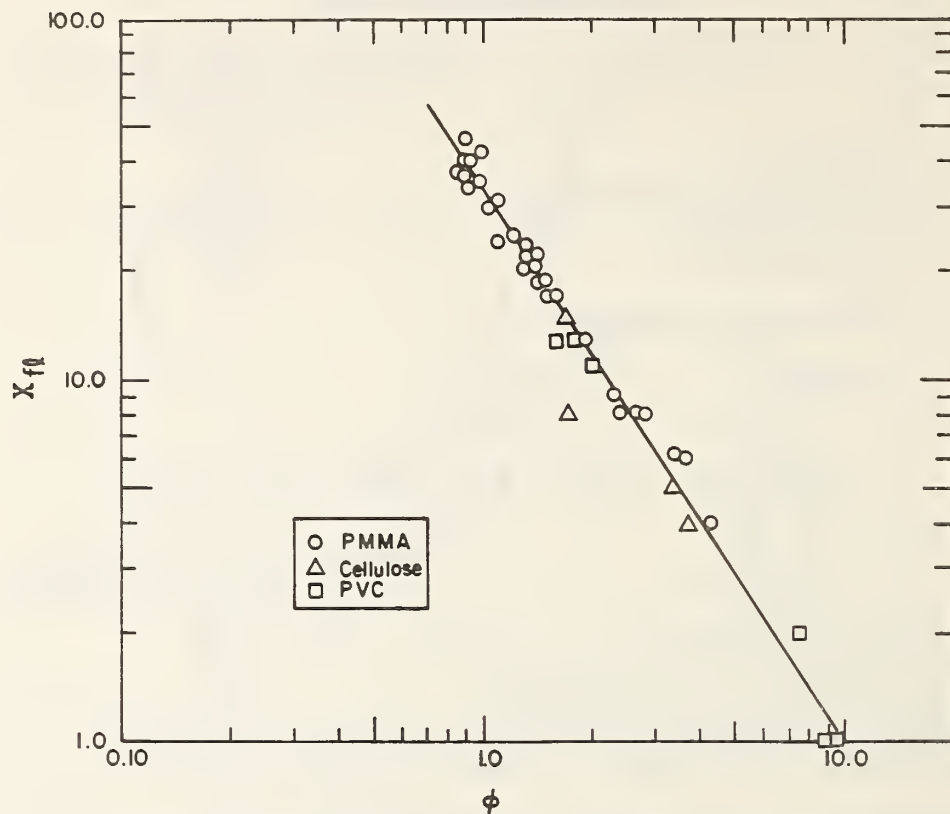


Figure 3 Pagni's normalized flame height as a function of ventilation parameter (taken from ref. 4)

Discussion After A. Tewarson's Report on IDENTIFICATION OF FIRE PROPERTIES
RELEVANT TO THE PREDICTION OF FIRE GROWTH

SAITO: You stated that the generation of smoke and gas depends on the ventilation and infrastructure of materials, but I think that the heat flux also will work as a factor. I may have missed that when you mentioned the heat flux, but don't you think that will have something to do with it?

TEWARSON: In my presentation, in the first few slides I concentrated on generation of fuel vapors where I mentioned what parameters were important, and flame heat flux was one of those.

SAITO: The generation rates of smoke and fuel vapors, of course, are related to the ventilation for combustion rates. When we think about wooden material being burned, and the fuel vapor and the gas being ventilated, the properties of gas and fuel vapor will change in accordance with the pyrolysis and the charring of the material, in this case, wood.

TEWARSON: Yes. It is also a function of time. For example, in enclosure fires, if it is a hot layer which sits there for some time, depending on the temperature of the hot layer, there may be an additional pyrolysis going on as a result of which, for example, the alcohol, the aldehydes that come out from wood will go into carbon monoxide and one would see very high ratios of CO over CO₂. For example, in the enclosure fires which were done at NBS by Gross and Robertson, they reached almost a veritable limit of .56.

MITLER: As Prof. Emmons has pointed out a number of times, the equations of nature are independent of time. Therefore, you cannot have these properties as a function of time directly; I'm sure you must mean indirectly as integrals of certain properties.

TEWARSON: Yes, of course.

SAITO: My question is whether or not that property of a fuel gas and the smoke will change in accordance with heat flux levels? I don't think that this property can be expressed simply or directly with equations such as heat flux times time.

TEWARSON: There are two things we have to keep in mind and, of course, there will be complications. However, at least for simple fuels, we find that for overventilated conditions for these properties are constant. But for underventilated sets, they may change so one may have to do some kind of approximations.

GANN: It has been our experience that both the quantity or rate of product generation and the nature of those products is extremely dependent on the rate of energy input to the sample.

CONCEPTS ON FLAME SPREAD TESTING

Toshisuke Hirano

Engineering Research Institute
Faculty of Engineering
University of Tokyo
Bunkyo-ku, Tokyo 113

Toshisuke Hirano

1. INTRODUCTION

The fire growing process depends on the flame spread over combustible material surfaces of floors, walls, ceilings, equipments, pieces of furniture, etc., so that the limit or rate of flame spread over a certain material is considered as a measure of hazard of that material at accidental fires. So far, several types of flame spread testing have been proposed for the performance assessments of various materials under fire conditions. All of these tests are based on experimental evidences and/or theoretical concepts[1-6]¹.

Recently, extensive studies on flame spread over solid combustibles have been performed, and the controlling mechanisms of flame spread have been made clear to a further extent[7]. At this time, it seems worthwhile to reconsider flame spread testing on the basis of the present understanding of the controlling mechanisms of flame spread.

2. CONTROLLABLE FACTORS

2.1 Factors Affecting Flame Spread Phenomena

Since the purpose of a certain flame spread test is to evaluate the performance of each material under fire conditions, the performance of the material under various conditions, which are supposed to be similar to those at real fires, should be inferred by using the results of the flame spread test.

Obviously, the flame spread phenomena depend on the gasification, mass diffusion, combustion reaction, heat transfer, and solid temperature rising processes near the pyrolysis(or evaporation) front and leading flame edge² (Fig. 1). In some cases, the melting or charring process should be added to these processes. Every factor that is related to the above processes must affect the flame spread phenomena. Effects of such a factor on the flame spread phenomena have been examined in many previous studies[7]. Based on those studies, a set of the conditions, under which a flame spread test is to be performed, should be determined. A brief description on the effects of each factor on the flame spread phenomena seems helpful to consider flame spread testing.

¹Numbers in brackets refer to the literature references listed at the end of this paper.

²For flame spread in gas flows opposing the direction of propagation, the pyrolysis front is very close to the leading flame edge, while for flame spread in gas flows in the same direction as that of propagation, the flame leading edge precedes the pyrolysis front. In the latter case, the spread rate of the pyrolysis front is often adopted for discussion on the flame spread mechanisms.

2.2 Effects of Each Controllable Factors

Flame Spread Direction

One of the most familiar factors which affect the flame spread phenomena is the direction of flame spread. It is well known that the flame spread phenomena depend strongly on the inclined angle of the test piece and the direction of flame spread[8-14]. The upward flame spread rate is usually of a few orders in magnitude larger than the downward one. Also, in general, upward spread is accelerative, while downward one is steady[7]. Further, under real fire conditions, a flame spreads not only in the direction opposed to or concurrent with that of the gas flow induced by the buoyancy, but also in the lateral direction[6,15].

When a material is burning, a gas flow is induced due to the buoyancy effect of the hot combustion products. The mass transfer process obviously depends on this gas flow, and its change causes the changes of other processes. The effects of the flame spread direction on the flame spread phenomena are attributable to the fact that the variation of the flame spread direction affects the gas flow near the pyrolysis front, where main processes of flame spread occur.

Test Piece Dimension and Configuration

The downward flame spread rate for thermally thin sheets of a solid combustible is known to be inversely proportional to the thickness, while that for thermally thick sheets is independent of the thickness [13,16]. A similar relation is valid for the flame spread along rods of a solid combustible[10].

As mentioned previously the flame spread phenomena depend on the temperature rising process of the unburned material ahead of the pyrolysis front to its gasification temperature. This process is closely related to the heat transfer process to the unburned material. A part of the heat to the unburned material is transferred through the solid phase. The ratio of this part of the heat to the total heat to the unburned material is negligible for the thermally thin sheets and increases with the test piece thickness to a constant[7,16]. Based on this discussion, the dependence of the flame spread phenomena on the test piece dimension can be interpreted[7].

The effect of the test piece width or configuration of the flame spread phenomena is also expected to be significant in some cases[13,17], because the heat transfer process can be easily supposed to depend on these factors.

External Radiation and Test Piece Temperature

Under real fire conditions, a certain part of the solid combustible in a room is generally exposed to the radiation from other burning parts before the leading flame edge reaches there. Thus, many studies of the external radiation effect on the flame spread phenomena have been performed[10,14,17-22].

At an initial stage of a fire, the external radiation intensity is low, and a quasi-steady assumption of the surface temperature may be valid. Under such a condition, the flame spread rate increases with the external radiation intensity. At a developed stage of a fire, on the other hand, the external radiation intensity is usually so large that the temperature of the exposed surface continues to increase until the leading flame edge reaches there or it ignites[6]. In this case, therefore, no test can be performed at a steady state.

The external radiation affects largely the heat transfer process. The temperature of the material surface increases with the external radiation intensity. This temperature rise reduces the difference of the temperature far from the leading flame edge and that for the pyrolysis reaction. Consequently, the flame spread rate increases[7]. This effect of the temperature rising of the unburned solid surface is usually more significant than that of the radiative heat flux to the surface in the preheat zone just ahead of the pyrolysis front during flame spread.

Heat Sink

If there is a certain heat sink such as a backing or frame of larger conductivity for a thin sheet of a solid combustible, the flame spread rate over it is lower than that without such a heat sink[13,23]. This effect is obviously due to the reduction of heat transferred to the unburned material. At the same time, it has to be noted that if the backing material enhances the heat transfer to the unburned material ahead of the pyrolysis front, the flame spread rate becomes larger[13].

Ambient Gas Flow

A gas flow inside a chamber is easily induced by burning only a small amount of combustible material. To simulate real fire conditions, therefore, an ambient gas flow of a finite velocity should be considered.

The effects of an ambient gas flow on flame spread phenomena have been examined in previous studies in detail[7]. When the ambient gas flow is opposed to the flame spread direction, its increasing reduces the spread rate to extinction[18,22,24-27]. On the other hand, when it concurs with the flame spread direction, its increasing enlarges the spread rate[18,28].

Under real fire conditions, an ambient gas flow is likely to fluctuate. The results of recent studies on the flame spread over a paper sheet in an air stream with a velocity change indicate that the fluctuation of the ambient air flow affects significantly the flame spread phenomena[29,30].

Obviously, the mass transfer process and other processes relating to it near the Pyrolysis front must vary with the ambient gas flow, and its effects on the flame spread phenomena are attributable to the variation of these processes with the ambient gas flow[7].

Ambient Oxygen Concentration

In order to reveal the chemical kinetics of flame spread processes, the informations of flame spread phenomena in the atmospheres of various oxygen concentrations are very important. Also, fires in artificial airs should be considered in particular cases. Thus, flame spread experiments have been performed by varying ambient oxygen concentration.

In general, the flame spread rate increases with oxygen concentration [23,26,31]. The increase of the flame spread rate is mainly attributable to the increase of the chemical reaction rate.

Ambient Pressure

In particular circumstances where there is a possibility of fire occurrence, the ambient pressure is not always atmospheric pressure. Also, on the pressure model experiments for simulating fires, the pressure is above atmospheric pressure. Furthermore, the flame spread experiments under a reduced pressure give us important informations of the flame spread mechanisms. Thus, many studies have been conducted of the ambient pressure effects on flame spread phenomena[23, 31-33]. As the oxygen pressure is increased, the flame spread rate increases and its limits for other factors expand.

The thermal and mass diffusivities, pyrolysis and chemical reactions, induced buoyant force, etc. depend on the pressure. The variation of the flame spread phenomena with the ambient pressure is attributable to the variations of these quantities with the ambient pressure.

Gravity ~~Force~~

For a particular purpose, the flame spread experiments have been conducted by varying the gravity ~~force~~[31]. Since the buoyancy ~~force~~ depends on the gravity ~~force~~, the flame spread phenomena, closely related to the buoyancy ~~force~~, must be emphasized with the increase of the gravity ~~force~~.

Test Facility and Procedure

If the size of a test chamber is sufficiently large, its effect may be neglected. However, if it is small, the flow induced at the burning part of a test piece in it may affect the flow field near the pyrolysis front and the gas composition in it. Consequently, its size usually affects the spread test results.

In some cases, the procedure of testing also affects significantly the spread test results. For a material which is likely moisturized, the period from the instant of picking the test piece up from a drying chamber to that of igniting affects the results. Also, for flame spread tests under external radiation, the initial stage of the pyrolysis reaction starts at the exposed surface before the front of the main pyrolysis zone reaches there. This means that the surface characteristics changes with time, so that the period from the instant of setting a test piece to that of igniting affects the results. Other effects of the characteristics of the ignition system or ignition procedure on the flame spread phenomena are likely to be significant in some particular cases.

2.3 Secondary Effects Caused by Changing Controllable Factors

When a controllable factor is changed, some other factors changes consequently. Such changes of other factors are sometimes unexpected and often neglected in the interpretation of the effect of the controllable factor on the flame spread.

The most significantly affected factor when almost every controllable factor except for itself changes is the gas flow near the pyrolysis front. A typical example of such a case is shown in Fig. 2. When the intensity of external radiation to a thin sheet of paper is changed, the gas velocity profile ahead of the leading edge of the flame spreading over it changes consequently[22]. This change in the gas velocity profile causes the heat flux profile in the preheat zone as shown in Fig. 3. Similar effects of the gas flow change caused by changing other controllable factors are expected.

The radiation from a spreading flame also changes when every controllable factor is changed. If the flame size or flame temperature increases by changing a controllable factor, the radiation from the flame must increase. Since the flame size increases with the test piece dimension, the intensity of flame radiation increases and the increase of the flame spread rate with the test piece dimension is expected.

In particular cases, especially in the case under near-extinction conditions, the flame spread phenomena depend strongly on the area of the pyrolysis zone. A typical example of this effect is shown in Fig. 4[30]. When the ambient air flow velocity u_{∞} is instantaneously increased

from that $u_{\infty 1}$ for stable flame spread to that $u_{\infty 2}$ just above the stable flame spread limit, delayed extinction is observed [29,30]. In Fig. 4, the dependence of the time τ_e from the velocity change to extinction on $u_{\infty 1}$ is presented. It can be found that τ_e depends not only on $u_{\infty 2}$, but also on $u_{\infty 1}$, i.e., the dependence of τ_e on $u_{\infty 1}$ cannot be neglected in this case.

It is usual that in the discussion on the flame spread limit, the balance between the residence time and the chemical reaction time at the leading flame edge is considered. This balance depends on the gas velocity, temperature, and species distributions near the leading flame edge, which are supposed to be affected by the pyrolysis zone length.

There must be many unknown secondary effects caused by changing controllable factors. To reveal those secondary effects, detailed studies are needed.

3. A DESIRABLE FLAME SPREAD TEST

3.1 Characteristics to be Evaluated

Of the characteristics representing the performance of a certain material under fire conditions, the limiting conditions of flame spread and/or the flame spread rate under particular conditions are estimated in the previously established flame spread tests [1-6].

In order to estimate the limiting value of a factor for flame spread, only the factor concerned has to be changed by keeping other controllable factors constant. If only the oxygen concentration is changed, the limiting oxygen index can be obtained [1]. The limiting radiation intensity for flame spread can be evaluated by changing the radiation intensity [3,4,6].

For estimating the flame spread rate under a certain set of conditions, all controllable factors should be kept constant. It is obvious that a large number of test runs are needed to reveal the dependence of the flame spread rate on only one factor. Thus, it is practically impossible to examine the flame spread rate under every imaginable set of conditions by means of only a certain flame spread test.

3.2 Requirements for a Flame Spread Test

Once a test method of flame spread is established, many data for various materials have to be obtained by using it. Therefore, the most important requirement for a test method of flame spread is the feasibility to repeat tests.

Based on the test results, the performance of a material should be

distinguished from that of any one of other materials. Thus, the reproducibility of the test results is required.

Furthermore, by using the test results obtained under a certain conditions, the behavior of the tested material under another set of conditions is desired to be predicted. This means that the test results must be of generality.

A flame spread test should be at least of these three characteristics, i.e., feasibility, reproducibility, and generality.

3.3 Possibility to Satisfy the Requirements

By providing an appropriate test facility and test conditions, desirable ^{feasibility} ~~facility~~ and reproducibility can be satisfied. However, it is not so easy to realize the generality of test results. Upward flame spread phenomena seem difficult to be predicted by using only the results of downward flame spread tests. Flame spread phenomena in an oxygen enriched atmosphere cannot be predicted by using only the results of flame spread tests.

In order to predict the performance of a material under conditions different from those at the tests, the characteristics of the material such as its thermal and chemical properties and the knowledge mentioned in the section 2 are needed in addition to the test results. In such a case, the purpose of the flame spread test seems to be only to provide a reference for the prediction.

In some cases for evaluating the performance of a material under fire conditions, its thermal and chemical properties or the flame spread mechanisms might be more important than the results of the flame spread tests.

However, the above discussion has not been presented to deny the necessity of flame spread testing. At present, flame spread testing is the most convenient means to evaluate the performance of a material under fire conditions. Furthermore, even if a reliable prediction method would be established, a certain flame spread test should be done for the confirmation of the predicted results.

A flame spread test of a feasible procedure to obtain reproducible and general results is desirable. Such a flame spread test will be established on the basis of better understanding of the controlling mechanisms of flame spread. Once a complete spread test is established, flame spread over a material under every imaginable set of conditions will be predictable by using its results and the thermal and chemical properties of the material.

4. CONCLUDING REMARKS

Flame spread testing for evaluating the performance of a material under fire conditions is reconsidered on the basis of the present understanding of the controlling mechanisms of flame spread.

Brief description on the effects of controllable factors on the flame spread phenomena is presented. The effects of even the test facility and procedure cannot be neglected in some cases. The discussion on secondary effects caused by changing controllable factors are also performed. The secondary effects are sometimes unexpected and often neglected in the interpretation of the effects of the controllable factor concerned on the flame spread phenomena.

A desirable flame spread test should be at least of a feasible procedure to obtain reproducible and general results. By providing an appropriate test facility and test conditions, desirable feasibility and reproducibility can be satisfied, while it is not so easy to realize the generality of the test results. In particular cases, for evaluating the performance of a material under fire conditions, the thermal and chemical properties of the material or the flame spread mechanisms might be more important than the results of the flame spread tests. What the flame spread test can provide in such cases is a reference for the prediction of flame spread phenomena.

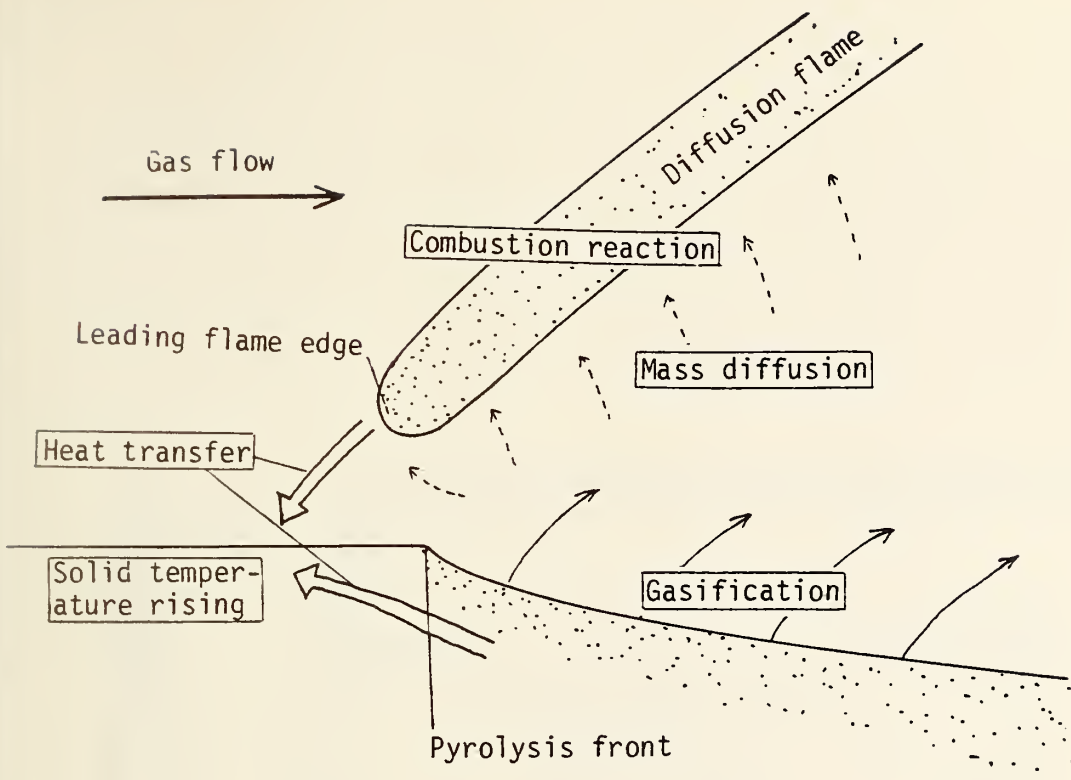
At present, however, flame spread testing is the most convenient means to evaluate the performance of a material under fire conditions. It is desirable that flame spread over a material under every imaginable set of conditions is predictable by using the results of a flame spread test and the material properties. Such a flame spread test will be established on the basis of better understanding of the controlling mechanisms of flame spread.

REFERENCES

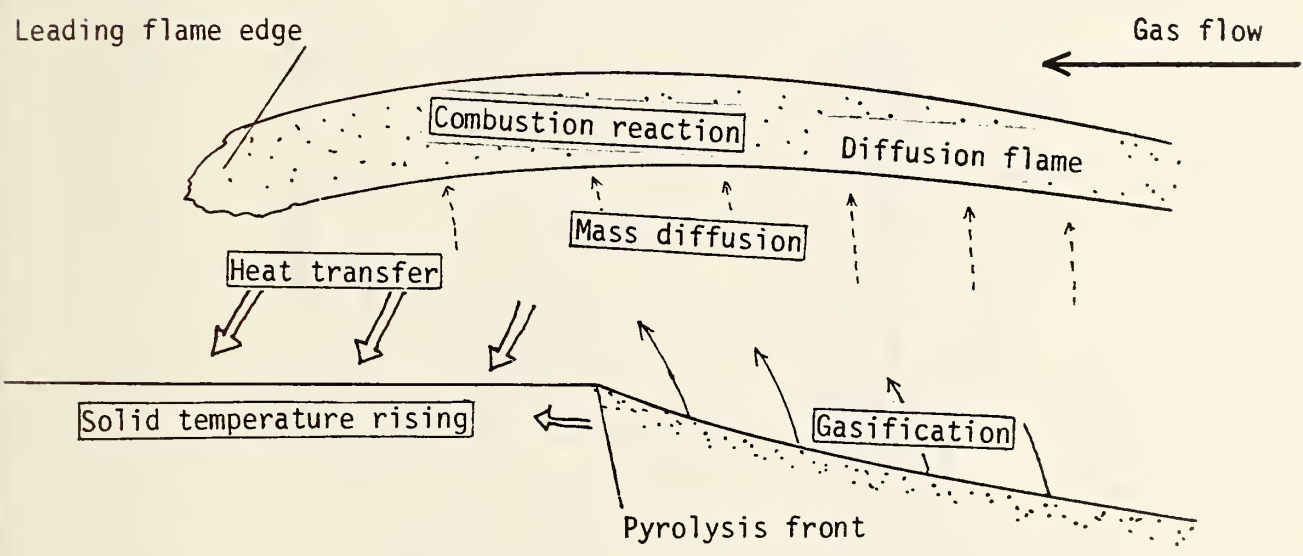
1. Fenimore, C. P. and Martin, F. J., "Flammability of Polymers," *Combustion and Flame*, 10, 135-139(1966).
2. Fristrom, R. M., Grunfelder, C., and Hunter, L. W., "Exploratory Studies in Polymer Ablation, Ignition and Extinction by the Moving Wire Technique," *Combustion and Flame*, 27, 33-49(1976).
3. Rockett, J. A., "Mathematical Modeling of Radiant Panel Test Methods," in *Fire Safety Research*, National Bureau of Standards, NBS SP 411, Nov.(1974).
4. Quintiere, J. G., "The Application and Interpretation of a Test Method to Determine the Hazard of Floor Covering Fire Spread in Building Corridors," in *Fire Safety of Combustible Materials*, University of Edinburgh, Edinburgh(1975).
5. Mikado, T. and Akita, K., "Evaluation of Flammability of Polymers for Electric Cable," *J. Fire & Flammability*, 12, 143-156(1981).
6. Quintiere, J. G., "A Simplified Theory for Generalizing Results from a Radiant Panel Rate of Flame Spread Apparatus," *Fire and Materials*, 5, 52-60(1981).
7. Fernandez-Pello, A. C. and Hirano, T., "Controlling Mechanisms of Fire Spread," *Fire Science and Technology*, 2, 17-54(1982); *Combustion Science and Technology*, 32, (in press)(1983).
8. Markstein, G. H. and de Ris, J. N., "Upward Fire Spread over Textiles," 14th Symposium(Int.) on Combustion, The Combustion Institute, Pittsburgh, Pa., 1085-1097(1973).
9. Sibulkin, M., Hetelhut, W., and Feldman, S., "Effect of Orientation and External Flow Velocity on Flame Spreading over Thermally Thin Paper Strips," *Combustion Science and Technology*, 9, 75-77(1974).
10. Sibulkin, M., Lee, C. K., "Flame Propagation Measurements and Energy Feedback Analysis for Burning Cylinders," *Combustion Science and Technology*, 9, 137-147(1974).
11. Hirano, T., Noreikis, S. E., and Waterman, T. E., "Postulations of Flame Spread Mechanisms," *Combustion and Flame* 22, 353-363(1974).
12. Hirano, T., Noreikis, S. E., and Waterman, T. E., "Measured Velocity and Temperature Profiles of Flames Spreading over a Thin Combustible Solid," *Combustion and Flame*, 23, 83-96(1974).
13. Fernandez-Pello, A. C. and Williams, F. A., "Laminar Flame Spread over PMMA Surfaces," 15th Symposium(Int.) on Combustion, The Combustion Institute, Pittsburgh, Pa., 217-231(1975).

14. Kashiwagi, T. and Newman, D. L., "Flame Spread over an Inclined Thin Fuel Surface," *Combustion and Flame*, 26, 163-177(1976).
15. Quintiere, J. G., Harkleroad, M., and Walter, W., "Measurement of Material Flame Spread Properties," National Bureau of Standards, NBS IR 82-2557, August(1982).
16. Hirano, T., Koshida, T., and Akita, K., "Flame Spread Mechanisms over PMMA Surfaces, Bull. Japanese Association of Fire Science and Engineering, 27, 33-39(1977).
17. Mikado, T. and Akita, K., "Burning Characteristics of Grouped PVC Cables," *J. Fire & Flammability*, 13, 24-32(1982).
18. Hirano, T. and Sato, K., "Effects of Radiation and Convection on Gas Velocity and Temperature Profiles of Flames Spreading over Paper," 15th Symposium(Int.) on Combustion, The Combustion Institute, Pittsburgh, Pa., 233-241(1975).
19. Kashiwagi, T., "A Study of Flame Spread over Porous Material under External Radiation Fluxes," 15th Symposium(Int.) on Combustion, The Combustion Institute, Pittsburgh, Pa., 255-265(1975).
20. Fernandez-Pello, A. C., "Downward Flame Spread under the Influence of Externally Applied Thermal Radiation," *Combustion Science and Technology*, 17, 1-9(1977).
21. Fernandez-Pello, A. C., "Upward Laminar Flame Spread under the Influence of Externally Applied Thermal Radiation," *Combustion Science and Technology*, 17, 87-98(1977).
22. Hirano, T., and Tazawa, K., "A Further Study on Effects of External Radiation on Flame Spread over Paper," *Combustion and Flame*, 32, 95-105(1978).
23. Frey, A. E. and T'ien, J. S., "Near-Limit Flame Spread over Paper Samples, *Combustion and Flame*, 26, 257-267(1976).
24. Hirano, T., Sato, K., and Tazawa, K., "Instability of Downward Flame Spread over Paper in an Air Stream," *Combustion and Flame*, 26, 191-220(1976).
25. Tazawa, K. and Hirano, T., "Upward Flame Spread over Paper in an Air Stream," Bull. Japanese Association of Fire Science and Engineering, 27, 9-16(1977).
26. Fernandez-Pello, A. C., Ray, S. R., and Glassman, I., "Downward Flame Spread in an Opposed Forced Flow," *Combustion Science and Technology*, 19, 19-30(1978).

27. Fernandez-Pello, A. C., Ray, S. R., and Glassman, I., "Flame Spread in an Opposed Flow: The Effect of Ambient Oxygen Concentration," 18th Symposium(Int.) on Combustion, The Combustion Institute, Pittsburgh, Pa., 579-589(1981).
28. Fernandez-Pello, A. C., "Flame Spread in an Forward Forced Flow," Combustion and Flame, 36, 63-78(1979).
29. Hirano, T., Sato, K., and Minami, H., "Response of Flame Spread Phenomena to Ambient Air Stream Velocity Changes," Proceedings of the 6th Joint Panel Meeting UJNR Panel on Fire Research & Safety, 597-615(1982).
30. Sato, K., Miki, K., and Hirano, T., "Flame Spread over Paper in an Air Stream with a Velocity Change," in Fire Dynamics and Heat Transfer, ASME HTD-Vol. 25, 9-15(1983).
31. Altenkirch, R. A., Eichorn, R., and Shang, P. C., "Buoyancy Effects on Flames Spreading Down Thermally Thin Fuels," Combustion and Flame, 37, 71-83(1980).
32. Alpert, R. L., "Pressure Modeling of Upward Fire Spread," Factory Mutual Research Corporation Report No. OAOR8.BU(1979).
33. Alpert, R. L., "The Role of Radiation in Pressure Modeling of Upward Fire Spread," ASME-AIChE National Heat Transfer Conference, San Diego, CA., ASME publication No. 79-MT-28(1979).



a



b

Figure 1. Schematic representation of the processes of flame spread over the surface of a solid combustibile. a: opposed gas flow; b: concurrent gas flow.

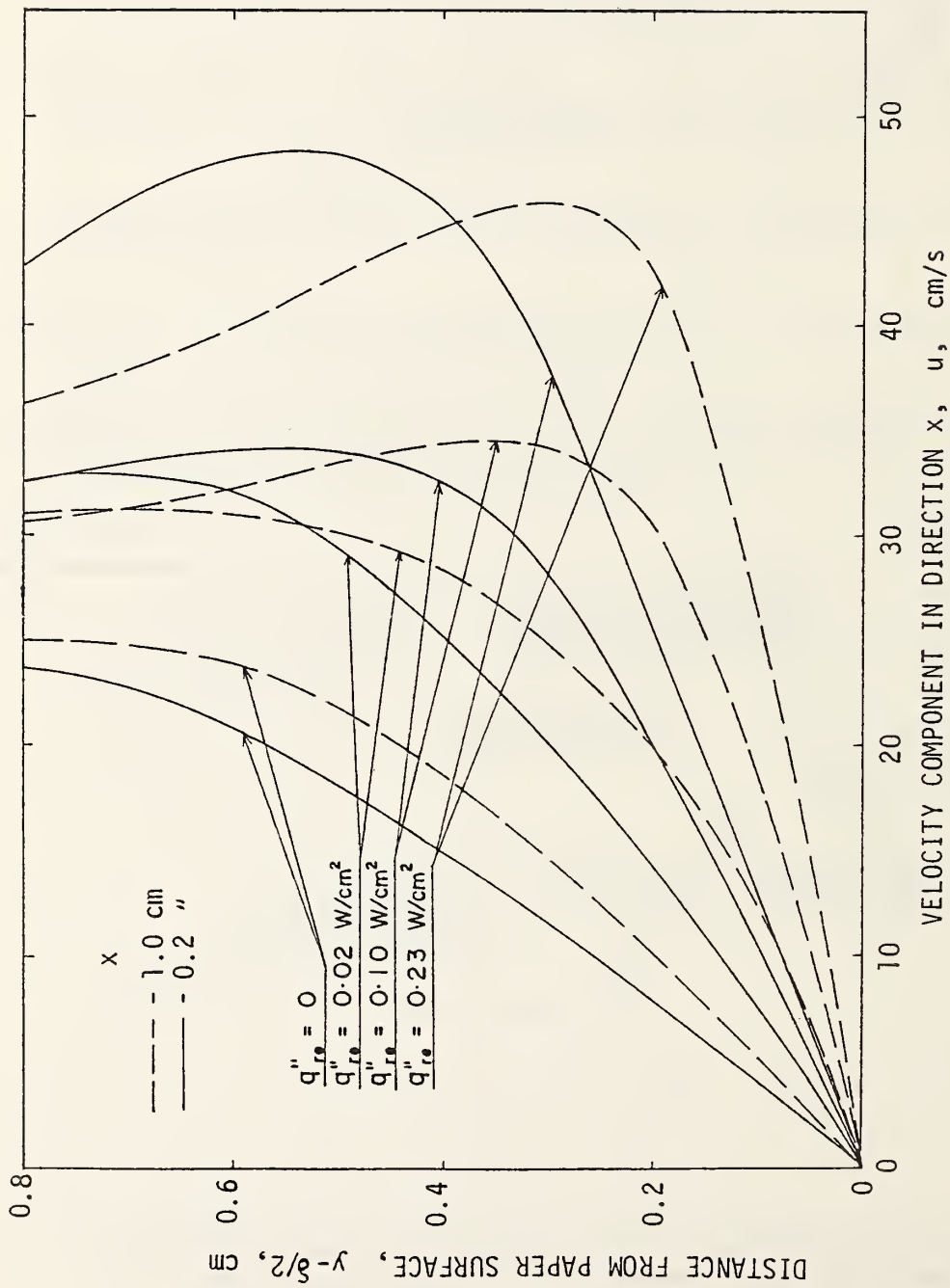


Figure 2. Velocity profiles just ahead of the pyrolysis front. x : distance from the pyrolysis front; δ : test piece (paper sheet) thickness = 0.026 cm; q''_{re} : external radiation intensity.

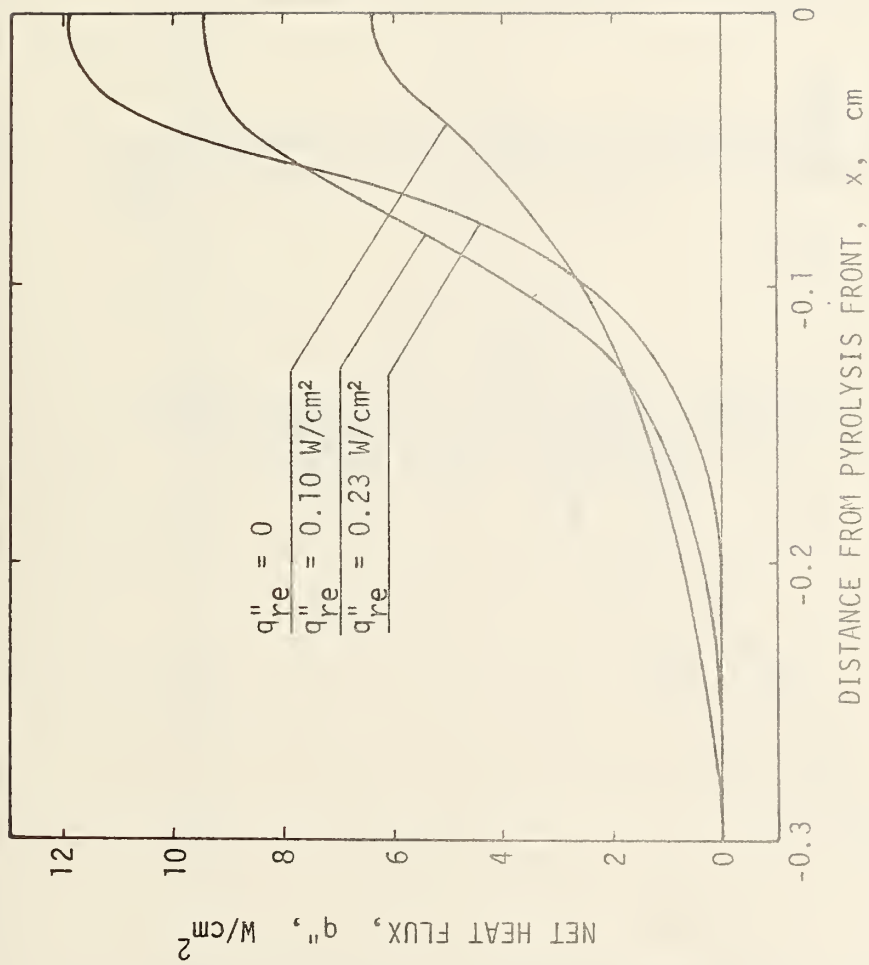


Figure 3. Net heat flux profiles to the unburned solid in the preheat zone.

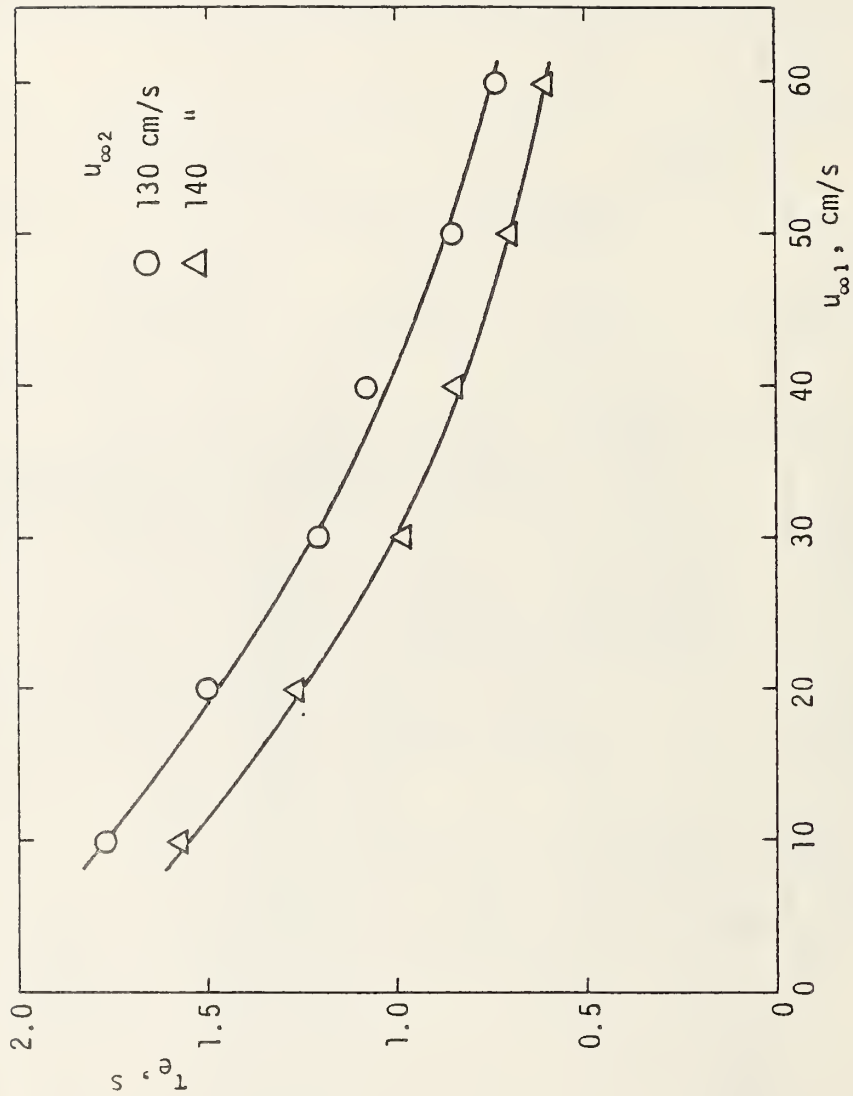


Figure 4. Dependence of the time τ from the ambient air velocity change to extinction on the ambient air velocity $u_{\infty 1}$ before its change. $u_{\infty 2}$: ambient air velocity after its change; Test piece: paper ($\delta = 0.026$ cm).

A METHODOLOGY OF THE SENSITIVITY ANALYSIS OF
BUILDING PROPERTIES ON THE OCCURRENCE OF FLASHOVER

Yuji Hasemi

Research Member, Building Research Institute
Guest Worker, Center for Fire Research
National Bureau of Standards

1. INTRODUCTION

Elucidation of the correlation between physical properties of buildings, furniture, etc., and fire hazard is obviously counted among the most important objectives of the research of "fire properties". A sensitivity analysis of the properties on the occurrence of so-called flashover should be one of its central problems, since flashover is generally regarded as the transient process which has the most significance on fire safety in buildings.

As the prediction of fire phenomena is essential for a quantitative evaluation of fire safety, mathematical models of building fires are thought to be useful tools for the research of fire properties; however, it seems that methodologies of the practical application of the mathematical fire models to fire safety evaluation have not been discussed sufficiently in spite of the considerable improvement of the physics and convenience of the models. Some concepts representing fire hazards or characteristic fire phenomena including flashover are still very "descriptive" or ambiguous, and it seems that they are not useful as measures for engineering fire safety design; one important thing in developing methodologies of quantitative evaluation of fire safety using mathematical fire models is a mathematical characterization of these concepts.

Recent studies on the global behavior of enclosure fires have correlated one of the mechanisms of flashover with the instability of the solution of a mathematical model of fire [1,2]. Characterizing flashover as the thermally unstable realm in a fire, concepts representing the fire safety of flashover will be formulated by using the stability of the basic equations describing

the fire growth. The stability of a system of ordinary differential equations can be investigated according to the sign of each eigenvalue of its functional matrix; however, it may not be easy to investigate the nature of the functional matrix of the functions forming a zone model because the structure of zone models is becoming complicated more and more through the improvement of their physics. While the Ljapunov function has been conventionally applied to evaluate the stability of a system of ordinary differential equations whose analytical treatments such as the calculation of derivatives are difficult, it seems to be still difficult to find a Ljapunov function generally applicable to zone models of fire.

The critical condition for flashover to appear is represented in the stability theories by the singularity of the Jacobian of the basic equations of a zone model; the condition should be equivalent with the extremum of the curvature representing the equilibrium state of a zone model [2]. The extremum of the equilibrium curvature of a model described as

$$V_i \cdot dT_i/dt = H_i(T_1, T_2, \dots, T_n), \quad i = 1, 2, \dots, n \quad (1)$$

can be obtained by calculating the maximum or the minimum of one parameter under $H_i(T_1, T_2, \dots, T_n) = 0$ as the constraint condition. Since a lot of practical techniques including numerical methods which work without calculation of derivatives of the objective function have been developed to solve such optimization problems, the extremum is thought to be a more practical idea than the singularity as the description of the critical condition.

The analysis of the author's previous report [2] has also shown that the temperature of each zone at the extremum of the equilibrium curvature can be a measure of the thermal state at the onset of flashover. Consequently, optimization techniques will be useful tools for quantitative fire safety design if we only discuss the critical conditions on the occurrence of flashover and its onset.

A procedure to solve an optimization problem with constraint conditions is generally divided into two stages, the transform of the problem to an optimization problem without constraint conditions and its solution; the important thing in applying optimization techniques to the evaluation of flashover using zone models is to adopt a way which does not need a calculation of differentials at each stage. In this paper, we will discuss the problems arising from the application of optimization techniques to the present problem and show a few examples of sensitivity analysis of the building properties on the appearance of flashover. As the mathematical fire modeling is still being developed, the focus of the paper is not to show a practical list of fire properties, but to derive a methodology to get it using zone models.

2. NONLINEAR CHARACTERISTICS OF ENCLOSURE FIRES

The methodology described in the introduction assumes the existence of an extremum in the equilibrium solution of a zone model; recent theoretical and experimental works on enclosure fires have shown some nonlinear characteristics of enclosure fires which suggest the existence of multiple equilibria of burning behavior, namely the existence of the extremum (Figure 1) [1-5]. The

existence of multiple equilibria was first predicted theoretically by Thomas who analyzed fire growth using the Arrhenius law of reaction rate [3]. Quintiere et al have shown the existence of multiple equilibria on a quasi-steady zone model which assumes the proportionality of fuel volatilization rate to the heat flux applied to the fuel surface [4]. On the basis of this, Thomas et al have shown how the radiation feedback would lead to the appearance of thermal instability and correlated this mechanism with flashover [1]. Takeda et al [5] have shown experimentally a discontinuity in the relationship between the fuel volatilization rate and opening factor, which was expected from the stability theory of flashover [1,2]. This chapter will describe some nonlinear characteristics of the experimental enclosure fires which are related to the basic assumptions of the present study*.

2.1 Description of Experiments

Experiments were conducted using a 0.40 m cubic enclosure of calcium silicate with methanol in square trays (0.10, 0.15 and 0.20 m) as the fuel (Figure 2). The fuel was supplied to the tray so that the height of fuel surface could be maintained. The set-up is almost similar with Takeda et al [5], except for the opening which was designed such that its width could be easily changed during an experiment. Measurements were made on temperature, velocity at the opening and fuel consumption rate. Total heat flux to the fuel surface was measured on 0.15 m tray.

*See reference [6] for more detail.

2.2 Experimental Results

Figure 3 shows the relationship between opening factor and fuel consumption rate at the steady state. The fuel consumption rate of each tray appears to change dramatically at one value of opening factor. The flame behavior is also quite different across the discontinuity; for opening factors less than the criticality, the flame formed above the tray has reached the ceiling and flowed out of the opening, whereas it has remained just above the tray for the opening factors greater than the criticality. The discontinuity in the fuel consumption rate is, thus, thought to correspond with the boundary between the ventilation-controlled and fuel-controlled regimes.

Figure 4 through Figure 6 show the time histories of ceiling temperature measured at 0.10 m apart from the center of the trays, and it is clearly seen in Figure 4 and Figure 6 that a rapid temperature rise which is attributed to so-called flashover is particularly seen for such opening conditions as leading to a ventilation-controlled fire. Although the difference among the time-temperature curves is not so significant for 0.15 m tray, it is quite obvious in the time history of the total heat flux to the fuel surface (Figure 7). The above results demonstrate that the discontinuity seen in Figure 3 should correspond with the critical condition for flashover to appear. Figure 8 shows examples of hysteresis in the relationship between fuel consumption rate and opening factor, which were obtained by changing the opening width slowly in the direction shown with arrows. Although Figure 8 does not appear to reproduce the curves in Figure 3 partly due to the enforcement of the enclosure for significantly longer experiments, the existence of hysteresis implies the existence of two extremum conditions in the equilibrium

state, one of which should correspond with the critical condition for flash-over to appear.

3. NUMERICAL CALCULATION METHOD OF THE STABILITY LIMIT OF THE EQUILIBRIUM SOLUTION OF ZONE MODELS

The extremum of a function, $f(x)$, under the constraint conditions $g_i(x) = 0$, $i = 1, 2, \dots, n$ can be obtained without calculating its partial derivatives by a successive search of the optimum of the augmented Lagrange function of $f(x)$. The augmented Lagrange function of $f(x)$, $L(x^*)$, is defined as

$$L(x^*) \equiv f(x) - \sum_{i=1}^m p_i g_i(x) + k \sum_{i=1}^m g_i^2(x), \quad k > 0 \quad (2)$$

where p_i is the Lagrange multiplier of x_i and the third term of the RHS is the penalty for the break of the constraint conditions. The optimum of $L(x^*)$ can be obtained by iterating temporary optimization of $L(x^*)$ under assumed value of p_i ($i = 1, 2, \dots, n$) until $L(x^*)$ becomes considerably stable. The advantages of the augmented Lagrange function method are the fast convergence due to the existence of penalty and that the sensitivity of a break of each constraint condition on calculation results can be evaluated by the value of the responsible Lagrange multiplier.

The purpose of this chapter is to discuss practical problems in applying the above method to the estimation of flashover criteria from a zone model of fires. The discussions will be made by comparing the extremum of the equilibrium curve of a simple zone model calculated by the above method and its analytical stability limit. The model used for the analysis is described as

[2]

$$V_1 \cdot \frac{dT_1}{dt} = H_1(T_1, T_2) = (1-\epsilon) \sigma(T_2^4 - T_1^4) + \epsilon \sigma(T_\ell^4 - T_1^4) + \alpha_{1\ell}(T_\ell - T_1) + \exp(\alpha - E/RT_1) + Q_{01} + Q_1 \quad (3)$$

$$V_2 \cdot \frac{dT_2}{dt} = H_2(T_1, T_2) = (1-\epsilon) \sigma(T_1^4 - T_2^4) + \epsilon \sigma(T_\ell^4 - T_2^4) + \alpha_{a2}(T_a - T_2) + Q_{02} + Q_2 \quad (4)$$

The heat transfer between each zone and the ambience, Q_{01} or Q_{02} , is described as $Q_{oi} = \alpha_{oi}(T_o - T_i)$, $i = 1, 2$ at the steady state. Assuming $T_\ell = T_1$, the stability limit of the equilibrium of the model is described as

$$\left| \partial(H_1, H_2) / \partial(T_1, T_2) \right| = \{4\sigma T_1^3 + \alpha_{01} + \alpha_{1\ell} - E/RT_1^2 \cdot \exp(\alpha - E/RT_1)\} \times (4\sigma T_2^3 + \alpha_{02}) - \{4\sigma(1-\epsilon)\}^2 T_1^3 \cdot T_2^3 = 0 \quad (5)$$

The combination of Q_1 and Q_2 at the criticality can be obtained analytically by substituting the combination of T_1 and T_2 which satisfies equation (5) into $H_1(T_1, T_2) = H_2(T_1, T_2) = 0$ [2]. The criticality in terms of Q_1 and Q_2 can also be calculated by an optimization to search the maximum of either of Q_1 and Q_2 under a given value of the other of Q_1 and Q_2 and $H_1(T_1, T_2) = H_2(T_1, T_2) = 0$ as a constraint condition. Applying the augmented Lagrange function method to calculate the critical condition in terms of Q_1 , the augmented Lagrange function will be

$$L^*(T_1, T_2) = -Q_1 - (p_1 H_1 + p_2 H_2) + k(H_1^2 + H_2^2) \quad (6)$$

3.1 Critical Conditions on the Occurrence of Flashover

While it is generally believed that the precision of an optimization using penalty terms would be improved by increasing the value of penalty coefficient, k , it is also anticipated that, if k is considerably large, the direction of the search might be strongly governed by a penalty term of the augmented Lagrange function so that the "real" optimum might never be approached. Here, we will discuss the determination of k by applying the augmented Lagrange function method to the model described by (3) and (4) under the parameter conditions shown in Table 1.

Figure 9 shows the critical condition of the heat flux to the zone 1, Q_1 calculated for various values of Q_2 and $k = 100$. Some numerical results are considerably far from the analytical stability limit, and Figure 9(b) obviously demonstrates that a numerical criticality is significantly influenced by the initial setting of temperatures. Most of the numerical results concentrate on the curve $H_2(T_1, T_2) = 0$, and this implies that the augmented Lagrange function would be strongly governed by the constraint condition $H_2(T_1, T_2) = 0$. Distribution of the augmented Lagrange function with the resulting values of the Lagrange multipliers shown in Figure 10 demonstrates that the curve representing $H_2(T_1, T_2) = 0$ forms a significant "watershed" on the distribution of the objective functions. In such a case, a search in an axial direction from the apparent optimum, A, will give a larger value of L^* than that at the point A; the point A would be taken for the "real" optimum.

Figure 11 shows the criticalities calculated for $k = 0.01$ in terms of heat flux, Q_1 , Q_2 and temperature, respectively. The numerical results seem to be in good agreement with the analytical stability limit; however for a still smaller value of the penalty coefficient, i.e., $k = 0.0001$, L^* appears to be governed almost only by Q_1 during the first iteration cycle, and this has resulted in a slower convergence of the objective function.

While the precision of a numerical calculation on such simple models as the above example can be checked by comparing its results with those obtained analytically, this way of investigation is not applicable to complicated models. Considering that the error in the above example is attributed to the sensitivity of a constraint condition on the value of the augmented Lagrange function, we can assume that the value of each Lagrange multiplier could be a measure to evaluate the precision. The value of each Lagrange multiplier is obtained as a by-product of the iterative calculation of the optimum of L^* . Table 2 summarizes the resultant Lagrange multipliers, λ_1 and λ_2 , of the above study for $k = 100, 0.01$ and 0.0001 . The absolute value of λ_2 is far superior to λ_1 for $k = 100$, whereas λ_1 and λ_2 are comparable for small values of k . This implies that the value of L^* would be strongly governed by $H_2(T_1, T_2)$ if k is considerably large because the order of the possible values of $H_1(T_1, T_2)$, $H_2(T_1, T_2)$, Q_1 and Q_2 should be comparable in the early stages of a compartment fire. The above calculation also suggests that the value of the penalty coefficient should be chosen such that the constraint conditions would not govern L^* strongly after a hyperplane practically satisfying one constraint condition has been approached. In other words, if $0(f) \gtrsim 0(p_i g_i)$ is satisfied for the resultant value of p_i , the calculated optimum of L^* is thought not to be far from its real optimum; this seems to offer a useful

guide to check the precision of the numerical results. As the order of $|Q_1|$ should be comparable with $|H_1(T_1, T_2)|$, the condition for a calculation result to be adequate is that $|p_1|$ is not far from 1.

3.2 Estimation of the Thermal State at the Transition of Fire to Flashover

Characterizing the so-called flashover by the instability of the energy conservation equations describing fire growth, the onset of flashover can be formulated as the singularity of the Jacobian of the functions forming the energy conservation equations; we will refer to the temperature of each zone at the singularity as the "critical temperature" [2]. The critical temperature of combustible zone, T_c , is supposed to have its upper and lower bounds; the upper bound corresponds to the asymptote of T_c to $T_i \rightarrow T_0$ or $T_i \rightarrow 0$, $T_i \neq T_c$ *. The lower bound, on the other hand, should be the asymptote to $T_i \rightarrow \infty$, $T_i \neq T_c$. Practically, the upper bound of T_c can be obtained from the equilibrium solution of a zone model by substituting $T_i = T_0$ or $T_i = 0$, $T_i \neq T_c$ into the model and optimizing a parameter appearing as a constant term in the basic equations. The lower bound can be estimated by the similar optimization assuming a considerably large constant heat supply to each zone except for the combustible zone. Figure 12 shows that the critical temperature of the zone 1 of the model described by (3) and (4) approaches to its analytical lower bound by the increase of the heat supply to the zone 2.

* As the temperature of any zone in the fire room will never be lower than ambient temperature, the asymptote of T_c to $T_i \rightarrow T_0$ is thought to give the actual upper bound of the critical temperature. The asymptote of T_c to $T_i \rightarrow 0$, a more strict condition, may offer an easier calculation.

4. APPLICATION TO A QUASI-STEADY MODEL

In order to demonstrate that some evaluations concerning flashover can be made practically using a zone model, we will apply the methodology described in the former chapter to the quasi-steady model of Quintiere et al [4]. Although Takeda et al [5] have pointed out some problems to be refined in the model, we will use it for convenience because the detailed description of its program has been published. It should be noted in advance that the methodology described in the former chapter is basically applicable to any zone model described in a system of ordinary differential equations.

The enclosure for the study is a 40 cm cubic room with pool fire as the fire source. Model formulation and the data of the standard condition of the enclosure are described in Table 3 and in Table 4, respectively. Assuming the proportionality of fuel volatilization rate to the heat flux to the fuel surface as well as the dependence of reaction rate on the oxygen supply condition of the enclosure, it is possible that the model has an instability due to the radiation feedback from smoke layer, ceiling, etc. to the fuel surface. This implies that multiple equilibria may appear for some parametric conditions.

4.1 Estimation of the Flashover Criteria

While the critical condition for the occurrence of flashover can be obtained in terms of every parameter appearing in a model, practical measures for fire safety design should be the critical conditions in terms of such specifications as size or combustibility of furniture or building components.

Let the conditions in Table 4 be the standard conditions, we will investigate the influences of combustion heat of combustible objects and heat transfer coefficient of walls on the relationship between the volatilizing area and opening width at the criticality. The augmented Lagrange function for this problem is

$$L^* = f - \sum_{i=1}^n p_i \cdot g_i + k \sum_{i=1}^n g_i^2 \quad (7)$$

where f is the parameter to be optimized, g_i is the LHS of the i -th constraint condition, namely one of the energy balance equations and the mass balance equations in Table 3. $k = 0.01$ has resulted in $\lambda_i \approx 0(10^{-1}) \sim 0(10^0)$ in all cases studied here.

Figure 13 depicts the A_v and W_o relationship for three conditions of combustion heat, one of which was chosen to represent methanol; the result obviously shows that the sensitivity of combustion heat on the stability limit is significant and that combustion can be an index to evaluate fire safety concerning flashover. The results of similar calculations on different values of heat transfer coefficients of the surrounding walls (Figure 14) show that the sensitivity of the heat transfer coefficient on the criticality is considerably less significant. Considering that it should be difficult to control the heat transfer coefficient of walls without influencing the daily conditions of room environment, a control of fire growth through thermal properties of wall should not be productive.

4.2 The Upper Bound of the Critical Temperature of Smoke Layer

Radiation feedback from the ceiling, smoke layer, etc., to fuel surface is one of the most important mechanisms leading to the appearance of thermal instability in the present model. Temperature of the ceiling or smoke layer seems to represent an onset of the occurrence of flashover. Figure 15 shows the upper bound of the critical temperature of the smoke layer which was calculated by substituting the ambient temperature into the ceiling temperature appearing in the quasi-steady model. The steady-state smoke layer temperature is higher than the upper bound of the critical temperature for every opening condition; this implies that a rapid temperature rise of smoke layer which should be attributed to flashover would appear before a steady-state fire is approached.

5. CONCLUSIONS

Correlation between the nonlinear characteristics of enclosure fires and the critical condition of the appearance of one mechanism of flashover was clarified experimentally. It was also shown that the criteria can be calculated directly from an equilibrium state zone model of enclosure fire by using the augmented Lagrange function method. CPU time to obtain one critical condition was approximately twice the time to calculate one steady state solution.

6. ACKNOWLEDGMENTS

The author is grateful to the contribution of Mr. T. Tokunaga, formerly of the Science University of Tokyo, who collaborated on the experiments described in chapter 2.

References

- [1] Thomas,P.H., Bullen,M.L., Quintiere,J.G. and McCaffrey,B.J.,"Flashover and Instabilities in Fire Behavior", Combustion and Flame, 38, p.159(1980).
 - [2] Hasemi,Y.,"Mathematical Basis for Physical Evaluation on Flashover", BRI Research Paper, No.88(1981).
 - [3] Thomas,P.H.,"Some Problem Aspects of Fully Developed Room Fires", ASTM-NBS Symposium on Fire Standards and Safety, NBS, Washington,D.C.(1976).
 - [4] Quintiere,J.G., McCaffrey,B.J. and DenBraven,K.,"Experimental and Theoretical Analysis of Quasi-steady Small Scale Enclosure Fires", NBSIR 78-1511(1978).
 - [5] Takeda,H. and Akita,K.,"Critical Phenomenon in Compartment Fires with Liquid Fuels", 18th Symposium(International) on Combustion, University of Waterloo (1980).
 - [6] Hasemi,Y.,"Theoretical and Experimental Study of Flashover", CSNI Specialist Meeting on Interaction of Fire and Explosion with Ventilation Systems in Nuclear Facilities, Los Alamos(1983).
- For numerical optimization methods, see
- [7] Jacoby, S.L.S. et al,"Iterative Methods for Nonlinear Optimization Problems", Prentice-Hall(1972).
 - [8] Powell, M.J.D. ed.,"Nonlinear Optimization 1981", Academic Press(1982).

Terminology(Except for those defined in Table 3 and Table 4)

$A\sqrt{H}$: Opening Factor(\equiv (Opening Factor) $\times\sqrt{\text{Height of Opening}}$)

C_p : Specific Heat of the Mixture of Combustion Products and Air

E : Activation Energy

Q_i : Heat Generation or Heat Application to the Zone "i"

R : Gas Constant

T : Absolute Temperature

V_i : Heat Capacity of the Zone "i"

χ_d : Height of Smoke Layer

t : Time

ϵ : Absorption Coefficient

σ : Stefan-Boltzman Constant

λ : Augmented Lagrange Function

ψ_{ij} : Shape Factor to see "j" from "i"

Table 1 Input of the Parameters for the Case Study

E/R	10^4 K	$\alpha_{1\ell}$	20 kcal/m ² hK
ϵ	0	$\alpha_{2\alpha}$	20 kcal/m ² hK
σ	4.88×10^8 kcal/m ² hK	α_{01}	2 kcal/m ² hK
T_0, T_α	300 K	α_{02}	2 kcal/m ² hK

Table 2 Relationship between the Penalty Coefficient and the Resultant Values of Lagrange Multipliers

"k"	Lagrange Multiplier for $H_1(T_1, T_2)=0$	Lagrange Multiplier for $H_2(T_1, T_2)=0$
100	-0.781	62.5
0.01	-0.991	0.744
0.0001	-0.999	0.758

Table 3 Outline of the Quasi-steady zone model (Based on [4])

(a) Volatilization Rate of Fuel Gas, \dot{m}_v

$$\dot{m}_v = \dot{q}_s A_v / \{C_{fuel} (T_s - T_a) + \Delta H_v\}$$

(b) Burning Rate, \dot{m}_b

$$\dot{m}_b = \dot{m}_v, \quad \dot{m}_a / \dot{m}_v > r^*$$

$$\dot{m}_a / r^*, \quad \dot{m}_a / \dot{m}_v < r^*$$

(c) Energy Balance of Each Zone

$$\sum_{j \neq i} K_{ij} A_{ij} (T_j - T_i) + \sum_{j \neq i} \epsilon_i \epsilon_j (1 - \epsilon_{ij}) \sigma \psi_{ij} A_{ij} (T_j^4 - T_i^4) + \sum_{j \neq i} \dot{m}_{ij} C_p (T_j - T_i) + Q_i$$

$$= 0, \quad i=1, 2, \dots, n$$

(d) Flame Height, H_f

$$H_f = 16.5 \sqrt{\frac{(r^* + \rho_a / \rho_v)^2 \omega}{\rho_a^2 g (1 - \omega)}} \cdot \dot{m}_b, \quad \omega = 1 + \Delta H / r^* C_g T_a$$

(e) Air Flow Rate through Opening, \dot{m}_a (inflow), \dot{m}_g (outflow)

$$\dot{m}_a = \frac{2}{3} \alpha W_o \rho_a \sqrt{2g(1 - T_a/T_g)(X_n - X_d)} \cdot (X_n + \frac{X_d}{2})$$

$$= \left(\frac{\rho_a}{\rho_v}\right) \omega \dot{m}_v \{(\beta X_d + 1)^{5/2} - 1\}, \quad \beta = \frac{4}{5}(1 - \omega) \sqrt{5\pi^2 g \rho_v^2 k_e^2 / 12 \dot{m}_v \omega^3}$$

$$\dot{m}_g = \frac{2}{3} \alpha W_o \rho_a \sqrt{2g(T_a/T_g)(1 - T_a/T_g)(H_c - X_n)^3}$$

(f) Height of Neutral Zone, X_n

$$X_n = \frac{H_c \Delta P}{\rho_a (1 - T_a/T_g) g}$$

(g) Mass Balance of the Enclosure

$$\dot{m}_a + \dot{m}_v - \dot{m}_g = 0$$

Table 4 Input of Parameters for the Case Study

Theoretical air to fuel mass rate, r^*	6.45
Combustion heat, ΔH	2.23×10^7 J/kg
Heat of Volatilization, ΔH_v	1.1×10^6 J/kg
Temperature of fuel volatilization, T_g	340 K
Density of fuel gas, ρ_v	1.9 kg/m^3
Specific heat of fuel, C_{fuel}	2.52 J/kgK
Temperature of diffusion flame,	1400 K
Absorption coefficient of flame,	1.3 m^{-1}
Heat transfer coefficient at fuel surface,	$2.5 \text{ W/m}^2\text{K}$
Absorption coefficient of smoke layer, k_e	1.9 m^{-1}
Thermal conductivity of wall,	0.14 W/mK
Heat transfer coefficient at floor,	$10 \text{ W/m}^2\text{K}$
Heat transfer coefficient through ceiling,	$5 \text{ W/m}^2\text{K}$
Orifice coefficient of opening, α	0.7
Specific heat of air, C_p	1046 J/kgK
Temperature of ambient air,	300 K
Density of ambient air, ρ_a	1.18 kg/m^3

Figure 1 Nonlinear Characteristics of Enclosure Fire

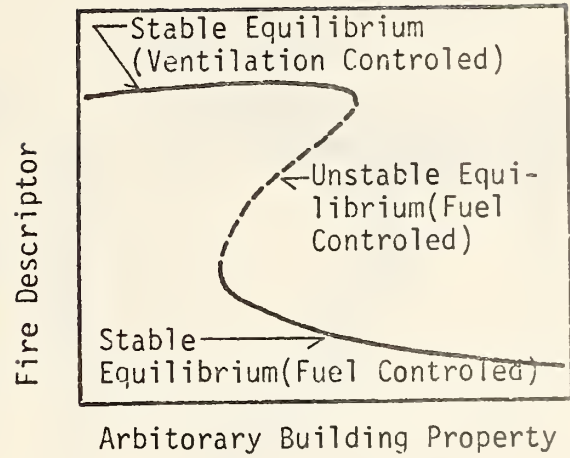


Figure 2 Experimental Set-up

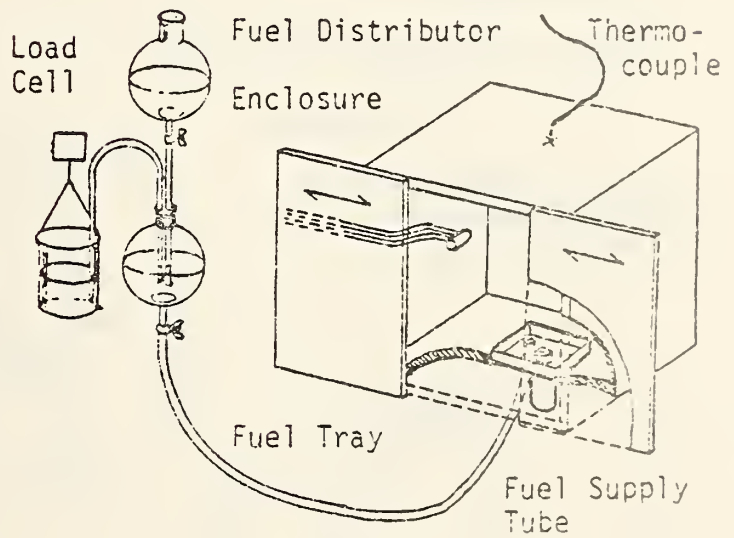


Figure 3 Relationship between Opening Factor and Fuel Consumption Rate (0.4m cubic enclosure) (Solid:ventilation controlled, Open:fuel controlled)

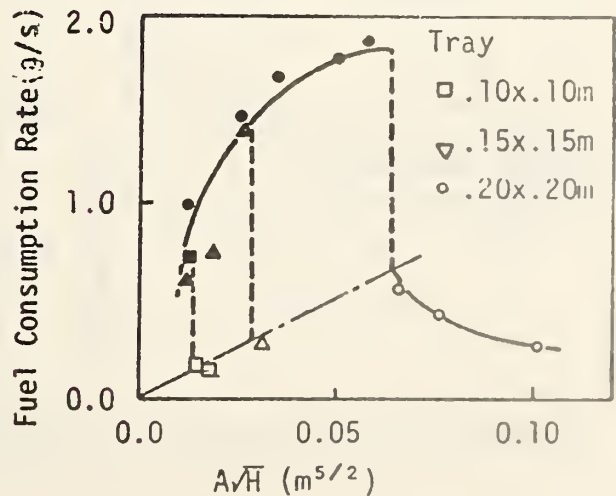


Figure 4 Time History of Ceiling Temperature (0.10x0.10m Tray)

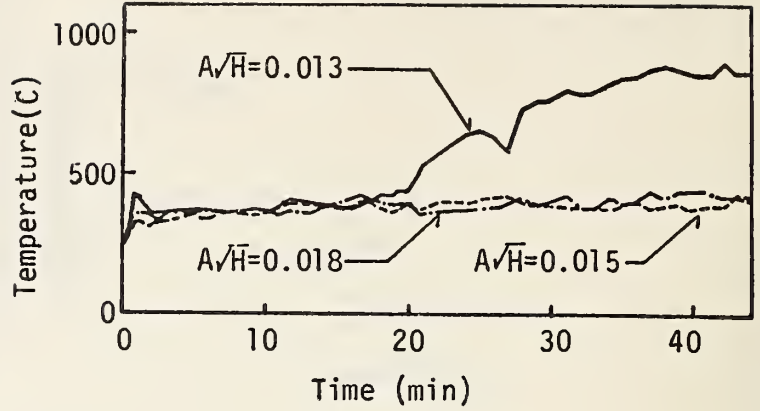


Figure 5 Time History of Ceiling Temperature (0.15x0.15m Tray)

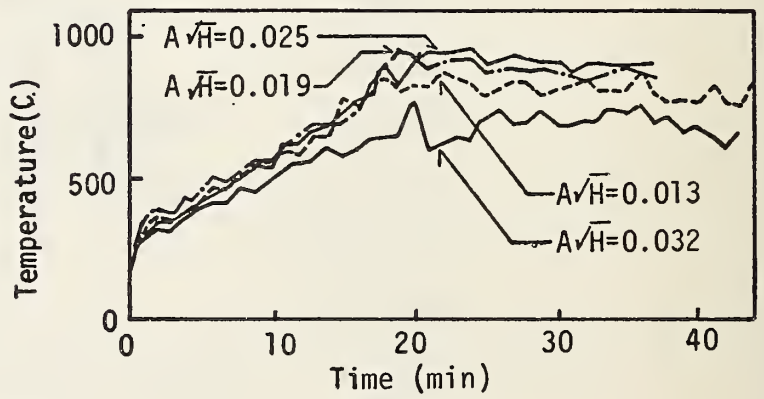


Figure 6 Time History of Ceiling Temperature (0.20x0.20m Tray)

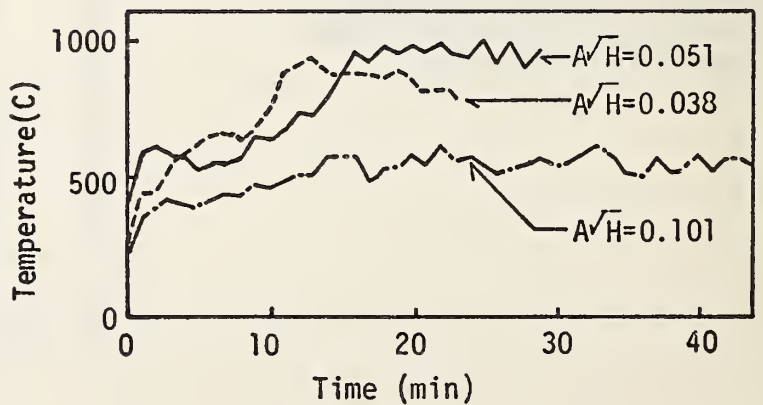


Figure 7 Time History of Total Heat Flux to Fuel Surface (0.15x0.15m Tray)

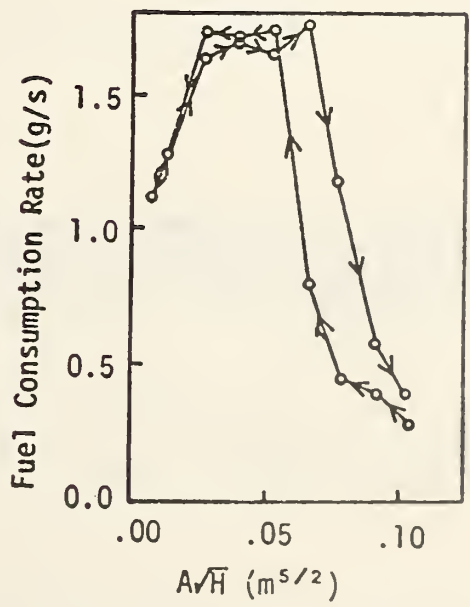
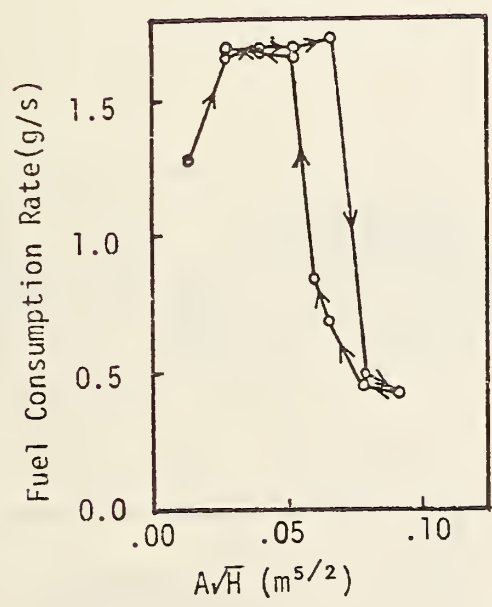
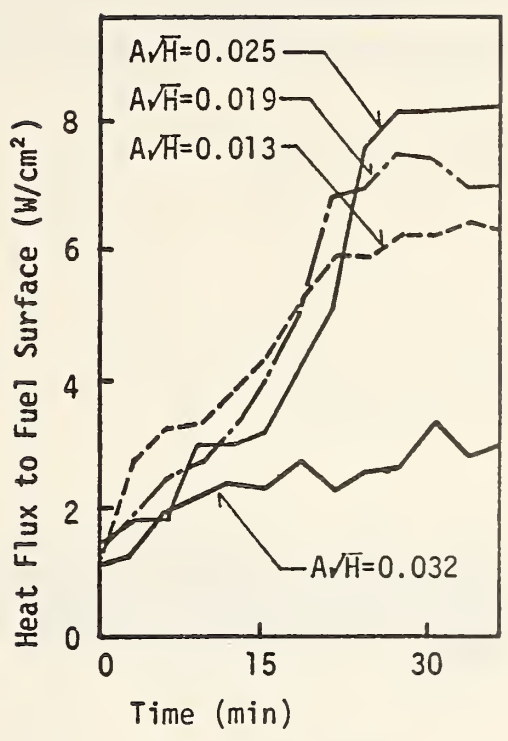


Figure 8 Hysteresis of Fuel Consumption Rate to Opening Factor(0.20m Tray)

Figure 9(a) Comparison of Analytical and Numerical Criteria on the Occurrence of Flashover(Numerical Calculation by Augmented Lagrange Function Method with $k=100$)

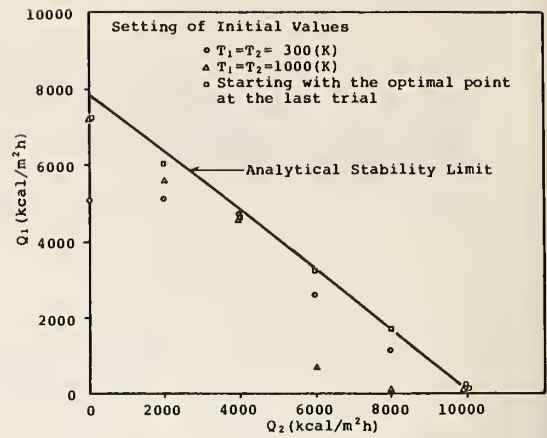


Figure 9(b) Comparison of Analytical and Numerical Stability Limit of Equilibria(Numerical Calculation by Augmented Lagrange Function Method with $k=100$)

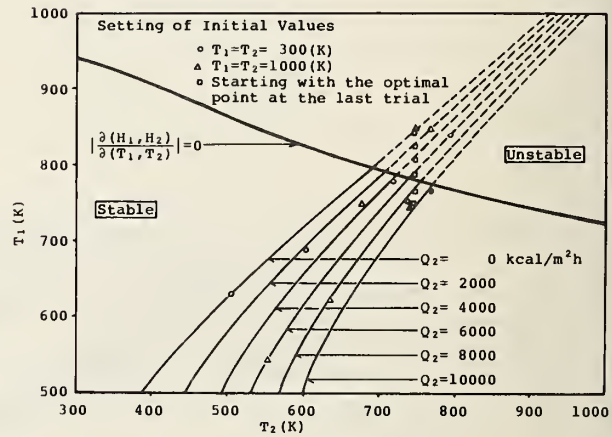


Figure 10 An Example of the Distribution of Augmented Lagrange Function in the Near Field of one Equilibrium Curve on Q_2

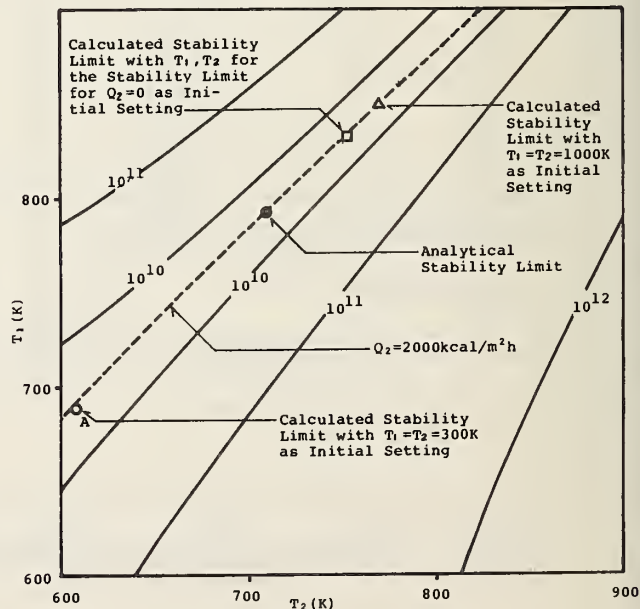


Figure 11(a) Comparison of Analytical and Numerical Criteria on the Occurrence of Flashover (Numerical Calculation by Augmented Lagrange Function Method with $k=0.01$)

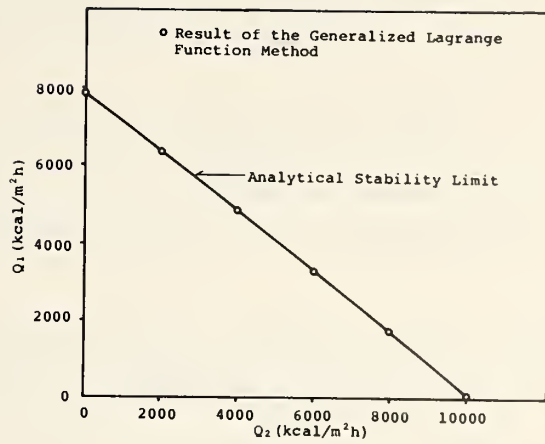


Figure 11(b) Comparison of Analytical and Numerical Stability Limit of Equilibria (Numerical Calculation by Augmented Lagrange Function Method with $k=0.01$)

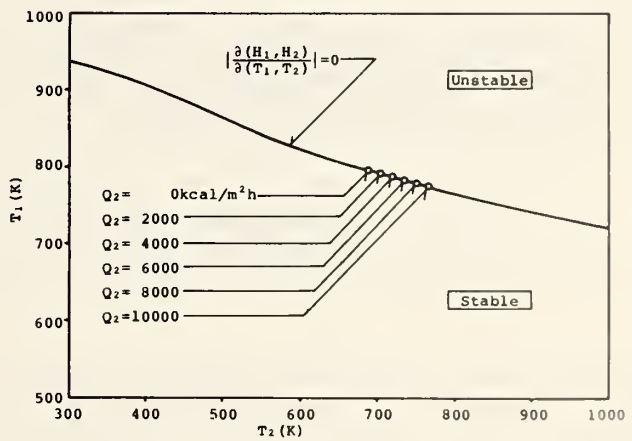


Figure 12 Comparison of Analytical and Numerical Lower Bounds of the Critical Temperature of Zone 1

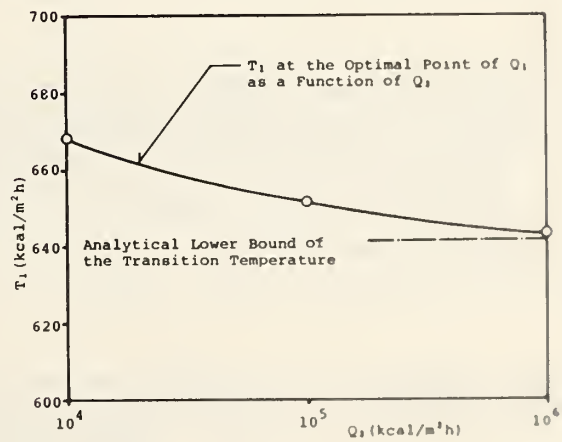


Figure 13 Influence of Combustion Heat of Material on the Criteria of the Occurrence of Flashover

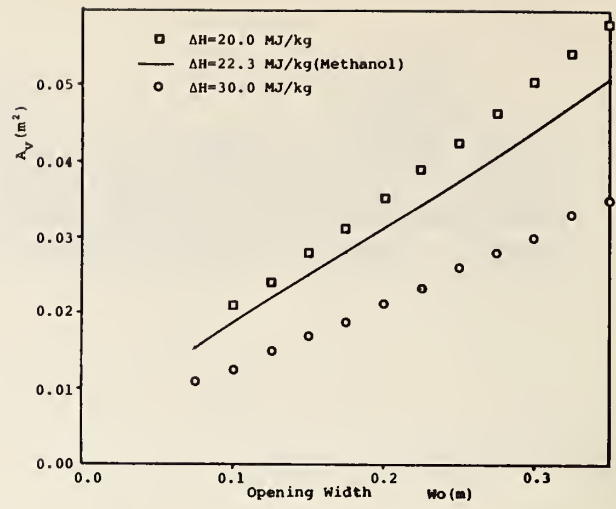


Figure 14 Influence of Wall Heat Transfer Coefficient on the Criteria of the Occurrence of Flashover

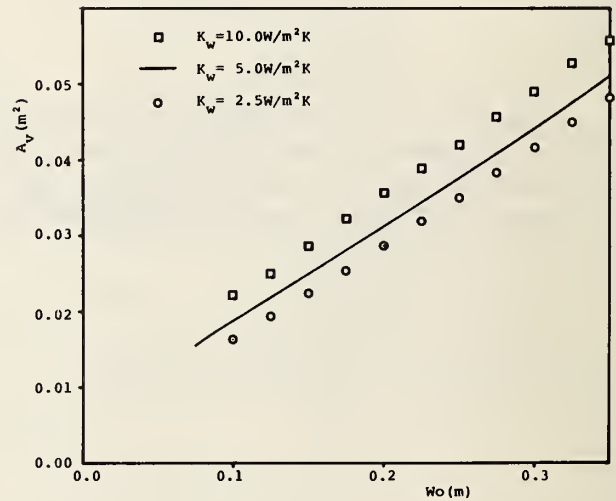
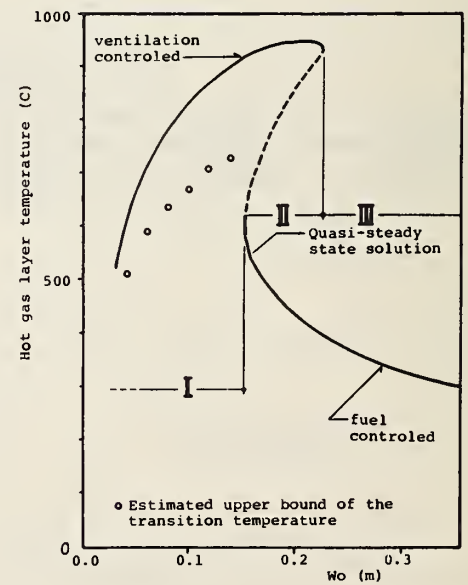


Figure 15 Upper Bounds of the Critical Temperature and Steady-state Temperature of Smoke Layer (The bounds were estimated by Augmented Lagrange Function Method)



Discussion After Y. Hasemi's Report on A METHODOLOGY OF THE SENSITIVITY ANALYSIS OF BUILDING PROPERTIES ON THE OCCURRENCE OF FLASHOVER

EMMONS: Flashover is identified in this analysis as a point of instability. In the literature, experimentally flashover has been identified as various things. The movement of flame from initial objects to many others, the burning of the hot layer, the flames come out of the door, ventilation limited. Has there been any validation of the new definition on the basis of instability? Which of these phenomena are being described, if any?

HASEMI: First, we have to assume that flashover itself is a very sense oriented concept. Therefore, there are various definitions of flashover but one thing which is consistent in all of the definitions of flashover is that there is a sudden change in temperature. In an experiment where liquid fuel, such as alcohol, is used, the burning area of the combustion peak will not change. Therefore, flashover, being a sudden change in temperature, is difficult to take place. In this experiment, the changes in temperature are rather mild. The temperature change such as this, can be considered the one which corresponds to flashover in cases of fire. The previous diagram corresponds to the particles of 10 centimeters. A sudden change in temperature you saw in a previous slide corresponding to here; these boxes show the area where the temperatures did not change much. The same phenomena is happening even though the sizes of fire sources have changed. I think one may assume that this continuity is the limit of where flashover takes place. For the materials we used in this experiment, as I said, the combustion area will not change. We may need a different definition of fluctual graph when the combustion area changes as well as the temperature. But I feel that this way of thinking can be applied when, for instance, a bed is burning, in which there is also a fire, the fire source is fixed.

EMMONS: When one optimizes a function with a LaGrange multiplier, the LaGrange multiplier generally has an important, sometimes very important, physical meaning. Have you identified any physical meaning with respect to your LaGrange multiplier. For example, in statistical mechanics, the LaGrange multiplier is the temperature. Do the physical quantities you have used correspond to any important physical phenomena?

HASEMI: We adjusted very simply by optimizing it, so I don't think in this case there was any physical meaning.

EMMONS: Yesterday Dr. Takeda introduced a factor f . Have you calculated the f factors for your critical conditons to see whether or not they agree or disagree?

HASEMI: I did not calculate the f factor. As I said yeserday during the discussion time, even though I do not understand the physical meaning of our f parameter, when we use methanol, even if f is large, this continuity will take place.

ZUKOSKI: In the experimental apparatus, was the height of the ceiling, the interface between the hot layer and the cold layer, measured? Did it change dramatically when you went across the instability?

HASEMI: We measured the hot layer and it changed drastically when fluctuation took place.

QUINTIERE: In conjunction with Prof. Emmon's first question, isn't it possible for us to distinguish between a definition of flashover based on our senses and observations and causes of flashover, which are mechanisms for what we then perceive to be flashover. I think if we can agree on such definitions, then perhaps we would clear up some facets of discussion.

HASEMI: Flashover is defined in a very sense oriented way. But at least when we compare the flashover, in fire or in simulation, I think we need a definition of flashover in accordance with the mechanism and also we need a mathematical definition.

FIRE ENGINEERING TEST DEVELOPMENT: BENCH-SCALE
TESTS TO PREDICT FULL-SCALE BEHAVIOR

Vytenis Babrauskas
Center for Fire Research
National Bureau of Standards
Washington, D. C.

Paper for presentation at
7th UJNR Panel on Fire Research and Safety

October 24-28, 1983

FIRE ENGINEERING TEST DEVELOPMENT: BENCH-SCALE
TESTS TO PREDICT FULL-SCALE BEHAVIOR

Vytenis Babrauskas
Center for Fire Research
National Bureau of Standards
Washington, D. C.

Abstract

The work done at the National Bureau of Standards (NBS) over the last ten years in predicting full-scale fire behavior from bench-scale tests is summarized. Test methods for flooring materials, mattresses, and upholstered furniture are discussed. An emphasis is placed on the newer methods of measuring rate of heat release, in both full and bench scale, which use oxygen consumption as the measurement principle. Even though current predictions are based on data correlations rather than a complete analytical model, it is seen that good agreement is obtained.

Key words: Fire tests; flame spread; mattresses; rate of heat release; upholstered furniture; wall linings

In earlier times bench-scale flammability tests were used merely to rank products or materials according to some intuitive sense of performance. In the United States credibility of this approach was challenged by the actions of the Federal Trade Commission (FTC) around 1974 against several plastic foam manufacturers. The FTC reasoned that the results from a number of standardized tests, approved by the American Society for Testing and Materials, a consensus standards group, were misleading because their ratings, as used, did not correspond to actual full-scale fire experiences with the same products.

The typical response to the FTC action was to consider most bench-scale testing dubious and to go to full-scale testing in many cases. Over the intervening years a substantial amount of expertise in full-scale testing has now been gained and significant data bases built up in several product areas. With that experience came the realization that full-scale testing has its own drawbacks. Cost is an obvious limitation. More troublesome is the question of inter-laboratory comparability. So far there has not been a single round-robin series demonstrating that one laboratory could replicate another's findings. Informal observations have shown, instead, that minor factors in setup, specimen preparation, or test operation can significantly influence the results.

Bench-scale tests are generally at least an order of magnitude less expensive than full-scale fires. Also, interlaboratory agreement is usually much easier to reach. Thus, significant benefits can be seen to bench-scale testing if adequate validity in predicting full scale performance can be achieved. The approach that is needed is to establish a firm relationship between the full-scale hazard that is to be quantified and the bench-scale measures of the appropriate variables. This relationship has to be established for both very high hazard and very low hazard materials, with a suitable number of intermediate points. Further testing can then be done only in the bench-scale. Because of the practical complexities of real combustibles, a separate relationship has to be determined and proved out for each different class of products, e.g.,

a test procedure developed for beds is of little use for measuring ceiling panels. Note that this does not imply that standardized bench-scale tests cannot be developed, but rather that test conditions and data analysis procedures need to be validated for each separate product class.

Variables of Interest

In the course of the last decade the realization has come that the single most important variable in describing a fire is the rate of heat release. This is, in fact, what we mean when we ask "how big is the fire?" While this may seem obvious now, it is important to realize that until the late 1970's there were essentially no fire studies done where rate of heat release was presented, as a function of time, for a fire of interest.

Thermal effects of fire are not the only ones of concern. Toxicity and smoke obscuration can also constitute limits to escape or survivability. We realize now that these may be expressed not as independent variables but as multipliers to the basic burning rate. The present state of understanding of toxicity and of soot production is rather crude. Although there is hardly such a thing as a strictly material fire property, independent of boundary conditions, such an engineering assumption is often operationally useful. For engineering calculations at the present time, toxicity and smoke production are considered as constants, per gram of material. The toxicity or smoke problem then becomes separable into a burning rate (kW or, better, kg/s) multiplied by a toxic species or soot generation constant in units per-kg-pyrolysate. These properties are taken as constants only to the first approximation-- further studies will presumably lead to more detailed characterizations.

Describing the rate of release of heat and toxic species and smoke production is generally sufficient to characterize the full-scale source fire (we will not consider here the distribution of the fire products throughout a building or its effects on the structure). Other questions of practical importance can be seen to be intimately connected to rate of heat release. For instance, time to initial item ignition or second item ignition, flame spread rates, and time to flashover are all factors in determining the complete rate of heat release history.

Bench-scale testing is occasionally, but rarely, simply testing of reduced scale models. More commonly, in order to determine the complete full-scale performance, physically separate processes must be separated in bench-scale testing. To make this clear, the full-scale heat release rate can be expressed as

$$\dot{q}_{fs}(t) = \sum_i \dot{q}_{fs,i}''(t) \cdot A_{fs,i}(t),$$

where $\dot{q}_{fs}(t)$, the full-scale heat release rate, as a function of time, is to be viewed as a summation over i objects or areas, $A_{fs,i}$. With each area is associated an incremental heat release rate, $\dot{q}_{fs,i}$. Objects enter the summation only after their ignition. The areas involved, $A_{fs,i}$, are functions of time, as indicated, since a flame spread process may well be an important part of the fire development.

How should the $\dot{q}_{fs}''(t)$ terms be evaluated? In the very simplest case, the combustible may be thick, homogeneous and heated by a uniform heating flux. In that case, a Δx by Δy small specimen tested in bench-scale can directly give the required full-scale $\dot{q}_{fs}''(t)$ value.

Such a simple case rarely occurs in practice. More commonly

- the incident fluxes may be non-uniform and difficult to determine;
- the material may be thin and subject to burnout;
- the material may be layered, rather than homogeneous;
- the actual thickness may be much greater than testable in bench-scale, thus not permitting a similar burning time;
- the full-scale object(s) may be highly irregular and not feasible to approximate by plane surfaces; or
- the full-scale fire may involve melting, collapse, or other large-geometry changes.

Each such practical limitation will effectively prevent the specimen's behavior from being successfully analyzed by the simple model above. In that case a more empirical approach, based on appropriate correlations, is required. The results cannot then be expected to predict fine details of the burning process, but should at least predict important features, such as peak heat release rate.

In addition to bench-scale tests for heat release rate and for smoke and toxic species production, two other variables emerge as important: ignitability and flame spread. Bench-scale procedures are needed to determine these, for use in prediction relationships.

Examples of Quantitative Methods

The first example of a "modern" fire engineering test method -- one with a rigorous connection between full and bench-scale -- was the flooring radiant panel test, developed in 1975 [1]. The variable to be predicted was the flame spread along corridor carpeting, as a function of radiant fluxes from the ceiling layer. A full-scale data base was established for floor irradiances. Based on this, a flame spread test was developed which allowed the minimum external flux required for flame propagation to be determined. This test method was later adapted to also serve for the testing of attic floor insulation.

The next example is the burning of institutional mattresses. In this program [2,3] a series of full-scale tests on simulated beds was conducted in a realistic manner -- a full set of bed linens was used and ignition was with a trash-filled plastic wastebasket. An examination of the results showed that flame spread and ignitability played no role, since these were controlled solely by the (standard) bed linens and not by the mattresses. The rate of heat release was clearly the most important quantity to determine. Optical obscuration properties were also measured in full-scale and could be determined in bench-scale.

In bench-scale, a research quality heat release rate calorimeter had just been developed by Tordella in 1978 for making such measurements [4]. Since irradiance values and burning areas were not known in the

full-scale, the proper bench-scale conditions -- the heating flux and the averaging period -- had to be determined by best-fit techniques. Details have been given in [3], where it was shown that a 25 kW/m^2 irradiance and a 180 s averaging period gave the best results. Figure 1 shows the correlation obtained. Smoke measurements were made in the NBS smoke chamber according to a technique developed by Breden and Meisters [5] and analyzed as described in [6]. The results are shown in Figure 2. Test specimen details are listed in Table 1. It can be seen that total heat content would not be a sufficient measure of the fire performance, and that there is some correlation between generic material classes and actual heat release rate, but that correlation is not strong enough to obviate the need for bench-scale testing.

The technique adopted for making bench-scale heat release measurements for mattresses was the NBS-II calorimeter [4]. This instrument, while having numerous attractive features for research use, is costly and complex and could not be expected to be used for regular testing purposes. At about the same time the principle of oxygen consumption was being actively explored for use in fire testing applications. The principle of oxygen consumption measurements is based on the observation that the rate of heat released per gram of oxygen used is nearly constant for all hydrocarbon fuels. Correct heat release rate measurements by normal means had been extremely difficult to do in bench-scale and essentially unfeasible in full-scale. Fortunately, oxygen concentration measurements are relatively easy to make to a suitable precision in both full and bench scale. This was initially studied at NBS in 1974 by Parker [7], later by Sensenig [8] and others, and systematized by Huggett [9] and Parker [10]. It has also been applied to make, for the first time, accurate heat release measurements in full-scale room fires [11].

The application of the oxygen consumption principle to bench-scale tests was first done as a modification to a widely available commercial test apparatus [12]. This showed that significant improvements in accuracy were thus made possible but that to fully utilize the principle would require an apparatus designed from the start for this type of operation. This work was started in 1980, the apparatus was completed in 1982 [13]

and has been termed the "cone calorimeter" because of the truncated cone shape of the heater (figure 3). The apparatus, which is relatively simple to construct and operate, can be used to heat uniformly up to 100 kW/m² specimens in either a horizontal or vertical orientation, and to measure up to 12 kW heat release rates. In addition to determining mass loss rates and heats of combustion, analyzers for CO, CO₂, H₂O, and total hydrocarbons are used to aid in combustion characterization.

About five years ago also we started realizing that conducting room fire tests may not be the best way of characterizing the full-scale burning behavior of discrete, floor-standing combustibles, especially furniture. The reasoning was followed that the important variable to determine was the free-burn rate of heat release. This value would then be applicable as input data to predicting room fires in rooms of any description, during pre-flashover burning. Conversely, if measurements were made in room fires where flashover was reached early in the test, subsequent data would not be applicable to any other fire scenario. The free-burn rate of heat release could not have been readily determined without the use of the oxygen consumption principle. With its use, however, it became straightforward to design a "furniture calorimeter" [14]. A view of the furniture calorimeter is shown in figure 4.

One major test series has been conducted so far where both these two newest measuring instruments were employed, the furniture calorimeter for full-scale data and the cone calorimeter for bench-scale data. A series of upholstered chairs and sofas, constructed with various frame, filling, and fabric materials, were tested in full-scale [14]. Specimens consisting of filling/fabric composites were then prepared and tested in the bench-scale cone calorimeter. For predicting the peak rate of heat release, the following model was adopted

$$\dot{q}_{fs} = b \cdot \dot{q}_{bs}'' \cdot [M] \cdot [FF] \cdot [SF] ,$$

where \dot{q}_{fs} is the full-scale peak heat release rate (kW); \dot{q}_{bs}'' is the heat release rate per unit area determined in the cone calorimeter (kW/m²); M is the mass of the full-scale specimen, excluding non-combustible

parts, if any (kg); FF is a frame factor; and SF is a style factor derived from the full-scale tests. The frame factor was found to be

- 1.66 for non-combustible frames
- 0.58 for melting plastic frames
- 0.30 for wood frames
- 0.18 for charring plastic frames.

The style factor is needed to account for enhanced fire involvement of curvy surfaces and is set between 1.0 for rectilinear items and 1.5 for highly curvy ones. The factor b is a scaling factor and has to be determined from a data correlation; the best fit was obtained for $b = 0.63 \text{ m}^2/\text{kg}$. The test specimens are described in Table 2. Figure 5 shows the results -- good agreement is achieved.

Flame spread tests have been available in the United States for more than 40 years. Traditional ones, however, are very limited -- the heating fields are poorly defined; melting, composite, or fabric materials usually cannot be accommodated; and a theoretical analysis is not available. Recent NBS interest started with the formulation of a theory by Rockett [15] for radiatively dominated flame spread. Several apparatuses have been constructed in recent years for measuring flame spread in a way as to give theoretically analyzable results. The latest (shown in figure 6) was designed especially for fabric/filling composites. It subjects horizontal specimens to a uniform irradiance and shows fabric tension to be maintained during the course of burning. Work is in progress on this apparatus. Data analysis will use validation by comparison to full-scale tests on identical materials.

Ignitability does not play as strong a role in determining fire hazard as do the rate of heat release and flame spread properties. This aspect is illustrated in figure 7, where systems ranging from a highly fire-resistant wool/neoprene combination to a well flammable polyolefin/unretarded polyurethane foam are shown. The tests were conducted using the cone calorimeter, as a separate ignitability apparatus is not needed. The differences are real but are not very large. The area where it is

perhaps most important to quantify ignition behavior is for computing the ignition of the second-to-ignite object in a room fire. This problem is amenable if a separation of variables is made: the radiant heat fluxes of the assumed first-to-ignite item can be measured and combined with the ignitability curve generated for the second-to-ignite item. Irradiances as a function of height and radial distance have been measured and catalogued for a number of furniture items [16]. There is some suggestion that these irradiances could be predicted from mass loss rate or rate of heat release data, but a firm connection has not yet been established [14,16].

Conclusions and Future Directions

This brief review has shown how full-scale/bench-scale test correlations have been pursued at NBS and illustrated some successes of the last ten years. It is evident that for the product classes where in-depth studies were undertaken good predictiveness was obtained. For numerous other product categories, however, studies still remain to be done. Areas where additional efforts will be placed in the future include the treatment of combustible room wall linings, and the prediction of burning rates in post-flashover room fires.

Bench-scale measurement techniques will also continue to be upgraded. The existing standard technique for smoke production measurement [17] is a static one and has, therefore, some distinct limitations. The development of the cone calorimeter has provided a good dynamic combustion products generation environment. Work is now being started to develop two methods of smoke measurement with the cone calorimeter. The first is a filter mass sampling technique, using a gas stream probe with a controlled flow rate. The second is an optical technique (figure 8) using a He-Ne laser light beam.

References

1. Benjamin, I. A., and Adams, C. U., Proposed Criteria for Use of the Critical Radiant Flux Test Method, (NBSIR 75-950). [U.S.] Nat. Bur. of Stand. (1975).
2. Babrauskas, V., Combustion of Mattresses Exposed to Flaming Ignition Sources, Part I. Full-Scale Tests and Hazard Analysis, (NBSIR 77-1290) [U.S.] Nat. Bur. Stand. (1977).
3. Babrauskas, V., Combustion of Mattresses Exposed to Flaming Ignition Sources, Part II. Bench-Scale Tests and Recommended Standard Test, (NBSIR 80-2186) [U.S.] Nat. Bur. Stand. (1981).
4. Tordella, J., and Twilley, W. H., Development of a Calorimeter for Simultaneously Measuring Heat Release and Mass Loss Rates (NBSIR 83-2708). [U.S.] Nat. Bur. Stand. (1983).
5. Breden, L. H., Meisters, M., The Effect of Sample Orientation in the Smoke Density Chamber, J. Fire and Flammability, 7, 234-247 (April 1976).
6. Babrauskas, V., Applications of Predictive Smoke Measurements, J. of Fire and Flammability, 12, 51-64 (January 1981).
7. Parker, W. J., An Investigation of the Fire Environment in the ASTM E84 Tunnel Test (Tech. note 945). [U.S.] Nat. Bur. Stand. (1977).
8. Sensenig, D. L., An Oxygen Consumption Technique for Determining the Contribution of Interior Wall Finishes to Room Fires (Tech. Note 1128). [U.S.] Nat. Bur. Stand. (1980).
9. Huggett, C., Estimation of Rate of Heat Release by Means of Oxygen Consumption Measurements. Fire and Materials, 4 61-65 (1980).
10. Parker, W. J., Calculations of the Heat Release Rate by Oxygen Consumption for Various Applications, (NBSIR 81-2427) [U.S.] Nat. Bur. Stand. (1982).
11. Proposed Method for Room Fire Test of Wall and Ceiling Materials and Assemblies. American Society for Testing and Materials (Nov. 1982).
12. Krause, R. F., Jr. and Gann, R. G., Rate of Heat Release Measurements Using Oxygen Consumption. J. Fire Flammability, 11, 117-130 (April 1980).
13. Babrauskas, V., Development of the Cone Calorimeter -- A Bench-Scale Heat Release Rate Apparatus Based on Oxygen Consumption (NBSIR 82-2611). [U.S.] Nat. Bur. Stand. (1982).
14. Babrauskas, V., Lawson, J. R., Walton, W. D., and Twilley, W. H., Upholstered Furniture Heat Release Rates Measured with a Furniture Calorimeter (NBSIR 82-2604). [U.S.] Nat. Bur. Stand. (1982).

15. Rockett, J. A., Mathematical Modeling of Radiant Panel Test Methods, pp. 90-96 in Fire Safety Research (SP-411). [U.S.] Nat. Bur. Stand. (1974).
16. Babrauskas, V., Will the Second Item Ignite? Fire Safety J., 4, 281-292 (1981/82).
17. Standard Test Method for Specific Optical Density of Smoke Generated by Solid Materials (E 662). American Society for Testing and Materials, Philadelphia (1979).

TABLE 1

Mattress specimens tested in Full and in Bench-scale

<u>Specimen</u>	<u>Combustible Mass (kg)</u>	<u>Total Fuel (MJ)</u>	<u>Filling Material</u>	<u>Ticking Material</u>	<u>Bench-Scale Heat Release Rate (kW/m²)</u>
M01	14	415	polyurethane	polyvinylchloride	399
M02	6	184	polyurethane	polypropylene	138
M03	11	225	cotton felt	polyvinylchloride	60
M04	19	742	latex	polyvinylchloride	479
M05	6	175	polyurethane	rayon	179
M06	12	268	cotton/nylon/ polyester batting	polyester	127
M07	13	287	cotton, jute	cotton	43
M08	18	474	neoprene	cotton	89
M09	3.2	95	polyurethane	polyvinylchloride	152
M10	6	149	neoprene	polyvinylchloride	83 ^(a)

(a) Measured in OSU apparatus; all other measurements in NBS-II apparatus.

TABLE 2

Upholstered Furniture Specimens Tested in Full and in Bench-scale

Specimen	Mass (kg)	Filling Material	Fabric Material	Frame Factor	Bench-Scale		Frame Factor	Style Factor	Predicted		Measured Full-Scale Heat Release Rate (kW)
					Heat Release Rate (kW/m ²)	Heat Release Rate (kW)			Full-Scale Heat Release Rate (kW)	Full-Scale Heat Release Rate (kW)	
F21	28.3	PU foam, FR ^(a)	polyolefin	wood	326		0.30	1.0	1740		1970
F22	31.9	cotton batting, cotton FR	cotton	wood	83		0.30	1.0	500		370
F23	31.2	cotton batting, polyolefin FR	polyolefin	wood	128		0.30	1.0	750		700
F24	28.3	PU foam, FR	cotton	wood	119		0.30	1.0	640		700
F25	27.8	PU foam, NFR	polyolefin	wood	357		0.30	1.0	1880		1990
F26	19.2	PU foam, FR	polyolefin	wood	326		0.30	1.0	1180		810
F27	29.0	PU foam, NFR/ cotton/ polyester	cotton	wood	204		0.30	1.2	1340		920
F28	29.2	PU foam, NFR/ cotton/ polyester	cotton	wood	99		0.30	1.2	660		730
F29	14.0	PU foam, NFR	polyolefin	polypropylene	357		0.58	1.2	1950		1950
F30	25.2	PU foam, NFR	polyolefin	polyurethane	357		0.18	1.2	1020		1060
F31	40.0	PU foam, NFR	polyolefin	wood	326		0.30	1.0	2460		2890
F32	51.1	PU foam, FR	polyolefin	wood	326		0.30	1.0	3150		3120

(a) PU = Polyurethane; FR = Fire retardant, sufficient to meet minimum California State Flammability requirements, 1980 edition; NFR = Not fire retardant treated.

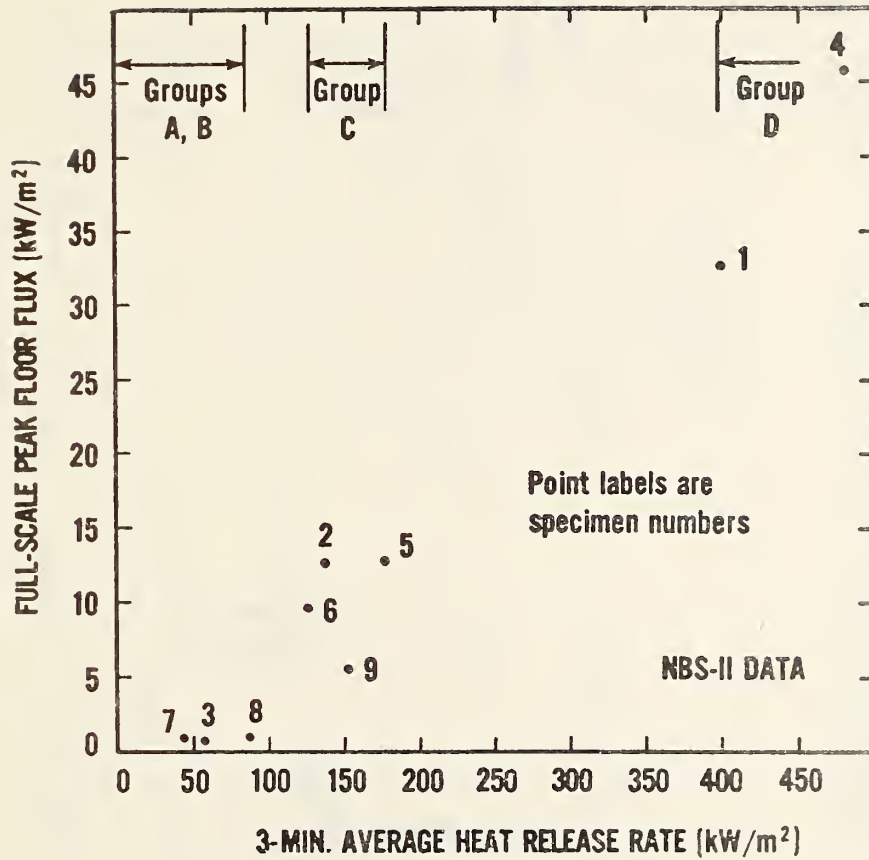


Figure 1. Relation between bench-scale heat release rate measurements and full-scale behavior of mattresses in room fires

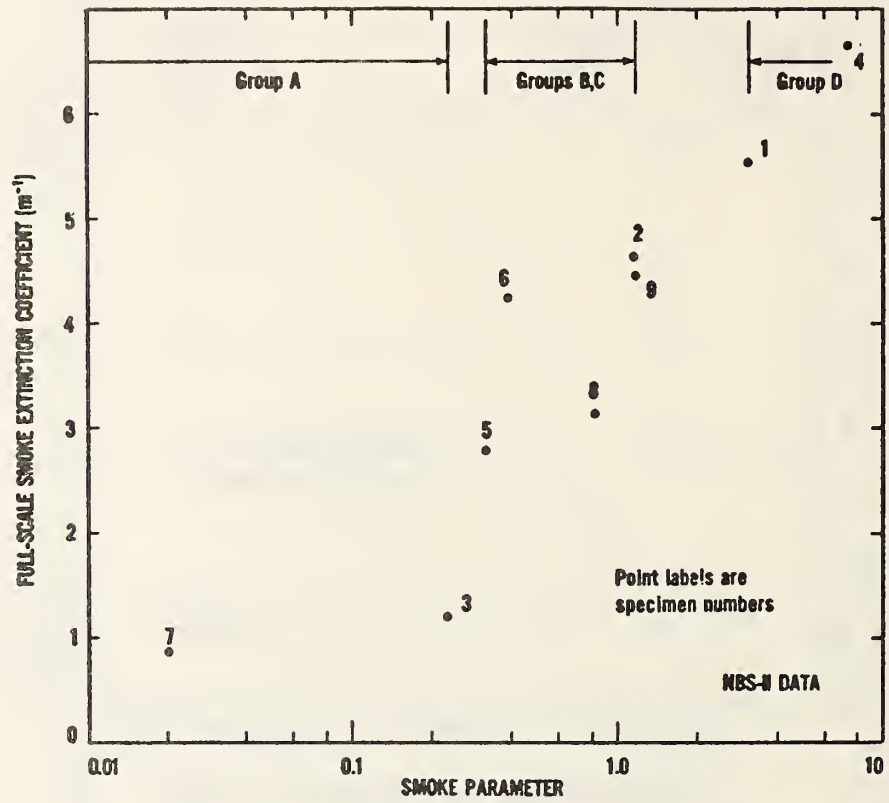


Figure 2. Relation between smoke measurements taken in bench-scale and full-scale behavior of mattresses in room fires

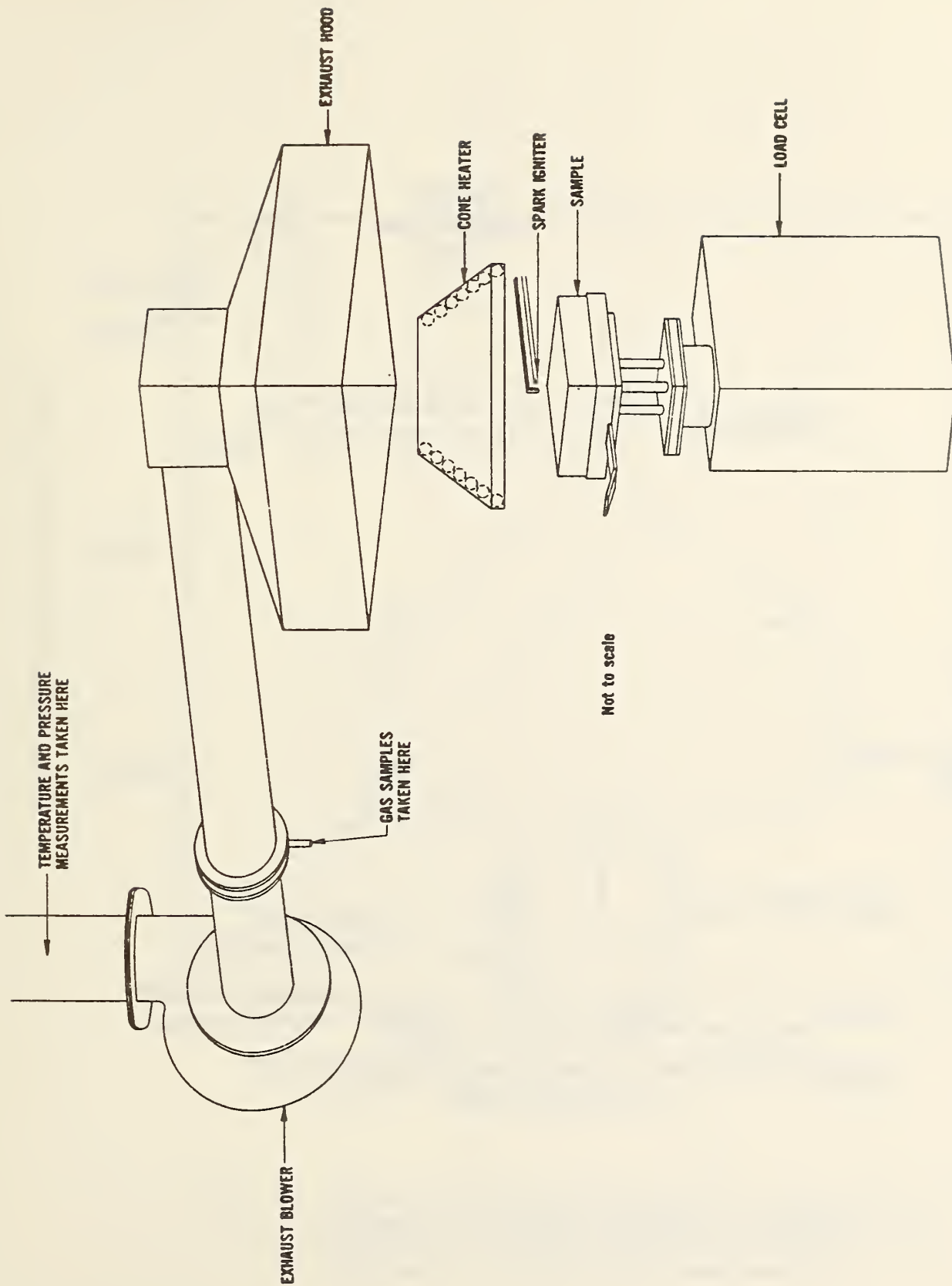


Figure 3. Schematic layout of cone calorimeter

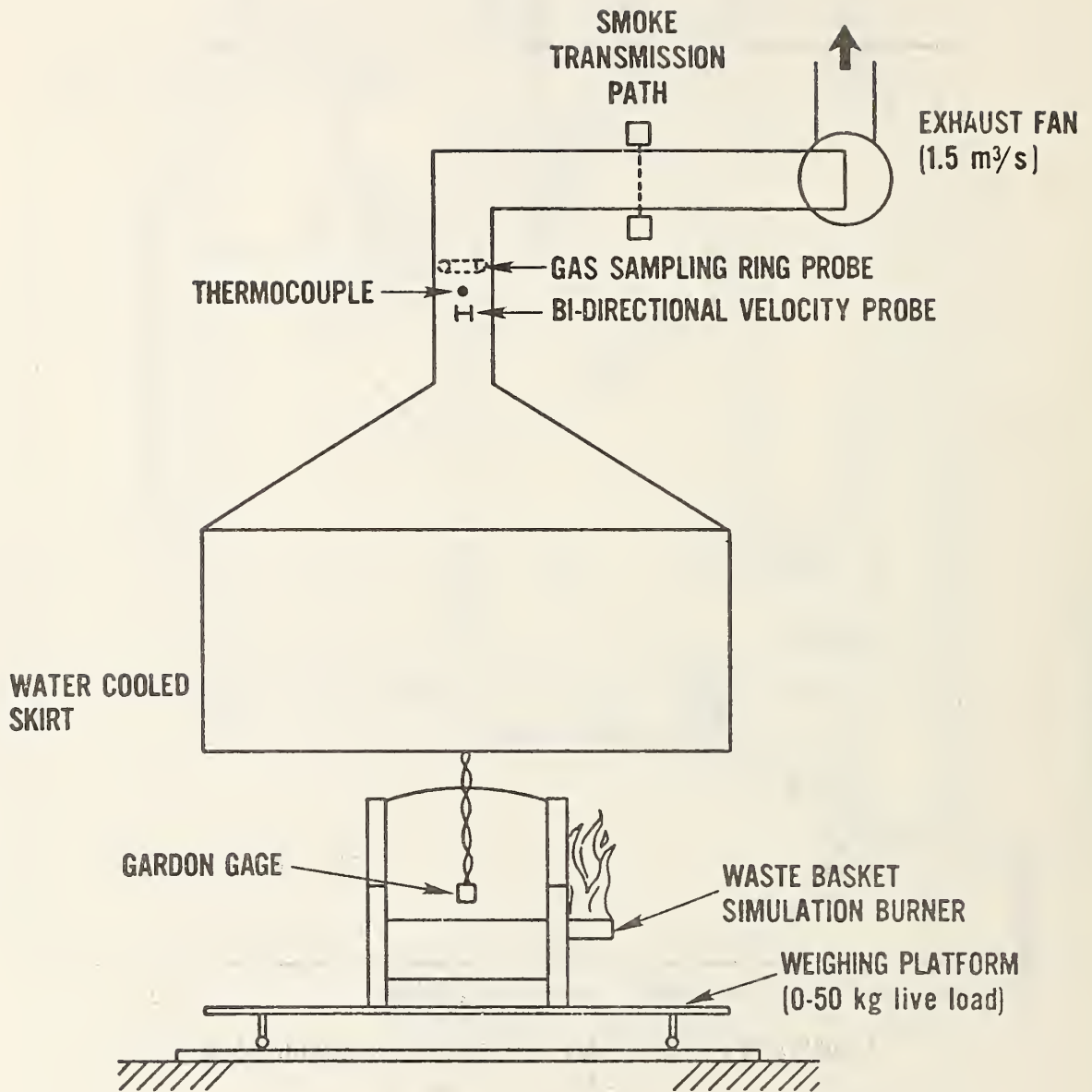


Figure 4. Schematic layout of furniture calorimeter

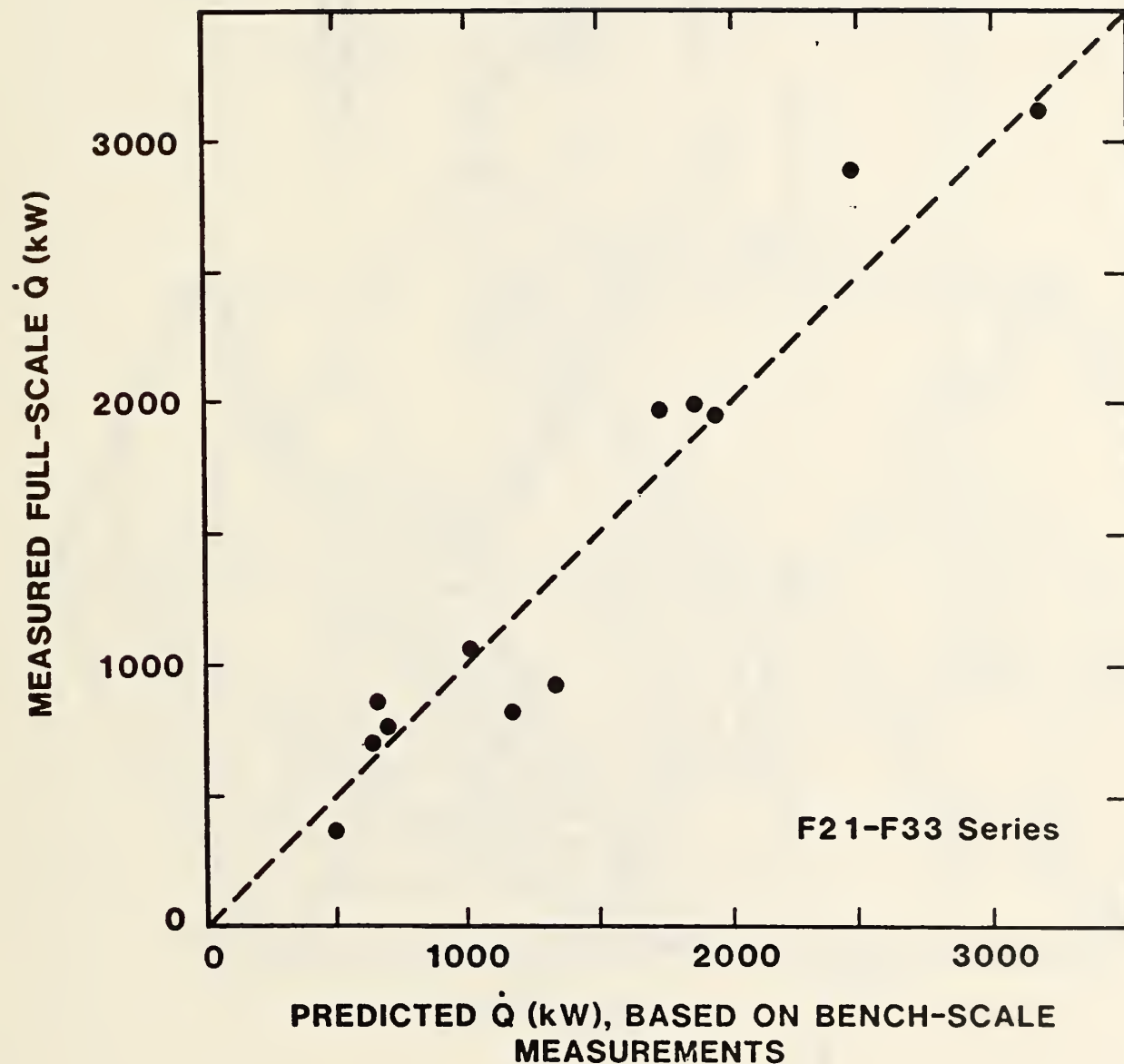


Figure 5. Comparison between peak full-scale heat release rate values for upholstered furniture measured in the furniture calorimeter and estimated values based on bench-scale cone calorimeter measurements

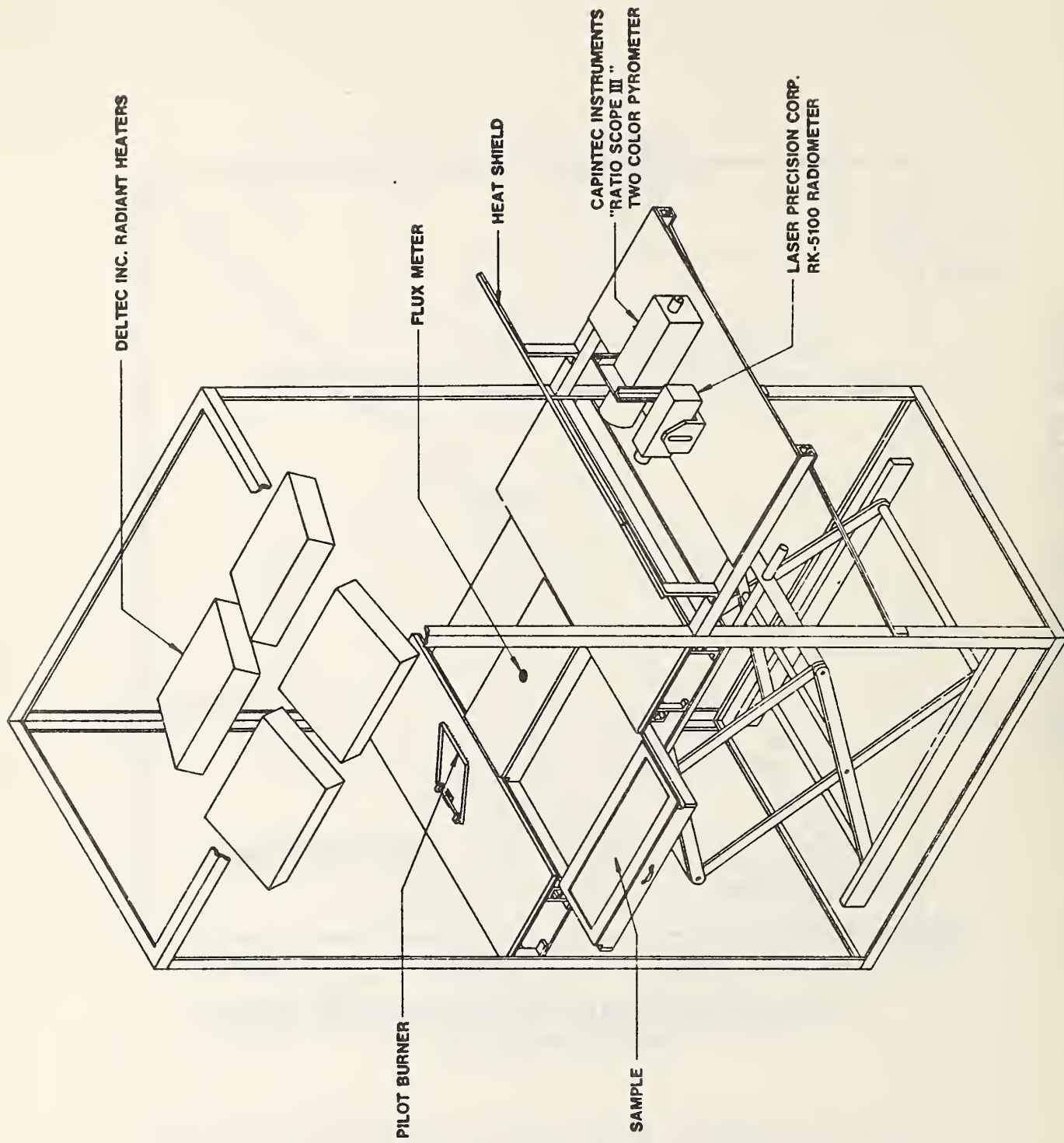


Figure 6. View of horizontal flame spread test apparatus, designed for testing fabric/filling composites

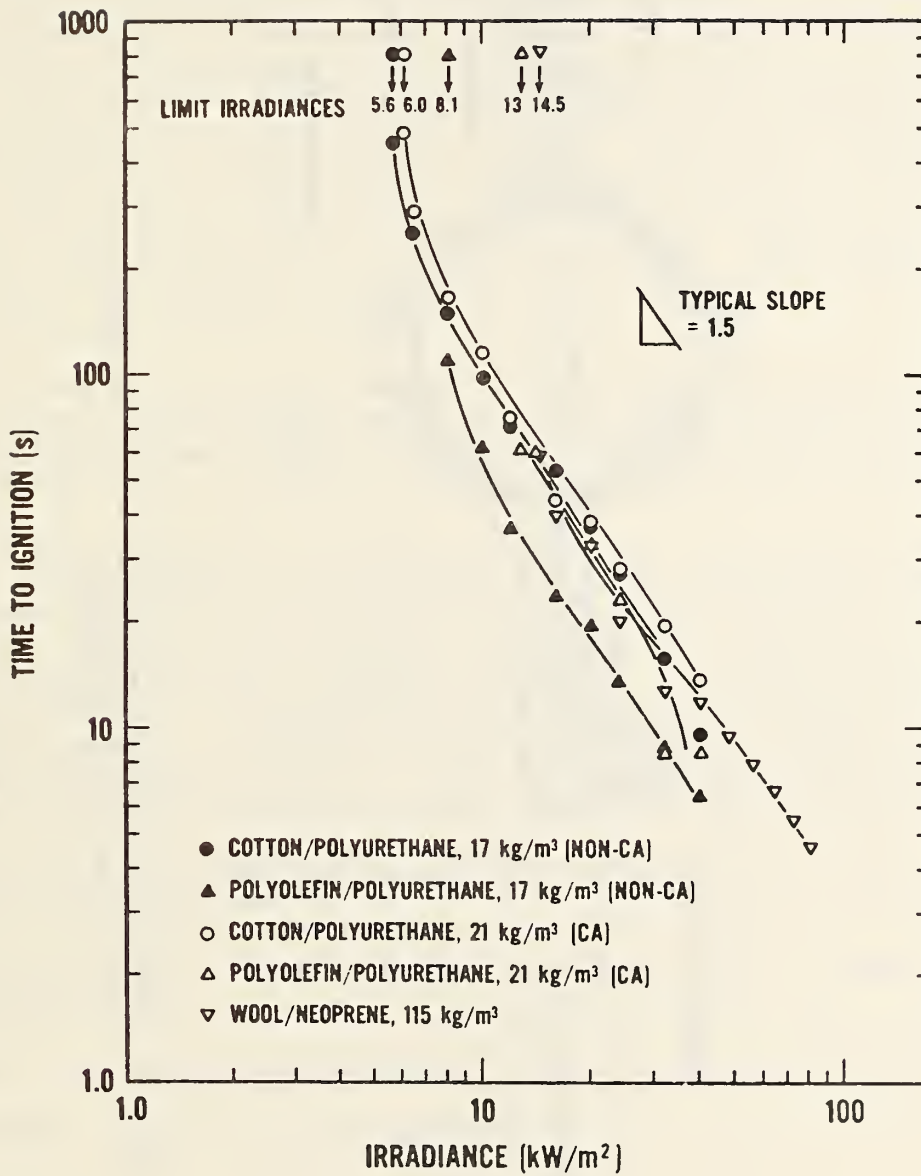


Figure 7. Typical ignition curves for a range of upholstered furniture fabric/filling combinations

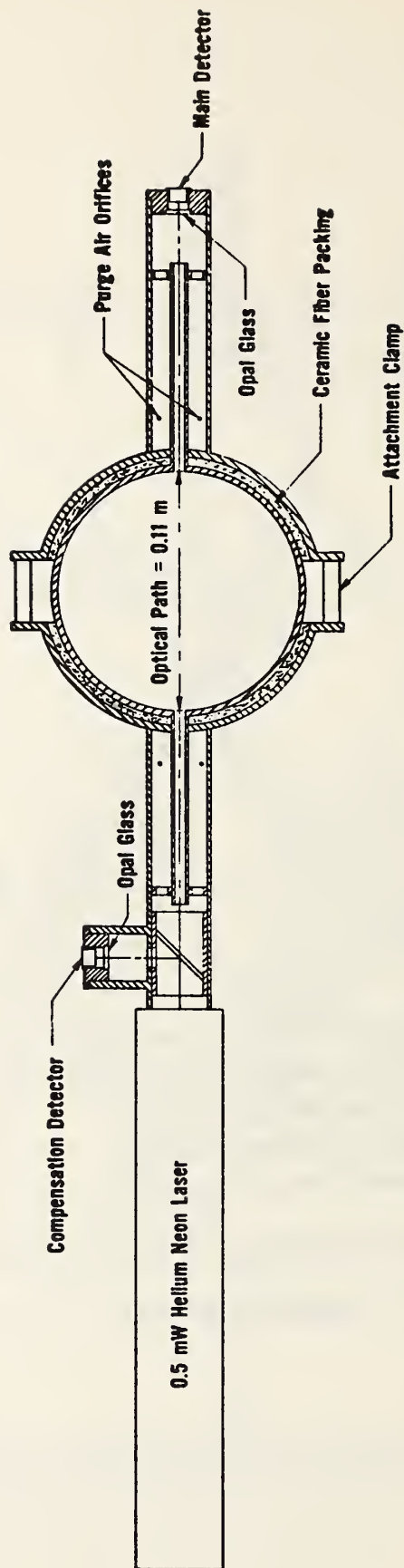


Figure 8. Extinction beam instrumentation for the exhaust duct of the cone calorimeter

Discussion After V. Babrauskas' Report on FIRE ENGINEERING TEST DEVELOPMENT:
BENCH-SCALE TESTS TO PREDICT FULL-SCALE BEHAVIOR

JIN: On the bench model, are the tests run as ambient oxygen concentration?

BABRAUSKAS: In the bench scale test, we have run all the tests just as ambient oxygen concentration. In the case of comparing the furniture calorimeter to the room fire, I think there was agreement before the start of testing that we would expect this to agree well up to the point of flashover. The interesting question was: What happens after flashover? We knew that if we went into ventilation limit then, of course, there is no comparison with free burning rate. So we designed a series of experiments to reach flashover, to go past flashover, but not to go into ventilation limiting. The variations that we got in the tests were about a random variation. This was only tested for the upholstered chair, and upholstered chairs, when they burn, have a pretty big fire. If, for instance, we would have a room with very many, very small packages, then that may not be true because each of these fires will be small and will not be optically thick. So this would be very interesting to study but we have not had a chance to study that yet.

PAGNI: When we used oxygen depletion, we have some difficulty getting accurate results and I think perhaps Dan Gross or someone else at the Bureau, along with Archie Tewarson, has instead developed a method using CO and CO₂, which we found to be more accurate. Would you consider that as useful in your efforts?

BABRAUSKAS: No, and for a very good but maybe not an obvious reason. First of all, I would say that it is possible to get good, low noise in oxygen readings. We can put a stripchart recorder on the output of an oxygen meter running nitrogen and get ± 50 ppm as the RMS noise, and that is possible to achieve with well set up commercial equipment. Now that is not quite the answer to your question. The real answer is the difference between what Archie studies and what I study. Dr. Tewarson usually likes to study simple materials where he has had an ultimate analysis. I feel it's my obligation to be able to test non-homogeneous composites and, of course, the CO₂ valence would not be so useful.

HIRANO: When you conducted the ignition test, how did you place test p, horizontal or vertical?

BABRAUSKAS: We did both; in the case of the data that I showed, they were horizontal.

HIRANO: Did you find any difference between horizontal and vertical?

BABRAUSKAS: Usually about 15 percent.

MATERIALS FIRE PROPERTIES AND
TEST METHODS TO BE DEVELOPED

Hiroaki SUZUKI

Smoke Control Division

Environment, Design and Fire Department

Building Research Institute

Ministry of Construction

Seventh Joint Meeting

UJNR Panel on Fire Research and Safety

Washington, U.S.A., October 24-28, 1983

MATERIALS FIRE PROPERTIES AND
TEST METHODS TO BE DEVELOPED

H. Suzuki

1. Introduction

Many test methods have been developed in countries for evaluation of building materials against fire. Each test method, however, only watches a certain phase of a fire. The data from these test methods actually give information about partial fires, but most of them seem to show an apparent fire properties. They are not essential to evaluate actual fire properties of materials in a building fire. Recently, therefore, a new test method has been required to develop measurement of real properties of materials in fire.

This paper deal with a direction of getting materials fire properties which are needed for prediction of fire growth in a building.

2. Items Required for Input Data in Modeling

In order to predict a spread of fire in a room/building, materials fire properties are essential to be known. Materials fire properties can't be taken as physical values like specific heat, latent heat etc., but also taken as evaluation standard for fire hazard.

Then the concept of "easiness of spreading of a fire" or "easiness of occurrence of flashover in a room" must be established.

Oxygen consumption indexes and B number introduced by Spalding¹⁾ may be example for indexes of "easiness of spreading of a fire." Inducement of evaluation indexes will be required for fire properties.

For the application of the fire growth model in a room/building, the new proper fire test method which will supply the following items will be required.

- A. Ignitability of materials
- B. Latent heat of materials
- C. Chemical composition of thermal decomposition products
- D. Released heat accompanied by thermal decomposition of materials
- E. Heat transfer in complex elements
- F. Thermal property of simple compartment made of non-combustible materials

A. Ignitability of Materials

When we predict the growth of a fire in the coarse model which was presented in "The Models to be Developed in Fire Safety Design Project" by Tanaka in the theme 2 "Fire Growth Prediction", pyrolysis of materials may be considered to occur in proportion to the received heat flux of the materials. Then, any ignitability test can be negligible.

However, many materials are treated by fire retardant agents, or covered with non-combustible materials, so we can take as thermal

decomposition occurs after ignition of materials.

If we consider the ignition of materials, it occurs under the circumstance of existence of radiation and pilot flames. As ignitability depends upon the intensity of radiation as well as heated time, ignitability should be written as a function of intensity of radiation and time. This means that the time until sufficient amount of combustion products is released to ignite. Therefore, there is no need to consider the effect of concentration of oxygen in the environment.

B. Latent heat of materials

The mass loss rate of materials can be calculated as follows

$$\dot{M}'' = \dot{Q}'' / L$$

where L : latent heat of thermal pyrolysis for steady burning, \dot{Q}'' : incident heat flux (Kw/m^2), \dot{M}'' : mass loss rate per unit area ($\text{Kg/m}^2\text{S}$).

Heat transfer can be calculated. Latent heat of materials is needed as properties of materials.

C. Chemical composition of thermal decomposition products

As the thermally decomposed products of materials are assumed to burn in the room, the composition of the decomposed products is required to be known in order to get the composition of gases in the room when the materials burn steadily. If it is difficult to know the chemical composition of the decomposed products, then the original composition of

materials will be substituted for this purpose. In this case, there may occur the difference between the composition of original materials and the decomposed if the original become char.

D. Released heat accompanied by thermal decomposition of materials

The bomb calory metry is one of methods for getting released heat from combustibile materials. In many cases, however, materials remain charred residue at actual fires. But there may occur the difference between the values from the calorimetry and from an actual fire. The value at the steady burning of materials will be required for modeling.

E. Heat transfer in Complex elements

Building elements are abundant in variety of their composites which involve hollows, insulation materials, etc. Moreover it is difficult to know the thermal properties of the most composite materials at elevated temperatures. Therefore an appropriate test method for getting the thermal property of these materials will be most practically reliable. In this case, various data will be obtained according to the heating conditions.

As it is difficult to carry out nemerous number of tests using actual sizes of building elements, another research for the criteria of heat transfer from the exposed surface to the other side will be

required to get a function as follows

$$f(I_i, t)$$

where I_i : Intensity of incident heat flux

t : time

The surface temperatures of the exposed materials relate to the heat transfer between the materials and combustion products in the fire room. The temperatures should be determined as the same way.

F. Thermal property of a simple compartment made of non-combustible materials

In a complex compartment, the thermal properties through the partitionings should be pursued by both of experimental tests and theoretical heat transfer. In this case, the accuracy, however, cannot be satisfactory. And moreover it will cost to carry the experiments.

In a simple compartment made of non-combustible materials, it may be easy to evaluate the heat transfer through the partitionings by resolving thermal equation. This may be applicable to the different thermal conditions the elements.

As this method may be only applicable to non-combustible materials, the thermal properties of many materials at elevated temperatures will be desired to be measured.

Discussion After H. Suzuki's Report on MATERIALS FIRE PROPERTIES AND TEST METHODS TO BE DEVELOPED

GANN: You've laid out a very ambitious list of needed tests. Do your plans or BRI plans include developing any of those in particular?

SUZUKI: Are you asking about a test method in order to obtain fire properties or are you talking about the modeling which is necessary prior to the development of test methods?

GANN: Specifically, the fire property measurement methods.

SUZUKI: As I said before, we do not have any ideas concerning the test method. Are you asking whether or not we are in the process of developing these test methods?

GANN: Either in the process of developing or have you any specific ideas for what you would do first?

SUZUKI: Even though I do not have any concrete ideas at this time, I am sure that some of the ideas proposed in my presentation can be investigated.

GENERAL DISCUSSION

SAITO: What we are looking for, Dr. Babrauskas, is how we can get properties of full-scale tests from the result of bench-scale tests. When we conduct those tests we have to know many combustion parameters of the materials; there are several parameters we can consider, including the combustion rate or heat release rate. But I have a very optimistic thought, that as long as we can get accurate heat release value in terms of time history, this parameter can be successfully applied from bench-scale tests to full-scale tests as far as prediction of properties are concerned.

BABRAUSKAS: We have tried both per unit area and per unit gram in analysis of the data. What I think is best to do is to normalize per unit of surface area. There is a problem in doing that with furniture, however. With furniture in the full-scale we don't have a way of easily measuring the area. But, it's much easier to measure the weight of the full-scale specimen. We measure in the bench-scale per unit 100 mm x 100 mm area and then multiply, not by the area in the full-scale item, but by the weight. I know that is an empiricism, but it works better than nothing; measuring of areas, I think, is too arbitrary with full-size irregular objects.

NELSON: Dr. Suzuki, does your concept of modeling the room of origin include modeling a combustible lining?

SUZUKI: It is included in our thinking as part of the materials, but it is not included as part of the gradual burning state.

NELSON: Gradual...meaning before flashover?

SUZUKI: Propagation.

NELSON: If so, I believe you also said that you assumed that all of the material burned in the room of origin.

SUZUKI: When the temperature rose to a certain degree within a certain time, we consider that material will be burned in a formal manner.

NELSON: You are assuming that no pyrolysis products will be discharged unburned through the vent in the room. Is that correct?

SUZUKI: I think that is possible, some of the pyrolysis products will escape through the vent unburned. But in our experiment we are trying to keep the lining as simple as possible and, as the temperature increases, pyrolysis gases will be generated and these will burn in layers. If the oxygen is not sufficient in these layers, then those pyrolysis products will escape through the vents.

NELSON: Our test experience with rooms lined with plywood indicate a large portion of the pyrolysis products escaped the room and burned outside.

TANAKA: In my models, fuel inputs are specified. So, in order to accommodate just what you said, we have to have some data concerning the fuel rates for materials, for example, some kind of test or experiment in order to accommodate that.

NELSON: That's the same with the model that Jones showed you and the model that Cooper is using and several other models.

PAGNI: Dr. Hasemi, in your paper, are the titles of Tables 1 and 2 switched?

HASEMI: Yes, that is correct.

PAGNI: I want to know when I can get away with the smallest possible penalty coefficient? When can I use your model with 10^{-4} ?

HASEMI: One thing which is necessary is that the penalty coefficient can be prefixed and the LaGrange multiplier cannot be prefixed. However, the evaluation of results can be done only by applying the LaGrange multiplier. In order to get the accurate result of the calculation, two LaGrange multipliers should be approximately the same. In this case, the penalty coefficient is illustrated as k is about .01 and it varies quite close. One is .01, the other is .001 but these are quite similar as the result of the calculation. But, empirically I can tell you when the penalty coefficient is very small, I take too much time to calculate it. So, in reality, what is desirable is that the LaGrange multiplier should be in the same range and at the same time k values should be quite large. So, in this case, when k is .01 computation is much faster than when the k is .001; not only is the computation faster, but the accuracy is about the same.

PAGNI: When you say the LaGrangian multiplier should be the same, do you mean that the two LaGrange multipliers for 1 k are the same? Or, do you mean that for two different k , when I do the computation, I get LaGrange multipliers which are similar for the two k ?

HASEMI: LaGrange multiplier will be dominated by these constrained conditions. Therefore, you will get as many LaGrange multipliers as constrained conditions, and these LaGrange multipliers desirably should be the same. So that is what is desirable and in actuality, that is what is desirable ideally, and they do not have any relationship to penalty coefficients.

HANDA: During today's presentations, I felt that each one by the Americans was closely related to the subject of the session. I'm sure that they all are utilized in the Harvard computer code. I would like to know, Dr. Babrauskas, are you going to make your paper available to the Harvard Code? That is, as you have obtained the value of bench-scale tests, are you planning to use these values as parameters?

BABRAUSKAS: Well, I think we can use them in a computer code as soon as there is a proper place in the computer code to accept that kind of data. At the moment, we're waiting for that, but the moment is not yet here. We can gather the data and we can hold onto it, and we can wait for those computer subroutines to become available. When they are available, then this will be an opportunity to put the data in there and hopefully to get a good prediction.

COMBUSTION TOXICITY AND 2ND EXPERT MEETING OF THE COOPERATIVE
RESEARCH GROUP OF COMBUSTION PRODUCTS

Richard Gann, Koichi Kishitani, and Fumiharu Saito
Session Chairmen

PROGRESS REPORT
on
COMBUSTION TOXICITY RESEARCH IN THE U.S.
by
Dr. Richard G. Gann
Chief, Fire Measurement and Research Division
Center for Fire Research
National Bureau of Standards

In the last few years, smoke toxicity has progressed from being only a suggested factor in fire hazard to a measurable parameter of considerable dispute. Much of this has been realized since the Sixth UJNR Panel Meeting. At present, despite the controversial status of the field, many manufacturers of both materials and finished products are considering or performing (confidential) toxicity testing, and consideration of several methods for standard testing or regulatory use is underway.

A variety of approaches to measuring combustion product toxicity has appeared. These are presented in detail in recent reviews of current measurement capability. The report by Benjamin/Clarke Associates (1) was commissioned by the National Fire Protection Association. The Southwest Research Institute document (2) reflects the interest of the plastics industry. The Arthur D. Little study (3) responds to the commercial and political pressures for product control. Each of these reviews discusses the strengths and weaknesses of the available approaches, devices, and measurement philosophies. Each review presents significant reservations regarding each apparatus and/or procedure, leading to the general conclusion that more work is necessary before current capability becomes encoded.

Nevertheless, there are three methods under consideration in committee E-5 (Fire Tests) of the American Society for Testing and Materials (ASTM). These were developed by Hilado at the University of San Francisco (4), by Birky, Levin, and coworkers at the National Bureau of Standards (5,6) and by Packham and Stacy at the Weyerhaeuser Co. (7). All are in the early stages of subcommittee discussion and are progressing at a slow pace. Only the NBS method has been subjected to an interlaboratory evaluation (8). Limited discussions on toxicity testing have also occurred at meetings of the National Fire Protection Association (NFPA).

In addition, the State of New York has funded a study to determine whether regulation of commercial products by their smoke toxicity is practical (3). Using an extensive list of operational criteria, the contractors identified two test methods, those of NBS (6) and the University of Pittsburgh (10), which were then submitted to extensive testing. They concluded that, while it was at present inappropriate to pass or fail products based on smoke toxicity, the performance (under the Pittsburgh test) of products to be sold in New York State should be published. The State has solicited the reaction of the technical peer community to these recommendations; it has not yet acted on the input.

Relatively few materials have been "tested" to date. (The exception is Hilado's work. However, serious questions have been raised as to what that method actually measures.) Of those few, virtually all produce smokes that are roughly comparable to each other in their acute inhalation toxicity. Otherwise stated, the LC_{50} values for a wide range of materials lie within a factor of ten. The one substance found to date that lies outside this range

is polytetrafluoroethylene (PTFE), whose smoke toxicity appears to be one hundred to one thousand times that of other smokes. Recent studies have confirmed hypotheses that this high toxicity depends strongly on the combustion conditions (9). However, the specific toxicant in the smoke and its generation mechanism are still unknown.

The principal result of all of these exploratory studies is that there is now a small but experienced community that is prepared to investigate both the measurement and physiological issues in a scientific manner. Indeed, our thinking in this field has evolved from the early concept of searching for a "supertoxicant," to recognizing that the measurement of the acute inhalation toxicity of fire smoke is but one component needed to evaluate the total fire hazard of a situation. This component has to be combined with such other factors as ease of ignition, rate of heat release, quantity of material present, its orientation, proximity to other combustibles, ventilation conditions, the presence of fire protection systems, and the building occupancy to assess the total hazard. Mathematical models of fire growth are beginning to be modified to include a capability for toxic hazard analysis.

In this context, it becomes even more important to know the "why" of a material's toxicity. If the LC_{50} can be explained on the basis of the known, "prime" toxicants, such as CO, HCN, HCl, etc., then we can consider the material as "normal" and use the gas generation data as input into the hazard model. If, on the other hand, an unexpectedly high toxicity (not explained by the prime toxicants) is observed for the smoke, then clearly further examination of that material and its combustion behavior is warranted.

What, then, are the pressing toxicity measurement issues to which research efforts must be directed to enable a confident assessment of toxic hazard?

We need:

1. A rationale and design for an appropriate small-scale combustor for generating smokes that can replicate those produced in the wide range of real fires.
2. Criteria for quantitative transport of these combustion products from the combustion chamber to the test animals and/or analytical instrumentation.
3. Appropriate animal models to examine diverse toxicants and various sublethal effects: incapacitation, non-fatal physiological damage, disorientation.
4. Experimental studies to explain the effects of the interaction of combinations of harmful smoke components.

The likely timeframe for success in these directions is uncertain. While much effort is being expended in debating the propriety of testing and in performing such tests, there are few active laboratories and scientists in the U.S. performing research. At present, NBS, Southwest Research Institute, and the University of Pittsburgh are the principal institutions involved, although American industry is conducting some highly important experiments related to specific products. All of these studies will serve to advance our knowledge of fire toxicology, but at a slow rate.

In view of this situation, it is all the more important that we build on related studies in other countries. In that way, by the Eighth Panel Meeting we hope to have advanced to the point where we can discuss the merits of a specific toxic hazard analysis methodology.

REFERENCES

1. Clarke III, F. B., "Toxicity of Combustion Products: Current Knowledge," *Fire Journal*, p. 84, September 1983.
2. Kaplan, H. L., Grand, A. F., and Hartzell, G. E., "A Critical Review of the State-of-the-Art of Combustion Toxicology," Southwest Research Institute Report No. 01-6862, June 1982.
3. Anderson, R. C., Croce, P. A., and Sakura, J. D., "Study to Assess the Feasibility of Incorporating Toxicity Requirements Into Building Materials and Furnishing Codes of New York State," Arthur D. Little, Inc., Report 88712, 1983.
4. Hilado, C., *Journal of Fire and Flammability*, 2, 298, 1975.
5. Birky, M. M., Paabo, M., Levin, B. C., Womble, S. E., and Malek, D., "Development of Recommended Test Method for Toxicological Assessment of Inhaled Combustion Products," National Bureau of Standards Report NBSIR 80-2077, 1980.
6. Levin, B. C., Fowell, A. J., Birky, M. M., Paabo, M., Stolte, A., and Malek, D., "Further Development of a Test Method of the Acute Inhalation Toxicity of Combustion Products," National Bureau of Standards Report NBSIR 82-2532, 1982.

7. Packham, S., "Proposed Method of Test for Toxic Combustion Products," submitted to ASTM Committee E-5, 1981.
8. Levin, B. C., Paabo, M., and Birky, M. M., "An Interlaboratory Evaluation of the 1980 Version of the NBS Test Method for Assessing the Acute Inhalation Toxicity of Combustion Products," National Bureau of Standards Report NBSIR 83-2678, 1983.
9. Williams, S. and Clarke III, F. B., Fire and Materials, 6, 161, 1982.
10. Alarie, Y. C. and Anderson, R. C., Toxicology and Applied Pharmacology, 51, 341, 1979.

Discussion After R. Gann's Progress Report on COMBUSTION TOXICITY RESEARCH IN THE U.S.

ROBERTSON: I'm involved in TC92, the subcommittee on toxic hazards and fire, and my own feeling is that we have been missing one of the important and, I think, perhaps one of the crucial problems in toxic fatalities and that is the irritancy of fire gases on the victims. I have a feeling that many of the fatalities are probably caused by the loss of vision due to the extreme irritancy of many decomposition products. The victims are forced to become disoriented; they are forced to exist until they're dead in a toxic atmosphere.

YUSA: You mentioned that we need data which can be used as input to the mathematical models which, as you mentioned, is one of the most important projected needs we face at this time. I'm sure that you do not have a complete idea what kind of input data we would be needing, but do you have any feeling what sort of data for inputting?

GANN: If the toxicity of the combustion products can be represented by a small number of single gases and we know how to combine the toxic effects of those gases, then the gas data itself goes into the model. The math models right now can handle gas transport and gas solution. If the toxicity of the combustion products is more complicated, and if the combustion products are non-condensable, then we can use a diluted LC₅₀ perhaps in the model. If it is not a simple material and if some of the products are condensable, we don't know what to do.

U.S.A. - CANADA - JAPAN
COOPERATIVE RESEARCH ON EVALUATION
OF
COMBUSTION GAS TOXICITY
(OVER VIEW)

October 1983

Fumiharu SAITO, Dr. Eng.,
Testing Laboratory
Center for Better Living

Introduction

The development of toxic evaluation method for combustion products from materials upon building-fire is an important problem to the estimation of toxic potential on actual fire and to the development of a new material. Toxic evaluation method for combustion gas includes testing procedure with testing apparatus and heating means, and physiological evaluation method for products released during combustion. Sorts and quantities of combustion products from materials depend on the burning condition, i.e. the aspect of fire. Therefore, in order to develop more reasonable testing method, it is necessary to clarify combustion behavior of materials in a full scale compartment as well as the component and quantities of combustion products, and to reproduce them by a laboratory scale experiment. The toxicity of combustion products should depend on a physiologically reasonable evaluation method.

As the development of toxic evaluation method of combustion gas from materials needs many research works, the joint research has been proceeded in cooperation among USA, Canada and Japan. About the assignment scope of each research on these studies for three countries, the basic agreement was adopted in Ottawa in June, 1982, followed by opening the specialists-meeting of three countries in Japan in November 1982. For these studies, research expenses from the special funds of the Science and Technology Agency in Japan has been provided to the related research organizations. As the research work in Japan was actually started in beginning of this year, the scheduled research plan is regretablely obliged to be delayed.

1. Research System

For the proceeding of this research work, Research Promotion

Committee (Chairman: Prof. K. Kawagoe) were established in Science and Technology Agency. Three working Groups were also established as sub-organization in the Committee as follows:

WG 1 : Setting up of burning conditions and analysis of combustion process (Dr. F. Saito)

Elucidation of heat-load onto materials and burning behavior, using a full scale compartment

WG 2 : Development of testing apparatuses (Mr. M. Furuya)

Development of testing apparatuses which can be adapted for thermoplastic and non-thermoplastic materials, and also can reproduce burning conditions obtained from the results of research works of WG 1.

WG 3 : Toxic evaluation of combustion gas (Prof. Y. Nishimaru)

Toxic evaluation by animal test using pure gas, physiological analysis, and studies on toxic evaluation method by chemical analysis.

Although each WG sometimes has a meeting individually, basically they have joint-WG meetings in which they have been proceeding their studies obtaining mutual understandings, because the WGs have close relations each other. The mutual relations of each WG are shown in Fig. 1.

2. 1983 Research Budget

According to the basic principle of Science and Technology Agency, research works have been divided into Phase I and II. On

Phase I, it has been required to design burning test apparatuses and to make a draft of toxic evaluation and method, which can be proposed to ISO. From the results of Phase I, it will be decided whether research plan of Phase II can be approved or not.

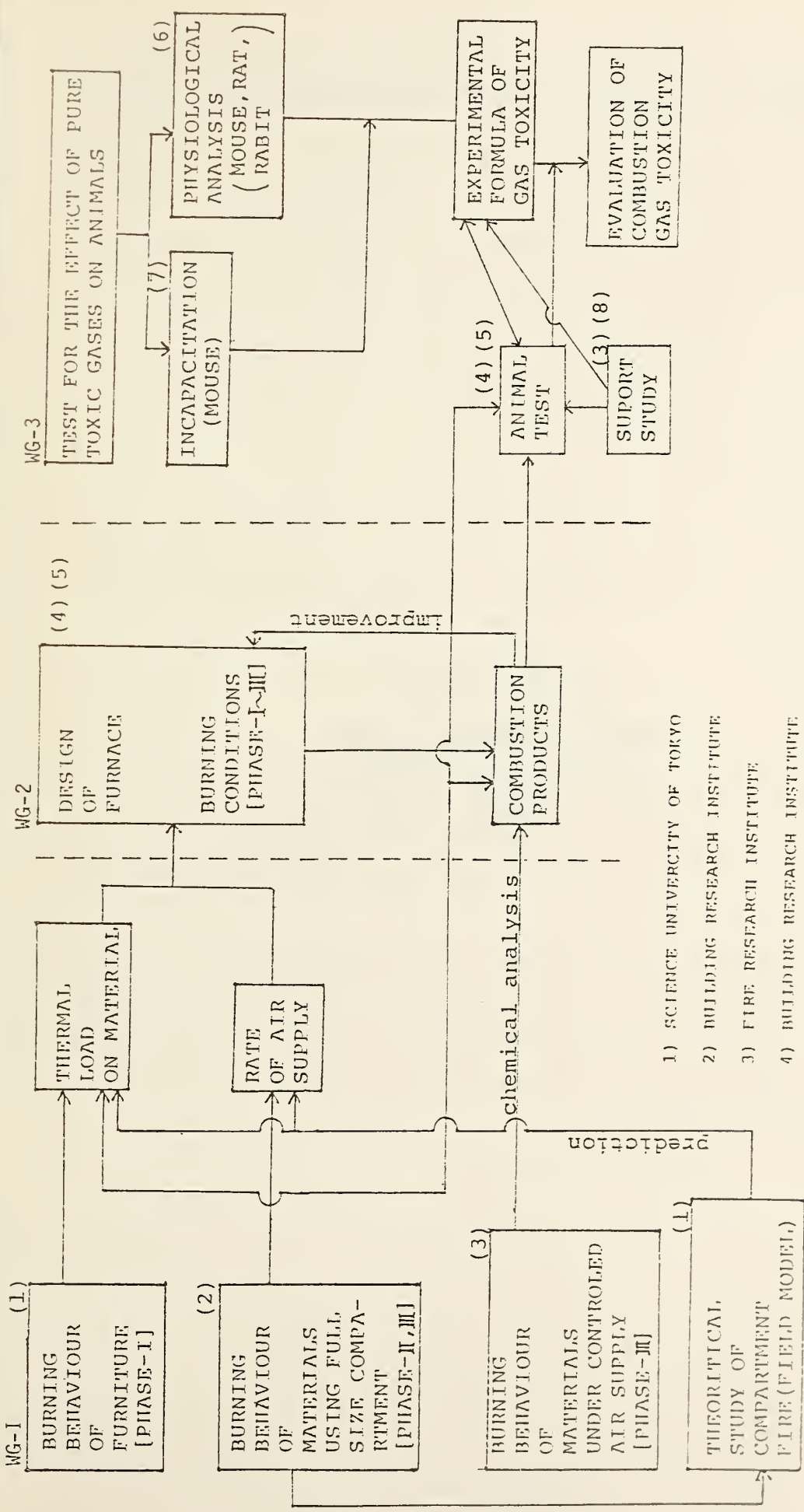
In 1982 fiscal year, 530,000 Dollars in total of research expenses were distributed to 5 national research institutions, 2 universities and 1 organization.

In 1983 fiscal year, however, the situation is that budget may be decreased to about 280,000 Dollars and the research plans shall be changed.

3. Future Works

On the last stage of Phase I, the execution of a round robin test in Japan using developed testing apparatuses and the design of basic plan for full scale fire experiments have been scheduled.

As the scope of these studies cover many fields, it is necessary to have full understanding for each research work and to clarify mutual research assignments in order to proceed the research works more efficiently with cooperation of three countries. Therefore, it is very important to have close exchange-informations with each other.



- 1) SCIENCE UNIVERSITY OF TOKYO
- 2) BUILDING RESEARCH INSTITUTE
- 3) FIRE RESEARCH INSTITUTE
- 4) BUILDING RESEARCH INSTITUTE
- 5) RESEARCH INSTITUTE OF POLYMER AND TEXTILE
- 6) YOKOHAMA CITY UNIVERSITY
- 7) RESEARCH INSTITUTE OF MARINE ENGINEERING
- 8) INDUSTRIAL PRODUCTS RESEARCH INSTITUTE

FIG. 1. MAIN FLOW CHART OF GAS TOXICITY RESEARCH IN JAPAN

STUDIES ON DETERMINATION OF BURNING CONDITION FOR THE TOXICITY TEST

by

Takeyoshi Tanaka

Building Research Institute

Ministry of Construction

Japan

INTRODUCTION

In an attempt to contribute the relevant experimental data on the burning condition of products and materials in fire to the rational designing of the laboratory scale test apparatus to be developed in the U.S. - Canada - Japan trilateral project for toxicity assessment, it was decided that, in charge of the respective institute, Japan conducts the researches on the following subjects:

(A) Analysis of Burning Condition in Fire:

- (a1) Burning Condition in Early Stage of Fire (by SUT),
- (a2) Burning Condition in Developing through Developed Stage of Fire (by BRI).

(B) Investigation into Burning Behavior of Materials in Fire:

- (b1) Burning Behavior of Building Materials (by BRI),
- (b2) Burning Behavior of Plywoods (by FFPRI),
- (b3) Burning Behavior of Textile Products (by RIPT),
- (b4) Burning Behavior of Daily Goods (by FRI).

The subjects classified into (A) aim at analyzing the thermal and atmospheric condition to which materials are exposed in fire, and those classified into (B) intend to produce the data pertaining to the combustion of materials in realistic fire situation with which the data from the laboratory scale tests can be compared to examine whether the test apparatus is designed properly in any respect.

Of these subjects, some are supposed to start from the second fiscal year according to the research plan, and some are somewhat behind the schedule because of budgetary reason etc. So, only three of these, which, at the moment this paper is written, have not advanced either as was scheduled, are described here.

-
- (Note) SUT : Science University of Tokyo
BRI : Building Research Institute, Ministry of Construction
FFPRI : Forestry and Forest Products Research Institute,
Ministry of Agriculture and Fishery
RIPT : Research Institute of Polymer and Textile,
Ministry of International Trade and Industry
FRI : Fire Research Institute, Ministry of Home Affairs

Various types of furniture are considered to be the major media to develop a small fire e.g. a lighted cigarette or a candle fire to a hazardous one. The increasing use of plastic materials to furniture may bring more rapid fire spread than ever, so there is growing importance in studying the burning behavior of furniture to better understand the nature of fire in early stage. The burn tests were run in the test room of Center for Fire Science and Technology, Science University of Tokyo for various kinds of chairs as a representative furniture to investigate into the intrinsic burning properties and the potential hazard of the chairs.

The burn room and the positions of measurement probes are shown in Figure 1. The measurements were made of the temperature profile of the fire plume, weight loss of the chairs, optical smoke density in the room, flame height, smoke layer height in the room, radiation from the flame, doorway flow velocity, O₂, CO₂, and CO concentration in the room. Here are some of the primary findings of the experiments:

(a) Burning Rate

The ratio RW*, which is given as

$$RW^* = \frac{w - w_{Tmax}}{w_0 - w_{Tmax}} \quad (1.1)$$

where w : residual weight of the chair
 w₀ : original weight of the chair
 w_{Tmax} : final residual weight of the chair

is plotted with time for each chair. The burning rate of a chair just after the ignition may vary one after another depending on the way it is ignited, but if we focus our attention on the primary period of the burning, almost every chair looks to exhibit similar tendency. The test data on weight loss were analyzed assuming that the burning rate of a chair at any given time within primary period of burning is proportional to the residual weight, hence the burning rate of each chair was reduced to the following expressions:

$$R = A w_0 e^{-At} \quad (1.2)$$

where R : burning rate
t : time
A : constant that is specific to the material

Table 1 shows the value of constant A experimentally obtained for each chair.

(b) Flame Radiation

As is shown in Figure 3 for example, the changes of burning rate and radiation flux look very alike, and a close relationship can be perceived between the two. In fact, by looking into the burning rate and radiation flux at at the most vigorous period of burning, it can be found that the measured flame radiation flux is proportional to the burning rate.

Also, the relationship described as follows:

$$Q_R \sim X^{-1.80} \quad (1.3)$$

can be observed between the experimentally measured radiation flux(Q_R) and the distance of the radiometer from the fire source center(X).

These findings and the data regression as shown in Figure 4 yield the final result as follows:

$$Q_R = 274 R X^{-1.8} \quad (1.4)$$

where R : burning rate(g/s)
X : distance from the center of fire(m)
 Q_R : radiation heat flux(kcal/m²h)

BURNING CONDITION OF DEVELOPING THROUGH DEVELOPED STAGE OF FIRE

This study is to analyze the thermal and atmospheric condition to which products or materials are exposed in fire by means of full scale experiments. The experiments are supposed to be run using full scale fire test facility of BRI, which is shown in Figure 5. However, with the limitation in the expense and work force, it is difficult to run a large number of experiments until we get fair results. It is felt that to conduct the experiments and to analyze the results effectively, we have to, first of all, get some means to reasonably estimate the rate of flow

through the doorway of our test facility. The flow rate must be given from some easily and quickly measurable quantities because otherwise we will have to conduct very long experiments even for studying the phenomena at steady state condition, and furthermore we will have a lot of trouble when we attempt to investigate transient fire.

Although it was encouraging that Steckler(1) has successfully correlated the opening flow rate with the temperatures in the fire room and at the opening, we had not been sure that the same kind of correlation holds for our case where test facility consists of two rooms, and fire was expected to be more intense than the Steckler's case. Consequently, the preliminary tests for doorway flow rate were conducted with the consultation of Steckler of NBS, who were invited to Japan during the experiments. The test data were reduced in basically the same way as Steckler's. The results of out- and inflow rate, which are respectively shown in Figures 6 and 7, suggest that the doorway flow can be reasonably estimated by the room temperatures and a simple hydraulic model with 0.68 for flow coefficient.

Once we have the inflow rate of air through the opening at our disposal, we can proceed to estimate the mole outflow rate of species. Assuming that the compositions of the fuel are known, the mole outflow rates of species are given as follows:

$$\dot{n}_f^s = \dot{n}_f^o - \frac{1}{W_f} \frac{X_{CO_2}^A + X_{CO}^A}{D} \dot{n}_{O_2}^o \quad (2.1)$$

$$\dot{n}_{O_2}^s = \dot{n}_{O_2}^o - \frac{a(X_{CO_2}^A + \frac{1}{2} X_{CO}^A) + (\frac{b}{4} - \frac{c}{2})(X_{CO_2}^A + X_{CO}^A)}{D} \dot{n}_{O_2}^o \quad (2.2)$$

$$\dot{n}_{CO_2}^s = \frac{a X_{CO_2}^A}{D} \dot{n}_{O_2}^o \quad (2.3)$$

$$\dot{n}_{CO}^s = \frac{a X_{CO}^A}{D} \dot{n}_{O_2}^o \quad (2.4)$$

$$\dot{n}_{H_2O}^s = \dot{n}_{H_2O}^o + \frac{\frac{b}{2} X_{CO_2}^A + X_{CO}^A}{D}}{\dot{n}_{O_2}^o} \quad (2.5)$$

$$\dot{n}_{N_2}^s = \dot{n}_{N_2}^o + \frac{\frac{d}{2} (X_{CO_2}^A + X_{CO}^A)}{D}}{\dot{n}_{O_2}^o} \quad (2.6)$$

and also heat release rate in the burn room can be given as follows: By applying the oxygen consumption method to the room,

$$\dot{Q} = \frac{E_1 \left\{ a(X_{CO_2}^A + \frac{1}{2} X_{CO}^A) + \left(\frac{b}{4} - \frac{c}{2} \right) (X_{CO_2}^A + X_{CO}^A) \right\} - (E_1 - E_2) \frac{1}{2} X_{CO}^A}{D}}{W_{O_2} \dot{n}_{O_2}^o} \quad (2.7)$$

and these equations are related with mass inflow rate of air as given by the following equations:

$$\dot{n}_{O_2}^o = \frac{X_{O_2}^{A^o} (1 - X_{H_2O}^{A^o})}{D'} \dot{m}_a \quad (2.8)$$

$$\dot{n}_{N_2}^o = \frac{(1 - X_{O_2}^{A^o}) (1 - X_{H_2O}^{A^o})}{D'} \dot{m}_a \quad (2.9)$$

$$\dot{n}_{H_2O}^o = \frac{X_{H_2O}^{A^o}}{D'} \dot{m}_a \quad (2.10)$$

$$\text{where } D' = W_{N_2} (1 - X_{O_2}^{A^o}) (1 - X_{H_2O}^{A^o}) + W_{O_2} X_{O_2}^{A^o} (1 - X_{H_2O}^{A^o}) + W_{H_2O} X_{H_2O}^{A^o}. \quad (2.11)$$

It can be said that the above equations for the mole outflow rates of species through the opening of the fire compartment provide a basic tool to analyze the phenomena that are going on in the fire room. The symbols in the equations are given in Appendix.

BURNING BEHAVIOR OF DAILY GOODS

This study, conducted by Fire Research Institute, aims at contributing basic data on toxicity hazards, in particular to the determination of burning condition for toxicity test apparatus as well as to evacuation, rescue and fire fighting activity etc. Various kinds of combustibles are burned in the semi-full scale model compartment under forced ventilation condition, and the generation characteristic of species from the combustible are investigated.

A small scale combustion chamber has a disadvantage in that it cannot produce a realistic fire condition. By a tube furnace, on the other hand, one may run tests under the conditions that is nothing to do with real fire, since it can attain any condition. Contrarily, full-scale tests are too costly to run, although most desirable in the other respect. This study using semi-full scale compartment will play a part to bridge the small scale to large scale fire tests.

(1) Experimental Setup

The apparatus used for this experiment is a cubic steel chamber lined with insulation material as shown in Figure 8, and is equipped with a mechanical air supply system, a vent and a weight loss measurement system.

Various liquid fuels, and element materials of products i.e. n-hexane, wood, cotton, methacrylate, polyetyrene, polystyrene etc. are to be burned as the fuel, and analysis is to be made of the gas sampled at the vent together with air supply rate, mass burning rate, smoke density, and the room temperature profile.

(2) Test Results

The experiments and the analysis of this study are still under way, so the followings are the outline of the intermediate findings.

CO, Acrolein and NO_x are mentioned as the primary toxic combustion products of n-hexane and wood. The maximum generation of CO was 0.3 g per

1.0 g fuel for wood and that of n-hexane was less than half of that value for wood. The maximum generation of acrolein was about 3 mg both for wood and n-hexane.

The generation of acrolein, CO and CO₂ for the wood combustion are plotted versus "air supply rate/burning rate"(relative burning rate) as shown in Figure 9-(1), (2), and (3). The generation rate of CO₂ per unit weight loss tends to be small at initial period when water vaporization is included in the weight loss. The generation of acrolein is largely affected by temperature, in other words by whether or not flame is formed, in which a secondary decomposition occurs. A significant fluctuation was observed in the generation of CO probably because of the difference of temperature in local position in the chamber. The generation rates both of CO and acrolein due to the burning of PMMA and PE were smaller than the case of n-hexane. It is suspected that the flame formed in case of the burning of these material facilitate the transition of CO to CO₂.

When the air supply rate was large, flame was observed above the vent(or chimney), which means the combustion was not completed, in a strict sense, at the bottom of the vent, where the gas was sampled for the analysis. But in case that flames are observed, the gas analysis shows that the concentrations of CO and organic species are rather low while CO₂ concentration was high, so the sampling point would not have made much difference if it were positioned above the flame.

The concentration of NO_x higher than 100 ppm were not observed.

The data of the various gas components in the combustion product gas other than acrolein are now being analyzed.

REFERENCES

- (1) Steckler, K.D.: Flow Induced by Fire in A Compartment, NBSIR 82-2520, 1982.
- (2) Mizuno, T. and Kawagoe, K.: Burning Behavior of Upholstered Chairs, to be presented to the 7th UJNR meeting as a support paper, 1983.
- (3) Nakaya, I., Tanaka, T. and Yoshida, M.: A Measurement of Doorway Flow Induced by Propane Fire, to be presented to the 7th UJNR meeting, 1983.
- (4) Parker, W.J.: Calculation of The Heat Release Rate by Oxygen Consumption for Various Application, NBSIR 81-2427-1, 1982.

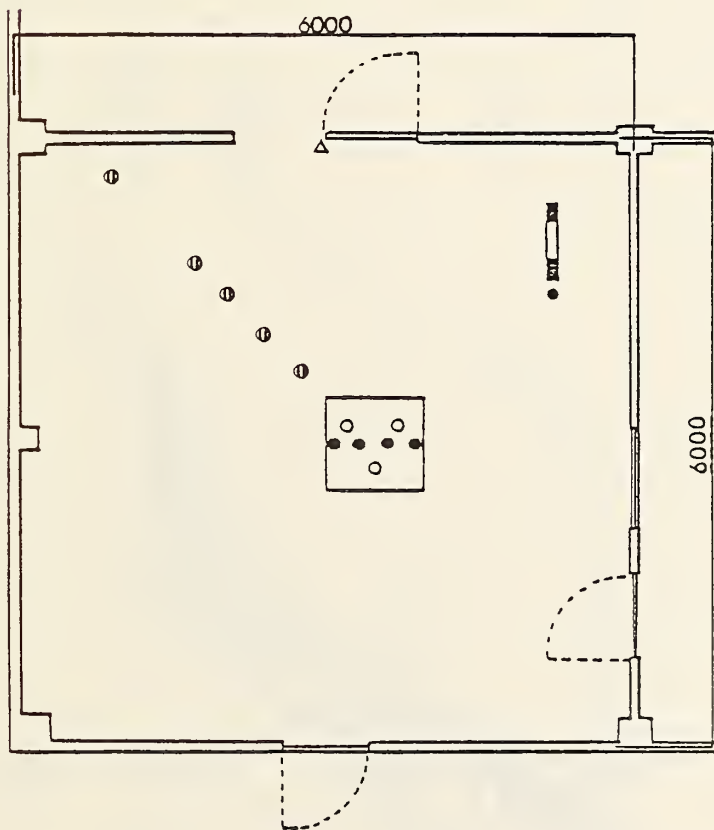
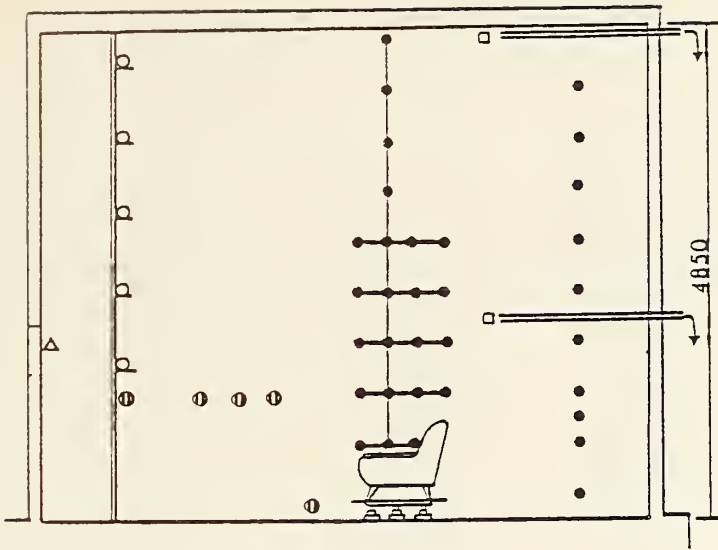


Figure 1. Experimental Setup of Burning Tests of Chairs

- Temperature
- Smoke density
- ⊙ Radiation
- △ Flow velocity
- Gas concentration

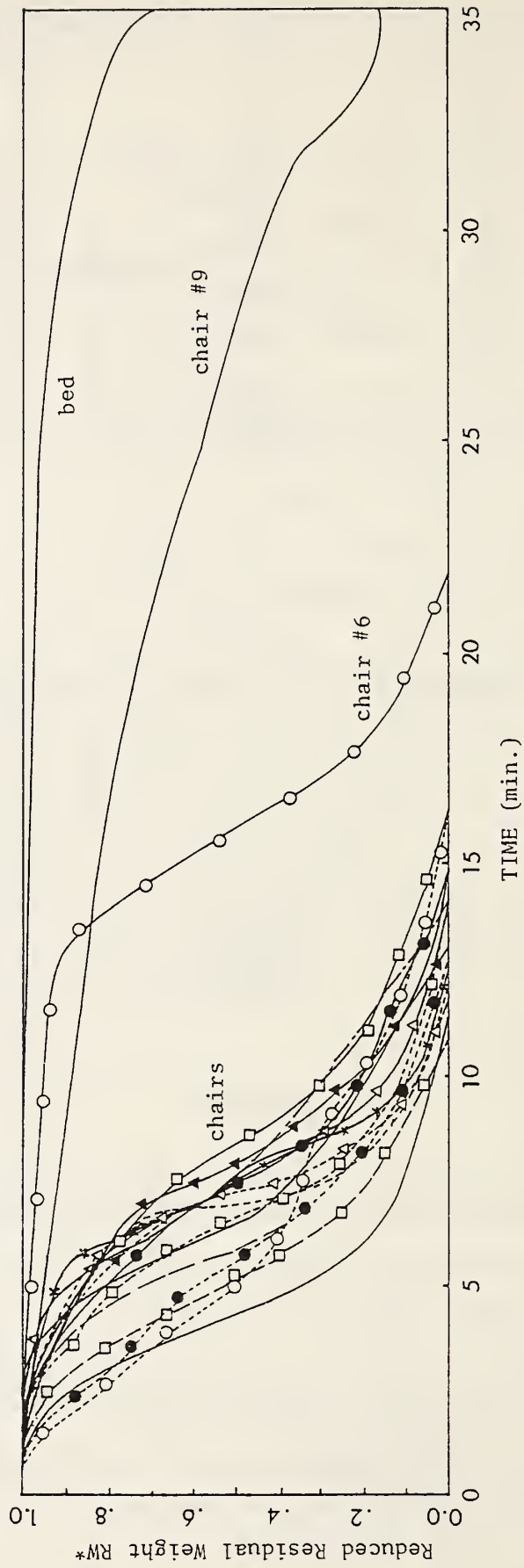


Figure 2. Reduced Residual Weight RW*

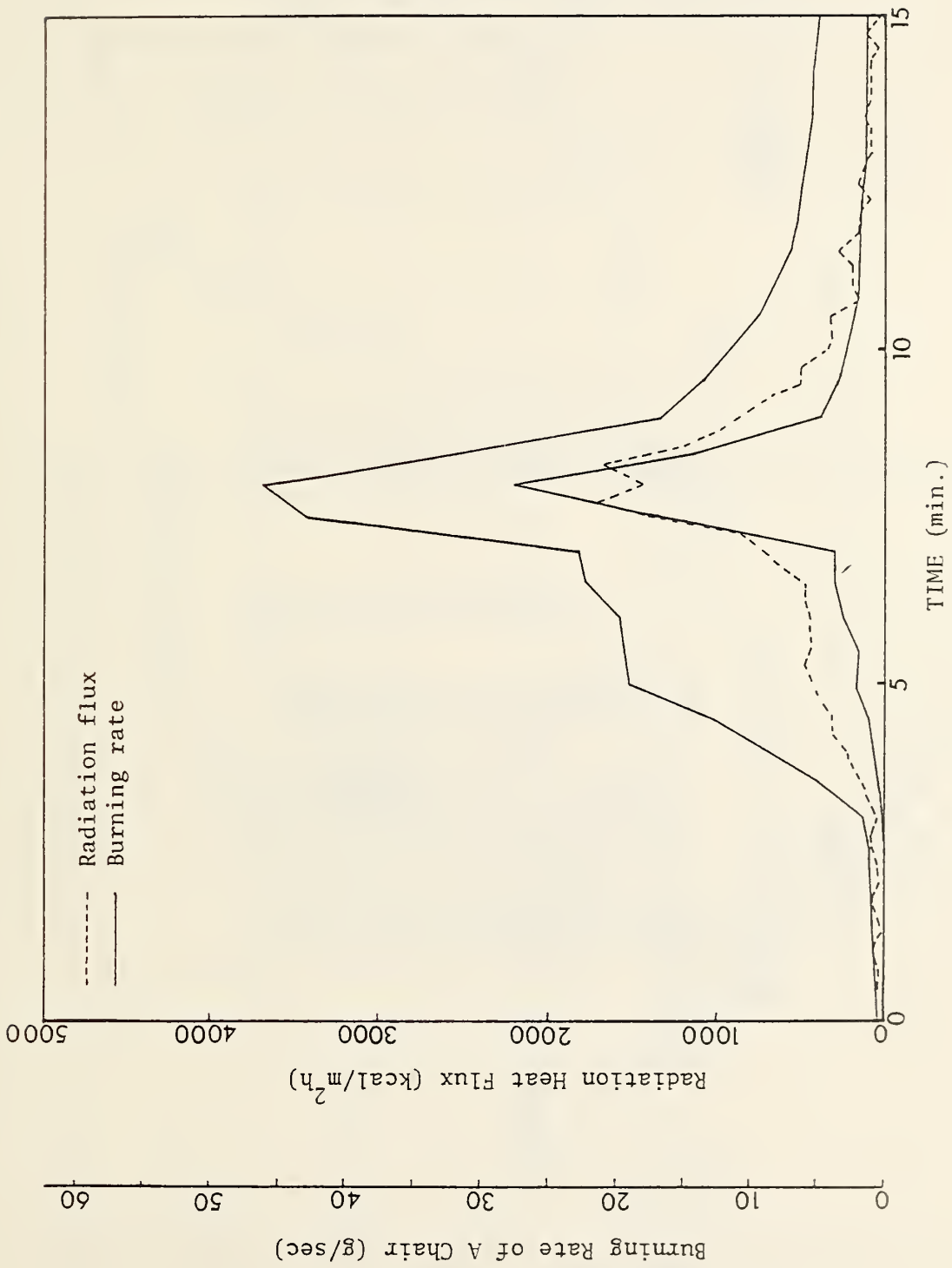


Figure 3. Burning Rate and Radiation Intensity

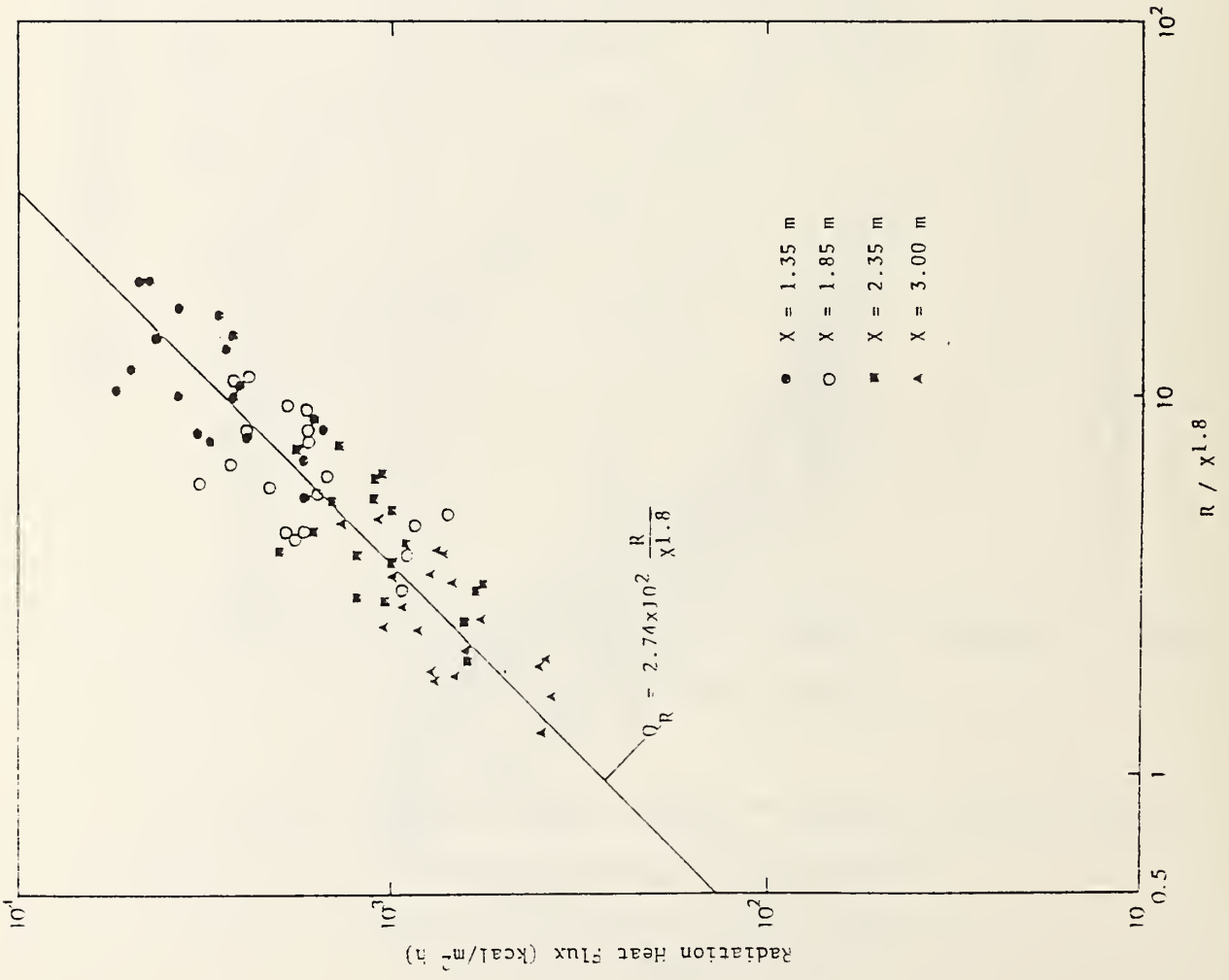


Figure 4. Radiation Heat Flux as a Function of $R/X^{1.8}$

Table 1.

Table 1. The Value of Λ

Chair No.	Λ
1	0.0048
2	0.0042
3	0.0084
4	0.0139
5	0.0084
6	0.0063
7	0.0093
8	0.0063
9	-----
10	0.0050
11	0.0032
12	0.0050
13	0.0066
14	0.0096
15	0.0052
16	0.0070
17	0.0051

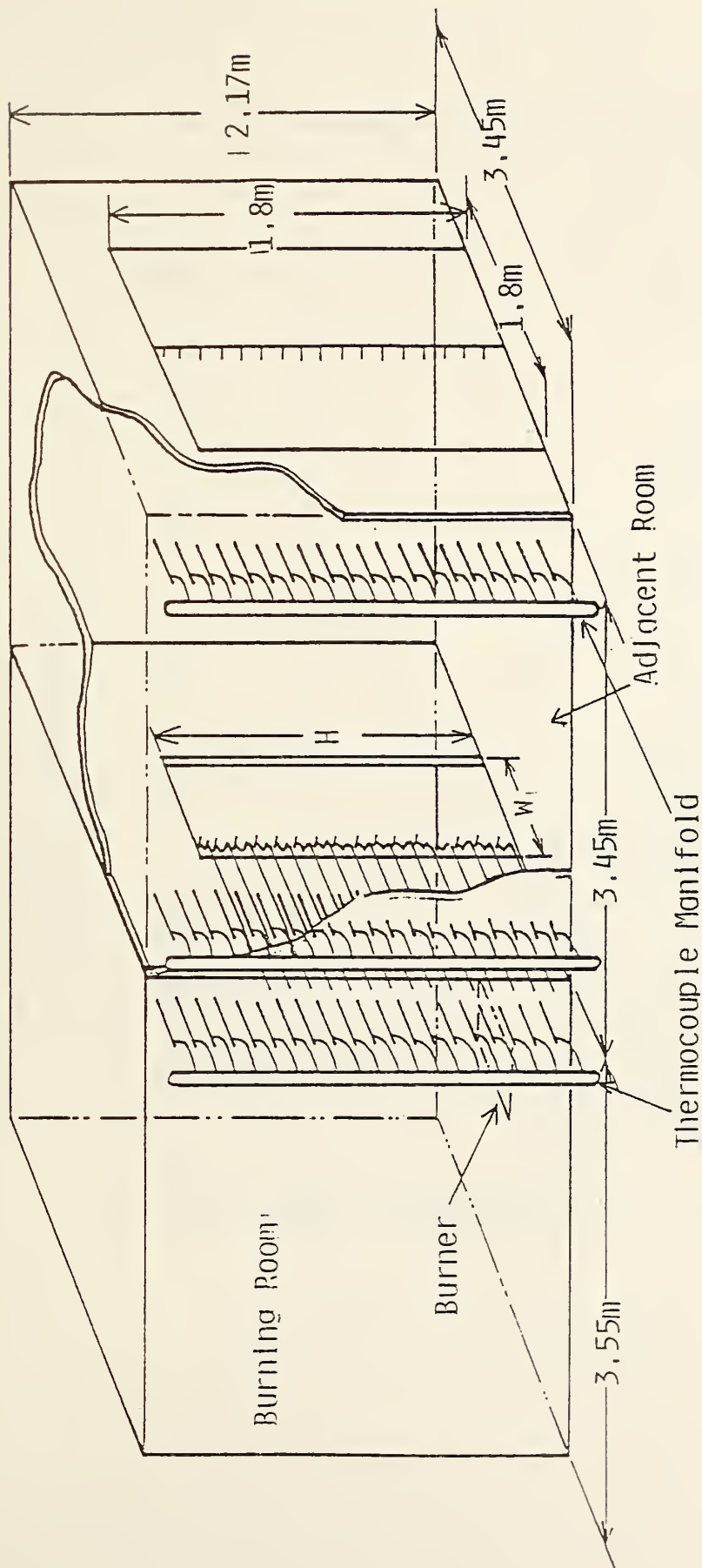
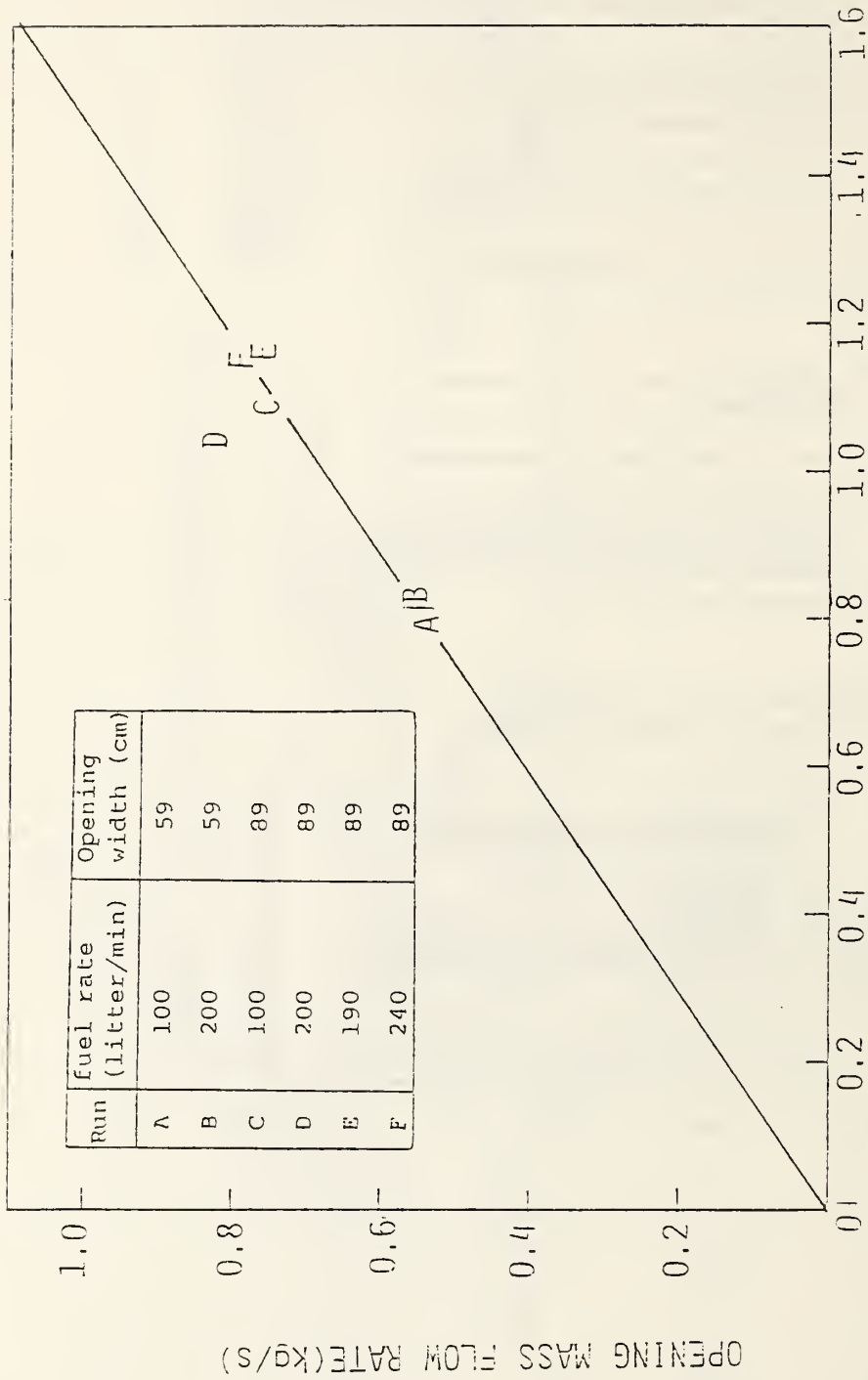
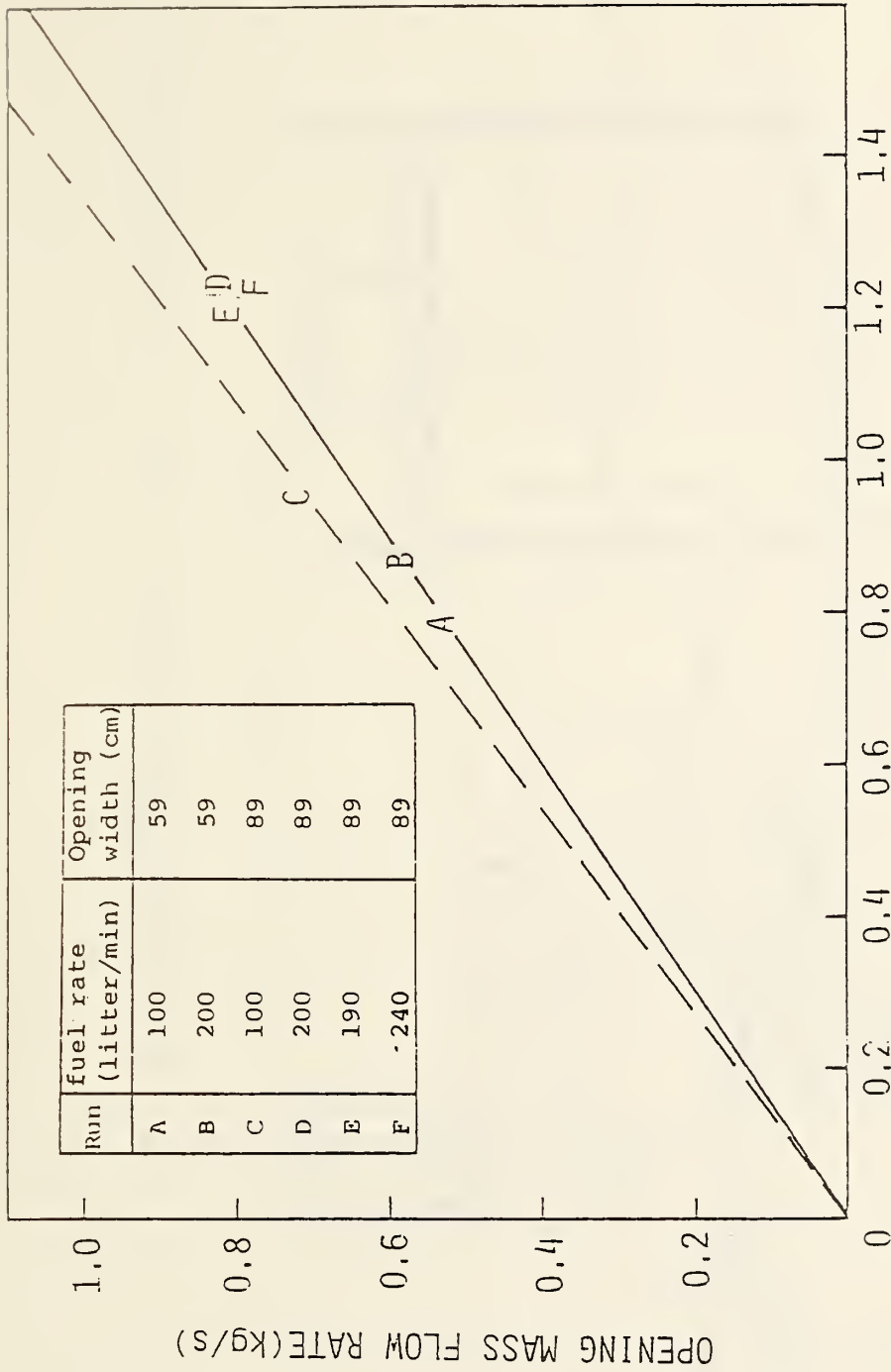


Figure 5. Full Scale Fire Test Facility of BRI



$$W \rho_{\infty} T_{\infty} \int_0^N \left[(2g/T_a) \int_z^N (1/T_a - 1/T_r) dz \right]^{1/2} dz$$

Figure 6. Correlation of Opening Mass Flow Rate with Idealized Flow Model (Outflow)



$$W \rho_{\infty} T_{\infty} \int_N^0 \left[(2g/T_F) \int_N^z (1/T_a - 1/T_F) dz \right]^{1/2} dz$$

Figure 7. Correlation of Opening Mass Flow Rate with Idealized Flow Model (Inflow)

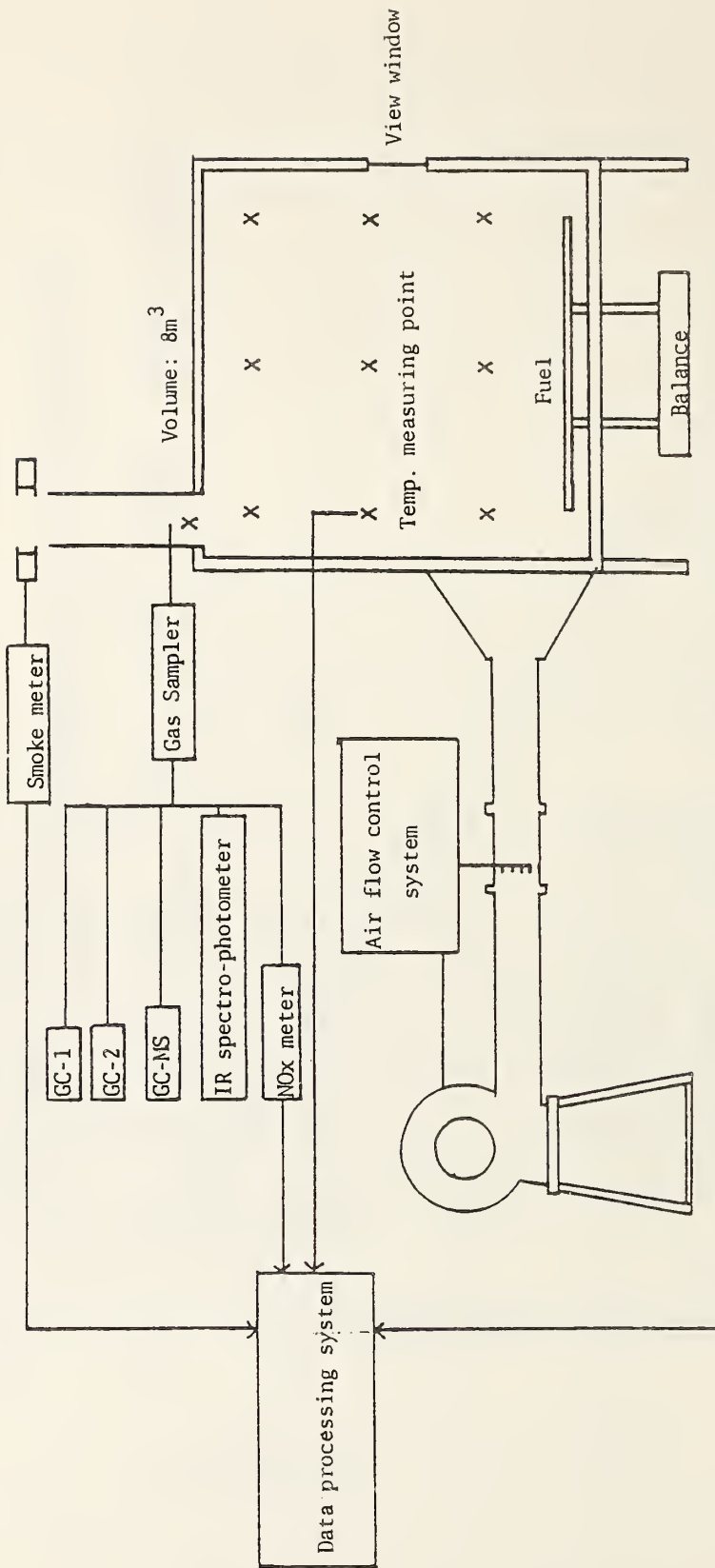


Figure 8. Experimental Arrangement of FRI

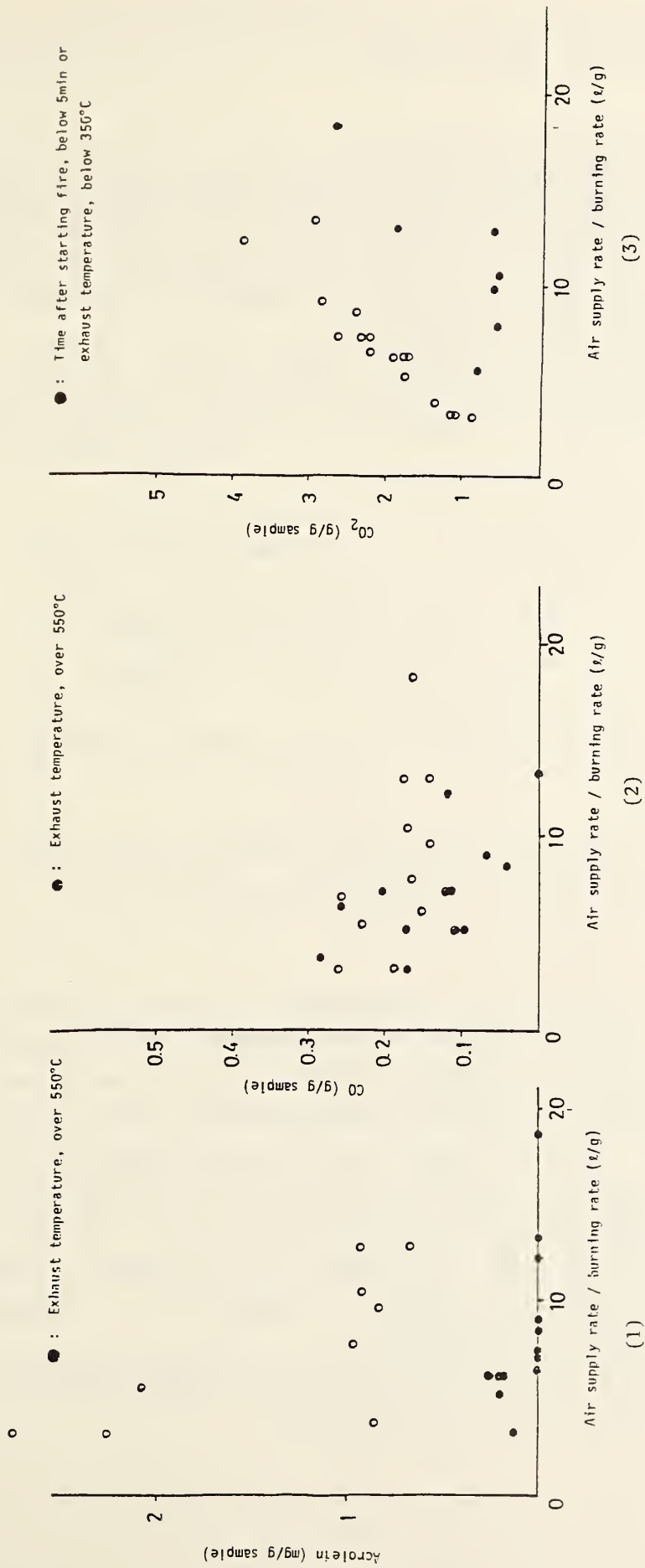


Figure 9. Evolution of acrolein, CO and CO₂ from burning wood cribs as a function of air supply rate/burning rate

Appendix: A METHOD TO ANALYZE THE BURNING BEHAVIOR GASEOUS FUEL
IN COMPARTMENT FIRE EXPERIMENTS

Combustion in fire usually consists of the thermal decomposition of solid combustible and the gas phase combustion of the gasified fuel. Since it is quite difficult to deal with such coupling phenomena, it will be more prudent to approach the gas phase combustion only first of all separately from the solid decomposition.

The experimental facility shown in Figure A-1 can be used to investigate the phenomena that take place in the gas phase combustion in fire by burning gaseous fuel in the burn room. The primary targets of this experiment are, for the first step:

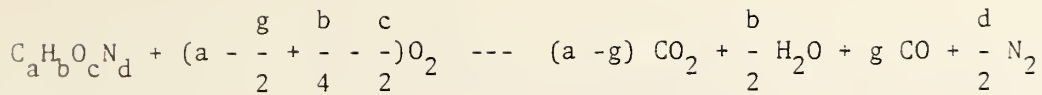
- (1) To obtain empirical relationships between the indexes that describe the fire phenomena, e.g. the consumption rates of fuel and oxygen, the generation rates of carbon dioxide and carbon monoxide and etc., and the factors that affect the burning behavior, e.g. fuel input rate, air inflow rate, room fire temperature, species concentrations, etc.
- (2) To investigate into how the species in the effluent gas from the room of origin undergo change in the adjacent room.

and for the next step:

- (3) To elucidate the mechanism of gas phase combustion in fire and to develop a model to predict the combustion, in particular the formation of the species in fire room.

To address these goals, it is obvious that not only the species concentration but also the consumption or generation rates of the species are needed. For this purpose, of course, if the more gas analyzers are available, it will be the more advantageous, however, they are often practically limited to those for oxygen, carbon dioxide and carbon monoxide in point of view of reliability and ease of handling. So, it will be indispensable to implement the way to obtain the above mentioned rates making best use of the gas analyzers available. The method described by Parker(1) regarding the application of oxygen consumption method will be most suggestive.

It is assumed here that the following chemical formula holds for the combustion of the fuel used in the experiments:



which seems to be a reasonable assumption for engineering objectives. Among the species that appear in the formula, the generation rate of carbon monoxide will strongly depend on the fire conditions, and also there is a chance that a part of the input fuel flow out of the room when the input rate largely exceeds the air supply through the opening.

Let \dot{n}_f^s , $\dot{n}_{O_2}^s$, $\dot{n}_{CO_2}^s$, \dot{n}_{CO}^s , $\dot{n}_{H_2O}^s$ and $\dot{n}_{N_2}^s$ be the mole outflow rate of fuel, O_2 , CO_2 , CO , H_2O and N_2 , respectively. We only deal with a quasi-steady condition, then the conservation equations for each species turns out to be as follows:

$$\dot{n}_f^s = \dot{n}_f^o - \dot{n}_f^* \tag{1}$$

$$\dot{n}_{O_2}^s = \dot{n}_{O_2}^o - \dot{n}_f^* W_f (a - \frac{g}{2} + \frac{b}{4} - \frac{c}{2}) \tag{2}$$

$$\dot{n}_{CO_2}^s = \dot{n}_f^* W_f (a - g) \tag{3}$$

$$\dot{n}_{CO}^s = \dot{n}_f^* W_f g \tag{4}$$

$$\dot{n}_{H_2O}^s = \dot{n}_{H_2O}^o + \dot{n}_f^* W_f \frac{b}{2} \tag{5}$$

$$\dot{n}_{N_2}^s = \dot{n}_{N_2}^o + \dot{n}_f^* W_f \frac{d}{2} \tag{6}$$

where \dot{n}_f^* , W_f and \dot{n}_f^o are respectively the mole burning rate, mole weight and mole input rate of the fuel, and $\dot{n}_{O_2}^o$, $\dot{n}_{H_2O}^o$ and $\dot{n}_{N_2}^o$ stand for the mole inflow rate of O_2 , H_2O and N_2 from exterior space, which is assumed to be at ambient condition in any aspect.

We assume that the gas analyzers are available only for O_2 , CO_2 and CO , and water is filtered out in the sampling line before the analyzers. Assuming in addition that the fraction of each species in the sampling line is the same as that in the sampled gas, we have the following relationships between the mole flow rate of each species and its measured value:

$$X_{O_2}^A = \frac{\dot{n}_{O_2}^s}{\dot{n}_f^s + \dot{n}_{O_2}^s + \dot{n}_{CO_2}^s + \dot{n}_{CO}^s + \dot{n}_{N_2}^s} \quad (7)$$

$$X_{CO_2}^A = \frac{\dot{n}_{CO_2}^s}{\dot{n}_f^s + \dot{n}_{O_2}^s + \dot{n}_{CO_2}^s + \dot{n}_{CO}^s + \dot{n}_{N_2}^s} \quad (8)$$

$$X_{CO}^A = \frac{\dot{n}_{CO}^s}{\dot{n}_f^s + \dot{n}_{O_2}^s + \dot{n}_{CO_2}^s + \dot{n}_{CO}^s + \dot{n}_{N_2}^s} \quad (9)$$

From Eqs.(3), (4), (8) and (9), we get

$$g = \frac{X_{CO}^A}{X_{CO_2}^A + X_{CO}^A} a \quad (10)$$

Also from Eqs.(2), (7), (3)+(4) and (8)+(9)

$$\frac{\dot{n}_O^s - \dot{n}_f^* W_f \left(a - \frac{g}{2} + \frac{b}{4} - \frac{c}{2} \right)}{\dot{n}_f^* W_f \{ (a - g) + g \}} = \frac{X_{O_2}^A}{X_{CO_2}^A + X_{CO}^A} \quad (11)$$

Noting these relations, the mass burning rate of fuel, $\dot{n}_f^* W_f$, can be given as:

$$\dot{n}_f^* W_f = \frac{X_{CO_2}^A + X_{CO}^A}{a(X_{O_2}^A + X_{CO_2}^A + \frac{1}{2} X_{CO}^A) + \left(\frac{b}{4} - \frac{c}{2} \right) (X_{CO_2}^A + X_{CO}^A)} \dot{n}_{O_2}^o \quad (12)$$

Substituting Eq.(12) into Eqs.(1)-(6) yields the equation for each species in the effluent gas from the room of origin as follows:

$$\dot{n}_f^s = \dot{n}_f^o - \frac{1}{W_f} \frac{X_{CO_2}^A + X_{CO}^A}{D} \dot{n}_{O_2}^o \quad (13)$$

$$\dot{n}_{O_2}^s = \dot{n}_{O_2}^o - \frac{a(X_{CO_2}^A + \frac{1}{2} X_{CO}^A) + (\frac{b}{4} - \frac{c}{2})(X_{CO_2}^A + X_{CO}^A)}{D} \dot{n}_{O_2}^o \quad (14)$$

$$\dot{n}_{CO_2}^s = \frac{a X_{CO_2}^A}{D} \dot{n}_{O_2}^o \quad (15)$$

$$\dot{n}_{CO}^s = \frac{a X_{CO}^A}{D} \dot{n}_{O_2}^o \quad (16)$$

$$\dot{n}_{H_2O}^s = \dot{n}_{H_2O}^o + \frac{\frac{b}{2} (X_{CO_2}^A + X_{CO}^A)}{D} \dot{n}_{O_2}^o \quad (17)$$

$$\dot{n}_{N_2}^s = \dot{n}_{N_2}^o + \frac{\frac{d}{2} (X_{CO_2}^A + X_{CO}^A)}{D} \dot{n}_{O_2}^o \quad (18)$$

$$\text{where } D = a(X_{O_2}^A + X_{CO_2}^A + \frac{1}{2} X_{CO}^A) + (\frac{b}{4} - \frac{c}{2})(X_{CO_2}^A + X_{CO}^A) \quad (19)$$

Since $\dot{n}_{O_2}^o$, $\dot{n}_{H_2O}^o$ and $\dot{n}_{N_2}^o$ in the Eqs.(12)-(19) are mole flow rates of oxygen, water vapor and nitrogen that flow into the burn room, they can be easily estimated provided that the air inflow rate is given. The other quantities are either known or measurable. So, it follows that the consumption rate of fuel and oxygen, and the generation rates of carbon monoxide can be obtained.

In addition, if the oxygen consumption method is employed, the heat release rate in the burn room can also be obtained as follows:

According to the oxygen consumption method,

$$\dot{Q} = W_{O_2} \left\{ E_1 (\dot{n}_{O_2}^o - \dot{n}_{O_2}^s) - (E_1 - E_2) \frac{1}{2} \dot{n}_{CO}^s \right\} \quad (20)$$

where E_1 : Heat release per unit mass of oxygen consumed due to complete combustion (MJ/kg O_2)

E_2 : Heat release per unit mass of oxygen consumed due to burning of CO to CO_2 (MJ/kg O_2)

Substituting Eqs.(14) and (16) into Eq.(20) and eliminating n_{O_2} and n_{CO} yield:

$$\dot{Q} = \frac{E_1 \left\{ a(X_{CO_2} + \frac{1}{2} X_{CO}) + (-\frac{b}{4} - \frac{c}{2})(X_{CO_2} + X_{CO}) \right\} - (E_1 - E_2) \frac{1}{2} X_{CO}}{D} W_{O_2} \dot{n}_{O_2}^o \quad (21)$$

Mole flow rate of O_2 , H_2O and N_2 that flow into the burn room can be obtained also based on the method given by Parker(1). Assuming that inflow air is not polluted with CO_2 , we get

$$X_{O_2}^o = \frac{\dot{n}_{O_2}^o}{\dot{n}_{N_2}^o + \dot{n}_{O_2}^o + \dot{n}_{H_2O}^o} \quad (22)$$

$$X_{N_2}^o = \frac{\dot{n}_{N_2}^o}{\dot{n}_{N_2}^o + \dot{n}_{O_2}^o + \dot{n}_{H_2O}^o} \quad (23)$$

$$X_{H_2O}^o = \frac{\dot{n}_{H_2O}^o}{\dot{n}_{N_2}^o + \dot{n}_{O_2}^o + \dot{n}_{H_2O}^o} \quad (24)$$

When the gases are analyzed by filtering out water in sampling line, the relationships between mole flow rates and measured concentration will be

$$X_{O_2}^{A^o} = \frac{\dot{n}_{O_2}^o}{\dot{n}_{N_2}^o + \dot{n}_{O_2}^o}, \quad X_{N_2}^{A^o} = \frac{\dot{n}_{N_2}^o}{\dot{n}_{N_2}^o + \dot{n}_{O_2}^o} \quad (25)$$

Then, from Eq.(21)/(Eq.(21)+Eq.(22)) and Eq.(24) we obtain

$$\frac{X_{O_2}^o}{X_{O_2}^o + X_{N_2}^o} = \frac{\dot{n}_{O_2}^o}{\dot{n}_{O_2}^o + \dot{n}_{N_2}^o} = X_{O_2}^{A^o}$$

or

$$X_{O_2}^o = X_{O_2}^{A^o} (X_{O_2}^o + X_{N_2}^o) = X_{O_2}^{A^o} (1 - X_{H_2O}^o) \quad (26)$$

We cannot measure $X_{N_2}^o$, however, since we have $X_{O_2}^{A^o} + X_{N_2}^{A^o} = 1$,

$$X_{N_2}^o = X_{N_2}^{A^o} (1 - X_{H_2O}^o) = (1 - X_{O_2}^{A^o}) (1 - X_{H_2O}^o) \quad (27)$$

A H_2O analyzer may not be available, but the way the concentration of H_2O can be estimated is also given in Ref.(1).

To obtain the mole outflow rate of each species, we further need to have fairly accurate inflow rate of air through room opening, \dot{m}_a . If we can have accurate enough air inflow rate, we can use the following relation:

$$W_{N_2} \dot{n}_{N_2}^o + W_{O_2} \dot{n}_{O_2}^o + W_{H_2O} \dot{n}_{H_2O}^o = \dot{m}_a \quad (28)$$

Dividing Eq.(28) by $\dot{n}_{N_2}^o + \dot{n}_{O_2}^o + \dot{n}_{H_2O}^o$, we get

$$\frac{\dot{n}_{N_2}^o + \dot{n}_{O_2}^o + \dot{n}_{H_2O}^o}{W_{N_2} X_{N_2}^o + W_{O_2} X_{O_2}^o + W_{H_2O} X_{H_2O}^o} = \frac{\dot{m}_a}{\dot{n}_{N_2}^o + \dot{n}_{O_2}^o + \dot{n}_{H_2O}^o} \quad (29)$$

Substituting this into Eqs.(22)-(24), and using Eq.(25) and (26) yield:

$$\dot{n}_{O_2}^o = \frac{X_{O_2}^{A^o} (1 - X_{H_2O}^o)}{D'} \dot{m}_a \quad (30)$$

$$\dot{n}_{N_2}^o = \frac{(1 - X_{O_2}^{A^o})(1 - X_{H_2O}^o)}{D'} \dot{m}_a \quad (31)$$

$$\dot{n}_{H_2O}^o = \frac{X_{H_2O}^o}{D'} \dot{m}_a \quad (32)$$

$$\text{where } D' = W_{N_2} (1 - X_{O_2}^{A^o})(1 - X_{H_2O}^o) + W_{O_2} X_{O_2}^{A^o} (1 - X_{H_2O}^o) + W_{H_2O} X_{H_2O}^o \quad (33)$$

Equations (12)-(19) and (30)-(33) provide a way to obtain the mole outflow rates of species and thus present a basic method to analyze what is going on in the room of origin. Probably the same discussion as the above can be applied to the doorway opening between the adjacent room and the exterior space to analyze the phenomena that take place in the two room structure. This is important, in particular when one attempts to clarify how the excess fuel behaves outside the room of origin.

REFERENCES

- (1) Parker, W.J.: Calculation of the Heat Release Rate by Oxygen Consumption for Various Applications, NBSIR 81-2427-1, 1982.

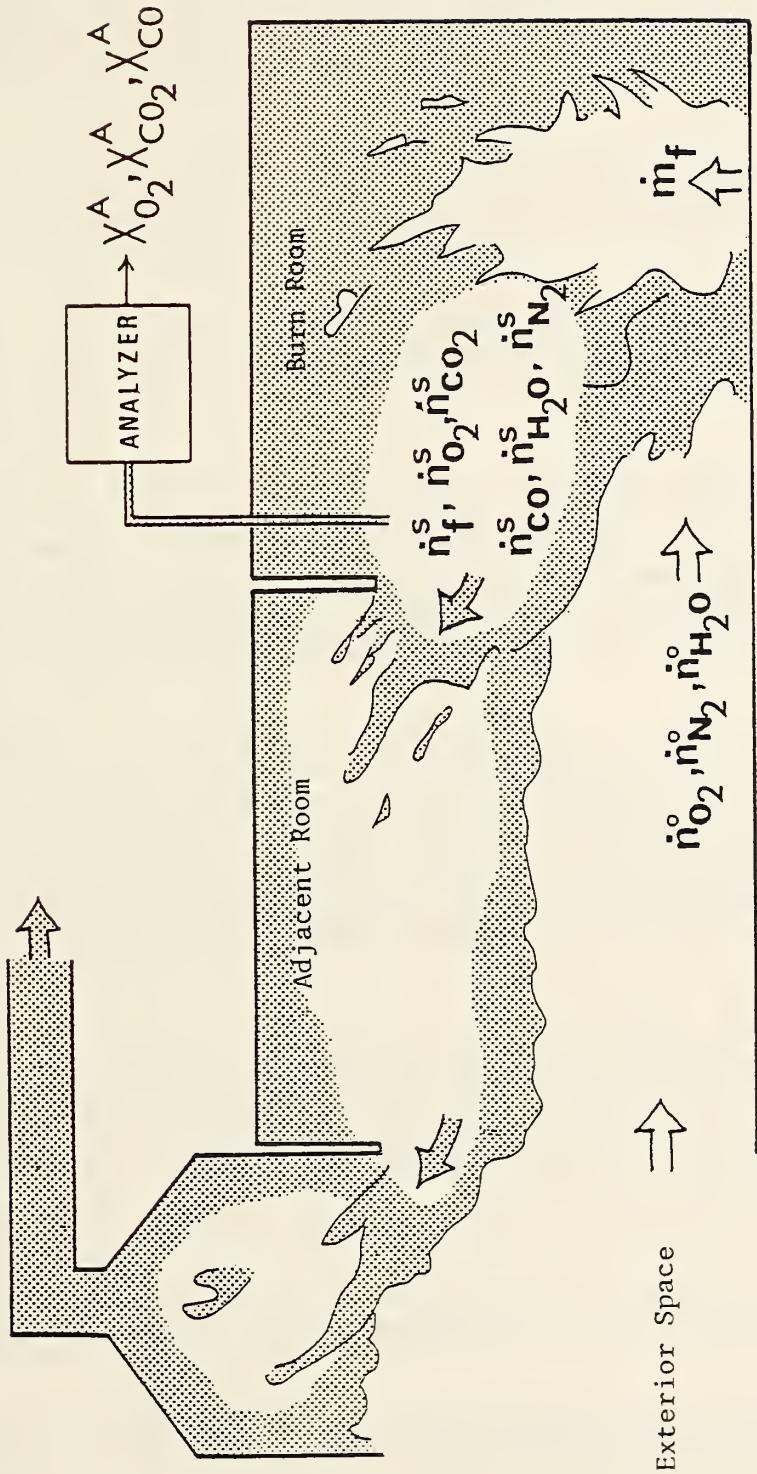


Figure A-1. Schematic of The Experimental Facility

Discussion After T. Tanaka's Report on STUDIES ON DETERMINATION OF BURNING
CONDITION FOR THE TOXICITY TEST

TSUCHIYA: Dr. Tanaka performed experiments in which CO and CO₂ occurred from burning wood. We have done similar experiments but on a smaller scale. Is it possible to combust the data into our methods of expression so that we can compare our results?

TANAKA: First of all, this study was conducted not by me but by Mr. Morikawa of the Fire Research Institute. I am not sure whether or not this kind of combustion will be possible or not but I'm sure Dr. Saito may be able to help. He has more knowledge about this matter.

GANN: Dr. Tanaka, in your two room burn experiments, do you think that the outer room affected the flow through the doorway between the rooms? Or, worded differently, would you expect the same results if the outer room were not threatened?

TANAKA: I think it's possible that the next compartment has a certain effect on the floor. When conducting this test between the second compartment and the outer space, there was a very large opening. So at the current stage because of this opening, I don't think there was a substantial effect of outflow from the doorway. I think it will be wise to study, when we conduct the next experiment, more openings between the second compartment and outside, so we can check what kind of effect it has.

STECKLER: Certainly if a hot layer forms in the second room, it will affect flow through the doorway. In these experiments a hot layer certainly did form. The flow is driven through the doorway as a result of the differences between the static pressure profiles. The temperature profiles in the room, in turn, establish the pressure profiles. The second room certainly does have an effect on the flow through the door. These experiments confirm that this relationship with this model works when you are working between two rooms, both with hot layers.

GANN: We have an informal report from Southwest Research that they burned a large room, with a large fuel load and it flashed over. They then repeated the experiment with a corridor connected outside of the room and the same fuel in the room and no flashover. I have not seen the data upon the gases coming out the door of the room, but I suspect that they are two very different cases.

ALARIE: In the chair burn experiments, how were the chairs ignited?

MIZUNO: We used about 150 of methanol and we used Softex, that is a kind of illustration board, and we soaked the illustration board with methanol and put it on the chair and ignited it.

ALARIE: Please show us again the residual way versus the time way? The best chairs are chairs #6 and #9. What are they made of?

MIZUNO: Chair #9 is kind of traditional type of chair and in a similar material. Chair #6 is polyurethane foam. I think that either way the upholstery is treated with a retardant. The furniture we used to burn are used ones so we do not have much information about the treatment.

ALARIE: What are the worst chairs, chairs #5 and #13, made of?

MIZUNO: I think the filling is the same as in #6 and #9. However, the upholstery cover was easier to ignite, easier to burn and also #6 was much easier to burn and it burned quickly.

CONDITIONS CONDUCIVE TO THE GENERATION OF HYDROGEN
CYANIDE FROM FLEXIBLE POLYURETHANE FOAM

by

Barbara C. Levin, Maya Paabo,
Mary Lou Fultz and Cheryl Bailey
Fire Toxicology Research
Center for Fire Research
National Bureau of Standards
Washington, D.C. 20234

7th Joint Meeting
U.S. - Japan Panel on Fire Research and Safety
UJNR, Washington, October 1983

Conditions Conducive to the Generation of Hydrogen Cyanide from Flexible Polyurethane Foam

Introduction

The greatest number of fire deaths in the United States results from fires which occur in one and two family residences [1]¹. While the initiation of most U.S. fires are attributed to heating and cooking accidents, those fires responsible for the largest percentage of fire deaths are initiated by cigarettes inadvertently discarded on soft furnishings, such as upholstered furniture and bedding materials [1,2]. Similar results have been found in Canada and the U.K. [3]. One of the scenarios leading to these fire deaths is envisioned as follows: the occupant falls asleep with a lit cigarette which drops into the crevice of a chair where it smolders for an undetermined length of time. The person may wake during this time and go to bed not realizing the cigarette is still smoldering in the chair crevice. The unsuspecting family may be asleep when the chair finally ignites causing a fire which can now spread and produce flashover conditions in the room. In many of these cases, the family members die from smoke inhalation (not burns) either in their beds or close to their beds, an indication of little or no effort to escape. Whether the occupants are incapacitated or killed by the toxic combustion products which are generated by the early smoldering conditions or those generated when the chair bursts into flames is unknown.

More than 90% of the upholstered furniture manufactured today contains some formulation of flexible polyurethane foam [4]. In 1980, over three million tons of flexible polyurethane were produced for use in the furniture, transportation, building, leisure, and shoe industries [5]. Flexible poly-

¹Numbers in brackets refer to the literature references listed at the end of this paper.

urethane foams, therefore, are important materials to evaluate for fire safety. Most of the tests that have been proposed for upholstered furniture assess ignitability characteristics, burning rates, and smoke production [3]. In addition, the toxicity of the total gaseous atmosphere produced by the thermal decomposition of flexible polyurethane foams under different conditions has been examined [6,7,8] and extensive chemical analyses of the combustion products have been performed [9].

All nitrogen-containing polymers, including flexible polyurethane foam, are potentially capable of producing the highly toxic combustion product - hydrogen cyanide (HCN). This work describes a two-phase thermal decomposition process which simulates a realistic fire scenario. These circumstances produce higher concentrations of HCN from flexible polyurethane foam than if the same material is thermally decomposed under strictly smoldering, pyrolytic, or flaming conditions.

Materials and Methods

The flexible polyurethane foams, GM-21 and GM-24, that were used in this study were obtained from the Products Research Committee (PRC) on the Fire Safety Aspects of Cellular Plastic Products, Office of Standard Reference Materials, National Bureau of Standards [10]. The formulation of GM-1 consisted of 68% polyol (glycerine-based polyoxypropylene and ethylene glycol) and 24% isocyanate (toluene diisocyanate 2,4 isomer - 80%; 2,6 isomer - 20%). The formulation of GM-24 is the same as GM-21 except for an added chlorinated phosphonate ester fire retardant (4.7% by weight).

GM-21 was tested under small-scale laboratory conditions according to the NBS toxicity test method [7] under flaming (25°C above its autoignition temperature) and non-flaming (25°C below its autoignition temperature) conditions. The material samples in these experiments were decomposed in a preheated cup furnace (Fig. 1) located below the 200 liter animal exposure chamber (Fig. 2). The system is static, i.e., all combustion products generated in the cup furnace go directly into the exposure chamber and remain there. Syringe samples of the gaseous atmosphere were analyzed for HCN with a gas chromatograph equipped with a thermionic detector [11]. In most experiments, natural convection was the only means of mixing the gases in the chamber. However, in some experiments, the addition of a stirrer to the exposure chamber made no difference in the measured gas concentrations when compared to the experiments without the stirrer. This indicated that satisfactory mixing occurred even without the stirrer.

Large-scale room burns of GM-21 were performed as follows: slabs of polyurethane foam (approximately 41 x 64 x 15 cm) were placed on a load cell in a room (2.4 x 3.0 x 3.0 meters) (Fig. 3). Smoldering of the foam was initiated by a heated wire. In other experiments, polyurethane chairs were burned in the same room. In these experiments, the smoldering was initiated by a lighted cigarette placed into the crevice formed by the seat cushion and right side arm. Smoldering proceeded for approximately one hour before the chairs burst into flames. In both the large-scale room burns of slabs and chairs, the HCN sampling point was from the 1.7 meter probe (Fig. 3). The gases in the room were not homogeneous, but layered due to the hot buoyant plume.

Experimental Results

When GM-21 was tested according to the NBS toxicity test method, toxicologically insignificant concentrations of HCN were generated (Fig. 4). Thirty mg/l and 20 mg/l of GM-21 produced 15-20 ppm and 5-10 ppm of HCN in the flaming mode and non-flaming mode, respectively. Burning the polyurethane foam under flaming conditions from the start did not produce the increased amounts of HCN regardless of the temperature at which the cup furnace was set. Figure 5 shows two flaming experiments, one where the cup furnace was set at 420°C and the other where the furnace was 800°C. In both cases, no more than 20 ppm of HCN was generated throughout the experiments, which, in these cases, lasted 60 minutes.

In the large-scale room burns of slabs of GM-21, little HCN was generated (approximately 10-20 ppm) as long as the material continued to smolder. However, if after an initial smoldering process, the material burst into flames (a phenomenon, which often occurred), the levels of HCN rapidly increased (Fig. 6). This increase in HCN immediately following the point of flaming was also seen in experiments in which the polyurethane foam chairs were burned (Fig. 7).

Dr. Alarie, using the University of Pittsburgh toxicity test method, has also observed an increase in HCN generation when GM-21 bursts into flame [6]. In the University of Pittsburgh method, the material is thermally decomposed at temperatures which increase 20°C per minute and will flame when it reaches its autoignition temperature.

In order to understand this HCN production, we attempted to reproduce the large scale conditions in a small scale laboratory test. First, we heated GM-21 at 375°C (non-flaming conditions) in the cup furnace for different time periods and then raised the temperature of the furnace in an attempt to ignite the remaining sample. Ignition was not achieved, but heating the residue caused a large increase in HCN. Figure 8 shows the HCN production after heating the samples (20 mg/l) at 375°C for various times from 15 minutes to 60 minutes. As long as the temperature of the cup furnace remained constant at 375°C, less than 20 ppm of HCN was generated. At the arrows, the temperature of the furnace was raised such that the temperature increased at a rate of approximately 13°C per minute until it reached 800°C when the experiments were terminated. The large increase in HCN follows the rise in temperature in each case. Figure 8 also shows a pronounced dip in the HCN concentrations about 20 minutes after the start of the temperature ramping. The reason for this reduction in HCN at this point is not known.

Examination of the residue at the end of the 375° temperature exposure showed both a black char and a yellow oil. The black char was removed and placed into a clean cup furnace which was preheated to 600°C. Figure 9 shows that most of the HCN is generated by heating the black char, although small amounts were produced when the yellow oil was heated. These results differ from those of Woolley [9] who heated flexible polyurethane foam at a low temperature (200-300°C) and then collected and condensed the yellow smoke that was emitted. When the condensed yellow smoke was heated to 800-1000°C, HCN was generated. In the NBS experiments, the residue remaining after the initial low temperature exposure was heated, not the smoke condensate.

As we now knew that the HCN was being produced from the char that was formed during the initial low temperature exposure, we hypothesized that increasing the char yield might increase the HCN production. Since many phosphorus-containing fire retardants in polyurethane foams act by increasing the char yield, we tested GM-24, a fire retarded PRC material. Figure 10 shows that the fire retarded foam produced twice as much HCN as the corresponding non-fire retarded foam when exposed to this two phase decomposition procedure. Residues from both GM-21 and GM-24 were generated from 30 minute low temperature exposures (375°C). These residues, when removed, cooled, weighed and reheated to 800°C, produced approximately the same amount of HCN as their respective virgin foams exposed to the two phase decomposition procedure without interruption (Fig. 10).

The possibility that the HCN was adsorbed on the char and released by heating was examined by both alkaline and acid extractions of the chars. No HCN was produced indicating that the HCN is not adsorbed but more likely is being generated from the breakdown of a nitrogen-containing compound peculiar to the char. Elemental analyses of the foams and the chars showed that the percent nitrogen (% N) relative to the starting material is increased in the char (Table 1). The fraction of nitrogen in the fire retarded char (GM-24) is equivalent to that found in the non-retarded char. Table 2 shows that 0.3 grams of char were formed from heating 3.88 grams of GM-21, whereas 0.7 grams of char were formed from 3.88 grams of GM-24. It is thus likely that the fire retarded char produces twice as much HCN upon heating because GM-24 produces twice as much char as GM-21.

If all of the nitrogen in the foam formed HCN, the theoretical yield of HCN from the total foam (3.88 grams or 20 mg/l) would be 1450 ppm. In experiments at 375°C, an average concentration of 10 ppm or 0.7% of the total theoretical yield is observed. At 800°C, 8% of the total nitrogen appeared as gaseous HCN. Analysis of the chars in the same way showed that 40% of their total nitrogen was recovered as HCN. These results suggest that the nitrogen-containing compound found in the chars is more likely to generate HCN when heated than the nitrogen-containing molecules in the original foams. More work is in process to determine the chemical and physical mechanisms of HCN production from the chars.

Conclusion

This study has shown that simple, single-mode thermal exposures (flaming or non-flaming) of flexible polyurethane foam do not generate the HCN found in the dominant real fire situation. A two-stage chemical process in which first a char is formed during the smoldering of the polyurethane and then HCN is produced when that char is heated is the more likely and potentially more dangerous scenario. The chemistry of the process remains to be elucidated.

References

1. Fire in the United States, 2nd Edition. Federal Emergency Management Agency, U.S. Fire Administration; July 1982, 181 p.
2. Clarke, F.B. and Ottoson, J., Fire death scenarios and fire safety planning. *Fire J.* 70:20-22, 117-118 (1976).
3. Sumi, K., and D'Souza, M.V., Fire safety of soft furnishings - an overview. *Fire and Materials* 6:16-22 (1982).
4. Krasny, J., National Bureau of Standards, personal communication 1983.
5. Woods, G., in Flexible Polyurethane Foams. Chemistry and Technology. Applied Science Publishers, London and New Jersey (1982).

6. Alarie, Y.C. and Anderson, R.C., Toxicological and acute lethal hazard evaluation of thermal decomposition products of synthetic and natural polymers. *Tox. Appl. Pharm.* 51:341-362 (1979).
7. Levin, B.C., Fowell, A.J., Birky, M.M., Paabo, M., Stolte, A., and Malek, D., Further development of a test method for the assessment of the acute inhalation toxicity of combustion products. *Nat. Bur. Stand. (U.S.)* NBSIR 82-2532, June 1982, 143 p.
8. Hilado, C.J., Relative toxicity of pyrolysis products of some foams and fabrics. *J. Comb. Tox.* 3:32-60 (1976).
9. Woolley, W.D. and Fardell, P.J., The prediction of combustion products. *Fire Research* 1:11-21 (1977).
10. Products Research Committee. Materials bank compendium of fire property data. *Nat. Bur. Stand. (U.S.)*, [Washington, DC] February 1980.
11. Paabo, M., Birky, M.M., and Womble, S.E., Analysis of hydrogen cyanide in fire environments. *J. Comb. Tox.* 6:99-108 (1979).

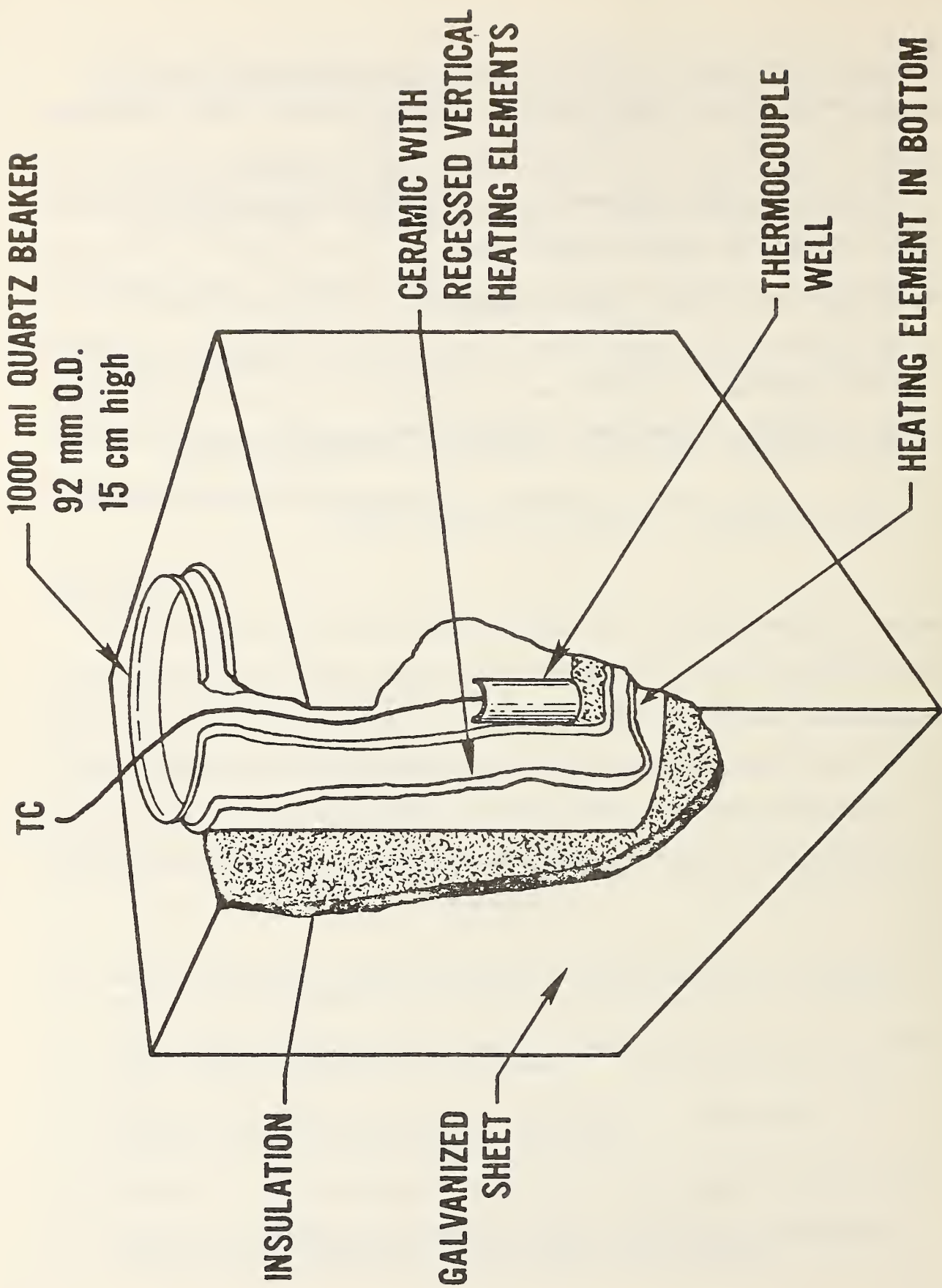


Figure 1. Pyrolysis/combustion furnace used in small-scale tests.

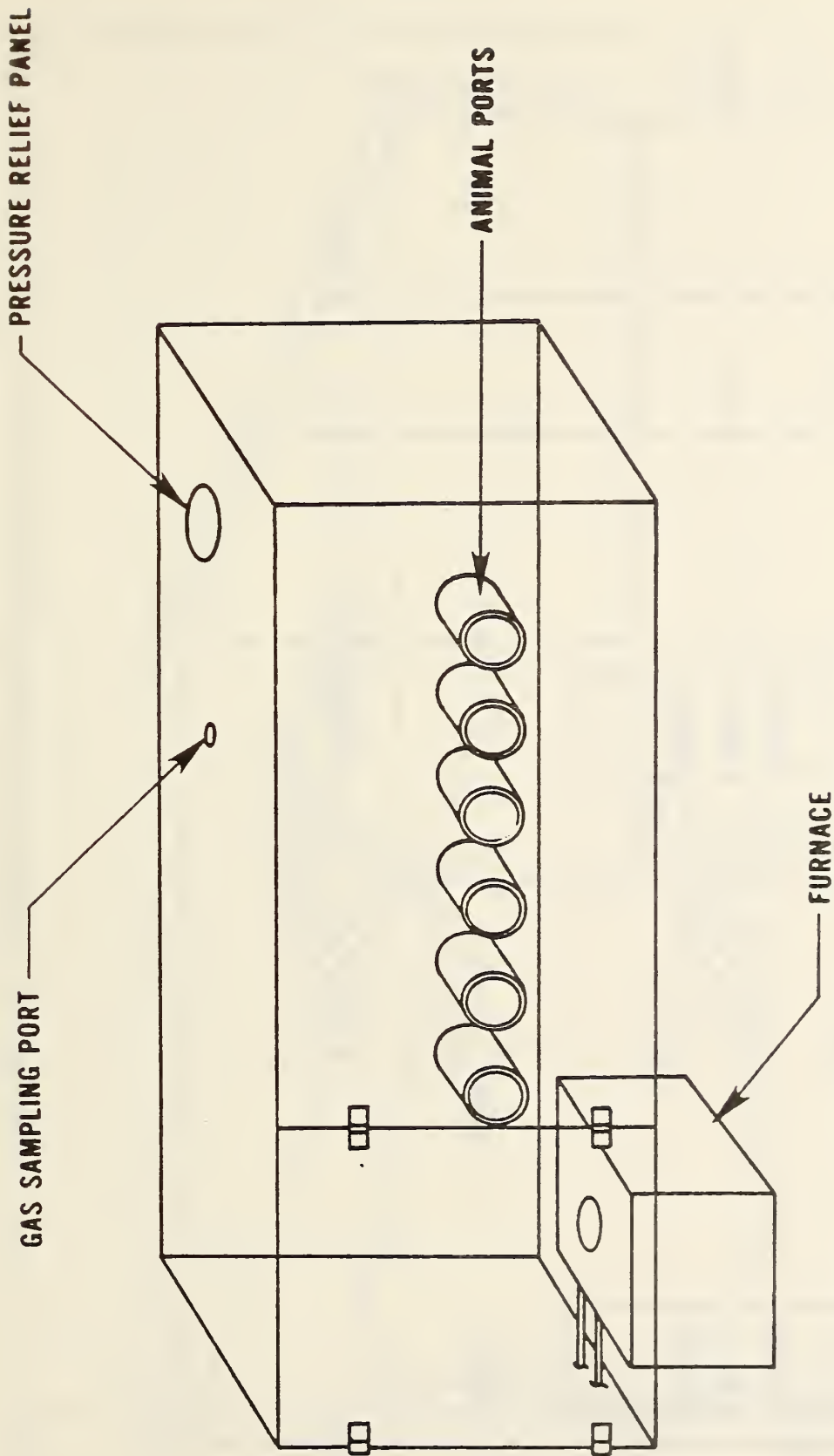


Figure 2. Exposure chamber for small-scale tests.

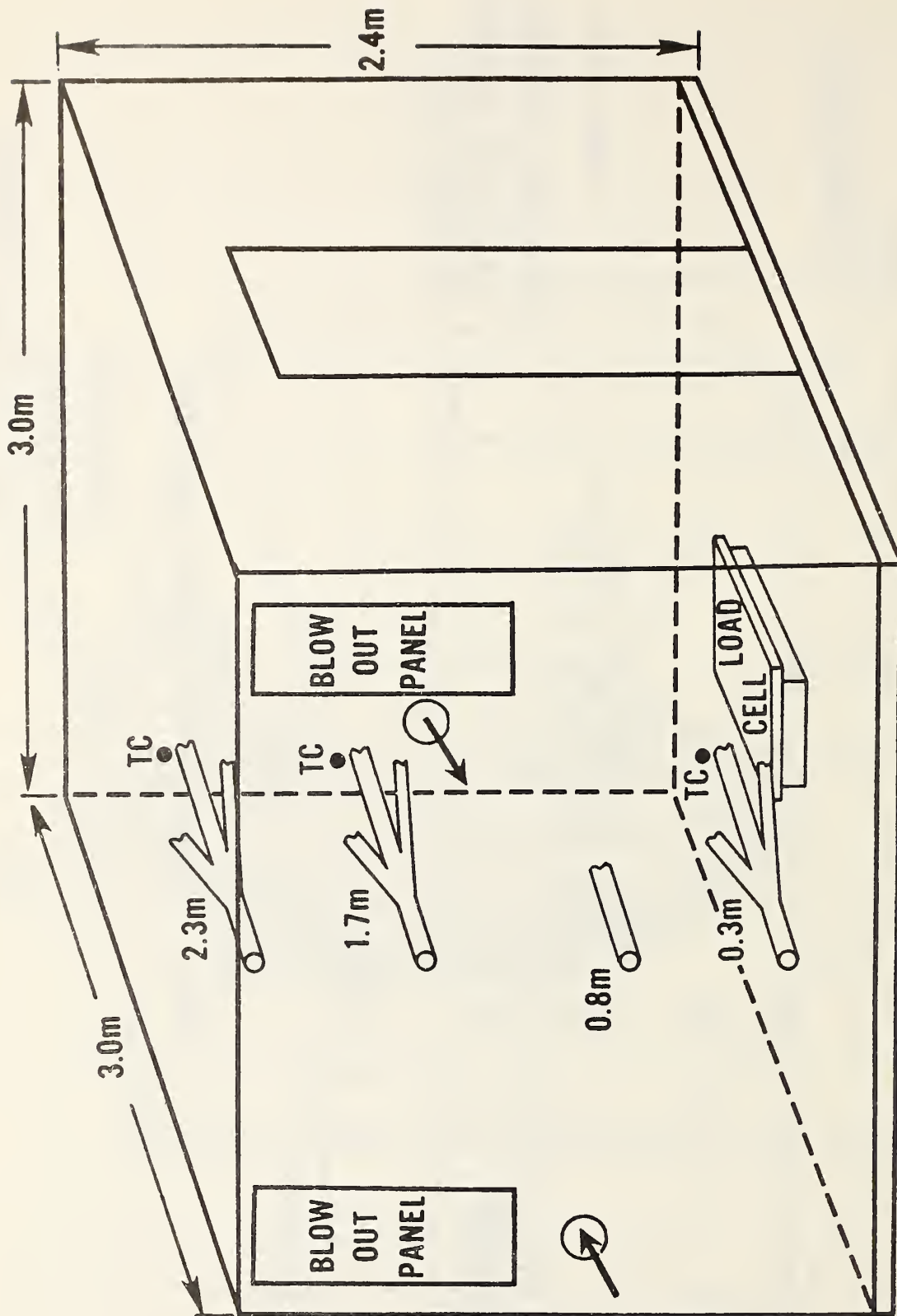


Figure 3. Configuration of large-scale test room.

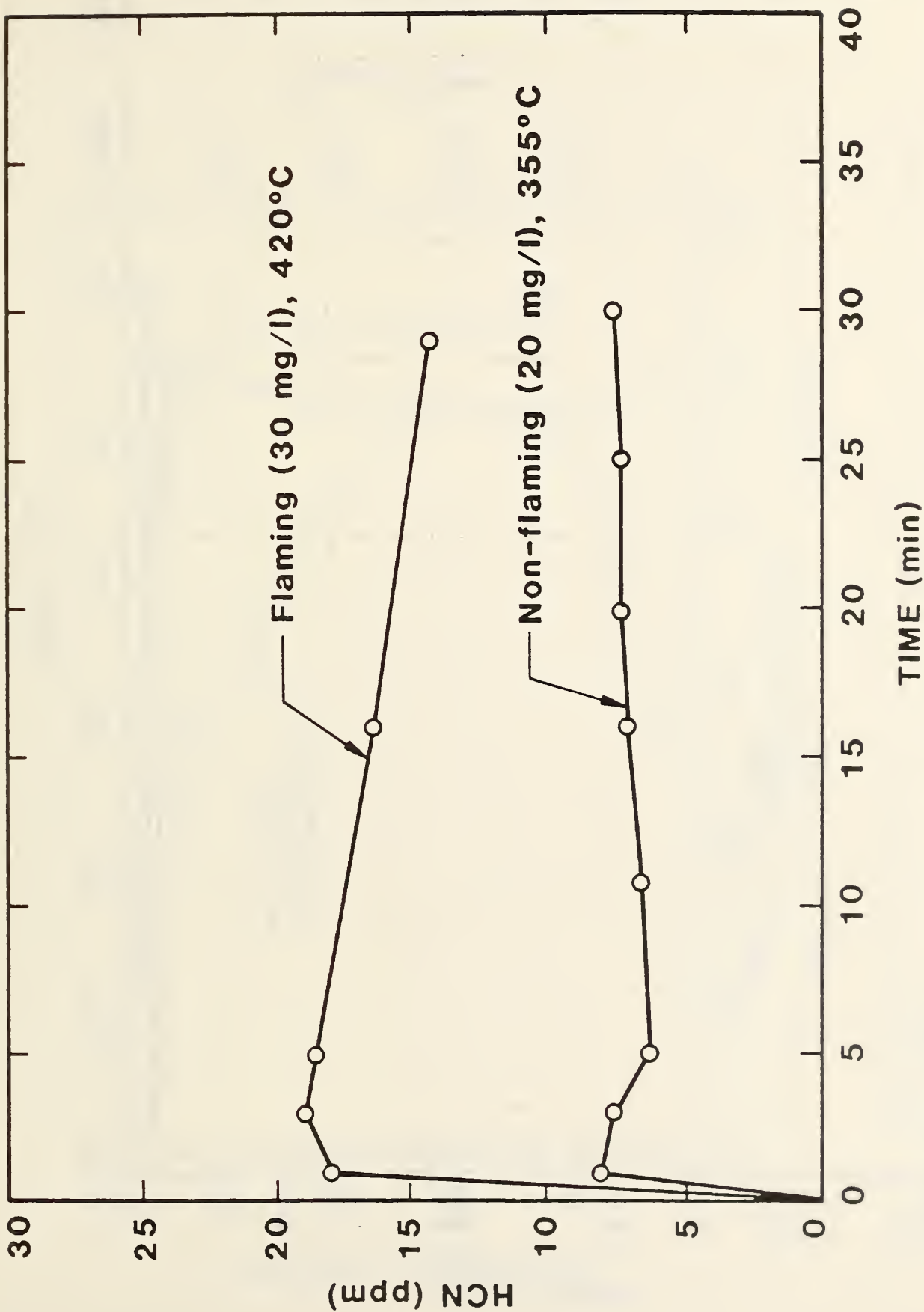


Figure 4. HCN generation from small-scale laboratory tests on flexible polyurethane foam, GM-21.

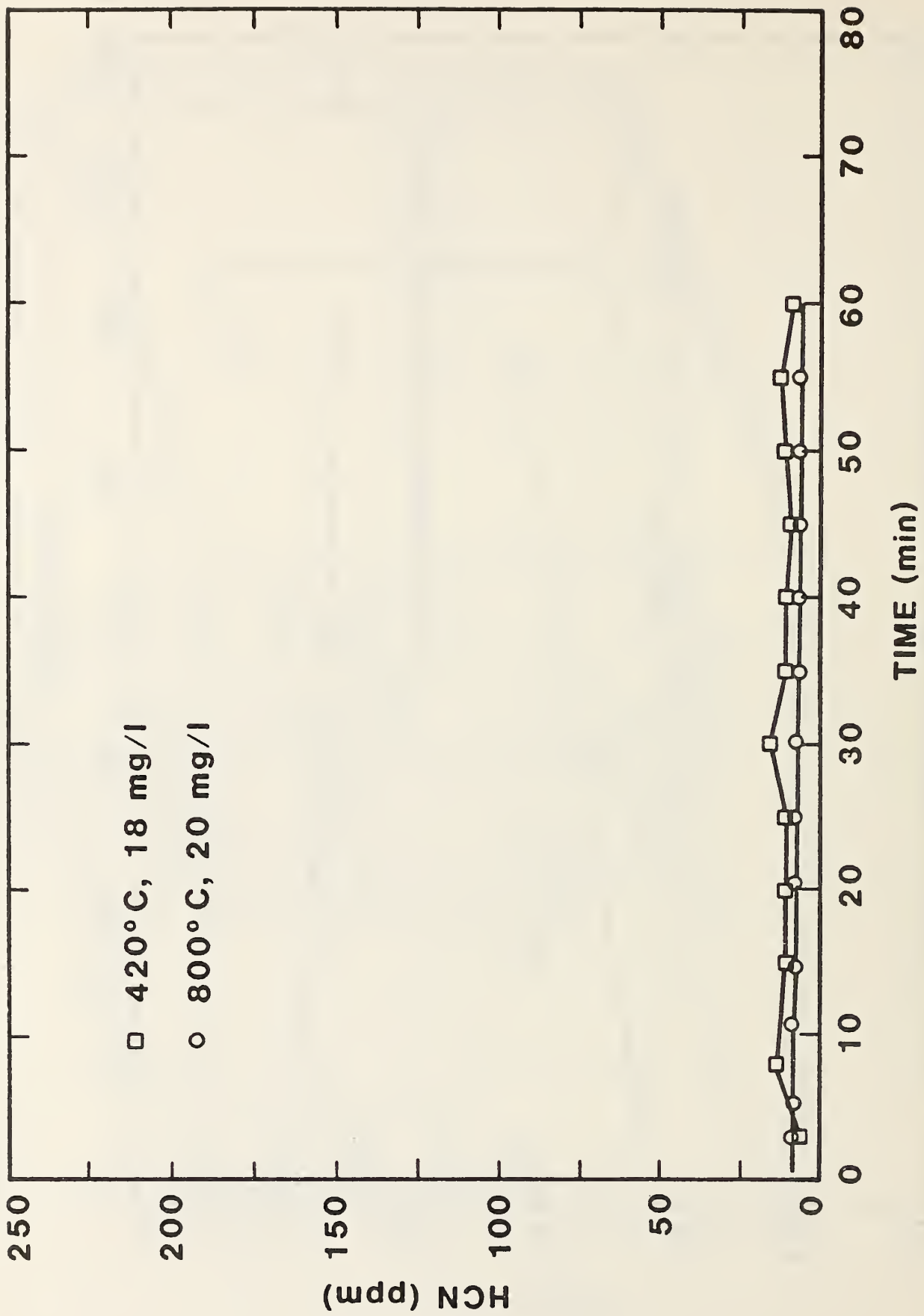


Figure 5. HCN generation from flexible polyurethane foam (GM-21) decomposed in the flaming mode at 420°C and 800°C.

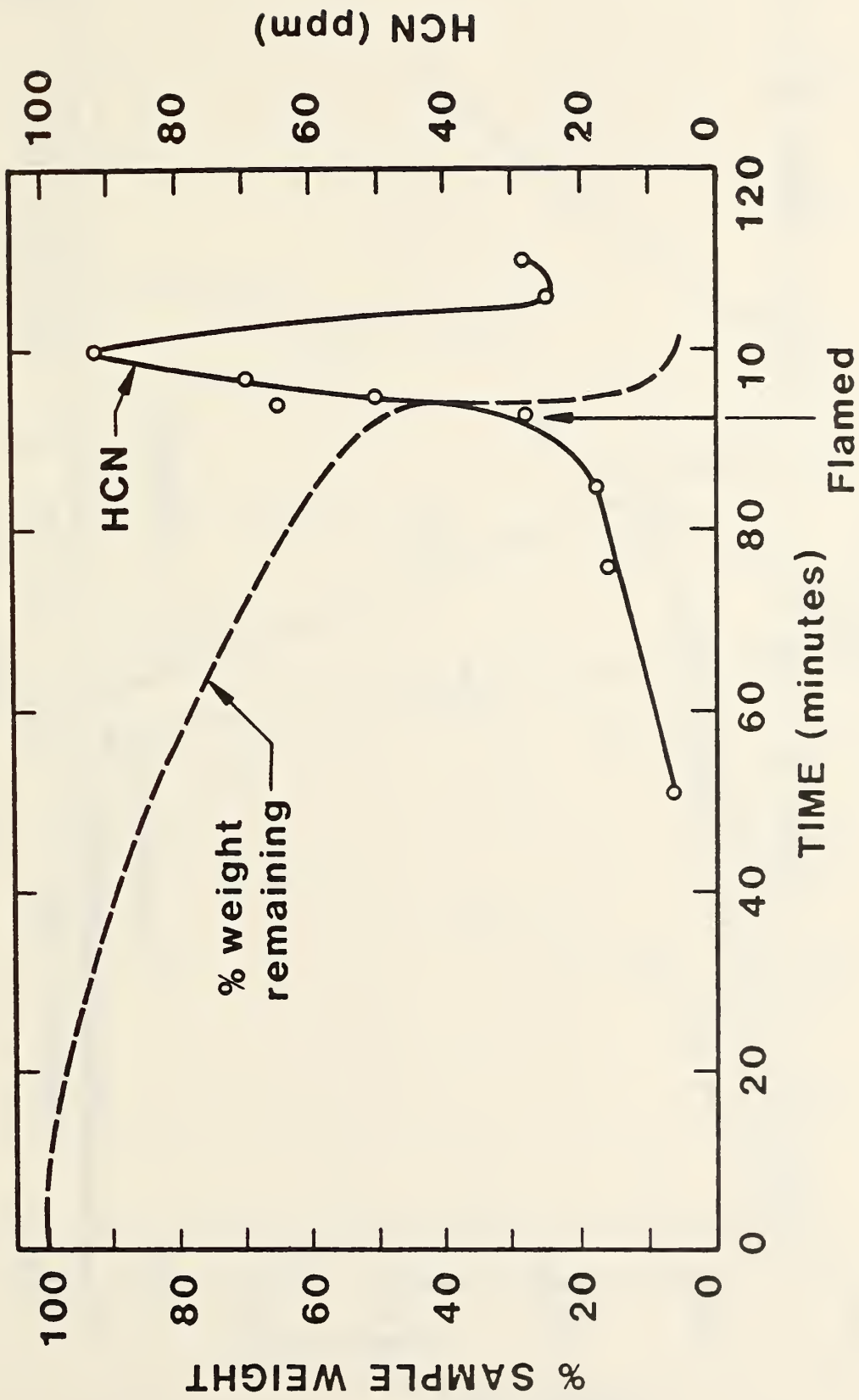


Figure 6. HCN generation and weight loss during large-scale room burn of flexible polyurethane foam, GM-21.

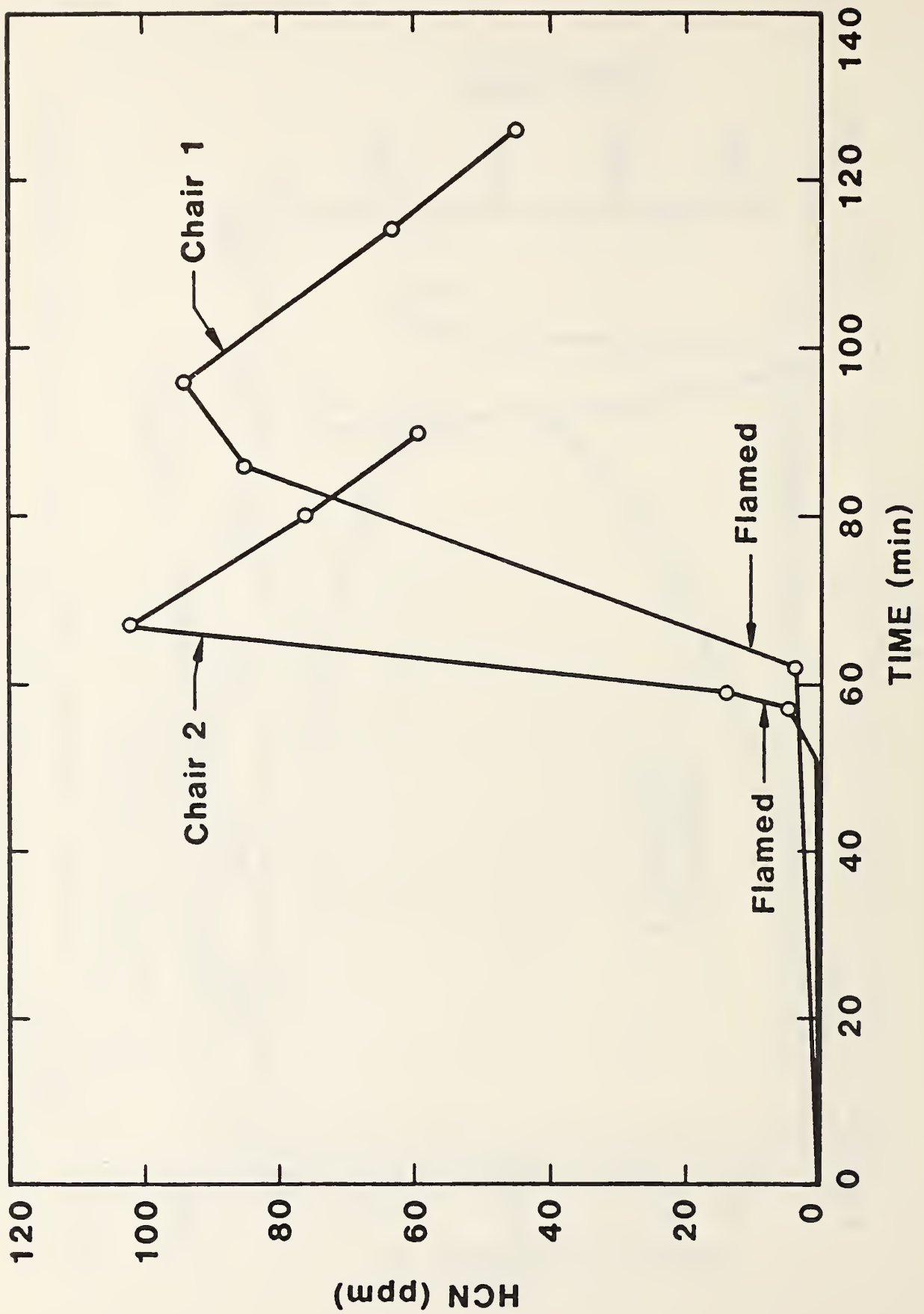


Figure 7. HCN generation from the thermal decomposition of flexible polyurethane foam chairs.

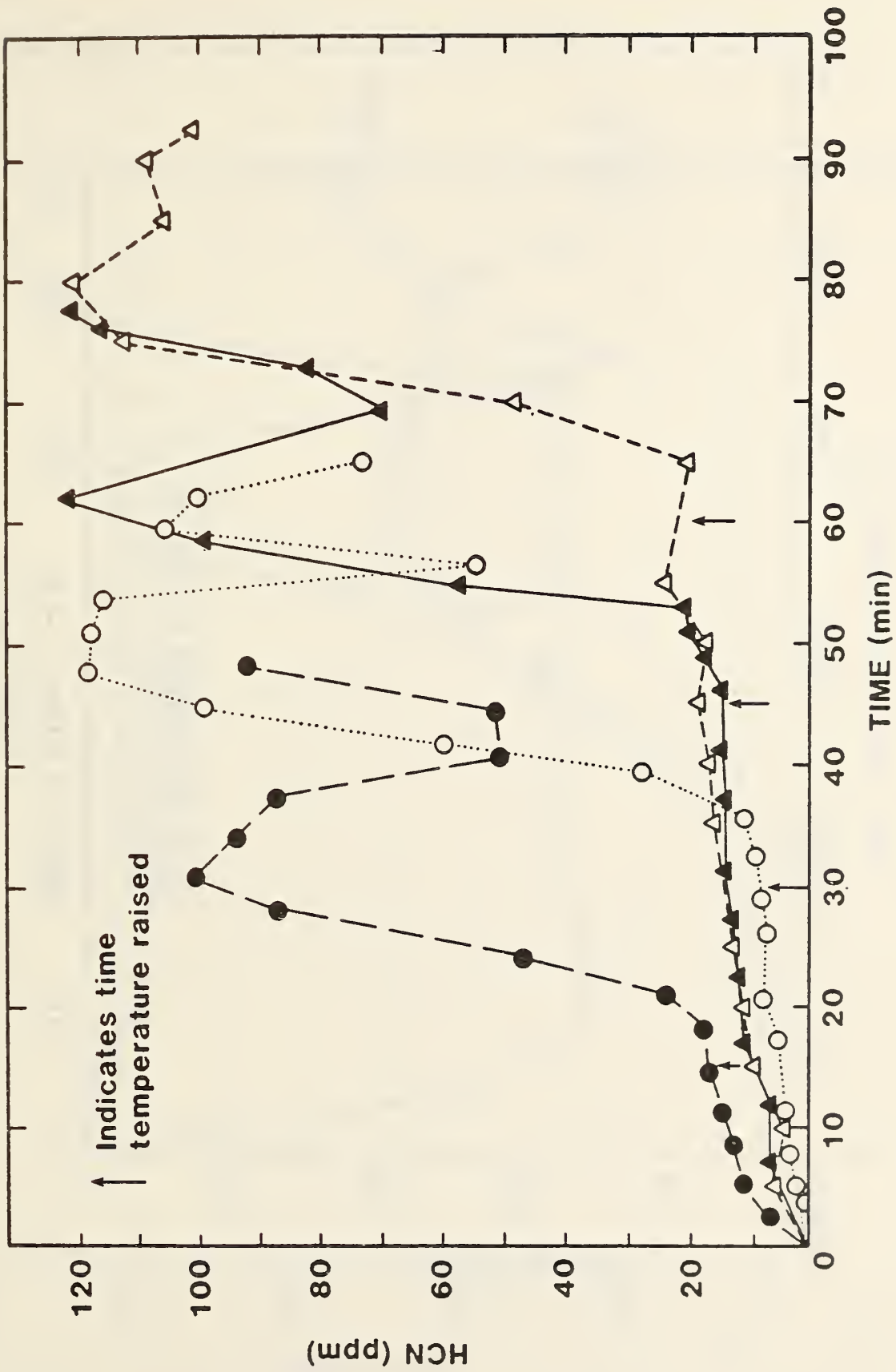


Figure 8. HCN generation from flexible polyurethane foam (GM-21) exposed to a two-phase decomposition process.

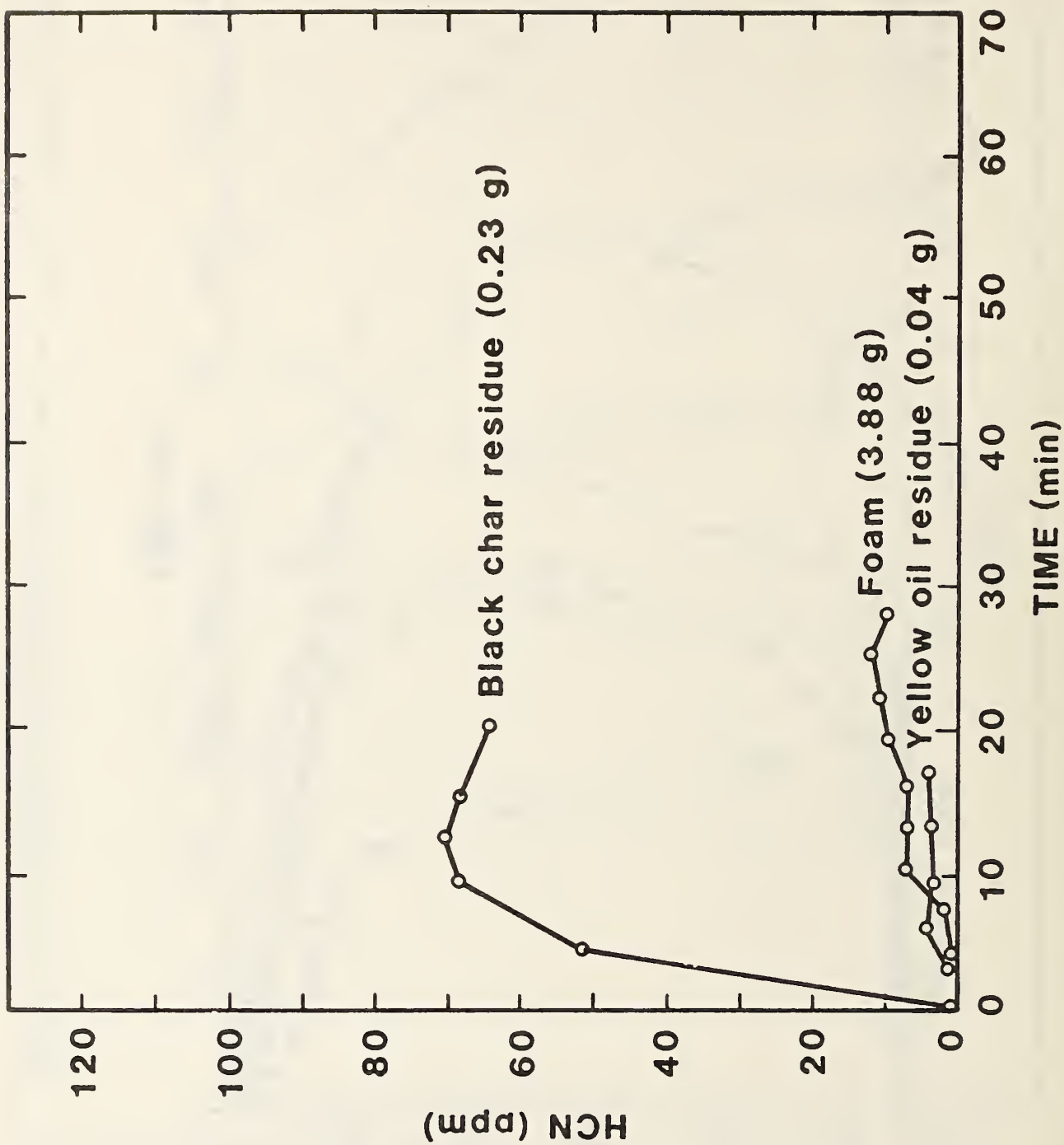


Figure 9. HCN generation from flexible polyurethane foam (GM-21) and the black char and yellow oil residues.

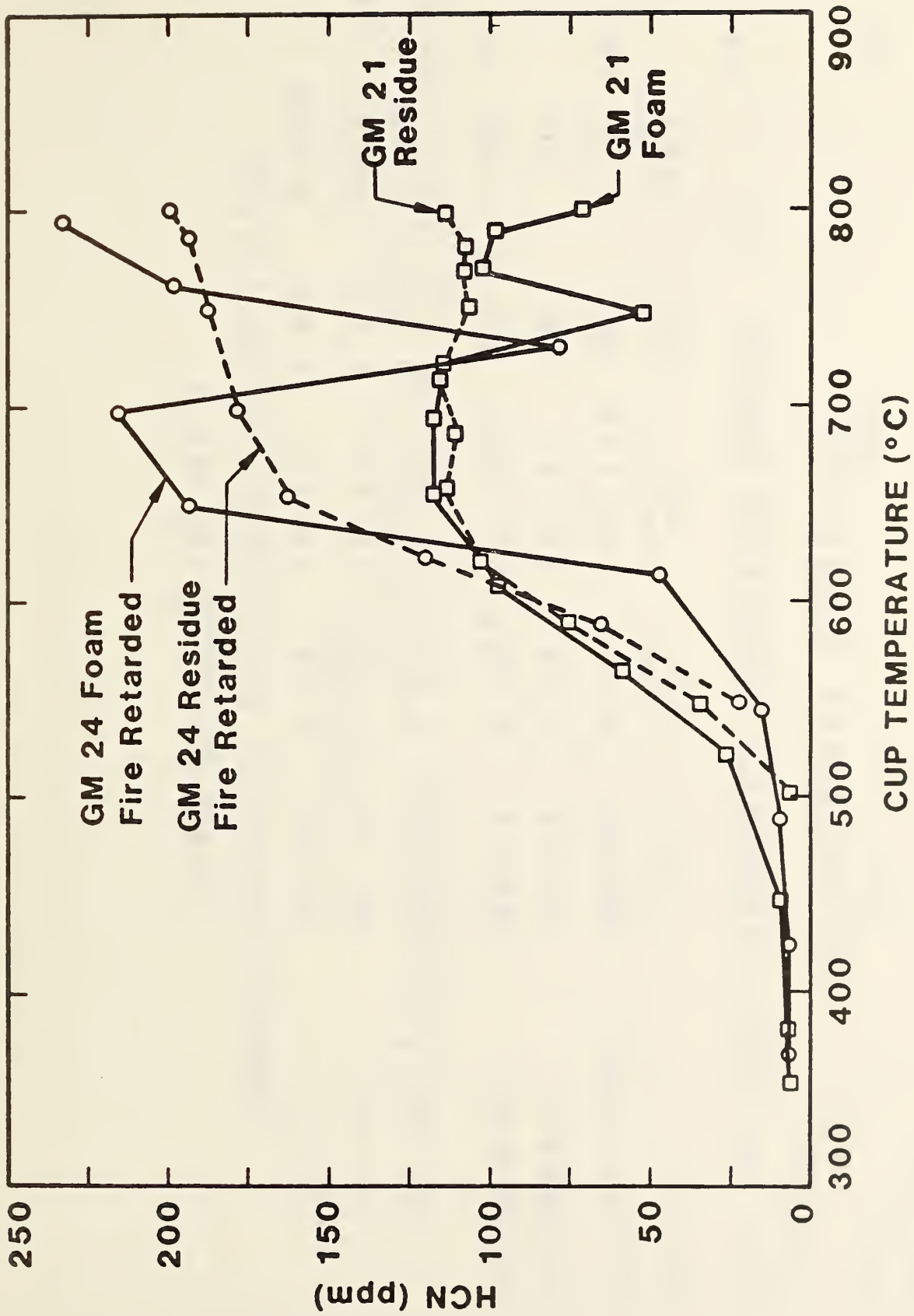


Figure 10. HCN generation from fire retarded (GM-21) and non-fire retarded (GM-21) flexible polyurethane foam and their residues.

Table 1

ELEMENTAL ANALYSIS OF FLEXIBLE POLYURETHANE

	<u>%C</u>	<u>%H</u>	<u>%N</u>	<u>%P</u>	<u>%Cl</u>
FPU GM21	61.20	8.70	4.21	ND	ND
Char A	60.37	2.84	12.12	ND	ND
Char B	63.71	3.22	11.13	ND	ND
FPU GM 24	59.23	8.65	4.25	0.69	1.69
Char A	60.17	2.93	10.17	2.42	0.027
Char B	59.82	2.92	10.16	2.44	0.025

Table 2

GENERATION OF HCN FROM FLEXIBLE POLYURETHANE FOAM

	HCN (ppm)			
	Theoretical		Experimental	
	375°C	800°C	375°C	800°C
FPU-GM 21 (3.88 g)	1450	10	120	0.7
Char (0.3 g)	280	-	120	40
FPU-GM 24 (3.88 g)	1450	5	230	0.3
Char (0.7 g)	610	-	200	33

Discussion After B. Levin's Report on CONDITIONS CONDUCIVE TO THE GENERATION OF HYDROGEN CYANIDE FROM FLEXIBLE POLYURETHANE FOAM

TSUCHIYA: I remember there was an instance in Japan, about 10 years ago, in which two elderly people were killed in a small fire involving a polyurethane mattress. As a result of this incident, there were serious discussions between a person representing the polyurethane industry and two toxicologists who analyzed hydrogen cyanide level in blood. The study on the evolution of hydrogen cyanide from various nitrogen-containing materials involving polyurethane was advanced very much, five to ten years ago in Japan. I'd like to comment on Mr. Morita's work on the generation of hydrogen cyanide. I hope you are aware of that paper in the Journal of Combustion Toxicology. Also we performed our own study on the subject and included these results. I'd like to mention the formation of hydrogen cyanide in fire. Hydrogen cyanide formation is almost proportional to the nitrogen content of materials, except in some materials like polyethylnitrate, which produces hydrogen cyanide much easier than others. The second point, in pyrolysis conditions hydrogen cyanide formation depends on temperature, the higher the temperature, the easier the formation of hydrogen cyanide. In flaming, the temperature after pyrolysis of the sample increases. From smoldering to flaming the temperature increases, that's why hydrogen cyanide formation is viscous. For a rather brisk flame, hydrogen cyanide was formed and consumed in the flame. Once hydrogen cyanide formed but by the flame, hydrogen cyanide is consumed and it is converted to nitrogen oxide. So, probably what you are finding in your experiment can be explained this way. Another point, in flame retardant polyurethane, you found more than non-treated polyurethane. So I suspect in non-treated polyurethane, flaming is easier. In flaming, the temperature is higher than treated polyurethane.

LEVIN: In the experiments that we did in the hot furnace, there was no flame. We just heated the chars. When we tried to heat the material immediately, it would flame and we did not see the cyanide. But in the experiments where we smolder for 15 or 30 minutes and then raise the temperature, we did not see any flaming...just heating the chars.

ALARIE: You said that when the sample is heated prior to ignition, there is a better way to represent real-life situations in terms of HCN production for smoldering polyurethane. Is that what you said?

LEVIN: I said that it simulates the more realistic situation.

ALARIE: So, if this is correct, I will put a statement to you. Since the small scale combustion system of the University of Pittsburg simulates exactly the HCN release of the real-life situation of smoldering polyurethane, would you agree that the University of Pittsburgh method is a much better method than the NBS method?

LEVIN: I do not think that any one method at this time is going to tell us all that there is to know about how materials react in fire.

ALARIE: That was not my question. I asked a very specific question for a very specific material under a very specific condition. It is clear to me that the NBS way of decomposing polyurethane in no way comes even close to simulating smoldering polyurethane.

LEVIN: I think it does show us how smoldering polyurethane reacts. What it doesn't do is show us this transition from the smoldering to the flaming. I think it was through our efforts now that we have found out about the char formation.

ALARIE: But I think this is irrelevant. What is relevant is this: If, when you burn polyurethane in the NBS combustion system and you get no hydrogen cyanide whatsoever, while in the real-life condition you generate a tremendous amount of hydrogen cyanide, then it's obvious to me that the NBS method does not simulate the real-life condition. To me that's the important aspect of it.

LEVIN: Well, I have to agree that we do realize there are some limitations to the combustion system that we now have. It is for this reason that we are now designing a new combustion system.

ALARIE: Thank you, that's what I wanted to hear. To me there is no sense doing toxicity with systems that are nowhere close to producing the gases that we see in real life situations. Now I would say that when you start working with a combustion system, it's difficult to predict if it will match, let's say, a medium scale situation. We don't do real large scale, more medium scale. But, I think when you find afterwards that the method is not good, you should stop using it.

DEVELOPMENT OF LABORATORY TEST APPARATUS FOR
EVALUATION OF TOXICITY OF COMBUSTION
PRODUCTS OF MATERIALS IN FIRE

Shyuitsu Yusa

Organic Materials Division
Building Research Institute
Ministry of Construction

Seventh Joint Meeting
U.S.-Japan Panel on Fire Research and Safety
UJNR, Washington, DC, October, 24-28, 1983

DEVELOPMENT OF LABORATORY TEST APPARATUS FOR
EVALUATION OF TOXICITY OF COMBUSTION
PRODUCTS OF MATERIALS IN FIRE

Shyuitsu Yusa

1. INTRODUCTION

To develop a laboratory scale burning test apparatus is one of the main goal of the United States-Canada-Japan Trilateral Research Group on Toxicity of Combustion Products from Building Materials and Interior Goods.

In Japan, according to the planed activity, Building Research Institute, Ministry of Construction, and Research Institute of Polymer and Textile, Ministry of International Trade and Industry are conducting research programs on developing the laboratry scale burning test apparatus for the evaluation of the toxicity. The main research program is shown in Figure 1, and both BRI and RIPT are in the step of the examination of characteristics of the apparatuses. The apparatus developed at BRI is designed to supply air in furnace and the one developed at RIPT is closed type.

The BRI has proceeded the study using a testing apparatus for evaluation of toxicity with thermal radiation and forced ventilation. The goal of this study is to develop laboratory test apparatus that is able to evaluate the toxicity of combustion products of materials in fire both by biological method (namely animal exposure method) and by chemical analysis method. In this test apparatus, the burning condition is to simulate the condition to which the materials are exposed in real fire. It is desirable that the test apparatus be made capable of producing useful data for the assesment of toxic hazards as well as being used for the purpose of screening the extremely toxic materials.

In case of evaluating the toxicity of combustion products of materials by the procedure which makes the test animals inhale the products until some kinds of symptom appear, there will be various factors for variation such as scatter in the animals themselves.

Furthermore, the condition of generation of toxic products will vary due to variation in combustion condition, e.g., furnace geometry, air supply rate, material size, combustion mode, etc.

Both BRI method¹⁾ and NBS method²⁾ have limited suitability for low density materials, laminates, coated specimens, and many other commercial products because of using the crucible type combustion furnace. Therefore, in the first step, the test apparatus is designed to use a thermal radiation device. An advantage of this test method is that it permits the evaluation of many end use materials. The surface of materials are exposed to heat, which is the way materials are likely to be exposed in certain stages of a real fire. Additionally, the atmospheric oxygen concentration which may affect the gas phase combustion can be controlled.

The laboratory toxicity test apparatus that we are seeking to develop in this project is supposed to be given the burning condition determined based on the analysis of the full scale fire experiments. However, there are still many other flexibilities in designing the test apparatus which may affect the test results, e.g., geometry and dimensions of the furnace, dimension and orientation of test samples, heating method and flow system. Accordingly, we will take an approach to these items in the second step.

2. BASIC DESIGN OF THE APPARATUS

Taking into account the goal of this project, and assessing the advantage and disadvantage of various kinds of toxicity test methods and flammability test methods in Japan, United States, Canada and some other countries, we started the development of the apparatus with a trial development of the apparatus whose specifications are described in the following, and set up the apparatus as shown in figure 2.

- (1) The combustion system
- :heating system ----- electric radiation heater (cone furnace of ISO type)
 - :furnace ----- cone shaped quartz tube (40 mm in inner diameter at the upper part, 164 mm in inner diameter at the lower part, 3 mm thick)
 - :air supply system --- mechanical supply (air, air+N₂ mixture), air temperature control system
 - :test sample ----- commercial products, horizontal orientation and vertical orientation*
- (2) The exposure system
- :exposure method ----- static, whole body exposure, 15-30 minutes of exposure, more than 16% of O₂ chamber concentration, less than 35°C of chamber temperature
 - :animal ----- species: mouse
- (3) Measurements
- :mass loss ----- continuous measurement during the test
 - :chamber atmosphere -- continuous measurement of the concentrations of O₂, CO₂, CO, and temperature: concentrations of HCN and HCl at a fixed time interval
 - :effect to animals --- time to incapacitation, time to death, LC₅₀, etc.

Note: * In the second step

3. METHOD OF TESTING

(1) Examination of Characteristics of the Test Apparatus

The characteristics of the quartz tube furnace are examined by burning the several representative materials i.e. insulation board, lauan, polymethylmethacrylate (PMMA), etc. under several sets of

conditions of radiative flux, O₂ concentration, air supply rate, supplied air temperature, and analysing the concentrations of O₂, CO₂, and CO at the top of the quartz tube. In the tests of quartz tube furnace, test samples are burned also in vertical orientation to explore the feasibility of testing thermoplastics and thermo-setting materials with the same furnace.

Experiments of this series, however, have not carried out wholly, and, therefore, partial data have been released in this report.

(2) Animal Exposure Tests

As stated earlier, static exposure is the basic method to expose animals to combustion products. Since air is supplied mechanically and may cause unsuitably high pressure in the exposure chamber, some device such as an air bag is introduced to prevent the high pressure and still to retain the advantage of static exposure method. Furthermore, this system could have a constant volume in which the combustion products diffuse by emptying the air bag inside the exposure chamber.

The exposure chamber is designed to make flexible the time to introduce the combustion products to the chamber so that only the combustion products from steadily burning materials could be introduced. Additionally, it is also designed to produce a square wave exposure condition to the animals. The nominal volume of the chamber is 125 liters, and the volume of the air bag is about 60 liters at maximum.

However, no data have as yet been released showing test results obtained from the animal exposure test. Therefore, findings of this test method concerning biological assay cannot be drawn at this time.

(3) Method of Conducted Tests

The object of these tests is, first, to obtain the information for discussing whether the apparatus is to represent burning condition and burning behavior of materials in fire, and secondly, to collect the data for conducting animal exposure tests appropriately.

The materials used for testing are indicated in Table 1. The materials were made into specimens 10 cm in diameter and 10 mm in thickness, and conditioned in a constant humidity chamber maintained at 50 to 60% relative humidity at a temperature of 21-25°C for a period of more than 72 hours prior to testing.

The testing apparatus is as indicated in Figure 2 and comprises combustion device and an exposure chamber of 125 liter capacity made of polymethylmethacrylate. The cone quartz combustion tube is held inside a cone radiative electric furnace, called ISO cone heater. The cone quartz tube is 40 mm, and 164 mm in diameter at the upper and lower parts, and 3 mm in thickness. The mass loss of the samples during the tests is measured continuously by the load cell. From the bottom of the quartz tube and around the sample, air or air, N₂ mixture (this time air only) is supplied to continue the combustion. At the top of the cone quartz tube, the gasket is set up to make the time to introduce the products arbitrary so that a selected part of combustion could be introduced.

The gas concentration in the exhaust path is measured by a magnetic type analyzer for O₂, and by an infrared ray analyzer for CO₂ and CO.

Radiative flux level is fixed to 2.5 w/cm², and samples are under flaming conditions as earlier as possible by using electric spark ignitor. The supplied air rate is varied for each material from about 3.8 to 15.3 liter per second per unit surface area of sample (l/sec/cm²). Those figures correspond to 5 to 20 l/min in the tests.

4. RESULTS AND CONSIDERATIONS

Since all experiments have not yet conducted, general conclusion on animal exposure method must await further research for development. However, following results have been drawn on the characteristics of combustion for char forming materials.

The mass loss rate of insulation board is nearly divided in two phases, i.e., flaming and embers states as shown in Figure 3. In the flaming state, the mass loss rate is affected by air supplying rate and shows about two weak peaks. However, by visual observation, the flame was got out of shape under shorter air supply than 5.0 l/sec/cm^2 .

The evolution of CO from insulation board differs due to the air supply rate as can be seen from the CO concentration in Figure 4, and the extent of variation is greater than that of mass loss rate even if considering the dilution effect of the air supply. The CO evolution under the embers situation is relatively high, and this can be seen more clearly from CO/CO₂ ratio which is indicated in Figure 5, and from the relationship between CO yield and air supply rate shown in Figure 9. This property will come into question in developing appropriate strategy for dealing with combustion toxicity by using animal exposure method.

Above characteristics may apply to the results of lauans as shown in Figures 6 to 9, and it is conceivable that wooden materials may have similar characteristics. So problem will be encountered with corresponding the combustion toxicity of embers situation to real fire scenarios when these materials are burned away.

Therefore, for the evaluation of combustion toxicity by the animal exposure method, it will be one of the useful method to expose animals to the specific burning conditions such as flaming and/or embers.

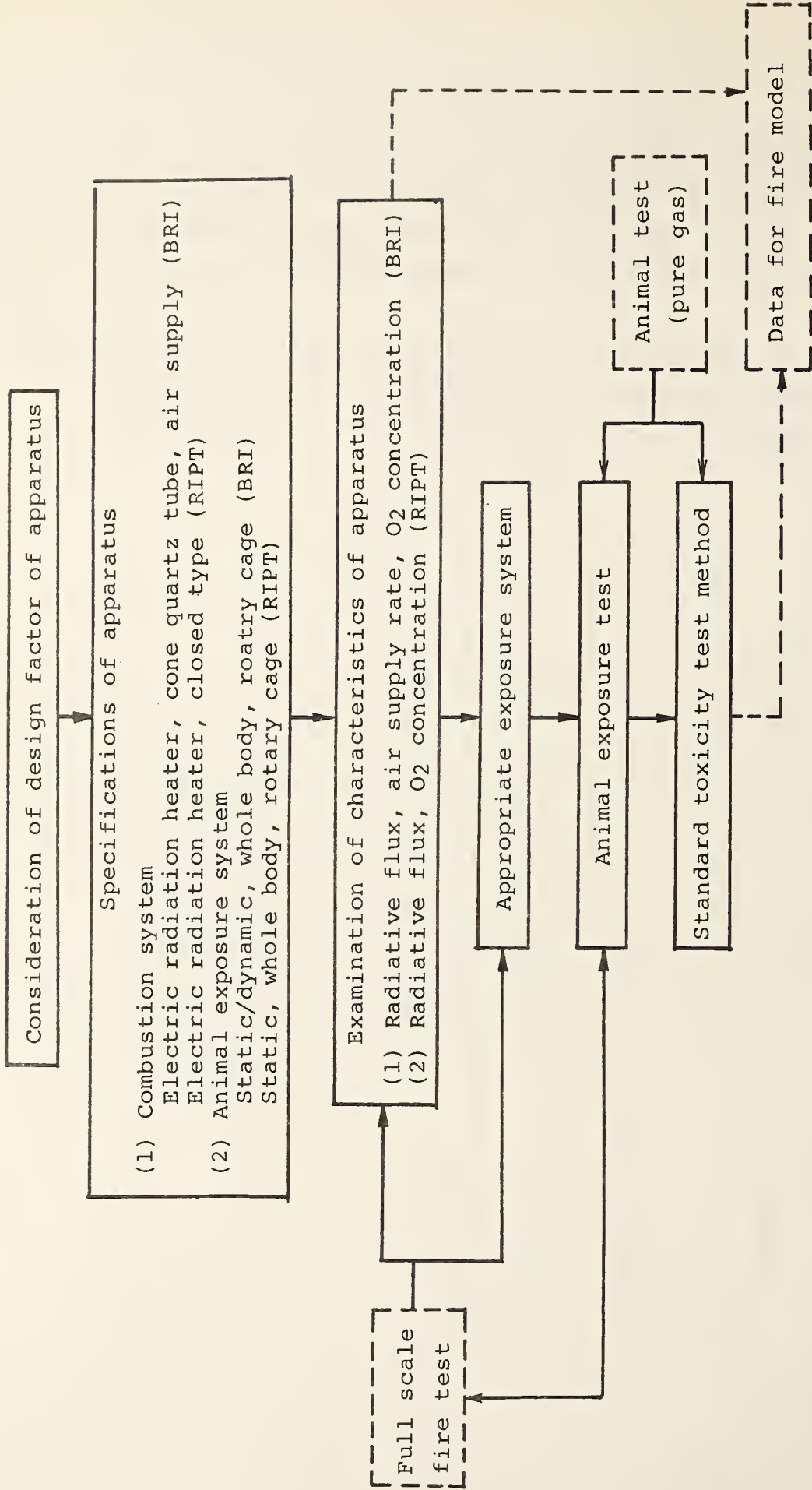
5. REFERENCES

- [1] Yusa, S., Saito, F. and Yoshida, M., US-Japan cooperative research on evaluation of toxicity, paper presented at the 6th Joint Meeting, U.S.-Japan Panel on Fire Research and Safety, UJNR, Tokyo, May 10-14, 1982.

- [2] Levin, B. C., Fowell, A. J., Birky, M. M., Paabo, M., Stolte, A. and Malek, D., Further development of a test method for the assessment of the acute inhalation toxicity of combustion products, Nat. Bur. Stand. (U.S.), NBSIR 82-2532 (1982).
- [3] Furuya, M., Closed-type Burning Testing Apparatus for Plastic Materials, to be presented at the 7th UJNR Joint Meeting as a support paper, Washington D.C., Oct. 24-28, 1983.

Table 1. Materials tested

Material	Form	Thickness (mm)	Density (g/cm ³)
Insulation board	Board	10	0.25
Lauaun	Board	10	0.46-0.56



Note; BRI: Bulding Research Institute, Ministry of Construction
 RIPT: Research Institute of Polymer and Textile, Ministry
 of International Trade and Industry

Figure 1. BRI and RIPT Research Program

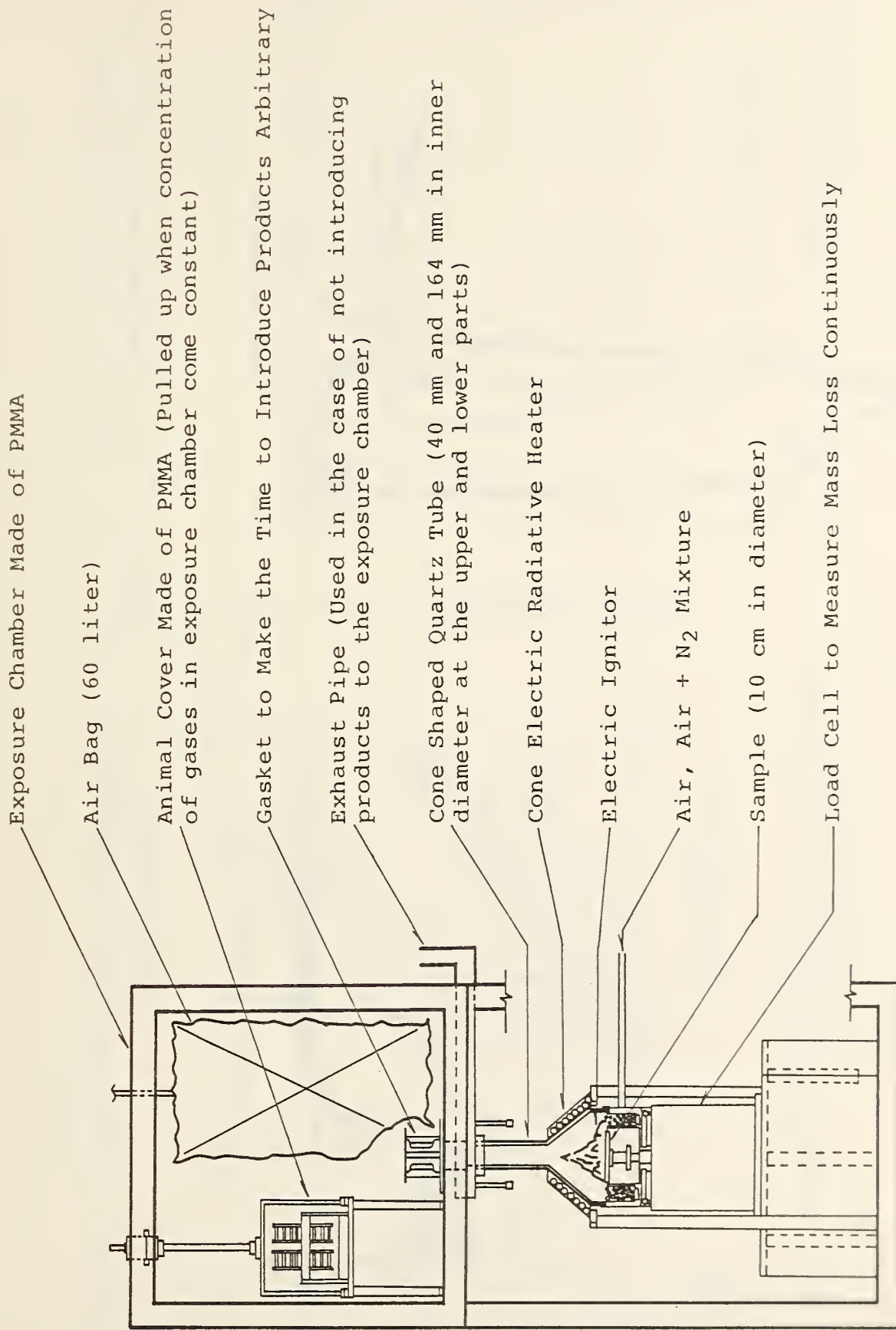


Figure 2. Test apparatus

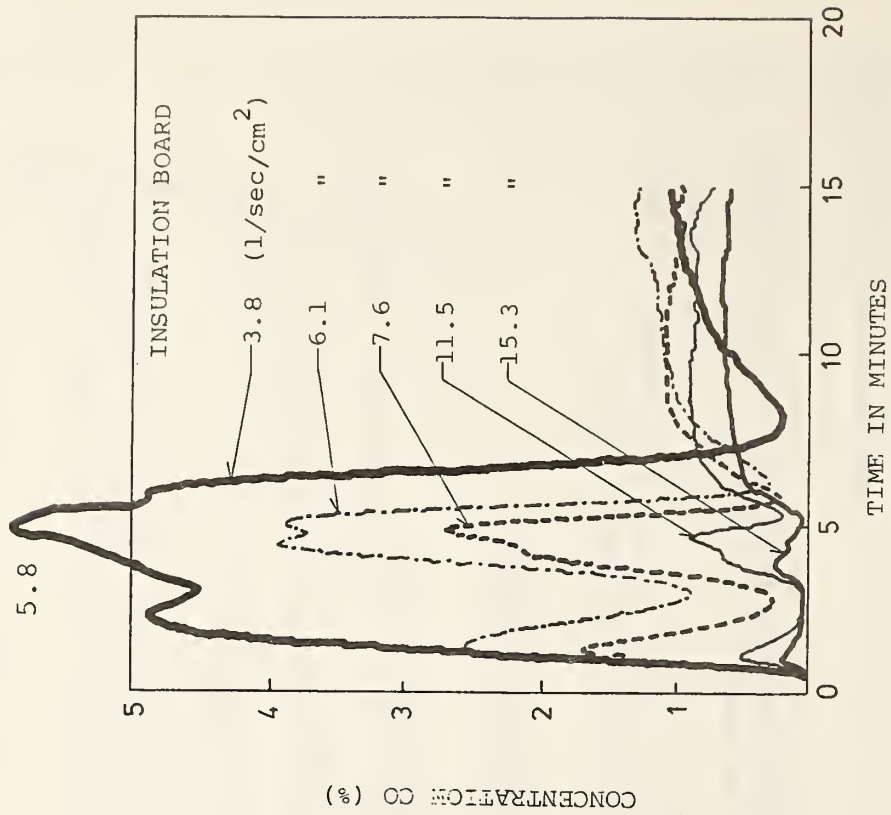


Figure 4. CO concentrations in the exhaust path from insulation boards

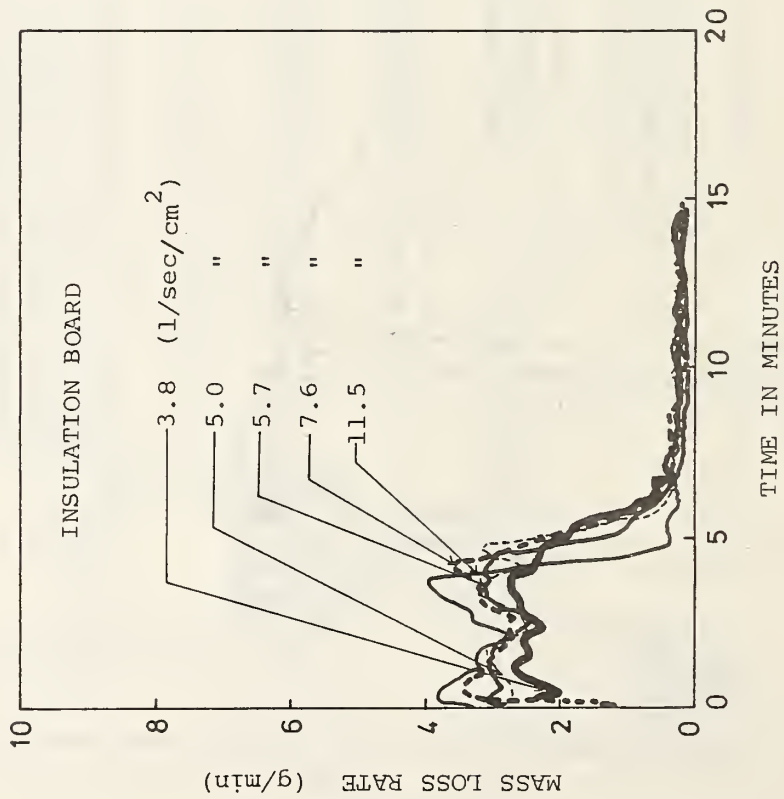


Figure 3. Mass loss rates of insulation boards

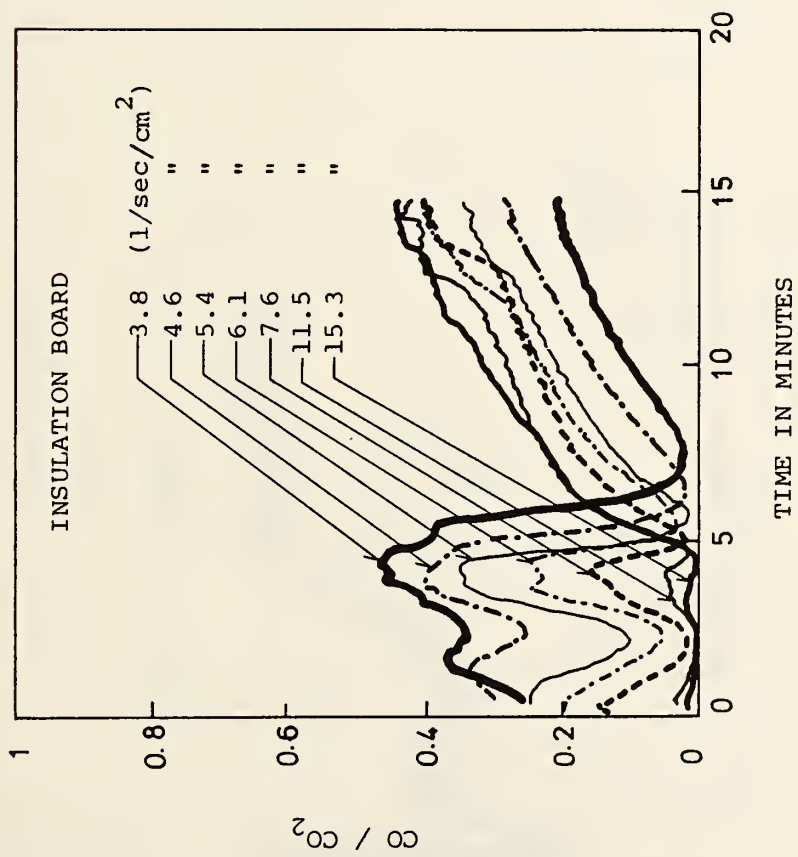


Figure 5. CO/CO₂ ratio at the combustion of insulation boards

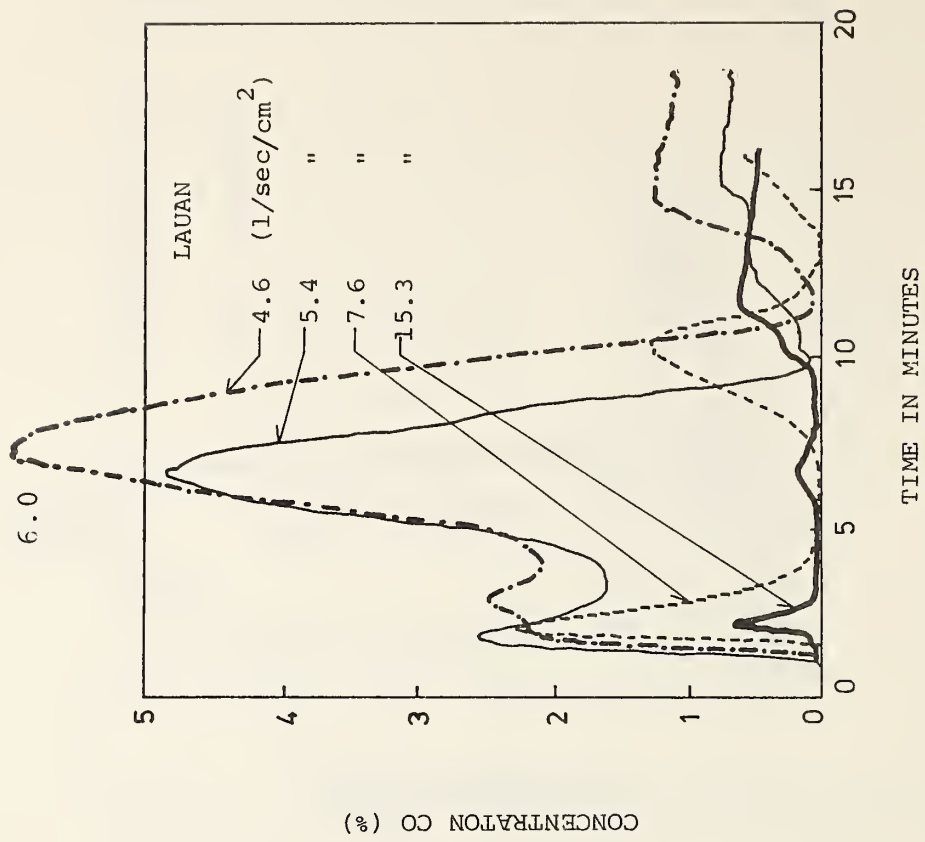


Figure 7. CO concentrations in the exhaust path from lauans

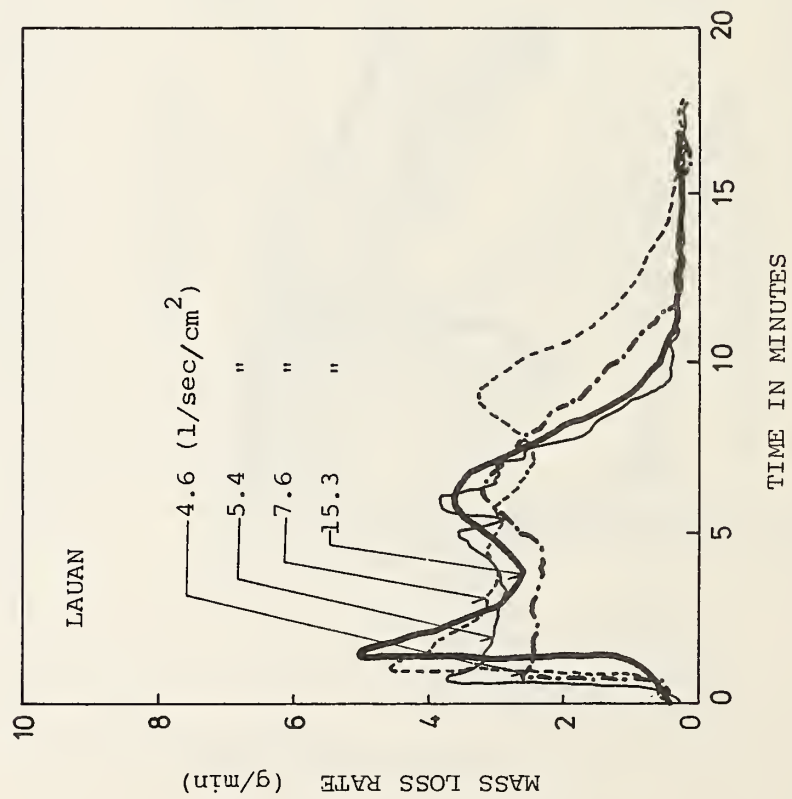


Figure 6. Mass loss rates of lauans

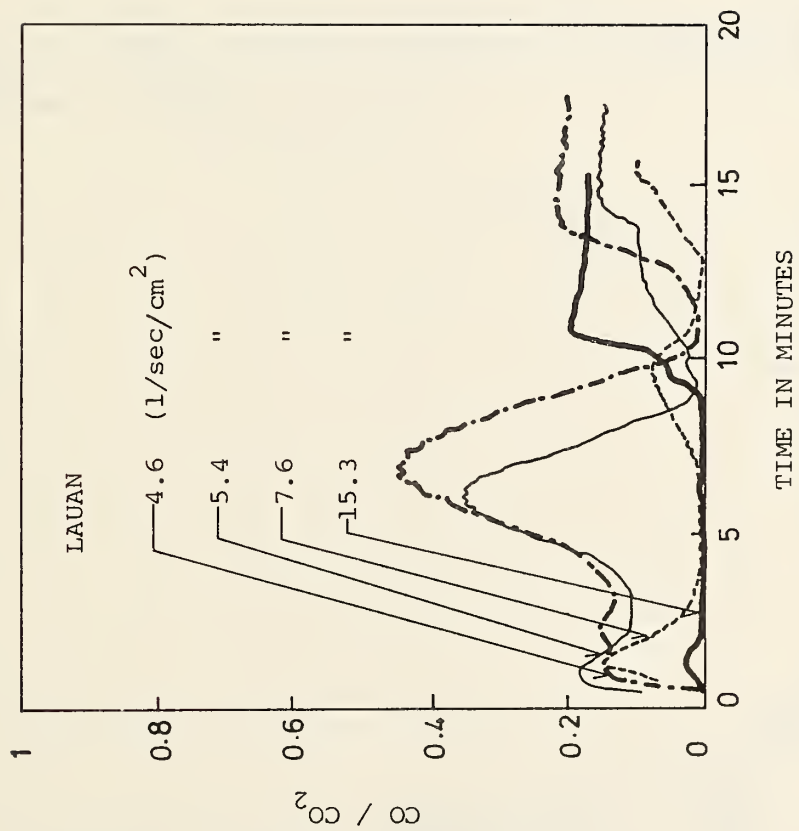


Figure 8. CO/CO₂ ratios at the combustion of lauans

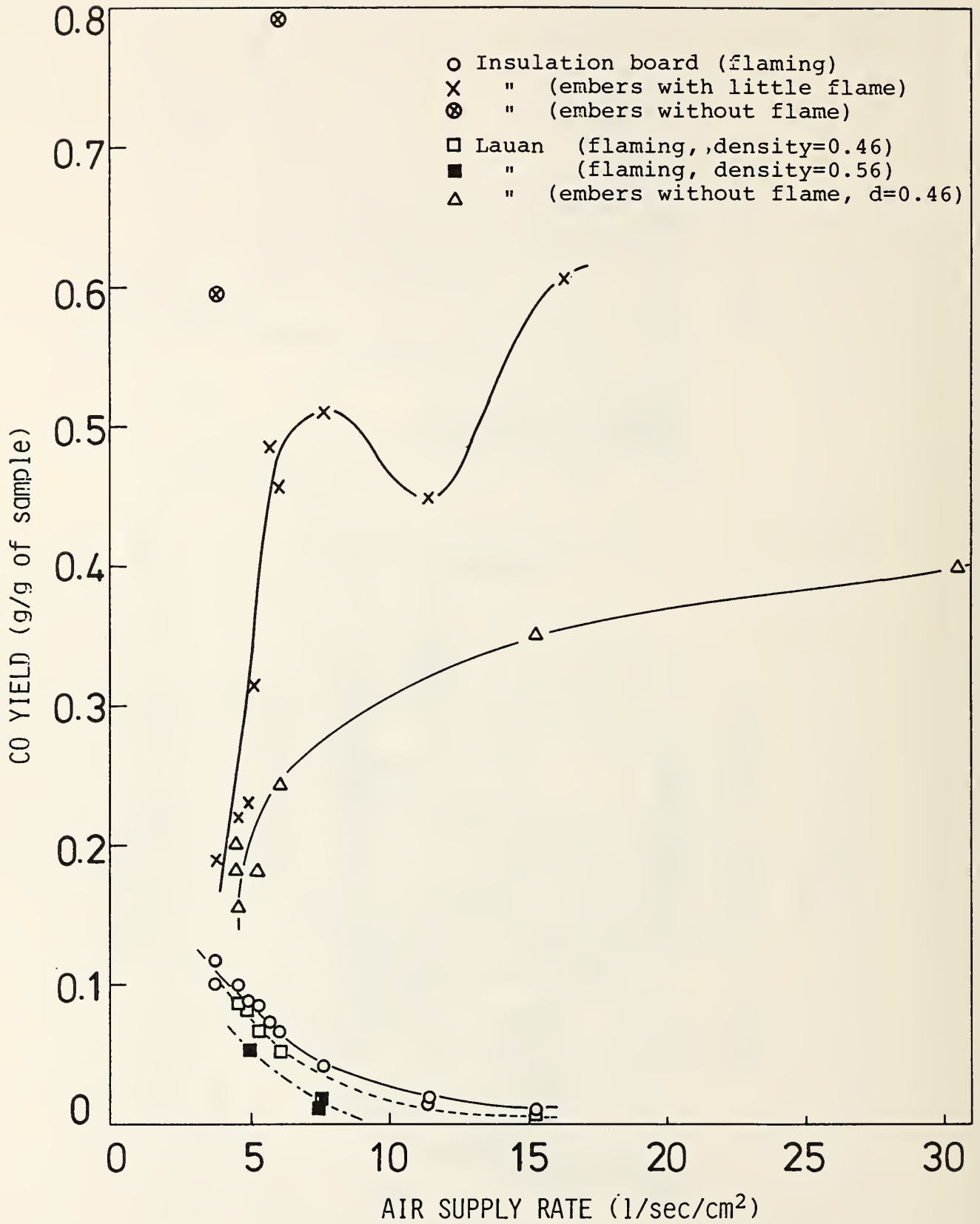


Figure 9. Relationship between CO yield and air supply rate

Discussion After S. Yusa's Report on DEVELOPMENT OF LABORATORY TEST APPARATUS FOR EVALUATION OF TOXICITY OF COMBUSTION PRODUCTS OF MATERIALS IN FIRE

ALARIE: I would think that the apparatus that you have been building and have shown us is the best that will be available for toxicity and I think it went a little bit this way. Dr. Yusa mentioned that the modelers will ask the mass loss rate and the radiative blocks. If we look at the methods that are available today, we have the National Bureau of Standards method, it does not measure the mass loss rate, it does not measure radiated flux. We have the University of Pittsburgh method, it measures the mass loss rate but it does not measure radiated flux. The method that you are proposing will measure both, both will be available. I think your method also will have one big advantage over everybody else and that is you can do a square wave exposure at any time during your burning, and nobody can do that. I have one question: How do you measure hydrogen cyanide in combustion gases today?

YUSA: As for the analysis of hydrogen cyanide, at a certain time the Japanese JIS method specified the calorific method, but we are just about to start the construction of an apparatus to use ion chromatography. This also will be able to measure HCl.

ALARIE: The reason I ask that question is that a lot of HCN data in the literature, I think, is suspect because in the older methods there was too much interference. I think it's very important to have a very, very good method for HCN when we do toxicity experiments.

Evaluation of a method for acute toxicity
of smoke from polymeric materials

Yves Alarie, Ph.D.
Professor of Respiratory Physiology and Toxicology
The Toxicology Laboratory
Department of Industrial Environmental Health Sciences
Graduate School of Public Health
University of Pittsburgh

Presented at the 7th United States-Japan Panel on Fire Research
and Safety, October 24-28, 1983 at the National Bureau of Standards

Introduction

There is a need to develop methods to evaluate the acute toxicity of smoke from synthetic and natural materials. This need arises from the fact that synthetic polymers, because of their chemical composition, will release smoke qualitatively different from smoke obtained from commonly used natural polymers such as cotton and wood. Also the rate of release of smoke from synthetic polymers can be much higher than for wood and finally the yield of principal toxicant(s) may be higher. An ideal solution would be to have a complete qualitative and quantitative chemical analysis of the smoke but this cannot be obtained easily. Therefore, we rely on animal models to rapidly evaluate possible differences in potency of smoke from various materials. There are two basic problems with this approach. The first one is that a fire model must be used to decompose the samples. The second one is extrapolation to humans of the results obtained in animals. This report presents the approach we have taken (1,2) the basis for ranking materials for their acute toxicity, the reasons why in general smoke from synthetic materials is more toxic than smoke from wood and the corrections to be made in extrapolating the results to humans.

Fire Model

There is no perfect small scale method to simulate large or medium scale fires. Also there is no single small scale method capable of supplying energy in the same manner to all possible samples in need of investigation. A large enough muffle furnace where any sample can be heated by radiation and convection seems to be the only solution available but several other methods have been used (3). Thus, using such a furnace with a linear heating rate of 20°C/minute an attempt was made to simulate a developing fire, leaving the material being investigated to react to the energy being supplied.

The general criteria followed in this approach, with a diagram of the apparatus used presented in Figure 1, were as follows:

1. The final temperature reached should be high enough to decompose all the samples.
2. There should be sufficient air (oxygen) available surrounding the sample at all times during decomposition.
3. Temperature (or energy) should not be above what is normally found in average fires.
4. Residence time of decomposition products at elevated temperature is important. If the residence time is very long decomposition products will be further degraded to gases such as CO, CO₂, H₂O, HCN, NO₂, HCl, HBr and HF with proportional decrease in the larger molecular weight constituents. This is to be avoided since it simulates incineration rather than a fire condition.
5. The method should permit investigation of non-flaming or flaming conditions or the first one followed by the second one if autoignition occurs as energy is being supplied.

6. The rate at which the samples are decomposing (mass loss rate) must be monitored.
7. The furnace (or system) must be large enough to accommodate low density materials, layered materials, composite materials, etc. in a configuration appropriate for their intended use.
8. Monitoring of gases such as CO_2 , O_2 and CO is required as a minimum. For nitrogen or halogens containing polymers measurements of HCN , HCl , HBr , HF are required. Such measurements are required to explain the toxic effects and to extrapolate the results obtained in animals to humans.
9. The combustion system must allow for concentration-response relationships for acute toxicity to be obtained. This can be accomplished in two ways, a) the size of the sample can be changed while keeping the dilution air constant or b) the size of the sample can be kept constant while changing the dilution air. In the approach presented here we have used the first way but both are equally valid.

Acute Lethality

By definition toxicity is based on the amount of chemical or physical agents necessary to produce a given level of effect and classifications for potency are made by comparing the dose, on a mg/kg basis, to kill 50% of the animals (4,5). For inhalation toxicology classes of toxicity are based on a fixed period of exposure and determination of the concentration to kill 50% of the animals following the exposure (5). This is referred to as the LC_{50} and since it is an exposure concentration given in ppm or in mg/m^3 it is not an expression of toxicity as with an oral LD_{50} given in mg/kg but rather an expression of exposure intensity necessary to produce a given effect. Nevertheless, the dose received by the animal will in proportion to the exposure concentration, albeit this quantity is seldom known or measured, and the LC_{50} is taken as an expression of toxicity and used to compare the potency of various chemicals. Since the objective in toxicological studies of smoke from polymeric materials is to compare the potency of various materials it follows that the LC_{50} must be determined. This must be determined for a fixed period of exposure and in this field 30 minutes has been arbitrarily selected as "appropriate" for fire situations. The second interesting aspect about toxicity is rapidity of action since time to escape from a fire is a critical element. Thus two gases having the same potency or toxicity, i.e. similar LC_{50} , may have different rapidity of action which is important to know. Unfortunately, since determination of the LC_{50} requires that all animals be exposed for the same period of time and deaths be observed following exposure little can be obtained to determine the rapidity of action and this approach is not as useful in combustion toxicology as it is for general inhalation toxicology. The approach can be modified so that both toxicity or potency as well as rapidity of action can be measured simultaneously. This can be done as follows recognizing that biostatisticians will raise minor objections because not all animals will be exposed for the same period of time:

1. A reference material is selected against which all other materials will be compared.

2. Exposures to various concentrations of smoke from the standard material are conducted so that 50% of the animals will die at the end of the time period selected (i.e. 30 minutes). Thus the LC50 (amount of material loaded in the furnace necessary to produce sufficient smoke to kill 50% of the animals) and the LT50 (time of exposure at the LC50 required to kill 50% of the animals) are obtained. Thus both potency and rapidity of action are measured. Obviously this will necessitate a series of experiments with proper statistical analysis of the LC50 value. There is no statistical evaluation of the LT50 in this protocol. This value is obtained by reviewing the data from the series of experiments conducted and finding the time at which 50% of the animals were dead at the calculated LC50 value or the experiment closest above this value.

In practice it is impossible (unless one is incredibly lucky) to kill 50% of the animals at exactly the end of the time period selected and one must accept the LT50 to be close to the exposure time selected. In the example given below when wood (Douglas fir) was selected as the reference material the LT50 obtained was 22 minutes instead of being at 30 minutes which was the desired time. The important points to consider with this approach are as follows:

1. All materials to be tested will be compared to the standard on the basis of a fixed biological effect, i.e. 50% mortality (LC50) but the time to produce this effect (LT50) at this exposure concentration will vary. It is important to remember that comparison of rapidity of action (LT50) can be made only when the level of effect for all materials is the same, i.e. at the LC50, or in practice as close as possible to it.

2. The LT50 is not a measure of toxicity since it reflects absorption and distribution of the inhaled materials as well as their intrinsic rapidity of action. In combustion toxicology it also depends on the rate at which the toxicants are produced in the apparatus used to decompose the materials. In the examples given below the beginning of the planned 30-minute exposure period was initiated with the start of decomposition of each material. This varied considerably among materials and also as given below the rate of decomposition of materials varied widely.

Materials and Methods

a) Thermal decomposition and animal exposures.

The system for thermal decomposition and animal exposure has been given in details previously (1) and schematically presented in Figure 1. Briefly, samples were decomposed by heating them at 20°C/minute, starting from room temperature, in the furnace with the airflow through it maintained at 11 liters/min. The smoke from the furnace was then diluted with 9 liters/min of air and entered the 2.3 liter glass exposure chamber. For each experiment four male Swiss-Webster mice were used. The exposure started when 0.2% weight loss occurred for each sample (corrected in the cases of halocarbons blown foam) and continued for a period of 30 minutes or until all animals died. Animals which died during the 30 min. of exposure and 10 min. recovery period were counted in the LC50 statistical evaluation. The time at which 50% of the animals died was recorded at the sample weight killing 50% of the animals or the sample weight nearest above it. The description of one series of samples tested with this method is given in Table 1 with the LC50 and LT50 values obtained.

Results and Classifications

Table 1 presents the LC50 and LT50 values of materials tested and Figure 1 also presents these results as well as a suggested way to combine both the LC50 and LT50 results to arrive at classifications A, B, C or D. In Figure 2 the classification for concentration-response relationship (toxicity or potency) was arrived at by placing the LC50 value of Douglas fir (taken as a reference material) at the middle of an order of magnitude on a logarithmic scale. All materials with an LC50 within this order of magnitude are then classified "as toxic as wood." Then classifications of more toxic and much more toxic than wood follow, each spanning an order of magnitude.

The classification for time-response relationship (i.e. rapidity of action) was also arrived at by using Douglas Fir as the reference material. The LT50 was placed at the middle of one-half an order of magnitude on a logarithmic scale. However, it should be noted that the time scale was arranged so that one order of magnitude on the time scale of this graph is equivalent to two orders of magnitude on the concentration-response scale. This is arbitrary but helps in separating materials for their rapidity of action. Again, classifications of faster and much faster acting than wood follow. To combine both potency and rapidity of action quadrants were included in Figure 2. The quadrants are parallel, all starting from the potency scale and ending on the time scale to encompass areas defining four classes of materials. Thus, a summary of potency and rapidity of action can be easily presented for materials in comparison to wood or any other material used as a standard.

Reasons for differences in toxicity between synthetic polymers and wood.

The results in Table 1 and Figure 2 show that there are differences between synthetic polymers and wood and between wood and cellulose fiber insulation. Of the materials reported in Table 1 and Figure 2 the following examples were selected to explain how such difference occurred.

Wood vs. cellulose fiber insulation

As shown in Figure 3 CO increased just before and with flaming ignition continued to increase and was the main toxicant responsible for the death of the animals. Cellulose fiber (a heavily flame retarded sample) did not ignite and decomposed very differently than wood and with a much higher yield of CO. Thus, this sample was found to be approximately 6 times more toxic than wood and the reason is the much higher yield of CO.

Phenol formaldehyde foam and urea formaldehyde foam

Figure 4 illustrates some interesting characteristics of these two materials. Both are known to be highly resistant to flaming and did not ignite during the test. The weight loss was only 50% for phenol formaldehyde but the yield of CO was very high and, therefore, this sample was found to be 10 times more toxic than wood because of this high yield. On the other hand urea formaldehyde released less than 100 ppm of CO but yielded a high amount of hydrogen cyanide and since this gas is more toxic than CO the reason for this sample being 25 times more toxic than wood is obvious. What is interesting to note is that most of the cyanide was produced above 450°C and from a very

small quantity of sample remaining above this temperature. Both phenol formaldehyde and urea formaldehyde released formaldehyde at low temperatures.

Polytetrafluoroethylene

Decomposition of this sample started at high temperature as shown in Figure 5. There was negligible amount of CO released but the toxicity was found to be extremely high. In fact this sample was found to be 150 times more toxic than wood. The reason for this finding is that polytetrafluoroethylene yields octofluoroisobutylene (6) which is extremely toxic (7). The LC50 for a 10-minute exposure in rats for this gas was found to be 17 ppm (7). This is at least 10 to 20 times more toxic than hydrogen cyanide. Therefore, it is not surprising to find such a high toxicity for this polymer. Similar results were found for polyfluoroethylenepropylene (8) which also releases the same extremely toxic gas (6).

Polystyrene foam

The results are shown in Figure 6. Here the generation of toxicants is extremely rapid and because there is less air volume available for dilution very high concentration of CO as well as other toxicants are reached rapidly.

If we take the average of the LC50 and LT50 values for series of synthetic polymers we have tested we find them to be 5 to 6 times more potent and to kill animals almost twice as fast as with wood. From the examples given above and published data (1,2) the reasons for these findings can be summarized as follows:

- i) some polymeric materials release a much higher yield of CO than wood
- ii) some polymeric materials release HCN which is more potent and faster acting than CO, the principal toxicant obtained from wood
- iii) some polymeric materials release perfluoroisobutylene which is extremely toxic and obviously more potent than CO, the principal toxicant obtained from wood
- iv) some polymeric materials release toxicants which may be the same as wood but because the mass loss rate is so much faster than wood there is less dilution air available to reduce their toxicity.

Extrapolation of the results for humans

If the principal toxicants are CO or HCN extrapolation of the results obtained in mice can be made for humans since their mechanism of action is the same in both species although their action is more rapid in mice than in man due to their difference in minute ventilation/body weight ratios (10,11). The lethal levels in humans for these gases (10) is also close to the potency ratio found in mice since the LC50 was 166 ppm for HCN and 3,500 ppm for CO for a planned 30-minute exposure (9).

Difficulties arise in the case of polymers releasing large quantities of HCl, HBr and HF. These gases are highly water soluble and reactive and are very effectively scrubbed by the nose of small rodents thus greatly lowering their toxicity in comparison to what would happen in humans (12, 13,14). This is illustrated by the fact that 1,000 ppm of HCl is considered dangerous for humans for a short period (11) while the LC50 for 30 minute exposure in mice was found to be 10,157 ppm (12). However, if a tracheal cannula is fitted in mice to by-pass the nose the LC50 in cannulated mice is only 1,095 ppm, in agreement with the predicted dangerous level in humans. Similarly the LC50 for thermal decomposition products from polyvinylchloride was found to be 15.2 grams in normal mice but only 2.2 grams in cannulated mice (12). No difference was found for the LC50 of CO or HCN between normal and cannulated mice (9). Therefore, when HCl is the major toxicant the LC50 found in normal mice must be divided by 7 to 10 in order to extrapolate to humans and this must be done with polyvinylchloride. There may be other instances when such correction factors will be needed depending upon the nature of the principal toxicant(s) involved.

Reproducibility of the results

For any test method it is important to have some estimate of the reproducibility of the results. This can be obtained from the data presented in Table 2. The reproducibility is quite good considering that there are two sources of variability, i.e. decomposition of the samples and biological variation. In fact the results obtained here are well within the variation obtained with oral LD50 tests (15).

Extrapolation to medium scale fire

The number of experiments performed with medium scale fires are too few to permit firm conclusions to be reached. However, in both instances (16, 17) materials tested in the small scale test described above were ranked in the same order of toxicity in medium scale fire tests.

Conclusions

A test method has been developed to evaluate the acute toxicity of smoke from natural and synthetic polymers. It is useful to rapidly determine if smoke from various materials is more potent and faster acting than smoke from wood. With appropriate chemical analysis of the smoke and knowing the mass loss rate the differences in toxicity can be explained.

References

1. Alarie, Y. and Anderson, R.C. Toxicologic and acute lethality hazard evaluation of thermal decomposition products of synthetic and natural polymers. *Toxicol. Appl. Pharmacol.* 51, 341-362, 1979.
2. Alarie, Y. and Anderson, R.C. Toxicological classification of thermal decomposition products of synthetic and natural polymers. *Toxicol. Appl. Pharmacol.* 57, 181-188, 1981.
3. Kaplan, H.L., Grand, A.F. and Hartzell, G.E. *Combustion Toxicology, Principles and test methods.* Technomic Publishing Co., Lancaster, Pa., 1983.
4. Klaassen, C.D. and Doull, J. Evaluation of Safety: toxicologic evaluation. Chapter 2. In: Casarett and Doull's, *Toxicology the Basic Science of Poisons*, Second Edition. Doull, J., Klaassen, C.D. and Amdur, M.O. Eds. MacMillan Publishing Co., N.Y., 1980.
5. Hodge, H.C. and Sterner, J.H. Tabulation of Toxicity Classes. *Am. Indus. Hyg. Assoc. Quart.* 10, 93-96, 1949.
6. Arito, H. and Soda, R. Pyrolysis products of polytetrafluoroethylene and polyfluoroethylenepropylene with reference to inhalation toxicity. *Ann. Occup. Hyg.* 20, 247-255, 1977.
7. Smith, L.W., Gardner, R.J., and Kennedy, G.L. Short-term inhalation toxicity of perfluoroisobutylene. *Drug and Chem. Toxicol.* 5, 295-303, 1982.
8. Y. Alarie and Stock, M.F. Toxicity of Teflon^R, similar results obtained with radiant-convective heat sources or in hot fire gases. *Fire and Materials*, in press.
9. Matijak-Schaper, M. and Alarie, Y. Toxicity of carbon monoxide, hydrogen cyanide and low oxygen. *J. Combust. Toxicol.* 9, 21-61, 1982.
10. Haldane, J. The action of carbonic oxide on man. *J. Physiol.* 18, 430-462, 1895.
11. Henderson, Y. and Haggard, H.W. *Noxious gases and the principles of respiration influencing their action.* Second and Revised Edition, Reinhold Publishing Corp. N.Y., 1943.
12. Anderson, R.C. and Alarie, Y. Acute lethal effects of polyvinylchloride thermal decomposition products in normal and cannulated mice. *Society of Toxicology Meeting, Abstract of papers*, page A-3, 1980.
13. Morris, J.B. and Smith, F.A. Regional deposition and absorption of inhaled hydrogen fluoride. *Society of Toxicology Meeting, Abstract of papers*, page A-4, 1980.

14. Morris, J.B. and Smith, F.A. Regional deposition and absorption of inhaled hydrogen fluoride in the rat. *Toxicol. Appl. Pharmacol.* 62, 81-89, 1982.
15. Weil, C.S., Carpenter, C.P., Est, J.S. and Smyth, H.F., Jr. Reproducibility of single oral dose toxicity testing. *Amer. Ind. Hyg. Assoc. J.* 27, 483-487, 1966.
16. Alarie, Y., Anderson, R.C., Stock, M.F., Dombroske, R.L., Keller, L.W., Hayduck, L.W. and Park, R.E. Toxicity of thermal decomposition products; an attempt to correlate results obtained in small scale and large scale tests. *J. Combust. Toxicol.* 8, 58-68, 1981.
17. Alarie, Y., Stock, M.F., Matijak-Schaper, M. and Birky, M.M. Toxicity of smoke during chair smoldering tests and small scale tests using the same materials. *Fundam. Appl. Toxicol.*, in press.
18. Anderson, R.C., Croce, P.A., Feeley, F.G., III and Sakura, J.D. Study to assess the feasibility of incorporating combustion toxicity requirements into building material and furnishings codes of New York State. Final Report to Department of State, Office of Fire Prevention and Control, Albany, N.Y. May 1983.

TABLE I
SAMPLES TESTED AND SUMMARY OF THE RESULTS

Abbreviation	Sample name—description	LC50 (g)	LT50 (min)	Class ^a
PRC materials^b				
GM 21	Flexible polyurethane foam	12.9	13	B
GM 23	Same as GM 21, with fire retardant	10.4	18	B
GM 25	High resilience, flexible polyurethane foam	8.3	19	B
GM 27	Same as GM 25, with fire retardant	14.4	15	B
GM 29	Rigid polyurethane foam	10.4	28	B
GM 31	Same as GM 29, with fire retardant	8.2	23	B
GM 35	Rigid polyurethane foam, fluorocarbon blown	7.5	17	B
GM 37	Same as GM 35, CO ₂ blown	8.0	15	B
GM 41	Rigid isocyanurate foam	6.4	18	B
GM 43	Same as GM 41, contains some polyurethane	6.1	16	B
GM 47	Polystyrene expanded	5.8	11	B
GM 49	Same as GM 47, with fire retardant	10.0	9	B
GM 57	Phenol formaldehyde—phenol resin, expanded with blowing agent	6.3	20	B
Non-PRC materials				
PTFE	Polytetrafluoroethylene resin	0.64	8	C
PVC	Polyvinylchloride (92% homopolymer)	7.0	10	B
PVC-A ^c	Polyvinylchloride (46% homopolymer)	15.2	15	B
PVC-CN	Polyvinylchloride (92% homopolymer + 5% zinc ferrocyanide)	2.3	7	C
PCP-CN	Polychloroprene (92% homopolymer + 5% zinc ferrocyanide)	2.5	6	C
ABS-3	Standard acrylonitrile/butadiene/styrene	6.3	9	B
Mod.	Modacrylic	4.9	18	B
Wool	Wool fibers—undyed	3.0	27	B
UF	Urea formaldehyde foam	2.5	22	B
Cellulose	Blowing type cellulose fiber insulation	11.9	21	B
D. Fir	Douglas Fir	63.8	22	A
Fiberglas	Fiberglas building insulation, 3.5 in. thick with paper and vapor barrier	35.7	25	A
P.E. I	Polyester resin—commercial acrylic modified unsaturated	34.8	14	B
P.E. II	Polyester resin—experimental acrylic modified unsaturated	57.4	18	A
H.P.E.	Polyester resin—Styrenated halogen modified	14.4	16	B
SPF Wood	Compressed spruce, pine, fir slab	48.7	19	A

^a From Fig. 2

^b Obtained from the Product Research Committee (PRC) sample bank at the National Bureau of Standards.

^c In the previous article (Alarie and Anderson, 1979) this sample was erroneously identified as being 92% homopolymer.

TABLE 2

Reproducibility of LC₅₀ values

Material	LC50 in grams loaded in the furnace		
	University of Pittsburgh	Biotecs** Laboratory	Arthur D. Little***
Douglas fir*	64 78 56	57 61 64 59	50
Average for Douglas fir \pm (S.D.) = 61.1 (8.2)			
Phenol Formaldehyde Foam (GM 57)*	6.3	7.4	4.8
Polyester-Fiberglass PEI*	35	36	
Polyester-Fiberglass PE II*	57	58	
Vinyl coated wire*	15		15
Polyurethane foam flexible	13		9
Polyester-Fiberglass Halogen retardant HPE*	14	15	

* Samples used by all laboratories was furnished by the University of Pittsburgh.

** Data supplied by Dr. C.P. Carpenter.

***From reference 18.

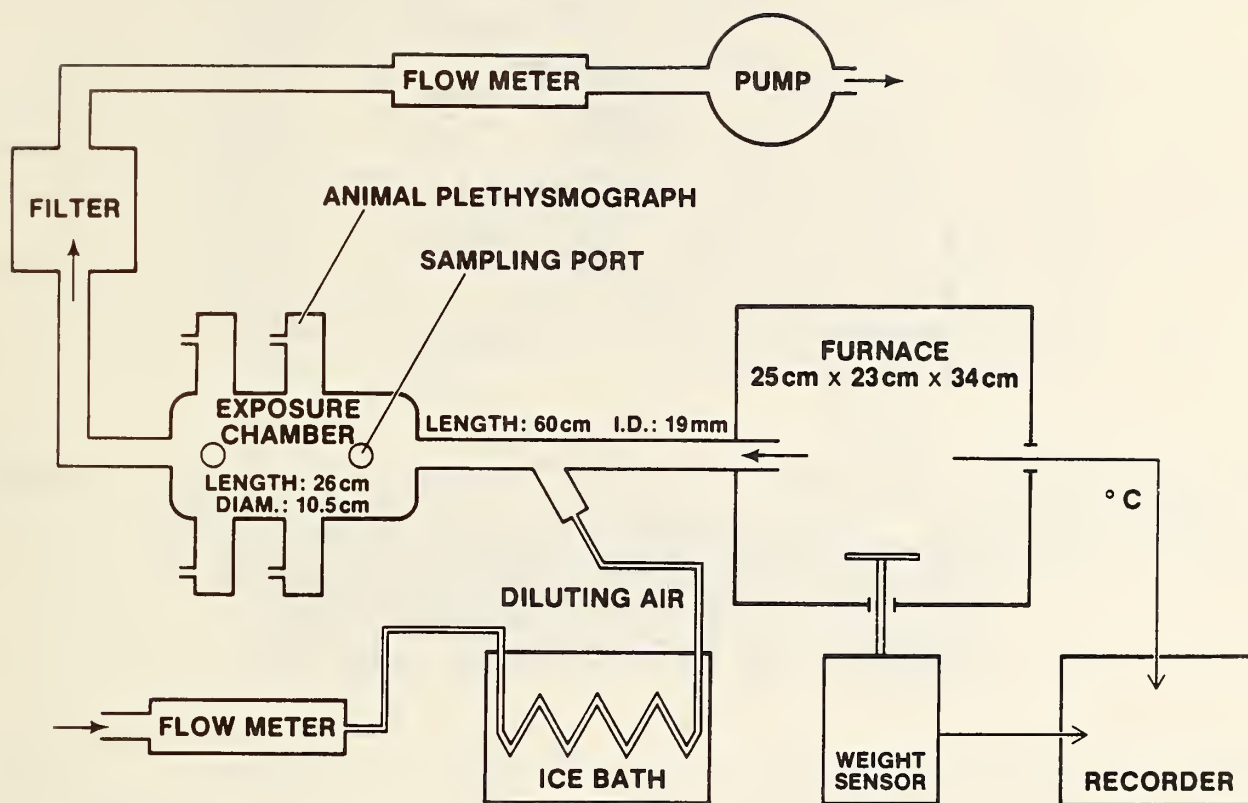


Figure 1. Experimental arrangement to study toxicity of smoke from thermal decomposition of synthetic or natural polymers. From Alarie and Anderson, 1979.

In this system the sample is placed on a platform connected to a weight sensor so that weight loss can be recorded during thermal decomposition. The temperature of the furnace increases from room temperature at $20^{\circ}\text{C}/\text{minute}$ up to 900°C or until the material is entirely decomposed. The animals, 4 mice, are placed in restraining tubes (animal plethysmograph) with only the head of the animals protruding into the exposure chamber. Air flows through the chamber continuously and is regulated at 20 liters/minute. The air drawn into the chamber comes from the furnace (11 liters/minute) and 9 liters/minute of diluting air supplied at $15\text{-}16^{\circ}\text{C}$. Exposure of the animals to the smoke produced is initiated when the material begins to decompose and continues for 30 minutes unless all the animals die. A recovery period of 10 minutes is observed following exposure. In these experiments respiratory rates of the animals are obtained by attaching a pressure transducer to a port on each animal plethysmograph. This also permits recognition of sensory irritation and asphyxiation during exposure to the smoke. Death is determined to have occurred if no respiratory effort is made by the animal for a period of 17 seconds.

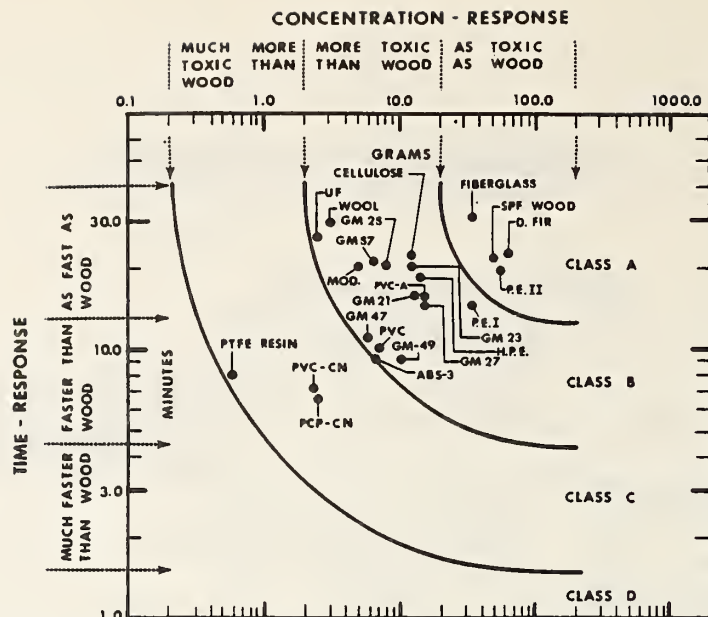


Fig. 2 Each point represents the amount of material (gram on the X axis) which produced sufficient smoke to kill 50% of the animals (LC50) and the time (minutes on the Y axis) required to kill 50% of the animals (LT50) using that amount of material. Reading the graph vertically each material is classified in terms of potency while each material is classified in terms of onset of action by reading horizontally. To combine both, parallel quadrants separate class A, B, C, and D. For clarity some materials listed in Table 1 have been omitted. However, Table 2 contains the results for all materials.

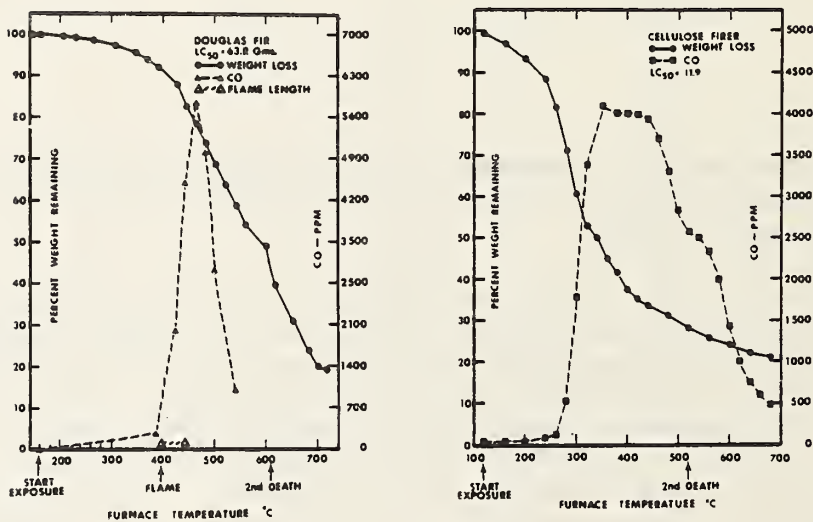


Figure 3. Decomposition pattern of Douglas fir and cellulose fiber (with flame retardant) and carbon monoxide evolution. Arrow at second death indicates the temperature at which the second of four exposed animals died (50% lethality).

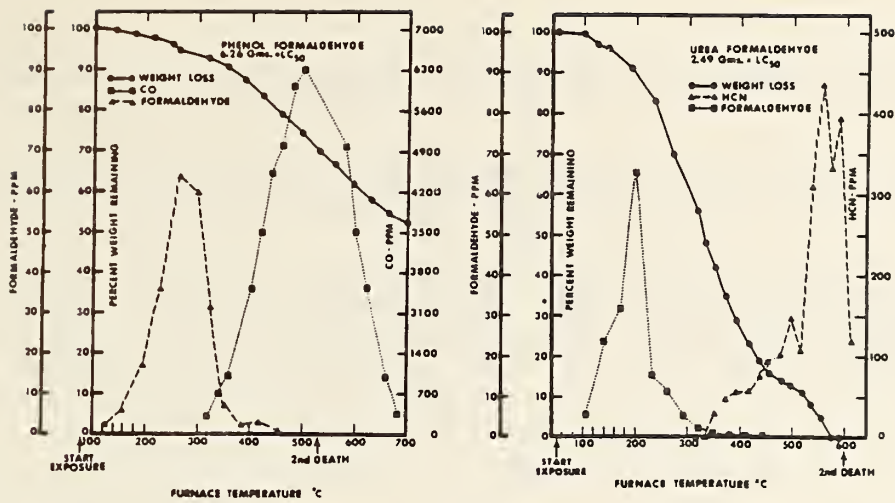
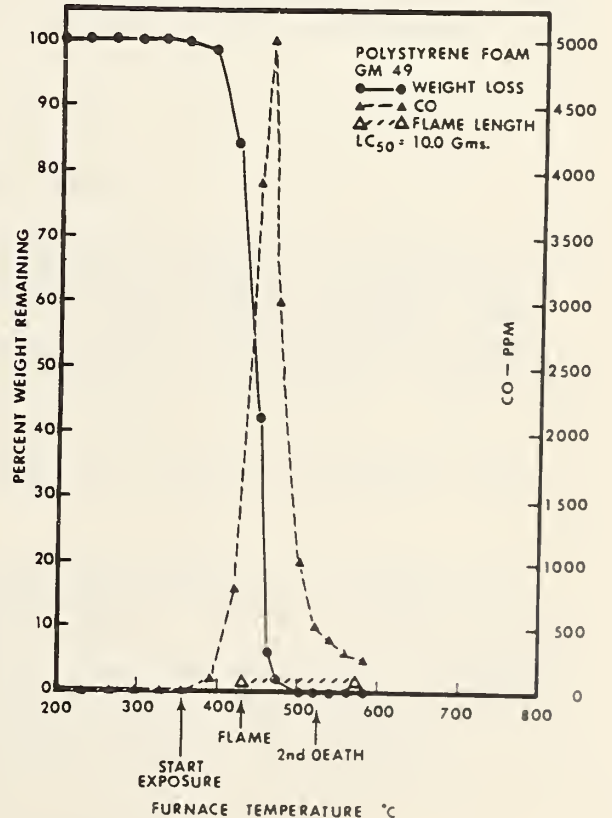
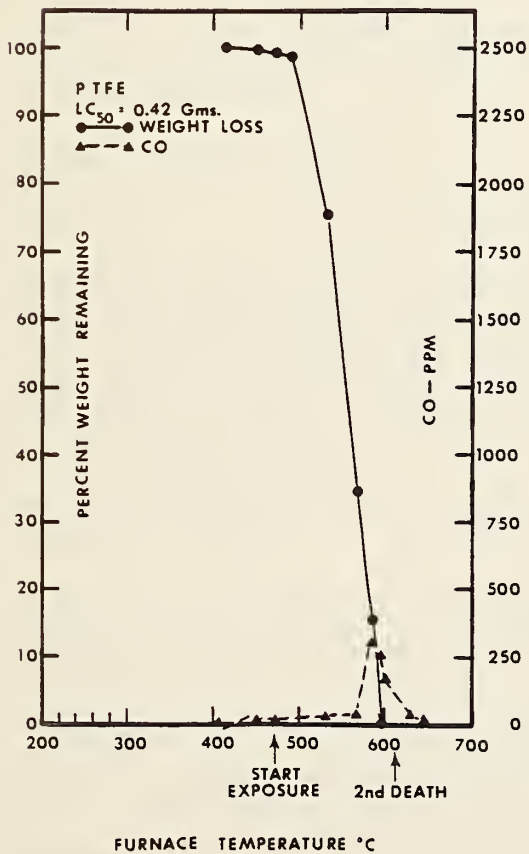


Figure 4. Decomposition pattern of phenol formaldehyde foam and urea formaldehyde foam with evolution of formaldehyde, carbon monoxide and hydrogen cyanide. Arrow at second death indicates the temperature at which the second of four exposed animals died (50% lethality).



Figures 5 and 6: Decomposition pattern of polytetrafluoroethylene (PTFE) and polystyrene foam with evolution of carbon monoxide. Arrow at second death indicates the temperature at which the second of four exposed animals died (50% lethality).

Discussion After Y. Alarie's Report on EVALUATION OF A METHOD FOR ACUTE TOXICITY OF SMOKE FROM POLYMERIC MATERIALS

PAGNI: If the HCl is more toxic in the mice than in the humans, don't you have to multiply by that factor instead of divide.

ALARIE: No. The HCl is less toxic for mice than it is for humans. The reason for this is that in mice it is absorbed in their nose and it is prevented from reaching the lungs and the systemic circulation. To simulate a human with a mouse, we can bypass their nose by putting a tracheal cambia; when we do that, the order in mice is the same as in men.

PAGNI: Does the protocol by which you change the temperature in the furnace change your class results?

ALARIE: If we change the heating rate, it will change the mass loss rate. By changing the mass/loss rate, we can change the toxicity.

TSUCHIYA: You said that perfuroisobutylene is 30 times more toxic than HCN. How do you get this number?

ALARIE: Because we do an LC_{50} on perfuroisobutylene. We do an LC_{50} on HCN and then we do an LC_{50} on CO. So we have the ratio perfuroisobutylene, HCN, and CO.

TSUCHIYA: When you show the relation between time and concentration of carbon, you classified plastic in three categories. You showed the carbon lines of your unit in log scale.

ALARIE: That's correct.

TSUCHIYA: Isn't it better to use a straight line?

ALARIE: No, biological systems move in a progressive manner. We humans are not differentiators; we are integrators. If you want to change our reaction by a lot, you have to change the dose by a lot. So, if you double the dose, you usually don't do very much. You have to go three times, ten times, 30 times, 100 times. So all biological responses are plotted on a logarithmic scale, not on an arithmetic scale.

TSUCHIYA: No. It's all right on a logarithmic scale but that boundary isn't shown as linear.

ALARIE: No, it shouldn't be there and you put that back in. You want the quadrant to be curved and not straight lined, because you want to punish the materials that are fast acting. If we would need to do this, I think we would accomplish it just as well as when you do this. But, it would give us more categories and I don't want to make too many categories at this time. This is also why I made this range fairly large...that's one order of magnitude. I think if we made a smaller range it would be very difficult to depend on.

TSUCHIYA: Are you taking arbitrary decisions and drawing lines?

ALARIE: No, I don't think it's an arbitrary decision to give negative points to very fast acting materials. That is not arbitrary at all.

TSUCHIYA: How about data obtained by Southwest Research Institute?

ALARIE: There is no data presented by Southwest Research Institute that confirms Haber's Law. Haber was a very brilliant German toxicologist. He used Haber's Law for a very specific purpose. It is for cumulative toxic effect with time. The two principle killers we have in the smoke are CO and HCN. Neither one of them is a cumulative poison, and neither one of them will every fit Haber's Law by any test.

TSUCHIYA: But do you know the data...I don't know Haber but the data presented by Packham, Patel.

ALARIE: The data is worthless! The best data on CO and HCN was presented by the Japanese. That's the best data and the data from the Japanese will deny any Haber's Law. The data from the Japanese is in the previous conference. They have these curves for HCN and for CO with the time in the concentration. This is the best data and one of my students reproduced the data of the Japanese. It is always log scale. There is no such thing as plotting these curves on arithmetic scales. The Japanese plotted them on the log scales. We plot them on the log scales.

NISHIMARU: Using mice I think one has shown the ratio was 7 to 10 for the level to human being and what was the basis for that ratio?

ALARIE: We see in humans that about 1000 parts per million of HCl would kill a human being in a short time. We did the experiment with noble mice and we found, I think, 10,000 parts per million would kill those noble mice, which is 10 times higher than this. Then we took mice with trachael cannulae and we found that about 1000 parts per million would kill them. When we did the same experiment with polyvinyl chloride and noble mice, the LC₅₀ was 50.2 grams. When we used a tracheal cannula, the LC₅₀ was 2.1 grams...so this is about 7 times. That's why we picked 7 to 10. We also did the same experiment with noble mice and tracheal cannulated mice with CO and with HCN and with a synthetic polymer that releases CO. There is no difference in the LC₅₀. It's only when HCl is the primary toxicant that we have to apply this factor.

NISHIMARU: The tracheal cannula you used in testing for toxicity results in a very unique experiment. We would like to know if you found any discrepancy between the results obtained from mice and the results obtained from rats?

ALARIE: The results we obtained for HCN and CO in mice are the same as the Japanese results for those two gases in rats. However, for the irritant gases, mice are much more sensitive than rats.

NISHIMARU: We obtained the same results, but why did you pick the difference between rats and mouse irritants?

ALARIE: We know they are more sensitive than rats but I don't know why.

Theme
Toxicity

Closed-type Burning Testing Apparatus
for Plastic Materials

by

Masazo Furuya

Research Institute for Polymer and Textile.
Agency of Industrial Science and Technology
Ministry of International Trade and Industry

7th Joint Meeting

U.S.-Japan Panel on Fire Research and Safety

UJNR, Washington. DC. Oct 24-29, 1983

Closed-type Burning Apparatus
For Plastic Materials

By

Masazo FURUYA

The aim this study is to develop a laboratory testing apparatus which can evaluate the toxicity of combustion products of plastic materials. This apparatus has a closed-type chamber. Both gas component and smoke density, resulting from combustion of plastic materials, can be determined correctly. By equipping a mouse monitor with the exposure chamber, the animal toxicity due to the gas is also evaluated conveniently.

Test Method

1. Apparatus

As shown in Fig. 1-1. the chamber (0.5 m^3) is consisted of combustion section, smoke-density measuring section and gas analysis. Volume of the animal exposure chamber is 0.125 m^3 .

The combustion section has heating furnace, sample pan and sample weighting device. the heating furnace is heated electrically, and provides a constant voltage control device.

2. Smoke-density measuring device

The device consists of a light source and a receptor, and provides a smoke deposit preventing means, a means of maintaining a constant voltage and an indicator.

3. Gas analysis

A non-diffusion type infrared spectro-photometer shall be used for analysis of CO and CO₂ gases. The analysis shall be carried out continuously by suctioning gas from the combustion chamber at the rate of 3 - 5 l/min.

HCl and HCN gases are taken from the chamber by suction at the rate of 5 l/min into each appropriate absorbent solution, and are analysed

quantitatively by thiocyan mercuric acid method and pyridine-pyrezolone method respectively.

Results and Considerations

1. Effect of the mass of test portion on the test result

Preliminary tests were carried out with various mass of test portions of PC, PS (cellular) and PA, their behaviours in burning and thermal flow vary depending on their chemical structures and forms. The test results are shown in table 1.

The values of burned mass calculated from the burned residues and the mass of test portions used are plotted as shown in Fig.1. From Fig. 1 it can be seen that the linear relation exists between the mass of test portion and the burned mass for each polymer, and its burning rate is nearly constant.

2. Relation between the burned mass and the smoke density

The relation between the burned mass and the smoke density of three polymers under the same burning conditions is shown in Fig. 2.

For PS and PC, a line nearly passing through the original point of a graph is obtained, while for PA bending in a line is seen at around 4 to 5 grams of the burned mass and indicating its peculiarity.

Fig. 3 shows the relationship between the burning rate and the amount of generated smoke per 1 g of the test portion. In case of PC, a tendency of saturation in the amount of evolved smoke can be seen with increase in the mass of test portion, while in case of PA, an amount of smoke tends to increase with increase in the mass of test portion.

Thus, such distinction appeared in the behaviour of smoke evolution among them makes it possible to characterize the polymers.

3. Relation between the burned mass and the formation of CO and CO₂

Fig. 4 shows the relationship between the burned mass of each of three polymers and its evolved amount of CO under the same burning conditions.

From this graph it can be seen that there exists a linear relationship between them, though an amount of CO varies with the type of polymer.

Fig. 5 is the converted graph of Fig. 4 into that of an amount of evolved CO per 1 g of sample. The amount of CO per 1 g of sample for PS increases with greater mass of sample, and for PC and PA decreases with increase in the mass of sample. As to CO₂ the similar mode can be seen in Fig. 6.

When plotted these values correlating CO with CO₂, Fig. 7 is obtained. Fig. 7 shows apparently that the value of ratio CO/CO₂, that is a tendency to incomplete burning, becomes to be greater with increase in burned mass of sample.

4. Burned mass and consumed oxygen concentration

Oxygen consumed by burning is expressed as

$$\text{Consumed oxygen concentration (\%)} = (\text{Oxygen concentration in the chamber at test starting})(\%) - (\text{Oxygen concentration in the chamber after burning})(\%).$$

Fig. 8 shows the consumed oxygen concentration in relation with the burned mass of PS, PC and PA, respectively.

Ignition time and burning time with various mass of samples are shown in Fig. 9.

Since amounts of smoke, CO and CO₂ generated by combustion of polymers vary with their burned mass as seen in figures above mentioned, in the comparison of the burning behaviours of the various polymers, it is convenient to use the values expressed in per nit mass of each.

It may be considered in most cases that the relation between the burned mass and the amount of evolved smoke or gas is of linear, although it can not expected its line drawn would always pass through 0 point on the graph.

Nevertheless, in rating of the burning behaviours of polymers, no confusion would take place when making comparison with the values per unit mass. Furthermore, with such comparison it is possible to characterize the mode of formation of smoke or gas among polymers.

In this method values of evolved smoke, CO and CO₂ calculated per unit mass of burned sample are designated as an index of evolved smoke (I_{cs}), an index of evolved CO (I_{co}) and an index of evolved CO₂ (I_{co2}), respectively.

5. Experimental test results

Experimental test were carried out on various commercially available plastics by means of the proposed method at the three levels of test temperatures of $350 \pm 10^{\circ}\text{C}$, $550 \pm 10^{\circ}\text{C}$ and $850 \pm 10^{\circ}\text{C}$. For the purpose of comparison a wood sample was also tested.

Materials tested are shown in table 2.

5.1. Burning behaviour

Formation of smoke and gases by burning of plastics are closely related to their burning behaviours and depend on the circumstance conditions of burning.

Ignition time, burning time, burning rate and the percentage of burned mass of each test sample at 550°C and 850°C are shown in tables 3 and 4. In table 3, distinction of burning behaviour among plastics can be seen, with indicating characteristic values by type of plastic.

At 850°C these difference in burning characteristics among them become lesser substantially as the case of the percentage of burned mass which shows 100% or near to 100%.

Table 4 shows the burning behaviour such as ignition time and burning rate are activated under elevated temperature circumstance.

5.2. Formation of smoke and gases

In this experiment the behaviour in smoke evolution is represented by a light extinction coefficient (C_s) and an index of evolved smoke (I_{cs}). Results of C_s and I_{cs} at 550°C and 850°C are shown in table 5, together with the ratio of I_{co} at 550°C and that at 850°C .

C_s is the resulted smoke density from a certain mass of a test sample, which varies by sample as shown in tables 3 and 4. I_{cs} is the conversion of C_s into that per unit burned mass.

By comparing the value of I_{cs} with each other, a rating of plastic material in terms of smoke-related characteristics could be assessed on the nearly equivalent level of criterion.

Table 6 shows the values of I_{co} , I_{co2} and I_{co}/I_{co2} measured at 550°C and 850°C , together with the amount of gases of HCl and HCN evolved, expressed in mg per 1 g of burned mass of sample, and also with consumed oxygen (% by vol) during the test.

As seen in table 6, in all cases decrease in oxygen concentration in air were very slight within the range of decimal place, because of so large the capacity of the test chamber relative to the mass of test portion in this method.

Figs 10 and 11 are of I_{co}/I_{co2} and I_{cs} indicated by bar graph for various plastic materials.

6. Conclusion

At the present time relationship between circumference conditions of burning and the burning behaviours of plastic materials, including smoke and gases generated by combustion, can not be definitely explained. However, a rating of plastic material in terms of smoke-related characteristics may be assessed from the values of I_{cs} , I_{co} and I_{co}/I_{co2} together with the knowledge of concentration of HCl and HCN (mg/g).

The effect of flame-retardants and reinforcing materials on the burning behaviours of plastic materials can also be estimated by these

measurements.

At elevated temperature, some plastics generate much more amount of smoke and gases, while others less amount of smoke and gases. Such phenomena are inherent in natures of plastics and can be categorized into two groups.

From a viewpoint of this test method being capable of rating and categorizing the plastics material in terms of burning behaviour, this method could be considered useful as a measure as a measure of assessment of the burning behaviour of plastic materials.

Table 1 Test results of preliminary experiments.

sample	mass of test sample (g)	until flash ignition time (sec)	burning time (sec)	I _{cs}	gasses resulted by burning			
					I _{co}	I _{co2}	O ₂ (%/g)	HCN (mg/g)
P C	219	195	115	0.78	0.0111	0.204	0.206	-
	457	161	121	1.63	0.0125	0.224	0.198	-
	686	159.3	157.5	1.59	0.0124	0.214	0.223	-
P S (foam)	0.4	103.6	19.0	1.65	0.0160	0.254	0.336	-
	0.8	64.6	35.6	1.89	0.0153	0.333	0.245	-
	1.20	90.5	39.0	2.08	0.0137	0.291	0.148	-
P A	2.49	135.0	193.0	0.34	0.0051	0.278	0.327	27.8
	4.64	110.8	99.0	0.51	0.0053	0.276	0.329	19.3
	7.00	117.5	110.5	0.81	0.0062	0.234	0.321	18.3

Table 2 Tested materials

No	sample	remarks
1	polycarbonate PC	
2	polyacetal POM	
3	rigid poly vinyl chloride PVC	
4		PVC (r) fire retardant
5	high impact polystyrene HI-PS	
6	polystyrene PS (r)	fire retardant
7	A B S ABS	
8	polystyrene PS (f)	form
9	polyamide PA	
10	unsaturated polyester(fibre reinforced)	FRP
11		FRP (r) fire retardant
12	polyethylene PE	
13	polyurethane (form)	PUR
14		PUR (r) fire retardant
15	polypropylene PP	
16	poly methyl methacrylate PMMA	
17	urea-formaldehyde UF	
18	phenol-formaldehyde PF	
19	wood W	

Table 3 Test results (at 550°C)

No.	sample	mass (g)	thick- ness (mm)	until flash igniti- on time (sec)	burning time (sec)	burning rate (g/min)	percentage of burned mass (%)	remarks
1	PC	2.57	2.9	112.5	157.5	0.72	7.51	
2	POM	3.00	3.1	93.0	94.0	1.80	9.50	
3	PVC	2.80	3.2	103.0	78.5	1.80	8.46	
4	PVC(r)	3.25	3.6	165.0	75.0	2.22	8.40	
5	HI-PS	1.67	2.2	73.0	60.0	1.38	8.30	
6	PS(f)	1.83	2.0	76.0	102.0	0.90	8.58	
7	ABS	2.20	3.1	79.5	57.5	2.10	9.18	
8	PS(r)	0.33	3.8	93.0	24.0	0.54	4.85	
9	PA	2.45	3.1	108.5	80.5	1.74	9.39	
10	FRP	2.93	3.1	81.5	134.5	0.90	6.76	
11	FRP(r)	4.00	3.6	114.5	208.0	0.66	5.90	
12	PE	1.95	3.0	103.5	104.0	1.08	9.38	
13	PUR	0.73	10.1	53.5	27.0	0.89	5.47	
14	PUR(r)	0.78	9.1	heated for 84 sec		0.27	4.87	charred
15	PP	1.45	2.5	75.5	82.5	1.02	8.97	
16	PMMA	2.68	3.0	83.0	94.5	1.56	9.25	
17	UF	2.90	3.4	heated for 600 sec		0.28	9.74	not ignited
18	PF	1.60	2.0	297.5	131.5	0.604	8.28	
19	wood	2.00	6.0	271.0	143.5	0.714	8.658	

Table 4 Test results (at 850°C)

No.	sample	mass (g)	thick- ness (mm)	until flash igniti- on time (sec)	burning time (sec)	burning rate (g/min)	percentage of burned mass (%)
1	PC	2.25	2.9	15.0	39.0	3.46	10.00
2	POM	2.80	3.1	11.0	48.0	3.46	9.89
3	PVC	2.675	3.2	7.1	40.9	3.81	9.70
4	PVC(r)	3.45	3.6	4.8	74.7	2.61	9.43
5	HI-PS	1.45	2.2	4.0	38.0	2.26	9.86
6	PS(f)	1.60	2.0	3.0	34.0	2.70	9.56
7	ABS	2.15	3.1	6.0	26.3	4.90	10.00
8	PS(r)	0.975	3.8	2.0	21.0	2.79	10.00
9	PA	2.30	3.1	10.0	44.0	3.14	10.00
10	FRP	3.00	3.1	5.0	65.0	2.24	8.10
11	FRP(r)	3.85	3.6	8.0	85.0	2.10	7.4
12	PE	1.90	3.0	11.3	40.6	2.81	10.00
13	PUR	1.05	10.1	0.0	12.3	5.12	10.00
14	PUR(r)	1.10	9.1	0.0	14.0	4.71	10.00
15	PP	1.475	2.5	8.0	35.0	2.53	10.00
16	PMMA	2.15	3.0	5.5	44.0	2.93	10.00
17	UF	2.95	3.4	11.0	106.0	1.63	9.76
18	PF	1.67	2.0	8.5	43.3	2.09	8.99
19	wood	2.05	6.0	4.0	64.5	1.76	9.24

Table 5 Smoke evolution

No.	sample	C _s		I _{CS}		I _{CS} ⁵⁵⁰ /I _{CS} ⁸⁵⁰
		550°C	850°C	550°C	850°C	
1	PC	1.492	2.724	0.773	1.211	0.63
2	POM	0.002	0.010	0.001	0.004	0.25
3	PVC	4.050	4.124	1.710	1.589	1.08
4	PVC(r)	3.600	4.400	1.319	1.352	0.98
5	HI-PS	3.180	2.000	2.294	1.399	1.64
6	PS(r)	3.710	2.424	2.363	1.585	1.49
7	ABS	3.280	2.450	1.624	1.140	1.42
8	PS(f)	0.262	0.900	1.637	0.923	1.77
9	PA	0.742	0.450	0.322	0.196	1.64
10	FRP	2.300	2.274	1.161	0.936	1.24
11	FRP(r)	2.880	3.100	1.220	1.040	1.17
12	PE	1.214	1.100	0.664	0.579	1.15
13	PUR	0.568	0.364	1.422	0.347	4.10
14	PUR(r)	0.668	0.600	1.759	0.545	3.23
15	PP	1.190	1.064	0.915	0.721	1.27
16	PMMA	0.728	0.400	0.294	0.186	1.58
17	UF	1.226	---	0.434	---	---
18	PF	0.826	1.024	0.623	0.682	0.91
19	wood	0.200	0.550	0.116	0.290	0.40

Table 6 Gases resulted by burning.

No.	sample	Ico		Ico ₂		Ico/Ico ₂		HCL (mg/g)		HCN (mg/g)		O ₂ (%vol)	
		550°C	850°C	550°C	850°C	550°C	850°C	550°C	850°C	550°C	850°C	550°C	850°C
1	PC	0.0197	0.016	0.132	0.196	0.15	0.08	—	—	—	—	0.310	0.270
2	POM	0.0004	0.001	0.110	0.191	0.04	0.005	—	—	—	—	0.228	0.258
3	PVC	0.0253	0.013	0.027	0.038	0.94	0.34	2520	1875	—	—	0.105	0.107
4	PVC (r)	0.0219	0.019	0.018	0.027	1.22	0.70	1750	1200	*	—	0.091	0.103
5	HI-PS	0.0307	0.022	0.1605	0.336	0.19	0.07	—	—	—	—	0.342	0.521
6	PS (f)	0.0522	0.070	0.064	0.065	0.81	1.08	—	—	—	—	0.210	0.142
7	ABS	0.0284	0.022	0.1485	0.298	0.19	0.07	—	—	1.42	1.05	0.311	0.347
8	PS (r)	0.0277	0.028	0.1560	0.102	0.18	0.27	—	—	—	—	0.937	0.253
9	PA	0.0174	0.010	0.1565	0.278	0.11	0.04	—	—	5.35	3.90	0.347	0.310
10	FRP	0.0192	0.013	0.1285	0.218	0.15	0.06	—	—	—	—	0.267	0.281
11	FRP (r)	0.0318	0.019	0.1015	0.083	0.31	0.23	—	—	—	—	0.224	0.123
12	PE	0.0191	0.018	0.210	0.342	0.09	0.05	—	—	—	—	0.508	0.441
13	PUR	0.0013	0.009	0.026	0.143	0.05	0.06	—	—	3.0	1.8	0.325	0.799
14	PUR (r)	0.0026	0.023	0.026	0.118	0.10	0.19	*	—	3.6	1.5	0.342	0.240
15	PP	0.0092	0.020	0.204	0.338	0.05	0.06	—	—	—	—	0.523	0.168
16	PMMA	0.0060	0.004	0.145	0.281	0.04	0.01	—	—	—	—	0.302	0.340
17	UF	0.0152	0.001	0.158	0.128	0.10	0.01	—	—	—	—	0.236	0.151
18	PF	0.0039	0.017	0.093	0.159	0.04	0.11	—	—	—	—	0.410	0.205
19	wood	0.0031	0.011	0.080	0.155	0.04	0.07	—	—	—	—	0.148	0.176

Note : *trace

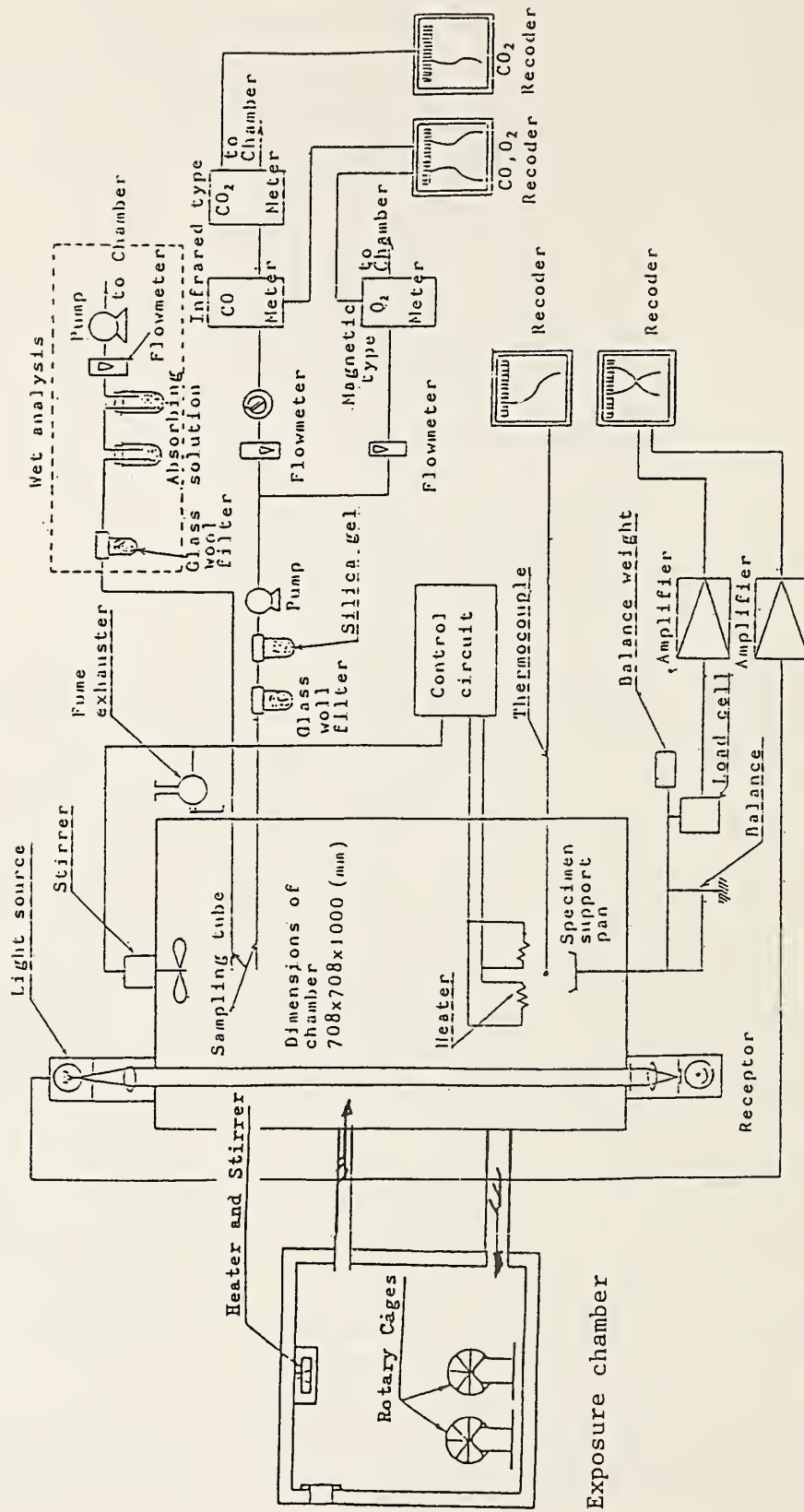


Fig. 1-1 Diagram of test apparatus

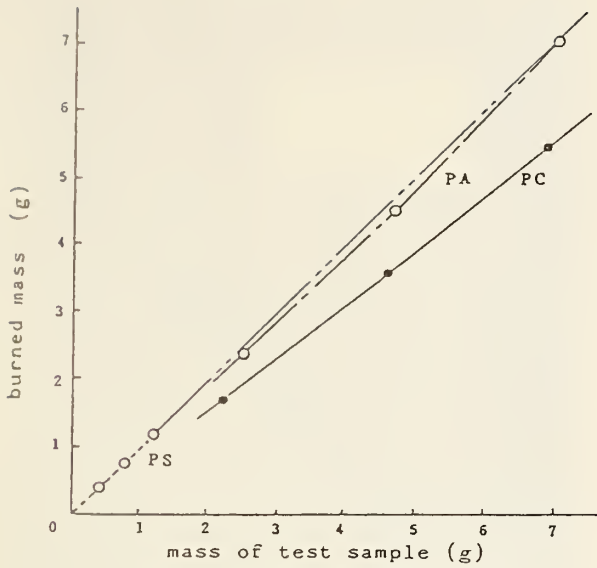


Fig. 1 Relationship between burned mass and mass of test sample.

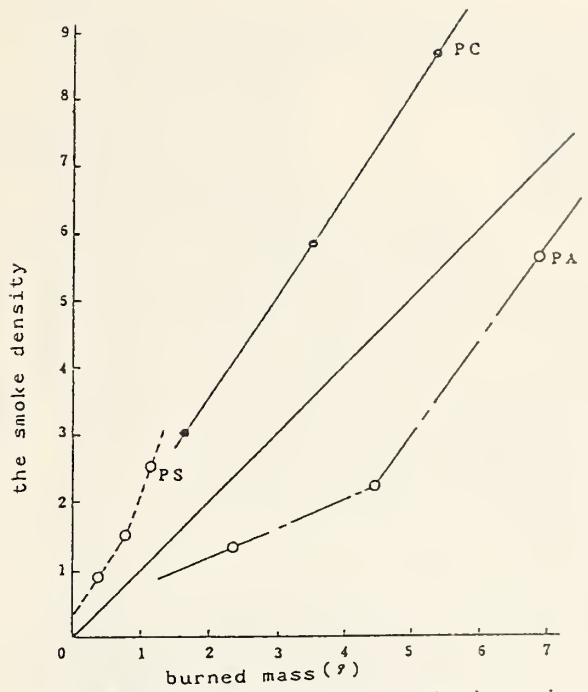


Fig. 2 Relationship between the burned mass and the smoke density.

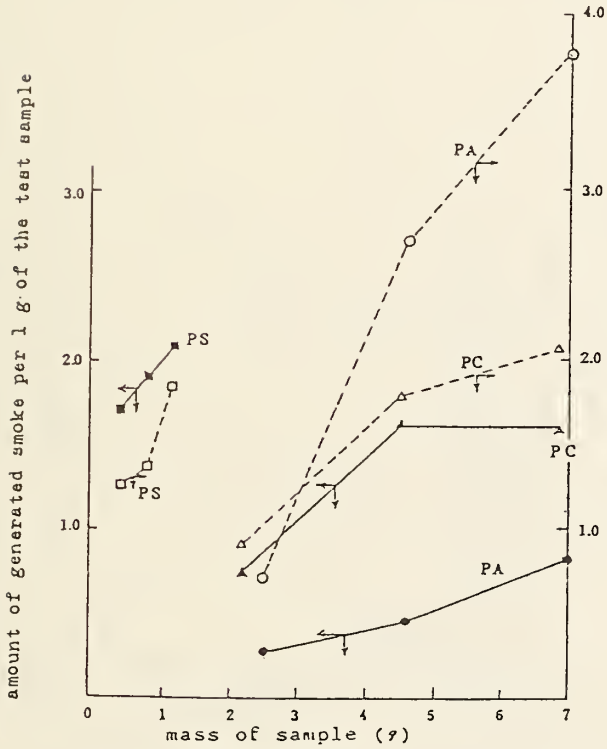


Fig. 3 Relationship between the burning rate and the amount of generated smoke per 1 g of the test sample.

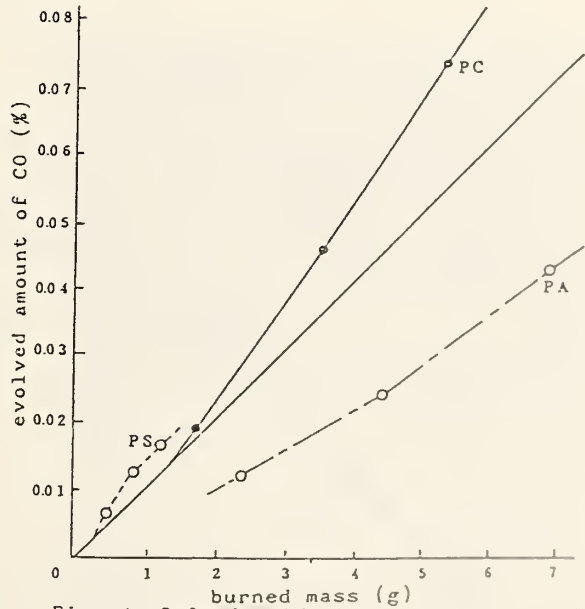


Fig. 4 Relationship between the burned mass and evolved amount of CO.

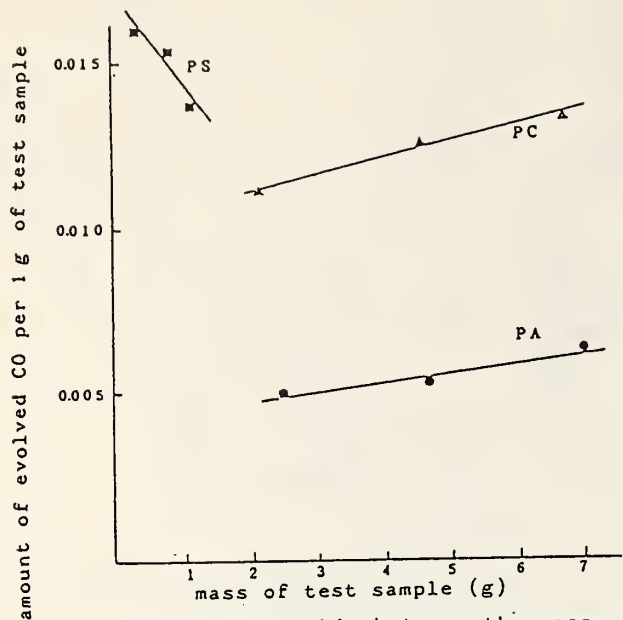


Fig. 5 Relationship between the mass of test sample and the amount of evolved CO per 1g of test sample.

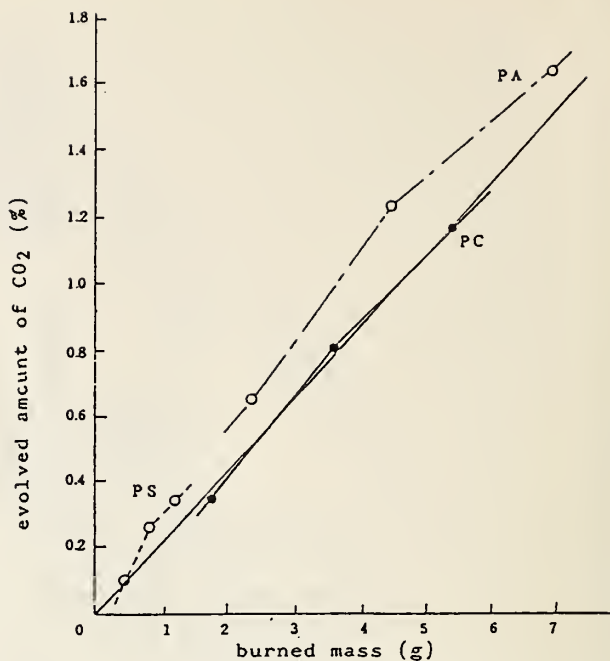


Fig. 6 Relationship between the burned mass and evolved amount of CO_2 .

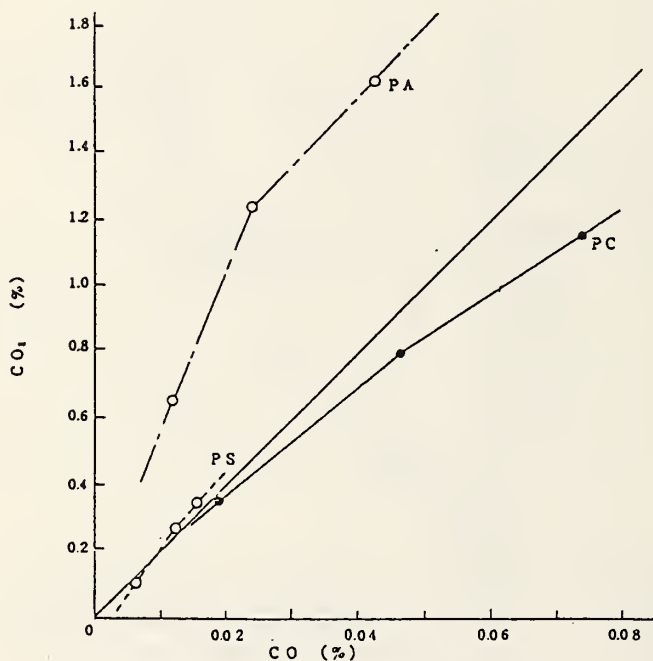


Fig. 7 Relationship between CO and CO_2 .

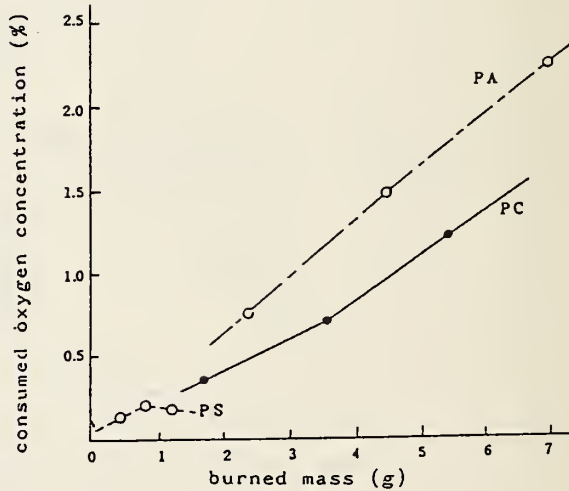


Fig. 8 Relationship between the burned mass and consumed oxygen concentration.

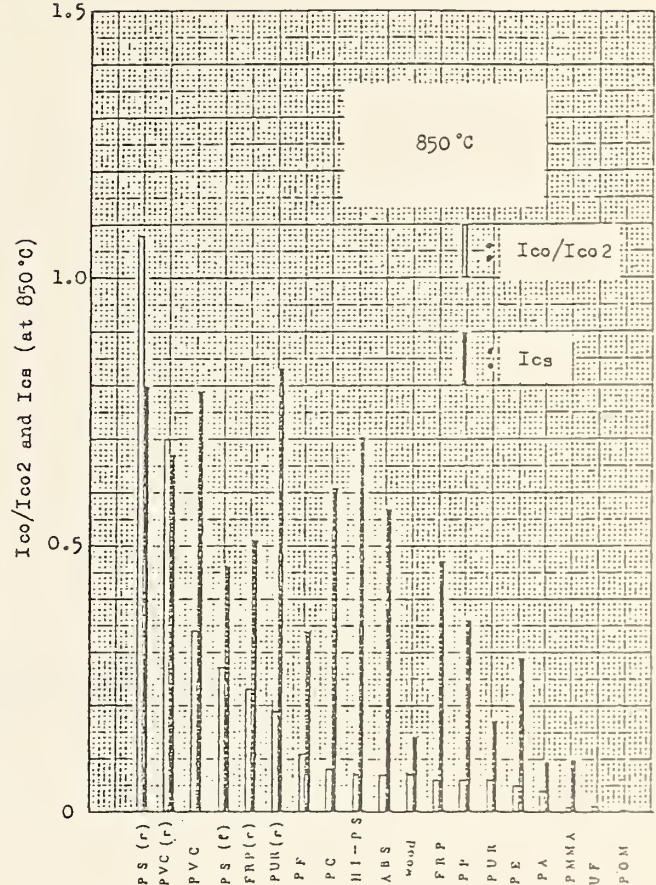
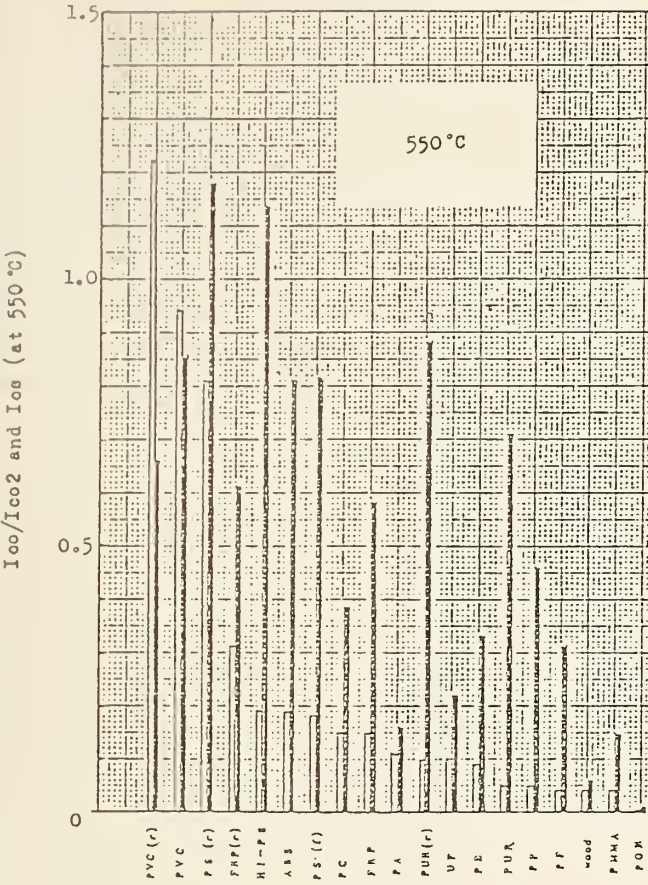


Fig. 10 Ico/Ico2 and Ics

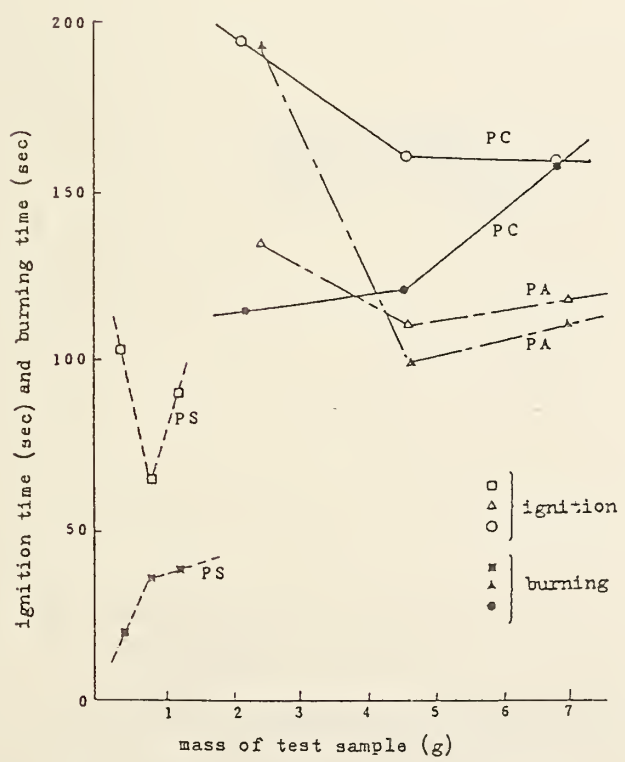


Fig. 9 Relationship between the ignition time and burning time with various mass of test samples.

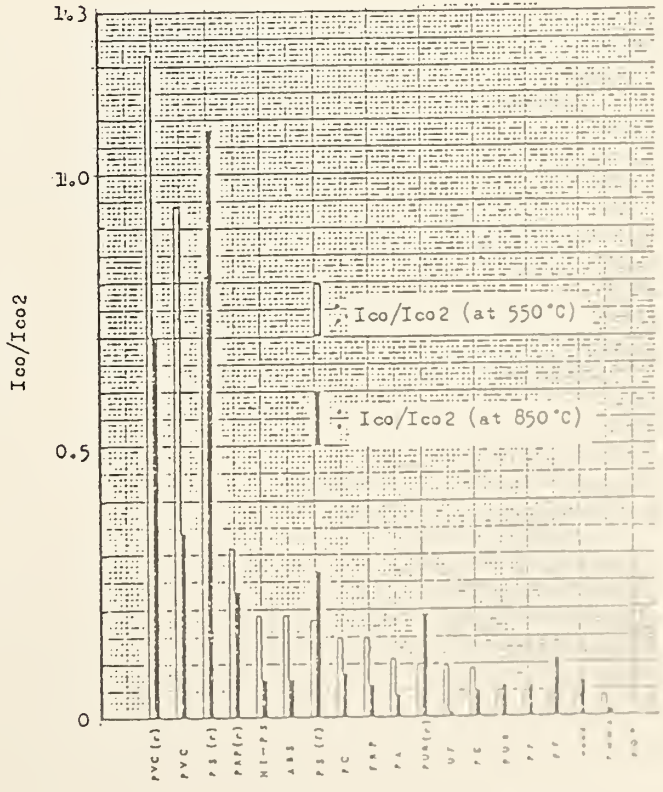


Fig. 11 Ico/Ico2 (at 550°C and 850°C).

MEASUREMENT METHODS

Patrick Pagni
Session Chairman

CURRENT U. S. ADVANCES IN FIRE RESEARCH TECHNIQUES

Raymond Friedman

Factory Mutual Research Corporation
Norwood, Massachusetts 02062, U.S.A.

(For Seventh U.S.-Japan Natural Resources Panel
Meeting on Fire Research and Safety)

September 1983



Factory Mutual Research

1151 Boston-Providence Turnpike
Norwood, Massachusetts 02062

Scope

This review is limited to very recent U. S. progress in experimental techniques applied to fire research. For the most part, work published before 1982 is not included. Work in progress is mentioned, insofar as the author is aware of it.

1. Measurement of Heat Release Rate

The largest accurate calorimeter used to date is described by Heskestad (1.1) and Lee (1.2) of Factory Mutual Research. It consists of a vertical duct 10.5 m tall and 1.5 m in diameter, below which is a cone opening to 6.1 m diameter. Combustion products are drawn into the cone by an exhaust fan, at a rate up to 30 kg/s. After passage through a mixing orifice, the temperature and composition of the gases are measured at a single point, yielding both the convective portion of the heat release rate and the total heat release rate inferred from oxygen consumption or carbon dioxide/carbon monoxide production. The useful range for accurate work is from 100 kW to at least 4 MW.

Babrauskas et al., (1.3) used a large calorimeter to measure heat release rates of furniture items, primarily upholstered chairs. The oxygen depletion method was used to determine heat release rate. Ignition was with a 50 kW natural gas burner for 200 s, intended to simulate a wastebasket fire. Peak heat release rates up to 3.7 MW are reported; however, the capacity of this apparatus is stated to be 2.5 MW.

Let us now consider heat release rate measurements on a smaller scale. Babrauskas (1.4) measured several gaseous and horizontal polymethyl methacrylate samples with the Ohio State University apparatus using two different techniques: 1) standard compensated thermopile measurement, and 2) oxygen depletion. Results showed substantially complete combustion according to oxygen depletion, but a varying incompleteness in excess of 20% with the standard sensible enthalpy-based procedure. Furthermore, plastic samples burned at a progressively increasing rate in the OSU apparatus, the rate doubling in the interval between 100 and 500 s, while identical samples burned at a constant rate over this interval in a different apparatus. Babrauskas proposes that, in the OSU apparatus, the external irradiance of the sample increases throughout a test because of flame impingement on the reflector and other nearby metalwork, instead of remaining close to the original nominal value.

Tordella and Twilley (1.5) have described development of a calorimeter for simultaneously measuring heat release and mass loss rates. Their apparatus provides a radiant flux from 25 to 80 kW/m² from gas-heated radiant panels to vertical specimens 300 x 300 mm or horizontal specimens 150 x 300 mm. The heat release rate is measured by the substitute gas burner technique. A problem was experienced on windy days -- fluctuations in flow rate of gas to the substitution burner caused by variable wind velocity at the top of the stack. Gusts caused baseline variations up to 150 kW/m².

Babrauskas (1.6) has reported on a bench-scale heat release rate apparatus using a cone calorimeter. The specimen may be vertical or horizontal-upward. Irradiance up to 100 kW/m² is achievable. Oxygen depletion, product gas flow, and sample weight loss are measured; heat release rate is calculated by assuming 13,100 kJ released per Kg of oxygen consumed, which is valid within ± 5% for most fuels.

2. Measurements in Flames and Plumes

Continued refinements have been made on laboratory techniques to probe small laminar flames. Colket et al., (2.1) and Fristrom (2.2) have studied reaction-quenching efficiency of small gas-sampling probes. Cattolica and Schefer (2.3) and Lucht et al., (2.4) have developed laser-fluorescence techniques for measuring hydroxyl radical concentration in flames. Knuth et al., (2.5) has described molecular-beam sampling of methane-air flames being extinguished by dry chemicals. Hughey and Santavicca (2.6) have studied techniques for reconstructing axisymmetric reacting flow fields from absorption measurements.

Turning now to turbulent flames and plumes, we find that Most et al., (2.7) have succeeded in measuring velocity profiles in a turbulent ethane diffusion flame burning close to a porous wall, by using laser-Doppler velocimetry. The flame was seeded with alumina particles. The method was based on random sampling of velocities in the measuring volume. Ikioka et al (2.8) have described a laser anemometer seeding technique for combustion flows with multiple stream injection.

Markstein (2.9) has developed a fiber-optic absorption probe which measures infrared diode radiation at 0.96 micrometers across a gap of 60 mm. This probe has been inserted into turbulent diffusion flames up to 762 mm in

diameter, and local absorption measurements may be interpreted to yield the spatial variations within the flame of absorption coefficient and corresponding soot volume fraction. Soot volume fractions as high as 1.9×10^{-6} have been measured in a propylene flame.

Tamanini (2.10) has built an apparatus for quenching the reaction at any desired height above the fuel surface for a turbulent pool fire. The principle is to draw the entire burning flow into a horizontal "catcher-quencher" heat exchanger located a variable distance above the pool surface. The heat exchanger is cooled with hot water to prevent condensation. Chemical analysis of the quenched gases is performed, as well as a flow-rate measurement. Analysis of propane data yields heat release rate and carbon-monoxide yield versus height in the flame. The apparatus is limited in that: 1) data taken with the heat exchanger very close to the pool surface are of doubtful significance; and 2) use with fuels much sootier than propane may be limited because of plugging of the heat-exchanger openings. Except for these limitations, the data appear to be reliable.

Kung (2.11) has described a method of measuring the convective heat flux in a buoyant turbulent plume over a large pool fire. The method is based on a limited number of temperature and velocity measurements at selected locations within the plume, and analysis involving curve-fitting to assumed Gaussian profiles of temperature and velocity. Results are in good agreement with those obtained by Heskestad's calorimeter (2.11). While the calorimeter is inherently more accurate, any given calorimeter will have a maximum capacity, while Kung's method has no such limitation.

Zukoski et al., (2.12) have applied the Ricou-Spalding technique (1961) to entrainment-rate measurements in 10 to 200 kW buoyant fire plumes of 0.1 to 0.5 m diameter. They find that small irregularities in the induced air inflow can cause substantial increase in entrainment rate. Delichatsios (2.13) is measuring entrainment by a similar technique, and is taking elaborate precautions to eliminate effects of flow irregularities on the results.

3. Fires in Compartments

Fisher and Williamson (3.1) have described a proposed standard room fire test method for evaluating interior finish materials (wall and/or ceiling materials). The test compartment is 2.4 m wide, 3.7 m long, and 2.4 m high,

with an open doorway. The ignition source is a propane-fired sand burner in one corner. The combustion products rising from the doorway are collected and mixed in a stack, and heat release rate is deduced from oxygen depletion. In addition, measurements are made of temperature 100 mm below the ceiling, heat flux to the floor, and light transmission through the stack gases. In a typical test leading to flashover, an average ceiling temperature of 600°C is achieved in a few minutes, and flames appear outside the door one or two minutes later (at which time the heat release rate is 750-950 kW). More recent data (August 1983) show that times to flashover for plywood correlate with moisture content and with presence of fire retardant.

Two papers have appeared which deal with techniques to study compartment fires. Cooper (3.2) is concerned with the leakage of smoke through door assemblies, and also overall wall and floor assemblies. He evaluated the proposed ISO test method DP5925, Part 3 for door assemblies and found certain problems with the method. After analyzing the reasons for lack of success, the author proposes a new test configuration which would hopefully remove the limitations and problems of the proposed ISO test method.

Steckler et al., (3.3) have carried out probably the most complete and accurate set of steady-state experiments conducted to measure the flow rate induced through an opening in a compartment by a simulated pool fire in the compartment. Movable bidirectional velocity probes and thermocouples were located on a grid of up to 144 points in the opening. A series of fire sizes and fire locations were studied. The resulting flow rates were well correlated by a hydrostatic model which requires measurement of vertical distribution of temperature, but no velocity measurements. An accuracy of the order of \pm seven percent is shown.

4. Droplets and Particulates

You and Symonds (4.1, 4.2) have used a unique instrument to measure water drop-size in sprinkler sprays. This is a custom-made device constructed by Particle Measurement Systems, Inc., Boulder, Colorado. A sheet of laser light is projected across a 61-mm gap onto a linear array of 64 detectors. A passing drop produces a shadow, the width and duration of which are measured. If the drop is known to be spherical, both the diameter and velocity may be deduced. On the other hand, given a non-spherical drop moving with

known velocity, its cross-sectional shape is obtainable. The output is stored in a computer and various statistical distribution functions may be displayed on a screen. Data are obtainable for droplets from a few tenths of a mm diameter up to 6 mm diameter. As long as the total water flux is low enough (below about 15 droplets/cm² min), an accurate measure of total water flux is also obtainable. At higher fluxes, some droplets are missed. However, tests with polydisperse stainless steel balls have confirmed the probe's ability to provide accurate particle distribution information, even at higher fluxes than indicated above. The system has built-in modes for coincidence error rejection, depth-of-field rejection, and edge rejection.

Turning now to measurement of smoke, Mulholland (4.3) has analyzed errors made by the widely used method of light extinction. What is measured is not only the transmitted light but also the forward-scattered light, which depends on the particulate diameter. Furthermore, the use of white light instead of monochromatic light causes deviations from Bouguer's law. Measurement errors of the order of 25% will result from each of these effects. A potential method for calibrating extinction instruments is described.

Quintiere (4.4) has made an extensive review comparing full-scale fire smoke data with laboratory test method results. In general, the correlations are rather poor. The author attributes this primarily to the importance of various physical factors affecting smoke formation rather than to faults of the various test methods. The identified factors influencing smoke in a large fire, which cannot be easily related to laboratory tests, are: 1) the variation of smoke production with time as the sample is heated; 2) the effect of external radiant flux; 3) oxygen concentration; 4) scale; 5) orientation; 6) flaming vs. non-flaming decomposition.

5. Toxicity

Toxicity is reviewed separately at this meeting so it will not be discussed here. However, two important papers, by Levin et al., (5.1) and by Williams and Clark (5.2) are noted. The former deals with development of a test protocol, while the latter shows that when polytetrafluorethylene is heated with a methane flame the toxicity of the products is about three orders of magnitude less than when it is pyrolyzed under non-flaming conditions. They propose that water which forms in the flame may act to hydrolyze and

deactivate the toxic species (the identity of which is uncertain). However, these data also show that pyrolysis of PTFE in the absence of a flame at 850°C gives products a factor of 300 less toxic than for pyrolysis at 700°C, suggesting that heat rather than water vapor deactivates the toxic species.

6. Miscellaneous

Robertson (6.1) has described a gas-fired radiant heat source for use in a fire test method. It can be operated at equivalent black-body temperatures of about 930°C, allowing specimen irradiance levels of 5 W/cm² for substantial periods, and could approach 7 W/cm² for short periods. A heated surface of 270 x 480 mm, fired with natural gas, was made of commercially available refractory tiles.

Steel (6.2) has tested several pressure probes of types used in fire endurance furnaces at room temperature and then compared in a furnace. It is suggested that the total pressure be measured instead of static pressure and that the most accurate probe is a small flush hole in the specimen.

de Ris (6.3) has proposed a concept for a new bench-scale test method to assess flammability of solid materials. It is based on the concept that the radiant emission of a material's own flame is a critically important property in determining its large-scale burning rate and spread rate. A small sample is electrically heated in an oven through which a nitrogen-ethylene mixture flows. The effluent nitrogen-ethylene-pyrolysis gas mixture is discharged upward from an orifice to form a candle-like laminar diffusion flame. Depending on flow rate and composition, this flame may be above its smoke point; i.e., releasing soot from the top. The flame height and soot formation are sensed automatically. The nitrogen and ethylene flow rates are automatically adjusted so as to hold the flame height constant while simultaneously keeping the flame just at its smoke point. The heat release rate is proportional to the flame height. Accordingly, as combustible pyrolysis gas is generated, ethylene flow must be reduced to maintain constant flame height. The ethylene flow reduction is a measure of heat release rate. Now, if the generated pyrolysis gas had the same soot-forming propensity as ethylene, no further adjustment would be needed to maintain the flame just at the smoke point. However, for example if the pyrolysis gas had a greater soot-forming propensity than ethylene, it would be necessary to increase the nitrogen flow sufficiently

to hold the flame at the marginal soot point. Thus, by proper interpretation of the ethylene and nitrogen flow rates as pyrolysis occurs while flame height and incipient soot formation are being held constant, one can deduce both soot-forming tendency and heat release rate of the sample. Correlations exist between soot-forming tendency and fire radiative emission for a series of hydrocarbons, but further data are needed for other combustibles. Also, the applicability to situations where volatile chemical retardants must be explored. Finally, the concept must be translated to practical hardware.

Kashiwagi and Kashiwagi (6.4) have used a high-speed, two-wave length holographic interferometer to study transient ignition events (500 frames/second) associated with high-flux CO_2 laser irradiation of a flammable liquid surface. This provides both temporally and spatially resolved temperatures and species concentrations. In this apparatus, a helium-neon red laser (632.8 nm) and an argon blue laser (688 nm) are used. The molar refractivities of the hydrocarbon vapor, oxygen and nitrogen at the two wavelengths are known. Fringe analysis from laser holograms reveals the temperature and composition information.

In another ignition study, Kashiwagi (6.5) explored the effects of sample orientation on spontaneous ignition delay using either a CO_2 laser or a gas-fired radiant panel to heat PMMA or red oak. Ignition occurred sooner and at lower minimum radiant flux with horizontal as contrasted with vertical samples. Sample size was also important. Although extensive discussion is provided, the full explanation for these effects is still not established. However, it is clear that auto-ignition of a surface is not uniquely determined by the incident radiant flux and the ambient atmosphere.

REFERENCES

- 1.1 Heskestad, G., "A Fire Products Collector for Calorimetry into the MW Range," Factory Mutual Research Corporation, J.I. 0C2E1.RA, June 1981 (100 pp).
- 1.2 Lee, J. L., "A Manual for Measuring the Convective and Radiative Heat Release Rates of Transformer Fluids Using the Fire Products Collector," Factory Mutual Research Corporation, J.I. 0G1E8.RA, February 1982 (23 pp).
- 1.3 Babrauskas, V., Lawson, J. R., Walton, W. D. and Twilley, W. H., "Upholstered Furniture Heat Release Rates Measured with a Furniture Calorimeter." NBSIR 82-2604, December 1982 (73 pp).
- 1.4 Babrauskas, V., "Performance of the Ohio State University Rate of Heat Release Apparatus Using Polymethyl Methacrylate and Gaseous Fuels." Fire Safety Journal 5, No. 1, pp. 9-20 (1982).
- 1.5 Tordella, J. and Twilley, W. H., "Development of a Calorimeter for Simultaneously Measuring Heat Release and Mass Loss Rates." NBSIR 83-2708, June 1983 (30 pp).
- 1.6 Babrauskas, V., "Development of the Cone Calorimeter - A Bench-Scale Heat Release Rate Apparatus Based on Oxygen Consumption," NBSIR 82-2611, November 1982 (75 pp).
- 2.1 Colket, M. B., Chiappetta, L., Guile, R. N., Zabielski, M. F. and Seery, D. J., "Internal Aerodynamics of Gas Sampling Probes," Combustion and Flame 44, 3-14 (1982).
- 2.2 Fristrom, R. M., "Comments on Quenching Mechanisms in the Microprobe Sampling of Flames," Combustion and Flame 50, 239-242 (1983).
- 2.3 Cattolica, R. J. and Schefer, R. W., "Laser Fluorescence. Measurements of the OH Concentration in a Combustion Boundary Layer," Combustion Science and Technology 30, pp 205-212 (1983).
- 2.4 Lucht, R. P., Sweeney, D. W. and Laurendeau, N. A., "Laser-Saturated Fluorescence Measurements of OH Concentration in Flames," Combustion and Flame 50, pp 189-205 (1983).
- 2.5 Knuth, E. L., Ni, W. F. and Seeger, C., "Molecular-Beam Sampling Study of Extinguishment of Methane-Air Flames by Dry Chemicals," Combustion Science and Technology 28, pp 247-262 (1982).

- 2.6 Hughey, J. and Santavicca, D. A., "A Comparison of Techniques for Reconstructing Axisymmetric Reacting Flow Fields from Absorption Measurements," *Combustion Science and Technology* 29, pp 167-190 (1982).
- 2.7 Most, M., Sztal, B. and Delichatsios, M. A., "LDV Measurements in a Turbulent Wall Fire," FMRC-CNRS, report in preparation, 1983.
- 2.8 Ikioka, L. M., Brum, R. D. and Samuelson, G. S. , "A Laser Anemometer Seeding Technique for Combustion Flows with Multiple Stream Injection," *Combustion and Flame* 49, pp 155-162 (1983).
- 2.9 Markstein, G., "Measurements on Gaseous-Fuel Pool Fires with a Fiber-Optic Absorption Probe." Submitted to *Combustion Science and Technology* (August 1983).
- 2.10 Tamanini, F., "Direct Measurements of the Longitudinal Variation of Burning Rate and Product Yield in Turbulent Diffusion Flames," *Combustion and Flame* 51, pp 231-243 (1983).
- 2.11 Kung, H. C., "Buoyant Plumes of Large-Scale Pool Fires," Nineteenth Symposium (International) on Combustion, The Combustion Institute, Pittsburgh, 1983, pp 905-912.
- 2.12 Zukoski, E. E., Kubota, T. and Cetegen, B., "Entrainment in Fire Plumes," *Fire Safety Journal* 3, pp 107-121 (1981).
- 2.13 Delichatsios, M., Factory Mutual Research Corporation, August 1983, Private communication.
- 3.1 Fisher, F. L. and Williamson, R. B., "Intralaboratory Evaluation of a Room Fire Test Method," NBS-GCR-83-421, January 1983.
- 3.2 Cooper, L. Y., "Measuring the Leakage of Door Assemblies During Standard Fire Exposures," *Fire and Materials* 5, No. 4, pp 163-174 (1981).
- 3.3 Steckler, K. D., Quintiere, J. G. and Rinkinen, W. J., "Flow Induced by Fire in a Compartment." Nineteenth Symposium (International) on Combustion, The Combustion Institute, Pittsburgh, Pennsylvania, 1983, pp 913-920.
- 4.1 You, H. Z. and Symonds, A. P., "Sprinkler Drop-Size Measurement, Part I: An Investigation of the FMRC PMS Drop-Size Measuring System," Factory Mutual Research Corporation, J.I. OG1E7.RA, December 1982, (57 pp).

- 4.2 You, H. Z., "Sprinkler Drop-Size Measurement, Part II: An Investigation of the Spray Patterns of Selected Commercial Sprinklers with the FMRC PMS Droplet Measuring System," Factory Mutual Research Corporation, J.I. 0G1E7.RA, May 1983 (95 pp).
- 4.3 Mulholland, G. W., "How Well Are We Measuring Smoke?" *Fire and Materials* 6, No. 2, pp 65-67 (1982).
- 4.4 Quintiere, J. G., "Smoke Measurements: An Assessment of Correlations Between Laboratory and Full-Scale Experiments." *Fire and Materials* 6, No. 3/4, pp 145-160 (1982).
- 5.1 Levin, B. C., Fowell, A. J., Birky, M. M., Paabo, M., Stolte, A. and Malek, D., "Further Development of a Test Method for the Assessment of the Acute Inhalation Toxicity of Combustion Products," NBSIR 82-2532, June 1982 (143 pp).
- 5.2 Williams, S. J. and Clarke, F. B., "Combustion Product Toxicity: Dependence on the Mode of Product Generation," *Fire and Materials* 6, No. 3/4, pp 161-162.
- 6.1 Robertson, A. F., "Development of an Improved Radiant Heat Source for Fire Testing," *Fire and Materials* 6, No. 2, pp 68-71 (1982).
- 6.2 Steel, J. S., "Furnace Pressure Probe Investigation," NBSIR 81-2415 (28 pp), November 1981.
- 6.3 de Ris, J., "Flammability Testing: State of the Art." Submitted to *Fire and Materials*, July 1983.
- 6.4 Kashiwagi, T and Kashiwagi, T., "A Study of the Radiative Ignition Mechanism of a Liquid Fuel Using High-Speed Holographic Interferometry," 19th Symposium (International) on Combustion, The Combustion Institute, Pittsburgh, 1983, pp 1511-1521.
- 6.5 Kashiwagi, T., "Effects of Sample Orientation on Radiative Ignition," *Combustion and Flame* 44, pp 223-245 (1982).

Discussion After R. Friedman's Report on CURRENT U.S. ADVANCES IN FIRE RESEARCH TECHNIQUES

JIN: I'd like to know more about the particular device which you sprayed water; what particular equipment or systems you have. Do you use a regular sprinkler?

FRIEDMAN: No, and we could not use regular sprinklers because we do not have a ceiling over the fire to collect the heat. We have this collector which draws the gases in an unnatural way into the duct. So we do an elaborate calculation of the heat release and deduce when sprinklers would have opened if a ceiling had actually been present. Then we apply water through small openings very close to the top of the fuel so that all the water reaches the fuel. For real sprinklers, only a portion of the water would have reached the fuel because the fire plume would have deflected a lot of the water. We measure that process in a separate set of experiments. Therefore, we separate the penetration problem from the extinguishment problem and study each problem separately.

HIRANO: What was the size of the water particle?

FRIEDMAN: Very fine, very tiny, miniature spray nozzles. The water hits the top of the carton and just becomes a sheet of water which runs over the sides; so it is not a droplet.

HIRANO: One question pertains to the timing of actual start of sprinkling water and then, of course, the volume of water. Suppose we have two major factors, one is time, the other one is volume of water. Which one should be more crucial than the other?

FRIEDMAN: Both.

HIRANO: Suppose you used the fixed volume of water, what time spent would you like to apply...continuously at once or over a certain period?

FRIEDMAN: It would depend, of course, on what you were protecting. In the problem we are concerned with, we have cardboard boxes containing, usually, polystyrene foam insulating packing material and electronic products inside. If you can control the fire before the cardboard has burned through, before the polystyrene is involved, then this makes it much easier to control the fire.

HIRANO: What was actual sprinkling time in this particular case?

FRIEDMAN: We started one minute after ignition and continued a long time, but you saw that the heat release was very low. The fire would probably never be put out. It might still be burning a half hour later but people could come and put it out. It would be a very small fire. The fire is underneath 7 meters of goods on top, so it is very hard to completely extinguish it.

NELSON: How close are we to unlinking these phenomena to put them back together in the model?

FRIEDMAN: A lot of progress. We have special people working on models.

NELSON: Have you got a fairly clear picture of the elements of the model?

FRIEDMAN: The model has a lot of empiricism in it at this point.

PAGNI: What was the ignition source?

FRIEDMAN: Ignition source was a half pint of alcohol (473 cc).

EMMONS: In the experiment, and I would expect in practice, all of the top portion had been extinguished, the bottom portion is not extinguished. You suggest that the lower portion is extinguished by hand. But how do you ensure the safety of those who do it from collapse?

NELSON: Isn't the basic underwriting theory to stop it from going to another pile, and actually it's acceptable if that pile burns out because the fire fighters can't reach it?

FRIEDMAN: I think the key thing is that that fire was reduced to less than 1/10 of a megawatt within half a minute. If the water had not been put on at that time, that fire would have been more than 30 megawatts. The water couldn't do anything once the styrene got going.

BEYREIS: The basic philosophy of commercial industrial sprinklers is to control the fire. That's why it is a difficult problem to go from that to people protection for residential hotel arrangement where the idea is to extinguish the fire.

COOPER: Could you say anything about the question of configuration; for example, what if you use shelves that are solid as compared to open.

FRIEDMAN: I said empirical which means all our modeling for that geometry. This is a fairly standard rack storage study. Hopefully it's a worst case.

VARIOUS MEASUREMENT METHODS ON FIRE RESEARCH

by

Shuzo Yamashika and Taro Yumoto

Fire Defence Agency

Ministry of Home Affairs

Seventh Joint Meeting

U.S.-Japan on Fire Research and Safety

UJNR, Washington, D.C. Oct.24-28,1983

Shuzo Yamashika and Taro Yumoto

1. INTRODUCTION

Burning rate of combustibles, temperatures of flame or hot plume, radiation from flame, velocity of hot flow and the compositions of combustion products are indispensable measuring items for fire research.

In this paper, the present status and problems of various measurement techniques which have so far been used in studies on the fires of buildings since 1979 in Japan will be described.

2. PRESENT STATUS ON BUILDING FIRE RESEARCH

2.1 Experiments of Full-Scale Building Fires

Kishitani et al.¹⁾ made an experiment on the fire of a, three-story, wood frame construction two-family house of a total floor area of 89.02 m² measuring the temperatures of 118 places in the house and 48 places of walls by 166 chromel-alumel thermocouples, as well as the concentration of smoke in 34 places in the house by 34 smoke density meters and radiant heat from the firing house to the environment by means of radiation meters and disk thermocouples. In addition, the concentrations of CO and O₂ in the central part of the rooms were continuously analyzed by using CO and O₂ analyzers, and the behaviors of mice put in such atmospheres were measured by the rotary behavior recorders.

In an experiment on the fire of a two-story light steel-frame house of a total floor area of 104.16 m², which was conducted by Oguni et al.²⁾, in addition to similar measurements mentioned above, the surface temperature of the house was measured by a thermo viewer. The pressures of 4 places in rooms are measured by 4 fine differential pressure meters combined with each Pitot-tube, and the states of fire were recorded by a 16 mm camera, still

photograph, and VTR.

Yamashita³⁾ measured, in an experiment of the fire of 12 wooden tenement houses, three-dimensional wind speeds at a level of 55 m above the ground and in a place about 40 m apart from the end of burning region down the wind by using a supersonic wind direction and speed meter provided with a large-size crane.

Sato et al.⁴⁾ also carried out a run on the fire of a single compartment in conventional wooden house with a floor area of 9.94 m^2 , in which 4 load cells were placed on the compartment and weight loss by burning was measured and the radiation of heat from the firing compartment to the environment was measured by 17 disk thermocouples and a radiation meter. The temperature of the inside of the compartment was measured by chromel-alumel thermocouples, the air current velocity at the openings was measured by 2 simple Pitot-tubes each of which is combined with fine differential pressure meters and also the concentrations of smoke at 4 places were measured by 4 suction type smoke density meters. In addition, the concentrations of CO_2 and CO were continuously analyzed by the infrared analyzers, the concentration of O_2 was measured by a dissolution type oxygen analyzer, and the behavior of mice was by the rotary type behavior recorders.

Sato et al.⁵⁾ carried out an experiment of fire for a three-story wood-based prefabricated house of a total floor area of 114.68 m^2 and similar measurements mentioned above were made.

Hayashi et al.⁶⁾ measured a strong radiant heat around a house on fire, in the experimental fire of a mortar-plastered house with a floor area of 40.5 m^2 , by using a water-cooled type heat sink type heat flux meter and obtained a radiation intensity of $70,000 \text{ kcal/m}^2 \cdot \text{h}$ at a level of 1.5 m above the ground and at a place 0.25 m from the outer wall.

2.2 Flow Behavior of Smoke in Full-Scale Building

In an experiment on the smoke filling in a single room with a floor

area of 13.65 m^2 and a height of 2.41 m , Mulholand et al.⁷⁾ measured the temperatures of 12 vertical positions in the room by using 12 chromel-alumel thermocouples and the smoke concentration of 5 vertical positions by using 5 smoke density meters.

Handa et al.⁸⁾ conducted an experiment on the flow behavior of hot fire products in a concrete corridor 150 m length, 3.3 m width, and 1.63 m height in which the weight loss of wood as a fire source was measured by a load cell. Velocity and temperature of the flow were measured by a smoke-wire method and an array of thermocouples. The tuft system was also employed for the demonstration of profiles and the estimation of velocity.

2.3 Burning Behavior of Furniture

Kawagoe et al.⁹⁾ burned each kind of furniture, e.g., cabinet, bookshelf, desk etc., in an experiment room with a floor area of 34.31 m^2 and a height of 3.0 m , and measured the weight loss rate of the furniture by a load cell, the temperatures of 6 places inside the room by 6 thermocouples, the temperatures of 43 places in the rising hot plume by 43 thermocouples, and the velocity along the center axis of the rising hot fire products by a combination of a bidirectional-pressure probe and a fine differential pressure meter. Also, the smoke concentrations at 8 places were measured by 8 smoke density meters and the smoke filling and the height of flame were recorded visually and photographically.

Mizuno and his coworkers¹⁰⁾ burned urethane foam mats in the same experimental room and similar measurements mentioned above were made.

2.4 Miscellaneous

Nakaya et al.¹¹⁾ also investigated the degrees of the change in temperatures in a 30 cm cube model room during fire, in which methanol and PMMA plate were burned in the model room, the temperatures of 9 places on the surface of ceiling and walls were measured by a 0.1 mm chromel-alumel thermocouple, and the temperatures of the space of the room were measured

by a 0.03 mm platinum-13%Pt-Rh thermocouple.

Hasemi and his coworker¹²⁾ obtained the radiation tolerance criterion of man by a method in which the whole body of a man is heated by a Schwank-burner 1.1 m in width and 1.8 m in height.

Kawagoe et al.¹³⁾ investigated the shape and height of flame by the contour line charts of flame on the basis of a set of photographs taken by concurrently operating the shutters of two cameras set in parallel.

Tachibana¹⁴⁾ also photographed flames of fire by a long-term exposure method on a thought that what necessary for the calculation of radiant heat of fire is not the instantaneous shape of flame but the average value within a period of time.

Masuda and his coworkers¹⁵⁾ made an experimental run of wind tunnel to compare an usual L-type Pitot-tube with a simple Pitot-tube in which two iron steel pipes whose tips are folded at right angles are combined in back-to-back manner, which was manufactured by them, on a thought that a probe to be used in the measurement of velocity of hot fire products during the full-scale fire experiment should be desirably strong against heat and impaction and also be inexpensive, and confirmed that the simple Pitot-tube was usable actually.

3. PROBLEM OF MEASUREMENT TECHNIQUE

3.1 Measurement of Temperature

In the measurement of temperatures, thermocouples have been used in all cases. In most cases, a 0.6 mm or 1.0 mm dia. of chromel-alumel thermocouple is being employed, although there was an experiment¹¹⁾ in which thermocouples of both 0.03 mm and 0.1 mm diameters were used. A question is wire diameter of thermocouples. Since the fire of buildings is in the unsteady-state burning in most cases, it is advisable to use a thermocouple of as much a small size as possible in the measurement of the inside temperatures of room space in particular from the standpoint of the responding speed of the thermocouples.

However, a too small thermocouple could not be used in an full-scale or large-scale fire experiments from the strength point of view, even if it can be used in small-scale experiment. For this reason, a method in which a 0.65 or 1.0 mm thermocouple wire is used till midway of a thermocouple and a 0.3 mm thermocouple wire is used by welding only for the portion near the hot junction is under consideration, although slightly troublesome.

3.2 Measurement of Pressure

In the measurement of pressures, bidirectional pressure probe or simple bidirectional pressure probe made of steel pipe have been used. The problems of pressure measurement arise in differential pressure transducer but not in the probes. As for fluids to be handled in studies on fire, the differential pressure is several mm Aq at maximum because of its high temperature and small density. In Japan at present, a transducer is capable of measuring the pressures of ± 7 mm Aq in maximum, but the present situation is that ones having one-figure degraded accuracy have been used because a set of the foregoing transducer and an exclusive amplifier costs us about a million yen.

3.3 Measurement of Radiant Heat

The measurement of radiant heat have been used radiation meter on the market and a disk thermocouple. Since the radiation meter on the market is very expensive, or costs 350,000 yen a set, many manually made disk thermocouples have been used in most cases in full-scale fire experiments. The question is the time constant of the disk thermocouples, as in the case of temperature measurement. The time constant is about 19 seconds¹⁶⁾. Considering that the fire of buildings is the unsteady-state burning, it is desirable to use ones of small time constants.

3.4 Measurement of Smoke Concentration

In the measurement of smoke concentration, smoke density meters have been used in all cases. The problem of the meter is the adherence of smoke particles to the lenses on the light pathway. Suzuki¹⁷⁾ tried a method in

which hot air is flowed near the lenses to heat the lenses in such a way as to prevent the adherence of smoke particles to the lenses and also to interrupt the reach of the smoke particles to near the lenses by the flow of air in order to prevent the adherence of the smoke particles.

3.5 Measurement of Gas Concentration

In the full-scale fire experiments, the continuous analysis of gases is desired. At the present time, those which can be analyzed continuously are only CO, CO₂, and O₂. The present situation is that since analyzers for CO, CO₂, and O₂ are still high in price and the number of the meters is limited, the concentrations of these gases in the central part of room have been presumed to be the average one of the room.

4. REFERENCE

- 1) Koichi Kishitani et al.: Annual Meeting of Architectural Institute of Japan, Sept. 1979, p.1833-1840
- 2) Katsuo Oguni et al.: Annual Meeting of Architectural Institute of Japan Sept. 1980, p.2125-2130
- 3) Kunihiro Yamashita: Ibidem, p.2161
- 4) Hiroshi Sato et al.: Annual Meeting of Japanese Association of Fire Science and Engineering, May, 1981, p.85-100
- 5) Hiroshi Sato et al.: Annual Meeting of Architectural Institute of Japan, Oct. 1982, p.2307-2316
- 6) Koji Hayashi et al.: Annual Meeting of Japanese Association of Fire Science and Engineering, May, 1983, p.59
- 7) George Mulholand et al.: Fire Science and Technology, Vol.1.1, 1981, p.1
- 8) Takashi Handa et al.: ibidem, p.45
- 9) Kunio Kawagoe et al.: Annual Meeting of Architectural Institute of Japan, Sept. 1979, p.1805
- 10) Tomoyuki Mizuno et al.: Fire Science and Technology, Vol.1.1, 1981, p.33

- 11) Ichiro Nakaya et al.: Bulletin of Japanese Association of Fire Science and Engineering, Vol.31, No.2, 1981, p.33
- 12) Yuji Hasemi et al.: Bulletin of Japanese Association of Fire Science and Engineering, Vol. 31, No.1, 1981, p.7
- 13) Kunio Kawagoe et al.: Annual Meeting of Architectural Institute of Japan, Sept. 1980, p.2093
- 14) Fusao Tachibana: J. of Japan Society for Safety Engineering, Vol.21, No.3, 1982, p.155
- 15) Hideaki Masuda et al.: Annual Meeting of Architectural Institute of Japan, Sept. 1979, p.1829
- 16) Takayoshi Tanaka et al.: Annual Report of the Building Research Institute, 1980, p.134
- 17) Hiroaki Suzuki: Annual Report of the Building Research Institute, 1981, p.178

QUINTIERE: I think the price of the heat flux meter is too high. There are companies in the United States that will sell a thermopile-type of heat flux meter or so-called Gardon-type meter for less than \$500. However, you mentioned radiometer, a radiant heat flux meter. Do you really mean a sensor only to measure radiation? If so, would you explain the type of radiant heat flux sensor that you are talking about? I realize that you are not the author of the paper.

JIN: This test actually tried to measure the radiant heat externally, from outside the building. If you are asking us whether or not we are also taking the convection into consideration besides radiation, that is not the case in the test because we have only tried to measure the radiation externally.

DAVIS: A comment about smoke measurement and soot deposition. If you use pitot tubes, and pass air into those tubes, you keep soot away from the optical system.

JIN: Yes, the study has dealt with this method, but I have used the method myself.

DeRIS: I would like to comment on the radiometer question. At Factory Mutual, we make a lot of radiation measurements using a little sensor which is the size of a transistor which has a microcircuit thermopile inside the sensor. It costs approximately \$120. We have various optical mirrors or angles, holes, etc. to make a very accurate radiation reading with extremely well-defined geometry.

NEW DEVELOPMENTS IN FIRE PROTECTION -
EVOLUTION TO THE SYSTEMS APPROACH
PRESENTATION TO
U.S.-JAPAN PANEL ON FIRE RESEARCH AND SAFETY

by J. R. Beyreis*

INTRODUCTION:

In earlier times, the outbreak of fire frequently led to the destruction of entire communities. Over the ages, fire regulations have developed which have made such occurrences largely a thing of the past. The earliest of these regulations was, perhaps, the banning of commonly used combustible materials such as thatched roofing. Efforts at suppression developed. At first, this involved hastily arranged bucket brigades which later led to organized fire companies of more modern times. In the last century, automatic sprinkler systems were introduced. By the early part of this century, the focus turned to the effort to

* - Managing Engineer, Fire Protection Department,
Underwriters Laboratories Inc., Northbrook, Illinois

contain fire to a single building by fire separation walls between buildings and later to the objective of confining fire to a single floor or single compartment within a building. Attention was also given to the objective of limiting rapid fire spread involving combustible materials in places of assembly such as theaters and night clubs.

In the last decade or two, the evolution in fire protection has tended to focus on eliminating or controlling fire in the compartment or region of its origin, or mitigating its effects. This has to a large extent been oriented toward providing for improved life safety protection for building occupants, that is, to keep fire and smoke away from people. The major symptoms of this phase of the evolution in fire protection has been a focus on understanding fire as a system involving the integration of many factors. In turn, this has resulted in the need for more performance characteristics information for the wide range of products involved in or related to fire protection.

This evolution in fire protection has been accompanied by the development of construction code documents describing acceptable construction practices. These code documents, together with various standardized test methods, form the basic framework within which developments in the art and science of fire, find their way into producing improvements in fire

protection in the human living environment. Within the context of these documents, it is evident that each aspect of fire protection - prevention, detection, suppression, limitation of growth and containment - has had its place.

Underwriters Laboratories Inc. (UL) conducts fire related testing for manufacturers who are required to provide fire performance information to authorities having jurisdiction as a condition of use of the product or material the manufacturer produces. Based on the activities at UL, it is becoming evident that an increasing integration of the individual elements of fire protection is taking place. More and more material, product and system data and information is being made available from testing. This information is gradually leading to the use of rational design processes that recognize the interaction of the fire protection elements. The availability of computers, to assist in collecting and analyzing test data, and to assist in the use of data for such purposes as mathematical fire modeling, are an important part of this evolution.

In order to more closely examine the evolution of fire protection, discussion of the elements of fire development and treatment in buildings is in order at this point. These include ignition, early fire growth, detection, suppression and containment.

IGNITION:

If the conditions required to produce an ignition are absent, then all other concerns relative to fire protection become moot. A major thrust of the activities of Underwriters Laboratories over the years has been to reduce the likelihood of an ignition to a reasonable minimum. This chiefly concerns energy using or producing appliances and devices, such as electrical appliances and equipment, and fuel consuming devices such as furnaces, kerosene heaters, and wood heating appliances. Developing technology has produced changes in many of these products requiring the recognition of new hazards. For example, the use of microprocessors in many appliances to control various functions including safety functions, creates new problems in assessing reliability of such appliances. For example, will the

software embedded on a chip reliably interrupt power when a sensor tells it that temperature limits are being exceeded? These and other problems posed by new developments in such products produce new challenges to the objective of reducing the likelihood of ignition.

But, despite the level of safety that may be built into various products, ignition can occur as a result of accidents, misuse of uncontrollable sources of ignition such as matches and smoking materials, or abuse and misuse of products which may otherwise be used safely. The entire field of fire protection encompassing ignition resistance, detection, suppression, growth limitation, and containment are all predicated on the expectation that unwanted ignition will occur from time to time, regardless of precautions taken.

EARLY FIRE GROWTH:

Building contents, including interior finish are recognized as having an important impact on early fire development. Furnishings and similar contents of buildings have not generally been regulated, except in a few applications such as decorations

in places of assembly, cubicle curtains in hospitals, carpets, and mattresses. However, furnishings and similar contents do provide the bulk of the fire load in most buildings and have been identified as a major element as the first item ignited in many major fires.

Fire Protection Department Engineers at UL are currently working closely with manufacturers of furniture in a fire evaluation program for building contents. Tests have been conducted with mattresses and upholstered furniture.

The present thinking is that Classification programs could be established on finished furniture, including consideration of the fire performance of specific components and growth characteristics such as total time dependent heat release rate produced under varying ignition scenarios. Such information would be developed using various ignition levels and positions on representative furniture articles to determine time dependent growth characteristics including heat release rate. Research experimentation on mattresses and furniture pieces by Babraskus at the National Bureau of Standards and other work set a pattern for the development of testing of these products at UL. Basic combustibility and ignition characteristics are also of increasing interest.

Room tests have been used for more than a decade in developing information on simulated actual installation configurations for interior finish materials. These tests have primarily involved measurements of gross phenomena such as determination of whether or not flashover occurred under specified ignition conditions, or extent of flame propagation and material damage. Limited instrumentation provided information on the velocity of gases flowing into and out of room openings, and on smoke development. Such information has been used for information purposes and has not been used in regulation.

More recently, the use of collection hoods has been introduced which provides for gathering additional information such as mass flow and other characteristics such as heat release rate, smoke development, and to a limited extent, combustion products composition. Efforts have been undertaken to develop reduced physical scale models of these room tests. The important role of heat release rate for materials has been recognized by the introduction of various heat release rate methods. UL operates an Ohio State University heat release apparatus to provide supplementary information on material characteristics.

As attention is being focused on fire phenomena in a more detailed fashion, including the relationship of gross heat release rate to room flashover, the interest in the use of mathematical models has grown. While mathematical models for room fire growth have not as yet found direct application in regulation, mathematical models are being studied with the objective of making information developed in tests more broadly useful. These are also being studied to assist in identifying proper tests to supply input to mathematical models.

DETECTION:

UL's Burglary Protection and Signaling Department has provided Certification Services for commercial burglary alarm installers for many years. These systems have provided important protection to banks and various commercial properties. More recently, UL has been asked to develop requirements for residential alarm systems. These systems are being integrated with other technical developments such as the rapid expansion of cable TV. The most recent developments provide recognition for fire monitoring elements of such systems. To a large extent this is made possible by the ready availability of relatively inexpensive microprocessor systems. The experience UL has gained in the investigation of sophisticated security systems using

advanced electronic components and voice communication channels has afforded considerable experience in developing performance requirements for these integrated cable systems. Such systems are investigated for fire and shock risks, in addition to reliability.

The conduct of investigations on such products involves knowledge of diverse fields, ranging from computer based communication systems, to fiber optics, and radio transmission methods.

SUPPRESSION:

Automatic fire suppression has been a major element of fire protection for more than a century. Until recently, the use of automatic fire sprinklers has been almost entirely limited to commercial and industrial occupancies. The primary emphasis has been to provide fire control, in order to limit fire size and reduce potential property damage.

New materials, warehousing methods, innovative building designs, water supply considerations and other changes have precipitated extensive testing and research of automatic fire sprinklers. As knowledge is gained that permits more rational design of automatic suppression for such environments, a need has developed for sprinkler hardware having specifically identified operating characteristics.

Development of this knowledge will further assist in defining proper application and use of such sprinklers. Sprinklers have been tested which have capability for extended coverage or rapid response and operation in the event of fire. Increasingly, testing of sprinklers is oriented toward developing operating characteristics information for individual sprinklers. This information is intended to be made available to sprinkler system designers, who can take into consideration the specific details of the premises to be protected. These rational design processes will require close cooperation between researchers, product testers and applicable code bodies if they are to evolve to a practical procedure.

In the last decade, sprinkler hardware and systems have been developed for residential occupancies. Such sprinklers are intended to react quickly to fire, with the intent that fires will not only be controlled, but actually be extinguished in their incipient stage. Because the water supply to residences is typically much more limited than that supplied to commercial and industrial occupancies, innovative supplemental water supply systems have been considered. These have included pressurized tanks and similar equipment.

In commercial and industrial occupancies, the potential property loss provides economic incentive for installation of sprinklers. In residential occupancies, the potential property loss is smaller. To make automatic sprinkler systems economically more attractive, alternate materials have been the subject of evaluation. These include steel pipe with lesser wall thicknesses and plastic pipe.

CONTAINMENT:

When all other elements of the fire protection system have entered the system and a fully developed fire still occurs, containment, or as it is most commonly referred, fire resistance, must be included in building design.

The basic concepts of containment have been in place for many years. To a great extent, the concepts remain unchanged. These concepts are to contain the fire and its products, including heat, smoke and gases, and to protect the integrity of the building structural system.

Over the years, hundreds of fire resistance tests have been conducted on floors, walls, and columns. These tests have served to establish the basic fire resistance characteristics for a wide range of building construction systems and materials. While new materials and structural approaches continue to expand this data base, there are other aspects of fire resistance which are receiving a greater focus. Firstly, the need for fire testing specific assemblies has continued to decrease, as the expanding data base permits system variations to be evaluated on the basis of study of existing data. The costly large-scale tests can also frequently be avoided by developing supplemental information on building components using small-scale furnaces for fire resistance tests. The number of tests conducted in such furnaces has increased dramatically in recent years.

Individual elements of construction which have the potential for disrupting the integrity of a fire resistive assembly, have also increasingly been the subject of evaluation. This has produced large numbers of tests of cable penetration protection systems, electrical fitting tests, plumbing components testing, and similar testing.

As a part of the continuing effort to extract an ever growing amount of information from available test data, new calculation methods are being introduced. These include such methods as the Fire Analysis of Steel Building Systems (FASBUS) model for calculating the response of a steel structural system under the conditions of steel member temperature increase produced by fire exposure. At present, such programs require the availability of test data in order to provide temperature time histories for structural members as input information. Development of computer programs such as Fire Response of Structures - Thermal Three (FIRES T3) have promise for replacing at least a part of the need for test data, by providing calculation methods for developing temperature time histories for protected structural elements. These approaches to calculating temperature rise and calculating structural response can be supplemented by room fire growth models which can serve to predict actual time temperature history to be used in specific environments. This three element computational approach has

important implications for the future, and should be the subject of continuing efforts. While details such as penetrations, protruding electrical devices, and other discontinuities in fire resistive assemblies represent particular challenges, they should not be beyond the potential for solution by mathematical means.

For many years, the appropriateness of the temperature time curve typically described in such fire test methods as ASTM E119, has been questioned as to whether it is representative of actual fire conditions. It is widely acknowledged that the conditions in any individual fire are likely different than the specific conditions in many other fire scenarios. While the standard time-temperature curve has proven to be an effective broad representation, there are circumstances where specific exposure conditions are preferred. One such area is the protection of structural support systems in petrochemical plants. In such facilities, a common exposure condition is the ignition of flammable liquid spills. In such fires, there tends to be a rapid temperature rise and associated developments of velocities and flux composition peculiar to flammable fuel fires. A fire test method has been developed for such exposures, and fire

resistance ratings are being developed for such circumstances. Since such materials are commonly found in severe outdoor exposures, fire performance for such materials are determined not only on material in its newly installed condition, but also after it has been exposed to representative solvents and extremes of temperature, humidity, and water.

As the need to provide protection to specific building elements broadens, the importance of protecting electrical wiring systems has also been recognized. In many cases, electrical control cables are installed in locations where there is typically little other combustible loading. Such materials are frequently required to meet minimum fire performance requirements such as ignition resistance and limited flame propagation requirements. In the past, such considerations led to the conclusion that fire resistance protection was not necessary. Several devastating fires have shown such assumptions to be unfounded, and as a result many fire tests have been conducted on such systems.

Within buildings, the long standing discussion over the importance of pressures in building fires is giving rise to conduct of tests under varying pressure conditions. In this context, tests have been conducted to develop information on leakage resistance of doors and dampers intended to be installed

in buildings. At present, such evaluations are conducted primarily under room temperature conditions. Ratings developed on doors and dampers under these conditions are intended to facilitate the design of smoke control systems in buildings. Such systems are intended to assure that the products of combustion from a fire are contained so that building occupants are not exposed to them.

SUMMARY:

This brief review of fire protection has attempted to identify changes of recent times. In addressing the respective elements of fire protection, it should be evident that the distinction between the relevance of these individual elements: ignition resistance, detection, suppression, limitation of growth and containment, are becoming less clear. The interdependence of these elements is being recognized and directed towards evolution to a systems approach. Each of these elements are individually subject to further development; the further development of mathematical models will aid in many ways in this evolutionary process. A major element of this overall development is the

availability of the computer over the last five years. The computer enhances the ability to extract additional information from individual tests, as well as to enhance the ability to use such information in an overall design process. With these continuing efforts, the evolution of fire protection toward improved property protection and life safety will continue at a more rapid pace.

A measurement of Doorway Flow
Induced by Propane Fire

I. Nakaya, T. Tanaka, and M. Yoshida
Building Research Institute
Ministry of Construction

Seventh Joint Meeting
UJNR Panel on Fire Research and Safety
Washington, U.S.A., October 24-28, 1983

1. INTRODUCTION

It will be one of the most important subject to measure exact mass flow rate (inflow and outflow) through an opening for analyzing various aspects of fire.

In strict way, this rate can be obtained by measuring the local gas velocities whole over the opening and integrating them. But this is too complex and tedious in most cases. When gas temperature in a room is nearly uniform like in the fully developed fire, it was shown by Kawagoe³ and Thomas⁴ that an opening mass flow rate can be easily calculated applying Bernoulli's relation and this relation was reduced to a simple equation,

$$M_a \propto AH^{1/2} \quad (1).$$

Where M_a , A and H are mass inflow rate of air, opening area, and opening height respectively. This equation is known to be powerful enough to show good approximation. But no simple relations have not been found when temperature in a fire room is not uniform.

Recently, Steckler intensively studied the relationship between the mass flow rates obtained from the local gas velocities measurement using bidirectional pressure probes and those calculated from the vertical gas temperature profile in and out of the room of origin applying Bernoulli's equation. From the results, he revealed the buoyancy driven flow model was also useful for small fire and proposed orifice constant (C) to be 0.73.

The burner used in his experiments did not have enough capacity to attain high temperatures (above 300°C) and the

opening of the burning room faced directly to the open space. In real fire, gas temperature becomes higher than 300°C and the doorway usually faces to a corridor. The objective of this study is to examine whether the method previously proposed by Steckler holds for the conditions in which fire is more intense and a different structure. So in this study, we used a high-calorie burner and an apparatus having two rooms (a burning room and an adjacent one.)

2. Description of experiment.

The structure used in this experiment had two rooms (3.45x3.45x2.17 m and 3.55x3.45x2.12 m) as shown in Fig.1. The concrete walls, ceiling and floors of the burning room were covered with calciumsilicate boards.

The burner used was rectangular of 60x60 cm and fuel gas was emitted through a porous plate.

With eleventh couples of movable bidirectional pressure probes and bare-wire thermocouples, the pressures and temperatures of the opening flows within the doorway between the burning and the adjacent rooms were measured at eight or ten positions, which is depending on the width of the opening.

Another set of seventeen bare-wire thermocouples measured the doorway temperature between the adjacent room and the ambient along the center line as shown in Figs.2 and 3.

And room gas temperatures were measured by the aspirated thermocouples at the following three positions,

- 1) in the front of the burning room,
- 2) in the rear of the adjacent room,

3) in the front of the adjacent room, as also in Figs.2 and 3. At a each position, seventeen thermocouples were set.

The measurements were started after near-steady conditions were established. The board used has high enough insulation performance to establish near-steady in about 30 minutes from the ignition of the burner. The fuel gas supplied to the burner is commercial propane gas (mixture of butane and propane.)

Experiments were conducted under the following six different conditions:

- A) fuel flow rate($V_f=100$ liter/min), opening width($W=0.59$ m),
- B) $V_f=200$, $W=59$,
- C) $V_f=100$, $W=89$,
- D) $V_f=200$, $W=89$,
- E) $V_f=190$, $W=89$,
- F) $V_f=240$, $W=89$,

Measurement were repeated by the five second interval and two hundred times at one position of the movable probe.

3. Experimental results

The temperatures of hot gas layer in the burning room were 200-450°C. These were larger than the Steckler's, which were about 300°C at their maximum.

The temperatures of hot gas layer in the burning room were 200-450°C and those in the adjacent room were 130-250°C. These

were larger than the Steckler's, which were about 300°C at their maximum.

The mass flow rate through the opening was determined by integrating the local mass flow velocities (ρv) over the area of the opening either above or below the zero-velocity level (neutral plane). The local velocity (v) was obtained from the bidirectional probe data and the local density (ρ) was established from the opening temperature data and ideal gas law. Horizontally averaged representative temperature profile data (fuel flow rate=200 liter/min, $W=59$ cm) are illustrated in Figs.4 and 5. The temperature differences between large diameter wire thermocouples (0.65 mm in dia.) and fine ones (0.1 mm in dia.) is not small. This difference will cause 5-10 % error in the flow rate evaluation. So, this means radiative emission and absorption is not negligible.

Furthermore, temperature profiles in the burning room, in the connected one and at the openings are in Fig.6. The temperature profiles indicate that the space in the room can clearly separate into two fairly homogeneous layers (hot and cold) as is observed in Steckler's experiments.

4. Flow through the opening

The temperature difference between the room (T_r) and its surroundings (T_a) induces a pressure difference which causes the flow at the opening. The application of Bernoulli's equation leads to the following formulation for the rate of mass flow from the burning room (M_g).

$$M_g = W \rho_\infty T_\infty C_i \int_N^H \left\{ (2g/T_a) \int_N^Z (1/T_a - 1/T_r) dz' \right\}^{1/2} dz \quad (2)$$

and into the room (M_a),

$$M_a = W \rho_\infty T_\infty C_o \int_0^N \left\{ (2g/T_a) \int_Z^N (1/T_a - 1/T_r) dz' \right\}^{1/2} dz \quad (3)$$

where

ρ_∞ : ambient gas density,

T_∞ : ambient gas temperature,

C_i, C_o : in- and out-flow coefficients,

N : neutral plane height from the sill,

Z : height from the sill,

g : gravity constant,

T_a, T_r : adjacent and burning room gas temperatures.

Figures 7 and 8 present the opening flow rates obtained from the experiments versus M_g' ($=M_g/C_i$) and M_a' ($=M_g/C_o$). The slopes of the lines represent the out- and in-flow coefficients,

$$C_o = 0.68 \quad (4)$$

$$C_i = 0.68 \quad (5)$$

As a little of trouble were observed in pressure transducer for experiments C and D, the unreliable data were replaced by interpolated values. So, experiments C and D have a slight problem in its reliability. This value of C is the close to that suggested by the water-kerosen analog experiments of Prahl and Emmons⁷ and a bit smaller than Steckler's⁵.

5. Summary

An experimental study for the rate of the flows induced by a propane gas fire in a structure composed of two rooms has been conducted. The characteristics of the measured opening flow rates can be explained by a simple hydrostatic model based on temperature distribution. Indeed, a good correlation between the measured and the calculated flow rates, which is obtained from idealized flows, taking into account the vertical temperature distribution, has been demonstrated even in the high temperature (200-450) and 2 room configuration, as previously shown by Steckler et al for the single compartment and for the temperature lower than 300°C.

6. Acknowledgement

We are greatly appreciate to Dr. Kenneth D. Steckler for his advice about the arrangements of probes and his intensive assist for computer programings and calculations.

7. References

1. Hugget, C., Estimation of Rate of Heat Release by Method of Oxygen Consumption Measurements, Fire and Materials, Vol.4, 61 (1980).
2. Nakaya, I., An Evaluation Method for CO, CO₂, O₂ Concentrations Under Turbulent Fire Conditions In a Compartment, Annual Meeting of Architectual Institute of Japan (1983).
3. Kawagoe, K., Fire Behavior in Rooms, Report No.27, Building Research Institute, Japan (1958).

4. Thomas, P.H., Heselden, A.J.M. and Law, M., Fully-Developed Compartment Fires--Two kinds of Behavior, Technical Paper No.18, Fire Research Station, England (1967).
5. Steckler, K. D., Flow Induced by Fire in a Compartment, NBSIR 82-2520 (1982).
6. Quintiere, J. G. and DenBraven, K., Some Theoretical Aspects of Fire Induced Flows Through Doorways in a Room-Corridor Scale Model, NBSIR 78-1512, National Bureau of Standards, USA (1978).
7. Prah1, J. and Emmons, H. W., Fire Induced Flows Through an Opening, Combustion and Flame Vol.25, 369 (1975).

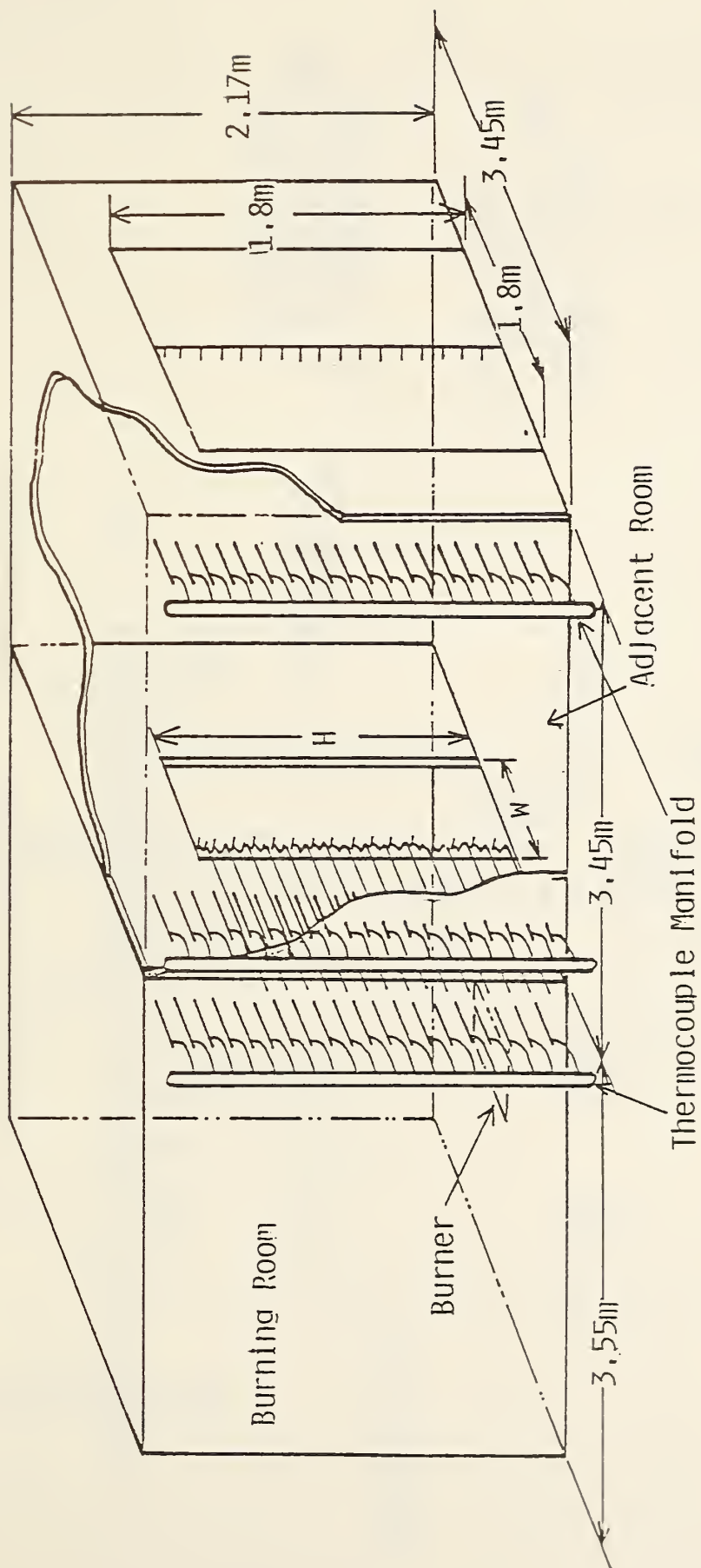


Fig.1 Experimental arrangement

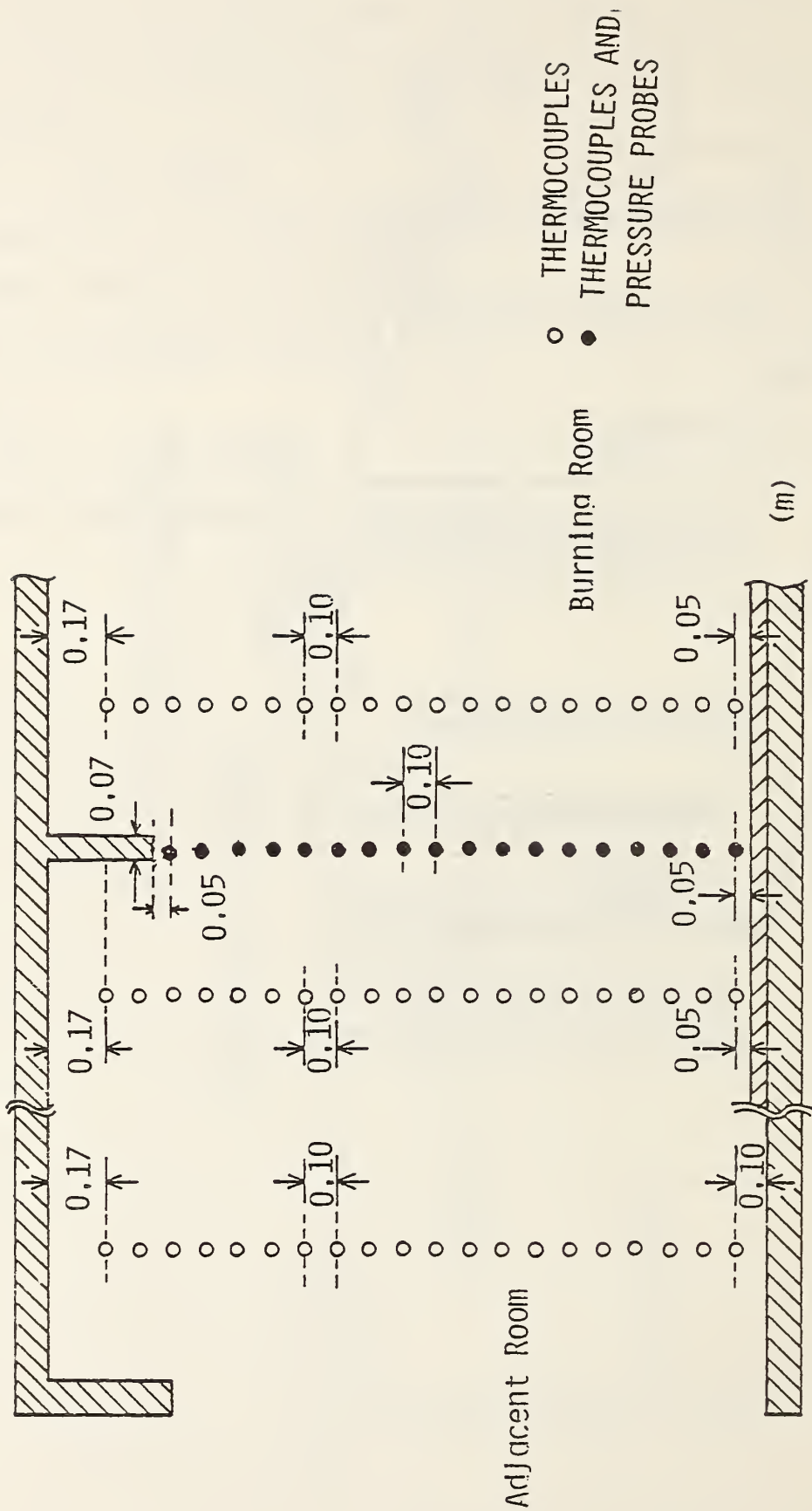


Fig.2 Probes Arrangement (Vertical View)

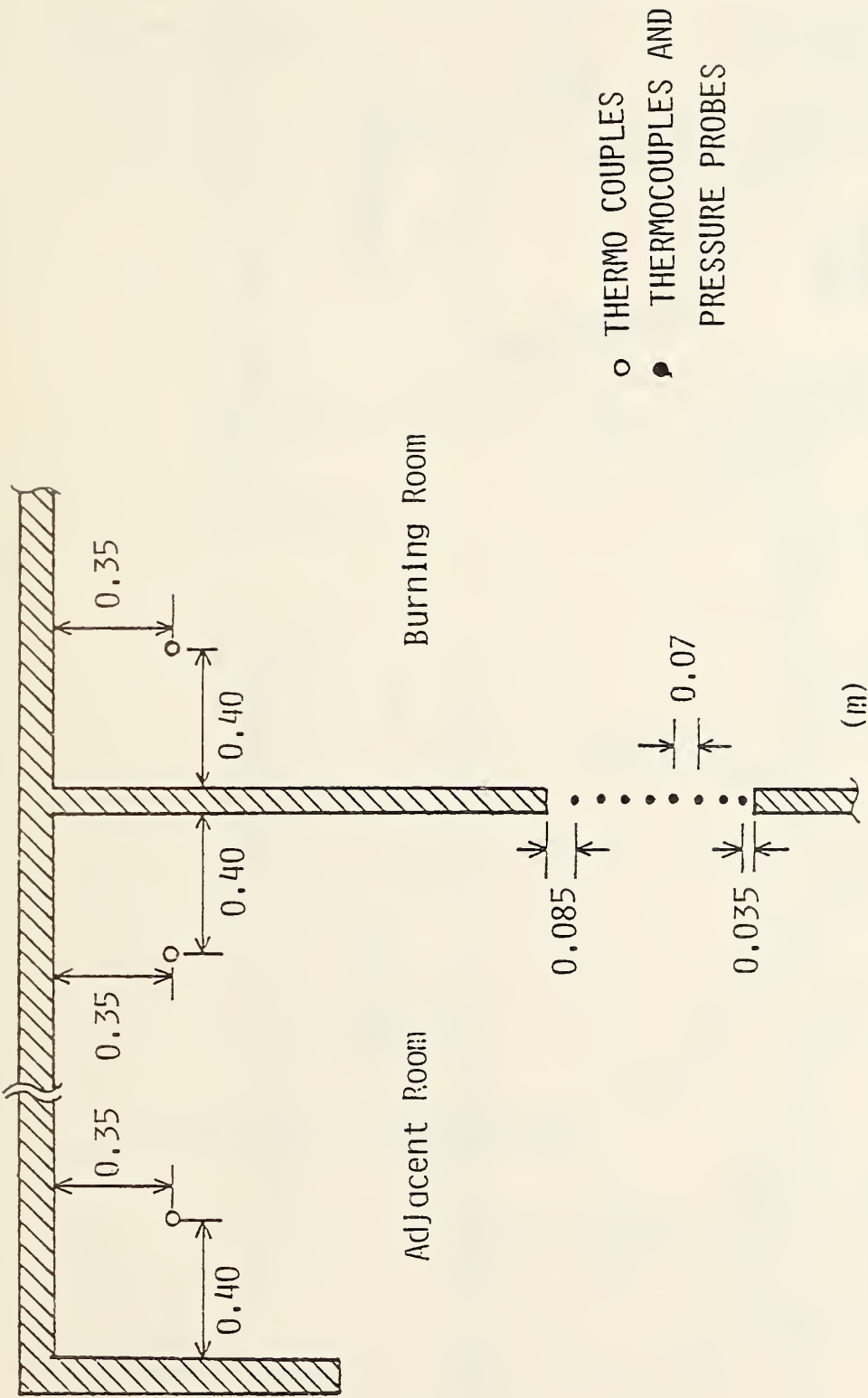


Fig.3 Probes Arrangement (Horizontal View)

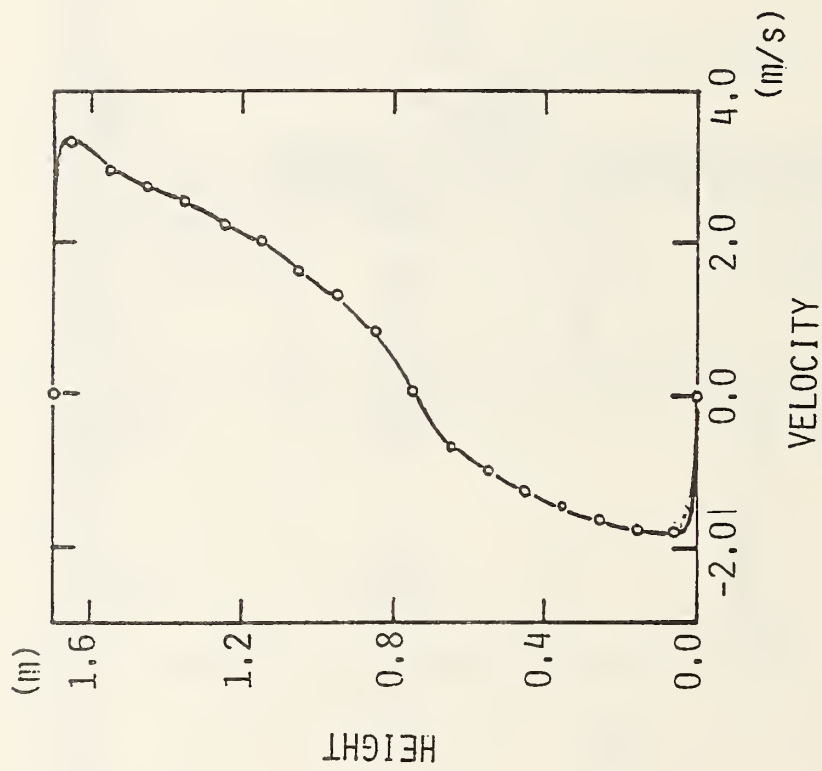


Fig.4 Velocity profile at an opening

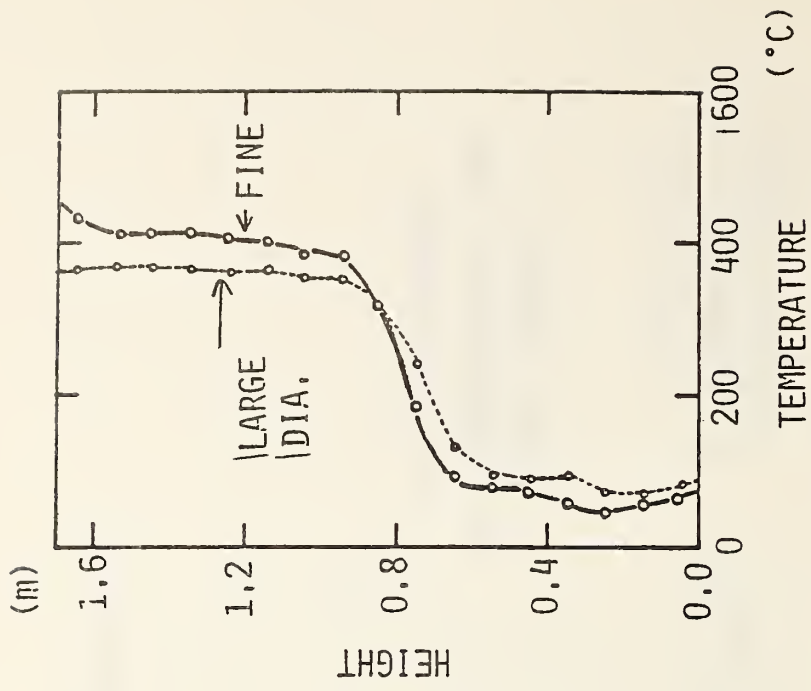


Fig.5 Temperature profile at an opening

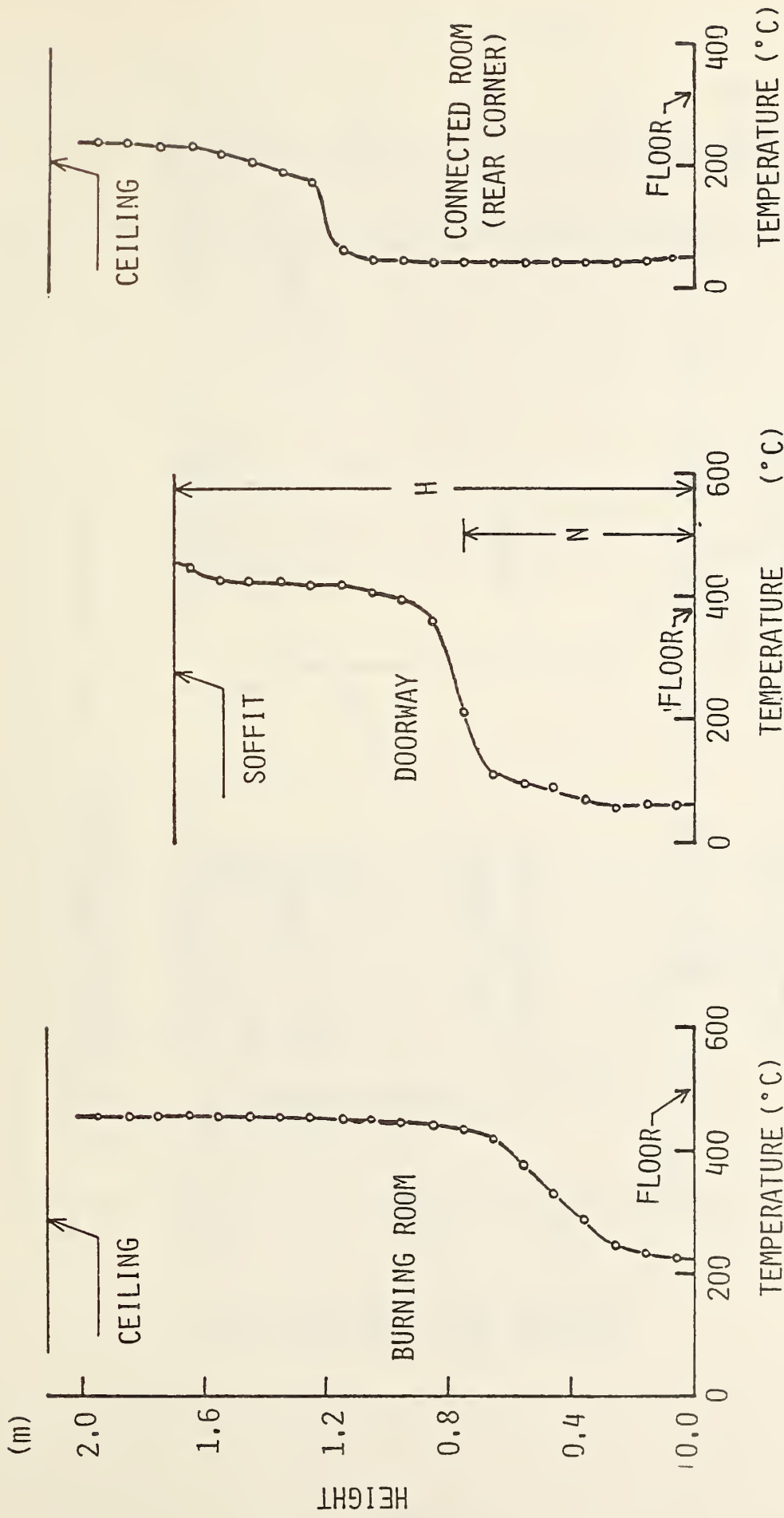


Fig.6 Temperature profiles

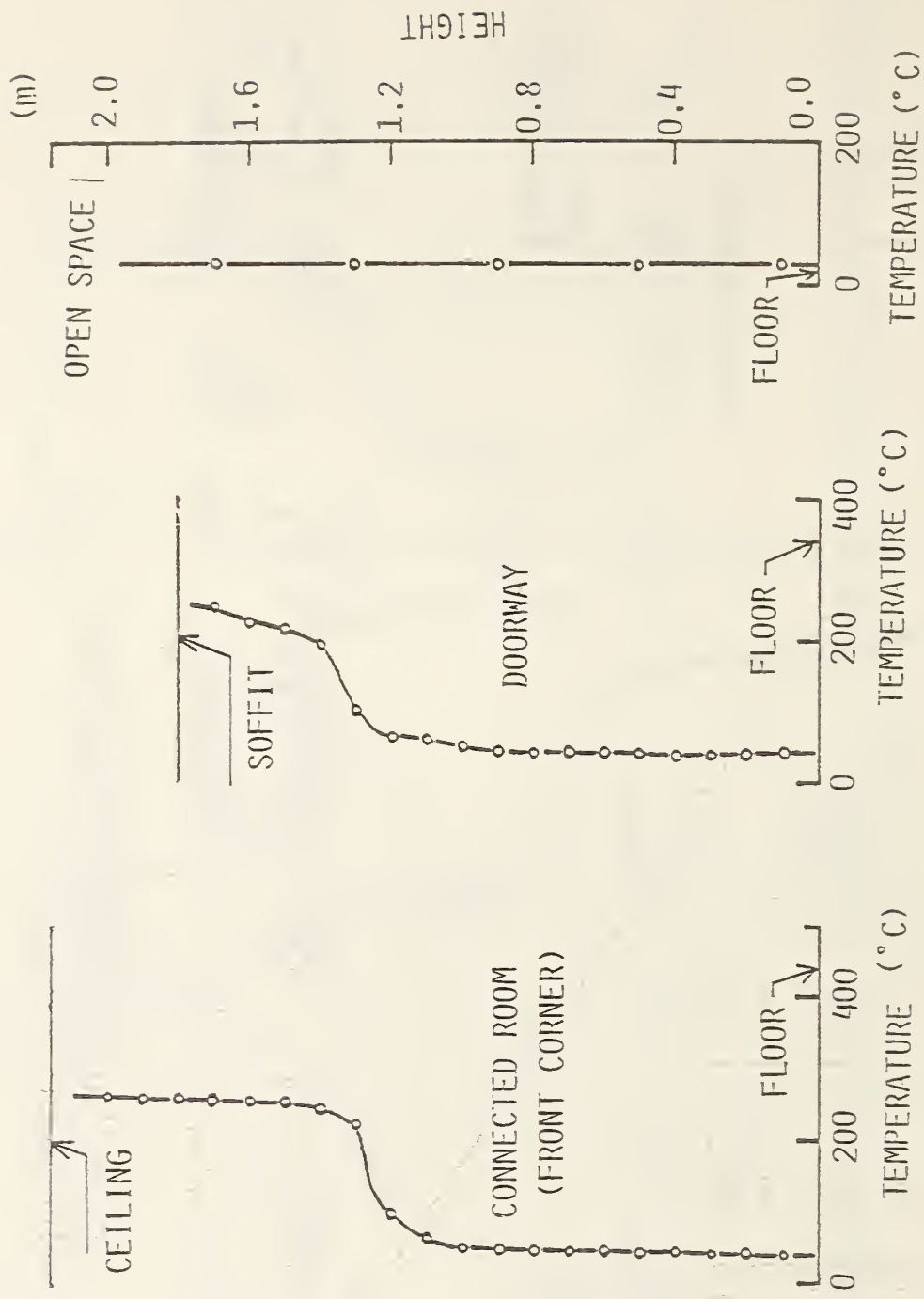
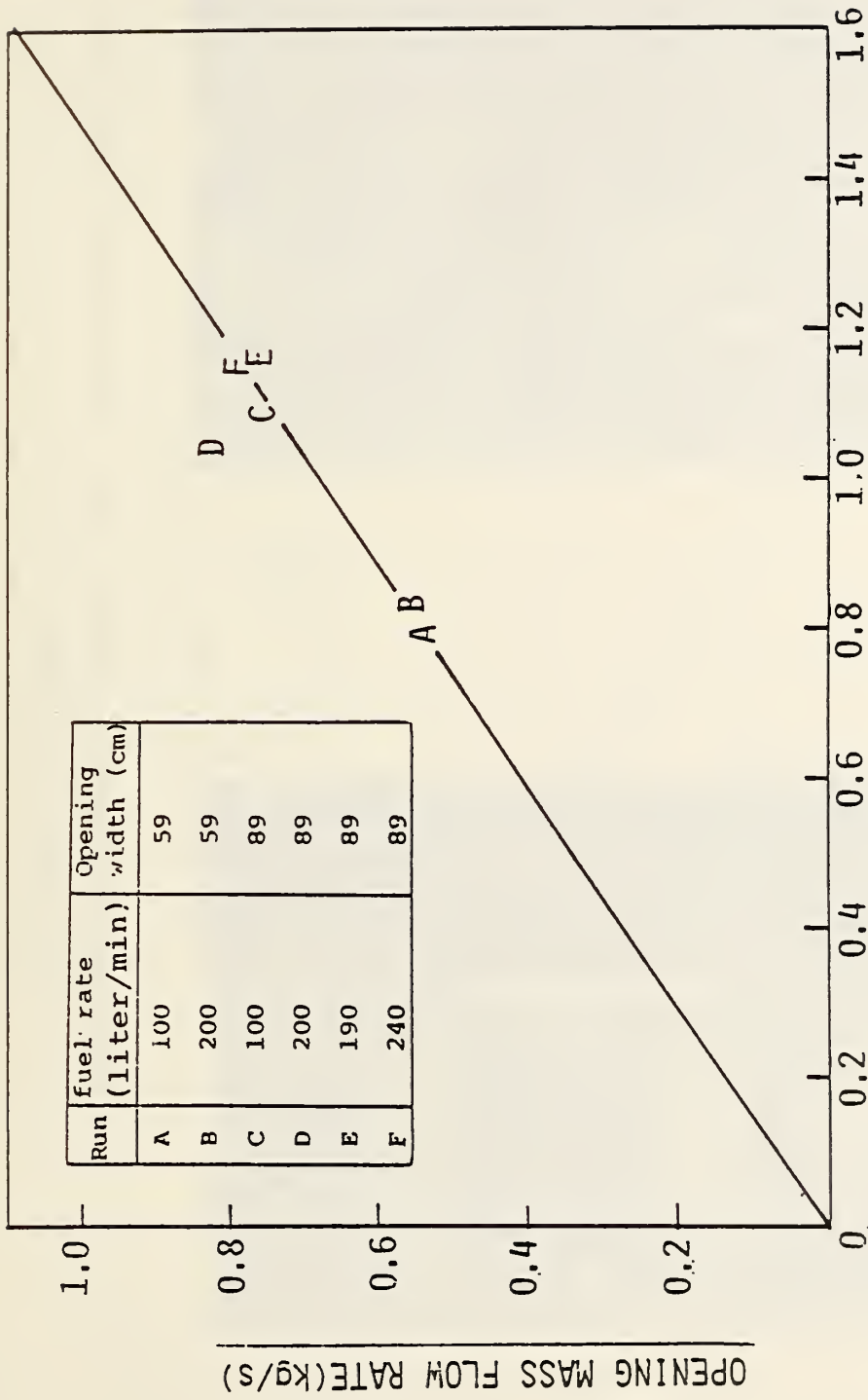
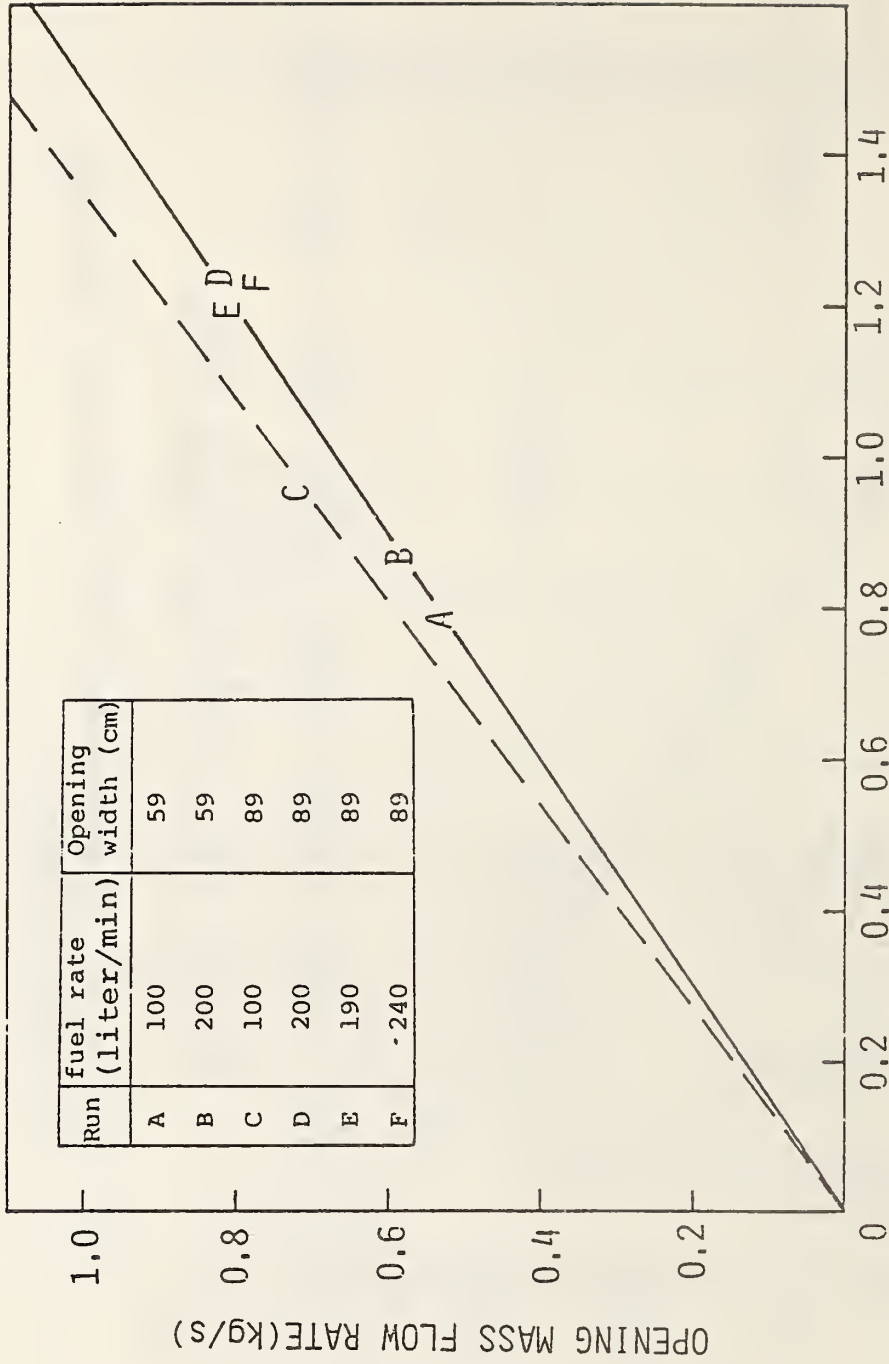


Fig.6 Temperature profiles (Continued)



$$M'_a = w \rho_\infty T_\infty \int_0^N \left[(2g/T_a) \int_z^N (1/T_a - 1/T_r) dz' \right]^{1/2} dz$$

Fig.7 Correlation of opening mass flow rate with Idealized flow model(Inflow)



$$M'_g = W \rho_{\infty} T_{\infty} \int_N^{H^0} [(2g/T_r) \int_N^z (1/T_a - 1/T_r) dz']^{1/2} dz$$

Fig.8 Correlation of opening mass flow rate with idealized flow model(outflow)

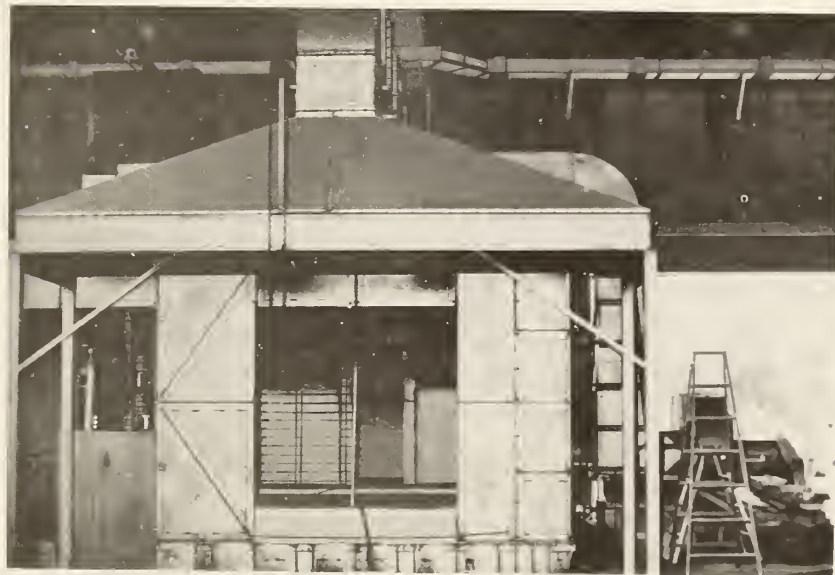
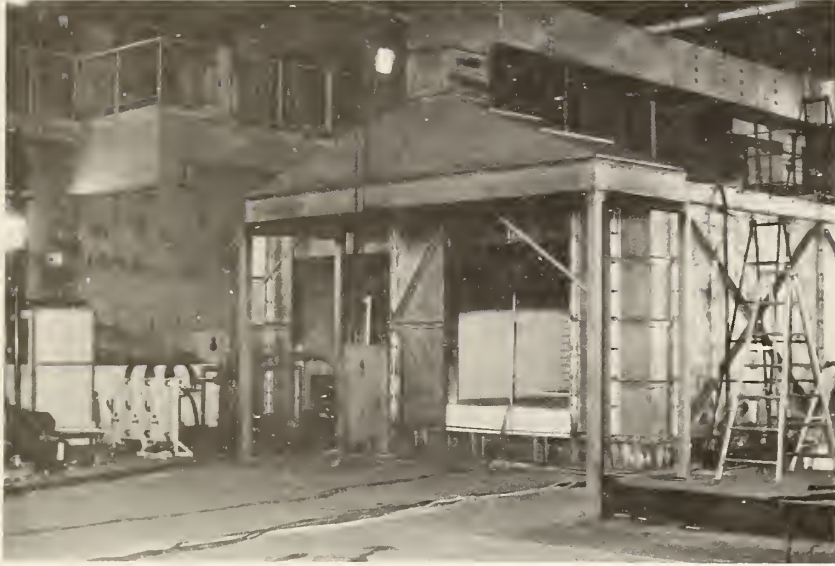


Plate. Full scale fire test room.

Discussion After T. Tanaka's Report on A MEASUREMENT OF DOORWAY FLOW INDUCED BY PROPANE FIRE

HANDA: We are not in fire, but with respect to the environmental issue, we have to later calculate the pollutant. When we have certain features which create the temperature difference over, say, 15°C, due to the particulate then at the doorway we have to have three-dimensional measurements. We usually use an ultrasonic device to measure it. We also have certain regulations. For instance, the time run should be less than 1 second. We once tested burning alcohol in the room and then we applied the ultrasonic tester which can scan the temperature as high as 200°. I clearly detected a three-dimensional flow. Because of the result I have detected, I've been wondering how, in the test just discussed, the mass flow rate is accurately captured?

WAKAMATSU: First, I'd like to know how you made your mass flow rate. Have you measured by velocity, for instance?

TANAKA: Yes, I have measured the doorway by measuring the pressure caused by the flow and then the temperature. By moving the measuring point gradually, we integrated the result, the velocity and temperature, moving this measuring point all the way around along the frame of the door. Assuming that the action has stayed stable during the time of measurement, this is assuming that the burning condition in the burning room remains steady. This is basically the routine procedure we have been applying in the area of fire study. There is one important point I believe I have omitted in my presentation. We have confirmed that the equation obtained by Mr. Steckler can be applicable to the cases where the existence of two chambers in the one building, you have to have the height temperature layer of mass in two conditions. This is the condition where we found that his formula can be applicable.

PAGNI: Why are your temperatures so much higher than Steckler's temperatures?

TANAKA: I think it is the mass of fuel we have burned in the room.

QUINTIERE: Another three-dimensional effect is the alignment of the velocity at the plane of the doorway. The alignment of the probe in the doorway is important. We have done some work and I think his was installed in a proper way. One indirect proof that it is correct is that after the measurement is taken, if the inflow befalls the outflow, then you might suspect that there was no substantial deviation to the premise that the "probe is aligned." Has anyone thought further about the measurement of species in that it might be useful to determine the profile of the species concentration and it might be related to the profile of the temperature or velocity concentration?

HIRANO: You're asking whether anyone has actually probed.

QUINTIERE: Yes, has anyone measured species concentration profile so that it could be combined with the measurements?

HIRANO: I'd like to respond to the previous question with respect to the velocity of the flow in the doorway. In case of fire study, especially the probe coefficient obtained by the study of Mr. Tanaka, I think that is determined by convergence of the flow occurring at the doorway. In general, I think in the area of hydrodynamics, when the flow moves from a wider area to the

narrow area, there is a tendency to curve at the corner. If you are to obtain integrated results, if the pressure changes in the beginning, that may not cause too much difference. However, it has to be assumed that the flow around the door must be somewhat compressed and we assume that velocity might be slightly increased at the point.

HANDA: Yes, you're right, the effect of the narrow flow. Please understand, I do not try to criticize the technique of the previous report, but I really believe that if we can obtain the result by measuring temperature, it would be a very good idea.

TANAKA: It seems like this doorway acts like a giant orifice. It seems like the coefficient he got was about .68, the orifice coefficient is about .62. Is that just the orifice effect we see here or is that actually some fire test?

STECKLER: Yes, we are treating the doorway as an orifice. As you said, the orifice coefficient in hydraulics is taken as .61, .62. That is for a unidirectional flow, but at the doorway we have concurrent flows. These experiments show that there is an added effect, as you point out, due to the concurrent flows or the three-dimensionality of the flows or the viscous effects. All of those effects are lumped into the flow coefficient and there seems to be a 10 percent difference.

FLAMMABILITY TESTING
STATE-OF-THE-ART

by

John de Ris
Factory Mutual Research Corporation
Norwood, Massachusetts 02062

ABSTRACT

Traditional material flammability tests are discussed in terms of their empirical foundation and oversimplified interpretation of fire phenomena. More recent rate-of-heat-release tests overcome some of these problems by measuring a material's response to different levels of fire exposure. However, no existing small-scale tests are sensitive to the radiant emission from the material's own flames. This radiant emission controls large-scale fire hazards. As a result, existing flammability tests cannot be expected to adequately characterize large-scale hazards. Some new approaches to this problem are discussed and a specific bench-scale test method is suggested which may overcome the identified problems of existing test methods.

BACKGROUND

Traditionally, the flammability of a building material has been evaluated by measuring its: 1) ease of piloted ignition; 2) ability to propagate a small creeping flame in the presence of an external radiant source; and/or 3) ability to propagate a larger under-ceiling fire as measured by the ASTM-E84 "tunnel test" which exposes a 25 ft (7.62 m) long sample to a sizeable propane ignition source. This latter test is legally recognized by most building codes. Since the piloted ignition and creeping flame spread phenomena are closely related and depend on similar material properties they are often jointly evaluated by the ASTM-E162 test apparatus which measures the creeping spread rate and extent of maximum flame travel under conditions of a spatially decreasing external radiant flux.

These tests were developed about thirty years ago at a time when building materials were based primarily on cellulose which has a limited range of flame properties. Also, at that time, lacking a basic understanding of fire behavior, it was implicitly assumed that all materials could be ranked on a single flammability scale based on some standard test which subjects a material to a single representative fire environment. In view of the need for some flammability assessment procedure and the absence of obviously contradictory full-scale (or loss) data this oversimplified approach appeared justified at its time. This traditional philosophy has now outlived its usefulness.

FULL-SCALE TESTING

Around 1970, after experiencing unexpectedly severe losses involving newly introduced fire retarded plastics, various full-scale corner tests were run to check their flammability rankings suggested by the ASTM-E84 test (Castino, 1975)³. A lack of correlation was observed which was particularly troublesome for those flame-resistant insulation materials having a flame spread rating less than 25. The ASTM-E84 ranking is based primarily on the extent of flame travel normalized so that red-oak has a rating of 100 and cement-board a rating of zero. Apparently some modern polymeric materials and especially flame-resistant foam insulations do not properly fit on this ranking scale.

This lack of correlation has led to a wide-spread mistrust of current standard flammability tests and the reluctant suggestion that one can only rely on full-scale tests for flammability assessment. Consistent with this full-scale test philosophy, ASTM and more recently, ISO (International Standards Organization) are developing a "Proposed Method for Testing Wall and Ceiling Materials and Assemblies" (ASTM, 1982)¹ which exposes a material to a large 176 kW propane burner flame placed in a lower corner of an 8 ft x 12 ft x 8 ft high (2.4 x 3.6 x 2.4 m) room whose wall and ceilings are lined with the material. The outcome of these corner/room tests is strongly dependent on the rather arbitrarily chosen heat release rate of the ignition source. For exposure heating rates above some (material dependent) critical value the fire will undergo a dramatic transition to flashover when the heat release rate from the burning wall material becomes comparable to the exposure fire heat release rate. Exposure fires smaller than this critical value are insufficient to initiate flashover and usually cause only local damage. Test engineers welcome such clear-cut go/no go tests because they have an indisputable outcome. However, a result from a single test run with a given exposure is relatively uninformative to a potential user interested in the outcome involving other levels of exposure. A potential user should probably wish to rank materials according to the exposure which will just cause run-away ignition (e.g. flashover) of the material. Unfortunately, at present, it is not possible to determine this critical exposure for a given material from a single full-scale test.

Full-scale tests are usually very expensive, difficult to reproduce, and require such large quantities of sample materials that they cannot be considered for screening new materials under development. Finally full-scale tests, being empirical, give little guidance for assessing hazards in related situations. Often small changes in geometric details have a profound effect on the outcome of a fire. In conclusion, full-scale tests should generally be regarded as essential for validating the general claims of standard flammability test methods, but cannot serve as a substitute because of their complexity, cost and large material requirements.

III FIRE PHENOMENA

It is now generally recognized that various materials can have markedly different flammability rankings in different situations depending on such factors as: 1) fire scale; 2) imposed heat flux levels; 3) geometric arrangement; 4) the presence of other nearby materials, and 5) the temperature, pressure and degree of vitiation of the surrounding atmosphere. Fires generally involve synergistic couplings between a material and its environment. Also, different fire scenarios are often governed by qualitatively different burning mechanisms which in turn are controlled by different combinations of material properties. It is important to understand these differences in burning mechanisms when interpreting flammability test results. In particular, it is important to appreciate the effects of fire-scale, if one wishes to infer full-scale fire behavior from small standard flammability tests.

3.1 SMALL-SCALE

The steady (constant area) burning rate of a small-scale fire is controlled by the convective heat transfer from the flames. Small-scale flames are not thick enough to emit significant radiation. As a result fuel mass transfer rates are primarily controlled by the heat required to vaporize unit mass of fuel. The overall heat release per unit area is given by the product of the fuel mass transfer rate and the heat of combustion of the fuel volatiles. Other factors controlling peak small-scale burning rates depend only on geometry for typical organic fuels burning by natural convection in air at atmospheric pressure. The important fuel property - namely the heat required to vaporize unit mass of fuel - can be directly measured by Tewarson's (Tewarson, 1980)²⁰ well known "FM Flammability Apparatus" which measures the fuel-mass-loss-rate and heat-release-rate under different applied radiant exposures.

Flame-retardants acting by inhibiting gas-phase reactions can significantly reduce, or even prevent, burning at small-scale. The effectiveness of such retardants has often been inferred from the LOI (Limiting Oxygen Index) test which measures the critical ambient oxygen concentration that is just sufficient to permit downward creeping flame-spread on a small sample. Because this test is convenient and requires only a very small test sample, it is widely

used in the chemical industry during material development. Unfortunately, the test results can be very misleading because large-hazardous-scale-fires are not significantly influenced by such gas-phase flame retardants (because large-scale flow times are so much longer than reaction times). Innumerable disappointments have occurred in recent years when supposedly non-flammable fire-retardant polymers burned vigorously in large-scale tests. For example, PVC plastics which usually have an excellent LOI rating burn more rapidly at large-scales than acrylics which generally have a poor LOI rating. Unfortunately the flame-retardants encouraged by this test often tend to significantly increase the smoke output and toxicity of the fire gases.

Fire-retardants which act by encouraging char-formation in the solid-phase can be very effective at all fire scales. By preventing transfer of carbon to the gas-phase they are triply effective by: 1) providing a thermal insulating char layer; 2) reducing the gas-phase heat-release-rate and resulting flame heights; and 3) reducing the flame luminosity and consequent radiant heat transfer which is of dominant importance at large-scales. It is speculated that some of these retardants act by encouraging the polymerization of the fuel vapors as they flow through the chemically active char layer (Parker, 1982)¹⁵ The effectiveness of these char-enhancing retardants can be evaluated by a rate-of-heat-release (RHR) apparatus which measures the transient combustion heat release per unit area of a material subjected to a controlled radiant flux. Tewarson's "FM Flammability Apparatus"²⁰ and Smith's "Ohio State Apparatus"¹⁹ are well known examples of such RHR tests. Tewarson uses a 10 cm diameter sample and Smith uses a 25 x 25 cm square sample. In both cases the material requirements are small enough to permit testing at a variety of imposed flux levels. However, neither test explicitly measures the flame luminosity or radiated fraction of the heat release. As a result, one should not directly extrapolate the test results to large-scales where radiation from the flames is a controlling factor.

Many modern polymeric materials are retarded by the simple addition of inert fillers which increase the heat required for fuel gasification and often leave a porous char-like insulating residue. These effects can be measured by the above mentioned RHR tests. In addition, some fillers incorporate a significant amount of water of hydration, which upon vaporization may possibly reduce soot formation and flame radiation. Unfortunately, the current lack of a flame radiation test has prevented measurement of how effective this water of hydration is in reducing the flame radiation.

The RHR test is particularly useful for examining charring flame-retarded materials such as polyurethane or PVC foams. Such materials can have a distinctly non-linear response to an imposed heat flux. Figure 1 shows the peak response of various polyurethane foams (NFPA Handbook, 15th Ed., pg. 4-7)¹¹. Notice the changes in rankings for various imposed heat fluxes. At very low flux levels the material surface temperature does not increase sufficiently for significant gasification. Above some critical flux level gasification occurs at a rate sufficient to support piloted ignition. Once ignition occurs the sample receives heat both from the external radiant source and the flames themselves. The added heat transfer from the flames typically decreases with increasing rates of gasification leading to a less than linear increase of heat release rate with increasing imposed flux.

A RHR test has the advantage of providing several important flammability parameters from a single test run versus time. Figures 2a and 2b show a typical RHR test arrangement and results (Ostman, 1982). The sample receives a uniform radiant heat flux. Measurement of oxygen depletion in the exhaust is now typically used to infer the rate-of-heat-release (Huggett, 1980). The initial time delay prior to gasification provides a measure of the ease of ignition. The rapid increase to the peak heat-release-rate is controlled by the material's heat of gasification. The subsequent decrease in heat-release-rate is due to increasing char insulation; while the final secondary peak results from acceleration of the pyrolysis wave as it approaches the thermally insulated back-surface of the sample or possibly the increased exposed area as the specimen breaks up. Figure 2b shows curves for several externally imposed fluxes. It simulates the effects of flame radiation in much larger fires. The heat flux actually received by the solid is augmented by the heat transfer from the flames produced by the sample itself. All of the above transient phenomena are being actively studied by various fire research groups (e.g., Delichatsios and de Ris, 1983)⁴. A possible criticism of most current RHR tests is their external radiant heat source. Gas panel radiant heat sources provide heat over a typical infrared wavelength range but their flux levels are often too low for realistic view factors; whereas quartz heaters provide plenty of heat but at unrealistically short wavelengths. Solid fuel response times are known to be quite sensitive to the imposed wavelength (Welker, 1969)²¹. Improved infrared gas fired radiant heaters using newly available high temperature ceramics may resolve this problem.

Except for the characterization of flame radiation, it is now generally believed that the rate-of-heat-release measurement will provide the most meaningful characterization of large-scale flammability. Upward fire spread hazards can be assessed from the time to piloted ignition and RHR both of which can be measured in the same RHR apparatus.

Before closing this discussion of small-scale fire phenomena, one should mention the wide body of research on the creeping flame spread associated with downward and horizontally propagating fires. This phenomenon is reasonably well understood for both flame-retarded and non-retarded materials having a smooth surface. It is addressed in part by the LOI test. Also Quintiere, in a series of studies, has shown that the ASTM-E162 flammability apparatus can be used to evaluate downward creeping flame spread rates under the influence of external radiation (Quintiere, et al, 1982)¹⁶. In particular, one can measure the minimum external flux required to sustain propagation. A similar apparatus and technique is now widely used for evaluating carpet flammability. Such tests point out materials capable of propagating creeping flames with low levels of external radiation. For example nitrocellulose lacquer paint can propagate a creeping flame with a minimal overall rate-of-heat-release. However, such circumstances are now relatively rare. While these advances are significant for the general flammability problem, the creeping fire spread phenomenon is not of central importance to most large-scale fire hazards. The marginal creeping flame-spread is governed by local chemical kinetics, gas phase diffusion and solid conduction, whereas the critical condition for large-scale upward fire spread is governed by solid ignition, the duration and intensity of rate-of-heat-release and the flame radiative heat feed-back. The associated phenomena are quite different and should not be expected to correlate.

3.2 LARGE-SCALE

As the scale of a fire increases, the flames become thicker increase in volume and involve more matter which can radiate. In general, the radiative heat transfer from flames to adjacent surfaces exceeds convective heat transfer for flame heights exceeding 30 centimeters (Orloff, de Ris, Markstein, 1975)¹². For organic fuels this radiation comes primarily from soot in the flames which makes them appear brightly luminous. Generally, the pyrolysis vapors from man-made polymeric materials are high in carbon content and

produce more soot than cellulosic fuels whose pyrolysis vapors have a significant amount of oxygen already bound to the carbon atoms. Fuels which generate copious amounts of smoke tend to have highly radiative flames and have higher large-scale burning rates. The black smoke is thought to arise from the flames losing so much heat by radiation that they are extinguished locally by this radiant loss.

All present day small-scale flammability tests attempt to simulate large-scale fire environments by imposing an independently controlled external radiative flux onto the fuel sample. This external flux generally dominates the radiation from the sample's own flames; so that the measured results are insensitive to the sample's own flame radiation and cannot be expected to provide a complete evaluation of the material flammability at large-scales. This insensitivity is advantageous insofar as it can yield a clear picture of the solid response to a controlled external environment. But it leaves out the essential ingredient - namely the flame radiation which typically represents 80% of the heat feedback at large-scales (Orloff, Modak, Alpert, 1977)¹³.

How should we cope with these problems? Clearly we cannot do away with standard flammability tests. If possible, we should have tests which require relatively small samples - say 30 cm square or even less - to encourage testing by industry involved in developing new materials. Of course results from such tests must be corroborated at full-scale for a selection of representative fuels. These problems appear surmountable as will be described below.

Rate-of-heat-release tests are clearly essential and several such tests are under development at various fire research institutions. The test measures the rate of combustion energy released per unit sample area versus time when subjected to various levels of externally supplied radiation. It is essential to evaluate material at various levels of irradiance because many materials have a strong non-linear response. Also, because charring materials typically have a strongly decreasing transient heat release subsequent to ignition, one should evaluate both the peak rate of heat release, maximum average rate-of-heat-release over selected time intervals (say 1, 2, 3 and 5 minutes) as well as the cumulative heat release. Results from these rate-of-heat-release tests can be directly used for estimating the evolved transient heat release rate and corresponding flame heights for the material when

subjected to a known source fire in different practical situations of interest.

Knowledge of the rate-of-heat-release leads directly to estimates of flame heights. In general, both laminar and turbulent flame heights are controlled only by the fire geometry and the actual heat release rates and not by other fuel properties such as its stoichiometric requirements (Masliyeh and Steward, 1970; Schug, Manheimer-Timnat, Yaccarino and Glassman, 1980)¹⁸.

To evaluate whether the evolved flames are powerful enough to significantly add to the exposure heat flux, and thereby induce a self-propagating wall or corner fire, one must evaluate the radiative properties of the flames. These properties are the effective flame radiation temperature T_f and the absorption-emission coefficient k_f which is essentially proportional to the amount of soot per unit volume. The radiation emitted per unit volume is equal to $4 \sigma k_f T_f^4$ where σ is the classical Stefan-Boltzmann constant.

The accompanying Figure 3 shows a scientific flammability apparatus being constructed at FMRC to evaluate these flame radiative properties for fire-retardant charring wall materials. The charring material on the left is subjected to an externally controlled radiant flux. The transient rate of heat release is measured by chemically sampling the gases leaving the top of the enclosure. A water-cooled heat transfer plate measures the total (radiative plus convective) heat feedback from the flames. It is shielded from the radiant heat source by a series of radiation baffles, so that it measures only the heat flux from the flames. In addition, we have built a dual radiometer which looks through the flames from the side in order to simultaneously measure both the effective flame radiation temperature T_f and absorption-emission coefficient k_f .

This apparatus is not intended as a standard flammability test. It is clearly too sophisticated for widespread use. It is a scientific apparatus intended to provide an in-depth analysis of the radiative properties of a few selected fire-retardant fuels; so that we can provide a rigorous scientific foundation for a subsequent simplified standard material flammability measuring apparatus. It also is intended to provide the basic flame property data needed for the development of mathematical models predicting corner and room flashover. In addition, provision has been made for providing vitiated air to the enclosure for studying the effects of oxygen depletion on flame radiation. This apparatus is the outcome of a long-range research program

aimed at providing a basic scientific understanding of flame radiation in fires.

NBS is currently developing a similar but simpler test apparatus which measures the total radiative-convective heat feedback flux from the upper flames. While it is not placed within an enclosure and consequently is not suitable for evaluating the effects of vitiation, it may eventually lead to a standard test method.

A SUGGESTED BENCH-SCALE FLAMMABILITY TEST

As discussed above, flammability (or fire hazard) of a material at large-scale is governed by three principle factors: 1) its piloted ignition time in response to an imposed heat flux; 2) the subsequent rate-of-heat-release of its pyrolysis vapors in response to the imposed heat flux; and 3) the radiant emission from the flames resulting from the burning of these pyrolysis vapors. Knowledge of the above factors should be sufficient, in principle, to predict both peak burning rates and upward fire growth rates involving simple fuel arrangements.

We have already discussed several test devices which can evaluate the rate-of-heat-release and ignitability of a material. Here we discuss a proposed test concept which in addition may evaluate the radiant emission. The suggested apparatus is also sufficiently compact to be placed on a laboratory bench.

As shown in Figure 4, the test examines a buoyant laminar (candle-like) diffusion flame produced by the pyrolysis vapors emerging from the heated test sample. As explained later, the ignition and rate-of-heat-release measurements are directly inferred from the resultant flame height and should produce results similar to existing test methods with the advantage of decoupling the flame heat-feedback from the pyrolysis process.

Of greater significance the test concept allows one to infer the expected radiant emission from material flames at large-scale. It does this by measuring the fuel's so-called "smoke-point". Recent research at FMRC shows there is a close correlation between large-scale flame radiation and the smoke-point for various hydrocarbon fuels*. The smoke-point is conventionally defined as the maximum height a buoyant laminar flame can attain without releasing soot (i.e. smoke). The aircraft industry has traditionally used the smoke-point of commercial liquid fuels as a measure of their relative smokiness and as well as their radiant output. Standard test methods exist for evaluating the

*Specifically the peak soot absorption coefficient in a 50 kW pool fire and the radiative fraction from a buoyant turbulent fuel jet ranging over 10-50 kW are both tightly correlated with the fuel smoke-point (Markstein, 1983)^{7,9}.

smoke-point of liquid and gaseous fuels (Schalla and Hibbard, 1957)¹⁷. The present concept extends these methods to solid fuels.

It is well-known that the radiation from both large- and small-scale diffusion flames comes principally from their luminous soot. This soot is both formed and oxidized within the flames. Fuels which produce more soot radiate more intensely. The radiative heat loss cools the flames and, if given enough time, can induce local radiative extinguishment accompanied by release of cold soot in the form of visible smoke. By increasing the fuel supply to a small candle-like flame, one increases its flame height and residence flow time, resulting in an increased fractional radiative heat loss. A sooty fuel such as propylene can maintain only a relatively short buoyant flame (2.9 cm high) without release of visible smoke; where as a less sooty fuel like propane can support a much taller (16.2 cm) diffusion flame without smoke emission (Shug, et al, 1980)¹⁸. These candle-like flames at their smoke-points release approximately one fifth of their chemical energy in the form of radiation. In the case of hydrocarbon fuels, this heat loss reduces the flame tip temperature to about 1550°K at which temperature soot oxidation rates are significantly reduced (Markstein, 1983)⁸. Smoke-point heights are easily measured because the flame undergoes a sudden transition to sooting and release of smoke. Measured smoke-points are independent of apparatus details provided the fuel is supplied at a given temperature and provided the buoyant flame is: well ventilated, shielded from stray laboratory air currents by a chimney, and not subjected to excessive induced forced ventilation (Schalla and Hibbard, 1957)¹⁷.

The accompanying figure shows the suggested measuring apparatus for solid fuels. A patent disclosure has been submitted. It is intended to simultaneously measure both the transient heat-release-rate and sootiness of the pyrolysis vapors emerging from a test sample (say 4-6 cm in diameter) placed in an oven at the start of a test run. Auxilliary supplies of fuel and inert gases are added to the pyrolysis vapors under feedback control to maintain both a constant overall heat-release-rate and degree of flame sootiness. In general, for organic fuels, the heat-release-rate of a laminar buoyant diffusion flame is directly proportional to its height, regardless of the fuel chemical composition or presence of added inert gas (Shug et al, 1980)¹⁷. Consequently, as the rate-of-heat-release from the pyrolysis vapors increases, the excess fuel controller will reduce the excess fuel supply while

maintaining a constant flame height as seen by the radiometer. This reduction in excess fuel supply provides a direct measurement of the sample's instantaneous heat-release-rate. The substitution technique should be both rapid and precise.

Similarly, the flame can be maintained in its marginal smoke-point state by a smoke detector which increases the supply of inert gas (say N_2) as the pyrolysis vapors increase in sootiness. An increase in inert gas flow suppresses soot formation without influencing the flame height (Shug et al, 1980)¹⁷. The added inert flow provides an instantaneous measure of pyrolysis vapor sootiness. The respective heat-release-rate and sootiness measurements are presumably independent of one another and can be performed simultaneously throughout the test run. Certainly the heat release measurement should be independent of the simultaneous soot-point measurements. Recently Calcote and Manos (1983) showed that the relative ranking of hydrocarbon fuels in terms of their sootiness in diffusion flames is not particularly sensitive to the measurement technique. This suggests that the relative sootiness of fuels will not depend importantly on the sample size, or the base point supply rates of excess fuel and nitrogen.

At present, the suggested test concept is in its early stages of development. Further data is needed for relating large-scale radiant fluxes in various fire situations in terms of measured fuel smoke-points. So far we have only used hydrocarbon fuels for evaluating the test concept. We do not know whether the principles can be extended to fuels having gas-phase chemical retardants. Also considerable effort will be required to develop a standard test method.

In spite of these caveats, one has little choice but to further investigate this suggested flammability test; because there are no other suggested alternative small-scale tests designed to assess flame radiative properties. Its bench-scale size and minimal material requirements should make it very attractive to the chemical industry; thereby eliminating the principal impediment to the development of truly fire-resistive materials.

REFERENCES

1. ASTM, "Proposed Method for Room Fire Test of Wall and Ceiling Materials and Assemblies," ASTM Subcommittee E-5, 1982 ASTM Book of Standards, Part 18, pp. 1618-38.
2. Calcote, H.F. and Manos, D.M., "Effect of Molecular Structure on Incipient Soot Formation," Combustion and Flame, Vol. 49, No. 1-3, 1983.
3. Castino, G.T., Beyreis, J.R. and Metes, W.S., "Flammability Studies of Cellular Plastics and Other Building Materials Used for Interior Finishes," Underwriters Labs, Subject 723, 1975.
4. Delichatsios, M.A. and de Ris, J., "An Analytical Model for the Pyrolysis of Charring Materials," presented at the CIB-14 Meeting, Boras, Sweden (May, 1983).
5. Fisher, F.L. and Williamson, R.B., "Intralaboratory Evaluation of a Room Fire Test Method," UCB-FRG 82-1, University of California, Berkeley, 1982.
6. Huggett, C., "Estimation of Rate of Heat Release by Means of Oxygen Consumption Measurements," Fire and Materials, Vol. 4, No. 2, pp. 61-65, 1980.
7. Markstein, G.H., "Measurements on Gaseous-Fuel Pool Fires with a Fiber-Optic Absorption Probe," FMRC Technical Report 83-BT-1, March 1983.
8. Markstein, G.H., "Soot Formation, Radiant Emission and Absorption in Laminar Ethylene and Propylene Diffusion," FMRC Technical Report in preparation, July 1983.
9. Markstein, G.H., "Buoyant Plume Radiation," work in progress.
10. Masliyah, J.H. and Steward, F.R., "Radiative Heat Transfer from a Turbulent Diffusion Buoyant Flame with Mixing Controlled Combustion," Combustion and Flame, Vol. 13, pp. 613-625, 1969.
11. NFPA Fire Protection Handbook, 15th Edition, pp. 4-7, 1981.
12. Orloff, L., de Ris, J. and Markstein, G.H., "Upward Turbulent Fire Spread and Burning of Fuel Surfaces," Fifteenth Symposium (International) on Combustion, The Combustion Institute, pp. 1285-1294 (1975).
13. Orloff, L., Modak, A.T. and Alpert, R.L., "Burning of Large-Scale Vertical Surfaces," Sixteenth Symposium (International) on Combustion, The Combustion Institute, pp. 1345-1354, 1979.
14. Ostman, B., "Rate of Heat Release from Building Materials," FoU-Brand 1981/1982, Fire Research and Development News, Sweden.

15. Parker, J.A. and Kourtides, D., "Optimization of Fire Blocking Layers for Aircraft Seating," 7th International Conference on Fire Safety, 1982.
16. Quintiere, J.G., Harkleroad, M. and Walton, W., "Measurement of Material Flame Spread Properties," NBSIR 82-2557, National Bureau of Standards, August 1982.
17. Schalla, R.L. and Hibbard, R.R., "Smoke and Coke Formation in the Combustion of Hydrocarbon-Air Mixture," Basic Considerations in the Combustion of Hydrocarbon Fuels with Air, Chapter IX, Report 1300, NACA, 1957.
18. Schug, K.P., Manheimer-Timnat, Y., Yaccarino, P. and Glassman, I., "Sooting Behavior of Gaseous Hydrocarbon Diffusion Flames and the Influence of Additives," Combustion Science and Technology, Vol. 22, pp. 235-250, 1980.
19. Smith, E.E., "Heat Release Rate of Building Materials," Ignition, Heat Release, and Noncombustibility of Materials, Ed. A.F. Robertson, ASTM Technical Publication 502, (1971).
20. Tewarson, A., "Heat Release Rate in Fires," Fire and Materials, Vol. 4, pp. 185-191, 1980.
21. Welker, J.R., Wesson, H.R., Sliepcevich, G.M., "Ignition of Alpha-Cellulose and Cotton Fabric by Flame Radiation," Fire Technology, Vol. 5, pp. 59-66, (1969).

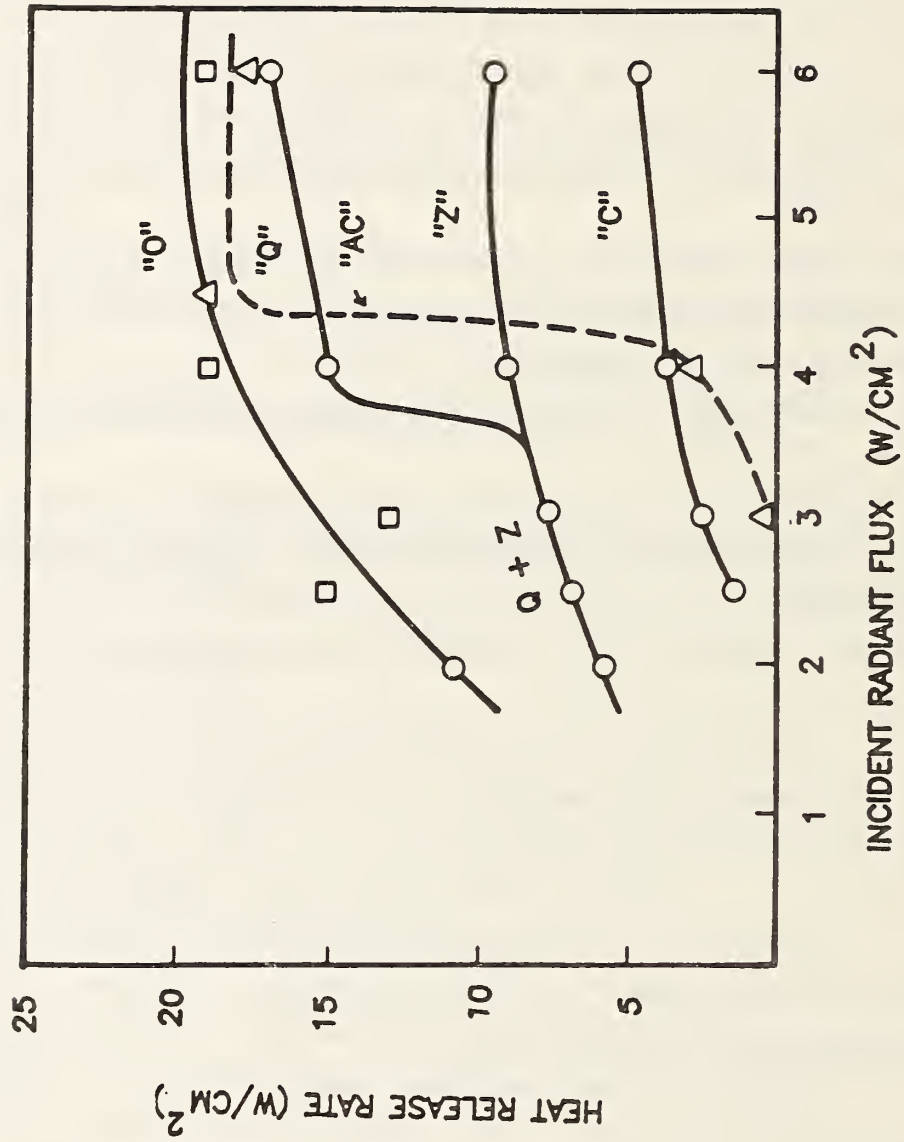


FIGURE 1: Heat Release Rate of Some Fire-Retarded Polyurethanes (Coded According to Castino et al, 1975).

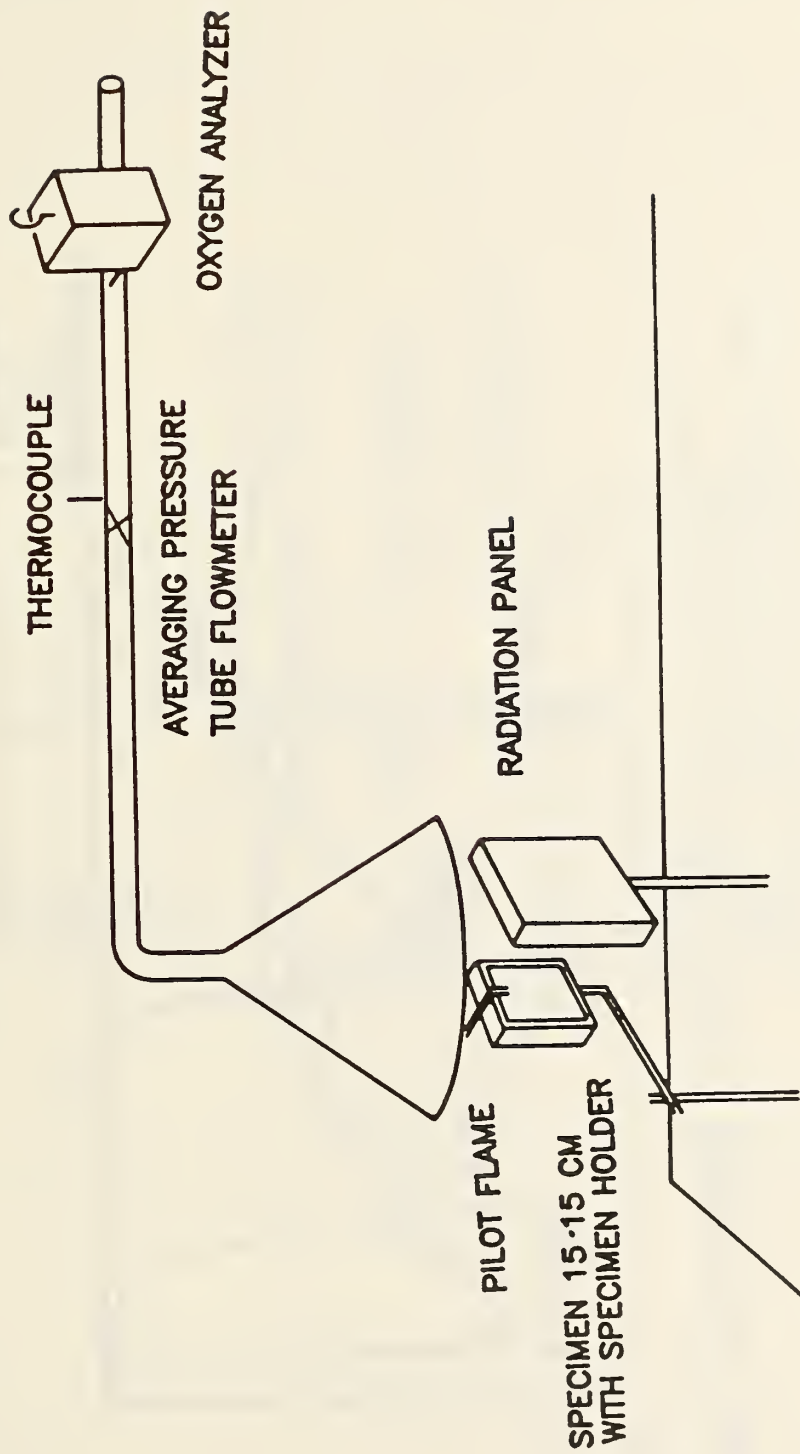


FIGURE 2A: Typical Rate-of-Heat-Release Apparatus (Ostman, 1982)

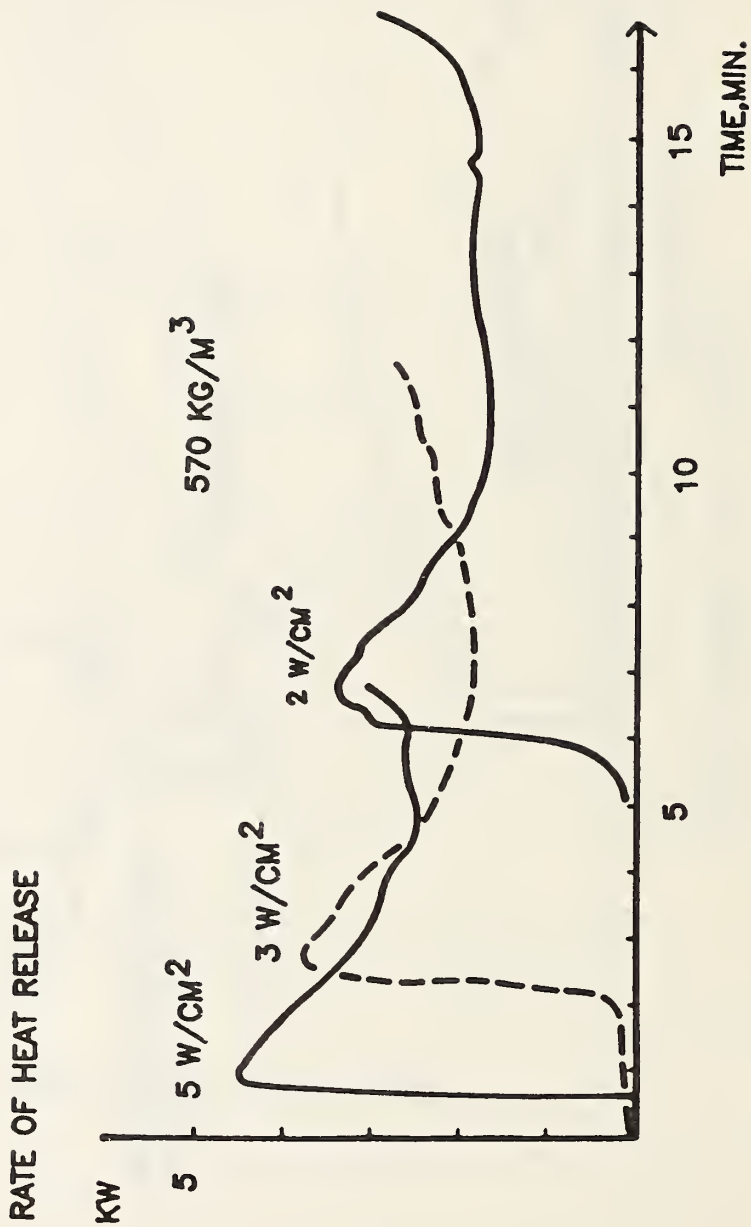


FIGURE 2B: Typical Rate-of-Heat-Release Curves versus Time for Charring Fuels (Ostman, 1982).

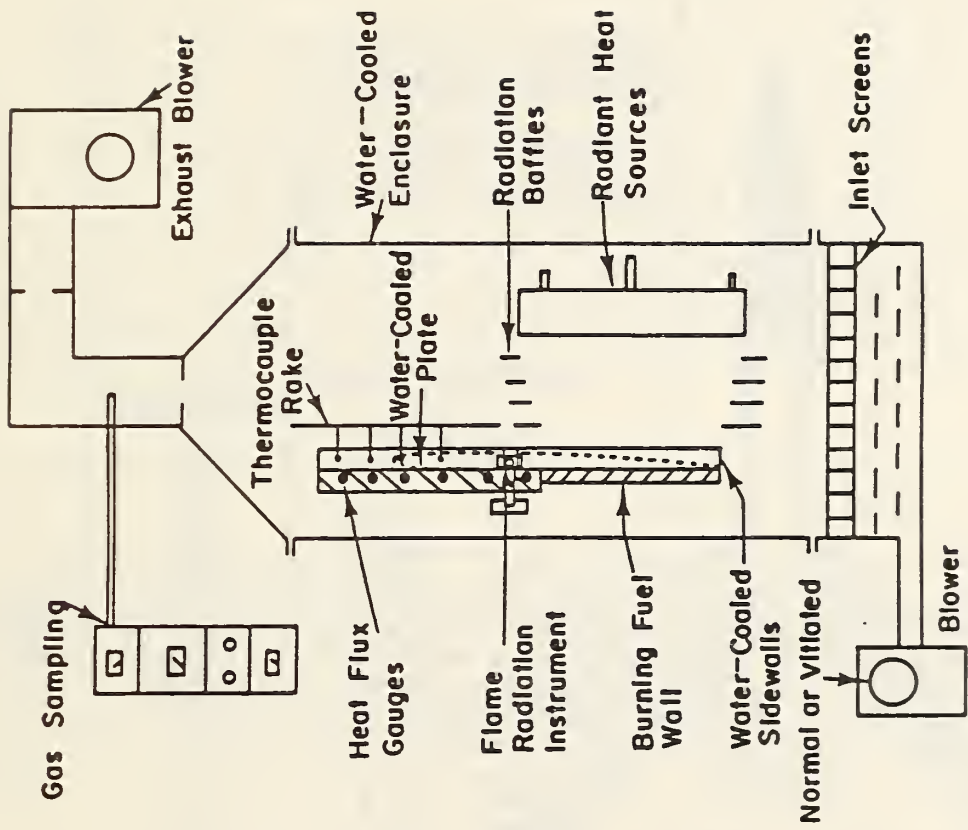
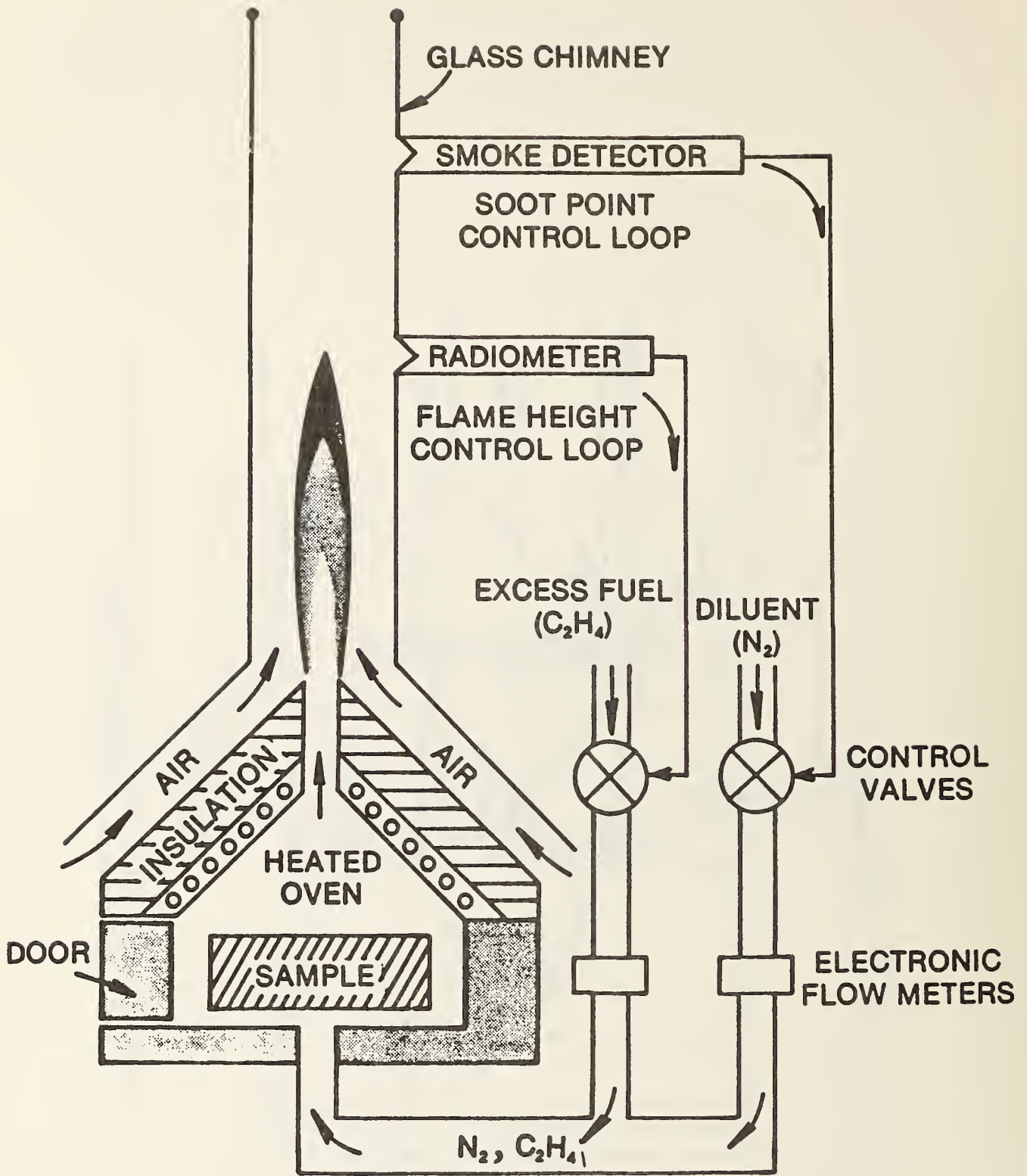


FIGURE 3: Material Flammability Apparatus of Measuring Flame Radiation in a Vitiated Atmosphere.



MATERIAL FLAMMABILITY TEST

FIGURE 4: Suggested Bench-Scale Material Flammability Apparatus for Measuring Both Rate-of-Heat-Release and Flame Radiation.

Discussion After J. deRis' Report on FLAMMABILITY TESTING: STATE-OF-THE-ART

MITLER: In that last apparatus, of course, the flame is visible to the central part of the sample above the optic axis. I suppose you might block that in some way or perhaps cut a hole in the sample.

DeRIS: My answer is that Henri is a perfectionist. I am also.

PAGNI: Earlier you showed on a slide of χ versus soot point with a variation from 40 percent to 20 percent for various fuels, and then later we saw a slide that showed that at the soot point, χ was always 30 percent. I'm a little confused about what the meaning of the first χ is when I see the second slide.

DeRIS: A turbulent diffusion flame has a certain micro-scale at which the combustion takes place. This micro-scale turns out to be very insensitive to the overall flame height. It corresponds to a dimension such as 2 or 3 cm. This micro-scale is controlled by the turbulent convection but it does not change with the fire size which can be shown by calculation. It is this micro-scale that defines or corresponds to a certain laminar flame height. The fuel, however, may have a soot point which is above or below this corresponding laminar flame height. Therefore, the actual radiant fraction from a turbulent flame depends on the ratio of this characteristic micro-scale flame height and the soot point flame height in the laminar case. This explanation leaves me quite comfortable, but it may not leave you comfortable, and it certainly has not been mathematically proven.

PAGNI: We need to change the scale of the answer in proportion to the size of the question.

HIRANO: My question might be related to the previous question. I think my method of radiation can be ultimately determined by three factors: soot point, type of fuel, and size of flame. Assuming that is correct, the burning condition is one factor. Earlier from your presentation, the soot point has been described as function of performance can be quite clear. But I believe that flame height, especially in various conditions, must play a big role but how do you concede the performance of flame sizing, the one that measured determinant.

DeRIS: When we perform many experiments for larger fires, the tendency is one models the fluid mechanics, the rate exactly, then the radiant fraction tends to not change once the fire is fully turbulent. However, this comment does not apply for very large fires.

COMBUSTION TOXICITY

Discussion After Y. Tsuchiya's Report on U.S.-CANADA-JAPAN COOPERATIVE RESEARCH
ON EVALUATION OF COMBUSTION GAS TOXICITY

(NOTE: No paper was submitted for the proceedings.)

LEVIN: The values that you use for your incapacitation and lethality values, are those values for 30 minutes?

TSUCHIYA: The data is from the literature and this is one of the examples. I showed the difference at the bottom. I can't tell if it's 30 minutes or not. These are lethal concentrations.

LEVIN: So you're not sure what the time frame would be for these values.

TSUCHIYA: Yes, about 30 minutes.

LEVIN: How many liters of gas does your MS/MS instrument use?

TSUCHIYA: We can operate the machine from .5 - 10 liters per minute.

GANN: In your plots of CO/CO₂ versus oxygen depletion, the large scale data that you use, is that taken from within the burn room?

TSUCHIYA: Yes, for the large scale...inside the burn room.

GANN: In the vicinity of the burning fuel of interest?

TSUCHIYA: I'm not sure.

GANN: Obviously there will be a difference between the upper layer and lower layer.

TSUCHIYA: Well, it depends upon the people who do the design.

GANN: In your OSU experiments, where was the gas measurement made?

TSUCHIYA: We take the gas off the top of the stack.

GANN: What we need to be very careful of is that it is the conditions in the vicinity of the burning material that we replicate. In both the large scale data that you reported from other people and the OSU data plus any other toxicity apparatus, there is always going to be a region where fresh air enters and an exhaust region where some average value of combustion products exists. Those conditions will always be apparatus or burn dependent. What we need to preserve is the conditions at the burning material.

TSUCHIYA: You're suggesting closer to the sample?

GANN: Close to the sample, yes.

TSUCHIYA: In that case, the action isn't complete.

GANN: But that's where the oxygen depletion measurement is important, even if the CO to CO₂ ratio isn't yet resolved. The alternative to sampling in the combustion environment is to have an extremely well defined air flow past the sample. This exists in, for instance, the cone calorimeter or perhaps in Dr. Yusa's apparatus, but that does not exist in the Smith machine.

TSUCHIYA: This was easily obtained at that time.

GANN: Yes, we have such a machine and it is sitting in the corner of the laboratory also unused.

SUZUKI: You mentioned that sometimes you don't need to use animal models, you can predict whether the animals will be killed or not killed. Don't you need to take into consideration interfering gas?

TSUCHIYA: With different types of materials you get several kinds of gases, pure gas and other types of gases.

SUZUKI: It is my opinion that at this stage, synergism is talked about very much by many people. If there is synergism shown by experiment, quantitatively we can adopt that information for our expression. In environmental inhalation toxicity, this synergism has been talked about but there is no quantitative data so far. Until quantitative data is presented, we can limit its effect.

LEVIN: I would like to add that we are now starting to do experiments with combinations of carbon monoxide and hydrogen cyanide and carbon dioxide and are seeing the effect of one gas upon the other.

TSUCHIYA: Southwest Research Institute mentioned the effect of combination gases many years ago.

LEVIN: I think a lot depends on the definition of synergism and additivity, but we find that with CO and HCN we can take half the LC₅₀ of each and arrive at a concentration that kills the animal.

TSUCHIYA: Combination of CO and HCN has been studied by many groups; a study was done by a Japanese group which was published in a Japanese forensic journal. This is a very good experiment.

LEVIN: There is data in the literature which shows there is synergism and there is data which shows there is not synergism. I've had papers I can show you that present both aspects.

TSUCHIYA: There is such data showing the synergistic effect but similar experiments have been done by others. If there are two toxic components, a and b, shown this way, and the synergistic effect is p and b, this value is very high compared to others.

STUDY ON EVALUATION OF TOXICITY
BY GAS USING PURE GAS

Yoichi NISHIMARU M.D. et al

Department of Legal Medicine
Yokohama City University
School of Medicine
Yokohama, JAPAN

- 1) Y. NISHIMARU and Y. TSUDA
- 2) T. SAKURAI
- 3) N. NAGAMURA, Y. KUCHINOMACHI, O. KASHIDA,
I. HIEDA and M. YAMAMURA
- 4) T. JIN and T. YAMADA

Study on Evaluation of Toxicity by Gas Using Pure Gas.

Four research groups are now doing research of the subject above; each group is researching a different aspect of the subject. We are now in the midst of the research and have not got final results. The method of our research and a part of the results are reported as follows.

(1) Study of Physiological Disorders in Animals Caused by Pure Gas.

1. Summary

a) To investigate whether or not we can get a definite interrelational expression between physiological disorder and gas density by using five toxic gases -- CO, CO₂, HCN, HCL and NO₂ -- or the mixture of them and measuring disorders in animals in each gas orgases and gas density in their blood.

b) To investigate whether or not we can get an definite interrelational expression between each degree of heat burn and gas density in blood by collecting blood from dead bodies found on the scene of fire or in similar cases and measuring gas density.

2. Experimental Method

Condition

1) Animals : Rats (mainly), mice, rabbits.

2) Exposure chamber : 0.5 x 0.5 x 0.5 m.,

It should have a fan and a heater and the temperature and the humidity in it should be controlled.

It should be a perfect air-tight box and have an alarm.

3) Gases : CO, CO₂, HCN, HCL, NO₂

4) Temperature : Normal temperature, 30°C, 40°C, 50°C and 60°C to observe the differences of heat burn at each temperature.

5) Multiple meterological record equipment : Observed the state of the change of respiration, E.E.G., and E.C.G. under each condition.

- 6) Analysis of gas density in blood : Measure the gas density and the pH value in blood of animals after finishing the inhalation of a gas or gases.

Procedure

- 1) Examine the respiration, E.E.G. and E.C.G. of experimental animals in a normal condition, analyze gas or gases in blood, and measure the pH value in it.
- 2) Analyze the changes of respiration, E.E.G. and E.C.G. in animals caused by changes of temperature --- normal temperature, 30°C, 40°C, 50°C and 60°C.
- 3) Analyze the changes of respiration, E.E.G. and E.C.G. after making experimental animals inhale each single gas whose density is varied at normal temperature.
- 4) Analyze the gas and measure the pH value in the blood of animals, after finishing the experiment of gas inhalation.

(2) Study on Evaluation of Toxicity of Gas Using Pure Gas.

1. Summary

This report describes the test results of investigation on relation between concentration of toxic gas and incapacitation time of mouse in the gas/air mixture. The tests were carried out with regard to 5 types of toxic gas (CO, CO₂, NO₂, NH₃ and HCL).

2. Test Method

Toxic gas (high purity) was supplied and diluted in a test chamber of combustion gas toxicity test apparatus through a gas control system. The concentration of the toxic gas was controlled by controlling the gas flow rate and duration of supplying to the test chamber, and it was monitored with gas concentration analyzer at each test. 8 rotating baskets with a mouse in each of them were set up in the test chamber immediately before supplying gas and a type of toxic gas was supplied in the chamber. Movement of the mice and gas concentration were observed.

At tests for CO₂, O₂ concentration was kept on about 21% by supplying O₂ into the chamber so as to eliminate the effect of hypoxia.

The mice for the tests were 5 weeks old female Jcl ICR type and their weight was 18-20g..

3. Appratus

Outline of the test chamber and gas control system is shown in Fig. 1.

<u>Gas</u>	<u>Method of Analysis</u>	<u>Type of Analyzer</u>
CO	Infrared Gas Analyzer	ZAL BG 152-11 (Fuji Electric Co. Ltd.)
CO ₂	" "	ZAL DL 952-10 (" ")
NH ₃	" "	ZAL ZJ 052-10 (" ")
NO ₂ (NO)	" "	ZAL pb 252-11 (" ")
	(with NO ₂ NO converter)	(" ")
O ₂	Magnetic Oxygen gas Analyzer	ZAJ IC O2 (" ")
HCL	Ion-electlode	ZBV (" ")

4. Test Results

Fig.2--Fig.6 show the test results. The incapacitation time of mouse is the time when themouse seases moving for more than 3 minutes after the time. In the figure, gas concentration is plotted by average incapacitation time of 8 mice for each test.

--- Fig. 1, 2, 3, 4, 5, 6 ---

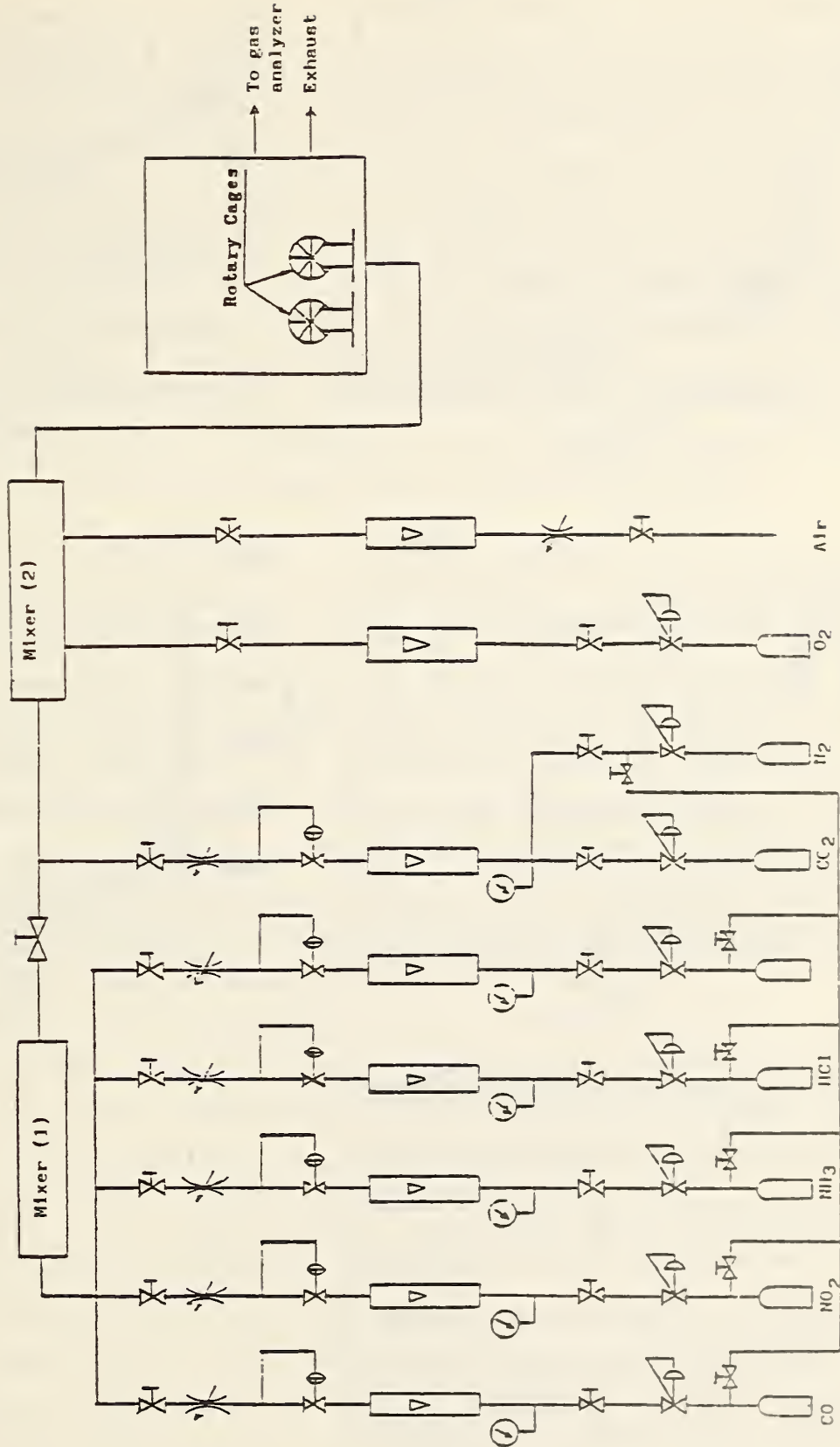
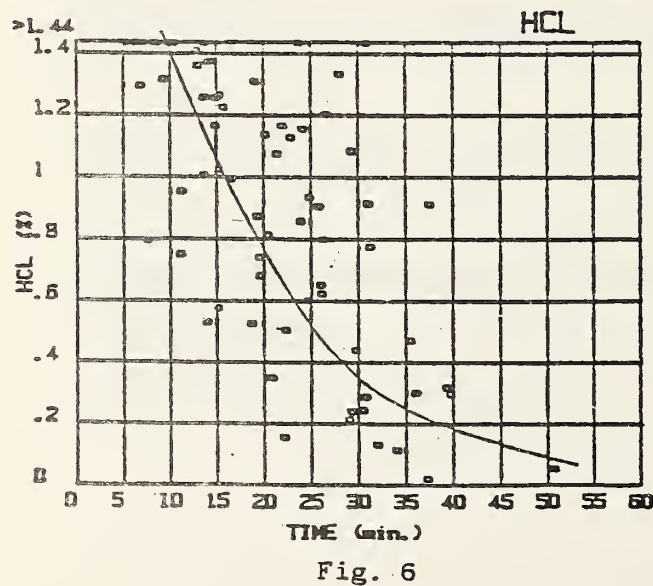
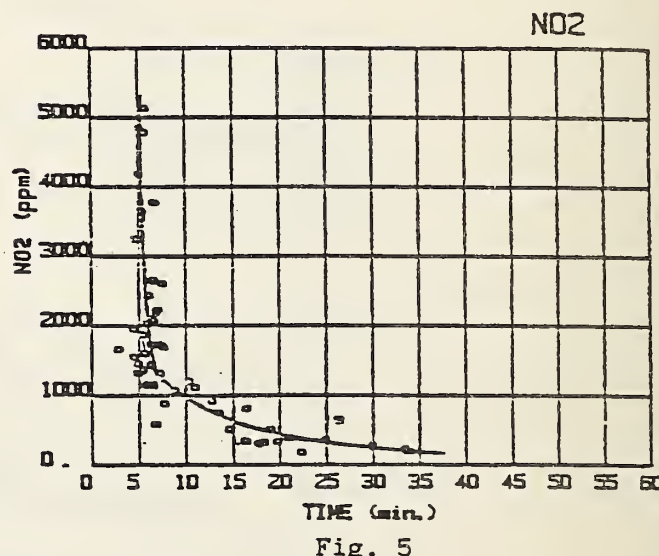
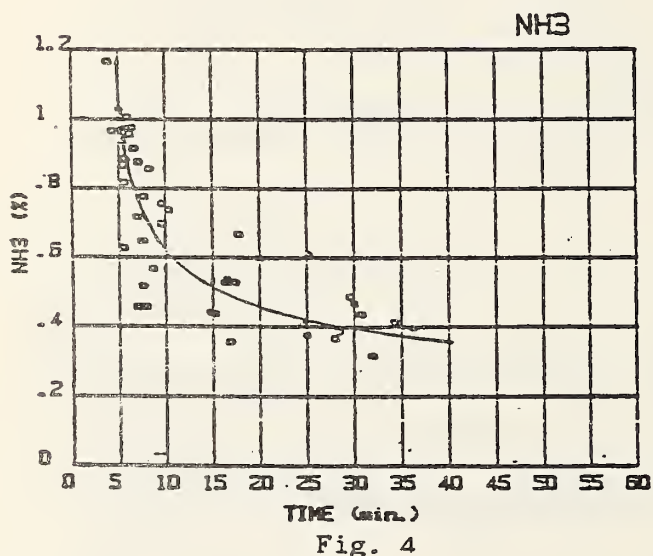
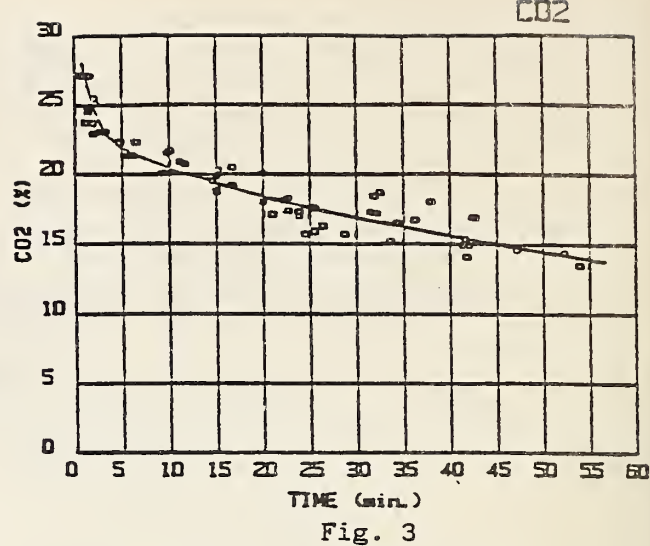
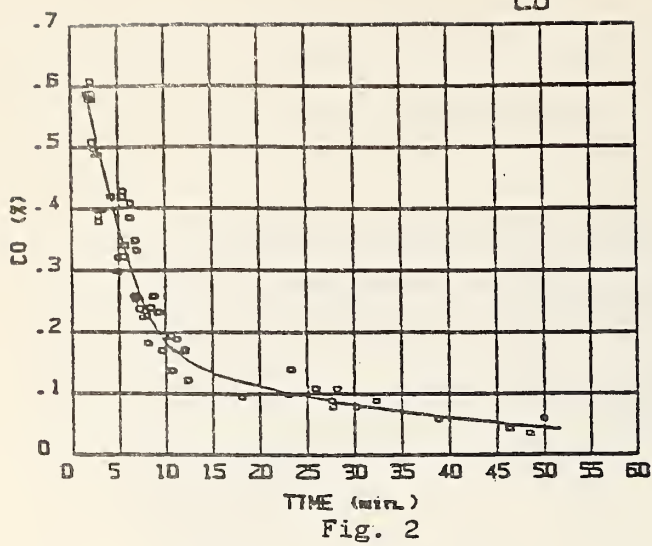


FIG. 1



(3) The Effect of Toxic Gas Upon Short Term Memory of Rats.

1. Introduction

The inhalation of CO or CO₂ concentrated air often causes the severe disturbance of consciousness and leads to the retrograde amnesia. This symptom is good for the measurement of these kinds of toxic gases.

In the present report, the effect of CO concentrated air on the short term memory of rats was examined by the use of the one-trial aversive learning situation.

2. Method and Procedure

The subjects were 18 male albino-rats of about 10 weeks old. They were tamed enough and got familiar with learning apparatus. The apparatus consisted of an open-field and small dark box which were connected with small entrance. The floor of the box was brass grid to be charged with alternate current for aversive shock.

The rats have a habit avoiding the bright open-field and preferring to the dark small place, therefore, the rats put down at the center of the open-field soon go to the small box and enter in it.

Each rat was allowed five times to enter the small box, and at each trial, the period between the moment the rat was left in the open-field and the moment he entered the small box was measured. This period indicates the intensity of dark box preference of each rat.

Then the rats were divided into three groups homogeneously on the preference intensity.

On the 6th trial the rat entered the box, its entrance was shut and the grid floor was charged with electric current of 100 V, 50 Hz for 10 seconds. The rats showed a violent emotionality, and learned to avoid the small box in spite of their preference with only one time of experience.

One minute after the shock experience, the rat was put

into the gas chamber and exposed to CO concentrated air for five minutes. CO concentrations were 0.75%, 0.50% and 0.25% respectively. Concentration of O₂ was kept constantly at 20%. Concentrations of CO and O₂ were continuously monitored by the gas analyzer.

The next day, rats were tested if they showed a retrograde amnesia or not, leaving again in the open-field and being observed their behaviors.

3. Results and Discussion

Three rats were excluded from consideration, because the one was given the misoperation of gas exposure and the others misoperation of electric shock.

Table 1 shows the numbers of rats entered the small box in test trial.

Table 2 shows the mean number of entrance and the mean duration stayed in the box. In Table 2, there was not found the statistically significant difference between the group of 0.75% and the group of 0.5% CO concentration.

Five minutes exposure to 0.25% CO have no effect on short term memory. The threshold may exist between 0.25% and 0.75% CO concentration.

Other conditions, such as poor oxygen air, CO₂ concentrated air or HCN are further investigating here.

Table 1. Number of rats entered in the small box

group	CO concentration (%)	N	Number of rats entered
1	0.75	4	3
2	0.50	6	3
3	0.25	5	0

Table 2. Mean number of entrance and mean duration stayed in the box

Measure	1	Group 2	3
number of entrance	2.5	1.5	0
duration	23.0 sec.	27.6 sec.	0 sec.

(4) Study of the Psychological Effects on the Occupants by the Smoke Generated in Early Stage of Fire

The main purpose of this study is to grasp the psychological and physiological effects on the occupants by the smoke generated in early stage of fire.

In the first fiscal year, we have a plan to measure the properties of the smoke generated from various interior materials, furnitures, etc., i.e., the density of smoke, size of smoke particles and the composition of stimulous gases.

Particularly the relation between smoke density and the mass rate of the stimulous gases are our concern, so we make an experimental studies with various materials and burning rates.

Discussion After Y. Nishimaru's Report on STUDY ON EVALUATION OF TOXICITY BY GAS USING PURE GAS

TSUCHIYA: When you use HCl, what part of the rat was exposed to HCl?

NISHIMARU: The whole body. In this test we used mice, not rats, and the whole body was exposed in the chamber.

TSUCHIYA: I thought it was only the nose that was exposed.

NISHIMARU: We knew the tradition, but we decided to expose the whole body of the mouse because in case of fire, the whole body would be exposed. So, at the first step we are using the whole body exposure due to hydrochloric acid being produced from HCl.

GENERAL DISCUSSION

SAITO: We would like to ask Dr. Sumi to give us a very brief review of his study because his study is related to the work in Group 1.

SUMI: We are building a room parameter. It will be used for surface lining materials and building contents, such as furniture and furnishings. We are following the proposed method of ASTM for room fire tests and wall and ceiling material. The method involves a fire in a standard room. If the room has an open doorway and products of combustion are sent into a hood connected to an exhaustor, measurements of rate of heat release, smoke and fire gases can be made in that time. The rate of heat release will be measured by the oxygen content method. Provision is made for exhaustor flow so that all the products of the combustion will go through. The instrumentation in the room, I think, initially was for very limited input, so we will have thermocouples in the room, heat flux gauges, load cells for measuring mass burning rate, and gas analysis will be carried out at the doorway. This is for monitoring CO, and CO₂. Oxygen and grab samples will be collected for analysis of hydrogen cyanide, nitrogen oxides, and aldehydes. I think it should be coming very clear to many of us that aldehydes are very important; very small concentrations could interfere with the escape of occupants from fire. The instrumentation in the duct was in the thermocouple, velocity probe, two types of smoke meters, and gas analysis, again, for monitoring CO and CO₂. We also intend to collect grab samples there. We hope to get information on possible loss of certain performance during migration. We initially intend to do three types of wood cribs, 30, 60, and 120 kilograms. The 60 kilogram size may be sufficient to reach flashover in the room. Other materials considered are polyurethane, polystyrene, nylon, polyethelene, polypropylene. With this heat release apparatus, it is convenient to compare rates of heat release and others for wall and ceiling lining materials. We can compare certain coating components, for instance, mattress versus mattress. I am in favor of standardizing ignition sources so that results obtained by different people in different laboratories can be compared. We are receptive to any suggestions in this direction.

SAITO: We would like to exchange our information with each concerned with the research done by Dr. Sumi.

NISHIMARU: I also feel it's not very good. I thought that we had suggested to expose the whole body to HCl. The one reason we decided to expose the whole body is that in a fire, the whole body would be exposed. You know that HCl liquefies easily, that's why we heated the two and the place where the HCl will be mixed so that the HCl will not be liquefied. That's how HCl was set into the chamber.

LEVIN: I have one question for Dr. Nishimaru. On these figures, is each point one animal or is each point the average of the three?

NISHIMARU: In this test we have eight mice in one exposure. Therefore, one point is the mean value of eight mice.

TSUCHIYA: My question, Prof. Nishimaru, can you continue this kind of research for other types of toxic gases, including ether?

NISHIMARU: I was supposed to give a talk on this subject in April next year, and I'm very exasperated as I'm behind schedule. I have to collect more data before the next lecture.

TSUCHIYA: You plotted your data on linear scale. It should be plotted on log scale.

NISHIMARU: We also have it plotted in log scales; if you like, we will supply that data.

TSUCHIYA: You can easily draw a straight line on the data?

NISHIMARU: It's okay for CO but it's not okay for the others.

GANN: Good data is independent of the axes.

OPEN TECHNICAL SESSION

Takao Wakamatsu
Session Chairman

ANALYSIS OF THE FIRE PROTECTION COST INDEX

H. Nakamura, Y. Yashiro

Planning Division
The Research Institute of
SHIMIZU CONSTRUCTION CO., LTD.
4-17, Etchujima 3-chome
Koto-ku, Tokyo, Japan

ANALYSIS OF THE FIRE PROTECTION COST INDEX

(as the ratio of electrical and mechanical works
in the whole estimation cost)

H. Nakamura, Y. Yashio

1. INTRODUCTION

This report presents the analysis of the costs of fire protection in the "electrical and mechanical" works. The purpose of this research is to evaluate an optimal cost for carrying out the fire safety, and to contribute to working out a rational design method of fire safety.

It is commonly believed that the costs relating to fire protection are usually unduly large in comparison with the entire construction cost of a building. Yet, on the other hand, detailed researches into the exact costs of fire protection do not seem to have been made. There are difficulties in such researches: many fire protection items are not merely made for the single purpose of fire fighting, but are multi-functional. For example, fire wall, stair case, safety zone etc. Under these circumstances, designers tend to take an easy way out and plan the fire protection only according to the relevant laws and regulations, instead of working out a fire protection plan which would be truly suitable and efficient for the characteristics of building that they designed.

In this report, being well aware of the situations described above, we must nevertheless start where we can: the "fire protection costs" included in our past estimates as such will be first extracted from the record of estimation, and will be analysed in relation to the characteristics of the buildings in which such items were used.

2. DATA BASE AND ITEMS TO BE ANALYSED

SHIMIZU CONSTRUCTION CO., LTD. has kept a systematic record of estimation of every building work they have undertaken since 1977. For each building the estimators enter their estimation results in the coding sheets according to the entry manual. A set of the coding sheets has about 2,000 different items, as shown in Table 1, for which 13,000 bytes are used in computer as random file. It is possible to search for any desired record, and the data of any item can be obtained by appointing the field number of random file. Now the data base has about 3,000 records, from which costs of electrical and mechanical works of 1,290 were extracted to analyze the fire protection cost index.

Table 1 The number of items for each occupancy

building works		electrical works		mechanical works	
specification of building	61	electric power	100	environment of air conditioning	108
construction costs	67	information, fire safety equipment	128	sanitation, fire extinguishment	119
areas (floor, public space, etc)	621	transportation, others	444	air conditioning, ventilation	159
		costs, quantities	81	costs, quantities	103

Table 2 Items for fire protection

	Construction	Electric	Sanitation	Air Conditioning	Transportation and Others
system or equipment for fire protection	<ul style="list-style-type: none"> . fire shutter . fire escape equipment . fire protecting cover* . suspension wall for smoke control 	<ul style="list-style-type: none"> . fire alarm . emergency illumination equipment . emergency power source . lightning equipment* . fire alarm system . electric leakage warning system . emergency reporting system . emergency reporting system to fire dep. . emergency voice communication system . escape guide lamp . gas leakage warning system . emergency gas controller 	<ul style="list-style-type: none"> . inside fire extinguishing equipment . sprinkler . foam fire extinguisher . drencher . fire dep. connector . suction pipe connection . water tank for extinguishment . water supply . fire hydrant 	<ul style="list-style-type: none"> . smoke evacuation apparatus . smoke ventilation . fire damper 	<ul style="list-style-type: none"> . emergency elevator
specification of fire protection	<ul style="list-style-type: none"> . smoke venting window . smoke control screen . fire door . compartmentation . emergency opening . noncombustible surface and lining . penetration works for fire compartment 	<ul style="list-style-type: none"> . refractory cable 			<ul style="list-style-type: none"> . control system of fire protection facility*
space for fire safety	<ul style="list-style-type: none"> . enclosed stairway . safety zone . space for fighting control room . space for fire protection facilities 				
planning	<ul style="list-style-type: none"> . zoning . arrangement of staircases 			<ul style="list-style-type: none"> . maintenance of fire protection facilities 	
running cost		<ul style="list-style-type: none"> . power source 			<ul style="list-style-type: none"> . portable extinguisher . fire safety officer . fire drill . renewal . slow burning improving . fire insurance . maintenance of fire protection facilities

In the design of fire safety, there are many fire protection items to be taken into consideration, as shown in Table 2. In our data base, most of their quantities are counted in terms of number or area, but their costs are stored in terms of more general categories of works. For example, the cost of a fire door is included in that of the fittings. For this reason it is not always possible to pick up the exact cost of each and every item. This is particularly so in case of the building structure. On the other hand, it is relatively easy to determine the costs relating to fire protection in case of the "electrical and mechanical" items.⁽¹⁾

In this report, therefore, only the fire protection costs extracted from "electrical and mechanical" works were used.

3. ANALYSIS

Table 3 and Fig. 1 show the fire protection cost index for each occupancy.

The mean values of the indices for all occupancies except for the hotels are higher than the median values. Fig. 1 shows that the fire protection cost index has a wide range particularly in shop and industry.

Table 4 shows the correlation coefficient between the number of stories, gross floor area and the fire protection cost index for each occupancy.

Fig. 2 and 3, for example, show the scatter plot between the number of stories, gross floor area and the fire protection cost index of shop and business building respectively.

No correlation is found between the number of stories, gross floor area and the fire protection cost index in any occupancy.

(1) These are the items shown in the column of "system or equipment for fire protection" in Table 2, except for those with symbol "*".

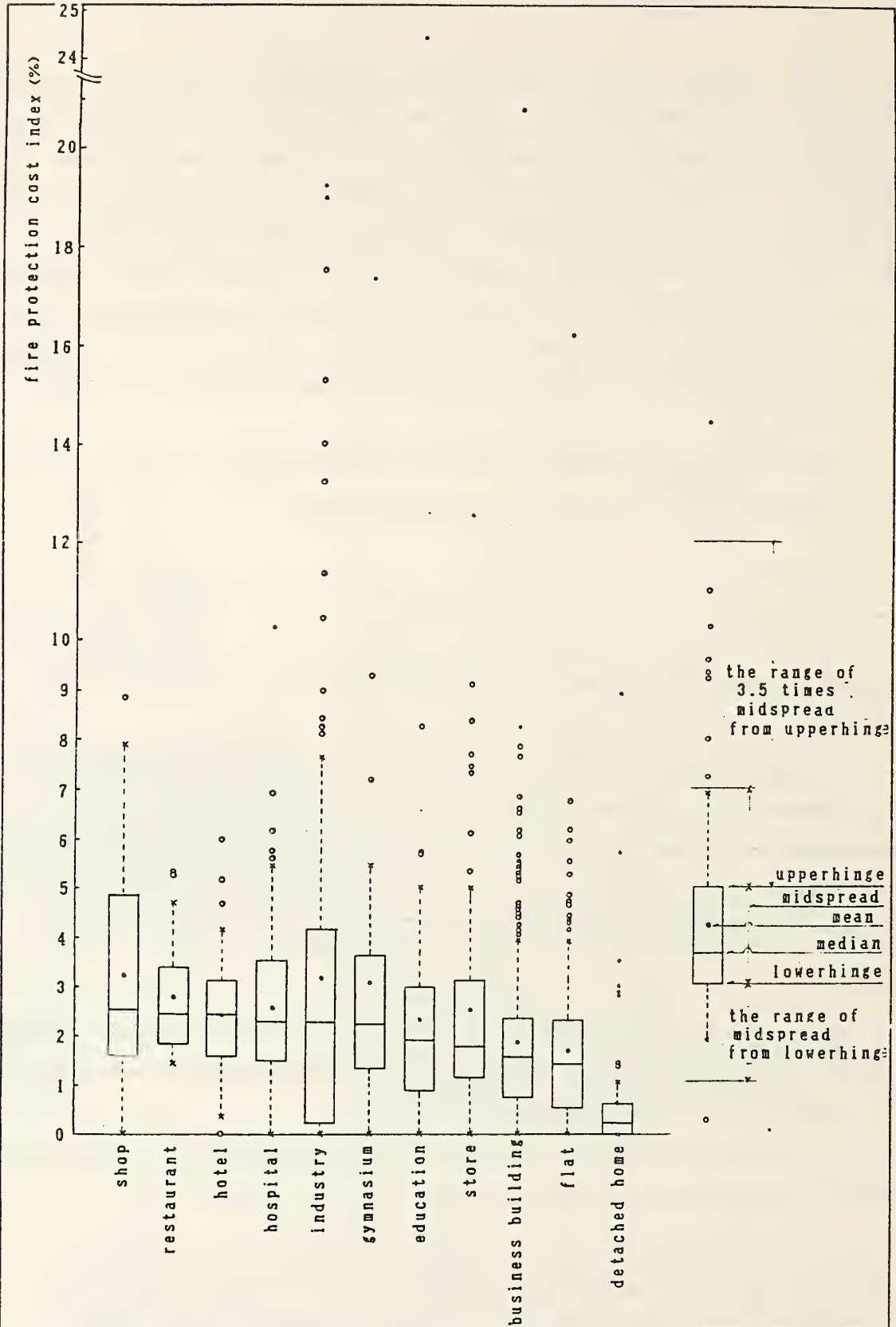


Fig.1 Box and whisker display of fire protection cost index for each occupancy.

Table 3 Average of the fire protection cost indices and other values

occupancy	average of stories	average of gross floor areas (m ²)	average of fire protection cost indices (X)	median of fire protection cost indices (X)	number of data	unit price (x10 ³ yen/m ²)
detached home	2.07	309	0.64	0.24	81	220
flat	4.92	2804	1.68	1.44	246	180
business build.	4.12	2229	1.86	1.59	403	160
shop	3.62	5971	3.26	2.53	66	130
restaurant	4.20	1386	2.79	2.49	15	210
industry	2.35	7031	3.18	2.29	144	130
store	2.44	3867	2.53	1.79	90	100
hotel	4.85	3288	2.43	2.44	40	200
hospital	3.65	1870	2.57	2.30	86	170
education	3.26	4157	2.34	1.92	89	180
gymnasium	2.43	2593	3.08	2.27	30	140

Table 4. Correlation coefficient between the number of stories, gross floor areas and the fire protection cost indices.

occupancy	corr. coeff. between stories and fire protection cost index	corr. coeff. between gross floor area and fire pro- tection cost index
detached home	0.317	0.273
flat	0.234	0.202
business building	0.209	0.283
shop	0.115	0.379
restaurant	0.031	0.130
industry	-0.033	-0.100
store	-0.120	0.033
hotel	0.488	-0.040
hospital	0.102	0.260
education	0.078	0.097
gymnasium	0.218	-0.041

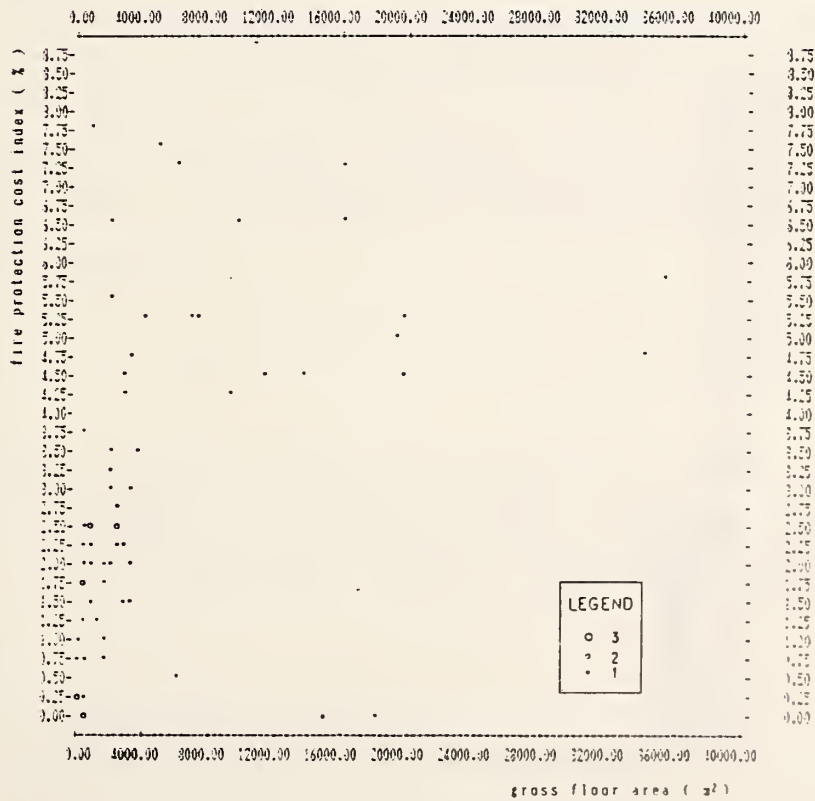
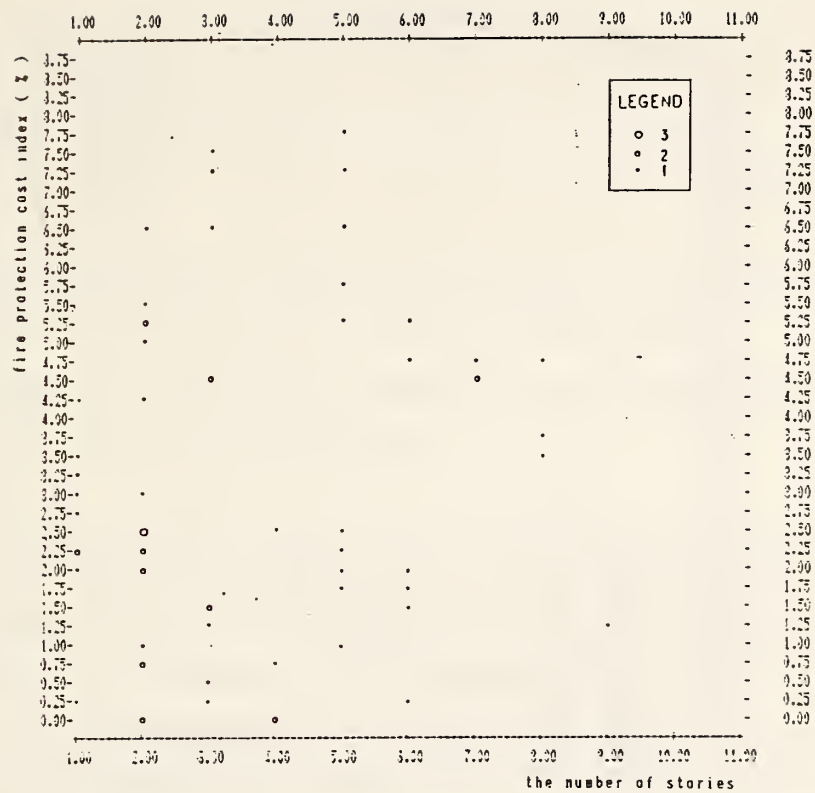


Fig. 2 Scatter plot between the number of stories, gross floor area and fire protection cost index of shop.

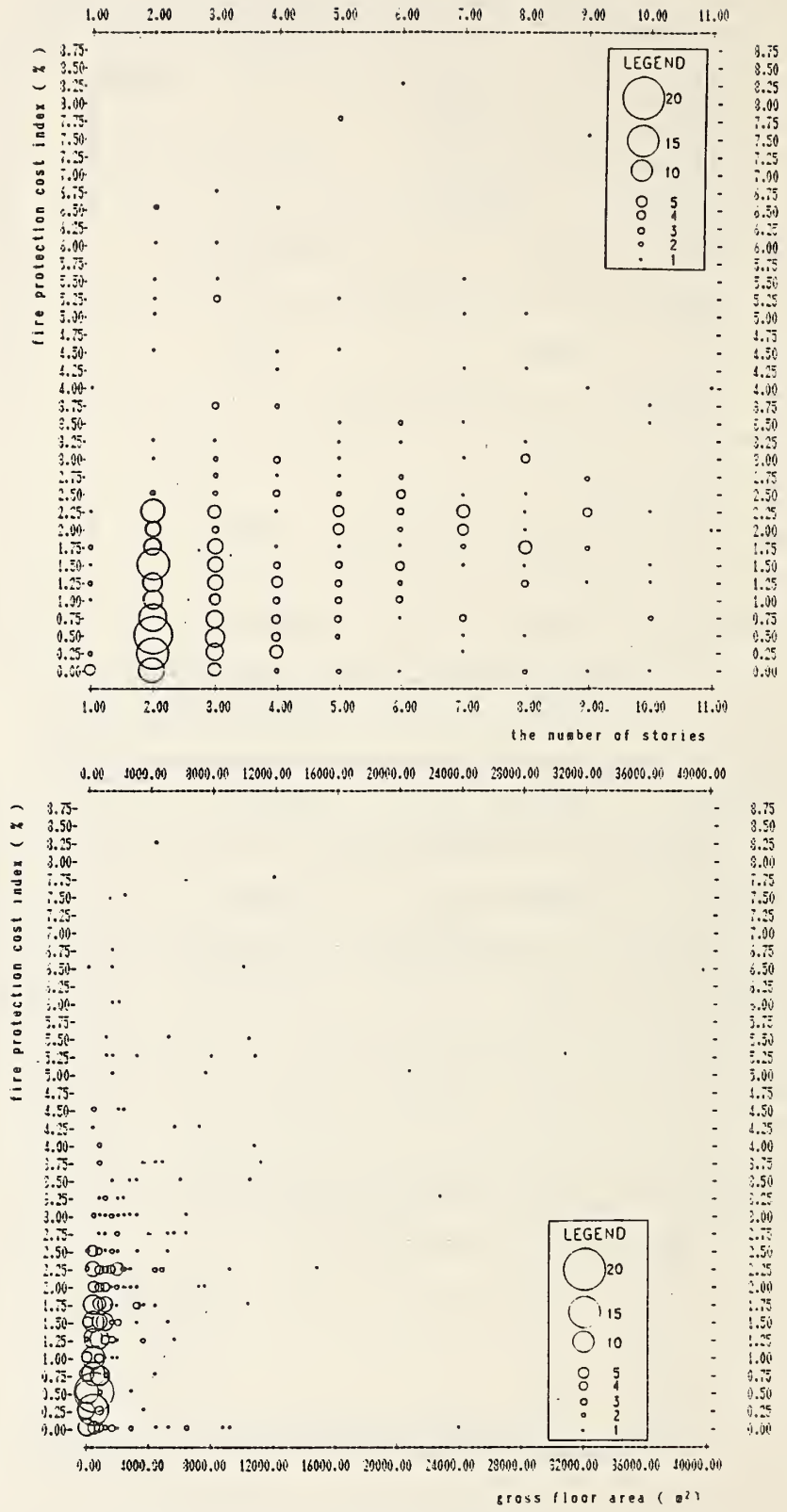


Fig. 3 Scatter plot between the number of stories, gross floor area and fire protection cost index of business building.

4. CONCLUSION

The foregoing analysis may be summarized as follows:

- The fire protection cost index has a wide range particularly in shop and industry.
- No correlation is found between the number of stories, gross floor area and the fire protection cost index in any occupancy.
- In our estimation, total fire protection cost of an entire building would generally be about 30 percent higher.

The reason why the fire protection cost index has such a wide range may be that different fire protection plans and fire protection items are rather randomly installed in different buildings, and possibly that there are unnecessary or duplicated installations in many cases. In order to look into this problem further, it would be necessary to extend the scope of our analysis to cover not only the items extracted from the "electrical and mechanical" works, but also all other items which have fire protection functions in some way or other, and to know what kind of fire protection functions are installed in a building and how many. It is thus our next task, to carry out such extended analysis with regard to the types of buildings and also to the functions and possible alternatives of various fire protection methods.

REFERENCE

1. H. Nakamura, Analysis of the fire protection cost index (as the ratio of electrical and mechanical works in the whole estimation cost), The Geneva Association Seminar, 23/24, March, 1983.

Discussion After H. Nakamura's Report on ANALYSIS OF THE FIRE PROTECTION COST INDEX

EMMONS: Is the index that you give the percentage of the cost of the building that is used for fire purposes...percentage of building cost?

NAKAMURA: Yes, it is.

EMMONS: Do I understand then, from your Figure 1, that some industries have a building with 17 percent of the cost of the building?

NAKAMURA: This is, of course, limited to one specified group of buildings, planned industrial and other purposes. That type of building can be constructed relatively cheap for the entire structure.

SEKIZAWA: My question is related. Let's take your conclusion on page 10. In part of your conclusion, you say that total fire protection cost of the building would generally be about 30 percent or higher. How can I relate this rather big figure to the figures we find in Figure 1?

NAKAMURA: The figure in Conclusions is inflated by 30 percent to what I had summarized in Figure 1.

HIRANO: I'd like to know, there must be a costing cost but we can probably divide it into two categories. One area of cost is mandatory, like regulatory policy, and the owner may have some additional costs due to some kind of work on fire protection. How do you divide, what is the ratio between the legal cost and the added cost?

NAKAMARA: To be honest, we cannot obtain a very accurate figure yet. The figure we have enumerated in this Figure 1 is actually for the type of fire protection our company standard requires. Of course, our company standard follows the requirement of the Japanese building code.

HIRANO: I'll add a follow-up to my previous question. I'd like to invite any comment from anybody here because I regard all of you here as authorities in this area. I'd like to know if anybody has some new idea what the ratio between the amount of cost to you and cost because of regulatory requirements and the requirements for older buildings.

NAKAMURA: I might say the amount we spend, because it is required by regulatory law, is close to 100 percent. This can be for buildings constructed under very strict and strong government regulatory requirements.

LEVINE: I was told once that the British Fire Research Station had studied the fraction of the building cost that was due to requirements for fire protection and came up with a number of about 5 percent. This was many years ago. I think this is very important work because if we are to convince people to use engineering methods of obtaining fire protection rather than codes that tell us exactly what should be put into a building, we must convince them that it is cheaper to use engineering methods.

KAWAGOE: An association has been studying very strenuously for several years to learn what's the correlation between the damage incurred by the fire and then the amount we invested in it to prevent the damage. I believe that as many as 11 nations in the EEC are still conducting this study. I have worked out a figure for monthly investment, but this is an average figure among EEC nations which is about 1 percent of GNP. The types of damage are: direct loss and indirect loss, and then expense for the fire department maintenance, the construction investment in the area of fire protection, premium for fire insurance. The total cost in the fire insurance industry and in human cost and in research cost are the major areas covered by the EEC study. Among these items, the one that is the most difficult to estimate is the construction investment. Incidentally, at the Association's last symposium the very first award was given to Mr. Nakamura.

AN EXAMPLE OF HUMAN BEHAVIOR IN A HOTEL FIRE

Soichiro Okishio
Takashi Handa
Kunio Kawagoe

Professor

School of Architecture

Faculty of Engineering

Science University of Tokyo

3, Kagurazaka 1-chome, Shinjukuku, Tokyo, 162

AN EXAMPLE OF HUMAN BEHAVIOR IN A HOTEL FIRE

Soichiro Okishio

1. INTRODUCTION

Monday morning, February 8, 1982, a hotel located in downtown Tokyo caught fire.

The fire incident was detected by a member of the front desk staff of the hotel as an odor of smoke in the ninth floor elevator hall. He noticed smoke issuing from an aperture of a guest room door in the ninth floor corridor. He and his colleagues tried to suppress the fire but their efforts were in vain.

The facility has about 500 guests rooms and about 350 guests were registered at the time of the fire incident. The ten story and two basement building of steel framed reinforced concrete construction was erected in 1960. The guest rooms of the hotel had no sprinkler systems. Automatic fire alarm systems of the hotel were switched off at the time of the fire to avoid false alarms. The report to the fire brigade was delayed considerably after the first detection of the fire. Because of those bad conditions, the fire caused the deaths of 33 persons. The time when the fire brigade received telephone notification of the fire was 03.39 a.m.

The headquarters investigating the fire heard the testimonies of the hotel's guests who had been registered at that time and produced a detailed written record. The written accounts were collected from 256 of the registered guests just after the fire incident.

The contents of the written accounts include the responses of the guests from awakening to evacuation, their observations of the other guests and of the fire, their movements within the building, and so on.

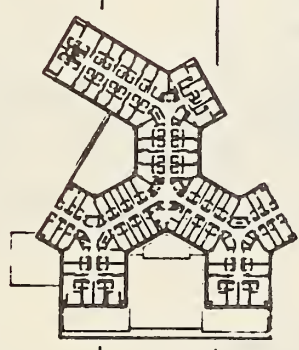
Those documented accounts were transferred to Individual Behavior Cards as shown in Table 1.

First, the sequence of fire and smoke propagation and of the actions of the hotel staff, guests and firemen were inferred from the studies of the mutual relation of the individual behaviors shown in those Individual Behavior Cards. Second, the behavior of the guests in the hotel was examined by utilizing those cards. This behavior study made reference to the papers on the Human Behavior in the Fire at the MGM Grand Hotel by Dr. John L. Bryan. *1,*2 The data presented in this paper are limited to the latter behavior study.

On the ninth floor where the fire originated, 40 of the 46 guests whose behavior was recorded on the Individual Behavior Cards left the room through the window. On the tenth floor, 9 of the 25 guests recorded also left the room through the window. The behavior of those guests was quite different from the behavior of the guests who evacuated through the corridor. Consequently, those guests who left through the window were excluded from the study population in

Table 1. An Example of Individual Behavior Cards

Time	Flame	Smoke	Information	Awareness	Leading	Behavior	Rescue	Note
		Smoke in Room ←		Awakened by Smoke Smelled		Attempted to Phone		No Answer
	Saw Flame Reflected on Ajacent Bldg. Window ←			Became Aware of Fire		Looked out of Window		
						Turned Light on		
						Notified Roommate		
						Dressed		
						Packed up Traps		
						Opened Door		
						Left Room		
		Less Smoke in Corridor ←				Went to Emergency Exit		
						Went Down Stairs to 2nd Floor		
						Attempted to Open Exit Door		Door Chained
						Went to Elavator Hall		Heard Woman's Shrieking
						Pushed Elevator Button		
						Remembered Danger of Elevator at Fire		
						Went to Exit Again		Fireman Unchained Door
						Left Hotel		
3.57-8						Looked at Watch		
Degree of Drinking: Undetermined Recognition of Emergency Exit: Recognized								
7th Fl.								
Name	Nationality	Age	Sex	Room No.	INDIVIDUAL BEHAVIOR CARD			
			M F.					



this paper. Two guests on the fourth floor and one on the eighth floor were out of the hotel at the time of the fire. Those guests were also excluded from the study population. Table 2 shows the number of the study population classified by floor level.

Table 2. Number of Study Population Classified by Floor Level

Floor	4	5	6	7	8	9	10	Total
Number of Individual Behavior Cards	25	14	44	47	55	46	25	256
Number of Study Population	23	14	44	47	54	6	16	204

The items examined and analyzed in this paper were as follows: the guests' recognition of emergency exits; the guests' means of awakening; the first three actions of the guests following their awakening; the guests' means of becoming aware of the fire; the first five actions of the guests following their recognition of the fire incident.

The first five actions of the guests following their recognition of the fire incident were examined in the manner presented in the papers of the MGM Grand Hotel Fire. Besides those actions, the first three actions of the guests following their awakening were also examined. Figure 1 shows the classification of guests' actions in this study.

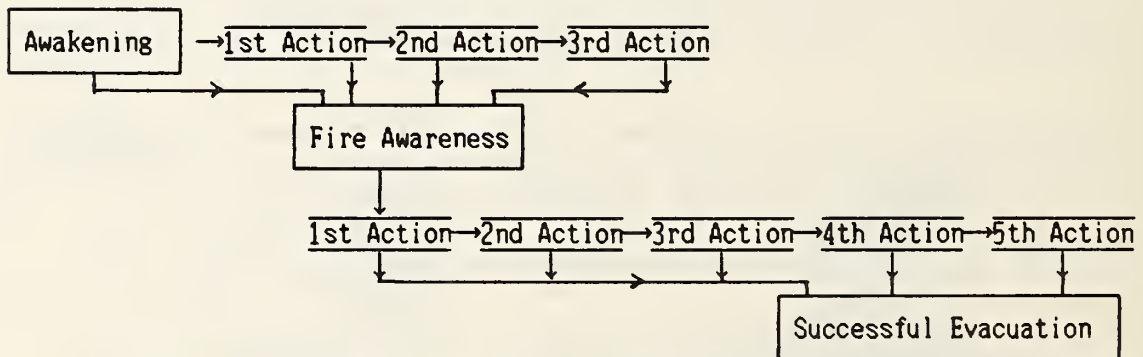


Figure 1. Classification of Guests' Actions

2. RECOGNITION OF EMERGENCY EXITS

Table 3 presents the analysis of the guests' recognition of emergency exits. A total of 138 members of the study population indicated their recognition or unrecognition of emergency exits prior to the fire incident. Figure 2 shows a percentage breakdown by sex, age, national origin and room type, of those 138 guests who recognized emergency exits prior to the fire incident. Figure 2 indicates that the older study population shows the higher percentage of previous recognition of emergency exits. It is assumed that the older guests were more careful than the younger guests in preparing for an emergency.

Table 3. Recognition of Emergency Exits

	Recognized Fire Exit	Unrecognized Fire Exit	Undeter- mined	Total
Male	33	64	38	135
Female	17	24	28	69
Age 10-19	3	10	8	21
20-29	6	13	9	28
30-39	6	26	7	39
40-49	11	17	17	45
50-59	8	12	12	32
60-69	11	8	10	29
70-79	4	1	3	8
Japanese	32	58	48	138
Foreigner	18	30	18	66
Single	20	39	18	77
Twin, Tatami	30	49	48	127
Total	50	88	66	204

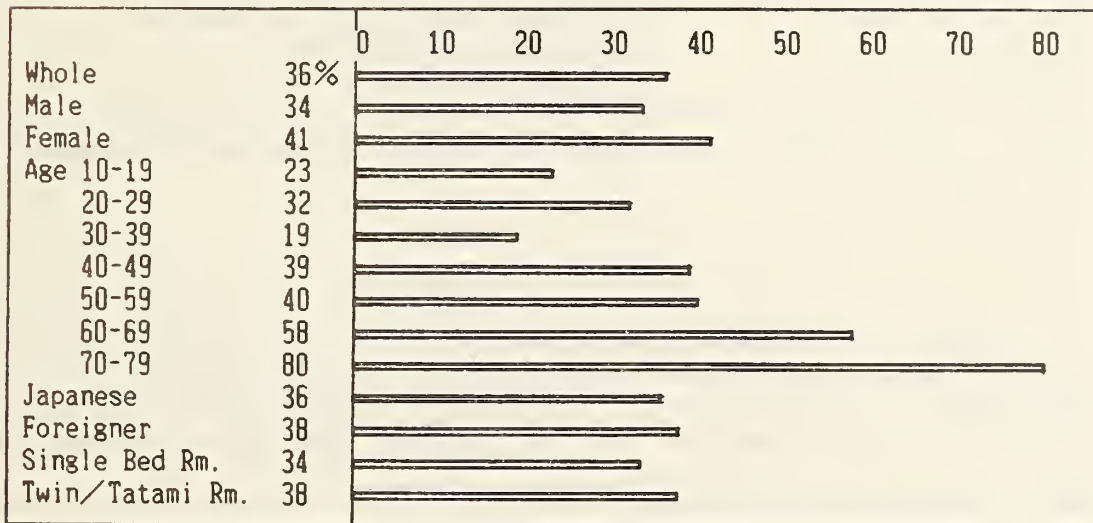


Figure 2. Recognition of Emergency Exits

3. MEANS OF AWAKENING

The means by which the study population were awoken are presented in Table 4. It should be noted that no one was awoken by fire apparatus such as a fire alarm or an emergency speaker system. The most frequent means of awakening cited was "Awakened by Roommate", which was listed by approximately 24 percent of the study population.

Figure 3 presents the percentage of the study population guests who were awoken by the five most frequent means of awakening excluding 10 persons who were awake at the time of the fire and 49 persons who were awoken by a roommate.

Table 4. Means of Awakening

Means	Number	%	4F	5F	6F	7F	8F	9F	10F
People Yelling	12	5.9	1	1	5	4	0	0	1
Noise of Window Broken	32	15.7	3	4	8	3	11	0	3
ditto & People Yelling	6	2.9	1	0	2	0	2	0	1
Voice & Noise in Corridor	4	2.0	0	0	0	2	0	1	1
Awakened by Roommate	49	24.0	6	2	12	9	15	1	4
Heard Noise	7	3.4	1	0	3	1	2	0	0
Sound of Explosion	5	2.5	1	0	0	1	0	0	3
People Shrieking	6	2.9	0	0	1	2	2	0	1
Smelled Smoke	19	9.3	1	1	1	5	9	1	1
Noise & Yelling	1	0.5	0	0	0	0	1	0	0
Awake	10	4.9	3	1	2	2	2	0	0
Stifled	15	7.4	0	1	2	6	3	2	1
Smoke & Yelling	4	2.0	0	1	0	1	1	1	0
Siren of Fire-engine	2	1.0	1	0	0	0	1	0	0
Knock on Door	24	11.8	5	1	7	8	3	0	0
Telephone Ringing	3	1.5	0	0	0	2	1	0	0
Others	5	2.5	0	2	1	1	1	0	0
Total	204	100	23	14	44	47	54	6	16

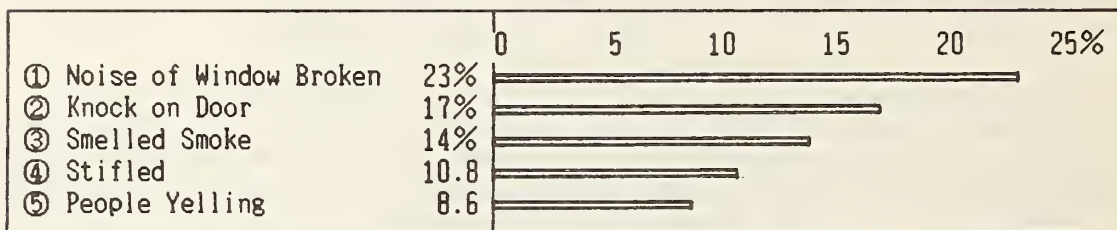


Figure 3. Means of Awakening excluding the Means of "Awakened by Roommate" and "Awoke"

4. MEANS OF FIRE AWARENESS

A total of 197 members of the study population indicated the means by which they became aware of the fire in the hotel. Table 5 presents the analysis of the means of fire awareness for this group. The most frequent means of awareness cited was "Saw Flame Outside", which was listed by approximately

Table 5. Means of Fire Awareness

Means	Number	%	4F	5F	6F	7F	8F	9F	10F
Saw Flame Outside	79	40.1	8	2	18	21	22	0	8
Saw Smoke Outside	6	3.0	0	0	2	0	2	0	2
Saw Smoke in Corridor	34	17.3	3	4	6	6	7	4	4
Smoke in Room	43	21.8	2	4	7	14	14	1	1
Told by Other Occupant	28	14.2	7	4	8	3	4	1	1
Smelled Smoke	3	1.5	1	0	1	0	1	0	0
Smoke & Yelling	1	0.5	0	0	1	0	0	0	0
Yell of 'Fire'	1	0.5	0	0	0	0	1	0	0
Saw Alarm Lamp	1	0.5	1	0	0	0	0	0	0
Saw Fire-engine	1	0.5	0	0	0	1	0	0	0
Total	197	100	22	14	43	45	51	6	16

40 percent of 197 members of the study population. The floor plan of the hotel is shaped like a combination of 3-Ys as shown in Table 1. It is assumed that the shape of the plan helped the guests to see flame or smoke emitted from the opposite side of the hotel.

An examination of the means of fire awareness presented in Table 5 indicates that the physical fire-generated cues used as a means of awareness were the phenomena of "Saw Flame Outside", "Saw Smoke Outside", "Saw Smoke in Corridor", "Smoke in Room" and "Smelled Smoke". These cues were the means of awareness of the fire for approximately 93.7 percent of 197 members of the study population.

5. ACTIONS OF THE GUESTS (1) -- ACTIONS FOLLOWING AWAKENING

Table 6 presents the first three actions of the guests following their awakening until they became aware of the fire. 48 guests of the 197 study population became aware of the fire incident at the time of their awakening. The number of actions by which the 197 study population became aware of the fire incident are presented in Figure 3.

Table 6. First Three Actions of the Guests Following Their Awakening till Their Fire Awareness

Actions	1st	2nd	3rd	Total
Looked at Watch	1	2	0	3
Looked out of Window	73	24	6	103
Opened Door	29	14	8	51
Dressed	5	5	1	11
Turned Light on	22	2	0	24
Packed up Traps	1	1	1	3
Went to Emergency Exit	0	0	1	1
Notified Roommates	9	6	0	15
Notified Others/Other Rm	0	1	0	1
Attempted to Phone	3	1	0	4
Examined in Room	6	2	0	8
Went to Bath Room	0	1	0	1
Total	149	59	17	

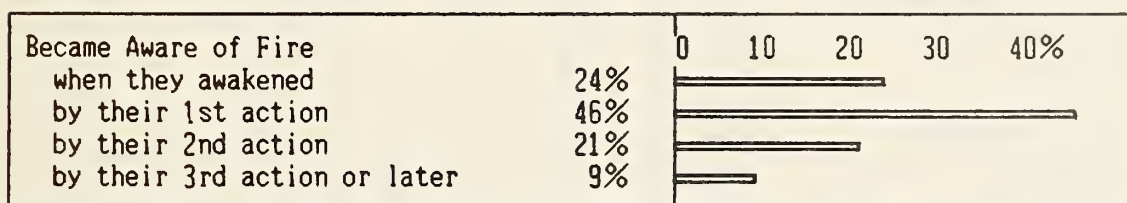


Figure 3. Number of Actions by which the Guests became aware of the Fire

An examination of the first three actions of the guests following their awakening as presented in Table 6 indicates that the predominant first actions of the guests were "information seeking actions", which were listed by approximately 74.5 percent of the first-action population, 70 percent of the second-action population and 82 percent of the third-action population. These

behaviors involved the actions of "Looked out of Window", "Opened Door", "Attempted to Phone" and "Examined in Room". Approximately 19 per cent of the first-action population and 15 percent of the second-action population were involved in "preparatory actions", including the actions of "Looked at Watch", "Dressed" and "Turned Light on". Approximately 6 per cent of the first-action population and 12 percent of the second-action population were "notifying actions", including "Notified Roommates" and "Notified Others / Other Rooms" (Table 7).

Table 7. Classification of First Three Actions of the Guests Following Their Awakening till Their Fire Awareness

Actions	First		Second		Third	
	Count	Percentage	Count	Percentage	Count	Percentage
① Preparatory Actions	28	19%	9	15%	1	6%
② Information Seeking Actions	111	74.5	41	70	14	82
③ Notifying Actions	9	6	7	12	0	0
④ Miscellaneous Actions	1	0.5	2	3	2	12
Total	149	100	59	100	17	100

6. ACTIONS OF THE GUESTS (2) -- ACTIONS FOLLOWING FIRE AWARENESS

Table 8 and Table 9 present the first five actions of the study population following their fire awareness. The predominant first and second actions of the guests were preparatory for evacuation: "Dressed", "Notified Roommates", "Packed up Traps" and "Went to Bath Room". The guests in the first-action

Table 8. First Five Actions Following Fire Awareness (Number of Persons)

Actions	1st	2nd	3rd	4th	5th	Total
Looked at Watch	9	0	0	1	0	10
Looked out of Window	6	1	3	0	0	10
Opened Door	10	1	0	1	0	12
Dressed	65	43	8	1	3	120
Turned Light on	10	2	0	0	0	12
Packed up Traps	26	40	21	5	3	95
Went to Elevator Hall	11	10	16	7	1	45
Looked for Emergency Exit	1	12	10	11	2	36
Went to Emergency Exit	10	28	48	55	36	177
Notified Roommates	24	7	1	1	0	33
Wet Towels - Face	1	3	3	0	0	7
Yelled 'Fire'	2	0	1	0	0	3
Opened Window	0	1	1	1	0	3
Pushed Alarm Button	0	1	0	1	0	2
Notified Others/Other Rm	5	4	9	4	0	22
Entered Room	2	4	4	4	0	14
Broke Window	0	0	1	0	0	1
Attempted to Phone	10	3	1	2	0	16
Went Down in Elevator	0	3	0	2	2	7
Put Towels Around Door	0	2	1	0	0	3
Followed Other Guests	2	7	14	6	0	29
Waited & Asked for Help	0	0	0	0	1	1
Led to Safety	2	10	12	6	4	34
Went to Bath Room	1	1	0	0	0	2
Went to Emergency Ladder	0	2	2	1	0	5
Total	197	185	156	109	52	

population also appeared to be greatly concerned with actions involving investigation of fire awareness cues in an attempt to obtain additional information to evaluate the threat of the fire as indicated by their actions of "Opened Door", "Looked out of Window", "Attempted to Phone" and "Looked at Watch" (Table 10).

Table 9. First Five Actions Following Fire Awareness (Percent)

Actions	1st	2nd	3rd	4th	5th
Looked at Watch	5%	0%	0%	1%	0%
Looked out of Window	3%	1%	2%	0%	0%
Opened Door	5%	1%	0%	1%	0%
Dressed	33%	22%	4%	1%	2%
Turned Light on	5%	1%	0%	0%	0%
Packed up Traps	13%	20%	11%	3%	2%
Went to Elevator Hall	6%	5%	8%	4%	1%
Looked for Emergency Exit	1%	6%	5%	6%	1%
Went to Emergency Exit	5%	14%	24%	28%	18%
Notified Roommates	12%	4%	1%	1%	0%
Wet Towels - Face	1%	2%	2%	0%	0%
Yelled 'Fire'	1%	0%	1%	0%	0%
Opened Window	0%	1%	1%	1%	0%
Pushed Alarm Button	0%	1%	0%	1%	0%
Notified Others-Other Rm	3%	2%	5%	2%	0%
Entered Room	1%	2%	2%	2%	0%
Broke Window	0%	0%	1%	0%	0%
Attempted to Phone	5%	2%	1%	1%	0%
Went Down in Elevator	0%	2%	0%	1%	1%
Put towels Around Door	0%	1%	1%	0%	0%
Followed Other Guests	1%	4%	7%	3%	0%
Waited & Asked for Help	0%	0%	0%	0%	1%
Led to Safety	1%	5%	6%	3%	2%
Went to Bath Room	1%	1%	0%	0%	0%
Went to Emergency Ladder	0%	1%	1%	1%	0%
Total	100%	94%	79%	55%	26%

Table 10. Classification of First Five Actions Following Fire Awareness

Actions	First		Second		Third		Fourth		Fifth	
① Information Seeking Actions	35	18%	5	3%	4	3%	4	4%	-	-
② Preparatory Actions for Evacuation	127	65%	102	57%	42	28%	13	13%	10	20%
③ Notifying Actions	7	3%	5	3%	10	7%	5	5%	-	-
④ Actions of Self-protection	1	1%	6	3%	6	4%	1	1%	-	-
⑤ Actions of Attempting Evacuation	14	7%	29	16%	40	26%	24	23%	3	6%
⑥ Evacuation Actions	11	6%	32	18%	48	32%	57	54%	38	74%
Total	195	100	179	100	150	100	104	100	51	100

An examination of the fourth-action shown in Table 10 indicates that the previous behavior periods of preparation for evacuation (②) and information gathering to structure the seriousness of the threat (①) have

passed, and the guests are now involved in evacuation (6) or attempting evacuation (5). This tendency is similar to the case of MGM Hotel fire.

Table 11 and Table 12 present the first five actions that the guests took after their fire awareness in relation to their recognition of emergency exits.

Table 11. Five Actions of the Guests who Recognized Emergency Exits

Actions	1st	2nd	3rd	4th	5th	Total
Looked at Watch	2	0	0	1	0	3
Looked out of Window	2	0	1	0	0	3
Opened Door	1	1	0	0	0	2
Dressed	12	8	2	0	2	24
Turned Light on	2	1	0	0	0	3
Packed up Traps	8	7	4	1	3	23
Went to Elevator Hall	3	2	1	1	0	7
Looked for Emergency Exit	0	1	1	1	0	3
Went to Emergency Exit	4	13	13	8	6	44
Notified Roommates	8	1	0	1	0	10
Wet Towels - Face	0	1	2	0	0	3
Yelled 'Fire'	1	0	1	0	0	2
Notified Others/Other Rm	1	1	4	1	0	7
Entered Room	1	1	1	3	0	6
Attempted to Phone	3	1	0	1	0	5
Put Towels Around Door	0	0	1	0	0	1
Followed Other Guests	0	0	0	1	0	1
Led to Safety	0	5	1	0	0	6
Went to Emergency Ladder	0	1	0	0	0	1
Total	48	44	32	19	11	

Table 12. Five Actions of the Guests who Unrecognized Emergency Exits

Actions	1st	2nd	3rd	4th	5th	Total
Looked at Watch	4	0	0	0	0	4
Looked out of Window	4	0	1	0	0	5
Opened Door	6	0	0	0	0	6
Dressed	38	17	4	1	0	60
Turned Light on	1	1	0	0	0	2
Packed up Traps	8	26	12	0	0	46
Went to Elevator Hall	4	6	8	5	1	24
Looked for Emergency Exit	0	6	7	8	1	22
Went to Emergency Exit	3	6	21	25	20	75
Notified Roommates	8	3	0	0	0	11
Wet Towels - Face	0	2	1	0	0	3
Opened Window	0	0	1	1	0	2
Pushed Alarm Button	0	0	0	1	0	1
Notified Others/Other Rm	2	1	4	2	0	9
Entered Room	1	2	0	1	0	4
Broke Window	0	0	1	0	0	1
Attempted to Phone	4	1	0	1	0	6
Went Down in Elevator	0	2	0	1	2	5
Put Towels Around Door	0	2	0	0	0	2
Followed Other Guests	2	3	10	4	0	19
Waited & Asked Help	0	0	0	0	1	1
Went to Bath Room	0	3	4	3	3	13
Went to Emergency Ladder	1	1	0	0	0	2
Total	86	82	74	53	28	

Figure 4 presents the number of actions by which the study population evacuated successfully in relation to their recognition of emergency exits. An examination of Figure 4 indicates that those individuals who recognized emergen-

cy exits prior to the fire incident evacuated successfully in a lesser number of actions than those who unrecognized emergency exits prior to the fire.

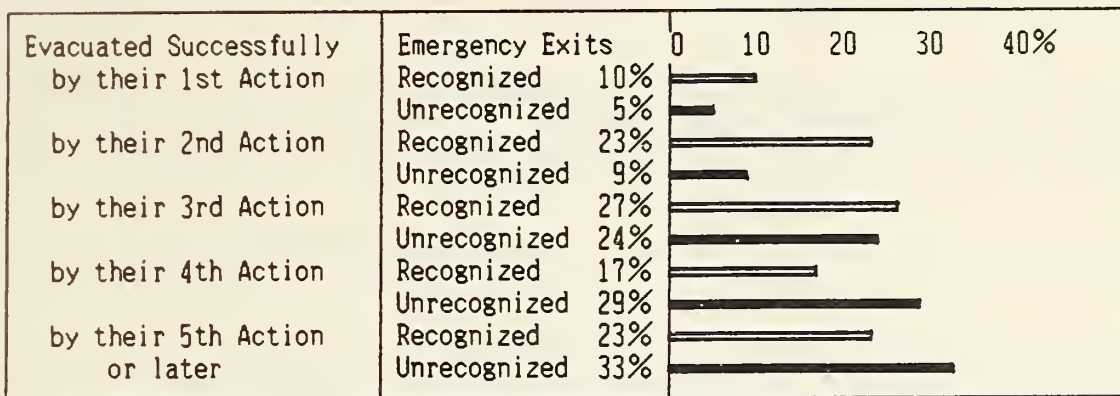


Figure 4. Number of Actions by which the Study Population Evacuated Successfully in relation to Their Recognition of Emergency Exits

7. SUMMARY

It appears that the actions and behavior of the guest study population following their awakening were primarily concerned with obtaining information.

The actions of the study population following their fire awareness were initially primarily concerned with preparations for evacuation and obtaining information about the fire threat. The actions then progressed to evacuation actions. This tendency is similar to the case of MGM Hotel fire reported by Dr. John L. Bryan. *1, *2

It also appears that the individuals who recognized emergency exits prior to the fire evacuated successfully in a lesser number of actions than those who unrecognized emergency exits prior to the fire. An examination of this study indicates that the older guests show the higher percentage of previous recognition of emergency exits.

ACKNOWLEDGEMENT

The study was completed only through the cooperation of the following persons : Professor Takao Uehara, Kazuo Kumai, Mikio Tsukada, Atsuyuki Ishibashi and Toshiyuki Fujino. Their cooperation is gratefully acknowledged.

REFERENCES

1. John L. Bryan: Human Behavior in the MGM Grand Hotel Fire ; Fire Journal (1982.3) ,p.37-48.
2. John L. Bryan: A Review of the Examination and Analysis of the Dynamics of Human Behavior in the Fire at the MGM Grand Hotel, Clark County, Nevada, as Determined from a Selected Questionnaire Population; Fire Safety Journal, 5 (1983) ,p.233-240.

Discussion After S. Okishio, T. Handa, and K. Kawagoe's Report on AN EXAMPLE OF HUMAN BEHAVIOR IN A HOTEL FIRE

QUINTIERE: Have you done subsequent analysis, such as what intervention action might have been done so that you can then decide how many people would have been saved or how the fire may have been limited? Have you had such thoughts or done such an analysis?

HANDA: Well, since this case is at trial, and as the chief investigator, I cannot comment on an ongoing case.

SNELL: In the U.S. we have the same problem as data from very careful reconstruction often does not become available for subsequent analysis and answering such questions. We are seeking means to alter this so that we get the benefit of the valuable data collected for the court sessions.

HANDA: I have frequently mentioned that we would greatly benefit.

LEVINE: Last month at a meeting in Washington of the Society for Fire Protection Engineers, the speaker recommended that U.S. hotels remove the signs that tell guests where to find the emergency exits and to put up signs to tell them to stay in the room with the door closed until they are rescued. What is your opinion on this?

HANDA: You see, Japan is plagued with earthquakes, but most hotels have steel doors.

PANEL DISCUSSION ON CAPABILITIES OF FIRE GROWTH PREDICTION

QUINTIERE: The intent of this panel should be to try to address the capabilities of current fire modeling. I request that we restrict our interests only to predictions dealing with the burning rate. Of course, by this it is meant that we include flame spread, ignition, pyrolysis, etc. I ask that the panelists give their opinions briefly, without extensive elaboration, because we do not have sufficient time. However, in giving their opinions, let us consider the full spectrum of fire conditions that can affect the burning rate. I will try to structure the discussion in terms of various scenarios and for each scenario panelists should think if that problem has been solved, if it can be solved, or if it cannot be solved with current knowledge. Especially where it cannot be solved, panelists should try to say why. Next slide. I indicate the scenarios here and by the arrows that is the sequence that we should discuss these. In the first scenario we are addressing flame spread on solids and their subsequent burn rate. I will now turn to the panelists and ask them to please, when they speak, identify themselves, and so I solicit their comments on the capabilities to predict flame spread, burning rate on solid materials. All panelists should not feel that they have to say something about every scenario, but I will request that we begin with Dr. Hirano.

HIRANO: My comment, a very simple spread of flame. Let's just say a few words on all the solved problems. We are in a position to make a prediction on the horizontal spread and sometimes upward spread. I think most specialists here understand violent conditions clearly. In these areas, I have a feeling we can solve both in the very, very near future. Given a clear, initial condition, the upward spread of the flame area, we might be able to solve soon. Or the theory for spread, to estimate the burning rate where the spread has already taken place. I would like to touch upon other specific cases of flame spread. I think that the area is becoming gradually clearer now. The areas which we cannot solve problems, such as fire pyrolysis involving the critical condition change, unless that factor is known to us. I do not think we can solve the problem; we cannot make predictions. Also properties of certain materials in terms of heat increase or chemical analysis, if that is unknown, again we cannot solve the problem. Of course, some of the materials we don't have to worry about but this is a categorical problem.

PAGNI: I agree with Prof. Hirano, in especially the first two cases. I would put those in the category "has been solved," that is horizontal spread and vertical up and down spread, based primarily on the work of Prof. Hirano and the work of Prof. Fernandez-Pello as described in the recent review at the August conference. The next category of a piece of furniture in a compartment, I think, is in the second category of a "can be solved" problem. I think it's important to add to the fire conditions spectrum, a material spectrum. Simple materials can be understood theoretically, but composite and charring and strangely behaving materials which require a much more detailed study represent a much greater level of difficulty.

QUINTIERE: I'll ask a point on the first scenario, dealing with flame spread and the burning of material. Are there any predictions that are capable of predicting the transient aspects of the problem?

EMMONS: I would like first to note that we should define what we mean by solution. If one of the major uses for such solutions would be use in a fire model, as such, the really useful solution will have to be non-steady prediction of fire spread burning rate, composition of gases, and so forth. From this point of view, we have an empirical solution. We can have a solution that depends upon growth from pneumatic properties using measured properties of the materials. The ultimate solution would be to have enough knowledge of chemistry to be able to predict from the first principles merely specifying the molecular composition. The last is, at present, impossible and in view of its complexity will remain so for many, many years. For pure materials, we are approaching the point at which, given a measure of the properties of the pure materials, we can calculate the spread rate in both of the first two items. At present, I do not believe we have quite reached the point at which the measurement of properties of a new material would permit us to calculate with sufficient confidence. An empirical solution, of course, is possible at present, but it is only available for a limited number of materials.

QUINTIERE: In view of the time, perhaps we can move on to burning within a compartment and let us consider the next two scenarios together in which we have the burning of a single item and then, perhaps, the possibility of the involvement of the second item. Would Dr. Tanaka like to present some views.

TANAKA: Last night at the dinner table I was given this table by Mr. Nelson. There are two teams on both ends, one is the design team, the other research team. What Mr. Nelson is interested in is the building of a bridge to join two groups with different languages. I also recognize that there is a big gap between the design people and the research people, but actually if you look more closely at the research group, among them I also find a certain gap. It is not quite as big as between the two teams. I think one type of study or school is very fundamental to people like us. On the other hand, a person like me who is a design person uses the other approach. We have more results of damage rate at the very last stage of the scenario where the actual victims, where the property damage occurs, we like to protect it, so that it is usually the starting point in our thinking tree. We really go backward because we, by all means, try to estimate property and human damage; but to understand that, we probably have to go back one stage if it doesn't give use enough or we may have to go back to the origin. In this kind of a mental or technical approach, when we come back to the very origin of where we have to think about flame spread or burning time, we tend to look for some kind of solution. Every year Japan introduces about 500 new materials to the market. To extract the burning mechanism among those materials, I think in the beginning it's necessary to take the simply structured material first. It might be too presumptuous to say this but, at this moment, I would like to limit myself to a study at that simple state where we can really have a sure hold of the subject matter.

QUINTIERE: In view of the time, I would just like to solicit some comments on the next to the last scenario which in the diagram is intended to mean post-flashover conditions. By postflashover we mean that flames are leaving the window and flames fill the enclosure. I would like to ask the panelists within the current level of fire modeling can we predict the production of fuel vapor for all possible fire conditions?

EMMONS: There are, I believe, two cases to be considered. One in which we can deem are ventilation limited, and another in which vigorous flames come out the door, but we still have indentifiable individual items burning. I believe we are very close to understanding how to handle correctly the second situation. The ventilation limited case has not, to my knowledge, had adequate research. I believe the ventilation limited case can be solved by computing merely the air that gets into the room through the vent. The oxygen which enters the room would then, I believe, burn in the excess fuel vapor inside and a determinable but not yet known fraction of the heat would be used to pyrolyze the solids. This would make it unnecessary to consider where inside the various material patterns could be. This is what I believe will work, but clearly I'm only guessing in view of the absence of any clear experimental data.

HIRANO: I'd like to comment on the very last portion of Dr. Quintiere's presentation. I think this is an area which is a total study and in explaining it, it might take longer to reach a conclusion. One possible experiment or study along these lines is what Mr. Takeda is conducting right here.

QUINTIERE: I would like to ask a question on the last point Prof. Emmons made. Could you further elaborate on what is needed in making the step between the assumed fraction of heat that goes into heat transfer to the fuels and then the subsequent pyrolysis rate? What is needed to describe this transfer process?

EMMONS: Briefly, I believe this will depend upon the nature of the fuel that is in the room. If, for example, it is a liquid fuel with a boiling point, then one would have heat transfer to that surface. It would boil through; you would have a known fluid temperature. If, as is more likely, you have many charring fuels, then I believe we will need various empirically determined, overall chemical reaction rates for the pyrolysis process. I believe the first thing that needs to be done, however, is to run experiments on such rooms with careful measurements of temperature, composition, and conservation. I suspect that no matter how much logic we put in ahead of the experiment, the observations will redirect our thinking.

CLOSING SESSION

Chairmen's Report of Technical Session
Fire Hazard/Risk Management Methods
J. Bryan and K. Kawagoe, Chairmen

Dr. Takao Wakamatsu, Building Research Institute, presented a comprehensive paper entitled, "Development of Design System for Building Fire Safety," the Ministry of Construction's five year project, initiated in April 1982 and previously reported at the 6th UJNR. The objective of this design system is to provide a rational and total design for building fire safety by systematizing the knowledge established in fire research. A total of seven committees and six working groups have provided input to the system.

The framework of the design system consists of four subsystems:

- (1) The outbreak and growth of fire subsystem,
- (2) The smoke control subsystem,
- (3) The evacuation subsystem,
- (4) The fire protection of the building subsystem.

The subsystems will be used to predict the performance of the various models. By the end of 1983 they expect to complete the design framework of the system and the subsystems, develop a data bank, and the fire growth prediction model.

Dr. John Keating, University of Washington, presented his report on the behavior of occupants during residential occupancy fires, entitled: "Human Reaction During Residential Fires: Establishing a Data Bank." The data was collected from 118 occupants in residential fires in Seattle and 240 occupants in New York City. The study utilized an interview technique with a narrative mode and an interrogatory mode. Contingency analyses were utilized to analyze the behavioral episodes of the occupants. The New York City interviews were conducted by twelve members of the emergency response staff of the American Red Cross, with the development of this data bank continuing. Planned improvements include placing burn victim information into the data bank, improving the contingency analysis, and the formulation of probability models of human responses.

Dr. Ai Sekizawa, Fire Defense Agency, presented the paper entitled: "A Study on Fire Risk Analysis Method of Multi-Use Buildings." This is a five year project initiated in 1982 to prepare an assessment manual for the fire service which assists in the diagnosis of the fire risk of multi-use buildings. The total program of the Fire Risk Analysis Method involves:

- (1) Fundamental studies on the contents of the fire risk in multi-use buildings,
- (2) Studies on evaluation methods of building fire safety,
- (3) Studies on the framework of the system and subsystems,
- (4) Studies on the elements and construction of each system with theories and statistical data,
- (5) Improvement of the fire risk analysis method to multi-use buildings,
- (6) Preparation of the fire risk assessment method for the fire service,
- (7) Development of the fire risk assessment method for use in the planning of new multi-use buildings.

This method evaluates three variables in the building fire risk:

- (1) Fire outbreak probability
- (2) Fire spread risk, and
- (3) Evacuation difficulty.

An outline of the existing data base consisting of 11,150 building fires from 1979 to 1981 was presented. It is currently planned to present a report on the completed form of this fire risk assessment method at the 8th UJNR.

Dr. Tadahisa Jin, Fire Defense Agency, presented the final paper on the Fire Safety Evaluation Method developed by the Tokyo Fire Department. The purpose of the method is to diagnose the fire safety of the building with a scoring system to identify problems and advise personnel on the improvements for fire safety. The 34 items and 102 components in the method were obtained from matrix analysis and event tree analysis of 134 fires. Counter measure scores for the categories of fire prevention, fire outbreak control, fire growth control, fire spread controls, and evacuation-escape are established. Total score for fire safety evaluation of the building involves a range from excellent to definitely unacceptable. The method has resulted in the development of a building owners manual for the application of the method to their building.

Chairmen's Report of Technical Session
Fire Growth Prediction
R. Friedman and T. Hirano, Chairmen

The morning session consisted of two summarizing progress reports, by Prof. Emmons for the U.S. and by Dr. Wakamatsu for Japan, as well as six lectures, three from the U.S. and three from Japan.

Prof. Emmons limited his review to recent U.S. research on fire spread mechanisms. He reviewed work by Prof. Tien, Prof. Carrier, Dr. Fendell, and Prof. Fernandez-Pello on the laminar flame spread problem involving wind. He reviewed in some detail the work of two of his recent graduate students: Dr. A. Atreya's study of spread on horizontal wood surfaces and Dr. C. Tan's study of spread on a series of cellular plastics.

A paper by Dr. Wakamatsu and Dr. Tanaka on fire growth modeling in Japan was presented by the former. Thirteen works were referred to including fire spread over materials, compartment fire phenomena, doorway flow, smoke movement, and a smoke-filling study of a new wrestling arena.

Dr. Quintiere, Mr. Steckler, and Mr. Corley assessed the prediction of vent flows into compartments containing fire. Dr. Quintiere presented a comparison of data with models prediction assuming two layers with no mixing gave vent flows and layer positions always within 50 percent of measured values. The discrepancy is due to vent mixing, primarily. Wall boundary layer flows are considered.

Dr. Takeda described a study of pre-flashover and flashover fire behavior. He compared a simple model with small-scale experiments using a slab of PMMA in a 0.4 meter cubic enclosure, with varying window size. He divided his solutions into three classes, depending on values of $F(= \text{fuel surface area}/L^2)$ and of the ratio $A \sqrt{H}/L^2$, where L is 0.4 meters. It is predicted that flashover will not occur in one of these three regions.

Prof. Zukoski gave a progress report of his current work with Prof. Kubota on a flame and plume interacting with a hot layer and a ceiling. Correlations for the free plume have been developed, but the interactions with the ceiling are still under active study.

In the afternoon, the presentation by Dr. Tanaka was concerned with models which have presently been developed in Japan for establishing a reliable fire safety design method. Detailed ideas of the evacuation/smoke control design method were carefully explained.

The topics presented by Dr. Jones were of future directions for modeling the spread of fire, smoke, and toxic gases. The interesting facts revealed by him include the smoke layer growth in a room far from the fire room and the smoke movement in various types of compartments.

Prof. Tsujimoto presented the results of theoretical prediction of smoke movement in a long corridor or inclined stairway and compared them with experimentally obtained ones. The discussion was mainly on the characteristics of the smoke flows.

Two additional topics were presented by using a video system. One was of the results performed by Dr. Saito on a box model fire test. The box was 0.84m wide, 0.84m high, and 1.68m long with an opening of 0.3m wide and 0.67m high. The inside walls are of plywood (3mm thick) covered by iron foil (0.25mm thick) and a crib was burned inside it. Intense flashover-like phenomena could be observed repeatedly. The other was presented by Dr. Takeda on a model compartment fire. The compartment was of a 0.44m cube with an opening of 0.16m (h) x 0.11m (w). The fuel burned in it was a 0.16m x 0.16m x 0.025m PMMA plate. It could be observed that at about 10 minutes after ignition oscillation started, and at about 12 minutes complete extinction occurred.

Chairmen's Report of Technical Session
Materials Fire Properties and Test Methods
T. Handa and H. Nelson

The session on fire properties and test methods included two progress reports and five papers. All of the presentations were relevant to the measurement and data for fire properties of materials in fire growth models. There was also a consistent emphasis on the need to provide accurate and appropriate data on rate of heat and/or mass release information to the models. The several papers viewed the state of the science and the problem from different aspects. It was clear, however, that there is a need for an appropriate combination of fundamental property data and sound tests for measurement of fire phenomenological parameters, some of which may be unique to the models.

The progress report by Prof. Pagni and Dr. Suzuki both provided overviews and a basic list of the types and items of property information that appears essential to predictive modeling. Professor Pagni also proposed an ultimate target of developing models on the basis of properties common across the scope of science rather than unique fire phenomena measurements.

The first paper, "Identification of Fire Properties Relevant to the Prediction of Fire Growth," by A. Tewarson reviewed the concept of material property measurement and proposed a system of fire phenomena parameters based on types of calculations typical to modeling and ratios or scaling factors useful in converting test data to predictive models.

The second paper, "Concepts on Fire Spread Testing," by Prof. Hirano presented an excellent statement of the critical consideration and properties involved in developing test information that can predict the spread of fire on a surface. As pointed out by Prof. Hirano, current flame spread tests do not meet all of the necessary objectives and development of a fully comprehensive test will be necessary to properly support the fire growth model.

The third paper, "A Methodology of the Sensitivity Analysis of Building Properties on the Occurrence of Flashover," by Dr. Hasemi presented a mathematical analysis approach to predicting the probability of flashover based on the sensitivity of the environment to parameters related to fire size, space size, and ventilation opening. Dr. Hasemi presented advanced prediction concepts involving calculation of the stability limit of the equilibrium solution to zone models. Dr. Hasemi uses an iterative approach involving successive searches of the optimum of an augmented Lagrange function.

The fourth paper, "Fire Engineering Tests Development: Bench-Scale Tests to Predict Full-Scale Behavior," by Dr. Babrauskas reviewed the development of fire phenomenology tests of furniture type fuel packages as undertaken by Dr. Babrauskas and his colleagues. Dr. Babrauskas proposes the development of fire phenomenology parameter measurements, particularly of rate of energy or mass release per unit mass or per unit area of exposed surface. Dr. Babrauskas also presented a concept of relating full-scale furniture calorimeter test data to bench-scale cone calorimeter results. The transition involved a conversion equation that includes adjustment factors for the mass, type of furniture frame, and the specific configuration of the furniture item.

The fifth paper, "Material Fire Properties and Test Methods to be Developed," by Dr. Suzuki covered both the subject material and a review of the sub-system of the Japanese design system for building fire safety that will relate to design methods for prevention of outbreak and growth of fire. Dr. Suzuki pointed out the need for data that can reasonably reflect a real world condition and the need for a family of new and proper fire tests that will provide parametric data demanded by the models within the design methods. The exact tests and data to be dictated by the model as it develops. Dr. Suzuki, however, listed needs for information on ignitability, latent heat, thermal decomposition products, heat released by thermal decomposition, and heat transfer in complex elements.

Chairmen's Report of Technical Session
Combustion Toxicity
and
2nd Expert Meeting of the U.S.-Japan-Canada Cooperative
Research Group on Toxicity of Combustion Products from
Building Materials and Interior Goods
R. Gann, K. Kishitani, F. Saito

The three sessions included three progress reports and six technical papers. They covered a range of topics from determining the conditions for small-scale measurement to the science behind toxic product generation from burning materials.

In his progress report, Dr. Gann described the current U.S. activity, showed the evolution of our thinking from toxicity to toxic hazard, and listed critical areas for future research. Dr. Saito presented the Japanese plan for developing a realistic small-scale measurement method. This involves three programs: one to determine the appropriate fire conditions, the second to develop a small-scale apparatus, and the third to develop the animal models for such a test. Dr. Tsuchiya presented the Canadian approach to fire toxicology which is based on an analytical approach with no animals. It includes combustion experiments generally using a modified OSU apparatus and detailed analysis of combustion products using novel techniques such as MS/MS.

Dr. Yusa, Mr. Furuya, and Prof. Alarie presented descriptions of their devices for measuring toxic effects on laboratory animals. The former two apparatuses are relatively new, and the first data was presented. There are excellent design features in each. Dr. Alarie's apparatus is more mature, and he presented a variety of results useful in explaining the lethality of the combustion gases.

Dr. Levin discussed her investigation of the generation of HCN from flexible polyurethane foam. Her results indicate that the simple combustion exposures developed in the past may not be sufficient to get a true toxicological measure of fire gases.

Dr. Tanaka and Mr. Mizuno presented theoretical and experimental aspects of full-scale Japanese studies to determine the fire conditions to be used in small-scale measurement. Burning chairs in a double room arrangement, they have obtained information on mass burning rates, radiative fluxes, and doorway flows.

Dr. Hartzell was unable to attend. However, his paper on toxic gas measurement from fires in full-scale furnished rooms was distributed. Results were obtained regarding hazards in the burn room, in an adjacent corridor, and in a second room down the hall.

Dr. Nishimaru discussed his studies on the physiological effects resulting from the exposure of rodents to five different toxic gases and their combinations. Incapacitation and memory loss were the two effects reported.

The "U.S.-Japan-Canada Cooperative Research Group on Toxicity of Combustion Products from Building Materials and Interior Goods" has agreed to meet again, probably in about one year's time. We will investigate holding that meeting in Canada.

The papers in these sessions reflect advanced thinking and increased laboratory capability from the last UJNR meeting. It is anticipated that at least equal progress will be reported at the 8th Panel Meeting.

Chairman's Report of Technical Session
Measurement Methods
P. Pagni

The measurement methods session was held Thursday morning in Building 224. Much of the tour of the laboratories in that building during the afternoon also was related to measurement techniques. The following speakers addressed this session:

(1) Dr. Friedman, Factory Mutual Research Corporation, "Current U.S. Advances in Fire Research Techniques."

This paper briefly reviewed 33 recent reports related to measurement techniques, including a review on toxicity by Clarke in the Fire Journal, September 1983 issue, which is not in the written paper. Dr. Friedman then described a very large scale extinguishment test at Factory Mutual. The apparatus is essentially a Tewarson system of 6m diameter. Stacked cartons filled with polystyrene packing and electrical components were ignited and the fire suppressed by water spray. The timing of water initiation was shown to be critical. The extended discussion which followed emphasized the difference between warehouses where fire confinement suffices for property safety and homes where full extinction is required for life safety.

(2) Dr. Jin, Fire Research Institute, "Various Measurement Methods on Fire Research."

Dr. Jin presented a very interesting review of a wide range of measurement systems used in Japan for fire research. The radiation detection problems stimulated much discussion. The ideas of using heated air to keep optics clear is clever. Dr. deRis described a microthermopile sensor in use at Factory Mutual.

(3) Mr. Beyreis, Underwriters Laboratories, "Developments in Fire Tests Related to Regulation."

The evolution of fire research techniques from large-scale tests to small-scale tests and then to mathematical models was traced. It was indicated that Underwriters Laboratories is now doing less large-scale testing and looking forward to interacting more with researchers on mathematical models in the future.

(4) Dr. Tanaka, Building Research Institute, "A Measurement of Doorway Flow Induced by Propane Fire."

Dr. Tanaka described detailed experimental results for flows between two rooms and into the surroundings. It was found that a flow coefficient of 0.68 sufficed for inflow and outflow both between the rooms and out of the last room. It also was found that fine thermocouples were needed to accurately track the temperature profile. The Steckler technique worked well in generating an equivalent two layer temperature. Three dimensional effects at the doorway were shown to be negligible in the informative discussion which followed.

(5) Dr. deRis, Factory Mutual Research Corporation, "Flammability Testing: State-of-the-Art."

Dr. deRis departed from his written report to present some exciting recent FMRC results relating χ , the radiative fraction of heat release rates in turbulent flames to l , the soot-point of laminar flames. The soot-point is defined as the flame height at which unburnt soot first appears at the tip of the flame. It was found that χ decreases as l increased approximately as

$$\chi = 0.42 - 0.020l/25\text{cm}$$

with χ for ethane ~20 percent, propane ~30 percent, and a maximum χ ~42 percent for very sooty flames. The peak absorption coefficient also decreased as l increased. The soot-point temperature and χ appear to be constant for most hydrocarbons at $1200^\circ\text{C} \pm 30^\circ\text{C}$ and 30 percent respectively. This discussion demonstrated the strong connection between flame radiation and soot-point. Based on these observations, a small-scale test which measures the soot-point the heat release rate for real charring fuels was developed. This test was described in detail by Dr. deRis. He urges its adoption by the fire research community and was pleased by the great interest shown it at this session.

RESOLUTIONS

KAMIMURA: According to the tradition, which means that this is to be read by both Japanese and American Resolution Committee Members, we will proceed accordingly. I ask Prof. Emmons to read the resolution.

EMMONS: The resolutions have been prepared by a committee of four. They met a number of times, making changes as either side had altered a proposal. The present draft is suggested as the final draft. For a point of information, should I just read all of it?

KAMIMURA: Yes, please.

EMMONS: The final draft is subject, of course, to correction by the whole committee. The resolutions the panel members of the UJNR Panel on Fire Research and Safety are very happy with the results of the Seventh Joint Meeting held in Gaithersburg, MD., October 24-28, 1983. The workshop on special topics proved to be especially valuable for all participants and so were the combustion toxicity sessions, held jointly with the meeting of the committee, Japan-United States-Canada Cooperative Research on Toxicity of Combustion Products of Building Materials and Interiors. The panel members herewith resolve:

1. The objectives of the meetings of this panel are to exchange information and to promote cooperative research on fire science and its application to building fire problems. For this purpose, the panel members are encouraged to:

(a) Make clear the contributions of fire science and engineering studies to building fire safety by making fire safety design more quantitative, leading eventually to performance fire codes;

(b) Develop the means to predict the growth of fire in compartments and facilities, the generation and distribution of smoke and toxic gases resulting from such fires, the time of automatic detection of fire, the evaluation of hazard associated with such potential fires;

(c) Exchange information through reports and video tapes and illustrative information;

(d) Do cooperative research on scientifically based models of fire phenomena, determinations of the relevant fire properties of materials and furnishings, the fire science and technology of measurement methods and the associated test methods to be used to determine the relevant data for fire models.

2. The 8th Meeting of the UJNR Panel on Fire Research and Safety for advancing the above objectives, especially the application of fire science to building fire safety, be held in Tsukuba, Japan in May or September 1985.

3. The format of the meeting should be as follows: The discussion of each of these topics should include information on the validation of the research results and their application to building fire safety to the degree that these are possible:

(a) The first few days be devoted to workshops on:

- (1) fire hazard, risk analysis methods,
- (2) fire growth prediction,
- (3) materials fire properties and test methods and fire research measurement methods,
- (4) evacuation and smoke control,
- (5) combustion toxicity,
- (6) modeling of fire detection and extinguishing, and

(b) These sessions to be held simultaneously as appropriate. The joint session with the Japan-United States-Canada Cooperative Research on Toxicity of Combustion Products of Building Materials and Interiors were especially valuable. The combustion toxicity session of the 8th UJNR Meetings should, if possible, again be joint with the meeting of that committee, and

(c) At the opening of each session and workshops progress overviews on each field between meetings be reported by both Japan and the United States with sufficient time allotted to permit some discussion.

4. Several cooperative fire research program should be started. These will be especially valuable where the facilities are somewhat different in our two countries. To be specific, it is suggested that joint research programs be organized on:

- (a) wall burn,
- (b) smoke movement and its validation tests.

5. The working personnel exchange be pursued more vigorously. One NBS employee, Mr. Steckler, spent a valuable two months in Japan. Dr. Hirata, of FFPRI, Dr. Hasemi of BRI, Dr. Takeda of Tokyo University, and Dr. Morita of Tokyo Science University, would stay in the United States to complete and/or conduct valuable cooperative research.

6. The panel members be encouraged to exchange information of interest through the respective chairmen between meetings. To accomplish significant exchanges between panel meetings, all research reports issued in each country should be exchanged every three months, January, April, July, and October. The titles of these reports could, in each country, be sent to all panel members who could check the ones they would like to receive. The desired reports could then be reproduced and distributed by the chairman.

7. All the relevant reports for the panel meetings be sent in time to be received in the other country in at least one month before the 8th Meeting.

KAMIMURA: Thank you very much, Prof. Emmons.

CLOSING ADDRESSES

KAMIMURA: I'd like to ask the American side to give us the closing remarks.

SNELL: The technical committee reports and the final resolutions of the conference reflect the significance of this meeting. We have heard of interesting and exciting new technical results and have seen in the formal papers and informal discussions many evidences of effective collaboration. We are all inspired by the continuing, outstanding work of the pioneering researchers in this field such as Drs. Kawagoe and Handa, as well as the exciting new ideas of the younger and newer members of the delegation. Dr. Kamimura, you and your delegation are commended. It has been our intention to create an atmosphere conducive to breeding close professional and personal relationships. The record of accomplishment of this panel, I believe, attests to steady progress in this regard. Change is as inevitable as the seasons and so it is in our human affairs. There have been numerous suggestions for making the possibility for more discussion and free time in our deliberations and these, I give, are welcome. We encourage their consideration for future meetings of our panels. Each of us has, before us a little bag, on this it says, tricks or treats, this is none but a treat. In the United States this is an important season. The harvest is in. This weekend our children will celebrate Halloween and next month is our national holiday of Thanksgiving. Therefore, I view it appropriate as this UJNR on Fire Safety and Research draws to a close, that we share with you this small token Halloween treat, our heartfelt thanksgiving for the opportunity this collaboration has created; we wish you all a safe journey home.

KAMIMURA: I would like to say a few words on behalf of the Japanese on this event. Dr. Snell and all of my friends and colleagues from the United States and Japan, on behalf of all of the friends of the Japanese panel, I feel very grateful and happy that the UJNR Fire Research and Safety Panel has successfully concluded its session here today. I feel that we owe a great deal and we feel very grateful for the scrupulous preparation and the very appropriate operation of American Fire Research and Safety members, particularly the chairmen of the American panel, Drs. Snell, Gann, and Kashiwagi in this effort. So I would like to express my heartfelt thanks and gratitude to everyone, particularly Drs. Lyons and Kramer and people of the National Bureau of Standards. The panel has lasted for five days and we have gained a great deal from the five day session and this result will help further in the future for both United States and Japanese researchers. My thanks also go to the people who prepared data and also made the arrangements for the meeting rooms and for the operation of the conference and for the interpreters. We also have received a very warm welcome and we appreciate the arrangements made for us when we went on a tour of the NBS facilities and sightseeing in Washington, D.C. I would like to express my thanks for all of those events. Thank you very, very much for your very warm welcome and heartfelt hospitality which was shown at the reception held at Dr. Snell's residence, the formal luncheons, the dinners we had at the Cracked Claw Restaurant and at Blackie's House of Beef and also the very enjoyable parties at Dr. Gann's house and Dr. Quintiere's house. Several of the Japanese members already have left Gaithersburg for home yesterday or the day before yesterday. The remaining 15 of us will leave Washington for home either tomorrow or the day after tomorrow with happy memories and useful information. The next, the 8th UJNR Cooperative Panel, in accordance with the resolutions, will be held in

Japan in the city of Tsukuba, either in May or September of 1985. Upon our return, we would like to embark upon preparations for that cooperative panel meeting as soon as possible. Last, but not least, we will be looking forward to seeing all of you at the next 8th UJNR Cooperative Panel. I hope that you will be successful in your future research and you will maintain your good health and we would like to say, really, thank you very much for all the American members and also finally we would like to express our thanks to the interpreters. Thank you.

Participant's Index

Alarie	445, 446, 469, 470, 487, <u>489</u> , 503, 504
Babrauskas	<u>369</u> , 391, 401, 402
Beyreis	536, <u>547</u>
Cooper	<u>17</u> , 29, 90, 91, 289, 536
Davis	545
deRis	545, <u>585</u> , 607
Emmons	29, 89, <u>95</u> , 189, 271, 285, 287, 288, 289, 299, 367, 536, 641, 658, 659, 673
Friedman	<u>523</u> , 535, 536
Gann	39, 87, 89, 288, 309, 323, 399, <u>405</u> , 411, 445, 611, 612, 626
Handa	89, 402, 583, 584, 655
Hasemi	<u>341</u> , 367, 368, 402
Hirano	287, <u>325</u> , 391, 535, 583, 607, 641, 657, 659
Jin	51, <u>53</u> , 87, 391, 535, 545
Jones	<u>209</u> , 271, 272
Kamimura	673, 674, 675
Kawagoe	40, 288, 642
Keating	<u>41</u> , 51, 87, 89
Kishitani	<u>13</u> , 91
Levin	<u>447</u> , 469, 470, 611, 612, 625
Levine	151, 190, 641, 655
Mitler	151, 272, 287, 288, 323, 607
Mizuno	445, 446
Morita	272

 underscored number indicates author's report

Nelson	<u>7</u> , 39, 77, 87, 89, 90, 91, 287, 401, 402, 535, 536
Nishimaru	504, <u>613</u> , 623, 625, 626
Pagni	77, 87, 177, 189, 190, 271, 285, 287, <u>293</u> , 299, 391, 402, 503, 536, 583, 607, 657
Quintiere	<u>121</u> , 151, 189, 271, 285, 287, 288, 299, 367, 368, 545, 583, 655, 657, 658, 659
Robertson	411
Rockett	190, 288, 289
Saito	323, 401, 413, 625
Sekizawa	<u>53</u> , 77, 91, 641
Snell	655, 675
Steckler	151, 445, 584
Sumi	625
Suzuki	<u>301</u> , 309, 393, 399, 401, 612
Takeda	<u>153</u> , 177, 288, 289
Tanaka	<u>191</u> , 287, 288, 401, <u>419</u> , 445, <u>565</u> , 583, 584, 658
Tewarson	<u>311</u> , 323
Tsuchiya	445, 469, 503, 504, 611, 612, 623, 625, 626
Tsujimoto	<u>273</u> , 285
Wakamatsu	29, <u>31</u> , 39, 40, 90, 91, 109, 288, 583
Yusa	411, <u>471</u> , 487
Zukoski	151, <u>179</u> , 189, 190, 271, 285, 288, 289, 299, 367

U.S. DEPT. OF COMM. BIBLIOGRAPHIC DATA SHEET (See instructions)	1. PUBLICATION OR REPORT NO. NBSIR 85-3118	2. Performing Organ. Report No.	3. Publication Date March 1985
4. TITLE AND SUBTITLE 7th Joint Panel Meeting of the UJNR Panel on Fire Research and Safety Proceedings			
5. AUTHOR(S) Nora H. Jason and Karen Davis, Editors			
6. PERFORMING ORGANIZATION (If joint or other than NBS, see instructions) NATIONAL BUREAU OF STANDARDS DEPARTMENT OF COMMERCE WASHINGTON, D.C. 20234		7. Contract/Grant No.	8. Type of Report & Period Covered
9. SPONSORING ORGANIZATION NAME AND COMPLETE ADDRESS (Street, City, State, ZIP)			
10. SUPPLEMENTARY NOTES <input type="checkbox"/> Document describes a computer program; SF-185, FIPS Software Summary, is attached.			
11. ABSTRACT (A 200-word or less factual summary of most significant information. If document includes a significant bibliography or literature survey, mention it here) The 7th Joint Panel Meeting of the United States-Japan Panel on Fire Research and Safety was held jointly with the Combustion Toxicity and 2nd Expert Meeting of the U.S.-Japan-Canada Cooperative Research Group on Toxicity of Combustion Products from Building Materials and Interior Goods at the National Bureau of Standards, Gaithersburg, Maryland, October 24-28, 1983. Technical sessions were in the areas of: Fire Hazard/Risk Management Methods; Fire Growth Prediction; Materials Fire Properties and Test Methods; Measurement Methods; Combustion Toxicity. Progress reports were presented in each area, in addition to state-of-the-art papers. The next conference will be held in Japan in May 1985.			
12. KEY WORDS (Six to twelve entries; alphabetical order; capitalize only proper names; and separate key words by semicolons) building fires; fire growth; fire hazards; fire models; fire test methods; human behavior; material properties; toxicity test methods.			
13. AVAILABILITY <input checked="" type="checkbox"/> Unlimited <input type="checkbox"/> For Official Distribution. Do Not Release to NTIS <input type="checkbox"/> Order From Superintendent of Documents, U.S. Government Printing Office, Washington, D.C. 20402. <input checked="" type="checkbox"/> Order From National Technical Information Service (NTIS), Springfield, VA. 22161		14. NO. OF PRINTED PAGES 648	15. Price \$44.50

