

**NIST NCSTAR 1-1C
Federal Building and Fire Safety Investigation of
the World Trade Center Disaster**

Maintenance and Modifications to Structural Systems

(Appendices A-G)

David A. Fanella
Arnaldo T. Derecho
S.K. Ghosh

Appendix A
TENANT CONSTRUCTION REVIEW MANUAL – 1971

TENANT CONSTRUCTION REVIEW

THE PORT OF NEW YORK AUTHORITY
NEW YORK, N.Y.

Reproduced with permission of The Port Authority of New York and New Jersey.

P R E F A C E

THE FOLLOWING IS A PRESENTATION OF THE TECHNICAL FUNCTIONS OF THE TENANT CONSTRUCTION REVIEW. IT HAS BEEN PREPARED IN AN EFFORT TO CLARIFY UNDERSTANDING OF THE CONCERNS OF THE PERSONNEL IN THE TENANT CONSTRUCTION REVIEW UNIT.

TABLE OF CONTENTS

	<u>SECTION</u>
PREFACE	I
TABLE OF CONTENTS	II
INTRODUCTION	III
CITIES AND THEIR CODES	1
GENERAL REQUIREMENTS	2
FUNCTIONAL REVIEW	3
ARCHITECTURAL REQUIREMENTS	4
STRUCTURAL REQUIREMENTS	5
CIVIL REQUIREMENTS	6
PROTECTION FROM POTENTIAL FUEL SPILLAGE POINTS	7
ELECTRICAL REQUIREMENTS	8
MECHANICAL REQUIREMENTS	9
PLUMBING REQUIREMENTS	10
FIRE PROTECTION	11

APPENDIX:

FORMS, MEMORANDA

INTRODUCTION

This pamphlet has been prepared to facilitate the proper and expeditious execution of review work in the Tenant Construction Review Unit. It tries to achieve this by subdividing a job into trades and thus clarifying the possible scope of a project from functional and technical points of view. Detailed checklists based on Building Codes, prepared for each trade, cover the main areas of design and detailing that are expected to receive special attention. Finally, design, safety and field coordination criteria additional to Building Code requirements are listed under each trade.

It is hoped that this pamphlet will create a degree of consistency in review work, and, will establish the basic minimum requirements which must be incorporated in the submitted plans and specifications.

Although New York City laws are predominantly used as basis,¹ the check lists may be used for any facility in conjunction with the local code.

CITIES AND THEIR CODES

NEW YORK CITY

- (1) N.Y.C. Building Code
 - (a) New Code, Effective December 6, 1968
 - (b) Old Code, Effective 1938
 - (c) N.Y.C. Electrical Code
- (2) Rules of "The Board of Standards & Appeals" of N.Y.C.
- (3) N.Y. State Labor Law

NEWARK (N.J.)

Building Code of City of Newark 1964, Title 7, incl. Appendix
N.J. State Plumbing Code

ELIZABETH (N.J.)

Standard Building Code of New Jersey including Supplements 1 and 2 with
supplement parts A, B, C, D & F.
Plumbing Code of The City of Elizabeth

JERSEY CITY (N.J.)

Basic Building Code, 1965 Edition as published by Building Officials Conference
of America , Inc., (BOCA)

TETERBORO AIRPORT

- Boro of Teterboro: Standard Building Code N.J.
- Boro of Moonachie National Building Code, 1967, Abbreviated
- Boro of Little Ferry: National Building Code, 1967
- Boro of Hasbrook Heights: Basic Building Code, 1965, (BOCA)
Plumbing Code of Boro of Hasbrook Heights

ADDITIONAL CODES

Where applicable the following shall be referred to:

National Electrical Code; NFPA Standards; N.J. State Labor Law; and
additional laws, rules and regulations adopted by the federal, state
and local municipal agencies.

GENERAL REQUIREMENTS

1. Applicant shall submit a completed application form, supplied to him by PONYA, along with his design criteria and plans.
2. For any work done on a roof structure with a valid bond, an affidavit shall be obtained by the tenant from the insurer, to the effect that the terms of the bond have not been violated.
3. In order for the P.O.N.Y.A. to obtain the N.Y.C. Fire Department approval of the proposed fire alarm installation, three sets of the following information are required to be sent to the P.O.N.Y.A., via the tenant's Alteration Application
 - a. A plot plan of the building showing the exact location of the fire alarm boxes and their relationship to site conditions, i.e. roads, sidewalk, fences, island, building exits, etc.
 - b. Details of fire alarm pedestal, foundation, cable and duct installation, etc.
 - c. Specifications for fire alarm equipment, cable, installation procedures, etc.
 - d. The above may be submitted in the form of Contract Drawings, sketches and formal specifications, for proper transmittal by PONYA to the NYC Fire Department.
4. Before starting the sprinkler work, tenant shall file with PONYA resident Engineer, sprinkler drawings bearing the acceptance stamp (s) of:
The Fire Service Office of N.Y. & The Kemper
~~The Fire Insurance Rating Organization of N.Y., or, The Employers' Group of Insurance Companies, or, the insurance carrier.~~
Insurance Group for our buildings
5. When an application is approved, two (2) sets of complete plans and specifications shall be submitted to PONYA. For new buildings and major applications one set shall be filed with the Building Department.
6. At the termination of construction a complete set of as built drawings, in cloth, shall be submitted to PONYA.
7. Each plan shall contain the registration number, seal, signature and address of Architect or Engineer who prepared the plans. Where the enforcement of this requirement with the Federal Agency could present difficulties, it is submitted that the following form of the comment should satisfy this requirement:

"Drawings shall bear the seal and signature of a Registered Architect or licensed Professional Engineer or the approved application should bear certification, by the Responsible Governmental Agency making this submission, that the plans were prepared in a manner consistent with the standards of professional practice established in the State of New York."

8. Contractors shall obtain PONYA permits for any welding and hot work, in addition to being licensed by the state or the municipality, where applicable.
9. In order to effectuate the policy of The Port of New York Authority, the owner of the premises to be altered, the Contractor shall comply with all provisions of federal, state, municipal, local and departmental laws, ordinances, rules, regulations, and orders which might affect the Contract and the performance thereof and those engaged therein, except where stricter requirements are contained in the Specifications or indicated on the Drawings, in which case the Contractor shall comply with the latter requirements. However, the Contractor shall not apply for any variance, license, waiver or permit of any kind in the name of or on behalf of the Port Authority.

FUNCTIONAL REVIEW

A functional review is a service to an Architect supplementing his feasibility study, reviewing his design criteria, acquainting him with PONYA interpretations of Building Codes and supplemental PONYA criteria where necessary. A functional review is a voluntary request on the part of an Architect. There will be no review of plans for extensive code compliance, but of items that may prohibit construction or substantially affect the design.

Submitted plans shall be accompanied by an application form and design criteria.

The following is a checklist of items to be reviewed for, but not limited to:

Building Code

1. Occupancy group
2. Construction classification
3. Fire integrity of spaces on the building as it applies to shafts, rating of interior separations, rating of exterior walls and sprink requirements.
4. Egress. Architect shall establish density of occupants and show adequacy of means of egress. Shall coordinate new tenant basic egress layout with existing conditions in existing buildings, in particular IAB, where existing conditions conform to Old Code; stairs are provided from each floor on basis of 75% of tenant space used as assembly (1 person per 10 SF) and 25% office (1 person per 100 SF); also an "exterior passageway" with minimum predetermined width is layed out on 3rd floor, to which egress can be made.
5. Unusual structural conditions, including foundations shall be referred to the structural reviewer.
6. Special mechanical problems, e.g., covered driveways or other deviations from code provisions, shall be referred to the mechanical reviewer.
7. Existing structures are to be reviewed for existing code violations and listed.

PONYA Criteria

1. Sprinklers in conveyor or baggage handling spaces.
2. Adaptation of code and NFPA standards to loading bridges, hangar buildings and terminal buildings

3. Protection of building areas exposed to fuel spillage and drainage.
4. PA requirements for carpets, furniture, etc.

Coordination with Airport Utilities

1. Electrical: Anticipated new power requirements shall be referred to the electrical reviewer.
2. Water supply: Coordination of any demand for chilled water, high temperature water, domestic water and high pressure sprinkler supply water with PA facilities, and the fire protection loop, shall be referred to the Civil, Mechanical, and Plumbing reviewers.
3. Any work affecting the fuel lines shall be referred to the hydraulic engineer.

STRUCTURAL

Notes:

1. Where structural review is required, structural calculations shall be submitted.
2. The Structural Reviewer is responsible for the structural integrity of all walls and partitions.
3. Upon completion of the soils and foundation review, the structural reviewer shall take all soils and foundation documents to the Engineer of Soils for his review and comments.
4. Upon completion of the superstructure review, the structural reviewer shall take all superstructure documents to the Chief Structural Engineer for his review and comments.
5. Building frames shall be checked for stability and inhibition of side sway and the effect of same on the slenderness ratio of the columns.
6. For Materials, Operations and Equipment subject to controlled inspection see pages 5.5 to 5.8 inclusive.

The following check list is based on the new New York City Building Code, but may be used for any facility in conjunction with the local code

Materials, Assemblies, Forms & Methods of Construction	Sub-Article C26-106.0
General Requirements	C26-106.1
Acceptance Requirements	C26-106.2
Inspection Requirements	C26-106.3
Plans Required	C26-110.2
Structural Plans	C26-110.2 (b)
 <u>LOADS</u>	
Dead Loads	Sub-Article 901.0
Floor Live Loads	C26-902.2 & RS 9-2
Live Loads For Sidewalks, Driveways & Railings	C26-902.3
Roof Loads	C26-902.6
Moving Loads	C26-902.7
Partial Loading Conditions	C26-902.8
Floor Live Load Reduction	C26-903.2
Contributory Floor Areas	C26-903.3
Wind Loads	Sub-Article 904.0 & RS 9-5
Thermal Forces	C26-905.7
Shrinkage	C26-905.8
Distribution of Loads	Sub-Article 906.0
 <u>STRUCTURAL WORK</u>	
General Requirements	C26-1000.6
Material & Methods of Construction	C26-1000.7
Inspection of Materials & Assemblies	Table 10-1
Inspection of Methods of Construction	Table 10-2
Use of Used & Unidentified Materials	C26-1000.9
Equivalent Systems of Design	C26-1000.10
Deferred Detailing	C26-1000.1
Combination of Loads	C26-1001.4
Load Tests	C26-1002.4
Masonry	Sub-Article 1003.0
 <u>UNREINFORCED MASONRY</u>	
	RS 10-1
General	Section 1
Definitions	" 2
Materials	" 3
Design	" 4
Lateral Support	" 5
Thickness & Height of Masonry	" 6
Empirical Provisions	" 6
Bonding	Section 7

Grouted & Filled Cell Masonry	Section 8
Anchorage	" 9
Miscellaneous Requirements	" 10
Veneer	" 11
Miscellaneous Structures & Systems	Section 12
<u>REINFORCED MASONRY</u>	RS 10-2
Concrete	Sub-Article 1004.0
Concrete Mixes	C26-1004.3
Short Span Concrete Floor and Roof Construction Supported on Steel Beams	C26-1004.8
<u>REINFORCED CONCRETE</u> - ACI 318-1963, Building Code Requirement, modified as specified in	RS 10-3
<u>STRUCTURAL STEEL</u> - AISC 1969 Specifications for the Design, Fabrication and Erection of Structural Steel for Building, modified as specified in	RS 10-5
<u>LIGHT GAGE COLD FORMED STEEL</u> - AISI 1968 Specification for the Design of Light Gage Cold Formed Steel modified as specified in	RS 10-6
<u>OPEN WEB STEEL JOISTS</u> - See RS 10-7 for governing specifications and modifications	
<u>WOOD</u> - See Sub-Article 1004.0 Table RS 10-8 and RS 10-9	
<u>ALUMINUM</u> - See Sub-Article 1007.0 Table RS 10-10 and RS 10-11	
<u>GLASS</u> - See Sub-Article 1011.0	
<u>SOIL & FOUNDATIONS</u>	
Depths of Foundations	C26-1100.7
Foundations at Different Levels	C26-1100.8
Borings	C26-1101.2
Probing & Geophysical Explorations	C26-1101.5
Foundation Loads	Sub-Article 1102.0
Classification of Soil Materials	C26-1103.1
Allowable Soil Bearing Pressures	C26-1103.4
Bearing Capacity of Nominally Unsatisfactory Bearing Materials	C26-1103.5
Soil Load Bearing Tests	Sub-Article 1104.0
Footings	C26-1105.2
Foundation Piers	C26-1105.3
Foundation Walls	C26-1105.4

PILE FOUNDATIONS

Administrative Requirements	C26-1106.1
Minimum Pile Penetrations	C26-1106.2
Minimum Spacing of Piles	C26-1106.5
Capping & Bracing of Piles	C26-1106.7
General Requirements for Installation of Piles	C26-1106.9
Allowable Axial Loads on Piles	C26-1107.1
Allowable Lateral Load	C26-1107.2

PILE DRIVING OPERATIONS

Equipment	C26-1108.1
Procedures	C26-1108.2

PILE TYPES

Timber Piles	C26-1109.2
Precast Concrete Piles	C26-1109.3
Cast-In-Place Concrete Piles	C26-1109.4
Compacted Concrete Piles	C26-1109.5
Steel "W" Sections	C26-1109.6
Concrete Filled Pipe Piles	C26-1109.7
Caisson Piles	C26-1109.8
Composite Piles	C26-1109.9
Underpinning	Sub-Article 1110.0
Stability	Sub-Article 1111.0

INSPECTION

Boring Operations	C26-1112.2
Piling	C26-1112.3
Subgrade for Footings, Foundation Piers & Walls	C26-1112.5
Support of Adjacent Properties or Building	C26-1112.6

MATERIALS, OPERATIONS AND EQUIPMENT
SUBJECT TO CONTROLLED INSPECTION
BY BUILDING CODE

(SEE C26-106.3 and C26-107.3)

I. CONCRETE

1. The inspection of materials for all structural elements proportioned on the basis of calculated stresses 70 percent or greater, of basic allowable values, Table 10-1, Article 10.
2. The making of preliminary tests of concrete, C26-1004.3 (a) (3).
3. Quality control and inspection at the batch plant C26-1004.3 (a) (5) except as provided in C26-1004.3 (b) (6).
4. Actual preparation of cylinders for strength tests, C26-1004.5 (a) (1).
5. The checking of all samples recovered for the purpose of strength tests for slump, air content, unit weight, and temperature in accordance with RS 10-3, C26-1004.5 (a) (2).
6. The measurement of forms for size and dimensions of members, C26-1004.5 (a) (3).
7. The checking of sizes and position of reinforcement, C26-1004.5 (a) (3).
8. The inspection of placement of concrete and the recording of and compliance with Building Code provisions attated to/of
 - (a) Temperatures
 - (b) Protections against excessive temperatures
 - (c) Curing
 - (d) Erection and connection of precast members
 - (e) Amount of water added in field
 - (f) Tensioning of all prestressed elements, C26-1004.5 (a) (3)
 - (g) Preplaced aggregate C26-1104.11 (c)
9. Inspection for the proper use of admixtures. Batch plant inspection required for all admixtures, other than air-entraining and water-reducing agents, C26-1004.6.

II. STEEL

1. Inspection of welding operations where stresses in welds are 50% or more of basic allowable values, Table 10-2.
2. Check of welders' licenses or qualifications in accordance with C26-1005.3 (2), C26-1005.3 (4).

3. Inspection of the tensioning of high strength bolts where stresses in bolts are 50% or more of basic allowable values, Table 10-2.

4. Inspection of the connection of fittings to wire cables, except where proof-loading to not less than 55% ultimate capacity, Table 10-2.

III. ALUMINUM

1. Inspection of welding operations where stresses in welds are 50% or more of basic allowable values, Table 10-2.

2. Check of welders' licenses or qualifications in accordance with C26-1007.3 (b) (2), C26-1007.3 (b) (4).

IV. WOOD

1. Inspection of the fabrication of glued-laminated assemblies and of plywood components, Table 10-2.

2. Check of sizes of members, of fit, and of gluing operations for glued-laminated assemblies, C26-1006.4.

V. REINFORCED MASONRY (Table 10-2, Article 10 of Building Code)

1. Inspection of fabrication of prefabricated units.
2. Inspection of placement and bedding of units.
3. Check of sizes of members, including thickness of walls and wythes.
4. Check of sizes of columns.
5. Check of sizes and position of reinforcement in place.
6. Inspection of means of protection against freezing.
7. Inspection of provisions for curing.

VI. UNREINFORCED MASONRY (based on structural analysis, RS 10-1, Section 4, Table 10-2, Article 10 of Building Code).

1. Inspection of placement and bedding of units.
2. Check of sizes of members including thickness of wall and wythes.
3. Check sizes of columns
4. Inspection of provisions for curing.
5. Inspection of means of protection against freezing.

VII. FOUNDATIONS

1. Inspection of boring operations, C26-1112.2.
2. Inspection of piling including load tests, C26-112.3

3. Inspection of subgrade for footings, foundation piers, and foundation walls (notification to PONYA Resident Engineer at least 2 days prior to installation required unless department inspection is waived under C26-120.5), C26-1112.5.

4. Inspection of underpinning operations, construction and excavation of temporary or permanent cofferdams, caissons, braced excavated surfaces and other constructions or excavations affecting support of adjacent properties or buildings. (Plans required), C26-1112.6.

5. Evaluation of laboratory field tests for the verification of the magnitude of stabilized overburden pressure, C26-1103.4 (b), (c).

6. Supervision of the placing of controlled fills, C26-1103.5 (a) (1) (Note that where foundation is to rest on, or be underlain by, nominally unsatisfactory bearing materials, a report based on soil tests, foundation analysis (including analysis of undisturbed samples), by architect of engineer is required, C26-1103.5, C26-1103.5 (b) (2).)

VIII. MATERIALS, ASSEMBLIES FORMS AND METHODS OF CONSTRUCTION

<u>CODE TEST METHOD</u>	Whenever the Building Code prescribes a method of testing such tests shall be made under the supervision of an architect or an engineer; or by a testing service or laboratory acceptable to the PONYA Resident Engineer C26-106.2 (a) (1).
-------------------------	---

IX. INSPECTIONS DURING PROGRESS OF WORK

The commissioner may accept signed statements by architects and engineers and supporting inspection and test reports without verifying inspection or test by department inspectors, C26-120.5.

X. FINAL INSPECTION

The architect, engineer, or other person who supervised or superintended the work is required to be present at final inspection by department, C26-120.6.

Appendix B

TENANT CONSTRUCTION REVIEW MANUAL – 1979

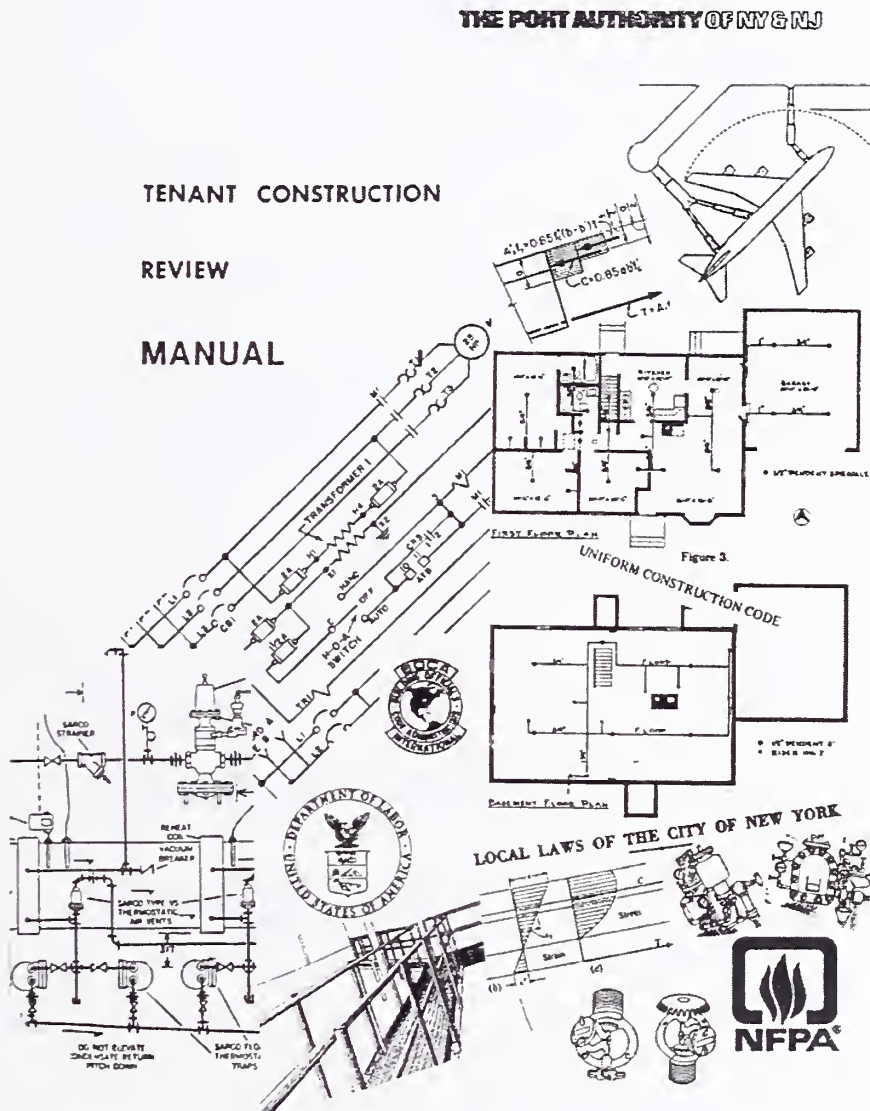

Reproduced with permission of The Port Authority of New York and New Jersey.

P R E F A C E

THE FOLLOWING IS A PRESENTATION OF TECHNICAL CRITERIA
USED IN THE REVIEW OF TENANT CONSTRUCTION. IT HAS
BEEN PREPARED IN AN EFFORT TO DEFINE THE CONCERNS OF
THE TENANT CONSTRUCTION REVIEW UNIT

TABLE OF CONTENTS

	<u>SECTION</u>
PREFACE	I
TABLE OF CONTENTS	II
INTRODUCTION	III
CODES, RULES & REGULATIONS	1
GENERAL REQUIREMENTS	2
FUNCTIONAL REVIEW	3
ARCHITECTURAL REQUIREMENTS	4
STRUCTURAL REQUIREMENTS	5
CIVIL REQUIREMENTS	6
PROTECTION FROM POTENTIAL FUEL SPILLAGE POINTS	7
ELECTRICAL REQUIREMENTS	8
MECHANICAL REQUIREMENTS	9
PLUMBING REQUIREMENTS	10
FIRE PROTECTION	11
MATERIALS, OPERATIONS AND EQUIPMENT SUBJECT TO INSPECTION REQUIRED BY BUILDING CODE	12
APPENDIX:	
WORK SHEETS RECOMMENDED TO FACILITATE TENANTS' PREPARATION OF APPLICATION AND P.A.'s REVIEW PROCESS	

INTRODUCTION

This pamphlet has been prepared to facilitate the proper and expeditious execution of review work in the Tenant Construction Review Unit. It tries to achieve this subdividing a job into separate disciplines and thus clarifying the possible scope of a project from functional and technical points of view. Detailed checklists based on Building Codes, prepared for each discipline, cover the main areas of design and detailing that are expected to receive special attention. Finally, design, safety and field coordination criteria additional to Building Code requirements are listed under each discipline.

It is hoped that this pamphlet will create a degree of consistency in review work, and, will establish the basic minimum requirements which must be incorporated in the submitted plans and specifications.

CODES, RULES AND REGULATIONS

NEW YORK

- (1) N.Y.C. Building Code
 - (a) New Code, Effective December 6, 1968
 - (b) Old Code, Effective 1938
 - (c) N.Y.C. Electrical Code
- (2) Rules of "The Board of Standards and Appeals" of N.Y.C.
- (3) N.Y. State Labor Law
N.Y. State Energy Conservation Construction Code

NEW JERSEY

Since January 1977 all communities in the State are required to conduct their construction activities in accordance with the STATE UNIFORM CONSTRUCTION CODE which was made part of the New Jersey Administration Code (NJAC) as Chapter 23 of Title 5. Under the code the following subcodes have been adopted:

1. Building subcode - The BOCA Basic Building Code/1978
2. Plumbing Subcode - The National Standard Plumbing Code/1978
3. Electrical Subcode - The National Electrical Code/1978
4. Fire Protection Subcode - Portions of BOCA & NEC
applicable to fire protection
5. Energy Subcode - (a) BOCA Basic Energy Conservation Code
(b) Illuminating Engineers Society Standard
EMS-1: Lighting and Power Budget Determination
Procedure

All above Subcodes were adopted with a provision that they shall "include all subsequent revisions and amendments thereto". Also certain specific sections of the subcodes have been altered or deleted.

Also in New Jersey the following codes are in effect:

1. Barrier-Free Design - promulgated by the Dept. of Treasury -
Division of Buildings & Construction
2. NJAC - Title 12 - The Labor Law
3. NJAC - Title 7 - Environmental Protection Laws

STANDARDS APPLICABLE IN ALL P.A. FACILITIES

1. Occupational Safety & Health Act (OSHA)
2. Federal Standard for Making Buildings Usable
by the Physically Handicapped (P.L.-90-480)
(ANSI A117.1)
3. Federal Floodproofing Regulations
4. F.A.A. - Standards (at Airports)

GENERAL REQUIREMENTS

1. Each application submitted must be accompanied by properly completed and executed application form, supplied to the tenant by the Port Authority.
2. For proper technical review besides the drawings, signed and sealed by the Registered Architect or the Professional Engineer, design criteria, specifications and calculations shall be submitted.
3. In order for the Port Authority to obtain the N.Y.C. Fire Department approval of the proposed fire alarm installation, three sets of the following information are required to be sent to the P.A., via the tenant's Alteration Application.
 - a. A plot plan of the building showing the exact location of the fire alarm boxes and their relationship to site conditions, i.e., roads, sidewalk, fences, island, building exits, etc.
 - b. Details of fire alarm pedestal, foundation, cable, installation procedures, etc.
 - c. Specifications for fire alarm equipment, cable, installation procedures, etc.
 - d. The above may be submitted in the form of Contract Drawings, sketches and formal specifications, for proper transmittal by P.A. to the NYC Fire Department.
4. Before starting work on sprinkler systems, dry chemical, Halon, or other fixed pipe fire extinguishing systems, shop drawings shall be submitted to the P.A. Risk Management Division, and then filed with the P.A. Resident Engineer or Facility Manager.
5. When an application is approved, two (2) sets of complete plans and specifications shall be submitted to P.A.; for new buildings and major applications, one set will be filed with the Buildings Department by the P.A.
6. At the termination of construction a complete set of as-built drawings, on microfilm, or on cloth, shall be submitted to the P.A. Specifications for microfilm mounted on aperture cards can be obtained from the Business Administration office at the facility.

7. Contractors shall obtain P.A. permits for any welding and hot work, in addition to being licensed by the state or the municipality, where applicable.
8. In order to effectuate the policy of the Port Authority of New York and New Jersey, the Tenant shall comply with all provisions of federal, state, municipal, local and departmental laws, ordinances, rules, regulations, and orders which might affect the contract and the performance thereof and those engaged therein, except where stricter requirements are contained in the specifications or indicated on the drawings, the latter shall be followed. The Tenant or his agents shall not apply for any variance, license, waiver or permit of any kind in the name of or on behalf of the Port Authority.

FUNCTIONAL REVIEW

A Functional Review is a service to a tenant, when requested by him, supplementing his consultants' feasibility study, reviewing their design criteria, and acquainting them with specific pre-existing conditions of compliance with a Building Code or PANY/NJ criteria that would affect the proposed work. Functional Reviews shall be confined to fundamental concepts, items that may prohibit construction or substantially affect the design.

Submitted plans shall establish the applicable Codes and be accompanied by design criteria.

The scope of the Functional Review shall include, but not necessarily be limited to, the following items.

BUILDING CODE

1. Occupancy group and construction classification of the altered and adjacent areas.
2. Fire integrity of spaces in the building as it applies to shafts, rating of interior separations, rating of exterior walls and sprinkler requirements.
3. Egress. Density of occupants and adequacy of egress shall be established. Alternately, tenant's architect/engineer may list the applicable sections of the Code on which the design is based. New tenant egress scheme shall be coordinated with existing conditions, e.g.,
 - a) in IAB, where basic egress conforms to Old Code, stairs are provided from each floor on basis of 75% of tenant space used as assembly (1 person per 10 S.F.) and 25% office (1 person per 100 S.F.).
 - b) Also in IAB an "exterior passageway" with a minimum predetermined width is laid out on 3rd floor, to which egress can be made.
 - c) On the third (3rd) floor of the Terminal Building at LGA a Safe Area exists in compliance with Article 8 of the 1968 Code as part of the overall means of egress from the floor.

4. Unusual structural conditions, including foundations, shall be referred to the structural reviewer.
5. Special mechanical or electrical problems affecting unusual environmental, energy or power commitments, or other deviations from Code provisions, shall be referred to the mechanical or electrical reviewer.
6. Existing structures shall be reviewed for existing Code violations.

PANY/NJ CRITERIA

1. Sprinklers in conveyor spaces.
2. Adaptation of Code and NFPA standards to loading bridges, hangars and terminal buildings.
3. Protection of building areas exposed to fuel spillage and drainage (See Section 7 of this manual).
4. Requirements for carpets, furniture, etc.

COORDINATION WITH AIRPORT FACILITIES

1. Electrical: Anticipated new power requirements shall be referred to the electrical reviewer.
2. Water supply: Coordination of any demand for chilled water, high temperature water, domestic water, high pressure sprinkler supply water, and connections to the fire protection loop, shall be referred to the Civil, Mechanical, and Plumbing Reviewers, and/or the Fire Protection engineer.
3. Any work affecting the fuel lines shall be referred to the appropriate engineer.

STRUCTURAL

A. PLANS, NOTES, SCHEDULES

Plans

1. Each plan shall contain the registration, seal, signature and address of the Architect or Engineer who prepared the plans. C26-110.2.
2. Structural plans shall contain the information required by the code. C26-110.2(b).

Notes

1. Where structural review is required, structural calculations shall be submitted.
2. Upon completion of the soils and foundation review, the structural reviewer shall take all soils and foundation documents to the Engineer of Soils for his review and comments.
3. Upon completion of the superstructure review, the structural reviewer shall take all superstructure documents to the Chief Structural Engineer for his review and comments.
4. Building frames shall be checked for stability and inhibition of side-sway and the effect of same on the slenderness ratio of the columns.
5. All materials, assemblies, forms or methods of construction and equipment that are subject to controlled inspection shall be listed on drawing. See Section 12 of this Manual.
6. Rules and Regulations listed on p. 5.4 shall also be referred to as required.

Schedules

All required schedules for structural and foundation elements are required to be on the plans, i.e. buttress and pier schedule, grade beams, column schedule, etc.

B. CHECKLIST

The following is a checklist of the more significant code items with which the review will be concerned, but not limited to:

Loads

- Dead Loads
- Floor Live Loads
- Live Loads for Sidewalks, Driveways & Railings
- Roof Loads
- Moving Loads
- Partial Loading Conditions
- Floor Live Load Reduction
- Contributory Floor Areas
- Wind Loads
- Thermal Forces
- Shrinkage
- Distribution of Loads

Structural Work

- General Requirements
- Material & Methods of Construction
- Inspection of Materials & Assemblies
- Inspection of Methods of Construction
- Use of Used & Unidentified Materials
- Equivalent Systems of Design
- Deferred Detailing
- Combination of Loads
- Load Tests
- Fire Protection Requirements

Soils and Foundation

- Depths of Foundations
- Foundations at Different Levels
- Slabs on Grades Construction
- Borings
- Problings & Geophysical Explorations
- Foundation Loads
- Classification of Soils Materials
- Allowable Soil Bearing Pressures
- Bearing Capacity of Nominally Unsatisfactory Bearing Materials
- Soils Loading Bearing Tests
- Footings
- Foundation Piers
- Foundation Walls

File Foundations

Administrative Requirements
Minimum Pile Penetrations
Minimum Spacing of Piles
Capping & Bracing of Piles
General Requirements for Installation of Piles
Allowable Axial Loads on Piles
Allowable Lateral Load

File Driving Operations

Equipment
Procedures

File Types

Timber Piles
Precast Concrete Piles
Cast-In-Place Concrete Piles
Compacted Concrete Piles
Steel "H" Sections
Concrete Filled Pipe Piles
Caisson Piles
Composite Piles
Underpinning
Stability

Inspection

Controlled Fills
Boring Operations
Piling; Installation and Testing
Subgrade for Footings, Foundation Piers & Walls
Support of Adjacent Properties or Building

Reports Required

Verification - Stabilized Overburden
Bearing Capacity of Nominally Unsatisfactory
Bearing Material
Alternate or Similitude Method for Pile Load
Verification
Substantiation of Higher Allowable Pile Loads

C. ADDITIONAL PORT AUTHORITY CRITERIA

Buildings designed and/or constructed by FANY/NJ that are being altered should be coordinated with the particular facility design group, especially for foundation requirements.

.5.3

RULES AND REGULATIONS RELATING TO STRUCTURAL ITEMS
(Applicable in N.Y.C.)

1. Rules and Regulations Relating to Resistance to Progressive Collapse Under Extreme Local Loads (Bldg. Dept.).
2. Rules and Regulations for the Design of Composite Construction with Metal Decks or Lightweight Concrete (Bldg. Dept.).
3. Rules Relating to Structural Designs Based on Electronic Computer Computations (Bldg. Dept.).
4. Rules and Regulations Relating to the Design and Installation of Curtain Wall Systems (Bldg. Dept.).
5. Rules for Application and Protection of Sprayed-On-Fireproofing (BSA Cal. #118-68-GR).
6. Rules and Regulations for Masonry Parapet Walls. (Bldg. Dept.)
7. Rules for Arc and Gas Welding and Oxygen Cutting of Steel Covering the Specifications for Design, Fabrication and Inspection of Arc and Gas Welded Steel Structures and the Qualification of Welders and Supervisors (BSA Cal. #1-38-SR).
8. Rules for Governing the Marking of Transparent Glass Doors and Fixed Adjacent Glass Sidelights (BSA Cal. #501-68-SR).
9. Rules for the Manufacture, Testing and Use of Concrete Masonry Units (BSA Cal. #639-40-SR).

MATERIALS, OPERATIONS AND EQUIPMENT
SUBJECT TO INSPECTION REQUIRED BY BUILDING CODE

The purpose of this section is to list some of the materials, operations and equipment which normally require the services of a licensed professional engineer in order to assure code compliance in conjunction with normal inspection procedures contained in Subarticles 106.0 and 107.0 of the N.Y.C. Building Code and Subchapter 2, sec. 5:22-2.6 of the New Jersey Uniform Construction Code.

MATERIALS

Concrete

Materials for all structural elements proportioned on the basis of calculated stresses 70 percent or greater, of the basic allowable values. Inspection includes making of preliminary tests for concrete and quality control and inspection at the batch plant.

Notes:

- a. For general provisions relating to inspection see building code section and reference standards.
- b. All structural materials subject to controlled inspection shall be tested and/or inspected at the place of manufacture and evidence of compliance shall be provided.
- c. Mill, manufacturer's, suppliers' inspection and test reports will be accepted as evidence of compliance with the provisions of the code for all structural materials and assemblies not subject to controlled inspection.

OPERATIONS AND METHODS OF CONSTRUCTION

Steel

1. Welding operations and the tensioning of high strength bolts in connections where the calculated stresses in the welds or bolts are 50 percent or more of basic allowable values.
2. Inspection of the connection of fittings to wire cables, except where proof-loading to not less than 55 percent of ultimate capacity.

Concrete

1. Actual preparation of cylinders for strength tests.
2. The checking of all samples recovered for the purpose of strength tests for slump, admixtures, air content, unit weight, and temperature.
3. The checking of sizes and position of reinforcement.
4. The inspection of placement of concrete and maintenance of records and verification for:
 - a. Temperatures
 - b. Protections against excessive temperatures
 - c. Curing
 - d. Erection and connection of precast members
 - e. Amount of water added in the field
 - f. Tensioning of all prestressed elements
 - g. Preplaced aggregate
5. Inspection for proper use of admixtures. Batch plant inspection required for all admixtures, other than air-entraining and water-reducing agents.

Aluminum

Inspection of welding operations where stresses in welds are 50% or more of basic allowable values.

Wood

Inspection of the fabrication of glued-laminated assemblies and of plywood components.

Reinforced Masonry

1. Fabrication of prefabricated units.
2. Placement and bedding of units; sizes of members, including thickness of walls and wythes; sizes of columns; the size and position of reinforcement, in place, and provisions for curing and protection against freezing for all reinforced masonry construction.

Unreinforced Masonry

Placement and bedding of units and sizes of members including thickness of walls and wythes; sizes of columns; and provisions for curing and protection against freezing for all masonry construction proportioned on the basis of structural analysis as described in the reference standard.

Soils and Foundations

1. Controlled Fills
2. Boring Operations
3. Piling; Installation and Testing
4. Subgrade for Footings, Foundation Piers and Walls
5. Support of Adjacent Properties or Building

Firestopping

Installation of all firestopping where required.

Fireproofing

All fireproofing other than the concrete encasement.

Notes:

- a. For general provisions relating to inspection see appropriate building code sections and reference standard.
- b. All construction operations designated for controlled inspection shall be inspected by the architect or engineer designated for controlled inspection during the performance of such operation.
- c. Certification by the fabricator or erector, as applicable, will be accepted as evidence of compliance with the provisions of this code for all construction operations not subject to controlled inspection.

EQUIPMENT

Required ventilating systems including functioning of any required smoke detection and fire protection devices.

Refrigerating Systems

Boilers

Fuel Burning Equipment

Chimney Smoke Test (where applicable)

* Fire Standpipe System

* Fire Pumps

* Fire Alarm & Signaling System Electrical Test

- * Sprinkler System
- * Voluntary Ventilating System with required Smoke Detection and Fire Protection Devices
- * Soil Percolation Test
- * Plumbing and Gas Piping System

(* The test of this item shall be witnessed by a facility representative).

Notes:

- a. For general provisions relating to inspection see appropriate building code sections and reference standard.
- b. All equipment testing designated for controlled inspection shall be inspected by the architect or engineer designated for controlled inspection during the performance of such operation.
- c. Certification by the manufacturer of equipment, as applicable, will be accepted as evidence of compliance with the provisions of this code for all equipment not subject to controlled inspection.

CHECKLIST OF ITEMS SUBJECT TO CONTROLLED INSPECTION

Only major construction items are listed here and therefore the controlled inspection shall not be limited to these items only.

1. Borings or Test Pits
2. Piles
3. Soil
4. Controlled Fill
5. Underpinning
6. Welding
7. Aluminum
8. Laminated Wood
9. High Strength Bolts
10. Fire Stops
11. Heating System
12. Ventilation System
13. Refrigeration System
14. High Pressure System
15. Prestressed Concrete
16. Precast Concrete
17. Chimney Smoke Vent
18. Cable Fittings
19. Spray-on Fireproofing.

Appendix C
TENANT CONSTRUCTION REVIEW MANUAL – 1990

Engineering Quality
Assurance Division

**TENANT
CONSTRUCTION
REVIEW MANUAL**

March 1984
Revised March 1990

Engineering Department
THE PORT AUTHORITY OF NEW YORK AND NEW JERSEY

Reproduced with permission of The Port Authority of New York and New Jersey.

TABLE OF CONTENTS

TABLE OF CONTENTS SECTION 1

INTRODUCTION SECTION 2

GENERAL REQUIREMENTS SECTION 3

CONCEPTUAL REVIEW SECTION 4

ARCHITECTURAL SECTION 5

STRUCTURAL SECTION 6

GEOTECHNICAL SECTION 7

CIVIL SECTION 8

ELECTRICAL SECTION 9

MECHANICAL SECTION 10

PLUMBING SECTION 11

FIRE PROTECTION SECTION 12

PROTECTION FROM AIRPORT RAMPSIDE FUEL SPILL FIRE SECTION 13

MATERIALS, OPERATIONS, AND EQUIPMENT
APPROVAL AND INSPECTION SECTION 14

ENVIRONMENTAL SECTION 15

ATTACHMENTS

LIST OF ATTACHMENTS

- A1 Specifications Governing The Flammability of Carpets.
- A2 Specifications Governing The Flammability of Drapery And Curtain Materials.
- A3 Specifications Governing The Flammability of Upholstery Material And Plastic Furniture.
- A4 Specifications Governing The Flammability of Plastic Laminate And Wood Veneer Furniture.
- S1 Cement Plaster Ceilings.
- S2 Lightweight Ceilings in New Jersey.
- S3 Lightweight Ceilings in The World Trade Center.
- C1 Taxiway Paving.
- C2 Protection of Underground Pipes.
- M1 Port Authority Bus Terminal South Wing - HVAC Criteria.
- M2 Port Authority Bus Terminal North Wing - HVAC Criteria.
- M3 Port Authority Bus Terminal - Electrical Criteria.
- F1 New York City Municipal Fire Alarm.
- RFS-1 Airport Rampside Clearances.

SECTION 2 INTRODUCTION

This Manual is published to present the technical criteria to be considered by Tenants at Port Authority facilities in connection with construction work undertaken by a Tenant, which is in addition to other requirements under the agreement between the Port Authority and the Tenant. This Manual also covers the Port Authority Engineering Department scope-of-review of the design documents (plans, specifications, calculations and other documentation) submitted by Tenants in connection with proposed construction or alterations. It shall not be deemed to imply that there will not be additional reviews by other Port Authority Departments.

Reviews will not address the proposed aesthetic or functional aspects of the design.

Construction documents for Tenant alterations will be reviewed by the Engineering Department for compliance with applicable Codes and Port Authority Engineering Standards. In the absence of a specific code provision, this Manual sets forth the applicable standards to be followed by Tenants except as may otherwise be required of the Tenant. All design documents shall reflect the existing construction as well as the proposed work in order to determine compatibility with existing conditions at facilities.

In this regard a list of all documents and guidelines which the Facility has provided to the Tenant, and which affects the design, should become an integral part of the Tenant's contract document submission. If the subsequent review process will be aided by the inclusion of the construction documents itemized on this list, such documents should also be included in the submission.

The Tenant Construction Review Unit of the Engineering Department will review the Tenant Construction or Alteration Application submitted by the Tenant in accordance with the criteria included in this Manual. The responsibility for engineering design shall remain with the Tenant's Engineer or Architect preparing the design. The Tenant Construction Review Unit will not impose solutions to engineering problems but will comment on the design presented.

SECTION 3 GENERAL REQUIREMENTS

1. All proposed construction shall be submitted for review, in completed form, accompanied by a "Tenant Construction or Alteration Application," Form PA531, which shall be provided to the Tenant by the appropriate Port Authority line department.

The line department shall specify to the Engineering Department, the technical disciplines to be reviewed for the submitted projects.

2. The design documents, such as drawings, reports, computations and specifications, required in connection with the proposed construction, shall be attached to and form a part of the Tenant Construction or Alteration Application, and shall reflect the existing construction as well as the proposed work, and be sealed and signed by the architect or engineer of record licensed to practice in the State in which the proposed construction is to be performed. The architect/engineer indicated on the Application shall be considered the A/E of record.

Where the A/E of record submits documents prepared by other consultants, he is responsible for assuring that the documents from all the consultants are properly coordinated.

Where other consultants have been acknowledged by the A/E of record, either in the Alteration Application or on the drawings, said consultants may seal and sign the documents they have prepared.

Where the Tenant retains two or more independently functioning consultants, they each become an A/E of record for the scope of their work, for which each will be required to submit a separate Alteration Application, and each such consultant shall seal and sign the documents he submits.

Responsibility for design or code compliance shall not be delegated to contractors.

3. Voluntarily installed systems, such as sprinklers, alarms, etc., shall comply with the provisions of the Building Codes for such systems.

4. Fire protection plans, as described in the New York City Building Code Section 27-228.1 (C26-124.1) et seq., shall be filed for review along with other design documents for construction projects in all the Port Authority facilities. After the approval of the project for construction, and before a certificate of occupancy is issued, one (1) copy of these plans shall be submitted to the manager of the facility where the project is located and two (2) copies shall be filed with the Quality Assurance Division of the Engineering Department.

5. In accordance with the policy of the Port Authority of New York and New Jersey, the Tenant shall comply with the provisions of all federal, state, municipal, local and departmental laws, ordinances, rules, regulations and orders that may affect the contract and all individuals involved therein. Where stricter requirements apply, i.e., those contained in the specifications or drawings, they shall be followed. The Tenant or his agents shall not apply for any variance, license, waiver or permit in the name of or on behalf of the Port Authority.

- D. Special structural conditions, including foundations.
- E. Special or unusual mechanical or electrical problems affecting environmental, energy or power requirements.
- F. Deviations from Code provisions.
- G. Existing structures shall be reviewed for existing Code violations.

III. PANY/NJ CRITERIA

Note: See the subsequent sections of this Manual for more specific criteria.

- A. Sprinklers in conveyor spaces inaccessible to firefighting equipment. Ceilings with lay-in panels are considered to be inaccessible.
- B. Adaptation of Code and NFPA standards to loading bridges, hangars, terminal buildings, etc.
- C. Protection of airport buildings from potential fuel spillage fires.
- D. Requirements for draperies, furniture, etc.
- E. PVC pipes, ducts, conduits and insulation for wires shall not be used within buildings.

V. COORDINATION WITH FACILITIES

- A. Electrical: New power requirements shall be indicated.
- B. Water supply: Coordination of any demand for chilled water, high temperature water, domestic water, high pressure sprinkler supply water, and connections to the fire protection loop, shall be fully described.
- C. Any work affecting the fuel lines shall be specified.

SECTION 6 STRUCTURAL

I. GENERAL

- A. The scope of the structural review shall comprise compliance with the applicable Codes, standards, and design criteria listed below.
- B. Computations shall be submitted with all structural plans.

II. CODES AND REGULATIONS

A. New York City:

- 1. New York City Building Code.
- 2. Rules and Regulations of the Department of Buildings, such as:
 - a. Resistance to Progressive Collapse Under Extreme Local Loads.
 - b. Design of Composite Construction with Metal Decks or Lightweight Concrete.
 - c. Structural Designs Based on Electronic Computer Computations.
 - d. Design and Installation of Curtain Wall Systems.
 - e. Masonry Parapet Walls.

B. New Jersey:

New Jersey Uniform Construction Code (NJUCC).

C. City of Yonkers:

The Uniform Fire Prevention and Building Code of New York State.

III. STANDARDS

AASHTO American Association of State Highway and Transportation Officials.

AREA American Railway Engineering Association.

7. PORT AUTHORITY DESIGN CRITERIA

A. All structures, including those in New York State, shall be designed for earthquake Zone 2 forces. BOCA provisions shall apply, unless more stringent local laws are adopted.

B. Roof Snow Load in New Jersey:

In calculating snow loads, BOCA "Ground Snow Load" shall be 25 psf.

C. Ceilings:

1. Cement plaster ceilings - see Attachment S1.
2. Lightweight ceilings in New Jersey - see Attachment S2.
3. Lightweight ceilings in WTC - see Attachment S3.

D. Vehicular Traffic (Airports):

1. Elevated roadways shall be designed for seismic forces according to the "Guide Specifications for the Seismic Design of Highway Bridges" by AASHTO, or the relevant State DOT standards for earthquakes, whichever is stricter.
2. The minimum loading for departure and arrival ramps servicing passenger terminals shall be BS 15-44. Use AASHTO design. All other ramps servicing cargo facilities or road overpasses: AASHTO design using BS20 minimum loading.

E. Highway Signs and Luminaries:

Standard Specifications for Structural Supports for Highway Signs, Luminaires and Traffic Signals; American Association of State Highway and Transportation Officials (AASHTO).

F. Loading Bridges (Airports):

1. Minimum Live Loads:

Floor (LL) - 40 psf or a concentrated load of 300 lbs.
Roof (RLL) - as per local code.
2. Minimum Wind loading (WL):

12.5 psf lateral for the extended (operational) mode (combined windward and leeward pressure).
25 psf lateral for the retracted (stowed) mode (combined windward and leeward pressure).

3. Minimum Load Combinations:
 - a. Extended: DL + LL + RLL
DL + LL + 1/2RLL + WL
DL + WL
 - b. Retracted: DL + RLL
DL + RLL + WL
DL + WL
4. Minimum Stability Factors: Overturning 1.5
 Sliding 1.5
 Uplift 1.5
5. Codes (except where stricter requirements are noted):
 - a. New York City - New York City Building Code.
 - b. New Jersey - The Construction Code (BOCA).

V. DETAILS OF STRUCTURAL REVIEW

The following are representative of details reviewed:

- A. The design calculations shall include but not be limited to:
 1. Design criteria and applicable Codes.
 2. Reference Standards.
 3. Materials.
 4. Type of construction and foundations.
 5. Design loads; including wind and other existing forces.
 6. Machinery and equipment loads in excess of 1000 lbs. including an evaluation of any potential vibration.
 7. Allowable soil bearing capacity.
 8. Pile type and capacity.
 9. Design analysis and drawings of all connections other than AISC standard framed or seated beam connections.
 10. Analysis and sketches of expansion joints.
 11. Design of bracing systems and rigid joints.
 12. Wind drift and deflections.

13. Ponding.
 14. Computer print-outs and users' manuals.
 15. Investigation of superimposed loads from adjacent construction on structure and foundation.
 16. Investigation of existing structural system and foundations under additional loads due to alterations.
 17. Where it has been established that post-construction settlements of foundations are to be monitored, the monitoring program, the limits of such differential settlement that the structure can tolerate, and the necessary adjustments shall be submitted for review.
- B. Drawings shall include but not be limited to the following information:
1. Design Code and Reference Standards.
 2. Materials.
 3. Design live loads, wind and other forces.
 4. Machinery and equipment loads in excess of 1000 lbs. including footprints or support layout(s) plus technical details of vibration isolators.
 5. Allowable soil bearing capacity.
 6. Pile type, capacity and minimum tip elevation.
 7. Column schedule showing accumulated design load at each level for dead and live loads.
 8. Stress diagram(s) for trusses.
 9. Datum and ground water elevations.
 10. Typical moment connection details.
 11. Details of non-standard connections.
 12. Listing of materials subject to controlled inspection.
 13. Construction sequence.

C. Specifications:

1. Shall clearly define the scope of work and materials required for the contract.
2. Shall include limitations, restrictions or conditions due to existing environs and/or requirements for the methods of construction or staging.

SECTION 14 MATERIALS, OPERATIONS, AND EQUIPMENT APPROVAL AND INSPECTION

I. GENERAL

The purpose of this section is to outline:

- A. The requirements for acceptance (approval) of materials, assemblies, forms, methods of construction, and the intended use of equipment.
- B. The requirements for inspection of materials and assemblies and construction.

II. CODES AND REGULATIONS

A. New York City:

- 1. New York City Building Code and its Reference Standards.
- 2. New York City Fire Prevention Code and Directives.
- 3. New York City Electrical Code.
- 4. New York City Local Laws.
- 5. Rules of the Board of Standards & Appeals (BS&A).
- 6. New York State Labor Laws.
- 7. New York State Multiple Dwelling Laws (Hotels).
- 8. New York State Energy Conservation Construction Code.
- 9. Directives and Memoranda of the Department of Buildings.

B. New Jersey:

- 1. New Jersey Uniform Construction Code, its bulletins and the sub-codes (BOCA, etc.) with their Supplements and Reference Standards.
- 2. Applicable Flood Controls.
- 3. New Jersey Uniform Fire Code.

C. The City of Yonkers:

The Uniform Fire Prevention and Building Code of New York State.

III. NEW YORK CITY

A. Approval/Acceptance of Materials, Equipment, etc.:

No material, assemblies, forms, method of construction, equipment, machinery and devices will be acceptable for the intended use unless:

1. Accepted by the Code test method by the Materials and Equipment Acceptance (MEA) division of the Office of the Commissioner of the Buildings Department of New York City.
2. Or approved by the New York City Board of Standards and Appeals (BS&A).

Resolutions of MEA or BS&A shall be submitted for review along with other review documents. Manufacturers' or distributors' letters shall not be acceptable.

The above requirements are abstracted from New York City Building Code Sections C26-106.1, 106.2, 107.1 and 107.2.

B. Inspection:

Controlled Inspection (Code Sections C26-106.3 and 107.3):

1. All materials, equipment, and construction, designated by the Code for "controlled inspection" shall be inspected and/or tested to verify compliance with the Code.
2. Controlled inspection shall be made and witnessed by or under the direct supervision of a registered architect (RA) or professional engineer (PE), retained by the tenant and acceptable to the architect or engineer responsible for the plans. The inspecting RA or PE shall be independent of the contractor.
3. All items subject to controlled inspection shall be listed on the title sheet of the plans, or the sheet immediately following.

The following list contains items subject to controlled inspections, as well as the items' relevant Code sections, where applicable:

- Borings or test pits C26-1112.2
- Piles..... C26-1112.3
- Soil
- Subgrade for foundation C26-1112.5

Controlled fill	
Underpinning	C26-1112.6
Concrete	Code Tables 10-1, and 10-2
Prestressed concrete	
Precast Concrete	
Formwork	C26-1904.3(b)
Steel	
i. Welding	Code Table 10-2
ii. H.S. bolts	Code Table 10-2
iii. Cable fittings	Code Table 10-2
Aluminum, welding	Code Table 10-2
Laminated wood	Code Table 10-2
Firestops	C26-504.7(g)
Spray-on fireproofing	C26-502.2(f)
Heating systems	C26-1401.1(a); 1401.2(b)
Ventilation systems	C26-1301.2; 1301.3
Refrigeration systems	C26-1301.4
High pressure systems	
Chimney smoke vent	C26-1501.1(e); 1504.1(b)
Exterior walls	C26-105.1
Structural integrity during construction operations	Department of Buildings, Rules.

IV. NEW JERSEY

A. Approval/Acceptance of Materials, Equipment, etc.:

Acceptance of materials, assemblies, equipment, forms, methods of construction, etc., shall be based on authenticated reports from approved agencies indicating compliance with accepted engineering practice. See BOCA Building Code Section 1300, BOCA Mechanical Code Section 4.02.0, and the Appendix A of these Codes for approved agencies and testing standards.

Note: The P.A. Engineering Department has accepted approvals from the New York City Board of Standards & Appeals (BS&A) and Material and Equipment Acceptance (MEA). See III.A above.

B. Inspection:

Construction Control - as per NJUCC 5:23-2.21(c):

1. The tenant shall assign a "responsible person in charge of the work" (RPIC), who shall be responsible for:
 - a. Review and approval of all documents pertaining to the construction phase.
 - b. Verification of all controlled materials.
 - c. Special inspection of critical construction components (see list in paragraph 2 below).
 - d. Necessary services to determine that the work is proceeding according to the approved documents.
 - e. At the completion of work, the RPIC shall submit a report to the P.A. attesting to the satisfactory completion of the project, including a list of deviations from the approved documents.
2. The following is the list referred to in the requirement for "special inspection of critical construction components," stated in item B.1(c) above. Effort has been made to make this list as inclusive as possible based on the current codes adopted by the NJUCC. Other construction aspects subject to "special inspection" as required by these codes, that have been omitted by this list must also comply. These inspections shall be performed by a licensed engineer or a registered architect, licensed to practice in the State in which the work will occur, and the reports submitted to the P.A.

- a. Foundations:
 - i. Boring operations.....BOCA, Section 1203.1
 - ii. Subgrade for foundations.
 - iii. Controlled fill.
 - iv. Piling (installation, testing, cut-off and tip elevations).....Section 1213.12
 - v. Support of adjacent properties.
 - vi. Underpinning.
 - vii. Foundations and walls up to grade prior to backfilling.
- b. Structure:
 - i. High strength bolts - see BOCA Building Code Table 1308.3.2.
 - ii. Welds.
 - iii. Concreting operations - see BOCA Building Code Table 1308.4.4.
- c. Plumbing:
 - i. Underground services.
 - ii. Rough piping.
 - iii. Water services.
 - iv. Sewer.
 - v. Septic service.
 - vi. Storm drains.
- d. Electrical:
 - i. Rough wiring.
 - ii. Panels and service installation.
 - iii. Insulation installation.
- e. Mechanical equipment systems.
- f. Heat producing systems.

3. The contractor shall, at the completion of the construction, certify that the construction has been executed in substantial accord with the approved documents, with all pertinent deviations specifically noted.

THE PORT AUTHORITY OF NEW YORK & NEW JERSEY

M E M O R A N D U M

To: W. Biancamano, R. Catlin, P. Ciano, E. Chalom, G. Doherty,
E.K. Farrely, W. Fife, P. Galya, R. Goode, G. Jensen, J. Kau,
J. Miller, M. Ronis, S. Smolenski, E. Takla, V. Volpicelli
From: Ennala Ramabhushanam
Date: October 23, 1990
Subject: TENANT CONSTRUCTION REVIEW MANUAL - AMENDMENT #1

Copy To: A. Erociner, P. Cooper, V. Dovletian, E. Fasullo, M. Poliacof,
O. Suros, TCRU Staff

Listed below are the pages of the Tenant Construction Review Manual that are amended and must be replaced by the pages attached herewith. The changes are highlighted with an *.

Pages 6-2,
9-5, (re-enumeration of paragraphs)
9-6
10-6 (new page)
11-3, 11-5

Please insert this sheet in the front of the Manual.

Ennala Ramabhushanam, P.E.
Manager
Quality Assurance Division

IV. PORT AUTHORITY DESIGN CRITERIA

- A. All structures, including those in New York State, shall be designed for earthquake Zone 2 forces. BOCA provisions shall apply, unless more stringent local laws are adopted.
- B. Roof Snow Load in New Jersey:
In calculating snow loads, BOCA "Ground Snow Load" shall be 25 psf.
- C. Ceilings:
 - 1. Cement plaster ceilings - see Attachment S1.
 - 2. Lightweight ceilings in New Jersey - see Attachment S2.
 - 3. Lightweight ceilings in WTC - see Attachment S3.
 - * 4. For the suspension of lightweight ceilings to resist earthquake forces see ASTM E580.
- D. Vehicular Traffic (Airports):
 - 1. Elevated roadways shall be designed for seismic forces according to the "Guide Specifications for the Seismic Design of Highway Bridges" by AASHTO, or the relevant State DOT standards for earthquakes, whichever is stricter.
 - 2. The minimum loading for departure and arrival ramps servicing passenger terminals shall be HS 15-44. Use AASHTO design. All other ramps servicing cargo facilities or road overpasses: AASHTO design using HS20 minimum loading.
- E. Highway Signs and Luminaries:
Standard Specifications for Structural Supports for Highway Signs, Luminaries and Traffic Signals; American Association of State Highway and Transportation Officials (AASHTO).
- F. Loading Bridges (Airports):
 - 1. Minimum Live Loads:

Floor (LL) - 40 psf or a concentrated load of 300 lbs.
Roof (RLL) - as per local code.
 - 2. Minimum Wind loading (WL):

12.5 psf lateral for the extended (operational) mode (combined windward and leeward pressure).
25 psf lateral for the retracted (stowed) mode (combined windward and leeward pressure).

Appendix D
TENANT CONSTRUCTION REVIEW MANUAL – 1997

Engineering Department
Quality Assurance Division

TENANT
CONSTRUCTION
REVIEW MANUAL

MARCH 1997

Engineering Department

THE PORT AUTHORITY OF NY&NJ

Reproduced with permission of The Port Authority of New York and New Jersey.

SECTION 1**TABLE OF CONTENTS**

TABLE OF CONTENTS	SECTION 1
INTRODUCTION	SECTION 2
GENERAL REQUIREMENTS	SECTION 3
CONCEPTUAL REVIEW	SECTION 4
ARCHITECTURAL	SECTION 5
STRUCTURAL	SECTION 6
GEOTECHNICAL	SECTION 7
CIVIL	SECTION 8
ELECTRICAL	SECTION 9
MECHANICAL	SECTION 10
PLUMBING	SECTION 11
FIRE PROTECTION	SECTION 12
PROTECTION FROM AIRPORT RAMPSIDE FUEL SPILL FIRE	SECTION 13
MATERIALS, OPERATIONS, AND EQUIPMENT APPROVAL AND INSPECTION	SECTION 14
ENVIRONMENTAL	SECTION 15
CORROSION CONTROL/ CATHODIC PROTECTION	SECTION 16
ATTACHMENTS	

1-1

Historical Notes:

First published 1971, Rev. 1979; updated March 1984, Rev. March 1990.

LIST OF ATTACHMENTS

- A1 Standard for Interior Plastic Signs
- A2 Specifications Governing the Flammability of Drapery and Curtain Materials in Unsprinklered Areas.
- A3 Specifications Governing the Flammability of Upholstery Material and Plastic Furniture in Unsprinklered Areas.
- A4 Specifications Governing the Flammability of Plastic Laminate and Wood Veneer Furniture.
- S1 Plaster Ceiling Design Standards.
- S2 Lightweight Ceiling Design Criteria.
- S3 Modifications to the New York City Building Code Earthquake Loads.
- C1 Civil Standard Details.
- C2 Protection of Underground Pipes.
- M1 Port Authority Bus Terminal - HVAC Design Criteria
- E1 Port Authority Bus Terminal - Electrical Design Criteria.
- F1 New York City Municipal Fire Alarm.
- RFS-1 Airport Rampside Clearances.

SECTION 2

INTRODUCTION

This Manual presents the technical criteria to be followed by Tenants, and their architectural and engineering consultants, at all Port Authority (PA) facilities in connection with construction work undertaken by a Tenant. These technical criteria are in addition to other requirements contained in the lease agreement between the Port Authority and the Tenant. This Manual also covers the Port Authority Engineering Department's scope-of-review of the design documents (plans, specifications, calculations and other documents) submitted by Tenants in connection with proposed construction or alterations. It shall not be deemed to imply that there will not be additional reviews by other Port Authority Departments.

The Design Standards (Tenant Construction Review) Unit of the Engineering Department's Quality Assurance Division will review the Tenant Construction or Alteration Application submitted by the Tenant in accordance with the criteria contained in this Manual. The responsibility for architectural and engineering design shall remain with the Tenant's Architect or Engineer (A/E) of record. The Design Standards Unit will not impose design solutions but will only comment on the design presented.

Reviews will not address the proposed aesthetic or functional aspects of the design.

Construction documents for Tenant construction or alterations will be reviewed by the Design Standards Unit for compliance with all applicable Codes and Port Authority Technical Standards. In the absence of a specific code provision, this Manual sets forth the applicable standards to be followed by Tenants except as may otherwise be required. All design documents shall reflect the existing construction as well as the proposed work in order to determine compatibility with existing facility conditions.

In this regard, a list of all reference documents and guidelines which the Facility has provided to the Tenant, and which affect the design, should become an integral part of the Tenant's contract document submission. If the review process will be aided by the inclusion of these reference documents, such documents should also be included in the submission.

SECTION 3

GENERAL REQUIREMENTS

- i. All proposed Tenant construction shall be submitted for review, in completed form, accompanied by a "Tenant Construction or Alteration Application," Form PA531, which shall be provided to the Tenant by the appropriate Port Authority line department.

The PA line department shall forward all tenant submittals to the Engineering Quality Assurance Division with a completed Tenant Alteration Application Review Request Form, PA2127, indicating the technical disciplines to be reviewed for the submitted project(s).

- ii. The design documents, such as drawings, reports, computations and specifications, required in connection with the proposed construction, shall be attached to, and form a part of, the Tenant Construction or Alteration Application, and shall reflect the existing construction as well as the proposed work. The design documents shall be sealed and signed by the architect or engineer of record licensed to practice in the State in which the proposed construction is to be performed. The architect/engineer indicated on the Application shall be considered the Architect or Engineer (A/E) of record.

The A/E of record is responsible for assuring that the documents prepared and submitted by other consultants are properly coordinated.

Where other consultants have been acknowledged by the A/E of record, either in the Tenant Alteration Application or on the drawings, said consultants may seal and sign the documents they have prepared.

Where the Tenant retains two or more independently functioning consultants, they each become an A/E of record for their respective scope of work. Each consultant will be required to submit a separate Tenant Alteration Application, and each consultant shall seal and sign their respective documents.

Responsibility for design or code compliance shall not be delegated to contractors.

- III. All revisions to previously submitted documents shall be properly identified, and shall be accompanied by a brief description of the revisions.
- IV. All voluntarily installed Fire Protection systems, including, but not limited to sprinklers, alarms, etc., shall comply with the provisions of the applicable Building Codes for such systems.
- V. Fire protection plans, as described in the New York City Building Code Section 27-228.1 et seq., shall be filed for review along with other design documents for construction projects at all Port Authority facilities. After approval of the project for construction, and before a Permit to Occupy or Use is issued, the Tenant shall submit one (1) copy of these plans to the Manager of the Facility where the project is located, one (1) copy to Risk Management, and two (2) copies to the Quality Assurance Division of the Engineering Department.
- VI. In accordance with the policy of the Port Authority of New York and New Jersey, the Tenant shall comply with the provisions of all federal, state, municipal, local and departmental laws, ordinances, rules, regulations and orders that may affect the construction or alteration contract and all individuals involved therein. Where stricter requirements apply, i.e., those contained in the specifications or drawings, they shall be followed. The Tenant, or designated agents, shall not apply for any variance, license, waiver or permit in the name of or on behalf of the Port Authority.

SECTION 4

CONCEPTUAL REVIEW

I. GENERAL

At the Tenant's request, a Conceptual Review will be performed to supplement the consultants' feasibility studies. These reviews will inform the consultants of established design criteria, pre-existing conditions that determine code compliance, and Port Authority requirements affecting the proposed work. The conceptual review shall be limited to fundamental concepts and items related to the criteria in this Manual that may significantly affect the design. The review will not address aesthetics or functional design.

Submitted conceptual plans shall indicate conformance to the applicable codes and design criteria.

The scope of the Conceptual Review may include the items enumerated in the following paragraphs:

II. BUILDING CODE

- A. Occupancy group and construction classification of the new, altered, and adjusted areas.
- B. Fire protection of spaces in the building as it applies to ratings of interior separations, shafts, exterior walls, and sprinkler requirements.
- C. Egress: Occupant load and adequacy of egress shall be established or the Tenant's architect/engineer may list the sections of the applicable Code on which the design is based. New Tenant egress scheme(s) shall be coordinated with existing conditions.
- D. Special structural conditions, including foundations.

- E. Special or unusual mechanical or electrical problems affecting environmental, energy, or power requirements.
- F. Deviations from Code requirements.
- G. Existing structures shall be reviewed for existing Code violations.

III. **PANY/NJ CRITERIA**

See the subsequent Technical Sections of this Manual for specific criteria.

IV: **COORDINATION WITH FACILITIES**

- A. Electrical: New power requirements shall be indicated.
- B. Water supply: Coordination of any demand for chilled water, high temperature hot water, domestic water, high pressure sprinkler supply water, and connections to the fire protection loop, shall be fully described.
- C. Any work affecting fuel lines shall be indicated.

SECTION 6

STRUCTURAL

I. GENERAL

- A. The scope of the structural review shall comprise compliance with the applicable Codes, standards, and design criteria listed below.
- B. Computations shall be submitted with all structural plans.

II. CODES AND REGULATIONS

- A. New York City:
 - 1. New York City Building Code.
 - 2. Rules of the City of New York, Title 1, Department of Buildings.
- B. New Jersey:
New Jersey Uniform Construction Code (NJUCC).
- C. City of Yonkers:
New York State Uniform Fire Prevention and Building Code.

III. STANDARDS

- | | |
|--------------------|--|
| AASHTO | American Association of State Highway and Transportation Officials. |
| AREA | American Railway Engineering Association. |
| ANSI/EIA/TIA-222-E | Structural Standards for Steel Antenna Towers and Antenna Supporting Structures. |

IV. PORT AUTHORITY DESIGN CRITERIA

- A. In the absence of provisions for earthquake design in the New York State Uniform Fire Prevention and Building Code, the New York City Building Code Shall be used for earthquake design in the City of Yonkers.

For modifications to the New York City Building Code Earthquake Loads, See Attachment S3.

- B. Floors in certain areas of the Port Authority Bus Terminal South Wing are of light weight low strength concrete construction. Concrete anchors are not permitted in these light weight slabs for the attachment of hangers for supporting ducts, utilities, ceilings, and other miscellaneous loads. These loads shall be supported directly from floor beams or supplementary framing connected to the floor beams. Information regarding the locations of the light weight slabs can be obtained from the Facility Tenant Liaison Office.

In areas where concrete inserts are permitted, only approved type stainless steel anchors rated for shock and vibration loads and elevated temperature shall be used.

- C. Ceilings:

1. Plaster Ceiling Design Standards - see Attachment S1.
2. Lightweight Ceiling Design Criteria - see Attachment S2.

- D. Vehicular Traffic:

1. Elevated roadways shall be designed for all loadings, including seismic effects, in accordance with the AASHTO "Standard Specifications for Highway Bridges" and the relevant State DOT Standards. In New Jersey, roadways providing access to interstate freight shall be designed for HS 25 loading.
2. The minimum loading for the departure and arrival ramps servicing airport passenger terminals shall be HS 15-44

AASHTO highway loading. All other ramps servicing cargo facilities or road overpasses shall be designed for HS20 AASHTO highway loading.

E. Highway Signs and Luminaries:

Standard Specifications for Structural Supports for Highway Signs, Luminaries and Traffic Signals; American Association of State Highway and Transportation Officials (AASHTO).

F. Aircraft Loading Walkways (Airports):

1. Minimum Live Loads: Floor (LL) - 40 psf or a concentrated load of 300 lbs. Roof (RLL) - as per local code.
2. Minimum Wind Loading (WL) 12.5 psf lateral for the extended (operational) mode (combined windward and leeward pressure). 25 psf lateral for the retracted (stowed) mode (combined windward and leeward pressure).
3. Load Combinations:
 - a. Extended: DL + LL + RLL
DL + LL + 1/2RLL + WL
DL + WL
 - b. Retracted: DL + RLL
DL + RLL + WL
DL + WL
4. Minimum Stability Factors:

Overturning	1.5
Sliding	1.5
Uplift	1.5

V. **DETAILS OF STRUCTURAL REVIEW**

The following are representative of items reviewed:

- A. The design calculations shall include but not be limited to:
1. Design criteria and applicable Codes.
 2. Reference Standards.
 3. Materials.
 4. Type of Construction and foundations.
 5. Design loads, including wind and other forces.
 6. Machinery and equipment loads in excess of 1000 lbs. Including an evaluation of any potential vibration.
 7. Allowable soil bearing capacity.
 8. Pile type and capacity.
 9. Design and details of all connections other than AISC standard framed or seated beam connections.
 10. Location and details of expansion joints.
 11. Bracing systems and moment-resisting frames.
 12. Deflections and wind drift.
 13. Ponding.
 14. Investigation and superimposed loads from new construction on existing structure and foundation.
 15. Investigation of existing structural system and foundations under additional loads due to alterations.
 16. Where it has been established that post-construction settlements of foundations are to be monitored, the

monitoring program, the limits of differential settlement that the structure can tolerate, and the necessary adjustments shall be submitted for review.

- B. Drawings shall include, but not be limited to, the following information:
1. Applicable Code and Reference Standards.
 2. Materials.
 3. Design live loads, wind, and other forces.
 4. Machinery, equipment, and other concentrated loads in excess of 1000 lbs. Including footprints or support layout(s).
 5. Allowable soil bearing capacity.
 6. Pile type, capacity, and minimum tip elevation.
 7. Column schedule showing accumulated design load at each level for dead and live loads.
 8. Stress diagram(s) for trusses.
 9. Datum and ground water elevations.
 10. Typical moment connection details.
 11. Details of non-standard connections.
 12. Construction sequence.
- C. Specifications shall include, but not be limited to:
1. The scope of work and materials required for the construction or alteration.
 2. Limitations and restrictions due to the existing conditions and/or requirements for the methods of construction or staging.

ATTACHMENT S3**MODIFICATIONS TO THE NEW YORK CITY BUILDING CODE EARTHQUAKE LOADS**

Revise Table No. 23-P of RS 9-6 by:

- a. Adding after II.1.b.
 "c. Overhead Signs 2.00";
- b. Adding after II.3.
 "4. Anchorage for suspended ceilings weighing more than 4 psf without the weight of light fixtures 0.75";
- c. Adding after III.1.
 "2. Elevator and counterweight guardrails and supports 1.25"
 "3. Sprinkler piping⁵ 2.00"
 "4. Gas and high hazard piping 2.00"
 "5. Other piping⁶ 0.67"
 "6. HVAC ducts⁶ 0.67"
- d. Adding the following notes after Note 4 at the bottom of the table:
- "5. The design of seismic restraints for sprinkler piping in compliance with NFPA 13 using a design acceleration of 0.15 is acceptable in lieu of compliance with these provisions.
6. Seismic restraints are not required for any of the following conditions for other pipe systems of HVAC ducts:
- i. Piping or ducts suspended by individual hangers 12 inches or less in length from the top of the pipe or ducts to the supporting structure.
- ii. Piping in boiler and mechanical rooms which has less than 1-1/4 inches inside diameter.

S3-1

- iii. Piping in other areas which has less than 2-1/2 inches inside diameter.
- iv. Ducts which have a cross-section area less than 6 square feet."

S3-2

SECTION 14

MATERIALS, OPERATIONS, AND EQUIPMENT APPROVAL AND INSPECTION

I. GENERAL

The purpose of this section is to outline:

- A. The requirements for acceptance (approval) of materials, assemblies, forms, methods of construction, and the intended use of equipment.
- B. The requirements for inspection of materials, assemblies, and construction.

II CODES AND REGULATIONS

See the Technical Sections of this Manual

III. NEW YORK CITY

- A. Approval/Acceptance of Materials, Equipment, etc.:

No material, assemblies, forms, method of construction, equipment, machinery, and devices will be acceptable for the intended use unless:

- 1. Accepted by the Code test method by the Materials and Equipment Acceptance (MEA) Division of the New York City Department of Buildings.
- 2. Or, previously approved by the New York City Board of Standards and Appeals (BS&A).

MEA or BS&A resolutions of approval shall be submitted for review along with other review documents. Manufacturers' or distributors' letters are not acceptable. The above requirements are abstracted from New York City Building Code, Sections 27-130, 27-131, 27-134, and 27-135.

B. Inspection:

Controlled Inspection (Code Sections 27-132 and 27-136)

1. All materials, equipment, and construction designated by the Code for "controlled inspection" shall be inspected and/or tested to verify compliance with the Code.
2. Controlled inspection shall be made and witnessed by or under the direct supervision of a registered architect (RA) or professional engineer (PE), retained by the tenant and acceptable to the architect or engineer responsible for the plans. The inspecting RA or PE shall be independent of the contractor.
3. All items subject to controlled inspection shall be listed on the title sheet of the plans, or the sheet immediately following.

The following list contains items subject to controlled inspections, as well as the items' relevant Code sections, where applicable. Effort has been made to make this list as inclusive as possible. Other items subject to controlled inspection, as required by NYC Building Code, that have been omitted in this list must also comply.

Borings or test pits	27-720
Piles	27-721
Subgrade for foundation	27-723
Controlled fill	27-679(a)
Underpinning	27-724
Concrete	Code Tables 10-1, 10.2
Formwork	27-1035(b)

Steel:

i.	Welding	Code Table 10.2
ii.	H.S. bolts	Code Table 10-2
iii.	Cable fittings	Code Table 10-2
	Aluminum, welding	Code Table 10-2
	Laminated wood	Code Table 10-2
	Masonry	Code Table 10-2
	Exterior Wall Insulation and Finish Systems	27-335.1(c)13
	Firestopping	27-345(h)
	Spray-on fireproofing	27-324(f)
	Heating and combustion equipment	27-793(a), 27-794(b)
	Ventilation systems	27-779, 27-780
	Refrigeration systems	27-781
	High pressure systems	Department of Buildings, Rules Section 20-02(b)(2)(i)
	Chimney smoke vent	27-856(e), 27-879(b)
	Welding of gas distribution piping	RS-16, P115.8(h)
	Curtain/Panel Wall	Rules of the City of New York, Title 1, Department of Buildings, Chapter 32.

Structural integrity during Rules of the City of New
construction operations York, Title 1, Department
of Buildings, Rules,
Chapter 16.

IV. NEW JERSEY

A. Approval/Acceptance of materials, Equipment, etc.:

1. Acceptance of materials, assemblies, equipment, forms, methods of construction, etc., shall be based on certified test reports from approved agencies. See BOCA Building Code Chapter 17 and BOCA Mechanical Code Chapter 4, as amended by New Jersey Uniform Construction Code (NJUCC).

Note: Approvals from the New York City Material and Equipment Acceptance (MEA) Division are acceptable. See Paragraph III.A.1.

2. See NJUCC, Section 5:23-4.26 for certification of building elements, such as trusses, fire walls, fire separation walls, wall panels, pre-stressed/prefabricated floor or roof panels and pre-engineered structural frames.

B. Inspection:

Construction Control - as per NJUCC Section 5:23-2.21(e):

1. The tenant shall assign a "responsible person in charge of the work" (RPIC), who shall be responsible for:
 - a. Review and approval of all documents pertaining to the construction phase.
 - b. Verification of all controlled materials.
 - c. Special inspection of critical construction components (see list in paragraph 2 below).

- d. Necessary services to determine that the work is proceeding according to the approved documents.
 - e. At the completion of work, the RPIC shall submit a report to the P.A. attesting to the satisfactory completion of the project, including a list of deviations from the approved documents.
2. All items subject to "special inspection," stated in item B.1.c, shall be listed on the title sheet of the plans, or the sheet immediately following.

The following is a list of items subject to "special inspection of critical construction components." Effort has been made to make this list as inclusive as possible based on the current codes adopted by the NJUCC. Other construction items subject to "special inspection" as required by these codes that have been omitted in this list must also comply:

- a. Inspection of Fabricators BOCA, Section 1705.2 as amended by NJUCC.
- b. Steel Construction:
 - i. Material Receiving BOCA, Section 1705.3.2.
 - ii. Erection:
 - Installation of High strength bolts..... BOCA, Section 1705.3.3.1.
 - Welding BOCA, Section 1705.3.3.2.
 - Details BOCA, Section 1705.3.3.3.

- c. Concrete Construction:
 - i. Materials BOCA, Section 1705.4.1
 - ii. Installation of Reinforcing and Prestressing Steel BOCA, Section 1705.4.2.
 - iii. Formwork BOCA, Section 1705.4.3.
 - iv. Concreting Operations... BOCA, Section 1705.4.4.
 - v. Inspection during Prestressing BOCA, Section 1705.4.5.
 - vi. Manufacturer of Precast Concrete BOCA Section 1705.4.6.
 - vii. Erection of Precast Concrete BOCA Section 1705.4.7.
- d. Masonry Construction BOCA, Section 1705.5.
- e. Wood Construction BOCA, Section 1705.6
- f. Foundations:
 - Prepared fill BOCA, Section 1705.7
 - Pile foundations BOCA, Section 1705.8

	Pier foundations	BOCA, Section 1705.9
g.	Wall panels and veneers	BOCA, Section 1705.10
h.	Sprayed fire resistive materials	BOCA, Section 1705.12
i.	Exterior insulation and finish systems	BOCA, Section 1705.13.
j.	Special Cases	BOCA, Section 1705.14

Appendix E
STANDARDS FOR STRUCTURAL INTEGRITY INSPECTION OF
WTC TOWERS A & B

WTC4098

Infrastructure Engineering
Design Division

**Standards for
Structural Integrity
Inspection of the
World Trade Center
Towers A and B**

March 1986

Engineering Department

THE PORT AUTHORITY OF NEW YORK AND NEW JERSEY

Reproduced with permission of The Port Authority of New York and New Jersey.

File: P802
March 1986

WORLD TRADE CENTER - BUILDINGS 1 AND 2
STRUCTURAL INTEGRITY STANDARDS

LESLIE E. ROBERTSON ASSOCIATES

TABLE OF CONTENTS

	<u>Page</u>
I. INTRODUCTION	1
A. Purpose, Character and Scope of the Program	
1. First Approach - Statistical Inspections	
2. Second Approach - Reports	
3. Third Approach - Continued Measurements	
B. Feedback and Revision	
II. GENERAL DESCRIPTION OF THE BUILDINGS	3
III. PRINCIPAL STRUCTURAL SYSTEMS AND ELEMENTS	5
A. Structural Systems	
B. Symmetry	
C. Redundancy	
D. Dampers	
E. Shaftwall	
IV. INSPECTION PROGRAM	8
A. Visual Inspections	
1. Periodic Inspections	
2. Occasional Inspections, Monitoring of Reports	
B. Periodic Measurements	
1. Natural Frequencies - Towers	
2. Natural Frequencies - TV Mast	
3. Natural Frequencies - Floor Construction	
4. Visco-Elastic Dampers	
5. Plumbness and Level	
V. INSPECTION PERSONNEL - IN-HOUSE	14
A. Inspection Supervisor	
B. Leader Qualifications	
C. Inspector Qualifications	
VI. OUTSIDE CONSULTANTS AND SUPPLIERS OF SPECIAL SERVICES	16
VII. RECORD-KEEPING AND FOLLOW-UP PROCEDURE	17
A. Structural Steel Defects and Signs of Distress	
1. Rust	
2. Cracks	
3. Buckles and Kinks	
4. Connection and Joint Defects	
5. Alignment, Excessive Deflection or Bowing	
6. Paint	
B. Reinforced Concrete Defects and Signs of Distress	
1. Scaling	
2. Cracking	
3. Spalling	

LESLIE E ROBERTSON ASSOCIATES

TABLE OF CONTENTS (CONTINUED)

	<u>Page</u>
C. Inspection Records	
1. Identification	
2. Description	
3. Special Reports	
4. Urgency	
D. Measurements and Test Records	
1. Periods of Vibration, Towers and Mast	
2. Floor Systems	
3. Additional Data	
4. Plumbness and Level	
E. Periods of Vibration	
1. Exterior Walls	
2. Floor Systems	
VIII. EXCLUDED WORK	22
IX. REFERENCES	23
APPENDIX A - STRUCTURAL INTEGRITY PROGRAM TELEVISION ANTENNA MAST	24
APPENDIX B - FIBER OPTIC BORESCOPE SUPPLIERS	31
APPENDIX C - TABLES, FIGURES AND DRAWINGS	
Table I: Eccentrically-Braced Columns in Elevator Shafts	32
Plan Details for Table I	33
Figure 1: Suggested Locations of Accelerometers for Measurement of Tower Natural Frequency	34
Figure 2: Zones for Floor Natural Frequency Measurement	35
Exterior Wall to Floor 9 Elevations	36
TV Mast Support Elevations	44

LESLIE E. ROBERTSON ASSOCIATES

I. INTRODUCTION

A. Purpose, Character and Scope of the Program

These Standards are designed to assist the Port Authority in the evaluation of the on-going structural integrity of the twin towers of the World Trade Center, New York. To date, the towers have performed well, and maintenance costs are reported to be as anticipated. Further, tenant complaints of structure motion, perhaps the largest single predicator of excessive swaying motion, are reported to be negligible. Still, should degradation of the structural system take place with time, remedial action is essential. These Standards, then, are designed to anticipate degradation, should it occur, and to allow for systematic repair.

The Standards make use of three separate approaches to the providing of a suitable framework for the monitoring of the structural integrity of WTC 1 and WTC 2...the two 110-story towers of the World Trade Center:

1. First Approach - Statistical Inspections

Under the first, periodic statistical visual inspections of selected structural components in higher-potential trouble areas will be made. It is proposed that, initially, this work be accomplished by qualified outside consultants under PANYNJ management. In the future, where this course is judged to be advantageous this task can be performed by PANYNJ in-house personnel. The periodic inspections will be supplemented by occasional visual inspections made possible by the exposure to view of structure during tenant remodeling or general maintenance work. Every opportunity should be used to take advantage of these more-or-less random exposures of the structural system. Occasional inspections would be done in-house where the involved area is not large enough to justify the use of an outside consultant.

2. Second Approach - Reports

In the second approach, various reports are examined as possible symptoms of underlying structural problems. Maintenance reports of non-structural repairs, water leakage and tenant complaints about unusual building movement, vibration or noise are examples of such reports.

3. Third Approach - Continued Measurements

In the third procedure, the performance of systems within the structure is evaluated through the continuing measurement of movement or deformation, using appropriate tests and instruments. These systems range in size from relatively small individual components repeated many times throughout the buildings, to an entire tower structure.

The accumulated inspection reports and measured test data in time will form a chronological record which can be consulted in assessing the significance of observed structural conditions or measurements. The periodic inspection procedure is adapted from the Port Authority Engineering Department "Standards for In-depth Structural Integrity Inspection of Buildings." The other sections of the program are designed to respond to needs dictated by the nature of the specific structures and the building occupancy, and so are unique to these towers.

B. Feedback and Revision

It is anticipated that feedback from the application of the program may generate changes in procedure and scope. These Standards then, are viewed as an evolving system, to be amended as needed.

March 1986

World Trade Center - Buildings 1 and 2
Structural Integrity Standards P802

Page 2

LESUE & ROBERTSON ASSOCIATES

II. GENERAL DESCRIPTION OF THE BUILDINGS

The two tower buildings rise more than 1,400 feet above their foundations, 1,438 feet for WTC 1 and 1,432 feet for WTC 2. The TV mast raises that height to 1,800 feet for WTC 1. Each tower has 111 floors, 116 framed levels including below grade service levels, with nearly one acre of space on a typical floor.

The towers were the first in the new family of very tall buildings to use the exterior walls as a thin tubular shell in structural steel; the tubular shell cantilevers from its foundations to supply all of the needed resistance to wind and earthquake forces and to stabilize the core against lateral buckling. Lateral strength is attained in this way without the need for conventional rigid-frame construction, and the story height is reduced to 12 feet. Gravity loads are carried by core and exterior columns.

Different grades (yield points) of steel were used to equalize the dead load stresses and shortening of the very tall columns while accommodating imposed loads from wind and gravity. The major trusswork spanning the railroad tracks also used a variety of steel grades to produce uniform deflection. A rooftop space frame in each tower controls the expansion and contraction due to unequal column temperatures, and provides also a "root" for the 362 foot high TV mast now atop WTC 1 (provisions for a similar tower are incorporated into WTC 2).

The prefabrication of structural components was developed to a point never before achieved in high-rise buildings:

- The tubular shell of the outside walls is made up of nearly 6,000 wall panels, generally 36 feet by 10 feet, three stories high and encompassing three columns in width, which were stacked one above the other, the column ends field bolted together, and the spandrels field bolted to the spandrels of adjacent panels. In this way field welding was held to a minimum in these members and connections subject to stress reversal from wind excitation. Some wall units were 56 feet by 10 feet and weigh as much as 54 tons.
- The prefabricated floor units in the typical tenant floors of each tower were generally 20 feet wide, with 60 foot and 36 foot lengths on different sides of the building; each floor unit contained steel deck and electrical raceways. Double trusses span the 60 foot and 36 foot directions; alternating perpendicular deck support members and transverse trusses form an integral part of the prefabricated floor unit. The double truss webs extend above the deck to provide composite action with the concrete, which was cast after installation of the prefabricated floor units. The transverse trusses were connected to adjoining units to provide two-way spanning action in the corners of the building and to provide bridging action (redundancy) in areas of one-way span. All core areas and all of the mechanical floors in the towers are framed with rolled structural steel sections.

The site has miscellaneous fill and debris over the old riverbed, with the ground water level averaging about 5 feet below existing grade. A slurry wall system embedded in rock was used on the site perimeter to permit dewatering and excavation to rock for the project foundations without damaging adjacent structures. Rock anchors stabilized the wall during excavation. The perimeter wall system participates in the carrying of lateral wind forces from the plaza down to rock.

March 1986

World Trade Center - Buildings 1 and 2
Structural Integrity Standards P802

Page 4

LESLIE ROBERTSON ASSOCIATES

III. PRINCIPAL STRUCTURAL SYSTEMS AND ELEMENTS

A. Structural Systems

The exterior walls are framed with closely-spaced columns and deep spandrels, acting effectively as a tubular shell to resist all lateral forces and to share in supporting gravity loads. The exterior columns are spaced 3 feet 4 inches on center in the superstructure. Columns 10 feet on center at Plaza level form the trunks of "tree" assemblies, generally branching out to become three columns above Floor 7. The columns are welded box sections consisting of four steel plates. The column field splices are made by bolting the base plate of the upper tier column to the cap plate of the column below. Interior horizontal diaphragm plates stiffen the column web and flange plates at critical locations. The spandrels are plates typically 1 3/8 inches thick by 4 feet 4 inches or more in height, usually replacing a portion of one of the column plates. Spandrels are field-bolted to the spandrels of adjacent panels with dual splice plates, providing for symmetrical (double shear) connections from panel to panel.

The cores support the balance of the gravity loading. Above the 7th floor the cores do not share in resisting lateral forces to any significant extent. The core columns in the upper stories are rolled wide-flange shapes; as column loads accumulate in the lower floors the rolled shapes are replaced by built-up box sections. Floor framing within the core consists of rolled steel beams supporting formed concrete slabs or slabs on steel deck. Below the 7th floor the cores are x-braced to carry lateral loads down to the plaza level and below.

Outside of the rectangular core, the floors span from the exterior walls to the core. In the typical tenant floors, concrete slabs on steel deck are supported by a shallow truss system. Paired trusses, with the pairs located 6 feet 8 inches from adjacent pairs, are on 60 foot and 36 foot spans, with perpendicular deck support members and transverse trusses alternating at 6 feet 8 inches on center. The overall depth of the trusses/deck/slabs is 33 inches. The truss webs extend above the deck to provide composite action with the concrete. The transverse trusses are connected to adjoining units to provide two-way spanning action, particularly at the building corners, contributing to a high reserve load capacity. The floor trusses are connected to alternate exterior columns, with a welded connection at the truss top chord, and a visco-elastic damper at the bottom chord cushioning the wind-engendered vibrations locally, and contributing to system-wide damping. The area outside the core at mechanical floors is framed by rolled steel beams supporting concrete slabs on steel deck; dampers are in their connection to the exterior wall panels.

March 1986

World Trade Center - Buildings 1 and 2
Structural Integrity Standards P802

Page 5

LESLIE E ROBERTSON ASSOCIATES

In both towers the space frame from Floor 107 to the Penthouse Roof is formed by the addition of structural steel diagonals along the core column lines in the orthogonal directions to create with the columns and beams a network of intersecting trusses. This system mobilizes the interconnected structure to limit differential temperature displacements, and serves also as a foundation for the TV mast atop WTC 1 (provisions for a similar tower, or four smaller towers, have been incorporated into the structure for WTC 2).

B. Symmetry

It is important to realize that clear lines of symmetry exist in much of the floor framing, particularly that of the prefabricated floor components, and that Towers 1 and 2 share more or less identical floor framing. In this work, then, considerable repetition exists. It is even more important to realize that like levels of symmetry do not exist in the prefabricated wall panels of the exterior tube:

- ° There is no symmetry about the building center line for any one face of any one building.
- ° No two faces are the same.
- ° The two towers are not the same.

This follows because the individual towers are not designed as stand-alone buildings. That is, full advantage is taken of the wind shielding that each tower gives to the other. Also, there is no symmetry in the juxtaposition of the plan location of the two towers and aerodynamic loading and responses vary with winds from each point of the compass.

C. Redundancy

A very considerable level of redundancy exists in the lateral force systems of the twin towers. This redundancy stems from the structural interaction of the Vierendeel tubular wall and from the staggering of the splices of individual wall panels. It is possible, then, to invalidate hundreds, perhaps thousands of individual connections in the tubular walls, while still carrying full gravity load and more common levels of wind loading. This redundancy makes unnecessary the need to ascertain that specific connections may have been subjected to structural degradation ... and one need turn one's concern to the larger issue of the possible systematic degradation of systems, as opposed to components.

The prefabricated floor system, also, carries considerable redundancy on account of the two-way nature of every part of this system.

Core framing carries a level of redundancy associated with the bending rigidity of so-called "simple" connections. This redundancy, while not easily amenable to calculation, is of the same order as is found in conventional steel buildings.

D. Dampers

As part of the development of structural systems for the twin towers a desire to improve the damping characteristics of these systems was both recognized and satisfied. A new damping system was developed by LERA, making use of viscoelastic materials manufactured by 3M Company. This product, later incorporated into Columbia Center (Seattle) and now planned for incorporation into several other buildings, is designed to reduce the swaying motion of the towers. The damping systems are not needed for structural integrity, but rather to reduce the perception of structure motion by building tenants. Individual dampers are not significant to damping performance as it is the summation of all dampers that contributes to the whole. Accordingly, the integrity of any one damper, or even of several hundred dampers, is not essential to the dynamic performance of the towers.

E. Shaftwall

While strictly speaking not a part of the structural system, the fire-resistive partition system used in the service core was developed by LERA with the goals of reducing the weight, the initial cost and the maintenance costs of these partitions. While these goals were realized, and while this system (now called Shaftwall) has found its way into nearly every new high-rise building, the elimination of masonry partitions results in a loss in building stiffness, structure damping and building density ... all of which lead to increased dynamic response under wind excitation. These losses are offset by the viscoelastic damping system described in the previous paragraph.

March 1986

World Trade Center - Buildings 1 and 2
Structural Integrity Standards P802

Page 7

LESLIE E ROBERTSON ASSOCIATES

IV. INSPECTION PROGRAM

A. Visual Inspections

Since the concurrent visual inspection of the entire structure or even a major portion of it is not a practical goal, a statistical approach is followed. This approach involves the sampling of those components and systems which are more important to structural integrity, and at locations with a relatively higher potential for occurrence of defects or problems.

Within the bounds of the suggested sampling procedure, the inspection frequency and the building layout, it is anticipated that the inspection work can be organized to proceed in a more or less linear sequence to minimize both waste motion and duplication of effort, and to help insure that no important item is missed. The inspection team should carry a set of reduced drawings, individual field notebooks, a camera and tape recorder. Equipment, clothing, methods and procedures should conform strictly to the Port Authority's safety regulations; Federal, state or local regulations may well govern some aspects of this work and should be respected.

Visual inspection should be supplemented by the use of simple hand tools, measurements, and recording techniques as needed. Where structural steel members or connections are covered by spray-on fireproofing, concrete or masonry encasement, remove loose, cracked or rust-stained cover material to examine the steel.

Where the location of an observed defect is difficult to describe accurately, the affected member can be field-marked with crayon to assist in locating it at a later date. When the nature or the location of the observed defect cannot be described simply, field sketches with measurements or 3" x 5" or larger clear color photographs should be made, and captioned at the site.

Where the inspection procedure involves the removal of spray-on, concrete, or block fireproofing from even a part of a structural steel member, or where it requires the removal of a portion of ceiling, the material removed should be properly replaced on completion of the inspection. It should be noted also that some asbestos-based fireproofing materials are known to be within the buildings and that special care need be taken in the removal and the handling of such materials. Where it is necessary to drill a hole through an element of a structural steel member to provide access for a borescope or other device, the hole diameter should be selected to provide the minimum clearance required; upon completion of the inspection, the access hole should be well sealed with weld metal, body putty, or caulking as appropriate. Where it is specified that exterior finishes such as column covers are to be removed, the material exposed should be provided protection from the weather until the permanent cover is restored.

March 1986

World Trade Center - Buildings 1 and 2
Structural Integrity Standards P802

Page 8

LESLIE E. ROBERTSON ASSOCIATES

Where signs of water leaks suggest the probability that water has entered a box column, use a borescope to examine the internal surfaces of the column at base, cap, or diaphragm plates at the levels immediately below.

1. Periodic Inspections (Remarks apply to both towers unless noted specifically for only one)
 - a. For the structural integrity inspection program for the TV antenna mast on top of WTC 1, see Appendix A. Make certain that none of the antennas on the mast will be operating during the inspection and repair procedures and that other proper and statutory safety precautions are taken.
 - b. Every year, examine all exterior roof and wall elements for signs of water intrusion. Roof leakage should be ascertained from a careful examination of the spaces immediately below the roof areas. Wall leakage should be determined from signs of water staining of interior finishes.
 - c. Every year, conduct an inspection of room occupancies and uses throughout WTC 1 and WTC 2, to verify that the design live load is not exceeded in any space. For reference in this survey, a schedule of allowable live loads must be maintained and up-dated as structural modifications are made; no such schedule now exists.
 - d. Every second year, examine all accessible column envelopes or fireproofing for signs of rust or cracking, bowing, or deviation from plumb. At columns in elevator shafts, where the column is braced directly on only one axis by connecting beams or abutting concrete slabs due to large beam offset dimensions, inspect for lateral displacement or rotation of the column about a vertical axis (refer to Appendix C, Table I). At Sub-level 5, examine the slabs on ground surrounding each column for signs of rust or deformation.
 - e. Every second year, examine the fireproofing envelopes or masonry partitions enclosing the diagonal bracing on the exterior column lines in both towers below Service Level Floor (Elevation 294'-0"), and the transfer trusses below Floor 1 in WTC 2 under exterior and core columns (refer to "Exterior Wall to Floor 9 Elevations," Appendix C, Drawings 125 through 128, prefixed SA for WTC 1, SB for WTC 2). Inspect for cracking, stains, and other possible signs of structural distress.
 - f. Every second year, inspect the bracing truss members between Floor 107 and the roof in the core area (refer to "TV Mast Support Elevations," Appendix C, Drawings 401 through 404, prefixed SA for WTC 1, SB for WTC 2).

March 1986

World Trade Center - Buildings 1 and 2
Structural Integrity Standards P802

Page 9

LESLIE E. ROBERTSON ASSOCIATES

- g. For the locations of the column and spandrel intersections and "tree" junctions described below, refer to "Exterior Wall to Floor 9 Elevations," Appendix C, Drawings 125 through 128, prefixed SA for WTC 1, SB for WTC 2.

Every fourth year, inspect four exterior box columns which center under "trees" (two each at WTC 1 and at WTC 2) below Floor 7 at levels described below. Unless otherwise noted, exterior aluminum column covers and spray-on fireproofing are to be removed to gain access to the exterior surface of the column and spandrel plates specified. In each instance, visually examine the steel column or spandrel plate for bowing or distortion, cracking, and corrosion. Visually inspect all accessible welds, and use ultrasonic testing to examine full or partial penetration welds and adjacent base metal where base metal thicknesses exceed 1 1/2 inches.

Drill an access hole in column or spandrel plate, located on the column center line at the approximate levels noted below, for use of a suitable borescope to examine the column box interior for the presence of water and the interior plate surface all around for rust.

Inspect the intersection of column and spandrel panel at Elevation 350'-3", and also at Floor 2, with access for the borescope at mid-height of the spandrel. For those column-spandrel junctions at Floor 2 which are below exterior Plaza level framing, a temporary opening cut through the plaster ceiling below Floor 2 outboard of the column is needed for access.

Inspect the "tree" junction, where three superstructure columns merge. Examine the top surface of the horizontal diaphragm plate that caps the tapered box just below the point at which the three separate columns appear. Inspect the exterior column plate between this point and the column splice at Elevation 372'-4".

- h. Every fourth year, inspect steel floor framing over mechanical spaces and other areas without suspended ceilings.
- i. Every fourth year, inspect concrete slabs, partitions, and finishes for signs of distress which might indicate excessive structural deformation.

March 1986

World Trade Center - Buildings 1 and 2
Structural Integrity Standards P802

Page 10

LESLIE E. ROBERTSON ASSOCIATES

2. Occasional Inspections, Monitoring of Reports

When general repairs or tenant remodeling involve removing ceilings, partitions, finishes or other cover, a thorough inspection should be made of the steel framing and connections and the concrete while they are exposed to view or under fireproofing. In particular where carpeting or other floor finish is removed or shows evidence of displacement, examine the slab top surface for cracking, spalling, and exposed or corroded top reinforcement.

Repair floor areas where rebars are corroded and slabs spalled near trench headers, as tenant relocation permits or on a priority basis where warranted.

Use collected general maintenance reports and tenant complaints to search for symptoms pointing to underlying structural defects. Water damage caused by leaks at roof or exterior wall, broken plumbing, partition or floor cracking should be reviewed to determine whether the problem is confined to the non-structural element involved, or is part of a pattern resulting from structural deformations. Tenant complaints of building sway, floor vibration, sagging ceilings, unusual noise, and the like, should be recorded in logs for each tower. Where a reasonable assessment of the data in reports or logs can be tied to a specific structural element or system, it should be followed promptly by visual inspection of the suspect area. In addition, report and log data should be correlated with testing and measurements made under Section B.

B. Periodic Measurements

Periodic measurements of building sway and vibration characteristics, plumbness and floor level are made for the purpose of monitoring changes in these indices, which could point to a change either of loading, or of stiffness, the latter reflecting possible structural deterioration.

1. Natural Frequencies - Towers

Install accelerometers on Mechanical Floor 75 in WTC 2; one at each exterior wall near its midpoint, oriented to respond to horizontal displacements parallel to the wall, and two near the geometric center of the floor to respond to displacements along the N/S and E/W central axes of the building respectively (refer to Appendix C, Figure 1). The accelerometers are to be connected to suitable amplifiers and recorders. Using this equipment, and the instrumentation already in place in WTC 1, natural frequencies are to be measured and recorded for each tower once a month for N/S and E/W translations and for torsional movements. Wind speed and direction at the time of measurement are to be recorded also, preferably based on reliable on-site measurements. A continuing log of significant weight changes of the towers needs to be maintained, to be used in the evaluation of measured deviations from previous frequency measurements.

2. Natural Frequencies - TV Mast

Install accelerometers and amplifiers within the heated enclosure of the 350 foot high TV antenna mast on top of WTC 1, at a level about 2/3 of the height of the mast above its base, to be connected to recorders within the building. One accelerometer is to be oriented to respond to N/S displacements and another to E/W displacements. Periods of vibration of the mast in each direction are to be recorded once a month, along with wind speed and direction.

3. Natural Frequencies - Floor Construction

Tenant change or remodeling presents an opportunity to measure the natural frequency of vertical vibration of floor sections at a time when the space has been emptied. In the typical floor, the area outside the core can be divided into zones of 3 types; within each type it can be expected that similar vertical dynamic characteristics will be found at any typical tenant floor. The 4 corner zones, each consisting of a 60 foot square area at a corner of the tower floor space constitute one such type. The remaining spaces between corner zones make up the other two types: two long span zones with a 60 foot span, and two short span zones with a 36 foot span. Refer to Appendix C, Figure 2.

In each tower, the Mechanical Equipment Floors 7, 41, and 75, and the tenant Floors 7, 43, and 77 directly above them are not to be included in the floor frequency measurement program; these floors are framed conventionally with steel beams, and are to be inspected visually.

Also, it should be noted that Telephone Equipment Floors 10 through 13 in WTC 2, framed with shallow trusses similar to the typical tenant floor construction but more heavily loaded and stiffer, will have different dynamic characteristics from corresponding zones of the typical floors.

- a. On each occasion where a zone substantially free of tenant loading is available, the natural frequency and damping values of the floor structure within the zone are to be measured by performing a "heel drop" test, in which vibrations induced in the floor structure by a vertical impact are recorded using an accelerometer attached to the floor, and associated equipment.
- b. Locate accelerometers at the same location on each floor, at or near points of maximum statical deflection, with the precise location to be determined by experimentation.
- c. The heel drop should be standardized. While actual values should be determined by experimentation, 100 pounds dropped approximately 6" onto a 1" thick neoprene pad should be about the right input level.

March 1986

World Trade Center - Buildings 1 and 2
Structural Integrity Standards P802

Page 12

LESLIE E. ROBERTSON ASSOCIATES

4. Visco-Elastic Dampers

The testing program for the visco-elastic dampers should continue, consisting of:

- a. Continuous measurement and recording of WTC 1 building movements of 3 or more inches, with concurrent wind speed and direction, at least until the end of 1985, and longer to the extent that funds are available.
- b. 12 visco-elastic damping units are to be removed from WTC 1 annually and tested by 3M, using 4 units from each of 3 floors, from Zones 1, 2, and 3, replaced by damping units from WTC storage. Testing is to include temperature effects and shear strength.
- c. A continuous log of tenant complaints on core noise and building sway will be kept.

5. Plumbness and Level

Plumbness and level surveys should be timed to coincide with periods of low wind speed and moderate temperature, as in the early morning hours in August.

- a. Make building plumbness and floor level checks semi-annually for each tower. Investigate plumbness by measuring the offsets from a vertical laser beam, projected up from the bottom of the shaft, to the shaft walls of Freight Elevator No. 50, at 20 story intervals, establishing permanent measurement stations on each wall. Accuracy of the order of 3/4 inch (20 mm) is desired at the top of the shaft, with proportionately greater accuracy at the lower levels.
- b. Establish 16 bench marks on the floor slab at Floor 70 of each tower, one at each corner and mid-point, adjacent to the exterior wall and adjacent to the core boundary as defined by the core columns. Measure the elevation of the remaining bench marks relative to one located near a corner of the core, using an engineer's level. Accuracy of levels should be to about 1/16th inch (1.5 mm).

March 1986

World Trade Center - Buildings 1 and 2
Structural Integrity Standards P802

Page 13

LESLIE E ROBERTSON ASSOCIATES

V. INSPECTION PERSONNEL - IN-HOUSE

A. Inspection Supervisor

The Supervisor of the Structural Integrity Inspection of the Buildings is under the direction of the Engineer of Design, Infrastructure. The Supervisor is responsible for planning and directing the inspection, and preparing the report. The Supervisor should possess the following minimum qualifications:

1. Licensing

Professional Engineering license in New York or New Jersey specializing in Structural Engineering.

2. Experience

Five years experience in responsible charge in structural design of buildings and five years experience in responsible charge in one or more of the following activities:

- a. inspection of building construction,
- b. inspection of existing buildings, and
- c. maintenance of building structures.

The Supervisor does not have to conduct the actual inspection, nor does the Supervisor have to be present at the site at all times when investigations are in progress. The Supervisor is expected, rather, to be familiar with the entire scope of the program, to provide leadership and guidance, and to be in close touch with all of the on-going activities in the various sub-programs.

He is responsible also for setting up and for supervising such training as is required for the team members.

B. Leader Qualifications

The leaders of each of the crews comprising the Inspection Team shall have, in addition to the general qualifications listed below for team members, three years experience in responsible charge in one or more of the following activities:

- a. inspection of building construction,
- b. inspection of existing buildings, and
- c. maintenance of building structures.

C. Inspector Qualifications

The field inspection crew members should be adequately qualified so as to be capable, after receiving moderate guidance on the initial run, of operating the program without detailed supervision. The most important qualifications for a field inspector are acute observation skills, common sense, strong motivation and persistence in carrying out any necessary follow-up procedures. The inspectors should be prepared to find serious defects rather than to assume that no problems exist. Where situations beyond the inspector's area of competence are encountered, guidance by supervisors should be sought.

As a minimum, the inspector should:

- be able to climb steel and function comfortably at great heights and in difficult positions;
- be a high school graduate or equivalent, with commensurate reading, verbal and written communication skills;
- read and understand construction drawings and other documents;
- letter legibly and be able to sketch technical details;
- be able to operate a camera;
- have a working knowledge of the use of measuring devices, such as rulers, tapes, gages, protractors and calipers; and
- exhibit a proper concern for safety while inspecting.

It is also desirable, but not mandatory, that the inspector have some prior experience in related work, such as high steel construction, structural maintenance or inspection, or surveying.

VI. OUTSIDE CONSULTANTS AND SUPPLIERS OF SPECIAL SERVICES

The consulting firm engaged to carry out periodic visual inspections, or to accomplish tasks requiring special skills and use of specialized equipment should assign a Supervisor who is a professional engineer licensed in New York or New Jersey and should have the ability to perform the work as demonstrated by a minimum of five years experience in the design and the field supervision of projects of comparable size and complexity. The personnel assigned to the project should possess, as a minimum, qualifications equal to those listed in "Inspection Personnel - In-house."

Before selection, the consultant should submit to PANYNJ a listing and description of comparable projects completed, and a list of the people to be assigned to the project with a resumé of experience and other qualifications for each.

March 1986

World Trade Center - Buildings 1 and 2
Structural Integrity Standards P802

Page 16

LESLIE E. ROBERTSON ASSOCIATES

VII. RECORD-KEEPING AND FOLLOW-UP PROCEDURE

The defects and signs of distress listed below are to be noted and recorded wherever encountered in elements falling into these categories.

A. Structural Steel Defects and Signs of Distress

1. Rust

Classify as "light", a light, loose formation pitting the paint surface, "moderate" a looser formation with scales or flakes forming, or "severe" heavy, stratified rust or scale with pitting of the metal surface. Measure net metal thickness and size of penetrations, if any, where pitting has occurred.

2. Cracks

Classify as "fine", "medium", or "open." Note length, size and location. Any crack is potentially very serious and should be reported immediately.

3. Buckles and Kinks

Note the type, location, extent and amount of deformation.

4. Connection and Joint Defects

Note fine cracks in the paint at joints as an indication of large strains due to stress concentrations. Note sheared, missing, deformed or loose bolts, and evidence of slippage between connection plies. Note gusset plate deformations normal to the face of the plate where an intersecting member connects to the face. Note cracks in welds or adjacent base metal.

5. Alignment, Excessive Deflection or Bowing

Sight along truss or space frame elements, beams or columns to detect misalignment, deflection or bowing. Record the deviation from true line, plumb, or level.

6. Paint

Examine for cracking, chipping, rust pitting and chalking.

March 1986

World Trade Center - Buildings 1 and 2
Structural Integrity Standards PS02

Page 17

LESLIE E ROBERTSON ASSOCIATES

B. Reinforced Concrete Defects and Signs of Distress

For definitions of the defects and classifications as to degree of severity, see Reference 1.

1. Scaling

Classify as light, medium, heavy or severe. Note the depth, extent and locations.

2. Cracking

Classify by type (partial or through the member; direction relative to framing or column lines; horizontal, vertical or diagonal; D-, map, or random cracks). Note the location, width, depth, and length.

3. Spalling

Classify as small, large, hollow area, joint spall, pop-out, or mudball. Note the depth, size or extent, and location.

C. Inspection Records

1. Identification

Each component should be identified as to general location (building number, floor or floors), description label (column, beam, floor truss, visco-elastic damper, slab, etc.), piece mark and column designations at each end as applicable, and the type and location of the affected part. For example:

- WTC 1 - Column 70, Floor 78 to Floor 79, east side of north flange.
- Floor 66, Floor panel F1 (NE), Floor truss C32T11, W of Column 157, connecting welds to Floor truss 24T7A on center line Column 210.
- Floor 78, Beam 3708 connection to Beam 3721, E of Column 802.
- Floor 78, slab bounded by center line Columns 123, 125, 206 and 208.

2. Description

Describe the defect or indication of distress. Provide measurements, sketches, or photographs in those instances where the written description can't adequately define the location or problem. Further comment can be entered on a tape recorder; the transcribed commentary can be appended to the inspection report. Prints of the framing plans or detail drawings or photocopies of relevant portions of them can be marked up when useful in clarifying location or condition.

3. Special Reports

All defects or indications of distress that appear to the Supervisor or to the inspection team to require more than routine attention should be included in a separate report to the Engineer of Design, Infrastructure. For conditions of a serious nature, such notification should be made immediately in person. Repairs of a routine nature can be recommended by the inspector.

4. Urgency

For each recommended repair, or condition requiring repair, the relative urgency of the action to be taken is to be categorized as "Immediate," "Priority," "Routine" or "Non-Priority":

- a. Immediate - Action includes possible closure of the area and/or structure affected, until interim remedial measures, such as shoring or removal of a potentially unsafe element (or structure) can be implemented. These items would have been acted upon immediately when discovered, but a description of the actions taken and recommendations for permanent repairs should be included in the text of the inspection report.
- b. Priority - This is for those conditions for which no immediate action may be required, or for which immediate action has been completed, but for which further investigation, design and implementation of interim or long term repairs should be undertaken on a priority basis; i.e. taking precedence over all other scheduled work.
- c. Routine or Non-Priority - Further investigation and/or remedial work can be undertaken as part of a scheduled major work program or other scheduled project, or routine facility maintenance depending on the action required.

D. Measurements and Test Records

1. Periods of Vibration, Towers and Mast

Tower vibration and on-site wind speed and direction measurements are being logged each month for each tower. The periods of vibration for N/S and E/W translations and for torsional movements should be determined for each tower and for the TV mast. Should comparison of the vibration periods with previously recorded data for towers or mast reveal a statistically significant deviation, the relevant data need be called to the immediate attention of the Engineer of Design, Infrastructure.

2. Floor Systems

The floor vibration measurements resulting from the "heel drop" tests should be compared with prior measurements for similar floor structure zones, where available. In the event that the frequency or the damping ratio deviates from previously recorded values, data need be forwarded immediately to the Engineer of Design, Infrastructure.

3. Additional Data

In conjunction with the floor truss visco-elastic damper testing carried out by 3M, records of WTC 1 building movements of 3 or more inches with corresponding wind speed and direction measurements will be kept at least until the end of 1985. In addition, logs of tenant complaints on core noise, building sway, and the like will continue to be kept, listing date, tenant's location, and nature of complaint.

4. Plumbness and Level

Data obtained from the semi-annual plumb and level surveys are to be compared to previous records to monitor possible building lean or floor tilt.

March 1986

World Trade Center - Buildings 1 and 2
Structural Integrity Standards P802

Page 20

LESLIE E. ROBERTSON ASSOCIATES

E. Periods of Vibration

Since a reduction in stiffness of a structural system is symptomatic of deterioration or damage, vibration period measurements are used to monitor stiffness. To interpret the significance of measured changes in vibration period of the system, it is necessary to take into account changes in weight of the system, for which purpose an initial tabulation of weight must be made, and a log of weight changes kept. To facilitate evaluation of future measurements, the initially measured value of the period T , in seconds, can be plotted against the system weight W at the corresponding time, using the relationship $k = CW/T^2$, and assuming any convenient value, such as 1 or 100, for the stiffness k and unity for C . Then, for any future reading for T greater than the value of T predicted by the chart for the tabulated system weight at that time, the percentage reduction in stiffness required to reconcile the two values can be calculated from the equation above.

1. Exterior Walls

Where the calculated reduction in stiffness is on the order of 5%, and where any discontinuity is found in k , an investigation into the possible causes is necessary. In the case of tower vibration period, this would indicate a possible problem in the exterior walls and an inspection of column/spandrel intersections in these walls would be the starting point.

2. Floor Systems

An apparent reduction in stiffness of one of the typical floor zones calls for inspection of the truss and bracing joint connections. Should the damping ratio obtained from a heel drop test for a typical floor zone be less than the initially measured value for a corresponding zone by 10% or more, deterioration of the visco-elastic dampers at the truss lower chord connections to the columns is a possibility.

VIII. EXCLUDED WORK

This standard is focused on structural steel and on reinforced concrete.

The following components are outside the scope of this standard and have been excluded:

Glass & Glazing
Facade Panels
Ceilings
Partitions
Elevators
Stairs
High-pressure steam equipment
High-voltage electrical equipment
etc.

March 1986

World Trade Center - Buildings 1 and 2
Structural Integrity Standards P802

Page 22

LESLIE E. ROBERTSON ASSOCIATES

IX. REFERENCES

1. Infrastructure Design Division, Engineering Department, PANYNJ: "Standards for In-depth Structural Integrity Inspection of Buildings," Port Authority of New York and New Jersey, October 1984.
2. U.S. Department of Transportation: "Bridge Inspector's Training Manual 70," U.S. Government Printing Office, 1970.
3. AASHTO: "Manual for Maintenance Inspection of Bridges," American Association of State Highway and Transportation Officials, 1983.
4. AWS: "Welding Handbook," Volume 1, Seventh Edition, American Welding Society, 1976.
5. Research and Development Division, Engineering Department, PANYNJ: "Measurement of the Dynamic Response of WTC Tower 'A' Under Wind Loads," Report No. 79-5, May 1979. Report No. 81-7, June 1981.
6. "Investigation of Aging Effects, World Trade Center Dampers," Robertson, Fowler & Associates P.C., October 1, 1984.
7. "Viscoelastic Damping Units," Report No. DU-1, Skilling Helle Christiansen Robertson, July 17, 1967.

March 1986

World Trade Center - Buildings 1 and 2
Structural Integrity Standards P802

Page 23

LESLIE E ROBERTSON ASSOCIATES

APPENDIX A

STRUCTURAL INTEGRITY PROGRAM
TELEVISION ANTENNA MAST

I. INTRODUCTION

A. History

As of this writing, the 350 foot tall television antenna mast on top of ONE WORLD TRADE CENTER is approximately 5 1/2 years old. Erection of the antenna was completed in November, 1979 and activation of the first commercial broadcasting in June, 1980.

Maintenance work and interim inspections, to date, have been performed primarily by television station personnel maintaining broadcast antenna units and PANYNJ maintenance personnel furnished under contract by Broadway Maintenance Corporation.

B. Scope of Program

This document is prepared to assist in the specifying of visual and non-destructive testing of the antenna with the goals of providing reasonable assurance to PANYNJ that the antenna is performing safely as a structure, as well as to assist in identifying preventive maintenance which should be performed on a scheduled basis.

This program consists of four sections:

1. Structural Steel Antenna Elements
2. High Tensile Bolts and Studs
3. Weatherproof Enclosure
4. Radomes

Structural integrity inspections should be performed on a continuing basis, as weather and operational restrictions permit. Every effort should be made to perform a complete review of the mast structure within the weatherproof enclosure each year; the balance of the program should be done at least once every three years.

C. Additional Work

Remaining for development and appending to this program are record keeping documents and integrity review procedures such as specific ultrasonic testing procedures, sampling locations and sampling percentages. Integrity inspections should be documented by diagrams, sketches and photos to the maximum extent practicable in order to amplify the written description of each integrity inspection.

March 1986

World Trade Center - Buildings 1 and 2
Structural Integrity Standards P802

Page 24

LESLIE E. ROBERTSON ASSOCIATES

D. Safety

Both integrity inspection personnel and maintenance personnel should verify that good housekeeping practices are fully in effect in order to minimize or eliminate conditions conducive to fire hazards, falling, electrocution and the like.

March 1986

World Trade Center - Buildings 1 and 2
Structural Integrity Standards P802

Page 25

LESLIE E ROBERTSON ASSOCIATES

II. STRUCTURAL STEEL ANTENNA ELEMENTS

A. Visual Inspection for Corrosion

Inspect each of the 18 tower sections, the tapered section and the channel 4/5 pole for freedom from corrosion. Use high intensity portable light source to assist viewing of structure.

1. Verify freedom from corrosion of all structural parts by visual inspection.
2. Record all locations where paint failure or corrosion are observed.
3. Record all locations, and extent of each such location, where structural parts cannot be directly viewed due to obstructions such as radome, conduits, antenna elements, weatherproof enclosure elements, lack of access, or other condition. Describe conditions preventing visual evaluation of each obstructed location.
4. To the extent possible, view portions of antenna obstructed from direct visual observation by use of appropriate fiber-optic viewing devices.
5. View those portions of antenna structure not accessible for clear viewing from within by direct access to the outside surfaces by appropriate means such as access by boatswain's chair.

B. Visual Inspection for Soundness of Base Metal and Welds

Inspect each section, the tapered section, and the channel 4/5 pole for sound base metal and sound welds.

1. Simultaneous with visual inspection for corrosion, verify freedom of all visible surfaces of base metal and of welds from cracks or other unacceptable discontinuities such as excessive pitting from corrosion, defects at weld ends, especially at access holes, chamfers and the like. Record all findings, even where apparently insignificant, for comparison with future observations.

C. Ultrasonic Inspection for Soundness of Base Metal

Inspect each section, the tapered section, and the channel 4/5 pole for sound base metal and sound welds.

1. Test solid round antenna mast vertical members by intensity method (sending and receiving transducers) and pulse transit time method (pulse-echo method) to assure freedom from cracking, especially in vicinity of structural welds and welds for mounting antennas and related parts. Transducer surfaces should be curved to fit the surface curvature of the part tested.

March 1986

World Trade Center - Buildings 1 and 2
Structural Integrity Standards P802

Page 26

LESLIE E. ROBERTSON ASSOCIATES

2. Test pipe members using pulse transit time method (pulse-echo method) with transverse sound waves to assure freedom of base metal from cracking or other discontinuities, especially in vicinity of structural welds and of welds for mounting antennas and related parts.
3. Test plate steel and rolled steel shapes with transverse or longitudinal waves, as appropriate, in locations as appropriate.
4. Locations of testing should be selected initially on the basis of review of fabrication drawings for the individual antenna structure sections and structural elements. Additional test locations should be selected in response to the results of the complete visual evaluation of the antenna structural steel.
5. UT equipment should be calibrated in accord with the appropriate ASTM, AWS and ASME standards. Additionally, it may be wise to prepare special calibration specimens representative of full size structural elements, so as to determine the best frequency and transducer size and geometry for providing meaningful and reproducible test results.
6. Thoroughness of UT examination for the bottom 101 feet of antenna structure should be based on the highest practicable sampling percentage because this length of antenna has been demonstrated more sensitive to temperature effects on material properties than the antenna sections above (Teledyne Technical Report TR-2315). Based on generated information, it may be possible to justify reduced sampling percentages for periodic scheduled UT integrity checks after study and evaluation of records of actual test results and observations. Fortunately, this portion of the antenna structure is available for examination on a far more continuous basis than the portion of the antenna above Elevation 101 (top of Section AC-10).
7. Record all significant ultrasonic indications (even though not of rejectable level) for comparison with results of future tests in the same location.

D. Water

Inspect all locations in antenna structure to assure that no location can pond or entrap water accumulations. The examination will require a preliminary review of each of the antenna structure fabrication drawings followed by visual examination of each part of each antenna section/element in the field.

III. HIGH TENSILE BOLTS AND STUDS

A. Corrosion

Inspect each bolt or stud connecting antenna sections or members within antenna sections for freedom from corrosion.

B. Cracks

Inspect each stud accessible and each bolt both large enough and accessible for freedom from cracks, especially at the root of threads.

C. Structural Integrity Check Items

1. Corrosion

Verify freedom from corrosion of all projecting bolt heads, nuts, washers and thread run-outs. Report for prompt maintenance (cleaning and painting) all bolt and stud parts where paint failure has occurred or rusting is in progress.

2. Use of Borescope

To the extent possible, view all portions of bolts and studs not accessible for direct viewing by use of fiber-optic viewing devices.

3. Ultrasonic Testing

Ultrasonically examine all studs and those bolts of sufficient size which can be reached for UT examination using longitudinal wave equipment. By comparison with results from appropriate calibration and reference specimens, verify that studs and bolts are free from cracking, especially in threaded and thread run-out zones.

Longitudinal wave testing probes should be selected for size and frequency on special calibration specimens representative of at least the threaded length plus a few inches of unthreaded rod to establish the type of ultrasonic response to be expected from the threaded lengths of bolts and studs.

IV. WEATHERPROOF ENCLOSURE

Purpose of these procedures is to assure maximum corrosion protection of antenna structural and system elements. Corrosion due to water penetration or due to excess humidity within weatherproof enclosure must be prevented. Temperature within weatherproof enclosure must be reliably assured to remain above 75°F (30°C) as recommended in Teledyne Technical Report TR-2315.

Detailed review should be made of the temperature maintained within the antenna structure below Elevation 101 (top of Section AC-10) since the date of installation.

A. Temperature and Humidity

Maintain accurate records of interior temperature and humidity.

B. Paint

Verify integrity of exterior painting system.

C. Seals

Verify integrity of exterior sealing systems against water penetration.

D. Weatherproofing System Integrity Check Items

1. Details around outrigger supports extending from tapered antenna base section to support microdish platforms.
2. Continuity and soundness of watertight seal welds for closure (cap) plates on top of AC-1, AC-7 and AC-10 and around sleeves penetrating closure plates.
3. Continuity and soundness of exterior caulking system (DYmeric by Tremco).
4. Soundness and continuity of seal welds and gaskets at joints in weatherproof closure steel wall plates, steel boots and FRP boots.
5. Protection from (and freedom from) rust for bolts, nuts, threaded studs, washers, bars and the like connecting sections to adjacent sections or to supports on antenna.
6. Use drawings TV-1, TV-0, TV1-TV2, TV50-TV58, TV111, TV121, TV131, TV141, TV151, TV161, TV171, TV181, TV191, and TV192 as guides in performing weathertightness check.

March 1986

World Trade Center - Buildings 1 and 2
Structural Integrity Standards P802

Page 29

LESLIE E. ROBERTSON ASSOCIATES

V. RADOMES

A. Connections

1. FRP radome sections end and edge connections.
2. FRP radome assembly connections to supporting structure.

B. FRP Shells

1. Condition of FRP shells in individual FRP radome sections.

C. Radome Integrity Check Items:

While the majority of radome integrity checks involve features within the radomes, the bolt heads and Belleville washers are on the outside surface of the radomes, the surface from which in-place retightening or replacement of radome assembly bolts and tensioning washers must be accomplished, if found necessary. Checking of radome connecting bolts will require the use of a boatswain's chair or other means of access to the outside of the antenna.

1. Examine each radome section to section connecting bolt and Esna elastic floating stop-nut assembly, bolt by bolt. Stop-nuts should be holding connecting bolts tight with sufficient tension to provide necessary clamping force in joints and splices between radome sections. Degree of tightness of each floating nut and bolt assembly should be checked. Corrosion or lack of corrosion of stop-nut assemblies should be determined.
2. Examine each radome section for freedom from cracking or other signs of potential distress. Pay special attention to zones around bolt holes near edge, and end lap splices of radome FRP sections.
3. Check condition of bolts connecting radomes to FRP Extren braces and support arms, as well as bolts connecting radome supports to structural steel supports. Check condition of Extren supports and braces.

APPENDIX B

FIBER OPTIC BORESCOPE SUPPLIERS

Addresses of some Fiber-Optic viewing instruments suppliers are:

Lenox/Fort
Lenox Instrument Company, Inc.
111 East Luray Street
Philadelphia, PA 19120
Telephone: (215) 324-4543

Reichert Fiber Optics
Warner-Lambert Technologies, Inc.
122 Charlton Street
Southbridge, MA 01550
Telephone: (617) 765-9744

American ACMI
Divison of American Hospital Supply Corporation
300 Stillwater Avenue
P.O. Box 1971
Stamford, CT 06904
Telephone: (203) 238-8654
(203) 357-8300

Olympus Corporation
Industrial Fiber Optics Department
4 Nevada Drive
Lake Success, NY 11042-1179
Telephone: (516) 488-3880

March 1986

World Trade Center - Buildings 1 and 2
Structural Integrity Standards P802

Page 31

LESLIE E ROBERTSON ASSOCIATES

APPENDIX C

TABLE I: ECCENTRICALLY-BRACED COLUMNS
IN ELEVATOR SHAFTS

<u>COLUMN NUMBER</u>	<u>FLOORS</u>	<u>SIMILAR DETAIL</u>	<u>REMARKS</u>
602	1 to 33, 43 to 68	A	
603	32 to 42, 44 El. 294	B	WTC 1 only
606	17 to 23, 25, 26, 44, 61, 62	B	
607	1 to 17, 44 to 55 El. 294	A	WTC 2 only
702	1 to 7	D	
703	8 to 33, 44 to 68 78 to 82, 94 to 101 106, 107, 108	C	
707	1 to 7	D	
802	8 to 17, 44 to 55	C	
803	78 to 94	C	
805	78 to 94	H	
806	95 to 101	G	
902	78 to 106	I	
907	78 to 87	C	
	3 to 8, 32 to 42	B	WTC 2 only
	43	B	
	7	B	WTC 2 only
	1, 2	B	

Notes:

1. Refer to paragraph IV. A.1.d.
2. Floor listings such as "3 to 8" are inclusive.
3. Listings apply to WTC 1 and WTC 2 unless noted otherwise.
4. At the Intermediate Level above Floor 1 and at Floor 8, inspect all columns in the elevator shafts.
5. For typical detail plans A through I, see the following page.

March 1986

World Trade Center - Buildings 1 and 2
Structural Integrity Standards P802

Page 32

LESLIE E ROBERTSON ASSOCIATES

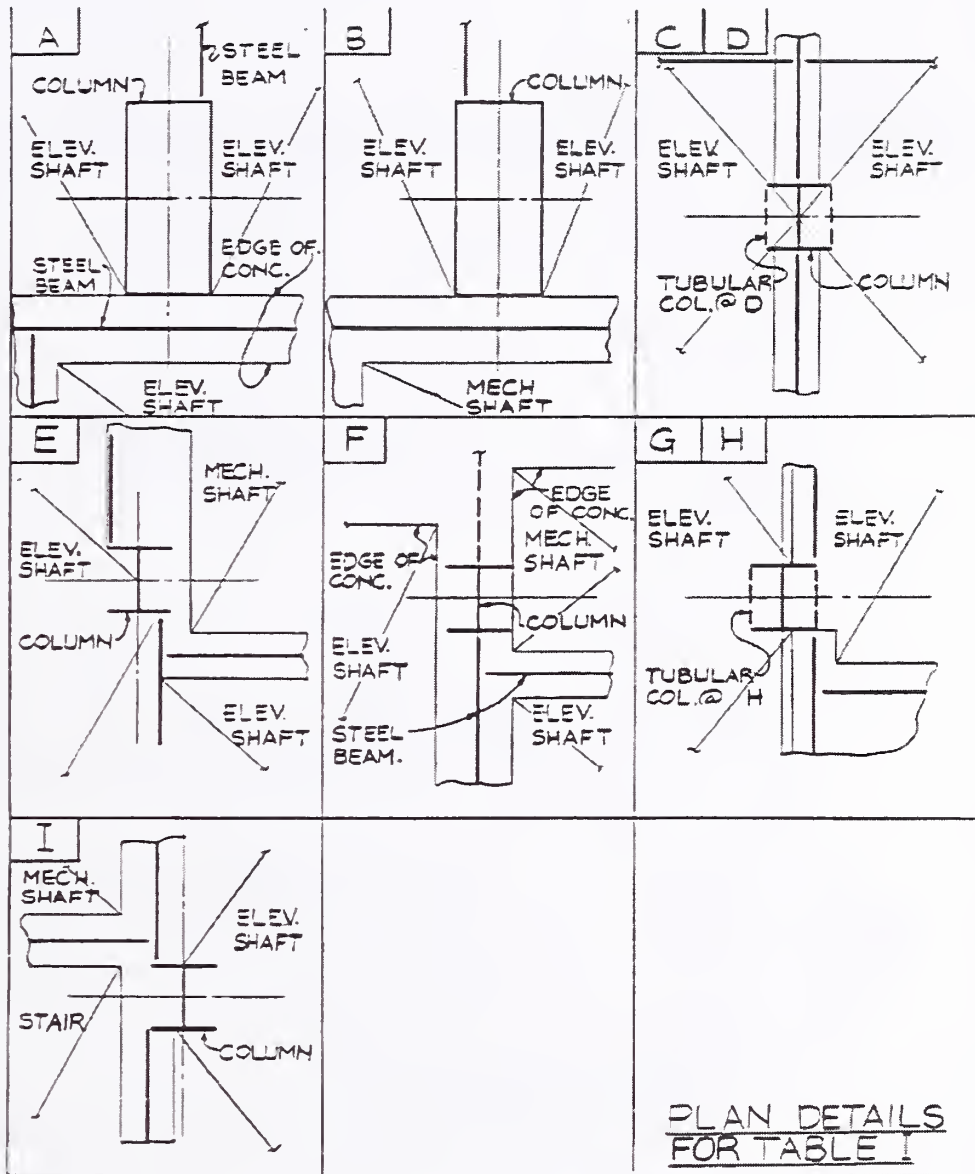

March 1986

World Trade Center - Buildings 1 and 2
Structural Integrity Standards P502

Page 55

LESLIE E. ROBERTSON ASSOCIATES

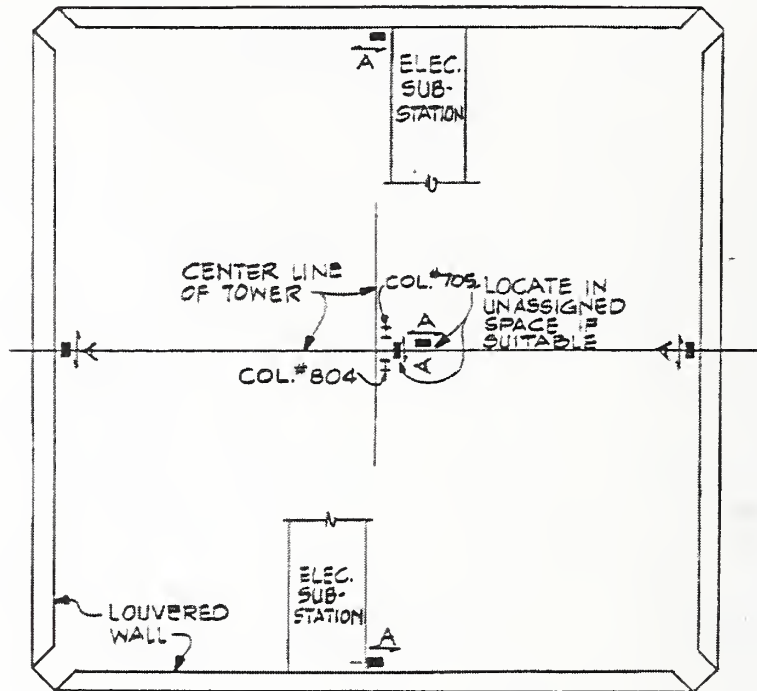

75TH FLOOR PLAN
MECHANICAL EQUIPMENT ROOM
2 WTC



SUGGESTED LOCATIONS OF ACCELEROMETERS
FOR MEASUREMENT OF TOWER NATURAL FREQUENCY

FIGURE 1

NOTES:

1. REFER TO PARAGRAPH II.B.1.
2. SUGGESTED ACCELEROMETER LOCATIONS ARE SHOWN THUS:  ARROW DESIGNATES DIRECTION OF MOTION TO BE RECORDED.
3. VARY THE LOCATIONS AS REQUIRED TO CLEAR MECHANICAL EQUIPMENT AND MAINTAIN ACCESS TO THE ACCELEROMETERS.

March 1986

World Trade Center - Buildings 1 and 2
Structural Integrity Standards P802

Page 34

LESLIE ROBERTSON ASSOCIATES

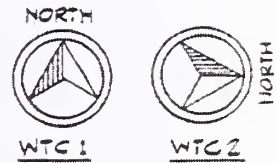
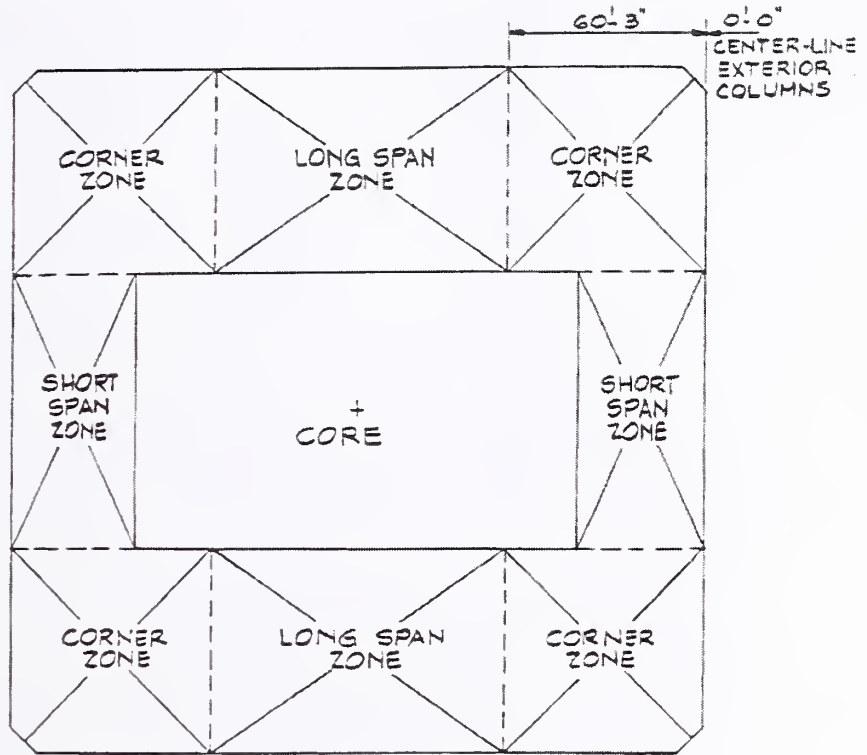

TYPICAL TENANT FLOOR PLAN
ZONES FOR FLOOR NATURAL FREQUENCY MEASUREMENT

FIGURE 2

NOTE: REFER TO PARAGRAPH IX.3.3.

March 1986

World Trade Center - Buildings 1 and 2
Structural Integrity Standards P802

Page 23

LESLIE S. ROBERTSON ASSOCIATES

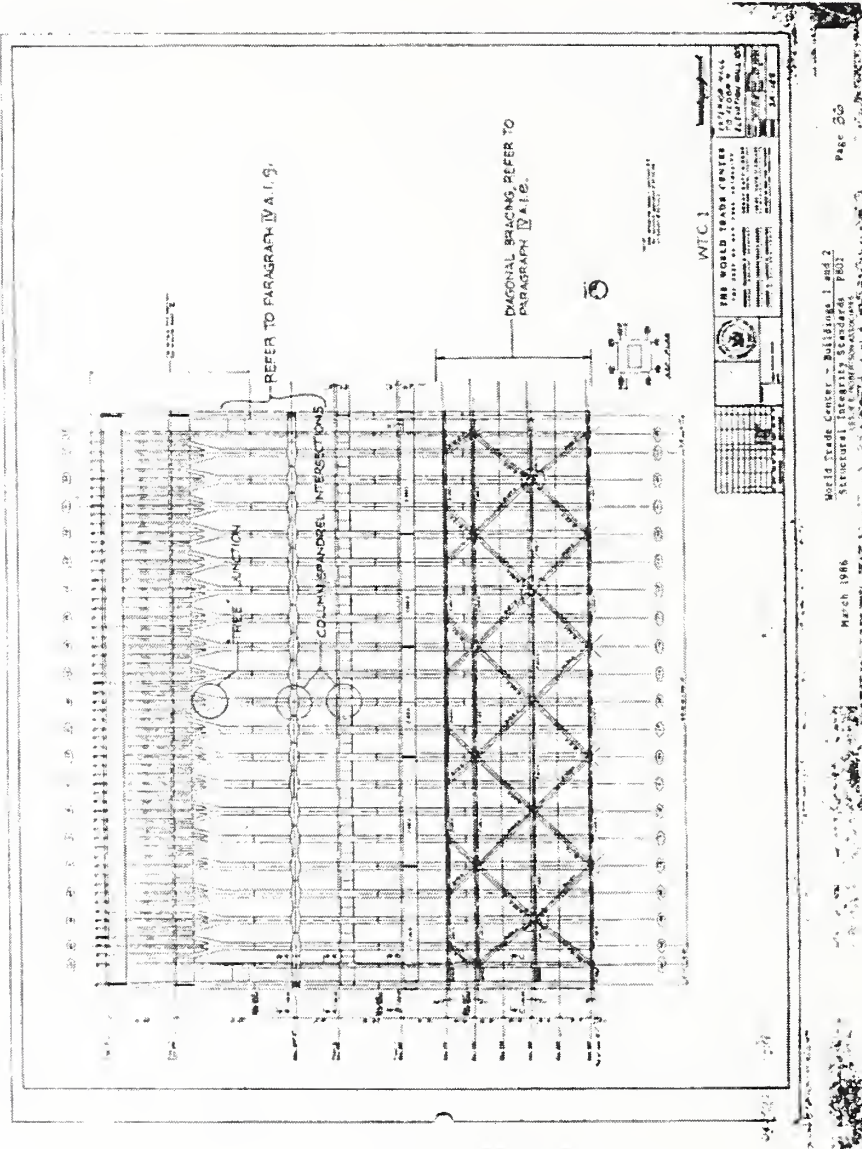

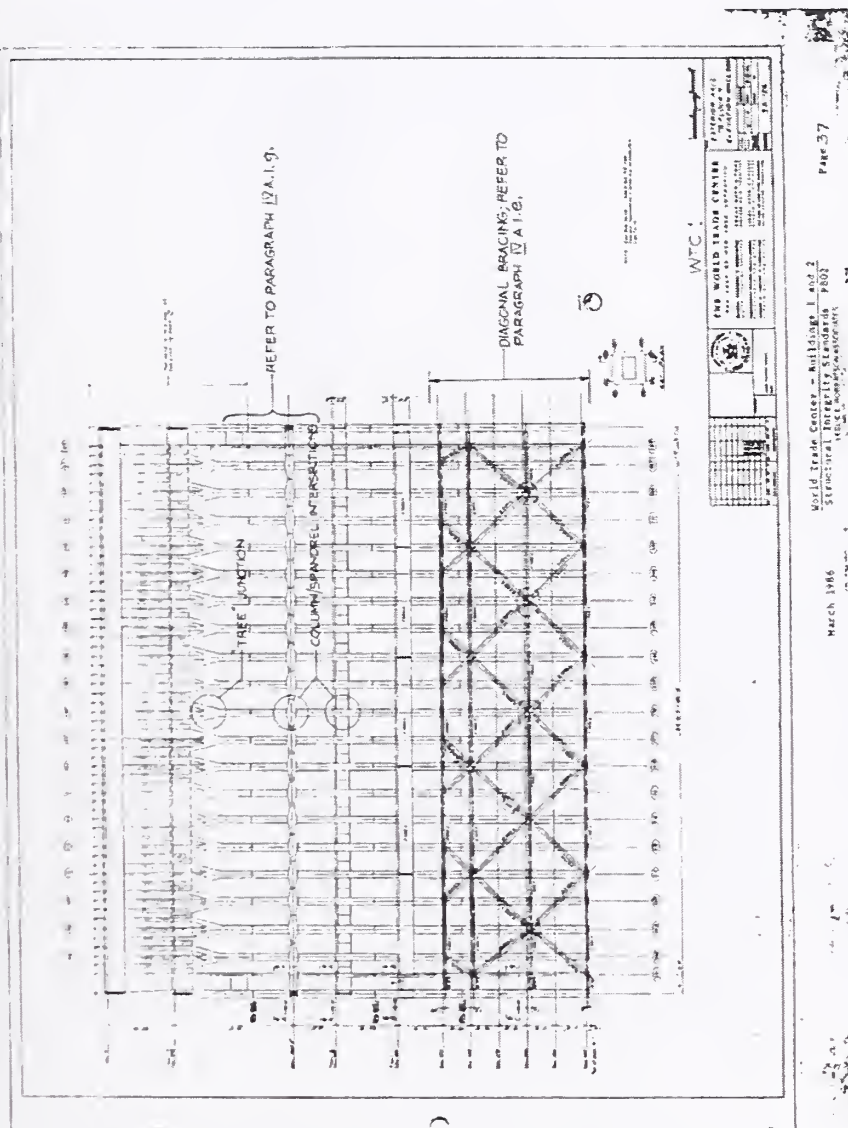

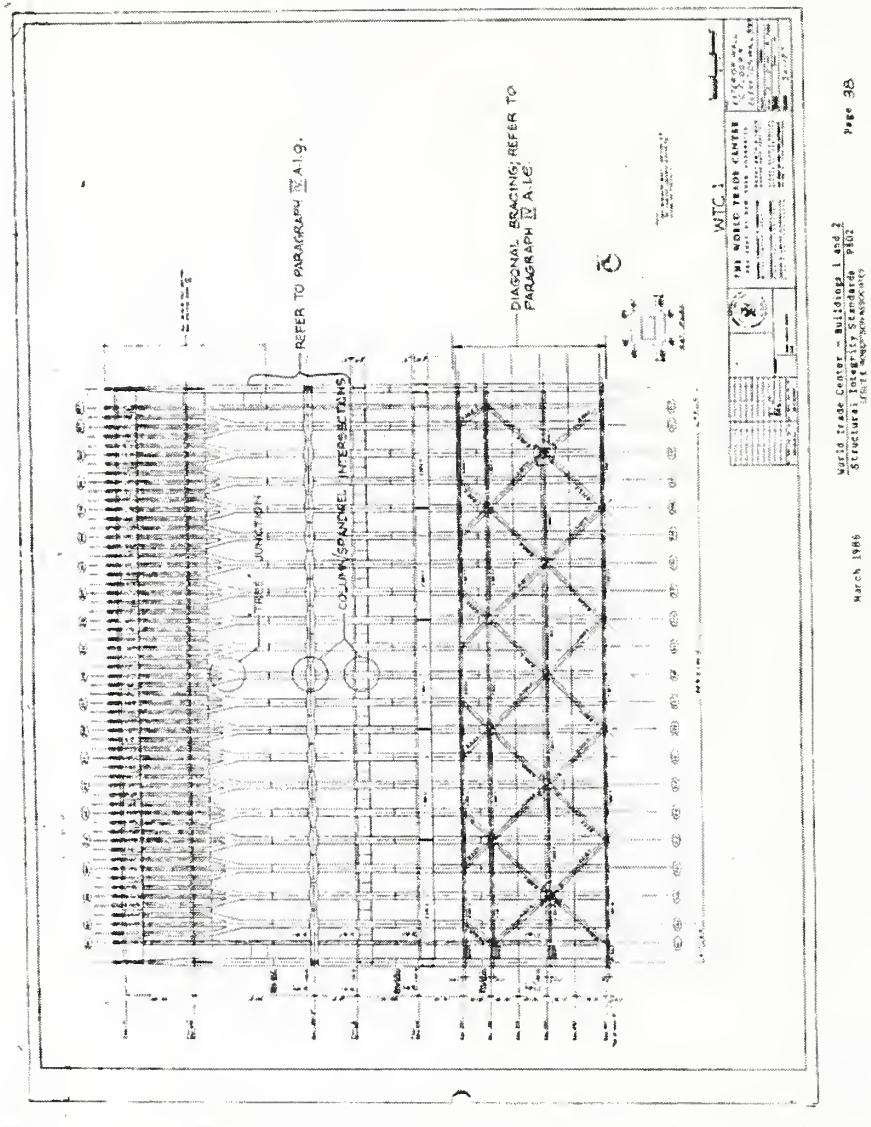

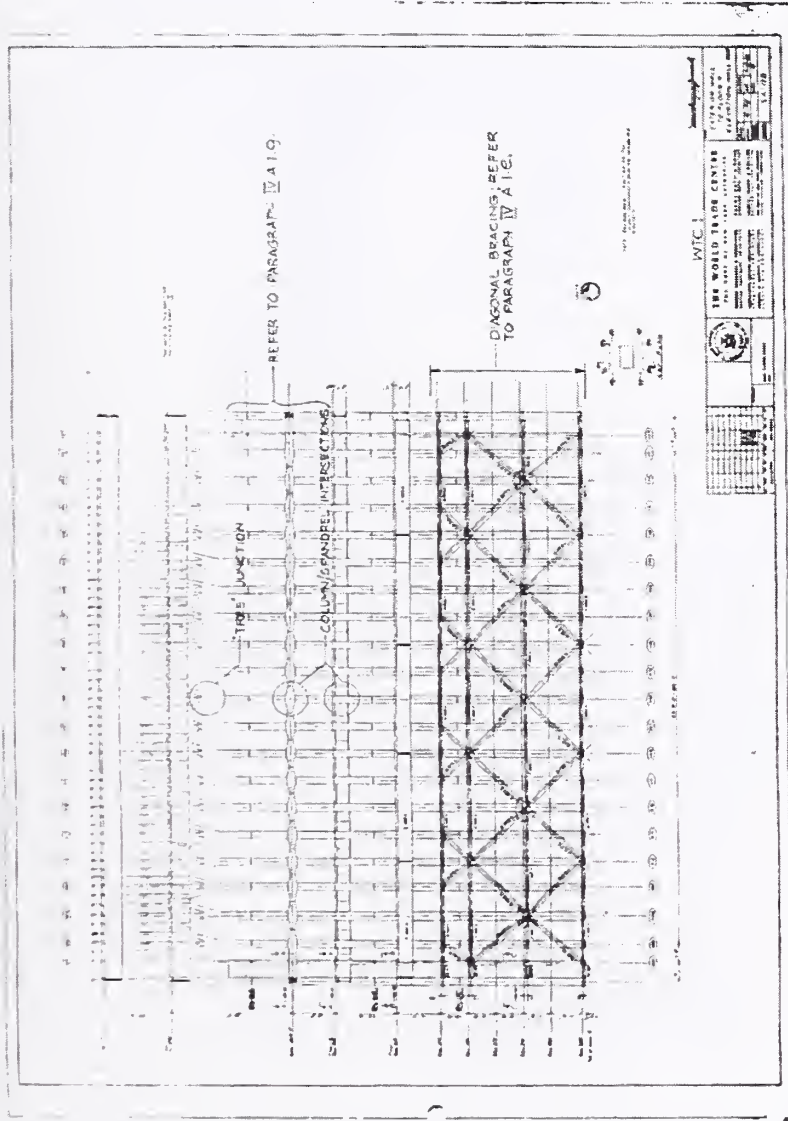

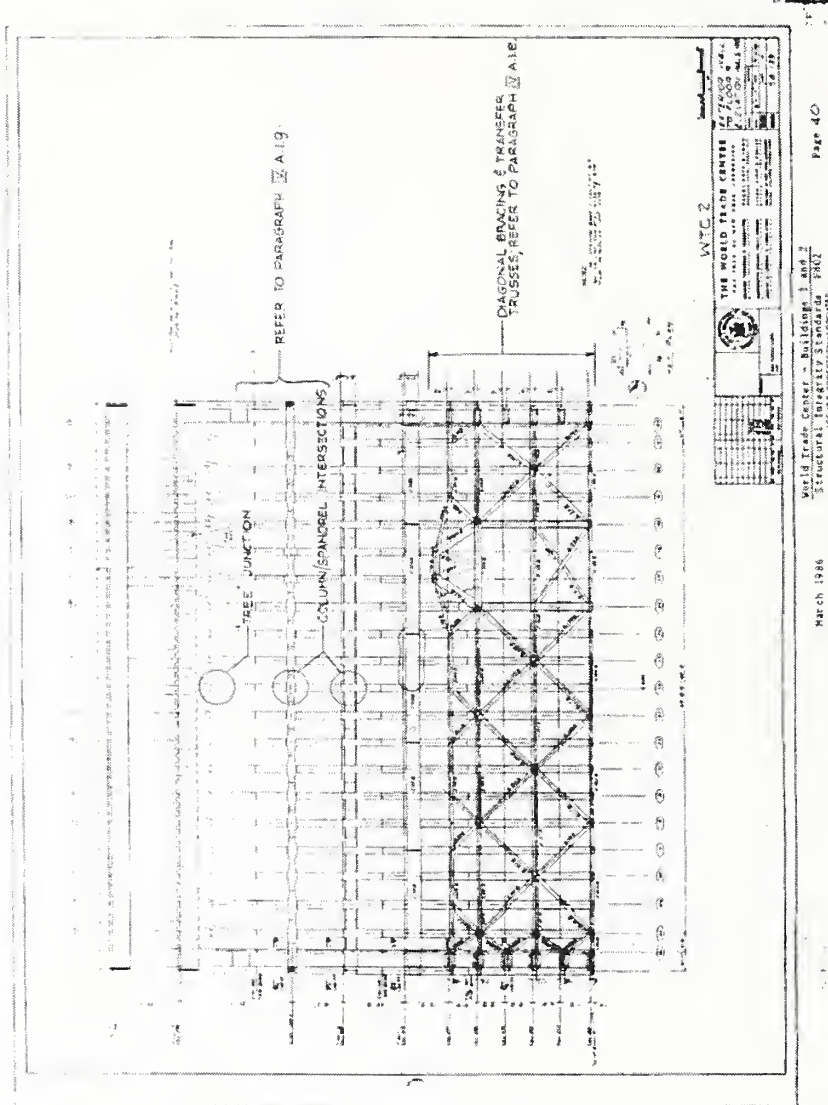

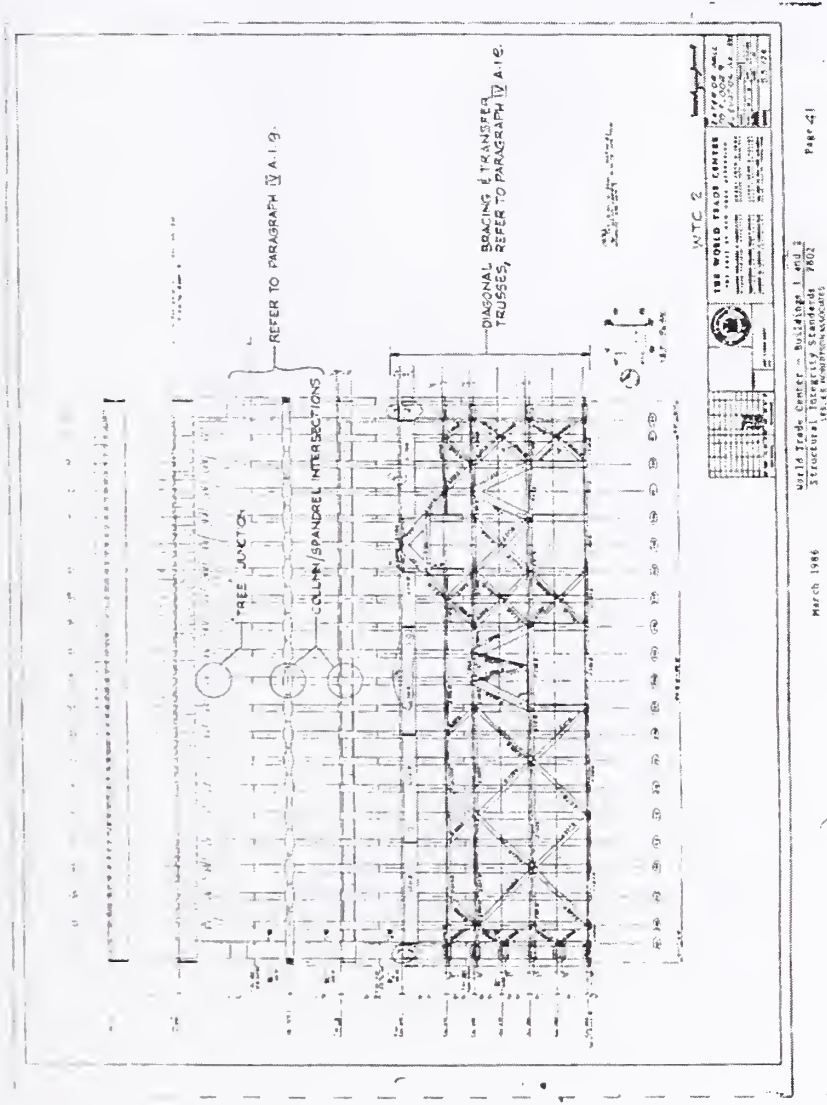

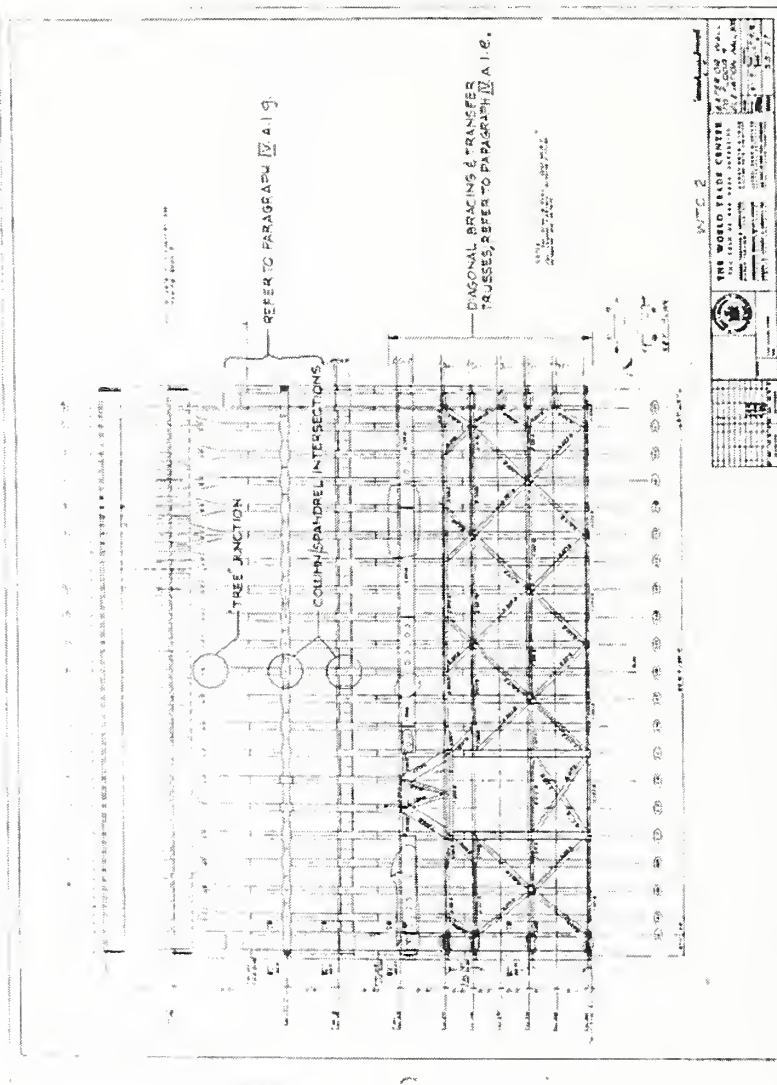

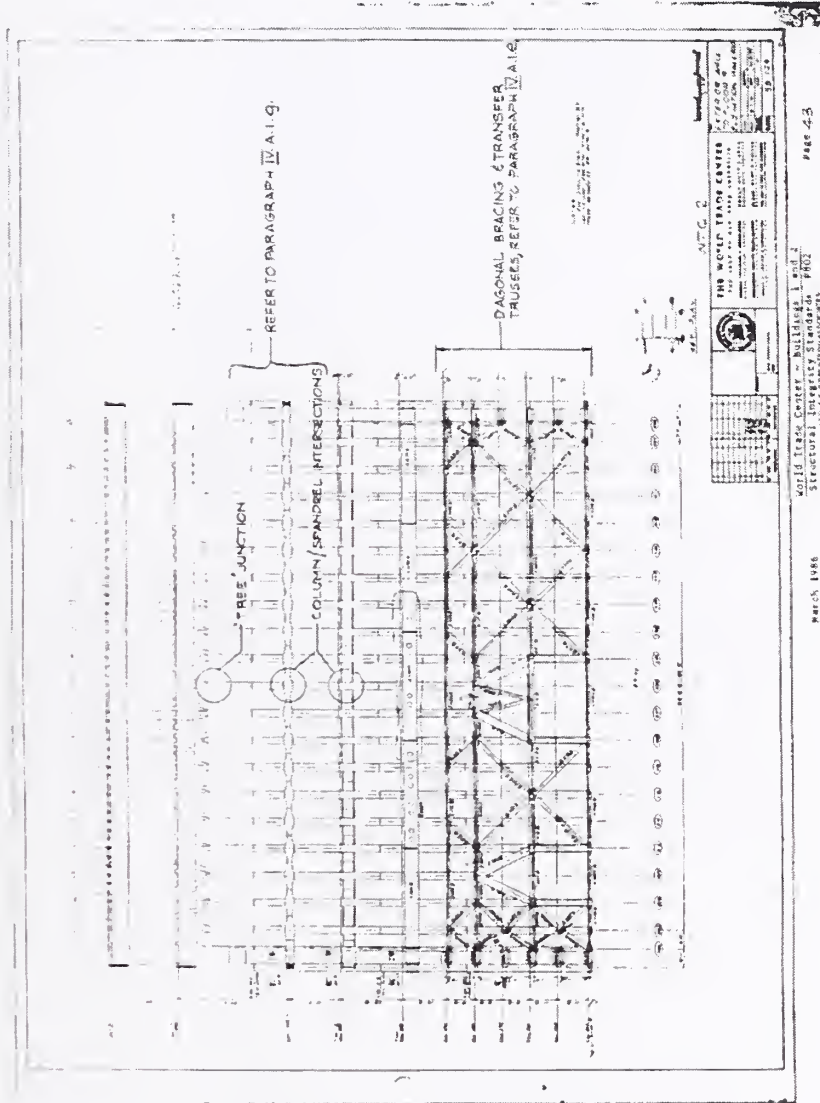

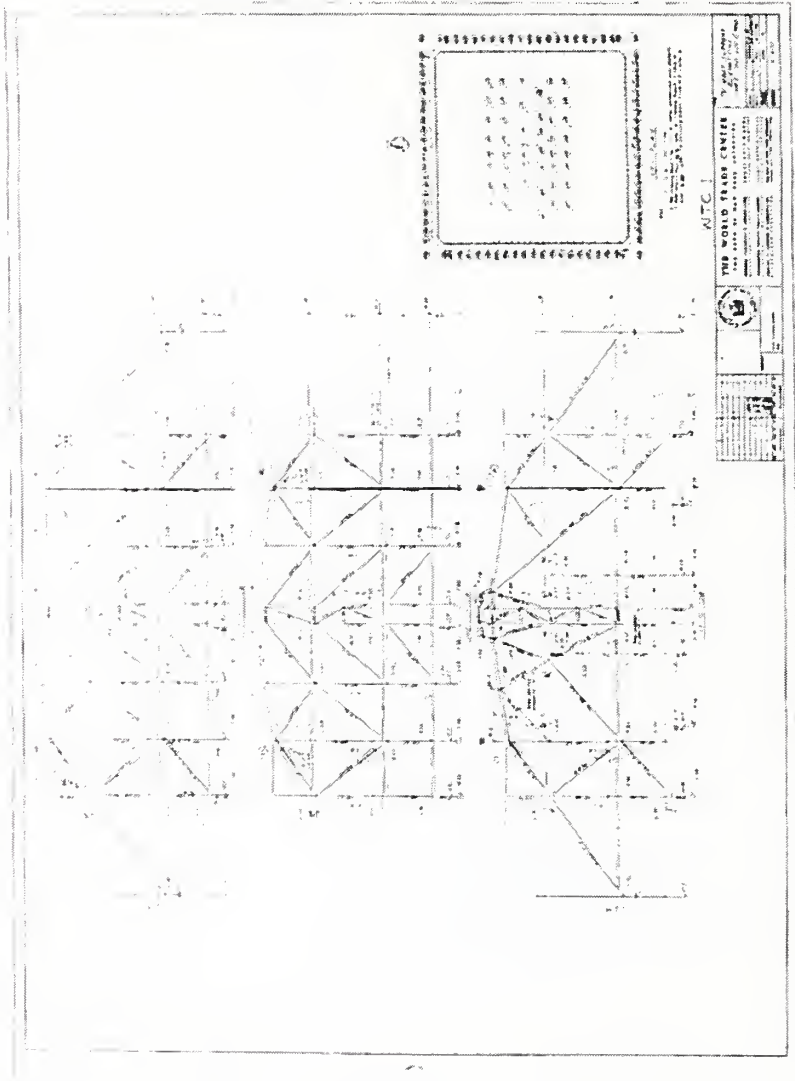

Page 14

World Trade Center - Buildings 1 and 2
Structural Integrity Standards - 1986
(10/18/86)

March 1986

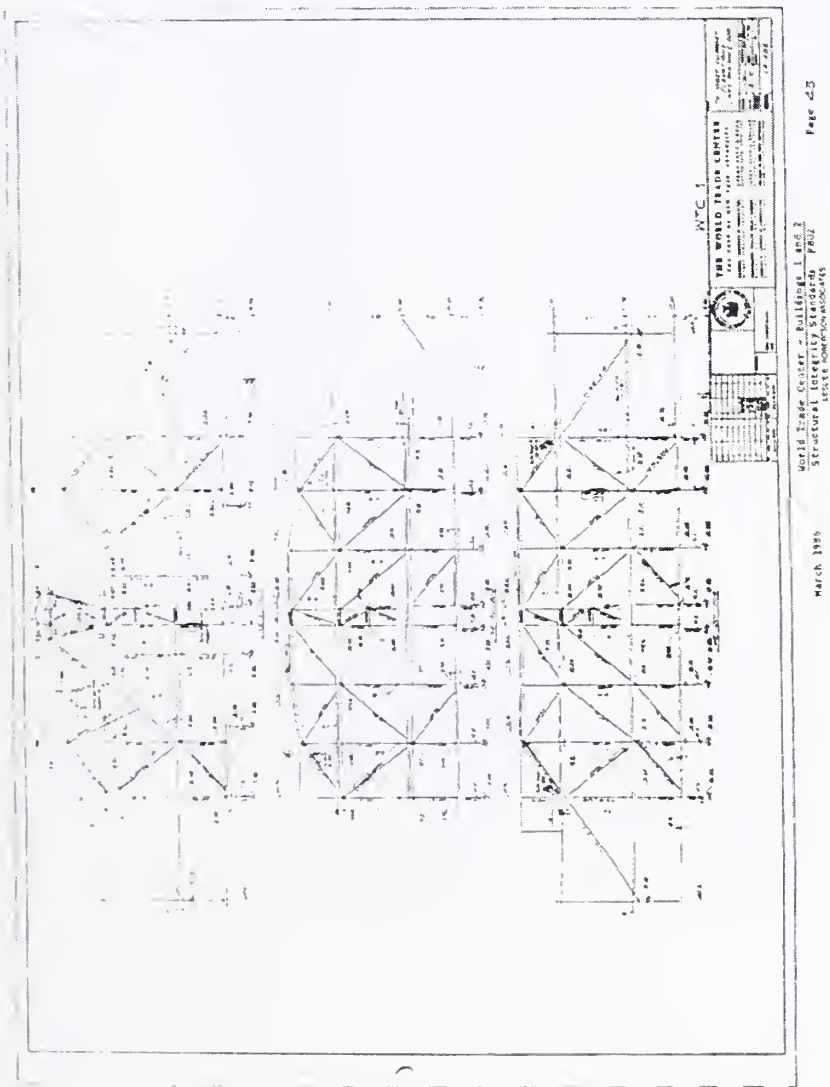

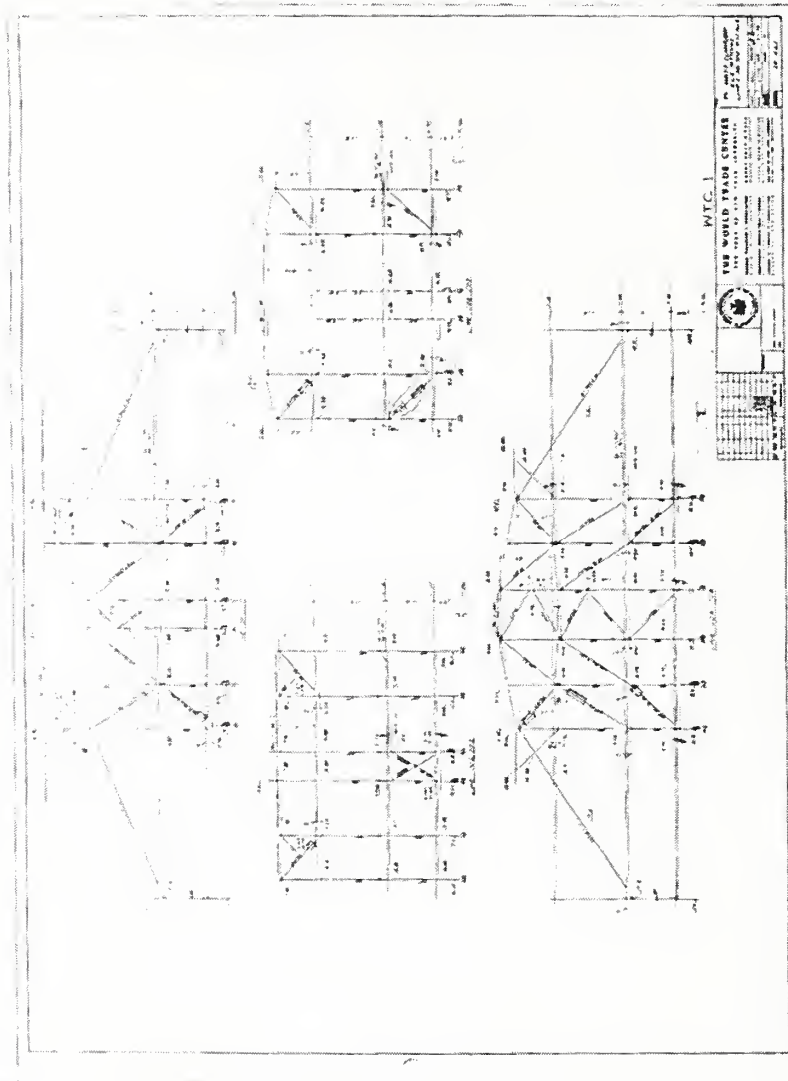

World Trade Center - Buildings 1 and 2
Structural Integrity Standards 1902
March 1946

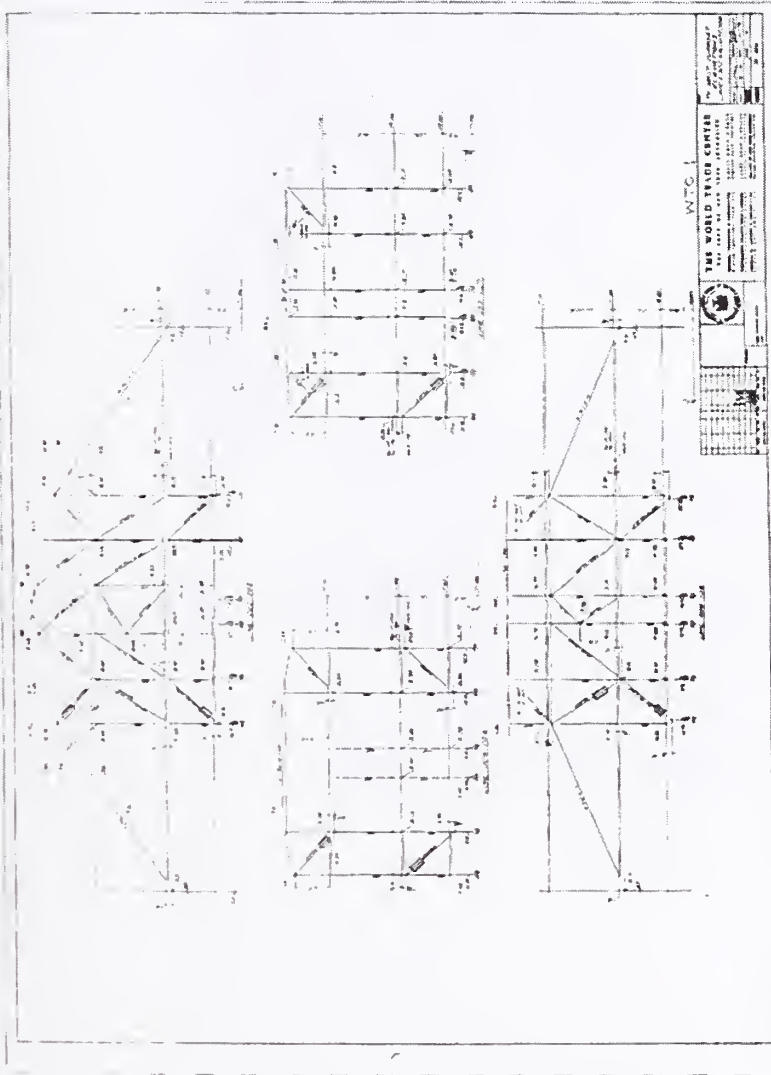

WTC I
THE WORLD TRADE CENTER
110 WALL STREET
NEW YORK, N.Y. 10038
ARCHITECT
CANNON DESIGN GROUP
STRUCTURAL ENGINEER
PERKINS EASTMAN
DATE: 03/19/96
DRAWN BY: [illegible]
CHECKED BY: [illegible]

World Trade Center - Buildings 1 and 2
Structural Integrity Standards "B01"
16247 Reg-0000-00000000

March 1996

Page 47

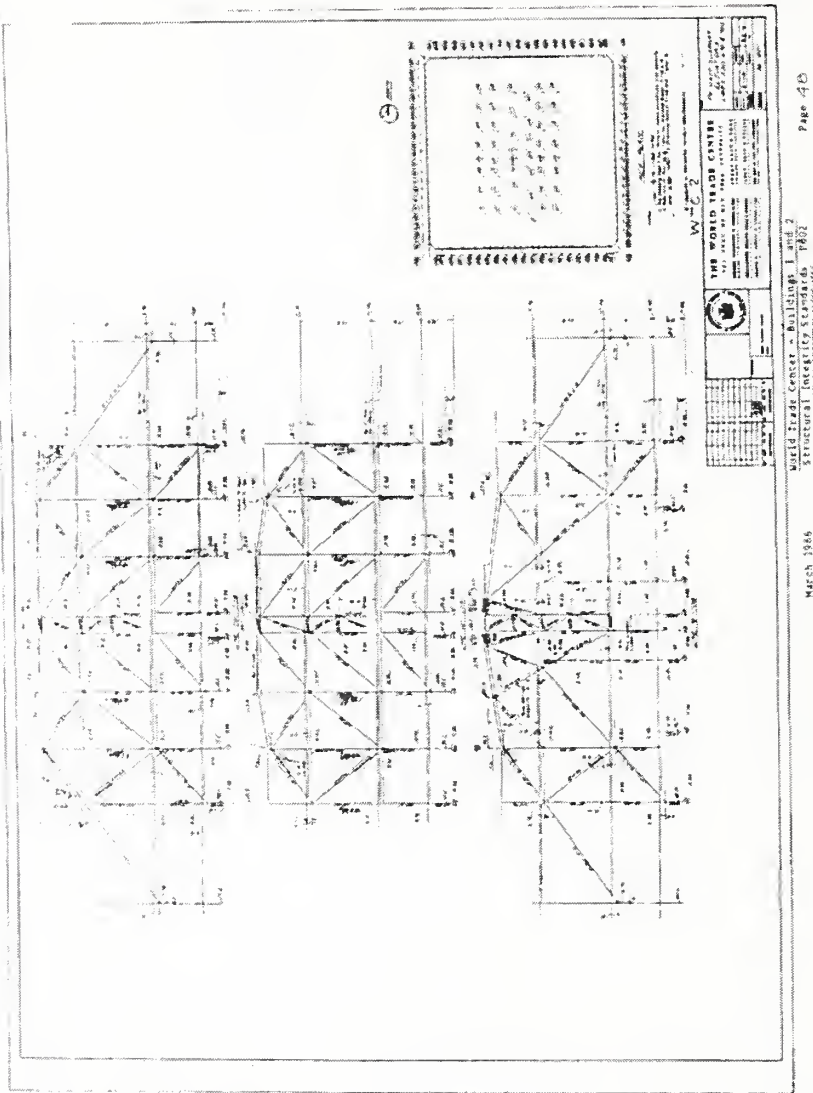

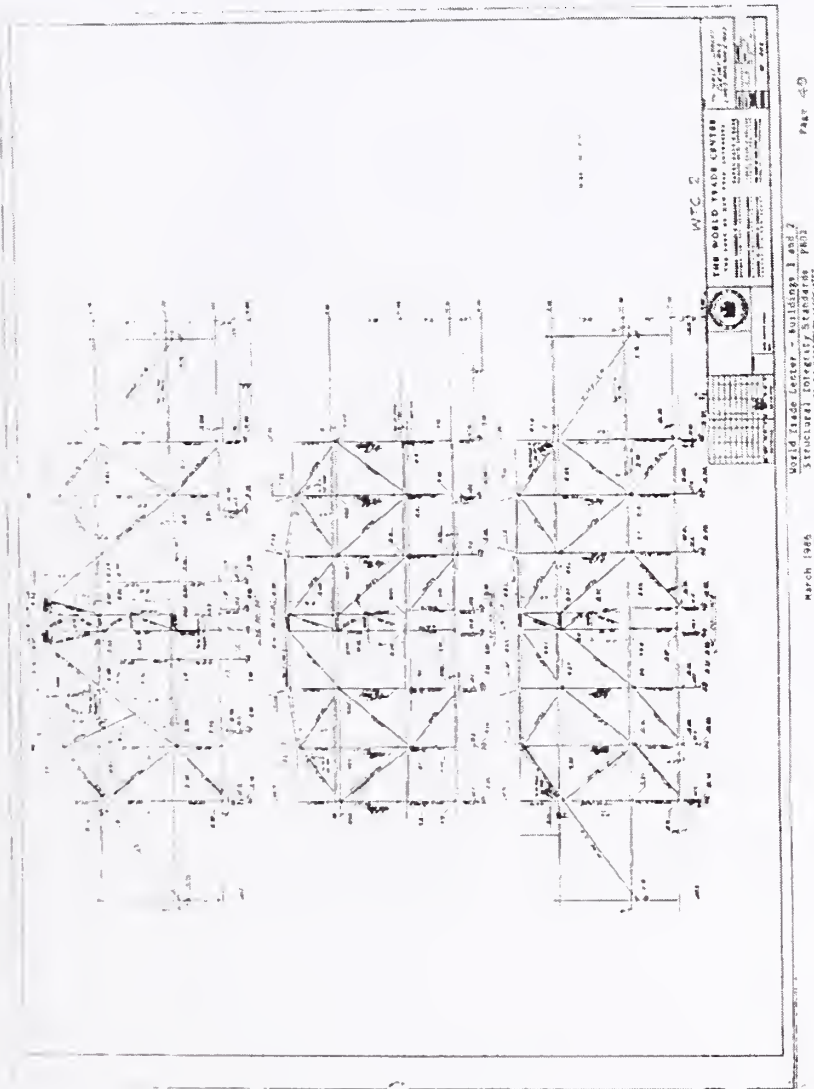

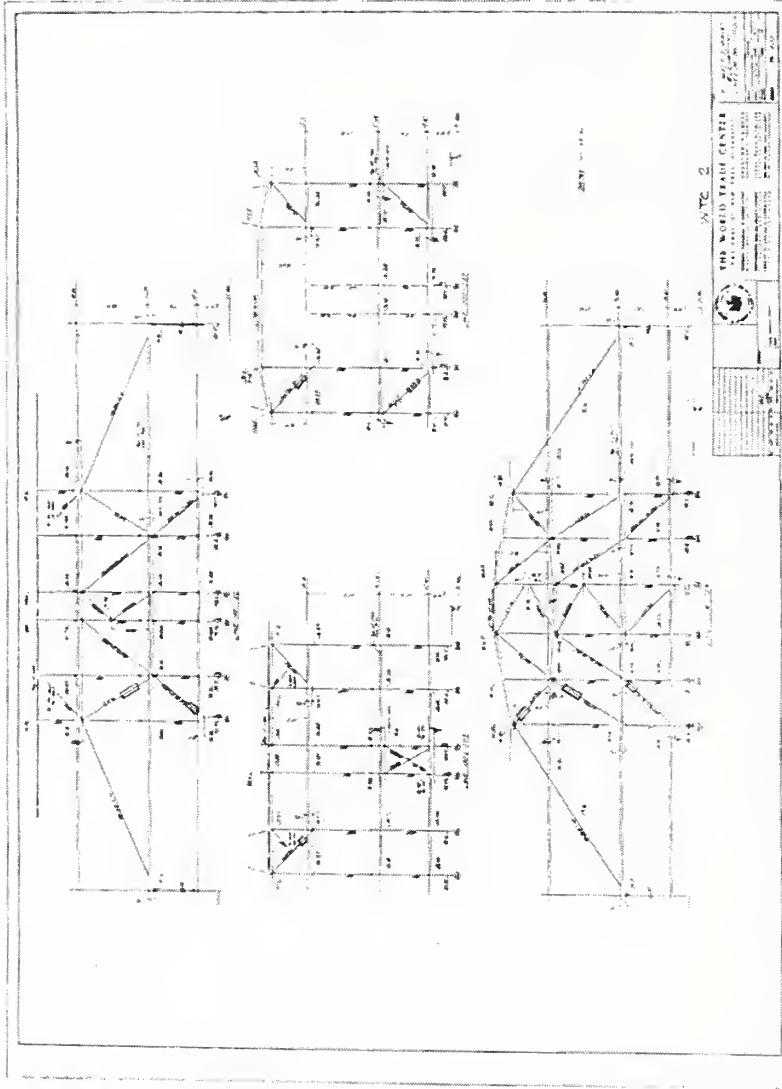

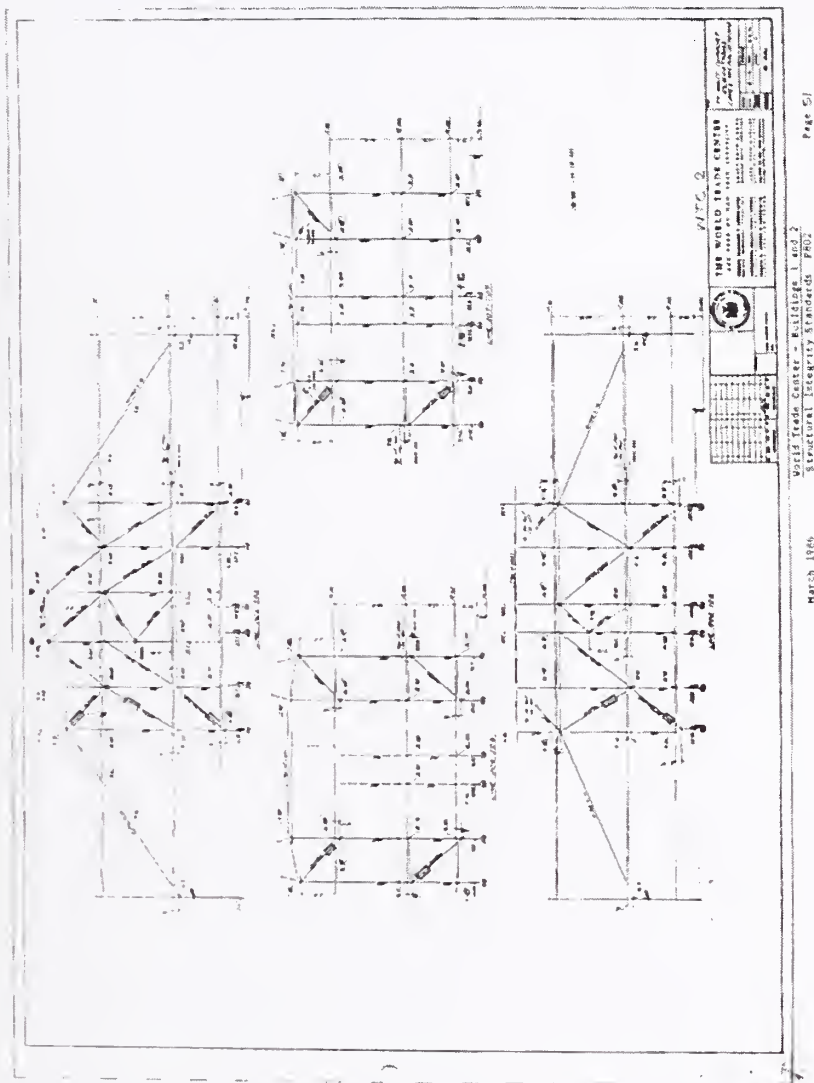

This page intentionally left blank.

Appendix F
ARCHITECTURAL AND STRUCTURAL DESIGN GUIDELINES,
SPECIFICATIONS, AND STANDARD DETAILS



**Architectural and
Structural Design
Guidelines, Specifications
and Standard Details**

Architectural
Structural

February 27, 1998

Reproduced with permission of The Port Authority of New York and New Jersey.

February 27, 1998

**THE WORLD TRADE CENTER
DESIGN GUIDELINES**

STANDARDS FOR ARCHITECTURAL AND STRUCTURAL DESIGN

STANDARDS FOR ARCHITECTURAL AND STRUCTURAL DESIGN

TABLE OF CONTENTS

<u>SECTION</u>	<u>TITLE</u>	<u>PAGE</u>
<u>ARCHITECTURAL DESIGN GUIDELINES</u>		
A.	GENERAL	1
B.	WALL AND CEILING CONSTRUCTION	3
C.	MATERIALS AND METHODS OF CONSTRUCTION	4
D.	SPECIALTY ROOMS AND EQUIPMENT	5
E.	CONTROLLED INSPECTIONS	5
F.	SIGNAGE	6
G.	SUBMISSION OF "AS BUILT" DRAWINGS	6
H.	RETAIL AND PUBLIC SPACE TENANTS	6
<u>STRUCTURAL DESIGN GUIDELINES</u>		
A.	GENERAL	7
B.	CALCULATIONS, LOADS AND DESIGN PARAMETERS	7
C.	CORE HOLES AND OTHER SLAB PENETRATIONS	9
D.	HUNG CEILINGS	9
E.	HVAC EQUIPMENT	10
F.	WALLS	10
G.	EXISTING STEEL	11
<u>STRUCTURAL DESIGN SPECIFICATIONS</u>		
1.	CORING CRITERIA AT TOWER P/T CELLS AND UNDER INDUCTION UNITS (for standard drawings STR-02 through STR-08)	12
2.	LIGHT WEIGHT CEILINGS FOR TOWER FLOORS W/DOUBLE TRUSS (for standard drawings STR-09 through STR-14)	15
<u>ARCHITECTURAL STANDARD DETAILS</u>		
ARCH-01	DRYWALL PARTITION	
ARCH-02	1-HOUR PARTITION	
ARCH-03	1-HOUR RATED PARTITION W/OFF-SET	
ARCH-04	2-HOUR RATED PARTITION	
ARCH-05	2-HOUR RATED PARTITION W/OFF-SET	
ARCH-06	WALL PLAN AT CONVECTORS	
ARCH-07	HEAD DETAIL/JAMB DETAIL (2-HOUR RATED)	

- ARCH-08 ELEVATION DETAILS OF FIRESTOPPING OF
TYPICAL OPENING IN RATED WALL ABOVE CEILING
- ARCH-17 DETAIL OF RAISED FLOOR AT PERIMETER
INDUCTION UNITS

STRUCTURAL STANDARD DETAILS

- STR-01 FLOOR LIVE LOADS - WTC TYPICAL TOWER FLOOR PLAN
- STR-02 CORING CRITERIA - WTC TYPICAL TOWER FLOOR PLAN (See also
Structural Design Specifications, Section A)
- STR-03 CORING CRITERIA - DETAIL AT BUILDING PERIMETER
- STR-04 CORING CRITERIA - PART PLAN - FLOORS 45-48 & 78-82
- STR-05 CORING CRITERIA - PLAN DETAIL OF SPACING AT OFFSET
CORED HOLES
- STR-06 CORING CRITERIA - REBAR SPLICE
- STR-07 CORING CRITERIA - REBAR SPLICE
- STR-08 CORING CRITERIA - REBAR REPAIR

- STR-09 LIGHT WEIGHT CEILING SUPPORT SYSTEM FOR FLOORS WITH
DOUBLE TRUSSES (See also WTC Structural Design
Specifications, Section B)
- STR-10 LIGHT WEIGHT CEILING SUPPORT SYSTEM FOR FLOORS WITH
DOUBLE TRUSSES - SECTION S-1
- STR-11 LIGHT WEIGHT CEILING SUPPORT SYSTEM FOR FLOORS WITH
DOUBLE TRUSSES - SECTION S-2
- STR-12 LIGHT WEIGHT CEILING SUPPORT SYSTEM FOR FLOORS WITH
DOUBLE TRUSSES - SECTION S-3
- STR-13 LIGHT WEIGHT CEILING SUPPORT SYSTEM FOR FLOORS WITH
DOUBLE TRUSSES - TYPICAL SECTION AT PARTITION WALLS
- STR-14 LIGHT WEIGHT CEILING SUPPORT SYSTEM FOR FLOORS WITH
DOUBLE TRUSSES - TYPICAL 2" CHANNEL SPLICE DETAIL

ATTACHMENT "A" - BS&A RULE 501-68-SR - Rules for Governing the Marking of
Transparent Glass Doors and Fixed Adjacent Glass Sidelights Rule.

ARCHITECTURAL DESIGN GUIDELINES

A. GENERAL

The following is a guide for the architectural design requirement and criteria for tenant alterations at the WTC. The scope of the architectural review shall be to ensure compliance with the applicable codes, standards, and WTD Design Criteria.

1. ADA Compliance

All tenant spaces must conform to the latest design criteria established by the Americans with Disabilities Act (ADA), and Local Law # 58. A note specifying compliance should appear in each set of drawings. These requirements include but are not limited to the following:

- a) **HARDWARE** - All hardware must conform to ADA requirements. Lever type knobs and panic bars are recommended for all doors.
- b) **ACCESS/CORRIDOR DIMENSIONS** - All spaces within the tenant area must be equally accessible to the handicapped as specified by the ADA.
- c) **STROBES** - All areas must be furnished with strobe lights (visual alarms). These strobes must be connected to the floor Class 'E' alarm system. See details in the Fire Alarm Design Guidelines.
- d) **TOILETS** - Plans and elevations of the toilet for disabled people shall clearly show all critical dimensions as per ADA requirements.

2. Asbestos

A leasehold may contain vinyl asbestos floor tiles (VAT) which were installed during the initial construction of the World Trade Center. They are probably in good condition and, if not disturbed are safe. If a tenant is planning construction or any modifications which may disturb these tiles, the removal of the VAT is required. The tenant may choose one of the following options for the abatement of the VAT:

- a) The tenant may obtain the services of a NYS Department of Labor licensed abatement contractor to remove the VAT. In this case a TAA must be filed with the Tenant Alteration Application Unit of the World Trade Department. Drawings of the required air lock enclosures and specifications for the asbestos removal must be submitted for review with copies of the contractors abatement licence and certificate of insurance.

The tenant is required to submit documentation of the project once completed.

- b) The tenant may retain the services of the World Trade Center Call-in abatement contractor. In this case the tenant must submit a written request to World Trade Department. Documentation will be issued to the tenant upon completion of the VAT removal.

3. Egress Analysis

An Egress Analysis shall be a part of all submissions in which the proposed work effects the movement of people through the space. This analysis will include at minimum, the following information:

- a) Construction Classification/Occupancy Classification
Generally office space and related spaces shall be designed to meet the requirements of occupancy Group E classification and Construction Class I-B, in accordance with the latest edition of the NYC Building Code.

Indicate the occupancy classification for all equipment and storage rooms (indicate type of storage) to ascertain the proper fire resistance rating for walls separating these rooms. Indicate the type of construction used to obtain the fire rating for all demising walls.

- b) Entrance and Egress
All exit doors and their sizes to be used to exit any space must be indicated on the drawing, as well as the allowed occupant load per exit width as per NYC Building Code.

- c) Travel Distances
Travel distances to primary and secondary exits must be indicated following the path of travel through each space.

No equipment, partitions, fixed tenant installations, or other facilities should be located where they may block or interfere with egress.

4. Occupant Load

The office floors have been designed to sustain a live load, including partitions, which shall not be exceeded. In areas where there is a concentration of files, storage, or heavy equipment, verification of the structural integrity of the floor system in these areas is required. See the Structural Design Guidelines for details.

B. WALL AND CEILING CONSTRUCTION

The WTD has available for the tenant's architect/engineer standard reference details which show examples of the depth and clarity of information required to be shown on the drawing for the construction of various wall and ceiling types. See attached WTC Standard Architectural and Structural Details.

1. Core Walls

All core wall shall have a 2-hour fire rating as required by the NYC Building Code.

2. Demising Walls

Walls separating tenants shall have a minimum 1-hour fire rating unless otherwise indicated by occupancy/use group.

3. Corridor Walls

Corridor walls shall have a fire-resistance rating of 2-hour as required by WTC and have a self-closing swinging type doors 1-1/2 fire resistance-rating.

4. Ceiling Construction

On tower floors with double trusses the WTC requires the suspended ceiling to be installed as detailed on the Standard Architectural Details STR-10 through STR-14 attached. All other areas and special installations must meet the requirements of the New York City Building Code.

A BS&A or MEA resolution of approval is required for ceiling tiles.

5. WTC Standard Ceilings

The new building standard suspended ceiling in public corridors is, 24" X 24" X 3/4" mineral fiber lay-in tile, Ultima RH90, beveled tegular, No.1782 for 9/16" slotted tee grid, by Armstrong.

C. MATERIALS AND METHODS OF CONSTRUCTION

No material, assemblies, forms, method of construction, equipment, machinery and devices will be acceptable for the intended use unless:

Accepted by the Code test method by the Materials and Equipment Acceptance (MEA) division of the Office of the Commissioner of the Buildings Department of New York City.

OR

Approved by the New York City Board of Standards and Appeals (BS&A)

Resolutions of MEA or BS&A shall be submitted for review. Manufacturers' or distributors' letters will not be acceptable.

1. Floor Coverings

The architect or engineer-of-record is required to obtain, certify, and supply for review documentation that the carpet has been tested by an independent laboratory (approved by the City of New York), showing the complete test data results in accordance with the New York City Building Code. Manufacturer's or supplier's data is unacceptable.

Carpet and carpeting assemblies shall not be installed in stairways designed to meet building code exiting requirements.

Carpets should be (~~but are not required to be~~) installed utilizing the "tackless" method which allows easier removal under the tenant's restoration obligation. The padding should be cemented to the subfloor at the perimeter with a "release" adhesive. Adhesives in all instances must be non-flammable. If rubber padding is used, all seams must be taped.

The tenant is required to provide all necessary access to trench header ducts and junction box cover plates for under floor conduit systems. If access is not provided, the tenant assumes all costs associated with the pulling-back, removing, and reinstalling of the carpet.

2. Raised Floor Systems

All raised floor systems must have a BS&A or MEA Resolution capable of withstanding the imposed loads.

For a raised floor not more than 10" in height, a minimum of 1-1/2" clearance is required between the edge of the raised floor and the induction unit (IU) enclosure. For furniture or a raised floor more than 10" in height, a minimum of 6" clearance shall be maintained between the edge of the raised floor and the front of the induction unit enclosure. Additional removable floor grilles should be installed on the edge of the raised floor in front of the induction unit. See

Architectural Detail ARCH-17 for installation of raised floors which meet at the perimeter induction units.

3. Window Treatments

The WTC standard window covering is a horizontal blind, brushed aluminum finish, with 1" slats.

4. Transparent Glass and Fixed Adjacent Glass Sidelights

Transparent glass walls are required to be marked as per BS&A Rule 501-68-SR, Rules for Governing the marking of Transparent Glass Doors and Fixed Adjacent Glass Sidelights Rule. (See Attachment "A" to these guides)

5. Fire Shutters

Where spaces are provided with automatic fire shutters used to maintain the fire-rating, a safe means of egress shall be provided for persons who may remain inside the space after the grill is closed due to fire emergency. This additional egress must be in accordance with code requirements.

6. Fabric and Vinyl Wallcoverings

All fabric and vinyl wall coverings must have a copy of the BS&A or MEA resolutions submitted for approval.

D. SPECIALTY ROOMS AND EQUIPMENT

1. Storage Areas

Provide appropriate fire separations according to occupancy classification as per the NYC Building Code.

2. Computer Rooms

See the Mechanical and Fire Protection Guidelines for inclusion of Pre-action and Halon fire suppression systems.

E. CONTROLLED INSPECTIONS

All materials, equipment, and construction designated by the Code for "controlled inspection" shall be inspected and/or tested to verify compliance with the Code. Controlled inspections shall be made and witnessed by or under the direct supervision

of a registered architect (RA) or professional engineer (PE) retained by the tenant and acceptable to the architect or engineer responsible for the plans. The inspecting RA or PE shall be independent of the contractor.

F. SIGNAGE

1. Office Tenants

The World Trade Center will provide each tenant with one door sign and directory listings in the main lobby, skylobby and on the tenant's floor. Each tenant is entitled, by lease to a 12" X 12" acrylic door sign engraved with the company name and suite number.

Tenants who desire a non-standard door sign must first obtain approval of the WTD's Tenant Services Unit before proceeding with any such installation. The maintenance, repair, replacement, etc. of non-standard door signs, is the sole responsibility of the tenant.

G. FINAL SUBMITTAL

All alterations made to tenant spaces must have "AS BUILT" drawings submitted to the Tenant Alterations Unit of the World Trade Department upon completion of the job. Such AS BUILTS shall be submitted in the form of one complete set of Mylar reproducible drawings stamped AS BUILT and signed and verified by the consultant of record and the contractor and one (1) cadd disk (3-1/2", 1.44 mega Bytes floppy).

The architect shall state in the general specification the submission of such AS BUILTS

H. RETAIL AND PUBLIC SPACE TENANTS

See "Interim Tenant Design Criterial" for aesthetic criteria in public spaces at the World Trade Center.

STRUCTURAL DESIGN GUIDELINES

A. GENERAL

Before starting any design work, the tenant's consultants must perform a field inspection of all pertinent areas to verify that they have the latest information about all structural elements. This includes information about truss reinforcement, if any, stair openings in slab and core-hole locations..

All calculations and construction drawings shall be submitted to the Port Authority for review and approval, and must be signed and sealed by a professional engineer or registered architect who must be licensed to practice in the state of New York.

Whenever calculations are submitted, a statement shall be made next to the seal on the cover sheet that "the professional seal and signature affixed hereon is all inclusive for the full contents of this document." Alternatively, a separate seal and signature on each individual calculation sheet will also be acceptable. Four sets of calculations will be submitted with the first submission, and four copies of each revised sheet in any required subsequent submissions.

B. CALCULATIONS, LOADS, AND DESIGN PARAMETERS

The proposed floor loads shall be compared with the allowable design loading. Drawing STR-01 shows the allowable loading for a typical tower floor and also indicates limitations on the dimensions of concentrated loads. The design loads take into consideration all live load reductions on the trusses and also include the weight of partitions. For additional information or information on the other buildings in the complex contact Mr. Suren Batra WTC Structural Engineer, at (212)435-2409

The tenant's loads must not overstress the existing structural system. If required, the floor system can be reinforced. Calculations to compare the proposed loading with the allowable, and any revision to the floor system shall be made in conformance with the latest edition of the NYC Building Code. Both, "Allowable Stress Design" and "Load Resistance Factor Design," are acceptable methods of design.

When applicable, in place of a detailed investigation of the stresses in the existing structure, the moments and shears due to the tenant's proposed live loads may be compared with the moments and shears produced by the original design live loads shown on drawing STR-01.

The corner sections of a typical floor, work as a two-way truss system. Portions of the corner areas can take greater loads than those shown on drawing STR-01. An analysis of the tenant's loads based on a two way truss grid may yield satisfactory results for higher loads placed in a non-critical area of the corners.

To cover an existing floor opening by a slab, all structural elements shall be designed for the strength of the adjacent existing areas, and not the theoretical design loads. This is particularly necessary for any slab which has an overload capacity to support local concentrated loads.

Show and locate on the construction drawings:

- a. The weight of any equipment, or cluster of equipment, exceeding 500 lbs.
- b. All files and shelves. Provide a legend showing each type of file or shelving unit, and indicate the size and number of tiers for files and the height for shelves.

The following minimum loads shall be used for calculations when applicable:

- a. File cabinets: 33 psf per tier, includes the weight of the cabinet.
- b. Open shelves for paper storage: 46 pcf of the net volume plus the weight of the shelves.
- c. Mechanized file storage: Use the manufacturer's indicated fully loaded weight, or the net weight of the storage unit plus 46 pcf for contents.
- d. Libraries:
 - 1) Aisle loading:
 - for aisle width equal to or less than 30", use 30 psf.
 - for aisle widths greater than 30", use 60 psf.
 - 2) Reading areas - 60 psf.
 - 3) Open shelves - 46 pcf of the net volume plus the weight of the shelves.
- e. File rooms aisle loading:
 - for aisle widths equal to or less than 30", use 30 psf.
 - for aisle widths greater than 30", use 50 psf.

Bases (and heads) for rail posts, auxiliary columns, etc. shall be designed for the required loads. Plates and bolts are to be fully detailed on the drawings, including the location and number of anchor bolts, manufacturer, type, size, embedment length, etc.

Wherever proprietary devices are used to transfer loads, submit for review, the BS&A number, the manufacturer's name, and a catalog cut.

C. CORE HOLES AND OTHER SLAB PENETRATIONS

A survey of slab penetrations in the vicinity of the proposed cores shall be submitted as early as possible in the review process, so that the need for repairs to the existing cores may be determined. Repairs shall be made as per attached details STR-06 through STR-08

Proposed penetrations or cores in the slab shall be clearly identified on the construction drawings for the trade that is expected to do the coring.

The dimensioned location of all new penetrations or cores shall be shown on the "As Built" drawings.

Proposed penetrations or cores in tower slabs shall meet the criteria for location, spacing, etc. as specified in the attached drawings STR-02 through STR-08, and Structural Design Specifications, page 12. New penetrations or cores are not allowed in "Prohibited" areas. Penetrations or cores may be located in "Restricted" areas. However, damaged steel must be repaired as per details shown on drawings STR-06 through STR-08. It is advisable to avoid "restricted" areas in the design. Each "restricted" area penetration or core shall be labelled as such on the drawing and reference made to STR-06 through STR-08, which shall then be included in the contract set.

Proposed cores in the vicinity of "Prohibited" or "Restricted" areas, shall be dimensioned on the drawings using the face of the glass as a reference.

D. HUNG CEILINGS

Where new ceilings are to be installed, unless otherwise noted, it will be assumed that the existing ceiling suspension system will be removed and replaced.

For ceilings in the double truss areas of the towers, the span between trusses requires that the size of the carrying channels and caddy clips be larger than that required by the NYC Building Code. Provide the details shown on Drawings STR-09 through STR-14 on the construction drawings.

The carrying channels must be perpendicular to the existing trusses. Concrete anchors into the slab shall only be used:

1. At the end of the trusses where the truss lower flange is at a higher than normal elevation (see Section S-1, on STR-10) and,
2. Where the the hung ceiling is not continuous at a partition and there is no truss within 10" of the partition (see STR-13, "Typical Section at Partition Wall."). In all other cases the ceiling rods shall be hung from the trusses.

In the rest of the facility (without double trusses), the ceiling shall comply with the NYC Building Code, Reference Standard 5-16, figures 3A, 3B and 3C. Concrete anchors shall be one of the preapproved anchors listed in the Structural Design Specifications, Section B. A complete detail with all the specified materials shall be shown on the drawings. The detail shall include the type and size of materials and the embedment length of anchors.

E. HVAC EQUIPMENT

For all HVAC equipment provide on the drawings the weight, dimensions, the proposed locations, and specify whether they are floor mounted or hung from above.

For hanging ducts, fans and AC units under 500 lbs., refer to the details shown on Drawings HVAC-21 through 28. The tenant's consultant is still responsible to verify the integrity of the existing structure from which the units are hung (information on the tenant loading from the floor above is available from WT Tenant Services). Where the weight of the unit exceeds the limits shown on the above drawings, calculations must be provided showing that the unit's proposed support system can carry the load.

For floor mounted equipment, provide calculations showing that the existing construction will not be overstressed due to the weight of the units and show all mounting details on the drawings.

F. WALLS

Where there is a wall over an opening such as a door or over a non-supportive material such as plastic, glass, etc., either a suitable lintel shall be designed or the wall may be suspended by studs from above. However, the top and bottom connections and diagonal braces attached to the slab above (where required for stability of the wall) shall be appropriately designed and detailed on the drawings.

G. EXISTING STEEL

Holes shall not be made in existing steel for hanging purposes. Welds shall not be made to the trusses. BS&A or MEA approved clamps shall be used.

STRUCTURAL SPECIFICATIONS

1. CORING CRITERIA AT TOWER P/T CELLS AND UNDER INDUCTION UNITS

Scope and General Notes

1. This criteria applies only to those holes cored into the Power/Telephone cells and under induction units and only in the following typical tenant floors:

1 WTC	10 to 40, 45 to 74, 78 to 105
2 WTC	14 to 40, 45 to 74, 78 to 106

2. For modifications of criteria at stair and escalator openings at floors 45 to 48 and 78 to 82 in both towers see Drawing STR-04.
3. Existing cored holes being reused are to be included in this criteria.
4. Maximum core size is 4" diameter, where permitted. Minimum average center to center spacing along a Power/Telephone cell for any four (4) consecutive cored holes including abandoned and filled holes is 1'-4". For restricted and prohibited zone destinations, see notes 5 and 6. For spacing criteria along Power/Telephone cells adjacent to holes offset from cells - see Drawing STR-05.
5. Restricted Zone:

Carefully locate cores to avoid cutting #4, #5 and #6 rebars, or repair cut and damaged rebars.

Where the proposed location of a new hole can be changed in order to clear the existing rebars and avoid the need for repairs, use a bar locator or electric hammer the slab to locate the rebars.

See Drawing STR-06 through STR-08 for rebar repair details.

6. Prohibited Zones:

Coring is prohibited, except within the induction units at the Power/Telephone Cells only, which should be considered a restricted area and as noted in part plan detail at building perimeter. See Drawing STR-03.

See Drawings STR-06 through STR-08 for rebar anchor repair details.

7. Existing cored holes which are to be abandoned and which do not have damaged rebars or column straps are to be filled with non-shrink grout. See detailed requirements rider C, paragraph 15 of the Tenant Alteration Application. Abandoned core holes which require repairs to straps will be repaired by the Port Authority.
8. Where concrete or fill material is to be removed, exercise due care not to damage existing reinforcement. Under no circumstances should column strap anchors be damaged.
9. Extension dimension are measured from the glass face at the exterior wall.
10. Drawings of the proposed core locations are to be submitted by the tenant for review. World Trade Construction must be notified in advance when coring or other work is to start so that provisions can be made for inspection.
11. Remove rust, grease, cement and other contaminants from structural steel and rebar surfaces before welding.
12. Tenant shall submit certification that welders are qualified in accordance with the NYC Building Code and with applicable laws and requirements for each specific welding procedure and process which the welder will use in the work.
13. Where information in the drawing conflicts with information in Rider C of the Tenant Alteration Application, this drawing governs.

Codes and Material

1. All work shall conform to the requirements of the New York City Building Code, latest edition and revision.
2. Where more stringent, the latest edition, with supplements to date where applicable, of the following codes shall apply to the work:
 - a. American Institute of Steel Construction, "Specification for the Design, Fabrication and Erection of Structural Steel for Buildings." Supplement 1 is specifically excluded.
 - b. American Concrete Institute, "Standard Building Code Requirements for Reinforced Concrete" (ACI 318).
 - c. American Welding Society, "Structural Welding Code - Structural Steel (AWS D1.1) and Reinforcing Steel" (AWS D1.4).

3. Added structural steel plates shall conform to ASTM A36.
4. Added rebar shall conform to ASTM A615, Grade 60.
5. Welding materials for structural steel shall be E7018 conforming to AWS A5.1 "Specifications for Covered Carbon Steel Arc Welding Electrodes." –
6. Welding materials for reinforcing steel shall be E7018.
7. Non-Shrink Grout shall be Crystex by L&M Construction Chemicals Company, or an equivalent material acceptable to the WTC.

2. LIGHT WEIGHT CEILING SUPPORT SYSTEM FOR FLOORS W/DOUBLE TRUSS

NOTES:

1. Materials

Concrete Anchors - 3/8" diameter Liebig safety bolts (type LSN or LSH) with a minimum embedment length of 1-3/4", or Hilti HSL or HSLB anchors, size M8 with a minimum embedments length of 2-1/2" and a maximum embedment length of 3".

Clip Angles - Hot rolled ASTM A36 steel.

Hangers - 1/4" diameter A36 galvanized steel rod

Carrying Channel - 2" cold rolled channels (Fy=33ksi minimum). Minimum weight 590 lbs./1,000 linear feet (painted).

Hanger to truss connection - at cover plate only

a. Thickness of bottom flange of truss $t < 0.75"$:

Caddy heavy duty flange clamps manufactured by Erico Products Inc. BSA 1312-64-SM.

b. Thickness of bottom flange of truss $t > 0.75"$:

Universal C-clamp Fig. 93 (wide throat) 0.41 pounds each as manufactured by Grinnell Corp., or approved equal. Install C-clamp with set screw in top position.

Hanger to carrying channel - Caddy Gat channel clamp, Model 4B2LS, as manufactured by Erico Products Inc. BSA 131-68-SM.

Wire ties - 16 Gauge stainless steel AISI - Type 304 Monel metal.

2. Removal of fireproffing shall be kept to a minimum and shall be replaced by the contractor as directed by the Port Authority.
3. The contractor shall be required to submit catalog cuts, samples, layout drawings and details of all components of the ceiling support system for the Port Authority's review and approval prior to the start of any work in the field.

4. The Ramset fastening system with Ladd drive pin number 684 (1-1/2" long), power level "RED" for installation, and the Ladd ceiling clip number 651 is permitted to substitute the hanger top connection detail shown in Section S-1 on STR-10, anchored into 3000 psi light weight concrete slab over galvanized metal deck.

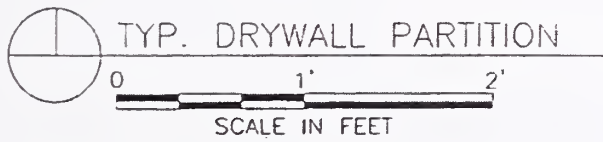
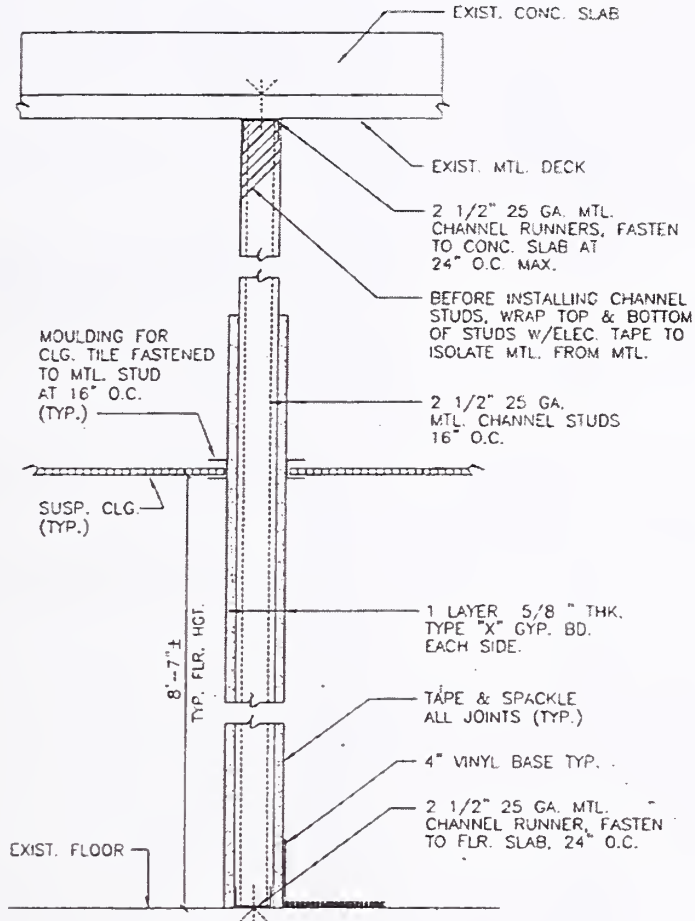

ARCH-01

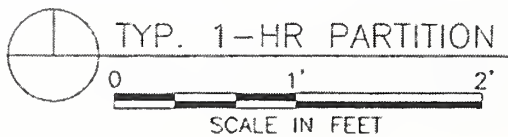
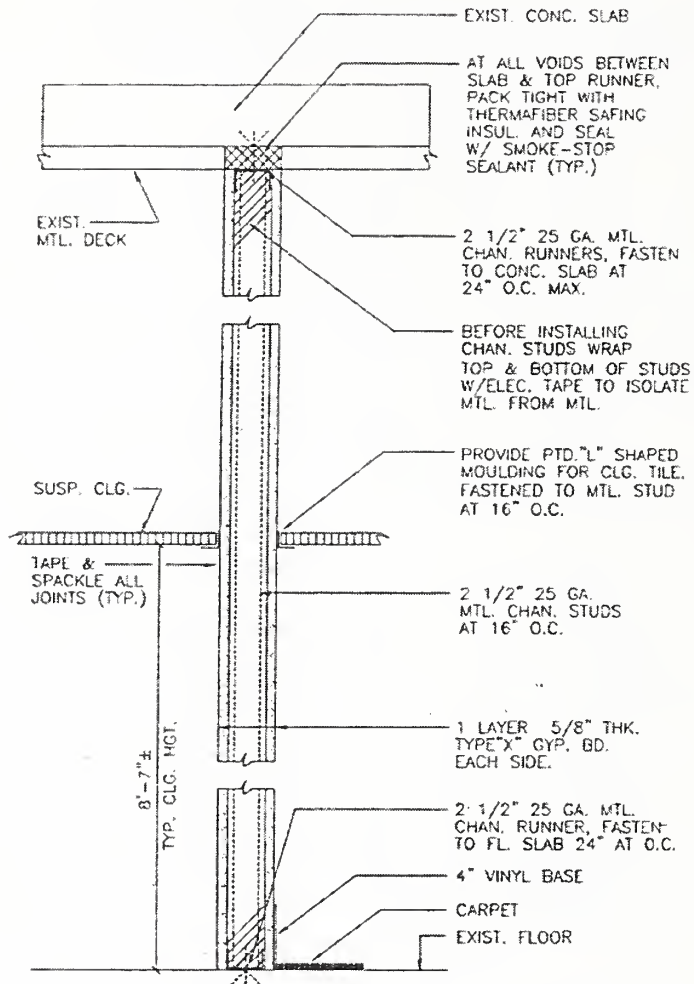

ARCH-02

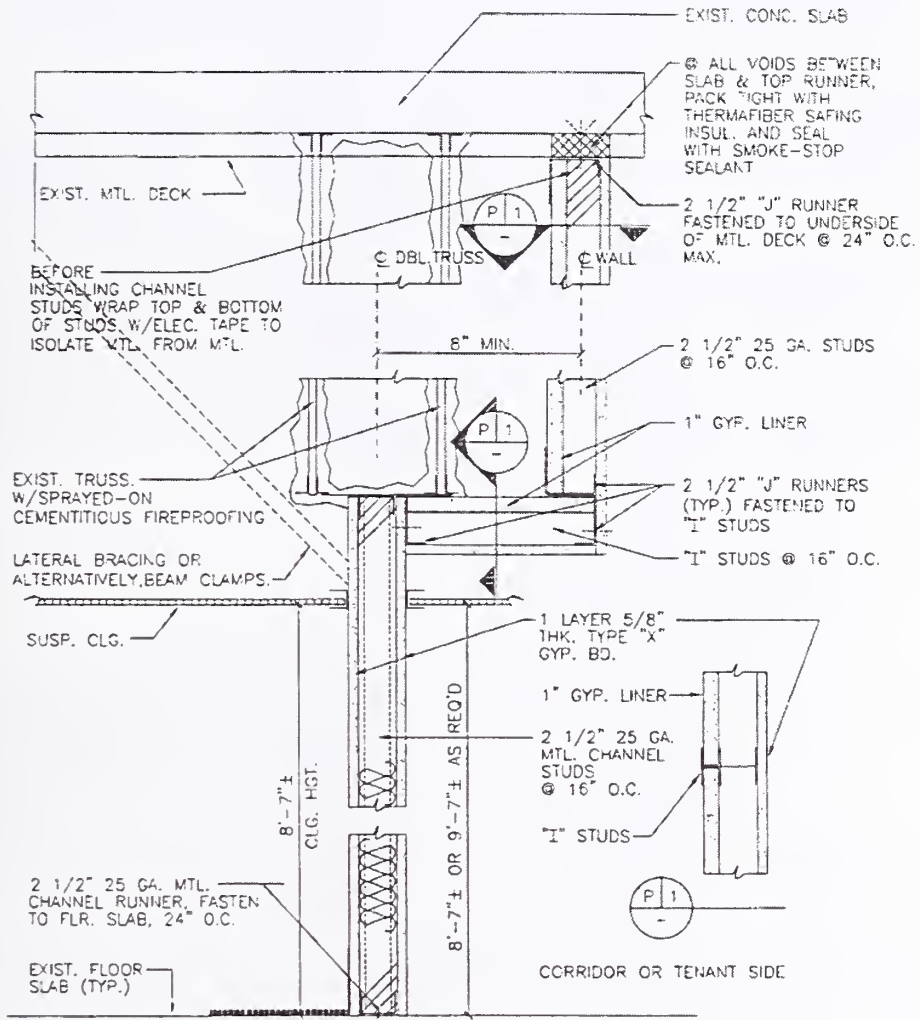

⊙ TYP. 1-HR PARTITION W/OFFSET

0 1' 2'

SCALE IN FEET

ARCH-03

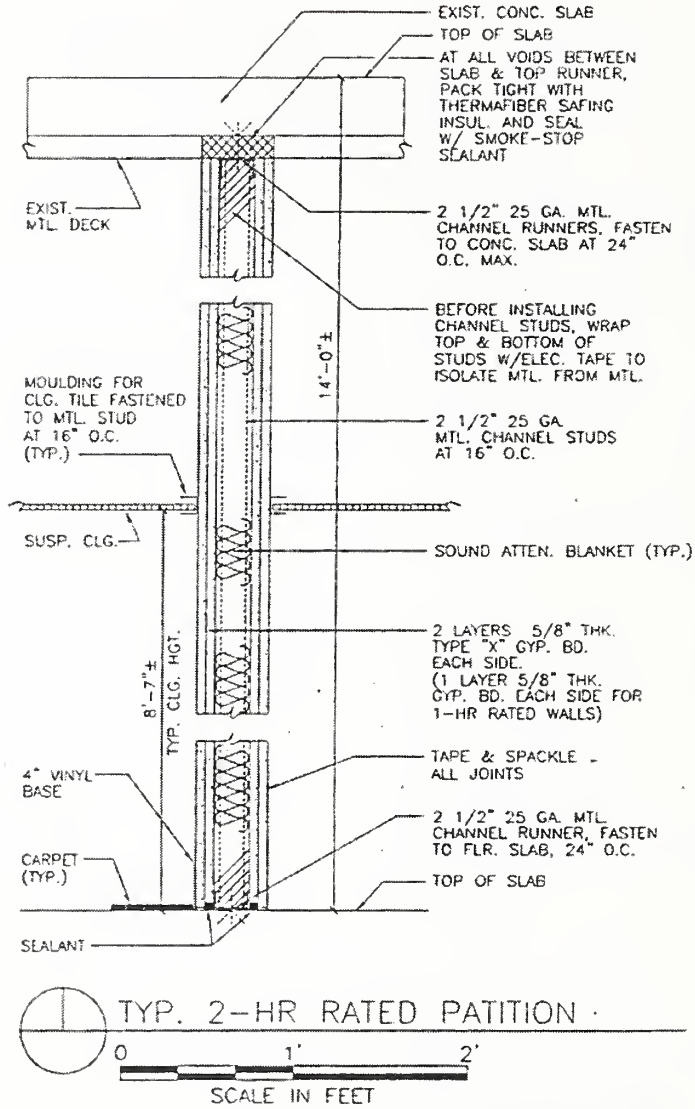

ARCH-04

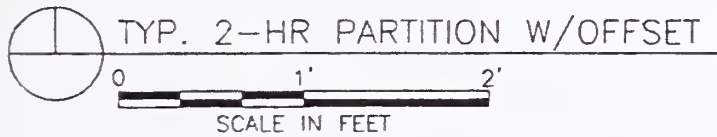
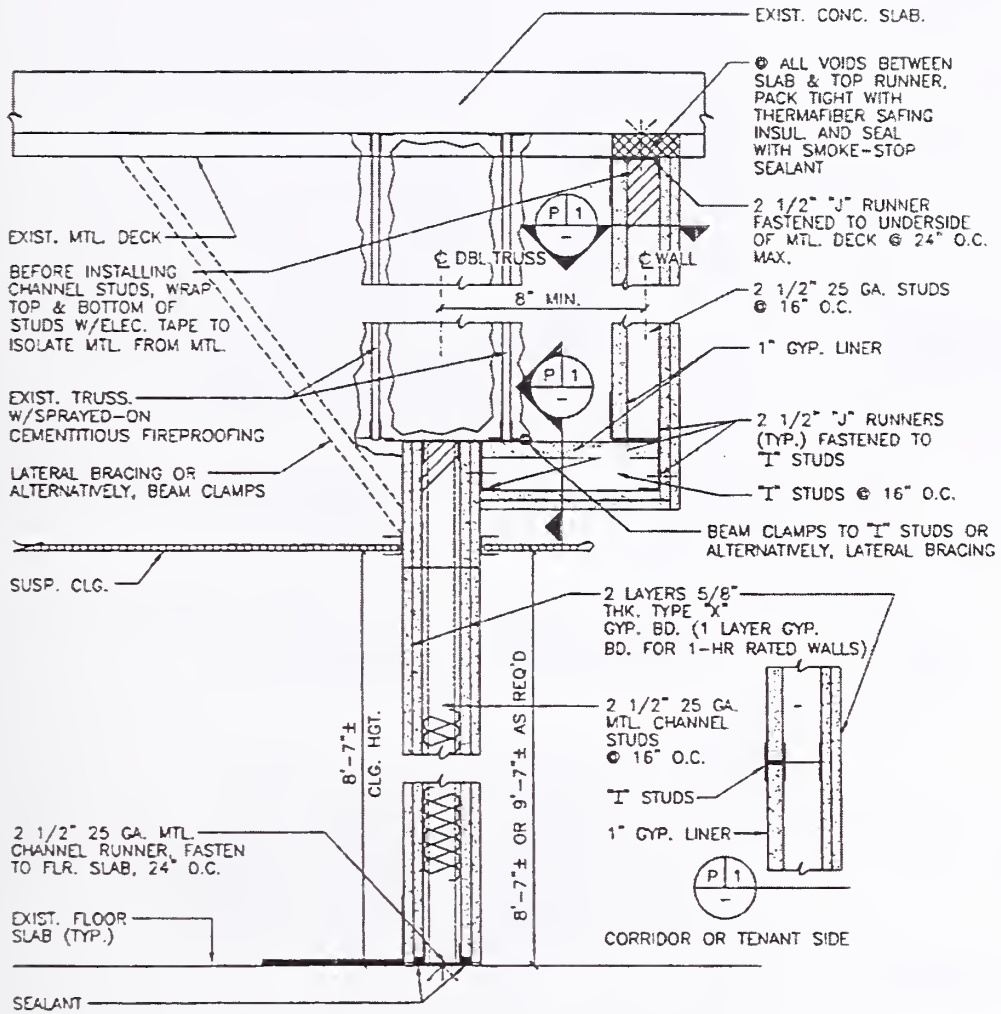

ARCH-05

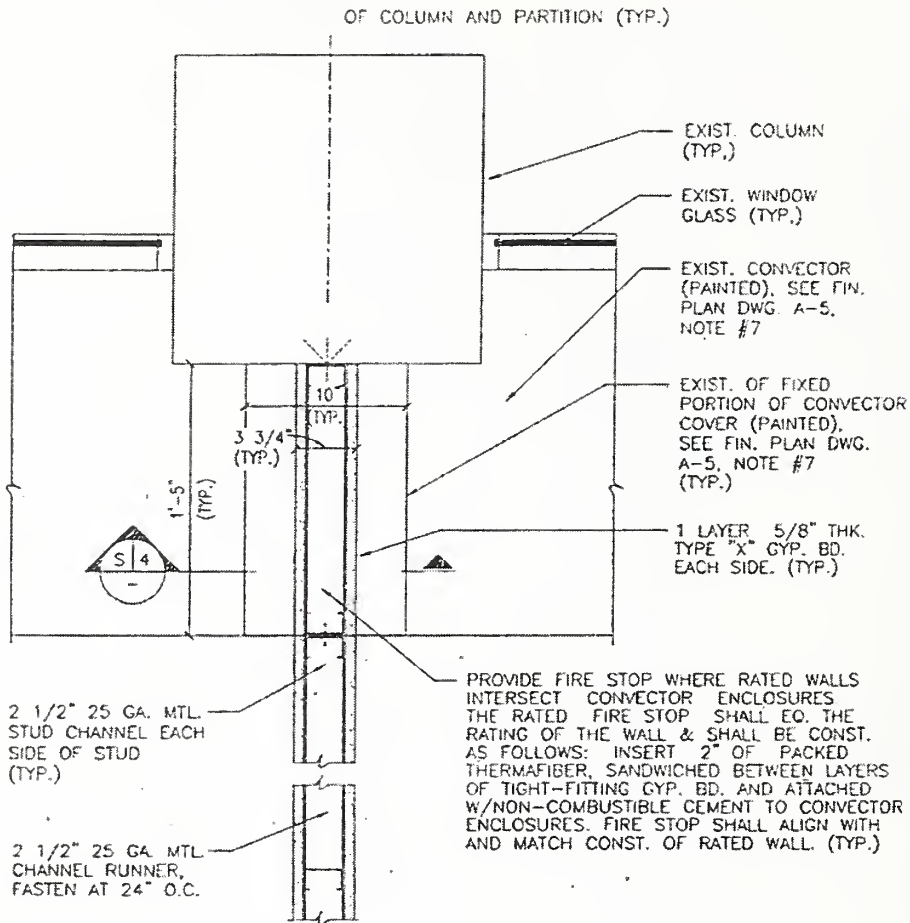

ARCH-06

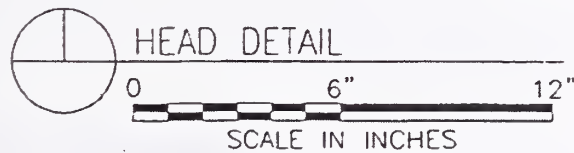
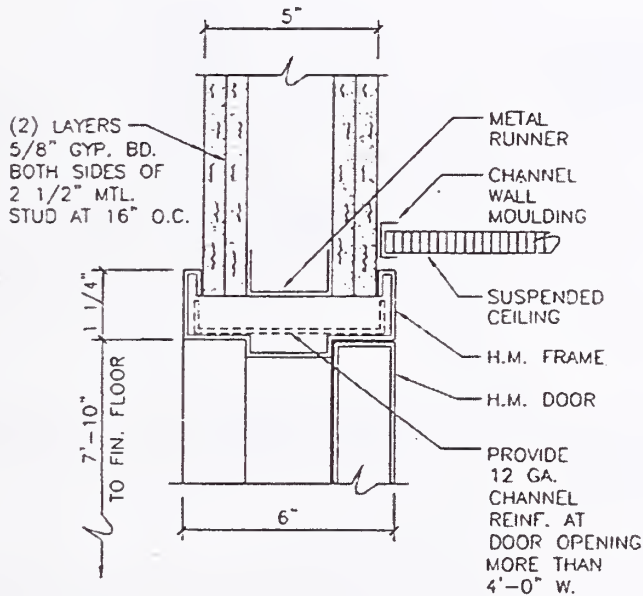
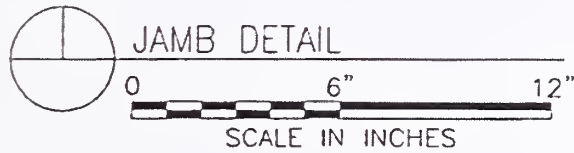
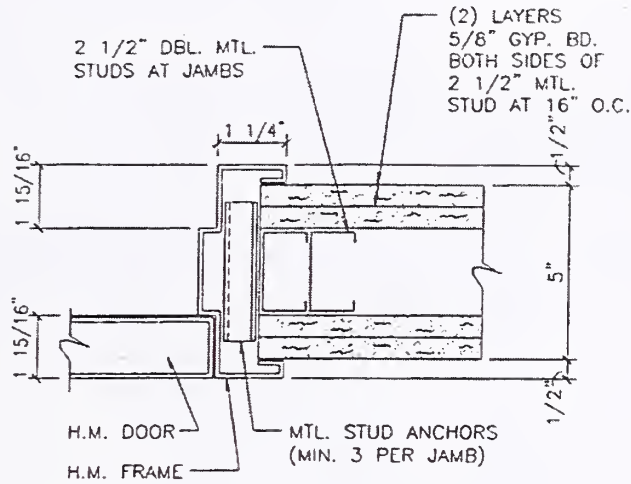

ARCH-07

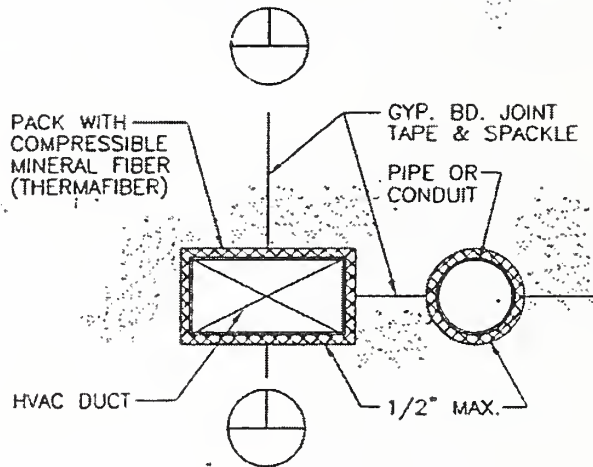
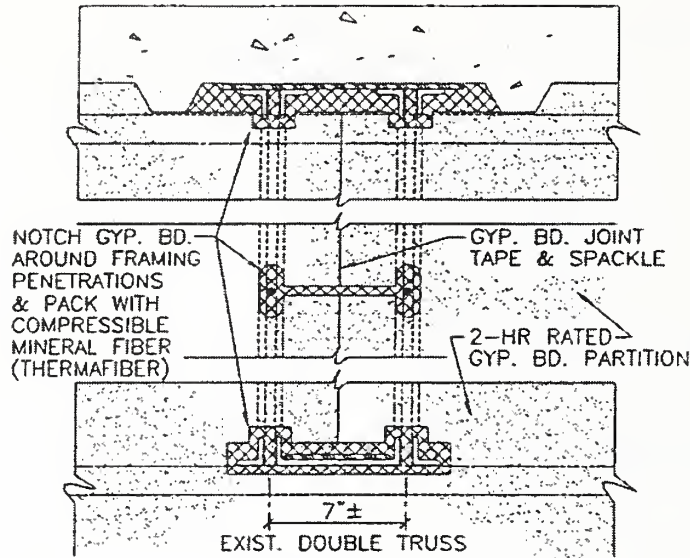

ELEVATION DETAILS OF
FIRESTOPPING OF TYP.
OPENING IN RATED
WALL ABOVE CEILING

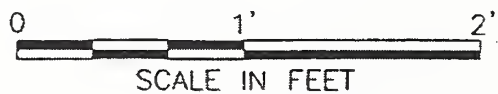

ARCH-08

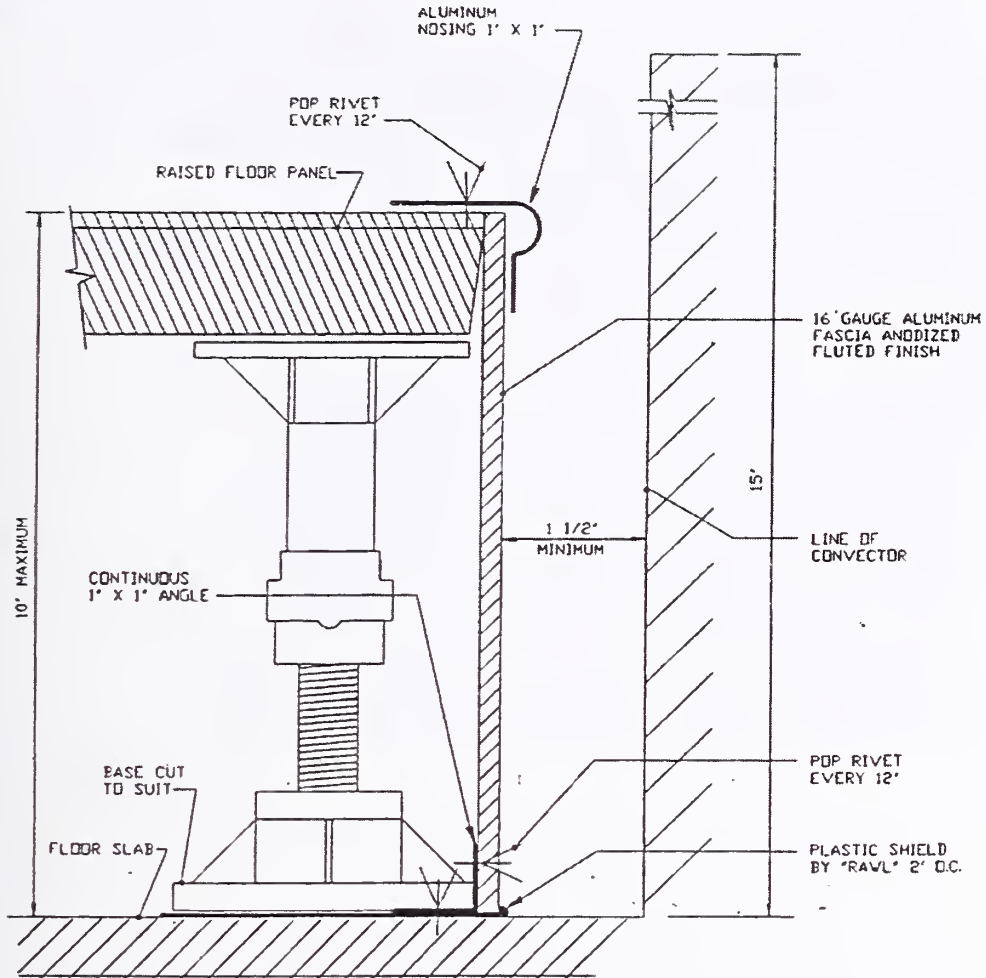

DETAIL OF RAISED FLOOR @ PERIMETER INDUCTION UNITS

NOT TO SCALE

NOTE: ADDITIONAL FLOOR GRILLS INSTALLED ON THE RAISED FLOOR DIRECTLY IN FRONT OF INDUCTION UNIT IS REQUIRED FOR THE EFFICIENT CIRCULATION OF AIR IN THE SPACE.

WTC - ARCH - 17

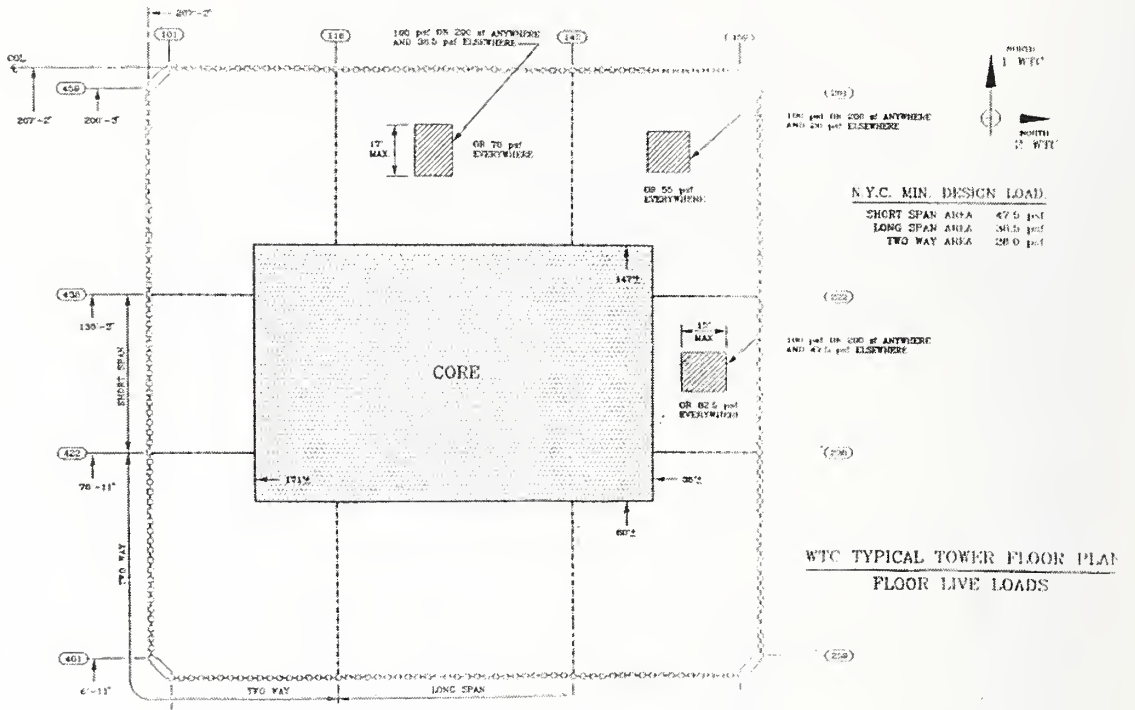

STR-01

 Restricted Zones

 Prohibited Zones

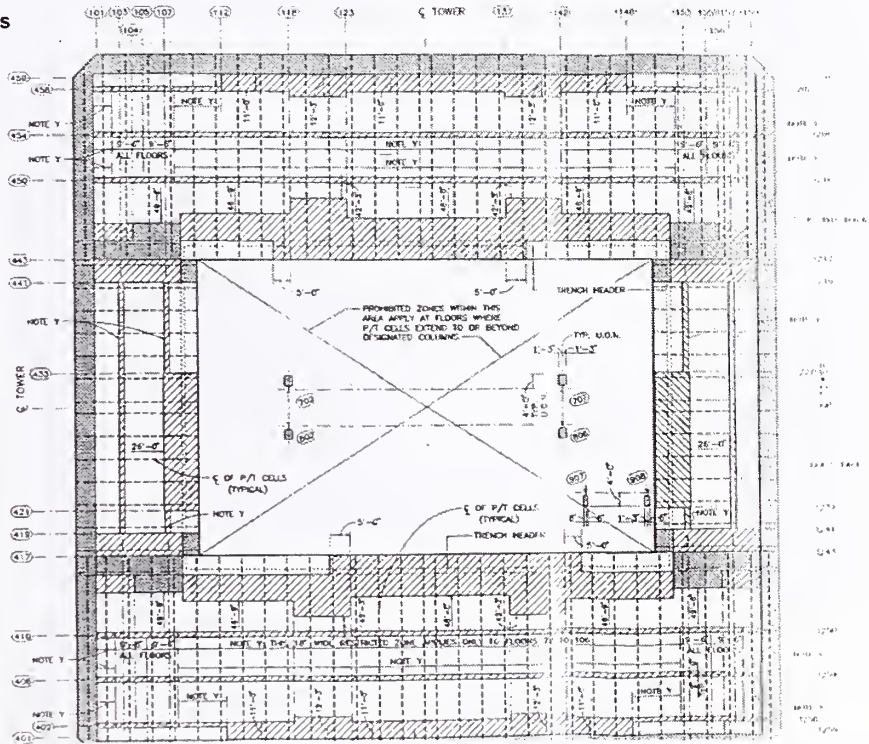

STR-02

LEGEND

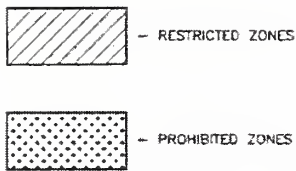

(SEE STRUCTURAL SPECIFICATIONS - SECTION A.)

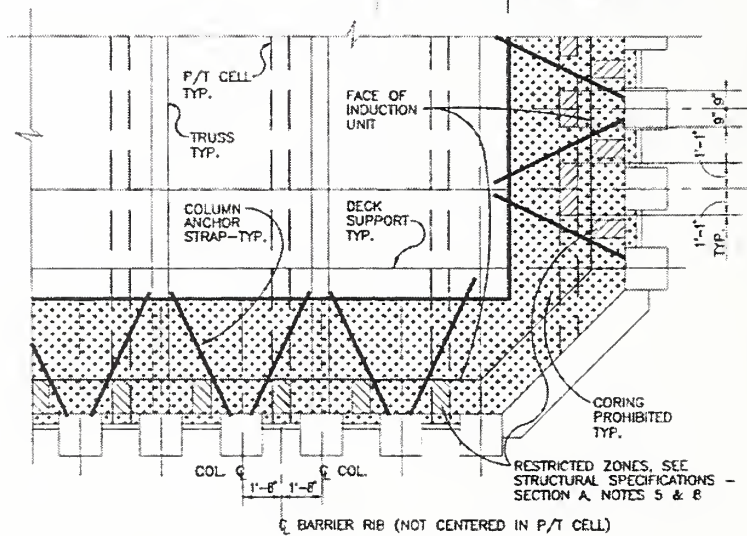
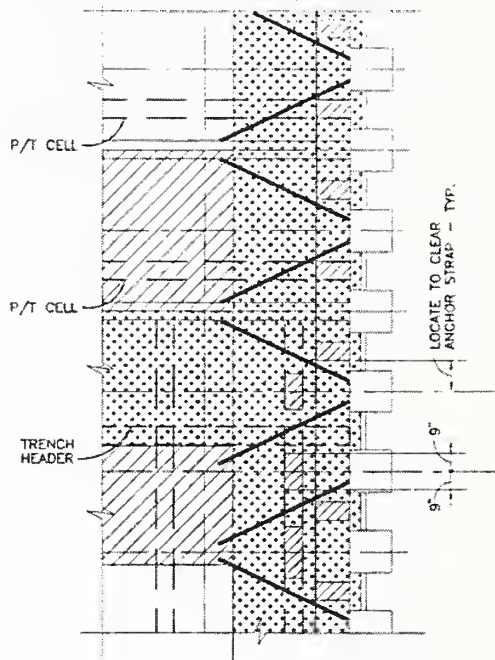

DETAIL AT BUILDING PERIMETER
CORING CRITERIA

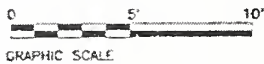

STR-03

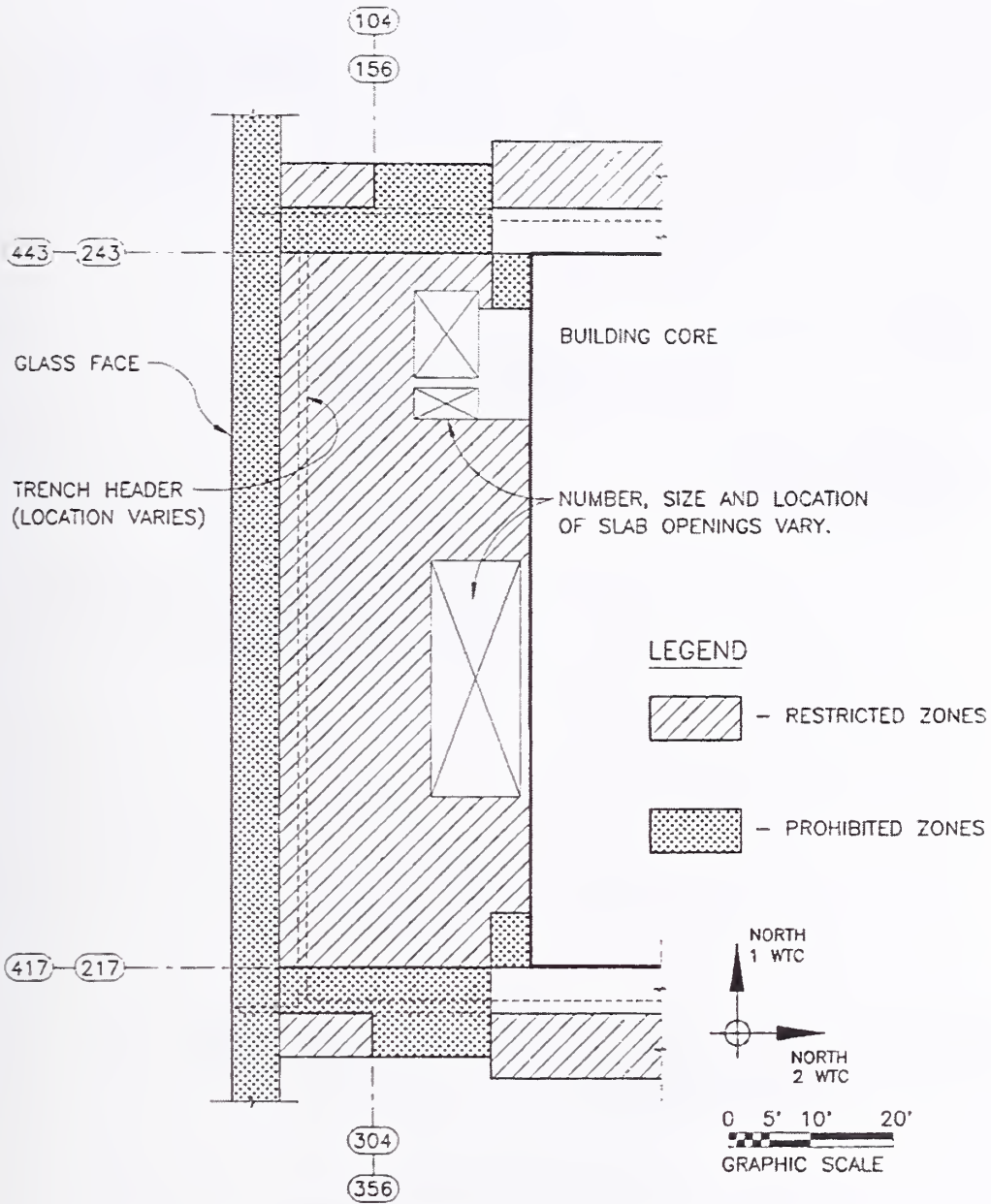

PART. PLAN - FLOORS 45 - 48 & 78 - 82
CORING CRITERIA

FOR BALANCE & INFORMATION NOT SHOWN
 SEE BASIC PLAN, PAGE STR-02

STR-04

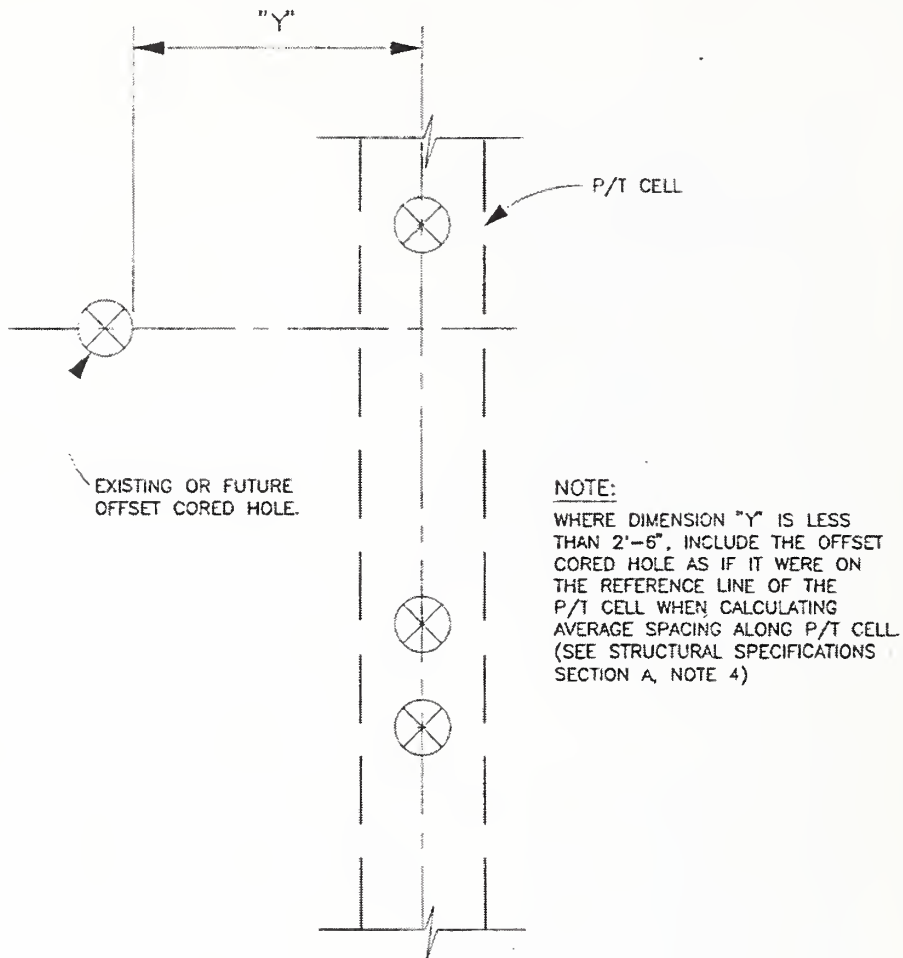

PLAN DETAIL OF SPACING CRITERIA AT OFFSET CORED HOLE
CORING CRITERIA

STR-05

REMOVE CONCRETE BY
MEANS OF ELECTRIC HAMMER
AROUND EXISTING CORED
HOLE TO EXPOSE CUT
REBARS. RECAST SLAB
WITH NON-SHRINK GROUT.

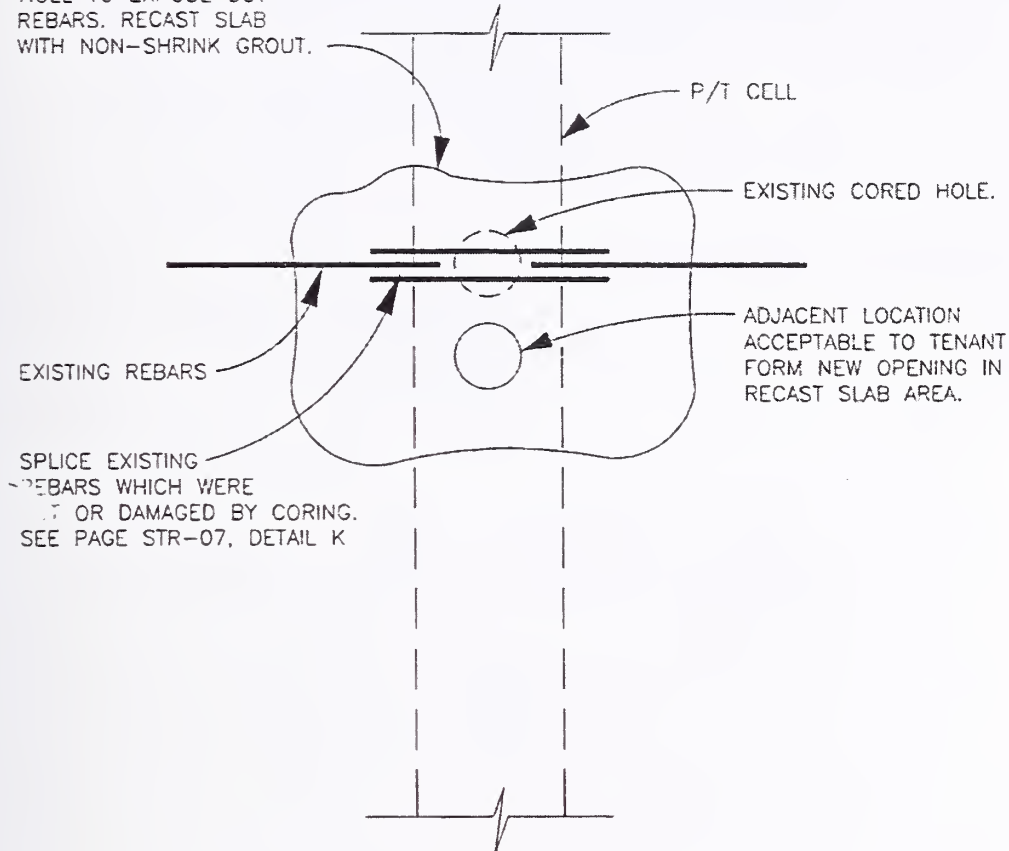

REBAR SPLICE

CORING CRITERIA

EXISTING HOLE, NOT PREVIOUSLY
INSPECTED, INTENDED FOR RE-USE.
ADJACENT LOCATION USED DUE TO
NEED TO REPAIR CUT REBARS.

STR-06

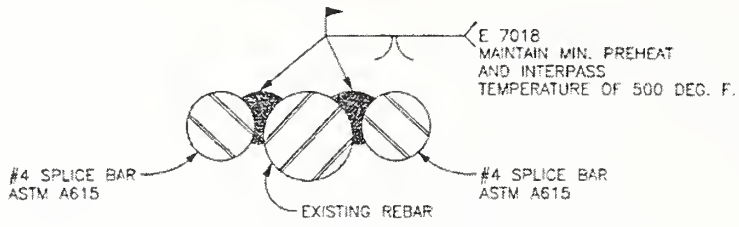

SECTION AT WELD

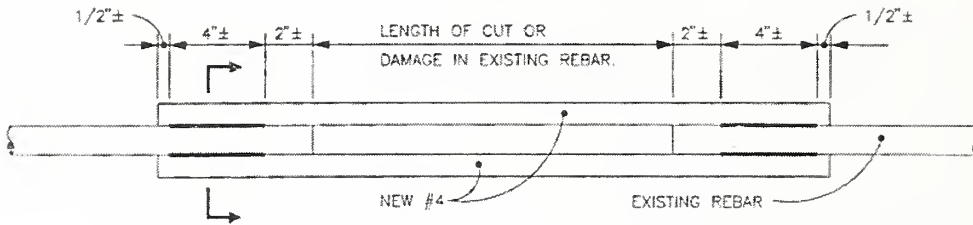

REBAR SPLICE
CORING CRITERIA

STR-07

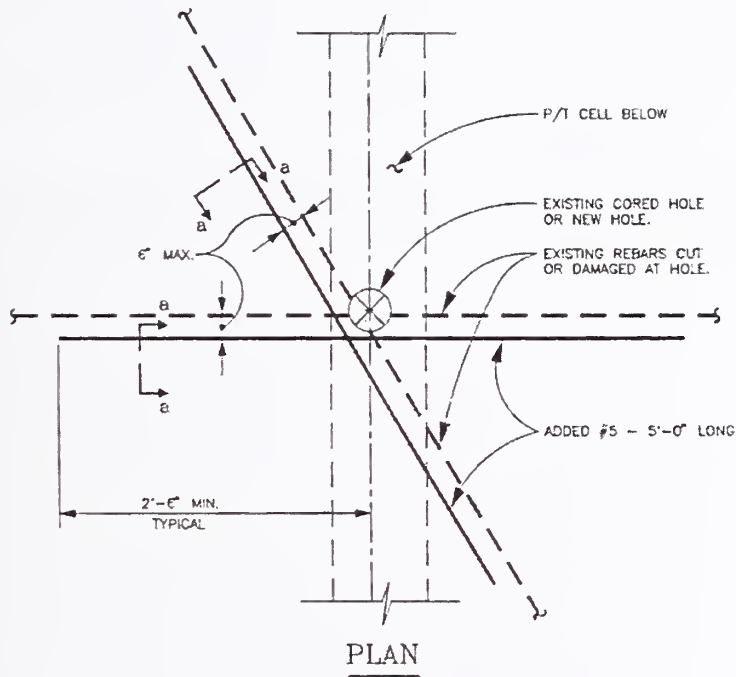
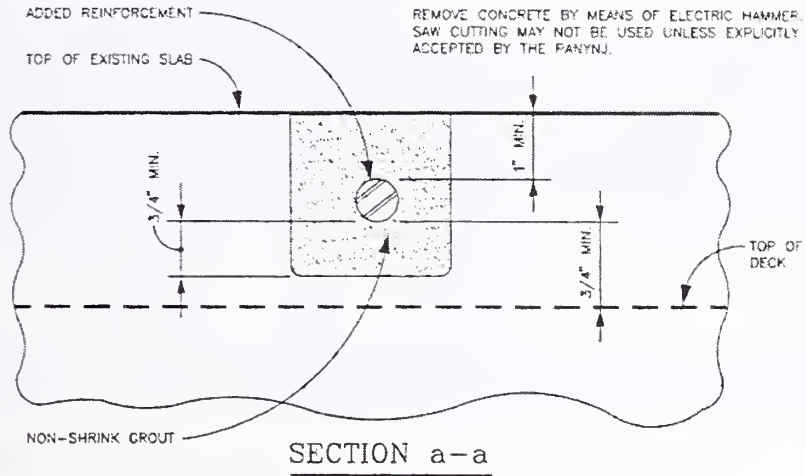

**REBAR REPAIR
CORING CRITERIA**

SCHMATIC REBAR REPAIR DETAIL WHERE HOLE CANNOT BE RELOCATED.
THIS DETAIL TO BE USED ONLY WITH PRIOR APPROVAL OF PANYNJ.

STR-08

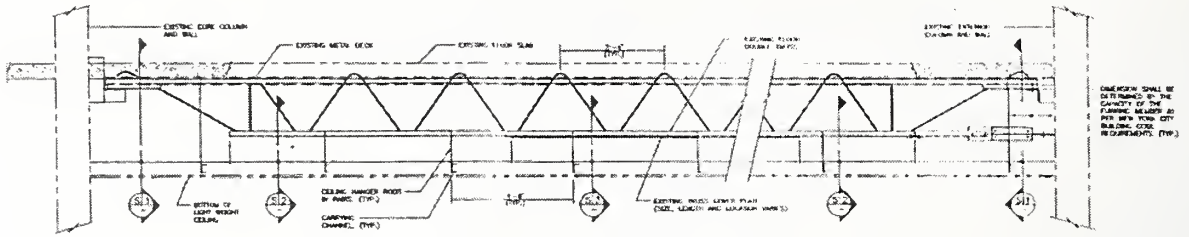

PART ELEVATION - TYPICAL FLOOR WITH DOUBLE TRUSS
LIGHT WEIGHT CEILING SUPPORT SYSTEM FOR FLOORS W/DOUBLE TRUSSES

STR-09

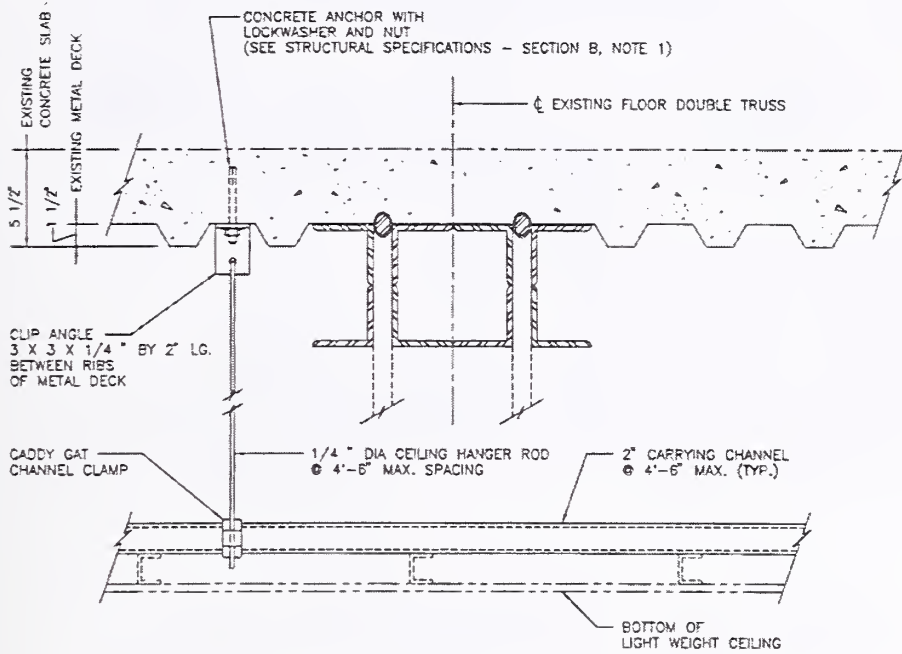

SECTION S-1

LIGHT WEIGHT CEILING SUPPORT SYSTEM FOR FLOORS W/DOUBLE TRUSSES

STR-10

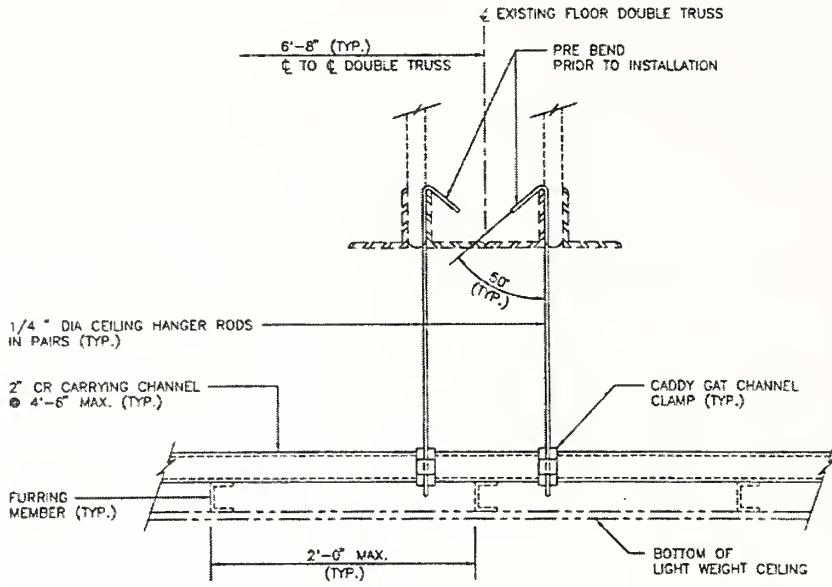

SECTION S-2

LIGHT WEIGHT CEILING SUPPORT SYSTEM FOR FLOORS W/DOUBLE TRUSSES

STR-11

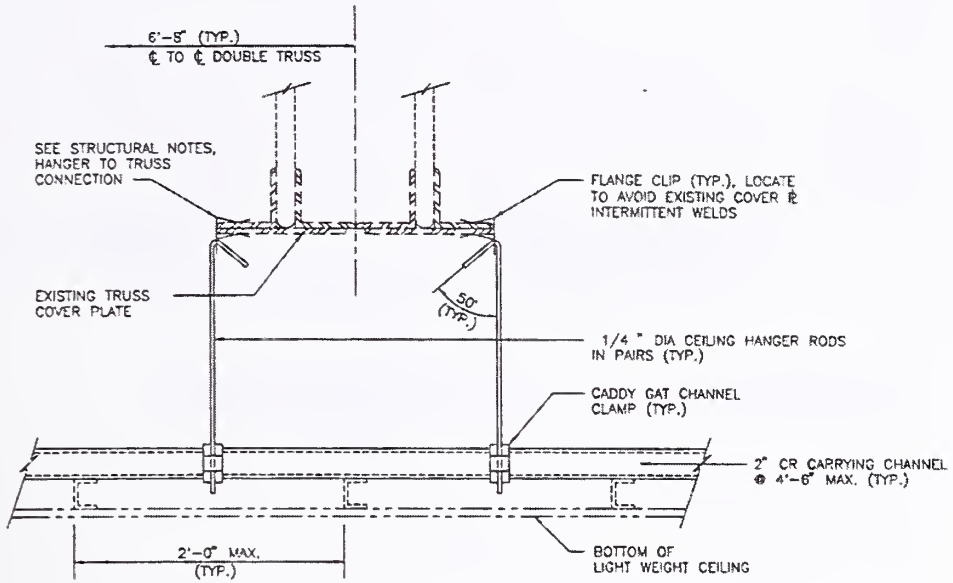

CEILING SUPPORT DETAIL
 AT COVER PLATE ONLY

SECTION S-3

LIGHT WEIGHT CEILING SUPPORT SYSTEM FOR FLOORS W/DOUBLE TRUSSES

STR-12

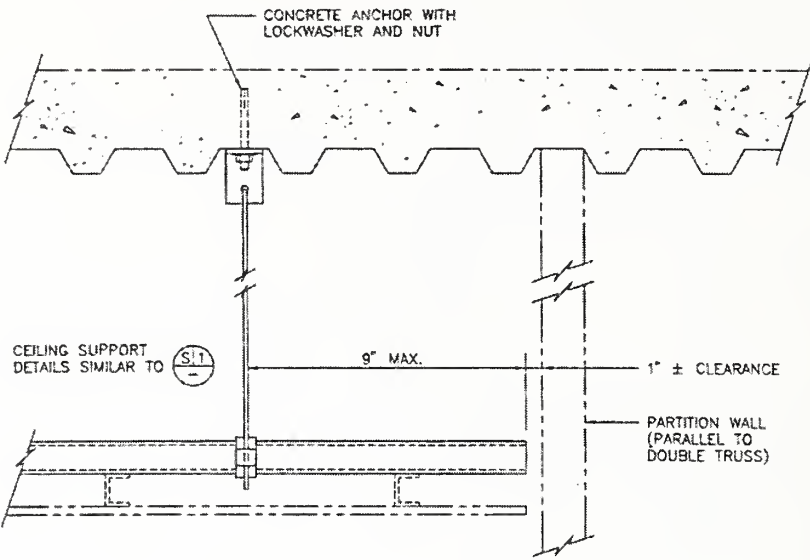

TYPICAL SECTION AT PARTITION WALL

TYPICAL SECTION AT PARTITION WALL
LIGHT WEIGHT CEILING SUPPORT SYSTEM FOR FLOORS W/DOUBLE TRUSSES

STR-13

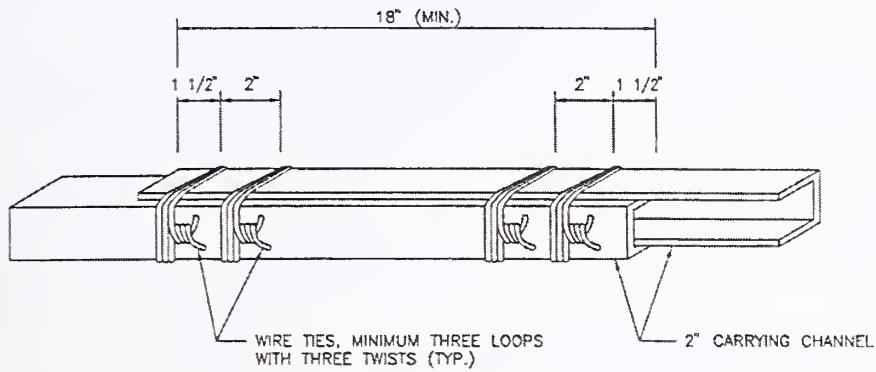

TYPICAL "2" CHANNEL SPLICE DETAIL

TYPICAL "2" CHANNEL SPICE DETAIL

LIGHT WEIGHT CEILING SUPPORT SYSTEM FOR FLOORS W/DOUBLE TRUSSES

STR-14

This page intentionally left blank.

Appendix G

SUPPORTING DOCUMENTS

This appendix contains the supporting documents that are referenced in this report. All of the documents contained in this appendix are reproduced with permission of The Port Authority of New York and New Jersey. Table G-1 contains a summary of supporting documents and their location within this appendix.

Table G-1. Supporting documents for report.

Document Title	Page(s)	
<i>Section 2.1.4 – Tenant Construction Review Manual (1997 Edition)</i>		
PANYNJ Memorandum dated August 8, 1995 from Oscar Suros, Manager of the Engineering Department Quality Assurance Division to Eugene J. Fasullo, Director and Chief Engineer	300	
<i>Section 3.2.1 – Structural Integrity Inspection Program (Overview)</i>		
Letter dated January 12, 1990 from Saw-Teen See of Leslie E. Robertson Associates to Suren Batra of the Port Authority of New York and New Jersey (WTCI-123-P)	304	
<i>Section 3.2.2 – Summary of Structural Integrity Inspection Program Reports</i>		
Locations of columns inspected in Accessible Columns Structural Integrity Inspection reports	1993 report	306
	1995 report	307
	1996 report	311
	1997 report	319
	1998 report	328
Historical Review of World Trade Center Damping Units (WTCI-230-L)	336	

PANYNJ Memorandum dated August 8, 1995

THE PORT AUTHORITY OF NY & NJ

MEMORANDUM

TO: Eugene J. Fasullo, P.E., Director of Engineering & Chief Engineer
FROM: Oscar Suros
DATE: August 8, 1995
SUBJECT: SEISMIC DESIGN - NEW YORK CITY BUILDING CODE

COPY TO: A. Aronowitz, A. Brociner, J. Buchsbaum, R. Davidson, J. Englot,
J. Kelly, T. Kelly, F. Lombardi, E. Ramabhushanam, EPMs

REF: Memo, Vanacore to Directors, October 4, 1988 and
Memo, Suros to Fasullo, June 7, 1994

THE PORT AUTHORITY OF NY & NJ
QUALITY ASSURANCE DIV.
ENGINEERING DEPT.

AUG 10 1995

RECEIVED

NOTED: _____

As established by the referenced memorandum, it has been our policy to design building structures and building components for seismic effects in both New Jersey and New York using the BOCA National Building Code. Recently the New York City Council and the Mayor enacted Local Law #17/95 providing requirements for seismic design of buildings and their components. This law adds provisions to the New York City Building Code that will be mandatory for all building or alteration applications filed on or after February 21, 1996.

Your approval is requested to start using the recently enacted changes to the New York City Building Code for all construction in New York City, including the revisions listed in Attachment A, effective immediately. The BOCA National Building Code will continue to be used for New Jersey and Yonkers construction.

The revisions in Attachment A are required in order to meet the stated intent of the seismic revisions to the New York City Building Code. This will insure that potential overhead hazards will not fall on building occupants as a result of a

COPY TO	
ER	_____
ED	_____
RP	_____
IB	_____
SB	_____
PD	_____
BF	_____
JH	_____
IR	_____
AT	_____
MA	_____
CK	_____
FILE	_____
POST	_____

E.J. Fasullo, P.E.

-2-

August 8, 1995

seismic event and that the building can be safely evacuated during and immediately following a seismic event. Similar provisions are included in the BOCA Code and are considered minimum requirements. No significant cost penalty is estimated due to the minor modifications included in Attachment A.



Oscar Suros, P.E.
Manager
E/A Design Division

APPROVED:

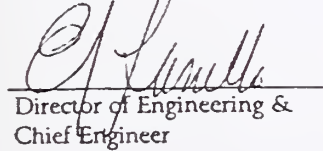
Director of Engineering &
Chief Engineer

Attachments

OS:cep

ATTACHMENT A

Revisions to the New York City Building Code

Revise Table No. 23-P of RS 9-6 by:

- (a) Adding after II. 1. b.
 "c. Overhead Signs 2.00";
- (b) Adding after II. 3.
 "4. Anchorage for suspended ceilings weighing more than 4 psf
 without the weight of light fixtures 0.75";
- (c) Adding after III. 1.
 "2. Elevator and counterweight guardrails and supports . . . 1.25"
 "3. Sprinkler piping⁵ 2.00"
 "4. Gas and high hazard piping. 2.00"
 "5. Other piping⁶ 0.67"
 "6. HVAC ducts⁶ 0.67"
- (d) Adding the following notes after note 4. at the bottom of the
 table:
 "5. The design of seismic restraints for sprinkler piping in
 compliance with NFPA 13 using a design acceleration of 0.15 is
 acceptable in lieu of compliance with these provisions.
 6. Seismic restraints are not required for any of the following
 conditions for other pipe systems or HVAC ducts:
1. Piping or ducts suspended by individual hangers
 12 inches or less in length from the top of the
 pipe or duct to the supporting structure.
 2. Piping in boiler and mechanical rooms which has
 less than 1 1/4 inches inside diameter.
 3. Piping in other areas which has less than 2 1/2
 inches inside diameter.
 4. Ducts which have a cross-section area less than 6
 square feet."

Table No. 23-P
HORIZONTAL FORCE FACTOR C_p ¹

ELEMENTS OF STRUCTURES, NONSTRUCTURAL COMPONENTS AND EQUIPMENT	VALUE OF C_p
I. Part of Portion of Structure	
1. Walls, including the following:	
a. Unbraced (cantilevered) parapets.	2.00
b. Other exterior walls above street grade ² .	0.75
c. All interior bearing walls.	0.75
d. All interior nonbearing walls and partitions around vertical exits, including offsets and exit passageways.	0.75
e. Nonbearing partitions and masonry walls in areas of public assembly > 300 people.	0.75
f. All interior nonbearing walls and partitions made of masonry in Occupancy I, II and III.	0.75
g. Masonry or concrete fences at grade over 10 feet high.	0.50
2. Penthouses (defined in article 2 of subchapter 2 of chapter 1 of title 27 of the building code) except where framed by an extension of the building frame.	0.75
3. Connections for prefabricated structural floor and roof elements other than walls (see above) with force applied at center of gravity.	0.75
4. Diaphragms ³ .	
II. Nonstructural Components	
1. a. Exterior ornamentation and appendages including cornices, ornamental statuary or similar pieces of ornamentation.	2.00
b. Interior ornamentation and appendages in areas of public assembly including cornices, ornamental statuary or similar pieces of ornamentation.	2.00
2. Chimneys, stacks, trussed towers and tanks on legs.	
a. Supported on or projecting as an unbraced cantilever above the roof more than one-half its total height.	2.00
b. All others, including those supported below the roof with unbraced projection above the roof less than one-half its height, or braced or guyed to the structural frame at or above its center of mass.	0.75
3. Exterior signs and billboards.	2.00
III. Equipment and Machinery⁴	
1. Tanks and vessels (including contents), including support systems and anchorage.	0.75

Notes:

1. See Section 2312(g)² for additional requirements for determining C_p for nonrigid equipment or for items supported at or below grade.

2. See Section 2312(h)2D(iii) and Section 2313(g)2.

3. See Section 2312(h)2l.

4. Equipment and machinery include such items as pumps for fire sprinklers, motors and switch gears for sprinkler pumps, transformers and other equipment related to life-safety including control panels, major conduit ducting and piping serving such equipment and machinery.

Letter dated January 12, 1990 from Saw-Teen See of Leslie E. Robertson Associates to Suren Batra of the Port Authority of New York and New Jersey (WTCI-123-P)

LESLIE E. ROBERTSON ASSOCIATES *Consulting Structural Engineers*
211 East 46th Street, New York, NY 10017-2989 *Phone: (212) 750-9000*
12 January 1990 *Fax: (212) 750-9002*
File: B1003900

Mr. Suren Batra
The Port Authority of New York & New Jersey
WTC Planning & Design Department
One World Trade Center - 74 South
New York, NY 10048
Via messenger

Reference: The World Trade Center Facilities:
Structural Integrity Inspections

Gentlemen:

We are pleased to submit our proposal to monitor the structural integrity of the physical facilities of The World Trade Center complex.

Experience

Over the past 20 plus years, we at LERA have gained unparalleled insights into the structural behavior of the World Trade Center complex. We believe that the continuity of experience with the project which the engineers of our firm have provides us an extensive, accessible base of knowledge about these structures unmatched anywhere else.

In 1986, we provided to you an action plan of testing and inspection so as to assure the continued long term structural integrity of the complex.

Economy

Although we were not charged with carrying out this plan, our designs for building renovation have impacted the testing and inspection activities which have been undertaken. For example, we have recently recommended that planned renovation projects be used to access Plaza level tower columns for inspection rather than incurring the high cost of removing exterior column covers especially for inspection.

Many examples occur wherein economies can be attained through coordination of renovation, operations and inspection activities. Even tenant renovations, many of which we engineer, offer such opportunities. And because of the small number of people within our firm who would accomplish both the renovation and inspection work, coordination is an easy matter.

WILLIAM J. FASCHAN
LESLIE E. ROBERTSON
SAW-TEEN SEE
PAUL A. ASP
ELAINE CASTELLANO
ERNEST T. LIU
W. JOHN PUGH
STANLEY L. SAFFER
DANIEL A. SESIL
RICHARD ZOTTOLO

LESLIE E. ROBERTSON ASSOCIATES

Mr. Suren Batra

-3-

12 January 1990

Other Facilities

This proposal addresses the monitoring of the structural integrity of the buildings that comprise The World Trade Center complex only. Monitoring of the structural integrity of the PANYNJ's Bathgate and Yonkers Industrial Parks, and Hoboken Piers, has not been included as part of this proposal. However, we would be pleased to prepare a similar detailed proposal for the inspection of these facilities.

We are most appreciative of this further opportunity to work with the PANYNJ and we hope for your favorable response.

Very truly yours,

LESLIE E. ROBERTSON ASSOCIATES



Saw-Teen See

WJF/blo
Enclosure

WJF, LER, RZ, DAS, EAC

Locations of Columns Inspected in Accessible Columns Structural Integrity Inspection Reports

- 1993 Accessible Columns SII Report (part of WTCI-66-L)

LERA

WORLD TRADE CENTER
Structural Integrity Inspection
Accessible Columns @ 1, 2, 4 and 5 WTC

P1103904 & 3927
29 January 1993
Page 6 of 9

TABLE A

Tower	Elevator Shaft Number	Floors Inspected	Adjacent Column Number	Face of Column Inspected
A (1 WTC)	21	4-78	606	East
		4-78	607	West
	36	1-32	701	East, South
		1-32	801	East, North
	63	45-67	701	East, South
		45-67	801	East, North
	73	43-74	703	North, West
		43-74	803	North, West
	83	78-93	701	East, South
		78-93	801	East, North
B (2 WTC)	15	4-78	602	North
		4-78	603	South, West
	29	1-16	707	South, East
		1-16	806	South, West
	56	45-54	707	South, East
		45-54	806	South, West
	78	78-86	707	South, East
		78-86	806	South, West
Northeast Plaza (5 WTC)	<u>E-7</u> 28	1-9	<u>E-7</u> 28	W

See Appendix A for the plan locations of the above columns.

- 1995 Accessible Columns SII Report (part of WTCI-66-L)

LERA

14 April 1995
File: 1113903
Page 1 of 4

LISTING OF INSPECTED COLUMNS AT 1 WTC

ELEVATOR SHAFT	COLUMN NUMBER	FLOORS INSPECTED	FACE OF COLUMN INSPECTED	LISTING OF PHOTOGRAPHS
1A	908	2-44 B2	WEST & SOUTH	1,2 3
2A	907	2-44 B2	EAST	4,5,6
3A	907	2-44 B2	WEST & SOUTH	7,8,9 10
4A	906	2-44 B2	EAST	- 11
6A	903	2-44 B2	WEST & SOUTH	12,13 -
9A	902	2-44 B2	EAST	14 15
12A	601	2-78 B2	EAST & NORTH	16,17 -
13A	602	2-78 B2	WEST & NORTH	- -
14A	602	B2	EAST	-
15A	603	B2	WEST & NORTH	30
18A	605	2-78 B2	EAST & NORTH	18,19 -
19A	606	2-78 B2	WEST	20 -
20A	606	B2	EAST & NORTH	31
21A	607	B2	WEST	-
22A	607	2-78 B2	EAST & NORTH	21 22

LERA

14 April 1995
 File: 1113903
 Page 2 of 4

LISTING OF INSPECTED COLUMNS AT 1 WTC

ELEVATOR SHAFT	COLUMN NUMBER	FLOORS INSPECTED	FACE OF COLUMN INSPECTED	LISTING OF PHOTOGRAPHS
23A	608	2-78 B2	WEST & NORTH	23, 24, 25 26
24A	807	B3	WEST & NORTH	-
29A	806	B3	EAST & NORTH	-
30A	806	B3	WEST & NORTH	-
35A	805	B3	EAST & NORTH	-
36A	801	B3	EAST & NORTH	-
41A	802	B3	WEST & NORTH	-
42A	802	B3	EAST & NORTH	34
47A	803	B3	WEST & NORTH	-
48A	905	B3	EAST & SOUTH	35
49A	704	B3	NORTH	32, 33
50A	704 703 803	2-108 2-78 2-108	WEST & SOUTH EAST EAST	27, 28 29 -

LERA

14 April 1995
 File: 1113903
 Page 3 of 4

LISTING OF INSPECTED COLUMNS AT 2 WTC

ELEVATOR SHAFT	COLUMN NUMBER	FLOORS INSPECTED	FACE OF COLUMN INSPECTED	LISTING OF PHOTOGRAPHS
1B	908	2-44 B2	EAST & SOUTH	36 -
2B	907	2-44 B2	NORTH	37 -
3B	907	B2	EAST & SOUTH	-
4B	906	B2	NORTH	-
5B	906	B2	EAST & SOUTH	66
6B	904	B2	EAST & SOUTH	-
7B	903	B2	NORTH	-
8B	903	B2	EAST & SOUTH	64,65
9B	902	B2	NORTH	-
10B	908	2-44 B2	EAST & SOUTH	38,39 40
11B	901	2-44 B2	EAST & NORTH	41,42 -
12B	601	2-44 B2	WEST & NORTH	43 -
13B	602	2-78 E2	WEST & SOUTH	44,45 -
14B	602	2-78 B2	NORTH	46,47
15B	603	2-78 B2	WEST & SOUTH	48,49 -
16B	603	B4	NORTH	-
17B	604	B4	WEST & SOUTH	50

LERA

14 April 1995
File: 1113903
Page 4 of 4

LISTING OF INSPECTED COLUMNS AT 2 WTC

ELEVATOR SHAFT	COLUMN NUMBER	FLOORS INSPECTED	FACE OF COLUMN INSPECTED	LISTING OF PHOTOGRAPHS
18B	605	B2	WEST & NORTH	51
19B	606	B2	SOUTH	52
20B	606	B2	WEST & NORTH	53
21B	607	B2	SOUTH	-
22B	607	2-78 B2	WEST & NORTH	54 -
23B	608	2-78 B2	WEST & SOUTH	55,56,57
36B	801	B3	WEST & NORTH	-
41B	802	B3	WEST & SOUTH	-
42B	802	B3	WEST & NORTH	-
47B	803	B3	WEST & SOUTH	67
49B	704	B6	WEST & SOUTH	62,63
50B	704 703 803	2-108 2-78 2-108	EAST & SOUTH NORTH NORTH	58,59 60,61 -

- 1996 Accessible Columns SII Report (part of WTCI-66-L)

LERA

One and Two World Trade Center
Structural Integrity Inspection
Accessible Columns

17 May 1996
File: P1133902
Page 4

4. LIST OF INSPECTED COLUMNS - 1 WTC

Elevator Shaft/Pit	Column Number	Pit/Floors Inspected	Face Of Column Inspected
6A	904	B4/2-106	West & South
7A	903	B4/2-106	East
16A	603	B4/2-78	East
17A	604	B4/2-78	West & South
34A	706	B1/2-24	East & North
35A	805	2-24	East & North
42A	802	2-40	East & North
43A	702	B1/2-40	East & North
55A	707	43	East, North & South
56A	806	43	East, North & South
61A	706	43/44-61	East & North
62A	805	43/44-61	East & North
63A	801	43	East, North & South
64A	701	43	East, North & South
67A	702	42	West, North & South
68A	802	43	West, North & South
69A	802	43/44-74	East & North
70A	702	43/44-74	East & North
78A	707	76	East, North & South
79A	806	76	East, North & South

LERA

One and Two World Trade Center
Structural Integrity Inspection
Accessible Columns

17 May 1996
File: P1133902
Page 5

4. LIST OF INSPECTED COLUMNS - 1 WTC (continued)

Elevator Shaft/Pit	Column Number	Pit/Floors Inspected	Face Of Column Inspected
82A	801	77	East, North & South
83A	701	77	East, North & South
88A	802	77/78-100	East & North
89A	702	77/78-100	East, North & South
94A	805	77/78-107	East & North
95A	706	77/78-107	East, North & South
96A	707	77/78-106	West & South
97A	806	77/78-106	West, North & South
99A	703/803	105/106-110	West

Previously Inspected

Elevator Shaft/Pit	Column Number	Pit/Floors Inspected	Face Of Column Inspected
1A	908	B2/2-44	West & South
2A	907	B2/2-44	East
3A	907	B2/2-44	West & South
4A	906	B2/2-44	East
8A	903	B2/2-44	West & South
9A	902	B2/2-44	East
12A	601	B2/2-78	East & North
13A	602	B2/2-78	West & North

LERA

One and Two World Trade Center
Structural Integrity Inspection
Accessible Columns

17 May 1996
File: P1133902
Page 6

4. LIST OF INSPECTED COLUMNS - 1 WTC (continued)

Previously Inspected

Elevator Shaft/Pit	Column Number	Pit/Floors Inspected	Face Of Column Inspected
14A	602	B2	East
15A	603	B2	West & North
18A	605	B2/2-78	East & North
19A	606	B2/2-78	West
20A	606	B2/4-78	East & North
21A	607	B2/4-78	East & West
22A	607	B2/2-78	East & North
23A	608	B2/2-78	West & North
24A	807	B3	West & North
29A	806	B3	East & North
30A	806	B3	West & North
35A	805	B3	East & North
36A	801	B3/1-32	East & North
37A	701	1-32	East & South
41A	802	B3	West & North
42A	802	B3	East & North
47A	803	B3	West & North

LERA

One and Two World Trade Center
Structural Integrity Inspection
Accessible Columns

17 May 1996
File: P1133902
Page 7

4. LIST OF INSPECTED COLUMNS - 1 WTC (continued)

Previously Inspected

Elevator Shaft/Pit	Column Number	Pit/Floors Inspected	Face Of Column Inspected
48A	905	B3	East & South
49A	704	B3	North
50A	704 703 803	2-108 2-78 2-108	West & South East East
63A	701	45-67	East & South
64A	801	45-67	East & South
73A	703	43-74	North & West
74A	803	43-74	North & West
82A	801	78-93	East & South
83A	701	78-93	East & North

LERA

One and Two World Trade Center
Structural Integrity Inspection
Accessible Columns

17 May 1996
File: P1133902
Page 11

5. LIST OF INSPECTED COLUMNS - 2 WTC

Elevator Shaft/Pit	Column Number	Pit/Floors Inspected	Face Of Column Inspected
6B	904	2-106	East & South
7B	903	2-106	North
18B	605	2-78	West & North
19B	606	2-78	South
20B	606	2-78	West & North
21B	607	2-78	South
34B	706	B1/2-23	West & North
35B	805	B3/2-23	West & North
42B	802	2-40	West & North
43B	702	B1/2-40	West & North
48B	905	B3	East & North
55B	707	43	East, West & North
56B	806	43	East, West & North
61B	706	43/44-61	West & North
62B	805	43/44-61	West & North
63B	801	43	East, West & North
64B	701	43	East, West & North
67B	702	42	East, West & South
68B	802	43	East, West & South
69B	802	43/44-74	West & North

LERA

One and Two World Trade Center
Structural Integrity Inspection
Accessible Columns

17 May 1996
File: P1133902
Page 12

5. LIST OF INSPECTED COLUMNS - 2 WTC (continued)

Elevator Shaft/Pit	Column Number	Pit/Floors Inspected	Face Of Column Inspected
70B	702	43/44-74	West & North
78B	707	76	East, West & North
79B	806	76	East, West & North
82B	801	77	East, West & North
83B	701	77	East, West & North
88B	802	77/78-100	East, West & North
89B	702	77/78-100	East, West & North
95B	706	77	West & North
96B	707	77/78-106	East, West & South
97B	806	77/78-106	West & South
99B	703/803	105/106-110	South

Previously Inspected

Elevator Shaft/Pit	Column Number	Pits/Floors Inspected	Face Of Column Inspected
1B	908	B2/2-44	East & South
2B	907	B2/2-44	North
3B	907	B2	East & South
4B	906	B2	North
5B	906	B2	East & South
6B	904	B2	East & South

LERA

One and Two World Trade Center
Structural Integrity Inspection
Accessible Columns

17 May 1996
File: P1133902
Page 13

5. LIST OF INSPECTED COLUMNS - 2 WTC (continued)

Previously Inspected

Elevator Shaft/Pit	Column Number	Pits/Floors Inspected	Face Of Column Inspected
7B	903	B2	North
8B	903	B2	East & South
9B	902	B2	North
10B	908	B2/2-44	East & South
11B	901	B2/2-44	East & North
12B	601	B2/2-44	West & North
13B	602	B2/2-78	West & South
14B	602	B2/2-78	North
15B	603	B2/2-78	West & South
16B	603	B4	North
17B	604	B4	West & South
18B	605	B2	West & North
19B	606	B2	South
20B	606	B2	West & North
21B	607	B2	South
22B	607	B2/2-78	West & North
23B	608	B22-78	West & South
28B	707	1-16	East & South
29B	806	1-16	West & South

LERA

One and Two World Trade Center
Structural Integrity Inspection
Accessible Columns

17 May 1996
File: P1133902
Page 14

5. LIST OF PREVIOUSLY INSPECTED - 2 WTC (continued)

Previously Inspected

Elevator Shaft/Pit	Column Number	Pit/Floors Inspected	Face Of Column Inspected
36B	801	B3	West & North
41B	802	B3	West & South
42B	802	B3	West & North
47B	803	B3	West & South
49B	704	B6	West & South
50B	704 703 803	2-108 2-78 2-108	East & South North North
55B	707	45-54	East & South
56B	806	45-54	East & West
78B	707	78-86	East & South
79B	806	78-86	East & West

- 1997 Accessible Columns SII Report (part of WTCI-66-L)

LERA

One and Two World Trade Center
Structural Integrity Inspection
Accessible Columns

23 May 1997
File: P1153903
Page 4

4. LIST OF INSPECTED COLUMNS - 1 WTC

Elevator Shaft/Pit*	Column Number	Pit/Floors Inspected	Face Of Column Inspected
10A	902	B1/2-44	West & South
11A	901	B1/2-44	East & South
24A(SO)	807	2-17	West & North
25A(SO)	708	2-17	West & South
40A	702	B1/2-33	West & North
41A(SO)	802	2-33	West & North
51A	807	43/44-54	West & North
52A	708	43/44-54	West & South
57A	806	43/44-61	West & North
58A	707	43/44-61	West & South
76A	807	77/78-86	West & South
77A	708	77/78-86	West & South
84A	702	77/78-93	West & South
85A	802	77/78-93	West & North
90A	703	77/78-100	West & South
91A	803	77/78-100	West & North

* (SO) Indicates the shaft only, not the pit, has been inspected

LERA

One and Two World Trade Center
Structural Integrity Inspection
Accessible Columns

23 May 1997
File: P1153903
Page 5

4. LIST OF INSPECTED COLUMNS - 1 WTC (continued)

Previously Inspected

Elevator Shaft/Pit	Column Number	Pit/Floors Inspected	Face Of Column Inspected
1A	908	B2/2-44	West & South
2A	907	B2/2-44	East
3A	907	B2/2-44	West & South
4A	906	B2/2-44	East
6A	904	B4/2-106	West & South
7A	903	B4/2-106	East
8A	903	B2/2-44	West & South
9A	902	B2/2-44	East
12A	601	B2/2-78	East & North
13A	602	B2/2-78	West & North
14A	602	B2	East
15A	603	B2	West & North
16A	603	B4/2-78	East
17A	604	B4/2-78	West & South
18A	605	B2/2-78	East & North
19A	606	B2/2-78	West
20A	606	B2/4-78	East & North
21A	607	B2/4-78	East & West
22A	607	B2/2-78	East & North
23A	608	B2/2-78	West & North

LERA

One and Two World Trade Center
Structural Integrity Inspection
Accessible Columns

23 May 1997
File: P1153903
Page 6

4. LIST OF INSPECTED COLUMNS - 1 WTC (continued)

Previously Inspected

Elevator Shaft/Pit	Column Number	Pit/Floors Inspected	Face Of Column Inspected
24A	807	B3	West & North
29A	806	B3	East & North
30A	806	B3	West & North
34A	706	B1/2-24	East & North
35A	805	B3/2-24	East & North
36A	801	B3/1-32	East & North
37A	701	1-32	East & South
41A	802	B3	West & North
42A	802	B3/2-40	East & North
43A	702	B1/2-40	East & North
47A	803	B3	West & North
48A	905	B3	East & South
49A	704	B3	North
50A	704	2-108	West & South
50A	703	2-78	East
50A	803	2-108	East
55A	707	43	East, North & South
56A	806	43	East, North & South
61A	706	43/44-61	East & North
62A	805	43/44-61	East & North
63A	801	43	East, North & South

LERA

One and Two World Trade Center
Structural Integrity Inspection
Accessible Columns

23 May 1997
File: P1153903
Page 7

4. LIST OF INSPECTED COLUMNS - 1 WTC (continued)

Previously Inspected

Elevator Shaft/Pit	Column Number	Pit/Floors Inspected	Face Of Column Inspected
63A	801	45-67	East & South
64A	701	43/45-67	East, North & South
67A	702	42	West, North & South
68A	802	43	West, North & South
69A	802	43/44-74	East & North
70A	702	43/44-74	East & North
73A	703	43-74	North & West
74A	803	43-74	North & West
78A	707	76	East, North & South
79A	806	76	East, North & South
82A	801	77	East, North & South
82A	801	78-93	East & South
83A	701	77	East, North & South
83A	701	78-93	East & North
88A	802	77/78-100	East & North
89A	702	77/78-100	East, North & South
94A	805	77/78-107	East & North
95A	706	77/78-107	East, North & South
96A	707	77/78-106	West & South
97A	806	77/78-106	West, North & South
99A	703/803	105/106-110	West

LERA

One and Two World Trade Center
Structural Integrity Inspection
Accessible Columns

23 May 1997
File: P1153903
Page 11

5. LIST OF INSPECTED COLUMNS - 2 WTC

Elevator Shaft/Pit*	Column Number	Pit/Floors Inspected	Face Of Column Inspected
5B(SO)	906	B1-44	East & South
24B	807	B3/2-16	West & South
25B(SO)	708	2-16	East & South
30B	806	B3/2-24	West & South
31B(SO)	707	2-24	East & South
36B(SO)	801	2-32	West & North
37B(SO)	701	2-32	East & North
48B(SO)	905	B1-40	East & North
51B	807	43-54	West & South
52B	708	43-54	West & South
57B	806	43-61	West & South
58B	707	43-61	East & South
63B(SO)	801	44-67	West & North
64B(SO)	701	44-67	West & North
67B(SO)	702	44-67	East & South
68B(SO)	802	44-67	West & South
73B(PO)	801	43	East, West & North
74B(PO)	701	43	East, West & North
76B(PO)	702	77	East, West & South
77B(PO)	802	77	East, West & South

LERA

One and Two World Trade Center
Structural Integrity Inspection
Accessible Columns

23 May 1997
File: P1153903
Page 12

5. LIST OF INSPECTED COLUMNS - 2 WTC (continued)

Elevator Shaft/Pit*	Column Number	Pit/Floors Inspected	Face Of Column Inspected
88B(SO)	802	79-100	West & North
89B(SO)	702	79-100	East & North
90B	703	77-100	East & South
91B	803	77-100	West & South

* (SO) Indicates the shaft only, not the pit, has been inspected

* (PO) Indicates the pit only, not the shaft, has been inspected

Previously Inspected

Elevator Shaft/Pit	Column Number	Pits/Floors Inspected	Face Of Column Inspected
1B	908	B2/2-44	East & South
2B	907	B2/2-44	North
3B	907	B2	East & South
4B	906	B2	North
5B	906	B2	East & South
6B	904	B2/2-106	East & South
7B	903	B2/2-106	North
8B	903	B2	East & South
9B	902	B2	North
10B	908	B2/2-44	East & South
11B	901	B2/2-44	East & North

LERA

One and Two World Trade Center
Structural Integrity Inspection
Accessible Columns

23 May 1997
File: P1153903
Page 13

5. LIST OF PREVIOUSLY INSPECTED - 2 WTC (continued)

Previously Inspected

Elevator Shaft/Pit	Column Number	Pit/Floors Inspected	Face Of Column Inspected
12B	601	B2/2-44	West & North
13B	602	B2/2-78	West & South
14B	602	B2/2-78	North
15B	603	B2/2-78	West & South
16B	603	B4	North
17B	604	B4	West & South
18B	605	B2/2-78	West & North
19B	606	B2/2-78	South
20B	606	B2/2-78	West & North
21B	607	B2/2-78	South
22B	607	B2/2-78	West & North
23B	608	B22-78	West & South
28B	707	1-16	East & South
29B	806	1-16	West & South
34B	706	B1/2-23	West & North
35B	805	B3/2-23	West & North
36B	801	B3	West & North
41B	802	B3	West & South
42B	802	B3/2-40	West & North
43B	702	B1/2-40	West & North

LERA

One and Two World Trade Center
Structural Integrity Inspection
Accessible Columns

23 May 1997
File: P1153903
Page 14

5. LIST OF PREVIOUSLY INSPECTED - 2 WTC (continued)

Previously Inspected

Elevator Shaft/Pit	Column Number	Pit/Floors Inspected	Face Of Column Inspected
47B	803	B3	West & South
48B	905	B3	East & North
49B	704	B6	West & South
50B	704	2-108	East & South
50B	703	2-78	North
50B	803	2-108	North
55B	707	43	East, West & North
55B	707	45-54	East & South
56B	806	43	East, West & North
56B	806	45-54	East & West
61B	706	43/44-61	West & North
62B	805	43/44-61	West & North
63B	801	43	East, West & North
64B	701	43	East, West & North
67B	702	42	East, West & South
68B	802	43	East, West & South
69B	802	43/44-74	West & North
70B	702	43/44-74	West & North
78B	707	76	East, West & North
78B	707	78-86	East & South
79B	806	76	East, West & North

LERA

One and Two World Trade Center
Structural Integrity Inspection
Accessible Columns

23 May 1997
File: P1153903
Page 15

5. LIST OF PREVIOUSLY INSPECTED - 2 WTC (continued)

Previously Inspected

Elevator Shaft/Pit	Column Number	Pit/Floors Inspected	Face Of Column Inspected
79B	806	78-86	East & West
82B	801	77	East, West & North
83B	701	77	East, West & North
88B	802	77/78-100	East, West & North
89B	702	77/78-100	East, West & North
95B	706	77	West & North
96B	707	77/78-106	East, West & South
97B	806	77/78-106	West & South
99B	703/803	105/106-110	South

- 1998 Accessible Columns SII Report (part of WTCI-66-L)

LERA

One and Two World Trade Center
Structural Integrity Inspection
Accessible Columns

4. LIST OF INSPECTED COLUMNS - 1 WTC

Elevator Shaft/Pit*	Column Number	Pit/Floors Inspected	Face Of Column Inspected
5A	906	2-44	South & West
14A(SO)	602	2-78	East
15A(SO)	603	2-78	North & West
25A(PO)	708	B1	South & West
28A	707	B1/2-16	North & East
29A(SO)	806	2-16	North & East
30A(SO)	806	2-24	North & West
31A	707	B1/2-24	North & West
37A(PO)	701	B1	North & East
46A	706	B1/2-40	North & West
47A(SO)	803	2-40	North & West
48A(SO)	905	2-40	East & West
55A(SO)	707	44-54	North & East
56A(SO)	806	44-54	North & East
67A(SO)	702	44-67	North, South & West
68A(SO)	802	44-67	North, South, & West
73A(PO)	703	43	North & West
74A(PO)	803	43	North & West
78A(SO)	707	78-86	North, East & South
79A(SO)	806	78-86	North, East & South

* (SO) Refers to the shaft only, not the pit

* (PO) Refers to the pit only, not the shaft

LERA

One and Two World Trade Center
Structural Integrity Inspection
Accessible Columns

4. LIST OF INSPECTED COLUMNS - 1 WTC (continued)

Previously Inspected

Elevator Shaft/Pit	Column Number	Pit/Floors Inspected	Face Of Column Inspected
1A	908	B2/2-44	South & West
2A	907	B2/2-44	East
3A	907	B2/2-44	South & West
4A	906	B2/2-44	East
6A	904	B4/2-106	South & West
7A	903	B4/2-106	East
8A	903	B2/2-44	South & West
9A	902	B2/2-44	East
10A	902	B1/2-44	South & West
11A	901	B1/2-44	East & South
12A	601	B2/2-78	North & East
13A	602	B2/2-78	North & West
14A(PO)	602	B2	East
15A(PO)	603	B2	North & West
16A	603	B4/2-78	East
17A	604	B4/2-78	North & West
18A	605	B2/2-78	North & East
19A	606	B2/2-78	West
20A	606	B2/4-78	North & East
21A	607	B2/4-78	West
22A	607	B2/2-78	North & East
23A	608	B2/2-78	North & West
24A	807	B3/2-17	North & West
25A(SO)	708	2-17	South & West
29A(PO)	806	B3	North & East

LERA

One and Two World Trade Center
Structural Integrity Inspection
Accessible Columns

4. LIST OF INSPECTED COLUMNS - 1 WTC (continued)

Previously Inspected (continued)

Elevator Shaft/Pit	Column Number	Pit/Floors Inspected	Face Of Column Inspected
30A(PO)	806	B3	North & West
34A	706	B1/2-24	North & East
35A	805	B3/2-24	North & East
36A	801	B3/2-32	North & East
37A(SO)	701	2-32	East & South
40A	702	B1/2-33	North & West
41A	802	B3/2-33	North & West
42A	802	B3/2-40	North & East
43A	702	B1/2-40	North & East
47A(PO)	803	B3	West & North
48A(PO)	905	B3	East & South
50A	704	63/2-108	North, South & West
50A(SO)	703	2-78	East
50A(SO)	803	2-108	East
51A	807	43/44-54	North & West
52A	708	43/44-54	North & West
55A(PO)	707	43	East, North & South
56A(PO)	806	43	East, North & South
57A	806	43/44-61	South & West
58A	707	43/44-61	South & West
61A	706	43/44-61	North & East
62A	805	43/44-61	North & East
63A	801	43	North & East
64A	701	43/45-67	North, East & South
67A(PO)	702	42	West, North & South
68A(PO)	802	43	West, North & South

LER A

One and Two World Trade Center
Structural Integrity Inspection
Accessible Columns

4. LIST OF INSPECTED COLUMNS - 1 WTC (continued)

Previously Inspected (continued)

Elevator Shaft/Pit	Column Number	Pit/Floors Inspected	Face Of Column Inspected
69A	802	43/44-74	North & East
70A	702	43/44-74	North & East
73A(SO)	703	43-74	North & West
74A(SO)	803	43-74	North & West
76A	807	77/78-86	West & South
77A	708	77/78-86	West & South
78A(PO)	707	76	North, East & South
79A(PO)	806	76	North, East & South
82A(PO)	801	77	North, East & South
82A(SO)	801	78-93	East & South
83A(PC)	701	77	North, East & South
83A(SO)	701	78-93	North & East
84A	702	77/78-93	South & West
85A	802	77/78-93	North & West
88A	802	77/78-100	North & East
89A	702	77/78-100	North, East & South
90A	703	77/78-100	West & South
91A	803	77/78-100	North & West
94A	805	77/78-107	North & East
95A	706	77/78-107	East & South
96A	707	77/78-106	South & West
97A	806	77/78-106	North, South & West
99A	703/803	105/106-110	West

LERA

One and Two World Trade Center
Structural Integrity Inspection
Accessible Columns

5. LIST OF INSPECTED COLUMNS - 2 WTC

Elevator Shaft/Pit*	Column Number	Pit/Floors Inspected	Face Of Column Inspected
3B(SO)	907	2-44	East & South
4B(SO)	906	2-44	North
8B(SO)	903	2-44	South & West
9B(SO)	902	2-44	North
16B(SO)	603	2-78	North
17B(SO)	604	2-78	South & West
25B(PO)	708	B1	East & South
28B(PO)	707	B1	East & South
29B(PO)	806	B1	North & West
31B(PO)	707	B1	South & West
37B(PO)	701	B1	North & West
40B	702	B1/2-32	South & West
41B(SO)	802	2-32	South & West
46B	703	B1/2-32	South & West
47B(SO)	803	2-40	South & West
49B(SO)	703	2-74	North
73B(SO)	703	44-74	South & West
74B(SO)	803	44-74	South & West
76B(SO)	807	78-86	East & South
77B(SO)	708	78-86	East & South
82B(SO)	801	78-93	North, East & West
83B(SO)	701	78-93	North, East & West
84B	702	77/78-93	East & South
85B	802	77/78-93	East & South
94B	805	77/78-107	North & East
95B(SO)	706	78-107	North & East

* (SO) Refers to the shaft only, not the pit

* (PO) Refers to the pit only, not the shaft

LERA

One and Two World Trade Center
Structural Integrity Inspection
Accessible Columns

5. LIST OF INSPECTED COLUMNS - 2 WTC (continued)

Previously Inspected

Elevator Shaft/Pit	Column Number	Pits/Floors Inspected	Face Of Column Inspected
1B	908	B2/2-44	East & South
2B	907	B2/2-44	North
3B(PO)	907	B2	East & South
4B(PO)	906	B2	North
5B	906	B2/B1-44	East & South
6B	904	B2/2-106	East & South
7B	903	B2/2-106	North
8B(PO)	903	B2	East & South
9B(PO)	902	B2	North
10B	908	B2/2-44	East & South
11B	901	B2/2-44	North & East
12B	601	B2/2-44	North & West
13B	602	B2/2-78	South & West
14B	602	B2/2-78	North
15B	603	B2/2-78	South & West
16B(PO)	603	B4	North
17B(PO)	604	B4	South & West
18B	605	B2/2-78	North & West
19B	606	B2/2-78	South
20B	606	B2/2-78	North & West
21B	607	B2/2-78	South
22B	607	B2/2-78	North & West
23B	608	B2/2-78	South & West
24B	807	B3/2-16	West & South
25B(SO)	708	2-16	East & South
28B(SO)	707	1-16	East & South
29B(SO)	806	1-16	North & West

LERA

One and Two World Trade Center
Structural Integrity Inspection
Accessible Columns

5. LIST OF INSPECTED COLUMNS - 2 WTC (continued)

Previously Inspected (continued)

30B	806	B1/2-24	South & West
31B(SO)	707	2-24	East & South
34B	706	B1/2-23	North & West
35B	805	B1/2-23	North & West
36B	801	B3/2-32	North & West
37B(SO)	701	2-32	North & East
41B(PO)	802	B3	South & West
42B	802	B3/2-40	North & West
43B	702	B1/2-40	North & West
47B(PO)	803	B3	South & West
48B	905	B3/B1-40	North & East
49B(PO)	704	B3	South & West
50B	704	B6/2-108	East & South
50B	803	B6/2-108	North
51B	807	43/44-54	South & West
52B	708	43/44-54	South & West
55B(PO)	707	43	North, East & West
55B(SO)	707	45-54	East & South
56B(PO)	806	43	North, East & West
56B(SO)	806	45-54	North & West
57B	806	43/44-61	South & West
58B	707	43/44-61	East & South
61B	706	43/44-61	North & West
62B	805	43/44-61	North & West
63B(PO)	801	43	North, East & West
63B(SO)	801	44-67	North & West
64B(PO)	701	43	North, East & West
64B(SO)	701	44-67	North & West

LERA

One and Two World Trade Center
Structural Integrity Inspection
Accessible Columns

5. LIST OF INSPECTED COLUMNS - 2 WTC (continued)

Previously Inspected (continued)

Elevator Shaft/Pit*	Column Number	Pit/Floors Inspected	Face Of Column Inspected
67B(PO)	702	42	East, South & West
67B(SO)	702	44-67	East & South
68B(PO)	802	43	East, South & West
68B(SO)	802	44-67	South & West
69B	802	43/44-74	North & West
70B	702	43/44-74	North & West
73B(PO)	801	43	East, South & West
74B	701	43	East, South & West
76B(PO)	702	77	East, South & West
77B(PO)	802	77	East, South & West
78B(PO)	707	76	North, East & West
78B(SO)	707	78-86	North & East
79B(PO)	806	76	North, East & West
79B(SO)	806	78-86	North & East
82B(PO)	801	77	North, East & West
83B(PO)	701	77	North, East & West
88B	802	77/78-100	East, South & West
89B	702	77/78-100	East, South & West
90B	703	77/78-100	East & South
91B	803	77/78-100	West & South
95B(PO)	706	77	West & North
96B	707	77/78-106	East, South & West
97B	806	77/78-106	East, South & West
99B	703/803	105/106-110	South

Historical Review of World Trade Center Damping Units (WTCI-230-L)

Historical Review of World Trade Center Damper

Ming-Lai Lai

Date	Event	Stiffness, kip/0.02" .75 "F
9/5/69	Specification defines stiffness and Warranty	$6 < F < 20$
3/12/70 to 4/18/72	Made Lots 1-43 and 50 about 20,000 dampers. Each lot (230 to 475 dampers): Tested 5 dampers for stiffness, 5 dampers for strength, 5 dampers for five year storage in controlled temperature and relative humidity at 3M to form 4 guarantee lots (total 237 dampers)	Avg. = 14.368 Lowest of 5 dampers = 10.178 Highest of 5 dampers = 17.157
9/24/71 to 10/20/76	3M retained extra dampers from guarantee Lots 1 (first 12 acceptance lots) and Lot 4 (last 10 acceptance lots) for internal testing besides the 5 year test required by Port Authority. Dampers were in temperature and humidity controlled room 3M tested 8 dampers every 6 months for 5 years	dropped from 13.92 to 9.987
5/7/75	6 fires set by arsonist in WTC Towers. 3M tested 3 dampers from 12th floor of WTC Tower A.	
spring to end of 1976	Completed 5 year test for the four guarantee lots. Port authority accepted the results. Shipped 162 dampers to Port Authority 21 dampers held by 3M (3M paid)	10.7 accepted
5/8/81	10 year aging data on 3M retains. A report was generated by Caldwell	9.5
7/6/82	Robertson submitted Port Authority the report by Caldwell on 3M in-house testing showing decrease in stiffness Caldwell suggested test 6 dampers from each tower and 6 dampers from storage.	
1/10/83	Caldwell told A D Nelson that gradual delamination of the 50 layers may be responsible for the decrease in stiffness. This delamination theory was shown in Caldwell's five and ten year aging report and was	

	shown to Port Authority by Lee Robertson 7/6/82	
12/17/82	8 dampers from each tower and 9 from storage (21 total) sent to 3M for testing. Data shown in the plot dated 1983. This was the first systematic test of dampers from the towers.	
4/20/76 to 6/8/81 and 11/9/83	Damper #10 K per C 02"=11.9 (4/20/75) 7.93 (6/8/81) 13.037 (6/8/81 after in 300 °F for two hours with a C-clamp on the damper) 5.278 (11/9/83)	
Sept. 1978 and Feb 1984	16 out of 162 storage dampers by Port Authority were tested twice by D.K. Guha of Port Authority Engineering Department A linear regression of the averaged stiffness kips/in was shown as $759.55 - 57.562t$ (temperature °F - 75 °F - 0.059t where t is number of days between date of testing and manufacturing.	12.2 and 11.0
4/4/84	Wind storm hit WTC. Maximum acceleration 27 mg which is equivalent to 27" sway. Maximum acceleration recorded was 37 mg on 108th floor of Tower A on 3/21/81.	
July and October 1984	Under Dr. P. Mahmoodi: 3M put 4 LVDT on 4 Tower A dampers per floor on 74th and 104th floors to test dampers in-place. 3M tested 22 dampers from Tower A and 10 damper from WTC stored spares. Data plotted and not shown a significant difference compared to 1983 test.	8105 for 16 dampers from Tower A. 8698 for 10 stored dampers.
7/17/84	Wind anemometer and recorder installed on WTC.	
10/1/1984	Report by Robertson, Fowler & Ass. on "Investigation of Aging Effects: World Trade Center Dampers"	
10/25/93	3M Tested 36 WTC Dampers in Storage	6.7 Average Range: 7.6-10.1
11/11/88	3M tested 4 dampers from WTC Tower	7810
12/18/95	3M tested 4 dampers from WTC Tower. Damper displacement was measured by LVDT.	7292

This page intentionally left blank.

