

NAT'L INST. OF STAND & TECH R.I.C.

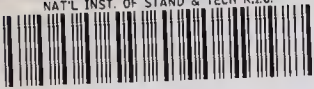

A11104 061294



NBS SPECIAL PUBLICATION 466

U.S. DEPARTMENT OF COMMERCE NATIONAL BUREAU OF STANDARDS

Standardization in Spectrophotometry and Luminescence Measurements

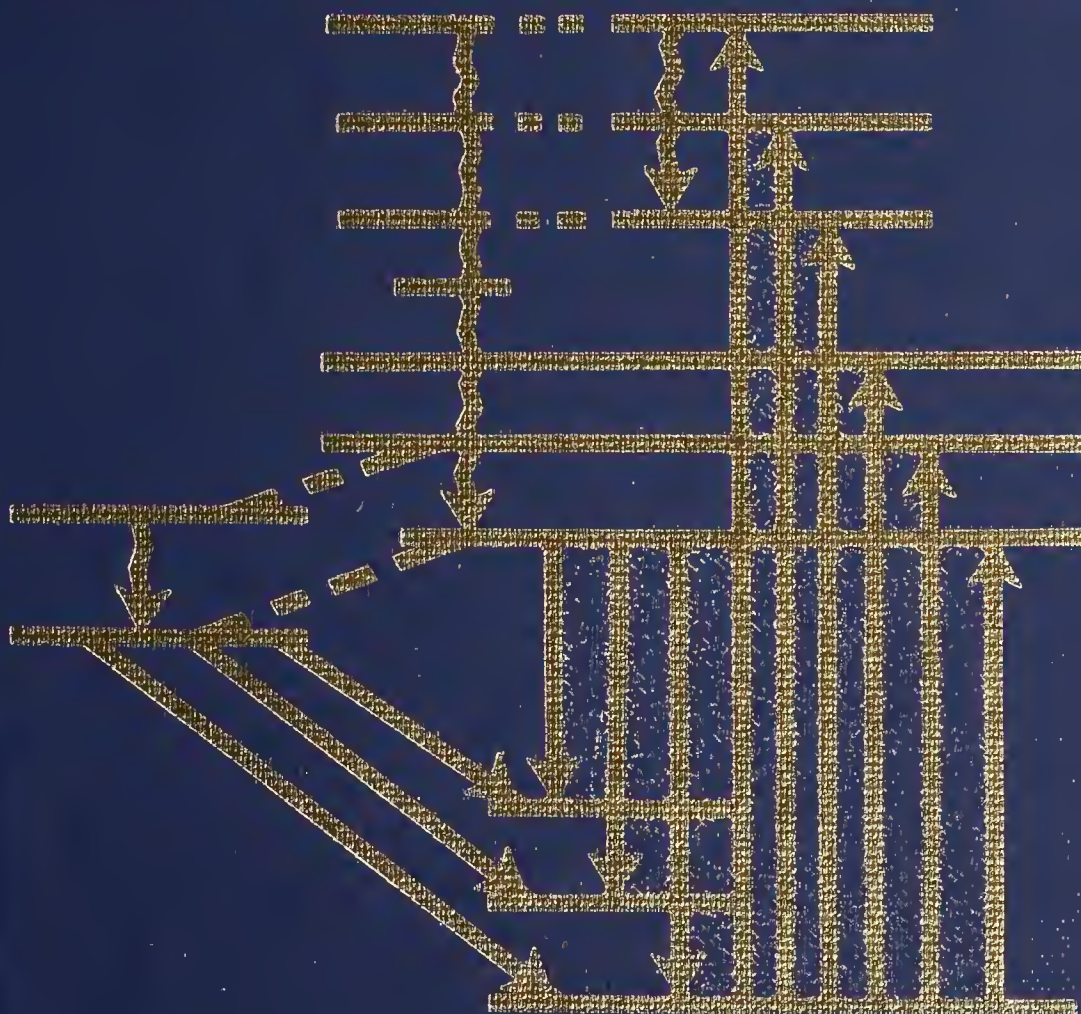

QC
100
.U57
1977
C.3

Standardization in Spectrophotometry and Luminescence Measurements

Proceedings of a Workshop Seminar
Held at the National Bureau of Standards
Gaithersburg, Maryland, November
November 19-20, 1975

Edited by:

K.D. Mielenz, R.A. Velapoldi,
and R. Mavrodineanu

Analytical Chemistry Division
Institute for Materials Research
National Bureau of Standards
Washington, D.C. 20234



U.S. DEPARTMENT OF COMMERCE, Juanita M. Kreps, Secretary

Dr. Sidney Harman, Under Secretary

NATIONAL BUREAU OF STANDARDS, Ernest Ambler, Acting Director

Issued May 1977

Library of Congress Cataloging in Publication Data

Workshop Seminar on Standardization in Spectrophotometry and Luminescence Measurements,
National Bureau of Standards, 1975.
Standardization in spectrophotometry and luminescence measurements.

(NBS special publication ; 466)

"Organized by the Analytical Chemistry Division, Institute for Materials Research, at the National Bureau of Standards."

"Reprinted from the National Bureau of Standards Journal of Research, Section A. Physics and Chemistry, vol. 80A, nos. 3 and 4, May-June, and July-Aug. 1976."

Supt. of Docs. no. C13.10:466

1. Spectrophotometry--Congresses. 2. Fluorimetry--Congresses.
3. Phosphorimetry--Congresses. I. Mielenz, K. D. II. Velapoldi, R. A.
III. Mavrodineanu, Radu, 1910- IV. United States. National Bureau of Standards. Analytical Chemistry Division. V. Title. VI. Series: United States. National Bureau of Standards. Special publication ; 466. QC100.U57 no. 466 [QD79.P46] 602'.1s [543'.085] 77-4739

Library of Congress Catalog Card Number:

National Bureau of Standards Special Publication 466

Nat. Bur. Stand. (U.S.), Spec. Publ. 147, 155 pages (May 1977)

CODEN: XNBSAV

Reprinted from the National Bureau of Standards
Journal of Research, Section A. Physics and Chemistry
Vol. 80A, Nos. 3 and 4, May-June, and July-Aug. 1976.

U.S. GOVERNMENT PRINTING OFFICE
WASHINGTON: 1977

For sale by the Superintendent of Documents, U.S. Government Printing Office, Washington, D.C. 20402
(Order by SD Catalog No. C13.10:466). Stock No. 003-003-01791-4 - Price \$5.25
(Add 25 percent additional for other than U.S. mailing).

Abstract

This volume contains 15 papers presented at the Workshop Seminar on Standardization in Spectrophotometry and Luminescence Measurements organized by the Analytical Chemistry Division, Institute for Materials Research, at the National Bureau of Standards, and held from November 19 to 20, 1975.

These papers discuss the problems encountered where accurate measurements are required in the fields of luminescence quantum yields, diffuse reflectance spectroscopy, and ultraviolet absorption spectrometry. They also define the needs for standardization of measurements in these fields and suggest materials that could be used as Standard Reference Materials. Considerations on some applications of such standards in the field of environmental pollution and health are included.

Key words: Accuracy; critical parameters; diffuse reflectance; fluorescence; instrumentation; luminescence; quantum yield; spectrophotometry; Standard Reference Materials; standardization.

Foreword

A major function of the Institute for Materials Research of the National Bureau of Standards is the development of Standard Reference Materials (SRM's). These are: *well characterized materials that can be used to calibrate a measurement system or to produce scientific data which can be referred to a common base*. In order to assure that these SRM's meet real needs and are certified to a realistic degree of accuracy, the Institute for Materials Research has sponsored a series of 'Workshop Seminars' in which leading domestic and foreign experts meet with NBS staff members to define the state of the art and to establish priorities for future efforts.

The Workshop Seminar on 'Standardization in Spectrophotometry and Luminescence Measurements' was organized by the Analytical Chemistry Division, and was held at the National Bureau of Standards in Gaithersburg, Md., on November 19 and 20, 1975. Approximately forty participants, coming from seven different countries and representing industries, universities, as well as standardizing laboratories, gathered to exchange ideas on improved standards and measurement techniques. Three specific topics were discussed: luminescence quantum yields, diffuse reflectance spectroscopy, and ultraviolet absorption spectrometry. The fifteen papers given represented the points of view of chemists and physicists using these techniques for widely different applications: analytical and clinical chemistry, photochemistry, photometry and colorimetry, laser physics, and space research.

Previous work in our Division has resulted in the development of several SRM's for spectrophotometry and luminescence spectrometry: neutral density filters for verifying the transmittance accuracy of spectrophotometers, liquid absorbance standards for the uv and visible, calibrated quartz cuvettes as pathlength standards for absorption spectrometry, and fluorescence emission standards to calibrate the spectral responsivity of luminescence spectrometers. These Proceedings will provide the basis for further progress.

Philip D. LaFleur, Chief
Analytical Chemistry Division

January 1977

Preface

Due to advances in optical instrumentation, electronics, and computer technology, spectrophotometric and luminescence measurements can now be performed with a precision that frequently exceeds the accuracy of the results by a wide margin. The achievement of comparable accuracies requires improved standards as well as a better understanding of the measurement process. Thus, in organizing this Workshop Seminar on 'Standardization in Spectrophotometry and Luminescence Measurements' at NBS, we have endeavored to provide an interdisciplinary forum for chemists and physicists to present their views on how to achieve this goal. In this manner, we could learn from one another and, perhaps, also close the communications gap that sometimes appears to exist in these fields.

The first part of these proceedings contains five invited papers on the measurement of luminescence yields. The introductory paper by J.B. Birks reviews the basic principles of fluorescence spectrometry and defines the parameters to be measured. A. Bril and A.W. de Jager-Veenis discuss radiometric methods of luminescence efficiency measurements, J.N. Demas and B.H. Blumenthal describe the actinometric determination of luminescence quantum yields, and J.B. Callis illustrates the use of calorimetric techniques. In the final paper of this section, K.H. Drexhage discusses the chemistry of fluorescent dyes and proposes new fluorescence standards.

In the section on diffuse reflectance spectroscopy, R.W. Frei reviews the numerous applications of this technique and H.G. Hecht summarizes the theories that are used for interpreting the results obtained. W. Budde discusses the calibration of diffuse reflectance standards, and J.B. Schutt and G.J. Buffone present practical examples of this technique in space technology and clinical chemistry.

Errors in spectrophotometry and standards used to avoid them are discussed by A.G. Reule and A.R. Robertson. The suitability of potassium dichromate solutions as ultraviolet absorbance standards is demonstrated by R.W. Burke and R. Mavrodineanu. Considerations on semi-reflecting metallic films as transmittance standards are presented by R. Mavrodineanu, and the physical parameters that affect the properties of these metallic films are discussed by H.E. Bennett and J.L. Stanford.

The important contributions of these authors are acknowledged with appreciation.

The Workshop Seminar was planned and organized by K.D. Mielenz, R.A. Velapoldi and R. Mavrodineanu (conference chairpersons), under the guidance of P.D. LaFleur (Chief, Analytical Chemistry Division) and J.R. DeVoe (Chief, Special Analytical Instrumentations Section), and with considerable help from R.B. Johnson, R.S. Maddox (Institute for Materials Research), S.R. Torrence (Office of Information Activities), E.S. Kershaw, E.L. Zimmerman, and C.I. Wingo (Analytical Chemistry Division).

J.N. Demas (University of Virginia), G. Weber (University of Illinois), F. Grum and R.N. Rand (Eastman Kodak Co.) and R.W. Burke (NBS) served as conference co-chairpersons and discussion leaders.

The seminar had the encouragement of R.S. Melville (Executive Secretary, National Institute of General Medical Sciences). NIGMS has also supported the development of advanced instrumentation for absorption and fluorescence spectrometry at NBS, and its use to develop and certify Standard Reference Materials for these fields.

The fifteen papers reprinted in this volume were originally published in the Journal of Research of the National Bureau of Standards, 80A, 389-428 and 551-658 (1976). Special thanks are due to D.D. Wagman (Associate Editor, J. Res. NBS), W.R. Tilley, M.S. Reid, and M.V. Betizel (Office of Technical Publications) for their considerable efforts in publishing these papers.

We hope that the collection of these papers in a single volume will be a worthy sequel to the Proceedings of the 1972 Conference on Accuracy in Spectrophotometry and Luminescence Measurements (NBS Special Publication 378, U.S. Govt. Print. Office, 1973).

K. D. Mielenz
R. A. Velapoldi
R. Mavrodineanu

January 1977

Contents

	Page
Foreword	iv
Preface	v
Part 1. Luminescence Quantum Yields	
Fluorescence quantum yield measurements. J. B. Birks	1
Some methods of luminescence efficiency measurements. Alfred Brill and A. Willy de Jager-Veenis.	13
On the actinometric measurement of absolute luminescence quantum yields. J. N. Demas and B. H. Blumenthal	21
The calorimetric detection of excited states. James B. Callis	25
Fluorescence efficiency of laser dyes. K. H. Drexhage	33
Part 2. Diffuse Reflectance Spectroscopy	
Diffuse reflectance spectroscopy; applications, standards, and calibration (with special reference to chromatography). R. W. Frei.....	41
The interpretation of diffuse reflectance spectra. Harry G. Hecht	57
Calibration of reflectance spectra. W. Budde	75
Understanding bidirectional reflectance and transmission for space applications. John B. Schutt	87
Standardization of light scattering measurement in conjunction with immunochemical analysis. Gregory J. Buffone	95
Part 3. Ultraviolet Absorption Spectrometry	
Errors in spectrophotometry and calibration procedures to avoid them. A. G. Reule	99
Standardization in transmission spectrophotometry in the visible and ultraviolet spectral regions. A. R. Robertson	115
Acidic potassium dichromate solutions as ultraviolet absorbance standards. R. W. Burke and R. Mavrodineanu	121
Considerations for the use of semi-transparent metallic thin films as potential transmittance standards in spectrophotometry. R. Mavrodineanu	127
Structure-related optical characteristics of thin metallic films in the visible and ultraviolet. H. E. Bennett and J. L. Stanford	133
Index of Key Words	149

Part 1. Luminescence Quantum Yields

Fluorescence Quantum Yield Measurements*

J. B. Birks

University of Manchester, Manchester, U.K.

(April 9, 1976)

Four *molecular fluorescence parameters* describe the behaviour of a fluorescent molecule in very dilute ($\sim 10^{-6} M$) solution:

- (i) the fluorescence spectrum $F_M(\bar{\nu})$;
- (ii) the fluorescence polarization P_M ;
- (iii) the radiative transition probability k_{FM} ; and
- (iv) the radiationless transition probability k_{IM} .

These parameters and their temperature and solvent dependence are those of primary interest to the photophysicist and photochemist. $F_M(\bar{\nu})$ and P_M can be determined directly, but k_{FM} and k_{IM} can only be found indirectly from measurements of the secondary parameters,

- (v) the fluorescence lifetime τ_M , and
- (vi) the fluorescence quantum efficiency q_{FM} ,

where $k_{FM} = q_{FM}/\tau_M$ and $k_{IM} = (1 - q_{FM})/\tau_M$.

The *real fluorescence parameters* $F(\bar{\nu})$, τ and ϕ_F of more concentrated ($c > 10^{-5} M$) solutions usually differ from the molecular parameters $F_M(\bar{\nu})$, τ_M and q_{FM} due to concentration (self) quenching, so that $\tau > \tau_M$ and $\phi_F < q_{FM}$. The concentration quenching is due to excimer formation and dissociation (rates k_{DMC} and k_{MD} , respectively) and it is often accompanied by the appearance of an excimer fluorescence spectrum $F_D(\bar{\nu})$ in addition to $F_M(\bar{\nu})$, so that $F(\bar{\nu})$ has two components. The *excimer fluorescence parameters* $F_D(\bar{\nu})$, P_D , k_{FD} and k_{ID} , together with k_{DM} and k_{MD} , and their solvent and temperature dependence, are also of primary scientific interest.

The *observed (technical) fluorescence parameters* $F^T(\bar{\nu})$, τ^T and ϕ_F^T in more concentrated solutions usually differ from the real parameters $F(\bar{\nu})$, τ and ϕ_F ; due to the effects of self-absorption and secondary fluorescence. The technical parameters also depend on the optical geometry and the excitation wavelength. The problems of determining the real parameters from the observed, and the molecular parameters from the real, will be discussed.

Methods are available for the accurate determination of $F^T(\bar{\nu})$ and τ^T . The usual method of determining ϕ_F^T involves comparison with a reference solution R , although a few calorimetric and other absolute determinations have been made. For two solutions excited under identical conditions and observed at normal incidence

$$\frac{\phi_F^T}{\phi_{FR}^T} = \frac{n^2 \int F^T(\bar{\nu}) d\bar{\nu}}{n_R^2 \int F_R^T(\bar{\nu}) d\bar{\nu}}$$

where n is the solvent refractive index.

Two reference solution standards have been proposed, quinine sulphate in $N H_2SO_4$ which has no self-absorption, and 9,10-diphenylanthracene in cyclohexane which has no self-quenching. The relative merits of these solutions will be discussed, and possible candidates for an "ideal" fluorescence standard with no self-absorption and no self-quenching will be considered.

Key words: Fluorescence lifetime; fluorescence quantum efficiency; fluorescence quantum yields; fluorescence spectrum; fluorescence standards; molecular fluorescence parameters; observed (technical) fluorescence parameters; polarization; radiative and non-radiative transition probabilities; real fluorescence parameters.

*Paper presented at the Workshop Seminar 'Standardization in Spectrophotometry and Luminescence Measurements' held at the National Bureau of Standards, Gaithersburg, Md., Nov. 19-20, 1975.

1. Introduction

Most atoms, molecules, polymers and crystals emit ultraviolet, visible or infrared photons following excitation of their electronic energy levels. This emission or *luminescence* is classified according to the mode of excitation:

photoluminescence due to optical (non-ionizing) radiation;

cathodoluminescence due to cathode rays (electron beams);

radioluminescence (scintillations) due to ionizing radiation;

electroluminescence due to electric fields;

thermoluminescence produced thermally after prior irradiation by other means;

triboluminescence due to frictional and electrostatic forces;

sonoluminescence due to ultrasonic radiation;

chemiluminescence due to a chemical process, commonly oxidation;

electrochemiluminescence due to a chemical process, initiated by an electric field; and

bioluminescence due to a biological process, usually enzymatic in origin.

Luminescent materials can be divided into several broad groups.

(i) *Aromatic molecules* constitute the largest group. They emit luminescence in the vapour, liquid, polymer and crystal phases and in fluid and rigid solutions [1]¹. They are used extensively in organic liquid, plastic and crystal scintillators [2], luminescent dyes and paints, detergent and paper whiteners, luminescent screens, dye lasers, etc.

(ii) Many *inorganic crystals*, including diamond, ruby, alkali halides, zinc sulphide and calcium tungstate, luminesce efficiently. The emission is usually from impurity centres (activators) or, in the absence of such impurities, from crystal defects [2]. Luminescent inorganic crystals are used as scintillators [2], luminescent screens, solid-state lasers, jewels, etc.

(iii) *Noble gases* (He, Ne, Ar, Kr, Xe) luminesce in the vapour, liquid, and solid phases and in liquid and solid solutions [2, 3]. They are used in discharge lamps, gas lasers and scintillators.

(iv) Many *simple inorganic molecules* luminesce in the vapour phase [4]. Some, like H₂, D₂, N₂, and Hg are used in discharge lamps; others, like N₂, I₂, and CO₂ are used in gas lasers.

(v) Some *inorganic ions*, notably those of the rare earth elements, are luminescent. They are used as activators in inorganic crystals (see (ii) above), glasses and chelates. Applications include inorganic crystal and glass scintillators and Nd glass lasers.

(vi) Many *biological molecules* are luminescent. These include

- (a) *aromatic amino-acids* (tryptophan, tyrosine, phenylalanine) in proteins;
- (b) *nucleotides* (adenine, guanine, uracil, cytosine, thymine) in DNA and RNA;
- (c) *retinyl polyenes* in the visual pigments;
- (d) *chlorophylls* and *carotenoids* in the photosynthetic chloroplast; and
- (e) several *vitamins* and *hormones*.

The study of biomolecular luminescence is an important area of biophysical research [5].

(vii) *Aliphatic molecules*, such as the paraffins and cyclohexane, once considered to be nonluminescent, are now known to emit in the far ultraviolet (~ 200 nm) with low quantum yield [6]. This list, which is not exhaustive, illustrates the wide range of luminescent materials and their applications.

2. Luminescence of Aromatic Molecules

2.1. Radiative transitions

The initial discussion is limited to aromatic molecules (i), but it will be later extended to other luminescent materials (ii)-(vii). Most aromatic molecules have an even number of π -electrons, giving a ground singlet electronic state S_0 in which the electron spins are paired. The *excited* π electronic states of the molecule are either

singlet states: $S_1, S_2 \dots S_p$; or
triplet states: $T_1, T_2 \dots T_q$.

A spin-allowed radiative transition (luminescence) between two states of the same multiplicity (e.g. $S_1 \rightarrow S_0$, $S_p \rightarrow S_0$, $T_q \rightarrow T_1$) is called *fluorescence* (F). A spin-forbidden radiative transition between two states of different multiplicity (e.g. $T_1 \rightarrow S_0$) is called *phosphorescence* (P). The energy difference between the initial and final electronic state is emitted as a fluorescence photon ($h\nu_F$) or phosphorescence photon ($h\nu_P$).

The fluorescence occurring immediately after the initial excitation of S_1 (or S_p) is known as *prompt fluorescence*. In some molecules or molecular systems there are mechanisms by which S_1 (or S_p) may become excited subsequent to the initial excitation, resulting in *delayed fluorescence*. The two principal mechanisms are as follows [1].

(i) Thermal activation of molecules in the lowest triplet state T_1 , which is long-lived because the $T_1 \rightarrow S_0$ transition is spin-forbidden, repopulates the fluorescent singlet state S_1 , resulting in *E-type* (eosin-type) *delayed fluorescence*, so called because it occurs in eosin and other dye molecules.

(ii) Diffusional interaction between pairs of T_1 -excited molecules in solution or T_1 excitons in a crystal creates singlet-excited molecules by the process

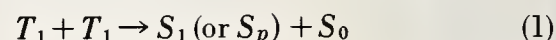

¹Figures in brackets indicate the literature references at the end of this paper.

resulting in *P-type* (pyrene-type) *delayed fluorescence*, so called because it occurs in pyrene and other aromatic hydrocarbons.

2.2. Radiationless Transitions

Radiative transitions are between electronic states of different energy. In a complex molecule or crystal there are also radiationless transitions between different electronic states of the same energy. These isoenergetic radiationless transitions are induced by molecular or crystal vibrations.

A spin-allowed radiationless transition between two states of the same multiplicity is called *internal conversion* (*IC*). A spin-forbidden radiationless transition between two states of different multiplicity is called *intersystem crossing* (*ISC*).

2.3. Vibrational Relaxation

After the initial excitation or after an isoenergetic radiationless transition, the molecule is usually in a vibronic state S_p^* (or T_q^*) corresponding to a vibrationally-excited level of a particular electronic state S_p (or T_q). In a condensed medium (solution, liquid, polymer, crystal) or a high-pressure vapour the excess vibrational energy $S_p^* - S_p^0$ (or $T_q^* - T_q^0$) is rapidly dissipated collisionally to the environment leading to *vibrational relaxation* (*VR*).

The dissipative *VR* process, which is distinct from the nondissipative *IC* and *ISC* processes, plays an essential role in the thermal equilibration of the excited molecules. At normal temperatures *VR* is rapid ($\sim 10^{-12} - 10^{-13}$ s, depending on the excess vibrational energy to be dissipated) and much faster than *IC*, *ISC*, *F* or *P*.

Isolated excited molecules in a low-pressure vapour, where *VR* is inhibited by the low collision rate, behave in a different manner than those in the condensed phase [6]. In an isolated molecule the fluorescence occurs from the vibronic state S_p^* initially excited or from isoenergetic vibronic states S_1^* , S_2^* . . . of lower electronic states populated by *IC*. This phenomena is called *resonance fluorescence*. In the condensed phase *VR* brings the excited molecules rapidly into thermal equilibrium and all the processes (*F*, *P*, *IC* and *ISC*) occur from an equilibrated system of molecules.

2.4. Photophysical Processes and Parameters

Figure 1 shows schematically the photophysical processes that can occur in an aromatic molecular system in very dilute solution ($\sim 10^{-6}$ M) following excitation into S_2 .

S_2 decays by

- IC* to S_1^* , followed by *VR* to S_1 ;
- IC* to S_0^{***} , followed by *VR* to S_0 ; or
- $S_2 \rightarrow S_0$ fluorescence F_2 .

$S_2 \rightarrow S_1$ fluorescence, which could potentially occur,

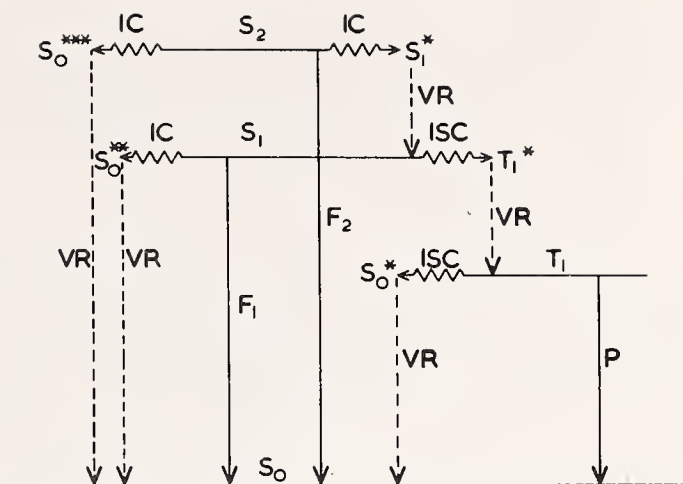

FIGURE 1. Schematic diagram of radiative (solid vertical lines), radiationless (wavy horizontal lines), and vibrational relaxation (broken vertical lines) transitions between electronic states (solid horizontal lines) S_2 , S_1 , T_1 and S_0 of an aromatic molecule in a condensed medium.

F = fluorescence, *P* = phosphorescence, *IC* = internal conversion, *ISC* = intersystem crossing, *VR* = vibrational relaxation.

is forbidden since S_2 and S_1 have the same parity (*ungerade*) [1].

S_1 , from (a), decays by

- $S_1 \rightarrow S_0$ fluorescence F_1 ;
- ISC* to T_1^* , followed by *VR* to T_1 ; or
- IC* to S_0^* , followed by *VR* to S_0 .

T_1 , from (e), decays by

- $T_1 \rightarrow S_0$ phosphorescence *P*; or
- ISC* to S_0^* , followed by *VR* to S_0

F, *P*, *IC*, and *ISC* are the rate-determining processes, since *VR* is much faster. k_{AB} is defined as the rate parameter of the $B \rightarrow A$ process, where *B* is the initial state and *A* is the product radiation (*F* or *P*) or final state (for *IC* or *ISC*) [1]. Subscripts $G=S_0$, $T=T_1$, $M=S_1$, and $H=S_2$ indicate the different states.

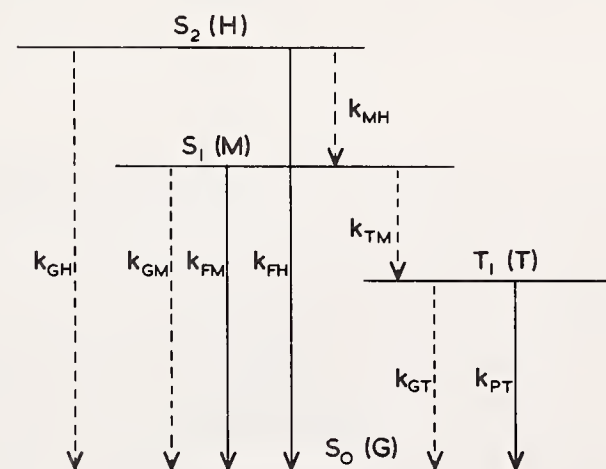

FIGURE 2. Rate parameters of radiative transitions (solid vertical lines) and radiationless plus vibrational relaxation transitions (broken vertical lines) between electronic states (solid horizontal lines) S_2 , S_1 , T_1 , and S_0 of an aromatic molecule in a condensed medium.

The notation of the states, radiations and rate parameters is indicated.

Figure 2 shows the rate parameters corresponding to the processes of figure 1. In the rate parameter description the VR subsequent to each IC or ISC is omitted, but the distinction between the isoenergetic radiationless transitions and the vibrational relaxation should not be overlooked.

The S_2 , S_1 and T_1 decay parameters are given by

$$k_H = k_{FH} + k_{MH} + k_{GH} = 1/\tau_H \quad (2)$$

$$k_M = k_{FM} + k_{TM} + k_{GM} = 1/\tau_M \quad (3)$$

$$k_T = k_{PT} + k_{GT} = 1/\tau_T \quad (4)$$

where τ_H , τ_M and τ_T are the S_2 , S_1 and T_1 lifetimes, respectively.

The quantum efficiency q_{AB} of any photophysical process, rate k_{AB} , from an excited state B is defined as the fraction of the excited molecules in B that decay by that process, so that

$$q_{AB} = k_{AB}/k_B \quad (5)$$

The $S_2 \rightarrow S_0$ and $S_1 \rightarrow S_0$ fluorescence quantum efficiencies are, respectively,

$$q_{FH} = k_{FH}/k_H \quad (6)$$

$$q_{FM} = k_{FM}/k_M \quad (7)$$

the $T_1 \rightarrow S_0$ phosphorescence quantum efficiency is

$$q_{PT} = k_{PT}/k_T \quad (8)$$

the $S_2 \rightarrow S_1^*$ internal conversion quantum efficiency is

$$q_{MH} = k_{MH}/k_H \quad (9)$$

and the $S_1 \rightarrow T_1^*$ and $T_1 \rightarrow S_0^*$ intersystem crossing quantum efficiencies are, respectively,

$$q_{TM} = k_{TM}/k_M \quad (10)$$

$$q_{GT} = k_{GT}/k_T \quad (11)$$

The rate parameters (fig. 2), the decay parameters and lifetimes (2)–(4), and the quantum efficiencies (5)–(11) are *molecular parameters*. They refer to very dilute ($\sim 10^{-6}M$) solutions, containing no dissolved oxygen or other impurity quenchers.

An increase in the solution molar concentration c does not change the unimolecular rate parameters, but it introduces bimolecular processes due to interactions between excited molecules in S_2 , S_1 or T_1 and unexcited molecules in S_0 , producing *concentration quenching*. To a first approximation the S_2 , S_1 and T_1 concentration quenching rates may be expressed as k_{CHC} , k_{CMC} and k_{CTC} , and the S_2 , S_1 and T_1 decay parameters become

$$k'_H = k_H + k_{CHC} = 1/\tau'_H \quad (2a)$$

$$k'_M = k_M + k_{CMC} = 1/\tau'_M \quad (3a)$$

$$k'_T = k_T + k_{CTC} = 1/\tau'_T \quad (4a)$$

respectively, where τ'_H , τ'_M and τ'_T are the S_2 , S_1 and T_1 lifetimes in a solution of molar concentration c . An exact treatment also considers the rate parameters of the *excimers* produced by the concentration quenching and their dissociation [1], but the Stern-Volmer approximation of (2a)–(4a) is adequate for the present discussion.

The quantum yield ϕ of any photophysical process in a solution of concentration c is defined in the same manner as the quantum efficiency, except that the limitation to very dilute solutions is removed. The $S_2 \rightarrow S_0$ and $S_1 \rightarrow S_0$ fluorescence quantum yields are, respectively

$$\phi_{FH} = \frac{k_{FH}}{k_H + k_{CHC}} = \frac{q_{FH}}{1 + K_{CHC}} \quad (12)$$

$$\phi_{FM} = \frac{k_{FM}}{k_M + k_{CMC}} = \frac{q_{FM}}{1 + K_{CMC}} \quad (13)$$

and the $T_1 \rightarrow S_0$ phosphorescence quantum yield is

$$\phi_{PT} = \frac{k_{PT}}{k_T + k_{CTC}} = \frac{q_{PT}}{1 + K_{CTC}} \quad (14)$$

The parameters $K_{CH} (= k_{CH}/k_H)$, $K_{CM} (= k_{CM}/k_M)$ and $K_{CT} (= k_{CT}/k_T)$ are the *Stern-Volmer coefficients of concentration quenching of S_2 , S_1 and T_1* , respectively.

The $S_2 \rightarrow S_1^*$ internal conversion quantum yield is

$$\phi_{MH} = \frac{k_{MH}}{k_H + k_{CHC}} = \frac{q_{MH}}{1 + K_{CHC}} \quad (15)$$

and the $S_1 \rightarrow T_1^*$ and $T_1 \rightarrow S_0^*$ intersystem crossing quantum yields are, respectively,

$$\phi_{TM} = \frac{k_{TM}}{k_M + k_{CMC}} = \frac{q_{TM}}{1 + K_{CMC}} \quad (16)$$

$$\phi_{GT} = \frac{k_{GT}}{k_T + k_{CTC}} = \frac{q_{GT}}{1 + K_{CTC}} \quad (17)$$

The above expressions for quantum efficiencies and yields all refer to direct excitation of the state from which the process occurs, and they require revision when the state is not excited directly. Thus for excitation into S_2 , the $S_1 \rightarrow S_0$ fluorescence quantum yield is

$$\phi_{FM}^H = \phi_{MH} \phi_{FM} \quad (18)$$

For excitation into S_1 , the $T_1 \rightarrow S_0$ phosphorescence quantum yield is

$$\phi_{PT}^M = \phi_{TM} \phi_{PT} \quad (19)$$

2.5. Vavilov's Law and Kasha's Rules

It is commonly assumed that $\phi_{MH} = 1.0$ for $S_2 \rightarrow S_1^*$ IC and that $\phi = 1$ for IC between higher excited states within the singlet (S_p) manifold, so that ϕ_{FM} is independent of the excitation wavelength λ_{ex} up to the ionization potential. This assumption, known as *Vavilov's law*, has been confirmed for many compounds in solution. Major deviations from Vavilov's law have, however, been observed for solutions of benzene, toluene, *p*-xylene, mesitylene, fluorobenzene, naphthalene, 2-methylnaphthalene, 1,6-dimethylnaphthalene [1], tryptophan, tyrosine and phenylalanine [7]. In each case it is observed that $\phi_{FM}^H/\phi_{FM} = \phi_{MH} < 1$. In benzene and its derivatives and possibly in the other compounds, the effect is due to efficient $S_2 \rightarrow S_0^{***}$ IC (k_{GH}) competing with $S_2 \rightarrow S_1^*$ IC (k_{MH}) [8]. In fluorescence quantum yield measurements it is essential either to verify that Vavilov's law applies, or to limit the excitation to the region of the $S_0 \rightarrow S_1$ absorption spectrum.

Kasha's rules [9], another well-known generalization, state that in a complex molecule luminescence occurs only from the lowest excited state of a given multiplicity, i.e., $S_1 \rightarrow S_0$ fluorescence and $T_1 \rightarrow S_0$ phosphorescence. For many years azulene and its derivatives, which emit $S_2 \rightarrow S_0$ fluorescence and negligible $S_1 \rightarrow S_0$ fluorescence, were the main exceptions to Kasha's rules. Recently the picture has changed dramatically.

In addition to the normal $S_1 \rightarrow S_0$ fluorescence, weak $S_2 \rightarrow S_0$ fluorescence has been observed in benzene, toluene, *p*-xylene, mesitylene, naphthalene, pyrene, 1:2-benzanthracene, 3:4-benzopyrene, 1:12-benzoperylene and ovalene, weak $S_3 \rightarrow S_0$ fluorescence has been observed in *p*-xylene, mesitylene, naphthalene, pyrene and 1:2-benzanthracene, and weak $S_4 \rightarrow S_0$ fluorescence has been observed in pyrene and fluoranthene [6, 10].

Such fluorescence from higher excited states was predicted by the author in 1954 [11]. Its detection is difficult, since it occurs in the region of the $S_0 \rightarrow S_p$ absorption spectrum, and its quantum yield is only $\sim 10^{-5} \phi_{FM}$ [6]. Subsequent attention will be focused on the main $S_1 \rightarrow S_0$ fluorescence.

2.6. The Fluorescence Spectrum

The $S_1 \rightarrow S_0$ fluorescence spectrum occurs from a system of S_1 excited molecules in thermal equilibrium in solution. The fraction of these molecules with vibrational energy E_v is proportional to $\exp(-E_v/kT)$, where k is Boltzmann's constant and T is the absolute temperature. A large majority are in the zero point level S_1^0 , and to a first approximation the fluorescence of the "hot" molecules can be disregarded.

The $S_1^0 \rightarrow S_0$ fluorescence occurs into S_0^0 , the zero-point level of S_0 , and into the many vibrational levels of S_0 . The $S_1^0 \rightarrow S_0^0$ transition, or *0-0 fluorescence transition*, of wavenumber $(\bar{\nu}_{00})_F$ is the highest energy transi-

tion in the $S_1^0 \rightarrow S_0$ fluorescence spectrum. In the vapour $(\bar{\nu}_{00})_F$ coincides with $(\bar{\nu}_{00})_A$, the corresponding $S_0^0 \rightarrow S_1^0$ *0-0 absorption transition*. In solution, due to solvent polarization effects

$$(\bar{\nu}_{00})_A - (\bar{\nu}_{00})_F = \Delta \bar{\nu}_{00} \quad (20)$$

where $\Delta \bar{\nu}_{00}$ varies from 0 to a few hundred cm^{-1} depending on the solvent [1]. In benzene the 0-0 fluorescence and absorption transitions are symmetry-forbidden and they are absent from the vapour spectra. They appear as weak solvent-induced bands (the Ham bands) in solution spectra, the intensity depending on the solvent [1].

At low temperatures the $S_1 \rightarrow S_0$ ($= S_1^0 \rightarrow S_0$) fluorescence spectrum $F_M(\bar{\nu})$ consists of a complex series of a few hundred narrow lines of different intensities, which may be analysed into progressions and combinations of the different vibrational modes of the unexcited molecule. When the temperature is increased, thermal broadening and solvent-solute interactions obscure most of the vibrational structure. At room temperature $F_M(\bar{\nu})$ commonly consists of a few prominent broad bands with little other structure. Thus $F_M(\bar{\nu})$ for anthracene in cyclohexane solution consists of a progression of 5 broad bands, spaced about 1400 cm^{-1} apart, corresponding to *CC* vibrational modes. Similar vibrational progressions occur in $F_M(\bar{\nu})$ for other condensed hydrocarbons [1]. For large molecules, e.g., dyes, with many degrees of vibrational and/or rotational freedom, $F_M(\bar{\nu})$ at room temperature often consists of a single broad band with no vibrational structure. Berlman [12] has recorded the fluorescence spectra of many aromatic molecules.

The solvent has a strong influence on $F_M(\bar{\nu})$ at room temperature. In a polar solvent like ethanol the vibrational bands are broad and poorly resolved, and the separation $\Delta \bar{\nu}_{00}$ between the absorption and fluorescence 0-0 bands is relatively large. In a non-polar aliphatic hydrocarbon solvent, like cyclohexane or *n*-hexane, the spectral resolution is improved and $\Delta \bar{\nu}_{00}$ is reduced. In a fluorocarbon solvent, like perfluoro-*n*-hexane (PFH), each of the vibrational bands has a well-resolved fine structure, similar to that in the vapour phase, and $\Delta \bar{\nu}_{00} = 0$ [13]. PFH is an ideal spectroscopic solvent, apart from cost and the low solubility of aromatic molecules in PFH.

At temperatures above about -100°C the "hot" vibrationally-excited S_1 molecules with a Boltzmann distribution of energies S_1^* ($= S_1^0 + E_v$) also contribute to $F_M(\bar{\nu})$. Each component $S_1^* \rightarrow S_0$ spectrum is similar to the $S_1^0 \rightarrow S_0$ spectrum, except that it is shifted by an amount E_v towards higher energies, and its intensity is proportional to $\exp(-E_v/kT)$. Most of the $S_1^* \rightarrow S_0$ spectral distribution lies below the $S_1^0 \rightarrow S_0$ spectrum and is obscured thereby. However, each component $S_1^* \rightarrow S_0$ spectrum extends beyond $\bar{\nu}_{00}$ to $\bar{\nu}_{00} + E_v$, giving rise to *hot fluorescence bands*, the intensity and extent of which increase with tempera-

ture. These hot fluorescence bands, which are an integral part of the $S_1 \rightarrow S_0$ fluorescence spectrum $F_M(\bar{\nu})$ at room temperature, occur in all aromatic molecules, although they are not often recorded. The emission bands are in the same region as the $S_0 \rightarrow S_1$ absorption, and special care is needed to observe them [6].

2.7. The rate parameters

Observations of q_{FM} and τ_M for a very dilute solution enable

$$k_{FM} = q_{FM}/\tau_M \quad (21)$$

$$k_{IM} = k_{FM} + k_{GM} = (1 - q_{FM})\tau_M \quad (22)$$

to be determined. Birks and Munro [14] have reviewed methods of measuring τ_M . Observations of q_{TM} ($=k_{TM}/k_M$), by one of the several methods described by Wilkinson [15], enable k_{TM} and k_{GM} to be evaluated. The measurement of q_{PT} and τ_T permits k_{PT} and k_{GT} to be determined [1]. Thus measurements of five quantities q_{FM} , τ_M , q_{TM} , q_{PT} and τ_T are required to determine the five S_1 and T_1 unimolecular rate parameters k_{FM} , k_{TM} , k_{GM} , k_{PT} and k_{GT} .

Observations of τ'_M and τ'_T (or ϕ_{FM} and ϕ_{PT}) as a function of the molar concentration c enable the bimolecular rate parameters k_{CM} and k_{CT} to be determined. The observations and analysis may be extended further to obtain the fluorescence (k_{FD}), ISC (k_{TD}), IC (k_{GD}) and dissociation (k_{MD}) rate parameters of the singlet excimer [1]. This involves observations of the molecular (ϕ_{FM}) and excimer (ϕ_{FD}) fluorescence quantum yields of concentrated solutions.

It is the *rate parameters* and their dependence on temperature, solvent, substitution etc. that are the quantities of interest to the photophysicist and photochemist, and not the properties from which they are derived. The latter may be of technical interest for particular applications. Of the three quantities q_{FM} , τ_M and q_{TM} required to determine the S_1 rate parameters k_{FM} , k_{TM} and k_{GM} , the published values of q_{FM} (or ϕ_{FM} , which is often implicitly equated to q_{EM}) show the largest scatter. When the solution concentration c is increased, self-absorption effects introduce difficulties in the determination of ϕ_{FM} . It is hoped that this paper will help to improve the situation.

2.8. The Fluorescence Rate Parameter

A theoretical expression for k_{FM} has been derived from the Einstein radiation relation using the zero-order Born-Oppenheimer approximation [16, 17]

$$k_{FM}^t = 2.88 \times 10^{-9} \frac{n_F^3}{n_A} \langle \bar{\nu}_F^{-3} \rangle_{AV}^{-1} \int \frac{\epsilon(\bar{\nu}) d\bar{\nu}}{\bar{\nu}} \quad (23)$$

where n_F and n_A are the mean refractive indices of the solvent over the $S_1 \rightarrow S_0$ fluorescence and $S_0 \rightarrow S_1$ absorption spectra, respectively, $\langle \bar{\nu}_F^{-3} \rangle_{AV}^{-1}$ is the

reciprocal of the average value of $\bar{\nu}^{-3}$ over the fluorescence spectrum, $\epsilon(\bar{\nu})$ is the decadic molar extinction coefficient, and the integral is taken over the $S_0 \rightarrow S_1$ absorption spectrum. Relation (23) has been tested for a number of molecules, and excellent agreement between k_{FM} and k_{FM}^t has been obtained for several molecules in different laboratories [1, 12, 16, 17, 18]. Such molecules may be useful as fluorescence standards.

If the solvent optical dispersion is small $n_F \approx n_A = n$, and (23) can be simplified to

$$k_{FM}^t = n^2 (k_{FM}^t)_0 \quad (24)$$

where $(k_{FM}^t)_0$ is a molecular constant, independent of the solvent and the temperature. Relation (24) has been verified for several solutes in different solvents over a wide temperature range [19].

In some molecules there are large discrepancies between k_{FM} and k_{FM}^t . A detailed study of these anomalies has revealed the presence of electronic states not observed spectroscopically [20, 21]. The nature and origin of such radiative lifetime anomalies are discussed elsewhere [22]. The factors determining the other S_1 and T_1 rate parameters k_{TM} , k_{GM} , k_{PT} and k_{GT} have been considered previously [1, 6, 8].

2.9. Molecular Fluorescence Parameters

The $S_1 \rightarrow S_0$ fluorescence of an aromatic compound in very dilute solution is characterized by the following molecular parameters.

- The fluorescence spectrum $F_M(\bar{\nu})$ depends on the solvent and temperature (see 2.6).
- The fluorescence polarization p_M depends on the direction of the transition dipole moment relative to the molecular axes. For a $\pi^* \rightarrow \pi$ electronic transition this lies in the molecular plane along one of two orthogonal axes depending on the symmetry of S_1 . For naphthalene the fluorescence is long-axis polarized; for anthracene it is short-axis polarized [1].
- The fluorescence rate parameter k_{FM} is proportional to the square of the transition dipole moment [1]. In the absence of any anomalies k_{FM}/n^2 is independent of the solvent and temperature (24).
- The S_1 radiationless rate parameter k_{IM} ($=k_{TM} + k_{GM}$) describes the processes competing with the fluorescence. k_{IM} usually depends markedly on the solvent and on the temperature [1].

$F_M(\bar{\nu})$ and p_M can be observed directly. The evaluation of k_{FM} and k_{IM} involves measurements of two secondary parameters:

- The fluorescence lifetime τ_M ; and
- the fluorescence quantum efficiency q_{FM} .

Several accurate methods are available for measuring τ_M [14]. Reliable methods are available for measuring q_{FM} , but they are often used incorrectly [23].

The molecular fluorescence parameters $F_M(\bar{\nu})$, p_M , k_{FM} and k_{IM} are independent of the molar concentration c . The secondary fluorescence parameters τ_M and ϕ_{FM} decrease with increase in c due to

- (g) the concentration quenching rate parameter k_{CM} .

k_{CM} , which depends markedly on the solvent viscosity and the temperature, is a further molecular parameter of photophysical interest.

3. Other Luminescent Materials

The preceding discussion of the luminescence of aromatic molecules is applicable to the other luminescent materials considered in the Introduction. It applies directly to biological molecules (vi) and aliphatic organic molecules (vii). Noble gases (iii) also have singlet ground states, and there are close analogies between them and the aromatic hydrocarbons, particularly in excimer formation [3]. There are no radiationless transitions in the noble gases ($q_{FM} = q_{FH} = 1.0$) because of the absence of internal vibrations. They form excimers in the vapour, liquid, and solid phases, and the vibrational modes of these may generate radiationless transitions and vibrational relaxation in the condensed phase [3].

Simple inorganic molecules (iv) are similar. They normally have singlet ground states and excited singlet and triplet states. Although they have internal vibrations, the vibronic state density is low, and there are normally no radiationless transitions except at high excitation energies, where predissociation may occur [4].

The luminescence of inorganic crystals (ii) and inorganic ions (v) in a solid matrix is closely related to that of aromatic molecular crystals. Unfortunately there are major terminological differences between inorganic crystal photophysics and organic molecular crystal photophysics. Table 1 is based on a brief survey of the inorganic luminescence literature, and may require revision in the light of any recent changes.

TABLE 1. Terminology of photophysical processes

Process	Organic	Inorganic
1. Luminescence, (a) spin-allowed (b) spin-forbidden (c) thermally-activated delayed	Fluorescence (F) Phosphorescence (P) E-type delayed fluorescence	Fluorescence Phosphorescence
2. Radiationless transition (a) spin-allowed (b) spin-forbidden	Internal conversion (IC) Intersystem crossing (ISC)	
3. Vibrational relaxation	Vibrational relaxation (VR)	
4. Radiationless transition plus vibrational relaxation	IC (or ISC) and VR	Multiphonon process

The inorganic luminescence terminology predates the discovery of electron spin, and it has not been adjusted to take account of this. Because of spin, processes 1(a) and 1(b) differ in lifetime by a factor of up to 10^8 , and it would seem appropriate to distinguish them. In 1933 Jablonski [24], the originator of figure 1, showed that the two slow emissions 1(b) and 1(c) observed in organic dyes originated from a common metastable state X , and he proposed that they be called β -phosphorescence and α -phosphorescence, respectively. Since 1944 when Lewis and Kasha [25] demonstrated that $X = T_1$, the lowest excited triplet state, 1(b) has been called simply phosphorescence, while 1(c) which has the same emission spectrum as 1(a) is called E-type delayed fluorescence.

Standardization of luminescence terminology is long overdue. Those responsible for organizing international luminescence conferences and publishing luminescence journals have unfortunately neglected to formulate a scientific language common to workers in organic and inorganic luminescence. Perhaps the National Bureau of Standards can assist in the matter.

4. Fluorescence Measurements

4.1. Fluorescence Spectra

A true (corrected) fluorescence spectrum is plotted as the relative quantum intensity $F_M(\bar{\nu})$ (relative number of quanta per unit wave-number interval) against wavenumber $\bar{\nu}$. A few spectrometers have been developed which record directly the true fluorescence spectrum. The majority provide spectra which require correction for the dispersion of the analyzing monochromator, the spectral response of the photomultiplier or detector, and any light losses. This involves the preparation of an *instrumental calibration curve*, by measurements

- with a calibrated lamp through a neutral filter;
- with a thermopile or bolometer;
- of reference solution fluorescence spectra [26]; or
- with a fluorescent quantum counter.

A *quantum counter* is a system which has a constant fluorescence quantum yield over a broad spectral range. To achieve this it should have a high and relatively constant absorption over the spectral range of interest, it should have negligible self-absorption (no overlap of fluorescence and absorption spectrum), it should obey Vavilov's law, and it should be stable photochemically. Systems commonly used as quantum counters include:

- 3 g l^{-1} Rhodamine B in ethylene glycol (210–530 nm),
- 4 g l^{-1} quinine sulphate in $N \text{ H}_2\text{SO}_4$ (220–340 nm), and
- $10^{-2} M$ 1-dimethylaminonaphthalene 5-(or 7-) sodium sulphonate in $0.1 N \text{ Na}_2\text{CO}_3$ (210–400 nm).

An extension of this list would be advantageous.

Three common optical geometries are used in fluorescence measurements;

- (a) front-surface or *reflection geometry*, in which the fluorescence from the irradiated surface of the specimen is observed;
- (b) 90° *geometry*, in which the fluorescence is observed in a direction normal to the incident beam; and
- (c) *transmission geometry*, in which the fluorescence is observed from the opposite side of the specimen to the excitation.

For very dilute solutions ($\sim 10^{-6}M$) the three geometries give the same fluorescence spectrum, quantum efficiency and lifetime. The 90° geometry, used by Birks and Dyson [17] and others, has the advantage of minimizing background incident light and of allowing the fraction of incident light absorbed in the specimen to be monitored directly.

An increase in the solution concentration c reduces q_{FM} and τ_M to ϕ_{FM} and τ'_M , respectively, due to concentration quenching. It also attenuates the high-energy region of $F_M(\bar{\nu})$ due to self-absorption arising from the overlap of the absorption and fluorescence spectra. As c is increased the intensity of the 0-0 fluorescence band decreases towards zero due to its overlap with the 0-0 absorption band. At room temperature and high c the self-absorption may extend to the 0-1 and 0-2 fluorescence bands, which overlap the 1-0 and 2-0 hot absorption bands, due to thermally activated molecules in the first and second vibrational levels of S_0 . These self-absorption effects are a maximum in the transmission geometry (c), somewhat reduced in the 90° geometry (b), and they are least in the reflection geometry (a), which is normally used for fluorescence studies of more concentrated solutions.

The effect of self-absorption on $F_M(\bar{\nu})$ observed in reflection can be minimized by Berlman's technique [12] of excitation at an intense absorption maximum, thereby minimizing the penetration depth d_{ex} of the exciting light. This technique does not, however, compensate for the secondary fluorescence produced by the self-absorption and which modifies ϕ_{FM} and τ_M , as discussed below.

4.2. Fluorescence Quantum Yields

Absolute determinations of fluorescence quantum yields have been made using integrating spheres to collect the fluorescence emission over a full 4π solid angle, by calorimetry to distinguish radiative processes from radiationless processes and vibrational relaxation, by actinometry to integrate light intensities photochemically, and by polarization and scattering measurements. These methods have been reviewed by Lipsett [27] and Demas and Crosby [28].

The superscript T is introduced to refer to the *observed (technical) fluorescence parameters* $F_M^T(\bar{\nu})$, ϕ_{FM}^T and τ_M^T , which may differ from the true fluorescence parameters $F_M(\bar{\nu})$, ϕ_{FM} and τ'_M , due to self-absorption and secondary fluorescence. Absolute

determinations of ϕ_{FM} are difficult and uncommon, and it is normal practice to measure ϕ_{FM}^T by comparison with a standard of known fluorescence quantum yield ϕ_{FR}^T . If $F_M^T(\bar{\nu})$ and $F_R^T(\bar{\nu})$ are the corrected fluorescence spectra of the specimen and standard, respectively, excited under identical conditions (same excitation wavelength, optical density and geometry) and observed *at normal incidence in reflection*, then

$$\frac{\phi_{FM}^T}{\phi_{FR}^T} = \frac{n^2 \int_0^\infty F_M^T(\bar{\nu}) d\bar{\nu}}{n_R^2 \int_0^\infty F_R^T(\bar{\nu}) d\bar{\nu}} \quad (25)$$

where n and n_R are the refractive indices of the specimen solution and the standard solution, respectively. The integrations are often made using a quantum counter [28].

The refractive index term is a correction for the solution optical geometry. The angular dependence of the fluorescence flux $F(\phi)$ from a small isotropically emitting source behind an infinite plane surface in a medium of refractive index n is

$$F(\phi) = F_0(\cos \phi)n^{-1}(n^2 - \sin^2 \phi)^{-1/2} \quad (26)$$

where F_0 is a constant ($\propto \phi_{FM}^T$) and $F(\phi)$ is the flux (in quanta $\text{cm}^2 \text{s}^{-1}$) falling on a small aperture at an angle ϕ from the normal to the face. For $\phi=0^\circ$ (26) reduces to

$$F(0) = F_0/n^2 \quad (27)$$

leading to (25). Relation (26) has been verified by Melhuish [29] who recommended the use of cuvettes with blackened back and sides for fluorescence yield measurements to minimize internal reflection errors.

Shinitzky [30] has pointed out a further potential source of error in fluorescence quantum yield and lifetime measurements. When a fluorescent system is excited by unpolarized light and its emission is detected without a polarizer, the emission intensity has a typical anisotropic distribution which is directly related to its degree of polarization. This effect can introduce an error of up to 20 percent in all fluorescence quantum yield and lifetime measurements, but it is eliminated when the fluorescence is detected at an angle of 55° or 125° to the direction of excitation, provided that the emission detection system is unbiased with respect to polarization. Procedures for the elimination of polarization errors for partially polarized excitation and biased detection systems were developed by Cehelnik, Mielenz, and Velapoldi [31] and Mielenz, Cehelnik, and McKenzie [32].

If n and n_R differ, it is recommended that the specimen and reference solutions be excited at 55° incidence angle and observed at normal incidence, to eliminate the polarization effect and simplify the refractive index correction. The latter correction disappears if $n = n_R$, and the excitation and front-face observation

directions need only differ by 55° . The angles of incidence and "reflection" should differ to minimize scattered light.

The self-absorption attenuates the high-energy end of $F_M(\bar{\nu})$, but it does not affect the low-energy end. If $F_M(\bar{\nu})$, observed in very dilute solution, and $F_M^T(\bar{\nu})$, observed at molar concentration c , are normalized in the low-energy region, then the parameter

$$a = \frac{A_M - A_M^T}{A_M} \quad (28)$$

where

$$A_M = \int_0^\infty F_M(\bar{\nu}) d\bar{\nu} \quad (29)$$

$$A_M^T = \int_0^\infty F_M^T(\bar{\nu}) d\bar{\nu} \quad (30)$$

represents the *self-absorption probability*. This normalization procedure, introduced for anthracene crystal fluorescence [33], has been applied by Birks and Christophorou [34] to concentrated solutions of aromatic hydrocarbons. Substitution of A_M in place of A_M^T in (25) gives ϕ_{FM} in place of ϕ_{FM}^T . For materials of low ϕ_{FM} (< 0.3), the linear Stern-Volmer plots of q_{FM}/ϕ_{FM} against c of gradient K_{CM} (13) confirm the validity of the procedure, which corresponds to assuming

$$\phi_{FM}^T = (1 - a) \phi_{FM} \quad (31)$$

This relation neglects the *secondary fluorescence* resulting from the self-absorption. Allowing for this, the author [11, 35] has shown that

$$\phi_{FM}^T = \frac{(1 - a)\phi_{FM}}{1 - a\phi_{FM}} \quad (32)$$

which approximates to (31) when $a\phi_{FM} \ll 1$, and that

$$\tau_M^T = \frac{\tau_M'}{1 - a\phi_{FM}} \quad (33)$$

Relation (33) is considered to be generally valid. Relation (32) is considered to be valid for the transmission and 90° geometries. It is also valid for the reflection geometry, except for specimens of high ϕ_{FM} . Under the latter conditions the secondary fluorescence contributes markedly to the observed fluorescence intensity, so that $\phi_{FM}^T > \phi_{FM}$ in reflection, although $\phi_{FM}^T < \phi_{FM}$ in transmission as predicted by (32). Figure 3 plots Melhuish's observations [36] of ϕ_{FM}^T as a function of c for 9,10-diphenylanthracene (DPA) in benzene solution, excited at 366 nm with front-face observation. Due to secondary fluorescence ϕ_{FM}^T increases from $q_{FM} = 0.83$ in very dilute solution to $\phi_{FM}^T = 1.0$ at $c \geq 1.5 \times 10^{-3} M$. Correction for self-absorption and secondary fluorescence, using a much more complex relation than (32), showed that $\phi_{FM} = 0.83 \pm 0.02$ over

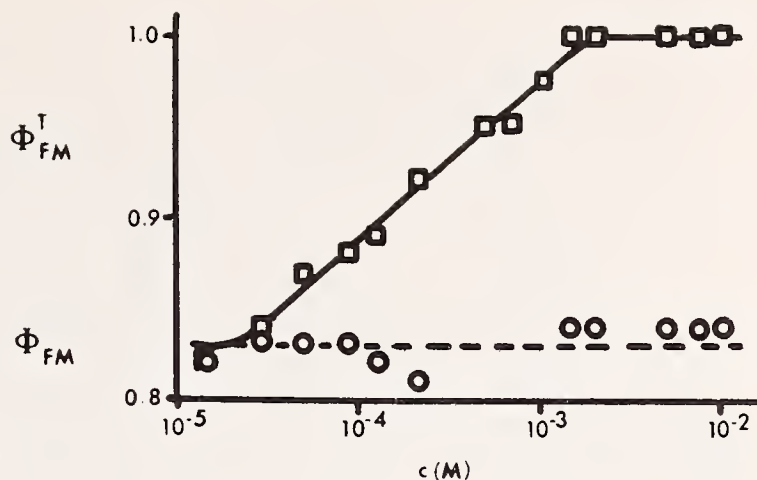

FIGURE 3. 9,10-diphenylanthracene in benzene.

Front-surface observation at $\lambda_{ex} = 365$ nm. Technical fluorescence quantum yield ϕ_{FM}^T (+) and true fluorescence quantum yield ϕ_{FM} (o) against molar concentration c . Data from Melhuish [36].

the whole range of c , thus demonstrating that DPA is immune to concentration quenching [36].

The secondary fluorescence contribution to ϕ_{FM}^T increases with decrease in the excitation penetration depth d_{ex} . Berلمان's [12] choice of an intense absorption band for excitation ($\lambda_{ex} = 265$ nm for DPA) minimizes d_{ex} . This minimizes the effect of self-absorption on $F_M^T(\bar{\nu})$, but it also maximizes the effect of secondary fluorescence on ϕ_{FM}^T . To reduce the latter, a weak absorption region should be chosen for excitation, and c should be kept as low as possible.

To summarize, there are no particular problems in determining ϕ_{FM} for (a) very dilute solutions (b) more concentrated solutions observed in the transmission or 90° geometries, and (c) more concentrated solutions of $\phi_{FM} < \sim 0.3$ observed in the reflection geometry. The effects of self-absorption and secondary fluorescence are, however, difficult to compensate in concentrated solutions of high ϕ_{FM} observed in the reflection geometry. One simple solution is to abandon the reflection geometry and to observe such systems in the more tractable transmission geometry. The alternative is to utilize one of the numerous mathematical relations, some simple [11, 35], some complex [27, 36], which have been developed to describe self-absorption and secondary fluorescence.

4.3. Fluorescence Standards

Melhuish [36] proposed the use of a $5 \times 10^{-3} M$ solution of quinine bisulphate (QS) in 1N sulphuric acid as a fluorescence standard. From careful measurements he obtained $\phi_{FM} = 0.510$ for $c = 5 \times 10^{-3} M$ increasing to $q_{FM} = 0.546$ at infinite dilution at $25^\circ C$. The value of ϕ_{FM} at any other concentration can be evaluated using the Stern-Volmer relation (13). The QS solution is stable under prolonged irradiation, its fluorescence is not quenched by dissolved air (unlike most aromatic molecules), and it has a very small over-

lap of the absorption and fluorescence spectra. It suffers from three minor disadvantages:

- (a) concentration quenching;
- (b) the temperature coefficient of ϕ_{FM} is about -0.25 percent per degree over the range 10° to 40° C; and
- (c) sulphuric acid is not a conventional solvent for aromatic molecules and this necessitates using the refractive index correction in (25).

Nevertheless the QS standard, and various secondary standards derived therefrom, have been adopted in this and many other laboratories [28, 37]. Quinine is the fluorescent entity, and the use of quinine sulphate in place of the bisulphate does not appear to affect the values of q_{FM} and ϕ_{FM} [28]. Unfortunately many authors have chosen to use $0.1 N$ sulphuric acid as the solvent, rather than $1 N$ as recommended by Melhuish [36], while assuming his fluorescence quantum yield values to be unchanged. There is evidence that ϕ_{FM} increases by 6–8 percent on increasing the solvent normality from $0.1 N$ to $1 N$ [28].

Table 2 lists comparative data on τ_M and q_{FM} for very dilute solutions of several aromatic compounds obtained using the QS standard [16–18]. The consistency of the data from three different laboratories is gratifying. The close agreement between the experiment values of $k_{FM}(=q_{FM}/\tau_M)$ and the theoretical values of k_{FM}^t from (23) for several compounds shows the error in q_{FM} for the QS standard to be small. Gelernt et al. [36] have recently calorimetrically determined q_{FM} for QS in $1 N$ sulphuric acid at 25° C. The calorimetric value of $q_{FM}=0.561 (\pm 0.039)$ agrees satisfactorily with the fluorimetric value of $q_{FM}=0.546$ [34]. Other fluorescence standards have been discussed by Demas and Crosby [28].

TABLE 2. Fluorescence lifetimes (τ_M) and quantum efficiencies (q_{FM}) of very dilute solutions

Compound	Solvent	τ_M (ns)	q_{FM}	k_{FM}/k_{FM}^t	Ref.
Quinine Bisulphate	$1N H_2SO_4$	20.1	0.54	0.73	[17]
	$1N H_2SO_4$	19.4	.54	.75	[18]
Perylene	benzene	4.9	.89	.93	[17]
	benzene	4.79	.89	.90	[16]
	benzene	5.02	.89	.90	[18]
Acridone	ethanol	11.8	.83	1.02	[16]
	ethanol	12.5	.825	1.05	[18]
9-Aminoacridine	ethanol	13.87	.99	1.15	[16]
	ethanol	15.15	.99	1.02	[18]
9,10-Diphenyl anthracene	benzene	7.3	.85	0.99	[17]
	benzene	7.37	.84	.98	[18]

Berlman [12] used a $10^{-3}M$ solution of 9,10-diphenylanthracene (DPA) in cyclohexane, excited at 265 nm (an absorption maximum) and observed in reflection, as a fluorescence standard. Under these conditions the DPA solution has a technical fluorescence quantum

yield of $\phi_{FM}^T=1.0$, due to self-absorption and secondary fluorescence, although the true fluorescence quantum yield is $\phi_{FM}=q_{FM}=0.83 (\pm 0.02)$ (fig. 3). Relation (25) requires that the specimen and standard be compared under identical conditions of excitation and optical density, so that the $10^{-3}M$ DPA solution standard is only suitable for observations of ϕ_{FM}^T on concentrated solutions in reflection geometry. The QS standard is more versatile since it does not limit the specimen concentration or optical geometry.

Berlman [12] observed τ_M^t with heterochromatic excitation and $F_M^t(\bar{\nu})$ with monochromatic excitation (these parameters need to be observed under identical conditions for (32) and (33) to be applicable [35]). He evaluated ϕ_{FM}^T by comparison with $F_R^t(\bar{\nu})$ for the DPA standard observed under similar conditions, although the optical densities and excitation wavelengths of the specimen and standard appear to have differed. Apart from the usual hot band elimination and some 0–0 band attenuation, $F_M^t(\bar{\nu})$ approximates to the molecular spectrum $F_M(\bar{\nu})$. ϕ_{FM}^T and τ_M^t do not correspond to q_{FM} and τ_M , as implicitly assumed by Berlman [12], who used them to “evaluate” k_{FM} . They require correction for self-absorption and secondary fluorescence to obtain ϕ_{FM} and τ_M , and these parameters need correction for concentration quenching to obtain q_{FM} and τ_M . Birks [1] tried to correct Berlman’s ϕ_{FM}^T data [12] by renormalizing them to $q_{FR}=0.83$ for DPA, but this procedure has since been shown to be invalid [23].

It is of interest to note the effect of substituting different fluorescence parameters in the relations used to evaluate k_{FM} and k_{IM} . From (3a), (13), (21), (22), (32) and (33)

$$\frac{q_{FM}}{\tau_M} = \frac{\phi_{FM}}{\tau_M^t} = k_{FM} \quad (34)$$

$$\frac{\phi_{FM}^T}{\tau_M^t} = (1-a)k_{FM} \quad (35)$$

$$\frac{(1-q_{FM})}{\tau_M} = k_{IM} \quad (36)$$

$$\frac{(1-\phi_{FM})}{\tau_M^t} = \frac{(1-\phi_{FM}^T)}{\tau_M^t} = k_{IM} + k_{CMC}. \quad (37)$$

An ideal fluorescence standard for aromatic solutions should

- (i) have no self-absorption,
- (ii) have no concentration quenching,
- (iii) be in a common solvent suitable for other aromatic molecules (to eliminate the refractive index correction),
- (iv) be readily available as a high-purity material (or be insensitive to impurities), and
- (v) be photochemically stable.

QS satisfies (iv) and (v) and it approximates closely to (i), but it does not satisfy (ii) and (iii). DPA meets criteria (ii)–(v), but it exhibits strong self-absorption. To minimize self-absorption in an aromatic hydrocarbon solution it is necessary that S_1 is a 1L_b state, so that the $S_0 \rightarrow S_1$ absorption is weak, and not a 1L_a state, giving strong $S_0 \rightarrow S_1$ absorption, as in DPA [1]. There are two hydrocarbons which exhibit no concentration quenching (ii), have $S = {}^1L_b$ so that self-absorption (i) is reduced, and satisfy (iii) and (v). These compounds, *phenanthrene* and *chrysene*, merit consideration as fluorescence standards. They can be obtained, but are not yet readily available, as high-purity materials (iv).

Aromatic excimers satisfy all the criteria for a fluorescence standard, since they have no self-absorption (i) or concentration quenching (ii) [1]. In concentrated solutions the excimer spectrum $F_D(\bar{\nu})$ can be readily distinguished from the attenuated monomer spectrum $F_M^T(\bar{\nu})$ [34], although the presence of the latter may be undesirable. It can be eliminated by the use of a pure liquid or crystal. A *pyrene crystal* has $\phi_{FD} = q_{FD} = 1.0$ at low temperatures and $\phi_{FD} = q_{FD} = 0.65$ at room temperature, a broad structureless fluorescence spectrum between 400 and 550 nm with a maximum at 470 nm, and no self-absorption in any optical geometry [1]. It would appear to be an ideal crystal fluorescence standard.

5. References

- [1] Birks, J. B., *Photophysics of Aromatic Molecules*, (Wiley-Interscience, London, and New York, 1970).
- [2] Birks, J. B., *The Theory and Practice of Scintillation Counting* (Pergamon Press, Oxford 1964).
- [3] Birks, J. B., *Excimers*. Rpts. Prog. Phys. **38**, 903 (1975).
- [4] Herzberg, G., *Molecular Spectra and Molecular Structure. I. Spectra of Diatomic Molecules* (Van Nostrand, Princeton 1950).
- [5] Birks, J. B., (Ed.) *Excited States of Biological Molecules*. Proc. Intern. Conf. Lisbon 1974 (Wiley-Interscience, London, and New York, 1976).
- [6] Birks, J. B., *Organic Molecular Photophysics*, Vol. II, Ed. Birks, J. B. (Wiley-Interscience, London, and New York, p. 409, 1975).
- [7] Tatischeff, I., and Klein, R., ref. [5], p. 375 (1976).
- [8] Birks, J. B., *Organic Molecular Photophysics*, Vol. I, Ed. Birks, J. B. (Wiley-Interscience, London, and New York, p. 1, 1973).
- [9] Kasha, M., *Disc. Faraday Soc.* **9**, 14 (1950).
- [10] Nickel, B., *Chem. Phys. Letters* **27**, 84 (1974).
- [11] Birks, J. B., *Phys. Rev.* **94**, 1567 (1954).
- [12] Berlman, I. B., *Handbook of Fluorescence Spectra of Aromatic Molecules* (Academic Press, New York. 1st edition, 1965; 2nd edition, 1971).
- [13] Lawson, C. W., Hirayama, F., and Lipsky, S., *J. Chem. Phys.* **51**, 1590 (1969).
- [14] Birks, J. B., and Munro, I. H., *Progress in Reaction Kinetics*, **4**, 239 (1967).
- [15] Wilkinson, F., *Organic Molecular Photophysics*, Vol. II, Ed. Birks, J. B. (Wiley-Interscience, London, and New York, p. 95, 1975).
- [16] Strickler, S. J., and Berg, R. A., *J. Chem. Phys.* **37**, 814 (1962).
- [17] Birks, J. B., and Dyson, D. J., *Proc. Roy. Soc.* **A275**, 135 (1963).
- [18] Ware, W. R., and Baldwin, B. A., *J. Chem. Phys.* **40**, 1703 (1964).
- [19] Cundall R. B., and Pereira, L. C., *J. Chem. Soc. Faraday Trans. II*, **68**, 1152 (1972).
- [20] Birks, J. B., and Birch, D. J. S., *Chem. Phys. Letters*, **31**, 608 (1975).
- [21] Birch, D. J. S., and Birks, J. B., *Chem. Phys. Letters*, in press.
- [22] Birks, J. B., *Z. Phys. Chem. (N.F.)* submitted for publication.
- [23] Birks, J. B., *J. Luminescence* **9**, 311 (1974).
- [24] Jablonski, A., *Nature* **131**, 839 (1933); *Z. Phys. Lpz.* **94**, 38 (1935).
- [25] Lewis, G. N., and Kasha, M., *J. Amer. Chem. Soc.* **66**, 2100 (1944).
- [26] Melhuish, W. H., *J. Phys. Chem.* **64**, 792 (1960).
- [27] Lipsett, F. R., *Progress in dielectrics* **7**, 217 (1967).
- [28] Demas, J. N., and Crosby, G. A., *J. Phys. Chem.* **75**, 991 (1971).
- [29] Melhuish, W. H., *J. Opt. Soc. Amer.* **51**, 278 (1961).
- [30] Shinitzky, M., *J. Chem. Phys.* **56**, 5979 (1972).
- [31] Cehelnik, E. D., Mielenz, K. D., and Velapoldi, R. A., *J. Res. Nat. Bur. Stand. (U.S.)*, **79A** (Phys. and Chem.), No. 1, 1–15 (Jan.–Feb. 1975).
- [32] Mielenz, K. D., Cehelnik, E. D., and McKenzie, R. L., *J. Chem. Phys.* **64**, 370 (1976).
- [33] Birks, J. B., and Little, W. A., *Proc. Phys. Soc. A* **66**, 921 (1953).
- [34] Birks, J. B., and Christophorou, L. G., *Proc. Roy. Soc. A* **274**, 552 (1963).
- [35] Birks, J. B., *Molec. Cryst. Liq. Cryst.* **28**, 117 (1975).
- [36] Melhuish, W. H., *J. Phys. Chem.* **65**, 229 (1961).
- [37] Parker, C. A., *Photoluminescence of Solutions*. (Elsevier, Amsterdam 1968).
- [38] Gelernt, B., Findeisen, A., Stein, A., and Poole, J. A., VIII Intern. Conf. Photochemistry, Edmonton, August 1975, Abstract 810.

(Paper 80A3–890)

Some Methods of Luminescence Efficiency Measurements *

Alfred Brill and A. Willy de Jager-Veenis

Philips Research Laboratories, Eindhoven, The Netherlands

(April 9, 1976)

Methods of absolute and relative radiant and quantum efficiency measurements are described for ultraviolet, visible, cathode-ray, and x-ray excitations. Data on some standard luminescent materials are given.

Key words: Cathode-ray excitation; luminescence; luminescence standards; phosphors; quantum efficiencies; radiant efficiencies; UV excitation; x-ray excitation.

1. Introduction

Methods of absolute radiant and quantum efficiency measurements are given together with methods of relative efficiency measurements. The methods are especially suitable for powder materials for which the angular distribution of the emitted luminescent radiation is Lambertian.

The relative measurements are performed with the aid of standard phosphors, whose efficiencies have previously been determined by absolute measurements. Methods are given for excitation of the phosphors by ultraviolet and visible radiation, cathode rays and x rays.

For samples with non-Lambertian emission distributions, a method is described in which an Ulbricht's sphere or an elliptical mirror is used.

2. Ultraviolet Excitation

All powder phosphors are measured using a thick layer (thickness about 2 mm) at the irradiated side. The detection takes place perpendicular to the plane of the phosphor, the excitation is at an angle of 50° with that plane (see fig. 1). The excitation wavelength (λ_{exc}) or regions are isolated from a high pressure mercury lamp by interference filters, the arc being focused on the phosphor with a quartz lens. In this way a high excitation density is reached, but generally well below the excitation region where saturation effects start. This is especially advantageous when a relatively insensitive thermoelement is used as a detector.

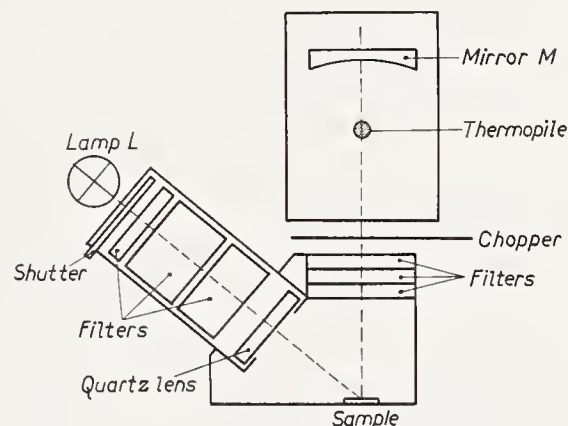

FIGURE 1. Schematic diagram of the apparatus for the efficiency measurements.

The radiant efficiencies, from which the quantum efficiencies are calculated, are determined directly (when the spectral power distribution is known).

2.1. Relative Measurements, Giving Absolute Efficiency Values

Phosphors can be measured with respect to the following standard samples whose efficiency is generally agreed upon.

- (a) The standards issued by the National Bureau of Standards, Washington, D.C. (See ref. [1-4]).
- (b) Sodium salicylate (See ref. [5]).
This phosphor is also suitable for excitation

* Paper presented at the Workshop Seminar 'Standardization in Spectrophotometry and Luminescence Measurements' held at the National Bureau of Standards, Gaithersburg, Md., November 19-20, 1975.

in the far ultraviolet (vacuum ultraviolet) because of its constant efficiency as a function of λ_{exc} up to 350 nm.

- (c) The standard "Ekta S10"¹ proposed by Grum [6].
- (d) "Lumogen T red GG," which can be used in the excitation region between 190 and 550 nm [7].

2.2. Absolute Measurements

The absolute radiant efficiency can in fact be determined with the aid of a relative measurement, being the ratio of the amount of emitted power and that of the absorbed exciting power [1].² For one or two wavelengths the absolute efficiencies can be determined. For other λ_{exc} the *relative* excitation spectrum can be determined from which the absolute efficiency at any λ_{exc} can be derived.

For this determination three quantities are measured:

- (a) The diffuse reflection of the exciting radiation against BaSO₄ for which the reflection is known.
- (b) The luminescence + reflection of the exciting radiation (without using a filter).
- (c) The luminescence of the phosphor, using a filter between phosphor and detector that passes only the luminescence.

From these three measured quantities the reflection and radiant efficiency of the phosphor can be determined.

The expressions found for the radiant efficiency η_p and the reflection r_p are given here for the case of using as a detector a thermopile or thermoelement with flat radiant response. Three emf's are measured, viz., V_R due to the reflection standard (e.g., BaSO₄ [8], reflection R), V_P due to the phosphor (luminescence intensity L + reflected exciting radiation of intensity I) and $V_{P,F}$ due to the phosphor when a filter F absorbing the exciting radiation is placed in front of the detector. We assume that the filter has a transmission τ in the emission region of the phosphor. This leads to the following equations:

$$\begin{aligned} CV_R &= IR \\ CV_P &= Ir_p + L \\ CV_{P,F} &= \tau L \end{aligned}$$

where C is a constant.

After solving for r_p and L we find

$$\eta_p = \frac{L}{I(1-r_p)} = \frac{R}{\tau(1-r_p)} \frac{V_{P,F}}{V_R}$$

$$r_p = R \frac{V_P - V_{P,F}/\tau}{V_R}$$

¹ In order to describe materials and experimental procedures adequately, it is occasionally necessary to identify commercial products by manufacturer's name or label. In no instance does such identification imply endorsement by the National Bureau of Standards, nor does it imply that the particular product or equipment is necessarily the best available for that purpose.

² Figures in brackets indicate the literature references at the end of this paper.

As a cross-check the reflection found in this way can be compared with that measured directly with a spectrophotometer.

The method described can be used in the same way for the case of a varying spectral response of the detector and/or a varying spectral transmission of the filter, even when the filter transmits partly in the region of the exciting radiation. Of course the equations become somewhat more complicated in this case.

The quantum efficiency q_p is found from the radiant efficiency by

$$q_p = \eta_p \frac{\int \lambda_p(\lambda) d\lambda}{\lambda_{\text{exc}} \int p(\lambda) d\lambda}$$

where $p(\lambda)$ is the emitted luminescent power and λ_{exc} is the exciting wavelength.

The NBS standards mentioned in 2.1 are not excited in the visible (only No. 1030 would be suitable in the blue-violet) region. Therefore, other standards are necessary in the visible region. These can be found among the "lumogen" phosphors. A yellow luminescent lumogen was described by Kristianpoller and Dutton [9], yellow and red ones by Vavilov [10], Morgenshtern, Neustruev and Epshtein [11] and Küttner, Selzle and Schlag [12]. The latter used 5-(p-dimethylaminobenzyliden)-barbituric acid as a red lumogen; they found a quantum efficiency of 45 percent at $\lambda_{\text{exc}} = 405$ nm.

We chose the red luminescent "Lumogen T red GG" which was already mentioned in section 2.1. It is commercially available from the Badische Anilin und Soda Fabrik (Ludwigshafen, Germany). The properties of the phosphor are described in reference [7]. It has a red luminescence and shows a quantum efficiency which is not quite constant but varies in a limited range between 40 percent and 60 percent in the spectral region between 220 nm and 550 nm (see fig. 2).

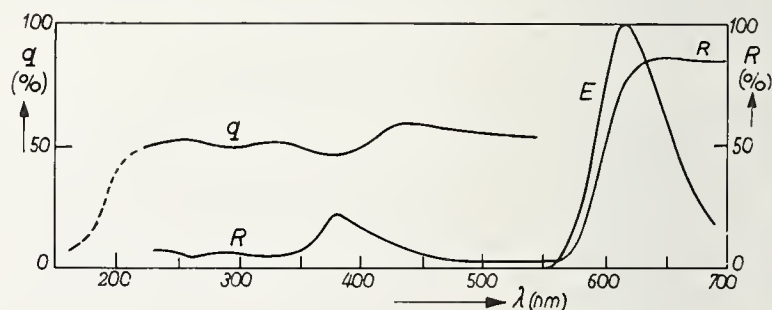

FIGURE 2. "Lumogen T red GG"

q = quantum efficiency, R = diffuse reflection and E = spectral power distribution.

The spectral power distributions at room temperature and liquid nitrogen temperature are given in figures 3 and 4. The temperature dependence curve is given in figure 5 for $\lambda_{\text{exc}} = 365$ nm. The quantum efficiency

together with the diffuse spectral reflection are given in figure 2. An important advantage of this phosphor over liquid standards like rhodamine B is that the absorption is high in the whole region, the lowest value being 78 percent near $\lambda = 380$ nm (diffuse reflection ≈ 22 percent).

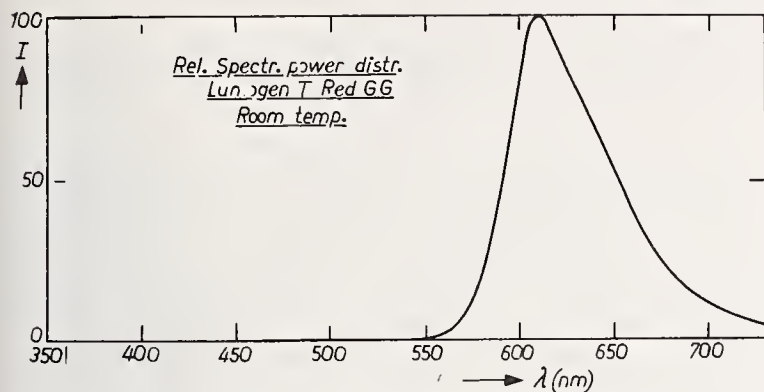

FIGURE 3. Spectral power distribution of "Lumogen T red GG" at room temperature.

I denotes the spectral radiant power in arbitrary units.

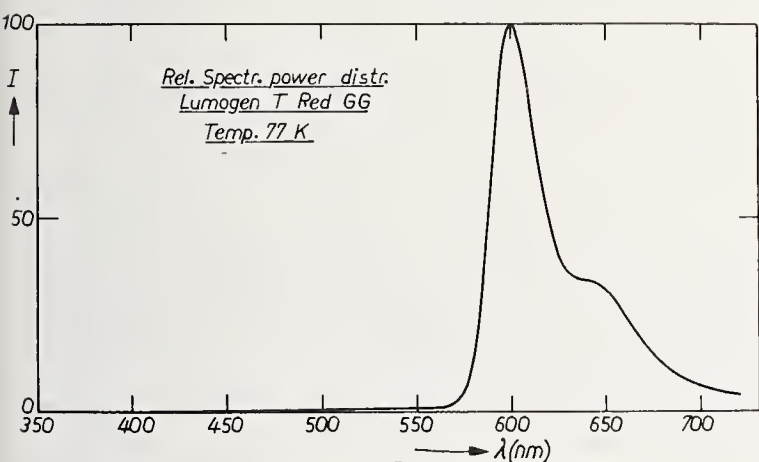

FIGURE 4. Spectral power distribution of "Lumogen T red GG" at liquid nitrogen temperature.

See further subscript fig. 3.

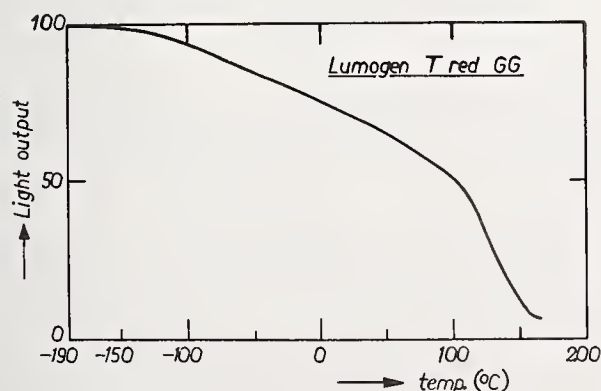

FIGURE 5. Temperature dependence of the luminescence of "Lumogen T red GG" for $\lambda_{exc} = 365$ nm.

The absorption of rhodamine B is given in figure 6, showing the enormous variation through the spectrum leading to a similar large variation in light output. Another drawback of liquid samples is the different geometry of the set-up needed for the measurement.

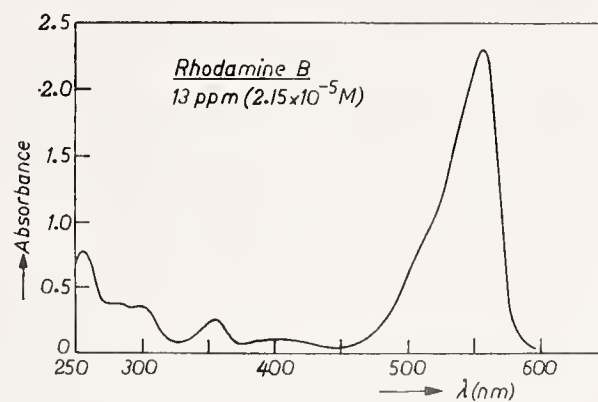

FIGURE 6. Spectral absorbance of rhodamine B.

Various authors have reported measurements using 254 nm mercury vapour discharge excitation. Here we give additional measurements on some standards for longer wavelength excitation at $\lambda_{exc} = 365$ nm. The phosphors measured were sodium salicylate, the "Ekta S10" sample, introduced by Grum [6] and "Lumogen T red GG" [7] (see tables 1 and 2).

The results for diffuse reflection at the exciting and emission wavelength, the practical and intrinsic radiant efficiencies, and the practical and intrinsic quantum efficiencies are given.

TABLE 1. Efficiencies at $\lambda_{exc} = 365$ nm

Phosphor	Diffuse reflection at		Radiant efficiency		Quantum efficiency	
	$\lambda = 365$ nm %	λ_{em} %	η_p %	η_i %	q_p %	q_i %
Na-salicylate	30	80	33	37	37	41
"Ekta S10"	15	67	37	45	41	50
"Lumogen T red GG"	13		25		41	

TABLE 2. Efficiencies at $\lambda_{exc} = 260$ nm

Phosphor	Diffuse reflection at		Radiant efficiency		Quantum efficiency	
	$\lambda = 260$ nm %	λ_{em} %	η_p %	η_i %	q_p %	q_i %
Na-salicylate	7	80	34	37	55	60
"Lumogen T red GG"	6		22		53	

Because of the thick layer used, a correction has to be made for the loss of the light absorbed in the layer. The intrinsic radiant efficiency η_i can then be approximated by [2]

$$\eta_i = \frac{2}{1 + r_\infty} \eta_p$$

where r_∞ is the reflection coefficient of the phosphor for an infinitely thick layer.

The diffuse reflection of "Ekta S10" is given in figure 7, the spectral power distribution in figure 8.

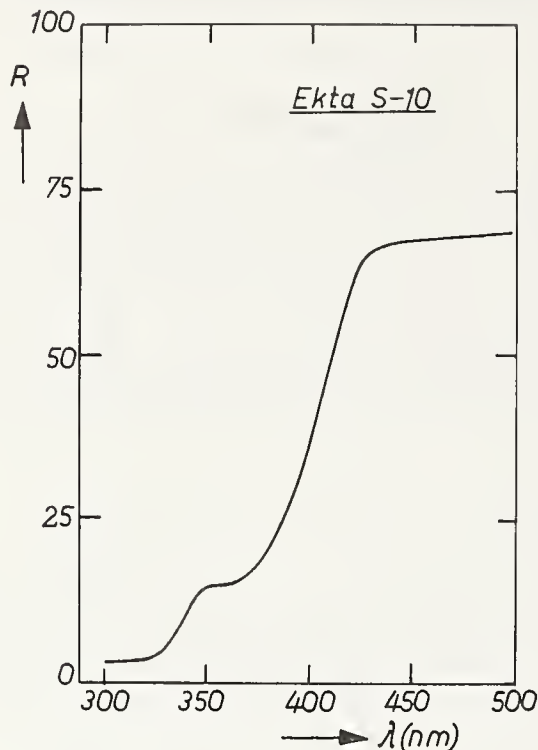

FIGURE 7. Diffuse reflection of "Ekta S10."

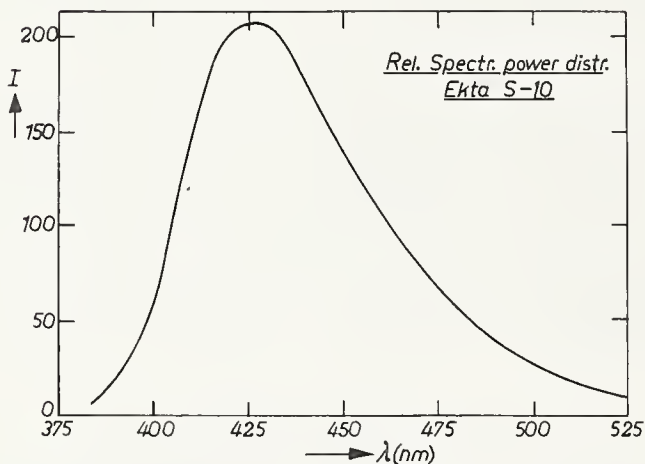

FIGURE 8. Spectral power distribution of "Ekta S10."

See further subscript fig. 3.

The efficiency data for Na-salicylate at $\lambda_{exc} = 260$ nm can be compared with the data given in Samson's book (ref. [3]) which are discussed by us in reference [7], together with some additional data.

Polarization effects in our measurements proved to be negligible, as may be expected for powder materials. Measurements were carried out with incident polarized UV radiation, in two directions perpendicular to each other.

The stability of the lumogen was also tested as well

as the dependence on excitation density. During one month the efficiency of the lumogen was measured every two days. The stability in time proved to be very good; no changes were observed within the error of measurement, which was of the order of ± 10 percent.

The efficiency values were not affected even when the intensity of the UV-radiation was attenuated a thousand times.

3. Excitation in Selected Narrow Absorption Peaks

A method to determine the efficiencies of phosphors that have a small absorption of a few percent in narrow, well defined excitation levels (for the normal case of $\lambda_{exc} \leq \lambda_{em}$) was described earlier by us [13, 14]. Examples of these powders are rare-earth activated phosphors, such as YVO_4-Eu^{3+} and $NaYF_4-Er^{3+}$, where the (visible) excitation peaks are those of the rare-earth ion. The host lattice absorbs in the UV region.

A diagram of the set-up is shown in figure 9. The phosphor is irradiated via a scanning monochromator. Two measurements have to be carried out, differing only in the filter used in front of the photomultiplier.

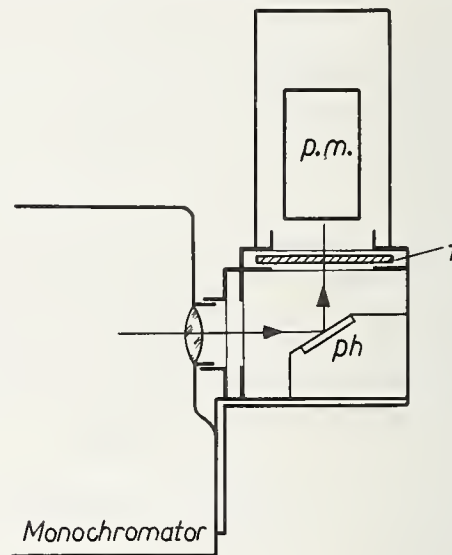

FIGURE 9. Schematic diagram of the experimental set-up: *ph* = phosphor sample, *f* = filters, *pm* = photomultiplier.

One filter transmits only the light reflected from the sample, giving the absorption spectrum. In the second measurement the other filter selects the emission wavelength region, thus obtaining the excitation spectrum of that emission. The curves are of the type shown in figure 10 for YVO_4-Eu^{3+} . The efficiency is calculated as follows.

The radiant efficiency is the ratio of the emitted power E to the absorbed exciting power A . The latter is determined by the area under the absorption curve of a certain peak with correction for the transmission τ_A of the filter used and for the photomultiplier response $G(\lambda_A)$ in the absorption region. The emitted

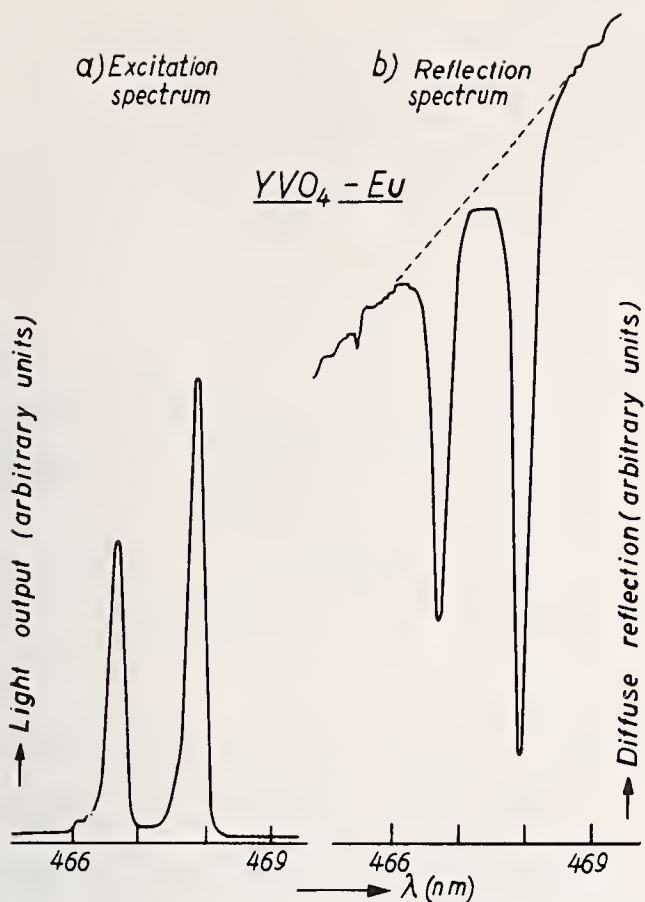

FIGURE 10. Relative light output of Eu^{3+} -emission (curve a) and diffuse reflection (curve b) as a function of wavelength for $\text{YVO}_4\text{-Eu}$.

For curve b the zero line is suppressed (the absorption peak has a depth of about 13 percent).

power E is determined by the corresponding area under the excitation curve with correction for the transmission τ_E of the filter used in this case and the response $G(\lambda_E)$ in the emission region. For single narrow peaks we can take the ratio of the ordinate maxima in the absorption and excitation spectra U_A and U_E , respectively, instead of the area. We then find for the emitted power

$$E = U_E \frac{\int p(\lambda_E) d\lambda_E}{\int p(\lambda_E) G(\lambda_E) \tau_E(\lambda_E) d\lambda_E}$$

where $p(\lambda_E) d\lambda_E$ is the relative emitted power in a region $d\lambda_E$ (integration extended over the total spectral region of the emission). The absorbed power is given by

$$A = \frac{U_A}{G(\lambda_A) \tau_A}$$

Then the radiant efficiency η is

$$\eta = \frac{E}{A} = \frac{U_E \tau_A G(\lambda_A) \int p(\lambda_E) d\lambda_E}{U_A \int p(\lambda_E) G(\lambda_E) \tau_E(\lambda_E) d\lambda_E}$$

The quantum efficiency q is derived from the radiant efficiency by

$$q = \eta \frac{\int \lambda_E p(\lambda_E) d\lambda_E}{\lambda_A \int p(\lambda_E) d\lambda_E}$$

The error in this type of measurement may be of the order of 10–25 percent, depending on the value of the absorption. This large error is caused by the low value of the absorption in the rare-earth ion.

4. Cathode-Ray Excitation

The radiant efficiency η_p for cathode-ray excitation [2–4, 15, 16] is generally defined as the ratio of the amount of emitted luminescent power in the spectral region under consideration to the power of the incident cathode-ray beam (and not to the power absorbed by the phosphor layer). Thus no correction is made for the loss due to reflection of primary electrons [2, 15, 16].

In this case two really absolute measurements are necessary, viz., that of the emitted power and that of the power of the cathode-ray beam (fig. 11).

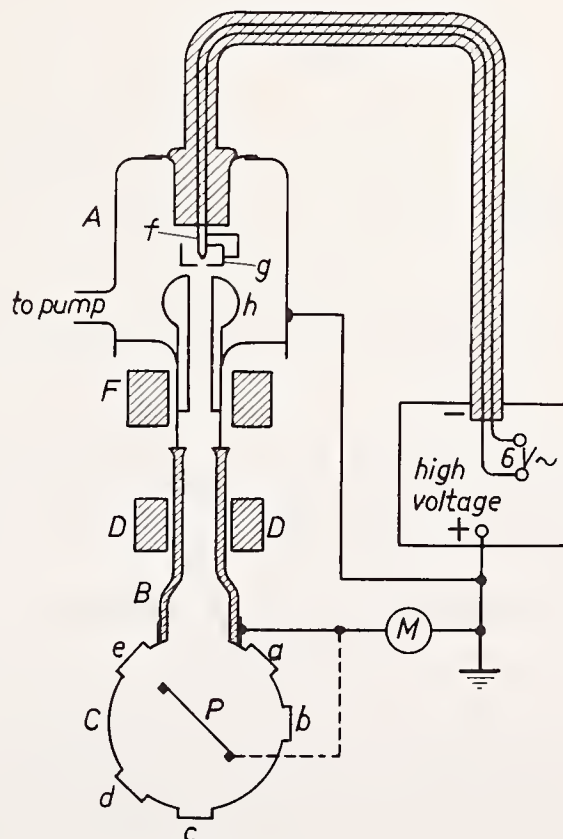

FIGURE 11. Experimental set-up for efficiency measurements with C. R. excitation.

A. metal chamber, h. anode, f. filament, g. cap, F. focusing coil, D. deflection coils, B. glass tube, C. metal cylinder, P. target plate, a, b, c, and d quartz windows, M. microammeter.

The measurements are carried out on thick layers at the irradiated side. Precautions should be taken to ensure that charging up of the layer is negligible.

The radiant output of the phosphor was compared with the radiation of a standard lamp which was diffusely reflected by a MgO layer. A thermopile was used [2] as a detector.

5. X-Ray Excitation

To measure radiant efficiencies with x-ray excitation [17-19] thin phosphor layers are used ($\approx 100\mu\text{m}$). This is necessary to minimize the loss in light output due to scattering and absorption of the emitted luminescence. The total back-screen emission is collected by a 2π -geometry elliptical mirror and focused onto the photomultiplier detector (see fig. 12),

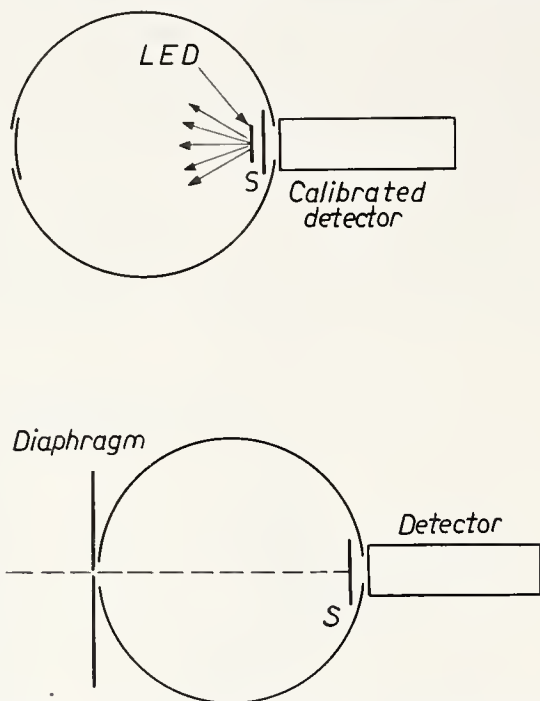

FIGURE 12. Diagram for efficiency measurement of light emitting diodes.

which is calibrated in absolute units (A/W). The x-ray absorption coefficients are measured with a scintillation crystal as well as calculated from the tables of Storm and Israel [20].

6. Measurements of Light-Emitting Diodes, Crystals, etc

In cases where the angular distribution of the emitted radiation does not obey Lambert's law it is not sufficient to measure the emitted radiation in one direction but the total radiation should be determined. This can be carried out with the aid of an Ulbricht's sphere or with an elliptical mirror.

The absolute output can be calibrated in two ways (see fig. 13):

(1) the luminescent output is measured with a

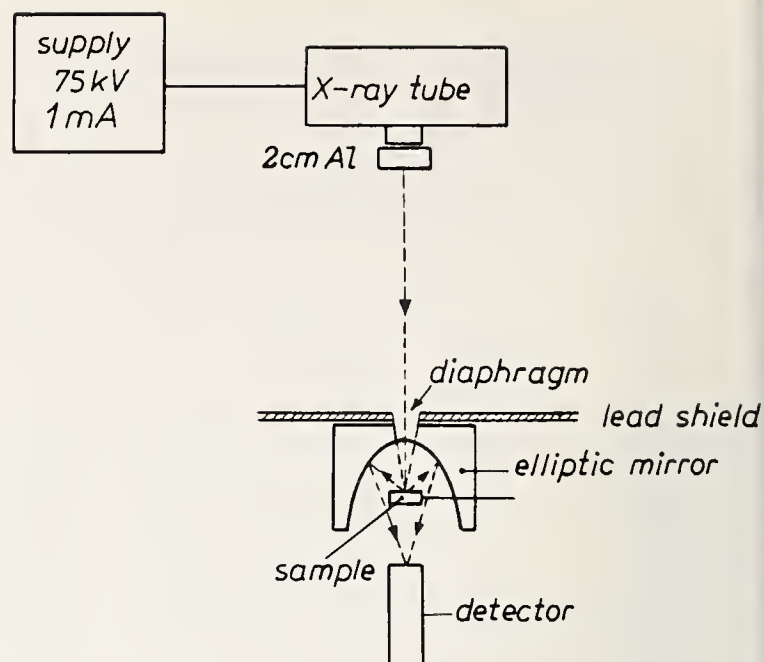

FIGURE 13. Experimental set-up for x-ray efficiency measurements.

calibrated detector ($\text{A/W} \cdot \text{cm}^2$), e.g., a 150 CV or 150 UV photocell (calibration National Physical Laboratory, Teddington, England).

(2) the luminescent output is compared with the output of a calibrated standard lamp, e.g., a 200 W or 1000 W tungsten-halogen lamp; calibrated by the National Bureau of Standards in Washington, D.C. ($\text{W/nm} \cdot \text{cm}^2$). In this case the diode to be measured is replaced by a BaSO_4 -coated screen S.

The use of a 2π -geometry elliptical mirror [21] instead of an Ulbricht's sphere gave nearly the same results.

7. References

- [1] Nat. Bur. Stand. (U.S.), Tech. News Bull. **42**, 145 (1958) Brill, A., and Hoekstra, W., Philips Res. Repts. **16**, 356, (1961) and Philips Res. Repts. **19**, 296 (1964).
- [2] Brill, A., in Kallman-Spruch, Luminescence of Organic and Inorganic Materials, p. 479 (John Wiley and Sons, Inc. New York 1962).
- [3] Ludwig, G. W., and Kingsley, J. D., J. Electrochem. Soc. **117**, 348 (1970).
- [4] Kingsley, J. D., and Ludwig, G. W., J. Electrochem. Soc. **117**, 353 (1970).
- [5] See e.g. Samson, J. A. R., Techniques of Vacuum Ultraviolet Spectroscopy, p. 216 (John Wiley and Sons, Inc., New York, 1967).
- [6] Grum, F., C.I.E.-Report of Subcommittee on Luminescence, 18th Session, London, 1975.
- [7] Brill, A., and de Jager-Veenis, A. W., The Electrochemical Society, Spring Meeting at Toronto, May 1975; J. Electrochem. Soc. **123**, 396 (1976).
- [8] Grum, F., and Luckey, G. W., App. Optics **7**, 2289 (1968).
- [9] Kristianpoller, N., and Dutton, D., Appl. Opt. **3**, 287 (1964).
- [10] Vavilov, V. S., J. Chem. Phys. Solids **8**, 223 (1959).
- [11] Morgenshtern, Z. L., Neustruev, V. B., and Epshtein, M. I., J. Appl. Spectros. **3**, 35 (1965).

- [12] Küttner, H. G., Selzle, A. L., and Schlag, E. W., *Z. Naturf.* **29a**, 224 (1974).
- [13] Bril, A., Blasse, G., and Bertens, J. A. A., *J. Electrochem. Soc.*, **115**, 395 (1968).
- [14] Bril, A., Sommerdijk, J. L., and de Jager, A. W., *J. Electrochem. Soc.* **122**, 5 (1975).
- [15] Lehmann, W., *J. Electrochem. Soc.* **118**, 1164 (1971).
- [16] Meyer, V. D., *J. Electrochem. Soc.* **119**, 920 (1972).
- [17] de Poorter, J. A., and Bril, A., *J. Electrochem. Soc.* **122**, 1086 (1975).
- [18] Ludwig, G. W., *J. Electrochem. Soc.* **118**, 1152 (1971).
- [19] Grum, F., Costa, L. F., Donovan, J. L., *J. Opt. Soc. Am.* **59**, 848 (1969).
- [20] Storm, E., and Israel, H. I., Report LA 3753, Los Alamos Scientific Laboratory of the University of California, 1967.
- [21] van der Dões de Bye, J. A. W., *Rev. Sci. Instrum.* **40**, 320 (1969).

(Paper 80A3-891)

On the Actinometric Measurement of Absolute Luminescence Quantum Yields*

J. N. Demas and B. H. Blumenthal

Chemistry Department, University of Virginia, Charlottesville, Virginia 22901

(April 9, 1976)

The theory of the measurement of luminescent quantum yields using chemical actinometry is described. The sample's emission intensity is measured by nearly completely surrounding the sample with an actinometer solution, and the excitation intensity is directly measured with the same type of actinometer. The ratio of the measured sample emission intensity corrected for the fraction escaping through the excitation ports to the measured excitation intensity is the absolute luminescence yield. Equations, a suitable cell design, and computer calculated correction factors for different cell dimensions and optical densities are given. The absolute yield of the actinometer is not needed, only its relative response with wavelength. New quantum-flat actinometers which should greatly simplify the measurements are described.

Key words: Absolute yield; chemical actinometry; correction factors; luminescence; quantum-flat actinometer; quantum yield.

1. Introduction

The measurement of absolute luminescence quantum yields is an important but experimentally difficult area [1, 2, 3].¹ Most yield measurements are made relative to a luminescence standard rather than by an "absolute" method. It is thus imperative for good accuracy that the luminescent standards be accurately calibrated. To date, these standards have been derived almost exclusively from calorimetry or by reference to a standard scatterer, usually with a luminescent quantum counter detector.

The history of quantum yield measurements has demonstrated quite painfully that it is exceedingly difficult to detect and eliminate all systematic errors. Thus, materials selected for standards should be tested by as many independent and presumably reliable "absolute" methods as possible and rechecked as new techniques become available.

We describe here the theory of a conceptually new "absolute" method for measuring luminescence quantum yields based on chemical actinometers. The technique avoids many of the intrinsic error sources of

the other methods and thus promises to be a useful check on existing and new standards. The current availability of numerous lasers with both high intensities and a wide range of wavelengths ranging from < 250 nm to > 800 nm coupled with new broadband, quantum-flat actinometers make the actinometric method most attractive. In addition to the theory we present a suitable cell design, tabular correction factors, and describe suitable actinometers.

2. Theory

The actinometric approach for determining yields measures the excitation intensity and the sample emission intensity by chemical actinometry; the ratio of the emission to excitation intensity, both corrected for the fraction of the excitation beam absorbed, is the absolute quantum yield. The total emitted intensity is measured by nearly completely surrounding the sample with the actinometer solution except for a small excitation port and correcting for the small port losses. The same type of actinometer is then used to measure the excitation beam intensity.

For the actinometer monitoring the emission intensity of the luminescent unknown, the amount of reaction in the actinometer, D_x (mol of product), is given by

* Paper presented at the Workshop Seminar 'Standardization in Spectrophotometry and Luminescence Measurements' held at the National Bureau of Standards, Gaithersburg, Md., November 19-20, 1975.

¹ Figures in brackets indicate the literature references at the end of this paper.

$$D_x = I_0 t_x F_x \phi F'_E \bar{\Theta}_x$$

$$F_x = T(1 - 10^{-A_x}) \quad (1)$$

where I_0 (einstein/s) is the incident excitation intensity, t_x (s) is the irradiation time, F_x is the fraction of incident excitation light absorbed by the unknown, T is the effective transmittance of the entrance window, A_x is the absorbance of the solution to the excitation beam, ϕ is the sample's absolute luminescence efficiency, F'_E is the fraction of emitted light captured by the actinometer, and $\bar{\Theta}_x$ (mol/einstein) is the actinometer's effective photochemical quantum yield for the emission band. It is assumed that the excitation beam is monochromatic, all of the emission passing into the actinometer is absorbed, and reabsorption-reemission corrections are negligible. $\bar{\Theta}_x$ is given by

$$\bar{\Theta}_x = \frac{\int_0^\infty F(\bar{\nu}) \Theta_x(\bar{\nu}) d\bar{\nu}}{\int_0^\infty F(\bar{\nu}) d\bar{\nu}} \quad (2)$$

where $\bar{\nu}$ is energy in cm^{-1} , $F(\bar{\nu})$ (relative quanta/ cm^{-1} of bandwidth) is the corrected relative emission spectrum and $\Theta_x(\bar{\nu})$ (mol/einstein) is the variation of the actinometer yield with excitation energy.

In the measurement of the excitation beam intensity, the amount of reaction in the actinometer, D_s (mol), is given by

$$D_s = I_0 t_s F_s \Theta_s \quad (3)$$

$$F_s = T(1 - 10^{-A_s})$$

where t_s (s) is the irradiation time, F_s is the fraction of the excitation beam absorbed by the actinometer, T is the same as eq 1, A_s is the absorbance of the actinometer solution to the laser, and Θ_s (mol/einstein) is the actinometer's yield at the excitation wavelength. The absolute luminescence quantum yield is then given by

$$\phi = \left(\frac{D_x}{D_s}\right) \left(\frac{t_s}{t_x}\right) \left(\frac{1 - 10^{-A_s}}{1 - 10^{-A_x}}\right) \left(\frac{\Theta_s}{\bar{\Theta}_x}\right) \left(\frac{1}{F'_E}\right) \quad (4)$$

The D 's, A 's and t 's are directly measurable and F'_E can be evaluated from geometric considerations (see below). At first it might appear that this method can be no more accurate than the absolute accuracy of the evaluation of the actinometer's yield, $\Theta(\bar{\nu})$, a process which is rarely good to better than 10 percent. In reality since eq 4 uses the ratio of Θ_s to $\bar{\Theta}_x$, only the variation of $\phi(\bar{\nu})$ with $\bar{\nu}$ need be known accurately. As long as data from the same workers are used, this error is likely to be substantially smaller than 10 percent and quite possibly less than 5 percent. Also, as we shall show, actinometers with intrinsically quantum-flat responses are becoming available which will make $\Theta_s/\bar{\Theta}_x = 1.000$ within ~ 1 -2 percent, regardless of how accurately the absolute yield is known.

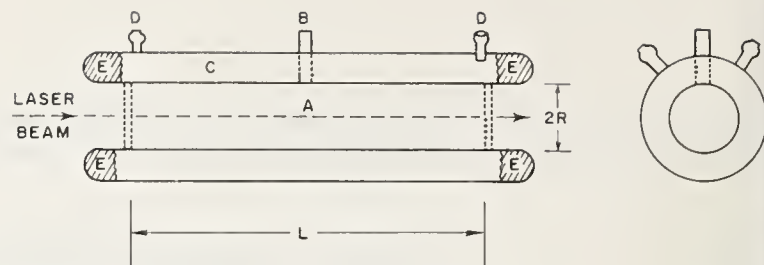

FIGURE 1. Cell design for luminescence quantum yield measurements by actinometry.

a. Luminescent sample. b. Filling stem for sample. c. Actinometer solution compartment. d. Filling stems for actinometer which are also suitable for a flow actinometer system. e. Silvering on actinometer jacket ends to reflect emission transmitted down glass walls back into solution. To extend the maximum wavelength of the actinometer, the entire actinometer jacket could be silvered to double the absorption path for emission.

The Model

Figure 1 shows an easily fabricated cell suitable for measuring absolute yields by actinometry. The cell, built much like a reflux condenser, has a long, central irradiation volume with a small diameter filling stem. The outer jacket contains the actinometer solution which intercepts and absorbs a large fraction of the emitted light. The two filling ports on the actinometer jacket facilitate filling and permit the use of flow actinometers.

This cell design has numerous advantages. The system is only suitable for use with laser excitation; therefore, the monochromatic laser light eliminates, in virtually all solution cases, the need for effective absorbance corrections arising from variation of absorbance over the excitation band [4]. Questionable refractive index corrections are also eliminated. The high symmetry and entering and exiting excitation ports simplify evaluation of F_x and F'_E ; further, the exit port removes unabsorbed excitation light from the system so that it cannot affect the actinometer. By silvering the ends of the actinometer jacket, radiation light piped down the glass walls can be directed back into the actinometer. By making L/R large, F'_E can be made to approach unity as closely as desired. By choosing a large L/R , one can easily absorb a large fraction of the exciting light and still keep the reabsorption-reemission correction small. Thus, the system combines some of the best features of the optically dense and dilute approaches.

Evaluation of F'_E

To evaluate F'_E we make several assumptions, all of which will be quite accurate or will introduce negligible errors in a well-designed cell. These assumptions are: (1) the laser beam is centered and its diameter is small compared to R , (2) all emission not directly striking the windows is absorbed by the actinometer, (3) all of the emission transmitted by the cell windows is lost, (4) reabsorption-reemission corrections are negligible, and (5) the windows and cell walls are nonabsorbing.

F'_E is divided into two terms, a geometric factor for direct capture of the emitted light and a correction for

the emitted light reflected by the windows back into the cell which is subsequently absorbed by the actinometer. F'_E is given by

$$F'_E = F_E + (1 - F_E)r_{eff}F_{RA} \quad (5)$$

where F_E is the fraction of primary emission that would be absorbed if the windows were perfectly transparent with no reflection losses, r_{eff} is the fraction of primary emitted radiation reflected back into the cell by the windows, and F_{RA} is that fraction of this reflected radiation which is eventually absorbed by the actinometer, the remainder eventually escaping. F_E can be evaluated by

$$F_E = \left(\frac{1}{2B}\right) \int_0^L \left\{ \cos \left[\arctan \left(\frac{R}{\ell} \right) \right] + \cos \left[\arctan \left(\frac{R}{(L-\ell)} \right) \right] \right\} Ad\ell \quad (6)$$

$$A = \frac{\epsilon C \exp [-\ln(10) \epsilon C \ell]}{\{1 - \exp [-\ln(10) \epsilon C \ell]\}}$$

$$B = 1 - \exp [-\ln(10) \epsilon CL]$$

where ϵ is the sample's molar extinction coefficient at the excitation wavelength and C is the sample concentration. The first and second cosine terms account for the fraction of radiation striking the entrance and exit windows respectively as a function of position in the cell. The A term accounts for the decrease in emission intensity along the tube caused by absorption. The B term corrects for the total fraction of excitation light absorbed in the cell.

For a very large L/R and not too high an optical density, F_E will approach unity. For extremely high optical densities, however, the emission front surfaces at the entrance window where half the radiation could escape, and F_E approaches 0.5.

Equation 6 has no obvious analytical solution and was evaluated numerically using Simpson's rule. Because of the discontinuities in the integrand at $\ell=0$ and $\ell=L$, the evaluation limits were just set very near both windows. Initially calculations were done on a Hewlett Packard 2000² system in time sharing BASIC, but its $\sim 6-7$ significant figures proved inadequate. All calculations presented here were done on a Hewlett Packard 9100 B programmable desk calculator which has 10-12 significant figures; there were no problems with convergence. Integration was performed over the range $\ell/L = 10^{-5}$ to 0.99999 with 200 subdivisions. Increasing the number of divisions to 1000 caused no changes in the fifth significant figure. Our calculated F_E 's are thus accurate to better than 0.1 percent. Calculated results for F_E 's as a function of L/R and A_x are given in table 1.

²In order to describe materials and experimental procedures adequately, it is occasionally necessary to identify commercial products by manufacturer's name or label. In no instance does such identification imply endorsement by the National Bureau of Standards, nor does it imply that the particular product or equipment is necessarily the best available for that purpose.

3. Discussion

Table 1 reveals that, as expected, F_E approaches unity for large values of L/R with low to intermediate values of A_x . Also, for very large values of A_x , F_E seems to approach 0.5. F_E decreases as A_x increases because of the movement of the emission towards one end where the escape factor is greater.

TABLE 1. Emission absorption fraction, F_E

$A_x \backslash L/R$	5	10	20	50	100	200
0.5	0.8141	0.9001	0.9479	0.9786	0.9892	0.9946
1.0	.7986	.8866	.9385	.9738	.9865	.9932
1.5	.7776	.8681	.9255	.9670	.9828	.9912
2.0	.7551	.8478	.9109	.9593	.9785	.9889
2.5	.7333	.8277	.8960	.9513	.9739	.9864
3.0	.7136	.8089	.8818	.9434	.9693	.9839
3.5	.6962	.7916	.8683	.9357	.9648	.9814
4.0	.6808	.7760	.8556	.9282	.9604	.9790
5.0	.6555	.7488	.8327	.9141	.9585	.9741
6.0	.6357	.7263	.8125	.9010	.9437	.9694
7.0	.6199	.7072	.7947	.8887	.9359	.9649
8.0	.6071	.6910	.7786	.8773	.9284	.9604
9.0	.5964	.6770	.7642	.8665	.9212	.9561
10.0	.5875	.6647	.7512	.8564	.9143	.9518

As a practical consideration F_E should be as close as possible to unity. Fortunately this is not difficult. Even for a cell which is only 2.5 times longer than its diameter ($L/R=5$), F_E is > 75 percent for $A_x \leq 2$, an acceptable value. More realistic values of L/R for actinometer cells would be 20-50 which yield $F_E > 90$ percent for $A_x \leq 2.0$. Even values of L/R of 100-200 are feasible; a 50 cm cell would be 0.5-1 cm in diameter; in these cases F_E would exceed 90 percent for $A_x \leq 3$. It is thus clear that excellent collection efficiency of the emission can be readily obtained.

In the evaluation of \emptyset , F'_E rather than F_E is actually required. We have not done a quantitative analysis for F'_E because r_{eff} and F_{RA} are quite difficult to evaluate, but in a well-designed cell the error associated with replacing F'_E by F_E is quite small. For example, in a cell with a large L/R , most of the emission incident on the cell windows will be at near normal incidence; thus, we can use $r_{eff} \sim 0.04$ for a glass-air interface. For $F_E = 90$ percent, F'_E will be < 0.5 percent greater than F_E , and the error falls for larger F_E 's.

Until recently the potential choices of actinometers were limited to ferrioxalate and Reinecke's salt. The ferrioxalate actinometer will yield total absorption of the emitted radiation up to ~ 480 nm using a 5 cm thick actinometer solution (0.15 F). The yield is not strongly wavelength dependent from 254 nm to 480 nm, and calibration is sufficiently detailed to permit accurate evaluation of $\bar{\Theta}_x$.

Reinecke's salt offers much deeper red penetration, ~ 610 nm for $2 \times 10^{-2} M$ solution and a 5 cm minimum cell length. The yield is more nearly constant than ferrioxalate over the 390-620 nm range. Unfortunately

Reinecke's salt has serious disadvantages. The yield changes sharply below 390 nm, and detailed data in this region are lacking. The complex is difficult to dissolve at high concentrations and undergoes a relatively rapid thermal reaction ($\sim 0.6\%/h$). Although it is about an order of magnitude less sensitive than ferrioxalate, this is not likely to be a problem with a high intensity laser excitation source.

New photosensitized actinometers promise to eliminate the previous difficulties. For example, the tris-(2,2-bipyridine)ruthenium(II) photooxidation of tetramethylethylene has been developed as an actinometer for high power lasers [5]. The system should be intrinsically quantum flat, because the lowest excited state is responsible for the sensitization; luminescence experiments have verified that the efficiency of population of the emitting state is constant to $\sim \pm 2$ percent over this region [6]. A solution $10^{-3}M$ in the ruthenium complex will absorb all radiation below ~ 520 nm in a 2 cm pathlength. By using similar osmium(II) complexes as the sensitizer [6, 7, 8], total absorption of the emission and a quantum flat response below ~ 700 nm should be realized. These systems use volumetric monitoring of the consumed O_2 and are thus not very sensitive, but laser excitation supplies adequate intensity. Finally, because the consumed O_2 must be replaced and inhomogeneity of the reactants can be a problem in a static system, these actinometers must be operated in a flow system.

An analogous system which also shows promise is the methylene blue sensitized photooxidation of tetramethylethylene. Solutions can easily be made totally absorbing to beyond 700 nm in a 1 cm pathlength, and the yield is comparable to the Ru(II) and Os(II) systems. The quantum yields may, however, not be perfectly flat, and minor corrections may be required.

In summary, we feel that the actinometric method, although too complex for routine measurements, will prove especially useful in developing primary luminescence quantum yield standards. This method eliminates most of the error sources inherent in other absolute techniques, and thus supplies a valuable check. The technique is currently feasible for compounds emitting below 520 nm, and with the natural evolution of actinometry, operation to 700 nm and beyond should soon be feasible.

Acknowledgment is made to the National Science Foundation, the donors of the Petroleum Research Fund, administered by the American Chemical Society, and to the Research Corporation for support of this work.

4. References

- [1] Lipsett, F. R., *Progr. Dielectrics*, **7**, 217 (1967).
- [2] Demas, J. N., and Crosby, G. A., *J. Phys. Chem.* **75**, 991 (1971).
- [3] Crosby, G. A., Demas, J. N., and Callis, J. B., *J. Res. Nat. Bur. Stand. (U.S.)*, **76A** (Phys. and Chem.), No. 6, 561-577 (Nov.-Dec. 1972).
- [4] Demas, J. N., *Anal. Chem.* **45**, 992 (1973).
- [5] (a) Demas, J. N., Harris, E. W., and McBride, R. P., *Lasers in Physical Chemistry and Biophysics* (Elsevier, New York, N.Y., 1975), p. 477.
(b) Demas, J. N., McBride, R. P., and Harris, E. W., *J. Phys. Chem.*, accepted.
- [6] Demas, J. N., and Crosby, G. A., *J. Am. Chem. Soc.* **93**, 2841 (1971).
- [7] Demas, J. N., Harris, E. W., Flynn, Jr., C. M., and Diemente, D., *J. Am. Chem. Soc.* **97**, 3838 (1975).
- [8] Demas, J. N., Harris, E. W., and McBride, R. P., submitted.

(Paper 80A3-892)

The Calorimetric Detection of Excited States*

James B. Callis

Department of Pathology, University of Washington Medical School, Seattle, Washington 98195

(April 9, 1976)

Calorimetric techniques offer the photophysicist and photochemist the opportunity to measure a number of parameters of excited states which may be difficult to obtain by other techniques. The calorimetric strategy seeks to measure the heating of a sample resulting from radiationless decays or chemical reactions of excited states. Heating is best measured through volume and pressure transducers, and four calorimeters based on these are described. With calorimetric instrumentation one can perform measurements on samples in the gas, liquid and solid phases over a wide temperature range. Moreover time dependent processes with time constants ranging from microseconds to seconds are amenable to study. Examples of the application of calorimetric techniques to the determination of quantum yields of fluorescence, triplet formation and photochemistry are given.

Key words: Absolute quantum efficiency; absolute quantum yield; calorimetry; luminescence; photoacoustic spectrometer; piezocalorimeter; transducers; triplet formation

1. Introduction

In understanding the nature of excited electronic states it is well appreciated that a wide variety of parameters are accessible to photometric measurement. Among them are the absorption spectrum of the excited state, the excitation spectrum, and the lifetime. If the excited state decays by emission of photons, one can also measure the spectral distribution of emission, the polarization, and the quantum yield of emitted photons. Unfortunately, it is not so generally appreciated that a number of parameters of an excited state are also accessible to calorimetric measurement. The calorimetric strategy seeks to measure how much of the light absorbed by a sample is converted to heat energy by radiationless processes and/or photochemistry. Parameters which can be measured include: the lifetime of an excited state, the excitation spectrum for a particular process, the energy yield of a radiationless process, and the enthalpy of a photochemical process.

A simple example illustrates how calorimetric measurements can complement photometric measurements. Most air saturated liquid solutions of luminescent organic molecules exhibit only fluorescence at room temperature. By measuring the ratio of the heating of the fluorescent substance in response to photoexcitation to that of a non-fluorescent but equally absorbing substance, one obtains the energy yield of radiation-

less processes Y_h [1, 2].¹ In the absence of photochemistry, the fluorescence energy yield is the complement of Y_h , and the quantum yield of fluorescence Φ_f is related to it by the formula

$$\Phi_f = (\bar{\nu}_a / \bar{\nu}_f) (1 - Y_h) \quad (1)$$

where $\bar{\nu}_a$ and $\bar{\nu}_f$ are the average frequencies of absorbed and emitted photons respectively. Calorimetric quantum yields determined in this manner [1, 2, 3] are among the most precise and accurate reported in the literature, and in addition provide a valuable independent technique for verifying the many assumptions that go into the derivation of quantum yields from photometric measurements [4, 5]. Despite these advantages, very few quantum yields have been measured calorimetrically. This unfortunate situation exists because most workers in the field are unfamiliar with calorimetric techniques, and moreover, the measurements are time consuming and tedious to perform. It is the purpose of this paper to point out some recent work which shows that using capacitor microphones and piezoelectric crystals as heat flow transducers, calorimetry can be a rapid, simple and sensitive technique for use in measuring a wide variety of parameters of excited states. Also, samples in the gas, liquid and solid phases, including thin films and monolayers are amenable to study.

*Paper presented at the Workshop Seminar 'Standardization in Spectrophotometry and Luminescence Measurements' held at the National Bureau of Standards, Gaithersburg, Md., November 19-20, 1975.

¹ Figures in brackets indicate the literature references at the end of this paper.

2. Types of Calorimeters Suitable for Measuring Photochemical and Photophysical Processes

The most obvious approach for detection of heat production is to use a conventional calorimeter based upon the usual temperature sensors: thermistors and thermopiles. We will not discuss these instruments here because they have already been reviewed [3, 4, 5] and because they have inherent disadvantages in sensitivity, risetime and speed at which measurements can be made. Instead, we will concentrate on alternative strategies for measuring heat flow based on volume and pressure changes produced in the sample.

In general, addition of an amount of heat dQ to the sample gives rise to both a pressure change dP and a volume change dV according to the thermodynamic relationship [6]

$$dQ = \frac{C_p dV}{\alpha V} + C_v \frac{\beta}{\alpha} dP \quad (2)$$

where C_p and C_v are the heat capacities at constant pressure and constant volume, V the volume of the solution, $\alpha = V^{-1}(\partial V/\partial T)_p$ is the coefficient of thermal expansion, and $\beta = -V^{-1}(\partial V/\partial P)_T$ is the compressibility of the sample. Three of the calorimeters we will describe use the capacitor microphone to detect volume changes in the sample. In all of these devices the sample is enclosed in a cell with rigid walls. One of these walls, generally normal to the direction of propagation of exiting light is replaced by the compliant diaphragm of a capacitor microphone. Because of the diaphragm, a second relationship between dP and dV must be simultaneously obeyed:

$$dP = \kappa dV/V. \quad (3)$$

We have assumed that the changes are small so that a linear relationship exists, and κ , the linear constant, is approximately given for a cubic cell by k/ℓ where k is the force constant for displacing the diaphragm, and ℓ is the linear dimension of the cell. Combining eq (2) and (3) we have

$$dV = \alpha V dQ / (C_p + C_v \kappa \beta). \quad (4)$$

Equation (4) shows that: (a) the volume change is independent of any gradients in the distribution of energy in the cells; (b) the largest volume changes are obtained for samples which have the highest values of α and the lowest heat capacities (gases give the largest signals; water gives low signals); (c) the compliance of the diaphragm must be kept low enough so that the product $\kappa\beta$ is as small as possible.

The capacitor microphone for measuring the volume changes consists of the diaphragm and a stationary electrode spaced a small distance apart; together they form a capacitor whose capacitance C is given by

$$C = \epsilon A/x \quad (5)$$

where ϵ is the dielectric constant, A is the area of the electrodes, and x is the spacing between them, and edge effects were neglected. If the change in spacing of the electrodes is small enough, the capacitance will be related to it linearly. Several methods have been used successfully for the detection of the capacitance change. In the most common method [7], the microphone is polarized either with an externally supplied dc voltage or by placing an electret [8] in the gap between the electrodes; when the capacitance changes, charge flows to maintain a constant voltage. The charge flow is then converted to a voltage change by a charge sensitive pre-amp [9]. Capacitance changes can also be detected with an ac bridge circuit [10]. Even with simple detection systems, a displacement of the diaphragm of the order of one angstrom is easily measured with a bandwidth of 10 kHz [6]. The frequency response of the microphone is linear over a very wide range; the upper limit is set by the lowest mechanical resonance of the diaphragm (10–20kHz), and the lower limit is determined by the low frequency cut-off of the electronics or the thermal instabilities of the system.

With these fundamental considerations in mind, we may now discuss three types of calorimeters based upon the use of capacitor microphone pressure transducers: the "acoustic spectrophone" for study of gas phase systems, the "optoacoustic cell" for study of thin films and thin sections of solid materials, and the "flash calorimeter" for studies of liquid samples.

The acoustic spectrophone has been widely used as a technique for infrared gas analysis [12] and for measuring vibrational relaxation rates [13]. A typical acoustic spectrophone [11] consists of a cylindrical cell with transparent windows at each end to allow radiation to enter and leave; the microphone is generally mounted on the cylindrical wall with the diaphragm normal to the direction of propagation of the excitation beam. Often, a regulated leak is provided so that long term pressure drifts can be relieved.

The design of acoustic spectrophones is discussed in detail by Rosengren [14], Parker and Ritke [11] and Kerr and Atwood [15]. The ultimate limit of signal to noise arises from the Brownian motion of the gas molecules. Present designs can come within two orders of magnitude of this limit at reasonable gas pressures. The present limitations arise from noise in the detection electronics, temperature instabilities (especially at low frequencies) and spurious contributions to the signal arising from gas adsorbed on the windows [14]. Even with these limitations, energy inputs as small as one microwatt may be easily detected. Parker has shown [11] that the rise time for the volume change is set by the lowest acoustical resonance frequency in the cavity whose frequency is given by $c/2l$, where c is the speed of sound in the gas, and l is the length of the cavity.

A device similar to the acoustic spectrophone has been developed by Rosencwaig [17] for the study of radiationless processes and photochemistry in thin films of solids, and semisolid materials such as crystals, evaporated films, powders, gels, thin layer

chromatography plates, and even thin layers of tissue. The photoacoustic cell is quite similar to the acoustic spectrophone of Parker, except it is much shorter in cavity length. The thin sample is simply mounted flush with the exit window, and the cell is filled with a suitable gas which is transparent to the exciting radiation.

The origin of the photoacoustic effect is believed to be as follows [11, 18]: irradiation of the sample with pulsed or chopped steady state light results in a localized heating due to non-radiative decay processes by the excited states. Some of the heating is transferred via diffusion from the solid to a thin boundary layer of gas adjacent to the solid. Adiabatic expansion of the gas then gives rise to a pressure wave in the gas which is detected by a capacitor microphone. A quantitative version of this process has been proposed [11, 18]. Like the acoustic spectrophone this device can easily detect microwatts of absorbed radiation, and the risetime is set by the transit time for sound in the cavity.

The third device based on the use of the capacitor microphone is the flash calorimeter of Callis, Gouterman and Danielson [6]. A schematic of the device is given in Figure 1. The sample cell is constructed from 25×25 mm square Pyrex² tubing. Joined to the sides are two 4-mm Pyrex-Teflon vacuum stopcocks. One of these provides connection to a vacuum line, allowing for introduction of degassed samples. The other stopcock opens into a small relief reservoir. It

provides a controlled leak so that liquid can slowly enter or leave the cell, thus preventing slow pressure changes that would occur in a completely closed cell subject to temperature drifts. To allow use of a circular diaphragm a short piece of 25-mm Pyrex tubing is fused to the top of the cell. The diaphragm is made from 1 mm aluminum, which is sufficiently thick so that it does not deform permanently under vacuum, yet not so thick that the product $\kappa\beta$ exceeds unity. The microphone consists of the diaphragm, an epoxy glass circuit board spacer, and a stationary electrode-guard ring assembly fabricated from brass and epoxy glass circuit board material. The spacer ring is ground down until the gap between diaphragm and stationary electrode is approximately 0.25 mm and the entire assembly is potted with epoxy cement. The cell is mounted in a brass block which is temperature stabilized by means of a thermoelectric heat pump. The entire assembly is mounted in an acoustically shielded aluminum box which rests on a vibration isolation table.

As with other devices based on the use of microphones, the rise time of the flash calorimeter is determined by the transit time for sound in the cavity. This limits the use of the instrument in kinetic studies to phenomena with time constants longer than 100 μ s. The sensitivity of the flash calorimeter is quite remarkable; a displacement of the diaphragm of 10⁻⁸ cm is easily detected with a bandwidth of 10 kHz. For ethanol this corresponds to a temperature rise of $\sim 10^{-6}$ °C or

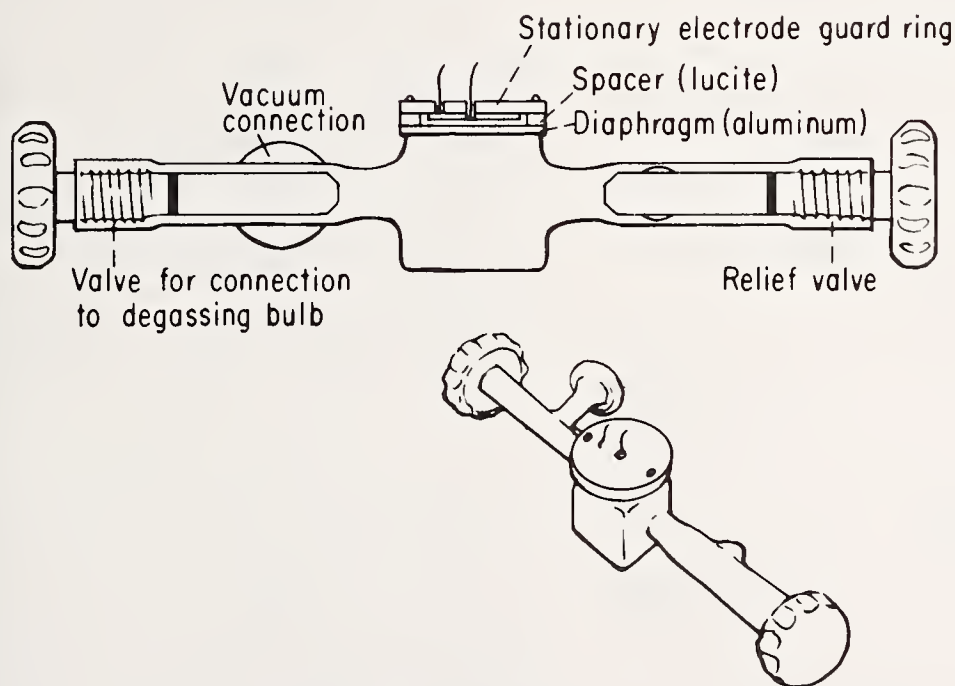

FIGURE 1. Flash calorimeter schematic.

²In order to adequately describe materials and experimental procedures, it is occasionally necessary to identify commercial products by manufacturer's name or label. In no instance does such identification imply endorsement by the National Bureau of Standards, nor does it imply that the particular product or equipment is necessarily the best available for that purpose.

an energy input of $\sim 64\mu$ J. The limits of detection at high frequencies are largely due to the noise in the preamplifier stage; we are presently many orders of magnitude above the limit imposed by the thermal noise of the sample.

We now describe an instrument which is particularly well suited for measurement of radiationless processes in bulk solids. This device, the piezoelectric calorimeter, uses a piezoelectric crystal to measure pressure changes in the sample. In certain crystals and polycrystalline materials with asymmetric charge distribution, an applied pressure results in displacement of the positive and negative charges relative to each other. The displacement of the charges can be measured by applying electrodes to the surfaces and measuring the potential difference between them caused by charge migration. Piezoelectric crystals are available which are rugged, inexpensive, and linear and which will perform at temperatures from 4 K to 700 K.

A simple piezoelectric calorimeter is shown in figure 2. It consists of a cylindrical sample (we have used polymethyl methacrylate samples in which the organic compound of interest is dissolved), and a cylindrical piezoelectric transducer of the same radius as the sample. The transducer and sample are clamped rigidly together by an aluminum frame.

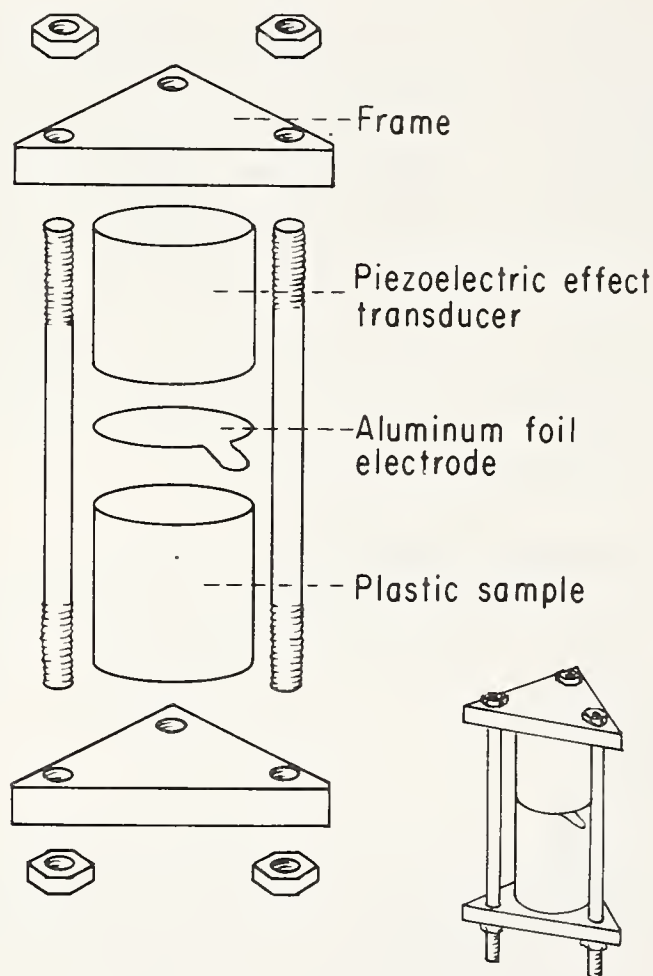

FIGURE 2. Piezocalorimeter schematic.

The piezoelectric crystal may be conveniently thought of as measuring the pressure generated by heating at constant volume. Equation (4) then becomes

$$dP = dQ\alpha/\beta C_V. \quad (6)$$

The open circuit voltage response to a pressure change is given by:

$$E = gtdP \quad (7)$$

where g is the open circuit voltage constant in units of m^2/C , t is the thickness of the crystal in m, and E is the voltage produced [7]. The simplest method for operating these devices is to use a charge sensitive preamplifier, as with the capacitor microphone. The upper end of the frequency response will then be limited by the lowest acoustic resonance, while the lower end will be limited by the low frequency response of the preamplifier.

The response of the piezoelectric calorimeter to an infrared heating flash shows characteristics similar to that of the flash calorimeter. The ring period is shorter due to the higher speed of sound in the cavity, but is not damped as effectively. With the present apparatus we can easily detect a step rise of $E \leq 10^{-3}V$ which corresponds to a pressure change of 0.073 dyn/cm^2 for a lucite rod of 1 cm thickness, which in turn corresponds to a temperature change of $6.7 \times 10^{-7} \text{ }^\circ\text{C}$. For our samples we find that $dQ \sim 4.7 \mu\text{cal}$ is easily detected.

In addition to the calorimeter, the measurement of calorimetric parameters also requires a light source, a means for selecting a bandwidth of the radiation, and suitable signal processing electronics. The ideal light source for calorimetry must be of high intensity, stable with time, and of high spectral purity. Clearly the laser approaches most closely this ideal, and a number of authors have employed both cw and pulsed lasers. For excitation spectrum studies a Xenon arc lamp-monochromator combination possesses the one advantage of infinite wavelength tunability and the capability of ultraviolet irradiation. Since the calorimeters are ac coupled, the light source must be intensity modulated. For a cw light source, a simple and common method to achieve intensity modulation is with a mechanical chopper. In this case, the most attractive form of signal processing is to use a phase sensitive amplifier, operated in synchrony with the chopper. If all of the heating from the sample appears with a rate constant greater than the chopping rate, then all of the signal will be in phase with the chopper. However, if some of the heating arises from processes which have rate constants comparable to or less than the chopping rate, then some of the heating will be out of phase. Quantitation of these effects leads to methods for measuring rates of relaxation of excited states and the yield of heating of a particular process. The disadvantages of modulation of a cw source and phase sensitive detection is that the signal decreases linearly with the frequency, and that a series of measurements must be made at a number of different frequencies if the order of the kinetics is to be specified.

For the measurement of the time dependence of the heating, the use of a pulsed light source is advantageous. Large amounts of energy can be output in very short times, thus providing a good signal to noise ratio for fast time dependent processes, as well as giving the heating curve directly. This technique re-

quires some method for transient recording and signal averaging is often desirable. A potential problem with pulsed excitation is that it strongly excites the lowest cavity resonance of the chamber. The resultant oscillation is superimposed on the signal and often obscures the heating curve at short times.

3. Applications of Calorimetric Techniques

3.1. Fluorescence Quantum Yields

In the introduction, we noted the advantages of the calorimetric strategy for determination of quantum yields. Thus far, all of these measurements have been done on dilute liquid solutions which are easily done photometrically. In contrast determination of quantum yields from thin layers of powdered samples is a very difficult procedure to perform photometrically [19, 20]. Some pioneering work by Rosencwaig [17, 21] illustrates how the optoacoustic spectrometer can be used to advantage on these systems. A number of trivalent rare earth ions show narrow absorption bands in the visible and ultraviolet which arise from inner shell $f-f^*$ transitions. Some of these levels exhibit fluorescence, and the fluorescence quantum yield of a particular level exhibits a marked dependence upon which level is excited [22]. Rosencwaig studied the photoacoustic excitation spectrum of samples of powdered holmium oxide. The first sample contained cobalt and fluorine impurities in sufficient quantity to quench all of the luminescence. He found that the photoacoustic spectrum, when corrected for the wavelength dependence of the relative output of the excitation beam, corresponded well with the observed absorption spectrum. In contrast, the photoacoustic spectrum of pure Ho_2O_3 exhibited a spectrum in which some of the lines were greatly diminished in intensity; the latter of course involve excited states which decay by radiative processes. The information contained in these two scans, together with lifetimes and luminescence spectra taken by exciting at each major absorbance would provide, for the first time, a complete picture of the dynamic interrelationships of these excited states.

3.2. Quantum Yields of Triplet Formation

A knowledge of quantum yields of triplet formation is important in understanding the intersystem crossing process, and also in understanding the many photochemical reactions and energy transfer process which take place through the intermediacy of a triplet state. A number of ingenious methods exist for determination of triplet yields [23] but all are based on the use of various assumptions which are difficult to verify experimentally. The calorimetric strategy offers an attractive alternative to the other techniques, and also provides an independent check on the assumptions used in the other methods.

The calorimetric method is based on the fact that the lifetime of the lowest triplet state of an organic molecule is long compared to that of its excited singlet

states. Thus, we expect that a delta function excitation pulse will produce fast heating due to relaxation of the singlet states, and slow heating due to relaxation of the triplet states. The heating may then be partitioned into

$$Q_{\text{tot}} = Q_{\text{fast}} + Q_{\text{slow}} \quad (8)$$

It has been shown (6) that Φ_t can be obtained from the relation:

$$\Phi_t = Q_{\text{slow}} [h\bar{\nu}_{in} - \Phi_f h\bar{\nu}_f] / Q_{\text{tot}} E_t \quad (9)$$

where Φ_f and Φ_t are the quantum yields for fluorescence and triplet yields, $\bar{\nu}_f$ and $\bar{\nu}_{in}$ are the average fluorescence and absorbed frequencies, and E_t is the energy of the triplet state.

As an example of the use of the flash calorimeter we show the heating response of $10^{-4} M$ acridine orange to flash excitation in figure 3. The results are the average of 100 flashes. Clearly, there are two kinds of heating, as expected. Furthermore, the observed heating obeys the expected [6] time dependent form,

$$Q(t) = [Q_{\text{fast}} + Q_{\text{slow}} (1 - e^{-k_p^* t})] e^{-t/RC} \quad (10)$$

where k_p^* is the triplet decay time, and RC is the decay time of the ac coupled electronics. For comparison, in figure 4 we show the heating response of $10^{-4} M$ anthracene in polymethyl methacrylate as studied with the piezoelectric calorimeter. It also shows the

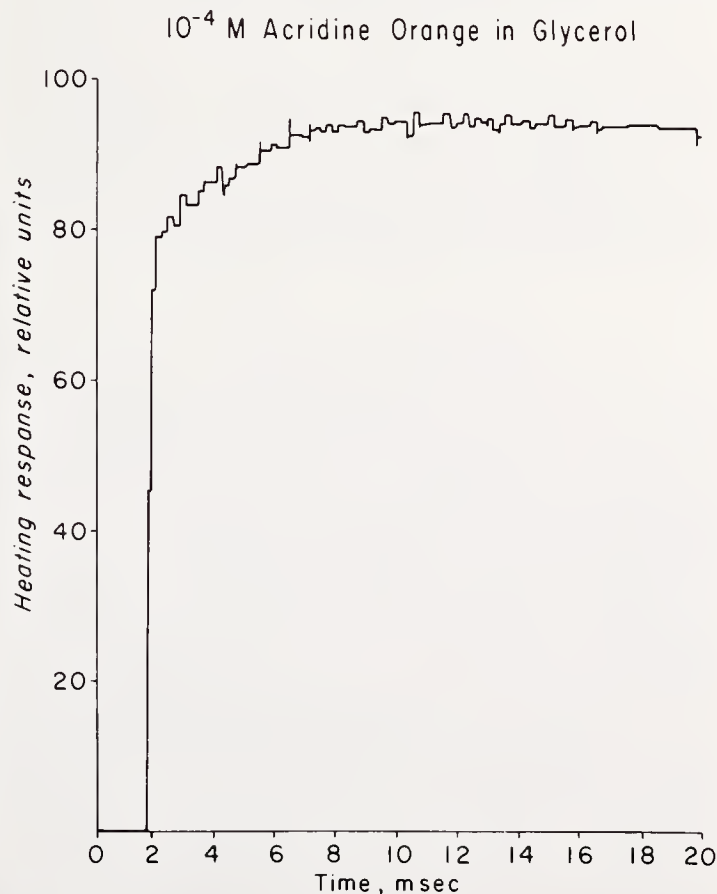

FIGURE 3. Calorimetric response of degassed acridine orange in glycerol at room temperature.

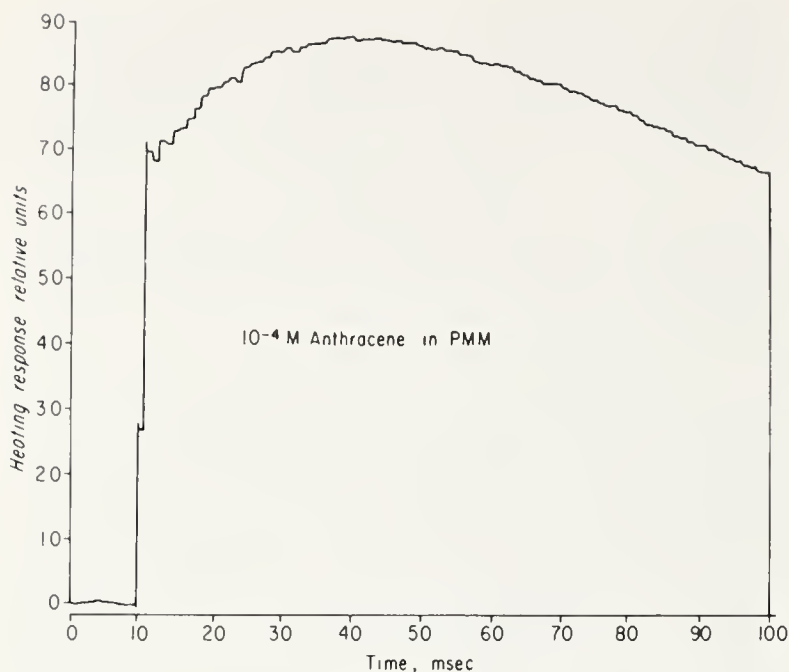

FIGURE 4. Calorimetric response of anthracene in polymethyl methacrylate at room temperature.

same type of heating response as predicted by eq (10). The value $\Phi_t = 0.72$ for anthracene in plastic compares well with that determined in mineral oil by other methods [23].

3.3. Applications to Photochemistry and Photobiology

In addition to heating from radiationless transitions, one may also detect heating from photochemical processes. Suppose that the sample is excited by N_{ex} photons of energy E_{in} , and either decays radiationlessly to the ground state, or by photochemistry with a probability Φ_p to a stable product state of energy E_p above the ground state. The total heating dQ will then be given by

$$dQ = N_{ex}(E_{in} - \Phi_p E_p). \quad (11)$$

Equation (11) shows that energy levels of photochemical products can be obtained if the yields are known, or the yields can be determined if the energy levels are known. Also, the rates of formation of the photochemical products can be measured or deduced and finally, as Rosencwaig has pointed out [17], the excitation spectrum of the photochemical process can be obtained, and compared with the conventional absorption spectrum.

The work of deGroot et al. [24] illustrates the use of the acoustic spectrophone to study photochemical processes of acetaldehyde. These authors find that at pressures below a few torr the optoacoustic spectrum in the region 230–360 nm resembles the normal absorption spectrum of the compound. When the pressure is increased, however, a minimum appears in the spectrum at 290 nm which indicates that at least some of the absorbed light energy is no longer converted to heat on the time scale of chopping. The

authors ascribe this phenomenon to the efficient formation of a high energy unstable intermediate, a dioxetene. Studies with a pulsed light source shows that the intermediate decays to stable low energy products with a time constant of 2 ms. At wavelengths shorter than 290 nm the heating is again rapid; this is ascribed to the rapid decomposition of vibrationally hot dioxetene to low energy products.

Another interesting study using the acoustic spectrophone has been reported by Kaya, Harshbarger and Robin [25]. These investigators observed the gas phase optoacoustic excitation spectrum of biacetyl under a wide variety of conditions. They were able to demonstrate that the lowest excited triplet could be populated only by excitation at wavelengths longer than 443 nm; irradiation at shorter wavelengths resulted in intersystem crossing to the second excited triplet which then decayed rapidly and directly to the ground state. In mixtures of benzene and biacetyl, the authors were able to show that energy transfer from benzene to the biacetyl triplet manifold takes place only when exciting into the lowest vibronic bands of the lowest excited singlet of the donor. In pyridine-biacetyl mixtures, the lowest $n - \pi^*$ state of pyridine was found to transfer to the triplet manifold of biacetyl, but the lowest $\pi - \pi^*$ state does not.

A final study by Callis, Parson and Gouterman [26] illustrates the potential application of calorimetric techniques to the study of photobiological systems. A very useful model system for the study of the bioenergetics of photosynthesis is the chromatophore of photosynthetic bacteria. The chromatophores are vesicular fragments of the bacterial membrane, which contain the photosensitive pigments and most of the enzymes necessary for light induced electron transport and coupled phosphorylation. In the chromatophore light induces a cyclic electron flow which is coupled in some unknown manner to the formation of high energy phosphate bonds, in which the free energy available from the photons are stored.

In the study of photochemical reactions in the liquid and solid phases using a volume transducer we must include the possibility of a volume difference ΔV_r between reactants and products, as well as a contribution from heating. For a system which either returns radiationlessly to the ground state or converts to a product state E_p with efficiency Φ_p , the total volume change ΔV will be

$$\Delta V = N_{ex}(E_{in} - \Phi_p E_p)(\alpha/\rho C_p) + N_{ex}\Phi_p \Delta V_r. \quad (12)$$

If E_p and ΔV_r are temperature independent, the measurement of ΔV at two different temperatures allows one to obtain E_p and ΔV_r .

Figure 5 shows the volume response of *Chromatium* chromatophores to weak flashes at temperatures of 23°C and 4°C. The traces labeled "light" were obtained in the presence of a strong cw light which saturated all photochemical processes, and resulted in the conversion of all of the input energy to heat. The light response at 4°C is much smaller due to the

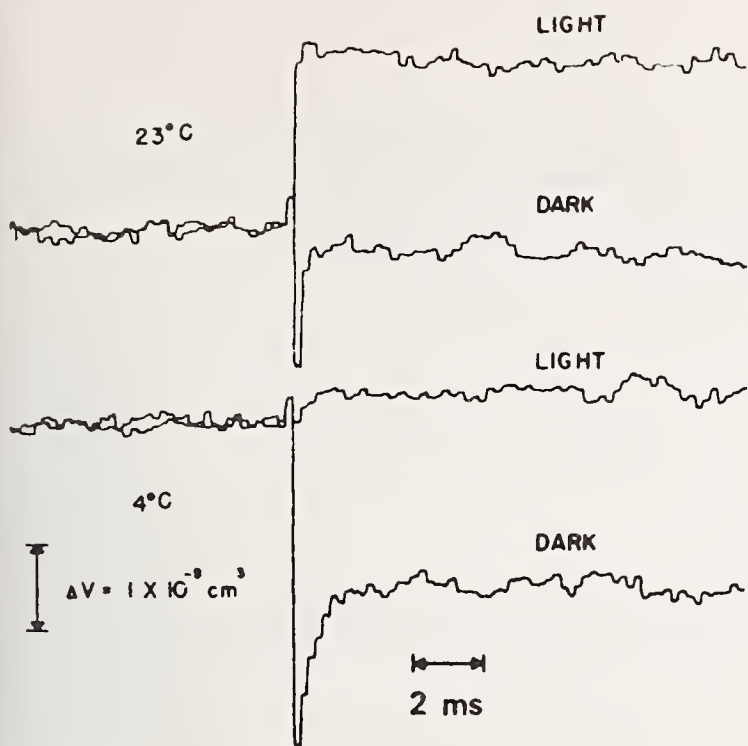

FIGURE 5. Volume changes of *Chromatium chromatophores* in response to flash excitation.

reduced magnitude of $\alpha/\rho C_p$ at this temperature. In the dark at 23 °C, a weak flash causes an instantaneous volume decrease which is then followed by a fast recovery almost to the base line. In the dark at 4 °C we observe an instantaneous volume decrease which recovers about half way with a time constant of 250 μ s. From a quantitative evaluation of these data, we have concluded that: (a) the initial high energy state of the photosynthetic apparatus does not possess a significant enthalpy change from the ground state, and thus the free energy change available from the photon is stored in an excited state characterized by negative entropy; (b) the high energy state also has a decreased volume from the ground state. Further studies have shown that the volume changes are altered by the presence of ion transporting antibiotics, and uncouplers of phosphorylation. The flash calorimeter thus appears to be a valuable tool for the study of energy conservation in photosynthetic systems.

4. Conclusions

Calorimetric techniques can be used to measure a number of parameters of excited states such as lifetimes, excitation spectra, energy yields of radiationless and photochemical processes, and enthalpies of photochemical reactions. Simple calorimeters capable of measuring these parameters have been developed

for the study of molecules in the gas, solid and liquid phases. A wide variety of measurements now exist which show the usefulness of calorimetric techniques for studies of absolute fluorescence quantum efficiencies, quantum yields of triplet formation, photochemical processes in the gas phase, and for studies of energy storage in photosynthesis. As more investigators realize how simple and convenient these measurements are, we can expect an increase in the use of calorimetric techniques in photophysical and photochemical studies.

5. References

- [1] Alenstev, M. A., National Research Council of Canada Technical Translation TT-433, *Zh. Eksp. Fiz.* **21**, 133 (1951).
- [2] Seybold, P. G., Gouterman, M., and Callis, J. B., *Photochem. Photobiol.* **9**, 229 (1969).
- [3] Gelernt, B., Findeisen, A., and Poole, J., *J. Chem. Soc. Faraday Trans. II*, **70**, 939 (1974).
- [4] Demas, J. N., and Crosby, G. A., *J. Phys. Chem.* **75**, 991 (1971).
- [5] Crosby, G. A., Demas, J. N., and Callis, J. B., *J. Res. Nat. Bur. Stand. (U.S.)*, **76A** (Phys. and Chem.), No. 6, 561-577 (Nov.-Dec. 1972).
- [6] Callis, J. B., Gouterman, M., and Danielson, J. D. S., *Rev. Sci. Inst.*, **40**, 1599 (1969).
- [7] Lion, K. S., *Instrumentation in Scientific Research* (McGraw-Hill, New York, 1959).
- [8] Sessler, G. M., and West, J. E., *J. Acoust. Soc. Am.*, **40**, 1433 (1966).
- [9] McCray, J. A., and Cahill, T. A., *Electronic Circuit Analysis for Scientists* (Wiley and Sons, New York, 1973).
- [10] Koidan, W., *J. Acoust. Soc. Am.* **29**, 813 (1957).
- [11] Parker, J. G., and Ritke, D. N., *J. Chem. Phys.*, **59**, 3713 (1973).
- [12] Hill, D. W., and Powell, T., *Non Dispersive Infra-Red Gas Analysis in Science, Medicine, and Industry* (Plenum, New York, 1968).
- [13] Cottrell, T. L., and McCoubrey, J. C., *Molecular Energy Transfer in Gases* (Butterworths, London, 1961), pp. 64-73.
- [14] Rosengren, L., *Appl. Opt.* **14**, 1960 (1975).
- [15] Kerr, E. L., and Atwood, J. G., *Appl. Opt.* **7**, 915 (1968).
- [16] Patel, C. K., Burkhardt, E. G., and Lambert, C. A., *Science*, **184**, 1173 (1974).
- [17] Rosencwaig, A., *Anal. Chem.* **47**, 592A (1975).
- [18] Rosencwaig, A., and Gersho, A., *Science*, **190**, 557 (1975).
- [19] Wrighton, M. S., *J. Phys. Chem.* **78**, 2229 (1974).
- [20] Bril, A., Somerdijk, J. A., and de Jager-Veenis, A. W. J., *Electrochem. Soc.* **122**, 660 (1975).
- [21] Rosencwaig, A., *Physics Today*, **28**, 23 (1975).
- [22] Wybourne, G. G., Ed., *Spectroscopic Properties of the Rare Earths* (Inter-science Publ., New York, 1965).
- [23] Callis, J. B., Ph.D. Thesis, University of Washington, Seattle, 1970.
- [24] deGroot, M. S., Emeis, C. A., Hesselman, I. A. M., Drent, E., and Farenhorst, E., *Chem. Phys. Lett.* **17**, 332 (1975).
- [25] Kaya, K., Harshbarger, W., and Robin, M., *J. Chem. Phys.*, **60**, 4231 (1974).
- [26] Callis, J. B., Parson, W. W., and Gouterman, M., *Biochem. Biophys. Acta*, **267**, 348 (1972).

(Paper 80A3-893)

Fluorescence Efficiency of Laser Dyes *

K. H. Drexhage

Research Laboratories, Eastman Kodak Company, Rochester, New York 14650

(April 9, 1976)

The fluorescence efficiency of xanthene dyes, oxazine dyes, and 7-aminocoumarins is discussed. Relations with the molecular structure are pointed out and dependence on solvent and temperature is explained. Several new fluorescence standards are suggested.

Key words: Aminocoumarins; carbazine dyes; deuterium effect; fluorescence quantum yield; laser dyes; molecular structure; oxazine dyes; quenching; xanthene dyes.

1. Introduction

The recent development of the dye laser [1]¹ has opened up an important new field of applications for organic dyes. This has led to a renewed interest in the theory of nonradiative transitions in dyes and also to the synthesis of new highly fluorescent dyes. In this article we review briefly the relations between fluorescence and molecular structure in the most important classes of laser dyes: xanthenes, oxazines, and 7-aminocoumarins. Following this discussion specific suggestions for improved fluorescence standards are made.²

2. Xanthene Dyes

The chromophore of xanthene dyes has typically the following structures

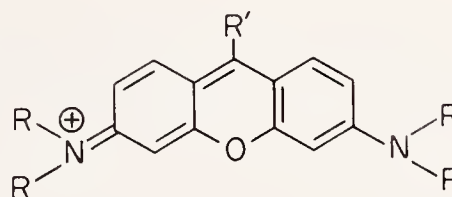
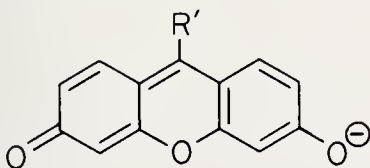

Depending on the end groups, in particular number and type of the substituents R , the maximum of the main absorption band falls somewhere in the range 480–580 nm. The transition moment is parallel to the long axis of the molecule [2]. With $R' = H$ and amino end groups the dyes are called pyronins. Due to a convenient syntheses with phthalic anhydride many xanthene dyes have $R' =$ carboxyphenyl and are called fluorescein or rhodamines (fig. 1). The methyl substituents of Rhodamine 6G have practically no influence on the optical properties of the dye except for the dimerization in aqueous solution which we are not concerned with here. The absorption maximum of the main band occurs almost at the same wavelength in pyronins and rhodamines, if the end groups are identical. The absorption band near 350 nm is stronger in rhodamines than in pyronins, and rhodamines show a slightly larger Stokes shift than pyronins. The chemical stability of rhodamines is generally superior, as pyronins in alkaline solution are readily oxidized by dissolved oxygen to form a colorless, blue fluorescing xanthone.

* Paper presented at the Workshop Seminar 'Standardization in Spectrophotometry and Luminescence Measurements' held at the National Bureau of Standards, Gaithersburg, Md., November 19–20, 1975.

¹ Figures in brackets indicate the literature references at the end of this paper.

² In order to describe materials and experimental procedures adequately, it is occasionally necessary to identify commercial products by manufacturer's name or label. In no instance does such identification imply endorsement by the National Bureau of Standards, nor does it imply that the particular product or equipment is necessarily the best available for that purpose.

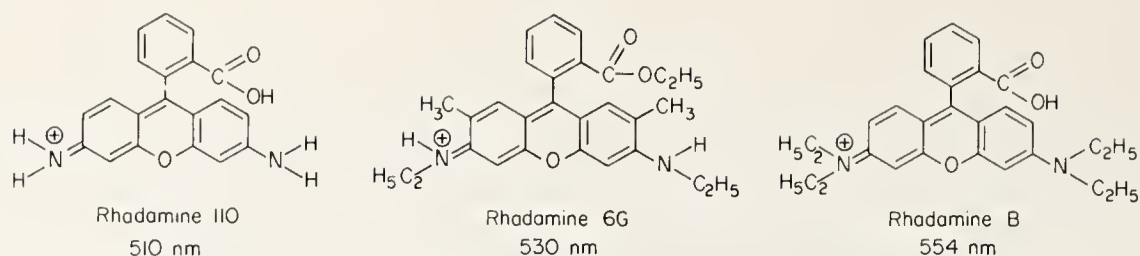
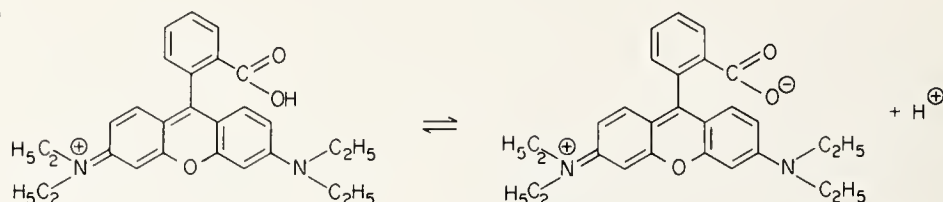

FIGURE 1. Molecular structure of rhodamine dyes; absorption maximum in ethanol.

Rhodamines like Rhodamine B react to pH variations in an interesting manner. The carboxyl group is completely protonated in acidic solution, but dissociates in alkaline solution. The negative charge has an inductive effect on the central carbon atom of the chromophore. The maxima of the main absorption band and of the fluorescence are shifted to shorter wavelengths, and the extinction coefficient at the absorption maximum is slightly reduced. While these effects are rather weak in aqueous solution [3], the wavelength shift amounts to about 10 nm in polar organic solvents (methanol, ethanol, etc.) [4, 5, 6, 7]. When Rhodamine B, which is usually obtained as the hydrochloride,

concentration (except for aqueous solutions, where aggregation takes place, and for strongly acidic conditions, where protonation of the amino groups occurs).

Because of the symmetry of the rhodamine chromophore, there is no dipole moment parallel to its long axis. As a consequence, the Stokes shift is small, and the fluorescence band overlaps strongly the absorption band (fig. 2) [10]. Also, there is only little variation of absorption and fluorescence maxima with solvent polarity [4, 5]. Provided there are no heavy-atom substituents, the rate of intersystem crossing from S_1 is very low in xanthene dyes, which is in accordance with our loop rule [11]. Phosphorescence is weak even in low temper-



is dissolved in ethanol, the relative amounts of the two forms of the dye are determined by this acid-base equilibrium. The dissociation increases on dilution causing a shift of absorption and fluorescence to shorter wavelengths. This concentration dependence of the spectra is therefore not due to a monomer-dimer equilibrium, as was claimed in recent papers [8, 9]. In less polar organic solvents (e.g., acetone) the unprotonated (zwitterionic) dye undergoes a reversible conversion to a lactone:

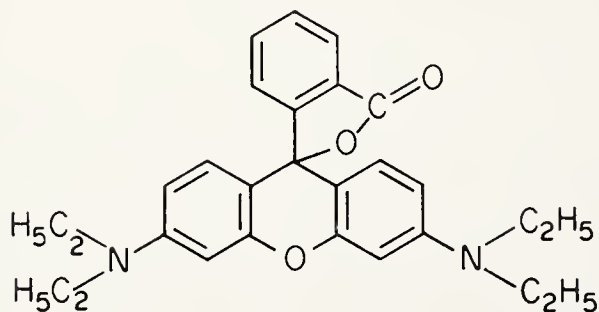

Because the conjugation of the chromophore is interrupted, this is a colorless compound. On addition of acid or complex-forming metal ions the chromophore is regenerated. If the carboxyl group is esterified as in Rhodamine 6G, all these reactions do not take place, and the absorption maximum is independent of pH and

ature glasses and has a lifetime in the order of 0.1 s, which is short compared with, for instance, acriflavine and some aromatic compounds.

The fluorescence of rhodamines is quenched externally by I^- and SCN^- , less efficiently by Br^- and Cl^- . No quenching was observed by ClO_4^- and BF_4^- [4, 5]. The quenching process apparently involves a charge transfer from the anion to the excited dye molecule. It is not a heavy-atom effect. In polar solvents like ethanol, Rhodamine 6G-iodide is completely dissociated at a concentration of 10^{-4} mol/l and no quenching takes place, because the lifetime of the excited state is of the order of a few nanoseconds, much shorter than the diffusion time the quencher would need to reach an excited dye molecule. In less polar solvents like chloroform the dye salt does not dissociate and its fluorescence is totally quenched. The perchlorate of Rhodamine 6G behaves strikingly differently: its fluorescence efficiency is independent [12] of solvent polarity (0.95 based on the value 0.90 for fluorescein). It is, however, reduced by heavy-atom solvents (0.40 in iodomethane), and the fluorescence of this dye is completely quenched by nitrobenzene, presumably due to the high electron affinity of this solvent.

There are two structural features that influence the rate of internal conversion in xanthene dyes: mobility of the amino groups and hydrogen vibrations.

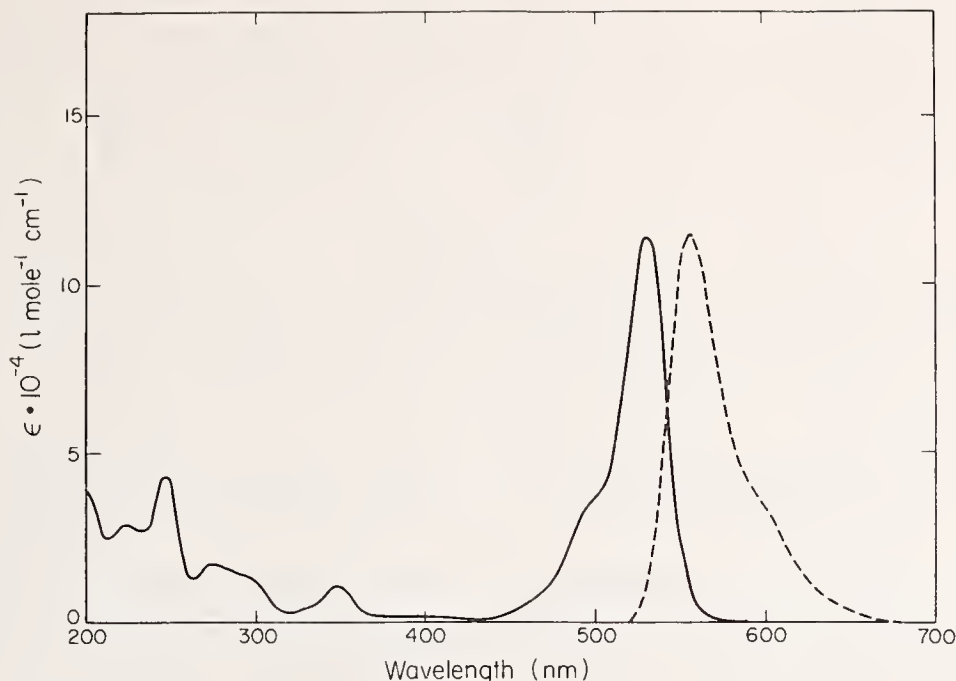
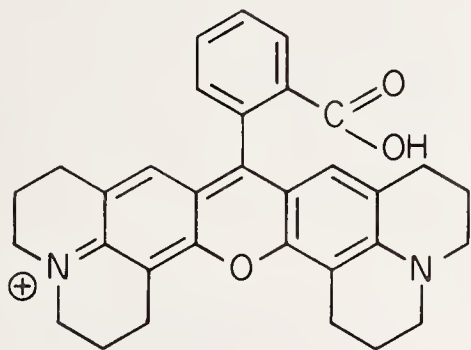

FIGURE 2. Rhodamine 6G in ethanol.

Absorption spectrum (ϵ molar decadic extinction coefficient); quantum spectrum of fluorescence (arbitrary units).

We found that the fluorescence efficiency of rhodamines that carry two alkyl substituents at each nitrogen, e.g., Rhodamine B, varies strongly with solvent and temperature [4, 5, 11]. We ascribe this to mobility of the amino groups. If the amino groups are rigidized as in the new dye Rhodamine 101 ($\lambda_{\text{abs}} = 577$ nm in ethanol) the quantum efficiency is practically unity,

Rhodamine 101



independent of solvent and temperature. It is interesting that the amino groups are not mobile when they are less than fully alkylated (Rhodamine 6G, Rhodamine 110). However, in such dyes there is a proba-

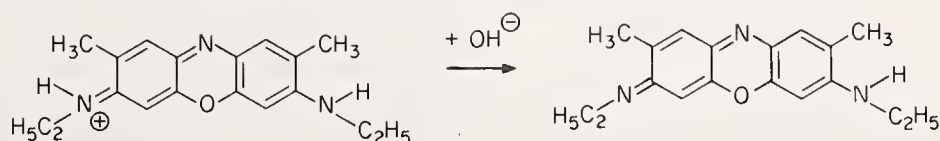

bility that the electronic excitation energy is funneled into $N-H$ vibrations, causing nonradiative decay to S_0 . Although this effect is rather weak in xanthene

dyes, it is noticeable for instance in Rhodamine 6G. On solution in O -deuterated ethanol, H is exchanged for D in the amino groups of the dye. With the greater mass of deuterium the nonradiative decay is less likely and the fluorescence efficiency increases from 0.95 to 0.99.

3. Oxazine Dyes

When the central carbon atom in the xanthene chromophore is replaced by nitrogen, the chromophore of an oxazine dye is obtained. The central N -atom acts as a sink for the π -electrons, causing a wavelength shift of about 80 nm to the red. As within the xanthene class the absorption of oxazines also shifts to the red with increasing alkylation of the amino groups (fig. 3). Apart from the pronounced red shift of the S_0-S_1 transition there is little difference between the electronic transitions of oxazines and rhodamines [2]. The electron-withdrawing effect of the central N -atom causes the amino groups to be more acidic. Thus addition of a little base to a solution of Oxazine 4 in ethanol changes the color from blue to red due to deprotonation of one of the amino groups:

Oxazines with fully alkylated amino groups do not undergo any change on addition of base. On the other hand, all oxazines are protonated in strong acids.

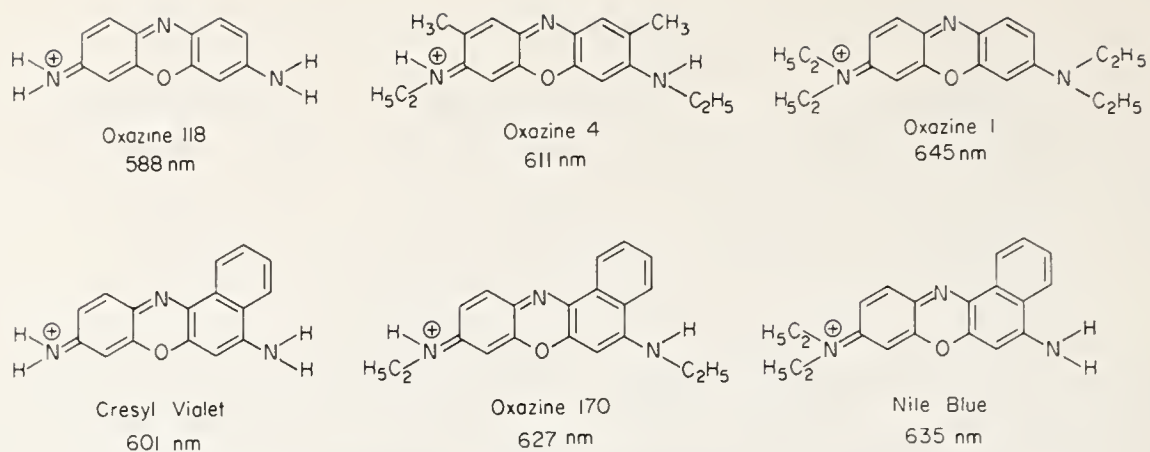

FIGURE 3. Molecular structure of oxazine dyes; absorption maximum in ethanol.

Some oxazine dyes have a structure modified by an added benzo group (fig. 3). This causes a slight red shift of absorption and fluorescence. Furthermore, the shape of the absorption spectrum is different than in other oxazine dyes and depends on the temperature [13]. These effects are probably caused by steric interference of the amino group with a hydrogen of the added benzo group [11].

The triplet yield of oxazines is generally very low in accordance with the loop rule. No phosphorescence has been observed in these dyes. The fluorescence quenching processes, discussed for xanthene dyes, are also found with oxazines. Owing to the smaller energy difference between S_1 and S_0 , internal conversion plays a greater role in oxazines than in rhodamines. Thus the fluorescence efficiency of Oxazine 1-perchlorate is less than 0.1 in ethanol, but much higher in dichloromethane and in 1,2-dichlorobenzene. Likewise, the effect of hydrogen vibrations is much more pronounced. The fluorescence efficiency of Oxazine 4 is a factor of 2 higher in *O*-deuterated ethanol than in normal ethanol.

4. 7-Aminocoumarins

The most important laser dyes in the blue and green region of the spectrum are coumarin derivatives that have an amino group in 7-position:



The chromophore is not symmetric as in the xanthenes and oxazines discussed above. The ground state can be described by structure A, the excited state S_1 by B. While there is some dipole moment in the ground state, it is much greater in the excited state.

As a consequence these compounds show a large Stokes shift, in particular in polar solvents (fig. 4). Absorption and fluorescence maxima depend much more on solvent polarity than is the case with xanthenes and oxazines [4, 5]. A large number of highly fluorescent derivatives have been synthesized in recent years [4, 5, 14–18]. Here we can give only a few examples (fig. 5). Absorption and fluorescence of 7-aminocoumarins are not influenced by a small amount of base present in the solution. However, they react with strong acids in a variety of ways [4, 5, 11]. The amino group of Coumarin 1, for instance, is easily protonated and thus decoupled from the chromophore. As a consequence the absorption band at 373 nm disappears. This reaction is inhibited, if the amino group is rigidized as in Coumarin 102. In the excited state S_1 , the keto group is more basic than the amino group and thus is protonated if sufficient acid is present so that the diffusion is faster than the decay of S_1 . Frequently a new fluorescence band appears due to the protonated form. Most coumarins are very soluble in organic solvents, but insoluble in water. However, derivatives have been reported recently that are highly soluble in water (fig. 6) [18].

5. Fluorescence Standards

The optical properties of an ideal fluorescence standard should be independent of the environment (solvent composition, temperature, etc.). This means, among other things, that the compound should not be involved in chemical equilibria. Alkaline solutions are to be avoided, because their alkalinity changes gradually due to absorption of carbon dioxide. Furthermore the fluorescence should not be quenched by oxygen and the fluorescence efficiency should be independent of temperature variations. The commonly used fluorescence standards fail badly on one or more of these requirements. A number of better standards can be suggested on the basis of the foregoing discussions.

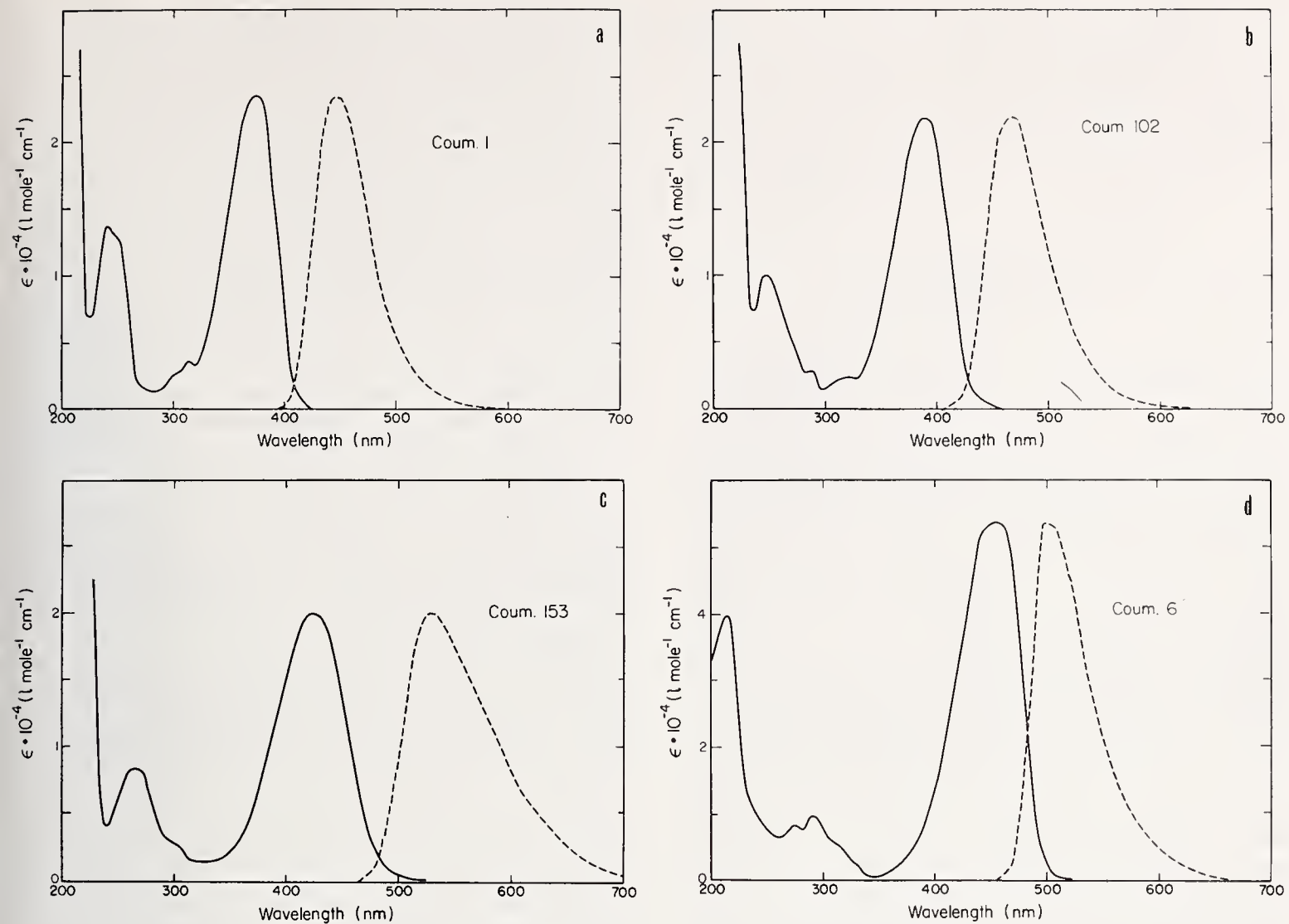

FIGURE 4a, b, c, and d. 7-Aminocoumarins in ethanol.

Absorption spectrum (ϵ molar decadic extinction coefficient); quantum spectrum of fluorescence (arbitrary units).

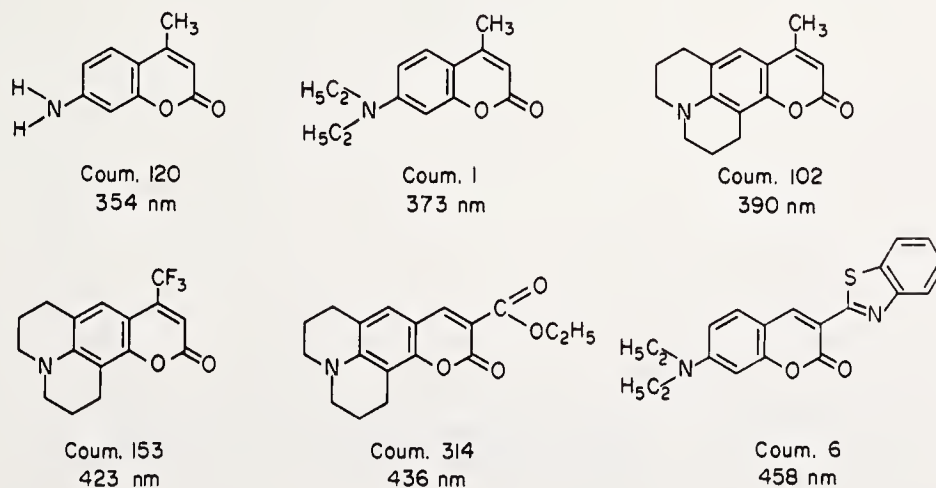

FIGURE 5. Molecular structure of 7-aminocoumarin derivatives; absorption maximum in ethanol.

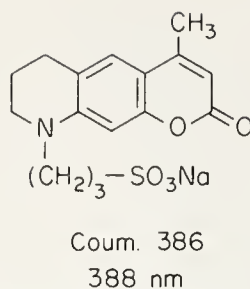
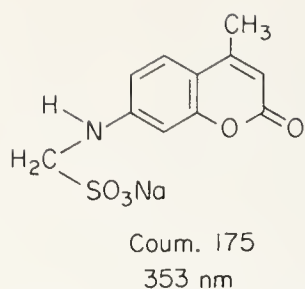

FIGURE 6. Molecular structure of water-soluble 7-aminocoumarins; absorption maximum in water.

Coumarin 1. This compound (7-diethylamino-4-methylcoumarin) is the most readily available 7-aminocoumarin. It is easily purified by recrystallization from ethanol. It is highly soluble in most organic solvents, but not in water. The fluorescence quantum efficiency is about 0.5 in ethanol, generally higher in less polar solvents, and is almost independent of temperature. There is little or no quenching by oxygen. A disadvantage is the possible protonation in acidic solvents. If this is a problem, Coumarin 102 or Coumarin 153 may be used. The latter compound is particularly interesting because of its large Stokes-shift and the very broad fluorescence spectrum. The fluorescence efficiency of Coumarin 102 was measured as 0.6 and that of Coumarin 153 as 0.4 (both in ethanol). Another compound, possibly useful as a standard, is Coumarin 6 (quantum efficiency 0.8 in ethanol), which absorbs at longer wavelengths than most other coumarin derivatives. The latter compounds are commercially available, but the price is still high. However, this should not be a deterrent, as the price will certainly come down and generally only a few milligrams are required. We feel that Coumarin 1

is superior to quinine bisulfate in every respect. It can be used in almost any solvent except water.

Rhodamine 6G-ClO₄. As was pointed out previously in this article, the frequently used standard Rhodamine B undergoes acid-base reactions that affect its optical properties. Its fluorescence efficiency depends strongly on type of solvent and temperature. Therefore it is not surprising that the quantum yield values reported in the literature vary considerably. As discussed above, Rhodamine 6G-perchlorate is superior to Rhodamine B, because its quantum efficiency has the value 0.95 almost independent of solvent and temperature. The dye chloride is readily available in rather pure form. It can be further purified by column chromatography on basic alumina with ethanol or methanol as the solvent. The perchlorate is insoluble in water and is easily prepared by adding HClO₄ to an aqueous solution of the dye chloride. It can be recrystallized from alcohol-water mixtures. The ethyl ester perchlorate of Rhodamine 101 has the same useful properties as Rhodamine 6G-perchlorate, while absorption and fluorescence are shifted about 50 nm to the red. However, this dye is not yet commercially available.

Oxazine 170-ClO₄. Of all available oxazines this derivative has the highest fluorescence efficiency (~0.5 in ethanol). Its fluorescence properties are closely related to those of Rhodamine 6G-ClO₄. Absorption and fluorescence are shifted by about 100 nm to the red (fig. 7). As in the case of Oxazine 4, the fluorescence efficiency increases nearly a factor of 2 on deuteration of the amino groups. Apart from this effect, it is almost independent of solvent and temperature. However, variations of temperature have some effect on the absorption spectrum due to the annellated benzo group. In this respect Oxazine

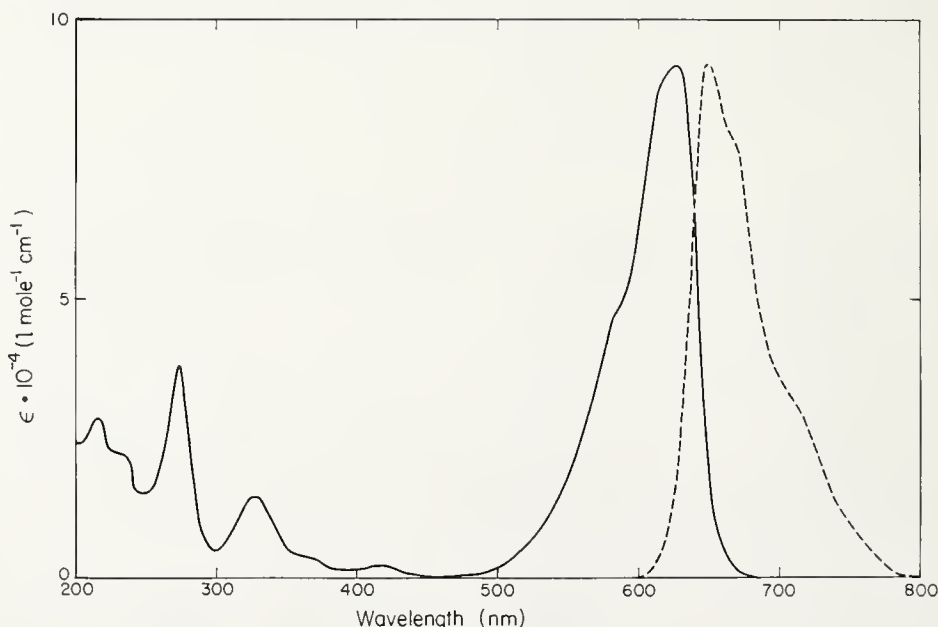
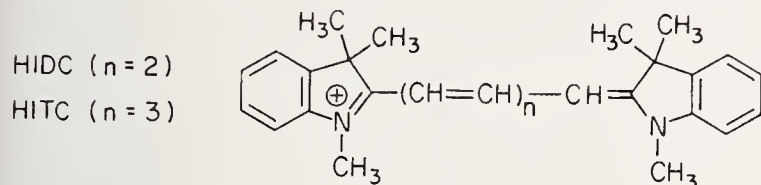

FIGURE 7. Oxazine 170 in ethanol.

Absorption spectrum (ϵ molar decadic extinction coefficient); quantum spectrum of fluorescence (arbitrary units).

4-ClO₄ would be preferable. As pointed out earlier, these dyes cannot be used in basic solution. Being perchlorates, they are practically insoluble in water.

Hexamethylindodicarbocyanine (HIDC) and Hexamethylindotricarbocyanine (HITC). Very few dyes are known that are relatively stable and fluoresce well in the infrared region of the spectrum. Of the commercially available materials, the cyanine dyes 1,1',3,3,3',3'-hexamethylindodicarbocyanine (HIDC) iodide and 1,1',3,3,3',3'-hexamethylindotricarbocyanine (HITC) iodide stand out on both counts. Contrary to the other compounds



suggested here, the fluorescence efficiency of these dyes depends markedly on type of solvent and temperature. It appears to be highest in sulfoxides (dimethyl sulfoxide, tetramethylene sulfoxide). As shown in figure 8, the fluorescence of HITC extends to 900 nm. The photochemical stability is much higher than in related thiacyanines. A concentrated solution of HIDC-iodide in dimethyl sulfoxide is currently in use in our laboratory as a photon counter that

operates up to 700 nm. It is much more sensitive than equally concentrated solutions of methylene blue as this has a lower fluorescence efficiency.

The fluorescence spectra and efficiencies of the suggested dyes need to be determined accurately. To us this seems to be of greater benefit than perpetuating bad standards whose only justification today is their common usage.

6. References and Notes

- [1] Dye Lasers (F. P. Schäfer, Ed.) Topics in Applied Physics, Vol. 1 (Springer, Berlin, 1973).
- [2] Jakobi, H., and Kuhn, H., Z. Elektrochem. Ber. Bunsenges. Phys. Chem. **66**, 46 (1962).
- [3] Ramette, R. W., and Sandell, E. B., J. Am. Chem. Soc. **78**, 4872 (1956).
- [4] Drexhage, K. H., VII Intern. Quant. Electron. Conf., Montreal, Canada, paper B.5 (1972).
- [5] Drexhage, K. H., Laser Focus **9**(3), 35 (1973).
- [6] Ferguson, J., and Mau, A. W. H., Chem. Phys. Lett. **17**, 543 (1972).
- [7] Ferguson, J., and Mau, A. W. H., Austral. J. Chem. **26**, 1617 (1973).
- [8] Selwyn, J. E., and Steinfeld, J. I., J. Phys. Chem. **76**, 762 (1972).
- [9] Wong, M. M., and Schelly, Z. A., J. Phys. Chem. **78**, 1891 (1974).
- [10] The absorption of Rhodamine 6G (2g/l in ethanol), whose maximum is at 530 nm, is still noticeable at 633 nm, far beyond the fluorescence maximum of 555 nm: a 5mW He-Ne laser excites yellow anti-Stokes fluorescence that can be observed visually.

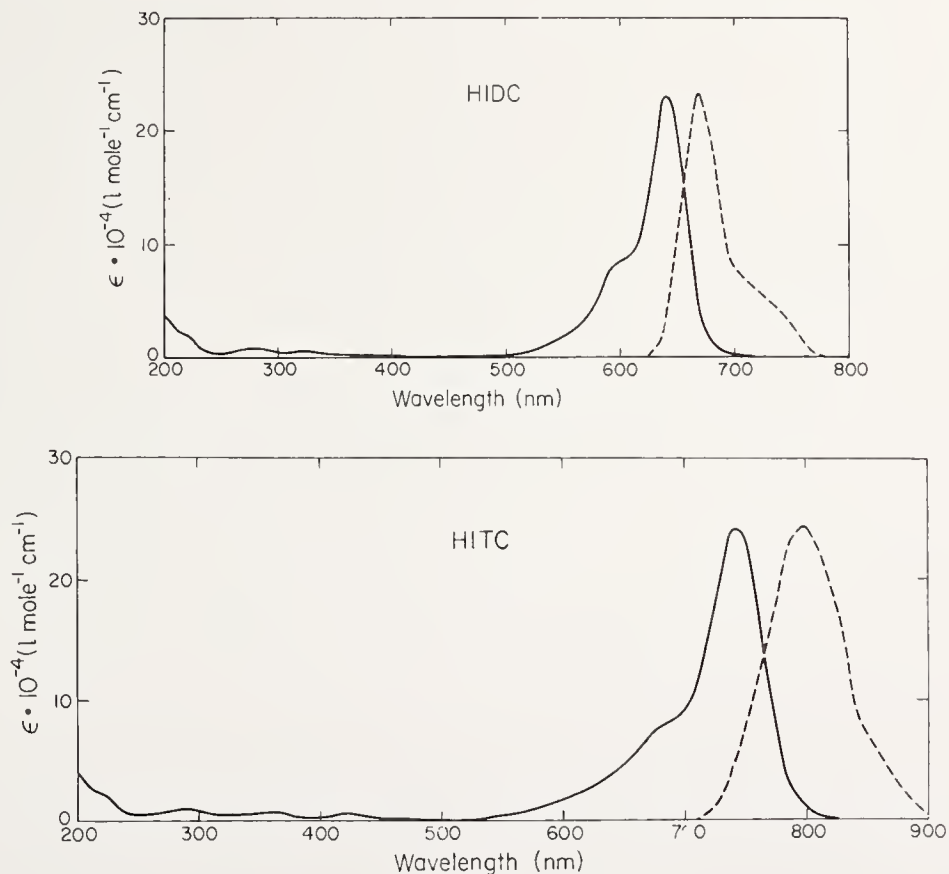

FIGURE 8a, and b. *HIDC and HITC in ethanol.*

Absorption spectrum (ϵ molar decadic extinction coefficient); quantum spectrum of fluorescence (arbitrary units).

- [11] Drexhage, K. H., Structure and properties of laser dyes, in: Dye Lasers (F. P. Schäfer, Ed.), Topics in Applied Physics, Vol. 1, p. 144 (Springer, Berlin, 1973).
- [12] This statement has to be taken with a grain of salt. We found indeed variations up to 10 percent with solvent. But the accuracy of our quantum efficiency measurements was probably less than this, when solvents with widely varying refractive index were involved. We feel, however, that the accuracy of the measurements was sufficient to justify the interpretations given here and elsewhere in this article.
- [13] Gacoin, P., and Flamant, P., Opt. Commun. **5**, 351 (1972).
- [14] Tuccio, S. A., Drexhage, K. H., and Reynolds, G. A., Opt. Commun. **7**, 248 (1973).
- [15] Drexhage, K. H., and Reynolds, G. A., VIII Intern. Quant. Electron. Conf., San Francisco, Calif., paper F.1 (1974).
- [16] Schimitschek, E. J., Trias, J. A., Hammond, P. R., and Atkins, R. L. Opt. Commun. **11**, 352 (1974).
- [17] Reynolds, G. A., and Drexhage, K. H., Opt. Commun. **13**, 222 (1975).
- [18] Drexhage, K. H., Erikson, G. R., Hawks, G. H., and Reynolds, G. A., Opt. Commun. **15**, 399 (1975).

(Paper 80A3-894)

Part 2. Diffuse Reflectance Spectroscopy

Diffuse Reflectance Spectroscopy; Applications, Standards, and Calibration (With Special Reference to Chromatography)

R. W. Frei

Analytical Research and Development, Pharmaceutical Department
Sandoz Ltd., 4002 Basel, Switzerland

(May 26, 1976)

The multitude of areas in which diffuse reflectance spectroscopy can be applied has been described in several books and reviews and ranges from color measurements of textiles, pharmaceuticals, building materials, paper and pulp materials etc., to adsorption studies and other basic investigations in physical, inorganic and organic chemistry.

The major area of application is still the measurement of color which has become indispensable in the quality control of colored products, dyes and pigments. Color matching practices and techniques with sophisticated instrumentation which can be fully computerized as well as the use of simpler filter instruments for quality control are mentioned.

Transferability of reflectance data i.e., color coordinates, depends on the quality of standards particularly when absolute measurements are desired. The difficulty of finding suitable "white standards" with good reflection properties at low UV and with a good long term stability is discussed. Similar arguments hold for sphere coating materials. For the measurement of fluorescing surfaces suitable standards are lacking which renders transfer of such data almost impossible.

The usefulness of diffuse reflectance techniques to study adsorption phenomena on small particle adsorbents is demonstrated with a malachite green-*o*-carboxylic acid lactone system studied by Kortüm. This or similar systems could be adopted to the measurement of relative surface areas on certain chromatographic adsorbents yielding more realistic values than the BET-method.

The most recent area of application has been in the field of chromatography for the in situ evaluation of chromatographic zones in flat-bed chromatography, electrophoresis and isoelectric focusing.

In chromatography, standardization is less problematic since usually relative measurements are sufficient. On the other hand one has to find suitable calibration procedures. The use of the Kubelka-Munk function is often questionable since we are usually not dealing with layers of infinite thickness and below 300 nm the conventional adsorbents such as silica gel, alumina or cellulose are strongly absorbing. Experiences with a new function combining the laws of Kubelka-Munk and Lambert-Beer are therefore presented.

The problem is also to find calibration techniques which account for chromatographic parameters. Until recently it was believed that a quantitative evaluation of chromatograms required a number of reference zones to be developed on the same chromatogram. In our experience this is no longer true. A novel calibration technique which utilizes the concept of transferable calibration factors is discussed. With this approach a quantitative evaluation of a chromatogram with only one reference spot is possible. Here again scanning and data acquisition can be fully automated. The application of proper calibration procedures to differential reflectance techniques and the measurement of multi-component systems is briefly mentioned.

Finally it is demonstrated that it is possible to carry out in situ quantitative measurements on low UV absorbing compounds (down to 190 nm) separated on silica gel surfaces, provided suitable techniques and instrumentation are used.

Key words: Chromatography; color matching; color measurement; diffuse reflectance; Kubelka-Munk function; reflectance; reflectance standards; thin layer chromatography

I. Introduction

Diffuse reflectance spectroscopy has found its application in a number of areas. The first and still most prominent is in the field of color measurement and color matching. The paper, paint, dye, textile, printing, and ceramics industries have made use of this technique for the measurement of color in routine quality-control functions as early as 1920. At that time the first useful filter reflectometers

became available [1]¹ and a little later a spectrophotometer type reflectometer [2] was manufactured.

A first comprehensive treatise of color measurement became available in 1936 [3]. Since that time the literature on color measurement has increased exponentially peaking out somewhat in the 1960's with not less than seven books appearing on this subject [4-10].

¹ Figures in brackets indicate the literature references at the end of this paper.

Later the principles of color measurements were extended to other areas including studies of biological systems, geological specimens, food stuff, building materials, and pharmaceuticals. With the expansion and improvement of the quality of available reflectometers on the instrumental scene it also became possible to carry out physical-chemical measurements, requiring extremely reproducible experimental and instrumental conditions. Comprehensive discussions and surveys have been given on these applications and on the instrumental developments in several books [11-15] and reviews [16-17].

Essentially no new aspects have been added to this to my knowledge. I see therefore not much point in repeating information which can be read in these cited references.

For pharmaceutical applications the technique is being used extensively for production control, formulation studies and for investigations of aging and illumination effects. This has been developed to the stage of automatic tablet inlet systems to the Hunter Color Meter² D25 DA.

The data acquisition is fully automated with a Hewlett-Packard 9100 desk calculator. This system will be discussed and published at an international pharmaceutical congress in Berlin in spring 1976 [18].

The field of instrumental color matching and color formulation has also strongly developed in the direction of automation and data evaluation by on-line and off-line computer systems, and I shall briefly mention this area.

The newest area of application of diffuse reflectance techniques has been in the field of chromatography [14-16, 19] for the in situ evaluation of chromatographic zones in flat-bed chromatography (PC, TLC), electrophoresis and isoelectric focusing. It is therefore not surprising that the most rapid changes and developments have taken place in this field, and I shall attempt to present some of the recent work in this area which has partially not yet been published.

Closely related to all these applications have been the problems of standardization and calibration. These, as we shall see, are still far from being solved satisfactorily and an assessment of the present status shall be attempted in this paper.

II. Instrumental Color Measurement

The technique of color matching and formulation by modern instrument-computer combinations is in a worldwide rapid development stage. This development is catalyzed by the growing need of color consuming industries to optimize the coloration processes. Color and dye manufacturers, instrument makers, and their customers alike are therefore responsible for this recent surge in color measurement technology.

² In order to adequately describe materials and experimental procedures, it was occasionally necessary to identify commercial products by manufacturer's name or label. In no instances does such identification imply endorsement by the National Bureau of Standards, nor does it imply that the particular product or equipment is necessarily the best available for the purpose.

Unfortunately, very little information is available on this relatively young science and much of it is already out of date. This is not astonishing, considering that the major developments come from color manufacturing industries and competition has prevented much of the know-how to become accessible.

One of the better accounts of the present state of the art was given by Gall [20]. Other workers, such as Brockes [21] and Kuehni [22], have also reported on this subject, the former specifically on textiles. A brief but very illustrative introduction into the concept of color in general and color measurement in particular has been given by Berger and Brockes [23] which can be highly recommended to new-comers in the field.

On the instrument side one can observe a trend to integration of on-line computers into more sophisticated reflectometers which results in a reduction of software requirements for the user. The disadvantage is the complete dependence of each operation step on the computer which can make trouble shooting difficult for the non specialist. Another trend on the market of such systems is an increased emphasis and demand for stand-alone formulation systems (available also to smaller colorists) rather than for time-sharing systems.

A. Types of Measuring Systems

Three different types of automatic color matching and formulation systems are now frequently used in larger companies in North America, Europe, Japan, and Australia.

(1) The first system consists of a high-quality spectrophotometer for automatic measurement of reflectance spectra, an electronic interface for data-storage, a connection to the teletype and a large centralized computer facility.

The spectrophotometer measures the reflectance of standard color samples (at least 6 different concentrations per dye) and of the samples to be matched. The reflectance data are transferred via the interface to the teletype and presented in a suitable form (cards or tapes).

One then feeds these data to the computer centre along with a characterization of the samples, dyes and substrates to be used for a computation of the formulation, price and metamerism. This can be done via a cable connection or completely off line.

(2) Following the trend of decentralization, instrument manufacturers are now marketing complete systems for automatic computation of formulations. They consist again of a high-quality monochromator instrument or a reflectometer equipped with filters producing spectral bands of 10 nm or 20 nm width. They then have an interface to a teletype and an on-line minicomputer. The spectral data are fed to the minicomputer and the same data as above are produced. The same system also can be utilized for corrections of formulations.

The teletype in this case has two functions. It serves as the means to feed-in manually or auto-

matically the additional data needed for formulation such as color codes and names of dyes and substrates, maximum number of dyes to be used per formulation (usually 3-4) etc. In addition it prints the final formulations, price, metamerism and other data. The software is often provided by the instrument manufacturer.

(3) Since systems of type 2 are still too expensive to be used by a smaller coloring outfit or the individual colorist in a laboratory, a third system has been developed (by CIC). It makes use of system 1 as a centralized facility in a large company or a centralized service facility for colorists and a low-cost filter colorimeter which is placed directly in the colorist's laboratory or production unit.

With this filter instrument the day-light color coordinates X , Y , Z of the sample are measured. In case of metamerism the color coordinates for an artificial illumination source have to be determined. These data are then transferred to the central facility. The spectrophotometer is then solely used to measure the dyes to be used in the formulation and the blank measurement on the substrate.

The disadvantages of this systems are time delays for the availability of the formulation and an increased risk for deviations from the true sample. This can be due to larger systematic errors on the low-cost unit and poor correlation of the measuring geometries on the two instruments.

B. Criteria for the Evaluation of Measuring Systems

The most important factors for the efficiency of a formulation computing system are the quality of the calibration samples of the dyes available for the formulation and the quality of the software. One would expect the following information to be provided by an useful system:

(1) Computation of all the possible alternatives for a formulation (combinations of 2-4 dyes) or indications for adjustments with one additional dye if none of the possible combinations leads to the desired result.

(2) For each possible formulation the degree of metamerism with respect to one or more standard illuminants and compared to day-light condition should be given.

(3) The color difference between sample to be matched and each of the possible formulations should be computed automatically for day-light condition.

The advantages of a color measuring system for computation of formulation as described above in comparison to the conventional use of sample collections are obvious:

(1) The computation and fine-adjustment can be done faster since the chances of hitting the correct solution are enhanced.

(2) An efficient system usually provides several solutions of which the optimal with regard to quality of the color, metamerism and price can be chosen

(such a choice of course requires the services of a specialist).

(3) The system is usually of sufficient flexibility to be used for trouble shooting in coloring processes (i.e., identification and quantitation of sources of error).

The systematic use of such formulation-computation systems will therefore result in a gradual upgrading of coloring techniques at lower prices.

III. Standardization

In the majority of cases for work carried out within one laboratory measurements relative to a reflection standard tailored to a particular experiment are sufficient. For adsorbate-adsorbent interaction studies for example, one would choose the same adsorbent as a reference material. The same holds for chromatographic work. Instruments are then utilized either in the substitution mode or the comparison mode (double beam operation). The level of instrument technology is now sufficiently good to assure a satisfactory reproducibility of measurements on the same instrument [14]. The problem arises when data have to be reproduced by several different laboratories. Instrument and measurement geometries are far from being uniform, which causes considerable variations in measured values. The trend for adaptation of a uniform integration sphere design which would permit at least the reproduction of reflectometer values with instruments of different manufacturers can now be observed. The inherent limitation of construction possibilities with such a standard sphere, however, still keeps many instrument designers reluctant to follow this trend.

But even this would not guarantee the availability of absolute reflectance values, independent of the instrumentation, since such a condition depends strongly on the quality of available standards. W. Erb [24] has recently discussed the current status of reflection standards and it is apparent that little progress has been made during the past years to obtain better standard materials.

The properties that one would expect from a useful standard are as follows:

- They should be rugged enough for transportation or at least easily reproducible in each laboratory.
- Along with this goes the demand for easy handling and a minimum of contamination danger.
- They should be relatively inert and stable toward radiation and temperature fluctuations and have good aging properties.
- Other requirements include an ideally diffuse reflecting, homogenous and smooth surface which is nontransparent, nonfluorescent and spectrally nonselective.

Obviously a reference material having all these properties does not exist.

A number of possible materials of fine powder texture have been investigated by Kortüm et al. [25], (see fig. 1). From this we can see that the condition of spectral nonselectivity is not ideally observed, particularly not in the lower UV-region. Of these MgO seems to have the best spectral properties and it has for a long time served as the most widely used standard. Its extreme sensitivity toward atmospheric conditions, UV-irradiation [27] and aging [14, 26] is well known. MgO-standards are also difficult to reproduce.

For this reason MgO has gradually been replaced by BaSO₄ whose spectral properties are not as good (see fig. 1) but whose stability is superior.

The limited transportability of powder standards

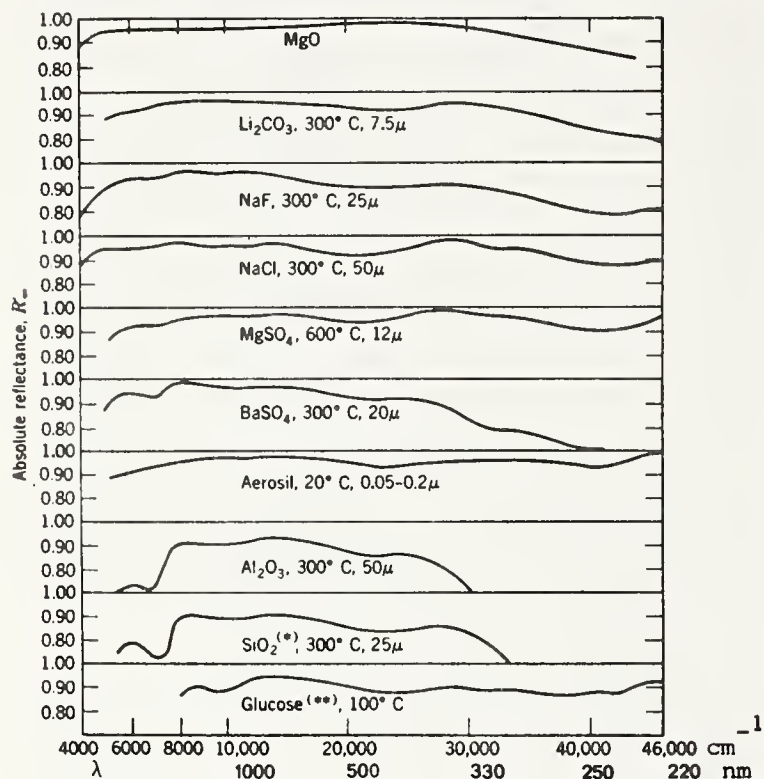

FIGURE 1. Absolute diffuse reflectance of several white standards as a function of wavelength.

Measurements with reference to freshly prepared MgO. (Temperatures given are drying temperatures; μ = maximum grain size) [25].

has prompted the development of glassy or ceramic standard materials such as Carrara, Didymium, Vitrolite etc., the latter being a white structural glass provided by NBS.

Since these materials have to have a matte surface (ideal diffusers), they are porous and therefore subject to contamination. Many of them have undesirable fluorescence and their spectral properties are inferior to the powders discussed particularly in the lower UV region < 250 nm.

The use of binders such as BaSO₄, to render powder surfaces more stable, is another approach frequently used. Organic binders mostly have been used (polyvinyl alcohols) which seriously decreases the reflectance in the 200-300 nm region.

Schutt et al. [28] have suggested a number of inorganic binders which guarantee a similar mechanical stability but with significantly increased reflectivity in the 200-300 nm region (see fig. 2.) The same workers also claim improved aging and irradiation characteristics which should render this material suitable for transportable standards or as a highly reflecting coating in integration spheres.

From the foregoing discussion it is obvious that the development of better reference standards is still of prime necessity particularly for the UV region and much imagination and ingenuity will have to go into this research area.

As of 1969 the International Commission on Illumination (CIE) has replaced all previous primary standards by the "perfect reflecting diffuser," possessing a reflectance of 100 percent. Since this can not be reached materially one can, beside the general improvement of standards, approach this problem from the instrumental side by basing the universally accepted reflectance scales on standardized instrumental designs. By relating such measurements on available standards to the "perfect reflecting diffuser" one obtains absolute reflectance values.

Instrument designs for the measurement of spectral radiance factors $\beta(\lambda)$ have been discussed by several groups. A recent account and the description of an apparatus at the "Physikalisch-Technische Bundesanstalt," Braunschweig, GFR, has been given by Erb [27].

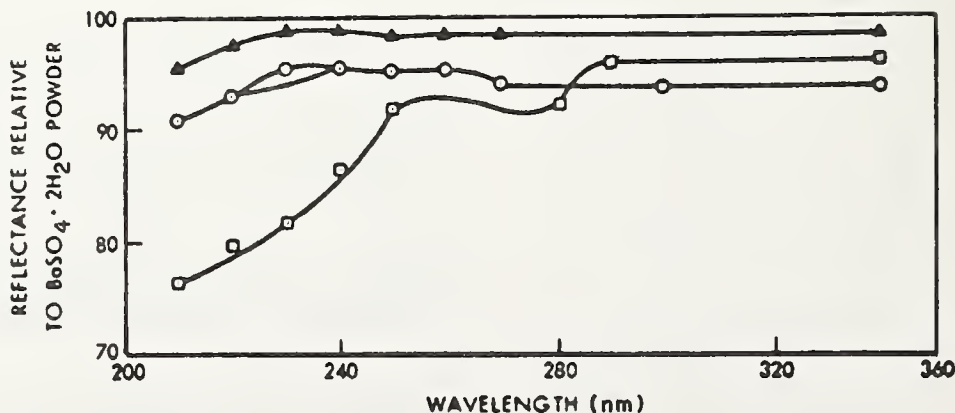

FIGURE 2. Reflectance spectra of barium sulphate coatings with different binders. \blacktriangle K₂SO₄ binder; \odot (NH₄)₂SO₄ · K₂SO₄ binder; \square (NH₄)₂SO₄ binder \square Polyvinyl alcohol binder [28].

This technique uses an integrating sphere with $d/0$ geometry and is based on the fact that the spectral radiance of the hemisphere irradiating the specimen could also be obtained if the "perfect reflecting diffuser" would be in place of the original standard.

Additional problems are encountered with the measurement and standardization of fluorescent surfaces, since for these the spectral distribution of the light source becomes another critical parameter. According to Berger and Strocka [29] artificial light sources coming as close as possible to the standard illuminant D 65 (xenon lamp) with regard to their irradiance distribution should be used.

The same group recommended the use of three standard samples for the assessment of fluorescent surfaces.

IV. Investigation of Solid Surfaces

Diffuse reflectance spectroscopy can be a powerful tool for the physico-chemical study of surfaces. It can yield valuable complementary data to other surface techniques such as ESCA, regular microscopy, scanning electron microscopy etc. Kortüm has given an excellent survey of these possibilities in his book on reflectance spectroscopy [13]. Most of the work has been done on systems in the adsorbed state and much light has been shed on processes such as Lewis acid-base reactions, electron donor-acceptor complexation, redox reactions, photo-chemical reactions and others on solid surfaces. Adsorption phenomena have also been studied by Zeitlin et al., using this approach [14]. Use of reflectance techniques at elevated temperatures has been done by Wendlandt et al. [11, 12]. This group utilized either isothermal or dynamic (continuous measurement over a temperature range) high-temperature reflectance techniques to investigate the degradation, deauration etc., of salts and metal complexes. These data were often used complementary to other thermoanalytical techniques, such as TGA and DTA.

Since chromatographic techniques often involve adsorption processes, the reflectance techniques can be adopted advantageously to preliminary investigations of actual chromatographic systems as one can see in the following example:

The reversible ring cleavage of compounds such as malachite green-*o*-carboxylic acid lactone (MGL) on active surfaces has been studied by Kortüm and Vogel [30] and Kortüm and Oelkrug [31]. A blue color develops upon adsorption of the colorless lactone on an activated adsorbent surface due to cleavage of the lactone ring. Since only chemisorption occurring in the first monomolecular layer can bring about this cleavage, the development of blue color will eventually reach a plateau at which point all adsorption sites have been covered. This phenomenon is demonstrated in figures 3 and 4. By extrapolation of the adsorption isotherm obtained for chemisorption, one can get a relative measure of the surface area of the adsorbent. The same phenomenon can

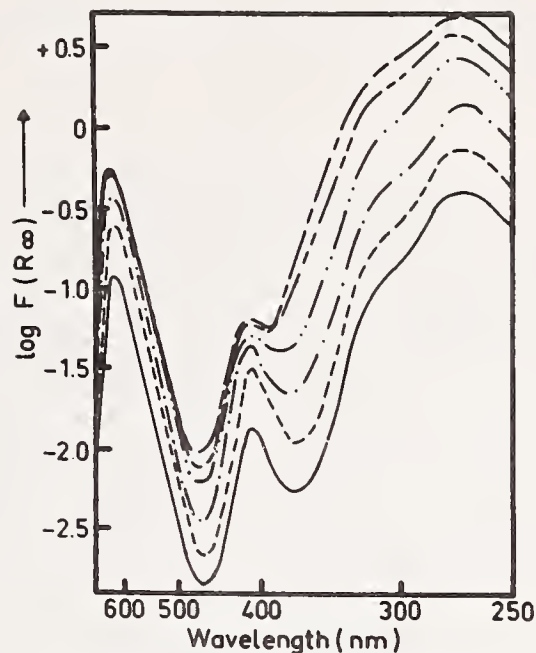

FIGURE 3. The dependence of the Kubelka-Munk functions of several bands of MGL on concentrations of MGL adsorbed on dry NaCl [30].

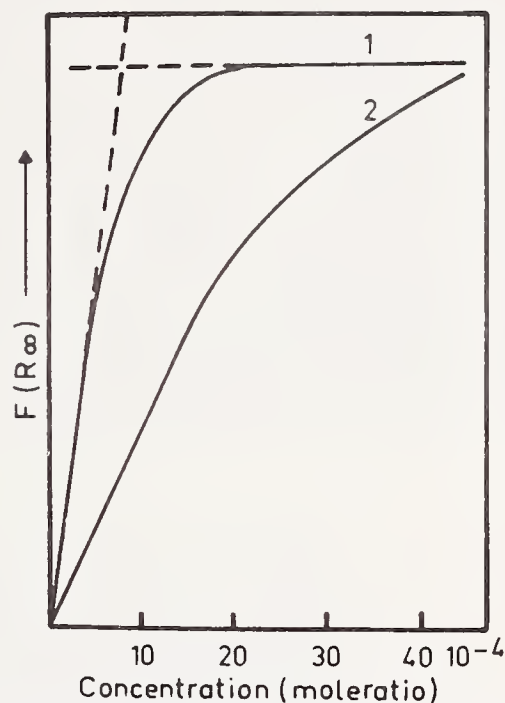

FIGURE 4. Adsorption isotherms of MGL adsorbed on dry NaCl [30].

also be observed on activated silica gels or alumina and offers an alternative to the BET-method for the determination of relative surface areas.

In modern high-pressure liquid chromatography adsorbents with pore sizes ranging from 60 Å to 1000 Å and more and accordingly decreasing surface areas are now available. It would therefore be valuable to determine relative surface areas with molecules larger than N_2 since, particularly in an adsorbent with small pore size, the nitrogen may reach active sites which are not necessarily available to the chromatographed organic compounds. The availability of such data facilitates the choice of the

proper adsorbents with regard to loading capacity and retention properties.

V. Calibration

A. Calibration Functions

The Kubelka-Munk function [32, 33] for light-scattering, infinitely thick media, is most widely used for investigations of a quantitative analytical nature by diffuse reflectance spectroscopy. Many different types of calibration functions have been proposed for the in situ evaluation of thin-layer or other open, flat-bed chromatograms by UV or visible reflectance spectroscopy [14, 19]. Most of the functions were modifications of the Beer-Lambert or the Kubelka-Munk laws; others were purely empirical. All of them claim reproducible linearity over various concentration regions even though the limitations are quite serious. The Beer-Lambert function gives reasonable linearity at very low concentrations; the Kubelka-Munk function works at medium concentration ranges but fails at lower and higher concentrations. The limitations of the Kubelka-Munk theory are quite obvious for chromatographic systems, since except for monochromaticity of the irradiated light, other conditions such as infinite layer thickness, homogenous distribution of absorbing material and nonabsorbing support are in most cases not fulfilled.

The inhomogeneity caused by tailing or other deformation of chromatographic zones has been countered by some workers by scanning chromatographic zones with a small spot of monochromatic light in a zig-zag fashion (flying spot principle [34]). Equal success, but with a technically simpler approach, has been reported by Treiber et al. [35], with a two-dimensional scanning approach (fig. 5).

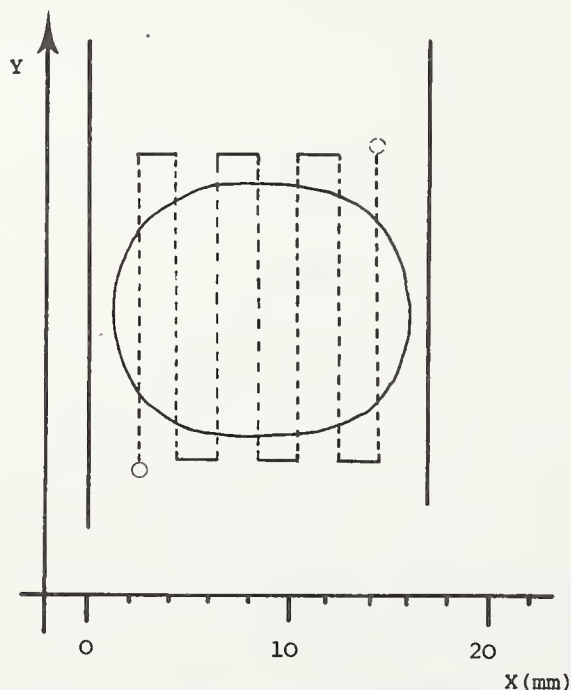

FIGURE 5. Schematic representation of the scanning pattern employed for the two-dimensional integration principle [35].

Such a scanning device is now commercially available. The same group [36] has proposed a combination of the two spectroscopic laws (Lambert-Beer and Kubelka-Munk; as shown below) in order to extend the linearity of the calibration range.

$$K_x \cdot C = K_t \cdot \ln \frac{I_0}{I_x} \quad \text{Lambert-Beer} \quad (1)$$

$$K_x \cdot C = K_r \cdot \frac{\left(1 - \frac{I_x}{I_0}\right)^2}{2 \cdot \frac{I_x}{I_0}} = \frac{(1 - R_\infty)^2}{2 \cdot R_\infty} = k \cdot \epsilon \cdot C \quad \text{Kubelka-Munk} \quad (2)$$

by combining 1 and 2 one obtains:

$$K_x \cdot C = K_r \cdot \frac{\left(1 - \frac{I_x}{I_0}\right)^2}{2 \cdot \frac{I_x}{I_0}} + K_t \cdot \ln \frac{I_0}{I_x} \quad (3)$$

A simple transformation: leads to

$$K_x \cdot C = K_R \cdot \left(\frac{I_0}{I_x} + \frac{I_x}{I_0} - 2\right) + K_T \cdot \ln \frac{I_0}{I_x} \quad (4)$$

K_x = constant depending on the substance chromatographed

$K_R(K_r), K_T(K_t)$ = constants depending on the properties of the adsorbent layer (determined empirically)

k = constant depending on the adsorbent layer

ϵ = molar absorbance of the substance chromatographed

C = concentration of the substance chromatographed in weight per surface unit

I_x = intensity of the light leaving the sample

I_0 = constant, maximal light intensity on the adsorbent layer free from any substance chromatographed.

A comparison of the K - M -function with the combined function eq (4) for sulforidazine scanned automatically by the two-dimensional technique at 275 nm is shown in table I with some statistically computed values.

A significant improvement can be noted particularly for the lower concentration region (0-2 μg).

Our own work [45] confirms that significant improvements can be obtained using the Treiber-function in comparison to plotting peak area or peak area square (F_{max} or F_{max}^2 in fig. 6). The study

was carried out with thioridazine as a test substance on Merck SiO₂ commercial plates. The measurements were carried out with a Zeiss-Chromatogram Spectrophotometer PMQ II, with automatic scanning unit.

For the data acquisition a combination with Infotronics Integrator CRS 208, W+W-recorder, Teletype ARS 33 and Hewlett-Packard HP-Calculator 9830 with plotter was used.

The following figures are direct plotter read-outs. Measurements were made at the two possible absorption maxima for thioridazine at 262 nm and at 315 nm.

TABLE I. A statistical comparison of calibration curves for sulforidazine

	Range μg	Slope	Correlation	Relative st. dev.
K-M-function:	0-10	1079	0.99778	25.5 (± 2.4 %)
	0-2	733	.97005	91.7 (± 12.5 %)
	2-10	1154	.99941	22.9 (± 2.0 %)
Combined function:	0-10	2088	0.99991	9.6 (± 0.46 %)
	0-2	2088	.99876	52.1 (± 2.5 %)
	2-10	2069	.99988	18.3 (± 0.88 %)

Figure 6 shows the relatively poor correlations obtained with the commonly used function A (F_{\max}) and A^2 (F^2_{\max}) over a concentration range of 1-10 μg/spot. For calibration plots using the Treiber-function, K_R in eq (4) has been kept constant at 1 and K_T has been varied as can be seen in figure 7. The best calibration plot going through the point of origin has been obtained for $K_T=0$, which means that the Beer-Lambert-term dropped out and that the system behaves essentially according to the Kubelka-Munk function. By studying the same system at a different concentration range (0.2-2 μg/spot) we can see in figure 8 that the Treiber-function is quite concentration dependent, now the optimum value for K_T

is 0.9 to 1.1 This means that the influence of the transmission effect (Beer-Lambert-function) is about equal to the reflectance effect (K - M -function), which is somewhat astonishing since at 262 nm one would not expect any energy to be transmitted through the plate.

DENSITOMETRISCHE REGRESSION

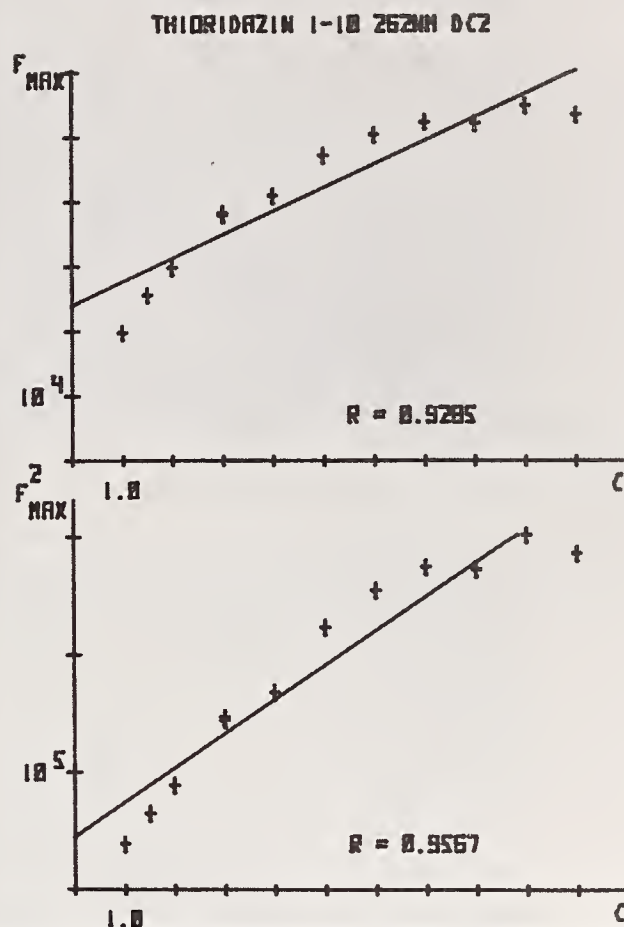

FIGURE 6. Calibration curves peak area (F) and peak area square (F^2) for thioridazine in the concentration range 1-10 μg/spot at $\lambda=262$ nm.



FIGURE 7. Treiber-functions (Tr.-f) with varying K_T -values. Conditions as in figure 6.

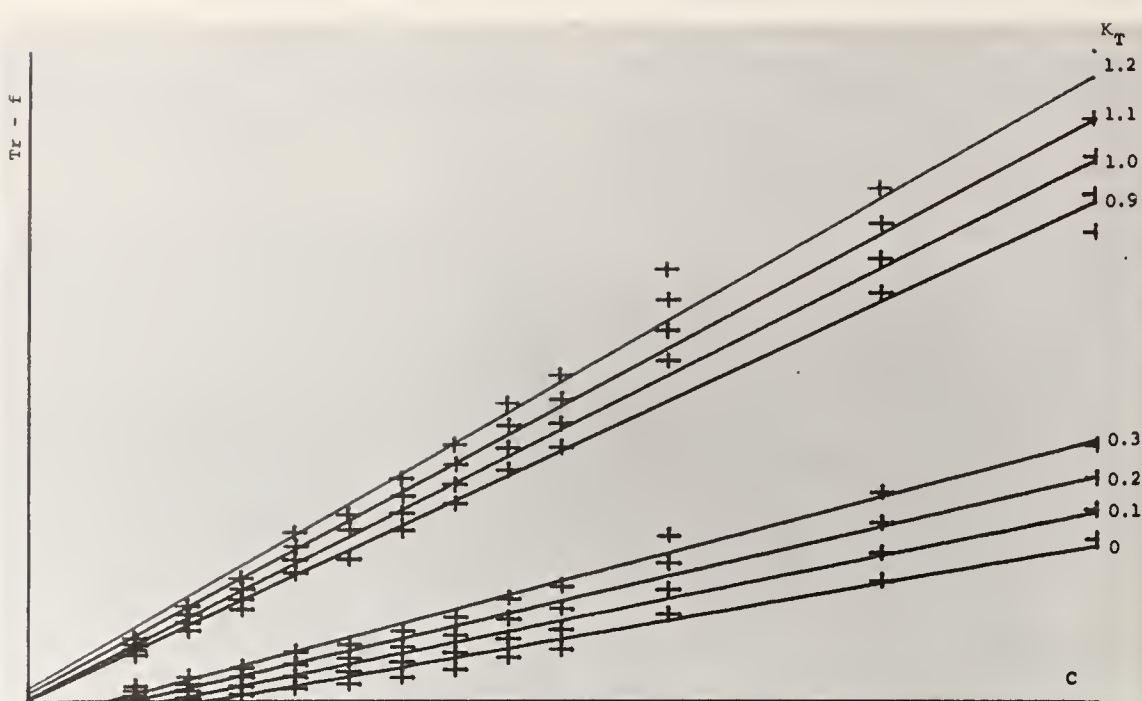

FIGURE 8. Treiber-functions ($Tr-f$) with varying K_T -values at 262 nm for a concentration range 0.2-2 $\mu\text{g}/\text{spot}$.



FIGURE 9. Treiber-functions ($Tr-f$) with varying K_T -values at 315 nm for a concentration range 1-10 $\mu\text{g}/\text{spot}$.

The Treiber-function is also wavelength dependent. This can be observed by comparing figure 9 to figure 7 where measurements have been made at 315 and 262 nm respectively at the same concentration range (1-10 $\mu\text{g}/\text{spot}$). The optimum K_T -value in figure 9 would be around 0.3 which means that a portion of the light is being transmitted. This is to be expected at 315 nm. The reason for the λ -dependence of the Treiber-function is easily explained, but at the moment we are unable to give a satisfactory reason for the concentration dependence. Treiber has not observed or at least not reported on these very important effects.

The above experiments demonstrate also that it is now possible to automate completely the entire densitometric measurement and data evaluation steps. This should enhance the usefulness of densitometric methods for routine analysis.

B. Control of Linearity

No matter which functions are utilized, one of the major requirements for a good quantitative procedure is a proper linear working range. This should be controlled by consistently checking the correlation coefficients of the calibration curves. A

simple approach to this end which is frequently used in our control laboratories is described below.

For the purpose of saving space for the application of unknowns, the system was restricted to 3 standard concentrations, hence only three fixed points determine the calibration curve and therefore even highly significant correlation coefficients do not yield much information.

In order to permit meaningful control of the linearity of our working concentration range and to have an absolute value of slope deviations from linearity a more realistic approximation has been proposed (see fig. 10).

$$A^2 = mc + n \quad (5)$$

$$A_1^2 = ac + n_1 \quad (5a)$$

$$A_2^2 = bc + n_2 \quad (5b)$$

$$a = \frac{A_{100}^2 - A_{80}^2}{c_{100} - c_{80}} \quad (6)$$

$$b = \frac{A_{120}^2 - A_{100}^2}{c_{120} - c_{100}} \quad (7)$$

The total regression of the 3 calibration points can be separated into two segments. As can be seen in figure 10, a deviation from ideal correlation has its most serious effect when the concentration of the unknown is closest to the ideal 100 percent standard concentration; in other words, the largest error could be expected for the best samples.

The magnitude of this poor correlation can be seen by comparing the slopes a and b respectively of the two segments (fig. 10): According to this, the slope difference $b - a$ is a measure of the calibration quality. With this quality factor, it is also possible to screen for the best linearity range. If $b - a$ is consistently positive or negative, we are definitely in a nonlinear range and another concentration region has to be chosen.

This systematic error cannot be seen by calculating the correlation coefficient.

After determination of the slope of each segment, one can compute the error of the analytical result, caused by the calibration error (see fig. 11).

c_U = concentration of unknown
 $c_{U \text{ exp.}}$ = expected concentration of unknown (true concentration)

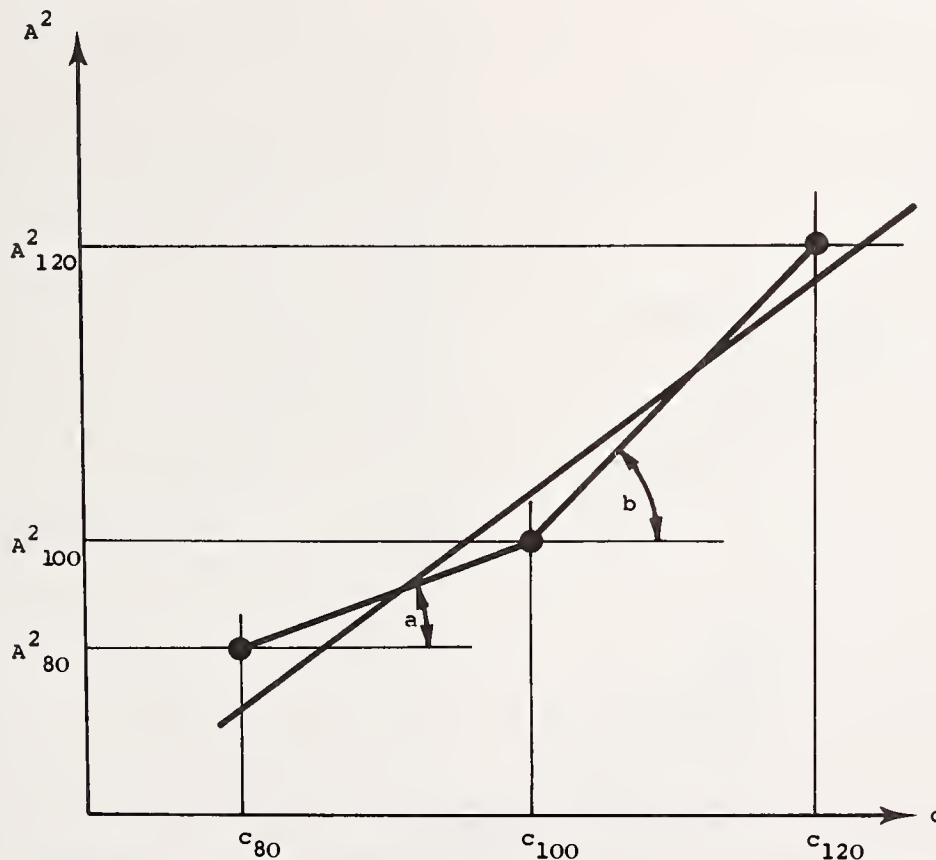

FIGURE 10. A schematic calibration curve depicting the deviation from ideal correlation.

c_{80} , c_{100} , c_{120} : concentration of the standard solutions with 80 percent, 100 percent, 120 percent of the expected concentration of unknown.

A_{80}^2 , A_{100}^2 , A_{120}^2 : squared values of the measured peak areas of the spots with c_{80} , c_{100} , c_{120} .

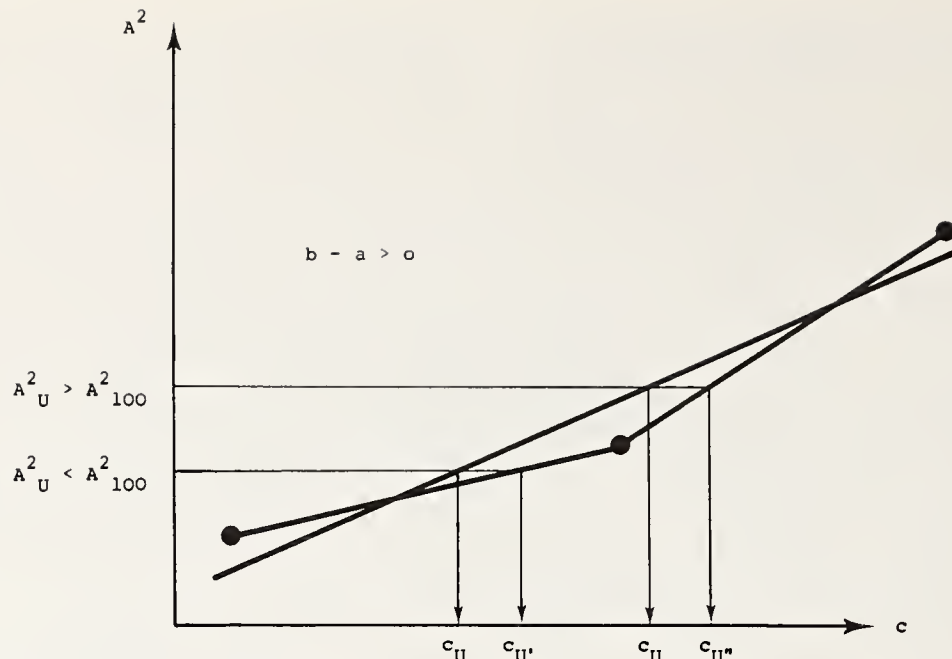

FIGURE 11. A schematic presentation of the errors that can be expected due to calibration errors.

$$\frac{c_U}{c_{U \text{ exp.}}} \cdot 100 = U [\%] \quad (8)$$

$$\frac{c'_U}{c_{U \text{ exp.}}} \cdot 100 = U' [\%] \quad (9)$$

$$\frac{c''_U}{c_{U \text{ exp.}}} \cdot 100 = U'' [\%] \quad (10)$$

From eqs 8-9 one derives the definitions for analytical errors ΔU

$$\Delta U = U' - U [\%] \quad (11)$$

$$\Delta U = U'' - U [\%] \quad (12)$$

consequently we have

$$\begin{aligned} \text{for condition } b-a > 0 : \Delta U > 0 \\ \text{for condition } b-a < 0 : \Delta U < 0. \end{aligned}$$

The term ΔU according to eqs 11 and 12 should always be considered for the computation of analytical results.

Chromato-plates which yield a ΔU higher than 2σ of the method should be rejected since for a 95 percent probability the analytical results have to be within $\bar{U} \pm 2\sigma$.

C. Transferability of Calibration Functions

The difficulties of external or transferable cali-

bration for the reflectance spectroscopic evaluation of thin-layer chromatograms are well known [14]. Usually each plate has to carry its proper set of standards. A quantitative method with transferable calibration curves by means of an internal standard has been described by Klaus [37, 38], but its general applicability is somewhat questionable. Our efforts were also directed towards achieving a maximum of external transferable information to enhance the analytical capacity of the method [39].

The usual picture for a set of calibration curves from different plates (see fig. 12) is a large variation of slopes for a given concentration range and the curves do not usually pass through the origin. As a result it is impossible to have a complete external calibration. At least two measured points are required to determine the coefficients for slope b and the ordinate intercept a ($A = a + bc$).

If one attempts to clear the tangle of calibration curves in figure 12 by sorting them out according to experimental series, one can see that they differ more from series to series than within the same series (figs 12a-12d). It is also apparent that they vary less in slopes b than in intercept a .

On the basis of these observations, we have tried to use the slope b for external calibration.

This was done by two different approaches:

1. Direct Transfer of the Mean Slope-Value

\bar{b} is computed from the slope values of several plates

$$A = a_1 + b_1 \cdot C \dots A = a_n + b_n \cdot c \quad (13)$$

$$\bar{b} = \frac{\sum b_i}{n} \quad (b_i \text{ individual slope value})$$

and is selected as the direct transfer factor. The individual ordinate intercept a_i for each plate is then computed from a single calibration value as shown below. (A_x, c_x : peak area and concentration of the standard).

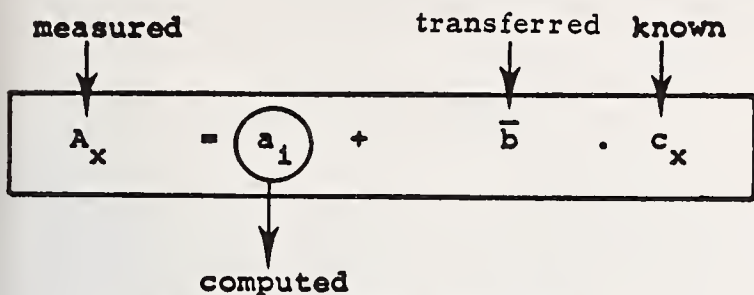

2. Transfer of a Relative Slope-Value

This approach was selected in order to compensate for the fluctuation of mean slope values \bar{b} between the different series (fig. 12).

Value b for each plate is divided by a reference value A_{id} which is ideally the mean value of the range of calibration.

$$A_{id} = \frac{\sum A_{STi}}{n} \quad (14)$$

A_{STi} = individual peak area of standard.

With three standards used as is usually the case for our routine methods this would be

$$A_{id} = \frac{A_{ST1} + A_{ST2} + A_{ST3}}{3} \quad (15)$$

The mean relative slope value \bar{b}_{rel} is then computed for several plates

$$b_{rel1} = \frac{b_1}{A_{id1}} \dots \dots b_{reln} = \frac{b_n}{A_{idn}} \quad (16)$$

$$\rightarrow \bar{b}_{rel} = \frac{\sum b_{reli}}{n} \quad (b_{reli}; \text{ individual rel. slope value}).$$

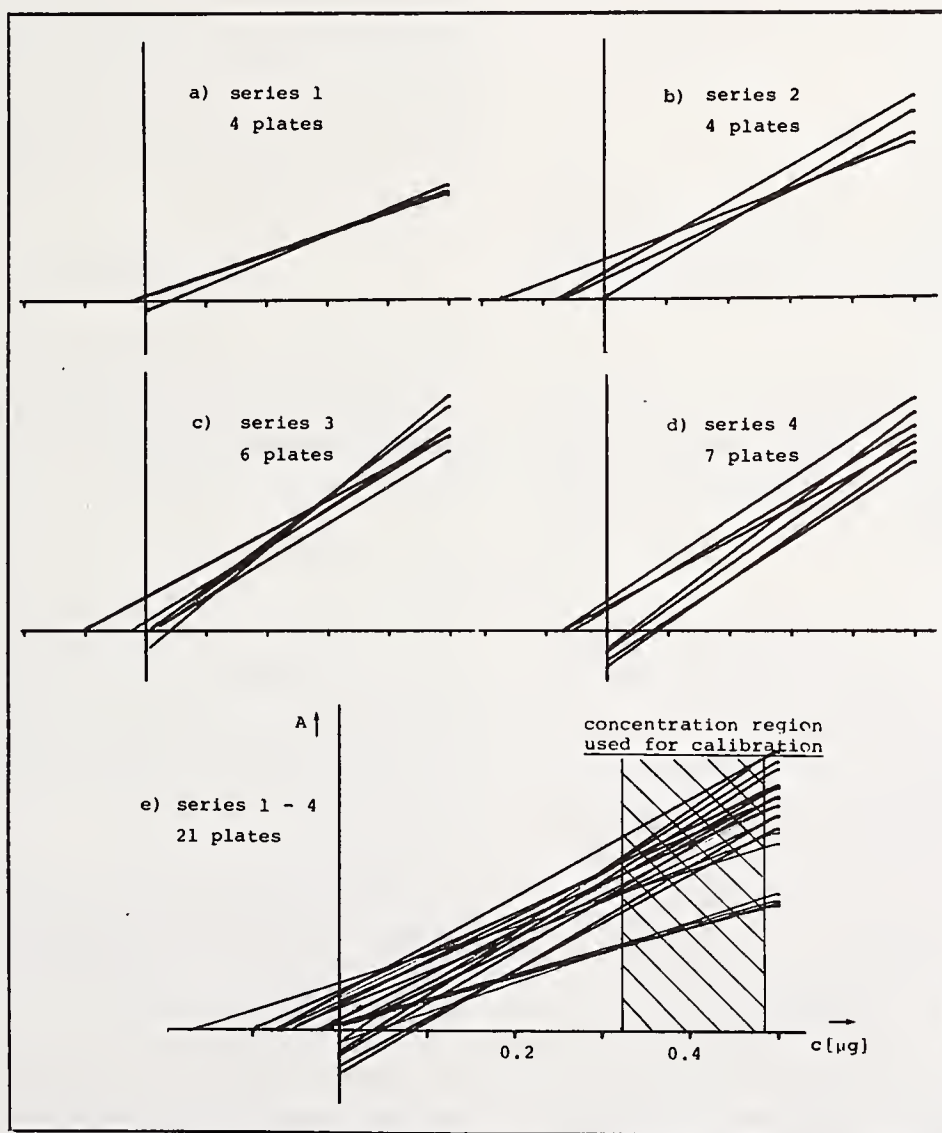
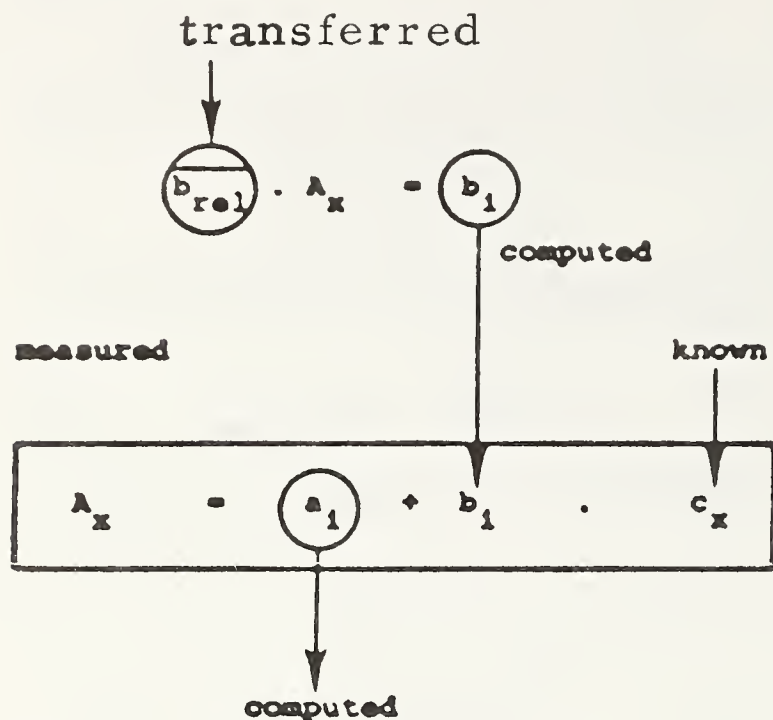

FIGURE 12. Calibration plots $A = a + bc$ for four different series of compound x [39].

Slope b_i of the individual calibration curve on each plate is calculated by back-multiplication of the measured value A_x of a single calibration spot with $\overline{b_{rel}}$ (see scheme below). The individual ordinate intercept a_i is then computed.



(17)

A comparison of these two techniques of transferred calibration was carried out with a drug substance for which multiple analyses were carried out (see also fig. 12).

The results are shown in table II. As is to be expected no significant improvement is observed between direct and relative transfer when the four separate series are considered. For the total series, however, the mean error for the direct transfer approach is twice as high.

TABLE II. Mean values of the relative errors of analyses of compound x corresponding to figure 12

Transferred value	ΔU_{rel} -Values after transferred calibration	
	4 Separated groups	Total series
\overline{b}	0.9%	1.2%
$\overline{b_{rel}}$	0.6%	0.6%

The mean error ΔU_{rel} is defined as

$$|\Delta U_{rel}| = \frac{U_{transf. calibr.} - U_{individual calibr.}}{U_{individual calibr.}} \cdot 100. \quad (18)$$

Thus, table II also shows, that transferred calibration

techniques are practically equivalent to individual calibration on each plate. Five analysis can be carried out per plate which represents an increase in capacity of 60 percent. The method is applicable to UV, visible and fluorescence measurements by reflectance techniques and also after utilizing dipping or spraying procedures.

The only limitation is that the test series is from the same concentration region and of course that they fall into a linear calibration range.

D. Multicomponent Systems

If this condition of linearity is adhered to (no matter which function is used) then it is also possible, analogous to regular spectrophotometric principles, to carry out differential reflectance measurements with highly or weakly absorbing compounds [40] or to evaluate multicomponent systems [41].

The latter has been demonstrated with dye mixtures on a silica gel substrate, and the Kubelka-Munk-function was used eq (2) as a linear relationship in the concentration range studied.

For a powder mixture containing n light-absorbing components whose reflectance functions are additive, the Kubelka-Munk function $F(R_\infty)$ can be adapted for simultaneous analysis. The function of the total reflectance $R_{\infty T}$ of the mixture at some wavelength i may be represented as the sum of all individual reflectance functions.

$$F(R_{\infty T})_i = \sum_{j=1}^n \tau_{ij} C_j \quad (19)$$

where j refers to components and τ is the slope of the Kubelka-Munk plot of $F(R_\infty)$ versus C .

Equation (19) can be written in a more explicit manner by writing as many equations as there are components in the mixture.

$$F(R_{\infty T})_1 = \tau_{11} C_1 + \tau_{12} C_2 + \dots + \tau_{1n} C_n \quad (20)$$

$$F(R_{\infty T})_2 = \tau_{21} C_1 + \tau_{22} C_2 + \dots + \tau_{2n} C_n. \quad (21)$$

The additivity of the $F(R_\infty)$ -values is shown in figure 13 for a mixture of Fuchsin and Brilliant green. From the corresponding calibration curves (fig. 14) the slopes are determined and utilized in eqs. (19-21) for a computation of the individual concentrations.

The precision, computed as relative standard deviation for four sets of four samples, was ± 2.4 percent and the deviation from the true value (accuracy) was 2.1 percent for Fuchsin and 3.1 percent for Brilliant green.

The same principle is also applicable in the UV-region. Mixtures of rutile and anatase [42] have been studied. Similar applications in the color industry and pharmaceutical industry have also been discussed [14].

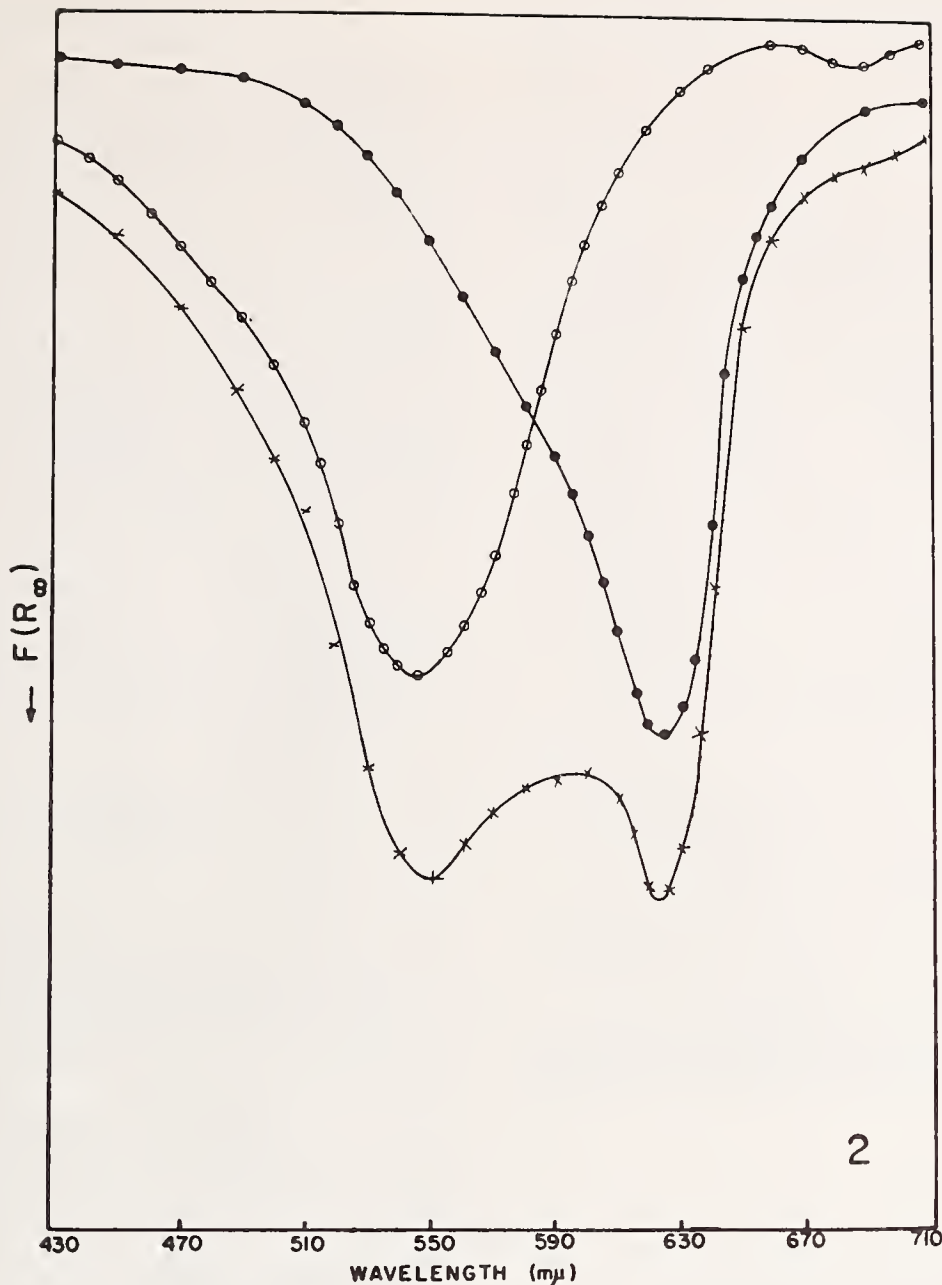

FIGURE 13. Reflectance spectra of \circ , Fuchsin; \bullet , Brilliant green; \times , a mixture of the two [41].

VI. Applications in Chromatography

Applications have been discussed in recent books [14, 15, 19] and the latest instrument developments have greatly enhanced the use of diffuse reflectance spectroscopy in this area. I do not feel that there is a need in this paper to go into further detail. I would just like to mention one recent application area mainly UV-reflectance spectroscopic measurements of chromatographic zones on silica gel in the wavelength range of 180–210 nm. U. Hexel [43] has shown that with the necessary precautions such as nitrogen purge below 195 nm (ultrapure N_2 below 190 nm), the use of good optics (to eliminate stray-light effects), and a special deuterium lamp and window (all items commercially available), it is possible to obtain quantitative results in this

spectral region. This is somewhat surprising since it is well known that silica gel starts absorbing strongly below 280 nm (see also fig. 1). However, the determination of the absolute reflectance of silica gel in this spectral region is difficult since good UV-reflectance standards are lacking.

The absorption spectrum and calibration curves of a trioleine compound [43] (triglyceride) are shown in figures 15 and 16. Measurements were done with the Zeiss Chromatogram spectrophotometer equipped with a suprasil window and a deuterium lamp H 30 DS. No nitrogen purge was necessary at the working wavelength λ 196 nm. A precision of ± 2 percent rel. S.D. is possible.

This approach has much merit for the investigation of compounds with $C=C$, $C=O$ or $C=N$ bonding and otherwise poor chromophores.

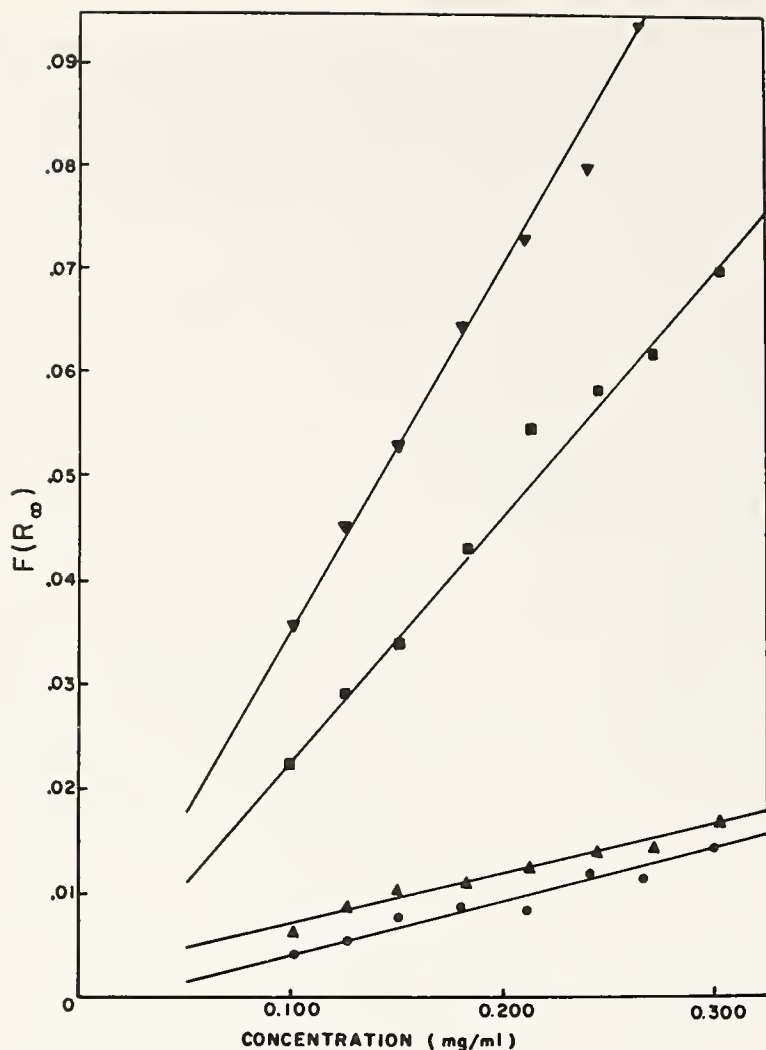

FIGURE 14. Kubelka-Munk plots for ▼, Brilliant green at 626 nm ▲, Fuchsin at 626 nm; ● Brilliant green at 545 nm and ■, Fuchsin at 545 nm [41].

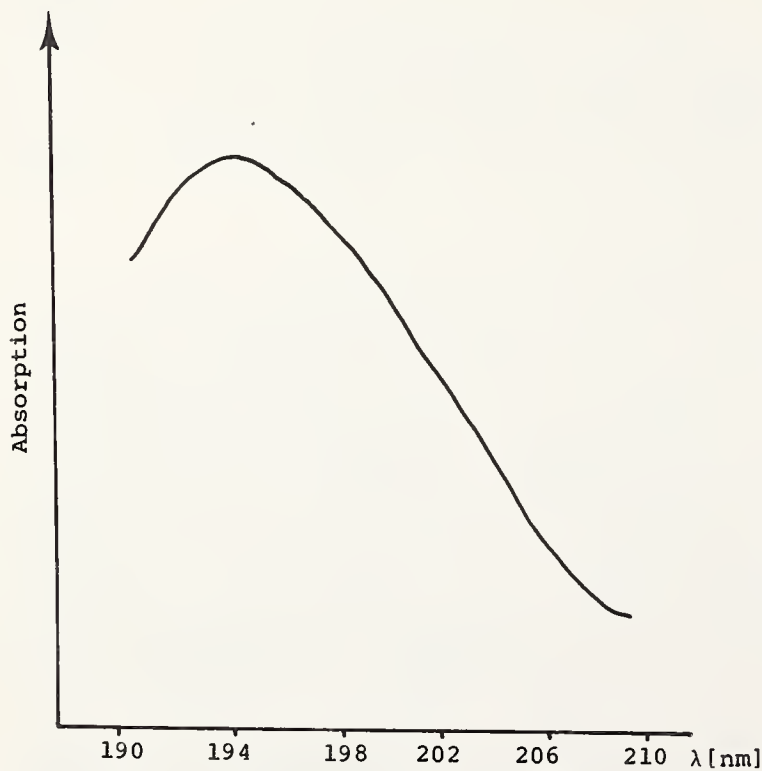

FIGURE 15. Absorption spectrum of trioleine standard measured by diffuse reflection [43].

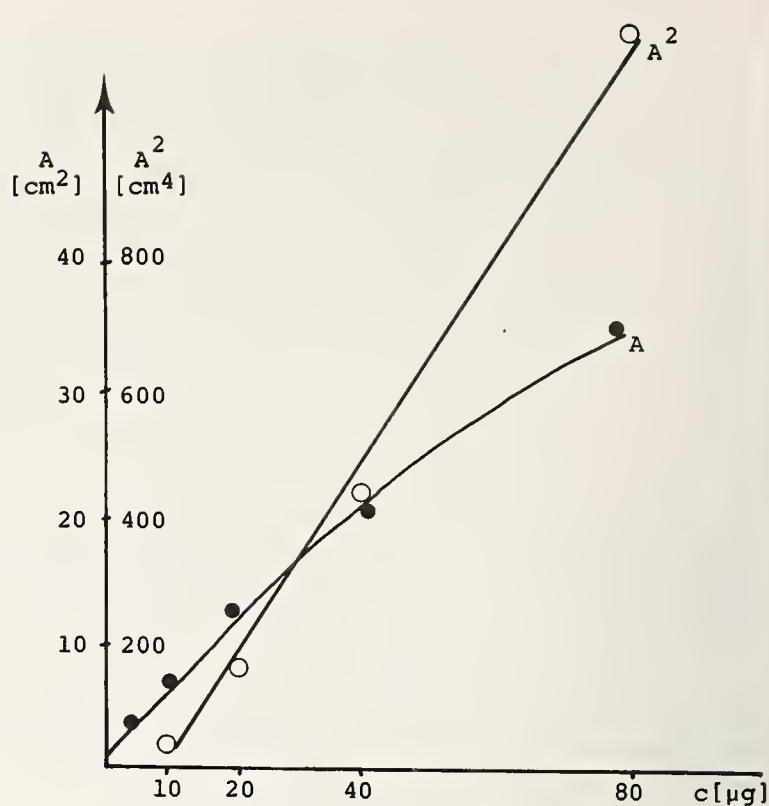

FIGURE 16. Calibration curves for the trioleine standard measured at 196 nm [43].

Actual groups of compounds tested to this date are caprolactams ($\lambda=194$ nm) [43], atropine sulfate ($\lambda=195$ nm) [43], Lipids ($\lambda=196-210$ nm) [44] and some peptides ($\lambda=200-220$ nm) [45].

VII. Conclusion

In conclusion one can say that diffuse reflectance spectroscopy is by no means a forgotten or obsolete technique. It is adopted heavily in highly specialized areas such as color measurement and chromatographic techniques. Automation and computer usage play an important role in both areas and the instrument technology is at a good level.

Some helpful innovations have been made on calibration techniques which can make quantitative diffuse reflectance spectroscopy competitive in some cases with transmission techniques.

The problem of standardization is very much with us with regard to finding better reference materials and better standardization of instruments. A great deal of effort and imagination will have to go into this areas for genuine progress.

H. Bethke, P. Buchner, U. Hezel, and H. Loof are to be thanked for providing some of the data and informations and for helpful discussions.

VIII. References

- [1] Taylor, A.H., *J. Opt. Soc. Am.* **4**, 9 (1919); Benford, F., *Gen. Elec. Rev.* **23**, 72 (1920).
- [2] Hardy, A.C., *J. Opt. Soc. Am.* **18**, 96 (1929).
- [3] Hardy, A.C., *Handbook of Colorimetry* (M.I.T. Press Cambridge, Mass. 1936).
- [4] Evans, R.M., *An Introduction to Color* (John Wiley and Sons, London, 1948).
- [5] Le Grand, Y., *Light, Colour and Vision* (Chapman and Hall, London, 1957).
- [6] Judd, D.B., and Wyszecki, G., *Color in Business, Science and Industry* (John Wiley and Sons, London, 1963), 2d. edition.
- [7] Billmeyer, F.W., and Saltzmann, M., *Principles of Color Technology* (Interscience, New York, 1966).
- [8] Wyszecki, G., and Stiles, W.S., *Color Science, Concepts and Methods, Quantitative Data and Formulas* (John Wiley and Sons, New York, 1967), 2d. edition.
- [9] Optical Society of America, *The Science of Color*; (Vail-Ballou Press, Binghamton, N.Y., 1968), 2d. edition.
- [10] Wright, W.D., *The Measurement of Colour* (Adam Hilger Ltd., London, 1969), 4th edition.
- [11] Wendlandt, W.W., and Hecht, H.G., *Reflectance Spectroscopy* (John Wiley and Sons, N.Y., 1966).
- [12] Wendlandt, W.W., *Modern Aspects of Reflectance Spectroscopy* (Plenum Press, N.Y., 1967).
- [13] Kortüm, G., *Reflexionsspektroskopie* (Springer Verlag Berlin, 1969).
- [14] Frei, R.W., and MacNeil, J.D., *Diffuse Reflectance Spectroscopy in Environmental Problem Solving* (CRC-Press, Cleveland, 1973).
- [15] Frei, R.W., Frodyma, M.M., and Lieu, V.T., *Diffuse Reflectance Spectroscopy; Wilson & Wilson Comprehensive Analytical Chemistry, Vol. IV* (Elsevier, Amsterdam, 1975).
- [16] Frei, R.W., *Critical Reviews in Analytical Chemistry* CRC-Press, Vol. 2, 1972), p. 179.
- [17] Surles, T., Erickson, J., and Priesner, D., *Internat. Lab.* May-June issue, 29 (1975).
- [18] Schönleber, D., and Koci, P., Sandoz internal communication.
- [19] Frei, R. W., *In Progress in Thin-Layer Chromatography and Related Methods, Vol. II* (Niederwieser, Pataki Eds.); (Ann Arbor Science Publishers, Ann Arbor, Mich., 1971).
- [20] Gall, L., *Computer Colour Matching; Colour 73*, (Adam Hilger Ltd., London, 1973), pp 153-178.
- [21] Brockes, A., *J. Am. Assoc. Text. Chem. and Colorists* **6** No 5 (1974).
- [22] Kühni, R., *J. Am. Assoc. Text. Chem. and Colorists* **6** No 8 (1974).
- [23] Berger, A., and Brockes, A., *Bayer Farbenrevue, Sonderheft No 3/1* (1971).
- [24] Erb, W., A summary of properties and reflection values of materials which are used as reflection standards; *Physikalisch-Technische Bundesanstalt, PTB-Report*, June 1975, Braunschweig.
- [25] Kortüm, G., Braun, W., and Herzog, G., *Angew. Chem. Intern. Ed.* **2** 333 (1963).
- [26] Terstiege, H., *Lichttechnik* **26** 277 (1974).
- [27] Erb, W., *Appl. Opt.* **14** 493 (1975).
- [28] Schutt, J. B., Arends, J. F., Shai, C. M., and Stromberg, E., *Appl. Opt.* **13** 2218 (1974).
- [29] Berger, A., and Strocka, D., *Appl. Opt.* **14** 726 (1975).
- [30] Kortüm, G., and Vogel, J., *Chem. Ber.* **93** 706 (1960).
- [31] Kortüm, G., and Oelkrug, D., *Z. Phys. Chem.* **34** 58 (1962).
- [32] Kubelka, P., and Munk, F., *Z. Tech. Phys.* **12** 593 (1931).
- [33] Kubelka, P., *J. Opt. Soc. Am.* **38** 448 (1948).
- [34] Goldman, J., and Goodall, R. R., *J. Chromatog.* **40** 345 (1969).
- [35] Treiber, L. R., Oertegren, B., Lindsten, R., and Oertegren, I., *J. Chromatog.* **73** 151 (1972).
- [36] Treiber, L. R., *J. Chromatog.* **100** 123 (1974).
- [37] Klaus, R., *J. Chromatog.* **40** 235 (1969).
- [38] Klaus, R., *J. Chromatog.* **62** 99 (1971).
- [39] Bethke, H., and Frei, R. W., *Anal. Chem.* **48** 50 (1976).
- [40] Lieu, V. T., Zaye, D. F., and Frodyma, M. M., *Talanta* **16** 1289 (1969).
- [41] Frei, R. W., Ryan, D. E., and Lieu, V. T., *Can. J. Chem.* **44** 1945 (1966).
- [42] Kortüm, G., and Herzog, G., *Z. Anal. Chem.* **190** 239 (1962).
- [43] Hezel, U., Zeiss Ltd., Oberkochen, Germany; private communication.
- [44] Murawski, U., Egge, H., and Zilliken, F., *Z. Klin. Chem. Klin. Biochem.* **12** 644 (1974).
- [45] Frei, R. W., Sandoz internal communication.

(Paper 80A4-901)

The Interpretation of Diffuse Reflectance Spectra

Harry G. Hecht

Department of Chemistry, South Dakota State University,
Brookings, South Dakota 57006

(May 26, 1976)

Numerous treatments of the diffuse reflecting properties of scattering media have been described. Many theories give an adequate account of the reflectance for a specific set of conditions for which the model was constructed and the solution tested experimentally. Only those models which are considered to be fairly general are considered here.

It is convenient to divide the theories into those based upon continuum models and those based upon statistical models. The continuum models typically describe the scattering and absorbing properties of a given medium in terms of two phenomenological constants. These models may all be regarded as varying levels of approximate solution to the general equation of radiative transfer. This provides a convenient basis for comparison of the various theories.

The statistical models are based upon a summation of transmittances and reflectances from individual layers or particles. Thus, some assumptions must be made about the nature of the fundamental units, and the validity of the ultimate result will depend upon how closely these assumptions correspond with reality. Only the statistical models lead to expressions from which absolute absorptivities and scattering coefficients can be calculated and related to the actual particle characteristics.

The relationship between the various models will be discussed and the features which typify the absorptivity and scattering coefficient according to each will be compared and related to the available experimental data. This leads to a consideration of the characteristics of appropriate model systems and standards.

Key words: Absolute absorptivities; continuum models; diffuse reflectance; radiative transfer; reflectance spectra; scattering coefficients; statistical models.

List of Principal Symbols Used

(Note: Where a given letter is used in both capital and lower case form (e.g., r, R and t, T), the capital letter refers to the macroscopic observable and the lower case letter to the corresponding variable for an individual particle or layer of the material. A bar over a given symbol means the average value for that variable).

		$H(\mu)$	H -integral of Chandrasekhar (equation (35))
		I	radiant intensity
		I'	component of source function for self-radiation (equation (5))
		j	scattering function (equation (2))
		J	source function (equation (4))
		k	absorptivity
		K	Kubelka-Munk absorption constant (equations (16) and (17))
a	total absorption of a single particle (layer); also $\frac{S+K}{S}$ (equation (18))	K_1, K_2	Attenuation constants in Gurevič layer model (equations (10) and (11))
a_j	Gaussian weighting function (equation (33))	l	particle diameter or layer thickness
a_{it}	} Rozenberg constants (equation (23)ff.)	l_r	"free" path length of Antonov-Romanovsky (equation (58))
a_{ijt}		L	Gurevič constant = $\sqrt{K_2^2 - K_1^2}$
b	$(a^2 - 1)^{1/2}$ (equation (21))	\bar{m}	mean number of reflections
C_t	I_i/I_1 polarization of radiant beam (equation (24))	M	transmittance of a particle for a single pass
r	fraction of radiation reflected (equation (75))	M_e	radiant flux density
f_t	fraction of radiation transmitted (equation (76))	p	phase function (equation (2))
$h(\mu, \mu_0)$	Rozenberg constant (equation (29))	$P_n(\mu)$	Legendre polynomial
		q	Rozenberg constant (equation (29))
		Q	Rozenberg multiple reflection constant (equation (26))

r	total reflectance of a single particle (layer)
r_0	simple reflectance of a single particle (layer) surface
\bar{r}^*	mean external reflection coefficient for side scatter
r_e	reflectance of a particle (layer) for externally incident radiation
r_i	reflectance of a particle (layer) for internally incident radiation
R	reflectance of a (macroscopic) layer
$\frac{R_\infty}{s}$	reflectance of an infinitely thick layer effective path length (equation (58))
S	Kubelka-Munk scattering constant (equations (16) and (17))
$S(\mu, \mu_0)$	Rozenberg weak scatter constant (equation (29))
t	total transmittance of a single particle (layer)
T	transmittance of a (macroscopic) layer
u	radiation emerging from a particle per unit solid angle
u_0	shading factor (equation (70))
u_d	fraction of radiation emerging from a particle in a downward direction
u_s	fraction of radiation emerging from a particle in a sideways direction
u_u	fraction of radiation emerging from a particle in an upward direction
x	length
y	Johnson multiple reflection factor (equation (51))
α	absorption coefficient
β	α/σ (equation (23))
γ	Fassler-Stodolski constant (equation (82))
δ	Fassler-Stodolski constant (equation (82))
θ	polar angle
κ	attenuation coefficient = $\alpha + \sigma$ (equation (1))
λ	wavelength
μ	$\cos \theta$
μ_j	one of the roots of the Legendre polynomial $P_n(\mu)$
ξ	effective hole cross section (equation (100))
ρ	density
σ	scattering coefficient (equation (2))
τ	optical thickness (equation (3))
ϕ	azimuthal angle
Φ_e	radiant flux
ω_0	albedo of single scatter (equation (30))

1. Introduction

It is now recognized that diffuse reflectance spectroscopy is a very useful companion technique to transmission spectroscopy. Not only can it provide absorption data in some cases where transmission measurements fail, but for many industrial and research applications, it may in fact be the preferred technique.

Our discussion will be concerned with the behavior of radiation within a scattering medium. For simplicity we assume the scattering centers, which may also absorb radiation, are imbedded in a medium which neither scatters nor absorbs. The medium may usually be taken as air, although there are many other cases of interest in which the refractive index of the medium is much greater than unity. We will not deal specifically with these cases in the present review, nor with those processes which alter the frequency of the radiation, such as luminescence and fluorescence.

Scattering takes place under a wide variety of conditions. One may be concerned with the glowing photosphere of the sun, which is surrounded by a cloud of electrons that reradiate the direct sunlight incident on them. Sunlight is also reradiated by cosmic dust, which accounts for the outer part of the corona.

In a more down-to-earth situation one may be dealing in the laboratory with the spectroscopy of a powder, paper, opal glass, photographic emulsion, etc. As so often happens, concepts developed in one area of science are slow to find their way into another. We will attempt to show that there is a close relationship between the astrophysical solutions, which are based largely on radiative transfer theory, and the various models which are more familiar to the spectroscopist.

Since we will not be following a historical development, it may be useful to point out some relationships between the early studies. The first attempt to account for transmission and reflection of a layered material was carried out by Stokes in about 1860 [1],¹ and led to some very useful relationships which have also been derived by other workers (vide infra). Lord Rayleigh [2] and Mie [3] developed the theory of single scatter to a high degree, but Schuster [4] was the first to consider multiple scatter. He was concerned with the cloudy atmospheres of stars, and developed a plane-parallel plate model in which the radiation field was divided into forward and backward components. This same model was used much later by Kubelka and Munk [5], whose names are usually attached to it by spectroscopists. Schwarzschild [6] showed that the radiation field should be characterized by a complete angular distribution, and if one integrates over the forward and backward hemispheres, the Schuster model is obtained as a first approximation. A further generalization of the Schwarzschild formulation leads to an integro-differential equation known as the equation of radiative transfer, which is very general in concept, but can be solved exactly in only a few cases.

The radiative transfer theory and various models stemming from it are referred to as Continuum Models. They have in common the characterization of the scattering and absorbing properties of the medium through phenomenological constants, usually two in number. These theories will be considered in section II. A completely satisfactory theory must of course relate the measurable quantities to

¹ Figures in brackets indicate the literature references at the end of this paper.

fundamental properties of the scattering material, such as particle size, refractive index, and absorptivity. This is the goal of the statistical theories. Many have been proposed; those which show the most promise are discussed in section III. In section IV we discuss some of the strengths and weaknesses of the various models and some relationships between them. Section V considers the meaning of the absorption and scattering coefficients often used to interpret reflectance data, as well as the characteristics required of appropriate model systems.

We will limit our discussion to ideal, homogeneous dispersions. There have been interesting developments in the theory of nonhomogeneous media, mixtures, luminescing materials, diffusing media in which photochemical reactions are taking place, and reflectance for materials dispersed in a highly refracting matrix, but these topics are considered to be outside the scope of the present review. Many of these topics are covered in the books which have been written on the subject [7,8,9]. Further information has been presented at various symposia which have been held, and the proceedings of at least two of them are available [10,11]. These sources, together with various reviews devoted to applications in particular fields, have made workers aware of the power of the technique. Thus we will confine ourselves to certain theoretical aspects.

The present paper may be regarded as an update to a former review of the subject by the author [12]. Most of the theoretical work of the intervening years has been in the development of more refined statistical models, and in showing the relationship between the various theories. At present there is some reason to feel optimistic that out of a morass of apparently divergent and unrelated theory, some order is beginning to emerge.

II. Continuum Theory

As is often the case with applications of physical theory, the real media with which diffuse reflectance spectroscopy is concerned are intermediate between two extreme cases, each of which is well understood. The one limiting case involves the propagation of radiation through quasi-homogeneous matter, where the radiation field is characterized by smoothly and slowly varying functions of the coordinates. The other extreme involves the emission, absorption, and scattering of radiation by single particles in a homogeneous medium. The local transformation of the radiation field at the boundaries of quasi-homogeneous media is a special case which has likewise been characterized for a long time, and leads to such well-known phenomena as reflection, refraction, etc.

In dense scattering media, it is important to consider the manner in which the radiation fields from the various scattering centers interact with one another. Rozenberg [13, 14, 15] has pointed out that the interaction can be treated as a sum of two parts,

one of which is coherent and the other incoherent. The coherent part is largely due to nearest neighbor interactions and gives rise to dispersion effects; i.e., is involved with changes of refractive index. The incoherent part is that with which we are primarily concerned in the present discussion. It involves multiple scattering as a sum of interactions throughout the entire medium. In most treatments the multiple scattering, because of its complexity, is separated rather arbitrarily from dispersive effects. Such a separation reduces the problem to one involving geometrical optics, and allows one to write a radiative transfer equation in which the absorbing and scattering properties of the medium are treated as phenomenological constants (spoken of as "external parameters" by Stepanov[16]).

The concept that each volume element is irradiated by scattering from every other volume element of the medium (The Principle of Self-Illumination), is a basic concept of radiative transfer theory which clearly pervades the writings of such early workers as Schuster [4, 17], King [18], and Schwarzschild [6]. The equation of radiative transfer can in fact be regarded as a simple statement of the law of conservation of energy. The change in intensity of a beam along its direction of propagation, dI , is equal to the radiation which is lost through absorption and scattering $-\kappa\rho Idx$, plus that which is scattered in this direction from all other directions, $j\rho dx$:

$$dI = -\kappa\rho Idx + j\rho dx \quad (1)$$

Here ρ is the density, κ is the attenuation coefficient, j is the scattering function, and dx is the element of path length. The scattering function can be written as

$$j(\theta, \phi) = \frac{\sigma}{4\pi} \int_0^\pi \int_0^{2\pi} p(\theta, \phi; \theta', \phi') I(\theta', \phi') \sin \theta' d\theta' d\phi' \quad (2)$$

where σ is the scattering coefficient and $p(\theta, \phi; \theta', \phi')$ is the phase function which defines the probability that radiation which travels initially in the direction (θ', ϕ') is scattered into the direction (θ, ϕ) . Equation (1) is usually solved in terms of the optical thickness

$$\tau = \int_{x_1}^{x_2} \kappa\rho dx \quad (3)$$

Defining θ as the angle with respect to the inward surface normal gives

$$\mu \frac{dI(\tau, \mu, \phi)}{d\tau} = I(\tau, \mu, \phi) - J(\tau, \mu, \phi) \quad (4)$$

where $\mu \equiv \cos \theta$ and $J \equiv j/\sigma$ is the source function.

The equation of radiative transfer can be generalized to include dispersion effects as well as scattering [14, 15]. In terms of the components of the Stokes vector, \mathbf{I} ,

$$\frac{dI_i(\theta, \phi)}{dx} = \sum_{j=1}^4 \left\{ -\kappa_{ij} I_j(\theta, \phi) + \frac{\sigma}{4\pi} \int_0^\pi \int_0^{2\pi} p(\theta, \phi; \theta', \phi') I_j(\theta', \phi') \sin \theta' d\theta' d\phi' \right\} + I_i'(\theta, \phi). \quad (5)$$

The term $I_i'(\theta, \phi)$ accounts for possible self radiation of the volume element, which is of importance in the infrared spectral region or in luminescing media. As mentioned above, this term will be suppressed in the present discussion.

A. The Layer Model

A model in which the scattering medium is approximated by plane-parallel layers has been used by numerous workers as a basis for reflectance theory [7, 8]. We consider a pair of adjacent layers, with R_i, R_j and T_i, T_j as the reflectances and transmittances for radiation incident in one direction, and R_r, R_r and T_r, T_r as the reflectances and transmittances for radiation incident in the other direction.

If the incident beam is of unit intensity, then the portion R_i is reflected and the portion T_i transmitted by the first layer. At the second layer the portion $T_i R_j$ is reflected and $T_i T_j$ is transmitted. The beam $T_i R_j$ strikes the underside of layer i where $T_i R_j T_r$ is transmitted, while $T_i R_j R_r$ is reflected. Continuing this process indefinitely (see fig. 1) we find that the transmittance and reflectance of the combined layers are given by

$$T_{i+j} = T_i T_j (1 + R_r R_j + R_r^2 R_j^2 + \dots)$$

$$R_{i+j} = R_i + T_i T_r R_j (1 + R_r R_j + R_r^2 R_j^2 + \dots)$$

Summing the geometric series gives

$$T_{i+j} = \frac{T_i T_j}{1 - R_r R_j} \quad (6)$$

$$R_{i+j} = R_i + \frac{T_i T_r R_j}{1 - R_r R_j} \quad (7)$$

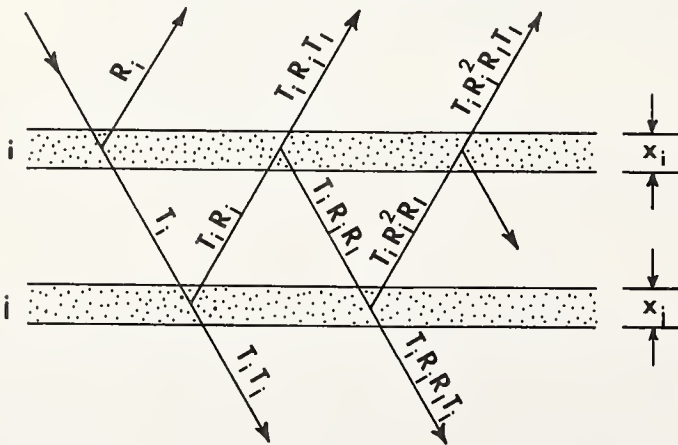

FIGURE 1. Reflectance and transmittance of a pair of inhomogeneous layers (Kubelka [19]).

We generally deal with the case where $T_i = T_r$ and $R_i = R_r$; i.e., where the reflectance and transmittance of a layer do not depend on the direction of incidence. This is quite a general condition which applies even to the case of nonhomogeneous sheets [19]. With these substitutions eqs (6) and (7) reduce to

$$T_{i+j} = \frac{T_i T_j}{1 - R_i R_j} \quad (8)$$

$$R_{i+j} = R_i + \frac{T_i^2 R_j}{1 - R_i R_j} \quad (9)$$

We now make the assumption that the layers are homogeneous and thick compared with individual particle dimensions so that no intrinsic inhomogeneities are evident. We can then write that the reflectance of a given layer is proportional to its thickness [20],

$$R(dx) = K_1 dx. \quad (10)$$

Similarly we write

$$T(dx) = 1 - K_2 dx. \quad (11)$$

Here K_1 and K_2 are phenomenological constants which characterize the medium. We assume that $K_2 \geq K_1$, where the inequality applies to absorbing media and the equality to nonabsorbing media. We substitute $R(x)$ and $T(x)$ for R_i and T_i in eqs (8) and (9), with $R(dx)$ and $T(dx)$ from eqs (10) and (11) being substituted for R_j and T_j . Writing R_{i+j} and T_{i+j} as $R(x+dx)$ and $T(x+dx)$ allows eqs (8) and (9) to be expanded in series to give

$$dR = K_1 T^2 dx$$

and

$$dT = -T(K_2 - K_1 R) dx.$$

Integrating this set of coupled differential equations subject to the boundary conditions $R(0) = 0$, $T(0) = 1$ gives

$$R = R_\infty \frac{1 - e^{-2Lx}}{1 - R_\infty^2 e^{-2Lx}} \quad (12)$$

$$T = (1 - R_\infty^2) \frac{e^{-Lx}}{1 - R_\infty^2 e^{-2Lx}} \quad (13)$$

R_∞ is the reflectance of an infinitely thick layer, and it is related to K_1 and K_2 through

$$R_\infty = \frac{K_2 - L}{K_1} = \frac{K_2 - \sqrt{K_2^2 - K_1^2}}{K_1} \quad (14)$$

while L is given by

$$L = \sqrt{K_2^2 - K_1^2} \quad (15)$$

Equations (12) and (13) were derived long ago by Stokes [1] for plane-parallel plates, with similar subsequent derivations by Schuster [4, 17] and Gurevič

[20] for light-scattering layers. These are now known to be a special case of the more general Kubelka-Munk theory [21], which we will now consider.

B. The Kubelka-Munk Theory

The Kubelka-Munk theory [5] is based upon a model in which the radiation field is approximated by two fluxes, the one, I_+ , traveling from the illuminated sample surface, and the other, I_- , traveling toward the illuminated surface (see fig. 2). As radiation travels from the surface, its intensity is decreased by scattering and absorption processes, both assumed to be proportional to the thickness of the medium traversed. This is partially offset by scattering from the other beam, so we have

$$dI_+ = -(S+K)I_+dx + SI_-dx. \quad (16)$$

The component travelling toward the illuminated surface is similarly described:

$$dI_- = (S+K)I_-dx - SI_+dx. \quad (17)$$

The constants which we have introduced here are once again phenomenological constants which describe scattering (S) and absorption (K) within the medium. If we make the following definition,

$$a \equiv \frac{S+K}{S} \quad (18)$$

we can write

$$\frac{-dI_+}{Sdx} = -aI_+ + I_-$$

$$\frac{dI_-}{Sdx} = -aI_- + I_+$$

which can be combined into a single differential equation,

$$\frac{dR}{Sdx} = R^2 - 2aR + 1 \quad (19)$$

where $R \equiv I_-/I_+$. Equation (19) can be easily integrated over the entire thickness x of the scattering medium to obtain [5]

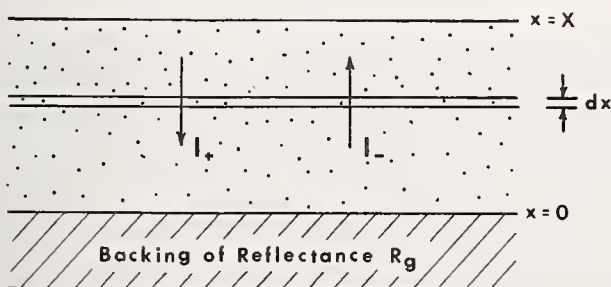

FIGURE 2. Model for the Kubelka-Munk analysis of reflectance and transmittance of a scattering medium [5].

$$R = \frac{(R_g - R_\infty)/R_\infty - R_\infty(R_g - 1/R_\infty) \exp[SX(1/R_\infty - R_\infty)]}{R_g - R_\infty - (R_g - 1/R_\infty) \exp[SX(1/R_\infty - R_\infty)]} \quad (20)$$

R_g is the reflectance of the background (see fig. 2) and R_∞ is once again the reflectance of a layer which is so thick that further increase in thickness does not alter the reflectance. If eq (19) is integrated over the limits $x=0$ to $x=\infty$, a simple formula results [5]

$$R_\infty = \lim_{x \rightarrow \infty} R = a - (a^2 - 1)^{1/2} \equiv a - b \quad (21)$$

Using eq (18) this can be rearranged to give the well-known Kubelka-Munk function $F(R_\infty)$

$$F(R_\infty) \equiv \frac{(1 - R_\infty)^2}{2R_\infty} = \frac{K}{S}. \quad (22)$$

We note in passing that this result follows directly from eq (12) in the limit $x \rightarrow \infty$ [23], which once again shows the close relationship of the Gurevič and Kubelka-Munk models.

C. Rozenberg Solutions

For a homogeneous semi-infinite medium, a good approximate treatment of the reflectance for strong absorbers has been given by Rozenberg [13-15]. The solution involves summing various successive contributions to the reflecting power by scattering of different degrees of multiplicity, and is based upon concepts developed by Kuznetsov for problems of visibility [23]. To the n th degree of approximation, the reflected intensity in an isotropic medium is given by

$$I_i^{ref}(\theta, \phi) = I_1^0 \sum_{i=1}^n \frac{a_{ii}(\theta, \phi)}{(1+\beta)^i}. \quad (23)$$

In this case θ and ϕ define the direction of observation, I_1^0 is the incident beam intensity, $\beta = \frac{\alpha}{\sigma}$ is the ratio of the absorption and scattering coefficients, and the index i runs over the four components of the radiation field (see eq (5)). The a_{ii} coefficients in eq (23) are given by

$$a_{ii} = \sum_{j=1}^4 a_{ij}(\theta, \phi) C_j^0(\theta_0, \phi_0)$$

where the $C_j^0(\theta_0, \phi_0) \equiv I_j^0/I_1^0$ define the polarization of the incident beam, and the $a_{ij}(\theta, \phi)$ are coefficients which depend only on the angles of incidence (θ_0, ϕ_0) and observation (θ, ϕ) , and on the form of the scattering indicatrix.

The reflectance of the medium is given by

$$C_i R = \sum_{i=1}^{\infty} \frac{a_{ii}}{(1+\beta)^i} \quad (24)$$

where $C_i = I_i/I_1$ is the polarization of the reflected radiation. It will be observed that as β increases, scattering of higher multiplicities becomes less important. Ambartsumian [24] has shown that the mean multiplicity of scatter in the case of reflection from a semi-infinite turbid medium is $\sqrt{1+1/\beta}$. Thus when $\beta \geq 1/3$, a fairly accurate solution is obtained by inclusion of terms up to second or third degree. It is further assumed that the scatter is independent of β , which should be a good approximation for mixtures of polydispersive media with different α and σ ; i.e., as with the addition of dye to a suspension. The resulting equation is

$$\frac{R_0}{R} = \frac{(1+\beta)^2}{1+\frac{\beta}{Q}} \quad (25)$$

where R_0 is the reflectance of the medium itself (when $\beta = \beta_0$), and

$$Q = 1 + \sum_{i=1}^{\infty} \frac{a_{1, i+1}}{a_{11}(1+\beta_0)^i} \quad (26)$$

Thus Q is a quantity which defines the relative contribution of higher multiplicities of scattering when $\beta = \beta_0$. Both it and R_0 are constants which are independent of the nature and concentration of the colorant.

Equation (25) may be regarded as a generalization of Lambert's law to the case of colored media. It has been derived in a somewhat different form by Chekalinskaia [25] from scattering theory. In terms of the reflection (r), forward scatter (t), and absorption (a) constants of a single scattering layer ($a+r+t=1$) used by Chekalinskaia, the Rozenberg constants can be written

$$\beta = \frac{a}{r+t}; \quad Q = 1 + \frac{t}{r+t} \quad (27)$$

Il'ina and Rozenberg [26] have demonstrated the validity of eq (25) in several instances. Obviously in a highly absorbing medium where $\beta \gg 1$, eq (25) further simplifies to

$$\frac{R_0}{R} \approx Q\beta \quad (28)$$

In the other limit; i.e., where $\beta \ll 1$, Rozenberg [15, 27] has shown that the reflectance can be written as an exponential of the form,

$$R_{\infty}(\mu, \mu_0) = \frac{I_0 \mu_0}{\pi} h(\mu, \mu_0) \exp[-4\sqrt{q\beta}S(\mu, \mu_0)] \quad (29)$$

where $h(\mu, \mu_0)$, $S(\mu, \mu_0)$, and q are quantities which depend on the form of the scattering indicatrix. Romanova [28] has determined these quantities by exact solution of the radiative transfer equation.

In problems of spectroscopy we often assume isotropic scatter. We know that in no case is single scatter actually isotropic [3], although the random distribution of anisotropic particles and scatter apparently tends toward an isotropic result [15]. Problems in highly anisotropic scattering media have been considered by some workers [29-34]. A detailed discussion of these solutions, often obtained by numerical computer methods, will not be discussed here.

For the simple case of isotropic scatter, the phase function (see eq (2)) can be written

$$p(\theta, \phi; \theta' \phi') = \omega_0 = \frac{\sigma}{\sigma + \alpha} \quad (30)$$

Here ω_0 is known as the albedo of single scatter. It represents the fraction of the radiation lost by scattering in a medium where both absorption (α) and scattering (σ) take place. With this assumption, the equation of radiative transfer for a plane-parallel semi-infinite medium becomes independent of the azimuthal angle ϕ and we have

$$\mu \frac{dI(\tau, \mu)}{d\tau} = I(\tau, \mu) - \frac{1}{2} \omega_0 \int_{-1}^{+1} I(\tau, \mu') d\mu' \quad (31)$$

The integral occurring in eq (31) may be approximated by a Gaussian quadrature, in which case a set of coupled linear differential equations is obtained,

$$\mu_i \frac{dI_i}{d\tau} = I_i - \frac{1}{2} \omega_0 \sum_{j=-n}^{+n} a_j I_j \quad (32)$$

The constants a_j are Gaussian weighting functions given by

$$a_j = \frac{1}{P_n'(\mu_j)} \int_{-1}^{+1} \frac{P_n(\mu)}{\mu - \mu_j} d\mu \quad (33)$$

and μ_j is one of the zeros of the Legendre polynomial, $P_n(\mu)$.

Passing to the limit $n \rightarrow \infty$ gives an exact solution which Chandrasekhar [35] has shown to be of the form,

$$I_r(\mu) = \frac{\omega_0}{4} \Phi_e(\mu_0) \frac{\mu_0}{\mu + \mu_0} H(\mu) H(\mu_0) \quad (34)$$

Here $I_r(\mu)$ is the reflected intensity in the direction μ from a collimated incident beam in the direction μ_0 , whose flux per unit area normal to the beam is $\pi\Phi_e(\mu_0)$. The H -integrals are defined by

$$H(\mu) = 1 + \frac{\mu H(\mu)}{2} \int_0^1 \frac{H(\mu')}{\mu + \mu'} d\mu' \quad (35)$$

and tables of them have been given by Chandrasekhar [35].

Giovanelli [36] has given explicit expressions for several cases of interest. The total reflectance for light incident in the direction μ_0 is

$$R(\mu_0) = 1 - H(\mu_0)(1 - \omega_0)^{1/2} \quad (36)$$

while that for diffused incident radiation is

$$R_D = 1 - 2(1 - \omega_0)^{1/2} \int_0^1 \mu H(\mu) d\mu. \quad (37)$$

Tables of the first moment of the H - integral, which occurs in eq (37), have also been given by Chandrasekhar [35].

Exact solutions to the equation of radiative transfer can be derived for other phase functions as well. In general, the phase function may be expanded as a series of Legendre polynomials

$$p(\cos \theta) = \sum_{l=0}^{\infty} \omega_l P_l(\cos \theta)$$

where axial symmetry is assumed. Terms higher than first degree contribute very little [36, 37], and thus the approximate phase function.

$$p(\cos \theta) = \omega_0(1 + x \cos \theta) \quad (0 \leq x \leq 1)$$

is sometimes used. Exact solutions are available for scatter according to this phase function also [36].

Equations (36) and (37) for isotropic scatter can be readily applied using tables given by Giovanelli [36], and they of course are of considerable theoretical interest since they represent exact solutions to which the various approximate theories can be compared. We do not expect all media to scatter isotropically, but we might expect the range of applicability of the equations to be extended if an appropriate average scattering coefficient were used. If we consider a diffuser in which each scattering center scatters light symmetrically about the direction of incidence, we may write [38]

$$\sigma_{\text{eff}} = (1 - \bar{\mu})\sigma \quad (38)$$

where

$$\bar{\mu} = \frac{\int_{-1}^{+1} I(\mu) \mu d\mu}{\int_{-1}^{+1} I(\mu) d\mu} \quad (39)$$

In this approach it is assumed that the same isotropic solutions (eqs (36) and (37)) may be used for arbitrary angular distributions of scatter, so long as the scattering is averaged according to eqs (38) and (39). Blevin and Brown [38] have shown that the reflectance curves are essentially the same for isotropic scatter or for scatter according to the phase functions $1 + P_1(\mu)$, $1 + P_2(\mu)$, and $1 + P_3(\mu)$. This suggests that the reflectance is not a sensitive function of the scattering indicatrix, and the isotropic

solutions are in fact a good approximation for real scattering media.

III. Statistical Theory

Continuum models, as we have seen, are somewhat limited. They involve the use of phenomenological constants with no obvious relationship in general to the fundamental constants with which we are familiar (molar absorptivity, refractive index, particle size and shape, etc.). Statistical theories, on the other hand, involve the construction of an appropriate model and the success of the theory depends on just how closely the model approximates real sample conditions.

It appears certain that one of the most severe limitations of continuum models is the assumption that they remain valid even when infinitesimal thicknesses are considered. This is in fact contrary to the assumption of homogeneous layers previously invoked (see section II-A), and it is this contradiction which is largely responsible for limiting the range of applicability of continuum models, as our subsequent discussion will show.

Let us return to eqs (8) and (9) and assume that we are now dealing with thin layers whose thickness is that of the individual particles. If we take layer i to be the first layer and layer j to be the combination of all the other layers of an n -layer sample, we have

$$t_{1,2,3,\dots,n} = \frac{t_1 t_{2,3,4,\dots,n}}{1 - r_1 r_{2,3,4,\dots,n}} \quad (40)$$

and

$$r_{1,2,3,\dots,n} = r_1 + \frac{t_1^2 r_{2,3,4,\dots,n}}{1 - r_1 r_{2,3,4,\dots,n}} \quad (41)$$

Passing to the limit $n \rightarrow \infty$, we write

$$t_{1,2,3,\dots,n} = t_{2,3,4,\dots,n} = T_{\infty} = 0$$

$$r_{1,2,3,\dots,n} = r_{2,3,4,\dots,n} = R_{\infty}$$

Equation (41) then becomes

$$R_{\infty} = r + \frac{t^2 R_{\infty}}{1 - r R_{\infty}} \quad (42)$$

where we have assumed that all layers are the same so the subscripts on r and t can be dropped. Equation (42) can be solved for R_{∞} to give an expression for the reflectance of an infinitely thick sample in terms of the reflectance and transmittance of a single layer. The result is

$$R_{\infty} = \frac{1 + r^2 - t^2}{2r} - \sqrt{\left(\frac{1 + r^2 - t^2}{2r}\right)^2 - 1}. \quad (43)$$

This equation is fundamental to essentially all statistical theories, the only difference being in the method used to calculate r and t .

We have seen that the Kubelka-Munk theory leads to a solution of the form,

$$\frac{(1-R_\infty)^2}{2R_\infty} = \frac{K}{S}$$

When this is solved for R_∞ , we get

$$R_\infty = \frac{K+S-\sqrt{(K+S)^2-S^2}}{S} \quad (44)$$

which is not of the same form as eq (43).

We assume with Simmons [39] that the plane-parallel layers of the Kubelka-Munk model cannot be made infinitesimally small, but are restricted to layers of finite thickness l , where l may be interpreted as the mean particle diameter of the sample. Then the fundamental differential equations of the Kubelka-Munk theory (eqs (16) and (17)) are replaced by the finite difference equations:

$$\frac{dI_+}{dx} \cong \frac{(I_+)_{i+1} - (I_+)_{i-1}}{l} = -(K+S)(I_+)_{i-1} + S(I_-)_{i+1} \quad (45)$$

$$\frac{dI_-}{dx} \cong \frac{(I_-)_{i+1} - (I_-)_{i-1}}{l} = (K+S)(I_-)_{i+1} - S(I_+)_{i-1} \quad (46)$$

where the subscripts i and $(i+1)$ refer to the i th and $(i+1)$ st sample layers, respectively. Now for an infinitely thick sample,

$$R_\infty = \frac{(I_-)_{i-1}}{(I_+)_{i-1}} = \frac{(I_-)_{i+1}}{(I_+)_{i+1}}$$

and Eqs (45) and (46) can be solved to give

$$R_\infty = \frac{2(S+K-KlS-K^2l/2) - \sqrt{4(S+K-KlS-K^2l/2)^2 - 4S^2}}{2S} \quad (47)$$

Equations (43) and (47) are identical if we make the following identifications:

$$S = r/l$$

$$K = (1-r-t)/l = a/l$$

where a is the fraction of the incident radiation which is absorbed by the layer.

The difference between the traditional and modified Kubelka-Munk solutions may be seen by writing eq (47) in the form,

$$F(R_\infty) = \frac{K}{S} - K - \frac{K^2l}{2S} = a \left(\frac{1}{r} - 1 \right) - \frac{a^2}{2r} \quad (48)$$

It will be recognized that the difference lies in the addition of the last two terms. It is well known that a

plot of $F(R_\infty)$ versus K deviates from linearity for high values of K [7-9], and it appears that eq (48) can be used to explain the deviations in part. It should be recognized that the deviations at high values of K are probably a result of anomalous dispersion effects also, but eq (48) does represent an improvement in the range of validity and shows the need to consider the particulate nature of scattering media in developing a more precise theory by which absolute absorptivities can be determined.

A. The Bodó Model

Bodó [40] used a procedure similar to that used to derive eq (43) for the derivation of r and t . We will denote the simple reflectance of the layer surface by r_0 , the absorptivity (defined through $I = I_0 \exp(-kx)$) by k , and the layer thickness (equivalent to the mean particle diameter) by l . Then according to figure 3, the reflectance and transmittance of a single layer are given by

$$r = r_0 + (1-r_0)^2 d^{-2kl} + (1-r_0)^2 r_0^3 e^{-4kl} + (1-r_0)^2 r_0^5 e^{-6kl} + \dots$$

$$t = (1-r_0)^2 e^{-kl} + (1-r_0)^2 r_0^2 e^{-3kl} + (1-r_0)^2 r_0^4 e^{-5kl} + (1-r_0)^2 r_0^6 e^{-7kl} + \dots$$

Summing these series gives

$$r = \frac{r_0[1 + (1-2r_0) \exp(-2kl)]}{1 - r_0^2 \exp(-2kl)} \quad (49)$$

$$t = \frac{(1-r_0)^2 \exp(-kl)}{1 - r_0^2 \exp(-2kl)} \quad (50)$$

Equations (49) and (50) together with eq (43) constitute the Bodó formulation, which is in fact equivalent to that of Stokes [1] and Girin and Stepanov [41]. Bodó [40] obtained good results with these formulae for powdered glass samples using the arbitrary assumption that $r_0 = 0.10$. Karvaly [42] has shown that this was at least in part due to a particularly favorable position for the absorption band

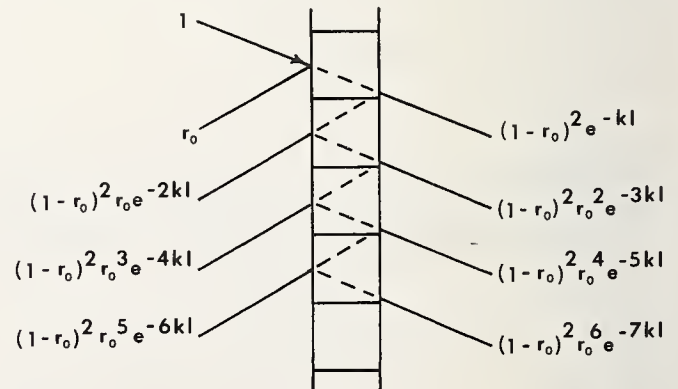

FIGURE 3. Reflectance and transmittance of a single layer of thickness l according to Bodó [40].

chosen for study, but in the general case, R_∞ is a very sensitive function of r_0 .

Bauer [43] showed that in some cases the layers should be considered to have rough surfaces where total internal reflection can take place, and he has derived expressions analogous to eqs (49) and (50) for this case.

B. The Johnson Model

Johnson [44] has carried out the summation somewhat differently than Bodó, but with quite similar results (see fig 4). It is assumed that there are p layers and that the mean number of attenuating reflections which the rays undergo in the $2p$ traversals is yp , so that the reflectance is given by

$$R_p = r_0 + 2r_0 \sum_p (1-r_0)^{yp} \exp(-2kpl). \quad (51)$$

Thus y can be regarded as an adjustable parameter which gives a semi-empirical account of multiple reflections as well as scattering losses. The sum for an infinite number of layers is

$$R_\infty = r_0 + 2r_0 \frac{\exp[y \ln(1-r_0) - 2kl]}{1 - \exp[y \ln(1-r_0) - 2kl]} \quad (52)$$

which is equivalent to eq (43) with

$$r = r_0 [1 + (1-r_0)^y \exp(-2kl)] \quad (53)$$

$$t = (1-r_0)^{y/2} \exp(-kl). \quad (54)$$

The denominator of equation (52) can be expanded to give

$$R_\infty = r_0 \left[\frac{2(1-r_0)^y \exp(-2kl)}{2kl - y \ln(1-r_0)} + 1 \right]. \quad (55)$$

This result could also be obtained directly by integration of eq (51), which suggests that it may in fact be a more realistic representation of a real sample whose particles actually have a range of diameters.

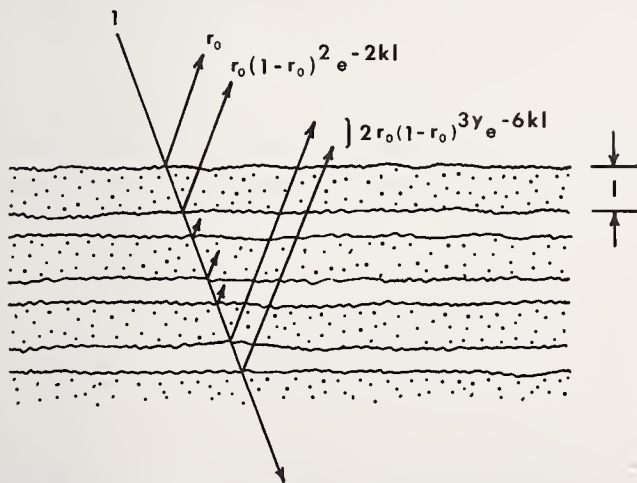

FIGURE 4. Model for Johnson analysis of reflectance from a scattering medium [44].

It will be observed from figure 4 that y should be set equal to 4 for the case of no multiple reflections. In such a case only one half of the incident light is reflected, however. Johnson has suggested that y can be estimated from eq (55) by setting $R_\infty = 1$ for $k=0$. This gives

$$\frac{(1-r_0)^{y-1}}{y} = \frac{1}{2} + \frac{1}{4} r_0 + \frac{1}{6} r_0^2 + \frac{1}{8} r_0^3 + \dots \quad (56)$$

from which $y=2$ is seen to be a satisfactory approximation for refractive indices smaller than 1.5. A smaller value of y is required for larger refractive indices. Companion and Winslow [43] have used a model similar to Johnson's, but which includes all multiple reflections. The summation was carried out by computer and no explicit expression for the reflectance was given by these workers.

Johnson [44] also suggested that r_0 be equated to 1.5 times the normal Fresnel reflectance. This is meant to account for the random distribution of particle surfaces and corresponds with an average incidence angle of approximately 30° . It was shown [44] that eq (55) yields absorption coefficients for KCl:Tl, KBr:Tl, and didymium glass which agree satisfactorily with those obtained by transmission measurements of the same materials.

C. The Antonov-Romanovsky Model

Antonov-Romanovsky [22] has developed expressions which can be used to calculate the true absorption coefficient from reflectance measurements by connecting the Kubelka-Munk and Bodó theories. Antonov-Romanovsky treats two limiting cases of regularly-shaped sample particles, spheres and parallelepipeds (see fig. 5).

For spherical particles the radiation impinges on the surface from within at the same angle that it entered the particle, since the angles which the cord of a circle makes with respect to the surface normal must be the same. Therefore, total internal reflection is impossible, and \bar{l} will approximate the particle diameter, l , actually being somewhat smaller.

In the case of the parallelepiped, some total internal reflection is possible, but most radiation probably exits through an opposite face without further reflection. In this case also it is obvious that \bar{l}

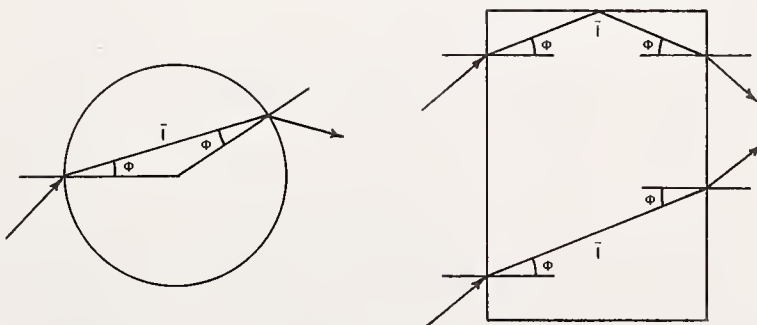

FIGURE 5. The Antonov-Romanovsky model for regular spheres and parallelepipeds [22].

is approximately of the same magnitude as l , but somewhat larger.

Thus for regularly shaped particles it is assumed that $\bar{l} \approx l$ and

$$k \approx \frac{1}{2l} \ln \frac{(1-r_0)^2 - 2r_0(1-2r_0)F(R_\infty)}{(1-r_0)^2 - 2r_0F(R_\infty)}. \quad (57)$$

This is an approximate form of the Bodó model which is valid for media in which $r_0^2 \ll 1$.

For irregularly shaped particles it is assumed that the emerging radiation meets the surface of the particle with an equal probability for all angles. This will be the case if the mean number of reflections in the layer \bar{m} , is large:

$$\bar{m} \gg 1 \quad (n > 1.5).$$

This condition requires that

$$kl_f \ll 1$$

where l_f is defined as the "free" path length. The effective path length is then

$$\bar{s} = \bar{m}l_f, \quad (58)$$

and it is assumed by Antonov-Romanovsky that

$$l_f \approx l/2. \quad (59)$$

The assumption that the emerging radiation is independent of angle allows us to divide it equally between the two sides of the layer whose thickness is l , the mean particle diameter. We write

$$r - r_0 = t \quad (60)$$

and from the law of conservation of energy,

$$(1-r_0)(1-\exp(-\bar{s}k)) = 1-r-t. \quad (61)$$

Equations (60) and (61) can be solved to give

$$r = \frac{2r_0 + (1-r_0) \exp(-\bar{m}kl/2)}{2} \quad (62)$$

$$t = \frac{(1-r_0) \exp(-\bar{m}kl/2)}{2} \quad (63)$$

Using these in eq (43) gives

$$k = \frac{2}{\bar{m}l} \ln \frac{(1-r_0)^2 - (1-r_0)F(R_\infty)}{(1-r_0)^2 - 2r_0F(R_\infty)}. \quad (64)$$

D. The Melamed Model

In contrast with the statistical theories previously discussed, Melamed carried out a summation over the reflectance and transmittance of individual particles rather than layers [46]. Some features of this model are better understood using an alterna-

tive derivation of Karvaly [47], which we follow here (see fig. 6). A single particle of the surface layer is shown in the figure; it is shifted laterally with each reflection to illustrate the path of the radiation.

Of the diffuse radiation which is incident on a given surface particle, the fraction $2u\bar{r}_e$ is reflected, where the subscript e is used to indicate reflection of externally incident radiation. Here u is defined as the radiation emerging per unit solid angle from a particle. $4\pi u$ is the solid angle which would be observed from the second layer if a particle were removed (see fig. 7).

Of the radiant flux $(1-2u\bar{r}_e)$ which enters the particle, the part $(1-2u\bar{r}_e)ut$ contributes to the reflectance from the first internal reflection, and the part $A_0 \equiv (1-2u\bar{r}_e)(1-u)t$ strikes the underlying layers, which are considered to form an infinitely thick powder mass of reflectance R_∞ . The transmission of an individual particle is represented by the symbol t . The part A_0R_∞ is reflected back into the layer, where $A_0R_\infty(1-\bar{r}_e)$ enters the particle and $A_0R_\infty\bar{r}_e$ is reflected back into the underlying layers. Of that part which entered the particle, $A_0R_\infty(1-\bar{r}_e)ut$ contributes to the reflectance and $A_0R_\infty(1-\bar{r}_e)(1-u)t$ is reflected downward again. This combines with that externally reflected to give $A_0R_\infty\bar{r}_e + A_0R_\infty(1-\bar{r}_e)(1-u)t = A_0R_\infty[\bar{r}_e + (1-u)t] \equiv A_0R_\infty Q$ as the flux reflected downward of which $A_0R_\infty^2Q$ returns to the layer, etc.

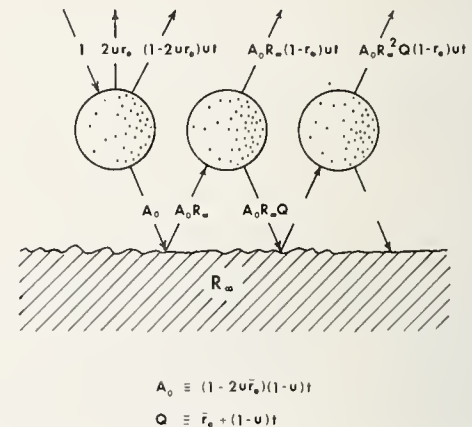

FIGURE 6. The Melamed Model for powder reflectance as viewed by Karvaly [47].

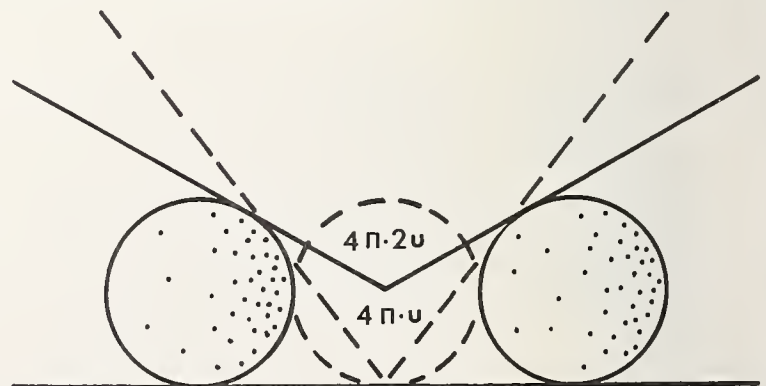

FIGURE 7. Illustration of the meaning of the radiant intensity factor u [47].

Proceeding in this manner we can write the following expressions for the reflectance and transmittance of a layer for radiation from outside (r_1 , t_1) and inside (r_I , t_I) the sample:

$$r_1 = 2u\bar{r}_e + (1 - 2u\bar{r}_e)u \cdot t \quad (65)$$

$$r_I = \bar{r}_e + (1 - \bar{r}_e)(1 - u)t \quad (66)$$

$$t_1 = (1 - 2u\bar{r}_e)(1 - u)t \quad (67)$$

$$t_I = (1 - \bar{r}_e)u \cdot t \quad (68)$$

Putting these expressions into (cf. equation (7))

$$R_\infty = r_1 + \frac{t_1 t_I R_\infty}{1 - r_I R_\infty}$$

for an infinite number of layers gives

$$R_\infty = 2u\bar{r}_e + \frac{(1 - 2u\bar{r}_e)(1 - R_\infty \bar{r}_e)u \cdot t}{(1 - R_\infty \bar{r}_e) - (1 - u)(1 - \bar{r}_e)R_\infty t} \quad (69)$$

The application of eq (69) requires some assumptions. Melamed assumes the sample to be composed of randomly-shaped particles which can be approximated as spheres. Then if we assume the absorbance is small ($kl \leq 1$) and that the radiation leaves the sphere isotropically,

$$u = \frac{u_0}{1 - (1 - 2u_0)t} \quad (70)$$

where the shading factor u_0 for close-packed spherical particles is 0.284. The transmittance of a single spherical particle including multiple internal reflections is written in terms of the internal reflectivity \bar{r}_i :

$$t = \frac{(1 - \bar{r}_i)M}{1 - \bar{r}_i M} \quad (71)$$

where

$$M = \frac{2}{(kl)^2} [1 - (kl + 1) \exp(-kl)] \quad (72)$$

is the transmittance of the particle for a single pass [48]. The mean external and internal reflectivities, \bar{r}_e and \bar{r}_i , were calculated by Melamed as the averages over the Fresnel reflectivity $r(\theta)$,

$$\bar{r}_e = 2 \int_0^{\pi/2} r(\theta) \sin \theta \cos \theta d\theta \quad (73)$$

$$\bar{r}_i = (1 - \sin^2 \theta_c) + 2 \int_0^{\theta_c} r(\theta) \sin \theta \cos \theta d\theta \quad (74)$$

for an ideal diffusing surface obeying the Lambert cosine law [49]. Here θ_c is the critical angle.

Fassler and Stodolski [50-52] have pointed out that the Melamed theory is not only cumbersome to apply, but contains an inconsistency as well. It is assumed in the Melamed treatment that the radiation is distributed isotropically. However, we have seen in the previous section that when the Melamed equation is expressed in terms of the general layer model, we require different reflectances and transmittances for external and internal radiation (see eqs (65-68)).

A model which preserves some of the features of the Melamed theory, but which removes the inconsistency, has been constructed by Fassler and Stodolski as follows: we assume radiation to be externally incident on a particle layer. The part \bar{r}_e is reflected at the surface, and the part $(1 - \bar{r}_e)$ penetrates the layer. If we use the symbol a to represent the part which is absorbed in the layer, including the effect of multiple reflections, then the part $(1 - a)(1 - \bar{r}_e)$ leaves the particle either above or below the layer. We use f_r and f_t to represent the fractions of the radiation directed upward and downward, where

$$f_r + f_t = 1.$$

Then the reflectance and transmittance of the layer are given by

$$r = \bar{r}_e + f_r (1 - a) (1 - \bar{r}_e) \quad (75)$$

$$t = f_t (1 - a) (1 - \bar{r}_e) \quad (76)$$

For weakly absorbing systems it is assumed that $f_r = f_t$, corresponding with the Antonov-Romanovsky treatment of irregular particles. In the general case, $f_r < f_t$. Equations (75) and (76) with $f_r = f_t = \frac{1}{2}$ can be put into eq (42) to get

$$F(R_\infty) = (1 - \bar{r}_e)^2 \frac{a}{1 + \bar{r}_e - (1 - \bar{r}_e)a} \quad (77)$$

$F(R)_\infty$ is once again the Kubelka-Munk function. Solving eq (77) for a gives

$$a = \frac{(1 + \bar{r}_e)}{(1 - \bar{r}_e)} \frac{F(R_\infty)}{[(1 - \bar{r}_e) + F(R_\infty)]} \quad (78)$$

If we assume the radiation within the powder layer to be isotropic, we can write $(1 - t)$ as the fraction absorbed, where t represents the transmittance of a given particle taking multiple reflections into account. Letting u_s represent the fraction of the radiation from a given particle which remains within the layer, we have $u_s t$ as the part which enters a neighboring particle where $(1 - t)u_s t$ is absorbed. Continuing in this way we once again generate a geometric series which can be summed to give the absorbance of the layer:

$$a = \frac{1 - t}{1 - u_s t} \quad (79)$$

Following Melamed [46] the radiation is distributed among the fractions going up (u_u), going down (u_d), and going sideways (u_s):

$$u_u + u_d + u_s = 1.$$

Since we assume an isotropic distribution of the radiation, we can write $u_d = u_u = u_0$, and so

$$u_s = 1 - 2u_0$$

where once again $u_0 = 0.284$ for spherical particles. Using this in eq (79) gives

$$a = \frac{\left(\frac{1}{t} - 1\right)}{\left(\frac{1}{t} - 1 + 2u_0\right)}.$$

Introducing eq (71) we can express this result in terms of the transmittance for a single pass,

$$a = \frac{\frac{1}{M} - 1}{\frac{1}{M} - 1 + 2u_0(1 - \bar{r}_i)}. \quad (80)$$

The Duyckaerts equation for M (eq (72)) leads to a very complex expression, but with the Felder approximation [53],

$$M \approx \exp \left[-\frac{2}{3} kl \right], \quad (81)$$

equations (78) and (80) can be combined to give

$$kl = \frac{3}{2} \ln \frac{1 + (\gamma - \delta)F(R_\infty)}{1 - \delta F(R_\infty)} \quad (82)$$

where

$$\gamma = \frac{2u_0(1 - \bar{r}_i)(1 + \bar{r}_e)}{(1 - \bar{r}_e)^2}$$

and

$$\delta = \frac{2\bar{r}_e}{(1 - \bar{r}_e)^2}$$

The parameters γ and δ may be treated as constants which depend only on the refractive index, n . When kl is small, $(\gamma - \delta)F(R_\infty) \ll 1$ and $\delta F(R_\infty) \ll 1$, and eq (82) simplifies to

$$kl = \frac{3}{2} \gamma F(R_\infty). \quad (83)$$

Thus there is a simple linear relationship between the true bulk absorption coefficient and the Kubelka-Munk function for weakly absorbing materials.

F. The Simmons Model

Simmons [54] has used a simplified particle model to relate diffuse reflectance to fundamental optical constants without the use of the cumbersome equa-

tions which result from the more refined Melamed theory [46].

The law of conservation of energy requires that the total radiant flux impinging on a particle (Φ_e) must equal that returning from it (Φ_e') except for the part which is absorbed:

$$\Phi_e = \Phi_e' + \Phi_e a.$$

If the spherical particles are assumed to scatter isotropically then $\Phi_e' = \pi l^2 M_e$, where M_e is the radiant flux density, and

$$\Phi_e = \pi l^2 M_e / (1 - a). \quad (84)$$

Since the reflectance of an infinitely thick sample is independent of depth, we can write the two alternative expressions for the reflectance,

$$R = \frac{(\pi l^2 M_e / 2)}{(\pi l^2 / 2) \int_0^{\pi/2} M_e(\theta) \sin \theta d\theta} \quad (85)$$

$$R = \frac{(\pi l^2 / 2) \int_{\pi/2}^{\pi} M_e(\theta) \sin \theta d\theta}{(\pi l^2 M_e / 2)} \quad (86)$$

Φ_e is the total flux integrated over the whole sphere, so eq (85) and (86) combine to give

$$\Phi_e = (\pi l^2 / 2) \int_0^{\pi} M_e(\theta) \sin \theta d\theta = \pi l^2 M_e (R + R^{-1}) / 2.$$

Equating this to eq (84) gives

$$R = [1 - (2a - a^2)^{1/2}] / (1 - a). \quad (87)$$

We let M equal the absorption from a single pass through the spherical particle. Of the incident radiation the fraction $(1 - \bar{r}_e)$ penetrates the particle where the fraction $(1 - \bar{r}_e)(1 - M)$ is transmitted, and of this, the fraction \bar{r}_i is internally reflected. The total fraction absorbed following an infinite number of such inter-reflections is

$$a = (1 - \bar{r}_e) [(1 - M) + \bar{r}_i M (1 - M) + \bar{r}_i^2 M^2 (1 - M) + \dots] \\ = \frac{(1 - \bar{r}_e)(1 - M)}{1 - \bar{r}_i M}$$

Again using the Felder approximation [53] (equation (81)) for spherical particles gives

$$a = \frac{(1 - \bar{r}_e)[1 - \exp(-2kl/3)]}{1 - \bar{r}_i \exp(-2kl/3)}. \quad (88)$$

A simple expression which is valid for small values of a can be derived by noting that eq (87) represents the leading terms of a series expansion of the form,

$$R = 1 - (2a)^{1/2} + a - \dots = \exp[-(2a)^{1/2}]. \quad (89)$$

If the exponential terms in Equation (88) are likewise expanded we find

$$a \approx \frac{(1-\bar{r}_e)2kl/3}{1-\bar{r}_i+2kl\bar{r}_i/3} \approx \frac{1-\bar{r}_e}{1-\bar{r}_i} \frac{2kl}{3}. \quad (90)$$

It can be shown that [54]

$$\frac{1-\bar{r}_e}{1-\bar{r}_i} = n^2.$$

With this result eq (90) can be combined with eq (89) to give

$$R = \exp[-2n(kl/3)^{1/2}]. \quad (91)$$

This gives a simple relationship between reflectance and the fundamental optical parameters which has been shown to be valid for weakly absorbing samples [54].

It was found that the above simple particle theory disagrees with the Melamed theory for large refractive indices [55]. The discrepancy has been attributed to a breakdown of the assumption that the externally incident radiation reflected at the particle surface is scattered equally in the upward and downward directions, an assumption which obviously becomes more questionable as n increases. By correcting the simplified particle model for this non-isotropic reflection of incident radiation, the relationship

$$r = \frac{3}{4} \bar{r}_e + (1-\bar{r}_i)(1-\bar{r}_e) \left(\frac{1}{2}t\right) \left[\frac{1}{1-\bar{r}_i t} - \frac{\left(1-\frac{1}{2}\bar{r}_i\right)\left(1-\frac{1}{2}\bar{r}_e\right)}{1+\frac{1}{2}\bar{r}_i t} \right] \quad (93)$$

$$t = \frac{1}{4} \bar{r}_e + (1-\bar{r}_i)(1-\bar{r}_e) \left(\frac{1}{2}t\right) \left[\frac{1}{1-\bar{r}_i t} + \frac{\left(1-\frac{1}{2}\bar{r}_i\right)\left(1-\frac{1}{2}\bar{r}_e\right)}{1+\frac{1}{2}\bar{r}_i t} \right]. \quad (94)$$

These equations for r and t are used with eq (43) to calculate the reflectance. It is found that the agreement with Johnson's data [56] is only qualitative, although the solution does have the feature that $R \rightarrow 0$ as $n \rightarrow 1$.

IV. Discussion of the Various Theories

If we assume isotropic radiation and the simplest Gaussian quadrature $n=1$ in eq (32), we obtain the Kubelka-Munk equations (16) and (17), with

$$S = \frac{\sigma}{\sigma + \alpha} \quad \text{and} \quad K = \frac{2\alpha}{\sigma + \alpha}.$$

Thus the Kubelka-Munk function may be regarded as a first approximation to the complete solution for the equation of radiative transfer. Detailed comparisons show that the two solutions differ by no more

$$R = \frac{1 + r_e(1-a)/2 - \sqrt{(2a-a^2)(1-r_e/4)}}{\bar{r}_e/2 + 1 - a} \quad (92)$$

was derived, which gives reflectances which agree well with those of the Melamed theory for large refractive indices [55].

Johnson [56] has pointed out that the Melamed theory [46] predicts that the diffuse reflectance decreases with increasing values of the relative refractive index, n . The same applies to the simplified particle model described above. Such behavior is reasonable for large values of n , but for values near unity it has been shown [56] experimentally that $R \rightarrow 0$ as $n \rightarrow 1$, as would be expected.

The failure of the Melamed theory and the simplified particle model theory of Simmons for n values near unity is thought to be due to the invalid assumption that radiation is returned equally in all directions from a given particle [57]. It is found that for a rough-surfaced particle; i.e., one whose surface obeys the Lambert cosine law, three-fourths of the incident radiation reverses its direction while one-fourth does not [55]. It is assumed that the radiation which is incident at a particle surface may be divided into that which is randomly scattered and that which is transmitted. If that part which is scattered becomes isotropically distributed and the direction of the transmitted radiation is essentially unchanged, then the following expressions can be derived:

than a few percent, and even this difference is of little consequence in a comparative-type measurement [12].

The Kubelka-Munk theory is in fact quite general, and encompasses many other two-constant theories which have been derived to suit certain select experimental conditions [7,23]. With the Kubelka-Munk solution expressed in terms of hyperbolic functions, it is possible to write formulas for many specific applications, and to show the connection with several other theories. It was shown explicitly by Kubelka [21] that the various equations of Gurevič [20] and Judd [58] could be derived from the Kubelka-Munk equations. The Gurevič and Judd theories are less general, however, and do not encompass completely the Kubelka-Munk results.

The Gurevič layer model is sufficiently general to allow us to use it in making some general observations concerning the continuum models and their range of applicability. Since Kubelka [21] has de-

rived eq (12) of Gurevič in terms of the hyperbolic solution, we have a connection between the parameters used in the two cases. In particular,

$$L \equiv (a^2 - 1)^{1/2} S = bS$$

where a is defined by eq (18), and R_∞ has the same meaning in the two theories. L and R_∞ are related in turn to the Gurevič constants K_1 and K_2 through eqs (14) and (15).

It will be recalled that K_1 and K_2 are positive definite constants which are characteristic of the light scattering medium (see eqs (10) and (11)). That is, we assumed thin homogeneous layers where T and R depend linearly on x .

We find, in fact, that eqs (10) and (11), and correspondingly all continuum model results, are applicable only within a limited range. From eq (11) we have the obvious restriction that $K_2 dx < 1$. It is equally obvious that the equations do not apply when dx is made arbitrarily small, since the assumption of homogeneous layers requires it to be large compared with the dimension l of the scattering particles [14, 39]. Thus we have [16]

$$l \ll dx < \frac{1}{K_2}$$

which can alternatively be written

$$K_2 l \ll 1.$$

We see that the attenuation due to absorption within a layer of thickness l must be very small compared with unity, and we are restricted to weakly absorbing and weakly scattering materials. It can in fact be shown by expanding eqs (12) and (13) in series as a function of x that eqs (10) and (11) follow only if one assumes that the medium scatters and absorbs weakly [59].

Several authors have investigated the relationship between continuum and statistical theories. ter Vrugt [60] compared the Kubelka-Munk and Bodó theories and found that the absorption constants determined by the two methods agree quite well. It was shown that for weak absorbers the parameters are related by

$$Kx = kl \quad (95)$$

and

$$Sx = \frac{2r}{1-r} \quad (96)$$

If the crystals are not too irregular, the mean path length of radiation in the particle will be approximately equal to the particle diameter and the absorption constants described by the two methods will be nearly equal. A more general relationship is

$$\exp(2kl) = \frac{2(1-r)}{F(R_\infty)/F(r) - 1} \quad (97)$$

which is valid for materials of medium absorption as well.

Poole [61] has shown that the Kubelka-Munk and Melamed theories lead to the same results for small values of the refractive index, n . In general, the absorption constants determined by the two methods are not the same and a curve is given by Poole which relates them as a function of n . It was subsequently shown by Karvaly [47] that the proportionality factor can be expressed analytically as

$$\frac{2}{3} n^2 \frac{1-r_e}{1+r_e} \quad (98)$$

and that this relationship can in fact be used to estimate n for a powdered material.

Several of the theories were compared by Companion [62] in an attempt to interpret reflectance spectra of metal oxides such as NiO and V₂O₅. It was found that the Kubelka-Munk theory gives unexplained distortions and peak shifts, the Melamed theory requires a shading factor $u_0 \sim 0.1$ rather than 0.284 which is appropriate for spherical particles, and the Johnson estimate of the factor y is not a good approximation. These discrepancies are all thought to be a result of the failure of the theories to explicitly include anomalous dispersion effects.

Karvaly [47] has shown that the Johnson model is a limiting case of the Bodó theory which should be valid in the limit of large particles or materials of large optical thickness. Antonov-Romanovsky's formulae for regularly shaped particles are likewise derivable from the Bodó theory [47]. Careful measurements of the reflectance of two didymium glass powder samples ($\bar{l} = 7.3$ and $12.2 \mu\text{m}$) by Karvaly and Pintér [63] have shown that the Bodó and Antonov-Romanovsky theories give absorption constants which are accurate to about ± 35 percent, whereas the Johnson and Melamed theories did not lead to satisfactory results in this case.

As mentioned above, the Melamed theory fails to predict that $R \rightarrow 0$ as $n \rightarrow 1$, as must be the case since there are then no scattering centers in the medium [56]. In the Johnson and Bodó models the path of the radiation is altered by internal and external reflections and refractions at particle surfaces, whereas in the Melamed model it is diverted by "scattering" according to the Lambert cosine law. In all three cases it is assumed that $l \gg \lambda$. This allows scattering to be neglected in the Johnson and Bodó models. The dependence of R on n in the Melamed theory is apparently due to the scattering of radiation internally incident on the particle surface which is taken to be independent of n . It is interesting to note that the three theories give about the same reflectance for refractive indices $1.7 < n < 2.0$.

It is of course not necessary to assume that the particles are rough-surfaced, i.e., that they scatter according to the Lambert cosine law. In the other limit they may be approximated as smooth-surfaced spheres whose reflection and refraction is governed by Fresnel's laws. This case has been treated by Simmons [64] and represents the opposite extreme between which most real systems lie.

The recently published modified particle model theory of Simmons [57] (Equations (93) and (94)) removes the discrepancy in the Melamed treatment. This modified particle model theory is thought by Simmons to be the most nearly correct of all diffuse reflectance theories [39]. It may very well be true, but its general acceptance must of course await a thorough testing under a variety of conditions by various workers.

The Fassler and Stodolski theory also shows considerable promise, but has not yet been thoroughly tested. It does lend itself to the investigation of important effects such as the influence of particle size distribution on reflectance properties [52, 65], and will probably receive considerable attention in the future.

V. Interpretation of Reflectance Parameters

One of the difficulties with weighing the relative merits of the various reflectance theories is the necessity of comparing them over a wide range of experimental conditions. In general, the data are rather incomplete and we must content ourselves with pointing out the physical significance of the parameters used. We will do this in the present section, together with making some remarks concerning the characteristics of appropriate model systems.

The internal transmittance of a powder layer in terms of hyperbolic functions has been given by Kubelka, [21]

$$T_i = \frac{b}{(a \sinh bSX + b \cosh bSX)}$$

where a and b are previously defined (eqs (18) and (21)). If we assume that S is small compared with K ,

$$a \approx b \approx \frac{K}{S}$$

and

$$T_i \approx \exp(-KX).$$

Under these conditions the transmittance follows a Lambert-type law and K can be regarded as an absorptivity characteristic of the substance.

The Kubelka-Munk constant K for a scattering medium is not equivalent to that which would be determined by transmission measurements on an identical material without scatter, however. For a beam traveling through the infinitesimal layer dx at an angle θ , the path length in the layer is $dx/\cos\theta$, and thus the mean path length of radiation traveling downward is

$$dx \int_0^{\pi/2} \frac{\partial I_+}{\partial \theta} \frac{d\theta}{\cos\theta} \quad (99)$$

where $\partial I_+/\partial \theta$ is the angular distribution of the intensity in the positive x direction. We of course have an analogous expression for the I_- component. If we assume that the medium is an ideal diffuser the intensity is the same in all directions, and the angular

distribution of intensity through a given plane becomes

$$\frac{\partial I_+}{\partial \theta} = I_+ \sin 2\theta$$

so that eq (99) becomes equal to $2dx$. Thus the effective path length in the scattering layer is twice the normal layer width because of the random angular distribution, and the apparent absorptivity should be larger by a factor of two.

The above result has been tested using colored filter glass by Kortüm and Oelkrug [66]. By measuring both the reflectance and scattered transmission of thin layers, both the scattering and absorption coefficients can be determined. Even though the powder cannot be packed to the same density as the original glass, the ratio of reflectance to transmittance values exceeded the theoretical limit, being in the range $K/k \sim 2.6-2.9$. This difference was attributed to effects of total internal reflection which should increase the path length even further [8]. There are numerous factors which can cause deviations from the factor of two in non-ideal samples, and these factors have been discussed by Van den Akker [67]. We will continue to restrict our discussion to ideal systems, however.

The statistical theories predict this ratio between absorptivity determined by reflectance and transmittance with varying degrees of success. As already mentioned, ter Vrugt [60] found them to be equal for weak absorbers (cf. eq (95)). The Antonov-Romanovsky theory [22] gives

$$\frac{K}{k} = \frac{1-r_0}{1+r_0}$$

For the BG 24 filter glass used by Kortüm and Oelkrug [66] the ratio is 0.92, which does not agree well with the experimental values.

For low refractive indices Poole [61] showed that the Kubelka-Munk and Melamed theories agree with a proportionality factor of 2.7, but much higher values are required for higher n values (cf. eq (98)). Fassler and Stodolski [68] have also derived a relationship between K and k which involves the refractive index of the medium:

$$\frac{K}{k} = \frac{1}{3u_0} \frac{n^2}{(1-\bar{r}_e)}$$

The ratio is calculated to be in the range 2.9-3.1 for the filter glass used by Kortüm and Oelkrug [66], which is in excellent agreement with the experimental values. The n^2 -dependence of K/k has also been calculated by Simmons [71] from his particle model theory. The result is

$$\frac{K}{k} = \frac{2n^2}{3}$$

which also agrees fairly well with the Kortüm and Oelkrug data [68].

Multiple scattering in dense media is a phenomenon which is not completely understood. Mie [3] has given an exhaustive treatment of single scatter and has shown that the scattering varies from the λ^{-4} -dependence of Rayleigh scatter for very small particles to a λ -independence for particles which are large compared with the wavelength of the radiation. There is no *a priori* reason to expect that these results would apply quantitatively in the case of multiple scatter, but it has in fact been found that there is a rather close correlation. Kortüm and Oelkrug [66] found that the scattering varies as $\sim\lambda^{-3.5}$ for $l<\lambda$, as $\sim\lambda^{-1}$ for $l\approx\lambda$, and as $\sim\lambda^0$ for $l>\lambda$, where l is the mean particle diameter. It is safe to assume that the scattering coefficient S is independent of wavelength in most studies, but deviations are sometimes observed in the short wavelength

$$S=l^{-1} \left\{ \frac{3\bar{r}_e+t}{4} (1-\bar{r}_e) (1-\bar{r}_i) \left[\frac{1}{1-\bar{r}_i t} - \frac{(1-\bar{r}_i/2)(1-\bar{r}_e/2)}{1+\bar{r}_i t/2} \right] \right\}.$$

Although this result appears to not yet be thoroughly tested, the term in braces is said to be relatively insensitive to changes in absorptivity [41], and probably varies significantly only with changes in refractive index, n . The same is true of the Antonov-Romanovsky result [22],

$$S=\left(\frac{2r_0}{1+r_0}\right) l^{-1}$$

and that derived by ter Vrugt [60] (see eq (96)). Quantitative calculations with the Antonov-Romanovsky expression give scattering constants that are too small by about a factor of three [47].

By taking the particle size distribution into account, Fassler and Stodolski [65] were able to calculate scattering coefficients which agree very well with those determined experimentally. Their expression is

$$S\bar{l}' = \frac{\frac{1+\bar{r}^*-\xi}{1-\bar{r}^*-\xi} a - (2f_i-1)(1-a)}{\frac{1+\bar{r}^*+\xi}{1+\bar{r}^*-\xi} + (2f_i-1)(1-a)} \quad (100)$$

where a and f_i have their previously defined meanings, it being recognized that the factor $(2f_i-1)$ defines the anisotropy of radiation in the particle layer. ξ is the effective cross section for holes in the particle layer, \bar{r}^* is the mean external reflection coefficient for side scatter taking account of holes and back scatter, and \bar{l}' is a parameter which is related to the mean particle diameter. For a particle size distribution function of the form

$$f(l)=Al^B e^{-Bl/\bar{l}}$$

\bar{l}' is given by

$$\bar{l}' = \frac{B+3}{B} \bar{l}.$$

end of the spectrum which are probably due to a breakdown of this assumption [69].

The scattering coefficient has been found in several studies to be inversely proportional to the mean particle diameter l , [70-72] the proportionality factor depending apparently on the nature of the material being studied. Using the simplified particle model, Simmons was able to derive the result [69].

$$S=l^{-1}.$$

This should not be taken as much more than an order of magnitude estimate, since a proportionality factor somewhat larger than unity is apparently more appropriate in many cases [66]. The modified particle model gives [39]

Fassler and Stodolski [65] emphasize the fact that the scattering is particle size-dependent, so that for quantitative reflectance spectroscopy it is essential to have a set of standards with known, small particle size distribution and of various mean particle diameters. Then it is possible to mix the sample with a standard of similar particle size so that the scattering characteristics are not greatly changed. This is important for comparative measurements.

The effect of particle shape is also important. It appears at the present time that there is no better way to test the various reflectance theories than to make transmission and reflectance measurements on a given glass sample before and after grinding, respectively. The characteristics of glass samples subjected to various grinding conditions have been studied by Karvaly and Pintér [73]. These factors will not be discussed here, but it should be emphasized that the proper definition of reflectance standards must certainly quantify not only size and shape, but the precise nature of any adsorbent materials and the surface conditions as well.

VI. References

- [1] Stokes, G. G., Proc. Roy. Soc. (London), **11**, 545 (1860-62).
- [2] Rayleigh, Lord, Phil. Mag. **41**, 107 (1871).
- [3] Mie, G., Ann. Physik, **25**, 377 (1908).
- [4] Schuster, A., Astrophys. J. **21**, 1 (1905).
- [5] Kubelka P., and Munk, F., Z. tech. Phys. **12**, 593 (1931).
- [6] Schwarzschild, K., Sitz. ber. Preuss. Akad. Wiss. Berlin **1914**, 1183.
- [7] Wendlandt, W. W., and Hecht, H. G., Reflectance Spectroscopy (Interscience, 1966).
- [8] Kortüm, G., Reflexionsspektroskopie, (Springer-Verlag, 1969; published also in an English edition).
- [9] Frei, R. W., and MacNeil, J. D., Diffuse Reflectance Spectroscopy in Environmental Problem-Solving (The Chemical Rubber Co. Press, 1973).
- [10] Transactions of the First Conference on the Spectroscopy of Light-Scattering Media, Moscow, 29-30 March 1956, Izvest. Akad. Nauk. SSSR, Ser. Fiz., **21**(11), 1957; (Columbia Technical Translation, Bull. Acad. Sciences SSSR, Physical Series, **21**(11) (1958)).

- [11] Wendlandt, W. W., Modern Aspects of Reflectance Spectroscopy, Proceedings of the American Chemical Society Symposium on Reflectance Spectroscopy, Chicago, 11-12 September 1967 (Plenum Press, 1968).
- [12] Hecht, H. G., The Present Status of Diffuse Reflectance Theory, in ref. [11], pp. 1-26.
- [13] Rozenberg, G. V., Usp. fiz. Nauk **56**, No. 2 (1955).
- [14] Rozenberg, G. V., Izvest. Akad. Nauk SSSR, Ser. Fiz. **21**, 1473 (1957).
- [15] Rozenberg, G. V., Usp. fiz. Nauk **69**, 57 (1959).
- [16] Stepanov, B. I., Izvest. Akad. Nauk SSSR, Ser. Fiz. **21**, 1485 (1957).
- [17] Schuster, A., Phil. Mag. **5**, 243 (1903).
- [18] King, L. V., Phil. Trans. Roy. Soc. (London), **A212**, 375 (1913).
- [19] Kubelka, P., J. Opt. Soc. Am. **44**, 330 (1954).
- [20] Gurevič, M., Phys. Zeits. **31**, 753 (1930).
- [21] Kubelka, P., J. Opt. Soc. Am. **38**, 448 (1948).
- [22] Antonov-Romanovsky, V. V., Zhur. ekspr. i teor. fiz. **26**, 459 (1954).
- [23] Kuznetsov, E. S., Izvest. Akad. Nauk SSSR, Ser. geog. i geofizika. **5** 247 (1943).
- [24] Ambartsumian, V. A., Dokl. Akad. Nauk Armenian SSR, **8**, 101 (1948); J. Phys. USSR **8**, 65 (1944).
- [25] Chekalinskaia, I. I., Izvest. Akad. Nauk SSSR, Ser. Fiz. **21**, 1494 (1957).
- [26] Il'ina, A. A., and Rozenberg, G. V., Dokl. Akad. Nauk SSSR **98**, 3 (1954).
- [27] Rozenberg, G. V., Dokl. Akad. Nauk SSSR **145**, 775 (1962).
- [28] Romanova, L. M., Opt. i Spektroskopia **17**, 250 (1964).
- [29] Romanova, L. M., Opt. i Spektroskopia **13**, 429, 819 (1962); **14**, 262 (1962).
- [30] Sagan, C., and Pollack, J. B., J. Geophys. Research **72**, 469 (1967).
- [31] Orchard, S. E., J. Opt. Soc. Am. **59**, 1584 (1969).
- [32] Reichman, J., Appl. Optics **12**, 1811 (1973); Egan, W. G., Hilgeman, T., and Reichman, J., *ibid.*, **12**, 1816 (1973).
- [33] Chu, C. M., and Churchill, S. W., J. Phys. Chem. **59**, 855 (1955); Evans, L. B., Chu, C. M., and Churchill, S. W., J. Heat Transfer, **87C**, 381 (1965); Chu, C. M., Churchill, S. W., and Pang, S. C., in Electromagnetic Scattering, M. Kerker, Ed. (MacMillan Company, New York, 1963).
- [34] Irvine, W. M., Astrophys. J. **152**, 823 (1968).
- [35] Chandrasekhar, S., Radiative Transfer, (Clarendon Press, 1950) (Reprinted by Dover Publications, Inc., 1960).
- [36] Giovanelli, R. G., Optica Acta **2**, 153 (1955).
- [37] Pitts, E., Proc. Phys. Soc. **B67**, 105 (1954).
- [38] Blevin, W. R., and Brown, W. J., J. Opt. Soc. Am. **51**, 975 (1961).
- [39] Simmons, E. L., Appl. Optics **14**, 1380 (1975).
- [40] Bodó, Z., Acta Phys. Hung. **1**, 135 (1951).
- [41] Girin, O. P., and Stepanov, B. I., Zhur. ekspr. i teor. fiz. **27**, 467 (1954).
- [42] Karvaly, B., Acta Phys. Chem. **16**, 107 (1970).
- [43] Bauer, G. T., Acta Phys. Hung. **14**, 311 (1962).
- [44] Johnson, P. D., J. Opt. Soc. Am. **42**, 978 (1952).
- [45] Companion, A., and Winslow, G. H., J. Opt. Soc. Am. **50**, 1043 (1960).
- [46] Melamed, N. T., J. Appl. Phys. **34**, 560 (1963).
- [47] Karvaly, B., Acta Phys. Hung. **28**, 381 (1970).
- [48] Duyckaerts, G., Spectrochim. Acta **7**, 25 (1955).
- [49] Judd, D. B., J. Res. Nat. Bur. Stand. (U.S.), **29**, 329-332 (Nov. 1942) RP1504.
- [50] Fassler, D., and Stodolski, R., Z. Chem. **11**, 276 (1971).
- [51] Fassler, D., and Stodolski, R., Z. Chem. **11**, 434 (1971).
- [52] Fassler, D., and Stodolski, R., Z. Phys. Chem. (Leipzig), **251**, 183 (1972).
- [53] Felder, B., Helv. chim. Acta, **47**, 488 (1964).
- [54] Simmons, E. L., Opt. Acta **18**, 59 (1971).
- [55] Simmons, E. L., Opt. Acta **22**, 71 (1975).
- [56] Johnson, P. D., J. Appl. Phys. **35**, 334 (1964).
- [57] Simmons, E. L., J. Appl. Phys. **46**, 344 (1975).
- [58] Judd, D. B., J. Res. Nat. Bur. Stand. (U.S.), **12**, 345-351 (Mar. 1934) RP660; *ibid.*, **13**, 281-291 (Sept. 1934) RP709.
- [59] Stepanov, B. I., Chekalinskaia, I. I., and Girin, O. P., Trudy (Transactions Inst. Phys. Math. No. 1, 152 (1956)).
- [60] ter Vrugt, J. W., Philips Res. Repts. **20**, 23 (1965).
- [61] Poole, C. P., Jr., Z. Naturforschung **19a**, 394 (1964).
- [62] Companion, A. L., in 'Developments in Applied Spectroscopy,' Vol. 4, E. N. Davis, Ed. (Plenum Press, 1965).
- [63] Karvaly, B., and Pintér, F., Acta Phys. Hung. **29**, 203 (1970).
- [64] Simmons, E. L., South African J. Sci. **70**, 219 (1974).
- [65] Fassler, D., and Stodolski, R., Z. Phys. Chem. (Leipzig), **252**, 133 (1973).
- [66] Kortüm, G., and Oelkrug, D., Z. Naturforschung **19a**, 28 (1964).
- [67] Van den Akker, J. A., Theory of Some of the Discrepancies Observed in Application of the Kubelka-Munk Equations to Particulate Systems, in ref. [11], pp. 27-46.
- [68] Fassler, D., and Stodolski, R., Z. Chem. **11**, 395 (1971).
- [69] Simmons, E. L., Opt. Acta **19**, 845 (1972).
- [70] Kortüm, G., Braun, W., and Herzog, G., Angew. Chem. Intern. Ed. **2**, 333 (1963).
- [71] Kortüm, G., and Haug, P., Z. Naturforschung **8a**, 372 (1953).
- [72] Kortüm, G., and Vogel, J., Z. Phys. Chem. N.F. **18**, 110 (1958).
- [73] Karvaly, B., and Pintér, F., Silikattechnik **21**, 7 (1970).

(Paper 80A4-902)

Calibration of Reflectance Standards*

W. Budde

National Research Council of Canada, Ottawa, Canada K1A 0R6

(May 26, 1976)

Measurements of the diffuse spectral reflectance are usually not made as direct measurement of the incident and the reflected radiant flux but rather as measurements relative to a standard of known reflectance value.

For the calibration of such standards, different methods have been described in the literature:

1. Goniophotometric methods, also called Indicatrix methods or point-by-point methods.
2. Methods based on the Kubelka-Munk theory.
3. Integrating sphere methods according to Taylor, Benford, Sharp-Little, van den Akker, Korte.

Various materials such as magnesium oxide, barium sulfate or opal glass are being used as standards. Their suitability as transfer or as working standards will be discussed.

The results of comparative measurements between some of these methods will be given.

Key words: Barium sulfate; diffuse reflectance spectra; magnesium oxide; opal glass; radiant flux; reflectance standards; standards calibration.

I. Introduction

Measurements of the diffuse spectral reflectance have been used for many years as a tool in the measurement of color [1].¹ However the extensive use of such measurements in analytical chemistry has been developed only recently [2]. In general the measurement of a reflectance requires the measurement of the flux reflected from a surface and that incident on this surface. Such measurements are difficult and therefore in most practical applications only reflectance measurements relative to a standard of known value are being made. The "calibration" of such standards is then done either by a definition or convention (e.g., to agree [5] that the reflectance of smoked MgO=1.0), or by suitable measurements.

It is the purpose of this paper to outline some of the most important methods for such calibrations, to discuss briefly the physical properties of various materials which are used as standards, and to present a few intercomparative data. In presenting the various methods only the main features will be given and those characteristics which are important for distinguishing the methods and the quantities which are measured. Giving the full theory for each method and all experimental details is beyond the frame of this paper and it must be left to the reader to study the details in the original references.

There are essentially three groups of methods for absolute reflectance measurements:

- (1) Goniophotometric measurements of the reflectance indicatrix with numerical integration.
- (2) Methods based on the Kubelka-Munk theory.
- (3) Methods using integrating spheres.

Although examples for all three groups will be given the emphasis will be on methods in the last group which has many interesting varieties and is most widely used.

II. Terminology

The terminology in this paper will generally be in accordance with CIE terminology [3] with the following exceptions and additions:

(1) The terms radiance and luminance are being used interchangeably. Luminance is used mainly where photometric measurements are involved, while radiance is used in the context of spectral measurements. Geometrically these terms are identical, however luminance refers to values measured with a detector whose spectral sensitivity distribution agrees with the CIE photometric standard observer function.

(2) Standards for diffuse reflectance measurements may be calibrated in three different geometries:

- (a) diffuse/diffuse (d/d)
- (b) normal/diffuse ($0/d$)
- (c) diffuse/normal ($d/0$).

*National Research Council Paper No. 15041.

¹ Figures in brackets indicate the literature references at the end of this paper.

The first term always describes the geometry of illumination whereas the second term describes the geometry of the measurement. Diffuse illumination is achieved by means of an integrating sphere. For the measurement of diffusely reflected radiation either a goniophotometer, a hemispherical mirror or an integrating sphere is used.

For colorimetric measurements the CIE recommends four geometries: $0/d$; $d/0$; $0/45$ and $45/0$. For the purposes of this paper the d/d geometry is added whereas the $0/45$ and $45/0$ geometries are not discussed. The reason for this selection is that many techniques in diffuse reflectance spectroscopy are based on the Kubelka-Munk theory which requires the use of an integrating sphere.

(3) The term "reflectance" applies only for the d/d and the $0/d$ geometry. For the $d/0$ geometry the term "reflectance factor" $\beta_{d/0}$ applies which is defined [3] as: ratio of radiant (luminous) flux reflected in the directions limited by the cone to that of the perfect reflecting diffuser identically irradiated (illuminated). If a sample is highly opaque and very matte so that its reflection indicatrix approximates that of a perfect diffuser, then the reflectance factor $\beta_{d/0}$ will have the same value as the reflectance $\rho_{0/d}$ and the reflectance $\rho_{d/d}$. For simplicity the term reflectance will occasionally also be used here for the $d/0$ geometry.

(4) In this paper the word "calibration" is used for two different procedures:

(a) Calibration of a physical standard means to establish its reflectance value by a suitable procedure. According to the old CIE convention [5] this procedure consisted of preparing a smoked MgO surface and giving this surface the reflectance value 1.0. Now [4, 6] this procedure consists in an absolute reflectance measurement which establishes the reflectance of a physical standard with respect to the perfect reflecting diffuser.

(b) Calibration of an instrument for relative measurements refers to the adjustment of this instrument so that correct reflectance values of arbitrary specimens can be determined. For this adjustment a suitable standard with a known reflectance value is used.

III. Goniophotometric Measurements

This method is also called the "indicatrix-method" or "point-by-point method." The sample is irradiated with a narrow beam usually in the direction of or near the normal (angle of incidence $\epsilon_1 \approx 0^\circ$) and the reflected radiation is measured at various angles (angle of observation $0^\circ \leq \epsilon_2 \leq 90^\circ$) and various azimuths. The incident flux ϕ_0 is determined by measuring either the intensity of the source [7] or the irradiance at the plane of the sample surface [8]. The reflected flux ϕ_r is determined by numerically integrating the measured goniometric values of the radiance [8] or the intensity [7] of the sample.

This method is usually time consuming and difficult. Since the reflected flux must be measured at many angles and the measurement of the incident flux requires a considerable change in the experimental set-up, great care must be taken that source and detector are stable over extended periods of time. The greatest difficulty arises from the fact that the incident flux and the flux reflected into the narrow cone defined by the photometer differ by about 3 to 4 orders of magnitude. This difficulty is usually overcome by using an auxiliary source which provides an intermediate level of signal so that two ratios of about 100 to 1 are to be measured.

This method was used for the earliest diffuse reflectance measurements, strangely enough for determining the reflectance of black materials such as soot [9-11]. However, after integrating sphere methods were developed the goniophotometric method was practically only used for comparison: e.g., McNicholas [12], Taylor [13], Korte [7] and Egan [14] report such comparison of values obtained by goniophotometry or with the integrating sphere method. In recent years Kartachevskaja [15] and Morren [8] used the goniophotometric method by itself to determine reflectances of various materials.

All measurements of the reflected flux at various angles and the integration may be combined into one single step if a hemispherical mirror is used. In figure 1 sample S and detector T are mounted in two closely spaced conjugate points of a hemispherical mirror M. The incident beam is first directed to the detector for the measurement of the incident flux. Then the beam is switched to irradiate the sample. The total flux reflected from the sample is collected by the hemispherical mirror and directed to the detector.

In this technique the reflectance of the hemispherical mirror must be known. It may be determined if a flat sample of the mirror material is mounted at the sample port and a normal measurement is made. The resulting ratio of the two responses is the square of the mirror reflectance.

This technique was used for the earliest reflectance measurements by Royds, 1910 [10] and Coblenz, 1913 [11] and more recently by Derksen et al in 1957 [16].

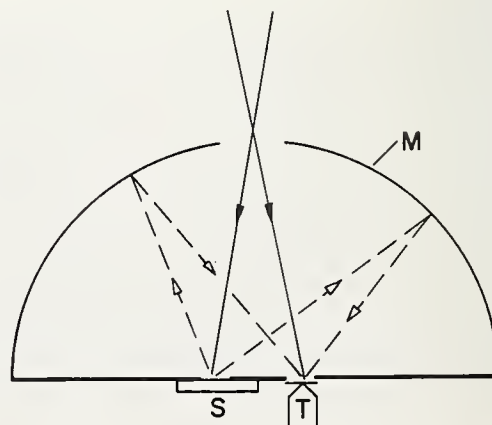

FIGURE 1. Hemispherical mirror method: M=hemispherical mirror; S=sample; T=detector=thermocouple.

The hemispherical mirror technique is not considered to be an integrating sphere technique because it consists in the actual measurement of the ratio of the reflected to the incident flux whereas in integrating sphere techniques the effect of the sample on the radiance of the sphere wall is utilized. This effect is considerably more complex than the simple reflection from the hemispherical mirror.

IV. Methods Based on the Kubelka-Munk Theory

The Kubelka-Munk theory [17, 18] provides various relations between reflectance values of translucent materials such as powders, sheets of paper, layers of paint over various backgrounds and other physical parameters such as thickness of the layer, "dilution" of a powder with other powders, transmittance, absorption coefficient, etc. These equations suggest certain methods for absolute reflectance measurements which have been tried and reported in the literature.

Stenius [19] measured the reflectance of a sheet of paper over backgrounds of different reflectances relative to a standard and was able to show how the absolute reflectance of the standard used for the relative measurements could be determined from these values (eqs. 12 and 14 of his paper). However it appears that his values are of poor accuracy and he concluded that the Kubelka-Munk equations are not immediately applicable to hand-made sheets of paper. In 1968 A. E. Aneliunas presented a paper at the annual meeting of the Canadian Pulp and Paper Association in which he investigated various aspects of Stenius' method and proposed a modification which consisted in the measurement of different numbers of sheets of paper thus varying the thickness of the layer by known amounts. From the thicknesses and the associated relative reflectances he determined the scattering coefficient and the absolute reflectance. Although the reflectance values for pressed MgO determined by this method agreed closely with those determined by other methods, indicating the suitability of this method, it was not published in print [63].

A different approach was taken by Butler [20] who was determining absorption coefficients, reflectances and scattering coefficients of various scattering materials from transmittance measurements of layers of various thicknesses. The theory shows that under certain conditions the optical density ($=\log(1/T)$ where T is the measured transmittance) is a linear function of the thickness X . The ordinate intercept of this line is related to the reflectance of an infinite layer of the material.

Law and Norris [21] used measurements on small glass spheres as a model particulate system to test the suitability of the method. However in these two papers reflectance values were only a by-product while other parameters such as refractive index, particle size, scattering and absorption coefficients were of major interest. No measurements of the

reflectance of commonly used reflectance standards are reported.

The third method was proposed by Lindberg [22] who "diluted" BaSO₄ powder with Fe₂O₃ powder in known concentrations and showed that from these concentrations and the relative reflectances measured for each concentration the absolute reflectance of the standard used for the relative reflectance measurements could be determined. For a pure BaSO₄ he found values very close to those published elsewhere. However, the method is time-consuming and it was estimated that the determination of the reflectance "should be good to 0.5 percent" which is a poorer level of accuracy than can be achieved by other methods.

It appears that only the last of these three methods was developed specifically for the calibration of reflectance standards. It was attempted to achieve this with instrumentation which is standard equipment in an analytical laboratory: a spectrophotometer with a reflectance attachment and a weight scale.

Interesting as these methods are their complexity and lack of accuracy and the fact that they are not immediately applicable to all types of reflectance standards seem to have precluded these methods from being adopted by major standardizing laboratories for the calibration of reflectance standards.

V. Integrating Sphere Methods

In 1912 Nutting [23] published a method for absolute reflectance measurements based on the theory of two parallel infinite planes (which he realized by means of a ring mirror). His method is not of interest and has rarely been used afterwards. His values were discussed and rejected in 1920 when three papers were published on reflectance measurements by means of integrating spheres.

A. The Taylor Methods

Based on certain considerations developed during the construction of an 88 inch integrating sphere for luminous flux measurements [24], A. H. Taylor in 1920 published a paper [13] in which "five absolute methods of measuring reflection factors are described, at least three of which are apparently new." One of these methods is for the measurement of specular reflectance and one is a goniophotometric method as described in section III. This latter method was used to verify the values obtained by the sphere methods. The three integrating sphere methods are the "new methods" and are described as follows.

First Taylor Method

The integrating sphere, see figure 2a, has two entrance ports A and C and one sample port S which comprises about 10 percent of the total sphere area. Through a viewing port V a photometer views an area on the opposite wall for measurements of the luminance ("brightness" in Taylor's terminology)

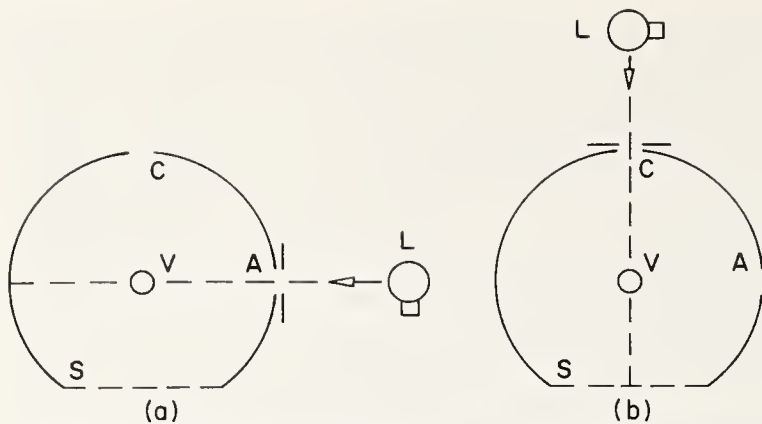

FIGURE 2. First and second Taylor method: A and C apertures for entering beam; V=window for photometer; S=sample aperture; L=light source.

of the wall. For this method the light source L remains at port A.

For the determination of the reflectance of the sphere wall two measurements are made

- (1) The sample port remains open or is covered with a nonreflecting sample. A luminance B_0 is measured.
- (2) The sample port is covered with a sample having the same paint as the sphere wall. A luminance B is measured.

From the measured ratio $k=B/B_0$ and the known geometrical constants of the sphere (diameter of sphere and sample port) the diffuse-diffuse reflectance ρ_w ("m" in Taylor's eq 9) is calculated. For the determination of the reflectance ρ_x of an arbitrary sample the sample port is covered with this sample and a luminance B_x of the sphere wall is measured. From the ratio $k_x=B_x/B_0$ (where B_0 is the luminance of the wall with S uncovered as before) the geometrical sphere constants, and ρ_w , the reflectance ρ_x is calculated.

This method obviously yields the diffuse/diffuse reflectance of sphere paint and sample. It is necessary to determine the reflectance of the sphere paint, before that of a sample can be determined. In Taylor's theory the apertures for photometer and entering beam are considered negligibly small. Preston [25] and Middleton and Sanders [26] expanded the theory to make corrections for these apertures and proposed some modifications to the experimental technique. While Taylor and Preston used white light for their experiments, Middleton and Sanders incorporated a monochromator in the apparatus and reported spectral values. Budde [27] used this method with a small sample aperture so that the difference between the flat sample area and the spherical cap over the sample area was negligibly small. Thus the theoretical considerations and the final equations were simplified and a close resemblance to the "fractional sphere method", see section 5.2, was obtained without the limitation of the fractional sphere method which is applicable to sphere paints only.

Second Taylor Method

In this method the reflectance ρ_w of the sphere paint is determined as in the first Taylor method. Then the source L is mounted at the entrance port C, see figure 2b. The sample port is again covered with the flat sample of the sphere paint and a luminance B' is measured on the sphere wall. Then the unknown sample is mounted at the sample port and the luminance B_x is measured. From the ratio $R=B_x/B'$, the geometrical sphere constants, and ρ_w , the reflectance ρ_x is calculated (Taylor's Eq 16).

In this method the d/d reflectance of the sphere paint is determined in the first step but in the second step the $0/d$ reflectance of the flat sphere paint sample is compared with that of the unknown sample. The assumption is that $\rho_{d/a}=\rho_{0/a}$ for the sphere paint which is only true if the paint is very matte and opaque.

Third Taylor Method

Taylor describes this method as follows: "the sample was placed in a sphere and a very narrow beam of light was projected through a small hole in the sphere wall onto the sphere surface at a point unshielded from the observation window, then onto the sample so placed that none of the first reflected light from it could reach the observation window. The ratio of the brightness of the window in the second case to that in the first case is the reflection factor of the test surface."

Taylor gives no drawings for this method but figures 3a and 3b may be used to explain the salient facts. The sphere has a screen B which blocks any direct radiation from the sample S to the observation window W which is probably a ground glass. It also may be the area viewed by a photometer through an aperture in the opposite wall. First the incident flux ϕ_0 irradiates the sphere wall and the observation window receives radiation directly from the irradiated area as well as by multiple reflection from the sphere. Then the source is moved around to irradiate the sample S. The observation window receives only radiation by multiple reflection. The ratio of the two irradiances at the window is the $0/d$ reflectance of the sample.

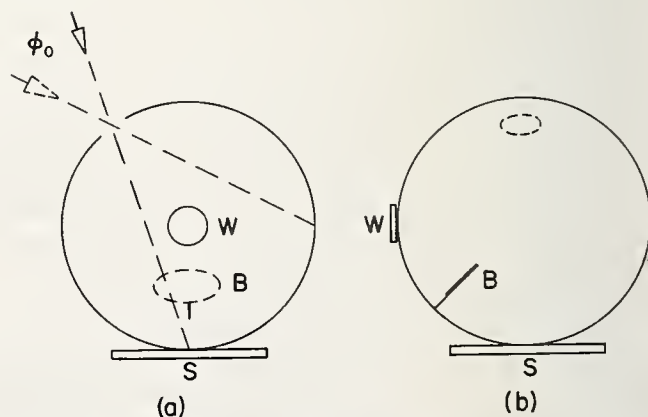

FIGURE 3. Third Taylor method: ϕ_0 =flux entering the sphere; S=sample; B=baffle; W=observation window.

The sphere is shown in two different views to illustrate the location of the baffle.

The essential feature of this method is the introduction of the screen **B** which blocks the observation window from receiving radiation from the irradiated spot on the sample. It is important to note that in this method it is not necessary to determine first the reflectance of the sphere paint. The measured ratio is not that of sample reflectance to sphere wall reflectance but rather the absolute reflectance of the sample itself.

For this method, Taylor constructed a simple instrument which is described in reference 28. The influence of the apertures and the goniophotometric properties of the sphere paint were investigated by Reule [28a].

It must be mentioned that in the literature the terms "Taylor Method" or "Taylor Sphere" are often used without a clear indication which of the three methods is meant.

B. The Fractional-Sphere Method

Also in 1920 F. A. Benford published a paper [29] on an integrating sphere method in which the sphere has one or more removable sections. The method is based on the fact that the luminance of the sphere wall depends, among other factors, on the reflectance of the sphere paint and on the actual amount of the wall area if the sphere is incomplete. If the sphere has removable areas so that two fractional spheres with remaining relative wall areas $a_1 = A_1/4\pi r^2$ and $a_2 = A_2/4\pi r^2$ are obtained and if the two luminances or irradiances of the wall measured in the two fractional spheres are R_1 and R_2 , the amount of radiation entering the spheres being identical, then it can be shown that the reflectance of the sphere wall is given by the simple relation

$$\rho_w = \frac{R_1 - R_2}{a_1 R_1 - a_2 R_2}$$

This method is directly applicable only for materials which can be applied to the inner surface of the sphere and yields the d/d reflectance of the material. It has a strong resemblance to the first part of the first Taylor method for the determination of the reflectance of the sphere paint. However in Taylor's method the removable portion of the sphere is flat and this makes Taylor's theoretical considerations and the final equation rather complicated. In Benford's method all removable sections are spherical and the theory and final equation are simple.

In two subsequent papers [30, 31] extensions and applications are described. In 1955 Tellex and Waldron [32] used this method for the determination of the reflectance of electrostatically deposited, smoked MgO.

C. The Sharp-Little Method

The third paper on integrating sphere methods published in 1920 was that by Sharp and Little [33]. This method is in fact a geometrical inversion of the third Taylor method and may be explained using figure 4. Flux ϕ_0 enters the sphere and forms an

irradiated spot at the wall from which flux ϕ'_0 is reflected. The sample **S** receives only indirect irradiation from the sphere wall due to multiple reflections because of the screen **B** while all other areas of the wall receive direct illumination from ϕ'_0 as well as the indirect radiation. The photometer **P** measures first the luminance B_s of the sample and then the luminance B_w of the unscreened sphere wall; the $d/0$ reflectance ρ_x of the sample is given by $\rho_x = B_s/B_w$.

Here again the essential part is the baffle **B** which prevents the direct illumination of the sample from the irradiated area (which may be considered a secondary source within the sphere).

The authors assumed that the apertures for the entering flux and for the photometer were negligibly small. Budde [34] expanded the theory to allow corrections for the apertures and also indicated that the same type of corrections are applicable to the third Taylor method.

The schematic diagram of an instrument [35] which may be easily converted from the Sharp-Little geometry to that of the third Taylor method is shown in figure 5. The lamp is imaged by lens L_1 into lens L_2 which in turn images the aperture F_1 onto the sphere wall. The baffle near the center of the sphere blocks any direct radiation from the image (the secondary source within the sphere) to the sample. The "Filter" is one of a set of interference filters in a filter wheel to allow spectral measurements. A photometer system, consisting of lens L_3 , aperture F_2 , an opal glass and a photomultiplier, measures the radiance of the sample B_s and then swings around to measure the radiance B_w of the sphere wall. It can be shown that

$$\rho_x = \frac{B_s}{B_w} \frac{A_0}{A_1 + A_2}$$

where $A_0 = 4\pi r^2$ = total sphere area, A_1 = area of sample port and A_2 = area of remaining sphere wall. The factor $A_0/(A_1 + A_2)$ represents a correction factor for the entrance aperture and the two observation apertures which are supposed to be black. In this set-up the instrument yields the diffuse/

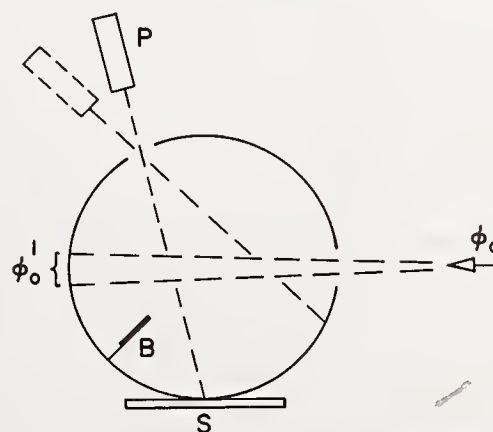

FIGURE 4. Sharp-Little method: ϕ_0 flux entering the sphere; ϕ'_0 = diffuse source within the sphere; **B** = baffle; **S** = sample; **P** = photometer viewing either the sample or the sphere wall.

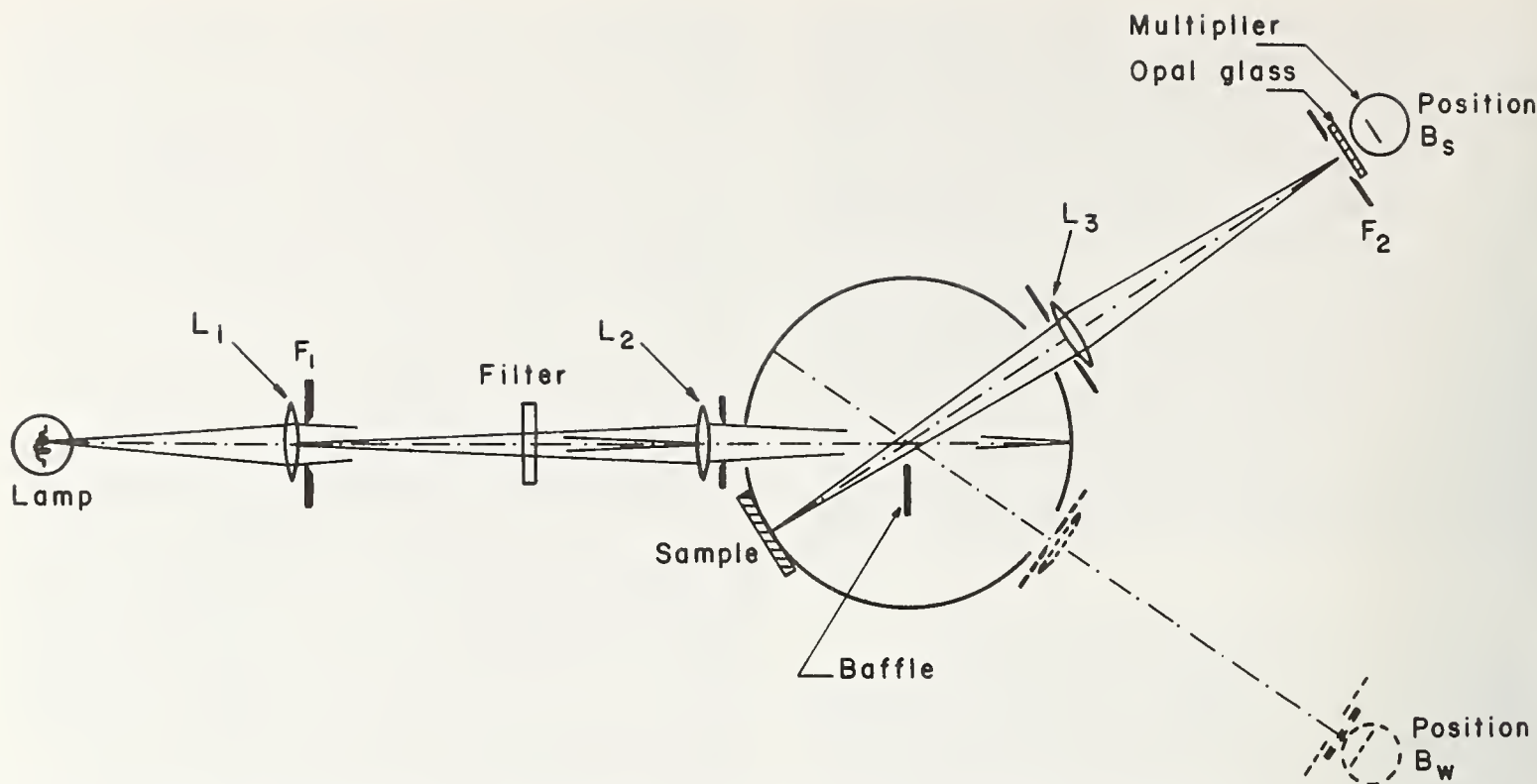

FIGURE 5. Detailed schematic diagram of an instrument for measurements of $\rho_{a|o}$ (according to Sharp-Little) or $\rho_{o|a}$ (according to the third Taylor method).

Explanations in the text.

normal reflectance factor according to the Sharp-Little method. It may be easily converted to the inverse geometry by exchanging the source (with lens L_1) and the detector (with the opal glass). Then it yields the normal/diffuse reflectance according to the third Taylor method.

This instrument has been constructed at the National Research Council of Canada and is being used for the calibration of reflectance standards [35].

D. The Double-Sphere Method

In 1966 van den Akker et al. [36] published a paper on absolute spectral reflectance measurements in which an auxiliary sphere is mounted at the sample port of the integrating sphere of a diffuse-reflectance, double-beam spectrophotometer, see figure 6. At the reference port of the spectrophotometer a flat sample is mounted which has the same paint as the auxiliary sphere. If the ratio of the port area of the auxiliary sphere to the total inner area of this sphere is p and the ratio of the reflectance of the auxiliary sphere to that of the flat sample (the ratio measured by the spectrophotometer) is r then it is shown that the diffuse/diffuse reflectance of the sphere paint, and the flat sample, is given by:

$$\rho_{a|a} = (r-p)/[r(1-p)]$$

An application of this method and some error analysis was published shortly afterwards in a paper by Goebel et al. [37], and this method was also adopted in ASTM and TAPPI Standards.

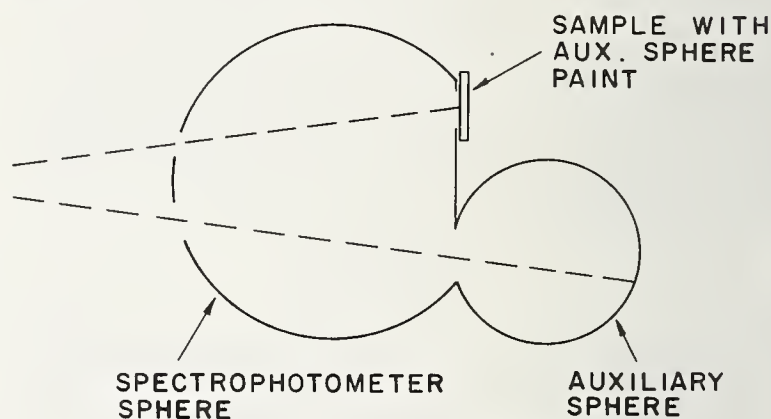

FIGURE 6. Double sphere method.

This method is presently used at the NBS for the calibration of reflectance standards.

E. The Korte (PTB) Method

While in all previous methods the samples were mounted at a port of the integrating sphere Korte [7] described a method where the sample is mounted in the center of an integrating sphere. Six lamps are mounted in one hemisphere so that they do not irradiate the sample surface directly. The sample is irradiated only indirectly from the other hemisphere, see figure 7. The ratio of the radiance L_s of the sample observed through window V_1 to the radiance L of the illuminating hemisphere observed through window V_2 gives the reflectance factor $\beta_{a|o} = L_s/L$ of the sample which in this case for a matte sample is equal to the reflectance, $\rho_{o|a}$.

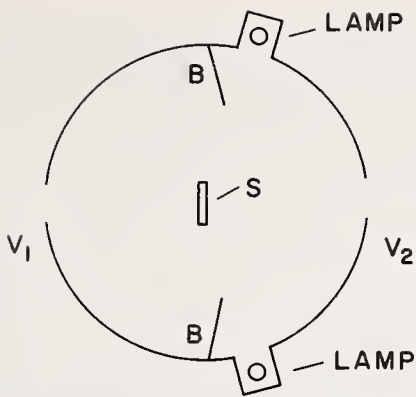

FIGURE 7. Korte-method: *B*=baffles; *S*=sample with front surface facing observation window *V*₁; *V*₁ and *V*₂=observation windows.

For the measurement of the sphere radiance the photometric system is looking past the sample at the sphere wall in the vicinity of window *V*₁.

The most important property of the instrumental arrangement is the uniformity of the radiance of the irradiating hemisphere. Korte reports that a test was made on this uniformity and that it was better than 0.1 percent. The irradiating hemisphere has an aperture for the photometer. A correction for this aperture, which is a nonirradiating area, must be made.

Erb [38] modified this method by placing just one lamp near the center of the sphere at the back of the sample.

This method was already described in principle by de la Perelle [39]. However Korte refined this method considerably to make it suitable for the calibration of standards at the PTB, Germany. Morren [53] also used this method in addition to his goniophotometric measurements for the extension of the wavelength range to the near infrared.

VI. Properties of Reflectance Standards

The "primary" standard of reflectance is the perfect reflecting diffuser which reflects all incident radiation ($\rho=1.0$) in a perfectly diffuse or Lambertian manner so that its radiance (luminance) is constant for all angles of viewing or that its radiant (luminous) intensity varies with the cosine of the angle between the normal and the angle of viewing. This theoretical concept will probably never be realized materially but the techniques for the measurement of absolute reflectances provide the calibration of material standards relative to this primary standard.

The selection of a material for calibration as a secondary reflectance standard must take into account not only the physical properties but also the application. The most important physical properties to be considered are

(1) *Reflectance value*: in most cases a very high reflectance is desirable so that in relative measurements ratios larger than 1.0 do not occur; however other specific values may be desired, e.g. for the measurement of one type of paper opacity a standard having a reflectance of 0.890 is required.

(2) *Goniophotometric indicatrix*: for certain applications a very matte standard is required while in other cases a glossy surface is preferable.

(3) *Opacity*: a very high opacity is usually desirable in order to avoid edge losses [59].

(4) *Uniformity*: across the surface.

(5) *Flatness of the surface*: some instruments are very sensitive to small distances between the sample surface and the plane of the sample port.

(6) *Stability*: either short term (days or weeks) or long term (months or years).

(7) *Cleanability*: the cleaning of a standard may be necessary, particularly in industrial use, and should not change its reflectance.

(8) *Transportability*: a standard may be required to be mechanically stable and rugged enough to be sent by mail.

(9) *Absence of*: fluorescence, hygroscopic effects, thermochromic and photochromic effects.

(10) *Spectral nonselectivity*: it may be necessary to have a spectrally nonselective standard.

Considering the application or use of reflectance standards two major categories must be distinguished:

(a) "Transfer Standards" which are used to transfer a calibration (or as it is sometimes expressed, a "scale") from one instrument to another, for example, from an absolute reflectometer to a commercial instrument for relative measurements.

(b) "Instrument Standards" which are used as day-to-day "working standards" in a particular instrument or as "master standards" for the periodical checking of a working standard. Ideally instrument standards are calibrated against a transfer standard in the instrument in which they are to be used.

The requirements with respect to most of the above listed physical properties are rather obvious for both categories of standards. However there are some significant differences which must be clearly understood.

Transfer standards which are exchanged between a laboratory with instrumentation for absolute reflectance measurements and a laboratory with an instrument for relative measurements, must be insensitive to differences in the geometric conditions, that is they should maintain their reflectance value.

Obviously a standard for an instrument with a *d/0* geometry should be calibrated in an absolute reflectometer with the same geometry. However, differences may exist in the diameter of the sphere, the existence or location of a gloss trap, the locations of detector aperture, screens, etc., and the transfer standard should be insensitive to them. This insensitivity to geometric differences requires that the standard be very matte, highly opaque and uniform. These are the most important characteristics of a transfer standard and the accuracy of a calibration will depend mostly on the conformity with these requirements.

Materials which approximate the ideal matte surface together with high opacity and uniformity are: pressed BaSO₄ plates [40], which according to Billmeyer [41] are Lambertian diffusers for angles of incidence up to 50°, pressed MgO and the Russian opal glass MS-20 [60] with a matte surface. Also carefully prepared BaSO₄ paint [42, 49] and matte ceramic tiles [35] may be used. Pressed BaSO₄ tablets are so indifferent against changes in geometry that $\beta_{a/0} = \rho_{0/a} = \beta_{a/8} = \rho_{8/a}$ [34, 43].

For instrument standards the major requirements are: long term stability and cleanability. The latter property is often achieved by giving the material a glossy surface which is much less liable to collect dirt and easier to clean than a matte surface. Examples of such instrument standards are Vitrolite,² opal glass, enamel tiles, or ceramic tiles. A glossy surface of the Russian opal glass MS-20 has also been used [44].

The differences in the requirements for both categories of standards cannot be emphasized enough. Translucent or glossy standards (such as Vitrolite) should never be used as transfer standards and even a change in the geometry within one instrument such as the introduction of a gloss trap necessitates the recalibration of the instrument standard if it is not matte and opaque.

Various properties of materials, particularly the stability, have been discussed in a paper by Erb [45].

Effects of polarization on the reflectance of materials for standardization purposes have recently been investigated [46-48], and it becomes quite obvious that matte powders do not depolarize incident polarized radiation and that radiation reflected from such surfaces is partially polarized even if the incident radiation is unpolarized. However this is not important for integrating sphere measurements because the geometry is usually symmetrical and polarization effects cancel out.

The stability of BaSO₄ and other reflectance standard materials or sphere paints was also discussed in a paper by Grum and Luckey [49].

The effect of pressure in the preparation of pressed tablets was investigated by Schatz [50] who concludes that "in general for oxide powders (BaSO₄, MgO, etc.) the reflectance of the compacts decreased with increasing pressure."

Some remarks are necessary on the Russian opal glass MS-20 which has been proposed for calibration purposes:

(1) A polished surface of this material seems to be adequate as a working standard. A depolished, matte surface may be used as transfer standard only for short periods. Cleaning such a matte surface is very difficult and requires a carefully established cleaning procedure in order to yield repeatable values.

²In order to adequately describe materials and experimental procedures, it was occasionally necessary to identify commercial products by manufacturer's name or trademark. In no instances does such identification imply endorsement by the National Bureau of Standards.

(2) The material is fluorescent if irradiated by radiation below 370 nm. This fluorescence appears as a faint orange general emission with occasional limited areas of considerably stronger orange emission. This clearly indicates some non-uniformity in the material which may be seen under grazing angles on a polished surface as a very faint difference in the surface texture. Consequently the material should be inspected for these inhomogeneities under fluorescent light and it should not be used in the UV.

A new material "Halon," which is a fluorocarbon, has been recently proposed by Grum [61]. However more experiences in practical applications are necessary before its suitability may be established.

VII. Reflectances of Transfer-Standard Materials

A survey and discussion of reflectance values of smoked MgO and of BaSO₄ and their properties was given by Budde in 1960 [51]. A very comprehensive literature survey of the properties and reflectances of smoked MgO, pressed MgO, pressed BaSO₄ and several integrating sphere paints was recently prepared by Erb [52]. A report on an international intercomparison of reflectance measurements organized by CIE Technical Committee 1.2, Photometry and Radiometry was prepared by Kartachevskaja et al [55].

For the purposes of this paper it is interesting to collect in a condensed form values measured according to those methods which are employed by various standardizing laboratories:

(1) Goniophotometric methods used at

- (a) LCE, Belgium [8]
- (b) PTB, Germany [7]
- (c) ETL, Japan [56]
- (d) VNIIM, USSR [15]
- (e) IEN, Italy [56]

(2) Sharp-Little method [34] used at NRC, Canada.

(3) Double sphere method [36, 37] used at NBS, USA and by Grum [49].

(4) Korte-method [7, 54] used at PTB, Germany and also by Morren [53] at LCE, Belgium.

Data which allow a comparison between goniophotometric and integrating sphere methods are difficult to find. Only in reference 55 are direct comparisons of measurements made in various laboratories on one material (BaSO₄) reported. Otherwise Taylor [13] finds satisfactory agreement between the goniophotometric method and his second integrating sphere method whereas Korte [7] states that his goniophotometric values are 0.3 to 0.4 percent higher than his sphere values. However he concludes that the difficulties of the goniophotometric method make it less accurate than his sphere method.

In collecting data from the literature either spectral reflectances or the luminous reflectance are found. For reflectance standards having approximately nonselective spectral reflectance distributions the luminous reflectance is very close or equal to the spectral reflectance at 550 nm. Consequently, if in the following tables only a value in the 550 nm column appears, the original value is a luminous reflectance.

Reflectance data for pressed BaSO₄ other than the Eastman White Reflectance Standard are given in table 1. In this table all values refer to BaSO₄ produced by Merck, Product No. 1748, distributed by C. Zeiss [43, 57] except for group 3 which refers to an average for powders of four different suppliers and for group 4b which refers to BaSO₄ produced by Merck, Product No. 1750 which has a slightly lower reflectance than Merck Product No. 1748 (see ref. 34 where data for both products are given).

Reflectance data for pressed BaSO₄ sold as Eastman White Reflectance Standard are collected in table 2. No reflectance data determined by the goniophotometric method were found.

These tables show two features:

(1) that the largest variation of values occurs at the blue part of the spectrum where the reflectance values start to decrease. This is also the spectral region where the reflectance changes slightly [62] for the first few days after pressing and where UV radiation produces the strongest changes in reflectance [38, 45].

(2) The double-sphere method always yields the highest values. There is, of course, a difference between the geometries: the double sphere method yields d/d -reflectance whereas the two other sphere methods yield $d/0$ reflectances and the goniophoto-

metric methods yield $0/d$ reflectances. Whether the discrepancies are inherent in the methods or are due to effects in the material such as retroreflectance is not known and will be the subject of future investigations.

The measurements given in table 1 and 2 refer to samples which were made by different persons in various institutes and possibly also from different charges. Consequently some variations in the reflectance values must be attributed to sample differences.

A direct comparison without such sample differences between the Korte-method and the Sharp-Little-method as modified by Budde [34] was arranged as follows: four BaSO₄ samples were pressed at NRC and their reflectances at 457 and 550 nm compared in an Elrepho. It was found that the reflectances of these 4 samples agreed to better than $\pm .02$ percent (about $\pm .0002$ in reflectance). Two of these 4 samples were hand-carried to PTB-Germany for measurements according to the Korte method and two were measured at NRC, Canada, according to the Sharp-Little method. The results are given in table 3. The agreement is rather satisfactory, particularly in view of the fact that different arrangements and theoretical treatments are used in the two methods.

VIII. Concluding Remarks

(1) At several stages in the preceding sections the simplifying assumption was made that the reflectance factor $\beta_{d/0}$ is equal to a reflectance $\rho_{d/0}$ which has the same value as the inverse reflectance $\rho_{0/d}$. It must be emphasized that this simplification is not generally permissible and that its applicability must be investigated. Only for very matte and opaque

TABLE 1. Reflectance of pressed BaSO₄ other than Eastman White Reflectance Standard

		Wavelength (nm)				
		400	500	550	600	700
1. Gonio-methods	$0/d$					
	LCE, Morren [53]			0.983		
	ETL [55]			.986		
2. Sharp-Little method NRC, Budde [34]	$d/0$	0.976	0.986	.985	0.986	0.987
3. Double-Sphere method NBS, Goebel [37]	d/d	.983	.989	.991	.990	.991
4. Korte-method	$d/0$					
	(a) PTB, Korte [7]			.984		
	(b) Morren [53]	.965	.980	.982	.983	.984
	(c) Erb [54]	.975	.983	.984	.986	.987

TABLE 2. Reflectance of pressed Eastman White Reflectance Standard BaSO₄

		Wavelength (nm)				
		400	500	550	600	700
1. Sharp-Little method NRC, Budde [34]	$d/0$	0.986	0.991	0.991	0.991	0.991
2. Double Sphere method Grum [49]	d/d	.995	.998	.998	.998	.997
3. Korte-method Morren [53]	$d/0$.980	.987	.987	.990	.990

TABLE 3. Absolute Spectral Reflectance Factors ($d/0$) of $BaSO_4$ —Comparison of NRC and PTB

$\beta_{d/0}(\lambda)$			$\beta_{d/0}(\lambda)$		
λ (nm)	NRC	PTB	λ (nm)	NRC	PTB
370	0.959	0.962	480	0.986	0.985
380	.968	.970	500	.987	.986
390	.974	.975	550	.988	.988
400	.978	.979	600	.988	.988
420	.982	.983	650	.987	.988
440	.985	.984	700	.988	.989
460	.986	.985	750	.988	.988

samples is such simplification permissible. Pressed $BaSO_4$ seems to be such a substance [34] and also the Russian opal MS-20, if ground matte.

(2) With respect to precision and accuracy of reflectance calibrations it is found that a precision of ± 0.002 is possible whereas accuracies in the order of ± 0.003 are claimed. However the discrepancies between values obtained in the double sphere method on one side or in the Sharp, Little and Korte-method on the other side are larger than these claimed accuracies and therefore only after these discrepancies have been explained can a more general statement on accuracy be made.

(3) The question may be asked why absolute measurements have been made mainly in national standardizing institutes and why instrument makers have generally refrained from making instruments which yield absolute values. The answer to this question is that absolute reflectance measurements, in spite of the apparent simplicity of the integrating sphere methods, are complex and accident prone. The design of an absolute reflectometer requires a complete understanding of the parameters which may affect the measurements. And to maintain an absolute reflectometer in perfect working order is often beyond the capabilities of an industrial testing laboratory. The International Organization for Standardization (ISO) has recognized this situation with its efforts to establish international agreement in reflectance measurements by delegating the calibration of transfer standards to a few recognized laboratories and recommending only relative measurements throughout the international paper industry [58]. Preliminary results justify this procedure.

Basically this procedure is used with many measured quantities such as resistance voltage, weight, etc., where standardizing laboratories provide the absolute calibration of standards while in industry only measurements relative to those standards are made. There are many good reasons for applying this procedure also to the complicated field of reflectance measurements.

IX. References and Notes

- [1] Formally spectrophotometry was introduced for colorimetric purposes with the adoption of the CIE 1931 Standard Colorimetric Observer. See Judd-Wyszecki: Color in Business, Science and Industry, 3rd edition (Wiley & Sons, 1975).
- [2] See, for example, Kortum G., Reflectance Spectroscopy Springer, Berlin, Heidelberg, New York, 1969). or: Frei, R. W., and MacNeil, J. D. Diffuse Reflectance Spectroscopy in Environmental Problem Solving (The Chemical Rubber Co., 1973).
- [3] Commission Internationale de l'Eclairage (CIE) Publication No. 17 (1970) International Lighting Vocabulary. Available in the United States from: Mr. L. E. Barbrow, Room B-152 Technology, National Bureau of Standards, Washington, D.C. 20234
- [4] CIE Publication No. 15 (1971) Colorimetry, available as per ref. [3].
- [5] CIE Proceedings 8th Session, Cambridge, 1931, p. 23.
- [6] CIE Proceedings 14th Session, Brussels, 1959, and Meeting of Committee E-1.3.1 Colorimetry, Washington, 1967.
- [7] Korte, H., and Schmidt: Uber Messungen des Leuchtdichtefaktors an beliebig reflektierenden Proben, Lichttechnik **19**, Nr. 11, p. 135A (1967).
- [8] Morren, L., Mesure Absolue des Facteurs de Luminance et de Reflexion, Lux, No. 45, 448 (1967).
- [9] Royds, T., Das Reflexionsvermoegen schwarzer Flaechen, Physik. Z. **11**, 316 (1910).
- [10] Royds, T., The reflective power of Lamp- and Platinum black, Philos Mag. **21**, 167 (1911).
- [11] Coblenz, W. W., The diffuse reflecting power of various substances, Bull. Bur. Stand. **9**, 283 (1913).
- [12] McNicholas, H. J., Absolute methods in reflectometry, J. Res. Nat. Bur. Stand. (U.S.), **1**, 29-73 (Oct. 1927) RP-3.
- [13] Taylor, A. H., The measurement of diffuse reflection factors and a new absolute reflectometer, J. Opt. Soc. Am. **4**, 9 (1920).
- [14] Egan, W. G., and Hilgeman, T., Integrating spheres between 0.185 and 12 μ m, Appl. Opt. **14**, 1137 (1975).
- [15] Kartachevskaja, V. E., and Skachkova, S. P., New method of determining the luminance factors and total reflectances of VNIIM sample plates, Svetoteknika **1**, 16 (1966). Also available as translation NRC, TT-1265 from National Research Council of Canada, Ottawa, Canada.
- [16] Derksen, W. L., Monohan, T. I., and Lawes, A. J., Automatic recording reflectometer for measuring diffuse reflectance in the visible and infrared regions, J. Opt. Soc. Am. **47**, 995 (1957).
- [17] Kubelka, P., and Munk, F., Ein Beitrag zur Optik der Farbanstriche, Z. tech. Phys. **12**, 593 (1931).
- [18] Kubelka, P., New contributions to the optics of the intensely light-scattering materials, Part I, J. Opt. Soc. Am. **38**, 448 (1948); Part II, J. Opt. Soc. Am. **44**, 330 (1954).
- [19] Stenius, A. S., The application of the Kubelka-Munk theory to the diffuse reflection of light from paper, Sven. Papperstidn. **54**, 663 (1951).
- [20] Butler, W. L., Absorption of light by turbid materials, J. Opt. Soc. Am. **52**, 292 (1962).
- [21] Law, S. E., and Norris, K. H., Kubelka-Munk light-scattering coefficients of model particulate systems, Trans. ASAE p. 914, 1973.
- [22] Lindberg, J. D., A Simple Method for Measuring Absolute Diffuse Reflectance with a Laboratory Spectrophotometer, National Technical Information Service, U.S. Dept. Comm. AD-771 216, Nov. (1973).
- [23] Nutting, P. G., A new method and an instrument for determining the reflectance power of opaque bodies, Trans. Illum. Eng. Soc. (1912), p. 412.
- [24] Rosa, E. B., and Taylor, A. H., The integrating photometric sphere, its construction and use, Trans. Illum. Eng. Soc. (1916) p. 453.
- [25] Preston, J. S., The reflection factor of magnesium oxide, Trans. Opt. Soc. (London) **31**, 15 (1929-30).

- [26] Middleton, W. E. K., and Sanders, C. L., The absolute spectral diffuse reflectance of magnesium oxide, *J. Opt. Soc. Am.* **41**, 419 (1951).
- [27] Budde, W., Die Messung des spektralen Reflexionsgrades von Weiss-Standards, I. *Die Farbe* **7**, 17 (1958); II. *Die Farbe* **7**, 295 (1958).
- [28] Taylor, A. H., A Simple Portable Instrument for the Absolute Measurement of Reflection and Transmission Factors, *Sci. Pap. Bur. Stand.* **17**, 1 (1920) No. 405.
- [28a] Reule, A., Zur Theorie der Taylor-Kugel *Zeiss Mitt.* **2**, 371 (1962).
- [29] Benford, F. A., An absolute method for determining coefficients of diffuse reflection, *Gen. Elec. Rev.* **23**, No. 1, 72 (1920).
- [30] Benford, F., A reflectometer for all types of surfaces, *J. Opt. Soc. Am.* **24**, 165 (1934).
- [31] Benford, F. A., Lloyd, G. P., and Schwarz, S., Coefficients of reflection of magnesium oxide and magnesium carbonate, *J. Opt. Soc. Am.* **38**, 445 (1948).
- [32] Tellex, P. A., and Waldron, J. R., Reflectance of magnesium oxide, *J. Opt. Soc. Am.* **45**, 19 (1955).
- [33] Sharp, C. H., and Little, W. F., Measurements of reflection factors, *Trans. Illum. Eng. Soc.* **15**, No. 9, 802 (1920).
- [34] Budde, W., and Dodd, C. X., Absolute reflectance measurements in the D/O° geometry, *Die Farbe* **19**, 94 (1970).
- [35] Budde, W., and Chapman, S. M., The calibration of standards for absolute brightness measurements with the Elrepho, *Pulp and Pap. Mag. Can.* **69**, No. 7, T206 (1968).
- [36] Van den Akker, J. A., Dearth, L. R., and Shillcox, W. M., Evaluation of absolute reflectance for standardization purposes, *J. Opt. Soc. Am.* **56**, 250 (1966).
- [37] Goebel, D. G., Caldwell, B. P., and Hammond, H. K., Use of an auxiliary sphere with a spectrophotometer to obtain absolute reflectance, *J. Opt. Soc. Am.* **56**, 783 (1966).
Note: There are misprints in eqs (1) and (2) in this paper and also in the equation in TAPPI Standard T679.
- [38] Erb, W., Aenderungen der strahlungsphysikalischen Eigenschaften von Reflexionsnormalen nach UV-Bestrahlung, *Lichttechnik* **7**, 345 (1973).
- [39] De la Perelle, E. T., Moss, T. S., and Herbert, H., The measurements of absorptivity and reflectivity, *Infrared Phys* **3**, 35 (1963).
- [40] Richter, M., and Terstiege, H., Bariumsulfat-Tabletten als Standard fuer Farbmessungen von Aufsichtsfarben, *Lichttechnik* **22**, 446 (1970).
- [41] Billmeyer, F. W., Lewis, D. L., and Davidson, J. G., Goniophotometry of pressed barium sulphate, *Color Eng.* (May/June 1971), p. 31.
- [42] Middleton, W. E. K., and Sanders, C. L., An improved sphere paint *Illum. Eng.* **48**, 254 (1953).
- [43] German Standard DIN 5033, Blatt 9 (1970) in which the preparation of pressed BaSO₄ tablets is described. It is stated that if the tablets are prepared according to the procedure described, the spectral reflectance factors $\beta_{d/8}$, $\beta_{d/10}$ and the reflectance $\rho_{8/d}$ are identical.
- [44] Clarke, F. J. J., High Accuracy Spectrophotometry at the National Physical Laboratory, *Nat. Bur. Stand. (U.S.)*, Spec. Publ. 378, 1-29 (May 1973); *J. Res. Nat. Bur. Stand. (U.S.)* **76A** (Phys. and Chem.), No. 5, 375-403 (Sept.-Oct. 1972).
- [45] Erb, W., Requirements for reflection standards and the measurement of their reflection values, *Appl. Opt.* **14**, 493 (1975).
- [46] Robertson, A. R., Effect of polarization on reflectance factor measurements, *Appl. Opt.* **11**, 1936 (1972).
- [47] Kaase, H., Depolarisation der an BaSO₄ diffus reflektierten Strahlung, *Optik* **38**, 433 (1973).
- [48] Clarke, F. J. J., Garforth, F. A., and Parry, D., Goniophotometric and polarization properties of the common white reflection standards, *NPL Report Mom 13*, Sept. 1975.
- [49] Grum, F., and Luckey, G. W., Optical sphere paint and a working standard of reflectance, *Appl. Opt.* **7**, 2289 (1968).
- [50] Schatz, E. A., Effects of pressure on the reflectance of compacted powders, *J. Opt. Soc. Am.* **56**, 389 (1966).
- [51] Budde, W., Standards of reflectance, *J. Opt. Soc. Am.* **50**, 217 (1960).
- [52] Erb, W., A summary of properties and reflection values of materials which are used as reflection standards, Report PTB-Opt-3, June 1975, Physikalisch Technische Bundesanstalt, Braunschweig, Germany.
- [53] Morren, L., Vandermeersch, G., and Antoine, P., A study of the reflection factor of usual photometric standards in the near infra-red, *Lighting Research and Technology* **4**, No. 4, 243 (1972).
- [54] Erb, W., Bestimmung des spektralen Leuchtdichtkoeffizienten fuer die Messgeometrie 45°/normal, *Die Farbe* **20**, 179 (1971).
- [55] Kartachevskaia, V. E., Korte, H., and Robertson, A. R., International comparison of measurements of luminance factor and reflectance of white diffusing samples, *Appl. Opt.* **14**, 2696 (1975).
- [56] Report of CIE TC-1.2 which is published in condensed form in Ref. [55].
- [57] Pamphlet No. 50-665/1-e, C. Zeiss, Oberkochen, Germany.
- [58] Budde, W., and Chapman, S. M., Measurement of brightness and opacity according to ISO standards, *Trans. CPPA* **1**, No. 2, 61 (1975). International Standards ISO 2469: Paper, board and pulps—measurement of diffuse reflectance factor; and ISO 2470: Measurement of diffuse blue reflectance factor (ISO brightness).
- [59] Atkins, J. T., and Billmeyer, F. W., Edge-loss errors in reflectance and transmittance measurement of translucent materials, *Materials Research and Standards* **6**, 564 (1966).
- [60] An earlier version of this, the MS-14 is described in: Voyshvillo, N. A., and Pavlova, L. I., The applications of opal glass standard instead of magnesium oxide in colorimetry, *Svetotekhnika* **7**, 16 (1965).
- [61] Grum, F., and Saltzman, M., New white standard of reflectance, Paper No. 77 presented at the 18th CIE Session, London, September 1975. To be published in the Proceedings of this session.
- [62] Terstiege, H., Spektralphotometrische, Untersuchungen an Weiss-Standards, *Lichttechnik* **6**, 277 (1974).
- [63] Correction in proof: it was published as follows: Aneliunas, A. E., and Chapman, S. M., A practical method for measuring absolute reflectances, *Pulp & Paper Mag. Can.* **69**, No. 16, 53 (19 July 1968).

(Paper 80A4-903)

Understanding Bidirectional Reflectance and Transmission for Space Applications

John B. Schutt

Goddard Space Flight Center, Greenbelt, Maryland 20771

(May 26, 1976)

Applications for optical diffusers in space projects are presented which include the functions of reflection, transmittance, and collection. These modes encompass such diverse uses as temperature regulation and ozone concentration monitors. Discussed is the co-operative aspect of diffuse reflectance and environmental stability. Magnesium oxide, sodium chloride and barium sulphate are evaluated in some detail. The importance of scene scattering behavior to modeling the earth's radiation budget and in determining thermal inertias of the earth's surface are discussed, because solar albedo serves as the weighting function in the solar input irradiance. Finally, work in the area of canopy reflectance modeling is reviewed with verification data included whenever available. Some knowledge of the bidirectional reflectance properties of vegetation is necessary for identification, acreage computations, and scene transference.

Key words: Bidirectional radiometry; canopies; diffuse reflectance; diffuse transmission; reflectance standards; scattering surfaces.

I. Introduction

Uses of diffusely reflecting and transmitting materials in spacecraft design are numerous, so numerous in fact that they are taken for granted. They are taken for granted in the sense that the extent of their diffuseness often is judged by eyeballing. Perhaps this turns out to be the situation because the experimental procedure for determining diffuseness requires great care, and becomes tedious if the hemisphere is to be covered for wavelengths comprising the solar spectrum, 250 to 2500 nm. On the other hand, it is customary to carry out bidirectional reflectance measurements on diffusers applied to the surfaces of integrating spheres, but normally in the principal plane only.

The nature of the application of diffusers usually puts them in a pivotal role. For example, in the control of satellite temperatures, mirror effects are eliminated whereby solar inputs exceeding one solar constant can occur for coupled surfaces. In the development of spacecraft paints, it turned out that certain pigments, particularly zinc oxide, can be processed to have greater environmental stability than any type of binder. Inorganic and silicone binders have intermediate stabilities, but can be well masked because they can accept high pigment concentrations, so high in fact that the resultant coating becomes a diffuser. Under these circumstances there results classes of paints which are surprisingly space stable [1].¹ Another pivotal role is that of a collector.

Reflectors are utilized in this manner to monitor ozone concentrations in the earth's atmosphere. The collector utilized in the Backscatter Ultraviolet Experiment (BUV) [2, 3] flown on Nimbus 3 and 4 is a ground aluminum plate overcoated with an evaporated layer of aluminum. This configuration was selected after much screening because its long term environmental stability is excellent [4]. Although it has an easily detected specular quality, the instrumentation is sufficiently sensitive to enable detection of components from 250 to 300 nm which comprise the earth's albedo and are representative of the ozone profile. To provide calibration of BUV, sounding rockets are launched from selected sites during overhead passage of the satellite. The pivotal element in this ozone monitoring experiment is a collector comprising a silica sphere coated internally with a transmission diffuser. Originally, smoked magnesium oxide was employed, but ease of application prompted a switch to barium sulphate bound with polyvinyl alcohol. In optimum configuration, however, Krueger [5] found that a black spot placed exterior to the sphere opposite to the exit neck could eliminate illumination fluctuations, thereby providing a more uniform flux to the detector.

Most recently, interest has developed in the reflective patterns of the earth and earth scenes. Nimbus F (currently in orbit) [6] has an experiment designed to monitor the earth's energy balance. Formally known as the Earth Radiation Budget Experiment (ERB), this experiment has been designed to hopefully permit the calculation of energy balances to an accuracy approaching one

¹ Figures in brackets indicate the literature references at the end of this paper.

percent. Broadly, the experiment views the sun as the satellite ascends from the South Pole. As it proceeds northward energies are measured from 0.3 to 50 μm . At the same time the entire disk is viewed and synopsized. The goniometric dependence is taken in the principal plane of the sun and assumed to characterize the reflectance hemisphere. These data provide all the necessary input for calculating terrestrial energy balances. Planned for launch in the spring of 1978 is a scanner designed to measure reflected energy from 500 to 1100 μm and characterize emitted energy in the 10.5 to 12.5 μm band. The purpose of the Heat Capacity Mapping Mission (HCMM) [7] is to characterize the earth's surface with respect to the mission spectroscopy. Because the spacecraft will pass over the same area at about 1:30 pm and 2:30 am, the most sophisticated application for its data will be for computations of thermal inertia. For a representative value of this quantity an energy balance must be established at the earth's surface. Simplifying assumptions which enter modeling of the energy balance are:

- (1) that the scene is Lambertian,²
- (2) that the 500 to 1100 μm band adequately estimates the solar albedo normally defined for energy balance purposes from 250 to 4000 μm ,
- (3) that the Planck function will peak in the 10.5 to 12.5 μm interval permitting a reliable brightness temperature to be calculated,
- (4) meteorological approximations which involve the connective and advective heat transfer between the earth and atmosphere,
- (5) radiation contributions which result from exchanges between earth and atmosphere, earth and sensor and earth reflected sky radiation,
- (6) an atmospheric transfer function in order to correct sensed radiations to the earth's surface.

If we are content with relative thermal inertias rather than representative values, certain of these approximations may be useful provided sufficient sensitivity is offered by such a modeling scheme to provide useful images. The simplest images offered by the HCMM are those obtained from mapping:

- (1) albedo
- (2) differential temperatures
- (3) a ratio of 1 to 2.

Of the three, the ratio of one to two offers the closest approximation to thermal inertia.

Finally, there are remote sensing requirements for crop signatures; these again may be representative or relative. But establishing a library of these data goes beyond spectral characterization alone and

² Although not explicitly included, the importance of albedo in weighting solar irradiance is self-evident because the sun is virtually always the dominant heat source by orders of magnitude.

would entail knowledge of the diffuse versus specular quality of the reflectance as a function of sun and sensor positions. For example, viewing mature barley and wheat from the nadir position does not provide a basis for differentiation, however, as the view angle is increased, distinctions become increasingly apparent [8]. Otherwise, exclusive use must be made of differing spectral signatures occurring from phenological changes recorded in conjunction with individual crop calendars. These data provide bases for crop identification and acreage estimations.

In the following sections a summary of white diffusers is given. Subsequently, radiation transfer models employed in calculating the reflectances of crops are presented and verification data included whenever available.

II. Summary of Information on Selected Diffusers

Of all the diffusers, magnesium oxide [9] generated and applied by burning magnesium under controlled conditions was probably the one most utilized until the development of the barium sulphate-polyvinyl alcohol system [10]. Disadvantages of magnesium oxide include:

- (1) its slow rate of deposition by virtue of the smoking process,
- (2) a thickness of 3 to 4 mm to provide capacity in the 0.7 to 2.4 μm region,
- (3) a coating with poor adhesion and weak cohesion,
- (4) a required investment in time of three days to two weeks of continuous effort to coat an eight inch diameter integrating sphere,
- (5) a coating not accessible to repairing,
- (6) a system of electrostatically charged particles reactive with atmosphere moisture to form Brucite, $\text{Mg}(\text{OH})_2$, with an accompanying decrease in infrared and ultraviolet reflectances.

Under ideal conditions the usefulness of this coating may extend to one year.

A more rugged integrating sphere coating possessing optical properties comparable to magnesium oxide can be provided by sodium chloride. Initially developed by Kneisel [12] at the National Bureau of Standards, the system was modified by Stuart [13] to increase its ease of application and mechanical strength. Initially sodium chloride was dispersed in alcohol, but improvements were obtained by employing an admixture of toluene and 1, 3 butanediol or propylene glycol with the alcohol. The resultant coating is free of the usual water bands occurring in the vicinity of 1200, 1400, and 1900 nm. Further-

more, the system is easily repaired and dries under sufficient compressive stress to provide a coating able to support a substantial shock. The life of the coating is known to be in excess of two years. Its major disadvantage resides in its moisture sensitivity. Relative humidities close to 90 percent cause sagging. Optically, the coating commences to lose reflectance around 360 nm, but remains the best all around integrating sphere coating for determining the solar albedo of materials.

Ease of application, repair, and optical stability make the barium sulphate-polyvinyl alcohol coating the most useful system. It does have infrared absorptions due to the presence of water, but sources of energy in this spectral region have sufficient intensity to eliminate this as a potential disadvantage. Furthermore the system does not suffer from the near ultraviolet fall off characteristic of sodium chloride. Over the spectral region employed in solar albedo calculations, this system has been found to have a lifetime in excess of two years. However, Krueger [15] has shown that a substantial loss in reflectance can occur from about 250 to 200 nm within a period of three months. In an attempt to better utilize the high reflectance of virtually pure barium sulphate in the region of 200 to 250 nm for the express purpose of detecting Cerenkov radiation [16], it was found that polyvinyl alcohol could be replaced by potassium sulphate while maintaining the reflectance of the system to within 2 percent of that of the powder. The coating was monitored for optical degradation in this region over a period of six months. All observed changes were found to be within the accuracy of the spectrophotometer, which is nominally one to two percent. Table 1 qualitatively summarizes some properties of these coatings.

III. Models of Canopy Reflectance

Investigations into the attenuation of light in a plant canopy were initiated utilizing a one parameter relation customarily referred to as the Bouguer-Lambert law [17]. This approximation accounts

satisfactorily for transmittance, while ignoring the reflectance of the medium. Stokes [18] extended the method to account for reflectance by including an additional parameter. He verified his approach in experiments with glass plates. Some years later Schuster [19] reassessed the problem of radiation diffusion and wrote down a system of two equations for radiation transfer in a medium with sources. He assumed that light passing through an infinitesimal layer (dx) is increased by the backscattered component and decreased by the forward component. For simplicity he assumed further that the forward (t) and back (s) scattered components here equal, viz:

$$\frac{dt}{dx} = -\mu t - \frac{1}{2} S t + \frac{1}{2} S s,$$

$$\frac{ds}{dx} = -\mu s - \frac{1}{2} S s + \frac{1}{2} S t,$$

where μ and S are the absorption coefficients. The source terms have been omitted. Rayleigh [20] showed later that equal scattering resulted only for the case where particles are much smaller than the wavelength of light. Silberstein [21] reformulated the Schuster equations eliminating the equality in forward and backscattered components. He also pointed out that the residue of unscattered radiation (I_x) passing through a medium is properly written

$$\frac{dI_x}{dx} = -(\mu + B + F)I_x,$$

where B and F represent back and forward scattered components. These results closely resemble those of the Kubelka-Munk [22] representation for canopy scattering,

$$\frac{dI_x}{dn} = -(\mu + S)I_x + Ss,$$

$$\frac{ds}{dn} = (\mu + S)s - SI_x,$$

TABLE 1. Summary of important properties of coatings Systems employed as diffuse standards

Material	Binder	Average reflectance values				Atmospheric stability	Directional reflectance
		0.2-0.25 μm	0.25-0.3 μm	0.3-0.8 μm	0.8-2.4 μm		
Freshly smoked MgO	Electrostatic, water	0.9	0.98	0.98	0.95	Poor	Lambertian to 45 degrees
NaCl	NaCl	Poor	Less than 0.7	.96	.96	Poor if RH is greater than 0.85	Unknown
BaSO ₄	PVA	.85	.93	.95	.92	Excellent	Ref. [11]
BaSO ₄	K ₂ SO ₄	.94	.97	.97	.92	Excellent	Unknown

where I_x is now interpreted as the forward scattered radiation.

In this case t has been replaced by I_x and n represents the cumulative leaf area index.³ Figure 1, taken from Allen and Richardson [23] shows some results obtained for stacked cotton leaves. The K-M parameters μ and S were obtained experimentally. Duntley [24] combined the equations of Schuster with observation of Silberstein concerning passage of the unscattered beam through a medium. Namely he chose to distinguish the forward diffusing scattered radiation from the unscattered radiation. Under these circumstances three equations result containing six parameters,

$$\begin{aligned} \frac{dI_x}{dx} &= -(\mu' + B' + F')I_x, \\ \frac{dt}{dx} &= F'I_x - \mu t - Bt + Fs, \\ -\frac{dS}{dx} &= B'I_x - \mu s - Fs + Bt. \end{aligned}$$

Primed quantities differentiate the behavior of the unscattered beam (I_x) from that of the diffused

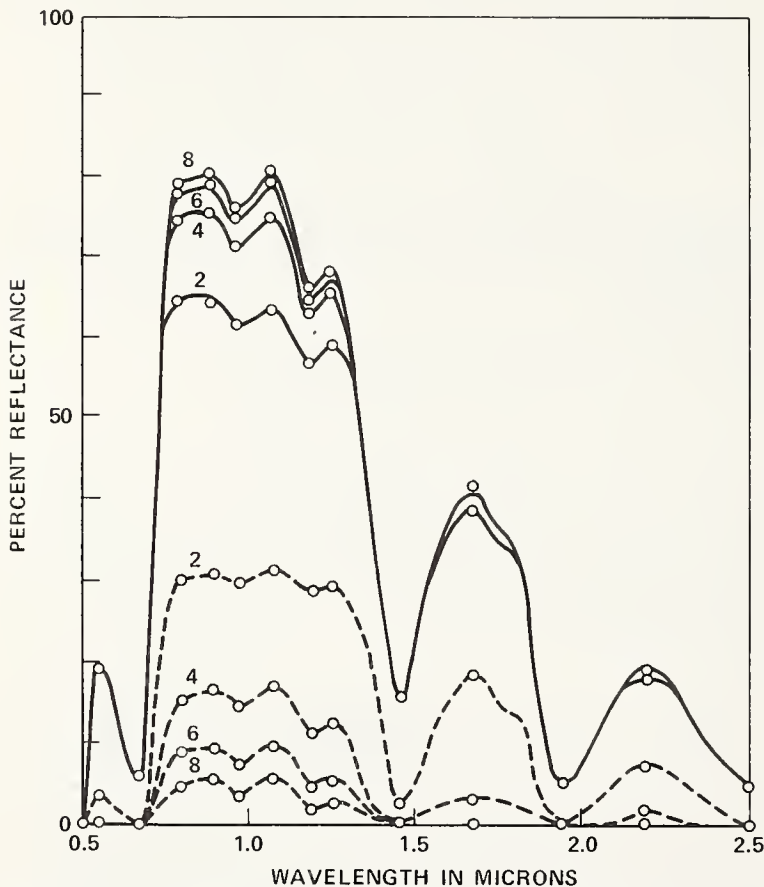

FIGURE 1. Reflectance (solid lines) and transmittance (dashed lines) of 2, 4, 6, 8, stacked mature cotton leaves.

The lines are theoretical; the circles are experimental. Standard deviation between observed and calculated points is about 1 percent [ref. 23].

³ Cumulative leaf area index is defined as the one sided leaf area per unit ground area, and represents the sum over all leaves encountered between top and base of the plant.

portion. First set up to model diffusion in pigmented materials from experiments carried out to give values of the phenomenological constants, it has been subsequently utilized by Suits et. al. [25], to calculate the bidirectional reflectance of corn. The approach necessitates a prior knowledge of the transmittance and reflectance of canopy components, usually only leaves. In addition these parameters are weighted by the projected area on the appropriate component plane. To compute the representation Suits et. al. refer to dividing the canopy into layers, and then rewrite Duntley's equation for the passage of the unscattered component as

$$\frac{dI}{dx} = kI$$

with $k = (\mu' + B' + F')$ in Duntley's notation. I , t , and S are now functions of the layer being considered and the position within that layer, x . In establishing equations for k , μ , B , B' , and F' plant geometry and optical constants were assessed, and diffusers assumed Lambertian.

Based on the successful application of K-M theory to predict the reflectance and transmittance of stacked cotton leaves, Allen and Richardson [23] indicated that their procedure was sufficiently general for application to plant canopy. Unfortunately this application has not been made by them. Although they do suggest that assuming uniform distributions of leaves would be a reasonable approximation, it was previously shown by Nichiporovich [26] and de Wit [27] not to be valid. Physically, the assumption amounts to suggesting that plant canopy reflectance would not vary during the day. That the effect is present is shown by many authors, in particular by Fritschen [28] for alfalfa, barley, wheat, oats, cotton and sorghum. It is precisely this behavior of crop canopies which led de Wit [27], and Idso and de Wit [29] to develop leaf distribution functions for six leaf inclinations: planophile canopies where horizontal leaves are most frequent; erectophile canopies where vertical leaves are most frequent; plagiophile canopies where leaves assume an oblique inclination; extremophile canopies, where leaves are least frequently at oblique inclinations; spherical canopies where the relative frequencies of inclinations is the same as the relative frequency of the surface elements of a sphere; and a measured leaf distribution for corn. For light incident at θ , averaged over the crop as a whole $OP(\pi/2 - \theta)$, corrected for the projection of the soil in the direction $(\pi/2 - \theta)$ and weighted for the area per leafy layer, S , Idso and de Wit derive for the reflectance ρ ,

$$\rho = \left[1 - s \frac{OP(\pi/2 - \theta)}{\cos \theta} \right] \frac{LAI}{S}$$

for a leaf area index, LAI, Figure 2 [29] shows a comparison of calculated and measured results for a stand of corn. Agreement appears to be best for the uppermost clusters of leaves. The model

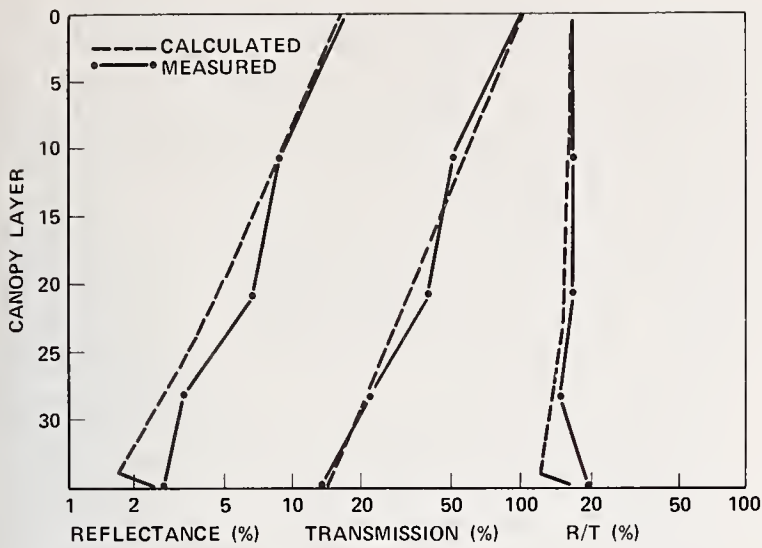

FIGURE 2. Calculated and measured profiles of reflection R and transmission T in a corn crop.

R is computed as upward moving radiation divided by incident radiation and T as downward moving radiation divided by incident radiation [ref. 29].

of Smith and Oliver [30, 31, 32] treats the interaction of radiant flux with the vegetation canopy utilizing a probability for the distribution of gaps and foliage elements within the canopy. Their starting point is then the Idso-de Wit equation given above for gap probability with

$$\frac{LAI}{n}$$

replaced by the difference between the number of canopy layers n and the number of contacts, k such that the probability distribution for k foliage contacts in the direction θ_r is [31]

$$P(k) = \binom{n}{k} \left[s \frac{OP(\theta_r)}{\cos(\theta_r)} \right]^k \left[1 - s \frac{OP(\theta_r)}{\cos(\theta_r)} \right]^{n-k}$$

Foliage elements are assumed to act as Lambertian-response surfaces. The problem is the determination of $OP(\theta_r)$. Idso and de Wit have expressed this quantity in terms of four angles: sun zenith angle, leaf inclination, and two boundary angles differentiating upperside and underside illumination of the leaves. Methods for obtaining an average plant and canopy scattering function have been reviewed by Oliver [31]. Techniques fall into two categories. The first is by a direct mensuration process and the second carried out photographically. One such approach involves the determination of plant geometry from photographs taken for orthogonal planes which are subsequently processed onto a grid. A second approach utilizes infrared photography. A diffuse image of the subject is obtained for bidirectional views. Utilizing these data, Oliver presents numerical methods by which gap and contact probabilities can be obtained. Employing the above equation for θ_r , and applying sequentially through the canopy for all k and n , there results an expression for the reflectivity $\rho(\theta'_r)$ [31]:

$$\rho(\theta'_r) = \frac{P(\theta'_r)}{\sin^2(\theta_r + \Delta\theta_r) - \sin^2(\theta'_r - \Delta\theta_r)}$$

for incidence in zone $(\theta_r + \Delta\theta_r)$. Figures 3, 4, and 5 show verification results for this model. Each series of curves shows maximum disagreement at about 650 nm. The authors attribute this behavior to possible specular reflection at the long wavelength chlorophyll absorption band. Overall agreement is quite good. In figure 6 relative reflectance is plotted as a function of zenith angle from data obtained by Watlington et. al., LANDSAT band 4 (500-600 nm). These reflectance data, plotted on a linear scale, show considerably less variation. Because the sensor viewed about one square foot of projected plant area, it is tentatively assumed that the dip at 64° results from polarization of the light. The sharp rise in reflectance beyond this point is as a result attributed to depolarization as the sensor viewing angle increases away from the Brewster Angle.

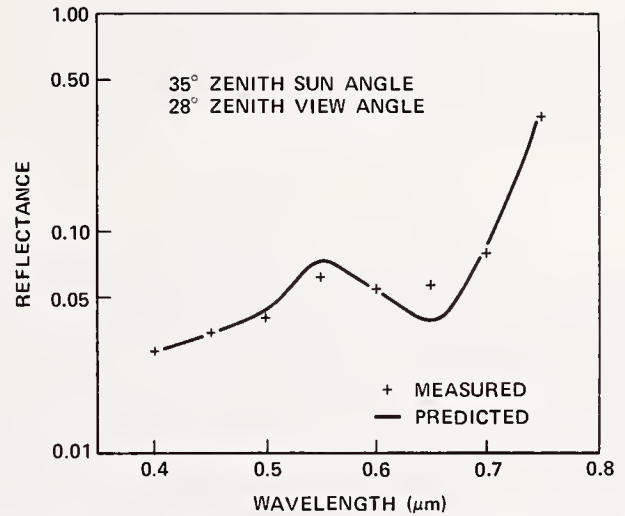

FIGURE 3. Comparison between model predictions and field observations for a dense canopy of blue grama.

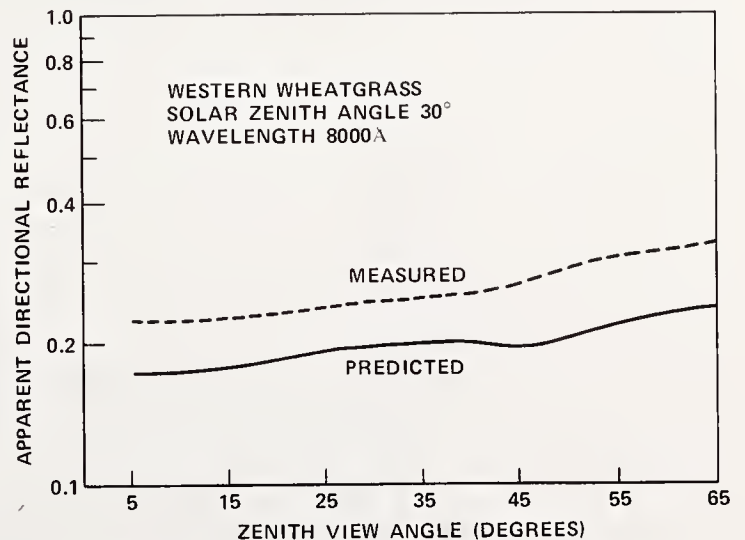

FIGURE 4. Comparison between model predictions and field observations for a sparse canopy of western wheatgrass.

The measurement was made at an azimuth of 45° from the sun and is believed to account for the apparent differences [ref. 31].

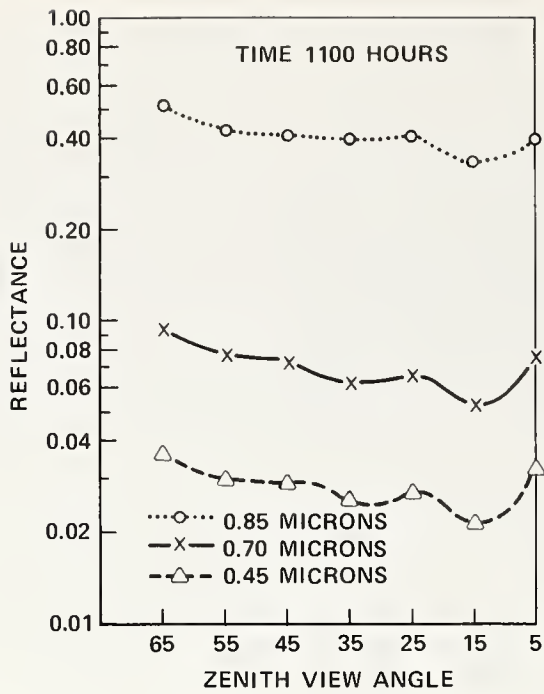

FIGURE 5. Angular variation in spectral response for three selected wavelengths.

The non-Lambertian spatial response for the apparent directional reflectance for the canopy is clearly evident. The solar disk was contained in the 25 degree sensor view angle band [ref. 30].

IV. Discussion

Based upon the coatings systems mentioned previously, it is apparent they share several formulating concepts to varying degrees. First of all, each pigment was chosen from combinations of elements in the Periodic Table whose electronegativity differences are closely maximized. This being the case, it is hardly possible to extend the ultraviolet absorption cutoff. Creating diffusers from such materials as sapphire, lithium fluoride, magnesium

fluoride and fused silica provides little help because roughening a surface or grinding a single high purity crystal simply serves to retract the ultraviolet absorption cutoff. Second, the pigments used are all of the highest purity. Third, the pigment to binder ratio is made as great as possible; for sodium chloride it is infinite.

In connection with the transmission diffuser previously mentioned, the ability of the barium sulphate polyvinyl alcohol system to diffuse a specular beam during a single pass through the coating was unsatisfactory. For this application a thickness of about six mils is normally applied. In a closed system such as an integrating sphere, this problem is not so serious. The black dot artifice of Krueger to block light having passed through the diffuser but once suggests that the diffuser could be more efficient or else its ability to diffuse is intensity dependent. It was pointed out to be by Heath, [34] that the accuracy of the BUUV is currently limited solely by fact that the specular component from the diffuser can be measured to no better than 2 percent. Common to crop reflectance models is the assumption that single reflections result in the total diffusion of specular inputs. So unless a canopy can approximate the action of an integrating sphere, the canopies will provide an observer with specular reflections. Then as the spatial resolution is decreased by observing larger and larger canopies, Lambertian behavior will provide an exact description.

It is interesting to note that accurate descriptions of diffusers are difficult to come by because particle shapes, sizes, and their dispersions within binders are not readily amenable to modeling. On the other hand, modeling a canopy for the spacecraft view is a tractable problem, if only for the fact that the components can be directly measured, photographed, and therefore represented geometrically.

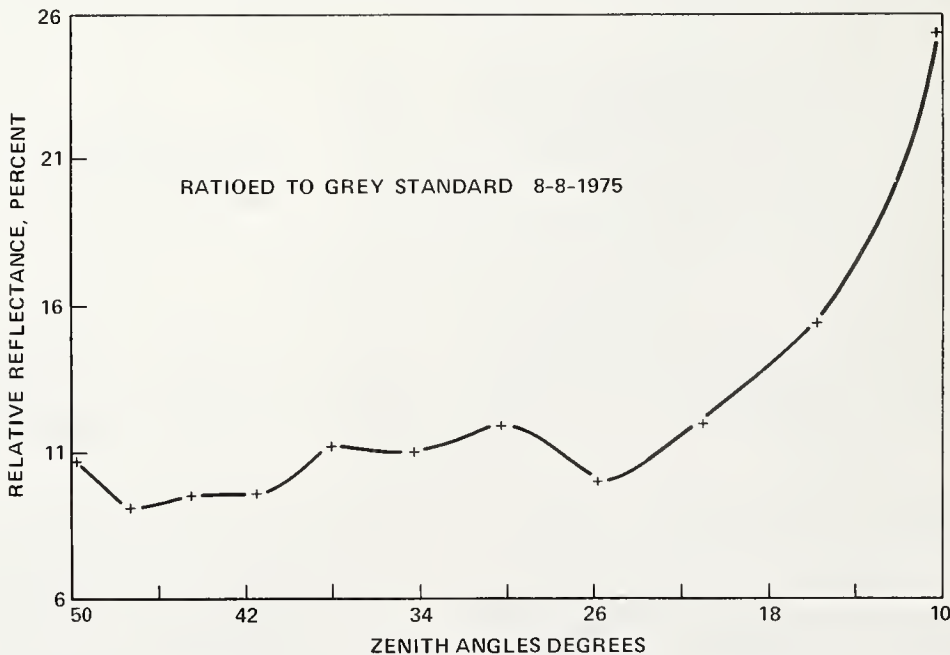

FIGURE 6. Reflectance of unstressed mature soybean plants taken for LANDSAT band 4 (500-600 nm bandwidth) [ref. 33].

Finally, it is interesting to note that the Idso-de Wit canopy model does work for the uppermost vegetation layers by considering geometrical factors only. Absent from the model are provisions for including optical properties. This leads to the conclusion that in setting up leaf distribution functions, probably all specimens were in the nearly turgid state. Subsequently for verification of their model, they chose a crop stand in very nearly the same state. This observation suggests that the evolution of crop canopy geometry with respect to moisture content may serve as a new basis for canopy reflectance modeling.

In conclusion it should be pointed out that in the development image processing algorithms, goniometric data may serve only a tutorial function, unless simpler schemes are developed for its acquisition. In conjunction with the profusion spacecraft imagery now available, however, it could serve the important function of allowing like subjects imaged at different times and in widely spaced locales to be accurately referenced with respect to one another.

V. References

- [1] Schutt, J. B., Shai, C. M., Formulation Procedures, Rationale, and Preliminary IMP-H Flight Data for Silicone Paints With Improved Stability, GSFC, X-764-73-373 (December 1973).
- [2] Nimbus III User's Guide, National Space Science Data Center, Goddard Space Flight Center, Greenbelt, Maryland, March 1969.
- [3] Nimbus IV User's Guide, National Space Science Data Center, Goddard Space Flight Center, Greenbelt Maryland, March 1970.
- [4] Unpublished data.
- [5] Private communication.
- [6] Nimbus VI User's Guide, National Space Science Data Center, Goddard Space Flight Center, Greenbelt, Maryland, February 1975.
- [7] Applications Explorer Missions (AEM), Mission Planners Handbook, Goddard Space Flight Center, Greenbelt, Maryland, May 1974.
- [8] Committee on Remote Sensing for Agricultural Purposes, Remote Sensing, National Academy of Sciences, Plate 9 (1970).
- [9] Tellex, P. A., Waldron, J. R., Reflectance of magnesium oxide, *J. Opt. Soc. Am.* **45**, 19 (1955).
- [10] Grum, F., Lucky, G. W., Waugh, G. P., Spectro Reflectometric Reference Standard and Method, U.S. Patent 3512895 (May 1970).
- [11] Brandenburg, W. M., Neu, J. T., *J. Opt. Soc. Am.* **56**, 97 (1966).
- [12] Unpublished notes.
- [13] Stuart, J., Diffuse Reflective Coating, **3**, 702, 775 Issued to NASA (November 14, 1972).
- [14] Private communication.
- [15] Private communication.
- [16] Schutt, J. B., Arens, J. F., Shai, V. M., Stromberg, E., Highly reflective stable white paint for the detection of ultraviolet and visible radiations, *J. Appl. Optics* **13**, 2218 (1974).
- [17] Hardy, A. C., Perrin, F. H., *The Principles of Optics* (McGraw-Hill Book Co., New York, 1932, 1st ed., Chil.), p. 24.
- [18] Stokes, G. G., *Proj. Roy. Soc. (London)* **11**, 545 (1862).
- [19] Schuster, A., *Astrophys. J.* **21**, 1 (1905).
- [20] Lord Rayleigh, *Proc. Roy. Soc. A* **90**, 219 (1914).
- [21] Silberstein, L., *Phil. Mag.* **4**, 129 (1927).
- [22] Kubelka, P., Munk, F., *Z. Tech. Physic.* **11**, 593 (1931).
- [23] Allen, W. H., Richardson, A. J., Interaction of light with a plant canopy, *J. Opt. Soc. Am.* **58**, 1023 (1968).
- [24] Duntley, S. H., The optical properties of diffusing materials, *J. Opt. Soc. Am.* **32**, 61 (1942).
- [25] Suits, G. H., Vincent R. K., Horowitz, H. M., Erickson, J. D., Optical Modeling of Agricultural Fields and Rough-textured Rock and Mineral Surfaces, NASA CR-134243, ERIM 31650 (1973).
- [26] Nichiporovich, A. A., *Soviet Plant Physiology*, **8**, 428 (1961).
- [27] de Wit, C. T., Photosynthesis of Leaf Canopies, *Agr. Res. Rept.* 663 (Wagenengen, 1965), chap. 4, p. 11.
- [28] Fritschen, L. J., *Agr. Meteorol.* **4**, 55 (1967).
- [29] Idso, S. B., de Wit, C. T., Light relations in plant canopies, *J. Appl. Optics* **9**, 177 (1970).
- [30] Smith, J. A., Flevei, R. E., Plant Canopy Models for Simulating Composite Scene Spectroradiance in the 0.4 to 1.05 Micrometer Region, *Proc. Eighth Inter. Symp. on Remote Sensing of the Environment*, p. 1333 (Oct. 1972).
- [31] Oliver, R. E., A Stochastic Canopy Model of Diurnal Reflectance, Dissertation, Colorado State Univ., 1974.
- [32] Oliver, R. E., Smith, J. A., Vegetation canopy Reflectance Models, Colorado State Univ., Final Report. U.S. Army Research Office, Durham, N.C., 1973 (DA-ARO-0-31-126-71-G165).
- [33] Watlington, R., Wood, F., Schutt, J., de Gasparis, H., Shima, L., Unpublished Data Taken at the Plant Industry Station; USDA, Beltsville, Md.
- [34] Private communication.

(Paper 80A4-904)



Standardization of Light Scattering Measurement in Conjunction With Immunochemical Analysis

Gregory J. Buffone

Department of Clinical Laboratories
Children's Hospital National Medical Center
and George Washington University
Washington, D.C. 20009

(May 26, 1976)

Light scattering methods for the physical analysis of synthetic and biological polymers necessitates the use of scattering standards and absolute light scattering measurements. Standardization has not been employed when light scattering has been used to monitor immunochemical reactions using a kinetic or thermodynamic mode.

The concentration of a specific protein present in a complex matrix such as urine, serum or cerebrospinal fluid, is measured by reacting the protein of interest with its specific antibody and then measuring the excess light scattering of the solution produced by the formation of antigen antibody complexes. The lack of established light scattering standards in the area of immunochemical measurements makes instrumental quality control difficult and has hindered direct comparison of data among investigators. Both solid and liquid light scattering standards would be necessary to encompass the wide range of instrumentation currently in use. Several solid standards which have been used in the past include reflecting diffusers such as vitrolite, magnesium carbonate crystals with a ground surface, magnesium oxide coatings on magnesium carbonate crystal, casein paint on vitrolite, and solid opal glass transmitting diffusers such as flashed opal glass and solid opal glass. These standards, while applicable to manual light scattering photometers, are not suitable for recently developed automated instrumentation. Liquid standards in the form of Ludox®, solutions of polystyrene, suspensions of small diameter latex spheres and even pure organic solvents could be used more easily with the continuous flow and discrete automated analyzers. The introduction of instrumental standards at this level of analysis would result in improved overall quality control and facilitate data and method comparison between laboratories.

Key words: Antibodies; antigens; biological polymers; immunochemical analysis; light scattering; polymers; proteins; solid standards.

I. Introduction

Nephelometry, as applied to immunochemistry, measures the excess scatter caused by antigen antibody complexes formed in solution. The concentration of the unknown analyte is determined by use of appropriate calibration materials. Since only relative nephelometric measurements are required, absolute standardization of instrumentation has not been necessary for internal laboratory accuracy. However, while lack of standardization has not been deleterious in internal accuracy, comparison of data between laboratories and day to day internal laboratory instrumental quality control has been difficult at best. Poorly defined protein standards make the definition of a more standardized measuring system an acute problem.

II. Application of Light Scattering to Immunochemistry

Quantitative immunochemical methods used since the 1930's include immunoprecipitation in solution

[1]¹ and in a gel matrix [2]. Both approaches rely on the formation of a precipitate for the quantitation of the analyte. The methods are time consuming and are considered relatively tedious and expensive. The resurgence of nephelometric methods for the measurement of the extent of immunochemical reactions beginning in 1969 to date, can be traced to the improvement in efficiency and sensitivity provided by this approach.

Manual and Flow Nephelometry. Fluorometers have been used almost exclusively to make 90° equilibrium light scattering measurements when following immunochemical reactions. Numerous manual methods for the measurement of urine, serum and cerebrospinal fluid proteins have been reported [3-5]. Continuous flow systems have made automation of immunochemical reaction measurements feasible.

Kinetic Light Scattering. The introduction of the centrifugal analyzer [6] has provided an automated instrument capable of precise kinetic measurement. The centrifugal analyzer has been applied to the

¹ Figures in brackets indicate the literature references at the end of this paper.

automated kinetic measurement of antigen antibody reactions. Centrifugal analyzers have been used to measure scatter from antigen antibody complexes at 90° [7] and at angles between 15 and 30 degrees [8], with the smaller angles providing greater sensitivity due to the large complex size.

Solid Phase Light Scattering. Recently Giaver [9] described the use of a solid phase protein preparation for the monitoring of immunochemical reactions. Protein or carbohydrate antigens were adsorbed onto a glass slide coated with small spheres of indium metal (~ 1000 Å in diameter). Incubation of the plates in an antiserum specific for the adsorbed antigen results in reaction between antigen and antibody causing a variation in the protein coat thickness on the metal spheres resulting in an increase in the amount of light scattered from areas of the plates at which a reaction has occurred. This technique can detect, by visual inspection, a reaction on a bovine albumin coated slide at an antibody concentration of 10⁻⁴g/l.

Mie Scattering. Application of light scattering to the detection of rheumatoid factor provides a more sensitive and potentially quantitative means of measurement [10]. A homogeneous distribution of latex spheres whose particle diameter is approximately equal to the wavelength of light used for analysis, will produce characteristic maxima and minima intensities when scattering is observed at different angles. Any agglutination of human IgG coated spheres by rheumatoid factor will result in a loss of homogeneity of particle size and the characteristic maxima and minima intensity pattern, with changes in maxima slopes being related to the concentration of rheumatoid factor.

Quasi-Elastic Light Scattering. The use of quasi-elastic light scattering holds the potential for measurement of antigen or antibody at a concentration of a few micrograms per liter, making this technique competitive with RIA in terms of sensitivity [11]. Broadening of laser spectral line widths caused by changes in the diffusion coefficient is used as an extremely sensitive means of detecting agglutination of antigen coated latex spheres.

III. Instrumental Standardization

The diverse methods and instrumentation just reviewed would require a versatile material for instrumental standardization. Here I consider the types of standards that have been used and some of the most recent commercial materials marketed for calibration.

Reflecting Diffusers. Several materials used as reflecting diffusers for measurement of primary beam intensity are outlined in table 1. These materials are useful for calibration of the instrument with respect to primary beam intensity, but do not provide the analogous calibration situation one encounters when using suspended scattering particles. Neutral filters for primary beam attenuation are usually necessary when using this approach. These

filters represent an additional variable and possible source of error.

Transmitting Diffusers, Flashed Opal Glass, is simply a white glass fused with clear glass. The two types of glass are drawn simultaneously from their respective tanks and fused immediately as they cool. The drawing is done by mechanical means and results in a reproducibly smooth surface. *Opal Glass,* is blown white glass. Manual manipulation results in a more variable product with a more irregular surface than the flashed opal glass.

TABLE I. *Reflecting diffusers* [12]

Material	Description	R ^a
a. Vitrolite	White structural glass ground with #320 carborundum	0.816
b. MgCO ₃	Block scraped with straight edge	.964
c. MgO	Layer (0.5 mm) smoked onto MgCO ₃ from burning chips	.990
d. Casein paint #1	Commercial brand, painted on Vitrolite	.885

* Absolute reflectance

When dealing with reflecting diffusers, it should be noted that depending on the angle of measurement and the type of phototube used, polarization effects caused by these diffusers can produce variation in the absolute intensity measured.

Amorphous Solid Scattering Materials. Zimm [13] has described the preparation of a polystyrene methyl acrylate material and its use as a scattering standard. The material is prepared by adding 5 percent methyl acrylate to the polystyrene when the polymerization is half complete. The mixture results in an opalescent material suitable for scattering or turbidity measurements. Zimm observed that the turbidity measurements were temperature sensitive as would be expected for an amorphous solid. Zinc oxide suspended in an acrylic resin has also been used as a standard. This preparation is also susceptible to temperature fluctuation.

Liquid Scattering Materials. Liquid turbidity standards have been used in industry for several years. The most commonly used material being a preparation known as Formazin [14]. Formazin, produced from a reaction between hydrazine sulfate and hexamethylenetetramine, is a suspension of relatively large particles which exhibit angular dependent light scattering and unsuitable sedimentation properties.

Other suspensions that have been used include silver iodide, silver sulfide, and barium sulfate, also known as McFarland's standard. These suspensions show only transient stability and should be used with care.

Solutions of polystyrene prepared in organic solvents have been used as calibration material for

scattering photometers, and provide a relatively stable standard when appropriately sealed and not subjected to excessive ultraviolet radiation.

An aqueous standard, in the form of highly cross linked spherical beads of styrene divinylbenzene, is available commercially from AMCO Service Company² (4151 Middlefield Road, Palo Alto, CA 94303). Particle size ranges from 0.1 to 0.8 μm . The suspension is reported to be temperature, time and pressure stable and to possess superior sedimentation characteristics relative to Formazin. Several advantages of the styrene divinylbenzene suspension make it attractive as a nephelometric standard: (1) the suspension can be infinitely diluted in an aqueous medium, (2) it can be accommodated in both manual and automated systems now in use for nephelometric or light scattering measurement and (3) it is nonreactive with glass vessels.

Ludox[®] is a commercial colloidal suspension of silica marketed by the Dupont Chemical Corporation. Ludox has gained popularity in recent years for calibration purposes because of its ease in handling. There are several forms of Ludox,[®] each having its own unique physical and chemical properties. Ludox[®] stability depends on silica solid content, temperature, size and surface area of silica particles, pH, particle charge, and salt concentration and character. The specific effect of each parameter is dependent on the Ludox[®] system under consideration. Ludox[®] can react with glass vessels if not properly stabilized. A detailed discussion of the chemical properties can be found in the Dupont technical publication entitled, *Properties, Uses, Storage and Handling of Ludox Colloidal Silica*.

IV. Applicability of Standardization

The following aspects of nephelometric immunochemical analysis would benefit directly from instrumental standardization.

Quality Control. The antigen antibody reaction is intricate, producing antigen antibody complexes with different characteristics at different antigen antibody ratios. Quality control in essentially all clinical laboratories consists of the measurement of one or two reference sera or plasma per assay representing discrete ratios in restricted zones of the calibration curve. Instrumental standards would provide a means of monitoring results in all zones without resorting to multiple reference measurements in each set of analyses.

Data Comparison. Currently the criteria for method acceptance consists of the evaluation of the clinical applicability of results generated by the method. Comparison cannot now be made on an analytical basis except by semiquantitative means due to the lack of reference methods and instrumental standardization.

² In order to adequately describe materials, it was occasionally necessary to identify the company and commercial products by name and trademark. In no instances does such identification imply endorsement by the National Bureau of Standards, nor does it imply that the particular product is necessarily the best available for the purpose.

Calibrator and Reagent Evaluation. A reference scattering material is necessary to allow for evaluation of both calibrators and biological reagents. These materials can vary from source to source and lot to lot.

The brief discussion of variables intrinsic to immunochemical methodology demonstrates the applicability of an instrumental standard to provide a point of reference for improved overall quality control, method comparison and quality control of reagents and calibrators.

V. Summary

Amorphous solid scatterers such as described by Zimm or liquid scatterers, such as a polystyrene solution or styrene divinylbenzene suspension, seem to be the most reliable and practical material for routine use based on the experience of this investigator.

Low molecular weight polystyrene samples (300–500,000 g/mol) dissolved in an organic solvent can serve as a scattering standard in both automated and manual systems and provide scattering independent of the angle of measurement. As mentioned earlier, scattering from the solutions can be relatively low and the sensitivity of the instrumentation should be considered. The stability of the individual scattering components with regard to temperature, pressure and also the sedimentation characteristics would be superior.

Styrene divinylbenzene and Ludox[®] suspensions exhibit relatively high scatter even at 90° and can be diluted in an aqueous medium eliminating refractive index differences that might arise when comparing an organic solvent standard and an aqueous standard in an absolute measurement. Styrene divinylbenzene and Ludox[®] need to be evaluated with respect to long term stability in reference to this type of application.

An amorphous solid scatterer made up of polystyrene and methyl acrylate or zinc oxide in an acrylic resin can provide a suitable standard for manual instrumentation if the temperature variation fluctuation is closely controlled.

Considerable work remains to be done with respect to the evaluation of long term stability and comparison of different light scattering standard materials before specific recommendations can be advanced.

VI. References

- [1] Heidelberger, M., and Kendall, F.E., A quantitative theory of the precipitin reaction. *J. Exp. Med.* **62**, 467 (1935).
- [2] Mancini, G., Carbonara, A.O., and Heremans, J.E., Immunochemical quantitation of antigens by single radial immunodiffusion, *Immunochem.* **2**, 235 (1965).
- [3] Ritchie, R.F., A simple, direct, and sensitive technique for measurement of specific protein in dilute solution, *J. Lab. Clin. Med.* **70**, 512 (1967).

- [4] Savory, J., and Killingsworth, L.M., Measurement of immunoglobulins in cerebrospinal fluid employing nephelometric immunoprecipitin techniques, *Clin. Chim. Acta* **43**, 279 (1973).
- [5] Alper, C.A., Automated nephelometric determination of serum haptoglobin, C'3 and α_1 -antitrypsin. In *Advances in Automated Analysis*, Technicon International Congress, 1970, 1, C.E. Barton, et al., Eds. (Thurman Assocs, Miami, Fla. 33132, 1971), p. 13.
- [6] Anderson, N.G., Computer interfaced fast analyzers, *Science* **166**, 317 (1969).
- [7] Tiffany, T.O., Parella, J.M., Johnson, W.F., and Burtis, C.A., Specific protein analysis by light scatter measurement with a miniature centrifugal fast analyzer, *Clin. Chem.* **20**, 1055 (1974).
- [8] Buffone, G.J., Cross, R.E., Savory, J., and Soodak, L., Measurement of laser-induced near front surface light scattering with a parallel fast analyzer system, *Anal. Chem.* **46**, 2047 (1974).
- [9] Giáver, J., The antigen-antibody reaction: A visual observation, *J. Immunol.* **110**, No. 5, 1424 (1973).
- [10] Blume, P., and Greenberg, L.J., Application of differential light scattering to the latex agglutination assay for rheumatoid factor, *Clin. Chem.* **21**, 1234 (1975).
- [11] Cohen, R.J., and Benedeck, G.B., Immunoassay by light scattering spectroscopy, *Immunochem.* **12**, 349 (1975).
- [12] Brice, B.A., Hawler, M., and Speiser, R., Photoelectric light scattering photometer for determining high molecular weights. *J. Opt. Soc. Am.* **40**, 768 (1950).
- [13] Zimm, B.H., Apparatus and methods for measurement and interpretation of the angular variation of light scattering; Preliminary results in polystyrene solutions, *J. Chem. Phys.* **16**, 105 (1948).
- [14] *Standard Methods for the Examination of Water and Waste Water* (American Public Health Assoc., 13th ed., p. 349-356, 1971).

(Paper 80A4-905)

Part 3. Ultraviolet Absorption Spectrometry

Errors in Spectrophotometry and Calibration Procedures to Avoid Them

A. G. Reule

Carl Zeiss, 7082 Oberkochen, Germany

(May 26, 1976)

Based on simple principles, spectrophotometry nevertheless demands a lot of precautions to avoid errors. The following properties of spectrophotometers will be discussed together with methods to test them:

Spectral properties—wavelength accuracy, bandwidth, stray light; photometric linearity; interactions between sample and instrument—multiple reflections, polarization, divergence, sample wedge, sample tilt, optical path length (refractive index), interferences.

Calibration of master instruments is feasible only by complicated procedures. With such a master instrument standards may be calibrated which greatly simplify performance checks of instruments used for practical work. For testing high quality spectrophotometers the use of emission lines and nearly neutral absorbing solid filters as standards seems to be superior, for some kinds of routine instruments the use of absorption bands and liquid filters may be necessary.

Key words: Bandwidth; calibration; errors in spectrophotometry; interferences; multiple reflections; photometric linearity; polarization; sample characteristics; stray light; wavelength accuracy.

I. Introduction

The comparison of measured results of different optical parameters reveals considerable differences in accuracy. There is no difficulty in stating refractive indices to within 5 decimals and tables of line spectra quote wavelengths to within 6 to 7 significant digits. In contrast, the transmittance of an object can be indicated to within 0.1 percent only, and even this allows merely statements as to random but not to systematic errors.

In 1973 the College of American Pathologists carried out a comparative test. A number of solutions was sent out and measured with spectrophotometers in 132 different laboratories. The results showed coefficients of variation in absorbance of up to 22 percent. When the test was repeated in 1974, the coefficients of variation among 135 laboratories still amounted to maximally 15 percent; although 24 laboratories had been excluded by a special test because their photometers had more than 1 percent stray light at 240 nm. This corresponds to a coefficient of variation in transmittance of up to 11 percent (table I) [1].¹

It is thus not surprising that spectrophotometer users call for standards to test their instruments.

These tests and many similar ones have been and are still carried out with solutions having several wide transmission maxima and minima. As references for photometric *and* wavelength accuracy of the instruments, measuring wavelengths are sometimes stipulated for the extremes and for values on the slopes of the transmission curves, although such an inference is often impossible. The author would therefore suggest separate tests for wavelength accuracy and photometric accuracy, even for routine work. Only then will it be possible to prove by a test not only the unreliability of measurements, but also to derive quantitative parameters suitable for correction of the results. The individual sources of error are, of course, dealt with and eliminated separately if instruments and equipment are tested in laboratories issuing and calibrating standards.

The individual sources of error and possible test methods are discussed in the following, with special consideration of two points of view: fundamental tests for specific errors in the standards laboratories and tests by the average users of spectrophotometers in clinical or analytical laboratories.

The result of a spectrophotometric measurement is expressed by two numbers: wavelength and trans-

¹ Figures in brackets indicate the literature references at the end of this paper.

TABLE I. Best, medium and worst values selected from table I group A of Beeler and Lancaster [1]

C.V. = Coefficient of Variation
 St.D. = Standard Deviation

$T, \Delta T/T = 2.303 \cdot \Delta A$, and ΔT have been calculated from A and $\Delta A/A$ given by B. and L.

Solution p. = potassium	Conc. mg/1	Wav. nm	$\Delta A/A$ C.V. %	A	T %	$\Delta T/T$ C.V. %	ΔT St.D. %
Acid p. dichromate.....	20	380	11.1	0.109	77.8	2.79	2.17
Alkaline p. chromate.....	40	300	15.1	.151	70.9	5.25	3.72
Alkaline p. chromate.....	40	340	9.2	.318	48.3	6.74	3.25
Acid p. dichromate.....	60	328	5.0	.432	38.0	4.97	1.88
Acid p. dichromate.....	100	366	5.8	.855	14.0	11.42	1.59
Acid p. dichromate.....	100	240	2.8	1.262	5.47	8.14	0.45

mittance. The transmittance of a sample as a function of the wavelength is generally expressed by a curve. Since the transmittance may vary more or less strongly with wavelength, both the spectral characteristics and the accuracy of the photometric result must be considered. Three groups of characteristics are therefore discussed: spectral characteristics, genuine photometric characteristics, and optical interactions between sample and photometer.

In practice there are other sources of error, such as environmental effects on photometer and sample, temperature, line voltage fluctuations, vibrations, contamination, or heating of the sample by the photometer. All these factors may impair the measured result, and ways and means are known to test and eliminate them. They are therefore disregarded in the following discussion.

There are numerous publications about tests of this kind, and each individual problem has been discussed in the relevant literature. This paper gives a survey of the problems and discusses methods the author would like to recommend or to warn against. The study is limited to photometers for UV, VIS, and near IR. A good survey of the literature published until 1972, especially regarding tests for photometric linearity, is included in the proceedings of the Conference on Accuracy in Spectrophotometry and Luminescence Measurements, held at the National Bureau of Standards in March 1972 [2], particularly in the contributions of Clarke [3], Mavrodineanu [4], and Sanders [5].

II. Testing the Spectral Characteristics

A. Accuracy of the Wavelength Scale

The wavelengths of a great number of emission lines within the ultraviolet and visible spectral regions are known exactly. Standards or industrial laboratories which have to supply the data for such scales encounter no difficulties in testing wavelength scales. Two facts deserve special mention:

(a) Even in regions without absorption the dispersion of prism materials is not as homogeneous as

may be expected. Thorough tests therefore require measurements at a great number of wavelengths (fig. 1).

(b) The fundamental errors of a sine bar mechanism (fig. 2), which is commonly used for rotation of gratings, should be covered by checks at four wavelengths. This does not apply, however, to periodic errors of the lead screw or its bearing, which sometimes cause surprising discrepancies (fig. 3).

A single wavelength suffices to test an instrument supplied free of defects by the manufacturer, because it is unlikely that the tested wavelength remains unchanged in case of damage during shipment or other sources of error. This is not true, however, if the user or the manufacturer's maintenance service carries out adjustments, which generally requires the checking of two to three wavelengths. This is not necessary in case of special designs (fig. 2a).

If the user wants to check the wavelength in instruments equipped with a deuterium source, he should use the emission lines of deuterium. Note the differences between deuterium and hydrogen lines (table II). However, many light sources contain in addition to deuterium higher or lesser amounts of hydrogen, which cause errors if the resolving power of the instrument is not adequate to separate the lines (fig. 4).

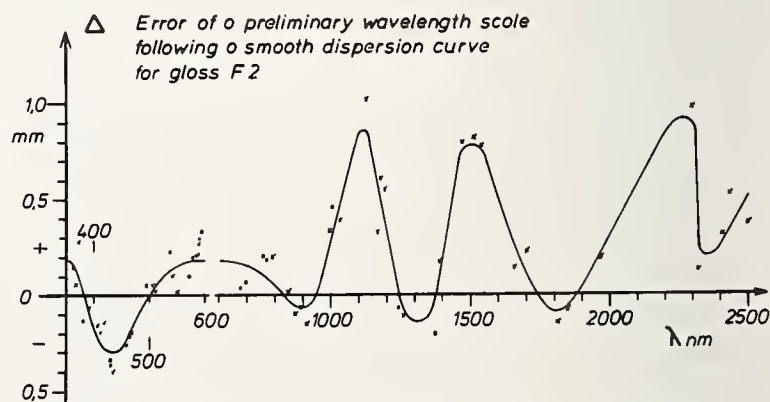

FIGURE 1. Irregularities in the dispersion of a prism made of F-2 glass (Schott).

Shown are differences between actual transmitted wavelengths and readings of a preliminary wavelength scale following a smooth dispersion curve. Projection scale with 50x magnification see figure 2. 1 mm on the groundglass screen corresponds to about 0.038 nm near 400 nm and about 5.5 nm near 1500 nm.

In an instrument without a deuterium source the aforementioned average user cannot be expected to equip it with a line source to check the wavelength; therefore absorption bands must be used for the test. The bands of the well-known didymium glass are not suited for wavelength checking because they are too wide, temperature-dependent and because didymium glass may contain varying amounts of several absorbing rare earths.

Holmium in aqueous solution has rather sharp absorption bands. Most of the bands of holmium glass are at nearly the same wavelengths as for holmium solutions but are somewhat wider with one striking difference near 450 nm (fig. 5). Because the glass matrix seems to influence Ho absorption there arises the question whether the wavelengths of absorption maxima of Ho-glass are the same for all melts.

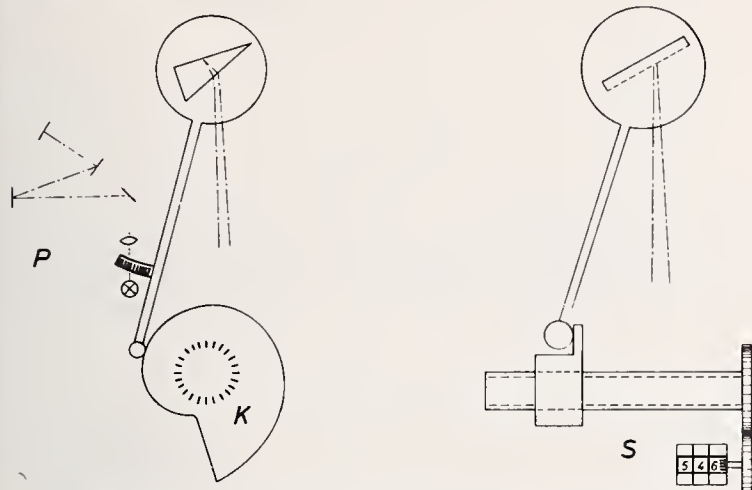

FIGURE 2. Different wavelength display systems.

To the left: (a) (Micro) projection scale rigidly connected with prism, (b) Wavelength cam and scale fixed to cam.

To the right: (c) Sine bar mechanism,

(a) nonlinear, high uniformity of different instruments of the same type, no backlash, no wear, no parallax

(b) can be made linear in λ or ν , less uniform, subject to backlash, wear and parallax (a projection system in connection with a cam avoids parallax only)

(c) linear in λ , uniform, subject to backlash and, less pronounced, to wear and parallax. Periodic errors possible (see fig. 3).

In single-beam instruments only narrow bands measured with small bandwidth allow the determination of absorption maxima by simply scanning the wavelength. If the bands or bandwidths are wider, the positions of the maxima are shifted due to the spectral variation of signal in the empty instrument (fig. 6). This can be avoided by using an absorption or transmission maximum near the maximum of the instruments' response curve, which is achievable by special interference filters (fig. 7). We found such interference filters to be most helpful for wavelength checks of instruments with bandwidths between 2 and 10 nm. The filters must, of course, be most carefully produced, and the wavelength of maximum transmittance given for each individual filter.

B. Bandwidth

Bandwidth is best checked by recording the signal as a function of wavelength, when the monochromator is irradiated with an isolated emission line (fig. 8). Bandwidths well above the limit of the resolving power produce the well known triangle, whereas bandwidths approaching the limit of resolving power result in a rounded curve.

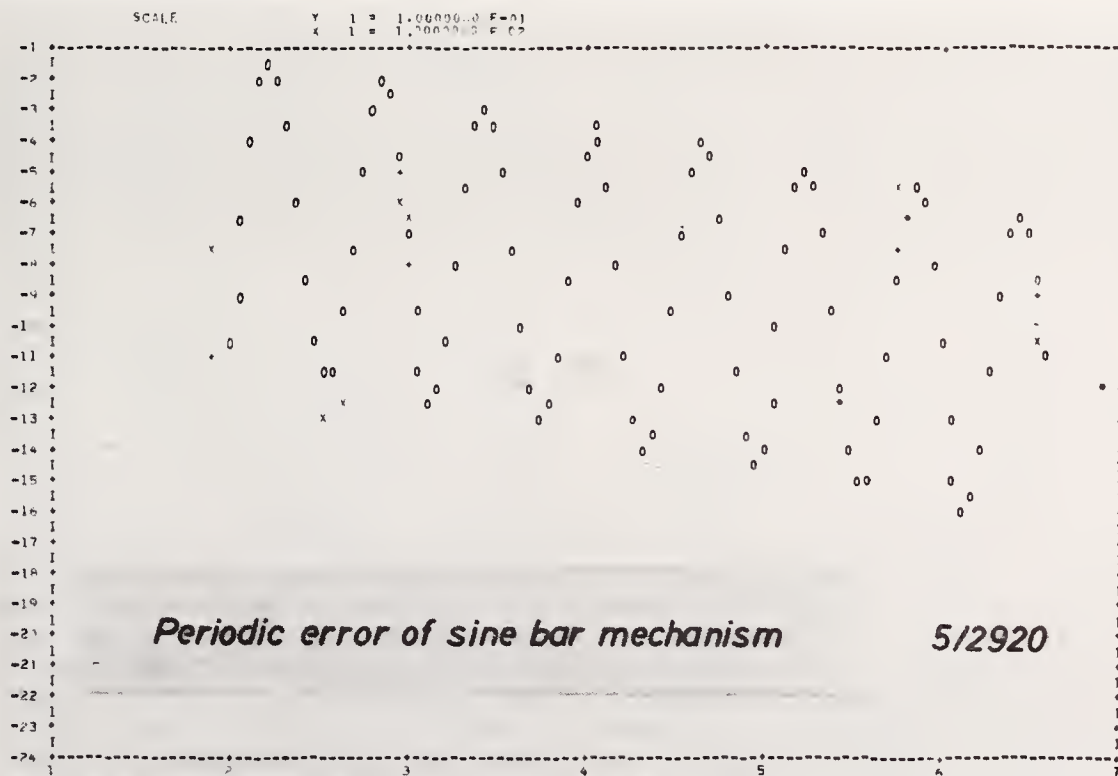

FIGURE 3. Periodic error of a sine bar mechanism (in this case due to an unsuitable ball bearing).

x measured lines (Hg), + and 0 best fitting curve.

TABLE II. Emission lines of hydrogen and deuterium

	H	D
α	656.285 nm	656.100 nm
β	486.133	485.999

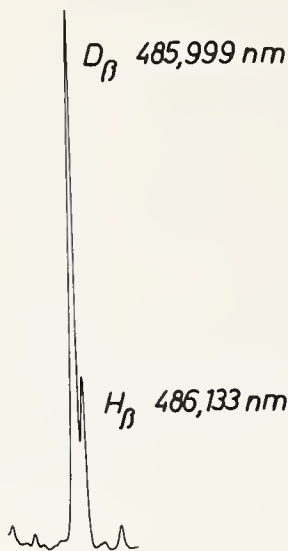

FIGURE 4. Line emission of a commercial deuterium source showing D and H lines.

The H/D intensity ratio is likely to increase with age.

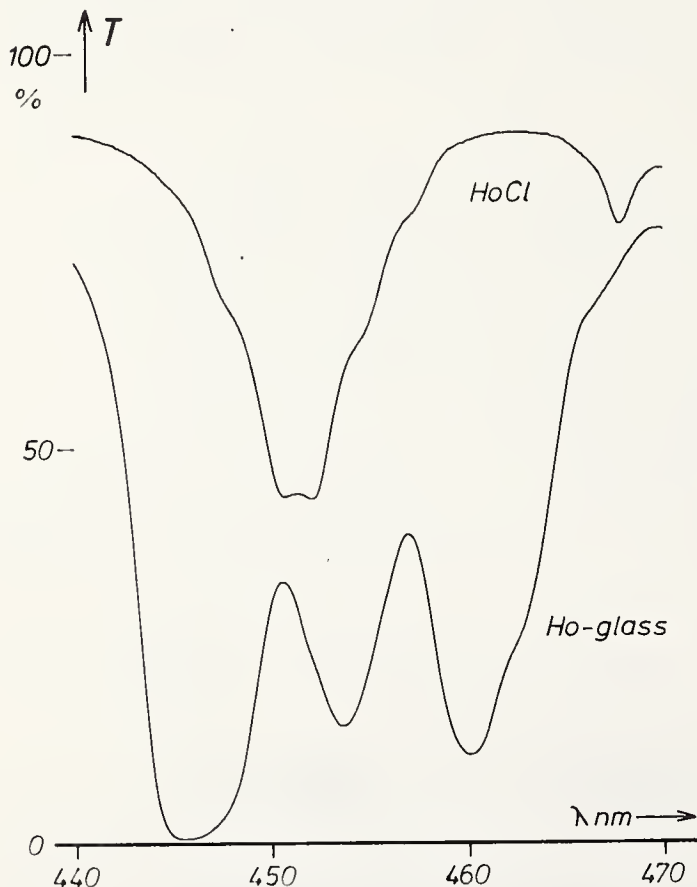

FIGURE 5. Spectral transmittance of Holmium in aqueous solution (1.14 g Ho_2O_3 in 100 ml 0.2 N HCl; 1 cm) and as an absorbing constituent of glass.

Part with the greatest differences; minor differences are observed with the other bands.

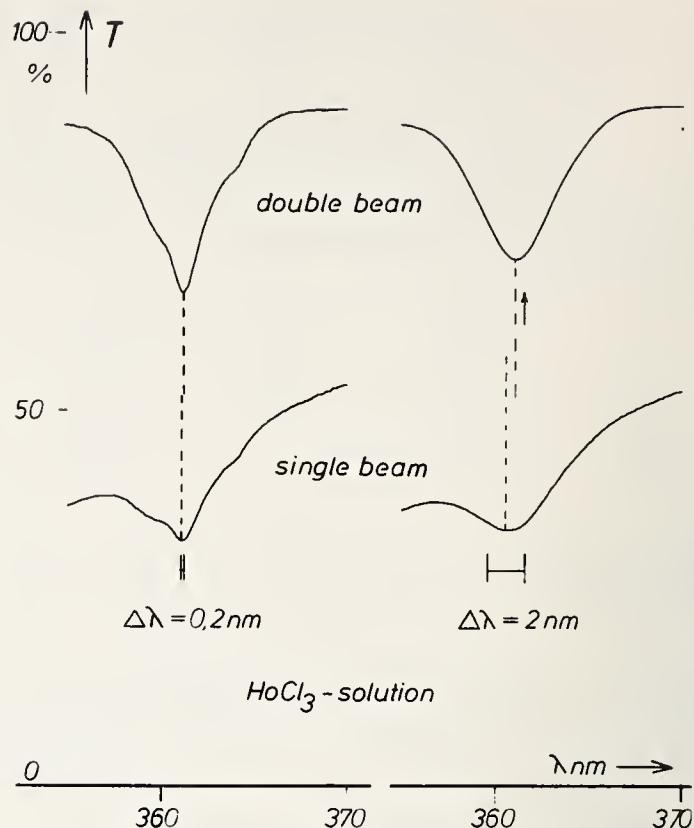

FIGURE 6. Spectral transmittance of Holmium chloride solution as in figure 5 measured in a double-beam instrument (ZEISS DMR 10) at 0.2 nm (left) and 2 nm (right) bandwidth (curves above), and in single-beam mode (curves below).

In single-beam mode the error is less than 0.05 nm at 0.2 nm bandwidth. At 2 nm bandwidth the double-beam curve shows a shift of 0.1 nm of the minimum due to skewness of the true transmittance. The single-beam minimum is shifted by 0.15 nm from the double-beam minimum (0.25 nm from the true one) due to skewness of the empty instrument signal.

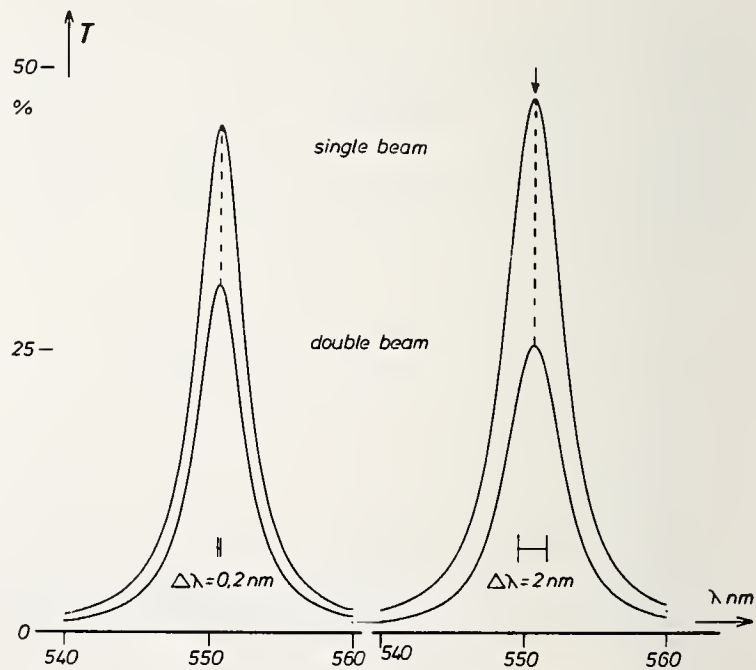

FIGURE 7. Spectral transmittance of an interference filter for wavelength calibration measured at 0.2 nm and 2 nm bandwidth in double-beam mode (curves below) and single-beam mode (curves above).

There is no difference in the position of the maxima up to 2 nm bandwidth; 0.4 nm shortwave shift at 5 nm.

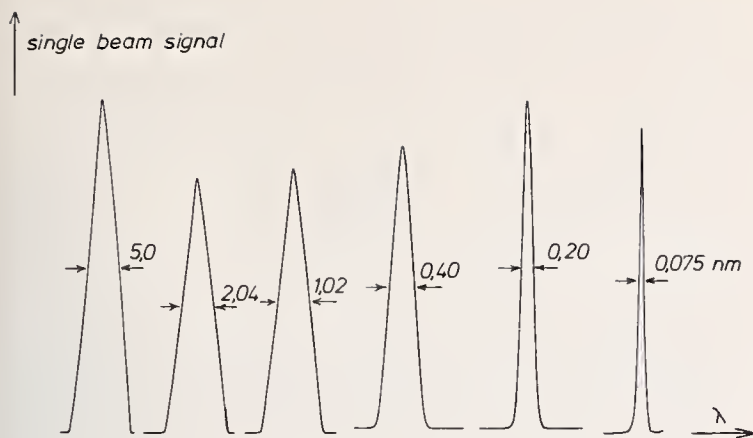

FIGURE 8. Bandwidth determination with isolated emission lines.

Recorded in single-beam mode with ZEISS DMR 10 Recording Spectrophotometer and mercury line 546.07 nm. Abscissa scale expansion changed to give nearly equal widths of the four larger bandwidths; ordinate expansion, voltage adjustment and neutral filters used to make amplitudes nearly equal. Nominal bandwidths ("spectral slit widths") set to 5-2-1-0.4-0.2 and below 0.1 nm.

The aforementioned deuterium lines are less suited for the determination of the bandwidth, because of other lines and continuous background in their vicinity.

The dip between two emission lines can be easily interpreted only if both lines are of equal intensity and if the transmission profile of the monochromator is symmetrical.

Absorption bands are generally not sufficiently pronounced or isolated. The only definite conclusion that can be derived from the resolution of two bands is that the bandwidth is smaller than the distance between the two.

As far as the author knows, previous comparative tests did not include bandwidth checks by the user. There is little danger of corresponding changes in good instruments. If a check by the user is necessary, the separation of absorption bands is probably the most convenient procedure.

C. Stray Light

In this connection the term stray light refers to heterochromatic stray light; that is, light of wavelengths outside the bandpass of the monochromator. Due to scattering, a fraction of this light passes through the monochromator, while outside the monochromator this light follows the regular path. In Germany the expression "Falschlicht" is used, similar to "false light," sometimes used in the U.S., to distinguish this unwanted radiation from radiation scattered by the sample or sample compartment optics and deviating from the regular path. The fraction of the signal (electric current) which is due to stray light falling on the detector is important for the measurement. This is called the stray light ratio and is especially large at the ends of the spectral range of the instrument, where slit width or amplification must be large. However, with a single monochromator this stray light ratio does not change as the slit width or the amplification changes [6].

There are various methods to determine the stray light ratio, of which the different versions of the absorption method, the slit height method, and Preston's method are of practical relevance.

The absorption method requires a substance that is completely opaque within the region of two bandwidths and is completely transparent outside this region. If the stray light occurs exclusively at the longwave or shortwave side, like at the ends of the spectral range, the substance may only have a long-wave or shortwave cutoff.

There is no substance which provides an ideal step function transmittance at one wavelength, but there are a number of substances having sharp cutoffs or narrow absorption bands in the center of the spectral range. Sharp shortwave cutoffs can, for instance, be produced with chlorides, bromides, and iodides (fig. 9). A 15 g/l aqueous solution of sodium chloride has, for instance, at 200 nm and 1 cm path length a transmittance of less than 0.1 percent. The cutoff is temperature-dependent, and even at low temperatures the concentration fulfills the requirements well. Generally the solution is selected as follows: a solution with suitable cutoff is measured in low concentration so that the transmittance lies between 20 and 50 percent (there is only little influence of stray-light) and the required concentration or path length is calculated. If the aforementioned sodium chloride solution is, for instance, used to test a double monochromator, 2 cm instead of 1 cm path length are used.

There are no substances with similarly steep long-wave absorption cutoffs, but interference barrier filters are of some help. The true transmittance of

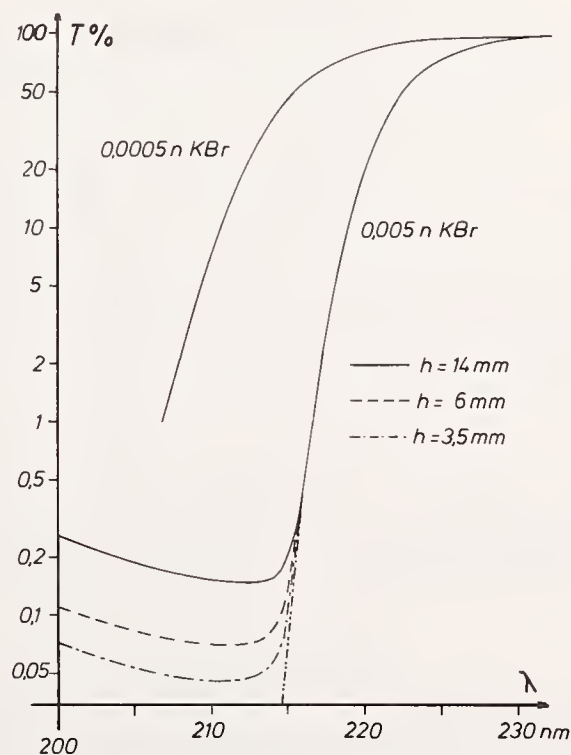

FIGURE 9. Determination of stray-light ratio and its variation with the slit height using KBr solutions in 1 cm cells.

The true transmittance of 0.005 N solution (dotted line) is calculated from the transmittance of 0.0005 N solution.

each filter must, of course, be measured in a double monochromator. The instrument user may carry out checks with absorbing solutions and interference barrier filters.

Slit height variation is the second method for stray-light tests [6]. Contrary to its independence of slit width, the stray-light ratio decreases linearly with the slit height, provided the heights of the entrance and exit slits are reduced simultaneously. For a quantitative determination all parts of the slit must contribute uniformly to radiant flux and signal. This requirement is hardly ever met, and reduction of the slit height therefore only reduces the stray-light ratio without allowing its quantitative determination. Some manufacturers equip their instruments with facilities to change the slit height, thus offering the user the possibility of estimating and reducing the stray light (fig. 9).

In Preston's method [7] one half each of the entrance and exit slits is covered. If the covering is such that an image of the free part of the entrance slit is produced on the free part of the exit slit, the transmitted radiation still contains signal light and stray light. Owing to the reduced slit height the stray light ratio is about fifty percent less than originally. If the other half of the exit slit is covered, only stray-light leaves the monochromator, which can be quantitatively determined. The accuracy of the determination is impaired, though, because for safety reasons the covering must be larger than the part of the slit through which the signal light passes. As this method requires manipulations in the slit plane, it usually cannot be applied by the instrument user.

III. Testing Linearity

A. Representation of Linearity Errors

Two methods of representation are in use which are both based on the fact that the photocurrent i_{\max} (or the equivalent readout on an instrument) which corresponds to a maximum value Φ_{\max} of the radiant flux is stipulated as a reference point. If i_d is the dark current, the following equation should hold for a current i_{lin} which has a strict linear relationship with the radiant flux Φ (fig. 10):

$$(i_{\text{lin}} - i_d) / (i_{\max} - i_d) = \Phi / \Phi_{\max}. \quad (1)$$

Differences between the actually measured value i and the value i_{lin} derived from the equation are called linearity errors:

$$\Delta i = i - i_{\text{lin}}. \quad (2)$$

Both methods express the linearity error as a fraction of a measured result, usually in percent. The two methods differ in that the error is referred either to the maximum value i_{\max} or to the actual reading i (fig. 11). In both cases the determined errors or derived corrections are valid only for measure-

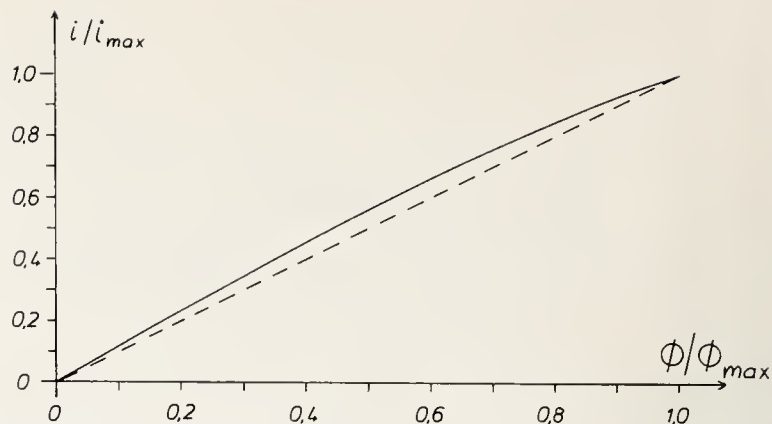

FIGURE 10. Nonlinearity of detector response (vertical distance between the characteristic curve giving the current i as a function of the incident radiant power Φ and the straight line).

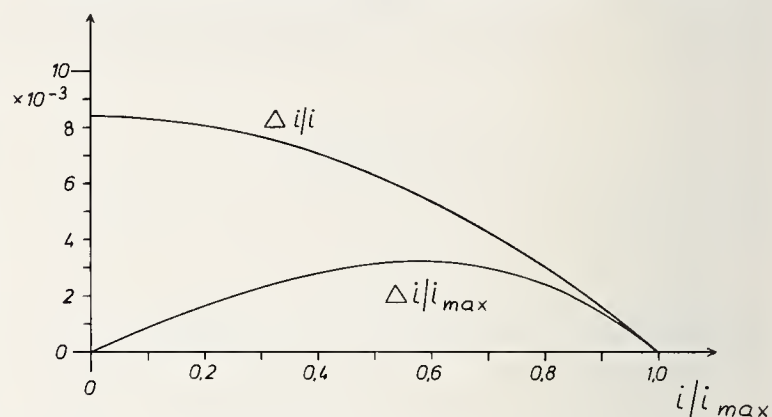

FIGURE 11. Expression of the nonlinearity by $\Delta i/i_{\max}$ or $\Delta i/i$.

ments which are based on the radiant flux Φ_{\max} . Which method is chosen depends on the user. In practice the reference to the maximum value is somewhat easier for the correction of transmittance, because the correction term can be added directly. Reference to the individual value has advantages if the transmittance is low or for measurements of absorbance A , because the following equation holds:

$$\Delta A = 0.434 (\Delta i/i). \quad (3)$$

B. Photomultiplier Characteristics

Most precision spectrophotometers are equipped with photomultipliers as detectors. Their characteristics; such as, spectral sensitivity of the cathode, dependance of gain on voltage, voltage drop at the anode resistor, variations of sensitivity across the cathode or with direction of incidence etc. are so well known that they will not be discussed here.

We should like to mention just a few effects which are not so well known. The first is the temperature-dependent sensitivity of the cathode [8] (table III). If a radiant flux of 10 nW falls on a cathode with a metal substrate, the rate of temperature increase due to absorption of radiation is approx. 0.5×10^{-6} °C/s. This value is so small that even with irradiation over extended periods the sensitivity does not change markedly due to the temperature increase

TABLE III. Variation of photocathode sensitivity with temperature [8]

Photocathode	Blue	Red
Ag O Cs	-0.24 %/°C	-0.14 %/°C
Sb Cs	-0.48	+0.64
Multialkali	-0.22	-0.24

caused by the radiation. However, the temperature rise time of cathodes on glass or quartz substrates (as in end-on types) may reach values which are interfering, yet are still too slow to reach thermal equilibrium.

Another troublesome characteristic of detectors is that the current generated depends not only on the present but also on the previous irradiation, an effect which is known as memory effect. Most detectors have memory effects of some tenths of a percent for a duration of a few seconds, if they are covered for a few seconds after long exposure to light. This holds true even when the anode currents are kept to values between 10^{-8} to 10^{-7} A. Some detectors show much larger memory effects. The effect is not only noticeable upon irradiation with continuous light, but also if the light is chopped at 50 Hz. Only recently, we observed a change of the signal amplitude in light pulses of 5 ms width and 15 ms dark time, dependent on whether or not pulses of equal amplitude and width were interspaced between these pulses. The change in amplitude of the original pulses amounted to -1.3 percent and covered a period of approximately 5 s (fig. 12) [9].

In keeping the measuring accuracy below 10^{-4} of the maximum current, there is the danger that these memory effects affect not only the measurement of the sample under test but also the methods for linearity tests. It will be difficult to distinguish between memory effect and nonlinearity. All readings must be done in a sequence of time which is exactly stipulated and reproducible. Residual memory effects in the results may be recognized by changing the time between readings.

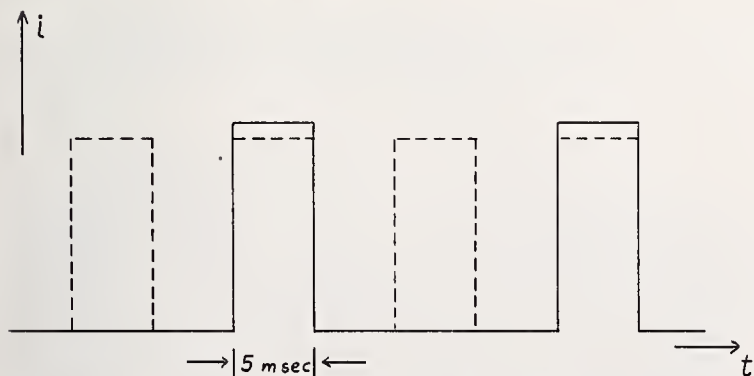

FIGURE 12. Short-term memory effect of photomultipliers.

The multiplier is at first illuminated with light pulses which result in the current given by the solid lines. If equal light pulses (dashed lines) are interspaced between the first ones, the current amplitude is reduced by an amount which depends on multiplier type and specimen. With pulses giving a current amplitude of 10^{-7} A a reduction of -1.3 percent was observed, which took about 5 s to reach the new level.

C. Light Addition Methods

As indicated elsewhere [10, 11], there are no samples the transmittances of which are known with sufficient reliability without photometric measurement. The standards laboratories must therefore determine the linearity of the instruments by special test methods. The addition method is the basic procedure for the design of an equidistant scale of any measuring parameter. Different versions of the method are in use in photometry [12]. There are setups with several apertures and setups with several light sources. The setups with two apertures (fig. 13) [13, 3, 4], with many apertures [14, 5], and with two light sources (fig. 14) [15, 10] are especially important in practice (the first—to the author's knowledge—and one or two recent papers are cited respectively).

Setups with two or several apertures have the advantage of needing only one light source, that is the one in the instrument under test. Neither is additional optics required in the beam path, so that the state of polarization of the radiation remains unaffected. However, the light in the instrument is reduced considerably by the aperture diaphragms, so that the method can only be applied if there is sufficient light available and if the cross section of the light beam is large. For these reasons, these methods cannot be applied to commercial instruments with small beam cross sections or other beam geometries (e.g., variable apertures, rotating sectors and mirrors, modulators etc.) that would be perturbed by the

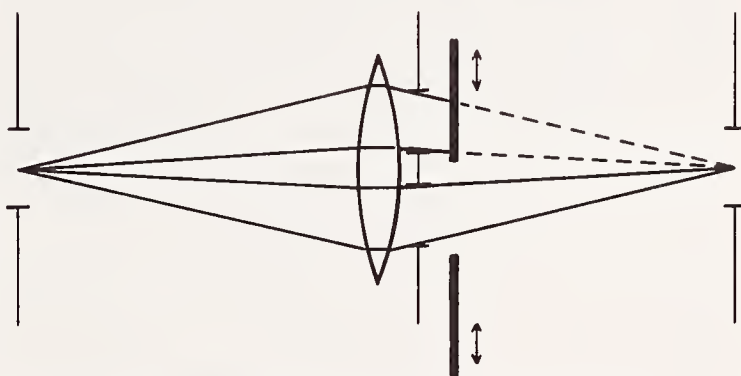

FIGURE 13. Arrangement for the double-aperture method.

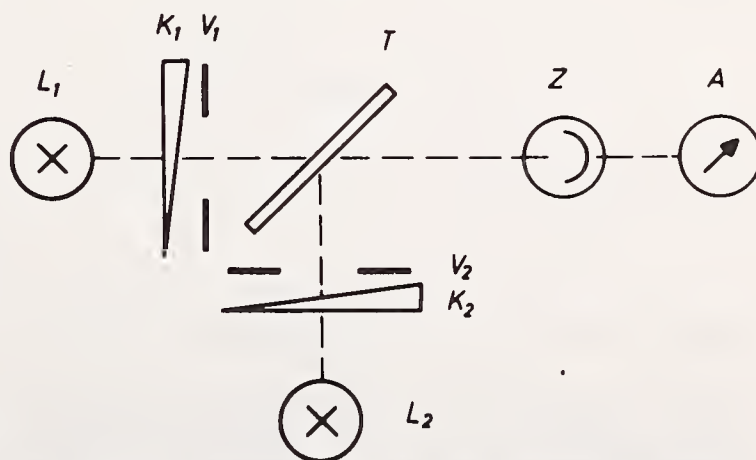

FIGURE 14. Arrangement for the supplementary-light method.

insertion of additional apertures. For example, an existing variable aperture stop may cause incomplete illumination of an inserted double aperture arrangement and, thus, render it useless. If, as another example, in an instrument using chopped light, the shape of the intensity versus time (as can be observed by an oscilloscope) is changed by an inserted double aperture other than merely in amplitude, linearity cannot be tested this way. Methods using two or several apertures however are well suited for testing the linearity of special equipment the design of which allows the use of the aperture method.

To guide the light beam the method with two sources requires more optical parts and a semi-transparent plate which may change the state of polarization. However this method can be adapted to commercial instruments as demonstrated by the author, even in a double-beam instrument [10].

D. Other Methods

As mentioned before [10, 11, 16], tests based on Lambert's or Beer's laws alone are inadequate. At least one point of the photometer scale must be established in another way. The same is true of the method discussed in detail in reference [11], in which neutral density filters or perforated screens are measured for varying attenuations of the beam.

Rotating sectors are not suited to test photometer scales of equipment with detectors having response times which are short compared with the open and dark periods of the sector [5, 10]. The detector signal changes between the dark period and the full value; the part of the characteristic curve which is essential for the measurement of an absorbing sample is not passed (fig. 15). The test can be made with a rotating sector only if the open and dark periods of the sector are short compared with the response time of the detector (in the IR range, for instance).

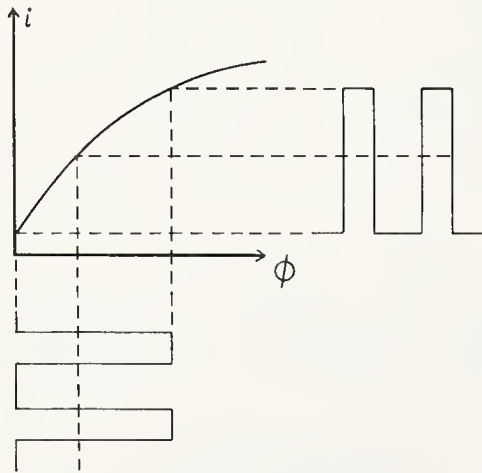

FIGURE 15. Current from a nonlinear fast detector illuminated through a rotating sector.

With the sector set to 40 percent open time the light pulses (shown below the detector characteristics) will cause current pulses with 40 percent on time (shown to the right of the detector characteristics), i.e., strict linearity. A sample of 40 percent transmittance illuminated with continuous light will cause a current amounting to about 50 percent of that without sample and showing striking nonlinearity.

Inspired by a theoretical treatment of Hansen, who introduced the derivative of flux with respect to reading [17], Ploke [18] has applied a simple method to test the linearity of detectors. A weak, chopped radiation is supplied to the detector under test, and is measured with a lock-in amplifier. Additional unchopped light is then supplied to the detector and the signal of the lock-in amplifier is observed, which approximates the derivative of reading with respect to flux. Each change of the signal is interpreted as a curvature of the characteristic curve and thus as a nonlinearity. This holds true if there is no memory effect and if the characteristic curve is the same for continuous and chopped radiation. In other cases the distinction of nonlinearity, frequency dependence and memory effect becomes difficult. The same disadvantage applies to the following method.

Jung [19] states an interesting method to determine the nonlinearity from the beat frequency of two radiations chopped at different frequencies. Although this method is interesting for testing multipliers, it is not suited for the direct calibration of a photometer. Jung also describes a method to improve the linearity of multipliers [20], which uses chopped measuring light and adds unchopped light to the weaker of the two light portions until the mean photocurrents are equal in both cases. The amount of added unchopped light need not be measured. However, Jung's own theoretical treatment of the method reveals that only the nonlinearity which is proportional to the radiant flux is rendered completely ineffective. Higher-order components of nonlinearity are reduced, but not eliminated. For this reason Jung's method can be assumed to improve linearity, although it does not eliminate the necessity to measure it.

The difficult testing of photometer linearity can only be carried out in standards laboratories. They must provide standards of known transmittance which are then applied by the user to test his photometers. The interaction between sample and photometer must be considered for the calibration of the standards and for their use.

IV. Interaction Between Photometer and Sample

A. Definition of True Transmittance

If the transmittance of a specific sample is measured in several photometers with defined linearity or known nonlinearity and arithmetically corrected, this would not be a guarantee for consistent results. This is due to a number of interactions between sample and photometer. The values obtained by measurements in a linear photometer cannot be regarded as true transmittance.

Corresponding to international standards organizations, we start with the theoretical definition of the internal transmittance of a homogeneous

sample limited by parallel plane surfaces. This internal transmittance τ_i is defined as the ratio of the outgoing radiant flux at the inside of the exit surface to the incoming radiant flux at the inside of the entrance surface. The radiation is assumed to be a quasi-parallel, sufficiently monochromatic light beam perpendicular to the boundary surface of the sample (fig. 16). A reflectance of the radiant flux of the amount r is assumed, owing to the refractive index discontinuity at the boundary surface. It follows that the transmittance determinable from the outside is, for a single passage of the radiation,

$$\tau = \tau_i (1-r)^2. \quad (4)$$

The radiant flux reflected by the inner exit surface returns to the entrance surface where it is again partially reflected. The result of the infinite series of multiple reflections is a somewhat higher transmittance.

$$\tau = \tau_i \frac{(1-r)^2}{1 - \tau_i^2 r^2}. \quad (5)$$

The first question is to what extent these multiple reflections will become effective in the photometer. Even in photometers with a collimated beam the light is not exactly parallel. The more it is reflected the more it diffuses and finally does not reach the detector any more. Therefore, in practice, an infinite number of reflections need not be considered; the first back and forth path in the sample alone produces the transmittance

$$\tau = \tau_i (1-r)^2 (1 + \tau_i^2 r^2). \quad (6)$$

For normal glass, r is approx. 0.04 (4%). Although the first back and forth reflection will change the transmittance of an absorption-free sample ($\tau_i=1$) by about 0.16 percent, the following would result in only 2.5×10^{-4} percent and can be neglected. The thickness of absorbing glasses used as standards is typically about 2 mm. Even in photometers with focused beam the expansion of the light beam over this distance is not large enough so that an

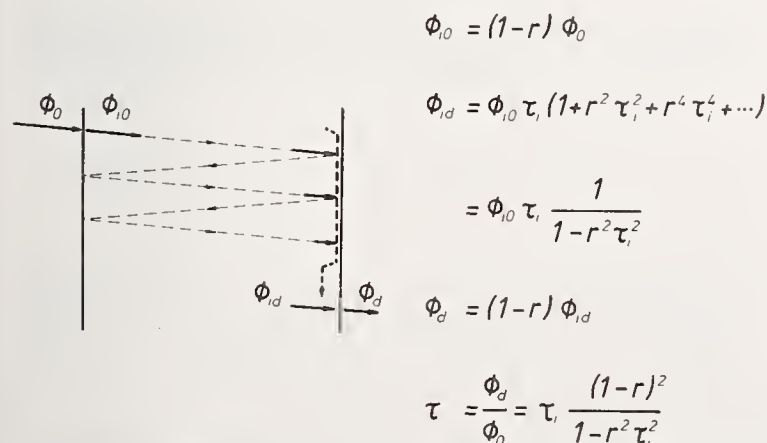

FIGURE 16. Influence of surface reflections on the transmittance of a homogeneous, isotropic, optically clear sample with plane parallel surfaces passed by a nearly parallel beam of light.

appreciable part of the reflected light would be lost. Thus, it is justified to define the transmittance according to the eq (6). After elimination of the causes of error mentioned, it can be expected that photometers with correct display will also measure this value, which does not differ from (5) within the stipulated measuring accuracy. The flux reflectance r was used for the calculation; thus possible interferences of coherent light are not considered for the definition. They will be discussed further.

B. Obliquity Effects

Not all rays passing through the sample in a photometer are parallel. This applies not only to commercial photometers with focused beams, but also to photometers with a collimated beam. The aperture limiting the divergence must have a finite diameter if energy is to pass. Deviation of the rays from the normal on the sample surface causes path length and reflection errors.

If the optic axis is perpendicular to the surface and if the path length for the maximum external angle of incidence φ_{\max} does not exceed $(1 + \epsilon)$ of the path length for normal incidence (fig. 17) the following equation must hold

$$\varphi_{\max}^2 \leq 2n^2\epsilon \quad (7)$$

where n is the refractive index of the sample.

If the light beam at the sample has a cross section A , this determines the light gathering power. From this value, the spectral radiance L_λ of the light source and the bandwidth $\Delta\lambda$ used for measurement, the radiant flux, and finally the number N_i of photoelectrons per unit time at the cathode can be calculated as follows

$$N_i = L_\lambda \cdot \Delta\lambda \cdot A \cdot \pi \cdot \varphi_{\max}^2 \cdot \tau \cdot q / h\nu \quad (8)$$

where q is the quantum yield of the cathode, τ the transmittance of the entire optical system including the efficiency of a sphere (if any), h Planck's constant, and ν the frequency of light. Due to shot noise, the

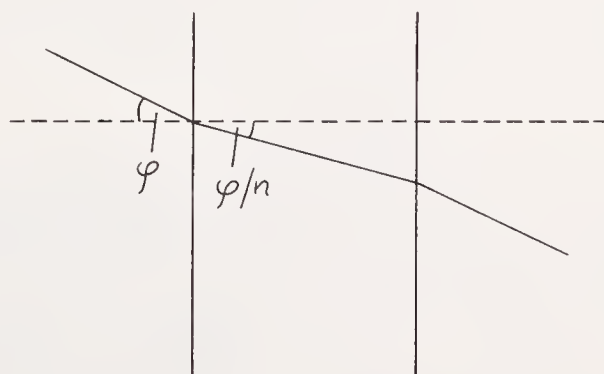

$$\sqrt{1 + (\varphi/n)^2} \approx 1 + \frac{1}{2}(\varphi/n)^2$$

FIGURE 17. Path length error caused by oblique incidence.

relative precision for a measurement with an integrating period t is

$$\frac{\Delta N}{N} = \frac{1}{\sqrt{N}} = \frac{1}{\varphi_{\max}} \cdot \frac{\sqrt{h \cdot \nu}}{\sqrt{\pi \cdot L_{\lambda} \cdot \Delta \lambda \cdot A \cdot q \cdot \sqrt{\tau} \cdot t}} \quad (9)$$

Numerical values are given in table IV. As can be seen from the table, difficulties are to be expected only if one tries to limit errors substantially below 10^{-4} .

The obliquity is generally greater in commercial photometers. The photometer reads an average value $\bar{\tau}_i$. It must be considered, however, that the instrument does not average the path lengths or absorbances, but transmittances. For a sample with an internal transmittance τ_{i0} for normal incidence, if traversed by a light beam containing rays of obliquity φ with a weight factor $g(\varphi)$ the following equation holds

$$\bar{\tau}_i = \int g(\varphi) e^{(\ln \tau_{i0}) / \cos(\varphi/n)} \cdot d\varphi. \quad (10)$$

Developing both the cosine and the exponential function in power series and truncating after the first term, yields the following result

$$\bar{\tau}_i = \tau_{i0} \left[1 - \ln(1/\tau_{i0}) \cdot \frac{1}{2n^2} \int g(\varphi) \cdot \varphi^2 \cdot d\varphi \right]. \quad (11)$$

When measuring samples which attenuate due to absorption (not reflection) such a photometer seems to read a linearity error referred to the maximum value of

$$\Delta \tau_i = -\frac{1}{2n^2} \cdot \tau_{i0} \cdot \ln(1/\tau_{i0}) \int g(\varphi) \cdot \varphi^2 \cdot d\varphi \quad (12)$$

or a linearity error referred to the corresponding individual value of

$$\Delta \tau_i / \tau_i = -\frac{1}{2n^2} \cdot \ln(1/\tau_{i0}) \int g(\varphi) \cdot \varphi^2 \cdot d\varphi. \quad (13)$$

TABLE IV

Shot noise influence on precision of transmission measurements if the cone angle φ_{\max} is limited by acceptable path length error ϵ . Calculated from eq (9) with $\Delta \lambda = 1$ nm, $q = 0.1$, $A = 0.196$ cm² (beam diameter 0.5 cm), $n = 1.5$

for $\lambda = 400$ nm with $\tau = 0.1$ and $L_{\lambda} = 2$ mW/cm² sr nm (Tungsten coil) and
for $\lambda = 200$ nm with $\tau = 0.01$ and $L_{\lambda} = 0.8$ mW/cm² sr nm (Deuterium lamp).

If the measuring time is assumed to be 1 s for 100 percent transmittance or 10 s for 10 percent transmittance, relative precision remains the same.

ϵ	φ_{\max} rad	φ_{\max} deg	$\Delta N/N$ (400 nm)	$\Delta N/N$ (200 nm)
10^{-3}	$6.71 \cdot 10^{-2}$	3.84	$3.0 \cdot 10^{-6}$	$2.1 \cdot 10^{-5}$
10^{-4}	$2.12 \cdot 10^{-2}$	1.215	$0.95 \cdot 10^{-5}$	$6.7 \cdot 10^{-5}$
10^{-5}	$6.71 \cdot 10^{-3}$	0.384	$3.0 \cdot 10^{-5}$	$2.1 \cdot 10^{-4}$

If $g(\varphi)$ contains all beams within a circular cone with the maximum aperture φ_{\max} (corresponding to the geometry of a point source irradiating a circular aperture, or corresponding to collimated light if the aperture limiting the divergence appears under the aperture angle φ_{\max} seen from the lens) the function $g(\varphi)$ with due consideration of the normalizing condition

$$\int g(\varphi) \cdot d\varphi = 1 \quad (14)$$

has the form

$$g(\varphi) = 2\varphi / \varphi_{\max}^2 \quad (15)$$

so that

$$\int g(\varphi) \cdot \varphi^2 \cdot d\varphi = \varphi_{\max}^2 / 2 \quad (16)$$

The curves in figure 18 are calculated with $\varphi_{\max} = 0.05$ and $n = 1.5$ to illustrate the eqs (12) and (13). The errors have been calculated by Hansen and Mohr for two apertures of finite size [21].

If the sample is tilted by the angle Ψ towards the optic axis, which may be necessary because of multiple reflections, Mielenz [22] stated for a point source and a square aperture the equation

$$\Delta \tau_i = -\frac{1}{3n^2} \cdot \tau_{i0} \cdot \ln(1/\tau_{i0}) \cdot (\varphi_{\max}^2 + 1.5 \Psi^2) \quad (17)$$

The reflection error is caused by oblique rays which are reflected differently than normal rays. The reflection of the component polarized parallel with the plane of incidence decreases, while the reflection of the perpendicularly polarized component increases. The effects are oppositely equal for small angles, which means that they cancel when unpolarized light or a symmetrical cone is used. Mielenz indicates the following equation [22] for the tilted sample

$$\Delta \tau = \pm 4\tau \cdot \frac{r}{n} \cdot \Psi^2. \quad (18)$$

C. Influence of Bandwidth

If the bandwidth used for measurement is not small enough to assume that the transmittance of

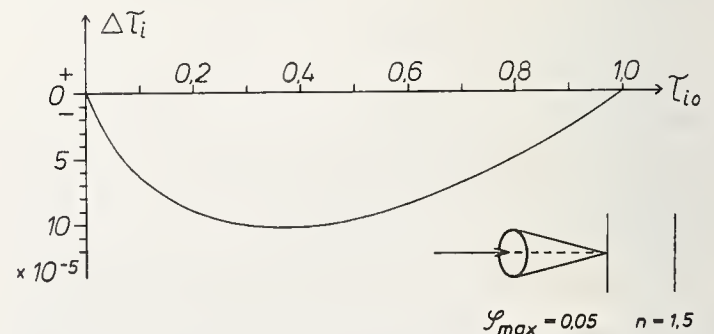

FIGURE 18. Apparent nonlinearity due to oblique incidence calculated from eqs (12) and (13) for a circular cone with the aperture angle $\varphi_{\max} = 0.05$ and $n = 1.5$.

the material within the bandwidth is constant, the spectrophotometer will supply an average value of the transmittance within the bandwidth, which is based on the internal transmittance

$$\bar{\tau}_i = \int g(\lambda) \cdot \tau_i(\lambda) \cdot d\lambda \quad (19)$$

where $g(\lambda)$ is the weight with which the individual wavelengths contribute to the total signal. If only one sample is measured, the conditions are fully described by this equation. However, the situation is

$$\bar{\tau}_i = \int g(\lambda) \cdot e^{(\ln \tau_{i0}) [1 + \alpha(\lambda)]} \cdot d\lambda = \tau_{i0} [1 - \ln (1/\tau_{i0}) \cdot \int g(\lambda) \cdot \alpha(\lambda) \cdot d\lambda]. \quad (20)$$

This equation is similar to equation (11) in the preceding paragraph, and shows the same dependence on transmittance. If non-neutral standards of the same material but with different thicknesses are measured in photometers with different bandwidths, differences are liable to occur between the measurements in accordance with figure 18.

D. Interreflections

Every photometer contains reflecting surfaces before and after the sample. Even if attempts are made to avoid such surfaces, which will be discussed further below, light source and detector themselves will become effective as surfaces of this kind. In commercial photometers the sample is generally arranged between plane or convex windows. The radiant flux will then not simply pass through the sample, but there are interreflected portions, as shown in figure 19. For the radiant flux passing through a sample with the transmittance τ_1 and the reflectance R_1 (reflectance of the entire sample, both front and rear surface) it follows that

$$\Phi = \Phi_0 \cdot \tau_1 [1 + R_1 \cdot (R_a + R_b) + R_a \cdot R_b \cdot \tau_1^2]. \quad (22)$$

where Φ_0 is the radiant flux passing without reflection, and R_a, R_b are the reflectances at the surfaces in the photometer. Consequently the radiant flux

$$\phi = \phi_0 [1 + R_a R_b] \quad (23)$$

passes through the empty photometer. If a second sample (τ_2, R_2) is measured relative to the first sample (τ_1, R_1), the ratio of the radiant fluxes is

$$\phi_2/\phi_1 = \tau_1 \tau_2 [1 - (R_1 - R_2) \cdot (R_a + R_b) - R_a \cdot R_b \cdot (\tau_1^2 - \tau_2^2)]. \quad (24)$$

If, however, the second sample is measured in the empty instrument, it follows that ($\tau_1 = 1, R_1 = 0$)

$$\phi_2/\phi_1 = \tau_2 [1 + R_2 \cdot (R_a + R_b) - R_a R_b (1 - \tau_2^2)]. \quad (25)$$

In all these equations R, R_1, R_2, R_a and R_b are treated as small quantities; powers higher than R^2 are neglected.

different if a thicker sample of the same material is measured, which has not only a different internal transmittance but also another wavelength dependency. Terming the absorption coefficient at a mean wavelength a_0 , and that at a different wavelength $a(\lambda)$, and the difference of the two values $\Delta a(\lambda)$, and defining

$$\alpha(\lambda) = \Delta a(\lambda)/a_0, \quad (20)$$

it follows for the average value of the internal transmittance that

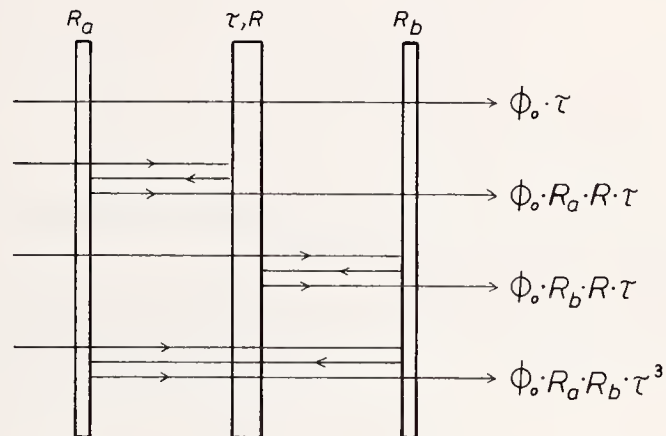

FIGURE 19. Interreflections in a transmission photometer.

R_a is the reflection coefficient for all optical surfaces before the sample for light incident from the sample side, R_b that for all surfaces behind the sample. R is the reflection coefficient, τ the transmittance of the total sample. ϕ_0 is the radiant power flowing directly from source to detector (without interreflections).

Due to these reflections the ratio of the radiant fluxes deviates from the value of the actual transmittance. Part of the reflections can be rendered ineffective by tilting the sample. The errors caused by the tilt must then, of course, be considered. Apart from the errors mentioned in section IV-B, these are the influences of a lateral displacement of the light beam. Mielenz [22] gave a good example, and subsequently Mielenz and Mavrodineanu [23] developed a method to determine $(R_a + R_b)$ by sample tilting.

However, tilting the sample affects only the term $(R_a + R_b)$, and does not permit the measurement of $R_a R_b$. An upper limit for this term may be estimated from

$$R_a \cdot R_b \leq \frac{1}{4} (R_a + R_b)^2. \quad (26)$$

For direct evaluation of $R_a R_b$ the following procedure is suggested here: a sample of approx. 58 percent transmittance (the function $\tau(1 - \tau^2)$ has its maximum at $\tau_M = 1/\sqrt{3} = 0.577$) is measured in the photometer under test. It is tilted so that the reflections by the sample do not impair the result, i.e., the term $(R_a + R_b)$ is eliminated. Two weakly absorbing plates with a transmittance τ_p of approx. 76 percent each are tilted opposite to each other and are placed before and after the sample so that their reflections are excluded, and that they do not cause interreflections with the tilted sample. The opposite

inclination cancels possible beam shifts. For the first measured ratio of the radiant fluxes it follows that

$$\phi_2/\phi_1 = \tau_M \cdot [1 - R_a \cdot R_b \cdot (1 - \tau_M^2)], \quad (27)$$

while the second measurement yields the following radiant fluxes

$$\phi_3 = \phi_0 \cdot \tau_p^2 [1 + \tau_p^4 \cdot R_a \cdot R_b], \quad (28)$$

$$\phi_4 = \phi_0 \cdot \tau_p^2 \cdot \tau_M [1 + \tau_M^2 \cdot \tau_p^4 \cdot R_a \cdot R_b]. \quad (29)$$

The ratio of these is

$$\phi_4/\phi_3 = \tau_M [1 - \tau_p^4 \cdot R_a \cdot R_b \cdot (1 - \tau_M^2)] \quad (30)$$

and consequently the difference of these ratios is

$$\phi_4/\phi_3 - \phi_2/\phi_1 = \tau_M \cdot (1 - \tau_M^2) (1 - \tau_p^4) \cdot R_a \cdot R_b. \quad (31)$$

$R_a R_b$ can be calculated from this equation. The reason for the proposed transmittance of 76 percent of the auxiliary plates is the difference $1 - \tau_p^4$ in eq (31) and the decrease by τ_p^2 of the total radiant flux. The function $\tau^2 (1 - \tau^4)$ has its maximum near

$$\tau_p = 1/\sqrt[4]{3} = 0.76.$$

The user of a commercial photometer cannot carry out such tests. He cannot work in the cell compartment without windows because of the danger of damage to optical surfaces by spilled chemicals or vapors. If the manufacturer has not eliminated the reflections, the user has to take the instrument as it is. Most spectrophotometers, however, are used to measure solutions. A cell with solution is measured relative to another one containing the solvent. Equation (24) states the "transmittance of the solution relative to the solvent." The errors tend to cancel, though not completely. Actually the user wants to determine the internal transmittance. If the solvent does not absorb, it follows from the above mentioned definition of true transmittance (equation 5 or 6) that

$$\tau_2/\tau_1 = \tau_i [1 - r^2 \cdot (1 - \tau_i^2)]. \quad (32)$$

For the reflection of the solvent

$$R_1 = r [1 + (1 - r)^2] \quad (33)$$

and the reflection of the solution

$$R_2 = r [1 + (1 - r)^2 \cdot \tau_i^2]. \quad (34)$$

If these terms are entered in equation (24) it follows that

$$\phi_2/\phi_1 = \tau_i \cdot [1 - (1 - \tau_i^2) \cdot \{r^2 + (R_a + R_b) \cdot r \cdot R_a + R_b\}] \quad (35)$$

The user calculates with the simple formula $\phi_2/\phi_1 = \tau_i$. Due to the multiple reflections in the instrument (provided they have not been eliminated by the manufacturer) he will experience an apparent nonlinearity according to eq (35) of

$$\Delta\tau_i = -\tau_i \cdot (1 - \tau_i^2) \cdot \{r^2 + (R_a + R_b)r + R_a R_b\}. \quad (36)$$

Though higher, it is of the same kind as that expressed in eq (32) for a reflection-free photometer with the following apparent nonlinearity

$$\Delta\tau_i = -\tau_i (1 - \tau_i^2) \cdot r^2. \quad (37)$$

The errors are so small that they are negligible in practice. Only very few cases are known to the author where the reflection within the sample was considered according to eq (32) or (37) for analytical applications. Consequently also the somewhat larger error due to eq (36) may be tolerable.

When designing instruments for standards laboratories, multiple reflections should be avoided. Mielenz achieved this by imaging with off-axis parabolic mirrors. This doubtless reduces multiple reflections to values which are negligible even for most exacting demands with regard to measuring accuracy. However, such an arrangement should always be checked for multiple reflections. Not only must the sample be placed exactly perpendicular to the optic axis, but aberrations must also be kept small and apertures must be blackened. One of these apertures is the monochromator exit slit, and it may be difficult to eliminate reflections from its sharp edges (fig. 20). In Mielenz's instrument, a blackened monochromator exit aperture was used successfully.

To avoid reflections the instrument designer can equip the instrument with off-axis mirrors (see above), tilt lenses and windows, or provide them with antireflection coating (which is, however, possible only for a limited spectral range). As far as the linear function of the photometer can be influenced, he can correct the apparent linearity error resulting from eq (35). In 1953 the author did this for ZEISS's ELKO II photometer.² The apparent errors according to eq (36) were eliminated together with the apparent errors from eq (12) which depend similarly on the transmittance, and possible genuine linearity errors [17]. They were eliminated by so-called correctors described by Hansen [24] (figs. 21, 22). The following numerical value was determined for correction:

$$\Delta\tau_i = +0.0084\tau_i(1 - \tau_i^2).$$

The above considerations reveal a danger in testing photometers with multiple reflections by standards which are calibrated against air. Multiple reflections do not only supply higher absolute values than actually available of the linearity error, but compared with the error involved in the measurement

² In order to describe materials and experimental procedures adequately, it was occasionally necessary to identify a commercial product by the manufacturer's name. In no instances does such identification imply endorsement by the National Bureau of Standards.

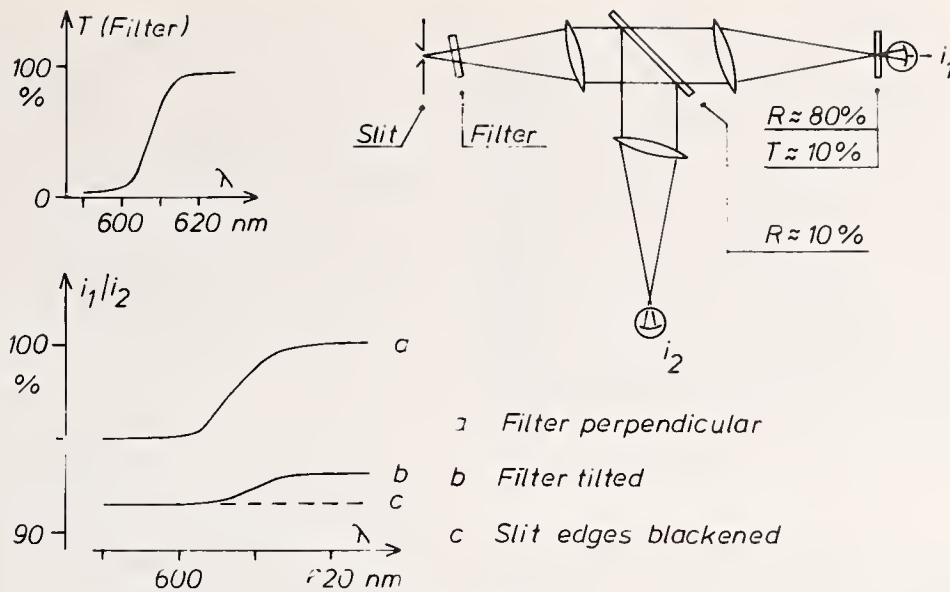

FIGURE 20. Interreflections in a system with collimated beam (simplified drawing of an arrangement studied by the author for other reasons).

The tilted lenses correspond to Mielenz's proposal of off-axis concave mirrors to eliminate the term R ($R_a + R_b$) in eqs (22) to (25). The interreflective term R_a . R_b has a very high value in the straight beam from left to right because of the high reflectance of the plate in front of detector 1 (signal i_1) and a very low one for the beam to detector 2 (signal i_2) because there is no reflecting plate and interreflections are attenuated by the low reflectance of the inclined beam splitting plate. At wavelengths below 600 nm the short cutoff filter suppresses interreflections in both beams, and the variation of the ratio i_1/i_2 with the wavelength shows the influence of interreflections.

The filter was at first perpendicular to the beam axis (a), then tilted (b), and finally the small reflecting edges of the slit were carefully blackened. The ratio i_1/i_2 arbitrarily set to 100 percent in one case, shows in curve a below 600 nm the influence of the front surface of the filter and above 620 nm the influence of both surfaces and of the slit edge. Curve b shows above 620 nm the influence of the slit edge alone.

In an actual photometer the effects will be smaller depending on the lower reflection values of the detector, but assuming a reflection of 1 percent, the intended accuracy of 10^{-4} will still leave amounts for consideration.

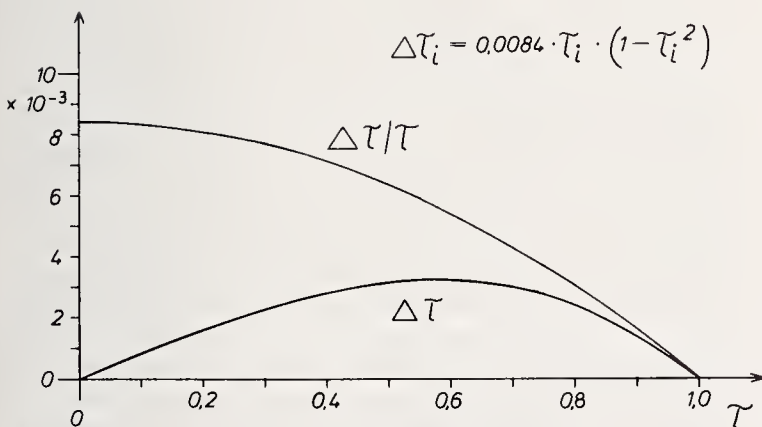

FIGURE 21. Correction of interreflections and oblique incidence applied to ELKO II photometer. Correction is positive because of the negative error.

of solutions against solvent this error has the opposite sign (compare eqs 25 and 35). If standards are used which are pairs of equally reflecting, yet differently absorbing substances, the errors caused by multiple reflections when measuring the standards and the samples themselves will be at least approximately equal, and the error caused by a multiple reflection will be eliminated at least approximately by the linearity correction.

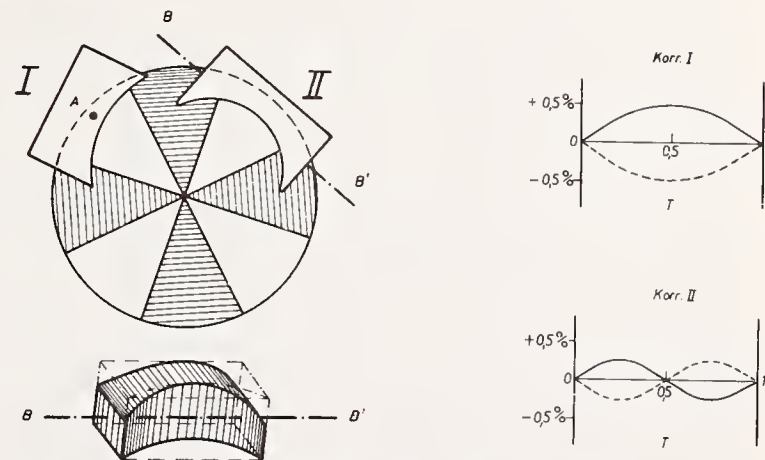

FIGURE 22. Correctors for the linearity adjustment of the ZEISS ELKO II photometer designed by Hansen [24].

The instrument is operated according to the "optical null" principle with a measuring diaphragm (shown in the drawing) consisting of 4 dark sectors of 45° central angle each, and 4 variable sectors with maximum 45° open angle. Corrector 1 is rotatable around an axis A perpendicular to the diaphragm plane, corrector 2 around an axis B parallel to the diaphragm plane. Also shown (as curves) are the linearity changes brought about by the correctors.

E. Interference

The calculation of multiple reflection given in section IV-D is based on the reflection coefficient of the radiant flux. With strictly collimated and monochromatic light, there will be interferences

at the parallel surfaces. The transmittance of such a sample will show periodic maxima and minima as a function of the wavelength. This is well known from IR instrument applications, but is also observed in the visible under special conditions. Mielenz has stated corresponding formulae [22]. These interferences are generally regarded as disturbances in spectrophotometric measurements and are eliminated, if possible. There are three ways to achieve this: sufficiently large bandwidth, varying thickness of the sample, and sufficiently large aperture angles.

If the sample has a thickness d and a refractive index n , the interference maxima at the wavelength λ will be at wavelength intervals of

$$\Delta\lambda_I = \lambda^2 / (2nd). \quad (38)$$

For a glass sample ($n=1.5$) of 1 mm thickness this yields at 500 nm a distance of 0.08 nm, and at 1000 nm as much as 0.33 nm. To average the interferences the photometer bandwidth $\Delta\lambda_h$ should be at least ten times the distance between interference maxima, [28] that is

$$\Delta\lambda_h \geq 10\Delta\lambda_I = 10\lambda^2 / (2nd) \quad (39)$$

which means that at 1000 nm the bandwidth must be at least 3 nm for a thickness of 1 mm, or that at 1 nm bandwidth the thickness must be at least 3 mm.

To get from one interference maximum to the next by changing the thickness, the change of thickness must be

$$\Delta d = \lambda / 2n. \quad (40)$$

If again 10 interference maxima (Fizeau fringes) are to be averaged [28], a thickness change of $3.3 \mu\text{m}$ is necessary at 1000 nm. Provided this is to be below 10^{-5} of the thickness, the sample should be at least 33 cm thick. Even if constancy of the thickness to within only 10^{-4} of its value is required, the required sample thickness would still be 3.3 cm. Interferences can thus not be compensated by intentional variation of the sample thickness over the measuring area unless the accuracy requirements are low.

The same applies to the compensation of interference by the use of larger aperture cones. The relation of oblique beam passage and change in path length has been derived in section IV-B. The same limits as mentioned above are true because, although with oblique rays (Haidinger rings) the change of the transmitted layer is desirable to compensate the interference, it is undesirable for the constancy of absorption. Interferences cannot be effectively compensated by the aperture cone in collimated-beam photometers of standards laboratories, however, the larger cone in commercial photometers causes freedom from interferences.

To calibrate standards of high accuracy, several measurements must be made at intervals of approx. $\frac{1}{2}$ of the wavelength difference indicated in eq (38), followed by averaging over one period of the interference, if interferences are detected.

The small increase in transmittance of gray glasses over the years may also be considered as an interference phenomenon. It is due to the formation of surface layers by a kind of aging, which have a reflection-reducing effect. For this reason, gray glasses should not be used alone but in combination with other glass types. It has up to now not been possible to obtain glass of equal refractive index and chemical composition which changes with time in the same manner as gray glasses.

F. Polarization

As a rule, the light in commercial photometers is partially polarized. The horizontal and vertical cross sections of the light beams being of different shape, this polarization affects the reflection at oblique incidence. If such a photometer is tested with standards having surfaces similar to those of the cells used for measurement, the error caused by polarization is corrected together with the linearity error.

An instrument with rotational symmetry of the beam cross section must be used to calibrate the standards. If this proves impossible, measurements must be made in the two preferred polarization directions.

To avoid systematic errors in partially polarized light, the standards should be free from birefringence, strain or optical activity.

G. Beam Shift Errors

As mentioned before, the sensitivity of all known photomultiplier tubes depends considerably on the position on the cathode and on the direction of incidence. If the beam is shifted when the sample is brought into the beam path, errors occur which differ even with instruments of the same type. Shifts of the light beam on the cathode may be due to wedge errors, tilt errors or focusing errors. This changes the cross section of the light beam at the cathode. If collimated light passes through the sample, the tilt and focusing errors will not shift the beam cross section in the focal plane of the collimator but the direction of the beams. If the light beam falls directly on the detector the cross section on the detector should not be too small. This is the reason for producing an image of the pupil on the detector. However, even with collimated light the sample may cause changes of the pupil image.

The best solution is to eliminate the dependency of the sensitivity on place and direction. This can be achieved with an averaging sphere, which because of its low efficiency has so far only been used in special equipment. Whether or not the progress made in designing averaging spheres [25] will make them suitable for commercial spectrophotometers remains to be settled.

V. How Can Routine Spectrophotometry Be Improved?

Whoever wants to improve spectrophotometry must know the inherent sources of error. According to the author there are enough means to test the spectral characteristics. But, to test the linearity of the transmittance scale, standards are required which must be issued by a standards laboratory. As far as the author knows there are being offered only two types of standards which are calibrated according to independent and published procedures: the gray glasses and solutions issued by NBS and the gray glasses of ZEISS (see note [26]).

A standards laboratory will be responsible for the increase in accuracy up to a technically feasible limit. Important progress has recently been made in this respect. Yet the errors mentioned at the beginning are about 3 orders of magnitude above the accuracies obtained in standards laboratories. It would be an important step forward if an accuracy of a few tenths of a percent were achieved for routine applications. Standards with transmittances guaranteed to within approx. 0.1 percent will do. They must be easy to handle and to clean and must, of course, be stable. They should also be neutral. Gray glasses meet these specifications for the visible spectral range, but the formation of a surface layer impairs the stability of the values with time. Changes of up to 1 percent of actual transmittance have been observed by us within ten years. If a material of higher stability is not found, it should be tried to calibrate these glasses with reference to a similar absorption-free glass, which would eliminate most of the time-dependency [27]. This would best meet practical requirements, and would ensure the smallest influence by multiple reflections.

Gray glasses cannot be used in the UV. Blackened quartz glass being commercially available, attempts should be made to produce quartz glass which absorbs in the UV almost independent of the wavelength.

Vacuum-deposited, neutrally transmissive metal coatings can be used within a much wider spectral range than glasses. In spite of this the author doubts their usefulness even for moderate accuracy requirements, because they reflect too much light. Even if such filters are tilted (by means of a suitable mount, for instance) to eliminate part of the errors due to multiple reflection, this may cause errors in commercial spectrophotometers, because the reflected light is much stronger than the reflection at glass surfaces; even a reflection on to a black surface may cause measuring errors. Furthermore, these coatings are very sensitive, but in spite of this the author would not recommend cementing with a coverglass, because all cementing agents are known to increase their UV absorption with time.

Solutions, even if they are transported in sealed ampoules, are still problematic with regard to durability, contamination and the cells required for their use. Other means not being available at present,

they are to the author's knowledge the only solution for the UV.

Photometers with fixed cells to measure liquids continuously or in cycles should be tested with reference to gray glasses. These usually can be inserted, because the cells must be removable for cleaning and replacement. Liquids are needed in the visible spectral range to test such photometers only if the cell cuts off the beam path and an additional gray glass cannot be provided.

The improvement of routine spectrophotometry is more a problem of instruction of the user and provision of suitable equipment than of improving the accuracy in the standards laboratories.

The author thankfully acknowledges the assistance of K.D. Mielenz and R. Mavrodineanu in revising the English text. His participation at the workshop seminar held Nov. 1975 at Gaithersburg was sponsored by NBS.

VI. References and Notes

- [1] Beeler, M. F., Lancaster, R. C., *Am. Journ. of Clinical Pathology* **63 Suppl.** 953-959 (1975).
- [2] Mavrodineanu, R., Shultz, J. I., Menis, O., (editors), *Nat. Bur. Stand. (U.S.), Spec. Publ. 378*, 268 pages (May 1973); *J. Res. Nat. Bur. Stand. (U.S.)*, **76A** (Phys. and Chem.), No. 5, (Sept.-Oct. 1972); No. 6, (Nov.-Dec. 1972).
- [3] Clarke, F. J. J., reference [2], pp. 1-29
- [4] Mavrodineanu, R., reference [2], pp. 30-51
- [5] Sanders, C. L., reference [2], pp. 63-79
- [6] Reule, A., *Coll. Spectr. Int. XVI*, Preprints **1**, 107-113 (1971)
- [7] Preston, J. S., *Journ. Sci. Instr.* **13**, 368 (1936)
- [8] Hamamatsu TV Co. Ltd. *Data Sheets No. 14E* (Aug. 1969)
- [9] Wiedmann, K., Personal communication (Carl Zeiss, Oberkochen, 1975).
- [10] Reule, A., *Appl. Opt.* **7**, 1023-1028 (1968)
- [11] Reule, A., *Zeiss-Mitt.* **1**, 283-299 (1959)
- [12] See references cited in [3], [4], [5] and Korte, H., Schmidt, M., *Lichttechnik* **6**, 355-359 (1954)
- [13] Buehmüller, F., König, H., *Bull. Schweizer Elektrotechn. Verein* **28**, 89-99 (1937)
- [14] Preston, J. S., Cuckov, F. W., *Proc. Phys. Soc. (London)* **48**, 869-880 (1936)
- [15] Elster, J., Geitel, H., *Wied. Ann.* **48**, 625-635 (1893).
- [16] Hawes, R. C., *Appl. Opt.* **10**, 1246-1253 (1971).
- [17] Hansen, G., *Mikrochim. Acta* **1955**, 410-415.
- [18] Ploke, M., Personal communication (Zeiss Ikon A.G., Kiel, 1961).
- [19] Jung, H. J., *Z. Angew. Physik* **30**, 338-341 (1971); see also reference [2], 72.
- [20] Jung, H. J., *Z. Angew. Physik* **31**, 170-176 (1971); see also reference [2], 75.
- [21] Hansen, G., Mohr, E., *Spectrochim. Acta* **3**, 584-598 (1949).
- [22] Mielenz, K. D., reference [2], 81-93.
- [23] Mielenz, K. D., Mavrodineanu, R., *J. Res. Nat. Bur. Stand. (U.S.)*, **77A** (Phys. and Chem.), No. 6, 699-703 (Nov.-Dec. 1973).
- [24] Hansen, G., *Optik* **8**, 251-277 (1951).
- [25] Mielenz, K. D., Mavrodineanu, R., Cehelnik, E. D., *Appl. Opt.* **14**, 1940-1947 (1975).

[26] In the discussion Dr. Clarke pointed out, that by N.P.L., Teddington, U.K. since many years transmittance standards, though not being offered for sale, are calibrated on request. The double aperture method is used for qualifying linearity.

Dr. Brill (Philips) reported that standards were available from International Commission on Glass, Charleroi, Belgium but the author could up to March '76 not get any more information.

[27] The apparently obvious solution, to use a thinner and a thicker glass of the same melt, is wrecked by the fact, that either one of these glasses had to be too thin as that it could be handled in a routine laboratory, or the photometric scale would be checked starting at a considerably smaller flux than present in normal use.

[28] Note added in proof:

If $m = 2\Delta\lambda_h/\Delta\lambda_I$, the influence of interferences cancels for $m = 2, 4, 6 \dots$ and reaches relative maxima for $m = 1, 3, 5 \dots$ with an amplitude of $4/m^2r^{-2}$ times the transmission modulation for $m \ll 7$. Because m cannot be made an even number for all wavelengths simultaneously, one has to deal with uneven m as the worst case. The condition $\Delta\lambda_h/\Delta\lambda_i=10$ given in the text $m=20$ and reduces the effect of interferences to $1/100$. In many cases $m=3$ will do, giving a reduction of interferences to about $1/20$.

Similar considerations hold true for Fizeau fringes and Haidinger rings.

(Paper 80A4-906)

Standardization in Transmission Spectrophotometry in the Visible and Ultraviolet Spectral Regions*

A. R. Robertson

Division of Physics, National Research Council,
Ottawa, Ontario, Canada K1A 0R6

(May 26, 1976)

In an instrument as complex as a spectrophotometer there are many potential sources of error. Because of this it is useful to have available standard materials whose spectral transmittances are known accurately. Periodic measurement of such standards provides a useful indication of whether a spectrophotometer is producing accurate results.

If the spectral transmittance functions of these standards are chosen suitably, the measurements can provide diagnostic information to indicate what type of error is occurring. Among the factors that most often lead to errors in spectrophotometry are the slit-width, the wavelength scale, the photometric scale, and stray radiation. Suitable material standards can provide indications of the occurrence of these errors. However it is sometimes difficult to identify a particular error since often several errors will occur at the same time.

Several sets of standards for testing spectrophotometers are available or can be constructed easily. Most of these are glass filters, but interference filters, perforated screens, and rotating sectors are also used. Liquid filters have some advantages, especially in the ultraviolet where glass filters absorb too strongly to be useful. However difficulties in preparing and handling liquid filters can introduce uncertainties.

It is important that standard materials are insensitive to environmental conditions (such as temperature) and that they are stable over a long period of time. Unfortunately, many of the materials with the most suitable spectral characteristics are least suitable in these respects, and it would be very useful if new and better materials could be developed.

Key words: Errors in spectrophotometry; photometric scale; slit width; spectral transmission; spectrophotometer standards; stray light; wavelength scale.

I. Introduction

A spectrophotometer is an extremely complex instrument and there are many potential sources of error. Tests are available that will detect the presence of each type of error but they are usually rather inconvenient to use in practice. It is often more convenient to have available a set of material standards whose spectral transmittances are known accurately. If the spectral transmittances are chosen carefully, measurement of them can provide a useful check on the performance of the instrument. There is no need to modify or make any additions to the instrument because the tests can be made with the instrument in the mode in which samples are normally measured.

In general, departure of the measured transmittance from the true transmittance will indicate the presence of an error, but will not indicate the type of error. (photometric, wavelength, slit-width, stray radiation, etc.). However, if the spectral transmittances of the standards are chosen appropriately, it is sometimes possible to use the measurements to diagnose what type of error is occurring.

The spectral transmittances must be chosen so that the error in question will have the maximum effect while other errors have very little or no effect. A problem is that two different errors will sometimes have the same or similar effects on the measured transmittances making it difficult to interpret the measurements, but nevertheless, departure of the measured transmittances from the true transmittances will always be an indication of problems even when diagnostic information cannot be derived.

If the standards are calibrated in one instrument and then used in another instrument of different design the situation may be very complex, and it will be quite difficult to determine exactly what is causing differences in the results from the two instruments, especially when more than one factor is involved. Standards are often much more valuable when they are used to detect changes in the performance of a single instrument. Periodic measurement of standard materials will give an early warning of problems that may be developing from dirty optical components, from wear of mechanical components, from aging of the source or detector or from any other cause. Standards are also useful

*National Research Council Paper No. 15510.

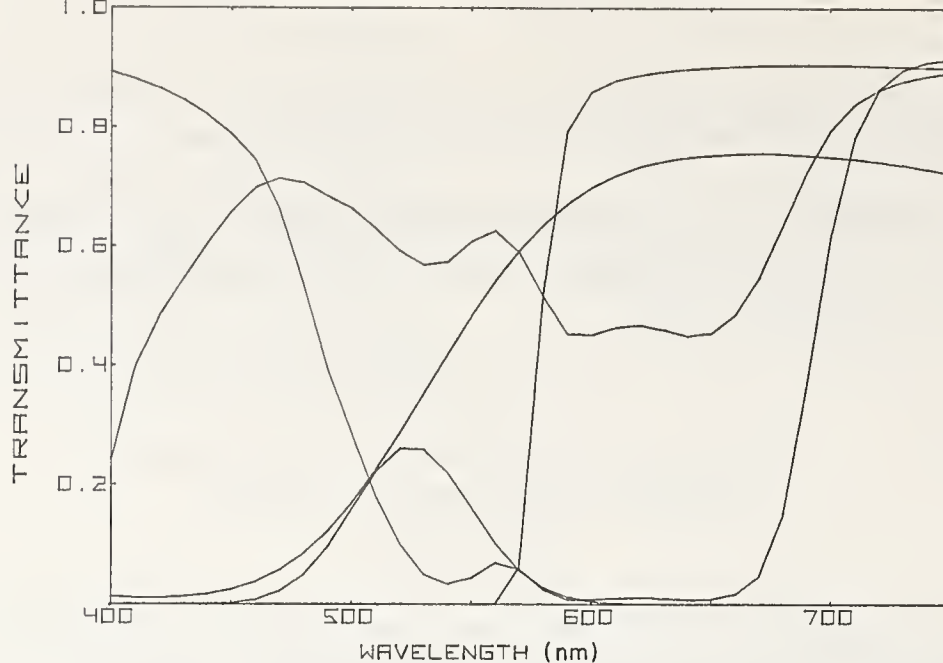

FIGURE 1. Spectral transmittances of the NBS 2100 series of five colored-glass filters for checking the performance of spectrophotometers [1].

in detecting and correcting faulty calibration or faulty experimental technique.

As well as having the desired spectral transmittance curves, materials to be used as standards must have certain other properties. They must be stable with respect to time, temperature, humidity and other environmental parameters; they must be uniform, nonscattering, nonfluorescent, and non-polarizing; and they must be easy to handle.

An example of a set of standards that is very useful in detecting and diagnosing errors in the visible spectral region is the 2100 series of five colored-glass filters issued by the National Bureau of Standards [1].¹ The spectral transmittances of these filters are shown in figure 1.

II. Use of Standards to Determine Different Types of Error

In this section some of the many types of error that can occur in spectrophotometry are discussed. Material standards that can indicate the presence of each type of error are described. Errors that can occur with special types of samples such as samples that fluoresce or that change the state of polarization of the measuring beam are not discussed.

A. Photometric Errors

Photometric errors can conveniently be divided into two types: errors of the endpoints of the photometric scale (0% and 100% transmittance) and failure of readings taken from the photometric scale to be linearly related to the amount of radiation striking the photodetector. Endpoint errors

can be detected easily by measurements with an opaque sample and with an empty sample compartment, but linearity is more difficult to check. A survey of methods of measuring photometric linearity has been given by Sanders [2]. The most fundamental method is the flux addition or superposition method. The simplest form of this is the double-aperture method described by Clarke [3] and by Mielenz and Eckerle [4]. The method requires special equipment and there are several systematic errors that may occur, so it is more convenient in routine work to use standards of known transmittance. To reduce or eliminate the effect of other errors, these standards should have a transmittance that does not vary with wavelength, but this is difficult to achieve in practice.

Filters made of metal screens with a large number of small holes have been suggested but there are problems with diffraction effects and with dirt accumulating in the holes [5]. In addition the position of the screens in the measuring beam is critical, especially if the cross-section of the beam is small or nonuniform. Rotating sectors are sometimes used but they may be too large to fit into the sample compartment and, in any case, their use depends on the assumption that the photo-electronic system obeys Talbot's law, an assumption that may not always be valid. Interference filters can be made spectrally neutral, but they reflect rather than absorb the untransmitted radiation so they may introduce stray radiation errors. In addition, pin-holes and other nonuniformities in these filters can cause errors.

Colored glass filters with an approximately neutral spectrum are probably the most satisfactory materials for checking photometric scales, but they too have some disadvantages. The spectral transmittances of a set of neutral glass filters that has been used at the National Research Council are shown in figure 2. A calibrated set of three similar filters is

¹ Figures in brackets indicate the literature references at the end of this paper.

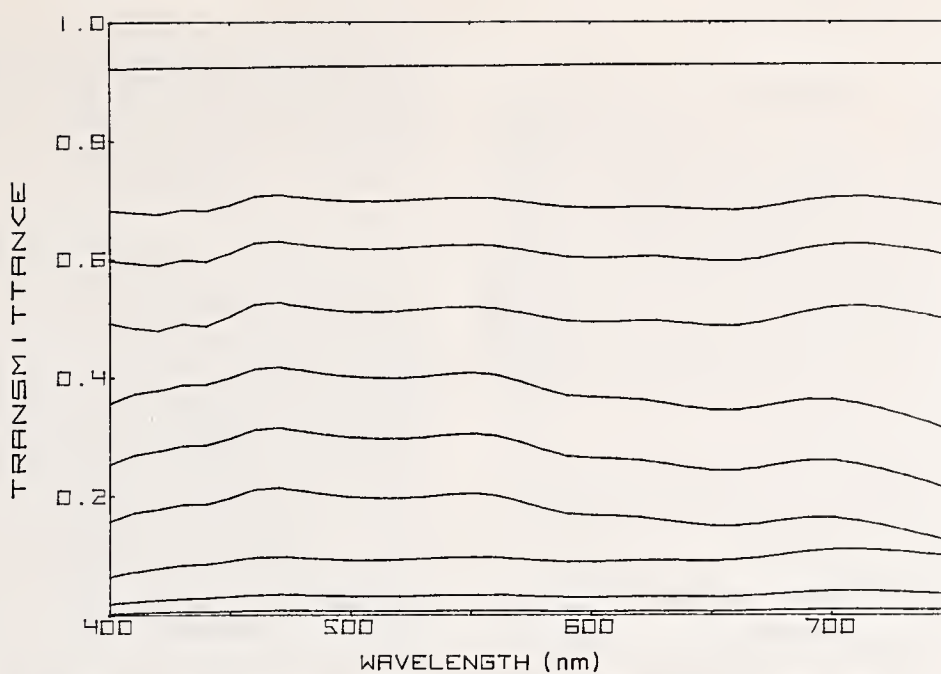

FIGURE 2. Spectral transmittances of ten neutral glass filters that have been used to check photometric scales.

available from the National Bureau of Standards [7]. Such filters can be used with the least uncertainty to check for changes in the photometric linearity of a single instrument. When they are used to compare two different instruments, the uncertainties are higher because geometrical differences between the two instruments may lead to different effective pathlengths through the filters. A disadvantage of these materials is that they are not perfectly neutral, so that wavelength and bandwidth errors may affect their transmittance, unless only the flat parts of the spectral transmittance curve are used, but even then stray radiation errors may influence the results. Another disadvantage is that the filters are not always stable over long periods of time[6]. Surface films of silicon oxide may form[7, 8] and there may be some leaching of metal oxides from the surface caused by the action of the atmosphere or by cleaning agents [3].

It must be noted that colored glasses can only be used to check a photometric scale if the transmittances of the glasses have been established in advance with an instrument whose linearity has been checked by a fundamental method such as the double aperture method. There is no way that they can be used on their own to establish photometric linearity [6]. It is sometimes assumed fallaciously that if the transmittances of two thicknesses of the same filter material (or two thicknesses or two concentrations of a liquid) obey the Lambert-Beer law (after suitable correction for surface reflections), then the instrument is linear. The justification of this fallacy is made as follows. Let the true spectral internal transmittances of two filters of the same material be $T_1(\lambda)$ and $T_2(\lambda)$, the thicknesses $d_1(\lambda)$ and $d_2(\lambda)$, and the spectral absorptivity $a(\lambda)$, then

$$T_1(\lambda) = 10^{-d_1 a(\lambda)}$$

and

$$T_2(\lambda) = 10^{-d_2 a(\lambda)}$$

Thus the ratio of the spectral absorbances $A_1(\lambda)$ and $A_2(\lambda)$ is

$$\frac{A_1(\lambda)}{A_2(\lambda)} = \frac{\log_{10} T_1(\lambda)}{\log_{10} T_2(\lambda)} = \frac{d_1}{d_2}$$

It is then assumed that if the ratio of the measured spectral absorbances is d_1/d_2 the photometric system is linear. This is not necessarily true. It is possible that the photometric system is such that the measured spectral internal transmittance $T'(\lambda)$ is given by

$$T'(\lambda) = [T(\lambda)]^x$$

where $x \neq 1$. In this case the measured spectral absorbance will be given by

$$\begin{aligned} A'(\lambda) &= -\log_{10} T'(\lambda) \\ &= -x \log_{10} T(\lambda) \\ &= xA(\lambda) \end{aligned}$$

and the relation

$$\frac{A'_1(\lambda)}{A'_2(\lambda)} = \frac{d_1}{d_2}$$

will hold, despite the nonlinearity. Apart from this, the Lambert-Beer law is often not obeyed, especially if the measuring beam is not collimated so that the pathlength is not exactly equal to the thickness of the filter.

B. Wavelength Errors

A survey of methods of checking the accuracy of the wavelength scales of spectrophotometers has been given recently by Alman and Billmeyer [9]. The best method for a spectrophotometer with a narrow waveband is the line spectra method, but for instruments with a wide waveband the linear filter method [10] is preferable. Again, however, these methods require auxiliary equipment and modifications to the spectrophotometers so it is convenient to have glass filters available with clearly defined transmittance minima that can be used as a simple check on the wavelength scale.

Two of the most commonly used materials are didymium [11] and holmium oxide glasses [12, 13]. One difficulty with these glasses is that the positions of the transmittance minima vary with both the width and the shape of the waveband transmitted by the spectrophotometer. The problem is especially bad when a minimum is not symmetrical or consists of two slightly separated individual minima. Holmium oxide is better than didymium in this respect but there is still some uncertainty if the waveband is not very narrow.

The effect of temperature on these filters is to increase or decrease the transmittances at the minima without changing the wavelengths significantly [14].

Both types of filter can be used with rather less uncertainty to check for changes in the performance of a single instrument, than to check one instrument relative to another. However it is sometimes difficult to distinguish wavelength errors from other types of error such as the error caused by the response of the recording mechanism being too slow to follow the changes of transmittance. An example of the latter is shown in figure 3. The broken line represents the

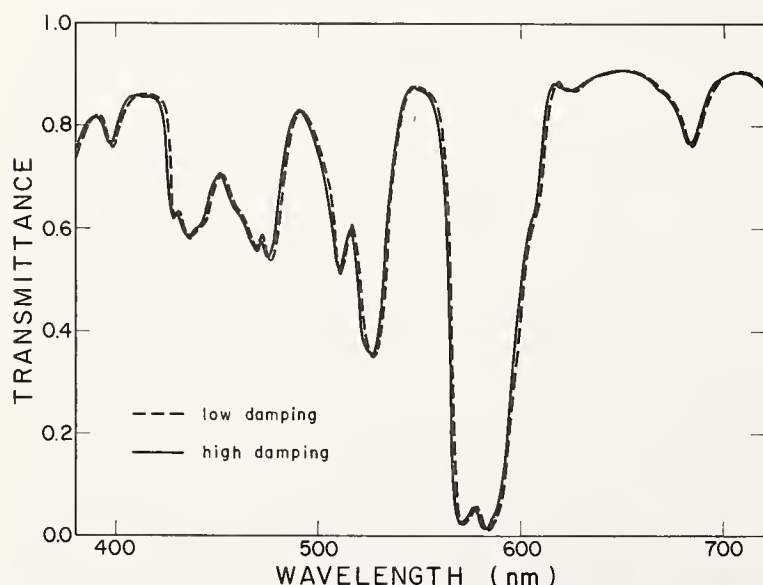

FIGURE 3. Spectral transmittance of a didymium glass measured with low and high damping of the recording system of a Zeiss DMC25 spectrophotometer.

The direction of scan is from high to low wavelengths.

measurement of a didymium filter measured with a fast-responding recorder and the full line represents the measurement of the same filter with a slowly responding recorder. (The direction of scan is from high to low wavelengths in both cases.)

C. Bandwidth

No spectrophotometric measurements are ever made with radiation of a single wavelength. There is always a finite band of wavelengths distributed around the nominal wavelength. The width and shape of this band is determined by the widths of the slits of the monochromator and by the spectral power of the source, the spectral transmittance of the optics, and the spectral responsivity of the photo-detector. The exact width and shape of the waveband is difficult to measure, but departures from a narrow band can be detected by measuring standards such as a didymium glass with several transmittance minima of different shapes. Figure 4 shows the spectral transmittance of such a filter measured on a Zeiss² DMC 25 spectrophotometer with 2.5 nm and 10 nm bandwidths. With the wider bandwidth the minima are broadened, the wavelengths of some of the minima are shifted, and some double minima are not resolved.

It is important to check for changes of the bandwidth of a spectrophotometer, especially in those instruments, such as the Cary 14, in which the slits are adjusted automatically to maintain a constant reference signal. In such instruments, changes of the bandwidth can indicate instrumental defects such as the accumulation of dirt or the deposition of films on the optical parts.

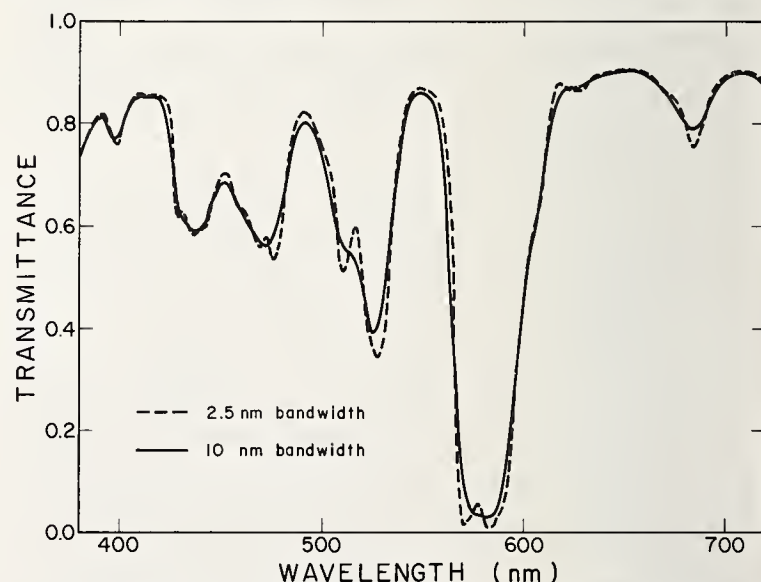

FIGURE 4. Spectral transmittance of a didymium glass measured on a Zeiss DMC25 spectrophotometer with narrow and wide slits.

² In order to adequately describe materials and experimental procedures, it was occasionally necessary to identify commercial instruments. In no instance does such identification imply endorsement by the National Bureau of Standards.

D. Stray Radiation

Two types of stray radiation should be distinguished. The first is stray radiation of the same wavelength as is being measured, but which reaches the detector without passing through the sample. It is caused by reflections and scattering between the various optical and mechanical components including the sample itself. It can be detected by measuring an opaque sample. If the measured spectral transmittance is not zero, stray radiation may be present, although an error of the 0 percent end-point of the photometric scale will have the same effect. Scattering or reflection by the sample can be exaggerated by painting the opaque sample white, or replacing it by a mirror.

The second type of stray radiation has wavelengths different from that of the measurement beam. It too can arise from unwanted reflections and from scattering by dirt, scratches and other defects in optical components. Another common cause is unwanted orders of diffraction in grating instruments. The effect of this stray radiation is often exaggerated greatly at the ends of the wavelength range because here the photodetector may be much more sensitive to the wavelengths of the stray radiation than to the measurement wavelength. This type of stray radiation can be detected readily by cut-off or band-pass filters that have zero transmittance for some wavelengths and high transmittance for others. Stray radiation of the former wavelengths will lower the measured transmittance at the latter, and vice-versa.

E. Nonuniformity of Photodetector

If the response of the photodetector is not uniform across its surface, errors will occur whenever a sample causes a change in the irradiated area, either by shifting it across the photodetector or by increasing or decreasing the area by altering the focus of the measurement beam. Such errors can usually be detected by measuring clear glass or quartz filters of different thicknesses or with a wedge shape. The errors should be avoided by using a suitable diffuser to increase the uniformity of the detector response [15].

F. Inertia Errors

The recording mechanism of a spectrophotometer often has significant inertia and lags or leads changes in spectral transmittance as the instrument scans through the spectrum. Mechanical or electrical malfunctions can often develop to cause such inertia even if the instrument was originally free from the problem. Errors caused by inertia can be detected readily by measuring standard materials whose spectral transmittance varies rapidly with wavelength. An example is shown in figure 5. In this case, measurement of the NBS 2100 series of filters and a didymium glass indicated very slow response in the

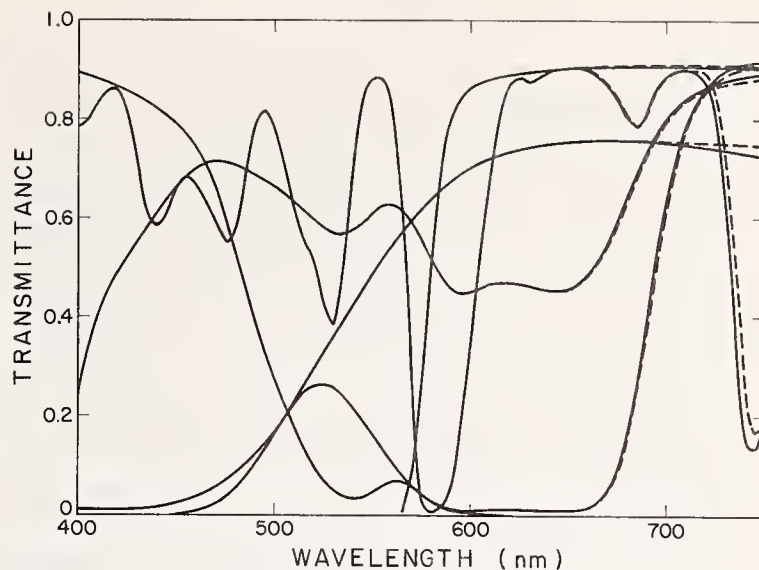

FIGURE 5. Spectral transmittances of the NBS 2100 series of filters and a didymium glass with a General Electric Hardy spectrophotometer functioning properly (full line) and with the same spectrophotometer with a malfunction causing poor response in the red part of the spectrum (broken line).

The direction of scan is from low to high wavelengths.

red region of the spectrum, but the response in the rest of the spectrum was satisfactory.

III. Standards for the Ultraviolet

Most of the examples of diagnostic standards given in the preceding section were for the visible spectrum. Exactly the same principles apply in the ultraviolet spectrum, but there are greater difficulties in finding suitable materials. In particular most glass filters cannot be used below about 350 nm because of their strong absorption below this wavelength. For this reason, liquid standards such as solutions of potassium chromate, copper sulphate, and cobalt ammonium sulphate have often been used [16]. Recently a number of other solutions have been suggested [17]. Unfortunately, variations in the preparing and handling of such liquid standards introduce some extra uncertainties so glass standards are preferable if they have appropriate spectral transmittance functions.

IV. Conclusions

Material standards provide a very useful and convenient way to check the performance of a spectrophotometer and to diagnose malfunctions, although they can never completely replace more fundamental methods of checking for errors. Materials are available with some of the desired properties, especially for the visible spectral region. However most of the presently available materials do have some drawbacks. Often the spectral transmittance functions are less than ideal and in many cases they are instable to environmental conditions such as temperature and are not sufficiently permanent over long periods of time. For these reasons it is very desirable that new and better standard materials should be developed in the future.

V. References

- [1] Keegan, H. J., Schleter, J. C. and Judd, D. B. Glass filters for checking performance of spectrophotometer-integrator systems of color measurement, *J. Res. Nat. Bur. Stand. (U.S.)*, **66A** (Phys. and Chem.), No. 3, 203-221 (May-June 1962).
- [2] Sanders, C. L., Accurate measurements of and corrections for nonlinearities in radiometers, *J. Res. Nat. Bur. Stand. (U.S.)*, **76A** (Phys. and Chem.), No. 5, 437-453 (Sept.-Oct. 1972).
- [3] Clarke, F. J. J., High accuracy spectrophotometry at the National Physical Laboratory, *J. Res. Nat. Bur. Stand. (U.S.)*, **76A** (Phys. and Chem.), No. 5, 375-403 (Sept.-Oct. 1972).
- [4] Mielenz, K. D. and Eckerle, K. L., Spectrophotometer linearity testing using the double-aperture method, *Appl. Opt.* **11**, 2294 (1972).
- [5] Vandenbelt, J. M., Investigation of screens as spectrophotometric absorption standards, *J. Opt. Soc. Am.* **52**, 284 (1962).
- [6] Hawes, R. C., Technique for measuring photometric accuracy, *Appl. Opt.* **10**, 1246 (1971).
- [7] Mavrodineanu, R., An accurate spectrophotometer for measuring the transmittance of solid and liquid materials, *J. Res. Nat. Bur. Stand. (U.S.)*, **76A** (Phys. and Chem.), No. 5, 405-425 (Sept.-Oct. 1972).
- [8] Blevin, W. R., Ageing of neutral glass filters, *Optica Acta* **6**, 99 (1959).
- [9] Alman, D. H., and Billmeyer, F. W., Jr., A review of wavelength calibration methods for visible-range photoelectric spectrophotometers, *J. Chem. Ed.* **52**, A281 and **52**, A315.
- [10] Van den Akker, J. A., Wavelength calibration of spectrophotometers, *J. Opt. Soc. Am.* **33**, 257 (1943).
- [11] Gibson, K. S., and Keegan, H. J., Calibration and operation of the General Electric recording spectrophotometer of the National Bureau of Standards, *J. Opt. Soc. Am.* **28**, 372 (1938).
- [12] Vandenbelt, J. M., Holmium filter for checking the wavelength scale of recording spectrophotometers, *J. Opt. Soc. Am.* **51**, 802 (1961).
- [13] McNeirney, J., and Slavin, W., A wavelength standard for ultraviolet-visible-near infrared spectrophotometry, *Appl. Opt.* **1**, 365 (1962).
- [14] Dodd, C. X., and West, T. W., Spectral transmittance properties of rare-earth glasses, *J. Opt. Soc. Am.* **51**, 915 (1961).
- [15] Mielenz, K. D., Mavrodineanu, R., and Cchelnik, E. D., Efficient averaging spheres for visible and ultraviolet wavelengths, *Appl. Opt.* **14**, 1940 (1975).
- [16] Schleter, J. C., Standards for checking the calibration of spectrophotometers (200 to 1000 nm), NBS Letter Circular LC-1017 (Jan. 1967).
- [17] Burke, R. W., Deardorff, E. R., and Menis, O., Liquid absorbance standards, *J. Res. Nat. Bur. Stand. (U.S.)*, **76A** (Phys. and Chem.), No. 5, 469-482 (Sept.-Oct. 1972).

(Paper 80A-907)

Acidic Potassium Dichromate Solutions as Ultraviolet Absorbance Standards*

R. W. Burke and R. Mavrodineanu

Institute for Materials Research, National Bureau of Standards, Washington, D.C. 20234

(May 18, 1976)

The absorbances of five concentrations of potassium dichromate in 0.001 *M* perchloric acid have been determined at eight wavelengths in the ultraviolet on the National Bureau of Standards Institute for Materials Research high-accuracy spectrophotometer. Four of the wavelengths—235, 257, 313, and 350 nm—correspond to absorbance maxima or minima in the HCrO_4^- spectrum and are useful wavelengths for checking the accuracy of the absorbance scale of narrow bandpass spectrophotometers. Although partial dimerization of HCrO_4^- to $\text{Cr}_2\text{O}_7^{2-}$ produces small positive deviations from Beer's law at these wavelengths, the apparent absorptivities calculated for each concentration are reproducible to one part in a thousand. The estimated uncertainties in the absorptivity values are ± 0.7 percent at 0.1 absorbance (*A*) and ± 0.2 percent near *A*=1. These uncertainties include all known sources of possible systematic error and the 95 percent confidence level for the mean. The remaining four wavelengths used for measurement are near two predicted isosbestic points in the $\text{HCrO}_4^-/\text{Cr}_2\text{O}_7^{2-}$ spectra. The absorptivities at 345 nm are sufficiently independent of concentration that this wavelength can be used for checking absorbance linearity to one part in a thousand over the range *A*=0.2-1.

Key words: Absorbance linearity; accuracy; acidic potassium dichromate solutions; calibration of ultraviolet spectrophotometers; liquid filters; transfer standards; ultraviolet absorbance standards.

I. Introduction

At present, there are no certified standards available from the National Bureau of Standards (NBS) for checking the accuracy of the absorbance scale of spectrophotometers throughout the ultraviolet. The number of analytical applications in this important region of the spectrum, however, continues to increase relatively sharply and the need for such standards is becoming increasingly acute.

The area with perhaps the most serious need for ultraviolet absorbance standards at the moment is clinical chemistry. Workers in this field, for example, frequently use molar absorptivity as an index of purity of their biological standards. Only recently, Burnett [1]¹ has discussed the importance of accurate molar absorptivity measurements in the clinical laboratory. He especially emphasizes the need for spectrophotometric accuracy in clinical enzymology. Not only must the molar absorptivity of the substrate or enzyme-catalyzed reaction product be known accurately but also the individual absorbance measurements on the test sample must be accurate. This dual requirement for accuracy

in this instance arises because high-purity and well-characterized enzyme preparations are not yet routinely available for use as standards.

A program has been under way at NBS in the Institute for Materials Research (IMR) since 1969 for the development and issuance of visible and ultraviolet transfer standards for use as Standard Reference Materials (SRM's). Two such standards are currently available: (1) SRM 930, consisting of a set of three neutral Schott NG glass filters and (2) SRM 931, an empirical inorganic solution available at three concentrations in 10-ml ampoules. Neither of these SRM's meets the present needs for absorbance standards in the ultraviolet. The glass filters do not transmit below about 350 nm while the inorganic solution is certified only at one wavelength in the ultraviolet (302 nm) and with an uncertainty of ± 1 percent. Transfer standards capable of being certified throughout the range of 200-350 nm and with a smaller uncertainty are being investigated, however. The most promising solid filter at the moment for this purpose is the metal-on-quartz type. Some recent experiences with this filter are discussed in the paper immediately following [2]. Of the chemical or liquid-type filters that have been proposed, the weakly acidic potassium dichromate system is considered the best. A critical evaluation of this system, as well as several other candidate materials, was presented in a previous paper [3].

*This work was supported in part by the National Institute of General Medical Sciences.

¹ Figures in brackets indicate the literature references at the end of this paper.

In this paper, we present absorptivity values for five concentrations of potassium dichromate in 0.001 *M* perchloric acid. These concentrations effectively span the absorbance range of $A=0.1-1.5$ when measured in 10 mm cuvettes. The absorptivities were calculated from transmittance measurements at eight wavelengths in the ultraviolet on the IMR high-accuracy spectrophotometer. Four of the wavelengths—235, 257, 313 and 350 nm—correspond to absorbance maxima and minima in the HCrO_4^- spectrum and are useful wavelengths for checking the accuracy of the absorbance scale of narrow bandpass spectrophotometers. Although partial dimerization of HCrO_4^- to $\text{Cr}_2\text{O}_7^{2-}$ produces small positive deviations from Beer's law at these wavelengths, the apparent absorptivities calculated for each concentration are reproducible to one part in a thousand. The estimated uncertainties in the absorptivity values are ± 0.7 percent at 0.1 absorbance (A) and ± 0.2 percent near $A=1$. These uncertainties include all known sources of possible systematic error and the 95 percent confidence level for the mean. The remaining four wavelengths used for measurement are near two predicted isosbestic points in the $\text{HCrO}_4^-/\text{Cr}_2\text{O}_7^{2-}$ spectra. The absorptivities at 345 nm are sufficiently independent of concentration that this wavelength can be used for checking absorbance linearity to one part in a thousand over the range $A=0.2-1$.

II. Experimental Procedure

The potassium dichromate ($\text{K}_2\text{Cr}_2\text{O}_7$) used in this study was a special lot of analytical reagent grade material obtained from the J. T. Baker Chemical Company.² Drying studies performed at 105 °C indicated that the surface moisture of this material was less than 0.01 percent. No measurement of possible occluded water was made. However, a recent paper [4] by Yoshimori and Sakaguchi has shown that $\text{K}_2\text{Cr}_2\text{O}_7$ typically contains 0.01 to 0.02 percent occluded water which can be removed only by crushing and drying at 350 °C.

Coulometric assay of the undried potassium dichromate gave a purity, expressed as an oxidant, of 99.972 ± 0.005 percent at the 95 percent confidence level. Emission spectroscopy indicated that the only significant elemental impurities present were sodium and rubidium. Their concentrations were estimated to be 0.02 and 0.03 percent, respectively.

The concentrations of the $\text{K}_2\text{Cr}_2\text{O}_7$ solutions used throughout this study are expressed on a weight/weight basis. Milligram samples of $\text{K}_2\text{Cr}_2\text{O}_7$ were weighed to the nearest microgram on a microbalance. After dissolution in distilled water shown to be free of reducing impurities (see Discussion), 1 ml of 1 *M* perchloric acid was added and the solutions were

diluted approximately to volume in 1-liter volumetric flasks. Each flask was fitted with a double-ribbed Teflon stopper (Kontes Glass Company, Vineland, New Jersey) to prevent evaporation. The weight of each solution was determined on a single-pan top-loading balance having a sensitivity of 0.01 g. NBS-calibrated weights were used to establish the accuracy of the balances. The concentrations of the solutions were then calculated after correcting all weights to vacuum. A solvent blank was prepared by diluting 1 ml of 1 *M* perchloric acid to 1 liter with distilled water.

The Institute for Materials Research high-accuracy spectrophotometer was used for performing the transmittance measurements which, in turn, were converted to absorbance. The design and construction of this instrument have been described in detail by one of us (RM) in reference [5] and will not be repeated here. Similarly, the quartz cuvettes used are also of NBS design and construction and have been described previously [6]. These cuvettes are currently available through the NBS Office of Standard Reference Materials as SRM 932. Each cuvette is certified for path length and parallelism to ± 0.0005 mm.

Prior to use the cuvettes were cleaned by soaking in concentrated (18 *M*) sulfuric acid for several hours. In order to minimize the heat of mixing, they were then transferred consecutively to 12, 6 and 3 *M* sulfuric acid before rinsing with distilled water. After rinsing thoroughly, the cuvettes were air-dried under an inverted Petri dish that served as a dust-protective cover.

For sample measurements, five calibrated cuvettes were placed in separate holders in the rotating sample compartment [5] of the IMR high-accuracy spectrophotometer and a reference filter (inconel-on-quartz) was placed in a sixth position. The cuvettes were left in their respective holders for the duration of the experiment. All transmittance/absorbance measurements were made relative to air in a temperature-controlled room at 23.5 ± 0.3 °C. The transfer of solvent blank and sample solutions to and from these cuvettes was made by means of borosilicate, Pasteur-type, disposable pipettes. After being rinsed with the test solution, a final transfer for measurement could be made in 10–15 seconds, after which time the cuvette was immediately stoppered with a snugly-fitting Teflon stopper.

Six sets of solutions having nominal concentrations of 20, 40, 60, 80 and 100 mg $\text{K}_2\text{Cr}_2\text{O}_7/\text{kg}$ were prepared. Each concentration within a set was measured a minimum of six times at the eight wavelengths of interest. The absorbance, $A = -\log(T_{\text{Sample}}/T_{\text{Blank}})$, was computed for each wavelength and concentration from the average of the six transmittance measurements (T). Absorptivities were then calculated after correcting the absorbances for systematic errors due to cuvette path length, beam geometry and internal multiple reflections. No correction was applied for the reflections discussed by Mielenz and Mavrodineanu [7] from

² In order to describe materials and experimental procedures adequately, it is occasionally necessary to identify the sources of commercial products by the manufacturer's name. In no instance does such identification imply endorsement by the National Bureau of Standards, nor does it imply that the particular product is necessarily the best available for that purpose.

internal components such as the lenses and slit jaws because these are adequately compensated for by the blank. A detailed account of these corrections and calculations will be given in an NBS 260 Special Publication which is now in preparation.

III. Discussion and Results

The ultraviolet absorbance spectrum of a 40 mg kg⁻¹ solution of potassium dichromate in 0.001 M perchloric acid is shown in figure 1. The four wavelengths selected for certification of absorptivity of this absorbing system, namely 235, 257, 313 and 350 nm, are also indicated. The maxima and minima are sufficiently broad that serious restrictions are not placed upon instrumental spectral bandwidth requirements. The half bandwidths of the 257 and 350 nm peaks, for example, are approximately 60 nm so that an instrumental spectral bandwidth of 3 nm or less is sufficient for obtaining at least 0.999 of the maximum peak intensities.

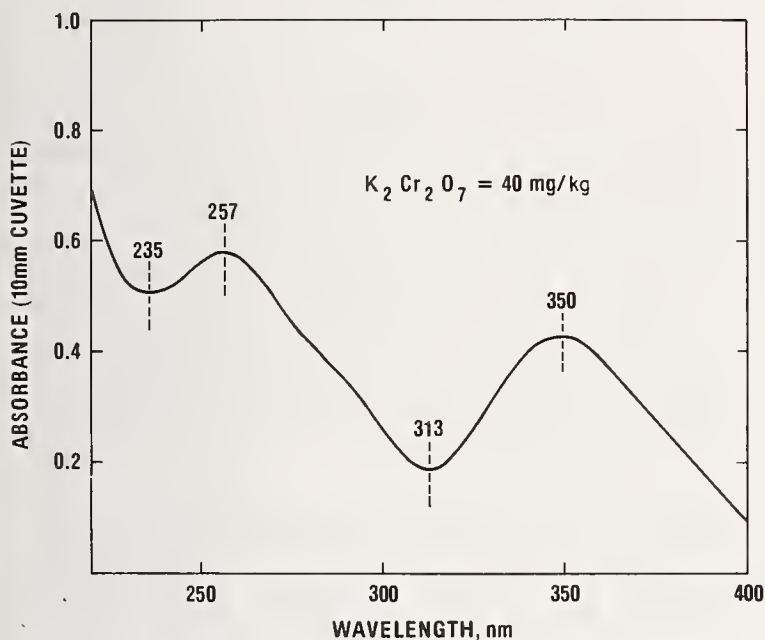

FIGURE 1. Absorbance spectrum of $K_2Cr_2O_7$ in 0.001 M perchloric acid.

The first experiment performed on the IMR high-accuracy spectrophotometer was the determination of the rinse behavior and reproducibility of the transmittance/absorbance measurements of the solvent blank. In the initial studies, measurements were made at 235 nm only, since any problems associated with the transfer of solution were expected to be the greatest at the shortest wavelength used. The results obtained for the five cuvettes employed are shown in figure 2. All exhibit a similar rinse pattern, attaining a minimum and constant absorbance value after 5-6 rinses (the term rinse as used here and throughout the remainder of this paper refers to the exchange of one cuvette volume for a second one). Once the blank measurements were in control, similar absorbance measurements were then made on the first series of $K_2Cr_2O_7$ solutions. Five concentrations having nominal concentrations of 20, 40, 60, 80 and 100 mg $K_2Cr_2O_7$ /kg were measured. Table I summarizes the results of these measurements together with the final solvent blank values for 235 nm. The cycle of measurements shown here was then extended to the other seven wave-

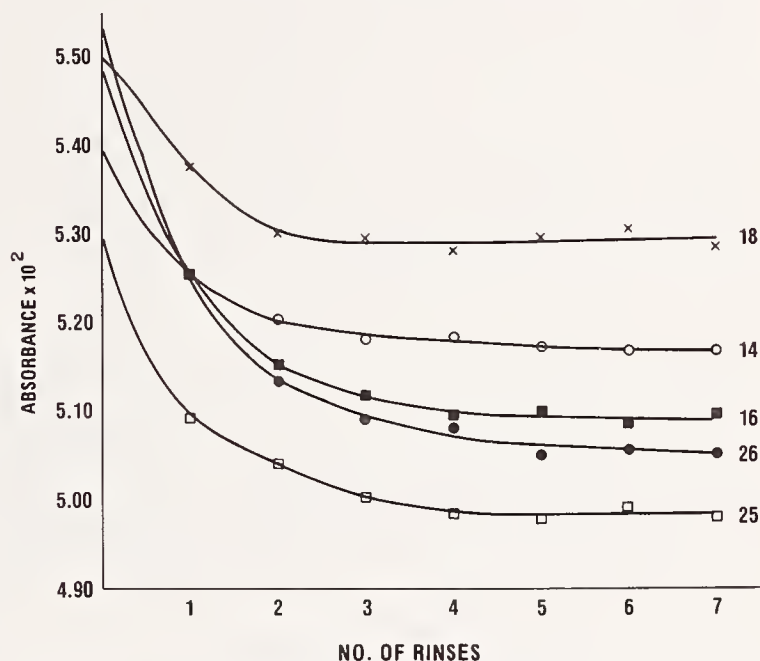

FIGURE 2. Apparent absorbances of the blank solvent in the five cuvettes used—Nos. 14, 16, 18, 25, and 26 ref. [6].

TABLE I. Reproducibility of absorbance measurements at 235 nm for a cycle of solvent and sample runs

Cuvette No.	Solvent	Sample	Sample	Solvent
	After 5 rinses	After 5 rinses	After 7 rinses	After 5 rinses
14	0. 05198	0. 30128	0. 30141	0. 05213
16	. 05099	. 55052	. 55057	. 05093
18	. 05310	. 80066	. 80074	. 05321
25	. 05002	1. 04863	1. 04855	. 05022
26	. 05064	1. 30351	1. 30333	. 05065
Ref. filter ^a	. 55913	. 55925	. 55936	. 55922

^a Inconel-on-quartz.

lengths of interest. In all, six sets of $K_2Cr_2O_7$ solutions were measured. Typically, two volleys consisting of three transmittance/absorbance measurements were made on each of the 30 solutions. The first volley was made after rinsing the cuvettes, initially containing solvent, with five rinses of sample and was repeated again after two additional rinses. Since no systematic increase in absorbance was ever observed when the results of the first volley of measurements were compared to the second, the six measurements were invariably averaged. The absorbances were obtained by subtracting the solvent blank values from the sample readings. After applying appropriate corrections for beam geometry and internal multiple reflections, the corrected absorbances (A_{corr}) were used to calculate the desired absorptivities, using the relationship

$$\text{Absorptivity} = A_{corr}/bc,$$

where b = internal light path in cm and c = concentration of $K_2Cr_2O_7$ solution in $g\ kg^{-1}$. The absorptivities computed for the five concentrations of $K_2Cr_2O_7$ solutions used are summarized in table II. The values tabulated were determined from least-squares plots of the experimental values and were subsequently normalized to the concentrations shown. The uncertainties given include all known sources of possible systematic error and the 95 percent (2σ) confidence interval for the mean. The random component of these uncertainties, based on standard deviations computed from residuals resulting from fitting the data to the various concentration levels for each wavelength, is 0.07 percent at the 2σ level.

It is observed that all absorptivities in table II increase with increasing $K_2Cr_2O_7$ concentration. These deviations from Beer's law are produced by the fact that, in weakly acidic media, chromium (VI) ions exist as two distinct absorbing species— $HCrO_4^-$ and its dimerization product, $Cr_2O_7^{2-}$. The equilibrium between these two species may be represented as

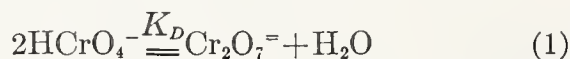

TABLE II. Absorptivities of $K_2Cr_2O_7$ in 0.001 M perchloric acid at 23.5 °C
Absorptivity, $kg\ g^{-1}cm^{-1}$

$K_2Cr_2O_7$ Conc., $g\ kg^{-1}$	235(1.2) ^b nm	257(0.8)nm	313(0.8)nm	350(0.8)nm	Uncertainty ^c
^a 0.020	12.243	14.248	4.797	10.661	0.034
.040	12.291	14.308	4.804	10.674	<i>d</i> .022
.060	12.340	14.369	4.811	10.687	<i>d</i> .020
.080	12.388	14.430	4.818	10.701	<i>d</i> .020
.100	12.436	14.491	4.825	10.714	<i>d</i> .019

^a Nominal concentration; all weights corrected to vacuum.

^b Wavelength and, (), spectral bandwidth.

^c Includes estimated systematic errors and the 95 percent confidence interval for the mean.

^d For wavelength of 313 nm, the uncertainty is reduced to half of these values for $K_2Cr_2O_7$ concentrations of 0.040, 0.060, 0.080 and 0.100 $g\ kg^{-1}$.

and the corresponding dimerization constant, K_D , is given by

$$K_D = \frac{[Cr_2O_7^{2-}]}{[HCrO_4^-]^2} \quad (2)$$

Although eq. (2) predicts that the formation of $Cr_2O_7^{2-}$ is strictly a quadratic function of $K_2Cr_2O_7$ concentration, the value of $K_D = 32.9\ (mol\ kg^{-1})^{-1}$ obtained previously [3] is of such magnitude that the percentage of total chromium present as the $Cr_2O_7^{2-}$ ion is very nearly a linear function of the $K_2Cr_2O_7$ concentration for the range of solutions studied. Calculated values of $HCrO_4^-/Cr_2O_7^{2-}$ speciation in this system are given in table III.

TABLE III. $HCrO_4^-/Cr_2O_7^{2-}$ speciation in 0.001 M perchloric acid solutions of $K_2Cr_2O_7$.

$K_2Cr_2O_7$ Conc., $g\ kg^{-1}$	Percent Cr as $HCrO_4^-$	Percent Cr as $Cr_2O_7^{2-}$
0.020	99.10	0.90
.040	98.22	1.78
.060	97.38	2.62
.080	96.56	3.44
.100	95.77	4.23

The direction and magnitude of the expected deviations from Beer's law for the acidic potassium dichromate system can be ascertained when the speciation data in table III are combined with the spectral characteristics of the two chromium (VI) species. Figure 3 shows the relation of the absorbance spectra of the $HCrO_4^-$ and $Cr_2O_7^{2-}$ ions. At wavelengths of 235, 257, 313 and 350 nm, the $Cr_2O_7^{2-}$ ion is shown always to have a larger absorptivity than the $HCrO_4^-$ ion. Hence, the measured absorptivities at these wavelengths should increase with increasing $K_2Cr_2O_7$ concentration.

From the same argument, the data in figure 3 also suggest that there are two wavelengths near 320 and 345 nm where Beer's law is obeyed. In an attempt to determine these isosbestic points experimentally, absorbance measurements were also made on the

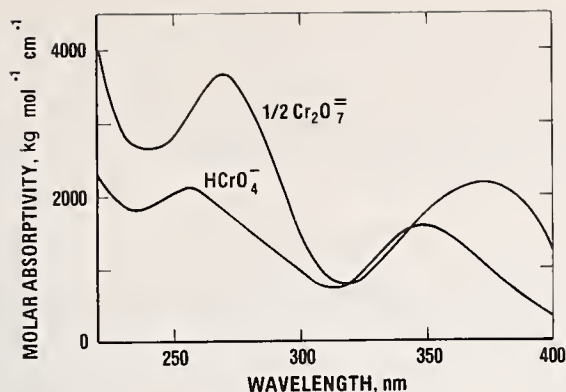

FIGURE 3. Absorbance spectra of the HCrO_4^- ion and its dimerization product, $\text{Cr}_2\text{O}_7^{=}$.

same solutions used above at 322, 323, 345 and 346 nm. The corresponding absorptivity values are given in table IV. Although small systematic deviations from Beer's law are still present, the absorptivities calculated for 345 nm are sufficiently constant that the acidic $\text{K}_2\text{Cr}_2\text{O}_7$ system can be used at this wavelength, over the concentration range shown, to check the absorbance linearity of narrow bandpass spectrophotometers to one part in a thousand.

The variation of absorptivity of the acid $\text{K}_2\text{Cr}_2\text{O}_7$ system with temperature is the smallest that we have observed for any liquid filter that we have studied to date. For the four wavelengths recommended for checking the accuracy of the absorbance scale—235, 257, 313, and 350 nm—the absorptivities decrease with increasing temperature. Over the range 20–30 °C, the corrections are, respectively, –0.05, –0.05, –0.02, and –0.05 percent per degree Celsius. The –0.02 percent correction found at 313 nm corresponds closely to the correction predicted from the thermal expansion of the solvent. Until further evaluation can be made of the temperature dependence of 345 nm wavelength recommended for checking absorbance linearity, measurements should be restricted to 23.5 ± 1 °C.

Several considerations were involved in the selection of perchloric acid for acidifying the $\text{K}_2\text{Cr}_2\text{O}_7$ solutions. First, perchloric acid was preferred over the sulfuric acid which has been used traditionally because perchlorate ion, unlike sulfate, has no tendency to form mixed complexes with chromium (VI) species. Secondly, the choice of 0.001 M acid rather

than 0.01 M was based on two factors: (1) the 0.001 M acid represented a practical compromise for minimizing conversion of HCrO_4^- to either H_2CrO_4 or $\text{CrO}_4^{=}$ and (2) the lower acid concentration substantially lowered the oxidation potential (~13 percent) of the chromium (VI) ions and hence improved the solution stability of the proposed $\text{K}_2\text{Cr}_2\text{O}_7$ standards.

A final point that needs to be emphasized concerns the quality of the distilled water used for preparing the standard solutions. Acidic potassium dichromate is a potential oxidant and consequently the distilled water used must be shown to be free of reducing impurities in order that the absorptivity data given in this paper be valid. A simple but yet definitive test is outlined in figure 4. In this study a 500-fold dilution of a 100 mg kg⁻¹ standard solution of $\text{K}_2\text{Cr}_2\text{O}_7$ was made with the distilled water in question and its absorbance measured at 350 nm. Not only did the measured absorbance agree with the predicted value, thus indicating no reduction of chromium (VI), but also subsequent measurements showed that this $\text{K}_2\text{Cr}_2\text{O}_7$ solution standard should be stable for at least two months provided it is adequately protected against evaporation. In instances where this test shows the distilled water to be suspect, it is recommended that the water be redistilled from alkaline potassium permanganate in order to preoxidize the impurities.

Finally, the general use of solid and liquid transfer standards for calibrating the absorbance scale of a precision commercial spectrophotometer is illustrated in figure 5. The measurements on the glass

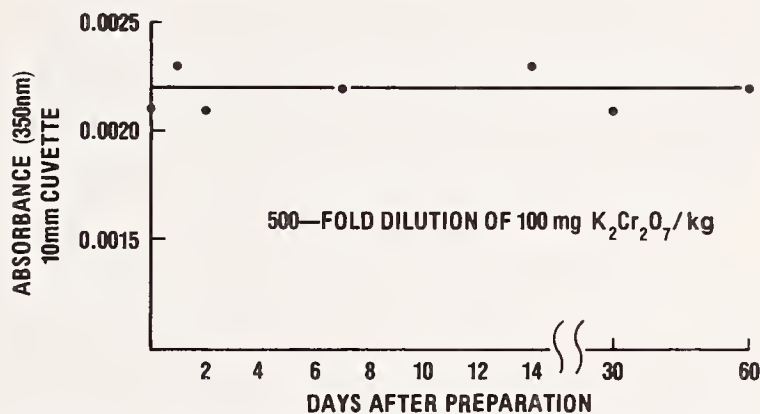

FIGURE 4. Test of the distilled water for reducing impurities.

TABLE IV. Absorptivities of $\text{K}_2\text{Cr}_2\text{O}_7$ in 0.001 M perchloric acid near two predicted isobestic wavelengths; temperature 23.5 °C

Absorptivity, $\text{kg g}^{-1} \text{cm}^{-1}$

$\text{K}_2\text{Cr}_2\text{O}_7$ Conc., g kg^{-1}	322 (0.8) ^b nm	323 (0.8) nm	345 (0.8) nm	346 (0.8) nm
^a 0.020	5.845	6.065	10.593	10.615
.040	5.842	6.062	10.595	10.621
.060	5.838	6.059	10.598	10.627
.080	5.835	6.056	10.600	10.632
.100	5.831	6.053	10.602	10.638

^aNominal concentration; all weights corrected to vacuum.

^bWavelength and, (), spectral bandwidth.

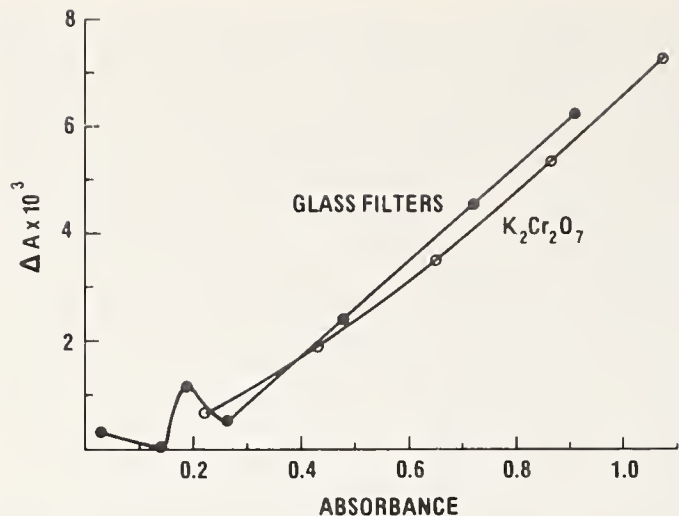

FIGURE 5. Correction ΔA for the absorbance scale of a precision commercial spectrophotometer.

filters were performed at 440 nm while the $K_2Cr_2O_7$ measurements were made at 350 nm. At both wavelengths the absorbances measured on the precision spectrophotometer are high and should be corrected by subtracting the appropriate ΔA values.

IV. Conclusion

Following widespread use in the collaborative testing of spectrophotometers for more than 25 years, the absorptivities of the acidic potassium dichromate system have now been determined with a known accuracy from measurements performed directly on the NBS Institute for Materials Research high-accuracy spectrophotometer. Later this year, crystalline $K_2Cr_2O_7$, together with detailed instructions on preparing solutions from it, will be available from NBS through its Office of Standard Reference

Materials as an SRM. In conjunction with the calibrated quartz cuvettes previously issued (SRM 932), it is believed that this material will provide a valid check of the accuracy of the absorbance scale of narrow bandpass spectrophotometers in the ultraviolet from 235–350 nm.

The authors gratefully acknowledge the assistance of the following persons at NBS during various phases of this work: K. D. Mielenz, for helpful discussions of fundamental spectrophotometric parameters; G. Marinenco, for performing the coulometric assay; J. A. Norris, for the the emission spectrographic analyses; H. H. Ku, for the statistical analysis of the data; and R. W. Seward, for supplying through the Office of Standard Reference Materials the samples of potassium dichromate.

V. References

- [1] Burnett, R. W., *J. Res. Nat. Bur. Stand. (U.S.)*, **76A** (Phys. and Chem.), No. 5, 483–489 (Sept.–Oct. 1972).
- [2] Mavrodineanu, R., *J. Res. Nat. Bur. Stand.* (1976), in press.
- [3] Burke, R. W., Deardorff, E. R., and Menis, O., *J. Res. Nat. Bur. Stand. (U.S.)*, **76A** (Phys. and Chem.), No. 5, 469–482 (Sept.–Oct. 1972).
- [4] Yoshimori, T. and Sakaguchi, N., *Talanta* **22**, 233–238 (1975).
- [5] Mavrodineanu, R., *J. Res. Nat. Bur. Stand. (U.S.)*, **76A** (Phys. and Chem.), No. 5, 405–425 (Sept.–Oct. 1972).
- [6] Mavrodineanu, R., and Lazar, J. W., *Nat. Bur. Stand. (U.S.)*, Spec. Publ. 260–32, 26 pages (Dec. 1973), and in *Clin. Chem.* **19**, 1053–1057 (1973).
- [7] Mielenz, K. D., and Mavrodineanu, R., *J. Res. Nat. Bur. Stand. (U.S.)*, **77A** (Phys. and Chem.), No. 6, 699–703 (Nov.–Dec. 1973).

(Paper 80A4–908)

Considerations for the Use of Semi-Transparent Metallic Thin Films as Potential Transmittance Standards in Spectrophotometry*

R. Mavrodineanu

Institute for Materials Research, National Bureau of Standards, Washington, D.C. 20234

(May 20, 1976)

Various characteristics of evaporated metal-on-fused silica filters are discussed in relation to their optical transmission properties. Special metal holders provided with shutters were designed to be used with these filters, and are described in detail. Transmittance measurements, performed in various conditions, are reported and indicate that the evaporated metal-on-fused silica filters might present an acceptable material as transfer standards in spectrophotometry.

Key words: Evaporated metal-on-quartz; filters, transmittance; neutral filters; standard reference materials; transmittance characteristics; ultraviolet-visible filters.

The use of solid materials, in the form of glass filters and of solutions of inorganic and sometime organic compounds, to test the correct functioning of spectrophotometers is a common practice [1].¹ A variety of materials are available from the National Bureau of Standards (NBS) which can be used as transfer standards to verify the accuracy of the transmittance scale and the short and long term stabilities of conventional spectrophotometers. Two Standard Reference Materials (SRM's) have been issued by NBS for the verification of the accuracy of the transmittance scale; these are SRM 930 and SRM 931.

SRM 930 is a solid material which consists of a set of three glass filters having nominal transmittance of 10; 20; and 30 percent. They are certified for transmittance in the visible spectral range from 400 nm to 635 nm. A detailed description of this SRM is given in NBS Special Publication 260-51 [2]. SRM 931 is a liquid standard which consists of a solution of cobalt and nickel in dilute perchloric acid contained in glass ampoules [3]. The transmittance of these solutions is certified from 302 nm to 678 nm and should be used in conjunction with cuvettes having a known light path; such cuvettes are available from NBS as SRM 932 [4].

Both SRM's 930 (the glass filters) and 931 (the liquids) are limited in their spectral transmittance range and require the use of spectral bandpasses, from 2.2 nm to 6.5 nm for the glass filters and from 1.0 nm to 6.5 nm for the liquid filters depending of wavelength, when accurate transmittance values are sought.

The need to provide similar transfer standards, but with expanded spectral range to the ultraviolet and with less stringent spectral bandpass requirements, has resulted in an investigation to find adequate materials for this purpose. Such materials should fulfill the following conditions: (a) be transparent in the spectral range of interest, usually between 200 nm and 800 nm; (b) have a transmittance independent of wavelength (optically neutral); (c) have a spectral transmittance independent of temperature; (d) have low reflectance and be free of interferences; (e) be nonfluorescent; (f) be stable, homogeneous, and free of strain; (g) have mechanical stability for the size used (thickness, length, width) and be easy to fabricate by conventional techniques used in optical shops; (h) be simple to use in conjunction with the conventional spectrophotometers available today in analytical laboratories; (i) be readily available and relatively inexpensive. Thus, various solid materials were examined and the final choice was the evaporated metal-on-(non-fluorescent) fused silica type filter.

The transmission characteristics of such filters are illustrated in figure 1 and are compared with that of three glass filters and Ronchi ruling on glass.

The major limitation of the evaporated metal-on-quartz filters results from their intrinsic property of attenuating the incident radiation by reflecting rather than absorbing part of it. As a consequence of this property, this type of filter could generate stray radiations in the sample compartment of conventional spectrophotometers and is susceptible to produce interreflections when used with instruments equipped with lenses.

To determine the practical value of such filters as a transfer transmittance standard, comparative meas-

*This work was supported in part by the National Institute of General Medical Sciences.

¹ Figures in brackets indicate the literature references at the end of this paper.

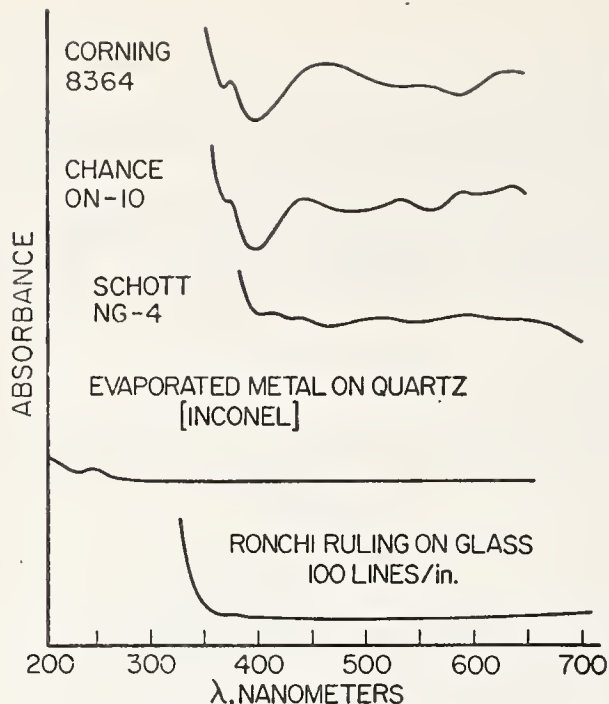

FIGURE 1. Spectral characteristics for five transparent materials from 200 nm to 700 nm.

measurements were performed with the National Physical Laboratory in England (NPL), and the results are given in table I. In this case the inconel-on-fused silica filter was protected by a clean fused silica plate held in place with an organic cement. Except for a filter which showed some mechanical flaws in its structure, the reproducibility of transmittance measurements was as good as that obtained for the absorbing glass filters (table II). The error which would result from positioning the inconel-on-fused silica was measured by rotating from 0° angle to 3°—6°—and 9°. From the results obtained (table III) it can be concluded that in the case of the high-accuracy spectrophotometer used at NBS a positioning error within 3° can be tolerated.

The interreflection error affecting the measurements when a filter is inserted in the radiation path between the two lenses of a spectrophotometer was examined in detail [5]. The measured error for a glass filter established for the high-accuracy spectrophotometer was one or two 10^{-4} transmittance units; a value which is about four times larger was found for an evaporated metal-on-fused silica filter. It should be mentioned here that both the positioning and interreflection errors are, for a given material, instrument dependent.

As a result of these considerations a decision was made to produce a limited number of sets of evaporated inconel-on-fused silica and to test these filters in actual measurements performed on the conventional spectrophotometers manufactured in the United States.

One of the filters from a set is shown in figure 2. From left to right one can see the main body of the filter holder made from an aluminum alloy anodized black. This body is provided with dove-tail grooves which can accept a front and rear shutter made

TABLE I. Comparison between the percent transmittances (%T) measured on three inconel-on-silica filters at NPL and NBS

Wavelength nm	NBS, %T		NBS, %T average	NPL, %T
	1	2		
450.0	24.87	24.88	24.87 ₅	24.93
550.0	23.78	23.82	23.80	23.86
650.0	23.38	23.39	23.38 ₅	23.46
450.0	49.35	49.33	49.34	* 49.56
550.0	47.60	47.60	47.60	47.81
650.0	46.85	46.85	46.85	47.14
450.0	72.17	72.20	72.18 ₅	72.30
550.0	72.05	72.11	72.08	72.20
650.0	72.20	72.34	72.27	72.33

Average difference between NBS and NPL percent T values = -0.30 percent

* This filter had a flaw in the form of a crack which was sometimes visible and other times invisible. The larger differences found in the measurements of this filter may be due to this flaw.

TABLE II. Comparison between the percent transmittances (%T) measured on three Schott NG-4 glass filters at NPL and NBS

Wave- length nm	NBS, %T March 12, 1971	NBS, %T May 18, 1971	NBS, %T average	NPL, %T February 1971
440.0	12.92	12.91	12.91 ₅	12.93
465.0	14.96 ₅	14.98	14.97 ₃	15.01
590.0	11.70	11.64	11.67	11.67
635.0	12.72	12.68	12.70	12.72
440.0	19.62 ₅	19.58	19.60 ₃	19.62
465.0	22.38 ₅	22.35	22.36 ₇	22.43
590.0	19.06	18.95	19.00 ₅	19.01
635.0	20.45 ₅	20.37	20.41 ₃	20.47
440.0	32.89	32.86	32.87 ₅	32.98
465.0	35.52	35.54	35.53	35.66
590.0	31.16 ₅	31.10	31.13 ₃	31.21
635.0	32.56 ₅	32.52	32.54 ₃	32.62

Average difference between NBS and NPL percent T values = -0.19 percent

TABLE III. Percent transmittance (%T) measured on a Schott neutral glass filter 2 mm thick, and an inconel-on-fused silica filter 2 mm thick at 590 nm, for normal incidence and for the angle of 3°; 6°; and 9°

		%T	
Angle	Filter	Schott NG-4 Glass	Inconel-on-fused silica
		Front	Back
0°		28.13	29.91
3°		28.10	29.98
6°		28.03	29.84
9°		27.98	29.92
			29.87
			29.87
			29.82
			29.90



FIGURE 2. *Filter holder with shutters.*

From left to right: front and rear view of the holder body provided with dove-tail grooves; retaining spring with nylon screw and washer; filter; two shutters; front view of the filter holder with front shutter; rear view of the filter with rear shutter; filter holder with both shutters closed.

from a black plastic (Delrin²). The last three units illustrate the holder with these shutters on. A more detailed dimensional drawing of the filter holder is shown in figure 3. The shutters provide two functions: one is to protect the filter from contamination, the other to detect if stray radiant energy (SRE) is produced in the spectrophotometer compartment as a result of reflections generated by the incident beam on the semi-transparent metal layer. The determination of stray radiant energy generated in the sample compartment of the spectrophotometer, due to the reflecting properties of these filters, may be assessed as follows: A background signal may be measurable when the instrument shutter at the photomultiplier tube is closed. Another slightly higher background signal may be detectable with the instrument shutter open and with the filter placed in the beam, in the sample compartment, with both sliding shutters closed. Both of these signals should be very small. A third signal may be detected when the front sliding shutter at the filter holder is removed and the rear sliding shutter is closed. If under these circumstances a signal is detected, it is very likely due to SRE produced by reflections resulting from the semi-transparent mirror which scatter from the walls of the cell compartment. This should also be low in magnitude. The transmittance of the filter is measured where both sliding shutters at the filter holder are removed.

² In order to describe materials and experimental procedures adequately, it was occasionally necessary to identify commercial products by manufacturer's name or label. In no instance does such identification imply endorsement by the National Bureau of Standards, nor does it imply that the particular product or equipment is necessarily the best available for that purpose.

Under these circumstances a source of systematic error can be from multiple reflections between the lenses in the instrument and the filter surfaces [5]. An indication of the existence and magnitude of such interreflection phenomena can be obtained by comparing the differences between the transmittance measurements and the certified values for SRM 930 and 931 to the corresponding differences for the inconel-on-fused silica filters.

Each set is made from three filters and one blank placed in individual metal holders which are provided with the front and rear sliding shutters. The selection of inconel as the semi-transparent metal layer was made on the basis of its relatively good optical neutrality in the spectral range from 250 nm to 700 nm. The fused silica substrate is of optical quality and non-fluorescent. All the silica filters, including the blank, were ground and polished at the same time and together to a parallelism of 0.02 mm and a flatness of less than 2 fringes (mercury 546.1 nm). The nominal dimensions are 30.5 mm by 10.4 mm by 2 mm thick, and the nominal transmittances of these filters are 1 percent; 20 percent; 30 percent; and 90 percent.³ The transmittances of each set were measured at 250 nm, 300 nm, 340 nm, 400 nm, 440 nm, 465 nm, 500 nm, 546.1 nm, 590 nm, and 635 nm. Sets of these filters were sent to the manufacturers of spectrophotometers for evaluation and tests on the individual instruments. The results of these

³ The filter holders and the evaporated inconel-on-fused silica filters were made in the NBS Instrument Shops.

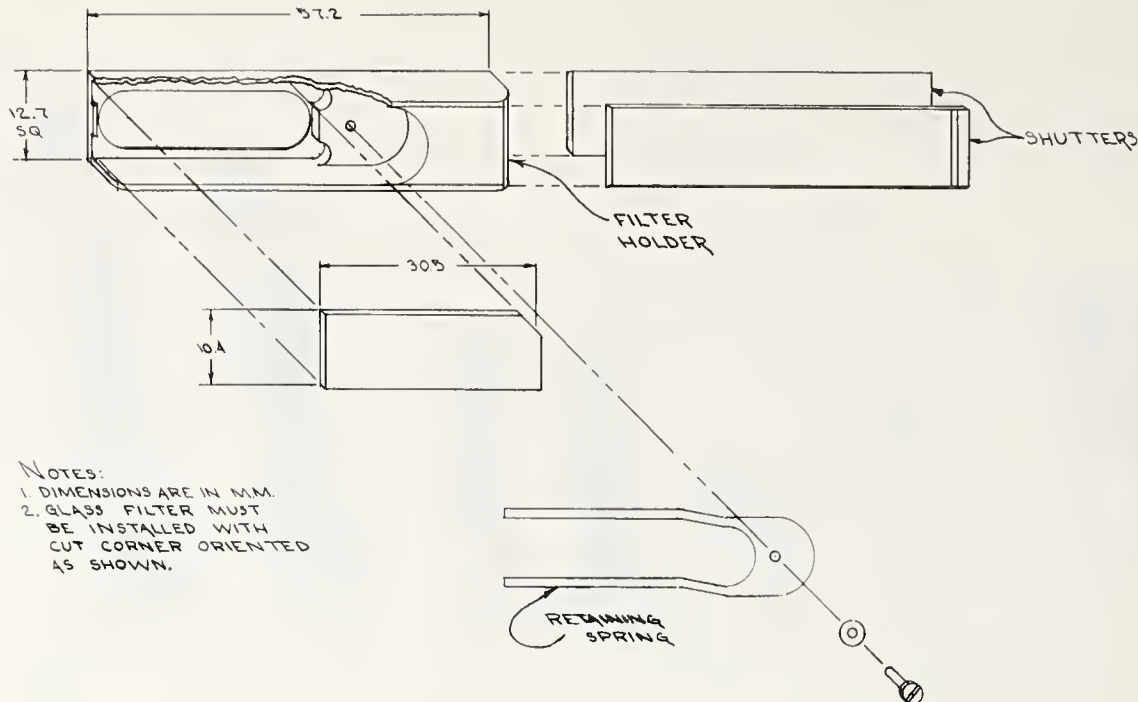

FIGURE 3. Details of the filter holder with shutters.

Nominal dimensions are in millimeters.

TABLE IV. Percent transmittance (%T) measured on four inconel-on-fused silica filters at 10 wavelengths and on the NBS-IMR high-accuracy spectrophotometer and on two conventional instruments A and B

Wavelength nm	%T									
	250	300	340	400	440	465	500	546	590	635
NBS-IMR	1.45	1.81	1.86	1.94	2.04	2.13	2.27	2.49	2.70	2.90
High-accuracy Spectrophotometer	21.39	21.27	20.33	18.93	18.33	18.09	17.90	17.83	17.86	17.95
Spectrophotometer A	28.68	29.92	30.20	29.96	29.70	29.55	29.44	29.44	29.49	29.57
Spectrophotometer B	91.42	92.34	92.66	92.90	93.01	93.05	93.11	93.16	93.19	93.23
Spectrophotometer A	1.53	1.84	1.93	2.00	2.12	2.20	2.34	2.55	2.75	2.95
Spectrophotometer B	21.37	21.24	20.31	18.91	18.29	18.07	17.89	17.82	17.84	17.92
Spectrophotometer A	28.67	29.87	30.19	29.95	29.70	29.58	29.49	29.46	29.52	29.60
Spectrophotometer B	91.59	92.60	93.32	93.20	93.30	93.30	93.42	93.46	93.50	93.58
Spectrophotometer A	1.49	1.85	1.90	1.97	2.07	2.16	2.31	2.53	2.83	3.06
Spectrophotometer B	21.6	21.5	20.5	19.1	18.5	18.3	18.1	18.0	18.3	18.5
Spectrophotometer A	28.8	30.0	30.2	30.0	29.9	29.7	29.5	29.5	29.9	30.0
Spectrophotometer B	91.4	92.6	92.6	93.1	93.3	93.3	93.3	93.3	93.9	93.9

tests will permit to establish the usefulness of these filters as SRM's in spectrophotometry.

In the mean time comparative measurements were performed on two conventional spectrophotometers available at NBS, and the results are assembled in table IV. These results are preliminary measurements and should be considered with caution. The data seem to indicate, however, that the evaporated metal-on-fused silica filters may be an acceptable material for use as transfer standards in spectrophotometry.

NOTE.—The semi-transparent metallic surface of the filters described in this paper is not protected from environmental exposure and careless handling. A solution to this problem was found recently. It consists in placing on top of the fused silica plate carrying the semi-transparent evaporated metal layer a clear fused silica plate, about 1.5 mm thick, adequately ground and polished, to achieve an optical contact with the evaporated semi-transparent metal layer surface. The two fused silica plates are slightly beveled, and an optical cement is applied to protect the edges. Under these conditions the two fused silica plate assembly, with the semi-transparent evaporated metal layer in between, behaves optically as if it were a single semi-transparent plate, and provides full protection of the metal layer. Several sets of these new filters were made for evaluation in actual working conditions.

References

- [1] Rand, R. N., Practical spectrophotometric standards, *Clin. Chem.*, **15**, 839-863 (1969).
- [2] Mavrodineanu, R., and Baldwin, J. R., Glass filters as a standard reference material for spectrophotometry—selection, preparation, certification, use, SRM 930, Nat. Bur. Stand. (U.S.), Spec. Publ. 260-51, 118 pages (Nov. 1975).
- [3] Burke, R. W., Deardorff, E. R., and Menis, O., Liquid absorbance standards, *J. Res. Nat. Bur. Stand.* (U.S.), **76A**, (Phys. and Chem.), No. 5, 469-482 (Sept.-Oct. 1972).
- [4] Mavrodineanu, R., and Lazar, J. W., Standard quartz cuvettes for high accuracy spectrophotometry, Nat. Bur. Stand. (U.S.), Spec. Publ. 260-32, 26 pages (Dec. 1973) and *Clin. Chem.* **19**, (9) 1053-1057 (1973).
- [5] Mielenz, K. D., and Mavrodineanu, R., Reflection correction for high-accuracy transmittance measurements on filter glasses, *J. Res. Nat. Bur. Stand.* (U.S.), **77A** (Phys. and Chem.), No. 6, 699-703 (Nov.-Dec. 1973).

(Paper 80A4-909)

Structure-Related Optical Characteristics of Thin Metallic Films in the Visible and Ultraviolet

H. E. Bennett and J. L. Stanford

Michelson Laboratories, Naval Weapons Center
China Lake, California 93555

(November 20, 1975)

Surface irregularities and crystalline order strongly influence both the scattered light and absorption of metallic films. These effects extend through all spectral regions but are particularly important in the visible and ultraviolet. Scattered light arises from several scattering mechanisms. Macroscopic irregularities such as dust, scratches and particulates are typically much less important than are microirregularities only a few tens of angstroms in height but covering the entire surface. For metals such as silver and aluminum, which have plasma edges in the ultraviolet, the excitation of surface plasmons resulting from these microirregularities causes additional incoherently reemitted or "scattered" light. Surface plasmon excitation also causes increased absorption in some wavelength regions. These effects are enhanced by dielectric overcoating layers, which both increase the absorption and scattering and shift the wavelength at which the peak occurs. Surface plasmon excitation is particularly important in the ultraviolet region, where the dielectric overcoating applied to prevent formation of an oxide film on aluminized mirrors, for example, can significantly change the mirror reflectance. Plasmon excitation is made possible by a momentum conserving process associated with material inhomogeneities and hence can presumably be caused by crystalline disorder in the metal surface as well as surface irregularities. If the disorder is present on a sufficiently fine scale, it also affects the band structure of the metal and hence its optical absorption. Examples of the effect of film structure on the optical properties of evaporated and sputtered metal films will be given.

Keywords: Absorption; dielectric layers; irregularities; metallic thin films; microirregularities; overcoating; plasmons; scatter.

I. Introduction

The optical characteristics of opaque metal films which are of most interest are the fraction of the light which is either absorbed or scattered by the films. The most commonly assumed mechanism for light scattering consists of reflection from numerous tiny scratches, dust particles and other surface blemishes which act as tiny mirrors oriented at various angles to the surface normal. This picture has marginal merit in the infrared, where scattering from particulates and surface blemishes usually is dominant, but is not the important mechanism for light scattering from optical surfaces in the visible and ultraviolet regions of the spectrum. To the extent that it is a geometrical optics phenomenon, scattering from surface blemishes such as scratches will be independent of wavelength. Particulate scattering, however, is largely a diffraction phenomenon. Closely related is resonant scattering and absorption associated with the polarization characteristics of individual irregularities in the metal surface. To the approximation that these irregularities are independent, i.e., that the scattering from one irregularity is unaffected by the presence of its neighbors,

we may compute the resultant scattering and absorption approximately from the Mie scattering theory. Particulate scattering and scattering from large "macroirregularities" can usually be regarded in this way. However the dominant source of scattered light for good optical surfaces in the visible and ultraviolet regions is closely spaced microirregularities only a few tens of angstroms in height. These microirregularities scatter and absorb collectively and cannot be regarded as independent. They can be treated statistically, and give rise to several interesting phenomena.

When monochromatic electromagnetic waves are incident on a smooth metal surface they induce virtual surface currents within the skin depth of the metal. The currents are virtual since the electrons in the metal have too much inertia to couple to the wave, but they have the same wave vector along the surface as the incident wave. Thus the radiation from these currents must also have the same wave vector along the surface as the incident wave, and the radiation leaves the surface in the specular direction. When surface irregularities are present, the current distribution is modulated according to the distribution of surface heights as well as their correlation

along the surface. Additional tangential components are thus introduced into the wave vector of the current distribution producing nonspecular or scattered light. If we confine ourselves to total integrated scatter (TIS) and ignore its angular dependence or polarization at nonnormal incidence, the scattering caused by perturbation of the virtual current distribution can be described by classical diffraction theory in the Kirchhoff integral approximation. This effect is the most important source of scattered light in the visible and ultraviolet wavelength regions.

Actual surface currents can exist in the skin depth of the metal but their allowed phase velocity is lower than that of the virtual currents induced on a smooth surface by an incident light wave and thus no coupling occurs. However when microirregularities are present, coupling can in some cases occur and these surface charge waves can absorb energy from the incident light. These surface charge waves are quantized into units termed surface plasmons with a fixed energy-wave vector relationship. Once excited they may decay thermally into single electron excitations or they may radiate because of their acceleration along the curved surface irregularities. Surface plasmons are strongly affected by the presence of a dielectric layer on the metal surface. Both absorption and scattering are often greatly enhanced, a result which has significant implications since protective dielectric overcoating layers must be used to prevent oxidation of aluminum reflectors in the ultraviolet or sulfide formation on silver reflectors used at longer wavelengths. To minimize surface plasmon related absorption and scattering in such cases the mirror must be extremely smooth.

Other structure-related mechanisms also affect the optical properties of metals. Both mechanical abrasion and the inherent disorder in polycrystalline films of vacuum evaporated or sputtered metals result in increased absorption. The crystalline imperfections in such metal samples modify the electron energy band structure, permit excitation of surface plasmons by the incident electromagnetic fields, and affect the motion of conduction electrons. In the latter case the effect is greatest in the infrared, where the optical properties of metals are determined by the mean free path and number of conduction electrons.

In the visible and ultraviolet the response of single electrons in metals to incident light is influenced significantly by interband electron transitions. Because the energy band structure results directly from the regularity of the lattice structure, lattice distortion produced by mechanical abrasion or polycrystalline film growth affects the optical response of metals. The optical properties of metals thus prepared are notoriously nonreproducible in the visible and ultraviolet. In addition to single electron effects, the inhomogeneities resulting from the disorder permit absorption via excitation of collective electron oscillations, namely, surface plasmon excitation. The combination of these two effects can significantly reduce the reflectance of metals in

the visible and ultraviolet through increased absorption.

Surface irregularities can also affect the mean free path of the conduction electrons near the metal surface. The conduction electrons have a de Broglie wavelength associated with their energy and may be thought of as a wave motion incident on the metal surface from inside. If the surface is perfectly smooth they reflect specularly and there is no change in their mean free path between collisions, i.e., the electron-surface interaction does not represent a collision in the specular case. If the conduction electrons are diffusely reflected, however, as they will be if surface microirregularities are present which are not adequately screened by the surface electron cloud, reflection from the surface does represent a collision and the electronic mean free path will be decreased with consequent increase in absorption. This "anomalous skin effect" [1]¹ is important in the infrared region of the spectrum [2].

Surface microirregularities as well as macroirregularities may modify the optical properties of a metal surface through resonant scattering and absorption of light associated with resonance effects in the polarization characteristics of individual irregularities. These effects are equivalent in many ways to scattering from small dispersed particles and may be calculated in the first approximation using Rayleigh or Mie scattering theory.

In this paper we will first discuss briefly the theoretical predictions for optical absorption and scattering in metal surfaces due to structure-related mechanisms. Those which appear to be most important in the visible and ultraviolet regions are scattering and absorption from isolated microirregularities, and diffraction effects from correlated irregularities including the optical excitation of surface plasmons. We will then discuss instrumentation for measuring scattering, absorption, and surface structure, and finally will show some experimental results for silver and aluminum surfaces.

II. Theory

A. Light Scattering and Absorption by Isolated Irregularities

If we assume that we can treat each scattering center independently, the scattering may be computed using the Mie theory. Consider first non-absorbing irregularities. Assuming spherical scattering centers and defining x as $x=2\pi a/\lambda$ where a is the particle radius, λ the wavelength and n the index of refraction, the ratio Q_s of scattering to geometrical cross section of the scatterer for $nx < 0.8$ is [3]

$$Q_s = \frac{8}{3} x^4 \left(\frac{n^2 - 1}{n^2 + 2} \right)^2 \left[1 + \frac{6}{5} \left(\frac{n^2 - 1}{n^2 + 2} \right) x^2 + \dots \right] \quad (1)$$

The Rayleigh $1/\lambda^4$ law for $x \ll 1$ follows from eq (1). For $x \gg 1$, $Q_s = 2$. In the region $x \sim 1$ a some-

¹ Figures in brackets indicate the literature references at the end of this paper.

times complicated resonance occurs. E. D. Bailey [4] has suggested the universal scattering curve shown in fig. 1 as a first approximation to this resonance. If the index of refraction of the scattering center is in the 1.3–1.4 range, the resonance then occurs when the diameter of the scattering center is approximately equal to the wavelength. Dust particles are probably largely nonabsorbing.

$$Q_e = -Im \left[4x \left\{ \frac{\tilde{n}^2 - 1}{\tilde{n}^2 + 2} + \frac{4}{15} x^3 \left(\frac{\tilde{n}^2 - 1}{\tilde{n}^2 + 2} \right)^2 \frac{\tilde{n}^4 + 27\tilde{n}^2 + 38}{2\tilde{n}^2 + 3} \right\} \right] + x^4 \frac{8}{3} \left| \frac{\tilde{n}^2 - 1}{\tilde{n}^2 + 2} \right|^2 \quad (2)$$

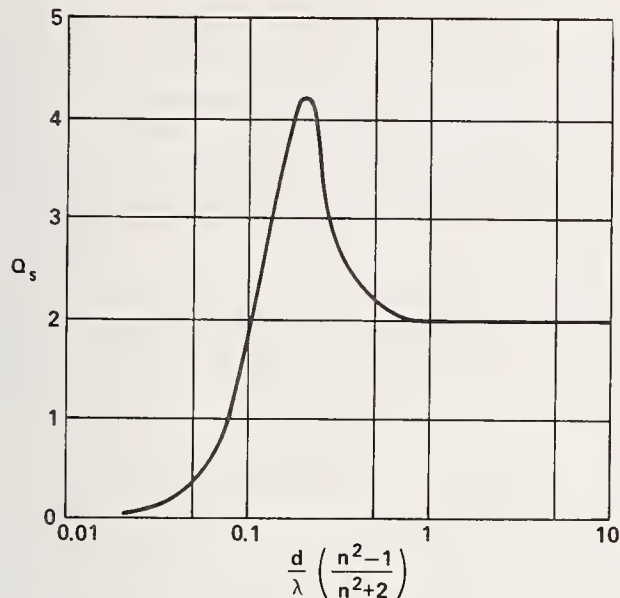

FIGURE 1. Theoretical prediction of scattering cross section Q_s as a function of the ratio of particle diameter d to wavelength λ times a function of index of refraction.

The graph is calculated for spherical, nonabsorbing particles. The effective area of each scattering center is $\pi d^2 Q_s/4$.

where the complex index $\tilde{n} = n - ik$ and k is the extinction coefficient. The term in brackets gives the absorption and the second term the scattering as in eq (1) except that now \tilde{n} is complex. A resonance would still occur in this case, but as k increases the short wavelength side of figure 1 will fall off less rapidly than for the nonabsorbing case.

B. Scalar Scattering Theory

In addition to particulates and other isolated irregularities on an optical surface, there are also closely spaced irregularities, often having very small deviations from the mean surface level (MSL), which scatter and absorb collectively. The effect of these interdependent irregularities may be understood by considering the surface current induced by an incident electromagnetic wave. Figure 2 illustrates the surface charge wave which would be induced if the electrons in the metal could move rapidly enough. These charge waves are virtual states under most conditions since the charge density waves which can actually exist within the skin depth of a metal have phase velocities ω/k_0 which are less than the velocity of light c/n in the dielectric in contact with the metal

If the index of refraction of the scattering center is complex, as would be the case if scattering were occurring from an asperity on the metal surface rather than from a dust particle, both absorption and scattering would occur. The ratio Q_e of extinction cross section to geometrical cross section, which includes both scattering and absorption, would then be given by [3]

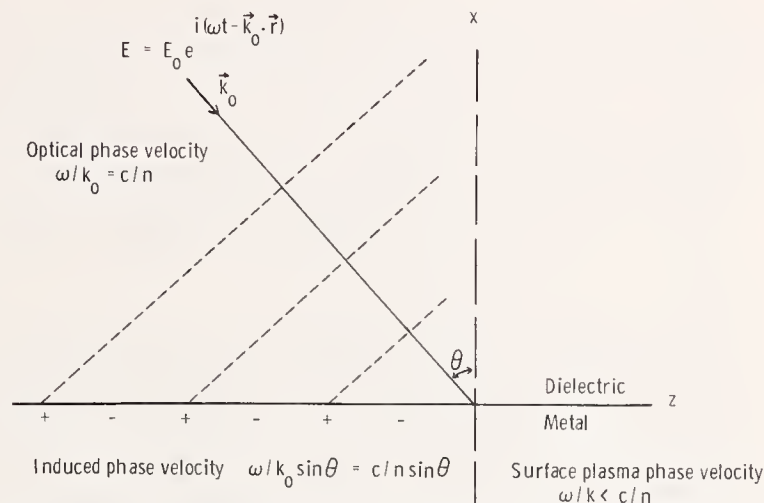

FIGURE 2. Surface charge wave induced by the electric field of an incoming electromagnetic wave.

The dashed lines indicate maximum field strength. The induced charge wave is virtual since its phase velocity is \geq the velocity of light, and a real surface plasma wave must have a phase velocity $\leq c/n$.

surface, whereas, as seen from figure 2, the phase velocity of induced surface charge waves is greater than c/n . The component of the wave vector of this induced virtual surface charge wave is $k_0 \sin \theta$ where k_0 is the wave vector of the incident light and θ the angle of incidence. The radiation from this induced current must also have the same wave vector component along the surface in order to satisfy the boundary conditions associated with the fields. Therefore, the radiation from the surface leaves in the specular direction. However if irregularities were present on the surface, the current distribution would be modified according to the heights of these irregularities as well as their correlation along the surface. Additional tangential components are thus introduced into the wave vector of the current distribution producing nonspecular or "scattered" light.

An example of the effect of correlated surface irregularities on light reflected from a surface is furnished by a reflection grating with groove spacing d shown in figure 3. The wave vector \mathbf{K} associated with the grating grooves is $K = 2\pi/d$. If light with wave vector \mathbf{k}_0 is incident on the grating, in the $N=0$ order, the light is reflected specularly and has a component of its wave vector along the surface of $k_0 \sin \theta$ as in the case for the smooth surface. In other orders the magnitude of the wave vector is unchanged (i.e., the wavelength of light reflected in various directions is the same) but the component of the

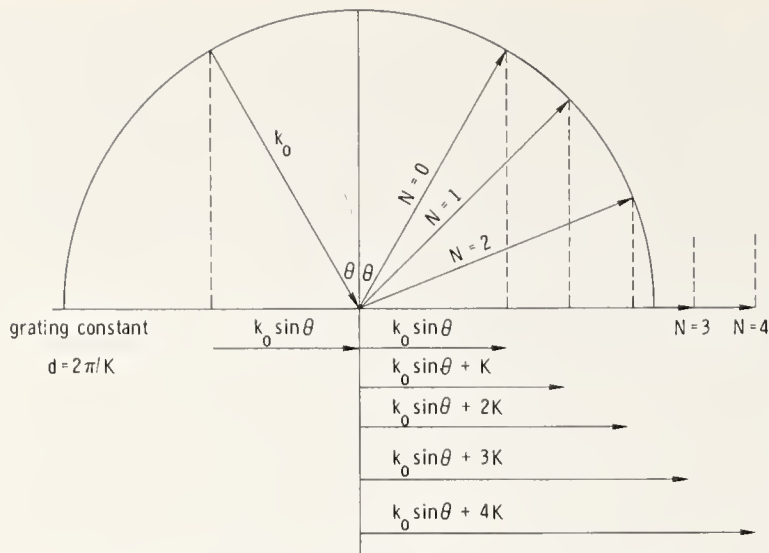

FIGURE 3. Momentum transfer from a grating surface to a light beam.

k_0 is the vector of the incident light, N the order of interference, d the line spacing on the grating, and K the wave vector for the grating surface.

wave vector along the surface of the grating is increased by multiples of K , the wave vector associated with the grating surface. Photons in the light incident on the grating have energies of $\hbar\omega$ and momenta of $\hbar k_0$. The photons reflected from the grating have the same energy but the component of their momenta along the surface has been altered by integral multiples of the momentum $\hbar K$ associated with the grating surface. The effect of a rough surface can thus be interpreted as supplying an additional tangential momentum component to the reflected photon without changing its resultant energy or total momentum $\hbar K_0 = \hbar\omega/c$. The momentum which the surface can supply is determined by the statistical character of its surface irregularities.

The angular dependence and polarization of scattered light requires an involved theoretical analysis [5,6]. However, if we confine ourselves to total integrated scatter from irregularities which are large laterally relative to the wavelength of light, the scattering caused by perturbation of the virtual surface current distribution can be described quite simply by classical diffraction theory in the Kirchhoff integral approximation [7-9]. A statistical representation of the surface irregularities is sufficient to make the calculation. Of primary importance is the height distribution function of surface irregularities about the MSL. Interferometric analyses using fringes of equal chromatic order (FECO interferometry) indicate that the height distribution function of real optical surfaces is very nearly Gaussian [10]. For a surface with a Gaussian height distribution the ratio of the specularly reflected light R to the total reflectance R_0 is [8]

$$\frac{R}{R_0} = e^{-(4\pi\delta/\lambda)^2} \quad (3)$$

where δ is the rms value of the height of surface microirregularities about the MSL. Equation (3) is exact [9] for all values of δ/λ and expresses the

fraction of the reflected light which is reflected coherently from different points on the surface. However as $\delta/\lambda \rightarrow 1$ an increasing amount of incoherently reflected or scattered light falls very near to the specular direction and cannot be separated from it experimentally. Therefore eq (3) is most useful in describing the experimentally observed scattered light for $\delta/\lambda \ll 1$. In this case the exponent may be expanded, giving the scattered light ΔR as

$$\Delta R = R_0(4\pi\delta/\lambda)^2. \quad (4)$$

Two precautions must be observed in using eq (4): (1) the *rough* surface total reflectance must be used for R_0 . It may or may not be equal to the smooth surface reflectance, and (2) scattering from surface plasmon excitation and decay must be excluded, i.e., scattering measurements to determine δ must be taken in wavelength regions where surface plasmon excitation is not important.

Figure 4 shows the fractional scattering $\Delta R/R_0$ predicted by eqs (3) and (4) as a function of wavelength and surface roughness. The solid diagonal lines give the theoretically predicted scattering levels. The dashed vertical lines show typical roughness values for superpolished optical surfaces, high quality glass optics and high quality metal optics polished by conventional techniques. In the photographic infrared typical metal coated glass mirrors will scatter about 0.1 percent of the reflected light. This value quadruples in the visible region and in the near ultraviolet approaches 1 percent. At shorter wavelengths it increases still further, although in the vacuum ultraviolet the situation is unclear. In the intermediate and far infrared scattered light caused by microirregularities becomes quite low and other types of scattering become important.

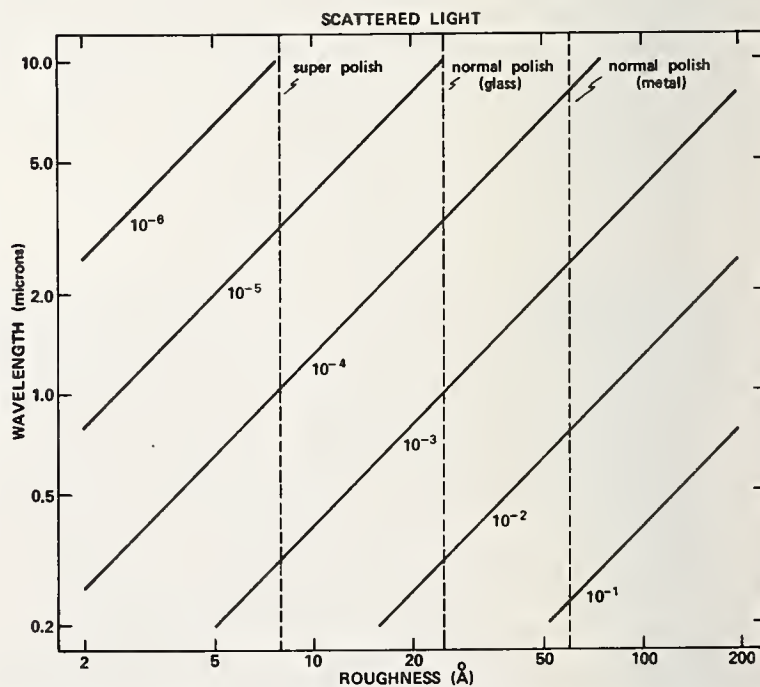

FIGURE 4. Theoretical predictions for scattering as a function of roughness and wavelength.

C. Optical Excitation of Surface Plasmons

The "scalar scattering theory" described above predicts a monotonic increase in scattering with decreasing wavelength. Several years ago we and others [11-13] found that slightly rough metal surfaces can exhibit resonant absorption in the spectral range near the metal's surface plasmon frequency. Accompanying this resonant absorption is increased scattering which also occurs predominantly in the surface plasmon region. These phenomena may be interpreted in terms of optical excitation of surface plasmons, [14], which then decay either thermally (absorption) or radiatively (scattering). Surface plasmons may be excited optically in either thin metal films, where the surface oscillations at the two surfaces can couple, or in thick films (i.e., significantly thicker than the optical penetration depth of the light, which for the best conductors is a few tens of nm). We will consider only the thick film case here.

The allowed surface charge waves which may exist on a conducting surface may be obtained directly from Maxwell's equations, which may be written in Gaussian units as [15]

$$\nabla \cdot D = 0 \quad (5)$$

$$\nabla \cdot H = 0 \quad (6)$$

$$\nabla \times E = -\frac{1}{c} \frac{\partial H}{\partial t} \quad (7)$$

$$\nabla \times H = i \frac{\omega}{c} (\epsilon_1 - i\epsilon_2) E \quad (8)$$

where ϵ_1 and ϵ_2 are the real and imaginary parts of the complex dielectric constant ϵ and the other symbols have their usual significance. Choosing a coordinate system at the metal-dielectric interface in which x is directed into the metal along the surface normal and y and z are in the plane of the interface, Maxwell's equations are satisfied by the transverse magnetic (TM) wave solution

$$E = E(x) e^{i(\omega t - k_0 z)} \quad (9)$$

where $E_y = H_x = 0$ at $x = 0$. From eqs (5), (8) and the wave equation given by $\nabla \times \nabla \times E$, we obtain

$$E_z = -\frac{i}{k_0} \frac{dE_x}{dx} \quad (10)$$

$$H_y(x) = \frac{\omega \epsilon}{ck_0} E_x \quad (11)$$

$$\frac{d^2 E_x}{dx^2} - \left(k_0^2 - \frac{\omega^2 \epsilon}{c^2} \right) E_x = 0. \quad (12)$$

Solving eq (12) gives

$$E_x = E_d e^{-(k_0^2 - \omega^2 \epsilon_d / c^2)^{1/2} x} \quad x > 0$$

$$= E_d e^{+(k_0^2 - \omega^2 \epsilon_d / c^2)^{1/2} x} \quad x < 0 \quad (13)$$

where subscripts m and d refer to the metal and dielectric respectively. E_z and H_y can be calculated from E_x using eqs (10) and (11). The TM surface charge waves are evanescent with phase velocity ω/k_0 . Boundary conditions are that ϵE_x and dE_x/dx are continuous across the metal-dielectric interface, giving

$$k_0 = \frac{\omega}{c} \left(\frac{\epsilon_m \epsilon_d}{\epsilon_m + \epsilon_d} \right)^{1/2} \quad (14)$$

Equation (14) is a general relation giving the wave vector of the surface charge wave in terms of the complex dielectric constants of the metal and dielectric. Note that a resonance can occur if $\epsilon_1 = -\epsilon_d$ where $\epsilon_m = \epsilon_1 - i\epsilon_2$ and that it will be strongest when $\epsilon_2 \cong 0$ i.e., damping is minimized. For real metals ϵ_m is a complicated function. However, for a free electron metal with no damping

$$\epsilon_m = \epsilon_1 = 1 - \omega_p^2 / \omega^2 \quad (15)$$

where ω_p is the plasma frequency. Substituting in eq (14) we obtain the dispersion curve for surface charge waves at a free electron metal-air interface:

$$\omega = \omega_p \{ 0.5 + (k_0/k_p)^2 + [0.25 + (k_0/k_p)^4]^{1/2} \}^{1/2} \quad (16)$$

where $k_p = \omega_p/c$. Letting $k \rightarrow \infty$ we see that there will be a maximum frequency ω_{sp} which the plasmon can have where

$$\omega_{sp} = \omega_p / (1 + \epsilon_d)^{1/2}. \quad (17)$$

For a metal-air interface, then, the maximum frequency which surface plasmons in a free electron metal can have is $\omega_p/\sqrt{2}$.

Equation (16) is plotted in figure 5 as the solid line. Note that the k_0 value for the surface plasma waves is always larger than that of the incident light waves having the same energy and becomes very much larger near the limiting frequency. The density of allowed states is highest in this energy region. The momentum which must be furnished by the surface for coupling to occur is, for normally incident light, all of that to the left of the surface plasma wave dispersion curve, since the wave vector of normally incident light has no component parallel to the surface and the wave vector of the surface wave is entirely in the surface. For grazing incidence light, only the difference between the "light line" $\omega = ck$ k_0 and the dispersion curve need be supplied and in the "retardation region" where $\omega \ll \omega_{sp}$ they approach coincidence. In the grating illustrated in figure 3 an order of interference could occur for which light would be diffracted at a grazing angle. If the frequency of the light were in the retardation region, coupling could then occur and energy would be absorbed by the grating from the beam to excite surface plasma waves. This situation does occur and is the origin

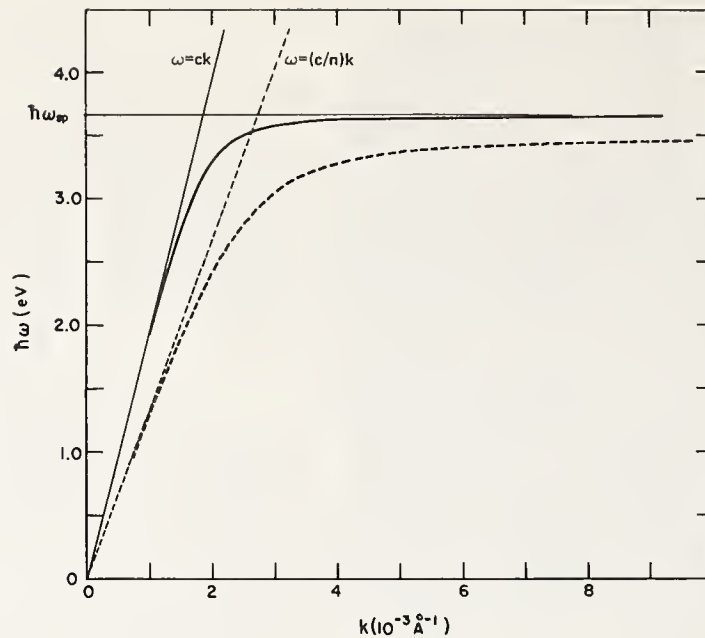

FIGURE 5. Dispersion curves for light waves and surface plasma waves at a metal-dielectric interface where the dielectric has a refractive index of unity (solid lines) and an index of $n > 1$ (dashed lines).

Surface wave modes exist for all values of ω below a limiting frequency ω_{sp} , but the density of states is highest near ω_{sp} . As the index increases ω_{sp} decreases and the k values for the surface waves remain larger than those associated with the light waves.

of the Woods anomalies in diffraction gratings. [11, 16].

A dispersion curve analogous to eq (16) can also be calculated from eqs (14) and (15) when the dielectric is not air. Such a curve is shown in figure 5 as the dashed line with its associated "light line." The effect of increasing ϵ_d is to lower ω_{sp} and move the frequency associated with a given k_0 to lower values. Thus when a dielectric is deposited on a metal surface without affecting the resultant k_0 values, we would expect resonances in absorption or scattering to move to longer wavelengths.

Calculating the coupling probability between incident photons and surface waves resulting from surface roughness is a difficult quantum mechanical problem. It has been attacked by Elson and Ritchie [17] by means of a perturbation calculation in which damping is neglected. They obtain the probability that a photon of energy $\hbar\omega$ incident normally on a rough surface will be converted into a surface plasmon, which may be written as the decrease in reflectance of the specular beam ΔR_{sp} where

$$\Delta R_{sp} = \delta^2 \left(\frac{\omega}{c} \right)^4 \frac{\epsilon_1^2}{[-(1+\epsilon_1)]^{5/2}} g \left(\frac{\omega}{c} \left[\frac{\epsilon_1}{1+\epsilon_1} \right]^{1/2} \right) \quad (18)$$

where g is the surface structure factor, which is the two dimensional Fourier transform of the autocovariance function of the surface roughness. In general, as the autocovariance length a of the surface irregularities becomes longer the momentum spectrum of surface roughness becomes more concentrated toward the origin in k_0 space and the

probability for photon-surface plasmon conversion becomes lower. Thus the optical excitation of surface plasmons will be relatively weak for gently rolling surfaces and much stronger for more jagged surfaces. In addition it will increase with the square of the rms height of surface irregularities and will also increase as the wavelength of the incident light decreases. Theoretical absorption curves calculated from eq (18) for optical excitation of surface plasmons on a free electron metal surface having Gaussian height distribution and autocovariance functions are shown in figure 6 for various values of a . As a becomes larger relative to λ_p the peak absorption decreases but the wavelength range over which an effect occurs becomes longer. Thus although the magnitude of effect is less for a gently rolling surface than for a jagged one, the wavelength range over which the effect may be important should increase.

III. Experimental Procedure

In order to accurately measure scattering and absorption in the visible and ultraviolet regions and to relate them to surface structure, various non-standard instruments are required. Four types of instruments which have been of particular help at Michelson Laboratory are the NWC Scatterometer and the Optical Evaluation Facility for measuring scattered light, the NWC Absolute Reflectometers for measuring reflectance, and the NWC FECO Scanning Interferometer for determining the structure of optically polished surfaces. A brief description of these instruments follows.

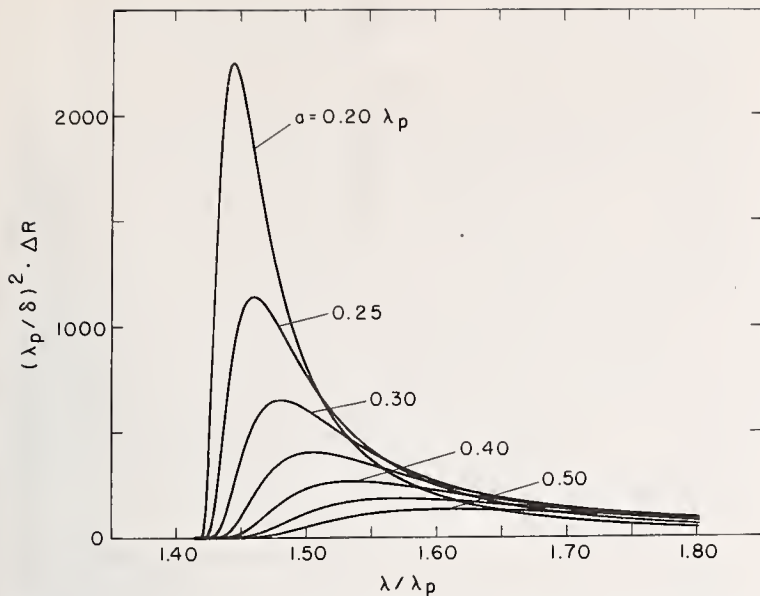

FIGURE 6. Absorption in a free electron metal caused by surface plasmon excitation.

λ_p is the limiting wavelength for surface plasmon excitation, δ the autocovariance length and δ the rms surface roughness, both assuming a Gaussian model, and ΔR the increase in absorption for wavelength λ . Calculations are based on the Crowell-Ritchie model.

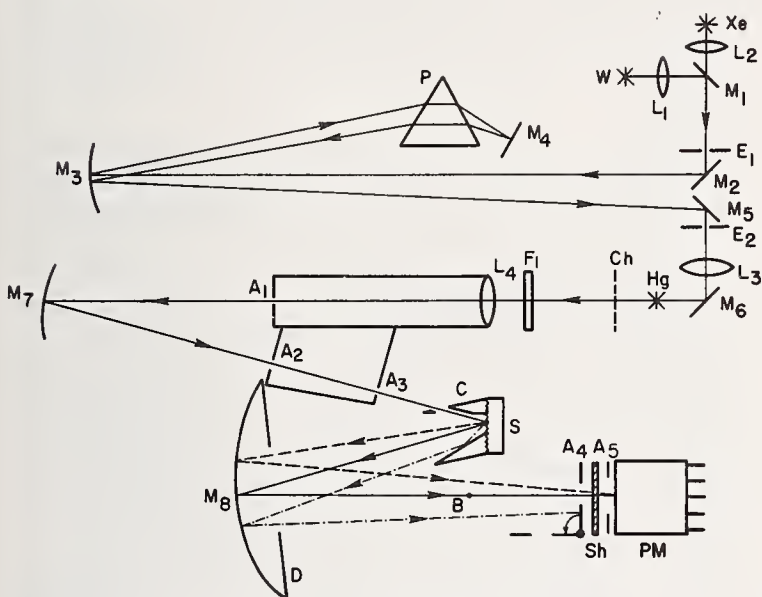

FIGURE 7. Schematic diagram of Scatterometer.

The symbols are defined in the text.

A. NWC Scatterometer

Figure 7 gives a schematic diagram of the NWC Scatterometer [18]. Mirrors are indicated by M, lenses by L, slits by E, apertures by A, the adjustable diaphragm by D, the photomultiplier by PM, and its shutter by Sh, and the dispersing prism by P. In operation dispersed light from either a high pressure xenon arc Xe or a tungsten filament W is used. Alternatively, a low pressure mercury arc Hg may be used as a monochromatic source with the aid of filters F. The light is collimated and a pencil beam 1 mm in diameter passes through A_3 to strike sample S, a plane circular sample 3.86 cm in diameter,

at an angle of incidence of 15° . Specularly reflected light passes out along the axis of internally aluminized cone C of semivertex angle $18^\circ 45'$ and is reflected by M_8 to PM. It may be entirely blocked by B, which is situated at the focus of A_3 and removes all light within a half angle of $37'$ of the specular direction. Light scattered within 20° of the specular direction strikes M_8 directly and is focussed at A_5 . At larger scattering angles light is reflected from C to M_8 , which then images the virtual object formed by reflection from C as a ring which can be blocked off by rotating aperture A_4 . By manipulating B, D, and A_4 light scattered into all angles or into a range of angles between $37'$ and $1\frac{1}{2}^\circ$ to 20° , may be ratioed to total sample reflectance. Advantages of this instrument are that it uses mirror optics and thus is nearly independent of wavelength, it does not rely on having a Lambertian surface as does an integrating sphere, and it is sufficiently efficient to measure scattering levels down to below 10^{-5} when care is taken to ensure that the detector and electronics are linear over this dynamic range. A three polarizer unit [19] is helpful for such linearity investigations.

B. Optical Evaluation Facility

For measuring scattered light from flat or curved samples of various shapes up to 40 cm in diameter the Optical Evaluation Facility shown schematically in figure 8 is useful. This instrument, which is somewhat more straightforward in concept than the Scatterometer, utilizes Coblentz spheres, indicated by C, and pyroelectric detectors D to measure scattered light in either reflection (for opaque samples) or transmission (for semitransparent ones). Back-scattering from transparent samples can also be measured. Approximate reflectance measurements can be made by using for comparison a reflectance standard R_s that has been calibrated in the absolute reflectometer. Over 20 laser lines ranging from the ultraviolet through the intermediate infrared are available, and by utilizing rotatable detector D_2 bidirectional reflectance distribution function (BRDF) measurements may also be taken. In addition to the pyroelectric detector a silicon detector for added sensitivity in the visible region is mounted on D_2 . Sample movement and data reduction are automated and computer controlled so that a sample surface can be scanned automatically to determine scattering levels as a function of position on the surface.

C. NWC Absolute Reflectometer

For making absolute spectral reflectance measurements the principle shown in figure 9 is employed. Light is reflected at nearly normal incidence from the sample S to a spherical mirror whose center of curvature is at the center of the sample surface. The mirror reimages the beam on the sample where it is again reflected and passes out to the detector. This scheme has several advantages. Most important

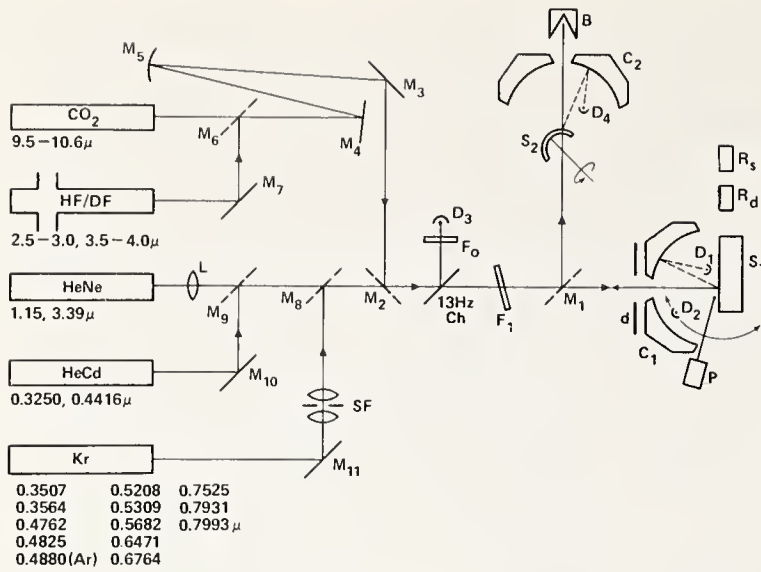

FIGURE 8. Schematic diagram of the Optical Evaluation Facility showing lasers and available laser lines, mirrors M , lens L , spatial filter SF , attenuation filters F , chopper Ch , diaphragm d , beam collector B , Coblentz spheres C , pyroelectric detectors D , samples S and R .

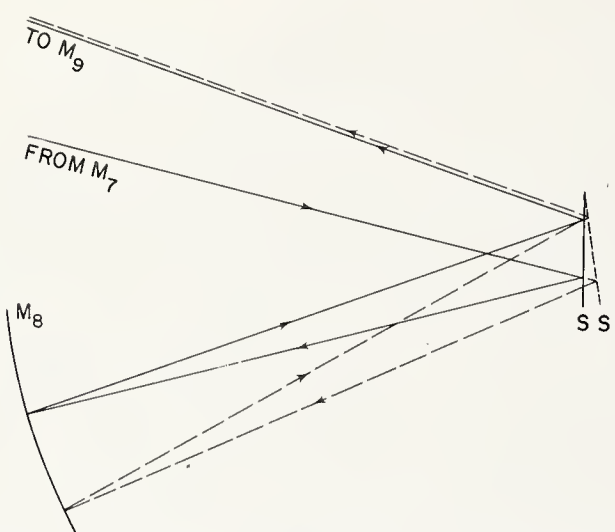

FIGURE 9. Principle of double reflection absolute reflectometer, showing cancellation of beam deviation caused by sample tilt.

is cancellation of beam deviation resulting from sample tilt. If the sample is tilted to S' , as shown in the figure, the beam is deviated through twice the tilt angle and strikes mirror M_8 at a slightly different place. A spherical mirror used at its center of curvature images an object at the same place regardless of where the light beam from the object strikes the mirror surface, so M_8 reimages at the same point for position S' as it does for position S . Since the sample is plane, on the second reflection the beam tilt introduced on the first reflection is exactly cancelled. M_8 has a long focal length to give a relatively large effective f number, so that both S and S' are within the focal range of the mirror. Thus, in our reflectometers one can reach in, tilt the sample manually and observe no change in the beam at the detector position even when it is viewed with a high power microscope. In this way the most common cause

of systematic error in reflectance measurements is eliminated.

Figure 10 shows a schematic diagram of one of our three absolute reflectometers [20, 21]. The sample is mounted at S and can be removed from the beam, in which case light falls on M_{11} , a mirror nearly identical to M_8 , and returns to follow the same optical path as for the sample-in position. The optical path length is the same for sample-out and sample-in, so no differential atmospheric absorption can occur and the same areas of the same mirrors are used for both cases with the exceptions of M_8 and M_{11} . By optically interchanging them by rotating the sample about a vertical axis in the plane of its surface, possible systematic errors resulting from differences in M_8 and M_{11} are cancelled.

Another advantage of a double reflection from the sample is that the beam is not reversed side to side. When a single reflection is used and the detector swung from the straight through, sample-out position to the reflected light position to make an absolute reflectance measurement, the beam is reversed side to side on the detector. Any nonuniformities in the detector or intervening optics will introduce a systematic error into the measurement. In a double reflection the beam is reversed twice so this error is eliminated. A similar argument can be made for the plane of polarization if it is not in the vertical direction.

The reflectometer shown in figure 10 uses mirror optics entirely so that measurements can be made from 0.3 to 30 μm. A double-pass monochromator is used to minimize light scattering in the infrared from wavelengths shorter than that used. For ultraviolet measurements double passing is less effective and a second absolute reflectometer shown in figure 11 employs a double monochromator. This reflectometer also has fewer reflections. The angle of incidence for both instruments is about 5°. For unpolarized light the reflectance at 5° differs from that at normal incidence by less than one part in 10⁴ for all real materials. A third absolute reflectometer consisting of a one-meter grating monochromator, a single sample reflection and a rotatable sodium salicylate-coated light pipe-photomultiplier detector system is used for measurements in the vacuum ultraviolet [20].

D. FECO Scanning Interferometer

In order to compare observed values of scattering and absorption caused by surface irregularities with theoretical predictions, a direct measurement of surface structure is required. The FECO Scanning Interferometer which was developed by J. M. Bennett of our laboratory [10, 20] is shown schematically in figure 12. Studies of individual irregularities and statistical surface characterization can be performed with this instrument. The sample to be measured forms the top half of the interferometer I and is illuminated in reflection by xenon arc lamp Z .

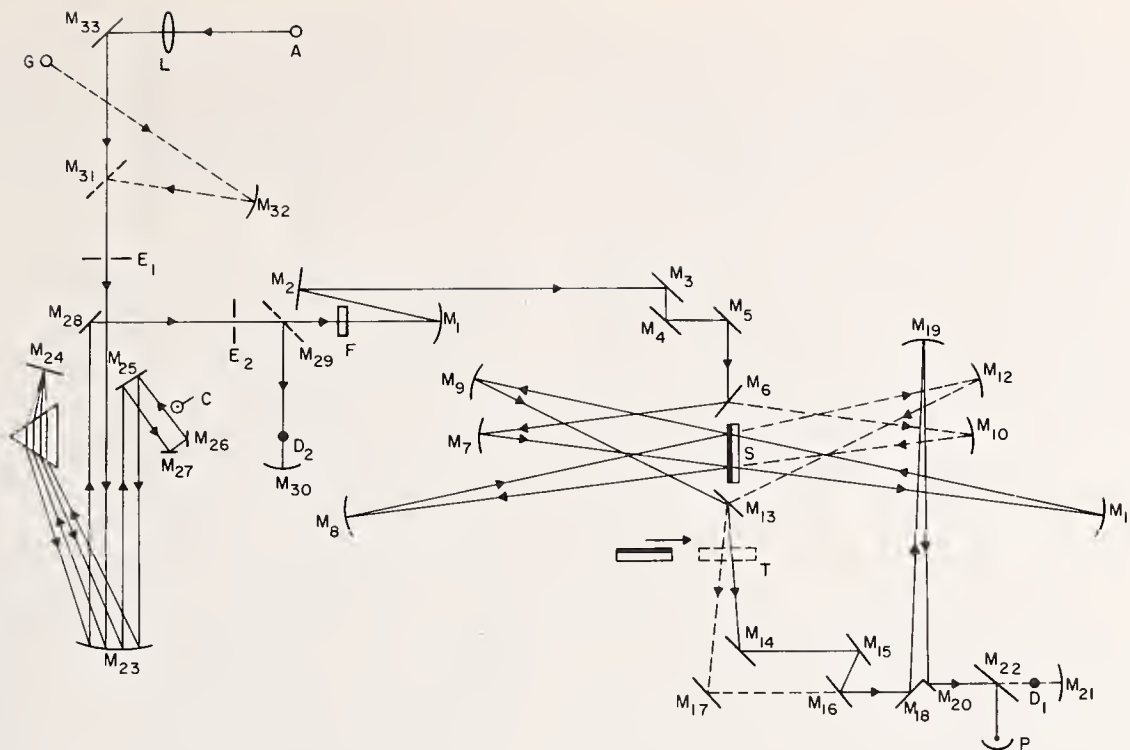

FIGURE 10. Schematic diagram of absolute reflectometer for use in visible and infrared wavelength regions employing principle illustrated in figure 9: sample *S*, transmission sample *T*, mirrors *M*, lens *L*, thermocouple detectors *D*, photomultiplier *P*, slits *E*, chopper *C*, visible light source *A*, global (infrared source) *G*, and filter *F*.

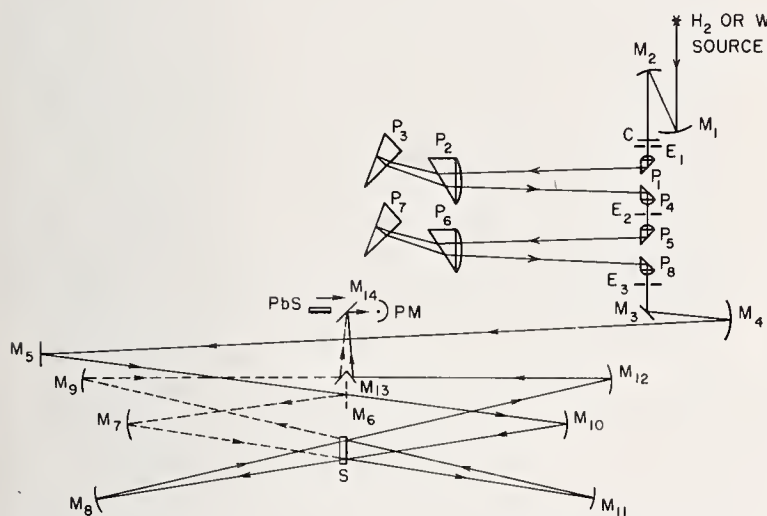

FIGURE 11. Schematic diagram of absolute reflectometer for use in the ultraviolet and visible wavelength regions employing principle illustrated in figure 9: sample *S*, mirrors *M*, prisms *P*, lead sulfide detector *PbS*, photomultiplier detector *PM*, slits *E*, chopper *C*, hydrogen H_2 or tungsten *W* sources.

FECO fringes contouring the surface are formed in the focal plane of a slow scan TV camera along with reference wavelengths for determining fringe position as indicated in the right portion of the figure. The output of the TV camera is fed to a computer system to provide the height distribution function, slope distribution function and autocovariance function characterizing the surface irregularities. The height of the spectrometer slit defines the 1 mm length of the long narrow section of the sample which is evaluated; the lateral resolution of the system is 2 μm . By translating the sample sideways the pro-

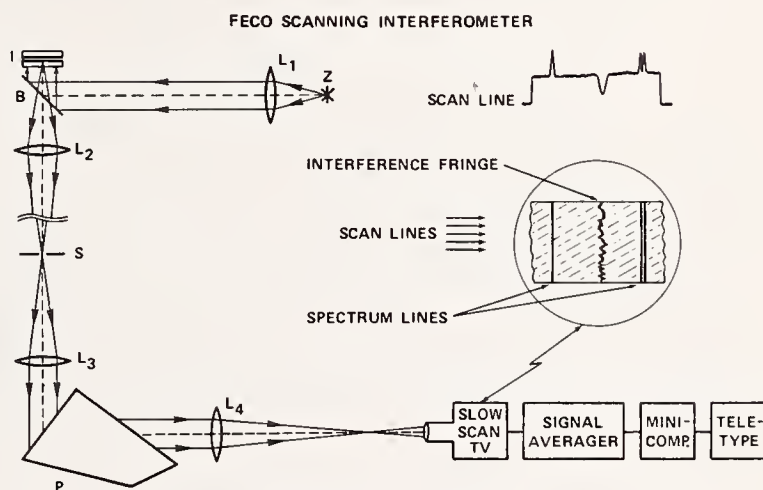

FIGURE 12. Schematic diagram of FECO Scanning Interferometer.

The image detected by the slow scan TV camera is shown at right center and a single scan line is shown above it: interferometer *I*, xenon arc *Z*, lenses *L*, beam splitter *B*, slit *S* and prism *P*.

jected slit can be made to sweep out an area on the sample surface for statistical characterization.

IV. Results

A. Scalar Scattering

The height and slope distributions for a super-polished Cervit flat [10], as determined using the FECO Scanning Interferometer are shown in figure 13. A Gaussian curve having the same area as the histogram giving the experimental data is also shown.

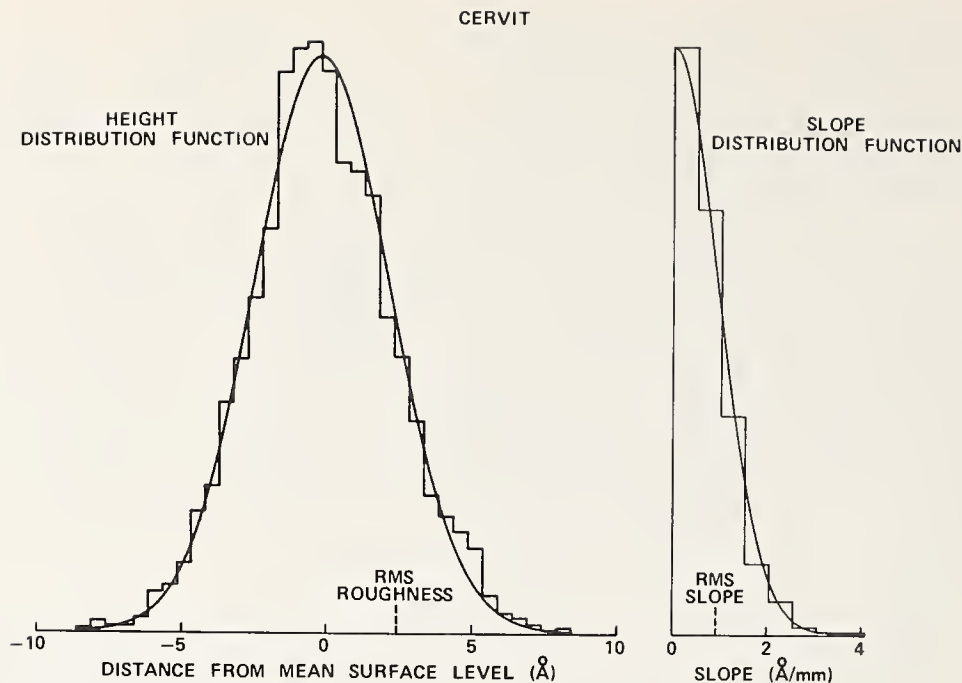

FIGURE 13. Height and slope distribution functions for a superpolished Cervit optical flat obtained with the FECO Scanning Interferometer.

The smooth curves are Gaussians that have the same area under the curves as the measured histograms.

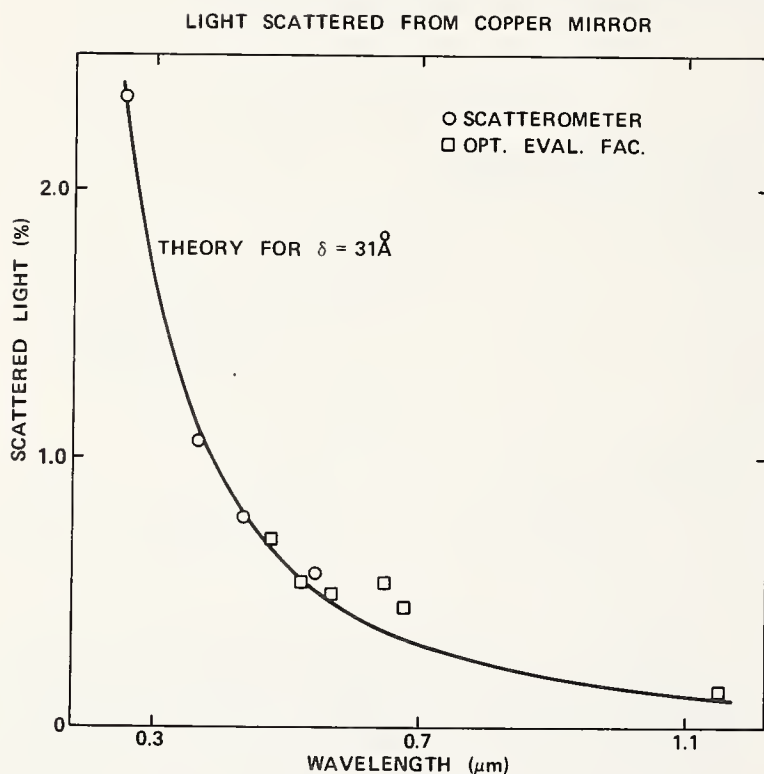

FIGURE 14. Scattered light as a function of wavelength for a polished copper mirror.

The circles represent the hemispherical scatter measurements taken on the Scatterometer and the squares measurements taken on the Optical Evaluation Facility. The solid curve is the hemispherical scattering predicted by the scalar scattering theory.

The fit is quite good so that eq (3) can be used to calculate the scattering level. Both glass and polished metal surfaces examined thus far do have height distribution functions that are nearly Gaussian [10], although their autocovariance functions are strongly non-Gaussian [10]. Figure 14 shows the light scat-

tered from a polished copper mirror. The circles represent data taken with the NWC Scatterometer and the squares data that are taken with the Optical Evaluation Facility. The agreement between the two instruments is quite good. The solid line is the scattering level predicted by eq (3) for a 31 Å rms surface. Agreement here is also quite good.

The rms roughness of an optically flat surface can be determined independently by using the FECO Scanning Interferometer. A comparison of values for polished glass surfaces [22] obtained from scattered light measurements and FECO interferometry is given in table I. Agreement again is quite good.

For some polished metal samples the agreement between FECO and scattered light measurements is not as good as that shown in table I. Reasons may be that the surface is gently rolling with a long autocovariance length, that optical excitation and reemission of surface plasmons is occurring, that the height distribution function is not quite Gaussian, that contributions to scattered light are being made by irregularities too small to be resolved by the

TABLE I. Comparison of rms roughness values of polished glass surfaces obtained from FECO interferometry and from scattered light measurements

Sample	δ_{FECO} (Å)	δ_{SCAT} (Å)
ULE Quartz	10.2	8.4
ULE Quartz	12.6	9.9
ULE Quartz	12.7	12.5
Fused Quartz	11.0	10.2
Fused Quartz	16.7	16.4
Fused Quartz	17.3	17.3
BK-7 Glass	19.3	19.1

FECO system, that a significant contribution to the scattering process is being made by scratches, etc., or for some other as yet unsuspected reason. For most optical surfaces, however, the agreement between predicted and actual scattering behavior in the visible and ultraviolet regions based on eq. (3) is excellent.

At infrared wavelengths the agreement between experimentally observed scattering levels and those predicted by eq (3) may be excellent or may be like that illustrated in figure 15. The circles represent the minimum scattering levels obtained from measurements at ten positions on an aluminized polished dense flint glass sample. The bars represent average values. The difference between the average and minimum values is indicated by the square points. Since an exponential becomes a straight line on log-log paper, the predictions of eq (3) are represented by the diagonal line. In the visible and ultraviolet regions there is good agreement between experiment and the theoretical predictions for a 29.5 Å rms surface. However, in the infrared the experimental points begin to deviate from theory and approach a nearly constant value which coincides with the variations from point to point on the surface. When this surface was examined under a microscope using oblique illumination, about 10^3 particles/mm² were observed as scattering centers as well as various streaks and scratches. We believe that the additional infrared scattering observed on this sample resulted from a change in dominant scattering mechanism from microirregularities to scratches and particulates. Scattering from both particulates and scratches should be nearly constant in the visible region where both would be expected to have dimensions larger than a wavelength. The variation from point to point on the surface of this sample is an order of magnitude less than the scattering caused by microirregularities, which suggests that scattering from

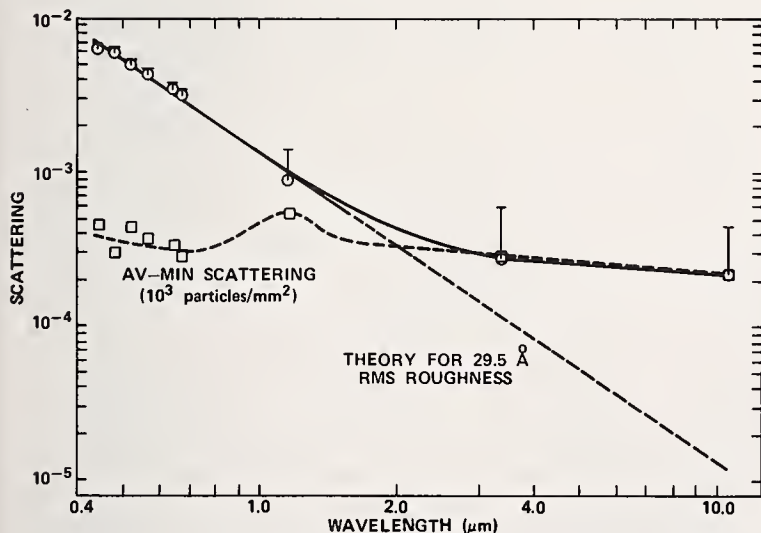

FIGURE 15. Scattering from an aluminized polished dense flint glass mirror.

The open circles are minimum scattering values obtained for 10 points across the surface; averages of the 10 values are indicated by the crossbars. The open squares are the differences between these average and minimum values. The solid line is a fit to the minimum values and the straight dashed line gives scattering levels predicted by eq (4).

scratches and particulates is negligible in the visible and ultraviolet. However, with increasing wavelength microirregularity scattering decreases and the scratch and particulate scattering becomes dominant.

The slight hump in the scattering curve shows up even more prominently when the average deviation in scattering from this sample is plotted in figure 16. A resonance would be expected for particulate scattering when the wavelength nearly equals the particle diameter [4] as seen in figure 1. If the particulate has an index of refraction of 1.5 and is not strongly absorbing, this resonance should occur at a particle diameter to wavelength ratio of about 0.7 according to figure 1, or at a wavelength of 1.4 μm if a 1 μm particle diameter is assumed. The observed resonance in figure 16 is in this wavelength range and may thus be caused by dust particles on the mirror surface, which if largely SiO₂ would have an index of about 1.5. That typical dust particles in our laboratory have a diameter of about 1 μm is shown by assembling the FECO Scanning Interferometer. Dust particles are used as spacers and the minimum order of interference which normally is possible is about 4, which would correspond to a 1 μm diameter dust particle. From these data we conclude that scattering from dust and scratches may be important in the infrared, but for good clean optical surfaces microirregularity scattering is the dominant scattering mechanism in the visible and ultraviolet wavelength regions.

B. Surface Plasmon Excitation

Microirregularities can give rise to scattered light not only through classical diffraction but also through surface plasmon excitation and reemission. This mechanism also introduces additional absorption. Figure 17 shows the near ultraviolet reflectance of silver deposited on substrates of varying roughness. A large increase in absorption with increasing roughness is observed at wavelengths slightly longer than the limiting wavelength for surface plasmon excitation, which for silver occurs at about 3390 Å where

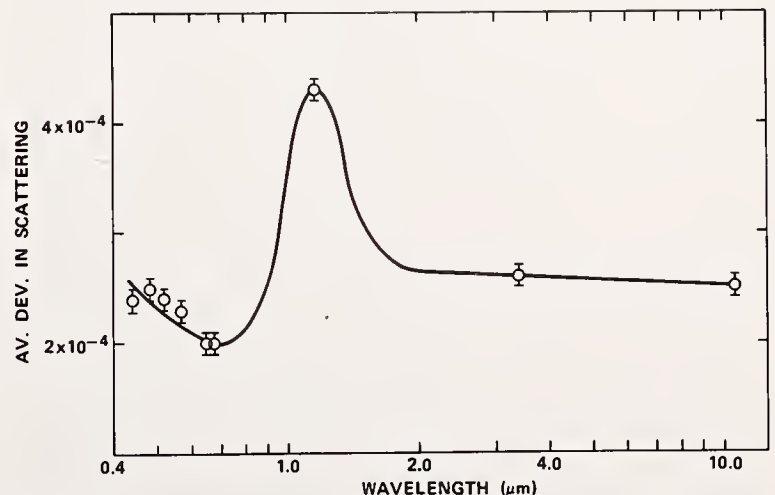

FIGURE 16. Average deviation in scattering from 10 points on the dense flint sample of figure 15.

Values obtained from same measurements as those shown in figure 15.

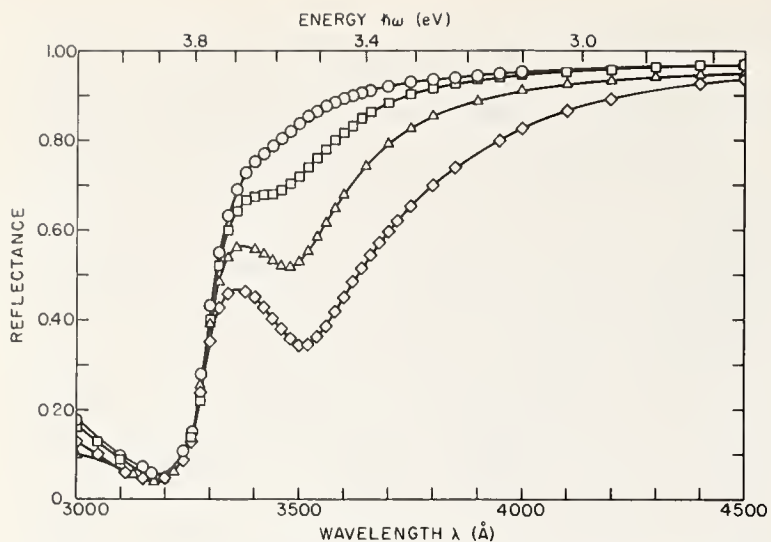

FIGURE 17. Normal incidence reflectance of silver for surfaces of various roughnesses.

As the roughness increases the reflectance decreases.

$\epsilon_1 = -1$. By subtracting the rough surface reflectance from the smooth surface reflectance the additional absorption introduced by the rough surface is obtained. The results for various surface roughnesses are shown in figure 18. The absorption peak occurs between 3500 and 3550 Å for this type of rough surface, which was produced by evaporating increasingly thick films of CaF_2 on an initially smooth substrate. Roughness values are shown under each absorption curve; the initial roughness of the fused quartz substrate was 12 Å rms. A comparison of roughness values for CaF_2 -coated substrates as determined from light scattering measurements and interferometrically is given in table II. The slightly lower values obtained from FECO measurements for the thicker CaF_2 films probably result from contributions to scattered light by crystallites too small to be resolved by the interferometer. The agreement between these two independent measurement techniques is still quite good.

The shape of the absorption curve which would be predicted if plasma excitation occurred at $\epsilon_1 = -1$ is given by the dotted curve in figure 18. A silver sulfide film only 9 Å thick would be enough to cause the observed shift in the resonance to longer wavelengths, but careful ellipsometric studies of the growth of silver sulfide on silver [23, 24] have established that the observed shift does not result from silver sulfide contamination. It probably occurs because the momentum required from the surface to excite a plasmon at the limiting wavelength would be much larger than that for plasmons in the retardation region (see fig. 5).

The growth of a surface film such as Ag_2S on the silver surface will move the plasma resonance to longer wavelengths and, if the film is absorbing, will damp it. Figure 19 shows the measured change in plasmon-induced absorption of silver on a rough surface as the sulfide film grows [23]. Sulfide film thicknesses τ were determined ellipsometrically. They could also be computed from the shift in peak posi-

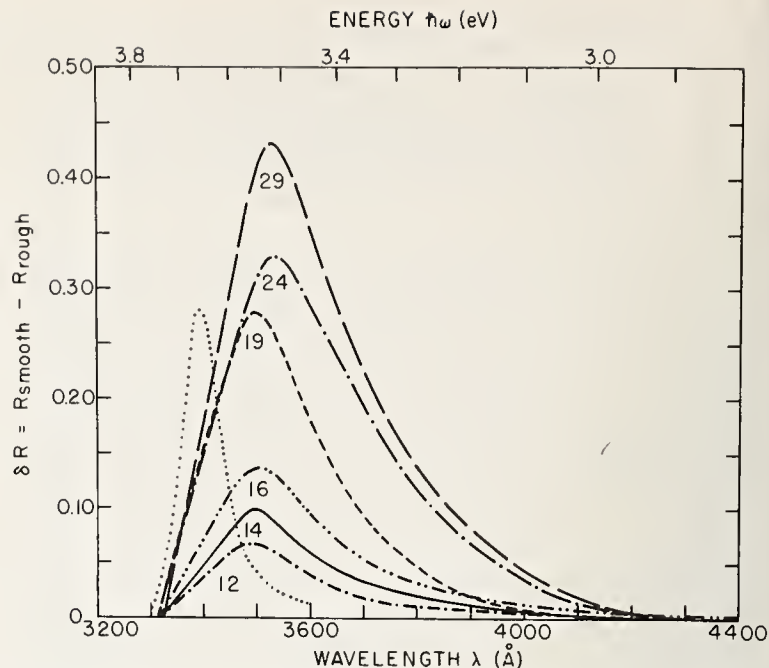

FIGURE 18. Optical absorption by rough silver coated surfaces resulting from surface plasmon excitation.

The roughness value in Å for each surface is given near the absorption peak. The dotted line shows the expected position of the absorption peak if there were no retardation effects.

TABLE II. Comparison of rms roughness values for super-polished optical flats coated with evaporated calcium fluoride films of various thicknesses as determined from FECO interferometry and scattered light measurements

CaF_2 Thickness (Å)	δ_{FECO} (Å)	δ_{SCAT} (Å)
0	11	10
875	12	13
1750	16	19
2625	19	26

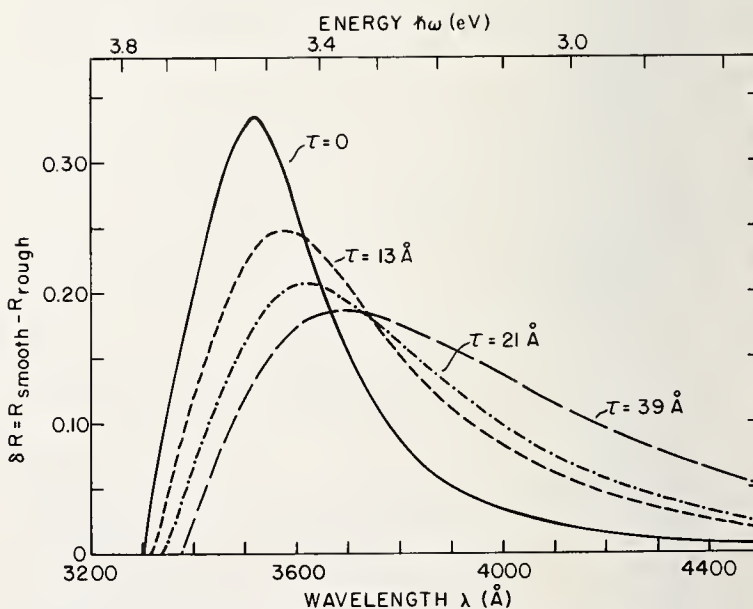

FIGURE 19. Optical absorption by tarnished silver surfaces resulting from surface plasmon excitation.

The τ values give the thicknesses of the different silver sulfide tarnish films.

tion of the absorption resulting from changes in the dispersion relation for a metal-thin film-air interface. The average difference between the values of τ obtained by these two techniques was only 1 Å in this case.

If the surface film is nonabsorbing, it not only moves the absorption peak to longer wavelengths but may also significantly enhance the absorption by surface plasmons [25]. In figure 20 the solid line represents the reflectance of silver deposited on a very smooth substrate and the circles and triangles silver deposited on a slightly rough and moderately rough substrate. When a 250 Å thick film of Al_2O_3 was deposited on the silver the slightly rough surface had the reflectance indicated by the squares and the moderately rough surface that indicated by the diamonds. Not only do the reflectance minima move to longer wavelengths but they are also greatly enhanced. This effect is of considerable importance for aluminized mirrors used in the vacuum ultraviolet. The protective MgF_2 overcoat used to prevent oxidation of the aluminum coating can significantly reduce mirror reflectance above 1600 Å through enhanced absorption by surface plasmons unless the mirror surface is extremely smooth. A similar effect is seen for silvered quartz back surface reflectors. The mirror often has a golden appearance because enhanced surface plasmon absorption reduces the reflectance in the blue region of the spectrum. By intentionally roughening the back surface the reflectance of silver in the blue region of the spectrum can be reduced nearly to zero.

Although most of the increase in absorption observed on rough silver surfaces is found at wave-

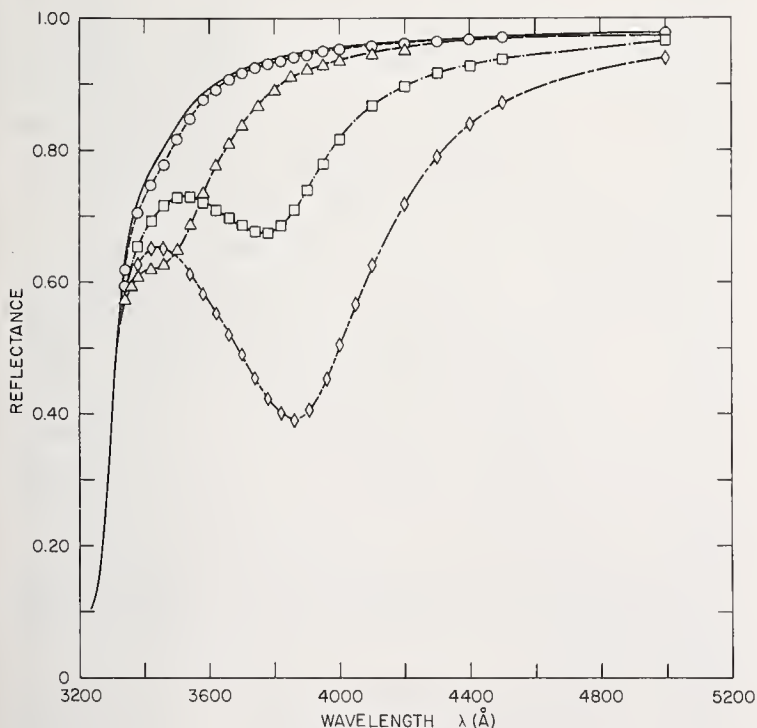

FIGURE 20. Normal incidence reflectance of slightly rough (circles) and moderately rough (triangles) silver surfaces.

The reflectances of the same surfaces after being coated with a 250 Å thick layer of Al_2O_3 are shown by the squares and diamonds, respectively.

lengths longer than the limiting wavelength for surface plasmon excitation, some increase in absorption is also observed at shorter wavelengths. Figure 21 shows the increase in absorption extending from the visible region into the vacuum ultraviolet. Also plotted is a line proportional to the reciprocal of the optical penetration depth. Although this line has no apparent relation to the observed absorption to the right of the surface plasmon limiting wavelength λ_{sp} it does fit that to the left of this wavelength rather well. In particular it reproduces both minima in the ultraviolet reflectance data at about 1400 Å and 3200 Å. In addition, it has approximately the exponential dependence to the left of the volume plasmon wavelength λ_b found experimentally by Hunderi and Beaglehole [26] and verified by these measurements. The magnitude of this additional absorption for $\lambda < \lambda_b$ for samples with varying degrees of roughness is directly proportional to the ratio between the rms roughness and the penetration depth. The intensity penetration depth for Ag in the interband region is about 150 Å. A 20 Å rms surface roughness will have a peak to valley height of irregularities of 50 Å or more, roughly a third of the penetration depth. Rougher surfaces will have irregularities which are an even larger fraction of the penetration depth. The band structure of a material derives its character from the regular crystalline array of the atoms. Modification of this array near the surface of the crystal should modify the band structure of the material somewhat. A possible explanation for this additional absorption is that the surface roughness introduces a perturbation of the band structure at the surface of the crystal where its optical behavior is determined. Interband transitions would be expected to be significantly affected by this perturbation, hence the anomalous absorption in the interband region for silver. Intraband transitions should be much less affected, as appears to be true for silver in the free carrier region.

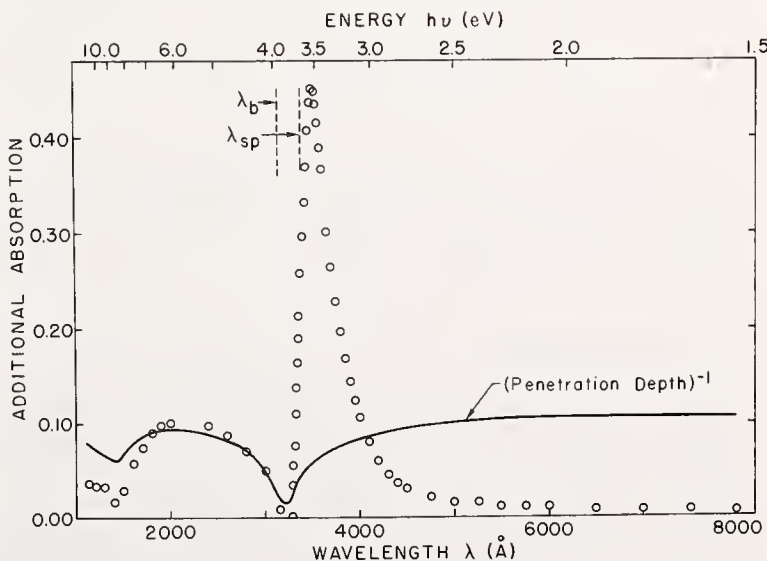

FIGURE 21. Comparison of the roughness induced increase in absorption at normal incidence for silver and the reciprocal of the optical penetration depth.

Note the agreement in minima both at 3200 Å and 1400 Å.

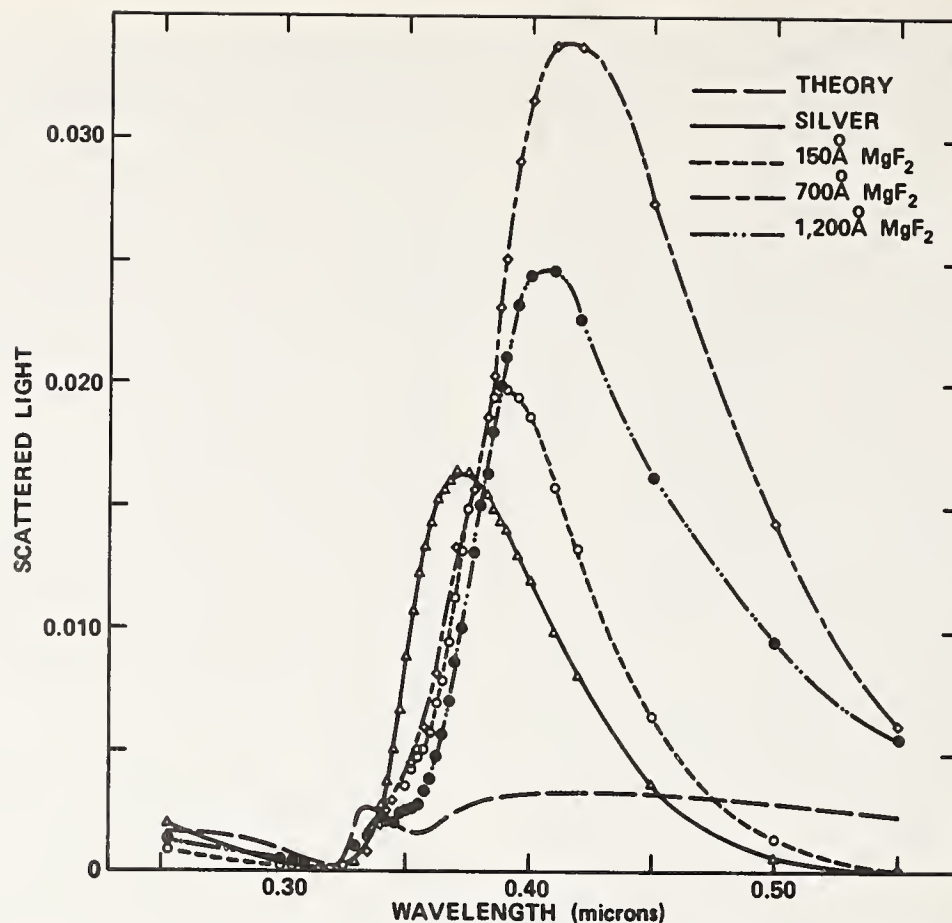

FIGURE 22. The long-dashed curve is the wavelength dependence of the ratio of the total scattered light to the incident light for a "rough" (21.5 \AA rms) silver surface calculated from scalar scattering theory.

Other curves are the difference between measured values and the calculated curve; solid curve is for a bare silver surface, and other dashed curves are for silver surfaces coated with the indicated thicknesses of magnesium fluoride.

In addition to additional absorption, surface plasmon excitations can also cause significant increases in scattered light [18]. Figure 22 shows the effect for silver deposited on a CaF_2 -roughened substrate having $\delta=21.5 \text{ \AA}$. The scattering level calculated for this surface from equation (3) is shown by the long-dashed line. The triangles and solid line show the additional scattering which was observed on the uncoated silver surface. When the surface was coated with various thicknesses of MgF_2 the scattering level rose again and then declined as a result of an interference effect. The peak scattering level was over an order of magnitude higher than that predicted from classical scattering theory for this relatively smooth optical surface.

C. Mechanical Abrasion and Surface Damage

Figure 23 shows the decrease in reflectance of bulk copper caused by mechanical abrasion [27]. Both copper samples were cut from the same OFHC copper block; one was electropolished, and the other mechanically polished on a silk-covered pitch lap. Both surfaces were optically flat and the electropolished data, which is in good agreement with other optical measurements on high quality bulk copper surfaces and copper films evaporated under good

deposition conditions, is representative of the intrinsic reflectance spectrum of copper. The mechanically polished surface has a reflectance spectrum which differs in shape from that of the electropolished sample and is lower by as much as a factor of two. Differences in reflectance persist to $30 \mu\text{m}$ in wavelength, the limit of the measurements, but are largest in the visible and ultraviolet regions.

Germanium is an even more graphic example of the importance of structure on the optical properties of absorbing materials. In the visible and ultraviolet region it is highly absorbing, strong interband transitions are occurring and the casual observer would think it was a metal. Germanium can be deposited in thin films either in a crystalline or an amorphous state. The reflectance spectra for both cases [28] are shown in figure 24. It is not obvious from the optical spectra that we are even dealing with the same material. However, the amorphous film can be recrystallized by annealing at high temperatures and its reflectance curve then reverts to that for the crystalline case.

The crystalline structure of evaporated metal films is quite complex and its effect on the optical properties is a story in itself. Sputtered metal films are even more complicated and it has been believed that the sputtering process is so uncontrollable that the highest reflectance metal films could not be ob-

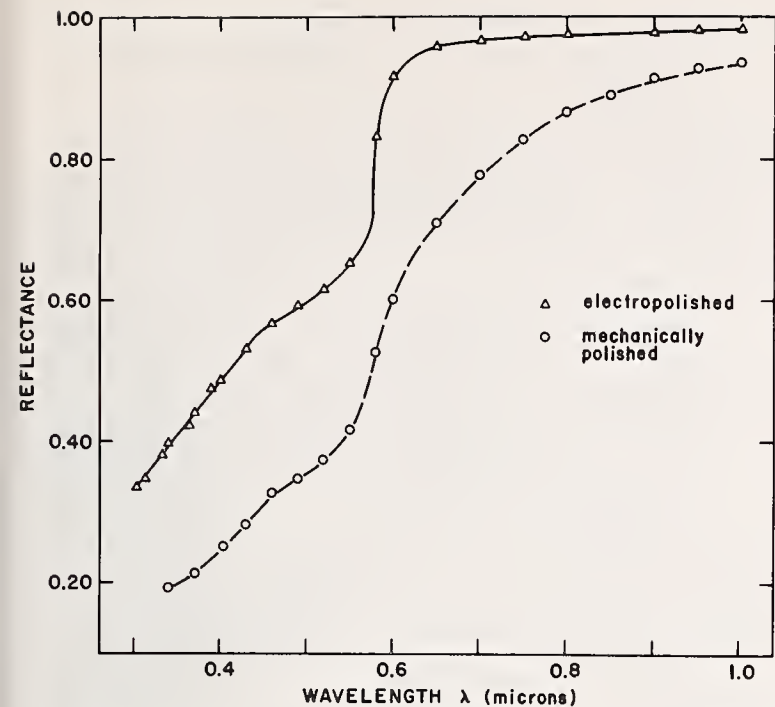

FIGURE 23. Reflectance of electropolished copper (triangles) and mechanically polished copper (circles) from 0.3 to 1.0 μm . Both samples were cut from the same high-purity ingot.

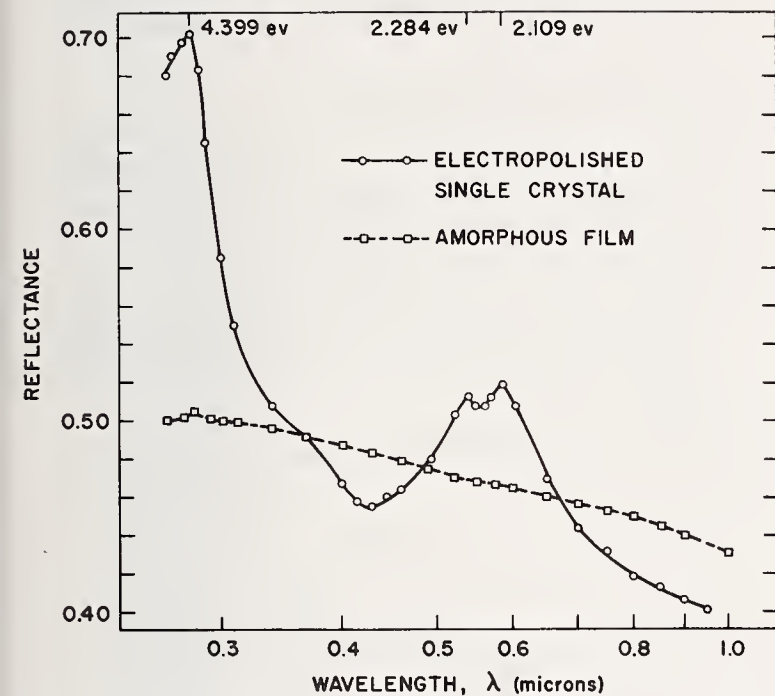

FIGURE 24. Reflectance of electropolished germanium (circles) and an amorphous germanium film (squares) from 0.26 to 1.0 μm .

tained using it. Sputtered silver, aluminum, and copper films have now been produced [29, 30] which have essentially the same reflectance as those produced by evaporation.

The kind of difficulty which is typically found in experimentally obtaining the theoretical optical properties of overcoated metal films is illustrated in figure 25. In this case an aluminum film was deposited by evaporation and then overcoated with a lead fluoride film [31]. The dashed line shows the reflectance

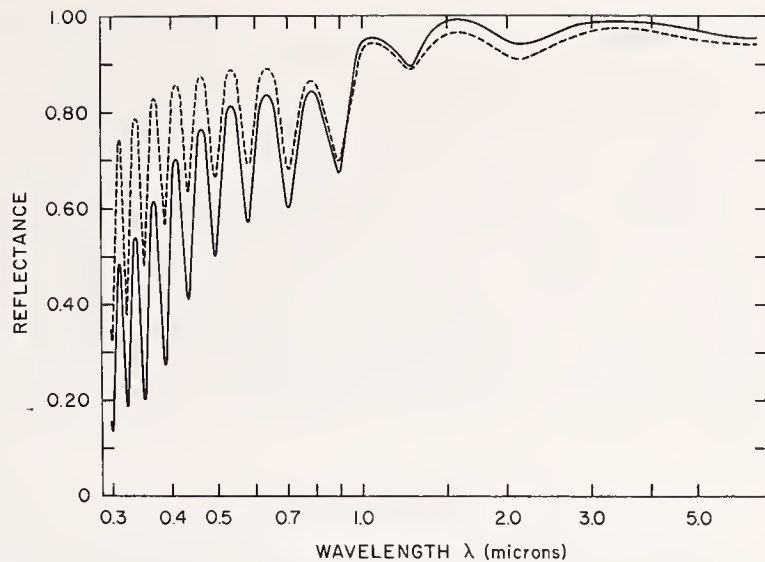

FIGURE 25. Measured reflectance (solid curve) and calculated reflectance (dashed curve) for an 8869 \AA film of lead fluoride on aluminum.

The optical constants used in the calculations were determined from measurements on evaporated films of the two materials.

tance spectrum which should have been obtained based on the optical constants of the two materials. The solid line shows that actually obtained. The difference is probably due in large part to the optical excitation of surface plasmons. In aluminum the ϵ_1 curve has a much more gradual shape than for silver, and surface plasmon effects are thus important over a much larger wavelength range. Other factors (which probably were not important) were conventional scattering caused by particulates, and surface roughness and structure-related conventional absorption in both the metal and the dielectric. Notice that the discrepancy between predicted and actual optical performance becomes larger as we go to shorter wavelengths. This example is typical of the problems faced by the optical designer in the visible and ultraviolet regions of the spectrum.

V. Conclusions

Surface irregularities and crystalline order strongly influence both light scattering and absorption of metal surfaces. These effects are more pronounced in the ultraviolet than at longer wavelengths. Although scattering from isolated irregularities such as dust, scratches and other surface blemishes occurs, it is typically much less important for optically polished surfaces in the visible and ultraviolet regions than scattering from closely spaced microirregularities. In addition to classical scattering from these microirregularities, which if polarization and angular dependence are ignored can be calculated from scalar scattering theory, scattering resulting from surface plasmon excitation and reemission can be very important. It is enhanced by a nonabsorbing dielectric coating, and in limited wavelength regions can exceed classical scattering levels by over an order of magnitude. Surface plasmon excitation also causes addi-

tional absorption, which is also enhanced by a dielectric coating. This effect is particularly important in the vacuum ultraviolet where aluminum, for example, must be coated with a nonabsorbing dielectric such as magnesium fluoride to prevent oxidation. Crystalline disorder at the metal surface introduces significant additional absorption, presumably both through surface plasmon excitation and band structure modification. For optimum optical performance of metal surfaces in the visible and ultraviolet regions of the spectrum it is thus essential that they have an absolute minimum of surface roughness and as undistorted a lattice structure as possible.

VI. References

- [1] Reuter, G. E. H., and Sondheimer, E. H., *Proc. Roy. Soc. (London)* **A195**, 336 (1948); Sondheimer, E. H., *ibid.* **A224**, 260 (1954); R. B. Dingle, *Physica* **19**, 311 (1953); R. B. Dingle, *Appl. Sci. Res.* **B3**, 69 (1953).
- [2] Bennett, H. E., Bennett, J. M., Ashley, E. J., and Motyka, R. J., *Phys. Rev.* **165**, 755 (1968).
- [3] van de Hulst, H. C., *Light Scattering by Small Particles* (John Wiley and Sons, Inc., New York, 1957), p. 270.
- [4] Orr, C., Jr., and Dallavalle, J. M., *Fine Particle Measurement* (The Macmillan Co., New York, 1959), p. 119.
- [5] Kretschmann, E., and Kroger, E., *J. Opt. Soc. Am.* **65**, 150 (1975); Maradudin, A. A., and Mills, D. L., *Phys. Rev. B* **11**, 1392 (1975); Elson, J. M., *Phys. Rev. B* **12**, 2541 (1975); Celli, V., Marvin, A., and Toigo, F., *Phys. Rev. B* **11**, 1779 (1975).
- [6] Elson, J. M., *J. Opt. Soc. Am.* **66**, 682 (1976).
- [7] Davies, H., *Proc. Inst. Elec. Engrs. (London)* **101**, 209 (1954).
- [8] Bennett, H. E., and Porteus, J. O., *J. Opt. Soc. Am.* **51**, 123 (1961).
- [9] Porteus, J. O., *J. Opt. Soc. Am.* **53**, 1394 (1963).
- [10] Bennett, J. M., *Statistical Characterization of Mirror and Window Surfaces, in Laser Induced Damage in Optical Materials: 1974* (Nat. Bur. Stand. (U.S.), Spec. Publ. 414, 157-162 pages (Dec. 1974).
- [11] Teng, Ye-Yung, and Stern, E. A., *Phys. Rev. Letters* **19**, 511 (1967).
- [12] Jasperson, S. N., and Schnatterly, S. E., *Bull. Am. Phys. Soc.* **12**, 399 (1967); *ibid.* **13**, 989 (1968); Jasperson, S. N., and Schnatterly, S. E., *Phys. Rev.* **188**, 759 (1969).
- [13] Stanford, J. L., Bennett, H. E., Bennett, J. M., Ashley, E. J., and Arakawa, E. T., *Bull. Am. Phys. Soc.* **13**, 989 (1968).
- [14] See Ritchie, R. H., *Surf. Sci.* **34**, 1 (1973) for a review of this field.
- [15] Jackson, J. D., *Classical Electrodynamics* (John Wiley and Sons, Inc., New York, 1962), p. 618.
- [16] Ritchie, R. H., Arakawa, E. T., Cowan, J. J., and Hamm, R. N., *Phys. Rev. Letters* **21**, 1530 (1968).
- [17] Elson, J. M., and Ritchie, R. H., *Phys. Stat. Sol. (b)* **62**, 461 (1974).
- [18] Bennett, H. E., Stanford, J. L., and Bennett, J. M., *Scattering From Metal Surfaces Used in Space Applications, in Space Optics* (National Academy Sci., Washington, D.C., 1974), pp. 717-738.
- [19] Bennett, H. E., *Appl. Opt.* **5**, 1265 (1966).
- [20] Bennett, H. E., and Bennett, J. M., *Precision Measurements in Thin Film Optics, in Physics of Thin Films*, G. Hass and R. E. Thun, Eds. (Academic Press, New York, 1967), Vol. 4, pp. 1-96.
- [21] Bennett, H. E., and Koehler, W. F., *J. Opt. Soc. Am.* **50**, 1 (1960).
- [22] Bennett, J. M., (private communication).
- [23] Stanford, J. L., *J. Opt. Soc. Am.* **60**, 49 (1970).
- [24] Bennett, J. M., Stanford, J. L., and Ashley, E. J., *J. Opt. Soc. Am.* **60**, 224 (1970).
- [25] Stanford, J. L., and Bennett, H. E., *Appl. Opt.* **8**, 2556 (1969).
- [26] Hunderi, O., and Beaglehole, D., *Phys. Letters* **29A**, 235 (1969).
- [27] Bennett, H. E., *Influence of Surface Roughness, Surface Damage and Oxide Films on Emittance, in Symposium on Thermal Radiation of Solids* (National Aeronautics and Space Administration SP-55, Washington, D.C., 1965), pp. 145-152.
- [28] Donovan, T. M., Ashley, E. J., and Bennett, H. E., *J. Opt. Soc. Am.* **53**, 1403 (1963).
- [29] Bennett, J. M., Green, A. K., Burkardt, L. A., Ashley, E. J., and Dancy, J. H., *Effects of Deposition Techniques on Optical Properties, in High Energy Laser Mirrors and Windows, Semi-Annual Report No. 6, Sep 1974-Mar 1975, ARPA Order 2175* (Naval Weapons Center, China Lake, California, 1975), pp. 5-23.
- [30] Temple, P. A., and Burge, D. K., and Bennett, J. M., *Optical Properties of Mirrors Prepared by Ultraclean dc Sputter Deposition, in Laser Induced Damage in Optical Materials: 1976 Nat. Bur. Stand. (U.S.)*, in press.
- [31] Bennett, J. M., Ashley, E. J., and Bennett, H. E., *Appl. Opt.* **4**, 961 (1965).

(Paper 80A4-910)

Index of Key Words

Absorbance linearity	121
Absorption	133
Absorptivity	95
Accuracy	121
Acidic potassium dichromate solutions	121
Actinometry	21
Aminocoumarins	33
Antibodies	95
Antigens	95
Bandwidth	99
Barium sulfate	75
Bi-directional radiometry	87
Biological polymers	95
Calibration of spectrophotometers	99, 121
Calorimetry	25
Canopies	87
Carbazine dyes	33
Cathode-ray excitation	13
Chromatography	41
Color matching	41
Color measurement	41
Continuum models	57
Correction factors	21
Deuterium effect	33
Dielectric layers	133
Diffuse reflectance	41, 57, 75, 87
Diffuse reflectance spectra	57, 75
Diffuse reflectance standards	41, 75, 87
Diffuse transmittance	87
Errors in spectrophotometry	99, 115
Evaporated metal-on-quartz filters	127
Excited states	33
Fluorescence	1
Fluorescence lifetime	1
Fluorescence spectrum	1
Fluorescence standards	1
Immunochemical analysis	95
Interferences	99
Irregularities	133
Kubelka-Munk functions	41
Laser dyes	33
Light scattering	95
Liquid filters	121
Luminescence	13, 21, 25
Luminescence standards	13
Magnesium oxide	33, 75
Metallic thin films	133
Micro-irregularities	133
Molecular fluorescence parameters	1
Molecular structure	33
Multiple reflections	99
Neutral filters	127
Observed (technical) fluorescence parameters	1
Opal glass	75
Oxazine dyes	33
Overcoating	133
Phosphors	13
Photo-acoustic spectrometer	25
Photometric linearity	99
Photometric scale	113
Piezo-calorimeter	25
Plasmons	133
Polarization	1, 99
Polymers	95
Proteins	95

Quantum efficiency or yield -----	1, 13, 21, 25, 33
Quantum-flat actinometer -----	21
Quenching -----	33
Radiant efficiency -----	13, 21
Radiant flux -----	75
Radiative and non-radiative transition probabilities -----	1
Radiative transfer -----	37
Real fluorescence parameters -----	1
Reflectance (see diffuse reflectance) -----	
Sample characteristics -----	99
Scatter -----	133
Scattering coefficients -----	57
Scattering surfaces -----	87
Semi-transparent metallic thin films -----	127, 133
Slit width -----	115
Solid standards -----	95
Spectral transmittance -----	115
Spectrophotometer standards -----	115
Standard Reference Materials -----	127
Standards calibration -----	75
Statistical models -----	57
Stray light -----	99, 115
Technical (observed) fluorescence parameters -----	1
Thin layer chromatography -----	41
Transducers -----	25
Transfer standards -----	121
Transmittance filters -----	127
Transmittance characteristics -----	127
Triplet formation -----	25
UV absorbance standards -----	121
UV excitation -----	13
UV-visible filters -----	127
Wavelength accuracy -----	99
Wavelength scale -----	115
Xanthene dyes -----	33
X-ray excitation -----	13

U.S. DEPT. OF COMM. BIBLIOGRAPHIC DATA SHEET	1. PUBLICATION OR REPORT NO. NBS SP-466	2. Gov't Accession No.	3. Recipient's Accession No.
4. TITLE AND SUBTITLE Standardization in Spectrophotometry and Luminescence Measurements, Proceedings of the Workshop Seminar held at NBS, Gaithersburg, MD, Nov. 19-20, 1975		5. Publication Date May 1977	6. Performing Organization Code
7. AUTHOR(S) K.D. Mielenz, R.A. Velapoldi, R. Mavrodineanu, eds.	9. PERFORMING ORGANIZATION NAME AND ADDRESS NATIONAL BUREAU OF STANDARDS DEPARTMENT OF COMMERCE WASHINGTON, D.C. 20234		8. Performing Organ. Report No.
12. Sponsoring Organization Name and Complete Address (Street, City, State, ZIP) Same as 9.		10. Project/Task/Work Unit No.	11. Contract/Grant No.
15. SUPPLEMENTARY NOTES Library of Congress Catalog Number: 77-4739		13. Type of Report & Period Covered Final	14. Sponsoring Agency Code
16. ABSTRACT (A 200-word or less factual summary of most significant information. If document includes a significant bibliography or literature survey, mention it here.) This volume contains 15 papers presented at the Workshop Seminar on Standardization in Spectrophotometry and Luminescence Measurements organized by the Analytical Chemistry Division, Institute for Materials Research, at the National Bureau of Standards, and held from November 19 to 20, 1975. These papers discuss the problems encountered where accurate measurements are required in the fields of luminescence quantum yields, diffuse reflectance spectroscopy, and ultraviolet absorption spectrometry. They also define the needs for standardization of measurements in these fields and suggest materials that could be used as Standard Reference Materials. Considerations on some applications of such standards in the field of environmental pollution and health are included.			
17. KEY WORDS (six to twelve entries; alphabetical order; capitalize only the first letter of the first key word unless a proper name; separated by semicolons) Accuracy; critical parameters; diffuse reflectance; fluorescence; instrumentation; luminescence; quantum yield; spectrophotometry; Standard Reference Materials; standardization			
18. AVAILABILITY <input checked="" type="checkbox"/> Unlimited <input type="checkbox"/> For Official Distribution. Do Not Release to NTIS <input checked="" type="checkbox"/> Order From Sup. of Doc., U.S. Government Printing Office Washington, D.C. 20402, SD Cat. No. CI3-10-466 <input type="checkbox"/> Order From National Technical Information Service (NTIS) Springfield, Virginia 22151		19. SECURITY CLASS (THIS REPORT) UNCLASSIFIED	21. NO. OF PAGES 147
		20. SECURITY CLASS (THIS PAGE) UNCLASSIFIED	22. Price \$5.25

