

A11102 485264

NAT'L INST OF STANDARDS & TECH R.I.C.
A11102485264
Wise, Jacquelyn A/Thermometer calibratio
QC100 .U556 NO.174 1986 C.1 NBS-PUB-C 19

NBS
PUBLICATIONS

THERMOMETER CALIBRATION:



**A Model for
State Calibration
Laboratories**



NBS MONOGRAPH 174
Jacquelyn A. Wise
Robert J. Soulen, Jr.

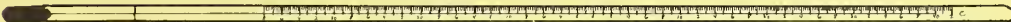

U.S. DEPARTMENT OF COMMERCE
NATIONAL BUREAU OF STANDARDS

QC
100
.U556
No. 174
1986
C. 2

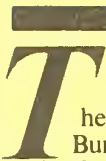

The National Bureau of Standards¹ was established by an act of Congress on March 3, 1901. The Bureau's overall goal is to strengthen and advance the nation's science and technology and facilitate their effective application for public benefit. To this end, the Bureau conducts research and provides: (1) a basis for the nation's physical measurement system, (2) scientific and technological services for industry and government, (3) a technical basis for equity in trade, and (4) technical services to promote public safety. The Bureau's technical work is performed by the National Measurement Laboratory, the National Engineering Laboratory, the Institute for Computer Sciences and Technology, and the Institute for Materials Science and Engineering.

The National Measurement Laboratory

Provides the national system of physical and chemical measurement; coordinates the system with measurement systems of other nations and furnishes essential services leading to accurate and uniform physical and chemical measurement throughout the Nation's scientific community, industry, and commerce; provides advisory and research services to other Government agencies; conducts physical and chemical research; develops, produces, and distributes Standard Reference Materials; and provides calibration services. The Laboratory consists of the following centers:

- Basic Standards²
- Radiation Research
- Chemical Physics
- Analytical Chemistry

The National Engineering Laboratory

Provides technology and technical services to the public and private sectors to address national needs and to solve national problems; conducts research in engineering and applied science in support of these efforts; builds and maintains competence in the necessary disciplines required to carry out this research and technical service; develops engineering data and measurement capabilities; provides engineering measurement traceability services; develops test methods and proposes engineering standards and code changes; develops and proposes new engineering practices; and develops and improves mechanisms to transfer results of its research to the ultimate user. The Laboratory consists of the following centers:

- Applied Mathematics
- Electronics and Electrical Engineering²
- Manufacturing Engineering
- Building Technology
- Fire Research
- Chemical Engineering²

The Institute for Computer Sciences and Technology

Conducts research and provides scientific and technical services to aid Federal agencies in the selection, acquisition, application, and use of computer technology to improve effectiveness and economy in Government operations in accordance with Public Law 89-306 (40 U.S.C. 759), relevant Executive Orders, and other directives; carries out this mission by managing the Federal Information Processing Standards Program, developing Federal ADP standards guidelines, and managing Federal participation in ADP voluntary standardization activities; provides scientific and technological advisory services and assistance to Federal agencies; and provides the technical foundation for computer-related policies of the Federal Government. The Institute consists of the following centers:

- Programming Science and Technology
- Computer Systems Engineering

The Institute for Materials Science and Engineering

Conducts research and provides measurements, data, standards, reference materials, quantitative understanding and other technical information fundamental to the processing, structure, properties and performance of materials; addresses the scientific basis for new advanced materials technologies; plans research around cross-country scientific themes such as nondestructive evaluation and phase diagram development; oversees Bureau-wide technical programs in nuclear reactor radiation research and nondestructive evaluation; and broadly disseminates generic technical information resulting from its programs. The Institute consists of the following Divisions:

- Ceramics
- Fracture and Deformation³
- Polymers
- Metallurgy
- Reactor Radiation

¹Headquarters and Laboratories at Gaithersburg, MD, unless otherwise noted; mailing address Gaithersburg, MD 20899.

²Some divisions within the center are located at Boulder, CO 80303.

³Located at Boulder, CO, with some elements at Gaithersburg, MD.

NE-100000000

NBS
RESEARCH INFORMATION
CENTER

NBS-0000

QC

100

U556

NO. 174

1986

C.2

Thermometer Calibration: A Model for State Calibration Laboratories

Jacquelyn A. Wise
Robert J. Soulen, Jr.

Temperature and Pressure Division
National Measurement Laboratory
National Bureau of Standards
Gaithersburg, MD 20899



U.S. DEPARTMENT OF COMMERCE, Malcolm Baldrige, Secretary
NATIONAL BUREAU OF STANDARDS, Ernest Ambler, Director

Issued January 1986

Library of Congress Catalog Card Number: 85-600636
National Bureau of Standards Monograph 174
Natl. Bur. Stand. (U.S.), Monogr. 174, 88 pages (Jan. 1986)
CODEN: NBSMA6

U.S. Government Printing Office
Washington: 1986

For sale by the Superintendent of Documents, U.S. Government Printing Office, Washington, DC 20402

TABLE OF CONTENTS

	Page
1. INTRODUCTION	1
2. LABORATORY AND EQUIPMENT	1
2.1 Laboratory Space and Environment	1
2.2 Temperature Baths	6
2.2.1 Ice bath	6
2.2.2 Variable, constant-temperature baths ...	8
2.3 Laboratory Standards	11
2.3.1 Primary standards	11
2.3.2 Check standards	13
2.4 Personnel	13
3. PERFORMING CUSTOMER'S CALIBRATIONS	14
3.1 Examination and Preparation of Thermometers for Calibration	14
3.2 Proper Method for Calibrating Specific Thermometers	15
3.2.1 Total-immersion thermometers	15
3.2.2 Partial-immersion thermometers	15
3.2.3 ASTM thermometers	16
3.2.4 Calorimetric thermometers	16
3.2.5 Beckmann thermometers	17
3.2.6 Clinical standard thermometers	17
3.2.7 Kinematic viscosity thermometers	17
3.2.8 Electronic temperature measuring systems	18

	Page
3.3 Calibration Procedure	18
3.3.1 Number and choice of calibration points	18
3.3.2 Use of the ice-point bath	18
3.3.3 Steam point (100 °C) as reference point	19
3.3.4 Role of primary liquid-in-glass thermometers	20
3.3.5 Routine adjustment to primary standard thermometer calibration data	20
3.3.6 Placement of thermometers in calibration bath	24
3.3.7 Reading sequence and recording data ...	25
3.3.8 Computation of bath temperature from readings of primary standard thermometers	27
3.3.9 Determining corrections for thermometers being calibrated	30
3.3.10 Stem-temperature corrections	31
4. DOCUMENTATION	36
4.1 Report of Calibration	36
4.2 Report of Test	39
5. MAINTAINING LABORATORY STANDARDS AND ESTIMATION OF LABORATORY UNCERTAINTY	46
5.1 Estimates of Inaccuracy of Calibration of Liquid-in-Glass Thermometers	46
5.2 Maintaining the Accuracy of Primary Laboratory Standards	46
5.3 Using Check Standards for Quality Assurance ...	47

	Page
6. CONCLUSION	51
7. ACKNOWLEDGMENTS	54
8. REFERENCES	54
9. COMMERCIAL SOURCES	55
9.1 Suppliers of Calibration Baths	55
9.2 Suppliers of Oils for Calibration Baths	55
9.3 Suppliers of Thermometers	56
9.4 Suppliers of Faden Thermometers	56
10. APPENDIX	57
Liquid-In-Glass Thermometry, NBS Monograph 150	57

1. INTRODUCTION

This publication is written primarily to assist State calibration laboratories to establish temperature calibration capabilities. It can also be used by any industrial organization or independent testing laboratory that wishes to establish a similar facility.

The range of the calibrations to be conducted extends roughly from 0 °C to 200 °C, while the target accuracy is ± 0.1 °C. Several types of thermometers could be used to maintain this stated range and accuracy, but liquid-in-glass thermometers have been chosen because they are dependable, easy to use and maintain, and economical.

Presented in this publication are detailed descriptions of the laboratory environment, equipment, type of training and personnel, calibration procedure, calculations, data analysis, and documentation needed for the calibration of thermometers. These descriptions and procedures are based on experience acquired at the National Bureau of Standards (NBS) for over 50 years.

If a laboratory is established and maintained as described in this publication, liquid-in-glass thermometers and electronic temperature measuring systems can be calibrated to an accuracy somewhat better than 0.1 °C over a range of 0 to 200 °C, and they will be traceable to NBS. A deviation from the procedures or specifications given may be acceptable, but any consequent errors should be determined and evaluated for acceptability by the manager of the laboratory. If laboratories follow these procedures, there will be more uniformity among these laboratories and this will result in better service to industry and to the public.

A checklist for establishing a calibration laboratory to the specifications described in this publication is provided in Section 6 (see Table 10).

2. LABORATORY AND EQUIPMENT

2.1 Laboratory Space and Environment

Liquid-in-glass thermometers submitted for calibration may be as long as 615 mm. They may be accidentally broken if an adequate distance is not kept between laboratory furnishings. Furthermore, any electronic temperature measuring systems submitted for calibration will require additional room around the calibration bath to place the digital readout device or other electronic components. The room chosen for the calibration laboratory should therefore be spacious; dimensions of approximately 7 m x 7 m x 3 m are adequate. A photograph of one room of the liquid-in-glass thermometer calibration laboratory at the NBS is shown in Figure 1 as an example. A floor plan of the entire facility is shown in Figures 2 and 3.

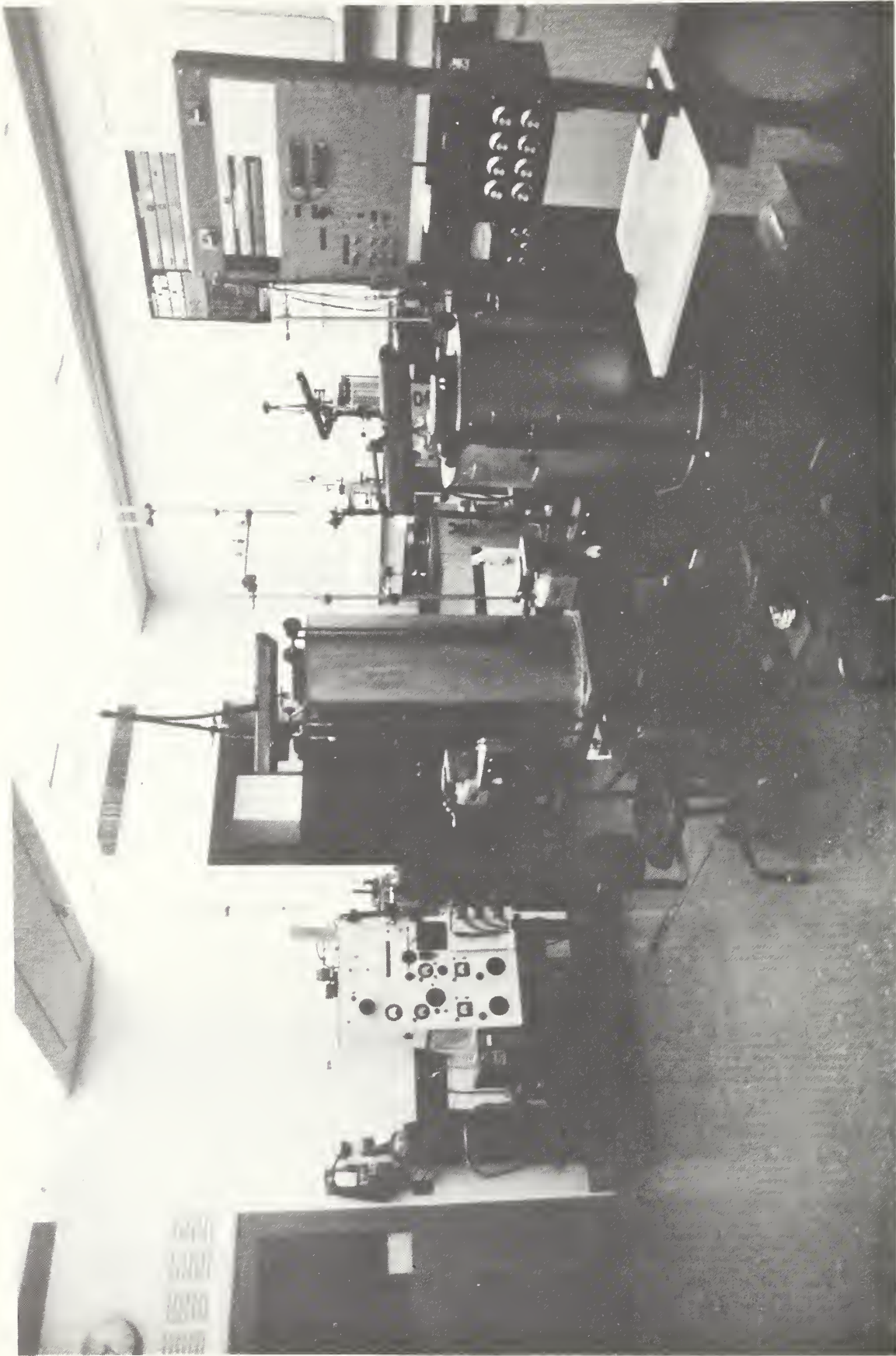

Figure 1. Liquid-in-glass thermometer calibration laboratory at the National Bureau of Standards.

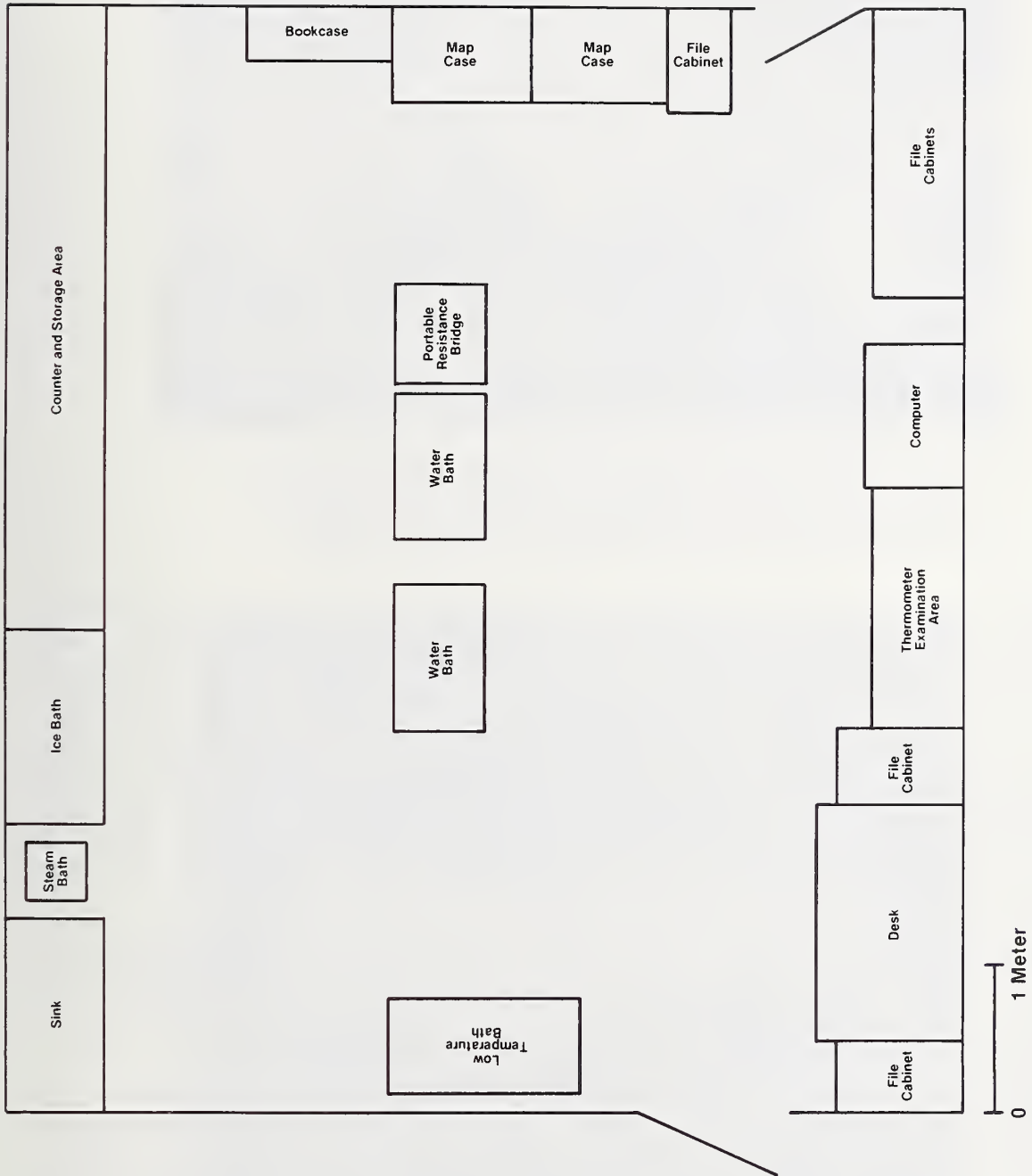

Figure 2. Floor Plan of room shown in Figure 1.

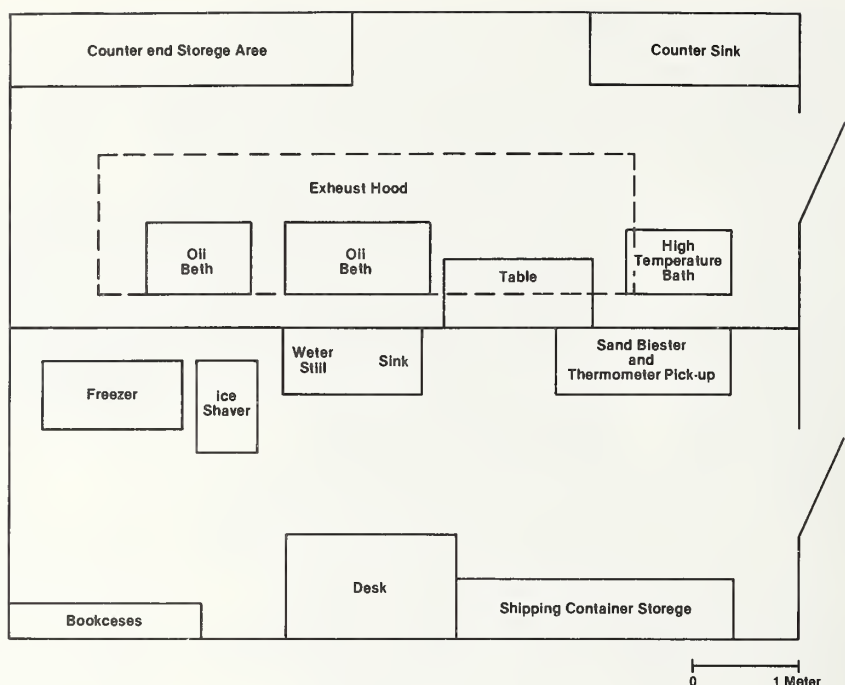

Figure 3. Floor plan of higher-temperature calibration room and room used for ice preparation and shipping of thermometers.

The laboratory should be maintained at a constant temperature and humidity. Many thermometers that will be submitted for calibration will be intended for use at partial immersion, in which case it is important that the emergent stem remain at a constant temperature while being tested. For example, if there is a one-degree change in the laboratory temperature, an error of approximately 0.01 °C can result in the calibration of a partial-immersion thermometer with 50 degrees emergent from the bath. The humidity should be maintained near 50% to keep any electronic components that may be in the laboratory from being adversely affected.

Any calibration bath that uses an oil as the medium should be operated under a hood. The hood should not be connected to the ventilation system of the building; instead it should be exhausted directly outside. Any filters in the system should be periodically checked and changed if necessary. Figure 4 shows the exhaust hood over the oil baths at NBS.

There must be a place in the laboratory to safely store the primary liquid-in-glass thermometer standards, as well as those submitted for calibration. A map case, having corrugated paper placed on the bottom of each drawer to keep the thermometers from rolling into each other when the drawer is opened, can be used for this purpose (see Figure 5). Another method commonly used is to store the thermometers vertically in a thermometer rack especially designed for this purpose. This method is shown in Figure 6.

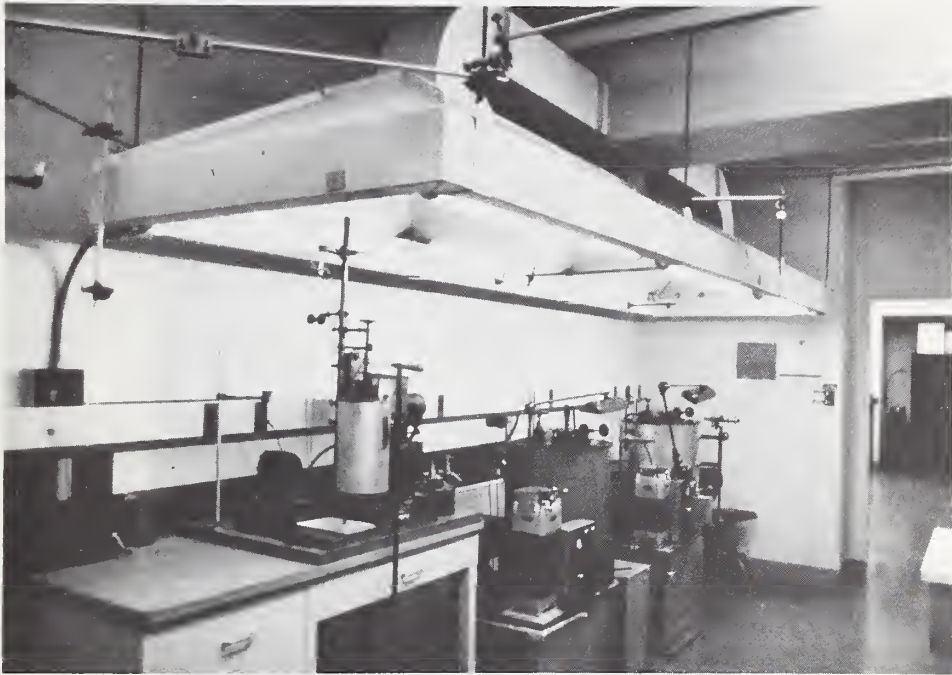

Figure 4. Exhaust hood over oil baths.



Figure 5. Thermometers stored on corrugated paper in drawer of map case.

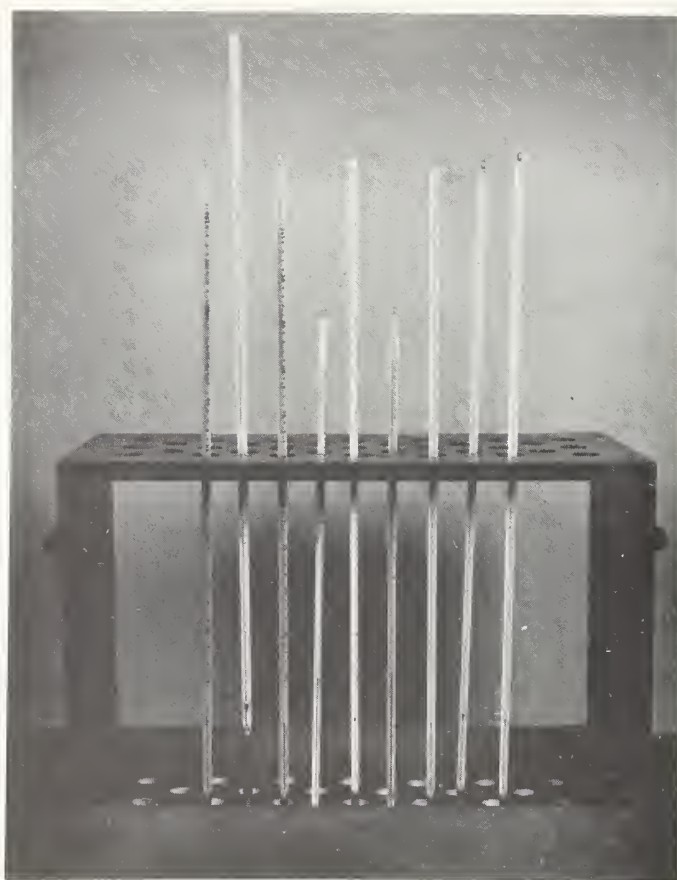

Figure 6. Thermometers placed in thermometer rack.

2.2 Temperature Baths

2.2.1 Ice bath

An ice bath (see Figure 7) is perhaps the most valuable and essential item in a thermometer calibration laboratory. This is because all liquid-in-glass thermometers suffer changes in bulb volume (due to thermal expansion and other factors). The method for correcting for such changes involves recalibration in most cases at the ice point (0°C). (See Section 5.2, NBS Monograph 150 [1]¹, and a discussion later in this Monograph.)

A typical ice bath consists of a Dewar flask approximately 36 cm deep and 8 cm in diameter. The outside of the flask should be covered with electrical or waterproof adhesive tape and enclosed in a metal sleeve to protect the operator in the event that it should break. The flask should be supported by a structure that will not allow it to tip over easily. An appropriate

¹Figures in brackets indicate references at the end of this Monograph.



Figure 7. Ice bath at NBS.

clip is placed above the top of the flask to hold the thermometer perpendicular to the telescope used for reading. A siphon is placed in the bottom of the flask to remove excess water that will form due to the melting of the ice during the day. A small soft mallet, which is used to gently tap the thermometers before reading, should be available.

Shaved ice (of quality described below) and distilled water are placed in the Dewar flask and allowed to reach a constant temperature, a process that takes approximately 15 to 30 minutes. After this time, any excess water should be siphoned off and additional ice added. When the ice bath is ready for use, there should be no floating ice in the flask and no excess water on the surface. There should be as much ice as can be forced into the flask and sufficient distilled water to fill the small crevices between the ice chips. Failure to follow this procedure can lead to vertical or radial temperature gradients, which can result in a calibration error as large as $0.01\text{ }^{\circ}\text{C}$ at the ice point.

Whenever the ice bath is used, care should be taken not to contaminate the ice or water. Thermometers should be rinsed with cool distilled water before being placed in the ice and plastic gloves should be worn by the operator or hands washed often while

taking ice points. It is important that impurities, such as salt from the hands, not be allowed to come in contact with the ice. This will cause a depression of the freezing point and result in an error in subsequent ice-point determinations.

From what has been stated in this section, it is clear that a calibration laboratory will need an adequate supply of distilled water and pure ice (see below). A still and storage tank can be purchased for this purpose. The distilled water that is produced can be frozen to form blocks of distilled water ice. The freezer and containers used for this purpose should not be used for anything else and kept as clean and free from impurities as possible. The containers should be washed thoroughly with soap and water and rinsed two or three times with distilled water before being used initially.

Ice purchased commercially can also be used if it is crystal clear. Some companies produce large blocks of ice by freezing the outside first. When ice is made in this manner, the impurities are forced to the center where the ice will be cloudy and white. This unclear portion is removed and only the crystal-clear portion is used.

An ice shaver, which can be purchased from restaurant supply companies, is used to shave the ice to the proper consistency. The ice chips should be approximately 2 to 5 mm in diameter. These particles are smaller than those produced by crushing or chipping the ice.

2.2.2 Variable, constant-temperature baths

In addition to the ice bath, which provides a calibration at a single temperature, it will be necessary for the laboratory to provide calibrations at several other temperatures from +1 °C to +200 °C. This requires the use of temperature baths (see Section 9.1 for sources) in which the temperature can be varied and then set to constant values for moderately long periods of time to permit calibrations. Spanning this temperature range requires, in general, two baths using different working media (water and oil). The water bath used at NBS is shown in Figure 8.

For calibration in the range of approximately +1 to +95 °C, water can be used as the bath medium. Distilled water is preferable, since no chemical deposits will form at the top of the bath. Water is plentiful, clean, and does not produce harmful vapors. In the range of approximately +95 to +200 °C, an oil should be used as the medium. Manufacturers of the calibration baths will generally recommend the type of oil that should be used in their baths and list suppliers (see Section 9.2 for sources). It is important that an exhaust hood be placed over the oil bath to remove vapors from the laboratory and that the oil is not used near its flash point. The division of the temperature range into two regions using two different media is not always required. In particular situations a laboratory might

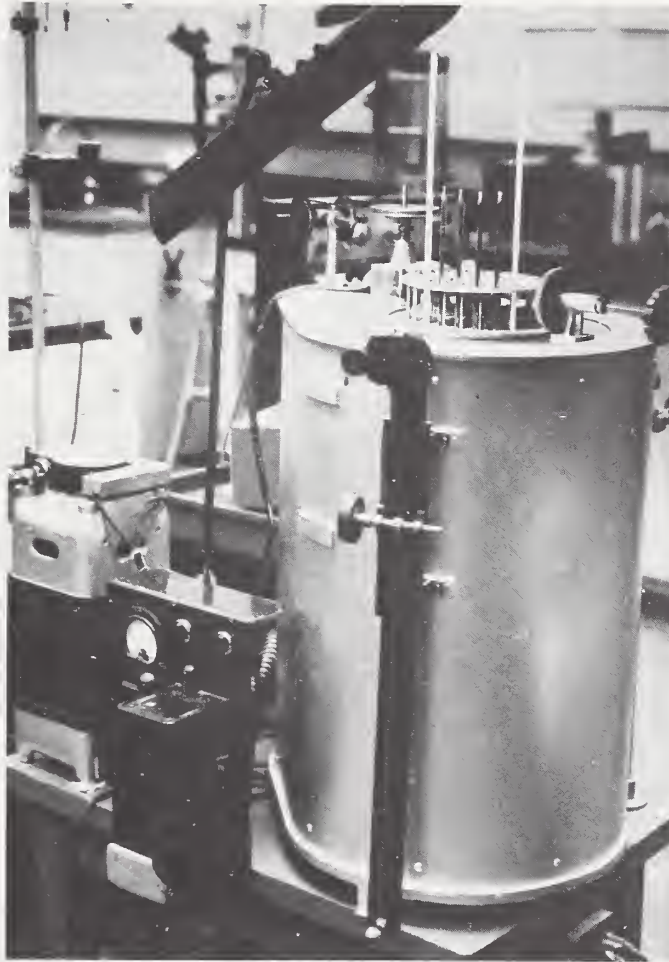

Figure 8. Variable, constant-temperature water bath.

find it more convenient to use a single oil bath to perform calibrations from $+1^{\circ}\text{C}$ to $+200^{\circ}\text{C}$.

A cover should be placed over any openings of the bath to prevent foreign material from entering the medium that might cause contamination or obstruct stirring.

Several factors must be taken into account in the decision for the purchase or construction of such baths. The most critical ones are: volume, temperature homogeneity, and temperature stability.

Constant-temperature baths may be purchased from any of several companies or they can be made at the calibration laboratory. Before the calibration bath is purchased or designed, one must determine what types of thermometers will be calibrated. If calibrations will include long, total-immersion liquid-in-glass thermometers, the depth of the bath must be sufficient to accommodate them. If several thermometers are to be tested at one time, the diameter at the top of the bath must be large enough to accept a holder containing several thermometers. The bath should have a provision for overflow or removal of the expanding fluid

that will result as the temperature of the medium is increased. It should also be easy to add fluid so that the liquid level can be maintained within 6 mm to 12 mm of the bottom of the thermometer holder.

A constant-temperature bath should have the heating and cooling coils isolated from the volume where the thermometers will be placed (see Figure 5 in NBS Monograph 150 [1]). There should be an unrestricted path of flow for the bath medium, which is stirred or pumped at a sufficient rate to maintain a uniform temperature throughout the medium. There should be adequate insulation around the bath. The holder for the thermometers should be designed so as to prevent heat loss.

Every bath should be checked to determine the magnitude of the horizontal and vertical temperature gradients. One way of doing this is to regulate the bath sequentially at several temperatures throughout the range. At each temperature a thermometer is placed in one position and constantly read to determine if the temperature of the bath is changing. A second thermometer, either another liquid-in-glass type or preferably a faster responding one, such as an electronic digital readout using a thermistor or small resistance device as the sensor, is placed next to the first one. When it is observed that the thermometer readings are not changing or are increasing at a rate of no more than 0.01 to 0.05 °C in 5 minutes, stability can be considered to have been reached. At this time both thermometers are read and the readings are recorded. While the stationary thermometer is monitored, the second thermometer is moved to other locations and depths in the bath and readings on both thermometers are recorded. If a liquid-in-glass thermometer is used to probe the bath, adequate time must be given for it to stabilize, since the response time may be slower than that of an electronic thermometer. After adjusting the reading of the second thermometer for any change that may be noted by the stationary thermometer, the change in the second thermometer reading at various locations will indicate the uniformity of the bath temperature. The accuracy of either thermometer is not important for this test, only its temperature sensitivity.

A common cause of bath temperature nonuniformity is inadequate circulation of the fluid. If this is suspected to be the case, it is necessary to increase the circulation rate and recheck the temperature gradients. On the other hand, circulation rates cannot be increased beyond the point where overheating and cavitation of the bath medium will occur (observable by the generation of temperature fluctuations). It is best to determine optimum rates experimentally.

A second problem can occur when the bath is used at elevated temperatures. In this situation, heat escapes from the top of the fluid, causing a vertical gradient in the upper 25-50 mm region of the fluid. Clearly, for accurate results, no part of the bulb or contraction chamber of a liquid-in-glass thermometer or the sensing portion of an electronic thermometer should be in

this region. When the bath is first installed, this gradient should be determined as a function of temperature.

Attached to all calibration baths, including the ice bath, should be a telescope mounted perpendicular to the axis of the thermometers that will be placed in the holder. If the telescope cannot be mounted on the bath, it can be placed on a stand near the bath, but care must be taken to see that it is always set perpendicular to the thermometer axis to avoid reading errors due to parallax. The telescope should be approximately 10 power and it is desirable to have a cross-hair to aid in reading the meniscus within the scale divisions.

2.3 Laboratory Standards

2.3.1 Primary standards

The laboratory should be equipped with two sets of "primary" standards and one set of "check" standards. The primary standards should be calibrated versus the International Practical Temperature Scale of 1968 (IPTS-68). This temperature scale is the latest version of a series of international temperature scales that have been developed by national standards laboratories like the NBS throughout the world. A complete description of this scale is given in the Metrologia article entitled, "The International Practical Temperature Scale of 1968 Amended Edition of 1975" [2].

The inaccuracy of IPTS-68 (that is, the best estimate of the difference between the scale and the correct temperature) in the region 0 to 200 °C is estimated to be ± 0.04 °C. It is possible to register temperature in this region with an imprecision much smaller than the inaccuracy of the temperature scale. For example, platinum resistance thermometers can be used to repeatedly register the freezing point of Gallium (near 29 °C) with a standard deviation of only 0.0001 °C (the imprecision) yet the temperature assigned to the Gallium point on the IPTS-68 will still remain inaccurate to ± 0.04 °C until a better temperature scale is developed. When such a temperature scale is developed (approximately every 10 or 20 years; last done in 1968) and compared to IPTS-68, a new difference table will be constructed. At that time at each temperature, a different systematic correction (or offset) must be applied.

By comparison to platinum resistance thermometers, the imprecision of liquid-in-glass thermometers under the best conditions has been found to be ± 0.03 °C (see Section 5.3). Thus, a State calibration laboratory can maintain a temperature scale based on the IPTS-68 using liquid-in-glass thermometers and the procedures given in this Monograph in which the inaccuracy and imprecision are comparable. Using liquid-in-glass thermometers, the laboratory will be able to provide calibrations with errors of about one-third the tolerance permitted in customers' thermometers.

Since total-immersion thermometers (which have virtually no mercury-containing stem exposed to ambient temperature) are more accurate than partial-immersion thermometers, the former should be chosen as standards. Given in Table 1 are ranges, graduation intervals, total length, and imprecision of thermometers that are recommended for use as primary standards. Commercial suppliers of these thermometers are given in Section 9.3. The reproducibility and accuracy of the thermometers chosen for standards should be better than or equal to that of the thermometers being calibrated.

TABLE 1
PRIMARY LIQUID-IN-GLASS THERMOMETERS

ASIM ^a Thermometers[3]				
ASIM No.	Thermometer Range	Graduation Interval	Total Length	Imprecision at Calibration Points ^d After NBS Calibration
63C	-8 to +32 °C	0.1 °C	374-384 mm	0.03 °C
64C	+25 to +55 °C with auxiliary scale at 0°C	0.1 °C	374-384 mm	0.03 °C
65C	+50 to +80 °C with auxiliary scale at 0°C	0.1 °C	374-384 mm	0.03 °C
66C	+75 to +105 °C with auxiliary scale at 0°C	0.1 °C	374-384 mm	0.03 °C
67C	+95 to +155 °C with auxiliary scale at 0 °C	0.2 °C	374-384 mm	0.05 °C
68C	+145 to +205 °C with auxiliary scale at 0 °C	0.2 °C	374-384 mm	0.1 °C
ANSI ^b Thermometers[4]				
SAMA ^c No.	Thermometer Range	Graduation Interval	Total Length	Imprecision at Calibration Points ^d After NBS Calibration
CT40	-1 to +51 °C	0.1 °C	460 mm	0.03 °C
CT45	-1 to +101 °C	0.1 °C	610 mm	0.03 °C
CT50	-1 to +201 °C	0.2 °C	610 mm	0.05 °C up to 100 °C 0.1 °C above 100 °C

^aASIM is an acronym for the American Society for Testing and Materials.

^bANSI is an acronym for the American National Standards Institute.

^cSAMA is an acronym for the Scientific Apparatus Makers Association.

^dFor imprecision between the calibration points see Section 5.4 of NBS Monograph 150 [1].

These thermometers must be free of foreign material in the capillary (such as glass chips or oxides of mercury), be numbered correctly (in proper numerical sequence), and be uniquely

identified by a serial number. The scale must be placed on the thermometer according to NBS specifications (see Section 7.3, NBS Monograph 150 [1]), which do not permit it to be graduated close to an enlargement in the capillary. The thermometers must meet all other requirements given in NBS Monograph 150 [1], such as being made of the proper glass and giving temperature indications within the specified tolerances. When ordering liquid-in-glass thermometers that will be used as standards, it is advisable to request the company to guarantee in addition that they will pass the NBS visual inspection. This service may increase the initial cost of the thermometer, but it will be replaced at no additional cost in the unlikely event that it is found ineligible for test by NBS.

To equip the laboratory with adequate primary thermometers, two liquid-in-glass thermometers from each range should be purchased from the choices given in Table 1. Then these thermometers should be sent for calibration to the NBS or another competent laboratory, accompanied by a letter or purchase order requesting calibration. In the former case, the thermometers will be calibrated by NBS personnel and returned to the sending laboratory along with Reports of Calibration, which list the corrections to be made at each calibration point. By virtue of their calibration at the NBS, such standard thermometers will automatically bear the IPTS-68 scale.

2.3.2 Check standards

The third set of liquid-in-glass thermometers, also chosen from the list given in Table 1, should be purchased for use as check standards. This set differs from the primary standards in that it is not sent to NBS for calibration. Rather, the appropriate thermometer from the set is incorporated as one of the thermometers in the calibration sequence (to be described in Section 3.3.7). By treating the check standard as one of the thermometers being calibrated in terms of the primary standards, it is used to check the calibration procedure, helping to insure that the calibration was done properly. A check standard may also be used as temporary backup for a primary standard in the event that one of a primary thermometers is broken. More than one check standard in each temperature range may be needed due to bulb volume expansion (see Section 3.3.5).

2.4 Personnel

The staffing level as well as the experience and education needed by the calibration staff will depend on several factors that are specific to the laboratory: budgeting, calibration income, calibration volume, and turnaround time. Thus a general prescription here would not be especially useful. For the purpose of reference, however, we mention the staffing situation at the NBS. The Liquid-in-Glass Thermometer Calibration Laboratory at the NBS is staffed by one individual who has had 3 years of

college education and 20 years experience in the laboratory. Approximately 800 liquid-in-glass thermometers and a small number of other types of thermometers are calibrated per year in this laboratory. An individual chosen to be employed in a thermometer calibration laboratory should be adept in mathematics, a stickler for details, and always striving for perfection. Depending on the initiative of the individual, we estimate that it would take 12 months of practice and experience for a high school graduate to operate a calibration laboratory as described in this publication. We strongly recommend that an individual chosen for this responsibility attend a session of the NBS Precision Thermometry Seminar which is given twice yearly. In the Seminar, participants are given lectures on all common types of calibration including liquid-in-glass thermometers, and the attendees also perform simulated calibrations at the NBS facility.

To summarize: when the laboratory has been properly equipped and staffed, and when NBS-calibrated primary thermometers have been incorporated into a careful measurement program, then the State calibration laboratory can be considered to be ready to perform calibrations, based on the IPTS-68, for its customers. We now turn to a discussion of the procedures to be followed in performing those calibrations.

3. PERFORMING CUSTOMER'S CALIBRATIONS

3.1 Examination and Preparation of Thermometers for Calibration

Every thermometer submitted for calibration must be examined under a microscope (preferably 15 or 20 power) for defects. One reason for this visual inspection is to detect a separated mercury column or small droplets of mercury that may be at the top of the thermometer. This condition can occur because of rough handling encountered during shipping. All of the separated mercury must be reunited with the main column before the thermometer can be calibrated.

Rough handling during shipping can also cause gas bubbles to form in the bulb, a defect that also can be detected during the visual examination. These gas bubbles will expand at a greater rate than the mercury that should be in these spaces; therefore, they must be removed. To reunite separated mercury and to remove gas bubbles in the bulb, see Section 8.4 of NBS Monograph 150 [1].

The third reason for examining each thermometer under a microscope is to look for foreign material in the capillary and defects in the thermometer. The foreign materials most often found are glass chips or oxides of mercury. These objects can hold gas or mercury and cause the reading of the thermometer to vary when the thermometer is repeatedly inserted into a regulated constant-temperature bath. The capillary of the thermometer must be clean and free of any foreign material, and it must also

appear to have a uniform diameter. If any variation in the diameter of the capillary can be seen under the microscope, the thermometer is not acceptable for calibration. The distance between scale graduations must be uniform, the scale must be placed on the thermometer according to NBS specifications (see Section 7.3 in NBS Monograph 150 [1]), and the thermometer must be numbered correctly and be free of cracks in the glass. If any of the above conditions are not met in a thermometer that has been submitted for calibration, it should be ineligible for test and should be replaced by the customer.

3.2 Proper Method for Calibrating Specific Thermometers

Thermometers usually are calibrated according to their types. A particular thermometer should be calibrated differently only if the customer specifically requests it. In this section is presented a discussion on the calibration of several types of thermometers.

3.2.1 Total-immersion thermometers

Total-immersion thermometers are calibrated with the bulb and all but approximately 6 mm to 12 mm of the mercury column immersed in the calibration bath. The upper 6 mm to 12 mm of the mercury column extends out of the bath surface to permit reading. The meniscus (the top of the mercury column) should never be immersed in the bath fluid, since distillation of the mercury can occur at high temperatures and cause mercury droplets to condense at the top of the thermometer.

After remaining at room temperature (23 °C) for 3 days, these thermometers are calibrated starting at the lowest temperature requested and proceeding in sequence to the highest point. At each calibration point the thermometer must be pushed deeper into the calibration bath to maintain the proper immersion.

If the thermometer has a contraction chamber (see Section 3 of NBS Monograph 150 [1]), it must be immersed well below the surface of the bath medium. The contraction chamber contains a great deal of mercury and this mercury must be at the same temperature as the mercury in the bulb for the thermometer to give a correct reading. If there is a temperature gradient at the surface of the bath, as may be the case in high temperature calibration baths, the contraction chamber must be placed below this gradient, even if this means changing the calibration point.

If the thermometer being calibrated is too long and cannot be immersed at the proper depth, a stem-temperature correction will have to be made as described in Section 5.3 of NBS Monograph 150 [1] and in Section 3.3.10 of this Monograph.

3.2.2 Partial-immersion thermometers

Partial-immersion thermometers must have either an immersion line or the proper depth of immersion engraved or printed on the

back (most thermometers have both). These thermometers are immersed only to the immersion line or specified depth. The portion of the stem that contains mercury above the immersion line is known as the "emergent stem". It tends to reach ambient temperature or the temperature prevailing above the calibration bath. If the emergent stem is to have a specified stem temperature, as is the case with all ASTM partial-immersion thermometers, a stem temperature correction must be made as described in Section 3.3.10.

Like total-immersion thermometers, calibration points are taken in the same sequence; the thermometer must remain at room temperature (23 °C) for 3 days before calibrating; and a contraction chamber must be immersed properly.

3.2.3 ASTM thermometers

Over 120 different thermometer specifications are listed in ASTM Standard E-1, Standard Specification for ASTM Thermometers [3]. The thermometers were designed to be used in specific equipment and test methods and are identified by having the acronym "ASTM" and a number written on the back. Specification E-1 lists the calibration points for all ASTM thermometers, stem temperatures for ASTM partial-immersion thermometers, and any special procedure that must be followed. An ASTM thermometer should be tested in accordance with the procedure outlined in E-1 and E-77, Standard Method for Verification and Calibration of Liquid-in-Glass Thermometers [5].

3.2.4 Calorimetric thermometers

In some cases it is only necessary to accurately measure a temperature difference rather than the absolute temperature. Calorimetric thermometers were designed for this purpose. They usually are 600 mm long, cover a short range of temperature (typically 6 to 16 degrees), and are graduated in intervals of 0.01 to 0.05 degree. The thermometers are usually calibrated every 50 to 100 scale divisions (in intervals of 0.5 or 1 degree). Because of the very small capillary diameter, they must be tapped lightly at each reading to eliminate a possible error due to a sticking mercury column, and they must be heated to the maximum calibration point before testing. Initially heating to the top point causes the bulb to expand to the maximum volume and eliminates the error that will occur because of the gradual expansion of the bulb as the thermometer is heated. In order to register accurate temperature differences, the bulb must be expanded before calibration and before use. The thermometer should be calibrated within 2 to 3 hours after it has been heated.

These thermometers are capable of measuring temperature differences with uncertainties of 0.01 °C, which will be beyond the capabilities of a State calibration laboratory following the procedures outlined in this publication. If a customer requests

this accuracy, the thermometer must be sent to another calibration laboratory, such as NBS.

3.2.5 Beckmann thermometers

These thermometers are instruments in which a narrow temperature interval (typically 6 °C) may be adjusted to fall within 0 to 100 °C. The graduations are 0.01 °C and the thermometer is of the enclosed-scale type, which consists of a capillary tube attached to a scale and enclosed in a glass tube. Since the narrow interval is adjustable, these thermometers are to be used only to register temperature differences.

The interval may be moved within the range 0 to 100 °C by adding or removing mercury to or from the bulb. Consider the following example for adjusting a Beckmann thermometer to indicate temperature differences from 20 to 26 °C: Before calibration, the amount of mercury in the bulb is adjusted to place the meniscus within ± 5 scale divisions of the "zero" indication when the thermometer is immersed in a medium having a temperature of 20 °C. This is referred to as a "setting of 20 °C". The thermometer is then calibrated in the range of 20 to 26 °C. For other settings, the temperature difference must be multiplied by the appropriate setting factor as shown in Section 6.4 of NBS Monograph 150 [1].

The Beckmann thermometer is a calorimetric thermometer and must be heated to the highest test point, tapped gently before reading, and calibrated every 0.5 °C. They are capable of measuring temperature differences with uncertainties of 0.005 °C and, like the calorimetric thermometers, will have to be sent to another calibration laboratory, such as NBS, if this accuracy is desired.

3.2.6 Clinical standard thermometers

Clinical standard thermometers are used by the manufacturers of fever thermometers, which are used for measuring body temperature. In the United States they are marked in degrees Fahrenheit with a range of approximately +90 to +112 °F. They are provided with an auxiliary scale at 32 °F and graduated in intervals of 0.1 °F. The calibration points are usually 32, 98, 102, and 106 °F and they are heated to 108 °F before calibrating to initially expand the bulbs. Since they are heated to 108 °F before calibrating, the ice points are taken after test. They are generally tested at total immersion and at partial immersion, immersed to approximately the 92 °F mark.

3.2.7 Kinematic viscosity thermometers

When measuring the viscosity of liquids, it is imperative to accurately measure one specific temperature. Kinematic viscosity thermometers are designed for this purpose and have a short 3 to 5 degree range with an auxiliary scale for an ice point. These

thermometers are calibrated at two points on the main scale. Ice points are measured afterwards.

3.2.8 Electronic temperature measuring systems

A thermometry calibration laboratory may occasionally be requested to calibrate an electronic temperature measuring system. It usually consists of a digital readout connected to a probe, which can be a thermocouple, thermistor, or resistor (most commonly an industrial platinum resistance thermometer). It must first be determined that the probe can physically be placed in the calibration bath with enough lead wire to enable the readout unit to be located near the bath. The probe must be long enough so that the sensing element is below the region of large temperature gradient that may occur at the top of the bath. If the probe cannot be placed directly in the fluid, it must be put in a tight fitting, protective tube to provide good thermal conductivity. The electronic system is calibrated in the same manner and readings taken in the same sequence as for liquid-in-glass thermometers.

3.3 Calibration Procedure

3.3.1 Number and choice of calibration points

A thermometer submitted for test should be calibrated at several points over at least 80% of the main scale.

The thermometer should be calibrated at the temperatures specified by the customer or at intervals of approximately every 100 scale divisions. Calibration points taken at no more than every 100 scale divisions will give acceptable interpolated corrections for temperatures between the calibration points. (See Section 5.4 of NBS Monograph 150 [1].)

The thermometer should be calibrated at the reference point, usually 0 °C or 100 °C, if there is one on the thermometer. The reference point is used to recalibrate the thermometer as described in Section 5.2 of NBS Monograph 150 [1] and in Sections 3.3.5 and 3.3.8 of this Monograph.

3.3.2 Use of ice-point bath

Make a fresh ice bath on the day that a calibration is to be performed (discarding any previous day's bath). As ice melts throughout the day, siphon off the water and add new ice. The bath is ready for use when no ice is floating and no excess water is on the surface of the ice.

For proper calibration at 0 °C, each liquid-in-glass thermometer should be inserted to a specified depth (the immersion depth) into the ice-point bath. Total-immersion thermometers should be inserted into the ice-point bath until the 0 °C mark on the thermometer scale is within one scale division of the top of the bath. For partial-immersion thermometers, the

depth is indicated either by an additional line scribed on the glass (immersion line) or by a number given on the back of the thermometer.

In order to prepare the bath to accept the thermometer, loosen an area of ice at the center of the bath with an object such as a clean glass rod to a depth approximately equal to the immersion depth. Clean the thermometer to be calibrated at the ice point by rinsing it with cool distilled water. (Never rinse with warm water, since this may expand the bulb.) Then gently place the thermometer through the holder and into the region of loosened ice. If the thermometer touches a firm surface before it is immersed to the immersion line or 0 °C mark, then remove the thermometer and loosen the ice further down into the bath to permit the thermometer to be immersed to the proper depth. If the immersion line or 0 °C mark on the thermometer passes below the surface of the bath before resting on a firm foundation, repack the ice and loosen the ice to the correct depth.

After the thermometer is properly immersed and perpendicular to the observer's telescope, firmly pack the ice around the thermometer. It is important to keep the ice clean while using the ice bath. The operator's hands must frequently be washed (with soap and water) or covered with plastic gloves. When the thermometer is resting on a solid section of ice in the bath and cannot be immersed further, when it is perpendicular to the telescope, when ice is firmly packed to the immersion line or one scale division below the 0 °C mark, and when any excess water is siphoned from the ice bath, the thermometer is ready to be read as shown in Figure 9.

The thermometer should remain in the ice bath for approximately one to two minutes. (Thermometers using an organic fluid instead of mercury as the liquid may require approximately 15 minutes because the organic fluid tends to cling to the wall of the capillary.) When stability is reached (the meniscus stops moving), gently tap the thermometer to free the mercury meniscus (which can sometimes stick) and record the ice-point reading.

3.3.3 Steam point (100 °C) as reference point

Although the ice point at 0 °C is most often the reference point, the steam point at 100 °C is sometimes used. A steam-point bath or hypsometer, as described in Section 5.1b of NBS Monograph 150 [1], is the fixed-point apparatus sometimes used at NBS to realize this temperature. Since the temperature is dependent on the atmospheric pressure, a barometer accurate to 0.1 mm of mercury must also be available.

It is not necessary to purchase a steam bath or barometer if the calibration laboratory has standard thermometers and an oil bath capable of being controlled at 100 °C. A thermometer having a reference point at 100 °C can be calibrated at this temperature in the oil bath. The change in bulb volume can be determined by subsequent recalibration at 100 °C.

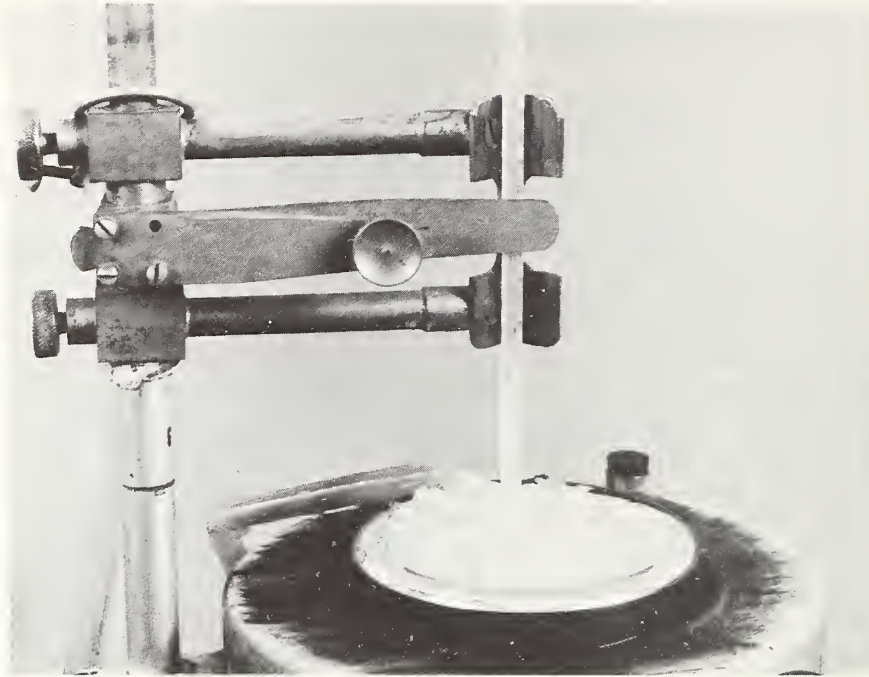

Figure 9. Thermometer properly placed in ice bath.

3.3.4 Role of primary liquid-in-glass thermometers

Precision liquid-in-glass thermometers that have been calibrated by NBS or another calibration laboratory are used to realize the current International Practical Temperature Scale [2].

When liquid-in-glass thermometers are used as primary standards, two of them should be used at each calibration point. Each thermometer is corrected to obtain the accurate temperature of the bath. The corrected readings of the two primary standards must agree within a specified tolerance before the calibration point is acceptable. NBS has found that 0.2 of a scale division is an achievable tolerance. Using two primary standards usually will reveal an error due to an incorrect reading of one of the primary standards. Averaging the carefully taken readings of two primary standard thermometer temperatures will give a more reliable value of the temperature of the calibration bath medium, especially at temperatures that differ from those where the primary standard thermometers were calibrated.

3.3.5 Routine adjustment to primary standard thermometer calibration data

There are three conditions that will prevent each primary liquid-in-glass thermometer standard used by the State

calibration laboratory personnel from indicating temperatures correctly. The first is permanent irregularities in the thermometer, such as nonuniform bore and inaccurate scale markings. This correction need only be obtained once when the thermometer is sent to a national standards laboratory such as NBS. Here the readings of the thermometer are compared with the temperatures determined from a precision standard platinum resistance thermometer that has been calibrated on the current IPTS. On the basis of these measurements, a Report of Calibration is issued, which gives a table of corrections for these permanent errors at the calibration points resident on this thermometer.

The other two conditions, caused by long-term or short-term changes in the bulb glass, must be corrected by personnel in the State calibration laboratory on a routine basis according to a procedure to be described later in this section. Briefly, glass, as a supercooled liquid, will slowly flow, and thus on a long-term basis (over the life of the thermometer) the volume of the bulb will change, causing the readings of the thermometer to change. This is easily detected and can be corrected by determining the correction at the ice point and shifting uniformly the corrections given on the Report of Calibration (see Section 5.2, NBS Monograph 150 [1]).

There is also a short-term (three days or less) change in the bulb glass. To understand this, we appreciate the well known fact that when a liquid-in-glass thermometer is heated to higher temperatures, the glass as well as the mercury expands. This expansion of the bulb, which has a greater effect on the thermometer readings than changes in the stem glass, can correspond to a change in temperature reading as great as 0.01 °C for every 10 degrees that it is heated. As the thermometer is cooled (e.g., to the ice point), the mercury will return to its original volume, but the bulb has been found to take approximately 3 days to return to its original volume. During this three-day period the thermometer will indicate that the temperature is lower than it actually is, because the expanded glass bulb volume causes the mercury column to fall lower in the stem. In order to obtain a correct temperature value, one must compensate for this temporary, short-term change in the bulb volume known as an "ice-point depression".

To illustrate this procedure, we provide the following example. Consider a primary thermometer that, for simplicity, we assume has no error in the graduations, i.e., all corrections on the Report of Calibration, which were obtained after the thermometer had been at room temperature (23 °C) for three days and calibrated from the lowest calibration point to the highest, are zero. (See column 2 of Table 2.) We conduct the following measurements: First, a measurement at 0 °C, taken after the thermometer had been at room temperature for not less than three days, shows no correction. The thermometer then is heated to a given temperature, (e.g., 50 °C) and then returned within a few minutes to the ice bath. The volume of the thermometer bulb has

been increased by virtue of the heating to 50 °C, so the mercury will not return to the original height in the glass tube and the reading at 0 °C will be lower (e.g., -0.05 °C). We now cycle the thermometer to 100 °C and note the new reading at the ice point (e.g., -0.10 °C) and then cycle to 150 °C and back to 0 °C for a fourth ice-point reading (e.g., -0.15 °C). The data thus obtained for this thermometer may be represented by Column 3 of Table 2.

TABLE 2
EXAMPLE OF ICE-POINT DEPRESSION

Calibration Point	Original Correction from Report of Calibration	Ice-Point Reading ^a	Ice-Point Correction ^a
(°C)	(°C)	(°C)	(°C)
0.00	0.00	0.00	0.00
50.00	0.00	-0.05	+0.05
100.00	0.00	-0.10	+0.10
150.00	0.00	-0.15	+0.15

^aDetermined after heating thermometer to calibration point and then returning to ice bath.

Now suppose the thermometer that has been heated to 150 °C is immediately returned to 50 °C. The reading at 50 °C will be influenced by the thermometer's having been heated to a higher temperature. That is, the reading of the thermometer will depend on its previous thermal history. The ice-point correction taken after heating the thermometer to 150 °C was +0.15 °C and, in this case, it will remain that value after the thermometer has been returned to 50 °C. The ice-point correction taken after the thermometer had been heated to only 50 °C was +0.05; therefore, when the thermometer is used at 50 °C after being heated to 150 °C, it will indicate that the temperature of the bath is 49.90 °C. The volume of the bulb had increased by an amount equal to 0.1 °C [+0.15-(+0.05)], thus causing the thermometer to read lower at 50 °C by 0.1 °C.

Having understood the long-term and short-term changes in the bulb glass, we are now ready to describe the procedure to be followed routinely by the State calibration laboratory.

The first step is to let the thermometer rest at room temperature (23 °C) for 3 days to enable the bulb to contract

back to its equilibrium volume. After this period of time an ice point is taken. If the ice point is the same as the one on the Report of Calibration, then it can be assumed that the corrections given on the report are current and valid. Since long-term changes can occur in the volume of the bulb with time and use, it would not be unusual for the ice point to have a different value. If the ice point has changed, all of the corrections should be changed by the same amount and in the same direction (see Section 5.2 in NBS Monograph 150 [1]). This technique gives the operator a current set of corrections and is a recalibration procedure followed by NBS for many years. If the primary standard thermometers are to be used only once or twice a week, with a 3-day waiting period between their use, and they will be used only from some lower point to some higher point, the corrections determined after changing the corrections for the change in ice point can be used. If the primary standard thermometers will be used several times within a week, as most standards are, then one must determine and compensate for the ice-point depression caused by the short-term, temporary change in the bulb volume.

The data in Table 2 provides the basis for establishing "adjusted scale corrections" in order to compensate for the ice-point depression and long-term changes that will occur in the volume of the bulb. This is done using the following equation.

$$C_1 = C_2 - C_3 \quad (1)$$

C_1 = Adjusted scale correction.

C_2 = Correction from table supplied in the NBS Report of Calibration or current set of corrections obtained from change in ice-point reading.

C_3 = Ice-point correction determined by the State laboratory after heating the thermometer to the calibration point and returning to the ice bath.

The value C_3 can be found after the thermometer is returned from NBS by taking the ice point after heating the thermometer to each of the calibration points and cycling back to the ice point as was done in the example given above (Table 2, Column 3). Adjusted scale corrections for the primary standard thermometer used in the example are given in Table 3, Column 4.

Altering the original corrections in this manner enables the user to know the influence of the ice-point depression on the thermometer reading as the thermometer is heated. When the adjusted scale correction is applied to the thermometer reading, the resulting temperature value will be correct only if the ice-point reading at that time is 0.00. Since the ice point will not always read exactly 0 °C after use, either because of the temporary ice-point depression or long-term changes in the bulb volume, it is necessary to take an ice point periodically (see

TABLE 3

EXAMPLE OF ADJUSTED SCALE CORRECTIONS

Calibration Point	Report of Calibration Correction (C ₂)	Ice-Point Correction ^a (C ₃)	Adjusted Scale Correction (C ₁)
(°C)	(°C)	(°C)	(°C)
0.00	0.00	0.00	0.00
50.00	0.00	+0.05	-0.05
100.00	0.00	+0.10	-0.10
150.00	0.00	+0.15	-0.15

^aDetermined after heating thermometer to calibration point and then returning to ice bath.

Section 3.3.7) while the thermometer is in use and to record the ice-point reading. This procedure will be discussed further in Section 3.3.8.

Given in Table 4 are adjusted scale corrections computed for two hypothetical primary standard thermometers, 1 and 2, used in the sample calibration that will be discussed in Section 3.3.8.

3.3.6 Placement of thermometers in calibration bath

The thermometers to be calibrated should be placed in the calibration bath in a row with one primary standard liquid-in-glass thermometer at one end and the other primary standard at the other end. This placement is shown in Figure 10. Total-immersion thermometers should be immersed with the meniscus of the mercury column approximately 6 mm to 12 mm above the surface of the bath medium and partial-immersion thermometers should be immersed to the immersion line or to the specified depth. Any additional thermometers (see Section 3.3.7) used to measure stem temperatures should be placed on the corresponding test thermometers. One method of doing this is by joining two electrical pee-wee clamps together and clamping the additional thermometer to one clamp. The second clamp is attached to the thermometer.

Ideally, for liquid-in-glass thermometer calibrations or when liquid-in-glass thermometers are used as standards, the temperature of the calibration bath should be rising slowly (no faster than one scale division of the primary standard thermometer in three minutes). It is also acceptable to control the bath temperature (by observing a more sensitive thermometer) within ± 0.005 °C. The temperature of the bath should not be decreasing during calibration because the mercury column at the

TABLE 4

ADJUSTED SCALE CORRECTIONS FOR HYPOTHETICAL
PRIMARY STANDARD THERMOMETERS 1 AND 2

<u>Primary Standard 1</u>			
Calibration Point	Report of Calibration Correction (C ₂)	Ice-Point Correction Determined after Heating to Calibration Point (C ₃)	Adjusted Scale Correction (C ₁)
(°C)	(°C)	(°C)	(°C)
0.00	+0.08	+0.08	0.00
20.00	+ .11	+ .10	+ .01
40.00	+ .02	+ .10	- .08
60.00	+ .07	+ .11	- .04
80.00	+ .10	+ .12	- .02
100.00	+ .06	+ .12	- .06

<u>Primary Standard 2</u>			
Calibration Point	Report of Calibration Correction (C ₂)	Ice-Point Correction Determined after Heating to Calibration Point (C ₃)	Adjusted Scale Correction (C ₁)
(°C)	(°C)	(°C)	(°C)
0.00	+0.01	+0.01	0.00
20.00	+ .17	+ .01	+ .16
40.00	+ .04	+ .02	+ .02
60.00	+ .11	+ .03	+ .08
80.00	+ .12	+ .04	+ .08
100.00	+ .06	+ .04	+ .02

meniscus can cling to the wall of the capillary of the thermometer and remain in an erroneously high position even though the temperature of the bath may have decreased. There is less chance for this problem to occur if the temperature of the bath is rising.

3.3.7 Reading sequence and recording data

After the thermometers have been placed properly in the calibration bath and it is regulated at the lowest point requested, the thermometers are read in the following sequence: Primary Standard 1, Thermometers T1-TX, Primary Standard 2, Primary Standard 2, Thermometers TX-T1, and Primary Standard 1. One of the thermometers T1-TX should be the check standard.

Any additional auxiliary thermometers used for stem temperature determinations should be read after this sequence. An auxiliary thermometer can be any thermometer that is accurate

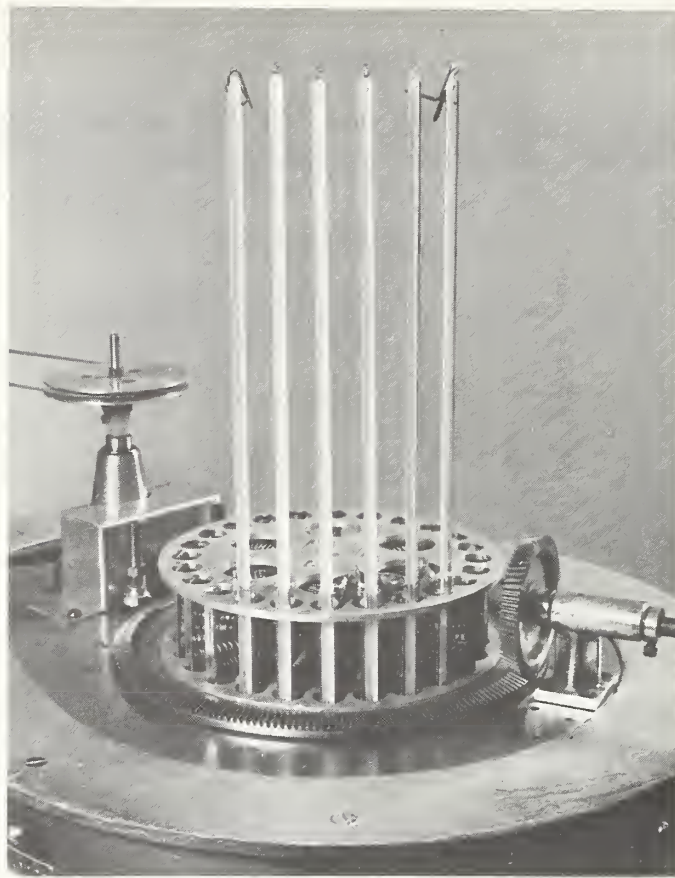

Figure 10. Correct placement of thermometers in calibration bath.

to within 1 or 2 degrees. It is used to measure the average temperature of the emergent stem, both for total-immersion thermometers used incorrectly at partial immersion, and for partial-immersion thermometers. NBS uses for this purpose a thermometer approximately 15 cm long with a range of 0 to 100 °C and graduated in intervals of 1 °C.

If two calibration operators are available, one should record the observed thermometer readings while the other reads the thermometers. The two operators should switch positions and take a second set of readings. It is preferable to have two observers, since this procedure will minimize reading errors. However, this is not absolutely necessary; at the NBS, all calibrations for 12 years have been done by one individual.

At specified intervals (typically, every 200 scale divisions), the two primary thermometers should be removed from the constant temperature bath and reinserted into the ice bath. The ice-point readings are recorded. This procedure is used to determine the "ice-point correction" (see Section 3.3.5 and Section 3.3.8) for the two primary standard thermometers. Then they are returned to the constant-temperature bath and further readings are taken at higher temperatures.

Table 5(a) gives an example in which three unknown thermometers (T1, T2 and T3) and a check standard (T4) were calibrated versus two primary standard thermometers (Primary Standard 1 and Primary Standard 2). All the thermometers in this example were total-immersion thermometers with graduations of 0.2 °C and having a range -2 °C to +102 °C. They were calibrated at the nominal temperatures 0 °C, 20 °C, 40 °C, 60 °C, 80 °C, and 100 °C. These particular points were chosen because they correspond to intervals of 100 scale divisions, a common practice used in calibration of liquid-in-glass thermometers. The calibration proceeded from 0 °C to 100 °C. The primary thermometers were removed from the bath after the readings were taken at 20 °C, 60 °C, and 100 °C and remeasured in the ice bath. This allowed ice-point corrections to their readings to be made at those temperatures (interpolation was used for the 40 °C and 80°C points).

After a set of data is obtained at a calibration point, it should be inspected to see that it looks reasonable. The calibrator should check for reading errors and to insure that the temperature during the calibration remained constant to ± 0.005 °C or was rising at a rate of no more than 1 scale division per 3 minutes. As mentioned earlier, it is not acceptable for the temperature of the bath to decrease while data is being recorded.

3.3.8 Computation of bath temperature from readings of primary standard thermometers

Once the data have been recorded in the format shown in Table 5(a), and after inspection indicates that there are no suspicious data points, computation of the corrections is done as shown in Table 5(b).

The first step is to convert the readings of the two primary thermometers to the correct temperature. This is done by using the following equation

$$T = T_r + C_1 + C_4 \quad (2)$$

T = True temperature.

T_r = Average of two readings for the primary standard thermometer.

C₁ = Adjusted scale correction.

C₄ = Ice-point correction taken after thermometer has been used.

Having established the set of adjusted scale corrections the only term that is necessary to determine the correct temperature is the ice-point correction determined by taking the ice point after the thermometer has been used (C₄).

As seen in Tables 5(a) and 5(b), if the thermometer is to be calibrated at several points over a narrow temperature range, it

is not necessary to take an ice point after every calibration point, but one should be taken at intervals of every 200 scale divisions. The ice-point correction between these points can be determined by interpolation. Adjusted scale corrections at temperatures between the calibration points can also be determined by interpolation.

In the far left and right columns of Table 5(b) are shown the calculations used to obtain T for Primary Standards 1 and 2. For example, at the nominal temperature 20 °C, Primary Thermometer 1 had the following parameters: $T_r = 19.76$; $C_1 = +0.01$; $C_4 = +0.20$, and thus T was calculated to be 19.97 °C. By a similar technique, Primary Thermometer 2 also indicated that the temperature of the calibration bath medium was 19.97 °C.

After the temperature of the bath has been determined for each primary standard and the calculated temperatures are found

TABLE 5 (a)
SAMPLE CALIBRATION SHEET

Readings (one observer)						
Nominal Temp (°C)	Primary Standard 1	T1	T2	T3	T4	Primary Standard 2
0		-0.10	-0.10	-0.03	+0.01	
20	19.75 19.76	19.92 19.93	19.94 19.95	19.93 19.93	19.99 20.00	19.72 19.73
0	-0.20					-0.09
40	39.71 39.72	39.90 39.92	39.90 39.91	39.88 39.88	39.83 39.85	39.70 39.71
60	59.70 59.71	59.86 59.86	59.93 59.94	59.89 59.90	59.80 59.81	59.68 59.69
0	-0.22					-0.10
80	79.79 79.80	80.03 80.04	79.96 79.96	79.90 79.91	80.02 80.03	79.81 79.81
100	99.71 99.71	99.88 99.88	99.86 99.88	99.86 99.87	99.91 99.92	99.73 99.74
0	-0.23					-0.11

TABLE 5 (b)

SAMPLE CALIBRATION SHEET

Computations (one observer)

Primary Standard 1		T1	T2	T3	T4	Primary Standard 2	
		-0.10	-0.10	-0.03	+0.01		
		+ .10	+ .10	+ .03	- .01 ^h		
19.76 ^a	19.75	19.92	19.94	19.93	19.99	19.72	19.72 ^a
+0.01 ^b	19.76	19.93	19.95	19.93	20.00	19.73	+0.16 ^b
+0.20 ^c							+0.09 ^c
19.97 ^e		19.92	19.94	19.93	20.00 ^f		19.97 ^e
		←-----19.97 ^g ----->					
	-0.20					-0.09	
		+0.05	+0.03	+0.04	-0.03 ^h		
39.72	39.71	39.90	39.90	39.88	39.83	39.70	39.70
-0.08	39.72	39.92	39.91	39.88	39.85	39.71	+0.02 ^d
+0.21 ^d							+0.10 ^d
39.85		39.91	39.90	39.88	39.84		39.82
		←-----39.84----->					
		-0.07	-0.06	-0.04	.00		
59.70	59.70	59.86	59.93	59.89	59.80	59.68	59.68
-0.04	59.71	59.86	59.94	59.90	59.81	59.69	+0.08
+0.22							+0.10
59.88		59.86	59.94	59.90	59.80		59.86
		←-----59.87----->					
	-0.22					-0.10	
		+0.01	-0.07	-0.03	+0.07		
79.80	79.79	80.03	79.96	79.90	80.02	79.81	79.81
-0.02	79.80	80.04	79.96	79.91	80.03	79.81	+0.08
+0.22							+0.10
80.00		80.04	79.96	79.90	80.02		79.99
		←-----80.00----->					
		-0.04	+0.04	+0.10	-0.02		
99.71	99.71	99.88	99.86	99.86	99.91	99.73	99.74
-0.06	99.71	99.88	99.88	99.87	99.92	99.74	+0.02
+0.23							+0.11
99.88		99.88	99.87	99.86	99.92		99.87
		←-----99.88----->					
	-0.23					-0.11	
		.00	+0.01	+0.02	-0.04		

^a Average of two readings for the primary standard thermometer (when rounding off the even number was chosen).

^b Adjusted scale correction computed for primary standard at indicated temperature.

^c Ice-point correction - taken after calibration point.

^d Interpolated ice-point correction.

^e Temperature of calibration bath medium as determined by the corrected primary standard.

^f Average of two readings for the thermometers being calibrated.

^g Temperature of calibration bath medium as determined by average of two corrected primary standard thermometers.

^h Corrections given on Report of Calibration for thermometers under test.

to agree within 0.2 of a scale division (in our example, $0.2 \times 0.2 = .04$ °C), or within other limits established by the operator's laboratory, the two values are averaged to obtain the temperature of the calibration bath medium. In our example this average is 19.97 °C.

3.3.9 Determining corrections for thermometers being calibrated

Having calculated the correct temperature of the two primary thermometers as described in Section 3.3.8, we may now obtain the corrections for thermometers T1, T2, T3, and T4.

The two readings of each thermometer being calibrated and the check standard are averaged and compared to the temperature of the bath medium. If the thermometer under test reads higher than the bath temperature, the correction is negative; if the thermometer under test reads lower than the bath temperature, the correction is positive.

Using the data taken for thermometers in Table 5(b) and the computed bath temperature of $T = 19.97$ °C, we calculate that their respective corrections are +0.05, +0.03, +0.04 and -0.03 °C at 20 °C. This procedure is followed for the other temperatures, thereby generating the data for the Reports of Calibration for these three thermometers. (The Report of Calibration for thermometer Serial Number T1 is given as Figures 17 and 18.)

Ice points should be taken on the thermometers that were calibrated not less than 72 hours after test. The second ice point should agree with the initial ice point within the expected accuracy of the thermometer. Thermometers with a range of 0 to 100 °C and graduated in 0.2 °C have an expected accuracy of 0.05 °C at the calibration points (see Section 6 of NBS Monograph 150 [1]). The ice points should agree within this limit. If the two ice points are not in agreement, indicating that the bulb has not recovered from expanding after heating (due probably to improper annealing), then the thermometer has to be completely recalibrated.

The data should be analyzed to see if the results are reasonable. A very useful technique for analysis is to plot the calibration data. An example for a total-immersion thermometer graduated in 0.2 °C divisions is shown in Figure 11. The corrections at 80 °C and 100 °C are suspect for two reasons: 1) the magnitude of the difference between adjacent corrections is close to one scale division, and 2) the sign of the correction changes. A deviation curve shown in Figure 11 can occur for liquid-in-glass-thermometers. If these data were taken by two observers, the probability for reading error is small and recalibration in this case is not necessary. If, on the other hand, the data were obtained by one observer, we recommend recalibration at 80 °C and 100 °C.

The plot may indicate another effect. If the trend of the curve is downward as the temperature is increased, the thermometer probably has gas in the bulb. The gas should be removed (see Section 8.4 of NBS Monograph 150 [1]) and the thermometer retested.

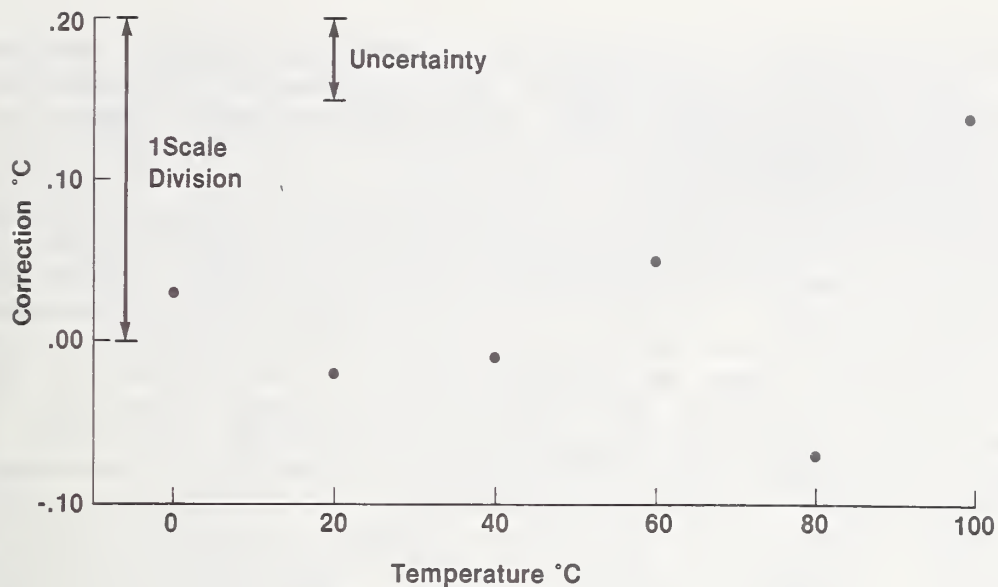

Figure 11. Thermometer correction versus temperature.

3.3.10 Stem-temperature corrections

If the thermometer being calibrated is a total-immersion thermometer used at partial immersion or an ASTM partial-immersion thermometer requiring a correction that reflects a specified stem temperature, it will be necessary to correct for the variation in the stem temperature.

Use the following formula to determine the stem-temperature correction.

$$\text{Stem-temperature correction} = kn(t_{\text{obs}} - t_{\text{sp}}) \quad (3)$$

k = differential expansion coefficient of mercury (or other thermometric liquid) in the particular kind of glass of which the thermometer is made,

n = number of scale degrees equivalent to the length of emergent stem (including the evaluated area above the immersion line),

t_{obs} = observed mean temperature of the emergent stem (auxiliary thermometer reading),

t_{sp} = specified mean temperature of the emergent stem (for which reported scale correction applies).

All stem-temperature corrections require that four values be determined. The first value is the differential expansion

coefficient of mercury (or other thermometric liquid) in the particular kind of glass from which the thermometer is made (k). These values have been established and used for many years and are given in NBS Monograph 150 [1], Table 4, and discussed in Section 5.3 of that publication.

The second value needed is the number of scale degrees equivalent to the length of emergent stem (n). This is essentially the number of degrees that is in the incorrect temperature environment. If it is a total-immersion thermometer with a portion of the stem above the bath, then the value n is the number of degrees from the degree mark at the surface of the bath medium to the meniscus (the top of the mercury column). If the thermometer is a partial-immersion thermometer the value n is the number of degrees from the immersion line to the meniscus. Since partial-immersion thermometers are not graduated to the immersion line, there is a portion of the stem containing no scale divisions. It must be determined how many degrees could be inscribed in this portion of stem and that number included in the value n . One way of doing this is to measure the distance from the immersion line to the lowest scale graduation, then move the ruler on the thermometer scale and determine how many degrees this distance represents.

The third value needed is the observed average temperature of the emergent stem (t_{obs}). This value is found by actually measuring the temperature of the environment where the emergent stem is located. The preferred way of doing this involves the use of faden thermometers as described in Section 5.3a of NBS Monograph 150 [1]. Because the availability of faden thermometers is limited (see Section 9.4 of this Monograph), the emergent stem temperature can also be measured by using one or more auxiliary thermometers. Whether one, two, or even three, auxiliary thermometers are needed depends on the length of mercury column emergent from the bath. Generally an auxiliary thermometer should be attached for every 120-mm to 150-mm length of emergent mercury column. If one auxiliary thermometer is used, then the center of its bulb should be placed at the midpoint of the emergent mercury column. If two auxiliary thermometers are used, then the center of their bulbs should be placed at $1/3$ and $2/3$ the height of the emergent mercury column. An average of the two auxiliary thermometer readings is used as the temperature of the emergent stem.

The fourth value is the specified average temperature of the emergent stem (t_{sp}). This value is the temperature at which the emergent stem should be. If the thermometer is a total-immersion thermometer having a portion of the stem out of the medium being measured, the specified temperature of that portion of the stem should be the temperature of the medium. If it is an ASTM partial-immersion thermometer, the specified temperatures should be the values given in ASTM Specification E-1 [3].

The stem-temperature correction is added to or subtracted from the initial correction. Examples are given in Tables 6(a)

and 6(b) and a discussion is given in Section 5.3 of NBS Monograph 150 [1].

In Tables 6(a) and 6(b), Thermometer T6 is an ASTM 33C thermometer and at 40 °C the correction should reflect a stem temperature of 30 °C as specified in ASTM E-1 [3]. The length of emergent mercury column is equal to 314 mm and the centers of the auxiliary thermometer bulbs are placed adjacent to the stem 105 mm and 209 mm from the immersion line. This procedure is shown in Figure 12.

TABLE 6(a)

EXAMPLE OF STEM-TEMPERATURE CORRECTIONS

Nominal Temp (°C)	Readings (two observers)					
	Primary Standard 3	T6 ASTM 33C 50 mm Immersion	T7 ASTM 34C 50 mm Immersion	Primary Standard 4	Aux ₁	Aux ₂
40	39.909	39.96	--	39.882	31	26
	39.923	39.97		39.883	31	26
	39.919	39.96	--	39.901		
	39.933	39.96		39.902		
0	-.138	-----		-.151		
	-.139	-----		-.150		
45	44.770	--	44.85	44.751	33	
	44.784		44.86	44.750	33	
	44.784	--	44.86	44.751		
	44.793		44.87	44.752		
0	-.139		-----	-.154		
	-.139		-----	-.153		

The indication on auxiliary 1 thermometer gives the average temperature of the lower portion of the emergent stem of T6 and that on auxiliary 2 thermometer the average temperature of the upper portion of emergent stem of T6. The average temperature of the emergent stem is the average temperature of the two auxiliary thermometers. Since in the example there are two observers, each auxiliary thermometer should be read twice. An average of the two values for each auxiliary thermometer is used.

TABLE 6 (b)

EXAMPLE OF STEM-TEMPERATURE CORRECTIONS

Computations (two observers)

	Primary Standard 3	T6 ASTM 33C 50 mm Immersion	T7 ASTM 34C 50 mm Immersion	Primary Standard 4	Aux ₁	Aux ₂
39.916 ^a -.032 ^b +.138 ^c <hr/> 40.022 ^d	39.909 39.923	39.96 39.97 39.96 ^e		39.882 39.883	39.882 ^a -.013 ^b +.150 ^c <hr/> 40.019 ^d	31 31 26 26
		<-----40.020 ^f -----> +.06 ^g				
39.926 ^a -.032 ^b +.138 ^c <hr/> 40.032 ^d	39.919 39.933	39.96 39.96 39.96 ^e		39.901 39.902	39.902 ^a -.013 ^b +.150 ^c <hr/> 40.039 ^d	
		<-----40.036 ^f -----> +.08 ^g +.07 ^h -.02 ⁱ <hr/> +.05 ^j		-.151 -.150		
44.777 -.042 +.139 <hr/> 44.874	44.770 44.784		44.85 44.86 44.86	44.751 44.750	44.750 -.035 +.154 <hr/> 44.869	33 33
		<-----44.872-----> +.01				
44.788 -.042 +.139 <hr/> 44.885	44.784 44.793		44.86 44.87 44.86	44.751 44.752	44.752 -.035 +.154 <hr/> 44.871	
		<-----44.878-----> +.02 +.02 -.02 <hr/> .00		-.154 -.153		

^a Average of two readings for the primary standard thermometer (when rounding off, the even number was chosen).
^b Adjusted scale correction computed for primary standard at indicated temperature.
^c Ice-point correction - taken after calibration point.
^d Temperature of calibration bath medium as determined by the corrected primary standard.
^e Average of two readings for the thermometer being calibrated.
^f Temperature of calibration bath medium as determined by average of two corrected primary standard thermometers.
^g Correction for thermometer under test excluding possible stem-temperature correction.
^h Average correction of two observers.
ⁱ Stem-temperature correction (see text for computation).
^j Algebraic addition of average correction of two observers and stem-temperature correction. This value is given on the Report of Calibration.

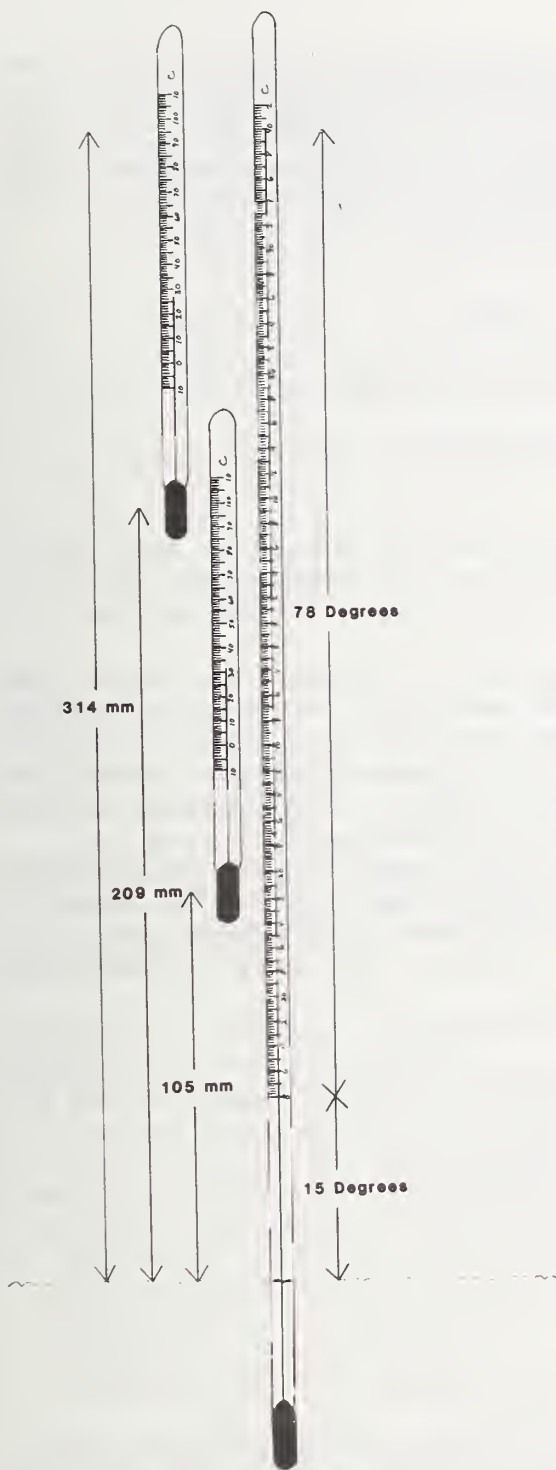

Figure 12. Measuring stem temperature on an ASTM 33C thermometer using two auxiliary thermometers.

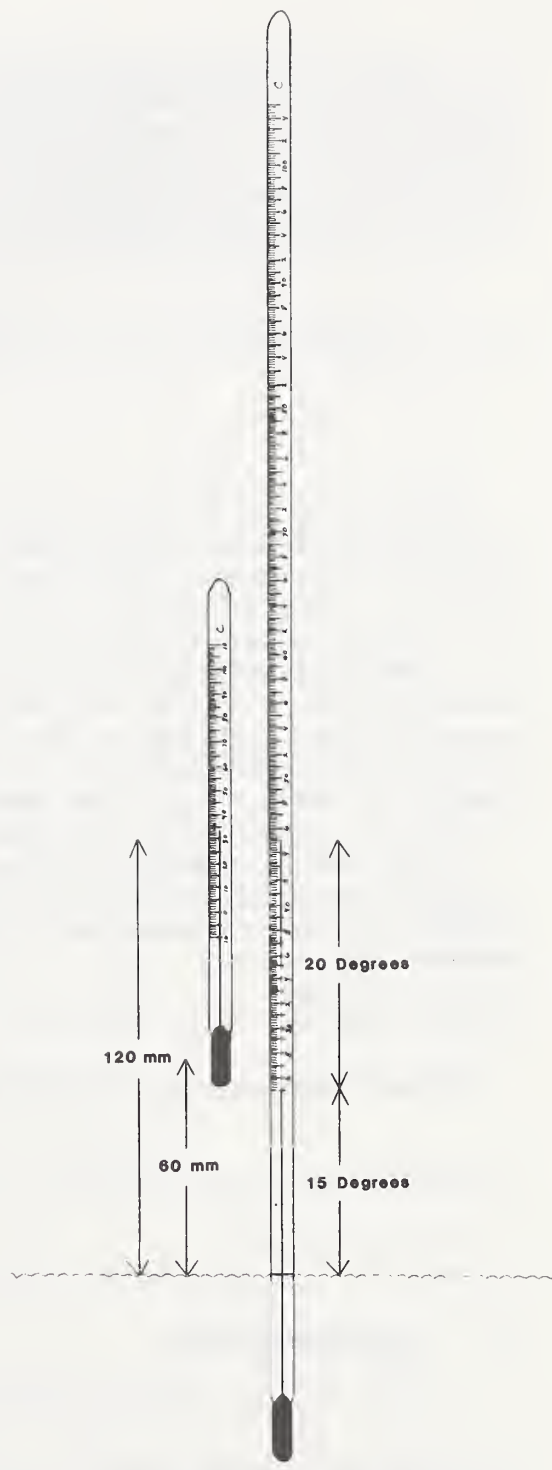

Figure 13. Measuring stem temperature on an ASTM 34C thermometer using one auxiliary thermometer.

The average observed stem temperature (t_{obs}) is 28.5 °C [(31+26)/2], the specified stem temperature (t_{sp}) is 30 °C, the coefficient of expansion of mercury in glass for Celsius thermometers is 0.00016 and the number of degrees emergent from the bath, including the portion from the immersion line to the first graduation (n), is 93 degrees.

$$\begin{aligned}\text{Stem-temperature correction} &= 0.00016 n (t_{obs}-t_{sp}) & (4) \\ &= 0.00016 (93) (28.5-30) \\ &= -0.02 \text{ } ^\circ\text{C}\end{aligned}$$

Notice that the values t_{sp} and t_{obs} are reversed in the above formula, as compared to the one given in NBS Monograph 150 [1], since we are applying this correction to a correction and not to the thermometer reading itself.

As a second example, thermometer T7 is an ASTM 34C thermometer. Since the length of the emergent mercury column is only 120 mm, placing the center of the bulb of one auxiliary thermometer adjacent to thermometer T7, 60 mm from the immersion line, is sufficient to measure the average temperature of the emergent stem. This example is shown in Figure 13.

In this example, the average observed stem temperature (t_{obs}) is 33 °C, the specified stem temperature is 37 °C, the coefficient of expansion of mercury in glass is 0.00016, and the number of degrees from the immersion line to the mercury meniscus is 35 degrees.

$$\begin{aligned}\text{Stem-temperature correction} &= 0.00016 n (t_{obs}-t_{sp}) & (5) \\ &= 0.00016 (35) (33-37) \\ &= -0.02 \text{ } ^\circ\text{C}\end{aligned}$$

4. DOCUMENTATION

4.1 Report of Calibration

After corrections are determined (see Section 3.3.9 of this Monograph), a Report of Calibration is generated for each thermometer. The Report should include the following:

- 1) Company, agency, or establishment that submitted the thermometer,
- 2) Manufacturer's trade name and serial number of the thermometer,

- 3) Range and graduation interval,
- 4) Calibration temperatures and corrections,
- 5) Temperature scale used (IPTS-68),
- 6) Instructions for use of corrections,
- 7) Estimated uncertainties,
- 8) Other notes concerning how the thermometer was calibrated and how it can be recalibrated.

The following list contains examples of notes given on NBS Reports of Calibration.

ALL TOTAL-IMMERSION THERMOMETERS.

The tabulated corrections apply for the condition of total immersion of the bulb and liquid column. If the thermometer is used at partial immersion, apply an emergent stem correction as explained in the accompanying stem correction sheet. (See Figures 14 and 15.)

ALL PARTIAL-IMMERSION THERMOMETERS WITH NO STEM-TEMPERATURE CORRECTIONS.

The thermometer was tested in a large, closed-top, electrically heated, liquid bath at an immersion of _____. The temperature of the room was about 23 °C (73 °F). If the thermometer is used under conditions which would cause the average temperature of the emergent liquid column to differ markedly from that prevailing in the test, appreciable differences in the indications of the thermometer would result.

PARTIAL-IMMERSION THERMOMETERS WITH THE SAME STEM TEMPERATURE AT EACH CALIBRATION POINT.

These corrections are applicable for _____ immersion and for an emergent stem temperature of _____.

PARTIAL-IMMERSION THERMOMETERS WITH DIFFERENT STEM TEMPERATURES AT EACH CALIBRATION POINT.

These corrections are applicable for _____ immersion and for temperatures of the emergent mercury column as given below:

Reading of thermometer _____
 Temperature of emergent mercury _____.

RECALIBRATION NOTE USING ICE POINT.

The tabulated corrections apply provided the ice-point reading is _____. If the ice-point reading is found to be higher (or lower) than stated, all other readings will be higher (or lower) by the same amount.

RECALIBRATION NOTE USING ICE POINT FOR TOTAL-IMMERSION
THERMOMETERS GRADUATED UNDER 150 °C AND IN GRADUATION INTERVALS
OF 0.2 °C OR LESS.

The tabulated corrections apply provided the ice-point reading taken after exposure for not fewer than 3 days to a temperature of about 23 °C (73 °F) is _____. If the ice-point reading is found to be higher (or lower) than stated, all other readings will be higher (or lower) by the same amount. If the thermometer is used at a given temperature shortly after being heated to a higher temperature, an error of 0.01 ° or less, for each 10° difference between the two temperatures, may be introduced. The tabulated corrections apply if the thermometer is used in its upright position; if used in a horizontal position, the indications may be a few hundredths of a degree higher.

STEAM POINT USED AS REFERENCE POINT.

The tabulated corrections apply provided the reading when the thermometer is immersed in steam at 100 °C (212 °F) is _____. If the reading is found to be higher (or lower) than stated, all other readings will be higher (or lower) by the same amount. The temperature of steam is 100 °C (212 °F) only if the pressure is 760 mm (29.921 inches). If the pressure differs from 760 mm (29.921 inches), allowance must be made for this. If the pressure is higher (or lower) than 760 mm (29.921 inches) the temperature will be higher (or lower) than 100 °C (212 °F) by approximately 0.037 °C per mm difference (1.68 °F per inch difference).

CALORIMETRIC THERMOMETERS HEATED TO TOP POINT BEFORE TESTING.

The thermometer, before testing, was heated to the temperature of the highest test point. The application of the tabular corrections to the readings of the thermometer will give true temperature differences provided the thermometer is used in its upright position and is heated previously (within an hour before using) to the highest temperature to be measured.

SETTING FOR BECKMANN THERMOMETERS.

The tabulated corrections apply for a "setting" of 20 °C. Setting factors for use with other settings are given on the accompanying sheet. (See Figure 16.)

ICE POINT TAKEN AFTER TEST, SUCH AS CLINICAL AND KINEMATIC
VISCOSITY THERMOMETERS.

The tabulated corrections apply for the condition of immersion indicated provided the ice-point reading, taken after heating to _____ for not fewer than 3 minutes, is _____. If the ice-point reading, which should be taken within 5 minutes after removal of the thermometer from the heated bath, is found to be higher (or lower) than stated

all other readings will be higher (or lower) by the same amount.

If there is any other information concerning the thermometer that the laboratory supervisor thinks is important for the user to know, a note should be written and included on the Report. If the thermometer was calibrated against NBS standards, it might be advisable to state that the thermometer is traceable to NBS and give the serial numbers of the standards and the NBS test number that the standards were tested under. (Figures 17 and 18 show a sample Report of Calibration that would be issued by NBS for Thermometer T1.)

4.2 Report of Test

A Report of Test is issued for an electronic temperature measuring system and should also include the name of the company that submitted the system, identification of the system (serial number and model), temperature scale used, calibration temperatures, and output of the sensor, which may be in volts, ohms, hertz, etc. All conditions of the test, such as the immersion depth of the probe and settings on the electronic readout device, should also be included in the Report. (Figure 19 is a sample Report of Test issued by NBS.)

CORRECTION FOR EMERGENT STEM

This stem correction sheet is designed to explain the process of computing the corrections for emergent stem, but has not been specifically adapted to the individual thermometer with which it is issued.

If a total-immersion thermometer is actually used with a part of the liquid column in the capillary emergent from the bath, a stem correction must be calculated and applied as explained below, making use of the formulas given.

The general formula used in computing the correction for emergent stem is:

$$\text{Stem correction} = k \times n(t_1 - t),$$

where k = the differential expansion coefficient of mercury (or other liquid in the thermometer such as alcohol, toluene, pentane, etc.) in the particular kind of glass of which the thermometer is made; (for numerical values see below)

n = number of degrees emergent from the bath;

t_1 = temperature of the bath;

t = mean temperature of the emergent stem.

EXAMPLE 1.—Suppose the observed reading was 84.76° C and the thermometer was immersed to the 20° mark on the scale, so that 65° of the column projected into the air, and the mean temperature of the emergent column was found to be 38° C, then—

$$\text{Stem correction} = 0.00016 \times 65 (85^\circ - 38^\circ) = +0.49^\circ \text{ C.}$$

The true temperature is therefore the observed reading, 84.76° C, + tabular correction as interpolated from the report, + emergent stem correction (+0.49° C).

EXAMPLE 2.—Suppose the observed reading was 780° F and the thermometer was immersed to the 200° mark on the scale, so that 580° of the column projected into the air, and the mean temperature of the emergent column was found to be 170° F, then—

$$\text{Stem correction} = 0.00009 \times 580 (780^\circ - 170^\circ) = +32^\circ \text{ F}$$

as a first approximation.

Since the result shows that the bath temperature was approximately 780° F + 32° F, a second approximation should be made, using $t_1 = 812^\circ \text{ F}$ instead of $t_1 = 780^\circ \text{ F}$. This gives—

$$\text{Stem correction} = 0.00009 \times 580 (812^\circ - 170^\circ) = +34^\circ \text{ F.}$$

The true temperature is therefore the observed reading, 780° F, + tabular correction as interpolated from the report, + emergent stem correction (+34° F).

It will be noted that if the average temperature of the stem is below that of the bulb, the sign of the correction will be +, while if the temperature of the stem is above that of the bulb, the sign of the correction will be —.

EXPLANATORY NOTES ON THE EMERGENT STEM CORRECTION

Some thermometers are pointed and graduated by the maker to read correct, or approximately correct, temperatures when the bulb and the entire liquid index in the stem are exposed to the temperature to be measured, while other thermometers are so pointed and graduated that they will read correct, or approximately correct, temperatures when the bulb and only a short length of the stem of the thermometer are immersed in the bath, the temperature of which is to be measured. Thermometers of the former class are known as "total-immersion thermometers," and those of the latter class as "partial-immersion thermometers."

Total-immersion thermometers are tested under the condition of total immersion and the corrections resulting from such a test will serve to reduce the observed readings of the thermometer to true temperatures only if the thermometer is used as a total-immersion thermometer. If such a thermometer is actually used as a partial-immersion thermometer, i. e., with a part of the mercury column emergent into the space above the bath, and with the emergent stem therefore either colder (or warmer) than the bulb, the thermometer will obviously read lower (or higher) than it would under the condition of total immersion. Hence, if a total-immersion thermometer is so used, a so-called stem correction must be applied to the observed reading in addition to the correction taken from the accompanying table of corrections. This stem correction is very large if the number of degrees emergent and the difference of temperature between the bath and the space above it are large. It may amount to more than 20° C (36° F) for measurements made with a mercury thermometer at 400° C (750° F).

The coefficient k is different for different kinds of glass and, even for the same kind of glass, it differs for different temperature intervals, i. e., different values of $(t_1 - t)$. Values for k for two widely used thermometric glasses, for use in calculating stem corrections are tabulated as follows:

VALUES OF k FOR MERCURY-IN-GLASS THERMOMETERS

For Celsius thermometers			For Fahrenheit thermometers		
Mean temp. $\frac{t_1 + t}{2}$	k for "normal" glass	k for "borosilicate" glass	Mean temp. $\frac{t_1 + t}{2}$	k for "normal" glass	k for "borosilicate" glass
0°	0.000158	0.000164	0°	0.000088	0.000091
100	158	164	200	88	91
150	158	165	300	88	92
200	159	167	400	89	93
250	161	170	500	90	95
300	164	174	600	92	97
350	-----	178	700	-----	.000100
400	-----	183	800	-----	103
450	-----	188			

If the kind of glass of which the thermometer is made is known, the value of k to be used in computing the stem correction may be taken from the above table. If the kind of glass is not known, use $k = 0.00016$ for Celsius or 0.00009 for Fahrenheit thermometers. High-grade thermometers are now generally made of "normal" or "borosilicate" glasses. If a thermometer is graduated only to about 450° C (850° F), it may be made of either of the above glasses; if it is graduated to 500° C (932° F) and is actually usable at that temperature, it is made of one of the borosilicate glasses or a similar glass.

The expansions of liquids such as alcohol, toluene, etc., vary quite rapidly with the temperature, so that k varies considerably for different temperature intervals. An approximate stem correction for such thermometers may be calculated by taking k in the above equation = 0.001 for Celsius thermometers or 0.0006 for Fahrenheit thermometers.

The value of t , the mean temperature of the emergent stem, is the most difficult of the terms in the above formula to estimate. It may be quite accurately measured by the use of special capillary thermometers. This is, however, very rarely done except in the testing laboratory, and then only when the stem correction must be determined with considerable precision (to 10 percent or better). In general, the value of t may be determined to a sufficient approximation by judgment or preferably by suspending an auxiliary thermometer close beside the emergent stem, with the bulb of the auxiliary thermometer somewhat nearer to the top of the bath than to the liquid meniscus.

Figure 14. Stem temperature explanation sheet attached to reports for total-immersion thermometers.

DIFFERENTIAL CORRECTION FOR EMERGENT STEM

This sheet is designed to explain a convenient process of computing the differential correction for emergent stem but has not been specifically adapted to the individual thermometer with which it is issued.

If a calorimetric or differential or a metastatic (Beckmann) thermometer is actually used with a part of its stem emergent from the bath, a differential stem correction must be calculated and applied as explained below, making use of the formulas there given.

EXAMPLE 1.—Suppose the point, I° , to which the thermometer was immersed was 16° C: its initial reading, T°_1 , was 24.127° ; its final reading, T°_2 , was 27.876° ; the mean temperature, t° , of the emergent stem was 26° ; then—

Differential stem correction = $0.00016(28 - 24)(24^\circ + 28^\circ - 16^\circ - 26^\circ) = +0.006^\circ$.

The result, 0.006° , should be added to the difference between T°_2 and T°_1 , found after applying to each the corrections tabulated on the Report of Calibration.

EXAMPLE 2.—Suppose a Beckmann thermometer was immersed to the 0° mark on its scale; its initial reading, T°_1 , was 2.058° ; its final reading, T°_2 , was 5.127° ; the mean temperature, t° , of the emergent stem was 24° C; and the setting, S° , was 25° C; then—

Differential stem correction = $0.00016(5 - 2)(25^\circ + 2^\circ + 5^\circ - 24^\circ) = +0.004^\circ$.

The result $+0.004^\circ$, should be added to the difference between T°_2 and T°_1 , found after applying to each the corrections tabulated on the Report of Calibration and multiplying the difference by the setting factor (1.0014 for a setting of 25°).

EXPLANATORY NOTES ON THE EMERGENT STEM CORRECTION

Calorimetric and differential and metastatic (Beckmann) thermometers are pointed and graduated by the makers to read correct or approximately correct temperature intervals when the bulb and the entire mercury index in the stem are exposed to the temperature to be measured, and such thermometers are standardized for the condition of "total immersion," and the corrections given in reports apply for the condition of total immersion.

In practically all cases, however, such thermometers are actually used with only the bulb and a portion of the stem immersed, the remainder of the stem projecting into the air above the bath.

In such cases the accuracy attained can be increased by applying the necessary corrections for the emergent stem. The emergent stem correction corresponding to any reading may be computed by means of the formula—

$$\text{Stem correction} = k \times n(T^\circ - t^\circ);$$

where k = the differential expansion coefficient of mercury in glass;

= 0.00016 for Celsius thermometers;
= 0.00009 for Fahrenheit thermometers;

n = number of degrees emergent from the bath;

T° = temperature of the bath;

t° = mean temperature of the emergent stem.

However, in differential measurements the parts of the scale on which readings are made are, in general, emergent from the bath and it is usually permissible to assume that t° will be constant during the measurement. In this case, instead of calculating the stem corrections for the initial and final readings, and applying them separately, the differential stem correction can be more conveniently computed by using the appropriate formula of the two given below.

Differential emergent stem correction for ordinary thermometers.—The differential stem correction may be computed from the following formula:

$$\text{Differential stem correction} = k \times d(T^\circ_1 + T^\circ_2 - I^\circ - t^\circ);$$

k = 0.00016 for Celsius thermometers;

= 0.00009 for Fahrenheit thermometers;

T°_1 = the initial reading;

T°_2 = the final reading;

d = $T^\circ_2 - T^\circ_1$;

I° = scale reading to which the thermometer was immersed;
 t° = mean temperature of the emergent stem.

It should be noted that this differential stem correction, as well as the difference d , may be either positive or negative, and the correction must be applied with due regard to these signs.

Differential emergent stem correction for metastatic (Beckmann) thermometers.—The differential emergent stem correction may be computed from the following formula, provided the thermometer is immersed to its 0° mark:

$$\text{Differential stem correction} = k \times d(S^\circ + T^\circ_1 + T^\circ_2 - t^\circ);$$

where S° = the "setting" of the thermometer, and k , d , T°_1 , T°_2 and t° have the meanings given in the preceding paragraph.

It should be noted that this differential stem correction, as well as the difference d , may be either positive or negative, and the correction must be applied with due regard to these signs.

A Beckmann thermometer of the ordinary type should not be used with any part of the lower portion of the stem exposed, as this part may contain from 5 to 10 times as much mercury per centimeter as the graduated portion, and if exposed introduces a large and uncertain error.

In case it is necessary to use such a thermometer with some of the lower portion of the stem emergent from the bath, the necessary correction may be computed from the above formula, provided S° in the formula is replaced by $S^\circ + m^\circ$, where m is the number of degrees the temperature of the thermometer must be lowered to bring the meniscus from the zero position on its scale to the point of immersion.

If the thermometer is immersed to some point other than its 0° mark, as would ordinarily be the case with thermometers having the 0° graduation at the top of the scale, the differential stem correction may also be computed from the above formula, provided S° in the formula is replaced by $S^\circ + m^\circ$, where m is the number of degrees the temperature of the thermometer must be lowered to bring the meniscus from the zero position on its scale to the point of immersion. Provided the points at which readings are made are above the point to which the thermometer is immersed, the preceding statement is applicable whether the point to which the thermometer is immersed is on the scale or below it.

Figure 15. Stem temperature explanation sheet attached to reports for calorimetric thermometers calibrated at total immersion.

This sheet gives a table of setting factors and an example to explain the processes employed in calculations. The example, however, has not been specifically adapted to the individual thermometer with which this sheet is issued.

The thermometer is said to have a given setting, for instance 20°C, if its scale reading is 0° when the temperature of the bulb is 20°C.

The following table, calculated for thermometers of Jena 16^{III} glass, gives a series of factors corresponding to different settings by which each observed temperature difference must be multiplied after applying the corrections given on the preceding page. This factor is made unity for a setting of 20°C.

For any scale length up to 15°

Setting	Factor	Setting	Factor
0°C	0.9935	55°C	1.0092
5	0.9951	60	1.0102
10	0.9967	65	1.0112
15	0.9984	70	1.0121
20	1.0000	75	1.0129
25	1.0014	80	1.0137
30	1.0029	85	1.0146
35	1.0042	90	1.0154
40	1.0056	95	1.0162
45	1.0070	100	1.0170
50	1.0082		

As an illustration, suppose the following observations were made:

Setting	= 25°C.	Lower reading =	2.058°
Stem temperature =	24°	Upper reading =	5.127°
		Lower	Upper
		Observed reading =	2.058
		Correction from certificate =	<u>+0.005</u>
		Corrected upper reading =	5.119
		Corrected lower reading =	<u>2.063</u>
		Difference =	3.056
Setting factor	1.0014	corr.	+0.004
		Emergent stem correction* =	<u>+0.004</u>
		Corrected difference =	3.064

* See accompanying stem correction sheet.

Figure 16. Table of setting factors attached to reports for Beckmann thermometers.

U.S. DEPARTMENT OF COMMERCE
NATIONAL BUREAU OF STANDARDS
NATIONAL MEASUREMENT LABORATORY
GAITHERSBURG, MD. 20899

REPORT OF CALIBRATION
LIQUID-IN-GLASS THERMOMETER.

TESTED FOR: NATIONAL BUREAU OF STANDARDS
DIVISION 522
MARKED: SURETY T1
RANGE: -2 TO +102 DEGREES C IN 0.2 DEGREE

THERMOMETER READING	CORRECTION (IPTS-68)**
- .10 C	.10 C
20.00	.05
40.00	-.07
60.00	.01
80.00	-.04
100.00	.00

**ALL TEMPERATURES IN THIS REPORT ARE BASED ON THE INTERNATIONAL PRACTICAL TEMPERATURE SCALE OF 1968, IPTS-68. THIS TEMPERATURE SCALE WAS ADOPTED BY THE INTERNATIONAL COMMITTEE OF WEIGHTS AND MEASURES AT ITS MEETING IN OCTOBER, 1968, AND IS DESCRIBED IN 'THE INTERNATIONAL PRACTICAL TEMPERATURE SCALE OF 1968 AMENDED EDITION OF 1975,' METROLOGIA 12, NO. 1, 7-17 (1976).

ESTIMATED UNCERTAINTIES IN THE ABOVE CORRECTIONS DO NOT EXCEED 0.05 DEGREE UP TO 102 DEGREES C .

FOR A DISCUSSION OF ACCURACIES ATTAINABLE WITH SUCH THERMOMETERS SEE NATIONAL BUREAU OF STANDARDS MONOGRAPH 150, LIQUID-IN-GLASS THERMOMETRY.

IF NO SIGN IS GIVEN ON THE CORRECTION, THE TRUE TEMPERATURE IS HIGHER THAN THE INDICATED TEMPERATURE; IF THE SIGN GIVEN IS NEGATIVE, THE TRUE TEMPERATURE IS LOWER THAN THE INDICATED TEMPERATURE. TO USE THE CORRECTIONS PROPERLY, REFERENCE SHOULD BE MADE TO THE NOTES GIVEN BELOW.

THE TABULATED CORRECTIONS APPLY FOR THE CONDITION OF TOTAL IMMERSION OF THE BULB AND LIQUID COLUMN. IF THE THERMOMETER IS USED AT PARTIAL IMMERSION, APPLY AN EMERGENT STEM CORRECTION AS EXPLAINED IN THE ACCOMPANYING STEM CORRECTION SHEET.

TEST NUMBER 999999
COMPLETED 1-22-85

Figure 17. Facsimile of page 1 of an NBS Report of Calibration for thermometer, Serial Number T1.

THE TABULATED CORRECTIONS APPLY PROVIDED THE ICE-POINT READING, TAKEN AFTER EXPOSURE FOR NOT FEWER THAN 3 DAYS TO A TEMPERATURE OF ABOUT 23 DEGREES C (73 DEGREES F), IS -0.10 C. IF THE ICE-POINT READING IS FOUND TO BE HIGHER (OR LOWER) THAN STATED, ALL OTHER READINGS WILL BE HIGHER (OR LOWER) BY THE SAME AMOUNT. IF THE THERMOMETER IS USED AT A GIVEN TEMPERATURE SHORTLY AFTER BEING HEATED TO A HIGHER TEMPERATURE, AN ERROR OF 0.01 DEGREE OR LESS, FOR EACH 10-DEGREE DIFFERENCE BETWEEN THE TWO TEMPERATURES, MAY BE INTRODUCED. THE TABULATED CORRECTIONS APPLY IF THE THERMOMETER IS USED IN ITS UPRIGHT POSITION; IF USED IN A HORIZONTAL POSITION, THE INDICATIONS MAY BE A FEW HUNDREDTHS OF A DEGREE HIGHER.

FOR THE DIRECTOR,
NATIONAL MEASUREMENT LABORATORY

TEST NUMBER 999999
COMPLETED 1-22-85

ROBERT J. SOULEN, JR.
CHIEF, TEMPERATURE AND PRESSURE DIVISION
CENTER FOR BASIC STANDARDS

Figure 18. Facsimile of page 2 of an NBS Report of Calibration for thermometer, Serial Number T1.

U.S. DEPARTMENT OF COMMERCE
NATIONAL BUREAU OF STANDARDS
GAITHERSBURG, MD 20899

REPORT OF TEST

Surety Model 1234 RTD Digital Thermometer S/N 4567
Resistance Thermometer S/N 999

Submitted by

National Bureau of Standards
Gaithersburg, Maryland

Resistance thermometer S/N 999, which was attached to a Surety Model 1234 RTD Digital Thermometer S/N 4567, was calibrated by intercomparison with a standard platinum resistance thermometer in stirred liquid comparison baths at four temperatures. The unit was allowed to warm up 20 hours before measurements were made. An ice point was taken before and after test by immersing the probe in an ice bath. The probe was immersed to a depth of 18 cm for all measurements and the ambient temperature of the laboratory was 23 °C. The results are given below.

Bath Temperature	Reading of Resistance Thermometer
0.00 °C	+0.40 °C
50.00	50.49
100.00	100.48
125.00	125.40
150.00	150.23
0.00	+0.40

The uncertainty of the bath temperatures given above is estimated not to exceed 0.01 °C to 100 °C and 0.02 °C from 100 to 150 °C.

All temperatures in this report are based on the International Practical Temperature Scale of 1968, IPTS-68. This temperature scale was adopted by the International Committee of Weights and Measures at its meeting in October 1968, and is described in "The International Practical Temperature Scale of 1968, Amended Edition of 1975", Metrologia 12, No. 1, 7-17 (1976).

For the Director
National Measurement Laboratory

Robert J. Soulen, Jr., Chief
Temperature and Pressure Division
Center for Basic Standards

Test No. 999999
Date : May 31, 1985

Figure 19. Facsimile of an NBS Report of Test for an electronic temperature measuring system.

5. MAINTAINING LABORATORY STANDARDS AND ESTIMATION OF LABORATORY UNCERTAINTY

5.1 Estimates of Inaccuracy of Calibration of Liquid-in-Glass Thermometers

The inaccuracy of a temperature measurement refers to a consistent offset or systematic difference between readings and the proper temperature. Several factors affect the accuracy of liquid-in-glass thermometer readings; the ones described in this Monograph include

- o Inaccuracy in IPTS-68. See Section 2.3.1.
- o Stem corrections for partial-immersion thermometers. See Section 3.3.10.
- o Improper preparation of ice bath. See Section 2.2.1.
- o Temperature gradients in temperature baths. See Section 2.2.2.
- o Bubbles or gas in mercury. See Section 3.1.
- o Expansion of bulb glass. See Section 3.3.5.

The first factor is beyond the control of the laboratory; the others will have to be carefully studied for the particular laboratory, and their influence on accuracy will have to be assessed.

To indicate how the values for inaccuracy were determined at NBS, we note the following. Ice baths prepared over a number of years were compared with a platinum resistance thermometer that has a measurement inaccuracy of 0.001 °C. It was found that the ice bath temperatures varied by ± 0.005 °C, so we assign an inaccuracy of this value to this factor. As for temperature gradients in the constant temperature baths, three platinum resistance thermometers read simultaneously were used to demonstrate that, for baths used from 0 °C to 100 °C, the maximum variation radially or horizontally was found to be 0.005 °C. For baths used from 100 °C to 200 °C the gradients were found to be 0.01 °C at 100 °C gradually increasing to a value of 0.025 °C at 200 °C. Concerning errors introduced by poor thermometer quality, thermometers used as primary standards at NBS did not have bubbles or gas, so these systematic errors were negligible. Finally, when liquid-in-glass thermometers were used as standards, expansion of the bulb was corrected for by the techniques discussed in this Monograph (Sections 3.3.5 and 3.3.8) and thus introduced no significant residual inaccuracy. We summarize these results in Table 7.

5.2 Maintaining the Accuracy of Primary Laboratory Standards

The experience at the NBS has been that no factors other than those summarized in Section 5.1 have a significant effect on the accuracy of primary liquid-in-glass thermometers. Indeed,

TABLE 7

MAJOR SYSTEMATIC ERRORS (INACCURACY) IN THE NBS
LIQUID-IN-GLASS THERMOMETER CALIBRATION SERVICE

<u>Effect</u>	<u>Inaccuracy</u>	
	<u>Range 1</u>	<u>Range 2</u>
	0 - 100 °C	100 - 200 °C
Ice bath	0.005 °C	0.005 °C
Bath gradients	0.005 °C	0.01 - 0.025 °C
TOTAL	0.010 °C	0.015 - 0.030 °C

many of them refer to laboratory techniques (ice bath, gradients in constant temperature bath) that, if properly established at the outset, will not introduce inaccuracies at a later time.

Of the remaining effects, the single largest source of calibration offset is the bulb volume change of the thermometers. If adjusted scale corrections are calculated for each primary standard thermometer, this effect will be accounted for each time the primary thermometers are used. By using two thermometers, the likelihood that the corrections are incorrectly applied will be small.

Use of these aforementioned techniques will preserve the original calibration accuracy of the primary thermometers provided by NBS. Thus the thermometers need not be returned to NBS for recalibration. In the event that the IPTS-68 is revised, NBS will provide the data so that the adjusted scale corrections may be changed accordingly.

5.3 Using Check Standards for Quality Assurance

In the previous section we reviewed the role of the two primary thermometers used in each calibration and the accuracy of the temperatures defined by them. In this section we describe the role of the check standard in evaluating the quality (that is, the imprecision) of the calibration process. Remember that the check standard is included in each calibration run. It is easy therefore to obtain a large number of data points on the check standard in a short period of time. We recommend that the laboratory construct a control chart (to be defined below) from these data. With a sufficient number of points, the data will

have statistical significance that, when analyzed, can indicate clearly the performance of the laboratory.

As an example, we discuss some data obtained at NBS for check standard Serial Number 48425. This thermometer is a total immersion type, with a range of $-2\text{ }^{\circ}\text{C}$ to $+102\text{ }^{\circ}\text{C}$, and with scale divisions of $0.2\text{ }^{\circ}\text{C}$. Using the measurement techniques described in this Monograph, the measurement resolution was found to be $0.01\text{ }^{\circ}\text{C}$ (the cross hair of the telescope is placed at the center of the scale division thus dividing the scale division into two equal parts; the meniscus was read to $1/10$ of these divisions). This thermometer was incorporated as a check standard in several calibrations conducted from 1976 to 1984. Measurements were repeated at many temperatures over the full range of the thermometer. In these experiments the bath temperature was not defined by two primary liquid-in-glass thermometers, but by a calibrated standard platinum resistance thermometer. The imprecision of this resistance thermometer is only $0.001\text{ }^{\circ}\text{C}$, so that no significant source of uncertainty was introduced in the temperature scale. The thermometer was allowed to rest at room temperature ($23\text{ }^{\circ}\text{C}$) for 3 days before being calibrated, allowing the volume of the bulb to recover from a previous thermal cycling. In Figures 20 and 21 we have plotted control charts for this thermometer. Such charts consist of the correction for the thermometer (before and after the ice point shift was accounted for) plotted versus time. We chose to show the data at four temperatures. Such plots immediately reveal the consistency of the calibration process and can indicate calculation errors or degradation of the process.

In addition to plotting the data in a control chart format shown in these figures, we recommend that the same data be submitted to elementary statistical analysis. At each temperature the average correction and the standard deviation may be calculated with the pressing of a few keys on almost any scientific hand-held calculator. In this way, the quality of the calibration process may be quantified. When this was done for the data for check standard Serial Number 48425, it was found that the standard deviation at all temperatures was $0.01\text{ }^{\circ}\text{C}$. This is perhaps understandable, given the fact that the measurement resolution is also $0.01\text{ }^{\circ}\text{C}$. At any rate, as more data are accumulated, these quantifiers may be used to watch for any changes.

For this liquid-in-glass thermometer, the imprecision (i.e., standard deviation) was found to be $0.01\text{ }^{\circ}\text{C}$. Since the imprecision of the primary thermometer was so small ($0.001\text{ }^{\circ}\text{C}$) in this case, no additional uncertainty was introduced by the primary thermometer. This will not be the case in the State calibration laboratory, where the primary thermometers will be liquid-in-glass thermometers of performance comparable with check standard Serial Number 48425. Thus, if two primary thermometers with performance similar to thermometer Serial Number 48425 are used to measure the bath temperature, and the measurements are assumed to be independent, then the standard deviation of the temperature

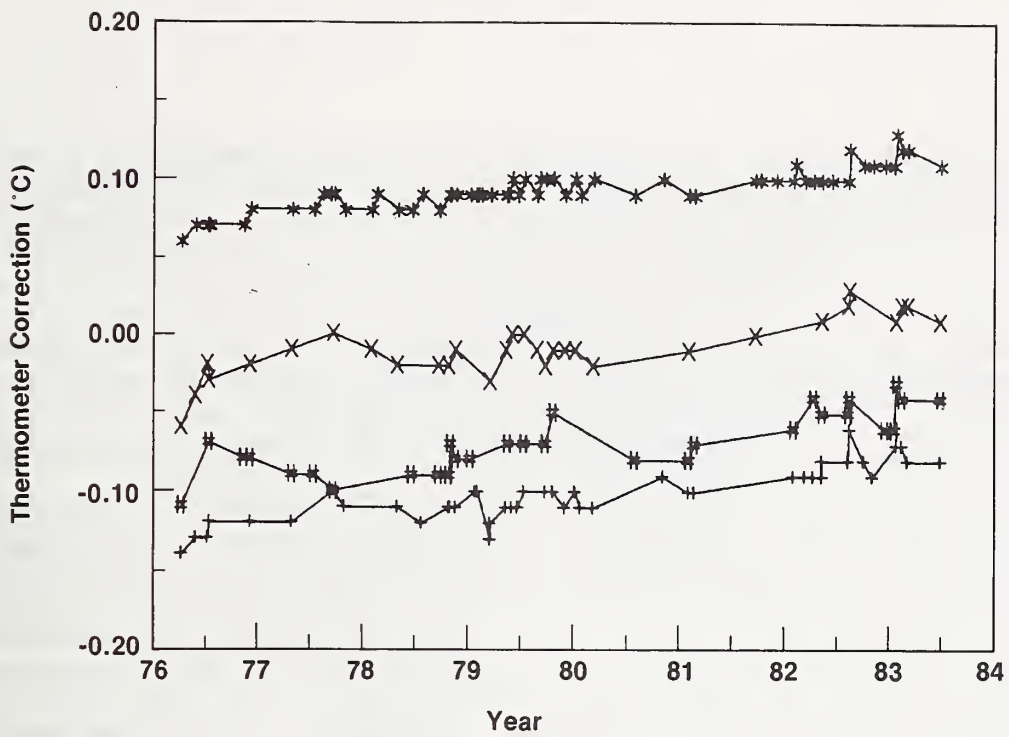

Figure 20. Control chart for thermometer, Serial Number 48425, at four temperatures (* at 0 °C, + at 40 °C, X at 80 °C, and # at 100 °C). The readings were not corrected for ice-point shifts.

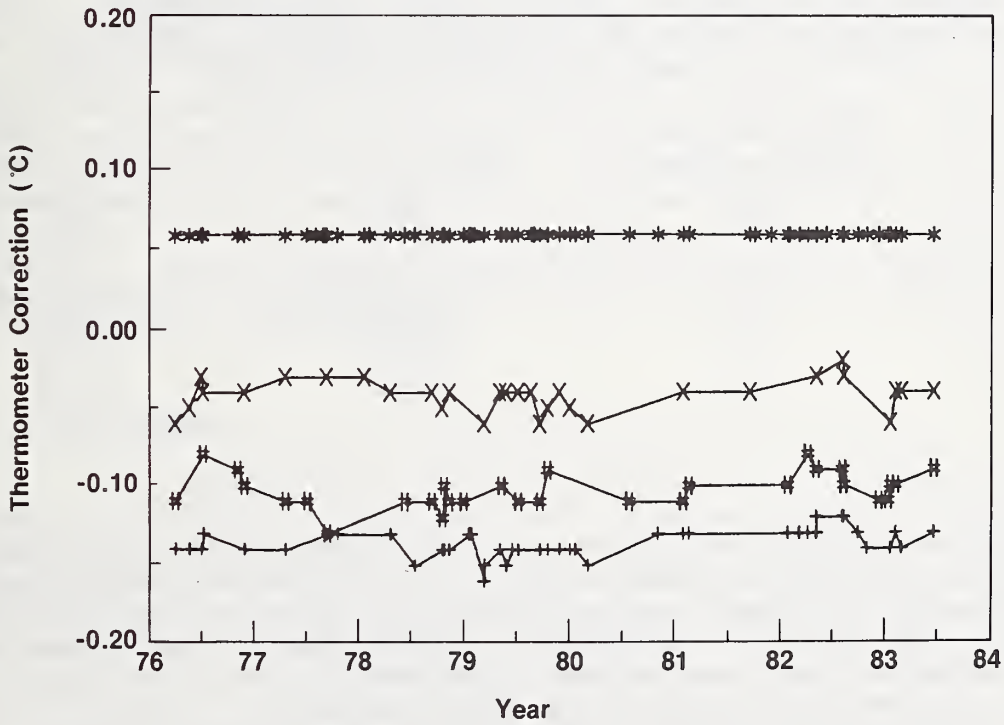

Figure 21. Control chart for thermometer, Serial Number 48425, at four temperatures (* at 0 °C, + at 40 °C, X at 80 °C, and # at 100 °C). The readings were corrected for ice-point shifts.

will be $\sqrt{2} \times (0.01 \text{ }^\circ\text{C}) = 0.014 \text{ }^\circ\text{C}$. If we now measure a check standard (again with a performance comparable with the other two) repeatedly versus these two primary thermometers, and construct a control chart, the standard deviation will be the square root of the sum of the squares of the standard deviation of the check standard and of the thermometers used to define temperature. Thus we would expect the standard deviation for a State calibration laboratory to be $\sqrt{3} \times (0.01) = 0.017 \text{ }^\circ\text{C}$. That is an increase by a factor of $\sqrt{3}$ is introduced into the standard deviation because two liquid-in-glass thermometers are used as the primary standards instead of a platinum resistance thermometer.

Check standards were studied at NBS versus a standard platinum resistance thermometer for four ranges in order to determine the standard deviation. We present these results in Table 8. Remember: The standard deviation expected at a State calibration laboratory using two other primary thermometers should be roughly a factor of $\sqrt{3}$ larger than that obtained by NBS. Note too that the standard deviation increases at higher temperatures, and that this is most likely due to the decreasing resolution of the liquid-in-glass thermometer and larger time-varying gradients in the bath.

TABLE 8

STANDARD DEVIATION (IMPRECISION) OF TEMPERATURE
OBTAINED WITH LIQUID-IN-GLASS THERMOMETERS COMPARED
WITH A STANDARD PLATINUM RESISTANCE THERMOMETER AT NBS

Temperature Range	Thermometer Graduations	Resolution	Std. Dev.
($^\circ\text{C}$)	($^\circ\text{C}$)	($^\circ\text{C}$)	($^\circ\text{C}$)
0 - 50	0.1	0.005	0.006
50 - 100	0.1	0.005	0.008
0 - 100	0.2	0.01	0.009
100 - 200	0.2	0.01	0.028

With this table and the discussion above, a State calibration laboratory can estimate its best achievable imprecision. This table should be compared with the value calculated from the actual data taken at the laboratory. The extent to which the two agree or disagree and the course of action to be taken depend on the goal for precision set by the laboratory.

To construct a final total laboratory uncertainty, the laboratory should assess the systematic errors described in Section 5.1 and add them to the estimated imprecision. As an example, we present in Table 9 the total uncertainty estimate for

the NBS liquid-in-glass calibration service. (We define the uncertainty as the sum of the inaccuracy and three times the imprecision).

TABLE 9
UNCERTAINTY ESTIMATE FOR NBS CALIBRATION SERVICE FOR
LIQUID-IN-GLASS THERMOMETERS

Temperature Range	(Imprecision) 3 Std. Dev.	(Inaccuracy) Systematic Error	Total Uncertainty
(°C)	(°C)	(°C)	(°C)
0 - 50	0.018	0.010	0.028
50 - 100	0.024	0.010	0.034
0 - 100	0.027	0.010	0.037
100 - 200	0.084	0.015 - 0.030	0.099 - 0.114

This table merits several comments. The uncertainty of the IPTS-68 is not included; the systematic error originates chiefly from estimates of the operator's ability to reproduce the ice point (0.005 °C), temperature gradients in the baths (0.005 to 0.025), plus the thermometer resolution. Note too, that we have tripled the standard deviation to insure that 99.7% of the measurements will be included. Assessment of systematic errors is a difficult task, and each laboratory will have to determine systematic effects according to the prescription given in this Monograph. This table is intended to provide an indication of the performance at NBS; practice (and thus these quantities) may differ at other laboratories.

6. CONCLUSION

In this monograph we have indicated the procedures by which a laboratory may be equipped and staffed so that temperature calibrations in the range 0 to 200 °C may be performed accurately within ± 0.1 °C or less. The temperature scale thus established is shown to be traceable to the IPTS-68. Detailed procedures are given for using liquid-in-glass thermometers as primary standards and for deriving calibration corrections for a variety of laboratory thermometers. A checklist for establishing a calibration laboratory to the specifications described is provided in Table 10.

TABLE 10

CHECKLIST FOR ESTABLISHING A
STATE CALIBRATION LABORATORY

- A. Range of Calibration: 0 to +200 °C
- B. Accuracy: ± 0.1 °C; traceable to NBS
- C. Types of devices that can be calibrated:
 - 1. Liquid-in-glass thermometers
 - a) total-immersion
 - b) partial-immersion
 - c) ASTM
 - d) calorimetric
 - e) Beckmann
 - f) clinical standards
 - g) kinematic viscosity
 - 2. Electronic temperature measuring systems
- D. Laboratory Specifications:
 - 1. Dimensions: 7m X 7m X 3m
 - 2. Other requirements
 - a) Constant temperature: 23 °C \pm 2 degrees
 - b) Constant humidity: approximately 50%
- E. Equipment:
 - 1. Thermometer rack or map case to store thermometers
 - 2. Microscope (15- or 20-power)
 - 3. Ice bath
 - a) tape-wrapped Dewar flask
 - b) thermometer clip
 - c) telescope (10-power with crosshair)
 - d) siphon
 - e) soft mallet
 - f) shaved ice
 - g) freezer or chest for ice storage
 - h) distilled water storage tank
 - i) water distillation apparatus or distilled water supply
 - j) plastic gloves
 - k) ice shaver

E. Equipment: (continued)

4. Constant temperature baths (one oil bath may be chosen to span the entire calibration range of 0 °C to +200 °C)

a) Water bath (range: +1 °C to +95 °C)

- 1) Sufficient to accommodate total-immersion liquid-in-glass thermometers
- 2) Overflow provision
- 3) Heating/cooling coils isolated from thermometers
- 4) Unrestricted flow for bath medium
- 5) Insulated
- 6) Thermometer holder designed to minimize heat loss
- 7) Capable of maintaining bath at a constant temperature ± 0.005 °C or a rise rate of no more than 0.1 °C in 3 minutes
- 8) Telescope (10-power with crosshair)

b) Oil bath (range: +95 °C to +200 °C)

- 1) Same specifications as water bath
- 2) Oil
- 3) Hood vented to outside

F. Standards:

1. "Primary"

- a) Two sets of total-immersion liquid-in-glass thermometers (See Table 1) guaranteed to pass NBS visual inspection
- b) Calibrated by NBS or other traceable laboratory

2. "Check"

One or more sets of total-immersion liquid-in-glass thermometers

G. Personnel Requirements:

1. At least a high-school graduate
 2. Detail oriented
 3. Adept in mathematics
 4. Should attend NBS Precision Thermometry Seminar
 5. Twelve months of practice and experience
 6. Capable of calibrating up to 800 thermometers per year
-

7. ACKNOWLEDGMENTS

We would like to thank the following individuals for assisting us in this effort.

Dr. Carroll S. Brickenkamp
Office of Weights and Measures, NBS

Mrs. M. Carroll Croarkin
Statistical Engineering Division, NBS

Mr. L. F. Eason
North Carolina Department of Agriculture
Consumer Standards Division

Mrs. Sylvia C. Ramboz
Temperature and Pressure Division, NBS

Dr. James F. Schooley
Temperature and Pressure Division, NBS

Mr. Charles R. Stockman
Maryland Department of Agriculture
Weights and Measures Section

Mrs. Ruth N. Varner
Statistical Engineering Division, NBS

Mr. Sidney Ween
Ever Ready Thermometer Co., Inc.

8. REFERENCES

1. Jacquelyn A. Wise, Liquid-in-Glass Thermometry. Nat. Bur. Stand. (U.S.) Monogr. 150; January 1976. 30 pages.
2. "The International Practical Temperature Scale of 1968, Amended Edition of 1975", Metrologia 12, No. 1, 7-17 (1976).
3. ASTM Designation E-1, Standard Specification for ASTM Thermometers, Annual Book of ASTM Standards, Vol. 14.01.
4. ANSI Z236.1, Specifications for General Purpose Laboratory Glass Thermometers.
5. ASTM Designation E-77, Standard Method for Verification and Calibration of Liquid-in-Glass Thermometers, Annual Book of ASTM Standards, Vol. 14.01.

9. COMMERCIAL SOURCES

9.1 Suppliers of Calibration Baths*

- 1) Hart Scientific
P. O. Box 934
Provo, UT 84601
- 2) Willard L. Pearce Associates
Manufacturers Representative
Box 200
Allison Park, PA 15101
- 3) Rosemount Engineering Company
4900 West 78th Street
Minneapolis, MN 55435
- 4) Techne Incorporated
3700 Brunswick Pike
Princeton, NJ 08540

9.2 Suppliers of Oils for Calibration Baths*

- 1) Dow Corning
Chemical Products Division
Midland, MI 48640
- 2) E. I. Dupont DeNemours and Co.
Freon Products Division
Wilmington, DE 19899
- 3) Exxon Company, U.S.A.
P. O. Box 1288
Baltimore, MD 21203
- 4) 3M Company
Commercial Chemicals Division
223-6S-04 3M Center
St. Paul, MN 55144-1000

9.3 Suppliers of Thermometers*

- 1) Brooklyn Thermometer Company, Inc.
90 Verdi Street
Farmingdale, NY 11735
- 2) Ever Ready Thermometer Company, Inc.
401 Park Avenue South
New York, NY 10016
- 3) H-B Instrument Co.
American and Bristol Sts.
Philadelphia, PA 19140
- 4) Walter H. Kessler Company, Inc.
160 Hicks Street
Westbury, Long Island, NY 11590
- 5) Miller and Weber, Inc.
1637 George Street
Ridgewood, Queens, NY 11385
- 6) Princo Instruments, Inc.
1020 Industrial Highway
Southampton, PA 18966

9.4 Supplier of Faden Thermometers*

Karl Schneider and Son
Am Bildacken 14
Postfach 13
Werthaim Main I
West Germany

*This list is not all-inclusive. It is intended to be only representative of commercial products. Certain commercial equipment, instruments, or materials are identified in this paper in order to adequately specify the experimental procedures. Such identification does not imply recommendation or endorsement by the National Bureau of Standards, nor does it imply that the materials or equipment identified are necessarily the best available for the purpose.

10. APPENDIX

APPENDIX A-NBS Mongraph 150

Contents

	Page
1. Introduction	1
2. Thermometer Calibration Services at the NBS	1
2.1. Kinds of thermometers accepted for calibration	1
2.2. Preliminary examination	2
2.3. Reports of Calibration	2
2.4. General instructions to applicants for tests	2
a. Initial arrangements	2
b. Shipping instructions	5
3. Definitions	5
4. Temperature Scales and Standards	6
5. Calibration	8
5.1. Equipment	8
a. Ice Bath	8
b. Steam Bath	8
c. Comparison Liquid Baths	9
5.2. Determination of scale corrections	11
5.3. Corrections for emergent stem	13
a. Measurement of emergent-stem temperature	13
b. Formula for total-immersion thermometers	14
c. Formula for partial-immersion thermometers	15
d. Formula for calorimetric thermometers	16
e. Formula for Beckmann thermometers	16
5.4. Number and choice of test points	16
6. Common Thermometers and Factors Affecting Their Use	17
6.1. Total-immersion thermometers	17
6.2. Partial-immersion thermometers	17
6.3. Low-temperature thermometers	19
6.4. Beckmann thermometers	19
6.5. Calorimetric thermometers	20
7. Thermometer Design	21
7.1. Materials of construction	21
7.2. Scale design and workmanship	21
7.3. Scale dimensions	22
7.4. Reference point	22
7.5. Marking of partial-immersion thermometers	22
8. Special Notes	23
8.1. Glass changes	23
a. Temporary changes	23
b. Permanent changes	24
8.2. Pressure effects	24
8.3. Lag	24
8.4. Separated columns	25
9. References	26

Liquid-In-Glass Thermometry

Jacquelyn A. Wise

This Monograph, which supersedes NBS Monograph 90, contains information of general interest to manufacturers and users of liquid-in-glass thermometers. Instructions explaining how to submit a thermometer to the National Bureau of Standards for calibration are provided, and the techniques and equipment, such as stirred liquid comparison baths, used in the calibration procedures are described. A discussion of important principles of acceptable thermometer design and factors affecting their use is included. Listed are tables of tolerances reflecting good manufacturing practices and reasonably attainable accuracies expected with liquid-in-glass thermometers. The calculation of corrections for the temperature of the emergent stem is given in detail for various types of thermometers and conditions of use.

Key words: Calibration; emergent stem; liquid-in-glass thermometer; reference point; stirred liquid comparison bath; temperature scale.

1. Introduction

It is the responsibility of the National Bureau of Standards (NBS) to accurately reproduce the International Practical Temperature Scale of 1968 [1]¹ as a basis for the uniform measurement of temperature throughout the scientific and industrial community of the United States. Because of this responsibility, NBS accepts for calibration with reference to this scale selected types of temperature-measuring instruments [2] for use as reference or working standards where precise temperature measurements are required. Certain liquid-in-glass thermometers are among the instruments accepted.

This Monograph is intended for those who may wish to submit thermometers for calibration or who desire information on the use of liquid-in-glass thermometers for precise temperature measurements. Practices employed at the NBS in the calibration of these thermometers are discussed. Also included is a brief discussion of the International Practical Temperature Scale of 1968, a description of the calibration equipment, and the accuracy capability of liquid-in-glass thermometers. Details of good thermometer design and factors affecting their use are presented in a copious manner.

2. Thermometer Calibration Services at the NBS

The liquid-in-glass thermometer is one of many precision instruments calibrated by the NBS. A complete description of calibration services offered by the NBS appears in NBS Special Publication 250 [2], which can be obtained by writing to the Office of Technical Information and Publications, National Bureau of Standards, Washington, D. C. 20234. Supplements to NBS Special Publication 250 are issued periodically indicating any changes in these services.

2.1. Kinds of Thermometers Accepted for Calibration

Not all thermometers classified as liquid-in-glass are acceptable for calibration by the NBS. In general they must be of an acceptable design and workman-

ship, and capable of being placed in the existing calibration facilities. The type known as laboratory or chemical thermometers, consisting of a solid stem with graduation lines and numbers permanently etched or placed on the stem, are regularly accepted. Others approved for calibration are Beckmann, calorimetric, and enclosed scale (Einschluss) laboratory thermometers. Industrial or mechanical type thermometers with special mountings can be accepted for test if they can be inserted in the comparison baths, or if the thermometer can be easily detached from the mounting.

Any thermometer, such as a household thermometer, consisting of a paper, plastic or metal mounting containing the scale graduations and attached to the unmarked glass thermometer by metal clips, is not acceptable for calibration. Maximum self-registering mercury-in-glass clinical thermometers are no longer tested at the NBS.

¹Figures in brackets indicate the literature references at the end of this Monograph.

It is advisable to contact the liquid-in-glass thermometry laboratory at NBS if there is any doubt concerning the acceptability of a thermometer for calibration. Every effort will be made to assist and satisfy the needs of the scientific and industrial community with problems involving temperature measurement.

2.2. Preliminary Examination

Every thermometer submitted for test must be uniquely identified by a serial number and pass a preliminary examination before final acceptance. These thermometers are viewed under a microscope having a magnification of 15 or 20X to assure that the mercury and capillary are clean. Any foreign matter found in the capillary or bulb that, in the judgment of the laboratory personnel, might tend to make the thermometer readings erratic, is reason for rejection.

Glass chips or oxides of mercury in the capillary or bulb are considered foreign matter that can cause the thermometer to indicate different readings at different periods of time. [For example, if a small chip of glass is located in the capillary at the 30 °C indication, each time the mercury column advances past this point, it could cause the reading of the thermometer to vary for temperatures above 30 °C, because of different quantities of gas that may be trapped around the chip. The movement of the chip to different locations in the capillary, or the trapping of mercury around the chip when the mercury column recedes, would also cause erroneous readings.]

Other reasons a thermometer may be ineligible for test are given below:

- (a) Defective design or workmanship.
- (b) Part of graduated scale not usable.
- (c) Errors in scale graduation or numbering.
- (d) Unsuitable bulb glass or inadequate annealing.
- (e) Inadequate gas filling.
- (f) Cracks in the glass.

A complete list of all possible causes for rejection is not feasible. The prime consideration in the preliminary examination is that the thermometer be capable of precise, reproducible readings.

2.3. Reports of Calibration

In most instances a Report of Calibration will be issued by NBS for every liquid-in-glass thermometer submitted for test that is found free from serious defects as determined by the preliminary examination. In order to receive a Report of Calibration, the thermometer must be calibrated at two or more calibration points. If only one point is requested, a Report of Test will be issued.

The Report of Calibration contains the corrections determined for each point requested and an estimate of the uncertainties associated with the corrections. Also stated on the document are the agency or firm requesting the test, the trade mark and serial number

on the thermometer, the NBS test number and completion date, and explanatory notes defining the conditions under which the results of the test are applicable. When necessary, accompanying the Report of Calibration is a sheet explaining how to calculate the corrections for emergent stem. If the thermometer is of the metastatic (Beckmann) type, the report will be accompanied by a second sheet containing a table of setting factors (See Sec. 6.4) enabling the user to apply the calibration results for settings other than the 20 °C setting for which the corrections are reported. A facsimile of a Report of Calibration is shown in figures 1 and 2.

Any departure from the conditions under which the corrections were obtained, as stated on the Report of Calibration, may significantly change the values of the corrections. Conditions of immersion are particularly important (Sec. 6). It should be emphasized that the estimates of error assigned to the scale corrections do not assure the user of this accuracy in a temperature measurement.

2.4. General Instructions to Applicants for Tests

Testing will be conducted in accordance with the policies of NBS as described in NBS Special Publication 250. The cost of calibration will depend on the number of calibration points requested, the temperature range, and the quantity of thermometers submitted. For tests not specifically outlined in the above publication, NBS should be consulted. If the required measurements appear feasible, and, in the opinion of NBS, sufficiently important to justify the work, such tests will be undertaken for a special fee determined by the nature of the work and time involved. In all requests for test the following procedures and information are pertinent.

a. Initial Arrangements

A letter or purchase order requesting the test must be sent to NBS either with the thermometer or separately. No work can be undertaken unless both the thermometer and letter or purchase order have been received. Information in the request for test should include the quantity and serial numbers of the thermometers sent, the calibration points required, (See Sec. 5.4) and the suggested method for return shipment. If it is desired that the thermometer be insured upon return, a statement to this effect must appear on the request, and a value assigned; otherwise, the thermometer will be returned uninsured.

NBS will assign a test number to each calibration request and acknowledge the receipt of the thermometer. On the acknowledgment will be stated the estimated completion date and estimated cost of calibration. Any foreseeable difficulty that may be encountered involving the calibration will be mentioned on the acknowledgment, as well as the name of someone in the testing laboratory who can be contacted if questions arise.

U.S. DEPARTMENT OF COMMERCE
NATIONAL BUREAU OF STANDARDS
INSTITUTE FOR BASIC STANDARDS
WASHINGTON, D.C. 20234

R E P O R T O F C A L I B R A T I O N
LIQUID-IN-GLASS THERMOMETER

TESTED FOR: NATIONAL BUREAU OF STANDARDS
DIVISION 221, SECTION 11
MARKED: SURETY 198692
RANGE: -2 TO +102 DEGREES C IN 0.2 DEGREE

THERMOMETER READING	CORRECTION (IPTS-68)**
-0.06 C	.06 C
20.00	.13
40.00	.05
60.00	.04
80.00	.06
100.00	.04

**ALL TEMPERATURES IN THIS REPORT ARE BASED ON THE INTERNATIONAL PRACTICAL TEMPERATURE SCALE OF 1968, IPTS-68. THIS TEMPERATURE SCALE WAS ADOPTED BY THE INTERNATIONAL COMMITTEE OF WEIGHTS AND MEASURES AT ITS MEETING IN OCTOBER, 1968, AND IS DESCRIBED IN "THE INTERNATIONAL PRACTICAL TEMPERATURE SCALE OF 1968," METROLOGIA, VOL. 5, NO. 2, 35 (APRIL 1969).

ESTIMATED UNCERTAINTIES IN THE ABOVE CORRECTIONS DO NOT EXCEED 0.05 DEGREE UP TO 102 DEGREES C .

FOR A DISCUSSION OF ACCURACIES ATTAINABLE WITH SUCH THERMOMETERS SEE NATIONAL BUREAU OF STANDARDS MONOGRAPH 150, LIQUID-IN-GLASS THERMOMETRY.

IF NO SIGN IS GIVEN ON THE CORRECTION, THE TRUE TEMPERATURE IS HIGHER THAN THE INDICATED TEMPERATURE; IF THE SIGN GIVEN IS NEGATIVE, THE TRUE TEMPERATURE IS LOWER THAN THE INDICATED TEMPERATURE. TO USE THE CORRECTIONS PROPERLY, REFERENCE SHOULD BE MADE TO THE NOTES GIVEN BELOW.

THE TABULATED CORRECTIONS APPLY FOR THE CONDITION OF TOTAL IMMERSION OF THE BULB AND LIQUID COLUMN. IF THE THERMOMETER IS USED AT PARTIAL IMMERSION, APPLY AN EMERGENT STEM CORRECTION AS EXPLAINED IN THE ACCOMPANYING STEM CORRECTION SHEET.

TEST NUMBER 311-11-74
COMPLETED 5-9-74

FIGURE 1. Facsimile of page 1 of a Report of Calibration.

THE TABULATED CORRECTIONS APPLY PROVIDED THE ICE-POINT READING, TAKEN AFTER EXPOSURE FOR NOT LESS THAN 3 DAYS TO A TEMPERATURE OF ABOUT 23 DEGREES C (73 DEGREES F), IS -0.06 C . IF THE ICE-POINT READING IS FOUND TO BE HIGHER (OR LOWER) THAN STATED, ALL OTHER READINGS WILL BE HIGHER (OR LOWER) BY THE SAME AMOUNT. IF THE THERMOMETER IS USED AT A GIVEN TEMPERATURE SHORTLY AFTER BEING HEATED TO A HIGHER TEMPERATURE, AN ERROR OF 0.01 DEGREE OR LESS, FOR EACH 10-DEGREE DIFFERENCE BETWEEN THE TWO TEMPERATURES, MAY BE INTRODUCED. THE TABULATED CORRECTIONS APPLY IF THE THERMOMETER IS USED IN ITS UPRIGHT POSITION; IF USED IN A HORIZONTAL POSITION, THE INDICATIONS MAY BE A FEW HUNDREDTHS OF A DEGREE HIGHER.

TEST NUMBER 311-11-74
COMPLETED 5-9-74

FOR THE DIRECTOR,
INSTITUTE FOR BASIC STANDARDS

James F. Schooley
JAMES F. SCHOOLEY
CHIEF, TEMPERATURE SECTION
HEAT DIVISION

FIGURE 2. Facsimile of page 2 of a Report of Calibration.

b. Shipping Instructions

To assure safe arrival of the thermometers, they should be packed firmly in their individual cases. A rigid material, such as wooden slats or corrugated paper, can be wrapped around the thermometer case as an additional aid against breakage. The package should contain enough packing material to absorb any shock that it may receive. Included with each shipment should be a packing list stating the number of thermometers shipped, the name of the company sub-

mitting them, and, if applicable, the company's purchase order number.

Unless otherwise specified, the thermometers will be returned via the best method in the judgment of NBS. Shipping charges, both to and from the NBS, will be paid by the applicant. All possible care will be taken in handling thermometers at NBS, but the risk of damage either in shipment or testing must be assumed by the agency, firm or individual submitting them.

3. Definitions

The principle features of a solid-stem liquid-in-glass thermometer are shown in figure 3. Not all of the features shown would necessarily be incorporated in any one thermometer.

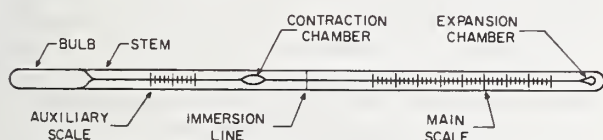

FIGURE 3. Principle features of a solid-stem liquid-in-glass thermometer.

Bulb: The reservoir for the thermometer liquid. The bulb of a thermometer will contain a volume equivalent to a specific number of degrees of the scale depending upon the coefficients of expansion of the thermometric liquid and bulb glass. For mercury in a bulb made of "normal" glass, the bulb volume is equivalent to approximately 6,222 times the volume of a 1 degree length of the capillary on the scale for Celsius thermometers, or 11,200 times the volume of a 1 degree length of the capillary on the scale for Fahrenheit thermometers. For organic thermometric liquids with higher coefficients of expansion than mercury, the bulb volumes are correspondingly less.

Stem: The glass capillary tube through which the thermometric liquid advances or retreats with changes in temperature.

Main Scale: The scale graduated in degrees or multiples or submultiples of degrees; in many instances the main scale constitutes the only scale.

Auxiliary Scale: A short scale including a reference temperature such as the ice point, to provide a means for checking the thermometer for a change in calibration with time (see Sec. 7.4). This scale is added when a suitable reference temperature is not included in the range of the main scale.

Expansion Chamber: An enlargement at the top end of the capillary bore having a volume equivalent to not less than the volume of a 20 mm length of unchanged capillary. Smaller chambers are not regarded as expansion chambers. The expansion chamber is

provided to prevent the buildup of excessive pressures in gas-filled thermometers as the liquid filling advances toward the top of the scale (see Sec. 7.1).

Contraction Chamber: An enlargement of the capillary bore which serves to reduce a long length of capillary or to prevent contraction of the entire liquid column into the bulb. This chamber is introduced below the main scale or between the main scale and an auxiliary scale.

Reference Point: A reference temperature, such as the ice point or steam point, used periodically to check the thermometer for changes in bulb volume. (See Sec. 5.2). The reference point can be included in the main scale or on an auxiliary scale.

Total-Immersion Thermometer: A thermometer designed to indicate temperatures correctly when the bulb and the entire liquid column is exposed to the temperature being measured. (See the definition for complete-immersion thermometer.)

Partial-Immersion Thermometer: A thermometer designed to indicate temperatures correctly when the bulb and a specified portion of the stem is exposed to the temperature being measured. The remaining portion of the stem, referred to as the emergent stem, will be at the ambient temperature, usually different from the temperature being measured. Such thermometers are generally marked with an immersion line to indicate the proper depth of immersion.

Complete-Immersion Thermometer: A thermometer designed to indicate temperatures correctly when the whole thermometer, including the expansion chamber, is subjected to the temperature being measured. In gas-filled thermometers the reading will be different for complete, as compared to total immersion, as a result of the effect of temperature on the gas pressure in the thermometer (see Sec. 8.2). Although the difference in readings under the two conditions is particularly significant at high temperatures, it is also significant at moderate temperatures if the bulb and expansion chamber are both relatively large.

Calibration Points: The temperatures on the thermometer scale (i.e., 0 °C) where calibrations are performed and corrections reported.

Accuracy: The accuracy of a measurement refers to the difference between the measured value and the true value of the quantity being measured. In this Monograph the accuracy of a given thermometer refers to its ability to indicate temperatures correctly on the International Practical Temperature Scale of 1968 [1] within the uncertainty stated (See tables 5-12) provided all corrections are applied and the thermometer is used in the same manner as when it was calibrated. The accuracy attainable is principally limited by the characteristics of the thermometer itself (See Sec. 6).

Instability of the thermometer glass, capillary forces at the surface of the thermometric liquid, non-uniformity of capillary bore, and inaccuracies in scale graduation are among the important factors. With partial-immersion thermometers, uncertainties in corrections for the emergent stem may greatly limit the accuracy. Observer errors are also involved, but with care these can usually be made relatively small.

Precision: The precision of measurement refers to the degree of agreement amongst repeated measurements at a given time of the same quantity.

4. Temperature Scales and Standards

The scale to which measurements of temperature should ultimately be referred is the Thermodynamic Kelvin Temperature Scale (TKTS). Values of temperature expressed on the TKTS are designated by the symbol T . The unit of temperature is the Kelvin, symbol K, which is a base unit of the Systeme Internationale (SI), and is defined as "the fraction 1/273.16 of the thermodynamic temperature of the triple point of water" [3].

Because of the difficulties that are encountered in the practical realization of the TKTS, it has been necessary to define and utilize practical temperature scales. The International Temperature Scale and defining text was first adopted in 1927 and later revised in 1948. The Eleventh General Conference of Weights and Measures in 1960 changed the name of the scale to the International Practical Temperature Scale (IPTS) of 1948 and adopted a revised text of the scale [4], although numerically the scale was not changed. In 1968, in accordance with the power given to it by Resolution 8 of the Thirteenth General Conference of Weights and Measures, the International Committee of Weights and Measures adopted the International Practical Temperature Scale of 1968 [1], henceforth referred to as IPTS-68. The IPTS-68 replaced the International Practical Temperature Scale of 1948 and may be expressed either as a Kelvin scale or as a Celsius scale.

The present Celsius scale has its zero 0.01 K below the triple point of water (essentially the ice point). The value of a temperature expressed on the Thermodynamic Celsius Temperature Scale is designated by the symbol t and is related to the value on the TKTS by

$$t = T - 273.15 \text{ K.}$$

The unit of the Celsius Scale is the degree Celsius, symbol $^{\circ}\text{C}$, which by definition is equal in magnitude to the Kelvin.

Values of temperature expressed on the International Practical Kelvin Scale are designated by the symbol T_{68} , and values of temperatures expressed on the International Practical Celsius Temperature Scale are designated by the symbol t_{68} . The relationship between T_{68} and t_{68} is

$$t_{68} = T_{68} - 273.15 \text{ K.}$$

The units of T_{68} and t_{68} , like the thermodynamic scales, are the Kelvin, symbol K, and degree Celsius, symbol $^{\circ}\text{C}$.

Due to the use of more sophisticated equipment and the ability to measure with more accuracy the defining fixed points, the new temperature scale more closely agrees with thermodynamic temperatures. This scale, IPTS-68, is intended to provide scientific and industrial laboratories throughout the world with a common basis for stating temperatures. Calibrations of thermometers at NBS, therefore, are made with reference to values of temperature on the IPTS-68.

Shown in Table I is the approximate difference in degrees Celsius between the values of temperature given by the IPTS-68 and the IPTS-48 [1]. The differences are listed in two separate sections for convenience and clarity. It can be seen, by studying these values, that the correction is important if quality control in the laboratory is to be maintained to the nearest 0.01 $^{\circ}\text{C}$. If, on the other hand, accuracies no better than the nearest 0.1 $^{\circ}\text{C}$ are desired, the correction becomes less significant in the liquid-in-glass thermometer region (-200 to $+600$ $^{\circ}\text{C}$) of temperature measurements.

Although values of temperatures on the IPTS-68 are expressed in degrees Celsius, thermometers that are graduated on the Fahrenheit Scale can be calibrated with reference to the IPTS-68 by using the conversion formula:

$$\begin{aligned} \text{temperature value in } ^{\circ}\text{F} &= 9/5 \\ &(\text{temperature value in } ^{\circ}\text{C}) + 32 \end{aligned}$$

The National Bureau of Standards has been performing calibrations with reference to the IPTS-68 since July, 1969. On all Reports of Calibration and Reports of Test issued after this date, it has been clearly indicated that the new scale was used.

In the range of temperatures normally covered by liquid-in-glass thermometry, the IPTS-68 is defined by four fixed points: the equilibrium between the liquid and vapor phases of oxygen (normal boiling point of oxygen) at -182.962 $^{\circ}\text{C}$; the equilibrium between solid, liquid, and vapor phases of water (triple point of water) at $+0.01$ $^{\circ}\text{C}$; the equilibrium between the liquid and vapor phases of water (nor-

TABLE I. — Approximate difference ($t_{68} - t_{48}$), in degrees Celsius, between the values of temperature given by the IPTS-68 and IPTS-48

1a. For the range -180 °C to 0 °C.											
t_{68} °C	0	-10	-20	-30	-40	-50	-60	-70	-80	-90	-100
-100	0.022	0.013	0.003	-0.006	-0.013	-0.013	-0.005	0.007	0.012		
- 0	0.000	0.006	0.012	0.018	0.024	0.029	0.032	0.034	0.033	0.029	0.022

1b. For the range 0 °C to 1070 °C.											
t_{68} °C	0	10	20	30	40	50	60	70	80	90	100
0	0.000	-0.004	-0.007	-0.009	-0.010	-0.010	-0.010	-0.008	-0.006	-0.003	0.000
100	0.000	0.004	0.007	0.012	0.016	0.020	0.025	0.029	0.034	0.038	0.043
200	0.043	0.047	0.051	0.054	0.058	0.061	0.064	0.067	0.069	0.071	0.073
300	0.073	0.074	0.075	0.076	0.077	0.077	0.077	0.077	0.077	0.076	0.076
400	0.076	0.075	0.075	0.075	0.074	0.074	0.074	0.075	0.076	0.077	0.079
500	0.079	0.082	0.085	0.089	0.094	0.100	0.108	0.116	0.126	0.137	0.150
600	0.150	0.165	0.182	0.200	0.23	0.25	0.28	0.31	0.34	0.36	0.39
700	0.39	0.42	0.45	0.47	0.50	0.53	0.56	0.58	0.61	0.64	0.67
800	0.67	0.70	0.72	0.75	0.78	0.81	0.84	0.87	0.89	0.92	0.95
900	0.95	0.98	1.01	1.04	1.07	1.10	1.12	1.15	1.18	1.21	1.24
1000	1.24	1.27	1.30	1.33	1.36	1.39	1.42	1.44			

Examples showing the use of these tables are given below to help clarify any difficulty that may be encountered.

I Standard thermometer reading	-36.56 °C
Correction from NBS Report of Calibration	+ .06
True temperature IPTS-48	-36.50 °C
Correction from the above table at -36.50 °C	+ .02
True temperature IPTS-68	-36.48 °C
II Standard thermometer reading	98.32 °F
Correction from NBS Report of Calibration	- .02
True temperature IPTS-48	98.30 °F
Converted correction from the above tables*	- .02
True temperature IPTS-68	98.28 °F

*The converted correction is obtained by:

- Convert the Fahrenheit temperature to Celsius $98.30\text{ °F} = 36.83\text{ °C}$.
- Find the correction from the table at 36.83 °C . It is -0.01 °C .
- Convert this correction to Fahrenheit by multiplying by $9/5$.
 $-0.01\text{ °C} \times 9/5 \approx -0.02\text{ °F}$.

mal boiling point of water) at 100 °C; and the equilibrium between solid and liquid phases of zinc (freezing point of zinc) at 419.58 °C. Temperatures in the range -182.96 to 630.7 °C are defined in terms of a standard platinum resistance thermometer that has been calibrated at the four fixed points, with interpolations and extrapolations between and beyond these points accomplished by employing specified equations [1].

When the highest accuracy is required in a calibration, the thermometer indications are compared directly with temperatures obtained using a standard platinum resistance thermometer. At NBS all calibrations are performed in this manner, with the exception of the ice point (See Sec. 5.2). If a lower accuracy is required, one of several mercury-in-glass thermometers with ranges and graduated in the intervals listed be-

low may be used as standards for total-immersion comparisons.

Range	Smallest graduation	Auxiliary scale
	°C	°C
0 to 50	0.1
0 to 100	0.2
50 to 100	0.1	at 0
100 to 200	0.2	at 0
200 to 300	0.5	at 0

Partial-immersion thermometers, known as "like standards," can be maintained for the calibration of thermometers manufactured to similar specifications.

These standards are calibrated for stem-temperature conditions expected to prevail during the use of these thermometers or for specified stem temperatures. This use of like standards eliminates the need for many of the precautions necessary when dissimilar thermometers are compared and permits the direct comparison of the indications of similar thermometers as long as

the bulbs are at the same temperature and the stem temperatures are essentially the same for all of the thermometers under comparison.

All of these liquid-in-glass standards should be calibrated with reference to the IPTS-68 through comparisons with a standard platinum resistance thermometer.

5. Calibration

In most instances, the determination of the liquid-in-glass thermometer scale corrections is accomplished by comparing its scale indications with a known temperature from a platinum resistance thermometer or mercury-in-glass thermometer standards. This comparison is achieved by placing the standard and the thermometers under test in a series of stirred liquid comparison baths (See Sec. 5.1c). A discussion of the equipment needed, the procedure followed, additional corrections that may be necessary, and the choice of calibration points is given in the following sections.

5.1. Equipment

a. Ice Bath

An ice bath can be easily assembled and consists of a container, a siphon tube, ice and distilled water. A Dewar flask, approximately 36 cm deep and 8 cm in diameter, can serve as a container for the ice. A vessel of this type is preferable, since the melting of the ice is retarded by the insulating properties of the Dewar flask. A siphon is placed in the flask to enable excess water to be removed as the ice melts. The clear or transparent portion of commercially purchased ice, or ice made from distilled water, can be used. The ice is shaved or crushed into small chips measuring 2 to 5 mm. The flask is one-third filled with distilled water and the shaved ice is added. This mixture is compressed to form a tightly packed slush and any excess water is siphoned off. Before the bath is used, adequate time (15 to 30 min.) should be given for the mixture to reach a constant temperature throughout.

Ideally there should be as much ice in the flask as possible, with the small spaces between the chips filled with distilled water. It will be necessary periodically to add ice and to remove the excess water while the bath is being used to maintain this ideal consistency. If care is taken to prevent contamination of the ice and water, the ice point can be realized to better than 0.01 °C by this means.

b. Steam Bath

A schematic drawing of a steam bath is shown in figure 4. Steam produced from the boiler circulates within a double-walled steam jacket permitting free

circulation of steam around the thermometers suspended within this space. A provision is made both for relieving any excess pressure in the space surrounding the thermometers and for determining the excess pressure by means of a small differential manometer.

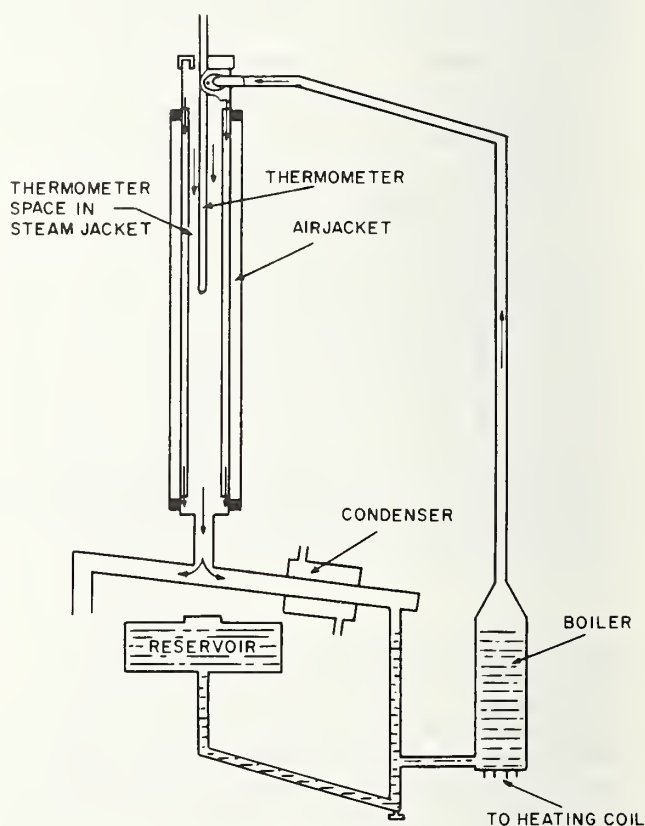

FIGURE 4. Schematic drawing of steam bath.

When the steam bath is used as a fixed-point apparatus, a barometer is a necessary accessory, since the temperature of the steam depends upon the prevailing atmospheric pressure. The usual adjustments are made to the barometer reading, including any necessary corrections for the value of local acceleration of gravity, for the difference in height between

the steam bath and the barometer, and for any excess pressure above atmospheric in the steam jacket. After the corrected pressure reading is obtained, the temperature of the steam can be derived from the values given in Table 2. With a barometer accurate to 0.1 mm Hg, this procedure is capable of an accuracy of 0.002 to 0.003 °C (0.004 to 0.005 °F). The Fortin type barometer will usually suffice for all but the most exacting measurements.

The steam bath can also be used as a comparison bath, with the temperature of the steam being determined at the time of test by means of a previously standardized thermometer. This method, which does not require the use of a barometer, may be preferable, particularly when a platinum resistance thermometer can be used as the standard.

c. Comparison Liquid Baths

At NBS two types of stirred liquid baths are used for comparison calibrations in the range -110 to 540 °C (-166 to 1004 °F). Each is equipped with a stirring unit to provide a uniform temperature throughout the medium and a controlled current to the heating coils for proper temperature regulation. A 5 to 7 cm thickness of insulation surrounding the baths and an insulated cover is provided to help minimize heat loss. Fitted into the top cover is a holder containing the thermometers. This holder can be rotated, enabling each thermometer to appear in the field of view of a vertically adjustable telescope attached to each bath.

TABLE 2. — (Thermometric) condensation temperature of steam [5]

[Asterisk (*) indicates change in integer]

Pressure in mm mercury (standard)										
P	0	1	2	3	4	5	6	7	8	9
Temperature in degrees of International Practical Temperature Scale of 1968										
500	88.674	0.726	0.778	0.830	0.882	0.935	0.987	*0.039	*0.090	*0.141
510	89.193	.244	.295	.347	.398	.449	.499	.550	.601	.652
520	89.702	.753	.803	.853	.904	.954	*.004	*.054	*.104	*.154
530	90.203	.253	.303	.352	.402	.451	.500	.550	.599	.648
540	90.697	.746	.795	.843	.892	.941	.989	*.038	*.086	*.135
550	91.183	.231	.279	.327	.375	.423	.471	.518	.566	.614
560	91.661	.709	.756	.803	.851	.898	.945	.992	*.039	*.086
570	92.133	.179	.226	.274	.320	.367	.413	.460	.506	.552
580	92.598	.644	.690	.736	.782	.828	.874	.920	.965	*.011
590	93.056	.102	.147	.193	.238	.283	.328	.373	.418	.463
600	93.5079	.5527	.5975	.6422	.6868	.7315	.7760	.8204	.8648	.9092
610	93.9534	.9976	*.0419	*.0860	*.1300	*.1740	*.2179	*.2617	*.3055	*.3493
620	94.3930	.4366	.4802	.5237	.5671	.6105	.6538	.6972	.7404	.7835
630	94.8266	.8696	.9126	.9555	.9985	*.0413	*.0841	*.1268	*.1694	*.2120
640	95.2546	.2972	.3396	.3819	.4242	.4665	.5087	.5508	.5929	.6351
650	95.6771	.7190	.7609	.8027	.8445	.8862	.9280	.9696	*.0112	*.0526
660	96.0941	.1355	.1769	.2182	.2595	.3007	.3419	.3830	.4240	.4650
670	96.5060	.5469	.5878	.6286	.6693	.7100	.7506	.7912	.8318	.8724
680	96.9128	.9532	.9936	*.0339	*.0741	*.1143	*.1546	*.1947	*.2347	*.2747
690	97.3147	.3546	.3945	.4343	.4741	.5138	.5535	.5931	.6327	.6722
700	97.7117	.7511	.7906	.8300	.8693	.9085	.9477	.9869	*.0260	*.0651
710	98.1042	.1431	.1821	.2210	.2598	.2986	.3373	.3761	.4148	.4534
720	98.4920	.5305	.5690	.6074	.6458	.6842	.7225	.7608	.7990	.8372
730	98.8753	.9134	.9515	.9896	*.0275	*.0654	*.1033	*.1411	*.1789	*.2107
740	99.2544	.2922	.3298	.3673	.4049	.4424	.4798	.5172	.5546	.5920
750	99.6293	.6666	.7038	.7409	.7780	.8151	.8522	.8893	.9262	.9631
760	100.0000	.0368	.0736	.1104	.1472	.1839	.2205	.2571	.2937	.3302
770	100.3667	.4031	.4395	.4760	.5123	.5486	.5848	.6210	.6572	.6934
780	100.7295	.7656	.8016	.8376	.8736	.9095	.9453	.9811	*.0169	*.0528
790	101.0885	.1242	.1598	.1954	.2310	.2665	.3020	.3376	.3730	.4084

The type of bath shown in figure 5 is suitable when the medium is liquid at room temperature. It consists of two cylindrical wells of different diameters with connecting passages at the top and bottom. The heating coil and stirrer are located in the smaller well, leaving the larger well unobstructed for the insertion of the thermometers. The fluid is forced past the heating coils, through the bottom opening into the larger well, around the thermometers, and back into the smaller well through the connecting passage at the top.

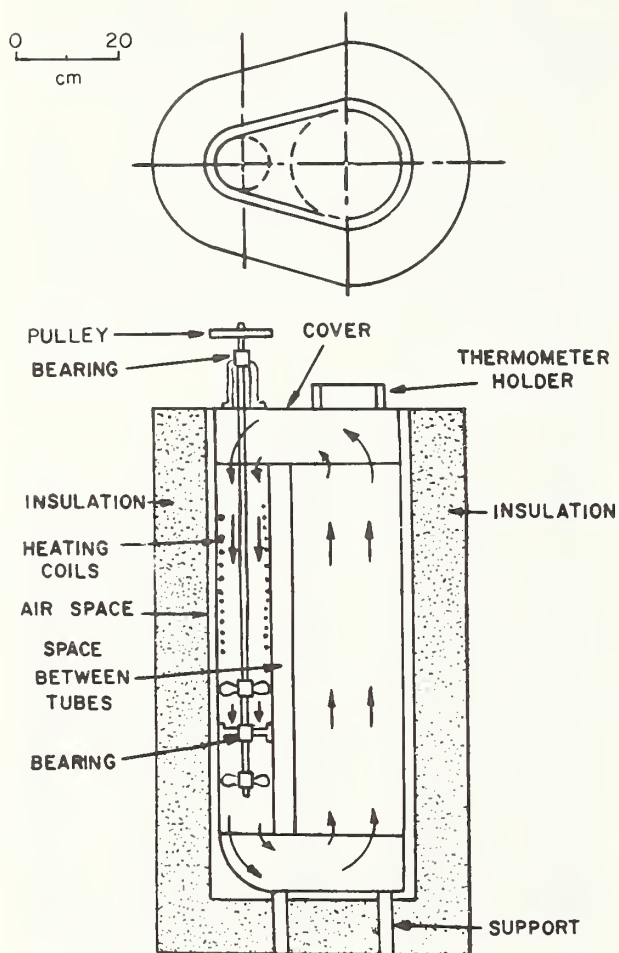

FIGURE 5. Stirred liquid bath.

The bath illustrated in figure 6 is designed for use with a medium that is solid at room temperature. A bath of this type is used at NBS for high temperature calibrations. Two coaxial cylinders are arranged in such a way as to permit the medium to circulate between the walls of the two cylinders and through the inner cylinder by means of openings at the top and bottom. The stirring propeller is situated near the bottom of the inner cylinder, leaving the majority of the space for the reentrant tubes into which the thermometers are inserted. The heater coils are wound on the outside of the outer cylinder. Both types of

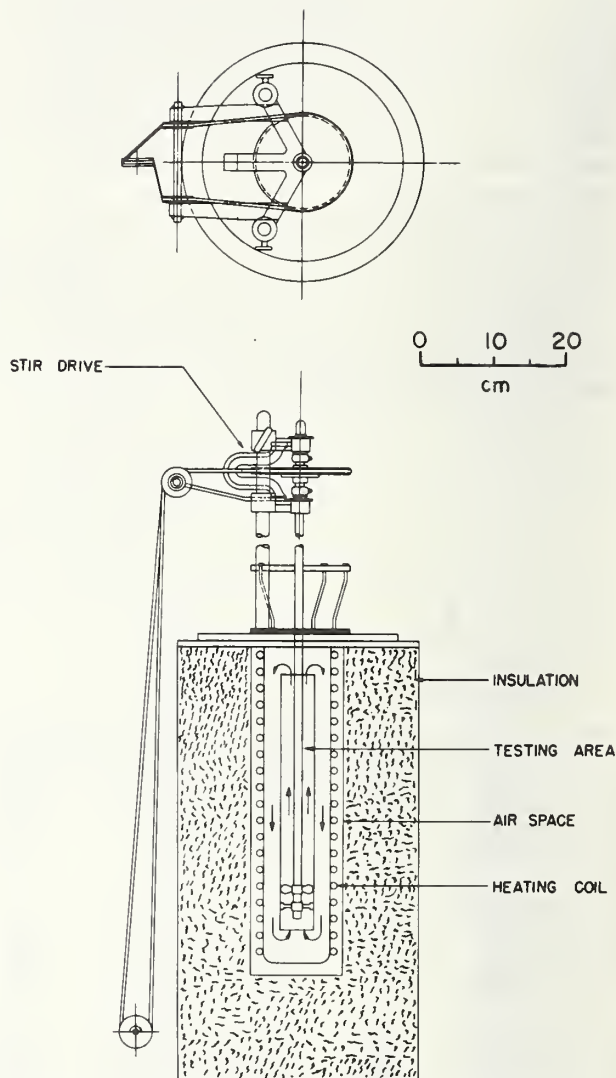

FIGURE 6. Stirred high temperature bath using liquid having freezing point above room temperature.

baths are designed to shield the thermometers from direct radiation from the heating units.

For calibrations in the range 1 to 99 °C (34 to 210 °F) water is used as the bath liquid. One grade of petroleum oil is used between 100 and 200 °C (212 to 392 °F) and a second grade between 200 and 300 °C (392 and 572 °F). The oils must not have flash points below the highest test temperatures, nor be too viscous to prevent adequate stirring at the lower test temperatures.

Calibrations from -1 to -110 °C (30 to -166 °F) are made in a cryostat similar to the one described by Scott and Brickwedde [6]. The cryostat, shown in figure 7, consists of an inner Dewar flask, D, which contains the bath liquid. This flask is surrounded by liquid nitrogen contained in the outer Dewar flask, C. The rate of heat transfer between the bath liquid and the liquid nitrogen is retarded by evacuating the space

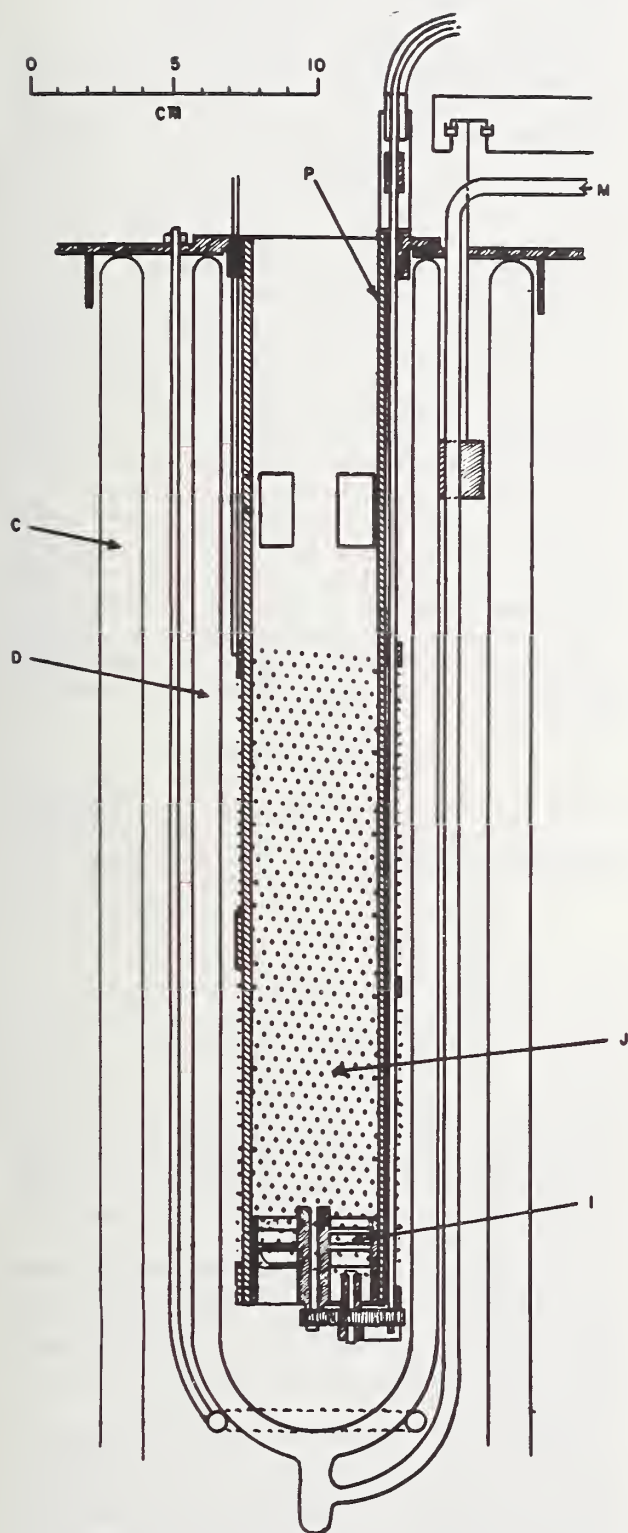

FIGURE 7. Vertical section of cryostat.

between the walls of the inner Dewar flask through the side tube, M, which is connected to a vacuum system. Vigorous stirring of the bath liquid is maintained by the propeller, I, which circulates the liquid around the walls of the stirrer tube, P, similar to the flow of the medium in the high temperature bath. The temperature of the bath is thermostatically controlled by heater coils, J, wound on the outside of the stirrer tube. The thermometers are immersed inside the stirrer tube, thus shielding them from the heater coils.

The bath liquid is a five-component mixture containing by weight 14.5 percent of chloroform, 25.3 percent of methylene chloride, 33.4 percent of ethyl bromide, 10.4 percent of transdichloroethylene, and 16.4 percent of trichloroethylene. This mixture freezes at approximately -150°C (-238°F), but readily absorbs moisture and becomes cloudy at somewhat higher temperatures. For this reason calibrations are not performed in this bath below -110°C (-166°F).

A comparison measurement can be made at approximately -196°C (boiling point of nitrogen) and -183°C (boiling point of oxygen). A silvered Dewar flask with a narrow transparent vertical strip is used as a container for the liquid nitrogen or oxygen. The liquid is agitated by bubbling nitrogen or oxygen gas in the corresponding liquid through a glass tube with an outlet near the bottom of the flask.

5.2. Determination of Scale Corrections

Thermometers submitted to NBS for test are generally calibrated by starting at the lowest test point requested and advancing to the higher test points. In most cases the ice point is the lowest point. Ice is packed firmly around the thermometer which has been placed in an ice bath and immersed to the proper depth as determined by the type of thermometer. The thermometer is gently tapped before reading to prevent the sticking of a falling meniscus. Care is taken not to tap too vigorously, as this may cause the mercury to rebound to an erroneously high reading.

The thermometer scale corrections quoted in the Report of Calibration apply as long as the ice-point reading remains the same as observed during the NBS calibration. Subsequent changes in the ice-point reading of the thermometer will result from small changes in the glass of the thermometer bulb which affects its volume. The volume of the capillary also changes, but the volume of mercury contained in the stem is so small, in comparison to the amount of mercury in the bulb, that changes in the stem volume can usually be ignored. As a result, changes in the ice-point reading of the thermometer, taken after an exposure of not less than 3 days at a temperature of approximately 23°C (73°F), will be reflected by similar changes in readings at each point along the scale. Therefore, when the correction at the ice point is found to be higher (or lower) than that observed at the time of calibration, the other reported scale corrections will be higher

(or lower) by the same amount. An example is given below:

Original Corrections from NBS Report	
Thermometer Reading	Correction
+ 0.011 °C	-0.011 °C
10.000	- .015
20.000	- .020
30.000	+ .008
40.000	- .033
50.000	.000

A later ice-point reading may be +0.019 °C. This means that the ice-point correction will be -0.019 °C and a new set of corrections should be made by subtracting 0.008 from all of the original corrections. The new table would look as follows:

Thermometer Reading	Correction
+ 0.019 °C	-0.019 °C
10.000	- .023
20.000	- .028
30.000	.000
40.000	- .041
50.000	- .008

Once a thermometer has been calibrated, an ice point check is all that is necessary to obtain a current calibration, provided the thermometer has not been abused.

Thermometer Reading	Current Correction	Ice-Point Reading After Heating to Test Temperature	Adjusted Scale Correction
+ 0.019 °C	-0.019 °C	+.019	0.000 °C
10.000	- .023	+.019	- .004
20.000	- .028	+.017	- .011
30.000	.000	+.010	+ .010
40.000	- .041	.000	- .041
50.000	- .008	- .012	- .020

When this thermometer is used as a standard, the ice point should again be taken after each calibration point. To obtain the actual temperature of the bath, the ice-point *correction* is added to the appropriate adjusted scale correction and thermometer reading. If the calibration temperature is 25 °C, the thermometer reads 24.983 °C, and the ice-point reading taken after the calibration is +0.014 °C, the actual temperature is computed as follows:

Thermometer reading	24.983 °C
Interpolated Adjusted Scale Correction	- .001
Ice-point correction	- .014
Actual Temperature of Bath Medium	24.968 °C

This method eliminates the need to wait 3 days for the bulb to recover and avoids the error due to the

Ice-point readings on the thermometers being calibrated are not taken after each test point on the scale. For thermometers graduated below 300 °C or 600 °F, ice points are taken before the comparison calibrations and 3 days (with the thermometer at room temperature) after the last test point to assure that the bulb has recovered within acceptable limits. With thermometers graduated above 300 °C or 600 °F, an ice point is taken and it is immediately tested at the highest test point on the scale. After a rest period of 3 days at room temperature a second ice point is taken. The agreement between the first and second ice point must be within the stated accuracy limit of the thermometer, or it is deemed unsuitable for calibration and no further testing is done.

The ice point is the only test temperature taken in the manner described above. Comparison measurements are made with the temperature of the bath slowly increasing at a steady rate, which does not exceed one scale division in 3 to 10 minutes [7]. All thermometers are read using a 10 power telescope, which is attached to each calibration bath and perpendicular to the thermometers. The telescope is a necessity if errors due to parallax are to be avoided.

When a liquid-in-glass thermometer is intended to be used as a standard, an ice point should be taken after heating it at each test temperature. The adjusted scale correction is determined by adding the ice-point *reading* to the current correction at the corresponding test temperature. The example shown above is modified in this way.

ice-point depression (See Sec. 8.1a) that appears when a thermometer is heated. The standard can be used at any time and at any temperature with no concern about the change in bulb volume, provided the ice point is taken after it is used.

It is advisable to use two liquid-in-glass standards when calibrating, in order to detect reading errors and maintain a cross check of the standards. The calibration procedure can best be described by following a hypothetical calibration of four thermometers, T_1 through T_4 .

Table 3 shows hypothetical observations taken in obtaining the corrections applicable to the thermometers at 20 °C. For simplification, all of the entries in the table reflect perfect thermometer performance with a temperature rise of 0.001 °C between each observation and no observer error.

TABLE 3. — Comparison of test thermometers with liquid-in-glass standards

Ice-point readings of test thermometers						
	S1	T1	T2	T3	T4	S2
Observer A		+0.02	-0.02	+0.02	0.00
Observer B		+ .02	- .02	+ .02	.00
Mean ice points		+ .02	- .02	+ .02	.00
Ice-point corrections		- .02	+ .02	- .02	.00
Thermometer comparisons						
Observer A reading left to right	19.87	19.98	19.96	20.02	20.03	19.89
Observer A reading right to left	19.88	19.99	19.97	20.03	20.04	19.89
Observer B reading left to right	19.88	19.99	19.97	20.04	20.05	19.90
Observer B reading right to left	19.89	20.00	19.98	20.04	20.05	19.90
Means	19.88	19.99	19.97	20.03	20.04	19.89.
Ice Points of Standards						
Observer A	-0.01					-0.08
Observer B	- .01					- .08
Mean ice points	- .01					- .08
Ice-point corrections	+ .01					+ .08
Adjusted scale corrections	+ .12					+ .04
Calculations of corrections						
Correction to standards	+0.13					+0.12
Mean temperature, each standard.....	20.01					20.01.
Mean temperature of all readings.....			20.01			
Corrections to test thermometers.....		+0.02	+0.04	-0.02	-0.03	

The first observations are the ice points of the thermometers under test. The test thermometers are then mounted in the comparison bath between the two standards. It is preferable to have two observers (A and B). Observer A reads in the order left to right as the thermometers appear in the table, and immediately repeats the observations in the order right to left, while observer B records the data. Observer B promptly reads in the same manner while observer A records. The bath temperature is increasing linearly with time and the observations are spaced uniformly in time. For this reason the mean of the observations with any one thermometer will correspond to the mean temperature value of the comparison bath medium during the observations of all of the thermometers. Immediately after the comparison observations, ice points of the two standards are observed and recorded. With the ice point data and the adjusted scale corrections for the standards, the temperatures indicated by the standards are calculated, and an overall mean temperature for the observations is obtained. This mean temperature is compared with the mean of the observations for each thermometer to

obtain a correction to the scale of the thermometers. The thermometer comparisons are repeated in the same manner at the next higher test point until the calibration is completed.

When a platinum resistance thermometer is used as a standard, the sequence of observations is the same, except that the one resistance thermometer is read in place of the separate observations of two liquid-in-glass standards. For more information on platinum resistance thermometers refer to NBS Monograph 126, Platinum Resistance Thermometry, available from the Superintendent of Documents, U. S. Government Printing Office, Washington, D. C. 20402.

5.3. Corrections for Emergent Stem

When a thermometer is calibrated and used under conditions of total immersion, no difficulty is encountered when the reported scale corrections are to be applied. The temperature of the thermometer bulb and the portion of the stem containing the mercury is definitely defined as the temperature of the bath medium. The corrections apply as given on the report, when this thermometer is used at total immersion.

Occasionally it becomes necessary to use a total-immersion thermometer with a portion of the stem emergent from the bath medium. The temperature of the environment above the bath, or apparatus containing the thermometer, may differ markedly from the temperature of the thermometer bulb. It is also possible to have pronounced temperature gradients along the length of exposed mercury column. A correction can be calculated to account for the difference in temperature between the bulb and the emergent stem. A reliable estimate of the mean temperature of the emergent stem is required and should actually be measured. The determination of the stem temperature should be repeated each time the thermometer is used in this way, or the accuracy of the correction will depend upon the constancy of the environmental temperature over a period of time. Significant variations in the temperature of the emergent stem may occur due to air circulation and variations in ambient temperature, even though the location of the thermometer does not change.

The same situation occurs in the case of partial-immersion thermometers. The reported scale corrections apply only for the indicated depth of immersion and a particular stem temperature. If the thermometer is used under conditions other than specified, the reported scale corrections are no longer applicable, and a stem temperature correction is required.

The following paragraphs describe methods for determining stem temperatures and calculating corrections. It will be seen how important the stem temperature correction is in relation to a desired accuracy.

a. Measurement of Emergent-Stem Temperature

There are two methods available for measuring the approximate mean temperature of the emergent stem. The first method consists of placing one or more small

auxiliary thermometers near the emergent stem as shown in figure 8(c). For a more accurate measurement faden or thread thermometers [8, 9] can be used. These thermometers have long bulbs measuring variously 5 to 20 cm, with wall thicknesses and bore sizes nearly the same as the stem of an ordinary thermometer. The bulb length is selected to approximate that of the emergent stem whose temperature is to be measured. The stem of the faden thermometer has a finer capillary than the bulb and is usually graduated in intervals of 2, 5, or 10 degrees Celsius. Stem temperature measurements taken at NBS are based upon the use of faden thermometers whenever possible.

A convenient method for measuring the emergent-stem temperature of a total-immersion thermometer that is used at partial immersion involves the use of a faden thermometer. The top of the faden thermometer bulb is placed on a horizontal plane with the top of the mercury column of the thermometer whose stem temperature is being measured. The faden thermometer chosen must have a bulb which is long enough to cover the vertical area of unknown temperature gradient necessary to be measured. This sometimes involves placing part of the faden thermometer bulb in the bath medium, since the top portion of the medium can be at a temperature different from the temperature of the total-immersion thermometer bulb. (This is especially true for measurements above 150 °C). The reading of the faden thermometer will indicate the mean temperature value of the area surrounding the bulb, which is also the mean temperature value of the adjacent portion of the total-immersion thermometer stem. A faden thermometer used in this manner is illustrated in figure 8(a).

If the stem temperature of a partial-immersion thermometer is to be measured, a similar approach is followed. In this case it is necessary to measure the mean temperature from the immersion line to the top of the mercury column of the partial-immersion thermometer. One or more faden thermometers with appropriate bulb lengths are chosen to accomplish this measurement. This procedure is shown in figure 8(b).

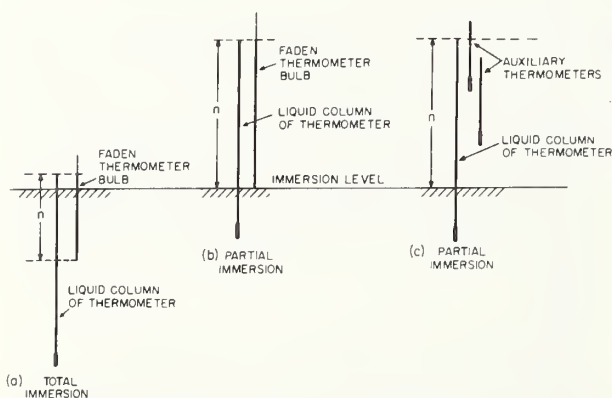

FIGURE 8. Schemes for measurement of emergent-stem temperature.

In calculating the emergent stem correction, it is convenient to express the length of the thermometer stem adjacent to the faden bulb in terms of degrees on the thermometer scale. If a faden thermometer, having a bulb which is 10 cm long, is used for a stem temperature measurement, then the number of degrees corresponding to the 10 cm length must be found by measuring a portion of the thermometer scale. This measurement should be made over the portion of the graduated scale which was adjacent to the faden thermometer bulb. This is particularly important with high-temperature thermometers, where the length of a degree is generally not the same throughout the entire length of the scale. In some instances the adjacent portion of the thermometer stem is not graduated. This is especially true with partial-immersion thermometers in the area above the immersion line. This ungraduated length between the immersion line and the first graduation must be evaluated in terms of scale degrees and included as part of the distance covered.

b. Formula for Total-Immersion Thermometers

When a thermometer which has been graduated and calibrated for use at total immersion is actually used at partial immersion, the correction for the emergent stem may be calculated by the general formula,

$$\text{stem correction} = kn (t_1 - t),$$

where

- k = differential expansion coefficient of mercury (or other thermometric liquid) in the particular kind of glass which the thermometer is made (see table 4),
- n = number of thermometer scale degrees adjacent to the faden thermometer bulb,
- t = average temperature of n degrees of the thermometer stem (faden thermometer reading),
- t_1 = temperature of the thermometer bulb.

The coefficient k varies for different kinds of glass, or for different temperature intervals, i.e., different values of $(t_1 - t)$. For purposes of computing the emergent-stem correction, the value of k may be considered as depending on the average of t_1 and t . Values of k as the function of $(t_1 + t) / 2$ for two widely used thermometric glasses are given in table 4. If the kind of glass is not known, it is acceptable to use $k = 0.00016$ for mercury thermometers graduated in degrees Celsius and $k = 0.00009$ for mercury thermometers graduated in degrees Fahrenheit.

The expansions of liquids such as alcohol, toluene, etc., vary quite rapidly with the temperature causing k to vary considerably for different temperature intervals. An approximate stem correction for such thermometers may be calculated by setting the value of k in the above equation as equal to 0.001 for Celsius thermometers or 0.0006 for Fahrenheit thermometers.

Calculation of the stem correction may be illustrated by the following example: A total-immersion thermometer indicates a reading of 90 °C in a bath when

TABLE 4. — Values of k for mercury-in-glass thermometers

Mean temperature $\frac{t_1 + t_2}{2}$	k for "normal" glass	k for "borosilicate" glass
For Celsius thermometers		
0°	0.000158	0.000164
100	.000158	.000164
150	.000158	.000165
200	.000159	.000167
250	.000161	.000170
300	.000164	.000174
350000178
400000183
450000188
For Fahrenheit thermometers		
0°	0.000088	0.000091
200	.000088	.000091
300	.000088	.000092
400	.000089	.000093
500	.000090	.000095
600	.000092	.000097
700000100
800000103

immersed to the 80 °C graduation mark on the scale. A 10 cm faden thermometer placed alongside the thermometer is adjacent to the scale between the 60 and 90 °C graduations and indicates a stem temperature of 80 °C. For this case $n = 90-60$ or 30 degrees. The stem correction is:

$$0.00016 \times 30 (90-80) = +0.048 \text{ }^\circ\text{C}.$$

This correction is added to the corrected thermometer reading to obtain the actual temperature of the bath medium. Note that when the temperature of the emergent stem is lower than the bath temperature, the sign of the correction is +, since the thermometer would indicate a higher temperature reading if immersed properly.

If a faden thermometer was not available in the above example, the emergent-stem temperature could be estimated by suspending a small auxiliary thermometer above the bath adjacent to the thermometer. The bulb of the auxiliary thermometer would be placed at the center of the emergent stem or at the 85 °C graduation. The reading of the auxiliary thermometer will indicate the approximate mean temperature of the 10 degrees (80° to 90 °C) emergent from the bath. For this correction the value for n would be 10. If the auxiliary thermometer indicates a reading of 60 °C, the stem correction would be:

$$0.00016 \times 10 (90-60) = +0.048 \text{ }^\circ\text{C}.$$

This method is not usually as reliable as the method involving the use of a faden thermometer [9].

c. Formula for Partial-Immersion Thermometers

The scale corrections for partial-immersion thermometers calibrated at NBS are applicable when the thermometer is immersed to the immersion mark and, unless otherwise requested, for the unspecified stem temperatures which prevailed over the comparison baths at the time of calibration. Frequently it is necessary to report scale corrections which are applicable when specified mean temperatures of the emergent stem are requested. In such cases the emergent stem temperatures are measured during calibration and the observations are corrected as necessary to account for any differences found between the specified stem temperatures and the stem temperatures observed during test. The magnitude of the stem correction will be proportional to the difference between the specified and observed stem temperatures, and may be calculated for Celsius mercurial thermometers by using the following formula:

$$\text{stem correction} = 0.00016 n (t_{sp} - t_{obs}),$$

where

t_{sp} = specified mean temperature of the emergent stem (for which reported scale corrections apply),

t_{obs} = observed mean temperature of the emergent stem (faden thermometer reading),

n = number of scale degrees equivalent to the length of emergent stem (including the evaluated area above the immersion line).

This formula may also be used to correct the indications of a partial-immersion thermometer, when, during use, the actual stem temperatures differ from the specified ones for which the scale corrections apply.

d. Formula for Calorimetric Thermometers

The stem correction is often important when thermometers are used for differential temperature measurements, as in calorimetry (Sec. 6.5). The correction may be computed from the following formula, which involves the difference between the initial and final readings, provided the mean temperature of the stem remains constant.

$$\text{Stem correction} = kd (t_i + t_f - I - t),$$

where

- k = factor for relative expansion of glass and mercury,
- t_i = initial reading,
- t_f = final reading,
- I = scale reading to which the thermometer is immersed,
- t = mean temperature of the emergent stem,
- d = $t_f - t_i$.

This correction must be applied (added if positive, subtracted if negative) to the difference of the readings to give the actual temperature difference.

Example: The thermometer was immersed to the 20° mark; the initial reading, t_i , was 25 °C; the final reading, t_f , was 30 °C; and the stem temperature was 20 °C. The correction is:

$$0.00016 \times 5 (25 + 30 - 20 - 20) = +0.012 \text{ °C.}$$

Since the difference between t_i and t_f was 5°, the actual difference between the initial and final temperature readings was:

$$t_f - t_i + \text{correction} = 5.012 \text{ °C.}$$

e. Formula for Beckmann Thermometers

The formula used to compute the stem temperature correction for Beckmann thermometers (Sec. 6.4) is similar to the one used for calorimetric thermometers. The formula given below is applicable provided the thermometer is immersed near the zero degree indication on the scale and the temperature of the stem remains constant.

$$\text{stem correction} = kd (S + t_i + t_f - t),$$

where

- k = factor for relative expansion of glass and mercury,
- t_i = initial reading,
- t_f = final reading,
- t = mean temperature of the emergent stem,
- d = $t_f - t_i$
- S = setting of the thermometer (Sec. 6.4).

A Beckmann thermometer should not be used with any part of the lower portion of the stem exposed to ambient temperature. Since this part may contain 5 to 10 times more mercury per centimeter than the graduated portion, a large and uncertain error will be introduced if this section is not in the bath medium. If it is unavoidable, and such a thermometer must be used in this way, the necessary correction may be computed from the above formula, provided S in the formula is replaced by $S + m$, where m is the number of degrees the temperature of the thermometer must be lowered to bring the meniscus from the zero mark on the scale to the point of immersion.

If the thermometer is immersed to some point other than the zero mark, as would ordinarily be the case with thermometers having the zero graduation at the top of the scale, the differential stem correction may be calculated from the above formula if S is replaced by $S + m$. The formula is applicable whether the point of immersion is on the scale or below it, provided the points at which readings are made are above the point to which the thermometer is immersed.

5.4. Number and Choice of Test Points

A thermometer is usually calibrated at points spaced uniformly over the entire range of the main scale. The number of calibration points chosen depends on the range of scale, graduation interval, and accuracy desired. The interval between the calibration points should not be unnecessarily small, nor should it be so large as to destroy confidence in interpolated corrections for temperature values between the calibration points.

For thermometers not graduated above approximately 200 °C, it is generally accepted that the interval between test points should not exceed 100 scale divisions, if the corrected temperature values between the calibration points are to have an expected accuracy of approximately one-half of one scale division. If accuracies of one or two-tenths of a scale division are desired, it will be necessary to reduce the calibration interval to every 40 or 50 scale divisions. If a thermometer is graduated above 200 °C, a 40 to 50 scale division calibration interval is required to produce corrected temperature values with expected accuracies of approximately one-half of a scale division, and a 20 to 25 scale division calibration interval is necessary for expected accuracies to be approximately one or two-tenths of a scale division.

The above results were derived from analysis of calibration data taken on more than 50 thermometers purchased from 1930 through 1956 for use as laboratory standards. The data indicated that there was considerable variation between individual thermometers and that scale corrections obtained over a given interval for a particular thermometer were not sufficient to predict whether or not more calibration points were required. The above studies were made with only a few of the many types of thermometers submitted to NBS for calibration, and may not necessarily be

applicable to other types. Experience with a particular type of thermometer seems to be the most reliable guide in the choice of its calibration points.

If a thermometer is submitted to NBS for calibration and the calibration points are not specified on

the purchase order, it will be tested at a reference point and at intervals of approximately every 100 scale divisions. A calibration should never consist of fewer than two points on the main scale, and should always be tested at a reference point, whether on the main scale or on an auxiliary scale.

6. Common Thermometers and Factors Affecting Their Use

A listing of tolerances and expected accuracies for common types of liquid-in-glass thermometers, which are accepted for calibration, are given in tables 5 through 12. The scale tolerances shown are chosen to be indicative of good manufacturing practice. When a thermometer is manufactured, small errors in pointing (marks placed on a blank thermometer at various temperatures to be used as guides for the placement of the graduation lines) and graduating are inevitable. These graduation marks are also subject to variations due to the inherent properties of the glass. The tolerances must be sufficiently restrictive to insure a satisfactory high-grade thermometer, and at the same time not cause undue manufacturing difficulties.

In addition to the scale tolerance limit, the error in any temperature interval should not exceed 5 percent of the nominal value of the interval. The purpose of this requirement is to eliminate thermometers having large corrections of alternating signs, which lead to uncertainties in the interpolation of scale corrections between the calibration points.

The word "accuracy" used in these tables refers to the best values attainable in the use of thermometers when all corrections are applied. The accuracy bounds may seem broad in some instances, but the definite limitations of liquid-in-glass thermometry become apparent when all factors are considered. For example, if the scale is expanded by reducing the diameter of the capillary, a practical limit is reached beyond which capillary forces, in combination with the elasticity of the thermometer bulb, will prevent a smooth advance or retreat of the mercury column. The movement of the mercury meniscus may be erratic and occur in steps appreciably large in comparison to the graduation interval. This is particularly true when the temperature of the medium is decreasing. Less rigid bulbs (relatively large diameters and/or thin walls), as well as capillaries of small diameters, may cause large "meniscus jumps." Excessively elliptical or flattened bores are not recommended for the same reason. Therefore, increasing the length of a degree on the scale, for practical bulb sizes, improves thermometric performance only to a certain point. Beyond this point precision of reading may readily be mistaken for accuracy in temperature measurement. A study of the effects of bulb and capillary dimensions on thermometer performance, made by Hall and Leaver [10], provides valuable guidelines for design purposes.

Other factors such as ice-point changes, unless exactly accounted for, and differences in external pressure may also account for inaccuracies much greater than the imprecision with which a scale having 0.1 or 0.2 degree graduations may be read.

6.1. Total-Immersion Thermometers

Thermometers pointed and graduated by the manufacturer to indicate correct temperatures when the bulb and the portion of the stem containing the thermometric liquid are subjected to the temperature being measured are known as total-immersion thermometers. While these thermometers are designed for immersion of all the mercury, it is not desirable to immerse the portion of the stem above the meniscus. The heating of this portion to high temperatures could cause excessive gas pressures resulting in erroneous readings and possibly permanent damage to the bulb.

In practice, a short length of the mercury column often must be left emergent from the bath or medium being measured so that the meniscus is visible. If the temperature difference between the bath medium and its surroundings is large, an appreciable temperature gradient may exist around the thermometer stem near the surface of the bath. This condition becomes more serious when a total-immersion thermometer is intentionally used at partial immersion. If either situation exists, an emergent stem correction, as explained in section 5.3b, will be necessary. The correction may be as large as 20 Celsius degrees (36 Fahrenheit degrees) if the length of the emergent liquid column and the difference in temperature between the bath and the space above it are large. Tolerances and accuracies expected of total-immersion thermometers are given in tables 5 and 6.

6.2. Partial-Immersion Thermometers

In many instances the use of a total-immersion liquid-in-glass thermometer for temperature measurements is inconvenient or impossible. For this reason partial-immersion thermometers are designed with scales graduated to indicate correct temperatures when the thermometers are immersed to specified depths. Unless otherwise stated, each Report of Calibration issued by NBS gives corrections which are applicable for temperatures prevailing above the comparison baths. No stem temperature correction is necessary when

TABLE 5. — *Tolerances for Celsius total-immersion mercury thermometers*

Temperature range in degrees	Graduation interval in degrees	Tolerance in degrees	Accuracy in degrees
Thermometer graduated under 150 °C			
°C			
0 up to 150	1.0 or 0.5	0.5	0.1 to 0.2
0 up to 1502	.4	.02 to .05
0 up to 1001	.3	.01 to .03
Thermometers graduated under 300 °C			
0 up to 100	1.0 or 0.5	0.5	0.1 to 0.2
Above 100 up to 300			
0 up to 1002	0.4	.02 to .05
Above 100 up to 200			
Thermometers graduated above 300 °C			
0 up to 300	2.0	2.0	0.2 to 0.5
Above 300 up to 500			
0 up to 300	1.0 or 0.5	2.0	.1 to .5
Above 300 up to 500			

TABLE 6. — *Tolerances for Fahrenheit total-immersion mercury thermometers*

Temperature range in degrees	Graduation interval in degrees	Tolerance in degrees	Accuracy in degrees
Thermometers graduated under 300 °F			
32 up to 300	2.0	1.0	0.2 to 0.5
32 up to 300	1.0 or 0.5	1.0	.1 to .2
32 up to 2122 or .1	0.5	.02 to .05
Thermometers graduated under 600 °F			
32 up to 212	2 or 1	1.0	0.2 to 0.5
Above 212 up to 600			
Thermometers graduated above 600 °F			
32 up to 600	5	4.0	0.5 to 1.0
Above 600 up to 950			
32 up to 600	2 or 1	3.0	0.2 to 1.0
Above 600 up to 950			

these thermometers are used under conditions similar to those existing during calibration. However, if conditions differ, especially the temperature of the emergent stem, the necessary emergent stem correction must be calculated as shown in section 5.3c. An unsteady or irreproducible environment surrounding the

emergent stem, together with the inherent difficulty of estimating or measuring the emergent-stem temperature with sufficient accuracy, can contribute markedly to the uncertainty of a given thermometer indication. For these reasons tolerances and accuracies expected of partial-immersion thermometers, as given in tables 7 and 8, are not as stringent as those for total-immersion thermometers.

TABLE 7. — *Tolerances for Celsius partial-immersion mercury thermometers*

Temperature range in degrees	Graduation interval in degrees ^a	Tolerance in degrees	Accuracy ^b in degrees
Thermometers not graduated above 150 °C			
0 up to 100	1.0 or 0.5	1.0	0.1 to 0.3
0 up to 150	1.0 or 0.5	1.0	0.1 to 0.5
Thermometers not graduated above 300 °C			
0 up to 100	1.0	1.0	0.1 to 0.3
Above 100 up to 300	1.0	1.5	.5 to 1.0
Thermometers graduated above 300 °C			
0 up to 300	2.0 or 1.0	2.5	0.5 to 1.0
Above 300 up to 500			

TABLE 8. — *Tolerances for Fahrenheit partial-immersion mercury thermometers*

Temperature range in degrees	Graduation interval in degrees ^a	Tolerance in degrees	Accuracy ^b in degrees
Thermometers not graduated above 300 °F			
32 up to 212	2.0 or 1.0	2.0	0.2 to 0.5
32 up to 300	2.0 or 1.0	2.0	0.2 to 1.0
Thermometers not graduated above 600 °F			
32 up to 212	2.0 or 1.0	2.0	0.2 to 0.5
Above 212 up to 600			
Thermometers graduated above 600 °F			
32 up to 600	5.0 or 2.0	5.0	1.0 to 2.0
Above 600 up to 950			
32 up to 600	5.0 or 2.0	10.0	2.0 to 3.0
Above 600 up to 950			

^a Partial-immersion thermometers are sometimes graduated in smaller intervals than shown in these tables, but this in no way improves the performance of the thermometers, and the listed tolerances and accuracies still apply.

^b The accuracies shown are attainable only if emergent stem temperatures are closely known and accounted for.

6.3. Low-Temperature Thermometers

The use of mercury-in-glass thermometers for low temperature measurements is limited by the freezing point of mercury, which is -38.9°C (-38.0°F). This limit may be extended to lower temperatures by forming an eutectic alloy consisting of mercury and 8.5 percent by weight of thallium. The freezing point of this alloy is approximately -59°C (-74°F). However, small differences in the quantity of thallium present have the effect of markedly raising the freezing point of the alloy. It has also been found that some thermometers containing this liquid have behaved erratically in the range of -59 to -57°C . Consequently, thermometers using a mercury-thallium alloy as the liquid should not be used below -56°C (-69°F).

Temperature measurements from -56°C (-69°F) to approximately -200°C (-328°F) can be made by using thermometers containing organic liquids. Alcohol, toluene, pentane, or other organic liquids, alone or in mixtures, have been used as fluids for low temperature thermometers. All of these fluids have limitations, and thermometers containing organic liquids are not considered to be as reliable as thermometers containing mercury or mercury-thallium alloy.

Organic liquids have the disadvantage of wetting a surface and leaving a film on the wall of the capillary when the liquid column recedes. This may lead to significant errors in the temperature indications if sufficient precautions are not taken. The thickness of the film on the capillary wall will depend, among other things, on the viscosity of the liquid, the interfacial action between the liquid and glass, and the rate at which the thermometer is cooled. Whenever possible the rate of cooling should be slow with the bulb cooled first, enabling the viscosity of the organic fluid in the capillary to be kept as low as possible until the final temperature is reached. This minimizes the amount of liquid left on the capillary wall. Sufficient time should always be allowed to assure complete drainage. Under adverse conditions this may take an hour or more.

In addition to good drainage characteristics, a satisfactory low-temperature fluid should not contain water, dirt, or other foreign material which will separate from the liquid. Because low-temperature thermometers are frequently designed for use above room temperature, the vapor pressure of the liquid must be low to prevent distillation at these higher temperatures. Any dye, added to the fluid for improved visibility, should be chosen for good color fastness with respect to light exposure or chemical action with the organic liquid.

Tolerances and accuracies applicable to low-temperature thermometers are given in tables 9 and 10.

TABLE 9. — Tolerances for low-temperature total-immersion thermometers

Temperature range in degrees	Type of thermometer	Graduation interval in degrees	Tolerance in degrees	Accuracy in degrees
Celsius thermometers				
-35 to 0	Mercury	1 or 0.5	0.5	0.1 to 0.2
-35 to 0do.....	.2	.4	.02 to .05
-56 to 0	Mercury-thallium.	.5	.5	.1 to .2
-56 to 0do.....	.2	.4	.02 to .05
-200 to 0	Organic liquid.	1.0	2.0	.2 to .5
Fahrenheit thermometers				
-35 to 32	Mercury	1 or 0.5	1.0	0.1 to 0.2
-35 to 32do.....	.2	0.5	.05
-69 to 32	Mercury-thallium.	1 or .5	1.0	.1 to .2
-69 to 32do.....	.2	0.5	.05
-328 to 32	Organic liquid.	2 or 1.0	3.0	.3 to .5

TABLE 10. — Tolerances for low-temperature partial-immersion thermometers

Temperature range in degrees	Type of thermometer	Graduation interval in degrees	Tolerance in degrees	Accuracy in degrees
Celsius thermometers				
-35 to 0	Mercury	1.0 or 0.5	0.5	0.2 to 0.3
-56 to 0	Mercury-thallium.	1.0 or .5	.5	.2 to .3
-90 to 0	Organic liquid.	1.0	3.0	.4 to 1.0
Fahrenheit thermometers				
-35 to 32	Mercury	1.0 or 0.5	1	0.3 to 0.5
-69 to 32	Mercury-thallium.	1.0 or .5	1	.3 to .5
-130 to 32	Organic liquid.	2 or 1	5	.8 to 2.0

6.4. Beckmann Thermometers

A metastatic, or Beckmann thermometer, usually of the enclosed-scale type, is constructed in a manner that permits mercury to be removed from, or added to, the bulb, making it possible to use the same thermometer for differential temperature measurements in various temperature ranges [11]. The scale usually consists of 5 or 6 Celsius degrees, although some micro types have a scale containing only 3 Celsius degrees.

The "setting" of a Beckmann thermometer refers to the temperature of the bulb when the reading on the scale is 0°. When the setting is changed, enabling the thermometer to be used at a higher or lower temperature range, the quantity of mercury affected by a temperature change is not the same. Therefore, two equal changes in temperature at different settings cause different indications on the scale, and a "setting factor" must always be used to convert reading differences into actual temperature differences whenever the thermometer is used at any setting other than the one at which the scale was calibrated. These setting factors combine corrections for the different quantities of mercury during equal temperature changes, and the difference between the mercury-in-glass scale and the International Practical Temperature Scale of 1968. Table 11 lists setting factors calculated for thermometers of Jena 16¹¹¹ 2 glass or, its American equivalent, Corning normal. The scale calibrations for Beckmann thermometers as reported by NBS are applicable for a setting of 20 °C. Consequently, the

TABLE 11. — Setting factors for Beckmann thermometers

Setting	Factor	Setting	Factor
0 °C	0.9935	55 °C	1.0092
5	0.9951	60	1.0102
10	0.9967	65	1.0112
15	0.9984	70	1.0121
20	1.0000	75	1.0129
25	1.0014	80	1.0137
30	1.0029	85	1.0146
35	1.0042	90	1.0154
40	1.0056	95	1.0162
45	1.0070	100	1.0170
50	1.0082		

As an illustration, suppose the following observations were made:

Setting = 25 °C.	Lower reading = 2.058°
Stem temperature = 24 °C.	Upper reading = 5.127°
	<i>Lower</i> <i>Upper</i>
Observed reading =	2.058 5.127
Correction from certificate =	+0.005 -0.008
	Corrected upper reading = 5.119
	Corrected lower reading = 2.063
	Difference = 3.056
Difference multiplied by setting factor (1.0014) =	3.060
Emergent stem correction (see accompanying stem correction sheet) =	+ .004
	Corrected difference = 3.064

²Certain commercial products and instruments are identified in this paper in order to specify adequately the experimental procedure. In no case does such identification imply recommendation or endorsement by the National Bureau of Standards, nor does it imply that the products or equipment identified are necessarily the best available for the purpose.

setting factor is 1.0000 at this temperature. For a setting other than 20 °C, the observed temperature difference must be multiplied by the appropriate setting factor as shown in the example given below the table.

For most Beckmann thermometers, the large bulb is joined to a fine capillary, which is backed by a milk-glass scale, by a capillary of much larger diameter. This large capillary is a source of some uncertainty when the thermometer is used at partial immersion and this portion is not entirely immersed. For appropriate emergent-stem corrections refer to section 5.3e.

Tolerance requirements for Beckmann thermometers are given in table 12. Under the heading "Accuracy of interval in degrees" is given the estimated accuracy attainable in the measurement of any interval within the limits of the scale. No tolerances for scale error are given, although it is desirable that it be no larger than 0.02 °C over a 1.0 °C interval.

TABLE 12. — Tolerances for Beckmann and calorimetric thermometers

Type of thermometer	Graduation interval in degrees	Allowable change in correction in degrees	Accuracy of interval in degrees
Beckmann	0.01 °C	0.01 over 0.5° interval for setting of 20 °C	0.002 to 0.005
Bomb calorimetric	.01 °C	0.02 over 1.5° interval	.005 to .01
Do02 °C	0.02 over 1.5° interval	.005 to .01
Do05 °F	0.04 over 2.5° interval	.01 to .02
Gas calorimetric1 °F	0.15 over a 5° interval	.02 to .05

6.5. Calorimetric Thermometers

Calorimetric thermometers include a specialized group of solid-stem mercury-in-glass thermometers which are used for accurate differential measurements. Since the accuracy of these thermometers at any one temperature is of less importance than the accuracy of the temperature intervals, no reference point is required.

Table 12 gives the scale error required of some typical calorimetric thermometers. Like the Beckmann thermometer, no tolerances for scale error are given, but it is desirable that the scale corrections be no larger than approximately five graduation intervals.

7. Thermometer Design

Reproducibility and accuracy of readings are influenced markedly by the design, choice of materials, and actual construction of the thermometer. The calibration laboratory personnel exercise judgment in deciding whether individual thermometers are likely to maintain a calibration; however, general recommendations for acceptable thermometer design and construction are given in the following sections.

7.1. Materials of Construction

While the cleanliness of the thermometer bulb, bore, and liquid filling have a pronounced effect upon the performance of a thermometer, equally important is the proper choice of the glass from which the thermometer is manufactured. The thermometer, and especially the bulb, must be made of glass suitable for use in the temperature range indicated on the stem. Some types of glasses commonly used in the manufacture of thermometer bulbs and reasonable upper temperature limits are estimated by Thompson [12] in table 13. Thompson's estimates are based upon the work of Liberatore and Whitcome [13]. The results show that significant changes in bulb volume may occur if the bulb is heated for long periods of time at temperatures higher than 130 °C (234 °F) below the strain point of the bulb glass. The strain point of a glass is defined as the temperature at which the glass has a viscosity of $10^{14.5}$ poises [14]. Thermometers may be used intermittently, to approximately 70 °C (126 °F) of the strain point. It should be noted that the use of a glass with a high strain point, such as borosilicate glass, results in better thermometer performance and stability even in thermometers used at temperatures much lower than the exposure limits given in table 13.

TABLE 13. — *Temperature exposure limits for various thermometer glasses*^a

	Strain point	Exposure limits				
		Continuous		Intermittent		
		°C	°C	°F	°C	°F
Corning normal 7560	500	370	700	^b 430*	^b 805*	
Kimble R 6	490	360	680	420	790	
Jena 16 III	495	365	690	425	795	
Corning borosilicate 8800	529	400	750	460	860	
Jena borosilicate 2954	548	420	790	480	900	
Corning 1720	668	540	1005	600	1110	
Jena Supremax 2955	665	535	995	595	1100	

^a From reference [12].

^b *405 °C or 760 °F if Corning Standard Thermometer 0041 glass is used for the stem.

The thermometer must also be adequately annealed to enable the bulb volume to remain reasonably stable

and causing only small changes in the thermometer readings with continued use. This is especially important for a thermometer graduated above 300 °C or 600 °F. The quality of the thermometer glass and the adequacy of the annealing process may be judged by the stability of the reference-point readings. A method for testing bulb stability is described in The American Society for Testing and Materials Method E77.

All high-temperature thermometers should be filled with a dry inert gas such as nitrogen under sufficient pressure to prevent separation of the mercury at any temperature indicated on the scale. Total-immersion thermometers graduated above 150 °C or 300 °F must be gas filled to minimize the distillation of mercury from the top of the mercury column. An expansion chamber at the top of the capillary or a specified length of unchanged capillary above the highest graduation is essential for thermometers containing a gas. The gas must have an adequate area for compression when the mercury is advanced toward the top of the scale: otherwise, excessive pressure in the capillary will cause the thermometer to burst.

For thermometers graduated below 150 °C or 300 °F a gas filling is optional, but is strongly recommended. The mercury column of a vacuum thermometer will tend to separate easily if the thermometer is inverted or subjected to a sudden shock.

7.2. Scale Design and Workmanship

Solid-stem thermometers must have the graduation marks placed directly on the stem and opposite the enamel back. If the thermometer is of the enclosed-scale type, the graduated scale must be securely fastened to prevent relative displacement between the scale and the capillary, or a datum line should be conveniently located to indicate at any time whether the scale is in its original position. The graduation marks should be clear cut, straight, of uniform width, and in a plane perpendicular to the axis of the thermometer.

The scale should be graduated in 1.0, 0.5, 0.2, or 0.1 degree intervals, or in decimal multiples. The divisions should be numbered in such a manner that the identification of any graduation is not unnecessarily difficult. Thermometers with scales graduated in 0.25 degree intervals, or submultiples, are sometimes difficult to read and the discontinuance of their production is desirable. If the thermometers are graduated in 0.1 or 0.2 degree intervals (or decimal multiples), every fifth mark should be longer than the intermediate ones and a number should appear at every tenth mark. Thermometers graduated in 0.5 degree intervals (or decimal multiples) require three lengths of graduation marks. These consist of alternating short and intermediate marks, with every tenth line distinctly longer than the others. A number should appear at every 10th or 20th mark.

The scale must not be extended to temperatures beyond which the particular thermometer glass is suited. A thermometer made of borosilicate glass, for example, should never be graduated to 500 °C (932 °F). It would be ruined in a short time if used at that temperature.

7.3. Scale Dimensions

Although optimum line width depends in some measure upon the intended use of a particular thermometer, coarse graduation marks do not represent good design. If the thermometer indications are to be observed precisely (for example to 0.1 of a division), the width of the graduation marks should not exceed 0.2 of the interval between the center lines of the graduations. In instances where the thermometer must be read quickly or in poor light, and less precision is expected, somewhat wider lines may be acceptable.

The graduation marks must not be too closely spaced. The closest permissible spacing depends upon the fineness and clearness of the marks. In no case should the distance between center lines of adjacent graduation marks on a solid-stem thermometer be less than 0.4 mm. The minimum permissible interval between graduation marks for an enclosed-scale thermometer is 0.3 mm if the lines are ruled on a milk-glass scale; otherwise, the minimum is also 0.4 mm. The minimum in no case represents good design, and well-designed thermometers will have graduation intervals considerably larger than the specified minimum.

In order for a thermometer to be usable over the entire range of the scale, the graduation marks must not be placed too close to any enlargement in the capillary. Appreciable errors may result if any of the following conditions exist. (1) There is insufficient immersion of the mercury in the main bulb or a capillary enlargement; (2) the graduation marks have been placed over parts of the capillary that have been changed by manufacturing operations; or (3) the graduations are so close to the top of the thermometer that excessive gas pressure results when the mercury is raised to this level. The distances given below are considered as minimum limits commensurate with good thermometer design:

(a) A 13 mm length of unchanged capillary between the bulb and the lowest graduation, if the graduation is not above 100 °C (212 °F); a 30 mm length if the graduation is above 100 °C (212 °F).

(b) A 5 mm length of unchanged capillary between an enlargement and the graduation next below, except at the top of the thermometer.

(c) A 10 mm length of unchanged capillary between an enlargement, other than the bulb, and the

graduation next above, if the graduation is not above 100 °C (212 °F); a 30 mm length if the graduation is above 100 °C (212 °F).

(d) A 10 mm length of unchanged capillary above the highest graduation, if there is an expansion chamber (see definitions, Sec. 3); a 30 mm length if there is no expansion chamber.

7.4. Reference Point

Thermometers graduated above 150 °C or 300 °F, or precision thermometers with an expected accuracy of better than 0.1 °C or 0.2 °F when calibrated for actual temperature measurement, must have a reference point. The effects of changes in the bulb volume on the thermometer indications may be followed throughout the life of the thermometer by periodic testing at the reference point. From the reference point observations, the thermometer corrections can be kept current as explained in section 5.2. If a suitable reference point, such as the ice or steam point, is not included in the range of the main scale, a short auxiliary scale containing a fixed point should be provided. To prevent the thermometer from being unduly long, a contraction chamber may be introduced between the auxiliary scale and the main scale. Any auxiliary scale must have graduations identical to those on the main scale, both dimensionally and in terms of temperature, and they must extend for a short interval both above and below the reference point. Similarly, when the main scale ends near a reference point, the graduations must be continued for a short interval beyond the reference temperature.

Reference points are not needed on thermometers intended for differential measurements (such as calorimetric thermometers), nor on thermometers graduated below 150 °C or 300 °F, if they are not to be calibrated to an accuracy of better than 0.1 °C or 0.2 °F.

7.5. Marking of Partial-Immersion Thermometers

Partial-immersion thermometers must be plainly marked "partial immersion" or the equivalent (for example, "76 mm immersion"), or a conspicuous line permanently placed on the stem to indicate the proper depth of immersion. This line must not be less than 13 mm above the top of the bulb. Special partial-immersion thermometers, made for use in a specific manner or instrument (for example, viscometers and flash-point testers where the thermometer is held in a ferrule or other mounting arrangement suited to the instrument), need not be marked.

8. Special Notes

The following brief notes on the characteristic behavior of mercury-in-glass thermometers are added to aid the user in understanding the behavior of these thermometers, and to better utilize the information contained in the Reports of Calibration.

8.1. Glass Changes

The changes which occur in the glass of a thermometer bulb after first heating to a high temperature within the acceptable exposure limits of the glass and subsequent cooling to ambient temperatures, are an involved function of time and temperature. They will depend upon the thermal history of the glass (both during manufacture and previous use), the time of exposure to the high temperature, and the rate of cooling. Evidence from many investigations [13, 15, 16] seems to indicate that when a glass is held indefinitely at some fixed temperature, density (and volume) changes proceed toward a preferred density corresponding to a quasi equilibrium condition characteristic of the particular kind of glass and the temperature. Since these changes involve molecular rearrangements, they proceed more rapidly at high temperatures where the viscosity of the glass is lower, and the molecular mobility consequently higher. For this reason, a close approach to quasi equilibrium may be reached in the order of hours at annealing temperatures, while infinite time may be required at much lower temperatures.

If a glass that has been heated to a high temperature is allowed to cool rapidly, it will be seen that equilibrium is not reached at the lower temperatures during cooling, and an equilibrium density more nearly corresponding to the high temperature is "frozen" into the glass. This characteristic behavior of glass has a lasting effect on the performance of liquid-in-glass thermometers. For the entire lifetime of the thermometer it may retain a "memory" of the thermal history at the higher temperatures.

The techniques of good manufacture are designed to produce in the thermometer glass a state which will result in maximum stability for the range of temperature indicated on the scale. To achieve perfect stability for all conditions of use is not possible in thermometer manufacture; therefore, changes in the ice-point readings are observed periodically. The changes observed at the ice point are reflected at all points on the scale by the same magnitude and sign, since they are the result of changes in the bulb volume (see Sec. 5.2) (changes in the stem have very little effect). Because of this behavior of glass, the changes in the bulb volume can be either temporary or permanent.

a. Temporary Changes

Upon heating to a high temperature, the bulb of a thermometer will expand from its initial state. After a short period of time, an equilibrium condition cor-

responding to that particular high temperature will appear to be reached. If the thermometer is cooled slowly through critical temperature regions, the glass will nearly return to its initial state, and the ice-point reading will show no change. If, on the other hand, the thermometer is cooled rapidly (such as cooling naturally in still air), the bulb will retain a portion of its expanded condition, and the ice-point reading will be lower than the reading taken before heating. This phenomenon is known as "zero, or ice-point depression." Thermometers which have been heated to high temperatures recover from this ice-point depression in an unpredictable way, and frequently there will be no significant recovery after a period of one year at room temperature. Since the ice-point depression has a reproducible value, ice-point readings may be used reliably to show changes in the volume of the thermometer bulb with time and use, provided the thermometer is allowed to cool in still air and the ice point is taken within a reasonable period of time, not to exceed one hour, after being heated.

Thermometers used below approximately 100 °C will usually exhibit a relatively rapid recovery from the ice-point depression, and the original bulb volume will recover within the equivalent of 0.01 or 0.02 degrees C in approximately 3 days. This phenomenon has an important bearing on the precision attainable with mercury thermometers, and must be taken into consideration, especially in the range of 0 to 100 °C. If a thermometer is used to measure a given temperature, it will indicate an erroneously low value if it has, within a short period of time, previously been exposed to a higher temperature. With the better grades of thermometric glasses the error resulting from this hysteresis will not exceed (in the interval of 0 to 100 °C) 0.01 of a degree for each 10-degree difference between the temperature being measured and the higher temperature to which the thermometer has recently been exposed. With the best glasses the error may only be a few thousandths of a degree for each 10-degree difference. The errors due to this hysteresis become somewhat erratic at temperatures above 100 °C. For these reasons it is customary, in precision thermometry, to apply a scale correction based upon an ice-point reading taken immediately after the temperature measurement (see Sec. 5.2).

Where the range of temperature is small and the time between observations is short (as in the use of calorimetric thermometers), it is more satisfactory, each time the thermometer is used, to first heat to the highest temperature to be measured, so that all of the depression has taken place before the observations are begun. The condition to be observed is that the time required for observations is so short that no appreciable recovery shall have taken place during this time. As this condition is fairly well satisfied in calorimetric work, and as it is the only one for which

consistent measurements of the same temperature interval can be made repeatedly, calorimetric thermometers should be used in this way.

b. Permanent Changes

A "secular change" in thermometer glasses, which may progress with time, results in a non-recoverable decrease in the bulb volume as indicated by an increase in the ice-point reading. At room temperature there may be a gradual change which will continue for years, but at high temperatures the changes will be markedly accelerated. With better grades of thermometer glasses the change will not exceed 0.1 °C over a period of many years, provided the thermometer has not been heated to temperatures above approximately 150 °C. Initially, at high temperatures, the secular change usually progresses more rapidly, but with continued heating and time it tends toward a lower rate of change. The rate of secular change will depend upon the kind of glass used in the thermometer bulb and the particular heat treatment given the thermometer in manufacture. Thermometers manufactured according to good practices will evidence only small secular changes. However, thermometers made of glass unsuitable for the temperature range indicated on the scale, or improperly annealed, may show changes as large as 12 °C or 21 °F after heating for approximately 200 hours at high temperatures [17]. Permanent changes in the bulb volume have also been observed when thermometers have been repeatedly cycled at low temperatures (between -30 and +25 °C) [18].

When using thermometers for high temperature measurements, one must use care to avoid overheating. After only a few minutes of heating the thermometer at a temperature higher than its intended range, the increased gas pressure above the liquid column may cause a permanent distortion of the bulb resulting in lower thermometer indications.

8.2. Pressure Effects

Since glass exhibits elastic properties, the volume of a thermometer bulb will change when either the internal or external pressure changes. Therefore, at a given temperature, the reading of a thermometer in a horizontal position will differ from the reading in a vertical position. Thermometer readings will also vary with altitude. Changes of approximately 0.1 °C (0.2 °F) per atmosphere have been observed for many thermometers with bulb diameters between 5 and 7 mm. This value can be used with some confidence for estimating the probable effect of an external pressure change. The effect of change of internal pressure is approximately 10 percent greater.

Formulas for both external and internal pressure coefficients have been derived by Guillaume [19]. He found the relation,

$$\beta_e = k \frac{R_e^2}{R_e^2 - R_i^2},$$

where R_e and R_i are external and internal radii of the bulb, and k is a constant containing elastic properties of the glass and a conversion factor for expressing the volume change in terms of change of thermometer reading in degrees. In the above formula, the external pressure coefficient β is defined as the change in scale reading in degrees resulting from a change of 1 mm Hg in external pressure. For Celsius thermometers, Guillaume found a value of 5.2×10^{-5} degrees C/mm Hg for k , but Hall and Leaver [10], by experiment, found a value approximately 25 percent lower for their thermometers. In cases where an accurate correction is necessary, the value, β_e , should be determined experimentally. A simple apparatus for this determination is shown in figure 9.

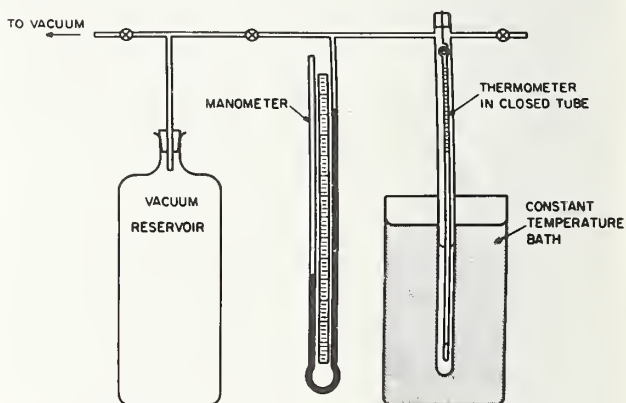

FIGURE 9. Apparatus for measurement of the external pressure coefficient.

The internal pressure coefficient, β_i , is more difficult to determine accurately, but may be calculated from the value, β_e , by means of the relation,

$$\beta_i = \beta_e + 1.5 \times 10^{-5}$$

for thermometers in Celsius degrees, or

$$\beta_i = \beta_e + 2.7 \times 10^{-5}$$

for thermometers graduated in Fahrenheit degrees.

8.3. Lag

Practically all theoretical treatments concerning thermometer lag are based on the assumption that Newton's law of cooling is applicable (that the rate of change in the reading of the thermometer is proportional to the difference between the thermometer temperature and the bath temperature). Consequently, when a thermometer is immersed in any medium, it does not indicate the temperature immediately, but approaches it asymptotically. A detailed discussion of this subject has been given by Harper [20].

If the temperature of the medium is varying uniformly, the thermometer always indicates what the temperature was at some previous time. The thermom-

eter readings are said to "lag" behind the temperature of the medium by an amount which may or may not be negligible, depending upon the rapidity of the temperature variation and the physical characteristics of the thermometer. In this case, the lag, λ , may be defined as the interval in seconds between the time when the bath reaches a given temperature and the time when the thermometer indicates that temperature. This lag is dependent upon the dimensions and material of the thermometer bulb, the medium surrounding the thermometer and the stirring rate of the medium. If a thermometer is suspended in still air, the lag may be as much as 50 times that of the same thermometer when it is immersed in a well-stirred water bath. Since the value of the lag for mercurial thermometers is not large (from 2 to 10 seconds in a well-stirred water bath), it is not generally necessary to correct for it. For example, if two thermometers, one having a lag of 3 seconds and another of 8 seconds, are read simultaneously in a bath with the temperature rising at a rate of 0.001 degree in 5 seconds, the former will read 0.001 degree higher than the latter, due to the lag. In the intercomparison of thermometers, the rate of temperature rise can usually be kept small, making the lag correction negligible.

A second interpretation of thermometer lag involves immersing a thermometer in a bath where the temperature of the medium remains constant. A certain time must elapse before the thermometer reading agrees with the temperature of the medium to 0.1 of a degree, and still longer for agreement to be within 0.01 of a degree. In this case the lag, λ , is the time required for the original difference in temperature between the thermometer and bath medium to be reduced to $1/e$ (that is $1/2.7$) of itself. In a length of time 4λ the difference will be approximately 1.5 percent of the original difference, and in a length of time 7λ approximately 0.1 percent. Determinations of λ for solid-stem laboratory thermometers, representative of American manufacture, have yielded values of approximately 2 to 3 seconds in a well-stirred water bath. Figure 10 shows the approach of thermometer readings to the water bath temperature for three selected thermometers having different values of λ . If the thermometer having $\lambda = 2.2$ seconds is initially at 25°C , and is immersed in a constant temperature bath at 75°C , the thermometer reading will be within 0.05°C (0.1 percent of 50°C) of the bath temperature in 15 seconds, and within 0.01°C in 19 seconds. The curve showing $\lambda = 3.1$ was obtained for an American Society for Testing and Materials (ASTM) specification 56C calorimetric thermometer with an outside bulb diameter of 7.9 mm and a bulb length of 44 mm. The value of $\lambda = 2.2$ was found for an ASTM 7C thermometer having bulb dimensions of 5.4 by 12 mm. The third curve, where $\lambda = 1.7$, was obtained for a bulb with dimensions of 5.4 by 34 mm. It is probable that most solid-stem thermometers of American manufacture will have values of λ lying within the range of the three curves shown. It will be noted that, according to Harper [20], the value

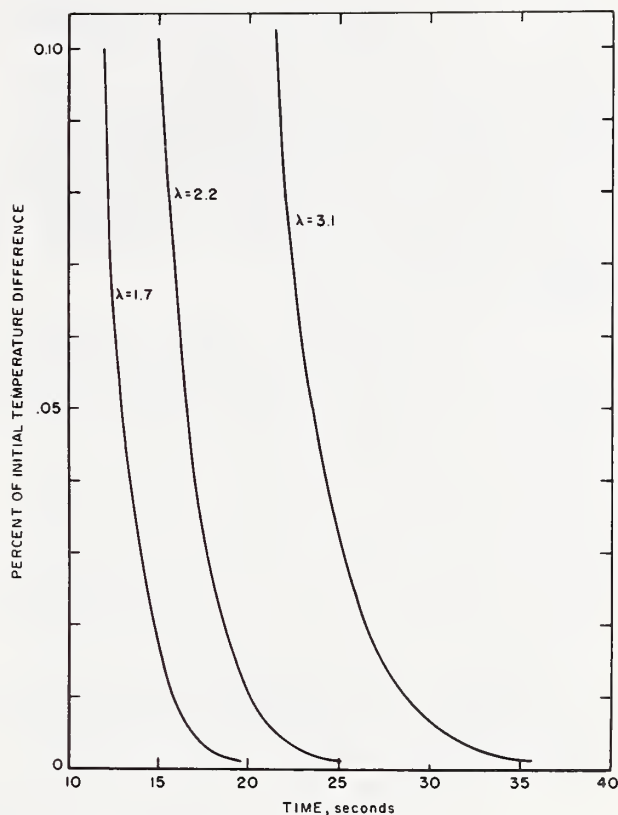

FIGURE 10. The approach to temperature in a stirred water bath for three thermometers with typical lag constants.

of λ for a given thermometer in a well stirred oil bath will be approximately twice its value in a water bath.

For a thermometer which is used to measure temperature changes (as in calorimetry), it has been shown by White [21] that the lag enters into the observations in such a way as to be eliminated from the results in applying the usual radiation corrections. Therefore the lag need not be considered, providing the initial and final readings are made when the temperature is varying uniformly. This is not strictly true, however, in the case of some Beckmann thermometers, which have no true value of λ , as is explained in the paper referred to above.

8.4. Separated Columns

Many inquiries are received concerning separated mercury columns which occur especially during shipment. Since no means of avoiding such occurrences has yet been found, some directions for joining the mercury may be helpful and are described below.

(a) The bulb of the thermometer may be cooled in a solution of common salt, ice, and water (or other cooling agent) to bring the mercury down slowly into the bulb. If the salt solution does not provide sufficient cooling, carbon dioxide snow (dry ice) may be used. Since the temperature of dry ice is approximately

—78 °C (—108 °F), and mercury freezes at approximately —40 °C (—40 °F), the mercury will solidify. Cool only the bulb and never the stem or mercury column. Moderate tapping of the bulb on a rubber stopper or similar soft spongy object, or the application of centrifugal force, by swinging the thermometer in a short arc (i.e. use of centrifugal force), usually serves to unite the mercury in the bulb. Care must be taken to warm the top of the bulb first, so that pressures in the bulb due to expanding mercury may be relieved.

(b) If there is a contraction chamber above the bulb or an expansion chamber at the top of the thermometer, the mercury can sometimes be united by warming the bulb until the column reaches the separated portions in either enlargement. Great care is necessary to avoid filling the expansion chamber completely with mercury, which might produce pressures large enough to burst the bulb. (The expansion chamber should never be more than 2/3 full.) Joining the mercury is more readily accomplished if the quantity in either cavity has first been shattered into droplets by tapping the thermometer laterally against the hand.

This procedure should not be used if it requires the thermometer to be heated above 260 °C (500 °F) and the bulb should never be heated in an open flame.

(c) As a last resort, especially for thermometers having no expansion chambers, small separated portions of the column can sometimes be dispersed by

warming into droplets tiny enough to leave space for the gas to by-pass. The thermometer is heated, and the droplets are collected by the rising mercury column.

The procedure for thermometers containing organic liquids is similar. Separated liquid in the stem can be vaporized and permitted to drain down the capillary. Another method consists of gently tapping the stem above the separation against the palm of the hand, forcing the organic liquid to break away from the wall of the capillary and flow down the bore to join the main column.

Minute gas bubbles, which are sometimes found along the surface of the mercury in the thermometer bulb, may be collected by "washing" the bulb with a large gas bubble. Bring all of the mercury into the bulb as outlined in section (a). Hold the thermometer in a horizontal position and gently tap it against the hand to form a large gas bubble. Force the bubble to travel around the walls of the bulb by rotating the thermometer and tapping it against the palm of the hand. When the entire surface has been "washed" rotate the bubble to the top of the bulb and reunite the mercury as described above.

All of these manipulations require patience, and experience is helpful, but they will yield results if care is used. A convenient method of ascertaining that all of the liquid has been joined is a check of the ice point or some other reference point on the scale.

9. References

- [1] "The International Practical Temperature Scale of 1968," *Metrologia*, Vol. 5, No. 2, 35 (April, 1969).
- [2] Calibration and Test Services of The National Bureau of Standards, NBS Spec. Publ. 250 (1970 Edition), Part 5. (Copies available from NBS on request).
- [3] Comptes Rendus des Séances de la Treizième Conférence Générale des Poids et Mesures (1967-1968), Resolutions 3 and 4, p. 104.
- [4] Stimson, H. F., The International Practical Temperature Scale of 1948, *J. Res. Nat. Bur. Stand. (U.S.)*, 65A (Phys. and Chem.), No. 3, 139-145 (May-June 1961).
- [5] Based on the data of Osborne, N. S., and Meyers, C. H., A formula and tables for the pressure of saturated water vapor in the range 0 to 374 °C, *J. Res. NBS* 13, 1 (1934) RP691.
- [6] Scott, R. B., and Brickwedde, F. G., A precision cryostat with automatic temperature regulation, *BS J. Res.* 6, 401 (1931) RP284.
- [7] American Society for Testing and Materials Designation E77-72, Calibration at Temperatures Other Than Fixed Points, Section 11.2.
- [8] Buckingham, E., The correction for emergent stem of the mercurial thermometer, *Bul. BS* 8, 239 (1912) S170.
- [9] Pemberton, L. H., Further consideration of emergent column correction in mercury thermometry, *J. Sci. Instr.* 41, 234 (1964).
- [10] Hall, J. A., and Leaver, V. M., The design of mercury thermometers for calorimetry, *J. Sci. Instr.* 36, 183 (1959).
- [11] Ween, Sidney, "The Beckmann Differential Thermometer: Its Principles of Construction and Application," *Materials Research and Standards, MTRSA*, Vol. 12, No. 8, August 1972, p. 31.
- [12] Thompson, R. D., Recent developments in liquid-in-glass thermometry, *Temperature, Its Measurement and Control in Science and Industry* 3, Part 1 (Reinhold Publishing Corp., New York, 1962) p. 201.
- [13] Liberatore, L. C., and Whitcomb, H. J., Density changes in thermometer glasses, *J. Am. Ceram. Soc.* 35, 67 (1952).
- [14] American Society for Testing and Materials Designation C162-56, Standard Definitions of Terms Relating to Glass and Glass Products.
- [15] Lillie, H. R., and Shaver, W. W., Method of tempering glass, U.S. Patent No. 2,148,630 (Feb. 28, 1939).
- [16] Liberatore, L. C., Method of stabilizing the molecular arrangement of glass thermometers, U.S. Patent No. 2,610,445 (Sept. 16, 1952).
- [17] Ruh, E. L., and Conklin, G. E., Thermal stability in ASTM thermometers, *ASTM Bul. No.* 233, 35 (Oct. 1958).
- [18] Martin, W. I., and Grossman, S. S., Calibration drift with thermometers repeatedly cooled to —30 °C, *ASTM Bul. No.* 231, 62 (July 1958).
- [19] Guillaume, C. E., *Traité Pratique de la Thermométrie*, Gauthier-Villars et Fils, Paris (1889) p. 99.
- [20] Harper 3d, D. R., Thermometric lag, *Bul. BS* 8, 659 (1912) S185.
- [21] White, W. P., Lag effects and other errors in calorimetry, *Phys. Rev.* 31, 562 (1910).

U.S. DEPT. OF COMM. BIBLIOGRAPHIC DATA SHEET (See instructions)	1. PUBLICATION OR REPORT NO. NBS/MONO-174	2. Performing Organ. Report No.	3. Publication Date January 1986
4. TITLE AND SUBTITLE Thermometer Calibration: A Model for State Calibration Laboratories			
5. AUTHOR(S) J. A. Wise and R. J. Soulen, Jr.			
6. PERFORMING ORGANIZATION (If joint or other than NBS, see instructions) NATIONAL BUREAU OF STANDARDS DEPARTMENT OF COMMERCE GAITHERSBURG, MD 20899			7. Contract/Grant No. 8. Type of Report & Period Covered Final
9. SPONSORING ORGANIZATION NAME AND COMPLETE ADDRESS (Street, City, State, ZIP) Same as #6.			
10. SUPPLEMENTARY NOTES Library of Congress Catalog Card Number 85-609636 <input type="checkbox"/> Document describes a computer program; SF-185, FIPS Software Summary, is attached.			
11. ABSTRACT (A 200-word or less factual summary of most significant information. If document includes a significant bibliography or literature survey, mention it here) This document describes the means by which a state calibration laboratory can establish a calibration service based on liquid-in-glass thermometers. Discussed are: ice-point baths, controlled-temperature baths, thermometer inspection, calibration techniques, and control chart procedures.			
12. KEY WORDS (Six to twelve entries; alphabetical order; capitalize only proper names; and separate key words by semicolons) Calibration; IPTS-68; liquid-in-glass thermometers; temperature			
13. AVAILABILITY <input checked="" type="checkbox"/> Unlimited <input type="checkbox"/> For Official Distribution. Do Not Release to NTIS <input checked="" type="checkbox"/> Order From Superintendent of Documents, U.S. Government Printing Office, Washington, D.C. 20402. <input type="checkbox"/> Order From National Technical Information Service (NTIS), Springfield, VA. 22161			14. NO. OF PRINTED PAGES 88 15. Price

NBS *Technical Publications*

Periodical

Journal of Research—The Journal of Research of the National Bureau of Standards reports NBS research and development in those disciplines of the physical and engineering sciences in which the Bureau is active. These include physics, chemistry, engineering, mathematics, and computer sciences. Papers cover a broad range of subjects, with major emphasis on measurement methodology and the basic technology underlying standardization. Also included from time to time are survey articles on topics closely related to the Bureau's technical and scientific programs. Issued six times a year.

Nonperiodicals

Monographs—Major contributions to the technical literature on various subjects related to the Bureau's scientific and technical activities.

Handbooks—Recommended codes of engineering and industrial practice (including safety codes) developed in cooperation with interested industries, professional organizations, and regulatory bodies.

Special Publications—Include proceedings of conferences sponsored by NBS, NBS annual reports, and other special publications appropriate to this grouping such as wall charts, pocket cards, and bibliographies.

Applied Mathematics Series—Mathematical tables, manuals, and studies of special interest to physicists, engineers, chemists, biologists, mathematicians, computer programmers, and others engaged in scientific and technical work.

National Standard Reference Data Series—Provides quantitative data on the physical and chemical properties of materials, compiled from the world's literature and critically evaluated. Developed under a worldwide program coordinated by NBS under the authority of the National Standard Data Act (Public Law 90-396).

NOTE: The Journal of Physical and Chemical Reference Data (JPCRD) is published quarterly for NBS by the American Chemical Society (ACS) and the American Institute of Physics (AIP). Subscriptions, reprints, and supplements are available from ACS, 1155 Sixteenth St., NW, Washington, DC 20056.

Building Science Series—Disseminates technical information developed at the Bureau on building materials, components, systems, and whole structures. The series presents research results, test methods, and performance criteria related to the structural and environmental functions and the durability and safety characteristics of building elements and systems.

Technical Notes—Studies or reports which are complete in themselves but restrictive in their treatment of a subject. Analogous to monographs but not so comprehensive in scope or definitive in treatment of the subject area. Often serve as a vehicle for final reports of work performed at NBS under the sponsorship of other government agencies.

Voluntary Product Standards—Developed under procedures published by the Department of Commerce in Part 10, Title 15, of the Code of Federal Regulations. The standards establish nationally recognized requirements for products, and provide all concerned interests with a basis for common understanding of the characteristics of the products. NBS administers this program as a supplement to the activities of the private sector standardizing organizations.

Consumer Information Series—Practical information, based on NBS research and experience, covering areas of interest to the consumer. Easily understandable language and illustrations provide useful background knowledge for shopping in today's technological marketplace.

Order the above NBS publications from: Superintendent of Documents, Government Printing Office, Washington, DC 20402.

Order the following NBS publications—FIPS and NBSIR's—from the National Technical Information Service, Springfield, VA 22161.

Federal Information Processing Standards Publications (FIPS PUB)—Publications in this series collectively constitute the Federal Information Processing Standards Register. The Register serves as the official source of information in the Federal Government regarding standards issued by NBS pursuant to the Federal Property and Administrative Services Act of 1949 as amended, Public Law 89-306 (79 Stat. 1127), and as implemented by Executive Order 11717 (38 FR 12315, dated May 11, 1973) and Part 6 of Title 15 CFR (Code of Federal Regulations).

NBS Interagency Reports (NBSIR)—A special series of interim or final reports on work performed by NBS for outside sponsors (both government and non-government). In general, initial distribution is handled by the sponsor; public distribution is by the National Technical Information Service, Springfield, VA 22161, in paper copy or microfiche form.

U.S. Department of Commerce
National Bureau of Standards
Gaithersburg, MD 20899

Official Business
Penalty for Private Use \$300