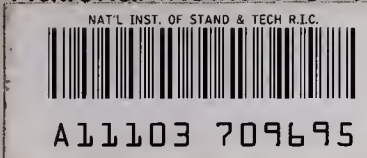


United States Department of Commerce
National Institute of Standards and Technology



NIST Special Publication 824

Ceramic Bearing Technology

Proceedings of the NIST/DARPA
Workshop on Ceramic Bearing Technology
April 17-18, 1991
Gaithersburg, Maryland

Said Jahanmir, Editor



QC
100
U57
#824
1991
C.2

NISTC
DC10
U.S. 17
#824
1991
C.2

NIST Special Publication 824

Ceramic Bearing Technology

**Proceedings of the NIST/DARPA
Workshop on Ceramic Bearing Technology
April 17–18, 1991
Gaithersburg, Maryland**

Edited by
Said Jahanmir

Ceramics Division
Materials Science and Engineering Laboratory
National Institute of Standards and Technology
Gaithersburg, MD 20899

Sponsored by
Defense Advanced Projects Agency
National Institute of Standards and Technology

Issued November 1991



U.S. Department of Commerce
Robert A. Mosbacher, Secretary

National Institute of Standards and Technology
John W. Lyons, Director

National Institute of Standards
and Technology
Special Publication 824
Natl. Inst. Stand. Technol.
Spec. Publ. 824
219 pages (Nov. 1991)
CODEN: NSPUE2

U.S. Government Printing Office
Washington: 1991

For sale by the Superintendent
of Documents
U.S. Government Printing Office
Washington, DC 20402

Executive Summary

The objectives of the workshop were to assess the status of ceramic bearing technology, and identify the key research topics needed to expand the range of applications for ceramic bearings. The principal advantages of advanced structural ceramics, such as silicon nitride, over metallic counterparts are lower density, higher abrasion resistance, higher chemical inertness, and electrical and magnetic insulation. Advanced structural ceramics have been evaluated during the past twenty years as balls, rollers, and races in bearing applications. Currently, silicon nitride hybrid bearings (ceramic balls with steel races) are being used quite successfully as instrument bearings and as machine tool spindle bearings. In general, progress in research and in the implementation of research results for utilization of ceramic bearings has been slow. Therefore, this workshop was organized to identify the major impediments and recommend possible solutions.

A total of eleven invited presentations were given at the workshop which was attended by seventy-five representatives from industry, government, and universities. The presentations and subsequent discussions covered present and potential future applications of ceramic bearings, and topics related to processing, machining, quality control, design, testing, and performance evaluation. The following recommendations are based on the presentations and the subsequent discussions by the workshop participants:

- 0 Research activities should focus on cost reduction, while maintaining or improving the current level of performance reliability. All aspects of bearing production from powder processing to bearing assembly should be examined for means of cost reduction.
- 0 Research in powder processing, compaction, and densification should address optimization of microstructure for best bearing performance, as well as cost control.
- 0 New and improved cost-effective machining techniques should be developed for ceramic bearing races. Special attention should be given to dimensional tolerance and surface integrity of the finished components.
- 0 Non-destructive evaluation techniques and quality control methods should be developed for use in various stages of bearing production. It should be recognized that only the applications requiring a high level of reliability should be subjected to expensive inspections.
- 0 Although the current silicon nitride bearing materials are adequate for use in hybrid bearings, new and improved materials that are being developed should be evaluated for use in high-temperature all-ceramic bearings.

- 0 New and improved computerized design procedures and life prediction methods should be developed for ceramic bearings. These computer programs should include dynamic analysis of the total bearing system, performance data, and models for wear, fatigue, and lubricant degradation.
- 0 Detailed understanding on the mechanisms of wear and rolling contact fatigue, and the role of microstructure on these mechanisms are needed to allow developments of new and improved bearing materials.
- 0 Performance data on presently available materials should be collected and made available to the bearing industry to allow proper selection of bearing materials.

Foreword

DARPA sponsorship of this workshop is related to a program initiative in ceramic bearings technology. Over the last three months I have been talking to many of the participants in this workshop concerning needs and opportunities in this technology area. The viewpoints expressed by those in companies characterized as ceramic fabricators, ball finishers, bearing companies, or end users, as well as the tribologists in both companies and government laboratories, were very useful to me in getting an understanding of the needs in this technology area. Because of the differing perspectives of those involved in developing and applying ceramic bearing technology, I thought a topical workshop would be useful in exchanging viewpoints and promoting interactions.

The Defense Department has an interest in ceramic bearing technology because it is an enabling or enhancing technology for weapon systems and platforms. The low density of ceramics compared to metals makes them attractive as high-speed rolling elements since centrifugal forces are reduced. Ceramic bearings out-perform metal bearings in most corrosive and/or erosive environments; also ceramic bearings are required for high-temperature applications. Additional applications result from material properties including high electrical resistivity, non-magnetic, and reduced catalytic activity for decomposition of lubricants.

Factors limiting the greater utilization of ceramic bearings include their cost relative to metal bearings and questions of reliability and predictability of performance. It is hoped that this workshop will contribute to identification of research opportunities, which will result in increased usage of ceramic bearings in both military and non-military applications.

William S. Coblentz
Defense Sciences Office
Defense Advanced Research
Projects Agency

Acknowledgments

The financial support for this activity was provided jointly by the Defense Advanced Research Project Agency (DARPA) and the National Institute of Standards and Technology (NIST). Funds from DARPA were received under ARPA Order No. 8080, Program Code No. 1Y10.

This workshop was conducted at the suggestion of Dr. William Coblenz in an informal meeting at NIST. The editor is grateful to Dr. Coblenz for his encouragements and advice. Dr. Larry Fehrenbacher of Technology Assessment and Dr. Karl Mecklenburg of the U.S. Air Force assisted in the selection of the technical presentations and the invitation list. The workshop speakers, discussion group chairs, and participants made this workshop a complete success.

Special thanks are due to Kathy Kilmer and Lori Phillips of NIST for the site selection and the detailed arrangements of the workshop. I am particularly indebted to Karen Lusk and Margaret Robinson for the preparation of this report and taking care of all other details that are necessary for conducting a workshop.

Disclaimer

The opinions expressed in this report are those of the editor and authors, and are based on the presentations and discussions at the workshop. These opinions and recommendations do not necessarily represent the views of the Defense Advanced Projects Agency, or the Government of the United States.

Information on product names, manufacturers, or suppliers are included in this report only for clarification. This does not imply endorsement of the products or services by NIST.

Cover Photograph

The cover photograph is courtesy of Dr. John W. Lucek, CERBEC, Ceramic Bearing Company.

Table of Contents

	<u>Page No.</u>
Executive Summary.....	iii
Foreword.....	v
Acknowledgements.....	vi
1. Workshop Summary.....	1
2. Discussion Group Summaries.....	15
Ceramic Processing and Blank Fabrication.....	17
Subhas Malghan, NIST, and Jim Hannoosh, CERBEC	
Machining, Quality Control, and NDE	21
K. Subramanian, Norton, and Grady White, NIST	
Design, Performance Testing, and Life Prediction.....	27
James Dill, Mechanical Technology, Inc. and Marshall Peterson, NIST	
3. Technical Presentations.....	37
Advantages of and Issues in the Application of.....	39
Ceramic and Ceramic Hybrid Bearings Jim Dill, Mechanical Technology, Inc.	
Payoffs and Challenges in Utilization of.....	55
Ceramic Components in Spacecraft Mechanisms Paul D. Fleischauer, The Aerospace Corp.	
Hybrid Ball Bearing for Naval Applications.....	69
Gerry J. Phillips, David Taylor Research Center	
Instrument Bearing Requirements and Issues.....	99
Robert A. Westerholm, Litton Guidance and Control Systems	
High-Temperature Applications and Challenges.....	107
of Ceramic Bearings Lewis B. Sibley, Tribology Systems, Inc.	
Effects of Composition, Microstructure, and.....	121
Processing on Ceramic Rolling Element Bearing Performance R. Nathan Katz, Worcester Polytechnic Institute	

Effects of Machining and Finishing on Performance.....	131
Mike N. Gardos, Hughes Aircraft Company, and Julian R. Pratt, Spheric, Ltd.	
Requirements and Issues in Quality Control	141
and NDE of Ceramic Bearings B. T. Khuri-Yakub, Stanford University	
Ductile Regime Grinding of Brittle Materials.....	169
Tom A. Dow, Steven C. Fawcett, and Ronald O. Scattergood, North Carolina State University	
Design and Life Prediction Issues for Ceramic Bearings.....	181
Crawford Meeks, AVCON, Inc.	
Tribology Issues Related to Machining	199
and Performance of Ceramic Bearings Said Jahanmir, NIST	
Appendix A: Workshop Agenda.....	219
Appendix B: Workshop Attendance List.....	221

Section 1

Workshop Summary

Workshop Summary

The objectives of the workshop were to assess the status of ceramic bearing technology, and identify the key research topics needed to expand the range of applications for ceramic bearings. The principal advantages of advanced structural ceramics, such as silicon nitride, over metallic counterparts are lower density, higher abrasion resistance, higher chemical inertness, and electrical and magnetic insulation. Advanced structural ceramics have been evaluated during the past twenty years as balls, rollers, and races in bearing applications. Currently, silicon nitride hybrid bearings (ceramic balls with steel races) are being used quite successfully as instrument bearings and as machine tool spindle bearings. In general, progress in research and in implementation of research results in utilization of ceramic bearings has been slow. Therefore, this workshop was organized to identify the major impediments and recommend possible solutions.

A total of eleven invited presentations were given at the workshop which was attended by seventy-five representatives from industry, government, and universities. The presentations covered both present and potential future applications of ceramic bearings, and discussed topics related to processing, machining, quality control, design, testing, and performance evaluation. Following the invited presentations, the workshop was divided into three discussion groups: 1) Ceramic Processing and Blank Fabrication, 2) Machining, Quality Control, and NDE, and 3) Design, Performance Testing, and Life Prediction. After extensive discussions, the chairman of each group presented the summary of the discussions to the workshop participants. These summaries and the abstracts of invited presentations, as well as the viewgraphs used in these presentations, are included in this report. The workshop agenda and the list of attendees are included in the Appendix.

The following summary is based on the presentations and discussions at the workshop. The applications where ceramic bearings can be used, and the associated benefits, are listed. The major issues in design and life prediction; processing and materials; machining, non-destructive evaluation, and quality control; and bearing performance are described in detail. This discussion is concluded by a list of major recommendations for research.

Applications and Benefits:

The present and future applications for ceramic bearings can be classified into five categories depending on the design and the requirements of the application.

1) Marginally Lubricated systems: In these applications hybrid bearings lubricated with grease and oil have the advantages of lower heat generation and better overall performance due to reduced contact area (determined by the elastic modulus of the materials). Specific applications include: machine tool spindle bearings, fuel-lubricated turbine engine bearings, fuel pumps, fuel hydraulic systems, fuel controls, pump motors and generators for naval auxiliary machinery, gyroscopes, space gimbles,

momentum and reaction wheels, solar array drives, turbopumps, antenna and sensor pointing systems, instrument bearings, and bearings for computer disc drives.

2) High-Speed Liquid Lubricated Applications: In high-speed bearings it may be possible to improve bearing life by using silicon nitride rolling elements with steel races. The principal advantage is the reduction of the outer race stresses due to lower centrifugal force as a result of lower density of silicon nitride. Applications include: high-speed spindle bearings, turbine engine mainshaft bearings, and air cycle machines.

3) Low-Speed Solid Lubricated Applications: At low to moderate speeds and at temperatures to 450°C, solid lubricated hybrid bearings show improved wear life when compared with steel bearings. Smaller contact area and reduced microslip in hybrid bearings give an overall reduced wear and improved life. Applications include: turbine engine auxiliaries, air motors, nozzle actuators, space gimbals, and x-ray tube rotating cathodes. Some of the applications cited for marginally lubricated systems may benefit from solid lubrication if the technology becomes available.

4) High-Speed Solid Lubricated Bearings: The primary benefits of hybrid bearings capable of operation at high-speeds and temperatures to 450°C with solid lubrication are reduced weight, and reduction of engine size due to the elimination of the liquid lubrication system and gearbox. Other advantages are engine storability, and lower torque and starting requirements at low temperatures.

5) High-Speed Solid Lubricated All-Ceramic Bearings: Solid lubricated all-ceramic bearings capable of operating at temperatures up to 750°C and at high-speeds would offer significant advantages in advanced turbine engines. Other applications of all-ceramic bearings include flywheel bearings for electric-powered automobiles, turbomachinery, advanced heat engines, and bearings for nuclear reactors. Much past research has been directed toward this type of bearing; but significant issues in materials, lubricants, mounting, lubricant supply, and cooling need to be resolved.

Utilization of advanced structural ceramics in bearings can result in many technical benefits, which will undoubtedly result in lower operating cost of the overall mechanical systems. Major benefits are as follows:

- 0 The lower density of silicon nitride will reduce the cage forces at high acceleration rates. Also, reduced weight is beneficial during launch of space mechanisms.
- 0 Ceramic rolling elements may reduce noise, resulting in quieter bearings.
- 0 All-ceramic bearings offer chemical inertness compared with steel bearings; they are superior in applications where lubricated by process fluids.

- 0 In electrical applications, ceramic parts improve electrical isolation and eliminate damage due to electrical discharge.
- 0 Improved precision of ceramic balls can improve performance, i.e., smooth operation with low vibration, in a wide range of applications.
- 0 Reduced sensitivity to loss of lubricant and higher fatigue life can increase reliability and increase the overall life of the bearing.
- 0 Higher hardness of the ceramics may result in lower damage due to particulate contamination in the bearing.

Design and Life Prediction:

A rolling element bearing is a highly complex mechanical component since numerous variables must be considered in its design. The design process consists of analysis and optimization of key design variables. Some of the important design variables for a rolling element bearing include: geometric parameters (ball diameter, contact angle, pitch diameter, raceway curvature, and ball-cage pocket clearance), external loads (radial and axial forces, moments, unbalanced forces, and vibrations), internal loads (centrifugal and gyroscopic forces, dynamic collision of cage and rolling elements, and skidding forces), material and lubricant parameters, and operational variables (such as temperature and speed). It should also be recognized that some of these variables are interdependent. Conventional design techniques mostly consider the geometric aspects and load-carrying capacity of bearings. Although this may be sufficient for low-speed, low-load, well-lubricated bearings, it is not possible to use these techniques to design reliable, high-speed bearings made with new advanced materials such as ceramics. Development of ceramic bearings requires dynamic analysis of the total bearing system including the motion of individual balls, the cage, and the races.

The design process is not complete until the bearing geometry, materials, lubricants, and integration of the bearing with shaft and the housing has been achieved. At this point the potential failure modes must be identified and the variables adjusted to accommodate normal wear of the system. Finally, the life of the bearing and the reliability factor for the intended application must be determined. Several advanced design and analysis programs are currently available, which can be used on personal computers or work stations. These programs not only can be used as a guide to design ceramic bearings, but also can be used to analyze the effect of bearing parameters on the performance, and to warn against potential failures. These programs, however, have been developed for design of bearings for certain applications, and may not be suitable for the wide range of applications where ceramic bearings can be implemented. Since the design requirements and performance issues depend heavily on the application, and are not the same for all anticipated applications, these programs must be modified.

The specific design issues for each application category are different; these issues are discussed in the discussion summary of the Design and Performance Testing. For hybrid marginally lubricated bearings, for example,

which have the potential for the most wide-spread use, the important issue is design predictability. In order to improve the design predictability of hybrid bearings, material life factors are needed for both the steel and ceramic parts run together. Development of these life factors will require performance data on fatigue, wear and lubricant degradation, as well as heat generation and its effect on performance. In addition, the lower thermal expansion coefficient of ceramics compared to metals must be incorporated in the design. Furthermore, the balance between increased stresses due to higher elastic modulus of the ceramic balls and the lower centrifugally induced loads at high speeds must be carefully accounted for in bearing design and life calculations. While these are key factors in design, the general consensus is that given adequate data on material properties and life factors, designers know how to account for these in the design.

Processing and Materials Issues:

Based on limited available data, it can be concluded that performance of silicon nitride is superior to other advanced structural ceramics for bearing applications. The current route of processing silicon nitride bearing components is by powder beneficiation, compaction and densification. Processing of powders, starting with fine powders through densification, is intensive in capital and energy; therefore, it is expensive. An accurate assessment of the cost of blank formation is not possible with the available data, but it is obvious that by starting with lower-cost raw materials, and by reducing rejects or recycle, the overall cost can be decreased. In addition, the cost can be dramatically reduced if volume of production can be increased. In the immediate future, current methods of powder processing are expected to dominate. Therefore, further research and developments in powder processing are required to establish low-cost methods for production of densified silicon nitride materials suitable for bearing applications.

A large number of unit operations are involved in powder processing and densification. Each operation is considered to be a cause for increased cost and a source of introduction of impurities. At present, due to small batch operations, the cost of process monitoring and operation are high. Also, the end properties are overly sensitive to small changes in the process parameters. Because of difficulties in controlling and reproducing all the processing parameters, batch-to-batch variation and the uniformity of composition and microstructure have become major problems. To enhance reproducibility and uniformity, a large number of measurements are usually made on the powder, slurry, green body, and densified ceramic components. But, the measurements contribute to increased production cost of the bearing components. Hence, there is a need for identification of specific measurements that have a major impact on the processing parameters.

All conventional methods of shape forming (dry pressing, injection molding, and colloidal filtration) involve a number of steps that require powder handling in different stages. Though densification by hot iso-static pressing (HIP) is the preferred mode of processing, it is expensive and leaves behind a glassy surface layer which must be removed by machining. If fully utilized, the cost of HIP can be decreased and cost due to rejections can be reduced. However,

pressureless sintering of suitable compositions should be explored as possible cost-effective densification alternatives for bearing materials.

The starting powder, additives, processing method, and processing variables strongly influence the final composition and microstructure of the material. No data exist on the optimization of microstructure for best wear resistance or bearing performance. In most cases, existing materials have been tested under only a few selected test conditions for fatigue and for wear. Published data, although very limited, suggest that the amount of grain boundary phase, the inclusion content, and the porosity level must be kept as small as possible. The influence of grain size, grain aspect ratio, additive chemistry, alpha/beta ratio, and grain boundary composition require further investigation.

One reason for the lack of systematic studies on the effect of compositional, microstructural, and processing variables is the difficulty of holding any of these constant as the others are varied. An alternate approach is to identify the detailed mechanisms controlling failure, i.e., spalling and wear, and investigate the effect of important parameters affecting the failure process using statistically designed experiments. The result of such studies could be used to optimize the processing conditions that would provide the best microstructure for bearing performance.

Machining and Finishing Issues:

The performance and reliability of ceramic rolling element bearings are controlled not only by microstructure and composition, but also by surface roughness and integrity, which are controlled by machining. Formation of defects and residual stresses due to machining can be detrimental and promote early failure by fatigue and spalling. In addition to the contribution of machining damage to performance, machining also contributes to the high cost of ceramic bearings. Therefore, it is imperative to optimize the present machining methods and find innovative and cost-effective methods to machine ceramic bearing components that are free of machining generated defects.

Although there are no standard procedures for machining ceramic balls and races, it appears that diamond grinding and polishing are the most commonly used techniques. The machining procedure for silicon nitride balls consists of grinding and polishing of near net-shape spheres to obtain the desired tolerances and surface finishes. Currently, this process is slow and requires several hours. However, excellent tolerances and surface finishes can be obtained. Recent studies have shown that the polishing rate and the tolerances, as well as the surface finish, depend on several factors including the microstructural parameters, processing procedure and mechanical properties of the material. For example, hot-pressed materials seem to be inferior to HIP'ed materials, because of the microstructural anisotropy obtained in hot pressing. Grinding and polishing rates depend on the fracture toughness and hardness of the material through the influence of microstructural parameters on these properties. It should be pointed out that formation of machining defects and residual stresses also depend on the microstructure and the processing conditions, since each material may respond differently to the applied surface forces and thermal conditions during the machining process. Nevertheless, ball grinding and

polishing can be considered as an established technique. As already stated, it is time-consuming and costly; any improvements that result in the reduction of cost and improvements in the surface quality would be beneficial. An example of a new technique is polishing by magnetic levitation, which appears to produce excellent quality at higher production rates.

Machining techniques for ceramic rollers and races have not been established, although diamond grinding and polishing are being used. Machining of races for all-ceramic bearings from a block of silicon nitride is costly, and often results in a large rejection rate. New machining techniques and/or optimization of the grinding process are badly needed. It should be recognized that machining is a complex process and involves a large number of interdependent variables. For example, in grinding one must consider the machine tool, the grinding wheel, the grinding fluid, the machining parameters, and of course the workpiece. Therefore, machining in general, and grinding in particular, must be considered as a system. The effect of these parameters on the machining rate and the quality of finished components must be determined, in order to optimize the machining practice.

Before improvements in machining operations can be made, specific knowledge of the surface requirements of the finished bearing must be known: e.g., shape, size, expected stresses, and expected modes of failure. With this knowledge in hand, it would be possible to know if existing machining technology would be adequate to finish the bearings to an acceptable reliability level or whether modifications to current machining practices (or even completely new practices) would be required. Regardless of the particular machining process employed, there is a need for generalized guidelines for machining which would outline standard procedures as well as recognized risks and benefits associated with those procedures.

Studies have shown that quality of finished surfaces and the degree of precision obtained in grinding of high-strength ceramics, such as silicon nitride, is very much influenced by machine stiffness. Since rolling element bearings require a high level of precision, it is important to recognize the effect of machine tool design on the quality of finished components. State-of-the-art stiff machine tools can currently be used in a creep-feed grinding mode to remove large amounts of material at high rates. These recent developments must be evaluated for machining of silicon nitride races for all-ceramic bearings.

Another recent development in machining of "brittle" materials is the ductile regime grinding process. The concept of ductile regime grinding is based on the idea that at very small depths of cut the material can be removed by plastic deformation rather than fracture, which is usually observed for brittle materials. The critical depth of cut for transition to ductile regime depends on hardness and fracture toughness of the material being machined. For silicon nitride and silicon carbide the critical depth of cut is in the range of 200 to 300 nm. It may be possible to increase the critical depth of cut by analyzing the effect of chemical environment on the process of chip formation, with the goal of improving the grinding process through selection of proper chemical compounds for addition to the grinding fluid. This approach may also be instrumental in the reduction of the overall machining cost by decreasing the

wear rate of the diamond grains used in grinding.

A major factor contributing to the high cost of ceramic bearings is the small number of bearings currently being produced. As the demand increases, the cost per component is expected to decrease. Presently, machining is done in a batch mode. In order to achieve automation in ceramic machining, and allow for a flexible manufacturing environment, research in on-line sensors, process models, control strategies, and mechanistic understanding is needed. The need for increased research in ceramic machining has also been recognized by NIST and DOE. It is important to coordinate the machining activities of DARPA with other agencies to achieve a faster technology development and eliminate the potential of duplication.

NDE and Quality Control:

Performance of ceramic bearings can be influenced by any factors that negatively affect the failure process. For example, large grains, voids, inclusions, and microcracks near surfaces can promote excessive fatigue and/or wear by acting as sites of crack nucleation. In addition to these surface or near-surface defects, one must also determine the dimensional tolerance and surface topography. Furthermore, any internal defects such as large inclusions, cracks, and density variations may cause premature fracture and failure of the bearing components. The fear of premature failure may be the single most important barrier to the greater use of ceramics in bearing applications.

In order to ensure reliable bearing performance, non-destructive evaluation (NDE) and quality control are necessary. Reliability is, in practice, made up of two components: true reliability and perceived reliability. For many applications, current ceramic bearings are already sufficiently reliable, but the consumer's perception is contrary to this fact. Because of the perceived low reliability, utilization of ceramic bearings for certain applications requiring high reliability is limited. However, it should be pointed out that for many near-term applications, good process control coupled with sampling plan and destructive analysis or some established NDE techniques may be adequate. Advanced NDE techniques are costly and may raise the price of the bearing components; they may even hinder use of ceramic bearings in lower-risk applications that do not require such stringent inspections.

In order to select an existing NDE technique or develop a new one, one must first determine the potential failure modes for the intended application. It is critical that the failure modes be determined in real bearings rather than in simulated tests such as rolling contact fatigue. Next, it is necessary to identify what kinds of flaws must be detected, since flaw size, shape, and location all influence the selection of NDE procedure. Clearly, the identification of the flaws to be detected is determined by the reliability criteria appropriate for the specific application. Once the types of critical flaws have been identified, it should be possible to judge whether known evaluation techniques are applicable or whether new techniques need to be developed, either from scratch or by modifications of existing procedures.

In the last fifteen to twenty years, several techniques have been developed for the non-destructive evaluation of dense ceramics. These include: x-ray computed tomography, microfocus x-ray, thermal imaging, nuclear magnetic resonance, and ultrasonics, in addition to visual optical inspection and fluorescent penetrant technique. Most of these techniques are suitable for detection of flaws larger than 50 microns in the bulk sample, with the exception of high-frequency ultrasonics and thermal wave measurements with laser. The latter techniques, although still in the experimental research stage, seem to be capable of detecting smaller surface flaws generated on and near the surface from machining operations.

Detection of machining generated defects is crucial to bearing performance, because surface fatigue cracks initiate at or very near the surface. Also, as the quality of ceramic materials improve and the density of the bulk defects is reduced through improved processing techniques, it is expected that surface defects become more detrimental to the bearing performance. It is, therefore, necessary to extend the capabilities of the thermal wave imaging and ultrasonic technique for the detection of machining generated defects. Future research must address the NDE of actual ceramic bearing components, i.e., balls, rollers, and races, and must be capable of inspecting the entire surface.

It should also be emphasized that application of NDE and quality control should not be limited to the finished component. All other steps in the manufacture of the bearing require inspection and control. Each of these steps is interrelated with the others, and maximum reliability requires that improved understanding occur at each step. It is important to consider where NDE should be applied in the manufacturing process, and whether certain rough-part geometries and certain stages during manufacturing, for example green machining or powder processing, are easier to inspect. Inspection of powder, slurry, and green compacts for defects and rejection of defective parts at the early stages of production can decrease the production cost. In-process monitoring of powder processing unit operations for particle size distribution, agglomerate concentration, dispersion chemistry, green density, and geometric dimensional variations of green bodies can lead to significant improvements in the overall process reliability.

Performance-Related Issues:

Wear and rolling contact fatigue (i.e., spall formation) are the two general mechanisms of failure in ceramic bearings. Fatigue cracks are usually initiated on the surface or near the surface from inhomogeneities in the material; for example, microcracks, inclusions, cavities, and grain boundaries. Initiation and propagation of fatigue cracks are influenced by the physical and thermal properties of the material and the environment. In the latter, chemical reactions between the environment and the crack tip can accelerate the propagation of the crack, resulting in premature failure. Wear, or gradual removal of material, is generally accompanied by deformation and fracture, and often cyclic fatigue at a scale much smaller than the spall formation. Plowing and damage by hard foreign debris and wear debris also can cause considerable damage to the bearing. Tribochemical reactions between the surface and the

environment and removal of the reaction film is another mechanism for wear, as documented for silicon nitride.

Although past research has provided some insights into potential failure mechanisms in ceramic bearings, the details of these processes and the role of important variables influencing failure have not been explored systematically. In the absence of such information, laboratory test programs have been used to evaluate fatigue and sometimes wear of ceramic bearing materials. One such example is the rolling contact fatigue (or RCF) testing, in which a circular rod of silicon nitride is rotated against three steel balls. Although this test is useful to rank different materials, it is generally believed that many potentially acceptable materials are rejected because the high loads used in the RCF test do not simulate the conditions in real bearings. Furthermore, recent experience with ceramic bearings indicates that rolling contact fatigue is not the only failure mechanism. In this respect it is important to determine the primary failure mechanism for each class of applications and optimize the material design for that application. It is possible that optimization of material properties for resistance to fatigue may negatively affect the wear resistance. For applications requiring resistance to surface fatigue there is a need to develop standardized tests conducted on relevant bearing components, e.g., ceramic balls instead of cylindrical rods. Such tests should also allow the evaluation of the effects of machining damage on performance.

Although the wear mechanisms of advanced structural ceramics have been the subject of recent investigations, much of the current understanding may not be relevant for ceramic rolling contact bearings, due to the differences in the test conditions used in wear studies and the operating conditions in bearings. But it is clearly established that wear occurs by deformation and fracture, and is often influenced by tribochemical reactions. Recent studies have shown that the rate of wear can suddenly increase by two orders of magnitude if a threshold value of contact load is exceeded. The wear process at higher loads is related to the fracture of material near the surface. In order to avoid the transition to severe wear, one must reduce the coefficient of friction by lubrication, and/or increase the fracture toughness of the material.

Transition from mild to severe wear by fracture is highly sensitive to the coefficient of friction, because of the effect of friction on the tensile component of stress at the trailing edge of the contact. Therefore, even a small reduction in the coefficient of friction can result in a large increase in the transition load, and a major reduction in the rate of wear. The coefficient of friction can be reduced by hydrocarbon lubricants and polar additives. Although limited data have been published, the details of boundary lubrication mechanisms of silicon nitride are not known. Particularly, the adsorption mechanism of polar compounds on ceramic surfaces and the role of chemical structure on the adsorption process need to be analyzed. This type of information can be used to develop effective lubricants for ceramic bearings.

Chemical reaction between the ceramic surface and the lubricant is also an important mechanism for lubrication. Chemically reacted films with low shear strength can provide a low coefficient of friction. The current liquid lubricant technology is based on the accumulated knowledge on reaction mechanisms between metals and lubricants. A parallel set of information on reactivity of ceramics

with lubricants is needed to develop lubricant additives for ceramic bearings. In many applications, lubricant degradation through oxidation is the life-limiting process. In this respect, it is necessary to develop a better understanding of thermal and oxidative breakdown of liquid lubricants, including greases, for use with silicon nitride bearings.

For high-speed, high-temperature applications the key to success is finding adequate race and cage materials and a lubrication system that can work to provide stable bearing operation both mechanically and thermally at the speeds and temperatures required. Hydrocarbon liquid lubricants have a limited performance at elevated temperatures or under vacuum environments due to severe degradation and evaporation. Solid lubricants are the only viable alternative. The main problems, however, include adhesion of the solid lubricant coating to the substrate, high wear rate of the coating and inadequate response of the coatings to the temperature variations. It is necessary to pursue other high-temperature solid lubricants and lubricant delivery methods such as powder lubrication and the self-lubricating cage materials. In the latter, lubrication is provided by a composite cage containing the solid lubricant as a second phase. Recent research results have confirmed that in these materials lubrication is achieved by the formation of a transfer film, which contains materials from both the composite and the counterface, as well as tribochemical reaction products. Therefore, a better understanding of the formation of the transfer film and the relationship between microstructure of the composite and mechanical properties of the transfer film are needed to optimize the microstructure and composition of self-lubricating materials.

Recommendations:

The following recommendations are based on the technical presentations and discussions at the workshop:

- 0 Research activities should focus on cost reduction, while maintaining or improving the current level of performance reliability. All aspects of bearing production from powder processing to bearing assembly should be examined for means of cost reduction.
- 0 Research in powder processing, compaction, and densification should address optimization of microstructure for best bearing performance, as well as cost control.
- 0 New and improved cost-effective machining techniques should be developed for ceramic bearing races. Special attention should be given to dimensional tolerance and surface integrity of the finished components.
- 0 Non-destructive evaluation techniques and quality control methods should be developed for use in various stages of bearing production. It should be recognized that only the applications requiring a high level of reliability should be subjected to expensive inspections.

- 0 Although the current silicon nitride bearing materials are adequate for use in hybrid bearings, new and improved materials that are being developed should be evaluated for use in high-temperature all-ceramic bearings.
- 0 New and improved computerized design procedures and life prediction methods should be developed for ceramic bearings. These computer programs should include dynamic analysis of the total bearing system, performance data, and models for wear, fatigue, and lubricant degradation.
- 0 Detailed understanding of the mechanisms of wear and rolling contact fatigue, and the role of microstructure on these mechanisms, is needed to allow developments of new and improved bearing materials.
- 0 Performance data on presently available materials should be collected and made available to the bearing industry to allow proper selection of bearing materials.

Section 2

Discussion Group Summaries

Ceramic Processing and Blank Fabrication
Discussion Group Summary

S. G. Malghan and J. G. Hannoosh

A number of issues were discussed by the participants. The following four issues were specifically identified as the major hurdles for the widespread application of ceramic bearings:

- Blank cost reduction
- Powder-processing-microstructure-performance interrelationships
- Reliability
- Uniformity of terminology

Blank Cost Reduction

The current cost of production of silicon nitride bearings from powder as the starting material are approximately \$400/kg. The main problem to address is the reduction of the production cost by at least 80%. The major cost-components of the production of bearings are:

- Powder, and other starting materials
- Processing, including densification
- Finishing, including machining
- Inspection, including non-destructive evaluation.

The starting powder costs range from \$60-100/kg for fine-sized pure powders. However it appears that by starting with a lower-cost powder, such as silicon, the overall cost does not decrease substantially. Hence, an accurate assessment of the cost is not possible with the available data. However, it is obvious that by starting with lower-cost raw materials, and by reducing rejects or recycle, the overall cost can be decreased. Since the conversion of Si, SiO₂, or SiCl₄ to Si₃N₄ is an energy- and capital-intensive process, the overall cost should decrease substantially with increased volume of production. In addition, the current practice of Si₃N₄ powder production and processing may not be the best approach in the long run. An example is Sullivan Mining process, in which powder is not the starting material.

However, in the immediate future, current methods of processing powders are expected to dominate. Therefore, powder processing studies are required to establish not only the methods of overcoming deficiencies in the specific powders, but also the impact of specific impurities on the final properties of the ceramic.

Processing of powders, starting with fine powders through densification, is a capital-, energy-, and manpower-intensive activity. A large number of unit operations are involved, in which each subprocess is considered to be a cause for increased cost and a source of introduction of impurities. All three conventional methods of shape forming (dry pressing, injection molding, and

colloidal filtration) involve a number of steps that require powder handling in different stages. Though densification by hot isostatic pressing is the preferred mode of processing, it is expensive and leaves behind a glassy surface layer. Pressureless sintering and suitable compositions should be developed as cost-effective densification alternatives.

Additional issues discussed by the participants were: batch-to-batch oxygen variation of powders; control of surface layer during glass-encapsulated HIP; research versus manufacturing issues; development of powder specifications that yield reproducible properties; failure mechanisms (fatigue--static, mechanical, thermal, etc.) at low stresses; development of new materials and processes with different types of powders; application of statistical methods to solve technical and engineering problems; process modelling based on fundamental understanding of flow behavior and heat transfer; and kinetics during densification by HIP especially for large components (currently balls larger than 10 cm diameter cannot be processed by HIP).

Finishing of dense silicon nitride bearings can often constitute up to 50% of the overall cost. Machining and surface finishing are time-consuming, costly steps that often induce surface defects. Near-net-shape forming and cost-effective machining are potential areas of research.

Inspection of powder, slurry, green body, and dense silicon nitride is one of the primary requirements in the production of defect-free bearings. At present, due to small, batch operations, the end-properties are overly sensitive to small changes in the process parameters. To enhance reproducibility, a large number of measurements are being made. Data on batch-to-batch variation of powders and effect of such variation is not available, but such changes are considered detrimental to reproducibility.

Powder-Processing-Microstructure-Performance Interrelationships

In general, no data exist on the optimization of powder-processing-microstructure versus rolling and sliding contact. In most cases, existing materials have been tested under a few selected wear conditions. Specifically, the effect of grain size, chemical compositions, powder processing methods, and densification method have not been studied. Systematic variation of microstructure or composition of silicon nitride has also not been examined.

Though silicon nitride has emerged as the most promising material for bearings applications, other candidate materials of suitable microstructure should be examined. In the case of silicon nitride, most of the data exist on $MgCO_3$ or MgO as the sintering aid. Other compositions have not been addressed with respect to their suitability for wear applications.

An understanding of the interactions between silicon nitride composition and the lubricant used during bearing operation should be developed for a given application. Lubricant chemistry is an important issue in providing a lower wear rate and in the development of self-lubricating systems.

Reliability

Due to extensive in-process evaluation during powder processing and non-destructive testing of green and sintered bodies, bearings reliability has increased. However, these efforts add to the manufacturing cost. Accurate quantitative assessment of bearings produced by different manufacturers would help the users community.

Uniformity of Terminology

In order to assist the users of bearings, the terminology related to ceramic bearings has to be made uniform and interrelated to conventional terminology used in the bearing industry.

Machining, Quality Control and NDE
Discussion Group Summary

K. Subramanian and G. White

This session was attended by about 30 people. The consensus seemed to be that the central theme of this session should be reliability of the bearing and that "reliability" reflects not only the machining and evaluation processes but all other steps in the life of the bearing: raw material, processing, and applications. Each of these steps is interrelated with the others, and maximum reliability requires that improved understanding occurs at each step. In addition, "reliability" is made up of two components: true reliability and perceived reliability. For many applications, current ceramic bearings are sufficiently reliable, but the consumer needs to be educated to this fact.

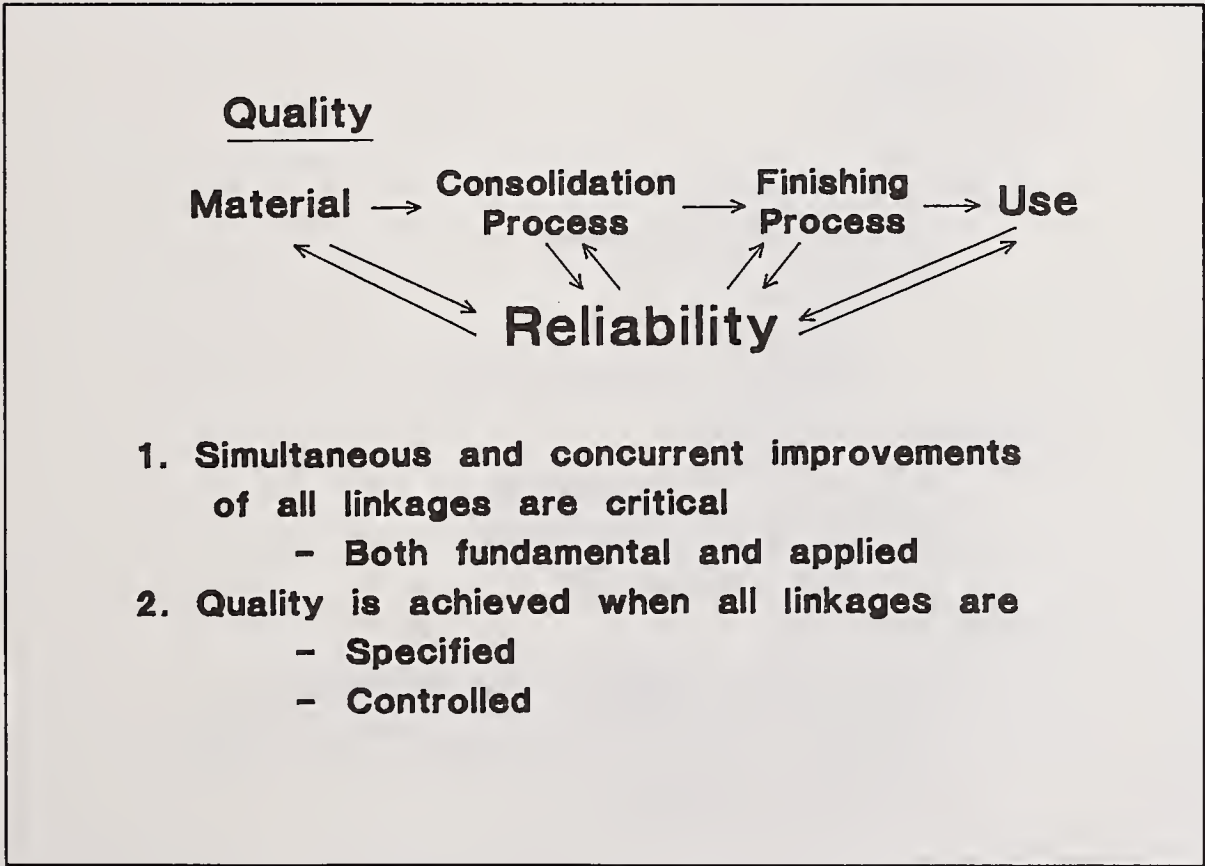
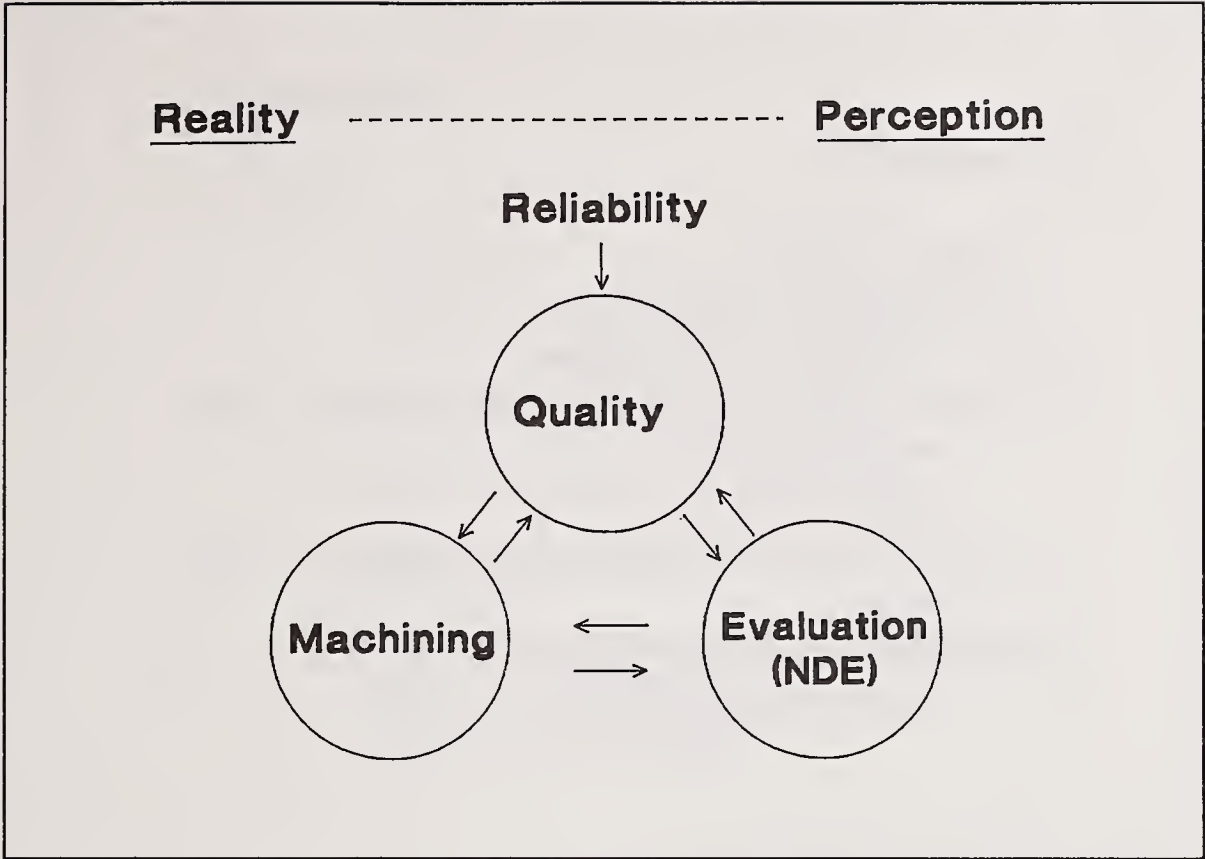
For other applications, there remains a need for improvement, not only in the processes of machining and bearing evaluation, but also in the determination of what "reliability" means; i.e., what are the failure modes for specific applications? This question is critical for the determination of specifications both for machining and non-destructive evaluation procedures. In addition, the group felt strongly that tests of different failure modes must be related to real bearings rather than to simulations.

In terms of machining, the group felt that, before improvements in machining operations could be made, specific knowledge of the surface requirements of the finished bearing must be known: e.g., shape, size, expected stresses, expected modes of failure. With this knowledge in hand, it would be possible to know if existing machining technology would be adequate to finish the bearings to an acceptable reliability or whether modifications to current machining practices (or even completely new practices) would be required. Regardless of the particular machining processes employed, the group recognized the need for the existence of a generalized guideline for machining practices which would outline standard procedures as well as recognized risks and benefits associated with those procedures.

Needs for evaluating the bearings are very similar to those stated above for machining practices. First, it is necessary to identify what kinds of flaws must be detected; i.e., flaw size, shape and location all influence the type of test procedure employed. Clearly, the identification of the flaws to be detected is determined by the reliability criteria appropriate for the specific application. Once the types of critical flaws have been identified, it should be possible to judge whether known evaluation techniques are applicable or whether new techniques need to be developed, either from scratch or by modifications of procedures used in other applications. One question which was not resolved concerned the methodology of developing new evaluation procedures. Should a standard (material, size, shape, etc.) test specimen be created which can be used throughout the industry, or should each company generate specific test specimens suitable for each application? Clearly, there are tradeoffs in either case, and probably, some combination of the two should be the goal. There was universal agreement, however, that evaluation tests must reflect real needs

applications.

Finally, the idea of education reoccurred repeatedly during discussions. In the first case, there needs to be a great deal more exchange of basic information among the companies involved with ceramic bearings. The feeling was emphasized that proprietary concerns were reducing the competitiveness of American bearing companies as a whole, as well as individually. In the second place, the bearing consumer needs to be educated as to the benefits and reliability of ceramic bearings. In addition, the feeling was expressed that consumer demand for ceramic bearing reliability was far more stringent than similar demands on metal bearings and that this discrepancy reflected further need for education of the consumer.



Reliability

1. Failure Mode
 - How is it defined?
 - Application dependent
2. Failure Modes determine specifications for
 - Machining
 - NDE
3. Tested Failure Modes must relate to real bearings
4. Reliability includes failure avoidance as well as acceptance/rejectance criteria

Machining:

1. What is needed
 - Surface requirements
 - Shape
 - Geometry
 - Surface considerations
2. How to machine
 - Develop new technology
 - Modify known technology
 - Transfer technology
3. Methodology
 - Generalized guideline for beginning
 - Reduce cycle time by optimization and system integration

Evaluation:

1. What to evaluate

- Flaw size
 - Flaw type
 - Surface/bulk flaw
- } Determined by
reliability criteria

2. How to evaluate

- Develop new techniques
- Modify known techniques
- Transfer technology

3. Methodolgy

- Standardized specimen (material, size, shape, application)
- Commercial specimen

Design, Performance Testing and Life Prediction
Discussion Group Summary

J. Dill and M. B. Peterson

Issues in these areas depend heavily on the application and are not the same for all anticipated uses of ceramic bearing components. Applications can be broken down into classes which have similar requirements. Classes which were discussed included:

- o High-Speed Liquid Lubricated Hybrid Bearings
- o Liquid Lubricated Hybrid Bearings for Instrument and Space Applications
- o Hybrid Bearings for Low-Noise Operation
- o Process Fluid Lubricated Bearings
- o Low-Speed Solid Lubricated Bearings
- o High-Speed Solid Lubricated Hybrid Bearings
- o Solid Lubricated Instrument and Space Mechanism Bearings
- o High-Speed Solid Lubricated All-Ceramic Bearings

Once an agreement was reached on these classes of bearings with common issues, the key issues for each class were discussed. Since the issues of design and life could not be discussed without discussing materials and NDE, those issues were also discussed, especially relative to how they impact design and life. This summary will address the issues by class and then end with some general comments. High-speed liquid lubricated hybrid bearings and liquid lubricated hybrid instrument bearings are two of the most widespread of the initial applications and therefore were discussed first.

High-Speed Liquid Lubricated Hybrid Bearings

Table 1 itemizes the main concerns relative to this type of application and identifies some of the applications. The starred items indicate the most critical issues which must be resolved if ceramics are to see wide use in this type of bearings.

For liquid lubricated hybrid bearings to achieve wide acceptance, the major design issue which must be resolved is the current inability to predict the life of a specific bearing design in a given application. To bring hybrid bearing design to the current level of all-steel bearing design will require the development of materials life factors for both the steel and ceramic parts when run together. Development of these life factors will require both element tests such as rolling contact fatigue rod tests and full bearing testing. Fatigue can only be defined for each component in the materials couple when tested together (including the lubricant) since the lubricant/material combination will affect the results.

Table 1: HIGH-SPEED LIQUID LUBRICATED
HYBRID BEARINGS

- o Definition of Skidding Margin and Damage
- o Lubricant Formulation for Use With Ceramic Components
- o Prediction of Fatigue Life in Specific Applications*
- o Effects of Ceramic Materials on Metallic Parts
- o Failure Detection for Non-Metallic Parts
- o Non-Destructive Evaluation*
- o Secondary Damage to System on Failure of Ceramic
- o Cage Materials Optimized for Use with Ceramics*
- o Race Coatings for Wear/Lubrication Enhancement*
- o Hybrid Lubrication Concepts (Solid Film/Liquid)
- o Performance with High-Temperature Liquid Lubes (PPE/PFAE)*
- o Industry Standards and Material Specifications

For high-speed liquid lubricated bearings, in addition to fatigue life, heat generation and lubrication requirements (i.e., grease versus oil mist versus oil jet) are also key issues. The balance between increased stresses due to the higher elastic modulus of the ceramic component and the lower centrifugally induced loads at high speeds must be carefully accounted for in bearing design and life calculations. While these are key factors in design, the general consensus is that given adequate data on material properties and life multipliers, designers know how to account for these factors.

NDE is an issue primarily for higher reliability applications such as aircraft turbine engines where extreme levels of reliability are required. In applications such as machine tool spindles, a benefit could be realized from improved NDE, but because of the lower-risk, NDE requirements are not as critical. There is a concern that if the stringent NDE required for turbine engine bearings is applied to components for lower-risk applications such as spindles, the price increase will overshadow the potential benefits and eliminate the use of ceramic components. NDE must be appropriate to the application. For example, a large part of the price differential between a class 7 spindle bearing and a class 7 turbine engine bearing (which can be a factor as high as 10 for similar sizes) is due to the added inspection and documentation required for the turbine engine bearing.

With the present state of the art of the ceramic materials and NDE, it is better to focus on the lower-risk applications where there is a clear benefit. For many turbine engines, it is not possible to show a clear benefit with ceramic rolling elements even if the stringent NDE requirements can be met. Also, if a theoretical benefit can be shown in a turbine engine by using a hybrid bearing, in most cases, the life of the current all-steel bearings is more than adequate and is not considered an issue by the manufacturers. At the present time, the payback on promoting turbine engine applications of hybrid bearings is probably not worth the efforts which would be required to get them accepted.

For many high-speed applications such as machine tools, it may be desirable to develop improved cage materials for use with ceramic balls. Testing has shown

that in low-lubricity liquids the standard silver-plated steel cage used in many high-speed bearings is not adequate. Data on the wear of different cage materials with lubricants of interest will increase the understanding of bearing life in hybrid bearing applications.

To take full advantage of the wear resistance of the ceramic rolling element materials, it may be necessary to improve the wear resistance of the races by the use of hard coatings. While it has been shown that hard coatings such as titanium nitride and titanium carbide can improve race fatigue and wear performance, coating processes are variable in their reliability. A well-controlled coating process with demonstrated performance could further enhance hybrid bearing performance over that of a hybrid bearing with bare steel races.

For higher-temperature advanced turbine engines, such as those being developed under the IHPTET initiative, there may be a benefit to using hybrid bearings with advanced high-temperature lubricants such as polyphenyl ethers and perfluoroalkyl ethers. The poorer lubricating properties of these lubricants may require ceramic hybrid bearings to achieve adequate performance for the systems. As these engines evolve over the next ten years, this technology should follow a natural evolution, especially if ceramic bearing components can be developed to wider usage in other applications first.

Liquid Lubricated Hybrid Bearings for Instrument and Space Applications

In these types of bearings, generally loads are low and speeds are moderate. Table 2 details the key issues for this type of bearing. Again, the issues felt to be of primary concern by the group are starred.

**Table 2: Liquid Lubricated Hybrid Bearings
for Instrument and Space Applications**

- o Lubricant Formulation for Use With Ceramics
- o Lubricant Life and Degradation Models*
- o Lubricant Supply Mechanisms*
- o Designs to Accommodate Thermal Expansion Mismatch*
- o Evaluation of Cage vs. Cageless Designs*
- o Ceramic Materials for Precision Finishing
- o Race Coating for Wear Reduction and Lubrication*
- o Database on Performance of Ceramic Balls
- o Definition of Vibration Reduction From Improved Precision
- o Definition of Sphericity Improvements vs. Steel
- o Effects of Improved Precision of System (Pointing and Control)
- o Definition of Reduction in False Brinelling and Fretting

Fatigue is not generally a problem in this type of bearing. The major bearing failure mode is generally degradation of the lubricant. In this class of bearing, a thin film of lubricant is generally applied to the race for the life of the bearing. The retainer may be a porous phenolic type of material which supplies some additional lubrication via release of an impregnated liquid lubricant. Testing has shown that substitution of a ceramic ball for a steel

one in an instrument bearing will improve bearing life by reducing the degradation rate of the lubricant. The amount of this improvement needs to be quantified and adequate lubricant life models developed. Since the phenolic cages were designed for use with steel balls, alternate cage materials and lubricant supply mechanisms may need to be developed to achieve optimum performance.

Relative to design, component designs which accommodate the lower thermal expansion of the ceramic balls are required. The information is available to develop these designs, but system designers must be aware of the best techniques for mounting to accommodate the thermal expansion mismatch.

For ceramic hybrid bearings, the use of full complement designs needs to be explored. Tests have shown benefits for full complement designs with all steel bearings, but to date, little effort has gone into investigating full complement hybrid bearings. In all-steel full complement bearings, the ball-to-ball contacts can be a problem. In a hybrid full complement bearing, the ceramic to ceramic ball contacts may perform better. This issue needs to be evaluated.

To achieve full benefit of the reduction of lubricant degradation by eliminating active metal asperity sites in the contacts of the bearing, it may be necessary to coat the races with a ceramic hard coating such as titanium nitride. There was no discussion of any experience with testing which would indicate if a further benefit can be realized in a hybrid bearing with coated races over one with uncoated races.

Hybrid Bearings for Low-Noise Operation

Table 3 lists the key issues for low noise bearings. In general, low-noise bearings run at moderate loads and speeds, and their life is more often defined by the length of time that they remain quiet than by the fatigue life of the components. The starred items were those felt to be of primary concern.

Table 3: Hybrid Bearings for Low-Noise Operation

- o Definition of Wear Mechanisms
- o Performance Data on Quiet Life
- o Definition of the Effect of Better Geometry on Noise
- o Influence of Cage Interactions on Noise
- o Lubricant Formulation for Use With Ceramics*
- o Race Coatings and Coating Process Control*
- o Definition of Skidding Margin Benefits
- o Grease Formulation*
- o Ceramics Capable of Providing Better Sphericity in Balls*

Quiet life is influenced by race wear and damage caused by debris and marginal lubrication in grease lubricated bearings. Testing indicates that ceramic hybrid bearings do have a longer quiet life, but this needs to be better quantified.

Debris damage to the balls is reduced in a hybrid bearing, but remains the same on the races. Further improvements in bearing quiet life may be realized if reliable hard coatings can be developed for low-noise bearings.

For some of the highest performance applications, fatigue life may be a problem which can be improved by using ceramic rolling elements. The life improvement can be achieved because the lower density of the ceramic rolling element results in a better skidding margin in the bearing, meaning that the bearing can be run at reduced preload thus resulting in a longer life with proper design.

Because greases for low-noise bearings have been formulated for all-steel bearings, they need to be re-evaluated to determine if the same formulations are optimum for hybrid bearings. Improved grease formulations may be possible with hybrid bearings, and these need to be evaluated.

Because it can be very difficult and costly to replace a bearing in a low-noise shipboard application, high reliability is required for all bearing components. While NDE requirements similar to those for manrated turbine engines are not necessary, a qualified quality control process which has demonstrated the ability to reliably produce quality ceramic balls, time after time, is required for low-noise bearings if they are to be used.

Process Fluid Lubricated Bearings

For process fluid lubricated bearings, Table 4 lists the areas discussed relative to where hybrid or all-ceramic bearings might be of benefit and what some of the issues are. The general feeling was that in this area, the key concerns are dependent on the specific application and will closely parallel the issues of concern with the liquid lubricated equivalent application. The major difference is that process fluids are generally low-lubricity materials. Use of a hybrid bearing generally provides better performance than an all-steel bearing, but is very application-specific.

Table 4: Process Fluid Lubricated Bearings

APPLICATIONS	TECHNICAL ISSUES
o Chemical Industry	o Performance Data
o Polyethylene Reactors	o Chemical Resistance Data
o Water/Slurries	o Cage Materials
o Freon/Freon Replacement	o Wear
o Rocket Propellants	o Coatings for Races
o Jet Fuel	o Mounting Ceramic Races

All-ceramic bearings, even made from lower-performance ceramics, may have applicability in the chemical industry if they can demonstrate performance advantages over steel bearings which frequently corrode quickly. Bearing suppliers felt, however, that cost is generally a key issue in the chemical industry and that prices have to drop significantly before they will be used.

Low-Speed Solid Lubricated Bearings

There are a wide range of low-speed solid lubricated applications for hybrid and all-ceramic bearings which are being considered. Some of these and the technical issues associated with them are listed in Table 5.

Table 5: Low-Speed Solid Lubricated Bearings

APPLICATIONS

HIGH TEMPERATURES

- o T/E Nozzle Actuators
- o Control Surface Actuators
- o Rolling Mills
- o High-Temperature Manufacturing Processes
- o X-ray Rotating Cathodes

TECHNICAL ISSUES

HIGH TEMPERATURES

- o Separator Materials
- o Design
- o Corrosion of Steel Races
- o Oxidation of Ceramic
- o Torque/Friction Increase
- o High Loads
- o Brinelling of Steel Races
- o Thermal Cycling Effects
- o Ceramic Material

APPLICATIONS

LOW TEMPERATURES

- o Control Surface Actuators
- o Fire Control Radar
- o Swash Plate Bearings
- o Electro-optic Actuators

TECHNICAL ISSUES

LOW TEMPERATURES

- o Fatigue Life
- o High Loads
- o Expansion Coefficients
- o Contamination Effects

High-temperature applications include some of the first applications in turbine engines such as exhaust nozzle actuators. Low-temperature applications of particular interest include radar and electro-optical actuators.

For these applications, adequate lubricants at the expected temperature of operation, separator materials, fatigue life or wear life, and proper mounting to accommodate the low thermal expansion coefficient of the ceramic are key issues. For x-ray cathode bearings, the insulating properties of the ceramic may be a problem since the current steel bearings are used to make the electrical connection to the cathode.

High-Speed Solid Lubricated Hybrid Bearings

Table 6 lists the key issues which must be addressed in solid lubricated hybrid bearings for high speeds. The factors listed are in addition to those listed in Table 1 for high-speed liquid lubricated hybrids. Starred items indicate key concerns.

Table 6: High-Speed Solid Lubricated Hybrid Bearings

- o Adequate 300-500°C Race and Cage Materials*
- o Solid Lubricant Formulation and Supply*
- o Cooling Techniques
- o Ceramic Material Optimization
- o Wear and Fatigue Life Models*
- o Clearance Control Over Wide Temperature Range

There is a significant payoff which can be realized in limited life turbine engines such as those used in cruise missiles and drones by using solid lubricated hybrid bearings. In order for this to be accomplished, however, significant materials issues must be addressed. Key to success is finding adequate race and cage materials and a lubrication system which can work to provide stable bearing operation both mechanically and thermally at the speeds and temperatures required. To date, investigation of solid lubricant coatings has been unsuccessful. It may be necessary to use powdered solid lubricants in an air carrier to achieve adequate life at the speeds of interest.

To arrive at a successful demonstration of such a bearing, the bearing design must be approached as a system. The cooling required will be determined by the friction coefficient which can be achieved and the ability to minimize the heat generation in the bearing. Optimum race materials with one lubricant may not be optimum with another.

A significant advantage of a solid lubricated hybrid bearing over an all-ceramic one is the ease of mounting and elimination of concerns about the brittle fracture of the inner race at high speeds. Such a bearing will probably be limited to 500°C because of the limitations of steel race materials. The composition of the ceramic material will also play a more significant part in the overall performance of such a hybrid bearing. It may be necessary to develop a ceramic composition optimized for such bearings, which is different from current materials that have been optimized for use in liquid lubricated applications.

Solid Lubricated Instrument and Space Mechanism Bearings

The issues which must be faced in solid lubricated instrument and space mechanism bearings, were regarded as essentially the same as those for liquid lubricated bearings for these applications. The main difference is that instead of lubricant degradation life being an issue, solid film wear life is the primary bearing life determining factor. Since this type of bearing is generally a low-temperature application, operating at low loads and moderate speeds, the specific chemistry of the ceramic is not a critical issue. Lubricant film adherence to ceramic materials is clearly a key issue since current solid films were developed to adhere to metallic bearings.

High-Speed Solid Lubricated All-Ceramic Bearings

Table 7 details the key issues which must be addressed for this application. While the majority of the research funded by the Department of Defense to date in ceramic bearing technology has focused on this application, significant materials and systems design issues still remain for this type of bearing.

Table 7: High-Speed Solid Lubricated All-Ceramic Bearings

- o Cooling Requirements and Techniques
- o Improved Race Fracture Toughness*
- o Mounting Techniques for Ceramics on Metallic Shafts
- o Lubrication Techniques and Lubricants*
- o Cage Materials*
- o Definition of Load Capacity
- o Performance Testing and Life Demonstration*
- o Shock Load Capability
- o Wear Models and Wear Life Prediction
- o Allowable Stress Levels
- o Rolling Contact Fatigue Life Models
- o Optimized Ceramic Materials
- o Surface Modification for Improved Performance
- o Non-destructive Evaluation of Ceramic Components
- o Reinforced Ceramics for Bearing Applications

If all-ceramic bearings are ever to achieve the operating speed required for use in a turbine engine, a critical issue which must be addressed is the low fracture toughness of the current ceramic materials. Fracture toughness of $11-16 \text{ MPa}\cdot\text{m}^{1/2}$ must be achieved for safe operation at high-speeds. High fracture toughness is particularly important with the higher surface traction values present in a solid lubricated bearing which will tend to increase the tensile stresses in the surface of the bearing races.

The development of such bearings requires a systems approach with lubricant composition, ceramic composition, and cage material all requiring optimization. Despite reasonable levels of funding for this area over the past 10 years, the materials problems remain significant. Speeds achieved remain on the order of 50-75% of what is required. As the materials technology develops, performance testing is required to evaluate the selection of the best materials.

The major design issue is mounting of the ceramic race if the system requires use of a metallic shaft. While a number of approaches have been tried, to date none has been completely satisfactory.

Of all of the applications of ceramic bearing components, this application remains the most developmental despite the significant efforts which have been devoted to this area. At the present, it is not possible to judge whether current ceramics are adequate since lubricants have not been found which work with them.

General Comments About Ceramic Bearings

In discussing ceramic bearing components in general, the following issues were identified as the key ones:

- o Cost
- o Machining Techniques
- o Near-Net-Shape Parts (Reduced Machining Costs)
- o Material Composition
- o Tougher Ceramic Materials

The sense of the group was that for ceramic bearing components to become more widely used in the applications where their current performance is adequate, costs must be reduced. While customers are willing to pay a premium for improved performance, especially in military systems, price is an issue. This is especially true in the lower-performance applications where steel bearing costs can be quite low even for a high-precision bearing.

For all-ceramic bearings, costs are particularly an issue because of the high cost of ceramic races even relative to ceramic balls. Table 8 lists some ideas generated on potential applications for all-ceramic bearings with the current state of the art of the materials. Some of the applications may evolve because of the systems benefits which can be realized.

Table 8: All-Ceramic Bearing Applications

- o Replacement for Non-Magnetic Bearings, Like BeCu
- o Applications Requiring Electrical Isolation
- o Chemically Aggressive Environments
- o Fire Control Radar (Reduced Radar Interactions)
- o Chemical Laser Blowers
- o High-Temperature Mechanisms
- o High-Load Non-Magnetic Gimbals
- o Highly Abrasive Environments
- o High-Stiffness Mechanisms

Section 3

Technical Presentations

Advantages of and Issues in the Application of Ceramic
and Ceramic Hybrid Bearings

James F. Dill
Mechanical Technology Inc.
Latham, NY 12110

This presentation focuses on the current and future potential applications for ceramic and hybrid ceramic bearings. The application focus is on military and government systems, but extensions are made where possible to commercial applications.

The potential applications are broken down into four possible classes including high DN and marginally liquid lubricated ones and hybrid and all ceramic solid lubricated ones. The requirements and performance advantages are discussed for each class of application.

For marginally liquid lubricated bearings, there is documented evidence that heat generation and lubricant degradation are reduced in hybrid ceramic bearings. This means that performance advantages can be realized in a wide range of applications including grease and mist lubricated bearings, process fluid lubricated systems and lubricated for life systems like gyroscopes and gimbal bearings.

In high DN applications, the low density of the ceramic rolling elements in a hybrid bearing can improve life by reducing the centrifugally induced stresses on the outer race. If the outer race stress controls the bearing life, a life improvement will be realized. Whether such an improvement can be achieved, is a function of the details of the externally applied loads and the centrifugally induced stresses. For some of the more frequently mentioned applications of this type, such as turbine engine mainshaft, current bearing life of all-steel bearings may be more than adequate making any theoretical improvement of little importance when the higher costs of ceramic components are considered.

Solid lubricated hybrid bearings for low speed applications may be the first turbine engine application of this technology. When hybrid bearings are used in such applications as exhaust nozzle actuators significant improvements in wear life may be possible.

Solid lubrication of all-ceramic bearings has been the focus of much of the government funded research and development. If this technology can be successfully developed it could have a significant impact on the design of advanced turbine engines and other high speed machinery. However, substantial technical barriers still remain to the application of this technology in any real system. Emphasis on research in this area has possibly skewed the interest of American producers relative to foreign suppliers, especially the Japanese, who are much more focused on near term applications like liquid lubricated hybrid bearings. This emphasis has given the Japanese at least a perceived advantage in technology implementation at the current time.

Factors inhibiting the full utilization of ceramic bearing technology include material properties such as fracture toughness and thermal expansion coefficient, finishing techniques including machining and NDE, and cost issues. The current cost of hybrid bearings relative to all-steel bearings of 2-5 times cannot be justified in many of the lower risk applications where experience could be gained with the material. If applications are to expand significantly prices need to be reduced to 1.2-1.5 times that of all-steel bearings.

The presentation concludes with a summary of the key issues for liquid and solid lubricated applications, NDE, and materials testing which must be addressed if the application of ceramic bearing components is to be expanded.



Advantages of and Issues in the
Application of Ceramic and Ceramic Hybrid Bearings

by

Dr. Jim Dill
Mechanical Technology Inc.

April 17, 1991

MECHANICAL TECHNOLOGY INCORPORATED
17-91

HIGH COST LIMITS APPLICAT

LIMITED APPLICATIONS IN

HIGH COST LIMITS APPLICATIONS

LIMITED APPLICATIONS INCREASE

HIGH COST LIMITS APPLICATIONS

LIMITED APPLICATIONS INCREASE COST

HIGH COST LIMITS APPLICATIONS

Applications of Hybrid Bearings

	Low CTE	Quiet Running	High Speed	Extended Life	Minimal Lubrication	Corrosion Resistance	High Stiffness	High Temperature	Low Friction	Extended Wear	Lighter Weight	Special Attributes
Cruise Missile Mainshafts		✓		✓	✓		✓	✓		✓	✓	
Air Starters			✓	✓	✓		✓	✓	✓			
Auxiliary Power Units			✓	✓	✓		✓	✓	✓			
Gyro Platforms			✓	✓	✓		✓	✓	✓			
Gyro Gimbals			✓	✓	✓		✓	✓	✓			
Machine Tool Spindles		✓		✓		✓		✓	✓	✓		
Turbochargers			✓					✓		✓		
X-ray Tubes					✓		✓	✓				✓
Submarine Machinery	✓		✓		✓	✓		✓	✓			
Vacuum Pumps	✓			✓				✓	✓	✓		
Centrifuges		✓				✓		✓	✓	✓		
Disk Drives	✓	✓		✓				✓	✓	✓		
Chemical Applications			✓	✓			✓	✓	✓	✓		
Nuclear Applications			✓	✓	✓			✓	✓	✓		
Dental Drills		✓	✓	✓		✓		✓	✓	✓		
Helicopter Gearboxes		✓	✓	✓	✓			✓	✓	✓		
Furnace Mechanisms			✓	✓	✓		✓	✓	✓	✓		
Satellite Gimbals	✓	✓		✓		✓		✓	✓	✓		
Satellite Momentum Wheels	✓	✓	✓	✓				✓	✓	✓		

Marginally Liquid Lubricated Applications

In marginally liquid lubricated systems, there is documented evidence of lower heat generation and better overall performance in hybrid bearings.

Technical Issues:

- Reduced contact area and contact microslip reduce heat generation.
- Possibly some reduction in surface initiated failures (may be due to dissimilar materials).

Applications:

- Grease and oil mist lubricated machine tool spindles
- Fuel lubricated expendable turbine engine bearings
- Computer disc drives

Marginally Liquid Lubricated Applications

Possible Extensions:

- Fuel pumps, fuel hydraulic systems, fuel controls
- Space Gimbals, momentum wheels, etc.
- Motors, APU's
- Turbopumps (?)

Comment:

- May be desirable to explore possible performance advantages of hybrid bearings with high temperature liquid lubricants like PPE and PFAE.

Status:

- Current materials are more than adequate for this application. Reduced costs will expand use.

High DN Liquid Lubricated Applications

In high DN bearings (generally 2 + MDN), it may be possible to improve bearing life by using ceramic rolling elements to reduce outer race stresses.

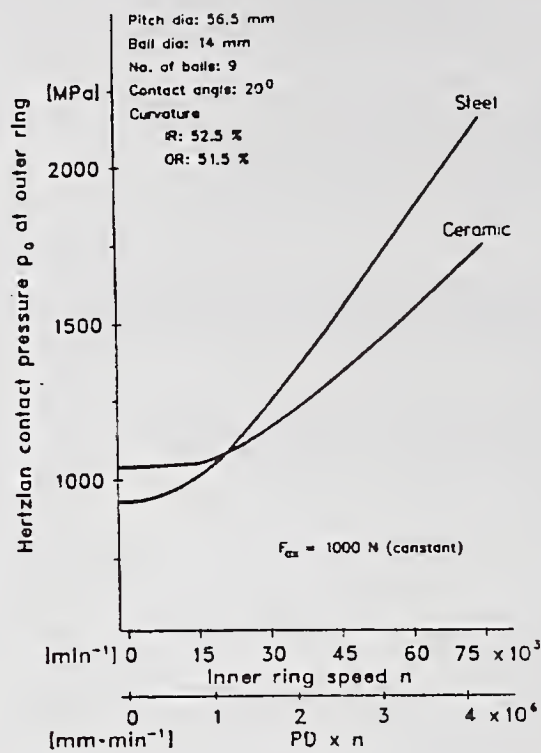
Technical Issues:

- Low density of Silicon Nitride (40% of steel) reduces the centrifugally induced forces on outer race.
- If centrifugal force due to rolling elements controls bearing life, an improvement will be seen.
- High modulus of ceramic can cancel benefits of lower density in many applications.

Applications/Extensions:

- High speed spindles
- Turbine engine mainshaft (?)
- Air cycle machines
- Any high DN bearing application

Effect of Centrifugal Force on Outer Ring Stress



Taken from ASME
GAS Turbine Paper
90-GT-166
F. Ebert
FAG

High DN Liquid Lubricated Applications

Comment:

- Depends heavily on balance of external load and total speed range expected. Demonstration of advantage depends on life calculation technique.
- May solve a current nonproblem, i.e., fatigue life is not an issue in the current cruise missile engine for example or in most man-rated engines.
- Essentially, a ball bearing problem since roller bearings are generally not life limited because of low stresses.

Status:

- Current ceramic materials are more than adequate.
- Clear advantage not seen in many applications.

High DN Solid Lubricated Hybrid Bearing Applications

A hybrid bearing capable of operation to 2.5×10^6 DN and temperatures to 600 – 1000°F with solid lubrication would permit several advantages in cruise missile engine design to be realized.

Advantages Cited:

- Weight, cost and engine envelop reduction via elimination of lubrication system and gearbox.
- Possible advantages in engine storability and low temperature starting may be achieved also.

Comments:

- Partial benefit could be realized by eliminating gearbox and using electrical lube pumps.
- Fuel lubricated bearings may offer comparable advantages.
- A supplemental solid lubricant supply like powder lubrication may be required to meet strategic missile engine life requirements.

Status:

- Current work has shown little improvement over previous all steel bearing work.
- Significant work on tribomaterials system (races/rolling elements/lubricants) and lubrication approach required.

Low Speed Solid Lubricated Applications

At low to moderate speeds and temperatures to 600 – 1000°F, solid lubricated hybrid bearings show improved wear life when compared to all steel bearings.

Technical Issues:

- Smaller contact area, reduced microslip and dissimilar materials in contact combine to give overall reduced wear and improved life.
- Differences in expansion of races and rolling elements may make clearance control over entire temperature range difficult.

Applications/Extensions

- Turbine engine auxiliaries – air motors, nozzle actuators
- Space gimbals and other mechanisms
- X-ray tube rotating cathodes

Comments:

- This may be the first real turbine engine application
- High friction in vacuum may require improved solid lubricants

Status:

- Current ceramic materials adequate
- Improved solid lubricants and steel races could expand applications

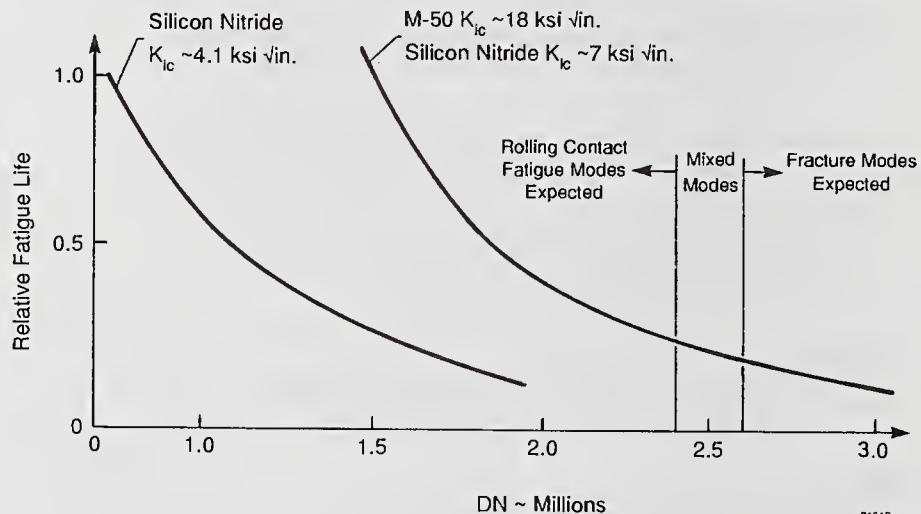
High DN Solid Lubricated All Ceramic Bearing Application

Solid lubricated all ceramic bearings capable of operating at temperatures up to 1500°F or above and 2.5 - 3.0 MDN would offer significant advantages in advanced turbine engines.

Technical Issues/Status:

- The bulk of ceramic bearing research funded by the Air Force and Navy has been directed ultimately toward this application.
- Fracture toughness of current materials is inadequate.
- Significant issues in materials, lubricants, mounting, lubricant supply and cooling need to be resolved.
- Despite advances in material science, results to date have been disappointing when compared to 25-year old Fairchild-Stratos work.
- Ceramic material requirements differ from those for liquid lubricated hybrid bearings.
- Research emphasis in this area has biased American efforts relative to Japanese.

Mainshaft Bearing Lives and Expected Failure Mode as a Function of Speed for a Constant Bore Size



Other Applications Where Ceramic Components
Offer an Advantage

- The lower density of silicon nitride will reduce cage forces at high acceleration rates. Hybrid bearings may perform better than all steel as backup bearings for magnetic bearings.
- Ceramic rolling elements may reduce noise resulting in quieter bearings.
- All ceramic bearings offer chemical inertness superior to steel. The Japanese are investigating lower performance SiC and Si₃N₄ materials in process lubricated applications.
- In electrical applications, ceramic parts improve isolation.
- Improved precision of ceramic balls can improve performance in a wide range of applications.

Manufacturing Related
Applications Issues

Cost:

- Hybrid Bearings Currently 2-5 X Steel
- Ball Cost 10 X Steel

Machining:

- More Efficient Machining Techniques
- Minimization of Material Removal
- Variation of Parameters with Composition
- Narrower Spread of Ball Sizes (Race Matching)

NDE:

- Bulk Defects
- Surface/Machining Damage
- Flaw Size

Steel vs Ceramic Part Finishing

Steel	Ceramic
<ul style="list-style-type: none">● Bulk of Machining in Softened State	<ul style="list-style-type: none">● Bulk of Machining in Hardened State
<ul style="list-style-type: none">● Final Grinding of Hardened Parts Removes Small Amount of Material	<ul style="list-style-type: none">● Diamond Grinding Required to Remove Relatively Thick Surface Layer from HIPING.
<ul style="list-style-type: none">● Even in Hardened State, Steel Parts have a much Lower Hardness than Ceramic	<ul style="list-style-type: none">● High Hardness Makes Machining Very Difficult and Costly
<ul style="list-style-type: none">● NDE Done on Simple Shapes, Rods and Tubes	<ul style="list-style-type: none">● Near Net Shape Forming Precludes Inspection of Simple Shapes
<ul style="list-style-type: none">● NDE for Bulk Defects Done on Raw Stock	<ul style="list-style-type: none">● NDE Later in Process Done on Higher Value Added Part
<ul style="list-style-type: none">● Defect Size within Current NDE Capabilities	<ul style="list-style-type: none">● Lower Toughness Results in Critical Flaw Size at Limits of NDE

Materials Related Application issues

Composition:

- Bearing Quality Silicon Nitride Not a Single Composition Like Steels
- Optimum Material Composition May Differ for Liquid Lubed and High Temperature Solid Lubed Applications

Physical Properties

- Fracture Toughness - critical for all ceramic bearings
- Thermal Expansion - control of internal clearance
- Elastic Modulus - increases stresses at high applied loads
- Density - decreases stresses at high speeds

Design Related
Application Issues

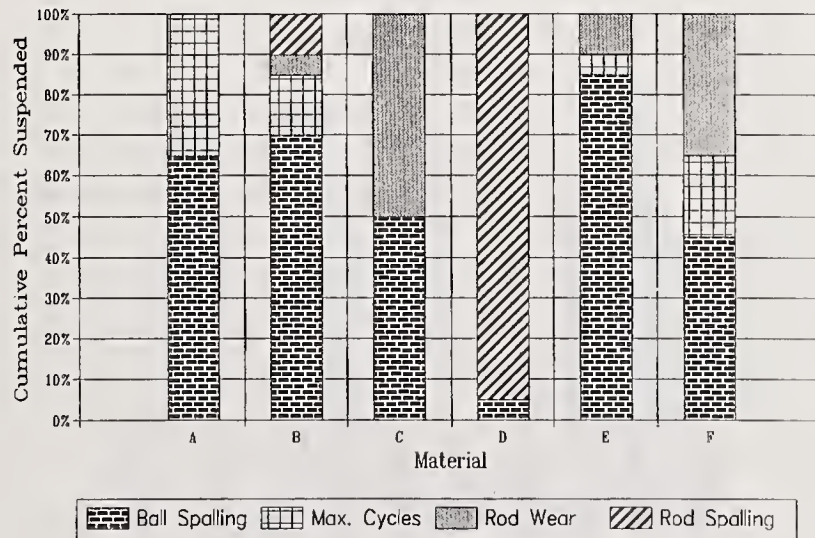
Analysis:

- Life Prediction Techniques (endurance limit)
- Optimization of Internal Geometry
- Control of Clearance Over Wide Temperature Range
- Mounting of All Ceramic Bearings

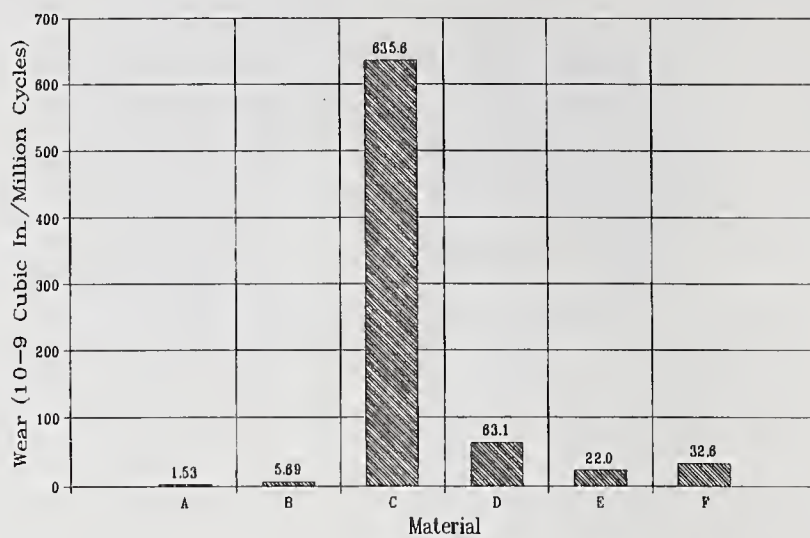
Performance Testing:

- Rolling Contact Fatigue
 - of ceramic
 - effects on steel
- Wear
- Full Scale Bearing Tests

Suspended Tests
Reasons

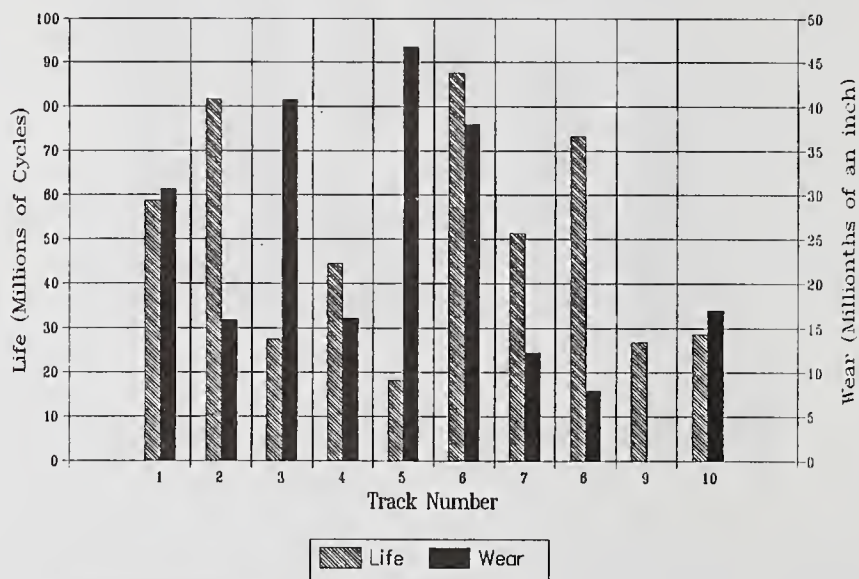


Volumetric Wear/Cycle 120 Hour Tests



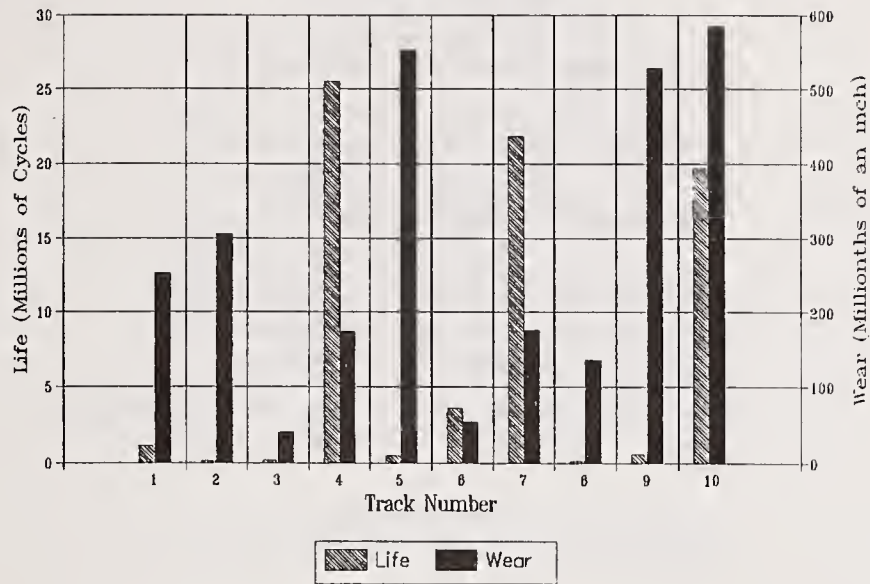
Material A

Track Life & Wear



Material C

Track Life & Wear



KEY TECHNICAL CONCLUSIONS

Liquid Lubricated Applications

- A number of current silicon nitride materials are adequate for many hybrid bearing applications.
- Parts are expensive both because of blank costs and finishing costs.
- Applications for liquid lubricated all ceramic bearings are limited (corrosive environments, nonmagnetic requirements, electrical isolation).
- Advantages/disadvantages must be carefully weighed
 - lower centrifugal forces on outer race do not always lead to increased bearing life.
- Hybrid roller bearings have a narrower range of usage and are more difficult to produce - consequently, they have received less development attention.

KEY TECHNICAL CONCLUSIONS

Nondestructive Evaluation

- NDE is limited and thus limits applications to some extent.
- Costly NDE additions driven by perceived high end market – T/E mainshaft – may raise prices and kill real lower risk applications that don't require such stringent controls.
- For many/most near term applications, good process control coupled with sampling plan and destructive analysis or NDE may be adequate. Especially when coupled with a process control specification.
- Need to consider where NDE is applied in the manufacturing process and if certain rough part geometries are easier to inspect.
- Need to compare NDE requirements for ceramics in a given application with steel components in the same application.

KEY TECHNICAL CONCLUSIONS

Solid Lubricated Applications

Low Speed/Low Temperatures:

- Advances in Solid Lubrication for Space Mechanisms Have Been Significant
- Current Ceramics are Adequate

High Speed/High Temperatures:

- Improved Fracture Toughness Required to Meet DN Needs for All Ceramic Bearings
- Hybrid Bearings with High Temperature Metallic Races May Be Nearer Term Than All Ceramic Bearings
- Mounting Remains a Major Issue
- Significant Advances in Solid Lubrication Are Still Required
- Optimum Ceramic Compositions Can Only be Determined in Conjunction with Lubricant Development

KEY TECHNICAL CONCLUSIONS

Materials Testing

- High Stress Rolling Contact Fatigue Tests
May Overload Some Good Materials
- Optimizing a Material for Rolling Contact
Fatigue May Negatively Effect Other Properties
(Fracture Toughness vs Hardness)
- Standardized Tests are Needed for Both Materials
Optimization and Machining Optimization
- Need to Understand Both Fatigue and Wear Properties
of Ceramic Materials
- Composition/Finish of Ceramic Parts May Affect Steel
Part Life

Payoffs and Challenges in Utilization of Ceramic Components
in Spacecraft Mechanisms

Paul D. Fleischauer
Mechanics and Materials Technology Center
The Aerospace Corporation
El Segundo, CA 90009

Technology advancements in spacecraft mechanical systems and components are critical if proposed lifetime and performance requirements for advanced programs are to be met. Equivalent advancements have been made at a far more rapid pace in other technology areas, *vis.* electronics, optics, power, and thermal control; and, consequently, tribological mechanisms are becoming the limiting systems for present programs. Ceramic parts and coatings offer a relatively uncharted avenue for improvements in operating performance and life of precision bearings and gears and for some actuators. Although the volume of parts and production for space applications is small, at over 100 million dollars per spacecraft, the potential payoffs are very large. As an example, a recent extension in the predicted life of a satellite from three to five years, due to the incorporation of a synthetic oil in its scanner bearings, may mean that two of the projected vehicles in the current series will not need to be built (savings of \$200 to 300 million). Ceramic bearings in that system could extend the life even further.

The mechanisms that experience tribological problems and continue to plague spacecraft designers and engineers include solar array drives, momentum and reaction wheels, antenna and sensor pointing systems, sliding electrical contacts such as those found in slip-ring assemblies, and cryopumps and coolers. Problems are manifested as pointing errors, deployment failures, attitude instabilities, electrical noise generation, and cooling/pumping abnormalities. Causes of the problems invariably are associated with lubricant failure, friction noise, and wear.

The approach we have found to be successful in resolving these types of operational problems combines fundamental materials properties research with analytical models of the application and simulation testing in the laboratory. The results are finally inserted into life tests and then into satellite construction. The payoffs are realized in terms of improved surface finishes and wear resistance of moving, contacting parts (which produce lower torques and torque noise, longer operating lifetimes, and less power consumption), reduced weight (which lowers launch and operating costs), and improved strength (which provides the possibility for reducing the complexity and cost of design).

Specific examples of applications of ceramics for space systems include the demonstration that TiN coatings or Si_3N_4 balls in boundary applications of perfluoropolyalkylether oils can extend operating life up to a factor of ten, and the testing of coatings and solid ceramic parts in the spin bearings and gears of certain momentum wheels. The opportunities for additional insertion of ceramics are significant and are just beginning to be appreciated.

The challenges for effective use of ceramics in space applications are probably similar to those in other areas. They include establishing the utility of lubricants and additives on relatively unreactive, often primarily covalent, ceramics compared to reactive metals; determining their wear rates when lubricated in sliding, rolling, and mixed contact regimes; and understanding the behavior of lubricants in boundary and EHD regimes on ceramic surfaces. The latter point is essential if models of bearing and gear performance are to be applied to determine satellite design criteria.

Some research on bonding properties of ceramic surfaces has been done, but much more is needed to fully exploit these materials in space applications. For example, a common additive for mineral (and synthetic) oils under boundary conditions, lead naphthenate, provides protection on steel during wear by forming a protective lead metal layer. The formation of this layer appears to require the presence of metallic iron on the steel surface. Nonmetallic nitrides probably cannot provide the necessary reducing agent for lead formation, so this probably is not a good additive for those materials. Other chemical compatibilities and reactivities need to be well understood before the proper, effective combinations of material and lubricant can be identified.

Payoffs and Challenges in the Utilization of Ceramic Bearings in Spacecraft Mechanisms

Paul D. Fleischauer

Mechanics and Materials Technology Center
The Aerospace Corporation
El Segundo, CA 90245

Presented to:
NIST/DARPA
Ceramic Bearing Technology Workshop
17 April 1991

Ceramic Components in Spacecraft Mechanisms

OUTLINE

Introduction - Spacecraft Mechanisms

Types of Tribological Problems

Lubricant Degradation vs. Parts Failure (Wear)

Payoffs for Ceramics - Performance Improvements

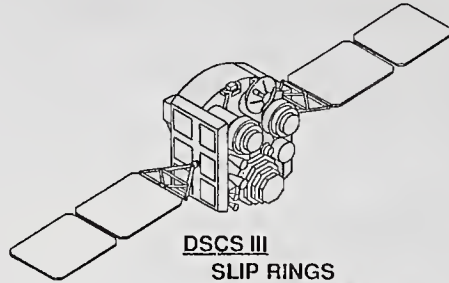
Challenges for Ceramics - Research/Testing Needs

Coatings vs. All Ceramic Parts

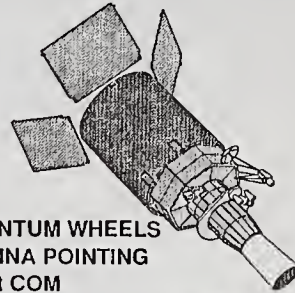
Summary



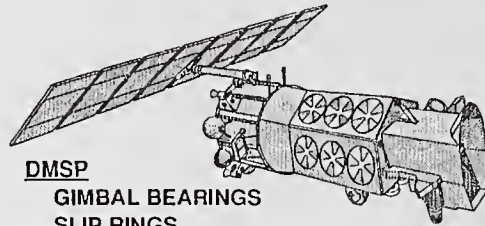
Lubricants for Space



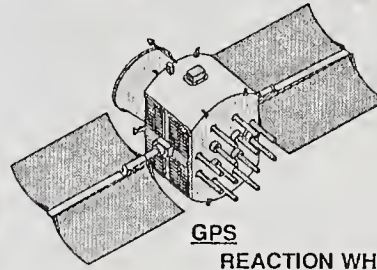
DSCS III
 SLIP RINGS
 SOLAR ARRAY DRIVE
 REACTION WHEEL



DSP
 MOMENTUM WHEELS
 ANTENNA POINTING
 LASER COM



DMSP
 GIMBAL BEARINGS
 SLIP RINGS
 MOMENTUM WHEEL
 SOLAR ARRAY



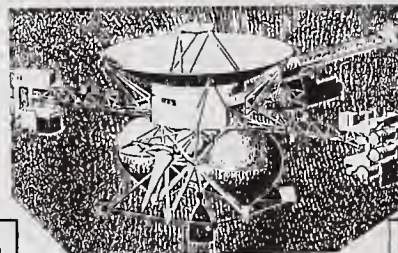
GPS
 REACTION WHEELS
 SLIP RINGS
 SOLAR ARRAY DRIVE

M/91-6399

MOVING MECHANICAL ASSEMBLY FUNCTIONS

*DEPLOYMENT &
 ARTICULATION*

*STABILIZATION/
 ATTITUDE CONTROL*



*SENSOR &
 ANTENNA
 POINTING*

*CONDUCTION THROUGH
 ROTATING INTERFACES*

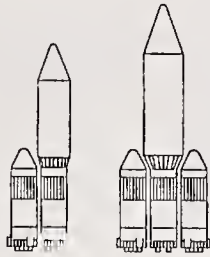
TRIBOLOGY FOR SPACE SYSTEMS IN THE NINETIES

U. S. & European Assessments

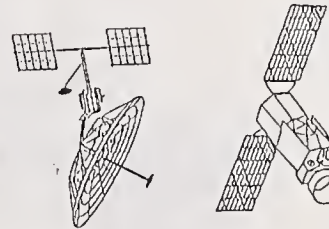
Large Systems
Long Life
Environment
Stability



Launch Vehicles
Larger
Cheaper



Sensing &
Surveillance
Better
Pointing



*Other technologies developing faster
Tribology rapidly becoming weak link*

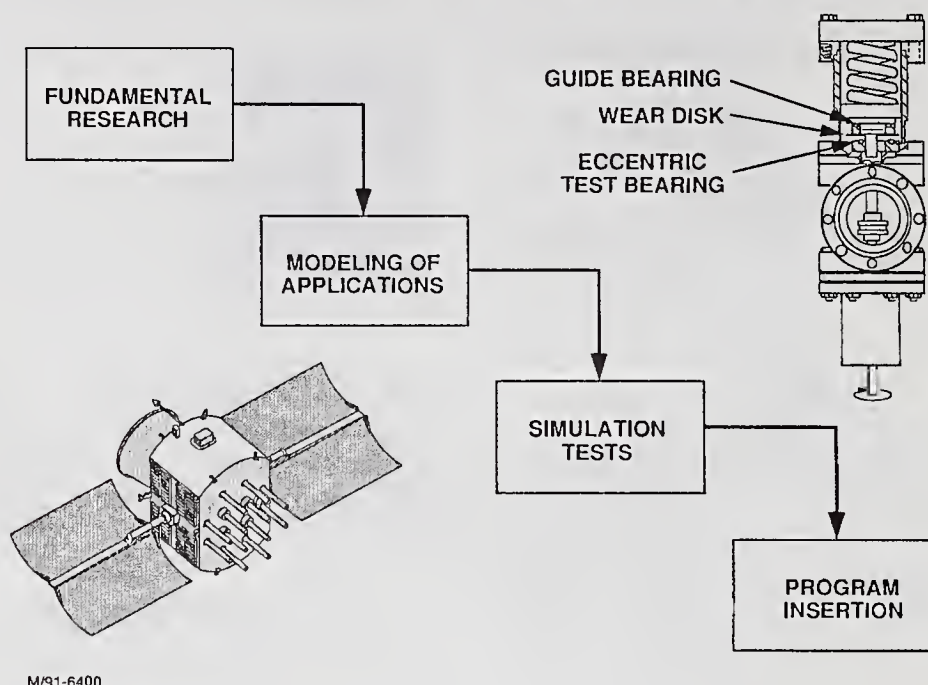
TRIBOMECHANISM/COMPONENT PERFORMANCE

Current tribology problems with active spacecraft

- Number one recurrent problem is with bearings in *CMGs*
also with *momentum/reaction wheels & gyroscopes*
- Second leading problem is with *actuators, gears, & gimbals*
operating in boundary lubrication regime
- Third problem concerns low noise operation of *slip rings*
- Other problems with *turbo machinery, cryopumps, coolers*



Lubrication Problem Solving



Ceramic Components in Spacecraft Mechanisms

Payoffs for Ceramics - Performance Improvements

Improved surface finishes and wear resistance

Lower torque & noise - Better pointing control

Longer operational life

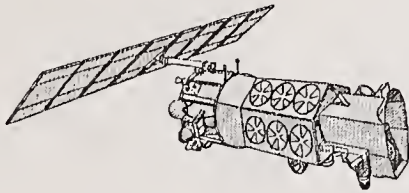
Less power consumption

Reduced weight - Lower (launch & orbit) costs

Improved strength - Potential reduction in complexity/cost



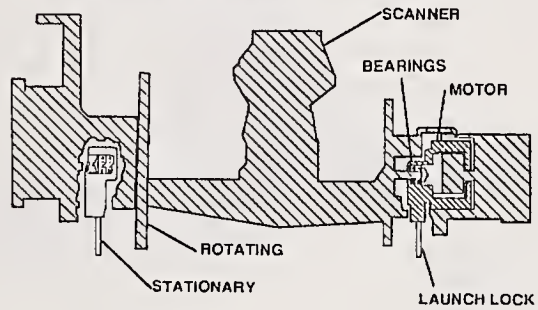
Lubrication of DMSP OLS



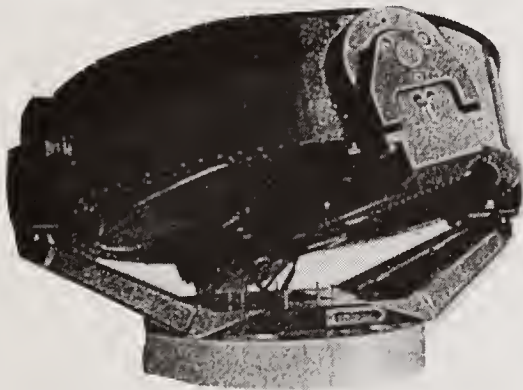
PROBLEM:
LUBRICANT LIFE FOR
5-YEAR MISSION

APPROACH:
SYNTHETIC
HYDROCARBON OIL
POLY- α -OLEFIN NYE
188B

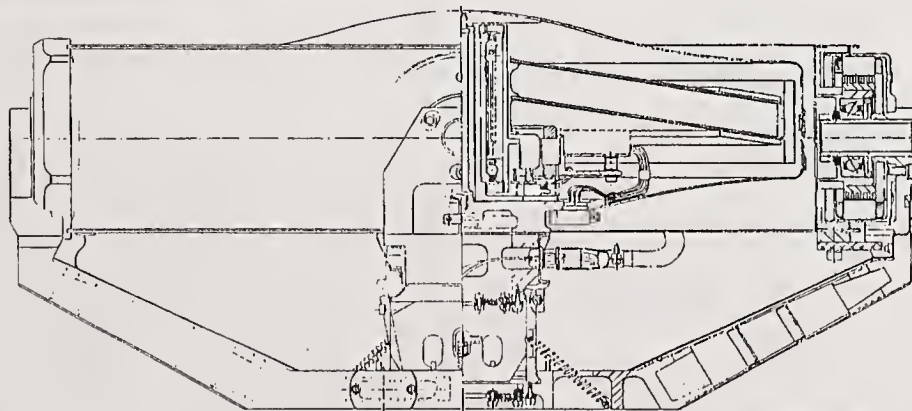
OLS OSCILLATING ASSEMBLY



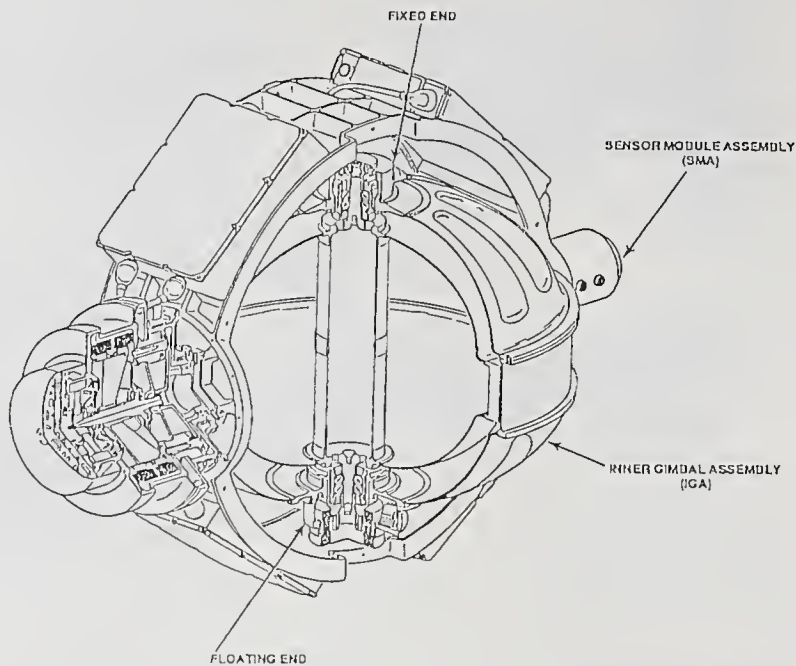
M/91-6401



CONTROL MOMENT GYROSCOPE



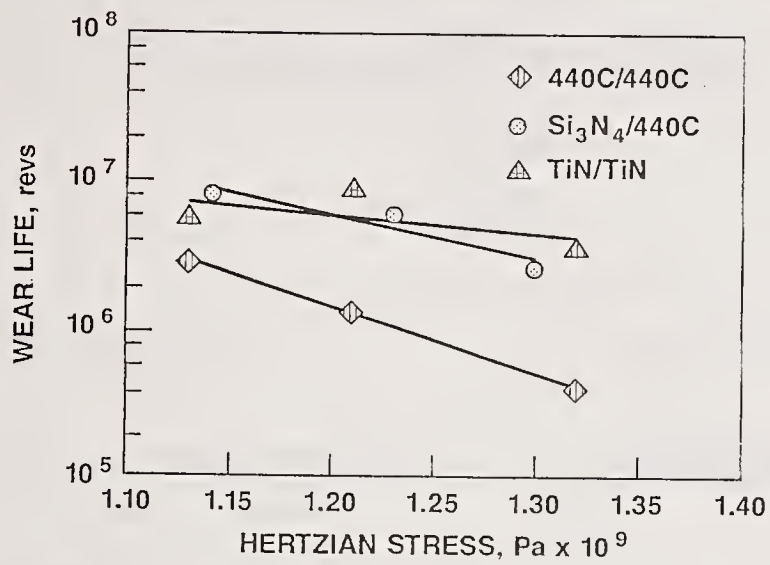
Control Moment Gyro



Tribology Components: Requirements/Technologies

Tribology Requirements	Low Friction	Low Wear Rate	Extreme Environ.	Elec./Therm. Cond.	Periodic Motion	Gas/Vac. Compat.	Storage	Non-confam.	Controlled Backlash
<u>Rolling Contact</u>									
Spin Bearings	X	X	X	X	X	X	X		
Gimbal Bearings	X	X	X	X	X	X	X	X	
Sensor Supp. Brgs.	X	X	X	X	X	X	X	X	
Motor, Synchronous	X	X	X	X			X	X	X
Solar Array Brgs.	X	X	X	X	X		X	X	
<u>Mixed Regime</u>									
Gears	X	X	X	X	X	X	X	X	X
Harmonic Drives	X	X	X	X	X	X	X	X	X
Technology "Solution"	Fluid Lubes	Solid Lubes	Hard Coats	Composite Mat.	Additives	Bulk Mat's	Ceramic		

Wear Life as a Function of Hertzian Stress



Ceramic Components in Spacecraft Mechanisms

Challenges for Ceramics - Research/Testing Needs

Effectiveness of lubricants with ceramic vs metal surfaces

Surface chemical interactions

Electronic structure considerations

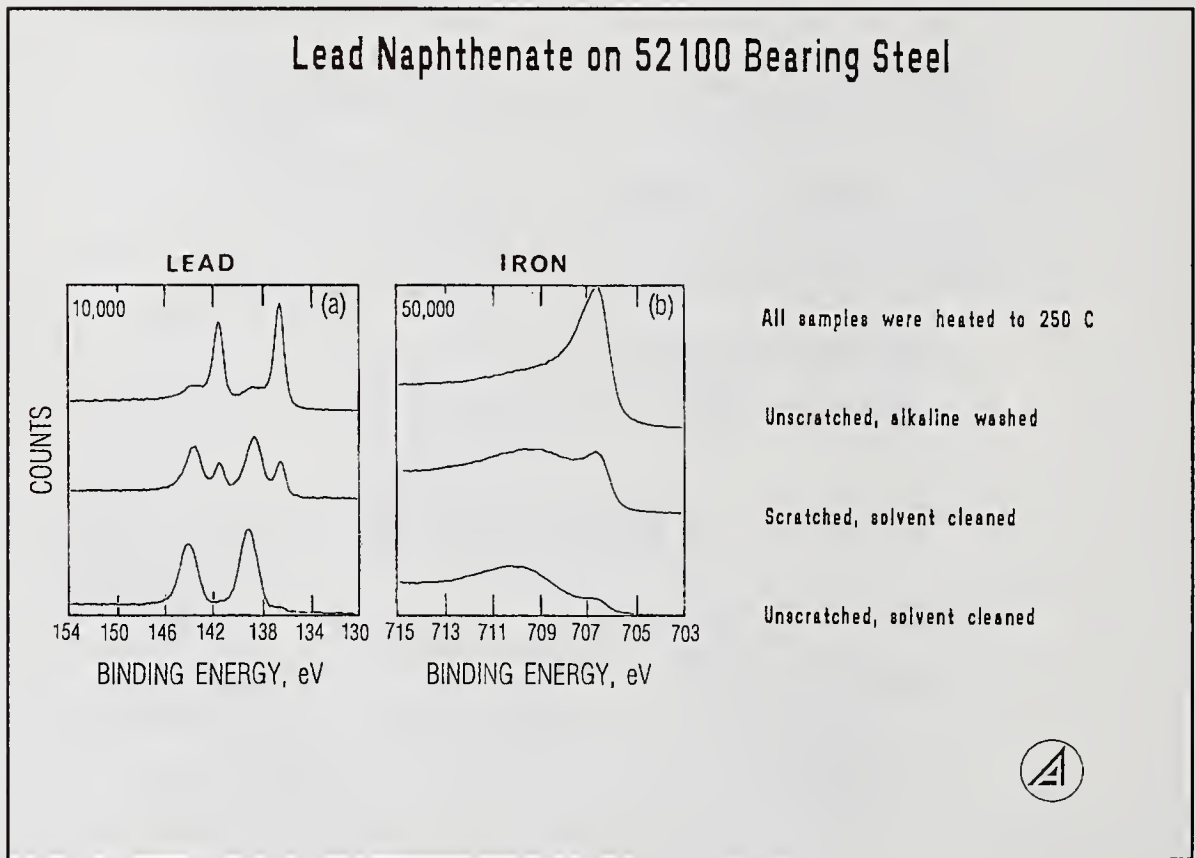
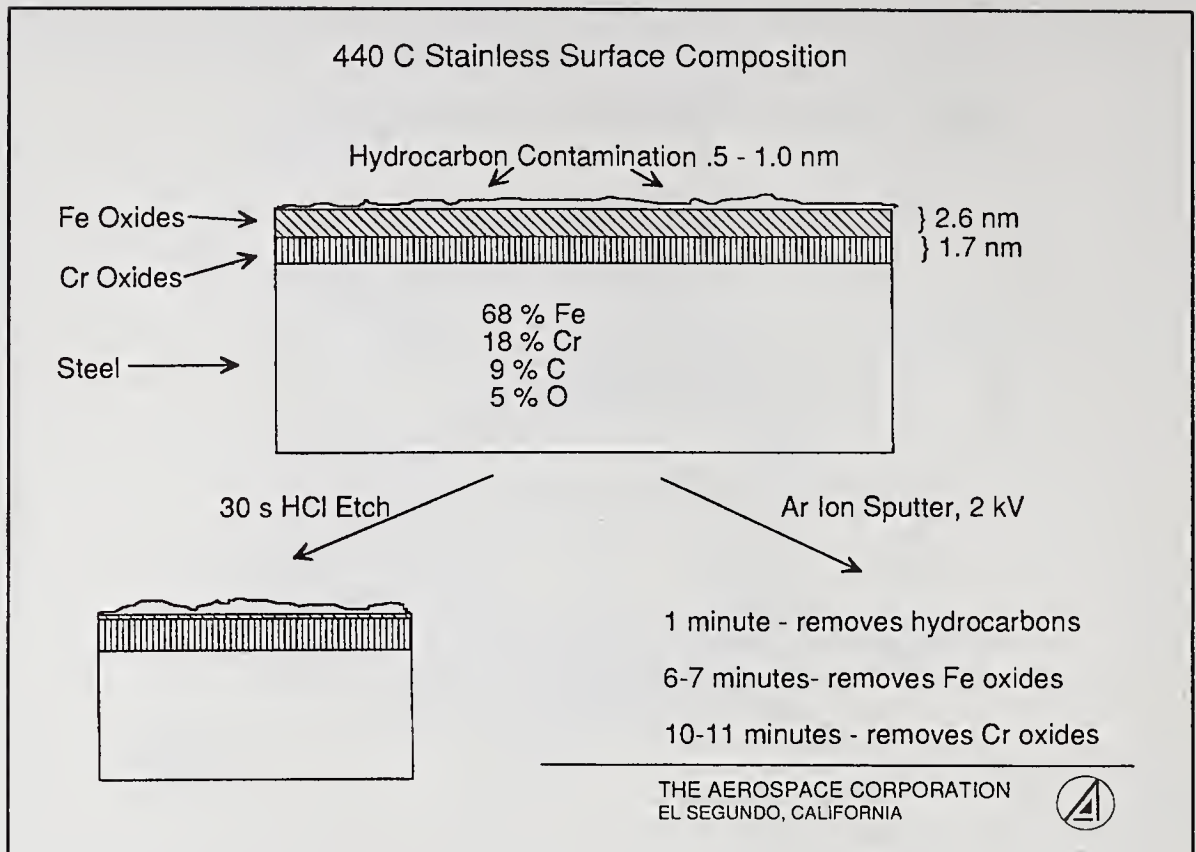
Lubricated wear rates in rolling, sliding, & mixed regimes

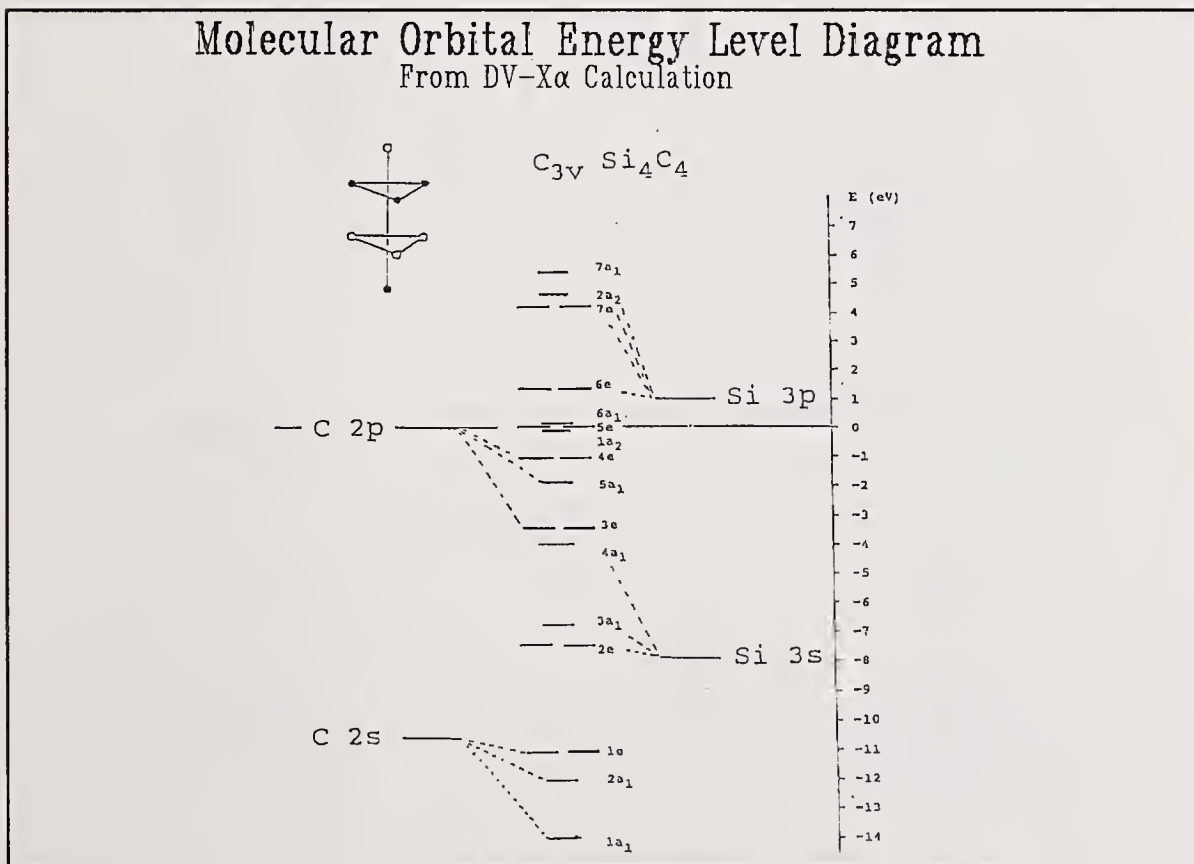
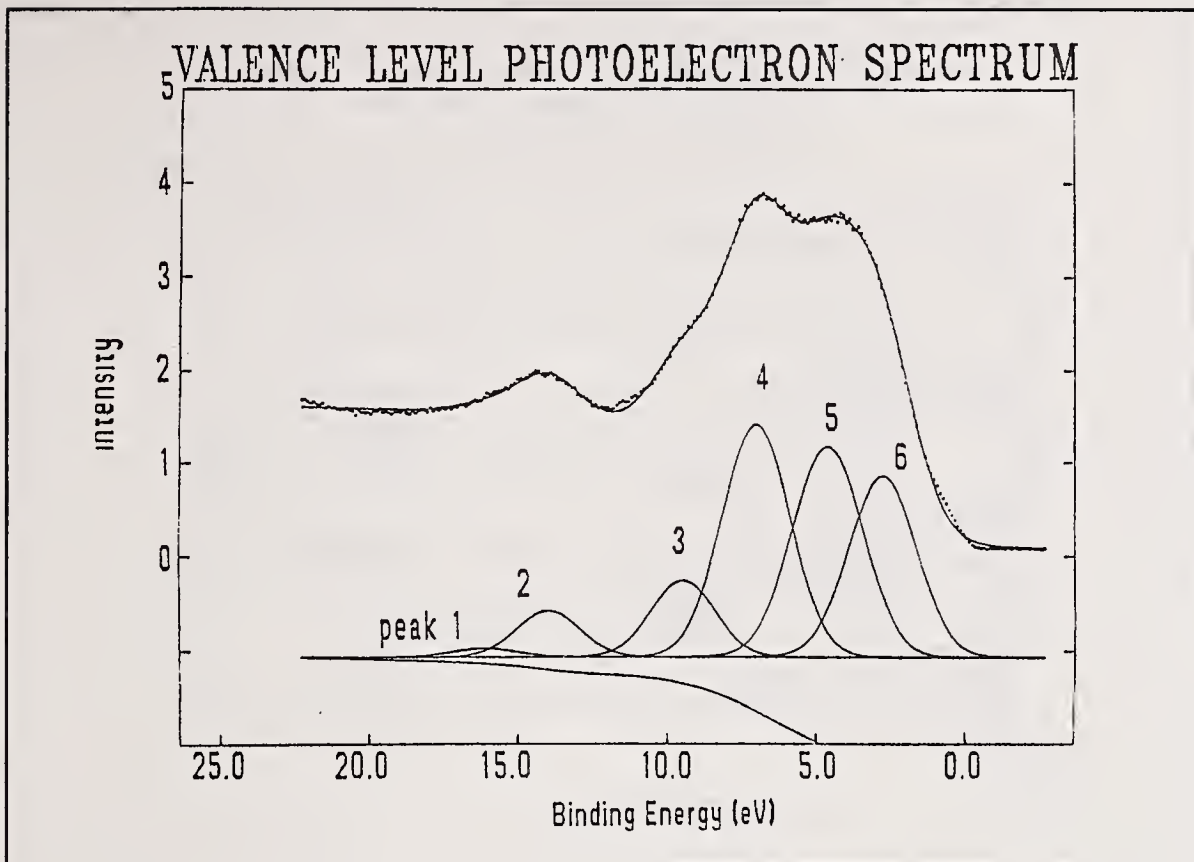
Boundary versus EHD lubrication

Surface roughness

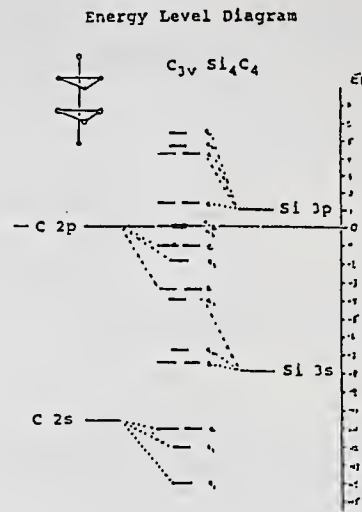
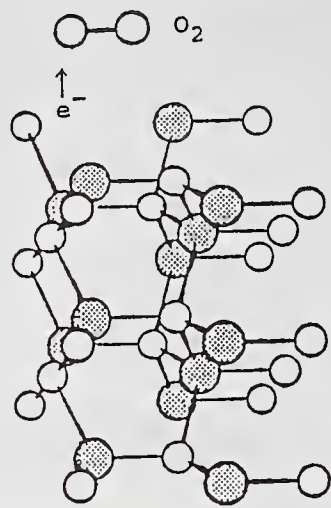
Film thickness





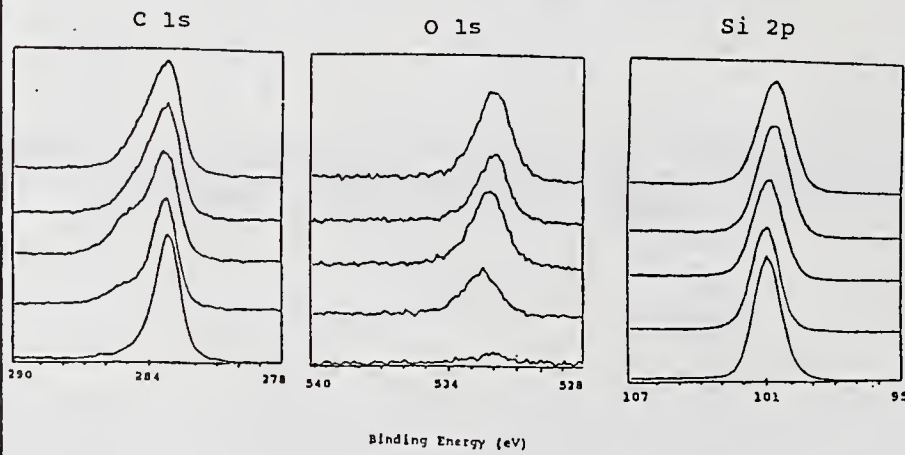


Interaction of Oxygen with SiC



Core Level XPS Spectra

Sputter/Anneal Cycles



Ceramic Components in Spacecraft Mechanisms

Summary of Lubricant Considerations for Ceramics

Surface additives often require chemical reaction with steel

Lead formation requires metallic iron

TCP forms "active" phosphate

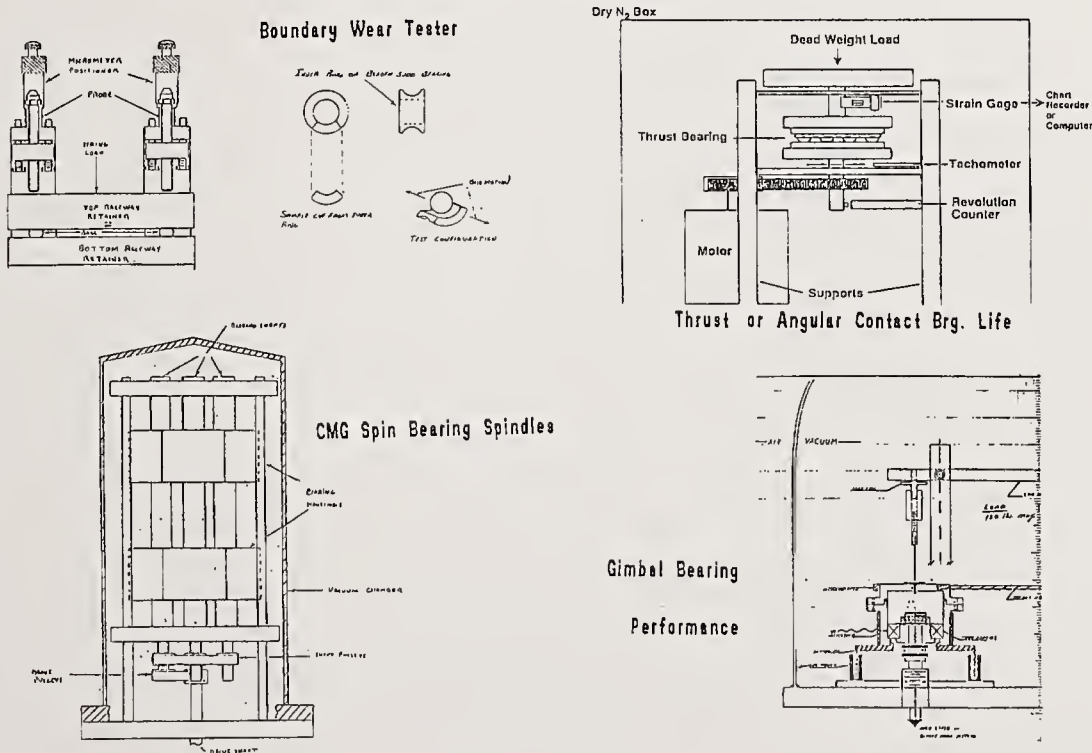
Ceramics generally covalent, nonmetallic

Knowledge of bonding orbitals/energy levels allows
selection of proper additive(s)

Tests (component level, life tests) required for verification



Test Facilities For Ceramic Bearings



Ceramic Components in Spacecraft Mechanisms

Summary

Ceramics provide potential for significant increases in performance and life of spacecraft mechanisms

Payoffs include reduced torque and noise, reduced wear, reduced weight; all of which → lower cost (\$\$\$)

Challenges involve lubrication schemes and verification testing

Must convince programs to use what is available!!

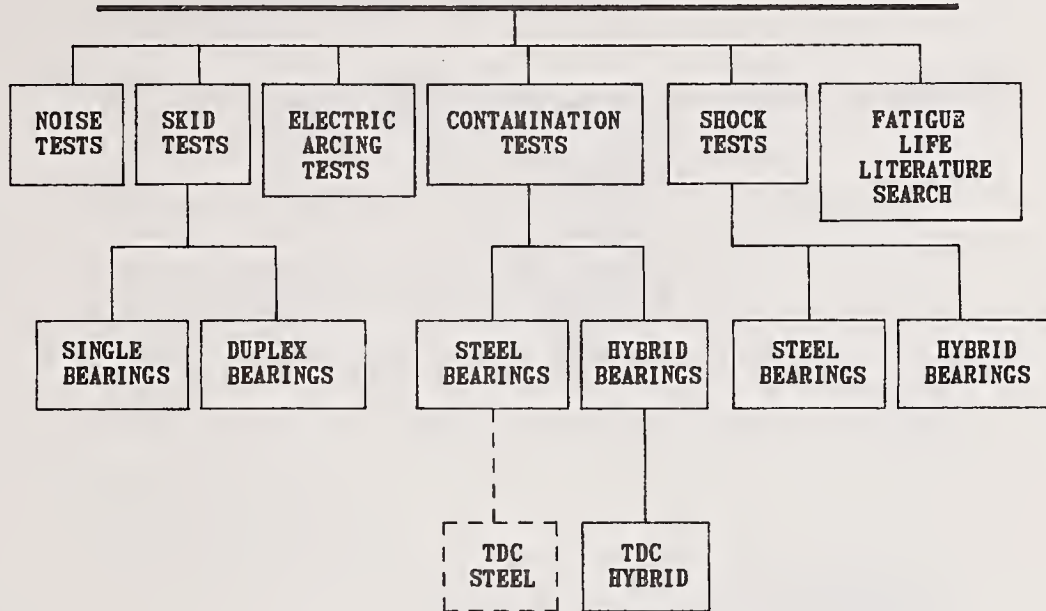


Hybrid Ball Bearing For Naval Applications

Gerry J. Phillips
David Taylor Research Center
Annapolis, MD 21402

Ball bearings comprised of steel rings and silicon nitride balls have undergone extensive testing and evaluation for application in naval auxiliary machinery. These hybrid bearings have outperformed standard all-steel bearings in every test conducted to date and shipboard evaluations are being pursued. Key advantages demonstrated over standard bearings include extremely good wear resistance, electrical insulation, lower preload requirements and excellent shock resistance.

HYBRID BEARING DEVELOPMENT



NOISE TEST RESULTS 3/4" BALL BEARINGS

BAND	ANDERONS		
	LOW	MID	HIGH
HYBRID	15	4	7
STEEL	18	8	15
NT-4 LIMITS	24	17	18
NT-3 LIMITS	24	20	20

FAFNIR SIZE 310 CARTRIDGE TYPE

NOISE TEST RESULTS 1-1/16" BALL BEARINGS

BAND	ANDERONS		
	LOW	MID	HIGH
HYBRID	11	5	13
STEEL	12	6	19
NT-4 LIMITS	32	21	22
NT-3 LIMITS	32	24	32

BARDEN SIZE 2315 ANGULAR CONTACT

NOISE TEST RESULTS 1-3/16" BALL BEARINGS

BAND	ANDERONS		
	LOW	MID	HIGH
HYBRID	26	44	169
BARDEN STEEL	22	10	19
NT-4 LIMITS	32	23	25
NT-3 LIMITS	40	24	32

CERBEC SIZE 318 DEEP GROOVE

FATIGUE LIFE

LITERATURE SEARCH

- FATIGUE DATA AVAILABLE FROM NAVAIR PROGRAMS 1970-1980
- Si_3N_4 (NC 132) SUPERIOR WEAR AND FATIGUE LIFE
- SPALLING FAILURES SIMILAR TO THAT OF STEEL BALLS
- BILLET-PRESSED MATERIAL SIGNIFICANTLY BETTER THAN NEAR-NET-SHAPE CERAMIC MATERIAL
- FATIGUE LIFE STRONGLY INFLUENCED BY FINISHING PROCESS
- FATIGUE LIFE 10× THAT OF M50 BEARING STEEL POSSIBLE

RECOMMENDATION

- ENDURANCE PROOF TEST FOR NEW BEARING DESIGNS

ELECTRIC ARCING TEST RESULTS

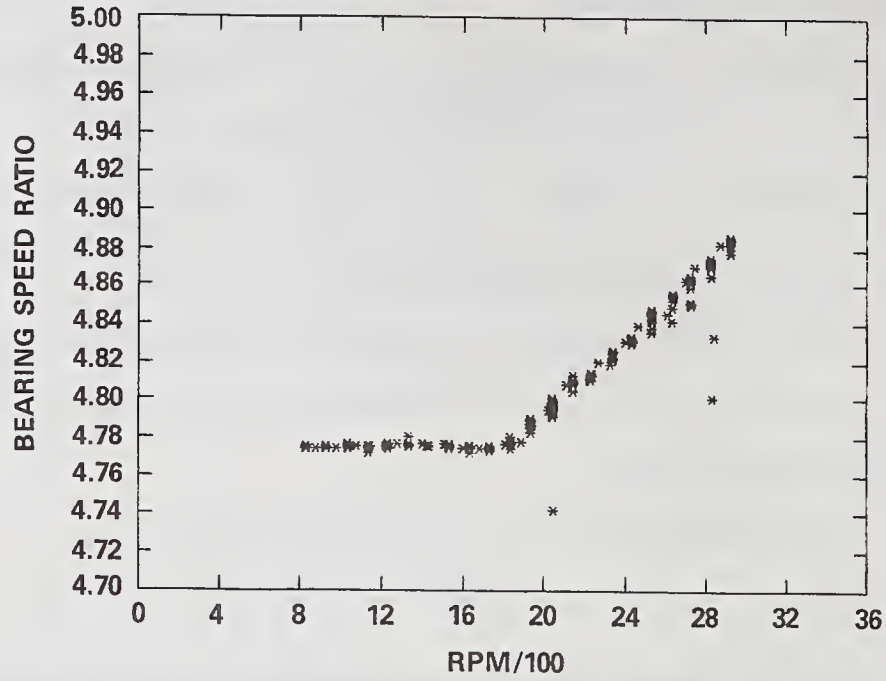
STANDARD BEARING

- CAN BE DAMAGED BY ELECTRIC ARCING
- EXTENT OF DAMAGE DEPENDS ON ENERGY OF DISCHARGE

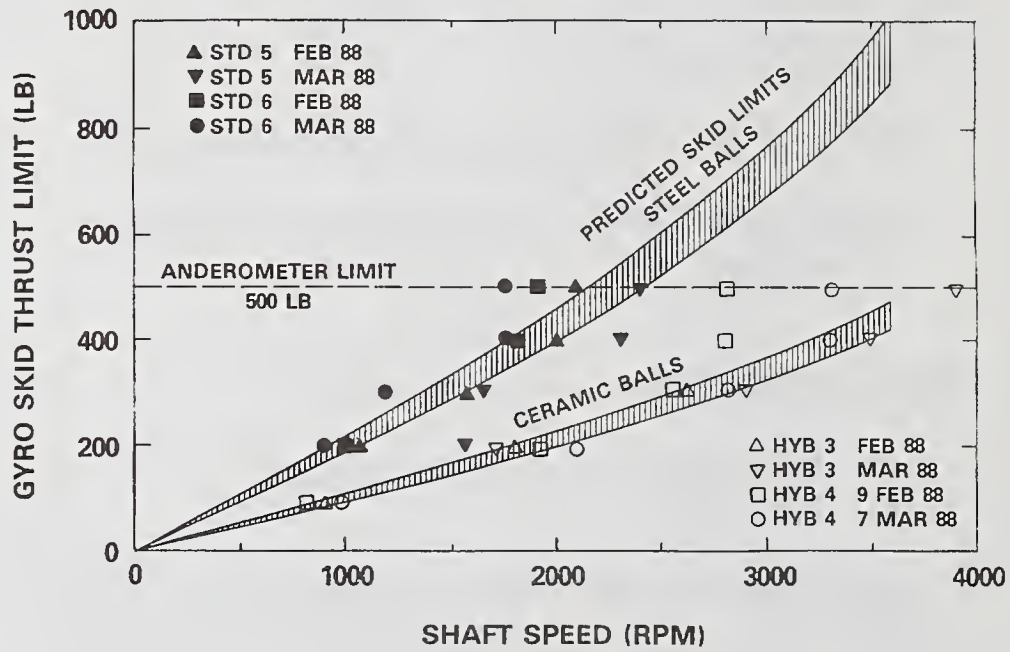
HYBRID BEARING

- CERAMIC BALLS DO NOT CONDUCT ELECTRICITY
- BEARING CANNOT BE DAMAGED BY ELECTRIC ARCING

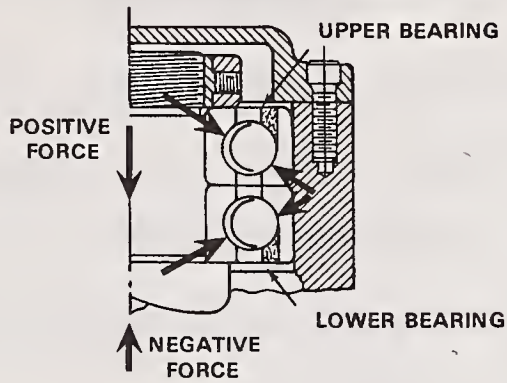
**SKID TEST HYBRID BEARING SN 6
THRUST 500 LBS ROYCO 28 GREASE
4 MAR 1988**



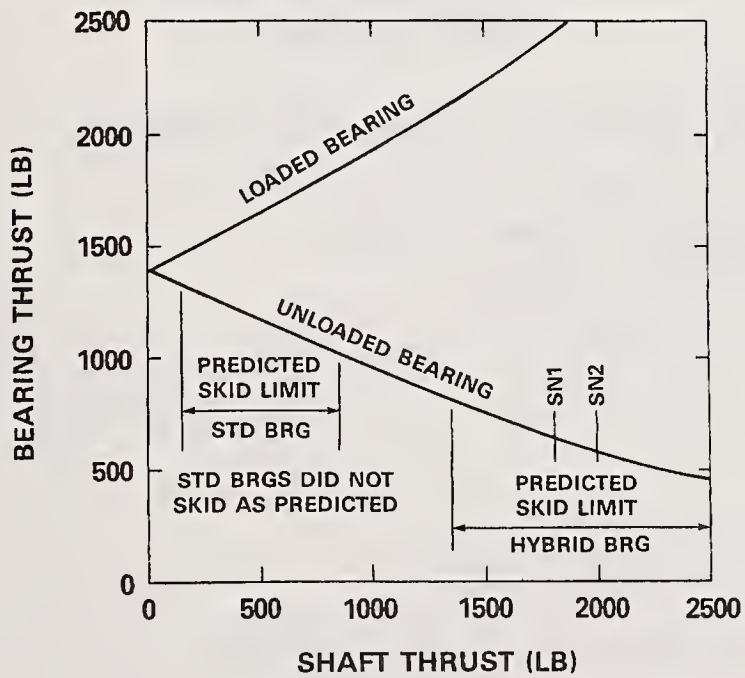
INDIVIDUAL BEARING SKID TEST RESULTS



BEARING LOADING ILLUSTRATED



SKID TEST RESULTS DUPLEX PAIRS (DB) 3600 RPM 1000-LB PRELOAD



CONTAMINATION TESTS HARDWARE

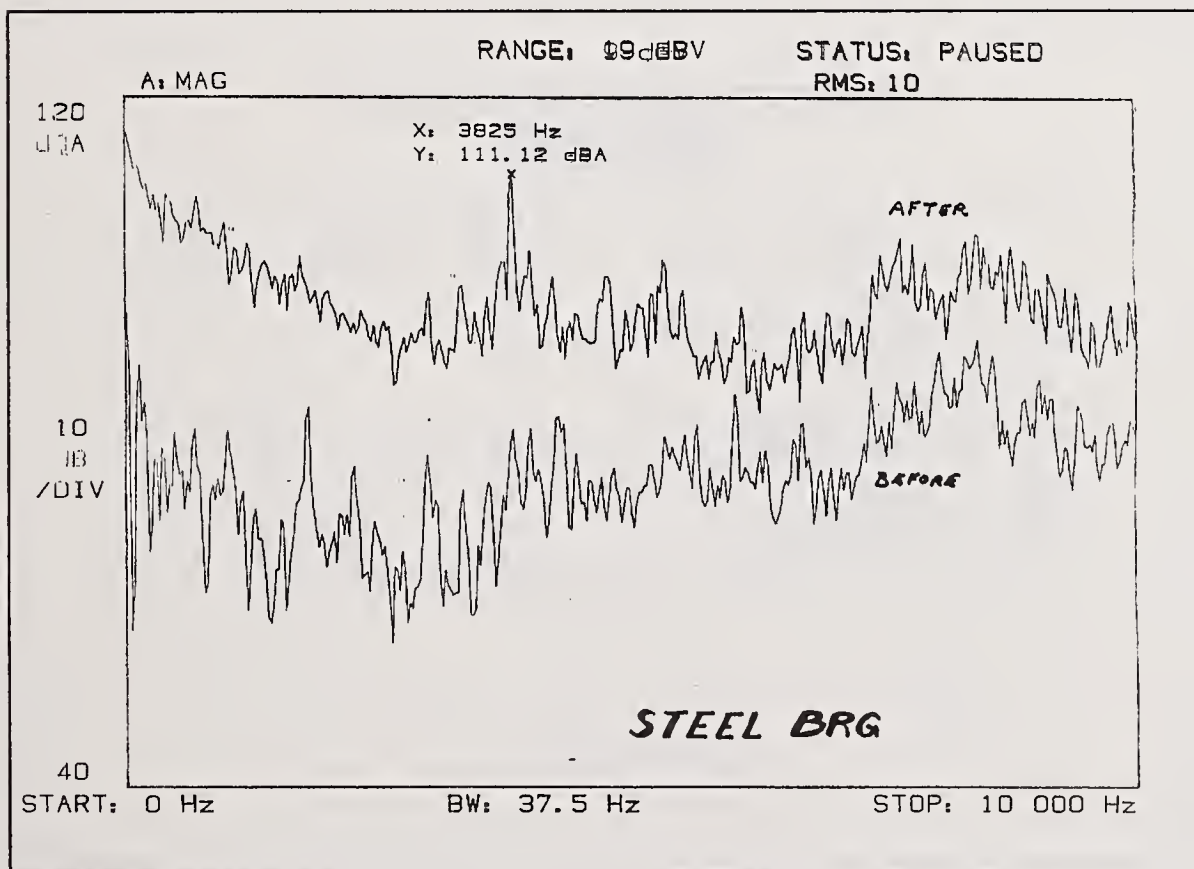
- MAIN FEED PUMP MOTOR
- 7315 DUPLEX BEARING (1,000 lb Preload)
- DUPLEX BRG UPPER END CAP REMOVED
- ACCELEROMETERS ON BRG HOUSING
- FOBM ON BRG RING

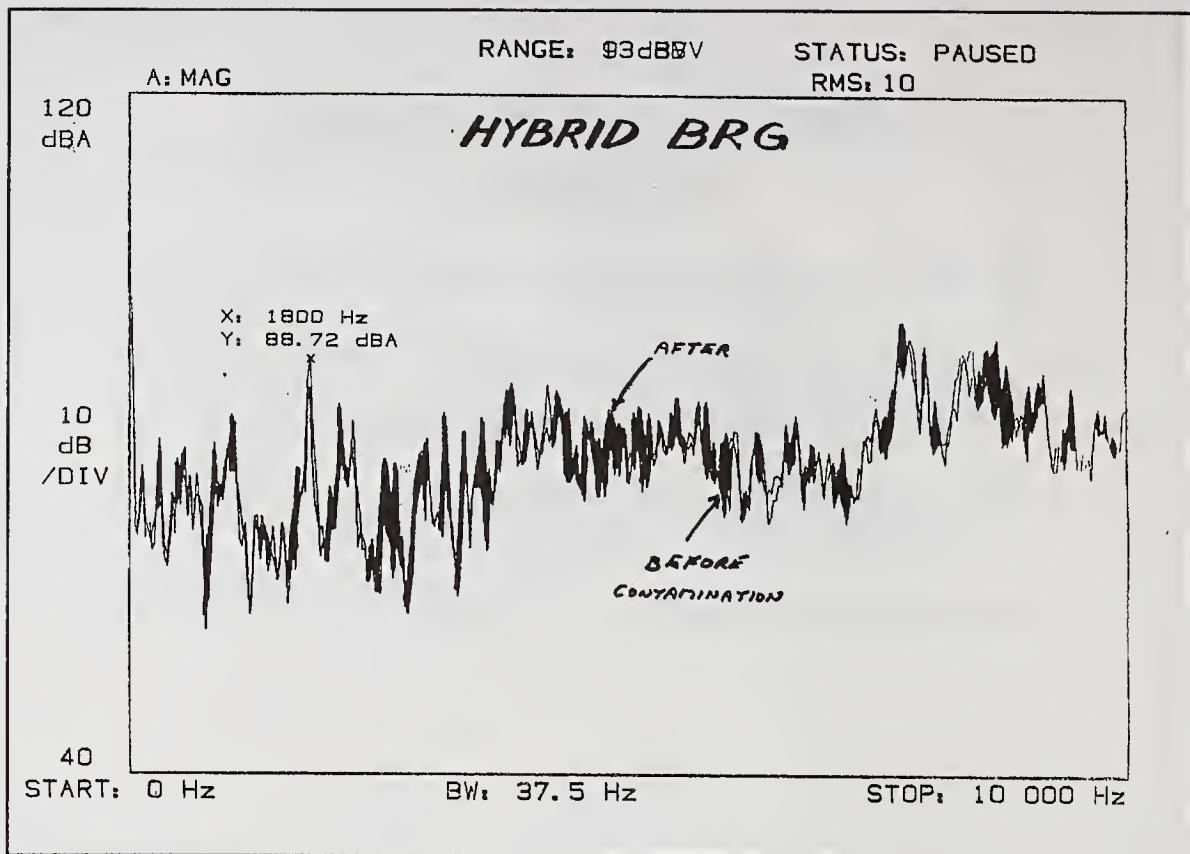
CONTAMINATION TESTS CONTAMINANT

- CARBON DUST - From DC Generator
- 8 GRAMS - Over 5 Hours

CONTAMINATION TESTS SEQUENCE

- STEEL BEARINGS FIRST
- CONTAMINANT ADDED UNTIL NOISE LEVELS DRIVEN UPWARD
- REPEAT SAME CONTAMINATION AMOUNT/TIMES WITH HYBRID
- REPEAT SAME WITH TDC BRGS





CONTAMINATION TEST RESULTS (ANDERONS)

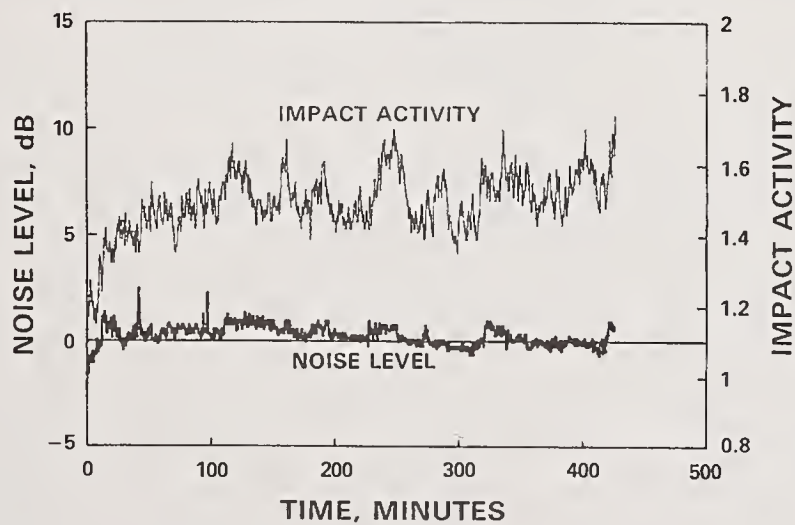
	<u>BEARING CONDITION</u>	<u>STANDARD BEARING</u>	<u>HYBRID BEARING</u>	<u>MIL-B-17931</u>
LOW BAND	BEFORE	14	13	40
	AFTER (WITH CARBON DUST)	32	19	
	AFTER (CLEANED)	28	13	
MEDIUM BAND	BEFORE	7	7	25
	AFTER (WITH CARBON DUST)	80	10	
	AFTER (CLEANED)	80	10	
HIGH BAND	BEFORE	24	16	26
	AFTER (WITH CARBON DUST)	440	50	
	AFTER (CLEANED)	420	55	

TDC*

- CORROSION PROTECTION 10x Better Than Stainless
- WEAR RESISTANCE 5x Better Than Std Brgs
- FATIGUE LIFE 2x Longer Than Std Brgs
- LUBRICATION Less Sensitive To Inadequate Lubrication

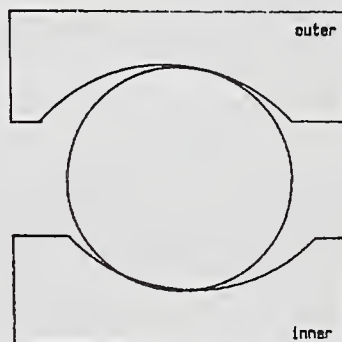
• THIN DENSE CHROME

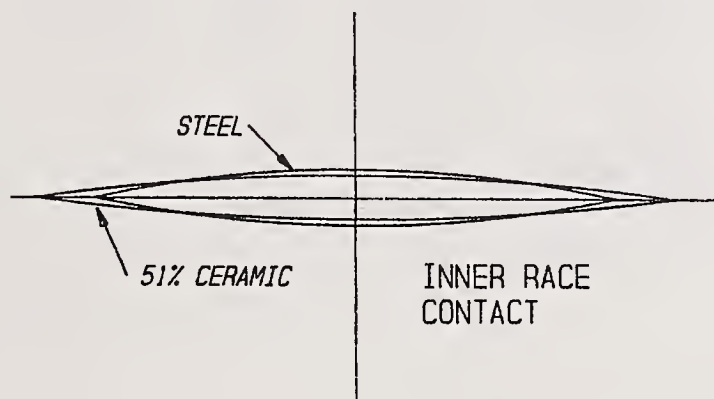
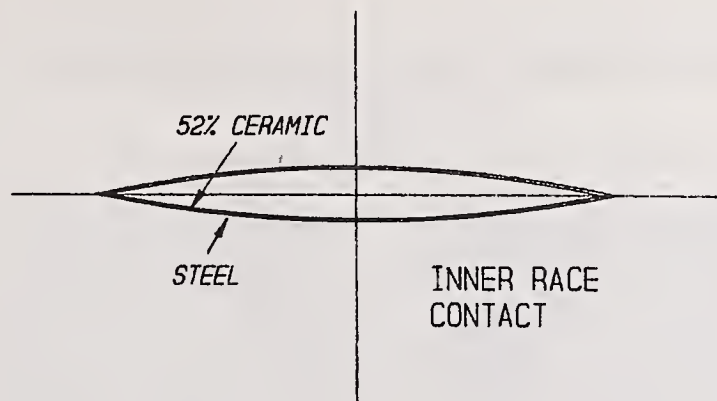
CONTAMINATION TEST TDC HYBRID



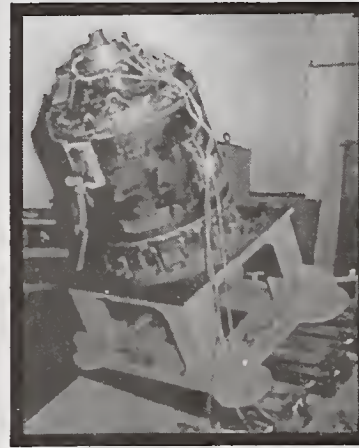
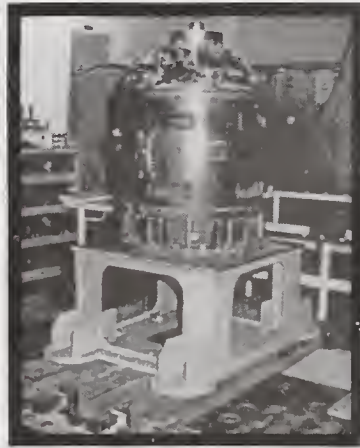
CONTAMINATION RESULTS

		<u>MIL SPEC</u>	<u>STD BRG</u>	<u>HYBRID BRG</u>	<u>TDC HYBRID</u>
LOW BAND	BEFORE	40	14	13	18
	AFTER		32	19	20
	CLEANED		28	13	15
MID BAND	BEFORE	25	7	7	7
	AFTER		80	10	10
	CLEANED		80	10	13
HIGH BAND	BEFORE	26	24	16	18
	AFTER		440	50	82
	CLEANED		420	55	83



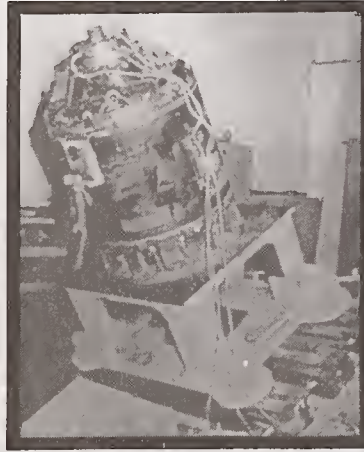
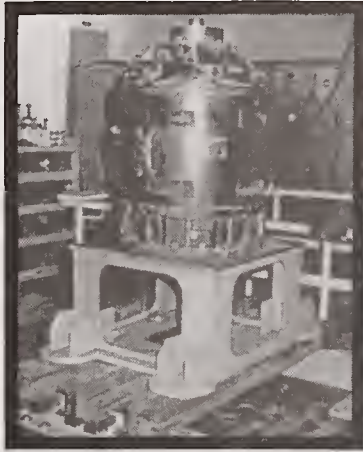


HYBRID BEARING SHOCK TESTS MIL-S-901C



<u>BLOW NO.</u>	<u>PLATFORM ORIENTATION</u>	<u>MOTOR CONDITION</u>	<u>DROP HEIGHT</u>	<u>TABLE TRAVEL</u>
1	LEVEL	RUNNING	1.75'	3''
2	LEVEL	STILL	2.75'	3''
3	LEVEL	RUNNING	2.75'	1.5''
4	30 DEGREES	STILL	2.25'	3''
5	30 DEGREES	RUNNING	4.0'	3''
6	30 DEGREES	STILL	4.0'	1.5''

HYBRID BEARING SHOCK TESTS MIL-S-901C



PEAK G'S

	1	2	3	4	5	6	
BRG CAP V	74	88	86	66	82	78	STEEL BEARINGS
SHAFT	-	129	-	84	-	102	
BRG CAP H	12	33	10	41	37	-43	

PEAK G'S

	1	2	3	4	5	6	
BRG CAP V	73	92	86	68	78	72	HYBRID BEARINGS
SHAFT	-	137	-	-	-	-	
BRG CAP H	22	18	18	20	16	41	

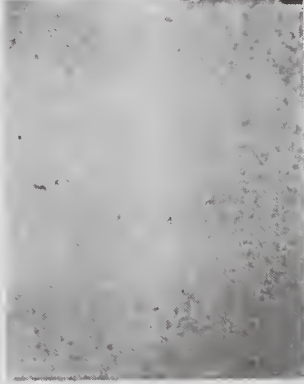
MAX. BEARING SHOCK = 137 g's = 51,642 lbs.
AFBMA STATIC THRUST CAPACITY = 46,772 lbs.

SHOCK TEST RESULTS

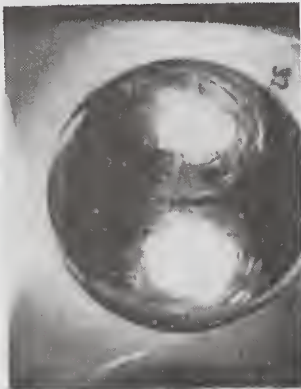
BALL DAMAGE



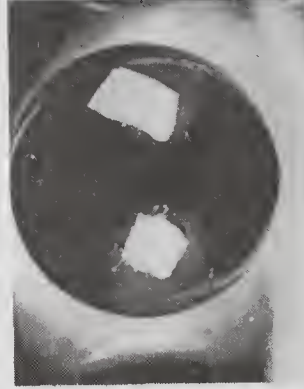
TYPICAL STEEL BALL
(100x)



TYPICAL CERAMIC BALL
(100x)



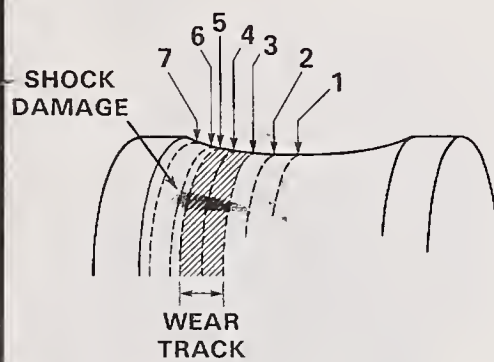
TYPICAL STEEL BALL
(2.5x)



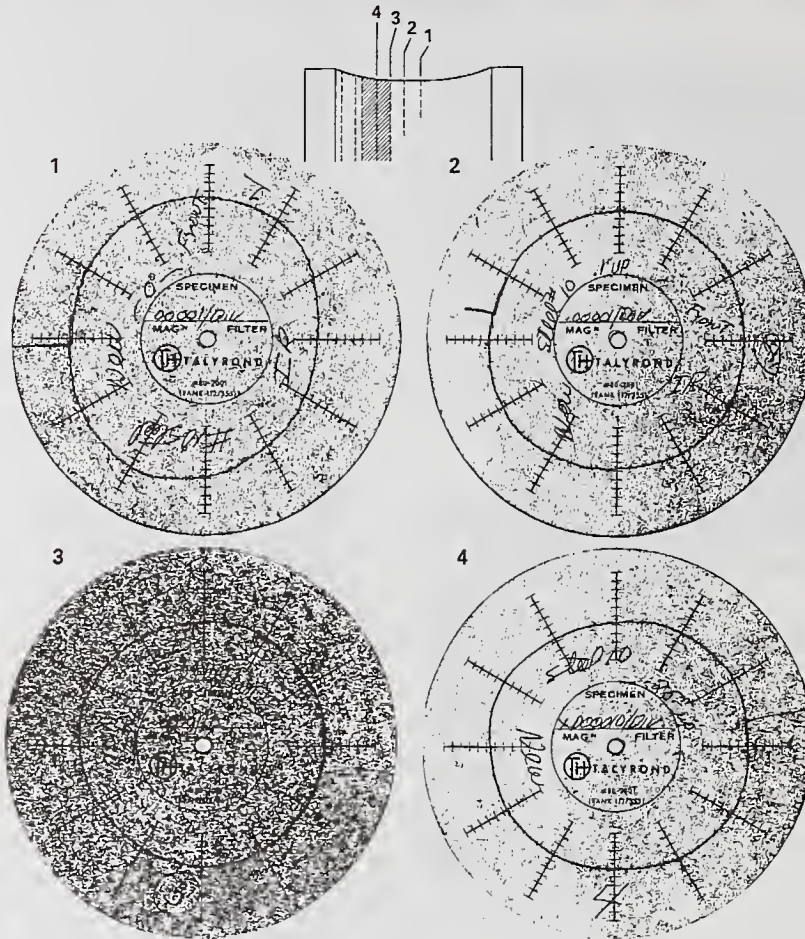
TYPICAL CERAMIC BALL
(2.5x)

SHOCK TEST RESULTS

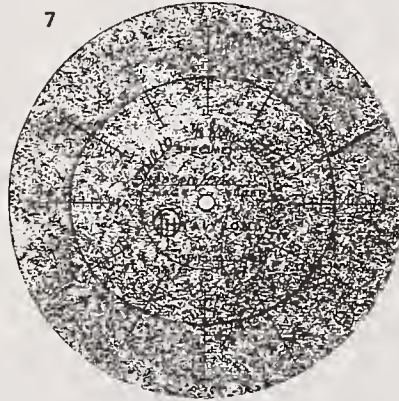
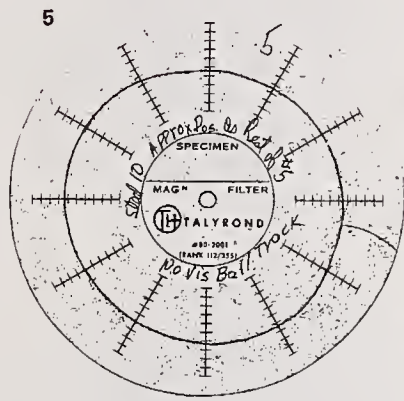
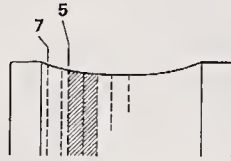
AXIAL POSITION OF ROUNDNESS TRACES



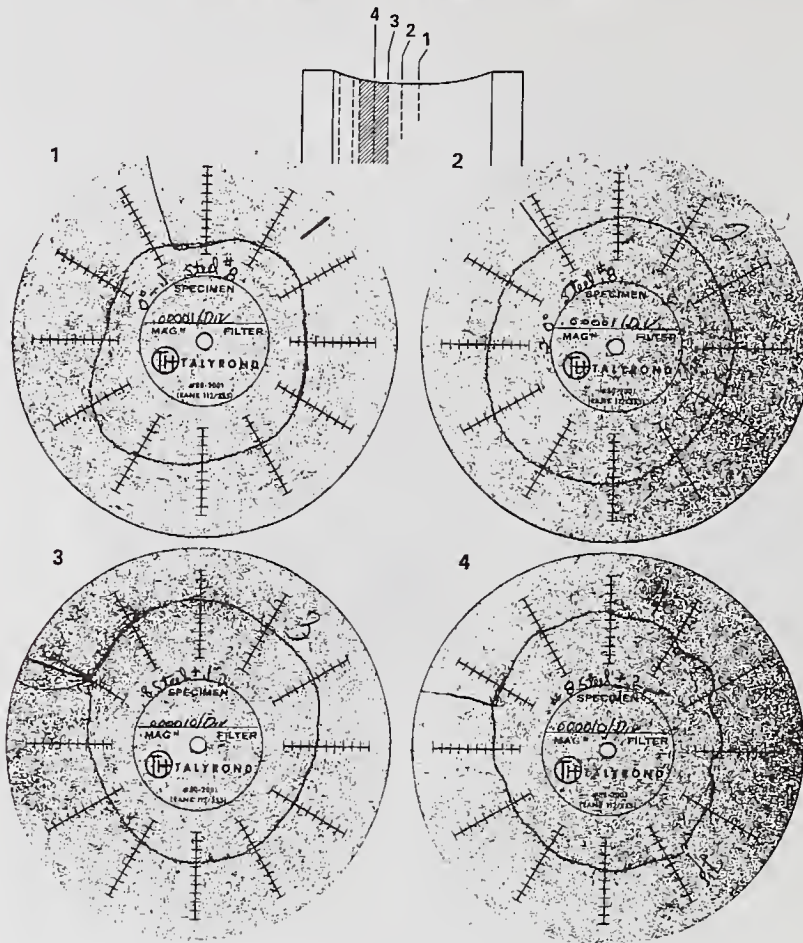
NEW BEARING ROUNDNESS TRACES



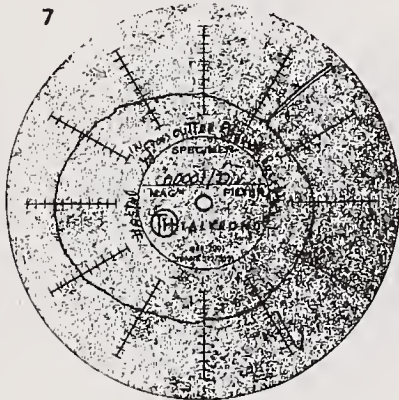
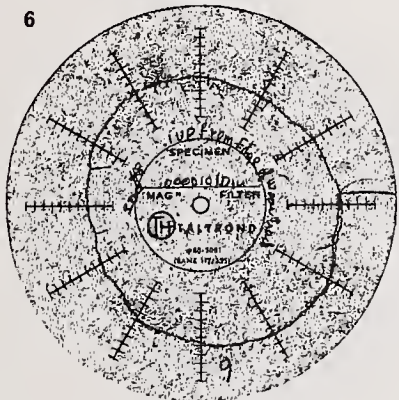
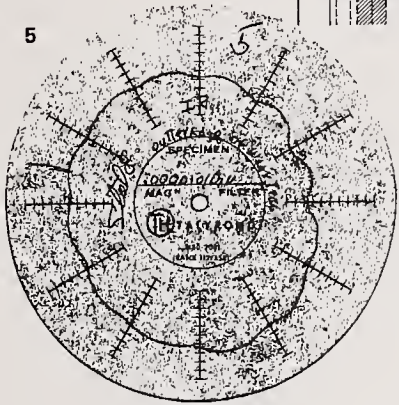
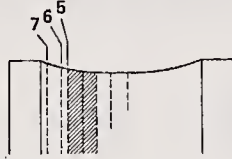
NEW BEARING ROUNDNESS TRACES



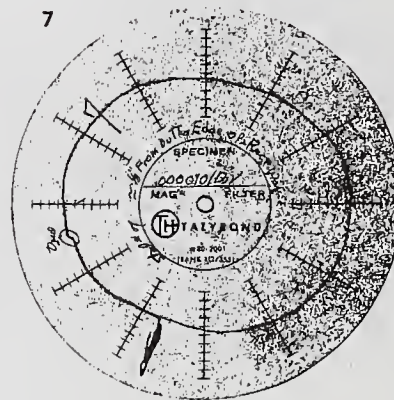
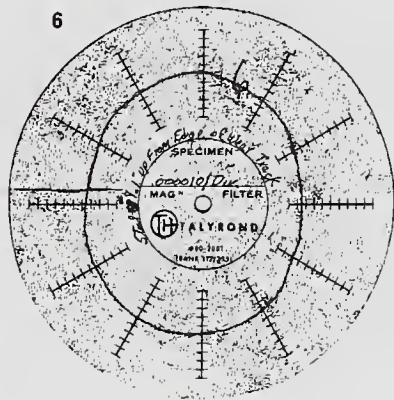
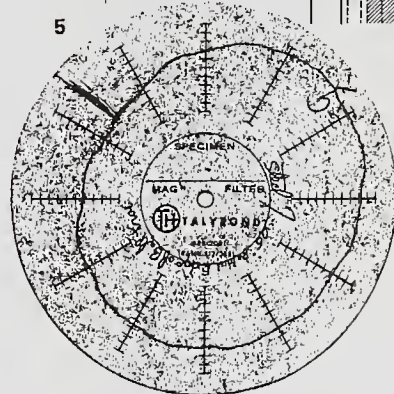
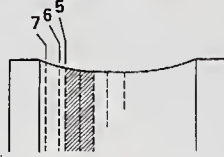
SHOCK TEST RESULTS STEEL BEARING NO. 8



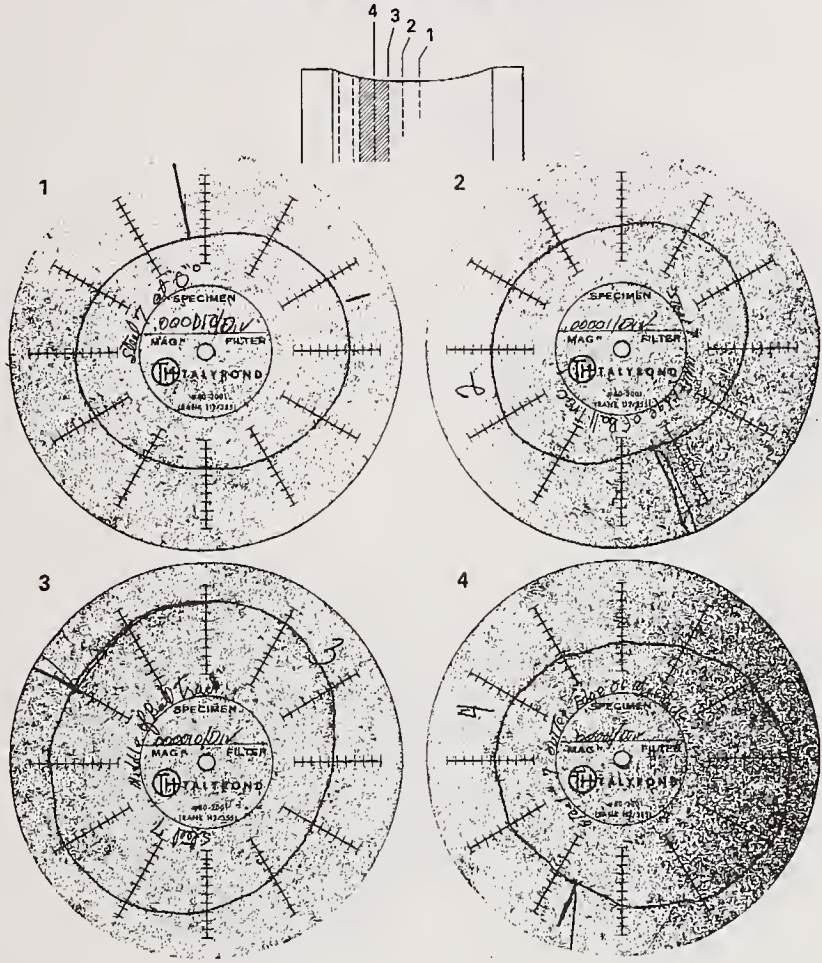
SHOCK TEST RESULTS STEEL BEARING NO. 8



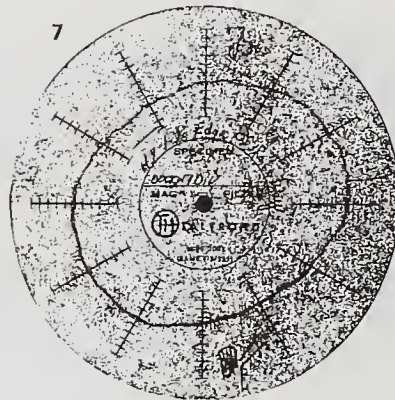
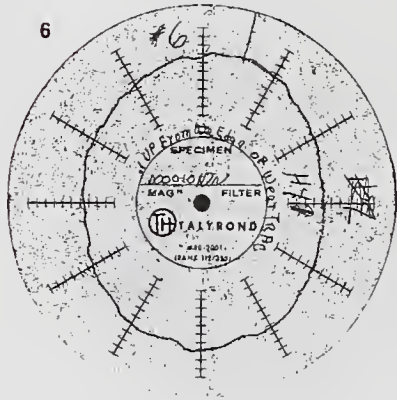
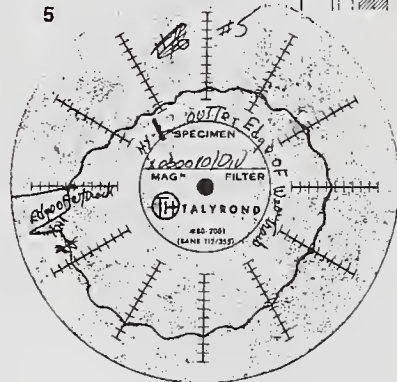
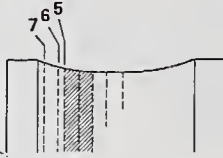
SHOCK TEST RESULTS STEEL BEARING NO. 7



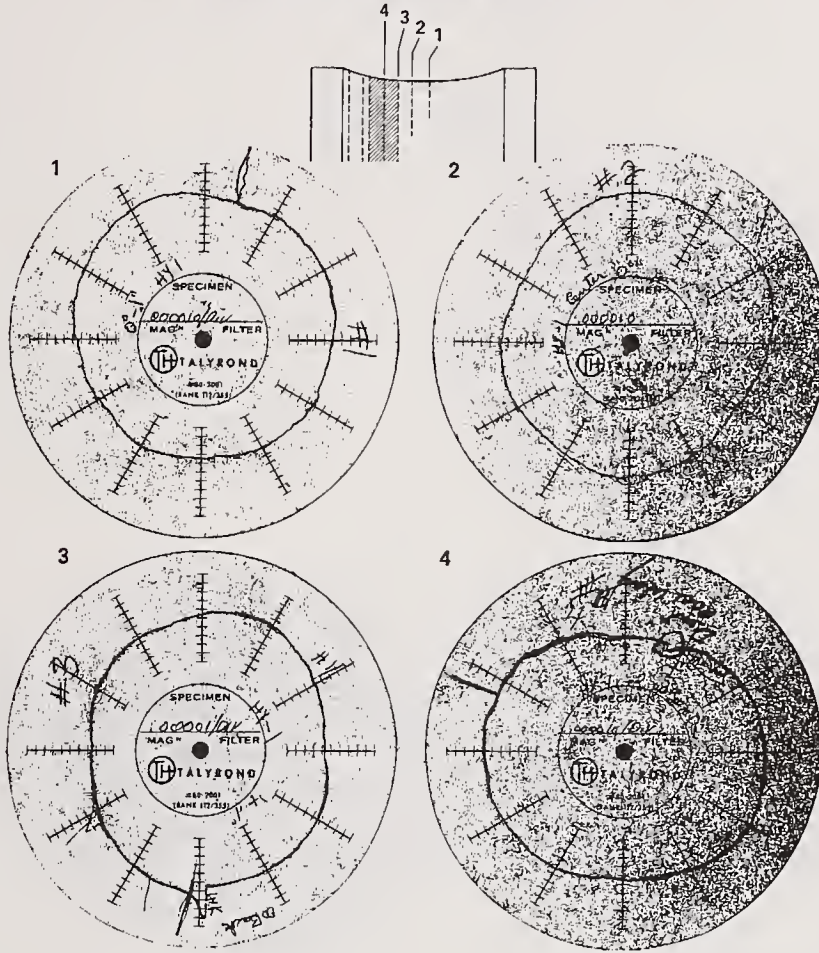
SHOCK TEST RESULTS STEEL BEARING NO. 7



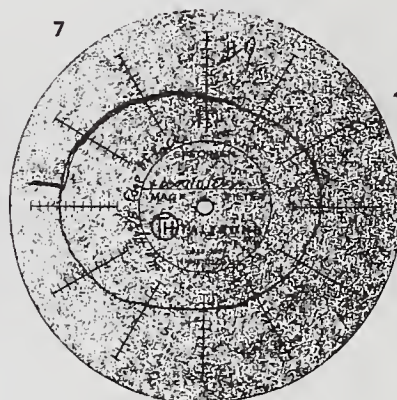
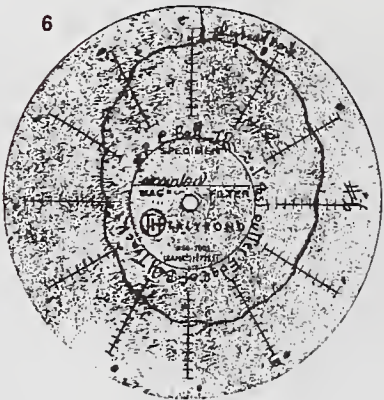
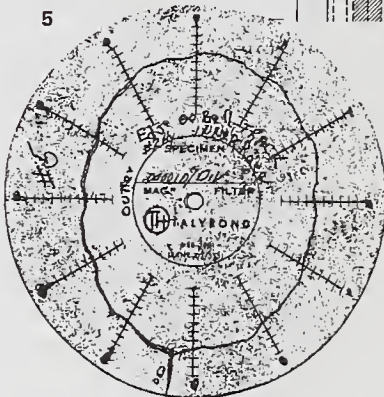
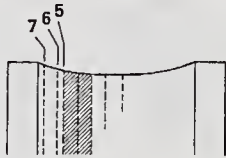
SHOCK TEST RESULTS HYBRID BRG. NO. 1



SHOCK TEST RESULTS HYBRID BRG. NO. 1

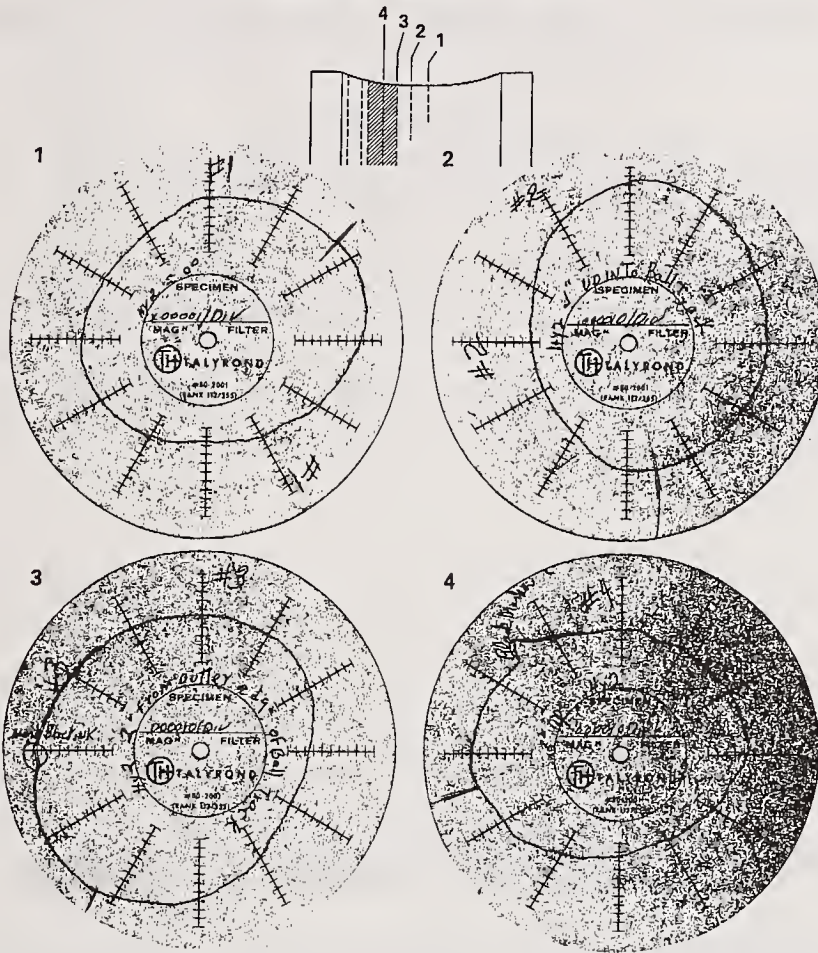


SHOCK TEST RESULTS HYBRID BRG. NO. 2



SHOCK TEST RESULTS

HYBRID BRG. NO. 2



SHOCK TEST RESULTS

RING RACEWAY DAMAGE

	<u>ECCENTRICITY</u>	<u>DENTS</u>
NEW BEARING	20	--
UPPER STL #8	50	10
LOWER STL #7	45	5
UPPER HYB #1	55	10
LOWER HYB #2	60	5

ADVANTAGES OF HYBRID BEARINGS

- LIGHTER WEIGHT - STD BRG 7.0 LB, HYB BRG 5.7 LB
- HIGHER SPEED - GREATER DN CAPACITY
- REDUCED SKIDDING - LOWER PRELOAD
- BETTER WEAR RESISTANCE
- LONGER FATIGUE LIFE
- LESS SENSITIVE TO LUBRICATION PROBLEMS
- SUPERIOR CORROSION RESISTANCE
- ELECTRICALLY NON-CONDUCTIVE
- HIGH TEMPERATURE CAPABILITY

HYBRID SUMMARY

- * ALL TESTING OF CERAMIC BALLS SO FAR HAVE SHOWN POSITIVE RESULTS.
- * SILICON NITRIDE IS AN EXCELLENT MATERIAL FOR BEARING APPLICATIONS.
- * TDC RACEWAY COATINGS ARE NOT RECOMMENDED AT THIS TIME.
- * SHIPEVAL OF HYBRID BEARINGS IS RECOMMENDED.

Instrument Bearing Requirements and Issues

Robert A. Westerholm
Litton Guidance and Control Systems
Woodland Hills, CA 91365

Ceramics for instrument ball bearings have advantages beyond recognized high strength, corrosion resistance, and high temperature properties for which they are usually selected.

The author's company manufactures inertial navigation systems which use instrument bearings in both moderately high speed gyroscope rotors and low speed or oscillatory gimbals. Rolling element instrument bearings may be defined as bearings which:

1. Accurately maintain the position of a rotating element,
2. Are smooth running with limited vibration,
3. Have very low, very stable torques.

Applications include gyroscopes, tape and disc drives, encoders, flowmeters, etc.

Because of moderate load requirements instrument bearings do not fail by fatigue of the bearing races or balls but by combined lubricant breakdown and surface wear.

Re-lubrication is usually impossible, bearings are often inside hermetic containers and sometimes in spacecraft. Therefore, they are lubricated once for life.

A program to develop improved ceramic coatings for ball bearings was begun under subcontract to Hughes Aircraft Co. and the sponsorship of DARPA and AFML. An extensive survey of potential materials and processes identified chemical vapor deposited (CVD) hard coatings from a Swiss laboratory as a potential technology for instrument ball bearings.

Sputtered hard coatings, not surprisingly, did not adhere strongly enough for ball bearings. Tests of CVD coatings were first aimed at proving the strength and adherence of the coatings. The test vehicle was a half-inch diameter bearing from a production gyroscope for which test equipment and a large body of experience existed. The bearings contained eight, three thirty-second inch diameter balls with a conventional porous phenolic retainer impregnated with a hydrocarbon oil.

Bearings of several configurations were tested while axially loaded (thrust) at about ten times normal loads; maximum hertzian stress were about 300,000 to 400,000 psi. Material combinations included titanium carbide (TiC) coating over tungsten carbide (WC) balls, titanium nitride (TiN) coating over

titanium carbide (TiC) balls, titanium carbide (TiC) coating over steel balls and steel races, and all-steel bearings.

Results were that (1) coating integrity was excellent; there were no coating failures. (2) Performance of both coated steel and coated ceramic balls, as well as coated steel balls with coated steel races, was uniformly excellent with virtually no wear, while all-steel bearings generally suffered significant wear. The hybrid bearings with ceramic ball surfaces on steel performed as well, for these conditions, as ceramic balls with ceramic coated races.

A life test program followed. With loads about three times normal bearings were run in excess of 20,000 hours in many instruments. Bearing life was extended from two to more than five times.

As a result, bearings with TiC coated balls were eventually qualified introduction gyros; and many thousands of gyros have since been delivered. In addition silicon nitride balls have been incorporated in gimbal bearings for production systems and additional applications are being considered.

To summarize: Ceramic and ceramic coated balls in steel bearings have been found to substantially improve life, reliability, and production yields in guidance system gyroscopes and gimbals while at the same time improving performance. Improved materials and processes, reduced cost, and adapting designs to ceramic properties are goals being pursued.

INTRODUCTION

- OBVIOUS ATTRIBUTES OF CERAMICS
- OTHER USEFUL ATTRIBUTES

BACKGROUND - LITTON BEARING APPLICATIONS

- INERTIAL GUIDANCE SYSTEMS
- GYROSCOPES WITH SMALL INSTRUMENT BEARINGS
- GIMBAL SYSTEMS WITH LARGER "INSTRUMENT" BEARINGS

INSTRUMENT BEARINGS

- ACCURATELY MAINTAIN THE POSITION OF A ROTATING ELEMENT
- SMOOTH RUNNING, LOW VIBRATION
- LOW, UNIFORM TORQUES
- LOW TO MODERATE LOADS
- LESS THAN 30 MM DIAMETER
- RELUBRICATION NOT APPLICABLE
- MINIMAL LUBRICANT AVAILABLE

INSTRUMENT BEARING FAILURE MODES

- METAL FATIGUE FAILURES DO NOT OCCUR
- LUBE BREAKDOWN ACCOMPANIED BY LIGHT WEAR
- PRECISION LOCATION AFFECTED
- TORQUES AFFECTED

PROGRAM TO IMPROVE GYRO BEARING PERFORMANCE IN GYRO BEARINGS

- ENTERED AN EVALUATION PROGRAM TO IDENTIFY IMPROVED MATERIALS AND OR PROCESSES
- DARPA/AFML/PROGRAM TO DEVELOP HIGH TEMP, SOLID LUBRICATED BEARINGS
- EXTENSIVE SEARCH FOUND CVD CERAMIC COATED BEARINGS IN ADVANCED STATE OF DEVELOPMENT

vugraw1

17 April 1991

EVALUATION OF MATERIALS/METHODS

- FIRST EFFORT TO USE SPUTTERED COATINGS FAILED
- CVD CERAMIC COATINGS WERE PROMISING
- TEST PROGRAM USED A STANDARD LITTON GYRO BEARING FOR A TEST VEHICLE
- BEARING TEST EQUIPMENT AND EXTENSIVE BASELINE DATA ON STANDARD BEARINGS IN PLACE

vugraw1

17 April 1991

MATERIAL COMBINATIONS TESTED

- **TITANIUM CARBIDE COATING OVER SOLID TUNGSTEN CARBIDE BALLS (TiC/WC)**
- **TITANIUM NITRIDE COATING OVER SOLID TITANIUM CARBIDE BALLS (TiN/TiC)**
- **TITANIUM CARBIDE OVER 440 STEEL BALLS (TiC/440C)**
- **440C AND 52100 STEEL RACES**
- **TITANIUM CARBIDE COATING OVER 440C RACES**

vugraw1

17 April 1991

TEST CONDITIONS AND OBJECTIVES

- **OPERATE AT EXAGGERATED STRESS LEVELS TO TEST INTEGRITY OF COATING**
- **RUN MANY MILLIONS OF CYCLES TO TEST ENDURANCE**
- **TEST FIVE TIMES LOAD, 22500 RPM, UP TO 300 HOURS, WITHOUT FAILURE**
- **LIFE TEST UP TO 20,000 HOURS**

vugraw1

17 April 1991

TEST RESULTS

- EXCELLENT PERFORMANCE OF TiC COATED STEEL BALLS
- PERFORMANCE OF THE TiC COATED STEEL BALLS ON STEEL RACES EQUALLED THAT OF SOLID CERAMICS AND TiC COATED RACE COMBINATION

vugraw1

17 April 1991

SUBSEQUENT ACTION

- EXPLORED OTHER POTENTIAL SOURCES FOR COATINGS AND CERAMICS
- INVESTIGATED MEANS OF COST REDUCTION
- BEGAN FORMAL QUALIFICATION TESTING IN GYROSCOPES
- SUCCESSFULLY INCORPORATED TiC COATED STEEL BALLS IN PRODUCTION GYROS

vugraw1

17 April 1991

RESULTS IN SYSTEMS

- LIFE IN GYROSCOPE BEARINGS IS SHOWN TO BE INCREASED FROM TWO TO FIVE TIMES
- PRODUCTION YIELDS INCREASED DRAMATICALLY
- POOR PERFORMING BEARING LOTS, ONCE COMMON, HAVE ALMOST DISAPPEARED

vugraw1

17 April 1991

SOLID CERAMIC BALLS

- BENEFITS IN EXTENDED LIFE OF BEARINGS ARE SIMILAR TO COATED BALLS
- LOW THERMAL COEFFICIENT CREATES A MISMATCH WITH MATERIALS USED IN INSTRUMENT CONSTRUCTION
- COST TO USER ARE EXPECTED TO BE SIGNIFICANTLY LOWER THAN COATED BALLS
- SiN BALLS HAVE BEEN INCORPORATED INTO GIMBAL BEARINGS WHERE DESIGN MODS COULD BE MADE
- SiN BALLS CURRENTLY ON TEST FOR A NEWER DESIGN GIMBAL-LIKE APPLICATION

vugraw1

17 April 1991

WHY HYBRID BEARINGS WORK

- DISSIMILAR MATERIALS RESIST ADHESION IN HIGH PRESSURE CONTACT, ELIMINATE ASPERITY WELDING AND ADHESIVE WEAR
- REDUCED HEAT, ABSENCE OF FRESH, NASCENT STEEL WEAR PARTICLES REDUCES LUBRICANT BREAKDOWN RATES
- HARD, SMOOTH FINISHES RESIST WEAR, REDUCE FRICTION

vugraw1

17 April 1991

SUMMARY

- CERAMICS, IN HYBRID STEEL BEARINGS CAN PROVIDE SPECTACULAR LIFE AND RELIABILITY IMPROVEMENTS IN ORDINARY ENVIRONMENTS
- THE DEVELOPMENT OF SOURCES FOR MATERIALS, COATING METHODS AND ALTERNATIVES MATERIALS AND PROCESSES ARE IMPORTANT GOALS.

vugraw1

17 April 1991

High-Temperature Applications and Challenges of Ceramic Bearings

Lewis B. Sibley
Tribology Systems, Inc.,
Paoli, PA 19301

Application of silicon nitride to ball and roller bearings is reviewed, including recent developments of unique self-contained solid-lubricant systems for use over wide temperature ranges. New ceramic materials developments for bearings with improved ductility over current monolithic silicon nitrides are described. Building on early experience with special bearings for nuclear reactors, turbomachines and adiabatic diesel engines, a methodology for computer modelling of solid-lubricated ceramic bearings is used in the design of reliable, integral, long-life systems for new critical applications. An interdisciplinary team has been organized to provide the synergy of materials and bearing technologies needed to meet the most demanding design objective.

Tribology Systems, Inc. (TSI) is in the process of significantly extending the state-of-the-art in the design of solid-lubricated all-steel and ceramic bearings. TSI is working in four critical areas in this regard. First is the recent availability (enhanced under subcontract from TSI) of the PKG, Inc.'s ADORE dynamic bearing analysis computer program. Second is the USAF-funded development of advanced new-generation solid lubricants by TSI. Third is the TSI-developed, self-contained, internal lubricant replenishment system. Last is the TSI temperature-compensating bearing/shaft/housing mounting system for all-ceramic bearings.

By using this modern computer dynamic analysis, the motions and forces of all the elements in a bearing are computed in very small time steps to establish the basic dynamic stability of the bearing and the equilibrium balance of wear rates of the solid-lube films and other wearing parts in the bearing. The dynamic analysis is uniquely suited for solid lubrication, compared to the classical computer quasi-static analyses used in the past for bearing engineering in the industry, which with conventional cut-and-try methods, occasionally (and unpredictably) result in catastrophic failures of solid-lubricated bearings. Dynamic analyses of conventional bearing designs at typical high-speed operating conditions with solid lubrication do not reach equilibrium but predict excessive wear and increase in friction sometimes sufficient to cause the seizure of current-design bearings. Stable operation is predicted by using a unique (patent pending) lube-ring design and bearing internal geometry together with solid-lube materials in the pockets and lands and coatings on the balls or rollers and races having the right balance of friction and wear properties.

Greatly improved compositions of solid-lubricant materials and engineering ceramics have been identified for operation at high temperatures and both low and high speeds in bearings of these special designs. Also, a unique proprietary method of mounting all-ceramic inner and outer bearing rings on the metal shaft and housing structures having several times the thermal expansivity of the ceramic has been developed. Metal compensator rings pressed onto the shaft and in the housing have tapered faces contacting the ceramic bearing rings designed

so that the bearing mounting clamp forces do not vary with the large temperature changes expected in high-performance machines.

HIGH-TEMPERATURE APPLICATIONS AND CHALLENGES OF CERAMIC BEARINGS

by

Lew Sibley

Presented at

NIST/DARPA CERAMIC BEARING TECHNOLOGY WORKSHOP

April 17, 1991

Rockville, MD



Telephone (215) 889-9088

BREAKTHRU IN LONG-LIFE SELF-LUBE BALL AND ROLLER BEARINGS

TRIBOLOGY SYSTEMS, INC.

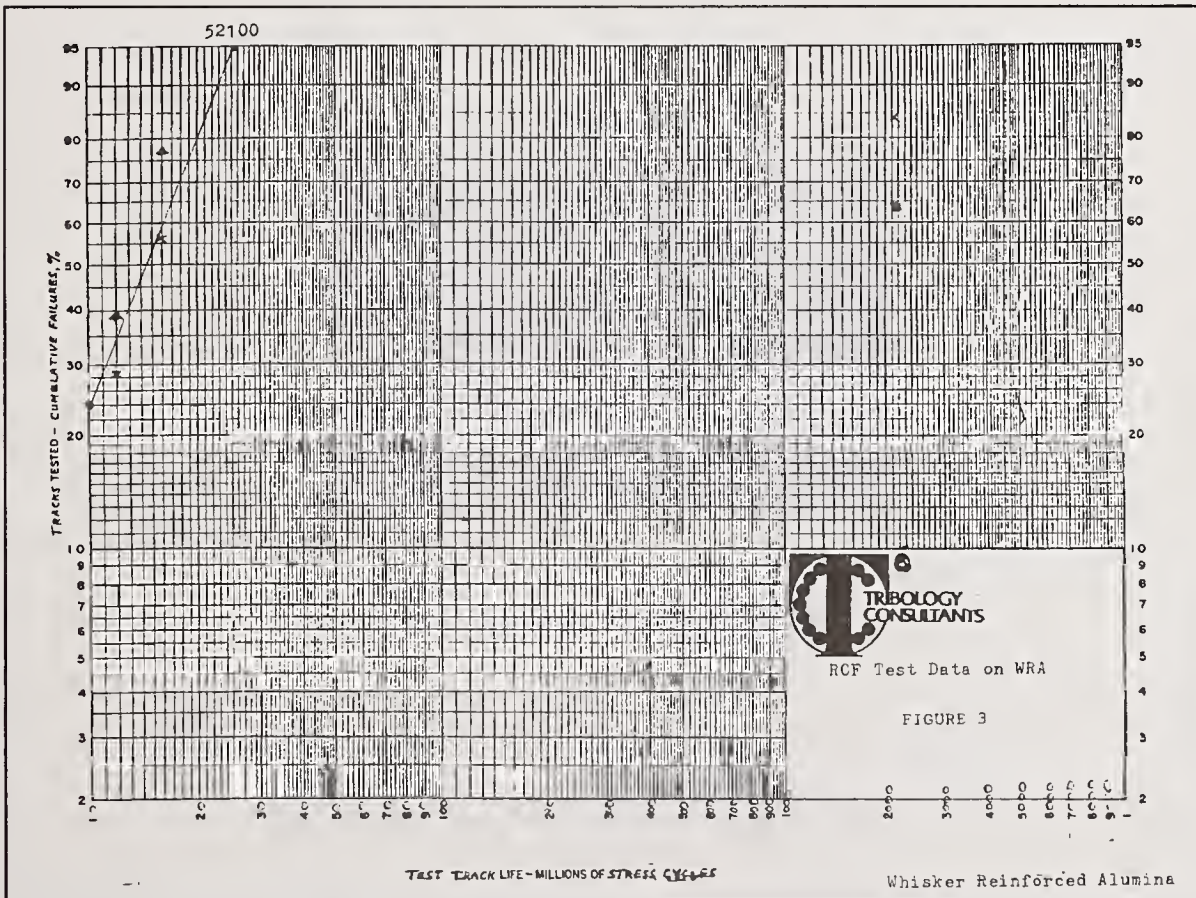
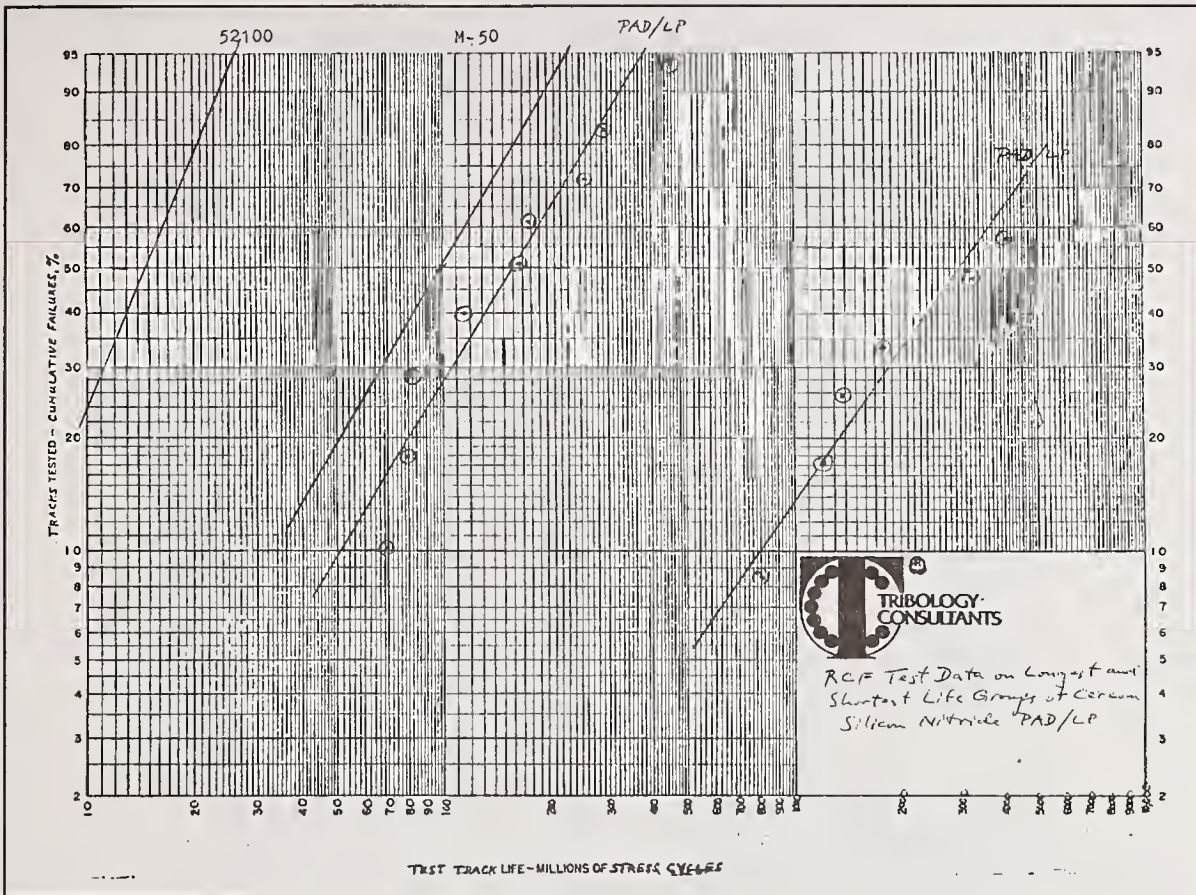
PAOLI, PA

CERAMIC BEARINGS - A TECHNOLOGY WHOSE TIME HAS COME

- NO RUST
- THREE TIMES AS HARD AS BEARING STEEL
- THREE TIMES THE TEMPERATURE LIMIT OF STEELS
- SIXTY PERCENT LIGHTER THAN STEEL
- EASIER TO LUBRICATE (DOESN'T GALL)

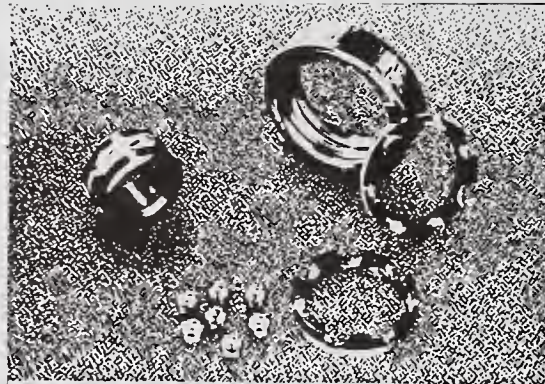
SOLID LUBRICANTS - BETTER MATERIALS AND DESIGNS

- FOUR TIMES THE TEMPERATURE LIMIT OF OILS
- FORM TRANSFER FILMS IN BEARINGS FOR REPLENISHMENT
- INTERACTIONS WITH BEARING DYNAMICS CLARIFIED



CERAMIC ELEMENT BEARING ENDURANCE TESTING

TEST NO.	RUNNING TIMES (HR)		BEARING S/N		REMARKS
	TEST	TOTAL AT SUSPENSION	#1	#2	
1	813	813	07	11	CAGES FAILED
2	1019		06	02	#2 CAGE FAILED
2A	3	1022	06	02	VISCOSEALS FAILED, O.O.R. BALLS
3			06	11	VISCOSEALS FAILED
SKF PERF.			03		
SOLAR PERF.	12 (33)		10	03	
4			10	03	ROTOR DYNAMICS, #1 HIGH ΔT
4A	295	307	10	03	DRIVE FAILURE
GRAND TOTAL		4284	[AGGREGATE, ON (6) BEARINGS]		



From Taylor, K. M., Sibley, L. B., and Lawrence, J. C.,
"Development of a Ceramic Rolling Contact Bearing
for High-Temperature Use," *Wear*, 6, (3),
226-40 (1963).

Figure 1. Special Solid Lubricated 204 Size Ceramic Ball Bearing
After 12 Hours Operation at 1500 F and 8000 RPM under
300,000 psi Contact Stress

DYNAMIC MEASUREMENTS OF SOLID-LUBRICATED CERAMIC CONTACTS

- SPECIAL TEST RIG CLOSELY SIMULATES BEARINGS
IN HIGH-PERFORMANCE MACHINES
- BOTH HIGH SPEEDS (20,000 FPM) AND TEMPERATURES (1500F)
- IMPACT FRICTION MEASUREMENTS OF SOLID-LUBE CAGE POCKETS
- TRACTION MEASUREMENTS OF CERAMIC BEARING CONTACTS

COMPUTER SIMULATIONS OF BEARING DYNAMICS

- USING TEST RIG DATA TO DESIGN SELF-LUBE BEARINGS
- BALANCE INTERNAL GEOMETRY AGAINST SOLID LUBE FILM WEAR
- RESULTS IN STABLE BEARING OPERATION OVER LONG LIFE
- BEARING CARTRIDGE DESIGNED FOR DIRECT MOUNTING IN
MACHINES

FAILURE MODES OF TRIBOLOGICAL ELEMENTS

- SPALLING FATIGUE AT DESIGN LIFE
- LUBRICATION DISTRESS & CHEMICALLY REACTIVE BOUNDARY FILMS
- EXCESSIVE PARASITIC LOADS & DEBRIS DENT INITIATED SPALLS
- SMEARING OR SCUFFING UNDER SEVERE SLIDING
- SKID DAMAGE FROM INERTIAL LOADS
- HIGH SPEED LUBRICANT STARVATION
- CORROSION, OVERHEATING AND LUBRICANT INCOMPATIBILITY
- FAIL-SAFE VIBRATION VERSUS CATASTROPHIC SEIZURE

Computer Modeling of Rolling Bearings

Practical Significance of the Quasi-Static and Dynamic Models

Quasi-Static Models

Overall load distribution
 Contact stresses
 Nominal lubricant film thickness
 Fatigue life
 Bearing stiffness

Dynamic Models

Cage instability
 Rolling element skid and skew
 Lubrication effects
 Wear modeling
 Bearing heat generation
 Applied bearing torques
 Dynamic applied loads
 Irregular bearing geometry
 Optimization of manufacturing tolerances
 Bearing noise

PKG Inc

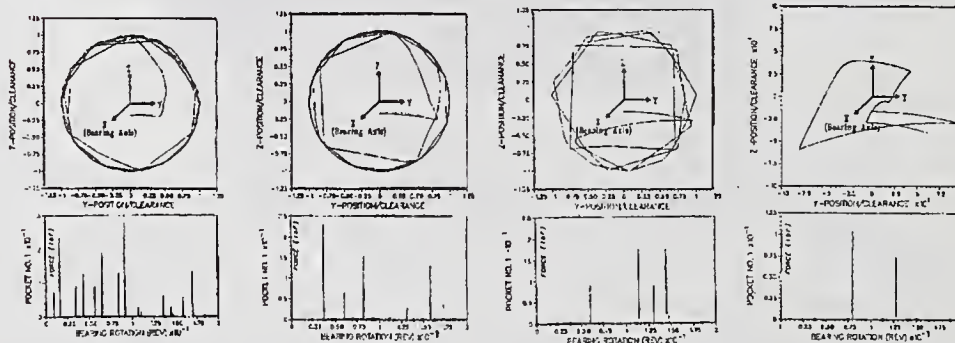
ADORE Advanced Dynamics Of Rolling Elements

PKG Inc

Presented by Lewis B. Sibley - 1990 STLE Annual Meeting, 7-10 May 1990, Denver, Colorado

EXAMPLE

Cage Pocket Clearance Optimization in a High-Speed Solid-Lubricated Roller Bearing
 Guide Land Clearance = 0.015 in



Poc Clearance = 0.005 in

Poc Clearance = 0.010 in

Poc Clearance = 0.015 in

Poc Clearance = 0.020 in

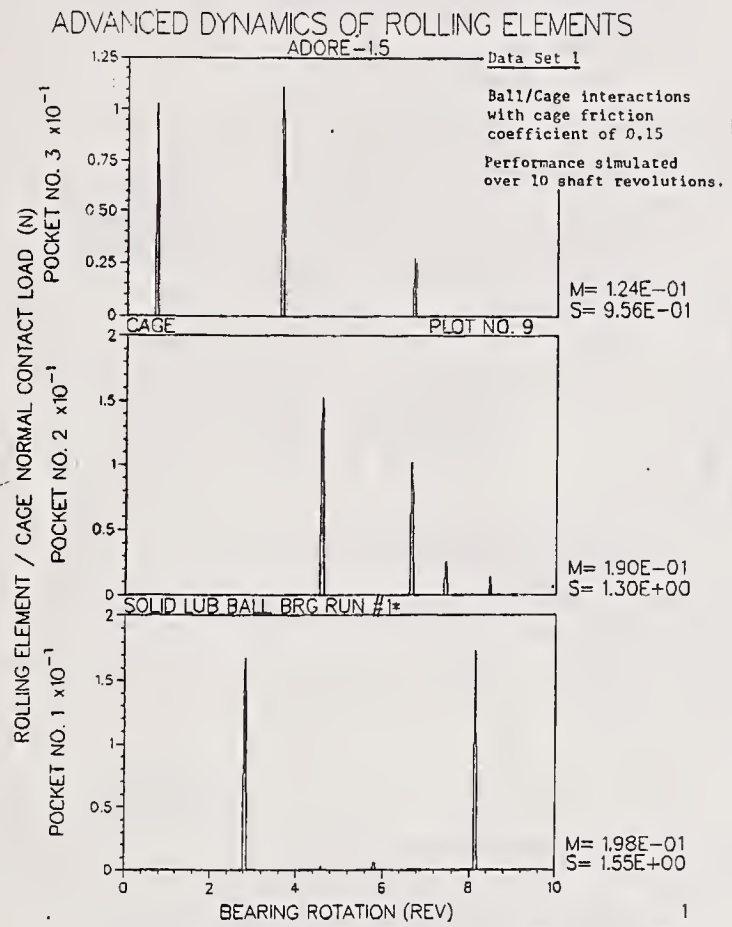


Figure 4. ADORE Computer Simulated Plots of Solid Lubricated Ball/Cage Impact Loads

ADVANCED DYNAMICS OF ROLLING ELEMENTS

ADORE-1.5

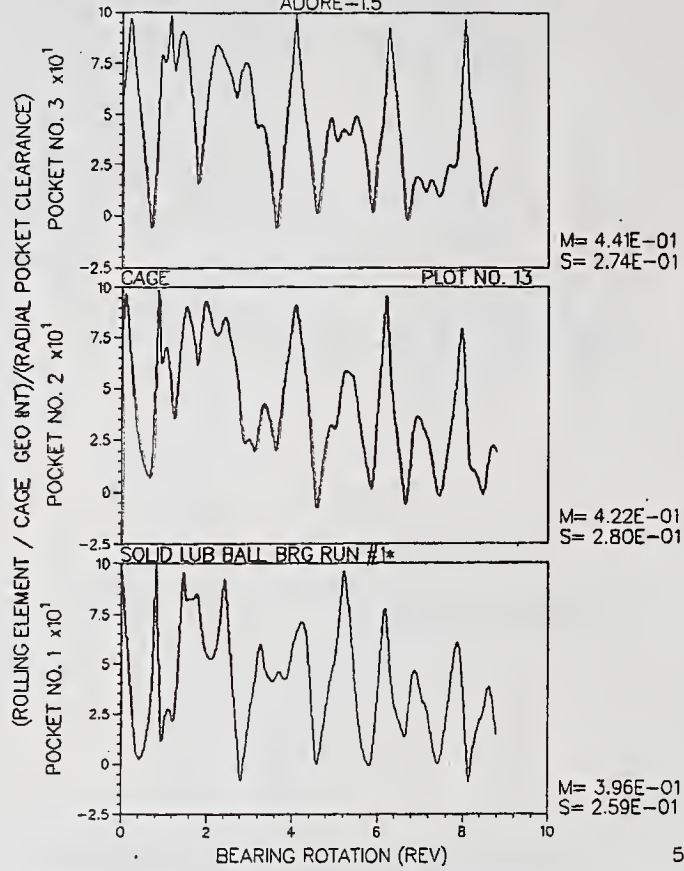
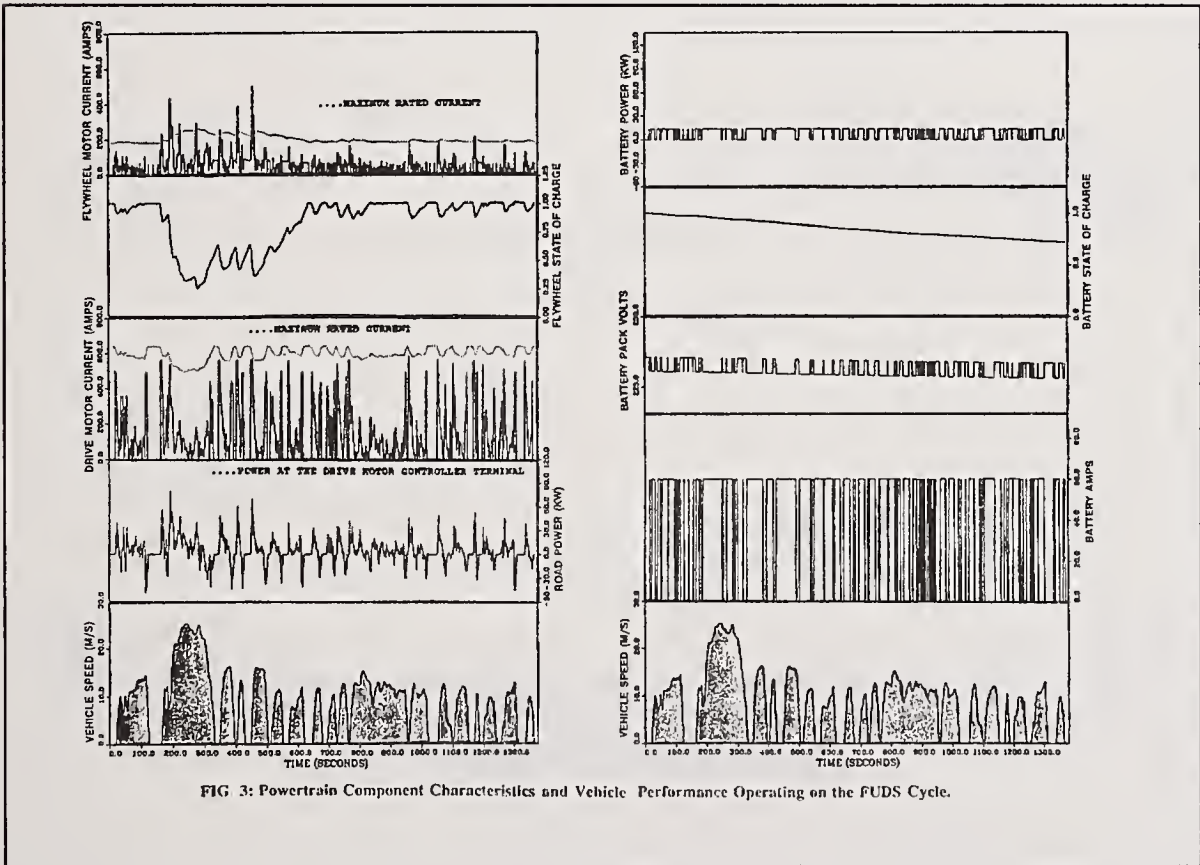
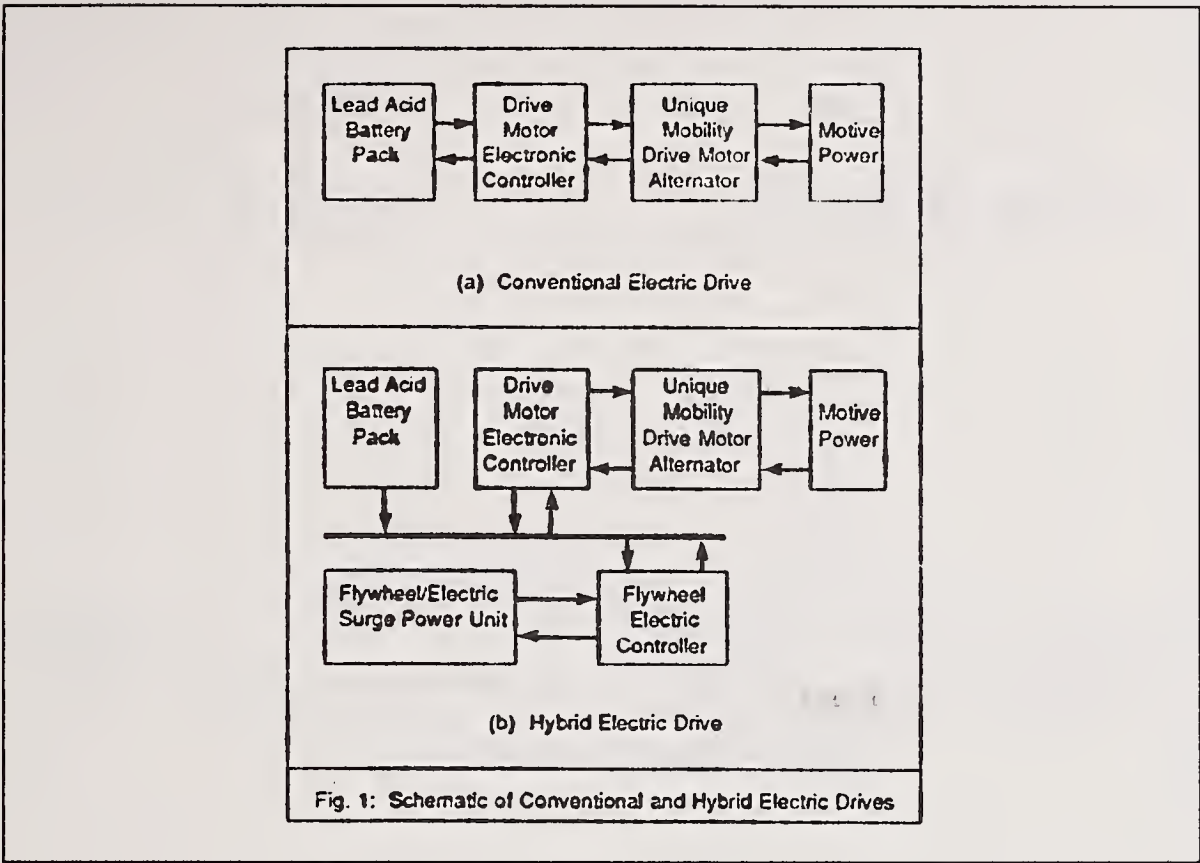


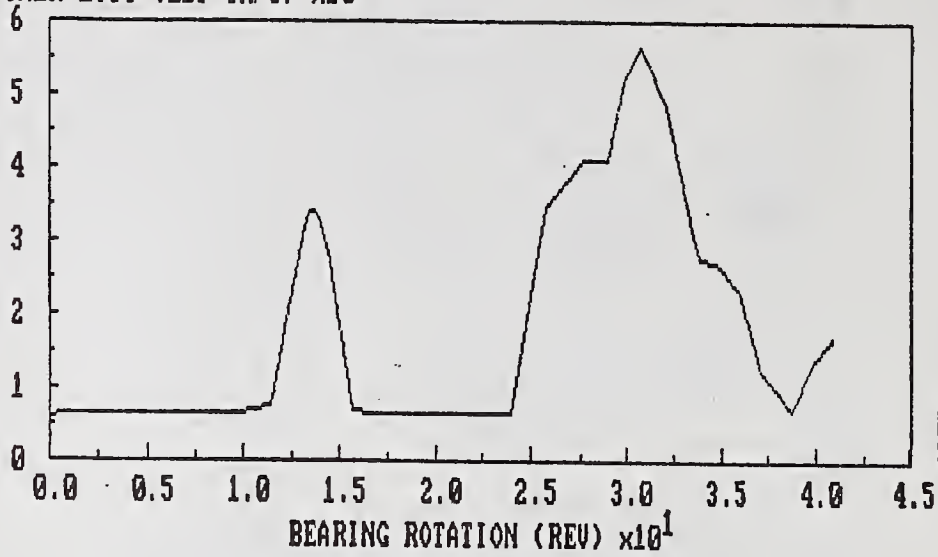
Figure 5. ADORE Computer Simulated Plots of Solid Lubricated Ball/Cage Relative Motions Producing Impacts in Fig. 4



UNIQ 206

PLOT NO. 1A

POWER LOSS (LBF*IN/S) $\times 10^{-3}$



M= 1.82E+03
S= 1.50E+03

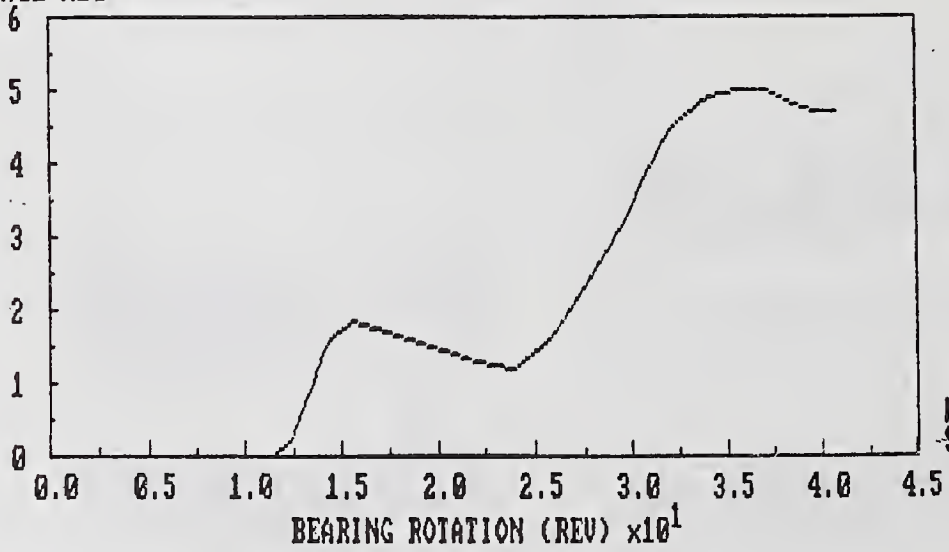
1A

UNIQ 206

PLOT NO. 3C

TIME AVERAGE WEAR RATES (IN**3/S)

CAGE $\times 10^7$



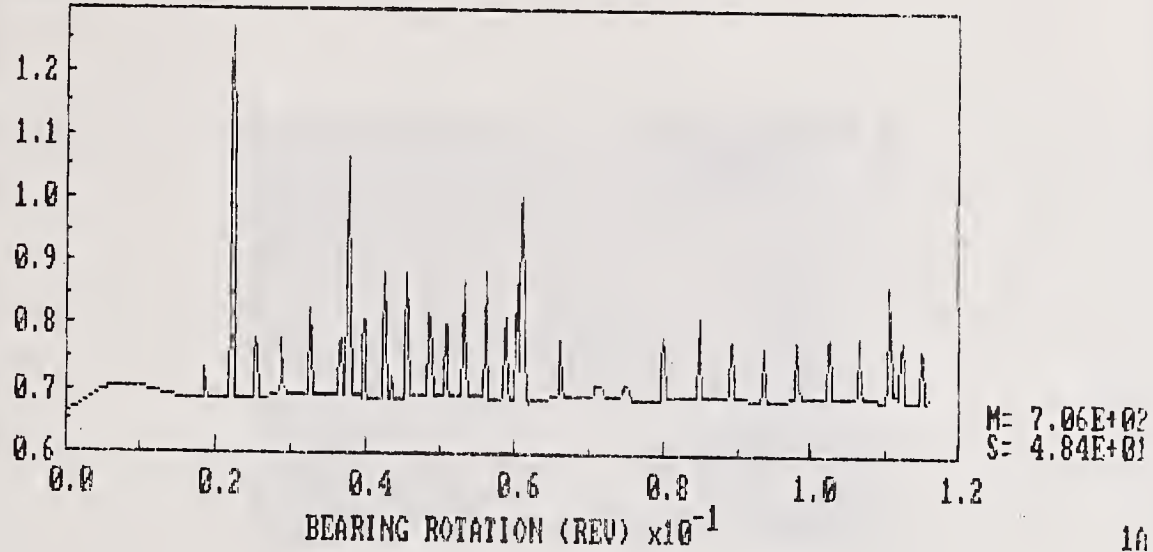
M= 1.98E-07
S= 1.84E-07

3C

UNIQ 206

PLOT NO. 1A

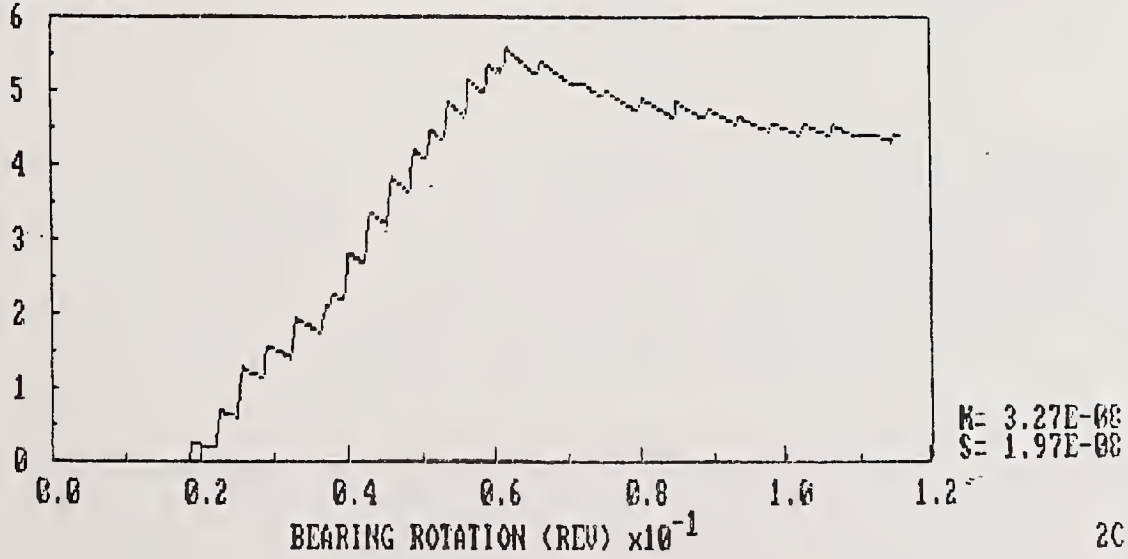
POWER LOSS (LBF*IN/S) $\times 10^{-3}$



1A

UNIQ 206
TIME AVERAGE WEAR RATES (IN**3/S)
CAGE $\times 10^{11}$

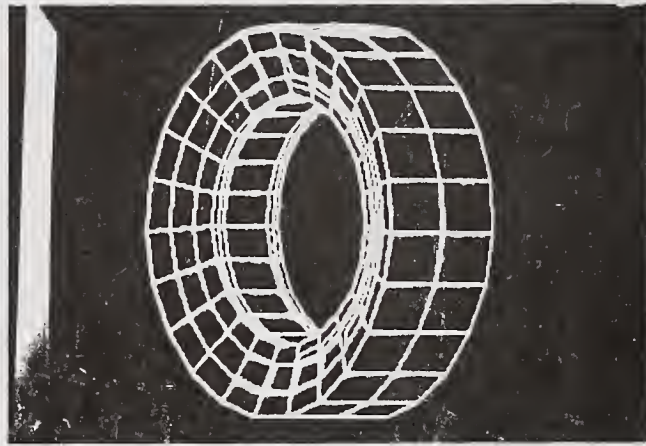
PLOT NO. 3C



2C

FEA Model of

Ceramic Bearing Inner Ring



Effects of Composition, Microstructure, and Processing on Ceramic
Rolling Element Bearing Performance

R. Nathan Katz
Worcester Polytechnic Institute
Worcester, MA 01609

Ceramic rolling element bearings provide properties which can enhance the performance of many systems. During the past decade ceramic rolling element bearings (CREB's) have been commercially applied in several niche markets ranging from machine tool spindle bearings to North Sea oil well pump bearings. However, further exploitation of these bearings, particularly in very high performance military applications such as aircraft engine mainshaft bearings, will require simultaneous reductions in cost and improvements in reliability. In accomplishing these goals, understanding of the role of composition, microstructure and processing is essential. It will be seen that the available literature documenting the effect of these three variables on bearing performance is extremely limited. In fact there is no documentation of any studies where composition, microstructure or processing have been independently varied and bearing performance measured. Trends discussed in this paper will therefore be inferred or suggested based on what literature is available.

In defining the role of composition on the performance of CREB's there are two levels to consider; differences between compositional "families" of ceramics (i.e., zirconia versus silicon carbide versus silicon nitride), and differences within a single "family" (i.e., silicon nitride with 1 % MgO versus silicon nitride with 4 % yttria). While it is "well known" that fully dense silicon nitrides are superior to other ceramic rolling elements, there is remarkably scant documentation in the literature. McLaughlin [1] performed comparative rolling contact fatigue (RCF) tests on several grades of silicon nitride, silicon carbide, and a transformation toughened zirconia, all at a Hertz stress of 860,000 psi. The zirconia and HIP silicon carbide were both found to have average RCF lives 2 to 3 orders of magnitude less than any of the silicon nitrides.

There have been no documented, systematic studies of the effect of compositional variations within a given material family (i.e., silicon nitride with starting powder, processing parameters, grain size, etc. held constant but type and percent of densification aid varied). However, several studies exist where several different silicon nitrides were tested in an identical manner. These studies (for example the data of Lucek [2]) tend to suggest that the less additive the better the RCF behavior of silicon nitride.

Detailed descriptions of microstructural variables such as grain size, morphology, phase content and distribution, porosity, etc., are universally lacking in the literature documenting RCF or bearing test results. A paper presented by Mandler and Musolff [3] suggests that porosity is a key microstructural variable in the RCF of silicon nitride. Available data can be interpreted to suggest that the influence of the differing percentages and compositions of densification aid is a result of differing type and percent of

grain boundary glass phase.

The influence of processing is clearer. Lucek [2], has demonstrated dramatic improvements in RCF performance of silicon nitride with 1% MgO, as one changes process from hot pressing to HIP'ing to HIP'ing low WC content powder.

One reason for the lack of systematic studies of the effects of compositional, microstructural, and processing variables is the difficulty of holding any of these constant as the others are varied. Thus, an alternative strategy to address the influence of basic material parameters on bearing performance is required. Taking into account that the failure mode of silicon nitride in RCF is spall formation, if one could identify the materials properties related to the formation of the spall, one could design microstructures for optimized bearing performance. Such an alternate strategy will be presented.

In summary, based on the limited available studies it would appear that a silicon nitride optimized for bearing application would be HIP'ed, have minimal grain boundary phases, minimal porosity, and a minimal inclusion content. Influences of such features as grain size, L/D, effect of additive chemistry, and alpha/beta phase ratios require investigation.

References

- [1] J. J. McLaughlin, "Alternate Ceramic Roller Bearing Program" Final Report, Contract N00019-81-C-0284, November 1983.
- [2] J. W. Lucek, "Rolling Wear of Silicon Nitride Bearing Materials," ASME Paper No. 90-GT-165, June 1990.
- [3] W. F. Mandler and C. F. Musolff, "Rolling Contact Fatigue Testing of Silicon Nitride," Paper No. 85-C-86, presented at Am. Ceram. Soc. Annual Meeting, Chicago, March 1986.

**Role of
Composition, Microstructure and Processing
on the
Performance of Ceramic Rolling Element Bearings**

**R. Nathan Katz
Worcester Polytechnic Institute**

**Presented at NIST
17 April 1991**

- **Ceramic Rolling Element Bearings Have Demonstrated Unique Capabilities for Several Niche Applications and Have Considerable Promise In Many More Areas**
- **To Broaden Their Applications Base We Must Find Ways to ↓ Cost and ↑ Reliability**
- **What Is The Role of Compositional, Microstructural and Process Variables In Attaining The Above Goal?**

DESIRED PROPERTIES FOR BEARING MATERIALS

Fracture Toughness, K_{Ic}	High	$> 5 \text{ MN m}^{-3/2}$
Hardness	High	$> 1200 \text{ kg mm}^{-2}$
Elastic Modulus	Low	$< 210 \text{ GPa}$
Density	Low	$< 4 \text{ Mg m}^{-3}$
Bend Strength	High	$> 700 \text{ MPa}$
Corrosion Resistance	High	-
Upper Use Temperature	High	$> 800^\circ\text{C}$
Failure Mode	"Steel-Like" Spallation	Small Spalls

PROPERTIES OF HIGH PERFORMANCE STRUCTURAL CERAMICS VERSUS M-50 STEEL

Property	Silicon Nitride	Silicon Carbide	Alumina	Zirconia	M-50 Steel
Description	HIP'ed NBD-200	Sintered	Fully Dense Sintered	Sintered Transformation-Toughened	Wrought Ingot
Fracture Toughness, K_{Ic} /MN m ^{-3/2}	5-6	4	5	8-10	12-16
Hardness, H /kg mm ⁻²	~1800-2000	~2800	~2000	~1300	~800
Elastic Modulus, E /GPa	310	410	385	205	210
Density, ρ /Mg m ⁻³	3.2	3.1	4	5.6	8
Modulus of Rupture /MPa	750	450	550	600-900	NA
Corrosion Resistance	High	High	High	High	Moderate
Upper Use Temperature /°C	1100	1400	1000+	800-900	325
Failure Mode	Spalling	Fracture	Fracture	Spalling	Spalling

COMPOSITION

- One "Family" of High Performance Ceramics vs. Another (i.e. Si_3N_4 vs. SiC)
- Compositional Variations Within A Given Family

- No Studies Of The Effect of Composition on Rolling Contact Bearing Performance
 - i.e No Studies Where:
 - . Grain Size
 - . Process Method
 - . Grain MorphologyWere Kept Constant and Composition Varied
- Similarly No Studies Where Microstructure Was Systematically Varied
- Experience in the Development NC 132 → NBD 100 → NBD 200 Provides Some Information on the Effect Processing

Comparison of the RCF Behavior of Several Ceramics

Material	Ave Cycles to Failure	Failure Mode
Si ₃ N ₄ - NC-132 (1%MgO)	6.9 X 10 ⁷	"small" spalls
Si ₃ N ₄ - Sintered & HIP (Y ₂ O ₃ + Al ₂ O ₃)	1.5 X 10 ⁵	"line" spalls
PSZ (ZrO ₂)	1.6 X 10 ⁴	"large" spalls
SiC - HIP	1.3 X 10 ⁴	"large, line" spalls
Si ₃ N ₄ - Sintered & HIP (AY4)	1.0 X 10 ⁷	no spalls on rod (ball spalls)
Si ₃ N ₄ - HIP (1% MgO)	6.9 X 10 ⁷	"small" spalls

- Hertz Stress = 860,000 psi
- Materials of varying processes and developmental maturities

Source: J.J. McLaughlin

Effect of Composition on Si₃N₄ Rolling Element Bearings

Material	Process	H (GPa)	L ₁₀ (10 ⁶ cyc)	Weibull m	Wear (m ³ *10 ⁻¹⁰)
7% Y ₂ O ₃ + 5% Al ₂ O ₃ (SIALON)	Sintered	13.5	1.66	1.09	~ 1.6
5% Y ₂ O ₃ + 2% Al ₂ O ₃	Sintered & HIP	15.6	3.36	1.39	~ 0.25
1% MgO	Hot Pressed	16.4	0.58	0.59	~ 0.1
1% MgO	HIP (low WC)	16.5	> 10.1	2.03	< 0.1

- All RCF Tests @ 6.4 GPa
- No Information on Grain Size, Morphology Starting Powder, etc.
- Wear Measured @ 200 km Element Travel

Source: J. Lucek

RCF Evaluation of Three Si₃N₄ Materials

Material	Hertz (Ksi)	Weibull Parameters			Porosity	
		B ₁₀ ⁺	B ₅₀ ⁺	m	Peak	Max
M-50 steel	797	3.4	11.6	1.55	-	-
NC-132	893	74.5	109.6	4.88	2-3 μm	6-7 μm
SN-A	500	1.23	3.09	2.04	6-7 μm	6-7 μm
SN-B	507	0.007	0.14	0.63	2-4 μm	35+ μm

- Materials A & B - Sintered Si₃N₄, no other data provided
- + = X10⁶ stress cycles

Source: W.F. Mandler & C.F. Mosloff
 Cummins Engine Co.
 Presented @ 88th Annual Meeting
 of the American Ceramic Society
 Paper 85-C-86 (1986)

Effect of Processing on RCF of Si₃N₄ with 1% MgO

Process	H (GPa)	L ₁₀ (10 ⁶ cycles)	Weibull m
Hot Pressed	16.4	4.08	0.59
HIP	16.4	4.08	1.26
HIP (low W.C.)	16.5	> 10.1	2.03

- Grain Size ≈ constant, but in H.P. is anisotropic
- All tests at 6.4 GPa

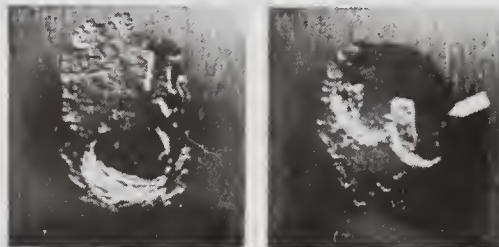
Source: J. Lucek
 ASME 90-GT-165
 (June, 1990)

TABLE 1
Rolling Four-ball Fatigue Life Test Data on 17.5mm CVM M-50 Steel and Silicon Nitride Balls Finished by Various Methods

Spindle ball	Spindle speed /rpm	Max. Hertz stress /GPa (ksi)	No. of CVM M-50 steel support ball set failures	Test life /10 ⁶ revs	Spindle ball condition after test
M-50	5200	4.7 (680)	0	20.2	Spalled
			0	3.2	Spalled
			1	26.0	Spalled
			0	11.0	Spalled
			0	7.1	Spalled
			0	11.7	Spalled
As-received silicon nitride (NC-132)	10000	5.5 (800)	2	117.3	Spalled
			1	12.0	Spalled
			0	66.6	Spalled
			0	24.6	Spalled
			1	41.5	Spalled
			2	18.3	Spalled
Diamond lapped silicon nitride (NC-132)	10000	5.5 (800)	1	190.8	Intact
			1	183.6	Intact
			3	183.0	Intact
			1	182.4	Intact
			3	102.0	Spalled
			3	183.6	Intact

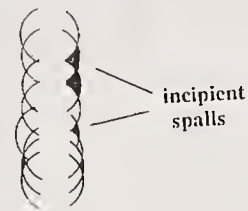
THE KEY PROPERTY OF FULLY DENSE Si₃N₄ FOR BEARINGS

**THE FAILURE MODE - SPALL FORMATION
NOT CATASTROPHIC FAILURE
THIS IS THE SAME FAILURE MODE AS HIGH-PERFORMANCE BEARING STEELS**



Mechanism Of Failure For Si_3N_4 In RCF

- Tensile Stress at the Boundary of the Wear Track → Circumferential Cracks @ Edge of Wear Track Just Beyond the Contact Ellipse



- These Cracks Grow Slowly Until a Spall Forms - Due to Crack Linkage and Elimination of Unfractured Area Beneath the Spall

Crack Growth Mechanisms That Could Affect RCF Performance

- Static Fatigue
Nature and Composition of Grain Boundary Phases
- Mechanical Fatigue
Grain Size, Grain Morphology, Grain Boundary Phase Composition and Nature, Stress Amplitude
- Thermal Fatigue
Thermal Physical Properties, Strength Determining Micro-Structural Features
- Stress Induced Phased Transformations
May be Important for Transformation Toughened Materials

Factors Expected to Influence Wear of Ceramics in RCF

- Hardness and Fracture Toughness
(i.e.

$$\text{Wear} \propto \frac{\text{Load}^Q}{K_{Ic}^m \cdot H_v^n} \cdot (E/H_v)^P \cdot \text{Distance}$$

where: m & n \approx 0.5
Q & P \approx 0.8 - 1.2)

- Surface Chemistry - Tribochemical Wear
(i.e. SiO₂ Formation)
- Surface Quality, Voids, Defects, etc.

Suggested Strategy to Predict RCF Behavior

Since in Most Ceramics it is Difficult if not Impossible to Independently Vary Grain Size, Morphology, Composition and Processing:

- Evaluate: Mechanical Fatigue
Static Fatigue
Wear
Etc.
for Candidate Bearing Ceramics
- Correlate These Results with RCF Performance
- If Correlations Exist, Use These Laboratory Tests as Prediction Tests and in Materials Optimization Studies

Effects of Machining and Finishing on Performance

Michael N. Gardos
Hughes Aircraft Company
El Segundo, CA 90245

and

Julian R. Pratt
Spheric Ltd.
W. Sussex, England

Technical Issues of Precision HIP-Si₃N₄ Ball Polishing

For the first time in the history of tribology, production ball grinding and polishing apparatus were used as tribometers. The volume attrition rates of near net-shape ceramic balls and the sphericity of the final bearing balls were used to examine the premises that (a) only homogeneous Si₃N₄, with isotropic structural integrity, can be converted into precision balls, and (b) the abrasive (polishing) wear resistance of the ceramics are inversely proportional to their respective ($K_{Ic}^{0.75} \times H_v^{0.5}$) factors (the Evans-Wilshaw wear relationship). Under the auspices of the 1986-1990 DARPA/Hughes Tribological Fundamentals of Solid Lubricated Ceramics Program (Part I),* Spheric Ltd. ground and polished one hot-pressed (HP) and five hot-isostatically pressed (HIP) Si₃N₄ ceramics into 0.5 in. dia bearing balls under identical preparatory conditions, after having determined the hardness and fracture toughness of the ball stocks by Vickers indentation and the crack-tip-extended-indentation-indicated K_{Ic} measurements. The removal rates of the respective ceramics were periodically monitored until the desired ball diameter was reached. The log of the volumetric wear rates (y) were then plotted as a function of each $x = (K_{Ic}^{0.75} \times H_v^{0.5})^{-1}$, with a high correlation coefficient of 0.99.

The data confirmed both hypotheses: (a) only isotropic HIP-Si₃N₄ can be polished into precision-spherical bearing balls, and (b) the Evans-Wilshaw wear factor is an excellent predictor of the abrasive (polishing) wear of the ball ceramics. Some of the end-products are slated for hybrid bearing tests in LOX applications.

Socio-Political and Economic Issues Controlling the Technology Insertion of Ceramic Balls in Hybrid Bearings

In spite of the extensive data-base showing (a) the commercial availability of at least one highly reproducible, excellent quality near-net shape ball stock

* M. N. Gardos, "Determination of the Tribological Fundamentals of Solid Lubricated Ceramics, Volume 1: Summary; Volumes 2 and 3: Appendices," WRDC-TR-90-4096, Hughes Aircraft Company, El Segundo, CA, November 1990 (in press).

fabricated from HIP-Si₃N₄ and (b) the ability to turn the spherical preforms into super-high-grade, low wear rate ceramic balls, a firm capable of producing such balls is facing the following major obstacles of technology insertion:

- There is no standard ceramic material (or materials) everyone agrees upon;
- There is no standard ball-polishing process (ceramic ball fabrication is more an art than a science);
- The bearing industry is conservative with no vision (it has no wish to change, i.e., to use anything but all-steel bearings);
- One must find a progressive technologist at each bearing manufacturer to champion the cause of precision hybrid bearings (ceramic balls with steel races);
- Not everyone needs a Grade 1 (ultrahigh precision) ball (every bearing customer may need ceramic balls conforming to different specifications).

Once the industry recognizes the almost unlimited potential of hybrid bearings, in time HIP-Si₃N₄ balls and steel races will replace 50 or 60 percent of all-steel bearings currently in use.

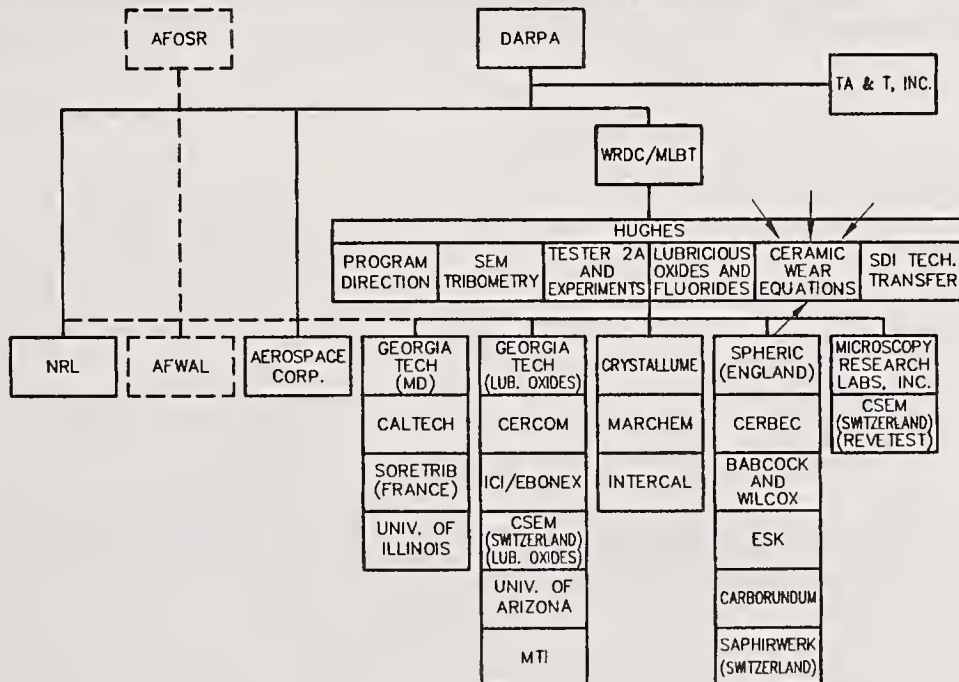
EFFECTS OF MACHINING AND FINISHING
 ON PERFORMANCE

MIKE GARDOS (HUGHES)

AND

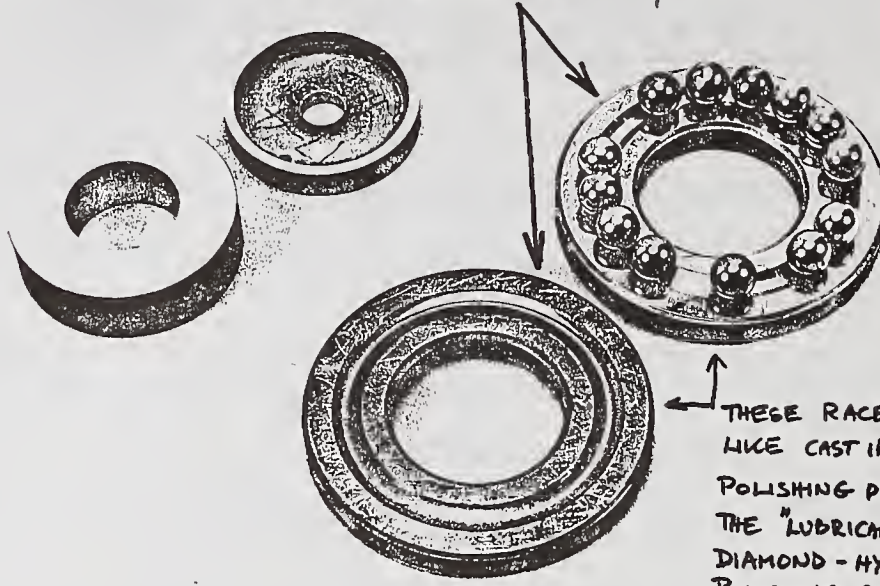
JULIAN PRATT (SPHERIC)

SPHERIC'S ROLE IN THE
 DARPA/HUGHES "FUNDAMENTALS" PROGRAM



THIS IS A THRUST BEARING, BUT THIS IS ALSO HOW
BALLS ARE POLISHED!!!

3



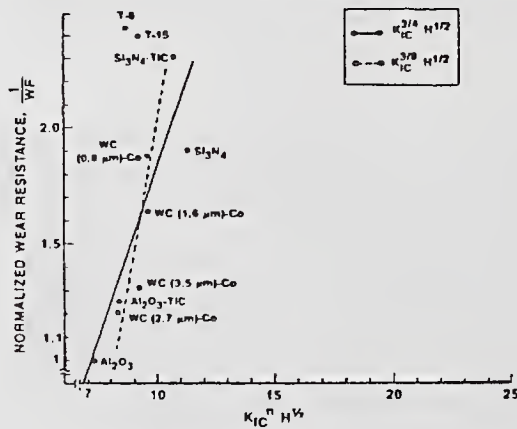
THESE RACES ARE
LIKE CAST IRON/BRONZE
POLISHING PLATES, AND
THE "LUBRICANT" IS THE
DIAMOND - HYDROCARBON
POLISHING SLURRY.

1 2 3

WEAR OF CERAMICS AS FUNCTIONS
OF K_{Ic} AND H
(THEORY AND LITERATURE DATA)

HUGHES

4



Evans & Wilshaw, Acta Metall., 24, 1976:

$$V_{wear} \propto \frac{1}{K_{Ic}^{3/4} \cdot H^{1/2}} \sum_{i=1}^{i=N} P^{5/4} \cdot d$$

- V = WEAR VOLUME;
- K_{Ic} = FRACTURE TOUGHNESS;
- H = HARDNESS;
- P = NORMAL LOAD;
- N = NO. OF ABRASIVE PARTICLES;
- d = SLIDING DISTANCE.

Fig. 7—Wear resistance of the tested materials plotted as a function of $K_{Ic}^{3/4} H^{1/2}$ (closed data points) or $K_{Ic}^{3/4} H^{1/2}$ (open data points).
[Baldoni, et al, ASLE Trans., 29, p.347, 1986]

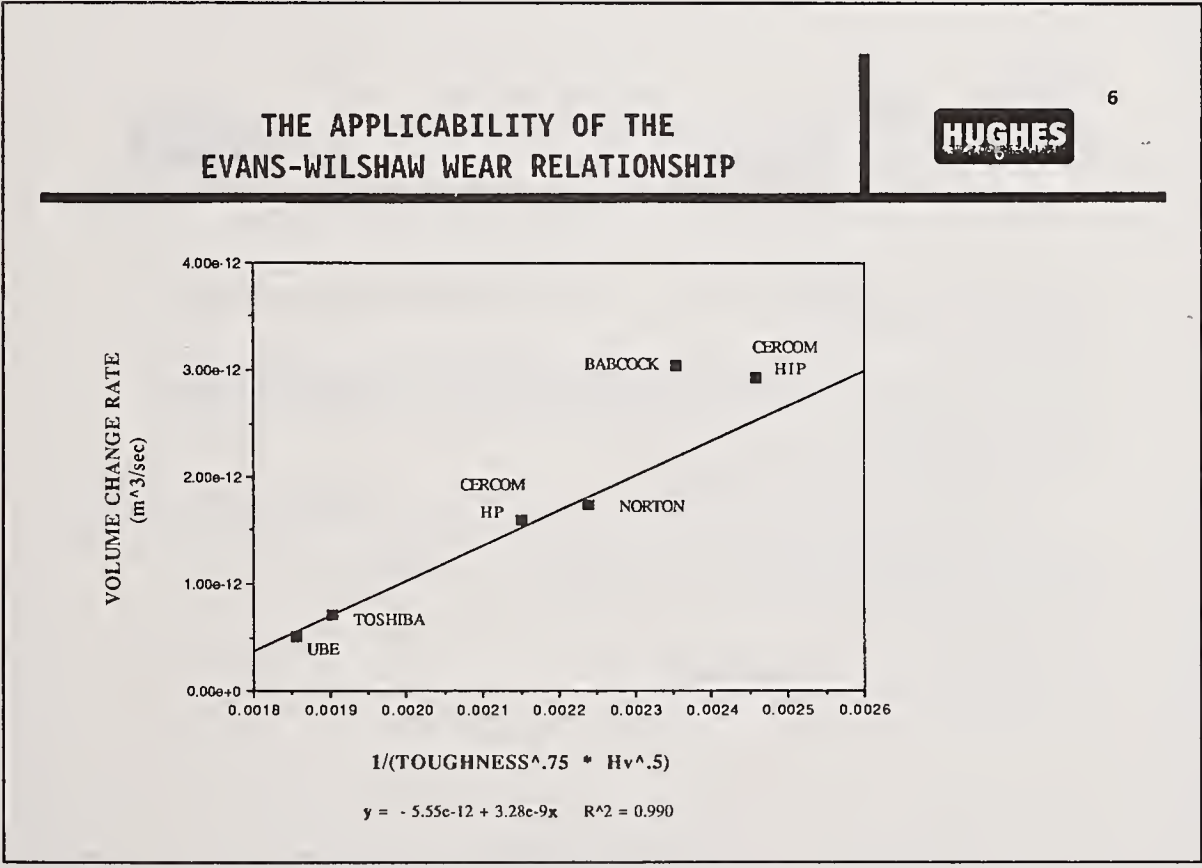
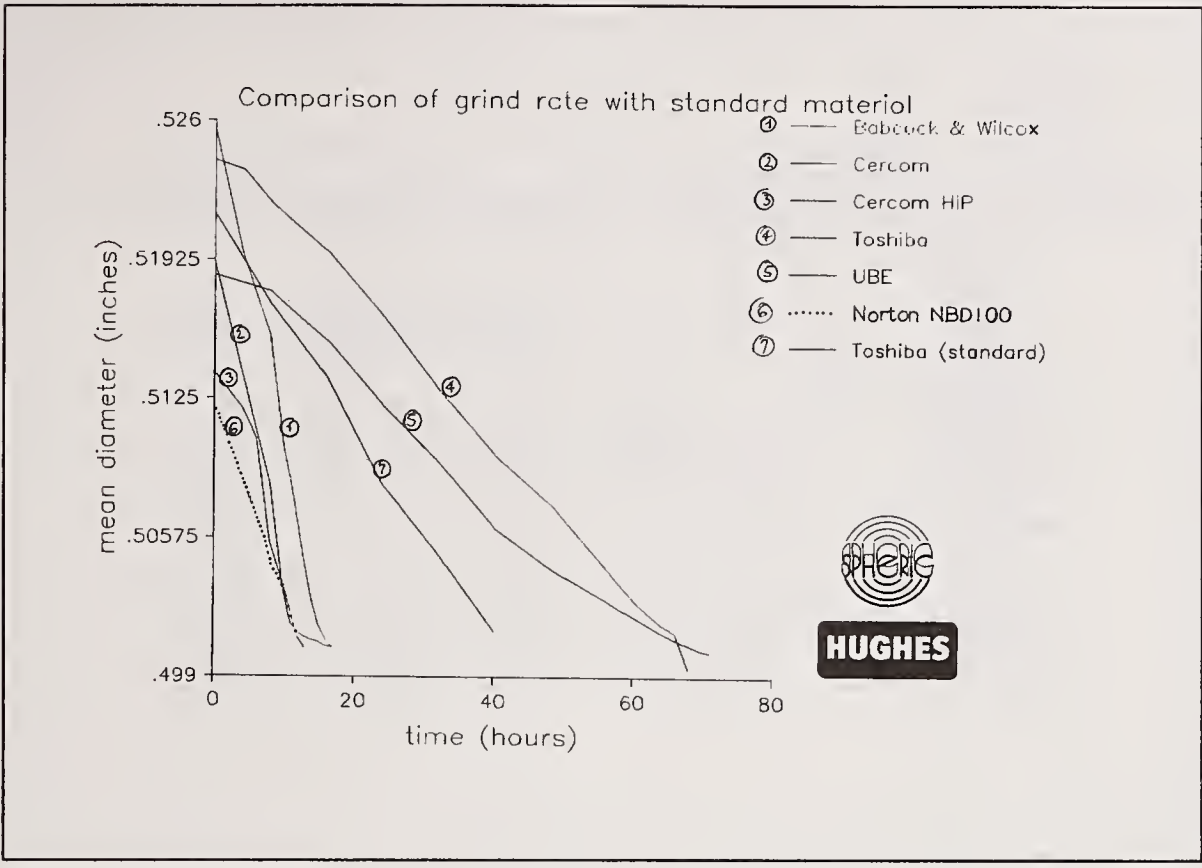


Table 16. Ball/grinding/polishing data for precision bearing balls fabricated from selected HP/HIP-Si₃N₄ materials.

MATERIAL		CERCOM ^{HP}	B&W	CERCOM ^{HP}	NORTON	TOSHIBA	UBE
SPHERIC DATA							
BALL GRADE		5	5	25	10	5	5
START DIA	in.	0.510500	0.519500	0.508350	0.512260	0.522047	0.517717
END DIA	in.	0.500900	0.501530	0.500450	0.500900	0.499409	0.500236
TIME	hours	6	11	9	12	60	63
HARDNESS Hv (5kg)	Kg/mm ²	1655	1390	1570	1820	1545	1610
TOUGHNESS	MPa m ^{1/2}	4.70	5.60	5.82	5.00	6.93	6.97
DIA REDUC. RATE	in./hr	0.001600	0.001633	0.000877	0.000946	0.000377	0.000277
Hv x TOUGHNESS		7778.5	7784.0	9137.4	91000.0	10706.9	11221.7
VOL CHANGE RATE	in. ³ /hr	0.000642	0.000668	0.000350	0.000381	0.000154	0.000112
1/Hv *1/2		0.002581	0.026822	0.025237	0.023440	0.025441	0.024922
1/TOUGHNESS ^{3/4}		0.313275	0.274700	0.266874	0.299069	0.234126	0.233117
1/(TOUGH ^{3/4})(Hv ^{1/2})		0.007700	0.007368	0.006735	0.007010	0.005956	0.005809
CONVERTED TO SI UNITS							
START DIA	m	0.012967	0.013195	0.012912	0.013011	0.013260	0.013150
END DIA	m	0.012723	0.012739	0.012711	0.012723	0.012685	0.012706
TIME	sec	21600	39600	32400	43200	216000	226800
VOL CHANGE RATE	m ³ /sec	2.92E-12	3.04E-12	1.60E-12	1.74E-12	7.03E-13	5.14E-13
HARDNESS Hv	MPa	16230.59	13631.73	15396.99	17848.74	15151.82	15789.27
TOUGHNESS	MPa m ^{1/2}	4.70	5.60	5.82	5.00	6.93	6.97
1/(TOUGH ^{3/4})(Hv ^{1/2})		.002459	.002353	.002151	.002239	.001902	.001855

PROBLEMS WITH H_V/K_{Ic} AS WEAR-DETERMINING PARAMETERS

HUGHES

8

- HARDNESS IS NOT A FUNDAMENTAL PROPERTY; IT DEPENDS ON BOTH THE ELASTIC AND PLASTIC RESPONSE OF THE MATERIAL.
- K_{Ic} (THE CRITICAL STRESS INTENSITY FACTOR, WHICH IS A MEASURE OF FRACTURE TOUGHNESS) DEPENDS HIGHLY ON
 - * THE RESIDUAL STRESSES IN THE CERAMIC; AND
 - * THE SIZE/TYPE/FREQUENCY OF SURFACE FLAWS LEFT BEHIND BY THE GRINDING/POLISHING PROCESS.
- ARE K_{Ic} AND H_V ENOUGH TO DEFINE "BEARING WORTHINESS" OF A CERAMIC? (IS RCF RESISTANCE @ 1×10^6 PSI/R.T. IMPORTANT?)
- WHAT HAPPENS IN HIGH TEMPERATURE AIR?

FIRST LESSON



9

SPHERIC ENGINEERING LIMITED

- NO STANDARD MATERIAL

SECOND LESSON



10

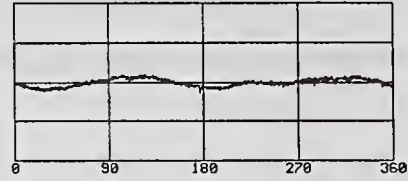
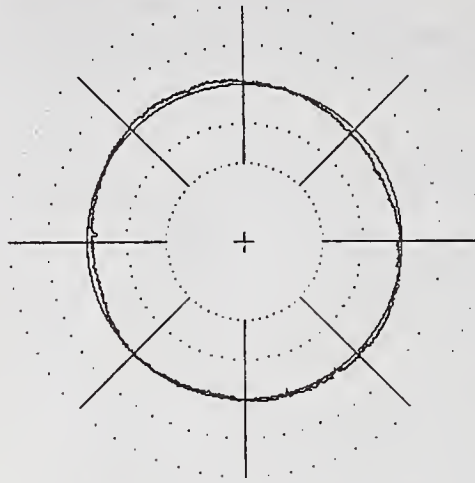
SPHERIC ENGINEERING LIMITED

- NO STANDARD MATERIAL
- NO STANDARD MANUFACTURING PROCESS

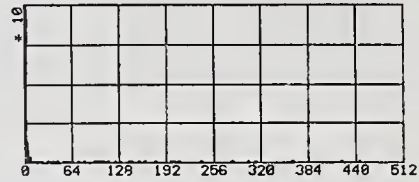
Screen 1 - 1. POLAR DIAGRAM 2: 0.1 μm / Unit (100000)

green - Configuration
measuring range

MS 0 1



LSC: $\Delta r = 0.0458 \mu\text{m}$



NIP = 1024 7.0 rpm 03/07/91 09:39:51
7/32In Master



SPHERIC ENGINEERING LIMITED

LESSONS LEARNED (A REMINDER)



14

SPHERIC ENGINEERING LIMITED

- NO STANDARD MATERIAL
- NO STANDARD MANUFACTURING PROCESS
- NO VISION, A CONSERVATIVE INDUSTRY
- NO WISH TO CHANGE



- EVERY BEARING CUSTOMER MAY NEED A DIFFERENT SPECIFICATION BALL

Requirements and Issues in QC and NDE of Ceramic Bearings

B. T. Khuri-Yakub

E.L. Ginzton Lab.
Stanford University
Stanford, CA 94305

In the last fifteen years, several ultrasonic techniques have been developed for the non-destructive evaluation of dense ceramics. Techniques for the detection of both bulk and surface defects have been established with detection limits in the micron range. A number of these techniques will be reviewed to show their viability. For instance, we will show how it is possible to use long wavelength scattering to determine the stress intensity factor, and hence the fracture stress, of a part due to the presence of a surface crack. We will also show how very high frequency (100-500 MHz) ultrasonic waves can be launched in hot pressed ceramics in order to investigate the presence of small bulk defects.

More recently, we have adapted one such technique to the problem of inspecting ceramic bearing balls. A medium frequency (100 MHz) acoustic microscope capable of measuring amplitude and phase has been used to scan ceramic bearing balls with spalls, surface cracks, and shallow depressions. We demonstrated the ability to detect defects a few microns in size in hot isostatically pressed silicon nitride. We also made a rotation scanner capable of rotating bearings under a static acoustic microscope lens.

Many ultrasonic techniques have been developed to successfully inspect ceramic materials. The problem of inspecting ceramic bearings can be addressed with an adaptation of some of the old techniques, along with the development of a new method for global sorting or inspection of the bearings for defects in both the bulk and the surface.

Requirements and Issues in QC and NDE
of
Ceramic Bearings

B.T.Khuri-Yakub

E.L.Ginzton Lab.
Stanford University
Stanford, CA 94305

OUTLINE

- 1- Introduction
- 2- NDE requirements of ceramic bearings
- 3- Comparison of available technologies
- 4- Review of ultrasonic ceramic NDE techniques
- 5- Ultrasonic ceramic bearings NDE
- 6- Conclusions

NDE Requirements of Ceramic Bearings

- 1- Bulk density variations.
- 2- Bulk cracks.
- 3- Inclusions: large grains
 voids
 Fe, Si, other densifying agents
- 4- Surface defects: gouges
 vertical cracks
 narrow, shallow depressions

Table VI. The State of the Art in Ceramic NDE

NDE Technique and Reference	Material	Defect Type	Defect Size (μm)	Current Limitations
Microfocus X-Ray with Image Enhancement [26]	HP Si_3N_4	Inclusions: • High Density • Low Density	~25 250	• Sensitivity • Material Thickness Greater than 0.250 in.
	RB Si_3N_4	Inclusions: • High Density • Low Density	125 250	• Low Density Inclusions
High Definition X-Ray Microradiography [25]	RB Si_3N_4	Pores and Surface Defects	20 (Film) 100 (Image Intensifier)	• Non-Film Imaging • Sample Thickness
Conventional and Microfocus X-Radiographic Techniques [27]	Green and Sintered SiC and Si_3N_4	Seeded Voids	115 (100% Detection) 80 (< 50 % Detection)	• Sample Thickness • Requires Fine Grained Film and Special Developing Methods
Dye Penetrants [26]	HP Si_3N_4 Siliconized SiC Sintered SiC	Surface	~250	• Sensitivity • Surface Conditions
			250-500	
Scanning Laser Acoustic Microscope (SLAM) [26]	HP Si_3N_4	Surface	100	• Undefined
	Injection Molded RB Si_3N_4	Subsurface Laminations	100	• Material Porosity

Notes: RB = Reaction-Bonded; HP = Hot-Pressed. Other less successful techniques include Vibration Analysis, Acoustic Emission, Microwaves, and Optical Holographic Interferometry [25]. The format of this table is adapted from a table in [26]; the specific entries are collected from a variety of sources, as cited above.

Table VI. The State of the Art in Ceramic NDE (continued)

NDE Technique and Reference	Material	Defect Type	Defect Size (μm)	Current Limitations
Laser Photoacoustic Spectroscopy [26]	RB Si_3N_4	Surface Near Surface	50-100 100	• Undefined
Ultrasonics (45 MHz) [26]	HP Si_3N_4	Inclusions: • High Density • Low Density	~50 ~50	• Component Geometry
	RB Si_3N_4	Inclusions: • High Density • Low Density	125 125	• Component Geometry • Attenuation (RB Si_3N_4)
Ultrasonics (250 MHz) [26]	HP Si_3N_4	Inclusions: • High Density • Low Density	25	• Contact Techniques
Ultrasonic Surface Wave Pulse-Echo Techniques (100 MHz) [3]	HP Si_3N_4	Surface: • Planar • Neck Region of Turbine Blade	25 50	• Sensitivity to Variations in the Water Coupling Length
Ultrasonic Surface Wave Pulse-Echo Techniques (< 10 MHz) [3,28]	HP Si_3N_4	Surface	50-250	• Contact Techniques
Ultrasonic Surface Wave Pulse-Echo Techniques (20 MHz and 50 MHz) [29]	Alpha-Sintered SiC	Surface Cracks and Pores	50	• Defect Type Characterization

Notes: RB = Reaction-Bonded; HP = Hot-Pressed. Other less successful techniques include Vibration Analysis, Acoustic Emission, Microwaves, and Optical Holographic Interferometry [25]. The format of this table is adapted from a table in [26]; the specific entries are collected from a variety of sources, as cited above.

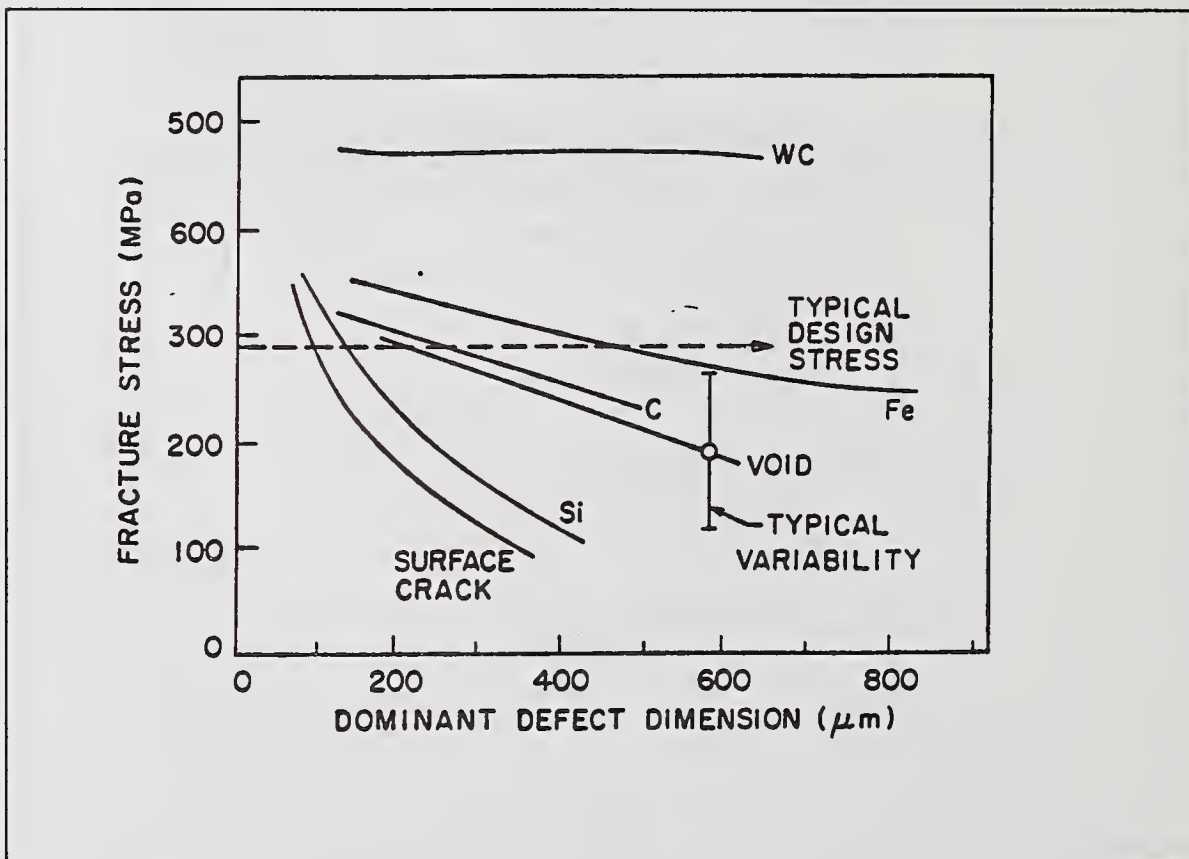
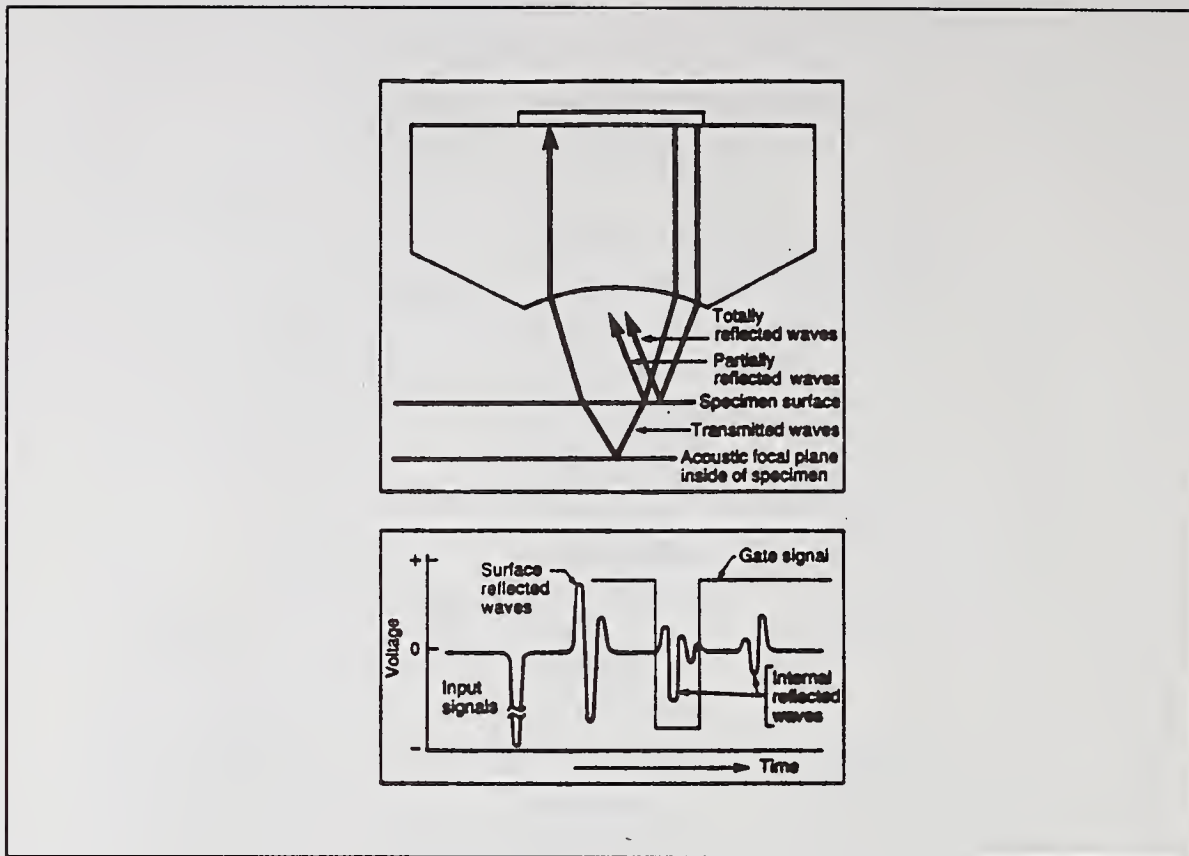
Comparison of Available Technologies

- 1- X-Ray computed tomography
- 2- Microfocus X-Ray
- 3- Thermal imaging
- 4- Visual optical inspection
- 5- Fluorescent penetrant
- 6- Nuclear magnetic resonance
- 7- Ultrasonic: Low frequency
 High frequency
 Scanning acoustic microscopy

BULK ULTRASONIC TECHNIQUES

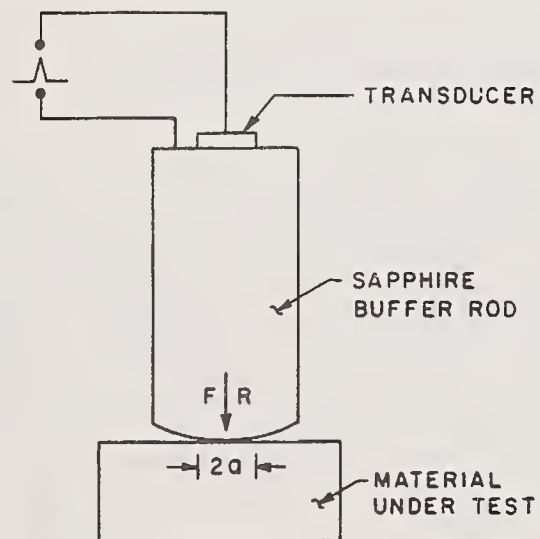
- 1- C-Scan imaging at 10-100 MHz
 - a- Flaw detection
 - b- Velocity mapping
 - c- Porosity mapping

- 2- A-scan at 100-500 MHz
 - a- Flaw detection
 - b- Velocity mapping
 - c- Porosity mapping
 - d- Attenuation measurement

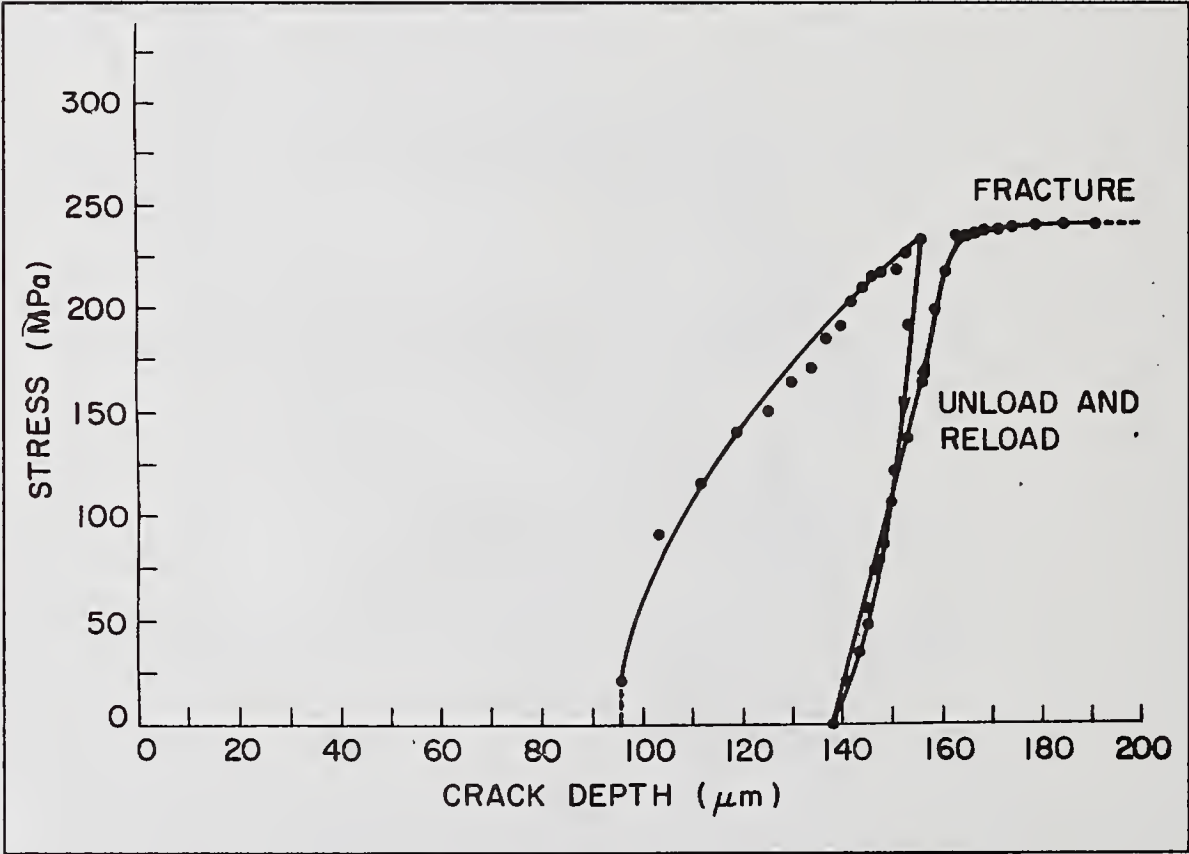
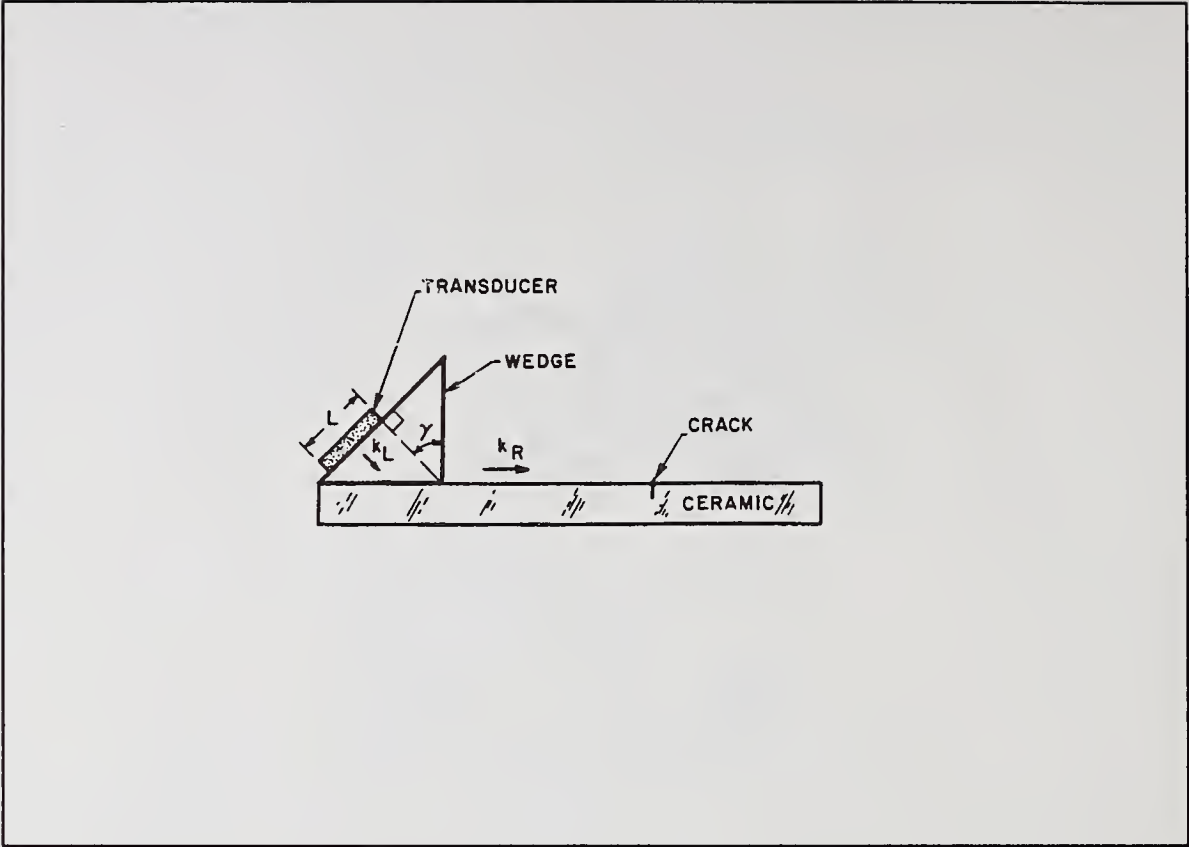


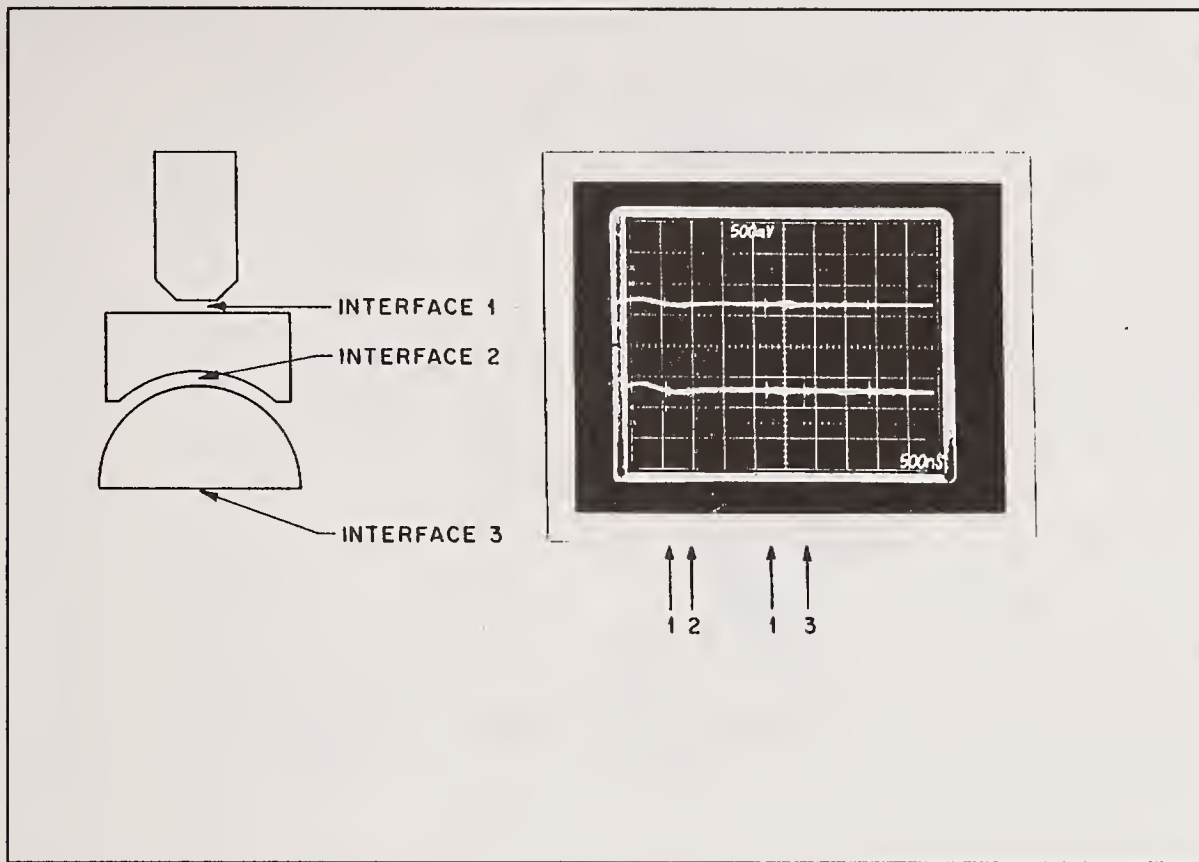
MODES OF OPERATION OF C-SCAN

- Pulse with sub-surface gate.
- Pulse with gate at back wall.
- Pulse with gate at back wall, measure time delay.
- Pulse defocus to isolate SAW signal.
- Pulse with sub-surface multiple gates.
- Pulse with sub-surface gate and phase (180 degrees) measurement ability.



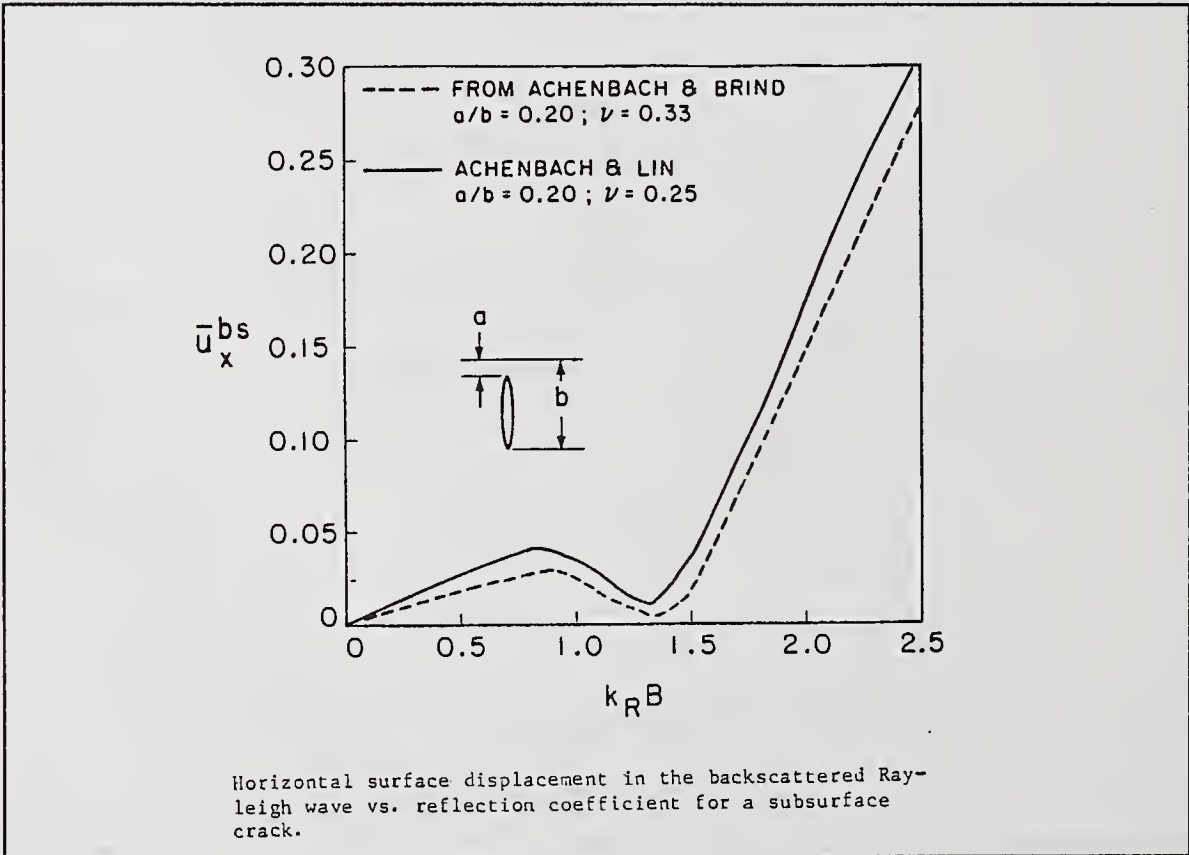
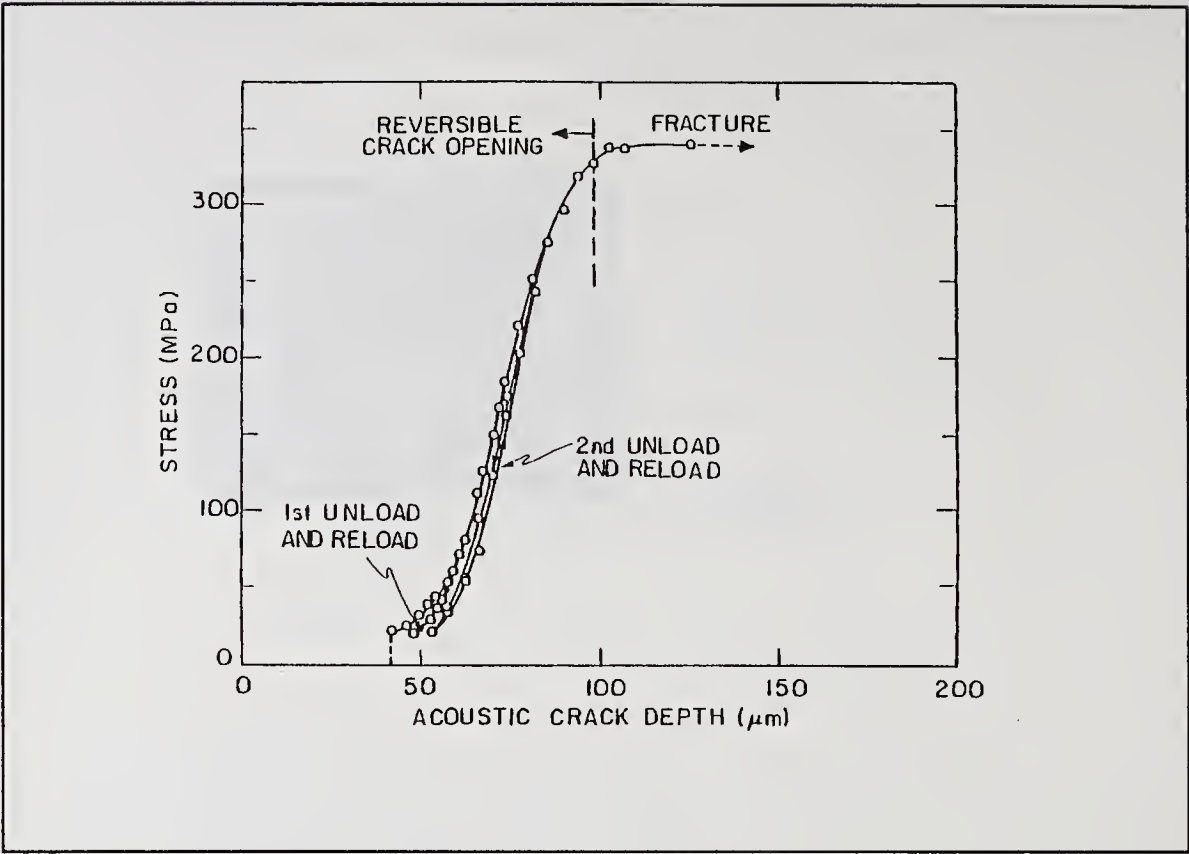
$R = 20 \text{ cm}$
 $2a = .1 \text{ cm}$
 $F = 172 \text{ N} \cong 39 \text{ Lbs.}$

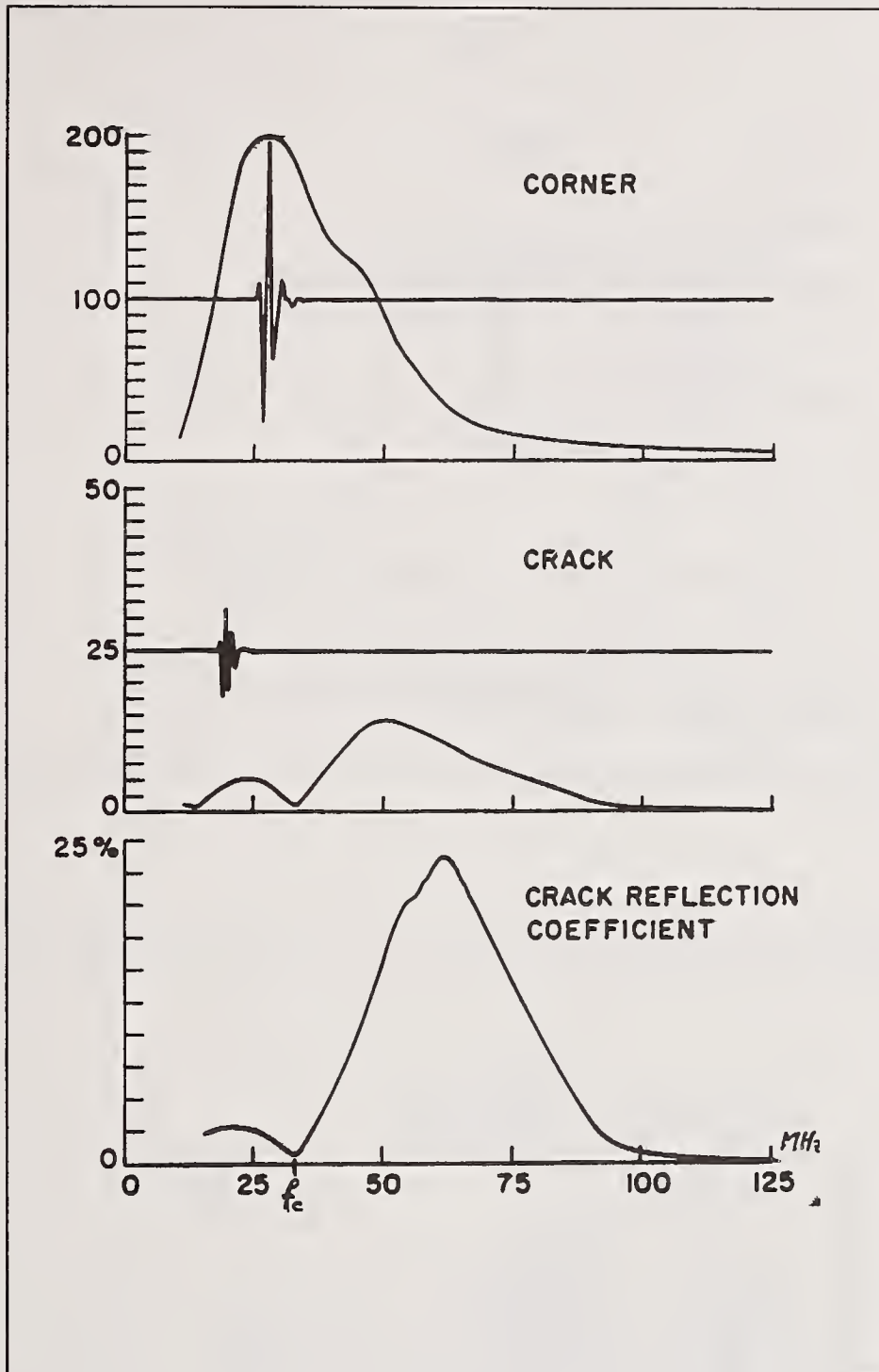




SURFACE ULTRASONIC TECHNIQUES

- 1- Low frequency 1-10 MHz
 - a- Single crack sizing and SIF determination
- 2- Medium frequency 10-100 MHz
 - a- Single scratch sizing and SIF determination
 - b- Machining damage evaluation
- 3- High frequency
 - a- Scanning acoustic microscopy





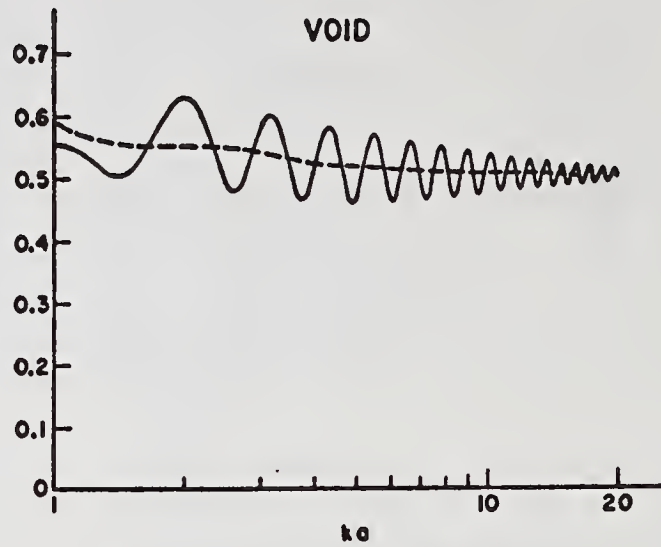


Fig. 3a. The scattering cross-section σ from a void in Si_3N_4 as a function of ka .

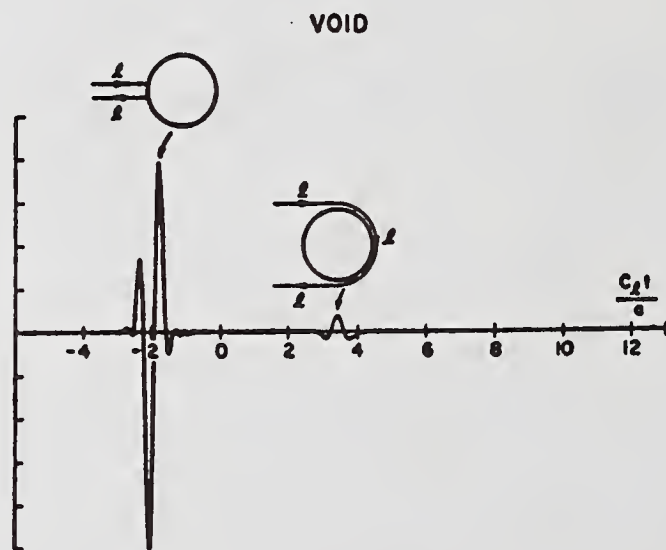
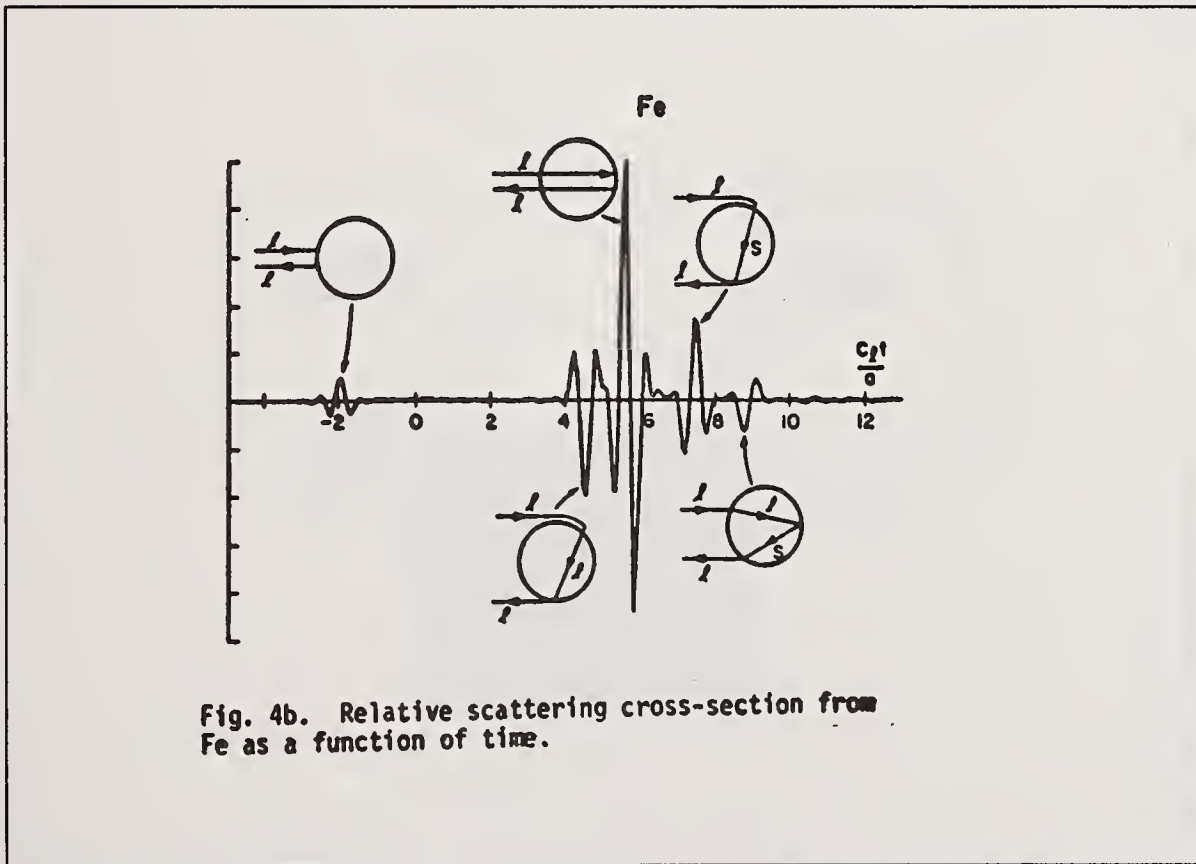
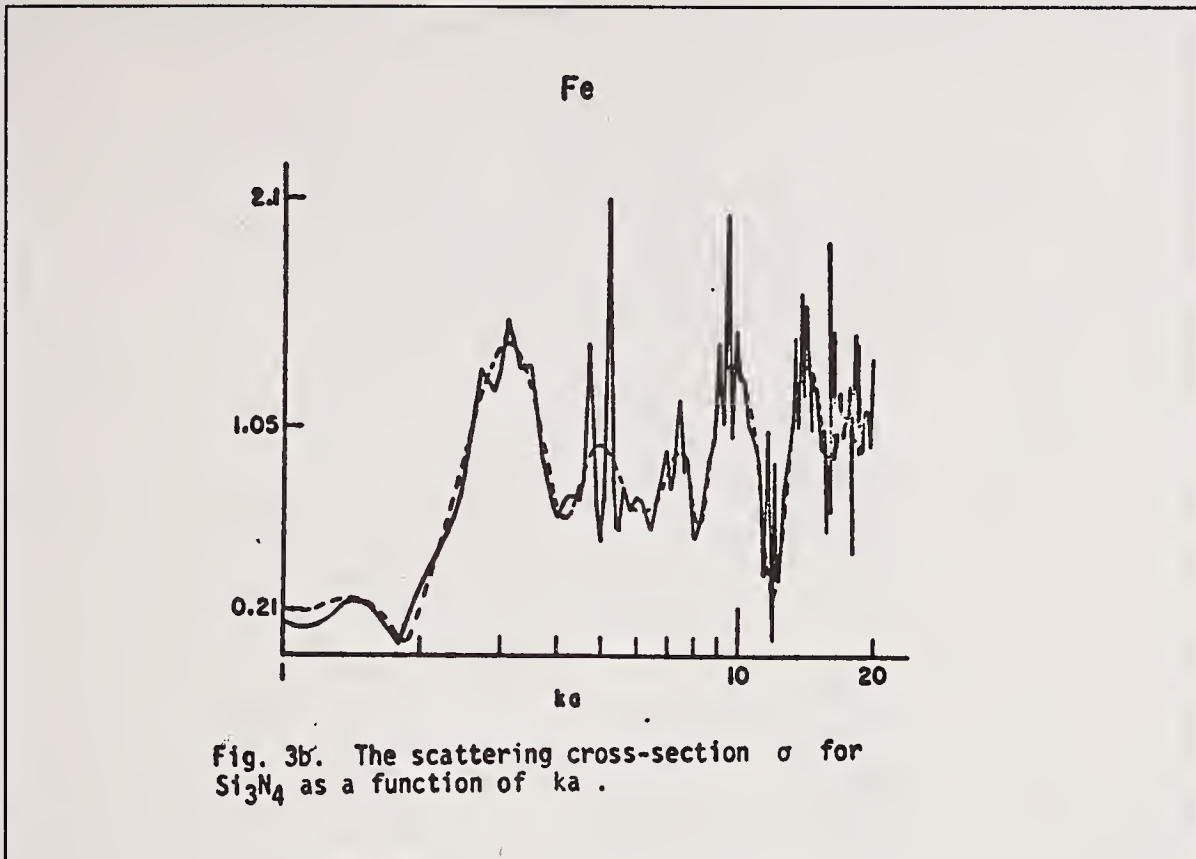


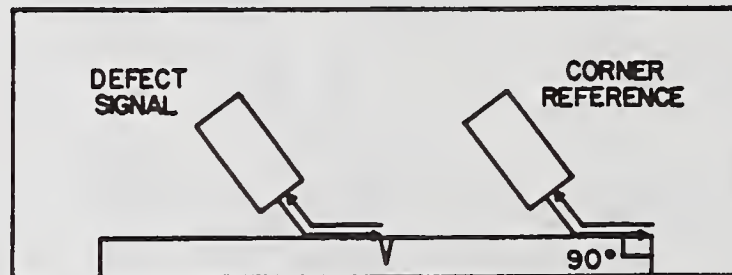
Fig. 4a. Relative scattering cross-section from a void as a function of time.



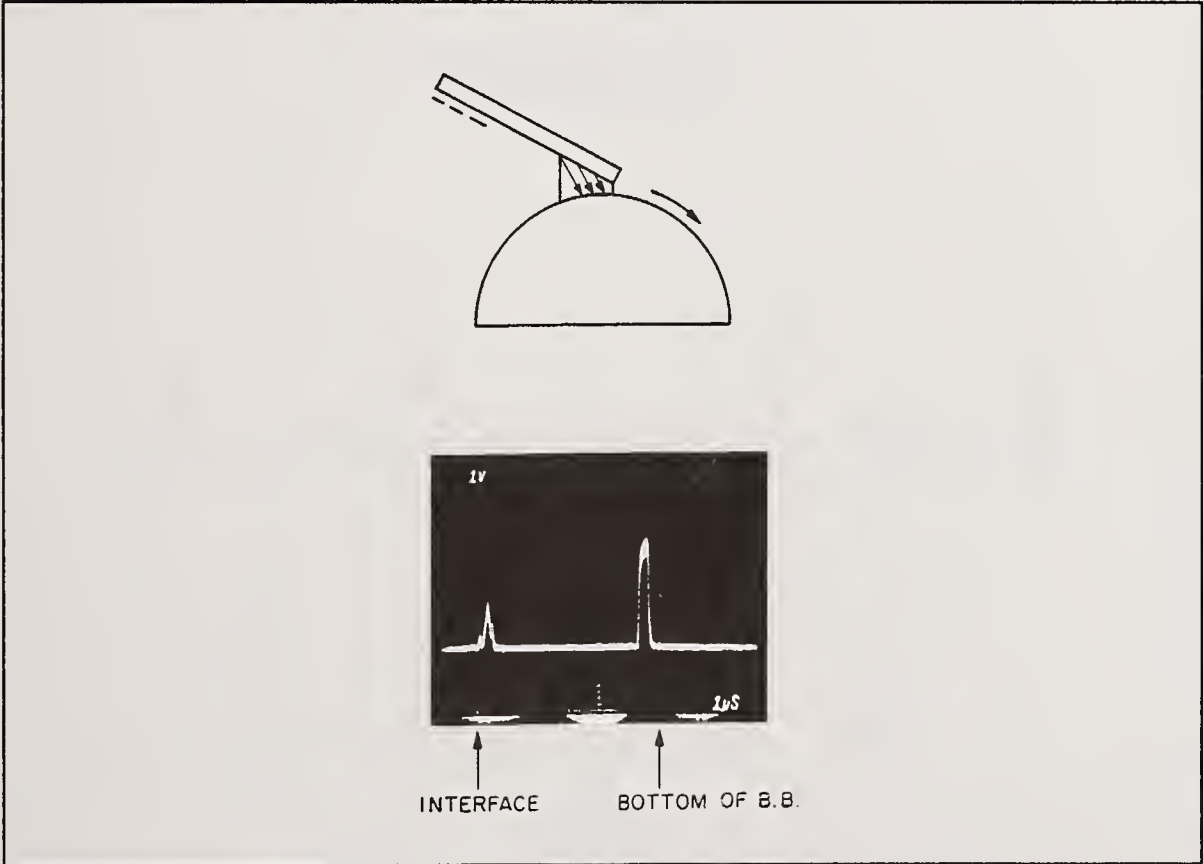
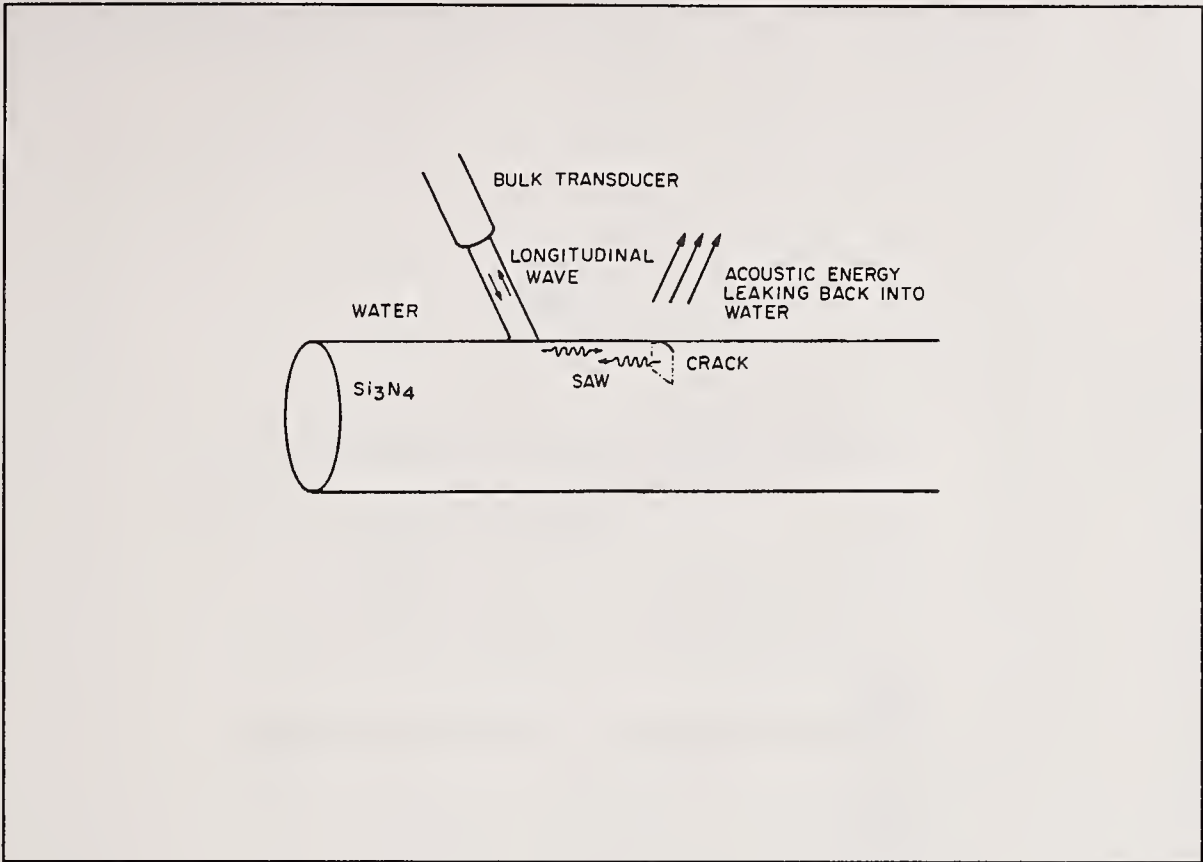
Typical Grinding Damage Data from

Silicon Nitride Samples

Sample Description	Range of Maximum Predicted Depths (μm)	Range of Typical Separations Between Significant Defects (μm)
5 μm cut undressed wheel 180 grit	22-40	120-260
10 μm cut dressed wheel 180 grit	25-45	150-200

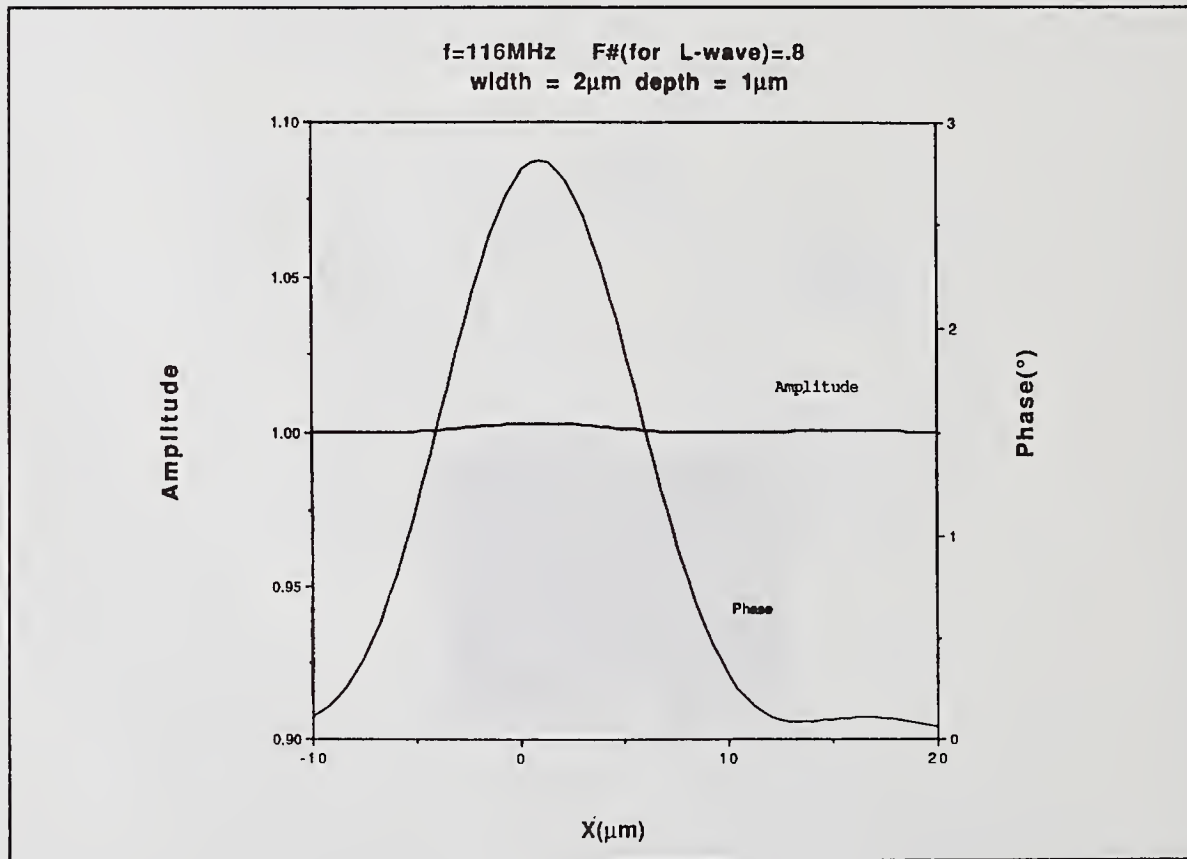


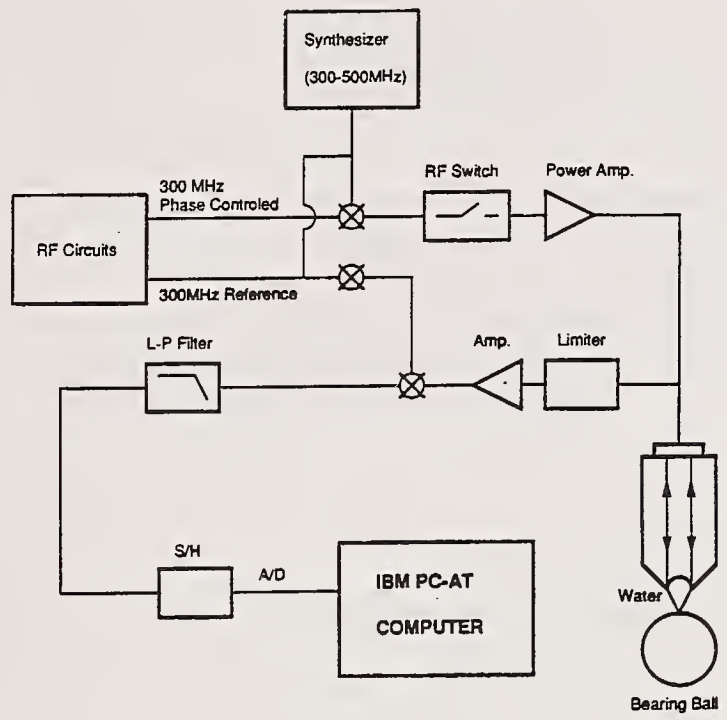
TRANSDUCER-SAMPLE GEOMETRY FOR SINGLE CRACK DATA





Different Kinds of Defects of Ceramics Bearing Balls

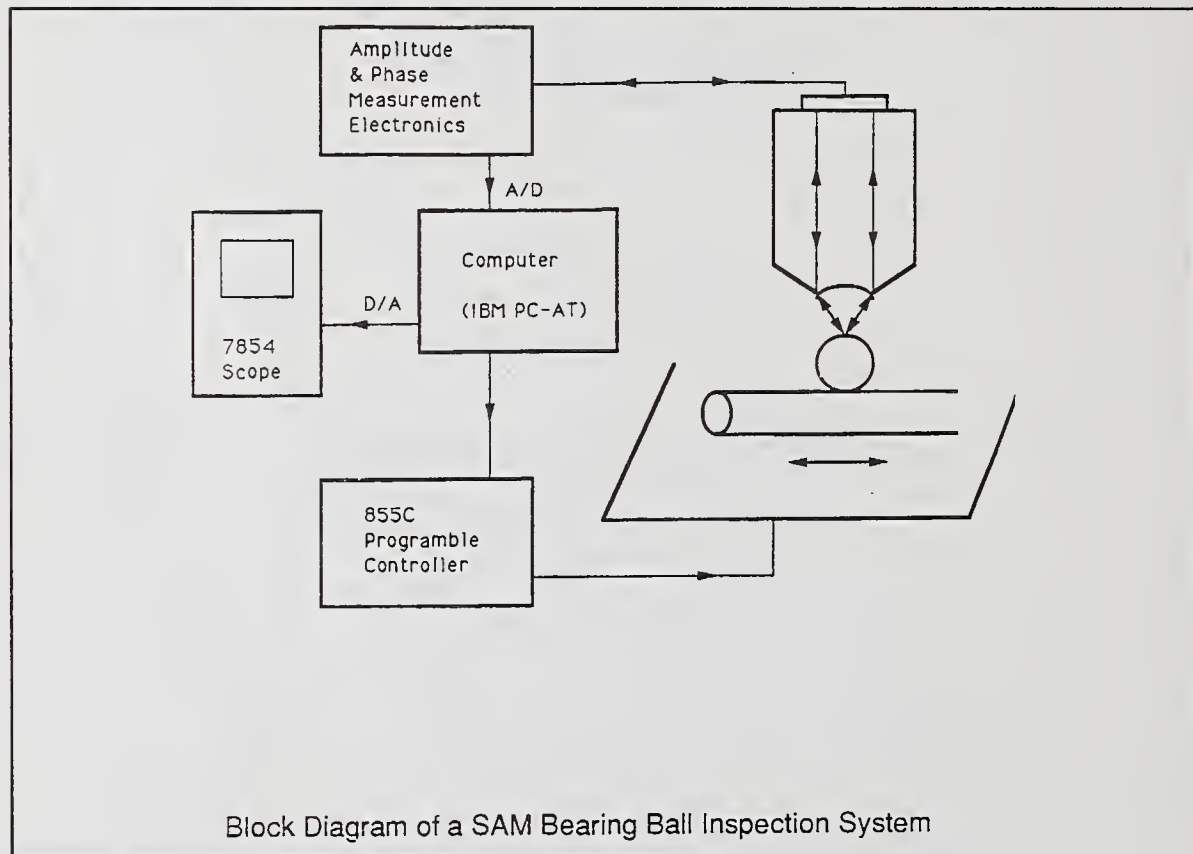




Block Diagram of the Amplitude Phase Measurement system

Why use SAM ?

- Operation for both ceramics and metals.
- The ability to detect not only the surface damage but also subsurface cracks and bulk defects.
- Higher sensitivity to detect very shallow surface depressions than conventional optical microscopes; more tolerant to vibrations than confocal scanning optical microscopes.



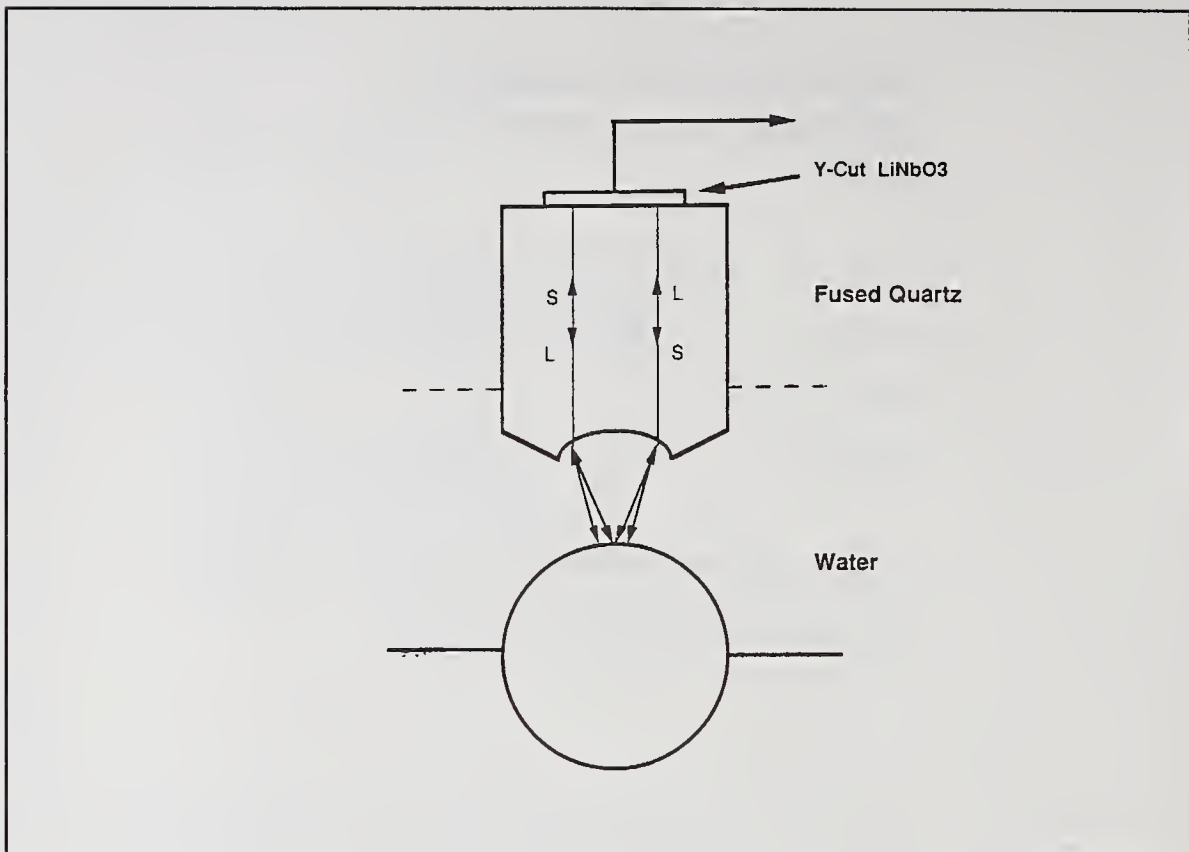
Performance of phase and amplitude measurement system

Noise Level	Amplitude(p-p)	phase
Electronics	0.7%	$\pm 0.5^\circ$
Rotation Scanner	2%	$\pm 4^\circ$
x-y Scanner	4%	$\pm 7.5^\circ$

The high noise level is caused by the vibration of the scanning system which is not acceptable for ball bearing inspection.

Solution -- Differential phase measurement:

- Use mixed mode transducer to generate both longitudinal and shear waves in fused quartz buffer rod.
- Develop a differential phase measurement system to detect the phase difference between the two beams.



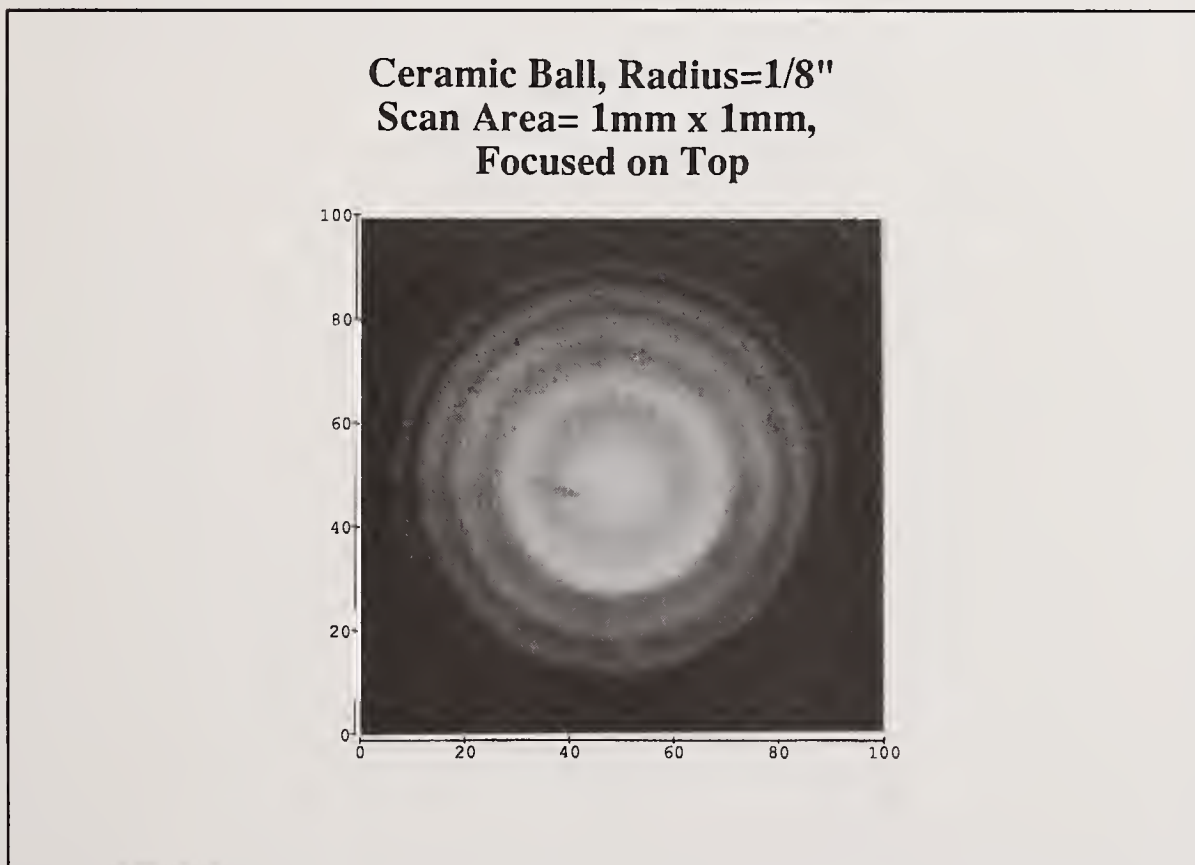
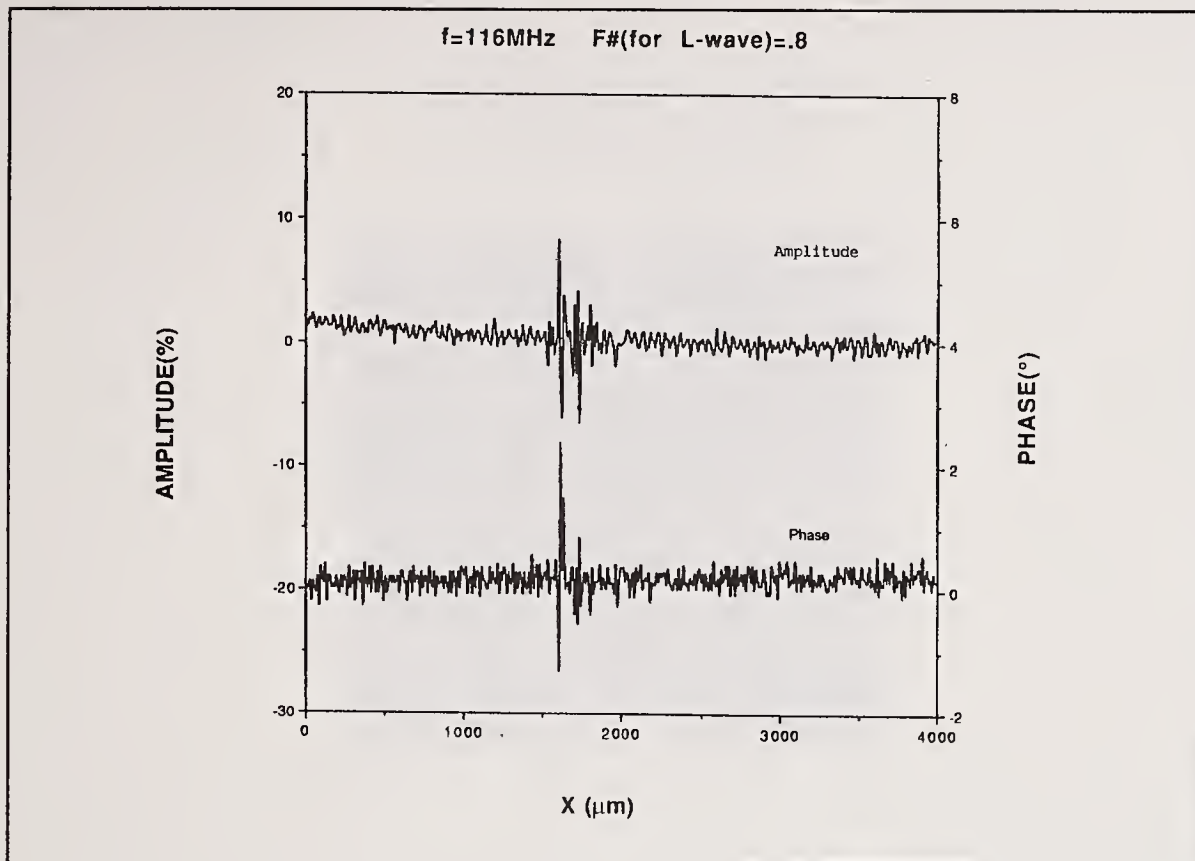
Performance of simple phase measurement system :

Noise Level	Amplitude	phase
Electronics	0.7%	1°
Rotation Scanner	2%	8°
x-y Scanner	4%	15°

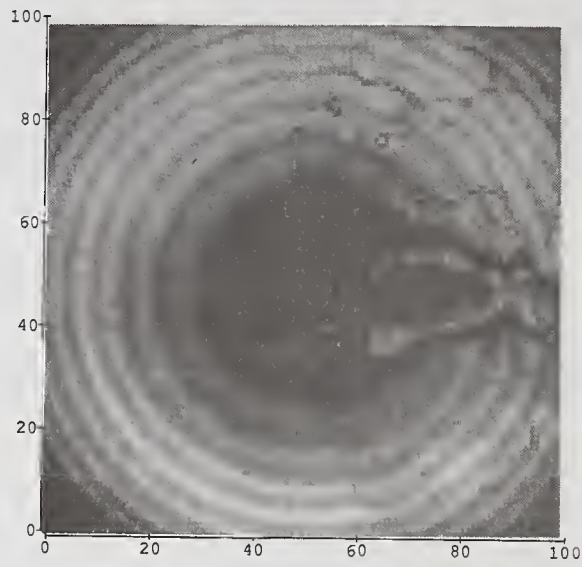
The high noise level is caused by the vibration of the scanning system which is not acceptable for ball bearing inspection.

Performance of differential phase measurement system :

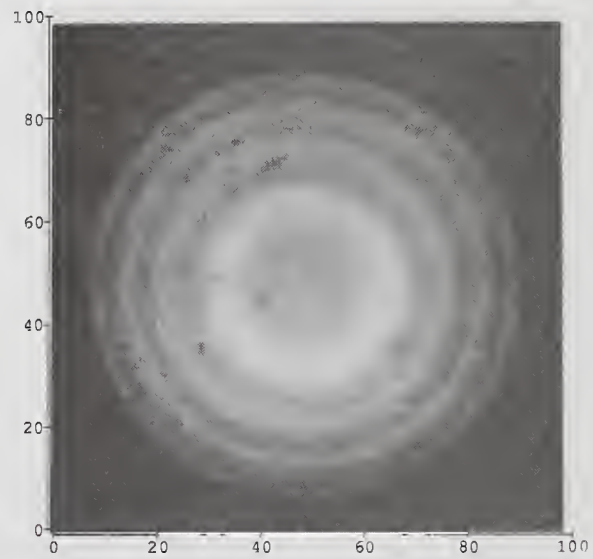
Rotation Scanner	2%	0.8°
------------------	----	------

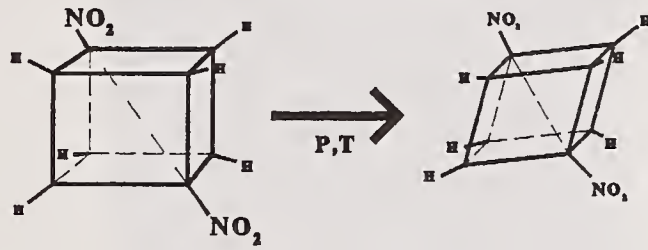


Ceramic Ball, Radius=1/8"
Scan Area= 1mm x 1mm,
Defocused 0.40 mm



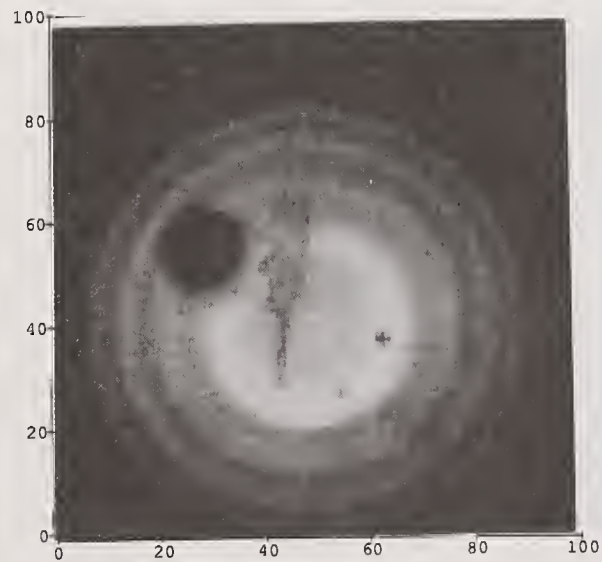
Ceramic Ball, Radius=1/8"
Scan Area= 1mm x 1mm,
Defocused 0.10 mm



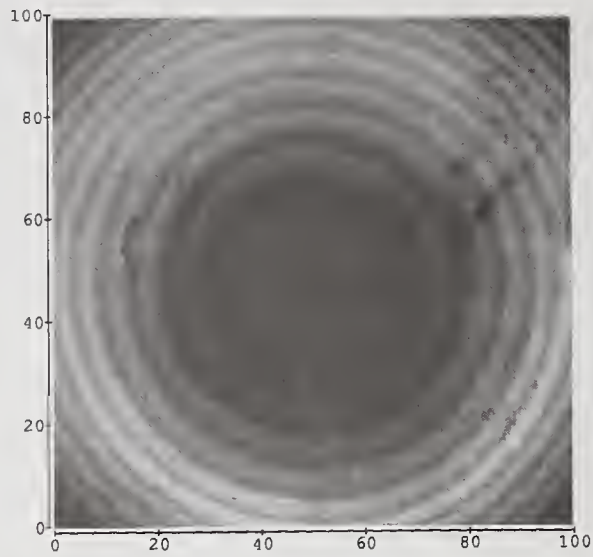


1,4 DINITROCUBANE

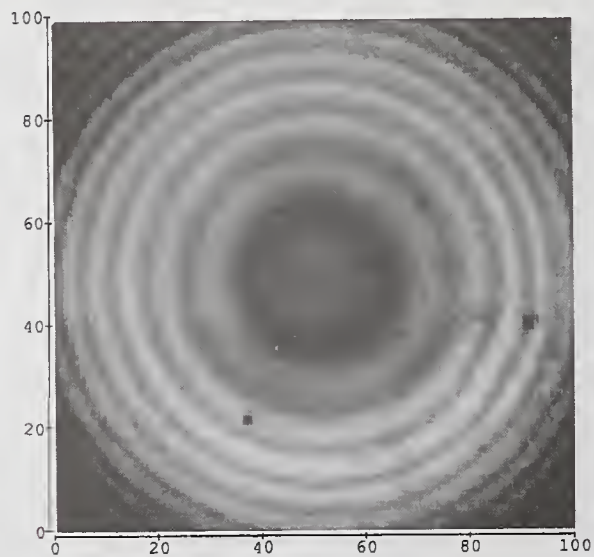
Ceramic Ball, Radius=1/8"
Scan Area= 1mm x 1mm,
Defocused 0.25 mm



Ceramic Ball, Radius=1/8"
Scan Area= 1mm x 1mm,
Defocused 0.35 mm



Ceramic Ball, Radius=1/8"
Scan Area= 1mm x 1mm,
Defocused 0.25 mm



CONCLUSIONS

- 1- Ultrasonic NDE shows most promise.
- 2- NEEDS:
 - a- A global method of inspection.
 - b- A green ceramic inspection method.
 - c- A method for single defect evaluation.

Ductile Regime Grinding of Brittle Materials

Thomas A. Dow, Steven C. Fawcett, and Ronald O. Scattergood

Precision Engineering Center
North Carolina State University
Raleigh, NC 27695

Over the past several years, many researchers have studied the process of material removal in brittle materials including diamond turning and fixed abrasive grinding. A regime of material removal called *ductile regime* turning and grinding has been defined for which there is no apparent damage to the finished surface. The operating conditions and material properties (modulus E, fracture toughness K_c , and hardness H) which define the limits of this regime can be written in terms of a critical depth of cut expressed as:

$$d_c = \beta \left(\frac{K_c}{H} \right)^2 \left(\frac{E}{H} \right)$$

This model can be used to predict the relative performance of different ceramic materials.

It has been observed that the appearance of a fracture free surface does not mean the material was removed exclusively by plastic or ductile processes. In fact, it has been shown that for diamond turning of brittle materials such as silicon and germanium, much of the material removal is by brittle fracture and only the material closest to the final surface is removed by plastic flow. The chip producing mechanism is said to be in the *ductile regime* if the dimensions of the chip do not exceed the critical depth over the finished surface of the workpiece. Experimental measurements have corroborated this model and demonstrated the relationship between the uncut chip thickness and the damage to the surface for the geometry of plunge grinding and diamond turning with a round nose tool. However the case of the contour grinding is more complicated and has lead to a computer simulation of the chip geometry and prediction of the resulting damage.

The results of the model prediction can be compared to the actual roughness achieved in contour grinding of SiC. The measured surface roughness and its increase with feed rate as well as the calculated roughness and the theoretical finish assuming infinite speed of the grinding wheel (Equation (1)). The predicted surface finish closely matches the measured surface roughness to provide a strong correlation between the simulation and actual ground parts. Since the surface finish results from several factors (machine vibrations, brittle fracture sites, geometric relationships, relative rotational speeds, etc.), the measured value could vary greatly from the simulated finish. However, in this particular experiment, the parameters were selected such that the maximum chip thickness was less than the critical value and little damage was observed on the final surface. Therefore, the geometrical features created by the

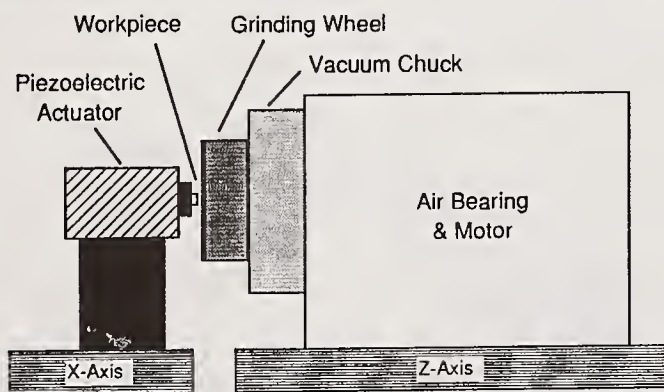
interaction of the grinding wheel and the part were the main cause of the surface roughness.

The geometric chip model can be used to evaluate the contribution of the material, geometry of the wheel, and the operating conditions on the surface damage. Damage, in the form of fractures, will occur at the location where the chip thickness exceeds a critical value. These cracks will penetrate some distance into the material. If this penetration is less than the thickness of the material removed on subsequent passes of the wheel, a damage-free surface will result. The 3-D shape of the chip illustrates the variation in thickness in the cutting direction as well as the feed direction. By using the thickness of the chip over the finished surface, the amount of fracturing on the finished surface can be estimated from 1-D plunge grinding experiments. Because the grinding wheel makes a specific number of revolutions for each revolution of the workpiece, the uncut chip thickness will decrease as the grinding wheel moves toward the center of the part. For this reason, the values are plotted versus part radius. The predicted percent fracture appears to give an accurate description of the fracturing that remains in the surface after the grinding operation is completed.

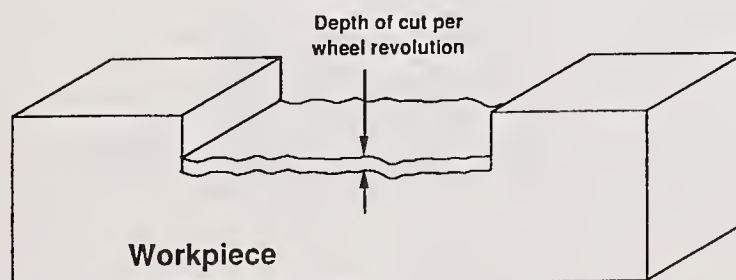
DUCTILE REGIME GRINDING OF BRITTLE MATERIALS

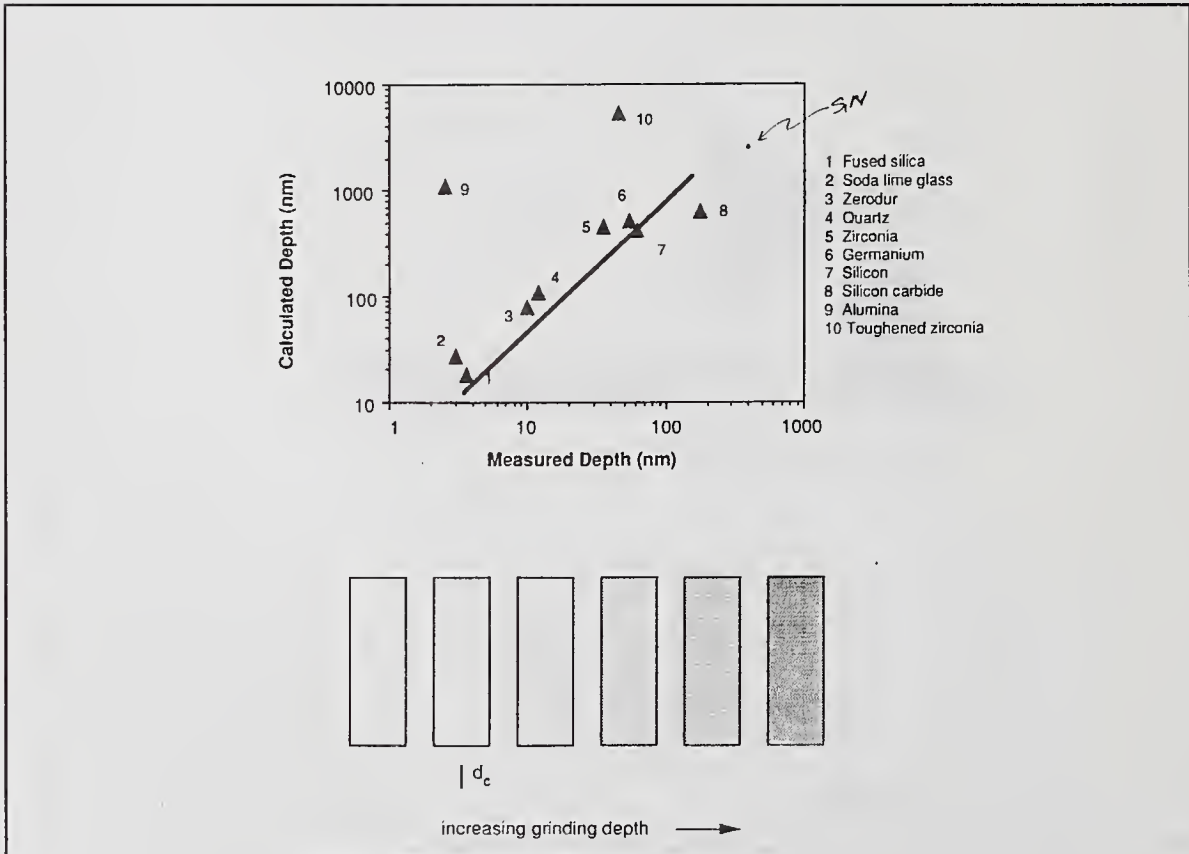
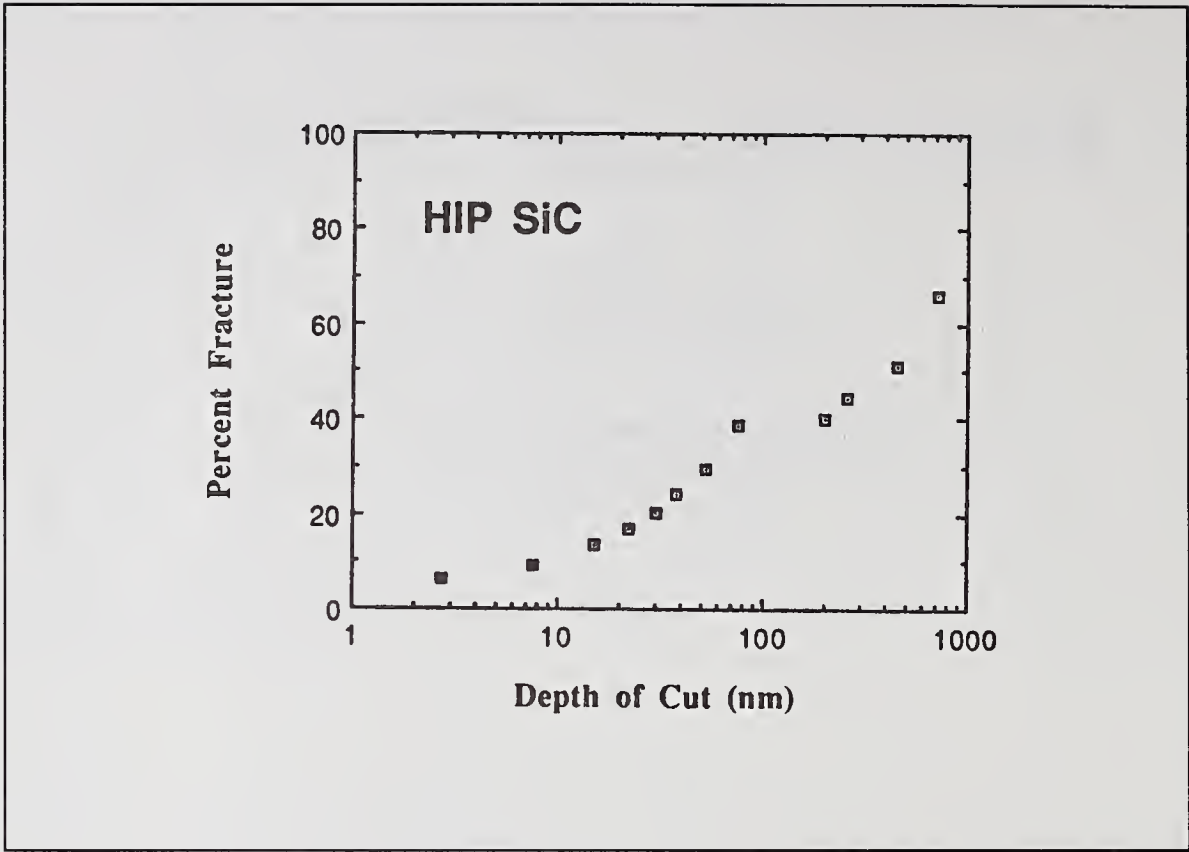
Tom Dow
Steve Fawcett
Ron Scattergood

Precision Engineering Center
North Carolina State University
Raleigh, NC



Schematic of the plunge grinding apparatus.





$$d_c = \beta \left(\frac{K_c}{H} \right)^2 \left(\frac{E}{H} \right)$$

where

d_c = Critical depth of cut for ductile response

β = Factor involving wheel, diamond, and coolant

K_c = Fracture toughness for small cracks

E = Young's modulus

H = Hardness for small penetration depths

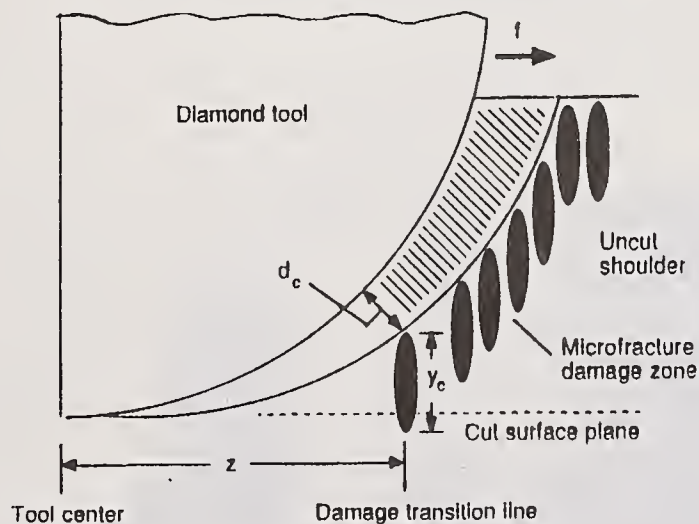


IMAGE ANALYSIS SYSTEM

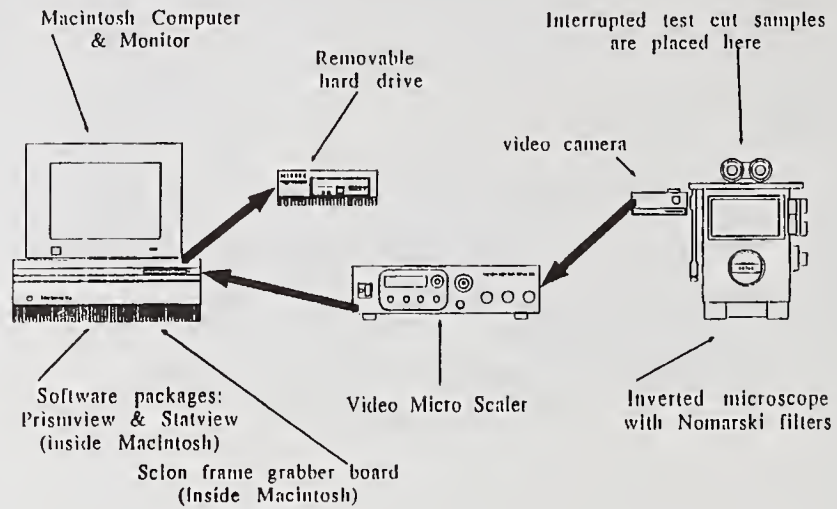
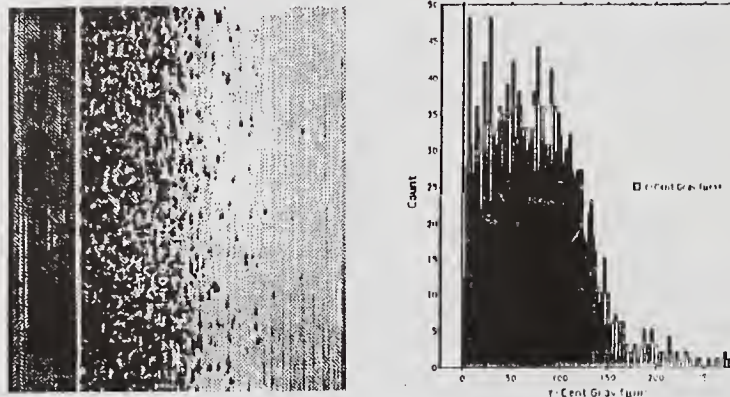
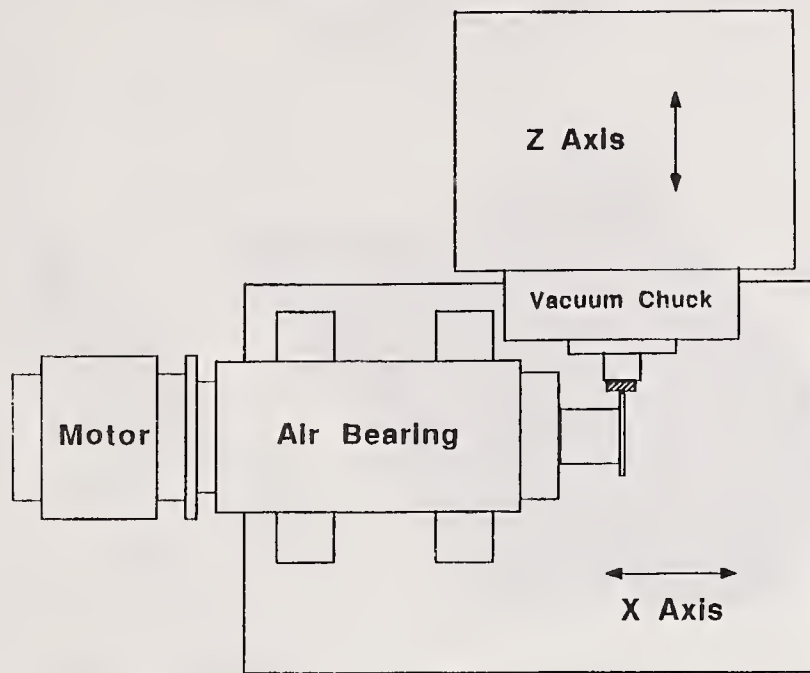


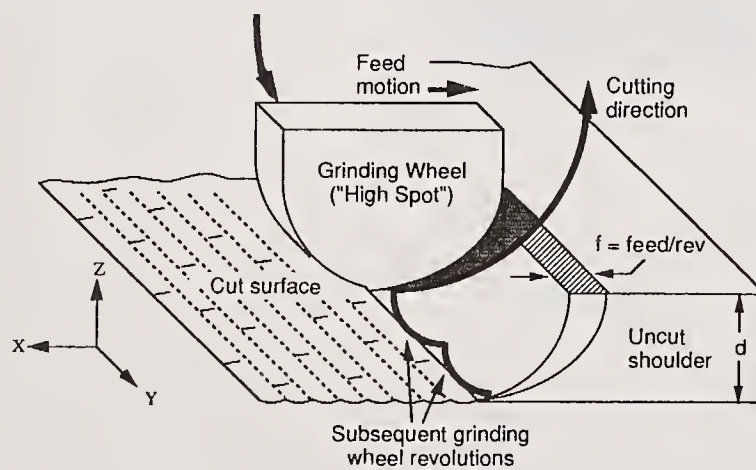
IMAGE ANALYSIS OF SHOULDER CUTS (Interrupted cutting tests)



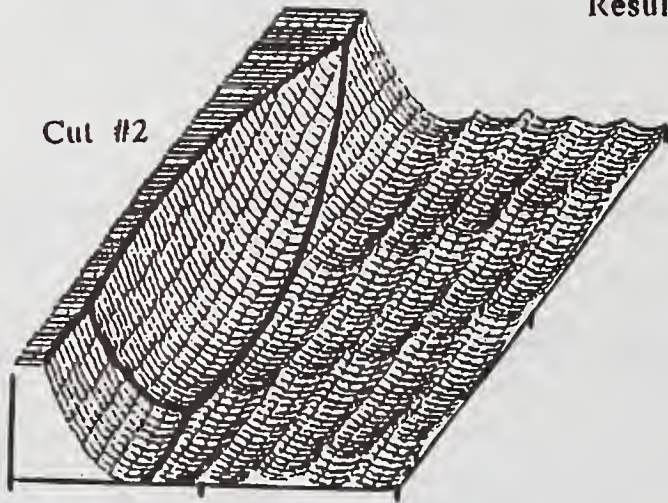
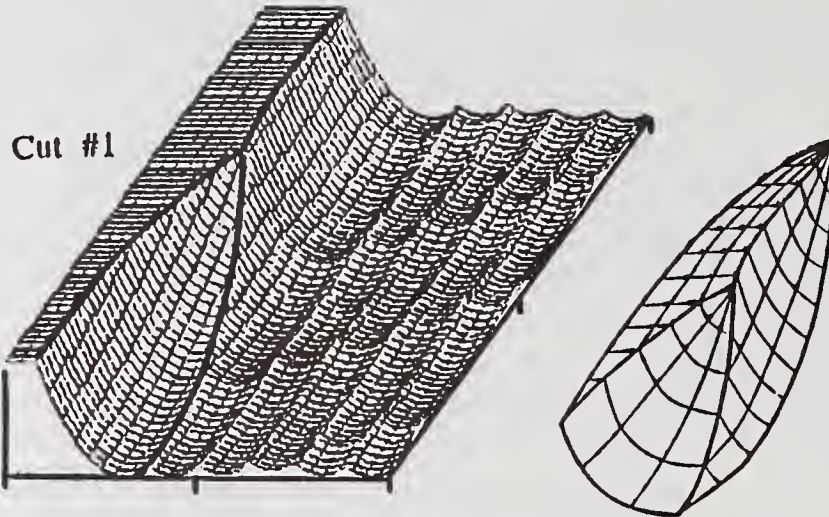
DTM Grinding Spindle

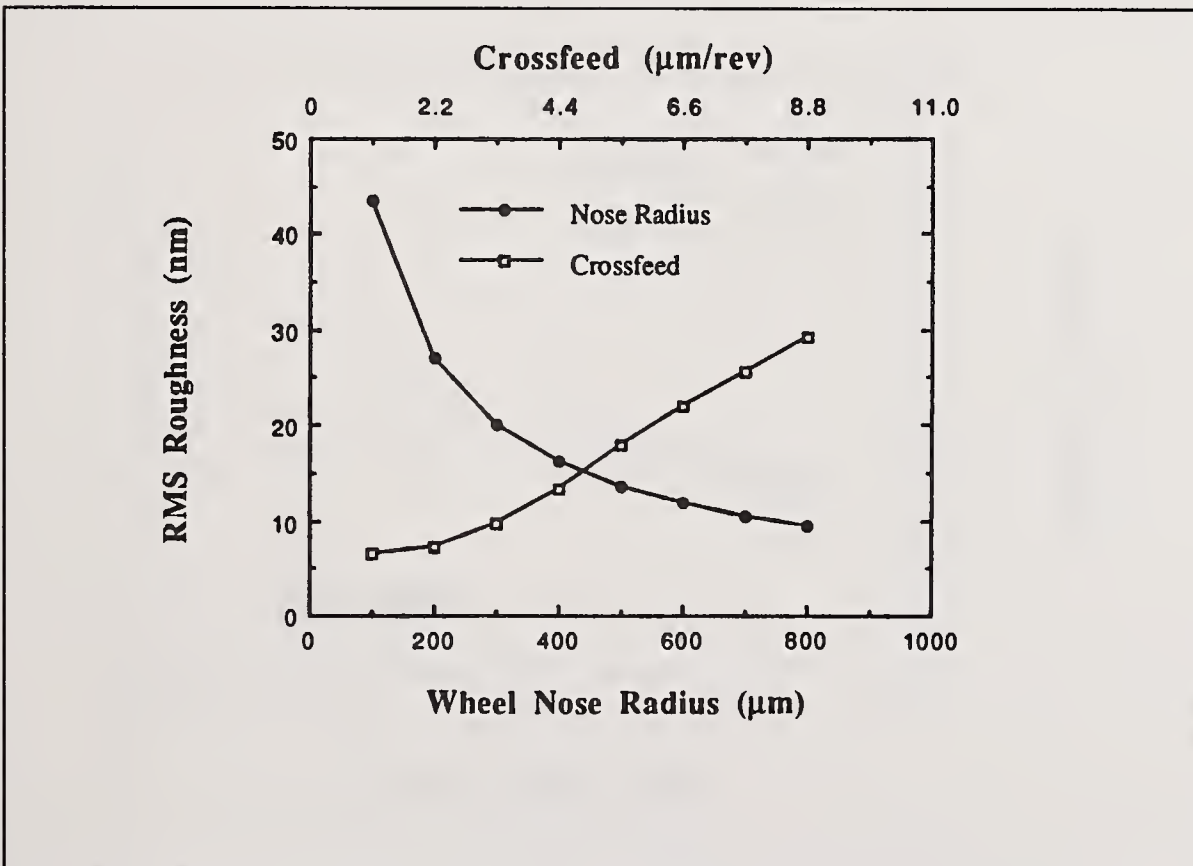
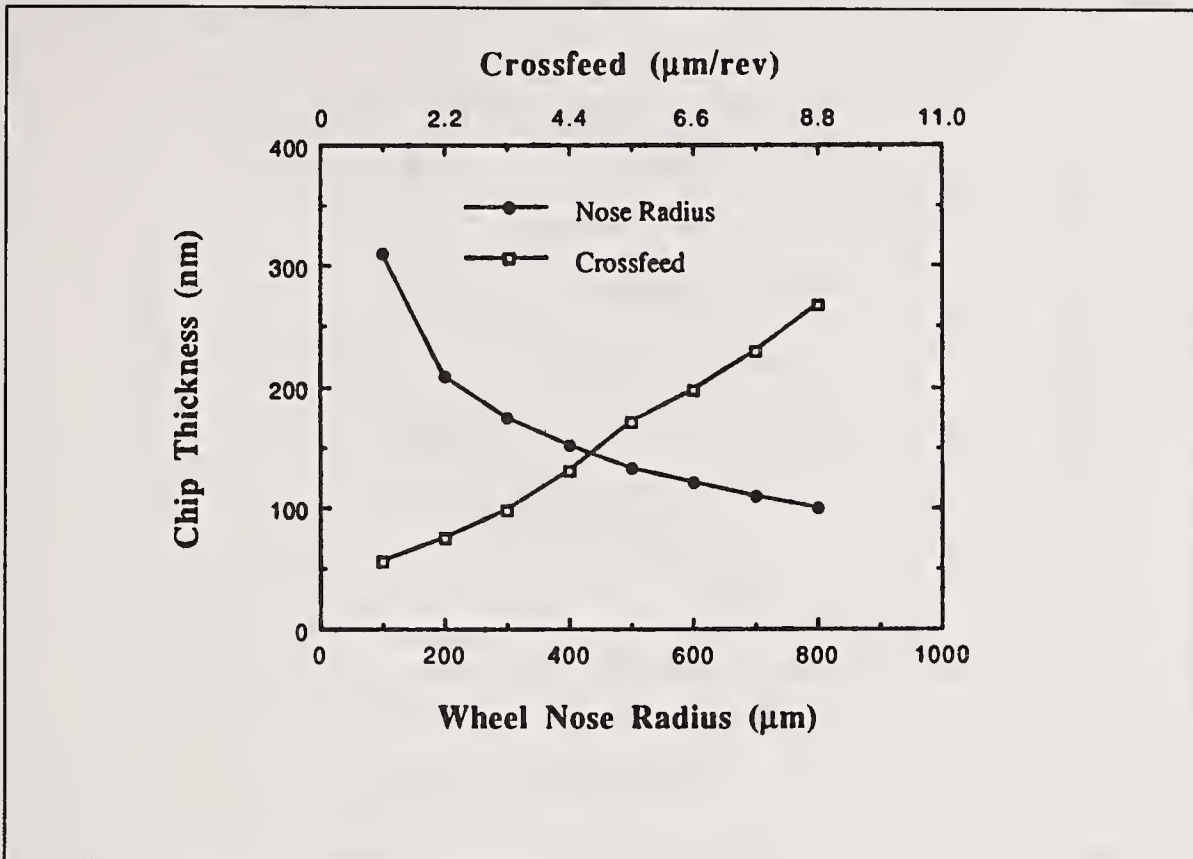


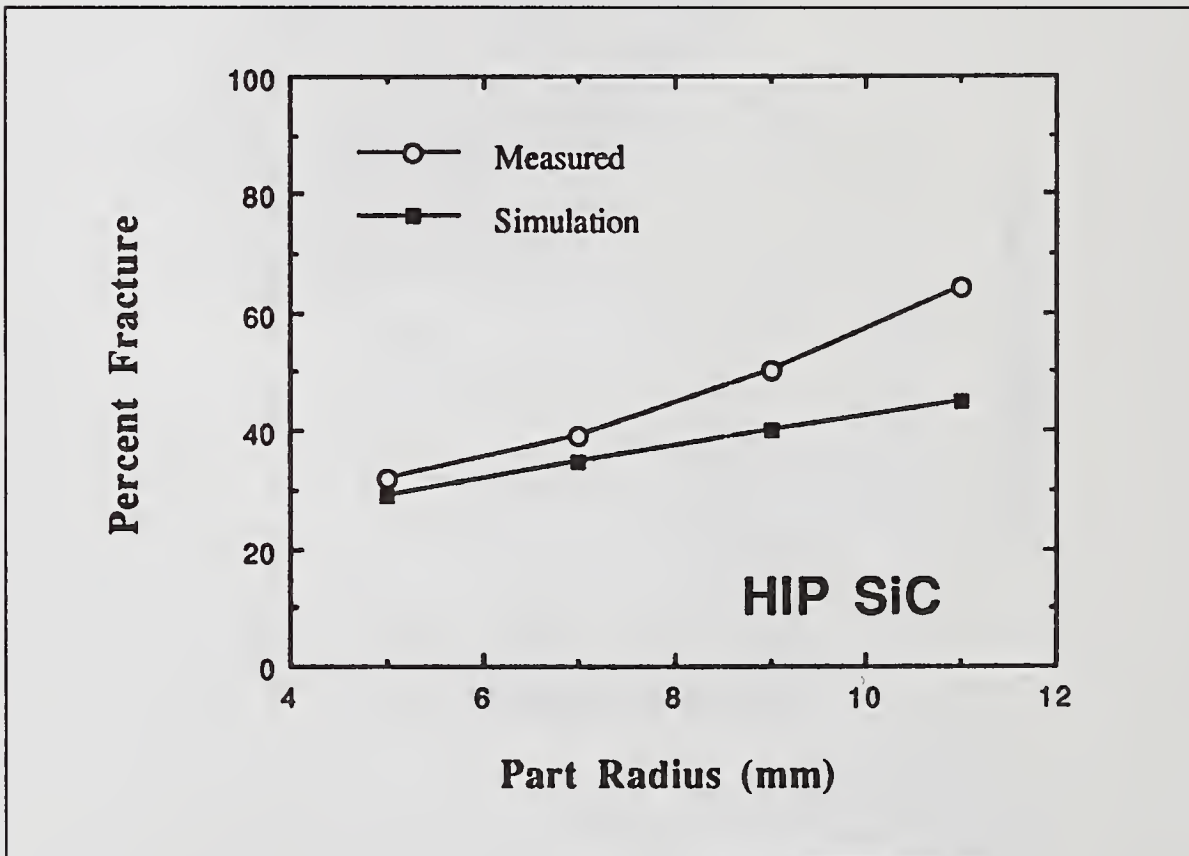
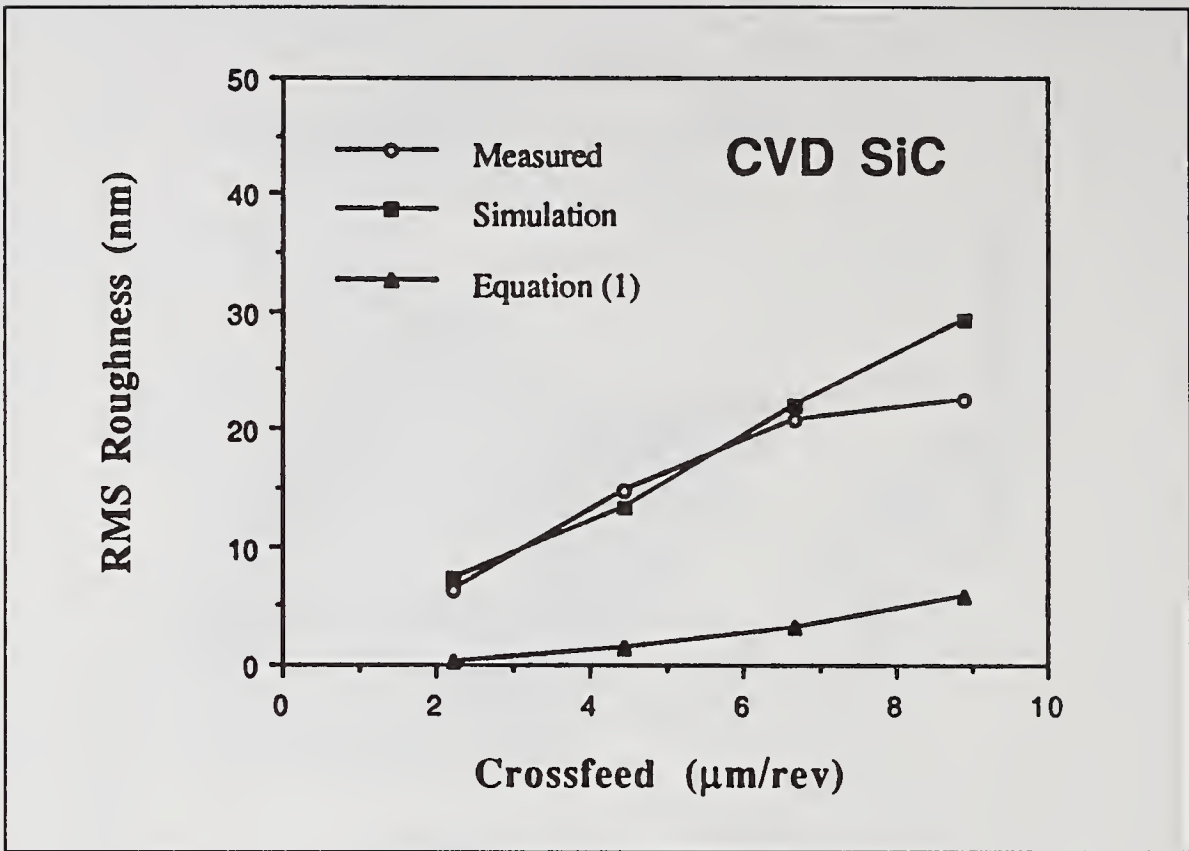
Grinding Chip Formation Geometry



Evolution of Grinding
Chip Geometry







MACHINING OF CERAMICS FOR BEARING APPLICATIONS

- High-precision machine tools
- "Ductile-regime" conditions
- Machine variables and wheel parameters
- Mechanisms, process models, and control strategies
- Applications to precision mechanical as well as optical and electronic surfaces

Design and Life Prediction Issues for Ceramic Bearings

Crawford Meeks
AVCON, Inc.
Northridge, CA 91324

The development of ceramic bearing technology offers many benefits for DOD applications from advanced aircraft gas turbines, to inertial guidance instruments, to ultra-precision pointing and tracking gimbals.

Development of advanced bearings utilizing ceramic materials and transfer lubricants is a highly heuristic process. The materials technologist and bearing designer must work in concert to be effective. Even the best materials system will not perform effectively in a poorly designed rolling element bearing.

The bearing designer aids the materials technologist by establishing goals for materials performance such as friction coefficients, traction coefficients, strength and modulus of elasticity requirements. The designer, through creative synergy, aims to devise design solutions to thermal expansion mismatches, and wear rates that result in finite limits on potential life. Examples of such design processes abound in the ceramic bearing field from composite ball cages of metal with transfer film inserts to compliant mounting schemes for race-to-shaft and race-to-housing interfaces. Non-symmetrical ball cage pocket arrangements, and deliberately unbalanced ball cages are examples of the designer aiding in the assimilation of advanced materials technology into the bearing design process.

Because of the complexity of rolling element bearings, computer methods are necessary for just analyzing stress versus load relationships. For example, just determining the load, working contact angle, and stress of each ball in a bearing requires solution of five complex simultaneous equations N number of times (here N is the number of balls in the bearing). In critical performance applications and high speed bearing design, the computer becomes the only means for predicting bearing component behavior.

Over a period of several years, a comprehensive ball bearing analysis tool "BABERDYN" has been developed. This computer program is based on the use of "smart" algorithms to achieve high accuracy and computational efficiency. These algorithms were developed by writing the equations of motion of the balls and ball cage in a rotating coordinate frame. This results in very simple one and two term equations that are numerically integrated to obtain velocities and displacements from the basic Newtonian acceleration equations. The results are then transformed to an inertially fixed coordinate system through transformation matrices. This method both improves computational accuracy and computational efficiency. In fact these algorithms are so efficient, that a personal computer (PC) versions of the program now yields useful analytical results in over *five shaft revolutions* in run times of about one half hour.

BABERDYN has been proven valid and accurate through comparison of results with empirical data on ball cage motions and through demonstration of problem

solving ability by elimination of existing failures or poor performance in real bearing applications.

Besides the process of design synthesis through computerized analysis of rolling element bearing design and defining of performance goals for tribological materials systems, computerized design tools can be useful in predicting life and reliability of bearing/materials systems. By identifying the potential failure modes of bearings and testing for the critical values of materials system operation such as wear rates, and fatigue spalling functions, regression analysis can be used to develop algorithms for predicting bearing long term performance characteristics and life can be analyzed.

The key potential failure modes in ceramic bearings are:

- o ball wear
- o raceway wear
- o ball cage wear
- o fatigue
- o insufficient (or excessive) lubricant transfer to the races or balls.

By identifying these failure modes and performing tribo-materials tests on specimens and real bearings, data can be developed for predicting the severity of such degradation effects and to predict the longevity of bearings.

A comprehensive program is needed that will:

1. Expand and improve on existing computerized analysis tools.
2. Establish a research/development program in which the **designer/analyst**, and **tribologist** work in close concert to establish materials "windows" of performance to guide the tribological research.
3. Create a team effort in which the designer/analyst apply tribomaterials systems to new bearing designs and iterate the designs based on results of bearing environmental and performance tests.
4. Modify, and improve upon, existing regression analysis tools for predicting bearing life factors based on ongoing research that characterizes ceramic materials systems (wear rate, fatigue, etc.) and incorporate these into existing computer models.

Such a comprehensive, cooperative program integrating the efforts of research tribologists, bearing designers and computer analysts will maximize the potential for success and permit giant strides in improvement of performance of advanced ceramic bearing systems.

DESIGN AND LIFE PREDICTION ISSUES

for

CERAMIC BEARINGS

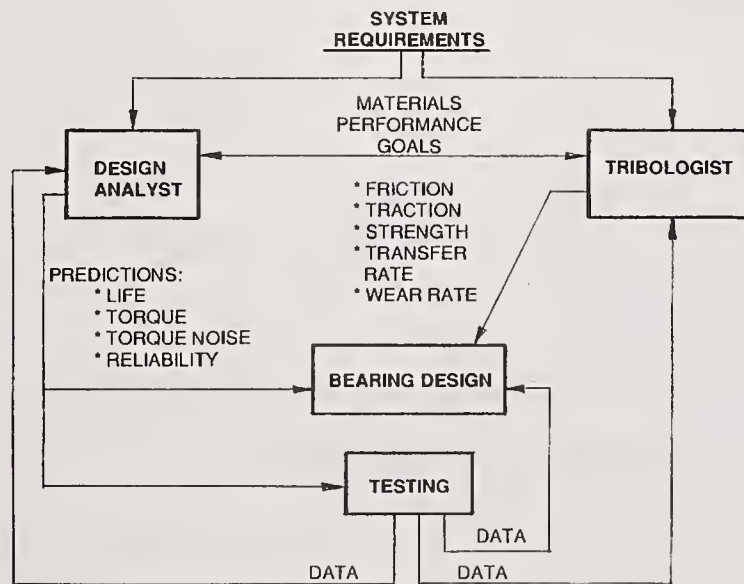
by

CRAWFORD MEEKS

AVCON-Advanced Controls Technology, Inc.
19151 Parthenia Street, Unit G
Northridge, CA 91324
(818)886-0250

DEVELOPMENT OF ADVANCED CERAMIC
BEARINGS IS A HIGHLY HEURISTIC PROCESS

AVCON



DEVELOPMENT OF HIGH DN, HIGH TEMPERATURE BEARINGS REQUIRES OPTIMUM DESIGN AS WELL AS ADVANCE TRIBO-MATERIALS SYSTEMS

AVCON

IMPORTANT DESIGN VARIABLES IN ROLLING ELEMENT BEARINGS:

BALL BEARINGS

- BALL DIAMETER
- CONTACT ANGLE
- PITCH DIAMETER
- RACEWAY CURVATURE (INNER and OUTER)
- NUMBER OF BALLS
- SHOULDER HEIGHT
- BALL-CAGE POCKET CLEARANCE
- DENSITY OF BALLS, BALL-CAGE
- PRELOAD
- SYMMETRY

- FACE-TO-FACE OR BACK-TO-BACK
- TYPE OF BALL-CAGE DESIGN
 - CYLINDER POCKET
 - CYLINDER CONE POCKET
 - RACE GUIDED
 - CROWN OR SOLID RAIL

ROLLER BEARINGS

- ROLLER DIAMETER
- ROLLER CONE ANGLE
- PITCH DIAMETER
- GUIDE FLANGE HEIGHT
- ROLLER-CAGE POCKET CLEARANCE (LONGITUDINAL & LATERAL)
- ROLLER-CAGE TO RACE LAND CLEARANCE
- DENSITY OF ROLLERS, ROLLER-CAGE
- PRELOAD (OR DIAMETRAL CLEARANCE)
- SYMMETRY
- TYPE OF ROLLER CAGE DESIGN
 - MACHINED
 - FORMED
 - TRANSFER FILM INSERTS
- FACE-TO-FACE OR BACK-TO-BACK

SEVERAL FACTORS CONTRIBUTE TO LOADS AND STRESSES IN WEAR AFFECTED ZONE IN ROLLING ELEMENT BEARINGS

AVCON

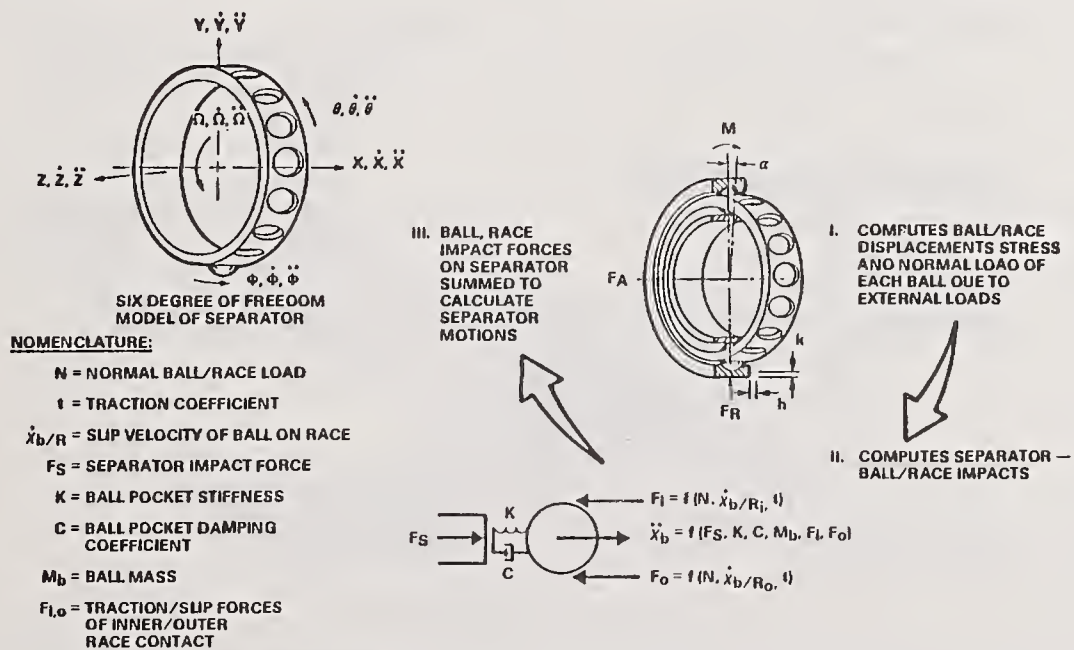
EXTERNAL LOADS

- RADIAL
- AXIAL
- MOMENT
- UNBALANCE
- "FRAME" VIBRATION

INTERNAL LOADS

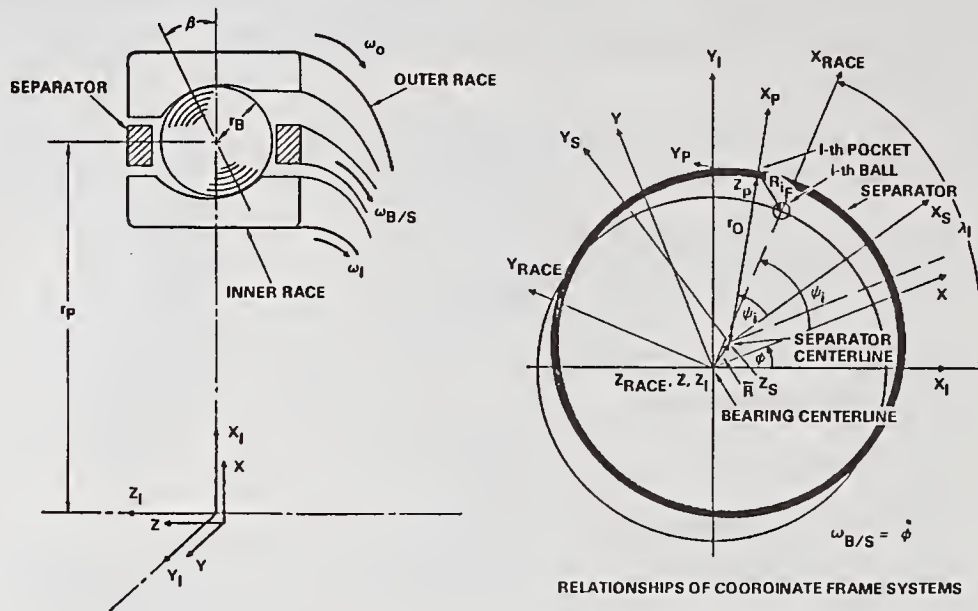
- CENTRIFUGAL
- GYROSCOPIC
- DYNAMIC COLLISION OF CAGE AND ROLLING ELEMENTS
- BALL/ROLLER-TO-RACE SKIDDING FORCES

- ANALYSIS AND OPTIMIZATION OF KEY DESIGN VARIABLES
- OPTIMIZATION OF COMPLEX INTERDEPENDANT FUNCTIONS SUCH AS:
 - BALL-CAGE CLEARANCES (POCKET and LAND)
 - TRACTION COEFFICIENT
 - MASS PROPERTIES OF BALL-CAGE
- APPLICATION OF EXPERIENCE, JUDGEMENT FROM REAL BEARING TESTS
- INTEGRATION WITH SHAFT, HOUSING
 - FITS
 - EXPANSION MISMATCH
 - PRELOADING SCHEME (SOFT or HARD)
- INTUITION !!



BEARING SCHEMATIC SHOWING AXIS COORDINATE SYSTEMS

AVCON



RELATIONSHIPS OF COORDINATE FRAME SYSTEMS

THE SELECTION OF A ROTATING COORDINATE SYSTEM FOR WRITING EQUATIONS GREATLY SIMPLIFIES MATHEMATICAL INTEGRATION BUT PRESERVES RIGOROUS SOLUTION

AVCON

SEPARATOR NOMINAL SPIN RATE ($\omega_{B/S}$)

$$\omega_{B/S} = \frac{1}{2} [\omega_i(1-\gamma) + \omega_o(1+\gamma)] \quad [1]$$

WHERE; $\gamma = \frac{r_B}{r_P} \cos \beta$ [2]

USING SMALL ANGLE APPROXIMATIONS, THE BALL-SEPARATOR TO SEPARATOR-FIXED TRANSFORMATION IS:

$$A = \begin{Bmatrix} 1 & \theta_z & -\theta_y \\ -\theta_z & 1 & \theta_x \\ \theta_y & -\theta_x & 1 \end{Bmatrix} \quad [3]$$

THE MATRIX $[B_i]$ DEFINES THE POSITION OF THE i^{th} POCKET IN THE SEPARATOR AS:

$$[B_i] = \begin{Bmatrix} \cos \psi_i & \sin \psi_i & 0 \\ -\sin \psi_i & \cos \psi_i & 0 \\ 0 & 0 & 1 \end{Bmatrix} \quad [4]$$

THE TOTAL FORCE ON THE SEPARATOR IS:

$$\bar{F} = \sum_i [B_i]^T \Delta \bar{F}_i \quad [1]$$

AND, THE TOTAL MOMENT ON THE SEPARATOR IS:

$$\bar{M} = \sum_i [B_i]^T \Delta \bar{M}_i \quad [1]$$

NOMENCLATURE:

- $\Delta \bar{F}_i$ = TOTAL INCREMENTAL FORCE VECTOR
- $\Delta \bar{M}_i$ = TOTAL INCREMENTAL MOMENT VECTOR
- r_B = RADIUS OF BALL
- r_P = PITCH RADIUS OF BALL ORBIT
- β = CONTACT ANGLE
- $\theta_x, \theta_y, \theta_z$ = SMALL ANGLES (X_S, Y_S, Z_S IS OBTAINED BY ROTATING X, Y, Z THROUGH THESE ANGLES)
- ψ_i = ANGULAR POSITION OF THE i -TH BALL
- ω_i = ROTATION RATE OF INNER RACE
- ω_o = ROTATION RATE OF OUTER RACE

VERY SIMPLE VECTOR EQUATIONS ARE INTEGRATED TO SOLVE FOR FORCES AND ACCELERATIONS OF BEARING COMPONENTS

OUTPUTS OF BABERDYN COMPUTER PROGRAM

AVCON

- CAGE DISPLACEMENTS: $X_c, Y_c, Z_c, \theta_x, \theta_y, \theta_z$
- CAGE VELOCITIES AND ACCELERATIONS
- Σ ENERGY DISSIPATION IN BALL POCKETS AND CAGE LANDS AND BALL/RACE SKIDDING
- BALL POCKET NORMAL FORCES
- BALL/RACE SLIP VELOCITIES AND ACCELERATIONS
- TORQUE, TORQUE NOISE
- TORQUE DUE TO GEOMETRIC IMPERFECTIONS

OPTIMIZATION OF BALL-CAGE FOR MINIMUM BALL-POCKET WEAR

AVCON

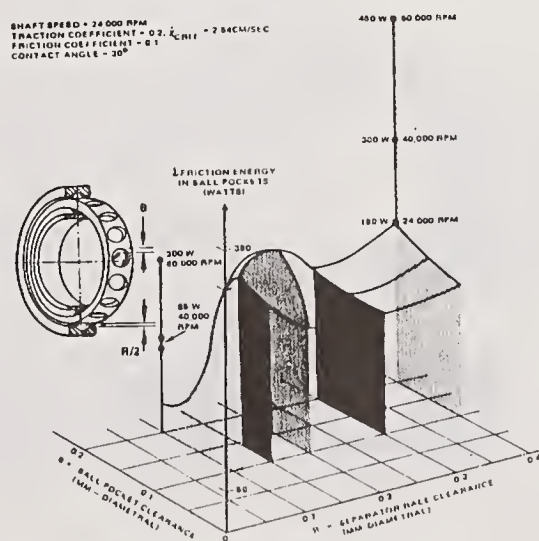


Fig. 14—Optimization of ball separator for minimum ball-pocket WEAR

OPTIMIZATION OF BALL CAGE FOR MINIMUM BALL-POCKET FORCE

AVCON

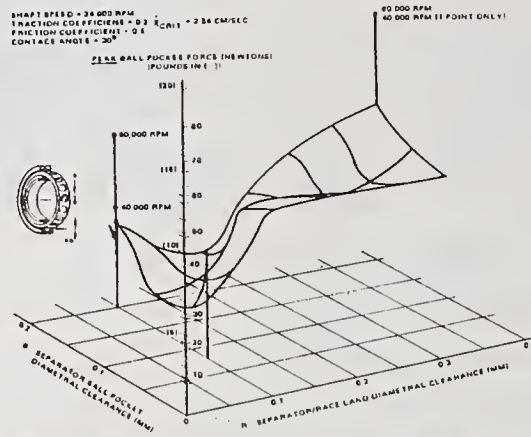


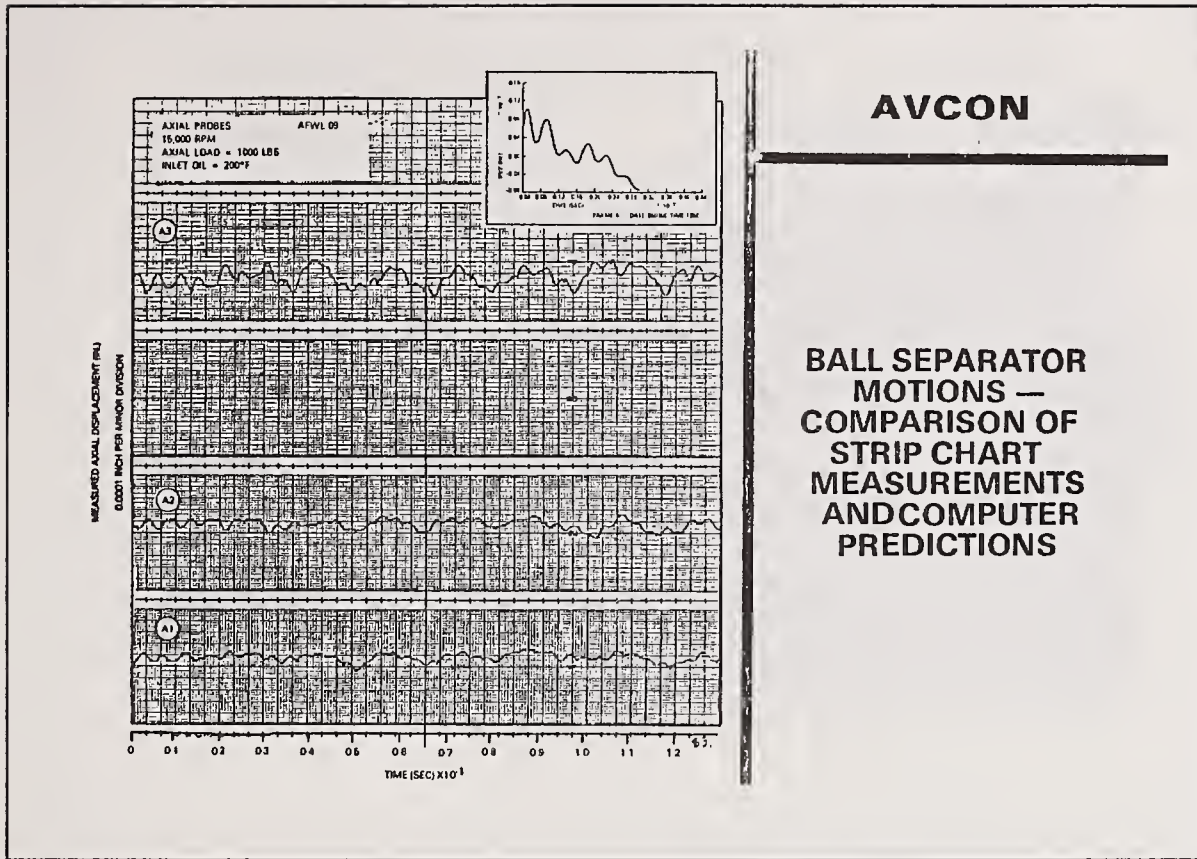
Fig. 15—Optimization of ball separator for minimum ball-pocket FORCE

FOLLOWING DESIGN GUIDELINES DEVELOPED BY BABERDYN INCREASED 600°F, 40,000 BEARING LIFE FROM 3 MINUTES TO 38 MINUTES

AVCON

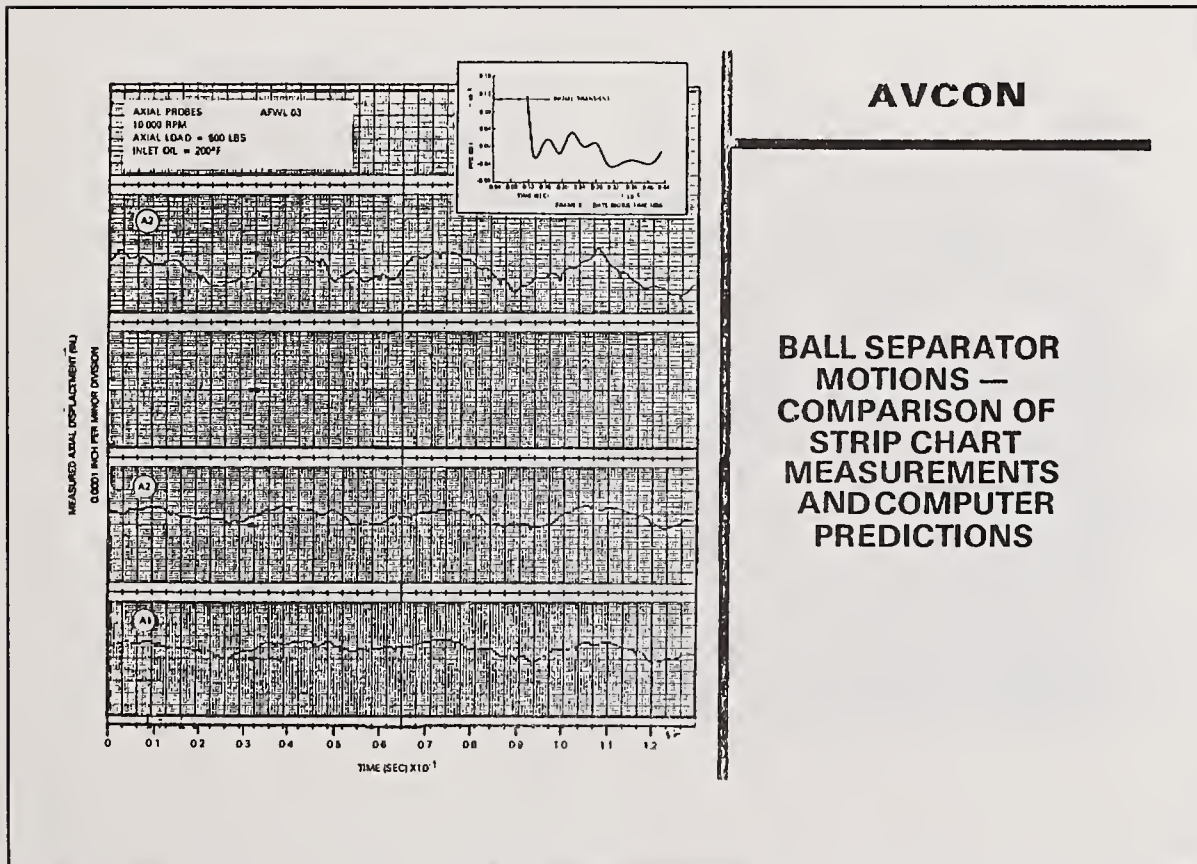


Figure 8. Self-lubricating polyimide composite separators after Bearing Test No. 2, prepared from cylindrical 3D graphite fiber weaves (AC-1/T50C2).



AVCON

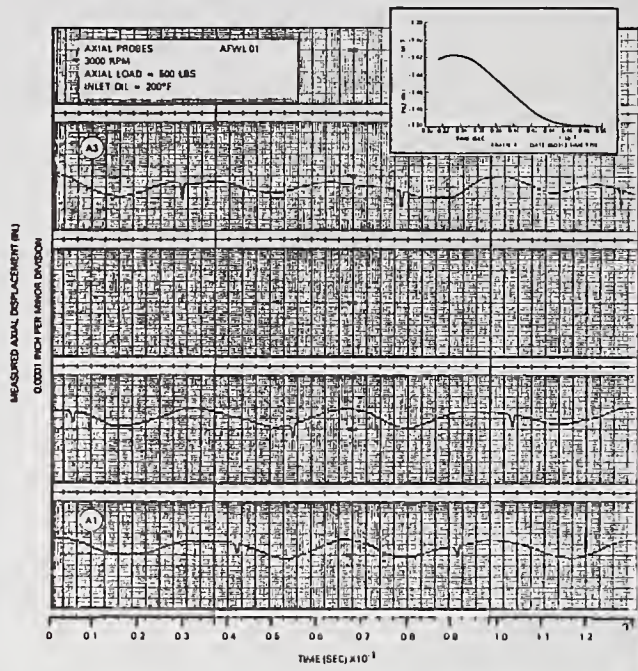
**BALL SEPARATOR
 MOTIONS —
 COMPARISON OF
 STRIP CHART
 MEASUREMENTS
 AND COMPUTER
 PREDICTIONS**



AVCON

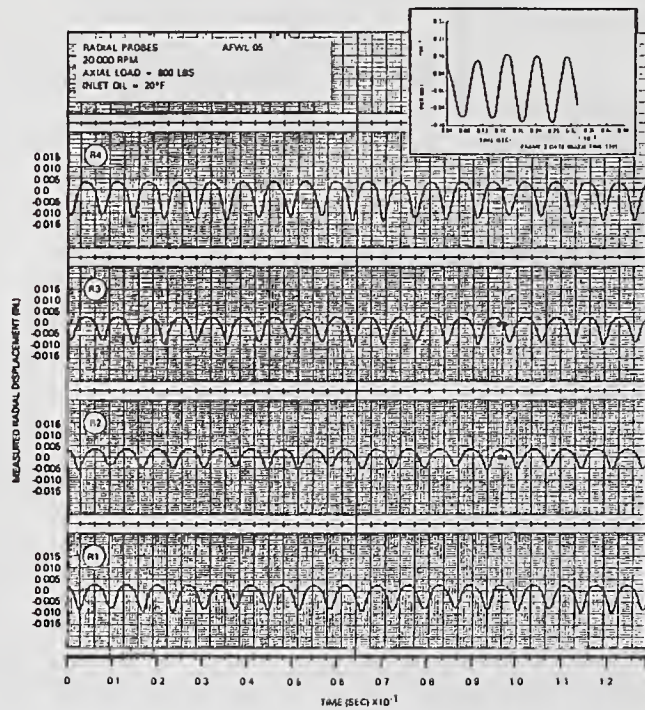
**BALL SEPARATOR
 MOTIONS —
 COMPARISON OF
 STRIP CHART
 MEASUREMENTS
 AND COMPUTER
 PREDICTIONS**

AVCON

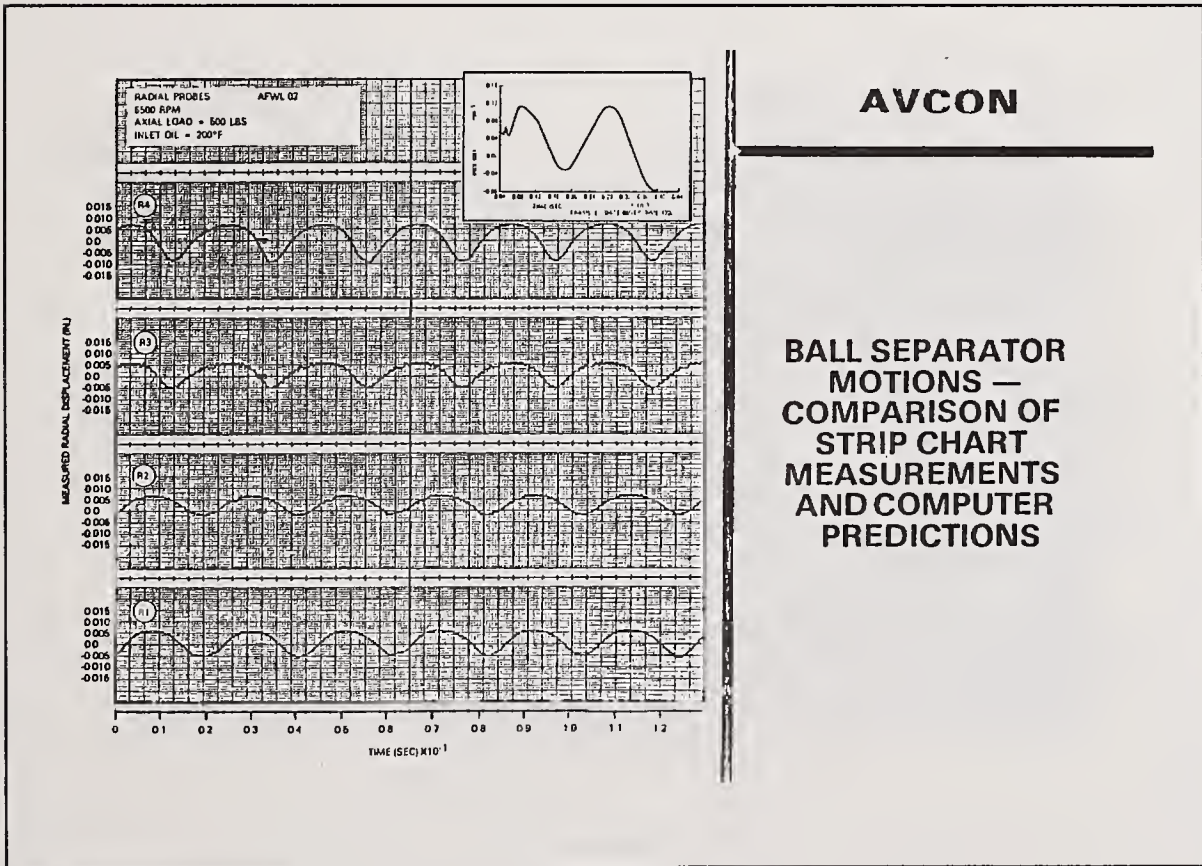
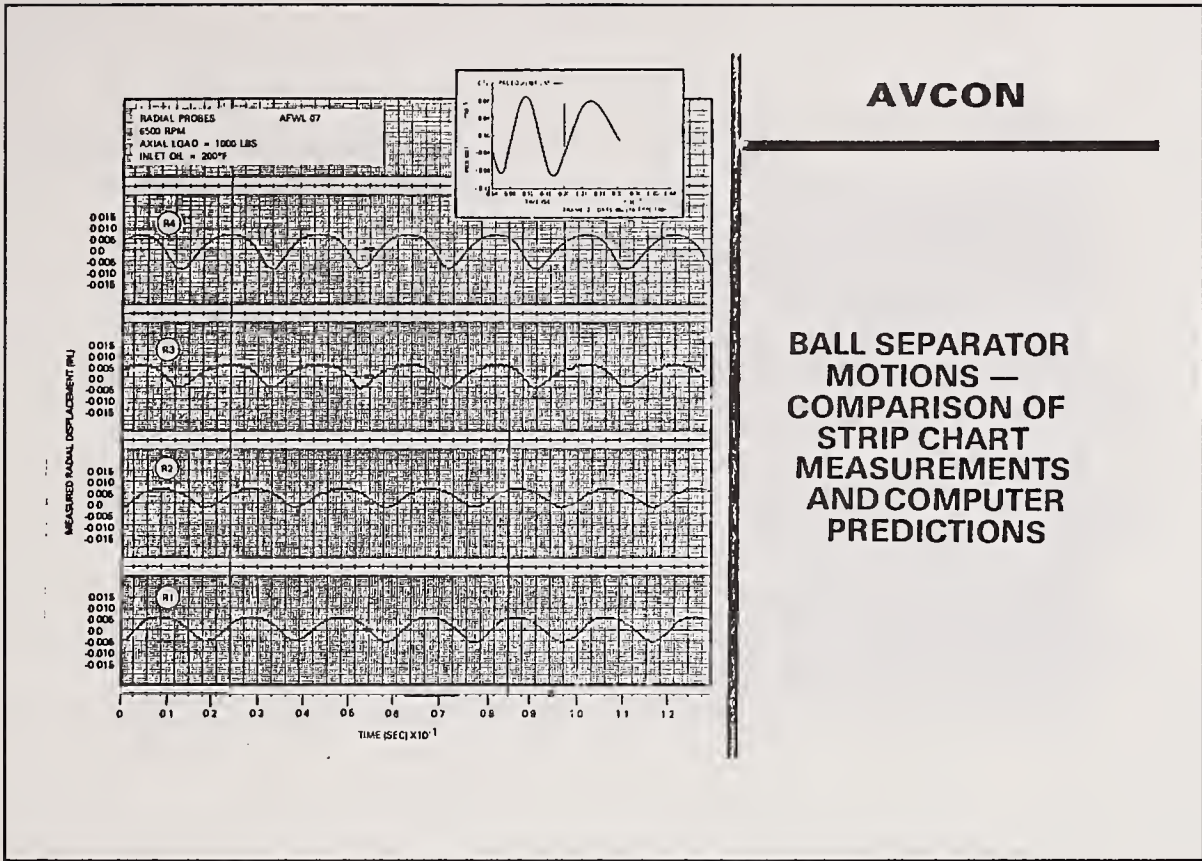


**BALL SEPARATOR
MOTIONS —
COMPARISON
OF STRIP CHART
MEASUREMENTS
AND COMPUTER
PREDICTIONS**

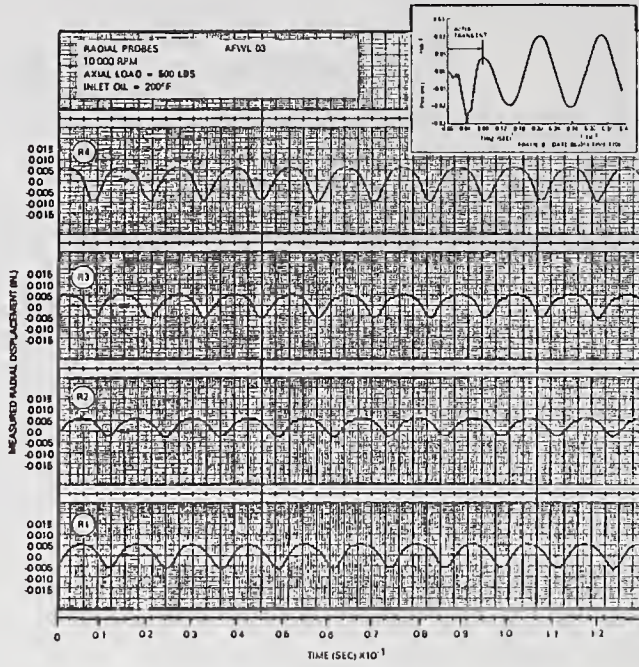
AVCON



**BALL SEPARATOR
MOTIONS —
COMPARISON OF
STRIP CHART
MEASUREMENTS
AND COMPUTER
PREDICTIONS**

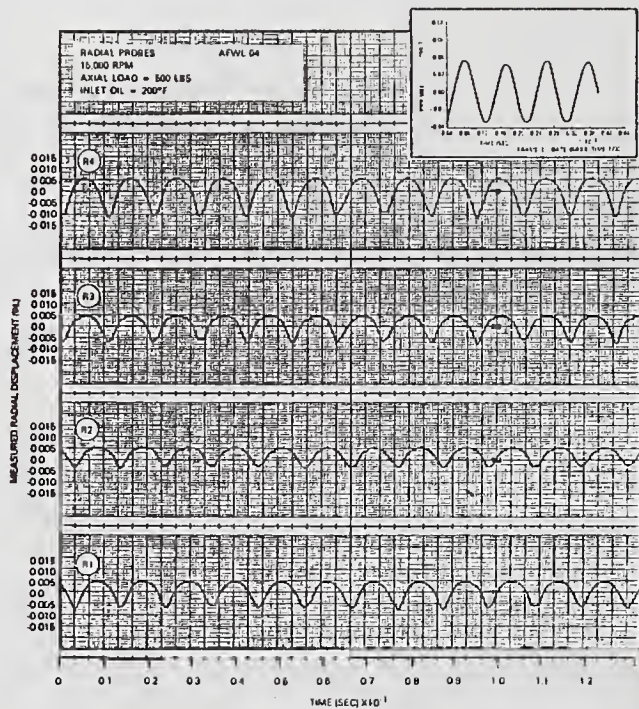


AVCON



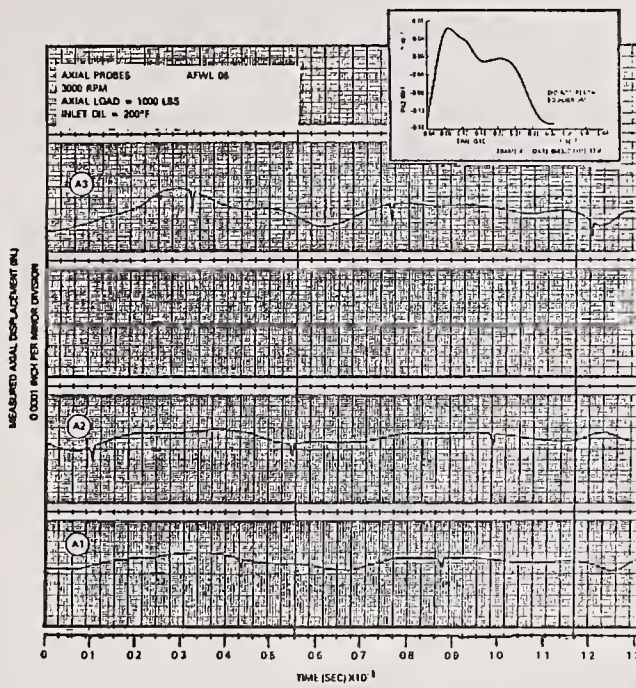
**BALL SEPARATOR
MOTIONS —
COMPARISON OF
STRIP CHART
MEASUREMENTS
AND COMPUTER
PREDICTIONS**

AVCON



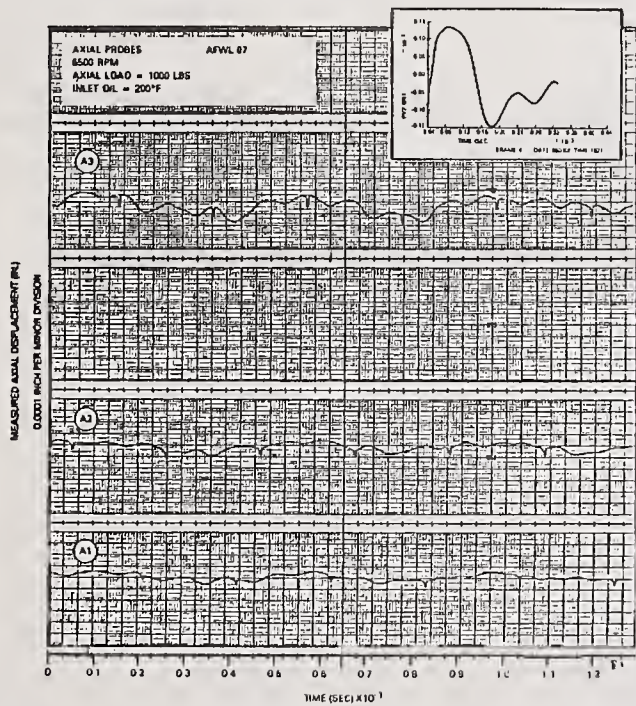
**BALL SEPARATOR
MOTIONS —
COMPARISON OF
STRIP CHART
MEASUREMENTS
AND COMPUTER
PREDICTIONS**

AVCON



BALL SEPARATOR
MOTIONS —
COMPARISON
OF STRIP CHART
MEASUREMENTS
AND COMPUTER
PREDICTIONS

AVCON



BALL SEPARATOR
MOTIONS —
COMPARISON
OF STRIP CHART
MEASUREMENTS
AND COMPUTER
PREDICTIONS

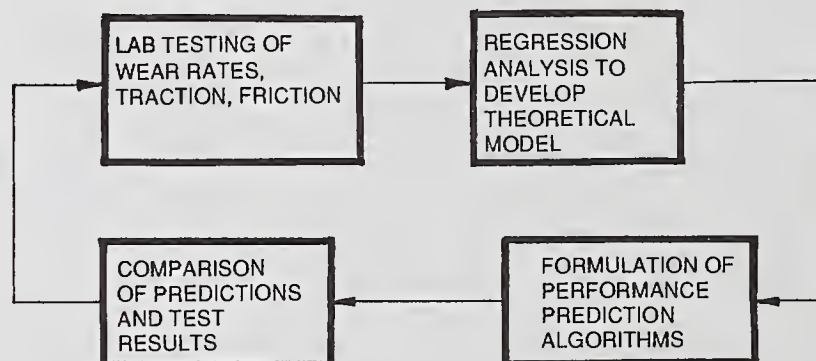
BABERDYN VALIDITY HAS BEEN VERIFIED
EXPERIMENTALLY

AVCON

1. CORRELATION OF FORCE PREDICTIONS WITH
CANTILEVER BEAM INSTRUMENTED BALL-CAGE
2. CORRELATION OF CAGE MOTION PREDICTIONS AND
PROXIMETER MEASUREMENTS OF CAGE MOTION
(BOTH AIRFORCE AND COMSAT)
3. GGIII GYRO BEARING CAGE FAILURES ELIMINATED
4. CMG WHEEL BEARING GROAN ELIMINATED
5. IT FOLLOWS THAT IF CAGE MOTION PREDICTIONS
ARE CORRECT, THEN, PREDICTIONS OF COLLISION
FORCES, BALL SLIP, TORQUE NOISE AND HEATING
RATES ARE VALID SINCE CAGE MOTIONS ARE
DETERMINED BY INTEGRATING COLLISION FORCES
AND DIFFERENTIATING RESULTS FOR VELOCITIES
AND DISPLACEMENTS
6. THE COMPUTER PROGRAM WAS SHOWN TO BE VERY
COST EFFECTIVE BY PREDICTING AN AVERAGE OF
OVER 7 SHAFT REVOLUTIONS IN TEN CASES
ANALYZED FOR AN AVERAGE OF LESS THAN 16
MINUTES OF CPU TIME

PERFORMANCE AND LIFE PREDICTION
ARE ANALYTICAL PROCESSES

AVCON



THE FIRST STEP IN PREDICTING BEARING LIFE IS TO IDENTIFY FAILURE MODES

AVCON

FAILURE MODES OF "SOLID" LUBRICATED CERAMIC BEARINGS:

- WEAR OF RACES
- WEAR OF BALLS OR ROLLERS
- WEAR OF CAGE
- TOO HIGH OR TOO LOW FILM TRANSFER
- FATIGUE

RACEWAY WEAR MAY BE DETERMINED FROM BEARING TESTS OR BASIC FRICTION-WEAR TEST MACHINES

AVCON

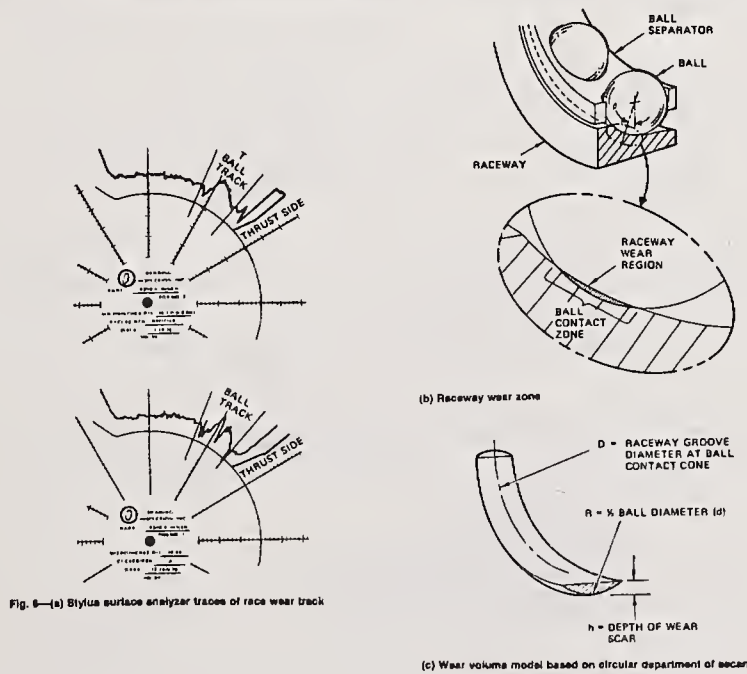
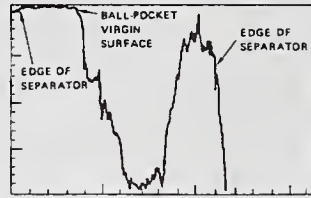


Fig. 6—(a) Stylus surface analyzer traces of race wear track

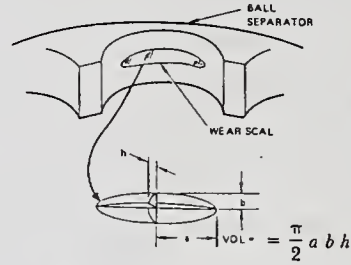
(c) Wear volume model based on circular department of sector

BALL-CAGE POCKET WEAR MAY BE DETERMINED FROM BEARING TESTS OR FRICTION/WEAR TEST MACHINES

AVCON



Surface analyzer trace of ball-separator ball-pocket wear

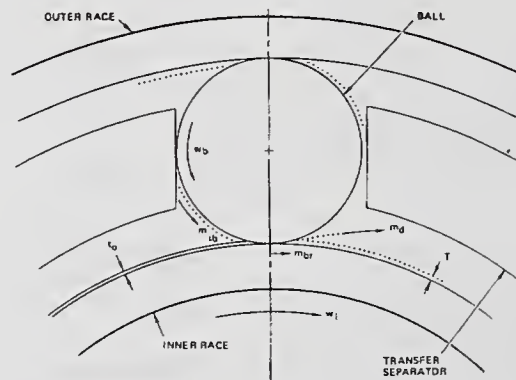


where

- V = wear scar volume (cm^3)
- a = half length of elliptical wear scar (cm)
- b = half width of elliptical wear scar (cm)
- h = depth of wear scar (cm)

SCHEMATIC OF TRANSFER LUBRICANT SYSTEM OF CERAMIC BEARING

AVCON



EQUILIBRIUM CONDITION:

$$T = t_0 + \frac{m_{tr}}{\rho a} - m_d - w \quad (1)$$

WHERE

- T = FILM THICKNESS (CM)
- t_0 = INITIAL FILM THICKNESS (CM)
- m_{tr} = LUBRICANT TRANSFERRED BALL TO RACE (GM)
- m_d = LUBRICANT WORN OFF RACEWAY (GM)
- m_{tb} = LUBRICANT TRANSFERRED FROM SEPARATOR TO BALL (GM)
- w = RACEWAY WEAR (CM)
- ρ = DENSITY (GM/CM^3)
- a = AREA OF BALL WEAR CONTACT ZONE (CM^2)

FROM LUNDGERG AND PALMGREN, THE CLASSICAL
APPROACH TO BEARING FATIGUE LIFE IS:

$$\ell_n \frac{1}{\mathcal{R}} = 0.1053 \left(\frac{t}{\ell_{10}} \right)^e \quad [23]$$

where

- \mathcal{R} = reliability for time t
- e = Weibull slope $\sim 10/9$ for ball bearings
- t = operating time in hours
- ℓ_{10} = Fatigue life (hours) for 0.90 reliability associated
with the corresponding load stress condition

This equation can be extended to allow for decreasing
preload in the following way (2):

$$(t/\ell_{10})_{\text{equivalent}} = t \sum_{i=1}^n \frac{(CD)_i}{(\ell_{10})_i} \quad [24]$$

where

- $(CD)_i$ = percent of the total running time in question to
be spent at a given load/stress condition
- n = chosen number of increments to allow for
changing the stress conditions

1. IDENTIFY FAILURE MODES
2. TEST FOR WEAR RATE IN LAB TESTS
 - (A) BALL/RACEWAY
 - (B) BALL-CAGE POCKET
 - (C) BALL-CAGE TO LAND
3. MODIFY CLASSICAL* FATIGUE MODELS
ANALYTICALLY FOR CERAMIC MATERIALS SYSTEMS
4. DETERMINE LOADING CONDITIONS FROM
ANALYTICAL DYNAMIC MODELS
5. COMBINE EFFECTS FOR OVERALL BEARING SYSTEM
LIFE, RELIABILITY PREDICTION

* BASED ON OIL LUBRICATED, 52100 BEARING STEEL
TESTS

**GIANT STEPS FORWARD IN CERAMIC BEARING
TECHNOLOGY CAN BE REALIZED**

AVCON

A COMPREHENSIVE, COOPERATIVE PROGRAM THAT INTEGRATES THE EFFORTS OF THE TRIBOLOGIST, BEARING DESIGNER AND COMPUTER ANALYST WILL MAXIMIZE THE PROBABILITY OF SUCCESSFUL HIGH TEMPERATURE, HIGH DN BEARINGS.

SPECIFICALLY:

1. EXPAND AND IMPROVE ON EXISTING COMPUTERIZED ANALYSIS TOOLS,
2. ESTABLISH A RESEARCH/DEVELOPMENT PROGRAM IN WHICH THE DESIGNER/ANALYST AND TRIBOLOGIST WORK IN CLOSE CONCERT TO ESTABLISH MATERIALS "WINDOWS" OF PERFORMANCE TO GUIDE THE TRIBOLOGICAL RESEARCH,
3. CREATE A TEAM EFFORT IN WHICH THE DESIGNER/ANALYST APPLY TRIBOMATERIALS SYSTEMS TO NEW BEARING DESIGNS AND ITERATE THE DESIGNS BASED ON RESULTS OF BEARING ENVIRONMENTAL AND PERFORMANCE TESTS.
4. MODIFY, AND IMPROVE UPON, EXISTING REGRESSION ANALYSIS TOOLS FOR PREDICTING BEARING LIFE FACTORS BASED ON ONGOING RESEARCH THAT CHARACTERIZES CERAMIC MATERIALS SYSTEMS (WEAR RATE, FATIGUE, ETC.) AND INCORPORATE THESE INTO EXISTING COMPUTER MODELS.

Tribology Issues Related to Machining and Performance
of Ceramic Bearings

Said Jahanmir
Tribology Group
National Institute of Standards and Technology
Gaithersburg, MD 20899

This presentation will provide a brief summary of recent research at NIST related to machining and tribological performance of ceramic rolling element bearings. The specific topics to be covered include: the effect of contact load and temperature on wear, boundary and solid lubrication of silicon nitride, self-lubricating composites for bearing cages, and chemically assisted ductile regime grinding.

The goal of our project on wear of ceramics is to elucidate the fundamental mechanisms of wear of different ceramic tribomaterials tested under various conditions of load and temperature. The testing program on two materials (AD-998 alumina and NBD-100 silicon nitride) was recently completed. The results have been assembled in wear transition diagrams, which are two-dimensional plots showing different regimes of tribological behavior separated by solid lines depicting the transitions between the regimes. For example, the tribological behavior of alumina can be divided into four regimes: lubrication with films formed by tribochemical reactions with water vapor, mild wear by plowing, severe wear by fracture, and glass-phase lubrication at high temperatures. The tribochemical reaction, plowing, and fracture regimes are also observed for silicon nitride. As the temperature is increased, selective oxidation of various second phases in silicon nitride is also observed, and at higher temperatures oxidation of the primary phase is found to contribute to the wear process. Preliminary results on silicon carbide (Hexoloy SA) have shown that, similar to silicon nitride, tribochemical reaction, fracture, and oxidation control the wear process of this material. A linear elastic fracture mechanics model was used to analyze the contact fracture process. The model has confirmed that propagation of cracks from pre-existing flaws controls the fracture process. Furthermore, the model substantiated the strong role of friction coefficient that has been observed experimentally. Future research should evaluate the effect of microstructure and composition on the transitions. This information could lead to the development of ceramic tribomaterials with a larger load-carrying capacity and improved reliability.

Transition from mild to severe wear by fracture is highly sensitive to the coefficient of friction, because of the effect of friction on the tensile component of stress at the trailing edge of the contact circle. Therefore, even a small reduction in the coefficient of friction can result in a large increase in transition load, and a reduction in the rate of wear. The coefficient of friction can be reduced by hydrocarbon lubricants and polar additives. Although limited data have been published, the details of the boundary lubrication of silicon nitride are not known. Particularly, the adsorption mechanism of polar compounds on ceramic surfaces and the role of chemical structure on the

adsorption process need to be analyzed. This type of information can be used to develop effective lubricants for marginally lubricated ceramic bearings.

Hydrocarbon liquid lubricants can not be used at elevated temperatures or under vacuum environments due to severe degradation and evaporation. Solid lubricants must be used under these conditions. One of the problems is the delivery of the solid lubricant to the contact. In rolling element bearings solid lubrication may be provided by a self-lubricating composite cage containing the solid lubricant as a second phase. Our research in this project has been concentrated on understanding the mechanisms of wear and transfer film formation in both metal-matrix and ceramic-matrix composites. Our recent results have confirmed that in these materials lubrication is achieved by the formation of a transfer film, which contains materials from both the composite and the counterface, as well as tribochemical reaction products. Therefore, a thorough understanding on the formation of the transfer film and the relationship between the microstructure of the composite and mechanical properties of the transfer film are needed to optimize the microstructure and composition of self-lubricating materials.

The performance and reliability of ceramic rolling element bearings are controlled by such factors as microstructure and composition, surface roughness and integrity, and contact conditions. Machining and final finishing of ceramic components can have a strong influence on reliability and performance because of the damage produced during these operations. Formation of defects and residual stresses due to machining can be detrimental and promote early failure by fatigue and spalling. In addition to the effect of damage on performance, machining contributes to the high cost of ceramic bearings. Therefore, it is imperative to find innovative and cost-effective methods to machine ceramic bearing components that are free of machining generated defects. Our machining program is focused on four topics: chemically assisted machining, damage characterization and sensor development, optimization of the diamond grinding process, and intelligent machining systems. Our efforts on chemically assisted ductile regime grinding is one of the projects focused on finding new ways to machine damage-free high-precision surfaces. Recent results have shown that ductile regime grinding of advanced ceramics, such as silicon carbide, is feasible. The concept of ductile regime grinding is based on the idea that at very small depths of cut the material can be removed by plastic deformation rather than fracture, which is normally observed for brittle materials. In our program, we are investigating the effect of chemical environment on the process of chip formation, with the goal of improving the grinding process through selection of proper chemical compounds for addition to the grinding fluid.

TRIBOLOGY ISSUES RELATED TO MACHINING
AND
PERFORMANCE OF CERAMIC BEARINGS

Said Jahanmir
National Institute of Standards and Technology

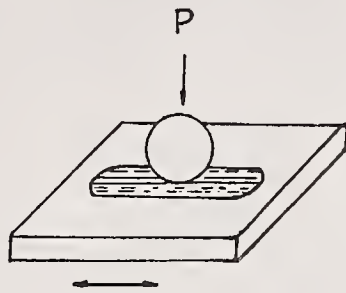
April, 17, 1991

- O Sliding Wear and effect of contact conditions
- O Boundary and solid lubrication
- O Self-lubricating composites
- O Chemically assisted machining

Project Goals:

- Determine the effect of contact condition and microstructure on wear mechanisms of advanced ceramics
- Assemble data in simple diagrams for use by design and materials engineers
- Develop mechanics models to predict the effect of parameters on severity of wear

HIGH TEMPERATURE TRIBOMETER



LOAD: 0.5 -- 15 kg

SPEED: 1 mm/sec. -- 10 mm/sec.

TEMPERATURE: 21 C -- 1000 °C

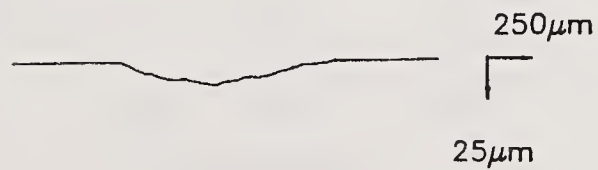
STROKE LENGTH: 0 -- 60 mm

ENVIRONMENT: AIR

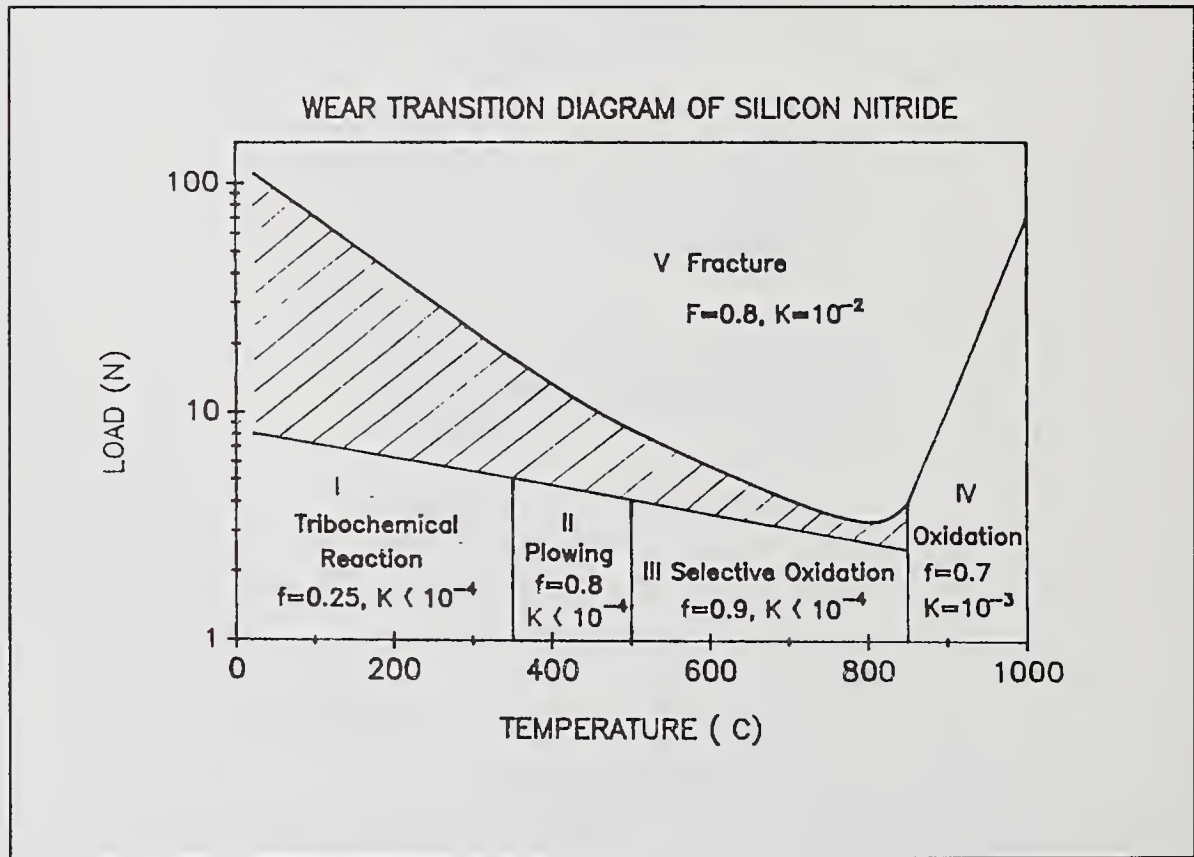
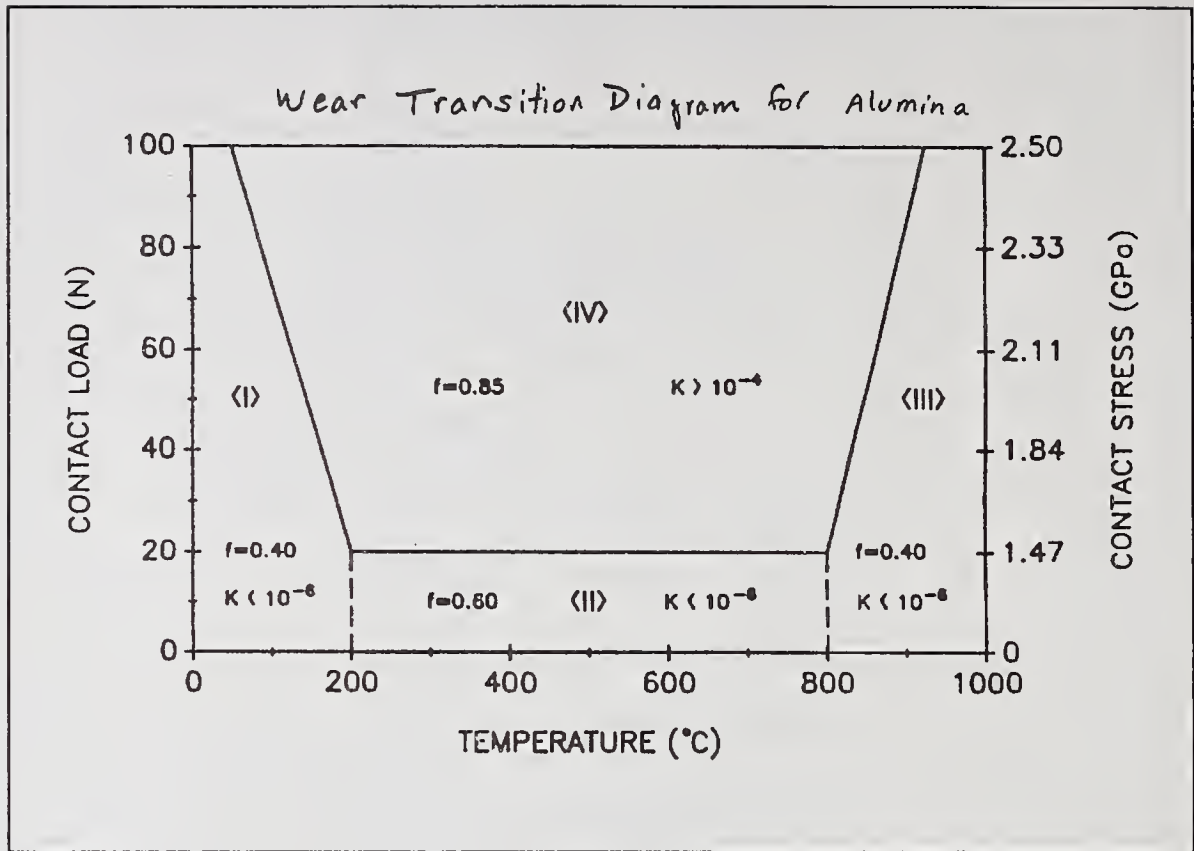
SURFACE PROFILE



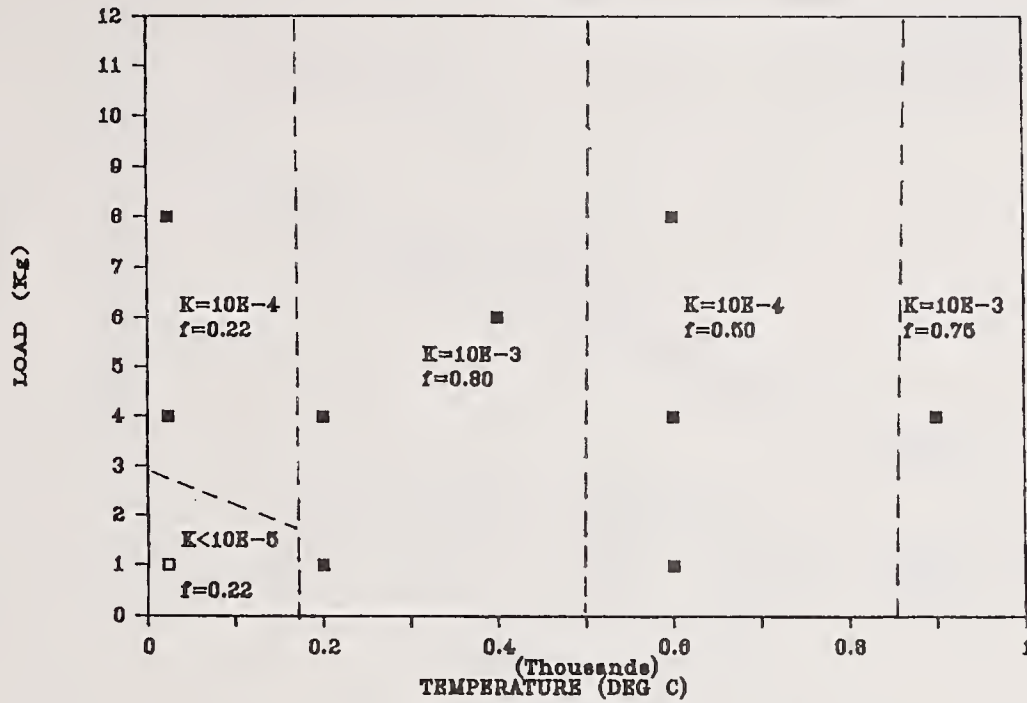
6 kg, 200°C, 120 min.



6 kg, 400°C, 120 min.

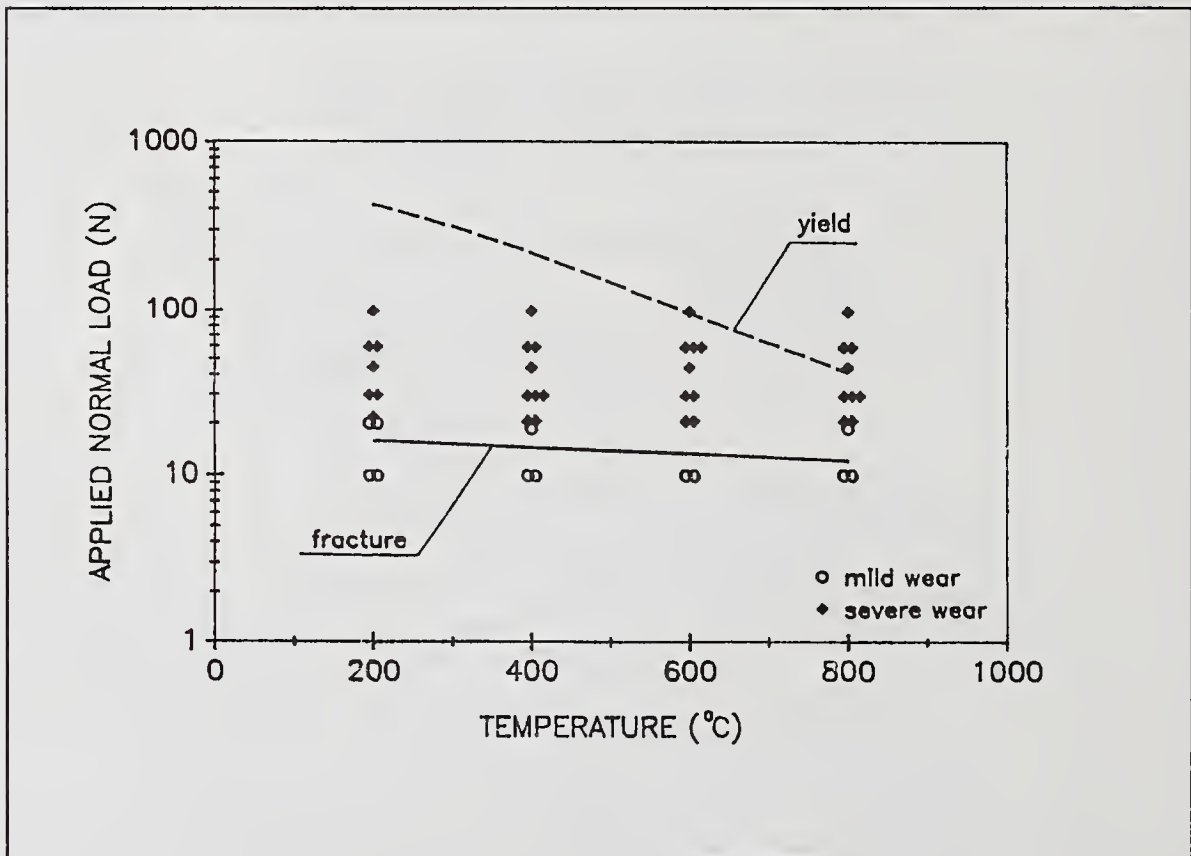
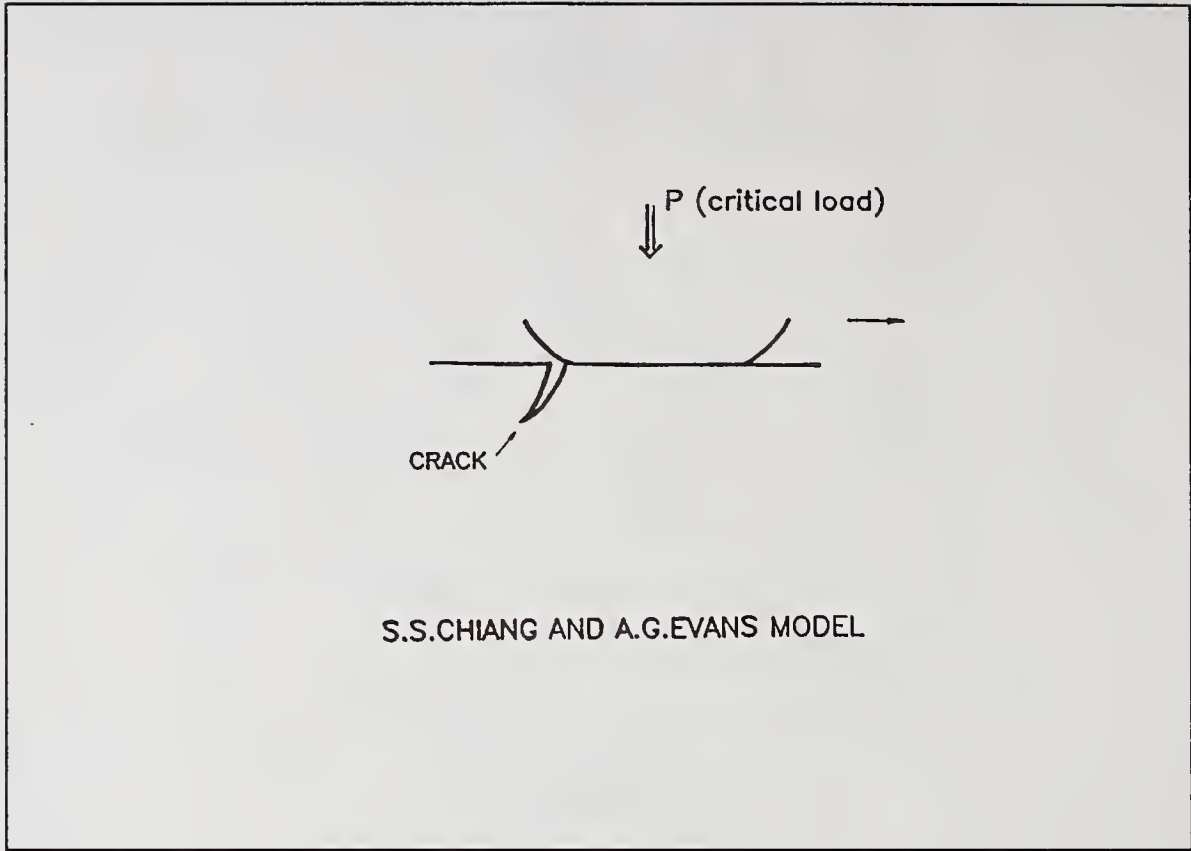


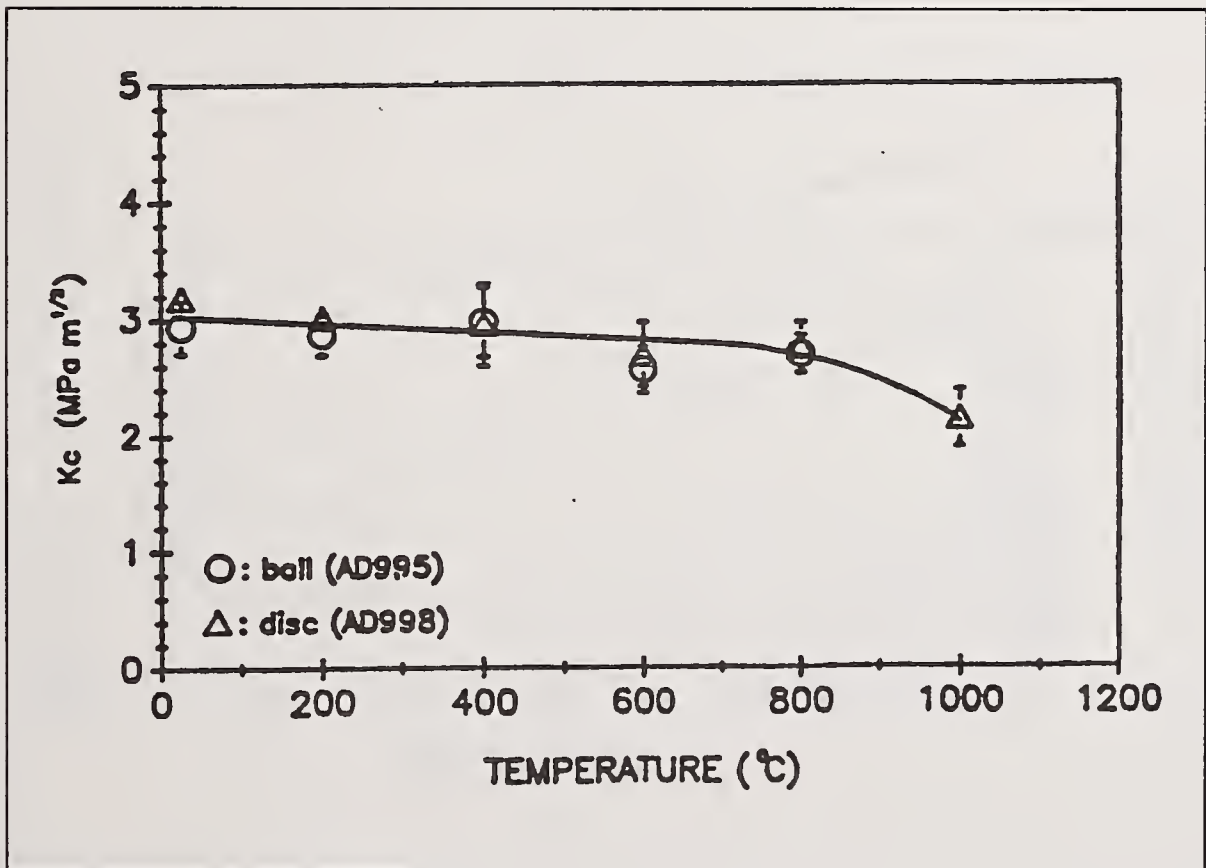
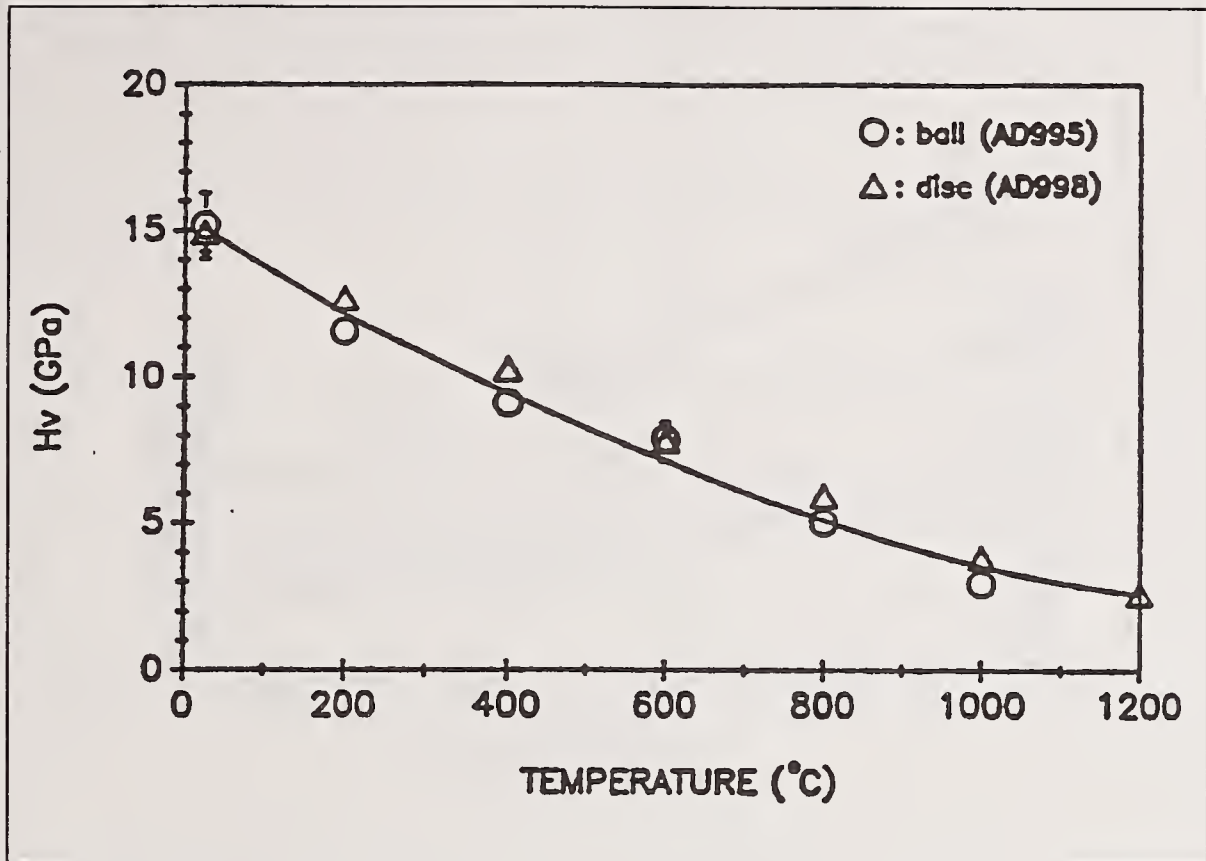
ALPHA SiC

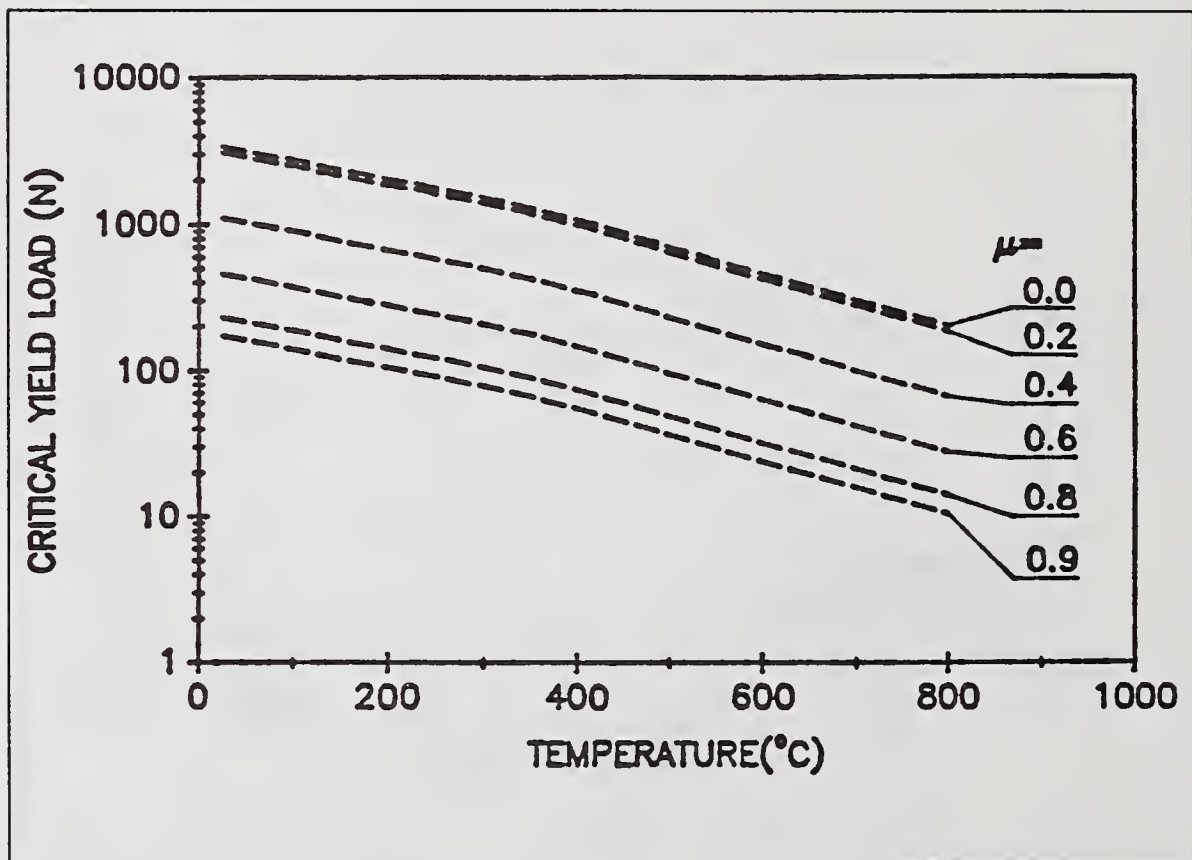
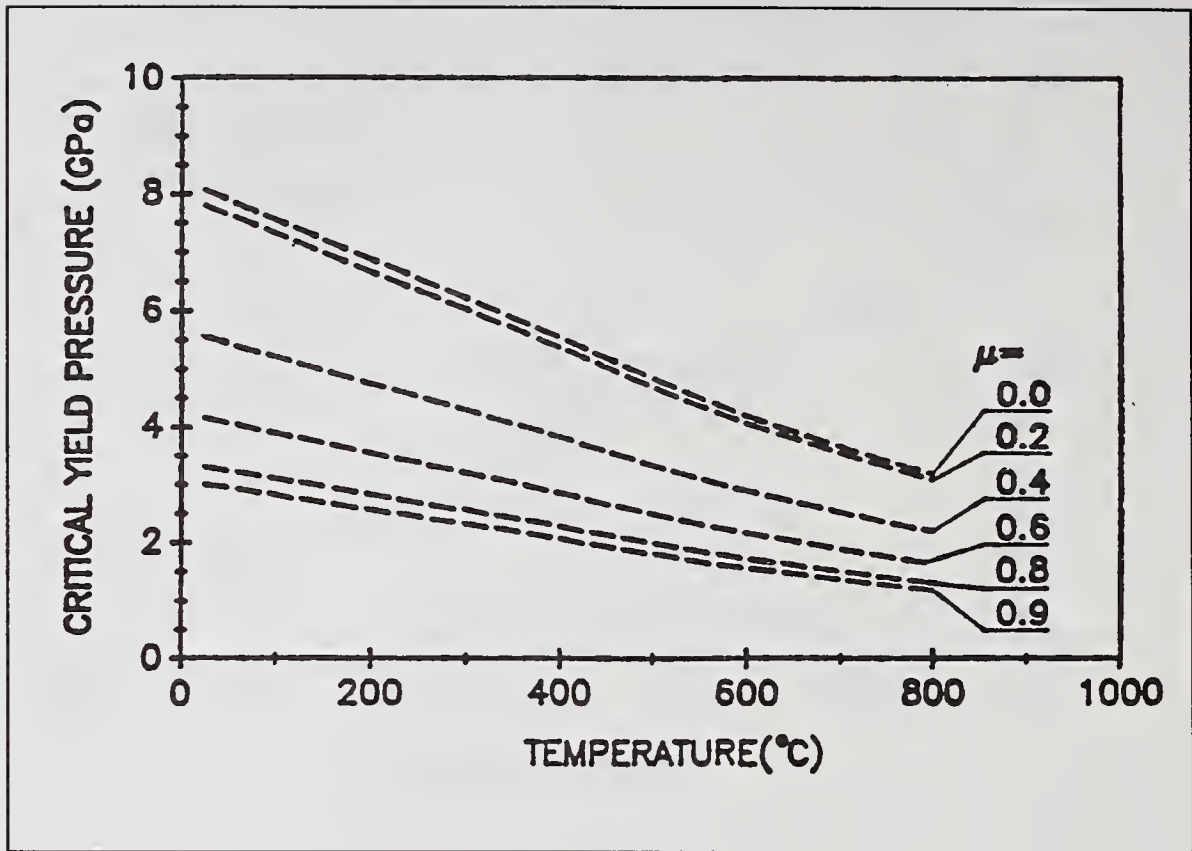


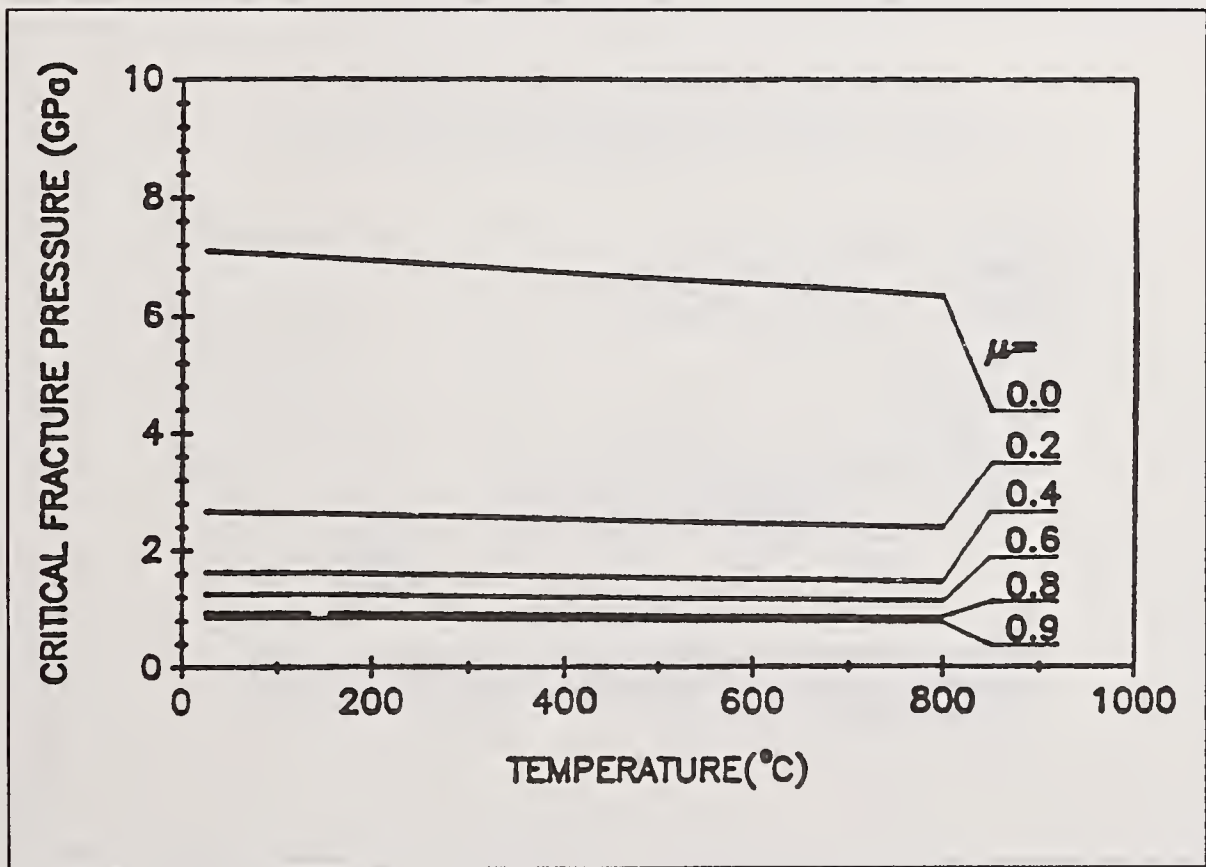
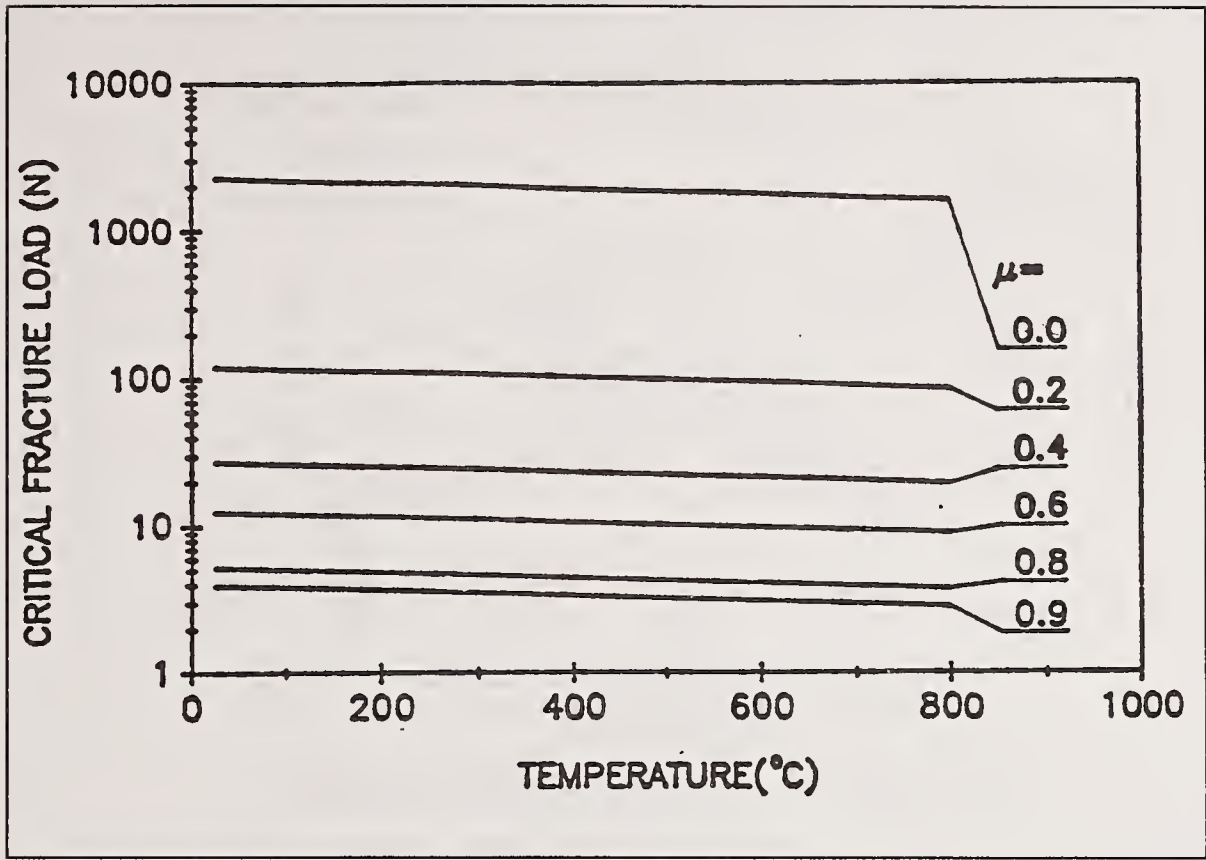
Possible Fracture Initiation Modes

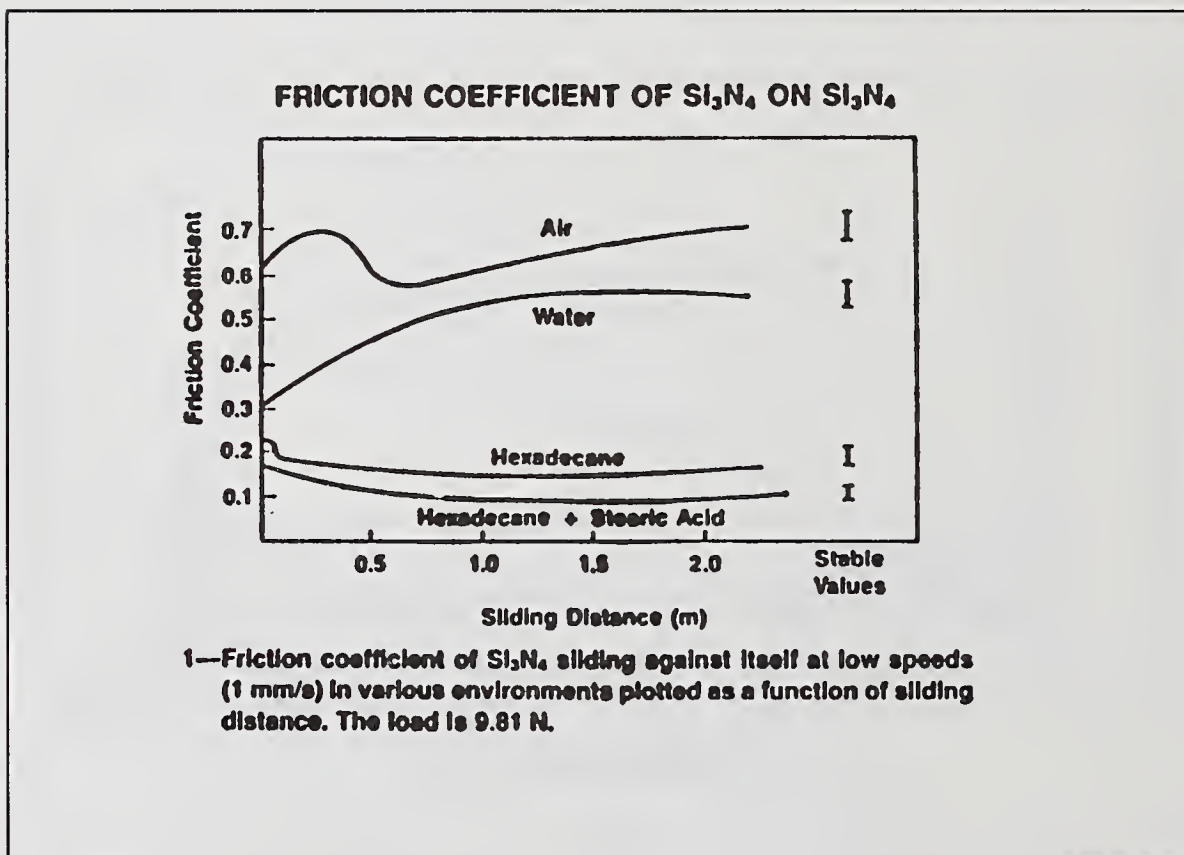
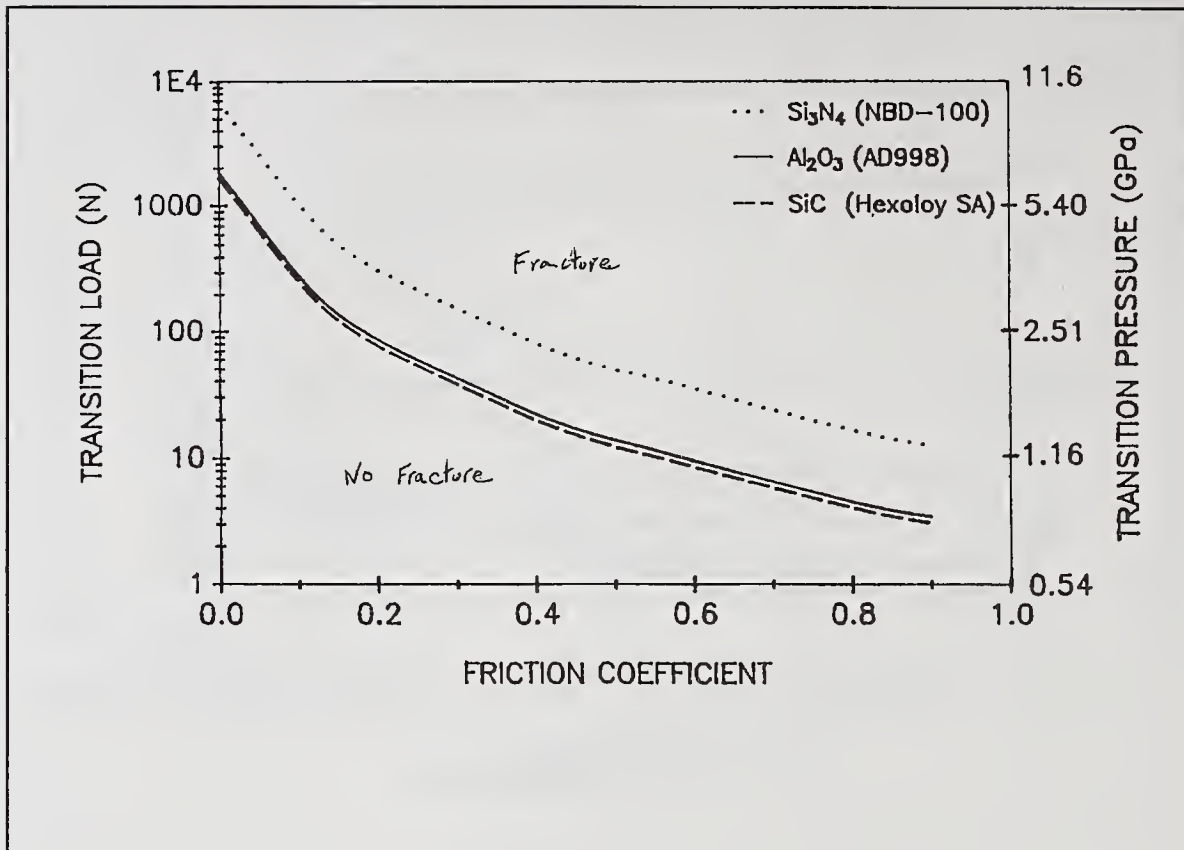
- 1) Shear and microplastic deformation below the contact.
- 2) Tensile microcracks behind the contact.

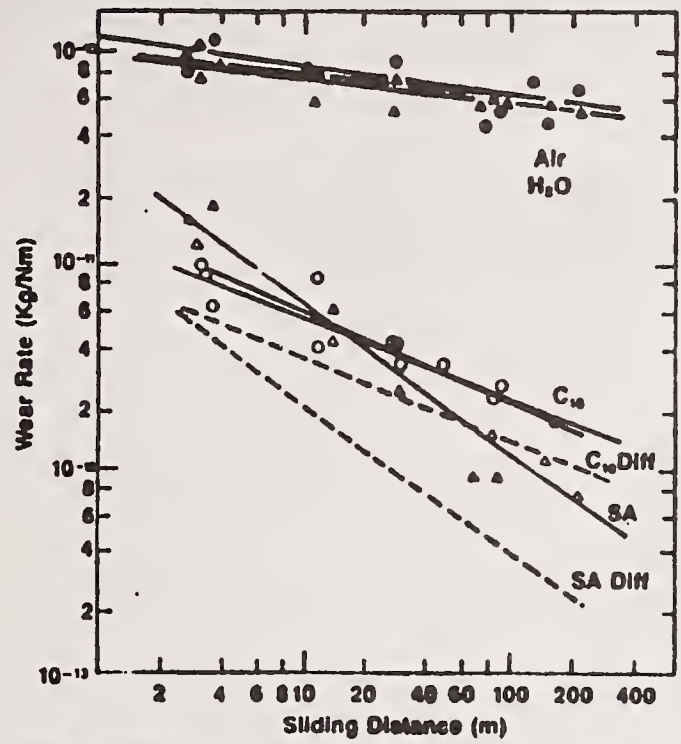












—Logarithmic plot of the wear rate of Si₃N₄ sliding against itself at low velocity in various environments.

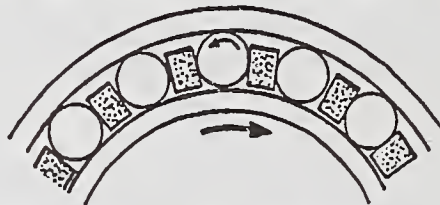
Approaches to High Temperature Ceramic Components

- Ring/Liners ----- "Once Through" Fluid System
- Valves/Guides ----- Self Lubricating Materials
- Rolling Contact Bearings ----- Self Lubricating Cage
- Brakes ----- Composite Materials

PURPOSE OF NIST PROJECT

DEVELOP THE KNOWLEDGE BASE FOR
LOWER WEAR, SELF-LUBRICATING
COMPOSITES FOR GAGES, GEARS,
BEARINGS AND SEALS.

CAGE-LUBRICATED SOLID LUBRICATED BEARINGS



Technical Advantages

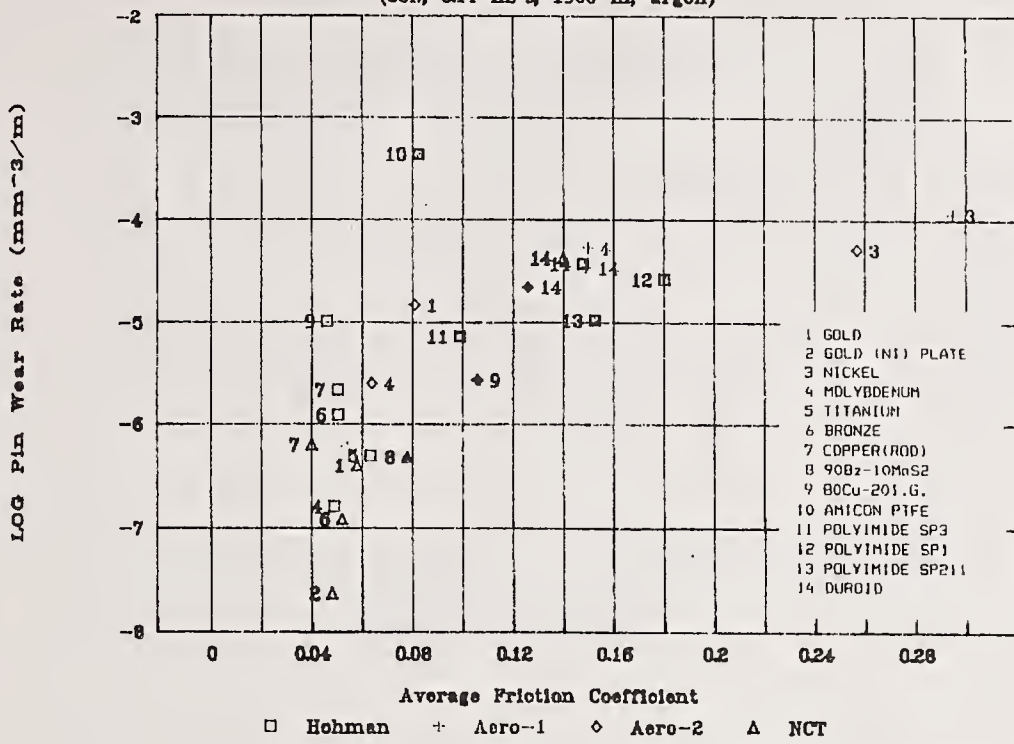
- Low cost, low maintenance
- Simple, self-contained system
- High temperature and vacuum capability
- Oil-free applications

Technical Issues

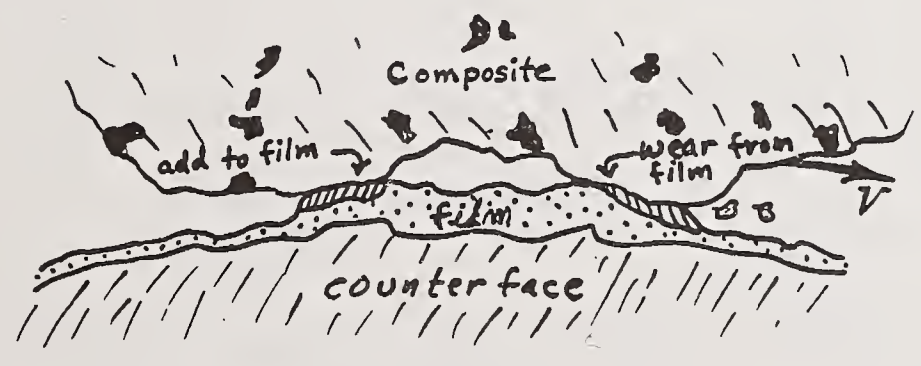
- Understand wear and transfer mechanisms for cage/ball and ball/race contacts.
- Optimize cage materials and bearing designs for low wear and long life.

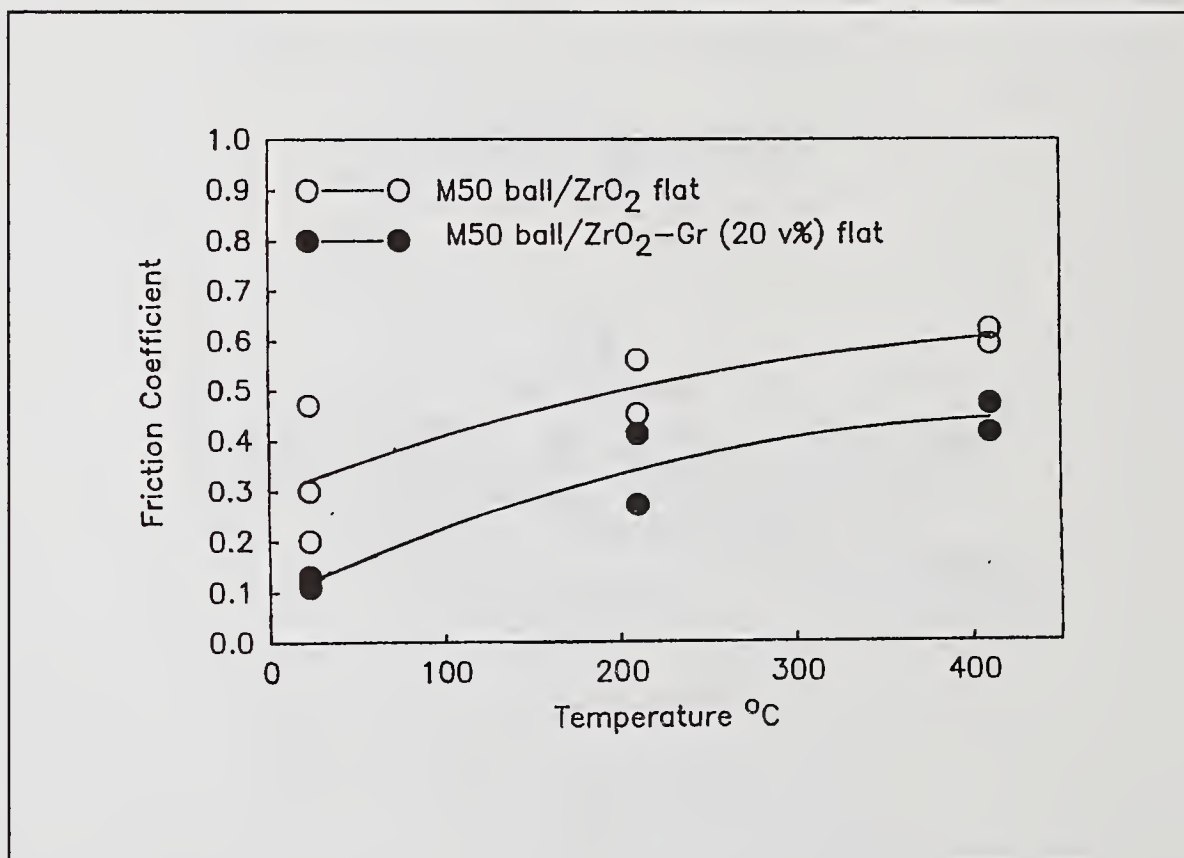
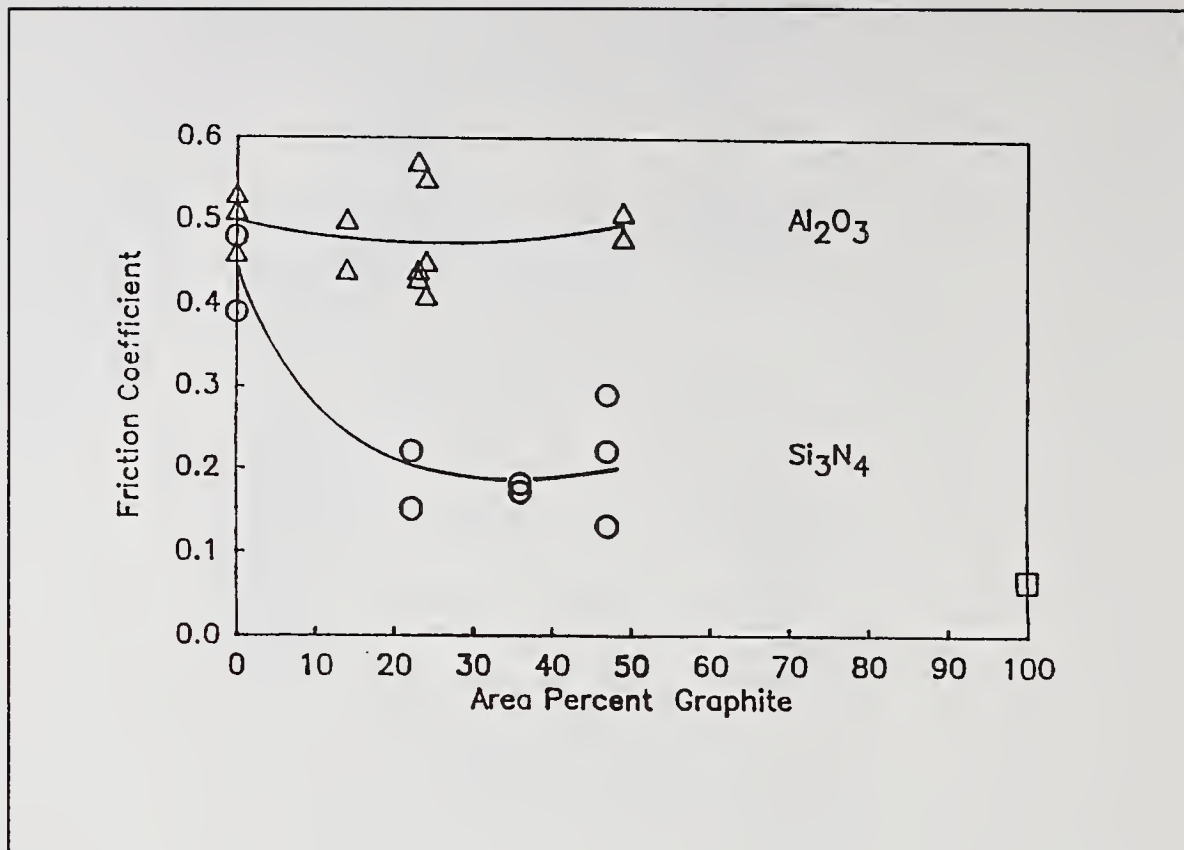
CAGE MATERIALS vs MoS2 COATED 440C

(33N, 0.14 m/s, 1900 m, argon)



WEAR MODEL





- Cost-Effectiveness - The Primary Impediment to Utilization of Advanced Ceramics
- Machining/Finishing - A Significant Portion of Component Cost
- Component Reliability - A Function of Quality of Finished Surface

Industrial Needs

- o Methods of Rapid Material Removal with Minimal Damage
- o In-situ and Post-machining NDE Techniques for Damage Analysis
- o Assessment of Surface Damage Effects on Strength and Performance

NIST PROGRAM ON RAPID MACHINING

Projects:

- (1) Rapid Chemical Assisted Machining
- (2) Damage Characterization and Sensor Development
- (3) Optimization of Diamond Grinding Process
- (4) Intelligent Machining System

Mechanisms of Material Removal

a) Ductile
Chip
Formation



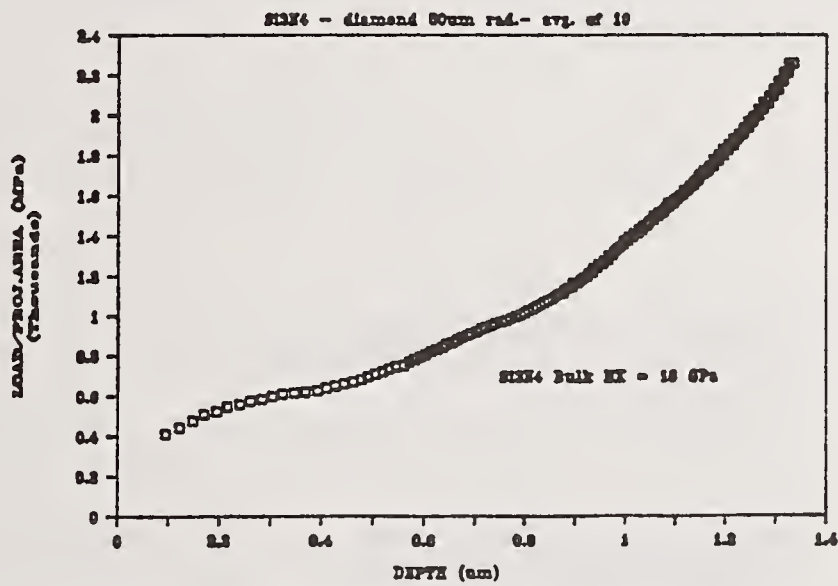
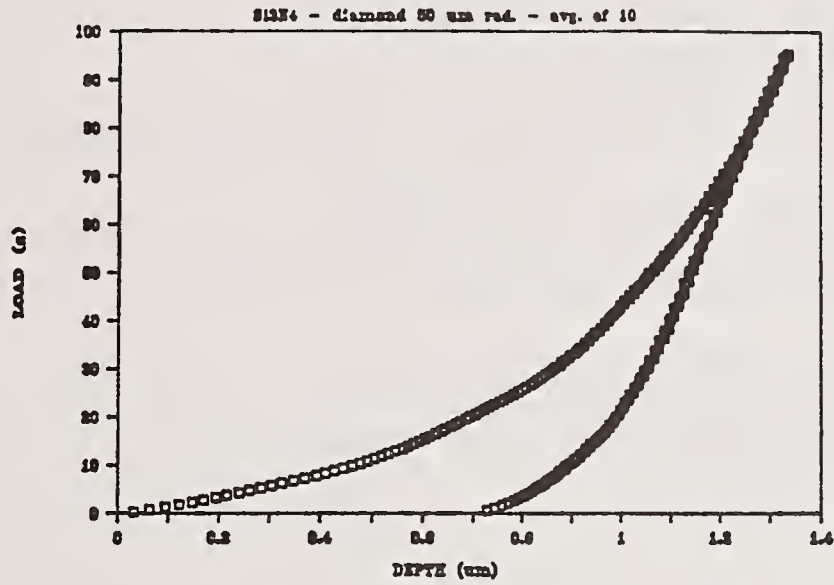
Plastic
Deformation
Residual
Stress

b) Brittle
Fracture



Cracks and
Plastic
Deformation
Residual
Stress

Typical Results on Si₃N₄ for Nano-Indenter



NIST Precision Machining Research Facility
SiC Ductile Grinding Program, FY '91

- CVD SiC and siliconized SiC
 - resin bond wheels
 - optimize finish/sub-surface damage
 - low damage microgrinding vs ductile regime grinding
- Metal bond wheels (for lower wear)
 - dressing and truing for nm class run-out
 - performance vs resin bond
- Chemical effects
 - enhanced transition depths?
 - slow speed scratch tester, single grit and machining trials

CONCLUDING REMARKS

- Ceramic rolling element bearings must be designed with minimum sliding
- Lubrication is critical to bearing performance
- Combination of self-lubricating cages and solid lubricated races is recommended
- Reliable models are needed for failure prediction
- Chemically assisted ductile regime grinding can provide damage-free precision bearing components

Appendix A

NIST/DARPA
CERAMIC BEARING TECHNOLOGY WORKSHOP

April 17-18, 1991
Sheraton-Potomac Hotel
Rockville, MD

April 17

- 8:30 am Introductory Remarks
 Dr. Said Jahanmir, NIST, Workshop Chair
- 8:35 Welcome and Overview of Materials Science and Engineering Lab.
 Dr. Lyle Schwartz, NIST
- 8:45 Workshop Agenda
 Dr. Bill Coblentz, DARPA
- 9:00 Advantages of Ceramic and Ceramic Hybrid Bearings for Military
 Applications
 Dr. James Dill, Mechanical Technology, Inc.
- 9:30 Payoffs and Challenges in Utilization of Ceramic Bearings in
 Spacecraft Mechanisms
 Dr. Paul Fleischauer, Aerospace Corp.
- 10:00 Coffee Break
- 10:15 Surface and Subsurface Navy Applications and Requirements
 Dr. Gerry Phillips, NSRDC
- 10:45 Instrument Bearing Requirements and Issues
 Bob Westerholm, Litton Guidance
- 11:15 High Temperature Applications and Challenges
 Dr. Lewis Sibley, Tribology Systems, Inc.
- 11:45 LUNCH
- 1:00 pm Effects of Composition, Microstructure, and Processing on Ceramic
 Bearing Performance
 Prof. Bob Katz, Worcester Polytech
- 1:30 Effects of Machining and Finishing on Performance
 Dr. Mike Gardos, Hughes, and Julian Pratt, Spheric, Inc.

2:00 Requirements and Issues in Quality Control and NDE of Ceramic Bearings
Prof. Pierre Khuri-Yakub, Stanford University

2:30 Coffee Break

3:00 Ductile Regime Grinding of Ceramic Bearings
Prof. Tom Dow, North Carolina State University

3:30 Design and Life Prediction Issues for Ceramic Bearings
Crawford Meeks, AVCON, Inc.

4:00 Tribology Issues Related to Machining and Performance of Ceramic Bearings
Dr. Said Jahanmir, NIST

4:30 Discussion Groups Convene

- o Ceramic Processing and Blank Fabrication
Dr. Jim Hannoosh, CERBEC, & Dr. Subhas Malghan, NIST
- o Machining, Quality Control, and NDE
Dr. K. Subramanian, Norton, & Dr. Grady White, NIST
- o Design, Performance Testing, and Life Prediction
Dr. James Dill, Mechanical Technology Inc., & Marshall Peterson, NIST

6:00 Happy Hour (Cash Bar)

7:00 Dinner
Invited Speaker: Dr. John Alic, Senior Associate, Office of Technology Assessment, "U.S. Manufacturing: An Agenda for Competitiveness"

April 18

8:00 am Discussion Groups (continue)

10:00 Coffee Break

10:15 Recommended Research (presentations by Group Chairs)

11:30 Discussions and Concluding Remarks
S. Jahanmir and W. Coblentz

12:00 Lunch/Adjourn

Appendix B
Final Participants List

Jim Aeschliman
MPB Corp.
P.O. Box 547
Keene, NH 03431-0547

John Alic
U.S. Congress
Office of Technical Assessment
Washington, DC 20510

Dave Almy
UES, Inc.
4401 Dayton-Xenia Road
Dayton, OH 45432-1894

Brian Bergsten
U.S. Air Force
WL/POSL
WPAFB, OH 45433

Duncan A. Boyce
Raytheon
50 Apple Hill Drive
Tewksbury, MA 01876

Harold Burrier
The Timken Co.
1835 Dueber Ave., SW
Canton, OH 44706

Bernard J. Busovne
Garrett Ceramic
19800 S. Van Ness Ave.
Torrance, CA 90501

Y. P. Chiu
The Torrington Co.
59 Field St.
Torrington, CT 06790

William J. Chmura
The Torrington Co.
59 Field St.
Torrington, CT 06790

William S. Coblenz
DARPA/DSO
1400 Wilson Blvd.
Arlington, VA 22209

John H. Coleman
INSACO, Inc.
P.O. Box 9006
Quakertown, PA 18951

Thomas L. Daugherty
David Taylor Research Center
Annapolis, MD 21402

James F. Dill
Mechanical Technology
968 Albany-Shaker Road
Latham, NY 12110

Sokka Doraivelu
UES, Inc.
4401 Dayton-Xenia Road
Dayton, OH 45432-1894

Thomas A. Dow
Precision Engineering Center
North Carolina State Univ.
Box 7918
Raleigh, NC 27695-7918

William A. Ellingson
Argonne National Laboratory
9700 South Cass Ave.
Mail Stop 212
Argonne, IL 60439

Andre Ezis
Cercom, Inc.
1960 Watson Way
Vista, CA 92083

Robert H. Feest
The Barden Corp.
200 Park Ave.
Danbury, CT 06810

Traugott Fischer
Stevens Institute of
Technology
Materials Department
Hoboken, NJ 07030

Paul D. Fleischauer
The Aerospace Corp.
P.O. Box 92957
Los Angeles, CA 90009-2957

Rosendo Fuquen
The Timken Co.
1835 Duebei Ave.
Canton, OH 44706

Michael N. Gardos
Hughes Aircraft Co.
P.O. Box 902
El/F150
El Segundo, CA 90245

George Gazza
U.S. Army Materials Tech. Laboratory
SLCMT-EMC
Watertown, MA 02172

Robert B. Gilbert
Allied Signal Aerospace Co.
Garrett Engine Division
111 S. 34th St., P.O. Box 5217
Phoenix, AZ 85010

Willard W. Goodwin
New Hampshire Ball Bearing
Route 202 South
Peterborough, NH 03458

Clark Griffiths
Splits Ballbearing
Highway Four
Lebanon, NH 03766

John Halloran
University of Michigan
Department of Materials
Science & Engineering
Ann Arbor, MI 48109

James G. Hannoosh
CERBEC
10 Airport Park Road
East Granby, CT 06026

Roy Hansen
Litton Systems
5500 Canoga Ave.
Woodland Hills, CA 91365

Andrew C. Harvey
Foster-Miller, Inc.
350 Second Ave.
Waltham, MA 02154

Allen Hopper
Battelle Corp.
505 King Ave.
Columbus, OH 43201

George W. Hosang
Sundstrand Power Systems
4400 Ruffin Road
P.O. Box 85757
San Diego, CA 92186-5757

Lewis K. Ives
National Institute of
Standards & Technology
Bldg. 220, Rm. A215
Gaithersburg, MD 20899

Steven R. Johnson
General Electric
1 Neumann Way
MD A328
Cincinnati, OH 45215-6301

Robert Katz
Worcester Polytec. Institute
Dept. of Mechanical
Engineering
100 Institute Rd.
Worcester, MA 01609

John E. Keba
Rockwell International
Rocketdyne Division
6633 Canoga Ave.
Mail Stop 1A32
Canoga Park, CA 91303

B. T. Khuri-Yakub
Stanford University
3 Encina Hall
Stanford, CA 94305

E. Kingsbury
C.S. Draper Laboratory
Mail Stop 42
555 Technology Square
Cambridge, MA 02139

Gerald P. KoHutovic
United Technologies
Pratt & Whitney Aircraft
400 Main St.
East Hartford, CT 06108

Bruce Kramer
National Science Foundation
1800 G St., N.W.
Washington, DC 20550

Frank M. Kustas
Martin Marietta
P.O. Box 179
Mail Stop - B3085
Denver, CO 80201

Philip G. Laferriere
Aviation Applied
Technology Directorate
U.S. Army Aviation
ATTN: SAVRT-TY-ATP
Ft. Eustis, VA 23604-5577

Jorn Larsen-Basse
National Science Foundation
1800 G St., N.W.
Washington, DC 20550

John Law
Teledynes CAE
1330 Laskey Road
Toledo, OH 43612

Subhas Malghan
National Institute of
Standards & Technology
Bldg. 223, Rm. A256
Gaithersburg, MD 20899

Francis Marchand
C.S. Draper Lab.
555 Technology Square
Cambridge, MA 02139

Bobby D. McConnell
TriboTech Consultants
43 Monterey Road
Dayton, OH 45419-2566

Karl D. Mecklenburg
U.S. Air Force
Materials Lab.
594 Dorado Drive
Fairborn, OH 45324

Crawford Meeks
AVCON
19151 Parthenia St.
Unit G
Northridge, CA 91324

Raymond Middleton
U.S. Army Materials and
Technology Laboratory
405 Arsenal St.
Watertown, MA 02172

T. W. Mohr
The Timken Co.
1835 Dueber Ave.
Canton, OH 44706

Yngve Naerheim
Rockwell International
Science Center
1049 Camino Dos Rios
P.O. Box 1085
Thousand Oaks, CA 91360

Jim O'Donnell
Naval Air Propulsion Center
P.O. Box 7176
Code PE32:IOD
Trenton, NJ 08628

Barry O'Dwyer
Miniature Precision Bearings
Precision Park
P.O. Box 547
Keene, NH 03431

Mark Parish
CPS Superconductor
155 Fortune Blvd.
Milford, MA 01757

Marshall Peterson
National Institute of
Standards & Technology
Bldg. 220, Rm. A215
Gaithersburg, MD 20899

E. Pfaffenberger
General Motors Corp.
Allison Gas Turbine Division
P.O. Box 420
Speed Code S-48
Indianapolis, IN 46206-0420

Gerry Phillips
David Taylor Research Center
Code 2832
Annapolis, MD 21402

Robert S. Polvani
National Institute of
Standards & Technology
Bldg. 220, Rm. A107
Gaithersburg, MD 20899

Julian R. Pratt
Spheric Engineering Ltd.
Fleming Way
Crawley
West Sussex, RH10 2SQ
England

K. S. Ramesh
Battelle Memorial Institute
505 King Ave.
Columbus, OH 43201

Mark Rhoads
General Electrical
Aircraft Engineering
One Neumann Way
Mail Stop M85
Cincinnati, OH 45215-6301

William Ruff
National Institute of
Standards & Technology
Bldg. 220, Rm. A215
Gaithersburg, MD 20899

Lyle Schwartz
National Institute of
Standards & Technology
Bldg. 223, Rm. B309
Gaithersburg, MD 20899

Lewis Sibley
Tribology Systems, Inc.
225 A. Plank Ave.
Paoli, PA 19301

Tony Sides
NAVSEA
Washington, DC 20362

Frederick Slaney
Textron-Lycoming
550 Main St.
Stratford, CT 06497

K. Subramanian
Norton Co.
1 New Bond St.
Worcester, MA 01606

Bob Westerholm
Litton Systems
5500 Canoga Ave.
Woodland Hills, CA 91365

Grady White
National Institute of
Standards & Technology
Bldg. 223, Rm. A256
Gaithersburg, MD 20899

BIBLIOGRAPHIC DATA SHEET

1. PUBLICATION OR REPORT NUMBER
NIST/SP-824

2. PERFORMING ORGANIZATION REPORT NUMBER

3. PUBLICATION DATE
November 1991

4. TITLE AND SUBTITLE

Ceramic Bearing Technology: Proceedings of the NIST/DARPA Workshop on Ceramic Bearing Technology, April 17-18, 1991

5. AUTHOR(S)

Said Jahanmir (Editor)

6. PERFORMING ORGANIZATION (IF JOINT OR OTHER THAN NIST, SEE INSTRUCTIONS)

U.S. DEPARTMENT OF COMMERCE
NATIONAL INSTITUTE OF STANDARDS AND TECHNOLOGY
GAITHERSBURG, MD 20899

7. CONTRACT/GRANT NUMBER

8. TYPE OF REPORT AND PERIOD COVERED
Final

9. SPONSORING ORGANIZATION NAME AND COMPLETE ADDRESS (STREET, CITY, STATE, ZIP)

Defense Advanced Projects Agency
National Institute of Standards and Technology

10. SUPPLEMENTARY NOTES

11. ABSTRACT (A 200-WORD OR LESS FACTUAL SUMMARY OF MOST SIGNIFICANT INFORMATION. IF DOCUMENT INCLUDES A SIGNIFICANT BIBLIOGRAPHY OR LITERATURE SURVEY, MENTION IT HERE.)

The objectives of the workshop were to assess the status of ceramic bearing technology, and identify the key research topics needed to expand the range of applications for ceramic bearings. A total of eleven invited presentations were given at the workshop which was attended by seventy-five representatives from industry, government and universities. The presentations and subsequent discussions covered present and potential future applications of ceramic bearings, and topics related to processing, machining, quality control, design, testing and performance evaluation. The report includes short abstracts and the viewgraphs used in the presentations, summary of the discussions, and a list of recommendations for future research.

12. KEY WORDS (6 TO 12 ENTRIES; ALPHABETICAL ORDER; CAPITALIZE ONLY PROPER NAMES; AND SEPARATE KEY WORDS BY SEMICOLONS)

bearing design; ceramic bearings; ceramic machining; ceramic processing; friction and wear; non-destructive evaluation; silicon nitride; surface fatigue; tribology

13. AVAILABILITY

UNLIMITED

FOR OFFICIAL DISTRIBUTION. DO NOT RELEASE TO NATIONAL TECHNICAL INFORMATION SERVICE (NTIS).

ORDER FROM SUPERINTENDENT OF DOCUMENTS, U.S. GOVERNMENT PRINTING OFFICE, WASHINGTON, DC 20402.

ORDER FROM NATIONAL TECHNICAL INFORMATION SERVICE (NTIS), SPRINGFIELD, VA 22161.

14. NUMBER OF PRINTED PAGES

219

15. PRICE

NIST Technical Publications

Periodical

Journal of Research of the National Institute of Standards and Technology—Reports NIST research and development in those disciplines of the physical and engineering sciences in which the Institute is active. These include physics, chemistry, engineering, mathematics, and computer sciences.

Papers cover a broad range of subjects, with major emphasis on measurement methodology and the basic technology underlying standardization. Also included from time to time are survey articles on topics closely related to the Institute's technical and scientific programs. Issued six times a year.

Nonperiodicals

Monographs—Major contributions to the technical literature on various subjects related to the Institute's scientific and technical activities.

Handbooks—Recommended codes of engineering and industrial practice (including safety codes) developed in cooperation with interested industries, professional organizations, and regulatory bodies.

Special Publications—Include proceedings of conferences sponsored by NIST, NIST annual reports, and other special publications appropriate to this grouping such as wall charts, pocket cards, and bibliographies.

Applied Mathematics Series—Mathematical tables, manuals, and studies of special interest to physicists, engineers, chemists, biologists, mathematicians, computer programmers, and others engaged in scientific and technical work.

National Standard Reference Data Series—Provides quantitative data on the physical and chemical properties of materials, compiled from the world's literature and critically evaluated. Developed under a worldwide program coordinated by NIST under the authority of the National Standard Data Act (Public Law 90-396). NOTE: The Journal of Physical and Chemical Reference Data (JPCRD) is published bi-monthly for NIST by the American Chemical Society (ACS) and the American Institute of Physics (AIP). Subscriptions, reprints, and supplements are available from ACS, 1155 Sixteenth St., NW., Washington, DC 20056.

Building Science Series—Disseminates technical information developed at the Institute on building materials, components, systems, and whole structures. The series presents research results, test methods, and performance criteria related to the structural and environmental functions and the durability and safety characteristics of building elements and systems.

Technical Notes—Studies or reports which are complete in themselves but restrictive in their treatment of a subject. Analogous to monographs but not so comprehensive in scope or definitive in treatment of the subject area. Often serve as a vehicle for final reports of work performed at NIST under the sponsorship of other government agencies.

Voluntary Product Standards—Developed under procedures published by the Department of Commerce in Part 10, Title 15, of the Code of Federal Regulations. The standards establish nationally recognized requirements for products, and provide all concerned interests with a basis for common understanding of the characteristics of the products. NIST administers this program as a supplement to the activities of the private sector standardizing organizations.

Consumer Information Series—Practical information, based on NIST research and experience, covering areas of interest to the consumer. Easily understandable language and illustrations provide useful background knowledge for shopping in today's technological marketplace.

Order the above NIST publications from: Superintendent of Documents, Government Printing Office, Washington, DC 20402.

Order the following NIST publications—FIPS and NISTIRs—from the National Technical Information Service, Springfield, VA 22161.

Federal Information Processing Standards Publications (FIPS PUB)—Publications in this series collectively constitute the Federal Information Processing Standards Register. The Register serves as the official source of information in the Federal Government regarding standards issued by NIST pursuant to the Federal Property and Administrative Services Act of 1949 as amended, Public Law 89-306 (79 Stat. 1127), and as implemented by Executive Order 11717 (38 FR 12315, dated May 11, 1973) and Part 6 of Title 15 CFR (Code of Federal Regulations).

NIST Interagency Reports (NISTIR)—A special series of interim or final reports on work performed by NIST for outside sponsors (both government and non-government). In general, initial distribution is handled by the sponsor; public distribution is by the National Technical Information Service, Springfield, VA 22161, in paper copy or microfiche form.

U.S. Department of Commerce
National Institute of Standards and Technology
Gaithersburg, MD 20899

Official Business
Penalty for Private Use \$300

