

NBSIR 75-960 (R)

FILE COPY  
2994-440.02  
250 cps #11

# The Police Patrol Car: State of the Art

12/9/75  
OP

R. G. Massey

Institute for Applied Technology  
National Bureau of Standards

November 1975

Final

Prepared by  
Law Enforcement Standards Laboratory  
National Bureau of Standards

Prepared for  
National Institute of Law Enforcement and Criminal Justice  
Law Enforcement Assistance Administration  
U.S. Department of Justice



NBSIR 75-960

# THE POLICE PATROL CAR: STATE OF THE ART

R. G. Massey

Institute for Applied Technology  
National Bureau of Standards

November 1975

Final

Prepared by  
Law Enforcement Standards Laboratory  
National Bureau of Standards

Prepared for  
National Institute of Law Enforcement and Criminal Justice  
Law Enforcement Assistance Administration  
U.S. Department of Justice



---

**U.S. DEPARTMENT OF COMMERCE, Rogers C.B. Morton, *Secretary***  
**James A. Baker, III, *Under Secretary***  
**Dr. Betsy Ancker-Johnson, *Assistant Secretary for Science and Technology***  
**NATIONAL BUREAU OF STANDARDS, Ernest Ambler, *Acting Director***



## ACKNOWLEDGMENTS

This report was prepared by the Law Enforcement Standards Laboratory of the National Bureau of Standards under the direction of Jared J. Collard, Acting Manager, Police Vehicle Program, and Jacob J. Diamond, Chief of LESL. Appreciation is extended to the National Association of Fleet Administrators, the Ford Motor Company, the General Motors Corporation, the Chrysler Corporation, the American Motors Company and other contributors for their assistance. The preparation of this report was sponsored by the National Institute of Law Enforcement and Criminal Justice (NILECJ), Lester D. Shubin, Program Manager for Standards. It is also being printed by NILECJ under the designation LESP-RPT-0403.00.



# The Police Patrol Car: State of the Art

## CONTENTS

	Page
1. Introduction . . . . .	1
2. Background . . . . .	1
3. Functions of a Patrol Car . . . . .	2
3.1 General Functions . . . . .	2
3.1.1 Transportation of Personnel . . . . .	2
3.1.2 Equipment Carrier . . . . .	2
3.1.3 Protection . . . . .	2
3.1.4 Office Space . . . . .	2
3.1.5 Temporary Detention Facility . . . . .	3
3.1.6 Deterrence and Presence . . . . .	3
3.2 Duty Functions . . . . .	3
3.2.1 Urban Patrol . . . . .	3
3.2.2 Highway or Freeway Patrol . . . . .	3
3.2.3 Moving Surveillance . . . . .	4
3.2.4 Undercover Operations . . . . .	4
3.2.5 Utility or General Transportation . . . . .	4
3.2.6 Other . . . . .	4
3.3 Discussion . . . . .	4
4. Vehicle Performance Characteristics . . . . .	6
4.1 Speed and Acceleration . . . . .	6
4.2 Handling and Maneuverability . . . . .	7
4.3 Brake Reliability . . . . .	7
4.4 Durability and Maintainability . . . . .	8
4.5 Human Factors . . . . .	8
4.6 Vehicle Size . . . . .	9
4.7 Engine Performance . . . . .	10
5. Vehicle Subsystem Problems that Affect Police Mission Performance . . . . .	10
5.1 Brake System . . . . .	10
5.2 Suspension System . . . . .	12
5.3 Engine . . . . .	13
5.4 Cooling System . . . . .	16
5.5 Body and Interior . . . . .	17
5.6 Tires . . . . .	18
5.6.1 Bias Ply . . . . .	20
5.6.2 Radial Ply . . . . .	21
5.6.3 Bias Belted . . . . .	22

5.7	Electrical System . . . . .	22
5.8	Steering . . . . .	23
5.9	Emission Control System . . . . .	24
6.	Patrol Car Acquisition . . . . .	25
6.1	Design Specifications . . . . .	26
6.2	Performance Specifications . . . . .	27
6.3	Acquisition Procedures . . . . .	28
6.4	Life Cycle Costs . . . . .	29
7.	Vehicle Performance Testing . . . . .	30
8.	Vehicles in Current Use as Patrol Cars . . . . .	31
9.	New Developments . . . . .	41
9.1	Pollution Control . . . . .	41
9.1.1	Stratified Charge Engine . . . . .	41
9.1.2	Wankel Rotary Engine . . . . .	41
9.1.3	Stirling Cycle Engine . . . . .	44
9.1.4	Diesel Engine . . . . .	44
9.1.5	Gas Turbine . . . . .	44
9.1.6	Electric Engine . . . . .	44
9.1.7	Intake Valve Throttled Engine . . . . .	48
9.2	Fuel Efficiency . . . . .	48
9.3	Brakes . . . . .	48
9.4	Tires . . . . .	52
9.5	Safety Regulations . . . . .	52
9.6	Special Police Vehicle . . . . .	53
10.	Vehicle Fleet Management . . . . .	53
11.	Summary . . . . .	54
	Appendix--References . . . . .	56



# THE POLICE PATROL CAR: STATE OF THE ART

## 1. INTRODUCTION

One of the major items of equipment used in law enforcement is the patrol car; an estimated 65,000 automobiles costing in the range of \$200,000,000 are purchased each year.

To learn more about the problems of police vehicles, the National Institute of Law Enforcement and Criminal Justice, in 1972, requested the Law Enforcement Standards Laboratory (LESL) to initiate a study of the current state of the art of vehicles used as police patrol cars. The objective of this study was to develop an understanding of the vehicles, the accessories and the options that are available for police patrol; the activities for which patrol cars are used by law enforcement agencies; and, the problems encountered by the users in performing the required activities with the available vehicles. The study points to areas where vehicle performance is not meeting law enforcement requirements and could be improved within the present state of the art.

A list of publications referred to in the text or consulted by the author in producing this study is provided in the bibliography. In addition, numerous officers and officials of police departments across the country contributed their views and experiences. In particular, mention should be made of the departments of the City of Los Angeles; City of New York; Ladue, Missouri; Montgomery County, Maryland; St. Louis County, Missouri; California Highway Patrol, and Michigan and Maryland State Police.

## 2. BACKGROUND

It has been stated that, "Law Enforcement is simply the protection of life and property and the preservation of the peace. This is the purpose of all police departments, and the best way to achieve this purpose is through the use of an effective and efficient patrol and patrol plan." [1]\* The major functions of patrol forces are: (1) to prevent and deter crime, and to apprehend criminals; (2) to respond to calls for assistance from the public; and, (3) to regulate traffic.

\*The numbers in brackets indicate references listed at the end of the report.

To accomplish these tasks, patrol forces employ all forms of transportation: walking, bicycles, horses, motor scooters, motorcycles, automobiles, water craft, and aircraft. Of these, the automobile is by far the most important. Various types are used, including trucks, vans, and station wagons, but the passenger car used for patrol purposes represents the largest category of vehicles, in terms of total numbers.

### 3. FUNCTIONS OF A PATROL CAR

#### 3.1 General Functions

The police patrol car performs a variety of specialized functions during the course of day-to-day operations. A listing of these functions would include [2]:

##### 3.1.1 Transportation of Personnel

The basic function of any vehicle is transportation. For police patrol, this includes transporting patrol officers in performance of their duties, as well as transporting prisoners and other personnel.

##### 3.1.2 Equipment Carrier

A vehicle may carry a variety of equipment to assist the patrolman in performing his duties. Equipment may include radio communications equipment, spotlights, weapons, fire extinguishers, gas masks, shovels, flares, clothing, protective equipment, and innumerable other items as required.

##### 3.1.3 Protection

The patrol car provides protection not only from the elements, but also occasionally against armed adversaries and irate citizens.

##### 3.1.4 Office Space

The patrol car functions as a patrolman's office for completing forms, writing reports, and interviewing people. When used by a supervisor or commander, the patrol car may be a tactical or operational headquarters.

### 3.1.5 Temporary Detention Facility

The patrol car is routinely used to detain arrested persons until they can be transferred to normal detention facilities.

### 3.1.6 Deterrence and Presence

The well-marked police car is considered by some to be a deterrent to potential violators. It provides visible notice of the presence of police officers to those seeking help. The patrol unit may represent to many citizens the most familiar and common contact with their police force and their local government.

## 3.2 Duty Functions

Another method of describing patrol car functions is based on the type of patrol duty. This widely used approach analyzes the performance characteristics needed in a vehicle for each general type of patrol. One authority [3] has defined the vehicles as follows:

### 3.2.1 Urban Patrol

The vehicle used in urban areas is expected to idle or travel at speeds of 15-30 mph (25-50 km/h)\* much of the time and to have good acceleration in the 30-50 mph (50-80 km/h) range. Excellent handling and stability are required to permit safe maneuvering in traffic. Because of the slower, controlled traffic in dense urban areas, a high top speed capability of 110 mph (160 km/h) or more is usually not required. To some departments, an intermediate-size vehicle is considered acceptable.

### 3.2.2 Highway or Freeway Patrol

Highway patrol requires cruising routinely at 50-60 mph (80-95 km/h) or more on high speed roads. All the characteristics of the urban patrol vehicle are desirable, except that the vehicle may be larger and heavier and high speed performance is required. Rapid acceleration is required between 70 and 100 mph (115 and 160 km/h) with a top speed of about 120 mph (195 km/h).

\*Standard International (SI) metric equivalents appear in parentheses throughout the report as a convenience to the reader. Speeds in kilometers-per-hour have been rounded to the nearest zero or 5, since all miles-per-hour speeds are approximations.

### 3.2.3 Moving Surveillance

Moving surveillance involves keeping a person, usually traveling in a car, under surveillance without being observed. A vehicle similar to that for urban patrol in handling, braking, and speed characteristics is desirable. The appearance of these unmarked vehicles must allow them to blend into the general vehicle population. Pursuit capabilities are required, since these unmarked vehicles are frequently used for traffic enforcement.

### 3.2.4 Undercover Operations

An undercover vehicle is used in vice control, narcotics investigation, and other activities where the officer's identity must be concealed. For this service, vehicles must blend with the vehicle population in which they are used and may vary from high-priced luxury automobiles to compacts. Any special police equipment, other than a heavy duty suspension might compromise the identity of the police officer and his mission.

### 3.2.5 Utility or General Transportation

Automobiles equipped with lower performance engines are adequate for administrative and general transportation. Vehicles without special equipment that can meet a wide range of general transportation functions reduce procurement and maintenance costs. Compact vehicles are being used more frequently for this function in order to conserve gasoline.

### 3.2.6 Other

Vehicles used for field supervision, special communications functions, logistical supply, emergency rescue and other duties which might be considered supplementary to basic patrol functions should be equipped, as a minimum, with a heavy-duty suspension. This description of patrol cars includes compact cars. Sub-compact cars are also being used for one-man patrols in a few areas.

## 3.3 Discussion

While the patrolman is unlikely to think of the individual functions of his vehicle in the above terms, each of them has to be considered by those responsible for the management of a motorized patrol force. The extent to which the vehicle used

in patrol satisfies these requirements has an impact on patrol effectiveness. There are at present only limited data which one can use as a basis for assessing vehicle performance relative to these functional uses.

The general functional approach to describing a patrol car should be more helpful than the duty approach in any study designed to improve patrol car performance. Functional needs should be defined for a particular agency's duties and considered when ordering patrol cars. Basically, this approach should define the acceptable levels of performance required to meet the patrol's functional needs, such as: who and how many are to be transported; in what kind of environment will the vehicle operate (urban, rural, or mixed); for what will the vehicle be used (pursuit, traffic, surveillance, etc); how much and what equipment needs to be mounted, and where; how much and what kind of space is needed for office-type activities; and so on. With a clear definition of these requirements, the vehicle manufacturer may then be able to select and bid on his most suitable model and the procuring agency will have some basis upon which to evaluate the various offerings.

The duty approach, on the other hand, represents the current general practice of defining patrol car requirements in terms of design characteristics, equipment options and accessories thought necessary to accomplish specific types of patrols. This design approach has been pursued cooperatively by the producers and the users to modify essentially standard passenger cars to achieve better acceleration, speed, braking, handling, and stability than is exhibited by a similar passenger car.

Neither the duty nor the design approach is adequate by itself, since one focuses on the man and the other on the machine. Both approaches must be considered. The environment in which the patrol functions must also be recognized as an important part of the total system.

Economic considerations are not addressed by either approach. While cost may not be of direct concern to the individual patrolman using the vehicle, it is important to the fleet administrator, to the responsible governmental body, and ultimately to the tax-paying citizen.

#### 4. VEHICLE PERFORMANCE CHARACTERISTICS

It is difficult to think of any police activity where vehicles are not involved in some manner. If these activities are limited to those assigned to patrol cars, the activities can be grouped into crime patrol, traffic management and a general activity that might be called "community service" or just "service."

Crime patrol can be described as looking for criminal activity in progress, deterring criminal activity by being present, and responding to calls for assistance when criminal acts have been or are being committed. An analysis of radio dispatcher calls in one large city indicated that about 16 percent of the patrol activity was crime related [2].

Traffic management is concerned primarily with the enforcement of traffic laws, with promoting the free flow of traffic, and with traffic accident investigation.

Service includes all the other activities, generally not crime related, such as responding to fires, assistance to citizens, search or rescue operations, and medical emergencies. These activities may occur in a variety of environments, from the wide-open spaces of the interstate highway system to the congested narrow streets of urban areas.

These three main activities can be analyzed to determine what performance characteristics are required in patrol cars to carry out the law enforcement mission.

##### 4.1 Speed and Acceleration

Pursuit of offenders requires a high speed capability. Highway patrols normally specify a top speed of 125 mph (200 km/h) or more for their patrol cars. Pursuit speeds rarely reach 100 mph (160 km/h) in urban areas due to road design, or the presence of other traffic or pedestrians.

Cruising speeds also differ widely between highway and urban areas. Highway vehicles normally cruise near the speed limit, 50 to 60 mph (80 to 95 km/h), while urban vehicles usually cruise at 25 to 30 mph (40 to 50 km/h), or less.

Acceleration is important in pursuit situations. Vehicles must be brought to pursuit speed as quickly as possible from either a cruise speed or a full stop. For the highway patrol car, the most important acceleration range is from 50-60 mph (80-95 km/h) to 100-110 mph (160-175 km/h). In the city, the important acceleration range is from about 25-30 mph (40-50 km/h) to 50-60 mph (80-95 km/h).

"High speed pursuit" is a patrol car activity which requires acceleration, speed, good handling, maneuverability, and stopping capability. The elimination of a high speed pursuit capability from a patrol car would appear to have a significant effect on patrol car design and maintenance. For instance, smaller engines might be feasible. Theoretically, smaller engines have advantages such as better gasoline mileage, less heat in the engine compartment along with its detrimental effects on components, less air pollution, and lower vehicle weight.

#### 4.2 Handling and Maneuverability

While the standard passenger car usually provides adequate handling and maneuverability for general transportation, patrol cars must be capable of performance nearly like that of a sports car. The patrol car needs to maintain a steady, controllable posture on any type of road surface at high speeds and be easily maneuverable in such situations as turns at high speeds or on congested streets. Standard passenger cars will nose-down in a high speed stop, or "lean" to the outside in a turn, thus limiting the vehicle speed. These characteristics should be minimized in a patrol car. Favorable handling characteristics have been variously labeled "good cornering ability," "roadability," and "maneuverability."

#### 4.3 Brake Reliability

Brake reliability is important in any vehicle, but it is particularly critical in patrol cars which are routinely subjected to continuous stop and go or high speed driving under a wide range of environmental conditions. Data from the Bunten/Klaus survey [4] indicate that reliability is decreased substantially by frequent brake applications.

#### 4.4 Durability and Maintainability

Maintenance is an important factor in patrol car performance. Oil and coolant changes, tune-ups and other types of routine maintenance are usually performed at shorter intervals than on normal-use vehicles. To maximize in-use time, maintenance and repairs should be easy to accomplish.

The extent to which a patrol car continues to function with only routine maintenance is important to the accomplishment of police missions, as well as to the cost of police operations. Vehicles that break down frequently or fail to provide the expected service are a serious handicap to a police department.

#### 4.5 Human Factors

Police patrol performance can be affected in numerous ways when "human factors" are not given adequate consideration; these include seating, location of instrumentation, interior space, door sizes, personal safety devices, etc.

Because of the large number of hours the patrolman spends in his patrol car, comfort is a factor in his ability to perform his mission. An officer's efficiency is materially affected by seating, arrangement of instruments, equipment and controls, visibility, temperature and humidity. Ease of entrance and egress and seat belt design can also affect the effectiveness of the officer's performance.

The National Safety Council [5] reports that for ages 20-59 years, police officers driving patrol cars have significantly more accidents than the general male population of the same age group. Occupant safety, therefore, is very important. Safety of all occupants of the patrol car should be a concern. Although seat belts are an effective safety device, many police officers claim they are a handicap in the performance of their duties, since the officers are in and out of their vehicles numerous times during a shift. Seat belts also may catch on equipment carried on the officer's person, particularly his side arm, and have been reported to have caused personal injury.

Automobile seats are designed for average use, not for continued 24-hour a day service. The automobile manufacturers offer an optional "heavy-duty" seat for police use, which incorporates thicker padding and a reinforced frame and spring. The upholstery material should be porous to permit maximum



ventilation. Soft seats will break down with continued use, requiring the patrolman to assume a less comfortable posture and cause backaches.

The installation of barriers between the front and back seats to protect officers from prisoners in the back seat often restricts movement of the front seat to the position most comfortable for the driver. Some barriers reduce rear seating space and may also adversely affect the use of some occupant safety devices (i.e., head rest and shoulder harness) as well as presenting a hazard to rear seat passengers in an emergency stop.

The arrangement of vehicle operating instruments and controls for lights, side view mirrors, windshield wipers, and horn, as well as the police-added equipment controls for radio, siren, and warning lights, are other factors which affect a patrolman's performance. The illumination and space provided for writing and reading reports must be adequate. The arrangement and availability of storage space for equipment that must be immediately available is also of concern.

The protection afforded the patrolman by the vehicle body is an important characteristic. While protection from the weather is the main function, occasionally the body provides protection against thrown objects and, to a limited extent, from gunfire. Along with the driving characteristics, the various aspects of the vehicle body are some of the most important characteristics of the patrol car that affect mission performance.

#### 4.6 Vehicle Size

Comfort, safety, and roadability may be major reasons for the more general use of standard size cars for patrol. Intermediate-size cars, however, are found in significant numbers in county and large city departments where cost and urban congestion may affect the size decision. Aside from the subjective quality of roadability for highway use, the difference between the standard and intermediate-size alone does not appear critical to mission performance.

Smaller vehicles, such as compacts and subcompacts, may offer some advantages, such as economy and maneuverability in congested areas. However, the compact size vehicle may also

have negative effects on patrol performance. For instance, it may be too small for the officer's comfort and convenience, for passenger and prisoner transportation, or for carrying necessary equipment. Some compacts may also have reduced stability, durability, acceleration, speed, and load carrying capabilities. Even if these potentially negative aspects are proven to be unfounded, the ability of compact or subcompact cars to withstand severe police usage for the usual two-to-three year life cycle remains to be demonstrated.

#### 4.7 Engine Performance

Engine horsepower is generally equated with pursuit capability. A significant amount of power, however, is also required to operate electrical equipment, such as radios, lights, sirens, and public address systems installed on patrol cars. Except for speed, and perhaps to some extent acceleration, there are no established or widely accepted criteria for measuring or specifying a desired level of patrol car engine performance.\*

### 5. VEHICLE SUBSYSTEM PROBLEMS THAT AFFECT POLICE MISSION PERFORMANCE

In evaluating the performance characteristics of motor vehicles, a number of components or subsystems can be defined that individually, or in combination, contribute to each characteristic.

The major relevant subsystems include the engine and power train, the braking system, the suspension system, the electrical system, the steering system, the body including its interior, and the cooling system. These subsystems are usually individually considered when purchasing patrol vehicles which have the desired characteristics.

#### 5.1 Brake System

According to the Buntzen/Klaus survey [4], 31 percent of the responding police departments rated brake performance poor over 70 mph (115 km/h), and only 21 of the 50 largest cities rated brake performance excellent under 30 mph (50 km/h). The brake system was selected as the second highest cause of service/repair by all departments, with the larger city

\*Mr. G. Ray Wynne, Chief of the Los Angeles Police Department's Motor Transport Division, suggests that the weight-to-power ratio should not be more than 16 pounds per net horsepower (9.75 kg/net kW) for pursuit vehicles, and 20-to-1 (12.2 kg-to-1 kW) for administrative vehicles.

categories showing the highest rate of repair concern. The survey also reported that the brake system exceeded all other patrol car features as needing performance standardization. Sixteen percent of the survey respondents rated brakes as the most dangerous feature of the patrol car.

The most often cited cause of inadequate braking performance was fade, a decrease in friction between the braking surfaces. Brake fade usually occurs when the brakes are overheated by either a number of closely spaced applications or by an extended high speed application. These occur most often in highway patrol operations or in stop-and-go urban situations. Fade is also caused when the braking surfaces become wet.

Two approaches have been taken to reduce the brake fade problem: the use of disc brakes and the development of more fade resistant brake lining materials. Disc brakes have long been recognized as superior to drum brakes due to their ability to absorb and dissipate heat by having relatively more surface exposed. Since 1968 disc brakes have become increasingly prevalent on U.S. production cars and were standard on the front wheels of 1974 vehicles offered for patrol car use.

Disc brakes, although offering desirable qualities in reducing fade and dissipating heat, have an inherently inadequate parking brake action. This drawback is claimed by the manufacturer to be the most significant reason why disc brakes are not incorporated on all four wheels. However, since two-thirds of the braking effort is accomplished by the front brakes, the performance gains of disc brakes on the rear would be small and the cost higher. In cases where disc brakes are offered on all four wheels, small auxiliary drum brakes are incorporated to provide the parking brake action.

Brake lining materials of three general types are used: organic, metallic, and semi-metallic. Organic linings at low brake temperatures have good fade resistance and offer long life. At high brake temperatures, organic linings fade, tend to grab, and have a short life. Metallic linings at low brake temperatures provide poor braking action, but at high temperatures, they offer better braking action and fade resistance. Metallic linings tend to be noisy, however.

Semi-metallic linings, composed of metal particles bonded with resin, are designed to combine the best properties of the metallic and organic type linings. High temperature performance is good, and the other performance properties are generally rated between those of organic and metallic linings. At least one major patrol car manufacturer is providing semi-metallic linings as standard equipment on police vehicles.

All brake systems must meet FMVSS 105, "Hydraulic Brake Systems." However, it would appear from the low reliability rating brakes received in the Bunten/Klaus survey that FMVSS 105 may not be adequate for patrol cars. A revision of FMVSS 105 is scheduled to become effective September 1, 1975. This new standard may correct some of the problems of patrol car brakes.

## 5.2 Suspension System

Of all the components of an automobile, the modifications made in the suspension system may be the most extensive in converting a standard passenger car to a vehicle suitable for patrol car use. Most American passenger cars are designed to provide a "soft" ride. When an automobile is designed for maximum control during maneuvers at any speed or road condition, a stiffer suspension is generally used, and the soft ride disappears.

In recognition of the importance of the suspension system to stability and control in a patrol car, manufacturers offer "heavy duty suspensions", "special handling packages", or "police suspensions". These suspensions are ordered on the majority of patrol cars and particularly on those patrol cars to be used in pursuit operations. Generally, the suspension modifications will include higher rate (stiffer) springs, larger, stiffer shock absorbers, stabilizer bars, and often changes in various bushings, frame reinforcement, and installation of various other heavy duty components. The result is a vehicle that has a stiffer ride but can corner more safely at higher speeds and can be better controlled in adverse road conditions. A side benefit is possibly a more durable vehicle.

Design or modification of a suspension system for a vehicle to obtain the desired handling characteristics is a complicated engineering problem. The technique for balancing the effects

of the interactions of components of the suspension system is called "tuning". Some examples of component interactions will help illustrate the complexity of suspension system design.

Understeer is a handling characteristic of a vehicle that tends to increase the turning radius as the vehicle progresses through a turn, requiring the driver to apply increasing force on the steering wheel in the direction of the turn. Oversteer is the the opposite of understeer: the vehicle seems to turn too easily or too fast. Neutral steer is a handling characteristic of a vehicle that tends to follow the desired course during a turn with a minimum of adjustment of the steering wheel by the driver.

Ideally, cars should have a neutral steer characteristic. However, understeer is considered easier and safer to control, so, generally, U.S. cars are designed to understeer. Installation of stiffer springs and a rear sway bar to improve stability tends to reduce understeer; on the other hand, a front sway bar tends to increase understeer. From this example, it can be seen that a modification to improve the handling and stability of a vehicle may have the opposite effect, if not properly engineered.

### 5.3 Engine

The broadest range of choices for a patrol car exists for engine options. These range from four cylinders with approximately 140 cubic inch displacement (CID) (2.3 liters) to eight cylinders with 460 CID (7.5 liters). Carburetors may have one, two, or four barrels.

Standard-size cars designed for pursuit capability usually have large engines, because it is assumed horsepower determines acceleration and speed. For urban patrol and the often mixed urban and highway patrol environment of county operation, the eight cylinder engine is still preferred. The Bunten/Klaus survey estimates an average of 91 percent of all patrol cars specified by all departments in 1972 were equipped with eight cylinder engines. In county departments, which account for almost half of the total police cars purchased in 1972, 85 percent specified eight cylinder engines.

When selecting an engine size, police departments generally consider top speed, acceleration capability, and power required

to operate equipment to be the primary considerations. Initial cost is likely to be another factor. It would appear that maintenance and operating cost should also influence engine size decisions, but, until recently, were often secondary to requirements for mission performance. Recent trends in engines generally have been toward continuously increasing horsepower and engine displacement.

Since 1968, several changes affecting engine size and performance have taken place. Vehicles have significantly increased in size and weight. There has been an increase in the installation of safety devices and accessories, particularly air conditioning, power steering, and power brakes. The addition of emission control equipment has resulted in higher engine temperatures, a reduction in gasoline mileage, and some reduction in power output. A major portion of this reduction was due to a change in rating procedures, but was not a loss of real horsepower.

Prior to the 1972 model year, engine horsepower was rated by the SAE (Society of Automotive Engineers) "A" curve. Since 1972, horsepower has been rated according to the SAE "C" curve. This has had the effect of reducing the ratings by about 20%, although actual engine performance has not been affected.

These trends in engines have resulted in several problems in patrol cars:

1. Police officers claim the present generation of patrol cars are less satisfactory for pursuit purposes because of poorer acceleration and, to some extent, lower top speed.

2. The high percentage of idling and low speed operating time of patrol cars, always a detrimental factor, has had an increasingly adverse affect on acceleration and high speed operation.

3. Engines are operating at increasingly higher temperatures, causing various components to require maintenance, repair, or replacement at much closer intervals than in the past. One cause of higher engine temperatures is the increased use of emission control systems. Table 1, an excerpt from a report of one large city police department, aptly illustrates this point. Comparing the 1968 and 1972 models, maintenance cost per vehicle doubled, and engine

Table 1

Before-After Comparisons of Emission Control Effects  
(1968 and 1972)

<u>Agency</u>	<u>1968 Average</u>	<u>1972</u>
Indianapolis Police Department (Fords)*		
Engine Size	289 CID (4.7 liters)	351 CID (5.8 liters)
Miles per gallon	16	4-5
Valve jobs	\$1500/month	\$3000/month
Oil change intervals	5 weeks	4 weeks
Engine losses	0	7
Marion County (Ind.) Sheriff (Mercurys)		
Engine Size	429 CID (7.0 liters)	440 CID (7.2 liters)
Miles per gallon	.14	3-7
Indiana State Police (Mercurys)		
Engine Size	429 CID (7.0 liters)	440 CID (7.2 liters)
Miles per gallon	14	<8
Other problems with 1972 fleets:		
oil breakdown and excessive engine wear		
transmission band failures (e.g., in 20% of State's fleet)		
exhaust manifold deterioration		
disintegration of belts and wires		
loss of permanent antifreeze		

\*Comparisons based upon 280 vehicles in each year.

failures, attributed to the effects of heat, increased drastically from 0 to 7.

4. While not directly affecting individual officer performance, the necessity for an agency to increase patrol fleet funding to cover the cost of increased gasoline consumption and increased maintenance for patrol cars ultimately might affect decisions on equipment, manpower, and training of a police department. These decisions will affect mission performance.

#### 5.4 Cooling System

In police service, vehicles are subjected to the type of use that imposes severe stress on many components of the vehicle. One of these components, especially critical to overall vehicle operation, is the cooling system. Low speed vehicle operation, operation of the engine while standing, and use of large amounts of electrical power for radios, air conditioning, etc., are common to urban operation and can cause engine overheating.

High-speed operation at high ambient temperatures, such as experienced in the South and Southwest, is another condition which strains the cooling capacity of the standard vehicle. The California Highway Patrol has reported that radiators boil over in high speed chases in hot desert areas and has instructed drivers to shut off air conditioners to reduce the cooling load in such circumstances.

One of the most common causes of mechanical failure is loss of lubrication between moving parts. If the cooling system allows the engine temperature to exceed design limits, oil and grease viscosities may be reduced excessively or other lubricant properties damaged, resulting in excessive wear and eventual failure.

Another possible result of inadequate engine cooling is degradation of the anti-freeze. Generally, anti-freeze formulations include anti-rust and acid inhibitors to protect the engine cooling system from corrosion. Heat accelerates these chemical reactions and the consumption of these inhibitors, thus reducing life expectancy of the anti-freeze. The New York Police Department, for example, changes anti-freeze about once a month, rather than seasonally.



Automobile manufacturers have provided modifications and supplements to standard vehicle cooling systems to meet the requirements imposed by patrol car service. For engine cooling, these changes may include a heavy-duty radiator, a fan with additional blades to increase its capacity, additional exhaust ventilation openings in the engine compartment, a specially designed fan shroud, and a small radiator to cool the engine oil. An additional transmission oil cooler may also be provided. The engine coolant may be a 50/50 mixture of permanent-type anti-freeze and water for year-round use. A switch may be provided to automatically shut off the air conditioner compressor under high stress conditions.

Each manufacturer has adopted some combination of these cooling system modifications to provide a vehicle for patrol car service.

The main function of the cooling system is to dissipate the excess or waste heat produced by the engine. Generalizing from the "Handbook for Mechanical Engineers," [6] approximately one-third of the energy in the fuel burned is used to operate the vehicle and equipment, one-third is released through the exhaust, and one-third is dissipated through the cooling system. The present design practice of locating the radiator in front of the engine would appear to compound engine compartment heat problems since the heat dissipated from the radiator is blown directly back into the engine compartment. This concentration of heat in the engine compartment must be assumed to be a major contributor to the degradation of the performance and durability of most of the components located there.

## 5.5 Body and Interior

Installation and location of police-related equipment in patrol cars presents a problem. Each change in body styling may mean some modifications in installation procedures. These may include modifying the rack which holds the radio transmitter/receiver in the trunk, modifying the attachment and location of the radio control head in the driver's compartment, and modifying and relocating siren and warning light controls, or spotlight attachment.

Along with learning how to handle a new patrol car, the patrolman has to re-learn the location of these controls. Some departments have estimated this familiarization process takes 2 to 7 days before the operation of the patrol car again becomes "second nature" [4].

## 5.6 Tires

Tires are the interface of the brake, suspension, and steering systems, and the road. They provide the friction on the road surface that stops and starts the vehicle; they absorb a portion of the initial impact with a road defect; they provide traction necessary for sure steering; and they contribute to the comfort characteristics of the body and affect the performance obtained from the engine and its emission devices. Keeping safe, effective tires on patrol cars is a major maintenance cost for police fleets.

The best type of tire for use by a particular department is not at all clear. The bias ply tire was standard for many years and is still specified by some departments. Many departments have switched to bias belted tires on the basis that better vehicle performance and greater tire mileage offset the increase in cost. Currently, a number of departments are experimenting with radial tires, expecting to achieve lower operating costs per mile. Although no extensive data are yet available, several agencies, primarily state police, are reporting such reductions. On the other hand, some departments have found radial tires more prone to sidewall damage. One department has reduced the damage to acceptable levels by driver education and by charging drivers for the cost of tires judged to have been damaged through careless driving.

Tire manufacturers claim that their capacity for producing radial tires is limited at present. They also predict that as their capacity is increased, radial tires will become the predominant tire because they contribute to improved handling and provide significantly increased gas and tire mileage. It will be some time before the data and technical expertise on radial tires approach our present knowledge of bias construction. U.S. radial tire production was initiated less than 10 years ago, with high-speed radial tires for pursuit application first offered about 1970.

Most tires on the market, of all grades and constructions, are not suitable for high speed police use. Tests conducted by the U.S. Department of Transportation indicate that such tires will fail at average speeds of about 100 mph (160 km/h) [12]. A recent investigation of steel belted radial tires in police use [12] revealed that two deaths and several injuries occurred when such tires failed at high speeds. It is important that patrol cars, which are likely to be used in sustained high speed driving, be equipped with tires which are certified by the manufacturer for use at speeds of 125 mph (200 km/h). Such tires are available for police use.

Maintaining recommended tire pressure is critical to vehicle performance. Although some effects of over or under

inflation may appear advantageous, maintaining the manufacturer's recommended inflation appears most desirable. Some of the more important effects of varying from the recommended tire pressure include:

1. Uneven tire wear, either in the center of the tread or on its edges.

2. A softer ride at low pressure and a stiffer ride at high pressure.

3. Increasing tire pressure tends to change the vehicle's steering characteristic toward oversteer, while under inflation increases understeer. It is the oversteer or understeer characteristic that is most important to the driver in controlling a vehicle in a turn.

4. Increasing tire pressure results in a tire running cooler because it flexes less. Heat is the greatest factor in tire failure.

5. Increasing tire pressure will reduce the amount of impact the tire absorbs. The result may work the suspension system harder and cause it to wear faster. Decreasing the tire pressure has the reverse effect, resulting in the tire absorbing a higher proportion of impact load than intended. This may cause cord breakage or cracking of the casing.

6. Varying tire pressure from the recommended level will also tend to vary the "roll couple" control designed into the vehicle. "Roll couple" may be loosely defined as the rocking motion of the front and rear of a vehicle about its center of gravity combined with side to side roll. One of the main functions of the suspension system is to control these "roll" movements, so the driver can maintain control of his vehicle. These, and other effects related to tire pressures, are used in the "tuning" of suspension systems during design, development, and certification of a vehicle. A vehicle user who departs from the recommended tire size, type, and pressure may change the handling characteristics of the vehicle and run some risk of degrading the handling performance.

Tire design affects suspension system performance in a number of ways. Generally, the suspension deflection is 10 times that of the tire deflection. That is, for a 1-inch (2.5 cm)

deflection, only a 150-pound (68.18 kg) load is required on the suspension system compared to a 1500-pound (681.8 kg) load on a tire. If this deflection ratio is changed, as can be done in a number of ways, the change will be reflected in a change in the reaction of the suspension system and in the handling characteristics of the vehicle. Generally speaking, the lower the deflection ratio the softer the ride and, consequently, the poorer the handling performance of the vehicle.

All major tire manufacturers develop and offer tires certified for speeds up to 125 mph (200 km/h) to meet the high speed pursuit requirements of patrol cars. In contrast, passenger car tires generally are certified for maximum speeds of no more than 85 mph (140 km/h) under the FMVSS. However, tire certification has other ramifications.

Before a motor vehicle can be sold in the United States, it must meet the standards of both the National Highway Traffic Safety Administration (NHTSA) and the Environmental Protection Agency (EPA). Individually components and subsystems of the vehicle (i.e., lights, brakes, tires, bumpers, restraints, etc.) are covered by NHTSA's Federal Motor Vehicle Standards (FMVSS), and must be certified by the automobile manufacturer. Under EPA regulations, the total vehicle system must be tested and certified as satisfying emission standards. Once a particular combination (model) is certified, the manufacturer is limited in the number of changes he can make, or options he can sell with that vehicle, without retesting and recertification.

As a consequence of the certification procedures, continuing use of the designated tire types is important to retaining the performance of the patrol car as purchased.

All three types of tire construction--bias, bias-belted, and radial--reportedly have been certified by various tire manufacturers for 125 mph (200 km/h) police service. According to the Rubber Manufacturers Association, it is preferable that all four tires on a car be of the same size and construction. Under some circumstances, mixing of radials and non-radials is acceptable, but not preferred. However, radial tires should never be placed on the front wheels if anything other than radials are on the rear wheels.

#### 5.6.1 Bias Ply

Bias ply tires have stiffer sidewalls largely because of the angle of the cords and the number of plies in the body. They have more rubber in the tread, primarily in the shoulders. In general a bias ply tire has:

1. Good low speed ride properties.
2. Low road noise.
3. Lighter steering load at low speeds and in parking when compared with radial construction.
4. Good break away resistance in a high stress maneuver, i.e., no sudden or unexpected loss of traction.
5. Good resistance to sidewall damage.
6. Fair tread life.

Since the bias ply tire is so widely used in this country, supply is no problem.

#### 5.6.2 Radial Ply

Radial ply tires have quite flexible sidewalls and stiff treads with no shoulder. In general, a radial ply tire when compared to a bias ply tire has:

1. Lower rolling resistance and improved gasoline mileage.
2. Longer tread life.
3. Better cornering ability.
4. Better traction and braking grip.
5. More ability to roll over small grooves or ridges in the road with less direction change or wander.
6. Better high speed ride.
7. Greater susceptibility to sidewall damage.

The radial tire is just coming into common use on U.S. automobiles; the 1974 models were the first to be designed to use them. Radial tires require more process steps in their construction than do bias or bias belted tires; hence, they will likely continue to be the highest in purchase cost into the foreseeable future.

It should be noted that most radial tires (like those of other constructions) are not suitable for use at speeds above about 100 mph (160 km/h). Some, however, are specially designed for use at speeds of 125 mph (200 km/h); these may be belted with either steel or synthetic material. Departments which require such high speed performance should purchase only tires which are certified by the manufacturer to be capable of such performance on the basis of sustained high speed track tests.

### 5.6.3 Bias Belted

Generally, the performance properties of bias belted tires are somewhere between those of bias ply and radial ply tires. A bias belted tire has:

1. Better high speed ride than bias tires and better low speed ride than radial tires.
2. At low speeds, a heavier steering load than bias ply tires, but a lighter steering load than radial tires.
3. Less resistance to sidewall damage than bias ply tires, but more resistance than radial tires.
4. Longer tread life than bias ply tires, but less tread life than radial tires.
5. Better cornering ability than bias ply tires, but less than radial ply tires.

### 5.7 Electrical System

Most motor vehicles equipped for police patrol have a large number of electrically powered devices installed in them. These may include: mobile radio transceiver; additional mobile radio receivers; siren (electronic or electro-mechanical); emergency lights; public address system; spotlights; and additional stoplights or colored warning lights.

In addition, there is an increasing tendency to install more electrical accessories such as: air conditioner, deck lid release, power windows, power door locks, and power adjustable seats. Police often find it necessary to operate much of the electrical equipment while the engine is idling or even turned off. These extended electrical drains sometimes cause starting and battery maintenance problems. Furthermore, in high speed chases air conditioners and electro-mechanical sirens drain off significant engine power and reduce maximum speed.

Several innovations have been made by manufacturers to promote longer electrical system life. Higher capacity alternators, both in normal output and idle speed output, have been installed. Shields have been placed around the battery to protect it from heat, as well as from stones thrown up from the road. Deterioration of the alternator belt has been a long-standing problem. Dual alternator drive belts were tried, but have been discontinued by most manufacturers. The best solution to belt deterioration ultimately is to make improvements in belt quality. Research is underway to develop belts made of Kevlar, a high strength synthetic fiber.

Other electrical system problems may also be attributed to heat effects. Electrical conductor failures, such as short circuits, are often the result of insulation breakdown accelerated by engine compartment heat. The ignition wiring is one of the common victims. Efforts are being made to combat heat by the use of high temperature resistant wire insulation, but this problem has not been completely solved. Heat degradation problems appear likely to increase since the trend is to increase engine operating temperatures.

With the seemingly continuous addition of new electrically operated equipment to vehicles, additional electrical capacity and maintenance of system reliability has become an ever increasing problem. Many of the solutions offered involve replacing electro-mechanical devices with solid state electronic equipment: sirens, emergency lights, ignition, and voltage regulators. Electronic ignition, which is claimed to eliminate much of the maintenance required to keep an engine operating efficiently, is standard presently on one manufacturer's vehicles and available on some others.

## 5.8 Steering

Steering characteristics are important to mission performance at any speed. A report on police vehicle accidents in a large city shows the majority occur while cruising at low speeds [5]. The ease with which a patrol car steers contributes significantly to the driver's comfort and efficiency. Precision of steering is important in pursuit operations, particularly in evasive maneuvers, regardless of the speed.

Domestic motor vehicles used for patrol cars are equipped with a type of steering gear known as the recirculating ball and nut. These have been combined with power assist and developed to a degree that police consider steering performance at normal vehicle speeds satisfactory [4]. If the components in the steering system are not kept in adjustment and in good repair, however, the likelihood of steering malfunctions are increased. Faulty adjustment and poor maintenance can not only adversely reflect steering performance, but can increase operating costs unnecessarily. Not only the steering gear itself, but all the components which work together as the steering system are critical. These include not only the ball joints, tie-rods, bushings, pitman arm, etc., but also such things as front wheel alignment and tire balance.

### 5.9 Emission Control System

As seen in table 1, emission control devices appear to be an important factor in patrol car performance. Since the introduction of emission controls:

1. Horsepower produced for a given engine displacement volume has decreased.
2. Vehicle weight has increased.
3. Gasoline mileage has decreased.
4. Higher engine compartment heat levels have increased heat failures in insulation, gaskets, valves, etc.

Current emission control devices can be considered only interim measures. The Federal emission standards effective on 1975 model automobiles are being met on some makes of cars by the use of a catalytic converter, a special device which is installed in the exhaust system and which converts the harmful emissions into water and carbon dioxide through a chemical process. Those converters in current use, however, will be seriously damaged by leaded gasoline.



## 6. PATROL CAR ACQUISITION

Each time a law enforcement agency acquires new vehicles, a set of specifications is prepared and offered to vendors for bid. An examination of the specifications obtained from police organizations across the country shows a wide variation in approach, from brief one page lists to very detailed, multi-page lists. A general pattern is apparent, however. Usually, a very brief statement is furnished to the bidder regarding use of the vehicles. This may be a few words such as "automobiles for police activity", "sheriff patrol cars", "four-door sedans with heavy duty police equipment", or "for routine police patrol, traffic control, and other work required in the operation of a police department".

In a few cases, service requirements have been described at some length. For instance, the specification of the City of Milwaukee, Wisconsin, states that "the vehicle...will be exposed to the most severe service to which a vehicle can be subjected," and then describes in qualitative terms the extent of use and wear to be expected on various parts of the vehicle. The necessity of providing heavy-duty parts and options is stressed. Another example of more definitive service requirements is that supplied for the California Highway Patrol, Class "A" Special Service Vehicle.

"It is the intent of these specifications to describe an automobile to be used in high speed highway traffic and law enforcement work. The vehicle will at times be operated at speeds considerably in excess of 100 miles per hour (160 km/h) for both short and long durations. It will be driven on all types of roads and road surfaces and at altitudes ranging from approximately 200 feet (60 meters) below sea level to 10,000 feet (3050 meters) above sea level. Temperatures to which the vehicle will be exposed will range from approximately minus 20°F (-29°C) to plus 120°F (+49°C).

"It is intended that the manufacturer in the selection of components will use materials and design practices that are the best available in the industry for the type of operating conditions to which the vehicle will be subjected. Engine, transmission, drive line, differential, brake, suspension, wheel, tire, and other component parts of the vehicle shall be selected to give maximum performance, service life, and safety and not merely meet the minimum requirements of this specification.

"The term 'heavy duty' as used in these specifications shall mean that the item to which the term is applied shall exceed the usual quantity, quality, or capacity supplied with standard production vehicles; and it shall be able to withstand unusual strain, exposure, temperature, wear and use."

## 6.1 Design Specifications

The vehicle requirements are commonly spelled out in what might be called "design" terms. This means the specifications will list requirements such as the number of cylinders, cubic inch displacement, and horsepower of the engine; the type of alternator; the size of cooling fan; type of brakes; number of doors, and the size of the wheelbase. In addition, the accessories may be listed: air conditioning, spotlights, remote-controlled outside mirrors, inside hood and trunk releases, hand throttle, and others desired.

The "design" approach, describing a vehicle for patrol car use by specifying the individual components, appears to have developed from the practice of the automobile manufacturers offering a large number of options and accessories for their police patrol vehicles. Through experience and in consultation with the manufacturers, patrol car users have apparently reached reasonably effective vehicle "designs" for their specific requirements.

There are serious disadvantages to using the "design" approach for specifying vehicles for patrol use. The majority of persons responsible for developing specifications are police officers, who have developed their knowledge of vehicles largely through using them. Only a handful of the larger departments have automotive engineers on their staffs. The use of design specifications requires a thorough understanding of automotive design to provide the most satisfactory vehicle for a given service.

Almost every model year, manufacturers offer new options and new accessories. Although organizations should take advantage of these new items whenever patrol performance would be improved, few departments have the capability of evaluating optional equipment to determine what benefits might be provided.

The lack of in-house expertise often results in specifications being developed that cannot be met. Some problem specifications develop when there is an unawareness of technological advances, certification procedures, or physical design limitations.

Perhaps the most important disadvantage is that the purchaser has no guarantee that the vehicle he "designed" and purchased will provide the performance or the service desired, and if it does not, he can do little to require the manufacturer to correct the problem.

## 6.2 Performance Specification

Another approach to writing specifications is to specify a level of performance. Specified levels of performance and tests for handling or roadability, braking, acceleration, and top speed illustrate this type of specification. The city of Los Angeles has been a leader in developing specifications based on performance. The city and county of Los Angeles use the same specifications, which include the following roadability and brake test procedures:

### "ROADABILITY TEST:

Vehicles will be tested for cornering, steering, and other road handling characteristics at the Pomona Fair Grounds Sports Car Track or other suitable place designated by the Sheriff's Department. Vehicles will be evaluated by the driver and passengers conducting the test and the opinions will be considered in rating the vehicles for over-all suitability. The actual test shall be conducted by two or more separate Los Angeles County drivers who will take four practice laps of the designated course to familiarize themselves with the vehicle. Following this, four additional laps will then be completed and the roadability of the vehicle noted by the driver. The drivers will evaluate the vehicle for ease of handling in corners and turns, for ease of control at high speed and ease of steering at slow speeds. Vehicles must accelerate from 0 to 60 mph (95 km/h) in not more than 9 seconds, and have a top speed of not less than 115 mph (185 km/h).

### BRAKE TEST:

The brake test shall consist of two parts as follows:

1. Four stops of impending skid type from a speed of 90 miles per hour (145 km/h) at two minute intervals followed by a panic stop from 60 miles per hour (95 km/h) will be made, at which the ability of the vehicle to stop in a straight line will be evaluated.
2. Five minutes after the panic stop has been completed, four more stops at 90 miles per hour (145 km/h) of the impending skid type at two minute intervals followed by a 60 mile per hour (95 km/h) panic stop will again be performed, and the ability of the vehicle to stop in a straight line will be evaluated.
3. Cars equipped with a self-adjusting brake feature will be subjected to the following test immediately following conclusion of the above brake test:

There will be four (4) successive brake applications made on the vehicle with the car being driven in reverse. If it is found that the self-adjusting brake feature adjusts the brakes to the extent that the wheels drag when the rear drums cool down the vehicle will not be acceptable.

Vehicle deceleration rates will be recorded by the use of a decelerometer and pressometer to determine the brake fade characteristics of the vehicles submitted for testing. Vehicles failing to pass this test will not be considered qualified for this bid."

More and more jurisdictions every year refer to the results of the Los Angeles tests to guide their procurement. It should be pointed out, however, that these tests have been developed by the LAPD to meet their particular operational requirements and driving conditions, and cover only intermediate-size vehicles.

### 6.3 Acquisition Procedures

A general pattern is apparent in patrol car acquisition procedures. Specifications are generally prepared on a model year basis, shortly after information is released on the new models. The development of written specifications varies widely, but in most cases police agencies are given major responsibility. Vehicles are normally purchased on low bid, but in some cases specifications appear to be written to favor a desired make or model. This latter approach has been used when a department has had good performance and service from a particular vehicle, good service from the dealer on maintenance and repairs, and so on. Bids are usually opened in November or December, and delivery generally starts in January or February. Quite often provisions are made to purchase replacements for wrecked vehicles during the model year.

Used vehicles are often traded in on the new vehicles. Some agencies conduct their own sales of used vehicles, claiming a better return. The North Carolina Highway Patrol over the years has extensively refurbished its used patrol cars and sold them to smaller jurisdictions for police use, thereby minimizing its net acquisition costs. A few agencies use their cars until there is essentially no residual value; New York City is one agency that follows this practice.

#### 6.4 Life Cycle Costs

Although the initial cost and the maintenance cost of a vehicle may not be associated with patrol performance, high costs for vehicles coupled with budget restrictions might limit an agency's ability to meet its transportation requirements. This, in turn, would presumably reduce the agency's effectiveness.

Costs of new, full-size, four-door sedans equipped for police use vary from about \$3300 to \$4000, depending upon the options ordered. Trade-in values for two-year old cars in 1972 ranged from \$900 to \$1300. Net costs appear to range from \$2000 to \$3100 per new car.\*

A fuller discussion of patrol car economics can be found in the section of this report on vehicle fleet management.

The LAPD procedure in acquiring new vehicles varies from the norm and is worth specific mention.

1. Specifications for vehicles are sent to the manufacturers shortly after the new model information becomes available each year.

2. Automobile manufacturers submit models equipped according to specifications of the LAPD for test in accordance with the specified procedures.

3. Vehicles which pass the tests are impounded until the bidding procedure has been completed. Manufacturers whose vehicles do not pass the tests are not eligible to bid.

4. Vehicles are purchased on low bid, after which the impounded vehicles of unsuccessful bidders are released. The vehicle of the successful bidder is retained for comparison with the first fifty vehicles delivered by the contractor.

\*This survey was conducted in 1973-1974. Costs do not reflect current market prices or trade-in values.

This procedure, developed over a period of time in conjunction with the automotive manufacturers, has resulted in patrol cars which are considered by many to be among the best in the country. The procedure has also provided the automotive manufacturers with an independent evaluation of their police car models.

## 7. VEHICLE PERFORMANCE TESTING

In order to provide a vehicle of optimum characteristics for a particular police application, an evaluation procedure is desirable. Criteria related to the user requirements, against which the evaluation would be conducted, are also desirable. There are no performance oriented tests available that have been developed for the total patrol car, highway or urban.

There are some tests required by law that apply to certain aspects of performance. For example, certain performance tests are already required of all vehicles by the FMVSS. The FMVSS cover brakes in Standards 105 and 106, tires in 109 and 110, and bumper impacts in Standard 215, to mention a few. However, while the test procedures adequately cover standard passenger cars, no procedures include the conditions under which police vehicles are expected to perform. For instance, many patrol cars are specified for operation to 125 mph (200 km/h), up to 45 mph (70 km/h) beyond the test range of the FMVSS. Handling and maneuverability are critical to police usage, but high stress maneuvers, such as lane changing, turns, and cornering at high speeds, are not covered in the FMVSS. Controlled stopping from high speeds is another patrol car performance attribute not covered in the FMVSS.

Recently, the Highway Safety Research Institute (HSRI), Ann Arbor, Michigan, completed a project for the U.S. Department of Transportation (DOT) to provide data on the effect of high stress maneuvers on vehicle stability [7]. The HSRI study developed some test procedures that could be highly relevant to police patrol car requirements. HSRI developed reproducible techniques for measuring the response of vehicles moving at 50 mph (80 km/h) to such things as lane changing, turning, turning with braking, and turning with braking on a rough road surface. While this work was performed on a variety of vehicles for research purposes, the techniques appear quite applicable for evaluating the performance of police vehicles.

With adequate test procedures, it would be possible to conduct annual performance tests of all the vehicles offered as patrol cars by the various manufacturers. These tests should include acceleration through various speed ranges, braking under varying conditions, cornering and lane changing at various speeds, and off-road properties (curbs, median strips, etc.). Properly designed and expeditiously performed and reported, the results could serve as a factual input to any law enforcement organization purchasing new patrol cars. There are a number of independent test centers which appear to be capable of conducting patrol car performance tests, once the test procedures have been developed.

## 8. VEHICLES IN CURRENT USE AS PATROL CARS

The Buntzen/Klaus survey provides a description of the typical patrol car specified for purchase in 1972. A total of 530 police departments provided data concerning their patrol car experiences. This survey included data from the police departments of 47 of the 50 states, 46 of the 50 largest cities, and representative samples of counties, smaller cities, and townships. It should be emphasized that the data in the survey are based on the specification last used by each reporting department to purchase patrol cars and hence does not present a truly accurate picture of the total fleet in current use.

Based upon survey data, the total number of police patrol cars in use was estimated to be 160,000. However, this is considered to be low since an estimated 10,000 to 12,000 small and part-time police departments were not included in the survey. By including these small departments, the total could easily be 10,000 to 20,000 higher. If the survey data are applied to the estimated national patrol car fleet, it can be estimated that of these 160,000 vehicles, 60 percent were standard-size 4-door sedans, or 73 percent when 2-door sedans are included, 21 percent were intermediate-size 4-door sedans, or 23 percent when 2-door cars are included. The remainder were station wagons and compact cars. A more detailed breakdown is shown in table 2.

These vehicles were not all equipped with special police options. About 80 percent, or about 127,500 cars, were found to have heavy-duty suspensions. The other 32,000 vehicles were apparently standard vehicles, i.e., without police heavy-duty suspensions, or the other heavy-duty options associated with the patrol car. Details are given in table 3. The division by vehicle type is substantiated by the estimate of 65-70,000 new cars equipped with police options sold by the manufacturers in the 1973 model year.

Table 2

## Estimated Composition of National Patrol Car Fleet Based on 1972 Specifications

Department Type	Estimated Total	Full Size Sedan		Interm. Size Sedan		Station Wagon		Compact
		2-door	4-door	2-door	4-door	Station Wagon	Compact	
State	29,150	1,330	25,650	737	881	443	109	
County	70,896	2,874	37,221	2,245	24,650	2,514	1,392	
Township	6,296	49	5,271	-	634	342	-	
City 1-9 Officers	10,897	1,015	8,731	-	745	406	-	
City 10-49 Officers	10,123	198	8,429	22	682	418	374	
City 50+ Officers	15,900	642	11,409	100	2,814	521	414	
50 Largest Cities	16,055	30	12,938	37	2,472	478	100	
Total	159,317	6,133	109,649	3,141	32,878	5,122	2,389	
Percent	100	4	69	2	21	3	1	

Source: Buntten/Klaus survey. Derived by applying department percentages, table 2A-1, to estimated total, table 2A-4.



Table 3

Patrol Car Specifications in 1972

"Police Option" Equipped vs. "Standard Vehicles"

	<u>"Police Option"</u>	<u>"Standard"</u>	<u>Estimated Total</u>
State	28,567	583	29,150
County	48,209	22,687	70,896
Township	5,666	630	6,296
City 1-9 Officers	8,282	2,615	10,897
City 10-49 Officers	8,807	1,316	10,123
City 50+ Officers	13,356	2,544	15,900
50 Largest Cities	<u>14,610</u>	<u>1,445</u>	<u>16,055</u>
Total	127,497	31,820	159,317
Percent	80	20	100

Source: Buntten/Klaus survey. The figures shown were calculated from data in tables 2A-4 and 12-2, based on the assumption that "heavy-duty suspension" equated to a "Police Option" equipped vehicle, i.e., a vehicle offered by the manufacturer specifically as a police car.

The optional equipment specified by the departments studied in the Bunten/Klaus survey is shown in table 4. Of the thirteen options listed, six were specified for over 80 percent of all vehicles: automatic transmission, 8-cylinder engine, power steering, power brakes, front disc brakes, and heavy duty suspension. A comparison of these 1972 options with the police vehicle specifications of 1974 model year vehicles offered by the four domestic manufacturers, tables 5 and 6, shows that all of the first six listed options are now standard equipment for full-size police vehicles. Of the other seven options listed in the survey, the interior hood latch release has become standard on full-size cars and on some intermediate-size cars. Certain features that are options to the general public have become standard features in a police vehicle for the 1974 model. The features in the so-called "police package" listed for the 1974 model year include:

- Automatic transmission
- Power brakes (front disc)
- Special handling package (heavy-duty suspension)
- Special radiator cooling package (heavy-duty)
- Power steering
- Interior hood latch release
- Heavy-duty front seats
- Calibrated speedometer
- Heavy-duty wheels
- Police special tires
- Higher capacity alternator
- Higher capacity battery

In addition to these features, manufacturers may add other equipment which is deemed necessary to provide the performance required of patrol cars. Quite often, for instance, vehicles equipped with the largest engines will have auxiliary transmission oil coolers and external engine crankcase oil coolers.

Generally, all of the optional equipment available to any car buyer is also available for inclusion in a patrol car. The lower part of table 4 shows air conditioning, tinted glass, an interior hood release, a light in the trunk and an interior trunk release included on large percentages of patrol cars. The rationale for including these items is that they improve the effectiveness of the patrolman. Air conditioning is provided to reduce fatigue. Tinted glass reduces the effect of solar heat and improves the efficiency, but reduces night vision. The interior hood release is intended to prevent theft and preserve the integrity of the vehicle. The interior trunk release and the light in the trunk speed access to equipment stored in the trunk. Some features may have an additional justification based on improving the resale value of the patrol car. From table 4 it would appear that state agencies lead in adding options.

Table 4

Options and Accessories on Patrol Cars Based on 1972 Specifications

DEPARTMENT TYPE

	PERCENT									
	All Dents					City				
	State	County	Town-ship	Officers 1-9	Officers 10-49	Officers 50+	Largest 50			
1. Automatic Transmission	95	87	90	95	98	95	100			
2. 3-cylinder Engine	94	85	93	95	94	93	100			
3. Power Steering	90	79	93	85	94	95	89			
4. Power Brakes	86	82	83	80	88	84	89			
5. Disc Brakes	84	79	83	77	82	86	96			
6. HD Suspension	83	68	90	76	87	84	91			
7. Air Conditioning	59	53	52	43	59	71	63			
8. Tinted Glass	52	39	45	41	51	67	54			
9. Interior Hood Release	49	47	45	37	43	42	63			
10. Light in Trunk	45	46	59	44	42	37	30			
11. Interior Trunk Release	37	32	62	21	38	36	39			
12. Locking Gas Cap	10	8	0	9	8	7	28			
13. Bucket Seats	4	4	0	2	3	4	15			

Source: Buntent/Klaus survey, Table 12-1.

Table 5

Typical Full-Size 4-Door Sedans Offered for Police Patrol by the Manufacturers 1974 Model Year

MANUFACTURER MODEL NAME ENGINE SIZE (1)	American Ambassador		Chrysler Fury/Monaco		Ford Custom 500/Galaxy		General Motors Belair/Impala	
	Med.	Max.	Med.	Max.	Med.	Max.	Med.	Max.
Displacement, CID (2)	360-2	401-4	360-2	440-4	400-2	460-4	400-2	454-4
AUTOMATIC TRANSMISSION	STD(3)	STD	STD	STD	STD	STD	STD	STD
Lowgear Lockout	STD	STD	SO(4)	SO	STD	STD	OPT(5)	OPT
Auxiliary Cooler	SO		OPT	OPT		STD		
ELECTRIC SYSTEM								
Alternator, AMP	62	62	65	65	70	90		
Generator, AMP							42	42
Battery, AMP	80	80	70	70	80	80	80	80
Electronic Ignition			STD	STD	STD	STD		
BRAKES, Front Disc	STD	STD	STD	STD	STD	STD	STD	STD
Power	STD	STD	STD	STD	STD	STD	STD	STD
STEERING, Power	OPT	OPT	STD	STD	STD	STD	STD	STD
Oil Cooler								
HEAVY DUTY HANDLING PKG.								
Springs, Front and Rear	STD	STD	STD	STD	STD	STD	STD	STD
Shock Absorbers, F&R	STD	STD	STD	STD	STD	STD	STD	STD
Stabilizer Bar, Front	STD	STD	STD	STD	STD	STD	STD	STD
Rear	STD	STD			STD	STD	-	STD
Front Strut Bushings	STD	STD						
Upper Suspension Arm Bush	STD	STD						
Control Arm Bushings			STD	STD	STD	STD		
Front Spindles					STD	STD		
Reinforced Frame			STD	STD	STD	STD		
SPECIAL COOLING	STD	STD	STD	STD	STD	STD	STD	STD
High Capacity Fan	STD	STD	STD	STD			STD	STD
Fan Shroud	STD	STD	STD	STD			STD	STD
High Capacity Radiator	STD	STD	STD	STD				
Coolant Recovery System	STD	STD	STD	STD	STD	STD	STD	STD
External Crankcase Oil Cooler	SO	SO			OPT	STD		
HEAVY DUTY WHEELS, 15x6.5			STD	STD	STD	STD		
15x6.0	STD	STD					STD	STD
TIRES								
Bias, 4 Ply Nylon			STD	STD	STD	STD	OPT	STD
Bias Belted, 4 Polyester and 2 Fiberglass Belts	OPT	OPT	SO	SO			STD	OPT
Radial, 2 Polyester and 4 Rayon Belts	OPT	OPT	SO	SO	OPT	OPT	OPT	OPT
OTHER ITEMS								
HD Front Seats	STD	STD	STD	STD	STD	STD	STD	STD
HD Floor Mats	OPT	OPT	STD	STD	OPT	OPT	STD	STD
HD Flasher Unit					STD	STD		
Interior Hood Release	STD	STD	STD	STD	STD	STD	STD	STD
Interior Trunk Lid Release	OPT	OPT	OPT	OPT			SO	SO
Single Key Locking System	OPT	OPT	OPT	OPT	OPT	OPT	SO	SO
Calibrated Speedometer	STD	STD	STD	STD	STD	STD	STD	STD
Automatic Parking Brake Release					STD	STD		

- NOTES: (1) Data on models with different size engines gives some indication of diversity in equipment offered.
- (2) Displacement data also shows number of barrels in carburetor(s) in the figure after the dash. "440-4." Usually 4 barrels indicate the use of 2 carburetors. Metric equivalents of CID are as follows in liters: 360 (5.9), 401 (6.6), 360 (5.9), 440 (7.2), 400 (6.6), 460 (7.5), 400 (6.6), and 454 (7.4).
- (3) "STD" means standard equipment on vehicles offered for police use. May or may not be standard on regular production models.
- (4) "SO" means available only on special order; sometimes only if a minimum number are ordered.
- (5) "OPT" means available as regular production option.

Source: Specifications released by manufacturers in August 1974.

Table 6

Typical Intermediate Size 4-Door Sedans Offered for Police Patrol by the Manufacturers, 1974 Model Year

MANUFACTURER MODEL NAME ENGINE SIZE (1)	American Matador		Chrysler Satellite/Coronet		Ford Torino		General Motors Chevelle
	Med.	Max.	Med.	Max.	Med.	Max.	Max.
Displacement, CID (2)	360-2	401-4	360-4	440-4	351-2	460-4	400-2
AUTOMATIC TRANSMISSION	STD(3)	STD	STD	STD	MD(4)	MO	STD
Lowgear Lockout	STD	STD	SO(5)	SO	STD	STD	SD
Auxiliary Cooler	SD	SO	DPT(6)	OPT			
ELECTRIC SYSTEM							
Alternator, AMP	62	62	65	65	70	90	61
Generator, AMP							
Battery, AMP	80	80	70	70	77	77	80
Electronic Ignition			STD	STD	OPT	STD	
BRAKES, Front Disc	STD	STD	STD	STD	STD	STD	STD
Power	STD	STD	STD	STD	STD	STD	STD
STEERING, Power	DPT	DPT	DPT	OPT	MO	STD	MO
Oil Cooler					STD	STD	
HEAVY DUTY HANDLING PKG.	STD	STD	STD	STD	STD	STD	STD
Springs, Front and Rear	STD	STD	STD	STD			STD
Shock Absorbers, F&R	STD	STD	STD	STD			STD
Stabilizer Bar, Front	STD	STD	STD	STD			STD
Rear	STD	STD		STD	STD	STD	
Front Strut Bushings	STD	STD					
Upper Suspension Arm Bush.	STD	STD					
Control Arm Bushings			STD	STD			
Front Spindles							
Reinforced Frame			STD	STD	STD	STD	STD
SPECIAL CODLING	STD	STD	STD	STD	STD	STD	STD
High Capacity Fan	STD	STD	STD	STD			STD
Fan Snroud	STD	STD	STD	STD			STD
High Capacity Radiator	STD	STD	STD	STD	STD	STD	STD
Coolant Recovery System	STD	STD	STD	STD	STD	STD	STD
External Crankcase Oil Cooler							
HEAVY DUTY WHEELS, 15x7.0							OPT
15x6.5			STD	STD			
15x6.0	STD	STD					
14x6.0							STD
TIRES							
Bias, 4 Ply Nylon			STD	STD	OPT	STD	OPT
Bias Belted, 4 Polyester and 2 Fiberglass Belts	OPT	OPT	SD	SD			OPT
Non Police					STD		
Radial, 2 Polyester and 4 Rayon Belts	OPT	OPT					
Fabric					OPT	DPT	OPT
OTHER ITEMS							
HD Front Seat	STD	STD	STD	STD	STD	STD	SO
HD Floor Mats	OPT	OPT	STD	STD	OPT	OPT	SD
HD Flasher Unit							
Interior Hood Release	OPT	DPT	OPT	OPT	STD	STD	STD
Interior Trunk Lid Release	OPT	DPT	OPT	OPT	OPT	OPT	SO
Single Key Locking System	DPT	OPT	DPT	OPT			SO
Calibrated Speedometer	STD	STD	STD	STD	STD	STD	STD

- NOTES: (1) Data on models with different size engines gives some indication of diversity in equipment offered.
- (2) Displacement data also shows number of barrels in carburetor(s) in the figure after the dash, "440-4." Usually 4 barrels indicates the use of 2 carburetors. Metric equivalents of CID are as follows in liters: 360 (5.9), 401 (6.6), 360 (5.9), 440 (7.2), 351 (5.2), 460 (7.5) and 400 (6.6).
- (3) "STD" means standard equipment on vehicles offered for police use. May or may not be standard on regular production models.
- (4) "MO" means an option that must be ordered (mandatory for a police car).
- (5) "SO" means available by special order, sometimes only if a minimum quantity is ordered.
- (6) "OPT" means available as regular production option.

Source: Specifications released by manufacturers in August 1974.

An analysis of the A. L. Craig survey of highway patrols [8] completed in July 1973, table 7, shows that vehicle specifications changed only slightly from the Dunten/Klaus survey. These changes reflect an increase in specifications of the options, many of which have become standard on police pursuit cars in 1974: automatic transmission, 8-cylinder engine, power steering, power brakes, front disc brakes, and heavy-duty suspension (see tables 5 and 6). The number of departments specifying air conditioning did not change. This is understandable since the states not specifying air conditioning are located in the northern part of the country.

The picture that emerges of patrol cars in current use is as follows:

1. Standard-size 4-door sedan with 8-cylinder engine, automatic transmission, power steering, power brakes (front disc), and heavy-duty suspension as standard equipment. Air conditioning, tinted glass, and an interior hood release are standard equipment for most departments. State agencies equip most of their vehicles with trunk light and interior trunk release. These larger vehicles, "fully-equipped," are used almost universally by State agencies and are largely preferred by other departments except counties. Standard-size vehicles account for only about 52 percent of county police cars.

2. Intermediate-size 4-door sedan equipped similarly to the full-size sedan. While they represent over 20 percent of the total fleet, the largest users are county and larger city departments.

3. Station wagons appear to be largely special purpose, i.e., emergency, rural patrol vehicles. They represent about 3 percent of the total fleet.

4. Compact-size cars appear to be used mostly by counties and larger cities, but not the 50 largest. They represent about one percent of the total fleet.

5. A trend to the use of sub-compacts, i.e., 100-inch (254 cm) wheel base or less, is under way, judging by news media articles. The emphasis on fuel economy may accelerate this trend. Indications are that some smaller residential jurisdictions are having success with sub-compacts.

Table 7

National Survey State Patrol Pursuit Cars  
1972 - 1973

	<u>1972 [4]</u> <u>%</u>	<u>1973 [8]</u> <u>%</u>
Automatic Transmission	100	98
8-Cylinder Engine	100	94
Power Steering	100	90
Power Brakes	100	86
Disc Brakes	100	84
Heavy Duty Suspension	100	83
Air Conditioning	80	81
Tinted Glass	70	52

While the preceding tabulation might indicate some agreement on vehicle "design" which corresponds to the requirements of a particular type of department, such is definitely not the case. It is quite possible that no two departments in the United States order exactly the same vehicles for patrol purposes. These variations could be interpreted in a number of ways:

1. Agencies know their performance requirements very well and are tailoring the vehicle specifications to these requirements,

2. Agencies do not know their requirements well and are being "sold" certain vehicles,

3. Agencies use what ever information, data, or expertise is available and specify based on experience,

4. Agencies are restricted in some measure by policy, funding, opinion, etc. to specifications and/or purchase without regard to police requirements.

5. Trade-in value, low cost, maintenance cost, etc., rather than functional performance, may be over-riding considerations in purchasing police vehicles.

Whatever the reason, the Buntzen/Klaus survey indicates that patrol cars were considered to be the primary police equipment problem. Interviews and conversations with representatives of police agencies and vehicle producers across the country tend to confirm that confusion regarding a department's functional requirements, and a lack of definitive data on vehicle performance, are the real problems in obtaining the functionally optimum patrol car for a particular jurisdiction. For instance, the type of vehicle which appears most suitable for patrolling high speed highways hour after hour may not be optimum for use in low speed patrolling of congested urban areas or residential areas. Top speed and acceleration are two characteristics that should differ. Engine cooling and electricity generation under idle conditions are other characteristics that may need to differ. Vehicle size may be another differentiating characteristic. While there is an indication that some agencies are optimizing vehicle configuration for functional patrol requirements, most are not.



## 9. NEW DEVELOPMENTS

No industry is static--the automotive industry least of all. In addition to industry-generated developments, environmental considerations, safety, and energy conservation are factors affecting automobile development. In this section we list some impacts, large and small, that may affect the automobile in its role as a patrol car.

### 9.1 Pollution Control

Currently used approaches for meeting EPA standards are going to continue to decrease horsepower. A study of the literature and discussions with automobile industry representatives reinforce the conclusion that the current pollution control devices which have been added to the reciprocating gasoline engine are interim measures which have degraded the power output, driveability, and fuel efficiency of the vehicle. Manufacturers are studying other approaches to meeting EPA emission requirements. Some of the potential solutions under study include:

#### 9.1.1 Stratified Charge Engine

This is an internal combustion engine in which the combustion chamber is divided into two parts. In the smaller first chamber, the fuel to air ratio is high and combustion is initiated. In the larger second chamber, the fuel to air ratio is lowered by adding more air and combustion is completed. A current example of this type of engine has been developed by the Honda Motor Company of Japan, licensed to Ford and Chrysler, and is being studied by General Motors. See figure 1.

#### 9.1.2 Wankel Rotary Engine

This engine, widely described in the literature, reportedly can pass 1975 EPA standards, and with the addition of a relatively simple exhaust reactor can pass 1976 EPA standards. This engine is currently proven in use but appears at a disadvantage on fuel economy when compared with similar size reciprocating engines. Rotary engines are relatively new and improvements are likely to be made. See figure 2.

# STRATIFIED CHARGE

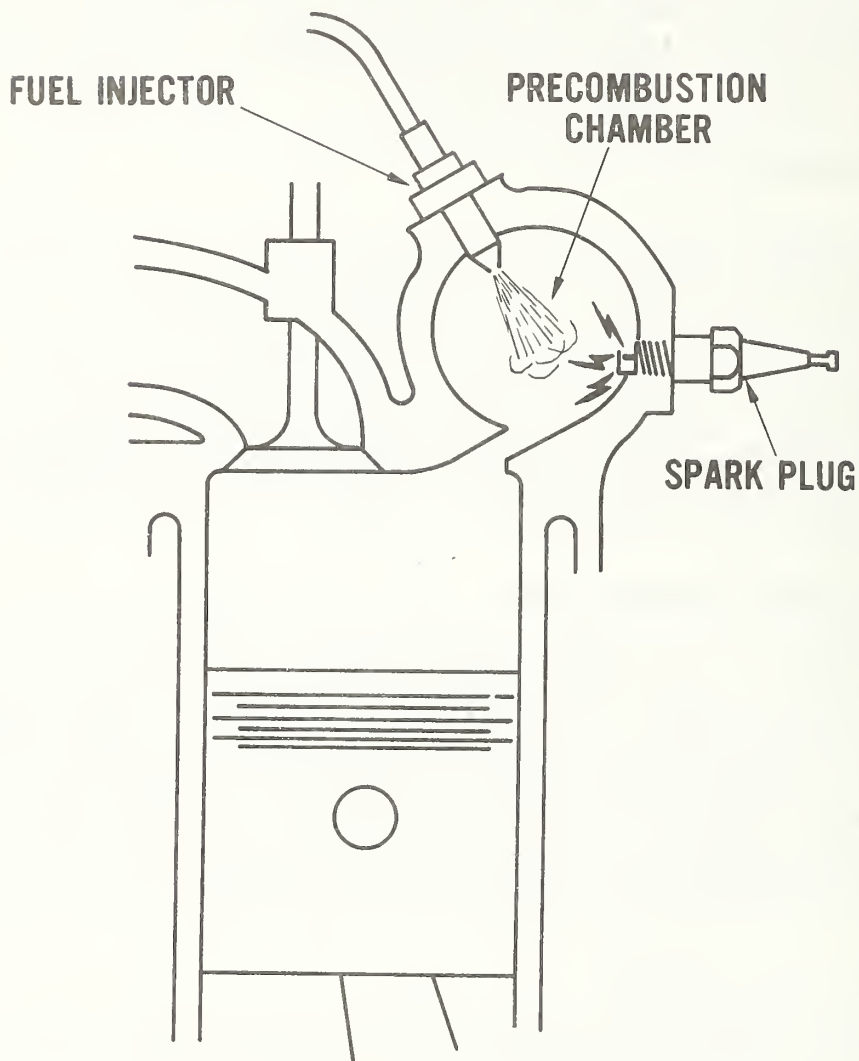

Combustion in a stratified charge engine is much like cupping your hands to light a cigarette in the wind. A precombustion chamber tightly encloses all the elements necessary to start combustion: fuel delivered by an injector, a small pocket of air and a spark from the nearby sparkplug. The initial mixture is very rich and easy to ignite. As the charge burns, it moves out across the piston driving it down. Some unburned fuel is also driven out of the small pocket and it mixes with additional air in the cylinder. This forms a fuel-air mixture that is progressively leaner with increasing distance from the precombustion chamber. Hence the charge is "stratified" (varying in fuel-air ratio). All other aspects of the engine are typical of current piston powerplants.

Figure 1.

Reprinted with permission  
of "Car and Driver."

# WANKEL

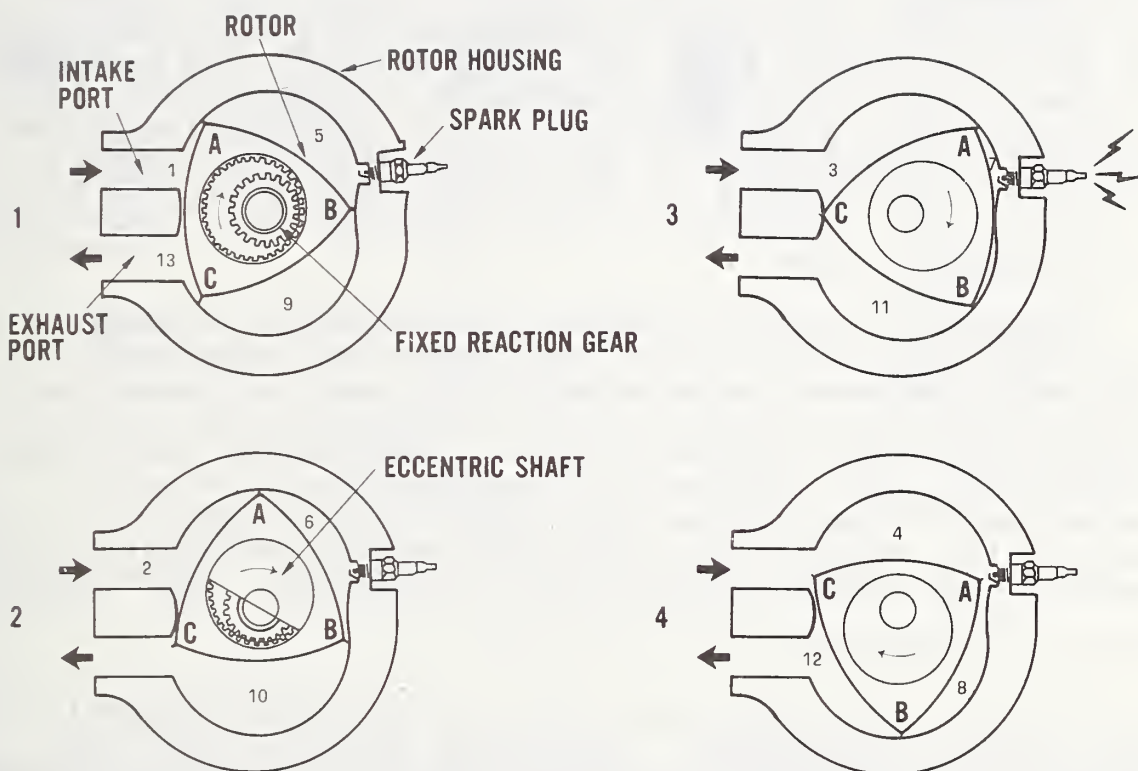

Instead of pistons and valves, the Wankel engine has one or more triangular rotors. They move through a combination of sliding and rotating motion determined by both an eccentric shaft and a reaction gear fixed to the chamber's end plate. The true relationship between the rotor, the fixed gear and the eccentric shaft is shown cutaway in view 2. The gear set is shown alone in view 1. The eccentric shaft is illustrated separately in views 3 and 4. As the rotor moves to uncover the intake port, a fuel-air mixture is drawn in (1,2,3,4) and the compressed (5,6) before being ignited by the spark plug (7). The rapidly expanding gases created by combustion (7,8,9) drive the rotor around the chamber, while delivering power to the eccentric shaft. The spent gases are then swept out the exhaust port by the rotor (10,11,12,13). The process is continuous on all three sides of the rotor.

Figure 2.

### 9.1.3 Stirling Cycle Engine

This is an external combustion engine. Fuel is burned outside the cylinders in which a working gas is sealed. The heat expands the gas, which drives a piston to the opposite end of the cylinder on the power stroke. On the return stroke, the hot gas is pushed through a regenerator which removes some heat to the lower chamber of an adjoining cylinder. The cooled gas is compressed by this second piston on its power stroke and returned through the regenerator to the upper section of the original cylinder where the gas is reheated and the cycle repeated. See figure 3.

### 9.1.4 Diesel Engine

The only currently available diesel-powered cars easily pass 1975 EPA standards, but fail to meet the proposed 1976 standards. However, even Mercedes-Benz does not regard the diesel as a viable alternative to the conventional gasoline engine; the weight-to-power ratio and the cost of the diesel are too high when compared to a gasoline engine of equal horsepower. Diesel technology, however, has remained essentially unchanged for many years, and it is unrealistic to believe that further advances will not be made. See figure 4.

### 9.1.5 Gas Turbine

The gas turbine has been installed and tested primarily by the Chrysler Corporation. The turbine does not pass 1975 emission standards and is on the lower side on fuel economy and acceleration, important to patrol operations. Production costs are a deterrent to broad acceptance. Chrysler Corporation has recently reported improvements in turbine design which may change the picture significantly. See figure 5.

### 9.1.6 Electric Engine

Small vehicles which operate on electric power are available. Pollution, of course, is no problem, but speed and range (50 mph [80 km/h] and 80 miles [130 km] per charge) make the electric motor unacceptable for patrol use, except in limited situations.

## STIRLING CYCLE

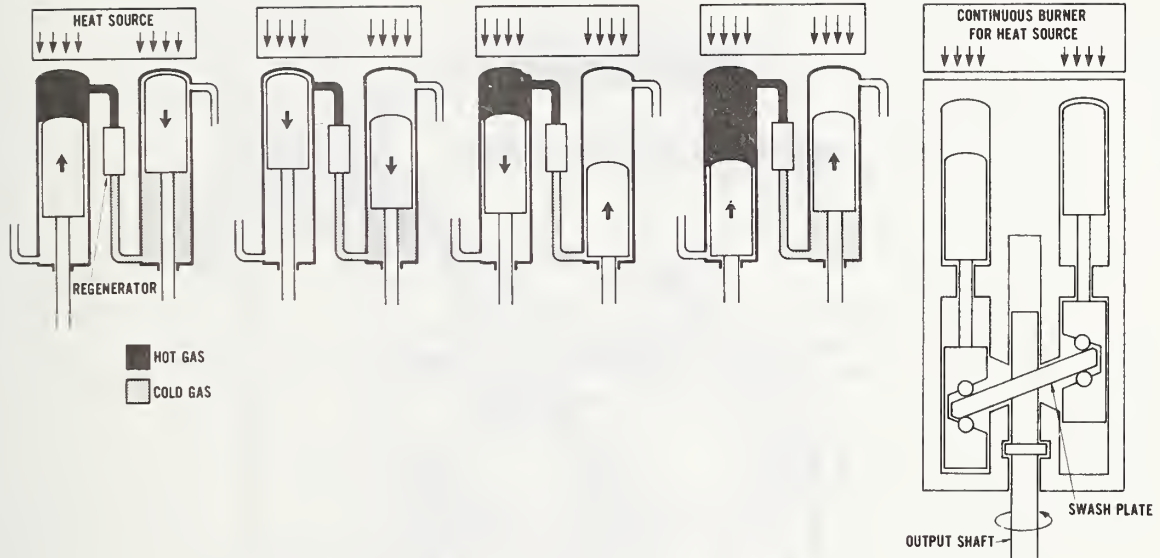

The Stirling cycle engine is an example of external combustion: fuel is burned outside the engine to heat a working fluid sealed inside. A series of chambers are formed by the volume above one piston, interconnected to the volume below the next piston. These chambers are independent of one another and the working fluid remains sealed in each one. The two pistons move to change the total volume of the chamber and transfer the fluid from the cold side below one piston to the hot volume above the next piston. As the gas is transferred, it passes through a regenerator that adds heat to the cold gas or removes it from the hot gas. But the bulk of the heat flows from the continuous hot source above each piston. The axial reciprocating motion of the pistons is transformed into rotary motion by a "swash plate" that is solidly attached at an angle to the output shaft. A total of four pistons produce the power and the following sequence of events occurs in one revolution of the Stirling engine:

Between views 1 and 2, the pistons move from positions where the chamber volume is a maximum to the point where the volume is a minimum, compressing the working fluid. Between 2 and 3, the cold, compressed fluid is pumped from beneath the right side piston through the regenerator, where it is heated, and into the volume above the left piston. There has been no change in total chamber volume but heat from the source quickly raises the pressure of gases above the left piston. This causes the gas to expand, driving the left piston down (between views 3 and 4). This is the power stroke and the piston's downward motion forces the swash plate to rotate. Between views 4 and 1, the left piston pumps the working fluid through the regenerator, where some heat is removed, and back into the volume under the right piston. The cycle is then ready to repeat itself.

Figure 3.

Reprinted with permission  
of "Car and Driver."

# DIESEL CYCLE

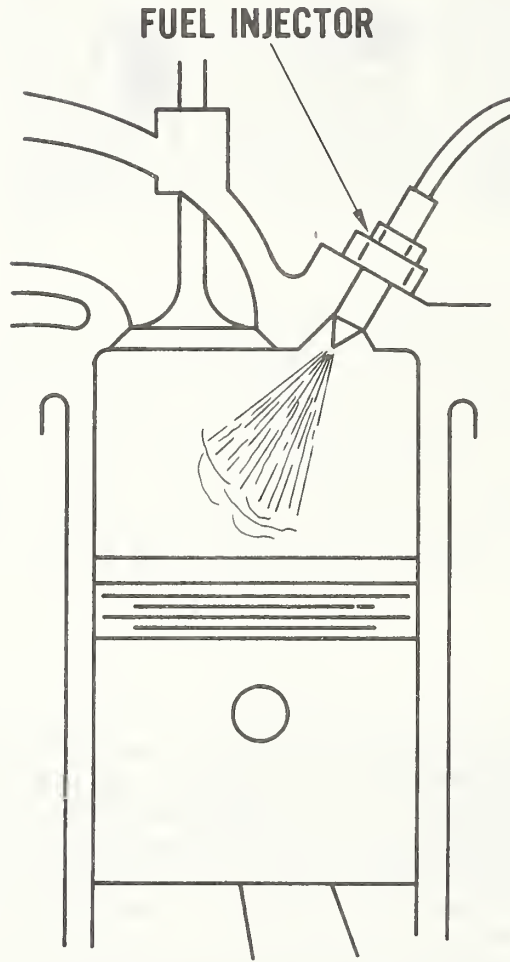

Envision a conventional spark ignition engine with the spark plugs replaced by fuel injectors. The intake valve delivers only air and the upward moving piston compresses it to such a high pressure and temperature that combustion is spontaneous the instant fuel is delivered by the injector. This combustion drives the piston down in the normal manner to deliver power to a crankshaft. The spent gases are then pumped out through a standard exhaust valve.

Figure 4.

Reprinted with permission  
of "Car and Driver."

# GAS TURBINE

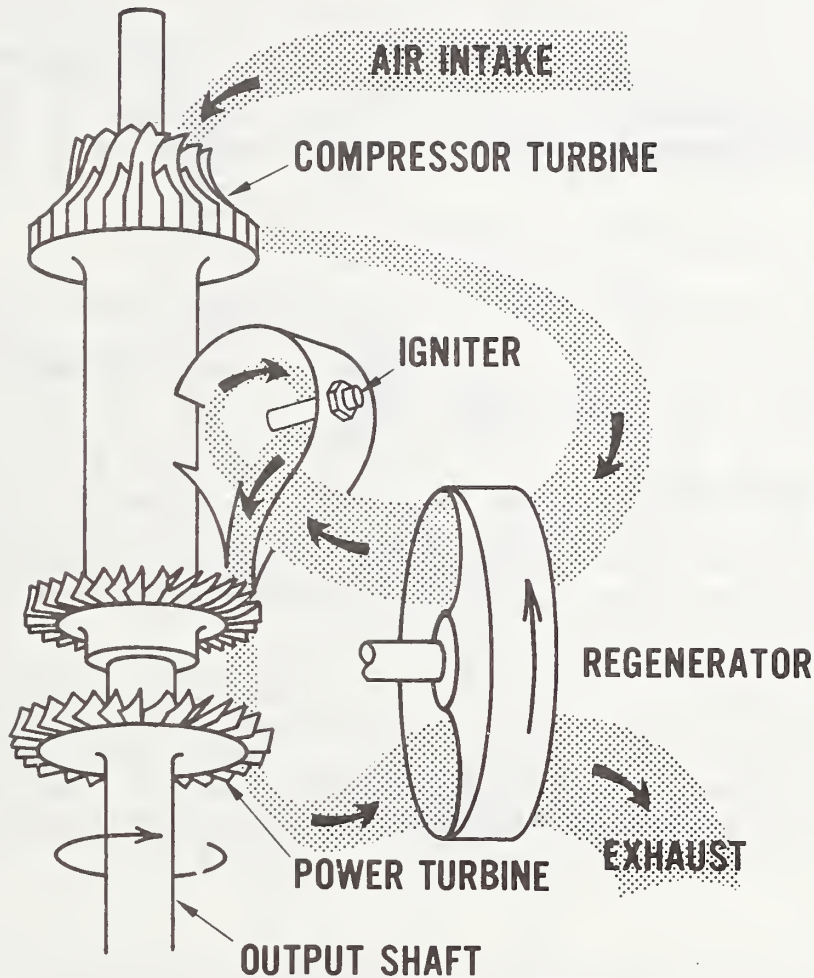

In the gas turbine, a compressor wheel draws in air, compresses it and then pumps it through a regenerator section. This rotating device is like a "heat sponge" - it soaks up waste from the exhaust and delivers it to the air flowing in. A combustion chamber encircles the turbine's central shaft and here the compressed, heated air mixes with fuel and is ignited by a single spark plug device. Combustion is continuous with the exiting burning gas displaced by additional air flowing in. The outgoing gases leave at temperatures near 1700° F. to first drive a compressor turbine and then the main power turbine. The compressor turbine is connected directly to the compressor wheel, while the power turbine is linked only to the output driveshaft. After the hot gases have done their work against the power turbine, they exit through the hot side of the regenerator. Here the spent gases relinquish their heat prior to discharge into the atmosphere.

Figure 5.

Reprinted with permission  
of "Car and Driver."

### 9.1.7 Intake Valve Throttled Engine

In this internal combustion engine, there is no throttle valve in the carburetor or intake manifold. Throttling is obtained by varying the size of the intake valve opening by means of a mechanical linkage. Extremely lean fuel-air mixtures have been found to burn well over a wide range of conditions. Consequently, this engine might be developed to meet emission standards. Principal considerations appear to be the complicated valve controlling mechanism and some loss in fuel economy. See figure 6.

### 9.2 Fuel Efficiency

The need to conserve gasoline has prompted some departments to experiment with fuel saving devices. One fuel saving approach is the use of fuel additives designed to keep the engine surfaces clean. Oil additives also fit in this category. While such approaches to fuel saving have been promoted for many years, the results in practice have often appeared to fall short of the claims made. However, there is no question that an engine operates more efficiently if it is free of carbon and metallic deposits. The oil companies, automobile manufacturers, and others continue to work on the engine cleanliness problem.

Another approach to fuel conservation is to install screens or other devices in the carburetor to improve the fuel/air mixture and promote better combustion. Again, the claims for these devices usually exceed the actual results. What are lacking are valid methods of evaluation to provide guidance on use of such additives and devices.

### 9.3 Brakes

The use of disc brakes on all four wheels is one development that is expected to improve the performance of patrol cars and possibly reduce one of the major areas of complaint. Installation of disc brakes on the front wheels, where 55 to 60 percent of the braking effort is accomplished, has provided significant improvement in brake performance. Conversion of the rear wheel drum brakes to disc brakes appears to be under development by all manufacturers. While a few 1975 luxury models offer four wheel disc brakes, manufacturers claim they are not satisfied with the current design for providing the parking brake function. At present the arrangement generally provides for a drum-type parking brake inside the rear disc brake rotors.



## INTAKE VALVE THROTTLED

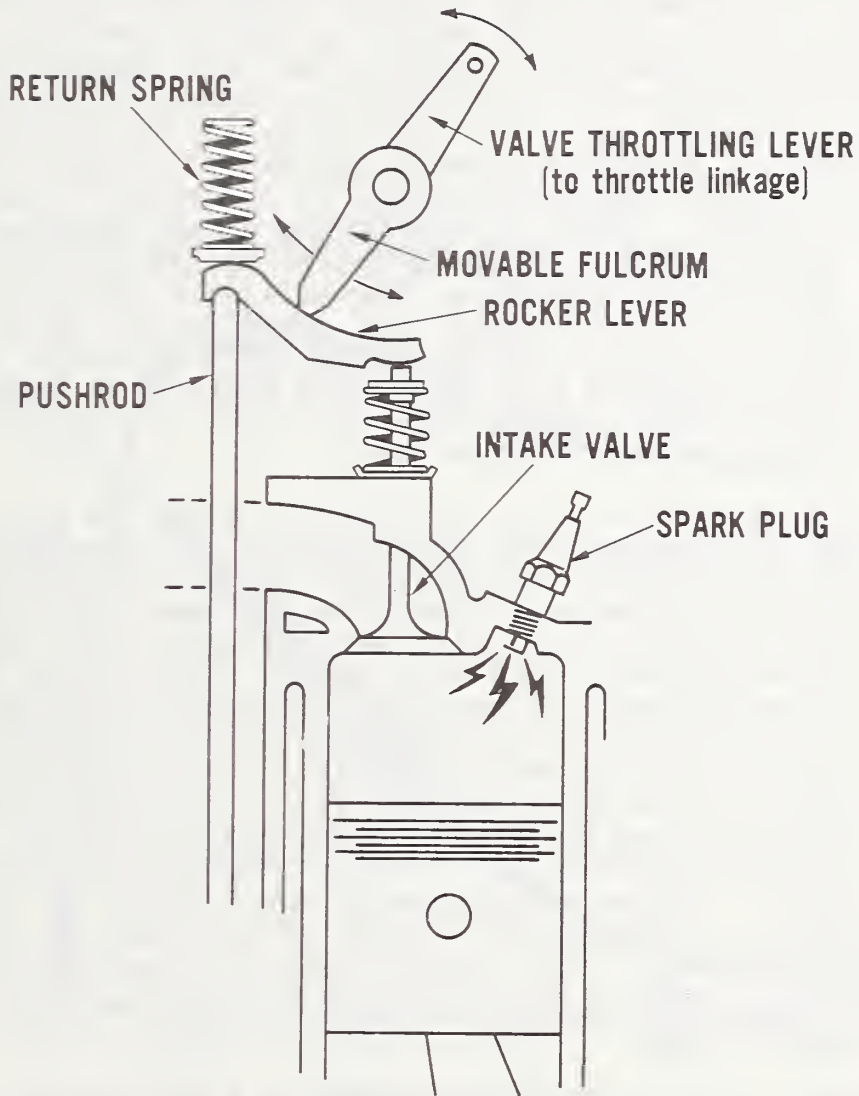

In the intake valve throttled engine, there is no throttle valve in the carburetor or intake manifold. Instead, the amount of fuel-air charge that enters the cylinder is controlled by varying the size of the intake valve opening. A movable fulcrum connected to the throttle linkage slides along a rocker lever. This rocker lever transfers motion from a camshaft and a pushrod to open the intake valve. The amount of motion transferred becomes intake valve lift and depends solely on the position of the movable fulcrum. This engine is identical to current piston engines in every other respect.

Figure 6.

Brake lining material is also under continuous development to find better ways to dissipate the heat generated in braking. Functionally, the brakes convert the kinetic energy of the moving vehicle to heat energy. The effect of high temperatures on organic brake lining is to reduce the coefficient of friction of the surface of the lining in contact with the brake drum or disc. This causes the brake to fade. However, metallic linings become more effective at high temperatures because their coefficient of friction increases as the brake temperature increases. On the other hand, at low temperatures the coefficient of friction between the organic material and the brake surface is higher than that of the metallic material. An additional factor, which is considered objectionable for police operations, is the noise generated by the sliding contact of the metallic lining on the metallic brake surface. These factors have led to general use of so-called semi-metallic brake linings for patrol cars. This material consists of metal particles bonded with resin and appears to represent a satisfactory compromise between the desirable and undesirable properties of the other two materials.

The most effective braking is obtained when the tire-to-road friction is the greatest, which occurs at approximately 15 percent wheel slip between the tire and the road surface. This may be visualized as the condition existing when the road speed of a vehicle is 100 mph (160 km/h) and the wheels are turning at a rate equivalent to 85 mph (135 km/h). This means that of the energy being absorbed in stopping the vehicle, 85 percent is absorbed in the brakes and 15 percent is absorbed at the tire-road interface. Locking the wheels to prevent their rotation forces all the stopping energy to be absorbed at the tire-road interface, making braking performance highly dependent on road surface condition and effectively eliminating steering control. These relationships can be seen in figure 7, where the braking effectiveness (curve A) is seen to peak at about 15 percent wheel slip. Controllability (curve B) is shown to approach zero as the vehicle nears 100 percent wheel slip (locked wheels).

One system that is designed to improve brake action is the antilock brake which acts to limit or prevent wheel lock-up. The device works by sensing wheel lock-up and immediately reducing line pressure on the brake shoe or pad to permit wheel rotation to resume. For a reasonably proficient driver, in a car with well-balanced brakes, antilock provides an advantage on all roads, but especially on wet or icy road surfaces, according to a study funded by DOT. [11] It should be pointed out that a number of current police specifications for patrol cars require that the brakes can be locked, which automatically rules out use of antilock brakes, even though the feature may be desirable.

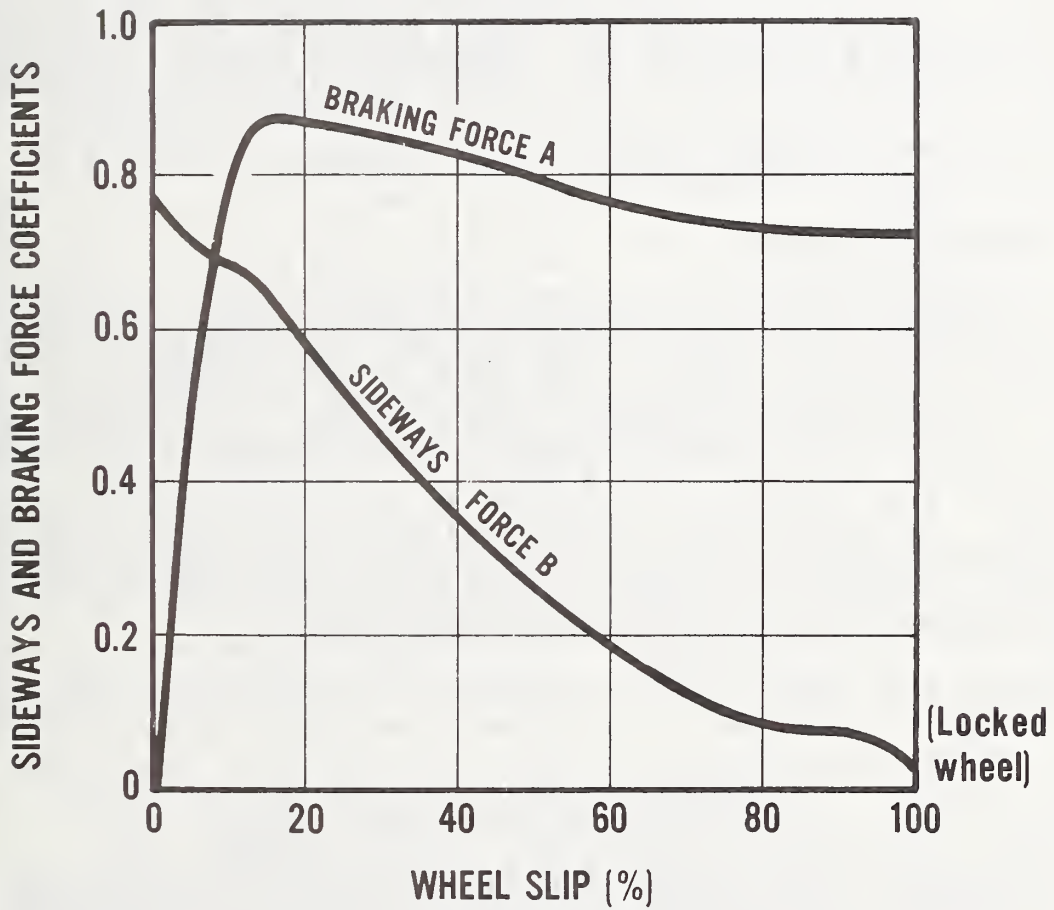

Figure 7. Relationship of wheel slip to braking and controllability.

Another approach that is being studied is variable proportioning of braking pressure. In this system, the braking load is sensed by a mechanical measurement of the distance between the axle and the body, or by measuring the deceleration of the vehicle. From this measurement, the pressure can be proportioned between the front and rear brakes to better balance total braking action.

#### 9.4 Tires

New developments in tires for patrol cars appear to center on improvements in tire construction and the use of new materials. Tires made with Kevlar are being put on the market in 1975. The specifications for these Kevlar belted tires call for a high speed capability of 125 mph (200 km/h) for sustained periods. The use of radial tires appears to be increasing because of the improved handling, gas mileage and tread wear which they seem to provide.

#### 9.5 Safety Regulations

While the intent and effect of the Federal Motor Vehicle Safety Standards have been to reduce the risk of injury to automobile occupants, some of the newer standards appear to pose some problems in police use of vehicles. The National Highway Traffic Safety Administration is becoming aware of the problems posed by some of the standards in police patrol operations, but little has been done so far to alleviate these problems. Police agencies are beginning to make their special problems and requirements known and actions have been proposed to provide relief from certain standards which appear to excessively restrict police vehicle operations.

On the other hand, there is mounting evidence that police vehicles may require special consideration under Federal motor vehicle safety standards. It should be evident to anyone who has ever ridden in a patrol car that the special equipment mounted in the front seat area exposes the occupants to additional risk during a collision. Knobs, buttons, and handles protrude from radios, speed measuring instruments and spotlights; shotguns are often mounted vertically in special racks; radio control heads and lamps present sharp, unpadded edges. These potential hazards require additional evaluation and special attention.

## 9.6 The Special Police Vehicle

A subject of recurring discussion is the so-called "super police car." The concept generally suggests that all of the best existing automotive technology be incorporated into a vehicle that would provide the most desirable characteristics for all the functions required of patrol cars. While automotive engineers and designers might come close to designing such a vehicle, a great deal of difficulty can be anticipated in providing in one vehicle the varying requirements perceived by different types of police departments. In fact, the urban and the highway patrol requirements appear so different that possibly at least two designs might be required.

The greatest deterrent to the "super police car" is probably cost. The present market for "police equipped" cars is about 65,000 per year at an average of about \$3500 each, or a net cost of \$2500 with trade-in. If these vehicles were produced in a special factory instead of on the standard automotive production lines, the cost estimates range from \$20,000 to \$40,000 per vehicle, with the possibility there would be no trade-in value because of the special characteristics of the vehicles. Moreover, repair and maintenance of these vehicles might present serious problems for most departments.

The potential advantages of a specially designed patrol car, as well as some of the disadvantages cited above, seem to dictate that at least a feasibility study should be made. This study should develop quantitative criteria, explore alternate approaches to meeting the criteria, and provide a cost/benefit analysis.

## 10. VEHICLE FLEET MANAGEMENT

Much has been written about the acquisition, maintenance, and disposition of vehicles that are operated as a fleet. While it is important that the patrol car fulfill as nearly as possible the patrolman's functional requirements for transportation, it is equally important that the vehicle be available to the patrolman when he needs it. This availability perhaps can be loosely described as the function of fleet management. The important function of police fleet management is thoroughly discussed in a study by Rosalie T. Ruegg prepared for the Law Enforcement Assistance Administration by the Law Enforcement Standards Laboratory of the National Bureau of Standards [9].

## 11. SUMMARY

Considering that the basic function of a patrol car is to provide transportation for the patrolman, the vehicles currently available are reasonably adequate, particularly if the law enforcement agency elects to use the vehicles offered by the manufacturers as "police cars."

Problems do exist in using currently available automobiles for patrol purposes. Some of the more apparent problems include the following:

1. The automobile industry seems to be headed to the production of smaller vehicles. While some departments are converting a portion of their fleets to these smaller cars, others are reluctant to depart from the use of the full-size sedan, in spite of the economic advantages involved.
2. Police agencies need vehicles that provide certain performance characteristics. The agencies lack performance criteria, hence they write design specifications to indirectly specify the performance requirements when purchasing patrol cars.
3. Many of the needed test methods for measuring performance are lacking, or at best rudimentary.
4. Information on tires, specifically oriented to police requirements, is not readily available to departments, except from tire companies.
5. Certain aspects of patrol car performance are being reduced, i.e., speed, acceleration, and gasoline mileage, while at the same time maintenance costs are increasing.
6. Some of the Federal Motor Vehicle Safety Standards appear to run counter to the operational needs for police patrol. For instance, the seat belt interlock system probably served to increase the emergency response time. On the other hand, special safety standards for patrol cars appear to be justified for protection against the many additional handles, knobs, and other sharp or protruding objects commonly found in a police car.

In summarizing the state of the patrol car art, one could very well come to the conclusion that there is no such special vehicle; that police are driving, as one patrolman claimed, "the same cars that are used in taxicab fleets." Perhaps some patrolmen are; some patrolmen are also using standard passenger vehicles.

Upon closer scrutiny, however, one reaches the conclusion that vehicles specifically intended for the patrol car function are available and are widely used. These vehicles are found to be structurally reinforced and equipped with heavy duty subsystems deemed necessary by the manufacturer to better endure police patrol use. It seems fair to say these changes and modifications have been developed primarily to improve the capability of these vehicles for high speed pursuit. This, of course, has led to large engines, a need for special, high speed tires, and a sacrifice in operating economy and maintenance costs.

Whether the user requirements of the many and varied police agencies have been adequately met by the vehicles provided is open to question, and the manufacturers would be the first to agree. When one considers that there are between 19,000 and 24,000 police agencies, each with its own set of purchase specifications, buying from essentially only four automobile manufacturers, one might ask how the patrol car has achieved any distinct characteristics at all. To the extent this has been accomplished, credit must be given to those representatives of the automotive manufacturers and the police community who have recognized the problems and attempted to solve them over the years.

Despite these efforts to provide a "patrol car," the conclusion is inescapable that currently available products are not adequately meeting all police requirements. About 20 percent of vehicles used for patrol are not those the manufacturers offer as "patrol cars." There are problems with the inability of users to quantify their needs and to communicate them to the producer. Production technology has not yet provided solutions to the user's unique requirements.

Herein lies the challenge: can performance-oriented guidelines, tests, and standards be developed for police patrol cars that will satisfy the functional requirements of individual agencies and that, at the same time, can be met by vehicle manufacturers at a reasonable cost?

## APPENDIX--REFERENCES

1. Brostron, C., "Strategy and Tactics," Police Patrol Readings, Samuel G. Chapman, editor, (Thomas, Springfield, Illinois, 1970) p. 151.
2. Ludwig, H. G., "Study of the Police Patrol Vehicle," Wayne State University, College of Engineering, February 1971.
3. Wynne, G. R., "Police Transportation Management," (Coda, Studio City, California, 1965).
4. Buntin, E. D. and Klaus, P. A., LESP-RPT-0007.00, "LEAA Police Equipment Survey of 1972, Volume VII: Patrolcars," Department of Justice (in press).
5. Planek, T. W., et al., "The Development of an Injury and Damage Reduction Function for Municipal Police," National Safety Council, 1971.
6. Baumeister, Theodore, "Standard Handbook for Mechanical Engineers," 7th edition, (McGraw-Hill, 1967).
7. Ervin, R. D., et. al., "Vehicle Handling Performance," Highway Safety Research Institute, Ann Arbor, Michigan, November 1972.
8. Craig, A. L., "National Survey State Patrol Pursuit Cars," North Carolina Highway Patrol, Raleigh, North Carolina, 1973.
9. Ruegg, Rosalie T., LESP-RPT-0402.00, "Life Cycle Costing of Police Patrol Cars," U. S. Department of Justice, October 1974 (in press).
10. Pfefferkorn, R. G., "Patrol Car Vehicle Emission Control," Problem Investigation Report, ID Number ILEAA-01, Mitre Corporation, May 1973.
11. Murphy, Ray W., "A Procedure for Evaluating Vehicle Braking Performance," Highway Safety Research Institute, Ann Arbor, Michigan, October 1971, DOT HS 800 628.
12. Collard, Jared J., "Report on an Investigation of the High Speed Hazards of Steel Belted Radial Tires on Police Patrol Cars," National Bureau of Standards, May 1975 (in press).



U.S. DEPT. OF COMM. BIBLIOGRAPHIC DATA SHEET	1. PUBLICATION OR REPORT NO. <b>NBS IR 75-960</b>	2. Gov't Accession No.	3. Recipient's Accession No.
4. TITLE AND SUBTITLE <b>The Police Patrol Car: State of the Art</b>		5. Publication Date <b>NOVEMBER 1975</b>	6. Performing Organization Code
7. AUTHOR(S) <b>R. G. Massey</b>		8. Performing Organ. Report No.	
9. PERFORMING ORGANIZATION NAME AND ADDRESS <b>NATIONAL BUREAU OF STANDARDS DEPARTMENT OF COMMERCE WASHINGTON, D.C. 20234</b>		10. Project/Task/Work Unit No. <b>4409380</b>	11. Contract/Grant No.
12. Sponsoring Organization Name and Complete Address (Street, City, State, ZIP) <b>National Institute of Law Enforcement and Criminal Justice, LEAA Department of Justice Washington, D.C. 20531</b>		13. Type of Report & Period Covered <b>Final</b>	14. Sponsoring Agency Code
15. SUPPLEMENTARY NOTES			
16. ABSTRACT (A 200-word or less factual summary of most significant information. If document includes a significant bibliography or literature survey, mention it here.)  <b>This report, entitled "The Police Patrol Car: State of the Art" describes the functional requirements of police agencies for patrol cars, the manner in which these requirements are met, or not met, by vehicles currently in use, and a discussion of new automotive technology which might affect patrol car performance in the future.</b>			
17. KEY WORDS (six to twelve entries; alphabetical order; capitalize only the first letter of the first key word unless a proper name; separated by semicolons) <b>Functional requirements; patrol cars; performance of patrol cars; police patrol cars; problems with patrol cars; state of the art survey</b>			
18. AVAILABILITY <input type="checkbox"/> Unlimited  <input checked="" type="checkbox"/> For Official Distribution. Do Not Release to NTIS  <input type="checkbox"/> Order From Sup. of Doc., U.S. Government Printing Office Washington, D.C. 20402, SD Cat. No. CI3  <input type="checkbox"/> Order From National Technical Information Service (NTIS) Springfield, Virginia 22151	19. SECURITY CLASS (THIS REPORT)  UNCLASSIFIED	21. NO. OF PAGES  <b>56</b>	
		20. SECURITY CLASS (THIS PAGE)  UNCLASSIFIED	22. Price





