

NAT'L INST. OF STAND & TECH R.I.C.

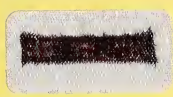

411105 036098



NIST  
PUBLICATIONS



# NBS SPECIAL PUBLICATION 260-72

U.S. DEPARTMENT OF COMMERCE / National Bureau of Standards

*Standard Reference Materials:*

**SRM 900, ANTIEPILEPSY  
DRUG LEVEL ASSAY STANDARD**

C  
00  
57  
), 260-72  
81  
2

## NATIONAL BUREAU OF STANDARDS

The National Bureau of Standards<sup>1</sup> was established by an act of Congress on March 3, 1901. The Bureau's overall goal is to strengthen and advance the Nation's science and technology and facilitate their effective application for public benefit. To this end, the Bureau conducts research and provides: (1) a basis for the Nation's physical measurement system, (2) scientific and technological services for industry and government, (3) a technical basis for equity in trade, and (4) technical services to promote public safety. The Bureau's technical work is performed by the National Measurement Laboratory, the National Engineering Laboratory, and the Institute for Computer Sciences and Technology.

**THE NATIONAL MEASUREMENT LABORATORY** provides the national system of physical and chemical and materials measurement; coordinates the system with measurement systems of other nations and furnishes essential services leading to accurate and uniform physical and chemical measurement throughout the Nation's scientific community, industry, and commerce; conducts materials research leading to improved methods of measurement, standards, and data on the properties of materials needed by industry, commerce, educational institutions, and Government; provides advisory and research services to other Government agencies; develops, produces, and distributes Standard Reference Materials; and provides calibration services. The Laboratory consists of the following centers:

Absolute Physical Quantities<sup>2</sup> — Radiation Research — Thermodynamics and Molecular Science — Analytical Chemistry — Materials Science.

**THE NATIONAL ENGINEERING LABORATORY** provides technology and technical services to the public and private sectors to address national needs and to solve national problems; conducts research in engineering and applied science in support of these efforts; builds and maintains competence in the necessary disciplines required to carry out this research and technical service; develops engineering data and measurement capabilities; provides engineering measurement traceability services; develops test methods and proposes engineering standards and code changes; develops and proposes new engineering practices; and develops and improves mechanisms to transfer results of its research to the ultimate user. The Laboratory consists of the following centers:

Applied Mathematics — Electronics and Electrical Engineering<sup>2</sup> — Mechanical Engineering and Process Technology<sup>2</sup> — Building Technology — Fire Research — Consumer Product Technology — Field Methods.

**THE INSTITUTE FOR COMPUTER SCIENCES AND TECHNOLOGY** conducts research and provides scientific and technical services to aid Federal agencies in the selection, acquisition, application, and use of computer technology to improve effectiveness and economy in Government operations in accordance with Public Law 89-306 (40 U.S.C. 759), relevant Executive Orders, and other directives; carries out this mission by managing the Federal Information Processing Standards Program, developing Federal ADP standards guidelines, and managing Federal participation in ADP voluntary standardization activities; provides scientific and technological advisory services and assistance to Federal agencies; and provides the technical foundation for computer-related policies of the Federal Government. The Institute consists of the following centers:

Programming Science and Technology — Computer Systems Engineering.

<sup>1</sup>Headquarters and Laboratories at Gaithersburg, MD, unless otherwise noted; mailing address Washington, DC 20234.

<sup>2</sup>Some divisions within the center are located at Boulder, CO 80303.

*Standard Reference Materials:*

**SRM 900, ANTIEPILEPSY  
DRUG LEVEL ASSAY STANDARD**

---

Dennis J. Reeder, Bruce Coxon, Delmo Enagonio, Richard G. Christensen,  
Barbara F. Howell, Robert C. Paule, John Mandel, and Robert Schaffer

National Measurement Laboratory  
National Bureau of Standards  
Washington, DC 20234

Sponsored by the  
National Institutes of Health  
National Institute of Neurological and Communicative  
Disorders and Stroke  
Federal Building  
Bethesda, MD 20205



---

U.S. DEPARTMENT OF COMMERCE, Malcolm Baldrige, Secretary  
NATIONAL BUREAU OF STANDARDS, Ernest Ambler, Director

Issued June 1981

Library of Congress Catalog Card Number: 81-600062

National Bureau of Standards Special Publication 260-72

Nat. Bur. Stand. (U.S.), Spec. Publ. 260-72, 79 pages (June 1981)

CODEN: XNBSAV

U.S. GOVERNMENT PRINTING OFFICE  
WASHINGTON: 1981

---

For sale by the Superintendent of Documents, U.S. Government Printing Office, Washington, D.C. 20402

Price \$4.25

(Add 25 percent for other than U.S. mailing)

## PREFACE

Standard Reference Materials (SRM's) as defined by the National Bureau of Standards are well-characterized materials produced in quantity and certified for one or more physical or chemical properties. They are used to assure the accuracy and compatibility of measurements throughout the Nation. SRM's are widely used as primary standards in many diverse fields in science, industry, and technology, both within the United States and throughout the world. They are also used extensively in the fields of environmental and clinical analysis. In many applications, traceability of quality control and measurement processes to the national measurement system is carried out through the mechanism and use of SRM's. For many of the Nation's scientists and technologists it is therefore of more than passing interest to know the details of the measurements made at NBS in arriving at the certified values of the SRM's produced. An NBS series of papers, of which this publication is a member, called the NBS Special Publication - 260 Series, is reserved for this purpose.

This 260 Series is dedicated to the dissemination of information on different phases of the preparation, measurement, certification and use of NBS-SRM's. In general, much more detail will be found in these papers than is generally allowed, or desirable, in scientific journal articles. This enables the user to assess the validity and accuracy of the measurement processes employed, to judge the statistical analysis, and to learn details of techniques and methods utilized for work entailing the greatest care and accuracy. These papers also should provide sufficient additional information not found on the certificate so that new applications in diverse fields not foreseen at the time the SRM was originally issued will be sought and found.

Inquiries concerning the technical content of this paper should be directed to the authors. Other questions concerned with the availability, delivery, price, and so forth will receive prompt attention from:

Office of Standard Reference Materials  
National Bureau of Standards  
Washington, D.C. 20234

George A. Uriano, Chief  
Office of Standard Reference Materials

## OTHER NBS PUBLICATIONS IN THIS SERIES

- Catalog of NBS Standard Reference Materials (1979-80 edition), R. W. Seward, ed., NBS Spec. Publ. 260 (April 1979) \$3.00\* SN003-003-02048-6
- Michaelis, R. E., and Wyman, L. L., Standard Reference Materials: Preparation of White Cast Iron Spectrochemical Standards, NBS Misc. Publ. 260-1 (June 1964). COM74-11061\*\*
- Michaelis, R. E., Wyman, L. L., and Flitsch, R., Standard Reference Materials: Preparation of NBS Copper-Base Spectrochemical Standards, NBS Misc. Publ. 260-2 (October 1964). COM74-11063\*\*
- Michaelis, R. E., Yakowitz, H., and Moore, G. A., Standard Reference Materials: Metallographic Characterization of an NBS Spectrometric Low-Alloy Steel Standard, NBS Misc. Publ. 260-3 (October 1964). COM74-11060\*\*
- Hague, J. L., Mears, T. W., and Michaelis, R. E., Standard Reference Materials: Sources of Information, NBS Misc. Publ. 260-4 (February 1965). COM74-11059
- Alvarez, R., and Flitsch, R., Standard Reference Materials: Accuracy of Solution X-Ray Spectrometric Analysis of Copper-Base Alloys, NBS Misc. Publ. 260-5 (March 1965). PB168068\*\*
- Shultz, J. I., Standard Reference Materials: Methods for the Chemical Analysis of White Cast Iron Standards, NBS Misc. Publ. 260-6 (July 1975). COM74-11068\*\*
- Bell, R. K., Standard Reference Materials: Methods for the Chemical Analysis of NBS Copper-Base Spectrochemical Standards, NBS Misc. Publ. 260-7 (October 1965). COM74-11067\*\*
- Richmond, M. S., Standard Reference Materials: Analysis of Uranium Concentrates at the National Bureau of Standards, NBS Misc. Publ. 260-8 (December 1965). COM74-11066\*\*
- Anspach, S. C., Cavallo, L. M., Garfinkel, S. B., Hutchinson, J. M. R., and Smith, C. N., Standard Reference Materials: Half Lives of Materials Used in the Preparation of Standard Reference Materials of Nineteen Radioactive Nuclides Issued by the National Bureau of Standards, NBS Misc. Publ. 260-9 (November 1965). COM74-11065\*\*
- Yakowitz, H., Vieth, D. L., Heinrich, K. F. J., and Michaelis, R. E., Standard Reference Materials: Homogeneity Characterization on NBS Spectrometric Standards II: Cartridge Brass and Low-Alloy Steel, NBS Misc. Publ. 260-10 (December 1965). COM74-11064\*\*
- Napolitano, A., and Hawkins, E. G., Standard Reference Materials: Viscosity of Standard Lead-Silica Glass, NBS Misc. Publ. 260-11 (November 1966). NBS Misc. Publ. 260-11\*\*
- Yakowitz, H., Vieth, D. L., and Michaelis, R. E., Standard Reference Materials: Homogeneity Characterization of NBS Spectrometric Standards III: White Cast Iron and Stainless Steel Powder Compact, NBS Misc. Publ. 260-12 (September 1966). NBS Misc. Publ. 260-12\*\*
- Spijkerman, J. L., Snediker, D. K., Ruegg, F. C., and DeVoe, J. R., Standard Reference Materials: Mossbauer Spectroscopy Standard for the Chemical Shift of Iron Compounds, NBS Misc. Publ. 260-13 (July 1967). NBS Misc. Publ. 260-13\*\*
- Menis, O., and Sterling, J. T., Standard Reference Materials: Determination of Oxygen in Ferrous Materials - SRM 1090, 1091, and 1092, NBS Misc. Publ. 260-14 (September 1966). NBS Misc. Publ. 260-14\*\*
- Passaglia, E., and Shouse, P. J. Standard Reference Materials: Recommended Method of Use of Standard Light-Sensitive Paper for Calibrating Carbon Arcs Used in Testing Textiles for Colorfastness to Light, NBS Misc. Publ. 260-15 (June 1967). (Replaced by NBS Spec. Publ. 260-41.)
- Yakowitz, H., Michaelis, R. E., and Vieth, D. L., Standard Reference Materials: Homogeneity Characterization of NBS Spectrometric Standards IV: Preparation and Microprobe Characterization of W-20% MO Alloy Fabricated by Powder Metallurgical Methods, NBS Spec. Publ. 260-16 (January 1969). COM74-11062\*\*
- Catanzaro, E. J., Champion, C. E., Garner, E. L., Marinenko, G., Sappenfield, K. M., and Shields, W. R. Standard Reference Materials: Boric Acid; Isotopic and Assay Standard Reference Materials, NBS Spec. Publ. 260-17 (February 1970). Out of Print

- Geller, S. B., Mantek, P.A., and Cleveland, N. G., Standard Reference Materials: Calibration of NBS Secondary Standard Magnetic Tape (Computer Amplitude Reference) Using the Reference Tape Amplitude Measurement "Process A," NBS Spec. Publ. 260-18 (November 1969). (See NBS Spec. Publ. 260-29.)
- Paule, R. C., and Mandel, J., Standard Reference Materials: Analysis of Interlaboratory Measurements on the Vapor Pressure of Gold (Certification of Standard Reference Material 745). NBS Spec. Publ. 260-19 (January 1970). PB190071\*\*
- Paule, R. C., and Mandel, J., Standard Reference Materials: Analysis of Interlaboratory Measurements on the Vapor Pressures of Cadmium and Silver, NBS Spec. Publ. 260-21 (January 1971). COM74-11359\*\*
- Yakowitz, H., Fiori, C. E., and Michaelis, R. E., Standard Reference Materials: Homogeneity Characterization of Fe-3 Si Alloy, NBS Spec. Publ. 260-22 (February 1971). COM74-11357\*\*
- Napolitano, A., and Hawkins, E. G., Standard Reference Materials: Viscosity of a Standard Borosilicate Glass, NBS Spec. Publ. 260-23 (December 1970). COM71-00157\*\*
- Sappenfield, K. M., Marineko, G., and Hague, J. L., Standard Reference Materials: Comparison of Redox Standards, NBS Spec. Publ. 260-24 (January 1972). COM72-50058\*\*
- Hicho, G. E., Yakowitz, H., Rasberry, S. D., and Michaelis, R. E., Standard Reference Materials: A Standard Reference Material Containing Nominally Four Percent Austenite, NBS Spec. Publ. 260-25 (February 1971). COM74-11356\*\*
- Martin, J. F., Standard Reference Materials: National Bureau of Standards-US Steel Corporation Joint Program for Determining Oxygen and Nitrogen in Steel, NBS Spec. Publ. 260-26 (February 1971). 85 cents\* SN003-003-00786-2
- Garner, E. L., Machlan, L. A., and Shields, W. R., Standard Reference Materials: Uranium Isotopic Standard Reference materials, NBS Spec. Publ. 260-27 (April 1971). COM74-11358\*\*
- Heinrich, K. F. J., Myklebust, R. L., Rasberry, S. D., and Michaelis, R. E., Standard Reference Materials: Preparation and Evaluation of SRM's 481 and 482 Gold-Silver and Gold-Copper Alloys for Microanalysis, NBS Spec. Publ. 260-28 (August 1971). COM71-50365\*\*
- Geller, S. B., Standard Reference Materials: Calibration of NBS Secondary Standard Magnetic Tape (Computer Amplitude Reference) Using the Reference Tape Amplitude Measurement "Process A-Model 2," NBS Spec. Publ. 260-29 (June 1971). COM71-50282
- Gorozhanina, R. S., Freedman, A. Y., and Shaievitch, A. B. (translated by M. C. Selby), Standard Reference Materials: Standard Samples Issued in the USSR (A Translation from the Russian). NBS Spec. Publ. 260-30 (June 1971). COM71-50283\*\*
- Hust, J. G., and Sparks, L. L., Standard Reference Materials: Thermal Conductivity of Electrolytic Iron SRM 734 from 4 to 300 K, NBS Spec. Publ. 260-31 (November 1971). COM71-50563\*\*
- Mavrodineanu, R., and Lazar, J. W., Standard Reference Materials: Standard Quartz Cuvettes, for High Accuracy Spectrophotometry, NBS Spec. Publ. 260-32 (December 1973). 55 cents\* SN003-003-01213-1
- Wagner, H. L., Standard Reference Materials: Comparison of Original and Supplemental SRM 705, Narrow Molecular Weight Distribution Polystyrene, NBS Spec. Publ. 260-33 (May 1972). COM72-50526\*\*
- Sparks, L. L., and Hust, J. G., Standard Reference Materials: Thermoelectric Voltage, NBS Spec. Publ. 260-34, (April 1972). COM72-50371\*\*
- Sparks, L. L., and Hust, J. G., Standard Reference Materials: Thermal Conductivity of Austenitic Stainless Steel, SRM 735 from 5 to 280 K, NBS Spec. Publ. 260-35 (April 1972.). 35 cents\* COM72-50368\*\*
- Cali, J. P., Mandel, J., Moore, L. J., and Young, D. S., Standard Reference Materials: A Referee Method for the Determination of Calcium in Serum, NBS SRM 915, NBS Spec. Publ. 260-36 (May 1972). COM72-50527\*\*
- Shultz, J. I. Bell, R. K. Rains, T. C., and Menis, O., Standard Reference Materials: Methods of Analysis of NBS Clay Standards, NBS Spec. Publ. 260-37 (June 1972). COM72-50692\*\*
- Richmond, J. C., and Hsia, J. J., Standard Reference Materials: Preparation and Calibration of Standards of Spectral Specular Reflectance, NBS Spec. Publ. 260-38 (May 1972). COM72-50528\*\*
- Clark, A. F., Denson, V.A., Hust, J. G., and Powell, R. L., Standard Reference Materials The Eddy Current Decay Method for Resistivity Characterization of High-Purity Metals, NBS Spec. Publ. 260-39 (May 1972). COM72-50529\*\*

- McAdie, H. G., Garn, P. D., and Menis, O., Standard Reference Materials: Selection of Thermal Analysis Temperature Standards Through a Cooperative Study (SRM 758, 759, 760), NBS Spec. Publ. 260-40 (August 1972.) COM-72 50776\*\*
- Wood, L. A., and Shouse, P. J., Standard Reference Materials: Use of Standard Light-Sensitive Paper for Calibrating Carbon Arcs Used in Testing Textiles for Colorfastness to Light, NBS Spec. Publ. 260-41 (August 1972) COM72-50775\*\*
- Wagner, H. L., and Verdier, P. H., eds., Standard Reference Materials: The Characterization of Linear Polyethylene, SRM 1475, NBS Spec. Publ. 260-42 (September 1972). COM72-50944\*\*
- Yakowitz, H., Ruff, A. W., and Michaelis, R. E., Standard Reference Materials: Preparation and Homogeneity Characterization of an Austenitic Iron-Chromium-Nickel Alloy, NBS Spec. Publ. 260-43 (November 1972). COM73-50760\*\*
- Schooley, J. F., Soulen, R. J., Jr., and Evans, G. A., Jr., Standard Reference Materials: Preparation and Use of Superconductive Fixed Point Devices, SRM 767, NBS Spec. Publ. 260-44 (December 1972). COM73-50037\*\*
- Greifer, B., Maienthal, E. J., Rains, T. C., and Rasberry, S. D., Standard Reference Materials: Powdered Lead-Based Paint, SRM 1579, NBS Spec. Publ. 260-45 (March 1973). COM73-50226\*\*
- Hust, J. G., and Giarratano, P. J., Standard Reference Materials: Thermal Conductivity and Electrical Resistivity Standard Reference Materials: Austenitic Stainless Steel, SRM's 735 and 798, from 4 to 1200 K, NBS Spec. Publ. 260-46 (March 1975). SN003-003-01278-5
- Hust, J. G., Standard Reference Materials: Electrical Resistivity of Electrolytic Iron, SRM 797, and Austenitic Stainless Steel, SRM 798, from 5 to 280 K, NBS Spec. Publ. 260-47 (February 1974). COM74-50176\*\*
- Mangum, B. W., and Wise, J. A., Standard Reference Materials: Description and Use of Precision Thermometers for the Clinical Laboratory, SRM 933 and SRM 934, NBS Spec. Publ. 260-48 (May 1974). 60 cents\* SN003-003-01278-5
- Carpenter, B. S., and Reimer, G. M., Standard Reference Materials: Calibrated Glass Standards for Fission Track Use, NBS Spec. Publ. 260-49 (November 1974). SN003-003-01344-7
- Hust, J. G., and Giarratano, P. J., Standard Reference Materials: Thermal Conductivity and Electrical Resistivity Standard Reference Materials: Electrolytic Iron, SRM's 734 and 797 from 4 to 1000 K, NBS Spec. Publ. 260-50 (June 1975). 1.00\* SN003-003-01425-7
- Mavrodineanu, R., and Baldwin, J. R., Standard Reference Materials: Glass Filters As a Standard Reference Material for Spectrophotometry; Selection; Preparation; Certification; Use-SRM 930, NBS Spec. Publ. 260-51 (November 1975). \$1.90\* SN003-003-01481-8
- Hust, J. G., and Giarratano, P. J., Standard Reference Materials: Thermal Conductivity and Electrical Resistivity Standard Reference Materials 730 and 799, from 4 to 3000 K, NBS Spec. Publ. 260-52 (September 1975). \$1.05\* SN003-003-01464-8
- Durst, R. A., Standard Reference Materials: Standardization of pH Measurements, NBS Spec. Publ. 260-53 (December 1975, Revised). \$1.05\* SN003-003-01551-2
- Burke, R. W., and Mavrodineanu, R., Standard Reference Materials: Certification and Use of Acidic Potassium Dichromate Solutions as an Ultraviolet Absorbance Standard, NBS Spec. Publ. 260-54 (August 1977). \$3.00\* SN003-003-01828-7
- Ditmars, D. A., Cezairliyan, A., Ishihara, S., and Douglas, T. B., Standard Reference Materials: Enthalpy and Heat Capacity; Molybdenum SRM 781, From 273 to 2800 K, NBS Spec. Publ. 260-55 (September 1977). \$2.20\* SN003003-01836-8
- Powell, R. L., Sparks, L. L., and Hust, J. G., Standard Reference Materials: Standard Thermocouple Material, Pt.-67:SRM1967, NBS Spec. Publ. 260-56 (February 1978). \$2.20\* SN003-003-018864
- Call, J. P. and Plebanski, T., Guide to United States Reference Materials, NBS Spec. Publ. 260-57 (February 1978). \$2.20\* SN003-003-01883-0
- Barnes, J. D. and Martin, G. M., Standard Reference Materials: Polyester Film for Oxygen Gas Transmission Measurements. SRM 1470, NBS Spec. Publ. 260-58 (in press).
- Chang, T. and Kahn, A. H., Standard Reference Materials: Electron Paramagnetic Resonance Intensity Standard: SRM 2601, NBS Spec. Publ. 260-59 (August 1978). \$2.30\* SN-003-003-01975-5



- Velapoldi, R. A., Paule, R. C., Schaffer, R., Mandel, J., and Moody, J. R., Standard Reference Materials: A Reference Method for the Determination of Sodium in Serum, NBS Spec. Publ. 260-60 (August 1978). \$3.00\* SN003-003 01978-0
- Verdier, P. H., and Wagner, H. L., Standard Reference Materials: The Characterization of Linear Polyethylene (SRM 1482, 1483, 1484), NBS Spec. Publ. 260-61 (December 1978). \$1.70\* SN003-003-02006-1
- Soulen, R. J., and Dove, R. B., Standard Reference Materials: Temperature Reference Standard for Use Below 0.5 K (SRM 768). NBS Spec. Publ. 260-62 (April 1979). \$2.30\* SN003-003-02047-8
- Velapoldi, R. A., Paule, R. C., Schaffer, R., Mandel, J., Machlan, L. A., and Gramlich, J. W., Standard Reference Materials: A Reference Method for the Determination of Potassium in Serum, NBS Spec. Publ. 260-63 (May 1979). \$3.75 SN003-003-02068
- Velapoldi, R. A., and Mielenz, K. D., Standard Reference Materials: A Fluorescence Standard Reference Material Quinine Sulfate Dihydrate (SRM 936). NBS Spec. Publ. 260-64 (January 1980). \$4.25\* SN003-003-02148-2.
- Marinenko, R. B., Heinrich, K. F. J., and Ruegg, F. C., Standard Reference Materials: Micro-Homogeneity Studies of NBS Standard Reference Materials, NBS Research Materials, and Other Related Samples, NBS Spec. Publ. 260-65 (September 1979). \$3.50\* SN003-003-02114-1
- Venable, W. H., Jr. and Eckerle, K. L., Standard Reference Materials: Didymium Glass Filters for Calibrating the Wavelength Scale of Spectrophotometers (SRM 2009, 2010, 2013), NBS Spec. Publ. 260-66 (October 1979). \$3.50\* SN003-003-02127-0
- Velapoldi, R. A., Paule, R. C., Schaffer, R., Mandel, J., Murphy, T. J., and Gramlich, J. W., Standard Reference Materials: A Reference Method for the Determination of Chloride in Serum, NBS Spec. Publ. 260-67 (November 1979). \$3.75\* SN003-003-02136-9
- Mavrodineanu, R. and Baldwin, Jr., Standard Reference Materials: Metal-On-Quartz Filters as a Standard Reference Material for Spectrophotometry-SRM 2031, NBS Spec. Publ. 260-68 (April 1980). \$4.25\* SN003-003-02167-9
- Velapoldi, R. A., Paule, R. C., Schaffer, R., Mandel, J., Machlan, L. A., Garner, E. L., and Rains, T. C., Standard Reference Materials: A Reference Method for the Determination of Lithium in Serum, NBS Spec. Publ. 260-69 (July 1980). \$4.25\* SN003-003-02214-4
- Marinenko, R. B., Biancaniello, F., Boyer, P. A., Ruff, A. W., DeRobertis, L., Standard Reference Materials: Preparation and Characterization of an Iron-Chromium-Nickel Alloy for Micro-analysis, NBS Spec. Publ. 260-70 (in press).
- Reeder, D. J., Coxon, B., Enagonio, D., Christensen, R. G., Schaffer, R., Howell, B. F., Paule, R. C., Mandel, J., Standard Reference Materials: SRM 900, Antiepilepsy Drug Level Assay Standard, NBS Spec. Publ. 260-72 (in press).
- \* Send order with remittance to Superintendent of Documents, US Government Printing Office, Washington, DC 20402. Remittance from foreign countries should include an additional one-fourth of the purchase price for postage.
- \*\* May be ordered from: National Technical Information Services (NTIS), Springfield, Virginia 22151.

TABLE OF CONTENTS

	PAGE
1. Introduction . . . . .	2
2. Development of the SRM . . . . .	2
2.1 Studies of the Drugs Used in the SRM. . . . .	2
A. Chemical Structure, Name, Molecular Weight, Source. . . . .	2
B. Initial Stability Testing and Solubility Studies. . . . .	4
C. Thin-Layer Chromatography . . . . .	4
D. Pulse-Fourier Transform Proton Nuclear Magnetic Resonance Spectroscopy at 90 MHz of Fractions Obtained by Liquid Chromatography. . . . .	4
2.2 Serum Base Developments . . . . .	11
A. Choice of Matrix. . . . .	11
B. Procedure for Preparation of a Human Serum Base . . . . .	16
C. Addition of Drugs to the Processed Serum Base . . . . .	16
D. Dispensing the Drug-Spiked Serum. . . . .	17
E. Freeze-Drying the Spiked Serum. . . . .	17
3. Protocol for Certification of the SRM. . . . .	18
3.1 Homogeneity of the Reconstituted Samples. . . . .	18
3.2 Quantitative Liquid Chromatography. . . . .	18
A. Qualification of the Method . . . . .	18
B. High Performance Liquid Chromatography Assay. . . . .	24
3.3 Gas Chromatographic Analysis and Quantitation . . . . .	25
A. Derivatized Drug Methods. . . . .	25
B. Underivatized Drug Determinations . . . . .	26
3.4 Analysis of Drugs in Serum by the Enzyme Multiplied Immunoassay Technique . . . . .	30
A. Experimental Procedures . . . . .	30
B. Results . . . . .	30
C. Interferences . . . . .	35
4. Statistical Analysis for Certification of SRM 900. . . . .	36
5. Summary and Conclusions. . . . .	36
6. SRM Use. . . . .	36
A. Water for Reconstitution. . . . .	36
B. Storage . . . . .	38
7. References . . . . .	38
Acknowledgements . . . . .	38
Appendix I — National Bureau of Standards Certificate, SRM 900 . . . . .	39
Appendix II — Construction of an Improved Differential Refractometer . . . . .	41
Appendix III — Reagent Water Specifications — College of American Pathologists. . . . .	47

## LIST OF TABLES

TABLE NO.	PAGE
1. Proton chemical shifts of antiepilepsy drugs. . . . .	10
2. Quantitative analysis of drug mixtures in Sephadex-fractionated human serum by reversed phase liquid chromatography. . . . .	11
3. Target values for drugs in serum (in $\mu\text{g/mL}$ ) . . . . .	17
4. Homogeneity of reconstituted samples. . . . .	18
5. Scintillation counting of fractions from liquid chromatography of phenytoin-4- $^{14}\text{C}$ in ethanol . . . . .	19
6. Scintillation counting of fractions from liquid chromatography of bovine serum solutions of phenytoin-4- $^{14}\text{C}$ . . . . .	20
7. Scintillation counting of fractions from liquid chromatography of an aqueous solution of ethosuximide-1- $^{14}\text{C}$ . . . . .	21
8. Scintillation counting of fractions from liquid chromatography of bovine serum solutions of ethosuximide-1- $^{14}\text{C}$ . . . . .	22
9. Scintillation counting of fractions from liquid chromatography of phenobarbital-2- $^{14}\text{C}$ solutions. . . . .	23
10. Scintillation counting of fractions from liquid chromatography of primidone-4,6- $^{14}\text{C}_2$ solutions . . . . .	24
11. Drugs and internal standards used in GC analysis. . . . .	26
12. EMIT assays of phenobarbital in bovine serum. . . . .	34
13. Comparison of EMIT determinations of drugs in SRM 900 . . . . .	35
14. Compilation of data from certification runs - 1978. . . . .	37

## LIST OF FIGURES

FIGURE NO.	PAGE
1. Proton NMR spectrum of phenytoin. . . . .	6
2. Proton NMR spectrum of ethosuximide fraction 2 from liquid chromatography . . . . .	7
3. Proton NMR spectrum of ethosuximide . . . . .	8
4. Proton NMR spectrum of phenobarbital. . . . .	9
5. Proton NMR spectrum of primidone. . . . .	10
6. Comparison of bovine serum with human serum using high performance liquid chromatography. . . . .	12
7. High performance liquid chromatogram of human serum after fractionation on Sephadex. . . . .	13
8. Reversed-phase liquid chromatogram of antiepilepsy drugs in Sephadex-treated human serum matrix (detection at 254 nm) . . . . .	14
9. Preparation of serum base . . . . .	15
10. Procedure for preparation of tubes containing drugs for quantitative gas chromatography employing a bracketing technique . . . . .	27
11. Procedure for extraction of drugs for quantitative gas chromatography . . . . .	28
12. Gas chromatogram of antiepilepsy drugs. . . . .	29
13. EMIT calibration curve for phenytoin. . . . .	31
14. EMIT calibration curve for phenobarbital. . . . .	32
15. EMIT calibration curve for primidone. . . . .	33

## Abstract

Recognition of the efficacy of monitoring the concentrations of therapeutic drugs in the blood of patients has revealed many needs for standardization of the laboratory tests used for such monitoring. The National Bureau of Standards was asked to provide a Standard Reference Material (SRM) consisting of three serum samples, each to contain four anti-epilepsy drugs at different concentrations. The four drugs are phenobarbital, phenytoin, primidone, and ethosuximide. The SRM would fill a basic role for the achievement of accurate analysis to help ensure the reliability of analyses for these drugs.

The needs that had to be fulfilled to produce the SRM included: (1) analytical criteria for purity of the drugs; (2) serum to be used as a matrix for the drugs; (3) techniques for achieving homogeneity and stability of the SRM; and (4) two independent, highly accurate analytical methods for the certification.

This document describes development of methods and procedures used to produce and certify the SRM.

**Key Words:** Anticonvulsants; antiepilepsy drugs; blood analysis; chromatography, gas; chromatography, liquid; drug standards; enzyme immunoassay; epilepsy; ethosuximide; mass spectrometry; nuclear magnetic resonance spectroscopy; phenobarbital; phenytoin; primidone; reference material; serum base modification; serum matrix.

## Disclaimer

Identification of commercial products does not imply recommendation or endorsement by the National Bureau of Standards nor that the product is necessarily the best available for the purpose.

## 1. Introduction

The value of monitoring antiepilepsy drug levels in serum has been demonstrated repeatedly over the past 10 years. This has resulted in an overwhelming number of publications describing methods for analysis. Many of these methods have been adopted by laboratories that provide clinical analyses. As demands for drug level tests have increased by physicians who recognize their usefulness, many clinical laboratories responded by establishing routine testing procedures for samples submitted by physicians. In many instances, however, these laboratories did not have extensive experience in drug monitoring techniques.

As a result of a blind survey taken in 1974 by Pippenger et al., [1],<sup>1</sup> it became obvious that not all laboratories were reporting accurate serum drug levels. In fact, the majority of the laboratories surveyed reported unacceptable results. Such results were not unanticipated by researchers at the National Institutes of Health (NIH). In 1972, Dr. J. Kiffen Penry of the National Institute of Neurological Diseases and Stroke (now the National Institute of Neurological and Communicative Disorders and Stroke) initiated efforts to assure the development of adequate standards for clinical laboratories performing patient serum monitoring for anticonvulsant drug levels. A research proposal was invited from the National Bureau of Standards (NBS) for work that would ultimately lead to the issuance of Standard Reference Materials (SRM's) for anticonvulsant drugs in serum. With funding from NIH, work began in 1974 to develop methods and competences that would result in state-of-the-art analytical measurements for the drugs in a serum matrix.

We present in this report information regarding the preparation, measurement, and certification of the Antiepilepsy Drug Level Assay Standard, which NBS issues as SRM 900.

## 2. Development of the SRM

### 2.1 Studies of the Drugs Used in the SRM

#### A. Chemical Structure, Name, Molecular Weight,<sup>2</sup> Source.

The following four drugs were used in the SRM, after extensive characterization for purity:

##### 1. Phenobarbital (5-ethyl-5-phenylbarbituric acid); mol wt 232.23

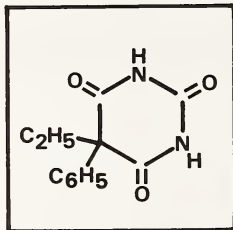

1

Lot No. 3-TT-1038

Source: Gane Chemical Works, Inc.  
Carlstadt, NJ

<sup>1</sup>Figures in brackets indicate the literature references at the end of this publication.

<sup>2</sup>Data for molecular weights taken from the Merck Index, 8th ed., published by Merck & Co., Inc., Rahway, NJ.

2. Phenytoin (5,5-diphenyl-2,4-imidazolidinedione); mol wt 252.26

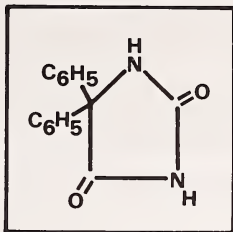

2

Lot No. 415781

Source: Parke Davis & Co.  
Detroit, MI

3. Ethosuximide (2-ethyl-2-methylsuccinimide); mol wt 141.17

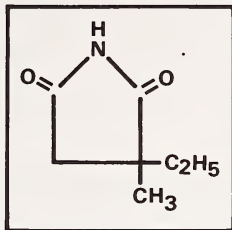

3

Lot No. 409470

Source: Parke Davis & Co.  
Detroit, MI

4. Primidone (5-ethyl-5-phenylhexahydropyrimidine-4,6-dione); mol wt 218.25

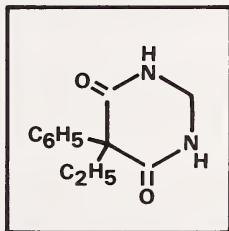

4

Lot No. 81-6275-2

Source: Ayerst Laboratories  
New York, NY

## B. Initial Stability Testing and Solubility Studies

Initial testing of the stability of drugs in alkaline solution was performed by spectrophotometry at pH 11.6 (in buffer) or at pH 12 (unbuffered). Monitoring was performed at the following wavelengths: for phenobarbital at 238 nm, phenytoin at 259 and 264 nm, ethosuximide at 243.5 nm, and primidone at 251.5, 257.5, and 264 nm. The drugs were relatively stable in these solutions for the first two to three hours (decrease in absorbance less than 1 percent), but by 24 h there was clear evidence of instability (absorbance decrease of at least 5 percent).

Some working measures of the solubility of the drugs in methanol (M), acetone (A), and chloroform (C) at about 25 °C were obtained. In mg/mL these are: for phenobarbital, approximately 230 (M), 275 (A), and 15 (C); Phenytoin, approximately 25 (M), 32 (A), and 1.3 (C); Primidone, approximately 6.4 (M), 2.4 (A), and 0.35 (C); Ethosuximide, greater than 1000 in (M), (A), and (C).

## C. Thin-Layer Chromatography

A single, thin-layer chromatographic system separated the four drugs on the same plate. Solvent: 14:8:1 (v/v) chloroform-1-butanol-concentrated ammonium hydroxide. Adsorbent: silica Gel GF. The drugs showed the following mobilities ( $R_f$ ): phenobarbital 0.49; primidone 0.62; phenytoin 0.83; and ethosuximide 0.93. The detection level for each neat drug was in the range of 2 to 5  $\mu$ g with use of fluorescence quenching. With this system and using 0.25 mm thick layers, between 200 to 300  $\mu$ g of a drug could be chromatographed as a discrete spot; except for primidone, whose insolubility limits the test. In the latter case, maximum feasible application is 40  $\mu$ g.

At maximum loading of the plates, no impurities were detected. However, concentrated effluents from preparative columns could be spotted on the plates and the presence of impurities could be observed.

## D. Pulse-Fourier Transform Proton Nuclear Magnetic Resonance Spectroscopy at 90 MHz of Fractions Obtained by Liquid Chromatography

An in-depth study of the purity of the crystalline drugs was accomplished by utilizing the separating capabilities of liquid chromatography (LC) together with the proton nuclear magnetic resonance (proton NMR) spectra of the drugs.

### 1. Liquid Chromatography

A survey was made of possible liquid chromatographic conditions for characterizing the four drugs. Four adsorbents, each with a different functional group, were identified as offering the diverse range of features needed for separating impurities: a polyvinylpyridine crosslinked by divinylbenzene (PVP), a polyvinylmethacrylate modified to have chemically available carboxyl groups, sulfonated polystyrene as the ammonium salt, and sulfonated polystyrene as the silver salt.

Chromatography of approximately 1-gram samples (with analysis by mass balance recovery) was undertaken on the polyvinylpyridine-divinylbenzene. Testing of chromatography fractions could then be performed by utilizing any of the other adsorbents in an analytical scale chromatographic mode, and by other techniques.

Phenobarbital was run on PVP using distilled ethanol as the mobile phase. Recoveries were slightly above 100 percent. Impurities may total less than 0.3 percent.

Ethosuximide was run on PVP using distilled methanol as the mobile phase. Recoveries were slightly above 100 percent. Impurities may total 0.3 percent.

Phenytoin was run on PVP using distilled methanol as the mobile phase. Recovery was slightly below 100 percent. Impurities may total 0.6 percent.



Primidone chromatography was run using distilled ethanol. (Primidone is much more soluble in DMSO than in most other solvents. Solutions of higher concentrations could be introduced by using this solvent, but the effect of the solvent on the adsorptive properties of the column packing and the difficulty of recovering dry fractions from DMSO made use of it as a solvent unattractive.) The sample for chromatography was prepared by ultrasonic mixing of 1.0 g of primidone with 50 mL of ethanol for 4-5 h at about 40 °C, and then allowing the saturated solution to cool to about 22 °C before introducing the supernatant into the chromatographic column. Because of the limited solubility of this compound, merely dissolving all of a small, weighed quantity and then undertaking chromatography would provide little information for measuring purity; instead the possibility of detecting impurities was examined by attempting to extract them from an excess amount of primidone. While this approach to measurement of the purity of primidone was indirect, the evidence indicated that the sample was of high purity.

## 2. Proton Nuclear Magnetic Resonance Spectroscopy of the Drugs

a) Phenytoin fractions. In general, fractions (in methanolic solution<sup>3</sup>) were prepared for proton NMR analysis by filtration, followed by evaporation under a stream of nitrogen. The residues that resulted were not further dried to avoid the possible loss of volatile impurities. Each residue was extracted with acetone-d<sub>6</sub> (3 x 0.03 mL, 100% D) and the soluble material was transferred into a cylindrical NMR microcell (capacity 0.06 mL). Up to 35,000 scans were taken of each fraction.

The spectra of fractions 1, 2, and 4 show methyl and methylene signals at high field that indicate the presence of an ethosuximide-type of impurity in these fractions, although the equivalence of the methylene proton signals of the ethyl group that was observed for the fractions suggests that the impurity does not contain an asymmetric carbon atom adjacent to the ethyl group, as does ethosuximide itself. In order to confirm that ethosuximide was not a genuine impurity in phenytoin, liquid chromatography of the latter drug was repeated with a column that was thoroughly prewashed with acetic acid to ensure removal of possible residues from previous analyses.

The repeated LC invariably gave a fraction 2 that contained a strongly UV absorbing impurity, present at very low levels. Because of its strong UV absorption, this impurity could not have been ethosuximide. However, the spectra of fraction 2 generally showed strong proton multiplets whose chemical shift indicated the presence of aromatic molecules other than phenytoin. The structure of the multiplets was similar to that of the proton signals of phthalate, a common impurity in commercial organic materials. It appears probable that this material was responsible for the unusually strong ultraviolet absorption of fraction 2 at 254 nm that was observed. The mass balance experiments indicate that the impurities present in fraction 2 comprise not more than 0.1 percent of the crystalline phenytoin.

The acetone-soluble materials of all of the fractions also contained significant quantities<sup>4</sup> of hydrocarbon impurities that originate principally from the purified methanol solvent used in the liquid chromatography. This interference problem was studied further by NMR examination of the residues obtained by (a) evaporation of purified methanol (500 mL) under a stream of nitrogen as used for the fractions, (b) evaporation of methanol (500 mL) by means of a rotary evaporator, so as to avoid possible contamination from the nitrogen supply, and (c) evaporation of methanol (500 mL) that had been passed through the column of polyvinyl pyridine resin.

<sup>3</sup>The methanol used was purified at NBS by sub-boiling distillation [2].

<sup>4</sup>In this context "significant quantities" means that the hydrocarbon impurities give proton NMR signals that are of equal or greater intensity than those of the impurities derived from the drug.

All three of these residues showed significant quantities of the same hydrocarbon contaminants that are characterized by a methylene : methyl group ratio of 3.0-3.5:1. Examples of structural possibilities for hydrocarbon impurities that would fit this intensity ratio are 2-methyldodecane, 2,15-dimethylhexadecane, 2,17-dimethyloctadecane, and 2-methyltetradecane. A mass spectrometric total ion chromatogram obtained from a direct probe sample suggested the presence of three components including a phthalate compound that gave a stable aromatic ion, and a molecular ion of low intensity that corresponded to a methyltetradecane. Reports in the literature suggest that pristane (2,6,10,14-tetramethylpentadecane) and phytane (2,6,10,14-tetramethylhexadecane) occur in such commercial solvents as methanol and pentane that have been derived from fossil hydrocarbons. However, the spectroscopic evidence indicated that the hydrocarbon impurities encountered in this work were less highly branched than pristane and phytane. The same type of hydrocarbon impurities (as characterized by the chemical shift of the methylene groups) had been encountered in previous work in which cholesterol was chromatographed on polyvinyl pyridine in chloroform solution and cortisol in ethanol solution.

The proton NMR spectrum of the column residue preparation described in (c) above showed (in addition to the methanol hydrocarbon) only low levels of aromatic and methylene proton signals that are probably due to a slow bleed of divinylbenzene oligomers from the column material used. The intensities of the NMR signals indicate that this source of contamination (column bleed) is much less significant than that originating from the methanol.

The proton NMR spectra (fig. 1) of solutions of phenytoin in acetone- $d_6$  display a single complex multiplet for the chemically identical phenyl groups, but separate singlets of widely differing line width for the inequivalent NH protons. The broadness of the NH signals disappears when methylsulfoxide- $d_6$  is used as solvent (Table 1) suggesting that the rate of chemical exchange of the NH protons is diminished by their hydrogen bonding with this solvent.

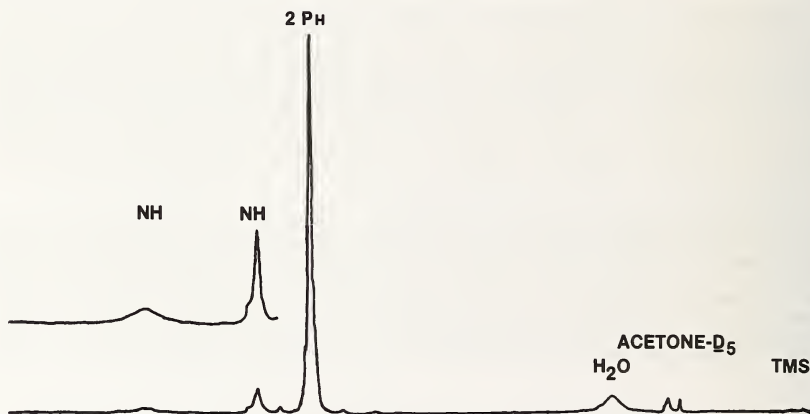

Figure 1. Proton NMR spectrum of phenytoin.

b) Proton NMR spectroscopy of LC fraction 1 of ethosuximide indicated only the presence of hydrocarbon artifacts derived from the redistilled solvent used for the LC. However, the proton NMR spectrum of fraction 2 (see fig. 2) showed the presence of ethosuximide, hydrocarbon artifacts, and an unknown impurity that displayed a five line, probably two-proton multiplet in the olefinic proton region, at 5.7 p.p.m. Comparison of the integrated intensity of this multiplet with that of one of the methylene multiplets of the ethosuximide

indicated that the olefinic compound is present at less than one-seventh the level of the ethosuximide. Since fraction 2 represented only 0.07 percent of the mass of ethosuximide, the olefin was present in the crystalline drug at a level of less than 0.01 percent.

The proton NMR spectra of fractions 4 and 5 of ethosuximide showed only the resonances associated with the solvents used for liquid chromatography and proton NMR analysis, but the spectrum of fraction 6 indicated that it was composed principally of ethosuximide, suggesting the occurrence of some long-term bleeding of the main component from the LC column packing material. As mentioned before, this problem was obviated, with respect to subsequent usage of the same column, by washing the column packing with acetic acid prior to each analysis.

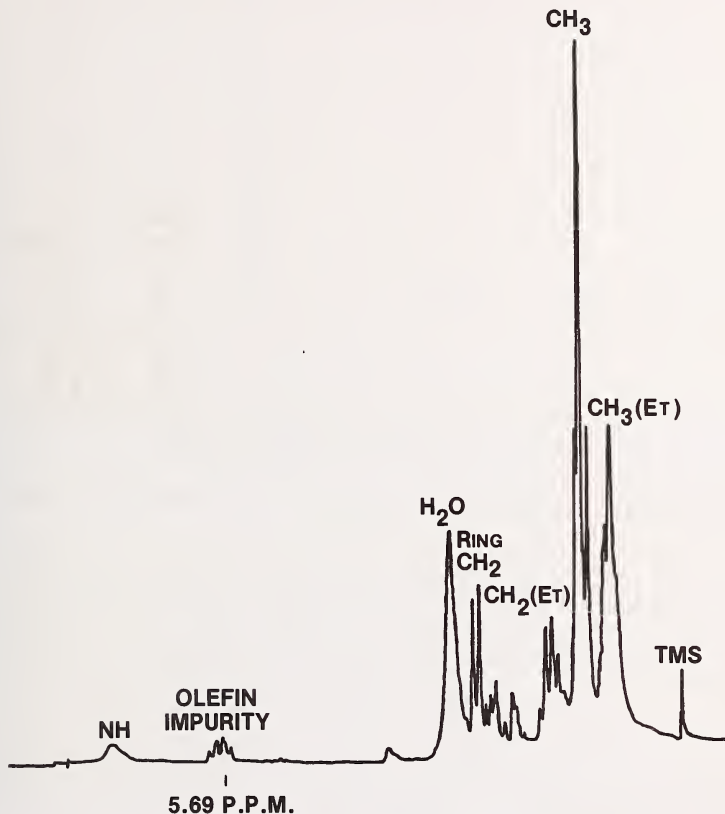

Figure 2. Proton NMR spectrum of ethosuximide fraction 2 from liquid chromatography.

Solutions of this drug in acetone- $d_6$  yielded a more characteristic proton NMR spectrum (fig. 3) in which the ring methyl substituent and methyl part of the ethyl group resonate as a singlet and triplet, respectively, at high field. Owing to the fact that the quaternary carbon atom of ethosuximide is asymmetric, each methylene group contains a pair of chemically inequivalent protons, and the ring methylene group resonates as an AB quartet, whereas

the methylene part of the ethyl group gives a complex multiplet instead of the simple quartet which would be expected if the methylene protons of the ethyl group were equivalent. These observations are relevant to the characterization of fraction 2 of phenytoin since the proton NMR spectrum of this fraction is similar to that of ethosuximide except for the absence of inequivalent methylene proton signals at higher field.

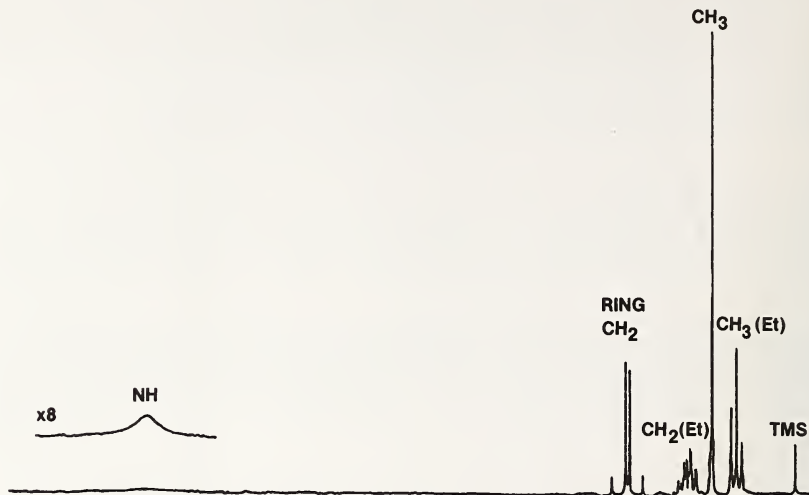

Figure 3. Proton NMR spectrum of ethosuximide.

The NH signal of ethosuximide occurs as an extremely broad singlet at low field that is best detected by multiple scanning of the spectrum.

c) Phenobarbital. The block averaging NMR technique was used for some of the LC fractions of phenobarbital for which spectra with a high signal:noise ratio were desired. Implementation of this technique involved signal averaging in both the time and frequency domains. The advantage of also averaging in the frequency domain is that the dynamic range of the spectrum is not limited by the computer word-length, since, in the frequency domain, strong signals may be allowed to overflow memory. A further advantage of performing some averaging in the frequency domain is that arithmetic uncertainties in the computation of the Fourier transforms tend to average out. The dynamic range of the transform is known to be limited by these uncertainties and by other factors. The block averaging technique has been implemented in the Nicolet data system which is being used for this work by two methods. Signal averaging is performed first in the time domain until the data almost fills the memory. This data block is then Fourier transformed, phase corrected and either (a) added to a second block of memory, or (b) stored on a magnetic disk and co-added with a running data file on that disk. Automation of the whole procedure is achieved by means of a series of linked commands.

Proton NMR spectra of LC fraction 1 of phenobarbital indicated that it contained phenobarbital as a major component, solvent hydrocarbons, and an additional aromatic compound that displayed a multiplet at 7.7 p.p.m., slightly downfield from the phenyl multiplet of phenobarbital. Comparison of the intensities of these multiplets indicates that the aromatic impurity is present at a level of one-tenth that of the phenobarbital in fraction 1. Since this fraction comprises only 0.01 percent of the mass of phenobarbital chromatographed, the aromatic impurity is present in the phenobarbital at a level of less than 0.001 percent.

The proton NMR spectra of fractions 2-6 indicated only the presence of phenobarbital and solvent impurities in each fraction.

The amide form of phenobarbital contains a plane of symmetry and so only a signal at low field is seen for the NH protons, and the usual triplet and quartet at high field for the methyl and methylene protons, respectively, of the ethyl group (fig. 4). The very broad signal of phenobarbital at low field is removed by addition of deuterium oxide to the solution thus confirming the assignment of this signal as NH.

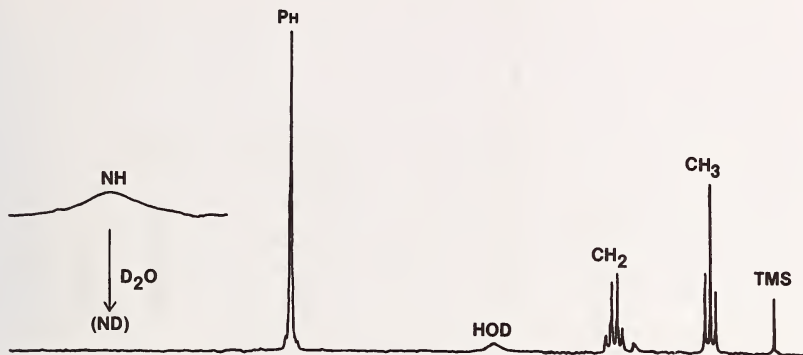

Figure 4. Proton NMR spectrum of phenobarbital.

d) Primidone. The proton NMR spectrum of LC fraction 1 of primidone showed only the presence of solvent impurities. Spectra of fractions 2, 3, and 5 indicated the presence of primidone in each fraction in addition to solvent impurities. However, the spectrum of fraction 4 displayed an additional multiplet in the aromatic region at 7.72 p.p.m., the intensity of which indicated a level of one-fifth that of the primidone present in the fraction. Since fraction 4 comprises 0.21 percent of the total mass of primidone chromatographed, the aromatic impurity must be present in the primidone at a level no greater than 0.04 percent.

The proton NMR spectrum (fig. 5) of primidone in dimethylsulfoxide- $d_6$  solution displays the NH signals (two, according to integration of the spectrum) as a doublet which suggests spin coupling of the NH and ring methylene protons. The effect of this coupling is seen in only one half of the ring methylene multiplet which indicates that only one of these methylene protons is favorably oriented for coupling with NH protons that are three bonds distant. Chemical exchange of the NH protons must be a particularly slow process in dimethylsulfoxide- $d_6$  for coupling of the NH protons to be observed.

The NH signal of primidone in acetone- $d_6$  solution could not be detected. Moreover the ring methylene group now resonated as a simple AB quartet. Evidently, the weaker hydrogen bonding of the NH protons in acetone- $d_6$  permits a more rapid chemical exchange which removes the effects of the NH-methylene coupling, and causes the NH signal to become so broad that it is lost in the baseline noise. The phenyl group of primidone resonates as the usual complex multiplet and the ethyl group as a triplet and simple quartet at high field (fig. 5).

In summary, the proton NMR spectra of concentrated solutions of phenytoin, ethosuximide, phenobarbital, and primidone were studied and the spectra indicated that the preparations selected were of high purity. The assignments of the NH proton signals of the drugs were generally confirmed by deuterium exchange with added deuterium oxide. The proton chemical shifts of the drugs and their spectral multiplicities and assignments are summarized in Table 1.

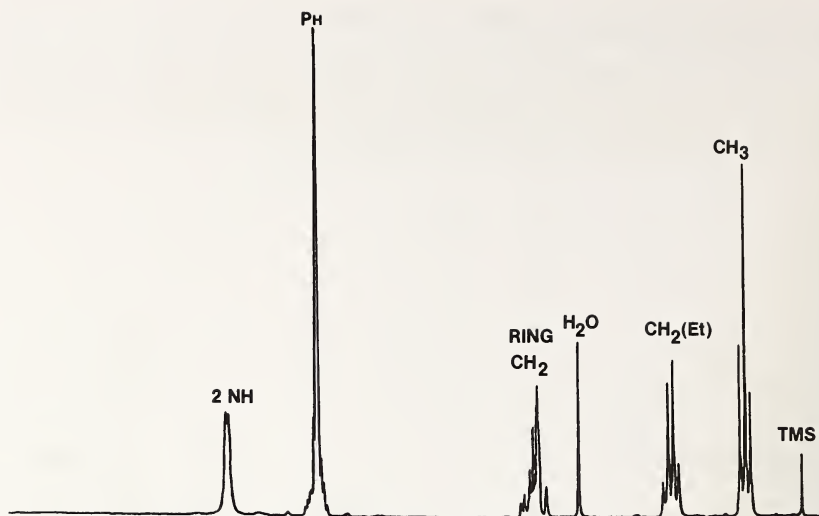

Figure 5. Proton NMR spectrum of primidone.

Table 1. Proton chemical shifts<sup>a</sup> of antiepilepsy drugs.

Drug	Solvent	CH <sub>3</sub> (Et)	CH <sub>2</sub> (Et)	CH <sub>3</sub> (on ring)	CH <sub>2</sub> (in ring)	Ph	NH
Phenytoin	(CD <sub>3</sub> ) <sub>2</sub> CO	-----	-----	-----	-----	7.42m <sup>b</sup>	8.23s, <sup>c</sup> 9.93s <sup>d</sup>
	(CD <sub>3</sub> ) <sub>2</sub> SO	-----	-----	-----	-----	7.38m	9.32s, 11.11s
Ethosuximide	(CD <sub>3</sub> ) <sub>2</sub> CO	0.89t	1.64m	1.27s	2.56q	-----	----- 9.92s <sup>d</sup>
Phenobarbital	(CD <sub>3</sub> ) <sub>2</sub> CO	0.97t	2.44q	-----	-----	7.40m	10.23s <sup>d</sup>
Primidone	(CD <sub>3</sub> ) <sub>2</sub> CO	0.93t	2.07q	-----	4.25q	7.36m	----- <sup>e</sup>
	(CD <sub>3</sub> ) <sub>2</sub> SO	0.86t	1.98q	-----	4.03sx	7.32m	8.68d (x2)

<sup>a</sup>Parts per million from internal tetramethylsilane.

<sup>b</sup>Multiplicities of NMR signals are indicated by s (singlet), d (doublet), t (triplet), q (quartet), sx (sextet), and m (complex multiplet).

<sup>c</sup>Broad singlet.

<sup>d</sup>Very broad singlet.

<sup>e</sup>Signals not detectable.

## 2.2 Serum Base Developments

### A. Choice of Matrix.

Since the intended SRM was to have a serum matrix, procedures were established to assure that the drugs would be soluble in serum, that they would disperse homogeneously, that they would not be irreversibly bound to protein, and that they would not precipitate or segregate when the matrix was freeze-dried and subsequently reconstituted with water.

Bovine serum at first appeared to be an adequate serum base. It is easy to obtain in bulk quantities and is generally free from the myriad of drugs found in pooled human serum. One concern was that the bovine serum would not have the same handling properties and characteristics as those of clinical (human) samples. High performance liquid chromatography using an octadecylsilane (C<sub>18</sub>) column in a reversed-phase system revealed the relative complexities of the candidate sera (figure 6). The liquid chromatogram of the bovine serum demonstrated that the serum is quite free of interfering peaks in the region where the drugs are eluted. In contrast, chromatograms of human serum show a variety of peaks in this region. They were found to cause substantial interference in quantitative determinations, especially of phenobarbital, which has a similar retention volume to that of the strongly absorbing serum component labeled A in the human serum chromatogram. Although the human serum is more complex than bovine serum and contains many more interferences, we nevertheless decided to pursue the preparation of human serum processed to remove those interferences. A critical factor in this decision was the finding that preparations of a bovine-based drug preparation did not give accurate quantitation with a currently-used, enzyme-based, immunoassay method, due to cross-reacting antibodies to bovine components.

We first attempted to prepare interference-free human serum by passing it through a 1.5 x 30 cm column of Sephadex G-50 (Pharmacia, Piscataway, NJ), equilibrated with 0.15 mol/L NaCl. The liquid chromatogram of the serum protein peak is shown in figure 7. It may be seen by comparison with figure 6 that the serum components that elute in the region of the drugs were removed by passage of the serum through the Sephadex. The treated serum was then spiked with known amounts of all four drugs and subjected to quantitation by liquid chromatography. A typical chromatogram of this spiked, treated matrix is shown in figure 8 and the quantitative results are shown in Table 2. A relative precision of 2-3 percent was achieved during the first quantification efforts for phenytoin, ethosuximide, and phenobarbital, but quantification of primidone was more difficult owing to its low concentration at therapeutic levels.

Table 2. Quantitative analysis of drug mixtures in Sephadex-fractionated human serum by reversed phase liquid chromatography.

Drug	Concentration of drug injected (µg/mL) <sup>a</sup>	Drug found (µg/mL)	± σ	RSD <sup>b</sup> %
Phenytoin	16.6	16.6	0.3	1.9
Ethosuximide	78	75.0	2.5	3.3
Phenobarbital	22	23.6	0.7	3.0
Primidone	4 <sup>c</sup>	----	---	---

<sup>a</sup>Volume injected: 0.2 mL.

<sup>b</sup>Relative standard deviation.

<sup>c</sup>This concentration of primidone gave a peak that was too small to be reliably recognized by the integrator in use. Measurement of a higher concentration of primidone (9 µg/mL) yielded a found value of 9.05 µg/mL. At this level, the error was estimated to be 5-10 percent and presumably could be diminished in proportion to the injection of larger volumes of serum.

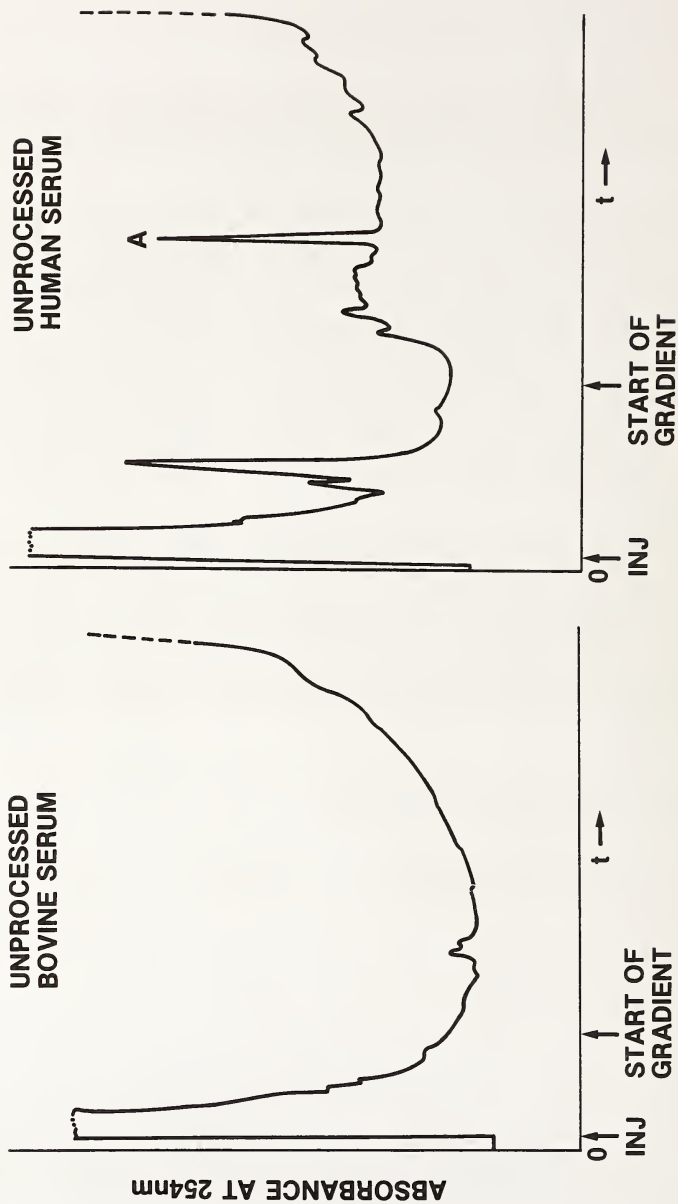

Figure 6. Comparison of bovine serum with human serum using high performance liquid chromatography. Strongly absorbing peak A in human serum interferes with phenobarbital determination.



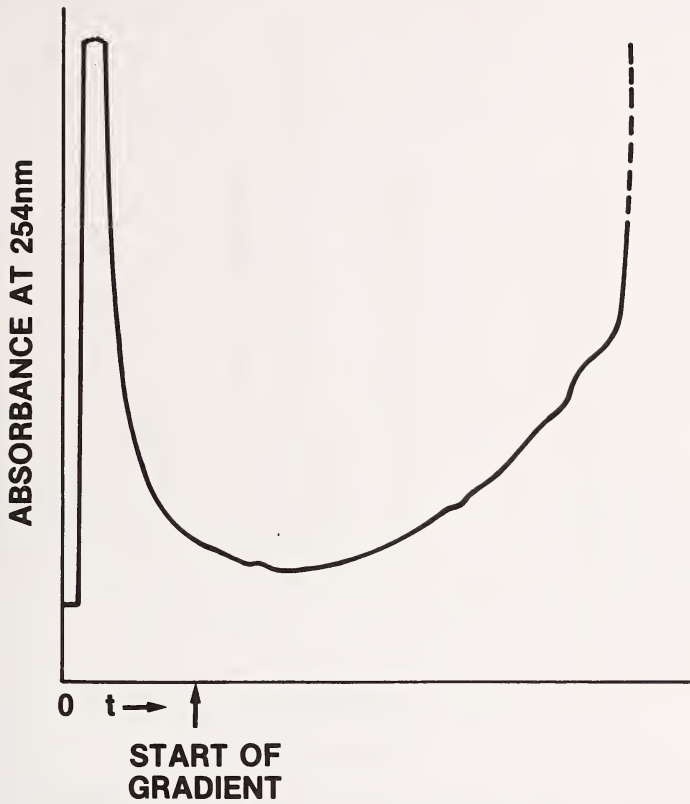

Figure 7. High performance liquid chromatogram of human serum after fractionation on Sephadex.

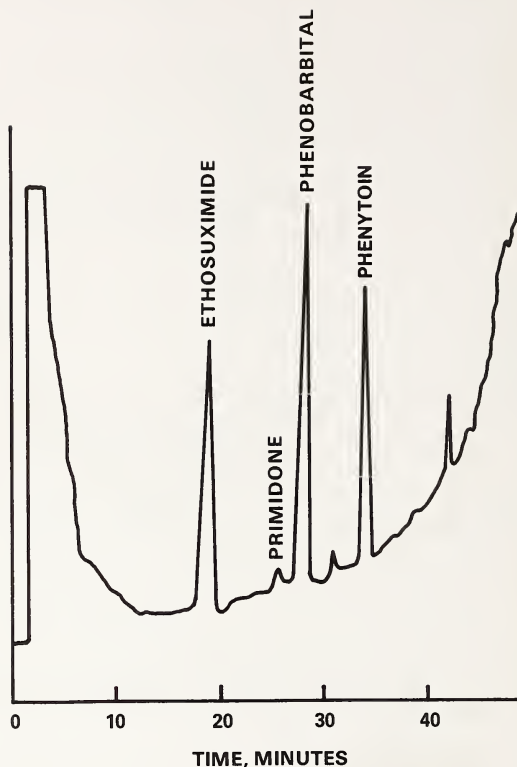

Figure 8. Reversed-phase liquid chromatogram of antiepilepsy drugs in Sephadex-treated human serum matrix (detection at 254 nm).

The process of fractionation of human serum on Sephadex suffered from the disadvantage that it appeared to be applicable only to rather small volumes of serum. The processing of batches of serum with total volume requirements approximating fifty liters would require exceedingly large columns or many individual separations on smaller columns. A procedure for serum treatment that was applicable to large batch-mode processing was developed by making modifications to portions of a human serum pool and then following the disappearance of serum components that elute in the same region as the drugs. Some treatments were more effective than others in removing specific components from the serum. A sequence of operations was finally devised that consistently produced serum suitable for freeze-drying and substantially free from interferences that elute in the same region as the drugs. The procedure is outlined in figure 9 and described in the following section.

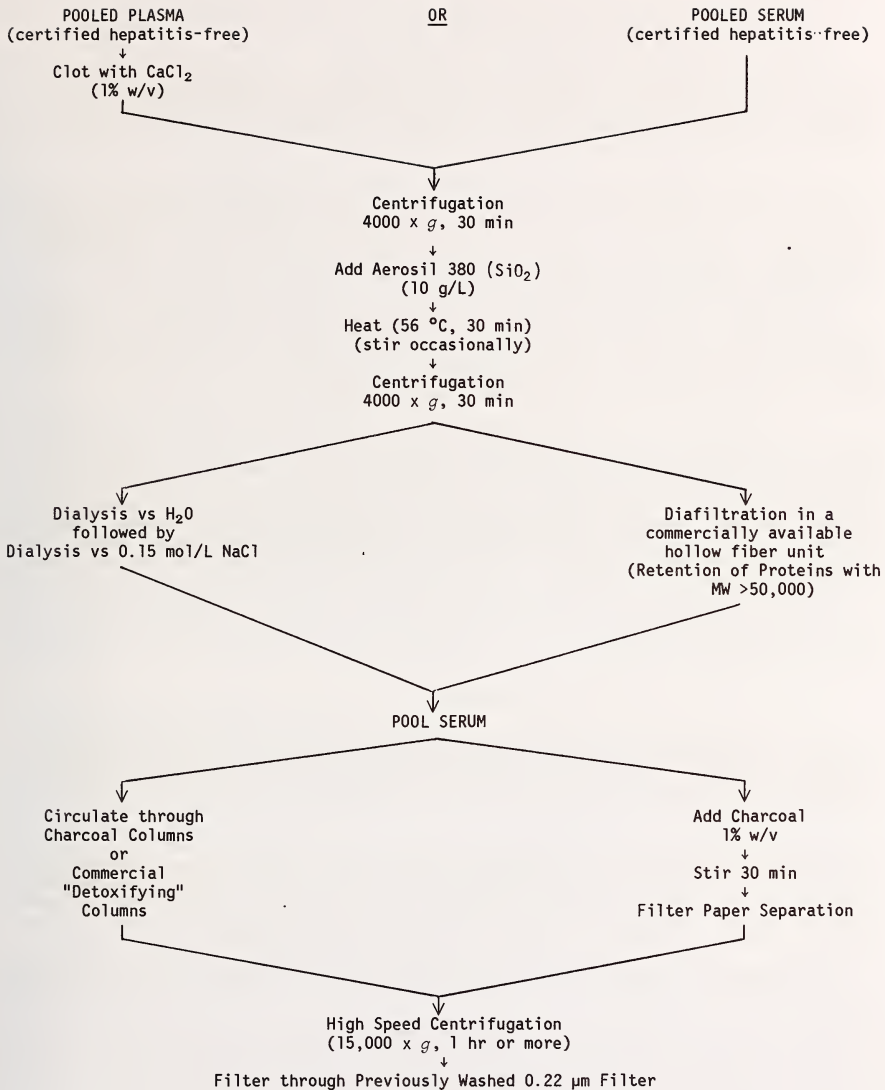

Figure 9. Preparation of serum base.

## B. Procedure for Preparation of a Human Serum Base

Certified hepatitis-free plasma from several donors is combined in a single container. Calcium chloride is added to a final concentration of about one percent (w/v), or until clotting is observed. The addition of glass microscope slides or glass beads often enhances the clotting. After the clot is retracted, the supernatant liquid is centrifuged at 4000 x *g* to remove debris and provide a clarified serum.

Aerosil 380, (Degussa, Inc., Teterboro, NJ, 07608) a SiO<sub>2</sub> product, is added to a level of about 10 g/L and the mixture is heated to 56 °C and stirred for 30 minutes. This step removes substantial portions of lipoproteins and deactivates some enzymes. The removal of lipoproteins is necessary to obtain a clear solution upon reconstitution from the freeze-dried state. Alternative delipidation procedures consisting of treatment with dextran or frown were judged to be less effective. They also require extra steps of processing.

The mixture is centrifuged at 4000 x *g* for 30 min to pellet the Aerosil. The supernatant liquid is transferred into previously boiled and washed dialysis bags, for dialysis against deionized or distilled water at 4 °C. This procedure is continued with periodic changes of water until the conductivity of the dialysate is constant for two hours or more and is near to the conductivity of the water used for the dialysis.

The serum, while still in the dialysis bags, is equilibrated with 0.15 mol/L NaCl at pH 6.5 to 7.0 until the conductivity of the dialysate is constant (±1 percent) for two hours or more. The contents of each dialysis bag are pooled and passed through charcoal filters to reduce the serum content of non-protein substances. For this procedure coconut charcoal (6-14 mesh) may be packed in a long glass column and the serum pumped through the charcoal packing. Commercial columns such as the Hemodetoxifier unit (B-D Life Support Systems, Sharon, MA 02067) were found useful. Alternatively, finely-divided charcoal such as Norit may be added (1 percent w/v) and then removed by centrifuging at high speed (15000 x *g*) for one hour or more.

Finally, the material is filtered through 0.22- $\mu$ m pore-size membrane filters into sterile, tared glass containers.

## C. Addition of Drugs to the Processed Serum Base

The direct addition of crystalline drugs to a serum base imposes the possibility of obtaining a nonhomogenous mixture due to poorly solubilized drugs. Conversely, the addition of drugs dissolved in an organic solvent risks protein denaturation and precipitation. Further, solvent impurities might contribute to the problem of non-specific interference in analytical procedures.

We found that ethyl alcohol (95%) was a suitable solvent for all four drugs, and that it was consistently free from interfering peaks in both liquid and gas chromatography. Ethyl alcohol was found to precipitate proteins from the serum bases but only when added at a rapid rate or if its proportion exceeded about five percent (v/v). Lower alcohol concentrations, e.g., 1 percent in serum, obtained by slow, dropwise addition with constant stirring, resulted in no change in the optical clarity of the serum base.

Some SRM target values for the concentrations of the four drugs in serum, expressed in  $\mu$ g/mL are listed in Table 3.

Table 3. Target values for drugs in serum (in  $\mu\text{g/mL}$ ).

	<u>Subtherapeutic</u>	<u>Therapeutic</u>	<u>Toxic</u>
Phenytoin	4	17	62
Ethosuximide	11	78	177
Phenobarbital	5	22	104
Primidone	3	8	19

In order to achieve these concentrations of drugs in the serum matrix, appropriate quantities of the drugs are dissolved in alcohol at 100 times the target level; an excess volume of the solution is prepared. The drugs are dissolved with the aid of ultrasonic oscillation to effect their complete dissolution. The volume of alcohol-drug solution added is one percent of the serum base volume. For example, 60 mL of the alcohol-drug solution is added dropwise to 6000 mL of processed serum.

#### D. Dispensing the Drug-Spiked Serum

The homogeneity of the standard is dependent upon uniform quantities of the drug-spiked serum being dispensed into vials prior to freeze-drying. Experience with manual dispensers such as hand-held pipettes has shown that precision of dispensing is limited to about 1.0 percent relative standard deviation (RSD) at 5.0 mL volumes. However, use of automated pipettor-dilutors has resulted in RSD's in the range of 0.01 - 0.05 percent with similar volumes. These automated instruments must be pre-calibrated to assure that delivery of the serum is accurate. The instrument must be operated in a uniform manner in order to obtain consistent dispensing. For example, there needs to be 1) a routine sequence for handling the vials and dispensing the serum so that the delivery stream does not splash; 2) a routine of touching the end of the delivery tip to the vial to remove the nascent drop; and 3) a fixed, limited time interval between dispensing so that evaporation from the tip is minimized.

#### E. Freeze-Drying the Spiked Serum

Since there are known to be differences in residual moisture in separate lots of protein-based products that are freeze dried in the same freeze-dryer, it is essential that the protocol for freeze-drying be designed to minimize lot-to-lot variations. For example, residual moisture can be affected by the length of time the dryer is in operation, the degree of vacuum employed, the final shelf and product temperature, the size of the "plug" of dried serum, the capacity of the freeze-dryer, and the final conditions inside the chamber at the time the vials are sealed. As an additional concern, if the residual moisture is too high, shelf life of the product could be decreased; whereas if the moisture is too low, the dried protein may not dissolve readily in the reconstituting water.

Stopping the vials under a high vacuum may be a source of problems if there is subsequent leakage of moisture-laden air into the vial. However, if the freeze-dry chamber is repressurized with dry nitrogen to only slightly below atmospheric pressure (approximately 0.9 atmosphere) before the vials are stoppered, there is less likelihood of significant moisture entering the vials. The design of the freeze-dryer is an important factor in the achievement of a dry, nitrogen atmosphere. Most commercial freeze-dryers have the condenser situated in close proximity to the product shelves, and when nitrogen is admitted, moisture may be picked up by the gas so that moisture may re-enter the product. This is obviated if the design of the freeze-dryer provides for the physical separation of the product chamber from the condenser chamber. At the completion of the freeze-dry cycle, the condenser chamber is partitioned from the product chamber with a valve, the dry nitrogen can be admitted directly to the product chamber, bypassing ice in the condenser chamber.

### 3. Protocol for Certification of the SRM

#### 3.1 Homogeneity of the Reconstituted Samples

It is essential that each level of drug be homogeneous in the entire lot of serum and that the serum be dispensed uniformly with respect to fill volume into each vial. While local inhomogeneities of drug in serum may initially exist when the drugs are added, stirring before and during the filling operation overcomes that. Inhomogeneity due to filling can be detected by weighing. After freeze-drying is completed, homogeneity among vials can be determined after reconstituting by testing with a sensitive differential refractometer (see Appendix I for a description of the instrument built at NBS).

Random sampling of individual production lots is required to ensure a meaningful estimation of vial-to-vial variations in concentration. A sampling of at least 25 vials from each 1000 vials is required. Sample vials are selected from the lot of vials as identified from a list generated from a table of random numbers. The contents of the vials are then reconstituted with 5 mL of water, which is dispensed from a constant volume pump or pipette. The vials are weighed before and after the water is added to correct for variance in the addition of the water. The standard deviation we found in the amount dispensed was about 0.5 microliter. The refractive indices of individual, reconstituted sera obtained in a differential refractometer are then compared with that of a reference solution which contains about 100 g of KCl per liter of water. The refractive index of this solution differs from water by about 0.012 units. The measured differences are then corrected for weight and instrument drift, if any, and the values are then analyzed for evidence of systematic filling errors or drift in the dispensed volumes. The sensitivity of this method is sufficient to determine vial-to-vial differences in concentration as small as 0.03 percent. The reproducibility of the differential refractometer we used was about  $3 \times 10^{-6}$  refractive index units. Since the lot of unspiked (blank) serum was dispensed in the same manner as the drug-spiked serum, and the inhomogeneity in the latter was less than 0.5 percent in all cases, we did not derive homogeneity figures for the blank. The findings are tabulated in Table 4.

Table 4. Homogeneity of reconstituted samples.

<u>Sample</u>	<u>Percent Standard Deviation by Differential Refractometry</u>
Blank	(not run)
Subtherapeutic	0.086
Therapeutic	0.080
Toxic	0.305

#### 3.2 Quantitative Liquid Chromatography

##### A. Qualification of the Method

Preliminary studies were performed to determine whether each of the four drugs could be quantitatively separated from serum proteins by reversed phase liquid chromatography. Bovine serum was used as a base in these initial experiments. The drugs labeled with  $^{14}\text{C}$  or  $^3\text{H}$  were chromatographed concurrently and the fractions were counted. The data provided evidence for the purity of these labeled drugs.

# 1. Phenytoin-4-<sup>14</sup>C

A solution of 0.56  $\mu\text{Ci}$  of phenytoin-4-<sup>14</sup>C in ethanol was chromatographed on  $\mu\text{Bondapak C-18}$  using a water-methanol gradient of 0-50 percent methanol, and a flow rate of 2 mL/min. An aliquot (1 mL) from each of 35 fractions was mixed with counting cocktail (10 mL) before scintillation counting was carried out. The results for phenytoin-4-<sup>14</sup>C are shown in Table 5 in which it may be seen that the only significant activity other than that present in the major component (fractions 20-27) occurs in fractions 2 and 3. The latter fraction contained only 0.05 percent of the total activity injected.

Table 5. Scintillation counting of fractions from liquid chromatography of phenytoin-4-<sup>14</sup>C in ethanol.

<u>Fraction</u>	<u><math>\mu\text{Ci} \times 10^{-6}</math></u>
1	3.2
2	127.3
3	149.1
4	18.6
5	15.5
6	12.6
7	11.8
8	7.7
9	10.9
10	11.6
11	17.8
12	18.0
13	18.1
14	16.5
15	19.4
16	18.3
17	19.9
18	24.9
19	41.2
20	123.2
21	341.3
22	519.3
23	122.8
24	2,470.3
25	84,355.1
26	292,634.6
27	216,773.4
28	759.9
29	562.4
30	381.8
31	187.6
32	226.8
33	234.5
34	61.0
35	57.0
Total	600,373.9 (0.600 $\mu\text{Ci}$ )
Activity injected	0.56 $\mu\text{Ci}$

Results from the liquid chromatography of a solution of phenytoin-4-<sup>14</sup>C in bovine serum are shown in Table 6. Chromatographic conditions are the same as those used to separate the drug dissolved in ethanol (Table 5). It may be seen that practically all (99.5%) of the radioisotope appears in one peak (fractions 25-26) and only 0.1 percent of the activity is associated with the protein peak (fractions 2-3).

Table 6. Scintillation counting of fractions from liquid chromatography of bovine solutions of phenytoin-4-<sup>14</sup>C.

<u>Fraction</u>	<u>Counts (total <math>\mu\text{Ci} \times 10^{-6}</math>)</u>
1	)
2	483.0
3	142.5
5	46.6
6	15.6
7	42.8
8	37.7
9	22.0
10	16.7
11	37.9
12	24.4
13	30.3
14	18.7
15	12.6
16	12.5
17	19.2
18	26.1
19	45.1
20	---
21	69.5
22	987.3
23	80.1
24	139.6
25	12,175.6
26	604,663.4
27	2,878.9
28	327.7
29	255.0
	<hr/>
Total	622,209.8 (0.622 $\mu\text{Ci}$ )
Activity injected	0.62 $\mu\text{Ci}$



## 2. Ethosuximide-1-<sup>14</sup>C

Results from scintillation counting of fractions from liquid chromatography of 0.013  $\mu\text{Ci}$  of ethosuximide-1-<sup>14</sup>C in aqueous solution are shown in Table 7 and, for chromatography of similar solutions of this drug in bovine serum, in Table 8.

The activities found in fractions 2 and 3, 5, and 8 in Table 7 indicate the presence of impurities in the ethosuximide-1-<sup>14</sup>C corresponding to levels of less than 0.25, 0.1, and 0.1 percent, respectively.

Table 7. Scintillation counting of fractions from liquid chromatography of an aqueous solution of ethosuximide-1-<sup>14</sup>C.

<u>Fraction</u>	<u><math>\mu\text{Ci} \times 10^{-6}</math></u>
1	3.57
2	23.53
3	17.37
4	7.27
5	21.31
6	11.33
7	6.65
8	15.40
9	6.28
10	4.68
11	2.83
12	0.99
13	0
14	0.99
15	1.36
16	2.09
17	1.97
18	105.09
19	15,029.29
20	773.45
21	147.96
22	51.13
23	11.70
24	4.44
25	3.82
26	2.59
Total	16,257.10 (0.016 $\mu\text{Ci}$ )
Activity injected	0.013 $\mu\text{Ci}$

Table 8. Scintillation counting of fractions from liquid chromatography of bovine serum solutions of ethosuximide- $l$ - $^{14}C$ .

Fraction	Run 1		Run 2	
	$\mu Ci \times 10^{-6}$		$\mu Ci \times 10^{-6}$	
1	0.74		----	
2	23.65		34.74	
3	20.94		19.59	
4	3.33		5.05	
5	9.73		6.90	
6	7.76		30.31	
7	29.94		7.02	
8	8.38		17.99	
9	14.91		5.17	
10	2.09		3.70	
11	3.70		0.99	
12	0.74		0.99	
13	0		1.97	
14	0		2.34	
15	0		0	
16	1.23		2.96	
17	3.45		4.19	
18	45.46		9,374.53	
19	14,720.06		6,045.79	
20	555.88		210.92	
21	97.82		65.91	
22	35.73		22.05	
23	9.61		7.89	
24	5.05		4.56	
25	2.71		3.94	
26	3.45		3.82	
Total	15,606.4	(0.016 $\mu Ci$ )	15,883.3	(0.016 $\mu Ci$ )
Activity injected		0.013 $\mu Ci$		0.013 $\mu Ci$

The fact that the percentage of radioactivity in fractions 2 and 3 (which also contain the protein) is only 0.3 percent of the total activity (Table 8) and is not significantly greater than the radioactivity found in fractions 2 and 3 when the labeled drug is chromatographed in the absence of protein, indicates that this drug is separated virtually quantitatively from the protein and that the drug-protein binding is negligible under the conditions of the chromatography.

### 3. Phenobarbital- $2$ - $^{14}C$

The results from scintillation counting of fractions from separations of phenobarbital- $2$ - $^{14}C$  from ethanolic and bovine serum solutions are shown in Table 9. Again the activity at the protein location (fractions 2 and 3) is comparable to the activities in fractions 2 and 3 in the absence of protein ( $\sim 0.5$  percent). Other minor quantities of impurities were detected at fraction 23 or 24 ( $\leq 0.3$  percent) and at fraction 27 or 28 ( $\leq 0.2$  percent).

Table 9. Scintillation counting of fractions from liquid chromatography of phenobarbital-2-<sup>14</sup>C solutions.

Fraction	Run 1 (in serum)	Run 2 (in serum)	Run 3 (in EtOH)
	$\mu\text{Ci} \times 10^{-6}$	$\mu\text{Ci} \times 10^{-6}$	$\mu\text{Ci} \times 10^{-6}$
1	24.0	49.4	52.5
2	439.3	501.4	462.8
3	142.7	189.8	142.1
4	53.0	39.9	29.8
5	57.9	41.0	27.0
6	35.8	35.5	34.8
7	32.5	89.7	39.7
8	73.7	54.4	48.6
9	73.4	44.8	71.4
10	48.7	28.5	51.2
11	50.3	84.2	63.5
12	113.6	91.2	92.2
13	109.8	204.4	91.7
14	181.1	96.5	144.3
15	158.3	123.0	516.7
16	105.2	50.9	3,086.6
17	71.6	83,113.4	11,410.8
18	113,545.3	45,122.4	32,601.9
19	13,506.6	158.0	60,456.8
20	152.4	86.7	20,974.6
21	104.0	46.4	104.1
22	109.2	43.0	69.3
23	176.8	396.7	121.9
24	445.2	196.3	296.0
25	82.5	34.6	295.8
26	106.9	163.0	
27	200.2	208.6	
28	246.6	121.3	
29	130.6	106.2	
30	60.3	23.7	
	Total 130,637.6 (0.13 $\mu\text{Ci}$ )	131,544.7 (0.13 $\mu\text{Ci}$ )	131,286.1 (0.13 $\mu\text{Ci}$ )
Activity injected	0.13 $\mu\text{Ci}$	0.13 $\mu\text{Ci}$	0.13 $\mu\text{Ci}$

#### 4. Primidone-4,6-<sup>14</sup>C<sub>2</sub>

Chromatography of 0.025  $\mu\text{Ci}$  aliquots of primidone-4,6-<sup>14</sup>C<sub>2</sub> afforded similar activities (~0.2 percent) in fractions 2 and 3, whether the drug was dissolved in bovine serum (leftmost columns of Table 10) or aqueous methanol (rightmost column of Table 10), and again indicated virtually complete separation of the drug from proteins, with negligible binding.

The activity in other fractions, e.g., 11-13 with 0.4-0.6 percent of total activity, indicates the presence of small proportions of impurities in the labeled drug.

In summary, the data from scintillation counting of the fractions obtained from liquid chromatography of separate solutions of the four labeled drugs in bovine sera demonstrated that the complete separation of drugs from protein can be achieved. The drugs in serum behaved like drugs in aqueous or alcoholic solutions under the conditions of the reversed phase liquid chromatography. The degree of binding between the drugs and serum proteins is insignificant.

Table 10. Scintillation counting of fractions from liquid chromatography of primidone-4,6- $^{14}\text{C}_2$  solutions.

Fraction	Run 1 (in serum)		Run 2 (in serum)		Run 3 (in $\text{H}_2\text{O-MeOH}$ )	
	$\mu\text{Ci} \times 10^{-6}$		$\mu\text{Ci} \times 10^{-6}$		$\mu\text{Ci} \times 10^{-6}$	
1	6.0		7.3		1.3	
2	31.8		34.0		34.0	
3	17.1		15.5		11.7	
4	7.4		1.0		2.3	
5	1.2		2.1		3.5	
6	2.8		1.6		3.0	
7	6.8		5.3		7.4	
8	18.3		17.1		13.4	
9	9.1		8.6		7.5	
10	5.8		4.9		2.8	
11	29.6		72.7		60.9	
12	56.0		43.7		61.7	
13	21.4		16.5		20.8	
14	11.1		7.7		13.5	
15	11.9		9.2		10.6	
16	37.0		97.7		69.8	
17	20,925.7		23,264.5		23,139.4	
18	2,934.2		335.6		1,052.5	
19	73.1		24.5		27.3	
20	11.8		10.4		10.9	
21	11.8		15.7		11.8	
22	6.7		7.1		5.3	
23	3.0		4.7		5.4	
24	3.2		10.3		3.0	
25	1.8		5.0		3.4	
26	2.8		2.8		2.2	
27	5.8		8.4		9.5	
28	5.0		3.5		4.0	
29	3.4		4.2		3.5	
30	2.3		3.5		1.2	
Total	24,770.6	(0.0248 $\mu\text{Ci}$ )	24,045.1	(0.0240 $\mu\text{Ci}$ )	24,591.9	(0.024 $\mu\text{Ci}$ )
Activity injected		0.0211 $\mu\text{Ci}$		0.0211 $\mu\text{Ci}$		0.018 $\mu\text{Ci}$

#### B. High Performance Liquid Chromatography Assay

The liquid chromatographic (LC) assays of the drug concentrations in the three human serum samples containing drugs were made directly on the reconstituted serum, without an intermediate extraction step. Reversed-phase LC was employed with a 0.01 mol/L phosphate buffer at pH 6.5 and a water-to-methanol gradient. The flow-rate was 2.0 mL/min and the gradient was advanced linearly from 0 to 60 percent methanol in 30 minutes. The column was then flushed with 100 percent methanol for 1-2 minutes, a reverse gradient was run from

100 to 0 percent methanol in 5 minutes, and another 5 minutes was allowed for equilibration to ready the column for another run. A Waters Associates (Milford, MA 01757)  $\mu$ -Bondapak C-18 column was used throughout. The volumes of serum injected were 200  $\mu$ L for the sub-therapeutic, 100  $\mu$ L for the therapeutic, and 50  $\mu$ L for the toxic levels. Detection was by absorbance at 254 and 210 nm. A digital integrator was used with the 254-nm absorbance detector to calculate peak areas. Peak heights were also measured at 254 nm. Peak heights alone were measured at 210 nm.

Three solutions were used as calibrating standards with each of the serum samples. They were made up to contain slightly less, about the same, and slightly more of each drug than the target value for the sample under analysis. The standards were made up by weighing the drugs in aluminum-foil boats, on a gram electrobalance which had been calibrated with a carefully checked weight. The boats containing drugs were then placed into 500-mL volumetric flasks. Since the mass of each boat was about 10 mg, no significant volume error was introduced. Flasks were then made up to volume with distilled water containing 20 percent (v/v) of methanol. This was found necessary in order to keep the phenobarbital and phenytoin in solution. Tests showed that the injection of methanol with the drugs did not measurably alter the peak heights unless a methanol concentration above 30 percent was reached, i.e., with the injection of 200  $\mu$ L of solution.

On each day when measurements were made, a vial of the serum was reconstituted and analyzed alternately with the calibrating standard solutions for as many runs as could be made in one day. On succeeding days other vials were similarly prepared and analyzed until six or more vials had been measured. On a typical day, about five calibrating standards and about four serum samples were analyzed. A calibration factor for each drug was calculated daily. In those cases where drift was evident, the calibration factors were calculated as a function of time. It is assumed that drift up to 1 percent per hour arose because of a decreasing flow rate as the pumping system warmed up.

### 3.3 Gas Chromatographic Analysis and Quantitation

#### A. Derivatized Drug Methods

Initially, the method used to analyze these samples by gas chromatography was based on a procedure reported by Kupferberg [3].

In that procedure, 1 mL of serum is pipetted into 37-mL screw-capped centrifuge tubes. To the serum aliquots are added internal standards (at levels close to the nominal levels of the drugs in the serum), buffer solution (pH 7.2), and chloroform (10 mL).

The samples are extracted for 15 minutes by mechanical shaking. The aqueous phase is aspirated off and discarded. The  $\text{CHCl}_3$  layer is transferred to smaller centrifuge tubes and the  $\text{CHCl}_3$  evaporated by means of a rotary evaporator. Dilute HCl and n-heptane are added to the residue and the tubes are shaken. Serum-derived components, particularly lipids, are extracted into the n-heptane. The heptane is aspirated off and the aqueous layer is extracted with 1,2-dichloroethane. The aqueous layer is aspirated off and the organic layer is taken to dryness on the Buchler apparatus. Methylating reagent is added to the residue and the mixture is vortex-mixed. The reagent for methylation is trimethylphenylammonium hydroxide (TMPAH), prepared by reacting trimethylphenylammonium iodide with silver oxide in methanol over a period of several hours. The solids are filtered off and the reagent is stored in a brown screw-capped bottle at 4 °C.

A "control" or "reference" sample is taken through the procedure at the same time, and in the same way. This reference sample consists of unspiked serum and measured amounts of both the drugs and the internal standards. Injected 1.0- $\mu$ L volumes of the solution are chromatographed and the peak areas of the drugs and internal standards are measured.

The chromatography is performed using an all glass column packed with 3 percent OV-17 on Chromosorb WHP 100/120 mesh (Supelco, Inc., Bellefonte, PA 16823). The oven temperature is programmed from 200 to 290 °C at 8°/min with an initial hold period of 2 minutes and a final hold of 4 minutes at 290 °C.

The amounts of the drugs in the unknown sample are calculated from the peak area ratios (drug to internal standard) measured in the control and unknown samples.

The procedure was modified for ethosuximide because of its high volatility and the volatility of its internal standard. Before evaporation of the dichloroethane in the final recovery of the drugs, four drops of iso-amyl acetate is added. The dichloroethane is evaporated, leaving an iso-amyl acetate solution of the drugs. Methylating reagent is added and the mixture is chromatographed.

The procedure gives reasonably well-shaped peaks with some tailing, particularly those of the internal standards. The peaks for phenobarbital and phenytoin always have additional small peaks associated (fused) with them.

The early attempts at quantification showed considerable imprecision, although by making several injections in the chromatography it was usually possible to arrive at average values that were within a few percent of the "target" value.

## B. Underivatized Drug Determinations

### 1. Conditions

Our best analytical results were obtained using a special column packing, GP 2 percent SP-2510 DA on 100/120 Supelcoport, (Supelco, Inc., Bellefonte, PA 16823) which had been developed to separate anticonvulsant drugs and their metabolites in underivatized forms.

A gas chromatograph equipped with flame ionization detectors (FID) was used under the following conditions: initial temperature 150 °C; temperature program rate 16 °C/min; final temperature 265 °C; final temperature—hold 4 minutes; injector temperature 300 °C; FID temperature 265 °C; and helium carrier gas at 50 mL/min. The signal output is interfaced with a computing integrator.

### 2. Bracketing Technique

a) Tube preparation. Analytical accuracy is improved by using a bracketing method performed as follows: Amounts of internal standard for each drug, calculated to be equivalent to the target values are placed into a 100 mL volumetric flask. The internal standards used for each of the four drugs in the SRM are listed in Table 11. The flask is filled to the mark with ethyl alcohol and the contents are mixed thoroughly. Ethyl alcohol was used for solubilizing drugs because it was found to have fewer contaminating peaks. An automatic pipettor is used to dispense 100- $\mu$ L volumes of the solutions into clean screw-capped centrifuge tubes (29 mm x 140 mm).

Table 11. Drugs and internal standards used in GC analysis.

<u>Drug</u>	<u>Internal Standard</u>
Phenytoin	5-(p-Methylphenyl)-5-phenylhydantoin
Ethosuximide	$\alpha$ -Methyl- $\alpha$ -propylsuccinimide
Phenobarbital	5-Ethyl-5-p-tolyl-barbituric acid
Primidone	4-Methylprimidone

Standard solutions of the drugs are prepared similarly, one at a level about two percent lower than the target value and another about two percent higher than the target. The automatic pipettor is used to dispense 100- $\mu$ L volumes of these drug solutions into the separate tubes containing internal standards (see the outline in figure 10). For example,

80 tubes are loaded with the internal standards in ethanol. Forty of these are reserved as Tube A, 20 are loaded with the mixture having the higher concentration of drugs (Tube B), and 20 others are loaded with the mixture having the lower level of drugs (Tube C). The alcohol is allowed to evaporate to dryness, and the tubes are then capped. The internal standards and drugs may be kept for several weeks in a dried state.

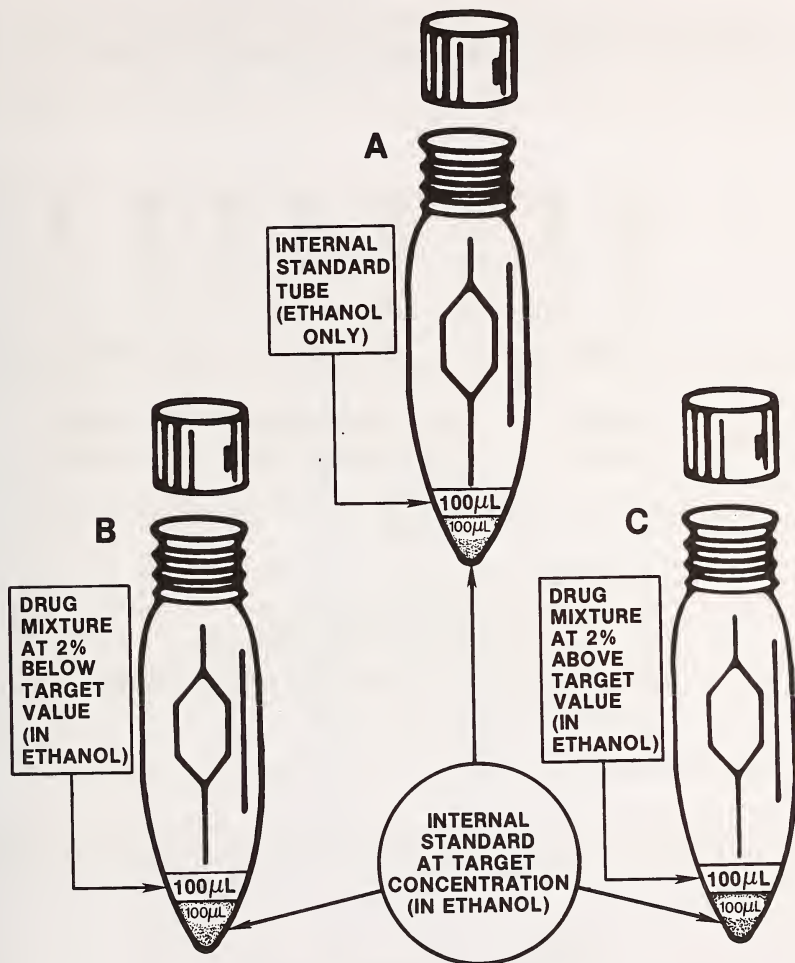

Figure 10. Procedure for preparation of tubes containing drugs for quantitative gas chromatography employing a bracketing technique.

b) Extraction and use. For use, 1.0 mL of reconstituted SRM is added to a tube that contains only the internal standard (Tube A, fig. 10). At the same time, 1.0 mL of a serum blank is pipetted into the tubes containing both the internal standards and the drugs at high and low bracketing concentrations (Tubes B and C). Usually, four tubes with SRM and two each of the high and low bracketing tubes are processed as a group.

The samples are acidified with three drops of 3 mol/L HCl to pH 1-2 and then extracted with high-purity chloroform (10 mL). After shaking and centrifugation of the tubes, the aqueous upper layer is aspirated and discarded and the chloroform is decanted into a 15 mL conical centrifuge tube. The chloroform is evaporated at 20 °C under vacuum on a roto-evaporator. The concentrate is redissolved in 50 µL of chloroform and vortex-mixed. One microliter of this residue is then injected into the gas chromatograph. This procedure is summarized in figure 11.

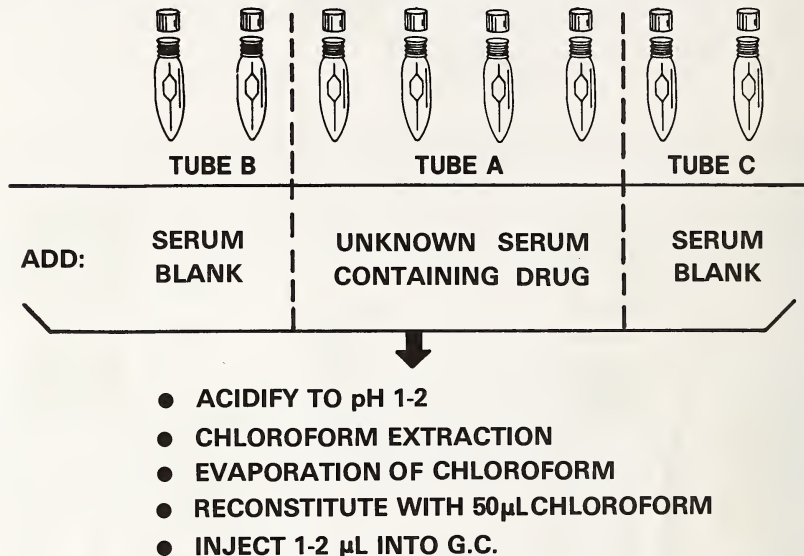

Figure 11. Procedure for extraction of drugs for quantitative gas chromatography.

c) Results and calculations. A typical separation of drugs and their internal standards is illustrated in figure 12. Peak areas are obtained and ratios of drugs to internal standard are calculated. Concentration of drugs in the serum is then calculated using the formula:

$$\left[ \frac{R_x - R_{low}}{R_{high} - R_{low}} \times (C_{high} - C_{low}) \right] + C_{low} = C_x$$



where

$$R_{\text{high}} = \frac{\text{Area of Drug Peak}}{\text{Area of Internal Standard Peak}} \quad (\text{for high standard})$$

$$R_{\text{low}} = \frac{\text{Area of Drug Peak}}{\text{Area of Internal Standard Peak}} \quad (\text{for low standard})$$

$$R_x = \frac{\text{Area of Drug Peak}}{\text{Area of Internal Standard Peak}} \quad (\text{for sample})$$

$C_{\text{high}}$  = Concentration of Drug in  $\mu\text{g/mL}$  (for high standard)

$C_{\text{low}}$  = Concentration of Drug in  $\mu\text{g/mL}$  (for low standard)

$C_x$  = Concentration of Drug in  $\mu\text{g/mL}$  (for sample)

Alternatively, peak height ratios may be used instead of peak area ratios.

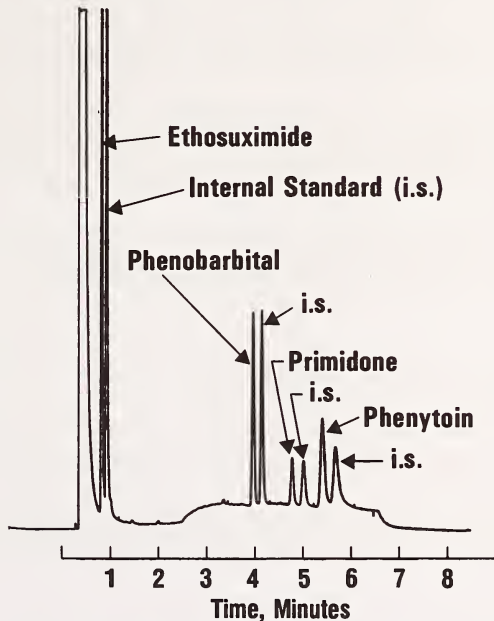

Figure 12. Gas chromatogram of antiepilepsy drugs. Conditions described in Section 3.3,8,1.

#### 3.4 Analysis of Drugs in Serum by the Enzyme Multiplied Immunoassay Technique<sup>4</sup>

Analysis of three of the drugs in bovine serum by the enzyme multiplied immunoassay technique (EMIT) was first studied to determine whether this serum is a suitable matrix for preparation of standard drug solutions that could be used to calibrate all of the methods for analysis of anti-epilepsy drugs that are used in the field, including the recently introduced EMIT procedure. Assays by the EMIT method could only be performed for phenytoin, phenobarbital, and primidone due to the non-availability (at that time) of commercial EMIT reagents for the assay of ethosuximide.

##### A. Experimental Procedures

Analysis of the drug solutions by the EMIT method was performed at 30 °C using the equipment combination for this method recommended by the SYVA Corporation (Palo Alto, CA 94304), and also with a Gilford Model 250 spectrophotometer (Gilford Instrument Lab., Inc., Oberlin, OH 44074) in combination with a Micromedic pipettor-dilutor. The spectrophotometer was equipped with a chart recorder instead of the calculator and digital print-out of the SYVA EMIT system. The EMIT method was adapted to the Gilford instrument as follows. It was found that the Micromedic pipettor-dilutor could be used for accurate dispensing of reagents if the samples were shaken gently by inversion when aliquots were to be removed for a subsequent assay step. In order to obtain reproducible sampling from the conical shaped plastic beakers, it was necessary to make a diagonal cut at the tip on the intake tube of the rapid sampler of the Gilford, and use a vacuum setting of 55 kPa. The volume of diluent was increased to 300  $\mu$ L instead of 250  $\mu$ L as specified in the EMIT system instructions for addition of reagents. The larger sample size (1.1 mL) was necessary because the Gilford 250 system has a greater volume between the sample and cell measurement region than does the SYVA rapid sampling device, which employs the Gilford Model 200-N.

The sample size is controlled by adjustment of sample timing. A 1-mL dilutor pump, 50- $\mu$ L sampling pump and 0.03-cm tip were used with the Micromedic equipment for dispensing the volumes of reagents. Absorbance values were measured on the chart recorder 15 and 90 seconds after mixing of the reagents. If the values for replicate samples did not agree within six milliabsorbance units, additional samples were analyzed until this precision was attained.

By using these procedural modifications, it was possible to make equally accurate measurements with either the Gilford 250 spectrophotometer in combination with the Micromedic pipettor-dilutor, or the EMIT equipment marketed by SYVA.

##### B. Results

Examples of EMIT calibration curves for phenytoin, phenobarbital, and primidone are shown in figures 13, 14, and 15, respectively.

The ordinate represents the difference ( $\Delta A - \Delta A_0$ ) between the change in absorbance ( $\Delta A$ ) at 340 nm for various standard solutions containing a drug in a range of known concentrations and the change in absorbance ( $\Delta A_0$ ) of a blank solution containing no drug.

The abscissa represents the drug concentration in  $\mu$ g/mL. The differential change in absorbance at 340 nm which is measured indicates the quantity of NADH produced by reduction of NAD on release of the drug-labeled enzyme from a drug-labeled enzyme-antibody complex.

---

<sup>4</sup>EMIT is a patented procedure marketed by Syva Corp., Palo Alto, CA.

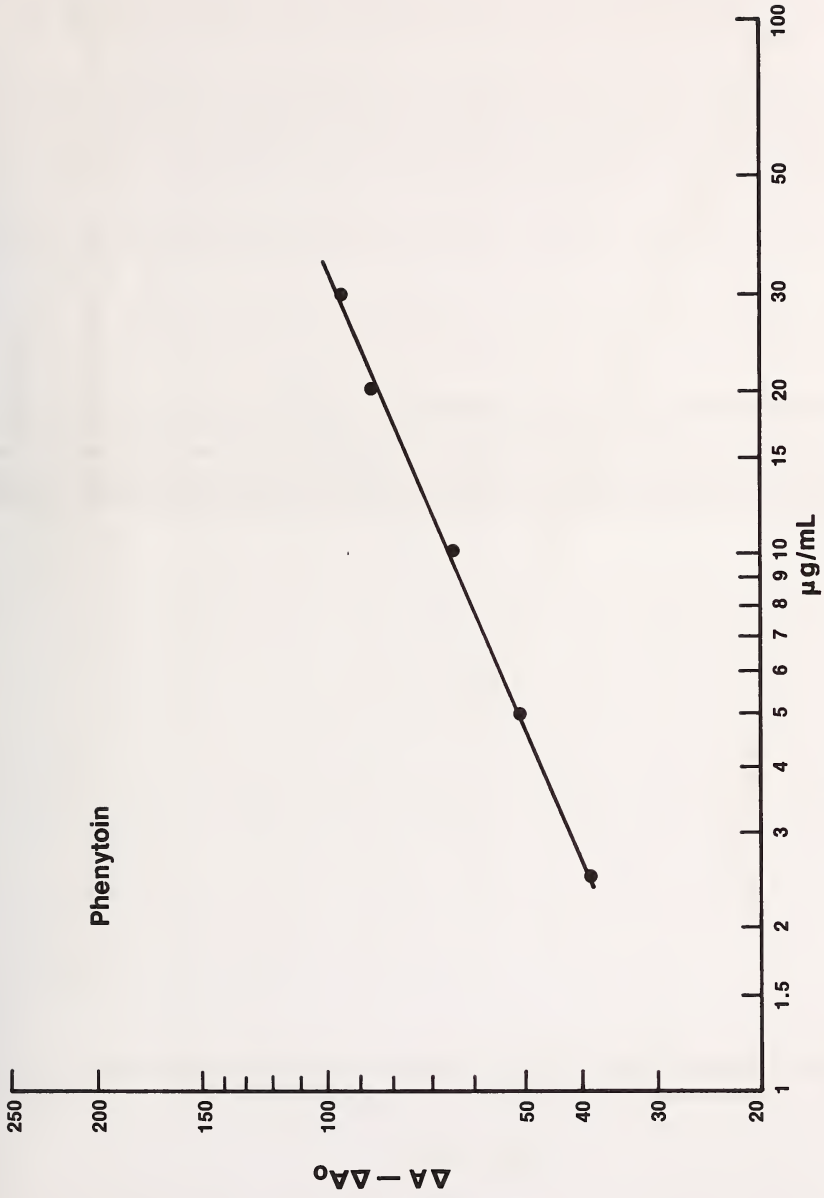

Figure 13. EMIT calibration curve for phenytoin.

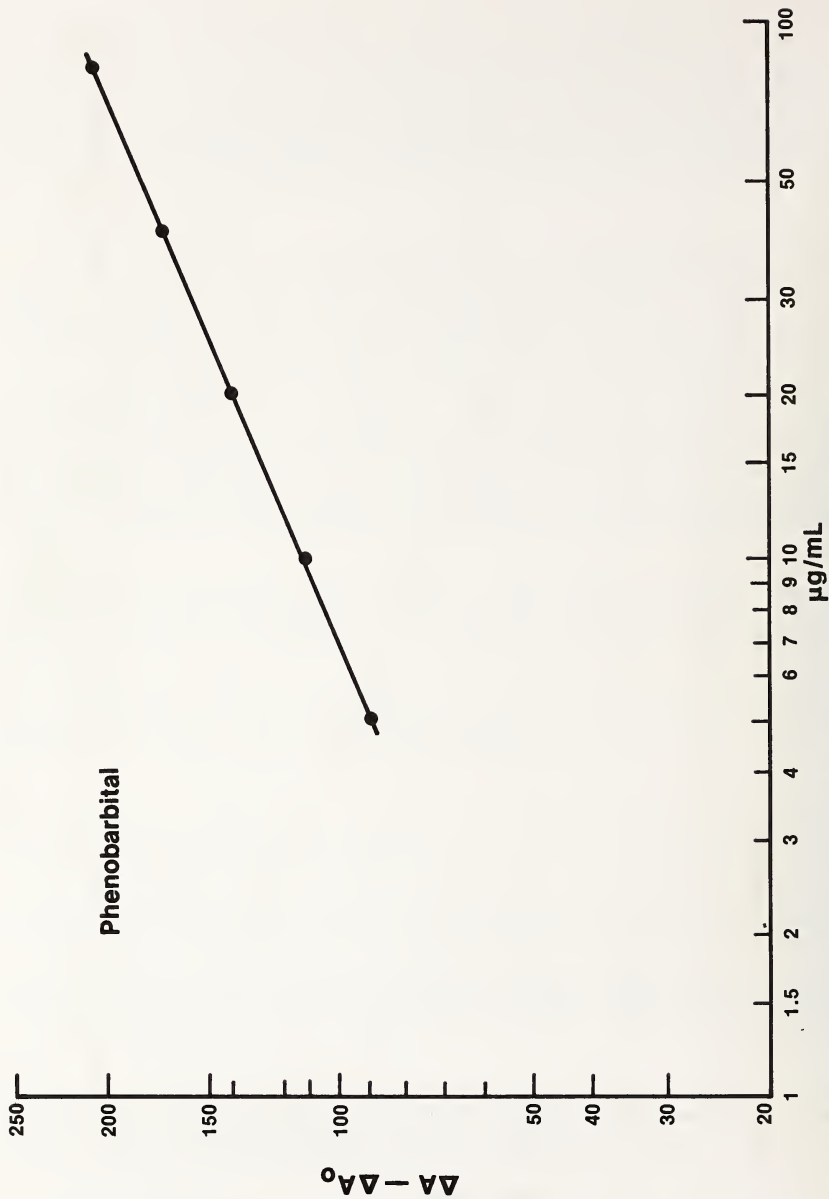

Figure 14. EMIT calibration curve for phenobarbital.

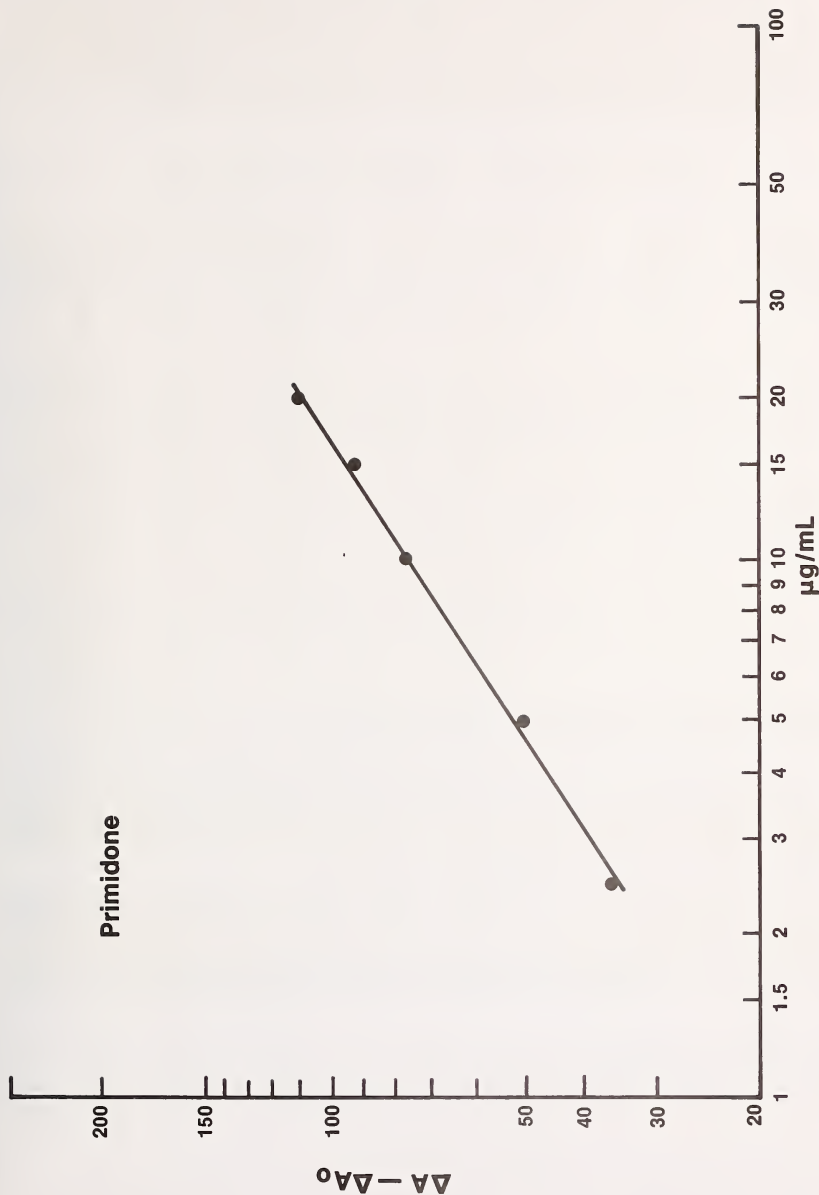

Figure 15. EMIT calibration curve for primidone.

The EMIT method was applied to solutions of phenytoin, phenobarbital, and primidone in bovine serum and to freeze-dried preparations of these materials. Typical results for phenobarbital are shown in Table 12 in which may be compared the drug concentrations determined by the EMIT method and those weighed into the solutions. The limited agreement between these concentrations is thought to be due to cross reactions caused by use of bovine albumin as a base for the drug standards. Bovine serum had been used as a carrier for the production of antibodies in the commercial reagents for EMIT assays.

Table 12. EMIT assays of phenobarbital in bovine serum.

<u>Matrix</u>	<u>Sample</u>	<u>Drug Level from Weight (<math>\mu\text{g/mL}</math>)</u>	<u>Measured Level<sup>a</sup> (<math>\mu\text{g/mL}</math>)</u>	<u>Percent Difference</u>
Serum	A	7.49	2.65	64.6
	B	48.68	28.2	42.1
	C	12.33	13.5	9.5
	D	113.31	85	25.0
	E	41.37	41	0.9
	F	80.11	80	0.1
	G	8.05	10.5	30.4
Freeze-dried	E	41.37	56	35.4
	E	41.37	50	20.9
	F	80.11	84	4.9
	F	80.11	Off-scale	---
	G	8.05	13.5	67.7
	G	8.05	13.3	65.2

<sup>a</sup>Average of duplicate measurements.

In order to provide a check on the accuracy of the commercial calibrating solutions for EMIT analyses of the drugs, we prepared calibrator solutions for use with the EMIT reagents. Liquid chromatographic analysis showed reasonably good linearity for these solutions within the relevant range of drug concentrations.

The drug concentrations in the human serum based SRM were determined at NBS and in four other laboratories by use of the EMIT system. Results are shown in Table 13. The averaged values obtained were close to the values obtained by liquid chromatography and gas chromatography but did not have the precision necessary for including them in the certification. They are useful, however, as information values and indicators of the kind of results that might be seen in routine use of the EMIT technique in a clinical laboratory.

Table 13. Comparison of EMIT determinations of drugs in SRM 900.

Drug	Weighed-In Target Value (µg/mL)	NBS (µg/mL)	Lab A	Lab B	Lab C	Lab D
Phenytoin	4.2	4.3(2.4) <sup>a</sup>	4.4(4.8)	4 (-4.8)	5 (19)	4.2(0)
	16.4	17.4(6.1)	17.0(3.7)	17.8(8.5)	18.0(9.8)	16 (-2.4)
	59.8	64.0(7.0)	62.0(3.7)	65.3(9.2)	60.5(1.2)	62 (3.7)
Ethosuximide	10.9	11.1(1.8)	11.0(0.9)	14.0(28.4)	-----	14.0(28.4)
	74.4	79.2(6.5)	78.0(4.8)	80.5(8.2)	-----	72.5(-2.6)
	170.5	181 (6.2)	181 (6.2)	180.5(5.9)	-----	140 (-17.9)
Phenobarbital	5.0	5.4(8.0)	5.3(6.0)	4.2(-16)	5.5(10)	5.2(4)
	21.2	20.2(-4.7)	20.0(-5.7)	19.4(-8.5)	21.0(-0.9)	19 (-10.4)
	100.2	102 (1.8)	94.0(-6.2)	101.8(1.6)	104 (3.8)	110 (9.8)
Primidone	3.4	3.3(-2.9)	3.2(-5.9)	3.7(8.8)	3.5(2.9)	3.6(5.9)
	7.9	7.7(-2.5)	9.0(13.9)	9.6(21.5)	9.0(13.9)	7.4(-6.3)
	18.5	19.2(3.8)	20.0(8.1)	20.0(8.1)	20.0(8.1)	20.0(8.1)

<sup>a</sup>Figures in brackets indicate the percent deviation from target.

### C. Interferences

During the early production phase of the SRM, samples were sent to selected laboratories for testing in a variety of analytical systems as well as for comments on the ease of reconstitution, handling characteristics, and clarity of the reconstituted serum. Those laboratories, using off-column methylation procedures, reported that they experienced problems with phenobarbital quantitation. Investigation revealed a problem due to the presence of an extraneous peak that co-eluted with phenobarbital under most gas chromatographic column conditions.

Further identification of this interfering compound was made by use of gas chromatography/mass spectrometry. The spectrum from the isolated peak was indicative of phthalic anhydride (MW 148), probably derived from a common plasticizer during our serum work-up procedure.

The source of the plasticizer may have been the original plastic storage bags for the serum, since all materials coming in contact with the serum subsequent to pooling had been thoroughly conditioned and washed with large amounts of distilled water.

Although charcoal was used in the processing of the serum, the quantity may have been insufficient to eliminate phthalate esters from the product. Subsequent production lots of serum were more thoroughly treated with the charcoal and were monitored more stringently for interferences. Experience with the later material with a variety of laboratory analytical methods has not revealed any further serious interferences.

#### 4. Statistical Analysis for Certification of SRM 900

The determination of satisfactory sample homogeneity is the first step in the certification process. This determination was described in Section 3.1 where the refractive index of a random sampling of each of the three concentration levels of SRM 900 was tested. The standard deviations of these measurements were found to be between 0.1 and 0.3 percent of the value. This was considered to represent satisfactory sample homogeneity.

The concentrations of the four drugs at the three concentration levels used in SRM 900 were measured at NBS by liquid chromatography using as many as three separate peaks, and by gas chromatography using as many as three separate runs. For each drug and level, the standard error of concentration at each peak or run was calculated. These values, which were calculated from the detailed laboratory records, represent the internal variability for each peak or run. The measured peak or run values and their standard errors are reported in Table 14 in the "NBS LC" and "NBS GC" columns. Only these data were used for the SRM 900 Certificate values and uncertainties. For comparison purposes, however, values from other measurement sources as well as the "NBS EMIT" values, are also listed in Table 14. In general, the agreement is quite satisfactory.

The certified concentrations for each drug and level were obtained as weighted averages of the measured values. For each average the relative weights were calculated, using both the internal variances and the between peak and or run component of variance. The standard errors of the certified values were also calculated using combinations of both of these variances. These standard errors were then smoothed by a linear least squares fit of the standard errors for each drug versus the concentrations. The standard errors listed on the SRM certificate are from this fitting process and are believed to be a better representation of the uncertainty of the overall NBS measurement and certification process.

#### 5. Summary and Conclusions

SRM 900 represents the first SRM issued by NBS that is certified for trace amounts of organic compounds (in this case, drugs) in a complex matrix. Careful characterization of the drugs and their purity was carried out before analytical methods were developed. Total separations by liquid chromatography of the drugs from serum were experimentally proven with radioactive drugs. Methods for "stripping" the serum matrix to provide an interference-free base were developed. The correspondence of results from independent analytical methods assured that the certified values are accurate.

The SRM is intended for use (1) in the calibration and standardization of procedures employed in clinical laboratories for the determination of drugs in serum, and (2) for the critical evaluation of working or secondary reference solutions prepared either in-house or supplied commercially.

#### 6. SRM Use

##### A. Water for Reconstitution

It is recommended that high-purity water be used for reconstitution of the freeze-dried materials. A low-quality water may contribute substances that may cause false or spurious peaks to appear in the gas or liquid chromatograms. Water that is equivalent to Type II reagent grade water as specified by the College of American Pathologists (CAP) (see Appendix IV) is sufficiently pure. Permission to include the CAP specifications for water in this publication was kindly granted by the College of American Pathologists. The National Committee for Clinical Laboratory Standards (Villanova, PA 19085) has also published guidelines for water as NCCLS Tentative Standard, TSC-3, "Specifications for Reagent Water Used in the Clinical Laboratory".



Table 14. Compilation of data from certification runs - 1978.

Drug	Weighed-in Target Value (g/mL)	NBS LC <sup>a</sup>	NBS GC <sup>b</sup>	Other GC <sup>c</sup>	NBS EMIT <sup>d</sup>	Final Certified Value <sup>e</sup>
<u>Phenytoin</u>						
Blank	0	0	0	-	0	0
Sub-Therapeutic	4.2	4.10±0.06	4.21±0.04	4.3 ±0.05	4.3	4.2 ±0.1
Therapeutic	16.4	16.45±0.11	17.38±0.37 16.64±0.21 16.69±0.05	16.2 ±0.50	17.4	16.7 ±0.3
Toxic	59.8	62.18±0.80 60.94±0.81	59.38±0.45	60.8 ±0.61	64	60.7 ±0.9
<u>Ethosuximide</u>						
Blank	0	0	0	-	0	0
Sub-Therapeutic	10.9	11.74±0.13	11.94±0.28	13.6 ±0.25	11.1	11.8 ±0.4
Therapeutic	74.4	75.74±0.84 72.85±0.68	76.46±0.78 78.28±0.16 75.81±0.31	74.55±1.35	79.2	75.88±0.5
Toxic	170.5	175.41±0.52 175.53±1.13 174.09±0.67	174.00±0.58	178.43±3.58	181	174.67±0.6
<u>Phenobarbital</u>						
Blank	0	0	0	-	0	0
Sub-Therapeutic	5.0	5.44±0.10 5.62±0.08 5.29±0.13	4.92±0.08	5.60±0.05	5.4	5.3 ±0.2
Therapeutic	21.2	21.44±0.15	21.82±0.17	22.13±0.13	20.2	21.6 ±0.2
Toxic	100.2	103.77±0.26 103.35±0.54	102.77±0.66	106.15±0.85	102	103.6 ±0.3
<u>Primidone</u>						
Blank	0	0	0	-	0	0
Sub-Therapeutic	3.4	3.62±0.07	3.34±0.38	3.28±0.03	3.3	3.6 ±0.1
Therapeutic	7.9	7.98±0.14	8.08±0.06	6.68±0.13	7.7	8.1 ±0.2
Toxic	18.5	19.20±0.13	17.88±0.38	16.28±0.28	19.2	18.6 ±0.7

<sup>a</sup> ± One standard error.<sup>b</sup> Underivatized value ± one standard error.<sup>c</sup> Derivatized value ± one standard error.<sup>d</sup> From duplicate measurements.<sup>e</sup> The certified value is based on the NBS LC and NBS GC values. The ± value is one standard error and includes all known sources of imprecision.

## B. Storage

Once reconstituted, the SRM should be used within one day. Beyond that time, several variables may be encountered: 1) evaporation leading to concentration of the drugs; 2) deterioration of the drugs; 3) degradation of the serum base.

Should a laboratory decide to store the reconstituted SRM for additional studies with the material, the reconstituted serum should be distributed among small, screw-top vials, which are tightly sealed and stored at -20 °C. Avoid repeated freezing and thawing. Material thus stored should not be used in critical calibration procedures or regarded as long-term stable controls.

## 7. References

- [1] Pippenger, C. E.; Penry, J. K.; White, B. G.; Daly, D. D.; Buddington, R. Inter-laboratory Variability in Determination of Plasma Antiepileptic Drug Concentrations. *Arch. Neurol.* 33: 351-355; 1976.
- [2] Kuehner, E. C.; Alvarez, R.; Paulsen, P. J.; Murphy, T. J. Production and Analysis of Special High-Purity Acids Purified by Sub-Boiling Distillation. *Anal. Chem.* 44: 2050-2056; 1972.
- [3] Kupferberg, H. J. Quantitative Estimation of Diphenylhydantoin, Primidone, and Phenobarbital in Plasma by Gas-Liquid Chromatography. *Clin. Chem. Acta* 29: 283-288; 1970.

---

We would like to thank the following scientists for their help in evaluating early prototype reference materials and providing comparison analyses after production of the SRM: Dr. Kenneth Dudley and associates, particularly Mr. Daniel L. Bius at the University of North Carolina School of Medicine, Chapel Hill, NC; Dr. Harvey J. Kupferberg, National Institutes of Health, Bethesda, MD; Dr. Marjorie Horning, Baylor College of Medicine, Houston, TX; Dr. Charles E. Pippenger, Columbia-Presbyterian Medical Center New York, NY; Dr. Henn Kutt, Cornell University Medical College, New York, NY; Dr. Dorothy D. Schottelius, University of Iowa Hospital, Iowa City, IA; Ms Elizabeth B. Solow, Indiana University School of Medicine, Indianapolis, IN; Drs. Richard Bastiani and John G. Miller, The SYVA Co., Palo Alto, CA; Dr. Donald J. Fishman, The Neurology Center, Bethesda, MD; Dr. Steven J. Soldin, The Hospital for Sick Children, Toronto, Canada; Dr. Robert W. Burnett, Hartford Hospital, Hartford, CT; Dr. Reginald J. Adams, the Perkin-Elmer Corp., Norwalk, CT; Dr. H. Bryan Bente, Hewlett-Packard Analytical Instrument Group, Avondale, PA; Dr. Erich L. Gibbs, Gibbs Laboratories, Wilmette, IL.

The work at NBS was performed in the Center for Analytical Chemistry. Special thanks go to Ms. Rosalie Angeles, Dr. Lorna Sniegowski, Dr. Alex Fatiadi, and Mr. Alex Cohen for their work in characterizing a variety of pure drug samples sent for evaluation.

We thank Drs. Philip D. LaFleur and Curt W. Reimann from the Center for Analytical Chemistry for their support and encouragement throughout this program. Support from the Office of Standard Reference Materials was continually present from Mr. J. Paul Cali, Mr. George Uriano and from Mr. R. Keith Kirby.

Special thanks are extended to Mrs. Joy Shoemaker and Ms. Teresa Sperow of the Text Editing Facility for their efforts in manuscript production which included typing, editing, and formatting.

Funding for the project was initiated by the National Institute of Neurological and Communicative Disorders and Stroke, the National Institutes of Health.

U.S. Department of Commerce  
 Juanita M. Kreps  
 Secretary  
 National Bureau of Standards  
 Ernest Ambler, Director

# National Bureau of Standards

## Certificate

### Standard Reference Material 900

### Antiepilepsy Drug Level Assay Standard

This Standard Reference Material (SRM) is certified for concentrations of four antiepilepsy drugs—phenytoin, ethosuximide, phenobarbital, and primidone—in a processed human serum base. It is intended for use (1) in the calibration and standardization of procedures employed in clinical laboratories for the determination of these drugs in serum, and (2) for the critical evaluation of working or secondary reference solutions prepared either in-house or supplied commercially. The certified concentrations apply to the four materials supplied, after each serum is reconstituted, following the procedures described in "Instructions for Use."

Concentration Level,  $\mu\text{g}/\text{mL}$

Drug	Toxic	Therapeutic	Subtherapeutic	Blank
Phenytoin	$60.7 \pm 0.9$	$16.7 \pm 0.3$	$4.2 \pm 0.1$	0
Ethosuximide	$174.7 \pm 0.6$	$75.9 \pm 0.5$	$11.8 \pm 0.4$	0
Phenobarbital	$103.6 \pm 0.3$	$21.6 \pm 0.2$	$5.3 \pm 0.2$	0
Primidone	$18.6 \pm 0.7$	$8.1 \pm 0.2$	$3.6 \pm 0.1$	0

The uncertainties represent one standard error for the above certified values. The imprecisions observed both within and between the liquid and gas chromatographic analyses used for this certificate are included in the standard errors. The statistical analyses were made by R. C. Paule and J. Mandel.

The modified human serum base was processed, vialled and packaged by Microbiological Associates, Walkersville, Maryland. Analyses leading to certification were performed in the NBS Center for Analytical Chemistry by R. Angeles, R. G. Christensen, A. Cohen, B. Coxon, D. Enagonio, D. J. Reeder, and L. T. Sniegoski. Valuable correlating analyses were also performed by: E. Berman, Cook County Hospital, Chicago, Illinois; K. Dudley, The University of North Carolina at Chapel Hill; and H. J. Kupferberg, National Institute of Neurological and Communicative Disorders and Stroke, NIH.

The overall direction and technical measurements leading to the certification were under the chairmanship of D. J. Reeder and R. Schaffer.

The technical and support aspects concerning the preparation, certification, and issuance of this Standard Reference Material were coordinated through the Office of Standard Reference Materials by R. Keith Kirby.

Washington, D.C. 20234  
 April 5, 1979  
 (Editorial Revision of Certificate  
 dated 11-17-78)

J. Paul Cali, Chief  
 Office of Standard Reference Materials

(over)

The analytical techniques used in the certification of this Standard Reference Material were liquid chromatography, calibrated with external standards, and gas chromatography, calibrated by bracketing and internal standards. The drug concentrations have also been determined with commercially available reagents that are based on immunoenzymatic assay principles. The mean values obtained by this methodology were close to the certified values; however, the precision was not sufficient to be included in the certification data.

The Standard Reference Material is intended for "in vitro" diagnostic use only.

**WARNING: HANDLE AS IF CAPABLE OF TRANSMITTING HEPATITIS.** Source material from which this serum base was derived was found non-reactive for Hepatitis B antigen when tested with licensed third-generation reagents. No known test method can provide complete assurance that products derived from human blood will not transmit hepatitis.

#### Instructions for Use

This Standard Reference Material is supplied as a set of four different freeze-dried preparations. They should be stored at refrigerator temperature ( $\sim 4^{\circ}\text{C}$ ) and should not be exposed to sunlight or ultraviolet radiation. Under such storage, the SRM is expected to be stable for at least 2 years. Samples of this SRM will be monitored. Should statistical evidence indicate a degradation of the certified properties, purchasers will be notified by NBS. It is recommended that the material not be used after 2 years from the date of purchase.

For use, it is necessary to reconstitute the freeze-dried materials with high-purity water.\* When a vial is opened, remove the rubber stopper carefully so as not to dislodge any serum particles that may adhere to the stopper. Add 5.0 mL of water to the vial from a calibrated volumetric pipet or other dispenser of known accuracy. Replace the stopper and allow the contents to stand at room temperature for 20-30 min. Finally, mix the contents by gentle swirling. DO NOT shake vigorously because denaturation and frothing may result.

After reconstitution, the contents should be used within one day; otherwise, the certified values cannot be assured. Storage of the reconstituted material beyond 12-24 hours may result in deterioration of the drugs or in degradation of the serum base.

This Standard Reference Material has been measured and certified at the Laboratories of the National Bureau of Standards, Gaithersburg, Maryland. All inquiries should be addressed to:

Office of Standard Reference Materials  
Room B311, Chemistry Building  
National Bureau of Standards  
Washington, D.C. 20234

The date of issuance and certification of this Standard Reference Material is November 17, 1978.

\*Equivalent to Type II reagent grade water as specified by the College of American Pathologists (CAP).

## CONSTRUCTION OF AN IMPROVED DIFFERENTIAL REFRACTOMETER

## A. Introduction

Several years ago, it was decided to construct a differential refractometer which would be an improvement over the modified Brice-Phoenix [1,2]<sup>1</sup> refractometer constructed earlier by Wagner [3]. The improvements desired were to provide easier sample introduction and an objective means of readout. It was felt that the former could best be provided by means of flow-through sample cells; and that the latter would require some sort of photocell to detect the position of the image, such as that described by Penther and Noller [4]. Since the design criteria included the specification that the instrument should be operable up to 150 °C, the use of an absolute interferometric refractometer was ruled out. The larger cells required would be too difficult to thermostat and to provide with flow-through sample introduction.

A commercial instrument embodying flow-through cells and photocell readout of image position, the Waters Associates Model R-4, was available, but it lacked sufficient range and readout precision for use as a general purpose differential refractometer. It was designed for use as a liquid chromatography detector. Also, because of the compact arrangement of its components, it did not lend itself to direct modification for high temperature use.

## B. Details of Modifications to the Refractometer

It was decided to incorporate the sample cells and photocell readout of the R-4 instrument into a new instrument with a linear rather than a folded optical path. The folded optical path was eliminated by removing the focusing-collimating lens and the mirror from the original cell chamber and drilling a hole in it to permit light to pass straight through the cell. The components are all bolted to a steel bar 2.5 x 12.5 x 60 cm which serves as an optical bench (figure 1). The original rotating null-glass block was removed and another substituted which was about four times as thick, thereby increasing the range. The original screw-driven lever which rotated the block was replaced by a slightly longer one and the screw was replaced by a 0-2 inch micrometer head. The face of the micrometer bears against a small ball imbedded in the lever. Thus the micrometer reading,  $L$ , is a linear function of  $\sin \theta$  (see glossary of symbols).

Temperature stability was achieved as follows: The original cell chamber was removed from the heat exchanger block of the R-4 and installed in a copper box of external dimensions 12 x 12 x 10 cm, having walls 1.25 cm thick. The cell chamber is mounted in the box by attaching it to a brass plate, which is in turn affixed to the bottom of the copper box by push-pull alignment screws. The stainless steel inlet tubings to the cell are soldered to the lid of the box for about 30 cm to provide heat exchange for the entering liquids. The inlet tubings pass through the cell chamber to the bottom of the cell holder where they are connected to the cell compartments with a teflon gasket. The outlet tubings are connected to the top of the cell compartments with another teflon gasket. The copper box is attached to the optical bench with legs of bakelite and is further insulated with about 4 cm of balsa wood. Glass windows are fitted in holes in the insulation along the optical path. Thermal coupling between the box and the cell chamber was adjusted by packing in wads of copper turnings to give a time constant of about 10 minutes. This was found by experiment to be the optimum. Longer time constants gave rise to drift of the cell temperature and shorter time constants permitted ripples in the temperature of the cell chamber due to temperature oscillations of the outer box.

Heating of the copper box is accomplished by cartridge heaters inserted in bores, one in each side. The two main heaters are variable up to 50 W each, and the two control heaters are 15 W each. The control thermistor is placed in a well about 2 mm from one of the control heaters. Tests with a thermistor bridge sensitive to about 0.0002 degrees showed no periodic variation in the temperature of the cell chamber.

<sup>1</sup>Figures in brackets indicate the literature references at the end of this appendix.

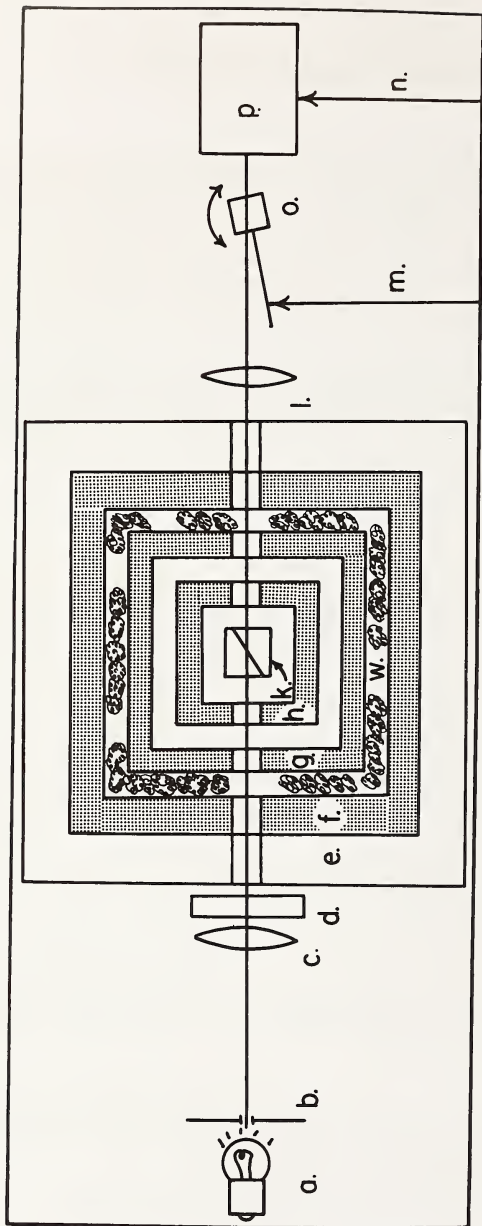

Figure 1. Schematic diagram of modified refractometer.

- a. light source
- b. slit
- c. collimating lens
- d. interference filter

- e. balsa wood insulation
- f. copper box
- g. aluminum cell chamber
- h. cell holder

- k. cell
- l. focusing lens
- m. micrometer
- n. zero adjustment screw

- o. glass block
- p. photocell block
- w. copper turnings

The light source is the same as that used in the R-4, a tungsten filament bulb. Since high intensity is not required, an interference filter can be placed in the optical path to give the desired wavelength. A slit is placed near the bulb and a simple lens of 50-mm focal length is used as a collimator. Between the collimator and the cell box is mounted a holder for interference filters.

The cell, also from the Waters R-4 instrument, is their "90 degree" cell. It is a rectangular glass box divided into two compartments by a glass partition at such an angle that the angle of incidence upon it of light from the source is 63 degrees. Each compartment has a hole at the top and at the bottom where the outlet and inlet tubings, respectively, are connected. The volume of each compartment is about 70 microliters.

When the collimated beam exits from the copper box, it is focused by a 150-mm focal length lens through a glass block which can be rotated to nullify any displacement of the image. At the focal plane of this lens is a beam splitter in the form of the edge of a front surface mirror which throws light from a part of the image onto a photoresistive element. The remainder of the light passes the beam splitting mirror and falls on another photoresistive element. These are two arms of a Wheatstone bridge. The output of this bridge is amplified and displayed on a stripchart recorder. It was found necessary to modify the original photocell block as shown in figure 2 in order to correct its sensitivity to changes in the state of polarization of the incident light.

In addition to the micrometer which rotates the glass block to return the image to a null position, there is a zero adjustment screw which bears directly on the photocell block. It is used to position the photocell block so that when the refractive index difference is zero and the setting of the micrometer is zero, the bridge is balanced. The system was aligned by use of a laser beam to define the optical axis. The noise level of the instrument corresponds to about  $2 \times 10^{-7}$  in refractive index. If the sensitivity is taken as 2 times the noise level, the sensitivity is about  $4 \times 10^{-7}$ , corresponding to about 0.0001 inch on the micrometer. The range of the instrument is about 0.004 in refractive index, corresponding to about 1 inch on the micrometer.

### C. Operation of the Differential Refractometer

In use, the device is turned on and allowed to warm up. This usually takes several hours. The end of the warm-up period is determined by cessation of baseline drift. With solvent in both sides of the cell and with the micrometer set at zero, the zero adjusting screw is used to balance the bridge. Then the recorder trace is set to near the center of the paper. The solution to be measured is introduced into one compartment of the cell. Since the combined volumes of the inlet tubing and cell are only about 350 microliters, three rinses of 1 mL each suffice to flush the cell adequately. The trace is then brought back to near the center of the paper, the micrometer being set to the nearest whole thousandth of an inch, the ten thousandths being interpolated by the position of the chart trace. After several solutions have been measured, solvent is re-introduced and a baseline is drawn. Interpolations of the micrometer readings are made with reference to this baseline, thus eliminating the effect of any drift in the instrument.

### D. Calibration of the Refractometer

Probably the most satisfactory liquids to use in calibrating differential refractometers are the salt solutions which have been studied by Kruis [5] who has measured  $\Delta n$  of solutions of a number of salts at various wavelengths. His instrument was an absolute interferometric differential refractometer of great sensitivity and considerable range.

Since the optical relationships of the various components of the refractometer are readily derived, it was at first felt that it would be desirable to fit the calibration data to an equation, the functional form of which was known *a priori*. The image displacement given by a rotation of the glass block is given by: (see glossary of symbols)

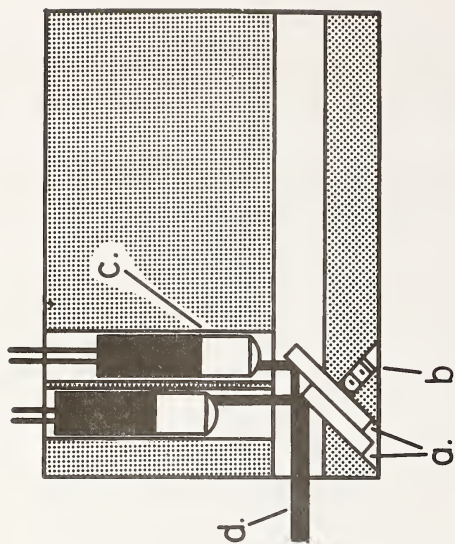

Modified

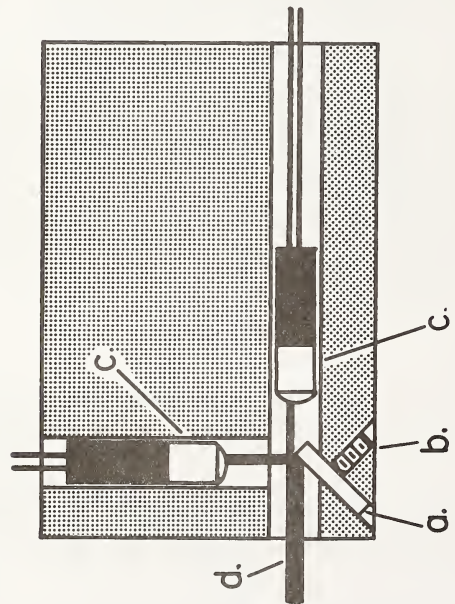

Original

Figure 2. PhotoCell block modifications.

- a. beam splitter mirror
- b. clamping screw
- c. photocell
- d. light beam



$$d = t \sin \phi \left( 1 - \frac{\sqrt{1 - \sin^2 \phi}}{\sqrt{n'^2 - \sin^2 \phi}} \right) \quad (1)$$

a relation readily derived from application of Snell's Law. The angle of deviation of the light beam induced by the refractive index difference is not precisely proportional to the refractive index, but is given by:

$$\sin \theta = \sin A \left( \sqrt{n^2 \cos^2 A + 2n \Delta n + \Delta n^2} - n \cos A \right) \quad (2)$$

which is also straightforwardly arrived at from the laws of refraction. Since for small angles:

$$\theta = \frac{d}{f} \quad (3)$$

it is possible to obtain a relation between the reading of the micrometer and  $\Delta n$ . A complication arises when  $\theta$  is not zero, because the angle of incidence on the glass block becomes  $\theta + \phi$ . This is easily taken into account, but proves to be negligible. The calibration constant thus obtained is a value of  $f$ , the image distance of the focusing lens. Slight errors in other measured quantities can be lumped into it without causing serious difficulty, since the function is nearly linear. A possible refinement is to calculate values of  $\theta$  from equation 2 and fit them to a function of  $L$ . This will allow the dependence of  $\theta$  on  $n$  as well as  $\Delta n$  to be taken into account. Since it is so nearly negligible, the fact that the angle of deviation is dependent on  $n$  as well as  $\Delta n$  seems to have been generally disregarded in discussions of prism-cell refractometers. In this instrument, errors in  $\Delta n$  as large as 0.1 percent can arise when calibrating with water solutions and measuring benzene solutions.

Attempts to put the foregoing into practice were not successful. Standard deviations of  $\Delta n$  about the calculated line were about  $4 \times 10^{-6}$ . Astigmatism in the image produced by the rotation of the glass block is likely to be the cause. Since the image is perhaps 0.2 mm wide and the photo cells are attempting to determine the position of the center to about 0.1 micrometer, any change of focus is critical.

In lieu of the above procedure,  $\Delta n$  vs.  $L$  were fitted by least squares to a third order polynomial. Using a wavelength of 546 nm, seven potassium chloride solutions were measured against water and against each of the other solutions. Fitting these 28 data points to a polynomial in  $L$  yielded this calibration equation:

$$\Delta n \times 10^6 = 0.2 + 4443.9 L - 172.5 L^2 + 311 L^3$$

with an estimated standard deviation in  $\Delta n$  about the calculated line of  $1.6 \times 10^{-6}$  in refractive index.

## References

- [1] Brice, B. A. and Halwer, M., J. Opt. Soc. of America, 41, 1033 (1951).
- [2] Certain commercial instruments are identified by manufacturer's name or label. In no instance does such identification imply endorsement by the National Bureau of Standards nor does it imply that the particular products or equipment are necessarily the best available for that purpose.
- [3] Wagner, H. L., J. Res. Nat. Bur. Stand. (U.S.), 76A, No. 2, 163 (1972).
- [4] Penther, C. J. and Noller, G. W., Rev. Sci. Instr., 29, 43 (1958).
- [5] Geffken, W. and Kruis, A., Z. Physik. Chem., B23, 175 (1933).

## Glossary of Symbols

A	Angle of incidence at the septum of the prism-cell, here about $63^\circ$
d	Lateral displacement of the image
L	Micrometer reading
$\phi$	Angle of rotation of the glass block
$\theta$	Angle of deflection by the prism-cell
t	Thickness of the glass block
f	Image distance of the focusing lens
$n'$	Refractive index of glass block
n	Refractive index of solvent
$\Delta n$	Refractive index difference between solvent and solution

COLLEGE OF AMERICAN PATHOLOGISTS



# REAGENT WATER SPECIFICATIONS

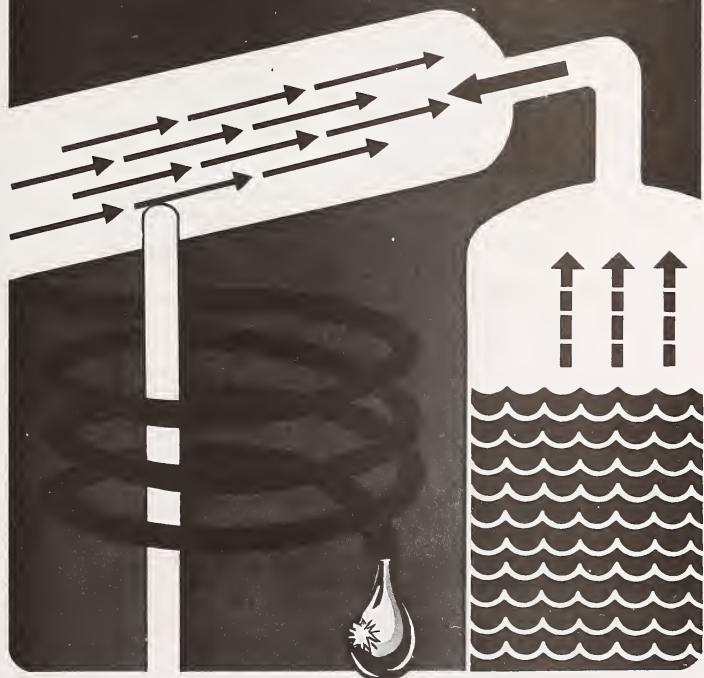

COMMISSION ON LABORATORY INSPECTION AND ACCREDITATION

---

**OFFICERS****TYRA T. HUTCHENS, M.D.****PRESIDENT—1978-79**University of Oregon  
Health Sciences Center  
Portland, Oregon 97201**LAWRENCE J. McCORMACK, M.D.****VICE PRESIDENT**Cleveland Clinic  
Cleveland, Ohio 44106**JAMES D. BARGER, M.D.****SECRETARY-TREASURER**Sunrise Hospital  
Las Vegas, Nevada 89114**HEADQUARTERS OFFICE****HOWARD E. CARTWRIGHT**

Executive Director

**FRANCES RYAN**Manager, Inspection and  
Accreditation**RITA MUELLER**Applications Coordinator,  
Inspection and Accreditation

---

Reprinted with permission of the College of American Pathologists,  
7400 Skokie Blvd., Skokie, IL 60077.

*Copyright 1978 College of American Pathologists. All rights reserved. None of the contents of this publication may be reproduced in a retrieval system or transmitted in any form or by any means (electronic, mechanical, photocopying, recording or otherwise) without the prior written permission of the publisher.*

**COMMISSION ON  
LABORATORY INSPECTION AND ACCREDITATION**

<b>MAJ. GEN. JOE M. BLUMBERG, M.D.</b>	<b>Chairman</b>
<b>JOHN K. DUCKWORTH, M.D.</b>	<b>Vice-Chairman and Interstate Commissioner</b>
<b>LESTER KIEFER, M.D.</b>	<b>Chairman, Checklist Sub-Committee</b>
<b>NORTHEAST REGION</b>	
<b>ISRAEL DIAMOND, M.D.</b>	<b>Commissioner</b>
<b>RICHARD W. BARR, M.D.</b>	<b>State Commissioner (Massachusetts)</b>
<b>MIDDLE EAST REGION</b>	
<b>ROBERT R. RICKERT, M.D.</b>	<b>Commissioner</b>
<b>JOHN J. MORAN, M.D.</b>	<b>Deputy Commissioner</b>
<b>LESTER KIEFER, M.D.</b>	<b>Deputy Commissioner</b>
<b>ROBERT J. HARTSOCK, M.D.</b>	<b>State Commissioner (W. Pennsylvania)</b>
<b>MANUEL A. BERGNES, M.D.</b>	<b>State Commissioner (Philadelphia)</b>
<b>ALFRED SCHWARZ, M.D.</b>	<b>State Commissioner (New York City and E. New York)</b>
<b>DONALD B. POLAN, M.D.</b>	<b>State Commissioner (W. New York)</b>
<b>STEPHEN HANSON, M.D.</b>	<b>State Commissioner (Delaware)</b>
<b>SOUTHEAST REGION</b>	
<b>VERNON E. MARTENS, M.D.</b>	<b>Commissioner</b>
<b>DEZSO K. MERENYI, M.D.</b>	<b>State Commissioner (Maryland)</b>
<b>DENNIS S. O'CONNOR, M.D.</b>	<b>State Commissioner (West Virginia)</b>
<b>GEORGE P. VENNART, M.D.</b>	<b>State Commissioner (Virginia)</b>
<b>E. ARTHUR DRESKIN, M.D.</b>	<b>State Commissioner (South Carolina)</b>
<b>GULF REGION</b>	
<b>HANS J. PETERS, M.D.</b>	<b>Commissioner</b>
<b>ROBERT DELASHMUTT, M.D.</b>	<b>Deputy Commissioner</b>
<b>DONALD M. TAFT, M.D.</b>	<b>State Commissioner (Alabama)</b>
<b>ANTHONY R. CLERCH, M.D.</b>	<b>State Commissioner (Florida)</b>
<b>G. LESTER FORBES, JR., M.D.</b>	<b>State Commissioner (Georgia)</b>
<b>JOSEPH C. ERWIN, M.D.</b>	<b>State Commissioner (Louisiana)</b>
<b>THOMAS F. PUCKETT, M.D.</b>	<b>State Commissioner (Mississippi)</b>

**SOUTH CENTRAL REGION**

FRANK M. TOWNSEND, M.D.  
MICHAEL H. SULAK, M.D.  
RICHARD J. TAYLOR, M.D.

RONALD E. BUCHANAN, M.D.

CLAUDE K. LEEPER, M.D.

ALVIN SMITH, M.D.

GLEN F. BAKER, M.D.

**WEST CENTRAL REGION**

C. W. REIQUM, M.D.  
NORMAN E. POND, M.D.

ROBERT FENNELL, M.D.  
FRED MIYA, M.D.

GREGORY BRONDOS, M.D.

**NORTH CENTRAL REGION**

MILTON SIMONS, M.D.  
CRAIG W. FREEMAN, M.D.  
JOHN GRUHN, M.D.

D. B. CLAUDON, M.D.

**GREAT LAKES REGION**

WILLIAM A. HAWK, M.D.  
GEORGE C. HOFFMAN, M.D.  
ROBERT L. COSTIN, M.D.

ROBERT S. HOWELL, M.D.

AARON LUPOVITCH, M.D.

**NORTHWEST REGION**

WILLIAM B. HAMLIN, M.D.  
ARCHIE Y. HAMILTON, M.D.  
DELBERT SCOTT, M.D.

**SOUTHWEST REGION**

ERNEST E. SIMARD, M.D.  
GERALD F. SIMON, M.D.

MARK G. KARTUB, M.D.

THOMAS KIDDIE, M.D.

Commissioner  
Deputy Commissioner  
State Commissioner  
(Kansas and Oklahoma)  
Asst. State Commissioner  
(Texas)  
State Commissioner  
(Arkansas and Missouri)  
Asst. State Commissioner  
(Kansas and Oklahoma)  
Asst. State Commissioner  
(Arkansas and Missouri)

Commissioner  
State Commissioner  
(New Mexico)  
Deputy Commissioner  
State Commissioner  
(Utah)  
State Commissioner  
(Wyoming)

Commissioner  
Deputy Commissioner  
State Commissioner  
(Illinois)  
State Commissioner  
(Wisconsin)

Commissioner  
Deputy Commissioner  
State Commissioner  
(Indiana)  
State Commissioner  
(Kentucky)  
State Commissioner  
(Michigan)

Commissioner  
Deputy Commissioner  
Deputy Commissioner

Commissioner  
State Commissioner  
(N. California)  
State Commissioner  
(Nevada and Arizona)  
State Commissioner  
(S. California)

## ACKNOWLEDGEMENTS

This manual was originally written by Alton Stier, M.D., Larry Miller, M.T.(ASCP) and Robert Smith, M.S. Their efforts were instrumental in filling a significant void in the information available to laboratories. This revision is intended to update that information and is in no way intended to detract from their initial, valuable efforts.

Likewise, Martha Winstead, M.T.(ASCP), who has been instrumental in causing people to be concerned about the water they use, cannot be praised enough for her efforts over many years in the face of overwhelming "disinterest." Her contributions indeed are the very basis for much of the material contained herein.

Lastly, mention must be made of the literally hundreds of technical people and chemists who have questioned, complained and persistently requested information. They, through these mechanisms, have served as the stimulus that has kept me working to complete this revision.

All of the above have contributed mightily to laboratory improvement!

WILLIAM B. HAMLIN, M.D.

## INTRODUCTION

Water, the most commonly used reagent in the clinical laboratory, has been consistently neglected over the years with respect to the investigation and definition of the required degree of purity that will insure reliable test results.

Historically, Winstead's (1) publication in 1967 was the first major effort to call attention to the effect of water on clinical laboratory test results and suggests ways to produce and monitor adequate water. In 1972 Stier et al. (2) published a manual which expanded considerably the definition of the problem and suggested specifications and testing methods for controlling water purity in the clinical laboratory. This effort was followed shortly by the 1973 American Society of Testing Methods (ASTM) Standards (3); and finally the National Committee for Clinical Laboratory Standards (NCCLS) has produced tentative specifications for reagent water which are appended to this manual (4).

The uncomfortable fact is that almost all the interest in the water used in clinical laboratories has developed within the last 10-15 years; and further, there is still today only scant, published, scientific information indicating what effect, and at what level, various contaminants in reagent water will have on clinical laboratory test results. Many of the current specifications are speculations as to the effect that a given contaminant will potentially have on clinical laboratory testing methods or procedures.

The specifications and grades defined herein represent suggestions for the minimum quality of water to be used in the *Clinical Laboratory*. The criteria proposed should be satisfactory for *most* uses within the laboratory. There may be some special uses that will require additional purification.

The specifications are for the end product, i.e. the water produced, regardless of the production method. If a production method gives water that is *always* negative for some contaminant, it may not be necessary to test for that contaminant as frequently as is suggested.

There is no specification for Type I water because the level of resistance precludes the presence of sufficient ions to obtain reliable pH readings. Possible contaminants such as sodium, chloride, sulfate, etc. have not been shown in the specifications. If such ions were present to a significant degree in the Type I water the resistance specifications could not be met.



These are not standards but recommendations of the Commission on Inspection and Accreditation for Water Quality Control.

## REAGENT WATER

- SCOPE:
1. To suggest minimum specifications for various grades of water suitable for use in the clinical laboratory.
  2. To suggest utilization limitations for the various grades of water.
  3. To describe testing methods for insuring that water conforms to the minimum specifications.

The *minimum* specifications suggested are as follows:

SPECIFICATIONS:

Specification	Water Grade or Type		
	Type I	Type II	Type III
1. Resistivity - Specific Resistance (megohms @ 25°C)			
a. In line	10		
b. Effluent (As Used)		2.0	0.1
2. Silicate (mg/liter S:O <sub>2</sub> )	0.05	0.10	1.00
3. pH	N.A.	N.A.	5.0-8.0
4. Microbiological Content (cfu/ml; max.)	10	10 <sup>4</sup>	N.A.

### NOTES:

- 1) Particulate Matter — Type I water should be “free” of particulate matter larger than 0.2 micron. Free of particulate matter is defined as less than 500 particles/liter which are greater than 0.2 micron.
- 2) Other parameters such as particle size, heavy metals and/or trace elements, and carbon dioxide content should be considered and monitored when appropriate for special or specific uses.
- 3) Organics, and other contaminants, may be reduced with the use of activated carbon.

### PREPARATION:

Any method of preparation of these three types of water is acceptable provided the end product meets the specifications. Deionization, distillation and reverse osmosis either alone or in various combinations are considered capable of providing water that conforms to the specifications. Each of these processes has its own requirements for source water; and each has its particular residual contaminants that must be considered.

REAGENT  
WATER  
UTILIZATION:

Suggestions for the utilization of the various types of water specified is as follows:

- Type I — Tissue and/or cell culture methods; ultra-micro chemical analyses, special and critical analytical chemical analyses where accuracy at nanogram and sub-nanogram levels is necessary; preparation of standard solutions.
- Type II — Most routine clinical laboratory methods in chemistry, immunology, hematology and other areas.
- Type III — Most qualitative procedures; most procedures in urinalysis, parasitology and histology; glassware washing; general laboratory tests not requiring Type II or better water.

TESTING:

The methods listed are basically those suggested in the NCCLS Tentative Standard PSC-3: *Specifications for Reagent Grade Water Used In The Clinical Laboratory*; although some modifications have been included in this manual.

### 1. RESISTIVITY

#### A. Equipment and Materials

- 1) Resistivity meter, temperature compensated, capable of measuring resistivity higher than that specified for the designated water. The meter should be used in accordance with the manufacturer's instructions.
- 2) Thermometer with graduations to 0.5°C and calibrated to conform to National Bureau of Standards (NBS) standards.
- 3) Potassium Chloride Stock Standard is prepared by dissolving 10.0 g. of pure, dry KCl in one liter of Type I water at 25°C. (Alternately, a stock standard solution can be prepared using NaCl. Dissolve 9.25 g. of pure, dry NaCl in one liter of Type I water at 25°C).

#### B. Sampling and Measurement

- 1) The specification for resistivity of all the types of water is at 25°C. If meters are used to measure resistivity which do not include an automatic temperature compensating circuit, an accurate measurement of temperature must be made simultaneously with resistivity measurements.

Whenever the temperature of the water measured is outside the  $25 \pm 2^\circ\text{C}$  range, the resistance should be corrected to 25°C according to the directions provided with the meter.

- 2) The resistivity of all the types of water should be measured as close as possible to the time of use of the water.

The measurement should be taken in accordance with the manufacturer's directions.

- 3) The resistivity of all types of water can be measured by using either an in-line meter or an off-line meter using the following precautions:
  - a. For in-line meters, follow the manufacturer's instructions carefully.
  - b. For off-line meters:
    - 1) Rinse the cell and container at least three times with separate aliquots of the water to be tested.
    - 2) Fill the cell and read as rapidly as possible.

#### C. Calibration

- 1) The resistivity meter should be calibrated and/or checked periodically in accordance with the manufacturer's instructions.
- 2) For some off-line meters, a KCl (or NaCl) solution may conveniently be used to monitor the day-to-day operation of the meter-electrode combination. Appendix II contains the details of preparing and using the stock standard solutions for this purpose. Read the resistance of the standard solutions in the same manner outlined for the water samples. Day-to-day consistency is more important than a precisely accurate resistance reading.

## 2. SILICATE

### A. Method

- 1) Silicates react with molybdate ion to form a complex which can be reduced by 1-amino, 2-naphthol, 4-sulfonic acid to produce a blue color. The intensity of the blue color is proportional to the concentration of soluble silica.

### B. Reagents

Prepare and store in plastic containers.

- 1) 1-amino, 2-naphthol, 4-sulfonic acid solution. Dissolve 1 g. of sodium sulfite ( $\text{Na}_2\text{SO}_3$ ) in 50 ml. of Type I water and add 0.5 g. 1-amino, 2-naphthol, 4-sulfonic acid. Mix to dissolve. Add this solution to 100 ml. of a solution containing 30 g. of sodium hydrogen sulfite ( $\text{NaHSO}_3$ ). Dilute to 200 ml. with water. Store in a dark, polyethylene bottle at room temperature (stable for two weeks).
- 2) Ammonium molybdate solution, 100 g./liter. Dissolve 10 g. of ammonium molybdate [ $(\text{NH}_4)_6\text{Mo}_7\text{O}_{24}\cdot 4\text{H}_2\text{O}$ ] in 100 ml. water. Store in a polyethylene bottle at room temperature (stable for three months).
- 3) Hydrochloric acid, approximately 6 mol/liter. Mix one volume of concentrated HCl with one volume of water.

Store in a polyethylene bottle at room temperature (stable indefinitely).

- 4) Oxalic acid solution, 100 g./liter. Dissolve 10 g. of oxalic acid in 100 ml. of water. Store in polyethylene bottle at room temperature (stable for three months).
- 5) Silica, standard solution (1 ml.= 1 mg.  $\text{SiO}_2$ ). Dissolve 4.732 g. of sodium metasilicate ( $\text{Na}_2\text{SiO}_2 \cdot 9\text{H}_2\text{O}$ ) in water and dilute to one liter. Store in polyethylene bottle at room temperature (stable for three months).

**C. Equipment and Materials**

Spectrophotometer. Ideally a setting of 802 nm. is desirable since that is the maximum absorbance wavelength for the compound to be measured. However, a setting of 700 nm. can be used for silica concentrations of 0.10 mg./liter or greater. The limit of detectability of this method using a wavelength setting of 802 nm. is .01 mg./liter.

**D. Sampling**

Collect 500 ml. samples of the water to be tested in chemically clean polyethylene bottles at 35°C or below.

**E. Standardization**

- 1) Prepare a series of standards covering a concentration range of 0.05 to 1.0 mg./liter of  $\text{SiO}_2$  by proper dilution of the standard silica solution. Treat 50 ml. aliquots of each dilution as described in the procedure.
- 2) Use a 50 ml. aliquot of silica-free water carried through the procedure as a blank.
- 3) Prepare a calibration curve, plotting absorbance against silicate concentration as  $\text{SiO}_2$  in mg./liter.

**F. Procedure**

- 1) Transfer, quantitatively, 50 ml. of water to be tested to a polyethylene or other suitable plastic container.
- 2) Add in quick succession 1 ml. of HCl and 2 ml. of ammonium molybdate solution. Mix well.
- 3) After exactly 5 minutes, add 1.5 ml. of oxalic acid solution and mix.
- 4) After one minute, add 2 ml. of the amino-naphthol-sulfonic acid solution. Mix well and allow to stand for 10 minutes.
- 5) Treat a 50 ml. aliquot of silica-free water exactly as described above and use to zero the spectrophotometer.
- 6) Measure the absorbance of the sample at 802 nm. (or 700 nm.).
- 7) Silica concentration in milligrams per liter, may be read directly from the calibration curve. Record the milligrams per liter in a permanent bench log.

**NOTE:** If desired, a visual assessment can be made by comparing the 0.1 mgm./liter standard with the test sample. If the test water is no darker than the standard color, the "water is acceptable for *Type II Reagent Water*."

**3. pH**

Pure water (2 megohm +) contains so few ions that it is unnecessary to obtain pH measurements.

**A. Reagents**

- 1) Reference buffer solutions. At least two buffers should be chosen: one with a pH of 7.0 and one with a pH lower than 7.0. Commercially available buffers may be used if verified against NBS reference buffers.
- 2) Potassium chloride, saturated.

**B. Standardization**

The room temperature must be recorded and the exact pH for the buffers at the temperature must be used to standardize the pH meter. Standardization should be done in accordance with the manufacturer's instructions.

**C. Procedure**

- 1) Standardize the pH meter.
- 2) Rinse the electrodes with at least three changes of water using a flowing stream.
- 3) Add one drop of saturated KCl to 50 ml. of water sample. Take the pH reading as quickly as possible, in accordance with the manufacturer's instructions.
- 4) Record the pH to the nearest 0.1 unit.

**4. MICROBIOLOGICAL CONTENT**

**A. Definition**

Microbiological content must include the evaluation of total colony count as determined by an accepted method after incubation at  $(36 \pm 1^\circ\text{C})$  for 24 hours and at  $(25 \pm 1^\circ\text{C})$  for 48 hours and reported as colony forming units per milliliter (cfu/ml.)

**B. Sampling**

- 1) Use a sterile closed container of adequate size to hold the entire sample and leave ample air space to permit mixing of the sample before examination. Sample sizes which result in 10 to 100 colonies on the membrane culture or plate are optimum for enumeration of results (approximately 0.1 ml. for Type II water and 5-10 ml. for Type I water).
- 2) Open tap fully for one minute, then restrict flow to allow filling of bottle without splashing.
- 3) The sample should be processed within one hour of collection or stored at  $2$  to  $8^\circ\text{C}$  for no longer than six hours.

**C. Total Bacterial Count Methodology**

The current NCCLS Tentative Standards describe three (3)

alternative methods for ascertaining total bacterial count in terms of colony forming units per milliliter. These are:

- 1) Standard Plate Count (Reference Method)
- 2) Membrane Filtration Method
- 3) Calibrated Wire Loop Method

It is our opinion that any of these three methodologies would be adequate for monitoring purposes and the specific technique used will depend on the type of laboratory, the nature or type of water being cultured (for example, a calibrated wire loop technique should not be used to monitor Type I water because of the very low bacterial concentration anticipated), resources available etc. Whatever method is selected, the appropriate and customary records of tests performed, results, actions taken etc. must be carefully documented.

Appendix III is a compendium of these three methods currently described in the NCCLS Tentative Standards.

---

## DEFINITIONS

1. *Microbiological Content* – The microbiological content of viable organisms, as determined by total colony count after incubation at 35-37°C for 24 hours; reported as colony forming units per milliliter.
2. *Particulate Matter* – A discrete quantity of matter existing in a solid state, dispersed in water to give a heterogeneous mixture.
3. *Free of Particulate Matter* – Defined as less than 500 particles/liter which are greater than 0.2 micron.
4. *pH* – The negative logarithm of the hydrogen ion activity measured electrometrically.
5. *Silicate* – The content of soluble silica; reported in milligrams per liter, as SiO<sub>2</sub>.
6. *Specific Resistivity* – The electrical resistance in ohms measured between opposite faces of a 1.00 centimeter cube of an aqueous solution at a specified temperature. For these specifications the specific resistivity will be corrected to 25°C and reported in megohms-cm.
7. *Specific Conductance* – The electrical conductivity, or the reciprocal of the resistance in ohms measured between opposite faces of a centimeter cube of an aqueous solution at a specified temperature. The measurement may be in part due to dissolved gases that ionize in solution. Unionized materials are not measured. The specific conductance is expressed in micromhos per centimeter at 25°C. (3)

## APPENDIX I

The current NCCLS publication *Specifications For Reagent Water Used In The Clinical Laboratory* (NCCLS Tentative Standard: PSC-3), lists the following specifications, usage recommendations and storage and handling requirements. A complete copy of the publication including testing mechanisms may be obtained by writing to:

National Committee For Clinical Laboratory Standards  
771 East Lancaster Avenue  
Villanova, Pennsylvania 19085

### SPECIFICATIONS:

All specifications are stated for water as measured at the time of production. The resistivity of Type I water must be measured in-line; all other specifications relate to the samples measured "off-line."

	Type I	Type II	Type III
Microbiological content, colony forming units/milliliter (maximum)	10	10 <sup>3</sup>	N.A.
pH	N.A.	N.A.	5.0-8.0
Resistivity megohms-cm. room temperature (25°C)	10	2.0	0.1
Silicate, mg./liter SiO <sub>2</sub> (maximum)	0.05	0.10	1.00

**NOTE:** Type I water must be free of particulate matter larger than 0.2 micron.

### PREPARATION:

Any method of preparation of these three types of water is acceptable provided the specifications are met. The following processes are considered capable of providing water that conforms to the specifications. These processes are examples only and any combination of them is satisfactory as long as the resulting water meets the specifications:

Reverse Osmosis  
Distillation  
Deionization

### INTENDED USE:

Manufacturers of in vitro diagnostic products and scientists using clinical chemical laboratory testing procedures should specify those interferences which must be avoided such as heavy metals, NH<sub>3</sub> and CO<sub>2</sub>.

Type I water should be used in test methods requiring minimal interference and maximum precision and accuracy. Examples of

such uses might be:

1. Atomic absorption and flame emission spectrometry.
2. Enzymatic procedures sensitive to trace metals.
3. Electrophoretic procedures.
4. High sensitivity chromatographic procedures.
5. Fluorometric procedures.
6. Buffer solutions (special buffers may also require CO<sub>2</sub>-free water).
7. Preparation of standard solutions.

**NOTE:** Even greater purity than Type I water will be required for selected purposes, such as pesticide analysis.

Type II water may be used for general laboratory testing other than the above and for glassware rinsing.

Type III water may be used for glassware washing, for preliminary rinsing of glassware (final rinsing should be with the water grade suitable for intended glassware use), and for feedwater for production of higher grade water.

#### STORAGE AND HANDLING:

Type I water should preferably be used immediately after processing. Storage of Type II water should be kept to a minimum in order to provide the quality consistent with the specific intended use. Storage and distribution systems should be constructed of materials that will protect the water from contamination.



## APPENDIX II

### USING STANDARD SOLUTIONS TO VERIFY THE RELIABILITY OF CONDUCTANCE METERS:

The most practical and at the same time reliable means of verifying the function of a conductance meter is to use standard solutions of known resistance. This can be done easily and cheaply by using either KCl or NaCl solutions.

The principle involved is based on the formula:

$$C_{\text{ppm}} = \frac{\text{M.W.}}{\kappa_0 R_s}$$

Where:  $C_{\text{ppm}}$  = Concentration in parts per million  
M.W. = Molecular weight  
 $\kappa_0$  = Equivalent conductance  
 $R_s$  = Specific resistance in ohms

In the use of KCl, the  $\kappa_0$  for KCl at 25°C is 149.86; while NaCl has an  $\kappa_0$  at 25°C of 126.45 (these values are listed in the Handbook of Chemistry and Physics.). The molecular weight of KCl is 74.56 while NaCl has a molecular weight of 58.44.

Thus, one has sufficient information to prepare a standard solution of any resistance desired assuming that the water used in preparing the solution is so pure as to not interfere in any way with the resistance of the prepared solution.

If one wishes to have a standard KCl solution with a resistance of 1.0 megohm at 25°C, substitution in the formula can provide the necessary information as follows:

$$C_{\text{ppm}} = \frac{74.56}{(149.86)(1.0)} = 0.4974_{\text{ppm}}$$

Therefore a solution containing 0.4974 mgm/liter of KCl will have a specific resistance of 1 megohm. By preparing an adequate stock standard solution and with appropriate dilutions, one can thus prepare the desired standard solution. In this case, the stock standard solution mentioned in the text contains 10,000 milligrams per liter. 1 ml. of the stock (10 mgm) diluted to 100 ml. would result in a solution containing 100 mgm/liter or 0.1 mgm/ml. Thus, 5.0 ml. of the diluted stock solution would contain 0.5 mgm. and that amount diluted to one liter produces the desired 1 megohm standard (0.5 mgm/liter - KCl).

Since the resistance of the water used to make the standard solutions will have an impact on the expected reading, the effect should be taken into consideration. This can be done by using the

formula based upon the fact that the resistance of two substances (the standard solution as calculated and the water used) is equal to the resistance of two resistances in parallel which is equal to the product over the sum:

$$R_s = \frac{(R_m)(R_t)}{R_m + R_t}$$

Where:  $R_s$  = The specific resistance  
 $R_m$  = The resistance of the make-up water (one solution)  
 $R_t$  = The resistance of the test solution (KCl solution)

If the water used (after equilibration with air from  $\text{CO}_2$ ) has a resistance of 2.0 megohms and the calculated resistance of the KCl solution as described above is 1.0 megohm that the actual resistance is:

$$R_s = \frac{(2.0)(1.0)}{2.0 + 1.0} = \frac{2}{3} = .6666 \text{ megohm}$$

Or if the make-up water has a resistance of 5 megohms, then:

$$R_s = \frac{(5.0)(1.0)}{5.0 + 1.0} = \frac{5}{6} = .8333 \text{ megohm}$$

## APPENDIX III

### TOTAL BACTERIAL COUNT METHODS:

#### A. Standard Plate Count (Reference Method)

##### 1. Equipment

- a. Petri plates, sterile and disposable, 15×100 mm.
- b. Laboratory incubator capable of maintaining temperature at 35 to 37 C and moisture content at 90% humidity. Periodic calibration is recommended.
- c. Magnification. 10× to 15× lens or dissecting microscope.

##### 2. Reagents

###### a. Nutrient medium

- 1) Tryptone glucose extract agar (TGE)\*, or
- 2) Tryptone glucose yeast agar (TGY)\*.

###### b. Buffered dilution water

- 1) Stock phosphate buffer solution\*. Dissolve 34.0 g. of potassium dihydrogen phosphate ( $\text{KH}_2\text{PO}_4$ ) in 500 ml. of Type I water. Adjust to pH 7.2 with 1.0 N NaOH. Dilute to 1 liter with water.
- 2) Working buffer solution. Add 1.25 ml. of stock phosphate buffer solution and 5.0 ml. magnesium sulfate (50 g.  $\text{MgSO}_4 \cdot 7\text{H}_2\text{O}$  per liter of water), to 1 liter of water. Dispense 100 ml. amounts in capped bottles. Autoclave at 121 C for 15 minutes. Store at room temperature, tightly capped.

##### 3. Procedure

- a. Shake sample vigorously (approximately 25 times) to ensure proper distribution of bacteria within the sample.
- b. Into 15×100 mm Petri dishes, pipet, in duplicate, appropriate aliquots of:
  - 1) Type I water: 1 ml. of undiluted sample.
  - 2) Type II water: 1 ml. of 1:100 dilution of sample in working buffer solution.
- c. Overlay unknown sample with 15 ml. of TGE or TGY agar, tempered to 45±1 C.
- d. Mix sample and agar. Solidify.
- e. Incubate at 36±1 C. for 24 hours, and follow at 25±1 C for 48 hours.

#### B. Membrane Filtration

##### 1. Equipment

- a. Petri plates, sterile and disposable, 15×60 mm.
- b. Filtration unit. Seamless funnel which fastens to porous plate for support of filter membrane.

\*Available from BBL, Cockeysville, MD; or equivalent.

- c. Filtration receptacle. One-liter flask with side arm or other suitable device which will exert a pressure differential on the membrane filter.
- d. Vacuum source.
- e. Sterile filter membranes, nontoxic, with 0.45 micron pore size.
- f. Sterile absorbent pads. Nontoxic, 48 mm in diameter, and capable of absorption of 1.8 to 2.2 ml. of nutrient.
- g. Instead of (a) through (f) above, a bacteriological monitoring kit\*\* or equivalent, including sterile monitors, ampoules of total count medium, and pre-sterilized disposable polypropylene syringes.
- h. Forceps, stainless steel, with smooth tips.
- i. Laboratory incubator capable of maintaining temperature at 35 to 37 C and moisture content at 90% humidity. Periodic calibration is recommended.
- j. Magnification. 10× to 15× lens or dissecting microscope.

## 2. Reagents

### a. Nutrient medium

- 1) M-Tryptone glucose yeast broth (M-TGY)\*.  
Prepare according to manufacturer's instructions. After sterilization, store tightly capped under refrigeration (stable for 30 days), or
- 2) M-TGE medium supplies in 1.8 ml. glass ampoules\*\* (stable for 1 year).

### b. Buffered dilution water

- 1) Stock phosphate buffer solution\*. Dissolve 34.0 g. of potassium dihydrogen phosphate ( $\text{KH}_2\text{PO}_4$ ) in 500 ml. of Type I water. Adjust to pH 7.2 with 1.0 N NaOH. Dilute to 1 liter with water.
- 2) Working buffer solution. Add 1.25 ml. of stock phosphate buffer solution and 5.0 ml. magnesium sulfate (50 g  $\text{MgSO}_4 \cdot 7\text{H}_2\text{O}$ /l water), to 1 liter of water. Dispense 100 ml. amounts in capped bottles, autoclave at 121 C for 15 minutes. Store at room temperature, tightly capped.

- c. Stain (supplementary material to aid in colony counting). Aqueous solution Malachite Green, 0.1 mg/liter, or stain supplied with the kit\*\*. Store at room temperature in capped bottle.

## 3. Procedure

- a. Shake sample vigorously (approximately 25 times) to ensure proper distribution of bacteria within the sample.

\*Available from BBL, Cockeysville, Maryland; or equivalent.

\*\*Available from Millipore Corporation, Bedford, Massachusetts; or equivalent.

- b. Preparation of nutrient pad. Place sterile absorbent pad in 15×60 mm Petri dish. Add 1.8 to 2.2 ml. M-TGE broth; remove surplus liquid.
- c. Filtration of sample.
  - 1) Filtration units should be sterile at the beginning of each filtration series. A filtration series is considered to be interrupted when an interval of 30 minutes or longer elapses between sample filtrations. After such interruption, any further sample filtration is treated as a new filtration series that requires resterilization of all membrane filter holders in use.
  - 2) Place porous plate on filtration receptacle.
  - 3) Using sterile forceps (dip in 95% ethyl or absolute methyl alcohol and then ignite fluid), place sterile membrane filter over porous plate.
  - 4) Place funnel unit over plate and lock in place.
  - 5) Filtration is then accomplished by passing sample (10 to 100 ml.) through filter under partial vacuum.
  - 6) Between samples, rinse funnel and membrane three times with at least 30 ml. of buffered dilution water.
  - 7) Unlock and remove funnel. Immediately remove membrane with sterile forceps, and place on sterile nutrient pad with rolling motion to avoid entrapment of air.
  - 8) Invert and incubate at  $36\text{ C} \pm 1\text{ C}$  with atmosphere of at least 90% humidity for 24 hours, followed by  $25 \pm 1\text{ C}$  for 48 hours.

## C. Calibrated Wire Loop Method

### 1. Equipment

- a. Sterile Petri plates, disposable, 15×100 mm.
- b. Calibrated loops — APHA platinum wire with 5% rhodium and checked monthly for proper calibration — to deliver; 0.01 ml. 19 gauge wire; inside loop, 4 mm.
- c. Laboratory incubator capable of maintaining temperature at 35 to 37 C and moisture content at 90% humidity. Periodic calibration is recommended.
- d. Magnification. 10× to 15× lens or dissecting microscope.

### 2. Reagents

- a. Nutrient medium
  - 1) Tryptone glucose extract agar (TGE)\*, or
  - 2) Tryptone glucose yeast agar (TGY)\*.

\*Available from BBL, Cockeysville, Maryland; or equivalent.

- b. Loop calibration dye
  - 1) Prepare stock dilution of Evans blue dye by adding 0.75 g. of Evans blue dye to 100 ml. distilled water.
  - 2) Filter through No. 40 Whatman filter paper.
  - 3) Store in stoppered bottle at room temperature. Good for 1 year.

### 3. Procedure

- a. Calibration of loop should be done monthly.
  - 1) Prepare accurate 1:500, 1:1000, 1:2000, and 1:4000 dilutions of stock dye solution and determine optical densities in a spectrophotometer at 600 nm. Plot OD on a linear scale against the concentration of dye.
  - 2) Delivery of loop (0.01) can then be checked by transferring 10 loopful of stock solution to 100 ml. distilled water, flamed, and cooled between each loopful. OD of this solution is determined in the spectrophotometer and should correspond to that of the 1:1000 dilution on the standard curve within  $\pm 20\%$ . If the error is greater, the loop should be replaced or an appropriate correction be made in colony counts using that loop.

- b. Calibrated loop culture procedure

- 1) Shake sample vigorously (approximately 25 times) to ensure proper distribution of bacteria within the sample.
- 2) Label two agar plates for each sample.
- 3) Flame and cool 0.01 loop, hold vertically and immerse just below surface of the sample. The loop is moved straight up and down.
- 4) Place this loopful of water sample on the center of the surface of the plate. Streak entire surface with a sterile bent glass rod.
- 5) Incubate at  $36 \pm 1\text{C}$  for 24 hours, followed by  $25 \pm 1\text{C}$  for 48 hours.

### 4. Counting Procedure

- a. Using  $10\times$  to  $15\times$  magnification, or dissecting scope, or counter, count all colonies.
- b. Colony counting on membrane filters may be aided by adding 2-4 ml. stain. After 8-10 seconds, pour off stain. Colonies appear white or yellow with a green background.
- c. Results are calculated to represent cfu/ml.

## REFERENCES

1. Winstead, M.; "Reagent Grade Water: How, When and Why?"; American Society of Medical Technologists, Bellaire, Texas 1967. Published by Steck Company, Austin, Texas.
2. Stier, A. R.; Miller, L. K.; and Smith, R. T.; "Water Specifications" College of American Pathologists, Commission on Laboratory Inspection and Accreditation, Chicago, Illinois, 1972.
3. 1973 Annual Book of ASTM Standards, Part 23, Water: Atmospheric Analysis. American Society for Testing and Materials, Philadelphia, Pennsylvania, 1973.
4. NCCLS-PSC-3: Specifications for Reagent Water Used in the Clinical Laboratory.
5. Otten, Gerard; "Measuring Water Purity by Specific Resistance"; American Laboratory, p.41, July 1972.

---

## NOTES



**COLLEGE OF AMERICAN PATHOLOGISTS**  
7400 N. SKOKIE BOULEVARD/SKOKIE, ILLINOIS 60077

---



U.S. DEPT. OF COMM. <b>BIBLIOGRAPHIC DATA SHEET</b> (See instructions)		1. PUBLICATION OR REPORT NO. NBS SP 260-72	2. Performing Organ. Report No.	3. Publication Date June 1981
4. TITLE AND SUBTITLE Standard Reference Materials: SRM 900, Antiepilepsy Drug Level Assay Standard				
5. AUTHOR(S) Dennis J. Reeder, Bruce Coxon, Delmo Enagonio, Richard G. Christensen, Barbara F. Howell, Robert C. Paule, John Mandel, and Robert Schaffer				
6. PERFORMING ORGANIZATION (If joint or other than NBS, see instructions)  NATIONAL BUREAU OF STANDARDS DEPARTMENT OF COMMERCE WASHINGTON, D.C. 20234			7. Contract/Grant No.	8. Type of Report & Period Covered  Final
9. SPONSORING ORGANIZATION NAME AND COMPLETE ADDRESS (Street, City, State, ZIP) National Institutes of Health National Institute of Neurological and Communicative Disorders and Stroke, Federal Building Bethesda, MD 20205				
10. SUPPLEMENTARY NOTES  Library of Congress Catalog Card Number: 81-600062  <input type="checkbox"/> Document describes a computer program; SF-185, FIPS Software Summary, is attached.				
11. ABSTRACT (A 200-word or less factual summary of most significant information. If document includes a significant bibliography or literature survey, mention it here)  Recognition of the efficacy of monitoring the concentrations of therapeutic drugs in the blood of patients has revealed many needs for standardization of the laboratory tests used for such monitoring. The National Bureau of Standards was asked to provide a Standard Reference Material (SRM) consisting of three serum samples, each to contain four antiepilepsy drugs at different concentrations. The four drugs are phenobarbital, phenytoin, primidone, and ethosuximide. The SRM would fill a basic role for the achievement of accurate analysis to help ensure the reliability of analyses for these drugs. The needs that had to be fulfilled to produce the SRM included: (1) analytical criteria for purity of the drugs; (2) serum to be used as a matrix for the drugs; (3) techniques for achieving homogeneity and stability of the SRM; and (4) two independent, highly accurate analytical methods for the certification. This document describes development of methods and procedures used to produce and certify the SRM.				
12. KEY WORDS (Six to twelve entries; alphabetical order; capitalize only proper names; and separate key words by semicolons) Anticonvulsants; antiepilepsy drugs; blood analysis; chromatography, gas; chromatography, liquid; drug standards; enzyme immunoassay; epilepsy; ethosuximide; mass spectrometry; nuclear magnetic resonance spectroscopy; phenobarbital; phenytoin; primidone;				
13. AVAILABILITY reference material; serum base modification; serum matrix			14. NO. OF PRINTED PAGES 79	
<input checked="" type="checkbox"/> Unlimited <input type="checkbox"/> For Official Distribution, Do Not Release to NTIS <input checked="" type="checkbox"/> Order From Superintendent of Documents, U.S. Government Printing Office, Washington, D.C. 20402. <input type="checkbox"/> Order From National Technical Information Service (NTIS), Springfield, VA. 22161			15. Price  \$4.25	



# NBS TECHNICAL PUBLICATIONS

## PERIODICALS

**JOURNAL OF RESEARCH**—The Journal of Research of the National Bureau of Standards reports NBS research and development in those disciplines of the physical and engineering sciences in which the Bureau is active. These include physics, chemistry, engineering, mathematics, and computer sciences. Papers cover a broad range of subjects, with major emphasis on measurement methodology and the basic technology underlying standardization. Also included from time to time are survey articles on topics closely related to the Bureau's technical and scientific programs. As a special service to subscribers each issue contains complete citations to all recent Bureau publications in both NBS and non-NBS media. Issued six times a year. Annual subscription: domestic \$13; foreign \$16.25. Single copy, \$3 domestic; \$3.75 foreign.

NOTE: The Journal was formerly published in two sections: Section A "Physics and Chemistry" and Section B "Mathematical Sciences."

**DIMENSIONS/NBS**—This monthly magazine is published to inform scientists, engineers, business and industry leaders, teachers, students, and consumers of the latest advances in science and technology, with primary emphasis on work at NBS. The magazine highlights and reviews such issues as energy research, fire protection, building technology, metric conversion, pollution abatement, health and safety, and consumer product performance. In addition, it reports the results of Bureau programs in measurement standards and techniques, properties of matter and materials, engineering standards and services, instrumentation, and automatic data processing. Annual subscription: domestic \$11; foreign \$13.75.

## NONPERIODICALS

**Monographs**—Major contributions to the technical literature on various subjects related to the Bureau's scientific and technical activities.

**Handbooks**—Recommended codes of engineering and industrial practice (including safety codes) developed in cooperation with interested industries, professional organizations, and regulatory bodies.

**Special Publications**—Include proceedings of conferences sponsored by NBS, NBS annual reports, and other special publications appropriate to this grouping such as wall charts, pocket cards, and bibliographies.

**Applied Mathematics Series**—Mathematical tables, manuals, and studies of special interest to physicists, engineers, chemists, biologists, mathematicians, computer programmers, and others engaged in scientific and technical work.

**National Standard Reference Data Series**—Provides quantitative data on the physical and chemical properties of materials, compiled from the world's literature and critically evaluated. Developed under a worldwide program coordinated by NBS under the authority of the National Standard Data Act (Public Law 90-396).

NOTE: The principal publication outlet for the foregoing data is the Journal of Physical and Chemical Reference Data (JPCRD) published quarterly for NBS by the American Chemical Society (ACS) and the American Institute of Physics (AIP). Subscriptions, reprints, and supplements available from ACS, 1155 Sixteenth St., NW, Washington, DC 20036.

**Building Science Series**—Disseminates technical information developed at the Bureau on building materials, components, systems, and whole structures. The series presents research results, test methods, and performance criteria related to the structural and environmental functions and the durability and safety characteristics of building elements and systems.

**Technical Notes**—Studies or reports which are complete in themselves but restrictive in their treatment of a subject. Analogous to monographs but not so comprehensive in scope or definitive in treatment of the subject area. Often serve as a vehicle for final reports of work performed at NBS under the sponsorship of other government agencies.

**Voluntary Product Standards**—Developed under procedures published by the Department of Commerce in Part 10, Title 15, of the Code of Federal Regulations. The standards establish nationally recognized requirements for products, and provide all concerned interests with a basis for common understanding of the characteristics of the products. NBS administers this program as a supplement to the activities of the private sector standardizing organizations.

**Consumer Information Series**—Practical information, based on NBS research and experience, covering areas of interest to the consumer. Easily understandable language and illustrations provide useful background knowledge for shopping in today's technological marketplace.

Order the above NBS publications from: Superintendent of Documents, Government Printing Office, Washington, DC 20402.

Order the following NBS publications—FIPS and NBSIR's—from the National Technical Information Services, Springfield, VA 22161.

**Federal Information Processing Standards Publications (FIPS PUB)**—Publications in this series collectively constitute the Federal Information Processing Standards Register. The Register serves as the official source of information in the Federal Government regarding standards issued by NBS pursuant to the Federal Property and Administrative Services Act of 1949 as amended, Public Law 89-306 (79 Stat. 1127), and as implemented by Executive Order 11717 (38 FR 12315, dated May 11, 1973) and Part 6 of Title 15 CFR (Code of Federal Regulations).

**NBS Interagency Reports (NBSIR)**—A special series of interim or final reports on work performed by NBS for outside sponsors (both government and non-government). In general, initial distribution is handled by the sponsor; public distribution is by the National Technical Information Services, Springfield, VA 22161, in paper copy or microfiche form.

**U.S. DEPARTMENT OF COMMERCE**  
**National Bureau of Standards**  
Washington, D.C. 20234

OFFICIAL BUSINESS

Penalty for Private Use, \$300

POSTAGE AND FEES PAID  
U.S. DEPARTMENT OF COMMERCE  
COM-215



SPECIAL FOURTH-CLASS RATE  
BOOK

---