

A11102 631166

NAT'L INST OF STANDARDS & TECH R.I.C.

NBS



A11102631166

Kokkala, M. A/Some observations on the s  
QC100 .U56 NO.87-3505 1987 V19 C.1 NBS-P

# Some Observations on the Shape of Impinging Diffusion Flames

---

M. A. Kokkala

Fire Technology Laboratory  
Technical Research Center of Finland  
02150 Espoo, Finland

and

W. J. Rinkinen

U.S. DEPARTMENT OF COMMERCE  
National Bureau of Standards  
National Engineering Laboratory  
Center for Fire Research  
Gaithersburg, MD 02899

January 1987



---

U.S. DEPARTMENT OF COMMERCE  
NATIONAL BUREAU OF STANDARDS

~~QC~~  
100  
.U56  
87-3505  
1987  
c.2



NBSIR 87-3505

**SOME OBSERVATIONS ON THE SHAPE OF  
IMPINGING DIFFUSION FLAMES**

---

M. A. Kokkala

Fire Technology Laboratory  
Technical Research Center of Finland  
02150 Espoo, Finland

and

W. J. Rinkinen

U.S. DEPARTMENT OF COMMERCE  
National Bureau of Standards  
National Engineering Laboratory  
Center for Fire Research  
Gaithersburg, MD 02899

January 1987

**U.S. DEPARTMENT OF COMMERCE, Malcolm Baldrige, *Secretary***  
**NATIONAL BUREAU OF STANDARDS, Ernest Ambler, *Director***



## TABLE OF CONTENTS

	<u>Page</u>
List of Figures .....	iv
Foreward .....	v
Abstract .....	1
1. INTRODUCTION .....	1
2. EXPERIMENTAL .....	3
3. CHARACTERISTICS OF PROPANE AND NATURAL GAS FLAMES .....	5
3.1 Propane Flames .....	5
3.2 Natural Gas Flames .....	7
4. DISCUSSION .....	7
5. CONCLUSIONS .....	10
6. REFERENCES .....	10

## LIST OF FIGURES

	<u>Page</u>
Figure 1. (a) Schematic view of the experimental set-up with the burner far from the ceiling .....	12
(b) Details of the diffusion burner .....	12
(c) Close up of the stagnation region .....	12
Figure 2. The shape of the propane diffusion flames as a function of the heat release rate $Q$ and the ceiling height $H$ .....	13
Figure 3. The shape of the natural gas diffusion flames as a function of the heat release rate $Q$ and the ceiling height $H$ .....	13
Figure 4. The free flame height $H_F$ (broken line) and the sum of ceiling height $H$ and the ceiling flame diameter $2H_R$ (different symbols) as a function of the nominal heat release rate of the propane diffusion flames .....	14
Figure 5. Complete rings of a propane flame with $H = 100$ mm and $Q = 7.6$ kW (1/60 s exposure) .....	15
Figure 6. Broken rings of a propane flame with $H = 100$ mm and $Q = 11$ kW (1/60 s exposure) .....	15
Figure 7. Stable daisy flower shape of a propane flame with $H = 20$ mm and $Q = 40$ kW (a flash photograph) .....	16
Figure 8. Swinging daisy flower of a propane flame with $H = 20$ mm and $Q = 7.6$ kW (1/60 s exposure) .....	16
Figure 9. Cellular daisy flower of a propane flame with $H = 20$ mm and $Q = 11$ kW (1/60 s exposure) .....	17
Figure 10. Stable disc of a natural gas flame with $H = 50$ mm and $Q = 10.5$ kW .....	17
Figure 11. Cellular daisy flower of a natural gas flame with $H = 20$ mm and $Q = 10.5$ kW .....	18

## FOREWARD

The work described in this report was carried out at the Center for Fire Research of the National Bureau of Standards as a part of a project on wall and ceiling fire dynamics.

The authors thank various members of the staff of the Center for Fire Research for inspiring discussions, and especially Dr. James Quintiere, who suggested this study.

The financial support by the Technical Research Center of Finland, by the National Bureau of Standards, and by the United States Educational Foundation in Finland is gratefully acknowledged.



# SOME OBSERVATIONS ON THE SHAPE OF IMPINGING DIFFUSION FLAMES

M.A. Kokkala and W.J. Rinkinen

## Abstract

The structure of impinging diffusion flames of propane and natural gas on a ceiling is described. In these experiments, a burner with a diameter of 64 mm was used. The spacing between the burner surface and the horizontal ceiling was varied in the range of 15 mm - 100 mm and the nominal heat release rate in the range of 2.9 kW - 11 kW. New kinds of regular flame shapes were observed: complete rings, broken rings, laminar disc, daisy flower, cellular daisy flower. Color photographs of the various flame shapes are presented. Combustion processes causing the instabilities are discussed qualitatively, and the differences between propane and natural gas flames are identified.

## 1. INTRODUCTION

Regular flame shapes are interesting for two different reasons. Transition from one shape to another offers a good check point for combustion models. In addition, the often symmetrical and colorful flames are esthetically attractive, and may inspire the minds of curious researchers.

Very often the regular shapes appear because of an instability in the flame front. In premixed flames the instabilities occur near the lean or rich concentration limits of flame propagation. The earliest observations of this phenomenon date back to the 19th century, but the real pioneering work was done by Markstein in the 1940's and the 1950's [5,6]. Markstein studied the cellular structure of the flames of various hydrocarbon/air mixtures. He

found, e.g., that the size of the flame cells is a function of the molecular weight of the hydrocarbon.

Mitani and Williams later studied the cellular structure of the flames of hydrogen-oxygen-nitrogen mixtures [7]. They found that the cell size depends on the ratio of the concentrations of hydrogen and oxygen. A remarkable change in the cell size occurs approximately at the point where the concentration of hydrogen is twice the concentration of oxygen.

Recently, several researchers have studied the structure of premixed flames in stagnation point flow [3,9,11]. Ishizuka and Law [3] studied the extinction and stability of stretched premixed propane and methane flames. They used both a counterflow burner and a stagnation flow burner with a water cooled wall. Depending on the concentrations and the flow or heat loss conditions, they could identify a variety of different flame configurations: cellular flames, star-shaped flames, groove-shaped flames, and vibrating flames.

Two possible causes for the cellular and other regular flame structures have been suggested: hydrodynamic instabilities or thermo-diffusive instabilities. The former is seldom observed, but the latter is regarded as the cause of most of the cellular structures [10]. The key parameter in the thermo-diffusional model is the Lewis number,  $Le$ , of the mixture. The critical Lewis number  $Le_c$  is of the order of 1. If  $Le > Le_c$  the flame is stable and if  $Le < Le_c$  the flame is unstable.

Cellular diffusion flames have been observed in systems in which the fuel flows out of a downward facing surface [2,4,8]. DeRis and Orloff [2] systematically studied the instability of a downward facing diffusion flame. They observed a transition from a laminar to a cellular flame when the Rayleigh number of the system exceeds a critical value of about 2400. The characteristic length in the Rayleigh number is the separation between the reaction zone and the solid surface. They also found that the cell size depends on the molecular weight of the fuel but their cells were about twice as big as those in Markstein's premixed flames.

The observations described in this report were made while the authors were studying the heat transfer to and the ignition of a horizontal surface by an impinging flame. This report is kept on a very descriptive level; a more thorough study would require a much more detailed instrumentation. Because the apparatus was not designed for this kind of study and because the main goal of the work was completely different, there is evident lack of systemacy. This paper is, however, written to inspire those working on basic combustion research to study these phenomena, which to our knowledge have never been observed before and which, we think, can result in much new and valuable information.

## 2. EXPERIMENTAL

The experimental apparatus is shown in Fig. 1. The burner is a cone filled with 6 mm glass beads up to about 5 mm below the 64 mm diameter upper surface, which is covered with a 16 mesh screen.

The burner is placed under a calcium silicate (Marinite) ceiling. At the center of the ceiling board there are three 0.4 m diameter plates with a total thickness of 38 mm. Outside the center there is only one 13 mm thick plate. The total diameter of the unconfined ceiling is 1 m.

A raised floor plate of the same diameter as the ceiling is located 1 m under the ceiling and 0.6 m above the floor of the room. The effect of the floor plate is believed to be negligible.

Several layers of screen surround the apparatus to damp disturbances in the flow of room air. Above the apparatus is a hood to collect all combustion products. The suction of the hood disturbs the flow around the apparatus. However, this does not seem to affect the flames described here.

In each run the mass flow of gas was kept constant. Radiation from the flame slowly heats up the glass beads. Heat exchange between the beads and the through-flowing gas raises the temperature of the gas during the course of the run, thereby continuously changing the flow velocity. With a lower gas flow rate (smaller flame) the effect of the radiation feedback is stronger. The flow rate is measured with a standard variable area rotameter. The nominal heat release rate is calculated assuming a heat of combustion of 46.4 MJ/kg for propane and 50.0 MJ/kg for natural gas.

### 3. CHARACTERISTICS OF PROPANE AND NATURAL GAS FLAMES

In the following we call the different flame shapes rings, broken rings, laminar disc, daisy flower, and cellular daisy flower. The meaning of these descriptive words is best understood by looking at the photographs shown in Figures 5 to 12 at the end of the report.

#### 3.1 Propane Flames

The experiments with propane cover roughly the region for which the spacing  $H$  is between 15 mm and 100 mm and the nominal heat release rate  $Q$  between 4 kW and 11 kW. A rough sketch of the "phase diagram" of the flame shapes in the  $H$ - $Q$  plane is shown in Fig. 2. The location of the phase boundaries is very approximate, because the data points, shown with a different symbol for each shape, do not allow us to locate the boundaries very accurately.

With  $H = 100$  mm and small  $Q$  the ceiling flames are concentric rings (see Fig. 5). As the heat output, i.e., the gas flow is increased the complete rings begin to break into shorter arcs, but the ring pattern still remains clear (see Fig. 6). The origin of the rings appears to be the pulsation of the flame, and the frequency of pulsation is within the resolution of our measurements the same as that of the corresponding free flame.

Raising the burner closer to the ceiling makes the necking of the flame disappear, and the flame diameter is at every height larger than the burner diameter. At  $H = 50$  mm and small  $Q$  the flame is a disc with the burner in the

center. Hardly any combustion takes place in the space between the burner and the ceiling. The diameter of the flame stays constant, and no periodic fluctuations are seen. At the perimeter of the disc the luminosity of the flame smoothly decreases and the perimeter looks like a red ornament around the yellow disc.

With an even smaller  $H$  the shape of the flame becomes dramatically different. The flame is stable, but the flame front is broken into several rays (see Fig. 7). The flame looks like a daisy flower or a star fish. With small gas flow rates the daisy flower keeps its shape for tens of seconds. With higher flow rates the rays swing like the legs of a star fish in water (see Fig. 8). The lifetime of an individual ray may be up to 30 s. Sometimes two adjacent rays combine into a new one and sometimes a new ray is born when two adjacent rays drift too far apart. The number of rays is  $15 \pm 1$  and that does not seem to depend on the spacing  $H$  or the gas flow rate.

With higher flow rates the rays of the daisy flower break into cells traveling outwards along the rays (see Fig. 9). There are as many rays in the cellular daisy flower as in the complete daisy flower. The cellular daisy flower also appears as the gas flow of the laminar disc flame is increased. The transition from a disc to a cellular daisy flower is not sudden, and at some points of the  $H$ - $Q$  plane the shape depends on the temperature of the ceiling surface (heat loss to the ceiling). For example, for  $H = 50$  mm the transition from a disc to a cellular daisy flower occurs somewhere between 6 and 10 kW. Flames in this intermediate region have features of both types of flames. The cellular daisy flower is also found with very small values of  $H$  when the radial flow velocity of the fuel from the spacing becomes so high that it creates an additional instability in the flow field.

### 3.2 Natural Gas Flames

For natural gas the phase diagram in the H-Q plane shown in Fig. 3 looks very different from that of propane. As in the case of propane, when the Q vertical part of the flame is necking and pulsating, the ceiling flames have the characteristic ring shape. When H is decreased or Q increased a laminar disc appears. The region in the H-Q plane, where the disc appears is much wider here. For example, with H = 50 mm and Q = 10.5 kW the flame is still an almost perfect disc with a diameter of about 400 mm (see Fig. 10). Under the same conditions propane forms a cellular daisy flower. With natural gas we did not find the perfect daisy flower shape. However, when H is decreased and the gas flow or Q increased the disc breaks into a shape which very much resembles the cellular daisy flower of the propane flame (see Fig. 11). The number of rays is now  $10 \pm 1$ , i.e., definitely less than the number of rays for the propane flames.

### 4. DISCUSSION

When trying to explain why these various flame shapes appear we should consider all the main processes of combustion: macroscopic flow dynamics, diffusion of reactants, reaction rates, and heat transfer processes. We have not tried to use any quantitative combustion models to explain the phenomena. Therefore, much of the following discussion is speculation based on physical reasoning and on ideas presented in the literature in connection with related problems.

The ring flames are probably a hydrodynamic instability in the flame arising from the pulsation of the vertical part of the flame. The rings under the ceiling are essentially similar vortex rings such as those found in free pool fires. The break-up of the rings with higher flow rates is probably caused by irregular disturbances in the flow field. The characteristic frequency of both complete and broken rings was found to be practically the same as that for the corresponding free flame. In the free pool the frequency is known to depend only on the diameter of the pool [1].

In the natural gas flame it was found that after the ceiling became hot, i.e., when the fuel in the quench layer became hot and light enough, a transition from the ring shape to the more stable disc shape occurred. For example, in one experiment in which the gas flow was kept constant, the ring shape existed several minutes in the beginning, but then within a period of about 15 seconds the flame turned to a stable laminar disc. During the transition the surface temperature of the ceiling was still below 400°C. Natural gas at 400°C is still about 30% heavier than the combustion products at 1200°C in the reaction zone.

No satisfactory explanation for the formation of the daisy flower shape has been found. The mechanisms involved in this kind of a problem are probably similar to those for the formation of cellular instabilities in premixed flames. Such instabilities are believed to be caused by heat transfer and diffusion. Cellular instabilities have never been observed in rich methane flames. The cellular daisy flower of the natural gas flame may therefore be caused entirely by the heavier impurities. The jetting of the fuel from the burner with a radial velocity of the order of 0.2 m/s may also

affect the flame shape. The flame is, however, a real diffusion flame, because the low flow rate is not able to entrain enough of air to make an assumption of a semi-premixed flame plausible.

The stability of the daisy flower flame may be enhanced by the fact that the sector of the ceiling surface under which a flame ray is once born becomes immediately hotter than the adjacent sectors making the hot gases flow along the same direction more easily thereafter.

The number of rays in the flower shaped flames depends on the molecular weight of the fuel. This assumption was verified by burning a pool of heptane close to the ceiling. With time dependent and uncontrolled burning rate we found more than twenty rays. The effect of the molecular weight is consistent with Markstein's observations [5].

For turbulent impinging flames the flame length along an unconfined ceiling approximately obeys the simple relationship,  $H + 2 H_R = H_F$ , where  $H_F$  is the free flame height and  $H_R$  the radius of the ceiling flame (both measured as an average flame length) [12]. Figure 4 shows the sum  $H = 2 H_R$  as a function of the nominal heat release rate for various kinds of flames. The values well below  $H_F$  are probably a sign of incomplete combustion.

The incomplete combustion is also indicated by increased soot production. In the daisy flower shaped flame angular variation of smoke production was observed. Close to the edge of the ceiling the flow of smoke formed clearly visible stripes. It was not possible to determine whether more smoke came from the rays or from between them.

## 5. CONCLUSIONS

The observations described in this paper are far from sufficient to characterize the instability phenomena occurring in impinging diffusion flames. Some, but by no means all, of the physical and chemical processes are understood qualitatively, but a quantitative understanding is lacking. A more systematic study under better controlled conditions is definitely needed.

## 6. REFERENCES

1. Byram, G.M. and Nelson, Jr., R.M., The modeling of pulsating fires. *Fire Techn.* 6 (1970) 2, pp. 102-110.
2. de Ris, J. and Orloff, L., The role of buoyancy direction and radiation in turbulent diffusion flames on surfaces. Fifteenth Symposium (International) on Combustion, Pittsburgh, 1975, The Combustion Institute, pp. 175-182.
3. Ishizuka, S. and Law, C.K., An experimental study on extinction and stability of stretched premixed flames. Nineteenth Symposium (International) on Combustion, Pittsburgh, 1982, The Combustion Institute, pp. 327-325.
4. Kashiwagi, T. and Newman, D.L., Flame spread over an inclined thin fuel surface. *Comb. Flame* 26 (1976), pp. 163-177.
5. Markstein, G.H., Instability phenomena in combustion waves. Fourth Symposium (International) on Combustion, Baltimore, 1953, The Williams & Williams Co., pp. 44-59.
6. Markstein, G.H. and Somers, L.M., Cellular flame structure and vibratory flame movement in n-butane-methane mixtures. Fourth Symposium (International) on Combustion, Baltimore, 1953, The Williams & Williams Co., pp. 527-535.
7. Mitani, T. and Williams, F.A., Studies of cellular flames in hydrogen-oxygen-nitrogen mixtures. *Comb. Flame* 39 (1980), pp. 169-190.
8. Orloff, L. and deRis, J., Modeling of ceiling fires. Thirteenth Symposium (International) on Combustion, Pittsburgh, 1982, The Combustion Institute, pp. 1541-1548.
9. Sato, J., Effects of Lewis number on extinction behavior of premixed flames in a stagnation flow. Nineteenth Symposium (International) on Combustion, Pittsburgh, 1982, The Combustion Institute, pp. 1541-1548.

10. Sivashinsky, G.J., Comb. Sci. Tech. 15 (1977), pp. 137-146.
11. Tsuji, H. and Yamaoka, I., Structure and extinction of near-limit flames in a stagnation flow. Nineteenth Symposium (International) on Combustion, Pittsburgh, 1982, The Combustion Institute, pp. 1533-1540.
12. You, H.Z. and Faeth, G.M., Ceiling heat transfer during fire plume and fire impingement, Fire and Mat. 3 (1979) 3, pp. 140-147.

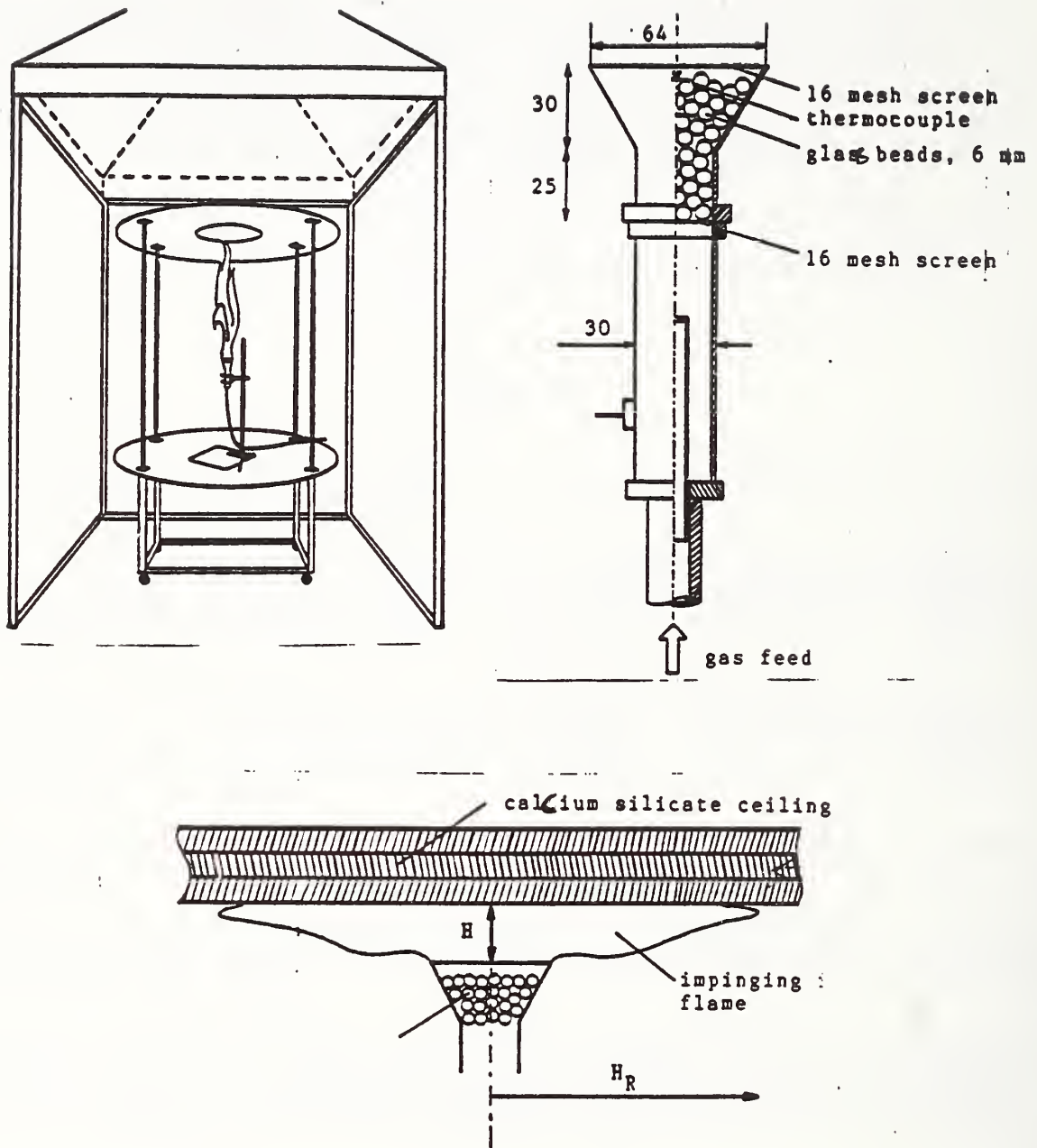

Fig. 1. a) Schematic view of the experimental set-up with the burner far from the ceiling.  
 b) Details of the diffusion burner.  
 c) Close-up of the stagnation region.

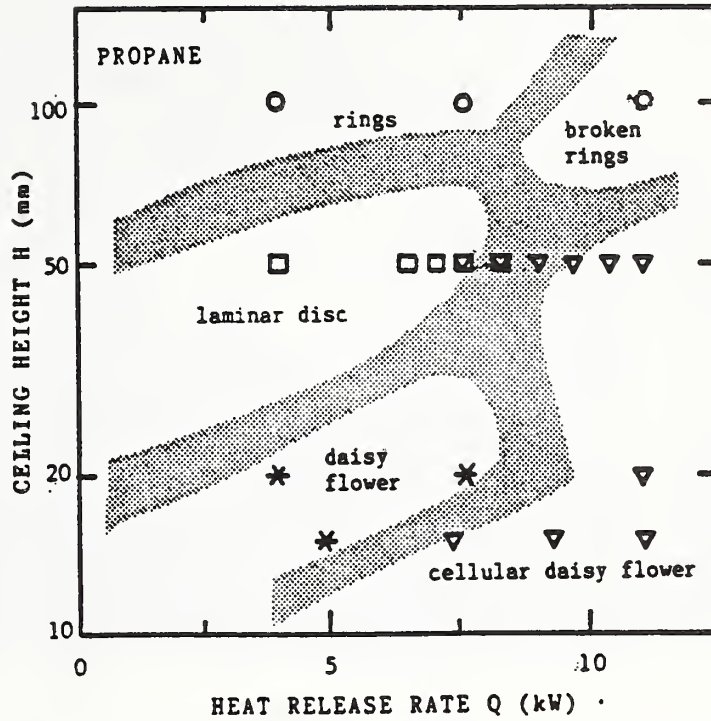

Fig. 2. The shape of the propane diffusion flames as a function of the heat release rate  $Q$  and the ceiling height  $H$ .

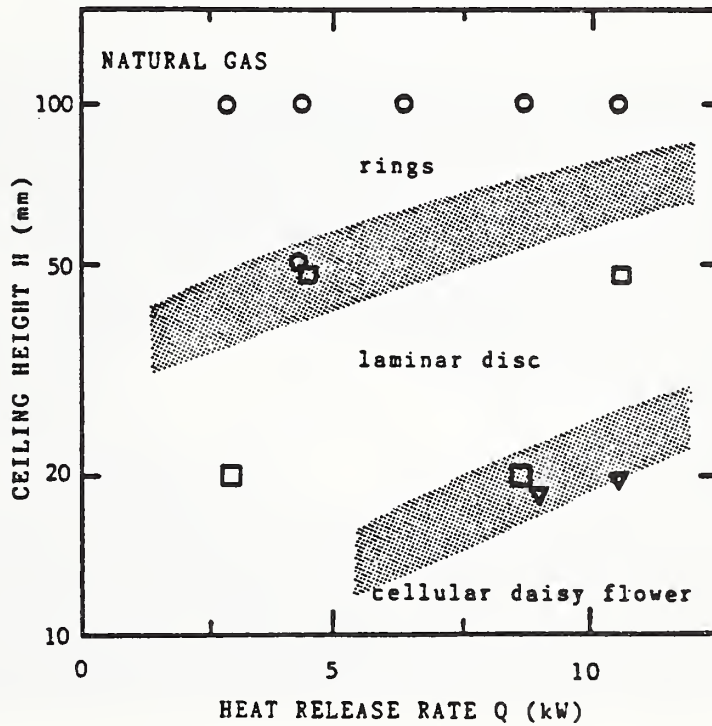

Fig. 3. The shape of the natural gas diffusion flames as a function of the heat release rate  $Q$  and the ceiling height  $H$ .

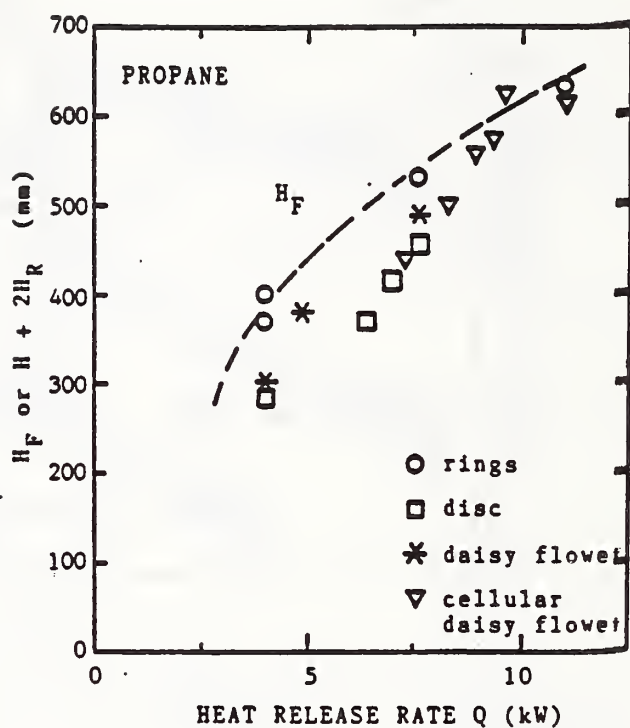

Fig. 4. The free flame height  $H_F$  (broken line) and the sum of ceiling height  $H$  and the ceiling flame diameter  $2H_R$  (different symbols) as a function of the nominal heat release rate of the propane diffusion flames.

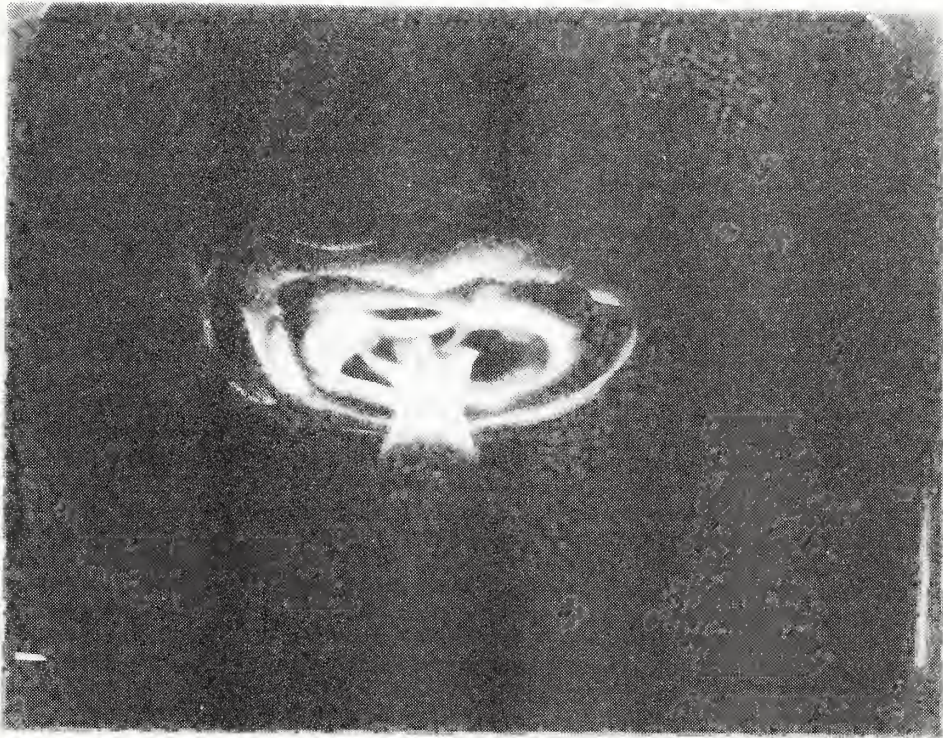

Fig. 5. Complete rings of a propane flame with  $H = 100$  mm and  $Q = 7.6$  kW (1/60 s exposure).

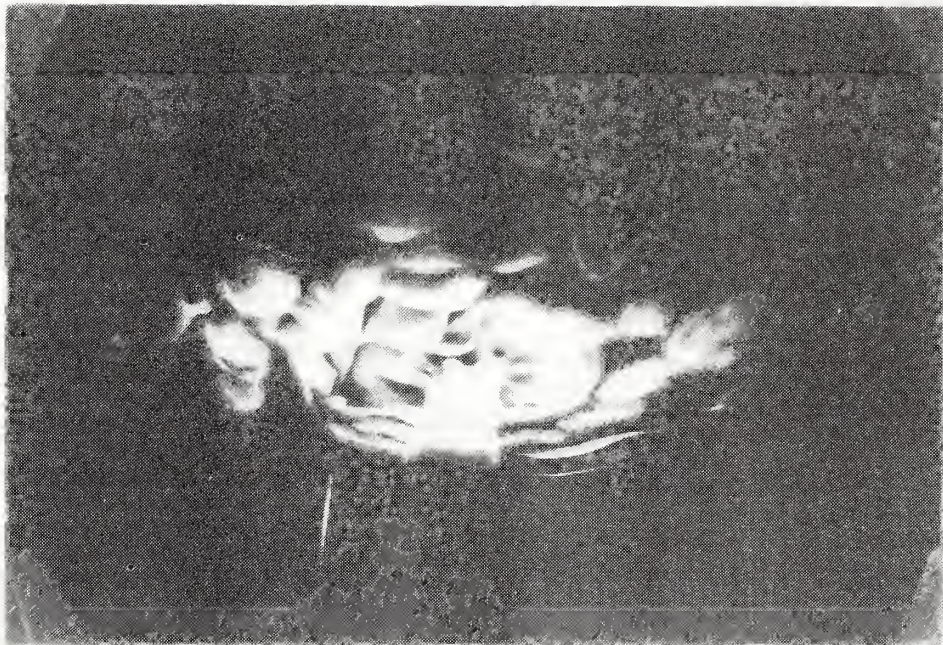

Fig. 6. Broken rings of a propane flame with  $H = 100$  mm and  $Q = 11$  kW (1/60 s exposure).



Fig 7 Stable daisy flower shape of a propane flame with  $H = 20$  mm and  $Q \approx 4.0$  kW (a flash photograph).



Fig. 8. Swinging daisy flower of a propane flame with  $H = 2.0$  mm and  $Q = 7.6$  kW (1/60 s exposure).

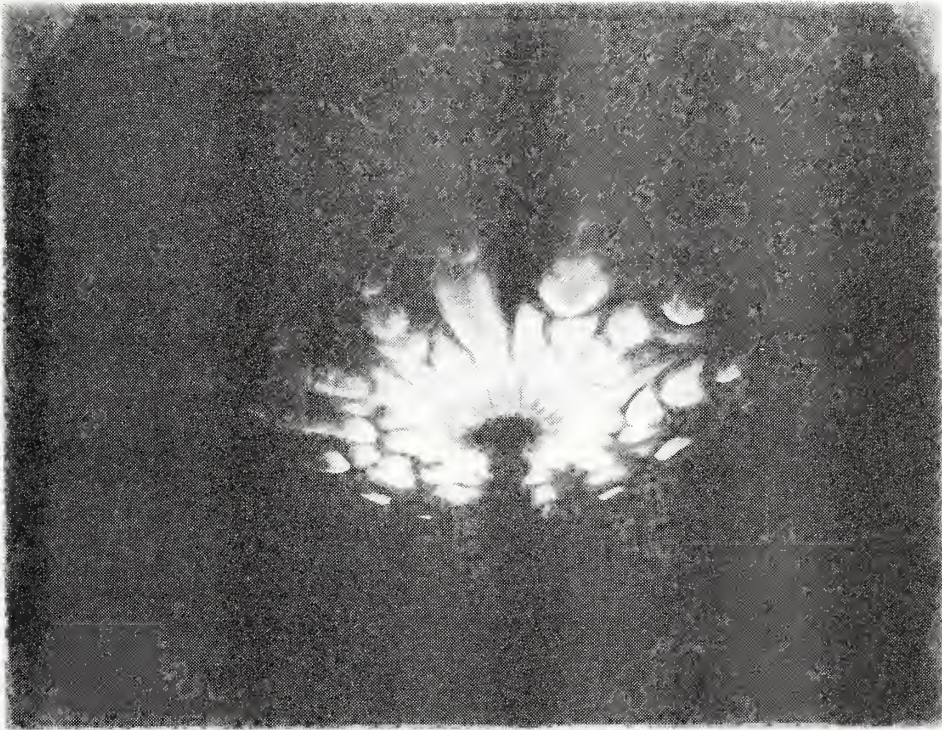

Fig. 9. Cellular daisy flower of a propane flame with  $H = 20$  mm and  $Q = 11$  kW (1/60 s exposure).

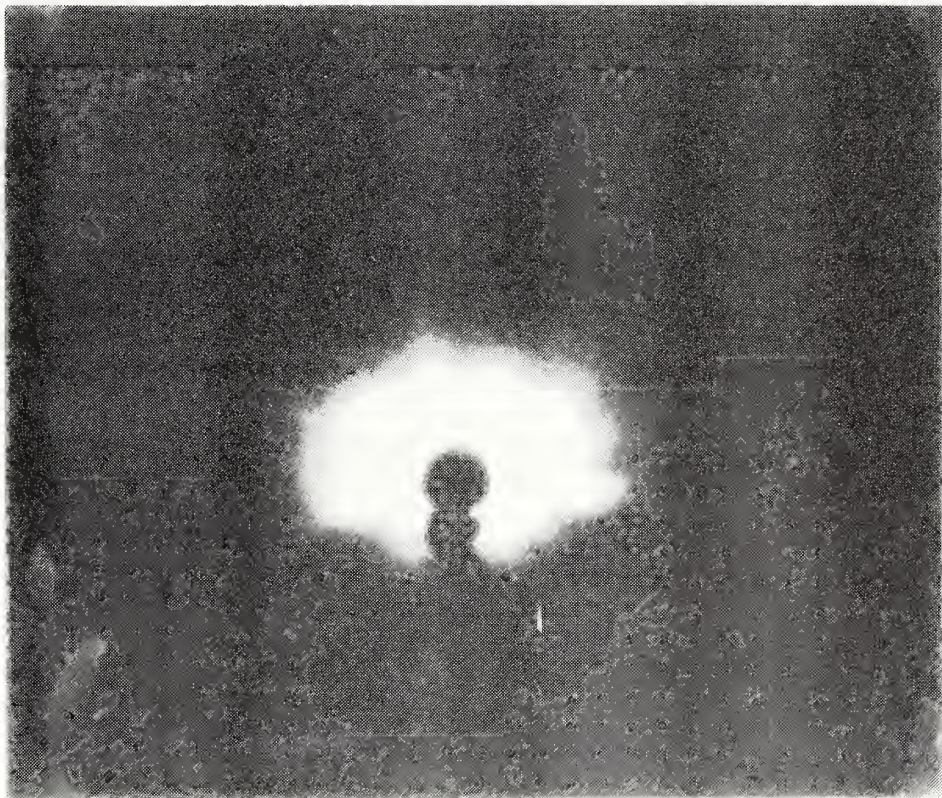

Fig. 10. Stable disc of a natural gas flame with  $H = 50$  mm and  $Q = 10.5$  kW.



Fig. 11. Cellular daisy flower of a natural gas flame with  $H = 20$  mm and  $Q = 10.5$  kW.

U.S. DEPT. OF COMM. <b>BIBLIOGRAPHIC DATA SHEET</b> (See instructions)	<b>1. PUBLICATION OR REPORT NO.</b> NBSIR-87/3505	<b>2. Performing Organ. Report No.</b>	<b>3. Publication Date</b> January 1987
<b>4. TITLE AND SUBTITLE</b> <p style="text-align: center;">Some Observations on the Shape of Impinging Diffusion Flames</p>			
<b>5. AUTHOR(S)</b> M.A. Kokkala and W.J. Rinkinen			
<b>6. PERFORMING ORGANIZATION</b> (If joint or other than NBS, see instructions)  National Bureau of Standards Department of Commerce Gaithersburg, MD 20899		<b>7. Contract/Grant No.</b>	<b>8. Type of Report &amp; Period Covered</b>
<b>9. SPONSORING ORGANIZATION NAME AND COMPLETE ADDRESS</b> (Street, City, State, ZIP)			
<b>10. SUPPLEMENTARY NOTES</b>  <input type="checkbox"/> Document describes a computer program; SF-185, FIPS Software Summary, is attached.			
<b>11. ABSTRACT</b> (A 200-word or less factual summary of most significant information. If document includes a significant bibliography or literature survey, mention it here) <p>The structure of impinging diffusion flames of propane and natural gas is described. In these experiments, a burner with a diameter of 64 mm was used. The spacing between the burner surface and the horizontal ceiling was varied in the range of 15 mm - 100 mm and the nominal heat release rate in the range of 2.9 kW - 11 kW. New kinds of regular flame shapes were observed: complete rings, broken rings, laminar disc, daisy flower, cellular daisy flower. Colour photographs of the various flame shapes are presented. Combustion processes causing the instabilities are discussed qualitatively, and the differences between propane and natural gas flames are identified.</p>			
<b>12. KEY WORDS</b> (Six to twelve entries; alphabetical order; capitalize only proper names; and separate key words by semicolons) ceiling flame dynamics; cellular structured flames; impinging diffusion flames; new regular flame shapes; unstable flame fronts			
<b>13. AVAILABILITY</b> <input checked="" type="checkbox"/> Unlimited <input type="checkbox"/> For Official Distribution. Do Not Release to NTIS <input type="checkbox"/> Order From Superintendent of Documents, U.S. Government Printing Office, Washington, D.C. 20402. <input checked="" type="checkbox"/> Order From National Technical Information Service (NTIS), Springfield, VA. 22161		<b>14. NO. OF PRINTED PAGES</b> <p style="text-align: center;">24</p> <b>15. Price</b> <p style="text-align: center;">\$9.95</p>	





