

A11103 066526

NAT'L INST OF STANDARDS & TECH R.I.C.



A11103066526

Workshop on Asbestos/Proceedings of Work
QC100 .U57 NO.506, 1978 C.2 NBS-PUB-C 19



NBS SPECIAL PUBLICATION 506

U.S. DEPARTMENT OF COMMERCE / National Bureau of Standards

Workshop on Asbestos: Definitions and Measurement Methods



NATIONAL BUREAU OF STANDARDS

The National Bureau of Standards¹ was established by an act of Congress March 3, 1901. The Bureau's overall goal is to strengthen and advance the Nation's science and technology and facilitate their effective application for public benefit. To this end, the Bureau conducts research and provides: (1) a basis for the Nation's physical measurement system, (2) scientific and technological services for industry and government, (3) a technical basis for equity in trade, and (4) technical services to promote public safety. The Bureau's technical work is performed by the National Measurement Laboratory, the National Engineering Laboratory, and the Institute for Computer Sciences and Technology.

THE NATIONAL MEASUREMENT LABORATORY provides the national system of physical and chemical and materials measurement; coordinates the system with measurement systems of other nations and furnishes essential services leading to accurate and uniform physical and chemical measurement throughout the Nation's scientific community, industry, and commerce; conducts materials research leading to improved methods of measurement, standards, and data on the properties of materials needed by industry, commerce, educational institutions, and Government; provides advisory and research services to other Government Agencies; develops, produces, and distributes Standard Reference Materials; and provides calibration services. The Laboratory consists of the following centers:

Absolute Physical Quantities² — Radiation Research — Thermodynamics and Molecular Science — Analytical Chemistry — Materials Science.

THE NATIONAL ENGINEERING LABORATORY provides technology and technical services to users in the public and private sectors to address national needs and to solve national problems in the public interest; conducts research in engineering and applied science in support of objectives in these efforts; builds and maintains competence in the necessary disciplines required to carry out this research and technical service; develops engineering data and measurement capabilities; provides engineering measurement traceability services; develops test methods and proposes engineering standards and code changes; develops and proposes new engineering practices; and develops and improves mechanisms to transfer results of its research to the ultimate user. The Laboratory consists of the following centers:

Applied Mathematics — Electronics and Electrical Engineering² — Mechanical Engineering and Process Technology² — Building Technology — Fire Research — Consumer Product Technology — Field Methods.

THE INSTITUTE FOR COMPUTER SCIENCES AND TECHNOLOGY conducts research and provides scientific and technical services to aid Federal Agencies in the selection, acquisition, application, and use of computer technology to improve effectiveness and economy in Government operations in accordance with Public Law 89-306 (40 U.S.C. 759), relevant Executive Orders, and other directives; carries out this mission by managing the Federal Information Processing Standards Program, developing Federal ADP standards guidelines, and managing Federal participation in ADP voluntary standardization activities; provides scientific and technological advisory services and assistance to Federal Agencies; and provides the technical foundation for computer-related policies of the Federal Government. The Institute consists of the following divisions:

Systems and Software — Computer Systems Engineering — Information Technology.

¹Headquarters and Laboratories at Gaithersburg, Maryland, unless otherwise noted; mailing address Washington, D.C. 20234.

²Some divisions within the center are located at Boulder, Colorado, 80303.

NOV 28 1978

not academic

RC 115

US 9

100.00

1978

Proceedings of Workshop on Asbestos: Definitions and Measurement Methods

Proceedings of a Workshop on Asbestos held at
the National Bureau of Standards,
Gaithersburg, Maryland, July 18-20, 1977

Edited by

C. C. Gravatt, Philip D. LaFleur,
and Kurt F. J. Heinrich

National Measurement Laboratory
National Bureau of Standards
Washington, D.C. 20234

Sponsored by
National Bureau of Standards
of the Department of Commerce
and Occupational Safety and Health Administration
of the U.S. Department of Labor



U.S. DEPARTMENT OF COMMERCE, Juanita M. Kreps, Secretary

Dr. Sidney Harman, Under Secretary

Jordan J. Baruch, Assistant Secretary for Science and Technology

NATIONAL BUREAU OF STANDARDS, Ernest Ambler, Director

Issued November 1978

Library of Congress Catalog Card Number: 78-600109

National Bureau of Standards Special Publication 506

Nat. Bur. Stand. (U.S.), Spec. Publ. 506, 490 pages (Nov. 1978)

CODEN: XNBSAV

U.S. GOVERNMENT PRINTING OFFICE

WASHINGTON: 1978

For sale by the Superintendent of Documents, U.S. Government Printing Office
Washington, D.C. 20402 - Price \$6.75

Stock No. 003-003-01993-3

FOREWORD

Asbestos is a generic name used to describe a variety of hydrated silicate materials which exist as fibers. Because "asbestos" resists heat and acids, is noncombustible, and can be woven into fabrics, it is a valuable industrial material. Asbestos has been known and used since ancient times. Today, it is used in some 3000 commercial applications, from potholders, to brake linings, to construction materials.

Concern over the use of asbestos has arisen from studies which indicate an increased incidence of various serious diseases among people who work with it. Meaningful regulation requires proper definitions of workplace air concentrations of asbestos and effective measurement methods for these minerals. This Workshop was organized to evaluate the existing state-of-the-art in measuring "asbestos" and is part of an interagency program dealing with definitions and measurement methods for asbestos between the National Bureau of Standards of the Department of Commerce and the Occupational Safety and Health Administration of the Department of Labor.

Philip D. LaFleur, Chief
Center for Analytical Chemistry

PREFACE

This Workshop was organized to provide a forum for representatives of industrial corporations, trade associations, regulatory and other federal agencies, state and local agencies and other researchers to discuss asbestos definitions and measurement methods.

The Workshop was divided into four topical areas: Mineralogical Aspects, the Relationships Between Chemical and Physical Properties and Health Effects, Analytical Methods, and Regulatory Aspects. The format of the Workshop included presentations of technical papers by invited experts, followed by verbal discussions. At the conclusion of each session there was a general discussion of the material presented. The general discussions served to define those factors for which there is general agreement, what points of controversy exist, and to identify additional research that is required to resolve the remaining problems.

The following protocol was employed for the preparation of these proceedings. Each author/speaker submitted a written manuscript based on and containing the material given in the oral presentation. The questions, answers, and comments which followed each talk have been transcribed from the tape recordings made of the Workshop, edited both to remove extraneous material and to improve readability, but without changing the meaning. These discussion sections are printed immediately following the manuscript. The general discussions which followed each session have been similarly transcribed, edited, and printed at the end of each topic section. In addition, any questions, answers, comments, or discussion material which was submitted to the editors in writing has been inserted in the appropriate section of the Proceedings and the material has been designated as "submitted in writing - not in recording of Workshop." I wish to express my gratitude to all those who, through participation in the Workshop or preparation of these proceedings, made this undertaking a success. These proceedings were expertly typed and prepared by Mrs. Joy Shoemaker and members of her Text Editing Facility and the assistance of Mrs. Betty Garrigues in correcting proofs was invaluable. The able assistance of Drs. Ryna Marinenko and John Small in editing the Analytical Methods Session is gratefully acknowledged.

It is hoped that these Proceedings will provide useful information to those currently involved in formulating measurement methods, definitions, and regulatory positions with respect to asbestos and other fibrous materials.

C. C. Gravatt, Chief
Office of Environmental Measurements

ABSTRACT

This document contains invited papers which were given at a workshop on "Asbestos: Definitions and Measurement Methods" which was jointly sponsored by the National Bureau of Standards of the U. S. Department of Commerce and the Occupational Safety and Health Administration of the U. S. Department of Labor. The discussion portions of the Workshop also have been included as has written material appropriate to the topics under consideration which was submitted to the editors at a later date. The Workshop covered four major topics: Mineralogical Aspects, the Relationship Between Chemical and Physical Properties and Health Effects, Analytical Methods, and Regulatory Aspects. Also included in these Proceedings is a summary of each of these topics. These summaries serve to define those factors for which there was general agreement at the Workshop, identify remaining points of controversy, and, in some cases, describe additional research required to resolve remaining problems.

Key Words: Amphibole; asbestos; fibers; light microscopy; mineralogical terminology; scanning electron microscopy; serpentine; talc; transmission electron microscopy.

TABLE OF CONTENTS

	PAGE
FOREWORD	iii
PREFACE	iv
ABSTRACT	v
SECTION I. MINERALOGICAL ASPECTS	
Chairman - Brian Mason, Smithsonian Institution, Washington, D. C.	
HISTORY OF ASBESTOS-RELATED MINERALOGICAL TERMINOLOGY.	1
Tibor Zoltai	
FIBROUS AND ASBESTIFORM MINERALS	19
James R. Kramer	
THE CRYSTAL STRUCTURES OF AMPHIBOLE AND SERPENTINE MINERALS.	35
Jack Zussman	
THE "ASBESTOS" MINERALS: DEFINITIONS, DESCRIPTION, MODES OF FORMATION, PHYSICAL AND CHEMICAL PROPERTIES, AND HEALTH RISK TO THE MINING COMMUNITY	45
Malcolm Ross	
GENERAL DISCUSSION OF MINERALOGICAL ASPECTS.	65
SESSION II. RELATIONSHIP BETWEEN CHEMICAL AND PHYSICAL PROPERTIES AND HEALTH EFFECTS	
Chairman - Marvin Schneiderman, National Cancer Institute of the National Institutes of Health, Bethesda, Maryland	
EPIDEMIOLOGICAL EVIDENCE ON ASBESTOS	7
W. J. Nicholson, A. M. Langer, and I. J. Selikoff	
MEASUREMENT OF ASBESTOS RETENTION IN THE HUMAN RESPIRATORY SYSTEM RELATED TO HEALTH EFFECTS	9
J. Bignon, P. Sebastien, and A. Gaudichet	
EPIDEMIOLOGIC EVIDENCE OF THE EFFECT OF TYPE OF ASBESTOS AND FIBER DIMENSIONS ON THE PRODUCTION OF DISEASE IN MAN.	12
W. Clark Cooper	
PATHOPHYSIOLOGY IN RELATION TO THE CHEMICAL AND PHYSICAL PROPERTIES OF FIBERS.	13
Paul Kotin	
THE CARCINOGENICITY OF FIBROUS MINERALS.	14
Mearl F. Stanton and Maxwell Layard	
NIEHS ORAL ASBESTOS STUDIES.	15
John A. Moore	
EPA STUDY OF BIOLOGICAL EFFECTS OF ASBESTOS-LIKE MINERAL FIBERS.	16
D. L. Coffin and L. D. Palekar	
A STUDY OF AIRBORNE ASBESTOS FIBERS IN CONNECTICUT	17
Leonard Bruckman	
GENERAL DISCUSSION OF RELATIONSHIP BETWEEN CHEMICAL AND PHYSICAL PROPERTIES AND HEALTH EFFECTS	19

SECTION III. ANALYTICAL METHODS

Chairman - K. Heinrich, Analytical Chemistry Division, National Bureau
of Standards

IDENTIFICATION OF SELECTED SILICATE MINERALS AND THEIR ASBESTIFORM VARIETIES . . .	201
William J. Campbell	
AN OVERVIEW OF ELECTRON MICROSCOPY METHODS	221
Clayton O. Ruud	
IDENTIFICATION OF ASBESTOS BY POLARIZED LIGHT MICROSCOPY	235
Walter C. McCrone	
MINERAL FIBER IDENTIFICATION USING THE ANALYTICAL TRANSMISSION ELECTRON MICROSCOPE	249
D. R. Beaman and H. J. Walker	
TRANSMISSION ELECTRON MICROSCOPICAL METHODS FOR THE DETERMINATION OF ASBESTOS. . .	271
Ian M. Stewart	
STATISTICS AND THE SIGNIFICANCE OF ASBESTOS FIBER ANALYSES	281
J. P. Leineweber	
SELECTION AND CHARACTERIZATION OF FIBROUS AND NONFIBROUS AMPHIBOLES FOR ANALYTICAL METHODS DEVELOPMENT	295
J. C. Haartz, B. A. Lange, R. G. Draftz, and R. F. Scholl	
ASBESTIFORM MINERALS IN INDUSTRIAL TALCS: COMMERCIAL DEFINITIONS VERSUS INDUSTRIAL HYGIENE REALITY	313
John M. Dement	
THE DETECTION AND IDENTIFICATION OF ASBESTOS AND ASBESTIFORM MINERALS IN TALC. . .	325
Harold D. Stanley	
MISIDENTIFICATION OF ASBESTOS IN TALC.	339
Jerome B. Krause and William H. Ashton	
AMBIENT AIR MONITORING FOR CHRYSOTILE IN THE UNITED STATES	355
Richard J. Thompson	
ENVIRONMENTAL PROTECTION AGENCY INTERIM METHOD FOR DETERMINING ASBESTOS IN WATER.	365
Charles H. Anderson	
INTER-LABORATORY MEASUREMENTS OF AMPHIBOLE AND CHRYSOTILE FIBER CONCENTRATION IN WATER	377
K. S. Chopra	
THE STANDARD FOR OCCUPATIONAL EXPOSURE TO ASBESTOS BEING CONSIDERED BY ASTM COMMITTEE E-34.	381
M. Cossette and A. A. Winer	
IDENTIFICATION AND COUNTING OF MINERAL FRAGMENTS	387
R. J. Lee, J. S. Lally, and R. M. Fisher	
PRACTICAL ASPECTS OF TALC AND ASBESTOS	403
C. J. Parmentier and G. J. Gill	
GENERAL DISCUSSION OF ANALYTICAL METHODS	413

SESSION IV. REGULATORY ASPECTS

Chairman - John Martonick, Occupational Safety and Health
Administration, Washington, D. C.

INTRODUCTION	421
John Martonick	
THE MINING ENFORCEMENT AND SAFETY ADMINISTRATION — REGULATIONS AND METHODS	423
Aurel Goodwin	
OCCUPATIONAL SAFETY AND HEALTH ADMINISTRATION METHODS.	431
Willard C. Dixon	
FDA PROJECTS AND METHODS	441
J. A. Wenninger, I. M. Asher, and P. McGrath	
CPSC REGULATION OF NON-OCCUPATIONAL EXPOSURE TO ASBESTOS IN CONSUMER PRODUCTS. . .	457
Robert M. Hehir, Steven P. Bayard, and June Thompson	
IMPACT OF ASBESTOS REGULATIONS ON THE MINING INDUSTRY.	467
C. S. Thompson	
GENERAL DISCUSSION OF REGULATORY ASPECTS	469
LIST OF ATTENDEES	479

Disclaimer:

Certain trade names and company products are identified in order to adequately specify the experimental procedure. In no case does such identification imply recommendation or endorsement by the National Bureau of Standards, nor does it imply that the products are necessarily the best available for the purpose.

HISTORY OF ASBESTOS-RELATED MINERALOGICAL TERMINOLOGY

Tibor Zoltai

Department of Geology and Geophysics
University of Minnesota
Minneapolis, Minnesota 55455

Abstract

Asbestos-related mineralogical terms such as fiber, fibrous, asbestiform, asbestos-like, and asbestos have been misinterpreted and redefined during the last few years in the literature of environmental and public health studies. The new definitions are inadequate for the proper description and study of various mineral particles and, at the same time, are causing considerable confusion in interdisciplinary communication.

The meaning of these terms is traced through the history of mineralogy. It is demonstrated that: the use of the term fiber has always required some resemblance to organic fibers; fibrous has been the term describing a crystallization habit in which the mineral appears to be composed of fibers; asbestiform has been used, without exception, to describe a special fibrous habit in which the fibers have higher tensile strength and flexibility than crystals in other habits of the same mineral; asbestos was initially the name of an independent mineral species and gradually became a collective term applied to all asbestiform varieties of minerals.

Key words: Acicular; amphibole; asbestiform; asbestos; fiber; fibrous; fragments; mineralogical; serpentine; terminology.

Introduction

Until a few years ago there was no problem with the asbestos-related mineralogical terminology. Mineralogists knew exactly what other mineralogists meant when they used terms like asbestos, asbestiform, fibrous, and acicular, even if some of these terms, like asbestiform, are not always defined in textbooks. The last syllable of asbestiform (that is, -form) is consistent with several adjectives used for the description of textures or crystallization habits (e.g., reniform, filiform, dentiform, colloform). Consequently, it is understood, without question, that asbestiform is a descriptive term for a certain texture or crystallization habit.

This situation of content was suddenly changed less than five years ago, when through the focusing of public and scientific attention on asbestos pollution this portion of the mineralogical terminology was picked up by environmental and public health scientists, by engineers and by lawyers. Unfortunately, they did not adopt the terminology as used by mineralogists but have introduced a redefinition of most of the critical expressions, in spite of the objection of leading mineralogists. The most important of these arbitrary changes of definitions included:

(1) Asbestos is understood by mineralogists as a collective term referring to the unusual crystallization of certain minerals in the form of long, strong, and flexible fibers, aggregated in parallel or radiating bundles from which the fibers can easily be

separated. The definition accepted by the Minnesota District Court during the trial of Reserve Mining Co. [63, p. 24],¹ however, was a different one:

Asbestos is a generic term for a number of hydrated silicates that, when crushed or processed, separate into flexible fibers made up of fibrils.
(emphasis by the author)

By this definition all amphiboles and a number of other minerals became possible candidates for inclusion in the term asbestos. Because of the perfect prismatic cleavage, upon crushing, amphiboles always produce acicular fragments. Of course, acicular fragments are not fibers, are not flexible and are not composed of fibrils. However, they may not be distinguishable from asbestos fibers in routine electron microscopic examination. In order to get around that problem the term fiber had to be defined in a more practical sense.

(2) The redefinition of fiber (U.S. District Court, District of Minnesota, Fifth Division, Fall, 1973) that was soon adopted by most environmental and public health scientists [28, p. 5] states that a fiber is:

a mineral which is at least three times as long as it is wide.^{2,3}

This definition of fiber eliminated the difficult task of testing the flexibility and the presence of fibril composition of submicroscopic particles, and retained only the shape of the particle as a decisive criterion. Accordingly, all acicular amphibole cleavage fragments became fibers and as indirectly implied, all amphibole minerals became asbestos.

(3) Leading mineralogists objected to calling amphibole cleavage fragments, asbestos fibers and amphiboles, asbestos minerals. In order to overcome that objection two less frequently used terms, "asbestiform" and "asbestos-like", were redefined in line with the new definitions of asbestos and fiber. The new definitions were introduced in the Minnesota courtroom [63], and subsequently in the language of the news media and the environmental literature:

Asbestiform became a prefix added to the name of any mineral which is known to occur as "asbestos" on occasion and/or produce "fibers" when crushed.

Asbestos-like was defined as any hydrous silicate particle which is at least three times longer than wide, that is, which is a "fiber".

Thus, all amphiboles became asbestiform minerals,⁴ instead of asbestos minerals, and amphibole fragments became asbestos-like fibers, underscoring its implied relationship with asbestos.

These new definitions provided a simplified mineralogical interpretation for the complex and not fully resolved problem of asbestos mineralogy. It simplified the identification of mineral particles by eliminating the need for distinction between asbestos fibers and acicular cleavage fragments. A fiber can simply be identified by its shape ($>3:1$ aspect

¹Figures in brackets indicate the literature references at the end of this paper.

²The $3>1$ aspect ratio limitation in the description of fibers was used before by some British and American regulatory agencies. However, this was the first incident when this fiber description became an asbestos fiber identification, as the use of the term fiber implied an identity between appropriately shaped amphibole fragments and amphibole asbestos fibers. This implicative use of the $3>1$ aspect ratio is apparent in most current environmental studies.

³It should be noted that sedimentologists use the term acicular for the description of particles "whose length is more than three times its width" [27, p. 5].

⁴The expression "asbestiform amphiboles" is basically valid. However, in the context of the new definitions it is erroneous as it includes all amphiboles. According to the proper mineralogical terminology the same expression is limited to those amphibole crystals which actually grew in the asbestiform habit.

ratio) and if its composition and lattice matches that of an amphibole, that particle can be called "asbestiform" amphibole, or simply, "asbestos". Consequently, all available data on the health hazards caused by the inhalation of asbestos fibers can be applied to acicular amphibole fragments, thus eliminating the need for the extensive job of determining the nature and the extent of the health effects of the actual particles, that is, the acicular amphibole fragments.

On the other hand, the new definitions created serious problems, probably not foreseen by the promoters of the new definitions. For example, jade became an asbestos in spite of the fact that jade is the toughest known natural substance [8]. One type of jade (nephrite) is mineralogically actinolite-tremolite, and according to the new definitions, it is an "asbestiform mineral" and its acicular fragments are "asbestos-like fibers". The other type of jade is jadeite, a pyroxene. Pyroxenes are similar to amphiboles as far as both are chain silicates and break into acicular fragments. The only major difference between these two groups of minerals, in terms of their qualifications for "asbestos", is that pyroxene is not "hydrated". Consequently, in terms of the new definitions jadeite is not an asbestos. However, one could argue whether the presence of OH is really necessary in the definition of asbestos.⁵

At the same time the new definitions include many non-asbestiform mineral varieties in the rank of asbestos, they also exclude a number of other minerals, (e.g., non-hydrous silicates) which in fact may also crystallize occasionally in asbestiform habit. Most of these minerals are rare and are not known to constitute commercial deposits. Nevertheless, a mineralogical definition should not be tied to commercial criteria.

The new definitions, of course, magnify the extent of the potential asbestos pollution problem by an exponential factor. If all amphiboles are "asbestiform" and their fragments are "asbestos-like" then every state in the union has some asbestos in the soils, drifts, and bedrocks. Kryvial, Wood, and Barrett show [44, p. 13] the distribution of "high concentration of asbestiform phases" of rocks in the continental United States. Only a few of the amphibole-bearing rocks included in that survey contain even a minor fraction of known, true asbestiform varieties of amphiboles.

The new definitions are not only contrary to mineralogical traditions but are inadequate for crystal chemical descriptions. They also can lead to ambiguity and contradiction. For example, Kryvial, et al. in their monograph [44, p. 5] wish to exclude hornblende from the "asbestiform" category of amphiboles; apparently because hornblende seldom crystallizes in asbestiform habit. However, the new definition of "asbestiform" does not allow them to use it in that sense, or to express the same concept in any other non-ambiguous way. They try to get around the problem by using the term fibrous in an ambiguous way by stating that hornblende is "seldom seen in a fibrous form". Yet in page 3 of the paper they state that all amphiboles "fragment into fibers", whether they are products of an "acicular form of a fibrous crystal" (?) or not. They admit that at a microscopic scale the fragments of hornblende are no different from that of other amphiboles. Apparently, what they are trying to say is that fibrous is not always fibrous, but the new terminology does not allow them to distinguish between these two types. The proper mineralogical terminology can do that.

Most mineralogists object to the misuse of the mineralogical terminology. Some mineralogists, however, have found themselves in situations where compromise was necessary and they used the new definition of fiber ($>3:1$ aspect ratio) and the term "fibrous" in an accordingly loose context [42,45,71], sometimes with comments on the disciplinary restrictions of that terminology [11].⁶

It is not entirely impossible that the minute acicular crystals of jade may turn out to possess some asbestos properties. In that case minute fragments of jade could appropriately be called asbestiform fibers.

The authors of [11] accept the new definition of fiber "in the context of studies of health hazards".

The true background and character of mineralogical concepts and the seemingly complex definition of the asbestos-related mineralogical terminology can be best illuminated through a historical analysis of the relevant terms and expressions. That will be attempted in the following pages.

Historical Review

Asbestos in history. Asbestos is probably the most unique substance in the mineral kingdom. To begin with, it does not even look like a stone, but looks more like some organic wool or cotton. Good quality asbestos is more elastic than other minerals and its high tensile strength is unique. Asbestos is not only stronger than organic fibers but it is also more durable, is fireproof, and for all practical purposes, amphibole asbestos is chemically inert.

The peculiar properties of asbestos have attracted the attention of man throughout history. In early times the use of asbestos was restricted either to the households of powerful and rich royalties or to special geographic areas. There are records that Egyptians, Greeks, Romans and even earlier civilizations had knowledge of asbestos and used it for special purposes. The Egyptians sometimes used coarse asbestos cloth to protect the embalmed bodies of Pharaohs from the ravages of time. The Romans made cremation wrappings to collect the unspoiled ashes of emperors. The lamps of the Vestal Virgins were furnished asbestos wicks which lasted forever. There are also some questionable records that the Romans threw asbestos and other toxic substances in the river flowing through the besieged city of Auxium, in order to break the resistance of the defendants. According to legend, Charlemagne had an asbestos tablecloth which he threw in the fireplace after dinner for the purpose of cleansing it, to the amusement of his company (fig. 1).

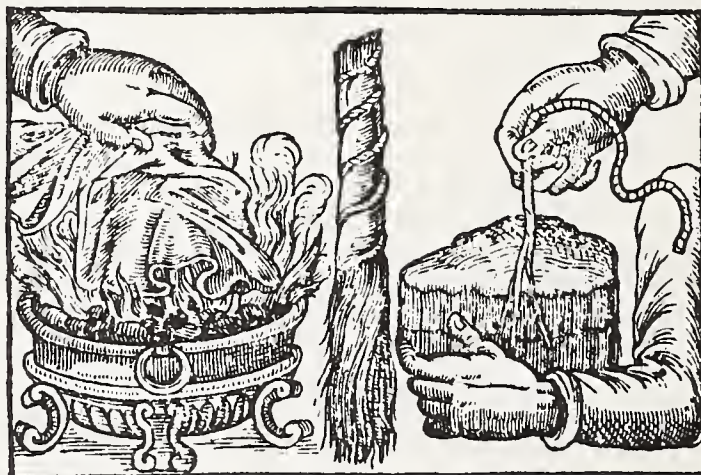

Figure 1. De Boot's [6] illustration of the fire-proof property and the making of asbestos cloth.

As it can be expected, in addition to the practical uses there were some less logical and more mysterious applications of asbestos in early and in superstitious civilizations. In medieval times, for example, asbestos was used as a major ingredient in an ointment (fig. 2) intended to cure a number of diseases. Loosely translated De Boot's prescription reads:

"Multiple application, miraculous asbestos ointment for juvenile tinea (head-fungus?) and shinbone (skin?) ulcer. Take 4 oz. asbestos, 12 oz. lead (oxide?), 2 oz. zinc oxide, and calcinate, thereupon pulverize into glass while adding vinegar, and agitate it daily for a month; after a month boil it for a quarter hour and let it cure until it becomes clear; thereafter add some vinegar, mix it with rose-petal oil until it becomes a homogeneous ointment: then go and smear it over the infant's head, to promote healing: for itches and shinbone ulcer smear it over the

affected area in the evening, for healing. The same mineral, mixed with aqua vitae and bamboo syrup, when applied in small quantities in the morning will sooth the pain of female white-menstruation (leukorrhœa?), and will soon heal."

*Miraculo-
sum A-
mianti
lapidis li-
nimentū.* Ex Amianto linimentum ad tineam puerorum,
& ad ulcera tibiariū miraculosum fit sequenti mo-
do. Accipiuntur Amianti unc. quatuor, plumbi
unciæ 12, tutiæ unciæ duæ, ac calcinantur, deinde
pulverifata in vitro macerantur cum aceto, ac quo-
tidie per mensem materia agitur semel; post men-
sem ebulliēda est unius horæ quadrante, ac quie-
scere sinitur, donec inclarescat: deinde illius aceti
clati quantitas, cum pari quantitate olei rosacci,
miscetur, donec bona fiat unio linimenti forma: eo
inungitur caput pueri totum ut cito sanetur: ad sca-
biam, & ulcera tibiariū vesperti partes unguuntur, *Ad ulce-
ra.*
donec sanentur. Si lapis hic cum aqua vitæ, & fac-
charo solvatur, ac exigua portio mane quotidie mu-
lieri albo menstruo laboranti detur, mox sanatur. *Ad alba
mēstrua.*

Figure 2. De Boot's prescription for the miraculous asbestos ointment [6, p. 384-5].

The industrial revolution opened an era yielding rich rewards for imaginative inventions. Asbestos, as other unique minerals, did not escape attention and a large number of applications were discovered. Some of these were practical and were adopted, such as fire-proof suits and other products (fig. 3). Some, on the other hand, were not well received by the public, like the refillable asbestos cigarette paper introduced in England during the 1880's [38].

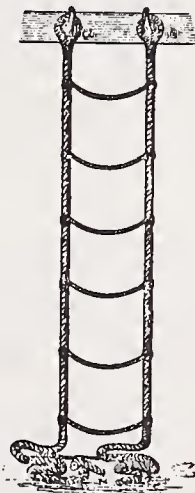

Asbestos Rope-ladder.



Portable Anti-thermal and Anti-septic Hut. (Frederick Jones & Co.)

Figure 3. Illustration of some early asbestos products, Jones [38].

Actually, industry was rather slow in adopting asbestos. Even after the discovery of the extensive and high-quality Canadian chrysotile deposits, asbestos-industrialists spent more time promoting their product than manufacturing it,⁷ at least for a few decades. After the turn of the century they began to succeed and asbestos soon became one of the most widely used industrial minerals.

Asbestos in mineralogy. Although there were several references to asbestos in the ancient literature, the first scientific-type descriptions were offered relatively late by Dioscorides [20] and Plinius [55]. Dioscorides called it αμιαντος amiantos (meaning immaculate, unpolluted) and Plinius added a comment that the Greeks used to call it ασβεστος asbestos (meaning incombustible, unquenchable, inextinguishable). Plinius also used the Latin name of linum vivum for the same mineral as he believed it to be a plant from India; a plant which grew in a part of the earth burned completely by the sun, thus became accustomed to that environment and learned to survive in the flame of fire.

During the scientifically dormant Middle Ages the nomenclature of Dioscorides and Plinius was neither challenged nor modified. Of the two names of asbestos, amiant appeared to be the more popular.

Almost two centuries ahead of the era of the scientific revival, Agricola [1] offered in 1546 the first criteria for mineral identification. According to Werner [66], Agricola recognized several basic categories of mineral properties such as color, transparency (translucida), resplendence (fulgor), luster (mitor), weight (gravitas), hardness (durities), flexibility (flexibilitas), cleavage (fissio), etc., and used descriptive terms as: globular (figura globi), cylindrical (figura cylindrica), conical (figura metae), hair-like (figura capillorum), star-like (figura stellarum), etc. It is easy to recognize in Agricola's expressions the prototypes of some modern terms. Although he did not expand our knowledge of asbestos, he did introduce the descriptive term capillary (haarförmig, hair-like) which was adopted later for the description of the shape of asbestos fibers.

The next stage of development in mineralogy was during the 18th century when scientists began the development of a mineralogical system divided into orders, classes and species on the basis of common and distinct external properties. These followed the natural history concepts and criteria used in botany and zoology. The first and still relatively crude classification was offered by Walerius [65] and by Cronstedt [15] and the first significant improvement of Agricola's list of external characters of minerals, and its application in mineral classification, was offered by Linneaus [47]. The term fibrous (fibrosum) appeared in his list of descriptive terms for minerals composed of parallel fibers.

This period was closed by Werner who published the first comprehensive and consistent system of mineralogy in 1774 [66]. He exerted unparalleled influence on the future development of mineralogy.⁸ His influence extended from the wide-spread acceptance of his system of mineralogy to the establishment of mining schools in many countries and to the practice of naming new minerals after personal names.

In his classification system, capillary is to be used for the description of asbestos fibers and fibrous is used to describe the breakage of bundles of fibers into small fibers.⁹ He constructed a complete system of minerals of about 300 species. Although never published, it was spread by his students and fellow mineralogists [34,26], and was adopted all over the

⁷Jones' book [38] may have been inspired by similar interests. He writes [38, p. VI] that "he hopes by this means (writing the book) to ... tend to develop the uses of" asbestos.

⁸Werner used the name oryctognosy for determinative mineralogy, after the Greek ορυκτος (fossil) and γνωσις (to know).

⁹Note that there is very little difference between saying that (1) fibrous crystals grow in bundles of fibers (as we would say it today) and (2) a bundle of fibers breaks down to fibrous crystals. However, the use of fibrous as a description of breakage was soon changed to a description of texture or habit by Blum [5, p. 30], Thomson [61, p. 256], Phillips [54, p. XXXVI and LXXII], etc.

civilized world, even before his death in 1817. In his system he recognized one asbestos species, with four subspecies, and two other [26] subspecies, asbestartiger or asbestarticher, one of actinolite and one of tremolite.¹⁰ Werner recognized a number of other fibrous, but not "asbestartiger" mineral varieties. He called those strahliger or fasriger. Jameson [36,37] translated Werner's terminology into English as asbestous, prismatic, and fibrous,¹¹ respectively for asbestartiger, strahliger, and fasriger. The comparison of the appropriate portion of Werner's and Jameson's classification are given in Table 1.

Table 1. Comparison of Warner's and Jameson's classification of asbestos and some fibrous minerals.

Werner, after Freiesleben [26]	Jameson [36]
<u>ERSTE KLASSE: ERDLICHE FOSSILIEN</u>	<u>CLASS II.</u>
3. <u>Kiesel Geschlecht</u>	<u>ORDER VI. SPAR</u>
Spischaft des Pistazits	<u>Genus I. Schiller Spar</u>
52. Anthophyllite	5. Prismatic Schiller Spar
a. strahllicher	or Anthophyllite
Sipschaft des Zeoliths	<u>Genus IV. Prehnite</u>
75. Prehnit	1. Axotomous Prehnite
a. fasricher	2d Subsp. Fibrous
77. Zeolith	<u>Genus IV. Zeolite</u>
b. Faser — Zeolith	7. Prismatic Zeolite
5. <u>Talk Geschlecht</u>	1st Subsp. Fibrous
Sipchaft des Talks	<u>Genus VIII. Augite</u>
137. Asbest	2. Hemiprismatic Augite
a. Bergkork	4th Subsp. Actynolite
b. Amianth	1st Kind Asbestous
c. gemeiner Asbest	2d -- Common
d. Bergholz	3d -- Glassy
Sipschaft des Strahlsteins	5th Subsp. Tremolite
138. Strahlstein	1st Kind Asbestous
a. asbestarticher	2d -- Common
b. gemeiner	3d -- Glassy
c. glasicher	6th Subsp. Asbestos
d. körnicher	1st Kind Rock-Cord
141. Tremolit	2d -- Flexible Asbestos
a. asbestarticher	3d -- Common Asbestos
b. gemeiner	4th -- Rock-Wood
c. gläsicher	

¹⁰The actual names of classification units vary from author to author. In order to avoid the lengthy comparison of the expressions used by different authors only "species", "subspecies", or "varieties" are used in the text (instead of "subspecies" and "kinds" of Jameson, for example).

¹¹Phillips and Allen [54, p. LXXII] used asbestiform as well as a special term fasciculated for minerals composed of fibers or acicular crystals occurring in bundles.

Jameson's asbestous was soon changed to asbestiform in English mineralogy textbooks: Thomson in 1836 [61, II., p. 22], Phillips and Allan in 1838 [54, p. 58] and Dana¹² in 1857 [17, p. 153].

Haüy [30] also adopted Werner's basic system and terminology, and translated most of his German terms into French, although he practiced more flexibility than Jameson did as he introduced a more chemical classification scheme. However, he makes no apparent distinction between asbestos and other fibrous varieties and uses the term fibreux for all. He translated Werner's asbestartiger Strahlstein and Tremolit as Actinote fibreux and Grammatite fibreuse,¹³ fasriger Prehnite as Prehnite fibreuse, and straliger Antophyllit as anthophyllite aciculaire. Although he does not distinguish between asbestos and other fibrous crystals, he seem to restrict the use of fascicle, and to a lesser degree fibre, to asbestos fibers. The term filamenteux was introduced into the French mineralogical literature by Brard [7], asbestoid by Beudant [4, p. 389] and asbestiforme by Cloizeaux [13, I, p. 80] as equivalent expressions for the German asbestartig and the English asbestiform.

It should be noted that all these early mineralogists, including Werner and his followers, used the term fibrous in a general sense and considered asbestiform (asbestous, asbestartig, feinfaserig, asbestoid) as a special class of fibrosity. Although none of them have defined the uniqueness of asbestiform fibrosity, the reason for that distinction was implied in their recognition of the unique properties and appearance of asbestos, including the unusual strength of asbestos fibers. Hoffmann (and Breithaupt) [33, Iib, p. 307], for example, pointed out that the asbestiform variety of tremolite is less brittle, that is, stronger than the common prismatic or acicular variety.

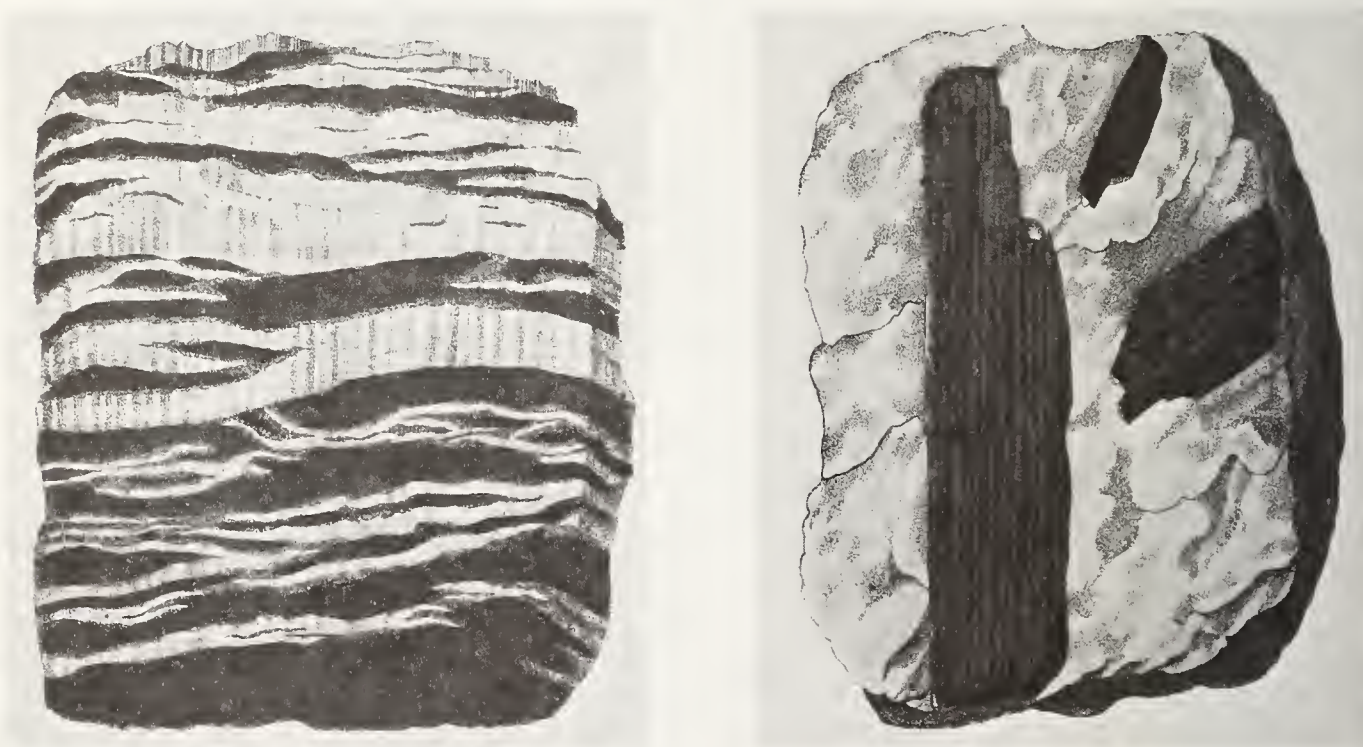

Figure 4. Handcolored illustrations of Schilletter Asbest (Amianth) and gemeiner (common) Tremolit in Schmidt's Mineralienbuch [60].

¹²At the bottom of this page Dana gives some exercise questions like: What is the crystallization of hornblende? Mention the characters of the varieties of actinolite - (i.e., glassy, radiated, asbestiform, massive).

¹³Occasionally, however, he used the German word "asbestartiger" in the French text without translation.

Werner's historical system of mineralogy was used without fundamental modifications for over a century, especially in popularized mineralogy books like that of Schmidt's [60]. Werner's strong influence on mineralogy resisted, for some times, the acceptance of the proposals of a new breed of mineralogists who advocated to change the system of mineralogy from the "natural history" type to a more chemical one. Mineralogists like Thomson [61], Beudant [4], Berzelius [57], Rammelsberg [56], and others believed that the chemical properties of minerals are much more important than their external and physical properties. Thomson was a strong opponent of the classification of minerals on the principles of natural history. He was especially critical of Mohs [49] who carried the natural history approach to such an extreme that it almost became free of chemistry. Thomson came out to say [61, p. 8]:

"It appears to me, that mineralogy is so closely connected with chemistry, and so dependent on it for its specific distinctions that it would be highly injurious to it, and therefore, very unwise to attempt to deprive it of so important an ally."

In line with the emphasis on chemistry came a new classification and the redefinition of mineral species. All those former species which had no distinct chemical composition were discredited. This included the degradation of Werner's one asbestos species to the rank of variety. Of course, asbestiform actinolite and tremolite were already considered variations (or subspecies) by Werner himself. Asbestos and its subspecies became classified, on the basis of relatively poor and inconsistent chemical analysis, as variations of amphiboles, epidote, pyroxenes, talc, and tourmaline by Beudant [4, p. 837], for example. Rammelsberg expressed this philosophy of the reclassification of the former asbestos species¹⁴ [56, Part I, p. 313] as:

"Mineral substances described by the name of asbestos (or amiant) do not appear to constitute an independent species. As their chemical compositions indicate, and it may be more appropriate as noted by Breithaupt, that the name asbestos represents a condition which can be obtained by several, thoroughly different kinds of minerals." (emphasis by author)

Berzelius, the Swedish chemist-mineralogist (also the major promoter of the "blowpipe analysis" which became one of the major mineralogical techniques for more than a century), was one of the most ardent pioneer advocates of this "scientific" system of mineralogy. In his 1846 publication [54, p. 213-214] Berzelius states that mineral species as previously defined don't exist. He proposed that instead of species, minerals should be identified and classified on the basis of:

"ingredients and different chemical proportions...as well as their definite bonding relationships." (Verbindungsverhältnisse = ? = crystal structure.)

The transfer of mineralogy from Natural History to Chemistry did not take place as proposed by Berzelius and his compeers. Instead, mineralogy developed gradually in that direction and assumed a unique position among the sciences, a status of transition between natural history and physical sciences. The concept of species was not fully abandoned either. In fact, with the meaning redefined in a chemical context, "mineral species" is still used today by some mineralogists, like Berry and Mason [3, p. 272-274]. The classification of minerals was also changed during the second half of the 19th century from categories of "common external properties" to groups of chemical units. Mineral species or individual minerals were defined by their chemical composition and crystal structure. Of course, crystal structures were not known at that time. Consequently, they had to be substituted for by the observable consequences of the crystal structure: the crystallography and physical-chemical properties of minerals. That is, if two minerals had the same composition but had different crystallography and physical properties they were considered to be two distinct minerals. That criterion was readily applicable to minerals which occurred in good crystal forms. However, the same could not be used for asbestos where there was not crystallographic

In the same book Rammelsberg recognized Krokydolite (crocidolite), named by Hausmann in 1831, as an independent species. That may, at first, look like a contradiction in his philosophy. However, it is not, as crocidolite's parent mineral riebeckite was only discovered many years later, in 1888, by Sauer.

data and the only non-chemical information available was the difference in the tensile strength and flexibility of the asbestiform versus the compositionally equivalent non-asbestiform mineral. That difference was considered by many mineralogists to be sufficiently distinct to warrant the recognition of some asbestiform varieties as independent minerals. Several dozen asbestos minerals were proposed and accepted during this stage of evolution.¹⁵

The chemical compositions of most of these asbestos minerals were known and their chemical identity with other minerals were recognized. The compositional equivalence of chrysotile and serpentine was realized since Kenngott's publication [40] in 1853. That was sufficient for some mineralogists to declare chrysotile as a variety of serpentine. Others however, still considered the differences in physical properties sufficiently significant to recognize chrysotile (under various names, like: metaxite, schweizerite, etc.) and serpentine as two distinct minerals. The other two major asbestos minerals, byssolite and crocidolite, were known to match amphibole compositions, byssolite since Scheerer's 185 analysis [59] and crocidolite since Delasse's 1847 analysis [19]. Crocidolite was first believed to be an asbestiform variety of arfvedsonite [50, p. 461] in spite of minor chemical differences. However, as soon as riebeckite was discovered by Sauer in 1888, crocidolite was reclassified by Naumann (and Zirkel) [51, p. 707], as its asbestiform (Asbestform in German) variety.

As a consequence of the undecisive significance of differences in physical properties versus compositional identities, the classification of asbestos minerals as independent minerals or as varieties was a function of the individual interpretation of mineralogists. For example, Hintze [31], Groth [29], and Naumann (and Zirkel) [51] recognized chrysotile as a variety of serpentine and crocidolite as a variety of riebeckite; E. S. Dana [16] classified both as independent species; Klockmann [41] and Rogers [58] recognized chrysotile as an independent mineral and crocidolite as a variety of riebeckite.

The asbestos nomenclature was further complicated during the last decades of the 19th and first decades of the 20th century when asbestos became a major industrial material. The industrially useful properties of asbestos obtained from certain deposits differed somewhat from that of others, and on the basis of that some asbestos were given distinct mineral names usually reflecting the name of a mining company or district (for example, bostonite: Boston Asbestos Packing Co.; amosite: Asbestos Mines of South Africa; montasite: Montana mine, South Africa; prieskaite: Westerborg mine, Prieska, South Africa). The use of these distinct mineral names, of course, provided some promotional advantages. The majority of these commercial mineral names never got into mineralogy text books, and those few which did were subsequently eliminated or discredited. Amosite, for example, was formally discredited in 1946 [2].

The discovery of x-ray diffraction produced a tool available for crystal structure determination. As the basic crystal structures of the former asbestos minerals were proved to be identical with that of compositionally equivalent major minerals they were all degraded to the rank of varieties, without further arguments. For example, the final decision on crocidolite's mineralogical identity with riebeckite was provided by Whittaker in 1949 [67] and by Drysdall and Newton in 1960 [22]. The asbestos varieties of minerals were consequently identified by the prefix of fibrous or asbestos-like [24, p. 578] or asbestiform (see Table for details). Fibrous¹⁶ was used as a more general term to include both asbestiform and non-asbestiform fibrous minerals. However, asbestiform was always restricted to asbestos varieties, as that was done consistently since Werner's time, 200 years ago.

¹⁵These asbestos mineral names included: Adigenite, agalite, antholite, baltimorite, beaconite, cyclopeite, dermatite, fibrolite, griquanlandite, hydrophite, ishkyldite, karachaite, kolskite, kymantine, metaxite, nemalite, picrolite, retinalite, rezhikite, rhoduzite, schweizerite, vorhausite, williamsite, zermattite, zillerite, xylotite, etc.

¹⁶Ford [24, p. 204] gave a more liberal definition of fibrous than usual. He states that "fibres may or may not be separable" in a fibrous mineral.

Table 2. Descriptive terms used by mineralogists to distinguish between asbestos and other types of fibrous^a textures.

(Frequently in conjunction with fibrous.)

Page number of an example is given.

Werner (Friesleben) [66, p. 10]	<u>asbestartich</u>	Naumann [50, p. 324]	<u>asbestartig</u>
Häuy [30]	<u>no distinction</u>	Naumann (Zirkel) [51, p. 707]	<u>Asbestform</u>
Hoffmann (Breithaupt) [33, 2b, p. 306]	<u>asbestartig</u>	Nicol [52, p. 152]	<u>asbestiform</u>
Jameson [36, II, p. 22]	<u>asbestous</u>	Tschermak [62, p. 444]	? <u>feinfaserig</u>
Phillips (Allan) [54, p. 58]	<u>asbestiform</u>	Groth [29, p. 151]	<u>asbestartig</u>
Thomson [61, I, p. 481]	<u>asbestiform</u>	E. S. Dana [16, p. 384]	<u>asbestiform</u>
Mohs (Haidinger) [49, II, 27]	<u>asbestous</u>	Hintze [31, II, p. 1195]	? <u>feinfaserig</u>
Beudant [4, p. 387]	<u>asbestoïde</u>	Klockmann [41, p. 567]	? <u>feinfaserig</u>
Brard [7, p. 206]	<u>filamenteux</u>	Doelter [21, II, p. 589]	<u>asbestartig</u>
Blum [5, p. 242]	? <u>feinfaserig</u>	Rogers [58]	<u>no distinction</u>
Rammelsberg [56, p. 358]	<u>asbestartig</u>	Ford [24, p. 578]	<u>asbestos-like</u>
Schmidt [60, p. 358]	<u>asbestartig</u>	Hurlbut [35, p. 446]	<u>asbestiform</u>
Bristow [9, p. 85]	<u>asbestiform</u>	Kraus, Hunt, Ramsdell [43, p. 392]	<u>asbestiform</u>
Cloizeaux [13, p. 81]	<u>asbestiforme</u>	Berry, Mason [3, p. 527]	<u>asbestiform</u>
J. D. Dana [17, p. 153]	<u>asbestiform</u>	Deer, Howie, Zussman [18, II, p. 243]	<u>asbestiform</u>

^a French: fibreux; German: faserig.

The term fiber, in reference to asbestiform fibers, was equivalent to the concept of organic fibers because the early natural historians believed that asbestos was actually a vegetable. Mineralogists from the 18th century on did not specifically state that the term fiber is used because of its resemblance with organic fiber. However, that reasoning is apparent in their description of asbestos fibers as hair-like or capillary or thread-like, and in the types of names they have given to asbestos minerals, such as mineral-wood, rock-cotton, mountain cork, rock-wood. Jones [38] provided extensive details in the description of the similarity between asbestos and organic fibers (fig. 5) and concluded [38, p. 221] that:

"The nature of the asbestos fibre is thus so far identical in structures with the organic fibres."

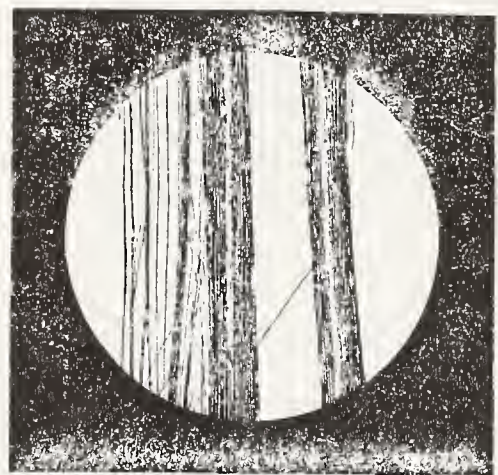
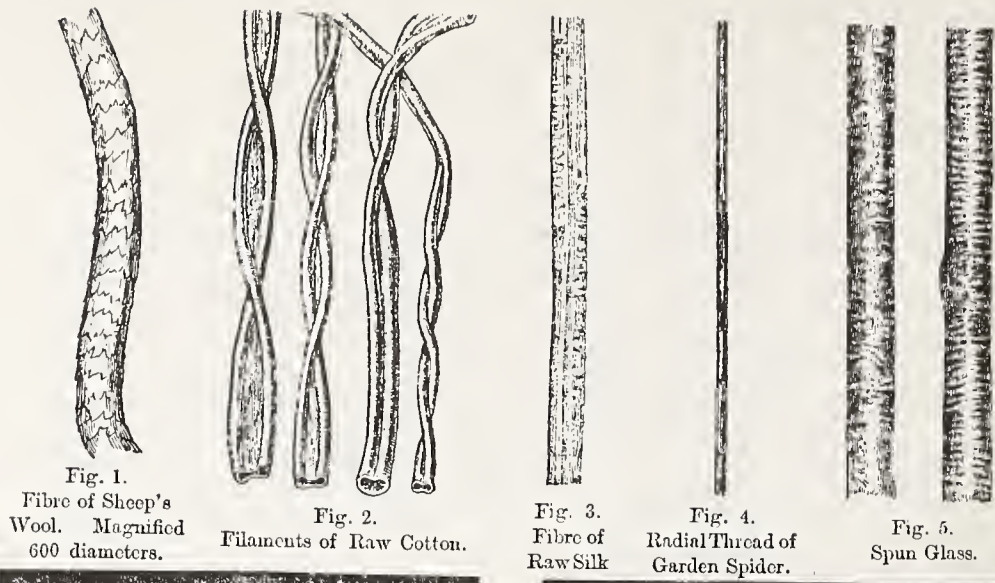

No. 1.—Thetford Ore.



No. 2.—Thetford Ore.

Figure 5. Jones' [38] comparison of asbestos and organic fibers.

Although the use of the term fiber has not been restricted to asbestos and included a number of other minerals they all had some characteristics reminiscent of organic fibers. In any case, the term fiber has never been used as a description of the elongated shape of crystals. For that acicular is the proper mineralogical expression.

The term asbestos was first a species name, as noted earlier it was introduced by Werner and his school. Later it became a collective term, like clays or gems, in reference to asbestiform varieties of a number of otherwise unrelated minerals. Parallel with the mineralogical terminology asbestos also became an industrial term for a category of mineral products containing asbestiform varieties of silicates. However, some commercial asbestos may be mixed with non-asbestiform acicular crystals or cleavage fragments. The quality of asbestos is related to: (a) the extent of the development of the preferred asbestos character (high tensile strength, flexibility, length of fibers) of the asbestiform fibers, and (b) the percentage of the less desirable non-asbestiform, acicular crystals or cleavage fragments present in the product. That is, the mineralogical and industrial definitions of asbestos are not fully coincident.

The unusual properties of the asbestiform fibers were always recognized by the early users of asbestos as well as by mineralogists. These properties included high tensile strength [for example, 32,33,38,64], increased flexibility (noticed by all mineralogists), unexpected optical properties [for example, 53,69] and differences in surface properties, like surface charges [for example, 28,42,45,72].

With the introduction of high-power electron microscopy, a new tool for mineralogical research and a new area of applied mineralogy was established. Electron microscopes permitted the examination of extremely small mineral particles and the study of the fiber of fibril structures of various asbestiform crystals. The long suspected cylindrical (tubular, scroll-like) structure of the chrysotile fibrils [68] was directly observed by Maser et al. in 1960 [48] and a more detailed record was offered by Yada [70]. In addition to the cylindrical fibril structure, Cressey and Zussman [14] reported on a polygonal chrysotile structure which appears to be the dominating fibril structure in the so called "schweizerite" and "Provlen-type" chrysotile varieties. Comparable work, although with less spectacular results, was done on asbestiform amphiboles by several investigators, for example, Chisholm [12], Franco, Hutchinson, Jefferson, and Thomas [25]. The asbestiform amphibole fibril structure appears to be more subtle than that of chrysotile. The increased tensile strength and flexibility may be due to the presence of systematic defects such as faults, dislocations and twinning, and/or to the lack of surface defects. Of course, we know that defects can interfere with the cleavage and fracture of solids and are frequently introduced artificially in alloys and other crystals to enhance their strength as it is elaborated on in the textbook of Kelly and Nicholson [39]. Undoubtedly, time and extensive research will be needed before the structural causes of the unusual properties of asbestiform amphiboles will be fully explained.

Conclusions

Several conclusions can be drawn from this review of the history of asbestos-related mineralogical terminology and its current misuse in environmental sciences:

- (1) Terms such as fiber, fibrous, asbestiform, and asbestos, have distinct meanings in mineralogy whether or not we can offer a complete crystal structural explanation for the development of the properties, reflected by these terms.
- (2) The asbestos-related mineralogical terminology is adequate and clear, and is not in need of revision. However, its full understanding requires a relatively comprehensive knowledge of mineralogy. Consequently, a set of detailed and unambiguous definitions should be prepared for interdisciplinary use.
- (3) The asbestos-related mineralogical terms have been grossly misinterpreted in most of the recent literature of environmental sciences. The implied definitions are inadequate for the description and discussion of the crystal chemical and crystal physical properties of minerals, and endanger the success of coordinated, interdisciplinary studies aimed at the understanding and the solution of the health hazards created by asbestos pollution.

The presence of any foreign particle in air and waters in excessive quantities is undesirable and is potentially harmful. It is imperative that all efforts be made to clean up the environment starting with one of the most dangerous mineral pollutants: asbestos. This job requires extensive interdisciplinary cooperation and the establishment of an unambiguous interdisciplinary language.

The extensive list of definitions offered in the recent U.S. Bureau of Mines Information Circular [10] are comprehensive and consistent with mineralogical traditions. The adoption of these definitions for the interdisciplinary language of asbestos studies should be considered.

The following definitions of the four most critical asbestos-related mineralogical terms are based on their historical review.

FIBER An acicular single crystal, or a similarly elongated polycrystalline aggregate, which displays some resemblance to organic fibers.

Examples for criteria of "resemblance to organic fibers" are: circular cross section, flexibility, silky surface luster, axial lineation, threaded appearance, etc. Most of these fiber characteristics cannot be observed at electron-microscopic scale. Consequently, any elongated particle may be called a fiber (when fiber used as a shape-descriptive expression) provided that it displays parallel edges and apparently equidimensional cross section. That is, elongated triangular-shaped or irregular particles cannot be considered to have the shape of a fiber.

FIBROUS The descriptive term used for a mineral which is composed of parallel, radiating or interlaced aggregates of fibers, from which the fibers are usually separable.

That is, the crystalline aggregate may be referred to as fibrous even if it is not composed of separable fibers, but has that distinct appearance.

ASBESTIFORM A special type of fibrous habit in which the fibers are separable, and are more flexible and possess higher tensile strength than crystals in other habits of the same mineral.

Increased flexibility and higher tensile strength are, apparently, the most distinct qualities of asbestiform fibers. These properties are undoubtedly due to certain structural variations and can justifiably be included in the definition.

ASBESTOS A collective mineralogical term which includes the asbestiform varieties of various (silicate) minerals. ^{17,18}

The justification for restricting asbestos to silicate minerals may be questionable from the mineralogical point of view, as non-silicate minerals may also crystallize in fibrous habit and the fibers may possess asbestiform properties. However, these properties are expected to be different in magnitude from those of the asbestiform silicates and, therefore, from the health study's point of view, are justifiably excluded from the category of asbestos.

¹⁷The development of fibrous habits must be due to certain unusual conditions which existed at the time of the mineral's crystallization. These conditions may be accompanied by structural modifications and by consequent changes in the mineral's physical properties. These changes, however, are usually not as conspicuous as they are in silicate asbestiform fibers. In fibrous gypsum, for example, the only readily observable change is in the mineral's fracture pattern. The usually absent ((111)) cleavage plane is perfect in fibrous gypsum and is responsible for its acicular rather than platy fragments. This change in the cleavage pattern is probably due to some structural modification. On the other hand, the conditions of crystallizations may be such that no change in the mineral's structure and properties is necessary. For example, if a fibrous mineral is altered to another, the new mineral may show pseudomorphic fibrous appearance. Dana [16, p. 678] believes that the appearance of fibrous talc is due to its alteration from enstatite.

¹⁸The industrial quality of asbestos depends, in part, on the degree of development of the asbestiform fiber structure in the mineral. That is, if more crystals have the scroll-like structure in chrysotile, or the crystals have higher density of defects or twinning in asbestiform amphiboles or have fewer surface defects, the asbestiform fibers are stronger and more flexible, and thus they are more desirable. A similar relationship may exist between the degree of development and the density of asbestiform fibers in the bundles, and their biological activity. That is, the gradation of asbestiform development in a mineral, from acicular cleavage fragments to asbestiform fibers, may constitute different health hazards.

The critical reviews offered by Drs. Edwin Roedder and James H. Stout are acknowledged with appreciation. This study was in part supported by a grant from the Regional Copper-nickel Study, Environmental Quality Council, Minnesota.

References

- [1] Agricola, Georgius (Bauer), De Natura Fossilium, (Basilea, 1546).
- [2] Amosite discredited, Am. Mineral. 34, 339 (1946).
- [3] Berry, L. G. and Mason, Brian, Mineralogy, (Freeman and Co., San Francisco, 1959).
- [4] Beudant, F. S., Traité Élémentaire de Minéralogie, (Verdière, Paris, 1824).
- [5] Blum, J. R., Lehrbuch der Oryktognosie, (G. Schweizerbart, Stuttgart, 1833).
- [6] Boot, Anselmus Boetius, de, Gemmarum et Lapidum Historia, (Lugduni Bataborum, 1647).
- [7] Brard, C. P., Nouveau elemens de Minéralogie, 2^e ed., (Meguinon-Marvis, Paris, 1824).
- [8] Bradt, R. C., Newnham, R. E., and Biggers, J. V., The toughness of jade, Am. Mineral. 58, 727-732 (1973).
- [9] Bristow, H. W., Glossary of Mineralogy, (Longman et al., London, 1861).
- [10] Campbell, W. J., Blake, R. L., Brown, L. L., Cather, E. E., and Sjoberg, J. J., Selected silicate minerals and their asbestiform varieties; mineralogical definition and identification-characterization, (U.S. Bureau of Mines. Int. Circ. No. 8751, 1977).
- [11] Champness, P. E., Lorimer, G. W., and Zussman, J., Fibrous cummingtonite in Lake Superior: Discussion, Canad. Mineral, 14, 394 (1976).
- [12] Chisholm, J. E., Planar defects in fibrous amphiboles, J. Material Sci. 8, 475-483 (1973).
- [13] Cloizeaux, A., des Manuel de Minéralogie, 2 vols., (Dunond, Paris. 1862).
- [14] Cressey, B. A. and Zussman, J., Electron microscopic studies of serpentinites, Canad. Mineral. 14, 307-313 (1976).
- [15] Cronstedt, A. F., Försöktill en Mineralogie, eller Mineral Rikets Uppstälning, (Stockholm, 1758).
- [16] Dana, Edward S., The System of Mineralogy of James Dwight Dana, Descriptive Mineralogy, 6th ed., (J. Wiley and Sons, New York, 1914).
- [17] Dana, James D., Manual of Mineralogy, (Henry H. Peck, New Haven, 1857, new ed. (1871).
- [18] Deer, W. A., Howie, R. A., and Zussman, J., Rock-Forming Minerals, 5 vols., (J. Wiley and Sons, 1962, 1963).
- [19] Delasse, A., (analysis of crocidolite) Compt. Rend. 44, 766 (1847).
- [20] Dioscorides, P., Περὶ ὑλῆς ἰατρικῆς (Materia Medica), (Approx. 50 A.D.).
- [21] Doelter, C., Handbuch des Mineralchemie, 3 vols., (T. Steinkopff, Dresden and Leipzig, 1912, 1914, 1918).
- [22] Drysdall, A. R. and Newton, A. R., Blue asbestos from Northern Rhodesia and its bearing on the genesis and classification of this type of asbestos, Am. Mineral. 45, 53-59 (1960).

- [23] Engleston, T., A Catalogue of Minerals and Synonyms, (J. Wiley and Sons, New York, 1892).
- [24] Ford, W. E., Dana's Textbook of Mineralogy, 4th ed., (J. Wiley and Sons, New York, 1951).
- [25] Franco, M. A., Hutchinson, J. L., Jefferson, D. A., and Thomas, J. R., Structural imperfection and morphology of crocidolite (blue asbestos), Nature 266, 520-521 (1977).
- [26] Freiesleben, J. C., A. G. Werner's Letztes Mineral-System, (Craz and Gerold, Freyberg and Wien, 1817).
- [27] Gary, M., McAfee, R., Jr., and Wolf, C. L., (editors), Glossary of Geology, (Am. Geol. Inst., Washington, D. C., 1972).
- [28] Great Lakes Research Advisory Board, Asbestos in the Great Lakes Basin, (February, 1975).
- [29] Groth, P., Tabellarische Übersicht des Mineralien, 4te Aufl., (Friedrich Vieweg und Sohn, Braunschweig, 1898).
- [30] Haüy, M. L'Abbe, Traité de Minéralogie, 5 vols., (Bachelier, Paris, 1801, 2^e edition, 1822).
- [31] Hintze, C., Handbuch der Mineralogy, Bd. 2, (Von Veit, Leipzig, 1897).
- [32] Hodgson, A. A., Fibrous silicates, Lect. Ser. 1965 No. 4, (The Royal Inst. of Chem., 1966).
- [33] Hoffmann, C. A. S., Handbuch der Mineralogie, (after Bd. 2a by A. Breithaupt), 4 vols., (Craz and Gerold, Freyberg, 1811-1818).
- [34] Hoffmann, C. A. S., (about Werner's Mineral System), 17th ed., Bergm. J. 1, 369 (1789).
- [35] Hurlbut, C. S., Jr., Dana's Manual of Mineralogy, (J. Wiley and Sons, New York, 1959).
- [36] Jameson, Robert, System of Mineralogy, (Archibald Constable, Edinburgh, 1816).
- [37] Jameson, Robert, Manual of Mineralogy, (Archibald Constable, Edinburgh, 1821).
- [38] Jones, R. H., Asbestos, its Properties, Occurrence and Uses, (Crosby Lockwood, London, 1890).
- [39] Kelly, A. and Nicholson, R. B., Strengthening Methods in Crystals, (Appl. Sci. Publ., London, 1971).
- [40] Kenngott, Adolf, Das Mohs'sche Mineral System, (C. Gerold, Wein, 1853).
- [41] Klockmann, F., Lehrbuch der Mineralogie, (F. Enke, Stuttgart, 1903).
- [42] Kramer, J. R., Fibrous cummingtonite in Lake Superior, Canad. Mineral. 14, 91-98 (1976).
- [43] Kraus, E. D., Hunt, W. F., and Ramsdell, L. S., Mineralogy, (McGraw-Hill, New York, 1959).
- [44] Kryvial, R. J., Wood, R. A., and Barrett, R. E., Identification and assessment of asbestos emissions from incidental sources of asbestos, (U.S. Env. Prot. Agency, EPA 650/2-74-087, Washington, Sept. 1974).
- [45] Langer, A. M., Approaches and constraints to identification and quantitation of asbestos fibers, env. Health Presp. 9, 133-136 (1974).

- [46] Light, W. G. and Wei, E. T., Surface charge and asbestos toxicity, Nature 265, 537-539 (1977).
- [47] Linneaus, C. A., Systema Naturae, (Holm, 1768).
- [48] Maser, M., Rice, R. V., and Klug, H. P., Chrysotile morphology, Am. Mineral. 45, 680-688 (1960).
- [49] Mohs, Frederich, Gründriss der Mineralogie, 2 vols., (Dresden, 1822). English: Treatise on Mineralogy, Transl. by W. Haidinger, 2 vols., (Hurst and Robinson, London, 1825).
- [50] Naumann, Carl F., Elemente der Mineralogie, 8te Aufl., (W. Engelmann, 1871).
- [51] Naumann, Carl F., Elemente der Mineralogie, 13te Aufl. by Ferdinand Zirkel, (W. Engelmann, 1898).
- [52] Nicol, James, Elements of Mineralogy, (A. and C. Black, Edinburgh, 1873).
- [53] Peacock, M. A., The nature and origin of the amphibole asbestos of South Africa, Am. Mineral. 13, 241-285 (1928).
- [54] Phillips, William, An Elementary Introduction to Mineralogy (1823), 4th ed. by R. Allan, (Longman, et al., London, 1837).
- [55] Plinius Secundus, C., Historia Naturalis, 27 books (77 A.D.)
- [56] Rammelsberg, C. F., Wörterbuch des Chemischen Theils der Mineralogie, (C. G. Luderitz, Berlin, 1841).
- [57] Rammelsberg, C. F., J. J. Berzelius' Neues Chemisches Mineral System (J. L. Schrag, Nürnberg, 1847).
- [58] Rogers, A. F., Introduction to the Study of Minerals, (McGraw-Hill, New York 1937).
- [59] Scheerer, Th., (analysis of byssolite) Pogg. Ann. 84, 389 (1851).
- [60] Schmidt, F. A., Mineralienbuch, (Krais and Hoffman, Stuttgart, 1855).
- [61] Thomson, Thomas, Outline of Mineralogy, Geology, and Mineral Analysis, 2 vols., (Baldwin and Cradock, London, 1836).
- [62] Tschermak, Gustav, Lehrbuch der Mineralogie, (Alfred Hölder, Wein, 1884).
- [63] U.S. District Court, District of Minnesota, 5th Division, Supplemental Memorandum, (No. 5-72, Civil 19, Appendix 5, Judge Miles Lord, May 11, 1974).
- [64] Vermaas, F. H. S., The amphibole asbestos of South Africa, Trans. Proc. Geol. Soc. South Africa 55, 199-229 (1952).
- [65] Walerius, I. A., Mineral-riket, (Holm, 1847).
- [66] Werner, A. F., Ausserlichen Kennzeichen des Fossilien, (Leipzig, 1774), English: On the external character of minerals, Transl. A. V. Carozzi (U of Ill., Press, 1962).
- [67] Whittaker, E. J. W., The structure of Bolivian crocidolite, Acta Crystallogr. 2, 312-317 (1949).
- [68] Whittaker, E. J. W., The structure of chrysotile, Acta Crystallogr. 6, 747 (1953).
- [69] Wylie, A., Optical properties of asbestiform amphiboles and their non-asbestiform analogues, U.S. Bureau of Mines, I.R. (in press).

- [70] Yada, Keiji, Study of chrysotile asbestos by a high resolution electron microscope
Acta Crystallogr. 23, 704-707 (1967).
- [71] Zoltai, T. and Stout, J. H., Comments on asbestiform and fibrous mineral fragments
(Minn. Poll. Contr. Agency, 1935 W. Co. Road B-2, Roseville, MN 55113, 1976).
- [72] Zoltai, T., Veres, I., Wagner, M. J., and Hammer, R. F., Surface charges of
asbestiform amphibole fibers, (in manuscript).

Discussion

M. COSSETTE: Could you tell me if the use of the word asbestoid implies that it is not quite asbestos?

T. ZOLTAI: Brard and Beudant used it in lieu of asbestartich or asbestiform, that is the expression is equivalent to asbestiform.

A. BOHMER: Are you suggesting that if a mineral has an asbestiform habit in its varieties and it has a three-to-one ratio it is asbestos? That is, should we limit our classification of asbestiform to those minerals?

ZOLTAI: Yes.

FIBROUS AND ASBESTIFORM MINERALS

James R. Kramer

Department of Geology
McMaster University
Hamilton, Ontario L8S 4M1
Canada

Abstract

Asbestiform minerals may be differentiated from other elongate minerals by comparing their length and aspect ratio distributions in the greatest percentile level. Individual fiber analyses of UICC and other well-characterized samples suggest a possible 20-40 percent intensity ratio variation relative to Si of major cations. There is a very small amount of evidence to suggest that fibers other than asbestos are toxic.

Key words: Acicular; asbestiform; asbestos; elemental composition; fibers.

Introduction

The ability to differentiate between acicular minerals, fibrous minerals, and asbestiform minerals is most significant to the work of analysts, health researchers, and mineralogists. Zoltai [21, p. 13-31]¹ defines the terms carefully, discusses the history of the relevant terms, and shows how the discrepancies in the use of the terms found today has evolved. In short, the differentiation of the terms asbestos, asbestiform, fiber, fibrous, and acicular has been obscured in many cases and in different applications. One reason for a large part of the overlap of the usage of the terms is the difficulty in separation of one term from another on an analytical basis at the scale of the transmission electron microscope. When enumerating elongate particles at the micrometer scale, in many cases a cleavage fragment can appear similar to a fiber or an asbestiform mineral. Thus the advent of the transmission electron microscope to identify and enumerate particles on an environmental monitoring basis has brought certain ambiguities.

The Glossary of Geology [1] defines some of the pertinent terms as follows:

"ASBESTOS: (a) a commercial term applied to a group of highly fibrous silicate minerals that readily separate into long, thin, strong fibers of sufficient flexibility to be woven, are heat resistant and chemically inert, and possess a high electric insulation, and therefore are suitable for uses (as in yarn, cloth, paper, paint, brake linings, tiles, insulation cement, fillers, and filters), where incombustible, nonconducting, or chemically resistant material is required. (b) a mineral of the asbestos group, principally chrysotile (best adapted for spinning) and certain fibrous varieties of amphibole (ex. tremolite, actinolite and crocidolite). (c) a term strictly applied to the fibrous variety of actinolite. syn: asbestus, amianthus, earth flax, mountain flax.

ASBESTIFORM: said of a mineral that is fibrous, i.e., that is like asbestos.

ACICULAR: (cryst) said of a crystal that is needlelike in form. cf. fascicular, sagenitic.

¹Figures in brackets indicate the literature references at the end of this paper.

FIBROUS: said of the habit of a mineral, and of the mineral itself (e.g. asbestos), that crystallizes in elongated, needlelike grains or fibers."

The more restrictive definition of asbestos (c) is not presently used. Thus asbestiform is a restricted usage of fibrous pertaining to asbestos. In the general field of mineralogy, asbestiform has not been a commonly used term.

Taken as a whole, one can easily imagine that overlap at an analytical level among the definitions of acicular, asbestiform, and fibrous definitions could occur. In a bulk sample the distribution (bundle, fibrils, splitting), fiber length, and concentration of fibers would be used to distinguish between asbestiform and fibrous in most cases. Acicular would be distinguished from fibrous and asbestiform in that the properties of a fiber (flexibility, bundles, splitting) are not present. When minerals are dispersed, occur separately and are examined at the micrometer scale, the distinguishing characteristics for these terms disappear or are highly obscured. At this microscopic level, it is most difficult to distinguish among cleavage fragments, acicular minerals, and fibers. In no cases, however, are cleavage fragments considered to fall into the definitions of asbestiform, fibrous, or acicular.

In another discussion of asbestiform [20, p. 19], it is considered "a type of mineral fibrosity in which the fibers and fibrils possess high tensile strength and flexibility. Spiel and Leineweber [18] point out that all asbestos minerals have overlapping tensile strengths; and methods of measurement are difficult "with large variations in results using the same and different techniques." Furthermore, there are virtually no tensile strength data on other fibers and cleavage fragments. Flexibility is related to the "harshness" or flexural modulus of fibers [18]. It is not clear what differences exist between asbestiform fibers and cleavage fragments of amphiboles. There is found considerable variation in the flexural modulus of chrysotile which may be due to the water content, mineral impurities, or orthorhombic and monoclinic crystal forms in the fibers.

Another approach to obtain a working definition and differentiation of asbestos fiber and other elongate (length/width ≥ 3) mineral fragments is to consider the definitions in terms of their health significance. Length and aspect ratios within certain defined limits have been proposed as the only important mineral parameters to be considered in respiratory disease. If one accepts this argument with no additional caveats, one could easily extend the length factor considerations to any elongate particle provided that the length and length/width criteria are met. This argument would then demote the analytical differentiation of the terms to a mineralogical wrangle; furthermore, there would be little necessity to distinguish among the various minerals in most cases. Following the extension of the length argument further, one then becomes faced with the conclusion that many mineral particles commonly occurring in rocks and soils on the earth's surface would be considered a health risk. Cralley [8] suggested that the ubiquity of occurrence of elongate mineral and non-mineral particles in autopsies may be related to the ubiquity of occurrence in the modern environment. He suggests that variable response in the lung may depend upon the chemical and physical characteristic of the fibers, but he does not state what specific characteristic should be studied. One might therefore conclude that all, or certain sizes of, elongate particles might be considered with variable response in the lung depending upon the mineralogy and surface properties. Lists of some of these common fibrous or acicular minerals are given in Kramer [12] and Zoltai [20].

There is very little epidemiological, animal, or cytotoxicity data on elongate and fibrous minerals other than asbestos. Table 1 summarizes the results obtained for studies on elongate/fibrous minerals other than asbestos from searching TOXLINE, MEDLINE, and Chemical Abstracts for the past few years. Almost all of the few elongate/fibrous minerals tested showed some toxicity, and there is some suggestion for endemic lung conditions related to soils. Many equidimensional minerals were not active or as active as the elongate/fibrous minerals in hemolytic studies. Almost all of the minerals tested were silicates, so it is not possible at present to generalize to all minerals.

Table 1. Toxicity of fibrous minerals other than asbestos.

<u>Mineral</u>	<u>System and effect</u>	<u>Reference</u>
General	soils and endemic pleural plaques	13
Sepiolite-palygorskite	increased enzyme activity lactic acid inhibition	11
	hemolytically active	17
	endemic pleural calcifications and soils	4
	tumors in rats, i.p. injection	15
Amphiboles	amphibole in soil and pleural plaques	5
Arfvedsonite	i.p. carcinogenicity in rats	16
Vermiculite	i.p. carcinogenicity in rats	10
Apatite-nepheline	dust effects	3
	i.t. effect, rat lungs	9
Talc (tremolite)	hemolytically active	17
Nemalite	hemolytically active	17
Gypsum	allergic reactions	14
	chronic bronchitis	14

There is no specific information on the nature of the surfaces of the minerals, except that in one study of Schnitzer and Pundsack [17], the hand cut specimens of asbestos and other fibrous minerals were not hemolytically active. Interestingly, amphibole asbestos is not hemolytically active. However, there are very little data available to arrive at any definitive conclusions. In addition, Webster [19] has noted that in animal studies with monkeys, non-fibrous nepheline dust has produced interstitial fibrosis. This suggests that other factors besides fibrosity are responsible for the development of fibrosis.

In summary, there is difficulty at the sub-micrometer level to differentiate asbestiform, fibrous, and acicular minerals. Furthermore, there is no health evidence which might be used in an alternate classification of elongate particles. The relative response of different fibrous minerals is not clear.

Since definitive animal studies and epidemiological information exist for asbestos minerals only, it is pertinent to investigate parameters which might be used to differentiate between asbestos minerals, other fibers, and cleavage fragments found in the environment. Length and aspect ratio distributions are examined for occupational asbestos samples and for environmental samples, and the composition of fibers and intra-fiber composition are examined to ascertain variations within a sample.

The fiber length and often the fiber width are characterized in virtually all toxicity studies, and the length is often considered the most important factor in health aspects of fibers. More often than not, the mass-median length or median length is stated in reports of research. It is not uncommon for the median length of occupational exposures to coincide with the median length of environmental measurements. Median length does not, however, provide information of the entire length distribution. Therefore, it is worthwhile to consider what variations if any exist for the entire length distribution of fibers measured in an occupational exposure and in an environmental exposure.

Figure 1 summarizes length data for both chrysotile and amphibole fibers. Figure 1a compares the length distribution of 300 environmental samples of fibers measured in air and water environments by this laboratory to the length distribution of UICC amosite and chrysotile measured by this laboratory and to surface and underground mine dusts compiled from du Toit [9]. Figure 1b compares fiber tailings from Lake Superior to UICC amosite analysis and to occupational exposures from du Toit, and figure 1c compares the distribution of the longest chrysotile sample measured in urban air in Ontario to UICC and occupational measurements of du Toit. All three cumulative length plots show that distributions for occupational exposure converge with environmental distributions at the 50 percentile level and that the fiber length from occupational exposures are greater than that from environmental exposures at the 99 percentile level.

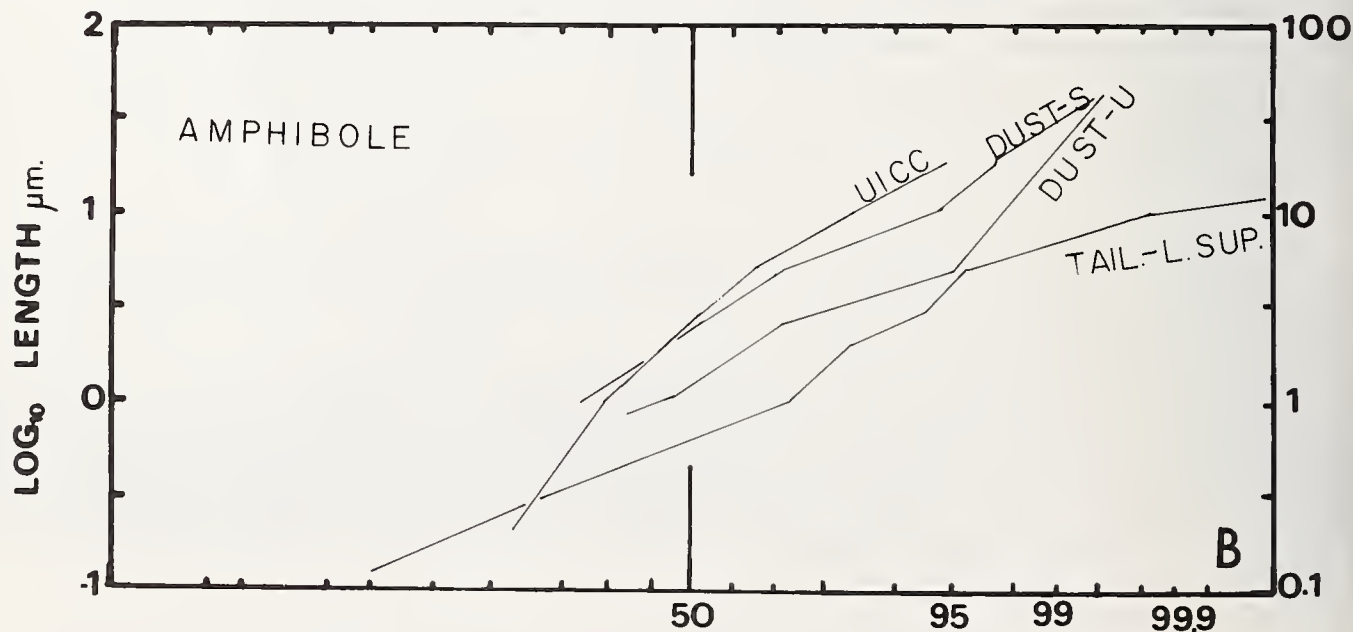
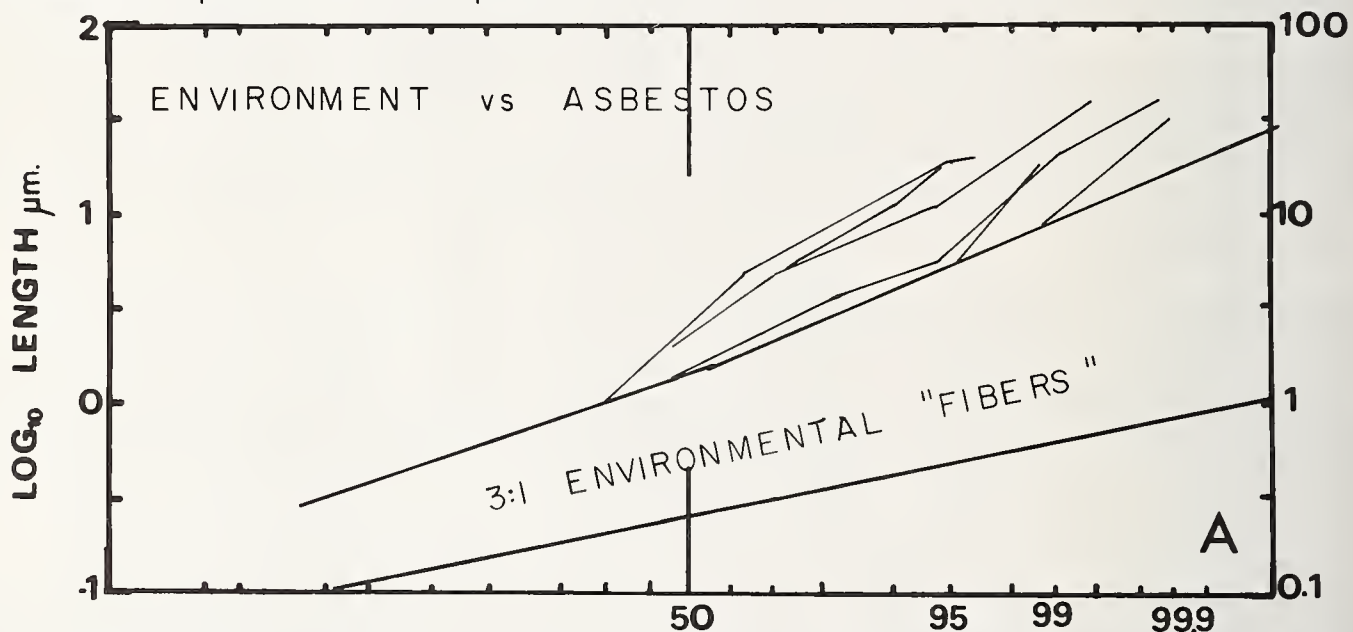

Figures 1a and 1b. (caption on the next page).

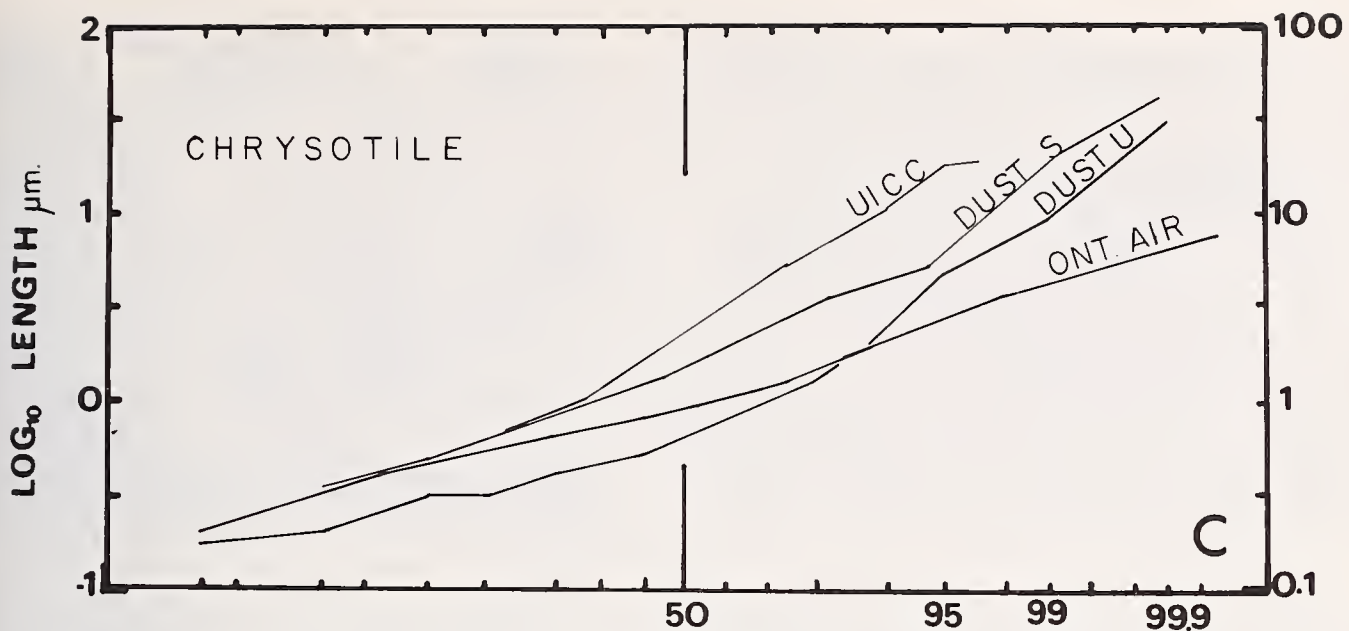

Figure 1. Distribution curves showing the difference in asbestos length and other fiber length. (a) About 600 analyses of elongate fibers compared to length distribution of UICC samples and from underground (U) and surface (S) dusts from South African Mines. (b) Comparison of amphibole in taconite tailings from Lake Superior to UICC amosite and surface and underground mine dust from South Africa. (c) Comparison of UICC chrysotile and surface and underground mine dusts with sample from atmospheric environment containing largest fibers. See figures 1b and 1c for figure 1a labelling of individual distributions.

Occupational and environmental samples show a broad length distribution over almost three orders of magnitude, and the only apparent differences in the length distributions are for the longest fraction. Therefore, characterization of the entire length distribution is mandatory for all studies.

Campbell, *et al.* [6, p. 44 ff] have carried out a similar analysis for aspect ratios. They show a great deal of overlap of aspect ratio for the milled asbestos form and the milled non-asbestos form of anthophyllite and tremolite. Furthermore, they show a distinct difference for a commercial milled chrysotile sample and an ambient air sample. In both cases, the distributions overlap, but the milled asbestos form has a small distribution of large length/width aspect ratios that is not found in the milled non-asbestos form, and the commercial milled chrysotile has a small distribution of larger aspect ratios that is not found in the ambient air sample. The aspect ratio distribution of hornblende is very similar to the aspect ratio distribution of the non-asbestos amphiboles. The difference in the aspect ratios between milled asbestos and milled non-asbestos minerals is found for the upper five percent or less. This difference in aspect ratio parallels the difference in length distributions of the largest percentile discussed above for occupational and environmental samples. In fact, the very large aspect ratios would be measured on the fibers of largest length. It may well be that the differences in aspect ratio and of length of the longest fibers will be most significant in health studies. Figure 2 shows the morphology of six different samples of cummingtonite-grunerite from the Wabush Lake, Labrador, area. The bulk composition and the mineralogy are the same for all six samples, and all of the samples were taken within about 500 meters of each other. Figure 2a is clearly an asbestiform sample and figure 2f is clearly equidimensional. The detailed morphology of these samples may show some significant toxicological differences. They are now being studied in detail mineralogically, and for hemolytic and cell activity responses.

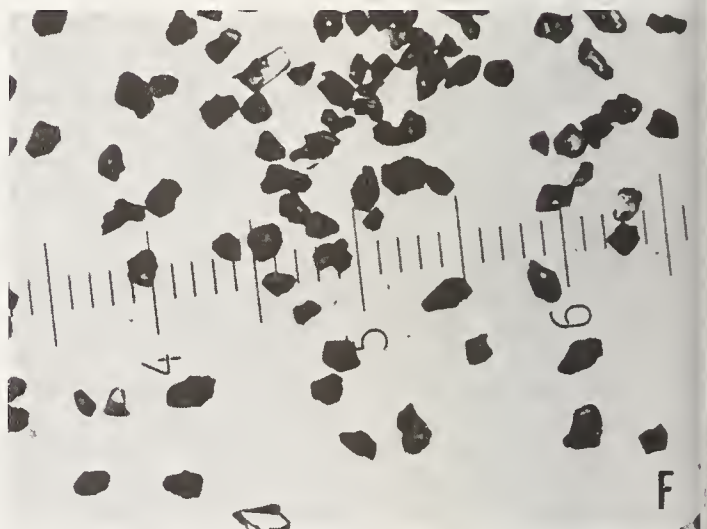
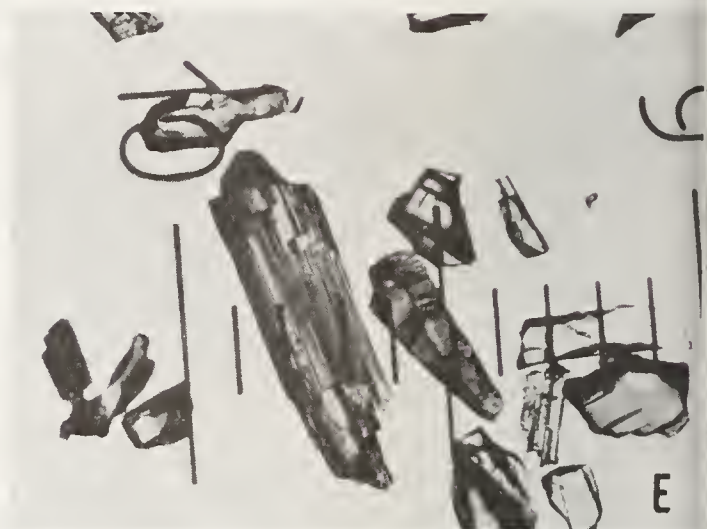
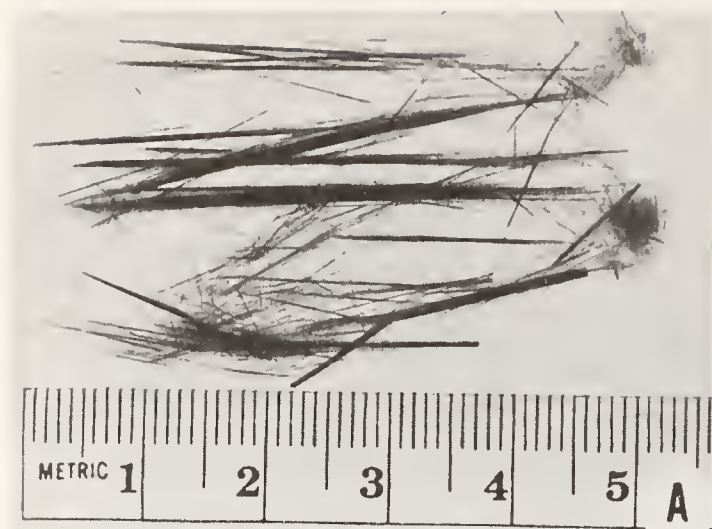

Figure 2. Asbestiform and equidimensional cummingtonite-grunerite from Labrador. (a) Asbestiform cummingtonite scale units are in cm. (b) - (f) Variations in fibers, cleavage fragments, and equidimensional cummingtonite-grunerite sampled within 500 meters of each other and the asbestiform variety. Each numbered scale unit is 0.1 cm.

Fiber Composition

Asbestos and other fibers vary in major element composition due to the substitution of octahedral coordinating cations (typically Mg, Fe²⁺, Fe³⁺, Al), tetrahedrally coordinated cations (Si, Al), and coordination of larger cations (Ca, Na, K). Chrysotile is a silicate sheet structure of nearly fixed composition, Mg₃Si₂O₅(OH)₄, but the amphibole asbestos minerals show more substitution of major ions. Hence the anthophyllite-gedrite series develops with substitution of Mg for Fe²⁺, Al for Fe²⁺, and Mg with substitution of Al for Si makes the charge balance; the cummingtonite-grunerite series with substitution of Mg for Fe²⁺; the tremolite-actinolite series with substitution of Mg for Fe²⁺ and substitution of Fe³⁺ for Al. "Amosite" is an asbestos acronym for a cummingtonite-grunerite of variable composition, and crocidolite is the asbestos variety for a glaucophane-riebeckite of variable composition. There are other less common amphiboles with asbestiform habit. In addition, there is substitution of trace elements and in some cases other elements (for example, Mn) may substitute in the amphibole structure to a large extent. Therefore, one may not conclude that there is any fixed composition for one asbestos mineral, and it is possible to have variations in composition within one sample depending upon the history of formation of the mineral. In addition, other asbestos minerals and other mineral impurities can and do often occur in asbestos samples.

Normally a fibrous sample from an occupational setting or known single source can be identified and characterized quite well even at the micrometer size range. This is possible because there would generally be a limited number of minerals to consider. An environmental sample, however, poses a most difficult analytical task if available in small amounts. There can be many common minerals, each of which may have a variable composition, and the net result is that many minerals may occur with overlap in composition, gross crystallographic properties and optical properties.

Health researchers often use well characterized samples from specific locations for their experiments. These samples have been chemically analyzed in bulk, but often individual fibers and variations in composition along a fiber have not been analyzed. UICC samples of amosite and crocidolite as well as one sample of tailings from Lake Superior and one asbestiform cummingtonite-grunerite sample from Labrador (fig. 2a) were subjected to analysis using energy-dispersive fluorescence spectroscopy in conjunction with a transmission electron microscope.

The analytical procedure is similar to that of Beaman and File [2]. Isolated fibers between 0.2 - 0.8 μm in width were subjected to analysis with an excitation voltage of 80 kV and a take-off angle of 36 degrees. The excited area was estimated to be about 0.2 μm when considering scattering effects. Counts were recorded and areas under peaks were estimated using a computer routine which also adjusted for background. Ratios of peak area of Mg, Fe, Na, and Ca relative to Si were calculated, and these ratios were adjusted for areal ratios determined on an adjacent blank portion of the grid. This later correction was normally negligible. In the following discussion, ratios of areal peaks to Si corrected for background of analyzer and grid background are reported. Champness *et al.* [7] have noted that the use of intensity ratios should correct for fluorescence variations due to specimen thickness variations.

Figure 3a shows elemental intensity ratios relative to Si for UICC amosite for 58 analyses on 15 fibers, whereas figure 3b shows similar results for 51 analyses on 15 fibers of UICC crocidolite. In both figures, the results are given for increasing Fe/Si intensity ratios, and the values between horizontal lines represent the intensity ratio value for the particular element. Both samples show a marked variation in elemental intensity ratios with between 30-60 percent variation about the mean for the corrected values. With reference to amosite, assuming all of the Fe is structural Fe²⁺, there should be a parallel decrease in the Mg/Si ratio as Fe/Si increases. This is obviously not apparent for the bulk analysis. Although the surfaces of all fibers were examined prior to analysis for optical density continuity so that surficial material such as Fe-oxides might be excluded, it is possible that some of the variation in the Fe/Si ratio is due to surface oxidation of Fe. But this would not explain the variation in Mg/Si ratios for amosite which, with the exception of two extreme analyses, varies about 20 percent about the mean of the ratio.

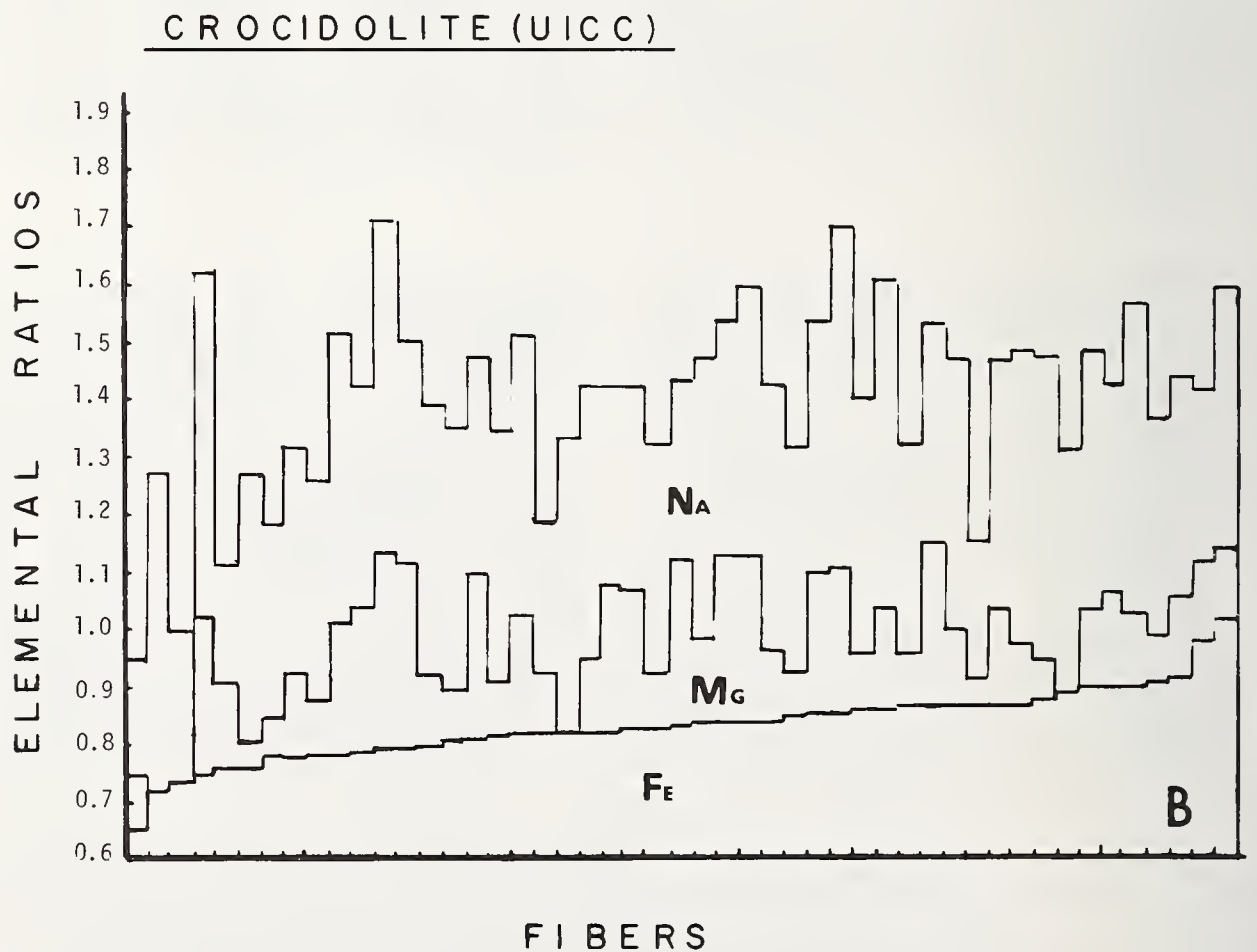
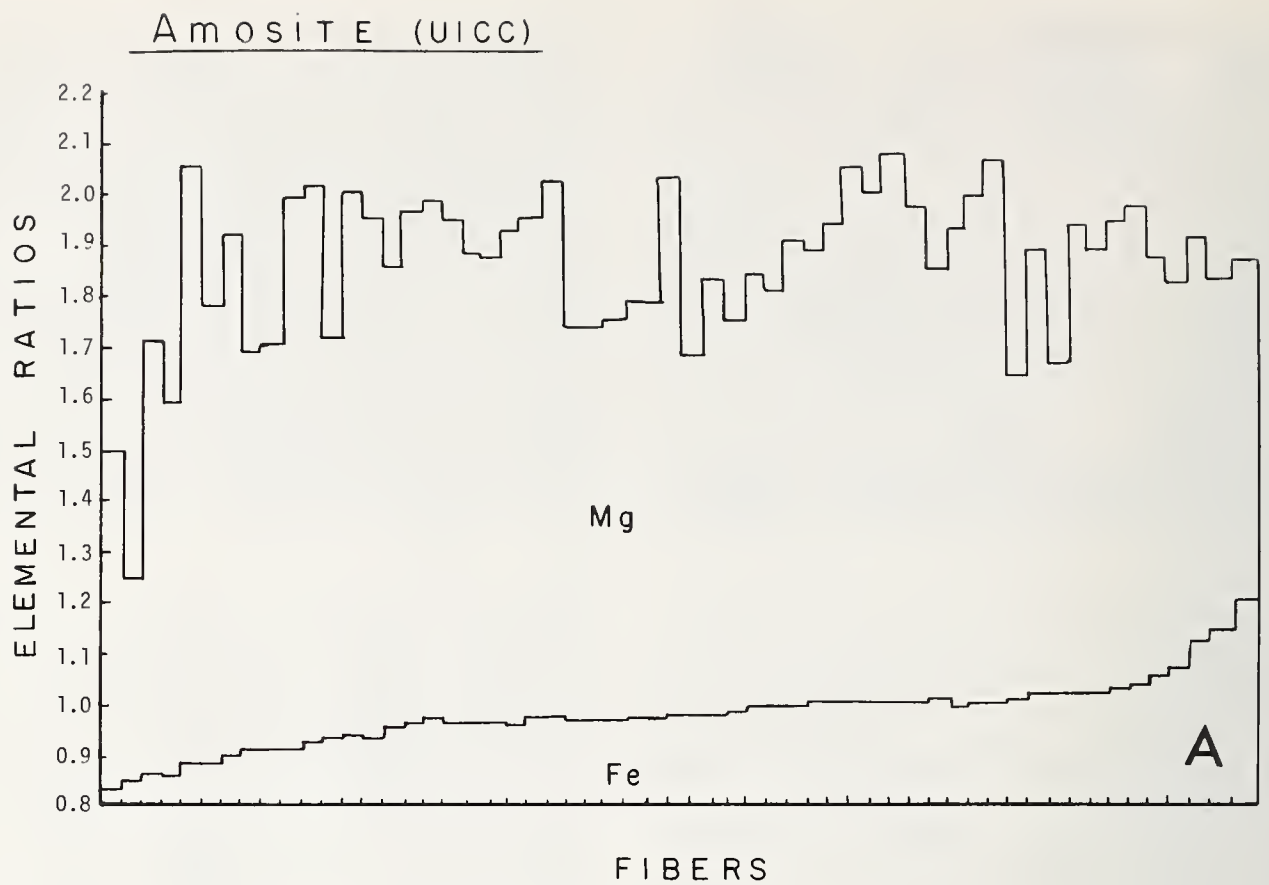

Figure 3. Corrected intensity ratios for UICC amosite (a) and UICC crocidolite (b). Intensity ratios are cumulative with the value for each element depicted as the difference between adjacent horizontal bars.

Crocidolite UICC. samples show similar variations with the Fe/Si ratios with a deviation of about 15 percent about the mean; Mg/Si varies about 15 percent about the mean, and Na/Si varies about 25 percent about the mean. There is no relationship between Mg or Na ratios and Fe ratios, but there is an apparent correlation between Na/Si and Mg/Si. This correlation could be due to radiation from Na, Mg, and Al.

Figure 4 shows elemental intensity ratios for one fiber of UICC crocidolite (4a) and one fiber of UICC amosite (4b). Variation of intensity ratios along the fiber length is between 5-10 percent, and this is much less than for the range in variation for all mineral fibers. This is true for all of the eight mineral fibers tested at multiple locations.

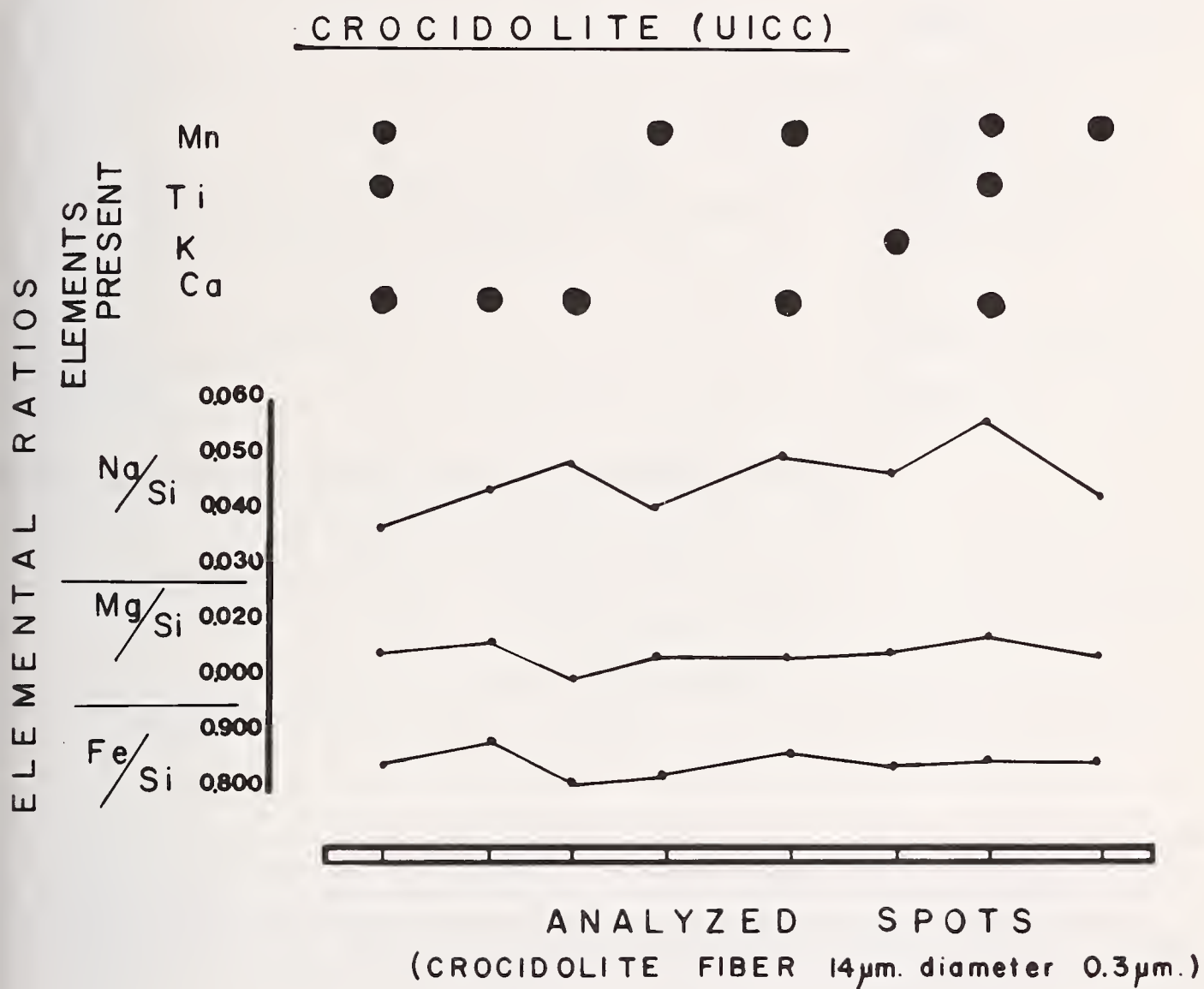

Figure 4a. Variation along a fiber of UICC crocidolite.

AMOSITE (UICC)

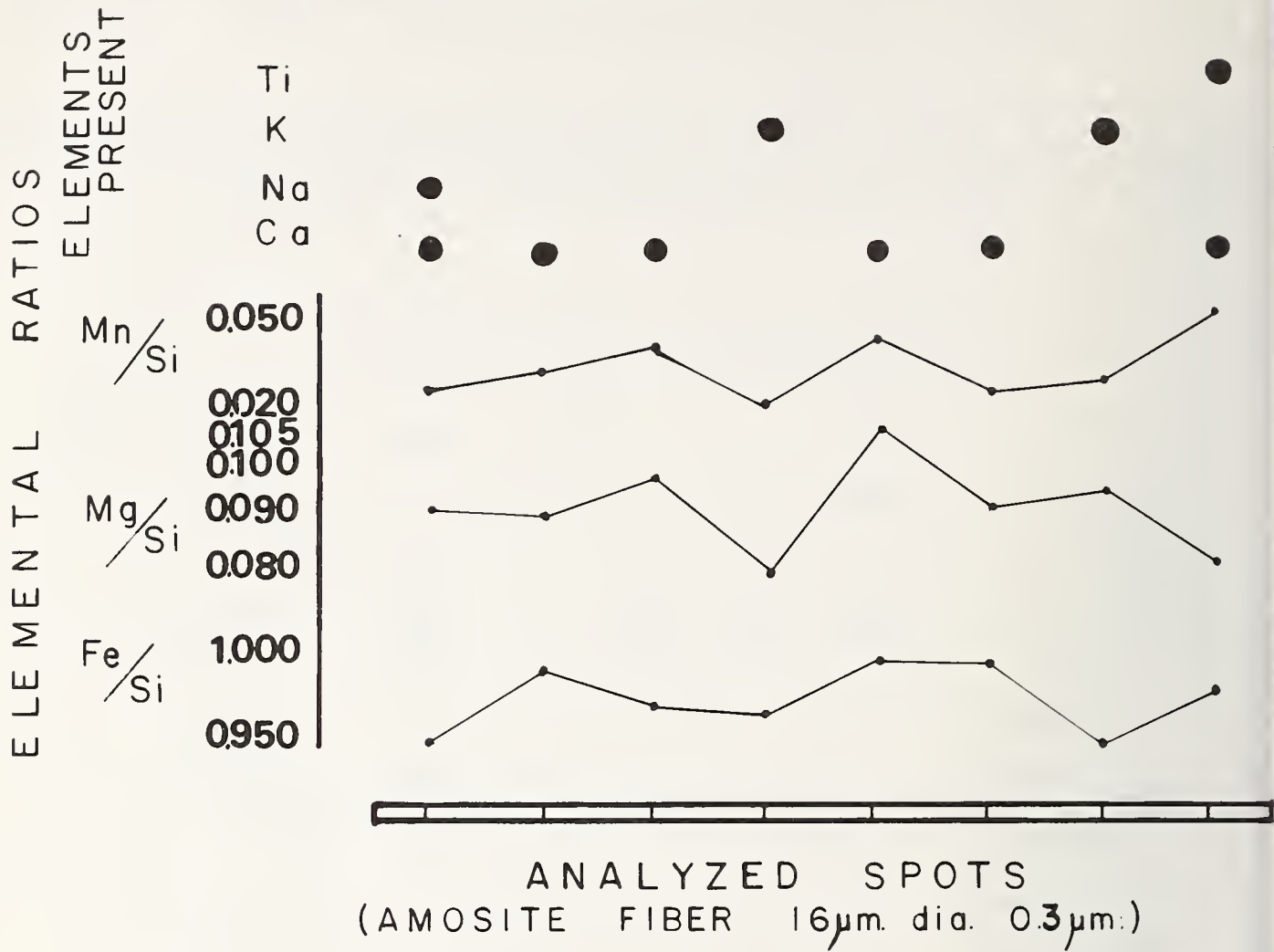

Figure 4b. Variation along a fiber of UICC amosite.

Figure 5 shows the results of 64 analyses on 14 fibers of asbestiform cummingtonite from Labrador. There is an approximate 50 percent variation of Fe/Si intensity ratios about the mean, and there appears to be a decrease in the Mg/Si intensity ratio with increasing Fe/Si ratio with only a few exceptions.

Cummingtonite

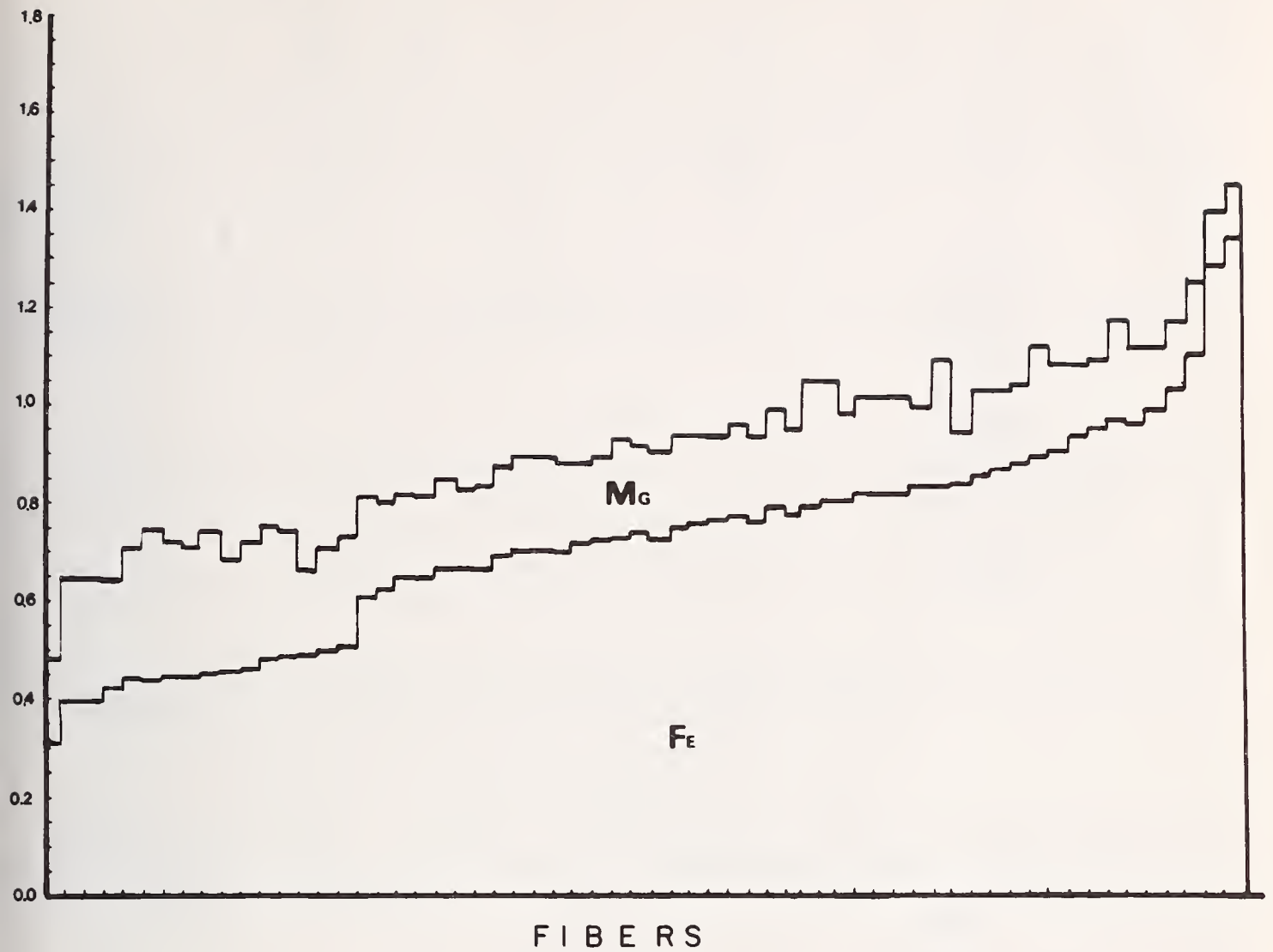
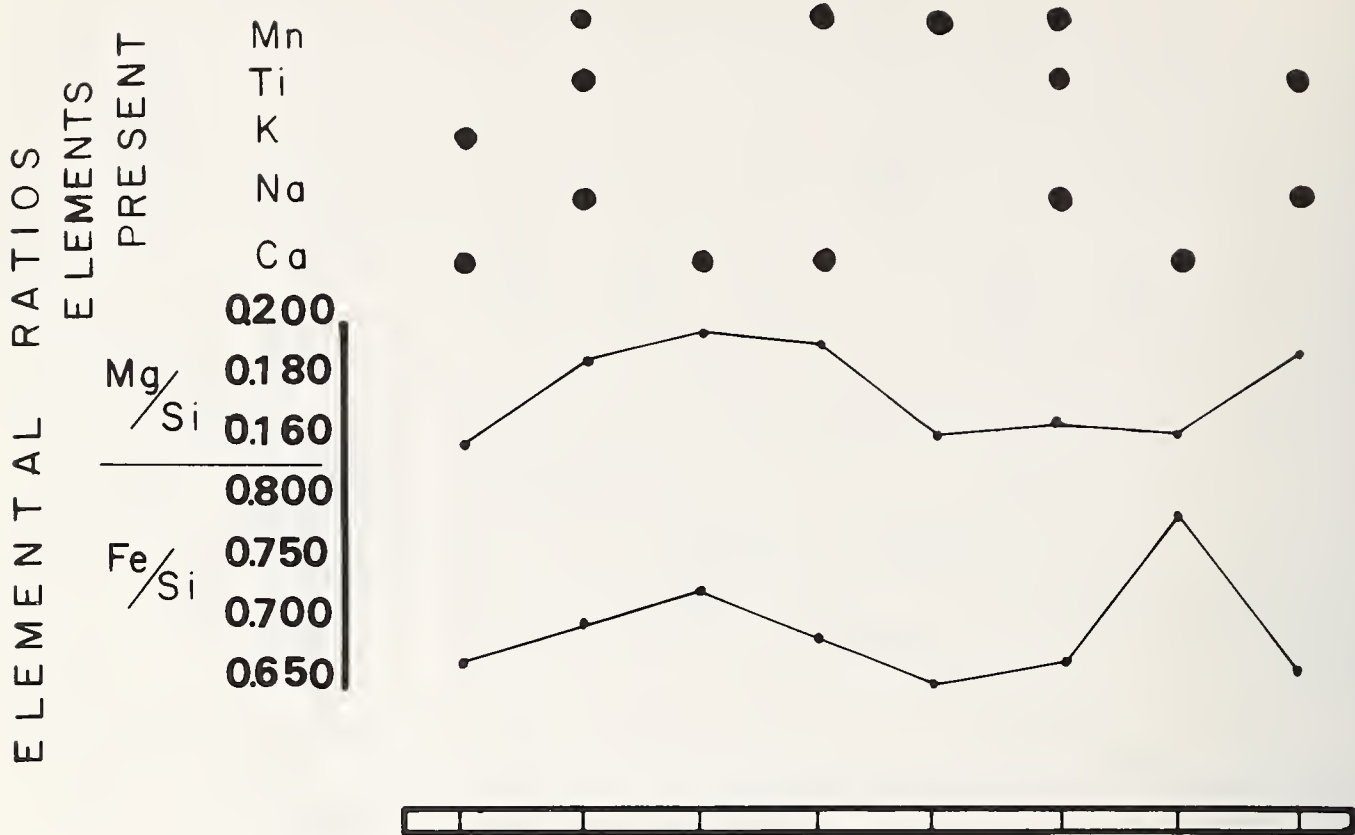

Figure 5. Corrected intensity ratios for analysis of 64 asbestiform fibers from Labrador (figure 2a).

Figure 6 shows two examples of the analysis of different locations on the same fiber for the Labrador cummingtonite-grunerite sample. Once again there is a much smaller variation (10 percent) of intensity ratios along an individual fiber with the exception of one location which showed an extremely high Fe/Si ratio. This very large ratio may be due to surface Fe-oxide, although there was no anomalous electron density visible.

CUMMINGTONITE



ANALYZED SPOTS
(CUMMINGTONITE FIBERS 16 μm. dia. 0.4 μm.)

CUMMINGTONITE

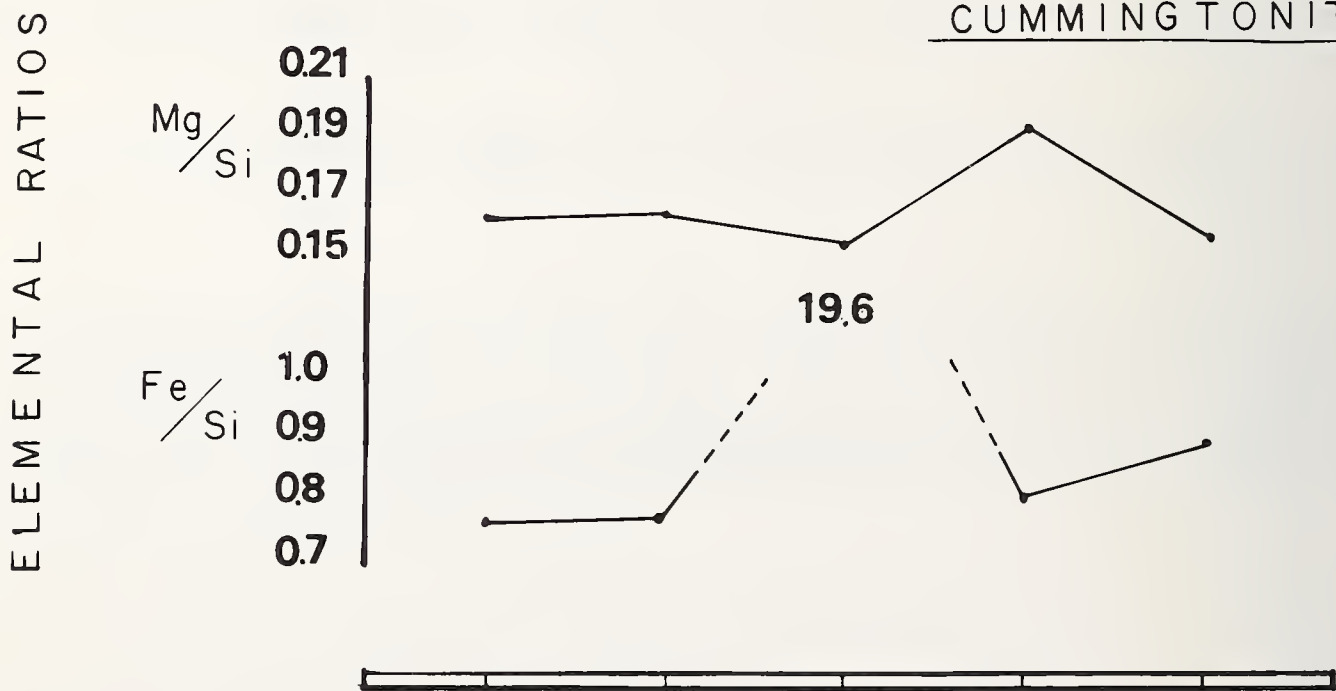

ANALYZED SPOTS
(CUMMINGTONITE FIBERS 16 μm. dia. 0.2 μm.)

Figure 6. Variation in intensity ratios for analyzed spots along two asbestiform cummingtonite-grunerite fibers from Labrador.

There appear to be two possible reasons for variations in areal intensity ratios. There can be a real variation in the composition of individual fibers in an apparently homogeneous phase, and/or the differences can be due to x-ray adsorption and secondary radiation especially from Fe in these samples. The fact that analysis on spots on a specific fiber gives an intensity variation less than 10 percent (with one exception in 200 analyses) compared to a 30-50 percent variation in bulk is strongly suggestive that the difference in the two variations (20-40 percent) is the approximate absolute variation in intensity ratio due to compositional variation that exists in these samples. If the coefficient relating intensity ratios to compositional ratios is not dependent upon other factors, one would anticipate a real variation in fiber composition of 20-40 percent maximum for the major elements.

One assumes generally that the composition of fibers within a relatively pure mineralogical phase is reasonably constant in composition. This assumption must be tested by detailed analysis of many fibers within a specific sample.

Conclusions

It appears that asbestos morphology differs from other elongate acicular-fibrous minerals and from environmental exposures in the largest percentile group. Therefore, the entire size distribution should be characterized before carrying on toxicity studies.

The composition of fibers within a well characterized sample may vary in composition. Hence analysis on individual fibers must always be carried out.

Finally the health significance of fibers other than asbestos should be studied. Primary cytotoxicity and mutagenicity testing of hydrated silicates, anhydrous silicates and non-silicates may well provide clues for more extensive studies.

Work supported in part by Inland Waters Directorate, Environment Canada. Microscope analytical work by O. Mudroch, and field work by R. Marttila are gratefully acknowledged.

References

- [1] American Geological Institute, Glossary of Geology, Washington, D.C., 1972.
- [2] Beaman, D. R. and File, D. M., Quantitative determination of asbestos fiber concentrations, Anal. Chem., 48, 101-110, 1976.
- [3] Borschchevskii, Y. M. and Konikova, T. S., Apatite and apatite-nepheline dust, Nauch. Tr., Leningrad Inst. Usoversk. Vrachei, 115, 108-116, 1973. (Chemical Abst: 080: 078900).
- [4] Burilkov, T. and Michailova, L., Sepiolite content of the soil in regions with endemic pleural calcifications, Int. Arch. Arbeitsmed, 29, 95-101, 1972.
- [5] Burilkov, T., Michailova, L., and Babadjov, L., Amphibole asbestos in the soil and its significance for the endemic occurrence of pleural plaques, Zh. Gesamte Hyg. Grenzgeb, 18, 802-809, 1972. (HEEP:74/02556).
- [6] Campbell, W. J., Blake, R. L., Brown, L. L., Cather, E. E., and Sjoberg, J. J., Selected silicate minerals and their asbestiform varieties, Bur. of Mines Info. Circ. 8251, 1977.
- [7] Champness, P. E., Cliff, G., and Lorimer, G. W., The identification of asbestos, J. of Microscopy, 108, 231-249, 1976.
- [8] Cralley, L. J., Inhalable fibrous materials. in H. A. Shapiro (ed), Pneumoconiosis, Oxford U. Press, 1970, p. 70-74.

- [9] du Toit, R. S. J., Dust in South African asbestos mines and fiberizing plants, in reference 8, p. 13-17.
- [10] Hunter, B. and Thomson, C., Evaluation of the tumorigenic potential of vermiculite by intrapleural injection in rats, *Brit. J. Indust. Med.*, 30, 167-173, 1973.
- [11] Koshi, Kimiko, Hayashi, Hisato, and Sakabe,, Hiroyuki, Cell toxicity and hemolytic action of asbestos dust, *Ind. Health.* 6, 69-79, 1968.
- [12] Kramer, J. R., Asbestos: Nomenclature, occurrence and redistribution in water, in *Drinking Water and Health*, U.S. Nat. Res. Counc., 1977 (in press).
- [13] Mikhailova-docheva, L., Hygienic evaluation of the mineral composition of soils in regions of the People's Republic of Bulgaria marked by the prevalence of endemic pleural calcifications, *Gig. Tr. Prof. Zabol.*, 16, 30-33, 1972. (HEEP: 73/04741).
- [14] Owinski, J., Effect of dust pollution and thermal microclimate on the incidence of chronic non-specific diseases of the respiratory system with regard to the gypsum workers industry in Gacki, part IV, Radiographic results and symptoms of chronic bronchitis, *Przegl Lek*, 32, 265-268, 1975. (MEDLINE).
- [15] Pott, F., Huth, F., and Friedrichs, K. H., Tumorigenic effect of fibrous dust in experimental animals, *Environ. Health Perspect.*, 9, 313-316, 1974.
- [16] Pylev, L. N. and Iankova, G. D., Carcinogenic activity of magnesite administered intrapleurally to nonbred rats, *Vopr. Onkol.*, 21, 71-76, 1975. (TOXBIB: 75/104450).
- [17] Schnitzer, R. J. and Pundsack, F. L., Asbestos hemolysis, *Environ. Res.*, 3, 1-13, 1970.
- [18] Spiel, S. and Leineweber, J. P., Asbestos minerals in modern technology, *Environ. Res.*, 2, 166-208, 1969.
- [19] Webster, I., Commentary, in reference 8, p. 133.
- [20] Zoltai, Tibor, History of asbestos-related mineralogical terminology, *This Proceedings*, Paper 1.
- [21] Zoltai, Tibor, Comments on asbestiform and fibrous mineral fragments relative to Reserve Mining Company taconite deposits, *Minn. Pollut. Contr. Agen.*, Minneapolis, 37 p + III append.

Discussion

C. RUUD: What was the accelerating voltage of your electron beam in all of these microanalyses?

J. KRAMER: We tried some studies varying it, but the value we used routinely was 80 kv. There are a lot of details of these findings on the analytical part which suggest problems. I would be happy to discuss these with individuals.

M. COSSETTE: Are you aware of any work with high pressure mercury porosimetry to differentiate between fibrous length groups?

KRAMER: No, do you have some data or know of some?

COSSETTE: No, I know of some people doing work in the area but nothing published.

A. WILEY: Do you use the polarizing microscope, and, if so, do the clino-amphiboles show parallel extinction?

KRAMER: Yes, within analytical error, but some of the cummingtonite fibers from Labrador may not show parallel extinction. They may have a small angle (5-10°).

WILEY: Your ordinary varieties do, though?

KRAMER: Yes, I think that this is a very important point to consider; this apparent optical difference and its significance to fiber morphology.

D. BEAMAN: 0.3 μm is not particularly large for an amphibole. I wonder to what extent you feel some of these trends may be due to the difference in the size of your fibers.

KRAMER: Yes, there may well be a size factor. 0.3 μm width is at the threshold of size effect upon intensity ratios according to your study published in Analytical Chemistry.

F. MUMTON: I'd like to ask you about your ion exchange measurements of these two types of materials; you didn't show any data, but yet you say there are differences. What range are you talking about? What did you do?

KRAMER: First of all, the ion exchange differences will depend upon the composition of the material. We worked mostly with cummingtonite from Labrador. What we are using basically are these minerals (see figure 2) as an exchange medium to compete against a copper-organic ligand. The procedure is analogous to an ion exchange column but we are using the minerals. We calibrate the system against known associations such as copper-glycine. We carried out the analyses using equidimensional, fibrous and asbestiform varieties and found little differences in conditional stability constants for the different varieties of the same composition. In addition, the exchange capacities appear to be very similar and typical of all silicate minerals (about 3-4 micro-equivalents/meter²).

W. EISENBERG: Have you modified your definition of a mineral species as a result of the data you've obtained?

KRAMER: No, you noticed I didn't give any definitions. I just quoted other people. Seriously, I am trying to point out that there are either analytical problems or variations in composition, or both, at the micrometer scale of a fiber. See Science, 198, 359-365 for some possible reasons.

THE CRYSTAL STRUCTURES OF AMPHIBOLE AND SERPENTINE MINERALS

Jack Zussman

Department of Geology
University of Manchester
England

Abstract

The crystal structures of the two main asbestos-forming minerals, the amphiboles and serpentines, are surprisingly very different. The amphiboles are "chain silicates" in which SiO_4 tetrahedra are linked to form bands four tetrahedra wide and of very great length. These bands run parallel to the asbestos fiber axis and are linked laterally by cations, mainly Ca and Mg in tremolite; Na, Mg and Fe in crocidolite; Mg and Fe in amosite and anthophyllite. The tempting correlation of the chain unit of crystal structure with asbestiform nature is, however, too facile. Many amphiboles are not asbestiform, and as the serpentine minerals show, some asbestiform minerals do not have a chain structure.

The serpentine minerals are "layered silicates" in which SiO_4 tetrahedra are linked to form thin sheets of great lateral extent. The tetrahedra all point in the same direction and their apical oxygens are part of an (O,OH)-Mg-(OH) sheet which is itself formed by Mg-(O,OH) octahedra. Thus the fundamental serpentine layer is polar and has a tetrahedral and octahedral component. The mismatch in dimensions of these two components generally leads to curvature of the layers and in chrysotile asbestos the layers form either scrolls or concentric cylinders with very high length/breadth ratio and with length parallel to the fiber axis. Other forms of serpentine, however, with chemistry very similar to that of chrysotile, do not exhibit asbestiform morphology.

For all minerals, the physical and chemical properties are important both for industrial usage and environmentally in determining the nature of the dusts produced in manufacturing processes and in subsequent abrasion. Factors which may influence properties in addition to the basic chemistry and "average" x-ray structure are the crystal morphology and mode of aggregation, and also the abundance and nature of structural defects.

Keywords: Amphibole; asbestos; chemistry; cleavage; defects; dusts; environment; fibers; morphology; serpentine; structure.

In this review I would like to describe briefly the crystal structures of the two main asbestos-forming minerals, the amphiboles and serpentines, to consider what they have in common and what are their differences, to identify if possible what are the fundamental criteria that lead to asbestiform habit, and to observe the crystallographic features that may contribute to their physiological behavior.

Amphiboles

These minerals are "chain silicates" in which SiO_4 tetrahedra are linked so as to form chains with composition Si_4O_{11} as shown in figure 1. The chains are four tetrahedra wide, of very great length, and they lie parallel to the fiber axis in the asbestiform amphiboles. One might say that amphibole asbestos is finely fibrous because of the chain structure, but this is an over simplification. Some amphiboles are not fibrous at all, let alone asbestiform.

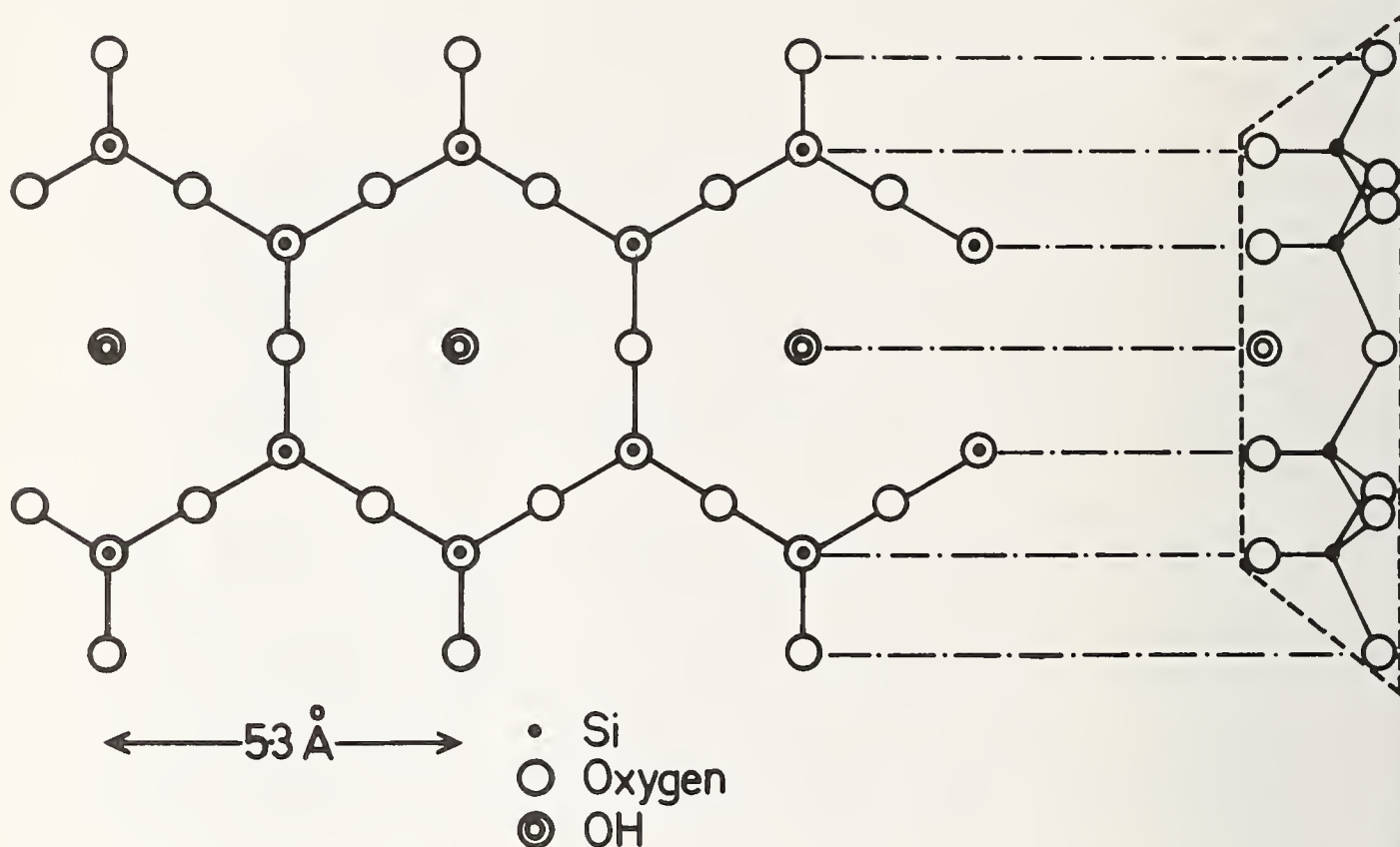

Figure 1. Plan and end-view of an idealized Si_4O_{11} amphibole chain together with additional (OH) ions.

No minerals could be formed from Si_4O_{11} chains alone and in the amphiboles there are cations linking chains laterally as shown in figure 2. The cations vary from one amphibole to another. In tremolite Mg ions link chains by means of a strip of $\text{Mg}(\text{O},\text{OH})$ octahedra. The oxygens of this strip are the apices of the Si-O tetrahedra and the OH ions occur as in figure 1. Calcium ions link the chains across the bases of the tetrahedra. An alternative view of the structure is one of almost continuous sheets of Mg and Ca polyhedra linked by Si ions.

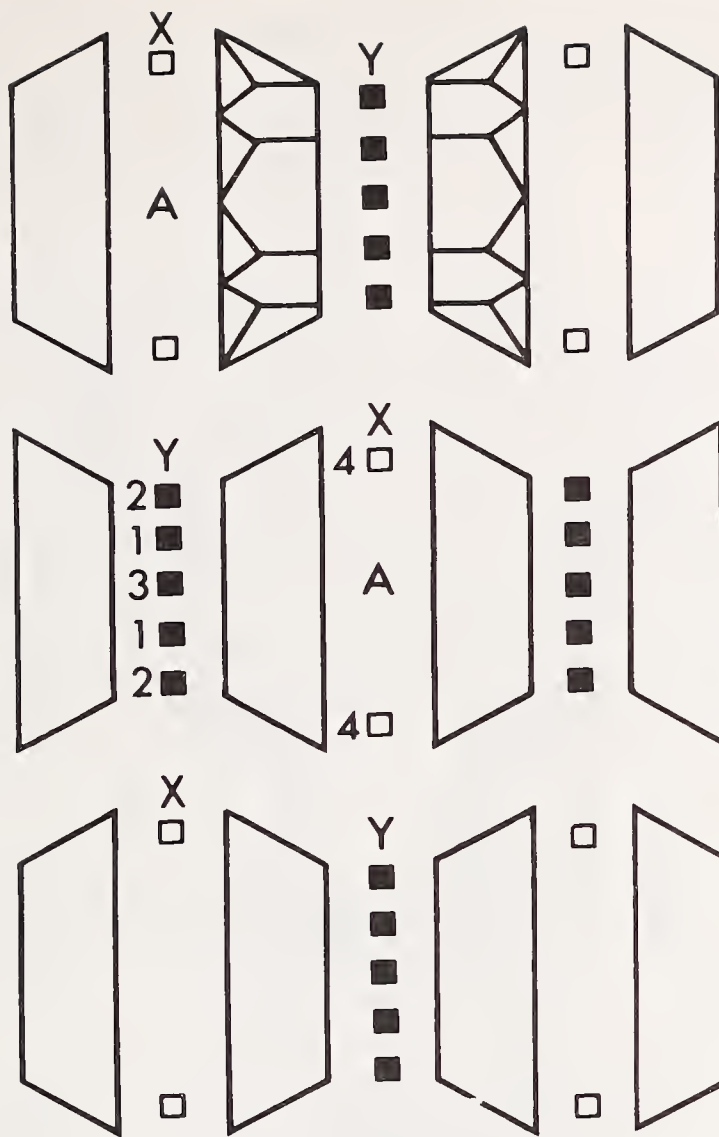

Figure 2. Schematic end-view of amphibole chains linked by cations in X and Y positions. In some amphiboles the site A is occupied. The amphibole formula can thus be written $A_{0-1}X_2Y_5(Si,AI)_8O_{22}(OH)_2$.

Other important amphiboles are: - anthophyllite in which largely Mg ions play the role of both Ca and Mg in tremolite; the cummingtonite - grunerite series, which contain Mg and Fe in varying proportions; and riebeckite, in which Mg, Fe and Na are the principal cations in addition to Si (see Table 1). The above-mentioned compositions are those most relevant to the consideration of asbestos, since in addition to the less common varieties of asbestos, tremolite and anthophyllite, there are the two more abundant and commercially more important varieties - 'amosite,' a form of cummingtonite - grunerite, and "crocidolite" (blue asbestos), a form of riebeckite.

Table 1. Cation distribution in idealised formulae of the amphibole minerals. Asbestos-forming amphiboles are marked*.

	A	X	Y	Z		
Cummingtonite-Grunerite*	}	(Mg,Fe) ₂	(Mg,Fe) ₅	Si ₈	} H O R N B L E N D E S	} CALCIUM AMPHIBOLES
Anthophyllite*						
Gedrite	-	(Mg,Fe) ₂	(Mg,Fe) ₃ Al ₂	Si ₆ Al ₂		
Tremolite*-Actinolite	-	Ca ₂	(Mg,Fe) ₅	Si ₈		
Common Hornblende	-	Ca ₂	(Mg,Fe) ₄ Al	Si ₇ Al		
Tschermakite	-	Ca ₂	(Mg,Fe) ₃ Al ₂	Si ₆ Al ₂		

Edenite	Na	Ca ₂	(Mg,Fe) ₅	Si ₇ Al		
Pargasite-Hastingsite	Na	Ca ₂	(Mg,Fe) ₄ Al	Si ₆ Al ₂		
Richterite	Na	NaCa	(Fe) ₅	Si ₈		
Katophorite	Na	NaCa	(Mg,Fe) ₄ Al	Si ₇ Al		
Mboziite	Na	NaCa	(Mg,Fe) ₃ Al ₂	Si ₆ Al ₂		

Glaucophane-Riebeckite*	-	Na ₂	(Mg,Fe) ₃ Al ₂	Si ₈		
Eckermannite-Arfvedsonite	Na	Na ₂	(Mg,Fe) ₄ Al	Si ₈		

For the sake of completeness at least, though it may also have some indirect importance, it should be noted here that the amphibole asbestos-forming minerals are monoclinic in symmetry except for anthophyllite which is orthorhombic. Cell parameters are given in Table 2.

Table 2. Amphiboles. Cell parameters.^a

	$\underline{a}\overset{\circ}{\text{A}}$	$\underline{b}\overset{\circ}{\text{A}}$	$\underline{c}\overset{\circ}{\text{A}}$	β
Tremolite [1] ¹	9.82	18.05	5.28	104°39'
Actinolite [2]	9.89	18.20	5.31	104°38'
Grunerite [3]	9.56	18.30	5.35	101°50'
Crocidolite [4]	9.74	17.95	5.30	103°54'
Anthophyllite [5]	18.56	18.01	5.28	90°

^a These cell parameters relate to particular specimens. Variations in chemical composition, particularly in Fe/Mg ratio, can be expected to yield a range of values but usually within 1 or 2 percent of those given.

¹Figures in brackets indicate the literature references at the end of this paper.

A well-known physical property of amphiboles is that they generally cleave readily along {110} planes. Assuming that the Si-O chain is a strong structural unit, and that the strongest inter-chain bonding is across the strips of octahedra joining tetrahedral apices, the probable paths of weakness can be traced as on figure 3, which on a macroscopic scale results in cleavages intersecting at approximately 120°, as observed.

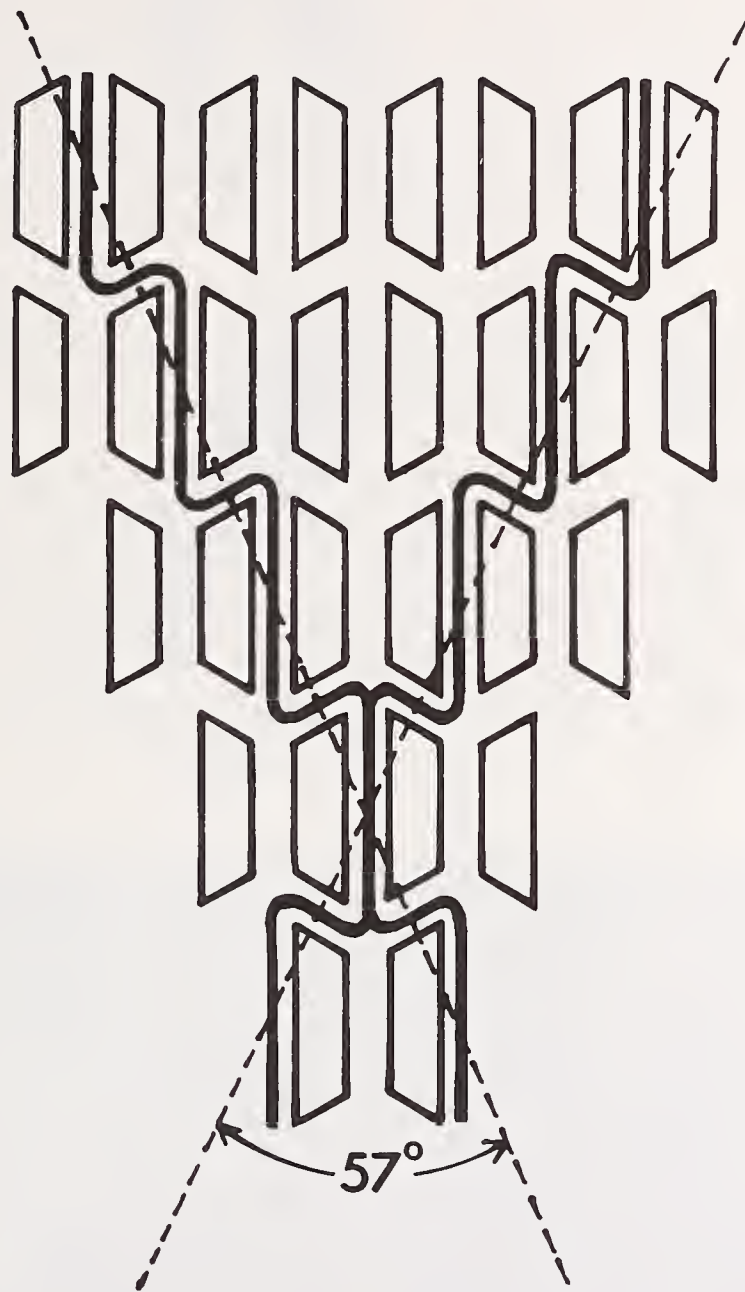

Figure 3. Schematic view of amphibole structure as seen down z axis, showing likely paths of weakness leading to cleavages intersecting at 57°.

Although the good prismatic cleavages explain the readiness of amphibole crystals to splinter into elongated particles, this is not necessarily relevant to the unusual physical nature of asbestos. It would be so if a block of asbestos was a single crystal and the production of hair-like fibers was the process of splitting off cleavage fragments. However, a block of asbestos, even when very small, is not a single crystal but an aggregate of single-crystals all lined up parallel to the fiber axis but with a range of azimuthal orientations. The process of stripping fibrils from asbestos is thus more likely to be one of breaking crystallites away from the aggregate at the grain boundaries across which there is weak cohesion.

The asbestiform nature of certain amphiboles is thus a consequence of the crystallite morphology which in turn is influenced by the conditions of crystal growth as well as the inherent chemical and physical features of a single crystal. The production of a fiber aggregate as in asbestos must depend upon independent nucleation of each fibril and its preference for growth along \underline{z} rather than at right angles to it.

It is perhaps significant that the group of amphiboles loosely referred to as "hornblendes" occur in roughly equidimensional crystal habits and not as asbestos. Table 1 shows a simplified scheme for the chemical compositions of amphiboles and it is seen that the hornblendes are characterized chemically by having appreciable substitution of Al for Si. Asbestiform amphiboles show little substitution of this kind. The minerals richterite and eckermannite, which also have little Al for Si substitution, are not known to occur naturally as asbestos, but synthetic products have been so described and are at least extremely fibrous [6,7]. I would suggest therefore that the substitution of Al for Si might be responsible for increased potential for growth of prism faces relative to growth in the \underline{z} direction.

Even if true, the above suggestion cannot be the only criterion that governs asbestos formation since tremolite itself can occur in asbestiform or non-asbestiform habit, each variety having the same major element chemical composition. In such circumstances other parameters such as the pressure and temperature conditions, rates of cooling or heating, or minor or trace element concentrations may be critical factors.

The mechanical properties of asbestos and related minerals are of importance both for the desirable physical attributes of articles made from asbestos, and environmentally in determining the nature of the dusts produced during the processes of manufacture or during subsequent abrasion. Factors which can give different mechanical properties are the nature of the fundamental particles and their state of aggregation (bundles of fibers versus single crystals). For single fibrils or crystals in the $\{110\}$ cleavages, and the resistance to breakage across other planes (roughly perpendicular to fiber length), will help to determine the morphology of the dust particles produced. Structural defects may also have an influence on physical properties.

Structural defects

It should be emphasized here that the published crystal structures of amphiboles (and serpentines), determined by x-ray diffraction, are the content of the "average" unit cell, the volume of specimen investigated consisting of something like 10^{15} unit cells. In real crystals the unit cells do not repeat perfectly and several kinds of defects may occur. These departures from the perfect structure are no doubt important in questions concerning crystal growth and they may well influence physical properties and physiological effects.

The two principal kinds of imperfection in amphibole structures are stacking defects and Wadsley defects. Stacking defects are illustrated schematically in figure 4. In the normal monoclinic amphibole, slabs of structure parallel to (100) are stacked alongside one another with regular displacements. In a faulted structure occasional errors in the direction of this displacement occur and the frequency of such faults varies from one specimen to another. When the faults are relatively infrequent the result can sometimes be described as a twinned crystal. Figure 5 shows a high resolution electron micrograph displaying twin components. Such defects are also seen in lower magnification electron micrographs and they have important effects on diffraction patterns. When the faults are frequent and regularly repeating, they are no longer really faults but are the regular displacement of a structure with a super-cell and perhaps different symmetry. The latter describes approximately the relationship between the orthorhombic and monoclinic amphiboles.

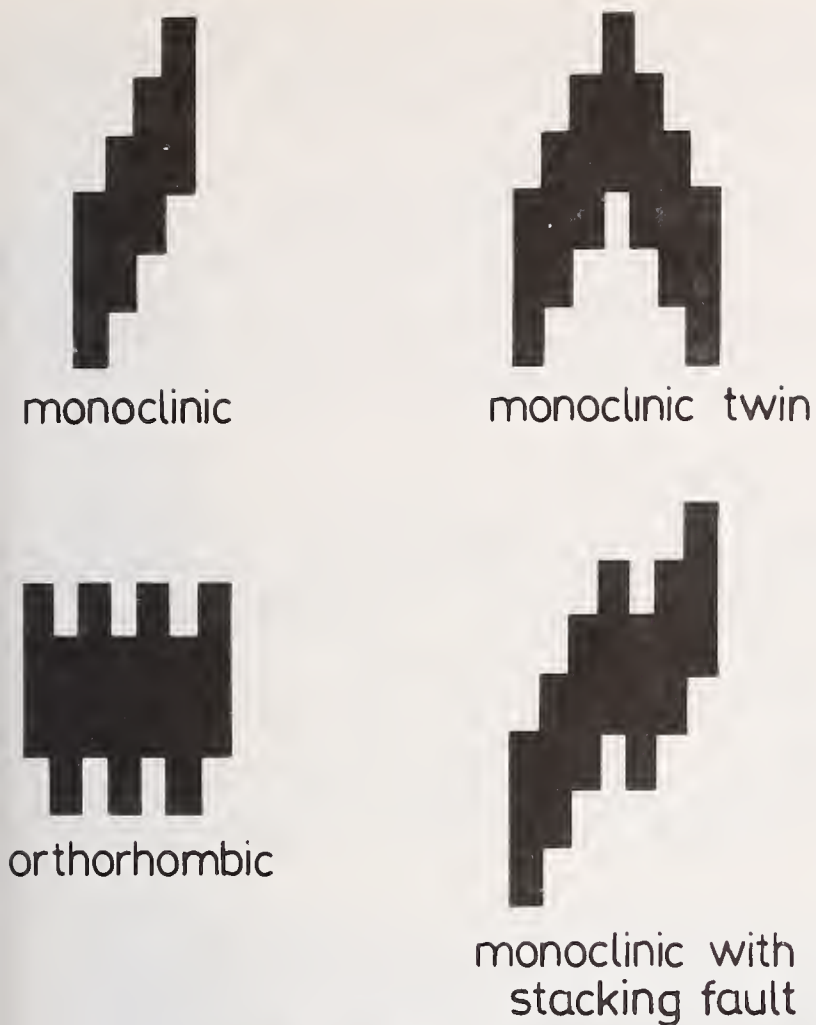

Figure 4. Illustration of the stacking of blocks of amphibole structure to form a) regular monoclinic, b) monoclinic twinned, c) monoclinic faulted, and d) orthorhombic structures. The fault plane is (100).

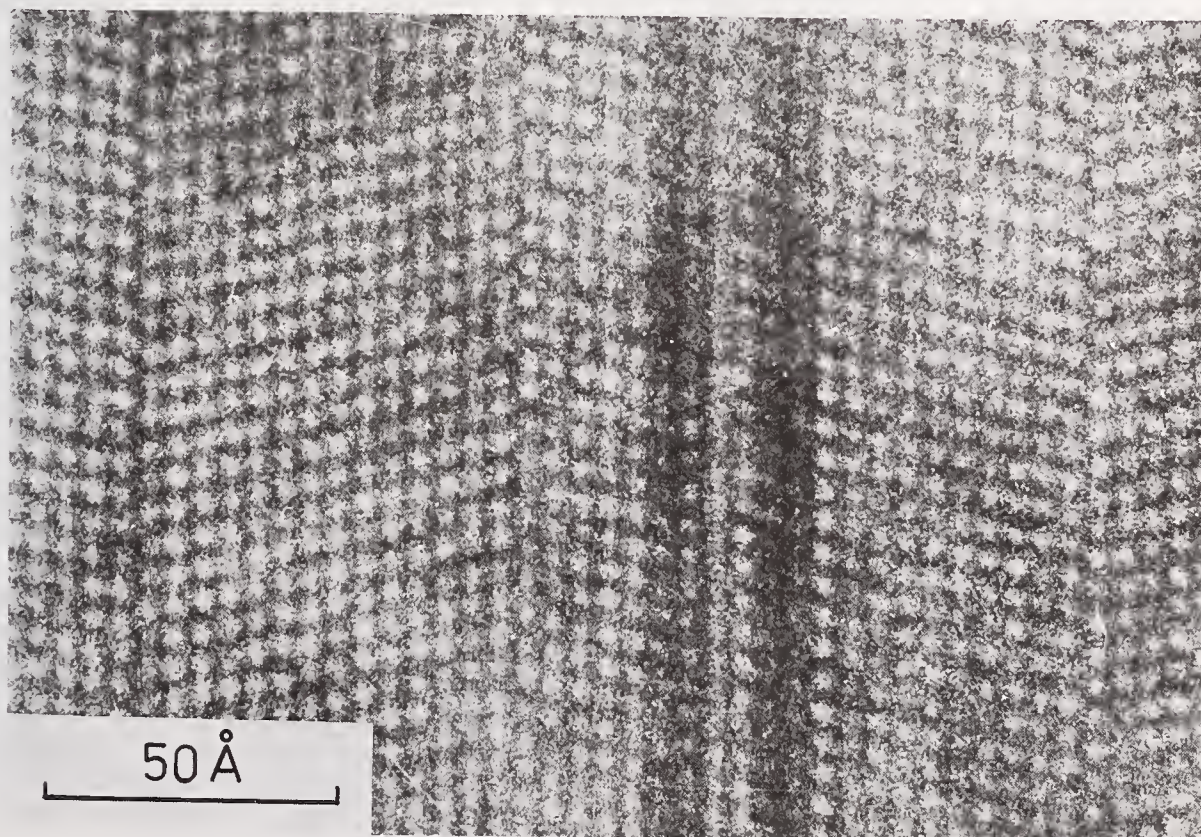

Figure 5. High-resolution electron micrograph of amosite showing faulted and twinned structures. (Electron beam parallel to y) Figure from J. L. Hutchinson *et al.* [8].

Figure 6 illustrates the Wadsley defect by showing how parts of an amphibole crystal might contain occasional triple or single Si-O chains distributed among the normal double chains. In low magnification electron micrographs such defects are seen as linear features parallel to (010) (fig. 7).

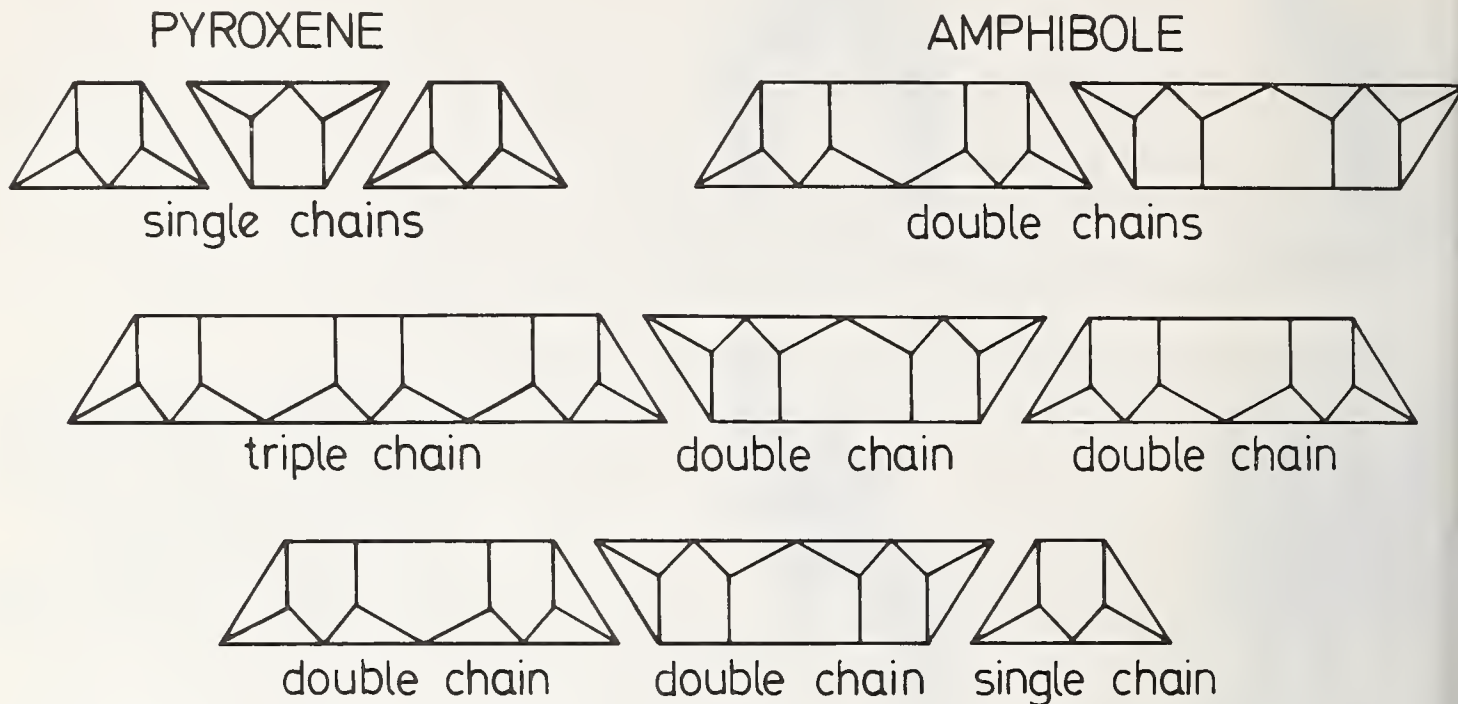

Figure 6. Schematic illustration of a) pyroxene structure, b) amphibole structure, c) amphibole with triple chain Wadsley defect, and d) amphibole with single chain defect.

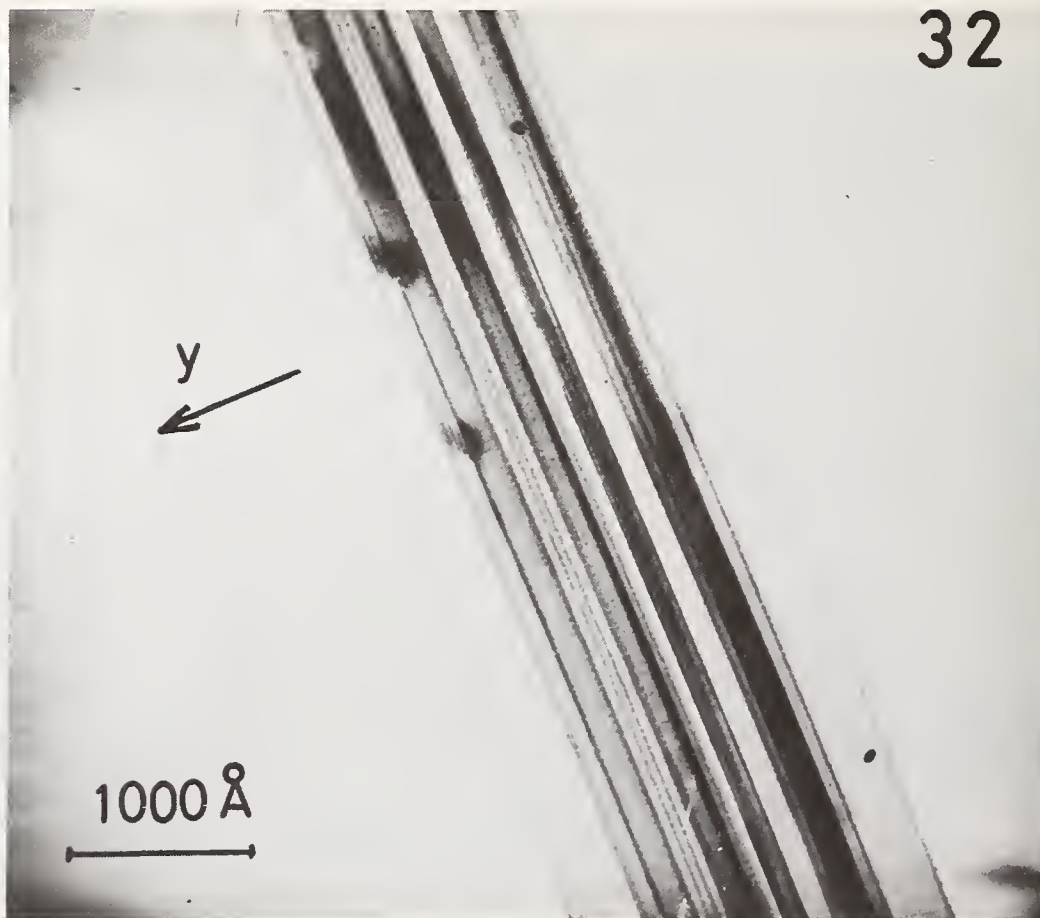

Figure 7. Electron micrograph of amphibole with beam perpendicular to y showing Wadsley defects on (010). Figure from J. E. Chisholm [9].

For environmental health considerations we do not yet have a causative understanding of the harmful effects of asbestos and do not know which properties of asbestos are involved. It is conceivable therefore that more subtle structural factors than those described above might be important. Although the structure described is broadly correct for all amphiboles, minor differences in atomic coordinates occur from one amphibole to another. Structure determinations have been performed for non-asbestiform tremolite, actinolite, anthophyllite and grunerite, but not for asbestiform specimens because of technical difficulties. For crocidolite, a fiber approaching a single crystal was used rather than a hair-like strand of asbestos. As part of the details of structure, variations can occur in the way in which Fe and Mg atoms are distributed among similar but not strictly equivalent octahedral sites. In some amphiboles the role of Fe^{3+} may be significant in oxidation-reduction processes, and there is the possibility of Na (or Ca) having a degree of cation exchange capacity.

Serpentine

Chrysotile, another important variety of asbestos is not an amphibole but is a member of the serpentine group of minerals. Because of its asbestiform character, and repeat distance in the unit cell of about 5.3 Å parallel to the fiber axis (similar to that in amphiboles), it was once thought to have a chain-like crystal structure. Later work, however, showed it to be a layered silicate with structure analogous to that of the clay mineral kaolinite, but with Mg instead of Al in its composition. The paradox of how a layered mineral could have asbestiform habit was solved largely by Whittaker [10,11,12] who deduced from x-ray diffraction patterns that layers are rolled to form concentric cylinders or scrolls with their long axes parallel to the fiber. This indirect evidence was supported by electron microscopy of transverse sections of chrysotile, culminating in the spectacular high-resolution photographs published by Yada (fig. 8).

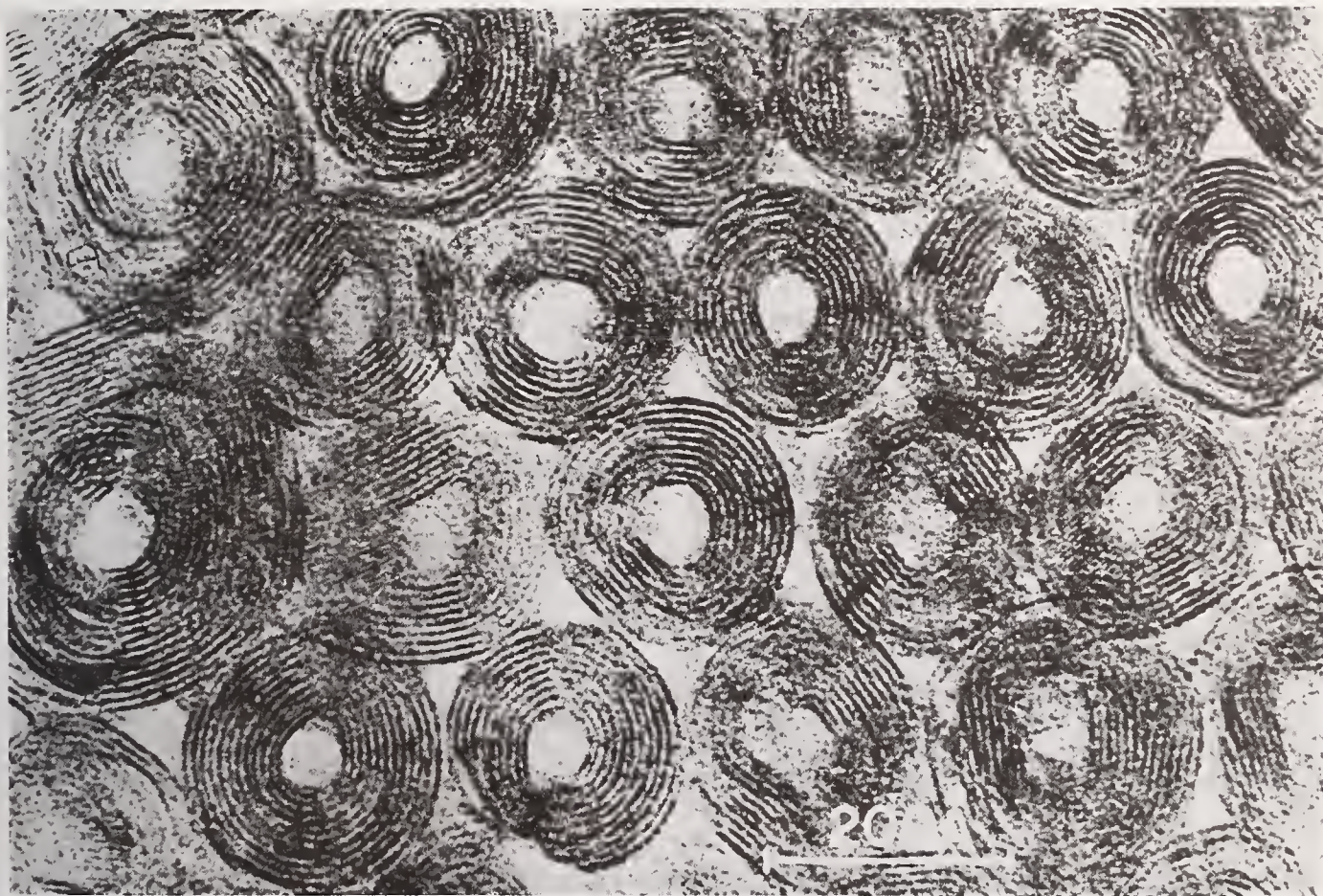

Figure 8. High resolution electron micrograph of transverse section of chrysotile asbestos. Figure from K. Yada [13].

The reason for the curving of the fundamental layers in chrysotile can be seen by examination of their chemical composition and structure. Each layer has two components, one a sheet of linked Si-O tetrahedra, and the other (joined to the first by sharing apical oxygens), a sheet of (Mg-O,OH) octahedra. A plan and elevation view of the composite layer, $Mg_3Si_2O_5(OH)_4$, is shown in figure 9. In order to form a flat-layered composite the dimensions of each component would need to match fairly closely. Reasonable estimates of the repeat distance of each show that the tetrahedral Si sheet has smaller dimensions than the octahedral Mg sheet, and this mis-match can be overcome by curvature, with the Mg sheet outermost, or by some other means of relieving structural strain. This leads to a number of strange structural configurations in serpentines, one of which is the tube-like character of chrysotile.

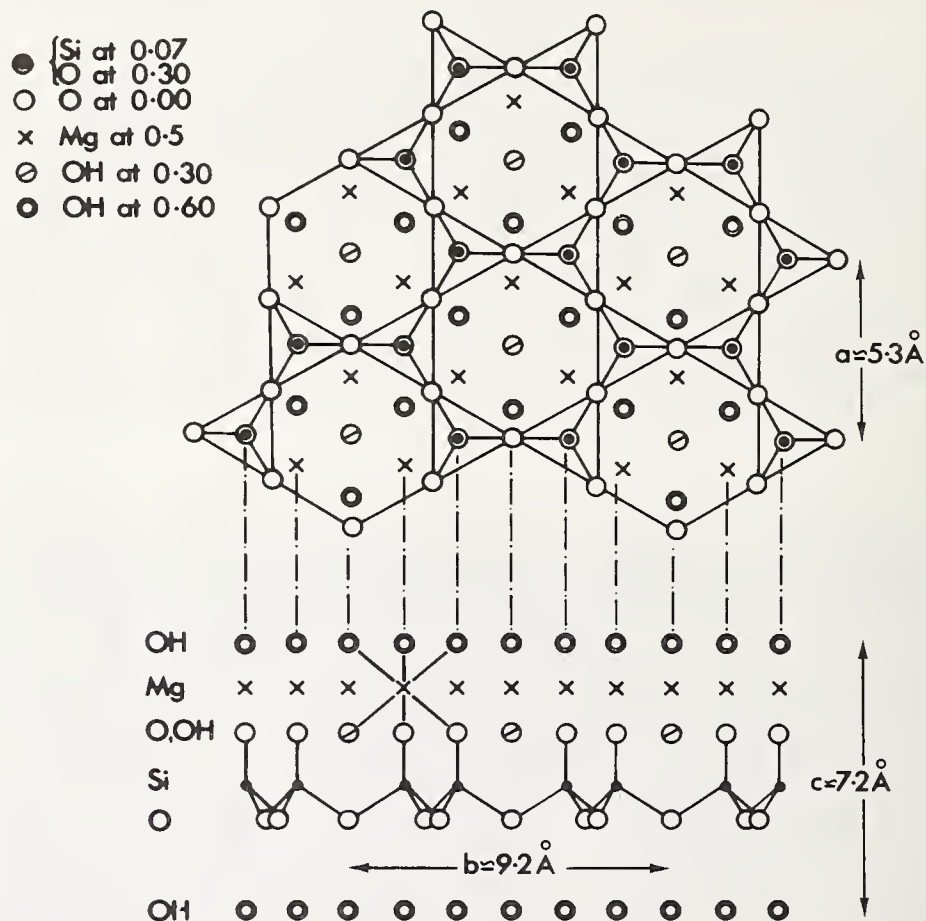

Figure 9. Plan and elevation views of idealized serpentine structure.

Electron micrograph studies of chrysotile asbestos show that diameters of natural fibrils are of the order of 100 to 500 Å, and the length/breadth ratios are of the order of 100 to 1 or greater. The limitation on growth in the radial direction is more easily understood for chrysotile than for amphiboles in that as successive layers are added during the growth process, the radius of curvature increases, eventually deviating too far from its ideal strain-free value to be energetically favorable. Thus chrysotile asbestos probably forms by multiple nucleation, usually on the walls of veins in massive fine-grained serpentinite rock, with relatively rapid growth in the fiber direction and limited growth at right angles to it.

It is pertinent in the context of possible environmental problems to consider the structure and morphology of other serpentine minerals which have very similar composition but are not asbestiform. One such mineral is antigorite. It too has a curved sheet structure, but the layers are corrugated rather than rolled (fig. 10). The corrugations have a rather regular wavelength so that quite well-formed crystals result. Sometimes they are equidimensional but they have a tendency to be thin, and lath-like parallel to y . Antigorite

is often found associated with other serpentine minerals; it does have a small but distinct difference in chemistry and is known to form under higher temperature conditions than the others [15].

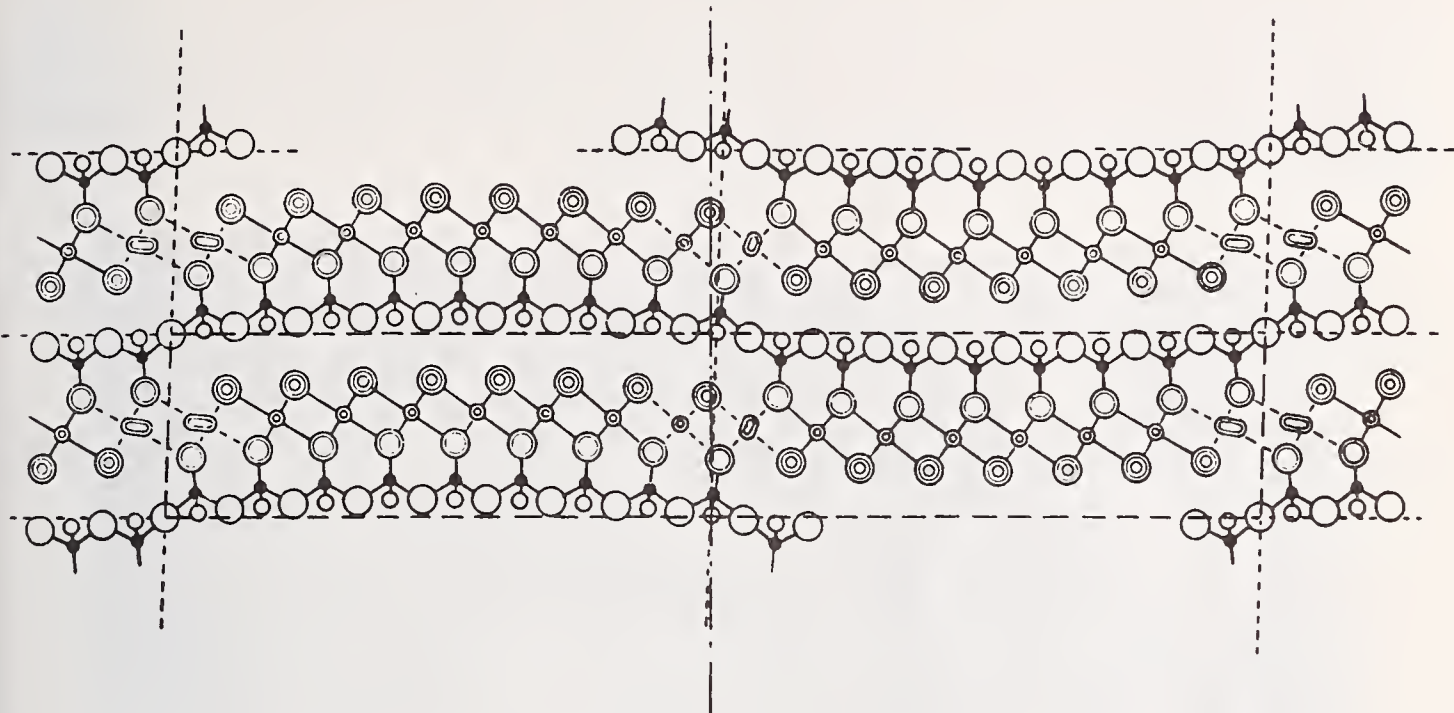

Figure 10. The "corrugated sheet" structure of antigorite viewed along the y axis. After G. Kunze [14].

A third kind of serpentine is the mineral lizardite, which in spite of the difficulties mentioned above does manage to achieve a more or less flat-layered structure [16]. The accompanying strain however means that crystals contain imperfections and usually grow only to very small dimensions. Thus a high proportion of apparently massive serpentine is composed of lizardite grains too small for optical resolution, but seen by the electron microscope to have platy morphology. The stacking of successive serpentine layers in lizardites can lead to 1,2,3,6 and even 9-layer repeats, and whereas lizardite platelets are usually not elongated, some of the multi-layer varieties yield lath-like crystals, and again, like antigorite a coarse splintery fiber. Cell parameters of serpentine minerals are given in Table 3.

Table 3. Serpentes. Cell parameters.^a

	<u>a</u> Å	<u>b</u> Å	<u>c</u> Å	β	Fiber Axis
clino-chrysotile [10]	5.34	9.25	14.65	93°16'	<u>x</u>
ortho-chrysotile [11]	5.34	9.2	14.63	90°	<u>x</u>
para-chrysotile [12]	≈5.3	9.24	14.7	90°	<u>y</u>
lizardite [17]	≈5.3	≈9.2	≈7.3 x <u>n</u> ^b	90°	<u>x</u> when fibrous
antigorite [14]	43.3 ^c	9.23	7.27	91.6°	<u>y</u> when fibrous

^a These cell parameters relate to particular specimens. Variations in chemical composition, particularly in Fe/Mg ratio, can be expected to yield a range of values, but usually within 1 or 2 percent of those given. For antigorite markedly different a values occur.

^b Lizardites with n = 1, 2, 3, 6, and 9 have been described.

^c Other large values of a are found.

Yet another strange morphology for a serpentine mineral has been discovered recently [18], and although it has not yet been studied extensively, it does appear to be quite common in occurrence. In this variety, flat lath-like serpentine layers are arranged to form polygonal prisms, sometimes surrounding a core of tubular chrysotile. A cross-section is illustrated in figure 11. Typical diameters are of the order of 1000 to 2000 Å. Serpentine specimens in which this structure seems to be prevalent are those which have a coarse splintery fibrous texture. Their fracture fragments are expected to have, and indeed show, lath-like morphology. Whether this material should be classed as a form of chrysotile or of lizardite is a moot point, and it may be better to call it "polygonal serpentine" with our present state of knowledge.



Figure 11. Electron micrograph of an ion-thinned serpentine specimen showing cross-sections of chrysotile tubes and polygonal serpentine. Figure from Cressey and Zussman [18].

Although for antigorite there is clearly a distinct chemical composition, there is no consistent chemical difference between chrysotiles and lizardites. The latter two can therefore be regarded as polymorphs and would be expected to have distinct (P,T) stability fields. Attempts to define these have not so far been successful. Examination of the mineralogy and textures of large numbers of serpentinite rocks have led to the conclusion that the chrysotile asbestos is formed secondarily from lizardite or antigorite and not directly from olivine and pyroxene, and that it is formed in a relatively low but rising temperature regime [19,20].

Concluding Remarks

There have not as yet been extensive tests comparing the physiological activities of asbestiform and non-asbestiform varieties of amphiboles or of serpentines. It would clearly be useful to know what, in addition to morphology, are the essential chemical and physical differences between asbestiform and non-asbestiform varieties. These differences might be

either consequences or causes of the contrasting morphology. Since, for any mineral, different specimens show variations in properties even when morphology does not change significantly, it is not easy to determine which, if any, are absolutely specific to asbestos. Such differences, if established, might be quite subtle but nevertheless important for physiological effects, but since the mechanism of the latter is unknown, we have no clues from this quarter to aid us in the search. If particle size and shape are the only important factors, then we need not trouble to look further (except as a fascinating geological problem). If other factors are important, and we do not know what they are, then any material to which people are exposed on a large scale needs to be tested for its physiological effects.

References

- [1] Papike, J. J., Ross, M., and Clark, J. R., Crystal-chemical characterization of clinoamphiboles based on five new structure refinements, in Pyroxenes and Amphiboles: Crystal Chemistry and Phase Petrology, Min. Soc. Amer. Special Publ. No. 2 117-136 (1969).
- [2] Mitchell, J. T., Bloss, F. D., and Gibbs, G. V., Examination of the actinolite structure and four other C2/m amphiboles in terms of double bonding, Zeit. Krist., 133, 273-300 (1971).
- [3] Ghose, S. and Hellner, E., The crystal structure of grunerite and observations on the Mg-Fe distribution. J. Geol., 67, 691-701 (1959).
- [4] Whittaker, E. J. W., The structure of Bolivian crocidolite, Acta Cryst., 2, 312-317 (1949).
- [5] Finger, L. W., Refinement of the crystal structure of an anthophyllite, Ann. Rep. Dir. Geophys. Lab., Carnegie Inst. Yr. Bk., 68, 283-288 (1970).
- [6] Fedoseev, A. D., Makarova, T. A., and Kosulina, G., Synthesis of fibrous richterite under hydrothermal conditions. Zap. Vses. Min. Obshch., 97, 722-725 (1968).
- [7] Goncharov, Yu, I., Balitskii, V. S., Khadzhi, I. P., and Popova, N. P., Replacement of phlogopite by amphibole asbestos of the eckermannite-arfvedsonite series in alkaline hydrothermal solutions, Zap. Vses. Min. Obshch., 103, 716-718 (1974).
- [8] Hutchison, J. L., Irusteta, M. C., and Whittaker, E. J. W., High resolution electron microscopy and diffraction studies of fibrous amphiboles. Acta Cryst., A31, 794-801 (1975).
- [9] Chisholm, J. E., Planar defects in fibrous amphiboles, J. Mat. Sci., 8, 475-483 (1973).
- [10] Whittaker, E. J. W., The structure of chrysotile, II., Clinochrysotile, Acta Cryst. 9, 855-862 (1956).
- [11] Whittaker, E. J. W., The structure of chrysotile, III, Orthochrysotile, Acta Cryst. 9, 862-864 (1956).
- [12] Whittaker, E. J. W., The structure of chrysotile, IV, Parachrysotile, Acta Cryst. 9, 865-867.
- [13] Yada, K., Study of chrysotile asbestos by a high resolution electron microscope, Acta Cryst. 23, 704-707 (1967).
- [14] Kunze, G., Die gewellte Struktur des Antigorits, I, Zeit. Krist. 108, 82-107 (1956).
- [15] Evans, B. W., Johannes, W., Oterdoom, H., and Trommsdorff, V., Stability of chrysotile and antigorite in the serpentinite multisystem. Schweiz min. petrogr. Mitt., 56, 79-93 (1976).

- [16] Rucklidge, J. C. and Zussman, J., The crystal structure of the serpentine mineral, lizardite $Mg_3Si_2O_5(OH)_4$, Acta Cryst., 19, 381-389 (1965).
- [17] Whittaker, E. J. W. and Zussman, J., The characterization of serpentine minerals by x-ray diffraction, Mineral. Mag., 31, 107-126 (1956).
- [18] Cressey, B. A., and Zussman, J., Electron microscopic studies of serpentines, Canad. Mineral., 14, 307-313 (1976).
- [19] Wicks, F. J. and Zussman, J., Microbeam X-ray diffraction patterns of the serpentine minerals, Canad. Mineral., 13, 244-258 (1975).
- [20] Wicks, F. J. and Whittaker, E. J. W., Serpentine textures and serpentinization, Canad. Mineral., 15, In press (1977).

Discussion

NOTE: Discussion of this paper was included in the General Discussion at the end of this session.

THE "ASBESTOS" MINERALS: DEFINITIONS, DESCRIPTION, MODES OF FORMATION, PHYSICAL AND CHEMICAL PROPERTIES, AND HEALTH RISK TO THE MINING COMMUNITY

Malcolm Ross

U.S. Geological Survey
National Center, 959
Reston, VA 22092

Abstract

The mineralogical description of "asbestos" given here is based on a very special feature common to all forms of commercial "asbestos" – the property that permits the minerals to separate into long tubes or fibrils only a few tens of nanometers thick. This separation can be accomplished by very light grinding or agitation; the common non-fibrous amphiboles do not separate into such fibrils even after intense grinding. The ease of such fibril separation may be caused by the special nature of the crystal structures of the commercial "asbestos" minerals. Repeated twinning on (100) in amosite and crocidolite, the curling of layers of chrysotile to form tubes, and the presence of triple, quadruple, n -tuple chains ("Wadsley" defects) in amosite, crocidolite, anthophyllite, and tremolite, are the structural features that probably promote the formation of thin fibrils. Stability diagrams in the system $MgO-SiO_2-H_2O$ indicate possible geochemical processes by which commercial "asbestos" can form.

The relative health risk posed by exposure to the "asbestos" minerals may be related to the fibril composition, crystal structure, size, shape, and total surface area. The relative chemical reactivity of the fibril surface is predicted to be

chrysotile < anthophyllite < amosite < crocidolite

on the basis of the types of oxidation-reduction and exchange reactions that may occur. According to epidemiological studies, the relative health risk appears to be anthophyllite < chrysotile < amosite < crocidolite.

"Asbestos" health risks in the mining and milling industry and environs are reviewed. Health studies done in the chrysotile mining district of Quebec, Canada, have presented good evidence that realistic "asbestos" dust standards can be set that not only protect the workers and residents of the mining areas from undue health risks but probably allow the industry to operate economically.

Key Words: Actinolite; ambient air; amosite; amphibole; amphibolite; anthophyllite; asbestos; asbestos stability; chrysotile; chrysotile emissions; chrysotile mining; crocidolite; cummingtonite; dust levels; grunerite; health risk; Homestake Mines, S.D.; hornblende; Hunting Hill Quarry, Rockville, Md.; lung cancer; mesothelioma; serpentinite, surface chemistry; talcbole; Thetford Mines, Quebec, Canada; tremolite; Urals; U.S.S.R.; and Wadsley defects.

Introduction

It is generally a rather straightforward, though often time-consuming mineralogical task to describe the physical and chemical properties of amphiboles and serpentines including those varieties referred to as "asbestos". Exceptions are minerals such as fibrous tremolite and fibrous talc that to date do not have adequate mineralogical descriptions. Defining minerals that constitute an "asbestos" health hazard is an entirely different and a much more complex problem, for it involves many factors not included within the science of mineralogy.

This commentary is concerned with the various definitions of "asbestos" as they relate to: (1) the medical profession, which must determine which types of mineral particles constitute an "asbestos" health hazard; (2) the legal and regulatory professions, which must enact and enforce the laws relating to "asbestos" use; (3) the mineralogical profession, which must describe the chemical, structural, and physical properties of such minerals; and (4) the mining and quarrying industries, which may be affected by these definitions.

What is "Asbestos"?

Three definitions of "asbestos" found in the Glossary of Geology [9, p. 41]¹ are quoted as follows: "asbestos (a) A commercial term applied to a group of highly fibrous silicate minerals that readily separate into long, thin, strong fibers of sufficient flexibility to be woven, are heat resistant and chemically inert, possess a high electric insulation, and therefore are suitable for uses (as in yarn, cloth, paper, paint, brake linings, tiles, insulation, cement, fillers, and filters) where incombustible, nonconducting, or chemically resistant material is required. (b) A mineral of the asbestos group, principally chrysotile (best adapted for spinning) and certain fibrous varieties of amphibole (esp. tremolite, actinolite, and crocidolite). (c) A term strictly applied to the fibrous variety of actinolite."

The term "asbestos", from a geoscientist's point of view, applies only to the minerals chrysotile (one of the serpentine polymorphs), "amosite" (a variety of grunerite), "crocidolite" (a variety of riebeckite), anthophyllite, tremolite, and actinolite when they are present in sufficient quantity to be commercially valuable for their special physical and chemical properties, which include fibrous habit, insulation qualities, low electrical conductivity, fire resistance, and suitability for weaving. Many other minerals sometimes possess habits described variously as acicular, asbestiform, elongate, fibrous, bladed, lamellar, filiform, prismatic, or columnar; for example, minerals of the zeolite group having acicular habit, fibrous calcite and quartz, acicular wollastonite, prismatic pyroxenes, elongate crystallites of attapulgite, and filiform sepiolite. Since these minerals are not exploited for the commercially valuable properties listed above, they are not called "asbestos" by geoscientists.

At present, the most widely used definition of "asbestos" by various groups concerned with environmental health problems, including the U.S. Environmental Protection Agency (EPA) and the U.S. Mining Enforcement and Safety Administration (MESA), is from the notice of proposed rule-making for "Occupational Exposure to Asbestos" published in the Federal Register (Oct. 9, 1975, p. 47652, 47660) by the U.S. Occupational Safety and Health Administration (OSHA). In this notice, the naturally occurring minerals chrysotile, amosite, crocidolite, tremolite, anthophyllite, and actinolite are classified as "asbestos" if the individual crystallites or crystal fragments have the following dimensions: length - greater than 5 micrometers, maximum diameter - less than 5 micrometers, and a length to diameter ratio of 3 or greater. Any product containing any of these minerals in this size range are also defined as "asbestos".

The crushing and milling of any rock usually produces some mineral particles that are within the size range specified in the OSHA rules. Thus, these regulations present a formidable problem to those analyzing for "asbestos" minerals in the multitude of materials and products in which they may be found in some amount, for not only must the size and shape of the "asbestos" particles be determined, but also an exact mineral identification must be made.

¹Figures in brackets indicate the literature references at the end of this paper.

A wide variety of amphiboles is found in many types of common rocks; many of these amphiboles might be considered "asbestos" depending upon the professional training of the person involved in their study and the methods used in mineral characterization. Campbell et al. [3] have carefully described the differences between the relatively rare fibrous varieties of the amphiboles and the common nonfibrous forms.

If the definition of "asbestos" from the point of view of a health hazard does include the common nonfibrous forms of amphibole, particularly the hornblende and cummingtonite varieties, then we must recognize that "asbestos" is present in significant amounts in many types of igneous and metamorphic rocks covering perhaps 30 to 40 percent of the United States. Rocks within the serpentinite belts; rocks within the metamorphic belts higher in grade than the greenschist facies, including amphibolites and many gneissic rocks; and amphibole-bearing igneous rocks such as diabase, basalt, trap rock, and granite would be considered "asbestos" bearing. Many iron formations and copper deposits would be "asbestos" bearing, including deposits in the largest open-pit mine in the world at Bingham, Utah. "Asbestos" regulations would thus pertain to many of our country's mining operations, including much of the construction industry and its quarrying operations for concrete aggregate, dimension stone, road metal, railroad balast, riprap, and the like. The "asbestos" regulations would also pertain to the ceramic, paint, and cement industries, and to many other areas of endeavor where silicate minerals are used.

We do not know whether health investigators will consider other minerals that commonly possess a fibrous or acicular habit to be health hazards; minerals such as wollastonite, the fibrous forms of calcite and quartz, acicular minerals of the zeolite mineral group, the pyroxenes, the sepiolite minerals including attapulgite, and the calcium silicates found in Portland cement. Certainly if the common amphiboles such as hornblende, tremolite, actinolite, gedrite, and cummingtonite with their typical prismatic cleavage are considered health hazards, the common pyroxenes having similar habits should also be considered health hazards.

A Mineralogical Description of Commercial "Asbestos"

The commercial deposits of "asbestos" contain one of the following minerals: chrysotile, $Mg_3Si_2O_5(OH)_4$; amosite, $(Fe^{2+}, Mg)_7Si_8O_{22}(OH)_2$ (a variety of grunerite); crocidolite, $Na_2(Fe^{2+}, Mg)_3Fe_3^+Si_8O_{22}(OH)_2$ (a variety of riebeckite); "fibrous" anthophyllite, $(Mg, Fe)_7Si_8O_{22}(OH)_2$; and "fibrous" tremolite and actinolite, $Ca_2(Mg, Fe)_5Si_8O_{22}(OH)_2$. Tremolite and actinolite are now, as they were in the past, of little economic importance; anthophyllite is of little economic importance now. About 95 percent of the commercial asbestos now used in the United States is chrysotile, of which about 90 percent is imported from Canada. No commercial amosite or crocidolite has ever been mined in the United States.

In addition to being compositionally different, the five amphibole forms of commercial "asbestos" have completely different crystal structures from that of chrysotile. The structure of chrysotile consists of double layers, each consisting of a layer of linked SiO_4 tetrahedra that is coordinated to a second layer of linked $MgO_2(OH)_4$ octahedra through the sharing of oxygen atoms; the composite double layer rolls up, like a window shade, to form long hollow tubes. The diameters of the individual tubes are on the order of 25 nm; the length-to-diameter ratio can vary from 5 or 10 to well over 10,000.

The structures of the amphibole minerals, on the other hand, are composed of strips or ribbons of linked polyhedra, which join together to form the three-dimensional crystal. The individual strips are composed of three elements—two double chains of linked $(Si, Al)O_4$ tetrahedra that form a "sandwich" with a strip of linked MgO_6 , FeO_6 , or AlO_6 octahedra. The structural relationship of the upper double tetrahedral chain to the octahedral part of the strip is shown in figure 1. The three-dimensional arrangements of these strips or "I-beams" [26] orthoamphibole (anthophyllite) and in clinoamphibole (tremolite, amosite, actinolite, and crocidolite) are shown in figure 2.

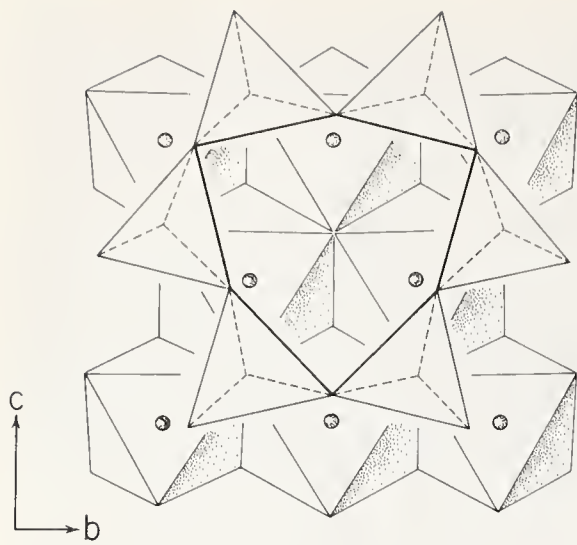

Figure 1. Structural relationship between the upper double chain of linked $(\text{Si,Al})\text{O}_4$ tetrahedra and the octahedra part of the amphibole strip of "I-beam." The circles represent Mg, Fe, or Al atoms in octahedral coordination; at the apices of the polyhedra are oxygen atoms. Tetrahedral Si and Al atoms are not shown. The "I-beams" extend infinitely in a direction parallel to the c -axis (the fiber axis). The width of the "I-beam" in the b -direction is three octahedra. Figure is modified from Papike and Ross [26].

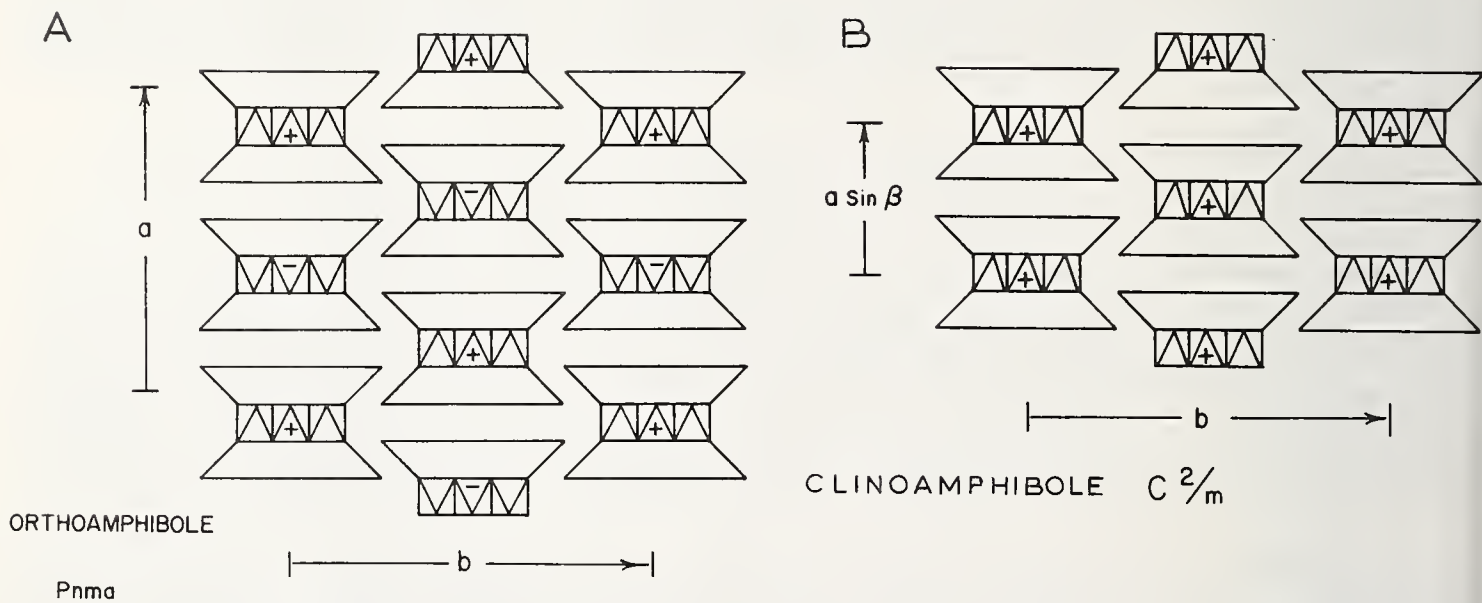

Figure 2. Arrangement of the amphibole strips or "I-beams" in (A) orthoamphibole (space group $Pnma$) and (B) clinoamphibole (space group $C2/m$). The "I-beams" are viewed end-on (parallel to the fiber c -axis). The central portion of the "I-beam" is composed of $(\text{Mg,Fe,Al})\text{O}_6$ octahedra; the upper and lower portions are composed of double chains of (Si,AlO_4) tetrahedra. The "I-beams" are stacked in two ways: (1) $+++...$ (clinoamphibole), and (2) $+ - + - ...$ (orthoamphibole). Figure modified from Papike and Ross [26].

One feature is common to the six "asbestos" minerals: their ready separation into long fibrils or tubes only a few tens of nanometers in diameter. This separation can be accomplished by very light grinding or by agitation in water by means of an ultrasonic separator. The common nonfibrous amphiboles do not separate into such fibrils even after intense grinding; instead, they break up along cleavage planes into rather short stubby prisms—though the length-to-diameter ratio may still be greater than 3:1.

What causes the special type of fibril separation found in commercial forms of "asbestos" but generally not in the nonfibrous amphiboles? Three observations are pertinent:

(1) Chrysotile, which forms individual hollow tubes, can separate into fibrils as thin as the diameter of the individual tube. The chemical bonding between tubes is very weak and perhaps is due only to van der Waals forces; thus, the tubes are easily separated from one another.

(2) Amosite and crocidolite "asbestos" from South Africa is repeatedly twinned on (100) as has been observed in electron microscope studies [4,15,25,34]. This "poly-synthetic" twinning, which produces repeated planar faults parallel to (100), is extremely rare in the nonfibrous calcium-rich amphiboles (tremolite, hornblende) and uncommon in nonfibrous amphiboles of the cummingtonite-grunerite series [30,31,32].

(3) Amosite, crocidolite, fibrous anthophyllite, and fibrous tremolite have been shown to possess chain defects, also called "Wadsley" defects [8,15,36,37,38]. These defects are caused by the formation of expanded "I-beams" that are composed of triple, quadruple...etc. chains of linked (Si,Al)O₄ tetrahedra rather than the double chains found in all amphibole crystal structures. If these "I-beams" are expanded indefinitely, the resulting strip becomes identical with the single talc layer of composition Mg₆Si₈O₂₀(OH)₄; recall that the composition of anthophyllite is Mg₇Si₈O₂₂(OH)₂. These expanded "I-beam" units can intermix with the regular amphibole "I-beams" to form a variety of minerals that I refer to as "talcboses" in allusion to their hybrid character-between talc and amphibole. Veblen [38] has described the detailed structures of four of these "talcboses" obtained from specimens originally described as "fibrous anthophyllite." In these crystal structures, "I-beams" of one or two types form an ordered three-dimensional structure. Veblen [38] showed evidence, as did Hutchison et al. [15], that disordered arrangements of these structural units also occur. Hutchison et al. [15] reported the presence of expanded "I-beam" structures in fibrous tremolite, and Franco et al. [8] reported the apparent presence of triple-chain lamellae, seen as planar faults on (010), in crocidolite from Western Australia.

Formation of "Asbestos"

How do chrysotile and the "talcboses" form? Modes of origin can be inferred from the stability relationships among talc, anthophyllite, enstatite, forsterite, antigorite, and chrysotile given by Hemley et al., [13]. Their mineral stability fields at 1 kbar H₂O, in terms of crystallization temperature and molality of aqueous silica, are given in figure 3. This figure shows a number of relationships pertinent to the problem of formation of "asbestiform" minerals. As the temperature decreases, forsterite (Mg-rich olivine) can react to form antigorite or chrysotile depending on the silica concentration in the aqueous solutions to which the olivine-bearing rock is exposed. One chemical reaction that may lead to the formation of brucite-bearing serpentinite is:

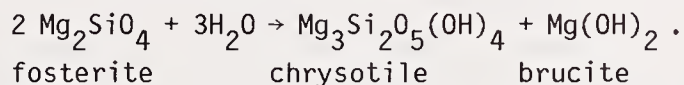

This reaction may explain the origin of the very long brucite needles, referred to as "nemalite," that are found in various serpentinites. Thirty-centimeter-long needles of this mineral were collected by C.E. Brown (U.S. Geol. Survey) from a Quebec serpentinite locality and were examined by single-crystal x-ray methods (Malcolm Ross, unpub. data). The brucite needles show hexagonal symmetry, $\underline{a} = 0.315$ nm, $\underline{c} = 0.474$ nm, and the long direction of the needles are parallel to the brucite \underline{a} -direction. The rather marked line broadening that appears in the x-ray pattern suggests that the brucite needles are composed of many small crystallites oriented so that their \underline{a} -axes are parallel to the fiber direction. The brucite needles are intergrown with chrysotile, for chrysotile x-ray reflections are superimposed on the diffraction pattern of brucite, and extremely long chrysotile fibrils remain when the brucite needles are dissolved by dilute HNO₃.

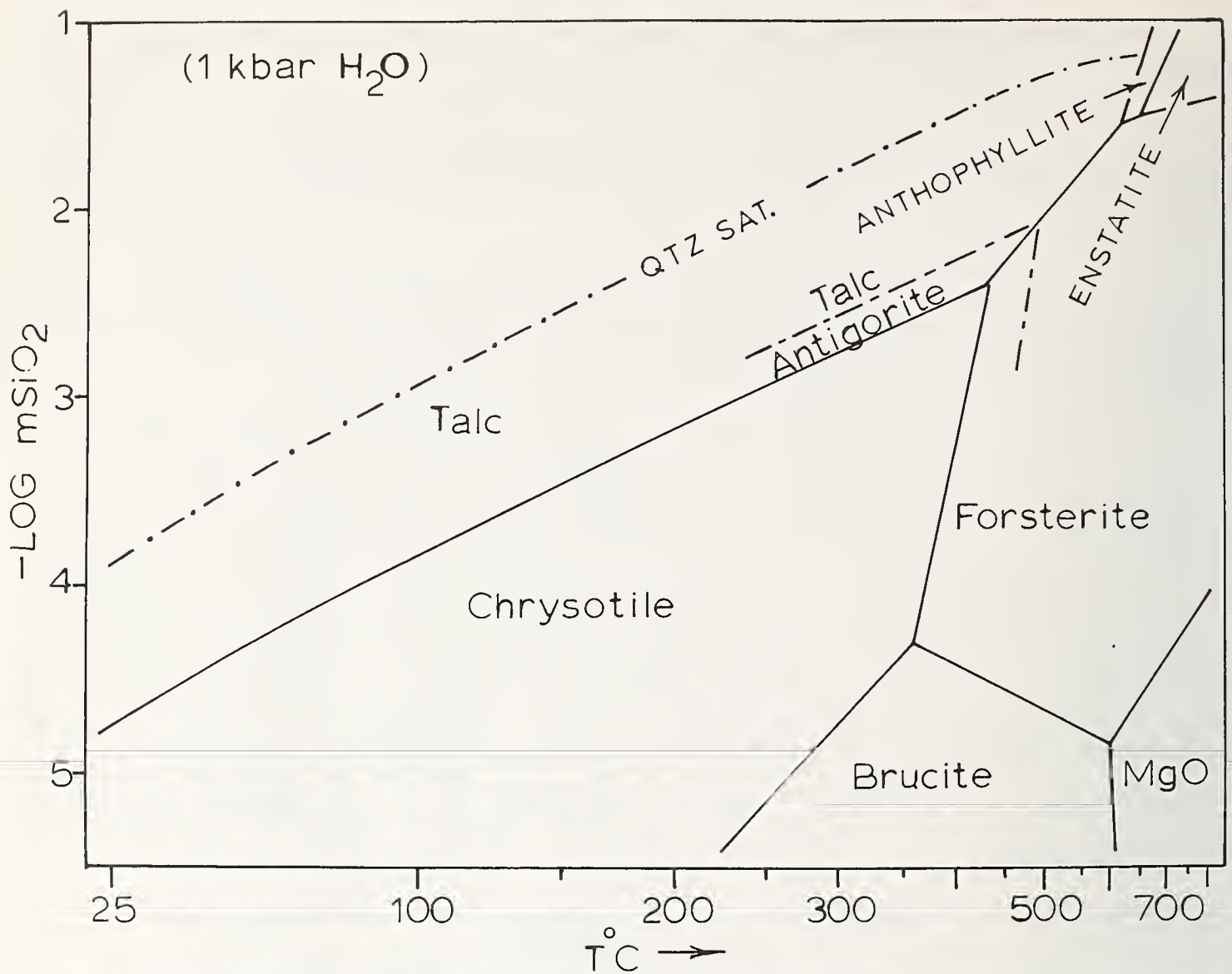
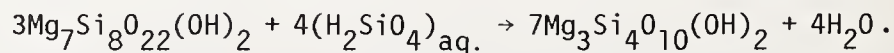

Figure 3. Mineral stability relations in the system $MgO-SiO_2-H_2O$ as a function of log of molality of aqueous silica and temperature, at 1 kilobar H_2O pressure. Figure modified from Hemley et al. [13].

At higher concentrations of aqueous silica, forsterite may alter to talc by the reaction:



At silica concentrations near the quartz saturation curve, anthophyllite can alter directly to talc by the reaction:



This reaction may be of importance for the formation of fibrous anthophyllite and talc. As the temperature decreases and the H_2O , Mg^{2+} , and silica activities remain within geologically reasonable limits, one probable reaction sequence is:

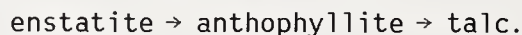

If the alteration of a chain silicate to talc proceeds by an intragranular reaction, "talcbole-type" phases may form as intermediates between anthophyllite and talc during low-temperature alteration [36,37,38]. Figure 4 shows the stability fields of forsterite, enstatite, anthophyllite, and talc in terms of temperature and molality of aqueous silica

[13]. A stability (or metastability) field for the "talcbolcs" (labelled "asbestos") is superimposed on this diagram, overlapping the fields of talc and anthophyllite. The fibrous nature of the "talcbolcs" can be explained if the alteration process of a chain silicate (anthophyllite) to a sheet silicate (talc) proceeds by reforming the double chains at the unit-cell level. In figure 4, the phase boundary between enstatite (a pyroxene having the formula $Mg_2Si_2O_6$) and anthophyllite suggests the possibility of having mixed single chain (pyroxene) and double chain (amphibole) structures.

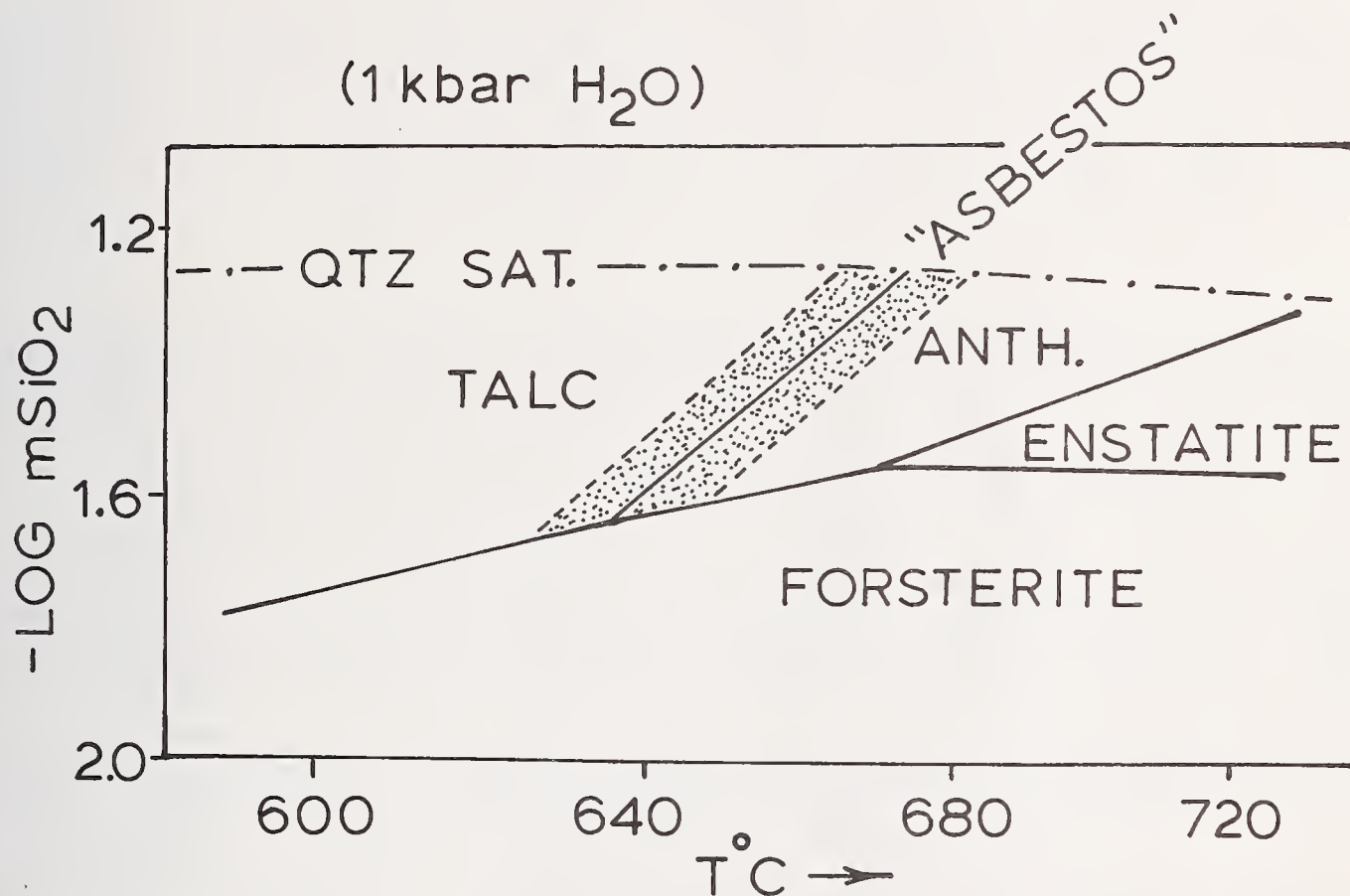

Figure 4. Adaptation of the enstatite-anthophyllite-talc-forsterite stability relationships at 1 kbar H₂O to show a possible stability or metastability field of "talcbolcs asbestos" (stippled). Figure modified from Hemley et al. [13]. anth. = anthophyllite.

The fibrous nature of commercial amosite and crocidolite appears to be related to the crystal growth mechanism; perhaps the crystallites nucleate at many centers and grow as individual fibers only a few tens of nanometers thick (see Franco et al. [8, figures 1,2]). The presence of (100) twinning and "Wadsley" defects may be the result of rapid growth and, in addition, may hinder growth in a direction perpendicular to the fiber axis.

Properties of "Asbestos" That May Be Related to Health Risk

Health studies suggest that of the four economically important forms of "asbestos," crocidolite has been responsible for the greatest health risk, followed by amosite, then chrysotile, and lastly anthophyllite [11]. If we assume that the health hazard caused by the commercial "asbestos" minerals is due to some combination of their chemical, structural, and physical properties, we can make some predictions about their relative biological activity.

All commercial "asbestos" minerals separate into very thin fibrils; possible reasons for this have been discussed previously. The thickness, length, and flexibility of the fibrils apparently is important in determining how the fibrils lodge in human tissue and

how readily they are cleared from the lung areas. The straight fibrils of small diameter, particularly those of crocidolite, can more readily move to the periphery of the lung, where they are in a position to penetrate the pleura and thus produce mesotheliomas [11]. That curly fibrils, especially those of chrysotile, are more readily arrested in the upper respiratory tract is given as a reason for the low incidence of mesotheliomas in chrysotile miners and millers [11,19,23]. Assessment of the role of fibril size in relation to lung cancer is less clear [11]; however, Gross [12] cited evidence that "asbestos" fibers less than 5 μm long cause negligible pathogenicity, both of the lung and pleura.

The problem of fibril size in relation to cancer incidence is of some importance, for the average ambient airborne "asbestos" fiber is shorter than the average fiber in the whole rock. Brulotte [2] reported that the average concentration of airborne dust particles in the chrysotile mining district of Thetford Mines, Quebec, was 80,500 ng/m^3 during active mining and 39,600 ng/m^3 during a 5-month period when the mines were closed. If we assume that the rock contains 4 weight percent chrysotile, these measurements suggest a minimum chrysotile dust concentration in the ambient air of 3220 and 1584 ng/m^3 .²

The total surface area of the inhaled fibrils and the chemical reactivity of this surface may have an important influence in the production of cancer.

Researchers have not yet determined whether this surface plays a direct part in the formation of cancerous tissue, or whether a carcinogenic chemical adheres to the mineral surface and the chemical itself later reacts with the tissue or in some way catalyzes the carcinogenic process. The high incidence of lung cancer in men who worked in the "asbestos" trades (textiles, brake-lining fabrication, insulating) and who also smoked [33] indicates that carcinogenic chemicals in the tobacco smoke may somehow interact with the "asbestos" fibrils. If many of the fibrils are not easily cleared from the lung, they may adsorb these chemicals and hold them indefinitely. Injection of "asbestos" fibrils directly into the pleura of animals causes a high incidence of mesothelioma [40]. These experiments suggest a direct relationship between the active fibril surface and production of pleural cancer. However, other dissimilar substances injected into animals also cause tumors; for example, nonfibrous hematite (Fe_2O_3), sanidine (KAlSi_3O_8), and corundum (Al_2O_3) [27].

As a generalization, the relative chemical reactivity of the exposed fibril surfaces of the four important forms of commercial "asbestos" in aqueous solutions is:

chrysotile < anthophyllite < amosite < crocidolite.

Chrysotile, the least reactive of the four, is composed of rolled-up layers that possess no broken chemical bonds except where the edges of the layers are exposed at the ends of the tubes. The three amphiboles, on the other hand, have broken chemical bonds on all surfaces of the fibrils.

Anthophyllite can alter to various other silicates in aqueous solutions, as has been explained above. Similar alteration mechanisms might also exist for crocidolite and amosite although, to my knowledge, these have not been documented. However, studies of the

²Conversion of these figures (nanograms chrysotile per cubic meter of air) to numbers of "fibers" per cubic centimeter of air (the value usually given in health studies) is estimated by using the following relations:

(1) density of chrysotile $\cong 2.5\text{g}/\text{cm}^3 = 2.5 \times 10^9 \text{ng}/\text{cm}^3$

(2) volume of 1 ng chrysotile = $4 \times 10^{-10} \text{cm}^3 = 400 \mu\text{m}^3$

(3) volume of chrysotile fibers in $\mu\text{m}^3/\text{cm}^3 = \frac{(\text{ng}/\text{m}^3)}{2500}$

(4) if a fiber having dimensions 1 μm x 1 μm x 5 μm (5 μm^3) is designated as a "standard fiber," then

1 ng chrysotile = 80 "standard fibers"

(5) number of chrysotile "standard fibers"/ $\text{cm}^3 = \frac{(\text{ng}/\text{m}^3)}{12,500}$

geochemistry of silicates indicate that the exposed surfaces of these two amphiboles present some interesting possibilities for chemical change. Amosite (and also crocidolite) can undergo oxidation-reduction reactions of the type,

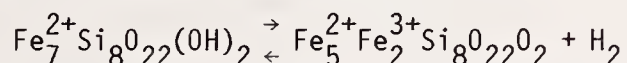

Ernst and Wai [6] have demonstrated that this reaction takes place in iron-bearing sodic amphiboles at 705 °C. The complete reversibility of such a reaction in the chemically similar silicate mineral biotite, has been demonstrated by Wones [42] and by Takeda and Ross [35]. In the experiments of Wones, auto-oxidation was accomplished in a neutral atmosphere (flowing argon) at 500–700 °C. Reduction was accomplished by passing hydrogen gas over the crystals. Analogous reactions can take place at much lower temperatures but also at much lower rates.

Cation exchange reactions take place in the amphiboles known as richterites [14]; exchange is accomplished within the A-site of the amphibole structure at 775–850 °C by the reaction:

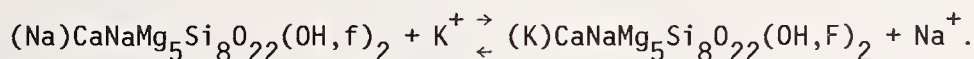

Crocidolite having a partially filled A-site such as that from Bolivia [41] can also undergo exchange reactions with potassium being replaced by sodium and possibly by oxonium and ammonium ions. Crocidolite with a partially or completely vacant A-site may undergo exchange reactions coupled with oxidation-reduction, e.g.:

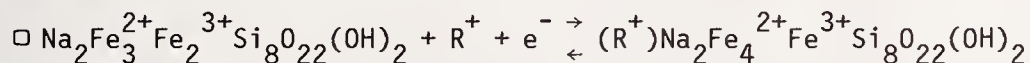

where $\text{R}^+ = \text{K}^+, \text{Na}^+, \text{H}_3\text{O}^+, \text{or } \text{NH}_4^+$, and $\square =$ a vacant site.

Whether such reactions can take place within animal tissue is not known, but the charged and reactive surfaces of crocidolite and amosite fibrils appear to offer excellent sites or templates for the initiation of complex chemical changes.

The surface area available for adsorption is, of course, directly related to fibril thickness or diameter. The specific surface of chrysotile, as measured both by nitrogen adsorption and permeability, is about twice that of amosite and crocidolite [28]. Because chrysotile forms hollow tubes, this larger area for adsorption in chrysotile is predictable if the average fiber thickness is similar for all three minerals.

The strain-free layer of chrysotile has a radius of curvature of about 8.8 nm [5]; thus, the minimum diameter of the tube should not be much less than 17 nm. The most frequently measured tube diameter is about 26 nm. Bates and Comer [1] found in a study of chrysotile from Arizona and Quebec a range of diameters from 11.4 to 85 nm; the average diameter was 25 nm. The fiber size ranges in the other forms of commercial "asbestos" have not come to my attention, although some crocidolite fibers from Western Australia [8] appear to be on the order of 50 nm wide.

"Asbestos" Health Risks in the Mining and Milling Industry and Environs

Although a significant health risk for those who work in the "asbestos" trades, particularly for those who smoke, has been well documented, the risk appears to be much lower for those in the chrysotile mining and milling industry and for those who reside in areas of such activity. The most detailed study of an "asbestos" mining community is that of the chrysotile mining areas of Quebec, Canada; the studies were started in 1966 and continue to the present [20–23]. Similar studies of chrysotile miners on a smaller scale have been undertaken by Kogan et al. [16] in the Urals, U.S.S.R., and by Vigliani [39] in Italy. According to McDonald [17,18] these other studies came to the same conclusions on health risk as the Quebec studies, the latter of which have led the way in making some assessment of the health risk relative to the amount of dust to which the workers were exposed. Health-risk studies of workers in the "asbestos" trades, for the most part, have not given reliable dust-exposure figures, or even the relative amounts and types of "asbestos" inhaled.

Chrysotile has been mined in the Thetford Mines, Black Lake, and asbestos localities of Quebec for nearly a century, beginning in 1886. Production has increased steadily since then, reaching 907,000 metric tons in 1956 and 1,500,000 metric tons in 1976. A tremendous amount of ambient dust has been generated over the years both by mining activities and by the winds blowing over the huge tailings piles. Even in 1974, when dust-emission controls had much improved over those of the earlier years (72 million particles per ft³ in 1950 to 4 million particles per ft³ in 1975 [20]) as a result of wet drilling, watering of haul roads, etc., emissions of particles from chrysotile mining and milling operations in the Province of Quebec amounted to 140,000 metric tons, of which about 4 percent (5600 metric tons) was "asbestos" dust [2]. The ambient dust levels for this region have already been discussed.

Is there a high incidence of cancer of the lung and pleura among the 35,000 residents of the Thetford Mines area of Quebec, 10 percent of whom are employed in the chrysotile industry? According to McDonald et al. [17-23], the cancer incidence for the male employees in the Quebec chrysotile industry is similar to that for Canada as a whole and only detectably raised in those with moderate to high levels of exposure. In Table 1 is given the proportional mortality from lung cancer and mesothelioma for the Quebec and North Italian chrysotile miners and millers, and also for the entire populations of various countries in the year 1970. In the period 1936-1973, seven cases of mesothelioma have been reported in the Quebec mining and milling industry [19, Table 12]. The worldwide incidence of mesothelioma in those who worked in the chrysotile mining and milling industry for the period 1958 to 1976 is 11 cases [19, Table 4]. The Canadian studies do show an increased incidence (2.1 to 3.6 times) of lung cancer for those workers exposed to the highest concentrations of dust -- 400 to 800 mpcf-yr³, but little evidence of health risk from this disease at levels below 200 mpcf-yr.

An unusually high number of deaths caused by lung cancer in Homestake gold miners during the period 1960 to 1973 has been reported by Gillam et al. [10]. The cohort consisted of 440 individuals who in 1960 had worked 5 years or more underground. Gillam et al. attributed the high incidence of lung cancer to inhalation of cummingtonite amphibole. They did not specify whether the hornblende amphibole, also present in the rock being mined, contributed to health risk. In rebuttal to this work, McDonald et al. [24] reported on a health analysis of a cohort of 1321 Homestake miners whose working period was from as far back as 1937 to the end of 1973; each of the miners had more than 21 years mining service. Deaths resulting from malignant neoplasm were very close to those expected (93 observed, 90.5 expected); this includes the subcategories of malignant neoplasm -- respiratory, gastro-intestinal, and "other" cancers. The excess death found in the Homestake miners was due in fact to silicosis, silico-tuberculosis, and heart disease. McDonald et al. [24] stated, "The pattern of mortality of men with long employment in this industry indicates a serious pneumoconiotic hazard characteristic of hard rock miners, but not of cancer."

Fears [7] has made an epidemiological study of cancer risk, including respiratory cancer, in 97 U.S. counties in 22 states known to be mining chrysotile or amphibole "asbestos." He found no excess of cancer mortality compared with cancer mortality rates in 194 demographically matched counties in which such minerals are not known to be mined; cancer mortality in both groups of counties was significantly below the national average.

³This unit expresses (in millions) the average number of particles (including approximately 4 percent chrysotile) contained in each cubic foot of air inhaled during a worker's career in the mines or mills times the number of years the worker was employed. If the dust is assumed to contain 4 percent chrysotile, then working for 50 years at a dust level of 16 mpcf (800 mpcf-yr) is roughly equivalent to inhaling 23 chrysotile particles for every cm³ of air taken into the lungs during the employment lifetime. A figure of 200 mpcf-yr is roughly equivalent to 6 particles of chrysotile/cm³. Conversion from dust particle measurements to chrysotile fibers per cm³ is difficult because chrysotile abundance varies from place to place.

Table 1. Proportional mortality from lung cancer and mesothelioma for selected male populations.

Group	Cohort		Deaths	
	No. men	All causes	% lung cancer	% mesothelioma
<u>General population</u> ^a				
Canada (1970)		82,052	5.3	0.03
USA (1970)		988,620	5.1	0.03
Finland (1970)		22,332	7.1	0.04
Italy (1970)		252,795	4.7	--
England - Wales (1970)		278,617	8.9	0.06
<u>Chrysotile mining-milling</u> ^b				
Quebec (1936-73)	10,951	3,938	5.7	0.18
N. Italy (1932-70)	1,098	270	2.2	0
<u>Anthophyllite mining-milling</u> ^c				
Finland (1936-67)	900	216	9.7	0
<u>"Asbestos" trades</u> ^d				
Insulators	26,505	2,137	19.6	6.7
Asbestos factory	10,781	1,422	15.0	3.1

^a Entire male population over 24 years of age [19, Table 13].

^b [19, Table 12; 20, p. 525].

^c [19, Table 12].

^d Composite figures [19, Table 12].

At present, people are concerned about the possible health hazards associated with the quarrying of serpentine rock at Hunting Hill quarry near Rockville, MD, and its use as a surface material for roads, playgrounds, and parks. The rocks being quarried here are very similar geologically to those of the chrysotile mining localities of Quebec, except that they contain much less chrysotile - about 0.5 weight percent. Rohl et al. [29] from Mount Sinai Hospital reported chrysotile fiber abundances of 500 to 4700 ng/m³ of air sampled adjacent to roads and a parking lot paved with loose crushed stone from the Hunting Hill quarry. The highest figures were measured during "moderate" motor vehicle use. The Mt. Sinai figures are equivalent to 0.2 to 1.9 μm³ of chrysotile per cm³ of air or 0.04 to 0.4 "standard fibers" per cm³ of air. Air samples taken near the perimeter of the Hunting Hill quarry gave chrysotile mass concentrations of from 0.02 to 64 ng/m³ or 2 x 10⁻⁶ to 5 x 10⁻³ "standard fibers" per cm³ of air (U.S. Bureau of Mines, State of Maryland, and McCrone Assoc., unpublished data). The present U.S. Government limits for "asbestos" content of air are 2 fibers/cm³ (OSHA) and 5 fibers/cm³ (MESA) where a fiber is defined as longer than 5 μm, less than 5 μm wide, and having a length-to-width ratio of 3:1 or greater.

The publicity about the possible health risk because of dust emission from the Hunting Hill quarry and its rock products had caused the quarry to lose about 30 percent of its business by July 1, 1977. Montgomery County, MD, expected to pay about \$2.3 million in its initial effort to seal the roads so as to reduce dust emissions and to remove loose stone from the parks (The Council Report, Montgomery County, vol. 6, no. 22, July 1, 1977). Apparently, other mining and quarrying operations along the "serpentine belt" of the eastern U.S. from Maine to Alabama also will be considered health risks to the general public [29]. Rohl et al. [29] suggested that exploitation of crushed amphibolite rock also raises the possibility of contamination of the air by "asbestos"-like minerals.

Discussion

The cancer incidence among those employed in the chrysotile mining and milling industry does not appear to be excessive when compared to national populations (Table 1). However, the incidence of cancer among those employed in the "asbestos" trades is very high (Table 1); incidence of lung cancer being 3 to 4 times that of the average population, incidence of mesothelioma being 130 to 220 times that of the average population. The "asbestos" trades generally utilized a variety of "asbestos" minerals including amosite and/or crocidolite, sometimes mixed into a paste for lagging. If we consider that about 90 percent of all the commercial "asbestos" ever mined was chrysotile, and that there is a low incidence of cancer in the chrysotile mining industry, we are led to conclude that either amosite and crocidolite are very hazardous or that there is an additional factor relating to health risk in the "asbestos" trades which has not yet been discovered. Previously, I have discussed some reasons why these two minerals may be more chemically reactive than chrysotile. Definitive epidemiological studies of the amosite mining regions of South Africa and the crocidolite mining regions of South Africa, Bolivia, and Australia appear to be lacking; such studies are needed in order to understand the high cancer incidence in certain trades utilizing these minerals. It is important to point out that the "asbestos" minerals should be considered separately when analyzing their effects on the worker's health. Reasoning by analogy is dangerous; high cancer incidence associated with one form of "asbestos" in a particular occupation does not necessarily mean that there will be the same incidence when utilizing another form of "asbestos" in that or another occupation. Unfortunately, this type of reasoning has led many to assume that any amphibole in any environment will cause high cancer mortality.

The operational problems in defining and characterizing fine mineral particles and the unknown health effects on humans by minerals not generally regarded as "asbestos" appear to be causing more and more investigators to accept rather broad definitions for "asbestos." The present analytical techniques used by the EPA and OSHA do not distinguish between amphibole cleavage fragments and the minerals geoscientists generally consider to be true "asbestos." In fact, if electron diffraction is not used expertly, many pyroxenes might be called "asbestos." For example, bronzite, a common orthopyroxene having the composition $(\text{Mg,Fe})_8\text{Si}_8\text{O}_{24}$, is very similar chemically to amphiboles of the cummingtonite-grunerite series, $(\text{Mg,Fe})_7\text{Si}_8\text{O}_{22}(\text{OH})_2$. Also, orthopyroxene gives an electron diffraction pattern similar to that of cummingtonite--both patterns possess 0.26 nm spacings between the diffraction row lines in the h0_l reciprocal lattice net. A full interpretation of the patterns is necessary for positive identification. Similarly, calcic pyroxenes might be confused with amphiboles of the tremolite-actinolite series or with hornblende. Cummingtonite (and possibly hornblende) is considered an "asbestos" health hazard by health investigators from the National Institute of Occupational Safety and Health (OSHA), as reported by Gillam et al. [10]. The Mt. Sinai group [29] suggested that crushed amphibole-bearing rocks (amphibolite) used as road-surfacing material may result in widespread "asbestos" contamination of community air.

Along with the general use of broader definitions of "asbestos" is a trend toward setting lower and lower limits on the acceptable amount of "asbestos" permitted in the environment (at present the OSHA standard is 2 fibers/cm³; the MESA standard is 5 fibers/cm³, but it will soon be changed to the OSHA value).

A more stringent "asbestos" health standard is presently being proposed by the National Institute for Occupational Safety and Health (Reexamination and Update of Information on the Health Effects of Occupational Exposure to Asbestos, December 1976; document prepared by NIOSH for transmittal to OSHA, as requested by the Assistant Secretary of Labor). This document states (p. 92-93): "Evaluation of all available human data provides no evidence for a threshold or for a safe level of asbestos exposure."

"In view of the above, the standard should be set at the lowest level detectable by available analytical techniques----."

"Since phase contrast microscopy is the only generally available and practical analytical technique at the present time, this level is defined as 100,000 fibers >5 μm in length/m³ (0.1 fibers/cc)----."

A definition of "asbestos" to include many amphiboles, chrysotile, and possibly other minerals that appear fibrous or acicular in the electron microscope coupled with a fiber-concentration standard of 0.1 fibers/cm³ should serve to shut down a large number of our hard rock mines and quarries. Also, nothing has yet been said about the effect of such standards on construction workers building highways, tunnels, bridges, or dams on amphibole-bearing rock, nor of the agricultural workers who are exposed to fiber-containing dust while working the croplands. If the present concept of low or "zero threshold" health risk and broad use of "asbestos" definitions continue, much of the crust of the earth could be considered a health hazard.

A way of minimizing the effect on the mining industry of the present and proposed "asbestos" standards, yet still maintaining a good level of health safety, is presented by the Canadian studies of the Quebec chrysotile workers. Here J. C. McDonald and his colleagues G. W. Gibbs, A. D. McDonald, M. R. Becklake, J. Siemiatycki, C. E. Rossiter, F. D. K. Liddell, O. A. El Attar, A. Harper, and many others [17-23] have undertaken not only to delineate areas of health risk in the Quebec environment but also to assess the exposure limits of rock dust where the incidence of cancer and other diseases is at an acceptably low level. No occupation can be considered to have a zero health risk. It would seem that similar studies in this field would be of value in the United States.

References

- [1] Bates, T. F., and Comer, J. J., Further observations on the morphology of chrysotile and halloysite, Clays Clay Min., 6, 237-247 (1959).
- [2] Brulotte, Raynald, Study of atmospheric pollution in the Thetford Mines area, cradle of Quebec's asbestos industry, Atmospheric Pollution, M. M. Benarie, ed., Elsevier Sci. Pub., Amsterdam, 447-458 (1976).
- [3] Campbell, W. J., Blake, R. L., Brown, L. L., Cather, E. E., and Sjoberg, J. J., Selected silicate minerals and their asbestiform varieties: mineralogical definitions and identification-characterization, U.S. Bureau of Mines Information Circular 8751, 56 pp. (1977).
- [4] Champness, P. E., Cliff, G., and Lorimer, G. W., The identification of asbestos, J. Microscopy, 108, 231-249 (1976).
- [5] Deer, W. A., Howie, R. A., and Zussman, Jack, Rock-forming Minerals, vol. 3, Sheet Silicates, Longmans, Green, and Co. Ltd., London (1962).
- [6] Ernst, W. G., and Wai, G. M., Mössbauer, infrared, x-ray, and optical study of cation ordering and dehydrogenation in natural and heat-treated sodic amphiboles, Am. Mineral., 55, 1226-1258 (1970).
- [7] Fears, T. R., Cancer mortality and asbestos deposits, Am. J. Epidemiology, 104, 523-526 (1976).
- [8] Franco, M. A., Hutchison, J. L., Jefferson, D. A., and Thomas, J. M., Structural imperfection and morphology of crocidolite (blue asbestos), Nature, 266, 520-521 (1977).
- [9] Gary, Margaret, McAfee, Robert, Jr., and Wolf, C. L., Glossary of Geology, (Am. Geological Inst., Washington, D. C., 1972).
- [10] Gillam, J. D., Dement, J. M., Lemen, R. A., Wagoner, J. K., Archer, V. E., and Blejer, H. P., Mortality patterns among hard rock gold miners exposed to an asbestiform mineral, Annals. N.Y. Acad. Sci., 271, 336-344 (1976).
- [11] Gilson, J. C., Asbestos cancers as an example of the problem of comparative risks, Inserm Symposia Series, 52, IARC Scientific Publications No. 13, Environmental Pollution and Carcinogenic Risks, 107-116 (1976).

- [12] Gross, Paul, Is short-fibered asbestos dust a biological hazard? Arch. Environ. Health, 29, 115-117 (1974).
- [13] Hemley, J. J., Montoya, J. W., Shaw, D. R., and Luce, R. W., Mineral equilibria in the MgO-SiO₂-H₂O system:II Talc-antigorite-forsterite-anthophyllite-enstatite stability relations and some geologic implications in the system, Am. J. Sci., 277, 353-383 (1977).
- [14] Huebner, J. S. and Papike, J. J., Synthesis and crystal chemistry of sodium-potassium richterite, (Na,K)NaCaMg₅Si₈O₂₂(OH,F)₂: A model for amphiboles, Am. Mineral., 55, 1973-1992 (1970).
- [15] Hutchison, J. L., Irusteta, M. C., and Whittaker, E. J. W., High-resolution electron microscopy and diffraction studies of fibrous amphiboles, Acta Cryst., A31, 794-801 (1975).
- [16] Kogan, F. M., Guselnikova, N. A., and Gulevskaya, M. R., The cancer mortality rate among workers in the asbestos industry of the Urals, Gig. Sanit. 37, 29-32 (1972).
- [17] McDonald, J. C., Cancer in chrysotile mines and mills, Biological Effects of Asbestos, Lyon, International Agency of Res. on Cancer, 189-194 (1973a).
- [18] McDonald, J. C., Asbestosis in chrysotile mines and mills, Biological Effects of Asbestos, Lyon, International Agency of Res. on Cancer, 155-159 (1973b).
- [19] McDonald, J. C., and McDonald, A. D., Epidemiology of mesothelioma from estimated incidence, Preventive Med., 6, 426-446 (1977).
- [20] McDonald, J. C., and Becklake, M. R., Asbestos-related disease in Canada, Hefte z. Unfallheilkunde, 126, 2. Deutsch-Österreichisch-Schweizerische, Unfalltagung in Berlin 1975, Springer-Verlag, Berlin, 521-535 (1976).
- [21] McDonald, A. D., Harper, A., El Attar, O. A., and McDonald, J. C., Epidemiology of primary malignant mesothelial tumors in Canada, Cancer, 26, 914-919 (1970).
- [22] McDonald, J. C., McDonald, A. D., Gibbs, G. W., Siemiatycki, J., and Rossiter, C. E., Mortality in the chrysotile asbestos mines and mills of Quebec, Arch. Environ. Health, 22, 677-686 (1971).
- [23] McDonald, J. C., Becklake, M. R., Gibbs, G. W., McDonald, A. D., and Rossiter, C. E., The health of chrysotile asbestos mine and mill workers of Quebec, Arch. Environ. Health, 28, 61-68 (1974).
- [24] McDonald, J. C., Gibbs, G. W., Liddell, F. D. K., and McDonald, A. D., Mortality after long exposure to cummingtonite-grunerite (abstr.), Am. Rev. Resp. Disease, Supp., 115, No. 4, 230 (1977).
- [25] Nord, G. L., Jr., "State-of-the-Art" of the analytical transmission electron microscope, in Proc. Symposium on Electron Microscopy and x-ray applications to environmental and occupational health analyses, Ann Arbor Sci. Publ., in press (1978).
- [26] Papike, J. J., and Ross, Malcolm, Gedrites: Crystal Structures and intracrystalline cation distributions, Am. Mineral. 55, 1945-1972 (1970).
- [27] Pott, F. and Friedrichs, K. H., Tumoren der Ratten Nach I. P. Injektion faser formiger Staube, Naturw., 59, 318 (1972).
- [28] Rendall, R. E. G., The data sheets on the chemical and physical properties of the U.I.C.C. standard reference samples, in Pneumoconiosis, H. A. Shapiro, ed., Oxford U. Press (1970).
- [29] Rohl, A. N., Langer, A. M., and Selikoff, I. J., Environmental asbestos pollution related to use of quarried serpentine rock, Science, 196, 1319-1322 (1977).

- [30] Ross, Malcolm, Papike, J. J., and Weiblen, P. W., Exsolution in clinamphiboles, Science, 159, 1099-1102 (1968a).
- [31] Ross, Malcolm, Smith, W. L., and Ashton, W. H., Triclinic talc and associated amphiboles from the Gouverneur Mining District, New York, Am. Mineral., 53, 751-769 (1968b).
- [32] Ross, Malcolm, Papike, J. J., and Shaw, K. W., Exsolution textures in amphiboles as indicators of subsolidus thermal histories, in Mineral. Soc. Am. special paper no. 2, J. J. Papike, ed., pp. 275-299 (1969).
- [33] Selikoff, I. J., Hammond, E. C., and Churg, Jacob, Asbestos exposure, smoking, and neoplasia, J. Am. Med. Assoc., 204, 106-112 (1968).
- [34] Seshan, K. and Wenk, H.-R., Identification of faults in asbestos minerals and application to pollution studies, in Proc. Electron Microscope Soc. Am., 34th annual meeting, G. W. Bailey, ed., 616-617 (Claitor's Pub. Div., Baton Rouge, LA, 1976).
- [35] Takeda, Hiroshi and Ross, Malcolm, Mica polytypism: Dissimilarities in the crystal structures of coexisting 1M and 2M₁ biotite, Am. Mineral., 60, 1030-1040 (1975).
- [36] Veblen, D. R. and Burnham, C. W., Triple-chain biopyriboles: Newly discovered intermediate products of the retrograde anthophyllite-talc transformation, Chester, Vt., (abstr.), Trans. Am. Geophys. Union, 56, 1076 (1975).
- [37] Veblen, D. R. and Burnham, C. W., Biopyriboles from Chester, Vermont: The first mixed-chain silicates (abstr.), Geol. Soc. Am. Abstracts with Programs 8, 1153 (1976).
- [38] Veblen, D. R., Triple-and mixed-chain biopyriboles from Chester, Vermont, Ph.D. thesis, Harvard University, Cambridge, Mass. (1976).
- [39] Vigliani, E. C., Asbestos exposure and its results in Italy, in Proc. International Conf. on Pneumoconiosis, Johannesburg, Oxford U. Press, 192-196 (1970).
- [40] Wagner, J. C., Berry, G., and Trimbrell, V., Mesotheliomata in rats after inoculation with asbestos and other materials, Brit. J. Cancer, 28, 173-185 (1973).
- [41] Whittaker, E. J. W., The structure of Bolivian crocidolite, Acta Cryst., 2, 312-317 (1949).
- [42] Wones, D. R., Physical properties of synthetic biotites on the join phlogopite annite, Am. Mineral. 48, 1300-1321 (1963).

Discussion

NOTE: Discussion of this paper was included in the General Discussion at the end of this session.

GENERAL DISCUSSION OF MINERALOGICAL ASPECTS

L. SWENT: Homestake Mining Company management is very aware of the implications that the Homestake mine study referred to by Mr. Ross will have for industry. We believe that we have a serious responsibility to see that a study is done and that it is a properly done study.

The first study, done by NIOSH without consultation with Homestake Mining Company, was published in June 1976, and contained a number of serious defects of procedure, assumptions, and reasoning, which make its conclusions invalid.

As a result, NIOSH and Homestake Mining Company have entered into a cooperative arrangement for a second study. The mortality analysis part of the study has been contracted to SRI International. NIOSH has begun the environmental sampling work in the mine, and SRI has started reviewing the Homestake personnel records for the mortality study.

Anyone interested in reading a critique setting forth the defects which invalidated the conclusions of the first NIOSH study may obtain a copy by writing to: L. W. Swent, Vice President-Engineering, Homestake Mining Company, 650 California Street, San Francisco, California 94108.

W. DIXON: I wanted to ask Malcolm Ross if he has studied fibers which are intermediate between talc and anthophyllite in their characteristics and composition?

M. ROSS: Yes, that is the work of Veblen, Buseck, and Burnham; their papers on this will be coming out within the next few months (Science, Vol. 198, p. 359-365). These minerals are intermediate chemically and structurally between anthophyllite and talc. They have been found in two or three places; I'm sure we'll probably find more.

DIXON: I'd like to make a general request that if anyone participating in this conference has comments to make on the toxicity of those types of materials mentioned above I would be glad to hear of any information that might be available.

NOTE: No response was received to this request. (CCG).

R. LEE: I would like to make a comment on a couple of things. First is the outward morphology of amosite versus cleavage fragments; it's generally been written in the literature, which I've seen, that they're indistinguishable. This is, I think, the way a lot of people look at it. We've been doing some studies on amosite, penge amosite versus grunerites, and we find that indeed in the amosite it's generally a (100) face when you get a single crystal diffraction pattern near 0,0 on your microscope. In the grunerites, they tend to lie about 28° away from this, which puts them on a (110) face, in other words a cleavage plane. The second comment is that our studies on the size distributions of airborne particles show that the aspect ratio of airborne serpentines and very fibrous amphiboles tend to be much, much larger than the size distribution of the corresponding cleavage fragments which were airborne. Something like a minimum of 30 to 1, or an average of 30 to 1 for the particles we observed in an electron microscope, versus about 7 or 8 to 1 for amphibole fragments. But the point I want to make is that we should not only be looking at the health effects, we should be making sure that we know whether we are looking at cleavage fragments or at amosite.

ROSS: To add to this, Ann Wiley brought up one clue as to whether amosite or grunerite is really similar to the penge amosite from South Africa. Do the minerals have parallel extinction at the very highest optical magnification? Most of the garden variety cummingtonite-grunerite minerals have inclined extinction; even for the individual crystallites. The parallel extinction is caused by small lamellae randomly oriented about the fiber axis. Optically the specimen looks orthorhombic; optical observation is the

first technique to use in order to get an idea whether an amphibole may be similar to the known commercial asbestos.

N. TATE: I wonder if you know of Judge Bowder's investigation among the miners in Quebec, where he's found very heavy incidence of disease which was not previously reported. Figures range from 45 percent among workers, nonsmokers with low exposures, up to 70 percent lung changes in workers with heavy exposures. I also had the opportunity of talking to Prof. McDonald just before I left London. He has a new study which will be published shortly; he says he's found excess disease among the miners at Thetford, half of it the normal asbestos diseases and half of it shows that asbestos workers have lower resistance to all disease. These are two studies which I think should be taken into account.

ROSS: Certainly, that's why I want to bring out the Canadian work. It should be taken into account; but you have to recall that these men have been exposed to heavy dust. Friends of mine who go there on geological field trips tell me that up until recently people would hose down the windows in the morning to see out of them, that's how thick the dust was up there. They have, in the past, gotten tremendous amounts of dust in their lungs. Now what the Canadian study is attempting to do is to divide the workers into what they consider low, intermediate, heavy, and very heavy exposure levels to see if they can see a difference in health risk. Now the reports I've seen indicate that below 200 mpcf-yr there's a very low health risk, but all I know is what I read in their papers. I want to point out that somewhere we have to find a tolerable health risk or we'll have to close down the surface of the earth.

A. SUNDARAM: Dr. Ross, I'm wondering how you graded the various types of asbestos in relation to the toxicity or pathogenicity? There are at least four distinct types of pathogenicity arising from asbestos exposure: asbestosis, lung cancer, mesothelioma, and cancer of the gastrointestinal track; also it is claimed in other organs. When you graded it so easily: crocidolite, amosite, anthophyllite, and chrysotile, did you do the gradation yourself or are you quoting any paper?

ROSS: I'm quoting Gilson.

SUNDARAM: And is the gradation based on animal data or epidemiological data?

ROSS: I can give you the reference (Inserm Symposia Series 52, p. 107-116 (1976)); it's a summary paper by Gilson where he suggested this generalization. Perhaps you can find something wrong with it, but it was a generalization. I made an additional generalization that the chemical activity of these four minerals seemed to be similar in that crocidolite can undergo on the surface more chemical reactions than amosite, and amosite more than anthophyllite, and chrysotile being the least chemically reactive. I'm just pointing this out as a generalization, something to start from; maybe it might give some clues for the formation of cancer, I don't know. It may not be that it is the only factor, because the shape and the aerodynamics are apparently very important, and the lung clearance functions are very important, so there are many parameters that have to be taken into consideration. The chemical reactivity of the surface is one of them. I believe that the chemical reactivity of the surface is important. Consider a standard fiber $1 \times 5 \mu\text{m}$ in size. There will be 100 times more surface area if you divide a standard fiber into 10,000 smaller fibers. So one big fiber might be a 100 times less effective, as far as the surface chemistry is concerned, than 10,000 small ones - yet they both would have the same weight in nanograms.

SUNDARAM: So you mean to say that the gradation is based on chemical reactivity and not on any toxic parameter?

ROSS: Well, I'm saying chemical reactivity may enter into the toxic parameters. What causes lung cancer? Does the fiber interreact with a chemical such as in tobacco smoke and then with the human tissue, and so forth? Does the fiber interreact directly with the human tissue chemically? I'm basically getting down to a chemical answer in the end.

B. WHITE: As you know we are in the process of putting together so called emergency regulations, relative to the Rockville Quarry. Now these regulations deal primarily with the containment of the crushed stone. You're inferring that you feel that this sort of approach is not indicated based on the Canadian work?

ROSS: The Canadian work would suggest there is not a health danger with this level of asbestos dust. Now all the data are not in. What we would need is ambient air measurements in the Rockville area. Dr. Selikoff suggested, at the National Institutes of Health hearing on this a few weeks ago, 45 nanograms is the limit in ambient air. What level of ambient air do you want to have for chrysotile? I haven't seen an ambient air figure for the Washington, D.C. area. I don't know what it is. I'm really pointing out that we can shut down all the serpentinite quarries on the East Coast. If it's serpentinite it is going to have some chrysotile in it. But then, where do we go from there? We also have tremolite; we can shut down other mines because of tremolite or because of fibrous hornblende and on and on and on. Now I think that I'm pointing out, from a mineralogical and geological point of view, that this is an immense problem. EPA is now getting set up to get crusher runs on mines and quarries all down the East Coast. It's going to run into millions of dollars. It's already running into millions in the Montgomery County area. Now I think that the health people have got to get together and decide what they're going to call asbestos, what dust levels are going to be considered dangerous, and what sort of mining operations they think they are going to have to shut down. You can shut down a mining operation very easily by putting so many requirements on it that the contractors say, "heck with it, I'll go to Frederick and get carbonate rock." I'm pointing out it's an immense problem, it's economic, it's political, it's health, and so forth.

WHITE: I agree with you very much; our intent is certainly not to close down the mine, and I agree also that the health people must come to grips with the issue of the ambient air. Now obviously since there are no standards, our approach is purely on the mechanical side of this, which is trying to reduce the dust emission as much as possible and, quite frankly, I feel until there is more data on the amount that can be floating around in the air that this is a very sensible approach, a preventive approach actually of dealing with the problem. Even though there is nothing that one can hang the hat on from the health side, I personally think that to allow the crushed rock to be used indiscriminately is just simply not a good approach to preventive medicine. Thank you.

R. DAVIS: We live in a complex world and you pointed out that contractors might use carbonate stone. A number of the state highway departments have shown that carbonate contributes to lower skid resistance. We are faced with the problem of how many people are going to die from cancer from the chrysotile type of material and how many are going to die from lowered skid resistance on the highways. These are very complex problems.

ROSS: What makes it so frightening is if you pull a string and all of a sudden a lot more string comes out, you don't know whether you've increased health risk or decreased it. You've decreased it in one area and perhaps increased it in the other. One possibility is that people would be so scared of asbestos, they won't use it for anything. Asbestos has saved many lives when used for fireproofing. We could carry on with fiberglass which has a lot of similarities to asbestos, or we can get rid of fiberglass, and we can insulate with organic chemicals, like some that form carbon monoxide and HCN when they burn. The total picture is a big one and I think that we all should try to get a feeling for the entire situation, and consider some of the problems that could arise.

E. COX: I'd like to ask M. Ross or Dr. Zoltai if you could tell us when the first commercial mining of asbestos took place, what type it was, and where it was?

T. ZOLTAI: About a couple of thousand years ago; on a commercial scale the major mines started in the late 19th century.

COX: About 1880-1890?

ZOLTAI: Yes.

COX: And where were they, sir?

ZOLTAI: In Canada.

COX: In Canada, and what were they?

ZOLTAI: Chrysotile.

K. HEINRICH: I'd like to ask Malcolm Ross if you have information of the size distribution of chrysotile in Thetford and if it is similar to that in Montgomery County?

ROSS: Tom Bates did a size study of chrysotile from the Thetford area, Canada, and also on the beautiful chrysotile from Arizona. I have the figures in my paper but I think in the Canadian chrysotile he had a minimum of 110 Å outside diameter and a maximum of several hundred with an average of about 250 Å. I think the Arizona chrysotile had a generally larger diameter. You meant length, I'm sorry, I was thinking of width. I don't know that, I don't have that figure. Some of the Canadian chrysotile was in beautifully long fibers. This material set the chrysotile industry off, because in 1886 they found these exceptionally good types of asbestos. I imagine some of it was very long fiber material, but of course much of it would be short fiber also as the Rockville chrysotile is.

J. ZUSSMAN: I have two comments and one question. One is the point about when some commercial use of asbestos started. I believe there is some record of something industrial in Italy with products like asbestos paper. There is also mention of the manufacture of asbestos socks and gloves at a place in Russia. These were both before the start of large scale mining at Thetford.

Another comment is in connection with Dr. Ross's remarks about the reactivity of various forms of asbestos, in which he put chrysotile low down on that scale. In one sense perhaps chrysotile is high up in the scale of reactivity in that it is less resistant to acid, and quite dilute acids can attack and start to dissolve away chrysotile. It has a rather exposed layer of magnesium hydroxide and this is obviously going to be quite reactive to dilute acids. I am not sure whether its reactivity in this sense makes chrysotile less or more physiologically harmful.

I'd like to ask one question of Dr. Ross about the synthesis. I was very interested to hear of his colleague Dr. Hemley's work on stability fields of the serpentine and amphibole minerals, and I would like to ask whether or not the chrysotile or amphibole formed was asbestiform or not. Quite a lot of work has been done on the stability fields of amphiboles and serpentines in general, but rather little pinpointing when long thin chrysotile fibers form and when other serpentines like lizardite and antigorite form; also when asbestiform and when non-asbestiform amphiboles form. I wonder if the products of those experiments were identified as asbestiform or not.

ROSS: Yes, Dr. Hemley's work, I think, was really one of the outstanding contributions we've had in this area of geochemistry this year. These experiments were very difficult; they are run at relatively low temperatures, so his run times were many weeks duration. Concerning the stabilities of the individual polymorphs of serpentine, he attempted to define an antigorite and chrysotile field. He did some electron microscopy, I believe, and found platy-serpentine, which he called antigorite. I asked Julian Hemley - "if you injected some chrysotile into the human blood stream or into the lung, what would you expect to happen?" He thought about the various parameters in the human body that might affect that system and he said, "I don't think anything would happen." Nevertheless, chrysotile is very soluble in dilute acids, and Dr. Langer will agree ingested chrysotile in the stomach should decompose quite readily. Hemley did not think that the pH range of the human body, other than the stomach, would contribute to any appreciable dissolution of the chrysotile. He suggested it would last and last.

O. MENIS: Being a chemist, I would like to ask the mineralogist why they have neglected the OH group, the hydroxylation process. I wonder if Prof. Zussman and others would like to comment on the role of the OH, the potential of local pH values of these materials, and the ease of the hydroxylation which is known from thermal data where you have a great difference between the various amphiboles and chrysotile.

ZUSSMAN: I look to my colleagues because I really don't know much about it, and I don't know that very much is known about the comparative effects of the hydroxyl in these different minerals. Certainly in the amphiboles, and crocidolite in particular, some work has been done on oxidation-reduction phenomena, because there you have not only the hydroxyl but you have the ferric ion and the combination of the two is conducive to chemical reactions going on. I don't know of any work which has examined the effect of OH in the grunerites or very much in serpentine except with regard to decomposition. If you heat them, then they break down at different temperatures, and you mentioned the question of differential thermal analysis giving different results. I think one has to be very cautious about this because it's notoriously easy for a variety of results to be obtained in the decomposition temperatures by DTA methods, which may or may not be significant. In the amphiboles, hydroxyl is there, and so is fluorine (I hadn't mentioned that because there was a limit to the complication that one could go into in the time available for my paper), but it's quite possible that the ratio of hydroxyl to fluorine, the presence of fluorine or the presence of chlorine could be relevant. These are all minor variables and there has not been much systematic study of how many of these variables are relevant to the comparison of asbestos and non-asbestos amphiboles or serpentines, and their effects. Malcolm Ross may have some comments on this.

ROSS: If you pass hot, inert gas over grunerite crystals, hydrogen will be removed and you'll get two atoms of trivalent iron. This is quite reversible, at least in other similar phases. Ernst and Wai have done this experiment with sodic amphiboles. Repeated experiments on biotite by Wones shows complete reversibility of this oxidation-reduction reaction. In amosite as well as crocidolite, the iron may be oxidized by removal of hydrogen. This can go very readily at higher temperatures. It is unknown whether this can go on in the human lung, but it is a possible chemical reaction. Also another reaction is ion exchange in crocidolite. You can oxidize or reduce the iron, and exchange oxonium, ammonium, potassium, or sodium in the vacant site. Thus there are some very interesting possibilities for chemical change on the surface of these crystals.

J. KRAMER: I might make a comment. I think back to the original question on chemical reactivity. One of the ideas of looking at surface reactions in the amphiboles originally was that these crystallites forming the asbestos form of the amphibole may be hooked together with OH bonds, and we thought we might see some differences here. Our type of measurements which I quickly alluded to, are crude. They're gross and are in no way domain measurements. We didn't find any differences. The other thing is of course that chrysotile versus the amphiboles has a much different zero point of charge, quite a bit different double layer in terms of surface reactions. One might want to compare these two groups in order to look at reactions involving the hydroxyl groups. But I think maybe Dr. Zoltai may like to comment upon some of his surface charge measurements because I think these are much more specific to the individual fiber. I'd like to hear your comments.

ZOLTAI: Actually we haven't done any sophisticated work to be able to answer a question of that level. All I can say is that what we were trying to do was to detect surface charges at the level of single fibers rather than in bulk quantities of fibers. By using distilled water containing positive or negative labelling sols in suspension, we tried to detect the surface charges of amosite from South Africa and non-asbestiform cummingtonite. In other words, there was only one experiment, and in that case the asbestiform material appeared to have much higher negative surface charge. However, the two specimens came from two different localities, besides being only one test that could not be considered very meaningful. Actually, the reason we did that was to see whether the technique is applicable to asbestos. It would be very nice to have a technique where you can get an indication of the surface charge at the scale of single fibers.

KRAMER: Did you notice any domains pertinent to your technique?

ZOLTAI: Occasionally, yes.

UNKNOWN: I'd like to ask Dr. Zussman a question. Have you any way of estimating what fraction of the total amphibole structure might be defective, what are the length dimensions of the defects, and how much of a chemical variation would you expect to be associated with the defects that you outlined?

ZUSSMAN: The little work that has been done on this shows the frequency of defects in the limited number of samples that have been looked at and, in some of the ones I can remember, the defect occurred about one every 50 cells, so it was a small proportion in that particular sample. Other samples may show a much higher density of defects, but I think just not enough samples have been looked at in that respect. As to the importance of defects, they could be very important in terms of crystal growth, and in terms of mechanical properties. Perfect crystals without defects have very different tensile strengths and other mechanical properties compared with crystals from the same substance but with defects, and it's conceivable that chemical reactivity may be concentrated at the sites of defects. It's an area which is not being looked into to my knowledge; perhaps somebody else can say otherwise. Added after meeting: My answer above about the density of defects was related to Wadsley defects. I omitted to say that the other kind of defect (stacking and twinning) have been reported as very abundant in crocidolite, amosite and tremolite asbestos. Only the Wadsley type of defect would have a direct effect on chemical composition, but it would be rather small if there are relatively few of them.

SUMMARY: Dr. Mason, the session chairman, indicated that he felt the General Discussion provided a very adequate summary of the mineralogical aspects.

EPIDEMIOLOGICAL EVIDENCE ON ASBESTOS

William J. Nicholson, Arthur M. Langer, Irving J. Selikoff

Environmental Sciences Laboratory
Mount Sinai School of Medicine of the City University of New York
One Gustave L. Levy Place
New York, New York 10029

Abstract

Data on the human health effects from occupational and environmental exposure to asbestos will be presented with special emphasis on the role of different asbestos minerals. Further, human tissue burdens of fibers and their association with asbestos related diseases will be discussed. Experimental animal data from various species and utilizing different routes of administration will also be presented, again with emphasis on differing fiber types.

Key Words: Asbestos; cancer; epidemiology; fibers; mesothelioma; occupational exposure.

PART I. HUMAN HEALTH EFFECTS

We have already heard in the session on mineralogical aspects of asbestos considerable comment and speculation about health effects. What I would like to do here is present some data on human health effects associated with different forms of asbestos, and to discuss briefly some of their meaning in terms of ambient air concentrations.

The modern history of asbestos disease dates from the turn of the century, when two reports were published documenting the effects of uncontrolled conditions in asbestos textile factories. One, the testimony of Dr. H. Montague Murray at a compensation hearing, described severe pulmonary fibrosis found at autopsy, in 1900, in the last survivor of a group of ten workers first employed 14 years previously in a carding room [1]¹. The second was the description by Auribault of deaths during the early years of operation of an asbestos weaving mill established at Conde-sur-Noireau, France, in 1890 [2]. During this period 50 men died, including 16 of 17 recruited from a cotton textile mill previously owned by the factory director.

Subsequently, cases of pulmonary fibrosis following inhalation of asbestos were published in the medical literature, including one by Cooke, who gave the disease its current name, asbestosis [3]. A 1929 study of asbestos textile operations by the British Factory Inspectorate revealed the existence and extent of a continuing problem [4]. In a clinical survey of mill employees, 80 percent of those employed for 20 years or more had x-ray evidence of asbestos disease. This finding stimulated the Factory Inspectorate to require the introduction of extensive environmental control technology in the industry and the establishment of an ongoing medical surveillance program.

Conditions in the United States were not improved significantly until the 1960's and in recent years the prevalence of abnormal x-rays among workers with 20 or more years of occupational exposure to asbestos has been high. Table 1 lists data of such abnormalities found among insulation workmen employed in the New York and New Jersey area prior to 1960 [5]. Most x-rays of the group were normal until 20 years, and if abnormal usually showed

¹Figures in brackets indicate references at the end of each part of this paper. There is also a set of references following the discussion.

Table 1. X-ray changes in asbestos insulation workers.

<u>Onset of exposure (yrs.)</u>	<u>No.</u>	<u>Percent normal</u>	<u>Percent abnormal</u>	<u>Asbestosis (grade)</u>		
				<u>1</u>	<u>2</u>	<u>3</u>
40+	121	5.8	94.2	35	51	28
30-39	194	12.9	87.1	102	49	18
20-29	77	27.2	72.8	35	17	4
10-19	379	55.9	44.1	158	9	0
0-9	<u>346</u>	89.6	10.4	<u>36</u>	<u>0</u>	<u>0</u>
Total	1,117			366	126	50

changes only of minimal extent. However, after 20 years most had abnormal x-rays and, when abnormal, often of significant degree. Thus, long term observations are required to obtain a valid assessment of lung scarring associated with asbestos exposure. Analysis of short-term data can be highly misleading.

Asbestosis was the only disease known to be present among occupationally exposed workers until 1935, when it was suggested that lung cancer might be associated with asbestos exposure. In that year and again in 1936 a clinical report was published of lung cancer in an asbestos worker who had died with evidence of pulmonary fibrosis [6,7]. While such reports were not sufficient to causally relate asbestos exposure to lung cancer, the possibility was raised. In 1947 it was confirmed by substantial data, which showed that 13 percent of individuals who died with asbestosis in Great Britain also had bronchogenic carcinoma [8]. Mesothelioma, a rare tumor of the lining of the abdomen or chest, was described in an asbestos worker in 1953 [9], found frequently to have followed potential asbestos exposure in 1960 [10], and unequivocally related to such exposure in 1965 [11]. Gastronintestinal cancer also was found to be in excess among asbestos insulation workers in the United States [12].

In 1975, three-quarters of a century after the first identification of asbestos-related deaths, society continues to be plagued by their presence, unfortunately, in ever increasing numbers. Moreover, the population at risk from the several asbestos-related cancers has expanded from those directly handling the mineral to those working nearby the application or removal of asbestos materials, and, finally, to those who simply live in the vicinity of an asbestos operation or in the household of an asbestos worker.

High Exposure Effects

The full spectrum of disease from asbestos exposure is best manifest in the data of Selikoff, Hammond, and Seidman on the mortality experience of 17,800 asbestos insulation workmen [13]. Table 2 shows the expected and observed deaths among this group of workers from January 1, 1967, through December 31, 1976. Among those individuals who have died, one in five deaths was due to lung cancer, about 5 percent to gastrointestinal cancer, approximately 7 percent to mesothelioma (a tumor so rare in the general population that it may account for only one in ten thousand deaths in the absence of exposure to asbestos), 10 percent to other cancers, and 7 percent to asbestosis, the disease first characterized seven decades earlier and wished away numerous times subsequently. The data on the mortality experience of this group of workmen are also sufficient to suggest that cancer at sites other than those mentioned above may also be increased from asbestos exposure. Here, however, the malignancies are less common. Overall, comparing the frequencies of deaths from the cancers and asbestosis with those among the general population, nearly 40 percent of the deaths in this group of workers can be attributed to their occupational exposure to asbestos.

Table 2. Deaths among 17,800^a asbestos insulation workers in the United States and Canada.
January 1, 1967 – December 31, 1976

	Number of men Man-years of observation	17,800 166,855	
	<u>Expected</u>	<u>Observed</u>	<u>Ratio</u>
<u>Total deaths, all causes</u>	1,660.96	2,270	1.37
<u>Total cancer, all sites</u>	319.90	994	3.11
Lung cancer	105.97	485	4.58
Pleural mesothelioma	b	66	--
Peritoneal mesothelioma	b	109	--
Cancer of esophagus	7.01	18	2.57
Cancer of stomach	14.23	22	1.55
Cancer of colon, rectum	37.86	59	1.56
All other cancer	154.83	235	1.52
<u>Asbestosis</u>	b	162	--
<u>All other causes</u>	1,351.06	1,114	0.82

^a Expected deaths are based upon white male age specific mortality data of the U. S. National Center for Health Statistics for 1967-1975 and extrapolation to 1976.

^b These are rare causes of death in the general population.

From: Selikoff, I. J., Hammond, E. C., and Seidman, H., Mortality experience of insulation workers in the United States and Canada, 1943-1977, to be published, Ann. N.Y. Acad. Sci.

Asbestos related disease has also resulted from exposures in asbestos factories. A study of production employees of the largest asbestos products manufacturing facility in the United States again demonstrated the presence of significant excess disease [14]. In this study, the mortality experience of all 689 individuals who were working on January 1, 1959, and who were first employed prior to 1939, was analyzed. From 1959 to 1976, it was expected that 188 deaths would have occurred in this group. Instead, 274 died, 46 percent more than anticipated. About 40 cancers were expected; 99 were observed. As shown in Table 3, the anticipated asbestos-related tumors were found in excess - bronchogenic carcinoma, mesothelioma, and gastrointestinal cancer.

Table 3. Expected and observed deaths among 689 factory workers, employed before January 1, 1939, during the seventeen years from January 1, 1959 through December 31, 1975.

	- - - - - 1959 - 1975 - - - - -		
	<u>Observed</u>	<u>Expected</u>	<u>Obs./Exp.</u>
<u>All causes</u>	274	188.19	1.46
<u>Cancer, all sites</u>	99	39.93	2.47
Lung cancer	35	12.53	3.91 ^a
Pleural mesothelioma	14	n.a.	--
Peritoneal mesothelioma	12	n.a.	--
Cancer of esophagus, stomach, colon, and rectum	15	7.99	1.88
Cancer all other sites	23	19.40	1.19
<u>All respiratory disease</u>	42	12.16	3.45
Asbestosis	35	n.a.	--
Other respiratory	7	b	--
<u>All other causes</u>	133	136.11	0.98
Person-years of observation		9,646	

^a Pleural mesothelioma included with cancer of bronchus in calculating ratio since expected rates are based upon "cancer of lung, pleura, bronchus, trachea."

^b This rate is virtually identical with that of "all respiratory disease."

n.a. = not available.

From: Nicholson, W. J., Case Study 1: Asbestos—the TLV approach, Ann. N.Y. Acad. Sci., 271, 152-169 (1976).

Time Effects - Lapsed Period

If one considers the time from onset of exposure to the clinical evidence of disease, one finds, just as with asbestosis, that there is a long-lapsed period from first exposure to appearance of asbestos related cancers. Data from the group of insulators illustrate this point in figure 1, where the excess cancer risk, calculated for equal but not aged standardized populations within each ten-year time interval, is plotted. A significant increase in risk is seen only after 25 years for lung cancer and after 30 years for mesothelioma. An increase in the ratio of observed to expected cases of the various asbestos cancers occurs prior to 20 years, but the total number of such cancers is small, as the population is relatively young.

This long-lapsed period creates significant difficulties in attempting to establish dose-response relationships. The disease seen today is from exposures decades past when few measurements were made of asbestos concentrations. Thus, we can only estimate past exposures, based on current knowledge. Further, such estimates can be unreliable, and the determination of the efficacy of standards based upon them cannot be made with certainty, until further decades have past. If we then find serious misjudgments have been made, asbestos disease will continue to plague us well into the twenty-first century.

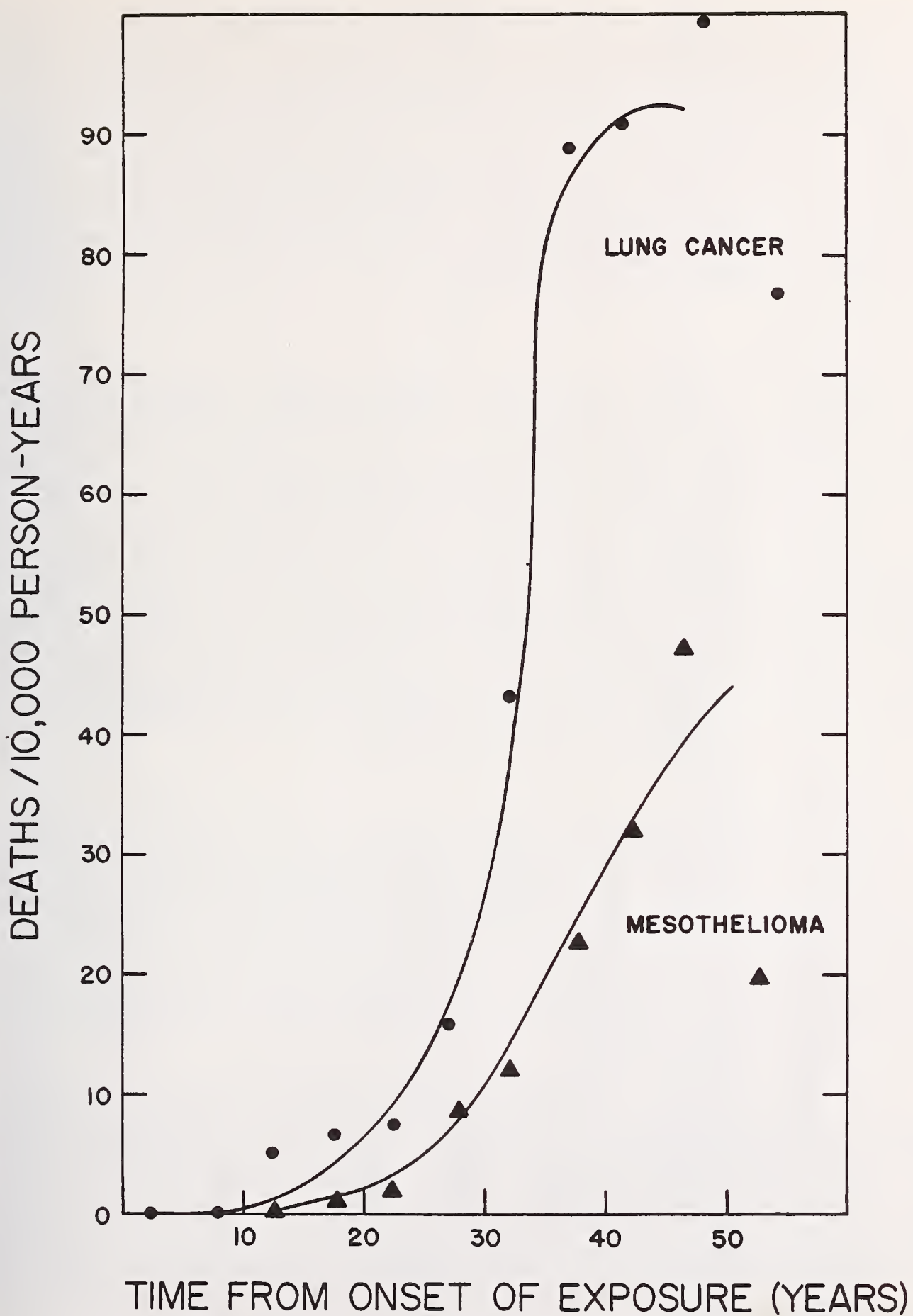

Figure 1. The excess, asbestos-related mortality rates for lung cancer and mesothelioma according to time from onset of asbestos disease.

Another aspect of time in the identification of carcinogens is seen in the data from the study of New York and New Jersey insulation workers over the period 1943 through 1973 [15]. Table 4 shows the mortality experience of 623 insulators, all with 20 years since first exposure in different time periods. One notable feature in these data is the deficit of deaths of all causes in the first 10-year observation period; an excess of total mortality appears only after several years from first observation (and 30 years from onset of exposure). It is common to observe such a deficit, often as great as 25 percent, in studies comparing the mortality experience of working groups with that of the general population (the "healthy worker effect"). This results in part because identified groups of workmen are healthier than a corresponding age group in the general population, which would include terminally ill individuals and others unable to hold a job because of disability. However, even in these early years, the excess asbestos cancers can be seen, although they are not yet the dominant contribution to total mortality.

Synergistic Effects

A second important concern is increasing evidence that many cancers may have a multiple factor etiology. For example, lung cancer in asbestos workers is strongly associated with cigarette smoking. In the large cohort of 17,800 insulators observed by Selikoff and Hammond, the smoking habits were obtained on the majority of workers in 1967 [16]. Table 5 illustrates the effect of cigarette smoking on lung cancer mortality of these workers. Among 2,066 non-cigarette smokers, only eight lung cancers were seen in a ten-year period, where 1.82 were expected, based on American Cancer Society data on the risk of lung cancer death in non-smokers. Inhalation of asbestos by insulators appears to multiply the risk by four or five times. Considering the data for men with a history of smoking, among 9,591, 325 deaths were observed versus 66.78 expected, also a fivefold increase. However, since cigarette smokers already have a ten to twenty times greater risk of lung cancer deaths than non-smokers (depending on cigarette consumption), the multiplicative effect of the asbestos exposure increases the lung cancer risk up to 100 times for smoking asbestos workers compared to non-smokers unexposed to asbestos. This was also shown by the experiences of a cohort of New York and New Jersey insulators [17]. Hence, it was estimated that the risk of dying of lung cancer for cigarette smoking asbestos workers was more than 90 times that of individuals who neither smoked nor worked with asbestos.

Indirect Asbestos Exposure

In 1968 it was pointed out by Harries that shipyard workers other than insulators were at risk from asbestos disease [18]. Among Devonport Dockyard employees, five cases of mesothelioma were found among men who had not been "asbestos workers" but had followed other trades in the yard. These men presumably had been inadvertently exposed to asbestos merely by working in the same shipyard areas where asbestos had been used. Continuing to follow this group, Harries later documented 55 cases of mesothelioma in this shipyard alone, only two of which occurred in asbestos workers [19], one, a man who had previously sprayed asbestos. A study of the distribution of all verified cases of mesothelioma found in Scotland between the years 1950 and 1967 is also revealing [20]. Of 89 cases available for study, 55 were in shipyard employees, dockers, or naval personnel. Of the 55, again only one was an asbestos insulation worker.

A third important study of workers in British shipyards is that of John Edge, who reviewed x-rays of former shipyard workers in Barrow [21]. A prospective study was conducted of 235 men whose x-rays, taken between 1955 and 1969, showed abnormalities characteristic of asbestos exposure (pleural plaques, scarring of the covering of the lung or lining of the chest), but no parenchymal fibrosis (scarring of the lung tissue). Most of these x-rays were of individuals (riggers, welders, carpenters, electricians, machinists, steamfitters, etc.) who had not worked directly with asbestos, but who could have sometimes been nearby when asbestos was used. In tracing the individuals who had such x-ray changes, it was found that 70 had died from 1970 to 1973. Of these 70 deaths, 13 were of lung cancer, two and one-half times the number expected, and 17 were of mesothelioma (none, of course, were anticipated).

Table 4. Expected and observed number of deaths among 623 New York-New Jersey asbestos insulation workers, 1 January 1943 — 31 December 1973, twenty or more years after onset of first exposure to asbestos.

	1943-1952			1953-1962			1963-1973			Total 1943-1973		
	Exp.	Obs.	Ratio	Exp.	Obs.	Ratio	Exp.	Obs.	Ratio	Exp.	Obs.	Ratio
<u>Total deaths, all causes</u>	88.22	82	0.94	111.05	170	1.53	101.38	191	1.88	300.65	444	1.48
<u>Cancer, all sites</u>	13.02	30	2.30	18.75	65	3.47	19.49	103	5.28	51.26	198	3.86
Lung cancer	1.83	13	7.10	4.20	29	6.90	5.65	47	8.32	11.68	89	7.62
Pleural mesothelioma	n.a. ^a	1	--	n.a.	2	--	n.a.	7	--	n.a.	10	--
Peritoneal mesothelioma	n.a.	1	--	n.a.	3	--	n.a.	21	--	n.a.	25	--
Cancer of stomach	2.13	2	0.94	1.87	10	5.35	1.10	6	5.45	5.10	18	3.53
Cancer of colon, rectum	2.22	7	3.15	2.74	9	3.28	2.54	6	2.36	7.50	22	2.93
<u>Asbestosis</u>	n.a.	1	--	n.a.	11	--	n.a.	25	--	n.a.	37	--
<u>All other causes</u>	75.20	52	0.69	92.30	94	1.02	81.89	63	0.77	249.39	209	0.84

632 members were on the union's rolls on 1 January 1943. Nine died before reaching 20 years from first employment. All others entered these calculations upon reaching the 20-years-from-onset-of-first-exposure point. Expected deaths are based upon white male age-specific death rate data of the U.S. National Office of Vital Statistics from 1949 — 1971. Rates were extrapolated for 1943 — 1948 from rates for 1949 — 1955, and for 1972 — 1973 from rates for 1967 — 1971.

^a U. S. death rates not available, but these are rare causes of death in the general population.

From: Reference [28].

Table 5. Deaths of lung cancer among asbestos insulation workers in the United States and Canada, 1967-1976; influence of cigarette smoking.

	<u>Observed deaths</u>	<u>Expected deaths^a</u>	
		<u>U. S.^b</u>	<u>Smoking specific^c</u>
1. History of cigarette smoking	325	60.07	66.78
Current smokers	228	31.87	39.69
Ex smokers	97	23.29	13.34
2. No history of cigarette smoking	8	14.11	1.82
Never smoked	5	8.49	0.98
Pipe/Cigar	3	5.63	0.84
3. Unknown history of cigarette smoking	<u>152</u>	<u>31.80</u>	<u>11.93</u>
Total	485	105.97	66.78

^a Age, year and sex specific.

^b Based upon age, specific data of the U. S. National Center for Health Statistics, cigarette smoking not considered.

^c Based upon American Cancer Society's Cancer Prevention Study, 1967-1972.

From: Hammond, E. C., Selikoff, I. J., and Seidman, H., Cigarette smoking and mortality among U. S. asbestos insulation workers, to be published in Ann. N.Y. Acad. Sci.

Environmental Asbestos Disease

In 1960 Wagner reviewed 47 cases of mesothelioma found in the Northwest Cape Province, South Africa, in the previous five years [10]. Of this number, roughly half were in people who had worked with asbestos. Virtually all of the rest, however, were in individuals who had, decades before, simply lived or worked in an area of crocidolite asbestos mining (one lived along a roadway in which asbestos fibers were shipped). This germinal observation demonstrated that asbestos exposure of limited intensity, often intermittent, could cause mesothelioma. The hazard was further pointed by the findings of Newhouse[11], who showed that mesothelioma could occur among people whose potential asbestos exposure consisted of their having resided near an asbestos factory or in the households of asbestos workers. Twenty of 76 cases from the files of the London Hospital were the result of such exposure, 31 were occupational in origin, and asbestos exposure was not identified for 25.

A recent extensive study of the effects of household exposure has been conducted by Dr. Henry Anderson and his colleagues of the Mount Sinai School of Medicine [22]. In a clinical survey of 489 family contacts of former factory workers, it was found that the x-rays of 36.2 percent of these individuals showed abnormalities characteristic of asbestos exposure. It did not matter greatly what the relationship to the worker was; the asbestos dust in the household could affect any resident - wife, sons, daughters, parents. While almost all were currently asymptomatic, and while most would perhaps suffer no impairment from their past exposure, others may be stricken with an asbestos-related cancer as a result of past household asbestos exposure. During the initial phase of the survey of deaths, mesothelioma had been identified in this group of family contacts.

Asbestos Fiber Types: Relation to Disease

Canadian asbestos mine workers by the McGill group has already been mentioned earlier in these proceedings. In the initial publication of their mortality study [23], a favorable mortality experience was reported with lung cancer and gastrointestinal cancer being found in excess only in the higher exposure categories. While this study was comprised of 11,788 individuals, it should be noted that nearly half (4,818) were in the lowest dust category (virtually no exposure) or had been employed in the mines and mills for less than one year. Further, many others would have had relatively recent employment. Thus, the potential for dilution of asbestos-related health effects exists. A concomitant study of x-ray changes among mine and mill employees may suffer even more from the disadvantage of short-term periods of observation [24]. Overall, 12.5 percent of 11,207 individuals were found to have abnormal x-rays. However, many of these had less than 10 years of employment and the x-ray that was read was the last maintained by the company of employment.

We have also conducted studies of Canadian mine and mill employees, but of individuals who had been employed for at least 20 years [25]. Table 6 lists the x-ray abnormalities found among 1,120 such individuals. As can be seen, extensive asbestos-related x-ray changes were present in this group of currently employed workers. Overall, 61 percent had abnormal x-rays. Table 7 presents the mortality experience of 535 men who were first employed in the mines and mills before 1941 and followed from 1961 [26]; 16 percent of the deaths were from asbestosis and 15 percent from lung cancer. One case of mesothelioma was found, considerably less than would have been expected on the experience of U. S. insulation workers or factory employees. The reason for this is unclear at this time. It may be related in part to the physical characteristics of the chrysotile fibers in the mine and mill environment, the fibers here being of a longer length than that encountered in manufacturing and end product use.

Table 6. X-ray changes among 1,120 Quebec asbestos mine and mill employees by time from onset of exposure.

<u>Time from onset of exposure (years)</u>	<u>Normal x-ray</u>	<u>Abnormal x-ray</u>	<u>Percent abnormal within category</u>
20 - 24	83	46	35.7
25 - 29	99	104	51.2
30 - 34	122	182	57.6
35 - 39	76	170	69.1
40+	<u>58</u>	<u>180</u>	75.3
Total	438	682	

Table 7. Expected and observed deaths among 544^a asbestos miners who were at least 20 years from onset of asbestos mining work at start of observation, 1961 through August 1977, by calendar years.

	- - - - - Total, 1961-77 - - - - -		
	<u>Expected</u>	<u>Observed</u>	<u>Ratio O/E</u>
<u>Total deaths</u>	159.92	178	1.11
<u>Total cancer, all sites</u>	36.73	49	1.33
Lung cancer	11.10	28	2.52
Pleural mesothelioma	b	1	--
Peritoneal mesothelioma	b	--	--
Cancer of stomach	3.65	4	--
Cancer of colon, rectum	5.03	6	1.19
Cancer of esophagus	0.87	--	--
All other cancers	16.08	10	0.62
<u>Asbestosis</u>	b	26	--
<u>Other non-infectious respiratory</u>	6.69	4	0.60
<u>All other causes</u>	116.50	99	0.85
Man years		7,408	

^a Expected deaths are based upon age-specific death rate data for Canadian white males.

^b Death rates not available but these have been rare causes of death in the general population.

Data are also available on exposure to amosite asbestos. From 1941 to 1954 a factory producing amosite insulation materials operated in Paterson, New Jersey. The mortality experience of individuals employed at any time between 1941 and 1945 is shown in Table 8. The usual asbestos diseases are seen to be present. Lung cancer is six times expected and 10 of 298 deaths are from pleural or peritoneal mesothelioma. An important aspect of this study is that individuals with relatively short exposures are shown to have an increased risk of death from asbestos-related causes. Table 9 shows the expected and observed deaths from lung cancer, mesothelioma, gastrointestinal cancer, and asbestosis according to time of employment in the plant. All time categories less than one year are elevated, and while a single one-month category does not have statistical significance, the longer periods up to six months do.

Table 8. Deaths among 933^a workers employed in an amosite asbestos factory, starting five years from onset of work 1941-1945 to December 31, 1974.

<u>Cause of death</u>	- - - - - Deaths 1946-1974 - - - - -		
	<u>Expected</u>	<u>Observed</u>	<u>Ratio</u>
<u>All causes</u>	285.62	483	1.69
<u>Cancer, all sites</u>	50.10	157	3.13
Lung cancer	12.45	83	6.67
G.I. cancer	12.05	24	1.99
Pleural mesothelioma	b	5	--
Peritoneal mesothelioma	b	5	--
"Asbestos" cancer	24.50	117	4.78
Other cancer	25.60	40	1.56
<u>Asbestosis</u>	b	28	--
<u>All other causes</u>	235.52	298	1.27

^a Expected deaths are based upon white male age-specific death rate data of the U. S. National Office of Vital Statistics, 1949-1972. Rates were extrapolated for 1946-1948 from rates for 1949-1955 and for 1973-1974 from rates for 1968-1972.

128 workers were omitted from these calculations: 33 had prior asbestos exposure; 38 died in the first five years after onset of employment. 49 were not completely traced; and eight had other asbestos employment after the five year from onset point.

^b U. S. death rates not available but these are rare causes of death in the general population.

Table 9. Deaths of all "asbestos disease" among 933^a workers employed in an amosite asbestos factory, starting five years from onset of work 1941-1945 to December 31, 1974. Effect of duration of exposure.

<u>Duration of employment</u>	<u>No.</u>	<u>Death of "asbestos disease" 1946-1974</u>		
		<u>Expected</u>	<u>Observed</u>	<u>Ratio</u>
<1 month	62	3.47	6	1.73
1 month	92	3.73	8	2.14
2 months	79	3.73	11	2.95
3-5 months	145	5.98	17	2.84
6-11 months	129	4.15	21	5.06
1 year	105	3.74	20	5.35
2 years	77	2.91	24	8.25
3-4 years	51	2.36	15	6.36
5+ years	<u>65</u>	<u>2.88</u>	<u>34</u>	<u>11.81</u>
Total	805	32.95	156	4.73

^a "Asbestos disease": asbestosis and chronic pulmonary insufficiency, lung cancer, pleural, and peritoneal mesothelioma, cancer of esophagus, stomach, colon-rectum.

128 workers were omitted from these calculations: 33 had prior asbestos exposure; 38 died in the first five years after onset of employment. 49 were not completely traced; and eight had other asbestos employment after the five year from onset point.

Finally, if one considers the fiber type that insulation workers were exposed to, data from manufacturers have indicated that it was only to chrysotile and amosite. No crocidolite was ever used as thermal insulation materials [27]. Further amosite was used in significant quantities only from 1940 through the early 1960's. As neither the period of use nor the incidence of mesothelioma among amosite workers listed above can account for the high frequency of this cause of death among insulation workers, it is clear that exposure to chrysotile asbestos is of importance here as well.

Summary

Accumulated human health data indicate that all major commercial varieties of asbestos, chrysotile, amosite, and crocidolite, produce significant disease. Lung cancer, asbestosis, mesothelioma, and gastrointestinal cancer are in significant excess among factory workers and insulators, while lung cancer and asbestosis are dominant causes of death among mine and mill employees. Further, evidence exists that environmental exposures, such as in the homes of workers or in the vicinity of mines and factories, have been sufficient to produce mesothelioma. Workers indirectly exposed to asbestos in their work, as shipyard workers, can be at significant risk.

Currently no data exist that would indicate a threshold for asbestos related cancers. Prudence would suggest that exposures to all asbestos fibers be reduced to the minimum commensurate with feasible environmental controls. Considerable data exist that most work environments can maintain concentrations well below the current asbestos standard. I believe the issue is not that reduction of standards will result in the closing down of the surface of the earth, as was suggested earlier in this symposium, but that reduction in standards, with feasible control measures, will allow us to use the surface of the earth safely.

References

- [1] Murray, H. M., Report of the Departmental Committee on Compensation for Industrial Disease, London, H. M. Stationary Office, p. 127 (1907).
- [2] Auribault, M., Bull. del'Inspect. du Travail, p. 126 (1906).
- [3] Cooke, W. E., Pulmonary asbestosis, Br. Med. J., 2, 1024-1025 (1927).
- [4] Merewether, E. R. A. and Price, C. V., Report on effects of asbestos dust suppression in the asbestos industry, Part I., London, H. M. Stationary Office (1907).
- [5] Selikoff, I. J., Personal communication.
- [6] Lynch, K. M. and Smith, W. A., Pulmonary asbestosis III: Carcinoma of lung in asbesto-silicosis, Am. J. Cancer, 24, 56-64 (1935).
- [7] Gloyne, S. R., A case of oat cell carcinoma of the lung occurring in asbestosis, Tubercle, 18, 100-101 (1936).
- [8] Merewether, E. R. A., Annual Report of the Chief Inspector of Factories, London, H. M. Stationary Office (1907).
- [9] Weiss, A., Pleurakrebs bei lungenasbestose, in vivo morphologisch gesichert, Medizinische, 3, 93-94 (1953).
- [10] Wagner, J. C., Sleggs, C. A., and Marchand, P., Diffuse pleural mesothelioma and asbestos exposure in the northwestern Cape Province, Br. J. Ind. Med., 17, 260-271 (1960).
- [11] Newhouse, M. L. and Thompson, H., Mesothelioma of pleura and peritoneum following exposure to asbestos in the London area, Br. J. Ind. Med., 22, 261-269 (1965).
- [12] Selikoff, I. J., Churg, J., and Hammond, E. C., Asbestos exposure and neoplasia, JAMA, 188, 22-26 (1964).
- [13] Selikoff, I. J., Hammond, E. C., and Seidman, H., Mortality experience of insulation workers in the United States and Canada, 1943-1977, to be published, Ann. N.Y. Acad. Sci.
- [14] Nicholson, W. J., Selikoff, I. J., Seidman, H., and Hammond, E. C., Mortality experience of asbestos factory workers: effect of differing intensities of asbestos exposure, Environ. Res. (in press). For earlier data, see: Nicholson, W. J., Case study 1: Asbestos - the TLV approach, Ann. N.Y. Acad. Sci., 271, 152-169 (1976).
- [15] Selikoff, I. J., Hammond, E. C., and Seidman, H., Cancer risk of insulation workers in the United States, In Biological Effects of Asbestos, Bogovski, Gilson, Timbrell, and Wagner (eds.), Lyon, IARC, pp. 209-215 (1973).
- [16] Hammond, E. C., Selikoff, I. J., and Seidman, H., Cigarette smoking and mortality among U. S. asbestos insulation workers, to be published in Ann. N.Y. Acad. Sci. For earlier data see: Hammond, E. C. and Selikoff, I. J., Relation of cigarette smoking to risk of death of asbestos-associated disease among insulation workers in the United States, in Biological Effects of Asbestos, Bogovski, Gilson, Timbrell, and Wagner (eds.), Lyon, IARC, 312-317 (1973).
- [17] Selikoff, I. J., Hammond, E. C., and Churg, J., Asbestos exposure, smoking, and neoplasia, J. Am. Med. Assoc., 204, 106-112 (1968).
- [18] Harries, P. G., Asbestos hazards in naval dockyards, Ann. Occup. Hyg., 11, 135 (1968).
- [19] Harries, P. G. et al., Radiological survey of men exposed to asbestos in naval dockyards, Br. J. Ind. Med., 29, 274-279 (1972).

- [20] McEwen, J., Finlayson, A., Mair, A., and Gibson, A. A. M., Mesothelioma in Scotland, Br. Med. J., 4, 575-578 (1970).
- [21] Edge, J., Asbestos-related disease in Barrow-in-Furness, J. Environ. Res., 11, 244-247 (1976).
- [22] Anderson, H. A. et al., Household contact asbestos neoplastic risk, Ann. N.Y. Acad. Sci., 271, 311-323 (1976).
- [23] McDonald, J. C., McDonald, A. D., Gibbs, G. W., Siemiatycki, J., and Rossiter, C. E., Mortality in the chrysotile asbestos mines and mills of Quebec, Arch. Environ. Health, 22, 677-686 (1971).
- [24] Rossiter, C. E., Bristol, L. J., Cartier, P. H., Gilson, J. G., Grainger, T. R., Sluis-Cremer, G. K., and McDonald, J. C., Radiographic changes in chrysotile asbestos mine and mill workers of Quebec, Arch. Environ. Health, 24, 388-400 (1972).
- [25] Comité d'étude sur la salubrité dans l'industrie de l'amiante: rapport préliminaire, Beaudry, R., Lagace, G., and Juteau, L. (eds.) (1976).
- [26] Nicholson, W. J., Seidman, H., and Selikoff, I. J., (to be published) Ann. N.Y. Acad. Sci. (Proceedings of Science Week).
- [27] Selikoff, I. J., Hammond, E. C., and Churg, J., Mortality experiences of asbestos insulation workers, 1943-1968, in: Shapiro, H. A. (ed.), Pneumoconiosis, Proceedings of the International Conference, Johannesburg 1969, Cape Town, Oxford University Press, pp. 180-186 (1970).

PART II. EXTRAPOLATION TO OTHER INORGANIC FIBERS

Current Status of the Asbestos Problem

Part I of this contribution discusses essential elements and factors related to asbestos fiber exposure and associated human disease. The historical perspective presented, in conjunction with recent data, may help define the emerging problem area concerned with the biological potential of inorganic fibers as a class of compounds. These may be outlined as follows:

The Time Required to Define the Asbestos Problem was Decades Long:

Asbestosis, the disease characterized by scarred lungs due to the inhalation of asbestos fiber, was first described over 70 years ago [1]. It was not until the 1930's and 1940's that an accumulation of evidence suggested that asbestos fiber inhalation was also associated with increased neoplastic risk, specifically carcinoma of the lung [2-5]. This effect was not anticipated, and was overlooked for extraordinarily long time periods. Problems focussing on the activity of mineral fibers, other than asbestos, may require lengthy time periods to define. This may be for lung scarring, an obvious effect associated with inhalation, and especially so for neoplasms.

The Different Asbestos Fiber Types Produce Similar Disease Patterns:

The disease stigmata produced by asbestos fiber inhalation are similar for the different fiber species. Inhalation of all commercial asbestos, chrysotile [6], amosite [7], crocidolite [8], anthophyllite [9], and mixtures of these fibers [10] produce both scarring and various forms of malignant disease. A range of mineral species with different physical and chemical properties can produce disease patterns in humans which are similar and occasionally indistinguishable. It should be stressed that the major difference in biological effects noted are the relative risks associated with each fiber type for each disease entity. Because the many varietal forms of asbestos fibers produce disease, and the non-asbestos fibrous minerals are similar structurally and chemically, any mineral entity which can be inhaled should be studied for health effects.

Extra-Pulmonary Organs in Humans are Involved in Asbestos Disease:

The disease patterns associated with asbestos exposure are complex. Although inhalation is the primary route of exposure to the individual in the workplace, extra-pulmonary organs may be affected as well. For example, asbestos fiber exposure has been associated with the development of intra-abdominal and gastrointestinal tumors [11,12]; excess malignancies of the buccal cavity, pharynx, larynx, esophagus, and stomach have also been reported [13,22]. Therefore, multiple organs and cell types are targets of asbestos fiber action. Importantly, hundreds of thousands of man-years of observation were required to statistically verify that excesses of less common tumors occurred in these workers. Organs other than lungs should be considered targets for other mineral fibers as well.

Occasionally, Multiple Primary Tumors May Simultaneously Occur in the Same Host:

Multiple primary tumors may occur in the same individual who had been occupationally exposed to asbestos fiber. Contributing causes of death, as well as the cause, are important in defining the extent of disease associated with mineral fiber exposure.

The Clinical Latency Period for Asbestos Disease is Extensive:

There exists a long latency period between the onset of exposure to asbestos fiber and the first clinical appearance of neoplastic disease. These stigmata have different lapse time intervals for manifestation, e.g., mesothelioma is greater (30-40 years) than for lung cancer (20-30 years) [15,16]. This time lapse works against the establishment of an etiological link between the agent and the disease; it may confound exposure history by implicating several "agents." It therefore requires many years of retrospective-prospective study to determine, qualitatively and quantitatively, the relationship between mineral exposure and disease.

Fiber Exposure Continues Throughout the Life of the Exposed Individual:

Although a long time period may elapse between the cessation of exposure to asbestos fiber and the appearance of disease, these materials tend to be retained in both lung parenchyma and extra-pulmonary tissues of exposed workmen [17-21]. Therefore, exposure in these individuals continues for their lifetime in that particles are often present, continuously interacting on the cellular level. Removal of an individual from immediate exposure to mineral fiber does not similarly remove him from "organ exposure." This concept holds for all inorganic fibers which are not readily soluble in vivo.

Fiber Dose-Response is a Function of both Duration and Intensity of Exposure:

Both the duration and intensity of exposure to asbestos fiber appear to influence the relative risk of developing the different asbestos diseases, and markedly influence the length of the clinical latency period in which the disease becomes manifest [22]. For example, a study of workers employed in an asbestos factory utilizing amosite fiber demonstrated that exposure to high concentrations of amosite for as little as three months significantly increased the relative risk of developing lung cancer (3.87x=SMR) [13,22]. Exposures in this instance were extremely high. However, if one were to establish an average threshold limit value based on man-years of exposure (average fiber levels multiplied by number of years employed at such levels), such levels would be only 0.1 to 0.2 f/mL, generally considered to be a "safe" level for prevention of asbestosis by today's OSHA standard. This would essentially ignore short-term, high-level exposures which evidently carry significant disease potential. As counterpart, those workers employed for short time periods (less than one year) required longer clinical latency period before their diseases became manifest. This dose-response relationship is likely to hold for mineral fibers other than amosite. Peak exposures may be more important than long-term exposures and, on the other hand, low exposures may require longer periods of observation to fully define neoplastic risk.

Co-Factors Exist in Asbestos Disease:

Cocarcinogenic and other synergistic factors are important in the production of asbestos disease. The importance of cigarette smoking has been demonstrated by evidence that carcinoma of the lung synergistically increases in cigarette-smoking asbestos workers [23-25]. However, present data indicate that cigarette smoking is important only for carcinoma of the lung, not for other malignancies. Lung cancer, cigarette smoking and inhalation of other inorganic particles, e.g., uranium mining, has been shown to be interrelated in the past. Therefore, such a synergism may exist for minerals other than asbestos.

The asbestos problem required decades of time to define through hundreds of thousands of man-years of observations. A range of materials produces similar disease patterns, acting singularly or in concert with other biologically active agents. The clinical latency period is long, target organs are many, and exposure related in part to fiber retention. No known safe level of exposure exists for the prevention of malignant disease. It may be logical to assume at present, that lessons learned from the study of the asbestos problem may be applied to other inorganic fibers as well; that these findings may be used as a model to guide and delineate in new and important areas.

The Nature of Mineral Fibers

Asbestos is the term which categorizes a specific group of natural silicate minerals which occur in fiber form. The term fiber indicates, by definition, that the mineral species grew with this morphology. It also indicates, by definition, that the plane surfaces which define the external symmetry of the mineral are crystal faces resulting from growth. Asbestos fiber consists of a polyfilamentous bundle of intergrown crystal units. The breaking open of such a fiber purportedly is brought about by separation along the juxtaposed crystal faces. The same mechanical treatment, as during grinding, of a non-asbestos, single crystal fiber, produces acicular cleavage fragments. The surfaces so formed are cleavage planes rather than crystal faces. It is generally considered that the majority of cleavage surfaces normally follow crystal face morphological development, in that both tend to occur parallel to "low energy" planes within the mineral [28]. Some investigators, however, considered that there may be significant physical-chemical differences between crystal faces and cleavage planes (see T. Zoltai, this Conference). If so, such differences between crystal faces and cleavage planes may result in different biological activities of these materials. This fundamental difference prevents direct extrapolation from asbestos fiber (bound by crystal faces) to fibrous rock-forming silicates (bound by cleavage planes).

In addition to the differences in surface character, some difference in other properties may exist as well. Asbestos minerals possess physical-chemical properties which are unique. Some of these properties, such as high fiber tensile strength and flexibility, are not observed in other mineral or synthetic fibers. These properties have been described in a number of recent documents [26,27]; their mineralogical character is detailed by others at this meeting (see, e.g., M. Ross, T. Zoltai, A. Goodwin). It is of very great importance to note that differences between asbestos fiber and other silicate fibers are based on megascopic properties, that is, those physical properties determined on bulk samples. The question arises as to whether or not these characteristics which distinguish asbestos from non-asbestos mineral fibers are derived from molecular properties (e.g., twinning). If they are, then these characteristics must also exist on the submicroscopic level as well. On the other hand, if these characteristics are determined by the physical nature of fiber bundles, that is, derived by properties related to the manner in which the units are intergrown, then separation of these units upon comminution destroys the "unique characteristics." Single fibers on the submicroscopic level, of asbestos or other mineral fibers, are often indistinguishable on the basis of morphology, structural characterization (by selected area electron diffraction), and chemistry (as determined by an electron microprobe technique). Since mechanical properties cannot be measured on the microscopic or submicroscopic levels, it is unknown at the present time if the "asbestos properties" carry through to the submicroscopic level. This focuses directly on the issue concerning the disease potential of fibrous silicates other than asbestos. If the "asbestos property" is only megascopic in nature, then size reduction of asbestos produces fibers essentially identical to acicular cleavage fragments of rock-forming silicates. The nature of the mineral fiber entity, on the submicroscopic level, prevents direct extrapolation concerning the biological activity

of other fibrous silicates. However, some extrapolation is currently possible on the basis of existing data.

Data Which Suggest Inorganic Fibers Other than Asbestos are Biologically Active

Small fibers of various chemical compositions may form stable aerosols, persist in the work environment (with an accompanying increased inhalation potential), penetrate deep into the alveolar portions of the lung, and tend to be retained in tissues for long time periods. It has been suggested that such factors as fiber chemistry, trace metals, adsorbed hydrocarbons, etc. are not important in terms of carcinogenic potential. It has also been suggested that any fiber species in contact with the mesothelial lining of the chest, or lung, may produce mesothelioma, possibly by means of an "Oppenheimer" effect [29]. Experimental work conducted with such materials as fibrous glass has demonstrated that even these man-made fibers may induce tumors when implanted at the mesothelial surface [30,31]. Clinical human evidence suggests that all varieties of asbestos fibers can produce disease, and that any sub-species of a single variety can also produce disease. If certain forms of mineral species, commonly referred to as asbestos, are active biologically, what factors are responsible for this activity? Currently, only the size and shape of fiber are common to all mineral species which have been demonstrated to produce disease.

It has been suggested that amphibole "fibers" observed in some industrial talcs are "acicular cleavage fragments" and therefore not asbestos per se.² This argument carries with it the unsupported argument that since these particles are not asbestos, they are therefore not biologically active. However, a literature exists which implicates "fibers" in talc as a factor in human disease. These fibers are commonly asbestiform fibers (acicular cleavage fragments). Although these latter forms cannot be easily distinguished from each other, studies have indicated that these common contaminants of industrial grade talcs are the agents responsible for human disease. The disease stigmata are as follows: fibrosis, with patterns identical to asbestosis [34-38]; occurrence of uncoated fibers and asbestos bodies in lung tissues of workmen with interstitial lung scarring, and accompanied by other asbestosis stigmata (e.g., pleural plaques in workers with "talcosis") [37,39-41]; and excess malignancies, some of which are markers for asbestos exposure, e.g., mesothelioma [42]. One may cautiously accept that there are biologically active fibers contaminating industrial grade talcs. This might also carry with it, with some caution, that crystal faces and cleavage planes have the same biological potential in terms of producing human disease.

Current Status

It has taken 70 years to define the asbestos problem. The work of defining the human hazards associated with exposure to fibrous minerals, other than asbestos, will require at least as much effort and time.

The varietal nature of asbestos, its broad range of mineralogical properties, suggests that other non-asbestos silicate fibers may be active as well. The argument centering on crystal face and cleavage plane difference extrapolated to biological potential requires study. The fact that a mineral fiber is non-asbestos does not extrapolate to its being non-active biologically.

²True asbestos, defined on the basis of mineral phase and its physical-chemical properties (flexibility and high tensile strength) does occur occasionally in talc deposits [32]. Asbestiform is defined as "formed-like or resembling asbestos...." This term refers to rock-forming fibrous silicates which are not flexible, do not have high tensile strength, yet when comminuted are identical to size-reduced asbestos. The term fiber in the present context is used to mean a morphological form, not necessarily the result of conditions of growth and therefore not necessarily bound by crystal faces. Since these characteristics cannot be easily measured on submicroscopic "fibers," the distinction is presently academic.

References

- [1] Murray, H. M., In: Report of the Departmental Committee on Compensation for Industrial Disease, Minutes of Evidence, Appendices and Index, c.d. 3495 - c.d. 3496, London, Wyman and Sons (1907).
- [2] Lynch, K. M. and Smith, W. A., Pulmonary asbestosis. III. Carcinoma of lung in asbestos-silicosis. Amer. J. Cancer, 24, 56-64 (1935).
- [3] Gloyne, S. R., Two cases of squamous carcinoma of the lung occurring in asbestosis, Tubercle, 17, 5-10 (1935).
- [4] Wedler, H. W., Asbestose und Lungenkrebs, Dtsch med. Wschr., 69, 575-576 (1943a).
- [5] Wedler, H. W., Uber den Lungenkrebs bei Asbestose, Dtsch. Arch. klin. Med., 191, 189-209 (1943b).
- [6] McDonald, J. C., Becklake, M. R., Gibbs, G. W., McDonald, A. D., and Rossiter, C. E., The health of chrysotile asbestos mine and mill workers of Quebec, Arch. environm. Hlth., 28, 61-68 (1974).
- [7] Selikoff, I. J., Hammond, E. C., and Churg, J., Carcinogenicity of amosite asbestos, Arch. environm. Hlth., 25, 183-186 (1972b).
- [8] Wagner, J. C. and Berry, G., Mesotheliomas in rats following inoculation with asbestos, Brit. J. Cancer, 23, 567-581 (1969).
- [9] Meurman, L. O., Koviluoto, R., and Hakama, M., Mortality and morbidity among the working population of anthophyllite asbestos miners in Finland, Brit. J. industr. Med., 31, 105-112 (1974).
- [10] Selikoff, I. J., Hammond, E. C., and Seidman, H., Cancer risk of insulation workers in the United States, In: Bogovski, P., Gilson, J. C., Timbrell, V., and Wagner, J. C., eds. Biological Effects of Asbestos, Lyon, International Agency for Research on Cancer (IARC Scientific Publications No. 8), pp. 209-216 (1973).
- [11] Keal, E. E., Asbestosis and abdominal neoplasms, Lancet, pp. 1211 (1960).
- [12] Selikoff, I. J., Churg, J., and Hammond, E. C., Asbestos exposure and neoplasia, J. Amer. med. Assn., 188, 22-26 (1964).
- [13] Selikoff, I. J., Epidemiology of gastrointestinal cancer, Environm. Hlth. Perspect., 9, 299-305 (1974).
- [14] Dohner, V. A., Beegle, R. G., and Miller, W. T., Asbestos exposure and multiple primary tumors, Amer. Rev. resp. Dis., 112, 181-199 (1975).
- [15] Selikoff, I. J., Hammond, E. C., and Churg, J., Mortality experiences of asbestos insulation workers, 1943-1968, In: Shapiro, H. A., ed., Pneumoconiosis, Proceedings of the International Conference, Johannesburg 1969, Cape Town, Oxford University Press, pp. 180-186 (1970).
- [16] Selikoff, I. J., Lung cancer and mesothelioma during prospective surveillance of 1249 asbestos insulation workers, 1963-1974, Ann. N.Y. Acad. Sci., 271, 448-456 (1975).
- [17] Pooley, F. D., An examination of the fibrous mineral content of asbestos lung tissue from the Canadian chrysotile mining industry, Environm. Res., 12, 281-298 (1976).
- [18] Langer, A. M., Rubin, I. B., Selikoff, I. J., and Pooley, F. D., Chemical characterization of uncoated asbestos fibers from the lungs of asbestos workers by electron microprobe analysis, J. Histochem. Cytochem., 20, 735-740 (1972b).

- [19] Fondimare, A. and Desbordes, J., Asbestos bodies and fibers in lung tissues, Environm. Hlth. Perspect., 9, 147-148 (1974).
- [20] Sebastein, P., Fondimare, A., Bignon, J., Monchaux, G., Desbordes, J., and Bonnaud, G., Topographic distribution of asbestos fibers in human lung in relation with occupational and non-occupational exposure, In: Walton, W. C., ed., Inhaled Particles and Vapours, IV, New York, Pergamon (in press).
- [21] Langer, A. M., Inorganic particles in human tissues and their association with neoplastic disease, Environm. Hlth. Perspect., 9, 229-233 (1974).
- [22] Selikoff, I. J., Cancer risk of asbestos exposure, In: Hiatt, H. H., Watson, J. D., and Winsten, J. A., eds., Origins of Human Cancer, Cold Spring Harbor, N.Y., pp. 1765-1784 (1977).
- [23] Selikoff, I. J., Hammond, E. C., and Churg, J., Asbestos exposure, smoking and neoplasia, J Amer. med Ass., 204, 106-112 (1968).
- [24] Doll, R., The age distribution of cancer: implications for models of carcinogenesis, J. roy. stat. Soc., 134, 133-166 (1971).
- [25] Berry, G., Newhouse, M. L., and Turok, M., Combined effect of asbestos exposure and smoking on mortality from lung cancer in factory workers, Lancet, ii, 476-479 (1972).
- [26] IARC Monograph Series: Evaluation of Carcinogenic Risk of Chemicals to Man, V. 14, Asbestos WHO-IARC Lyon, 1977, 106p.
- [27] Langer, A. M. and Wolff, M. S., Asbestos Carcinogenesis, In: Schrauzer, G., ed., Inorganic and Nutritional Aspects of Cancer, Plenum Press, N.Y., pp. 29-55 (1977).
- [28] Langer, A. M., Rohl, A. N., and Wolff, M. S., The nature of mineral surfaces and their role in biological interactions, Soc. Occup. and Environ. Hlth., Wash., 1977 (in press).
- [29] Oppenheimer, B. S., Oppenheimer, E. T., Stout, A. R., Danishefsky, I., and Eirich, F. R., Malignant tumors and high polymers, Science, 118, 783-784 (1953).
- [30] Stanton, M. F. and Wrench, C., Mechanisms of mesothelioma induction with asbestos and fibrous glass, J. nat. Cancer Inst., 28, 797-821 (1972).
- [31] Stanton, M. F., Some etiological considerations of fibre carcinogenesis, In: Bogovski, P., Gilson, J. C., Timbrell, V., and Wagner, J. C., eds., Biological Effects of Asbestos, Lyon, International Agency for Research on Cancer (IARC Scientific Publications No. 8), pp. 289-294 (1973).
- [32] Ford, W. E., Dena's Textbook of Mineralogy, N.Y. Wiley, 4th Ed., 678p (1957).
- [33] Bureau of Mines, Dictionary of Mining, mineral and related terms, ed. P. W. Thrush, Washington, D. C., U. S. Government Printing Office (1968).
- [34] Dreessen, W. C., Effects of certain silicate dusts in the lungs, J. Indust. Hyg., 15, 66-78 (1933).
- [35] Dreessen, W. C. and Dalla Valle, J. M., The effects of exposure to dust in two Georgia talc mills and mines, Publ Health Repts., 50, 1405-1415 (1935).
- [36] Siegal, W., Smith, A. R., and Greenburg, L., The dust hazard in tremolite talc mining, including roentgenological findings in talc workers, Am. J. Roentgenol., 4, 11-29 (1943).
- [37] Daymon, H., Latent silicosis and tuberculosis, Am. Rev. Tuberculosis, 53, 554-559 (1946).

- [38] Porro, F. W. and Levine, N. M., Pathology of talc pneumoconiosis with report of an autopsy, North. N.Y. State Med. J., 3, 23-25 (1946).
- [39] Hobbs, A. A., A type of pneumoconiosis, Am. J. Roentgenol. Radiol. Therap., 58, 488-497 (1950).
- [40] McLaughlin, A., Rogers, E., and Dunham, K. C., Talc pneumoconiosis, Br. J. Indust. Med., 6, 184-194 (1949).
- [41] Porro, F. W., Patton, J. R., and Hobbs, A. A., Pneumoconiosis in the talc industry, Am. J. Roentgenol., 47, 507-524 (1942).
- [42] Kleinfeld, M., Messite, J., Kooyman, O., and Zaki, M. H., Mortality among talc miners and millers in New York State, Arch. Environ. Health, 14, 663-667 (1967).

Discussion

M. SCHNEIDERMAN: You talked about short term exposures and problems of peak exposures. Then you divided an exposure by 20 years and that came out to some very small number, and you said that small number is substantially below the standards now set. Have you any information on the difference between biological results from peak exposures and long term exposures or should we consider only integrated exposures totaled over time and not consider problems of peak exposure?

A. NICHOLSON: We don't have good data on the effects of peak exposures per se. They may in fact be proportionally greater than an amount averaged over a longer period of time. Insulation workers' exposures are very peaky-like. That is, they tend to spend most of their time working in conditions that would have very low ambient air concentrations. The material is wet or else they're not using asbestos, but at times when they were mixing cement, cutting block, or doing something like that they had very high concentrations. This may be a factor. We just have no way of obtaining data on that particular item separately from the integrated exposures that we can make some estimate of.

E. COX: Dr. Nicholson, you mentioned an amosite exposure study of very short term nature and then went on to correlate that to the safe exposure over a long period of time. I believe your figures were three deaths, contrasted with an expected 1.34, from lung cancer for a person who was employed in that plant for one month or less. Was there any correlation with smoking done in that study?

NICHOLSON: No, there was not, and the number of deaths in each single category were small. The consistency over each of those month by month categories, though, was strong. That is, if you looked at all months together over the period of time for less than one month through five months, the results are of statistical significance. In terms of cigarette smoking, we know it is strongly correlated with asbestos exposure. What asbestos does, in essence, is multiply whatever existing risk of death from lung cancer that is already present. If an individual has a high risk from cigarette smoking, then additional asbestos exposure can multiply that from five to ten times. If he has a very low risk of death from lung cancer because he's a non-smoker, it can be increased perhaps five times by the asbestos exposure.

COX: Thus, there wasn't any correlation done. Now the other question would be with Dr. Langer's work, and perhaps you could answer it. It deals with the concentration of uranium involved in the mining danger. Langer had a chart, that went by rather rapidly, of the different things that are particularly dangerous and one was mining where uranium was involved.

NICHOLSON: Uranium mining produces a very high risk of lung cancer.

COX: Yes, I wonder if you could speak about the concentration of uranium? The amount of uranium in the ore body is the thing of interest to me.

NICHOLSON: Well, most ore bodies in the Southwest have two or three percent uranium oxide.

COX: Well, let me be more specific. Phosphate mining in Florida where the yield is one pound of uranium per ton of H_3PO_4 , would that be dangerous?

NICHOLSON: It would depend on what the air concentration of the material is. I couldn't answer the question directly.

COX: All right, thank you.

L. SWINT: I'd like to clear up that question on uranium mining. Actually the cancer is caused by radon daughters which come from the radium, which is a decomposition product of uranium. The amount of uranium in the ore has nothing to do with the lung cancer. It's really a function of the exposure to radon daughters rather than the amount of uranium present.

Although radon gas and radon daughters are decay products in the uranium decay series which, when in equilibrium, would be present in direct proportion to the amount of uranium present, for practical purposes they are independent because there are many events which occur that keep equilibrium of radon daughters and uranium from being established. Uranium and radium, the direct parent of radon, may be out of equilibrium due to differential leaching by groundwaters, since uranium is much more leachable than radium. The porosity and permeability of the rock affect the rate at which the rock will release radon gas into a mine atmosphere. Thus, the amounts of radon gas and radon daughters present in a mine atmosphere are not completely controlled by the amount of radium or uranium in the rock.

The grade of uranium ore mined in the U. S. through 1973 averaged between two and three tenths of one percent U3O8, but since 1973 this grade has steadily declined to fifteen hundredths of a percent in 1976.

SCHNEIDERMAN: In fact, in some of those studies, the hard rock miners who would have similar exposures to the kinds of things that Dr. Nicholson was talking about were used as controls so that one might measure whether it was the radioactive material or the fibrous material that was of consequence. Those might have been inappropriate controls now that we know better, but hard rock miners were used as controls.

NOTE: The following notes were sent following the meeting and were not part of the verbal discussion at the end of the session.

P. GROSS: Dr. Langer's presentation suggested that fiberglass is carcinogenic to man. Epidemiologic studies as well as experimental studies in which animals inhaled fiberglass or were injected intratracheally with it have provided evidence that glass fibers were not carcinogenic. Only when glass fibers of a special thinness and length are placed in the chest cavity (not the lungs) or injected into the abdomen of rats do cancers develop. According to a recent publication (Money Causes Cancer: Ban It, by G. E. Moore and W. N. Palmer, JAMA 238, 397, August 17, 1977), sterilized dimes placed into the abdomen of rats caused more than 25 percent of them to develop cancer within 14 months. The proclivity of certain rodents to develop cancers in response to various insoluble, solid materials embedded in their tissues is well recognized as "Solid-State Carcinogenesis" and should not be extrapolated to man.

A. LANGER: During my presentation I voiced concern that among fibers other than asbestos, synthetic insulation fibers, e. g., fibrous glass, when inhaled, may be biologically active. This concern has been raised by a number of investigators, in different laboratories, based on observations made during more than 20 years of experimental work. As early as 1955, Schepers and Delahant [1], utilizing the inhalation route of administration, exposed guinea pigs and rats to 6-micron diameter fibrous glass. These animals were serially sacrificed for time periods up to two years, and progressive pulmonary changes followed. Guinea pigs were observed to develop pneumonia, lung abscesses, emphysema, and systemic neoplasms. Rats, in addition to these alterations, also formed pleural plaques, a stigma normally associated with asbestos fiber inhalation. "Severe parenchymal changes" were

observed in both animal populations. In the same year, Schepers [2] published additional experimental data concerning the biological effects of intratracheally injected and inhaled glass wool. He observed persistence of glass in animal lung for up to 18 months after cessation of exposure. Glass wool fibers were observed in multinucleated giant cells and in areas of incipient atrophic emphysema. Epithelial hyperplasia was commonly observed. Inhalation experiments, conducted simultaneously with the same animals, produced epithelial hyperplasia and cellular desquamation; papillomas were observed in bronchioles. Focal cellular pneumonitis and other effects, such as alveolar wall thickening, were noted. Schepers considered some of these as "remarkable lesions" and suggested that ".... glass is not fibrogenic when retained in lung tissue. At the same time the gravity of the type of bronchiole lesion provoked necessitates caution in dismissing glass wool as innocuous. Indeed it should be regarded as a potentially harmful substance in circumstances leading to the inhalation of large quantities of the type of products studied in these experiments." It should be stressed that this early study did not provide a control group; however, one may cautiously accept these findings considering the nature of the diseases and the extent to which the animal colony succumbed.

In a number of animal studies which followed (e.g., Gross et al., 1959 [3]; Gross et al., 1970 [4]), pulmonary changes from a variety of synthetic fibers, in a number of animal models, appeared to occur. However, faced with some experimental caveats, these workers interpreted the results as not exclusively indicative of biological activity of the fibers. It was not until 1972 that Stanton and Wrench [5] demonstrated the ability of fibrous glass to induce malignant mesothelioma in experimental animals with appropriately vigorous control groups. This was substantiated further by Stanton in 1973 [6] and Pott et al., 1974 [7]. Further work by Wright and Kuschner, in 1976 [8] unequivocally demonstrated the ability of fibrous glass to act in a manner similar to asbestos fibers in animal tissues (formation of scar tissue). Finally, Wagner et al., 1976 [9], were able to produce mesotheliomas in Wistar rats, after intrapleural inoculation of glass fiber into chest cavities.

The extent and even the histopathic nature of induced lesions may not be so marked as those from asbestos; nevertheless, many reports in the experimental pathology literature unequivocally demonstrate the potent activity of synthetic fibers in animal models [10]. Dr. Gross is correct in suggesting that the ability to induce tumors in the experimental model may well be related to the "Oppenheimer effect" (solid state carcinogenesis). Extrapolating to humans, this may indeed be the very same reactions which evokes mesothelial tumors. Hence, it has often been said that mesothelioma merely requires the physical presence of a fiber at the pleural surface. If this is so, then the chemistry of the fiber, and its physical state, are secondary in terms of this particular biological response. Therefore, if inhalation of thin asbestos fibers (of any variety) produce mesotheliomas, the inhalation of thin glass fibers, which may also penetrate to the mesothelial lining of the lung, may produce the same response. The subject is still one which requires animal studies, and certainly human studies. It is an open issue.

Discussion References

- [1] Schepers, G. W. H. and Delahant, A. B., An experimental study of the effects of glass wool on animal lungs, Arch. Ind. Health, 12, 276-279 (1955).
- [2] Schepers, G. W. H., The biological action of glass wool, Arch. Ind. Health, 12, 280-287 (1955).
- [3] Gross, P., Westrick, M., and Mc Nerney, J. M., Glass dust: a study of its biologic effect, Arch. Ind. Health, 16, 10-23 (1959).
- [4] Gross, P., Kaschak, M., Tolker, E., Bobyak, M., and deTreville, R. T. P., The pulmonary reaction to high concentrations of fibrous glass dust, Arch. Environ. Health, 20, 696-704 (1970).
- [5] Stanton, M. and Wrench, C., Mechanisms of mesothelioma induction with asbestos and fibrous glass, J. Nat. Cancer Inst., 48, 797-821 (1972).

- [6] Stanton, M., Some etiological considerations of fiber carcinogenesis, In: IARC Mono., Biolog. Effects of Asbestos, Bogovski, P., et al., Eds, Sci. Pub. No. 8, Lyon, pp 289-294 (1973).
- [7] Pott, F., Huth, F., and Friedrichs, K. H., Tumorigenic effect of fibrous dusts in experimental animals, Env. Health Perspect., 9, 313-315 (1974).
- [8] Wright, G. and Kuschner, M., The influence of varying lengths of glass and asbestos fibers on tissue response in guinea pigs, In: BOHS-Inhaled Particles and Vapours, IV, Edinburgh (1976), in press.
- [9] Wagner, J. C., Berry, G., and Skidmore, J. W., Studies of the carcinogenic effects of fiber glass of different diameters following intrapleural inoculation in experimental animals, In: Occupat. Exp. to Fibrous Glass, A Symposium - HEW - NIOSH, Univ. Maryland, June, 1974, U. S. Govt. Printing Office, Wash. p. 193-204 (with discussion).
- [10] Occupational Exposure to Fibrous Glass: A Symposium, HEW - NIOSH, Univ. Maryland, June, 1974, U. S. Govt. Printing Office, Wash. 404 p.

MEASUREMENT OF ASBESTOS RETENTION IN THE HUMAN RESPIRATORY SYSTEM RELATED TO HEALTH EFFECTS

J. Bignon, P. Sebastien, and A. Gaudichet

Université Paris-Val de Marne – Institut de Recherche sur l'Environnement
Centre Hospitalier Intercommunal
94010 Créteil, France

and

Laboratoire des Particules Inhalées
Direction Départementale de l'Action Sanitaire et Sociale
75013 Paris, France

Abstract

The retention pattern of asbestos fibers in the human respiratory system is related to four mechanisms: penetration into the respiratory tract deposition on the surface of respiratory epithelium, clearance, and intra-tissular translocation of asbestos fibers. Knowledge of such retention pattern for people exposed to asbestos dusts could provide useful information concerning the role of these mechanisms and the pathogenicity of fibers. So, asbestos fibers content has been assessed by light and electron microscopy in different samples from the respiratory tract: sputum, broncho-alveolar washing fluid, lung parenchyma, parietal pleural, and mediastinal lymph nodes from people diversely exposed to asbestos dusts and affected by various asbestos-related diseases. In each sample, asbestos fibers, identified as chrysotile or amphibole, have been counted and measured (length and diameter).

It has been shown that asbestos fibers found in sputum and in broncho-alveolar washing fluid by light and electron microscopy were reliable for the assessment of inhaled asbestos fibers in the workplace or in the environment.

Analytical data concerning asbestos burden in respiratory tissues can be summarized as follows:

- despite the fact that most of the consumed asbestos is of chrysotile type, amphibole was more frequently found in lung parenchyma than chrysotile, in most cases;

- most of the fibers retained in lung tissues were less than 0.20 μm in diameter and shorter than 5 μm . The intra-alveolar fibers were shorter (3.3 μm) than fibers found in lung parenchyma (4.9 μm). Fibers encountered in mediastinal lymph nodes were shorter (2.5 μm) and of amphibole type, whereas fibers encountered in parietal pleura were the shortest (2.3 μm), and thinnest (0.06 μm in diameter) and mostly of chrysotile type.

The signification of these data concerning the topographic variation in the fiber type and size are discussed in relationship with adverse health effects, particularly carcinogenesis.

Key Words: Asbestos; carcinogenesis; fibers; pathogenicity; respiratory tract.

Introduction

The factors relevant to the assessment of public health risks of exposure to asbestos have been recently reviewed in two documents [1,2]¹. It is now well documented that exposure to asbestos dust can lead to the development of lung fibrosis, bronchogenic carcinoma, pleural plaques, pleurisy, mesothelioma, gastro-intestinal tumors, and perhaps other unexpected diseases. The most critical point today is the establishment of dose-response relationship. Regarding cancer, adequate data to establish a threshold limit are not yet available. "The existence of a theoretical no-effect level may even be doubted; however, there may exist a practical no-effect level, below which any excess incidence cannot be adequately established" [1].

As far as asbestos is concerned, because of the various possibilities of exposure, it is difficult to define retrospectively sharp conditions of exposure. So, the exposure-effect relationships are not very reliable and greater reliance should be put upon biological monitoring. Asbestos metrology in human samples could provide information about the most important questions arising for the assessment of dose-effect relationships and for the subsequent definition of prevention practices:

A. Is there any relationship between one or several body-burden parameters at autopsy and the cause of death, sex, age, and possibilities of exposure? The problem is that the latency period of asbestos-induced diseases can be very long (up to 30 or 40 years). As the accumulation of fibers in man occurs in a dynamic way (related to inhalation and clearance mechanisms), only the residue-burden can be investigated at autopsy. Research is needed to establish eventual relationships between autopsy residue-burden and burden at the time of disease onset.

B. What is the most suitable external indicator of body-burden during life? Such a contamination indicator, if it exists and if available for monitoring, could be very helpful for the detection or the survey of exposed people. If relationships could be established with related diseases or with any biological test, this kind of survey should be specifically relevant to biological monitoring.

C. What is the biological significance of physical and chemical properties of fibers (length, diameter, elemental composition, associated pollutants...) regarding the induction of diseases (particularly tumors)?

Recent experimental data using intrapleural implantation [3] or intraperitoneal injection [4] of fibers of different sizes indicated clearly that the size parameters are the most important for inducing cancer and that the most carcinogenic fibers, whatever the chemical composition, are those with diameters of less than 0.5 or 0.25 μm , and length more than 5 or 8 μm [5]. How can information provided by asbestos measurements in human respiratory tissues be correlated with these recent findings?

D. These studies on body-burden correlated to environmental monitoring could lead to more appropriate standards or quality guides for the future, in relation to the prevention of asbestos-related cancers.

General Considerations Related to Asbestos Retention

A. What Could Be the Definition of Body-Burden for Asbestos.

The actual amount of pollutants in humans at any time is called retention. The retention of particles in humans occurs in a dynamic way and reaches an equilibrium level depending on the relative rate constants of deposition and clearance processes. The model of lung retention, based on the ICRP Task Group report [6], is suitable for describing the general scheme of deposition, clearance, penetration, and translocation of fibers in humans, as shown in figure 1. So far, the penetration and retention of asbestos fibers through the gastro-intestinal tract have not been intensively investigated [7].

¹Figures in brackets indicate the literature references at the end of this paper.

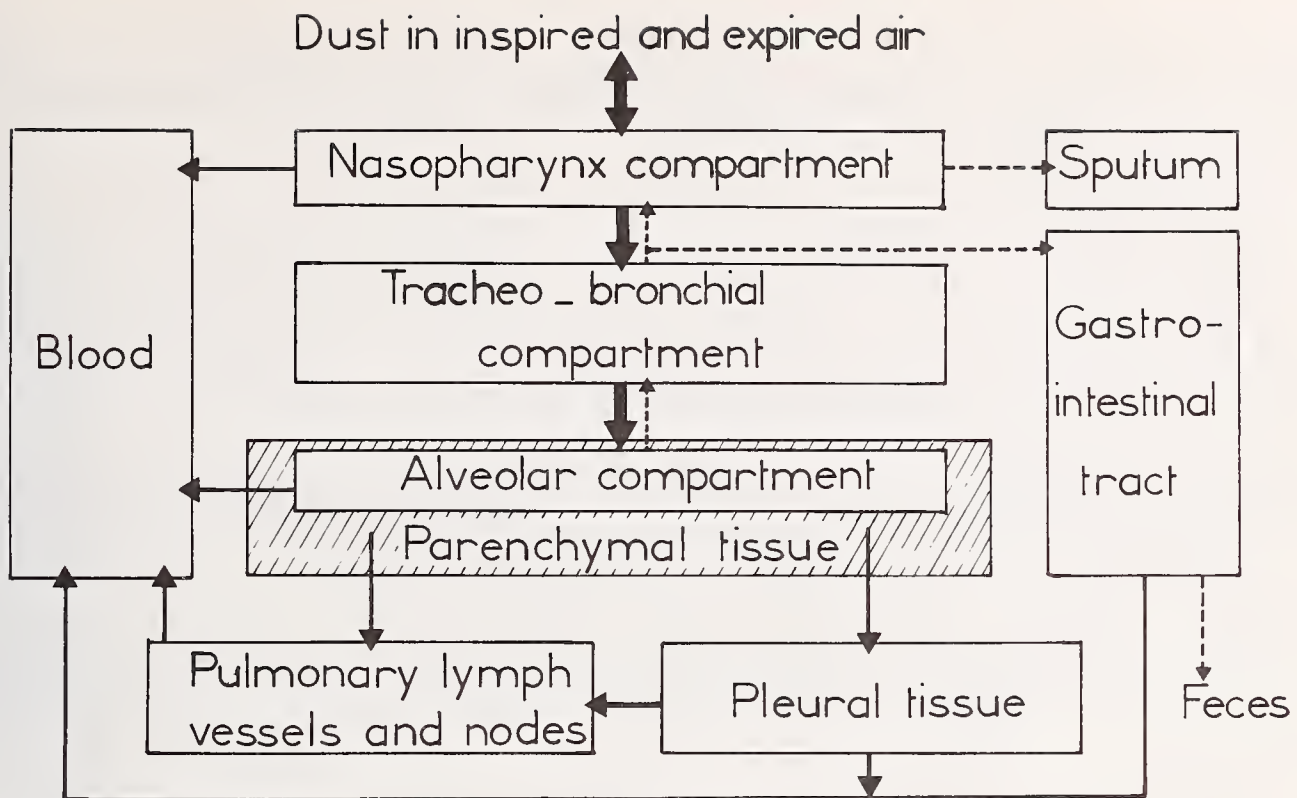

Figure 1. General scheme for deposition, clearance, translocation and retention of fibers, derived from the ICRP lung model [6]. (Heavy arrows : deposition; light dotted arrows : clearance pathway; light arrows : translocation pathways.)

As asbestos measurement in tissues requires a destructive process, the retention of asbestos fibers cannot be controlled continuously. Measurement of asbestos in organs will provide information on asbestos retention at a very definite time: time of death for autopsic material, or time of surgical intervention for biopsic samples. So far, few attempts have been made for monitoring asbestos retention in alive people either by means of external magnetic procedure involving no sampling [8], or by means of relating body-burden to the amount of asbestos in sputum [9,10], in gastric juice [11], and in feces [12].

B. Deposition.

Distinction has to be made between the two pathways for human exposure to asbestos: the pulmonary tract (PT) and the gastrointestinal tract (GIT).

Timbrell has reviewed the mechanisms by which particles deposit in the respiratory system and has addressed specifically to the problem of fibers deposition [13]. He identified settling, inertial impaction and Brownian diffusion as deposition mechanisms which operate for both compact particles and fibers. In addition, he listed a fourth mechanism, direct interception, which is of little significance for compact particles but which may be of marked importance for fibers. In this view, a model for deposition of fibers in the human respiratory system has been described [14]. The effectiveness of these deposition mechanisms depends on the anatomy of the respiratory tract, the effective aerodynamic diameter of the particles (size, shape, density), and the breathing pattern.

Asbestos fibers can also deposit in the gastrointestinal tract (GIT) either directly (because of the presence of asbestos in water, beverages and food) or indirectly (fibers coming from the respiratory airways and being swallowed). So far, there is little or no direct information regarding the way of fiber deposition at the surface of the human GIT.

It is obvious that accurate quantitative information on the deposition of asbestos fibers in humans is difficult to be obtained because of clearance and translocation mechanisms occurring simultaneously during lifetime. What we measure in the human body results from all these associated mechanisms!

C. Clearance.

Fibers which are deposited on the muco-ciliated blanket of the trachea and bronchi move toward the pharynx. The clearance of inhaled particles by this mechanism is believed to be more than 98 percent effective for most deposited particles [6]. However, the direct toxic effect of asbestos on the ciliated cells, as shown recently [15], must impair the effectiveness of this clearance mechanism.

The fibers deposited at the surface of the alveoli are either taken by alveolar macrophages or entrapped within the alveolar lining film. From there, some of them are cleared towards the ciliated airways while others should penetrate the alveolar membrane. The clearance is different according to the type of asbestos; for chrysotile, the clearance is important, since Wagner et al. [16], Morgan et al. [17] found that a large percentage of chrysotile asbestos entering the lungs of rats may be removed from the lungs within 58 days; but we do not know the mechanisms involved. However, most of the cleared fibers must reach the GIT as demonstrated by the study of Evans et al. [18] using inhaled neutron activated asbestos; up to 73 percent of this asbestos was found in the feces within 30 days.

Measurements related to clearance in human have been carried out in several kinds of samples: sputum [10,19,20], gastric juice [11], and feces [12]. Generally, the finding of asbestos in such samples was related to past exposure, pulmonary burden or pathological features. The feasibility of using such samples as indicators of body-burden will be discussed later.

D. Penetration and Translocation of Asbestos Fibers in the Human Body.

Measurements in tissues using the transmission electron microscope (TEM) have revealed the presence of numerous fibers and fibrils far more than was ever imagined when the fiber population was evaluated by light microscopy alone. These findings, occurring even in case of moderate exposure and long elapsed time from last exposure, suggest a very high penetration and retention rate for TEM size fibers. In humans, asbestos fibers have been found by TEM in lung parenchyma by many authors [21,22,23, 24,25,26,27] and also in bronchial tissue, lymph nodes [28], parietal pleura [25,26], pleural fluid [29,30], peritoneum [31], liver [24], stomach [32,33], bowel walls [34], and colon [35]. These findings suggest the penetration of asbestos in the human tissues and their migration throughout the whole body.

Experimentally, penetration of fibers across the alveolar epithelium has been described in TEM by Suzuki [36]. The extreme tendency of asbestos fibers to migrate has also been demonstrated experimentally after subcutaneous injection [37], intrapleural or intraperitoneal inoculation [38,39,40], or after ingestion [41].

However, the penetration of ingested fibers through the wall of the gastrointestinal tract is still in discussion. This point is mostly relevant to asbestos-related extra-thoracic cancers, such as peritoneal mesothelioma, ovarian carcinoma, kidney carcinoma, etc. Some authors pointed out that there was no penetration [42]. However, an experiment in progress in our laboratories has shown that ingested chrysotile and crocidolite fibers did cross the intestinal barrier in the rat, being recovered in the lymph of the thoracic duct [43].

Analytical Data Related to Asbestos Body-Burden in Humans

A. Samples Studied as Indicators of Asbestos Body-Burden.

So far, most of the samples studied in this laboratory for estimating asbestos body-burden in humans were collected from the respiratory tract. We will only focus on data obtained from measurements in 3 kinds of samples: lung washing fluid (LWF) obtained by broncho-alveolar lavage (BAL), sputum collected on alive people, and respiratory tissues (lung parenchyma (LP), parietal pleura (PP), and mediastinal lymph nodes (LN) sampled at autopsy).

According to the model shown in figure 1, it has been assumed that asbestos fibers found in LWF were related, on one hand to the intra-alveolarly deposited fraction of inhaled fibers, and on the other hand to the fraction cleared from the deep lung whereas those found in sputum must be related to the fibers cleared from the deep lung and from the tracheo-bronchial compartment [20]. The fibers detected by destroying lung parenchyma correspond to intra-alveolarly deposited fibers and intra-tissularly retained fibers at the time of autopsy.

The point is to know if LWF and sputum can be used as external indicators of asbestos body-burden. In this view, a systematic comparative study of fibers encountered in LWF, in sputum and in lung tissue has been carried out and is still in progress.

B. Analytical Procedures.

For this study, the patients were classified according to their past asbestos exposure. A meticulous history was obtained by questioning each patient in detail about their successive occupations since leaving school. When a history of asbestos exposure was found, the duration of this exposure and the lapse-time since last exposure was recorded (expressed in years). Thus, the degree of exposure was estimated on one hand in terms of its duration and on the other hand according to the type of work done by the patients.

All the biological samples were collected within 10 percent formalin. For autopsic lungs, the formalin was injected intratracheally. Pieces of tissue samples were cut and their volume measured. Typically, 1 cc of tissue was prepared for analysis.

Each sample to be analyzed was put in a glass vessel containing sodium hypochlorite. This digestive procedure was performed at room temperature during one or two hours. Then, the mixture was directly filtered through a 0.4 μm pore size Nuclepore membrane filter previously coated with a carbon layer.

At this stage the filter was scanned under the light microscope looking for ferruginous bodies.

For TEM study, a second carbon layer was deposited upon the filter and the particles, entrapped in a double carbon-film, were transferred to TEM grids. The preparations were scanned at X 30,000 direct magnification, looking for fibers. Each fiber encountered was identified on the basis of its morphological features and its electron diffraction pattern and was called chrysotile, amphiboles, or non-asbestos fiber. The length and diameter of each asbestos fiber was measured using a calibrated mark on the viewing screen. For each grid square scanned, the data (number, mineralogical type, and size of fibers) were recorded directly on a computer. Several grid squares were scanned until the variation around the mean calculated for numerical concentrations was less than 30 percent.

Concentrations of fibers were expressed in terms of number per sputum, number per total lung washing fluid recovered, and number per cc of tissue.

Identification of associated non-fibrous particles has been assessed by means of electron microprobe analysis [44], but quantitative information concerning numerical or mass concentration of such particles has not been obtained.

An intercomparison study between two laboratories (The University College of Cardiff - F. D. Pooley and Laboratoire des Particules Inhalées, Paris - P. Sebastien) has yielded very similar results concerning the assessment of asbestos fibers in tissues, using the procedure previously described [45].

C. Lung Washing Fluid (LWF).

The possibility of assessing the asbestos endo-alveolar content by means of broncho-alveolar lavage is now under investigation in diversely exposed people. Such a technique has been used by different workers in order to collect free cells and proteins from the human lung [46,47] and it has been shown in the baboon that pulmonary washing was an efficient procedure for the recovery of particles deposited in the alveolar compartment of the lung [48].

1. Material and Method

Up to date, this type of investigative procedure has been used in 26 cases (Table 1). The cases studied were divided in 4 groups:

Table 1. Groups of 26 patients investigated by broncho-alveolar lavage.

	Nb Cases	Asb. Exposure	Diseases
Group 1	9	Definite	Asb : 9
		Heavy	P1 P1 : 5 Br Ca : 1
Group 2	5	Definite	P1 P1 : 2
		Moderate	Silico-Asb : 1
			Sm irr op : 1 Chr bronch : 1
Group 3	3	Suspected	Fibrosis +
		Moderate	P1 P1 : 1
			P1 P1 : 1 Chr bronch : 1
Controls	9	None	Lar Ca : 1
			tuberculosis : 1
			fibrosis : 1
			histiocytt, x : 1 Chr bronch : 5

Abbreviations: Nb = number; Asb = asbestosis; P1 P1 = pleural plaques;
Br Ca : bronchogenic carcinoma; Sm irr op = small irregular
x-ray opacities; Chr bronch = chronic bronchitis;
Lar Ca = larynx carcinoma.

Group 1 included 9 cases with definite heavy asbestos exposure (DH), subdivided into 7 insulation workers, 1 asbestos-cement worker, and 1 asbestos-textile worker. Lung asbestosis from 0/1 to 2/2 was diagnosed by x-ray according to the ILO U/C International classification of radiographs of pneumoconiosis 1971. Asbestosis was associated with bronchial carcinoma in one case and with pleural plaques in 5 cases (Table 1).

Group 2 included 5 cases with definite moderate asbestos exposure (DM), confirmed by minutious occupational inquiries. The occupation and associated diseases are indicated in Tables 1 and 2.

Table 2. Occupations, associated diseases, and mineralogical results in cases of Group 2. (definite moderate exposure)

Results LWF in Group 2 (definite moderate exposure)

Cases	Occupation	Years occupation	Years since asb. exp.	Diseases	Nb coated fibers	Nb fibers	% A
MOU...	Boiler Fitter	10	19	P1 P1	10	+	0
GAN...	Glass Blower	27	0	P1 P1	0	0	-
MAR...	Asbestos Plate Cutting	19	11	Silicosis ± Asbest.	0	+	50
ESS...	Plumber with Welding, Brazing	18	3	Small Irr Opacities	0	0	-
BOD...	Isolation of Central Heating	3	24	Chronic Bronchitis	0	0	-

Abbreviations: P1 P1 = pleural plaques; Years occupation = years of occupational exposure; Nb = number; LWF = lung washing fluid; % A = ratio of amphiboles number/ amphiboles number + chrysotile number. (See Table 1 also.)

Group 3 included 3 cases with suspected (but not proven) moderate asbestos exposure (SM) according to the past occupational history of the patients. The occupation and associated diseases are indicated in Tables 1 and 3.

Table 3

Results LWF in Group 3 (suspected moderate exposure)

Cases	Occupation	Years occupation	Diseases	Nb coated fibers	Nb fibers	% A
ABD...	Automobile Worker	10	Chronic Bronchitis	0	+	0
MON...	Wood Worker	10	Fibrosis + P1 P1	0	+	0
DEC...	Plumber	25	P1 P1	0	0	-

Abbreviations: See Table 2.

The 9 control cases included patients without specific dust exposure.

The method used for broncho-alveolar lavage (BAL) has been extensively described elsewhere [49]. It was assumed that the volume of the lung washed by this procedure corresponded to about one segment. For mineralogical analysis, a 10 mL sample was taken from the whole lavage before the centrifugation was performed for cells recovery.

2. Results

No asbestos fibers have been detected by LM and TEM in the LWF of the 9 control cases. Some other non fibrous mineral particles have been encountered in 50 percent of these cases, identified as chlorite, calcite, quartz, aragonite, phlogopite, magnetite, and Al metal.

In the group 1 of heavily exposed patients (Table 4), the mean number of fibers was 12.1×10^6 per lavage. The mean number of alveolar macrophases (AM) was simultaneously estimated to be 12.6×10^6 per lavage. However, there was no correlation between the number of fibers and the number of AM. Asbestos fibers were mainly of the amphibole type in insulation or asbestos cement workers. The highest fiber count (50×10^6), only of the amphibole type, was observed in the patient working in an asbestos-cement plant. By contrast, in the case of having worked in an asbestos-textile plant, all the fibers were of the chrysotile type. The percentage of coated fibers was low, less than 1 percent in 7 out of 9 cases. The mean length and diameter were 3.3 and 0.13 μm respectively.

Table 4. Mineralogical studies of lung washing fluid (LWF).

Results LWF in Group 1 (definite heavy exposure)

Cases	Exp. type	Yrs exp.	Yrs since last exp.	Diseases	Nb A.M. 10^6	Nb fibers 10^6	% coated fibers	% A	Mean length μm	Mean diam μm
CHA...	I	16	2	A	7.6	21	5	100	3.9	0.15
KRE...	I	10	4	A	24.6	5	0.3	100	4.04	0.12
FRA...	I	11	3	A	26.1	6	0.5	100	3.02	0.14
CHE...	I	10	11	A + B, CA	-	2.4	0.15	100	2.9	0.10
BEN...	I	15	4	A	-	3.8	0.9	99	3.2	0.15
LAI...	I	11	0	A	9.7	11.4	2	90	3.05	0.12
MAA...	I	14	3	A + P1 P1	7.3	7	0.8	100	2.07	0.15
MAR...	AC	19	0	A	10.7	50	0.001	100	2.07	0.15
FAL...	AT	4	1	A	2.4	3	0.02	0	5.6	-
Average		12.2 ± 4	3.1 ± 3.1		12.6 ± 8.4	12.1 ± 14.4	1 ± 1.5		3.3 ± 1	0.13 ± 0.1

Abbreviations: Exp type = type of exposure; I = insulator; AC = asbestos-cement plant worker; AT = asbestos-textile plant worker; NB A.M. = number of alveolar macrophages per lavage; Nb fibers = number of asbestos fibers per lavage; % A = see Table 2; diam = diameter.

In the group 1, two parameters, duration of exposure in years and lapse-time since the last exposure, have been assessed and correlated with the fiber count in the LWF. The two curves show that the number deposited within the alveolus increases with duration of exposure, whereas this number decreases when the time since the last exposure increases (figure 2).

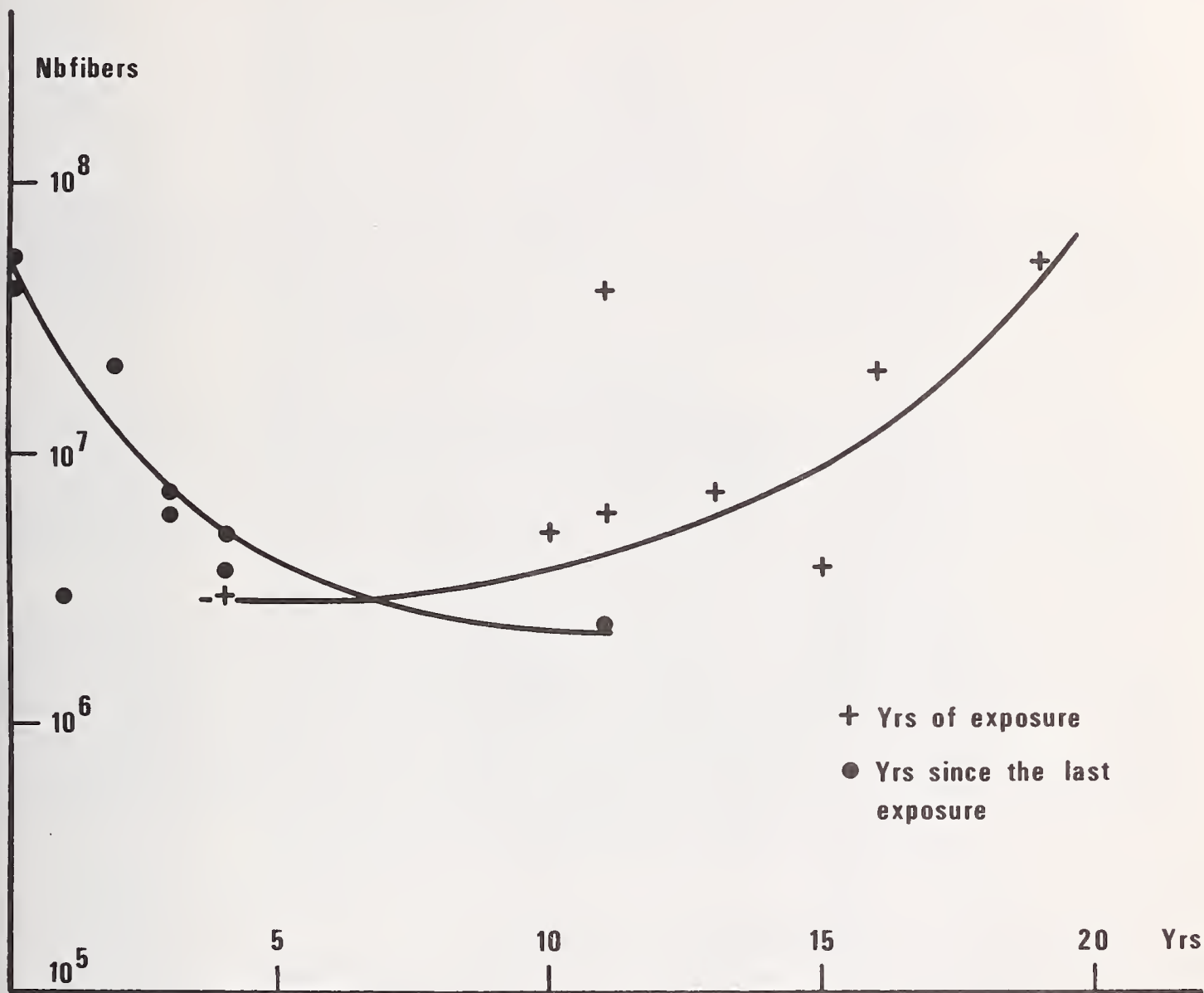

Figure 2. Relationship between fiber count in lung washing fluid and exposure patterns for cases of group 1 (definite heavily exposed people). The fiber count increases with the duration (years) of exposure; it decreases when the delay since the last exposure increases.

In this group, the fiber yield obtained by BAL and by collecting one sputum has been compared (Table 5). The numbers of coated and uncoated fibers were one or two orders of magnitude higher in LWF than in sputum. Moreover, the fibers were shorter in LWF (mean length $3 \mu\text{m}$) than in sputum ($5 \mu\text{m}$). Elsewhere, the proportion of amphibole type fibers was less in sputum.

By contrast, in groups 2 and 3, with moderate exposure, the asbestos fiber count in LWF yielded less significant results (Tables 2 and 3). In some cases, both LM and TEM analysis were negative. In others, only a few fibers were found, but at a level not allowing a significant count to be expressed.

Table 5. Comparison of asbestos fibers in sputum and lung washing fluid (LWF) from cases of Group 1 (9 cases).

	Coated fibers	Uncoated fibers	% amphibole type fibers	Mean length μm	Mean diameter μm
Sputum (one sample)	7.10^2	1.10^5	65	5	0.16
LWF (whole lavage)	3.10^4	5.10^6	88	3	0.13

In groups 2 and 3, the comparison of asbestos fibers found in sputum and LWF yielded the following results: in many cases, the numerical concentration was low or null; in other cases, one or the other sample showed some fibers. The asbestos content either in sputum or in LWF was similar, within the ranges: 0 to 10 for coated fibers and from not detectable to 5×10^5 for TEM size fibers, mostly of chrysotile type.

D. Sputum.

It has been demonstrated in this laboratory [9,11] and by others [10] that the amount of coated fibers or ferruginous bodies (FB) in the sputum was significantly related to the asbestos exposure and to the amount of FB in lung parenchyma further measured at the autopsy time [11]. This test is very simple and can be used as a retrospective proof of asbestos exposure, even in the case of long lapse time after the end of exposure. Another advantage is that the coating around the fibers is the evidence that the fibers have stayed in the lung.

The study of sputum can also be good in the case of light exposure if the TEM is used. As an example, in this laboratory the sputum has been studied from 45 people working inside buildings insulated with sprayed asbestos containing material. The TEM examination has shown the presence of TEM size asbestos fibers, only of the chrysotile type, in 13 cases (29 percent) (Table 6). The influence of duration of exposure on the presence or not of fibers in sputum has not been demonstrated. Chrysotile fibers were mostly short microfibrils (0.5 to 2 μm long) and forming clumps, probably entrapped in mucus (figure 3).

Table 6. Sputum monitoring for asbestos in 45 people working in asbestos-sprayed buildings.

TEM study	Nb	Percent	Mean duration of exposure (yrs)
Presence of Fibers	13	29	8.3
Absence of Fibers	32	71	8.1

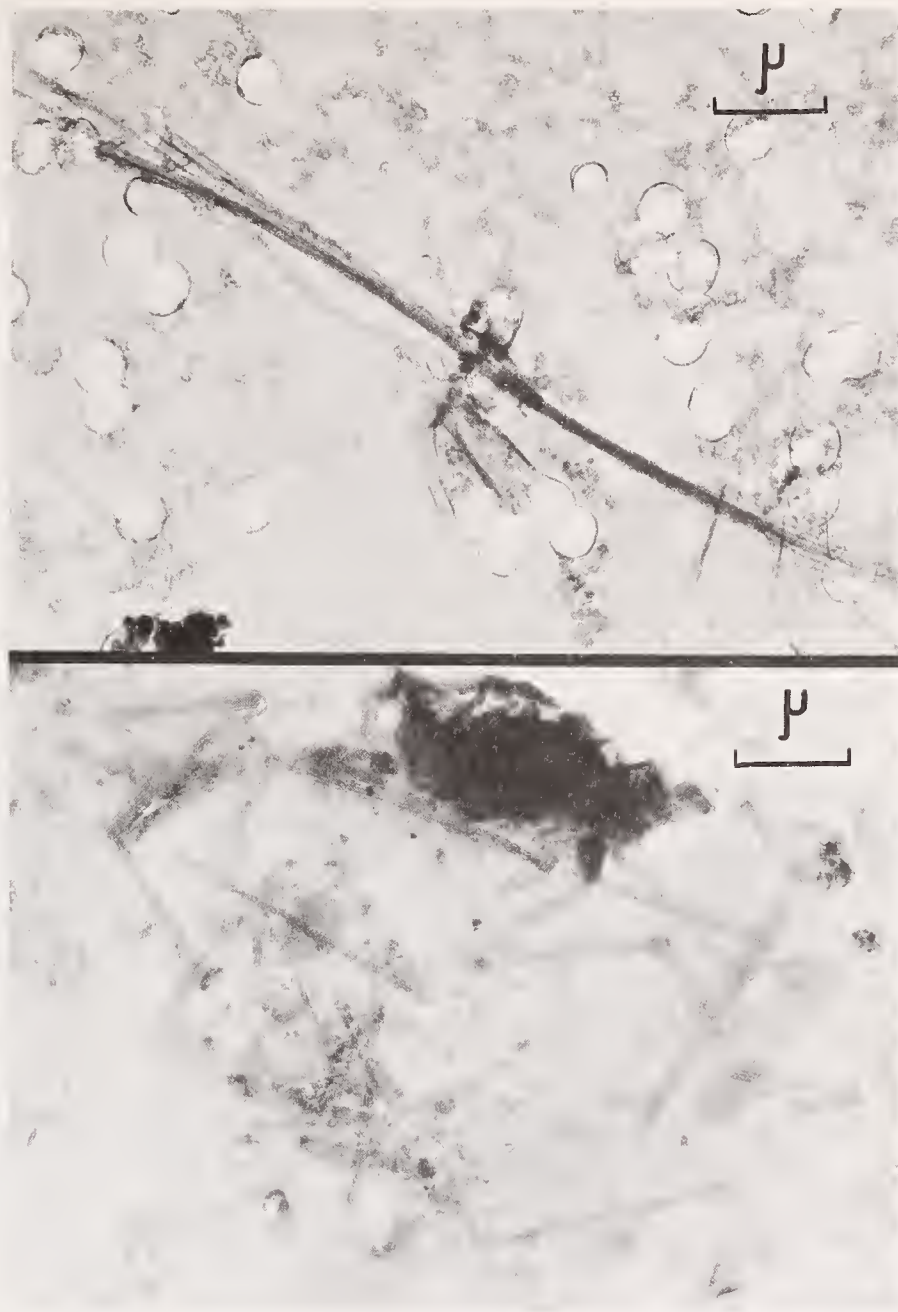

Figure 3. Electron micrographs showing chrysotile type fibers isolated from sputum in people resident inside asbestos sprayed buildings.

E. Respiratory Tissues.

1. Lung Parenchyma

Lung parenchyma samples from 27 autopsic cases diversely exposed to asbestos and with different malignancies have been studied by TEM. Four blocks of parenchyma were sampled in different sites of the same lung: central upper lobe, peripheral upper lobe, central lower lobe, and peripheral lower lobe, as described elsewhere [25]. The geometric mean of fiber count in the 4 sites has been calculated and then the cases have been classified in groups according to the asbestos lung burden (Table 7). The proportion of cases having more than 10^6 fibers/cc of lung parenchyma was 8 out of 10 for the asbestosis + respiratory cancer group, 5 out of 11 for the mesothelioma group, 0 out of 2 for the lung cancer (without associated lung fibrosis) group, and 2 out of 4 for the other malignancies group.

Table. 7. Asbestos fibers burden in lung parenchyma according to pathological features.

Pathological features	Fiber concentration in the lung, Nb cm ⁻³			Total
	<10 ⁶	10 ⁶ - 10 ⁷	≥10 ⁷	
Asbestosis ± Respiratory Cancer	2	5	3	10
Mesothelioma	6	3	2	11
Lung Cancer	2	0	0	2
Others Malignancies	2	2	0	4
Total	12	10	5	27

The mineralogical type of fibers encountered in lung parenchyma has been assessed by TEM and the results are expressed in Table 8 by the percentage of amphibole/all asbestos fibers. The parenchyma retention of amphibole type fibers has been found important in most cases, the amphibole proportion increasing with fiber concentration in all pathological groups. Moreover, whatever the fiber concentration in lung parenchyma, the highest mean proportion of amphibole type fibers was observed in the mesothelioma group.

Table 8. Mineralogical type of fibers in lung parenchyma: ratio amphiboles/(amphiboles + chrysotile) x 100.

Pathological features	Fiber concentration in the lung, Nb cm ⁻³			Average
	<10 ⁶	10 ⁶ - 10 ⁷	≥10 ⁷	
Asbestosis ± Respiratory Cancer	38	59	69	58
Mesothelioma	53	70	89	64
Lung Cancer	4			4
Others Malignancies	12	41		26

Several size parameters have been assessed: mean length, mean diameter, and proportion of fibers longer than 8 μm. The results are shown in Tables 9, 10, and 11 respectively. The main figures are: 1) the size of fibers increases when the concentration increases; 2) the mean diameter never exceeds 0.16 μm; 3) the mean percentage of fibers longer than 8 μm does not exceed 20.8 percent.

Table 9. Size of fibers in lung parenchyma: mean length (μm).

Pathological features	Fiber concentration in the lung, Nb cm^{-3}			Average
	$<10^6$	$10^6 - 10^7$	$\geq 10^7$	
Asbestosis \pm Respiratory Cancer	3.7	5.4	5.5	5.1
Mesothelioma	4.8	5.7	4.1	4.9
Lung Cancer	1			1
Others Malignancies	2.8	2.3		2.6

Table 10. Size of fibers in lung parenchyma: mean diameter (μm).

Pathological features	Fiber concentration in the lung, Nb cm^{-3}			Average
	$<10^6$	$10^6 - 10^7$	$\geq 10^7$	
Asbestosis \pm Respiratory Cancer	0.11	0.13	0.16	0.13
Mesothelioma	0.09	0.13	0.12	0.11
Lung Cancer	0.05			0.05
Others Malignancies	0.09	0.13		0.11

Table 11. Size of fibers in lung parenchyma: proportion of fibers longer than 8 μm (%).

Pathological features	Fiber concentration in the lung, Nb cm^{-3}			Average
	$<10^6$	$10^6 - 10^7$	$\geq 10^7$	
Asbestosis \pm Respiratory Cancer	11.6	20.1	20.8	18.6
Mesothelioma	13.1	20.5	11.4	15
Lung Cancer	0.7			0.7
Others Malignancies	1.6	6.3		4.1

2. Asbestos Fiber Parameters According to Sampling Sites in Respiratory Tissues: Parenchyma, Parietal Pleura, Mediastinal Lymph Nodes.

Besides lung parenchyma samples,, parietal pleura samples were available in 13 cases and mediastinal lymph node samples in 4 of these cases.

The comparison of fiber concentration in lung parenchyma and parietal pleura is indicated on figure 4. The absence of correlation between asbestos fiber content in parenchymal and pleural tissue is emphasized. It is noteworthy that in some mesothelioma cases, even with high concentration inside lung parenchyma, the fiber concentration in the parietal pleura was very low. By contrast, a correlation seemed to appear between the fiber concentration in parietal pleura and in lymph nodes (figure 5).

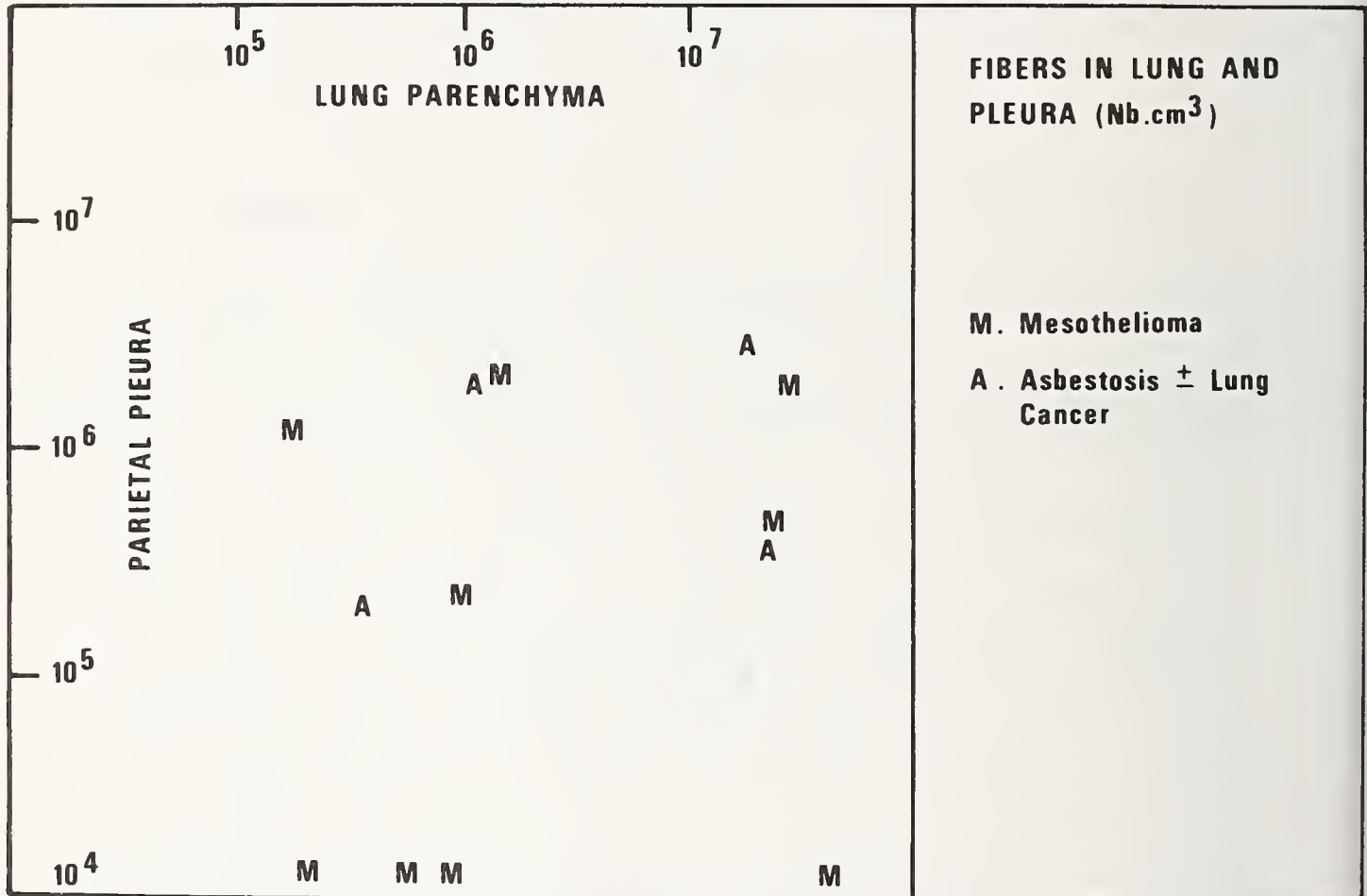

Figure 4. Correlation between asbestos fiber concentration in lung and in parietal pleura (see text for comments).

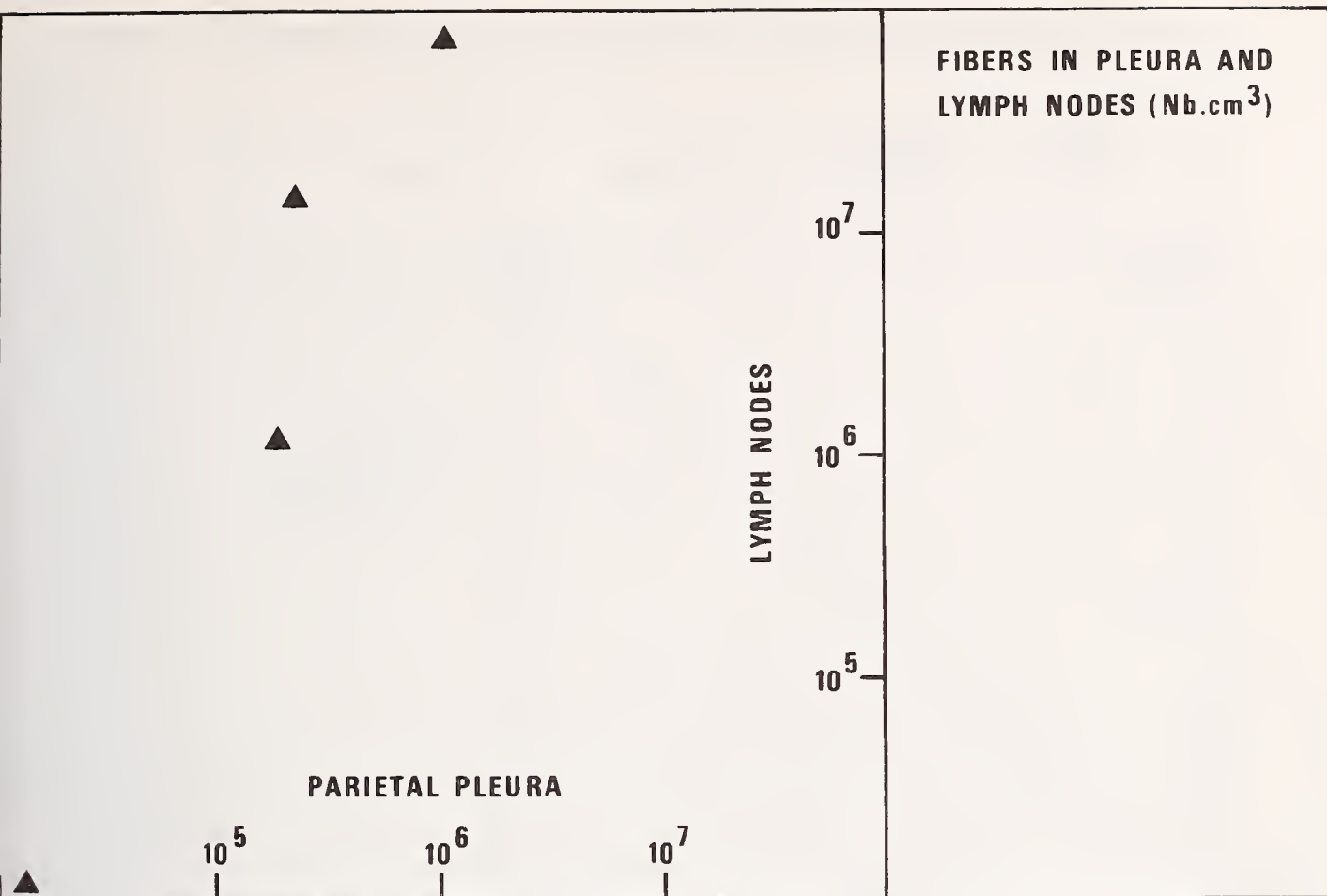

Figure 5. Correlation between asbestos fiber concentration in parietal pleura and mediastinal lymph nodes.

The comparison of mineralogical types has been carried out in the same way. The most striking features were:

a) Most of TEM fibers encountered in parietal pleura were of chrysotile type even when the proportion of amphibole/amphibole + chrysotile type fibers was higher than 0.5 in the lung parenchyma (figure 6).

b) By contrast, so far in the few cases studied, most of the fibers encountered in lymph nodes were of amphibole type (figure 6).

The fiber size has been compared in the different sampling sites (Table 12). The longest fibers were found in the lung and the thinnest in the parietal pleura. Mean fiber length was of 4.9 μm for lung parenchyma, 2.3 μm for parietal pleura, and 2.5 μm for lymph nodes.

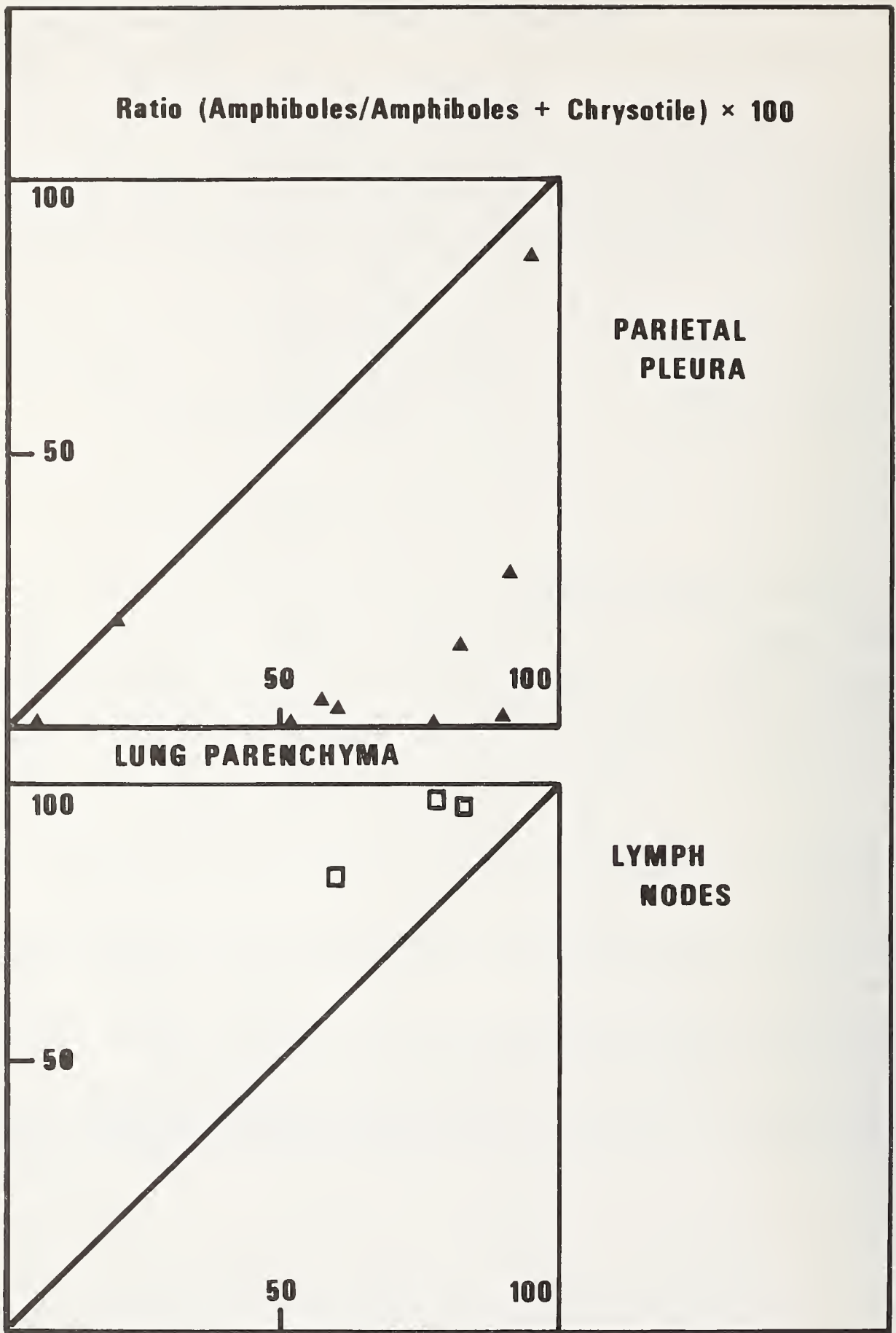

Figure 6. Ratio of amphiboles count/total asbestos fibers count in lung parenchyma compared to the ratio in parietal pleura (top) and to the ratio in lymph nodes (bottom).

Table 12. Fiber size in lung parenchyma, parietal pleura, and lymph nodes.

	Lung parenchyma	Parietal pleura	Lymph nodes
Mean Length μm	4.9	2.3	2.5
Mean Diameter μm	0.13	0.06	0.16
Proportion of Fibers Longer than 8 μm percent	15	2	3

Discussion

The contribution of this metrologic study of asbestos dusts in the human PT is relevant to three major points relating to the pathophysiology of fibrous particles:

- It allowed a check of the reliability of monitoring asbestos in sputum and lung washing fluid for the assessment of asbestos exposure.
- It provided a better understanding of the partition of fibers in the different compartments of the respiratory system, which allows hypothesis about the translocation of fibers in the PT.
- It yielded quantitative data concerning the actual fiber dimensions in humans in different diseases, including pleural mesotheliomata, which have to be discussed in view of recent experiments concerning the mesothelial response in relation to fiber dimension.

A. External Indicators of Asbestos Lung Burden.

The present work demonstrated that the study of sputum and LWF by LM and TEM was very reliable for the assessment of asbestos exposure in heavily exposed people. The advantage of LWF over sputum is that it yields a greater amount of fibers which are most representative of the alveolarly deposited fraction. This technique, which requires that the patient accept a fiberoptic bronchoscopy, might help to diagnose asbestos-related diseases. However, this possibility has some limitation. Indeed, the information provided by BAL carried out in moderately exposed people was much less reliable than the study of lung parenchyma. This can be easily understood since we will discuss later on that the percentage of intraalveolar fibers is very low compared to the fibers retained in lung parenchyma.

However, it seems that LM and TEM study of sputum is an excellent tool for detecting and following exposed people [9,11]. A cytological control of the sputum looking for AM is needed to be sure that it represents the mineral content of the deep lung. It is possible that the measurement of asbestos fibers in other biological samples could be better indicators of asbestos body-burden, as discussed elsewhere [50]. Thus the search for asbestos fibers in feces appeared to be a very sensitive method, allowing detection of low intake of asbestos fibers [12].

B. Translocation of Asbestos Fibers in the Respiratory System.

The figure 7 summarizes all the mean data concerning number, length, and diameter of fibers in four sites of the respiratory system: alveoli, LP, PP and LN. Moreover, the figure 8 gives the distribution of length fibers in these four sites.

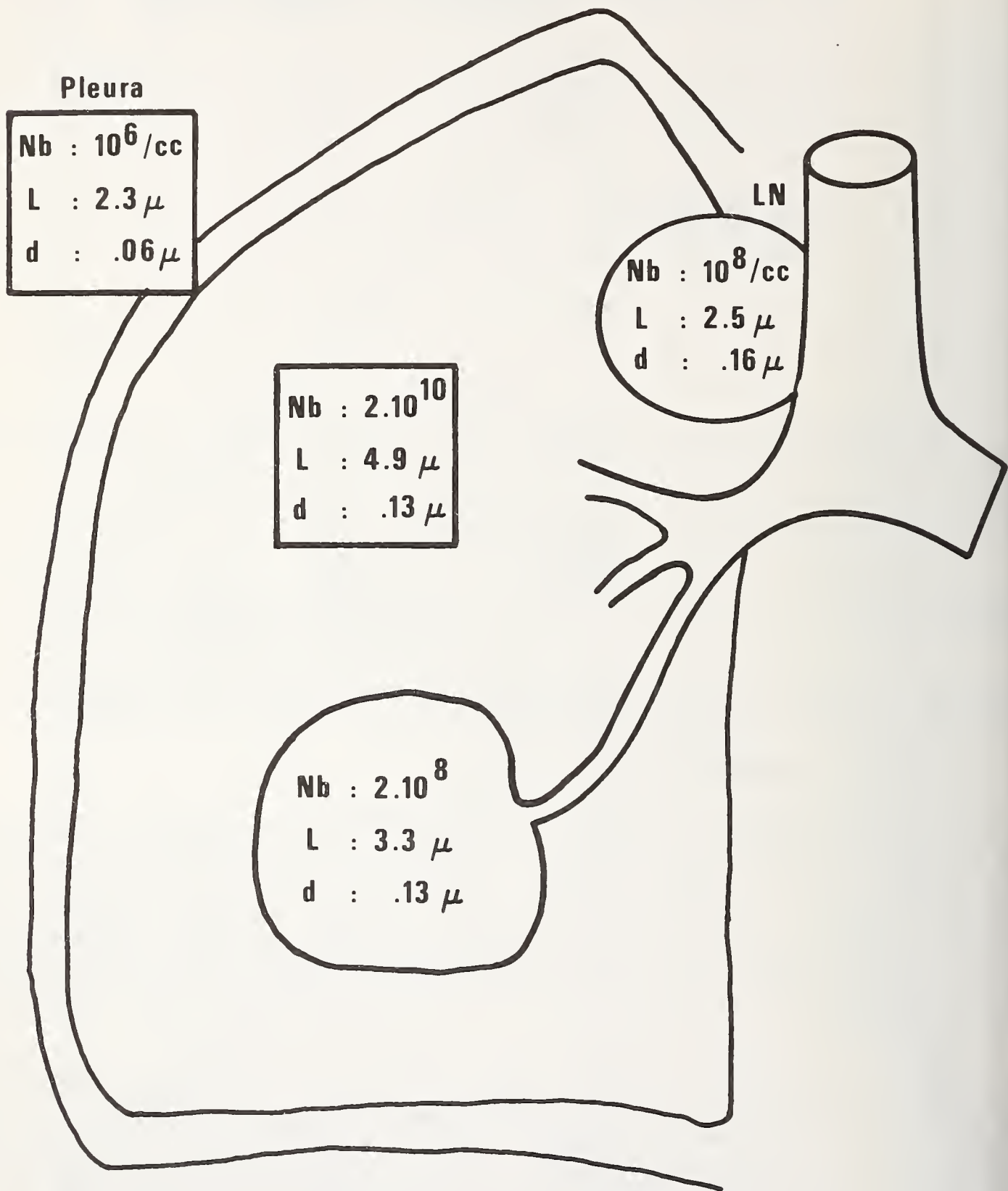

Figure 7. Diagram comparing the mean number (Nb), mean length (L) and mean diameter (d) of asbestos fibers in 4 sites of the respiratory system. Numbers have been estimated for the whole lung for parenchyma (Par) and alveoli (Alv), while they are given per cc of tissue for pleura and lymph nodes (LN).

percent

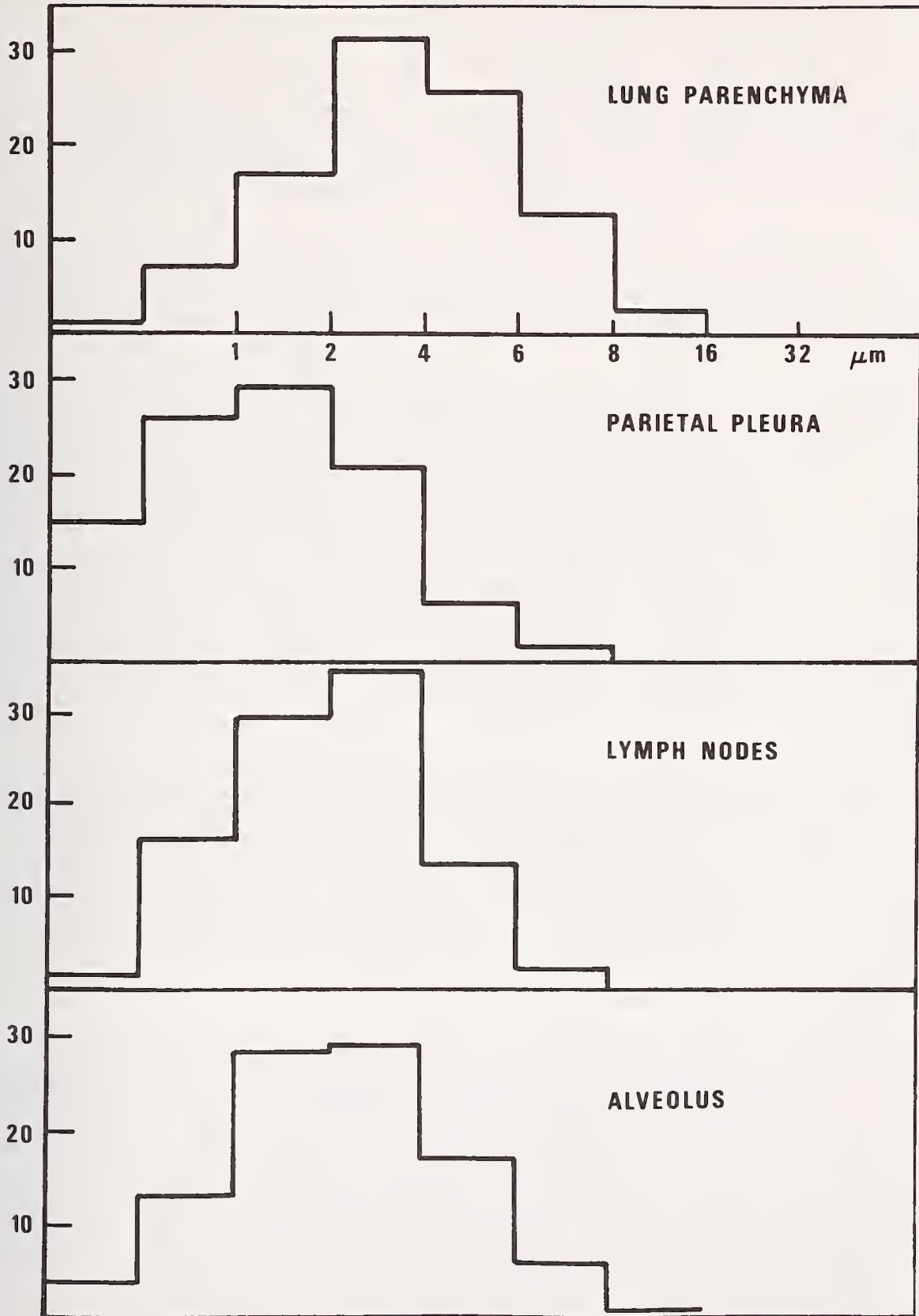

Figure 8. Distribution of fibers length in parenchyma, parietal pleura, lymph nodes and alveoli. Note that long fibers, more than 4 μm in length, are less frequent in pleura, lymph nodes and alveoli than in parenchyma.

For LP and alveoli, the fiber counts have been integrated for the whole lung distinguishing intra-alveolar fibers assessed by the BAL and intra-parenchymal fibers assessed by destroying LP. Thus, the fraction corresponding to LP totalizes fibers entrapped in the pulmonary interstitial tissue (plus fibers inside blood vessels?) and fibers within the alveolar compartment. For that estimation, the volume of total lung has been assumed to be 5000 mL and the fraction of alveolar spaces washed by the BAL to be 1/20 of the whole lung volume. Thus, the figure 7 shows that the intra-alveolar fraction of all intra-parenchymal fibers would only represent about 1 percent of all the fibers retained in lung tissue, when assumed that BAL recovered all intra-alveolarly deposited fibers.

The mineralogical type of alveolar and interstitial asbestos dusts did not differ significantly, as indicated on one hand by the electron diffraction pattern and on the other hand by the measurement of fiber diameters, identical in both sites (0.13 μm in mean diameter).

Elsewhere, it is noteworthy that the intra-alveolar fibers were significantly shorter (3.3 μm in mean length) than the interstitial fibers (4.9 μm in mean length for LP fibers). This difference must even be more important, because the mean length of interstitial fibers is probably reduced by adding the 1 percent of short alveolar fibers to the interstitial fibers when LP is studied; on the other hand, it is possible that the mean length of intra-alveolar fibers is increased by the addition of longer fibers deposited at the surface of the peripheral airways and washed out during the BAL. Indeed the mean length of fibers in sputum was found to be 5 μm (Table 5). These results clearly indicate a shorter length of fibers inside alveoli compared to pulmonary interstitial tissue. This can be related to two mechanisms, more or less associated (figure 9); either long fibers might penetrate more easily across the alveolar membrane or small fibers are more easily cleared from the interstitial tissue toward the alveolar spaces? As will be discussed, sizing of fibers in pleura and in lymph nodes brings a clue in the favor of the last hypothesis.

Indeed, in these two sites (PP and LN), the asbestos fibers were significantly shorter than in lung parenchyma (2.3 μm in PP; 2.5 μm in LN compared to 4.9 μm in LP). These findings are additional clues to the greatest translocation effectiveness of short fibers. The migration of fibers was found even more selective in this study, since most chrysotile fibers were found inside the PP, with a mean diameter of 0.06 μm , whereas mostly amphibole type fibers with a mean diameter of 0.16 μm were found in mediastinal LN. This selective migration of fibers might be mostly related to their dimension, as if only short and very thin fibers could be entrapped in the PP tissue (figure 9).

C. Fibers Dimension Related to Carcinogenicity.

The aforementioned recent animal experiments after implantation of fibers in the pleura [3,5] reinforced the idea that the carcinogenicity of fibers depends only on the dimension of fibers, whatever the chemical composition is, in such a way that the probability to induce pleural cancer reaches 100 percent when all the fibers are less than 0.25 μm in diameter and more than 8 μm in length (see Stanton et al., this meeting).

In humans, as demonstrated by this work and by others [24,26,51], all the asbestos fibers encountered in different sites of the respiratory system were found to have a diameter less than 0.25 μm . By contrast, the present study has clearly demonstrated that the mean length of fibers was always less than 8 μm in all sites (figure 7). However, a certain percentage of fibers was longer than 8 μm , especially in lung parenchyma (1 percent) (see Table 12 and figure 8). The point is to understand how such few fibers, distant from the parietal pleura, might induce the carcinogenetic transformation of mesothelial cells, or if other mechanisms specific to humans are to be considered.

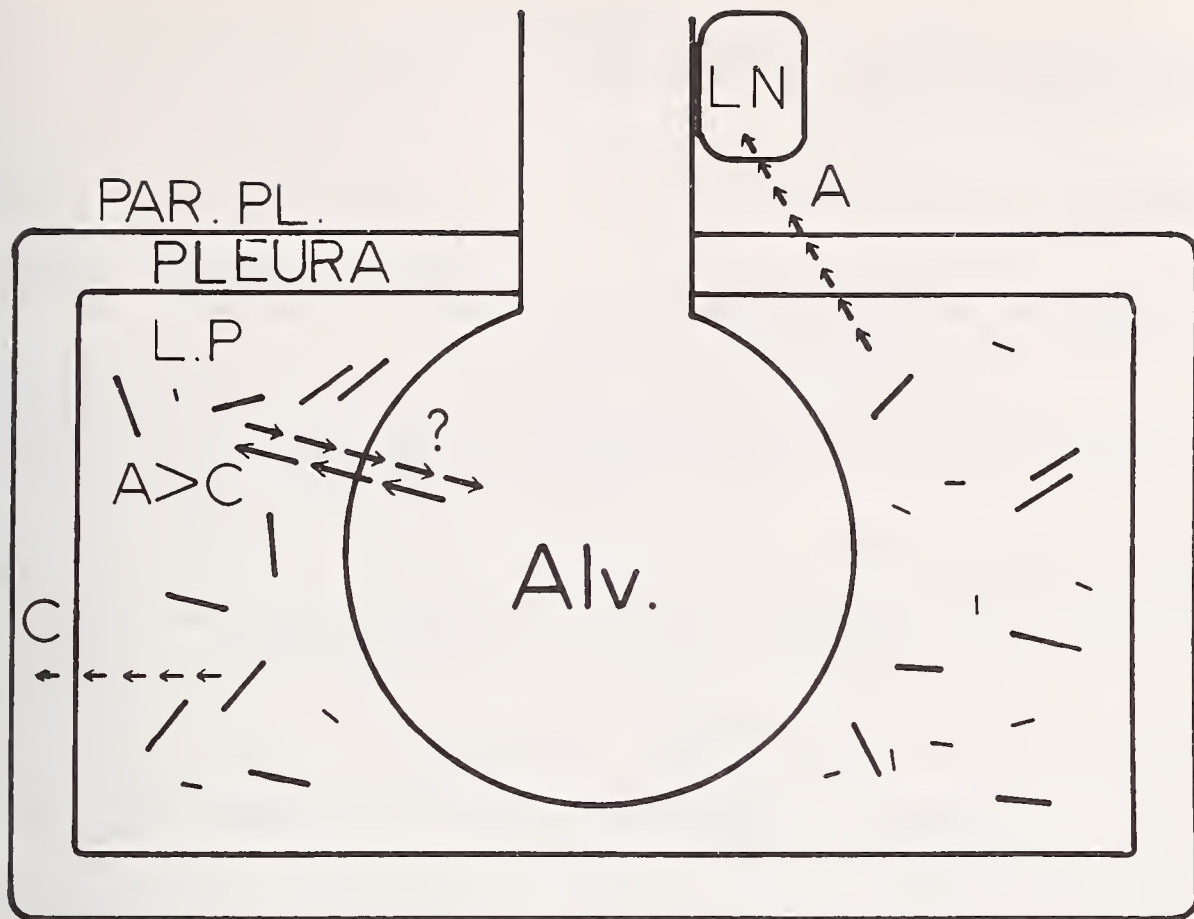

Figure 9. Diagram showing the hypothetical different selective translocation pathways of fibers in the respiratory system. The longest fibers are retained within the lung parenchyma (LP) with more amphibole-type fibers than chrysotile-type fibers ($A > C$). The shortest fibers migrate either towards the parietal pleura (Par Pl) and mostly of chrysotile-type (C), or towards the lymph nodes (LN) and mostly of amphibole-type (A). The fibers are shorter within the alveoli (Alv) than in lung parenchyma (LP); this must be due to the selective translocation of short fibers from the pulmonary interstitial tissue (?).

The microprobe analyses have been carried out in the Laboratoire de Biophysique Médicale (Pr P. Galle) in collaboration with J. P. Berry.

Part of this work has been supported by the Ministère de la Qualité de la Vie and by the Institut National de la Santé et de la Recherche Médicale.

References

- [1] IARC Monographs on the evaluation of carcinogenic risk of chemical to man, Asbestos, 14, WHO, IARC Publications (1977).
- [2] Zielhuis, R. L., Public Health risks of exposure to asbestos, European Economic Community, Directorate of Social Affairs, Health and Safety Directorate, Pergamon Press (1977).
- [3] Stanton, M. F., Layard, M., Tegeris, A., Miller, E., May, M., and Kent, E., Carcinogenicity of fibrous glass: pleural response in the rat in relation to fiber dimension, J. Natl. Cancer Inst. 58, 587-603 (1977).
- [4] Pott, F., Friedrichs, K. H., and Huth, F., Ergebnisse aus Tierversuchen zur kanzerogenen Wirkung faserförmiger Stäube und ihre Deutung im Hinblick auf die Tumorentstehung beim Menschen, Zbl. Bakt. Hyg. I Abt. Orig. B. 162, 467-505 (1976).
- [5] Meeting on the biological relevance of fiber parameters, IARC June 30-July 1, Lyon (1977).
- [6] Task group on lung dynamics, Deposition and retention models for internal dosimetry of the human respiratory tract, Health Phys. 12, 173-207 (1966).
- [7] Pontefract, R. D. and Cunningham, H. J., Penetration of asbestos through the digestive tracts of rats, Nature, 243, 352-353 (1973).
- [8] Cohen, D., Ferromagnetic contamination in the lungs and other organs of the human body, Science, 180, 745-748 (1973).
- [9] Bignon, J., Depierre, A., Bonnaud, G., Goni, J., and Brouet, G., Mise en évidence des corps ferrugineux par microfiltration de l'expectoration, Nouv. Presse Med. 2, 1697-1700 (1973).
- [10] Sluis-Cremer, G. K., Asbestosis in South Africa. Certain geographical and environmental considerations, Ann. N.Y. Acad. Sci. 132, 215-234 (1965).
- [11] Bignon, J., Sebastien, P., Jaurand, M. C., and Hem, B., Microfiltration method for quantitative study of fibrous particles in biological specimens, Environ. Health Persp. 9, 155-160 (1974).
- [12] Cunningham, H. M., Pontefract, R. D., and O'Brien, R. C., Quantitative relationship of fecal asbestos to asbestos exposure, J. Toxicol. Environ. Health, 1, 377-379 (1976).
- [13] Timbrell, V., The inhalation of fibrous dusts, Ann. N.Y. Acad. Sci. 132, 255-273 (1965).
- [14] Harris, R. L. and Fraser, D. A., A model for deposition of fibers in the human respiratory system, Am. Industr. Hyg. Assoc. J. 3, 73-89 (1976).
- [15] Mossman, B. T., Kessler, J. B., Ley, B. W., and Craighead, J. E., Interaction of crocidolite asbestos with hamster respiratory mucosa in organ culture, Lab. Invest. 36, 131-139 (1977).
- [16] Wagner, J. C., Berry, G., Skidmore, J. W., and Timbrell, V., The effect of the inhalation of asbestos in rats, Br. J. Cancer 29, 252-269 (1974).
- [17] Morgan, A., Evans, J. C., Evans, R. J., Hounam, R. F., Holmes, A., and Doyle, S. G., Studies on the deposition of inhaled fibrous material in the respiratory tract of the rat and its subsequent clearance using radioactive tracer techniques II. Deposition of the UICC standard reference samples of asbestos, Environ. Res. 10, 196-207 (1975).

- [18] Evans, J. C., Evans, R. J., Holmes, A., Hounam, R. F., Jones, D. M., Morgan, A. and Walsh, M., Studies on the deposition of inhaled fibrous material in the respiratory tract of the rat and its subsequent clearance using radioactive tracer techniques, Environ. Res. 6, 180-201 (1973).
- [19] Stumphuis, J., Epidemiology of mesothelioma on Walcheren Island, Br. J. Industr. Med. 28, 59-66 (1971).
- [20] Bignon, J., Sebastien, P., Monchaux, G. and Bonnaud, G., L'épuration à long terme des particules fibreuses chez l'homme, Colloques de l'INSERM, 29, 205-218 (1974).
- [21] Langer, A. M., Selikoff, I. J., and Sastre, A., Chrysotile asbestos in the lungs of persons in New York City, Arch. Environ. Health 22, 348-360 (1971).
- [22] Pooley, F. D., Electron microscope characteristics of inhaled chrysotile asbestos fiber, Br. J. Industr. Med. 29, 146-153 (1972).
- [23] Pooley, F. D., Methods for assessing asbestos fibers and asbestos bodies in tissue by electron microscopy. In Biological effects of asbestos, Proceedings of a Working Conference held at the IARC, Lyon, France, 2-6 October 1972. IARC Scientific Publications n° 8, pp. 50-53 (1973).
- [24] Fondimare, A. and Desbordes, J., Asbestos bodies and fibers in lung tissues, Environ. Health Persp. 9, 147-148 (1974).
- [25] Sebastien, P., Fondimare, A., Bignon, J., Monchaux, G., Desbordes, J., and Bonnaud, G., Topographic distribution of asbestos fibers in human lung in relation with occupational and non-occupational exposure. Fourth International Symposium on Inhaled Particles and Vapours of the BOHS, Edinburgh (22-26 September 1975).
- [26] Le Bouffant, L., Bruyere, S., Martin, J. C., Tichoux, G., and Normand, C., Quelques observations sur les fibres d'amiante et les formations minérales diverses rencontrées dans les poumons asbestosiques, Rev. Fr. Mal. Resp. 4, suppl. 2, 121-140 (1976).
- [27] Gross, P., Harley, R. A., Davis, J. M. G., and Cralley, L. J., Mineral fiber content of human lungs, Am. Industr. Hyg. Assoc. J. 35, 148- (1974).
- [28] Gross, P., Davis, J. M. G., Harley, R. A., and de Treville, R. T. P., Lymphatic transport of fibrous dust from the lungs, J. Occup. Med. 15, 186-189 (1973).
- [29] Pooley, F. D., Personal communication (1976).
- [30] Bignon, J. and Sebastien, P., Unpublished data.
- [31] Hourihane, D. O. B., A biopsy series of mesothelioma and attempts to identify asbestos within some of the tumors, Ann. N.Y. Acad. Sci. 132, 647-673 (1965).
- [32] Henderson, W. J., Evans, D. M. D., Davies, J. D., and Griffiths, K., Analysis of particles in stomach tumors from Japanese males, Environ. Res. 9, 240-249 (1975).
- [33] Chatel, A., Mignon, F., Sebastien, P., Hirsch, A., Bignon, J., Bader, J. P., and Chretien, J., Exploration oeso-gastrique avec recherche de fibres d'amiante d'une série de malades exposés à l'amiante, Arch. Mal. App. Dig. (in press).
- [34] Pooley, F. D., Locating fibers in the bowel wall, Environ. Health Persp. 9, 235 (1974).
- [35] Rosen, P., Savino, A., and Melamed, M., Ferruginous (asbestos) bodies and primary carcinoma of the colon, A.J.C.P. 61, 135-138 (1974).
- [36] Suzuki, Y., Interaction of asbestos with alveolar cells, Environ. Health Persp. 9, 241-252 (1974).

- [37] Roe, F. J. C., Carter, R. L., Walters, M. A., and Harington, J. S., The pathological effects of subcutaneous injections of asbestos fibers in mice: migration of fibers to submesothelial tissues and induction of mesotheliomata, Int. J. Cancer 2, 628-638 (1967).
- [38] Karacharova, V. N., Olshvang, R. A., and Kooan, F. M., On changes of certain organs after intraperitoneal administration of asbestos containing dust in experiment, Byull. Eksp. Biol. Med. 67, 117-120 (1967).
- [39] Morgan, A., Holmes, A., and Gold, C., Studies of the solubility of constituents of chrysotile asbestos in vivo using radioactive tracer techniques, Environ. Res. 4, 558-570 (1971).
- [40] Friedrichs, K. H., Hilscher, W., and Sethi, S., Staub und gewebe untersuchungen an rattennach intraperitonealer injektion von asbest, Int. Arch. Arbeits. Med. 28, 341-354 (1971).
- [41] Cunningham, H. M. and Pontrefact, R. D., Asbestos fibers in beverages, drinking water, and tissues: their passage through the intestinal wall and movement through the body, J. AOAC J6, 976-981 (1973).
- [42] Gross, P., Harley, R. A., Swinburne, L. M., Davis, J. M. G., and Green, W. B., Ingested mineral fibers, Arch. Environ. Health 29, 341-347 (1974).
- [43] Bignon, J., Masse, R., and Sebastien, P., Unpublished data.
- [44] Berry, J. P., Henoc, P., Galle, P., and Pariente, R., L'empoussiérage pulmonaire: étude par microscopie électronique, microanalyse par sonde électronique, microdiffraction d'électrons, J. Microscopie 17, 11-18 (1975).
- [45] Pooley, F. D. and Sebastien, P., Asbestos fibers from mesothelioma cases, Results of an intercomparison program (1976).
- [46] Reynolds, H. Y. and Newball, H. H., Analysis of proteins and respiratory cells obtained from humans lung by bronchial lavage, J. Lab. Clin. Med. 84, 559-573 (1974).
- [47] Daniele, R. P., Altose, M. D., and Rowlands, D. T., Immunocompetent cells from the lower respiratory tract of normal human lungs, J. Clin. Invest. 56, 986-995 (1975).
- [48] Nolibe, D., Metivier, H., Masse, R., and Lafuma, J., Therapeutic effects of pulmonary lavage, in vivo, after inhalation of insoluble radioactive particles, Fourth International Symposium on Inhaled and Vapours of the BOHS, Edinburgh, 22-26 September 1975 (in press).
- [49] Basset, F., Soler, P., Jaurand, J. C., and Bignon, J., Ultrastructural examination of broncho-alveolar lavage for diagnosis of pulmonary histiocytosis X, Thorax 32, 303-306 (1977).
- [50] Bignon, J., Sebastien, P., and Bientz, M., Review of some factors relevant to the assessment of exposure to asbestos dusts, International workshop on biological specimen collection, Luxembourg 18-22 April 1977 (in press).
- [51] Pooley, F. D., Oral communication, Meeting on the biological relevance of fiber parameters, IARC June 30-July 1, Lyon (1977).

Discussion

R. FISHER: I noticed you used the term amphibole in your tables. Since I believe these were insulation workers, you mean amosite rather than the general mineral group?

J. BIGNON: The identification of asbestos fibers has been done only by the morphology in TEM and by electron diffraction. As we did not use microanalysis to identify the different type of amphibole, and as we did not get accurate inquiries about the material used by patients, I cannot answer your question.

FISHER: But these were insulation workers, am I correct?

BIGNON: Yes. These workers sprayed a mixture of asbestos and other material; but as the material used by these workers changes from time to time, it is difficult to identify by a questionnaire the type of asbestos fibers to which the patients have been exposed.

FISHER: The type of amphibole used would be one that would be considered a commercial form of asbestos and would only be useful for that purpose if it did have the long fiber length that you showed in your tables. I am trying to distinguish between this type of amphibole and the more general, more widely occurring forms. I think that's an important point.

M. SCHNEIDERMAN: Is your question related to the fact that the type of amphibole used by the insulation workers is in some manner different from what one has in some other kinds of general exposures; is that what you're driving at?

FISHER: Exactly, yes.

SCHNEIDERMAN: Yes, I think Prof. Bignon agrees with you.

G. WRIGHT: I have one question which is becoming increasingly bothersome. In looking at old materials from autopsies, the question of whether or not the material that was used for fixing the lung contains asbestos fiber is beginning to be raised. I would ask whether the materials you used in fixing the lung had been demonstrated to be asbestos fiber-free? The other is a comment, because your study, I think, demonstrates rather well the following: the lung apparently is a concentrator of long fibers. In most occupational exposures, the ratio of fibers longer than 5 μm to those that are shorter is of the order of 20 to as much as 50 or 100 to 1. So if you find 17 percent of the residual fibers in the parenchyma are longer than 8 μm , this strongly suggests that the lung preferentially concentrates the long fibers. There is very recent evidence by Arthur Morgan, in experimental animals, of precisely what you've shown. In acute experiments lasting for several months, the animal rather rapidly clears the short fibers and retains the long ones. So it's a very nice confirmation of your observations.

BIGNON: The liquids we have used for lung fixation and processing were constantly filtered through 0.5 μm Millipore filters.

EPIDEMIOLOGIC EVIDENCE OF THE EFFECT OF TYPE OF ASBESTOS AND FIBER DIMENSIONS
ON THE PRODUCTION OF DISEASE IN MAN

W. Clark Cooper

Equitable Environmental Health, Inc.
Berkeley, California 94704

Abstract

There is epidemiologic evidence to indicate that all types of commercial asbestos, i.e., chrysotile, crocidolite, amosite, tremolite asbestos, and anthophyllite asbestos, when inhaled, can cause pulmonary fibrosis and increase the risk of lung cancer. All but anthophyllite asbestos have been associated with malignant mesothelial tumors. There is also strong evidence to support a decreasing gradient of pathogenicity as one proceeds from crocidolite to amosite to chrysotile, but this evidence does not clearly rule out the interrelated influence of fiber dimension, shape, and co-factors.

Clear-cut epidemiologic evidence related to differing fiber dimensions is scanty. Such information is critically needed. The most pressing need is to determine the pathogenicity of ultrafine fibers in the electron-microscope size range, and for fibers shorter than 5 micrometers, whether inhaled or ingested. It is suggested that there be expanded epidemiologic studies of populations which have been exposed to such fibers, without the presence of long fibers. This will probably occur where the exposures are incidental to operations other than commercial asbestos production. It is also recommended that there be systematic study of the fiber content of human lungs and other tissues, as related to causes of death.

Key Words: Asbestos; asbestosis; carcinoma; epidemiology; fine particles; mesothelioma.

When the seriousness of the problem of asbestos-related disease became generally recognized 15 to 20 years ago, it was regarded as arising solely from commercially-produced asbestos. Most evidence had been obtained from workers exposed during the mining, processing, or use of commercial chrysotile, amosite, crocidolite, anthophyllite asbestos, or tremolite asbestos, so studies logically focused on these types.

The scientific and practical importance of determining whether all these types of asbestos were equally hazardous became apparent. One of the first recommendations made by the Working Group on Asbestos and Cancer, under the auspices of the International Union against Cancer, meeting in New York City in October, 1964, was "that the importance of fiber type on the risk of developing asbestosis, carcinoma of the lung, and mesothelial and other tumors be investigated" [1]¹.

Eight years later, meeting in Lyon, the Advisory Committee on Asbestos Cancers to the International Agency for Research on Cancer [2], the successor to the subcommittee that arose out of the 1964 Working Group, answered its own question: "Are all commercial types of asbestos able to cause lung carcinoma?" as follows:

¹Figures in brackets indicate the literature references at the end of this paper.

"Yes. Since 1964 the evidence of a causal relationship has been increased by epidemiological studies showing exposure-response relations for the incidence of lung carcinomas. The production of lung carcinomas in certain animals by all types of asbestos supports this conclusion. The epidemiological evidence in man, however, shows that there are clear differences in risk, with type of fibre and nature of exposure."

With respect to mesothelioma, the Committee's report stated that,

"There is evidence that all commercial types of asbestos except anthophyllite may be responsible. Evidence for an important difference in risk in different occupations and with the type of asbestos has increased. The risk is greatest with crocidolite, less with amosite, and apparently less with chrysotile. With amosite and chrysotile there appears to be a higher risk in manufacturing than in mining and milling."

The Committee then made specific recommendations for projects assessing excess cancer risks following exposure to only one type of fiber, mentioning chrysotile, amosite, and crocidolite, with special emphasis on differences between those engaged in mining and milling and those engaged in the manufacture and use of these types of commercial asbestos.

It was further recommended that there be investigation of "talc-exposed groups in mining and manufacturing to establish any differences in morbidity or mortality which might be related to the amount and shape of the fine respirable particles."

In a related recommendation pertaining to experimental work, recognition was given to the need for more information about the role of fine particles, especially the influence of fiber size in the induction of tumors:

"These studies should be extended to include fibres other than asbestos. A subcommittee should be established to review the need for, and arrange the distribution of, standard samples of asbestos and other fibres in addition to the UICC reference samples."

Another pertinent recommendation was: "There is an urgent need for the quantitative assessment, size analysis, and characterization of particles and fibres in the lungs and other organs."

Participants in the present workshop are engaged in the continuing search for answers to the foregoing questions, and it is apparent definitive answers are not easy to obtain. There is an expanded appreciation of the ubiquity of mineral fibers with shapes resembling those of commercial asbestos, with diameters extending into a range below detectability by light microscopy, and with lengths below 5 micrometers (μm), now arbitrarily used as the lower limit for occupational standards. Decisions on pathogenicity for man are urgently needed with respect to these, the asbestiform varieties of many minerals, and for all durable fibers in the range below light microscopic detection, i.e., below 0.4 or 0.5 μm in diameter, and which are very short, i.e., less than 5 μm in length. How can epidemiologic evidence contribute to these decisions?

Epidemiologic studies cannot stand alone. They fit into a network of observations from many sources, including theoretical and observed information on the aerodynamic properties of particles, in vitro tests, studies in experimental animals, and isolated clinical observations. They are nevertheless, by definition, the final source for quantitative information in man, and ultimately must be the basis for establishing and evaluating environmental controls.

Some of the effects in man which lend themselves to quantitative study and correlation with occupational or non-occupational exposures include:

- (1) Evidence of asbestosis, such as fibrosis of the lung parenchyma, fibrosis or thickening of the pleura, calcification of the pleura, and other non-malignant reactions as demonstrated by radiography, functional tests, physical examination, or study of tissues.

- (2) Evidence of malignancy, notably carcinoma of the lung, mesothelioma of the pleura or peritoneum, or cancer of the gastro-intestinal tract, larynx, or other sites.
- (3) Evidence of past exposures, as demonstrated by fibers in various tissues, sputum, or urine.

It is generally accepted that fiber characteristics probably operate differently with respect to different pathologic effects, so that asbestosis, lung cancer, mesothelioma, and other malignancies will follow differing dose-response curves as we consider different types and dimensions of fibers. Hopefully, we can obtain useful epidemiologic evidence by considering the patterns of disease, as related to different types and dimensions of mineral fiber, in groups identified as follows:

- (1) Populations whose preponderant exposure has been to one type of asbestos or the asbestiform variety of a mineral, whether by inhalation, ingestion, or both, which can be observed for periods of at least 30 years and preferably 50 years after exposures began, and which can be compared with groups having little or no exposure to the same or related fibers;
- (2) Populations with suspect diseases, whose past exposures can be reconstructed by history, records, place of residence, or body burdens of fibrous particles, and which can be compared with a matched series having some disease unlikely to be asbestos-related. This case-study method is most useful in relatively rare diseases, such as mesothelioma.
- (3) Populations having differing concentrations, types, and sizes of mineral fibers demonstrated at autopsy, to determine whether or not the patterns of pathology and causes of death correlate with differing tissue burdens of fibers.

What evidence have we gathered to date, using the foregoing approaches?

Types of Asbestos Used Commercially

There is unequivocal evidence that chrysotile, amosite, crocidolite, tremolite asbestos, and anthophyllite asbestos can produce asbestosis and increase the risk of lung cancer. All but anthophyllite have been associated with an increased risk of mesothelioma. Grading the relative biologic activity of these several types of asbestos, in terms of the production of each type of asbestos-related disease, is more difficult. As Margaret Becklake [3] pointed out in her excellent review, it is not easy to control precisely for dosage and cofactors. Fiber diameter, length, and shape are highly interrelated with asbestos type and may be more important than chemical and crystal structure.

The consensus that crocidolite is the most hazardous commercial asbestos has been derived from a number of studies, but these do not all rule out an influence of shape and size. Emphasis on crocidolite as being particularly hazardous arose from its early association with mesothelioma in the Northwestern Cape Province of South Africa, as first described by Wagner et al. [4]. Although the relative absence of mesothelioma in the crocidolite areas of the Transvaal reported by Sluis-Cremer [5] was at first questioned because of the exclusion of black and colored miners, Webster [6] has confirmed that there is a much lower incidence of mesothelioma in the Transvaal. Timbrell [7,8] has offered as an explanation the fact that crocidolite in the Northwest Cape is of smaller diameter (therefore more respirable) and shorter (therefore more likely to avoid interception in the airways) than the crocidolite of the Transvaal. It should be emphasized that although the Transvaal fibers averaged three times as long as the Northwest Cape fibers, both samples had many fibers above 5 μm in length. Webster [6] on the basis of pathologic observations of the distribution of fibers in the lungs has questioned the foregoing explanation. He has suggested that possibly concurrent exposures to iron and manganese in the Northwest Cape may have an influence.

With respect to lung cancer, Enterline and Henderson [9] compared the experience of workers making asbestos cement pipe, where both crocidolite and chrysotile were used, with that of others exposed only to chrysotile. Those whose exposures included crocidolite had 6.1 times the expected number of deaths due to lung cancer, while those exposed only to chrysotile had 1.4 times the number expected.

Weill et al. [10] carried out comparative studies of two populations of workers, one making asbestos shingles containing chrysotile, and the other making shingles, flooring, and asbestos-cement pipe and exposed to both chrysotile and crocidolite. Those exposed to crocidolite had more small irregular opacities by x-ray, more pleural thickening, and significantly greater reduction in pulmonary function.

Despite the consensus that crocidolite is probably the most hazardous type of commercial asbestos, the evidence does not appear strong enough to support a 10-fold stricter standard for a time-weighted average, or a 60-fold stricter standard for 10-minute exposures, as applied in the United Kingdom [11].

Amosite has been positively identified as responsible for pulmonary fibrosis, lung cancer, and mesothelioma. Selikoff et al. [12] found a 10-fold excess of lung cancer, as well as 5 deaths from mesothelioma, in a population of 230 men who had been previously employed in an amosite-using plant, during the period 1960 to 1971. This has been one of the few opportunities in the United States to study workers without mixed exposures. The high rates of asbestosis, lung cancer, and mesothelioma in asbestos insulation workers have been in men with mixed exposures, to both amosite and chrysotile. The foregoing experience in an amosite-using industry is in striking contrast to that reported in the amosite mines in South Africa. Webster [6] states that of 232 confirmed cases of mesothelioma diagnosed in South Africa between 1956 and 1972, 78 had been in miners, but practically all had been exposed to Cape Blue crocidolite, with only two having had exposures only to amosite. As pointed out earlier, the fact that Transvaal amosite shared with Transvaal crocidolite the property of being thicker and longer than Northwest Cape crocidolite makes it impossible to ascribe the difference to type alone. Men exposed to crocidolite in the Transvaal also had relatively few mesotheliomas.

Chrysotile has been rated the least pathogenic type of the three major forms of commercially-produced asbestos on the basis of relatively few studies in which exposures were limited to this type. Most such studies have been in workers engaged in the mining and milling of chrysotile, in Canada, Italy, Russia, and Cyprus. A report by Braun and Truan [13] indicated that the incidence of lung cancer in chrysotile miners and millers in Quebec, while slightly elevated, was not nearly as great as had been described in asbestos workers in the United Kingdom or in U.S. insulators. These studies have been criticized for methodologic flaws, but it would now appear that they reflected a lower risk in chrysotile miners. More recent studies of Quebec miners and millers by McDonald et al. [14] show an excess of lung cancer, 5 times expected, only in the highest exposure group. Only 5 deaths from mesothelioma were found among 3,270 deaths. A more recent estimate by McDonald [15] gives the proportion of mesothelioma deaths as 8 out of 4,000 deaths. This is far less than the proportion found in U.S. insulation workers, where, for example, Selikoff found 77 of 1,092 deaths due to mesothelioma. Weiss [16] has recently studied the mortality in a group of 264 employees hired during the period 1935-1944 in a plant manufacturing chrysotile products, and who worked one year or more. The Standard Mortality Ratio (SMR) for lung cancer was only 0.93. Although the design of the overall study did not permit strict comparison with the study by Selikoff et al. [17] in an asbestos insulation material producing plant, comparison of groups with similar intervals from first exposure to end of operation indicated a significantly lower lung cancer risk in the Weiss study. These reports, combined with those of Weill et al. [10] and Enterline and Henderson [9] previously reported, suggest that chrysotile is less pathogenic than crocidolite or amosite. But, as Timbrell [8] has pointed out, the curliness of chrysotile fibers influences their deposition and transmigration, so shape and size may be more important than chemical composition per se.

The evidence on anthophyllite asbestos comes almost entirely from Finland, where this form of asbestos was commercially developed until recently, and where there have been widespread non-occupational exposures. The extraordinary incidence of pleural calcification associated with low level exposures is well-documented (Kiviluoto) [18]. Kiviluoto and Meurman [19] and Nurminen [20] have shown in studies of workers exposed to

anthophyllite asbestos that they have an increased risk of asbestosis and lung cancer, but mesotheliomas have not been reported. Meurman et al. [21] analyzed 248 deaths in 1,092 anthophyllite miners and millers. There were 21 deaths from lung cancer, where 12.6 were expected; no mesotheliomas were reported.

Studies of workers exposed to tremolite asbestos without associated exposures to other fibers are not sufficiently well documented to permit placing them in a gradient of response with other commercial types of asbestos. The same is true for actinolite asbestos.

Other Asbestiform Minerals

What is the evidence for the pathogenicity of mineral fibers other than the types of asbestos commercially exploited? It is almost non-existent because, in the absence of commercial development and occupational exposures, contacts have been incidental to other operations and have been poorly documented and usually of less magnitude. The best of such studies have been associated with commercial talc operations. The presence of tremolite asbestos, anthophyllite asbestos, and chrysotile in many talc deposits has confirmed the potential of these types to produce fibrosis, pleural plaques, and to increase the incidence of lung cancer. There are no studies to indicate that fibrous talc, in the absence of asbestos of the types mentioned, can produce disease in man, but one would predict that such fibers in the right size ranges would be pathogenic. Non-fibrous talc is apparently hazardous only if there is concurrent silica exposure. Rubino et al. [22] reported on the mortality pattern in 1,346 talc miners and 438 talc millers, in which there were 931 deaths. Although there was an increased incidence of silicosis and silico-tuberculosis, they reported no excess in cancer. They did not indicate any fibrous talc being present.

A promising source of information on a non-commercial asbestiform variety of mineral has been the population of the Homestake gold mine in South Dakota, where there have been exposures to amphibole fibers, described as predominantly in the grunerite series similar to those found in the Mesabi range of Minnesota, extending back for over 100 years. Unfortunately, results to date are far from conclusive, despite a published mortality analysis by Gillam et al. [23] and an environmental report by Dement et al. [24]. Gillam et al. reported a statistically significant excess of lung cancer deaths (10 contrasted with 2.7 expected) in 440 gold miners identified by the Public Health Service in a 1960 silicosis study. However, a more recent report by McDonald et al. (1977) covering deaths between 1937 and 1973 in 1,321 employees of the same mine who were members of the Homestake Veterans Club, and had worked 21 years or more, showed no excess lung cancer deaths. There were 660 deaths for analysis. There was an excess of deaths from pneumoconiosis and pulmonary tuberculosis. This, and the excess of non-malignant respiratory disease deaths reported by Gillam et al. is not surprising, since 39 percent quartz had been demonstrated in settled dust. Records kept by the mines since 1937 showed dust concentrations ranging from 11 to 25.5 million particles per cubic foot (mppcf) before 1952, greatly exceeding standards for free silica. The miners who died of non-malignant respiratory disease had begun work as early as 1916. Even if an excess of lung cancer were proven in the Homestake mine, attributing it to low concentrations of mineral fibers would not be justified without careful consideration of what is known of smoking histories and concurrent exposures to arsenic and radon daughters. Asbestiform minerals almost certainly cannot be held responsible for the excess deaths from non-malignant respiratory disease, in view of quartz exposures and death certificates which in most cases had diagnoses of silicosis. It is absurd to attribute fatal pneumoconiosis in such a situation to grunerite fibers at levels approximating one-tenth the current standard for asbestos.

Swent [25] has critically reviewed the Gillam study and documented ventilation back to 1916 and dust counts to 1937 which show that the assumption that past exposures to silica, arsenic, radon daughters, and fibers were the same as those found in a 1972 survey is untenable.

As matters now stand, the Homestake study cannot be regarded as supporting the pathogenicity of grunerite fibers. One awaits the results of new studies being supported

by NIOSH, which may establish the mortality patterns with more certainty and hopefully will permit more accurate estimates of past exposures.

Influence of Fiber Dimensions

Throughout consideration of types of asbestos, it is apparent that type cannot be separated from shape and size. This is true even when exposures are characterized solely on the basis of fibers in the light microscopic range (i.e., with diameters greater than 0.4-0.5 μm) and those greater than 5 μm in length. It has been demonstrated in recent years, however, that neither in standard reference samples of commercial asbestos (Langer) [26], nor in air and water samples, nor in lung tissue, are fibers mainly in the light microscopic size range. Furthermore, as Pooley [27] has shown, even chrysotile miners and millers contain large numbers of amphibole fibers, most of them in the microfiber range, in their lung tissues, so their exposures are mixed.

When we turn to consideration of epidemiologic evidence on fiber dimensions, either within a given species of commercially used asbestos, or in the asbestiform varieties of minerals not used commercially, there is relatively little to report. There is suggestive but not conclusive evidence from South Africa [7] that relatively short and fine fibers are more likely to produce mesotheliomas than longer and thicker fibers, but these are within the range of light microscopy and longer than 5 micrometers. There are no conclusive studies in man to support the strong evidence from animal studies that very short fibers (under 5 μm) are non-pathogenic.

In considering the influence of fiber size, the question of the ultrafine fiber must be separated from the question of the very short fiber.

The ultrafine fiber is defined as one below the level of resolution by the light microscope, i.e., less than about 0.4 μm in diameter, down to the size of the smallest chrysotile fibril, of the order of 0.025 μm or 250 Angstrom units. Evaluation of such ultrafine fibers is of great importance because:

- 1) diameter has a strong inverse relationship to falling speed, so such fibers remain airborne for long periods and are highly respirable, although their capture and retention will vary not only with diameter, but also with length;
- 2) they are found in large numbers in lung tissues, both in individuals occupationally exposed and those without such exposures, but seldom to the exclusion of large fibers [28];
- 3) they have been found to be widespread in community air [29] and in association with the quarrying and use of serpentinite rock [30];
- 4) they are not included in fibers counted by the methods currently recommended for monitoring work environments, and are not covered by current standards;
- 5) data are not being systematically collected on the numbers of ultrafine fibers in the air nor how their concentrations relate to the concentrations of larger fibers found in various occupational and environmental situations.

There are no epidemiologic studies in which ultrafine fibers are an isolated variable. All studies of populations exposed to commercial asbestos have involved heavy exposures within the light microscope range, i.e., to fibers larger than 0.5 μm in diameter, so the contribution of ultrafine fibers cannot be determined. On the evidence from studies in animals, it is likely that such fibers, when longer than 5 or 10 μm , would be pathogenic.

The problem of the very short fiber is more critical:

- 1) studies in animals strongly suggest a decreasing gradient of fibrogenic risk and carcinogenic potential (at least for mesothelioma) for fibers shorter than 5 to 10 micrometers;
- 2) samples of naturally occurring chrysotile, amosite, and crocidolite have been shown to contain a majority of fibers shorter than 5 μm in length [28];
- 3) lung tissue contains a high proportion of short fibers;
- 4) samples of ambient air in many areas, such as those collected near taconite mining operations in Minnesota, and associated with crushed rock in Montgomery County, Maryland, are predominantly short fibers [30];
- 5) since current monitoring methods for the occupational environment exclude fibers shorter than 5 μm , data are not being systematically collected.

The biologic activity of short fibers in man is not known. By analogy with studies in animals one would not expect fibers shorter than 5 μm or 10 μm in length to produce asbestosis or mesothelioma. The only epidemiologic study in which fibrosis and excess lung cancer has been attributed to exposures which were predominantly too short, ultrafine fibers is that of Gillam et al. [23] in the Homestake mine. Here 94 percent of fibers were less than 5 μm in length, the median diameter was 0.13 μm , and the median length was 1.1 μm . For reasons pointed out earlier, these exposures, which were described as consisting largely of grunerite with some fibrous cummingtonite and hornblende, are inconclusive. Neither the actual mortality experience nor the past exposures are well enough defined to be used as scientific evidence.

The case report by Miller et al. [31] in which a 63-year old man who died with extensive interstitial pulmonary fibrosis was found to have had large numbers of ultrafine, short fibers in his lungs cannot in itself establish a causal relationship, nor does it indicate how often such an association might occur. It is analogous to an earlier report by Miller et al. [32] who made a somewhat similar finding in a man who had been exposed for many years to talc in a rubber products plant and whose lungs showed enormous numbers of submicroscopic talc particles (non-fibrous). Both reports suggest that overwhelming concentrations of a reactive dust may in some individuals produce generalized interstitial fibrosis. It does not tell us how often such might occur, nor provide any information on relationships with malignancy.

The essentially negative evidence as to health effects from the airborne fibers associated with taconite mining operations in Minnesota, and the negative evidence from Duluth (Masson et al.) [33] with respect to the ingestion of ultrafine, short fibers in Lake Superior water are reassuring, but it is too soon to rule out effects with long latent periods, i. e., 25 years or more.

In summary, no populations whose exposures have been confined to ultrafine fibers, short fibers, or fibers which are both ultrafine and short, have been defined or studied long enough to permit epidemiologic evaluation.

There have been several studies in recent years in which the concentrations of fibers in lung tissue have been quantitated and described, with some attempt at correlation with pathologic changes. That of Ashcroft and Hepplestone (1973) [34] was limited to 35 individuals with asbestos bodies detected in histological sections, and all but one had definite or probable histories of occupational exposure. The authors found that from 12 to 30 percent of the fibers were optically visible, the rest being detectable only by electron microscopy. (They did not describe fiber lengths.) There was a general correlation between fiber concentration and asbestosis, up to the level of moderate asbestosis. Another study, by Doniach et al. [35], was limited to optically visible asbestos bodies in a London necropsy series. The study by Pooley [27] of the lungs of

individuals with asbestosis who had been employed in the chrysotile mining industry in Canada, and in 30 individuals who died with mesothelioma, provided valuable information on the relative proportions of chrysotile and amphibole fibers and on the large numbers of EM-sized fiber present, but no detailed data on lengths and diameters of fibers were presented. Its most interesting feature was the large number of amphibole fibers that were found in chrysotile miners. In short, we know of no large series of cases in which the numbers and sizes of fibers in tissues have been correlated with causes of death.

Studies Which Are Needed

How can the necessary epidemiologic evidence be obtained? It can be accepted without reemphasis that injection and inhalation studies in animals, testing various types of asbestos and asbestiform varieties of other minerals in appropriate size ranges, must be done. It is not likely that further study of individuals who mine, mill, process, or use commercial asbestos will do more than tune more finely what we already know. Even though this is desirable and necessary, it is not likely to answer questions about very fine or very short fibers, since the nature of commercial asbestos is such that long fibers are always present. Only if dust control measures preferentially increase very greatly the proportion of short fibers in the electron microscope range would studies in commercial asbestos operations provide useful information regarding fiber size.

We must turn to other populations, where exposures have been incidental to non-asbestos industrial operations but which liberate or disperse asbestiform varieties of minerals in the electron microscope range below 5 μm in length. The Homestake mine has had this type of population, but here a positive finding would lead to a need to consider several confounding variables. On the other hand, an absence of serious risk would be highly reassuring, if past exposures were found to have been high. Other populations which might be studied are those in association with taconite mining and milling operations, where, in some areas, the airborne mineral fibers are predominantly less than 3 μm in length and do not represent any form of commercial asbestos.

There are many sections of the United States where chrysotile and amphibole fibers are present in the natural rock and have been present in air or drinking water for long periods of time. Careful search should be made for areas which might permit comparisons of malignancy patterns as related to such exposures. The work of Fears (1976) [36], who found no excess of cancer in U.S. counties with known asbestos deposits, needs to be refined to concentrate on census tracts contiguous to operations which actually increase fiber concentrations in the air or water.

A second approach which should be expanded is the large scale study of the fiber content of human lungs and other tissues, with determination of fiber concentrations and fiber dimensions, for comparison with causes of death. This has been periodically suggested but never actively pursued. Stanton (1974) [37] stated,

"There is perhaps one way to determine the hazards of fibers without waiting the many years necessary for the effects of even massive exposure to become evident. Unlike most carcinogens, fibers that are a threat are sufficiently durable to remain in the tissues from which cancers are derived. Since carcinogenic response can be related to doses of sized fibers in experimental animals, it may be possible to equate the number and size distribution of fibers in human tissues to cancer in man. Although much has been accomplished in assessing large, protein-coated fibers in human lungs, surprisingly little has been done in assessing the size distribution and total quantity of all fibers in human tissues. This would be a tedious job, but it might determine the true significance of fibers as carcinogens in man."

It is believed that the design and organization of such a major study is long overdue. Without the information it might provide, environmental decisions involving ultrafine and ultrashort asbestos fibers or the asbestiform varieties of other minerals will continue on a very uncertain and often emotional basis. When one considers the tremendous outlays involved in containing or capturing such fibers in mining and quarrying operations, as well as in asbestos-using industries and in waste disposal, the cost of such studies would

appear a prudent investment. As Rohl, Langer, and Selikoff observed in their recent report [30] providing data on fibers found near Montgomery County roads where serpentinite rock had been used,

"The evaluation of the possible health hazard that may be associated with this exposure requires information that is not yet known in the scientific community: (i) the biological activity of short chrysotile fiber, (ii) the level of exposure to asbestos which is safe insofar as human cancers are concerned, if a safe level exists, and (iii) the biological activity of asbestiform silicates, not necessarily asbestos."

The same comment applies to numerous other environmental situations currently under scrutiny. We do not know what fiber concentrations expressed in nanograms per cubic meter or in total fibers per unit volume, when detected by electron microscopy, mean in terms of human health. Unfortunately, epidemiology does not yet provide the answers.

Summary and Conclusion

There is epidemiologic evidence to indicate that all types of commercial asbestos, i.e., chrysotile, crocidolite, amosite, tremolite asbestos, and anthophyllite asbestos, when inhaled, can cause pulmonary fibrosis and increase the risk of lung cancer. All but anthophyllite asbestos have been associated with malignant mesothelial tumors. There is also strong evidence to support a decreasing gradient of pathogenicity as one proceeds from crocidolite to amosite to chrysotile, but this evidence does not clearly rule out the interrelated influence of fiber dimension, shape, and co-factors.

Clear-cut epidemiologic evidence related to differing fiber dimensions is scanty. Such information is critically needed. The most pressing need is to determine the pathogenicity of ultrafine fibers in the electron-microscope size range, and for fibers shorter than 5 micrometers, whether inhaled or ingested. It is suggested that there be expanded epidemiologic studies of populations which have been exposed to such fibers, without the presence of long fibers. This will probably occur where the exposures are incidental to operations other than commercial asbestos production. It is also recommended that there be systematic study of the fiber content of human lungs and other tissues, as related to causes of death.

References

- [1] Report and Recommendations of the Working Group on Asbestos and Cancer, Ann. N. Y. Acad. Sci., 132, 706-721 (1965).
- [2] Report of the Advisory Committee on Asbestos Cancers to the Director of the International Agency for Research on Cancer, in Biological Effects of Asbestos, Proceedings of a Working Conference, Lyon, 1972, P. Bogovski, V. Timbrell, J. C. Gilson, and J. C. Wagner, eds., IARC Scientific Publications No. 8 Lyon, pp. 341-346 (International Agency for Research on Cancer, 1973).
- [3] Becklake, M. R., Asbestos-related diseases of the lung and other organs: their epidemiology and implications for clinical practice, Amer. Rev. Resp. Dis., 114, 187-227 (1976).
- [4] Wagner, J. C., Sleggs, C. A., and Marchand, P., Diffuse pleural mesothelioma and asbestos exposure in North Western Cape Province, Brit. J. Ind. Med., 17, 260-271 (1960).
- [5] Sluis-Cremer, G. K., Asbestosis in South African asbestos miners, Environ. Res., 3, 310-319 (1970).
- [6] Webster, I., Malignancy in relation to crocidolite and amosite, in Biological Effects of Asbestos, Proceedings of a Working Conference, Lyon, 1972, P. Bogovski, V. Timbrell, J. C. Gilson, and J. C. Wagner, eds., IARC Scientific Publications No. 8, Lyon, pp. 195-198 (International Agency for Research on Cancer, 1973).

- [7] Timbrell, V., Griffiths, D. M., and Pooley, F. D., Possible biological importance of fiber diameters of South African amphiboles, Nature, 232, 55-56 (1971).
- [8] Timbrell, V., Physical factors as etiological mechanisms, in Biological Effects of Asbestos, Proceedings of a Working Conference, Lyon, 1972, P. Bogovski, V. Timbrell, J. C. Gilson, and J. C. Wagner, eds., IARC Scientific Publications No. 8, Lyon, pp. 295-303 (International Agency for Research on Cancer, 1973).
- [9] Enterline, P. E. and Henderson, V., Type of asbestos and respiratory cancer in the asbestos industry, Arch. Environ. Health, 27, 312-317 (1973).
- [10] Weill, H., Ziskind, M. M., Waggenspack, C., and Rossiter, C. E., Lung function consequences of dust exposure in asbestos cement manufacturing plants, Arch. Environ. Health, 30, 88-97 (1975).
- [11] Guidance Note from the Health and Safety Executive: Asbestos-hygiene standards and measurement of airborne dust concentrations, Environ. Hygiene/10 (London, HM Factory Inspectorate, December 1976).
- [12] Selikoff, I. R., Hammond, E. C., and Churg, J., Carcinogenicity of amosite asbestos, Arch. Environ. Health, 25, 183-186 (1972).
- [13] Braun, D. C. and Truan, T. D., An epidemiological study of lung cancer in asbestos miners, Arch. Ind. Health, 17, 634-653 (1958).
- [14] McDonald, J. C., Becklake, M. R., Gibbs, G. W., McDonald, A. D., and Rossiter, C. E., The health of chrysotile asbestos mine and mill workers of Quebec, Arch. Environ. Health, 28, 61-68 (1974).
- [15] McDonald, A. D. and McDonald, J. C., Etudes epidemiologiques sur les maladies dues a l'amianté au Canada, Rev. Fr. Mal Resp., 4 (suppl 2), 25-38 (1976).
- [16] Weiss, W., Mortality of a cohort exposed to chrysotile asbestos in a manufacturing plant (in manuscript, 1977).
- [17] Selikoff, I. J., Hammond, E. C., and Seidman, H., Cancer risk of insulation workers in the United States, in Biological Effects of Asbestos, Proceedings of a Working Conference, Lyon, 1972, P. Bogovski, V. Timbrell, J. C. Gilson, and J. C. Wagner, eds., IARC Scientific Publications No. 8, Lyon, pp. 209-216 (International Agency for Research on Cancer, 1973).
- [18] Kiviluoto, R., Pleural calcification as a roentgenologic sign of non-occupational endemic anthophyllite-asbestosis, Acta Radiol. Suppl., 194, pp. 1-67 (1960).
- [19] Kiviluoto, R. and Meurman, L., Results of asbestos exposure in Finland, in, Pneumoconiosis: Proceedings of the International Conference, Johannesburg, 1969, H. A. Shapiro, ed., (Cape Town, Oxford University Press, 1970).
- [20] Nurminen, M., The epidemiologic relationship between pleural mesothelioma and asbestos exposure, Scand. J. Work Environ. Health, 1, 128-137 (1975).
- [21] Meruman. L. O., Kiviluoto, R., and Hakama, M., Mortality and morbidity among the working population of anthophyllite asbestos miners in Finland, Brit. J. Ind. Med., 31, 105-112 (1974).
- [22] Rubino, G. F., Scansetti, G., Piolatto, G., and Romano, C. A., Mortality study of talc miners and millers, J. Occup. Med., 18, 186-193 (1976).
- [23] Gillam, J. C., Dement, J. M., Lemen, R. A., Wagoner, J. K., Archer, V. E., and Blejer, H. P., Mortality patterns among hard rock gold miners exposed to asbestiform mineral, Ann. N. Y. Acad. Sci., 271, 336-344 (1976).

- [24] Dement, J. M., Zumwalde, R. D., and Wallingford, J. M., Discussion paper: Asbestos fiber exposures in a hard rock gold mine, Ann. N. Y. Acad. Sci., 271, 345-353 (1976).
- [25] Swent, L. W., Herrin, G. R., Waterland, J. K., and Bell, R. F., Mortality patterns among hard rock gold miners exposed to an asbestiform mineral - a critique. Presented at American Industrial Hygiene Conference, New Orleans, LA, May 26, 1977.
- [26] Langer, A. M., Mackler, A. D., and Pooley, F. D., Electron microscopical investigation of asbestos fibers, Environ. Health Perspectives, 9, 63-80 (1974).
- [27] Pooley, F. D., An examination of the fibrous mineral content of asbestos lung tissue from the Canadian chrysotile mining industry, Environ. Res., 12, 281-298 (1976).
- [28] Langer, A. M. and Selikoff, I. J., Chrysotile asbestos in lungs of residents of New York City, International Union of Air Pollution Prevention Association's Second International Clean Air Congress, Washington, D.C., December 6-11, 1970.
- [29] Nicholson, W. J. and Pundsack, F. L., Asbestos in the environment, in Biological Effects of Asbestos, Proceedings of a Working Conference, Lyon, 1972, P. Bogovski, V. Timbrell, J. C. Gilson, and J. C. Wagner, eds., IARC Scientific Publications No. 8, Lyon, pp. 126-130 (International Agency for Research on Cancer, 1973).
- [30] Rohl, A. N., Langer, A. M., and Selikoff, I. J., Environmental asbestos pollution related to use of quarried serpentine rock, Science, 196, 1319-1322 (1977).
- [31] Miller, A., Langer, A. M., Teirstein, A. S., and Selikoff, I. J., "Nonspecific" interstitial pulmonary fibrosis: association with asbestos fibers detected by electron microscopy, N. Engl. J. Med., 292, 91-93 (1975).
- [32] Miller, A., Teirstein, A. S., Bader, M. E., Bader, R. A., and Selikoff, I. J., Talc pneumoconiosis: Significance of sublight microscopic mineral particles, Am. J. Med., 50, 395-402 (1971).
- [33] Masson, T. S., McKay, F. W., and Miller, R. W., Asbestos-like fibers in Duluth water supply. Relation to cancer mortality, J. Amer. Med. Assn., 228, 1019-1020 (1974).
- [34] Ashcroft, T. and Heppleston, A. G., Asbestos fibre concentration in relation to pulmonary reaction, in, Biological Effects of Asbestos, Proceedings of a Working Conference, Lyon, 1972, P. Bogovski, V. Timbrell, J. C. Gilson, and J. C. Wagner, eds., IARC Scientific Publications No 8, Lyon, pp. 236 (International Agency for Research on Cancer, 1973).
- [35] Doniach, I., Swettenham, K. V., and Hathorn, M. K. S., Prevalence of asbestos bodies in a necropsy series in East London: Association with disease, occupation, and domiciliary address, Brit. J. Ind. Med., 32, 16-30 (1975).
- [36] Fears, T. R., Cancer mortality and asbestos deposits, Amer. J. Epidemiol., 104, 523-526 (1976).
- [37] Stanton, M. F., Fiber carcinogenesis: Is asbestos the only hazard? Editorial, J. Nat. Cancer Inst., March 1974, 633-634.

DISCUSSION

J. DEMENT: I'd like to make several observations dealing with a couple of points. First of all, Dr. Cooper pointed out that the Homestake mine study dealt with exposure to very short fiber lengths, and that's certainly true. However, you failed to point out that in most industrial settings, as high as 99 percent of the fibers, of chrysotile especially, are shorter than five μm in length with very typical lognormal distributions which follow closely to the Homestake study. Secondly, a couple of comments with respect to the Homestake study. In its publication, NIOSH did in fact recognize the possible contributory effects of free silicate exposures for non-malignant respiratory disease. Our study ascribed the cancers predominantly to fibrous grunerite exposures. With regard to the McDonald study, I'd also like to make a couple of comments. First of all, it was a group from a Veterans Association with 21 years minimum employment at Homestake, but not necessarily underground mining. The copy of the Homestake paper, which I have been given, does not indicate whether or not they were miners or surface workers. Homestake operates several above-ground facilities. One must question whether or not 21 years requirement isn't a selective population, especially with regard to the data we saw from Dr. Nicholson today where he indicated that even one month carries with it an excess risk. Thirdly, we at NIOSH of course do realize the importance of the study as evidenced by our increase in the scope of the study, mainly to get a larger cohort to study. I would like to express a bit of gratitude for your pointing out that lack of evidence should not be taken as lack of effect.

W. COOPER: With respect to the proportion of individuals underground, I can't answer that question. I think that the criticism of limiting it to individuals who had worked for 21 years or more is not a valid criticism. Actually, these were not retired miners, and even a study of retired miners is not necessarily a bad study; Enterline has developed the arguments pro and con very well. The fact that members of this club had been there for 21 years is not very different from the basis that Selikoff and Hammond used in selecting their population of insulating workers, which was limited to those who had their initial exposures, or rather had been insulators, 20 years or more. The same processes of selection which keep an insulating worker working for 20 years keep a miner working 21 years; I do not think that this is a valid criticism. As to whether or not the paper ascribes the non-malignant respiratory disease to asbestos or to silica, I think it is unmistakable. The paper, as I recall, does not use the word "silicosis," except in describing the population as having come from a Public Health Service study of silicosis. I will read from the conclusion: "The observed excess of malignant respiratory disease can therefore be attributed to asbestos, singly or in combination with cigarette smoke, and that of non-malignant respiratory disease can therefore be ascribed to asbestos with a possible additive role from low exposures to free silica dust." That's a direct quotation from the report, so I think the implication is that the non-malignant respiratory disease is asbestosis.

PATHOPHYSIOLOGY IN RELATION TO THE CHEMICAL AND PHYSICAL PROPERTIES OF FIBERS

Paul Kotin

Johns-Manville Corporation
Denver, Colorado 80217

Abstract

The array of asbestos-related diseases are reviewed in relation to their pathogenesis, pathology, and natural history. Biological availability following host entry is especially critical for the biological effect of asbestos. Experimental data consistently demonstrate that hazard is related to the geometry of fibers, with fiber diameter and fiber length being primary determinants. Controversy exists as to the extent of influence of the two major classes of asbestos fiber: chrysotile and amphibole. Considerations affecting the anatomic and metabolic fate of asbestos fibers are also discussed.

Key Words: Asbestosis; fibers; lung cancer; mesotheliomas, pathophysiology; toxicology.

Any postulated role for exogenous agents in the etiology (cause) and pathogenesis (development) of tissue change or clinical disease is critically dependent on the biological availability of the agent. Biological availability is defined here as, "possessing chemical, physical, and steric properties that allow reaction with receptor sites in the living system at the host, organ, tissue, cell, and macromolecule levels." In consequence, the environmental presence of a potentially toxic agent need not inevitably assume an adverse biological effect. For example, fly ash, no less than soot, contains carcinogenic hydrocarbons; yet the latter may be carcinogenic to man whereas the former is harmless since it cannot be respired. A low dose of a chemical may be metabolized to a harmless metabolite, while by an alternative biochemical pathway a higher dose may yield a proximate carcinogen, as, for example, with vinyl chloride. Perhaps nowhere does biological availability play a greater role in the pathogenesis of disease than in relation to fibers.

Clinical and epidemiological studies describing the asbestos-related diseases have already been presented, and later in this workshop Dr. Mearl Stanton will report on his elegant experimental studies on fibers. My presentation will attempt to describe in an omnibus and therefore relatively superficial fashion the continuum of environmental and host factors that result in pathology and disease due to exposure to excessive concentrations of asbestos.

To accomplish this, I will formulate a series of questions and let the answers provide the desired overview. Before doing this, however, let me emphasize now, and elaborate throughout my remarks, that the adverse effects of asbestos, like those of all environmental agents, occur in accordance with recognized toxicological principles. The chronic effects of asbestos exposure—*asbestosis*, *mesothelioma*, lung cancer, and possibly gastrointestinal cancer, if it indeed is truly related to asbestos exposure—are characterized by four relatively common aspects of environmental response:

1. A long latent period ensues following onset of exposure for either stigmata of exposure or clinical disease to appear. For the latter, time is measured in decades or segments of the total life span.

2. Exposure is in accord with recognized principles of dose-response in relation to disease development and appearance. Dose, the product of concentration or intensity of exposure multiplied by duration of exposure (time), is clearly the indispensable element in any current hazard analysis and in future projection. Dose-response considerations apply at all levels of response from the single cell to the intact host.
3. A no-effect level of exposure or threshold (if that particular word does create argument) exists for asbestos-related disease.
4. Multifactorial etiology plays a role for some of the asbestos-related diseases. The issue of the determinant and the modifier in a multicausation situation is a critical one. It appears to be that cigarette smoking is the determinant for lung cancer. The data on the role of cigarette smoking in the development of asbestosis, though a factor, are too recent to permit any conclusions even though a modifier role appears reasonable.

Now, the questions that can be used to provide an overview of our subject are:

1. Inasmuch as asbestos is a generic term for a group of fibrous crystalline hydrated silicates, which of the spectrum of characteristics of this group are of relevance to the initiation of asbestos-related disease?

The mineralogy and chemistry of asbestos have been reviewed in detail in this morning's session. Of the two major sets of characteristics, chemical and physical, fiber chemistry appears at this time to play only a minor role, if in fact any role at all, in relation to asbestos-associated disease. Physical characteristics, specifically fiber size, surface character, internal architecture and substructure, are all related in varying degrees to biological effect.

Prior to addressing the second question, a brief description of the gross and microscopic anatomy and the physiology of the respiratory tract is necessary. As can be seen in figure 1, fibrous particles enter the lungs via the trachea following inhalation through the nose or mouth and are distributed throughout the tracheobronchial tree, ultimately reaching the alveoli or air sacs. These air sacs are like the spaces in sponges and are lined by thin membranes in which the capillaries and venules flow.

The entry and penetration of fibers into the lung is governed by physical laws. For those particles which get into the tracheobronchial tree, some will settle on the lining and they will move upward (on the mucociliary escalator) where they will be unconsciously swallowed or spit out. Particles small enough to reach the alveoli will settle out on the lining of the air spaces where they may be engulfed by phagocyte cells (macrophages) which may neutralize them or carry them up to the mucociliary escalator so they can be removed. The mechanism whereby uningested fibers penetrate the lining of the tracheobronchial tree or the air spaces so that they may reach the pleura is largely unknown. Thus it is the mucociliary escalator and the macrophages that are the primary defense mechanisms of the lung. Of particular interest is the fact that cigarette smoke is the most potent and ubiquitous of all inhalants in its capability to neutralize or destroy the effectiveness of the lung defense mechanisms.

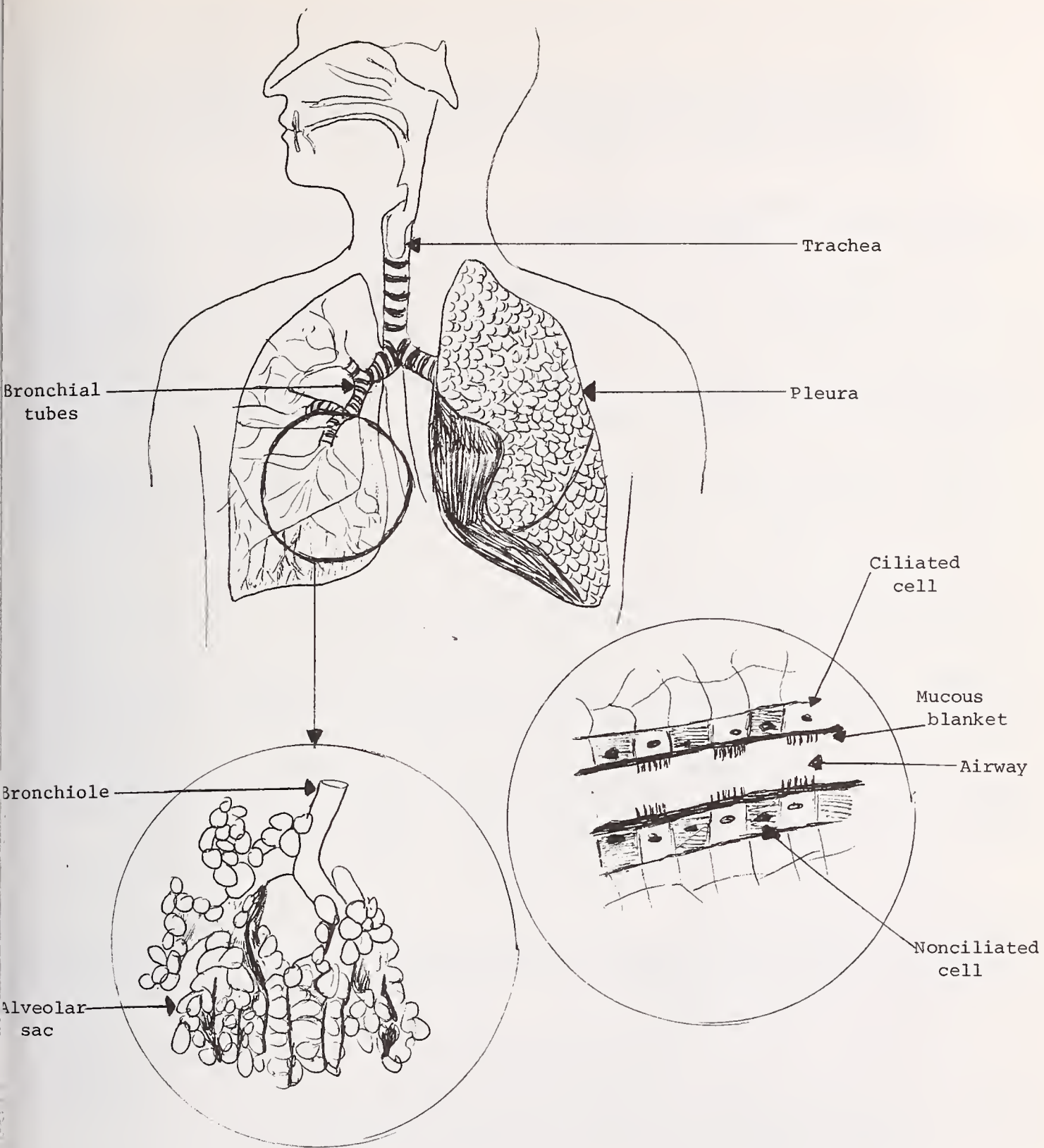

Figure 1. Anatomy of the respiratory tract.

The second question in relation to fiber effect is:

2. Following host entry, which of the anatomic and physiologic characteristics of the respiratory tract that I have just described affects the anatomic fate of the inhaled fiber? What is the algebraic summation of deposition, retention, parenchymal localization and mobilization as factors governing lung clearance?

With respect to the chemical characteristics of fiber, there appears to be no consistent identifiable effect of chemical composition after host entry of fibers by inhalation. With respect to physical characteristics the following effects are noted:

Size. Fibers greater than 5 μm in diameter are virtually entirely lodged in the nose and do not penetrate the respiratory tract. Fibers greater than 3 μm and less than 5 μm in diameter enter the trachea but do not reach the conducting airways deeply enough to be retained in the lung. Fibers less than 3 μm and more than one micron can penetrate to the smaller bronchi. Fibers in the millimicron range in diameter are deposited in the peripheral airways and air spaces through Brownian movement. All these dimensions are very close approximations.

Length is probably less critical than diameter in relation to anatomic localization but it is of great importance in relation to biological effect. One possible measure of localization is the length of fibers found in the lungs in both experimental animals and man following environmental exposure. There are few fibers longer than 100 microns. There are virtually none longer than 200 μm . The majority are less than 50 μm in length.

We can conclude that only fibers thinner than 3 μm and shorter than 200 μm are of significance in eliciting a biological response in intact animals.

Shape. Chrysotile asbestos is curly and spiral, whereas amphibole is harsh and rigid. It is imperative to emphasize that in relation to interception and deposition on the wall of air-conducting passages a curly or a spiral fiber behaves like a straight fiber having the diameter of the spiral fiber's maximum dimensional curl. Timbrell [1]¹ concludes from his studies that chrysotile fibers (curly, pliable) do not penetrate into the deeper and more peripheral portions of the lung to the extent that the more rigid fibers of crocidolite and amosite do. More recently, using isotopically labeled fibers, Morgan [2] has obtained data that tend to question this generalization.

It seems, then, that as a major determinant of biological localization and effect, shape is still an open question.

Surface Character and Internal Architecture. Surface charge and leaching characteristics have not been identified to date as being of major importance in relation to question two. Time may change this.

In contrast, internal architecture has been shown to be relevant. In fact, chrysotile stands in sharp contrast to the amphiboles. The long, pliable fibers are readily split longitudinally into progressively finer fibrils and this feature may be critically related to biological effect. An unanswered yet crucial question is the one of durability of fibers in living systems. Quantitative data on the splitting of fibers and their solubility in relation to persistence of fibers are an urgent need.

In summary, size and shape are the major determinants of anatomical localization and retention.

¹Figures in brackets indicate the literature references at the end of this paper.

Now let's move on to question three and see what can or may follow when fibers set up residence in the lung:

3. During and subsequent to anatomic localization, what characteristics affect the biological fate of asbestos fibers at physiological, pharmacological, and biochemical levels, and what is the sequence of the morphogenetic events and altered morphology resulting from asbestos exposure at cell, tissue, and organ level sites?

It is clear that as desirable as data from man might be in assessing the importance of the chemical and physical variables of asbestos in relation to asbestos-associated disease, reality forces the conclusion that observations on humans, alive or dead, are incapable of providing all the information necessary for this purpose. Most of our current knowledge is derived from laboratory experimentation, and it is to this resource that we must turn for our needs.

Experimental data have been derived from research in which animal models have been exposed (a) in chambers to clouds of asbestos fibers (the most physiological method and the most analogous to human environmental exposure experience); (b) by intratracheal installation of the test material (less physiologic but highly useful and informative); or (c) by intracavitary installation (the least physiologic and the most artifactual inasmuch as this method "forces" biological availability where, in fact, in the human situation none may exist; this method is useful as a tool for studying in-site cellular responses and mechanisms).

Chemical composition of the several forms of asbestos can be dismissed as a major factor in the pathophysiology of asbestos, not because fiber chemistry may not indeed play a role, but because at our current level of ignorance we have no proven concept of what such a role might be. In support of eliminating chemical composition as a factor is the consistent observation that in experimental models all forms of asbestos can produce asbestosis, lung cancer, and mesothelioma depending on the mode of exposure. The report on the federally supported asbestos feeding study, to be presented later during this workshop, may shed more light on this mode of exposure.

The size of the fiber, in sharp contrast to chemical composition, is the most clearly documented physical characteristic that determines biological effect. Data on the fiber size and cause-and-effect relationship are virtually entirely derived from the laboratory, since, in human experience, exposure has been in a mixed length and diameter milieu, thereby rendering epidemiological data worthless for assessing single size fiber effect.

If only one axiom were permissible in my remarks it would be that on the basis of the dynamics and kinetics of the behavior of airborne fibers, and in accordance with our knowledge of biological availability both anatomically and pathophysiologically, fibers thicker than 3.5 microns and longer than 200 microns, or thicker than 3.5 microns and shorter than 5 microns are devoid of biological effect. Inhalation experiments have confirmed this anatomically, and intrapleural studies support the conclusion pathophysiologically.

Three studies can be cited to challenge this statement:

1. Holt [3] reported the production of pulmonary fibrosis in animals exposed in chambers to a cloud of predominantly short fibers. However, his own data record the contamination of his sample with long fibers (greater than 10 microns).
2. King [4] is silent on the percent of longer fibers contaminating his short fiber sample when he reports fibrosis produced in animals. He says the sample was almost all short fibers, but he used a technique for sample preparation that in the hands of others (experienced fiber researchers) consistently fails to yield a "pure" short sample.
3. Pott and Friedrichs [5] recently reported the production of peritoneal mesothelioma with samples made up of fibers shorter than 2 microns. This is a serious challenge to the long-thin concept. I can suggest possible

factors confounding their experiment and conclusions, but at present suffice it to say that we are reviewing their findings in great detail.

This controversy would be rhetorical were it not that, except for the above, all physiological studies and research reports on biological mechanisms are compatible with experimental bioassay in relation to the role of fiber size. Briefly, the sequence of events is as follows:

Respired particles can settle at levels of the tracheobronchial tree which are covered by a mucous blanket that is constantly being propelled cephalad toward the pharynx by the ciliated cells. Clearance of the particles from the lung by this mechanism is brisk, rapid (minutes to hours), and effective. Particles can also penetrate to the distal bronchioli and air sacs (the nonciliated regions). They can be cleared here also, provided they do not penetrate but remain on the surface. This clearance is slow (days to years), moderately effective, and the particles may need help via phagocytosis to decrease penetration and to migrate up to the mucous escalator.

The importance of size can be demonstrated at this stage. Allison [6] and others have shown that short fibers (those less than 5 μm) appear to be readily and completely phagocytosed, whereas long fibers are not, even when simultaneously attacked by more than a single macrophage. This process may lead to cell fusion and the formation of giant cells which are usually found in abundance at the site. Estimates as to the efficiency of the combined clearance mechanisms range up to 95 to 98 percent. It is especially noteworthy, though, that mucociliary clearance is minimally affected during exposure to fibers, even in patients with asbestosis, while it is maximally affected by cigarette smoke.

The swallowing of fibers subsequent to their escalation to the throat is postulated as the mechanism for the reported low-level increased risk to gastrointestinal cancer in asbestos workers. When the term "ingestion" is used in relation to occupational risk to gastrointestinal cancer, it is this passive form of ingestion that is meant. I will say nothing about penetration of asbestos through the wall of the gastrointestinal tract because the data are meager and are truly conflicting.

The next step in the sequence of events depends on what happens to the retained fiber. One of two things may occur:

1. The short fibers, and to a certain degree the long fibers, are engulfed by pulmonary phagocytes or macrophages, the latter often fusing to engulf large fibers. These fibers then become coated with an iron/protein complex. On the basis of animal studies, coating is now believed to be an intracellular process and follows the engulfing of particles by macrophages to which they adhere. These coated fibers are what have traditionally been called "asbestos bodies"; now they are called "ferruginous bodies" because they are not necessarily limited to asbestos exposure and they take a positive iron stain due to the iron/protein complex coating the fiber. There is evidence to suggest that the coating of a fiber renders it nonfibrogenic.
2. A majority of the fibers, approximately 75 percent, will remain uncoated, which can facilitate effective penetration and retention of thin fibers, or the breakdown of thicker fibers into thinner fibrils. These fibers tend to accumulate in the peripheral regions of the lower lobes, the site of early fibrosis (asbestosis). The fibers remain in situ (static) for long periods of time. Some may migrate nakedly through the lymphatic channels, while others may follow the migration paths of the cells they have entered.

There is no entirely satisfactory or universally accepted explanation for fibrogenesis. Suggested mechanisms have included (a) simple irritation, (b) leaching out of metal ions or silicic acid, and now (c) the immune mechanism.

There are, however, cellular data that suggest a reasonable mechanism, and this mechanism assumes that fibrogenesis is evoked through the macrophage response. Such an explanation is attractive since:

1. It is compatible with the observation that long-thin fibers are the hazardous ones.
2. Macrophages tend to aggregate in the peribronchial area, site of the earliest fibrosis.
3. The cumulative effect of exposure is nicely explained by the repetitive and constant response of macrophages to asbestos exposure.

The sequence of fibrosis and its relation to other asbestos-associated diseases is unknown except for the mechanical impairment of cardiopulmonary function by the scarring. Fibrosis produces interference with lung function through replacement of the air spaces (alveolar septa) with scar tissue and by restricting the normal excursion of the lining during breathing.

Asbestos may affect anatomical sites in the following ways:

1. First and foremost, the gas exchange area or distal segments of the tracheobronchial-alveolar tree of the lung may be partially replaced by scar tissue, with resulting decreased lung function, x-ray changes, changes in physical findings, and blood gas changes.
2. The pleura (visceral and parietal) may thicken with the formation of plaques; pleural effusion may fill the chest cavity with fluid; or mesothelioma may spread and infiltrate all layers of the lung and chest wall. The peritoneum may also be affected, although how the fibers reach this site is unknown.
3. Lung cancer or bronchogenic cancer may result. The role of cigarette smoking and its impact on the mucociliary apparatus is a critical factor in the development of lung cancer.
4. Gastrointestinal cancer may occur through entry of fibers into the gastrointestinal tract by pharyngeal transpassage from the trachea.

The development of cancer, or carcinogenesis, is a multistage process in which the chemical interaction between the carcinogenic agent and the DNA is a necessary but certainly an insufficient step in itself for the development of clinical cancer. The issue of dose-response and no-effect level cannot be pursued in appropriate depth here, but suffice it to say that a synthesis of experimental and epidemiological data clearly supports a no-effect level.

The experience with asbestos has, very appropriately, given rise to concern that other fibers to which man is exposed may also represent a potential hazard to health. Organic fibers and manmade mineral fibers are in common use. I will limit my comments to manmade mineral fibers:

1. The dynamics of fiber entry, clearance, retention, and localization apply to manmade mineral fibers as they do to asbestos.
2. The concept of long-thin fibers as the source of potential hazard, as given for asbestos, also appears to be applicable to the chronic biological effect of manmade mineral fibers.
3. In relation to chemistry, however, manmade mineral fibers differ from asbestos. While chemistry may be dismissed in relation to asbestos, solubility, fiber integrity, fiber fracture, and fiber persistence in manmade mineral fibers are most logically related to the chemistry of manmade mineral fibers. For example, glass does not seem to split

vertically; rather it fractures horizontally. It is soluble, and in some exposure studies it seems to have disappeared from predicted sites of localization. A natural fibrous material like gypsum disappears so rapidly that it cannot be detected even at the site of administration after a very short interval. These facts are well recognized.

Lest one become overly sanguine as to the ease or speed with which critically necessary information about manmade mineral fibers can be obtained, it is sobering to reflect that despite our extensive knowledge of asbestos and asbestos-related disease, the following issues are still unresolved and subject to controversy:

1. Relation of fiber type to asbestos-associated disease.
2. The role of host factors (immunological state; peculiarities of respiratory tract architecture; concurrent or antecedent disease) in susceptibility to asbestos-related disease.
3. Progression of asbestos-related disease subsequent to cessation of exposure to asbestos and the specific etiological influence on cancer of the lung or gastrointestinal tract in the absence of asbestosis or other anatomic evidence of exposure to asbestos.

I can best conclude by reiterating that there are special characteristics of asbestos that, though specific and not unique, to the best of our knowledge, invoke no mystique. The principles of asbestos-related disease are those of environmental biology, specifically toxicology and carcinogenesis.

References

- [1] Timbrell, V., Aerodynamic Considerations and Other Aspects of Glass Fiber, in Occupational Exposure to Fibrous Glass—Proceedings of a Symposium, pp. 33-50 (HEW publication NO. (NIOSH) 76-151, Washington, 1976).
- [2] Morgan, A., Progress report to IOEH/QAMA, Montreal, Canada (1976).
- [3] Holt, P. F., Mills, J., and Young, D. K., Experimental asbestosis with four types of fibers: Importance of small particles, N.Y. Acad. Sci. 132, 87 (1965).
- [4] King, E. J., Clegg, J. W., and Rae, V. M., The effect of asbestos, and of asbestos and aluminum, on the lungs of rabbits, Thorax 1, 188 (1946).
- [5] Pott, F., Friedrichs, K.-H., and Huth, F., Results of animal experiments concerning the carcinogenic effect of fibrous dusts and their interpretation with regard to the carcinogenesis in humans, Zbl. Bakt. Hyg., I. Abt. Orig. B 162, 467-505 (1976).
- [6] Allison, A. C., Lysosomes and the toxicity of particulate pollutants, Arch. Internal Med. 128, 131-139 (1971).

Discussion

A. SUNDARAM: Dr. Kotin, I really enjoyed your talk. I would appreciate it if you could answer two simple questions that bother me. One, do you believe that fibrogenesis or fibrosis is an essential process that has to occur as a precarcinogenic lesion before you could find cancer? Two, do you think that fibers actually have to reach a parietal pleura before pleural mesothelioma can occur, or do you think it can be an indirect outcome of other toxic efforts?

P. KOTIN: Let me answer your second question first. I would say that the occurrence of parietal mesothelioma does not inevitably demand the presence of asbestos fibers.

For the first question, I would have to give you two answers. Fibrogenesis as a pathogenetic prelude to bronchogenic carcinoma, certainly not; as a temporal prelude, yes. For fibrogenesis in relation to mesothelioma, I would be hard put to think of how you wouldn't get some preliminary benign or even non-neoplastic fibrous tissue response before you got some malignant fibrous tissue response. So the answer to the question is yes, that there has to be some fibrosis, but really it's gall for me to answer that one with Berle Stanton sitting here who's had just eons of experience in this area.

M. ROSS: I still would like to get out into the open what you would consider a health risk. You're a high official at Johns-Manville. We have heard Dr. Nicholson speak of the horror of asbestos exposure to insulation workers, he's also mentioned Canada. We are now faced with the closing down of small quarries and mining operations because of small, peripheral asbestos hazards, for instance, the local quarry here in Rockville. Now, what is your opinion on this? Johns-Manville produces quite a bit of asbestos. You would think from what Nicholson is saying, that eventually we would say asbestos in general has to be banned, not only in mining but in use, unless we can come up with a level of health risk, a level of exposure, that we can accept. But I can see that the small mining industry is going to be wiped out because they can't handle this sort of thing as far as financing sample analysis and so forth. Could you address yourself to that problem?

KOTIN: Really, prudence says I should keep quiet, but I've never been prudent. Basically, I would agree with Bill Nicholson to the extent that I would say lung cancer and mesothelioma are horrible diseases. The inevitable corollary of that is not that exposure to asbestos is horrible. It can be; in the past it has been. I don't think it is now, at least in areas that I know anything about and I think that's important. The horrors of asbestos are the horrors of asbestos-related diseases, particularly lung cancer and mesothelioma. As to the question of the ubiquity of asbestos and so on, I'm glad you asked, since it gives me an opportunity to repeat what I said. I'm unaware of anything or any body of data that suggests that there isn't a dose-response relationship for asbestos; that just as for all hazardous agents there are non-hazardous levels and circumstances of exposure. Whether, indeed, the quarry situation is one such circumstance, I really can't say. I would suspect, however, it's a question that can be analyzed in terms of traditional dose-response considerations; you don't have to blaze any new trails.

J. SAUNDERS: We've heard earlier of some very elegant work on the identification of asbestos bodies in tissue and some measurements of their quantities in the various tissues involved the pleural lining, also. Your scheme of clearance from the lung, I think has been discussed previously, and I think you made some reference to perhaps some fibers directly penetrating the air sac from the aveola. My question to you is, do you believe that this is the site of biological activity or can you see from your mechanisms re-entry of the particle?

KOTIN: I think you have to discuss pathogenesis on the basis of the disease of which you're speaking. I believe that's the mechanism for the evolution of the disease, asbestosis, yes. For bronchogenic cancer, I think it's entirely different. I think bronchogenic cancer is caused by more than one thing. I think the attenuation of the defenses by concomitant cigarette smoking is indispensable to the evolution of the disease. Let me say it differently; for all practical purposes, I don't think there would be an asbestos-lung cancer link if by some divine mechanism cigarette smoking were to disappear from the face of the earth.

J. SAUNDERS: Perhaps I don't understand the answer. The question was do the fibers directly penetrate the lining?

KOTIN: Yes, they can penetrate.

SAUNDERS: Do you believe these are important agents in the genesis of the disease?

KOTIN: Of fibrosis only.

A. WILEY: Could you state again the fiber sizes, length, and width that you felt were of biological importance?

KOTIN: I will say it in microns; it took Dr. George Wright a year to get me to say micrometers. Fibers thicker than 3.5μ in diameter and longer than 200 are nonpathogenic, and that is an arbitrary number. The only reason I say 200 is because that is the maximum length of fibers that have been detected in lungs.

Up to 200μ and thinner than 3.5μ is the critical size range. If the diameter is thicker than 3.5μ length is irrelevant, because the fiber is not going to get down to the lower airways and air sacs.

WILEY: Question was inaudible.

KOTIN: What she is saying is, I am not convinced that 3 to 1 is necessarily the right ratio. I agree. While 3 to 1 is a very handy rubric, there is nothing sanctified about it.

THE CARCINOGENICITY OF FIBROUS MINERALS

Mearl F. Stanton

Laboratory of Pathology

and

Maxwell Layard

Biometry Branch

National Cancer Institute
National Institutes of Health
Public Health Service
Department of Health, Education, and Welfare
Bethesda, Maryland 20014

Abstract

The carcinogenicities of 37 different dimensional distributions of seven different durable fibrous materials were correlated with fiber dimension. Optimum correlation was attained with fibers that measured $<0.25 \mu\text{m} \times >8 \mu\text{m}$. Morphologic studies suggested that fibers in this dimensional range lie free in interstitial tissues, while fibers of smaller dimension are readily phagocytosed and fibers of larger dimension are sequestered by adherent phagocytes and fused phagocytic giant cells. Fibers that are fine and long may be more carcinogenic than others, simply because they are uncompromised by phagocytic activity.

Keywords: Aluminum oxide; asbestos; carcinogenicity; Dawsonite; fibers; fibrous glass; phagocytosis; potassium octatitanate.

For the past several years we have been interested in the question of how asbestos causes cancer once a fiber reaches susceptible tissues. We have approached this problem with the simple device of introducing various types of particles into the pleural space of rats and observing the resultant tumors during the subsequent two years. The methods that we have used can be summarized briefly [1,2,3].¹ A standard 40 mg dose of particles is applied by open thoracotomy directly to the left pleural surface of young female Osborne-Mendel rats. In each experiment, 30 to 50 rats are followed for two years and those surviving at two years are killed. All rats are necropsied and all pathological lesions examined histologically. Tumors that resemble the mesenchymal mesotheliomas of man generally develop after the first year. For the sake of precision we have called these tumors pleural sarcomas. During the second year, rats die at various times with and without pleural sarcomas; consequently, we have used actuarial computation to arrive at a valid estimate of the incidence of pleural sarcomas which takes into account differences in life-span [4]. Probability of pleural sarcoma has ranged from 0 to 100 percent depending on the materials used. Pleural sarcomas have not been observed in several thousand untreated controls; however, pleural sarcomas have occurred in rats treated only by simple thoracotomy. Our best estimate of these non-specific, background pleural sarcomas in treated controls is in the range of 2-4 percent. This is important to keep in mind since it makes interpretation of low level response unreliable with small numbers of animals.

¹Figures in brackets indicate the literature references at the end of this paper.

There are two separate features of asbestos particles that merit consideration as potentially carcinogenic. First, the chemical nature of their constituents and contaminants, especially those with a known potential for carcinogenicity such as the polycyclic hydrocarbons and heavy metals. Secondly, the physical structure of asbestos particles which in their fibrous fineness are somewhat unique in the natural world. It is our contention that it is the latter property, namely the simple quality of being an exceptionally fine, long, durable fiber, that is most critical to carcinogenicity. The supporting evidence for this hypothesis is derived primarily from the type of experiments described above, as carried out by us and others [1,2,3,5,6,7]. It can be summarized briefly as follows:

- (1) Vigorous extraction of natural and contaminating hydrocarbons from asbestos does not alter its carcinogenicity.
- (2) Hand-cobbed, hand-milled asbestos that is free of metallic mill contamination is no less carcinogenic than machine-milled asbestos.
- (3) Naturally occurring or contaminating carcinogenic metals such as nickel, cobalt, chromium, iron, magnesium, and silica, or hydrocarbons such as benzo(a)pyrene, of comparable quantity to that in asbestos, when attached to inert non-fibrous particles of a size comparable to asbestos, do not show the carcinogenicity of asbestos.
- (4) The carcinogenicity of asbestos is greatly reduced if implanted as whole unseparated sheets of fibers or implanted as very short submicroscopic fibrils.
- (5) The carcinogenicity of asbestos is greatly reduced if asbestos is heated sufficiently to increase its fragility or if pulverized to non-fibrous particles.
- (6) Finally, between the various types of asbestos, particularly crocidolite, amosite, tremolite, anthophyllite, and chrysotile, there are wide variations in chemical, crystalline, and molecular structure. Nevertheless, when similar dimensional distributions of these asbestoses are applied directly to the pleura their carcinogenic response is similar.

If the carcinogenicity of asbestos depends on its dimensional configuration, two corollary hypotheses are suggested. First, durable fibers of other materials if in the same dimensional range as asbestos should be as carcinogenic as asbestos. Secondly, there should be an optimal dimensional range of fibers relevant to carcinogenicity.

The data which I would like to present today relates to these two corollaries. Table 1 lists 37 experiments with seven different durable fibrous materials, each of differing dimensional distributions, but at or near the size distribution of asbestos. We have listed these in order of their probability of inducing pleural sarcomas, and as you can see the range runs the gamut from 0 to 100 percent. Asbestos fibers of a standard size characterized by a working group of the Unio Internationale contra Cancer would fall in the range of 65-80 percent [8].

The problem that follows is that of determining the dimensional distribution of the particles in each sample. To do this we used the straightforward method of measuring length and diameter from montage photographs of typical samples of the particles implanted. A minimum of 1000 particles were tabulated at magnification of 3000X to 29,000X. Subsequently, in samples containing large particles, magnifications of 1000X were used to tabulate fibers inadequately represented on electron micrograph grids. The proper ratio of microscopic to submicroscopic particles yielded a representative sum of measured particles which was then entered into an IBM System 370 computer. From the density and the sum of the calculated volumes, the weight of the counted samples could be obtained and the distribution of particles per microgram of the sample estimated. For convenience, the numbers of particles per microgram were grouped into 34 dimensional ranges as indicated in Table 2. Table 2 illustrates the tabulation of six of the experiments with different samples of glass. By simple inspection the six examples show an apparent relationship between tumor probability and particle distribution that has held for all of the fibers tested thus far. The examples suggest that particles in relatively thin (diameter $<0.25 \mu\text{m}$) and long (length $>8 \mu\text{m}$) dimensional categories are associated with the higher tumor probabilities.

Table 1. Cumulative list of experiments arranged by percent probability of pleural sarcoma.

	Percent
1. DIHYDROXY SODIUM ALUMINUM CARBONATE V.	100
2. POTASSIUM OCTATITANATE I	100
3. POTASSIUM OCTATITANATE II.	100
4. SILICON CARBIDE GTC #1	100
5. DIHYDROXY SODIUM ALUMINUM CARBONATE I.	95
6. BOROSILICATE GLASS (MOL)	85
7. BOROSILICATE GLASS (M6D)	77
8. BOROSILICATE GLASS + BINDER (KL)	74
9. BOROSILICATE GLASS (M6L)	72
10. ALUMINUM OXIDE -HC	70
11. BOROSILICATE GLASS + BINDER (KW)	69
12. DIHYDROXY SODIUM ALUMINUM CARBONATE VII.	68
13. DIHYDROXY SODIUM ALUMINUM CARBONATE IV	66
14. DIHYDROXY SODIUM ALUMINUM CARBONATE III.	66
15. BOROSILICATE GLASS (M6W)	64
16. ALUMINUM OXIDE #3.	44
17. ALUMINUM OXIDE #4 α	41
18. ALUMINUM NITRIDE + OXIDE #6 α	28
19. ALUMINUM OXIDE #2.	22
20. BOROSILICATE GLASS + BINDER (KCP).	21
21. BOROSILICATE GLASS - BINDER (KUP).	19
22. BOROSILICATE GLASS (M8L)	14
23. ALUMINUM OXIDE #4.	13
24. DIHYDROXY SODIUM ALUMINUM CARBONATE VI	13
25. DIHYDROXY SODIUM ALUMINUM CARBONATE II	12
26. BOROSILICATE GLASS (MOS)	8
27. BOROSILICATE GLASS + BINDER (K2P).	8
28. MINERAL WOOL (Hi-Ca, Mg)(O2P).	7
29. BOROSILICATE GLASS + BINDER (KFP).	6
30. BOROSILICATE GLASS + BINDER (Y2P).	6
31. HIGH CA-NA (P2P)	6
32. BOROSILICATE GLASS (M8S)	5
33. ALUMINUM OXIDE #5.	5
34. ALUMINUM OXIDE-LC (non-fibrous).	3
35. BOROSILICATE GLASS (YW) (vehicle) (n=270).	2
36. BOROSILICATE GLASS (M6S)	0
37. NICKEL TITANATE.	0

Table 2. Six example experiments illustrating fiber distribution into 34 dimensional categories by common log of the number of particles per microgram in each size category.

MOL 85.3%					KI 73.9%					
>0.8										
>4.0-8.0									0.67	
>2.5-4.0							0.67	1.52	0.97	
>1.5-2.5						1.45	0.67	2.03	2.19	
>.50-1.5	2.23	2.53	3.23	3.08		2.95	2.40	3.42	2.74	
>.25-.50	3.08			3.95	2.55	3.16			3.63	
>.10-.25	2.93	3.35		4.53	3.03	3.16	3.33		3.03	
>.05-.10		3.93		4.79	2.85	4.09	3.76		3.25	
.01-.05		3.46		4.65	3.03	3.73	3.03		3.03	
KCP 21.5%					M8L 14.3%					
>8.0				0.97						
>4.0-8.0			1.81	2.01	1.81				0.17	
>2.5-4.0		1.44	2.05	1.81			0.77	1.73	2.02	
>1.5-2.5		2.05	2.17	2.31	0.97	1.49	1.12	2.11	2.27	
>.50-1.5	3.00	3.59	3.17	2.85	2.01	2.60	1.45	2.35	2.42	
>.25-.50	3.24	3.38	3.10	2.55		1.85		2.38		
>.10-.25	3.24	3.28	3.10	2.50				1.85		
>.05-.10	2.50	2.90						1.85		
.01-.05	2.20	2.98	2.67							
MOS 8.3%					YW 2.8%					
>8.0								0.89	0.34	
>4.0-8.0			2.46	2.72				0.92	0.40	
>2.5-4.0		2.97	2.99	1.76				0.80	0.30	
>1.5-2.5		3.43	2.37	1.17				T.00	0.11	
>.50-1.5	3.88	3.91	2.76	2.46				T.10	0.41	
>.25-.50	4.34	4.02	3.69	3.37						
>.10-.25	4.43	3.88								
>.05-.10	5.90	4.19								
.01-.05	6.77	4.63								
	.01-1	>1-4	>4.8	>8-64	>64	.01-1	>1.4	>4.8	>8-64	>64
	Length μm									
Diameter μm										

<0.25 μm) and long (length >8 μm) dimensional categories are associated with the higher tumor probabilities.

Statistical regression techniques afford a method of analysis that can use a variety of explanatory variables to determine the best correlations between tumor probability and size distribution. The logit transformation [9] was applied to the estimated tumor probabilities (p) according to the formula:

$$\text{logit} = \log \left(\frac{p}{1-p} \right)$$

Then, linear regression methods which find the best fitting function of the form

$$\text{logit} = a + b_1x_1 + \dots + b_kx_k$$

were used to compare the common logarithm of the number of particles per microgram in various size categories to the probability of pleural sarcoma. After analyzing various dimensional ranges that might have narrowed the optimum tumor inducing size range, it was determined that the best fit was with the dimensions $\leq 0.25 \mu\text{m} \times > 8 \mu\text{m}$. The estimated regression equation was:

$$\text{logit} = \log \left(\frac{p}{1-p} \right) = -1.31 + .424x$$

with a correlation coefficient of 0.9. The regression curve for this dimensional range is illustrated in figure 1. Figure 1 also indicates clearly that none of the seven different types of fibers show consistently greater deviations from the curve than any other, and that the curve's steepest slope is between 3-4 log particles per microgram. There was no correlation with particles less than 8 μm in length, but relatively good correlations were also noted with numbers of fibers >8 μm in length and up to 1.5 μm in diameter (correlation coefficient 0.52 to 0.74). Figure 2 illustrates the 34 parameters used for carcinogenicity correlation and those categories in which relatively good correlation was obtained. It should be remembered that absence of correlation does not preclude a low level of tumor response outside these ranges.

Histologic observations suggest the reason for the difference in response to fine, long fibers and those fibers that are either very short or very thick. The lesions in those experiments with a low probability of pleural sarcoma were highly cellular, being composed primarily of fibroblast-laden vascular granulation tissue with a relatively low collagen content and an abundance of macrophages. In lesions from low tumor probability groups in which virtually all fibers were less than 10 μm in length, the fibers seemed completely contained within macrophages. On the other hand, in those lesions from low tumor probability groups in which the fibers were virtually all of large diameter, the fibers seemed sequestered from adjacent tissue by both macrophages and multinucleated giant cells that closely invested the fiber surface. In contrast, the high tumor probability lesions were relatively acellular, with an abundance of collagen at the site of implantation and the fine long fibers lay free in the interstitial tissues unaffected by phagocytes. In ancillary experiments with non-fibrous particles that stimulate collagen such as talc, silica, or carrageenin, collagen deposition equal to that of the high tumor probability lesion has been observed without the subsequent development of tumors. Therefore it seems evident that collagen itself is not the critical factor in carcinogenesis. However, the fact that the fine, long fibers were unaffected by phagocytic activity in the high tumor probability groups suggests that fibers that are fine and long may be more carcinogenic than others simply because they are uncompromised by phagocytic activity.

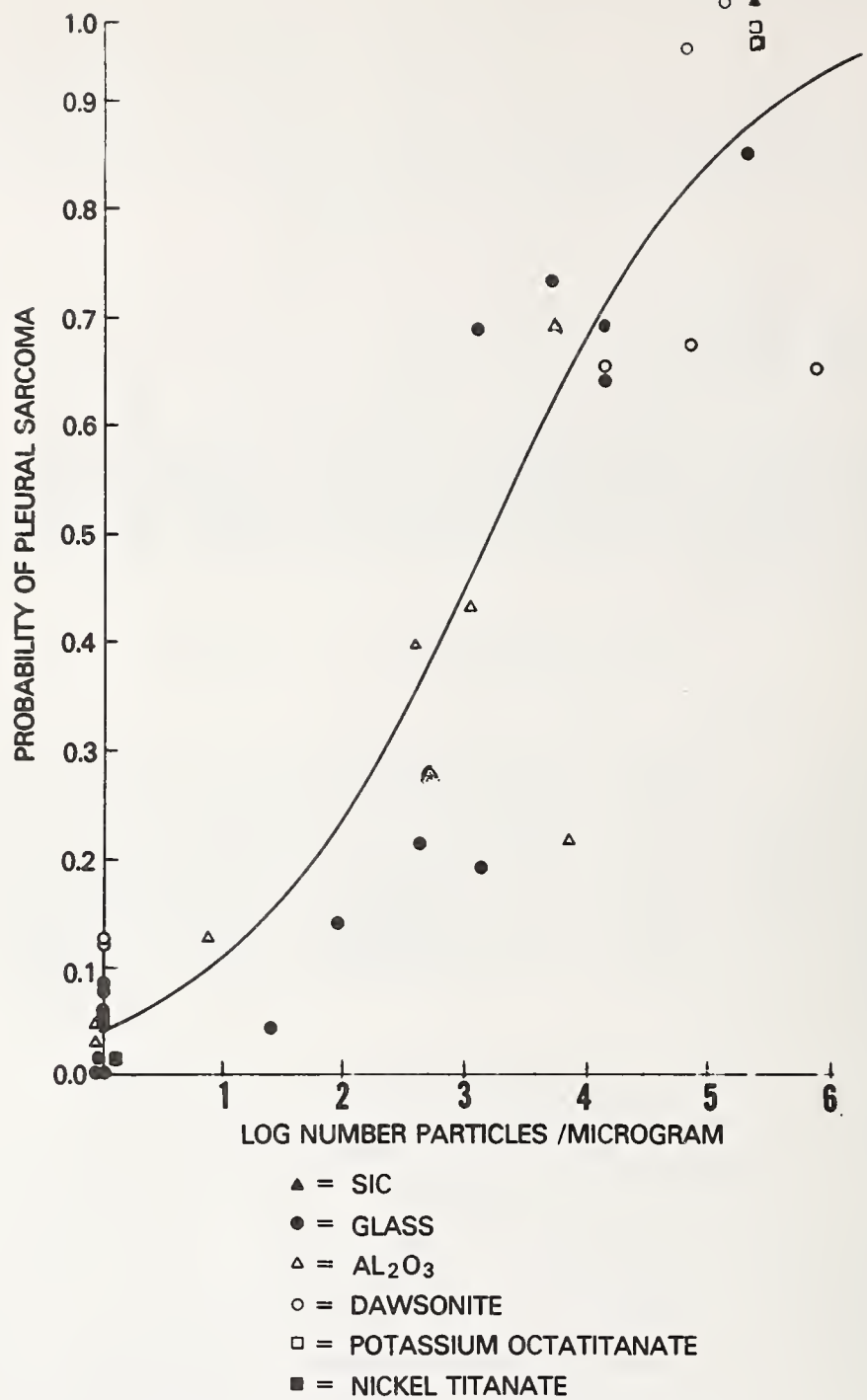

PARTICLE SIZE = $\leq 0.25 \mu\text{m} \times > 8 \mu\text{m}$ CORRELATION COEFFICIENT = 0.9

Figure 1. Regression curve relating tumor probability to the common logarithm of the number of particles per microgram with diameters $\leq 0.25 \mu\text{m}$ and lengths $> 8 \mu\text{m}$.



Figure 2. Graphic display of the 34 size categories in scale with phagocytic and mesothelial cells. The starred fibers are those that correlate with pleural sarcoma probability.

References

- [1] Stanton, M. F., Layard, M., Tegeris, A., Miller, E., May, M., and Kent, E., Carcinogenicity of fibrous glass: Pleural response in the rat in relation to fiber dimension, J. Natl. Cancer Inst. 58, 587-603 (1977).
- [2] Stanton, M. F. and Wrench, C., Mechanisms of mesothelioma induction with asbestos and fibrous glass, J. Natl. Cancer Inst. 48, 797-821 (1972).
- [3] Stanton, M. F., Some etiological considerations of fibre carcinogenesis in Biological Effects of Asbestos (Bogovski, P., Timbrell, V., Gilson, J., et al., eds.). Lyon, France, World Health Organization, International Agency for Research on Cancer, Publication No. 8, 1973, pp. 289-294.
- [4] Armitage, P., Statistical Methods in Medical Research, New York, John Wiley & Sons, 1971, pp. 376-377, 410-414.
- [5] Wagner, J. C., The pathogenesis of tumors following the intra pleural injection of asbestos and silica in Morphology of Experimental Respiratory Carcinogenesis (Nettesheim, P., Hanna, M. G., Deatherage, J. W., eds.). Oak Ridge National Laboratory, Oak Ridge, Tennessee, Atomic Energy Commission Symposium Series No. 21, 1970, pp. 347-358.
- [6] Smith, W. E., Miller, L., and Elasser, R. E., Tests for carcinogenicity of asbestos, Ann. N.Y. Acad. Sci. 132, 456-488 (1965).
- [7] Timbrell, V., Physical factors as etiological mechanisms in Biological Effects of Asbestos (Bogovski, P., Timbrell, V., Gilson, J. C., et al., eds.). Lyon, France, World Health Organization, International Agency for Research on Cancer, Publication No. 8, 1973, pp. 295-303.
- [8] Timbrell, V., Gilson, J. C., Webster, I., UICC standard reference samples of asbestos, Int. J. Cancer 3, 406-408 (1968).
- [9] Cox, D., Regression models and life tables, J. R. Stat. Soc. (B) 34, 187-220 (1972).

Discussion

A. SUNDARAM: These pleural sarcomas, are they localized? If you leave them for a duration of time do they metastasize?

M. STANTON: Yes, this is real cancer, but they do not metastasize early.

A. LANGER: You allow your animals to live only two years, whereas Wagner allows his rats to live three years. Have you had any control groups run for the duration of the animals' lives? In those animals which you are reporting here, you are reporting frank malignancy? How many of the other animals had hyperplastic lesions?

STANTON: It is difficult to detect precancerous lesions in mesenchymal tissues, so that it really is difficult to say what might be precancerous. We find that after two years plus the twenty weeks the animal has aged by the time we treat them, most rats are in their terminal stages. These rats do not have normal lung capacity and so they do not survive as long as the untreated rat does. By the end of the two years there is only a small percentage of the rats left.

P. KOTIN: This business of assuming that hyperplasia carries with it as a corollary, or is even indicative of subsequent malignant transformation or neoplasia, particularly in mesenchymal tissue, has no substance at all. Now I am speaking as a pathologist. The other thing is, there is a tendency to denigrate experiments which are terminated for the reasons you said, when in fact the confounding findings which arise in the last six to eight months of a rat or any experimental animals, are such as to muddy up the results. I'd like your comment on this. The elegance of the observation occurs before you get into

the agonal state, where the exposure of the animal probably has little as anything to do with what he ultimately gets and dies from.

STANTON: No further comment on that.

J. WARREN: Our firm recently completed a report for OSHA, "The Economic and Inflationary Impact Study for the Effects of a Proposed Standard for Asbestos in Construction," and in the process of doing this report for OSHA we had to talk to a lot of your firms, universities - everybody from environmentalists to producers, maybe not some of you in here personally. This type of meeting is needed. We need people not just talking to each other, but with each other, and I think you have seen this today. You got one group over here saying, "Lookout! we are going to put out of business x number of people." Another group says you have to protect the worker - the worker comes first even at zero exposure. The only way we are going to resolve this problem, and it is a very sticky problem, is by everybody talking together. So that is just a comment; we found there is not enough talking to each other; even if you don't agree you can still talk. Has anyone looked at the possibility of using experimental animals other than rats, say a primate? Would this change results or give better data if we had an animal that would live longer? Has anyone used a rat that has been exposed to cigarette smoke at the same time?

STANTON: Yes, other species have been used. Dr. Bill Smith is here today who has been using hamsters for many years and has some very elegant data with hamsters. We ourselves have used mice, and have been successful with mice as well as rats. I don't think that unless there was an exotic species that we would particularly contribute a great deal more by using another species. Chickens have been used and various other types of birds with some interesting results.

NIEHS ORAL ASBESTOS STUDIES

John A. Moore

National Institute of Environmental Health Sciences
P. O. Box 12233
Research Triangle Park, North Carolina 27701

Abstract

Epidemiologic data clearly associate inhalation of asbestos with an increased incidence of cancer. In addition to pulmonary and thoracic neoplasia, there are data which associate an increased incidence of gastrointestinal and peritoneal tumors. Controversy exists as to whether these latter types of neoplasia result from asbestos fibers that were ingested subsequent to clearance from the respiratory system. Exposure to ingested asbestos does occur in the general population through the presence of fibers in water and food.

The NIEHS oral asbestos studies in rats and hamsters represent a systematic attempt to assess the biological effects associated with primary ingestion of selected asbestos fibers. The objectives of the studies include: assessment of biological (carcinogenic) effects as a consequence of exposure to one of several types of asbestos; assess if an interaction may exist between a chemical carcinogen which is known to produce bowel cancer, and ingestion of asbestos. The specific experimental design of this series of ongoing studies will be presented.

Key Words: Asbestos; bowel cancer; cancer; epidemiology; fibers.

There is strong evidence that associates occupational exposure to chrysotile amosite, and crocidolite to a resulting high incidence of lung cancer. Exposure to these forms of asbestos has also been observed to result in an increased incidence of pleural and peritoneal mesothelioma and an excess risk of gastrointestinal cancer. Environmental exposure to asbestos through living in the neighborhood of asbestos factories or mines or through residing in households of asbestos workers also correlates with increased mesotheliomas [1].¹

It is plausible to speculate that the increased incidence of gastrointestinal cancer in occupationally exposed populations may be a consequence of asbestos fiber ingestion. Fiber ingestion in these circumstances may result through the swallowing of fibers cleared from the nasal or tracheobronchial tree. Direct ingestion of fibers deposited in the oral cavity also occurs.

Exposures of the general population to asbestos occurs through ingestion of materials and substances that contain fibers. For example, several million fibers per liter were found in Canadian tap water [2]; Great Lakes and St. Lawrence River water showed average concentrations of about 1.7 million asbestos fibers per liter [3]; water collected from the north shore of Lake Superior in the Silver Bay/Duluth region were found to have even higher fiber levels. A number of studies have reported the appearance of asbestos fibers in commercial beverages such as beer, vermouth, and soft drinks [2]. The fibers found in these products may be a result of the use of asbestos filters used in their preparation [2]. Food may contain asbestos through the use of asbestos filters or the use of talc, which has an asbestos impurity [4,5].

¹Figures in brackets indicate the literature references at the end of this paper.

In response to a growing concern about the possible biological effects of ingested asbestos, a conference was held in 1973, co-sponsored by the National Institute of Environmental Health Sciences and the Environmental Protection Agency. The meeting confirmed that the preponderance of biological data concerning exposure to asbestos focused on the inhalation and not the ingestion route of exposure. A consensus of that international conference was that research was needed on health effects associated with asbestos ingestion. A Subcommittee of the DHEW Committee to Coordinate Toxicology and Related Programs (CCTRP) subsequently reviewed the existing data, recommended that additional research be undertaken, and prepared a draft research protocol that it felt would be responsive to the scientific needs. This protocol was widely distributed for comments both within and outside the Government. Based on the comments received, a final protocol was developed and submitted as part of its final report. In response to the Subcommittee's report, Congress appropriated specific funds directing the National Institute of Environmental Health Sciences to research the effects of oral asbestos ingestion. The NIEHS is conducting this research primarily through its research contracts program. The Environmental Protection Agency also contributed funds for these studies. The design of these studies is in concert with the recommendations of the CCTRP Subcommittee. The basic design of the studies provides for an evaluation of chrysotile, a serpentine asbestos; and amosite and crocidolite, fibers representative of amphibole asbestos; plus a non-fibrous tremolite, which does contain low levels of asbestiform fibers.

The studies call for asbestos to be fed continuously in the diet over the entire lifespan of the test animal. Each form of asbestos is contained at a one-percent level in a pelleted rodent diet of constant ingredient formulation (NIH Feed 31). The proposal to incorporate the asbestos within a pelleted diet form was approved only after studies indicated that the pelleting process did not alter the physical integrity of the fiber. The utilization of an asbestos diet in a pelleted form has obvious advantages: it minimizes fiber aerosols which would occur with greater ease in a non-pelleted form; it minimizes variations of asbestos concentration in the diet due to segregation of fibers that would occur during shipping, handling, and feeding. Incorporating asbestos into food rather than water eliminates settling and subsequent uneven distribution.

All materials are being fed to the F-344 strain of rat; whereas two forms of asbestos, chrysotile and amosite, are also to be tested in hamsters. Golden Syrian hamsters represent a second test species and are being fed a serpentine or amphibole form of asbestos. All studies encompass the lifespan of the animal, which is defined as the age at which the animal begins eating solid food until its death. To insure asbestos ingestion at a young age, these studies are initiated by feeding the asbestos diet to a nursing mother, which is removed once the pups are weaned. These latter animals that begin eating asbestos at two weeks of age constitute the test generation.

In the basic studies, the test group size is 500, composed of equal numbers of males and females. In each of the rat and hamster studies, there is a composite total of 1000 animals that receive diet which does not contain asbestos and serve as controls. The experimental group size allows one to detect a statistically significant increase in gastrointestinal tumors in the treated groups at a two percent increase above the control population.

In another rat experiment, two subsets of 200 animals each are to receive asbestos from the first to the 28th day of life by gastric intubation. The rat pups received 2.35 mg of an aqueous asbestos suspension daily. At weaning, the rats are placed on the appropriate asbestos diet for the remainder of their lifespan. One subset of 200 animals is to receive chrysotile while another subset is to receive amosite. The objective of these experiments is to see if a possibility exists that neonates may be a special risk population.

There is also scientific interest in determining if asbestos in the diet alters the expression of intestinal neoplasms induced by a known chemical carcinogen. Studies of this type are performed in rats that are fed either chrysotile or amosite. A similar study will be conducted in hamsters receiving the chrysotile diet. There are 350 animals in each of these three groups. The chemical carcinogen to be utilized was selected after a series of dose-ranging experiments of one-year's duration was performed in each species. In these dose-ranging studies, both dimethylhydrazine and methylazoxymethanol were evaluated. The

results indicated that dimethylhydrazine was the chemical carcinogen of choice due to lower toxicity and greater specificity of intestinal tumor response. The dose selected is one that will produce approximately a 10 percent incidence of intestinal tumors. That dose for hamsters is 4 mg/kg, whereas for rats it was 7.5 mg/kg and 15 mg/kg in male and female rats, respectively. The dimethylhydrazine is administered by gavage once every fourteen days until five doses have been administered. The initial dose was administered at six weeks of age. Tables 1 and 2 summarize the design of the animal study. The animal testing phase of the experiments commenced in late 1975. Since the natural lifespan of the F-344 rat is 26-30 months and 18-23 months for the hamster, definitive interpretation of these studies is several years away.

Table 1. NIEHS oral asbestos study.

Golden Hamster

	<u>Chrysotile Intermediate</u>	<u>Chrysotile Short Range</u>	<u>Amosite</u>
Asbestos diet	500 ^a	500	500
Asbestos diet plus dimethylhydrazine ^a	350	ND	ND
Control diet ^b	500	250	250
Control diet plus dimethylhydrazine ^a	250	ND	ND

^a Number of animals (equal numbers of each sex).

^b Control allocations are descriptive only. Experimental response will be evaluated against total controls (1000). Subsets of control will reflect temporal differences in commencing phases of study which is expected to be aggregates of 250-350.

ND - Not done.

Studies conducted by Illinois Institute of Technology Research Institute, Chicago, Illinois.

Table 2. NIEHS oral asbestos study.

F-344 Rat

	<u>Chrysotile Intermediate</u>	<u>Chrysotile Short Range</u>	<u>Amosite Intermediate</u>	<u>Crocidolite</u>	<u>Tremolite</u>
Asbestos diet	500 ^a	500	500	500	500
Asbestos diet plus dimethylhydrazine ^a	350	ND	350	ND	ND
Preweaning asbestos gavage plus asbestos diet	200	ND	200	ND	ND
Control diet ^b	175	175	175	175	175
Control diet plus dimethylhydrazine ^a	250	ND	250	ND	ND

^a Number of animals (equal numbers of each sex).

^b Control allocations are descriptive only. Experimental response will be evaluated against total controls (1000). Subsets of control will reflect temporal differences in commencing phases of study which is expected to be aggregates of 250-350.

ND - Not done.

Studies conducted by Hazleton Research Laboratories, Vienna, Virginia.

All animals receive a thorough pathologic evaluation at time of autopsy. In conformance with the NCI Carcinogen Bioassay protocol, some thirty tissues in addition to any gross lesions will be examined under light microscopy.

The rat studies are being performed through a contract with Hazleton Research Laboratories, Vienna, Virginia; whereas the hamster experiments are being performed by the Illinois Institute of Technology Research Institute, Chicago, Illinois.

As a biologist, I wish to emphatically state that the most difficult decision in the design of these studies was determining the types and specific forms of asbestos that were to be fed. The literature clearly indicated that some previous studies were flawed due to unwitting physical violence imposed upon the asbestos during its preparation. In some cases, there was concern about contamination by organic chemicals. In medical research circles, the issue still rages with respect to the size of fiber that may be associated with observed neoplastic response. It is necessary to relate size that produces optimal biological response to the distribution of fiber sizes to which there is general human population exposure. The common fiber found in municipal water supplies represents one of serpentine origin. From a numerical standpoint, the preponderance of these fibers is of the low micron and submicron lengths. To accommodate to these circumstances, it was decided that there would be two chrysotile asbestos materials used in the rat and hamster studies. These are referred to as the NIEHS short-range chrysotile and the NIEHS intermediate-range chrysotile.

NIEHS short-range chrysotile was mined from the New Idria deposits in California. This chrysotile is of very small fiber length and diameter. It is a single lot produced by Union Carbide and is referenced by them as COF-25. The NIEHS intermediate-range chrysotile originated from the Johns-Manville Jeffrey Mine in Canada. This material has general analogies to their Plastobest 20.

One method of comparing these two chrysotile samples is by comparing surface area determinations. Table 3 presents the results of such tests; the UICC chrysotile surface area values are listed for comparison. The UICC samples have been the asbestos source for the majority of biological studies over the past several years. As can be seen from the table, the NIEHS intermediate-range chrysotile compares quite favorably with the UICC Canadian chrysotile. The two-fold increase in surface area of the NIEHS short-range chrysotile compared to its intermediate-range counterpart reflects the much smaller fiber size found in this sample.

Table 3. Comparison of UICC and NIEHS chrysotile samples.

<u>Asbestos Identification</u>	<u>UICC Value (m²/g)</u>	<u>IITRI Value (m²/g)</u>
UICC Rodesian Chrysotile	21.3 ± 1.5	22.35
UICC Canadian Chrysotile	26.8 ± 0.7	27.7
NIEHS Intermediate Range Chrysotile		27.8 ± 2.7
NIEHS Short Range Chrysotile		59.0 ± 6.2

The amphibole samples, amosite and crocidolite, were prepared by the Ontario Research Foundation under the direction of the U.S. Bureau of Mines' College Park Laboratory. This asbestos, purchased commercially, has been processed by air jet milling to better standardize the range of fiber size contained in the material.

The tremolite sample was mined and milled to -325 mesh by the R. T. Vanderbilt Company, Balmat, New York. It was subsequently blended by the U.S. Bureau of Mines personnel to insure homogeneity of the sample.

All test materials are being extensively characterized as to chemical and fiber size characteristics. The characterization data include x-ray diffraction parameters, chemical composition, DTA, TGA, optical constants, density, and surface area. These studies are being performed by the U.S. Bureau of Mines. Exhaustive electron microscopic characterization of each material as to fiber length, fiber diameter, surface area, distribution of fiber size, and selective pore volume measurements are being performed by the Fine Particles Laboratory of the Illinois Institute of Technology Research Institute, Chicago, Illinois.

The characterization studies on tremolite and the short-range and intermediate-range chrysotile are nearly complete. The characterization of amosite and crocidolite are scheduled for completion by the end of the year.

Two recent ingestion studies that have been reported within the past year yielded variable results. In a British study, a group of 32 Wistar rats were fed 100 mg per day of UICC Canadian chrysotile prepared in milk powder on a five-day-a-week schedule for a total of 100 days of ingestion. There were 16 control animals which were fed only the malted milk. The animals were then allowed to live out their lifetime, which was a mean survival of 619 days for those animals on chrysotile versus 641 days for the controls. One gastric leiomyosarcoma was observed in the chrysotile group. No tumors of this type were found to occur in the controls [6].

In a study reported in the East German literature, a statistically significant ($p < 0.01$) increased incidence of malignant tumors occurred in rats that received asbestos filter material in the diet [7]. The exact composition of the asbestos filter material was not given in this paper. In this study, 25 male and 25 female Wistar rats were given 50 mg/kg body weight per day of asbestos filter material which contained approximately 52 percent chrysotile asbestos. This asbestos containing filter material had been previously

powdered and added as a water suspension to the diet. In the group of animals which received the asbestos filter material, the average survival time was 441 days. Untreated controls had an average survival time of 702 days. Of the 42 treated rats available for pathologic evaluation, 12 malignant tumors were found. This is to be compared to seven tumors (two liver cell carcinomas and five mammary fibroadenomas) observed in 49 control animals. The tumor types observed in the animals fed the asbestos filter material included four kidney carcinomas, one lung carcinoma, three reticulum cell sarcomas, and four liver cell carcinomas. Two mammary fibroadenomas, as well as a lung adenoma, two cholangiomas, and two forestomach papillomas were also observed.

The NIEHS Oral Asbestos Studies should provide controlled data from large enough sample sizes to allow for initial formulation of basic principles as to the biological effects of exposure to ingested asbestos.

References

- [1] IARC Monographs on the Evaluation of Carcinogenic Risk of Chemicals to Man, Asbestos, Volume 14. International Agency for Research on Cancer, Lyon, France (1977).
- [2] Cunningham, H. M. and Pontefract, R. D., Asbestos fibers in beverages and drinking water, Nature (Lond.), 232, 332-333 (1971).
- [3] Cook, P. M., Glass, G. E., and Tucker, J. H., Asbestiform amphibole minerals: detection and measurement of high concentrations in municipal water supplies, Science, 185, 853-855 (1974).
- [4] Merliss, R. R., Talc and asbestos contaminant of rice, J. Amer. Med. Assoc., 216, 2144 (1971).
- [5] Wolff, A. H. and Oehme, F. W., Carcinogenic chemicals in food as an environmental health issue, J. Amer. Vet. Med. Assoc., 164, 623-629 (1974).
- [6] Wagner, J. C., Berry, G., Cooke, T. J., Hill, R. J., Pooley, F. D., and Skidmore, J. W., Animal experiments with talc, in Inhaled Particles and Vapours, IV, W. C. Walter, ed., New York, Pergamon (in press).
- [7] Gibel, W., Lohs, K., Horn, K.-H., Wildner, G. P., and Hoffmann, F., Tierexperimentelle Untersuchungen über eine kanzerogene Wirkung von Asbestifiltermaterial nach oraler Aufnahme, Arch. Geschwulstforsch, 46, 437-442 (1976).

Discussion

M. SCHNEIDERMAN: Dr. Moore completed his paper considerably earlier than the time allotted. Are there some questions concerning this particular elaborate set of experiments, and the experiment design? Are there some suggestions that people would have? When the results come in from these experiments, what kinds of doubts will exist in your mind? What sorts of things would you like to see answered that these are not going to answer? I hope that there are people here that have thought about these and might have some questions.

V. WOLKADOFF: Evidently Dr. Moore has brought up chrysotile, the short size range sample from Edra and the intermediate size sample from Jeffry, and an evaluation of the size by specific surface area. Amosite was size fractionated by air-jet milling, and tremolite, evidently by milling of some type, to minus 325 mesh. The chrysotile more or less has been characterized by specific surface area. Do you have information, within each of these categories, as to the crystallinity of the individual fibers, the four categories versus degradation of the crystallinity of individual fibers by the method of preparation, or is it too early to say? You mentioned data by x-ray diffraction, DTA, and optical microscopy. I also wanted to know if you are going to include the electron diffraction results in your studies.

J. MOORE: I think I mentioned the electron diffraction work as part of the study, and I'd rather let the Bureau of Mines personnel, who are here, or the IITRI personnel, answer your question with regard to the crystallinity. I'm sure it has been looked at, but I don't know if the data are in such a stage to make any comment about it.

WOLKADOFF: What about air-jet milling of amosite, do you have any data now?

MOORE: No, if I did, I would have presented it.

WOLKADOFF: The tremolite data also, you don't have anything then?

MOORE: No sir, it's not in complete form. As I mentioned in the paper, the characterization of the two chrysotile samples and the tremolite sample should be available within the next couple of months, and we would expect that the similar types of studies characterizing the amosite and the crocidolite will be done by the end of the year.

WOLKADOFF: Thank you very much.

W. CAMPBELL: All the data has been completed on tremolite, including optical microscopy, SEM, TEM, chemical data, and surface area. On chrysotile, the optical data is finished, the SEM data is about completed, and the TEM is about completed. So in answer to your question there are very extensive data available on the optical properties, the morphology, the crystallinity, the trace metals, and so forth. Surface area is just one of the many parameters being investigated.

MOORE: I may have misled you in my presentation by only showing the slide on surface area; I did that one because it did show a distinction between the two chrysotiles. I would point out that we do not wish to infer that there is a clear separation of fibers between these two materials. Certainly the intermediate range chrysotile sample does have fibers that are well into the size range of fibers that are found in the short range sample. The distinction between the two is the proportion of fibers that may exceed, with respect to length and diameter, those that were found only in the short range.

G. WRIGHT: You quite properly pointed out that the kind of occupational exposure which has led to what we know about tumor incidence is quite different from what's found in water supplies. In fact, the differences are very striking. On the other hand, in occupational exposure generally, and I say would say almost without exception, the percent of the total fibers that exceeds eight to ten and even five μm in length is of the order of less than five percent, and in many situations is only one or two percent. In the animal experiments that have been done by inhalation of asbestos, in general, the clouds created contained only one or two percent of what we call long fibers. For this reason, I think that to look at your samples in terms of percent, inferring that one, two, or three percent of long fibers present in a sample is acceptable when you're talking about short fiber samples is erroneous. We need to get around to the number of long fibers, not the percent. Now also I would like to ask if these experiments are designed to look at the occupational experience or at the water experience?

MOORE: I would hope that they would have relevance in both areas.

WRIGHT: What percent or what number of long fibers are still present in your so-called short sample?

MOORE: Well, at what length do you want to consider as a long fiber?

WRIGHT: Anything over 5 μm , because in water, you've said, it is under 5.

MOORE: I recall the raw data that are available on that; about 90 percent of the samples in the short range chrysotile would be below that.

WRIGHT: In other words, ten percent are still above 5 μm ?

MOORE: Right.

WRIGHT: Well, that's essentially what the occupational exposure is. I don't think you're looking at water related exposures.

W. BANK: I'll change the subject slightly. There have been some animal nutrition studies going on since 1965 in Japan, and more recently in the U.S., in which fibrous material, namely certain zeolites, have been fed to these animals. The results were that the animals gained weight faster, certain diseases seemed to disappear, and so on. It's recognized, however, that there is a possible long-range pathological effect that might be involved because of the fibrous materials. Have you heard or do you know of any such information?

MOORE: I'm not aware of that work coming out of Japan.

C. COOPER: I strongly support the observation made by George Wright that the 10 percent or even 5 percent of long fibers in your short fiber samples would leave serious doubts as to whether the results of these experiments would be applicable to water supplies. Another question that has bothered a number of people is whether or not consideration was given, in the design of this experiment, in the choice of samples, to actually including a sample of the material that has contributed a great deal to this whole controversy. That is, the amphiboles that are found in Lake Superior water, in the size distribution in which they were found. I can see the difficulties in doing this, but I wonder just what the course of reasoning was that led to this type of material not being included?

MOORE: We were advised, and I must say we also subscribe to the opinion, that with regard to ingestion studies we might, in an initial series of experiments, be better off by using materials that are known to have biological effects in test species. This is where we opted to go with the amosite, for example; it's probably the closest thing we have to being representative of a cummingtonite/grunerite which is the Lake Superior type of sample. The other problem that we had when we did discuss the possibility of using something from the water in that area, was the complete lack of agreement among people we talked to with regard to what actually should be the sample that would come out of that area. In addition there was the logistics of trying to get that sample; it was just that simple. I would also state that with regard to fiber size, maybe having too many fibers above 5 μm to permit direct relevance or extrapolation to municipal water supply samples, as was pointed out by Dr. Wright and yourself, I assume you gentlemen would accept a negative.

A. SUNDARAM: You quoted Dr. Gibel's paper from East Germany. Do you believe that study was well conducted, showing a significant effect of asbestos by oral ingestion?

MOORE: All I can comment on is the information which was available in the reprint, which brings questions to mind which certainly aren't explained in the materials and methods. For example, how they prepared the material, actually what was the other 48 percent since they inferred that 52 percent of the material was chrysotile. I think this sample size data may have some problems as well.

SUNDARAM: I agree to that, but in addition there is a significant point worth noting. The paper never mentions the number of animals affected over the control. There should be a significant increase in the number of animals that had tumors, not a significant increase in the number of tumors, because it may be one animal that had twelve tumors or it may be 12 animals that had 12 tumors. So it is the number of animals that were affected that's more important than the number of tumors. This paper has been quoted many times even though it just appeared in 1976. So many people quote it, and I thought it's better to point out this significant question that we should not miss.

MOORE: I thank you for your point, because the paper does not indicate as to whether, for example, the 12 malignant tumors found in 42 treated animals came from 12 separate individuals, or whether it was one or more animals which may have had multiple tumors.

D. ALTON: I am really wondering whether a dosage of 100 milligrams per day per unit weight of rat for the lifetime of a rat is comparable to the ordinary ingestion of asbestos fibers by man. Is there any relationship between those two figures for rat and man.

MOORE: I don't remember quoting 100 milligrams per rat per day, but suffice it to say that the level of asbestos that's in a diet at the 1 percent level certainly is in the high range of exposure.

COOPER: I have a very crass and practical question to ask. I know it's a matter of public record what a study of this magnitude costs, what kind of investment it involves, but I think the group would be interested in knowing just how much a major study like this represents in cost.

MOORE: It's estimated that by the time the studies that I have outlined are completed, which will include the characterization of the materials as well, it will probably be somewhere around 3-4 million dollars.

EPA STUDY OF BIOLOGICAL EFFECTS OF ASBESTOS-LIKE MINERAL FIBERS

D. L. Coffin

EPA Health Effects Research Laboratory
Research Triangle Park, North Carolina 27709

and

L. D. Palekar

Health Effects Research Laboratory
Northrop Services, Inc.
Environmental Sciences Group
Research Triangle Park, North Carolina 27709

Abstract

A large amount of the earth's crust is composed of rock containing mineral fibers which resemble asbestos to varying degrees in their physical and chemical properties. Consequently, such materials are likely to be encountered inadvertently during the extraction of various ores, the extraction of rock for commercial purposes, and even from rock moving operations encountered during highway construction, and the like.

Because the air and water may become contaminated by these fibers, it is of interest from the standpoint of environmental protection to know how the biological effect of such material compares with that of asbestos. Consequently, a study has been instituted by EPA to investigate the relative biological potency of such materials. The project is being approached on both in vivo and in vitro levels. The minerals being studied at the outset are fibrous amphiboles from a taconite mine, but it is the intent to broaden these studies as soon as possible. The animal studies are being conducted in pathogen-free rats by intratracheal instillation (with and without interacting organic carcinogens) and by intrapleural injections. The end points are tumor induction and other chronic diseases. Attention is also being given to early pathogenic sequences.

The in vitro studies consist of red cell lysis, pulmonary macrophage systems, and various biological and chemical studies connected with the influence of these agents on cell membranes and interaction with mutagens and carcinogens. The prime objective is to compare the biological effect of the minerals studied to the corresponding asbestos species to determine the comparative influence of such co-variables as fiber length, trace element content, surface area, zeta potential, and the like, on the biological outcome. Thus, the study will relate biological activity to mineralogical characterization so that generalization can be made on the basis of such factors.

Key Words: Alveolar macrophages; hemolysis; intrapleural injections; intratracheal instillation; multinucleated giant cell; PMP I; PMP II; Polyp.

The hazards for human health associated with the extraction and handling of various members of the commercial asbestos series are now well known. However, a new issue has recently come to the forefront of environmental toxicology concerning the possible health hazard from inhalation or ingestion of fibrous silicate minerals, not asbestos per se, that contaminate the air and water. Such silicate materials are ubiquitous in the earth's crust where amphibole-bearing rocks may serve as a potential source for a number of mineral species, for example, fibers from the cummingtonite-grunerite series, hornblende, etc.

When the above-mentioned facts became known, there was a tendency to class all of these materials as "asbestos" and to try to make inferences concerning their potential health effects in man merely on the basis of supposed analogy to commercial asbestos. We know now, however, that there is an enormous variation in these materials; some closely resemble the corresponding asbestos, and others do not. It would be folly, therefore, to base the threat to human health solely on such a crude determinant. This is particularly true since, despite the great number of epidemiological and biological studies carried out with asbestos, much remains to be learned concerning the exact causal mechanisms of the various lesions attributed to such exposure. For instance, one cannot safely postulate a common etiological mechanism for the usual lesions of asbestos exposure such as pulmonary fibrosis, carcinoma of the lung, and mesothelioma, and the possible role of asbestos for tumors in other locations which at this time is largely unexplored.

Because of these issues, the Environmental Protection Agency (EPA) has taken the initiative to study these matters to determine if a threat to health exists from non-asbestos minerals, and if it does, by means of its quantification, to determine how best to control it on the basis of health benefit versus cost. EPA is conducting a study of the relative pathogenic potential of such minerals compared to asbestos, silica, and other particulate substances of known toxicity. The prime purpose of these experiments is to relate biological effects to the physiochemical properties of the minerals. Beginning with the convening of an advisory committee, the following approach evolved, which includes mineralogical as well as biological studies.

Mineralogical Studies

Intensive study was made from 50 large rock specimens removed from a taconite mine. After preliminary lithological examinations, two of these were selected for employment in biological experiments, which are designated as PMP I and PMP II. Fibers were separated from the rock by such means as mechanical vibration, hand cobbing, air jet milling, spinning, and riffling. The final specimens were subjected to a detailed analysis by means of optical and electron microscopy, x-ray emission spectroscopy, and x-ray diffraction. Computations of surface area and determination of extractable organics were made. Comparisons were also made on the basis of the above parameters with UICC amosite (fibrous grunerite) and airborne material collected in the vicinity of the mine and the ore processing plant. On the basis of the above measurements, a decision was made to prepare a large amount of this material suitable for biological experimentation.

Figures 1 through 8 and Tables I-III illustrate various mineralogical characteristics of the samples chosen from the mine for biological studies, as well as samples from the airborne material in the vicinity of the mine and ore-processing area. Figures 1 and 2 represent electron micrographs of air samples from mine and processing areas respectively.

The chemical analysis of air samples revealed that in addition to magnetite and quartz particles there were predominantly two other types of minerals in both areas. The electron microscope x-ray analysis revealed the presence of Mg, Si, Ca, Mn, and Fe in one sample (fig. 3), whereas the second sample contained only Mg, Si, and Fe (fig. 4). Data from a careful analysis of size distribution of the air samples are presented in Table 1, showing two samples from each of the processing and mine areas. The majority of the particles in both areas were found to be less than 5 μm in length and less than 1 μm in diameter. A small percentage of particles were between 5 and 10 μm in length, with varying diameters. Air samples from the processing areas contained 66 to 70 percent fibers with diameters less than 0.5 μm as compared to 52 to 55 percent in the mine area. This may suggest that further fibrillation of the rock occurs during the processing.



Figure 1. Air sample from mine area showing long and straight fibers (10,000x).



Figure 2. Air sample from the area of processing plants also showing long and straight fibers (10,000x).

2/2

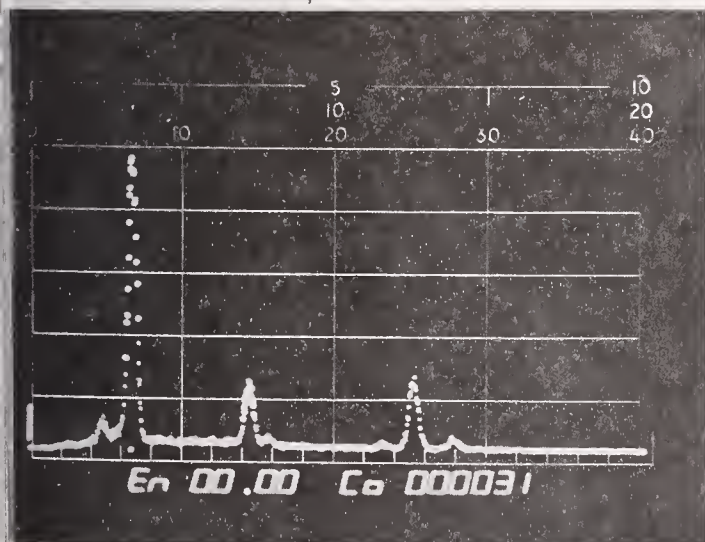

Figure 3. Electron microscope x-ray spectra of air sample indicating the presence of Mg, Si, Ca, Mn, and Fe.

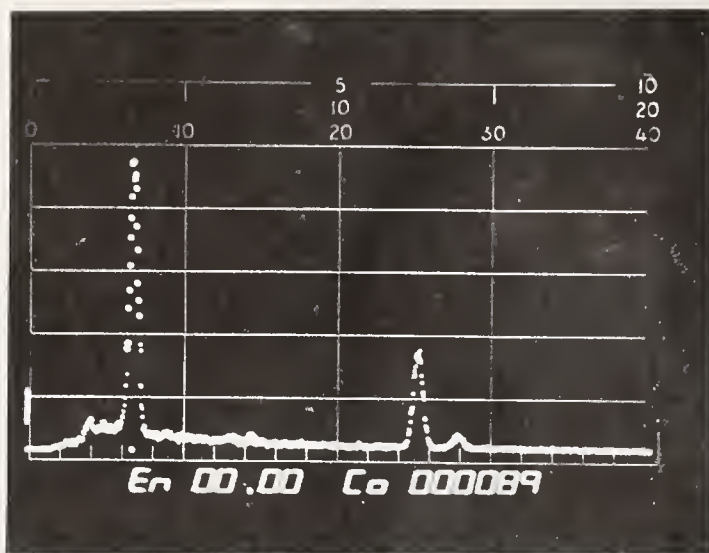

Figure 4. Electron microscope x-ray spectra of air sample indicating the presence of Mg, Si, and Fe.

Table 1. Summary data of size distribution of mineral fibers in ambient air samples.

- - - - - Lengths by Percent Number in Microns - - - - -

	<1	1-5	5-10	>10	Total
Air Sample No. 1					
<0.50	9	71	5	0	
0.51-1.00	0	12	2	0	
>1.00	1	0	0	0	
Total	10	83	7	0	100
	← 93%		×	7%	→
Air Sample No. 2					
<0.50	8	66	2	1	
0.51-1.00	0	13	1	0	
>1.00	0	2	6	1	
Total	8	81	9	2	100
	← 89%		×	11%	→
Air Sample No. 3					
<0.50	5	55	2	0	
0.51-1.00	0	21	4	0	
>1.00	0	4	8	1	
Total	5	80	14	1	100
	← 85%		×	15%	→
Air Sample No. 4					
<0.50	9	52	5	0	
0.51-1.00	0	21	3	0	
>1.00	0	3	5	2	
Total	9	76	13	2	100
	← 85%		×	15%	→
	Below 5 μm			Above 5 μm	

Diameter by Percent Number in Microns

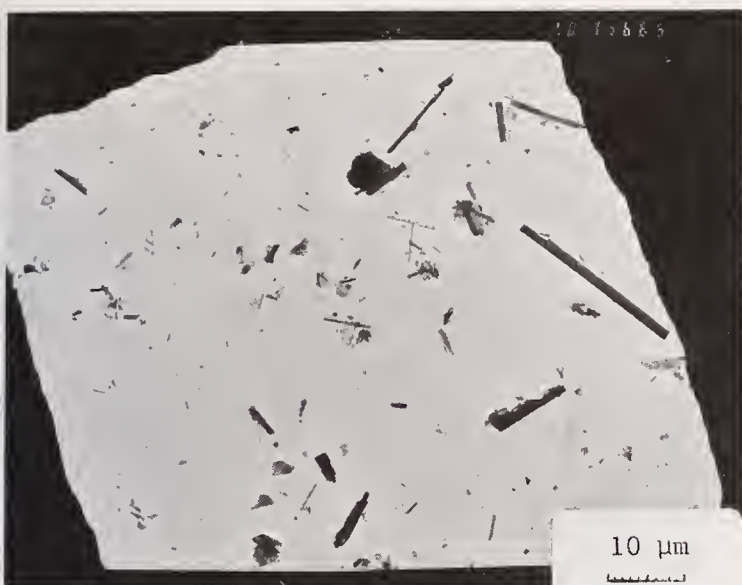

Figure 5. Electron micrograph of PMP I showing long and straight fibers with acicular particles (1000x).



Figure 6. Electron micrograph of PMP II indicating long and straight fibers and particles (1000x).

The electron microscope x-ray emission spectra of the fibers collected from the two rock samples revealed the presence of Mg, Si, Ca, Mn, and Fe on PMP I (fig. 7); and Mg, Si, and Fe on PMP II (fig. 8). The size distribution of the samples is given in Tables 2 and 3. The data indicate that the majority of the fibers are less than 5 μm in length and less than 0.5 μm in diameters in both samples.

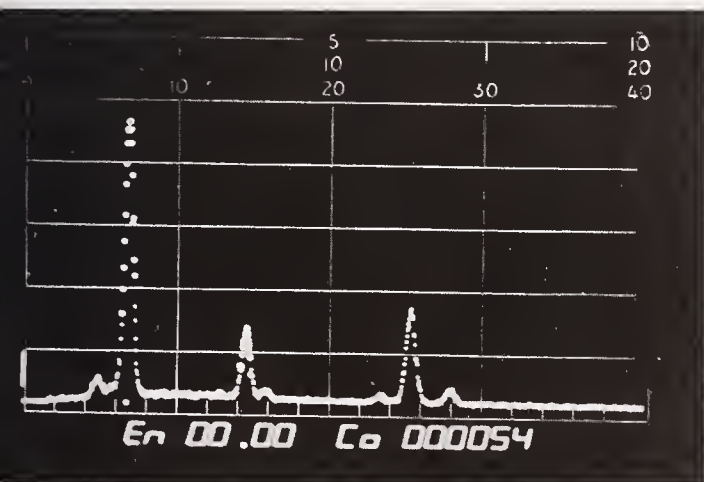

Figure 7. Electron microscope x-ray spectra of PMP I showing the presence of Mg, Si, Ca, Mn, and Fe.

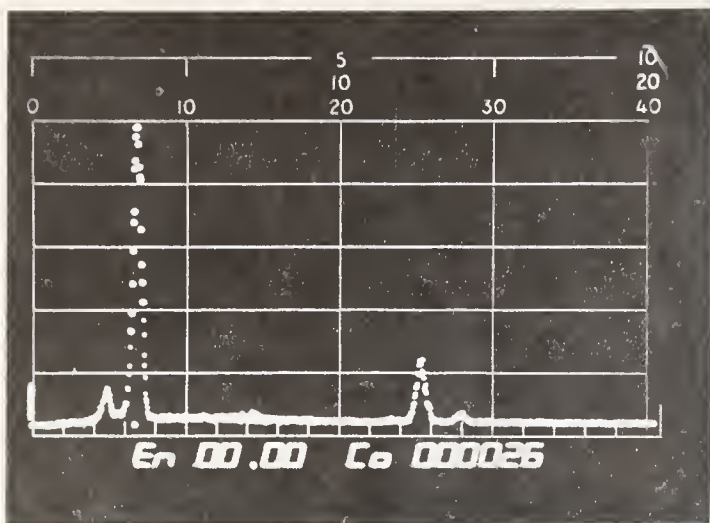

Figure 8. Electron microscope x-ray spectra of PMP II showing the presence of Mg, Si, and Fe.

Table 2. Size distribution of PMP I sample.

----- Lengths in Microns (μm) -----						
	0.00 - 0.50	0.51 - 1.00	1.01 - 5.00	5.01 - 10.00	10.01 - 25.00	Total
0.00 - 0.50	1.47	8.09	68.38	2.94	0.73	81.6
0.51 - 1.00	0.00	0.00	5.88	2.94	0.00	8.8
1.01 - 2.00	0.00	0.00	4.41	0.73	0.73	5.8
2.01 - 5.00	0.00	0.00	0.00	0.00	2.94	2.9
5.01 - 10.00	0.00	0.00	0.00	0.00	0.73	0.7
	←----- 88.23 -----→			←----- 11.74 -----→		99.9
	Below 5 μm			Above 5 μm		

Diameter by Percent Number in Microns

Table 3. Size distribution of PMP-2 sample.

	Lengths by Percent Number in Microns			
	<1	1 - 5	5 - 10	10 - 15
0.00 - 0.50	27.06	41.53	0	0
0.51 - 1.00	0	18.01	5.50	1.80
>1.00 - 10	0	0.80	3.90	1.80
	27.06	60.34	9.40	3.60
	←----- 87% -----→		←----- 13% -----→	
	Below 5 μm		Above 5 μm	

Diameter by Percent Number in Microns

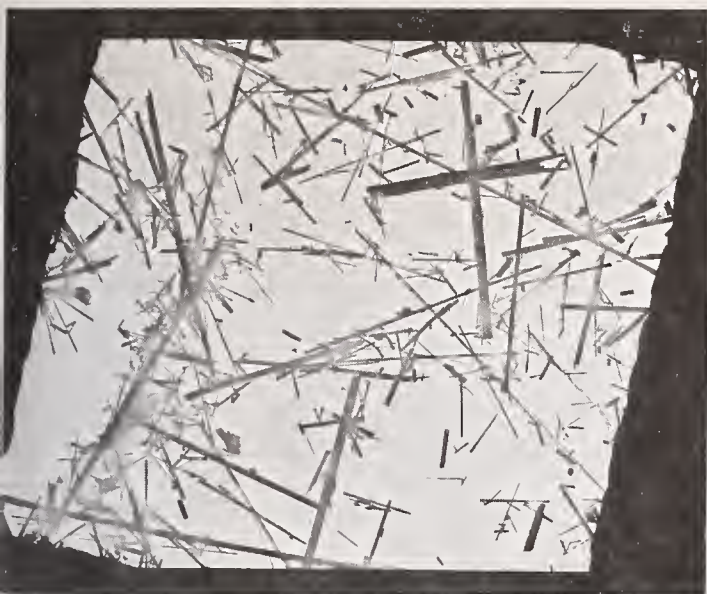

Figure 9. Fibrous grunerite (UICC amosite) showing the general shape of the particle which is long and straight (1000x).

Since the air samples and the rock samples seem to be representative of the grunerite family, a fibrous grunerite, namely UICC standard reference amosite, with known biological properties, was selected as a possible control for the studies, and characterized. The electron microscope x-ray analysis of amosite indicates the presence of Mg, Si, and Fe (fig. 10). Size distribution data for this material are presented in Table 4. Eighty-seven percent of the fibers were found to be less than 5 μm in length and 1.5 μm in diameter.

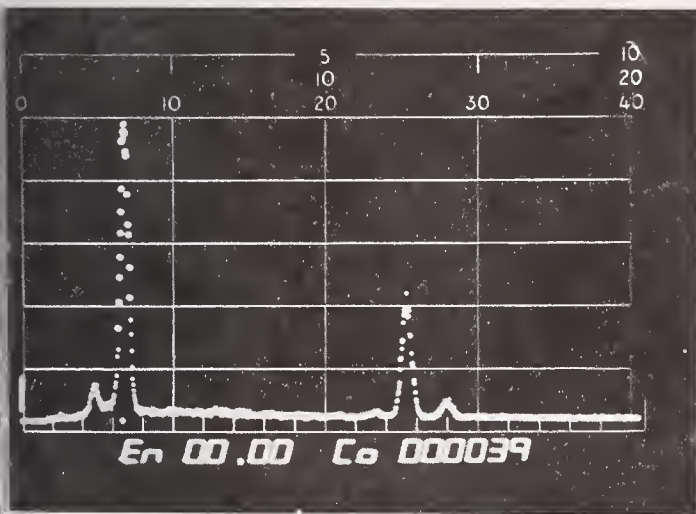

Figure 10. Electron microscope x-ray spectra of fibrous grunerite (UICC amosite) indicating the presence of Mg, Si, and Fe.

Table 4. Size distribution data of UICC amosite by IITRI method.

----- Lengths Distribution (by percent number), in Microns -----

	0.2-0.5	0.5-1	1-2	2-5	5-10	10-25	25-50	50-100	100-200	Total
0.00-1.10	15.90	3.48	1.64	1.80	0.57	0.20	--	--	--	23.39
1.10-0.40	8.69	13.49	18.24	16.40	5.16	1.68	0.41	0.20	0.01	64.28
0.40-1.50	--	--	2.54	4.75	1.31	1.84	2.69	0.20	--	12.93
	← 87%				← 7%		← 6%			

Diameter by Percent Number in Microns

The air samples, the fibers obtained from rocks, and amosite fibers were examined by electron microscope for their general shape. All samples contained straight and long fibers and acicular particles (figs. 5, 6, 9). These photographs are not representative of the size distribution.

Biological Studies

Toxicity evaluations are proceeding both in vivo and in vitro. Whole animal experiments are being carried out to determine the comparative effect of the above-mentioned mineral fibers in inducing lesions such as pulmonary fibrosis, lung cancer, and pleural mesothelioma. Basically, a comparison between a test amphibole of the cummingtonite-grunerite family, UICC amosite, and an inert particle is intended. These studies are being conducted in Fisher 344 pathogen-free rats during their life span. The particles are administered to the animals by intratracheal instillation and intrapleural injections. In vitro studies are conducted on sheep blood erythrocytes and rabbit alveolar macrophages. The cytotoxicity is evaluated by quantitation of red cell hemolysis and cell death respectively.

In Vivo Studies

The doses for the intratracheal instillations were determined by an initial range-finding study. Several doses of the particulates were administered to the animals and the highest tolerated dose was determined. Two series of intratracheal studies are planned. Inoculation of the animals in the first series is complete. The second series will be initiated in the near future.

Chronic Intratracheal Testing of PMP Amphibole

The first series will determine whether the particles alone cause significant toxicity to animals. The regimen for this series is as follows:

Series I:	Unknown Sample - PMP I Amphibole	600 animals
	Asbestos Control - UICC Amosite.....	200 animals
	Negative Control - Saline and Gel.....	200 animals

Chronic Interaction Studies by Intratracheal Instillations

The purpose of the second series is to determine whether the particles will interact with a known carcinogen to produce a higher incidence of tumors. A known amount of benzo(a)pyrene (BaP) will be coated on the particles to compare the synergistic effect of the carcinogen with amosite, the test amphibole, and hematite. The regimen of this series is as follows:

Series II:	PMP I Amphibole + BaP.....	300 animals
	UICC Amosite + BaP.....	300 animals
	Iron Oxide + BaP.....	300 animals
	PMP I Amphibole.....	200 animals
	Iron Oxide.....	200 animals
	BaP.....	200 animals

Chronic Intrapleural Testing of PMP Particles

Intrapleural studies employing 20 mg of particles injected once into the pleural cavity are being carried out as follows:

Series III:	Unknown Sample - PMP I Amphibole.....	150 animals
	Asbestos Control - UICC Amosite.....	150 animals
	Negative Control - Saline.....	150 animals

In addition to the lifetime experiments, exploration of the pathological sequences induced by these materials in the lung is in progress by experiments in which sequential sacrifices are being carried out. Figures 11 and 12 demonstrate epithelial polyps and fiber-containing giant cells observed in the parenchyma of rats treated with 12 weekly injections of 1 mg of amosite or the test sample PMP I, 50 days after the last inoculation. The polyps essentially consist of several multi-nucleated giant cells covered with columnar epithelium.

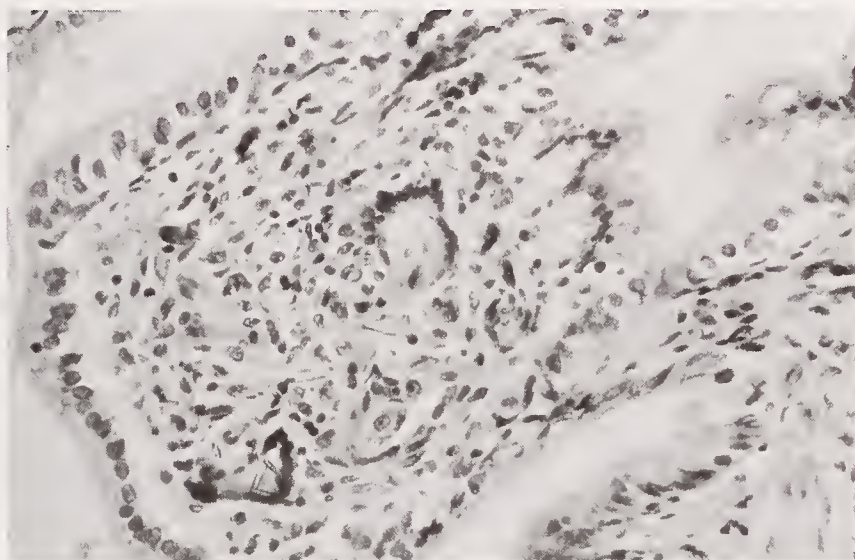

Figure 11. Epithelial polyps observed in the bronchi (250x).

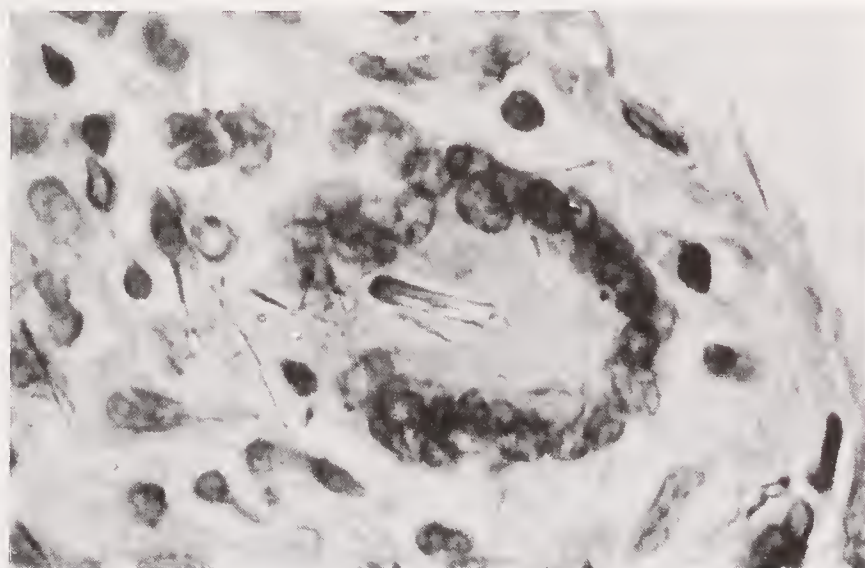

Figure 12. Multinucleated giant cell containing fibers (1000x).

In Vitro Studies

The second part of the biological studies consists of *in vitro* investigation to determine cytotoxicity of the particles. Two techniques are employed, namely, sheep erythrocyte hemolysis and rabbit alveolar macrophage destruction. A comparison was made between several commercial asbestos samples of known biological properties, PMP I and non-fibrous grunerite. The data presented in figure 13 suggest that the amphiboles are not as hemolytic as chrysotile fibers, requiring large doses to achieve 50 percent hemolysis. Among the amphiboles, anthophyllite, PMP I, and tremolite are similar in their effect. Crocidolite and amosite seem to be less hemolytic. In contrast, non-fibrous grunerite is non-hemolytic. In the rabbit alveolar macrophage study, amosite and PMP I caused marked depression of cellular viability, whereas non-fibrous grunerite showed no significant change in cellular viability (fig. 14). The sample PMP II is not yet tested.

A second advisory committee was convened to consider further investigations to increase our understanding of the mechanisms of mineral interactions with the biological systems. It was the opinion of the committee that the comparative study of minerals should be started as soon as possible. On the basis of the existing data, produced by different laboratories throughout the world, the problem of contamination of the environment with inorganic fibers may pose a significant health threat. Indeed, it may shed significant light on existing problems, e.g., asbestos in potable water supplies, asbestos released from degraded asbestos cement water pipes, natural sources, etc.

The selection of minerals and bioassays are as follows: fibrous and non-fibrous grunerite will be collected from different geological localities and their biological properties will be compared. The careful mineralogical analysis and bioassays may indicate whether there is some influence in terms of the crushing process that may create new fiber surfaces not present when communiting materials from other areas.

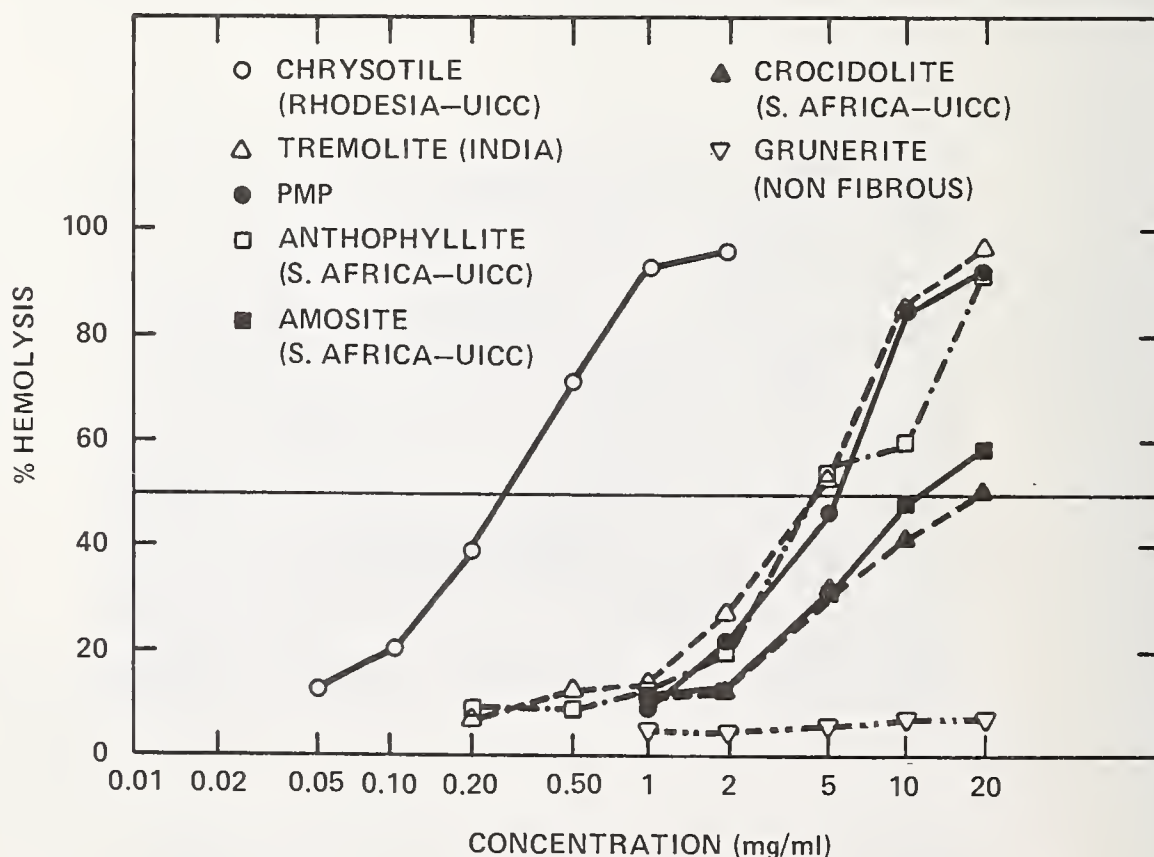

Figure 13. Hemolysis of sheep erythrocytes by various minerals.

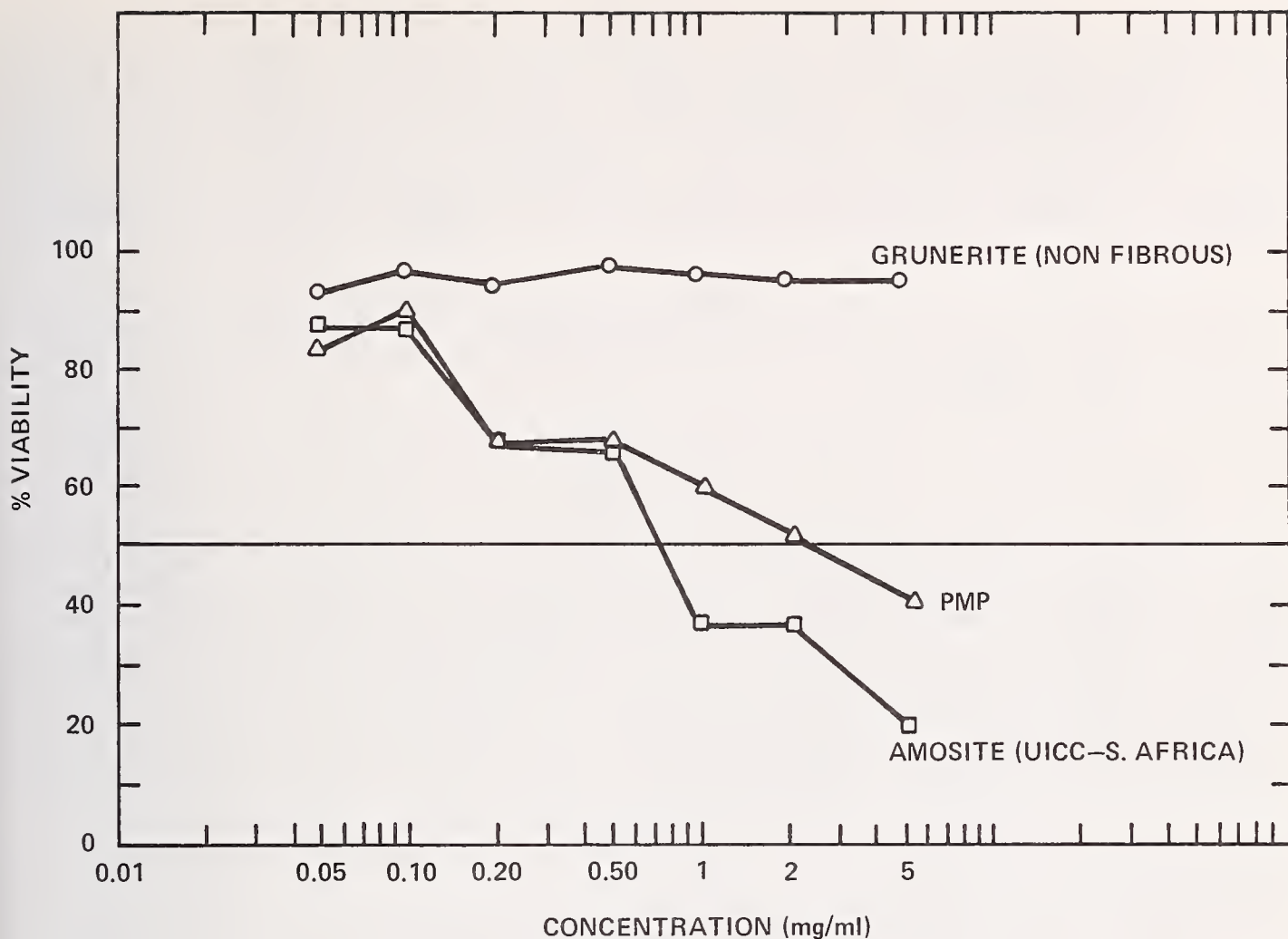

Figure 14. Cytotoxic effect caused by various minerals when exposed to rabbit alveolar macrophages.

For a proper comparison, a standard reference sample of fibrous grunerite (UICC amosite) containing particles of mixed sizes, and another sample specially prepared with short fibers will be used. Since relatively short fibers are observed in Lake Superior, the information obtained from these fibers will be useful.

Fibrous cummingtonite with a high magnesium content from several geological localities will also be studied for comparison to determine if different processing methods may alter surface properties and, in turn, affect the biological properties. In addition, minerals of known biological properties, such as UICC anthophyllite, UICC chrysotile A, chrysotile RG 144, UICC crocidolite, Indian tremolite, UICC actinolite, antigorite, fibrous glass, and quartz will be studied for comparison. Several assays will be employed to evaluate the biological properties of the minerals. The direct toxicity of the particles will be tested by hemolysis of sheep red blood cells, viability of rabbit alveolar macrophages, human lung fibroblasts such as strain WI-38 and perhaps the mouse ascitis tumor cell line P3881. The possible mutagenic effects of these materials will be evaluated in well-established mutagenesis test systems, such as the Ames test and the 5178Y mouse lymphoma cell assay. Neoplasm induction will be tested by the use of tracheal transplants, as well as transformation of Syrian hamster embryo (SHE) cells, or mouse fibroblasts, such as the C3H 10T_{1/2} or BALB/c 3T3 cell lines.

Conclusion

Preliminary in vitro tests show that both fibrous grunerite and PMP I amphibole are lytic to sheep erythrocytes and depress the viability of rabbit alveolar macrophages, while non-fibrous grunerite is inactive in both systems. The biological significance of these studies is at this time unclear. Hopefully the proposed investigation will contribute sufficient information to correlate mineral properties to health hazards associated with inhalation and/or ingestion of minerals other than the known commercial asbestos.

Mineralogical characterization was done by Illinois Institute of Technology, Chicago, Illinois. Contract #68-02-2451.

Discussion

C. COOPER: I want to congratulate Dr. Palekar for the description of what is getting under way, and the great care that has been taken apparently to obtain test materials that at least resemble some of the fibers in the taconite areas. I think an important question is how representative this is of the entire Mesabi range and I personally don't have figures available to me as to whether or not the size distributions found at the Peter Mitchell pit are representative of a larger area. I wonder if anybody in the audience here, or Dr. Palekar herself, have data on other areas in the Mesabi range to answer the question as to whether or not 15 percent, approximately, of the fibers are longer than 5 micrometers in length, because the representativeness of this sample is going to be, I think, an important issue in the future, and I wonder if anybody could address themselves to that?

L. PALEKAR: I don't have a clear-cut answer to your question, but if somebody in the audience wants to answer that...

A. LANGER: You mean the representativeness of the Peter Mitchell fibers?

COOPER: Yes.

LANGER: It's unlike anything in the rest of the Mesabi.

COOPER: Are there air samples in other areas with this same distribution?

LANGER: No there are not. Unfortunately for the Reserve Mining Company, the situation at the Peter Mitchell pit is unique for the Mesabi range. The mineral fibers have been originated through contact metamorphism with the Duluth Gabbro, which metamorphose the pre-existing materials here. Now Malcolm Ross is here, who has done work on the amphiboles in the area. He knows a great deal about the geochemistry of the amphibole/pyroxene phases; this is a high temperature metamorphic assemblage, while the rest of the Mesabi range, the rest of the Biwabik iron ore formation, are generally considered to be low temperature iron silicates. They do have problems with fibers, but these may not be as important biologically as the asbestiform amphiboles in the Peter Mitchell pit. This is just unique for that particular area.

W. NICHOLSON: In looking at the fiber distribution in other than the Reserve Mining areas, they are of a smaller size distribution and tend, rather than being regular fibers, (that is with collinear sides) to be chips of fibrous length. They are irregular fragments rather than the natural fibers that we've been hearing of, and they are in general of a size distribution somewhat smaller than that which has been described here, but there are many fibers (that is defined by a 3 to 1 length to width ratio) that are present in other areas.

P. GROSS: I would like to comment on the two microphotographs of tissue which Dr. Palekar showed. I was most interested in the visualization of fibers at that magnification, which indicated that the fibers were quite long, much longer than 5 microns. As a matter of fact, one of the fibers that I saw, where one of the giant cells was, was as

long as a giant cell, which probably was in the neighborhood of 100 μm in length. Also the photomicrograph of the bronchial-polyp, this sort of picture has been produced in my laboratory with long fibers of any kind: glass, silicon carbide, aluminum silicate, as well as asbestos. Again, it suggests the presence of a fairly considerable number of long fibers, and it seems to me that may be a reflection of an exceedingly high dosage administered even though your long fibers were less than 15 percent of the total.

PALEKAR: Yes sir, we administered the highest tolerable dose. The animals received twelve weekly injections of 1 mg.

A. WILEY: Since there seems to be a good deal of controversy about what's a fiber and what's not a fiber, I was interested in your characterization of a grunerite sample as non-fibrous and I'd like to know what you meant by it.

PALEKAR: The particles are not completely characterized at this time and it was presumptuous on my part to present the data. This is really a very preliminary study and no conclusions can be drawn at this time. We have asked our colleagues from IITRI to analyze this properly. Thus far I have just taken their word for the non-fibrous nature of the particles.

G. NORD: Yesterday we saw a great deal about the mineralogy of amphiboles. One of the things that was brought up was the defect structure of amphiboles. Amosite has a very high defect density; it's polysynthetically twin on a unit cell scale. The grunerite that you used, or I should say the minerals that you used from the Mesabi range sample, may have an entirely different defect population. Is there going to be any attempt to characterize this defect population? That could also go for the characterization of the samples discussed by the previous speaker. I have one other comment: It's not enough to characterize a fibrous mineral strictly by an energy-dispersive analysis. You cannot tell the difference between a low calcium pyroxene and a low calcium amphibole. It is not enough to characterize a low calcium amphibole merely by knowing its chemistry. It also has a different structure; you have orthorhombic amphiboles and you have monoclinic amphiboles. Grunerite/cumingtonites are monoclinic. You also have anthophyllites which are orthorhombic. If one is to characterize these samples adequately so one can separate out the very small differences, perhaps in the experimental data, you will have to do a great deal more work.

PALEKAR: Well, this paper is by no means the entire story. I never said that this is it, that this is the only thing we are going to do. We are open to ideas and we are going to characterize many more minerals more thoroughly; this is just the beginning and we intend to do further analyses.

B. SMITH: Dr. Palekar, I believe you said that the EM measurements that you had on a standard reference sample of amosite, UICC amosite, was showing about 87 percent of the particles shorter than 5 μm , and that the measurements that you had on the preparation, the PMP preparation that you made from taconite rock, showed about 85 percent of fibers running below 5 μm . Now, as I looked at the photographs you showed, the photographs of the taconite preparation had a micron scale on them, so we were looking at fibers that were being compared with a 1-micron scale. They didn't seem to be more than, or only a little bit more than the scale. They looked to me about 2 or 3 times the size of the scale, so I guess they were fibers that were about 2 or 3 μm long. In comparison, the photograph you showed of the UICC amosite was fitted with a 10-micron scale and there were an enormous number of fibers visible in that photograph that were much longer than the 10-micron scale. This presents a problem that has puzzled me many times in samples that I've looked at, where we've gotten electron microscopy measurements that are telling us that two samples really are about the same as far as the mean fiber length is concerned. When I look at them with an optical microscope, it's very apparent to me that there are an enormous number of long fibers that I can easily see at say 400X in one sample, and with the other sample that electron microscopy figures are telling me is about the same, I have a tough time seeing any fibers. Now how do we get around this problem?

PALEKAR: Yes, I agree with you wholeheartedly and I had the same questions to our mineralogist. The electron micrographs of the fibers are not representative. It is known that there is a tremendous variation between samples. One must make an effort to use the

same sample for mineralogical analysis and biological evaluations to establish a proper relationship between the two.

D. WALIA: I don't have a question but I'd like to address myself to some of the comments regarding the preparations and characterizations that we did for Dr. Palekar. The comment that electron microscopy is not the only criteria to distinguish one fiber from another is true, and we did not depend only on that. Instead we picked up the fibers from the filter samples, mounted them on glass fibers, and then performed x-ray diffraction studies on them. We then compared the data with the known fibers from the taconite mines, and also with the ASTM standards, and from that we were able to identify or pinpoint their identity as to the mineral species. Second, regarding the size distribution comments, if you remember the tables Dr. Palekar showed, in the case of UICC amosite, where we have compared our size distribution data, which is both by diameter and by length, you get a comparison within ± 6 percent. I believe this is a good comparison and from the table you see that UICC amosite has fibers which are as long as 200 μm . When we look at the taconite samples, which we have prepared, and the size distribution data, you see that there is no fiber greater than 20 μm . To my knowledge, from all the taconite rock samples I've seen, I've never come across any mineral fiber which, even using this ambiguous three-to-one aspect ratio criteria, that I can say is 200 μm in length. Another comment I'd like to address myself to is about the non-fibrous grunerite we used. This non-fibrous grunerite, which has some preliminary results that Dr. Palekar showed, was the one we got from bawabush iron ore formations in Canada, and the non-fibrous nature of this is based on the lack of flexibility of the fibers which you commonly see in UICC amosite type materials.

NOTE: The following notes were sent following the meeting and were not part of the verbal discussion at the end of the session.

GROSS: Dr. Palekar's description of the bronchial lesions that develop in animals following the intratracheal injections of long-fibered asbestos as "polyps" deserves explanation.

A polyp is generally conceived to be a tumor - a neoplasm. The intrabronchial lesions developing in animals after intratracheal injections of asbestos are not tumors. The lesions are composed of inflammatory tissues that surrounds impacted, aggregated asbestos. The inflammatory tissue extends (often in a finger-like manner) into the bronchial lumen and, in time, becomes covered by normal-appearing bronchial epithelium - hence its resemblance to a polyp.

R. BLEIFUSS: The reports submitted by the Illinois Institute of Technology Research Institute (IITRI) regarding the origin of the sample materials to be used in these biological studies indicates that the source material represents an unusual situation within the Peter Mitchell Pit (PMP) of Reserve Mining Company. The original sample material represents a unique occurrence within the PMP in the same sense that the PMP may be said to be unique to the rest of the Mesabi Range. IITRI personnel collected more than 100 samples in their initial survey on which they carried out extensive mineralogy studies to characterize the ore. Based on this initial information the sample location from which they extracted the fibers for the biological study was selected as described below.¹

"On October 2, 1975, approximately 750 lbs of high fibrous content ore were located and collected. It was found that the ore containing rich fibrous veins was a very localized phenomenon. Such samples were available only near the incursion of the Duluth Gabbro and occurred only in two very localized areas within approximately 100 m of each other."

¹IITRI Report No. C6321C02-11, Final Report, Contract No. 68-02-1687, "Amphibole Mineral Study to Complement the Ongoing Characterization of Finely Particulate Environmental Contaminants for Biological Experimentation."

"Fibers were separated from fiber-rich rocks using several methods. Both hand and vibratory cobbing were used to separate fibrous material (~1.5 kg) in veins. Several rocks were found to consist almost entirely of soft, light green or brown fibrous material. These rocks were crushed, ground, and sieved (<35 mesh) to produce a material (~3 kg) with a high fibrous-to-non-fibrous ratio."

"These separated fibrous materials are not necessarily representative in all respects of the majority of the fibers in the ore in the Reserve Mine or in the tailings from the magnetite extraction at Silver Bay, Minnesota. However, this method was used as large quantities of materials with a large fibrous fraction could be produced more easily than by separating fibers from the ore or the tailings."

The mineral composition of the sample prepared from this "high fibrous" ore, which has been encapsulated for the biological studies, was determined by x-ray diffraction. The minerals "definitely present" include cummingtonite, riebeckite, and rich(t)erite. Minerals "present as trace material" were tremolite and crocidolite. However, the basic mineralogy studies on the 100 original samples include no mention of riebeckite, richterite, or crocidolite. Both the riebeckite² and crocidolite³ have been described in the literature and are present only in trace amounts in the Peter Mitchell Pit. The sodium in these two minerals is considered to be of metasomatic origin. Richterite was not reported by previous workers in the area which suggests that it may be the result of local hydrothermal activity. Thus the sample prepared for these biological studies contains three minerals which were either unreported or considered to be present in trace amounts by previous authors. These minerals are all commonly reported to be of metasomatic origin, meaning that some of the critical elements (sodium) for their formation was introduced from outside the iron formation. The occurrence of these minerals in veins further suggests that they are related to metasomatism.

The sample which was finally selected and processed to produce the fibers for biological studies appears to have a unique metasomatic origin, or at least some of the minerals in that sample are related to metasomatism. The sample is certainly not representative of the potential tailings from the PMP. It cannot be classified as typical since three of the finer most important mineral components are certainly atypical in the PMP area. The sample was selected to provide a high "fibrous" to "non-fibrous" ratio that was unobtainable from representative taconite samples.

Biological experiments on this sample will contribute little to the resolution of the problem pertaining to the possible carcinogenic nature of taconite tailings. The argument that it is a means of establishing a bridge between a known carcinogen (amosite) and a possible, or suspected carcinogen (cummingtonite in taconite tailings) is not realistic. The direction of the sampling program was to obtain a fibrous sample as analogous to amosite as possible. In so doing it is so far removed from being representative, or typical, of taconite tailings as to make the final outcome essentially meaningless.

²Gundersen, J. N. and Schwartz, G. M., The Geology of the Metamorphosed Biwabik Iron-Formation, Eastern Mesabi District, Minnesota. Geological Survey Bulletin No. 43, 1962.

³White, D. A., The Stratigraphy and Structure of the Mesabi Range, Minnesota. Minnesota Geological Survey Bulletin No. 38, 1954, 92 pp.

A STUDY OF AIRBORNE ASBESTOS FIBERS IN CONNECTICUT

Leonard Bruckman

Air Compliance Unit - Engineering Section
Connecticut Department of Environmental Protection
Hartford, Connecticut 06115

Abstract

The following discussion describes actions taken by the Connecticut Air Compliance Unit for the purposes of studying the danger to public health associated with excessive airborne asbestos fiber concentrations.

In Connecticut, the criteria of mesothelioma was selected as the basis for developing an ambient air quality standard for asbestos (i.e., 30 ng/m^3 or $30,000 \text{ fibers/m}^3$, 30-day average) and compatible mass emission standard (i.e., 24 g/day) in lieu of EPA's qualitative asbestos regulations. An ambient air asbestos survey indicated that asbestos concentrations contiguous to manufacturing sources of asbestos emissions exceed Connecticut's proposed standard. Furthermore, asbestos levels adjacent to toll plazas were also elevated relative to levels removed from manufacturing sources, implicating vehicle brake lining decomposition as a significant source of airborne asbestos fibers. In addition to the aforementioned air asbestos survey, a preliminary study of mesothelioma was conducted. There were 133 Connecticut residents diagnosed with mesothelioma between 1935 and 1972. Although subject to diagnostic error, available statistics suggest that the combined sex age-adjusted mesothelioma incidence rate (AAR) per 100,000 Connecticut population has exhibited a possible 10-fold increase since 1935, rising from 0.02 during 1940 to 0.25 from 1960 to 1969. The trends for both men and women also showed sharp increases over the same time period (1940 to 1970). The rapid rise in Connecticut's mesothelioma incidence rate closely follows the increase in the State's cumulative asbestos consumption and suggests a linearly increasing cause-effect relationship which warrants further investigation.

Key Words: Air pollution; air quality data; air quality monitoring; air quality standards; asbestos; health effects; toxic substances.

Introduction

In 1973 the Federal EPA, recognizing the need to control the emission of asbestos fibers into the ambient air, promulgated National Emission Standards for Hazardous Air Pollutants (NESHAPS) - asbestos, mercury, and beryllium [1,2]¹. After an extensive review, Connecticut's Air Compliance Unit found EPA's asbestos regulation to be inadequate for the purposes of protecting public health in Connecticut and, consequently, developed its own asbestos regulation [3,4]. While EPA's asbestos regulation was written in rather general terms (i.e., "...no visible emissions or application of the best available control technology..."), Connecticut proposed a numerical ambient air quality standard of 30 ng/m^3 or $30,000 \text{ total}$ asbestos fibers (determined by electron microscopy) per cubic meter of air, 30-day average, and a compatible mass emission standard of 24 g/day , at public hearings held in July of 1973. In the judgment of the Connecticut Air Compliance Unit a "no visible

Figures in brackets indicate the literature references at the end of this paper.

emission" asbestos air quality standard does not provide the State's residents with an adequate degree of protection from this carcinogenic substance. In addition, Connecticut also proposed to more stringently control the demolition of asbestos-containing structures.

In order to define the magnitude of the environmental hazards posed by airborne asbestos fibers in Connecticut, prior to the promulgation of the State's asbestos standard, the Air Compliance Unit conducted an ambient air asbestos survey along with a study of asbestos-induced mesothelioma incidence [5,6]. The following discussion describes actions taken by the Connecticut Air Compliance Unit for the purposes of studying the danger to public health associated with excessive airborne asbestos fiber concentrations.

Sources of Airborne Asbestos Fibers in Connecticut

Outdoors, the principal source of airborne asbestos fibers in Connecticut is the manufacture of the many asbestos-containing products (e.g., friction products, gaskets). It is estimated that almost 10 tons of asbestos fibers might be released into the Connecticut atmosphere annually as a result of manufacturing operations, assuming reasonably efficient (i.e., 95% asbestos removal efficiency or greater) control equipment is employed. Another major source of airborne asbestos fibers is the erosion of asbestos-containing brake linings and clutch facings. This accounts for approximately two additional tons of airborne asbestos fibers each year [3,4]. Notwithstanding EPA's current regulations covering the demolition of asbestos containing structures, perhaps the largest potential future source of asbestos emissions might be the demolition of buildings which have been insulated and/or fireproofed with asbestos materials. The portion of the NESHAPS regulation pertaining to the demolition of asbestos-containing structures does not clearly state what requirements a demolition operator must meet in order to ascertain whether a structure to be demolished does or does not contain friable asbestos materials. The inherent difficulty in determining whether a building to be demolished contains any asbestos materials, and the associated costs involved in removing such materials if present, necessitate some type of formalized testing procedure. Briefly, such a test might entail taking samples from the walls, the insulation covering load-supporting structural members and the floor and ceiling tile, from at least one floor of the candidate structure, in addition to the insulation covering the boiler and pipes. A composite sample could then be created and analyzed to determine its asbestos content using relatively inexpensive techniques (x-ray diffraction). It is important that the asbestos content of floor and ceiling tiles be ascertained since these non-friable asbestos materials might be pulverized during the demolition of a structure creating a potentially serious asbestos air pollution problem, especially if the technique known as "explosive demolition" is used. The amount of asbestos fiber dust released into the outdoor air during the demolition of an asbestos-containing structure is unknown at this time, but would appear to be potentially large since there are over 2,000 demolitions in the State each year, and should thus be quantified as soon as possible.

Indoors, many do-it-yourself home projects create asbestos dust due to the mixing of dry, loose asbestos with water and subsequent application of such mixtures for the purposes of insulating and/or fireproofing boilers, pipes, etc..., and the cutting and sawing of asbestos-containing wallboard, ceiling, and floor tile. Perhaps the most serious public health hazard posed at this time by excessive asbestos fiber exposure has been created by the release of asbestos fibers from asbestos-containing surface coatings, which were applied indoors to walls, ceilings, exposed structural steel, air ducts, plenums, return air spaces, for insulating, decorating, and fireproofing purposes indoors. As a result of such activities, appreciable amounts of asbestos fibers may be released into the air indoors, during the application, again as the surface coating deteriorates, and finally, when the building is demolished. The asbestos fibers resulting from the spraying operation itself, as well as those released from the coating over a period of time due to its friable nature, should be of primary health concern. At least one state (i.e., New Jersey) and one local municipality (i.e., New Haven, Connecticut) have already promulgated regulations for the purposes of controlling and/or prohibiting the future use of spray-on asbestos surface coatings indoors. NESHAPS currently prohibits the use of such asbestos-containing spray-on insulation and fireproofing materials outdoors; a recent amendment to NESHAPS proposes to prohibit the future use of any type of spray-on asbestos coating indoors [7].

Ambient Air Asbestos Standard

The approach taken in developing Connecticut's proposed ambient air quality standard for asbestos was to derive a numerical standard which should not be exceeded at this time. In other words, all assumptions were made such that the standard could not be criticized as being too strict. Setting standards should be viewed as a dynamic process in that any value must be reviewed and revised periodically as additional pertinent information becomes available. Even a preliminary air quality standard is valuable because it provides some quantitative idea as to what health risk is associated with varying pollutant levels. Such a standard can be especially useful in developing a set of priorities for correcting environmental problems created by certain pollutants. For example, areas which are well below the standard need no immediate attention, while areas well above the standard require that some sort of corrective action be taken as soon as possible. Such an approach is particularly needed for toxic multi-media environmental pollutants, such as asbestos. In this manner limited resources can be effectively directed at solving the more serious aspects of the problem and, at the same time, actions based solely on emotional decisions by poorly informed administrators can be minimized. Connecticut's proposed asbestos standard should be viewed in this light; i.e., this standard is a first attempt at quantifying the adverse health effects posed to the general public by excessive airborne asbestos fibers. Hopefully, any questions raised by the rationale used in developing this standard will be answered by future studies using varied approaches.

Mesothelioma incidence was selected as the foundation for developing Connecticut's proposed air quality standard for asbestos for the following reasons [8-10]:

The high frequency of lung cancer in the general population makes it difficult to relate a given case of bronchiogenic carcinoma to asbestos exposure with the high degree of probability that exists for mesothelioma.

Some investigators suggest that the smaller asbestos fibers (i.e., those less than 5 μ in length) most likely encountered in the ambient air may be incapable of inducing lung cancer, however, it has not been demonstrated that these shorter asbestos fibers are incapable of producing mesothelioma.

Most of the information available on the adverse health effects caused by excessive asbestos fiber exposure has been collected in occupational environments (Table 1) [11-17].

Table 1. Incidence of mesothelioma and asbestos concentrations in occupational environments [11].

Industry	Cohort ^a number of individuals	Mesothelioma incidence percent	Reference	Highest ^b concentration fiber/cm ³	Lowest ^b concentration fiber/cm ³
Insulation	689	2.18	[11]	74.4	0.1
Shipyards	3000	0.73	[11],[14]	8.7	0.3
Construction	632	0.63	[11],[15]	7.1	0.9
Textile plants	716	1.50	[11],[13]	29.9	0.1
	1300	1.00	[11],[13],[16]	29.9	0.1
	~1300	1.20	[11],[12],[17]	29.9	0.1

^a Most of the individuals in these studies had been followed for 20 years or longer.

^b Concentrations for NIOSH document [18].

Unfortunately, quantitative dose-response relationships concerning environmental asbestos exposures and mesothelioma incidence in different industrial settings are not available. In 1973, the National Institute for Occupational Safety and Health (NIOSH) monitored asbestos concentrations in a number of occupational environments [18]. While these short-term fiber concentrations are of recent origin and, therefore, cannot be directly related to epidemiological studies of mesothelioma incidence, they can be used to obtain an estimate of the range of occupational asbestos exposure likely encountered in different industrial settings. For example, Selikoff and co-workers reported that for workers in the construction industry (followed for 20 years or longer) 0.63 percent contracted mesothelioma [15]. The variation in asbestos fiber exposure for the construction industry from the NIOSH study ranged from 0.1 to 29.9 fibers/cc which corresponds to a hypothetical probability of contracting mesothelioma of 63/10,000 (i.e., 0.63%). In a like manner, occupational mesothelioma incidence (provided by studies appearing in the open literature) and corresponding estimates of the range of asbestos fiber exposure (provided by the aforementioned NIOSH report) were used to construct a first generation occupational asbestos fiber exposure-mesothelioma incidence envelope (Figure 1).

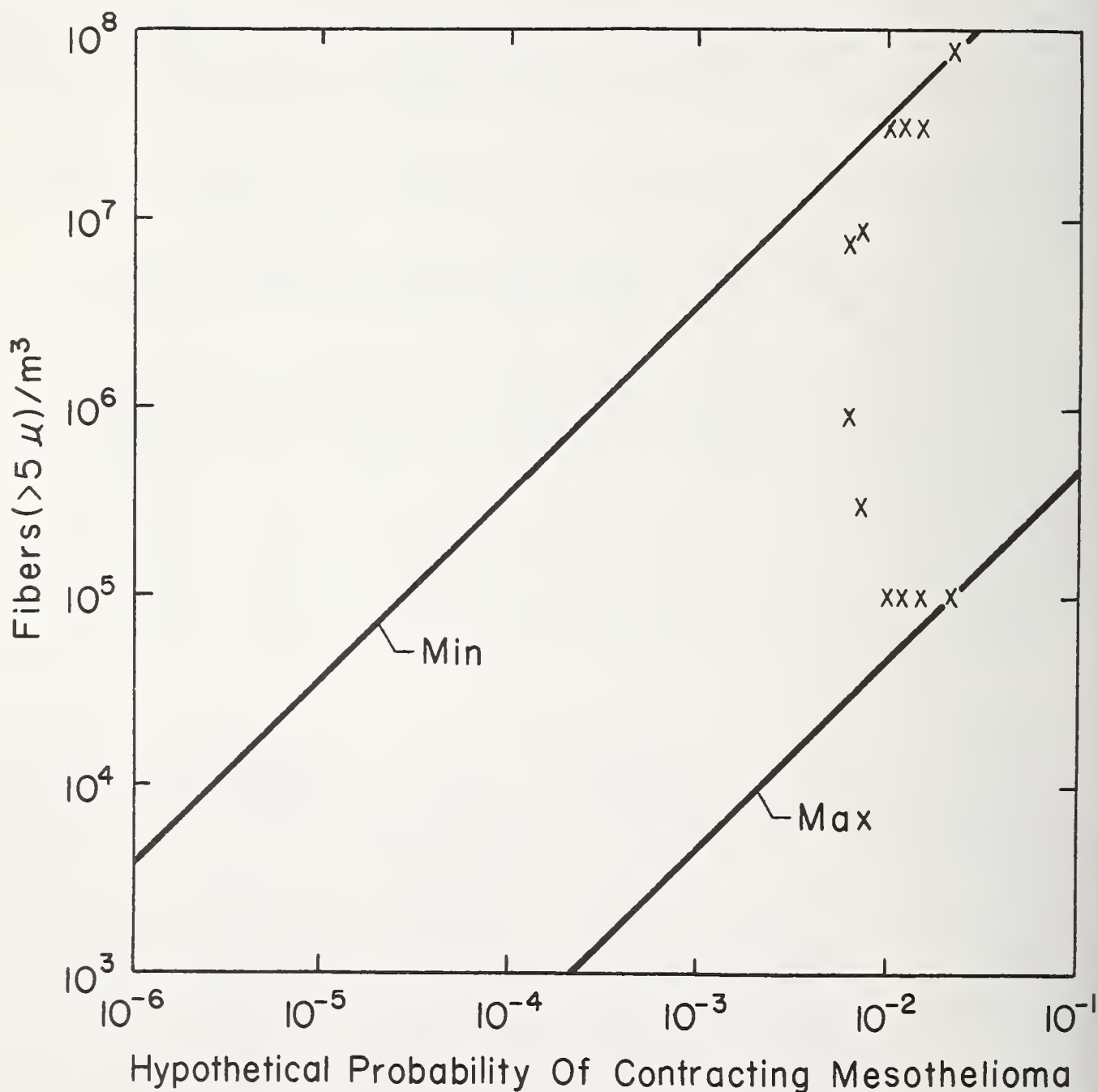

Figure 1. Expected incidence of contracting mesothelioma as a function of industrial air asbestos exposure (8 hr day, 5-day week).

Only asbestos fibers greater than 5 μ in length with an aspect ratio of 3:1 (as viewed by phase contrast light microscopy; 430X magnification) are monitored in industrial environments. These longer asbestos fibers account for approximately two percent of all asbestos fibers present (by number) [19]. Expressed in another manner, there are approximately 50 asbestos fibers for every 5 μ size fiber. Furthermore, it has been estimated that there are approximately 1,000 asbestos fibers per nanogram of asbestos [3,20,21]. Consequently, 20 "industrial size" asbestos fibers are equivalent to approximately one nanogram of asbestos. Other investigators have reported similar relationships between industrial size asbestos fibers, total asbestos fibers and their eight equivalents [3,19]. In addition, occupational exposure concentrations based on a 8-hour day, 5-day week should be related to general population ambient exposure levels. This can be accomplished by dividing occupational concentrations by 4.2 (i.e., 24-hour/8-hour \times 7 day/5 day = 4.2) [22]. Now the occupational mesothelioma incidence envelope depicted in Figure 1 can be converted to a general population mesothelioma incidence envelope (as a function of both weight and number of asbestos fibers per volume of air), from which an ambient air quality standard for asbestos can be selected (see Figure 2). Using the minimum line a level of 30 ng/m^3 or 30,000 fibers/ m^3 , which is projected to induce 150 mesotheliomas nationwide or 2 in Connecticut, was chosen. The use of the minimum line, which reflects the smallest probability of an individual contracting mesothelioma for a given exposure level, is consistent with the aforementioned objective of developing an asbestos standard which would be difficult to criticize as being too strict; the use of either the maximum or some average line would have yielded an asbestos standard some 2 orders of magnitude more restrictive (lower) than the proposed standard or the same response. The chosen standard should result in about 1/10 the yearly fatalities from airplane accidents and approximately the same number of deaths as from train mishaps (see Figure 3) [3].

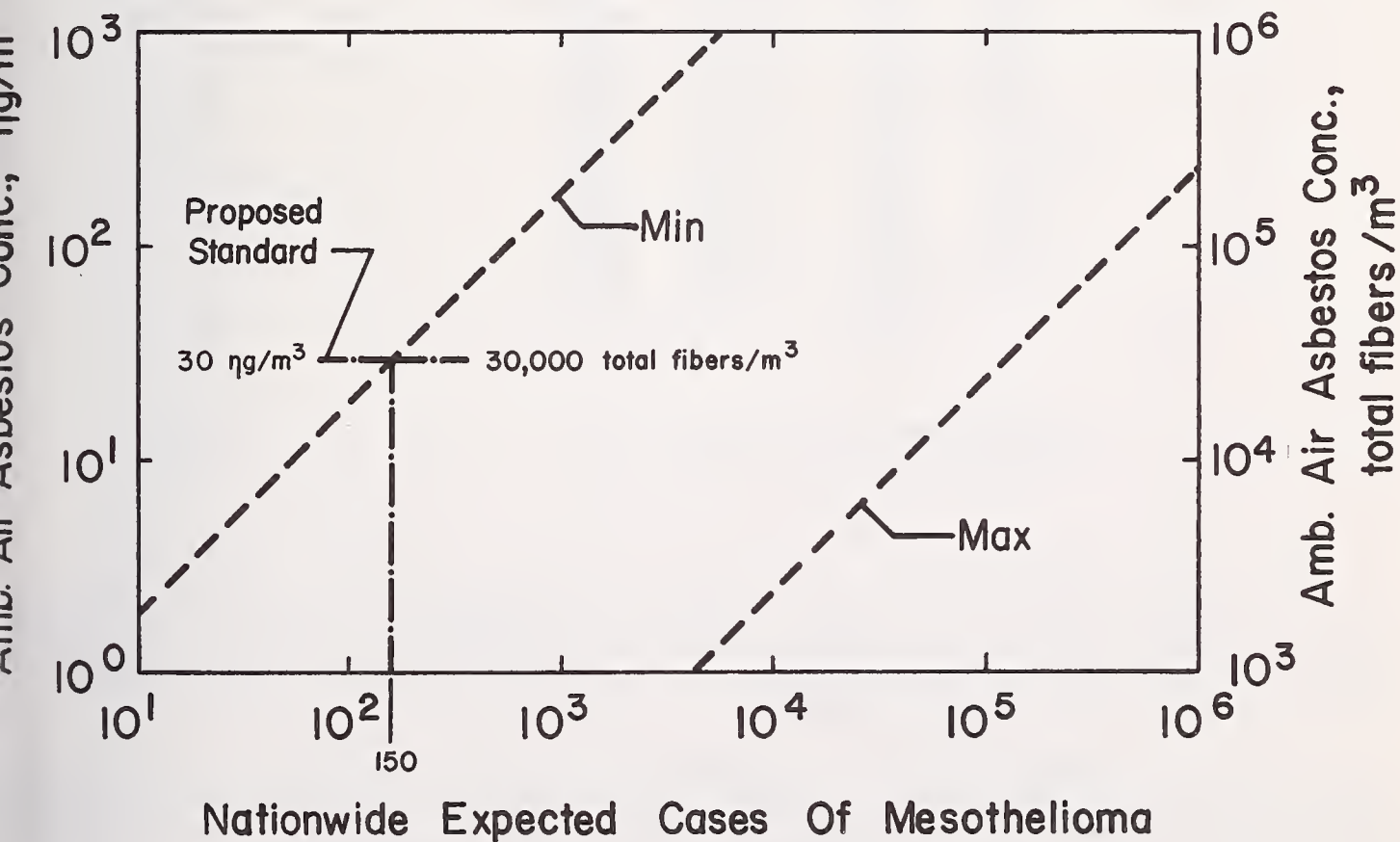

Figure 2. Nationwide expected cases of mesothelioma as a function of ambient air asbestos exposure (assumed population of United States was 230 million people).

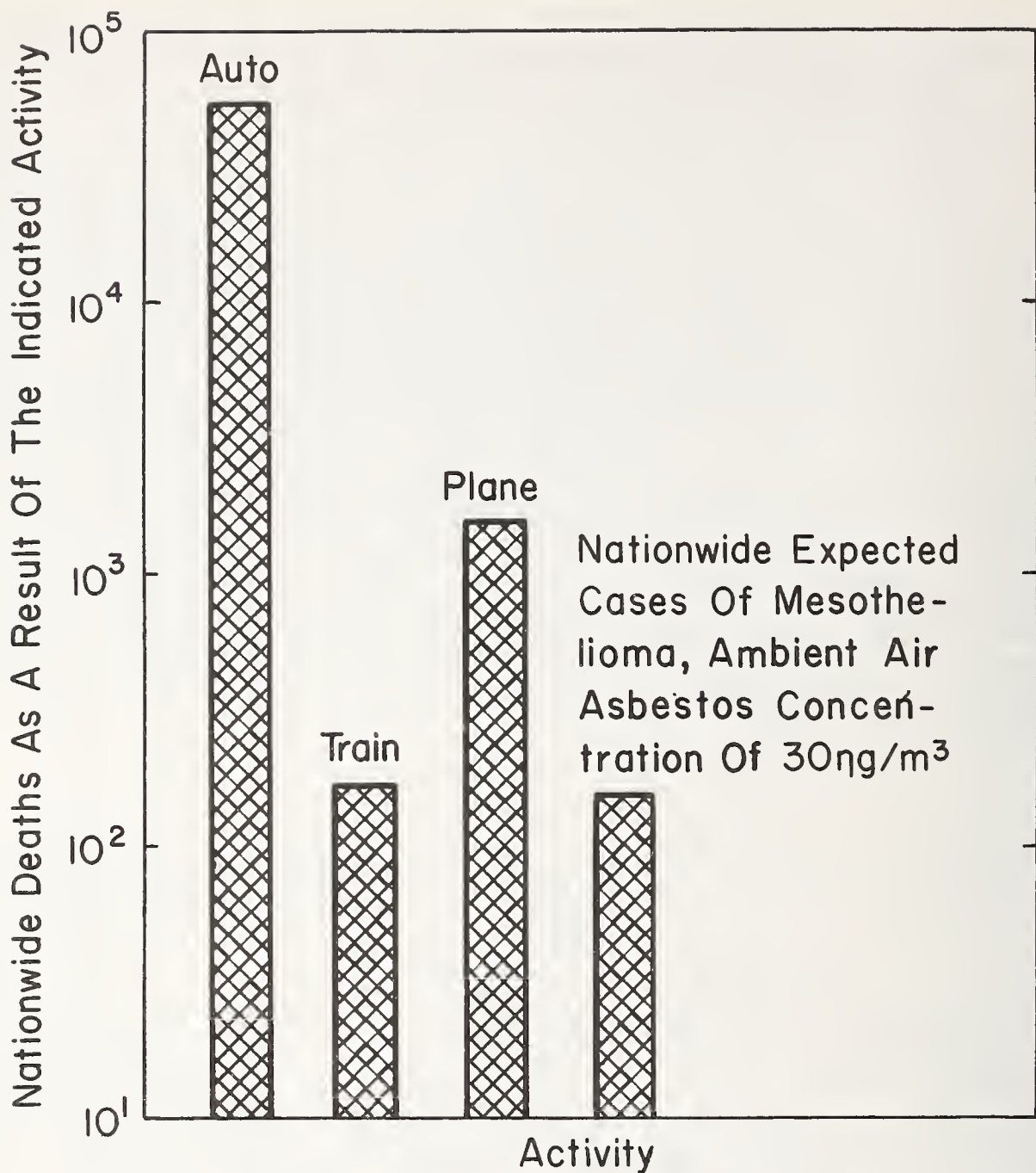

Figure 3. Nationwide mortality statistics due to different modes of travel and expected cases of mesothelioma.

The subject asbestos standard is equivalent to an occupational asbestos level of 0.0025 fibers ($>5 \mu$)/cc, well below the newly proposed occupational standard of 0.5 fibers ($>5 \mu$)/cc [23]. This strongly suggests that the aforementioned proposed occupational asbestos standard is not yet low enough to adequately protect the worker exposed to asbestos fibers from contracting mesothelioma.

Connecticut's ambient air quality standard for asbestos is based on a 30-day average sampling period instead of the more common 24-hour duration because a 1-month averaging time is more manageable from a monitoring standpoint and is not sensitive to short-term perturbations in air asbestos emissions, but at the same time provides the public with a high degree of protection from the adverse health effects caused by excessive asbestos fiber concentrations. Compliance with the proposed standard can be easily and accurately evaluated using Connecticut's low-volume particulate sampler (10-vol) [6,24].

In certain instances it may be necessary to impose asbestos emission standards on manufacturing and other sources of airborne asbestos fibers in order to attain the desired ambient air asbestos standard. A mass emission standard of 24 g/day (for an isolated point source of asbestos emissions) is consistent with the 30 $\mu\text{g}/\text{m}^3$ (30,000 fibers/ m^3) proposed standard. The development of this emission standard, in addition to a possible stack sampling train, are explained elsewhere [3,4].

Mesothelioma Incidence in Connecticut

The mesothelioma incidence trend in Connecticut men mounted through the 10 year period covering 1960 to 1969 from an age-adjusted rate (AAR), obtained using the indirect method, of 0.04/100,000 Connecticut population for the interval between 1940 and 1949 to 0.37/100,000 from 1960 to 1969. No mesotheliomas were diagnosed in Connecticut women until the period 1950 to 1959 when 12 were reported yielding an AAR of 0.1/100,000. The trend for females increased slightly to 0.15/100,000 in 1960 to 1969 (Figure 4). The combined sex AAR

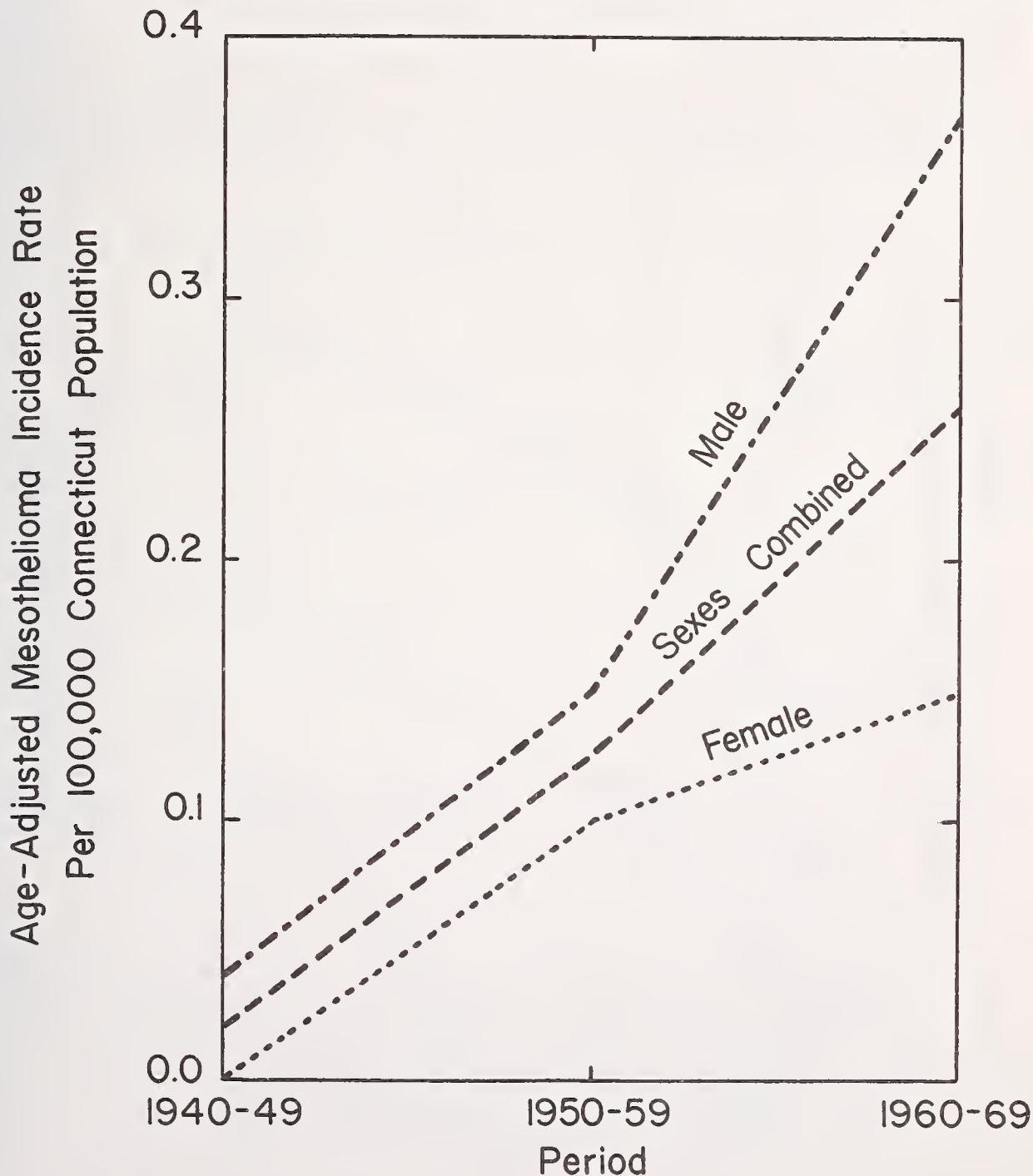

Figure 4. Connecticut mesothelioma incidence by 10-year period.

rose from 0.02/100,000 during 1940 to 0.25/100,000 from 1960 to 1969, over a 10-fold increase. The increase in cases over the years may in part reflect an increased awareness of this type of tumor and an attempt by pathologists to classify all malignancies. Though increases in both occupational and non-occupational asbestos fiber exposure are expected to have occurred over the last 40 years, only four people were reported with known exposure to asbestos. Eight others were felt to have experienced some exposure. Occupation at the time of diagnosis was obtained from hospital admission records and the usual occupation from death certificates. It was found that 44 individuals (33.0%) worked in the home or in like occupations. Thirty-six (27.1%) were reported to have worked in manufacturing industries. Nineteen (14.3%) worked in offices as professionals or clerical employees. Of the remaining individuals it is interesting to note that one person was listed as a toll collector. Unfortunately, complete occupational histories of each of those individuals afflicted with mesothelioma are not available at this time [5].

Cumulative United States asbestos consumption has increased rapidly since the beginning of the 20th century and is projected to exceed 60 million tons by 1980; [25] Connecticut's asbestos consumption has been estimated by proportionally allocating total U. S. consumption using the appropriate Connecticut to United States population ratio. A plot of both cumulative U. S. and Connecticut (estimated) asbestos consumption and Connecticut's combined-sex mesothelioma AAR/100,000 population as a function of time suggests that the sharp increase in mesothelioma incidence closely followed the rapid rise in the State's cumulative asbestos consumption for comparable intervals (i.e., 1940 to 1970) (Figure 5). This apparent cause-effect relationship warrants further investigation.

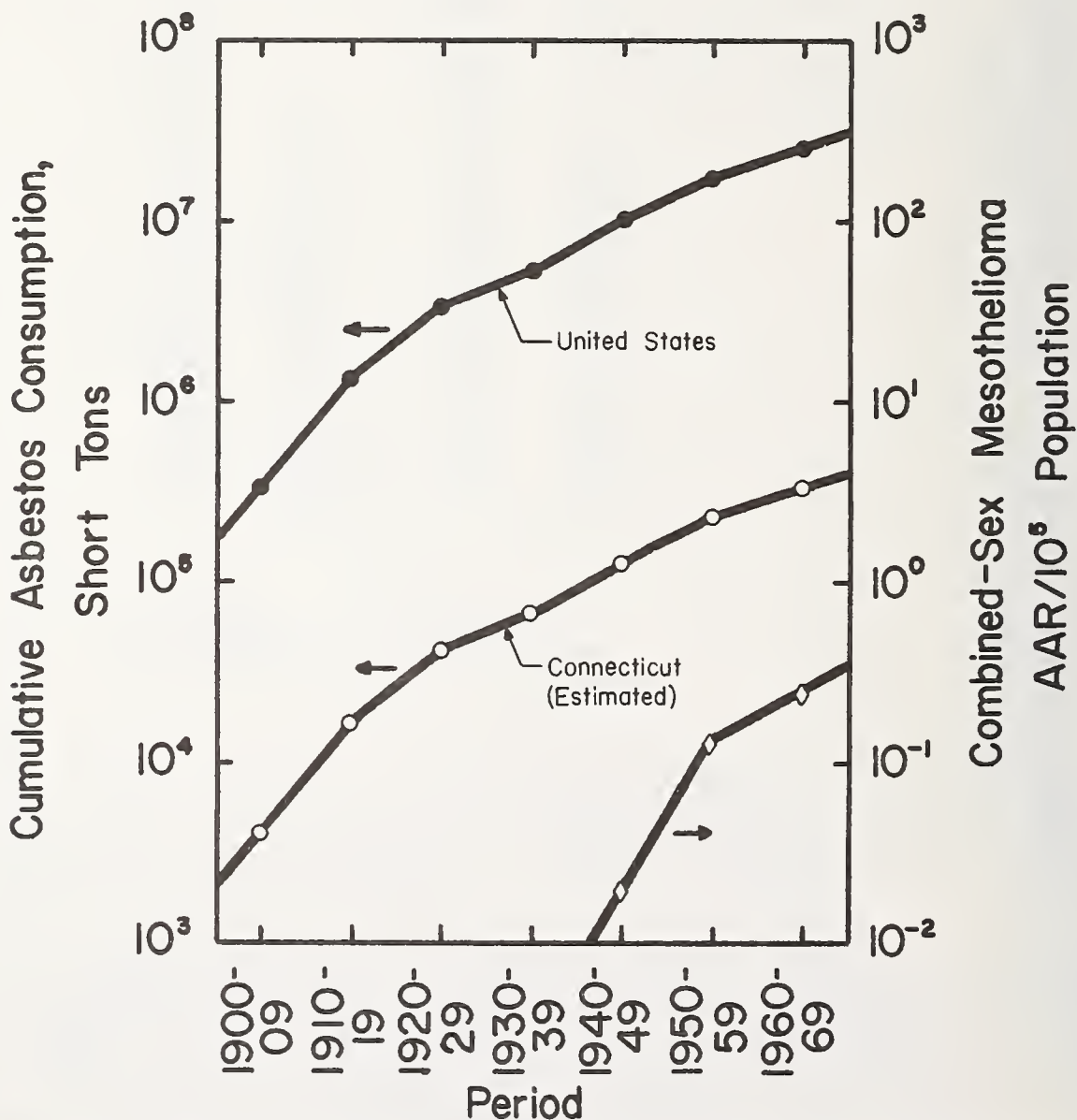

Figure 5. Cumulative asbestos consumption and Connecticut mesothelioma incidence as a function of time.

Air Asbestos Survey

An ambient air asbestos survey was conducted during late 1975 and early 1976 to define the magnitude of the health hazard posed by airborne asbestos fibers in Connecticut prior to the promulgation of the State's asbestos standard. The newly developed low volume particulate sampler (lo-vol) (see figure 6), which operates continuously for a 30-day interval at an air sampling flow rate of approximately 4 cfm, was used to collect ambient TSP samples. The lo-vol was equipped with special membrane filters (8" x 10", Gelman Metrical GN-6 0.45 μ pore size, non-nylon reinforced). The filters were analyzed for chrysotile asbestos by the Battelle-Columbus Laboratories using transmission electron microscopy in conjunction with electron diffraction (to confirm a minimum of 10 chrysotile asbestos fibers) [6].

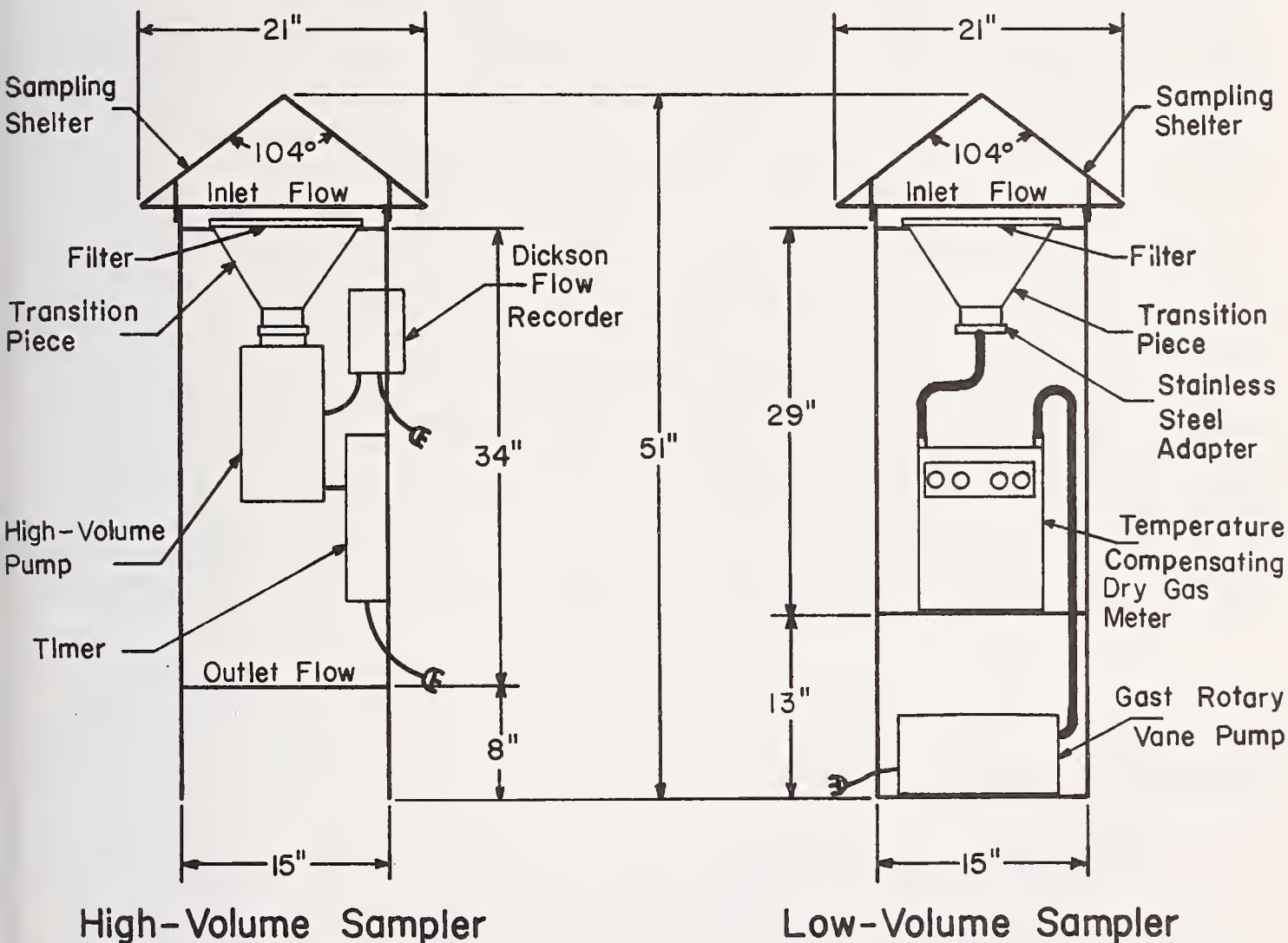

Figure 6. High volume (hi-vol) and low volume (lo-vol) TSP samplers.

Approximately 30 monitoring sites were selected; locations included "typical" urban sites removed from known sources of asbestos emissions, rural-background sites and stations contiguous to four industrial users of asbestos (i.e., manufacturers of friction products, insulated wire and cable, ammunition and molding compounds, respectively) and three toll plazas situated at various locations along Interstate 95. Ambient chrysotile asbestos levels removed from asbestos emission sources in both urban and rural location were below 10 ng/m^3 . However, chrysotile asbestos concentrations above the 30 ng/m^3 proposed standard were measured near each of the industrial users of asbestos (i.e., 32 ng/m^3 at a public works building located near the friction products manufacturer; 33 ng/m^3 at a junior high school located adjacent to the insulated wire and cable and ammunition manufacturer combination; 33 ng/m^3 at a private home near the molding compounds manufacturer).

Each of the subject point sources are in compliance with NESHAPS and other existing state and federal air quality regulations.

Ambient asbestos levels adjacent to the three toll plazas on I-95 were also elevated (in the 10 ng/m³ to 25 ng/m³ range), implicating asbestos emissions from vehicle brake lining decomposition as a significant source of airborne asbestos fibers. Asbestos concentrations at the rural toll plaza (11,000 cars/day eastbound lane; 12,000 cars/day westbound lane) were 10 ng/m³ (eastbound lane) and 14 ng/m³ (westbound lane); there are no known industrial users of asbestos near this rural toll station. Asbestos levels at one of the urban toll plazas (28,000 cars/day eastbound lane; 27,500 cars/day westbound lane) were 3 ng/m³ (Administration Building, south side of highway) and 25 ng/m³ (westbound lane). The asbestos concentration at the other urban toll plaza (27,000 cars/day eastbound lane; 28,000 cars/day westbound lane), which is also located near one of the largest industrial users of asbestos in Connecticut (i.e., the aforementioned friction products manufacturer), was 41 ng/m³ (Administration Building, south side of highway); this was the highest concentration measured during the subject survey. The ratio of the maximum asbestos concentration measured at the first urban toll plaza to that at the rural toll station was approximately equal to the ratio of the number of cars/day passing through each toll plaza (i.e., 1.8 versus 2.3) during the sampling interval. All of the aforementioned measured asbestos levels were 30-day average values, except the 41 ng/m³ concentration, which was approximately a 20-day average value (due to a sampler malfunction).

In addition to the ambient air asbestos survey described above, asbestos levels were also measured indoors at the boy's swimming pool located in the University of Connecticut's field house. The ceiling covering this pool was sprayed with an asbestos-containing insulating compound in 1955 and then re-sprayed some 10 years later. Chunks of this coating have been falling from this exposed ceiling for some two years. Analyses of a bulk sample of the ceiling material by the Connecticut State Department of Health revealed evidence of asbestos fibers (between 10-30%) within fiberglass and binding material. Subsequent electron microscopic analyses of the ceiling material by the Battelle-Columbus Laboratories indicated that the asbestos was of the amphibole variety. Four (4) long-term (i.e., 30-day) air samples were collected at various locations at the pool. Identical sampling techniques were used for both the indoor and outdoor air asbestos surveys. These indoor samples are being analyzed for amphibole asbestos using transmission electron microscopy and energy dispersive electron-diffraction by Walter C. McCrone Associates, Inc. The results of this indoor asbestos survey will be reported at a later date [26].

Conclusions and Recommendations

Connecticut's studies to-date indicate the existence of a potential health hazard posed by airborne asbestos fibers which warrants further investigation. Firstly, additional ambient asbestos monitoring should be performed as soon as possible to:

- 1) define the month-to-month variations in ambient asbestos levels at various locations, primarily in densely populated areas contiguous to manufacturing sources of asbestos emissions and especially those locations which already exhibited asbestos concentrations in excess of Connecticut's standard,
- 2) further quantify, asbestos levels near toll stations, the relationship between traffic counts and ambient asbestos concentrations, and determine how asbestos levels decline with increasing distance from a toll plaza,
- 3) define ambient asbestos concentrations contiguous to different types of demolition operations and how rapidly these levels approach background concentrations after the demolition activity is completed, and
- 4) quantify the hazard posed by asbestos concentration indoors where it is suspected that asbestos-containing spray-on materials are fraying and flaking.

Secondly, the relationship between asbestos consumption and mesothelioma incidence in Connecticut should be investigated in more detail. A thorough epidemiological study of the 133 reported cases of mesothelioma (as of 1972) should be performed as soon as possible to identify those cases which are likely associated with non-occupational asbestos fiber exposure. A prospective study of school children exposed to asbestos fibers indoors as a result of the spray-on application and deterioration of asbestos-containing surface coatings should be conducted to accurately quantify the health hazard posed by this type of asbestos fiber exposure.

It is recommended that Connecticut's standard be promulgated and applied both outdoors and indoors. The routine monitoring of asbestos levels should be initiated as soon as possible. The resulting measured concentrations (along with the populations exposed) should be compared to the standard so that a rational program and set of priorities can be formulated to minimize the health hazard posed by airborne asbestos fibers. This seems to be the most logical way to objectively determine how best to allocate the people's money in implementing sensible ways of controlling contamination of the environment by airborne asbestos fibers.

References

- [1] National emission standards for hazardous air pollutants (asbestos, beryllium, and mercury), Federal Register, 38, 66 (April 6, 1973).
- [2] Asbestos and mercury (proposed amendments to national emission standards), Federal Register, 39, 208 (October 25, 1974)
- [3] Bruckman, L. and Rubino, R. A., Rationale behind a proposed asbestos air quality standard, J. Air Poll. Control Assoc. 25, 1207 (1975).
- [4] Bruckman, L., The Environmental Impact of Asbestos in Connecticut, Internal report issued by the Connecticut Department of Environmental Protection, Air Compliance Unit, Engineering Section; March 12, 1973.
- [5] Bruckman, L., Rubino, R. A., and Christine, B., Asbestos and mesothelioma incidence in Connecticut, J. Air Poll. Cntr. Assoc., 27, 121 (1977).
- [6] Bruckman, L. and Rubino, R. A., Monitored asbestos concentrations in Connecticut, paper presented at the 70th annual meeting of the Air Pollution Control Association, Toronto, Ontario, June 20-24, 1977.
- [7] National emission standards for hazardous air pollutants; proposed amendments to asbestos standard, Federal Register, 42, 41 (March 2, 1977).
- [8] Health effects and recommendations for atmospheric lead, cadmium, mercury, and asbestos, Illinois Institute for Environmental Quality, Environmental Health Resources Center, Report No. EQ-73-2, Chicago, Illinois, 1973.
- [9] Gross, P., Is short-fibered asbestos dust a biological hazard, Arch. Environ. Health, 29, 115 (1974).
- [10] Gross, P., deTreville, R. T. P., and Haller, M. N., Asbestos versus nonasbestos fibers, Arch. Environ. Health, 20, 571 (1970).
- [11] Health effects and recommendations for atmospheric lead, cadmium, mercury, and asbestos, Environmental Health Resources Center, State of Illinois Institute for Environmental Quality, Report #IIEQ-73-2, Chicago, Illinois, 1973.
- [12] Lewinsohn, H. C., The medical surveillance of asbestos workers, Roy. Soc. Health J., 92, 69-77 (1972).
- [13] Newhouse, M. L., Berry, G., Wagner, J. C., and Turok, N. E., A study of the mortality of female asbestos workers, Brit. J. Ind. Med., 29, 134 (1972).

- [14] Stumphuis, J., Epidemiology of mesothelioma on Walcheren Island, Brit. J. Ind. Med., 28, 59 (1971).
- [15] Selikoff, I. J., Churg, J., and Hammond, E. C., Asbestos exposure and neoplasia, J. Am. Med. Assoc., 188, 22 (1964).
- [16] Newhouse, M. L., A study of the mortality of workers in an asbestos factory, Brit. J. Ind. Med., 26, 294 (1969).
- [17] Knox, J. F., Holmes, S., Doll, R., and Hill, I. D., Mortality from lung cancer and other causes among workers in an asbestos textile factory, Brit. J. Ind. Med. 25, 293 (1968).
- [18] Criteria for a recommended standard for occupational exposure to asbestos, U. S. Department of Health, Education and Welfare, Public Health Service, Health Services and Mental Health Administration, National Institute for Occupational Safety and Health, HSM #72-10267, Washington, D. C. 1973.
- [19] Lynch, J. R., Ayer, H. E., and Johnson, D. L., The interrelationships of selected asbestos exposure indices, Amer. Ind. Hyg. J., 31, 598 (1970).
- [20] Thompson, R. J., personal communication, preprint R. J. Thompson and G. B. Morgan, Determination of asbestos in ambient air, May 2, 1973.
- [21] Wesolewski, J. J., Asbestos in the California environment, Air and Industrial Hygiene Laboratory Report, AIHL #164, California State Department of Health, Berkeley, California, May, 1974.
- [22] Fulkerson, W. and Goeller, W. E., (eds.), Cadmium: the dissipated element, Oak Ridge National Laboratory, Report #ORNL-NSF-EP-21, Oak Ridge, Tennessee, 1973.
- [23] Occupational exposure to asbestos; notice of proposed rulemaking, Federal Register, 40, 197 (October 9, 1975).
- [24] Bruckman, L., Hyne, E., and Norton, P., A low volume particulate ambient air sampler, paper presented at the Speciality Conference: Measurement Accuracy as it Relates to Regulation Compliance, New Orleans, Louisiana, October 1975.
- [25] Clifton, R. A., Asbestos, preprint from the 1972 Bureau of Mines Minerals Yearbook, U. S. Department of the Interior, Washington, D. C. 1975.
- [26] Bruckman, L., Monitored asbestos concentrations indoors, paper presented at the Fourth Joint Conference on Sensing of Environmental Pollutants, November 6-11, 1977, New Orleans, Louisiana.

Discussion

NOTE: Discussion of this paper was included in the General Discussion at the end of this session.

GENERAL DISCUSSION OF RELATIONSHIP BETWEEN CHEMICAL AND PHYSICAL PROPERTIES
AND HEALTH EFFECTS

Editor's Note: This session was actually conducted on two days. The papers through Dr. M. Stanton's were given the first day and were followed by a general discussion. The remaining papers were presented the next day, followed by a second general discussion. These two general discussions have been combined below and are followed by a summary given by the Session Chairman, Dr. S. Schneiderman, at the start of the second day's papers. (CCG)

A. SUNDARAM: I would like to address this question to Dr. Kotin. He mentioned that he believes that there exists a no-effect level for asbestos. Assuming that he is right, what are the future steps that industry is going to take? Are they going to conduct animal studies at various dose levels, come up with a no-effect level, extrapolate to the human situation, and have a TLV? Alternatively, are they going to do more epidemiological studies and come up with a no-effect level which can directly apply to humans? If we do these two types of studies, we are still faced with the problem of variability of susceptibility between different groups of humans as well as between animals and humans.

P. KOTIN: The answer to the first part is obviously that industry has a responsibility to support studies at all levels, from fundamental mechanisms to bioassay. My own bias is that there is a no-adverse effect level. The question of what will demonstrate the no-adverse effect level is one that is going to require a fundamental understanding of carcinogenesis. I think there are occupational asbestos exposures of sufficient duration where, to the best of our knowledge as of now (and you always have to put that in), there seems to be a level of exposure to asbestos not associated with asbestos-related disease. I will say, in advance, I am aware of and accept all the caveats that just as the rats have not lived three years, these people have not been exposed for forty years, and maybe at that end of the distribution curve some evidence of some response may come. There is no answer to your question, and I wish that there were, other than to say that industry has a responsibility and would be incredibly shortsighted and incredibly stupid if it were not on the leading edge of supporting all research in relation to fiber and its relation to any adverse human effect.

M. SCHNEIDERMAN: Dr. Nicholson, would you care to comment on the no-adverse level problem since you presented information on individuals exposed one month?

W. NICHOLSON: In fact, I was going to ask Dr. Kotin to elaborate on that. I recall seeing a quote from you that was made sometime in the late sixties before some congressional committee, when you were Director of the NIH. You felt at that time that there was no evidence that would indicate that a threshold exists. If you could elaborate on that, particularly on the hard data that exist for asbestos. As one knows, you need enormous populations in order to see what the dose-response is at lower levels of exposure. I am in complete agreement with you that there is a dose-response effect at the levels we are speaking of; as you go down in exposure and dose, you certainly go down in effect, but to my knowledge the difficulty of finding the existence of a threshold exceeds our capability either in animals or in man.

KOTIN: The answer to your second part is the degrees of reliability that you are willing to accept in terms of the totality of any response. Let me elaborate a little more. First of all, indeed I did say that, not only before a congressional committee but before numerous congressional committees. I only have two comments: (a) I'm smarter now, and (b) I will send you reprints of three articles published in 1954 where I say, on the basis of what is now known, air pollution is infinitely more important to the evolution of bronchogenic cancer than cigarette smoking. If I am dumb initially, at least give me credit

for not being cast in concrete in opinion. No, the answer to your question is that there are no absolute data that a no-adverse effect level exists, because of the heterogeneity of man. So what I have chosen to do is look at the sequence of events that are necessary for the evolution of a cancer, and I have not used asbestos as a model but I have used other carcinogenic agents, such as aromatic amines and hydrocarbons. There is no such thing as a threshold for carcinogenesis, there are a series of thresholds. I am prepared to say that at the molecular level you may have a threshold, but in terms of clinical cancer and particularly in the laboratory, one can quantify the exposure to carcinogenic agents and predictably get a carcinogenic response, including no tumor formation within the normal life span of the animal, with no evidence of any abnormality. This is a mumbojumbo answer because it is not a clear thing, otherwise we would just have to go to the blackboard and make this a seminar on just chemical carcinogenesis, which I would be delighted to do, and then get down to specifics rather than these generalizations. Cancer is not a simple process. It is a highly complex sequential process, with sequential steps dependent on the antecedent step, and the sequential steps capable of occurring or not occurring on the basis of what happened in the immediate antecedent step and this can be quantified beautifully.

NICHOLSON: I don't think I want to pursue this, except to make one comment. Some of the extrapolation and theoretical predictions that one might make on the basis of chemical carcinogenesis, as opposed to asbestos carcinogenesis, may not be that direct. Let me ask a question of Dr. Stanton which has to do with relative risks of fibers of different lengths (as with the issue of threshold; it is a relative risk at different doses): finding in human tissue and in air samples the vast preponderance of fibers of the shorter sizes, less than 5 μm (we have had some air exposures where 99.5% are under 5 μm in length, others may be 98% or 95% depending upon the particular process), at what level can you say, or at what length can you say, that the shorter fibers are ten times or fifty times, or some rough estimate, less carcinogenic than the longer ones. Certainly your 8 μm value is not a sharp cut off. How might it go down with length, in other words just how does the response go down with dose?

M. STANTON: Any correlation data are simply that. It doesn't say that only certain fiber sizes are carcinogenic, nor does it say that short fibers are not carcinogenic. Correlation suggests that long, fine fibers are more carcinogenic than short fine fibers. There is no sharp demarkation line. I think, if anything, one should go back to the pathological data again, and I've been impressed by the fact that fibers up to 30 μm in length can be picked up and effectively handled by a phagocyte. So it may be that we are far under what can be considered very hazardous. Maybe only fibers over 30 μm in length are more hazardous. Now, what happens if you overload phagocytes? What happens if there are no phagocytes or they are inadequate to handle these fibers in individuals who have compromised the reticuloendothelial system? It may be the short fibers in such situations can be just as carcinogenic as long fibers. There is some suggestion that if the reticuloendothelial system is overwhelmed by foreign bodies, then perhaps short fibers can also be highly carcinogenic. What we are saying simply is that long, fine fibers seem to be the most carcinogenic; we are not saying that any fiber is non-carcinogenic.

W. SMITH: Question for Dr. Stanton: The experiments that we have had a chance to hear about this afternoon certainly present an animal model for asking questions and gathering information that would be extremely hard to get at through more complicated procedures such as inhalation exposures; but, Dr. Stanton, what do you think about extrapolation of information gained from intrapleural studies over to situations more comparable to human exposures that could be approached by inhalation studies? We have done a number of experiments by intrapleural exposure of another species, the hamster, to different kinds of minerals. With long thin fibers we have been getting tumors, and with short fibers we have not. One of the materials that has given us a great many tumors has been a preparation of long, thin glass fibers that have dimensions approximately like those that induce tumors in some of the experiments that you just described. However, Dr. Gross, I believe, has exposed rats to some very similar types of fibers by inhalation exposures, and these fibers gave him no tumors at all on the inhalation tests. So here we have a problem of how to extrapolate data from the intrapleural situation, where the fibers are trapped, to the inhalation type of exposure, where they are subject to physiologic clearing mechanisms.

STANTON: Clearly, our experiments are designed to find out what happens once the fibers get to the tissue that is going to respond. It doesn't take into consideration all the extraneous problems that might arise in the fiber getting to that tissue, which is what Bill Smith is saying. What about inhalation? There is no doubt about it; inhalation studies are the only ones that will really give us some reasonable means of extrapolating to human experience. Those experiments have not been adequately done, and there are not enough of them to really get a good handle on what's happening. Dr. Gross has done about the only experiments that have been done up to this point, with the exception of some that Chris Wagner did; he has shown that tumors develop in the lung from various types of asbestos inhalation. Glass has not been studied, or only studied as a large fiber or as non-fibrous material. Dr. Gross is in the audience and I am certain he would be pleased to tell us about his experiments with glass fibers.

P. GROSS: We exposed rats and hamsters to fibrous glass dust for a period of two years. The fibrous particles had an average diameter of 0.5 μm and a range of lengths 5 to 20 μm . Inasmuch as the average fiber length was 10 μm , one-half of the fibers were 10 to 20 μm long and the rest were shorter. Since the dust concentration was $\sim 100 \text{ mg/M}^3$, the exposure included $\sim 50 \text{ mg/M}^3$ of fibers 10 to 20 μm in length. Thin mineral fibers of this length have been found carcinogenic when implanted in the abdomen or thorax of rats. However, long-term exposure by inhalation of these long, thin glass fibers resulted neither in pulmonary fibrosis, lung cancer, nor mesothelioma in any of our animals. These were allowed to live out their lives.

I. ASHER: We are concerned about parenteral drugs, and we are wondering if anyone has any information about subcutaneous or intravenous injection of solutions that contain asbestos or fiberglass fibers?

EDITOR'S NOTE: No reply was received to the above question. (CCG)

R. LEE: Questions for Dr. Palekar: First, what is the unknown amphibole, PMP 1? Second, I'd like to point out that there were at least three or four people very familiar with scanning microscopy who picked up a possible trace quantity of potassium in what you called a non-calcium amphibole. It would be very surprising if that particular non-calcium amphibole x-ray spectrum looked just like that, and it was a grunerite! Next, I was wondering if PMP 1 is a mineral characteristic of the Peter Mitchell pit, and is that a fibrous or non-fibrous variety of material? Finally, what was the set of aspect ratios measured and particle sizes measured for the non-fibrous "grunerite?" Were they cleavage fragments or typical of amosite?

L. PALEKAR: Yes, PMP 1 is the unknown sample. We did some analyses of the air samples in the taconite mine and it happens to be Peter Mitchell pit; that's correct. There were two samples, one had calcium and the other didn't. The first sample I believe had calcium and the second didn't. I wasn't aware of the fact that there was a potassium peak on it. According to our mineralogist colleagues from IITRI, the studies were done by using several other techniques, and they didn't find any potassium.

LEE: In that particular spectrum you showed something which had at least, on a conservative estimate, one percent and possibly two percent potassium.

PALEKAR: I will have to take that into consideration. Your second question is whether we did any analysis on non-fibrous minerals. So far, we have not, but we intend to do it in the near future.

LEE: Was the sample identified as PMP 1 characteristic of the grunerite minerals that are found in the Peter Mitchell pit?

PALEKAR: Yes.

K. HEINRICH: I would suggest that there is a subject that hasn't been discussed, although it is of great practical importance. We frequently characterize particles by their shape, and grinding is a very common industrial process. This process will change the shapes, and the question is this: I have heard isolated statements here which range from the suggestion that a massive material on grinding acquires characteristics equal to natural

fibers, to the statement that you have to be careful in grinding asbestos because it loses its properties. Could we have a discussion of what the biological implications of grinding are and how one has to handle this situation?

A. LANGER: Dr. Heinrich has touched upon an extremely important problem which concerns the biological activity of small particles. The origin of the theory concerning grinding and subsequent alteration of the activity of minerals dates back some 25 years to Great Britain, to its Pneumoconiosis Research Unit. At that date, this unit boasted of having the finest laboratory of its kind in the world. They are remembered for their fine work. At that time, the pathologists in the group observed that the smaller the size of quartz particles, the more biologically active the dust was. Indeed, a 5 μm quartz particle was relatively "inert," if you can use that word, but a 3 μm particle of the same composition was a thousand times more active. A 1 μm quartz particle was a thousand times more active than the 3 μm particle, and a 0.1 μm quartz particle was yet more active. At that time this unit was interested in the interaction mechanism of the silica particles in biological systems. One such proposed mechanism involved the generation of silicic acids in tissue. These acids were thought to be the agent in the production of the response called silicosis. Production of silicic acid is enhanced as quartz is made soluble. Grinding of quartz produces a more "soluble" material. To "prove" this theory, workers ground quartz in a mortar. The ground powder was split into two equal parts. One aliquot was then washed in hydrofluoric acid and a strong alkali, removing all of the surface layers, including the Beilby layer, which is the surface disrupted layer. This disrupted layer on the surface may be demonstrated by x-ray diffraction techniques. There was x-ray line-broadening produced in the ground material, without "treatment," and a very sharp x-ray pattern generated by the material that was acid and alkali "washed." These two preparations, both quartz, were then instilled into animals. According to theory, the solubility theory, the materials which had not been "washed" should have been more active. The reverse was found to be the case. It was found that the materials that had the amorphous layers on the surface had less biological activity as compared to those materials which had been "washed." They observed the "fresh" surface to be more biologically active. This has been re-established in many experimental models.

If we carry this concept into the asbestos problem, one sees the extrapolation to the different sizes of the asbestos fibers and their different biological activities. The early investigators in this field were divided into two camps. One group demonstrated biological activity with short asbestos fiber; the other group demonstrated a lack of activity. The question may be asked as to how the same animal model, the same route of administration, and the same laboratory could produce conflicting sets of data? When one examines the process by which the experimental pathologists size reduced their materials, the explanation is there. These pathologists mechanically milled these materials to shorten the fiber length. They are not only dealing with short fiber, but also with milled fiber. We have looked at these reports in the literature, dating back to the 60's, many of which indicate that milling was used to reduce fiber length. Milling of chrysotile fiber produces a material with a disrupted surface. We have observed this with x-ray diffraction and electron microscopic studies. We have taken chrysotile asbestos so prepared and have examined it by x-ray diffraction step scan technique. We've followed the line-broadening and decreased crystallinity. We've looked at this material by infrared spectroscopy for specific structural changes corresponding to different molecular groups within the structure. We have examined the material in hemolytic test systems for altered membrane activity. We have looked at these materials in regard to the ability to reduce free radicals. We've looked at these milled fibers by many, many techniques and have observed that those fibers that are produced as "short" fibers show a progressive decrease in surface activity. I think that it is the preparation technique which alters the surface of the material. The experimental pathologist may indeed be working with materials that are not "truly" asbestos. The circumvention of the problem may be brought about by, instead of using mechanically milled materials, using air-jet milling, or if not air-jet milling, water sedimentation techniques to separate small fibers. Wagner's group in Penarth uses sonification methods, air-jet milling, and water fractionation to separate and collect small fibers. They produce biologically active small fibers.

G. WRIGHT: The inference has been made by Dr. Langer that the experiments using short fibers have no validity because the surface has been altered by grinding. I would like to report that Dr. Kuschner and I have used contrasting fibers prepared synthetically

and not involving any grinding. The short fibers produced no fibrosis, but from the same batch permitted to grow long, we got well developed, extensive pulmonary fibrosis from intratracheal injection into guinea pigs.

LANGER: Several years ago we ordered synthetic chrysotile from a company in Pennsylvania. The materials were obtained for animal work. We examined these materials very carefully; the material was half talc and half poorly crystallized chrysotile. I think when one talks about chrysotile grown in a thermal bomb in someone's laboratory, one has got to characterize it extremely well because the crystallization process is very difficult and very often one does not produce chrysotile. I see Julie Yang here in the audience who's done a great deal of work at Johns-Manville growing chrysotile. They had to use a number of compounds to grow really good chrysotile fibers. It is extremely difficult to do.

J. LEINEWEBER: I would just like to comment that the synthetic chrysotiles that were made in our laboratory were the ones referred to by Dr. Wright. I've also had the opportunity to see the samples that were made by Tempress. Julie Yang can comment on the great divergence in quality between the two samples. Ours were good. I did want to say that the synthetic chrysotiles that were prepared in our laboratory were of good quality crystals and this is absolutely important.

J. YANG: I worked for Johns-Manville making synthetic chrysotile. The synthetic chrysotile we made for Dr. Wright is the pure synthetic chrysotile; there was no mineralizer added. I think the electron micrograph shows the size distribution; it's all fibrous material.

LANGER: Julie, didn't you use cobalt or nickel in the preparation of those materials?

YANG: No, that's for a different purpose. When we put nickel or cobalt or iron into it, at that time, was for a different group of tests where we were trying to figure out whether or not any heavy metal substitution would cause carcinogenic effects. We also prepared the pure ones with no additives.

LANGER: I think that another important issue should be raised. There were many discussions of a number of studies in which short fibers produced no biological signs of activity. There is for every study which shows no activity, another one which does indeed show that small particles are active. As a matter of fact one of the first studies of short chrysotile fiber, which is cited extensively in the literature, is probably the most unread paper in the field today (Durkan, Vorwald, and Pratt on the biological activity of small fibers). These workers were interested in fiber length as related to biological activity. At that time they were impressed with the work to come out of Great Britain demonstrating that the small silica particles were far more active than the large silica particles. They of course used various size fractionated materials of chrysotile and in their paper stated that, although they saw no "increased effect" of short fiber they reported "more limited" activity of the short fiber. Mineralogical analyses of the dusts used experimentally showed the "short dust material" consisted of only some 17 percent chrysotile, the rest being other materials.

J. MOORE: I want to raise a question. Dr. Wright, is it possible for you to give me a reference for that work or to provide the audience with the data if it is not published?

G. WRIGHT: With regard to the comment that Dr. Langer made about the work of Vorwald and others at the Saranac Lake Laboratory - I was working there at the time and, in the samples which produced fibrosis, at least five percent of the fibers were of the long, or greater than 10-micrometer, variety. In answer to the question for a reference to the work by Dr. Kuschner and myself, this has been published recently, in part, in Proceedings of an International Symposium on Inhaled Particles, IV, held at Edinburgh in September of 1975. It is edited by Walton and published by Pergamon Press.

W. DIXON: I would like to ask about the toxic activity of several kinds of fibers: (1) partially coated asbestos fibers, for example asbestos fibers which have an organic coating, (2) talc fibers (I have seen true talc fibers, just as fibrous looking as any asbestos fibers), (3) fibers which are intermediate between talc and anthophyllite asbestos in composition, (4) substitute mineral fibers such as wollastonite which are used in place of asbestos.

EDITORS NOTE: No response was made to the above question by anyone in attendance or in writing. (CCG)

P. LEBER: I was interested in the macrophage work of Dr. Palekar. Do you have any information on the mechanisms of the site of toxicity? I'm thinking particularly whether you have any information supporting the cell membrane puncture ideas of Dr. Kotin, with the release of lysozymal enzymes or any organal changes that might occur after ingestion of these particles, or whether ingestion of particles is actually necessary for cytotoxicity?

L. PALEKAR: Well, the data that I presented was very preliminary and I don't want to make any conclusions. We performed some standard tests for acid phosphatase and lactate dehydrogenase and we did find release of these two enzymes into the medium as well as within the cell itself.

J. KRAMER: I have two questions. The first one is addressed to the taconite study. There were various comments earlier voicing concern about the characterization of the sample. I would like to add a few additional comments. First of all, I think that you will find that there is a large variation in the composition of both the tremolites-actinolites and the cummingtonites (Bonnichsen, 1969, Mineral. Soc. Amer. Spec. Paper 2; Kramer, 1976, Canad. Mineral, 14, 91-98), and I believe that you must be aware of these variants when you characterize your sample. You may wish to determine the cell constants, and there is literature relating cell volume to composition (Finger, L., 1967, The crystal structures and crystal chemistry of ferromagnesian amphiboles, PhD thesis, Univ. Minnesota). There are other factors to consider. The cummingtonites contain variable amounts of manganese, for example. There are a large number of mineralogical factors that you may wish to consider prior to your animal studies. Also I would suggest that if you look at the tailings you will be able to ascertain these mineralogical variations.

My second question regards the Connecticut survey. I think that there is one assumption that needs careful consideration, and that is the constant relationship between fiber number and mass. If this assumption is not valid, then your mass basis is not valid. Fibers appear to have size distributions over about two orders of magnitude. Therefore, the mass can be determined by a very small percentage of the fibers. In other words, if you consider one-100 μm fiber out of 100-1 μm fibers, you change your count by only one percent, but you change your mass by a factor of five or more times. Therefore, the size distribution of the largest few percentile of fibers will be most significant in your mass/fiber ratio. Why are you using a mass basis and not a count basis?

L. BRUCKMAN: There are many problems in developing that envelope besides what you just said, which are obviously important. What we were trying to do was to take today's information and develop some type of standard and again try and make it such that it would not be criticized as being too strict, and while we were studying and refining the relationships between dose-reponse, we'd at least have a standard. Now we have places in Connecticut which are above that level, and pretty much everybody has said that there are some problems with it, but the level looks basically reasonable and I think that it should be promulgated as a first step. It's a lot better than a no-visible-emission standard. I forgot the second part of your question.

KRAMER: No, it was basically related to why you used a mass standard rather than a count standard.

BRUCKMAN: At the time that we were doing our analysis, the procedures available which were basically developed by Dr. Thompson at EPA, were based on mass measurements of chrysotile. When we went out and did our ambient survey back then, and it took some time to get it done, that was the technique that was readily available. As we continued on, in order to get comparative numbers, in other words to say whether the levels were twice as high or

twice as low, we continued doing the same type of analysis through Battelle. I'm probably not the one to comment on which way is the best way to do it, but when Battelle did the work for us, their mass analysis, based on activated chrysotile samples, was ± 50 percent. It's a kind of reproducible, gross measurement of the amount of asbestos in the air, but it doesn't give you any information at all about fiber count. But mass was one way of relating back to our standard. The standard could also be expressed in terms of total asbestos fibers; I believe it's 30,000 total asbestos fibers for a cubic meter of air sampled. So if you do a number of determinations, you could still relate that back to the standard. Battelle does a mass analysis and that was the way we have been doing it all along.

C. COOPER: I also want to comment on Dr. Bruckman's very practical approach to an environmental problem. I'm not going to comment on the audacious assumptions that went into it, because I think he'd be the first one to say that was the case. My comments are two-fold, that is, I saw two important things. One was that the bottom line (and it was the literal bottom line in his graphs) was a probability of certain events occurring. This cut right back to the dialogue between Dr. Nicholson and Dr. Kotin yesterday afternoon. It assumed a no-threshold response; a straight line relationship, but it acknowledged that at some point that the straight-line relationship reached a probability, or a level of risk, that was very, very low. There's a great deal of difference between a 1 in 10 risk of getting something, and a 1 in 100 million risk. I think Dr. Bruckman at least faced up to this important question, regardless of the validity of the assumptions that went into determining the actual values. The second comment I wanted to make was that using his 30 nanogram limit, the levels of 12 and 25 did not seem particularly alarming. Since he was basing his original case on 168 hours of exposure during a week, probably what one might call a time-weighted average would be well within the 30 nanograms that was proposed. I was struck by how low these observed concentrations were, using the assumptions in scale.

R. BLEIFUSS: I want to return to the Peter Mitchell mine again and a sample prepared by IITRI for the EPA. If you read the IITRI reports, it is apparent that the sample site selected represents unique geological situation within the Peter Mitchell mine, in the same sense that the Reserve operation is unique on the Mesabi Range. It does not really appear to be typical of the taconite in that area. The sample represents a local segregation of a rather unusual mineral suite and it is doubtful that we should use such a sample on health studies. I really think we should go back and provide you with a better starting material for the kind of work you are proposing.

O. MENIS: I would like to address my question to Dr. Bruckman. I appreciate the advance of this mass measurement and simplification. I just have a question about the total volume of sample in which this was determined, and what kind of weight basis that was. What was the total sample of your low volume sampler that was used to establish the 40 nanograms or 10 nanogram levels that you distinguish between borderline cases and significantly high.

BRUCKMAN: If I understand you right, it's just a different type of sampling equipment that we developed for this purpose. If you wanted to get a 30-day average sample with a high-volume sampler, which only runs for one day, you'd have to collect 30 samples. Thirty samples at \$500 a throw is a lot of money.

MENIS: My question was, what was the total weight of the collected dust during that period of time?

BRUCKMAN: We didn't do that determination, because there are problems in getting total weight with cellulose nitrate membrane filters. They are very hygroscopic and that presents a lot of difficulty, but that would not affect the amount of asbestos there. So there were no total weight measurements made, only chrysotile asbestos determinations. We don't know what the total weights were. We did do total weight for one sample. It looked like we were getting reasonable numbers, therefore we didn't continue it.

M. COSSETTE: I have a comment that I'd like to address to Dr. Bruckman. One author, Mr. Rutner, has published a paper on 19 cases of mesothelioma in Switzerland. And of these, only two were related to asbestos exposure. Also, in experimental animal studies, mesothelioma has been produced with many other materials. In the case of your survey of mesothelioma in Connecticut, did you make any attempt to relate mesothelioma to anything besides asbestos?

BRUCKMAN: We only did a very preliminary study based on hospital records and death certificates. We'd like to get some money to do a detailed epidemiological study, a complete case history, occupational exposure, and whether these were relatives of people who worked in asbestos industries. We aren't able to do that. We haven't got any funds at all to do any of these studies, and it's impossible to carry them on without funding. We just haven't been able to get into it. Hopefully, the data that I reported on concerning mesothelioma incidence will be updated. My study was only up to 1972. It should be updated and maybe other types of potential causes, like fiberglass exposure or something like that, will come out of this.

COSSETTE: Thank you. The data that you showed indicates that the number of mesothelioma cases has gone up dramatically in the last few years. Do you think this may be partially due to the fact that it's more easily found now, that we have better determination techniques.

BRUCKMAN: I think that's definitely a contributing factor. I would say yes.

M. ROBERTS: A question for Dr. Palekar: Going back to the presentation of the slides, the slide with the 1 μ m scale showed an electron micrograph of ambient air at the process plant and at the mine, as compared to the slide with the 10 μ m scale showing the preparation, that you have apparently prepared for your inhalation studies. On the slide from the ambient air at the plant and mine there was very few fibers more than 1 μ m long, which was the scale shown on that slide, whereas the second preparation, on the 10 μ m slide, showed considerable material that was over 10 to 15 μ m. You have replied to a previous question that the rock selected to be used in your preparation was representative, and I would like to ask how this was selected? Can you give a complete history as to the location and selection of this material? Further, if these studies are to reflect the pulmonary response of exposure to the dust from these ores, should not the rock be prepared from a blind selection of typical mine ore? The principal question here is how the sample was selected, and can you give some detailed history of where and how this was selected?

PALEKAR: The purpose of this study was to evaluate the biological effects of the fibers which were emitted in the taconite mine. The air samples were procured from the mine area and the processing areas. Several samples were collected on filter papers and proper size distributions were made. I can understand the confusion here between the size distribution tables presented and the electron micrographs, and I would like to emphasize again that the electron micrographs are not truly representative of size. The tables presented are more accurate. Quite a few fibers were counted, and I think that the fiber size that I presented in those tables are more representative. Now, originally we selected air samples and characterized them, then we went back to the rocks. Several rocks were collected, about 50 or so, out of which we selected two rocks which represented the air samples and the processing area, as well as in the mining areas. We are studying the biological properties of these two samples. Currently we are not doing inhalation studies, we are doing intratracheal studies and intrapleural studies. In the future we plan to do inhalation studies.

LANGER: I wonder if I could add something to this. I think that everyone is missing a very obvious point: It appears that the regulatory agencies operate in a "management by crisis" mode, and everytime some new material is dumped into a lake or a river or is thrown into the air, a few million dollars is then invested in investigating the biological activity of that particular substance. It is the consensus of workers in the field that something should be known concerning the properties of fibers in terms of the mechanisms of interaction. Whether or not one could get pure Peter Mitchell pit fiber, whatever that is, is an academic point. There are many lithologies in this mine, as described in Gunderson and Schwart and the Beven French monographs. Whether a "representative" fiber exists is probably unlikely. It was then decided that the Environmental Protection Agency should investigate a fibrous rock-forming silicate which was not asbestos per se. The materials which were fibrous and "pure," yet not exactly characteristic of the cummingtonite/grunnerite within the Peter Mitchell pit, occurred in localized veins. They were fibrous on a megascopic level and when comminuted they resembled asbestos fibers. But they were not asbestos per se. These were rock-forming fibrous amphiboles. I think that if these

materials induce changes in biological test systems, then we shall go further and investigate others. We must know something about the mechanisms of interaction. If they are not active, then everything else is academic.

SCHNEIDERMAN: RECAP OF SESSION. The session yesterday afternoon seemed to me vigorous and active and ended on quite a high note. This morning's session is a continuation of that, and in view of the speakers we have this will be at least as exciting and as interesting as yesterday's session. At this time I would like to give you a very short summary of what I thought happened yesterday. In the instructions that were given to the Chairmen, we were asked to summarize what things people agreed on, what things were learned or said or now accepted as fact, what things were questioned, and where further work should be done. I made some notes on this during the course of the day and I made some notes yesterday evening after having gone out to Wolftrap to hear the Preservation Hall "Jazz Band." The last number they always play is "As the Saints Go Marching In" and I think that if anyone tries to tell you what people fully agree on he has to be a saint, or as you know, fools walk is where angels fear to tread. I'm going to be foolish and try to tell you what people agreed upon. But as I looked at my list, I discovered that that list of agreements was really quite small, and my list of disagreements was quite long and, therefore, the list of further work to be done is even longer. Any of you that are involved in the funding agencies, I want you to hear that work to be done is quite long. It seemed to me, in the agreements, from the notes I have for myself, are that asbestos, whatever it might be, in many of its subclasses and subdivisions, whatever they are called, is a material which can have adverse health effects. We talked a lot about the carcinogenic effects and talked about how some of these might be different or have less intensity for certain forms of this mineral than for others. The discussions were tempered by the fact that some people said what looked like very sharp differences in the past don't look like such sharp differences any longer, and these materials have effects that now appear to be closer to each other. All through that, there was an undercurrent that we really don't know this because we have great problems of determining doses to which people were exposed. There was also the undercurrent, although a great deal of emphasis was on cancer, that there are other health effects, and we have to talk about those. There were questions during the day, as you may recall, as to whether the cancer effects were dependent upon some of these other effects having occurred. Whether these were independent, or whether these ran parallel with each other. Do you have to have hyperplasia, for example, as a necessary component? Was it a pre-cancerous condition? The major questions that people raised during the course of the afternoon were questions concerning two things: first, questions concerning particle size. What are the particle size variables with respect to health effects? What are the particle sizes necessary in order to produce health effects? Are there particle sizes that are safe? Are there particles that don't produce these kinds of effects? To address themselves to these questions, Dr. Bignon of Paris showed us information on distribution of particle size found in the lungs and tissues of individuals with various diseases associated with asbestos and showed for us - at least in the trapped particles, the remaining particles, the particles that are still there - a tremendous overlap of the particle size in persons with illness and persons without illness. This is not necessarily indicating that these particle sizes that he found (by the way you will recall he found rather smaller particle sizes than most people have indicated) were necessary to induce certain of these illnesses. He made it clear, this was not to say that these smaller particles were the ones that induce the illness. It may very well be these were the only ones that remained, these were the ones that were trapped, but that is what he found. Dr. Kotin, in a rather elegant lecture that he labeled as a kind of lecture in pathology that one would give to sophomore medical students (I rather think it was more elegant than one would give to sophomore medical students, having taught sophomore medical students myself), gave us a lovely theoretical discussion of physiology of the lung and a lovely theoretical discussion on what might be going on in the pathogenesis of illness induced by, supported by, and/or stimulated by asbestos particles. Dr. Kotin remarked that he would attempt to be controversial; he succeeded at least in asserting the existence of thresholds, with which, as you know, there is a great deal of difference of opinion. He in turn was challenged on this by Dr. Nicholson, who had earlier presented data showing relatively very low levels of exposure. He was also challenged by Dr. Sunderlin of Canada and also a gentleman from the State of Maryland. The discussion, seemed to me, at one point got really highly theoretical, and I think Dr. Kotin and other people indicated that there would certainly be a need for a full scale discussion of this issue. There was one, by the way, in

Heidelberg last year; a whole meeting devoted to the problems of threshold. In relation to problems of particle size, Dr. Stanton and his colleague Dr. Layard described certain experiments they had done to see whether the carcinogenic effect that we found in these various materials was a carcinogenic effect peculiar to asbestos or whether it was an effect one would get from any particles of that size and of the same dimensions. The animal studies that Dr. Stanton described would seem to indicate that the very long, thin particles, longer than 8μ (I did not make a note of the diameter), but long thin particles, were the most carcinogenic. Stanton very carefully, it seemed to me, said these are (in answers to questions) the most carcinogenic, but he did not find a line below which you find materials which are not carcinogenic, that you could be certain that they are not carcinogenic. He said no he could not find such a line. It was just that these were more carcinogenic than others; the carcinogenicity fell off as the particles got shorter and stubbier, but he did not find any sharp line of demarcation. Now, this is a problem for the regulatory agencies because they have set a measure relating to the size of the particle.

There was then discussion concerning the sort of thing that Stanton had done, because he installs these particles where they can have their effect. People raised many questions about asbestos in the ambient air and problems that would be associated with such things as ubiquitous asbestos, most of which are smaller particles than the ones people are industrially exposed to. The questioning addressed - what about inhalation studies? The remark was made that with very few exceptions, the inhalation studies were not particularly well done. A nice reference was made to Dr. Gross saying that his studies were well done, and the remark further carried that the inhalation studies had not shown the same sorts of effects as the installation studies had shown. This brings to my mind the similar problem we have with tobacco carcinogenesis, where again in the inhalation studies, unless done in some very peculiar way, by slitting the trachea in the neck of the dog and having the dog smoke through the slit, nobody has produced, so far as I know, lung cancers in any of the experimental animals. So the inhalation studies still have some serious difficulties with them. A question was raised by Dr. Ross, a geologist, about these ambient materials and the problems that strict standards would raise for small businesses. I think Dr. Ross' hope is that one could establish that there were particles sizes or materials or levels that were in some sense absolutely safe. These economic problems might not be loaded on the small businesses. It seemed to me what we had was a general agreement on the carcinogenesis of these materials, and their capability of causing other illnesses and a very large set of statements of all kinds of things we just don't know, and all kinds of things that we still need to have some work on. I have tried to list those for you.

IDENTIFICATION OF SELECTED SILICATE MINERALS AND THEIR ASBESTIFORM VARIETIES

William J. Campbell

Particulate Mineralogy Unit, Bureau of Mines
College Park Metallurgy Research Center
College Park, Maryland 20740

Abstract

The problem of asbestiform particulates with its environmental and health implications has been compounded by the lack of precision with which the term "asbestos" has been used. In many instances, non-asbestiform mineral particles have been identified as microscopic fibers of asbestos-related minerals. This lack of precision in identifying these particulates not only works to the disadvantage of the minerals industry, but is also a handicap to rational science-based decision making by regulatory agencies.

This presentation summarizes methods and terminology suggested by the Bureau of Mines for the identification and characterization of asbestiform minerals and also sharpens the distinction between common serpentine and amphibole minerals and their relatively rare asbestiform varieties.¹ The continuing effort of the Bureau's Particulate Mineralogy Unit is to characterize mineral particles by morphological, compositional, and structural data using various instrumental analytical techniques and by developing new methods for identification and characterization.

Key Words: Asbestos; cleavage fragments; fibers; silicate minerals.

Introduction

The objective of this paper is to present a general introduction on the identification and characterization of asbestos-related minerals. Detailed discussions of specific analytical techniques are given in other papers presented at this workshop. At present there are three types of identification-characterization to supply the needs of regulatory agencies, medical researchers, and mineral scientists. It is hoped that through interactions such as this workshop a common mineralogical-based procedure can be developed that meets the needs of all concerned groups.

Until recently, emphasis in the United States was placed on occupational exposure of employees manufacturing or using asbestos products for insulation and other applications. Regulatory procedures were adopted from those used in Great Britain. The industrial-hygiene identification procedures were acceptable to industry, health, and regulatory organizations because the concern was restricted to several mineral products known collectively as asbestos. Although light optical microscopic procedures counted only the larger particles collected on the air filters, the procedure was adequate for correlating

¹This paper is an abbreviated version of the sections on mineral identification and characterization in Bureau of Mines Information Circular 8751 - Selected Silicate Minerals and Their Asbestiform Varieties: Definitions and Identification-Characterization, 1977, 56 pp, authored by W. J. Campbell, R. L. Blake, L. L. Brown, E. E. Cather, and J. J. Sjoberg. Copies of IC 8751 are available upon request to W. J. Campbell.

health effects to the number of fibers observed. Exact definitions for asbestos-related mineralogical terms were essential since all three groups (industry, health, and regulatory) clearly understood what was being counted and regulated.

The light optical microscopic procedures used by industrial hygienists were designed for control of asbestos-processing operations in which the chrysotile and asbestiform amphiboles are present as bundles of fibers as well as individual fibers [1]². These bundles may have an average diameter of 0.75 to 1.5 μm for chrysotile and 1.5 to 4.0 μm for the amphibole asbestos [2]. Particulates of these sizes can be readily observed at a magnification of X 450 to X 500. In contrast, samples from ambient air and personnel air monitors may consist of individual fibrils or small bundles of chrysotile 0.02 to 0.1 μm in diameter, and/or amphiboles 0.1 to 0.2 μm in diameter [3]. Fibrils and small fibers in this size range are not visible with the conventional light optical microscopic procedures. Therefore, the identification procedures currently used for regulating the U. S. mineral producing and consuming industries must be reexamined to insure that they are both mineralogically correct and applicable to the size range of the particles being regulated.

This discussion will be limited to the selected silicate minerals and their asbestiform varieties listed in Table 1. The objective is to point out the particle size at which the minerals can be identified and characterized by various analytical techniques [4]. Detailed descriptions of the various analytical and characterization techniques are available in numerous publications and textbooks.

Table 1. Selected silicate minerals and their asbestiform varieties.

<u>Mineral</u>	<u>Asbestiform variety</u>
AMPHIBOLE GROUP	
Anthophyllite: $(\text{Mg}, \text{Fe}^{+2})_7 \text{Si}_8\text{O}_{22}(\text{OH}, \text{F})_2$	Anthophyllite asbestos.
Cummingtonite-grunerite: $(\text{Mg}, \text{Fe}^{+2})_7 \text{Si}_8\text{O}_{22}(\text{OH})_2$	Cummingtonite-grunerite asbestos.
Tremolite-actinolite: $\text{Ca}_2(\text{Mg}, \text{Fe}^{+2})_5 \text{Si}_8\text{O}_{22}(\text{OH}, \text{F})_2$	Tremolite-actinolite asbestos.
Riebeckite: $\text{Na}_2\text{Fe}_3^{+2} \text{Fe}_2^{+3} \text{Si}_8\text{O}_{22}(\text{OH}, \text{F})_2$	Crocidolite.
SERPENTINE GROUP	
Serpentine: $\text{Mg}_6\text{Si}_4\text{O}_{10}(\text{OH})_8$	Chrysotile.

²Figures in brackets indicate the literature references at the end of this paper.

A crystalline mineral is defined primarily by its crystal structure and by its definite composition or range of compositions. Therefore, any system of mineral identification should be based principally on crystal structure and chemical criteria. Additional characteristics have to be determined to distinguish varieties. These varieties have similar basic crystal structures and composition, but are usually differentiated macroscopically by the characteristic habits and/or other specific features of the varieties. The objective is to summarize the methodology for identifying the mineral first by mineral group (such as serpentine and amphibole), then by mineral (actinolite, anthophyllite, or chrysotile), and finally by mineral variety.

Macroscopic Samples

At the macroscopic level (easily visible by the unaided eye), the obvious feature of the asbestiform varieties is the presence of fibers that can be easily separated, while the nonasbestiform varieties have a massive, blocky, bladed, or columnar appearance. Although chrysotile does occur very rarely in a nonasbestiform habit, in general the distinction between chrysotile and serpentine can be based on the presence or absence of separable fibers. In some serpentine samples where an obvious asbestos texture is not displayed, the distinction between serpentine varieties may require more specialized techniques [5,6]. The distinction between serpentine and amphibole minerals at the macroscopic level can be made by elemental analysis, differential thermal analysis, and x-ray diffraction techniques. For essentially pure samples, these techniques should also be sufficient to identify the individual amphibole minerals based on the elemental composition corresponding to the various members of the solid solution series.

Many macroscopic samples of interest to the occupational and environmental health personnel may contain low percentages of asbestiform minerals (for example, chrysotile in serpentine and tremolite asbestos in talc). As a supplement to optical microscopy, the presence or absence of serpentine or amphibole minerals can be determined in 10- to 100-mg samples by instrumental techniques such as x-ray diffraction, differential thermal analysis, or infrared spectrophotometry. In general, the sensitivity of these instrumental methods is approximately 1.0 weight-percent. Sensitivity is significantly affected by the presence of other minerals that give a response at or near the response peak of the serpentine and amphibole minerals. It is important to note that these methods usually only distinguish between mineral groups; light optical or electron optical microscopy is required to obtain morphological characteristics necessary to identify varieties of the same material.

Chemical characterization is generally necessary to assign a specific mineral name to an amphibole whose structure is known. The amphiboles have been described [7] using the structural formula $W_{0-1}X_2Y_5Z_8O_{22}(OH,O,F)_2$. Generally, $W = Na, K$; $X = Na, Ca, Mg, Fe^{2+}, Mn$; $Y = Al, Fe^{3+}, Ti$; and $Z = Si, Al$. In addition to the variation implied by the structural formula, a chemical analysis must take into account inclusions of other minerals that may be present. In contrast to the more formidable task of chemical characterization of amphiboles, the serpentine minerals generally show little deviation from the formula $Mg_3Si_2O_5(OH)_4$. For either structural or chemical characterization of a macroscopic sample, sufficient time must be spent in sample preparation to insure that relatively pure minerals are being examined.

Microscopic Samples

The petrographic microscope provides a general method by which particles larger than 5 μm can be characterized. By observing the optical properties characteristic of the structure and chemistry of a mineral, an experienced microscopist can distinguish amphiboles from serpentines and, in some cases, distinguish individual minerals within these groups [8]. The refractive indices are sufficiently different for the serpentine and amphibole groups to make a distinction between groups by using the appropriate index oil (Table 2). There is significant overlap in the range of the three refractive indices among the amphiboles, but a specific index (for example, α , β , or γ) can be determined to aid in identifying the amphibole species. Optical relationships can be confused, however, if the particle consists of fiber bundles or is some other form of crystalline aggregate.

Table 2. Refractive indices for the serpentine group and selected amphibole minerals.

	<u>Refractive index</u>	<u>Range of values</u>
Chrysotile	α	1.493 - 1.560
	β	1.504 - 1.550
	γ	1.517 - 1.562
Antigorite-lizardite	α	1.538 - 1.564
	γ	1.546 - 1.573
Anthophyllite	α	1.596 - 1.652
	β	1.605 - 1.662
	γ	1.615 - 1.676
Actinolite-tremolite	α	1.599 - 1.668
	β	1.612 - 1.680
	γ	1.622 - 1.688
Cummingtonite-grunerite	α	1.635 - 1.696
	β	1.644 - 1.709
	γ	1.655 - 1.729
Riebeckite	α	1.654 - 1.701
	β	1.662 - 1.711
	γ	1.668 - 1.717

The well-known parallel extinction of the commercial asbestos known as Amosite can be used to distinguish that variety from the nonasbestiform varieties of cummingtonite and actinolite. A method of using extinction angles and cleavage directions to distinguish specific asbestiform and nonasbestiform amphiboles has been described [9]; however, this technique is limited to particles with diameters greater than about 5 μm and cannot be universally applied to all amphiboles. There are many other optical parameters such as pleochroism, sign of the elongation, and color that are easy to obtain. Other parameters such as optic axial angle, optical orientation, and optic sign are relatively more difficult to obtain.

Except for the asbestiform variety, serpentines are usually massive, while amphiboles range from fine-grained massive to columnar or radiating aggregates of prismatic or acicular crystals. Amphiboles in acicular habit may appear to grade into the asbestiform varieties. The characteristic features of this habit may still be seen by electron microscopy. Terms such as "acicular" or "prismatic" may still be applied when seen, but the term "asbestiform" begins to lose its usefulness. For example, how may flexibility be demonstrated in a 2- μm bundle of fibers? As particle size decreases, the inability to manipulate the mineral grains restricts the use of the term "asbestiform" without altering the original sense of the word. High magnification necessitates the use of strictly dimensional terms such as size and aspect ratios to accurately describe the morphology of the amphiboles and serpentines. The degree of morphologic characterization possibly will depend on the magnification being used. An asbestos particle being described as a single fiber at low magnification may be seen to be a bundle of fibers at some high magnification. Therefore, the magnification must be stated in the description. Morphologic characterization using light microscopy can be accomplished on particles as small as a few micrometers. Electron optics can be used to characterize a wide range of sizes extending down to a few angstroms. Morphologic characterization alone will not identify a mineral without supplemental structural or chemical data.

Structural information on individual particulates can be obtained by use of a transmission electron microscope (TEM) in the selective area electron diffraction mode (SAED). The inclination of the single crystal fragments to the electron beam is very critical since a slight tilt of the crystal may change a relatively simple reciprocal

lattice pattern into a very complex one. Consequently, a special goniometer or tilting stage is necessary to obtain easily interpretable diffraction patterns. For the identification of the mineral, a goniometer or tilting stage is even more essential since dependable conclusions cannot be made from measurements on one reciprocal lattice plane. The quality of the SAED pattern is a function of fiber diameter. The larger diameter fibers ($>0.5 \mu\text{m}$) strongly absorb the 60- to 100-keV electrons used in a conventional TEM, while the very small-diameter fibers ($<0.2 \mu\text{m}$) do not give sufficient electron-diffraction intensity. A second problem with small-diameter fibers is the degradation of the single-crystal pattern by diffraction lines from nearby particles. A higher energy TEM, with the resultant greater penetration of the electron beam, can be utilized for large-diameter particles. However, these costly instruments are not widely available.

Although the magnitude of the characteristic C, the distance between the conspicuous layer lines for chrysotile and the amphiboles, is similar in direct space ($d_{001} \sim 5.3\text{\AA}$), the chrysotile pattern has very prominent streaks on these layer lines compared with the spot pattern for the amphiboles [10]. Researchers indicate that the ability to distinguish between the fibrous and nonfibrous variety of amphiboles by SAED is still to be resolved.

At the very high magnification available with a TEM, chrysotile's hollow-tube (scroll-like) structure, approximately 5 nm in diameter, is visible (fig. 1). This hollow-tube structure, together with chemical and structural data regarding the sample, is sufficient to identify the mineral variety. However, the hollow-tube structure is only visible for individual fibrils; fibers (composed of several fibrils) will not display this characteristic because of stacking of the fibrils.

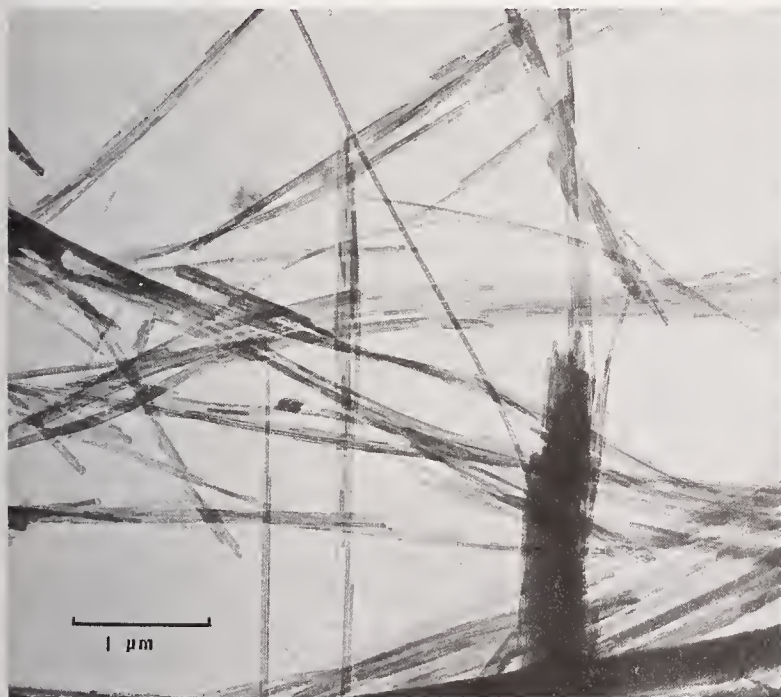

Figure 1. Chrysotile, showing individual fibrils, at two magnifications: X 18,000 (left) and X 35,000 (right). The hollow-tube structure is visible at the higher magnification. (TEM microphotographs.)

The elemental composition of microscopic grains is determined by either wavelength or energy-dispersive x-ray spectrography in conjunction with scanning or transmission electron microscopy. Extreme care must be taken in the calculation of elemental concentrations from x-ray spectral intensities because the spectral line intensities ($\text{FeK}\alpha$, $\text{MgK}\alpha$, $\text{CaK}\alpha$, relative to $\text{SiK}\alpha$) are dependent on particle diameter for small fibers [3].

Energy-dispersive x-ray spectral calibration data for each scanning or transmission electron microscope must be made using relatively pure standard minerals analyzed by accepted chemical-instrumental techniques. The analyst should be aware that other nearby grains may be contributing to the characteristic x-ray lines because of either penetration of the electron beam through the particles or secondary excitation of nearby particles from primary x-rays generated in the particle being measured. Modern electron optical instruments have electron beam diameters of 0.1 to 0.01 μm ; however, the sphere of excitation can be several micrometers in diameter as a result of scattered electrons and primary x-rays generated in this particle. Conversion of intensity into concentration using accepted computer programs such as "MAGIC" is limited in accuracy because these programs are designed for use with grains or particles several micrometers in diameter or larger, whereas the average mineral fiber diameter is less than 0.5 μm for chrysotile. A good example is the diameter size distribution of chrysotile fibers in ambient air samples (Table 3). The important point to note is that approximately 95 percent of these chrysotile fibers are 0.12 μm or less in diameter. Therefore, quantitative correction procedures applicable to large particles will be of limited value in mineral-fiber identification because the relative x-ray spectral intensities are dependent on fiber diameter below 0.2 μm .

Table 3. Frequency distribution of the width of chrysotile fibers in ambient-air samples, ^a percent.

Diameter of chrysotile fibers, μm	Sample					
	1	2	3	4	5	6
0.02 - <0.04	10	70	57	17	15	17
0.04 - <0.06	47	24	28	29	33	49
0.06 - <0.08	24	5	8	28	20	15
0.08 - <0.10	14	1	2	12	26	6
0.10 - <0.12	2	0	1	7	3	6
0.12 - <0.14	0	0	2	3	1	1
0.14 - <0.16	1	0	1	2	1	1
0.16 - <0.18	0	0	0	1	0	1
0.18 - <0.20	0	0	0	0	1	1
0.20 - <0.22	1	0	0	0	0	1
0.22 - 0.24	0	0	1	0	0	1
>0.24	1	0	0	1	0	1

^a Samples were collected 1-2 miles from a serpentine rock quarry.

Another problem with the elemental characterization of very small particles is the poor signal-to-background ratio. Longer counting times will help to improve the reliability of the measurement, but the best approach is to minimize the continuum background resulting from the interaction of the electron beam and the sample substrate.

This section addresses the practical considerations and limitations encountered when applying nomenclature and identification-characterization procedures to regulatory and environmental samples.

Applying Morphological Terminology

One of the obvious features of minerals and their particulates is their morphology or shape. The need for precise definitions of terms such as "asbestiform," "fiber," "cleavage fragment," and "fibril" was explained in IC 8751. These definitions were carefully structured to eliminate ambiguity and to be technically correct. Applying the definitions to samples requires careful thought as to what limits must be placed on interpretations resulting from the use of these terms and other mineralogical concepts. The underlying problem, recognized by both medical and regulatory personnel, is classifying the mineral particle as the asbestiform or nonasbestiform variety. In a mineralogical sense, the source of the mineral particulates must be considered, as explained in the following discussion.

Particulates From A Known Asbestiform Serpentine or Amphibole Source

The definition of asbestiform minerals includes three aspects: morphology, structure, and chemistry. Morphologically, asbestiform mineral varieties separate into flexible fibers or flexible bundles of fibers. Flexible fibers bend readily and only break across the fibers into distinct pieces with some difficulty. Structurally, the asbestiform minerals are limited, in common practice, to the serpentine and amphibole mineral groups. Chemically, these minerals are all hydroxylated silicates; the term "hydroxylated" is preferred over "hydrated" because these minerals contain OH ions rather than water of crystallization. The serpentines contain approximately 13 weight-percent water; the amphiboles, approximately 2.5 weight-percent water.

For the purpose of this discussion, assume that a hand specimen meeting these requirements is correctly identified as an asbestiform mineral. If this sample is crushed and its fragments examined at various magnifications, its fibrous nature would be apparent. These elongated fragments would be termed "fibers" and "bundles of fibers," and with the other available information would be called "asbestiform." As these asbestiform particles are examined at increasing magnification, smaller particles become visible, while the image of large fibers and fiber bundles may exceed the field of the microscope. At increasingly smaller sizes, while fibers or bundles of fibers are still the predominant shape, a few of the fibers are observed to have broken into shorter and shorter segments. These very short fiber segments are no longer described as fibers, but would be classified as fragments of fibers, or cleavage fragments if one or more cleavage planes govern their shape. Therefore, a known asbestiform sample would show an increase in the ratio of fiber fragments to fibers with a decrease in particle size.

Particulates From A Known Nonasbestiform Serpentine or Amphibole Source

If the hand specimen discussed previously does not separate into flexible fibers or bundles of fibers, the mineral would not be considered asbestiform. However, the specimen would be classified as serpentine or amphibole if the specific mineral is identified on the basis of optical properties, chemistry, and structure.

If crushed fragments of this known nonasbestiform mineral are examined at various magnifications, the particles would be primarily cleavage fragments, or irregularly broken fragments if cleavage does not govern breakage. However, a few elongated particles may resemble a fiber in appearance to the degree that they may be indistinguishable morphologically from fibers derived from an asbestiform mineral sample.

What can be stated morphologically about particles derived from crushing a known nonasbestiform mineral is that most of the particles are cleavage fragments with non-asbestiform texture; a few are fibrous in appearance, particularly at low magnification; and all of the particles are known to be derived from a nonasbestiform source.

Comparison of Particulates From Known Serpentine and Amphibole Minerals and Their Asbestiform Varieties

The appearance of particles generated by milling known serpentine and amphibole minerals and their asbestiform varieties is shown in figures 2 to 5. The samples shown in figures 2 to 4 were photographed using light optical microscopy at three magnifications to show that, at decreasing size (depicted by increasing magnification), the original habit generally persists. For the nonasbestiform amphibole minerals, there were a few elongated particles from the riebeckite and tremolite. Elongated particles of this type are typical of the prismatic cleavage of amphiboles. To increase optical contrast, the serpentine group samples were dispersed in an immersion oil considerably below the refractive indices for the serpentine.

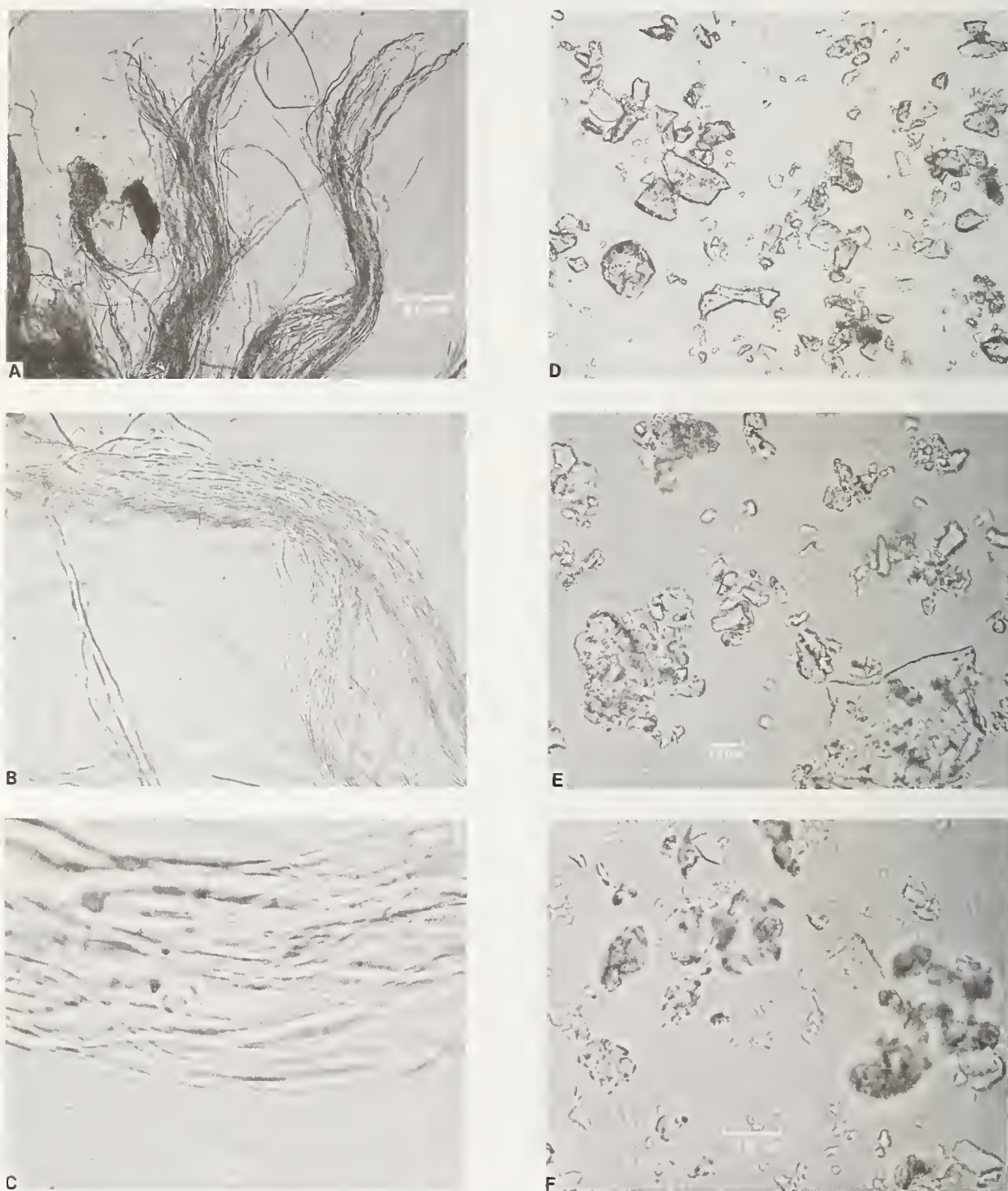

Figure 2. Light optical photomicrographs of chrysotile and antigorite-lizardite at three magnifications. Chrysotile (left) at A, X 100; B, X 500; and C, X 950. Antigorite-lizardite (right) at D, X 100; E, X 500; and F, X 950.

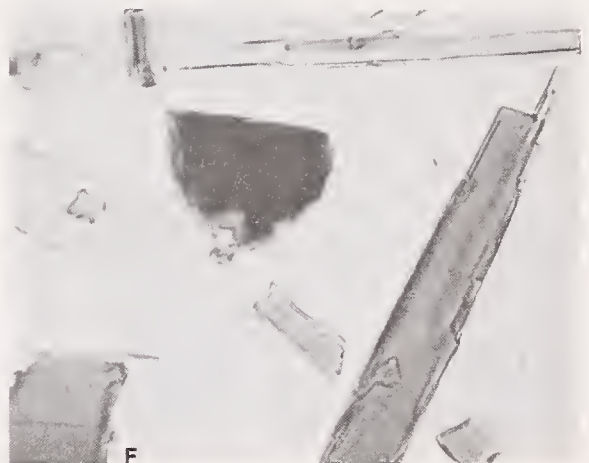
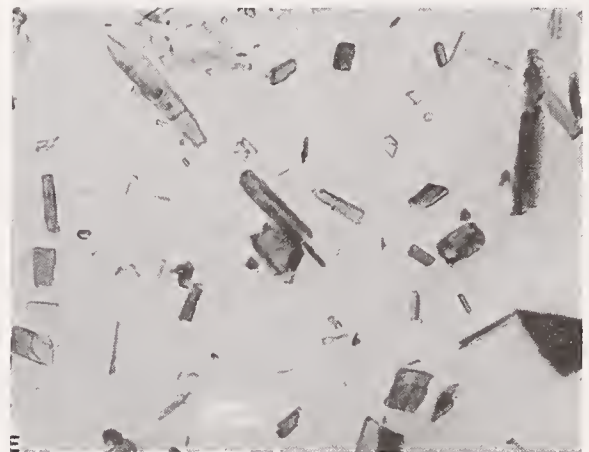

Figure 3. Light optical photomicrographs of crocidolite and riebeckite at three magnifications; Crocidolite (left) at A, X 100; B, X 500; and C, X 950. Riebeckite (right) at D, X 100; E, X 500; and F, X 950.

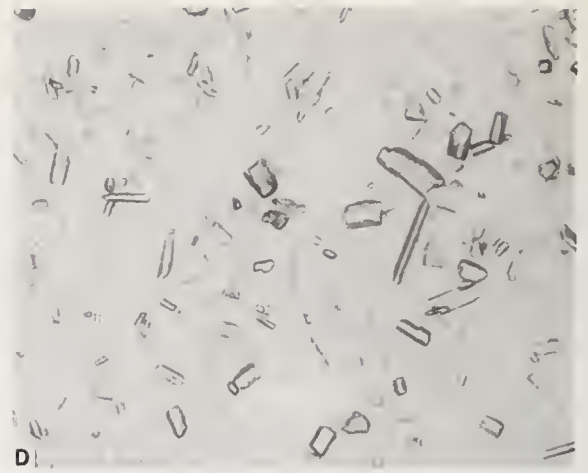

Figure 4. Light optical photomicrographs of tremolite asbestos and tremolite at three magnifications. Tremolite asbestos (left) at A, X 100; B, X 500; and C, X 950. Tremolite (right) at D, X 100; E, X 500; and F, X 950.

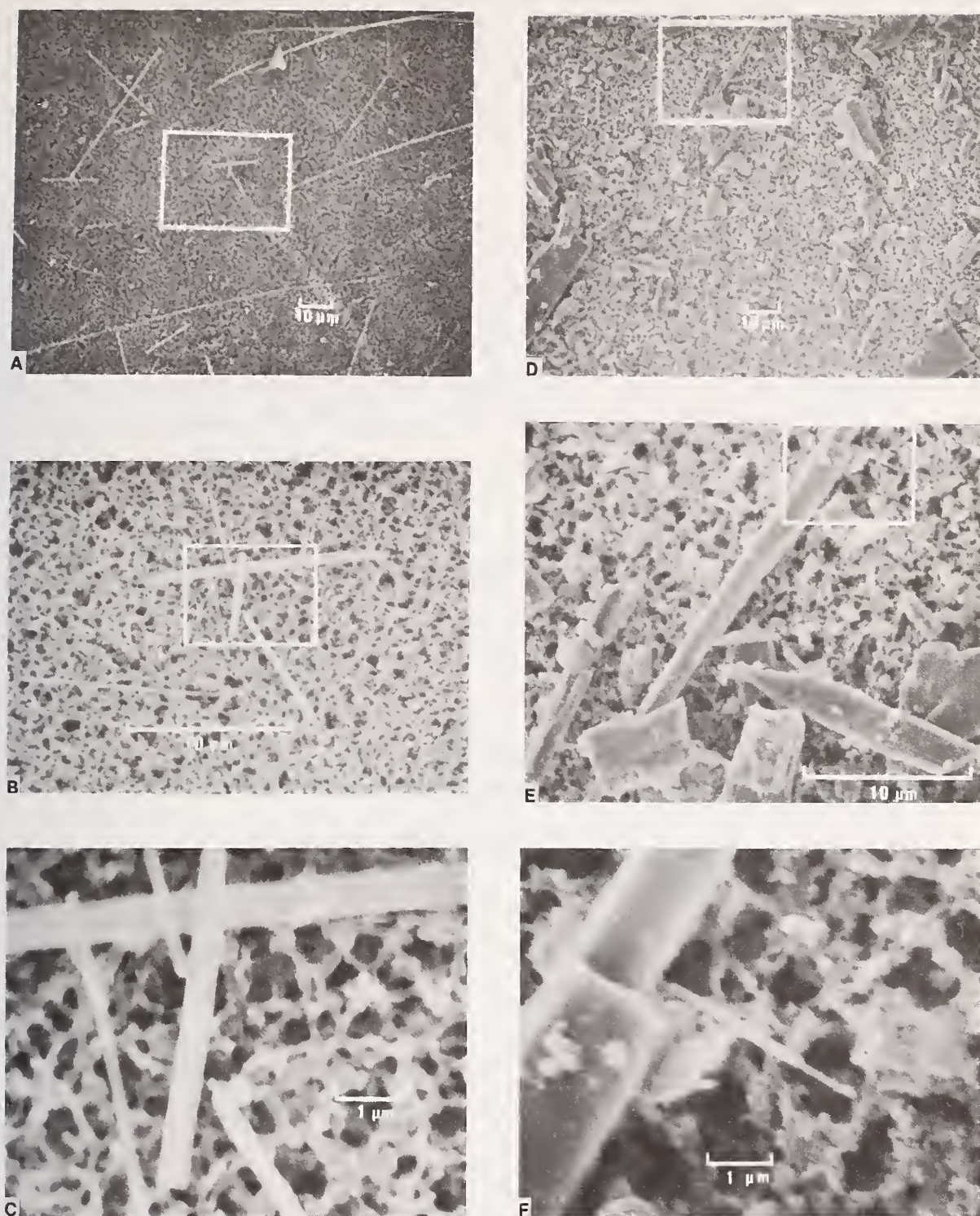

Figure 5. SEM photomicrographs of crocidolite and riebeckite at three magnifications: Crocidolite (left) at A, X 500; B, X 2,500; and C, X 10,000. Riebeckite (right) at D, X 500; E, X 2,500; and F, X 10,000. Rectangles indicate the area shown at the next higher magnifications.

Riebeckite and crocidolite particles are compared at higher magnifications in figure 5. The outlined areas in the scanning electron micrographs indicate the area displayed at the next higher magnification. Again, note the presence of a few elongated cleavage fragments of riebeckite visible at the higher magnification. In contrast, the aspect ratio of the crocidolite will decrease with decreasing particle size because the individual fibers cannot cleave further along the fiber axis; they can only break into shorter segments.

Aspect Ratio

Existing regulatory standards are based on counting specific mineral particulates with aspect ratios of 3 to 1 or greater. The aspect ratio has little mineralogical significance for individual particulates but is applicable statistically to a large number of particles. A few relatively long thin particles are produced as cleavage fragments from the crushing and grinding of many nonasbestiform minerals. Conversely, similar milling treatment will result in a few short segments of true fibers from the asbestiform varieties. However, statistically, the length-to-width characteristics of the milled amphiboles and serpentine and their asbestiform varieties are significantly distinct, as shown by the data in figures 6 to 9.

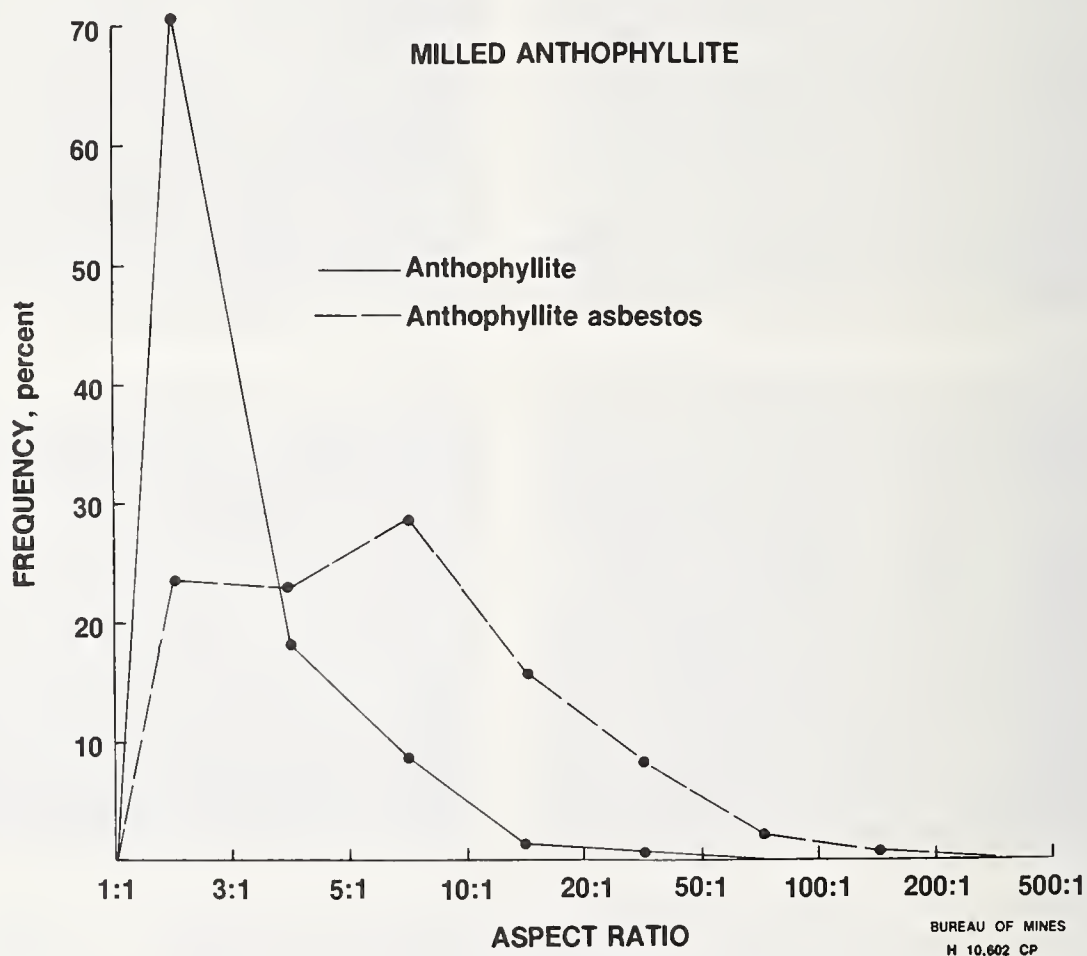

Figure 6. Frequency polygons for the aspect ratios of anthophyllite and anthophyllite asbestos.

MILLED TREMOLITE

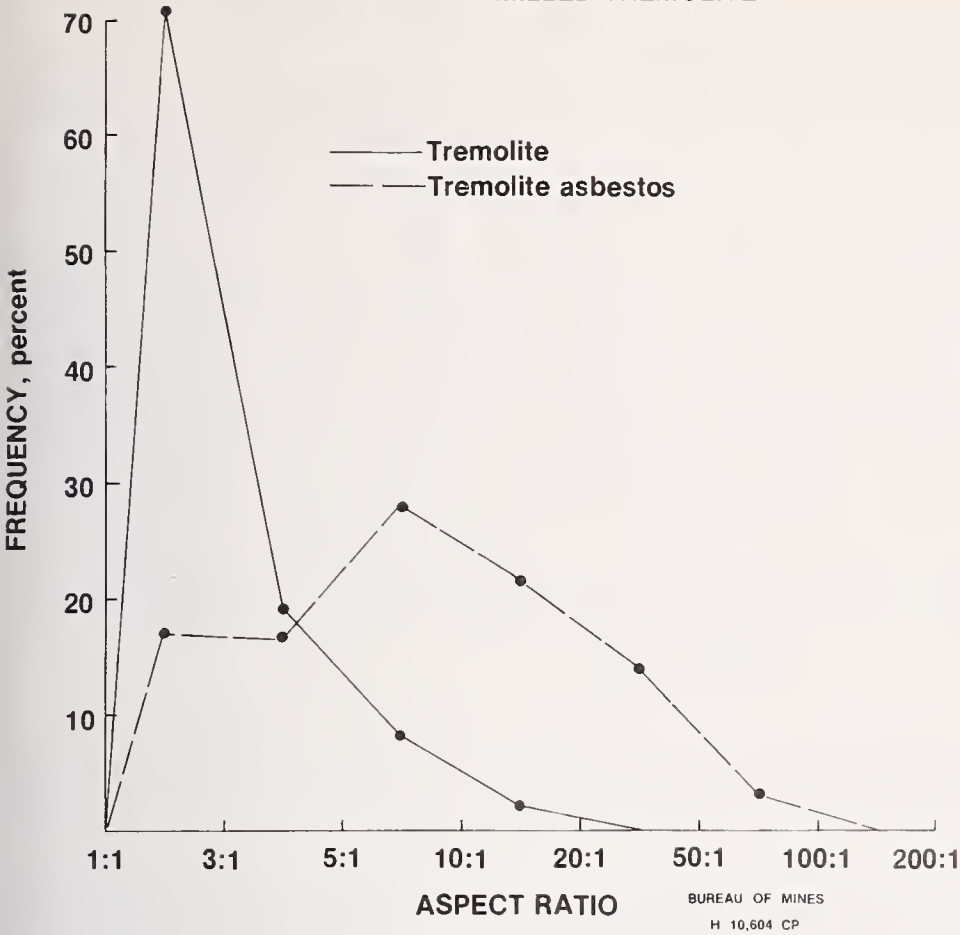

Figure 7. Frequency polygons for the aspect ratios of tremolite and tremolite asbestos.

MILLED HORNBLLENDE

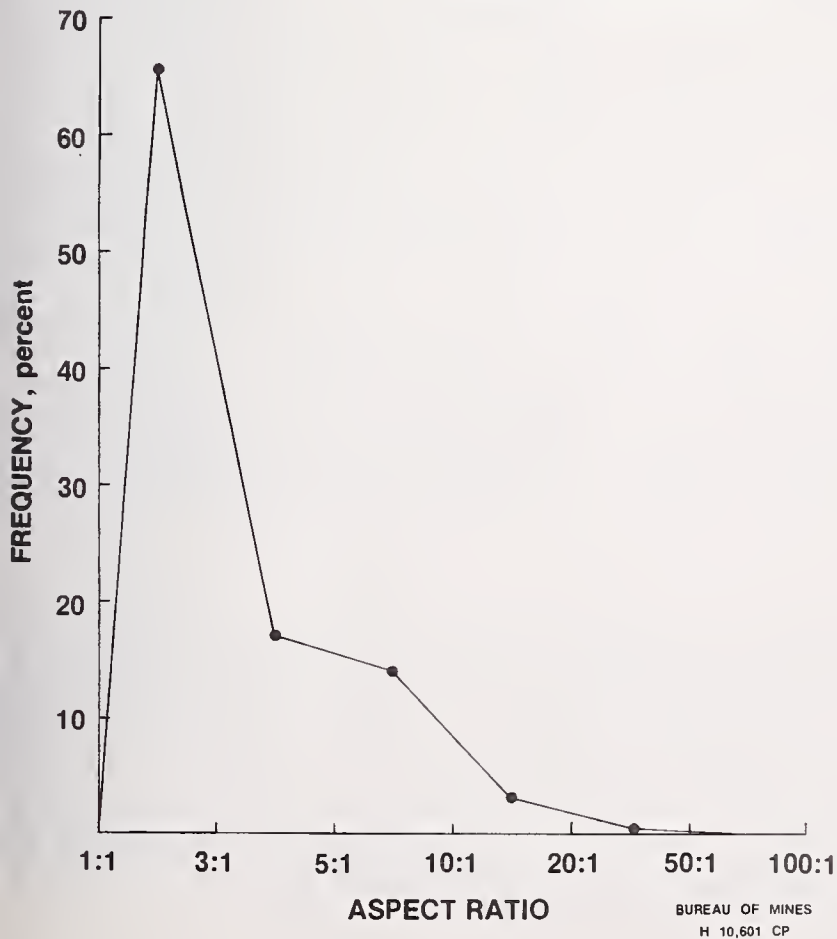

Figure 8. Frequency polygons for the aspect ratio of hornblende.

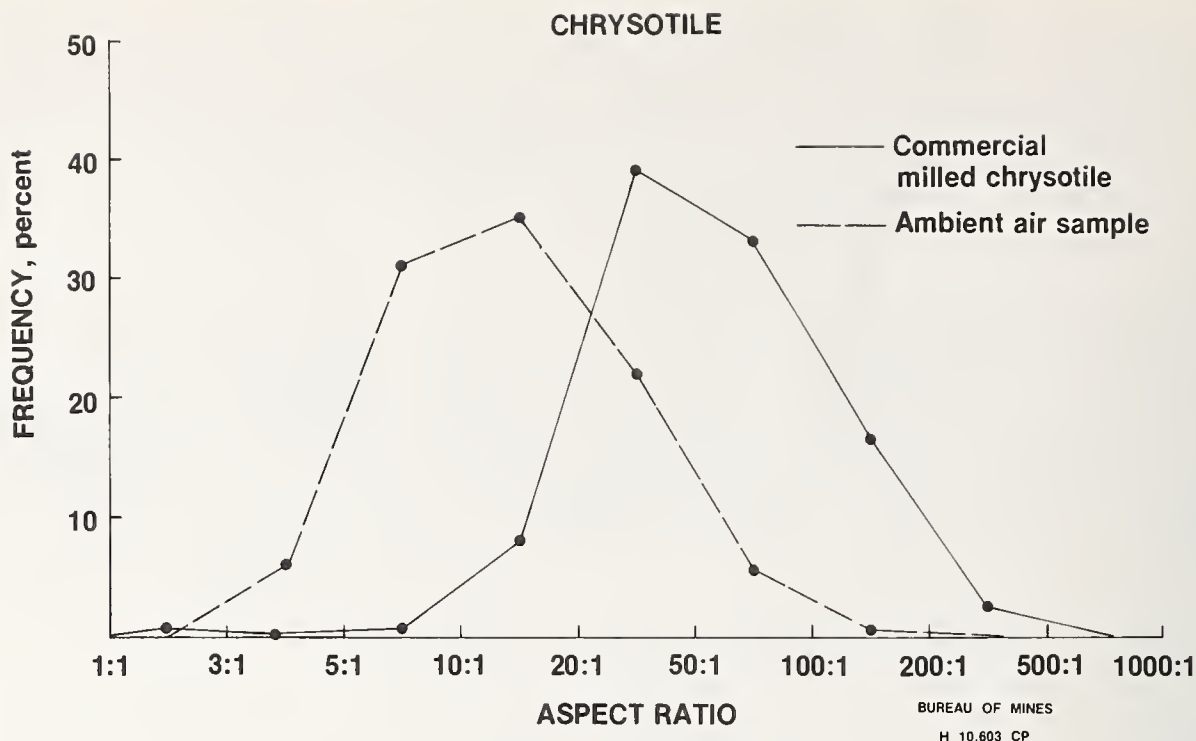

Figure 9. Frequency polygons for the aspect ratios of commercial-grade chrysotile and chrysotile in ambient air.

Figures 6, 7, and 8 show the frequency polygons of the aspect ratio distribution for milled samples of the normal nonasbestiform variety of three amphiboles--anthophyllite, tremolite, and hornblende, respectively. Note that in all three examples, approximately 70 percent of the particles have an aspect ratio of less than 3 to 1, and 95 percent of the particles have a length-to-width ratio of less than 10 to 1. The frequency distribution maxima of the aspect ratios for milled anthophyllite asbestos and tremolite asbestos are significantly higher than those for the normal, nonasbestiform variety. Thirty to forty percent of the asbestiform particulates are in the 10-to-1-or-longer class, with a significant number of particles having an aspect ratio greater than 20 to 1.

Figure 9 shows the distribution frequencies for a milled commercial grade of chrysotile asbestos and for chrysotile particulates collected on ambient air filters in the vicinity of a serpentine rock quarry. For the commercial-grade chrysotile, over 50 percent of the particles have an aspect ratio greater than 50 to 1, whereas the frequency distribution for the ambient air sample has a maximum between 10 to 1 and 20 to 1. These results are anticipated because the higher aspect ratios for the commercial-grade chrysotile are characteristic of the significantly longer starting material.

All of the aforementioned samples except the ambient air were milled, then dispersed in water for collection on a suitable substrate. The samples were then measured using electron microscopy at magnifications of 5,000 to 10,000. The ambient air sample, collected near a serpentine rock quarry, was measured using a TEM with magnifications of X 5,000 to X 32,000.

Based on these data, one test for distinguishing the presence or absence of the asbestiform variety of a mineral could be an examination of the frequency distribution of the aspect ratio for that mineral. Assuming positive identification of the mineral type, then the designation of variety would be based both on particle morphology and the frequency maximum of the aspect ratio. Cleavage fragments will generally have a frequency maximum less than 3 to 1, whereas the asbestiform varieties will fall between 10 to 1 and 20 to 1 or higher, depending on the characteristics of the mineral and the history of the sample, particularly the type and degree of milling. If any shape or size limits are placed on characterizing mineral particulates, such limits should be based on medical evidence or on some limitation of the characterizing technique and so stated.

Particulates From Unknown Sources

Samples such as environmental airborne or waterborne mineral particulates collected at a considerable distance from a possible source are examples of particulates from an unknown source. The samples could have been collected at a location so distant from a known source that other mineral particulates originating from other sources compose most of the sample.

The source of the particulates in an environmental sample may be located by taking additional samples at selected intervals in the direction of, and closer to, the suspected source. However, several factors must be considered: The direction of air and water currents with respect to the suspected source, and the proximity to and direction of other sources with regard to the suspected source. One study found very low concentration of airborne chrysotile upwind from a source compared with a concentration two orders of magnitude greater downwind [11]. Another important consideration is the level of natural or human disturbances of particulates; for example, strong versus weak winds, or heavy versus light vehicle traffic. In some instances, it may be possible to identify the source if the mineral particulates of interest have unique trace elements or combinations of elements that are specific to the probable mining or milling operation emitting the particulates. Detailed elemental analysis using the X-ray spectral capabilities of an SEM or TEM is required on both the suspected source and the particulates.

Applications

The following examples illustrate the application of mineral terminology and identification-characterization procedures to three types of problems: (1) chrysotile determination in ambient-air samples collected near a serpentine rock quarry, (2) identification of asbestiform minerals in ceilings and walls of public buildings, and (3) characterization of a mineral product. These examples illustrate, in order, the need for higher magnification than available with the light optical microscope, the use of various characterization techniques to screen and identify asbestiform minerals, and the judgment of the analyst in distinguishing cleavage fragments and asbestiform particles.

Ambient-Air Samples Collected Near Serpentine Rock Quarry

The Bureau of Mines is working with State and Federal officials to measure mineral particulates in ambient-air samples collected in the vicinity of a serpentine rock quarry. Optical microscopic procedures at about X 500 are limited to the identification of mineral particulates longer than 5 μm with an aspect ratio of 3 to 1 or larger (criteria set by the Mining Enforcement and Safety Administration and the Occupational Safety and Health Administration). The mineralogist can further identify the particles as belonging to the serpentine, amphibole, or other mineral group with index oils (Table 2).

The serpentine rock in the quarry is interlaced with small veins of chrysotile (figure 10). Optical microscopic procedures used for industrial hygiene are adequate for the detection of large chrysotile fiber bundles. These fiber bundles of commercial-grade chrysotile can be several micrometers or larger in diameter. In contrast, the mining and crushing operations in the quarry plus transport of particulates over a distance breaks bundles of fibers down to fibers or fibrils with diameters of 250 to 1,000A (Table 3).

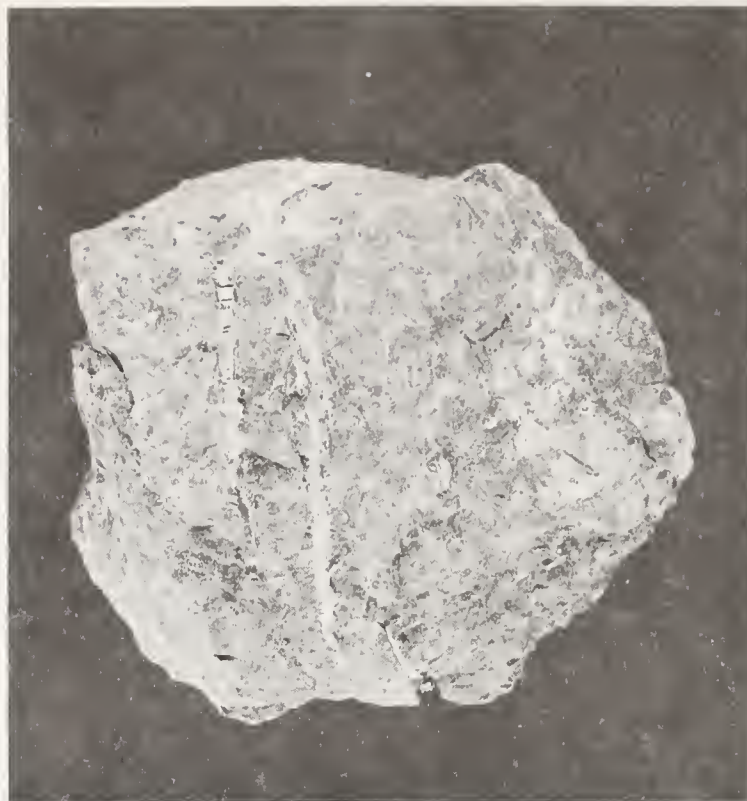

Figure 10. Macrophotograph showing chrysotile veins in serpentine rock (X 1).

Figure 11 is a series of SEM photomicrographs of a mixture of chrysotile and non-asbestiform serpentine handpicked from a small vein in the serpentine rock quarry. Note that at X 450 (corresponding to the optical microscope magnification), only one or two bundles of chrysotile are faintly visible; the predominant particles are the nonasbestiform serpentine. As the magnification is increased, the high concentration of chrysotile fibers becomes readily visible. The fiber diameter size data in Table 3 indicate that more than 95 percent of the chrysotile fibers in these ambient-air samples are below the limit of resolution of the optical microscope. Although many other scientists have pointed out the limitation of the optical procedures for chrysotile in ambient air, there is need for continuous emphasis that higher magnification techniques are necessary for environmental and regulatory samples.

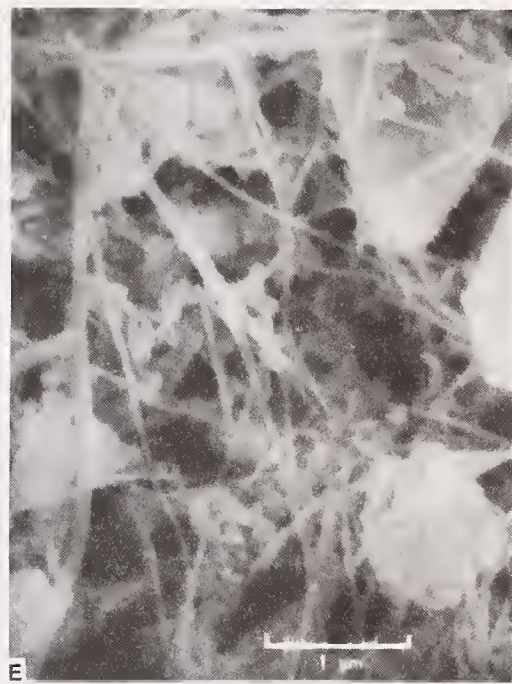
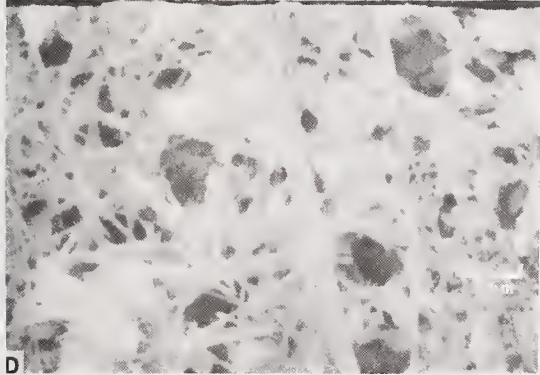
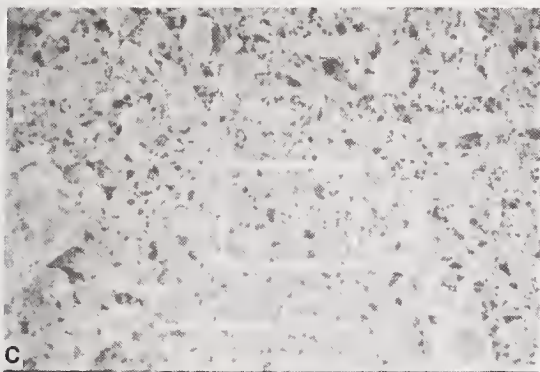
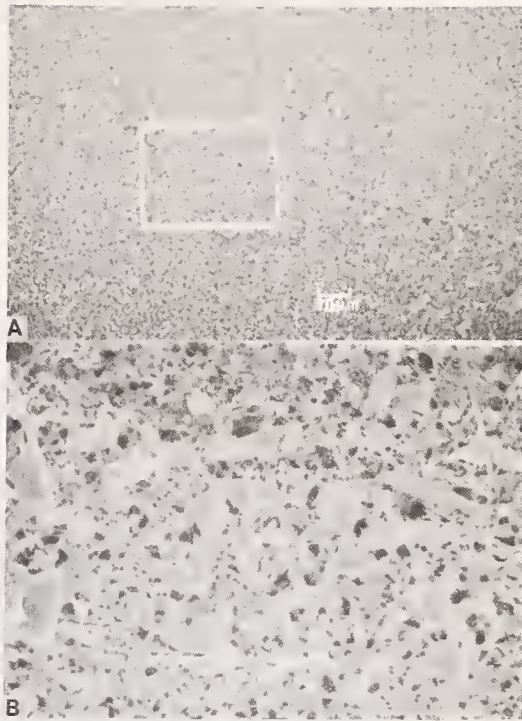

Figure 11. Mixture of nonasbestiform serpentine and chrysotile at five magnifications: A, X 450; B, X 2,250; C, X 1,800; D, X 9,000; and E, X 18,000. Rectangles indicate the area shown in the next panel.

Asbestos in Ceiling and Wall Materials

A possible environmental hazard is the release of asbestos from ceilings and walls in homes, churches, schools, and various other public and commercial buildings. Because of the very high number of potential samples to be examined by various State or Federal agencies, a rapid and reliable screening procedure is necessary to identify those samples that warrant further test. Three complementary analytical methods for screening, identification, and semi-quantitative estimate of the asbestiform mineral concentration are x-ray diffractometry, differential thermal analysis, and microscopy (light optical and scanning electron).

The screening identification procedures can be relatively simple because chrysotile is the principal asbestos mineral used for building insulation materials, with amosite used to a much lesser extent. In 18 samples from a midwestern municipal health department, chrysotile was a major constituent (>50 weight-percent) in 2 samples, a minor constituent (1 to 10 weight-percent) in 12 samples, and not detected in 4 samples. Other minerals present in various concentrations in these samples were calcite, quartz, gypsum, and mica. Amosite was found as a major constituent in the ceiling of an older building located on a university campus.

The presence of either serpentine or amphibole minerals in the insulation materials can be used as a probable indication of asbestos. Therefore, screening tests are based on the presence or absence of characteristic differential thermal analysis or x-ray diffraction peaks of either serpentine or amphibole minerals. For the positive samples, confirmation of the presence of the asbestiform variety requires some type of microscopic examination because the thermal and x-ray diffraction methods do not identify the mineral variety.

Some samples will be composed of a mixture of synthetic and natural fibers, such as the mixture of fiberglass and chrysotile shown in figure 12. Generally, it is not difficult to identify the synthetic fibers based on their larger diameter and the more uniform appearance.

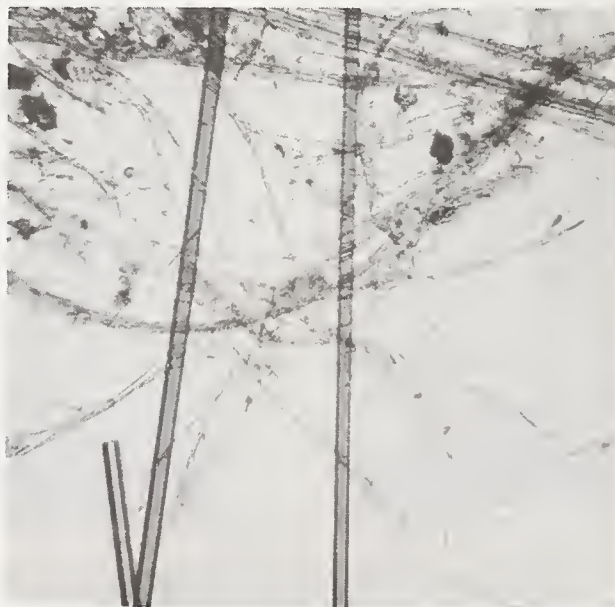

Figure 12. Sample from university building, showing a mixture of chrysotile and fiberglass (X 140).

Amphiboles and Talc

Asbestos-related health regulations are having a significant impact on the domestic talc industry from occupational exposure at the mines and mills and at various manufacturing plants that use talcs in their operations. Certification that the talc does or does not contain asbestiform minerals is important because the occupational health

requirements are much more restrictive if the talc is designated as containing asbestiform serpentine or amphibole minerals.

Talc is both the name of a specific mineral, $Mg_3Si_4O_{10}(OH)_2$, and a commercial term for a mixture of minerals ranging from essentially 100 percent talc to blends where the mineral talc is a minor constituent [12,13]. Semi-quantitative estimation of the serpentine and/or amphibole mineral concentration, if present, can be obtained by x-ray diffraction and differential thermal analysis. Several talc deposits contain a variable amount of tremolite. Therefore, the essential question faced by the analyst is whether or not the tremolite is fibrous. Judgment required of the analyst is illustrated by the sample shown in figure 13. This sample consists of platy talc, cleavage fragments of an amphibole, and minor to trace amounts of fibrous amphibole. For this latter sample, the 3-to-1 aspect-ratio criteria would greatly overestimate the number of fibrous amphibole particles collected on air filters or other monitors.



Figure 13. Platy talc, tremolite cleavage fragments, and a fibrous tremolite particle (A) (X 400).

References

- [1] Journal of the American Industrial Hygiene Association. Recommended Procedures for Sampling and Counting Asbestos Fibers. Vol. 36, pp. 83-90 (February 1973).
- [2] Berger, H., Asbestos Fundamentals. (Chemical Publishing Co., New York) 171 pp. (1963).
- [3] Beaman, D. R. and File, D. M., Quantitative Determination of Asbestos Fiber Concentrations. Anal. Chem., 48, pp. 101-110 (January 1976).
- [4] Langer, A. M., Approaches and Constraints to Identification and Quantification of Asbestos Fibers. Environmental Health Perspectives, 9, pp. 133-136 (1974).
- [5] Cressey, B. A. and Zussman, J., Electron Microscopic Studies of Serpentinites. Canadian Mineralogist, 14, pp. 307-313 (1976).
- [6] Mumpton, F. A. and Thompson, C. S., Mineralogy and Origin of the Coalinga Asbestos Deposit. Clays and Clay Minerals, 23, pp. 131-143 (1975).
- [7] Ernst, W. G., Earth Materials (Prentice-Hall, Inc., New York, 1969).

- [8] Deer, W. A., Howie, H. A., and Zussman, J., Rock Forming Minerals. (John Wiley & Sons, Inc., New York, 1963) 5 v.
- [9] Wylie, A., Optical Properties of Asbestiform Amphiboles and Their Nonasbestiform Analogs. Available from A. Wylie, Bureau of Mines, College Park, Maryland 20740.
- [10] Ruud, C. O., Barrett, C. S., Rissell, P. A., and Clark, R. L., Selected Area Electron Diffraction and Energy Dispersive X-Ray Analyses for the Identification of Asbestos Fibres, a Comparison, Micron, 7, pp. 115-132 (1976).
- [11] John, W., Berner, A., Smith, G., and Wesolowski, J. J., Experimental Determination of the Number and Size of Asbestos Fibers in Ambient Air. Calif. State Department of Health, Rept. AIHL/SP-1, 36 pp. (January 1976).
- [12] Hamer, D. H., Rolle, F. R., and Schelz, J. P., Characterization of Talc and Associated Minerals. J. American Industrial Hygiene Association, 37, pp. 296-304 (May 1976).
- [13] Rohl, A. N., Langer, A. M., Selikoff, I. J., Tordini, A., Klimentidis, R., Bowes, D. R., and Skinner, D. L., Consumer Talcums and Powders--Mineral and Chemical Characterization. J. Toxicology and Environmental Health, 2, pp. 255-284 (1976).

Discussion

J. LEINEWEBER: You brought up the question of cleavage fragments vs fibers, and asbestiform vs non-asbestiform varieties. I would like to ask why you attach so much significance to this. I think Dr. Kotin couched it most directly yesterday: the body doesn't have a dictionary. When we see fibers, if they are in the size range and if we accept this philosophy, does it matter where they come from?

W. CAMPBELL: I think all health data has been based on commercial asbestos, correct?

LEINEWEBER: Not necessarily commercial asbestos, but fibers of one type or another.

CAMPBELL: OK, fibers.

LEINEWEBER: Man-made mineral fibers or natural mineral fibers.

CAMPBELL: There has been little medical studies made upon cleavage fragments. Now these may be just as harmful as fibers, but until you find this out you should call them by their proper names. To call a cleavage fragment a fiber does not help anybody.

LEINEWEBER: I don't see any reason for muddying the waters with the semantic differences.

CAMPBELL: I think there is some dispute whether or not there is a difference between a fiber, based on surface properties and a much larger length-to-width, and a cleavage fragment. Until you find this out you should call it either a fiber or a cleavage fragment. They may be equally harmful if they are both 20:1 and 0.5 μm in diameter, but this really has not been studied. The whole problem with the Lake Superior region was the debate whether or not the cummingtonite fragments were the same as the amosite asbestos.

LEINEWEBER: This, in that context, was an argument based on the shenanigans that normally take place in the court of law, and here we are in a scientific environment.

CAMPBELL: I am not a medical scientist. Obviously I don't know if a cleavage fragment is the same harmful particle as an asbestiform particle, but until you find this out; you just call it by the proper name. It does not help to call them both the same when they may be different.

AN OVERVIEW OF ELECTRON MICROSCOPY METHODS

Clayton O. Ruud

Denver Research Institute
University of Denver
Denver, Colorado 80208

Abstract

According to a recent National Academy of Sciences Report, animal deposition model studies have shown the fiber size has some effect upon the toxicity of mineral microfibers, the long thin ones appearing to be most active [1]¹. However, the extrapolation of these results to the relative carcinogenicity in humans must be tempered by the consideration that an experimental animal model has not been established. Moreover, the size range to be considered long, thin microfibers is not clearly defined, that is to say, the shortest length may be on the order of one micrometer or ten micrometers. For this and other reasons most scientists in the field consider that it is necessary to obtain data on length and width, as well as on concentration and species of mineral fiber fragments in the environment.

Due to these considerations, microscopy methods are necessary for mineral fiber analysis, and because of the small size of the particles, electron microscopy is necessary. This paper will describe the methods and techniques of electron microscopy which are most generally applied. These are the transmission electron microscope-selected area electron diffraction (TEM-SAED) and the scanning electron microscope-energy dispersive x-ray spectroscopy (SEM-EDXS) methods. The advantages and disadvantages of these two techniques will be discussed, including their relative proficiency in detecting sub-micrometer fiber fragments. Their ability to identify the species of mineral, sample preparation techniques, statistical considerations and the cost of analysis will also be reviewed.

The application of various techniques and methods based upon the TEM-SAED or SEM-EDXS systems will be discussed, including situations where one or the other is the optimum method. The advantages of combined systems, scanning transmission electron microscopy with SAED and EDXS, will be discussed. Also new approaches of combination and computer controlled methods using both TEM and SEM will be described.

In conclusion, the state of the art will be discussed in terms of general considerations necessary for the selection of an electron microscopy technique for mineral fiber analysis.

Key Words: Amphibole asbestos; asbestos; chrysotile; electron diffraction; energy-dispersive x-ray spectroscopy; mineral microfibers; scanning electron microscopy; selected-area electron diffraction; transmission electron microscopy.

¹Figures in brackets indicate the literature references at the end of this paper.

Background

Collection of mineral particles for identification and counting is usually done by filtering the medium, air or water, through cellulose ester membrane (Millipore) or perforated polycarbonate (Nuclepore) filters, thereby concentrating them through deposition on the filter's surface. The effective minimum particle collection size is always less than one half a micrometer.

The optical microscope is used extensively for counting mineral fibers collected from occupational environments, but it is generally agreed that this is a matter of expedience and not due to adequacy. By far the greatest number of asbestos mineral fibers found in the environment, including occupational environments, are below the resolving power of the optical microscope. Since neither epidemiology nor animal studies on the relative toxicity of mineral microfiber have shown conclusively that those less than 0.5 μm in diameter or width are innocuous, it has been considered prudent to count, size, and identify all particles with an aspect ratio greater than 3 to 1 which are tens of micrometers in length and shorter. Although the long thin fibers seem to be more active in animal deposition-model studies, the shortest active fiber length has not been established [1]. Also, because a number of mineral and man-made microfibers are suspected of producing varying degrees of adverse health effects, the identification or classification of a mineral fiber as to species is important.

Until the effect of size, morphology, species and other properties of microfiber can be related to toxicity, it will be necessary for the analyst to characterize the distribution of a number of these parameters from environmental samples.

Electron Microscopy

The group of analytical instruments which provides more of what are considered the important parameters mentioned above is that of the electron microscopes. Both transmission and scanning electron microscopy have been used extensively for mineral fiber identification, sizing and counting, and both types of instruments and their related characterization techniques have their place.

The transmission electron microscope (TEM) with selected area electron diffraction (SAED) is considered the most widely applicable instrument, although it has some disadvantages which will be discussed. This technique requires that the image forming electrons travel through the sample and therefore the sample matrix must be transparent to the high kinetic energy (usually about 100 KeV) electrons. SAED also requires that the electrons travel through the matrix as well as some part of the microfiber to be identified. SAED is used to characterize the crystal structure of the particle of interest and is valuable for the identification of the type or class of fiber, e.g., serpentine asbestos, amphibole asbestos, non-crystalline or non-asbestos.

Scanning electron microscopy (SEM) can be compared with reflected light microscopy. However, images are formed electro-optically, usually by secondary electrons produced by a focused electron beam in the sample. The technique usually employed for species identification is energy dispersive x-ray spectroscopy (EDXS) which determines the energy of x-rays emitted from the sample. This emitted x-ray energy spectrum is caused by the electron beam interaction with the sample and can be used to qualitatively and semi-quantitatively identify the elemental content of a microfiber.

A third type of instrument which combines the advantages of both the TEM and SEM is the scanning transmission electron microscope (STEM). This instrument has been used by a number of laboratories, most of which have procured it specifically for asbestos microfiber counting and identification. Essentially it is a transmission electron microscope equipped with scanning and focusing coils so that a focused beam of electrons can be scanned over the sample or pinpointed in a particular area. The most general mode of application is to obtain a shadow image as with the TEM, then perform SAED and/or EDXS as desired. The focused beam should produce a brighter SAED pattern for particle identification than in the TEM, and if an elemental analysis is desired this may be obtained from the same particle without transferring the specimen to another electron beam instrument.

There is another type of electron microscope which has been used only sparsely for asbestos mineral fiber analysis. This instrument is an SEM with an electron detector below the specimen for transmission imaging. This allows a transmitted electron image to be formed and the instrument might be called a transmission scanning electron microscope (TSEM). Application of this technique will be discussed in a subsequent section.

Needless to say, combinations of SEM and TEM instruments have been and are being used for microfiber analysis also.

Applications

There are four important considerations in the selection of an electron microscopy method for the counting and characterization of microfibers. These are: observability, specificity, sample preparation and analysis cost.

Observability

Observability is concerned with the sharpness and contrast of the microfiber image against the matrix. This controls the relative ability of the microscopist to find microfibers, measure them, and characterize their morphology. Flinckinger and Standridge [2] compared fiber counts with SEM and TEM from water samples and concluded that for small fibers TEM gave much higher counts, about an order of magnitude or greater. Ruud et al. [3] showed the relative clarity of SEM and TEM images illustrating the superior contrast of the latter (see figure 1). The highly magnified shadowgraph obtained in transmission electron microscopy is for the most part an accurate representation of the length and width or diameter of the fiber. Chrysotile fibers are usually circular bundles of fibrils or round single fibrils. Often the fibrils can be distinguished in a TEM image by the fact that they are tubular and the hollow center can be seen in the electron microscope image [3]. While this tubular appearance is characteristic of chrysotile, it is not always present so that if a fiber does not appear to be hollow this does not rule it out as chrysotile. Amorphous material can be attached to the surface and fill the tubes, thereby giving the appearance, as far as density is concerned, that the fiber is solid [4]. At any rate it is well to have an identification method in addition to morphology for chrysotile and it is imperative for the amphibole minerals since non-asbestos material can appear in the electron microscope to be fibrous, i.e., they may have a 3:1 length-to-width ratio. Also, many chain silicate non-asbestos minerals fracture in the same general way as the asbestos minerals so that morphology does not lead to a reliable identification. See figure 2 from Ruud et al. [3]. The most effective additional identification method is selected area electron diffraction, which will be discussed subsequently.



Figure 1. Comparison of SEM and TEM image clarity for a microfiber from an environmental sample. Top is SEM image and bottom is TEM image. The marks in the upper left corner of each micrograph are 1 micrometer apart.

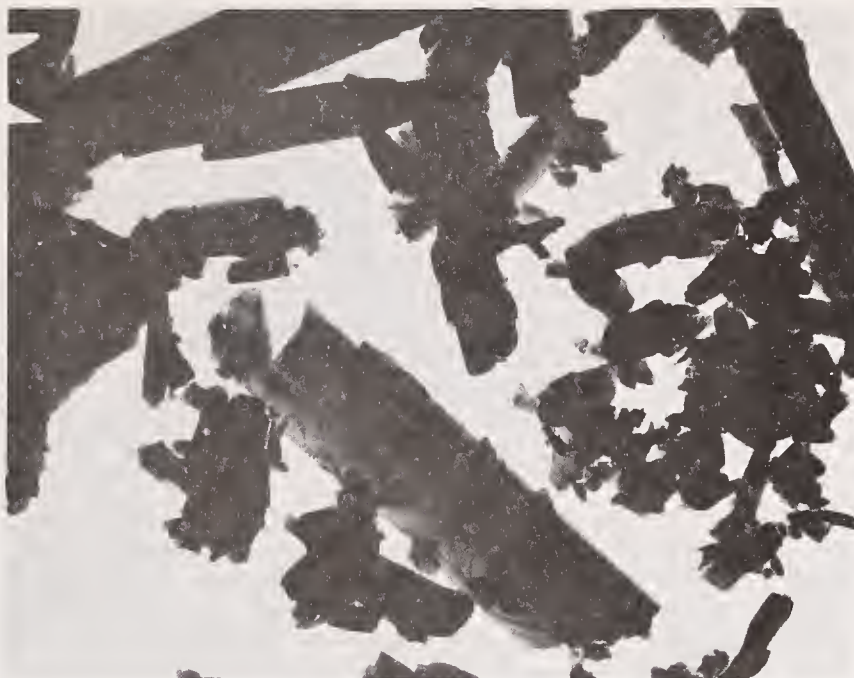

Figure 2. A TEM micrograph of the mineral wollastonite.

The superior image contrast of small microfibers and the clarity of internal voids in the TEM can be understood when the mechanism of image production and resolution of the two types of instrumentation is compared. The TEM relies upon the electron opacity of the microfibers which depends upon the thickness but which is invariably several times higher than that of the specimen substrate. SEM relies upon the production of secondary electrons for imaging and the relative difference of their efficiency of production between microfibers and substrate is often rather slight. In spite of these considerations, a recent report issued by the EPA [5] judged the two techniques as equal with respect to fiber counting. However, the sample type and analytical procedure covered in that report were very specific and not what may be generally expected or applied in environmental samples. The sample source was a laboratory prepared and dispersed Canadian chrysotile. The TEM sample preparation was one which is seldom if ever used in TEM preparation because it is complicated and prone to fiber loss and contamination. This report therefore cannot be used as justification for the general use of SEM for microfiber sizing and counting.

The electron microscope magnification used to locate and measure microfibers is an important concern and generally varies from 4000 to 20,000 times. It should be obvious that the lower the magnification used to find microfibers consistent with sharp contrast, the higher the likelihood of missing very fine ones. At 10,000X a 0.1 micrometer fiber would appear to be 1 mm wide and at 4000X it would be 0.4 mm wide. On the other hand, the lower the magnification used to search for microfibers the larger the area of electron microscope specimen observed, thereby improving counting statistics for a given amount of analysis time.

Specificity

Specificity is concerned with the identification of a microfiber species. In the SEM, clues as to the elemental content may be obtained by EDXS, and these can sometimes be used to identify the microfiber. With the TEM, SAED is usually employed for speciation. SAED produces a pattern which is indicative of the crystal structure of a microfiber. This crystal structure can then be related to the type or species of fiber. Usually only classification is possible, but in the case of chrysotile asbestos it is usually readily identified by SAED.

The basis for SEM-EDXS is that electron beam microchemical analysis may sometimes be used to distinguish particles of various minerals [6,7,8]. The most common method presently in use is the energy dispersive x-ray system (EDXS) attached to an SEM. X-ray wavelength dispersive analyzers and the conventional electron microprobe have been used; however, their routine application is negligible in asbestos microfiber analysis because the high electron beam currents required may damage the specimen and the microanalysis procedure is relatively time-consuming.

Semi-quantitative electron beam x-ray microchemical analysis in the electron microscope is based on the fact that a beam of high energy electrons incident upon a particle generates x-rays with energies that are characteristic of the elements present in that particle. Only those elements heavier than sodium (atomic number 11) can be practically detected. An EDXS detector placed in the electron microscope sample chamber close to the specimen converts the energy of the x-ray photons to voltage pulses which are amplified, digitized and stored in a multichannel analyzer or a minicomputer.

In the EDXS identification of microfibers, ambiguities can arise from x-rays produced by adjacent or adhering particles, from instrumental uncertainties in determining the exact chemical composition of a particle [9], or from the fact that a given mineral can exist over a wide range of compositions [10]. As much as a 10 percent variation in the element x-ray intensity can be expected from any one mineral sample [7] or even a single microfiber [11]. To further confuse the matter we have observed many mineral particles that are often associated with asbestos materials which show a 3:1 length-to-width ratio and give EDXS spectra that cannot be distinguished from the asbestos types. Figure 3 shows an example of SEM-EDXS data from an anthophyllite microfiber and a lizardite cleavage fragment with a greater than 3:1 aspect ratio. Anthophyllite is an amphibole asbestos mineral and lizardite is a non-asbestos polymorph of chrysotile. However, the EDXS spectrum from the two are indistinguishable. A number of examples of this type of possible misidentification of mineral microfiber appear in Ruud et al. [3].

In spite of the above considerations, a number of researchers have surmised that each of the asbestos minerals can give x-ray spectra that usually are characteristic enough, when combined with fiber morphology, to allow their mineral identification [6,7,12]. Visual observation of the semi-quantitative fiber x-ray spectrum is the usual method of fiber identification; however, three-component diagrams have been used after subtracting the continuous background from the semi-quantitative x-ray spectrum for further extrapolation of the data [6]. For these analyses, matrix corrections are rarely used. Typically, iron, magnesium, and silicon are plotted on the three component diagram and compositional boundaries for the asbestos minerals established. In addition to the major shortcomings mentioned in the previous paragraph, this added refinement suffers from its failure to use all compositional data obtained such as presence or absence of sodium, calcium, aluminum, and manganese which might aid in identification [6].

As has already been discussed, observation of proper elemental intensities by energy-dispersive x-ray analysis is generally not sufficient for positive identification of fibers. For example, chrysotile, anthophyllite, and fibrous talc, which have similar elemental compositions, may be difficult to differentiate [3,6].

These considerations make the sole use of SEM-EDXS unreliable in its general application to the identification of fibers and microfibers. There are specific cases where the source of the sample is well characterized and the absence of particles of nearly similar chemical composition has been confirmed that it may be useful.

Considering the uncertainties in SEM application to the identification of microfibers, it is understandable that transmission electron microscopy coupled with selected area electron diffraction has been selected by many researchers as the most viable method for identifying and counting asbestos fibers [1]. Although this method has some disadvantages, the overriding advantage is that usually it is specific with respect to the identification of chrysotile or amphibole microfibers and it permits accurate size measurement of particles even when that size is on the order of fractions of micrometers in diameter.

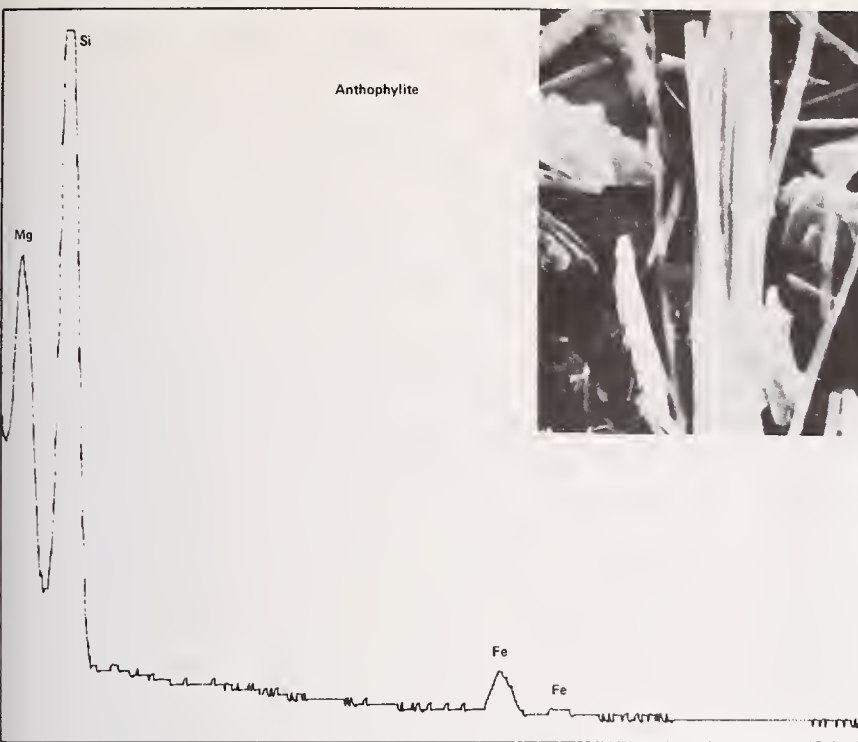
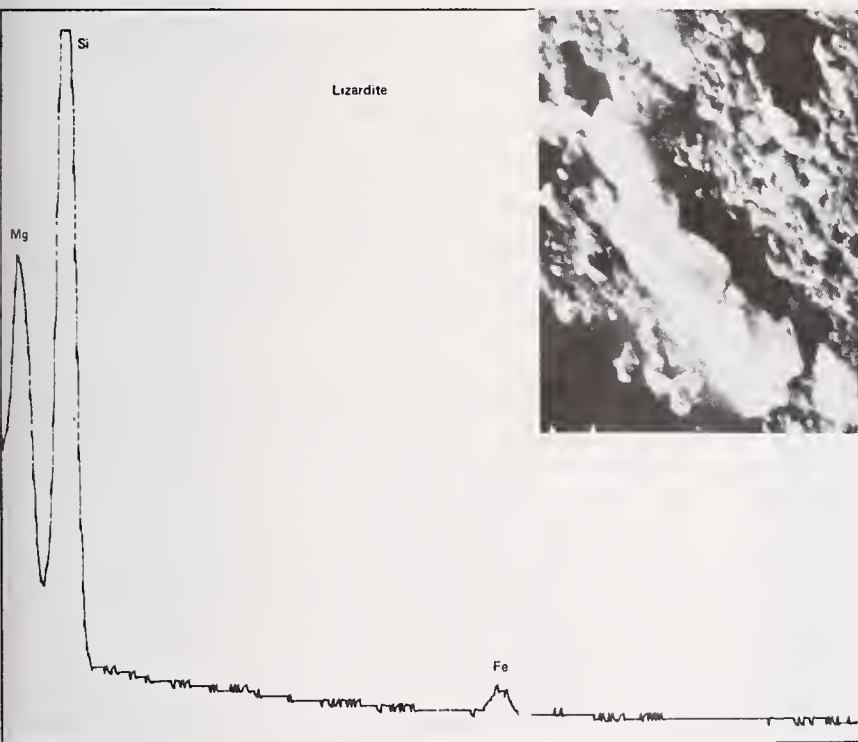

Figure 3. SEM-EDXS spectra from anthophyllite asbestos (top) and lizardite (bottom) samples.



Selected area electron diffraction can be readily accomplished on a modern transmission electron microscope and a pattern observed in about 10 seconds and recorded usually in less than two minutes. However it usually requires an experienced microscopist and some fine manipulation of the specimen in the SAED mode for production of a clear pattern. The two-dimensional SAED pattern of diffraction spots has the advantage, in the case of some asbestos microfibers, that it contains certain outstanding characteristics that can be recognized at a glance. This is particularly true for the more common type of asbestos, the serpentine mineral chrysotile [4,13], figure 4.



Figure 4. Chrysotile asbestos TEM micrograph (top) and SAED pattern (bottom).



The SAED pattern of a single chrysotile fiber or fibril is analogous to a rotating or oscillating crystal x-ray diffraction pattern in which the long dimension of the fiber tends to lie parallel or nearly parallel to the supporting membrane and therefore is perpendicular to the incident beam corresponding to the axis of rotation being normal to the beam in the usual type of rotating crystal x-ray exposure. This analogy is also

partially true for amphibole fibers. In x-ray patterns the spots are arranged in lines, universally called "layer lines," with the spacing between the lines dependent upon the periodicity of the crystal structure in the direction of the axis of rotation (see, for example, Barrett and Massalski [14]). The analogous layer lines in SAED are also very prominent and their spacing reveals the crystal periodicity in the direction of the fiber axis. From a quick view of the layer line spacing one cannot distinguish between chrysotile, tremolite, and amosite which all have layer line spacings corresponding to a periodicity of approximately 0.53 nm, but this group of materials can often be distinguished from some others of interest, for example wollastonite, lizardite, antigorite, albite, hedenbergite, or diopside [3].

Fortunately there is no need for a detailed study of the pattern in order to positively identify chrysotile. The chrysotile diffraction pattern has very prominent streaks on layer lines other than the central one, and some streaking also may be seen on the central one [13]. Some spots of normal sharpness also occur; these are on the central layer line and alternate ones (2nd, 4th, etc.). The streaks are seen on the pattern in figure 4 and can also be seen on the fluorescent screen of the electron microscope. The geometry of the pattern is known for orthochrysotile, clinochrysotile, parachrysotile and mixed ortho plus clino varieties [15], and the origin of the streaks is now well understood as resulting from disorder in the stacking of the prominent layers in the crystal (the hydroxyl, magnesium oxygen-hydroxyl, silicon and oxygen layers). The series of researches beginning with Warren in 1941 and extending through many studies by Hittaker in 1956, have shown that the layered structure is curved cylindrically around the axis of the fiber, the axis with 0.53 nm periodicity in clino and ortho varieties. This is called the c axis in some of the papers [16], but is called the a axis on others [15]. There is x-ray evidence [16] that the layers are wrapped in a helical cylindrical manner and this is confirmed by electron microscopic views of the cross-section of the chrysotile tubes by Yada [17]. This curvature of the structure accounts for the presence of the prominent layer lines, which are perpendicular to the length direction of the fiber.

Amphibole minerals exist in both asbestiform and massive varieties. Numerous names have been given to varieties of the amphibole groups, and the many different types of forms substituted in the different members of the groups [18] add to the natural difficulties of identifying them. It is not surprising that the Joint Committee on Powder Diffraction Standards x-ray powder data file contains many cards of diffraction patterns differing from each other by small amounts.

SAED patterns prepared in this laboratory of known samples of the amphibole asbestiform minerals tremolite, crocidolite and amosite have prominent rows of spots which resemble the layer lines of rotating crystal x-ray patterns and which we will also call 'layer lines.' There are especially closely spaced spots on each of these layer lines, far more closely spaced than they are in the rows of spots from the minerals hedenbergite, albite or wollastonite, for example [3]. We have rarely observed any non-asbestos material exhibiting the characteristic layer line spacing and spot patterns within the layer lines displayed by asbestos mineral fibers. However, this author has recently been informed that pyroxenes have been observed to produce asbestos-like SAED patterns.

Although chrysotile is usually readily distinguished from the asbestiform varieties of amphibole (crocidolite, amosite², anthophyllite, tremolite and actinolite), it is not easy to distinguish one variety of these amphiboles from another because the spacing of prominent rows of spots in these are the same, and the differences occur only in the arrangement of spots along the rows. However, an experienced microscopist can learn to distinguish on sight a pattern usually characteristic of an asbestos fiber from the patterns of most non-asbestos minerals commonly associated with them. Crystalline materials that exist in the form of thin plates also produce SAED patterns with many spots, but these in general are arranged in a two-dimensional array in which there are not such prominent layer lines in a single direction.

Amosite - a discredited term.

As mentioned above, SAED is used extensively as the major criterion for the identification of mineral microfibers [1,2,3]. However, it should be mentioned that the method is empirical and has not been rigorously tested. The possibility exists that some species of non-asbestos mineral fibers or microfibers may produce a high incidence of SAED patterns characteristic of chrysotile or the asbestos amphiboles. An example of this, which has been mentioned, is pyroxenes.

Transmission electron microscopes and STEM equipped with an energy dispersive x-ray detector are available which allow simultaneous observation of morphology, crystal structure and elemental composition. These microscope systems have been used to study fibers of known asbestos origin as well as environmental and material samples [12,19].

It would be highly advantageous if a thorough crystallographic examination of the SAED pattern could be performed in the few seconds in which patterns are now cursorily examined. This is technologically possible, but requires the building of a TEM or STEM with a television camera in place of the fluorescent screen coupled to a computer programmed to index and classify the pattern with respect to standard or calculated patterns. These facilities are extremely expensive and few laboratories will be so equipped in the near future. However, studies of the patterns with respect to mineral type, cleavage and fiber orientation are needed.

Sample Preparation

As previously mentioned, samples for electron microscopy analysis of microfibers are generally collected on cellulose ester membrane (Millipore) or perforated polycarbonate (Nuclepore) filter media [5,19]. For analysis by the SEM the latter medium, due to its smooth surface, is preferred. SEM preparation is usually done by coating the surface directly with an electrical conducting material, e.g. gold, silver, carbon or silicon monoxide [5]. More complicated methods have been used for SEM preparation of samples collected on Millipore [9]. These filters with their rough surface are not generally suitable for direct coating for SEM because small fibers may be masked by protrusions of the surface.

In TEM, STEM, and TSEM analysis, the matrix must be nearly electron transparent to electrons of about 100 KeV energy. This requires that the filtrate (particles) be mounted upon electron microscope grids with very thin, on the order of 100 Angstroms, carbon or metallic substrates and the filter material dissolved away. Several dissolution techniques are used, including the Jaffe wick and condensation washing. Generally these techniques are relatively simple and maintain the original particle size distribution and relative particle location. Some investigators have reported particle losses as high as 60 percent with the condensation washing technique compared with less than 10 percent with the Jaffe wick method [20]. Coating the filter and filtrate with a conductive layer prior to dissolution has been proposed as a technique to minimize particle loss [19,21]. Also, careful control of the condensation washer can reduce filtrate loss to much less than 10 percent. Most laboratories apply a second carbon, metallic or silicon monoxide coating to the filtrate after filter dissolution to reduce the probability of particle loss. The choice of conduction coating is varied; however, many laboratories have been considering fine grained metallic coatings because of superior contrast and the fact that a reference pattern is provided on the SAED patterns.

The general preparation technique discussed in the previous paragraph is known as the "direct transfer" method. A variety of more complicated techniques include the direct transfer procedure as the last few steps. This includes ashing of the sample which is required when a considerable amount of organic material is collected with the inorganic microfibers or sometimes is used as a preliminary step to redistributing the filtrate for a more uniform or more suitable concentration. Dissolution of the collection filter substrate and subsequent refiltering has also been used. Needless to say, whether TEM or STEM is performed, the particulates must be distributed as uniformly as possible on the filter sample. This is a vital consideration in the statistics of analysis which will be covered by another author in this publication. Ashing can be performed in a low temperature oxygen plasma device or at high temperatures in a muffle or tube furnace. There are pros and cons to all redistribution procedures which must be considered by the analyst; however, it is always highly desirable to process control specimens, i.e.,

blanks, when preparing samples for fiber counting and analysis. These blanks confirm a clean preparation environment or bear witness to laboratory contamination.

Another preparation technique which has been used off and on is the so-called "rub-out" technique. This was used early in the electron microscopy analysis of microfibers and has been applied by the Mount Sinai group [22]. High particle losses and the destruction of the true particle size distribution to produce only a mass concentration are cited as disadvantages with this technique. Other techniques have also been cited as viable, including that in a recent EPA report [5]. However, most have been discarded in favor of the direct transfer method alone or preceded by ashing only when necessary.

The added specimen handling necessary for transmission electron analysis has often been cited as a serious disadvantage to TEM, STEM and TSEM analysis. However, experienced laboratories have developed preparation routines and techniques which make particle losses, contamination and labor time negligible. The usual amount of time lag in preparation of a transmitted electron sample is about four hours.

Analysis Cost

The amount of electron microscope time necessary for an analysis is the major consideration affecting cost, and is dependent upon many factors, not the least of which is the sample from which the specimen was produced. The size distribution, particle loading and uniformity of distribution are just three of these. If a very limited amount of microscope time requires that the analyst use only a low magnification, e.g., 4000X, then the small microfibers may be missed. Computer image analysis has been used by a few laboratories [9] and can be applied directly on an electronic image as produced in the SEM, STEM and TSEM or on photomicrographs produced by an electron microscope. Direct computer image analysis is also possible with suitably modified imaging devices mounted into TEM's. This technique can greatly reduce the amount of microscope time required for microfiber searches but is prone to certain errors, especially where high concentrations of microfibers and other particles are present.

The application of microfiber identification techniques affects the microscope time as well as imaging. The TEM image is essentially instantaneous, whereas an SEM image must be acquired with time and takes several seconds to form. Furthermore, on a typical SEM the time for one EDXS analysis is 100 or more seconds. As a consequence most analysts working with SEM and STEM only obtain analyses from selected microfibers, not all of those found. SAED usually requires 10 to 30 seconds to form an image suitable for recognition by the microscopist and is usually performed on all microfibers found. Recording of this image is done selectively on a few microfibers and usually requires 100 to 200 seconds. The beam focusing feature available on all STEM and some TEM can reduce the recording time by producing a brighter SAED pattern.

Technique Development

A number of laboratories are evaluating the various electron microscopy techniques used in the analysis of microfibers. That this is necessary is evident from the wide discrepancy in results produced on similar samples by different laboratories and/or microscopists [23]. No two laboratories perform sample preparation or microfiber analysis exactly the same and some are markedly different. However, over the past three years a number of laboratories have markedly improved their analytical reliability in spite of the overwhelming statistical uncertainties.

This author is aware of some new approaches to the identification, counting and measurement of microfibers. United States Steel Research Laboratories are applying a specially equipped TSEM with an EDXS detector located for a very high x-ray take-off angle, higher than possible in a standard unit. This system is computer controlled using criteria from the transmitted electron image data at 10,000X magnification processed through an image analyzer to locate microfibers. The geometry of the system and the sample and x-ray detector distance (less than 1 cm) are such that a very adequate EDXS spectrum can be accumulated an order of magnitude faster than with standard electron microscopes, SEM or STEM. After a statistically significant number

of microfibers are found and EDXS data obtained from each, they are classified with respect to aspect ratio and EDXS spectrum. The specimen is then transferred to a TEM, a 1200 KeV instrument in this case, where some microfibers in each EDXS classification are selected and an SAED pattern obtained for identification. It is recognized that a 1200 KeV TEM is not readily available; however, the SAED could be performed on most TEM instruments with 80 to 100 KeV.

The advantage in the transmitted image over that usually produced in an SEM is greater visibility of particles, as has previously been stated. Moreover, the technique has a great advantage over those presently applied from the standpoint that a large number of microfibers are analyzed at least through classification and this is a tremendous statistical advantage.

Conclusion

In conclusion there are a few points that should be made.

1. The transmitted electron image is generally accepted as being superior for counting and measuring microfibers as compared with a secondary or backscatter electron image.
2. Selected area electron diffraction is generally accepted as the best criterion for the identification of asbestos mineral microfibers, although a few non-asbestos minerals may be mistaken for asbestos.
3. The statistical consideration affecting electron microscopy of microfibers is a source of considerable error and new techniques are being and must be developed to relieve these problems.
4. There are a few specific situations where the SEM can be applied to the counting of microfibers, especially where the source and species mixture are well characterized.
5. Although the TEM-SAED method of asbestos mineral microfiber counting and identification is not absolute, it is the best compromise of accuracy and cost available.

The author would like to thank C. S. Barrett and J. M. Dement for their contribution to this paper.

References

- [1] National Academy of Sciences, "Drinking Water and Health," Part I, 1977.
- [2] Flinckinger, J. and Standridge, J., Identification of fibrous material in two public water supplies, Env. Sci. and Tech. 10, No. 10, 1028-1032 (Oct. 1976).
- [3] Ruud, C. O., Barrett, C. S., Russell, P. A., and Clark, R. L., Selected area electron diffraction and energy dispersed x-ray analysis for the identification of asbestos fibers, a comparison, Micron 7, 115-132 (1976).
- [4] Mumpton, F. A., Characterization of chrysotile asbestos and other members of the serpentine group minerals, Siemens Review XLI, 7th Special Issue, 75-84 (1974).
- [5] Gerber, R. M. and Rossi, R. C., Evaluation of electron microscopy for process control in the asbestos industry, EPA-600/2-77-059 (Feb. 1977).
- [6] Rubin, I. B. and Maggiore, C. J., Elemental analysis of asbestos fibers by means of electron probe techniques, Env. Health Perspect. 9, 81-84 (1974).

- [7] Ferrell, Jr., R. E., Paulson, C. G., and Walker, C. W., Evaluation of an SEM-ES method for identification of chrysotile, In Proc. 8th Annual SEM Symposium, Johari, O. and Corvin, E. (eds.). IIT Research Institute, Chicago, Ill., 537-546 (1975).
- [8] Langer, A. M., Rubin, I., and Selikoff, I. J., Electron microprobe analysis of asbestos bodies, Histochem. Cytochem. J. 20, 735-740 (1975).
- [9] Pattnaik, A. and Maakin, J. D., Development of scanning electron microscopy for measurement of airborne asbestos concentration, U.S.E.P.A., Office of R and D Pub. No. EPA 650/2-75-029. Research Triangle Park, N.C., (1975).
- [10] Speil, S. and Leineweber, J. P., Asbestos minerals in modern technology, Env. Res. 2, 166-208 (1969).
- [11] Pooley, F. D., The identification of asbestos dust with an electron microscope microprobe analyzer, Norelco Reporter, 23, No. 2, 5-9 (Oct. 1976).
- [12] Dement, J. M., Zumwalde, R. D., and Wallingford, K. M., Asbestos fiber exposures in a hard rock gold mine, In Proc. N.Y. Acad. of Sci. Conf. Occup. Carcinogenesis. (1975).
- [13] Clark, R. L. and Ruud, C. O., Transmission electron microscopy standards for asbestos, Micron 5, 83-88 (1974).
- [14] Barrett, C. S. and Massalski, T. B., Structure of Metals, (McGraw-Hill, New York, 654, 1966).
- [15] Zussman, J., Brindley, G. W., and Comer, J. J., Electron diffraction studies of serpentine minerals, Amer. Mineralogist 42, 133-153 (1957).
- [16] Whittaker, E. J. W., The structure of chrysotile, Acta Cryst. 27, 659-664 (1956).
- [17] Yada, K., A study of microstructures of chrysotile asbestos by high resolution microscopy, Acta Cryst. 9, 855-857 (1971).
- [18] Deer, W. A., Howie, R. A., and Zussman, J., Rock Forming Minerals, (Wiley, New York, Vol. 3, p. 270, 1963).
- [19] Cook, P. M., Rubin, J. B., Maggiore, C. J., and Nicholson, W. J., X-ray diffraction and electron beam analysis of asbestiform minerals in Lake Superior waters. In Trans. Inst. Electrical Electronic Eng. (in press) (1974).
- [20] Beaman, D. R. and File, D. M., The quantitative determination of asbestos fiber concentrations. The Dow Chemical Company, unpublished report (1975).
- [21] Oriz, L. W. and Loom, B. L., Transfer technique for electron microscopy of membrane filter samples, Am. Ind. Hyg. Assoc. J., 423-425 (1974).
- [22] Rohl, A. N., Langer, A. M., and Selikoff, I. J., Environmental asbestos pollution related to use of quarried serpentine rock, Science, 196, 1319-1322 (17 June 1977).
- [23] Brown, A. L., Taylor, W. F., and Carter, R. E., The reliability of measures of amphibole fiber concentrations in water, Env. Res. 12, 150-160 (1976).

J. LEINEWEBER: I would like to make one comment with regard to Clay Ruud's remark about using the central channel of the chrysotile fiber for identification. This is good a reasonable percentage of the time, but you can run into chrysotile fibers such that this channel is not very visible and may be pretty well filled up with the non-cystalline material. So, it cannot be used as positive identification.

C. RUUD: I know.

R. FISHER: I want to get clarification whether you advocate visual identification from the diffraction patterns and visual counts in contrast to recording micrographs. It seems to me desirable to have your data in a form that others can confirm, look at your diffraction patterns, look at your counts, and not rely on visual observations that are just recorded in a pad or notebook.

RUUD: I hear what you say, and I would like to record every pattern or every micrograph that is projected on the screen, but I can't afford to do this; my sponsor won't stand for it. So, what we do is, we record typical SAD patterns we see in particular samples or sets of samples. When we see something different than that, something unusual, strange, we record it. I agree that it would be nice to have everything recorded for posterity, but it takes too much time.

FISHER: Well, at this stage it is essential to have records that can be accepted by others, I am afraid. I agree the costs are high, and people will have to pay them, but I think that any data that are not recorded for confirmation and detailed examination are going to be challenged in all kinds of situations.

RUUD: As I say, we record typical ones; we save the samples and since the samples are on finder grids any grid can be found and the data confirmed.

J. ZUSSMAN: I'd like to make three comments concerning Dr. Ruud's paper. One concerning electron diffraction patterns. I think he has very much underplayed the variations and variability one can get in electron diffraction patterns, depending very much upon the orientation of the grain, the way it lays on the stage. If you look at these patterns carefully, you see enormous numbers of different effects; I would have made this comment anyway; I make it still much more strongly now, having heard a lot of judgments are made perhaps without even taking photographs. From looking down on the screen you can certainly not see the subtle variations which are nevertheless important, produced by orientation effects.

Secondly, you mention the scanning electron microscope as being best for chemical analytical purposes. I don't think it is capable of an accuracy that can be obtained by the transmission electron microscope with suitable attachments, or STEM, which brings me to the third point. You showed that lizardite and anthophyllite were not distinguishable from their x-ray fluorescence spectra, and this is surprising. The magnesium-to-silicon ratio for lizardite is 1.5 to 1 in atomic ratio, the other ratio is 0.9 to 1, and I think there is a detectable difference. The reason why we may not pick up this difference is that your crystal has the wrong kind of thickness so that the crude ratios of peak height are not indicative of concentration. The crystal has to be of a suitable thickness for this to be so.

RUUD: Regarding the last comment, we can rotate the fiber or change the position in the microscope, and get different ratios, and, as someone pointed out yesterday, just be going along the fiber you may get different ratios. So, that's one reason why I do not have too much confidence in energy-dispersive x-ray spectroscopy. The first comment had to do with selected-area diffraction and the variability of patterns. We do not study them that carefully. We do not try to distinguish between the various amphiboles, amphibole asbestos materials. We do not have the time to study individual patterns that carefully. We looked at the possibilities of trying to get good d-spacings from them; it seems like it is a good possibility if we could connect the computer into a vidicon or a camera tube in the bottom of a TEM or STEM and put it directly into a computer; I think that would be great. But, so far I know of only one microscope equipped that way, and it is not used for asbestos analysis.

IDENTIFICATION OF ASBESTOS BY POLARIZED LIGHT MICROSCOPY

Walter C. McCrone

(Paper presented by John G. Delly)

McCrone Associates, Inc.
Chicago, Illinois 60616

Abstract

A number of analytical tools can be used to characterize and identify asbestos: infrared absorption, x-ray diffraction, DTA, SEM, TEM, and the light microscope. Each has advantages and limitations. The polarized light microscope (PLM) has many advantages, and the only disadvantages are 1) the asbestos particles must be at least a micrometer in largest dimension, and 2) considerable training in optical crystallography is needed.

PLM, on the other hand, is very sensitive (ppm range), extremely rapid (1-5 minutes to identify all components of most samples) and, of all the methods, only PLM will identify the individual amphiboles.

Key Words: Amphiboles; asbestos; dispersion staining; microscopy.

There are a number of analytical methods useful for the identification of asbestos. These include infrared absorption (IR), x-ray diffraction (XRD), differential thermal analysis (DTA), scanning electron microscopy (SEM), transmission electron microscopy (TEM) with or without electron microprobe analyzer (EMA), and polarized light microscopy (PLM) with or without dispersion staining (DS). Each has advantages and disadvantages.

Every analyst uses and should use the techniques in which he has the required training and with which he feels confident. At the same time, every sample should ideally be analyzed by the most suitable technique. Occasionally, of course, it may be wise to use two or more techniques and this is certainly true for asbestos. We would like to summarize our attitude toward the various techniques for asbestos and describe in more detail the technique we feel has many advantages and is under-utilized; this is polarized light microscopy, especially when supplemented by dispersion staining. First, however, the advantages and disadvantages of each technique:

TEM is most useful for the detection and identification of asbestos fibers smaller than the resolving power limit of the PLM. This is usually the case for water or beverages in general. Quantitative procedures are available so that the number, size, and identity of asbestos fibers per unit volume can be accurately determined. Identification by TEM depends on selected area electron diffraction (SAED). Occasionally energy or wavelength dispersive detectors are fitted to the TEM to make possible elemental analysis of individual fibers. Nothing can compete with TEM for the analysis of samples containing subpicogram particles.

SEM has no advantage over TEM except that it takes prettier pictures. It will also fail to see the smallest fibers, and lacking SAED it cannot identify all fibers. The energy dispersive detector on most SEMs is not as effective as the wavelength dispersive detectors on some TEMs and SEMs.

XRD is a useful method since it can be made quantitative. However, it cannot tell size or shape, is not very sensitive (about 1 percent or a bit better), and does not differentiate between most of the amphiboles. At best it supplements other techniques.

IR and DTA can also be dismissed for all except routine samples containing high percentages of asbestos.

This brings us to PLM and DS on which we wish to spend more time because of our conviction that, of all the microanalytical techniques for asbestos, it is by far the most effective. It is the only method depending on the unique optical crystallographic properties of the various crystal phases in the sample. These properties – refractive indices, dispersion of refractive indices, birefringence, sign of elongation and extinction angle – are unique to the crystalline state and therefore unequivocally identify chrysotile, anthophyllite, tremolite, actinolite, grunerite, cummingtonite, etc.

The background for dispersion staining has been adequately covered elsewhere [1]¹. Very briefly, it imparts color to any transparent particle mounted in a liquid whose dispersion curve intersects the dispersion curve for the particle in the visible. The colors, related to this matching wavelength, characterize and identify any given substance. With polarized light, isotropic substances show a single characteristic color, but anisotropic substances show different colors corresponding to the different refractive indices in different orientations. Chrysotile, for example, shows blue and blue-magenta colors, crosswise and lengthwise respectively, for each needle crystal when mounted in Cargille high dispersion liquid $n_D^{25} = 1.550$.

The colors shown by the various types of asbestos and a few other associated minerals are indicated in Figures 1-20 by the wavelengths on each crystal view. These are the wavelengths at which the liquid indicated and that direction in the crystal have the same refractive index. This matching wavelength, λ_0 , determines the dispersion staining colors.

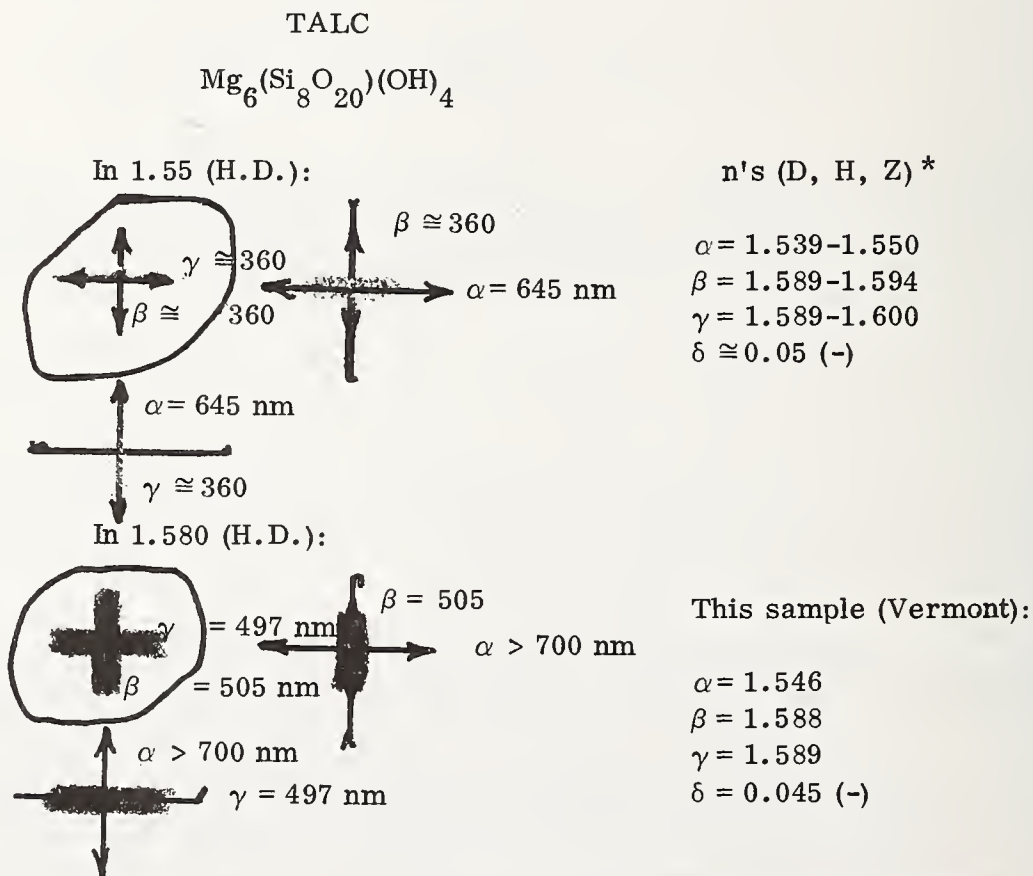

* Deer, Howie and Zussman.

Figure 1. Dispersion staining colors shown by talc crystals in Cargille high dispersion liquids $n_D = 1.550$ and $n_D = 1.580$.

¹Figures in brackets indicate the literature references at the end of this paper.

CHLORITE

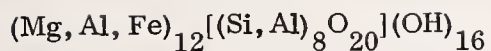

Figure 2. Chlorite.

In 1.55 (H.D.):

n's (D, H, Z)

pale yellow to golden yellow

$$\alpha = 1.57-1.66$$

$$\beta = 1.57-1.67$$

$$\gamma = 1.57-1.67$$

$$\delta = 0-0.01$$

n 1.580 (H.D.):

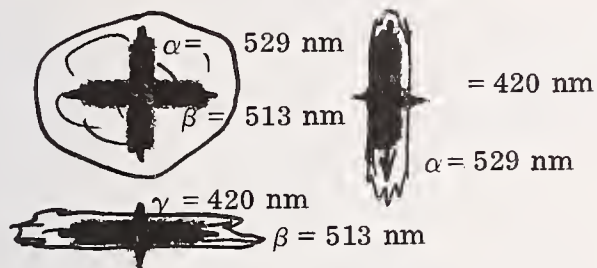

The sample (California):

$$\alpha = 1.586$$

$$\beta = 1.587$$

$$\gamma = 1.596$$

$$\delta = 0.010 (+)$$

CHRYSOTILE

Figure 3. Chrysotile.

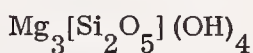

In 1.550 (H.D.):

n's (D, H, Z)

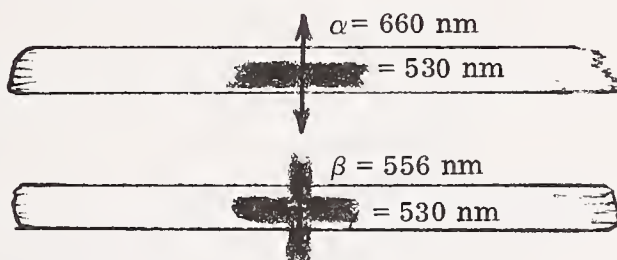

$$\alpha = 1.532-1.549$$

$$\beta = 1.540-1.553$$

$$\gamma = 1.545-1.556$$

$$\delta = 0.013-0.007 (-)$$

King's Mine, Quebec Sample $\rightarrow \alpha = 1.5444$

$$\beta = 1.5525$$

$$\gamma = 1.5555$$

$$\delta = 0.0111$$

ANTIGORITE

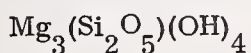
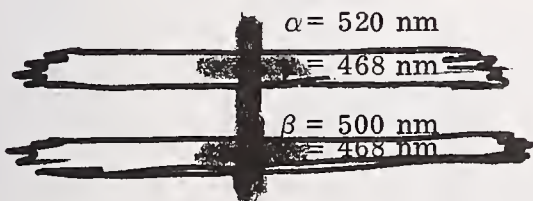

Figure 4. Antigorite.

In 1.550 (H.D.):

n's (D, H, Z)



$$\alpha = 1.558-1.567$$

$$\beta \cong 1.56 -1.57$$

$$\gamma = 1.562-1.574$$

$$\delta = 0.004-0.007 (-)$$

This sample:

$$\alpha = 1.555$$

$$\beta = 1.559$$

$$\gamma = 1.561$$

$$\delta = 0.006 (-)$$

LIZARDITE

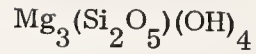

In 1.55 (H.D.):

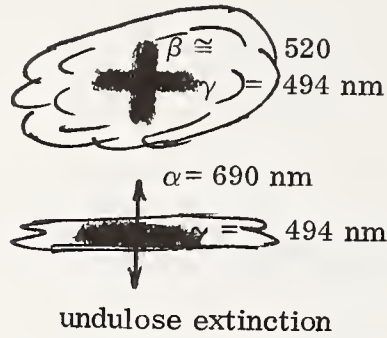

n's (D, H, Z)

$\alpha = 1.538-1.544$
 $\beta =$
 $\gamma = 1.546-1.560$
 $\delta = 0.016-0.008$

This sample:

$\alpha = 1.545$
 $\beta \approx 1.555$
 $\gamma = 1.557$
 $\delta = 0.012 (-)$

Figure 5. Lizardite.

TREMOLITE

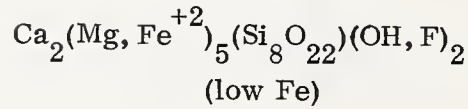

In 1.580 (H.D.):

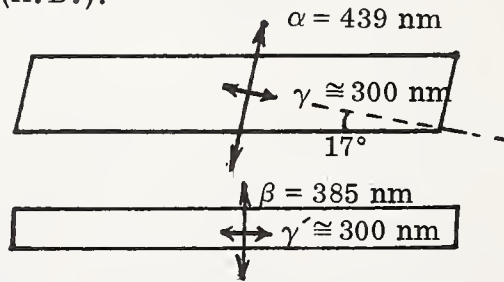

n's (D, H, Z)

$\alpha = 1.604-1.619$
 $\beta =$
 $\gamma = 1.627-1.642$
 $\delta = 0.021-0.023 (-)$

In 1.605 (H.D.):

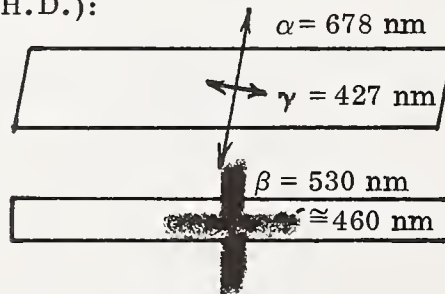

This sample:

$\alpha = 1.599^+$
 $\beta = 1.610^+$
 $\gamma = 1.621$
 $\delta = 0.022 (-)$

Figure 6. Tremolite.

ACTINOLITE

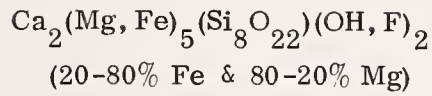

In 1.605 (H.D.):

n's (D, H, Z)

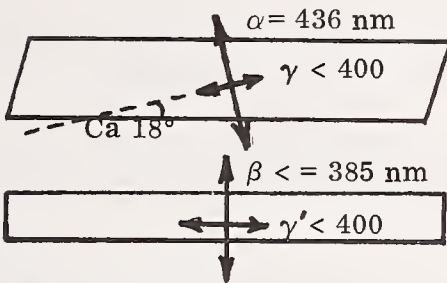

$\alpha = 1.619-1.668$
 $\beta =$
 $\gamma = 1.642-1.687$
 $\delta = 0.023-0.019 (-)$

In 1.640 (H.D.):

This Sample (Virginia):

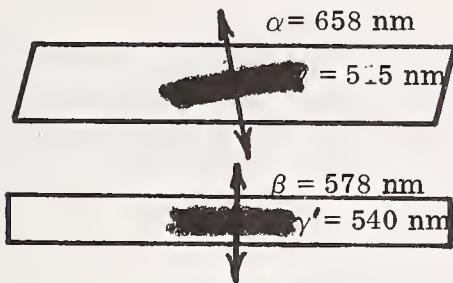

$\alpha = 1.633$
 $\beta = 1.641$
 $\gamma = 1.647$
 $\delta = 0.014 (-)$

Figure 7. Actinolite.

ANTHOPHYLLITE

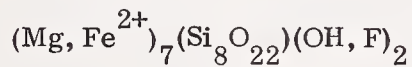

In 1.580 (H.D.):

n's (D, H, Z)

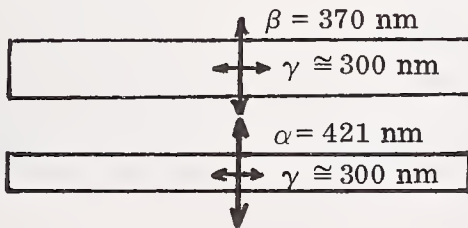

$\alpha = 1.596-1.694$
 $\beta = 1.605-1.710$
 $\gamma = 1.615-1.722$
 $\delta = 0.013-0.028$
 (+) (-)

In 1.605 (H.D.):

This sample (Pine Mt., Ga.)

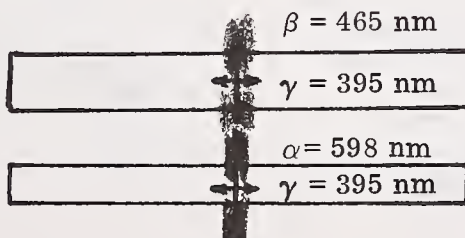

$\alpha = 1.601$
 $\beta = 1.618$
 $\gamma = 1.628$
 $\delta = 0.027 (-)$

Figure 8. Anthophyllite.

ANTHOPHYLLITE

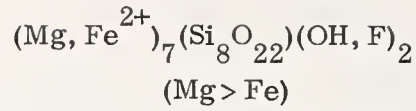

In 1.640 (H. D.):

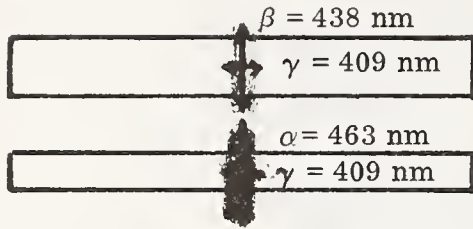

n's (D, H, Z)

$\alpha = 1.596-1.694$
 $\beta = 1.605-1.710$
 $\gamma = 1.615-1.722$
 $\delta = 0.013-0.028$
 (+) (-)

In 1.67:

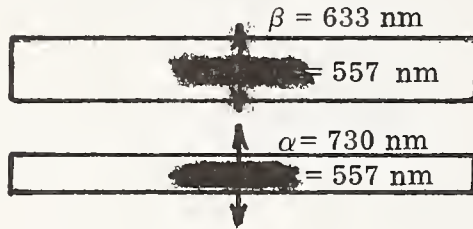

This sample (Connecticut):

$\alpha = 1.659$
 $\beta = 1.666$
 $\gamma = 1.674$
 $\delta = 0.015 (+)$

Figure 9. Anthophyllite.

GRUNERITE

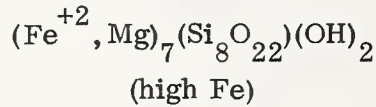

In 1.670:

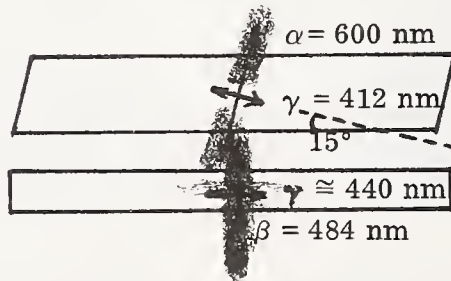

n's (D, H, Z)

$\alpha = 1.663-1.686$
 $\beta \cong 1.681-1.707$
 $\gamma = 1.697-1.729$
 $\delta = 0.034-0.043 (-)$

In 1.700:

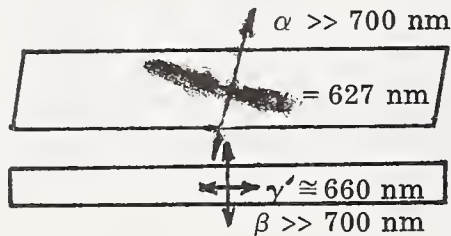

This sample:

$\alpha = 1.669$
 $\beta = 1.684$
 $\gamma = 1.697$
 $\delta = 0.028 (-)$

Figure 10. Grunerite.

CROCIDOLITE

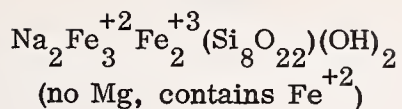

In 1.670:

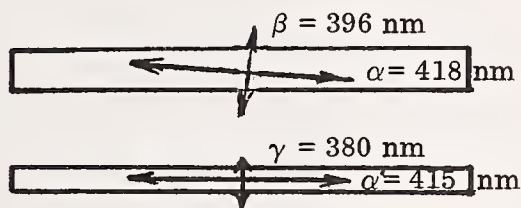

n's (D, H, Z)

$\alpha = 1.654-1.701$
 $\beta = 1.662-1.711$
 $\gamma = 1.668-1.717$
 $\delta = 0.006-0.016 (-)$

In 1.700:

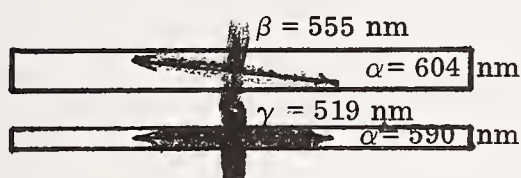

This sample (Orange River,
South Africa):

$\alpha = 1.698$
 $\beta = 1.703$
 $\gamma = 1.708$
 $\delta = 0.010 (-)$

Figure 11. Crocidolite.

APATITE

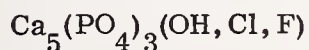

In 1.605 (H.D.):

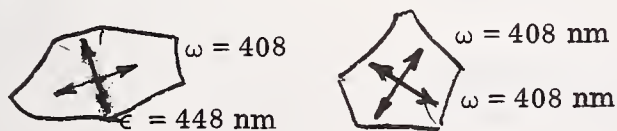

n's (D, H, Z)

$\epsilon = 1.624-1.666$
 $\omega = 1.629-1.667$
 $\delta = 0.001-0.007 (-)$

In 1.64 (H.D.):



This sample:

$\epsilon = 1.6295$
 $\omega = 1.6357$
 $\delta = 0.0062 (-)$

Figure 12. Apatite.

FORSTERITE

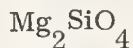

In 1.640 (H.D.):

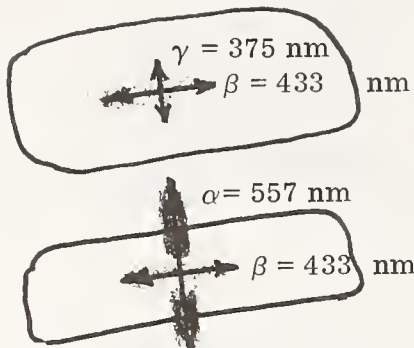

n's (D, H, Z)

$\alpha = 1.635^* - 1.827^{**}$
 $\beta = 1.651 - 1.869$
 $\gamma = 1.670 - 1.879$
 $\delta = 0.035 - 0.052 (+) (-)$

*pure forsterite
 **plus Fe^{2+} replacing Mg giving fayalite, Fe_2SiO_4

This sample:

$\alpha = 1.643$
 $\beta = 1.663$
 $\gamma = 1.682$
 $\delta = 0.039 (-)$

Figure 13. Forsterite.

HORNBLLENDE

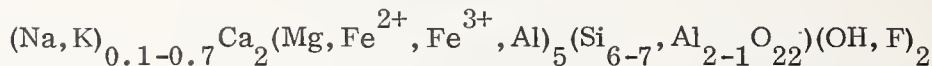

In 1.605 (H.D.):

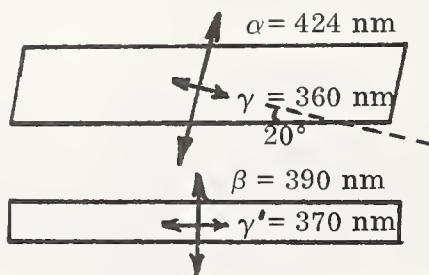

n's (D, H, Z)

$\alpha = 1.615 - 1.705$
 $\beta = 1.618 - 1.714$
 $\gamma = 1.632 - 1.730$
 $\delta = 0.014 - 0.026 (+)$

In 1.640 (H.D.):

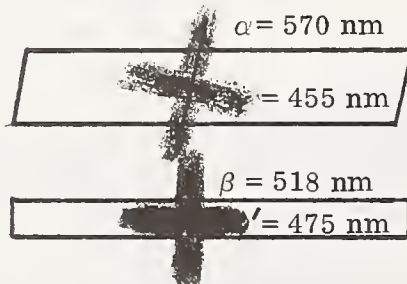

This sample:

$\alpha = 1.643$
 $\beta = 1.650$
 $\gamma = 1.660$
 $\delta = 0.017 (+)$

Figure 14. Hornblende.

WOLLASTONITE
Ca(SiO₃)

In 1.580 (H.D.):

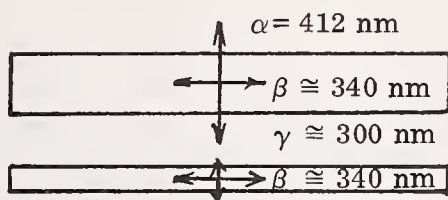

n's (D, H, Z)

$$\begin{aligned} \alpha &= 1.616-1.640 \\ \beta &= 1.628-1.650 \\ \gamma &= 1.631-1.653 \\ \delta &= 0.015-0.013 (-) \end{aligned}$$

In 1.605:

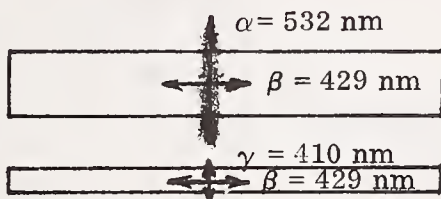

This sample:

$$\begin{aligned} \alpha &= 1.612 \\ \beta &= 1.628 \\ \gamma &= 1.632 \\ \delta &= 0.020 (-) \end{aligned}$$

Figure 15. Wollastonite.

CALCITE
CaCO₃

In 1.64 (H.D.):

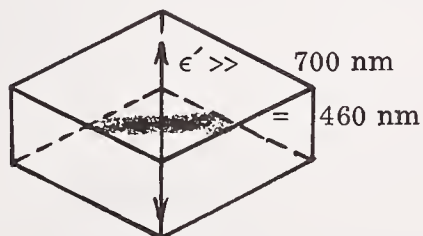

n's (D, H, Z)

$$\begin{aligned} \epsilon &= 1.486-1.550 \\ \omega &= 1.658-1.74 \\ \delta &= 0.172-0.190 (-) \end{aligned}$$

This sample:

$$\begin{aligned} \epsilon' &= 1.525 \\ \epsilon &= 1.486 \\ \omega &= 1.653 \\ \delta &= 0.167 (-) \end{aligned}$$

Figure 16. Calcite.

DOLOMITE

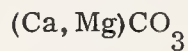

In 1.64 (H.D.):

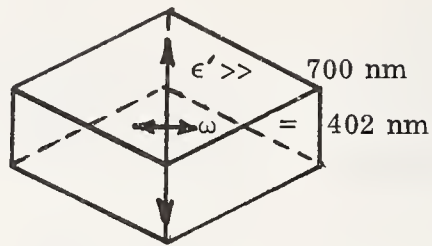

n's (D, H, Z)

$$\begin{aligned} \epsilon &= 1.500^* - 1.520^{**} \\ \omega &= 1.679^* - 1.703^{**} \\ \delta &= 0.179 - 0.185 (-) \end{aligned}$$

*pure dolomite

**plus Fe^{2+} for Mg

In 1.67:

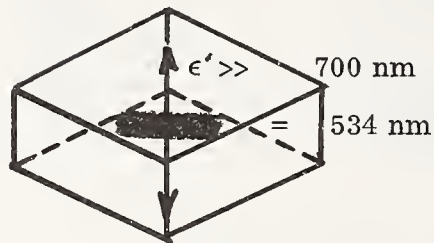

This sample:

$$\omega = 1.677$$

Figure 17. Dolomite.

MAGNESITE



In 1.670:

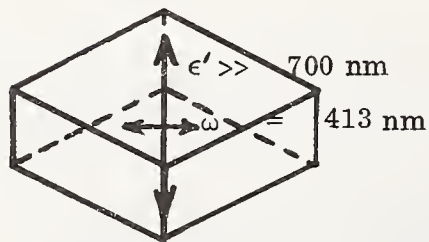

n's (D, H, Z)

$$\begin{aligned} \epsilon &= 1.509 - 1.563^* \\ \omega &= 1.700 - 1.782^* \\ \delta &= 0.190 - 0.218 (-) \end{aligned}$$

*with Fe replacing Mg

In 1.700:

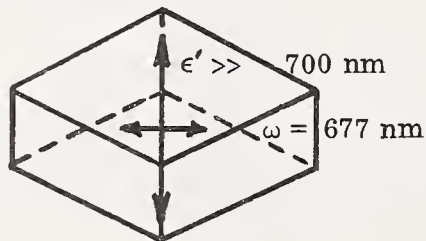

This sample:

$$\omega = 1.694$$

Figure 18. Magnesite.

QUARTZ



In 1.550 (H.D.):

n's (D, H, Z)



$\omega = 1.544$
 $\epsilon = 1.553$
 $\delta = 0.009 (+)$

This sample:

$\omega = 1.544$
 $\epsilon = 1.553$

Figure 19. Quartz.

ORGANIC FIBERS (1.550 liquid)

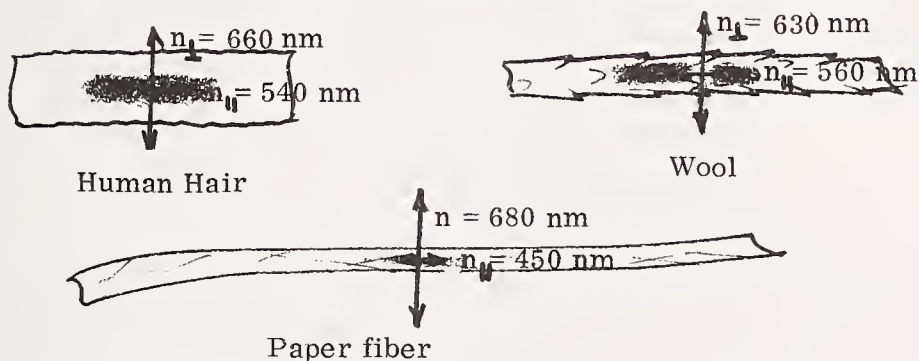

Figure 20. Organic fibers.

Although we speak of dispersion staining colors as specific for a given substance in a given liquid (at a given temperature) we sometimes observe closely similar colors for other substances. We must, especially when this possibility exists, make sure that we observe enough data to be able to state with certainty that the substance is, say, chrysotile. It is not sufficient to observe the proper color in one direction - both chrysotile and paper fibers can show the same blue color perpendicular to their lengths. Nor is it sufficient to observe the two colors on a single view of a crystal - both quartz and chrysotile can have two colors in common. If all colors shown by the crystal in all orientations correspond to the known data for a given substance, and if the crystal morphology shows the colors to be oriented properly, there is then very little chance of misidentification.

Another serious complication, especially with minerals, is the effect of substitutional solid solution on the optical properties. The substitution of F⁻ for OH⁻, Fe²⁺ for Mg²⁺, or Ca²⁺ for 2Na⁺ can drastically change the optical properties of many minerals. One of the most serious in this respect is anthophyllite. Nominally Mg₇Si₈O₂₂(OH)₂, anthophyllite forms a continuous series of solid solutions with iron replacing magnesium (Table 1) with corresponding changes in the refractive indices and dispersion staining colors. Anthophyllite can also have up to 14 percent MnO, 10 percent ZnO, or 15 percent Al₂O₃ with corresponding variations in the optical properties. Figures 8 and 9 show the dispersion staining properties for two different anthophyllites, one from Connecticut and the other from Georgia. In spite of the wide differences between these two anthophyllites, both samples show parallel extinction, a unique characteristic among the asbestos minerals, and the birefringence values, γ - β , β - α , and γ - α , as well as the optic axial angle remain quite uniform or change progressively and uniformly as the composition changes. If, for example, one observes refractive indices in the anthophyllite range, the possibility of tremolite, actinolite, ferroactinolite, or cummingtonite should be considered. The index range will tell which is present, and all of the latter differ from anthophyllite in that they show oblique extinction, usually about 20° rather than parallel extinction. In other words, anthophyllite is orthorhombic; all other amphiboles (and chrysotile) are monoclinic.

Table 1. Optical properties in the anthophyllite solid solution series.^a

<u>% Fe</u>	- - - - Refractive indices - - - -			
	<u>α</u>	<u>β</u>	<u>γ</u>	<u>2V</u>
0	1.596	1.608	1.615	120(-)
20	1.622	1.632	1.642	91(-)
40	1.641	1.650	1.665	68(+)

^a From Deer, Howie, and Zussman, "An Introduction to the Rock-Forming Minerals," Longmans, London (1966), pages 156-7.

Many interfering substances are just not fibrous, hence they can be ignored if only asbestos is the target. Quartz has only two refractive indices, 1.544 (ω) and 1.553 (ϵ), but these fall within the range of chrysotile, α = 1.544 and γ = 1.558. However, chrysotile is very fibrous whereas quartz is usually flakes or chips. Chrysotile shows three refractive indices α , β , and γ and a low 2V = 30-35° (+) and always shows nearly the maximum birefringence, 0.014 or 0.012. Quartz can show any birefringence value between 0.000 (ω - ω) and 0.009 (ϵ - ω) depending on orientation. Even a thin sliver of quartz oriented to show ϵ and ω (and therefore chrysotile colors) can be bounced into other more nearly isotropic orientations by tapping on the coverslip with a needle.

Organic fibers are not generally confused with asbestos because they have obvious morphological differences, e.g., pits, twists, central lumens, nodes, cross-over marks, etc. However, if mechanically broken down into tiny fibrils they lose this obvious morphology and some, e.g., wool and other animal hairs, may closely resemble chrysotile in optical properties. A careful examination of such fibers morphologically and optically will usually, however, end any confusion and permit certain identification.

Glass or mineral wool may happen to show a color near the chrysotile range but these, of course, are isotropic and morphologically quite distinctive.

With careful application, dispersion staining is capable of rapid certain identification of any transparent substance whose optical and morphological properties are known. It also quickly differentiates between fibrous and nonfibrous minerals and detects traces of any substance in extraneous mixtures.

Reference

- [1] Brown, K.M., McCrone, W.C., Kuhn, R. and Forlini, L., Microscope 13 311; 14 39 (1963).

Discussion

J. ZUSSMAN: I enjoyed this very beautiful demonstration of the method. This is an academic question, but I think I remember a phenomenon called "form birefringence" which is supposed to be effective in giving peculiar results for very fine particles of small dimensions. If you have a very fine piece of an isotopic material, there is a shape factor which can make it appear to be anisotropic. I wonder if you get any anomalies with this method coming up, particularly with chrysotile, with fine fibrils, because of form. I think it is called form birefringence.

J. DELLY: To answer your question, yes, there is an effect, but we don't apply this technique to a single isolated fiber, so there is not really much chance of being wrong on that. I agree with you, it is extremely fascinating academically, but in a practical sense with a bulk sample there are so many fascinating things associated with it that one spends actually a great deal of time with any one sample playing with colors.

R. DRAFTZ: We have been using some of the techniques, and run into a problem with paper fibrils, especially with parenteral contaminants. I wonder if you tried the dispersion technique with chrysotile and with paper fibrils and perhaps found some similarities in color since the refractive index range is about the same.

DELLY: You will see that the highest reported value of γ of chrysotile (Deer, Howie, Zussman) is 1.556. λ_0 in 1.550 HD refractive index liquid is about 515 nm. Figure 20 of the article shows that paper fibers in liquid 1.550 will show a λ_0 of 450 nm parallel to the fiber. This wide difference in wavelengths should be easily discerned by most people. In any case, the microscopist is in the enviable position of settling the matter finally by resorting to the familiar cuoxam test to determine whether a given fibril is cellulose or not.

J. LEINEWEBER: I appreciate your very elegant description of the technique, and it has aroused a lot of questions in my mind about how the dispersion staining really works, but I would also appreciate a comment or two on the advantages of this technique over ordinary petrographic techniques for fiber identification, and also the size limits that you are confined to in working with particular particles.

DELLY: Those are a couple of very good questions. First one: The major advantage is speed. For somebody who does primarily dispersion staining, he can complete an analysis in, probably, under five minutes. It is cheap and it is fast. It is a very quick survey type of thing, a very quick confirmation. I think that is probably the primary advantage of the technique. But the lower limit is a bit tricky. The abstract says that the major dimension should be one micrometer, which, if you are going to use 3:1, makes it about 0.3 μm or 0.25 μm for the minimum. This technique does not depend on resolving power. It could not; otherwise you would not put all these stops in the back focal plane that deliberately destroy the resolving power. But, the spread of the light is all you are really looking for. You don't want to see the particle. So, that the lower limit is probably nominally around 0.3x1 μm . The reason I say nominally is, as with any other technique, when you go to the limits of any instrumental technique, the art starts coming in as well as the science. There is no reason though, why you could not apply this technique with higher-aperture objectives as well and still carry it further down. I have not personally done it.

V. WOLKODOFF: I just cannot see the advantage of this particular technique compared to classical techniques. For example, even if crocidolite does or does not show the blue color, you can pick it up immediately under crossed polars. We have no difficulty whatever using classical methods for the time element or whatsoever the case may be. And as one gentleman pointed out, for paper fibers or textile fibers we can pick that up instantaneously. Also, we are looking for the resolution, and, as you well know, materials

containing asbestos fibers contain other materials as well. I must agree that the slides are extremely glamorous and picturesque, but I really believe that there is just no substitute for the classical petrographic or optical mineralogy when it comes to solid solutions that exist in several of these asbestos series. I just want to go on record on that.

DELLY: Dispersion staining methods do not exclude classical methods; indeed, they are used simultaneously. The commercial form of the dispersion staining objective has three positions of use: a central stop, an annular stop for dispersion staining, and a position free of any stops which is used for classical methods in conjunction with dispersion staining.

MINERAL FIBER IDENTIFICATION USING THE ANALYTICAL TRANSMISSION ELECTRON MICROSCOPE

D. R. Beaman and H. J. Walker

The Dow Chemical Company
Midland, Michigan 48640

Abstract

In a transmission electron microscope equipped with an energy dispersive spectrometer (EDS), it is possible to obtain the high resolution morphology, crystal structure, and elemental composition of sub-micron mineral fibers, particulate, and thin films. The reliability of fiber analysis is enhanced when fiber identification is based on the nearly simultaneous determination of these three characteristics because each of the individual modes can yield ambiguous information. Energy dispersive spectrometer data can be converted to elemental fiber compositions using known standard spectra or relative sensitivity factors which can be calculated or experimentally determined for a given instrumental configuration. Calculated and experimental sensitivity factors are found to agree within 15 percent for photon energies above 1.5 keV. The relative error in composition calculated from EDS spectra will generally be better than 10 percent, but only if the TEM column and components have been properly modified to reduce the effects of extraneous x-ray generation and electron scattering. The sources of these problems are described and a procedure for minimizing the effects outlined. Proper aperturing, collimation, selection of materials of construction, and operating conditions can provide useful mineral spectra. It is often necessary to correct for x-ray absorption even in fine mineral fibers, and this may be done using reference standards or sensitivity factors corrected for absorption. The effect of absorption increases rapidly as the difference between the mass-absorption coefficients of the elemental constituents of the mineral increases. Carbon contamination which degrades both EDS spectra and electron diffraction patterns can be minimized by using low current density and short analysis times.

Less than 15 percent of the chrysotile fibrils in a standard provided positive selected area electron diffraction patterns (SAED), but up to 50 percent did have the correct layer line spacing. The fraction of fibers providing good diffraction increases rapidly as the number of fibrils in a fiber increases. The reported differences in SAED quality arise primarily because investigators use differing criterion for defining a positive SAED pattern and the fiber size distribution examined varies. Sample preparation methods were reviewed and it was found that condensation washing is only reliable if loss corrections are applied, particularly in the case of amphibole fibers. In spite of the many problems, inter-laboratory and multiple sample reproducibility in the measurement of fiber concentrations can be ± 30 percent when using good procedures.

Key Words: Carbon contamination; electron diffraction; mineral fibers; transmission electron microscope; x-ray spectroscopy.

Introduction

The need to identify and determine the concentration of small mineral fibers in environmental samples provided motivation for the development of the analytical transmission electron microscope (ATEM) which consists of a conventional transmission electron microscope (CTEM) equipped with energy dispersive spectroscopy (EDS) and possibly scanning transmission electron microscopy (STEM) capabilities. In such an instrument it is possible to obtain from very small volumes of material high resolution morphology in the TEM or STEM mode, elemental data using the EDS, and structural information for crystalline materials in the selected area electron diffraction (SAED) mode. When identification is based on the nearly simultaneous determination of three quantities—morphology, elemental composition, and crystal structure—the reliability of the analysis is significantly improved because the individual modes sometimes yield ambiguous information. The limitations of each mode have been discussed previously [1,2]¹. All modes are adversely affected by the presence of adjacent non-fibrous debris and overlaying films. Fibers that are too thin or too thick do not provide sufficiently good SAED patterns for positive identification by comparison with standards. Less than 15 percent of the chrysotile fibrils in a particular standard gave positive SAED patterns. Chrysotile diffraction is further degraded by electron beam bombardment and instrumental contamination. Energy dispersive spectrometry is not a panacea because there are different minerals with similar compositions and elemental substitution is common. Morphology is often compromised by the environment and interfering solids. The hollow-core or tubular appearance of chrysotile is distinctive but often absent and degraded during analysis. It is difficult to establish a protocol for basing identification on three criteria, but when this is done the quality of the analysis is significantly improved.

This paper describes some of the difficulties associated with fiber counting in the ATEM with the goal of circumventing the problems. The data from an energy dispersive spectrometer can be converted to chemical concentrations but there is a need to calibrate the instrument and correct for x-ray absorption even in very fine fibers. There are instrumental limitations which degrade EDS spectra but can, to some extent, be avoided. Contamination seriously affects both the EDS spectra and SAED patterns, but there is little that can be done to avoid it in existing instruments other than to understand the problem. The reasons for the controversy concerning the quality of SAED patterns from mineral fibers are examined and criteria suggested for classifying chrysotile SAED patterns. Sample preparation methods are reviewed and some results of inter-laboratory reproducibility are presented.

Sample Preparation

The three methods of water sample preparation that are commonly used are summarized in table 1 and references 1-6. Water is vacuum filtered through 0.22 μm Millipore or 0.1 μm Nuclepore filters. Nuclepore has the advantage of being smooth and therefore not generating a replicated structure when carbon coated; it has the disadvantages of being prone to fiber loss during handling and sporadic occurrences of non-uniform solids deposition during filtration. Millipore retains fibers well but generates a structured background if carbon coated prior to destruction of the filter structure.

In the method of condensation washing [1,2,6], TEM grids with carbon-coated Formvar films are positioned on the Ni support screen of the cold finger in a condensation washer. A piece of Whatman filter paper placed between the TEM grid and the Ni support screen has been shown to reduce fiber loss during solvent extraction [7]. The grids are preconditioned by the application of a few drops of acetone beneath the Ni support screen to prevent warping of the filter section. The filter sections are placed, sample side down, on the TEM grid immediately following pre-conditioning. The Millipore is removed in 10-50 minutes of acetone vapor extraction. The complete procedure and sources of errors are described elsewhere [1,2].

¹Figures in brackets indicate the literature references at the end of this paper.

Table 1. Method of preparing liquids for ATEM analysis.

<u>Method</u> →	<u>Jaffe-fusion</u>	<u>Jaffe-wick</u>	<u>Condensation washing</u>
reference	3,4	5,6	1,2,6
filter medium	0.22 μ m Millipore	0.1 μ m Nuclepore	0.22 μ m Millipore
pre-treatment	fused in acetone vapor for 5-10 minutes	none	none
fiber fixation by vacuum evaporation of carbon	yes	yes	no
pre-conditioning	none	10 μ L droplet of solvent onto sample positioned on grid	acetone wetting of grid without filter
extraction configuration	filter section on grid on polyurethane in enclosed petri dish	filter section on grid on wire mesh on several layers of filter paper in enclosed petri dish	filter section on grid on cold finger in reflux column
solvent	acetone	chloroform	acetone
duration of extraction	12 hours	10-24 hours	10-50 minutes

In the Jaffe-wick method [5,6], the Nuclepore filter is carbon coated after filtration to fix the solids in place prior to filter extraction. The TEM grid is positioned on a wire mesh placed on several layers of filter paper in a petri dish. The carbon coated filter section is positioned on a grid and a 10 μ l droplet of chloroform is added to prevent warping. The layers of filter paper are saturated with chloroform and the Nuclepore extracted slowly (10-24 hours) in the covered petri dish.

In the Jaffe-fusion method [3,4], a portion of the Millipore filter is attached to a glass slide and placed for 5-10 minutes in acetone vapor. This short pre-treatment in acetone destroys the structure of the Millipore and therein avoids the formation of a replicated network structure during carbon coating which would interfere with fiber counting. The fused Millipore on glass is carbon coated and then extracted using acetone in the same manner as in the case of the Jaffe-wick method.

One of the prime sources of error in the analysis is the fiber loss which occurs during sample preparation. Condensation washing is a popular method of preparation, but it introduces variability in the results and yields higher fiber losses than Jaffe-type methods [1]. While some investigators have obtained good results with condensation washing [8,9], there are a sufficient number of technique problems [1,2] so that serious differences occur in inter-laboratory comparisons. It is possible to correct for the losses associated with condensation washing using partially-extracted Jaffe samples to determine the total fiber concentration [1]. This requires additional preparation time and TEM analysis. Fortunately the chrysotile losses associated with condensation washing are usually below 20 percent [1] and can be considered insignificant if the duration of wash is less than an hour in a properly controlled washer. We have obtained reproducible results using Jaffe extraction of carbon-coated Nuclepore [2] and loss corrections in conjunction with condensation washing.

All of the above discussion refers to water samples. In preparing air samples it is preferable to low-temperature ash the filter because of the heavy filter loading associated with air sampling. The ash is then suspended in water and processed as a water sample. Because the ash tends to be clumped, it is necessary to subject the suspended ash to ultrasonic treatment.

Instrumental Limitations

Instrumental problems arise when using energy dispersive spectrometers, because TEMs were never intended to be used in quantitative chemical analysis and ATEMs have been constructed by retrofitting EDS and STEM capabilities to existing systems. There are two prime sources of the instrumental problem: 1) the EDS is not a focusing spectrometer and is insensitive to the location of the x-ray source and, thus, will detect all x-rays with a line-of-sight path to the detector [3]; 2) in a typical CTEM column there is, in a confined volume, a high density of hardware such as pole pieces, apertures, anti-contamination surfaces, sample grids, samples holders and associated clips. These two features combine to yield remote x-ray generation, i.e., x-radiation originating from regions outside of the volume excited by the primary electron beam. This causes: 1) spectral peaks unrelated to the sample to appear in the EDS spectrum leading to quantitative inaccuracy and errors in identification; 2) increased background radiation which raises the detectability limits; and 3) a loss in spatial resolution. The sources of the problem are secondary fluorescence by characteristic and continuous radiation generated in the column apertures, backscattered electrons from the sample and its support, and scattered primary electrons.

The use of high voltages to penetrate thin samples and retain good spatial resolution leads to the generation of characteristic and continuous radiation in column apertures. The second condenser (C_2) variable aperture, which is the last aperture above the sample, poses the most serious problem. The maximum in the generated continuum at a beam energy of 100 keV and $PtK\alpha$ characteristic radiation both have wavelengths of about 0.2\AA and are readily transmitted by thin Pt apertures, e.g., over 40 percent of the 0.2\AA Pt radiation is transmitted by an $100\ \mu\text{m}$ thick Pt aperture. Most of this radiation will be dissipated by absorption in the column but any that does reach the sample area can generate secondary fluorescence at and near the sample which is unrelated to primary electron beam excitation.

Because almost all primary electrons are transmitted by thin films and small particles, the backscattered electron fraction is small as indicated for Au films in figure 1 [11]. If the beam voltage is high and the sample thin, less than 5 percent of the incident electrons will be backscattered. Any electrons that are backscattered toward the detector can penetrate the $7.5\ \mu\text{m}$ Be window of the EDS because they will, for the most part, have energies close to the incident beam energy. Eighty percent of the 100 keV electrons can penetrate $7.5\ \mu\text{m}$ of Be and in so doing lose less than 5 percent of their energy. Most backscattered electrons do not reach the detector because they are confined by the strong objective lens field. They can, however, excite remote particulate matter and the support grid.

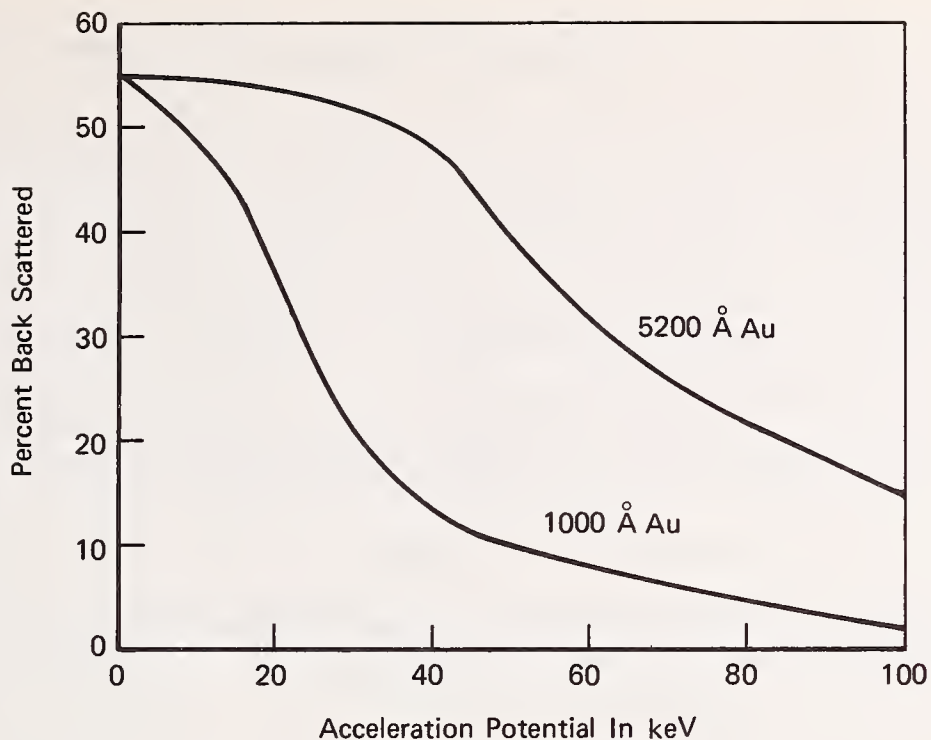

Figure 1. The percentage of backscattered electrons as a function of incident electron energy for two different thicknesses of Au. The data are from Philibert and Tixier [11].

Scattered electrons in the column cause electron beam tailing [12] which leads to excitation of areas in the sample immediately adjacent to the region of primary beam excitation. This effect is due to improper alignment and scattering by column components and increases in severity as the beam voltage is lowered.

The following list indicates some steps that may be taken to alleviate these instrumental problems. The magnitude of the problem and, therefore, the effectiveness of these alterations will vary appreciably from one instrument to another because of differences in electron optical configurations, alignment procedures, column cleanliness, aperturing (sizes, materials, thicknesses, and location), and operating mode (TEM vs. STEM).

- I. Reduce the generation in and transmission of radiation by column apertures.
 - a) Use thick apertures [13]
 - b) Use Pt apertures rather than Mo or Ta [12,14]
 - c) Use column inserts somewhere between C_2 and the sample [15]
 - d) The use of low acceleration potential reduces this problem, but promotes beam tailing, backscattering, and absorption effects
 - e) Determine if performance depends upon the emission current for the instrument being used and the type of sample being studied
- II. Reduce the excitation of material remote to the sample.
 - a) Specimen holders, specimens clamps, and support grids should be made of low atomic number materials (Be, graphite, or polymer) or coated with such materials [1,13,16]
 - b) Use support grids with maximum open area [13]

- c) Coat components near the specimen such as anticontamination devices and sample support rods with low atomic number materials (Aquadag[®])
- d) The objective aperture must be removed during EDS data acquisition
- e) The sample support film should be as thin and have as low an atomic number as possible
- f) Operate at as low a tilt angle as will provide adequate EDS intensities (less area of grid exposed to excitation)

III. Optimize the EDS detector configuration.

- a) Use the greatest Si(Li) crystal-to-sample distance that will provide adequate count rates [17]
- b) Collimate the detector with a low atomic number material
- c) The collimator should be thick enough or shielded with sufficient material (high z) to absorb any stray radiation [18]

IV. Minimize electron scattering

- a) Use a small (100 μm) condenser aperture [14]
- b) Operate at high acceleration potential
- c) Have the column clean and properly aligned

These effects of extraneous radiation can best be examined by comparing spectra obtained on and off the edge of a thin film or fiber or by comparing the spectra obtained with the beam positioned in a hole (hole-count) [12] with spectra obtained on the sample. In performing on- and off-film measurements on a Sn-Cu-Cr film, 3 percent of the Cr intensity was attributable to Cr plating on the sample hold-down clip while the Cu TEM grid was responsible for 15 percent of the Cu signal. Insertion of an aperture just beneath the variable C_2 aperture on a Philips EM300 operated in the TEM mode increased the Cu peak-to-background ratio and reduced the off-film Cu by 35 percent. The maximum peak-to-background ratios have been achieved using a column insert (1 mm ID x 2.57 mm OD x 3mm thick) in the lower end of the vacuum tube through which the variable C_2 aperture passes. Kyser and Geiss [18] have found that operation in the STEM mode reduces the extraneous background by about a factor of two.

Even after these precautions have been taken, it is still advisable to subtract the off-fiber spectrum from the fiber spectrum and to use as dilute a sample as feasible. A high density of solids on the grid may reduce the analysis time required to find fibers, but it seriously degrades the quality of SAED patterns and EDS spectra.

Quantitative Analysis

There are two aspects to quantitative fiber analysis of environmental samples in the ATEM, namely, the proper identification of the fibers coupled with the accurate determination of the number of fibers per unit area. When the concentration of a specific mineral is sought the best procedure is to compare unknown spectra and diffraction patterns with those obtained from well-characterized standards in the same instrument using constant operating conditions. When unknown samples are encountered, it is advisable to compare ATEM data with the results of x-ray diffraction, infrared spectroscopy, and x-ray fluorescence in conjunction with a careful consideration of the mineralogy of the problem. When the fibers, particles, or films of interest are thin, the following expression, originally proposed by Duncumb [19] and pursued by Cliff and Lorimer [20] and Russ [21], can provide good results:

$$\frac{C_A}{C_B} = S_{AB} \frac{I_A}{I_B} = S_{AB} \frac{(P-B)_A}{(P-B)_B} \quad (1)$$

where I is the net peak intensity corrected for background and peak overlap and S_{AB} is a relative sensitivity factor, i.e., the ratio of the detected intensities (I_B^o/I_A^o) for two pure thin standards of the same mass thickness. Absorption, secondary fluorescence, and backscattering effects must be negligible for eq. (1) to be applicable. S_{AB} is most easily measured on multi-element thin standards of known composition.

There are not many experimental data and the bulk of what is available has been published by Cliff and Lorimer [20] and Sprys and Short [22]. S_{AB} can be calculated from the following expression which is fully discussed elsewhere [21,23,24]:

$$S_{AB} = \frac{A_A \left(\frac{z_B^4}{10^6 + z_B^4} \right) G_B \ln \left(\frac{E_0}{E_{C,B}} \right) E_{C,A} \exp \left(- \frac{\mu}{\rho} \Big|_{Be}^B \cdot 13.9 \times 10^{-4} \right)}{A_B \left(\frac{z_A^4}{10^6 + z_A^4} \right) G_A \ln \left(\frac{E_0}{E_{C,A}} \right) E_{C,B} \exp \left(- \frac{\mu}{\rho} \Big|_{Be}^A \cdot 13.9 \times 10^{-4} \right)} \quad (2)$$

The subscripts A and B refer to the elements A and B. A is the atomic weight, z is the atomic number, G is the fractional emission in the line of interest, e.g., $G(K\alpha_{12}) = K\alpha_{12}$ intensity / ($K\alpha_{12}$ intensity + $K\beta$ intensity), E_0 is the acceleration energy in keV, E_C is the excitation energy in keV, and $\mu/\rho \Big|_{Be}$ is the mass absorption coefficient for A or B radiation by the 7.5 μ m Be window on the EDS detector.

Note that this expression shows no dependence on the instrumental configuration. However, S_{AB} values determined in different instruments may differ from each other and from theoretical values because: 1) the contribution of secondary fluorescence, backscattering, and beam tailing may be vastly different in different instruments; 2) the Be window thickness and detector efficiencies may be different and, in some instances, the Si dead layer and Si crystal thickness may be significant; and 3) the samples used to measure S_{AB} may not be truly thin with respect to absorption.

Figure 2 compares the values calculated from eq. (2) obtained using the Reed and Ware [25] values for G with the experimental values of Cliff and Lorimer [20]; the ratios are relative to Si, i.e., B = Si. As noted by Goldstein et al. [23] the agreement is poor below 2 keV and good above 2 keV. Table 2 also compares calculated and experimental S_{AB} values. For $S_{Mg Si}$, $S_{Al Si}$, $S_{Ti Si}$, and $S_{Fe Si}$, the agreement in the experimental values is generally better than 13 percent (fractional standard deviation or coefficient of variation), notwithstanding the variation in experimental configuration and conditions. With the exception of the $S_{Na Si}$ and $S_{Mg Si}$, the agreement between theory and experiment is better than 15 percent. The $S_{Mg Si}$ value determined from eight different mineral fiber standards using the data of Beaman and File [1] was 1.7 ± 0.2 (± 14 percent). This variation is primarily due to inaccuracies in the bulk chemical analysis of the mineral fibers. If $\Sigma C = 1$ and the S values are all relative to Si,

$$C_A = S_{A,Si} I_A / \sum_{i=A}^n S_{i,Si} I_i \quad (3)$$

Table 2. Calculated and experimental values of the relative sensitivity factor, S_{A-Si} for $K\alpha$ radiation.

Investigator and Conditions	----- Experimental S_{A-Si} Values -----					
	S_{Na-Si}	S_{Mg-Si}	S_{Al-Si}	S_{Ti-Si}	S_{Fe-Si}	S_{Cu-Si}
Cliff & Lorimer[13] EMMA-4 100 kV $\Theta=0^\circ$ $\Psi=45^\circ$ amphibole particles	5.77	2.07	1.42	1.08	1.27	1.58
Beaman & File[2] EM300 80 kV $\Theta=39^\circ$ $\Psi=26^\circ$ asbestos fibers=0.1 μm		1.7 \pm 0.2	1.4 \pm 0.2		1.25	
Sprys & Short[41] EM300 100 kV silicide particles			1.22	1.08	1.30	
Morgan et al.[30] EM300 80 kV $\Psi=42^\circ$ 3 μm iso-atomic drops	3.92	1.55	1.16	1.13	1.38	
Suzuki et al.[42] JEOL 100C 400 kV $\Theta=0^\circ$ mineral fibers		1.7	1.3		2.5	
	----- Calculated S_{A-Si} Values -----					
Goldstein et al.[22] 100 kV.	1.66	1.25	1.12	1.16	1.33	1.59
This report Eq.[11] 100 kV	1.52	1.13	1.09	1.07	1.22	1.46
Russ[4] 100 kV	2.01	1.39	1.12	0.95	1.12	1.34

Θ = tilt angle

Ψ = x-ray take-off angle

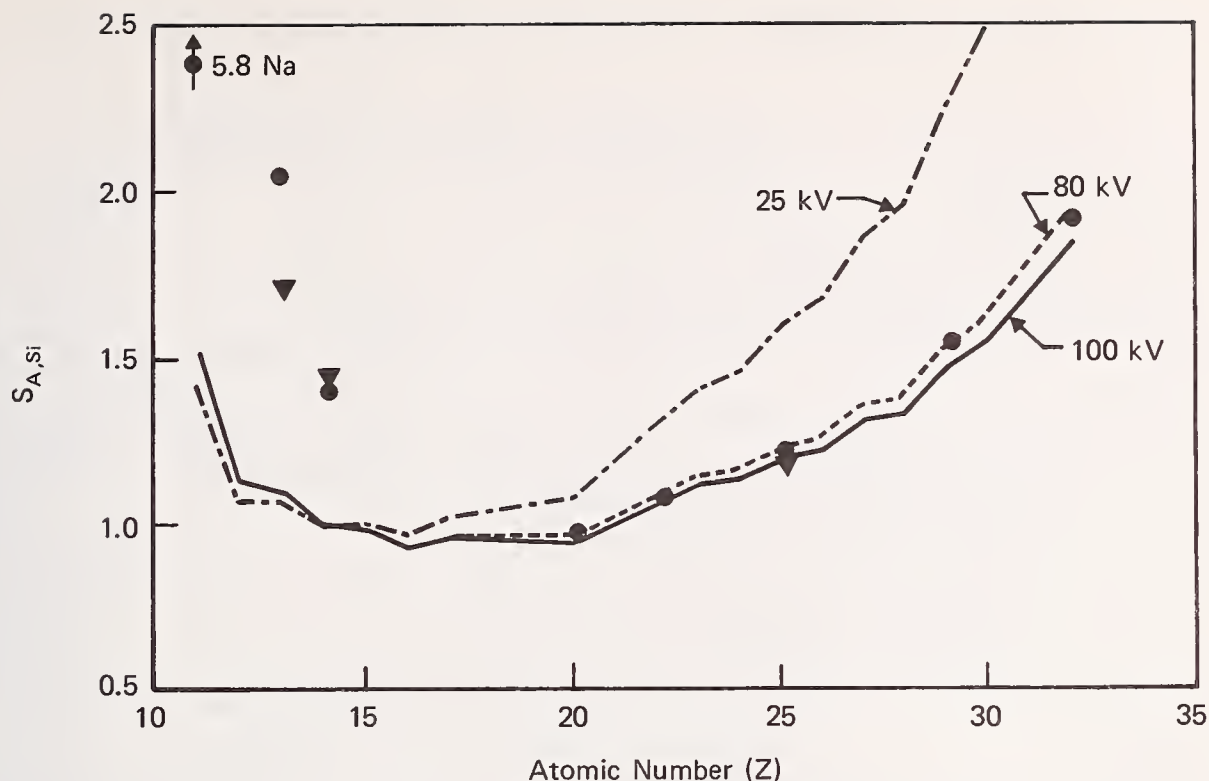

Figure 2. Relative sensitivity factors, $S_{A,Si}$, for $K\alpha$ radiation as a function of the atomic number of element A. The curves are calculated from eq. (2) and the points are experimental values from Cliff and Lorimer [20]; from Beaman [24].

Other relative sensitivity factors can be calculated from the Si values because $S_{AB}/S_{CB} = S_{AC}$.

If the S values are not relative to Si

$$C_A = I_A / (I_A + \sum_{i=B}^n S_{i,A} I_i) \quad (4)$$

We measured the composition of a 3000 \AA thick Cu-Sn-Cr film on a Cu TEM grid using Philips EM300 CTEM at 80 keV and a Cameca electron probe operated at 25 keV. The results are shown in Table 3 and compared with bulk chemical results. The ATEM results are seriously degraded by the secondary fluorescence and electron scattering as evidenced by the high Cu value resulting from the use of a Cu TEM grid. Off-film spectra were subtracted from the film measurements. The Cr/Sn ratio which is independent of the scattering problems is in good agreement with the chemical data (relative error = 11 percent). The Cu grid was used to demonstrate the difficulties associated with quantitation in the ATEM. As indicated previously, the results will be improved by using low atomic number grids and grids that do not contain any of the elements present in the sample. The results obtained in the electron probe, where scattering problems are minimized by the instrumental configuration and the use of low acceleration potential, are excellent (relative error <10 percent). From these limited data and other reported results on thin films [20,26], we conclude that the thin film model of eq. (1) is valid and capable of providing relative errors of less than 10 percent when using experimentally determined S_{AB} values. This represents reasonably good performance when compared with the 5 percent relative error obtained using EDS systems and bulk samples [27]. However, it must be stressed that this will only be attained in CTEMs after taking the precautions described previously. The accuracy will be best when measuring concentration ratios. The presence of oxide films or organic contamination on the surface and the tendency for surface segregation and particle inhomogeneity to occur complicates and degrades quantitative results.

Table 3. Experimental composition of a 3000 Å thick Cu-Sn-Cr film.

<u>Method</u>	Element →	Composition in weight percent			
		<u>Cu</u>	<u>Sn</u>	<u>Cr</u>	<u>Cr/Sn</u>
Neutron activation		14.6	77.6	7.8	0.101
A TEM at 80 keV with S_{AB} values		27	67	6	0.090
Electron probe at 25 keV with S_{AB} values and absorption corrected		15.6	76.7	7.6	0.099
Electron probe at 25 keV with S_{AB} values but no absorption correction		16.4	76.3	7.3	0.096

Correction of Quantitative Data

It has generally been assumed that if the sample was transparent to electrons, i.e., structure was visible in the TEM image, then the sample was sufficiently thin so that the only consideration necessary in quantitative analysis was the variation in x-ray generation by the primary electron beam. The loss of ionization through backscattering will generally be negligible for sub-micro diameter mineral fibers, if the acceleration potential is above 80 keV. From figure 1, it is seen that for an 1000Å film of Au the voltage could be as low as 50 keV and the backscatter fraction still below 10 percent, whereas over 50 percent would be backscattered by a bulk material.

Philibert and Tixier [11] have found that continuous fluorescence is negligible and that characteristic fluorescence will be negligible if $\mu/\rho \left\{ \begin{array}{l} B \text{ line} \\ \text{alloy} \end{array} \right. t \ll 1$. μ/ρ is the mass absorption coefficient for the exciting radiation, B, by the material. It is not presently clear how significant the characteristic fluorescence correction is for thin films because the limited accuracy of the analysis in most CTEMs obscures the effect of characteristic fluorescence. In order to make any corrections to the data, it is necessary to know the thickness which certainly complicates the analysis and detracts from the simplicity of standardless correction. However, for particles and fibers the thickness can often be accurately estimated from the TEM image.

Absorption effects in the analysis of mineral fibers were reported by Beaman and File [1] and figure 3 shows the dependence of I_x/I_{Si} on fiber size for various minerals. The ratio of intensity ratios at one fiber radius (r_1) to those at another fiber radius (r_2) can be determined from Beers law.

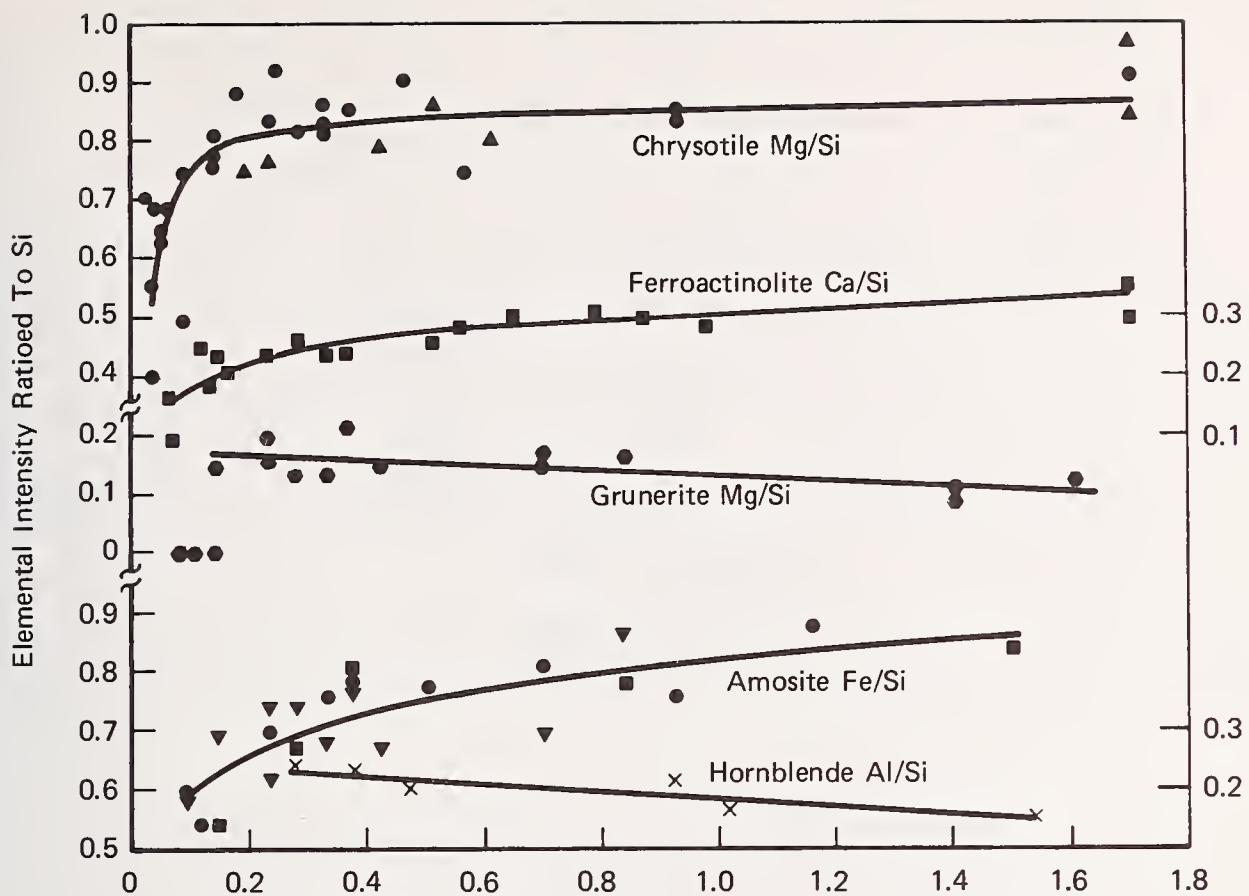

Figure 3. Elemental intensities ratioed to the Si intensity as a function of mineral fiber diameter. The scales for chrysotile, grunerite, and amosite are on the left and on the right for ferroactinolite and hornblende.

$$\frac{R_1}{R_2} = \frac{\left(\frac{I_x}{I_{Si}}\right)_{r_1}}{\left(\frac{I_x}{I_{Si}}\right)_{r_2}} = \frac{\left(\frac{I_x}{I_{Si}}\right)_{r_1}^0}{\left(\frac{I_x}{I_{Si}}\right)_{r_2}^0} \frac{\exp\left(-\frac{\mu}{\rho}\Big|_m^x \rho_m r_1 \csc \psi\right)}{\exp\left(-\frac{\mu}{\rho}\Big|_m^{Si} \rho_m r_2 \csc \psi\right)} \frac{\exp\left(-\frac{\mu}{\rho}\Big|_m^x \rho_m r_2 \csc \psi\right)}{\exp\left(-\frac{\mu}{\rho}\Big|_m^{Si} \rho_m r_2 \csc \psi\right)} \quad (5)$$

where $\mu/\rho|_m$ is the mass absorption coefficient for x or Si radiation by the mineral, ρ_m is the mineral density, ψ is the x-ray take-off angle and $(I_x^0/I_{Si}^0)_{r_2}/(I_x^0/I_{Si}^0)_{r_1}$ is the ratio of the generated intensities which is independent of r. The intensity is assumed to be generated at the center of the fiber. Rearranging yields

$$\ln \frac{R_1}{R_2} = \rho_m \csc \psi (r_2 - r_1) \left(\frac{\mu}{\rho}\Big|_m^x - \frac{\mu}{\rho}\Big|_m^{Si} \right). \quad (6)$$

This expression provides a satisfactory fit (± 10 percent) to the experimental data in figure 3 except in the case of contamination at small fiber diameters [1]. Equation 6 illustrates that it is the difference between the mass absorption coefficients that determines the magnitude of the absorption effect. When $\mu/\rho \Big|_{\text{mineral}}^{\text{Si}} \gg \mu/\rho \Big|_{\text{mineral}}^{\text{x}}$, a decrease in $I_{\text{x}}/I_{\text{Si}}$ occurs with decreasing size because the relative increase in emission will be greater for the element with the larger absorption coefficient. Thus, in grunerite there is a greater relative increase in Si emission ($\mu/\rho \Big|_{\text{grunerite}}^{\text{Si}} = 1455$) than in Fe emission ($\mu/\rho \Big|_{\text{grunerite}}^{\text{Fe}} = 65$) and a subsequent 25 percent decrease in $I(\text{Fe})/I(\text{Si})$ as the diameter decreases from 1.5 to 0.15 μm . When $\mu/\rho \Big|_{\text{mineral}}^{\text{Si}} \ll \mu/\rho \Big|_{\text{mineral}}^{\text{x}}$, $I_{\text{x}}/I_{\text{Si}}$ increases with decreasing size because the relative increase in emission is greater for x than for Si. Thus in grunerite, where $\mu/\rho \Big|_{\text{grunerite}}^{\text{Mg}} = 3460$ and $\mu/\rho \Big|_{\text{grunerite}}^{\text{Si}} = 1455$, there is a greater relative increase in Mg emission and a subsequent 50 percent increase in $I(\text{Mg})/I(\text{Si})$ as the size decreases from 1.5 to 0.15 μm . The easiest way of correcting for such effects is to use calibration curves of the type shown in figure 3.

Combining eqs. (1) and (5) shows that $(S_{\text{AB}})_{t_1} / (S_{\text{AB}})_{t_2} = R_2/R_1$ where t is the film thickness ($r = t/2$). In the case of a very thin film or fiber, taking the limit in eq. (6) as t approaches zero gives:

$$\ln \frac{S_{\text{AB}}(\text{not-so-thin})}{S_{\text{AB}}(\text{thin})} = -\rho_{\text{film}} \csc \psi \frac{t}{2} \left(\frac{\mu}{\rho} \Big|_{\text{film}}^{\text{B}} - \frac{\mu}{\rho} \Big|_{\text{film}}^{\text{A}} \right) \quad (7)$$

which is in accord with the expression published recently by Goldstein et al. [23]. The $S_{\text{Cu Si}}$, $S_{\text{Sn Si}}$ and $S_{\text{Cr Si}}$ values used to calculate the Cu-Sn-Cr values were corrected for absorption using S_{AB} (not-so-thin) values from eq. (7), and in all cases the relative error in concentration decreased as shown in Table 3. Figure 4 can be used as a guide to determine when an absorption correction is advisable. When the absorption coefficient difference for a given particle radius or film thickness is above the line, the absorption correction will be greater than 10 percent and should be taken into account. Many of the amphibole fibers with diameters of 0.2 μm and over require absorption corrections [1].

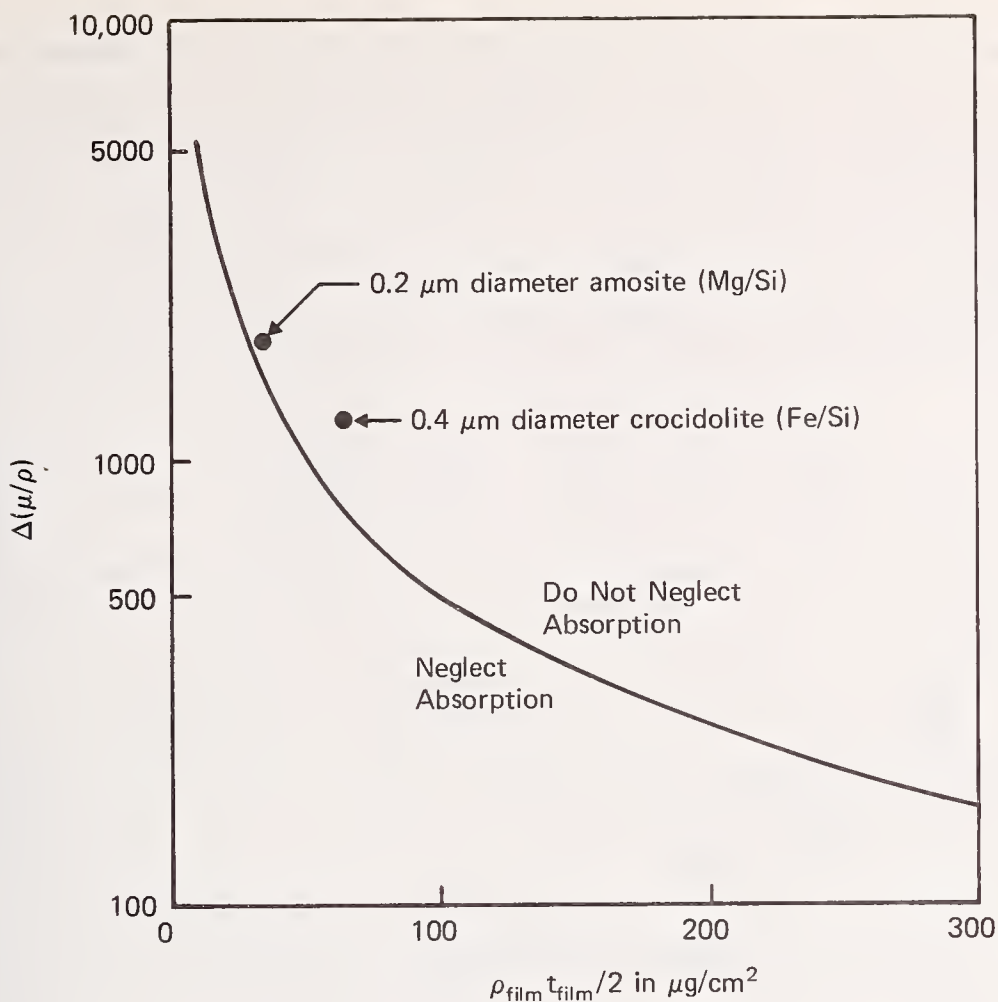

Figure 4. $\Delta(\mu/\rho) = \mu/\rho \left|_{\text{film}}^{\text{B line}} - \mu/\rho \left|_{\text{film}}^{\text{A line}}\right.\right.$
 $(\rho t)_{\text{film}}$ = film mass thickness.

When the value of $\Delta(\mu/\rho)$ for a particular film thickness is below the line, the absorption correction will be less than 10 percent. The absorption correction will exceed 10 percent for values above the lines. The values shown for amosite and crocidolite indicate that the absorption correction is significant for relatively thin fibers.

Instrumentally Induced Contamination

Superimposed on the absorption effects just described is the sample contamination which occurs when the hydrocarbons from the vacuum pump fluids are decomposed by the electron beam and deposited on the sample surface [10]. The deposited thickness can, in time, represent an appreciable portion of the total sample thickness. The magnitude of the problem depends upon: 1) the cleanliness of the vacuum system; 2) the electron beam current density; 3) the duration of the analysis; and, 4) the difference in absorption by carbon for the x-ray lines of interest. The magnitude of the latter effect can be estimated from the following expression:

$$\ln \frac{(I_x/I_{\text{Si}})_{\text{contamination}}^{\text{with}}}{(I_x/I_{\text{Si}})_{\text{contamination}}^{\text{without}}} = \rho_c t_c \csc \psi \left[\frac{\mu}{\rho} \left|_{\text{C}}^{\text{SiK}} - \frac{\mu}{\rho} \left|_{\text{C}}^{\text{X}} \right. \right. \quad (8)$$

where ρ_C is the density of carbon and t_C is the thickness of the carbon deposit in cm. Figure 5 shows the observed variation of I_{Mg}/I_{Si} in chrysotile with time for different current densities. The analysis of small (300-400Å) chrysotile fibers often requires a small electron beam (higher current density) and a longer analysis time (>5 minutes) to generate credible counting statistics. Even though $\mu/\rho \Big|_C^{Si} - \mu/\rho \Big|_C^{Mg}$ is 800, the rapid decrease in I_{Mg}/I_{Si} can only be partially accounted for by contamination implying other electron beam induced effects. When the difference in absorption coefficients is small, contamination is not a serious problem as indicated in figure 5 for the Cu-Cr-Sn film.

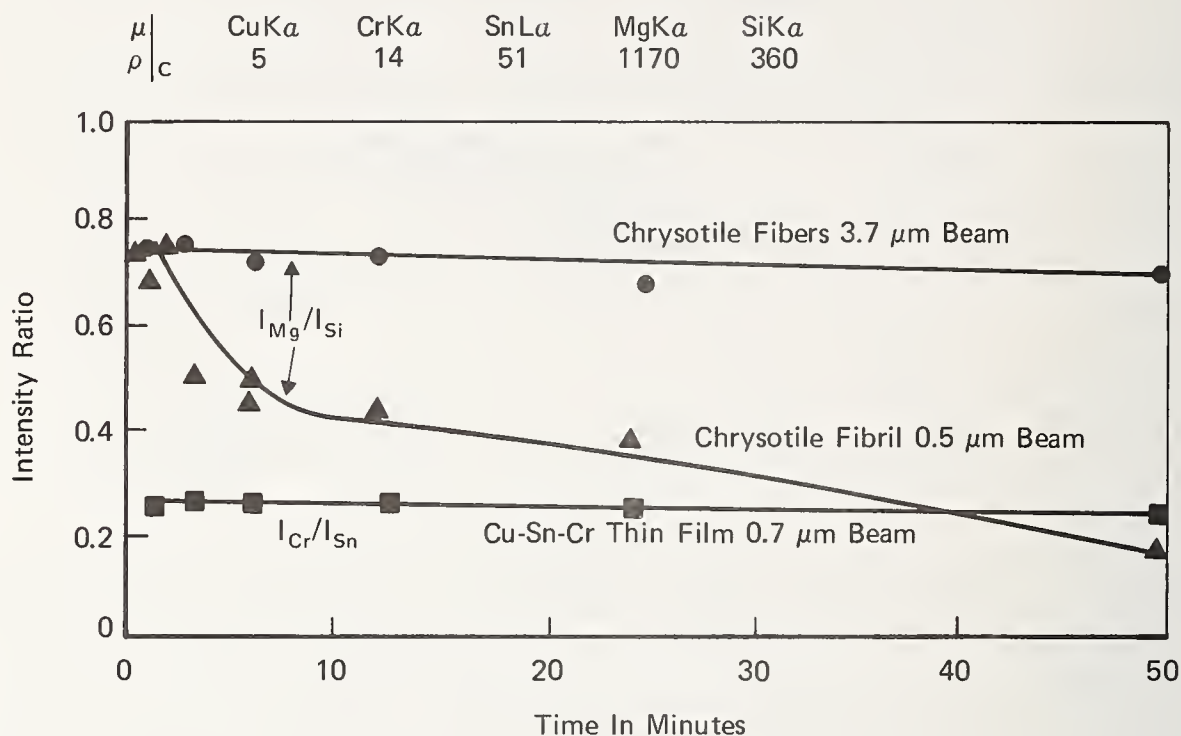

Figure 5. Elemental intensity ratios as a function of the duration of electron bombardment in an ATEM operated at 80 keV. I_{Mg}/I_{Si} and I_{Cr}/I_{Sn} are plotted for chrysotile asbestos fibers and a Cu-Sn-Cr thin film respectively. The beam diameter for each analysis is indicated on the curves. The mass absorption coefficients for the indicated radiation by carbon are also shown.

Optimum Conditions for Analysis

In thin films, theory predicts [24] that the peak-to-background ratio should vary approximately as $\ln U$ with E_0 , increasing rapidly at low U and then more slowly, where U is the over-voltage ratio, acceleration potential/excitation potential. This is not always observed experimentally as shown in Table 4. The failure to increase continuously with voltage is, in part, due to the background contribution from extraneous radiation which varies from instrument to instrument. The superiority of the STEM (vs. TEM) configuration is indicated in Table 4 where the two STEM instruments have their best peak-to-background ratios at the highest voltage. Unfortunately, fiber or particle counting in the STEM mode is not practical [2]. When column modifications are completed, the optimum operating conditions should be experimentally determined for each instrument. Note that low voltage operation will promote absorption and backscatter effects and reduce the effectiveness of SAED on thicker fibers.

Table 4. Experimental determinations of the acceleration potential providing the maximum peak-to-background ratios in the ATEM.

<u>Investigator</u>	<u>Instrument and mode</u>	<u>X-ray line</u>	<u>E₀ in keV for maximum peak to background</u>
This report	EM 300-TEM	CuK	60
This report	EM 300-TEM	SnL	40
Russ[39]	EM 300-TEM	FeK	50
Joy & Maher[25]	JEOL 100B-STEM	MgK	100
Mizuhira[29]	JEOL 100C-TEM	Na-ClK	20-40
Galle et al.[19]	Cameca-TEM	AlK, Au	20
Geiss & Kyser[27]	EM 301-STEM	Fe and CuK	100

While there are some mineralogical ambiguities that cannot be resolved by EDS, a well-designed ATEM with the appropriate column modifications used in conjunction with good analytical procedure can provide distinctive mineral spectra that are of great utility in fiber identification.

Selected Area Electron Diffraction

Vastly differing claims have been published as to the utility of SAED in the identification of mineral fibers: Ampian [28] finds that positive identification using SAED is only forthcoming from carefully indexed patterns yielding accurate lattice parameters. Ross [29] found SAED patterns of asbestos minerals difficult to obtain and interpret and that 200 keV was required to have distinct patterns. Beaman and File [1] reported that only about 10 percent of the chrysotile fibrils examined in a standard gave distinct patterns (40 percent were crystalline). Biles and Emerson [30] reported that most chrysotile fibers in beer did not give identifiable patterns. Samudra [31] reported that 99 percent of the chrysotile fibers in the size range of 200-1200 Å provided good patterns. Much of this variation can be accounted for.

A distinctive SAED pattern for chrysotile: 1) has a characteristic layer line spacing; 2) is streaked in alternate layer lines; and 3) shows some characteristic reflections, e.g., those in the second row from center are often quite distinctive. We classify as positive only those fibers exhibiting all of these characteristics. Fibers showing only the correct layer line spacing as determined visually on the fluorescent screen are classified as ambiguous; the streaking or characteristic reflections are not sufficiently distinctive to permit positive identification. Patterns without systematic reflections or distinctive layer lines are classified as unknown and the sum of positive, ambiguous, and unknown is termed crystalline. The percentage of fibers in each category has been determined as a function of fiber size using different instruments, standards, and sample preparation methods.

Droplets of 10 µL volume, prepared from the dispersion of a high purity chrysotile standard [32] in water, were placed on carbon-coated formvar films on TEM grids. The samples were examined at 0° tilt in a Philips EM300 at 80 keV and a JEOL 100B at 60 and 100 keV. Fiber searching was carried out in the selected area mode with the diffraction aperture in position and focused to minimize the time lapse between finding a fiber and obtaining a SAED pattern. The aperture size at the specimen level was 1-2 µm, the camera length was minimized, and the SAED patterns were focused with the diffraction and objective lens controls.

Figure 6 shows that less than 15 percent of the individual chrysotile fibrils (300-400 Å in diameter) provide positive SAED patterns. A significantly larger portion (20-50 percent) do exhibit the correct layer line spacing (positive + ambiguous) as observed on the fluorescent screen. For the fraction of positive fibers to exceed 50 percent, the fibers must contain over 3 fibrils.

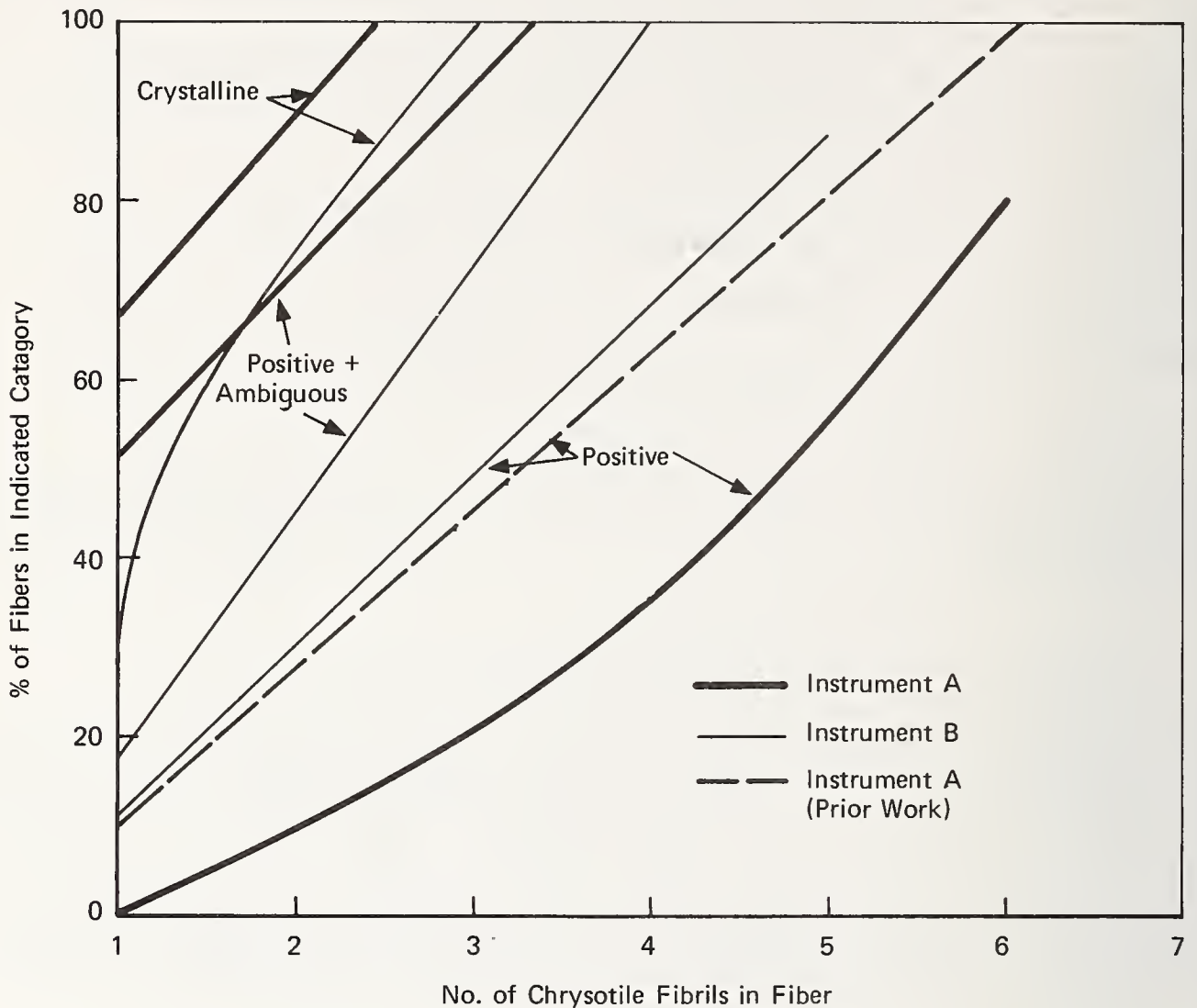

Figure 6. The percentage of chrysotile fibers in a standard providing the indicated quality of the SAED pattern is shown to depend upon the number of fibrils in the chrysotile fiber. The results obtained on two different instruments are plotted along with previously reported results [1]. All samples were prepared using 10 μ l water droplets containing suspended chrysotile.

The results obtained in instrument B were similar at 60 and 100 keV. The lower two curves in figure 6 compare the present results with earlier work [1]. The differences are due to the present use of slightly more stringent requirements for positive identification and possibly to the use of different standards (Wards in reference 1 vs. Union Carbide). Figure 7 illustrates that the percentage of fibers providing diffraction patterns in every category is lower when using samples prepared by the Jaffe extraction of carbon-coated Nuclepore as compared to water droplets. This is presumably due to the carbon coating and/or the presence of some residual Nuclepore. Note that the positive fiber category is not significantly affected by sample preparation.

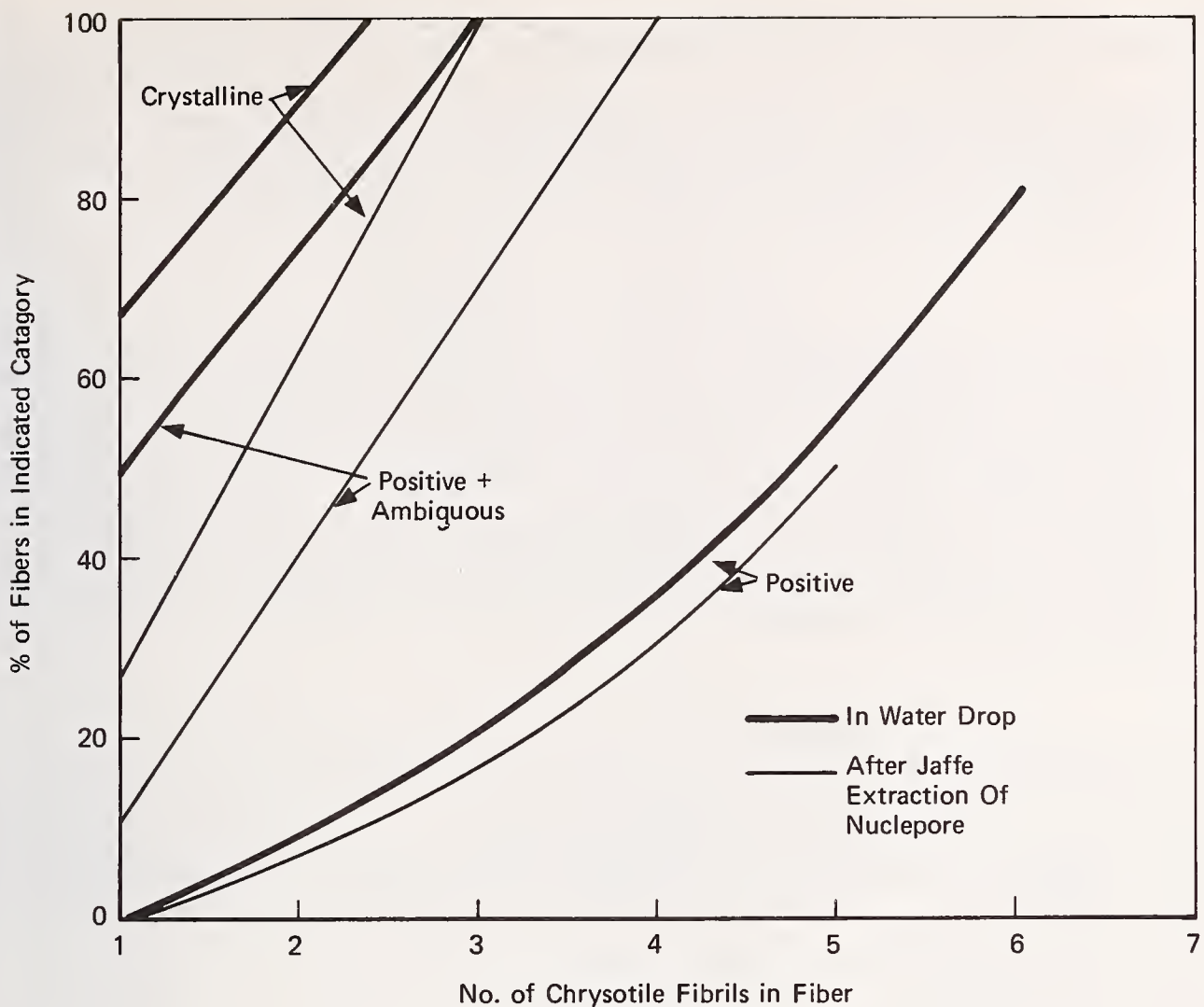

Figure 7. The percentage of chrysotile fibers providing the indicated SAED pattern quality is shown to depend, to some extent, on the method of sample preparation. The results for 10 μ L water droplets are compared with those obtained after Jaffe extraction of a Nuclepore filter in chloroform. All samples were examined in instrument A.

The primary reasons for the differing claims are the use of different criterion for classifying a pattern as positive and differences in the fibril content of the fibers being examined. A rigorous definition of positive SAED is needed if identification errors are to be avoided and interlaboratory agreement achieved. Figure 6 shows that over 70 percent of the fibers containing three fibrils show the correct layer lines spacing (positive + ambiguous category). Most published SAED patterns are not from single fibrils as indicated by the presence of partial rings and diffraction spot smearing or multiplicity [28,33]. To a lesser extent, the reported variation is due to differences in: 1) standard source and treatment; 2) sample preparation methods; 3) instrumental capabilities; 4) operator judgment; and 5) diffraction technique.

In the river, tap water, and lake samples we have studied, the chrysotile has consisted predominantly of fibers with 3 or less associated fibrils with single fibrils appearing most frequently. The fibers in 50 percent NaOH produced from chlorine cells using chrysotile asbestos diaphragms are predominantly fibrils and 80 percent have lengths less than 2 μ m and 95 percent have lengths less than 5 μ m. Identification based on morphology or SAED alone in these cases has not been particularly reliable because less than 20 percent of the chrysotile fibers had a tubular appearance and only 5-30 percent gave positive SAED patterns. Those fibers identified as chrysotile had EDS spectra and fibril diameters characteristic of chrysotile.

In counting fibers with the ATEM, searching with the diffraction aperture in place is not practical because the field diameter is decreased from about 7 μm to 1 μm . When counting in the TEM mode, the fiber is subjected to more electron beam bombardment before a diffraction pattern can be obtained. When searching with the diffraction aperture in position, the SAED patterns from chrysotile fibers containing three or less fibrils generally fade within 30 seconds to such an extent as to be unidentifiable. This electron beam induced change is due to dehydroxylation [28] and carbon contamination.

Reliability of the Method

If a sufficient number (typically 60-100) of fibers are analyzed [1,2], the method will generally provide concentrations that are accurate within a factor of two. The reproducibility is considered to be represented by the coefficient of variation or $100\sigma/\text{mean}$ fiber concentration. Inter-laboratory reproducibility between two different Dow laboratories measuring chrysotile in 50 percent NaOH, which is a relatively clean sample, has recently been better than 20 percent (see Table 5). This is reasonably good performance for the small amount of material being detected as shown in Table 5. The identification of an 1000Å long chrysotile fibril corresponds to the detection of 3×10^{-18} grams of material [24]. The results will not be this good for a series of laboratories using a variety of sample preparation techniques and differing criteria for fiber identification.

Table 5. Experimentally measured asbestos concentrations.

<u>Sample</u>	<u>Concentration in millions of fibers per liter</u>		<u>Mass of asbestos in parts per billion by weight</u>
Midland, MI Tap Water ^a	0.6		0.001
Waste Water Effluent ^a	10-400		0.2-10
50% NaOH ^a	50-5000		0.5-40
Duluth Tap Water ^b	25		25
	Dow Lab A	Dow Lab B	
50% NaOH ^a sample 1	380	380	
50% NaOH sample 2	380	300	
50% NaOH sample 3	530	520	
50% NaOH sample 4	1900	1500	

^a Chrysotile

^b Amphibole

In order to achieve good reproducibility, we adhere to the following:

1. Use a sample preparation method with proven low fiber loss such as the extraction of carbon-coated Nuclepore [2,5,6] or apply a fiber loss correction to each sample [1,2].

2. Count only samples that have a uniform distribution of solids on the TEM grid, i.e., the fibers per unit area should not fluctuate widely [1,2].

3. Count until a sufficient number of fibers (generally 60-100) have been detected so that number of fibers per unit area does not change significantly with additional counting [1,2].
4. Use a sample volume that provides a particulate density with minimum interferences from non-fibrous solids.
5. Modify the TEM column to reduce electron scattering and secondary fluorescence.
6. Subtract off-fiber EDS spectra from fiber spectra.
7. Correct for absorption, when present, using standards or relative sensitivity factors.
8. Minimize contamination rates, when possible, by the use of low current density and short analysis times.
9. Experimentally determine the optimum acceleration potential which often differs for EDS and SAED performance, necessitating a compromise.
10. Use a reasonable and consistent scheme for classifying fibers.

The authors wish to thank L. Sturkey and W. A. Knox of The Dow Chemical Company, Walnut Creek, California, for helpful discussions concerning selected area electron diffraction and R. H. Geiss and D. F. Kyser of IMB, San Jose, California, for their comments and critical review of the manuscript. The assistance of D. J. Peterson of Dow Chemical of Canada Ltd. and E. B. Bradford of Dow, Midland, in performing the experimental measurements is also gratefully acknowledged.

References

- [1] Beaman, D. R. and File, D. M., *Anal. Chem.* 48, 101 (1976), also in Proceedings Microbeam Analysis Society 10th Annual Conference, paper 31 (1975).
- [2] Beaman, D. R. and Walker, H. J., in FDA Symposium on Electron Microscopy of Microfibers (Aug. 1976) in press.
- [3] Ortiz, L. W. and Isom, B. L., in 32nd Annual Proceedings of EMSA 554 (1974).
- [4] Zumwalde, R., In FDA symposium on Electron Microscopy of Microfibers (Aug. 1976) in press.
- [5] Cook, P. M., Rubin, I. B., Maggiore, C. J., and Nicholson, W. J., in Proceedings of International Conference on Environmental Sensing and Assessment Section 34-1 I.E.E.E. Las Vegas (1976).
- [6] Anderson, C. H. and Long, J. M., Preliminary Interim Procedure for Fibrous Asbestos, U.S. Environmental Protection Agency, Athens, GA (1977).
- [7] Benefield, D., The Dow Chemical Company, Freeport, Texas, private communication (1977).
- [8] Millette, J. R., in FDA Symposium on Electron Microscopy of Microfibers (Aug. 1976) in press.
- [9] Stewart, I., in FDA Symposium on Electron Microscopy of Microfibers (Aug. 1976) in press.

- [10] Beaman, D. R. and Isasi, J. A., Electron Beam Microanalysis, STP506, American Society for Testing and Materials, Philadelphia (1972).
- [11] Philibert, J. and Tixier, R., in Physical Aspects of Electron Microscopy and Microbeam Analysis; Seigel, B.M. and Beaman, D.R., Eds John Wiley and Sons New York, 333 (1975).
- [12] Bolon, R. B. and McConnell, M. D., in Scanning Electron Microscopy/IITRI/SEM/76, Part 1 (1976).
- [13] Russ, J. C., in Scanning Electron Microscopy/IITRI/SEM/77 1 335 (1977).
- [14] Joy, D. C. and Maher, D. M., in Scanning Electron Microscopy IITRI/SEM/77 1 325 (1977).
- [15] Zaluzec, N. J. and Fraser, H. L., in Proceedings Microbeam Analysis Society, 11th Annual Conference, paper 14 (1976).
- [16] Packwood, R. H., Laufer, E. E., and Roberts, W. N., in Proceedings Microbeam Analysis Society, 12th Annual Conference, paper 115 (1977).
- [17] Geiss, R. H. and Huang, T. C., X-ray Spectrometry 4 196 (1975).
- [18] Kyser, D. F. and Geiss, R. H., in Proceedings Microbeam Analysis Society, 12th Annual Conference (1977) paper 110; also private communication with R.H. Geiss (1977).
- [19] Duncumb, P., J. de Microscopie 7, 581 (1965).
- [20] Cliff, G. and Lorimer, G. W., J. Microscopy 103, 203 (1975).
- [21] Russ, J. C., in Proceedings Microbeam Analysis Society, 8th Annual Conference (1973) paper 30; also in Edax Editor, 5, 11 (1975); also J. Submicr. Cytol., 6, 55 (1974).
- [22] Sprys, J. W. and Short, M. A., in Proceedings Microbeam Analysis Society, 11th Annual Conference (1976) paper 9; also private communication with Sprys, J.W. (1977).
- [23] Goldstein, J. I., Costley, J. L., Lorimer, G. W., and Reed, S. J. B., in Scanning Electron Microscopy IITRI/SEM/77 1, 315 (1977).
- [24] Beaman, D. R., in Modern Techniques for the Detection and Measurement of Environmental Pollutants, 10th Rochester International Conference on Environmental Toxicity (May 1977) in press.
- [25] Reed, S. J. B. and Ware, N. G., X-ray Spectrometry 3, 149 (1974).
- [26] Rao, P. and Lifshin, E., in Proceedings Microbeam Analysis Society, 12th Annual Conference, paper 118 (1977).
- [27] Beaman, D. R. and Solosky, L. F., in Proceedings Microbeam Analysis Society, 9th Annual Conference, paper 26 (1974).
- [28] Ampian, S. G., in FDA Symposium on Electron Microscopy of Microfibers (Aug. 1976) in press.
- [29] Ross, M., in FDA Symposium on Electron Microscopy of Microfibers (Aug. 1976) in press.
- [30] Biles, B. and Emerson, T. R., Nature, 219, 93 (1968).
- [31] Samudra, A. V., in Scanning Electron Microscopy IITRI/SEM/77 1 (1977).

32] Union Carbide chrysotile standard provided by K.S. Chopra, Union Carbide Corp., Niagara Falls, NY (1977).

33] Mueller, P. K., Alcocer, A. E., Stanley, R. L., and Smith, G. R., Asbestos Fiber Atlas, Environmental Protection Technology Series, EPA-650/2-75-036 (1975).

Discussion

K. HEINRICH: When you showed the variation of intensity with fiber diameter, was the scale in micrometers?

D. BEAMAN: Yes.

P. McGRATH: What can be done to develop criteria to reduce the energy-dispersive interferences so that we can develop criteria for asbestos?

BEAMAN: We can do much better with the EDS spectra than in the past by making column modifications and by subtracting background spectra from the fiber spectra.

Question (inaudible):

BEAMAN: You can make an identification in the STEM mode, but you cannot count fibers easily. It would be difficult to continuously switch from TEM to STEM.

C. PARMENTIER: I would like to make a comment concerning TEM-SAED and the lack of d-spaces and difficulty in measuring them for single-fiber chrysotile or amphibole asbestos on small particulates; we run into the same problem of rapidly decreasing signal intensity. We have used a cold finger with liquid nitrogen which allows d-spacings to be resolved on the screen, photographed, and subsequently measured and indexed directly on the negative, so we come up with very accurate d-spacings. The second point I'd like to make is in the spectrometric measurement of Mg-Si ratios. Have you seen varying Mg-Si ratios from chrysotiles of different locals, and is this taken into account in your analysis?

BEAMAN: We have used two chrysotile standards, but the chemical differences are smaller than data reproducibility. We could not detect any trend. We, of course, use a cold finger but still observe the rapid deterioration of SAED patterns in the case of chrysotile. Amphibole patterns on the other hand do not tend to fade.

TRANSMISSION ELECTRON MICROSCOPICAL METHODS FOR THE DETERMINATION OF ASBESTOS

Ian M. Stewart

Walter C. McCrone Associates, Inc.
Chicago, IL 60616

Abstract

Three criteria are given for the identification of a mineral fragment as asbestos: morphology, crystallography, and chemistry. The derivation of this information in the transmission electron microscope is discussed.

Quantification of asbestos fiber content in an environmental sample is considered and currently practiced techniques for quantification both by mass and by number are reviewed.

Key Words: Analysis; amphibole; asbestos; electron diffraction; electron microscopy; fibers; transmission electron microscopy; x-ray energy analysis.

The first meeting on methodology for determination of asbestos by electron microscopy was held almost exactly seven years ago. Sponsored by, as it then was, the National Air Pollution Control Administration, it was attended by about a dozen people. The explosion of interest in asbestos has led to a series of methodology meetings, particularly over the last two or three years, culminating in the massive attendance at the present meeting. It is clear, therefore, that there is considerable interest in asbestos and in particular, asbestos methodologies. There is thus no need to reiterate the reasons for this interest here.

What may be less obvious however, is why there should be such a necessity for the development of electron microscopical methods. Figure 1 shows an electron micrograph of a standard suspension of an ultrasonerated chrysotile sample which has been prepared to simulate material shed from asbestos filters used for parenteral drugs. The size range represented is quite wide and very closely approximates that which has been found in liquids filtered through an asbestos filter. If such a sample were to be characterized entirely by light microscopical methods, much of the material which can be seen in the electron microscope, for example fibers A and B in Figure 1, would be completely omitted. Figure 2 is an environmental sample, taken approximately three miles down stream from an asbestos plant and here again we have material below the detection range of the light microscope. The level of asbestos fibers determined by electron microscopy in this case was of the order of $10^8 - 10^9$ fibers/liter, several orders of magnitude higher than would have been determined if the light microscope was used. Again, in water samples from the Duluth and Silver Bay areas, the number of asbestos fibers that were identified by light microscopy was virtually zero, fewer than one dozen fibers being detected in over fifty samples by this method. Nevertheless, transmission electron microscopy, as shown in Figure 3, established that there were indeed high levels of fibrous amphiboles in these samples. Clearly then, in order to satisfactorily characterize the asbestos content of such samples, electron microscopy is a necessity.



Figure 1. Ultrasonerated chrysotile suspension simulating size distribution of fibers shed from asbestos filters used for parenteral drugs — 3200 X.

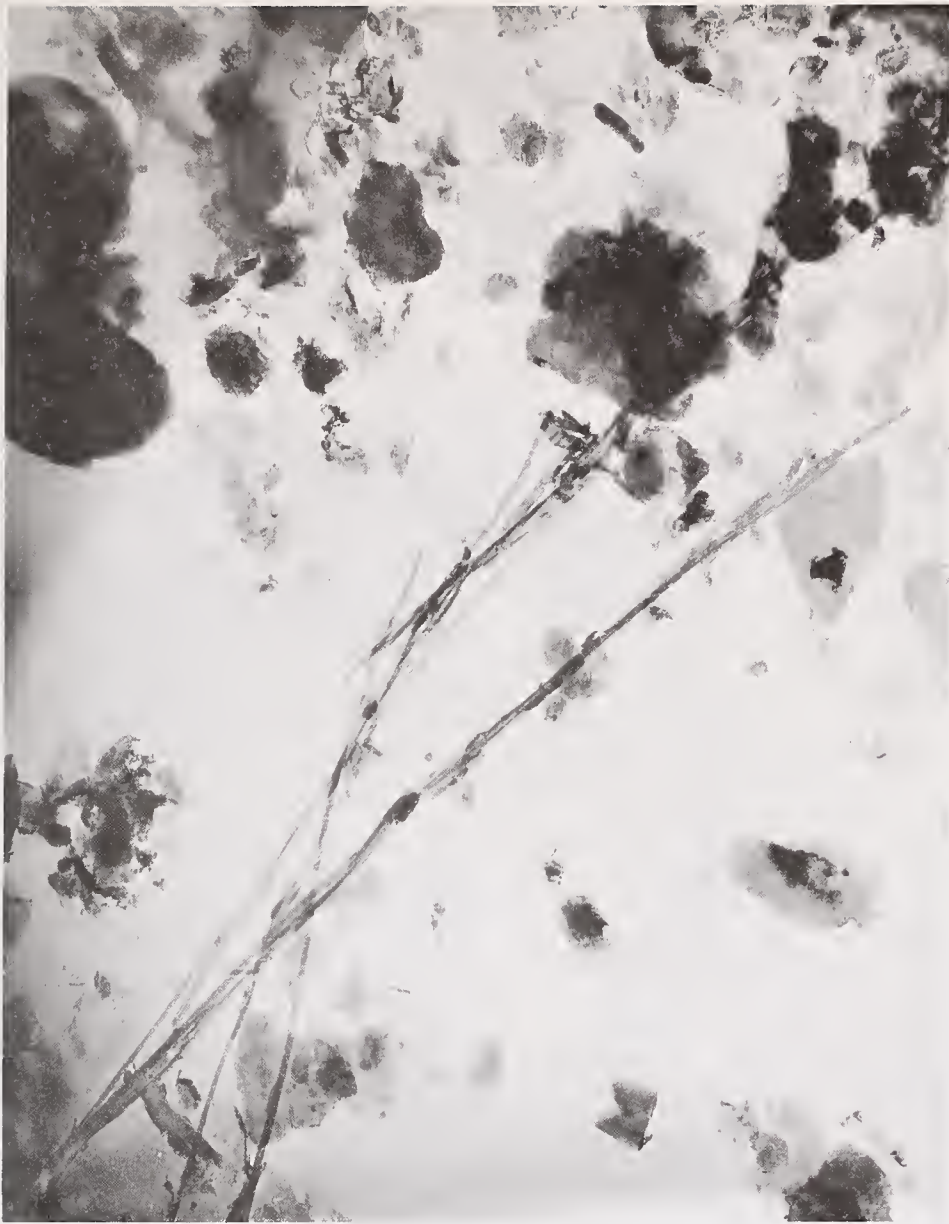

Figure 2. Filtered river water 3 miles downstream from an asbestos processing plant — 20,000 X.



Figure 3. Water from western arm of Lake Superior — 12,600 X.

Before discussing methods of preparing samples for examination in the electron microscope or for counting them, it is necessary to be sure what information we need to derive from the electron microscope in order that we can characterize a particular particle as an asbestos fiber. If one accepts the Federal Register definitions of asbestos and, from a legal standpoint, that is all that one can use at the present time, then to determine an asbestos fiber, one must show first that the material is fibrous, that is, that it has an aspect ratio of greater than 3:1 and, second, that it is a mineral of the type which is classed as asbestos by the Federal Register. The determination of the aspect ratio is quite straightforward. One measures the length and the width of the particle. The determination that the particle is indeed asbestos, however, is not so straightforward. There are basically two criteria which must be satisfied for a positive identification, certainly on the amphiboles, although for chrysotile perhaps only one of these criteria will suffice. These criteria are, firstly, that the particle in question belongs to the correct crystallographic system and has the correct crystallographic parameters for one of the asbestos minerals. Because of the unique structure of chrysotile, which will not be discussed here, the diffraction pattern of chrysotile can be regarded as sufficiently definitive without the addition of chemical information (Figure 4). In the case of the amphiboles, the diffraction patterns are less characteristic and careful diffraction work must be performed to establish that the particle is indeed an amphibole. Having established that it is an amphibole, one must then differentiate which of the several

amphibole types it may be. This can best be performed by chemical analysis in the electron microscope. At the present time the most popular method of determining this analysis is by use of an energy dispersive x-ray analyzer, fitted to the transmission electron microscope. Figures 5 and 6 show, respectively, the electron diffraction pattern and the energy dispersive spectrum of an amphibole fiber which can be tentatively identified as the commercial asbestos "amosite" - actually a fibrous grunerite. The word 'tentatively' is used deliberately since there are many problems associated with the interpretation of both the diffraction pattern and the energy dispersive spectrum. Thus, in general, it is prudent only to classify an amphibole as being within a certain series, such as the tremolite-actinolite series, or the cummingtonite-grunerite series.



Figure 4. Chrysotile diffraction pattern.

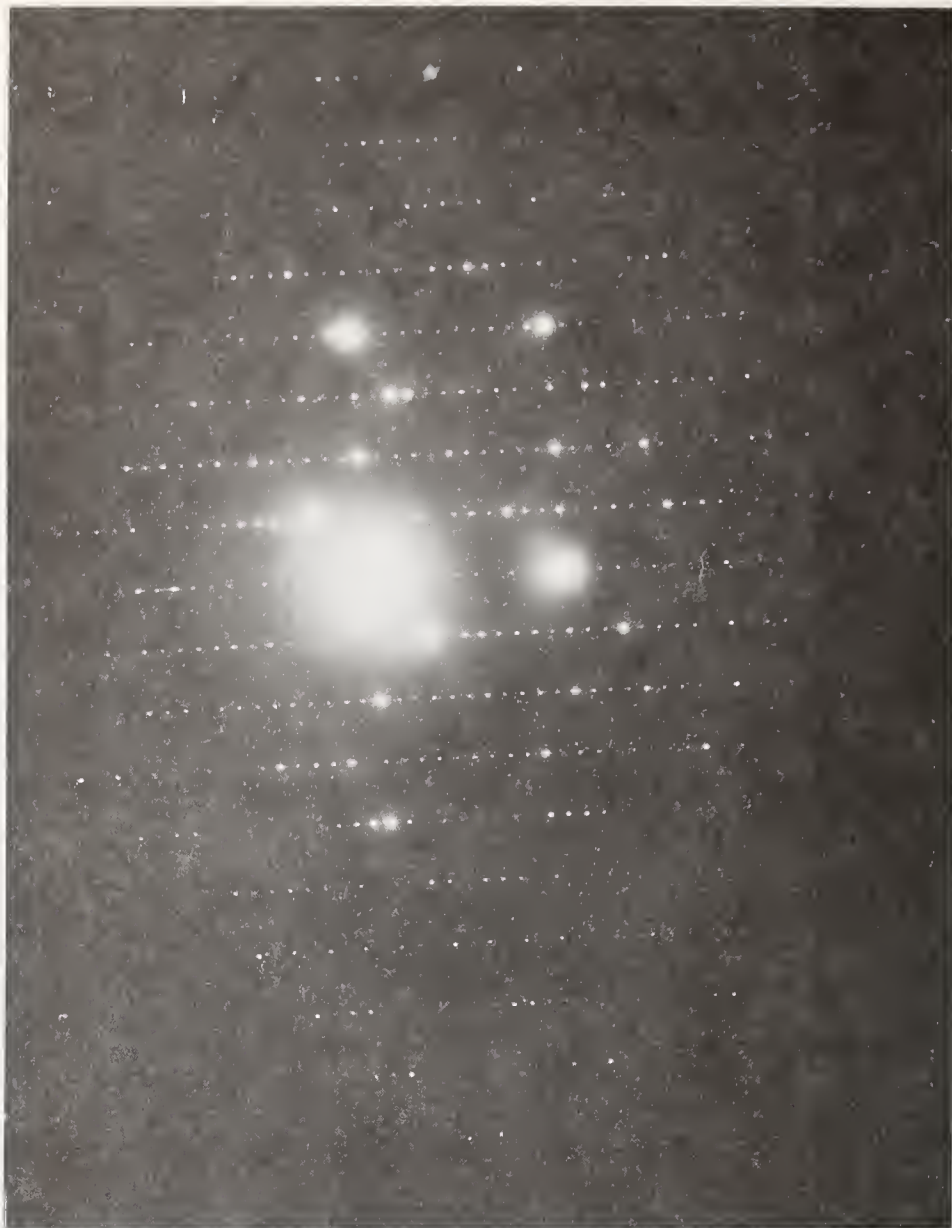

Figure 5. "Amosite" diffraction pattern.

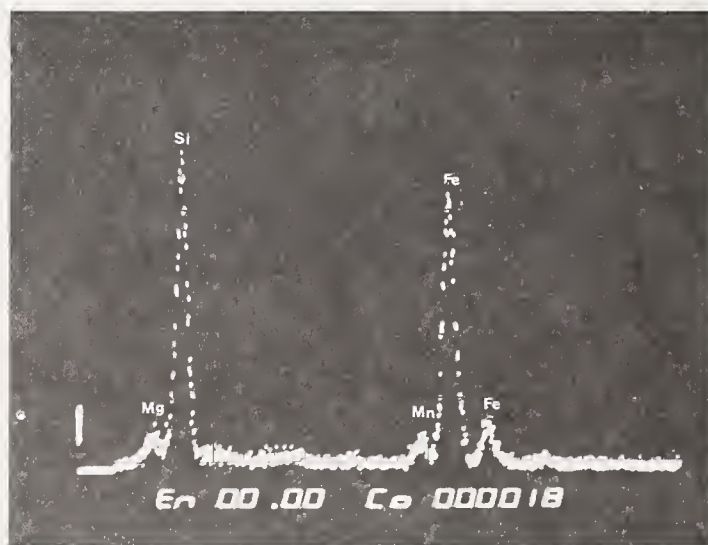

Figure 6. "Amosite" energy dispersive x-ray spectrum.

In order to determine these parameters simultaneously in the electron microscope, some idea should be given of how this information is derived. The morphology is obvious; this follows from the normal operation of the microscope as an image producing instrument. However, like all optical systems, the laws of diffraction apply in the transmission electron microscope. Thus, given an object with a periodic structure, the image of this object in the back focal plane of the objective lens will be a diffraction image related to the periodicity of the structure. In the transmission electron microscope, this image may be observed at higher magnification by adjusting the strength of one of the projection lenses, such that the back focal plane of the objective lens is in focus at the final viewing screen. As was stated above, the chemical nature of the particle under investigation can also be determined in the microscope by an energy dispersive x-ray system. This is because striking a target with a high energy electron beam will result in the emission of x-rays whose wavelengths or energies are characteristic of the chemical species at the point of impact. By suitably focusing the incident beam it is possible to isolate individual particles in the microscope and to either analyze their energies by an energy dispersive spectrometer or their wavelengths by a wavelength spectrometer. In practice the energy dispersive spectrometers are more common. They have the advantage that they detect all elements simultaneously from about sodium upwards in atomic number and they are also considerably cheaper to install on an instrument than the wavelength dispersive system which, although having a better signal to noise ratio, suffers a major disadvantage for rapid analysis in that it is sequential, analyzing only one element at a time. There are many factors which may interfere with or disturb the energy dispersive signal; factors such as particle size, shape, geometry, scatter from the instrument, and so forth, confuse the already complex chemistry of the amphiboles. These have been discussed in many other sources and will not be discussed in detail here. One should, however, be aware that such complications do occur and should interpret the spectra with appropriate caution.

Having settled on criteria by which one would identify the fibers, the next problems, "What does one wish to count or measure?" There are two philosophies which are current. One is that the important factor is to determine the number and size distribution of the fibers present as they exist in the sample. The other philosophy is that the mass concentration is important. We should discuss a little why these two schools of thought have arisen. It would seem to the lay observer, that, as yet, there is no sound medical reason in favor of determining one or the other. There are sound analytical reasons for suggesting either. The most attractive feature of the fiber number, size distribution and shape philosophy is that as well as giving information on levels that exist in the material, it also gives the size range, which may or may not be important, and much recent work has suggested that it is. It is also possible, by factoring in a geometric factor together with a density factor, to determine the mass of fiber present. One of the major drawbacks of such a method, however, is the tendency of fibers to overlap each other and also to overlap other material in the sample. It is particularly common in quarry samples, for example, to find intergrowths of chrysotile with the related serpentine mineral antigorite. Unless a good separation between the antigorite and the chrysotile is obtained, it may not be possible to positively identify the asbestos fibers and hence they will not be included in the count. Repeated over many fibers, and bearing in mind the multiplication factors which exist by virtue of the difference in area examined in the microscope relative to that represented by a membrane filter area, this can lead to quite dramatic differences in fiber counts or mass levels detected. In addition, the presence of one or two massive fibers can drastically skew the mass number, again because of the multiplication factors involved.

Mass concentrations have been determined by several workers, and several methods exist for preparation of samples to determine mass reasonably accurately. These methods, developed principally by Battelle, Mt. Sinai, and Johns-Manville, and ideally, applicable only to chrysotile asbestos, all involve the reduction of more massive fibers to the so-called unit fibril of chrysotile. In some methods these fibrils are then individually measured for length, and by geometric calculations the mass is determined. In the Battelle method, the intercepts of fibrils along a line are counted and compared to similar counts performed on a standard mass concentration sample. The advantage claimed for such methods is that they will separate the fibrils from interfering material. One disadvantage is the several preparation steps which may be involved in preparing the sample and which may lead to either cross contamination of the sample or loss of material

from the sample, leading to high and low readings, respectively. Additionally, such methods may liberate fibers which would not normally be considered free fibers and therefore presumably not hazardous. Details of these procedures have been published previously and will not be reiterated here.

As regards methods for sample preparation for fiber counting without destroying the identity of the fibers, one might say there are as many variations of sample preparation methods as there are electron microscopists working in this field. The state of the art does, however, seem to have boiled down to two basic direct transfer methods, one using condensation washing and one using a wicking technique. These methods will be discussed by Dr. Anderson, who has prepared an excellent document entitled "A Preliminary Interim Procedure for Determining Fibrous Asbestos", which spells out the basic steps in preparing samples and the criteria for asbestos identification. I believe this document represents the most acceptable state of the art on asbestos determination by transmission electron microscopy at the present time. Although there have been other methods proposed, these have not received as wide favor as the direct transfer methods. These other methods include placing a drop of the fluid suspected to contain asbestos on an electron microscope grid with a calibrated micro pipette. Assuming that all the material from the drop is deposited on the grid uniformly, and knowing the volume of the micro pipette, it is possible to derive the number of fibers per unit volume of fluid. In a similar method a calibrated micro pipette is not used, but a small drop of the liquid is placed on a grid and the diameter of the area occupied by the deposited solids after the droplet has dried is measured. It is assumed that the diameter of the evaporated circle represents the diameter of the original drop and hence the volume of the drop may be calculated and again the number of fibers per unit volume determined. One of the major drawbacks of many of these direct drop emplacement methods is the difficulty in holding the liquid in such a manner that none of the drop is transferred off the grid to its surroundings, for example by wicking up between the arms of a pair of tweezers or by contact with the substrate on which the grid may be supported. An additional disadvantage is the tendency for size separation to occur within the drying drop, resulting in an uneven distribution of fibers on the grid.

In any event, in any method involving direct transfer either from a liquid or from a filter it should be borne in mind that due to the overlapping nature of the particulate species present, the possible ambiguities of interpretation of diffraction patterns and/or chemistry due to such overlaps and the inability to see many of the fibers, the number of fibers counted will, in all cases (with the exception of bad housekeeping resulting in contamination), result in a minimal number for the total fiber loading per unit volume. A truer estimate of the loading per unit volume may be made by applying corrections for such overlaps or by additionally counting those ambiguous fibers which cannot be directly identified. There is, however, no hard and fast rule as to the magnitude of such corrections. In the case of methods reducing fibers to unit fibrils and estimating mass, these will again be minimal numbers if the criterion used is that the fiber must be positively identified, as, it is more difficult in general to obtain a positive identification of a small fiber than a large one either by electron diffraction or by chemical characterization.

Although this may paint a rather pessimistic picture in terms of establishing a standard using electron microscopy, some positive suggestions may be put forward. For example, if it is decided that the standard should be a certain number of asbestos fibers per unit volume, then it should be possible to set up the microscope parameters such that the microscopist can determine all fibers in a unit area quite rapidly. This can, in turn, be calibrated in terms of fibers per unit volume of the sample source. If none of these fibers are asbestos and the number is still below the statutory limit, then clearly it is not necessary to perform any identification on the fibers to determine if they are asbestos or not. Such a procedure could well be used for screening purposes. Again, a subjective opinion could be made by the microscopist as to what percentage of those fibers are asbestos. If the total fiber content was 2 or 3 times that which is permitted by the regulation but the asbestos content is clearly, say 10 percent, of the total fiber content, then again there should be no major problem. This would dramatically reduce the number of marginal cases in which the total asbestos content may be close to or exceed the statutory limit. Only in such cases would it be necessary to perform a complete and detailed analysis. It would be necessary, of course, to ensure valid documentation of the

data in those cases where it is said that the level does not exceed the statutory limit. A similar approach could also be applied to the mass method and indeed may be more readily applied if one is already estimating mass on the basis of number intercepts per unit area.

In the foreseeable future it is quite conceivable that automated methods for determining asbestos in the electron microscope may come to be a reality. The application of computer solution to the electron diffraction pattern as described by Fisher and Lee in these proceedings could be combined with the capability for electronically recording such diffraction patterns which is offered by the technique of scanning electron diffraction. This could then be integrated in one instrument with an x-ray energy dispersive x-ray system, and electron energy loss analysis system operating in the scanning transmission mode to provide a valuable and powerful tool for automating the asbestos identification process. It is unlikely, however, that such a tool would be applied on a routine basis, in view of the capital cost which would be involved.

Thus, there remains the major problem of characterizing asbestos particles in the submicroscopic size range and doing this economically. Work is currently in hand to effect separation of asbestos from other mineral species; separation from organic material may already be achieved by such techniques as low temperature ashing. Assuming that such separation can be both successful and complete the analytical procedures may well be simplified. Until such time, however, transmission electron microscopy must remain primarily a technique applicable to the research situation and is not presently an economically viable tool for monitoring and control programs on an extensive scale.

References

In trying to put together specific references to techniques mentioned in this paper, I realized how much of my information had been absorbed through discussions both privately and at meetings such as this -- a sort of mental osmosis. The following list is therefore not complete and should be more properly regarded as suggestions for further reading. I apologize in advance to those who may feel slighted by the omission of references to their work.

Descriptions of the mass method can be found in the following:

Leineweber, J. P., "A Method for Determination of the Fiber Content of Water", Johns-Manville Research and Engineering Center, Report No. E 404-37, August 1968.

Thompson, R. J. and Morgan, G. B., "Determination of Asbestos in Ambient Air," Proc. International Symposium on Identification and Measurement of Environment Pollutants, p. 154, June 1971.

Descriptions of direct transfer methods from filters are given in:

Anderson, C. M., "Preliminary Interim Procedure for Determining Fibrous Asbestos," July 1976. Available from Dr. C. M. Anderson. See also Dr. Anderson's paper in these proceedings.

Overlap, loss, and similar problems:

Knight, G., "Overlap Problems in Counting Fibers." AIHA Journal, p. 113-114, February 1975.

Beaman, D. R. and File, D. M., "Quantitative Determination of Asbestos Fiber Concentrations," Anal. Chem., 48, No. 1, p. 101-110, 1976.

Energy dispersive x-ray analysis is discussed in:

Beaman's paper cited above and

Ruud, C. O., Barrett, C. S., Russell, P. A., and Clark, R. L., "Selected Area Electron Diffraction and Energy Dispersive X-ray Analysis for the Identification of Asbestos Fibers, A Comparison," Micron, 7, p. 115-132, 1976.

Several general papers on the characterization, identification, and quantification of asbestos also appear in the Proceedings of the First FDA Office of Science Summer Symposium on Electron Microscopy of Microfibers, August 1976, currently in press.

Discussion

C. ANDERSON: Ian, it strikes me that to determine mass and to determine the number of fibers at a certain period of time are entirely incompatible for the reason that you state-that 10 percent or even less of the fibers contribute to 90 percent of the mass.

I. STEWART: That's exactly right.

ANDERSON: Therefore, for any kind of precision of mass you must count possibly 100 large fibers.

STEWART: Or 1000 fibrils or you just look at your intercept. But I wasn't putting it forward as being a way that we should go. You see the big problem is that you're like me, you're an analyst too, and the medical people haven't decided what they want from us -- mass data or fiber counts and sizes. If that problem is resolved, so too will many of the analytical problems.

ANDERSON: I wonder if you agree that determining mass and the number of fibers in the same amount of time is almost incompatible within a certain precision?

STEWART: Yes and no. You can get a mass number out. If you're too lazy to look at the statistics of the size distribution, the mass will give you an idea of whether you've got a lot of big fibers there; not always, but sometimes.

Written comments by Prof. J. Zussman to Dr. Stewart's paper.

J. ZUSSMAN: Dr. Stewart mentioned that fiber counts by electron microscopy would be expected to be in error on the low side, especially through overlapping particles. This effect can be lessened, of course, if specimen preparation is such as to produce not too dense a fiber population on the e/m grid. I would also like to mention that there are two factors leading to erroneously high fiber counts - the use of the rub out technique, and the process of ultrasounding if too vigorous.

STEWART: I agree in part. However, in the case of overlaps due to other suspended particulates, dilution may produce too low a fiber population for the data to be statistically valid. I also agree on the comments on erroneously high fiber counts. The rub out technique is only valid for mass data although I know that fiber counts produced by this technique have been quoted by some people.

STATISTICS AND THE SIGNIFICANCE OF ASBESTOS FIBER ANALYSES

J. P. Leineweber

Johns-Manville
Research & Development Center
Denver, Colorado

Abstract

The analysis of asbestos fibers by electron microscope methods involves many operations, each of which can affect the final results. Normal random fluctuations can be described by the Poisson distribution, which applies to any truly random process. Deviations from normal statistics, sample preparation losses, identification errors, and laboratory contamination are sources of error which are difficult to quantify. Each, however, can cause variations which will be greater than predicted by the Poisson distribution. The significance of each of the sources of error are discussed together with recommendations for experimental techniques, which should minimize the errors.

Key Words: Analysis; asbestos; electron microscope; errors; fiber; statistics.

Introduction

The counting of asbestos fibers by the "membrane filter" method, approved by the National Institute of Occupational Safety and Health, has been studied in considerable detail [1,2,3,4]¹. The procedures to be followed are specified in detail, and the precision and accuracy of the results have been analyzed by competent statisticians. The background data are based on several controlled experiments designed to describe the variations which can occur between operators in a given laboratory, as well as the variations which can occur between laboratories. Although there is considerable debate over the lower limit of fiber concentrations that can be accurately determined, the fluctuations that can occur with standard samples have been described to a reasonable degree.

In recent years, there has been increasing emphasis on the quantitative determination of fiber concentrations in the environment [5,6,7]. Analysis of these samples is much more difficult because of the extremely low fiber concentrations, the very small fiber dimensions involved, and the high concentrations of extraneous materials in the sample. Traditional methods of analysis cannot be used, so the analyst must rely upon the electron microscope to resolve, identify, count, and measure the fibers. This requires the introduction of several additional sample preparation techniques. Furthermore, the fraction of the sample actually examined is extremely small and there is much more latitude for operator interpretation.

The objective of this paper is to review the various sources of error in the counting of asbestos fibers by electron microscope methods, discuss how they might influence the results, and finally, suggest steps which might be taken to minimize these errors.

¹Figures in brackets indicate the literature references at the end of this paper.

Electron Microscopic Fiber Analysis Procedures

The techniques used to determine asbestos fiber concentrations with the electron microscope have gone through several evolutionary changes during the past decade. Although a "standard" procedure has yet to be agreed upon, all use most of the following steps [8,9].

- Sample collection
- Deposition on Filter
- Ashing and refiltration
- Clearing of the filter
- Scanning and counting

Each of these steps involves manipulation of the sample in the field or in the laboratory. Errors can be introduced with each step, and, as in any sequential system, the errors will be accumulative. The following are the principal factors which can influence the accuracy and precision of the analysis.

- Normal statistical fluctuations
- Deviations from normal statistics
- Sample preparation losses
- Identification errors
- Laboratory contamination

The significance of each of these sources of error will be discussed in more detail in the following sections together with recommendations for experimental techniques designed to minimize the errors.

Normal Statistical Fluctuations - The Poisson Distribution

In environmental systems such as air and water, it is reasonable to assume, as a first approximation, that the fibers are distributed in a purely random manner. Furthermore, it is also reasonable to assume that the random distribution will be maintained during the deposition of the sample on a filter. If this is the case, the variations to be expected can be described in terms of the Poisson distribution [10]. The distribution function can be represented as:

$$f(x, m) = \frac{m^x e^{-m}}{x!}$$

where: m = the mean value of a parameter for a series of trials
 x = the actual value for a specific event
 e = the base for natural logarithms
 f = the probability of occurrence for a specific value.

Figure 1 is a plot of the probability of occurrence for specific events for a Poisson distribution with a mean value of 10.0.

The Poisson distribution is actually a limiting case of the more general binomial distribution. It has the unique characteristics that:

- the variance is equal to the mean
- the standard deviation is equal to the square root of the mean.

For the fiber counting problem, the most significant characteristic is that the variance will be dependent on the total number of fibers counted—regardless of the number of fields that were examined to obtain the results.

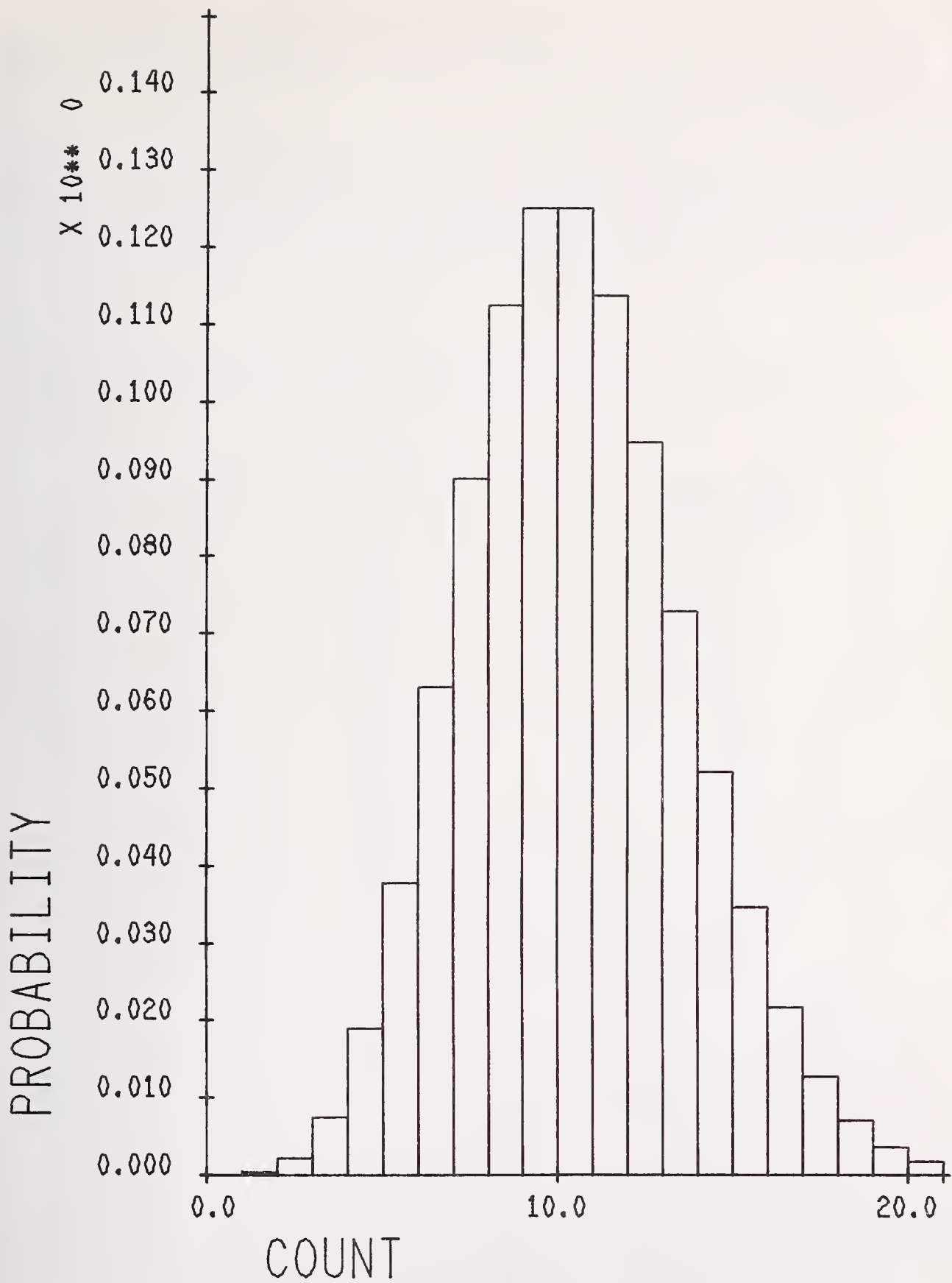

Figure 1. Poisson distribution mean = 10.

The consequences of the foregoing characteristics of the Poisson distribution are best illustrated by using the "two sigma" limits to define the range within which the results might be expected to fall for given total fiber counts. The "two sigma" limits are chosen on the basis of the hypothesis that about 95 percent of the results should be within two standard deviations of the mean value.

Table 1 lists the "two sigma" limits for total counts ranging from 1 to 100. Figure 2 is a plot of the range (upper limit/lower limit) for various total counts. This plot shows very dramatically how large the range can be for small total counts. Only when the total fiber count is 20 or greater does the range fall to a factor close to 2. It is also significant to note that the range decreases relatively slowly for total fiber counts in excess of 20.

Table 1. Two sigma limits for various fiber counts.

<u>Total Count</u>	Two Sigma Limits	
	<u>Lower</u>	<u>Upper</u>
1	0.00	3.00
2	0.00	4.83
3	0.00	6.46
4	0.00	8.00
5	0.53	9.47
10	3.68	16.32
20	11.06	28.94
30	19.05	40.95
40	27.35	52.65
50	35.86	64.14
60	44.51	75.49
70	53.27	86.73
80	62.11	97.89
90	71.03	108.97
100	80.00	120.00

RANGE--UPPER LIMIT/LOWER LIMIT

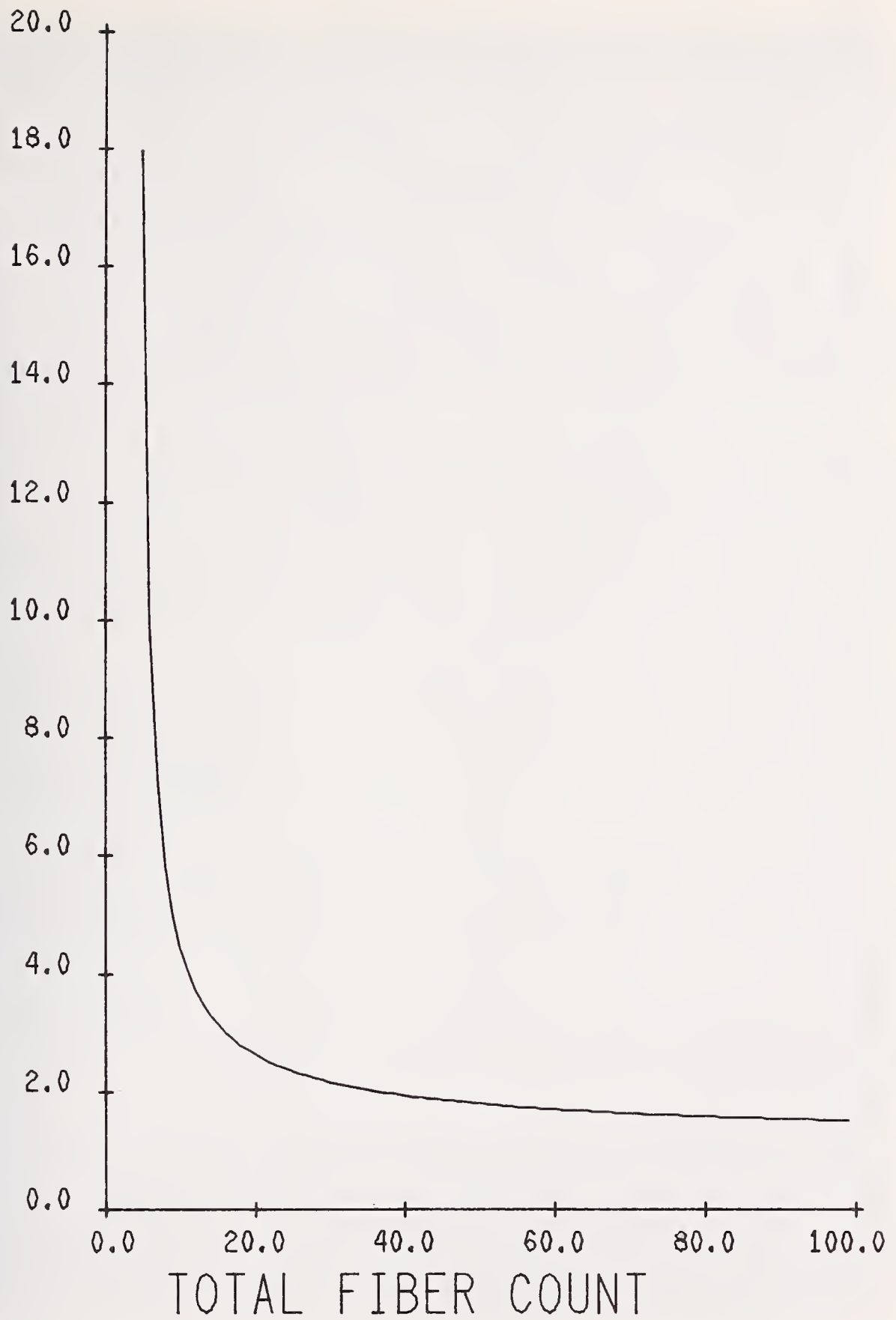

Figure 2. Range of 2 sigma limits.

The final, and most important point to be made in regard to this theoretical discussion is that the Poisson distribution can only be considered to be a limiting case. It represents the best that can be achieved under ideal circumstances. If the fibers are not deposited in a truly random manner, the variations will be larger than predicted. As a matter of fact, all available experimental data indicates that real world samples do not follow the Poisson distribution [11]. Although there is much more data available for optical counting, there is no reason to believe that electron microscope samples should be any better.

Causes for Non-Random Distribution - Experimental Results

The obvious causes for non-random distribution of fibers on a filter surface are inadequate mixing, eddy currents in the filter, and fiber clustering. With water samples, the first two of these can probably be controlled by good experimental technique. In the case of airborne samples, the operator will have little or no influence over the initial distribution and only some control over air currents which may influence the deposition.

Recently, an experiment was designed to test the validity of the Poisson distribution under reasonably ideal conditions. We had available a small amount of very well characterized glass fiber, 1.5 micrometers in diameter and 30 micrometers long. A carefully weighed quantity, calculated to contain one million fibers, was dispersed in one liter of water. One hundred (100) mL of this dispersion was filtered on a 25 mm membrane filter. The filter was then clarified and examined by phase contrast microscopy. Figure 3 shows a typical area near the center of the filter. The distribution appears reasonably random, but there also appears to be too many fibers lying closely parallel to each other to say that the distribution is completely random.

Figure 4 shows the configuration near the edge of the filter. The lower right hand corner is the region closest to the edge of the filter. Here the fibers show a tendency to align circumferentially. Next, there is a complete ring in which very few fibers are deposited. In the next few hundred micrometers, the fibers tend to be radially oriented. As we proceed toward the center of the filter, the distribution becomes more random, as was shown in the first photo in this series. Obviously, there are eddy currents near the side of the filter funnel which have strong influence on the fiber distribution.

Continuing the experiment as originally designed, 1000-80 micrometer square fields were counted. The expected number of fibers per field was 2.58. The average found was 3.18. This calculates back to 1.28 million fibers per liter. An excellent correlation, considering all the possible sources of error, including the original characterization of the fibers.

Figure 5 shows the actual distribution of the number of fibers per field versus the theoretical Poisson distribution for a mean of 3.18. Even in this well-controlled experiment, the distribution is significantly broader than predicted.



Figure 3. Glass fiber dispersion. Area near center of filter. Nominal dimensions of the fibers are 1.5 x 30 micrometers. Phase contrast.

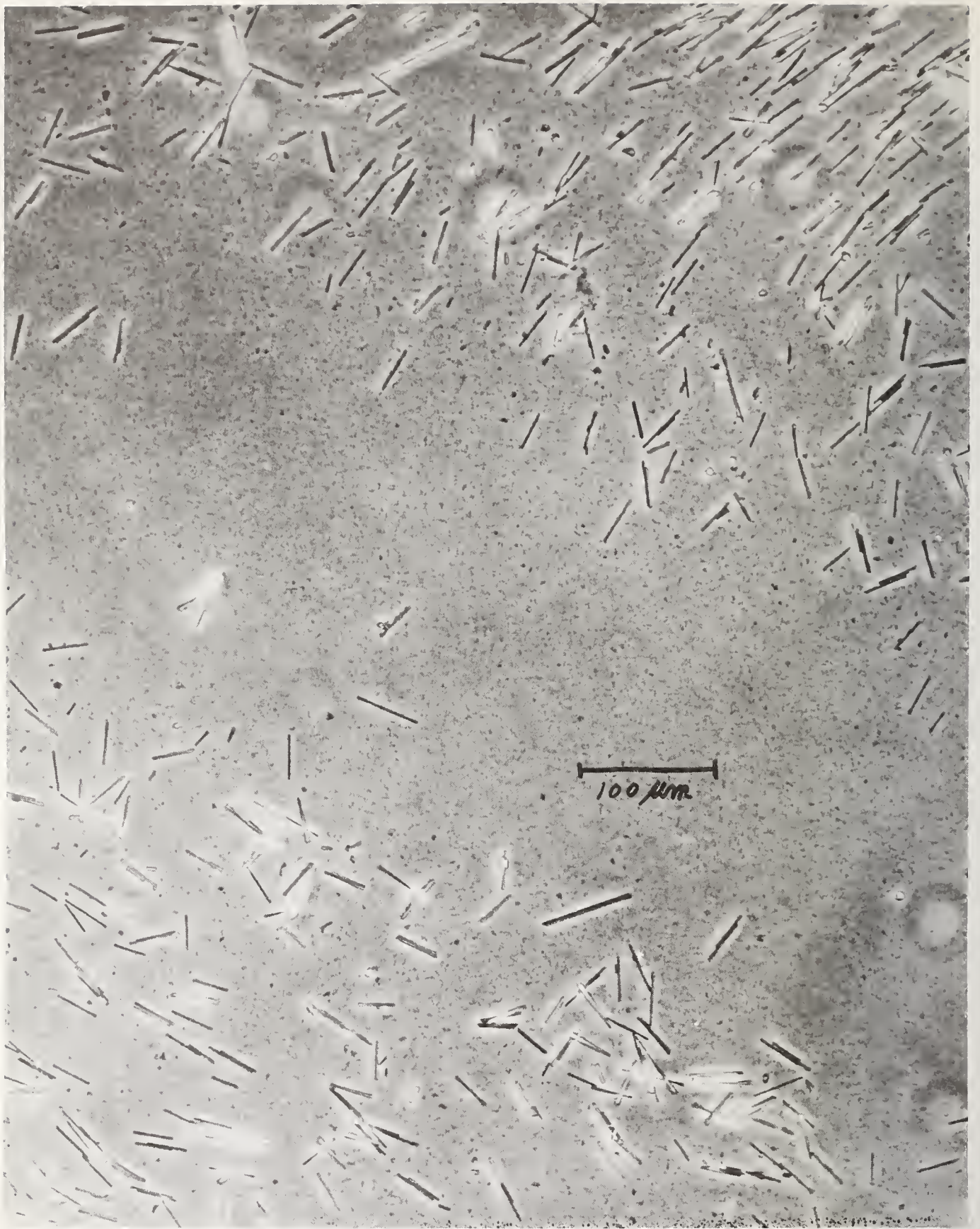

Figure 4. Glass fiber dispersion. Area near edge of filter. Nominal dimensions of fibers are 1.5 x 30 micrometers. Phase contrast.

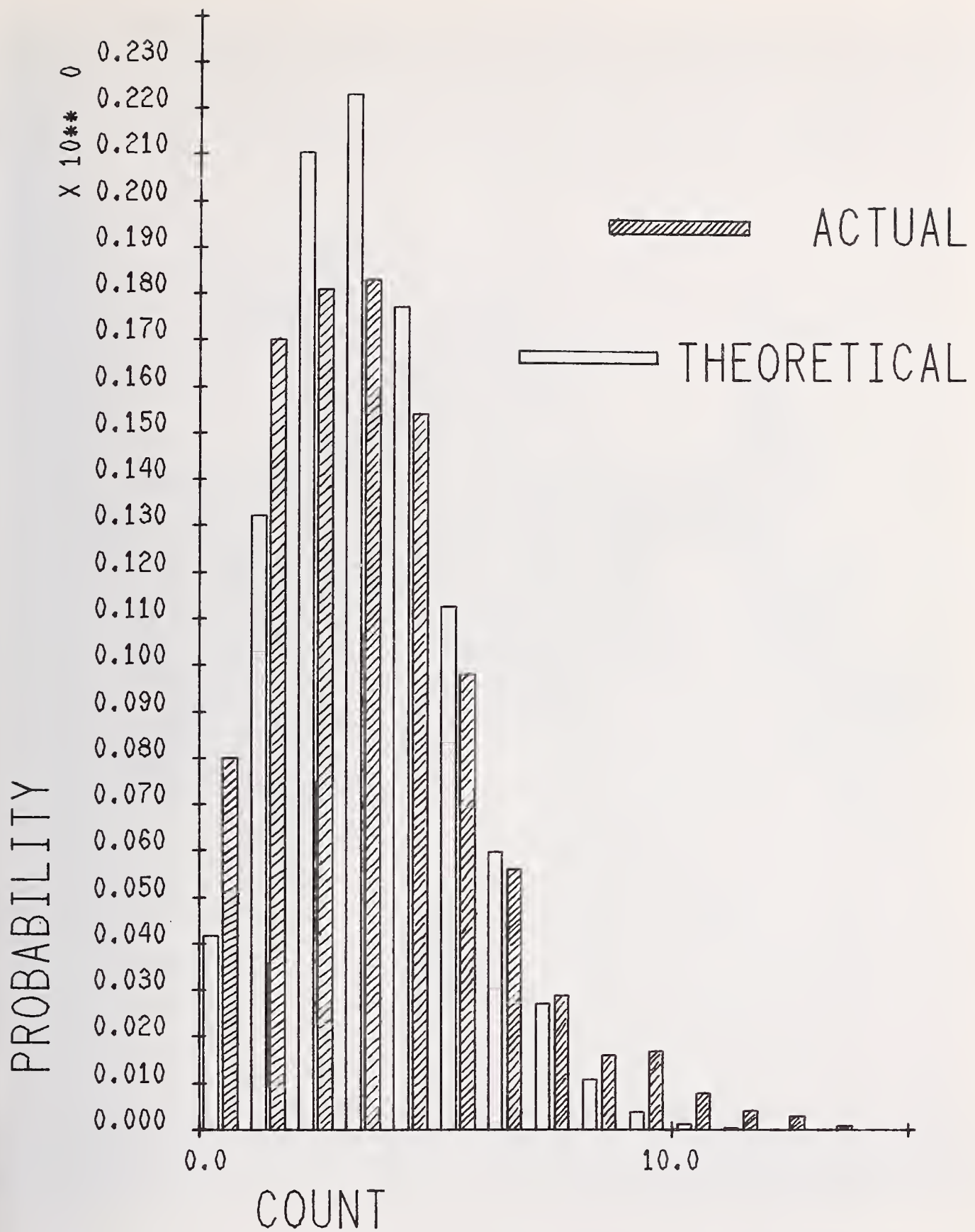

Figure 5. Actual versus theoretical fiber distribution.

Table 2 shows the results of actual electron microscope counts from some typical water and air samples. The fourth water sample and the fourth air sample are of particular interest. In the water sample, 8 grid squares were counted with a mean value of 12.13. The probability of finding a grid square with only 2 fibers is calculated to be about 4 in 10,000. Likewise, in the water sample 20 grid squares were counted with a mean value of 2.9, the probability of finding 11 fibers in one grid square is 2 in 10,000. These are both good examples of serious deviations from the theoretical Poisson distribution which will lead to greater than expected uncertainties.

Table 2. Typical counting results.

<u>Grid Opening</u>	<u>Water Samples</u>				<u>Air Samples</u>			
1	0	2	4	15	5	0	8	1
2	0	0	1	15	6	0	3	11
3	0	2	2	10	7	0	12	2
4	0	7	2	16	3	0	18	6
5	0	3	0	13	0	0	3	6
6	1	4	1	11	4	0	4	3
7	0	0	1	15	1	0	7	1
8	0	1	1	2	2	1	8	1
9	0	1	3		4	1	8	3
10	0	0	1		4	0	3	3
11	0	5	0					2
12	0	1	0			1		0
13	0	4	0			0		3
14	0	5	0			1		2
15	0	3	0			1		0
16	0	3	4			2		0
17	0	5	1			0		3
18	0	1	2			0		1
19	0	2	0			0		3
20	0	7	1			1		6

Figure 6 is a typical clump of fibers and other material found in a water sample. One can only speculate on whether such an agglomerate actually existed in the original sample or is an artifact caused by sample preparation. In any event, its occurrence can have serious consequences on the final results.

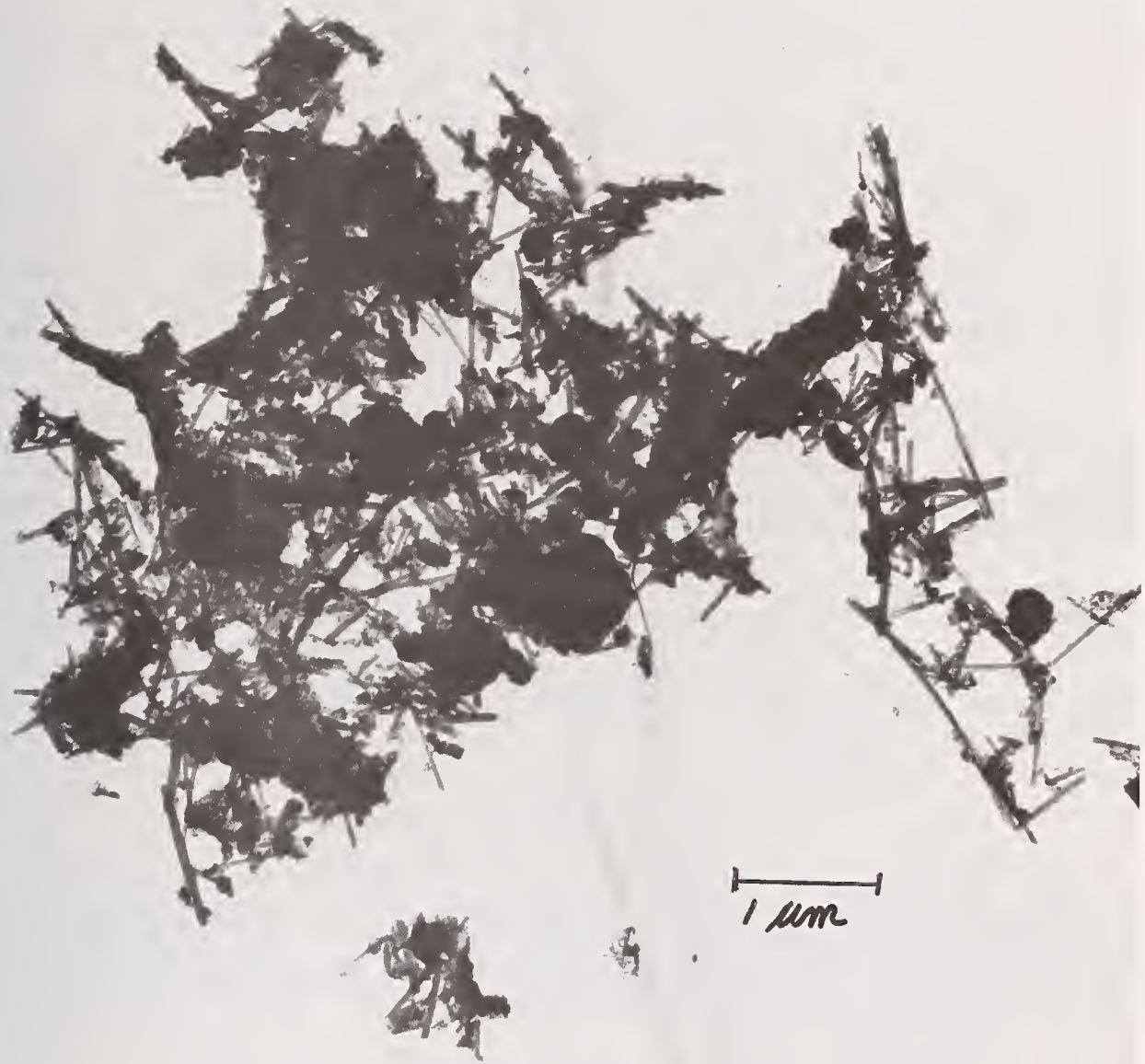

Figure 6. Fiber clump found in water sample. Transmission electron micrograph.

Sample Preparation Errors

After a sample has been collected on a filter surface, additional processing is necessary prior to examination in the electron microscope. A variety of methods can be used and each can be the source of significant errors. Perhaps the most serious of all is the loss of a significant number of fibers during the clearing or dissolution of the filter. The "cold finger" apparatus is commonly used to clear cellulose ester (Millipore) membranes, and the Jaffe wick method is used for clearing Nuclepore membranes. Both depend on dissolving the polymer in solvent vapors with the subsequent deposition of the entrapped particles on the carbon substrate. Some particles will always be washed away as the polymer is removed. How many and how consistently are very difficult to quantify. Beaman et al. [8], estimate that the losses can be as high as 50 percent for amphibole fibers. Extreme care must be exercised to avoid flooding when using the Jaffe wick method and to control the rate of boiling when clearing by the "cold finger" method.

In many cases, a sample might be contaminated with excessive organic material which interferes with the examination of the sample. Removal of the organic material can be accomplished by low temperature ashing followed by redispersion and deposition on a second membrane filter. Although this may be a necessary step, it can lead to serious clumping of fibers. Furthermore, the redispersion can alter the size distribution of the fibers. Chrysotile asbestos, for example, is extremely sensitive to dispersing agents such as Aerosol OT.

Another technique that is sometimes used in conjunction with low temperature ashing is the so-called rub-out method. This is useful for reducing the size of large extraneous particles, but does result in a radical change in the fiber dimensions. This method should not be used if the analyst is required to report fiber counts and fiber dimensions. It can only be used to estimate the total mass of fiber present.

In general, sample preparation errors lead to an understatement of the number of fibers present in a sample and can distort the size distribution. Some analysts multiply the counts by a factor which was established on the basis of a few controlled experiments. This practice could only be considered valid if the factor was determined for conditions identical to the reported analysis. This would require the analysis of a standard sample along with each group of unknown samples.

Fiber Identification Errors

The identification, or mis-identification, of the fiber species present can lead to either positive or negative errors in total fiber counts. With extremely fine fibers positive identification using electron beam techniques is very difficult. Diffraction patterns may have only a few discernible spots and can also be quite fugative. Elemental analyses by x-ray emission can also be erroneous due to the influence of nearby particles.

Fiber identification errors can be minimized by adequate operator training. Certainly, critical samples should be analyzed only by experienced operators.

Laboratory Contamination

Because of the extremely low levels of fibers encountered in environmental samples and the very small sample size, contamination of the specimens can be a serious source of error. Most laboratories concerned with fiber analysis have handled bulk fibers for many reasons. Fibers can also be present in the other media used to process the samples.

Good housekeeping practices can keep laboratory contamination to a minimum. It is advisable to handle all samples in an isolated area. A clean air hood equipped with HEPA Filters is most desirable. Obviously, no bulk fibers should be handled in this area. Finally, all solvents should be filtered immediately prior to use. Never rely on the fact that distilled water or other solvents, regardless of their purity, will be fiber free. Finally, it is advisable to run a blank sample through all of the steps of the procedure, along with each group of samples being analyzed.

Work to be Done

It is obvious from the foregoing discussion that the analysis of environmental samples for asbestos fiber is far from precise. Large errors can be the result of normal random variations and also the manipulations required for sample preparation. It is further obvious that additional work should be done to establish techniques which will minimize the controllable errors.

First, and foremost, among the tasks to be accomplished is to establish an acceptable standard procedure for fiber analysis. Work of this type is currently underway in several laboratories. This should be pursued with vigor so that methodology can be specified as soon as possible.

Second, and concurrent with the methodology development, should be a systematic study of filter clearing techniques. The objectives of this task would be to better describe the losses which can occur, and to seek improvements which might give smaller and more consistent losses.

Finally, serious consideration should be given to the preparation of a standard dispersion which could be used for comparative studies between laboratories. Such a standard dispersion would also be useful to assist in the quantification of the errors introduced by the various analytical steps.

Reporting Results

Because of the variety of procedures currently employed and the magnitude of the errors, it is important that as much information as possible be included with fiber analysis reports. This information should include:

- Sampling conditions
- Volume filtered
- Sample preparation method
- Number of fibers and fields counted
- Blank counts
- Identification problems
- Fiber dimensions

This information is absolutely essential. Too many reports are published which show only the number of fibers found in an environmental sample without any background information. Without this information, it is impossible to evaluate the true significance of any and all fiber analyses.

References

- [1] Beckett, S. T. and Attfield, M. D., Inter-Laboratory Comparison of Asbestos Fibers Samples on Membrane Filters, Ann. Occup. Hyg. 17, (1974).
- [2] Curtis, P. A. and Bierbaum, P. J., Technological Feasibility of the 2 Fibers/cc Asbestos Standard in Asbestos Textile Facilities, Amer. Ind. Hyg. Assn. J., 115-125 (February 1975).
- [3] Rajhans, G. S. and Bragg, G. M., A Statistical Analysis of Asbestos Fiber Counting in the Laboratory and Industrial Environment, Amer. Ind. Hyg. Assn. J., 909-915 (December 1975).
- [4] Walton, W. H., Attfield, M. D., and Beckett, S. T., An International Comparison of Counts of Airborne Asbestos Fibers Sampled on Membrane Filters, Ann. Occup. Hyg. 19, 215-224 (1976).

- [5] Cunningham, H. M. and Pontrefract, R., Asbestos Fibers in Beverages and Drinking Water, Nature (London), 232, 332-333 (1971).
- [6] Durham, R. W., and Pang, T., Asbestos Fibers in Lake Superior, Water Quality Parameters, ASTM STP573, American Society for Testing and Materials, pp 5-13 (1975).
- [7] Rohl, A. N., Langer, A. M., and Selikoff, I. J., Environmental Asbestos Pollution Related to Use of Quarried Serpentine Rock, Science 196, 1319 (June 1977).
- [8] Beaman, D. R. and File, D. M., Quantitative Determination of Asbestos Fiber Concentrations, Anal. Chem. 48, 101-110 (1976).
- [9] Anderson, C. H. and MacArthur Long, J. Preliminary Interim Procedure for Fibrous Asbestos, Analytical Chemistry Branch, USEPA, Athens, Georgia (July 31, 1976).
- [10] Miller, I. and Freund, J. E., Probability and Statistics for Engineers, Second Edition, pp. 77-82 (Prentiss-Hall, New Jersey, 1977).
- [11] Brown, A. L. Jr., Taylor, W. F., and Carter, R. E., The Reliability of Measures of Amphibole Fiber Concentration in Water, Environmental Research 12, 150-160 (1976).

Discussion

D. SARVADI: Are you familiar with the NIOSH proficiency analytical testing program, and do you have any feel for the inter- and intra-laboratory work they are doing on asbestos counts?

J. LEINEWEBER: They have done a fairly credible job on making inter- and intra-laboratory comparisons on standard samples, and even within one laboratory in attempting to compare the results of a group of operators. They have come a lot farther with optical counting than we have with EM counting. There are still problems, but I think they have their situation under a little better control than we do.

SELECTION AND CHARACTERIZATION OF FIBROUS AND NONFIBROUS AMPHIBOLES FOR
ANALYTICAL METHODS DEVELOPMENT

J. C. Haartz and B. A. Lange

U.S. Department of Health, Education, and Welfare
Public Health Service, Center for Disease Control
National Institute for Occupational Safety and Health
4676 Columbia Parkway, Cincinnati, Ohio 45226

and

R. G. Draftz and R. F. Scholl

IIT Research Institute (IITRI)
10 West 35th Street
Chicago, Illinois 60616

Abstract

More than 50 mineral specimens of fibrous and prismatic (nonfibrous) amphibole species, including tremolite, grunerite, and cummingtonite, were collected and characterized to determine their suitability for use as reference materials in the development of analytical methods. These methods will be used for the detection and measurement of hazardous materials which are found as workplace contaminants. The specimens have been characterized using light microscopy, x-ray diffraction (XRD), and differential thermal analysis (DTA). Some of these specimens have been purified by appropriate physical or chemical techniques and then ground to provide a material with a mass median particle size of less than 10 μm (major) diameter. The results of characterization studies of the minerals, including a comparison of the properties determined for each of the specimens, are presented. Differences in physical properties of the fibrous and prismatic tremolite specimens are indicated by the data obtained from DTA and XRD studies. While the prepared quantity of each mineral is quite limited, the source of each of the specimen materials and the appropriate methods of sample preparation have been carefully documented should additional quantities be desired.

Key Words: Amphibole asbestos; cummingtonite; grunerite; thermal analysis; tremolite; x-ray diffraction.

Introduction¹

Under the provisions of the Federal Occupational Safety and Health Act of 1970 (PL 91-596), the National Institute for Occupational Safety and Health (NIOSH) is charged with the responsibility for research related to occupational health, including the development and evaluation of analytical methods for the determination of hazardous workplace contaminants. To meet this charge, the Measurements Research Branch of NIOSH has a program concerned with the development of new analytical methods as well as with the

¹Mention of product or trace names does not constitute endorsement by the Public Health Service.

evaluation and improvement of existing methods. Many mineral dusts, such as those of the silica polymorphs, talc, and asbestos minerals, are included in the hazardous materials for which analytical methods are needed. Earlier work in the NIOSH laboratory showed that it was feasible to quantitatively determine by x-ray diffraction techniques (XRD) chrysotile, amosite, and crocidolite using either samples of the bulk material or of airborne dust collected on filters [1]². However, further work rather graphically demonstrated the fact that specimens of a mineral originating from different deposits often exhibit significant variations in impurity content and crystallinity [2], and consequently also exhibit vast differences in their response to analytical measurement techniques. It was obvious that reference materials were needed for the development of analytical methods, that these materials should be from natural sources, and that they be selected on the basis of purity, especially as to an absence of other similar minerals. Pure minerals could then be mixed with other materials to simulate the mixtures found in samples collected from occupational environments.

For asbestos, the International Union Against Cancer (UICC) Standard Reference Samples [3] are available as reference materials for chrysotile, amosite, anthophyllite, and crocidolite. These samples have been well characterized with respect to overall chemical composition (elemental weight o/o) and fiber length distribution [4]. There are also some data relating to sample response to heat treatment, and the electron and x-ray diffraction properties [4,5]. However, since these materials were collected and prepared to provide reference samples for inhalation and injection experiments, they were chosen not for phase purity but to be representative of the various types of asbestos used by industry. Further, the UICC samples do not include specimens of the prismatic (nonfibrous) forms of the minerals.

Other reference materials were also needed by NIOSH for the methods development and evaluation program. Consequently, an effort to collect and characterize at least four representative specimens of each of eighteen minerals from different geographical locations was initiated. Table 1 lists the minerals sought and the techniques used for preliminary characterization of the samples. Following the preliminary evaluation and characterization of these samples, the "best" source specimens were chosen for beneficiation, grinding to a respirable size range, and for further characterization and analysis for impurities. A one kilogram quantity of the ground material was established as the final, processed amount to be prepared of each mineral. It was expected that this amount would suffice as reference material for NIOSH analytical research; the source of selected specimens and the appropriate methods for sample preparation were carefully documented should additional quantities be desired.

The following discussion will cover the selection, preliminary separation techniques, beneficiation, grinding, and characterization of some of the amphibole species. Details concerning the other minerals will be published separately.

Selection of Minerals

More than 80 sources were contacted to obtain the approximately 50 samples of mineral specimens containing amphiboles which were received and inspected. Of these samples, 12 were discarded based on macroscopic examination; 38 were carried through the preliminary characterization steps prior to the final selection of the eleven "best" amphibole samples. Since the final quantity of each mineral needed was large (one kilogram), specimens were chosen based on (1) the least contamination by other minerals and the contrasting habit, and, (2) the amenability of the specimen to beneficiation for removal of contaminant phases.

²Figures in brackets indicate the literature references at the end of this paper.

Table 1. Reference materials sought.

Mineral	Characterization Techniques
Silica	
-Quartz	
-Cristobalite	
-Tridymite	
	X-ray Diffraction
Beryl	Infra-red Spectroscopy
Bunsenite (NiO)	Thermal Analysis
Fluorite	(TG and DTA)
Talc	
Fibrous Serpentine	
-Chrysotile	
Platy Serpentine	
-Antigorite	
Fibrous Amphiboles	
-Crocidolite	Macroscopic Habit
-Grunerite ("Amosite")	Light Microscopy
-Anthophyllite	X-ray Diffraction
-Tremolite	Thermal Analysis
Prismatic Amphiboles	
-Riebeckite	
-Grunerite	
-Cummingtonite	
-Anthophyllite	
-Tremolite	

After a macroscopic inspection of the specimens as received, using a hand magnifier, portions were hand ground in an agate or diamonite mortar and pestle. The ground samples were dry sieved to pass a 325 mesh screen and were further characterized using polarized light microscopy, qualitative x-ray diffraction (XRD), and qualitative differential thermal analysis (DTA). The types and quantities of impurities were noted for each of the specimens, and careful scrutiny was given to the mineral morphology, especially for the samples needed for the fibrous and prismatic (or nonfibrous) habits.

For macroscopic specimens, the mineralogical criteria distinguishing the fibrous from the prismatic habit are unequivocal. This is illustrated by the samples of tremolite which are shown in figures 1 through 4. The origin of the fibrous tremolite shown in figure 1 is Alaska, while that of figure 2 is a small sample from Italy which was collected in approximately 1890 and has since been in the collection of the Field Museum of Natural History in Chicago, IL. It was not possible to locate a contemporary source of fibrous tremolite in Italy. The prismatic tremolite in figure 3 is from South Dakota and is a fairly pure sample with an acicular radiated structure which is quite evident in the hand specimens. The sample shown in figure 4 contains interlaced prismatic tremolite, talc and other impurities. Although the individual tremolite "needles" are colorless, the sample has a lavender color which may be due to manganese substitutions [6].

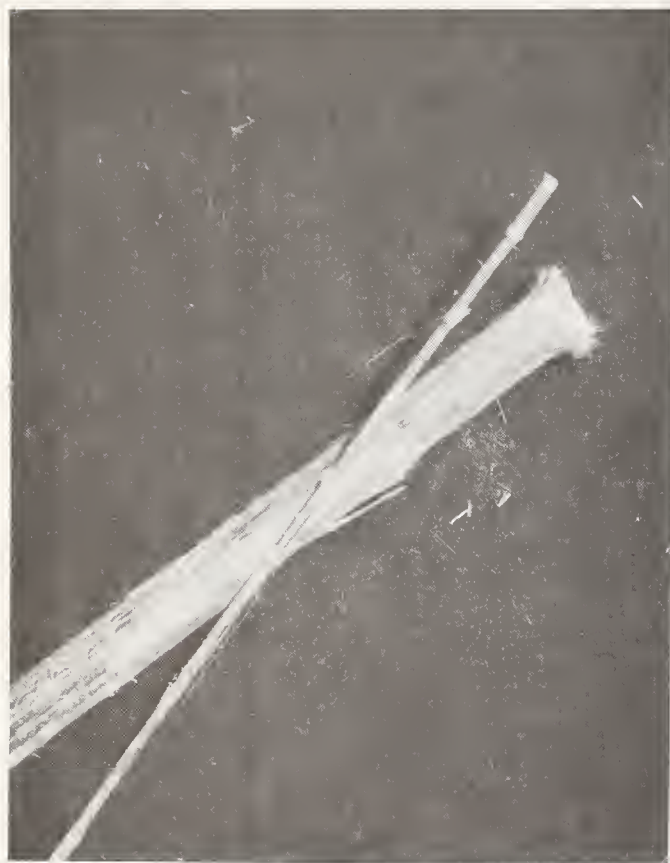

Figure 1. Fibrous tremolite:
Alaska, 1X.



Figure 2. Fibrous tremolite:
Tuscany, Italy, 1X.



Figure 3. Prismatic tremolite with calcite: South Dakota, 0.57X.



Figure 4. Prismatic tremolite with talc and other impurities, 0.5X.

Distinguishing between the fibrous and prismatic habits is less straightforward with microscopic specimens. The photomicrographs of tremolite (figures 5 and 6) illustrate the appearance of fibrous and prismatic tremolite specimens ground to a mean particle size of $3.1\ \mu\text{m}$ and $1.7\ \mu\text{m}$ respectively. Similarities in particle shape are evident, although the mean aspect ratio of the fibrous tremolite particles is greater than that of the cleavage fragments of the prismatic material.



Figure 5. Fibrous tremolite:
Rajasthan State, India, 407X.



Figure 6. Prismatic tremolite:
Gouverneur, New York, 407X.

Table 2 lists the amphiboles, and their sources, which were chosen for any necessary beneficiation and final grinding. The impurities listed are those contaminants determined by microscopic analysis of the hand-separated portions of the desired phase. Some of the amphiboles, including the samples of prismatic and fibrous tremolite as well as crocidolite, were obtained as nearly pure, single phase specimens. Others, such as the prismatic grunerite, anthophyllite, and cummingtonite were intermixed with accessory minerals. Hand specimens of the amphiboles selected for preparation as reference materials are illustrated in figures 7-14.

Table 2. Amphibole sources.

<u>Mineral</u>	<u>Geographical Origin</u>	<u>Representative Impurities</u>
Tremolite		
Fibrous	Udaipur District Rajasthan, India	Plant fragments (carbonaceous) & other minerals, $\leq 3\%$
Prismatic	Gouverneur, N.Y.	Talc, Limestone, Hematite, $\leq 2\%$
Cummingtonite		
	Homestake Mine, Lead, So. Dakota	Calcite, Quartz, other minerals, $\sim 30\%$
Grunerite		
Fibrous ("Amosite")	Lydenburg District Transvaal, South Africa	Magnetite & other minerals, $\leq 11\%$
Prismatic	Luce #1 Mine Newfoundland	Quartz, Magnetite, other minerals, $\sim 50\%$
Anthophyllite		
Fibrous	Bozeman, Montana	Magnetite, Calcite & other minerals, $\leq 11\%$
Prismatic	Bamble, Norway	Quartz, Mica, Rutile, Magnetite, other minerals, $\sim 25\%$
Crocidolite		
	South Africa	Phases which are too fine to identify, $\leq 2\%$
Riebeckite		
	St. Peter's Dome El Paso County, Colorado	Quartz, feldspar, iron oxide, and other minerals, $\sim 15\%$



Figure 7. Fibrous tremolite: Rajasthan State, India, 1X.



Figure 8. Prismatic cummingtonite with associated minerals: Homestake Mine, Lead, South Dakota, 0.8X.

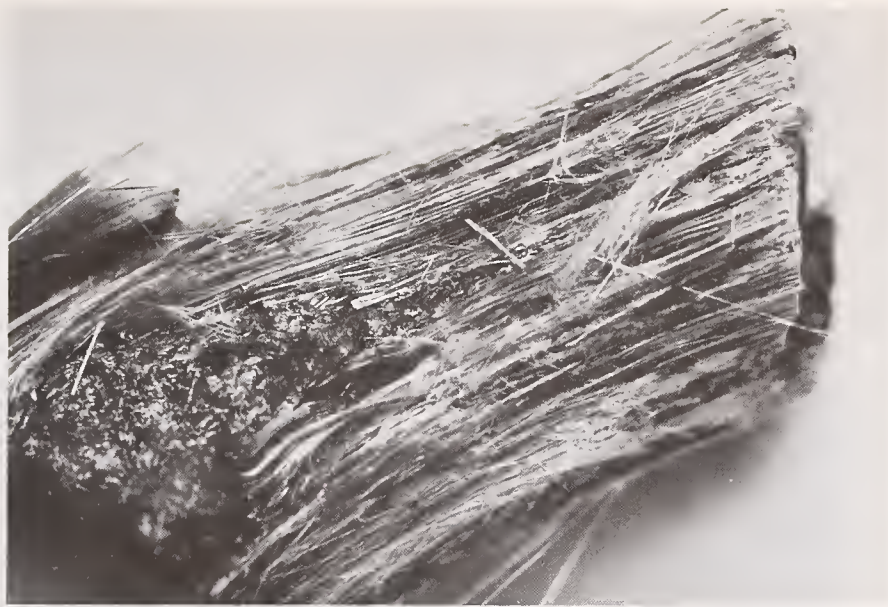

Figure 9. Fibrous grunerite ("Amosite"): Lydenburg District, Transvaal, South Africa, 0.8X.

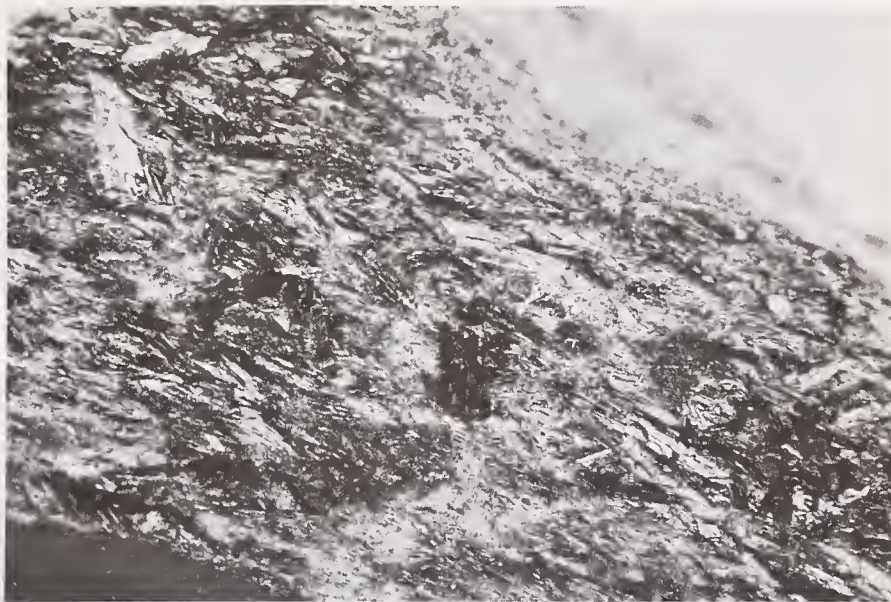

Figure 10. Prismatic grunerite with quartz: Luce No. 1 Mine, Newfoundland, 0.8X.

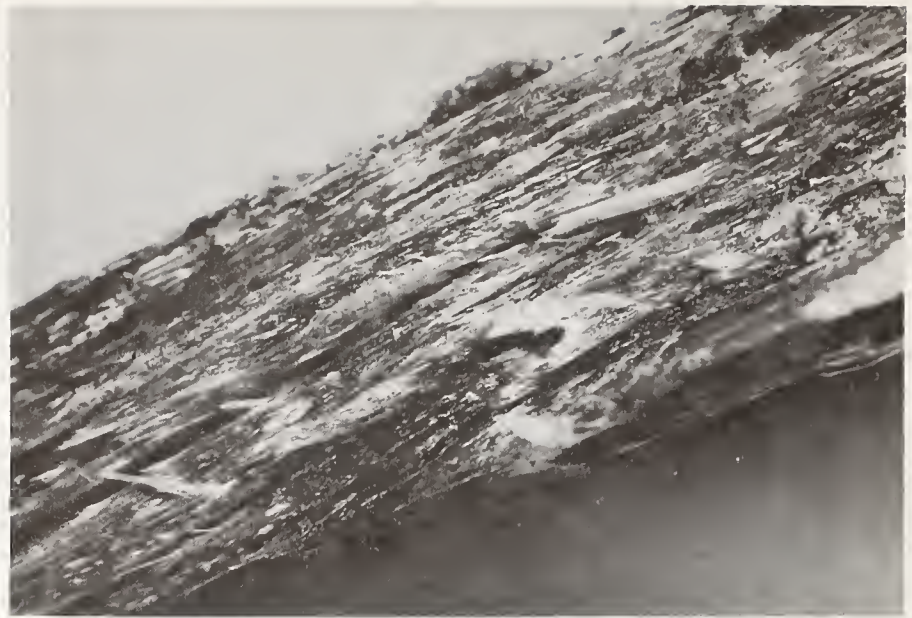

Figure 11. Fibrous anthophyllite: Bozeman, Montana, 1X.

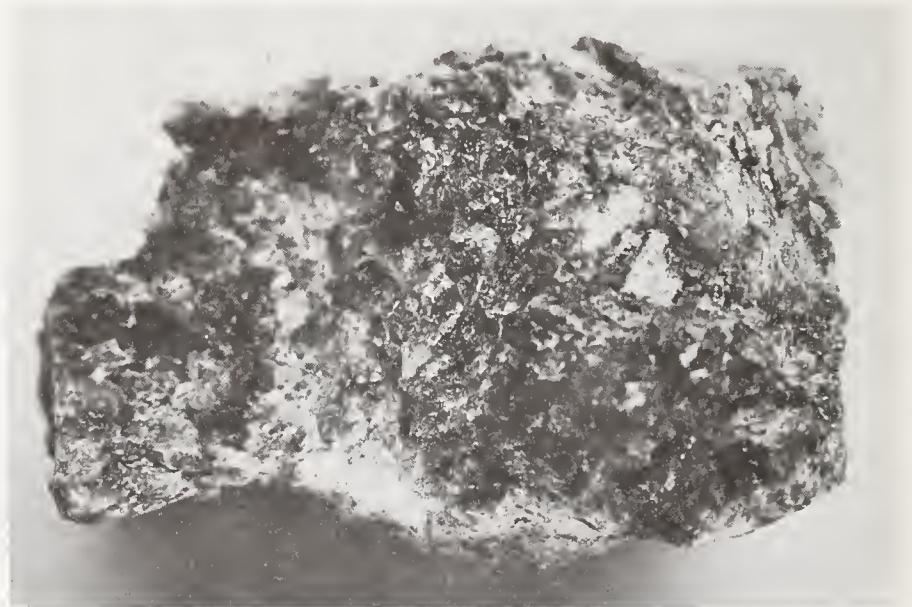

Figure 12. Prismatic anthophyllite with quartz: Bamble, Norway, 0.8X.



Figure 13. Crocidolite (fibrous riebeckite): South Africa, 0.57X.



Figure 14. Prismatic riebeckite (black) with quartz and feldspar:
St. Peter's Dome, El Paso County, Colorado, 1X.

For those samples which required beneficiation to produce the pure mineral separation techniques were chosen which would adequately liberate the desired phases and least adversely affect their purity. In order to conserve the selected mineral techniques were chosen which could be applied to material varying widely in size. The preliminary size reduction necessary for beneficiation and grinding of the fibrous amphiboles was accomplished using a rock saw with diamond-impregnated blades. For the nonfibrous amphiboles, a large mortar and pestle were fabricated from strongly magnetic stainless steels so that metals abraded from the equipment during crushing could be removed from the ground material using a magnet. All beneficiation steps were done before the final grinding to allow efficient use of the mineral extraction methods, which are severely limited if the particle size is too small. To avoid chemical alteration of the desired phases, beneficiation was generally limited to physical methods [7]. The final grinding was designed to produce nonfibrous materials which had a mass median aerodynamic diameter between 0.5 and 5.0 μm , and a maximum size of 10 μm . For the fibrous materials the desired median length was the range 2-10 μm , with a maximum length of 200 μm .

Beneficiation Methods

Simple, primarily physical methods of mineral extraction were employed. Three types of hand separation were used: (1) With a mason's hammer and chisels, the available specimen material was "high-graded" to obtain pieces with the greatest concentration of the desired phase; from these, the larger masses of impurities were cobbled. (2) The rock saw was used to cut cross-fiber vein materials into slabs one centimeter thick measured along the fiber length. The slabs were then chipped into small pencils of fibers for further beneficiation and/or preparation for milling. The saw was also used to cut wall rock from the margins of cross-fiber vein specimens of fibrous grunerite, anthophyllite and crocidolite. (3) Hand picking, or for ferromagnetic minerals a powerful hand magnet was used to remove small quantities of obvious contaminants at any stage in the size reduction procedure.

Only two beneficiation techniques were used in which mineral specimens were exposed to the risk of chemical alteration. Slow dissolution of carbonate minerals from specimens of tremolite and actinolite was accomplished by digestion in dilute ($\sim 3\text{ N}$) acetic acid. Bromoform and tetrabromoethane were used for density separations of quartz, micas, and other silicates from tremolite, cummingtonite and grunerite. After separation, the samples were rinsed repeatedly, with acetone or ethanol and then distilled water, to remove residues of the organic liquids.

Grinding Techniques

Research has shown that some grinding mechanisms degrade the crystalline structure of minerals, particularly asbestiform species, to a considerable degree. Shearing and cutting (in the sense of pinching) actions are reported to be very destructive to crystallinity [8]. Initial attempts in this program to grind asbestos in ball mills equipped with lifter bars confirmed this observation. Impact between air-suspended particles and/or impact of elongate fragments on cutting edges accomplished size reduction with much less reduction in crystallinity, as shown by x-ray diffraction studies. Therefore, grinding tests were made to identify milling devices which exploit the free impact principle and which could efficiently produce large quantities of respirable size particles.

For size reductions of fibrous amphiboles, a fiber mill (Retsch Ultracentrifugal-mill, Type ZM-1) was chosen. In this device a rotor with vertical pins at the periphery spins at 10,000 or 20,000 rpm impelling fibers outward against the perforated wall of the grinding chamber (sieve ring) on which cutting edges are angled toward the oncoming particles. The non-fibrous amphiboles were ground using a jet mill (Micron-master Jet Pulverizer) in which tangentially inward-directed jets of dry, filtered air (50 scfm at 90 psig) circulate the feed material in an annular grinding chamber. Size reduction is accomplished by impact between particles; the air stream minimizes particle contact with the walls of the grinding chamber. Additional advantages of the fiber mill and jet mill for this work are: (1) the carrying air stream controls heat build-up in the equipment

thereby reducing the risk of thermal degradation of the material being milled. (2) Virtually all particles are subjected to size reduction with each pass of material through the mill. (3) Each mill is provided with a cyclone collector, thus providing coarse and fine fractions. (4) The continuous processes permit efficient size reduction of kilogram quantities of fibrous and nonfibrous amphiboles to the specified size by iterative milling without additional size classification steps. Table 3 presents particle size distributions for fibrous and prismatic tremolite reduced to final size by the respective milling devices.

Table 3. Particle sizes^a of "reference" tremolite samples after grinding.

Fibrous (India)		Prismatic (New York)	
Size Range (μm)	Number Percentage	Size Range (μm)	Number Percentage
<2	37.4	<1	28.0
2-6	35.8	1-3	47.0
6-10	15.4	3-5	18.3
10-20	6.9	5-7	5.9
20-80	3.6	7-10	0.8
80-160	0.9	>10	0.0
>160	0		
3.1 μm Geometric Mean		1.7 μm Geometric Mean	

^a Particle sizes determined using optical microscopy. For fibrous tremolite, fiber length is reported; for prismatic tremolite, Feret's diameter.

Analytical Studies

Analytical studies have been initiated using two of the "reference" materials from this program, the fibrous and prismatic tremolite samples. In addition to these "reference" samples, which were processed by IITRI, and which were carefully characterized as to identity, source, and particle size, a number of samples from the NIOSH mineral collection were used. These samples were included in the analyses to allow comparisons of tremolite specimens from various sources and geographical locations to determine if general characteristics of tremolite specimens could be delineated by obtaining additional experimental data. The NIOSH specimens were ground in a SPEX freezer mill at liquid nitrogen temperatures, sieved through a 10 μm sieve, and sized using electron microscopy techniques. The ground material had a mean particle length or diameter of <3.0 μm . The following sections summarize the preliminary results obtained in the studies of tremolite.

Chemical Analyses

The relative iron, magnesium, and calcium content of several of the specimens used in these studies was determined in order to confirm the designation of these amphiboles as tremolite. To minimize contamination which could occur from contact with metallic surfaces during grinding, pieces of the hand specimens instead of ground material were used for the analyses. These pieces were dissolved by heating in a mixture of HF and concentrated HCl. Blind replicate analyses were done for each of the specimens using

atomic absorption spectrophotometry. The results (table 4) for the ratio (Fe + Mg : Ca) and the calculated weight percent FeO indicate that all of the samples fall within the empirical composition limits for tremolite [9], including a specimen previously identified as prismatic actinolite. In general, the specimens of fibrous tremolite contain more iron than the prismatic form although the South Korean sample of fibrous tremolite was an exception.

Table 4. Chemical analyses.

<u>Amphibole</u>	<u>Atom Ratio Fe : Mg : Ca</u>	<u>Atom Ratio Fe + Mg : Ca^a</u>	<u>Wt. % FeO</u>
Prismatic Tremolite			
Gouverneur, N.Y. ^b	1 : 205 : 78	5.3 : 2.0	0.21
South Dakota	1 : 44 : 21	4.3 : 2.0	1.03
Fibrous Tremolite			
Rajasthan, India ^b	1 : 13 : 6	4.7 : 2.0	2.87
Alaska	1 : 13 : 6	4.7 : 2.0	3.03
Korea	1 : 33 : 16	4.3 : 2.0	0.69
Italy	1 : 31 : 14	4.6 : 2.0	1.43
Prismatic Actinolite ^c			
South Dakota	1 : 15 : 7	4.6 : 2.0	2.63

^a Theoretical limit of ratio = 5:2.

^b "Reference" material, supplied by IITRI.

^c Classification based on color and location of source.

X-Ray Diffraction Studies

For the x-ray powder diffraction studies of the "reference" tremolites, both bulk powder samples (packed in cups) and thin layers on silver membrane filters were used. For the filter studies, homogeneous suspensions of known tremolite concentration in isopropanol were prepared using ultrasonic agitation to ensure dispersion. Aliquots of this suspension were filtered through 25 mm, 0.45 μ m pore size silver membrane filters. The calculated weight of tremolite deposited was confirmed by weighing, using a micro-balance. For both fibrous and prismatic tremolite the 310 and 110 peaks (3.14 Å and 8.38 Å, CuK α radiation) were step scanned to determine the integrated peak intensities. The calibration curves (figure 15) were prepared by plotting the net normalized integrated intensities of these peaks versus the amount of tremolite on the filters.

The data clearly indicate that quantitation of pure samples as small as 20 μ g is feasible. However, the ratios of the reflections, $I_{(110)}:I_{(310)}$, are different for filter deposits of fibrous and prismatic habits. The peak ratio (8.38 Å:3.4 Å) for prismatic tremolite is approximately 1.0 while that for the fibrous tremolite is approximately 0.40. Packed bulk samples of both tremolite habits give the same peak ratio, the value of which is 0.20. Information in the Powder Diffraction File [10] indicates a peak ratio of 1.0 for tremolite from St. Gotthard, Switzerland. The morphology is described as "white

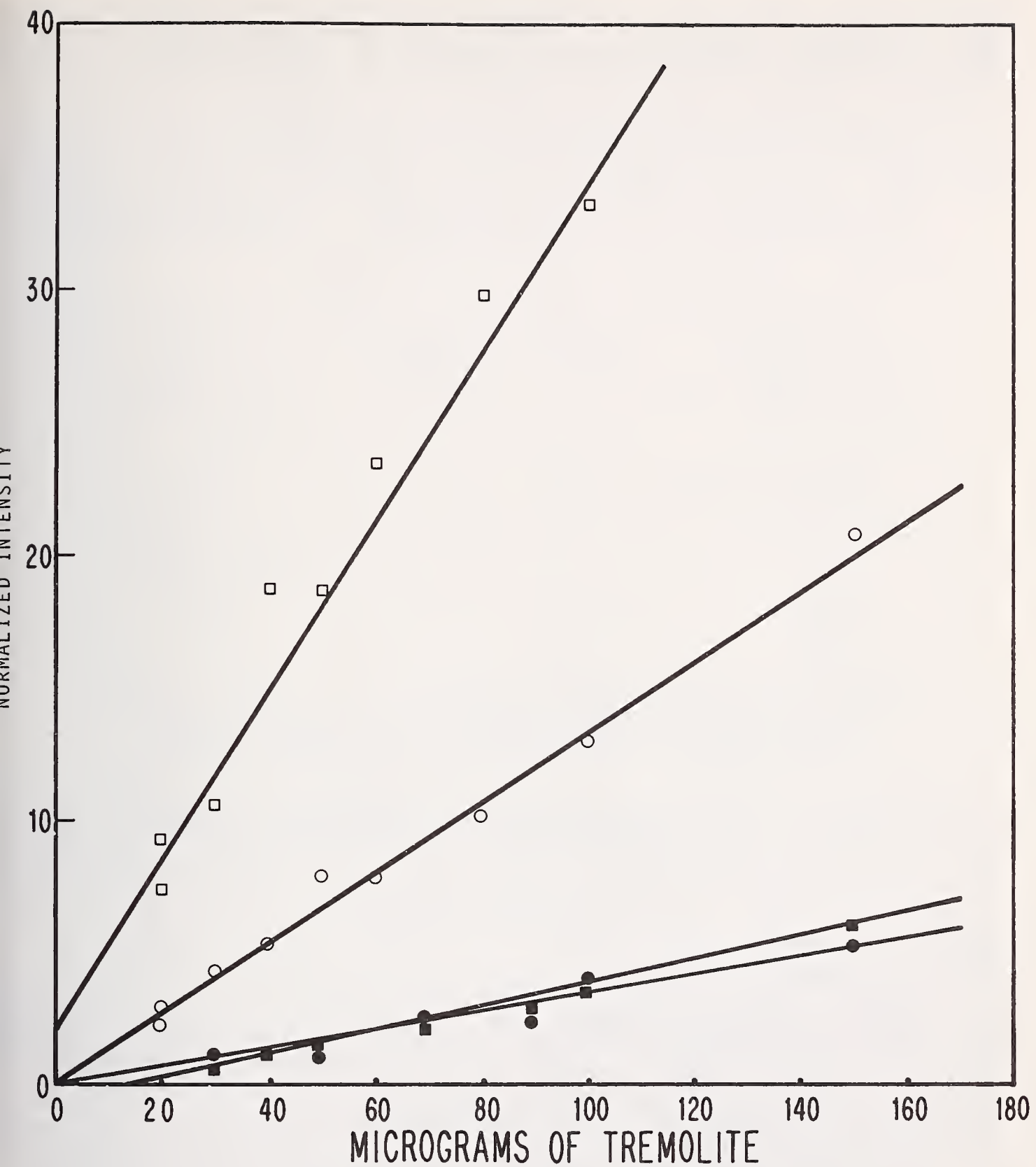

Figure 15. Calibration curves for fibrous and prismatic tremolite:
 Fibrous tremolite: □ 3.14 Å; ○ 8.38 Å
 Prismatic tremolite: ● 3.14 Å; ■ 8.38 Å

radiating fine fibrous masses," but the term "radiating" suggests it may be a prismatic form. Data obtained for specimens of tremolite from other geographical locations indicate that, for material deposited on filters, the samples of prismatic tremolite in general show a larger ratio for these peaks than do samples of fibrous tremolite (table 5).

Table 5. Ratio of XRD peaks observed for fibrous and prismatic tremolite.^a

<u>Amphibole</u>	<u>No. of Replicates</u>	<u>Ratio (8.38Å:3.14Å)</u>
Prismatic Tremolite		
Gouverneur, N.Y. ^b	7	1.04
South Dakota	5	1.08
Newburyport, Mass.	10	1.45
Fibrous Tremolite		
Rajasthan, India ^b	7	0.39
Alaska	10	0.55
Korea	5	0.35
Italy	5	1.25

^a 150 µg on 0.45 µm pore size silver filters.

^b "Reference" material, supplied by IITRI.

At this point no explanation can be advanced to account for the differences in peak ratios, although the effects observed may be due at least in part to preferred orientation of the particles in some or all of the samples. Regardless of the reason, the effect is seen for a variety of samples and for a wide range of filter loadings as demonstrated by the calibration curves. The distinctions observed using this technique may prove useful in analytical attempts to ascertain the type of material to which a worker is being exposed.

Thermal Analysis Studies

Preliminary differential thermal analysis (DTA) studies on tremolite samples have been completed. These studies included an evaluation of the feasibility of this technique for the quantitative analysis of tremolite and, while good calibration curves were obtained, DTA was not sensitive enough to detect microgram quantities of tremolite. The samples were heated in platinum cups to a temperature of 1150 °C at a heating rate of 10°/min in dry air flowing at 5.7 L/hr; the instrument was calibrated using SrCO₃, an NBS-ICTA Standard Reference Material.

In parallel with the XRD studies of the "reference" tremolite samples, differences between these samples (table 6) were observed during the thermal studies of fibrous and prismatic tremolite samples. These differences in peak position and the color of the decomposition product were observed for samples from other geographical locations as well as for the "reference samples." Similar differences were observed by IITRI for those specimens considered for selection as "reference" materials. All samples displayed the strong endotherm which is associated with the loss of structural water and the breakdown of the amphibole structure, which subsequently recrystallizes to a monoclinic pyroxene [11]. However, the data indicate that in general the fibrous tremolite samples dehydrate and recrystallize at a lower temperature than do the prismatic tremolite samples. This

behavior is analogous to that noted for serpentine, i.e., chrysotile loses structural water at a lower temperature than does antigorite [12]. Although it is recognized that differences in particle size, grinding techniques and experimental conditions can affect the position of a DTA peak [13], data obtained in both the NIOSH and IITRI laboratories are consistent in showing that the endotherm of fibrous tremolite is lower by approximately 50 °C than that of the prismatic tremolite. It was also observed that the pyroxenes formed from fibrous tremolite were always brown to tan in color while the pyroxenes formed from the prismatic tremolite were always white in color. However, XRD scans of the pyroxenes were virtually the same regardless of color or origin of the specimen and indicated that the final decomposition material was primarily diopside.

Table 6. Thermal analysis of tremolite.^a

<u>Amphibole</u>	<u>No. Samples</u>	<u>DTA^a Endotherm, °C</u>	<u>Color of Pyroxene</u>
Fibrous Tremolite			
NIOSH ^b	4	1026 ± 27	tan
IITRI	1	1002	not determined
Prismatic Tremolite			
NIOSH ^c	5	1078 ± 20	white
IITRI	4	1053 ± 11	white

^a NIOSH samples included those listed in Table 5 as well as two additional samples from the Gouverneur, N.Y. area; IITRI samples include those screened as potential "reference" materials.

^b Geometric mean particle length <3.0 µm.

^c Geometric mean particle maximum dimension <3.0 µm.

Summary and Conclusion

The analytical studies planned for the reference materials have been initiated using the tremolite specimens. These studies have indicated that x-ray diffraction may turn out to be an even more useful tool than expected. The detection limits obtained and the differences in peak ratios observed for samples of fibrous and prismatic tremolite on silver filters have potential for applications to analyses of hazardous, workplace contaminants.

The authors gratefully acknowledge the guidance and assistance received during this program from J. V. Crable of NIOSH and B. G. Woodland of the Field Museum.

References

- [1] Crable, J. V., Am. Ind. Hyg. Assoc. J., 27, 293 (1966).
- [2] Nenadic, C. M. and Crable, J. C., Am. Ind. Hyg. Assoc. J., 32, 539 (1971).
- [3] Timbrell, V., Gibson, J. C. and Webster, I., Int. J. Cancer, 3, 406 (1968).

- [4] Timbrell, V., "Pneumoconiosis. Proceedings Int. Conf.," Johannesburg, 1969, . 28-36.
- [5] Skikne, M. I., Talbot, J. H., and Rendall, R. E. G., Env. Res., 4, 141 (1971).
- [6] Deer, W. A., Howie, R. H., and Zussman, J., "Rock-Forming Minerals, Vol. 2, Chain Silicates," J. Wiley & Sons, N.Y., N.Y. 1963 p. 253.
- [7] Muller, L. D., "Laboratory Methods of Mineral Separation," CH. 1, in J. Zussman, ed., Physical Methods in Determinative Mineralogy, Academic Press, London & N.Y., 1967.
- [8] Ocella, E. and Maddalon, G., Med. Lavoro, 54 (#10), 628 (1963).
- [9] See, for example, Deer, W. A., Howie, R. A., and Zussman, J., "Rock-Forming Minerals, Vol. 2, Chain Silicates," J. Wiley & Sons, N.Y., N.Y. 1963, p. 251.
- [10] Powder Diffraction File. Joint Committee on Powder Diffraction Standards, 1601 Park Lane, Swarthmore, PA 19081.
- [11] Deer, W. A., Howie, R. H., and Zussman, J., "Rock-Forming Minerals, Vol. 2, Chain Silicates," J. Wiley & Sons, N.Y., N.Y. 1963, pg. 254.
- [12] Deer, W. A., Howie, R. H., and Zussman, J., "Rock-Forming Minerals, Vol. 3, Sheet Silicates," J. Wiley & Sons, N.Y., N.Y. 1962, pg. 180.
- [13] Martinez, E., Am. Miner., 46, 901 (1961).

Discussion

I. STEWART: Both DTA and x-ray diffraction are very sensitive to packing, and, of course, this can be related to shape. Did you do any tests to determine whether packing or repacking would change the relative ratios of peak heights or peak positions?

J. HAARTZ: No, we haven't.

STEWART: Or spinning the sample in x-ray diffraction perhaps?

HAARTZ: The relative ratios of the peaks in x-ray diffraction were the same for the bulk samples. For the samples that were deposited on a silver filter, that is a very thin layer; we did see the differences in the peak ratios. This was the case not only with samples of different origins, but with a great many replicas of the same material.

STEWART: I see. So, it was purely the fact that it was fibrous, you think? I didn't quite catch what you meant by your bulk sample. By bulk, I was equating that with "massive." You mean a bulk fiber sample.

HAARTZ: By a bulk sample, I mean a milligram or more, of either the massive or fibrous, showed the same diffraction pattern: identical. When these samples are deposited as a thin layer on a silver membrane filter and the pattern taken, we do see differences in the peak ratios.

ASBESTIFORM MINERALS IN INDUSTRIAL TALCS:
COMMERCIAL DEFINITIONS VERSUS INDUSTRIAL HYGIENE REALITY

John M. Dement

U.S. Department of Health, Education and Welfare
Public Health Service, Center for Disease Control
National Institute for Occupational Safety and Health
Division of Surveillance, Hazard Evaluations and Field Studies
Cincinnati, Ohio 45226

Abstract

As part of its industry-wide study of the talc industry, the National Institute for Occupational Safety and Health (NIOSH) has conducted Detailed industrial hygiene studies of mine and mill operations processing talcs contaminated with asbestiform minerals. The principal analytical method used for studies of asbestiform minerals in talc bulk samples and airborne dust samples is analytical transmission electron microscopy utilizing selected area electron diffraction and microchemical analysis for fiber identification. This presentation includes a discussion of the methods of analysis being used by NIOSH and comparisons of results of analysis with other analytical techniques. Also included are results of NIOSH industrial hygiene studies in asbestiform talc operations and comparisons of airborne fiber characteristics (fiber length, diameter, aspect ratios, etc.) in these operations with other industrial processes using asbestos fibers.

Key Words: Amphiboles; anthophyllite, asbestiform minerals; industrial talc; occupational health; tremolite.

Introduction

The mineral talc is a pure hydrous magnesium silicate $Mg_6(Si_8O_{22})(OH)_4$ which has a theoretical chemical composition of 63.5 percent SiO_2 , 21.7 percent MgO , and 4.8 percent H_2O [1,2]¹. However, this ideal chemical structure is rarely found in nature due to ionic substitution in the talc structure and due to common association with other minerals such as tremolite, anthophyllite, calcite, magnesite, quartz, dolomite, diopside, and serpentines (chrysotile, antigorite, and lizardite) [1,2]. Most talcs, as mined, are associated with varying proportions of some of these minerals [1] and sold as industrial talcs. In 1974 over 1.4 million short tons of talc were produced in the United States with major uses being in ceramics, elastomers, foundry facings, insecticides, paints, paper, roofing and toilet preparations [3].

The National Institute for Occupational Safety and Health (NIOSH) in cooperation with the Mining Enforcement and Safety Administration has underway an industry-wide study of the talc mining and milling industry. These studies include both epidemiological studies of exposed worker populations to determine health effects which may be attributed to occupational exposures and detailed industrial hygiene studies to characterize the various agents to which workers have been exposed.

¹Figures in brackets indicate the literature references at the end of this paper.

Since many talc deposits contain asbestiform amphiboles and in some cases chrysotile (a serpentine), a large portion of the NIOSH environmental studies is directed toward determining mineral fiber exposure patterns and characteristics. For such studies, the primary method used is analytical transmission electron microscopy. This report includes a description of the equipment and procedures used by NIOSH for its environmental studies of industrial talc exposures and results of industrial hygiene studies in a talc mine and mill producing talcs containing asbestiform amphibole minerals. Also discussed are commercially employed definitions of what constitutes asbestos and the relationship of these definitions to observed industrial asbestos exposure characteristics.

Analytical Methods

Equipment

A number of methods are available and have been used to identify and quantitate asbestos concentrations in environmental samples. These methods include x-ray diffraction, differential thermal analysis, phase contrast and bright field optical microscopy, petrographic microscopy, scanning electron microscopy, and transmission electron microscopy. Each of these methods have certain advantages and disadvantages [4,5]. However, many researchers today consider analytical electron microscopy to be the method of choice for studies of occupational and environmental asbestos exposures.

For NIOSH studies of industrial talc exposures, analytical transmission electron microscopy is employed along with other standard mineralogical techniques such as x-ray diffraction and petrographic microscopy. The analytical system consists of a combination transmission-scanning electron microscope with a side entry stage equipped with an energy dispersive x-ray detector which is fitted through a port in the microscope column parallel to the specimen holder. The specimen-to-detector distance is approximately 10 mm with the specimen tilted 39 degrees to the electron beam for optimum x-ray collection. The energy dispersive x-ray detector has an actual energy resolution of less than 170 electron volts, and spatial resolutions of less than 0.5 micrometers are easily realized. This combination of analytical instrumentation permits visual characterization of particulate morphology such as fiber shape, length, and diameter as well as fiber identification using both selected area electron diffraction and x-ray microchemical analysis. In addition, surface topography may be further studied with this instrument by use of the scanning mode of operation using secondary electron images.

Procedures

Either bulk quantities of materials of interest, such as talcs, or environmental samples collected on membrane filters are routinely analyzed. The majority of samples studied consists of airborne particulates collected in industrial operations for the purpose of determining occupational exposure patterns. These samples are routinely collected on Millipore AA, 37 mm diameter membrane filters at sample rates of 1.5-2.0 liters per minute. Sample durations may vary from 15 minutes in very dusty operations to six hours for operations with little visible dust.

The method presently used by NIOSH for preparation of membrane filter samples for electron microscopic analysis is a modification of a direct clearing method first described by Ortiz and Isom [6]. The NIOSH method has been described in detail elsewhere [4]. Briefly, this method consists of the following steps:

1. A section of the membrane filter is cut with a cork bore (8 mm diameter) or a scalpel. This section is removed and placed sample side up on a clean microscope slide with the edges fastened to the slide with either a gummed binder ring or tape.
2. The slide assembly containing the sample is placed in a glass petri dish on top of four Whatman filters which have been saturated with acetone and covered. The acetone vapors destroy the microporous structure of the filter by slow dissolution, producing a fused, microscopically smooth surface on

the sample side of the membrane filter. A 10-minute fusion time has been found to be generally acceptable for Millipore AA filters.

3. After fusion of the filter surface, the slide assembly is placed in a vacuum evaporator on a rotary stage where the sampled side of the filter receives a fairly heavy ($\sim 200 \text{ \AA}$) carbon coat. This carbon coat aids in retaining particles during subsequent filter dissolution and also provides for greater thermal stability during microscopic examination.
4. The final step is dissolution of the membrane filter and deposition of the particles onto electron microscope grids. A modified Jaffe Wick method is used whereby four Whatman filter papers are saturated with acetone. Two-hundred mesh carbon filmed grids are used and the coated filters are placed sample side down on them. The petri dish is then covered. Complete filter dissolution takes 8 to 16 hours. Acetone is replaced as necessary.

Using this method, many filters may be prepared as a "batch". Particle losses have been low and estimated at less than 10 percent [6].

Samples prepared by the preceding method are analyzed using analytical transmission electron microscopy whereby three pieces of data are gathered and used to identify each fiber (3 to 1 aspect ratio particles) observed. These include: (1) visual identification of single fiber electron diffraction patterns, (2) visual identification of semiquantitative elemental analysis spectra using x-ray microchemical techniques, and (3) observation of morphological characteristics, such as diffraction fringes, which may aid in identification. In addition, fiber length and diameter are also recorded. For most studies an accelerating voltage of 100 kilovolts is used with a screen magnification of approximately 17,000X. Beam currents are usually fixed at 100 microamps (not to be confused with specimen current).

Fiber concentrations are estimated using the average grid opening area as the calibrated counting area. To optimize statistical accuracy of the analysis while keeping analysis time to acceptable limits, 10 grid openings or 50 fibers are analyzed for each sample with a minimum of 5 grid openings. Analysis times range from 90 minutes to 3 hours per sample. Using this counting criterion for a typical 90 minute sample collected at 2 liters per minute, the lower limit of detection is estimated to be less than 0.1 fibers/cc. Precision and accuracy estimates from studies of the NIOSH phase contrast method [7] are considered generally applicable with a coefficient of variation of approximately ± 25 percent for most samples.

Environmental Studies of Talcs Containing Asbestiform Minerals

Methods

As previously mentioned, a large portion of the NIOSH industry-wide study of the talc industry involves industrial hygiene studies of worker exposures, including exposures to asbestiform minerals. One such operation recently studied involved a mine and mill producing industrial talcs certified by the mining concern to be free of asbestos. Apparently, the prime analytical methods relied upon by this company to conclude that its products were asbestos free were gross methods such as observation with a common hand lens or at best low power stereomicroscopy both of which were claimed to be sufficient and proper mineralogical techniques.

In order to evaluate these claims, a detailed industrial hygiene study was conducted at the mine and mill in question to evaluate worker exposures using best available sampling and analytical technology. Although a number of different sampling and analysis methods were employed, only results of the fiber samples are presented in this report.

In order to evaluate fiber exposures and exposure characteristics, personal, breathing zone samples were collected from workers in the mine and mill using 37 mm diameter, Millipore AA membrane filters operated at a flow rate of 1.7 liters per minute. Sample

filters were changed periodically throughout the work shift to prevent filter overloading. During the study, more than 220 such samples were collected and used to determine both peak and time-weighted-average exposures. All samples were analyzed for fiber concentrations (>5 µm) using the standard phase contrast method recommended by NIOSH [7].

In addition, approximately 15 percent of these samples were analyzed by the electron microscopic methods previously described.

Results

Results of the fiber concentrations in the mine and mill as determined by phase contrast optical microscopy are shown in Table 1. Highly elevated fiber concentrations were observed in both mine and mill operations with time-weighted-average exposures ranging from 0.8 to 9.8 fibers >5 µm/cc in the mine and 0.2 to 16.0 fibers >5 µm/cc in the mill. Peak exposures as high as 29.1 fibers >5 µm/cc were observed.

Table 1. Summary of fiber exposures in talc mine and mill operations as determined by optical microscopy.

Operation	- - - - - Fiber Concentrations (fibers >5 µm/cc) - - - - -			Highest Peak Conc. Observed
	Time-Weighted Averages			
	Mean ± SE	Median	Range	
Mine (N=54)	4.5 ± 0.8	4.4	0.8- 9.8	18.2
Mill (N=168)	5.0 ± 0.5	4.3	0.2-16.0	29.1

N = Number of individual samples collected SE = Standard Error

Time-Weighted averages represent full shift determinations

While the above fiber concentrations, determined by phase contrast microscopy, may include some fiber types other than asbestos (e.g., talc "fibers"), they nevertheless represent minimum estimates of true exposures to asbestiform minerals as most asbestiform fibers are less than 5 µm in length and, in addition, some fibers, although longer than 5 µm, may escape detection due to resolution limits of optical microscopy. These facts are demonstrated in Table 2, which show concentrations of positively identified asbestiform mineral fibers as determined by electron microscopy. Time-weighted-average exposures were found to range from 9.5 to 25.0 fibers/cc in the mine and 7.3 to 102.7 fibers/cc in the mill. The highest concentration observed on a single sample was 102.7 fibers/cc.

Table 2. Summary of asbestiform mineral fiber exposures in talc mine and mill operations as determined by electron microscopy.

Operation	- - Fiber Concentrations ^a (fibers (all lengths)/cc) - -			Highest Peak Conc. Observed
	Time-Weighted Averages			
	Mean ± SE	Median	Range	
Mine (N=8)	16.4 ± 0.9	15.3	9.5- 25.0	25.0
Mill (N=19)	30.0 ± 1.4	24.1	7.3-102.7	102.7

N = Number of air samples randomly chosen and analyzed by electron microscopy

SE = Standard Error

^a Concentrations reported include only those fibers positively identified as one of the asbestos minerals by analytical electron microscopy.

A typical electron photomicrograph of fibers in these operations is shown in figure 1 demonstrating the fibrous morphology of these particulates. The asbestiform habit of many of these fibers is evidenced by the "fiber bundle" effect. Results of the electron diffraction and microchemical studies on these fibers clearly demonstrated the presence of two amphibole fiber types; these being tremolite and anthophyllite. Analytical data for typical tremolite and anthophyllite fibers are shown in figures 2 and 3, respectively. The anthophyllite is seen to be low in iron content.

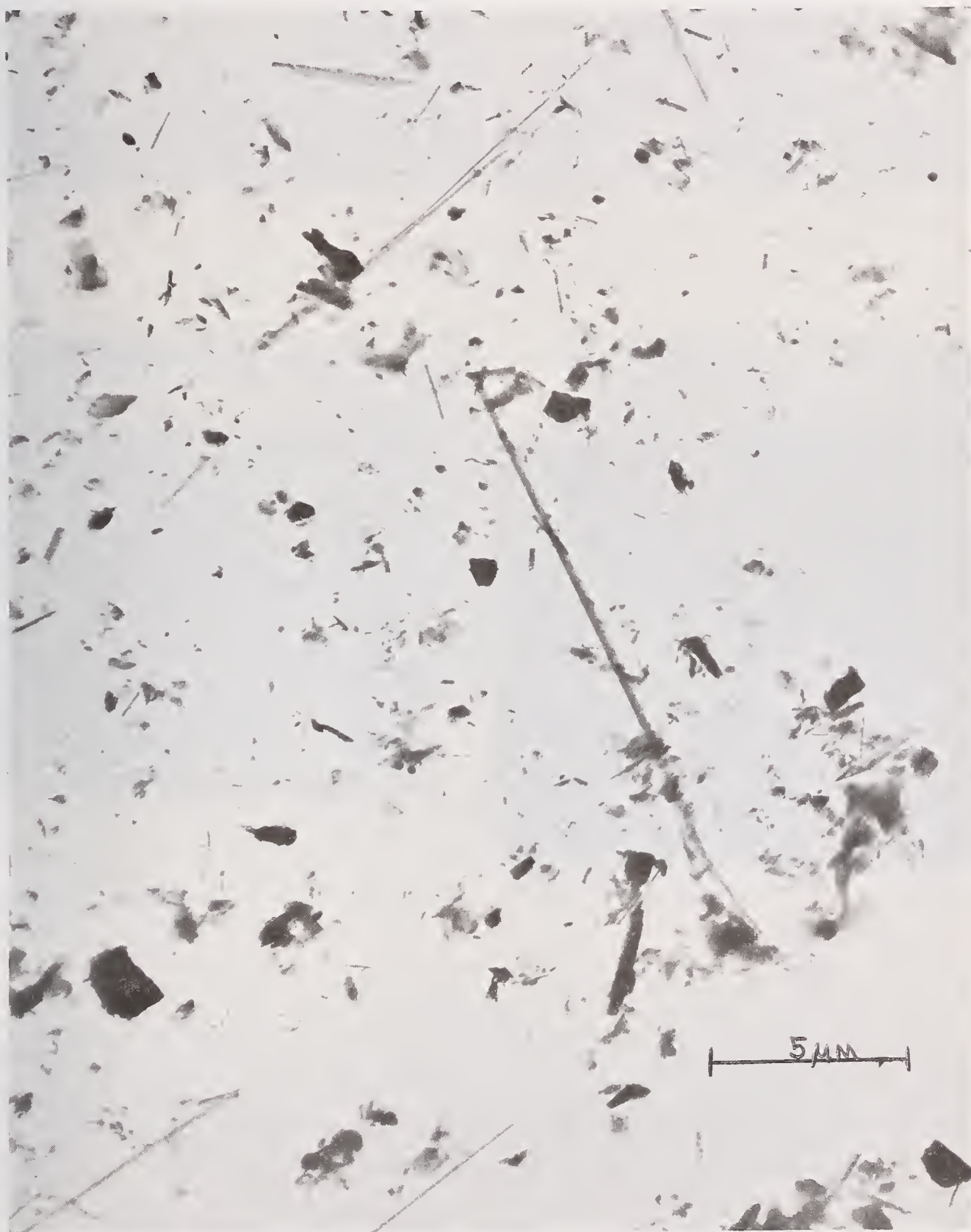
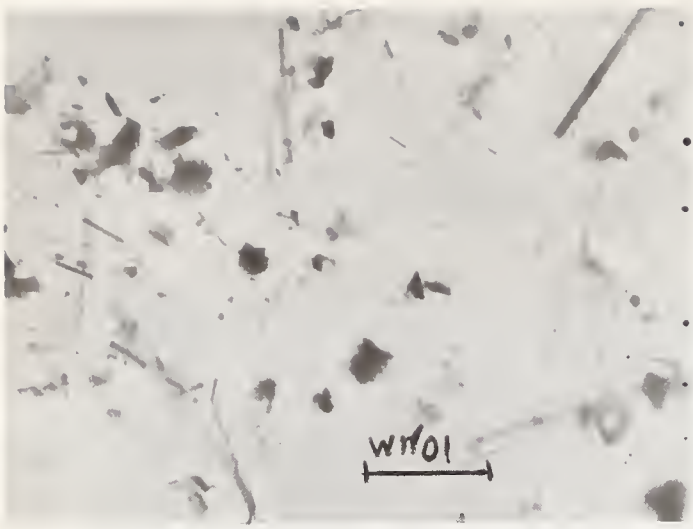

Figure 1. Electron photomicrograph of particles in talc certified as asbestos-free.



Electron photomicrographs



Diffraction pattern

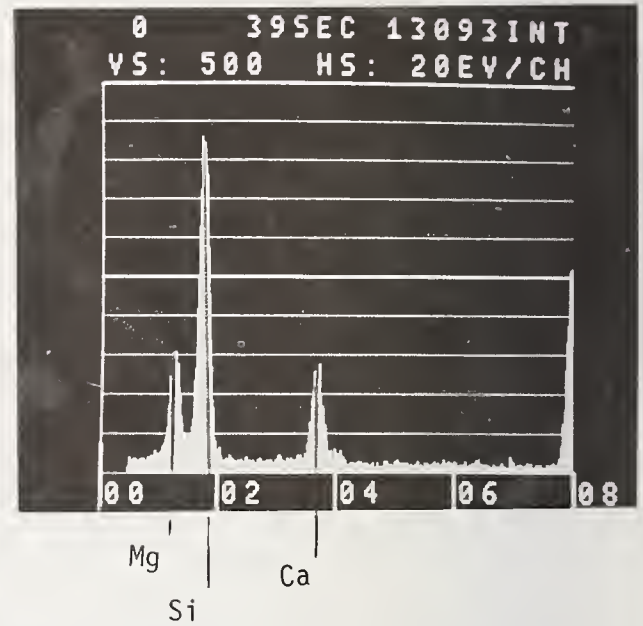

X-ray spectrum

Figure 2. Analytical data for tremolite fibers in talc certified as asbestos-free.

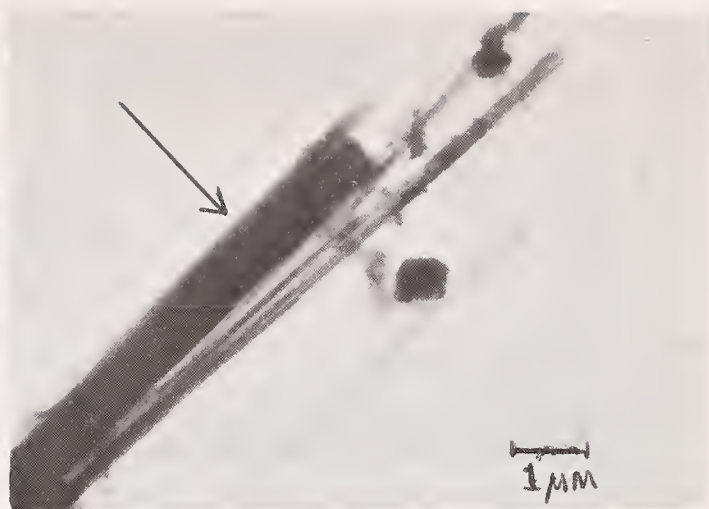
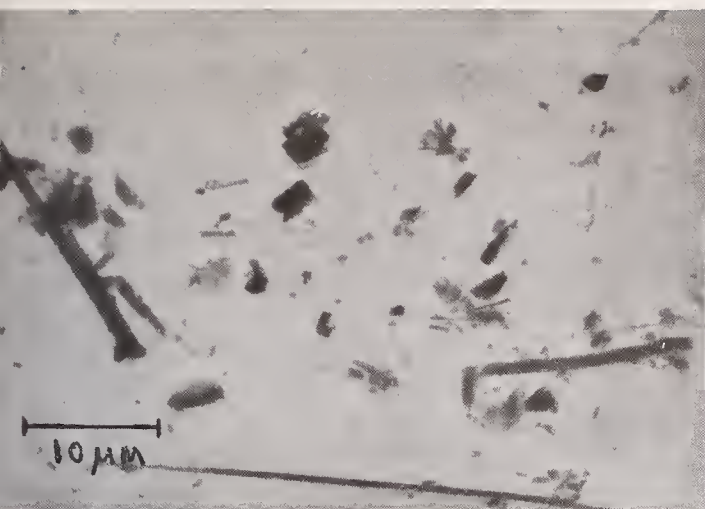

Electron photomicrographs



Diffraction pattern

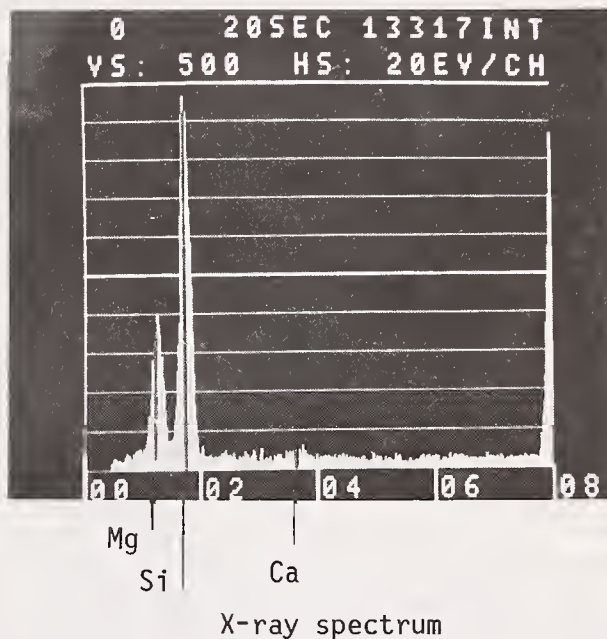

X-ray spectrum

Figure 3. Analytical data for anthophyllite fibers in talc certified as asbestos-free.

Tabulations of results of the fiber identification studies by electron microscopy are shown in Table 3. Of all airborne fibers (3:1 aspect ratio particles), 12-19 percent and 38-45 percent were found to be tremolite and anthophyllite, respectively, while 38-39 percent remained unidentified due to unrecognizable diffraction patterns. Tremolite fibers were observed to be generally shorter in length than anthophyllite fibers as demonstrated in Table 3 when only fibers longer than 5 μm were considered. Only 7 percent of the fibers longer than 5 μm were identified as tremolite whereas 65 percent were anthophyllite. This may also be observed in Table 4 where summary statistics of fiber length are given. While all median fiber lengths were found to be similar and not statistically different, the proportion of anthophyllite fibers longer than 5 μm in length was significantly ($P < 0.05$) greater than tremolite (8-10% for anthophyllite versus only 3% for tremolite).

Table 3. Summary of airborne fiber types in talc mine and mill operations as determined by analytical electron microscopy.

Fiber Length	Percent of all Airborne Fibers ^a			
	Tremolite	Anthophyllite	Nonasbestos	Not Positively Identified
All Fibers	12-19	38-45	1-2	38-39
Fibers \geq 5 μ m	7	65	3	25

^a Total number of fibers analyzed was approximately 1850.

Table 4. Summary of airborne fiber lengths for positive amphiboles in talc mine and mill operations as determined by electron microscopy.

Operation and Fiber Type	Median Length μ m	Geometric Standard Deviation	% \leq 5 μ m in Length
<u>Mine</u>			
Tremolite (N=83)	1.6	1.8	97
Anthophyllite (N=164)	1.5	2.6	90-92
<u>Mill</u>			
Tremolite (N=160)	1.5	1.9	97
Anthophyllite (N=687)	1.4	2.9	90

N = Number of individual fibers analyzed

Inasmuch as the NIOSH recommended phase contrast counting method defines countable fibers only on the basis of fiber length and aspect ratio, much controversy has arisen with various industrial and mining groups claiming that this liberal criterion would define many mineral fragments as being asbestos. In this regard, fiber aspect ratios for positively identified amphibole fibers in the talc mine and mill under study are shown in Table 5 for all fiber lengths, and similar data for fibers longer than 5 μ m are given in Table 6. These tables demonstrate that anthophyllite fibers in these talcs have larger aspect ratios than tremolite fibers and by comparison of Tables 5 and 6, aspect ratios increase with fiber length. Of interest is the fact that less than two percent of the positively identified amphiboles longer than 5 μ m in length had aspect ratios 5 to 1 or smaller.

Table 5. Aspect ratios (length to width) for airborne amphibole fibers (all lengths) in mine and mill operations as determined by electron microscopy.

Fiber Type	Median Ratio	% \leq 5 to 1	% \leq 10 to 1
Tremolite (N=164)	7.5	23-24	70
Anthophyllite (N=687)	9.5	15-17	70

N = Number of individual fibers identified and sized

Table 6. Aspect ratios (length to width) for airborne fibers $\geq 5 \mu\text{m}$ in length in mine and mill operations as determined by electron microscopy.

Fiber Type	$\% \leq 5 \text{ to } 1$	$\% \leq 10 \text{ to } 1$
Positively Identified Amphiboles	<2	37-38
Non-Asbestos or Unidentified Fibers	18	80

Approximately 1850 fibers analyzed

Discussion

Results of an industrial hygiene study of talc operations producing industrial talcs certified by the company under study to be asbestos free have been presented. Contrary to claims of this company that its products do not contain asbestos, this study demonstrated excessive exposures to airborne fibers of which more than 70 percent of the fibers $>5 \mu\text{m}$ in length could be identified as positive asbestiform amphiboles by best available analytical techniques. Repeated requests have been made of this company to clarify analytical methods and definitions of asbestos used to arrive at the conclusion that its products were free of asbestiform minerals. Apparently, the analytical method used was observation of hand ore specimens with a hand lens or, at best, use of low power stereomicroscopy. The definition of "asbestos" employed is less clear. Apparently the definition used is one which might best be termed a "commercial definition"; that is, in order for an amphibole to be considered to be asbestos it must have commercial value due to its fibrous shape.

This same company also operates another nearby talc mine and mill producing talc products which the company acknowledges as containing anthophyllite asbestos and labels these products with the warning required by the Occupational Safety and Health Administration. The determination made by the company that these talcs should be labeled was again based on macroscopic observation of hand specimens.

Having observed such elevated exposures as were presented in this report in operations considered by this company to be "asbestos free", it would seem logical to evaluate airborne fiber characteristics in this other operation acknowledged as containing asbestos. Such a study has been conducted using 10 airborne dust samples collected by the Mining Enforcement and Safety Administration during a 1975 survey. These samples were analyzed by identical electron microscopic methods which have been previously described and results are given in Table 7 along with comparisons with the other mine and mill operations producing products certified to be "asbestos free".

Table 7 clearly demonstrates that all airborne fiber characteristics between these two operations are remarkably the same. In fact, the mine and mill producing "certified" talcs were found to have a statistically ($P < 0.05$) significantly higher proportion of positive amphiboles based largely on a higher tremolite fiber content.

Considerations for what constitutes an "asbestos fiber" from an industrial health point of view warrants further discussion. Many researchers continue to promote unusable definitions based on the microscopic world whereas microscopic mineral fibers are of real concern for the health scientist. The data shown in Tables 4 and 7 demonstrate that more than 90 percent of all airborne amphibole fibers in the talc operations studied were shorter than $5 \mu\text{m}$ in length. Some individuals might argue that these fibers were mineral fragments and not "asbestos", however, it must be pointed out that all industrial operations using or processing asbestos generate airborne fibers similar to those seen in this study. This fact is demonstrated in Table 8 which compares airborne fiber lengths in various operations.

Table 7. Comparison of airborne fiber characteristics between two operations of the same company, one producing asbestos talcs and the other producing talcs certified by the company as asbestos free.

Airborne Fiber Characteristics	Mine and Mill Producing Labeled Talcs	Mine and Mill Producing Unlabeled Talcs	Statistical Significance
Proportion Positive Amphiboles	0.50	0.58	P<0.05
Proportion Anthophyllite	0.47	0.45	NS
Proportion Tremolite	0.03	0.13	P<0.001
Median Fiber Length			
Anthophyllite	1.61 μm	1.45 μm	NS
Tremolite	--- ^a	1.55 μm	--
Median Fiber Diameter			
Anthophyllite	0.16 μm	0.13 μm	NS
Tremolite	--- ^a	0.19 μm	--
Median Fiber Aspect Ratio			
Anthophyllite	9.9	9.5	NS
Tremolite	--- ^a	7.5	--
% of Fibers $\leq 5 \mu\text{m}$ in Length			
Anthophyllite	92	90-92	NS
Tremolite	--- ^a	97	--

^a Insufficient number of fibers observed for calculation of size distribution.

NS = Not significantly different at 0.05 level

Table 8. Comparison of airborne fiber length distribution in various asbestos operations.

Operation	Fiber Type	Median Length	% $\leq 5 \mu\text{m}$
Textile ^a fiber preparation and carding spinning, twisting, weaving	chrysotile	1.4	4
		1.0	2
Friction ^a mixing finishing	chrysotile	0.9	2
		0.8	2
Asbestos-cement pipe ^a mixing finishing	chrysotile	0.9	2
		0.7	1
Study Talc Mine and Mill	tremolite and anthophyllite	1.4 to 1.6	3-10

^a Taken from reference 8.

Conclusions

Based on the preceding discussion, the following conclusions are drawn.

1. Commercial definitions of asbestos, whereby asbestos fibers are defined on a microscopic scale, have little or no relevance to actual airborne fiber exposures where fibers of microscopic scale are of concern. Furthermore, those mineralogical or geological methods such as examination of ore specimens with a hand lens or low power microscopy are of limited value for routine identification of asbestiform mineral contamination in minerals or mineral products.
2. Users of products containing asbestos have a right to know that they have potential for exposures to asbestos or asbestiform minerals such that proper precautions may be taken to eliminate or reduce exposures. Producers of these products have an obligation to provide these data based on appropriate analytical techniques. Regulatory agencies must insist that appropriate techniques be employed and monitor results.
3. Inasmuch as considerable quantities of data are available suggesting that many fibrous materials may be biologically active [8], consideration should be given for establishing exposure standards for "mineral fibers" as a class of materials with similar health effects. The lives and health of American workers, America's most valuable resource, should not be compromised while the health scientist and the mineralogist disagree over definitions. As Dr. Paul Kotin of the Johns-Manville Corporation stated so well at this conference, the body has not read the asbestos regulations to decide which fibers should cause a biological response. Similarly, neither has the body read a mineralogy text to determine which particles of fibrous minerals should be considered "asbestos" or only mineral fragments.

References

- [1] Rohl, A. N. and Langer, A. M., Identification and qualitative of asbestos in talc, Env. Health Persp. 9, 95-109 (1974).
- [2] Stanley, H. D. and Norwood, R. E., The detection and identification of asbestos and asbestiform minerals in talc in Proceedings of the Symposium on Talc, U.S. Bureau of Mines, Washington, D. C., May 8, 1973.
- [3] Minerals in the U.S. Economy: Ten Year Supply - Demand Profiles for Mineral and Fuel Commodities (1965-74), United States Department of Interior Bureau of Mines (1975).
- [4] Zumwalde, R. D. and Dement, J. M., Review and Evaluation of Analytical methods for Environmental Studies of Fibrous Particulate Exposures, DHEW (NIOSH) Publication No. 77-204, May (1977).
- [5] Keenan, R. G. and Lynch, J. R., Techniques for the detection, identification and analysis of fibers, Amer. Ind. Hyg. J., 31, 587-597 (1970).
- [6] Ortiz, L. W. and Isom, B. L., Transfer technique for electron microscopy of membrane filter samples, Amer. Ind. Hyg. Assoc. J., 423-425 (1974).
- [7] Leidel, A. L., Bayer, S. G., and Zumwalde, R. D., USPHS/NIOSH Membrane Filter Method for Evaluating Airborne Asbestos Fibers, NIOSH, November (1975).
- [8] Dement, J. M., Zumwalde, R. D., and Wallingford, K. M., Asbestos fiber exposures in a hard rock gold mine, Ann. N.Y. Acad. of Science, 271, 345-352 (1975).

Discussion

NOTE: Discussion of this paper was included in the General Discussion at the end of this session.

THE DETECTION AND IDENTIFICATION OF ASBESTOS AND ASBESTIFORM MINERALS IN TALC

Harold D. Stanley

Pfizer Inc., MPM Division¹
Easton, Pennsylvania 18042

Abstract

Concern with the health hazards associated with the presence of chrysotile asbestos and/or the asbestiform minerals in talc has prompted widespread investigation of methods of analysis which would be consistent with good analytical practices. Of all the currently available techniques examined and evaluated, the two most reliable have been found by us to be Step Scanning X-ray Diffraction and Transmission Electron Microscopy (TEM), with Selected Area Electron Diffraction (SAED). The Step Scanning X-ray Diffraction technique allows quantitative detection and identification of tremolite and the asbestiform minerals down to 0.1 percent by weight. In the absence of chlorite it can detect and quantitatively determine chrysotile asbestos at the 0.5 percent level. Chlorite, however, is often associated with talc ore bodies. When present, chlorite will mask most of the main x-ray diffraction peaks of chrysotile. Additionally, the x-ray diffraction technique cannot distinguish between fibrous and non-fibrous forms of the asbestiform minerals. TEM is ideally suited to determinations of this type because of its high resolution and magnification capabilities, the morphological nature of the problem, and the mineralogical identification capability through SAED.

Key Words: Asbestiform; asbestos; chrysotile; detection; fiber; identification; light microscopy; selected area electron diffraction; talc; transmission electron microscopy; tremolite; x-ray diffraction.

Introduction

The pneumoconiotic and cancer-inducing health hazards of exposure to the asbestos and asbestiform minerals sometimes found associated with talc have been appropriately identified by recent research, the mass media publications [1-8]², and the papers heard earlier today. Because of Pfizer's position as a supplier of talc to many industries, we felt that a reliable method of detecting and identifying asbestos and asbestiform minerals possibly present in talc had to be developed. Prior to 1970, we were looking for just such a method.

Previous investigators had addressed themselves to the problem of identifying asbestos in bulk form or in airborne samples. We concerned ourselves with detecting and identifying the various forms of asbestos in the bulk talc matrix. As we were to later discover, this is indeed a hostile environment for the analyst.

¹Now with Degussa Corp., Rt. 46 at Hollistor Rd., Teterboro, N.J. 07608.

²Figures in brackets indicate the literature references at the end of this paper.

Our goals were:

1. Identifying the mineralogy of our products, specifically, that of our talcs.
2. The unambiguous determination of the crystal habit and crystal structure of the mineralogical species present.

Ideally, we were looking for a technique that would be simple and direct, but above all, it was mandatory that the technique be positive and unambiguous. The mineralogical and chemical nature of talc and that of the amphiboles or asbestiform minerals and chrysotile have been adequately described previously at this session. Currently available methods and methodology for detecting asbestos, tremolite, and the asbestiform minerals in the presence of talc were reviewed. Types of analyses which we tried included the following:

1. Infrared spectroscopy
2. Thermal analysis including TGA and DTA
3. X-ray diffraction
4. X-ray fluorescence
5. Adsorption from solution
6. Light microscopy including phase contrast, interference contrast, polarized light, and dispersion staining
7. Electron microscopy including transmission electron microscopy and scanning electron microscopy

After initial investigation, the three most likely candidates were:

1. Light microscopy
2. X-ray diffraction
3. Transmission electron microscopy

In order to determine which of the above would meet all criteria for the test, we secured samples of pure talc and tremolite from various deposits owned by Pfizer. Samples of pure and carefully characterized asbestos minerals were obtained from the International Union Against Cancer, (UICC), Pneumoconiosis Research Unit, Llandough Hospital, Penarth Glamorgan, United Kingdom. The talcs and asbestiform minerals were examined in the pure or as-received state, their characteristics noted and mixtures made to determine if detection of asbestos minerals was possible at low levels and, if so, what the minimum detection levels might be.

Experimental

X-ray diffraction patterns were obtained for all the minerals and mixtures used in this study employing the conventional technique of scanning at rates of 0.5 to 1.0 degrees 2 theta per minute. The samples were then subjected to scrutiny by optical and electron microscopy. During this procedure it was discovered that certain mixtures and mineral species shown to be free of asbestiform minerals by the conventional x-ray diffraction and light microscopy techniques exhibited fairly large percentages (5% or more) of fibrous tremolite and/or asbestiform minerals when viewed by transmission electron microscopy. Delineation of the reasons for this paradox enabled us to develop reliable techniques for detecting tremolite and the asbestiform minerals at the 0.2 percent level in most talcs by x-ray diffraction. Even lower levels of these minerals are detectable by transmission electron microscopy.

Light Microscopy

Techniques employing the optical microscope have been used to identify mineral specimens for a long time. Techniques that we have examined include polarized light microscopy, transmission light microscopy, phase contrast, and dispersion staining. The difficulty which we encountered in applying these techniques to the problem at hand is that while they work well with pure samples of fairly massive fiber length (3 to 5 microns

and larger), observations by transmission electron microscopy have shown that naturally occurring asbestiform minerals often lie below the working resolution of the light microscope. While massive fiber bundles can often be observed by either light or electron microscopy, the observation of individual fibers smaller than approximately 1 micrometer long by 0.02 micrometers wide requires the high resolution capability of the transmission electron microscope. In addition, the limit of detection is confounded by the presence of "apparent fibers" formed when thin talc plates curl up at the edge and roll into a cylindrical morphology. The limit of positive detection and identification of fibers is felt by us to be too high to be of any commercial value.

X-ray Diffraction

The d-spacings for talc, chlorite, tremolite, and the asbestiform minerals are seen in Table 1. The values given in Table 1 are averaged for pure materials and can shift as much as ± 0.02 to ± 0.03 nanometers depending upon sample preparation, the level at which the constituent is found in the parent matrix, and the specimens conformity to the idealized chemical composition. While attempting to detect tremolite and the asbestiform minerals in talc at concentrations of two to five percent or below, we found that the normal scanning rate of 0.5 to 1 degree 2 theta per minute was not satisfactory for the following reasons:

1. The noise level was too high providing a detection limit of only a few percent.
2. It was difficult to accurately quantify data from the high noise tracing obtained.

Table 1. Principal lattice spacings of talc and related minerals by x-ray diffraction Cu K alpha.

<u>Mineral Species</u>	- - - - Principal d-spacings in angstroms - - - -					
	<u>1</u>	<u>2</u>	<u>3</u>	<u>4</u>	<u>5</u>	<u>6</u>
Talc	9.51		4.73 4.62	3.14	2.61	2.50
Chlorite	14.00	7.03	4.70	3.53	2.82	
Tremolite		8.38	3.38 3.27	3.12	2.94 2.81	2.71 2.59 2.53
Chrysotile		7.38	4.55	3.66	2.45	1.54
Amosite		8.26	3.27	3.07	2.77	
Anthophyllite	9.50	8.40	4.58	3.25	3.13	3.06
Crocidolite		8.43	4.51	3.43	3.11	2.72

In order to avoid these difficulties, an automated step-scanning method was employed in which the diffractometer was moved in increments of 0.05 degrees 2 theta, and the intensity of x-ray radiation at each step measured for a total of two minutes. An intensity versus degrees 2 theta plot over the area of interest of 9 degrees to 11 degrees 2 theta was made. Figure 1 shows this step-scan method plotted for a talc which showed no evidence of any asbestos or asbestiform content. Calibration curves were established by integrating the area under the appropriate x-ray diffraction peak of mixtures of 1 to 10 percent of the species under investigation, the remainder being a sample of talc shown to be tremolite and asbestiform mineral free by the method of transmission electron microscopy to be outlined below. Figure 2 shows this step-scan plot for the one and five percent addition of tremolite to the base talc matrix. Figure 3 shows the calibration curve obtained by this technique for asbestos in talc, and figure 4 shows the same type of plot

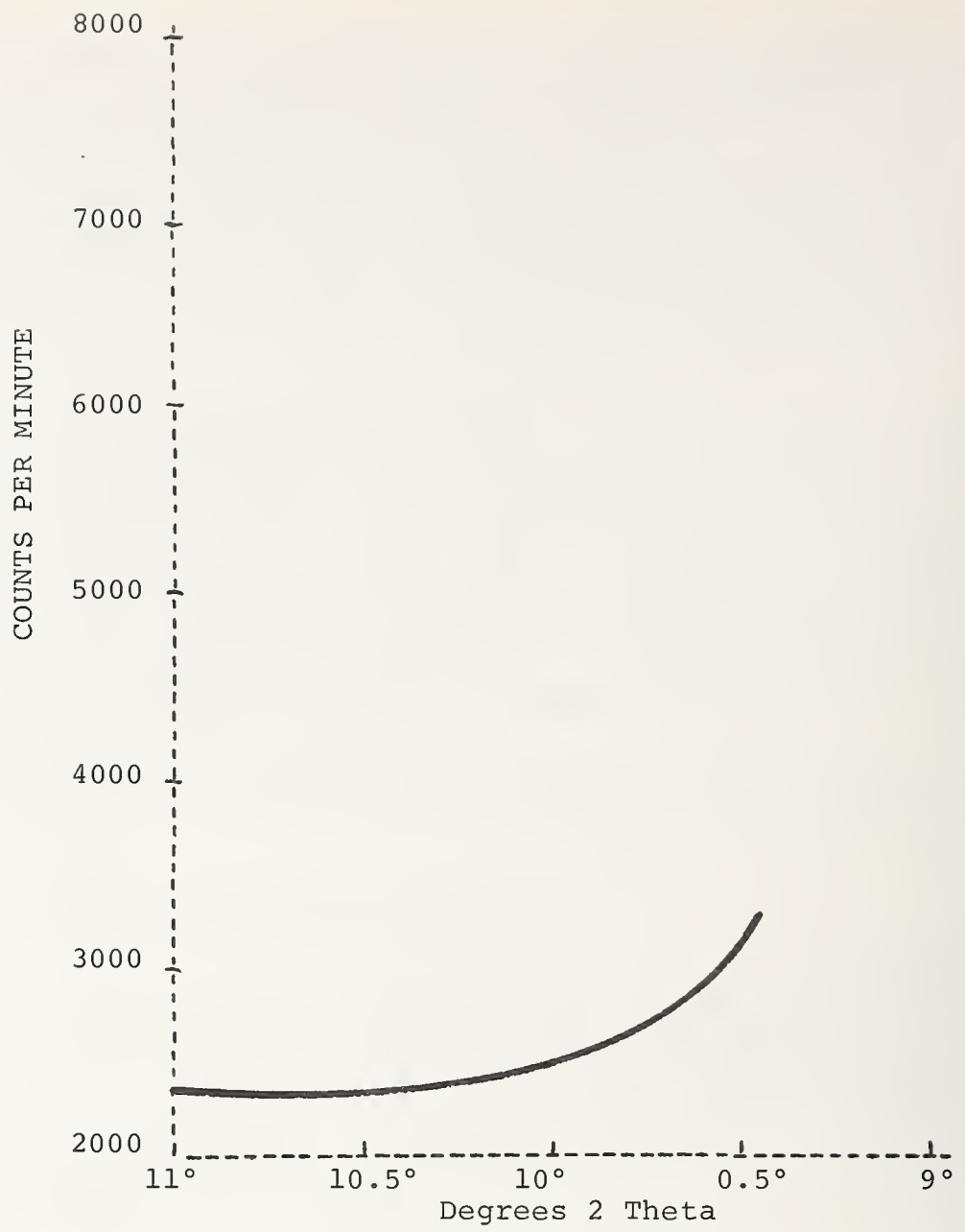

Figure 1. Step-scan plot of intensity versus degrees 2 theta for Pfizer, Inc. Montana Talc.

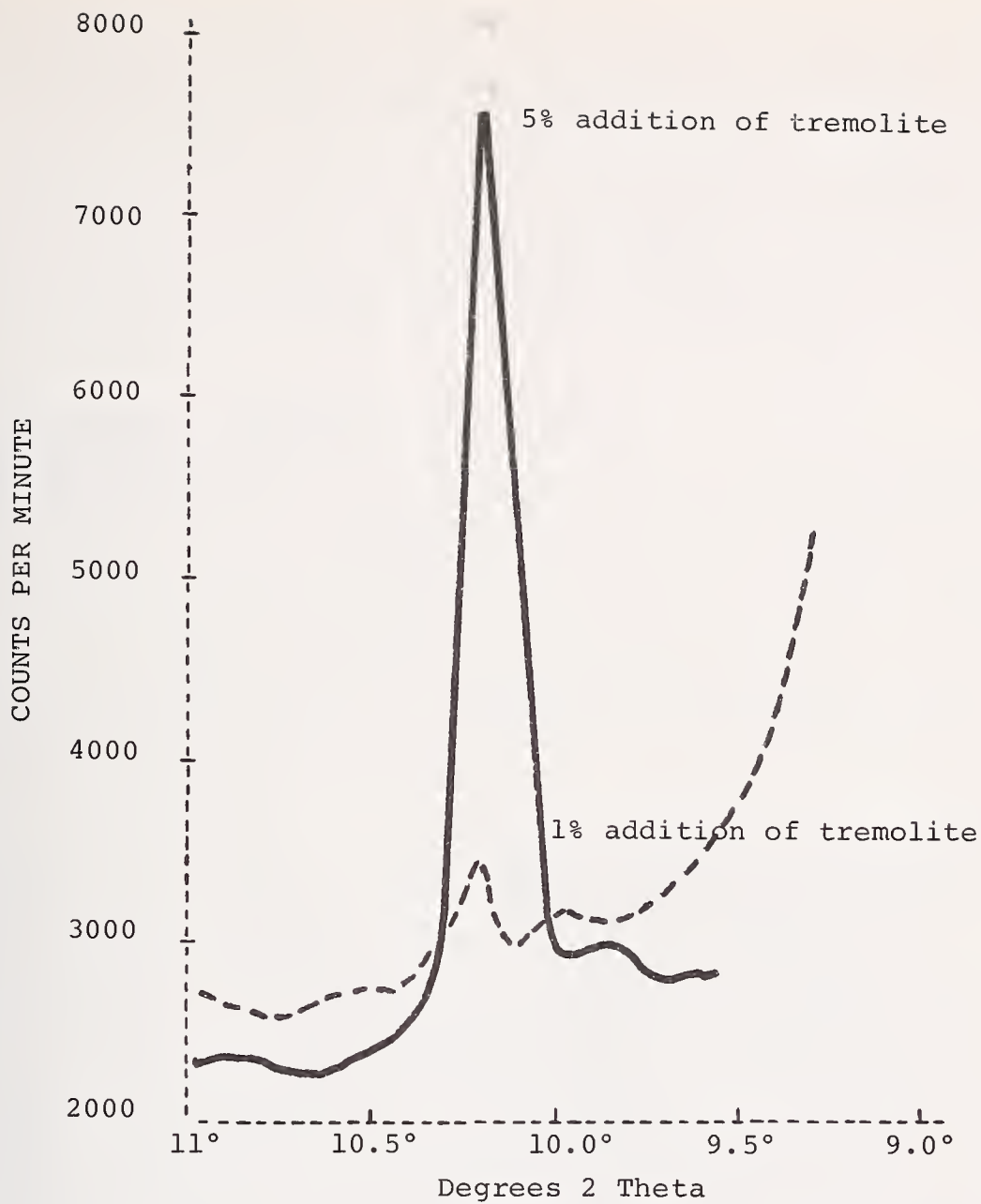

Figure 2. Step-scan plot of intensity versus degrees 2 theta showing the effect of adding 1% and 5% tremolite to talc.

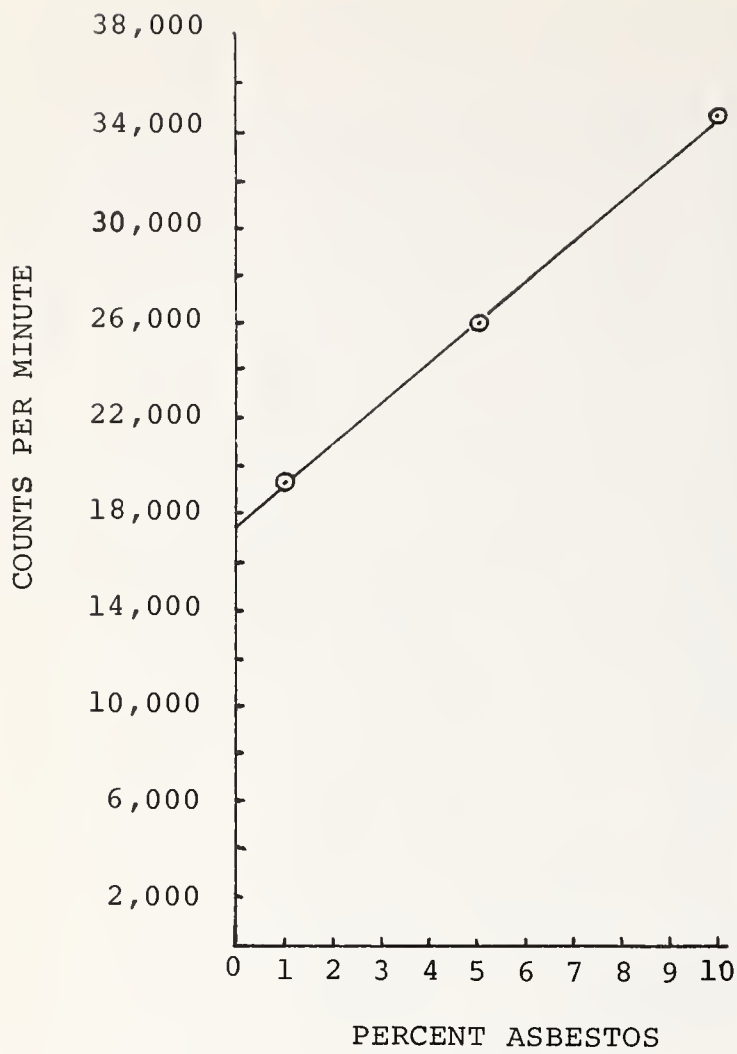

Figure 3. Percent asbestos as a function of intensity of diffracted x-rays.

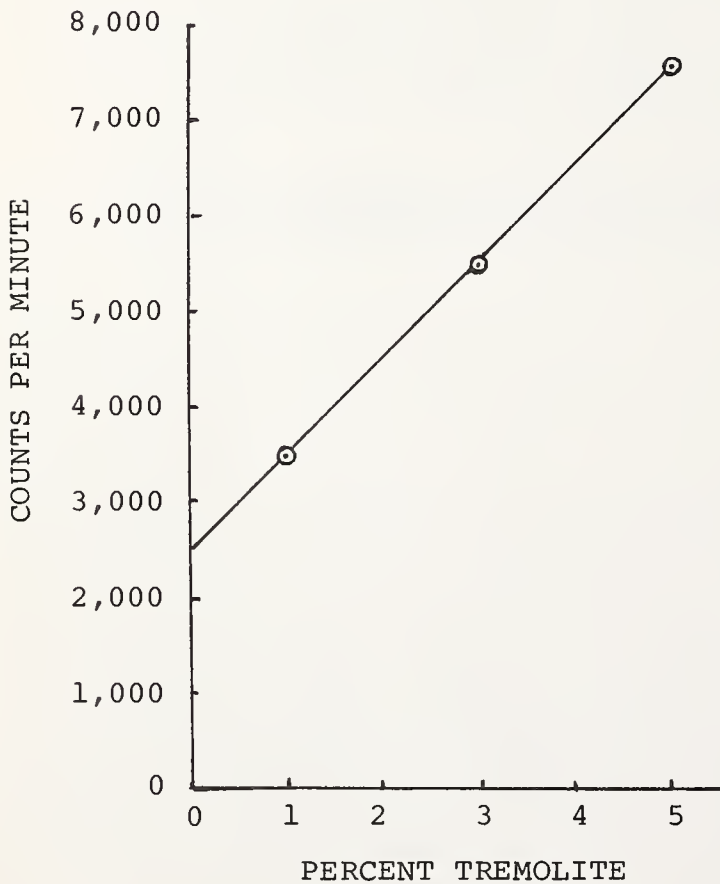

Figure 4. Percent tremolite as a function of intensity of diffracted x-rays.

for tremolite in talc. The minimum detection limit was calculated as that equivalent to three times the square root of the background. For tremolite in talc, the minimum detection limit was found to be approximately 0.2 percent. For chrysotile and the other asbestiform minerals, the minimum detection level obtained by this method is approximately 0.5 percent. This can only be achieved in the absence of chlorite, however. Attempts to remove chlorite by careful acid wash succeeded only in rendering the chrysotile amorphous to the x-ray beam with the result that no x-ray spectrum was obtained in the chrysotile region. Further experimentation revealed that the presence of tremolite at fairly low levels tended to mask or interfere with the detection of some of the other asbestiform minerals. It was thus clear that another technique would be required in these special cases in order to be able to achieve the unambiguous analysis originally required.

Electron Microscopy

By virtue of its ability to examine individual particles in minute detail and at very high magnifications, the transmission electron microscope has been found by us to provide the technique, ancillary to x-ray diffraction, that is needed to complete the unambiguous detection and identification of asbestiform minerals in talc. The morphology of the asbestiform minerals and tremolite is generally described as acicular or fibrous. This immediately serves to isolate them from the platy talc matrix even in the presence of chlorite, since the chlorite morphology closely resembles that of the talc. If the sample, made into a specimen for the transmission electron microscope, is or can be made homogenous, and a careful examination of approximately 100 different fields of view fails to reveal any fibrous material, then that talc is felt by us to be free of tremolite, chrysotile, and the other asbestiform minerals.

The lower detection limit of this technique is difficult to assess since one is often dealing with individual crystals. Figure 5 shows a typical field of view of the fiber free Montana talc used as a basis of comparison in this study. In order to obtain some idea of the amount of fibrous material in a talc, we carefully counted the number of fibers present in each of 100 fields of view of samples contaminated with 0.1, 0.5, and 1.0 percent by weight of fibrous asbestos. The average number of fibers in each field of view is then plotted as a function of the weight percent of fibers added. A linear relationship is seen to exist between the average number of fibers and the weight percent, as illustrated in figure 6. Table 2 shows the results of the fiber count and the raw data for the calibration curve construction. In the range of 0.1 to 1.0 percent, the linear relationship shows an excellent correlation coefficient [9]. We have plotted data of other investigators up to as high as five percent and found that this linear relationship still holds. An interesting point to note at this time is that the standard deviation for 0.1 weight percent of fibers is more than half of the value of the average number of fibers in the same field of view. Further investigations in our laboratories have

Table 2. Fiber count - calibration curve.

<u>Weight % fibers</u>	<u>Total fibers/100 FOV^a</u>	<u>Avg. # fibers/FOV</u>	<u>Std. deviation</u>
1.0	1183	11.83	7.07
0.5	634	6.34	2.49
0.1	206	2.06	1.39

^a FOV = field of view.

$$y = mx + b$$

$$m = 10.86$$

$$b = 0.95$$

$$3\sqrt{b} = 2.92 \text{ fibers/FOV}$$

$$\text{Correlation coefficient} = 0.99997$$

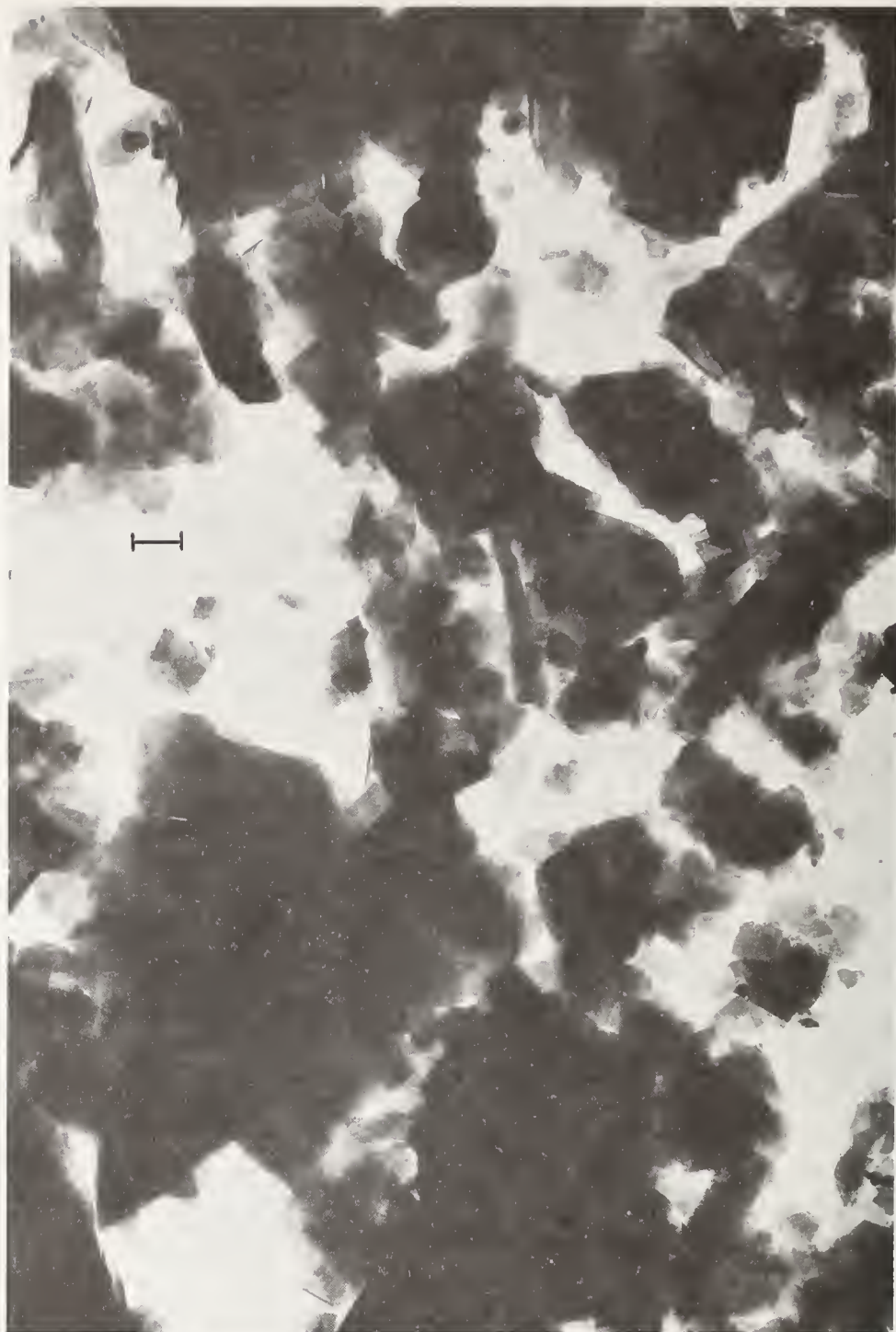

Figure 5. Pfizer, Inc. Platy Montana Talc. Bar is one micron.

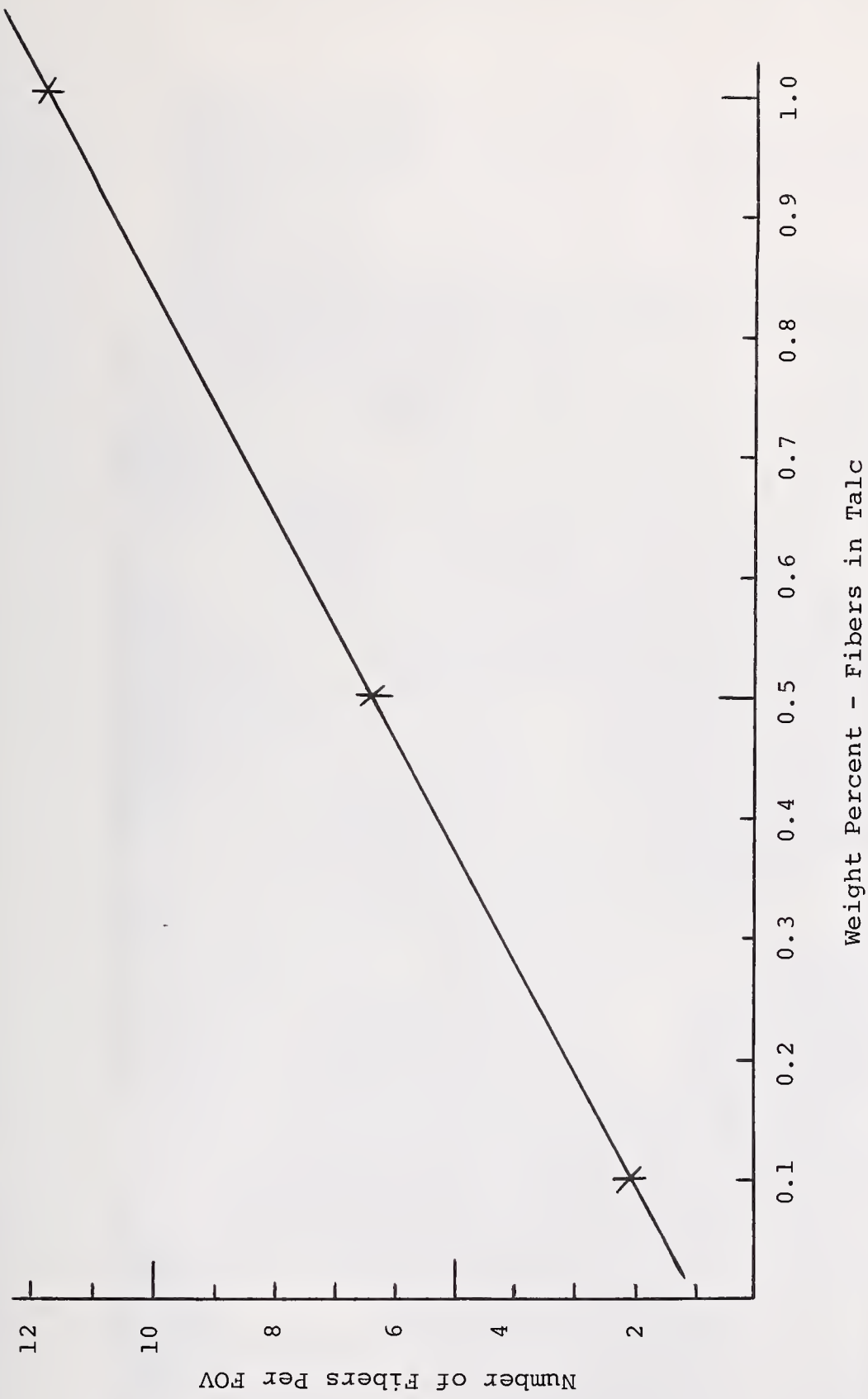

Figure 6. Fibers in talc.

convinced us that this linear relationship does not hold much below 0.1 percent. This is intuitively obvious upon an examination of figure 6 which, you will remember, does not pass through the origin. Somewhere below 0.1 weight percent of fibers in the talc, the linear relationship no longer holds, and the line curves down through the origin. Repeated examinations have confirmed the fact that the Montana talc used in this study is fiber free. Below 0.1 weight percent the data must become so scattered as to be meaningless on a statistical basis. A typical field of view of a Montana talc which was doped with 1.0 percent chrysotile fibers is seen in figure 7. A semi-qualitative estimate of the weight percent fiber content can be easily obtained by reference back to the calibration curve. It is mandatory, however, that the samples under investigation be prepared in exactly the same manner as the samples used in the original calibration curve construction. It is also mandatory that one be certain of the homogeneity of the calibration samples and the



Figure 7. Commercial talc product with a 1% addition of chrysotile asbestos. Bar is one micron.

sample under investigation. Great care must be exercised in the sample preparation, or the results become totally meaningless. Figure 8 shows a commercial talc in which approximately one percent of naturally occurring chrysotile was obscured from detection by the method of x-ray diffraction because of the presence of chlorite.



Figure 8. Commercial talc with naturally occurring co-deposits of chlorite and chrysotile asbestos. The asbestos is present at approximately the 1% concentration level. Bar is one micron.

Selected area electron diffraction was used in conjunction with the examination of morphology. Using this combined method, a single crystal or particle can be selected and analyzed. Single particles usually yielded spot patterns, but if a group or bundle of fibers was found and would transmit electrons, a polycrystalline ring type pattern would result. The use of selected area electron diffraction is mandatory to prove that the pseudo fibers of talc caused by plate-edge curling and talc plates on edge were actually talc, and not tremolite or an asbestiform mineral. A comparison of selected area electron diffraction patterns of these pseudo-fibers to that of the talc platelets showed that the identical compound, talc, was the only species present.

Table 3 lists the principle electron diffraction maximum for talc, tremolite, and the asbestiform minerals [10]. In almost all cases, many more spots or rings were observed than are reported here. In Table 3, only the strongest lines which are the ones most likely to be observed have been tabulated.

Table 3. Selected area electron diffraction maxima for talc and related minerals^a (in angstroms).

<u>Talc</u>	<u>Tremolite</u>	<u>Chrysotile</u>	<u>Amosite</u>	<u>Anthophyllite</u>
4.60	4.51	4.58	3.88	4.58
2.62	2.59	3.67	3.45	2.65
2.32	2.53	2.61	3.00	2.27
1.74	2.32	2.14	2.64	1.75
1.59	2.27	1.70	1.74	1.55
1.53	2.04	1.55	1.61	1.33
1.33	1.86	1.34	1.55	1.28
1.28	1.69	1.29	1.32	1.23
	1.65			

^a The data for chrysotile, amosite, and anthophyllite were taken from reference [11].

Conclusions

The present work has shown that properly prepared samples of talc can be examined by x-ray diffraction to detect tremolite at levels down to 0.2 percent and chrysotile at the 0.5 percent level in the absence of chlorite. In the presence of chlorite, and at concentration levels lower than those stated above, the transmission electron microscope was found to provide reliable detection and identification of fibrous tremolite and the asbestiform minerals. The transmission electron microscope is the most sensitive we have found, and appears to be a more or less referee technique since, when morphology observations are coupled with selected area electron diffraction studies, there are no known interferences. Light microscopy was helpful only in screening samples with large particles and high concentrations of objectionable fibers.

Using the above techniques, we have been able to screen large numbers of talc specimens. We have been able to detect chrysotile and/or tremolite and the asbestiform minerals at levels down to 0.1 weight percent of fiber. We have been able to detect the asbestiform minerals in low concentration specifically by transmission electron microscopy with selected area electron diffraction, when the presence of the asbestos was masked by the presence of chlorite (which was also present at less than 5% concentration). We, therefore, feel that we have a technique that allows us to detect and identify chrysotile fibrous tremolite, and asbestiform minerals at concentrations down to 0.1 percent by weight.

References

- [1] Cralley, L. J., Key, M. M., Groth, D. H., Lainhart, W. S., and Ligo, R. M., Fibrous and mineral content of cosmetic talcum products, J. Amer. Indus. Hyg. Assoc., 29, 350 (1968).
- [2] Hogue, W. L. Jr. and Mallette, L. S., A study of workers exposed to talc and other dusting compounds in the rubber industry, J. Indus. Hyg. Toxicol., 31, 359 (1949).
- [3] Smith, K. W., Plumonary disability in asbestos workers, Arch. Ind. Health, 12, 198 (1955).
- [4] Schepers, G. W. H. and Durkan, T. M., The effects of inhaled talc-mining dust on the human lung, AMA Arch. Indus. Health, 12, 182 (1955).
- [5] Brodeur, P., The magic mineral, New Yorker Magazine, p. 12, October 1968.
- [6] Merliss, R. R., Talc-treated rice and Japanese stomach cancer, Science, 173, 1141-1142 (1971).
- [7] Sax, N. Irving, Ed., "Talc", dangerous properties of industrial materials, Reinhold Publishing Corp., New York, 1963, p. 1217.
- [8] Sax, N. Irving, Ed., "Talc", dangerous properties of industrial materials, Reinhold Publishing Corp., New York, 1963, p. 469.
- [9] Stanley, H. D., The detection and identification of asbestos and asbestiform minerals in talc, 34th Annual Proceedings of the Electron Microscopy Society of America, p. 618-619, August, 1976.
- [10] Timbrell, V., Characteristics of the International Union Against Cancer Standard Reference Samples of Asbestos, Proc. Int. Pneumoconiosis Conf., Johannesburg, 1969.

Discussion

J. SCHELTZ: As the spokesman for the Cosmetic, Toiletry, and Fragrance Association, I would like to make several comments. First: In a survey conducted recently by that organization among its member companies, some thirty-four hundred samples of cosmetic talc from both domestic and international sources were analyzed and not a single sample was found to contain chrysotile asbestos. We are aware that the spiking of chrysotile asbestos into talc can be analyzed effectively by x-ray diffractometry. These samples of talc are cosmetic which, by definition, means that they contain at least 90 percent of the actual talc mineral species. I would also like to comment on quantitative analysis of amphibole minerals, by x-ray diffractometry. While x-ray diffractometry is a good technique to detect amphibole minerals, one needs to be very cautious in attempting to perform a quantitative analysis. I think Dr. Haartz from NIOSH just pointed out that there are major differences based not only on compositional variations, but also morphological characteristics that make not only peak heights but also integrated peak intensity variable. So, while x-ray diffractometry is a good method for detection, it is not necessarily good for quantitative analysis.

I would also like to point out that the Cosmetic, Toiletry, and Fragrance Association is currently undertaking an extensive analysis of consumer talcum products for the traces of amphibole minerals.

H. STANLEY: As I understand it, your first point is that x-ray diffraction is not particularly quantitative for determination of amphiboles in talc. We haven't found that to be the case in our laboratory, and I think there are a number of people here that I have been talking to the last several days that have had the same experience. The x-ray diffraction is good if you want to know, for example, the total amount of tremolite present, but if you want to know if some of that tremolite is fibrous, then as I attempted to point out, you have to go to transmitted electron microscopy with selected area diffraction.

SCHELTZ: That's exactly my point. (rest inaudible)

As to the second point, we were talking about cosmetic grade talc of at least 90 percent purity, the purity of the Montana talc is in excess of 96 percent, so I understand your point.

MISIDENTIFICATION OF ASBESTOS IN TALC

Jerome B. Krause

Colorado School of Mines Research Institute
Golden, Colorado 80401

and

William H. Ashton

Johnson & Johnson
Raritan, New Jersey 08869

Abstract

Both optical microscopy and x-ray diffraction (XRD) are widely used to detect minerals associated with talc. Optical microscopy can determine the morphology of a particle, but cannot always fully identify the specific mineral. Although XRD is an excellent screening technique for the detection of minerals associated with talc, the method can misidentify minerals due to interferences, interpretive errors, and the inability to determine morphology.

Methods for reduction or elimination of these problems include special techniques of sample preparation and x-ray diffraction, combined with microscopic examination (both optical and electron).

Key Words: Amphiboles; asbestos; chlorite; electron microscopy; fiber; morphology; optical microscopy; x-ray diffraction; talc.

Introduction

There are many ways to analyze and study any naturally occurring material. The conclusions reached will often vary widely depending on the expertise and specific interest of the investigator. That situation sums up the present status of "asbestos"; it is also the status of minerals which are associated with "asbestos"; and it is becoming the status of other minerals which can be naturally associated with talc.

Popular methods of analysis can give the wrong answer - namely that asbestos is present when it certainly is not. That problem (misidentification) is not so much one of limitations of the methods, but rather one of misinterpretation of data, and failure to recognize the mineralogical background required to certify mineral purity, for example, when analyzing sheet silicates for asbestos. Unfortunately, one main factor is that asbestos has now developed variable definitions, depending on whether the point of view is mineralogical, industrial, medical, or regulatory. The medical definition is most concerned with whether or not the particles are biologically active; the industrial definition is dependent upon flexibility and weavability; the mineralogical definition upon crystallography; and the regulatory definition upon size and aspect ratio.

The word "asbestos" stems from ancient Greek and has always referred to a very fibrous industrial mineral product. Since asbestos has historically related to a mineral exploited as an important industrial commodity, we think a combined mineralogical and industrial definition should take precedence [1,2]¹. Other presentations during this

¹Figures in brackets indicate the literature references at the end of this paper.

workshop have amply covered the aspects of asbestos terminology, and it is not our intent to provide comprehensive coverage of that subject. Our primary objective is to review some of the basic principles of analysis, and to point out problem areas where identification of "asbestos" has been abused.

Analysis Methods and Misidentification of Asbestos

It is useful to categorize the various analytical methods which have been applied to talc to highlight inherent principles which lead to misidentifying asbestos as being present. We offer the following general comments on the three principle determinative properties (chemical composition, morphology, structure).

Chemical Composition

It is well known that every mineral has a specific chemical composition, and that each mineral has an ideal theoretical chemical formula (configuration). Unfortunately, many investigators overlook the fundamental point that chemical composition does not identify a specific mineral. A simple example will bring that point into focus:

A pearl, an oyster shell, a slab of marble, a piece of chalk, and the minerals aragonite and calcite are obviously different materials, and yet each will be identified as calcium carbonate. That is to say, chemical analyses will identify them all as the same substance, where everyone knows that a pearl is not a piece of chalk.

The same situation exists in certain phases of asbestos analysis. For example, chrysotile, antigorite, lizardite, sepiolite, chlorite, and talc are all hydrous magnesium silicates. But a Meerscham pipe (sepiolite) is certainly not chrysotile asbestos in spite of the fact that chemical analysis alone could lead to that misidentification.

Accordingly, chemistry alone does not identify a mineral, nor do those sophisticated instrumental methods which are based on chemical principles, such as:

Wet Chemical Analysis

Classical (gravimetric, volumetric)

Instrumental (atomic absorption, flame emission)

Microprobe (electron and ion)

Emission Spectrograph

Mass Spectrograph

X-Ray Fluorescence

Morphology

Although the shape of a mineral particle is one of the key characteristics in the identification of a mineral, shape alone cannot be the sole determinant of a specific mineral species. There are hosts of minerals in different mineral classes whose particles have the same shape. They exist across the spectrum of all classes of minerals and the possibilities are beyond comprehension. Even if we limit ourselves to minerals which occur in the true fibrous state, we would estimate there are up to 100. There have been instances where nonasbestos particles have been misidentified as chrysotile in talc because shape alone was the index used.

Methods based on morphology include:

Optical Microscopy

Automated Image Analyzers

Electron Microscopy (SEM and TEM)

Structure

The configuration of atoms in the crystal lattice of a mineral does not necessarily determine a mineral species. The atomic arrangement at the molecular level does not always carry through to the external visible physical form. That is to say that methods based on molecular structure can misidentify a mineral. For example, chrysotile asbestos is classified with the sheet silicates because of its crystal structure arrangement, but it certainly does not occur in flat sheets like the micas or its sibling, antigorite.

Methods of identification which relate to molecular structure are:

- Infrared Spectroscopy
- Differential Thermal Analysis
- X-ray Diffraction
- Electron Diffraction

In general then, no single property defines a mineral, and no single method which depends on one property can identify a specific mineral.

Conversely, methods which depend on a single factor or characteristic of a mineral can give misidentifications.

Two Popular Methods

Optical microscopy and x-ray diffraction methods require some additional discussion primarily because they have received widespread attention by industry and government laboratories as possible monitoring techniques.

Although both these methods are fundamental to the science of mineralogy and are highly reliable in the hands of experts, complications arise when shortcuts are taken in the professional procedures.

Optical Microscopy

When an experienced optical mineralogist or crystallographer identifies a mineral with a petrographic microscope, he can come to a remarkably accurate conclusion. The reason for high accuracy is that not one but several specific properties are determined, such as refractive indices, extinction angle, birefringence, and optical orientation. Specific training and wide mineralogical background are required to get the right answer.

In contrast, current optical methods in federal regulatory proposals relating to asbestos presume that asbestos is present in the first place. The analyst then merely observes the mineral particle for size/shape. Consequently, those methods which depend solely on aspect ratio give misidentification. They misidentify the presence of asbestos by such simple oversights as looking at a platelet on edge and counting it as an asbestiform particle. It is not necessary to elaborate on the other shortcomings of those methods in view of the recent NBS report on the analysis of 80 industrial talcs [3] evaluating that methodology. The same shortcomings were also recently corroborated in a study conducted by Harvard University and NIOSH [4].

However, there are a few rare cases where abnormal crystal habit can be misleading and subtly can lead to a misidentification. Optical microscopy is most vulnerable to this type of misidentification. For example, talc normally occurs as micaceous plates, but rare acicular talc does exist, and one must be very careful to avoid misidentifying the rare occurrence as asbestos. As an example, our XRD examination of an industrial acicular talc sample has identified the presence of significant amphibole (probably tremolite). However, when the material was subjected to thorough petrographic examination it was found to be composed of free grains of columnar amphibole and acicular talc and composite talc-amphibole. The significance is that an erroneous conclusion could be reached by misidentifying such a rare talc variety as asbestos, if only aspect ratio and simple optical microscopy were used.

Thus, simple optical microscopy can determine the morphology of a particle, but if used alone it cannot always fully identify the specific mineral observed.

X-Ray Diffraction

Although x-ray diffraction (XRD) is a valuable technique, it cannot determine the physical shape of a mineral particle, and for that reason it cannot determine whether or not a sample is asbestos. Furthermore, it cannot distinguish between two mineral varieties in the same mineral class in cases such as the asbestos minerals and their nonasbestiform analogues. It is surprising that such a basic shortcoming continues to be overlooked by responsible investigators alleging to have identified asbestos by XRD.

One result of the inability of powder XRD to differentiate between the asbestiform and nonasbestiform varieties of a mineral is the potential error of prejudging an XRD detected phase to be the asbestiform variety. For example, preparing calibration standards of mixtures of talc plus chrysotile could have the effect of causing a serpentine peak in an unknown sample to be prejudged as the asbestiform variety, i.e., chrysotile. A mixture of talc spiked with the serpentine mineral chrysotile will give the same XRD pattern as a mixture of talc spiked with the very common platy serpentine mineral antigorite. It should be obvious that an unknown talc showing a serpentine peak cannot be prejudged or branded as containing chrysotile asbestos under such circumstances. Unfortunately, the literature has articles by responsible authors who have overlooked that error in logic [5,6,7].

For research purposes only, single crystal XRD can provide information as to whether or not the specimen could be asbestos. However, due to the difficulty of handling minute specimens, single crystal XRD is inadequate for particles smaller than about 20 x 5 μm , and, of course, is also inadequate for routine monitoring procedures.

Amphiboles

Each of the five amphibole minerals, anthophyllite, cummingtonite-grunerite, riebeckite, tremolite, and actinolite has an asbestiform variety, namely anthophyllite asbestos, amosite, crocidolite, tremolite asbestos, and actinolite asbestos, respectively. Tremolite asbestos is quite rare, and actinolite asbestos is so rare that a recent NIOSH project to prepare reference standard minerals has been unable to locate a source of pure actinolite asbestos [8].

The amphiboles (named from the Greek "amphibolos," meaning ambiguous) are characterized by similar crystal structure and wide variation in chemical composition and appearance. All amphiboles have XRD patterns which are similar, and are characterized by having their (110) or (210) diffraction peaks occur within $\pm 0.2\text{\AA}$ of each other (Table 1, Figure 1). Reliable identification of individual amphibole species is difficult in the absence of confirming composition data.

Examination of Table 1 and Figure 1 illustrates that attempted identification of a specific amphibole on the basis of $d_{(110)}$ or $d_{(210)}$ has good potential for being in error. For example, selection of Joint Committee on Powder Diffraction Standards (JCPDS) card 13-437 as being definitive of tremolite presents serious problems. Twenty-nine additional JCPDS amphiboles have their (110) or (210) peaks within $\pm 0.1^\circ 2\theta$ of this tremolite (110) peak at $10.56^\circ 2\theta$. Identification of an amphibole as tremolite on the basis of a peak at $10.56^\circ 2\theta$ is obviously an identification with very low reliability. In other words, a peak at that location is not necessarily the mineral tremolite since it could be one of 29 other minerals.

Table 1. Amphibole JCPDS Card No's., $d_{(110)}$ or $d_{(210)}$ peak position, and relative intensity.

JCPDS card #	$\overset{\circ}{\text{A}}^a$	$2\theta(\text{Cu})$	I	Name
23-118	8.58(1)	10.31	100	prieskaite
10-456	8.55(1)	10.35	100	richterite
20-734	8.53(1)	10.37	70	mboziite
20-378	8.52(1)	10.38	100	dashkesanite
14-633	8.51(1)	10.39	70	arfvedsonite
21-149	8.51(1)	10.39	55	hornblende
19-467	8.50(1)	10.41	100	ferropargasite, syn
20-982	8.50(1)	10.41	65	richterite, syn
23-665	8.48(1)	10.43	45	richterite, calcian, syn
23-664	8.47(1)	10.44	35	edenite, sodian, syn
23-667	8.47(1)	10.44	45	richterite, calcian, syn
23-663	8.46(1)	10.46	40	eckermanite, calcian, syn
9-434	8.45(1)	10.47	50	hornblende
13-499	8.45(1)	10.47	100	magnesioriebeckite
20-656	8.45(1)	10.47	100	magnesioriebeckite
20-470	8.44(1)	10.48	100	crossite
23-666	8.44(1)	10.48	40	tremolite, sodian, syn
20-469	8.43(1)	10.49	100	hastingsite
23-1405	8.43(1)	10.49	80	edenite
23-1406	8.43(1)	10.49	40	paragasite
20-1310	8.43(1)	10.49	40	tremolite, syn
10-428	8.42(1)	10.51	100	richterite, fluor, syn
23-603	8.42(1)	10.51	100	tirodite
10-431	8.41(1)	10.52	80	edenite, fluor, syn
19-1061	8.40(1)	10.53	100	riebeckite
20-481	8.40(1)	10.53	100	hornblende
20-1390	8.40(1)	10.53	90	winchite
23-302	8.40(1)	10.53	100	cumingtonite, mangoan
19-1063	8.39(1)	10.54	70	richterite
13-437	8.38(1)	10.56	100	tremolite
17-478	8.38(1)	10.56	65	kaersutite
23-495	8.38(1)	10.56	80	eckermanite
9-330	8.37(1)	10.57	100	tremolite, fluor, syn
17-750	8.36(1)	10.58	25	richterite, ferrian
20-386	8.35(1)	10.59	40	eckermanite, syn
22-531	8.35(1)	10.59	30	joesmithite
16-401	8.33(2)	10.62	70	anthophyllite, magnesian, syn
17-725	8.33(1)	10.62	100	grunerite
17-745	8.33(1)	10.62	100	grunerite
20-376	8.31(1)	10.65	100	crossite
17-726	8.30(1)	10.66	100	cumingtonite
20-484	8.29(1)	10.67	100	richterite
13-506	8.27(2)	10.70	80	gedrite
23-679	8.27(1)	10.70	90	glaucophane
9-455	8.26(2)	10.71	55	anthophyllite
20-453	8.26(1)	10.71	100	glaucophane
11-253	8.23(2)	10.75	100	ferrogedrite
23-310	8.20(1)	10.79	75	richterite, ferrian
13-401	8.11(2)	10.91	100	holmquistite

^a $(110)^1$ or $(210)^2$.

$$\text{Maximum } \Delta 2\theta(\text{Cu}) = 10.91^\circ - 10.31^\circ = 0.6^\circ$$

Table 1 illustrates the very close proximity of the (210) or (110) XRD peak of all amphiboles, showing the inability to identify a specific amphibole on the basis of $d_{(210)}$ or $d_{(110)}$.

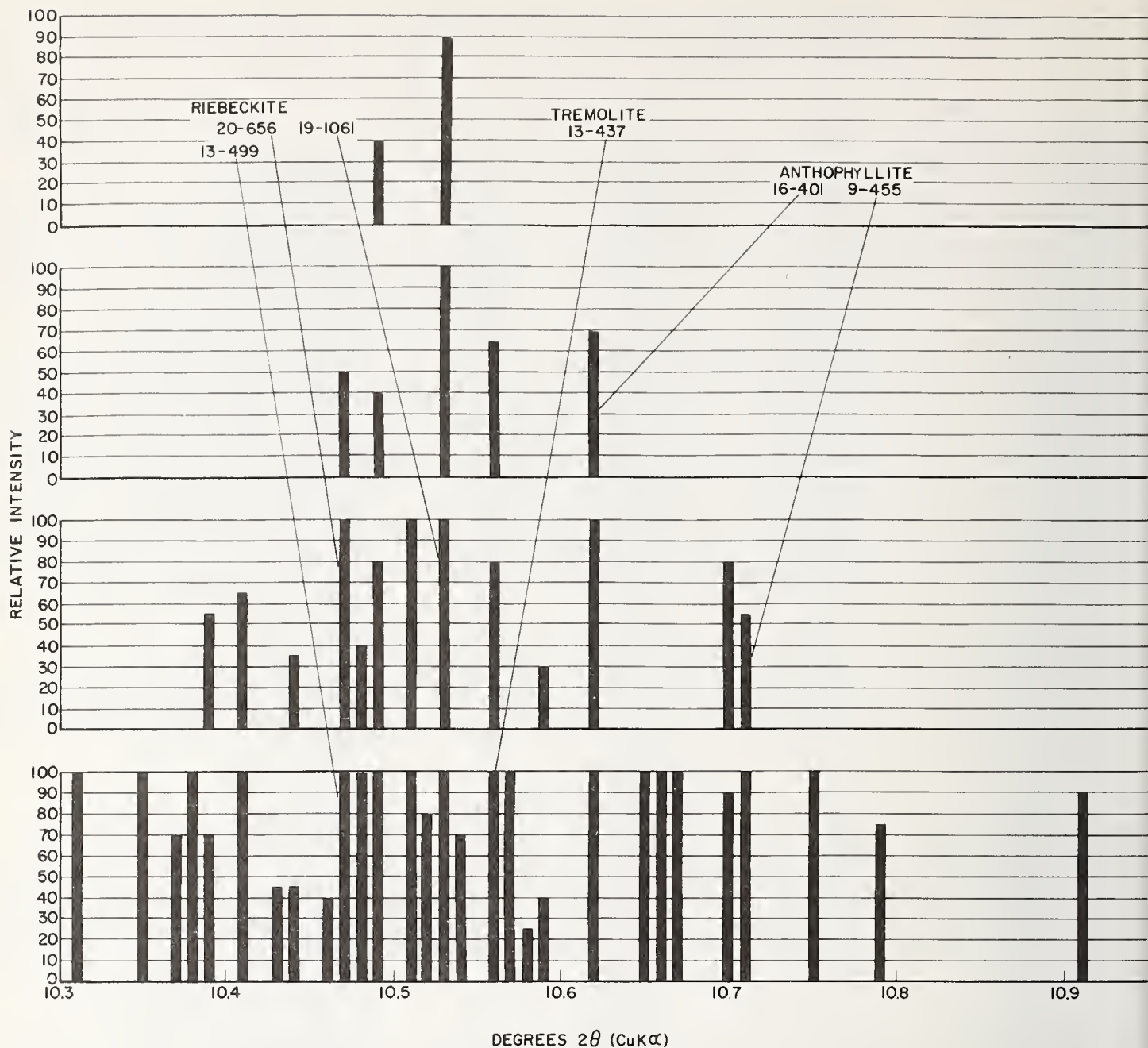

Figure 1. Amphibole $d_{(110)}$ or $d_{(210)}$ - peak positions (2θ for $\text{CuK}\alpha$) and relative intensity.

An additional problem further affecting the reliability of identification by XRD is the effect of shift in peak position caused by slight mispositioning of the sample surface in the instrument. For example, a $100\ \mu\text{m}$ mispositioning of the specimen surface will result in a shift of approximately $0.6\text{-}0.7\ \text{\AA}$ in d -spacing at low 2θ angles [9]. A slight shift in the position of the peak (from a different amphibole or mispositioning of the sample surface, for example) could go unnoticed, resulting in misidentification of an amphibole that is not even present.

In order to conclusively identify an amphibole by XRD, it is necessary to have an essentially complete diffraction pattern. In order to obtain such an XRD pattern, the sample must have a relatively high amphibole content and the pattern must be acquired with a time-consuming slow scan. Acquisition and interpretation of such patterns is time-consuming, and discourages proper application of the full procedure, especially for routine monitoring where large numbers of samples require analysis. Shortened procedures, such as single peak identification of amphiboles, provide good opportunity for misidentification. The shortened procedure of single peak identification was apparently used in a 1972 paper [7], where our examination of some of the same samples disagreed with identifications of serpentine, tremolite-actinolite anthophyllite, and anhydrite.

Chlorite-Serpentine

Chlorite is one of the most common accessory minerals found associated with talcs. The chlorite group of minerals are somewhat analogous to amphiboles in that they exhibit a wide variation in chemical composition and all have a similar crystal structure. The diagnostic chlorite basal XRD peaks (001), (002), and (004) are characteristic, and occur at about 14Å, 7Å, and 3.5Å, respectively. As in the case for the amphiboles, specific identification of a particular chlorite species by XRD is difficult. The XRD problem with chloritic talcs is that the serpentine first order basal peak overlaps the chlorite (002) peak, and the corresponding serpentine second order basal peak overlaps the chlorite (004) peak. Generally, however, the chlorite (004) and serpentine second order peaks are separate enough to allow unambiguous determination of the presence of both phases when present in adequate amounts to give definable peaks. Tables 2 and 3 and Figures 2, 3, and 4 are compilations of JCPDS data for the positions of the (004) basal peak for chlorites and (002), (004), or (0012) basal peak for serpentines, respectively.

Table 2. Chlorite JCPDS Card No's., $d_{(004)}$ peak positions, and relative intensity.

<u>JCPDS card #</u>	<u>Å</u>	<u>2θ(Cu)</u>	<u>I</u>	<u>Name</u>
10-183	3.60	24.73	100	penninite
20-671	3.60	24.73 ^a	90	kämmererite
16-351	3.59	24.80	70	chlorite 1b
12-185	3.57	24.94	85	kotschubeite
7-160	3.58	24.87	60	kotschubeite
19-749	3.56	25.01	80	clinochlore
7-77	3.558	25.03	50	sheridanite
16-362	3.55	25.08	80	chlorite 1a
19-751	3.55	25.08	65	sudoite
22-712	3.55	25.08	45	nimite
7-165	3.545	25.12	60	grochauite
7-78	3.541	25.15	60	thuringite
7-171	3.541	25.15	80	diabantite
12-242	3.54	25.16	100	leuchtenbergite
7-76	3.537	25.18	50	ripidolite
13-29	3.53	25.23	80	thuringite
7-166	3.523	25.28	50	daphnite
12-243	3.52	25.30	92	aphrosiderite
21-1227	3.52	25.30	100	thuringite
3-67	3.49	25.52	100	thuringite

^a $d_{(115)}$.

Table 2 illustrates variation in position of the chlorite $d_{(004)}$ XRD peak.

Table 2 should be compared with Table 3 to see that the chlorite and serpentine XRD peaks overlap and interfere with each other. Identification and quantification of serpentine in the presence of chlorite is extremely difficult at best.

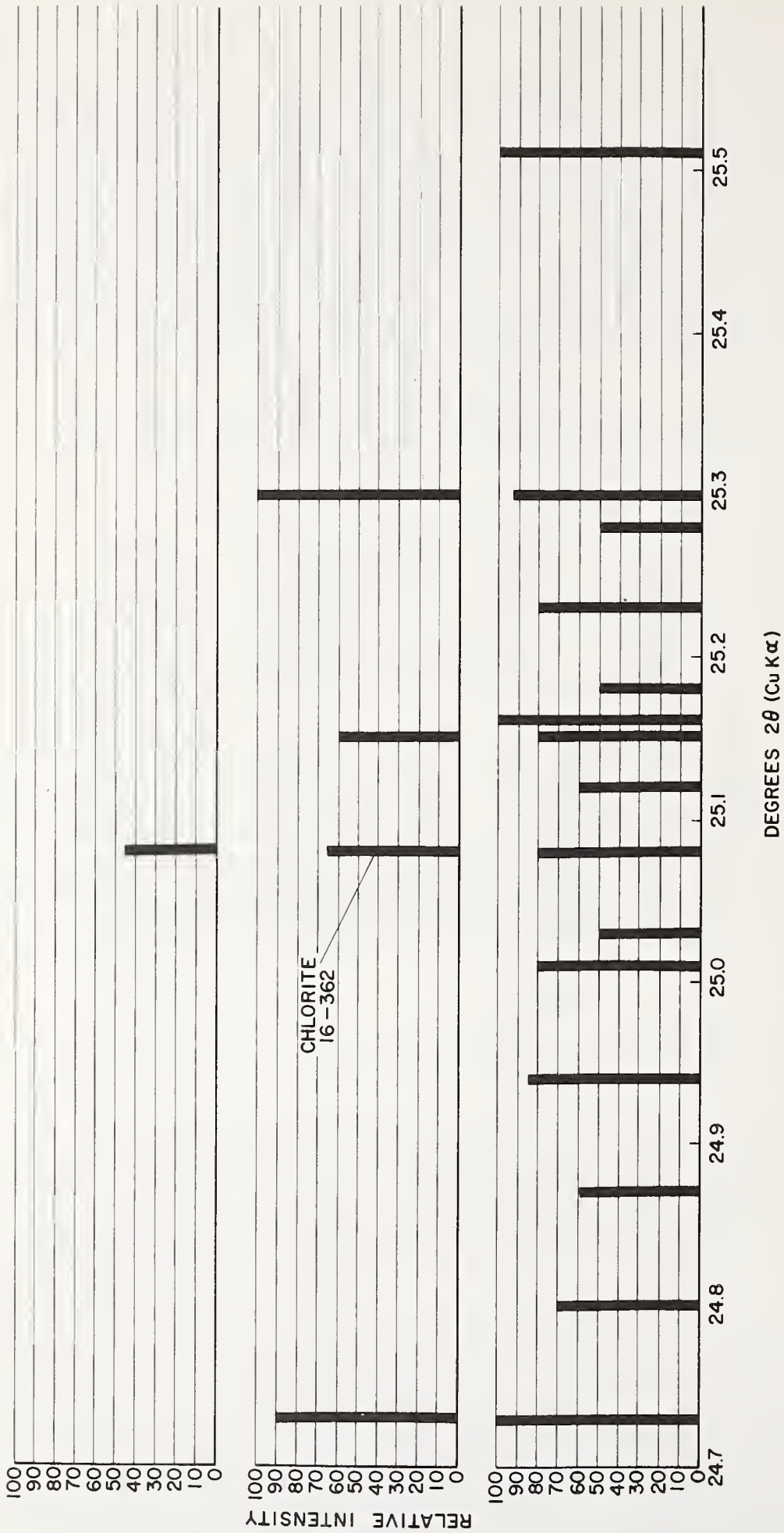

Figure 2. Chlorite $d_{(004)}$ - peak positions and relative intensity. The data of Table 2 are presented in graphical form showing the variation in position of the $d_{(004)}$ XRD peaks for different chlorites. Selection of JCPDS card 16-362 as diagnostic for chlorite can obviously result in misidentification.

Table 3. Serpentine, Kaolinite, Halloysite, and Dickite JCPDS Card Nos., peak position, miller index (hkl), and relative intensity.

JCPDS Card #	$\overset{\circ}{\text{A}}$	$2\theta(\text{Cu})$	<u>I</u>	<u>(hkl)</u>	<u>Serpentines</u>
18-779	3.67	24.25	80	(002)	lizardite, <u>1M</u>
9-444	3.66	24.32	100	(00 <u>12</u>)	antigorite, <u>60</u>
21-543	3.65	24.39	70	(004)	chrysotile, <u>2M</u>
7-417	3.63	24.52	300	(102)	antigorite, <u>6M</u>
11-386	3.62	24.59	60	(002)	lizardite, <u>10</u> , aluminian
21-963	3.61	24.66	80	(002)	antigorite, <u>6M</u>
12-583	3.56	25.01	80	(00 <u>12</u>)	antigorite, <u>60</u> , aluminian
13-4	3.56	25.01	70	(00 <u>12</u>)	antigorite, <u>60</u> , aluminian
7-339	3.55	25.08	100	(002)	berthierine
11-388	3.55	25.08	100	(00 <u>12</u>)	antigorite, <u>60</u> , syn
7-315	3.52	25.30	100	(002)	berthierine
9-493	3.52	25.30	100	(004)	amesite
<u>Kaolinites</u>					
6-221	3.58	24.87	100+	(002)	kaolinite, <u>1Md</u>
14-164	3.579	24.88	80	(002)	kaolinite, <u>1T</u>
12-447	3.56	25.01	50	(002)	kaolinite, <u>1T</u>
<u>Halloysite</u>					
9-453	3.63	24.52	90	(002)	halloysite, dehydrated
<u>Dickite</u>					
10-446	3.58	24.87	100+	(004)	dickite <u>2M₁</u>

Chlorite 2θ Range: 24.73 - 25.52

Table 3 illustrates variation in position of XRD peaks of serpentine, kaolinite, halloysite, and dickite. The XRD patterns of these minerals interfere with each other and with chlorite (see Table 2).

- SERPENTINE $d_{(002), (004), (0012)}$
- ▨ KAOLINITE $d_{(002)}$
- ▤ HALLOYSITE $d_{(002)}$
- DICKITE $d_{(004)}$

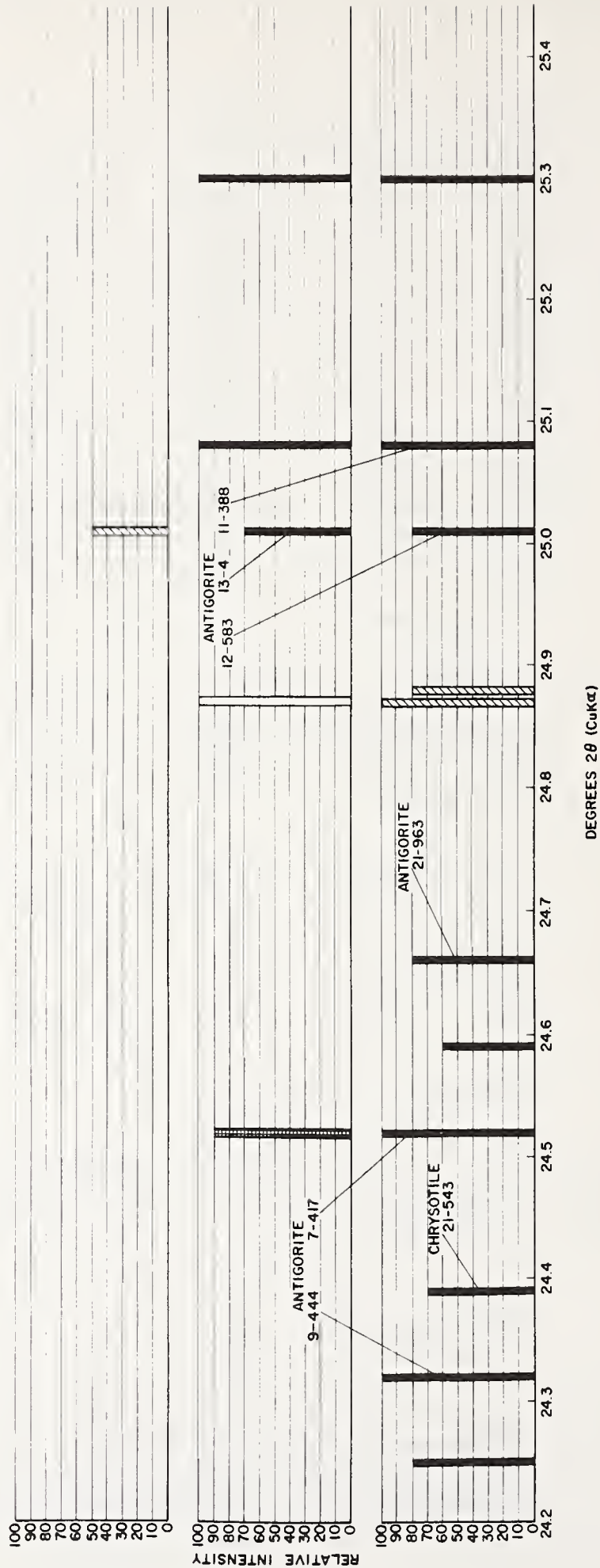

Figure 3. Peak positions and relative intensities. The data of Table 3 are presented in graphical form to illustrate the variation in position and interfering overlap of XRD peaks of serpentinite, kaolinite, halloysite, and dickite.

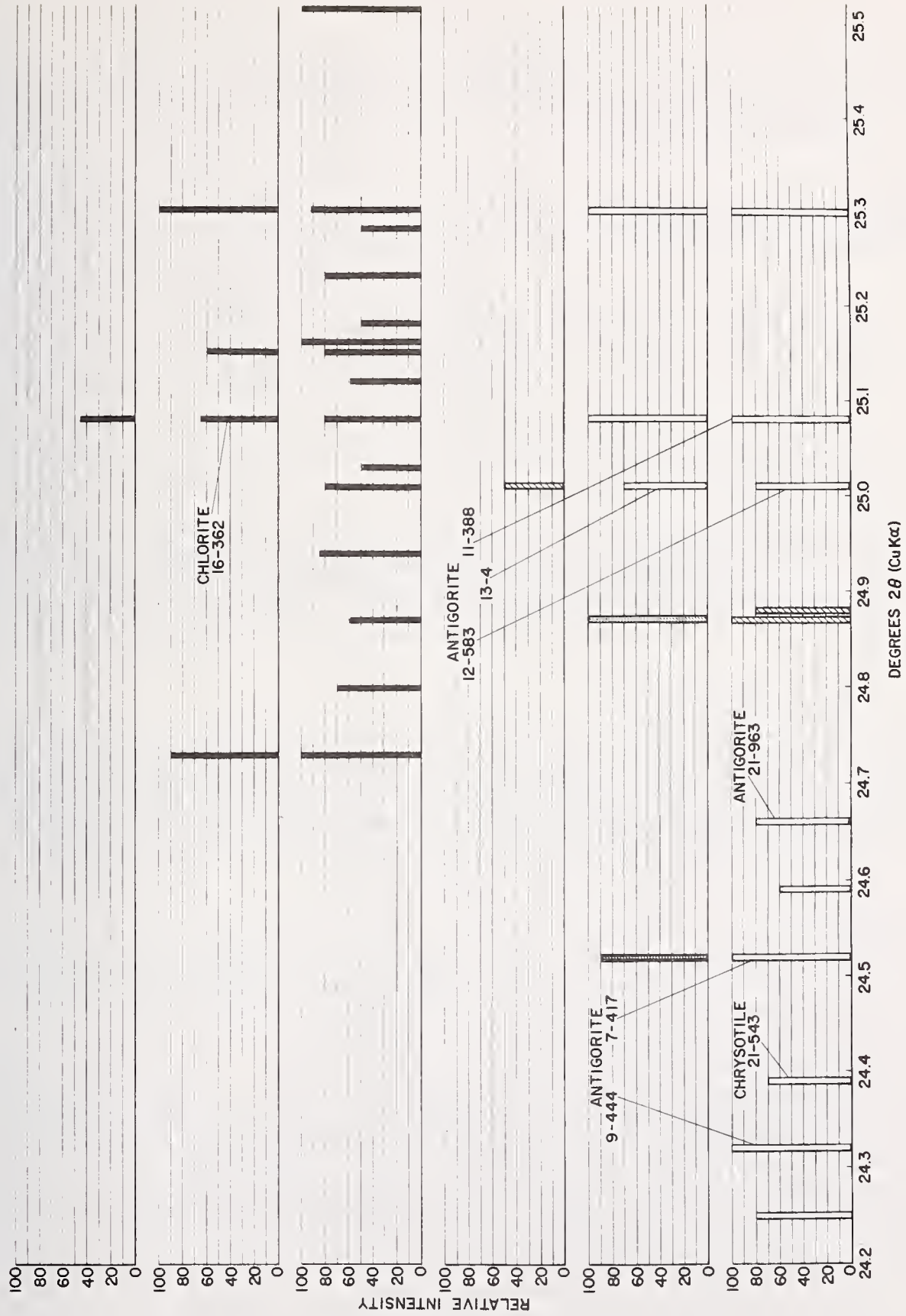

Figure 4. Peak positions and relative intensities. The data of Tables 2 and 3 are presented combined, illustrating the problems of XRD identification when chlorite and serpentine, and possibly kaolinite, halloysite, or dickite are also present.

Three essential features are demonstrated in Tables 2 and 3, and Figures 2, 3, and 4:

1. The diagnostic peaks show considerable variation in the position in which they occur ($\Delta 2\theta = 0.79^\circ$ for chlorites and 1.05° for serpentines).
2. The chlorites and serpentines overlap and interfere with each other.
3. Basal peaks of the clay minerals kaolinite, halloysite, and dickite overlap the positions of the chlorite and serpentine peaks, and will interfere when present.

The significance of the chlorite-serpentine interference is increased by the fact that chlorite is a very common accessory mineral associated with talcs, whereas serpentine is much less commonly associated.

In spite of the chlorite-serpentine problem, numerous investigators have performed XRD identification and/or quantification of serpentine in chloritic talcs. It is obvious to us that they have misidentified asbestos as being present by overlooking the chlorite/serpentine interference and by misconcluding that a chlorite peak was serpentine.

Other Methods

Infrared Spectroscopy (IR)

The infrared absorption spectrum of a material results from vibrational and bending frequencies of various atomic bonds within the structure. For example, Si-O stretching frequencies produce similar IR peaks for all silicate minerals. As a result, IR spectra are not particularly useful for identifying the minerals present in a mixture, and the method certainly is not capable of determining whether or not a detected mineral is the asbestiform variety.

Differential Thermal Analysis (DTA)

The rearrangement or decomposition of mineral crystal structures due to thermal heating is a characteristic and reproducible reaction. It follows that DTA can identify specific minerals in a mixture but the method is not capable of determining morphology. Therefore, any DTA data which might point to the presence of a serpentine mineral could lead to misidentifying chrysotile asbestos in a talc when the mineral could well be a normally occurring platy antigorite having the same DTA pattern.

Electron Microscopy

Electron microscopic techniques of identification of asbestos have been amply covered in other presentations during this workshop. We do not intend to cover that subject again, but rather to point out some areas where asbestos can be misidentified.

The high magnification attainable with electron microscopy is, in itself, inadequate as the sole index of mineral identity. For example, chrysotile is often identified by the presence of a hollow central core and streaked electron diffraction spots. But the clay mineral halloysite also crystallizes in that form and will produce a similar electron diffraction pattern. Therefore, in the absence of exact chemical composition, halloysite can be misidentified as asbestos. Similar care must be exercised to avoid misidentifying other fibrous clay minerals as asbestos, e.g., attapulgite and alpha sepiolite. In addition, talc ribbons can be mistaken to be asbestos, especially when some talcs have particles which roll up into spiral tubes giving the appearance of a chrysotile particle.

Selected area electron diffraction is routinely used to identify a mineral particle as amphibole. Many investigators simply observe the electron diffraction pattern in the microscope and decide on the basis of general pattern geometry whether or not the particle is an amphibole. This can lead to misidentification, since numerous other minerals can give electron diffraction patterns with amphibole pattern geometry [10,11]. Careful measurement of an electron diffraction pattern is required in order to identify the type

of mineral which produced the pattern. Chemical composition is further required in order to have a chance at identifying the particular species when the mineral is a member of a complex group such as the amphiboles. Otherwise, misidentification will result.

Cosmetic Talc Free from Asbestos

In the United States, we have a self-regulating association known as the Cosmetic Toiletry and Fragrance Association. In certifying the purity of the talcs which they use, they are aware that no single method can identify asbestos and their most recent specification for cosmetic talc [12] combines two methods (XRD and optical microscopy) for monitoring their types of talc.

The rationale is that a talc is first examined by XRD, and if even the smallest amount of amphibole is indicated, then the test proceeds into optical microscopy using a dispersion staining technique to determine whether or not the material contains asbestiform particles in the amphibole group.

Summary

This paper has categorized the main methods which have been used for detection of asbestos in talcs. The basic principles of the various methods were categorized to explain how asbestos has been and can be misidentified in talc. Generally, misidentifications arise by jumping to a conclusion from a single mineral characteristic, when, in fact, many characteristics are required to fully identify a mineral species and/or its variety.

Both optical microscopy and XRD required a more detailed review than other methods since they have received the most attention from a monitoring point of view.

This review is presented with the hope that our guidelines will enable analysts to avoid the misidentification of asbestos in talcs.

References

- [1] Ampian, S. C., Asbestos minerals and their nonasbestos analogs. Mineral Fibers Session, Electron Microscopy of Microfibers Symposium, Penn State Univ., August, 1976.
- [2] Thompson, C. S., Discussion of the mineralogy of industrial talcs. U.S. Bureau of Mines Information Circular 8639, Proceedings of the Symposium on Talc, Washington, D.C., May 8, 1973.
- [3] National Bureau of Standards Staff, A report on the fiber content of eighty industrial talc samples obtained from, and using the procedures of, the Occupational Safety and Health Administration, 51 pp. (1977).
- [4] Bowndy, M. G., Gold, K., Burgers, W. A., and Dement, J. M., Exposure to industrial talc in Vermont talc mines and mills: AIHA Conference presentation, May 1977.
- [5] Rohl, A. N., Langer, A. M., Selikoff, I. J., Tordini, A., Klimentidis, R., Bowes, D. R., and Skinner, D. L., Consumer talcums and powders: mineral and chemical characterization, Jour. of Toxicology and Environmental Health, 2, 255-284 (1976).
- [6] Rohl, A. N. and Langer, A. M., Identification and quantification of asbestos in talc, Environmental Health Perspectives, 9, 95-109 (1974).
- [7] Snider, D. W., Pfeiffer, D. E., and Mancuso, J. J., Asbestos form impurities in commercial talcum powders, Compass of Sigma Gamma Epsilon, 49, 65-67 (1972).
- [8] Scholl, R. and Drafts, R., 1977, XRD characterization of asbestiform reference minerals. Symposium on Electron Microscopy and X-Ray Applications to Environmental and Occupational Health Analyses, April 1977.

- [9] Jenkins, R., A review of x-ray diffraction procedures as related to the quantitative analysis of air particulates. Symposium on Electron Microscopy and X-Ray Applications to Environmental and Occupational Health Analyses, April 1977.
- [10] Zoltai, T. and Stout, J. H., Comments on asbestiform and fibrous mineral fragments, relative to Reserve Mining Company taconite deposits: Report to Minnesota Pollution Control Agency, 89 pp. (1976).
- [11] Lee, R., Electron optical identification of particulates: Symposium on Electron Microscopy and X-Ray Applications to Environmental and Occupational Health Analyses, April 1977.
- [12] CTFA Specification - COSMETIC TALC Issued 10/7/76, The Cosmetic, Toiletry and Fragrance Association, Inc.

Discussion

A. WILEY: You said that instantaneous recognition of SAD patterns is difficult. Could you give some examples as to what kind of confusions could exist in this? Can you confuse amphibole with serpentine or amphibole with talc, or is that kind of a gross mistake possible?

J. KRAUSE: Those kinds of mistakes probably would not generally happen if you are looking at pyroxenes or olivine. Electron diffraction is not one of my areas of real expertise, but I think that you could possibly get feldspars that would give confusing patterns, depending upon their orientation in the microscope.

L. MADSEN: We are using all the methods that have been talked about today for identification for asbestos materials and do not in any way limit ourselves to fiber length and aspect ratios.

J. WAGMAN: I would like to comment that it is possible by x-ray diffraction and through a special technique to identify and measure the presence of asbestos fibers even when they are in the presence of their non-fibrous counterparts. About two years ago this was demonstrated in a study which we supported at the Naval Research Laboratory in which samples were pre-treated so that fibers were first aligned and then the x-ray diffraction intensities measured at two different orientations with respect to the x-ray beam and in this way the intensity due to the non-fibrous counterparts could be subtracted from the total diffraction intensities.

KRAUSE: You were putting the fibers in some specific preferred orientation in the sample and then looking for those orientations by XRD.

WAGMAN: That is correct, and this had the advantage of not only making possible corrections, that is correcting for the non-fibrous material present, but also it greatly enhances the detectability for the fibers themselves.

KRAUSE: Is this method being currently used?

WAGMAN: This is a method whose feasibility was demonstrated and there are two publications on this in the literature. Actually our objective was to apply this method to airborne samples, which is a much more difficult application incidently, I should think than in the case of talc. The problem here is a preparative problem in that an air sample usually has a lot of organic material, sticky material present which interferes with the ability to orient the fibers. This is a preparative problem which will have to be overcome. But I should think that in the case of talc samples you probably would not have that problem.

K. HEINRICH: Would the talc plates interfere just as well with the orientation of the fibers?

WAGMAN: The orientation of the fibers is accomplished in an electric field, and the platy material does not preferentially orient itself.

HEINRICH: I mean, just in the sense of a passive restraint to the movement of the fibers.

WAGMAN: This of course would have to be tested experimentally.

A. LANGER: We heard today from a representative of one of the member organizations of the Cosmetic, Fragrance, and Toiletry Associations, that of 3800 consumer talcs examined none contained chrysotile. Today you presented some interesting information on the identification of crocidolite in talc. Have you seen crocidolite in many talcs you have examined?

KRAUSE: No I have not seen it, nor did I say that I have.

LANGER: It does not occur in consumer talcs, or is it industrial talc. I just do not see why the crocidolite issue was raised; have you seen it?

KRAUSE: Just because I have not seen it certainly does not mean that it could not conceivably exist. All I was trying to do was point out that choosing a specific amphibole peak as being representative and definitive for giving a good identification of a particular amphibole species has great potential for error. There are many, many other minerals that could fall within that same two theta region.

LANGER: I would agree with you that even though talcs occur in nature and they have great mineralogical variability they are still bound by the physical and chemical laws involving calcium-silicate rock systems. A mineral phase such as you described would not occur normally.

AMBIENT AIR MONITORING FOR CHRYSOTILE IN THE UNITED STATES

Richard J. Thompson

Analytical Chemistry Branch
Environmental Monitoring Support Laboratory
Environmental Protection Agency
Research Triangle Park, North Carolina 27711

Abstract

The only continuing national air monitoring has been conducted by the National Air Surveillance Network. The objective is long term trend assessment of air quality. The information has proven of value in setting standards, in consideration of health effects, in estimation of economic effects, and in showing patterns of pollutant distribution in both urban and non-urban areas.

In order to provide samples which could be analyzed for constituents not determinable in particulate matter samples collected with glass-fiber filters, a membrane sampling network was instituted. The only analyses of the samples conducted thus far has been for airborne asbestos using in part a method developed under contract which provides for the determination of the mass of chrysotile in the particulate samples.

A viewpoint will be presented on the method needed for air monitoring and an assessment of the mass method as the most suitable for this purpose. Data obtained will be examined which will include information on inter- and intra-laboratory replication.

Key Words: Air monitoring; airborne particulate; asbestos; chrysotile; filters.

National air monitoring had its inception in a Public Health Service survey of protein in airborne particulate matter conducted at seventeen sites in 1953-54. Sufficient amounts of material were collected using glass fiber filters to permit chemical analyses as well as the determination of total suspended particulate matter. In 1955 the Federal Air Pollution Research and Technical Assistance Act, Public Law 159, 84th Congress, was passed. The Network was expanded to 66 stations nationwide for every year sampling and 110 urban and 51 non-urban stations for an intermittent sampling and all the then 48 states and Alaska, Hawaii, and the Commonwealth of Puerto Rico. Currently some 270 stations collect particular matter in the National Air Surveillance Network (NASN).

Certain constituents of the particulate matter collected could not be determined when glass fiber filters were used. As a result, a membrane sampling network was instituted within the NASN in 1969. Until recently 51 stations were maintained, but currently only some two dozen are operated. Samples collected on the cellulose acetate membrane filters can be analyzed for constituents of glass such as boron and silica. The only analyses of the samples conducted thus far, however, have been for the mass of chrysotile in the particulate samples using the method developed by EPA under contract, or a variation of this method.

Ambient air samples collected by EPA had been analyzed by contract [1]¹ in 1966 by both ordinary light field techniques and with dispersion staining with the optical

¹Figures in brackets indicate the literature references at the end of this paper.

microscope and by scanning electron microscopy using magnifications up to 18,500 X. Fibers were noted which were believed to be chrysotile. Because chrysotile comprises approximately 95 percent of the total asbestos used in the U.S., chrysotile was the form of asbestos for which a monitoring method was desired. It was also decided that a mass method would be more appropriate for a survey tool than the fiber count method traditionally used in health effects studies. Although adverse health effects of asbestos on man is the reason for the interest in asbestos in air (airborne asbestos having no known adverse economic effect of significance), the optical method did not seem to be appropriate for analysis of ambient air monitoring samples, albeit effective in the work room where asbestos fibers of optically detectable size were known to prevail. An electron microscopic method would obviously be desired since submicroscopic particles were demonstrated. Chemical analyses obviously would not be an appropriate survey tool, unless sufficiently high concentrations of chrysotile would be found to permit x-ray diffraction as a possible tool for application. Using brake lining consumption figures and assuming that all of the asbestos remains airborne, it was estimated that the chrysotile content of air could under these conditions be in the nanograms per cubic meter range.

The objective of monitoring using the mass method would be to determine the quantity of chrysotile asbestos in ambient air. Thus the objective did not include a need for a knowledge of fiber length, fiber size distribution, and other factors that could be obtainable if the asbestos fibers per se as collected were to be examined. Since a known standard of asbestos in air was perceived a philosophical nightmare, the problem of a quantitative recovery of fibers from air without diminution or destruction, and a quantitative estimation of fiber size and length was considered to be unobtainable for routine application for monitoring chrysotile levels in ambient air.

One problem in particular was the problem of what is to be counted if one is to count that material which is taken from air directly without alteration and if particle recognition, using the morphology of chrysotile was to be employed as a working tool (chrysotile fibrils are cylindrical tubules). One would be posed with the problem of fibrils of chrysotile in ambient air samples of some 30 nm in diameter being present and fibers of chrysotile composed of hundreds of thousands of fibrils being also possibly present in the same sample (if taken at an urban sight where construction/demolition might be ensuing). How would one then handle the problem of counting a fiber and counting an artifact fibril from that fiber? Would they both be counted as fibers (assuming they met aspect ratio criteria)? Fibrils might be produced by one handling technique which might not be produced by what was thought to be the identical technique in the hands of another operator. Furthermore, the non-homogeneity of such a sample would make the counting statistics very unfavorable toward application at a reasonable level. Reasonable in this case is defined as being of the accustomed precision expected by analytical techniques that are more objective and less subjective than particle recognition based on morphology.

The method developed for monitoring of chrysotile in ambient air for EPA under contract [2] has been described in detail elsewhere [2,3]. The method was discussed in detail in a conference held at the Research Triangle Park, North Carolina, by EPA in July 1970 attended by representatives of all U.S. laboratories then known to be working on asbestos estimation from air samples and included representation of the United Kingdom. A method similar to the EPA method in some details was developed independently [4].

The method developed for EPA differed slightly from other mass methods employed at that time. The method in use at Johns-Manville used a gold labeling technique to achieve quantitation of chrysotile; a watch glass was used to grind a sample suspended in amyl acetate on a microscope slide. Gold 198 was added prior to ashing and the efficiencies of recovery was estimated by radioactivity measurements of the gold, the chrysotile was assumed to behave as did the gold standard [5]. The method then employed by Mount Sinai Laboratories involved grinding with a glass and spiking the samples with known weights of chrysotile from which a recovery factor was derived and used in calculation [6].

The method developed for EPA for the determination of the mass of chrysotile in ambient samples involves starting with a portion of a particulate matter sample taken on a cellulose acetate filter, ashing at low temperature, suspending in water with the aid of a surfactant, and grinding to fibrils by ultrasonication at high energy. The now homogenous samples containing shattered fibrils is filtered on a membrane filter coated with a 20 nm

layer of carbon, sectioned, the filter substrate removed with acetone, and the carbon film placed on a 200 mesh copper electron microscope support grid. The sample is examined at 20,000 X with a transmitting electron microscope (TEM), and the chrysotile fibers (fibrils) determined by counting grid openings to obtain a count of 100, or a minimum of 5 grid openings if a count of 100 is not obtained. The mass equivalent of the count is obtained from a working curve constructed from data derived by counting samples containing known amounts of added chrysotile.

Synthetic standards were made by addition of known quantities of pulverized sea sand, particulate matter collected from air, (ignited to 800 °C to destroy chrysotile) fly ash, and water. The samples so prepared were subjected to the procedure described. It was established that the curve obtained by plotting count versus mass of known chrysotile added may be derived satisfactorily by adding weighed known chrysotile to water alone.

Asbestos obtained from commercial supplies of mineralogical samples included chrysotile, amosite (which constitutes almost all of the non-chrysotile asbestos used in the U.S. commercially), and crocidolite. The chrysotile used in the developmental work was a "respirable pure" white chrysotile obtained from Johns Manville.

Advantages to be noted by this procedure are that if the ultrasonification is complete, there should be a uniform distribution of fibrils of a spectrum of lengths which is related to the energy of ultrasonification applied and that the uniformity of the sample and the (comparatively) tremendous number of fibrils of chrysotile to be determined enhances the statistical possibility of replication, at a reasonable level, using simplified counting techniques. There is of course the possibility of a recognition problem of any material in air which would behave as does chrysotile and appear as does chrysotile in the carbon replica which contains fibrils. The diameters of chrysotile fibrils from diverse geographical origins are said to be within a very narrow size distribution approximating 30 nm [4]. Confirmational data such as SAED and atom ratios by probe can be obtained.

The method was applied to samples taken from ambient air in urban areas where asbestos might be expected to be found on the basis of industrial activity and to samples taken from a remote location. Representative data are given in Table 1. The remote location was chosen as being as far from road traffic as could be found in one day's commuting from the laboratory and at a site where power existed. The replication at low levels was surprisingly good; triplicate samples gave mean values of approximately 0.1 nanograms per cubic meter with a replication within 10 percent of the value measured. Even at the level of 0.03 nanograms per cubic meter the spread of measured values was within 10 percent of the value measured. For samples which contain tens of nanograms per cubic meter, replication was achieved within 50 percent of the average value noted. The method was checked by a phenomenologically different approach wherein samples of asbestos, activated by neutron irradiation, were blown into a chamber and recollected. As shown in Table 2, radioassays and the TEM estimates agreed within 30 percent of the average value of the two readings recorded by the different methods. The replication found within the method in the limited comparison between methods lead one to believe that the two phenomenologically independent methods gave comparable results and that the electron microscopy method gave replication in the vicinity of 50 percent. It may also be noted that the Stokes diameter was checked at sites downwind from a point source at distances of 1 and 2 miles, the predominant diameter distribution in terms of the mass seemed to be in the fraction of asbestos particles which were in the 8 to 16 micrometers diameter stage of the collection device.

Table 1. Replication filter section determination (TEM).

<u>Site</u>	<u>Location</u>	<u>ng Chrysotile/m³ air</u>	<u>Average</u>
A	Near use site (1970)	280, 260	270
A	Near use site (1971)	110, 86	98
A	Near use site (1971)	7900, 7200, 9700	8200
B	Near use site (1970)	28, 40	34
B	Near use site (1971)	130, 117	124
A 1 ^a	Remote site	0.112, 0.102, 0.147	0.12
A 1 ^a	Remote site	0.094, 0.119, 0.106	0.10
A 2	Remote site	0.028, 0.024 0.026	0.03

^a Two samples taken concurrently.

Table 2. Method comparison check.

<u>Sample</u>	<u>Radio assay</u>	<u>TEM</u>	<u>Difference %</u>
1	8.3	11.0	29
2	34.0	40.0	15
3	17.6	20.8	15
4	4.7	4.0	18

Quarterly composites constructed from the 51 network sites were analyzed for chrysotile. The average of the analyses of some 521 of these composites samples is 2.6 nanograms of chrysotile per cubic meter of air sampled. The samples analyzed were quarterly composites of those samples collected through the second quarter of 1973. In Table 3 the data replicate slices of quarterly composites are given; these samples were provided to the contract laboratory on a blind basis for the purpose of an external audit. The percent of absolute deviation from the average of 22 individual sample sets was 40 percent. In Table 4 the internal QC replication of a different laboratory is given; note that in the analyses of 16 sets of replicate sections from samples, the percent absolute deviation from the average is 43. In Table 5 the data are shown obtained from a sample split program between the two laboratories conducted on a blind basis to the participating laboratories. Note that some of these data are common to Tables 3 and 4 also. It is of interest that in 24 sample sets of samples analyzed by each laboratory in some cases the data shown are averages of replicates within one of the laboratories. The percent absolute deviation from the average is 59 percent. From an examination of these data one gets the impression that the average percent deviations are roughly the same between laboratories and within laboratories. It is also of interest that in the inter-laboratory

Table 3. Intra-lab replicate analyses for chrysotile, (high cities, blinds external audit).

Site location	Sample period	Lab A		Mean	Average % absolute deviation from mean
		1st	(ng/m ³) 2nd		
A	1	1.7	1.2	1.5	33
	4	2.1	1.8	2.0	8
B	1	4.0	6.7	5.2	25
	4	7.4	7.2	7.3	3
C	1	4.0	3.7	3.9	4
	4	5.3	1.5	3.4	56
D	1	9.4	4.4	6.9	39
	4	11.0	3.1	7.0	57
E	1	8.4	8.0	8.2	3
	4	3.0	4.6	3.8	23
<u>1972 (quarter)</u>					
A	1	1.6	26.7	14.2	88
	2	3.7	2.8	3.2	34
B	1	6.1	2.8	4.5	73
	2	6.6	1.4	4.0	53
	3	9.6	1.6	5.6	71
Z	2	0.4	27.7	14.1	97
C	1	4.2	2.5	3.4	25
	2	0.7	1.2	1.0	25
D	1	6.8	2.0	4.4	50
	2	0.8	2.8	1.8	56
E	1	18.8	11.8	15.3	23
	2	3.1	1.6	2.3	31
Average					40

Table 4. Intra-lab replicates for chrysotile, internal Q.C.

Site location	Sample period quarter-year	Lab B			Average % absolute deviation from mean
		1st	(ng/m ³) 2nd	Mean	
F	1-70	0.8	0.4	0.6	33
G	4-69	20.3	12.6	16.5	23
A	3-69	110	80	95	16
H	3-69	25.3	13.5	4.5 14.4	48
I	3-69	5.4	3.3	4.4	23
J	2-70	1.1	0.1	0.6	83
B	3-69	5.2	3.1	4.2	24
C	4-69	62.3	17.7	40	56
D	4-69	1.3	0.0	0.7	85
Z	3-69	50	27	38	31
K	2-70	5.2	1.0	3.1	68
L	2-69	1.7	1.1	1.4	21
L	1-70	6.3	2.4	4.4	44
M	2-69	5.3	2.1	3.7	43
N	2-69	25	5.3	1.3 10.2	95
O	3-69	19.3	16.6	18	7
Average					43

data given in Table 5 one may note that of the 5 value sets (of the 24 given) which are not within a factor of 10 of each other, findings above 10 nanograms per cubic meter (which is twice the average value for the set including the high values) are involved, and that three of the high values were reported by one lab, and two by the other. It is possible that the samples of high value (for which the agreement is the poorest) have large particles of asbestos and are thus more inhomogenous than are the samples with lower asbestos contents. It is also of interest that in a comparison of mass by the sample count versus standard count method with a mass computed from fiber volume from direct fiber counts of replicates, a bias of the mass method toward higher readings is noted in Table 6.

Table 5. Replicate analysis for airborne chrysotile between laboratories (in ng/m³).

<u>City</u>	<u>Quarter</u>	<u>Lab B</u>	<u>Lab A</u>	<u>Mean</u>	<u>Average % absolute deviation from mean</u>
(Samples collected in 1969)					
A	2	0.4	1.8	1.1	63
	3	95	3.9	49	202
	4	0.7	15.6	8.2	182
B	2	3.9	5.3	4.6	15
	3	4.2	6.7	5.5	22
	4	8.0	3.5	5.8	39
Z	2	0.4	0.5	0.5	11
	3	1.2	0.5	0.9	41
	4	38	0.4	19.2	98
C	2	1.3	11.1	6.2	80
	3	1.5	0.7	1.1	36
	4	40.0	0.5	20.3	98
D	2	1.1	0.4	0.8	47
	3	11.8	0.5	6.2	92
	4	0.7	0.5	0.6	17
E	2	4.4	1.0	2.7	63
	3	0.7	1.1	0.9	22
	4	2.1	0.6	1.4	56
(Samples collected in 1970)					
A	1	1.0	1.4	1.2	17
B	1	6.5	1.3	3.9	67
Z	1	1.2	0.9	1.1	14
C	1	2.2	0.6	1.4	57
D	1	1.5	0.8	1.2	30
E	1	4.6	1.5	3.1	51
Average					59

Table 6. Mass methods comparisons, count vs. volume (in ng/m³).

<u>Sample</u>	<u>Mass by fibril count (C)</u>	<u>Mass computed from "fiber" volume-density (V)</u>	<u>Ratio C/V</u>
1	21	4	5.1
2	216	141	1.5
3	1,674	476	3.5

The consideration of the health effects of asbestos fibers, fibrils, fiber size, etc., will be considered elsewhere in this symposium. For the problem of monitoring for the definition of air quality on a long-term basis which conceivably could be used for regulatory purposes for citing standards and for control measures and possibly for interpretations with respect to human health, in my judgment the mass method outlined in this paper is a superior method. It may avoid two very significant problems in the estimation of the chrysotile content of air as measured in collected particulate matter. One is the problem of homogeneity which is a problem with every sample that one obtains from the air. For example, asbestos fibers may be put into the air by construction/demolition. The other is the problem of what constitutes a fiber? This is in a sense another aspect of the same problem. If one had a uniform distribution of fibrils over a sample, the fibrillar estimation would probably be comparable by both methods. If however, one obtains a fiber or two, here and there, obviously then the sample is automatically inhomogeneous since fibers could conceivably consist of 10^5 fibrils. In the method where the fibers and free fibrils are ground ultrasonically, the resulting particle size distribution should be a function of the energy put in. The procedure described should then yield a homogeneous mixture. It is not suggested that this approach is the final answer for all monitoring problems, or that it addresses anything at all concerning fiber length in real air samples of any form of asbestos, or fiber size distribution. It is patently apparent that information of this nature cannot be obtained reliably using a method wherein the material has been subjected to diminution.

References

- [1] Walter C. McCrone Associates, Inc. reports to E. C. Tabor, EPA, 1966.
- [2] Henry, W. M. et al., Development of a Rapid Survey Method of Sampling and Analysis for Asbestos in Ambient Air, Battelle Columbus Report, Contract No. CPA 22-69-110 (February 1972).
- [3] Thompson, R. J. and Morgan, G. B., Determination of Asbestos in Ambient Air. Proceedings, International Symposium on Identification and Measurement of Environmental Pollutants, 154-157 (June 1971).
- [4] Rickards, Anthony L., Estimation of Submicrogram Quantities of Chrysotile Asbestos by Electron Microscopy. Anal. Chem., 45, 809-811 (1973).
- [5] Spiel, S. and Fenner, E., personal communication.
- [6] Nicholson, W.J. et. al., Measurement of asbestos in Ambient Air, Mount Sinai School of Medicine, Contract CPA 70-92 (1971).

Discussion

O. MENIS: Are you familiar with the work of Spurny et al. on the Nuclepore and membrane filter retention and would you like to comment on it, because there appears to be some loss, 20 percent internal loss. Also, the question of prefiltering a lot of junk beforehand seems to be attractive.

THOMPSON: Let me tell you why I don't like prefiltering. When you use a filter that is composed of a bunch of fibers matted together as are our glass fiber filters and the membrane filters we use (that's not so with Nuclepore, obviously; they drill holes in their's) then you are dealing with a brush pile of fibers, and as you put that particulate matter on there I am convinced you go from a surface of the fiber to a particulate laden surface. After your first few minutes of sampling on a 24 hour basis, it's my belief that what you are dealing with is particulate matter filtration, and not filter filtration anymore. The particulate matter itself is now your filter, and to support that I will tell you of a two-week sampling shot I made to collect massive quantities of materials for detailed chemical analysis. I wanted the total elemental composition of particulate matter so I would know what I was up against analytically. Nobody had ever done that. You are filtering with particulate matter and here is why I think that.

You start off with a high volume sampler at about 60 cfm, and if you run about 10 days you find that the flow is down to a constant of about 30 cfm. You put in 8x10 cellulose acetate filter on the same type of device, calibrate it to draw what it should be, 60 cfm with the glass fiber filter, and you sample about 35 cfm through that membrane filter. After about 10 days you will be filtering about the rate of about 30 cfm. If you throw another kind of filter substrate on there you see the same thing. That loading, I think, is your terminal loading of particulate matter that affects flow, but I am convinced you are filtering with particulate matter. I do not like prefiltration for that reason. You are going to get stuff hung on there; you are going to lose material, and that filter is not smart enough to open up and let whatever it is you want through quantitatively. It just won't do it. We tried it and I have had notable lack of success with that approach. It sounds nice, that you could screen out the lumps, but in practice it doesn't work that way. I don't think it feasible, and I have never been able to accumulate data that were very satisfying.

ENVIRONMENTAL PROTECTION AGENCY INTERIM METHOD
FOR DETERMINING ASBESTOS IN WATER

Charles H. Anderson

Environmental Research Laboratory
U.S. Environmental Protection Agency
Athens, Georgia 30601

Abstract

The discovery of asbestos and asbestiform minerals in water supplies and drinking water has resulted in the requirement for a reliable analytical method. In order to meet this requirement, an interim method, based upon the state-of-the-art in asbestos analytical methodology, has been prepared. In this paper, the broad elements of the method are set forth and discussed.

Key Words: Analytical Chemistry; asbestos; environmental pollutants; water.

Introduction

Environmental concern following the discovery of asbestos and asbestiform minerals in water supplies and drinking water has resulted in a broad range of activities within the Environmental Protection Agency to improve detection sensitivity and to delineate human exposure and subsequent health effects. An important initial step is the development of a reliable analytical method for determining asbestos in water. Based upon the premise that a method should reflect the state-of-the-art of asbestos analytical methodology, an interim procedure has been written. As such, it is a working document subject to subsequent revision and validation. The method relies on previously published work [1-5]¹ together with the work that has been carried out at the Environmental Protection Agency's laboratories at Duluth, MN, Athens, GA, and Cincinnati, OH.

In this paper, the broad elements of the method and a discussion of the rationale for some of the decisions that were made when choosing between alternatives is presented. The basic features of the method are summarized in Table 1; the complete, detailed method is available upon request from the author.

¹Figures in brackets indicate the literature references at the end of this paper.

Table 1. Summary of EPA interim method for asbestos in water.

<u>Definition:</u>	<p>Chrysotile — A magnesium silicate, the fibrous form of serpentine, possessing a layered, helical cylindrical structure.</p> <p>Amphibole — A silicate mineral whose basic structural unit is a double silica chain, of variable composition, and layered structure.</p> <p>Fiber — A particle in the micron size range possessing parallel sides and a length/width ratio of greater than or equal to 3:1.</p>
<u>Instrumentation:</u>	Transmission Electron Microscope capable of selected area diffraction.
<u>Sample:</u>	One liter of water.
<u>Sample Preparation:</u>	<p>Filter sample through .1 μm Nuclepore or .22 μm Millipore using sample volume 50-500 mL. Maximum of 20 $\mu\text{g}/\text{cm}^2$ total particulate.</p> <p>High organic requires low temperature ashing and resuspension by mild ultrasonification.</p> <p>Portion of Millipore placed on TEM grid, dissolve by condensation washing or, carbon coat Nuclepore, dissolve by Jaffe Wick in chloroform.</p>
<u>TEM Examination:</u>	At 10,000-20,000 magnification. Count 100 fibers or 20 grid squares. Use field of view method if greater than 50 fibers/grid square.
<u>Identification:</u>	Chrysotile on the basis of morphology and SAED. Amphibole on the basis of morphology and SAED.
<u>Reporting:</u>	<p>Confirmed chrysotile and amphibole fibers in MFL (million fibers/liter)</p> <p>Mass/liter</p> <p>Distribution by length, width, and aspect ratio</p>

Definition of Asbestos

Before any quantitative analytical procedure could be outlined, it was obvious that the term asbestos required a definition in terms of measurable chemical and physical parameters. Of the two broad classes of asbestos, chrysotile is readily defined on the basis of its unique morphology, crystalline structure, and elemental composition. Amphibole's characterization, on the other hand, is not so straightforward. The broad class of amphiboles can be defined as silicate minerals whose basic structural unit is a double silica chain, a fibrous morphology, and elemental composition corresponding to the recognized amphibole asbestos types. In the EPA method, amphibole asbestos determination is based on crystal structure, amphibole morphology, and a fiber aspect ratio of 3:1 or greater. The basis for this fiber aspect ratio is conservative and reflects the state-of-the-art in asbestos analytical methods. Although this aspect ratio is lower than that proposed by Ampian [6], it would seem that the ultimate test, insofar as environmental samples are concerned, lies in the health effects of mineral fibers of different size and aspect ratio. Although health effects data will prove difficult to obtain, it seemed prudent to use this more conservative approach.

The Environmental Sample

As the EPA interim method would be applied to a variety of pollution sources and used for a variety of purposes, no attempt was made to furnish specific sampling instructions. Instead, only guidelines and precautions were included in the method. Asbestos is, in fact, a special type of particulate matter exhibiting a range of particle sizes, and a vertical distribution of asbestos concentrations may be present in a water supply. For example, Cook [7] has documented the variability of amphibole fiber concentrations in Lake Superior at the Duluth water supply intake and demonstrated that the amphibole fiber concentrations were dependent on the presence or absence of an ice cover on the lake, the direction and velocity of winds, and the depth of the thermocline. It is important, therefore, to plan a sampling program for a particular purpose and to use the results only in context of the sampling procedure.

Another analysis issue was whether the sample taken in the field should be filtered with the filter and its deposited particulates sent to the laboratory; or, whether the entire water sample should be collected and furnished to the analytical laboratory. Although each approach has advantages, it was considered that the possibility of contamination, the potential for loss from the filter paper, and the general lack of control of the filtration step were overriding disadvantages of filtration in the field. Collection of a sample of the water itself was therefore suggested as the better alternative.

The Analytical Approach

Choice of Instrumentation

In broad terms, the approach to the determination of asbestos in water uses preconcentration by filtration followed by direct microscopic identification and measurement of the asbestos fibers.

Because asbestos fiber diameters are below the range of optical microscopy techniques, electron microscopic methods must be employed. Although scanning electron microscopy (SEM) has been suggested to be applicable [8], those laboratories that have compared transmission electron microscopy (TEM) with SEM have concluded that TEM is the superior tool [1,4,9]. TEM allows examination at low ($\sim 200\times$) and high ($\sim 20,000\times$) magnification and gives excellent brightness and contrast. Furthermore, most modern TEM instruments readily allow selected area electron diffraction (SAED) to be carried out on individual fibers; such capability allows a positive identification of the characteristic crystalline structure of chrysotile and amphiboles. An energy dispersive x-ray (EDX) detector is adaptable to the newer TEM's and can furnish additional information on the elemental composition of individual fibers that are under examination, but its use was not required in the EPA-proposed method.

Preparation of Samples

The analytical sample, as received by a laboratory, will consist of a 1-liter polyethylene bottle containing a representative sample from the environmental source. The objective of preparing the subsample and subsequent microscopic sample is to transfer the asbestos particles from the environmental source to the TEM with a minimum loss. At the same time the particle size, shape, and size distribution in the original sample should be maintained. Furthermore, the TEM sample must allow the examination of single asbestos fibers with no overlapping or obscuration by extraneous material.

The initial step in the sample preparation is the filtration of a known volume of the water sample containing the suspended particles of asbestos onto a membrane filter. This filtering is a critical step whose function is not only to separate, but also to uniformly distribute the particulate matter with minimum of overlap. Some precautions are therefore necessary in this procedure. The liquid sample is agitated in a low-power ultrasonic bath prior to filtration to ensure homogeneity. A fixed volume, ranging from 50-500 mL, is added to a vacuum filtration apparatus containing a 0.1- μm Nuclepore or a 0.22- μm Millipore filter. The volume is determined by the amount of particulate matter present,

and the maximum loading that can be tolerated is 20 µg/cm, or about 200 µg on a 47-mm filter. The applied vacuum should be sufficient for filtration but gentle enough to avoid the formation of a vortex. Once the filtration has been initiated, no additional water should be added nor should the sides of the funnel be rinsed.

If the sample contains a substantial amount of organic material, a preliminary, ashing step is required, followed by resuspension and filtration. Low-temperature ashing in an oxygen plasma with resuspension in a fixed volume of water followed by mild ultrasonification has been found to be satisfactory.

Preparation of TEM Specimen

The transfer of a part of the filter on which the particulates have been deposited on the TEM grid and the subsequent elimination (by dissolution) of the filter material so that a TEM examination can be accomplished is probably the most critical step in the analysis procedure. As the examination in the TEM and subsequent calculations assumes a random orientation and little or no loss of particles, it is essential that the transfer be carried out not only without losing particles, but also with a minimum of movement. This goal becomes very difficult to achieve, largely because the asbestos fibers are in the colloidal size range; movement apparently can take place very easily.

Two approaches acceptable for TEM sample preparation are:

- a. The condensation washer method, which is used when a Millipore filter is employed.
- b. The Jaffe Wick method, which is used with a Nuclepore filter.

In the condensation washing technique [1,3], acetone vapors are condensed in a special reflux condenser at the position just below the TEM grids. Successful operation requires the delicate introduction of sufficient vapor to dissolve the filter in a reasonable time but not enough to cause pooling, movement, or wash-off of the deposited fibers. As a result, close control of bath temperature, cooling water temperature, and flow is required. McCrone [1] and Lishka, et al. [3] claim successful results with this procedure. Beaman [4] in a detailed study of the condensation washing technique, found, under his experimental conditions, amphibole fiber losses ranging from 37 to 60 percent. Chrysotile fibers apparently are less mobile, for Beaman found losses ranging from 0 to 21 percent. In spite of the criticisms of the condensation washer, the fact that at least two laboratories obtained successful results dictated the inclusion of the method as an alternative preparation step in the EPA procedure.

In the Nuclepore-Jaffe Wick technique, the Nuclepore filter is carbon-coated in a vacuum evaporator (after filtration) before attempting to dissolve the filter material from the grid. Fixed by the carbon coating, the particles are thereby rendered immobile and less susceptible to loss. The filter material is dissolved away by a simple wicking action that can be obtained from several layers of filter paper in a covered Petri dish containing chloroform. The dissolving time, although longer than that for the condensation washer, can usually be accomplished overnight. The Nuclepore filter is well adapted to carbon coating because it has a flat surface and no disturbing, replicated structure is found in the grid film. In contrast, the Millipore filter contains a fibrous-like structure that, when replicated, interferes with the TEM examination. Cook [5] at the Duluth Environmental Research Laboratory, Nicholson [2] at Mt. Sinai, Glass [10] at Ontario Research Foundation, and chemists at our laboratory have all obtained excellent results with the Jaffe Wick preparation method. An advantage of this method is that if a fiber is lost during the dissolving step a replica of the fiber remains; thus, an internal check on the procedure is preserved. The fact that such fiber replicas are rarely if ever observed gives substance to the conclusion that no significant loss or movement takes place during the preparation process.

Counting of Fibers

The prepared TEM grid holding the asbestos fibers and other particulate matter is initially examined at low magnification (300x-1000x) in order to determine whether the

grid preparation has been prepared satisfactorily. If the grid is too heavily loaded (>300 fibers/grid square), if the distribution is noticeably uneven, or if a majority of the grid squares have broken carbon films, a new preparation is required. For those natural waters that contain sufficient organic matter to obscure other particulates, the filtered material must be subjected to low temperature ashing, resuspension, and filtration.

The analytical procedure employs standard counting techniques at 10,000-20,000x in determining the number, dimensions, and type of asbestos fibers that are present in the area that is examined. Two general approaches—random search or systematic search—were suggested for the EPA method depending on the number of fibers present.

If an 80 μm x 80 μm grid square contains more than about 50-100 fibers, it is convenient to use the field of view method. Beaman [4] and chemists at the Athens Laboratory have found this method satisfactory for these situations. In this method, several grid squares are selected and random fields of view examined. The area of the field is known from the magnification of the microscope and the area of the projected image. The total fibers counted in the known number of fields of the known area can be then converted to million of fibers per liter (MFL) through a simple conversion factor that is dependent on the original filter diameter and the amount filtered.

If only a few fibers are found in each grid square, it is more convenient to systematically search up to ten whole grid squares and count the fibers lying within these areas. As the area of individual grid squares may vary by ~10 percent, the dimensions of each grid square examined should be recorded.

Ideally, 100 fibers are examined for each sample, 50 each from two grid preparations. In practice, however, some samples may contain so few fibers that considerations of time become important. In the EPA method, ten grid squares on two grid preparations are examined, and the number of fibers in this fixed area are counted when the fiber concentrations are quite low.

Identification of Fibers

Each fiber that is found should be subjected to further examination to determine whether it is asbestos and classified as chrysotile or an amphibole type. Chrysotile's unique tubular structure and its tendency to form bundles of single fibers makes it readily identifiable. For an unequivocal identification, however, a selected area electron diffraction (SAED) pattern of chrysotile gives a unique pattern exhibiting prominent streaks on the first layer line and a triple set of double spots on the second layer line. UICC standard asbestos fiber material is available to furnish standard comparison diffraction patterns.

Amphibole fibers are identified on the basis of lath-like morphology, aspect ratio, and an SAED pattern. Although it would be desirable to identify the different amphibole asbestos types, their diffraction patterns are almost identical and their differentiation by SAED is almost impossible and clearly impractical. Amphibole identification is more difficult than chrysotile because the amphibole SAED does not have the unique characteristics of the chrysotile pattern and requires some judgement in interpreting the SAED pattern. Some amphibole fibers show only partial patterns that are not sufficiently complete to allow positive identification; these are classified as "probably" amphiboles.

As Beaman [4] and Millette [11] have indicated, it is useful to determine the elemental composition of a fiber as an aid to identification. This is particularly true if a fiber fails to give an identifiable electron diffraction pattern and additional information is required for identification. Because the fiber width and thickness is less than that excited by the electron beam, the elemental x-ray intensities are a function of width. This variation with particle size can be partially overcome, however, by determining x-ray intensity ratios. But these ratios, because of differential absorption, are also a function of particle size. Because of the difficulty of specifying quantitative procedures based upon x-ray intensities, the EPA method suggests the use of energy dispersive x-ray analysis as a useful tool but does not require its use. As Ruud [12] has pointed out, even though a good quantitative analysis could be obtained from EDX, it should not be considered a definitive identification without an SAED pattern.

The length and width of each fiber positively identified, as well as the "probables", are recorded.

Precision of Analysis

The analysis precision obtained within an individual laboratory is dependent upon the number of fibers counted. If 100 fibers are counted and the loading is at least 3.5 fibers/grid square, computer modeling of the counting errors shows that a relative standard deviation of only about 10 percent can be expected. In actual practice, some degradation from this precision will be observed but should not exceed ± 20 percent if several grids are prepared from the same filtered sample.

The relative standard deviation of analyses of the same water sample in the same laboratory will increase because of sample preparation errors, and a relative standard deviation of about ± 20 -30 percent can be expected. Table 2 shows the results obtained on five sets of samples of asbestos and indicates that this range can be achieved. As the number of fibers counted decreases, the precision will also decrease approximately proportional to $N^{1/2}$ where N is the number of fibers counted.

Table 2. Precision of C-coated Nuclepore method.

Type asbestos	No. samples	Ave. conc. (MFL)	Standard deviation	Coefficient of variation
Chrysotile	10	23	4.7	23%
Crocidolite	9	13	1.7	13%
Crocidolite	10	16	2.8	17%
"Taconite"	10	21	5.0	24%
"Taconite"	10	28	3.4	12%
			Average	18%

Although there have been a number of interlaboratory testing programs, few of these have been carried out using the same procedure. Those that have been done indicate that agreement within a factor of two is achieved if 100 fibers can be counted. Results obtained among three laboratories at different locations within the Environmental Protection Agency are given in Table 3. Although these data are insufficient for statistical purposes, they indicate the analysis capability obtainable at the present time.

Table 3. Comparison of results—Nuclepore method (except as noted) positively identified fibers (MFL).

Sample	Asbestos type	Lab A	Lab B	Lab C
1	Amphibole	137	150	---
2	Amphibole	86	92	70 ^a
3	Amphibole	130	220	140
		13 ^a		120 ^a
4	Amphibole	44	58	58
		17 ^a		48 ^a
5	Chrysotile	29	14	---
		17 ^a		---
6	Chrysotile	66	58	60
		56 ^a		50 ^a

^a Condensation Washer.

Summary

The Environmental Protection Agency has written an analytical method for asbestos in water, based on what was considered to represent the state-of-the-art asbestos analytical methodology. In its present form, the method should be considered as an interim method having no official status. When the results of future research efforts and cooperative testing are available, it is expected to be proposed as a referee method for asbestos.

References

- [1] McCrone, W. C. and Stewart, I. M., Asbestos, Amer. Lab. 6(4), 10-18 (1974).
- [2] Nicholson, W. J., Analysis of amphibole asbestiform fibers in municipal water supplies, Env. Health Perspectives 9, 165-172 (1974).
- [3] Lishka, R. G., Millette, J. R., and McFarren, E. F., Asbestos Analysis by Electron Microscope in Proc. AWWA Water Quality Tech. Conf. American Water Works Assoc., Denver, CO, XIV-1 - XIV-12 (1975).
- [4] Beaman, D. R. and File, D. M., Quantitative determination of asbestos fiber concentrations, Anal. Chem. 48, 101-110 (1976).
- [5] Cook, P. M., Rubin, I. B., Maggiore, C. J., and Nicholson, W. J., X-ray Diffraction and Electron Beam Analysis of Asbestiform Minerals in Lake Superior Waters in Proc. Inter. Conf. on Environ. Sensing and Assessment 34, Las Vegas, NV, 1-9 (1976).
- [6] Ampian, S., Asbestos Minerals and Their Nonasbestos Analogs, paper presented at Electron Microscopy of Microfibers Symposium, Pennsylvania State University, University Park, PA, August 23-25, 1976.
- [7] Cook, P. M., Glass, G. E., and Tucker, J. H., Asbestiform amphibole minerals: detection and measurement of high concentrations in municipal water supplies, Science 185, 853-855 (1974).

- [8] Pattnaik, A. and Meakin, J. D., Development of an Instrumental Monitoring Method for Measurement of Asbestos Concentrations in or Near Sources, (U.S. Environmental Protection Agency, Washington, DC, EPA 650/2-73-016, 1973).
- [9] Flickinger, J. and Standridge, J., Identification of fibrous material in two public water supplies, Environ. Sci. and Tech. 10, 1028-32 (1976).
- [10] Glass, R. W., Improved Methodology for Determination of Asbestos as a Water Pollutant, Ontario Research Foundation Report, April 30, 1976, Mississauga, Ontario, Canada.
- [11] Millette, J. R. and McFarren, E. F., Eds of waterborne asbestos fibers in TEM, SEM, and STEM, Scanning Electron Microscopy/1976 (Part III) 451-460 (1976).
- [12] Ruud, C. O., Barrett, C. S., Russell, P. A., and Clark, R. L., Selected area electron diffraction and energy dispersive X-Ray analysis for the identification of asbestos fibers, a comparison, Micron 7, 115-132 (1976).

Discussion

R. LEE: I noticed in your description of the method that you rely on chrysotile which has a selected area diffraction, and has morphology. For amphiboles you rely on morphology plus selected area diffraction or chemistry. If you accept that as your definition of an asbestos particle, I think it is very important to know whether or not what you are telling me is that now I have to treat any cleavage fragment, any massive hand specimen which I grind down, in which there should be a more morphological and orientation difference, as an asbestos particle. Secondly I'd like to say that, before you answer, that we're going to show some preliminary data that suggest that we can give you a very close diagnostic method for distinguishing between them.

C. ANDERSON: This is not my idea of what should be done or should'nt be done, this is our concept of the consensus of the state of the art of analytical methodology in asbestos as it existed when we wrote the method. The state of the analytical methodology for amphiboles is just very, very muddy. We certainly are willing to listen to your suggestions as to how we can do this better.

LEE: Is there any reason to assume that all amphibole cleavage fragments are identical to amosite asbestos?

ANDERSON: I think that the critical issue is what are the health effects of one versus the other.

LEE: The only data we have seen on that to date was shown yesterday, indicating that grunerite had no cellular activity.

ANDERSON: I saw some slides showing almost any particle has some in vitro effects.

LEE: In this particular case grunerite (the non-fibrous variety) did not show any activity.

ANDERSON: What were the particle characteristics of the grunerite?

A. WILEY: I suggest that you change your title. Rather than identifying asbestos say that you are identifying chrysotile and amphibole. Since you can't say that it is asbestos, why not say just amphibole, period.

V. WOLKODOFF: I notice in your paper, for five fibers, you would say statistically significant, and anything less than that would be not statistically significant. Do you still hold to that?

ANDERSON: The five-fiber criterion was considered to be the state of the art, and I was happy to see Dr. Leineweber point out that at five fibers the statistics show you the range is between .48 and 10. It seems to me that five fibers is statistically significant to indicate asbestos is present.

WOLKODOFF: If you go by the Poisson distribution. But there are cases where less than five fibers is extremely important in the interpretation of particular problems to us, providing our background is zero.

ANDERSON: You apply the statistics to your problems in the context of what you are worrying about. What we did was, if you find less than five in the water samples you really can't say with much confidence how much is there.

WOLKODOFF: I'm glad to hear you say that and really it's a big help then. On this business of hornblende, is this your official stance or posture that these are not to be counted?

ANDERSON: I can't take any official stance. I claim in the method you will misidentify hornblende as an amphibole asbestos. If the mineralogists want to take issue with me, let me know. We will take that out.

WOLKODOFF: Have you gone into this as a subject?

ANDERSON: You mean as far as differentiating various types?

WOLKODOFF: Of the various types, yes.

ANDERSON: No.

WOLKODOFF: As far as you are concerned then, a hornblende is a hornblende. I mean, an amphibole is an amphibole.

ANDERSON: Right.

WOLKODOFF: Your people, like Milette and Cook and yourself, can you actually differentiate amphiboles by selected area electron diffraction? Have you gone into this subject?

ANDERSON: As differentiate types, no.

WOLKODOFF: As far as you are concerned, an amphibole is an amphibole.

ANDERSON: Right.

WOLKODOFF: I thought then perhaps that when you say that EDS is not absolutely necessary, that maybe there was a matter of cost reduction, but you are saying that for technical reasons, very much like Don Beaman pointed out.

ANDERSON: Look at this from my point of view. Suppose I say, Valdimir write a method that everybody agrees with and put it down specifically enough so that people can follow it. How do you do this with an EDS system? I don't know. I don't know that much; I strongly recommend using it, but I was not really very comfortable in just saying use the EDS like the manufacturer said to use it.

WOLKODOFF: For many of our problems it would be of great benefit.

ANDERSON: And, of course, there is a cost consideration involved here too.

WOLKODOFF: I must commend and compliment you on your paper. We felt it was very well done, and I think with some additions and so forth it will.....

ANDERSON: Thank you.

BEAMAN: I'd like to mention the EDS,. Charles, again I think there have been presented at this meeting and last year's some very serious challenges to the use of selected area electron diffraction identification and classification of amphiboles. I've heard people say it was almost impossible to classify cleavage fragments as an amphibole looking at the selected area electron diffraction pattern on the screen of the TEM. You may be able to classify by taking a photograph and indexing it, but I think that in conjunction with the energy dispersive spectrometry you are on much firmer ground.

ANDERSON: I agree, but I think what you have to remember is also the purpose of the method that we wrote. We wrote it from the point of view of not giving a complete characterization of the particulate matter that was in a water source. We consider that to be a little bit beyond the scope of an analytical method. There is a fine distinction between a very quick and dirty method and a research method in which you are characterizing the whole source and an analytical method that the broad analytical laboratory might want to use.

BEAMAN: If you were going to use just the SAED, then you have to put some confidence limits on it. The numbers that you present in an interlaboratory comparison, for example, you would have to put a range on there and say that those 60 or 150 could be as low as 5 or 10 if you were to make a positive identification.

J. MCALEAR: NBS Associates, I'm going to have to speak in behalf of some of the scores of laboratories who have been doing some scanning electron microscope analysis for asbestos for some years to make the point that the actual application in this area is fairly extensive using the SEM, and I think it is growing. I'm not going to take time now to make a detailed comparison here. It has been done at many places, but I think it is a very poor mistake to rule out scanning electron microscopy in a general, even interim method when such things have a tendency in fact to become regulations; become standards. I think that this needs to be objectively reviewed.

ANDERSON: Let me respond to that. I came into this program having little experience in transmission electron microscopy. My major experience was with scanning electron microscopes, wavelength electron probes, and energy dispersive x-ray detectors. I too thought that the people using TEM were crazy. As a matter of fact I tried hard to see if an SEM wouldn't do the job. I will be the last to make the broad statement that SEM's are no good; I know better than that. There are higher brightness sources, the LaB₆ source gives you an increased electron density, not too many people have been working with asbestos with better electron sources or field emission source; this can give you an increased yield of x-rays....I am trying to be objective, but you look at what people have done and compared SEM with TEM and they all come up with the same conclusion about the superiority of the TEM.

MCALEAR: We have many customers who use both TEM and SEM and I don't believe the votes are in on this as yet by a long shot.

ANDERSON: The whole difference is the size range that we are considering. We are considering asbestos in water and the asbestos fibers are very small--about 250Å wide.

I. STEWART: There was a comment about the statistical significance of results and, as I understand it, your phi is basically an attempt to be realistic and say that there will be backgrounds. Now, the gentleman from Johns Manville surprised me by mentioning there is zero background. We have done a lot of blanks with nothing in them but we do not call them zero background, which I think is totally unrealistic with asbestos. The values that have been published in the literature range from 30 fibers per grid square, reported by Tony Richards of Turner Bros., down to this claim for zero or near zero. Now if you take your 20 grid squares, that means you have six hundred fibers, at which point you are really talking about noise-to-signal ratio.

J. KRAMER: I'd like to address the question of SAED confirmation or chrysotile and the amphiboles. I think you ought to be complimented on the details of your general method of preparation, which I think all people need, and they can go through step by step and determine whether this works in their lab or not. But in the literature and here in terms of electron diffraction confirmation we have seen two different wall paper patterns.

I think Don Beaman came the closest to suggesting what specifically about these patterns should be used as a method of confirmation. Furthermore, we have always seen a pattern of an amphibole, generally one of the asbestos mineral species and chrysotile. I would like to point out particularly with water and environmental samples that there are probably two to three hundred other fibrous minerals by your definition, all having electron diffraction patterns. Dr. Zussman brought up the point yesterday, you need a three-dimensional orientation to know precisely what you are going to get, and that does not get into other problems of defects and so on. What bothers me is, nowhere have I seen anything but pictures in saying that this is different than that and I think, and maybe you have done this, we need a step-by-step procedure for confirmation of the amphibole group or the chrysotile group or something along this line. Then mineralogists can take these and they can say generally you'll get this or you won't get this. Watch out, these mineral species will do the same thing. I have not seen this anywhere and it is rather frustrating to say you need electron diffraction confirmation when you don't know what the step-by-step procedure is to the same degree you have so eloquently done with the sample preparation.

ANDERSON: We certainly recognize you have to balance the realities of the analysis in how much time can you really spend in analyzing an electron diffraction pattern from a single fiber. As Sumudra pointed out last spring, if you use a very small camera length you get a large percentage of fibers giving an electron diffraction pattern. They are reasonably characteristic, the amphibole pattern is reasonable, and certainly the chrysotile stands out. The amphiboles are certainly all very similar; they are all characteristic and there is certainly a judgmental factor involved, although we have compared our judgments on the Duluth amphiboles versus what Beaman published and we get almost the same curve. Our judgment was about the same as Beaman's and I guess that is all you can come up with, and I think that other people will find somewhat the same thing.

KRAMER: Let me repeat, because in these cases the amphiboles and the chrysotile have been worked with. There are many other minerals in the environment, such as chain silicates; I'm not saying there is a unique method, but I think we need to know as an interim method, if you want to call it that, the procedure by which these are to be confirmed. Then we can go ahead to the next step.

ANDERSON: Confirmed as far as identified?

KRAMER: As identified by SAED in your lab. Then we can go ahead to the next step.

ANDERSON: I don't care to confirm halite as halite; I don't care about some other minerals, all I care about is asbestos minerals.

P. McGRATH: What I contended, although I can appreciate the problem I have with the development on an interim method, I think we have to begin to realize that all of the analysts who are going to be doing this over the next few years are not going to be an Eric Chatfield or Jim Millette. I think that the EPA and other groups that are going to do an awful lot of this testing, and in all probability will end up setting the standards for the rest of the country, should look into other methods, and I agree with Jim McAlear that we have abused scanning electron microscopy and it's not going to be a panacea or an answer for all these things, but I know from my own experience and the experience in other laboratories that you can get reasonable counts and reasonable chemical information from the scanning electron microscopy, and in all probability quicker and at much reduced cost than you can with your method. You mentioned somewhere that this is a sort of a quick and dirty method; it is not a quick or dirty method.

ANDERSON: It is not a quick or dirty method.

McGRATH: It's a long and involved tedious thing, and the operator has to be an excellent operator to get the kind of results that you got, with Jim Millette and Phil Cook.

ANDERSON: Well I think the whole crux of the matter is whether the SEM with the conventional, lanthanum hexaboride, or field emission source can indeed detect two hundred angstrom wide fibers and also give sufficient x-ray data to identify that fiber as an amphibole or chrysotile.

NOTE: The following was a note sent following the meeting and was not part of the verbal discussion at the end of this paper.

D. JACKSON: Dr. Anderson could you comment on the areas which may prove problematic and the areas requiring particular attention in using your proposed Analytical Methodology for determining asbestos in water.

ANDERSON: The following areas appear to me to be the major problems to be overcome in determining asbestos in water.

- 1) Assuring that you have a representative sample.
- 2) Contamination, both during the sampling process and in the laboratory.
- 3) Filtering the sample in such a manner that the particulates deposit in a near-random distribution and without over-loading the filter.
- 4) The presence of a large amount of extraneous particulate matter in relationship to the amount of asbestos.
- 5) Dissolving the filter material without loss or movement of the asbestos fibers.
- 6) The identification of amphibole asbestos fibers.

INTER-LABORATORY MEASUREMENTS OF AMPHIBOLE AND CHRYSOTILE FIBER CONCENTRATION IN WATER

K. S. Chopra

Union Carbide Corporation - Metals Division
Niagara Falls, New York 14302

Abstract

ASTM Committee E-4 has been experimentally evaluating high magnification microscopic techniques being used for the analysis of fiber contamination in water. This paper will describe the procedures and present status of this technique evaluation.

Key Words: Amphibole; ASTM; asbestos; amphibole; chrysotile; fiber; transmission electron microscope; water.

Introduction

Great interest in the identification, characterization, and concentration determination of mineral fibers in environmental samples has been generated in recent years due to the fibers' potential carcinogenic effect for humans. The variety of sample preparation techniques, instrumentation, identification methods, technical definitions, and levels of analyst experience have often produced scattered and inconsistent results for related or shared samples.

A Task Group was formed under the ASTM E-4 Committee to study the reasons for this inter-laboratory divergence and to establish a recommended standard method for determining fiber concentrations in water. The Task Group is composed of 17 experts in fine particle analysis from government, industry, and commercial service laboratories in the United States and Canada.

Members of the Task Group agreed on the necessity of using a transmission electron microscope (TEM) for the determination of concentrations of very small fibers, such as asbestos fibers, which have diameters as small as 200 Å. The (TEM) technique will serve as a reliable method of calibration for other more rapid and less expensive techniques which, hopefully, can be developed. The scanning electron microscope (SEM) was not selected for use because:

1. The SEM lacks the selected area electron diffraction capability for identification of fiber mineral type (e.g., amphibole or chrysotile).
2. The SEM has inferior imaging capability because the image is distorted by sample movement, and the brightness and contrast are less than in the TEM at 20,000X.
3. Some distinctive fiber morphologies, such as the hollow core of single chrysotile fibrils (200-400 Å), cannot be observed by SEM.
4. Searching sample areas at magnifications of 10,000 to 25,000 Å for fibers is more fatiguing with the SEM. Analyst fatigue contributes significantly to a loss of precision.
5. These observations are meant to define the current limitations of the instruments.

The Task Group analyzed four Duluth, Minnesota, tap water samples containing amphibole fibers and two samples of filtered water with a chrysotile standard added. The laboratories were supplied with filtered samples on Nuclepore and/or Millipore filters.

Analytical Methods

Techniques for the preparation of samples and TEM counting of fibers have been published by Task Group members [1,2,3,4,5,6,7]¹. In almost every case, water is filtered onto Millipore or Nuclepore filters. Sections are cut from the filters and placed on TEM grids. The process, whereby the filter is dissolved in a solvent to leave the sample on or in a carbon film on the grid, is a direct transfer method. The filter dissolution step can be done in several different ways and is a key difference between many methods of sample preparation.

Most Nuclepore filter preparations are carbon-coated prior to the filter piece dissolution step so that the resulting grid has the fibers held in the carbon film on the grid. The inclusion of the fibers in the carbon film is made possible by the very flat surface of the Nuclepore filter and is intended to prevent loss of fibers during filter extraction in a Jaffe washer.

Millipore filter preparations usually involve the acetone dissolution of filter pieces on a carbon-coated grid in a condensation washer or a Jaffe washer. The condensation washer employs the careful regulation of the level of acetone condensation near a point in a condenser at or just below the position of the grid, so that only acetone vapor is present to dissolve the filter.

Fiber identification is often based on the morphology and selected area electron diffraction (SAED) characteristics of the fiber. Many laboratories also rely on energy-dispersive spectrometry (EDS) to classify fibers by elemental intensity ratio. The observation of morphology at high magnification in the TEM is particularly useful for identifying chrysotile fibrils because of the hollow core or tubular appearance frequently observable. SAED patterns are used to distinguish amphibole and chrysotile fibers from each other and other fibers which have different crystal structures or are amorphous. High-voltage TEM allows the analysis of SAED patterns from fibers too thick for SAED at the normal TEM operating voltages of 60-125 kV. The voltages available on most TEM's do not allow the identification of all mineral fibers, particularly if they are very thin or thick. Considerable controversy exists as to the adequacy of SAED for the positive identification of single chrysotile fibrils (200-400 Å diameter). Some analysts rely on the observation of the chrysotile magnesium/silicon intensity ratio in the energy-dispersive spectrum instead of a positive SAED pattern.

There are some cases when EDS spectra from different minerals are similar. Consequently, an identification based on a combination of morphology, SAED pattern, and EDS spectrum is considered most reliable, particularly for samples which are collected from previously uncharacterized systems. The members of the Task Group used the combinations TEM-SAED or TEM-SAED-EDS for characterization and identification.

Figure 1 shows the inter-laboratory reproducibility for the group analyses and is plotted chronologically. It must be stressed that the inter-laboratory reproducibility is a measure of precision and not accuracy. The Task Group is presently characterizing a sample containing a known chrysotile mass. It is apparent that improvement has occurred in a year and that reproducibility of ± 50 percent is possible for fiber concentrations above 70 MFL. The reproducibility at lower concentrations was not this good. The data imply that when all aspects of the analysis are under rigid control, the inter-laboratory reproducibility achievable with the existing TEM technique could be about ± 25 percent for relatively clean samples of the type studied herein. Considering the fact that these analyses correspond to the measurement of 50 ppb of amphibole fibers in environmental samples, reproducibility in the range of 25-50 percent is respectable.

¹Figures in brackets indicate the literature references at the end of this paper.

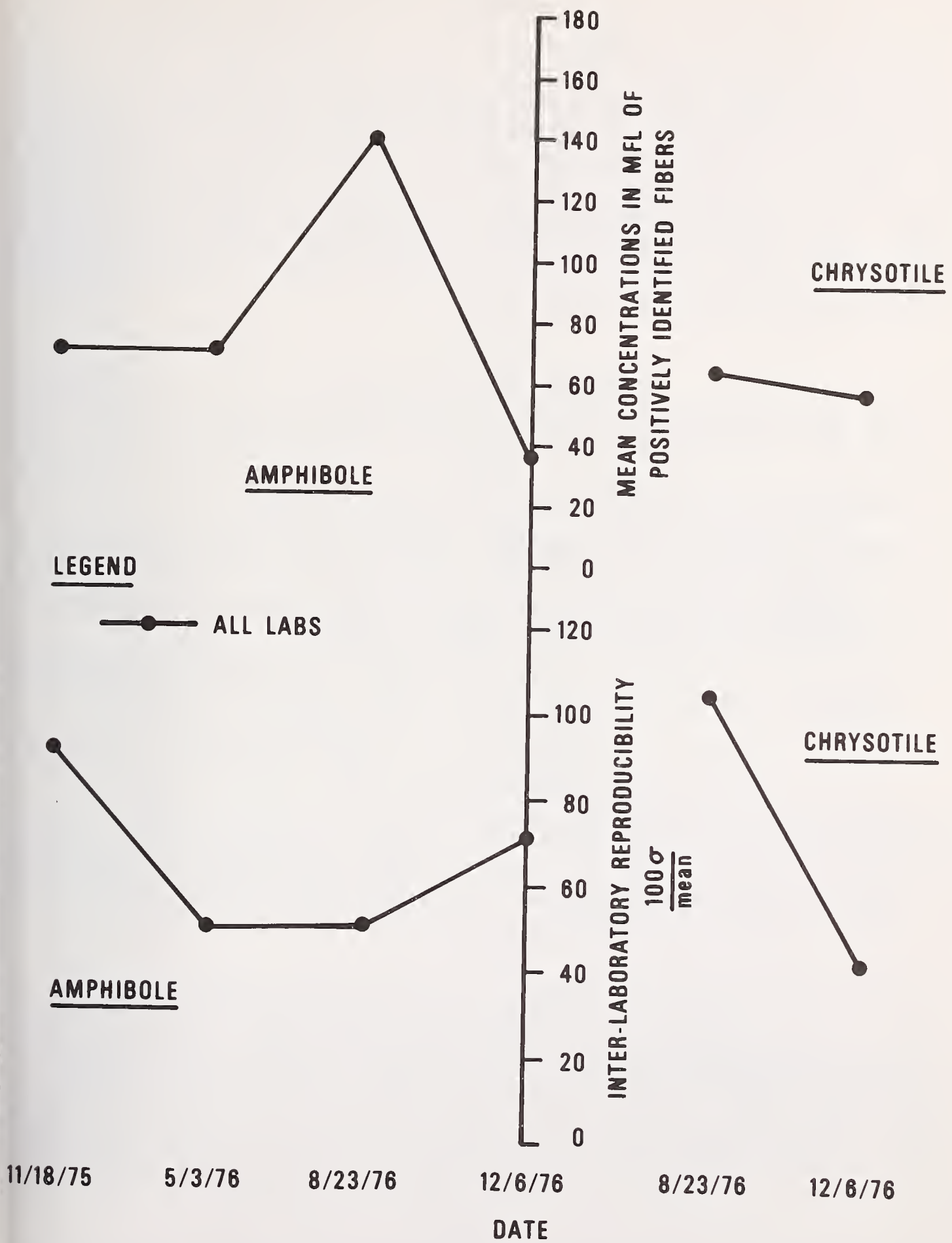

Figure 1. Plot of chronological inter-laboratory reproducibility for the group analysis.

Summary

These methods offer a feasible means of measuring relatively low levels of fiber contamination in environmental water samples. Other bulk-type methods lack the needed sensitivity and selectivity. The transmission electron microscope is the best basic instrument for performing analysis, particularly when equipped with selected area electron diffraction and energy-dispersive spectroscopy capabilities. The mean fiber concentration by different groups agree within a factor of two. The inter-laboratory reproducibility of 50 percent can be expected in relatively clean water samples unless the concentration is low. In samples with high concentration of interfering solids, the precision will not be as good. Inter-laboratory reproducibility of 25 percent is as good as the method can provide. When applied on a broad scale, there are variable (0-84%) and significant (mean = 30%) losses associated with the condensation washing of samples containing amphibole. The losses are low (mean = 14%) and less variable when using condensation washing to prepare samples containing chrysotile.

References

- [1] Cook, P. M., Rubin, I. B., Maggiore, C. J., and Nicholson, W. J., X-ray diffraction and electron beam analysis of asbestiform minerals in Lake Superior waters. Proc. Int. Conf. on Environmental Sensing and Assessment, 34(2), 1-9 (1976).
- [2] Millette, J. R. and McFarren, E. F., EDS of waterborne asbestos fibers in TEM, SEM, STEM scanning electron microscopy/1976 (Part III) 451-460 (1976).
- [3] Beaman, D. R. and File, D. M., Quantitative determination of asbestos fiber concentrations, Anal. Chem. 48(1), 101-110 (1976).
- [4] Anderson, C. H. and Long, J. M., Preliminary interim procedure for fibrous asbestos, U. S. Environmental Protection Agency, Athens, Ga. (1977).
- [5] Chatfield, E. J. and Glass, R., Improved methodology for determination of asbestos as a water pollutant, Report ORF, Mississauga, Ontario, Canada, Center for Inland Waters (1976).
- [6] Dement, J., Zumwalde, R., and Wallingford, K. M., Asbestos fiber exposure in Hard Rock Gold Mine, Annals of New York Academy of Sciences, 271, 341-352 (1976).
- [7] FDA Symposium on Electron Microscopy of Microfibers, August 19, 1976, Penn State University, State College, Pa. (in press).
- [8] Lee, R. J., Debray, D. R., and Szirmai, A., Sample preparation and measurement of losses in electron optical analyses of particulates in air and water samples, Thirty-fourth Annual Emsa Proceedings, Miami Beach, Fl., Aug. 1976, pp. 556-557.

This paper will be published in its entirety in the July 1978 issue of Testing and Evaluation published by ASTM.

Discussion

NOTE: Discussion of this paper was included in the General Discussion at the end of this session.

THE STANDARD FOR OCCUPATIONAL EXPOSURE TO ASBESTOS BEING CONSIDERED BY
ASTM COMMITTEE E-34

M. Cossette

Director, Centre for Technology of the Environment
University of Sherbrooke, Canada

and

A. A. Winer

CANMET
Industrial Minerals Laboratory
Ottawa, Canada

Abstract

This presentation reviews the consensus reached by the Task Group on Naturally Occurring Inorganic Fibers of ASTM Committee E-34. Significant differences with the OSHA regulation are pointed out on the following topics: Definitions, exposure limits, record keeping, monitoring, and the counting method. The reasons for these differences are outlined and a rationale in support of a dual standard is presented. This Task Group document is now under study according to official ASTM procedures.

Key Words: Asbestos; ASTM; consensus; definitions; exposure limits; monitoring; occupational exposure; record keeping.

Introduction

ASTM Committee E-34 is presently considering a standard for occupational exposure to asbestos. This standard differs from others in one very significant respect, in that it is a consensus document. There is input from both the regulators and the regulated, and this situation makes it a unique document.

Scope

This ASTM standard is applicable for all occupational exposures including mining and milling, as well as manufacturing and end-use industries. It is intended for use both in the USA, and in other countries where ASTM standards are in current usage.

Excluded from the scope of application are situations where the airborne fibrous particulates can be proven to be pathologically inert [1,2]¹. Recent epidemiological studies by Ahlmark at the University of Sweden, and by P. Radovan on two asbestos cement factories in Yugoslavia, in addition to a major study by Greg and Weiner at Battelle Pacific Northwest, are said to indicate that the biological activity of asbestos fibers is altered by the autoclave process of producing asbestos cement.

¹Figures in brackets indicate the literature references at the end of this paper.

This standard is flexible in application to the extent of recommending the use of only respirators for occasional work that may involve intermittent exposure. This would be the case where asbestos lagging must be removed from a valve, occasionally, in a chemical plant.

Definitions

The ASTM document presents the following mineralogical definitions:

asbestiform - mineral structured in the form of asbestos.

asbestos - generic term for naturally occurring, inorganic hydrated silicates that when crushed and processed separate into flexible fibers made up of fibrils [3,4]. Minerals defined as asbestos are the asbestiform varieties of the following: serpentine (chrysotile), riebeckite (crocidolite), cummingtonite (amosite), anthophyllite, tremolite, and actinolite [5-8].

fiber - for the purpose of this standard, fiber means naturally occurring inorganic fibers.

fibril - a single crystal in the form of a fiber [9].

fibrous particulate - for the purpose of this standard, fibrous particulate designates fibers, fiber fragments, and fiber agglomerates.

naturally occurring inorganic fiber - form of mineral characterized by properties of flexibility and length-to-width ratio in the order of 100, composed of definite crystal unit cells oriented with respect to a specific axis [4].

Note 1 - The designated 100:1 aspect ratio is considered to represent a reasonable lower limit for naturally occurring inorganic fibers. Fibers of these dimensions [10] can be broken into parts of fibers that may maintain their same surface properties and activities. Therefore fiber fragments may have to be evaluated for atmospheric monitoring purposes. However, attempting to define a fiber by its aspect ratio alone is inadequate since it is obvious that particles of non-fibrous material do not become fibers as their aspect ratio increases through comminution.

Other non-mineralogical definitions include:

aspect ratio - ratio of the length of a fibrous particulate to its equivalent diameter [11].

monitored particulate - fibrous particulate with an aspect ratio of at least 5:1, a minimum length of 5 μm , a maximum diameter of 3 μm , and the appearance of a fascine (bundle of sticks effect). Only particulates that fit these requirements are counted in the monitoring method [12-16].

peak sample - for the purpose of this standard, a sample taken over a short interval (not exceeding 15 min) to evaluate brief excursions in the airborne fibrous particulate concentration level [17].

Definitions applicable to monitoring include:

personal sample - sample collected on a membrane filter that is attached near to the operator or employee's breathing zone.

Geographical samples -

static sample - sample collected on a membrane filter at a fixed station.

dynamic sample - sample collected on a membrane filter transported over a fixed route at a specific speed.

Permissible Exposure Levels

The exposure level being considered for mines and mills is 5 fibers/cm³ (same as the present MESA regulation.)

The exposure level being considered for manufacturing and end use industries is 2 fibers/cm³ (same as the present OSHA regulation).

Rationale for a Dual Standard

The bases considered in reaching a consensus on a dual standard were the following:

Gibbs and Hwang [18] have shown that the particulate size distributions of airborne fibrous particulates differ for different types of asbestos, and for different occupations. For example the percentage of countable fibers (diameter smaller than 0.5 μm and length greater than 5 μm) was found to be 18.3 percent at one site where amosite insulation was installed, compared against 1.0 percent in a bagging area of a chrysotile mill. This implies that 18.3 percent of the airborne fibrous particulates would be invisible in the optical microscope in one case versus only one percent in the other case. In general, it appears that with each successive step in milling, and manufacturing, the fibers become more finely divided, and more of them become invisible in the optical microscope. On the other hand, the hazard may increase with finer fibers because more of them are likely to reach the lower airways.

It has also been demonstrated rigorously [19] that the likelihood of counting a fiber is a function of fiber length. A fiber 40 μm long has about a 10 percent higher probability of being counted than a 5 μm fiber. An 80 μm fiber has about 50 percent more probability of being counted than a 5 μm fiber. Now the manufacturing and end-use industries generally shorten the fibers. For example Gibbs and Hwang [12] have shown that the median length of airborne fibrous particulates in the bagging area of a mill (the last milling operation) was 1.00 μm versus 1.35 μm for the same type of asbestos in the carding area of a textile plant.

The International Labor Organization has established [20] that the highest risks are found in the insulation trade (an end-use industry). On the other hand "in chrysotile mining and milling, despite very heavy dust concentrations in the past, the incidence of severe asbestosis, asbestos cancers, and especially mesotheliomas has been low."

McDonald [21] has found that the mesothelioma-inducing potential was greater in asbestos manufacture and application than in mining and milling, and he stated: "This may be related to fiber size but also possibly to co-carcinogens in the industrial environment" "mining environments may well be free from co-carcinogens of the kind found in factories, ports and industrial cities."

The sedimentation velocity of airborne fibrous particulates has been shown to be a function of diameter [22]. Gibbs and Hwang [18] have shown that for a given type of asbestos the proportion of fibers finer than 0.5 μm was 67 percent in the ore drying area (beginning of milling process), 82 percent in the bagging area (end of milling) and 88 percent in the carding area (manufacturing). There is no question that fewer of the airborne fibrous particulates are respirable in mining and milling, than in manufacturing and end use industries. In addition fibers in mines and mills show a notably greater propensity to flocculate together, thus reducing their respirability while increasing their countability [23].

Time Weighted Average

The formula for the calculation of the 8-hour time weighted average that has been adopted is:

$$8 \text{ h TWA} = \frac{\sum N_i T_i}{\sum T_i}$$

where N_i = Number of fibrous particulates in the i th sample,
and T_i = Time period over which the i th sample was collected.

Medical Surveillance

A preplacement medical examination is mandatory. Enforcement of annual examination is recommended where legal to do so.

The question of starting medical surveillance at one-half the permissible exposure limits versus the full limit is still unresolved.

An interesting document on the diagnosis of asbestosis is annexed to the standard.

Medical Records

These are to be available to government agencies, and upon written request, to employees, or former employees. Records are to be kept 50 years. This is in recognition of the long latent period necessary for the manifestation of asbestos related diseases.

Labeling (Posting)

Materials containing asbestos, bound or reacted in such a way as to give off emanation of dust that can be demonstrated to be non-toxic, when produced by foreseeable activities are exempt from labeling.

Monitoring

The emphasis is placed upon personal samplers. Static geographical sampling is also called for. Areas above the permissible limits must be monitored every six months. Two to twelve samples per worker per shift are recommended [17]. Monitoring records are also to be kept 50 years.

The midget impinger may be used to obtain correlation data since it was the basis for the most reliable epidemiological data, but may not be used for referee testing.

Analytical Method

The method is based upon the use of a 37 mm diameter membrane with a pore size of 0.8 μm , and personal sampling pumps operating at 2 dm^3/min for periods of 15 min to 4h at concentrations of 1 to 20 fibrous particulates per cubic centimeter. Only fibrous particulates with a length greater than 5 μm , a maximum diameter of 3 μm , and an aspect ratio of at least 5 to 1 are counted.

The 5 to 1 aspect ratio was adopted when it was ascertained that the 3 to 1 ratio originally adopted by the British was strictly arbitrary [15], and when it was determined that the higher ratio could exclude many acicular rock slivers while making no appreciable difference with true fibrous particulates.

For referee purposes, it must be established that the items counted are indeed asbestos, as defined.

Typically, 4 to 7 samples per shift are demanded for 8-h TWA.

The details of pump calibration, microscope adjustment, and counting rules are like those presented in the NIOSH method, issued 30 Mar 77.

In view of the very low precision and accuracy obtained, we are not satisfied with the method of analysis based on counting. A gravimetric method based upon the collection of only the respirable fraction of fibrous particulates, and coupled with the quantitative analysis of asbestos present, would be preferred, and appears feasible. X-ray diffraction of fiber arrays, and acid titration at constant pH [24] appear promising for this purpose.

Conclusion

In conclusion, it should be emphasized that in spite of its shortcomings (it is the product of a committee) the ASTM document has the single advantage of being a consensus document, reflecting the views of both the regulators and the regulated.

References

- [1] Kogan, F. M., Gerasimenko, A. A., Bunimovic, G. I., Kler, O. V., Karacarova, V. N., Olsvang, R. A., Hygienic characteristics of the asbestos-cement dust, Collection of papers on silicosis, The Book Publishing Institution of Middle-Ural, Sverdlovsk, p. 173-85, 1966. English translation available from the same source as reference 23.
- [2] Rhodes, H., Detection of chrysotile asbestos in airborne dust from thermoset resin grinding, 3rd Int Conf Chem Phys Asbestos Min, Quebec 20 Aug 1975. (Same source as 23).
- [3] Federal Register, Vol. 38, No. 188 - Friday 28, 1973, page 27076 (Food and Drug Administration).
- [4] Ann. N.Y. Acad. Sci 132, 23-30, 1965.
- [5] Asbestos Fundamentals, Berger, H. and Oesper, R. E., Chemical Publishing Company Inc., New York, 1963, p. 1-3.
- [6] Federal Register, Vol. 39, No. 127 - Monday, 1 Jul. 1974, p. 24316. (U.S. Bureau of Mines).
- [7] Rutley's Elements of Mineralogy, 25th Ed. H. H. Read, Thomas Murry & Co, London.
- [8] Thompson, C. S., Proceedings of the Symposium on Talc, p. 22-42, Washington, D.C. 8 May, 1973. (Same source as 23).
- [9] ASTM Glossary of Terms, p. 585. D2946-71T.
- [10] Prasad, N. A. and Pooley, F. D., Characteristics of amphibole asbestos dust surfaces in aqueous media with reference to quartz, J. Appl. Chem. Biotechnol., 23, 675-87 (1973).
- [11] Federal Register, Vol. 9, No. 87, 3 May 1974, p. 15396.
- [12] Holmes, S., The measurement of airborne asbestos dust by the membrane filter method, Technical note #1, Asbestos Research Council, Box 40, Rochdale, Lancashire, England, 1971.
- [13] Timbrel, V., The inhalation of fibrous dusts, Proc. Conf. Biol. Effects Asbestos, N.Y. Acad. Sci. 1964.
- [14] Field Information Memorandum #74-92, OSHA, 21 Nov. 1974.
- [15] Holmes, S., The definition of an asbestos fiber, Asbestosis Research Council, P.O. Box 40, Rochdale, Lancashire, England OL12 7EQ.
- [16] Health Division Instruction Memorandum #8-Definition of asbestos fiber for tremolite occurring in talc, MESA, 13 Dec. 1974.
- [17] Leidel, N. A., Optimum sampling times for airborne asbestos fibers, NIOSH, 1014 Broadway, Cincinnati, OH 45202, Nov. 1972.
- [18] Gibbs, G. W. and Hwang, C. Y., Physical Parameters of Airborne Asbestos Fibers in Various Work Environments - Preliminary Findings, American Industrial Hygiene Association Journal, June 1975, pp. 459-466.

- [19] Comments of Johns-Manville Corp. with respect to notice of Proposed Rulemaking Occupational Exposure to Asbestos (Fed. Register, Oct. 9, 1975) to O.S.H.A., U.S. Dept. of Labor, April 1976.
- [20] International Labour Organization, Meeting of Experts on the Safe Use of Asbestos, Geneva, 11-18 Dec. 1973, Draft Report, p. 1-32.
- [21] McDonald, A. and McDonald, C., Epidemiology of Mesothelioma from Estimates of Incidence., 18th Int'l Congress on Occupational Health, Brighton, Sept. 16, 1975, p. 7-8.
- [22] Timbrell, V., The Inhalation of Fibrous Dust, Ann. N.Y. Acad. Sci., 132, 255-273 (1965).
- [23] Draft standard for occupational exposure to asbestos, Rationale supporting the selection of a dual ASTM standard, Second draft ASTM Committee E-34, 25 April 1977.
- [24] Barbeau, C., Roy, J. C., and Dupuis, M., Reactivity of magnesium silicates in acid solutions, Means of distinguishing between antigorite and chrysotile, 3rd Int. Conf. on the Physics and Chemistry of Asbestos Minerals, Laval U. 17-21 Aug. 1977.

Discussion

NOTE: Discussion of this paper was included in the General Discussion at the end of this session.

IDENTIFICATION AND COUNTING OF MINERAL FRAGMENTS

R. J. Lee, J. S. Lally, and R. M. Fisher

U. S. Steel Corp., Research Laboratory
Monroeville, Pennsylvania 15146

Abstract

Positive identification of submicrometer-diameter mineral fragments, especially amphiboles, requires both chemical and crystallographic analysis. At present, only electron optical methods can be used for this purpose, and considerable care must be taken to ensure that (1) the x-ray spectra and diffraction patterns pertain only to the particle in question (that is, spatial-resolution limitations must be recognized); (2) x-ray data are compared with well characterized reference standards; (3) overlapping chemical composition and/or similar crystal structures of mineral series are recognized; (4) crystal fragments are tilted into zone-axis orientation before recording the electron-diffraction pattern; and (5) appropriate statistical criteria are used to evaluate the significance of the results.

The required procedures are time consuming (and costly), but less rigorous methods are subject to considerable uncertainty, which limits the validity of the data and its usefulness in any assessment of biological effects. Adoption of a definition of mineral fibers based on an aspect ratio of 10:1 and parallel edges would eliminate most non-asbestos mineral fragments from consideration, and reduce the analytical problems to more manageable proportions.

Analysis of the face orientations of amosite fibers (commercial amphibole asbestos) and grunerite fragments (nonasbestiform amphibole) reveals pronounced distinctions which originate in their different crystal growth or cleavage characteristics.

Key Words: Amosite; amphibole; asbestos; electron diffraction; fibrous; grunerite; mineral identification; non-fibrous.

Introduction

The organization in 1977 of a workshop devoted to identifying points of agreement and disagreement on definitions and measurement methods for asbestos was a most welcome and logical initiative on the part of the National Bureau of Standards (NBS) and the Occupational Safety and Health Administration (OSHA). Changes in meaning of the term "asbestos fiber," which have occurred with the advent of concern about very fine particles (only observable in the electron microscope), have been discussed and deplored by Tibor Zoltai [1,2]¹. Such loosening of the definition of asbestos results in the inclusion of varieties of sheet silicates, chain silicates, and even non-silicates. Malcolm Ross [3] has pointed out that serpentine, amphibole, clay, mica, chlorite, and alumina-silicates are prime examples of widely occurring minerals that could be erroneously classified with "asbestos." As a further consequence, the term "emission sources" becomes broadened to include extended, naturally occurring geological formations.

¹Figures in brackets indicate the literature references at the end of this paper. Three digit bracketed numbers, e.g., [113] refer to reciprocal space vectors.

The use of vague terminology coupled with limited biological research data has blurred the distinction between scientific fact and speculation regarding the health hazard resulting from exposure to low concentrations of silicate dust particles. The correct identification of micrometer-size mineral particles and the accurate measurement of their concentration in air or water samples is not easy. Unfortunately, reported observations of mineral varieties in samples collected at locations where these minerals should not occur, coupled with differences of many orders of magnitude in the particulate concentrations reported by various laboratories, confuse those with the political or administrative responsibility for reacting to public concern about environmental quality. Hopefully, publication and distribution of the proceedings of the NBS/OSHA workshop will help repair the damage to the credibility of analysts and their procedures that public controversy has engendered.

United States Steel has expended a great deal of effort in developing reliable methods for identifying and counting particles. The details have been published elsewhere [4,5]. The purpose of the present report is to emphasize the precautions that must be taken to avoid errors and illustrate the results that can be obtained if appropriate methods are used. Fiber characteristics pertinent to the definition of "asbestos" are also discussed at the end of this report.

Particle Identification

It is necessary to use electron microscopy, either scanning (SEM) or transmission (TEM), to examine particles with dimensions of a few micrometers or less. Transmission electron microscopes can be adjusted to obtain electron-diffraction (ED) patterns from single particles which provide crystallographic information. Scanning electron microscopes are usually equipped with facilities for x-ray emission spectroscopy which provide elemental information about single particles (if properly dispersed). Some hybrid instruments combine SEM, TEM, ED, and x-ray functions.

Characteristic Diffraction Patterns. The term "characteristic pattern" has come into common use in connection with the identification of particles of minerals by transmission electron microscopy as if such characteristics (diagnostic patterns) could be ascribed to each mineral. As a general rule this is incorrect. Many minerals have very similar diffraction patterns, as illustrated in figures 1 and 2, and it is impossible to distinguish between them by visual inspection. If they are measured and interpreted (indexed as in figures 1 and 2), they can be used as references for other identical (not similar) pat-

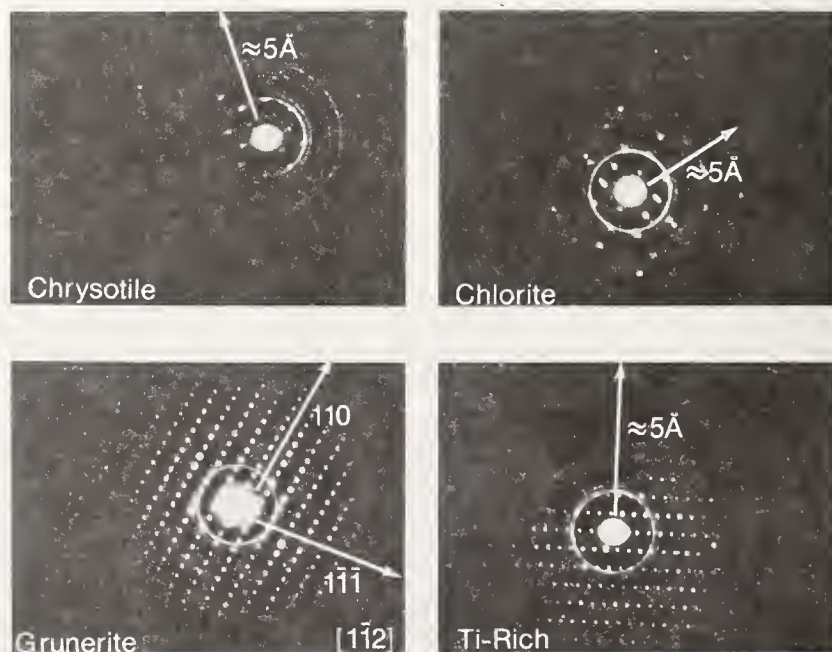

Figure 1. Selected area electron diffraction patterns of mineral particles which all show a d-spacing of about 5 Å.

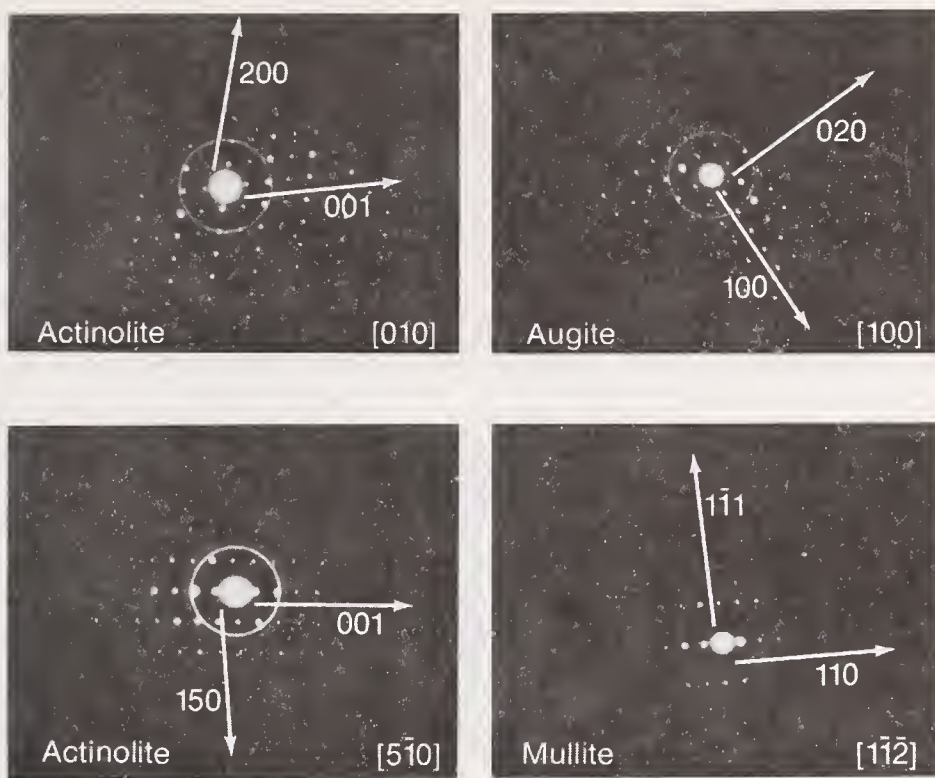

Figure 2. Indexed electron diffraction patterns of representative amphiboles and non-amphiboles showing essentially similar appearance.

terns. These are good patterns obtained by carefully tilting into a "zone axis" orientation. If this is not done, the patterns are diffuse, irregular, and useless. Because of its tubular shape and helical structure, the diffraction pattern of chrysotile is not strongly dependent on orientation and is recognized more readily.

Another factor affecting electron-diffraction analysis, as illustrated in Figure 2 for actinolite, is that every mineral has several different "zone axis" patterns, which depend on the orientation of the particle with respect to the electron beam. This is also illustrated in figure 3 for the amphibole mineral grunerite. However, the presence of extensive twinning, as in figure 3 for grunerite, or fine-scale exsolution in the pyroxenes (as in augite in figure 2), can give rise to closely spaced spots in a diffraction pattern. This may lead the unsuspecting microscopist to conclude that he is observing a large d-spacing when, in fact, the pattern contains "extra" spots due to reciprocal lattice spikes, multiple zone-axis orientations, or satellite spots.

The 5.3 \AA d-spacing of the c-axis is frequently taken as definitive of the amphiboles. Yet, of the eight diffraction patterns shown in figures 1 and 2, six have d-spacings $\sim 5 \text{ \AA}$, although only two of these are from amphibole particles. In general, as discussed by Zoltai [1], many minerals fragment into acicular particles and have d-spacings $\sim 5 \text{ \AA}$. Because of differences in fragmentation characteristics, the broad faces of the two mineral varieties, amosite and grunerite, occur along different crystallographic planes, so the patterns are usually different.

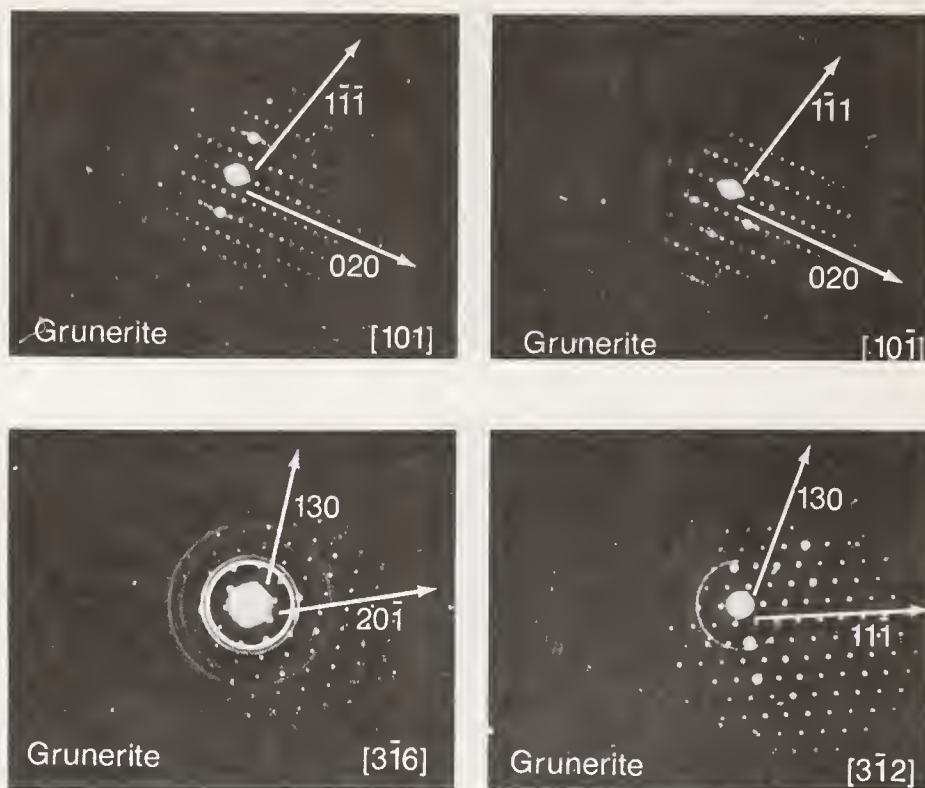

Figure 3. Indexed electron diffraction patterns of different orientations of grunerite achieved by tilting specimens in the electron microscope.

The characteristic growth habit of amosite asbestos gives rise to a fiber with the largest face on (100) planes, which will then lie flat on electron-microscope grids [6]. As a result, the nearest reciprocal lattice section will contain $b^* \times [103]^*$, as pointed out by Nord [7]. A typical pattern from amosite, shown in figure 4(a), contains $b^* \times [113]^*$, the basic vectors for zone axis perpendicular to the $[100]^*$ direction in reciprocal space. In contrast, a cleavage fragment should lie near a (110) face, and the expected zone-axis diffraction patterns nearly perpendicular to $[110]^*$ would not contain b^* . While the cleavage fragments are more randomly oriented, the diffraction pattern in figure 4(b), $[021]^* \times [2\bar{2}\bar{1}]^*$, and the pattern containing the twin spots $[1\bar{3}0]^* \times [111]^*$ in figure 3, are both within about 15° of $[110]^*$. Thus, the predominant face of the particle can be determined if the pattern is indexed on the assumption that the fiber axis c in real space, $[103]^*$ in reciprocal space, is perpendicular to the beam.

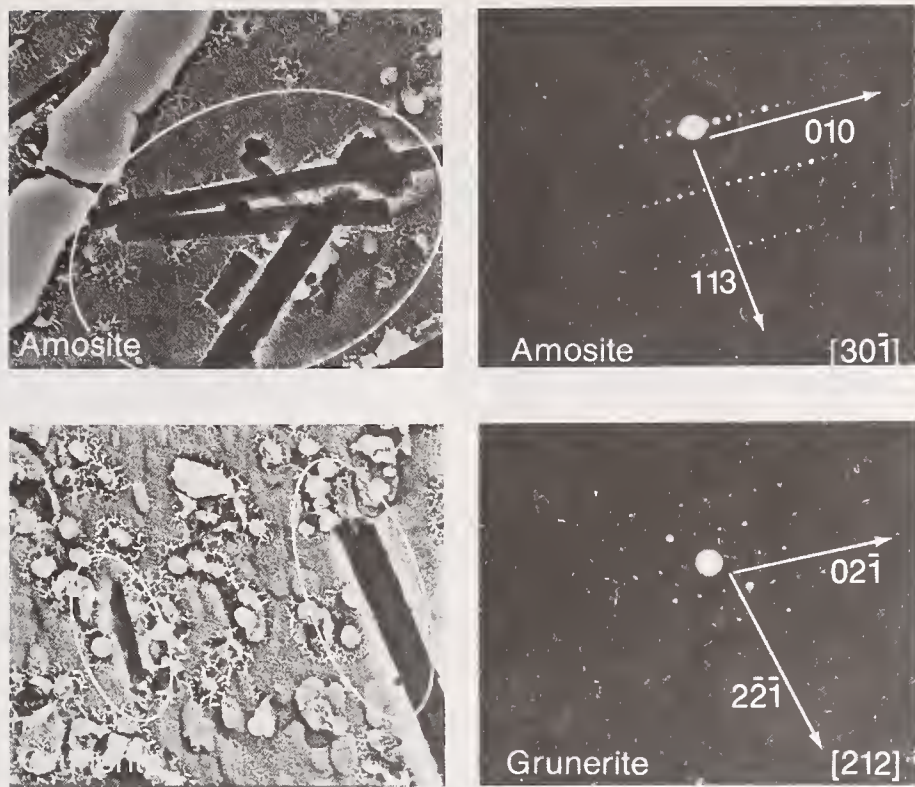

Figure 4. Electron micrographs and diffraction patterns of amosite and grunerite particles which indicate that the asbestos and non-asbestos varieties can be distinguished if the diffraction patterns are interpreted properly.

Preliminary results of a study of the typical orientations of a Penge amosite, and a grunerite from Presque Isle, Michigan, are shown in table 1. In this comparison, 75 percent of the amosite particles had b^* vectors within 10° of the normal to the electron beam, thus indicating they were lying on (100). Only 18 percent of the grunerite particles had this orientation. The remaining 75 percent were more than 30° away from $[100]^*$ on the $[010]^*$ side of the $[110]^*$ direction in reciprocal space. The cleavage fragments are not as tightly clustered about $[110]^*$ as the amosite particles are about $[100]^*$. These data suggest that it may be possible to distinguish amosite fibers from grunerite cleavage fragments by looking for b^* reflections. Very recent SEM observations of crystal-growth habits of amosite and grunerite have revealed that these distinctions between fiber formation by "delamination" and fragment formation by cleavage are also evident in bulk samples, figure 5.

Table 1. Face orientations of Amosite and Grunerite fibers.

<u>Face</u>	<u>Amosite</u>	<u>Grunerite</u>
(100)	17 (74%)	7
(010)	1	2
(110) ^a	5	30 (77%)

^a Cleavage plane.

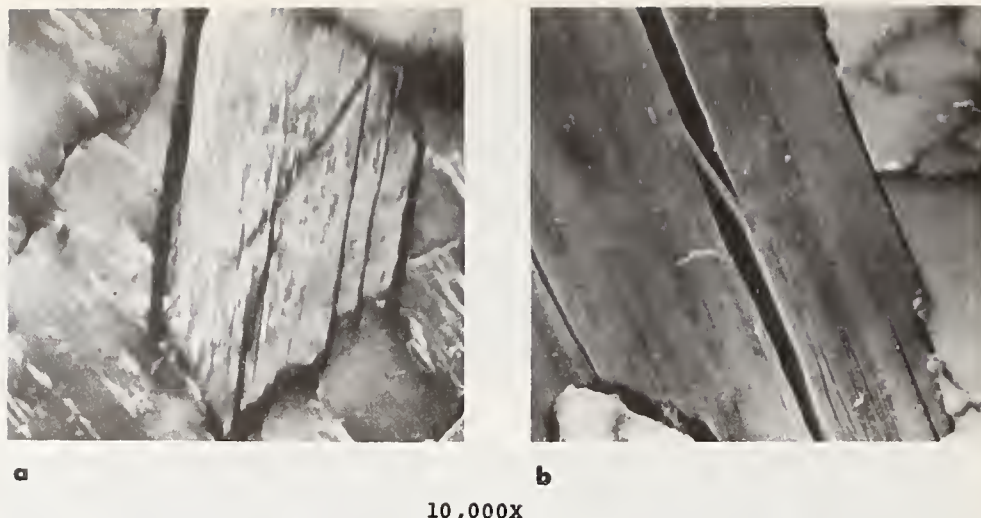

Figure 5. Cross-sections of grunerite and amosite looking down the c-axis.

- (a) Exsolution lamellae, cleavage traces and 100 parting are all evident in grunerite.
- (b) The delamination of thin lamellae produced by fine-scale twinning ($\sim 50 \text{ \AA}$) along (100) is shown. This leads to the development of amosite particles with large 100 faces.

X-ray Analysis. As mentioned, the development of energy-dispersive spectroscopy as an adjunct to scanning or transmission microscopy has made it possible to obtain information about the elemental composition of small particles. It is tempting to assume that the x-ray spectra are diagnostic, but in many cases this is not true. Unless precautions are taken, near-by particles can contribute to the x-ray spectra. Absorption and fluorescence effects depend on particle size and orientation, so their x-ray spectra may differ from those of reference standards. These effects are not great; but for many minerals, differences in composition are also not large, (as shown in figure 6 with x-ray spectra from amphiboles, serpentines, and non-amphiboles).

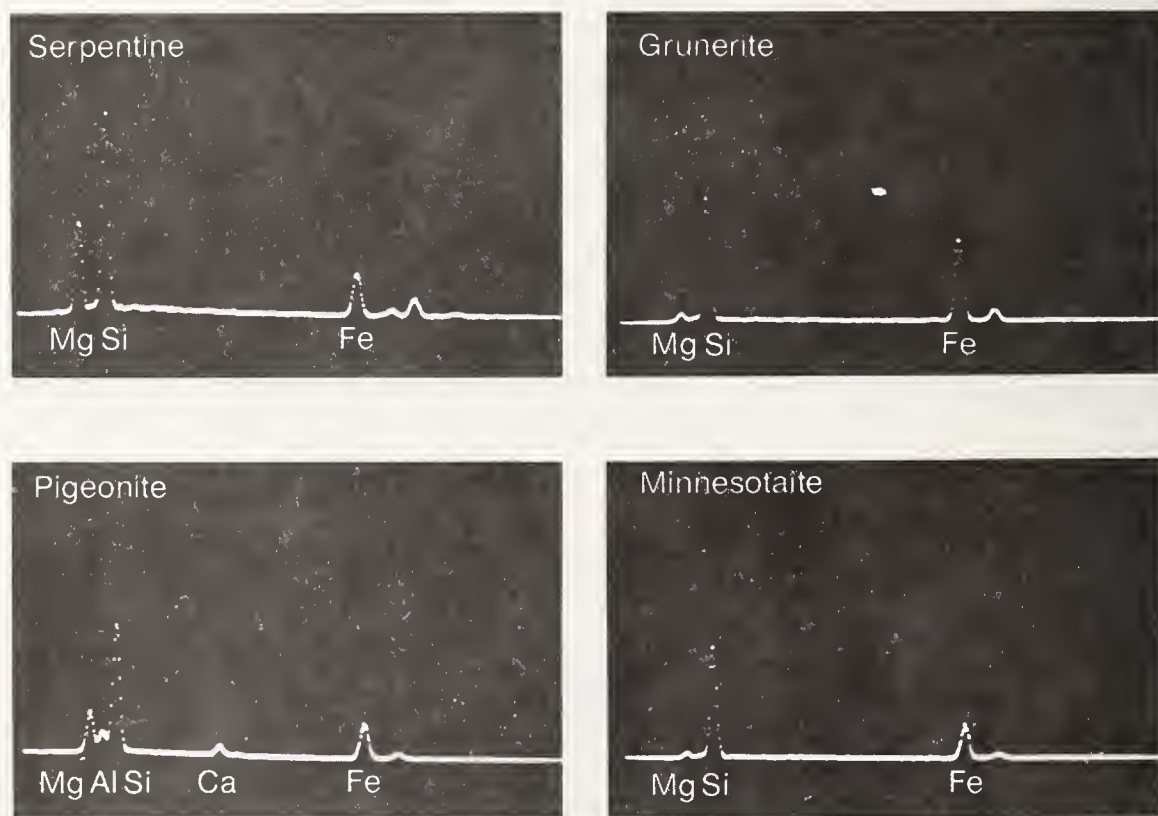

Figure 6. X-ray spectra of representative amphiboles, serpentines, and non-amphiboles showing essentially similar appearance illustrating difficulty of identifying silicate minerals by non-quantitative x-ray spectroscopy.

Improved Identification Techniques. These difficulties with identification, although formidable, have been overcome with effort and better understanding of electron-diffraction and x-ray spectroscopy. Key features of the method are (1) tilting of particle into one or two zone axis orientations; (2) obtaining an x-ray spectrum from the same particle; (3) comparison of diffraction and x-ray data by computer with a complete library of all minerals that could be present. Figure 7(a,b) [4,5] shows block diagrams for the program DIFFPAT, which simulates zone-axis diffraction patterns for any crystal with known unit-cell parameters and space-group symmetry, and SEARCH, which compares measured parameters obtained from zone-axis diffraction patterns with the simulated patterns generated by DIFFPAT. The minerals included in the computer library are listed in table 2. Prior consideration of chemical information eliminates many of these minerals and reduces computer time considerably.

Table 2. Silicate minerals used in programs "DIFFPAT" and "SEARCH".^a

<u>PYROXENES</u>	<u>AMPHIBOLES</u>	<u>SERPENTINES</u>	<u>TALCS</u>	<u>CHLORITES</u>
Augite	Actinolite	Amosite	Minnesotaite	Clinocllore
Diopside	Anthophyllite	Antigorite	Pyrophyllite	Penninite
Enstatite	Arfvedsonite	Berthierite	Talc	Prochlorite
Hedenbergite	Barkevikite	Chamosite		Talc-Chlorite
Hyperstene	Cummingtonite	Chrysotile		
Jadeite	Eckermanite	Cronstedtite	<u>MICAS</u>	
Johannsenite	Edenite	Greenalite		<u>CLAYS</u>
Pigeonite	Ferrogedrite	Lizardite	Biotite	Apophyllite
Spodumene	Gedrite		Clintonite	Illite
	Glaucophane	<u>KAOLINS</u>	Glaucosite	Montmorillonite
	Grunerite	Dickite	Lepidolite	Prehnite
<u>PYROXINOIDS</u>	Hastingsite	Donbassite	Margarite	Vermiculite
Pectolite	Holmquistite	Halloysite	Muscovite	
Rhodonite	Hornblende	Kaolinite	Paragonite	
Wollastonite	Kaesutite	Nacrite	Phlogopite	
	Katophorite		Stilpnomelane	
	Pargasite		Xanthophyllite	
	Richterite		Zinnwaldite	
	Riebeckite			
	Tremolite			
	Tschermakite			

^a Obtained from Ref. 1.

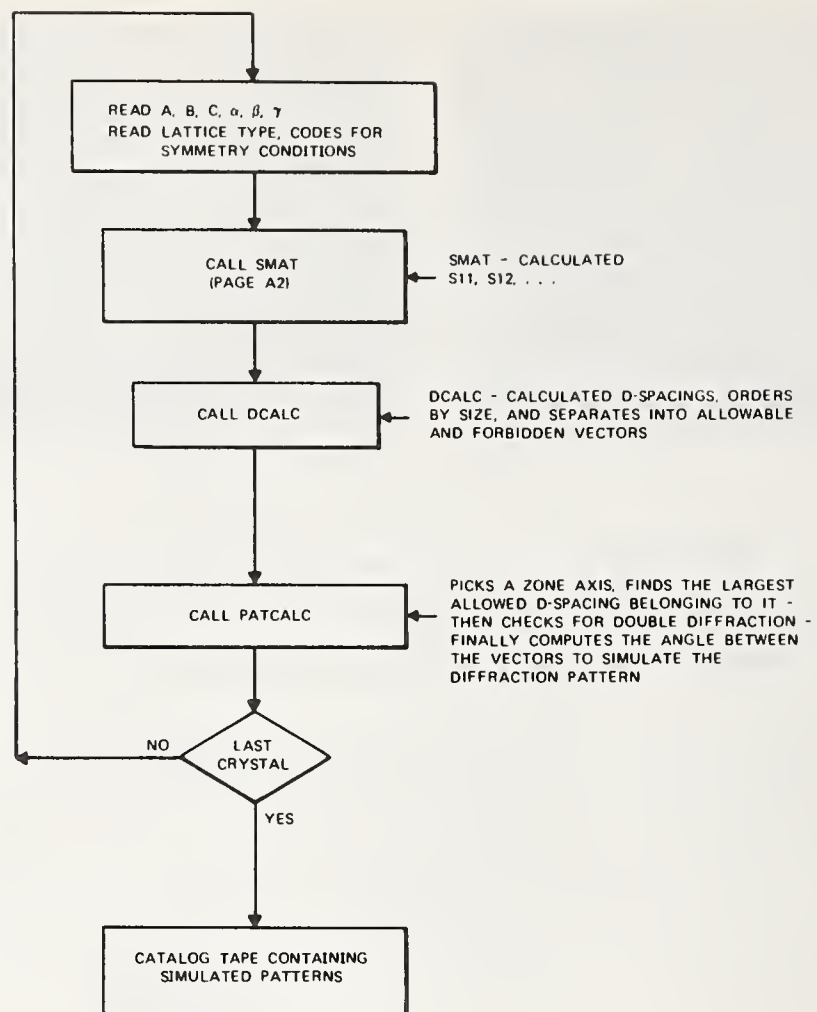

Figure 7. (a) Summary flow chart for computer program DIFFPAT which calculates reciprocal lattice diffraction patterns.

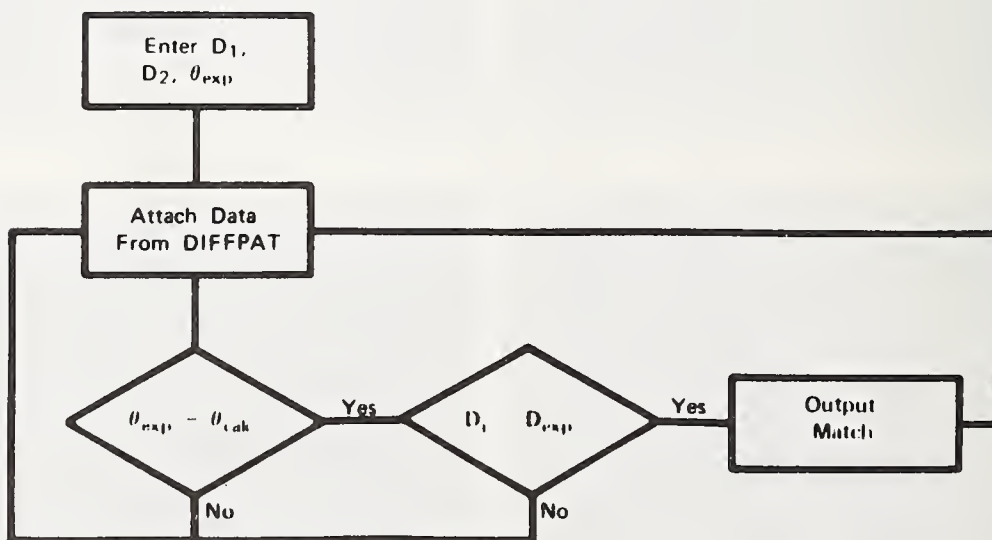

Figure 7. (b) Block diagram of the program SEARCH which compares measured parameters obtained from zone-axis diffraction patterns with simulated patterns generated by DIFFPAT.

In many cases, a well characterized x-ray spectrum and one good low-order diffraction pattern are sufficient for a positive identification. If the x-ray spectra are not available, or if there is more than one mineral matching the selected-area diffraction pattern, two patterns must be measured and indexed for positive identification. These two approaches to positive identification are illustrated in figure 8. These methods, although very reliable, are very time consuming. A much simpler method based on grouping particles into "classes" is described in the subsequent section, "More Rapid Electron Microscope Methods."

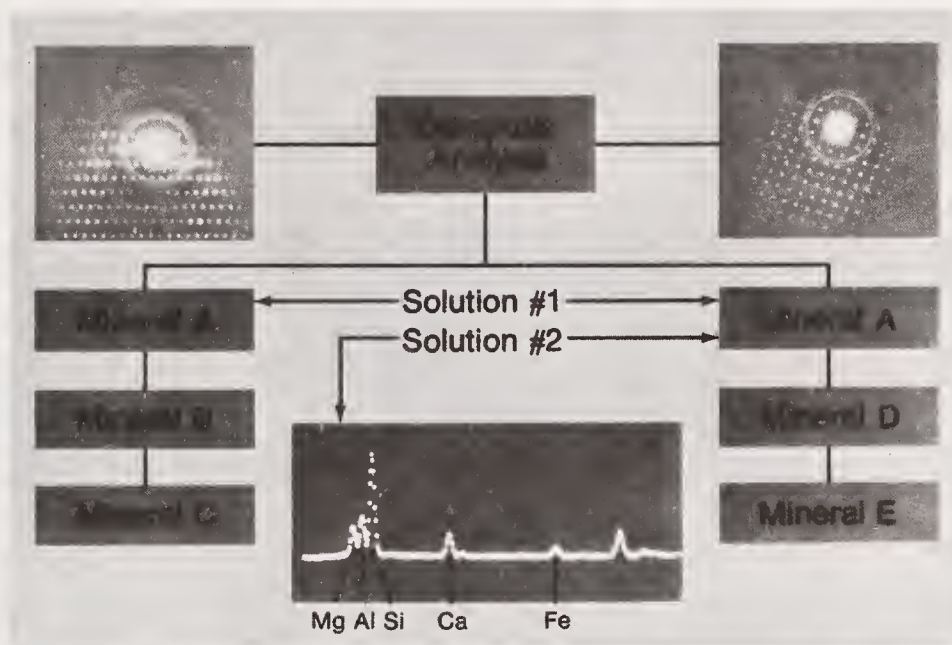

Figure 8. Schematic illustration of particle-identification criteria.

Sample Preparation and Particle Counting

Even when all necessary precautions are taken with particle identification, a number of factors can affect their apparent concentration. Very large variability between laboratories has been reported [8], in part due to problems with sample preparation methods, particulate losses, contamination, casual identifications, subjective definition of 3:1 aspect ratio, and inherent statistical limitations. Particularly large variations can occur for conditions of relatively high dust loadings. In this case the air sample volume is very small and the corresponding scale factor will be very large. The particle density on the electron-microscope specimen is still likely to be rather high, with the result that observation and positive identification of mineral fragments will be much more difficult than for low-particle-density samples of ambient air.

Improved Sample-Preparation Procedure. The block diagram of our well proven procedure [4] is shown in figure 9. The first step in sample preparation is to ash the filter and its contents. This low-temperature ashing is an important aspect of the sample preparation since it eliminates organic debris. Next, the sample is agitated ultrasonically to break up agglomerates. If friable material is present, this may result in some modification of the original size distribution. The alternatives to this procedure are "direct" examination or "rubout" procedures. In the first case, the sample may contain extensive debris; and in the second case, modification of the size distribution may occur.

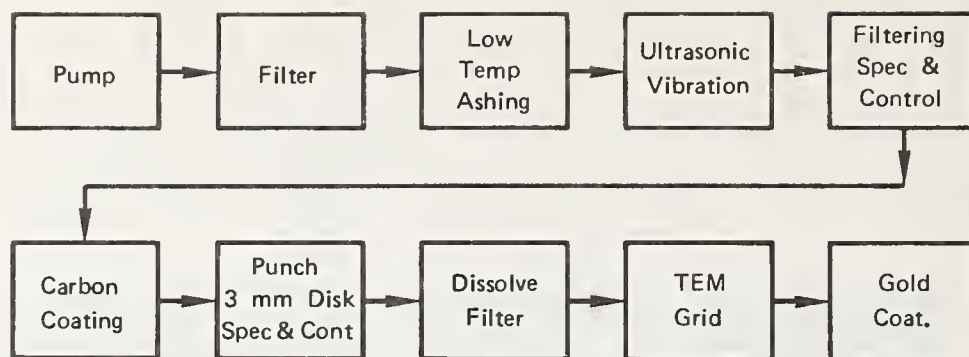

Figure 9. Block diagram of steps in sample preparation procedure.

The material is now collected on a second filter paper by suspending the sample in distilled water and pulling the water through a vacuum aspirator. Dilution may be used to control the amount of material deposited on the filter. In addition, the particle distribution will be much more uniform than that on the original filter. This second filter is carbon-coated. The carbon film serves to entrain the particles and provide a support material that is transparent to the electron beam. A 3-mm disk is punched from the laboratory filter; the filter material is then dissolved in acetone, leaving the carbon film and entrained particulates. The film is picked up on the lettered grid, which permits determination of the exact position of a particle. This technique is rapid, and does not differ in any substantive manner from any method in which a carbon film is deposited on the filter to entrain the particulates.

Finally, a thin film of gold is deposited on the replica, which serves as a calibration material for the diffraction work; failure to include this calibration precludes measurement of SAD patterns with sufficient accuracy to allow differentiation between the complex crystal structures of the minerals under consideration.

Particle Losses. In any sample preparation technique, particulate losses may be an important source of error and some method must be developed for quantifying any loss. To check on this, the same carbon-coated filter material was examined before and after dissolution. As illustrated in figure 10, the losses are negligible, confined only to those particles in the body of the filter that are not entrained in the carbon. Since filters with 0.2-micron-diameter pores are used, these losses are minimal. Other laboratories report losses as high as 40 to 80 percent of the particulate matter deposited on the filter.

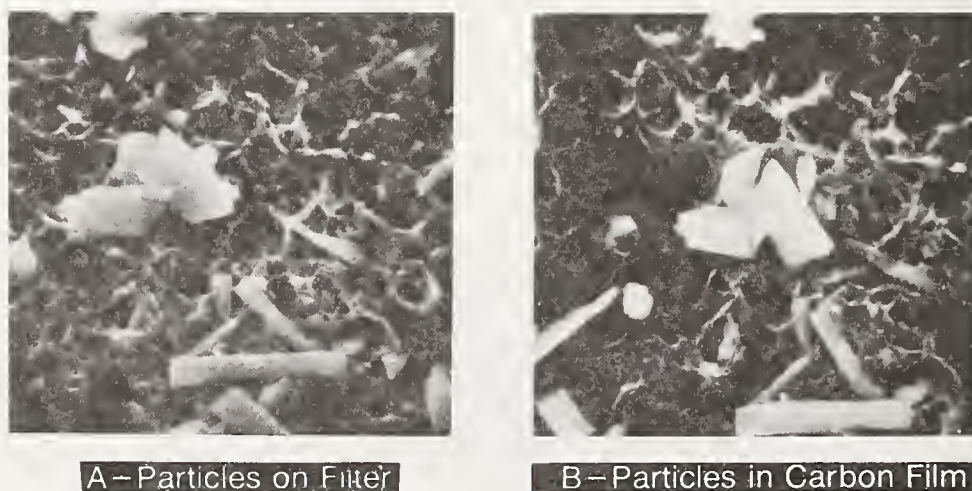

Figure 10. Comparison of samples before and after dissolving filter.
 (a) Particles on filter after carbon coating.
 (b) Identical particles entrained in carbon film after dissolution of the filter material.

Electron-Microscope Examination. Specimens are examined in the scanning electron microscope and the million-volt electron microscope, and micrographs are made of random areas until 35 to 50 particles with a 3:1 aspect ratio or larger are located. Visual examination, although obviously much quicker, is liable to large subjective errors in recognizing 3:1 "fibers" and in measurement of particle size. Permanent records are important in case of subsequent need for rechecking or confirmation by others. The total grid area photographed can be related to the original volume of air samples through the series of dilution and scale factors involved. Typically, one full grid opening corresponds to about 10 liters of clean ambient air and to about 10 mL of very dusty air or stack samples. In most cases, "average" concentrations of 2 to 10 particles per grid opening are about right. Smaller values lead to prolonged searching to obtain adequate statistics, and higher particle concentrations give difficulties with identification procedures.

Statistical Factor and Misidentification

Examination of a large number of samples has clearly demonstrated that the concentration (per unit area) of particles follows a Poisson distribution where the variance is about equal to the mean. The corresponding distribution of particles between grid openings is illustrated schematically in figure 11. The mean concentration is 2.5 particles per square. Obviously, differences of nearly an order of magnitude could result by chance if only the left-central or right-central four openings were examined with means of 0.5 and 3.3, respectively. This distribution effect can be minimized by continuing to search and record micrographs until enough data are obtained to be valid at a predetermined confidence level.

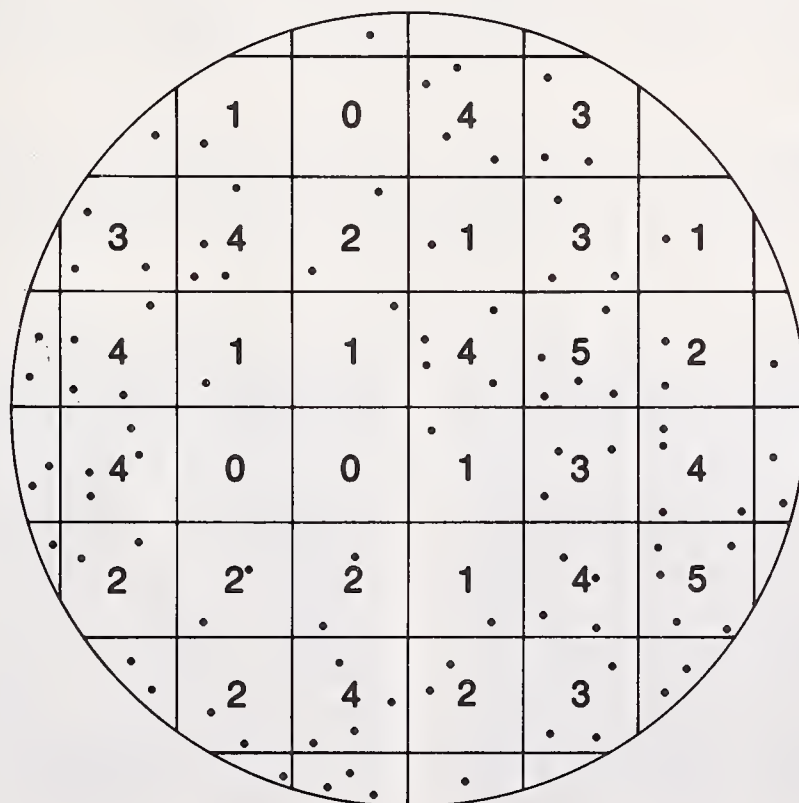

Figure 11. Schematic illustration of Poisson distribution of particles between grid squares.

Random Misidentification. Another source of error that is not so easily circumvented is the misidentification of mineral fragments if only electron diffraction is employed. This can occur by chance even when every care is taken to tilt the particle properly, the pattern is measured accurately, and comparison is made with an appropriate suite of minerals. This error is particularly serious in view of the growing tendency to equate "amphibole" with "asbestos".

The frequency of chance computer matches of diffraction patterns of randomly oriented mineral particles is shown in table 3. The chance of misidentification of a particle as an amphibole when minnesotaite and magnetite are both present ranges from 9 to 18 percent. The misidentification probability is reduced when lattice-symmetry effects are introduced into the calculation. An illustration of the effects of chance misidentification is shown in table 4. It was assumed that 35 particles of a non-amphibole mineral were counted and 7 misidentified as amphibole. If amphiboles could have been present, it is only possible to say that the concentration was less than $10^3/m^3$. Because of the larger scale factor for dusty air, or if only a few grid squares were scanned, an even larger apparent concentration would be reported (as has already occurred) [9].

Table 3. Computer matches of randomly generated diffraction patterns.^a

<u>Computer Indexed Solutions</u>	- - - - Randomly Generated Patterns From - - - -		
	<u>Minnesotaite</u>	<u>Actinolite</u>	<u>Magnetite</u>
Minnesotaite	100	<u>24</u>	<u>12</u>
Actinolite	<u>9</u>	100	<u>18</u>
Magnetite	<u>0</u>	<u>0</u>	100
Grunerite	<u>11</u>	<u>14</u>	<u>13</u>

^a Accidental matches are underlined.

Table 4. False identification as amphiboles, probability ~ 0.2 .

	<u>Scale Factor^a</u>	<u>Apparent Concentration</u>	<u>Actual</u>
Ambient Air	10^5	$\sim 5 \times 10^4/m^3$	$0^b - <10^3^c$
Dusty Air	5×10^7	$\sim 2 \times 10^7/m^3$	$0 - <10^5$

^a (Cubic meter per grid opening)⁻¹.

^b When none could be present.

^c Maximum if occurrence possible.

More Rapid Electron-Microscope Methods

The identification and counting procedures described in previous sections are very time consuming and expensive. Costs per individual air sample are in the range of \$300 to \$1500, depending on the methods used and the degree of reliability that the analytical laboratory is willing to certify. Deployment of more than 1000 air monitoring stations around the United States might easily be deemed necessary. The financial and manpower resources are just not available for electron-microscope analysis on this scale.

A more simplified method, currently under development, is to group particles observed in the microscope into classes based on their appearance and their x-ray emission spectra, that is, their approximate composition, using automatic image-analysis techniques for measurements and recording. Complete electron-diffraction identification is then carried out on randomly selected particles from each class. This cuts the time required by a factor of five or more, admittedly at some loss in certainty. However, the improved statistics appear to overcome this deficiency.

In some cases of particular interest, simpler methods may be developed to achieve reasonably reliable identification. For example, the development of different crystal faces by amosite and grunerite affect their orientation on the electron-microscope grid and the diffraction patterns most commonly observed. This could be used to screen samples for amosite and grunerite with a reasonable degree of accuracy on a quality-control basis. Other specific analysis problems might be solved in similar fashion. However, this method will not work on ambient-air samples, which could contain a large number of minerals or chemical compounds. Finally, automatic image-analysis facilities to process scanning electron-microscope images are coming into use. Effective methods of utilizing these devices are being developed to expedite analysis of air and water samples by eliminating manual data logging and particle counting and measurement.

Physical Characteristics of Mineral Fragments

Aside from questions of errors in identifying and counting amphibole and other mineral fragments, the very pronounced distinctions between their physical characteristics and those of asbestos must be recognized. In addition to obvious differences in particle size and shape, more subtle features such as crystal structure, face orientation, surface chemistry, associated impurities, lattice imperfections, and concentration could well be important in the biological response to small particles. These factors cannot be overlooked when attempting to generalize from health-effects studies with a particular mineral variety.

Scanning-electron-microscope micrographs in figure 12 demonstrate the difference in appearance of crocidolite fibers and several cleavage fragments of hornblende with a 5:1 aspect ratio. The difference in character between the two types of particles is quite apparent, yet there has been a growing tendency to equate them.



Figure 12. Scanning electron micrographs of crocidolite fiber and fragments of hornblende.

The cumulative distribution of particle aspect ratios of amosite fibers is shown in figure 13 with a similar plot for comminuted actinolite particles. Differences in the distribution of the aspect ratio of particles are marked. Very few actinolite cleavage fragments have an aspect ratio greater than 10:1, whereas very few amosite particles are less than 10:1.

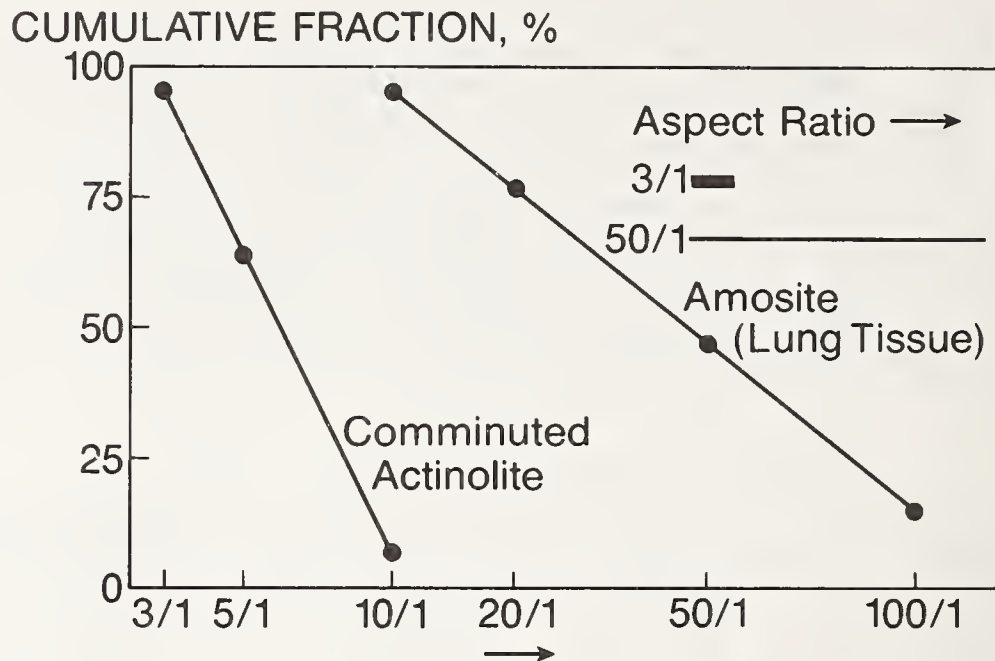

Figure 13. Plot of measured aspect ratio of amosite fiber and ground actinolite.

Studies of more basic structural differences are just beginning in a number of laboratories. Differences in cleavage properties and growth characteristics between amosite and grunerite that are reflected in particle morphology and surfaces were discussed in the Section, "Characteristic Diffraction Patterns." Planar lattice defects, responsible for extensive streaking in certain electron-diffraction patterns, can be seen by high-resolution electron microscopy [11]. When present, these grown-in faults may promote a tendency to split into long narrow fibers. Several years ago, electron-microscope studies revealed that chrysotile fibers are actually hollow tubes [12]. Recently, high-resolution studies of cross-sections of crocidolite have shown the presence of somewhat similar micropores between the fibers [13].

Summary

Identification of mineral fragments and determination of their concentration in air and water samples with a satisfactory degree of accuracy can be achieved using electron optical methods if the procedures reviewed in this report are followed. The most important precautions are:

1. Loss of particles or changes in their dimensions during specimen preparation must be avoided.
2. Crystal fragments must be tilted into a zone-axis orientation before selected-area electron-diffraction patterns are recorded.
3. Spot spacings and angles must be measured accurately and compared with computed patterns for any minerals that could occur in the sample.

4. X-ray emission spectral data from overlapping or closely adjacent particles must be discarded, effects of particle size on line intensities must be recognized, and data must be compared with well characterized reference standards.
5. Appropriate statistical criteria must be used to interpret the significance of apparent particle concentrations.

In our view, a definition of a fiber, incorporating the following points, would resolve most analytical difficulties and remain compatible with all known facts concerning health effects.

1. Aspect ratio greater than 10:1.
2. Parallel edges.

It is also necessary to establish a lower limit on particle size in keeping with capabilities of analytical procedures to ensure consistency in count between various laboratories. In the absence of any conclusive evidence for adverse biological effects due to very small particles, the current $>5 \mu\text{m}$ length standard should be maintained.

A recent Bureau of Mines Information Circular [14] contains discussion and documentation of many of the foregoing points including: (1) Detailed discussion of definitions relating to asbestos and the importance of eliminating loose terminology from the scientific and popular literature. (2) Discussion of the differing growth and cleavage origins of fibers and fragments as emphasized in this report. (3) Criticism of the 3 to 1 aspect-ratio criterion for mineral fibers on the basis that fibers from asbestiform minerals always average more than 10 to 1 and often go up to 200 to 1 or more, whereas the usual ratio for cleavage fragments is less than 10 to 1.

References

- [1] Zoltai, T. and Stout, J. H., "Comments on Asbestiform and Fibrous Mineral Fragments, Relative to Reserve Mining Company Taconite Deposits," Contract report to Minnesota Pollution Control Agency, March 1976.
- [2] Zoltai, T., "History of Asbestos-Related Mineralogical Terminology," Proceedings, Workshop on Asbestos: Definitions and Measurement Methods, National Bureau of Standards, Gaithersburg, Md., July 18 to 20, 1977.
- [3] Ross, M., "Minerals Commonly Occurring in the Earth's Crust That Might be Defined as Asbestos by Various Regulatory Agencies," Proceedings, Workshop on Asbestos: Definitions and Measurement Methods, National Bureau of Standards, Gaithersburg, Md., July 18 to 20, 1977.
- [4] Lee, R. J., "Electron Optical Identification of Particulates," Proceedings of Symposium on Electron Microscopy of Microfibers, Pennsylvania State University, August 23 to 25, 1976, in press (1977).
- [5] Lally, J. S. and Lee, R. J., "Computer Indexing of Electron Diffraction Patterns Including the Effects of Lattice Symmetry," Proceedings of Electron Microscopy Society of America Annual Meeting, Boston, August 22 to 26, 1977.
- [6] Champness, P. E., Cliff, G., and Lorimer, G. W., "The Identification of Asbestos," Journal of Microscopy, 108, Pt. 3, 231-249 (1976).
- [7] Nord, G. L., Jr., "State-of-the-Art of the Analytical Transmission Electron Microscope," Symposium on Electron Microscopy and X-ray Diffraction in Environmental and Occupational Health, in press (1977).

- [8] Brown, A. L., Jr., Taylor, W. F., and Carter, R. E., "The Reliability of Measures of Amphibole Fiber Concentration in Water," Environmental Research, 12, 000-000 (1976).
- [9] Nicholson, W. J., "Analysis of Mesabi Iron Range Samples," Environmental Sciences Laboratory, Mount Sinai School of Medicine, Contract report to Minnesota Pollution Control Agency, July 1975.
- [10] Chadfield, E., Ontario Research Foundation, private communication (1976).
- [11] Irusteta, M. C. and Whittaker, E. J. W., High-Resolution Electron Microscopy and Diffraction Studies of Fibrous Amphiboles, Acta Cryst. A31, 794 (1975).
- [12] Yada, K., High Resolution Electron Microscopy of Chrysotile, Acta Cryst. 23, 704 (1967).
- [13] Franco, M. A., Hutchison, J. L., Jefferson, D. A., and Thomas, J. M., "Structural Imperfection and Morphology of Crocidolite (blue asbestos)," Nature, 266, 7 (1977).
- [14] Bureau of Mines Information Circular (IC8751), "Selected Silicate Minerals and Their Asbestiform Varieties: Mineralogical Definitions and Identification-Characterization," U. S. Dept. of the Interior, 1977.

Discussion

NOTE: Discussion of this paper was included in the General Discussion at the end of this session.

NOTE: This manuscript was not presented at the Workshop but was submitted for inclusion in the Proceedings.

PRACTICAL ASPECTS OF TALC AND ASBESTOS

C. J. Parmentier and G. J. Gill

Cyprus Industrial Minerals Company
Talc Division
Los Angeles, California 90071

Abstract

The present day controversy and misunderstanding regarding talc and asbestos has existed for many years. This paper reviews some of the reasons for the widespread public misconception that all talcs contain asbestos.

The experiences of a major talc producer are discussed in relation to occurrences of talc and asbestos, and the analytical techniques required to substantiate a talc-asbestos relationship are reviewed.

Key Words: Asbestos; scanning electron microscopy; talc; transmission electron microscopy.

Introduction

Numerous environmental, occupational safety, and health agencies have recognized the medical hazards associated with asbestos minerals and have issued regulations for their use. However, during the past five years an increasing amount of controversy has been encountered regarding terms, definitions, and measurement methods.

Due to the ambiguities in these criteria and various misconceptions regarding the mineralogy of talc, disagreements also exist between industry, medical researchers, state and federal regulatory agencies concerning talc and asbestos.

This controversy affects a variety of industries, ranging from the talc producers themselves to the industrial consumers, their insurance carriers, and even the household consumer of the numerous products containing talc.

This presentation will highlight some observations and experiences of a major talc producer, in relation to occurrences of talc and asbestos. Analytical techniques used for identification of asbestos minerals and fibers in a talc matrix are also discussed.

Definitions

Asbestos:

As used in this presentation, the term "asbestos" pertains to fibrous forms of actinolite, tremolite, anthophyllite, and chrysotile. All of the six recognized asbestos minerals are not included in this review as the above mineral types are the only asbestos minerals this laboratory has found to occur in talcs to date.

The terms acicular, lath, bladed, cleavage fragments, rods, needle, and columnar are often used as synonyms for the term fiber or asbestiform. It is the term "fiber" which appears in need of a uniform definition. As used in this presentation, a fiber is described as a particle with a length to width ratio of 10:1 or greater. The present OSHA definition [1]¹ allows a length to width ratio of 5 or more to 1, with a maximum diameter of 3 μm . Figure 1 illustrates and compares the simulated appearance of particles with the aforementioned ratios. The 5:1 length to width ratio allows blocky particles to be classified as fibers, illustrating the need for more realistic definitions and size criteria of a fiber.

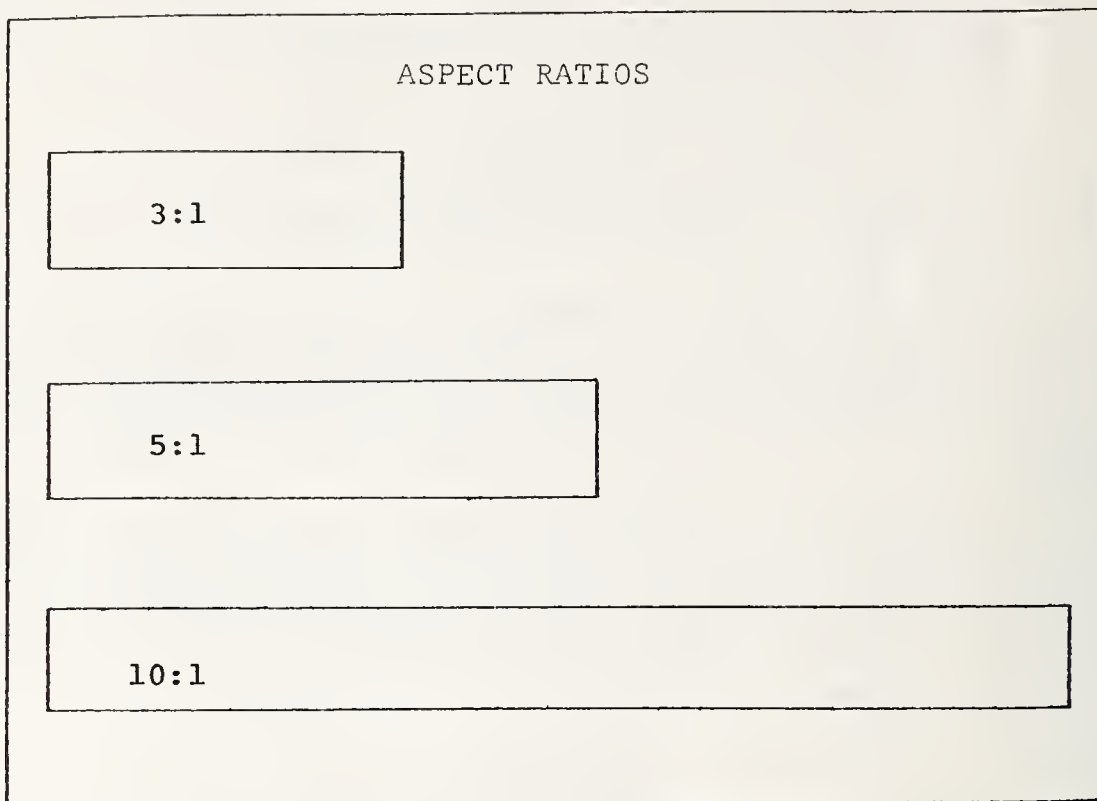

Figure 1. Illustrated by the above drawing are the geometric shapes which have been defined as fibers. The Asbestos Regulation CFR 1910.100L stipulates that a particle with an aspect ratio of 2:1 or greater is a fiber. However, these criteria were further modified by OSHA field information memorandum #74-92, November 21, 1974. The OSHA modification changed the criteria for a fiber from a 3:1 aspect ratio to a 5:1 length-to-width ratio with a maximum diameter of 3 μm .

The 10:1 aspect ratio is used at the Cyprus Industrial Minerals laboratory.

Talc

The term "talc" has also been misused in published studies and requires definition. Talc refers to a specific mineral with a hydrated magnesium silicate composition of laminar or sheet structure. The natural platelet diameter of a talc varies, depending on deposit location and geological condition. Both the size and orientation of the laminar plates, with respect to each other, determine the characteristic form of the talc, e.g., massive or steatite talc versus foliated or micaceous talc. It is this characteristic talc structure which most often determines end use applications. The large micaceous or foliated talcs are ideal for cosmetic applications; while the finer particle size, massive or steatite type talcs are most often used in filler and extender applications. The purity and locations of the talc deposit, in addition to the degree of beneficiation, also have a significant effect upon the end use application.

¹Figures in brackets indicate the literature references at the end of this paper.

Many misconceptions and misunderstandings of talc have existed due to improper use of terms such as tremolite talc, asbestiform talc, and fibrous talc. The majority of these improper terms were used to describe talc from the New York State talc district. In many earlier medical studies, which indicated a high incidence of talcosis, pneumoconiosis and mesothelioma among talc miners and millers from St. Lawrence County, New York, the supposition is made that talc dust was the cause. Kleinfeld and workers in 1967 [2] compared the mortality among talc miners and millers in New York State to findings among asbestos workers and noted similar pathological findings, to quote, "Rather characteristic was the presence of elongated, terminally clubbed bodies indistinguishable from asbestos bodies as seen in asbestosis." The talc dust exposure consisted predominantly of talc admixed with other silicates such as serpentine and tremolite, carbonates and a small amount of free silica, according to Dr. Kleinfeld. Additionally, Dr. Kleinfeld cites numerous other publications in which medical studies were performed on workers engaged in the milling or mining of the "fibrous variety of talc" [3-6]. However, none of these studies have differentiated between the mineral talc and the asbestiform variety of tremolite.

In a later publication [7], studies of New York State talc deposits and their asbestos contents were carried out. Mineralogical analyses of these materials indicated that all samples were predominantly asbestos.

The amount of asbestos impurities encountered in commercial talc ranges from <0.1 percent to over 50 percent. The majority of commercial talc samples analyzed have asbestos contents ranging from <0.2 percent to a maximum of 2 percent. Commercial production talc samples from New York State show a range of 20 percent to over 50 percent asbestos. A few additional commercial talcs have an asbestos content of 5 to 15 percent.

Figures 2 and 3 illustrate the asbestos contents of typical New York commercial talcs.



Figure 2. Talc-Fiber No. 1 from International Talc Co. Analyzed as asbestiform tremolite with minor talc content.



Figure 3. New York talc product used in the paint industry. Actual talc content is less than 40 percent. Majority of fibers are asbestos-tremolite, identified by TEM/SAED.

Cyprus Industrial Minerals Co. is one of the largest talc producers in the world. We have a continuing exploration program and over the past ten years have characterized talc deposits worldwide, in addition to analyzing numerous commercial talc samples. With this background and experience we feel justified in stating that not all talcs contain, or are associated with, asbestos. We also feel confident in stating that our ultra-fine grind Montana talc is the standard of talc purity throughout the world. Although high-purity talc deposits such as the Montana talcs are rare, asbestos-free talcs are not uncommon.

Based on our experience and bank of analytical data, we are aware that some talcs on the market do contain varying amounts of asbestos minerals. The most commonly encountered asbestos impurities in talc are tremolite and anthophyllite. There have been occurrences in which chrysotile asbestos has been found in selected talc samples. However, these occurrences are considered unusual but not unlikely.

Analytical Techniques

The methodology used for the analysis of asbestos fibers in talcs is a subject of considerable controversy. Following is a summarized description of the techniques used by the Cyprus laboratory and the reasons for their use.

Illustrated in Table 1 is the typical test procedure used to analyze talc for possible asbestos contamination. Although x-ray diffraction is shown as the initial method of analysis, it must be remembered that the primary function of the Cyprus Industrial Minerals laboratory is the characterization of talcs. If we were concerned with analyzing talcs for the presence of asbestos only, we would consider scanning electron microscopy as the most applicable technique to initiate analyses by screening samples for the presence of fibers.

Table 1. Analytical procedure flow sheet

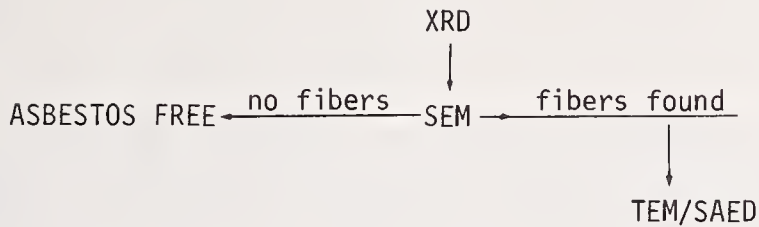

Scanning Electron Microscopy (SEM) has two very unique advantages compared to optical microscopy techniques. First is the capability to accurately identify a fiber by tilting the specimen, thus viewing a particle from various angles. Additionally, the added depth of focus characteristic of SEM allows the complete particle to be studied at the same time. Figure 4 is included to illustrate this advantage, and shows the typical curled edge of a talc platelet. If a similar talc platelet was observed by optical microscopy, the limiting depth of focus would dictate that only the curled edge was in focus and would appear as a fiber, or the plate would be in focus and appear as a separate particle.

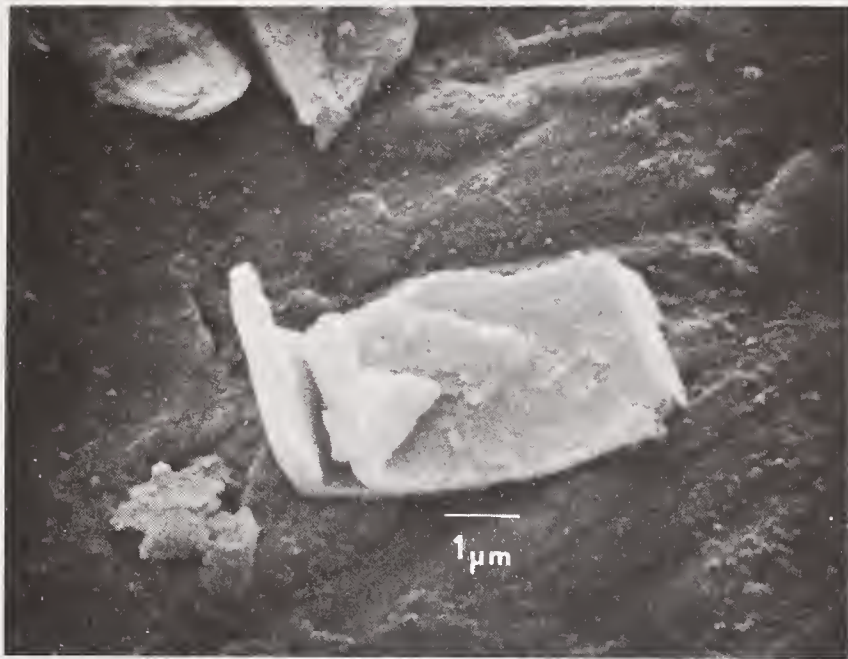

Figure 4. This micrograph illustrates the morphology of a typical curved talc platelet. The problems associated with attempting to define a fibrous structure by optical microscopy and its limited depth of focus can be seen. The optical microscope would make the above particle appear to be two separate particles, one of which would appear as a fiber and the other as a platelet.

The second advantage of SEM is the easily varied magnification capabilities with sufficient resolution to distinguish the presence of very fine fibers. In contrast, optical microscopy techniques can allow a large number of very fine fibers such as chrysotile to go undetected. Langer, Selikoff, et al., state "Many particles found in lung tissue are submicroscopic, measuring as little as 200 Å (0.02 microns) in diameter, therefore requiring electron microscopy" [1]). Suzuki and Churg also stated the preponderance of submicroscopic asbestos fibers observed in the successive steps in the development of the asbestos body were less than 1 µm in length, necessitating the use of the electron microscope [14].

Figures 5 and 6 are included to illustrate the SEM capabilities by revealing numerous chrysotile fibers present in a talc sample spiked with 1.5 percent chrysotile. Many of these fibers can be observed in figure 6 with sizes approaching single fiber diameters of ~20 nm (200 Å), well below the theoretical resolution limit of optical microscopy.

5 µm

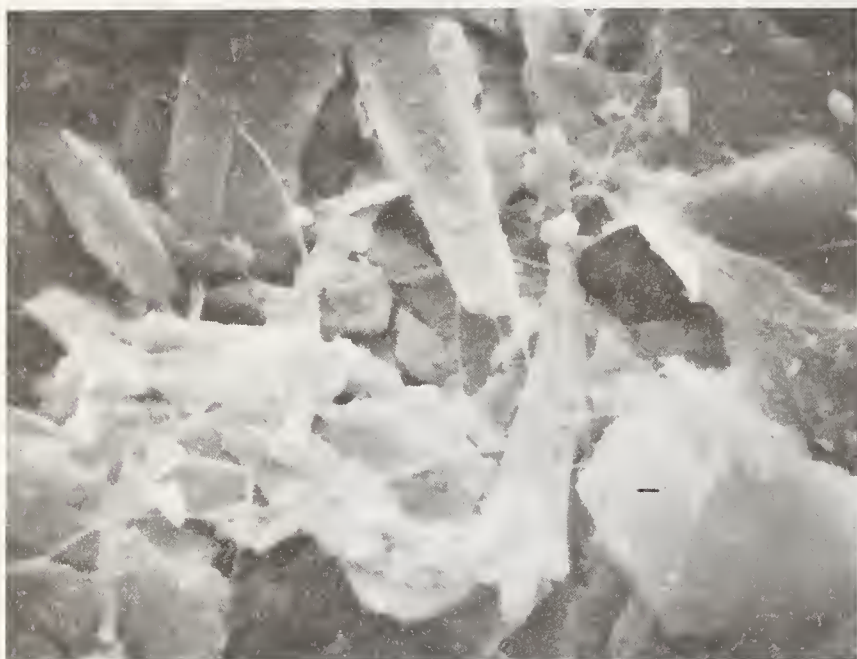

Figure 5. CTFA spiked talc by SEM. 1.5% chrysotile, 0.5% tremolite x 2800 at 40°.

1 µm

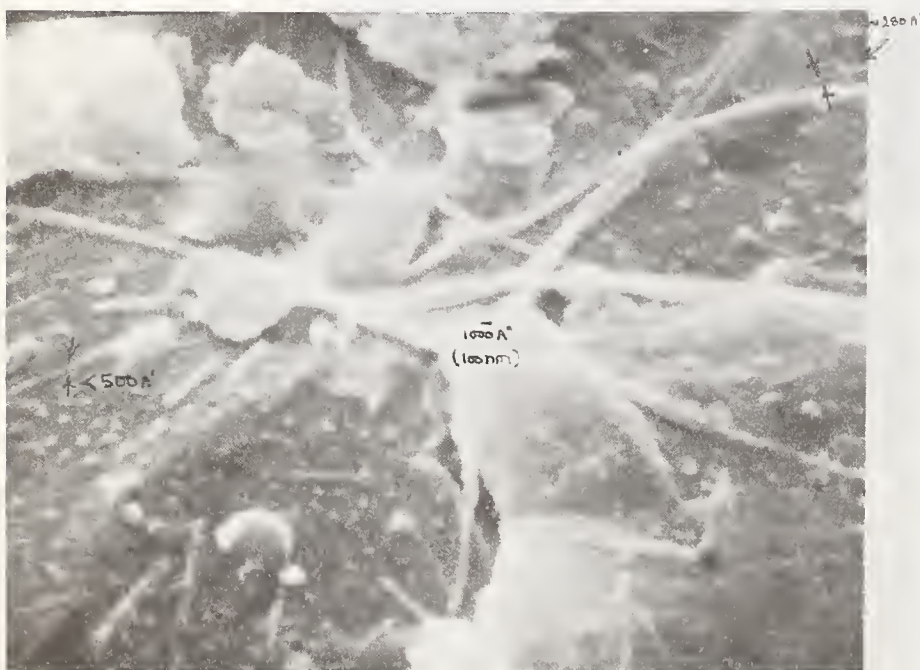

Figure 6. Spiked talc by SEM. 1.5% chrysotile x 13,500 at 35°.

Scanning electron microscopy for initial sample screening also has advantages compared to transmission electron microscopy methods. The sample preparation is considered easier and less time-consuming than TEM, which requires preparation of filmed specimen grids for sample mounting. Additionally, and most significant is the fact that by SEM screening of talc samples for fiber presence, the amount of sample examined is approximately an order of magnitude greater than TEM methods (0.1 mg vs. <0.01 mg). This difference becomes a major factor when investigating talc samples for trace fiber content (<1000 ppm.).

Transmission Electron Microscopy and Selected-Area Electron Diffraction

This powerful analytical technique is capable of furnishing a combination of morphological and crystal structure data of small single fibers which can result in very conclusive identification. However, this method requires a good deal of operator expertise and accuracy of data. We feel that fiber analysis via electron diffraction, supplemented with morphological data, provides a positive identification. We have observed, however, many cases where workers have identified minerals through using only partial diffraction patterns; that is to say, only the high angle reflections (low numerical spacings). These spacings are very similar between silicate minerals making absolute identification impossible without the more conclusive low angle reflections (high numerical spacings). Additionally, due to the unique possibilities of unusual mineral occurrences, which are more the expected than the unexpected in mineralogy, the morphology of a fiber does not, and should not indicate asbestos.

Along these lines, some examples of unexpected trace mineral fibers which have been encountered and subsequently identified in specific talc samples or deposits are: zeolite fibers (mordenite), clay mineral fibers (attapulgitite-polygorskite), and a rare fibrous variety of antigorite-serpentine known as picrolite [12,15]. These materials are not asbestos by definition.

All of the indicated fibers have similar d-spacings in the high angle reflections (numerically lower than $\sim 5.00 \text{ \AA}$), indicating the necessity for using only the numerically high, low angle spacings for positive identification.

Although SAED allows positive and undisputed identification of mineral fibers, only under specific conditions are SAED patterns considered positive identification. The following criteria must be met before an SAED pattern is considered accurate:

1. The camera constant must be determined on the same grid and same sample area as the SAED pattern, using a known standard. Preferred accuracy is obtained by shadowing the specimen preparation with a gold or aluminum metal which allows the camera constant to be calculated directly on the SAED pattern and acts as an internal camera constant.
2. The indexed d-spacings should include the most intense low angle spacings. Any pattern without d-spacings numerically higher than $\sim 5.00 \text{ \AA}$ (low angle) should be questionable, as many silicate minerals have similar d-spacings in the higher reflection angles.
3. Where applicable, unit cell parameters should also be used to supplement fiber identification.

X-Ray Diffraction

X-ray diffraction (XRD) is a standard mineralogical technique. Within levels of detectability and lack of interfering reflections, it allows the identification and quantitation of asbestos minerals in talc. The major limitations of XRD are the lack of morphological data and the lower levels of sensitivity can allow a large number of asbestos fibers to go undetected.

The information derived from XRD is invaluable for the characterization of a talc, and is of considerable help in the understanding of the mineralogical processes of forma-

tion and the possible impurities present. The background information of mineral phases present aids and expedites the TEM-SAED interpretation of unknown fibers.

Optical Microscopy

Optical microscopic techniques are considered of minimal value in the analyses of fine-grained complex silicate mineral mixtures, and often result in ambiguous data of questionable value. As previously mentioned, optical microscopy techniques can allow a large number of very fine fibers such as chrysotile to go undetected [7,13]. Due to these findings and the health and economic considerations involved, optical microscopy is not used at the Cyprus laboratory for asbestos in talc analyses or airborne asbestos fiber analyses.

Conclusions

This presentation has reviewed the misunderstandings and widespread misconceptions that all talcs contain, or are associated with, asbestos. Some of the reasons for these misconceptions were shown to be the lack of mineral background in the use of terms and definitions. However, the use of inadequate analytical methods has been shown to be a major cause. The use of ambiguous analytical techniques such as optical microscopy for reasons of expense, lack of experience, or ease of analysis has far-reaching economic and health implications. Only TEM-SAED techniques supplemented by SEM appear to give the necessary degree of accuracy needed for positive results.

The existence of large deposits of high-purity, asbestos-free talc are well documented, and it is hoped that future references to talc will be more clearly defined as to proper mineral content.

In view of the evidence presented from both the medical and mineralogical science fields, it is evident that state and federal regulatory agencies need to redefine terms, definitions, and analytical methods for the assessment of asbestos and talc. This applies to both airborne exposure and bulk samples containing asbestos.

References

- [1] Tremolite and Talc, U.S. Department of Labor, OSHA Field Information Memorandum #74-92, November 21, 1974.
- [2] Kleinfeld, M., Messite, J., Kooyman, O., et al., Mortality among Talc Miners and Millers in New York State, Arch. Environ. Health, 14, 663-667 (1967).
- [3] Kleinfeld, M., Messite, J., and Tabershaw, I. R., Talc Pneumoconiosis, Arch. Industrial Health, 12, 66-72 (July 1955).
- [4] Kleinfeld, M., et al., Lung Function in Talc Workers: A Comparative Physiologic Study of Workers Exposed to Fibrous and Granular Talc Dusts, Arch. Environ. Health, 9, 559-566 (Nov. 1964).
- [5] Messite, J., Redding, G., and Kleinfeld, M., Pulmonary Talcosis, A Clinical and Environmental Study, Ind. Health Perspect., 20, 408-413 (1959).
- [6] Siegal, W., Smith, A. R., and Greenburg, L., The Dust Hazard in Tremolite Talc Mining, Including Roentgenological Findings in Talc Workers, Amer. J. Roentgen., 49, 11-29 (Jan. 1943).
- [7] Kleinfeld, M., Messite, J., and Langer, A., A Study of Workers Exposed to Asbestiform Minerals in Commercial Talc Manufacture, Environ. Res., 6, 132 (1973).
- [8] Rohl, A. N. and Langer, A. M., Identification and Quantitation of Asbestos in Talc, Environ. Health Perspec., 9, 95-109 (1974).
- [9] Rohl, A. N., Asbestos in Talc, Environ. Health Perspec., 9, 129-132 (1974).

- [10] Rohl, A. N., Langer, A. M., and Selikoff, I. J., Environmental Asbestos Pollution Related to Use of Quarried Serpentine Rocks, Science, 196, 1319-1322 (June 1977).
- [11] Mumpton, F. A., Characterization of Chrysotile Asbestos and Other Members of the Serpentine Group of Minerals, Siemens Review XLI (1974).
- [12] Zussman, J., Brindley, G. W., and Comer, J. J., Electron Diffraction Studies of Serpentine Minerals, Amer. Minerals, 42, 133-153 (1957).
- [13] Ehrenreich, T., Mackler, A. D., Langer, A. M., Selikoff, I. J., Identification and Characterization of Pulmonary Dust Burden in Pneumoconiosis, Annals of Clinical Laboratory Science, 3, No. 2, 118-131 (1973).
- [14] Suzuki, Y. and Churg, J., American J. Path., 55, 79 (1969).
- [15] Deer, W. A., Howie, R. A., and Zussman, J., Rock-Forming Minerals, Vol. 3, Sheet Silicate 173-174.

GENERAL DISCUSSION OF ANALYTICAL METHODS

M. ROSS: I first would like to congratulate the U. S. Steel group. That was a beautiful presentation. I think that they have shown a method to use electron diffraction in a quantitative way, which is very important. Also, I like to mention that my own colleague at the U. S. Geological Survey, Gordon L. Nord, is also working in this area from a slightly different point of view, developing a method of indexing electron diffraction patterns. His and U. S. Steel's methods, I think, will have a great use in making electron diffraction really useful and quantitative and much simpler than it has been in the past. Next, I would like to address myself to the....

R. LEE: Malcolm, may I interrupt? We'd like to acknowledge the fact that without Gordon Nord there's an awful lot of twin patterns around my lab that wouldn't have been indexed.

ROSS: Gordon Nord will have a paper on the subject of indexing electron diffraction patterns coming out in a volume concerned with identification of microparticles based on a conference held earlier this year in Denver ("State-of-the-Art" of the analytical transmission electron microscope, in Proc. Symp. on Elec. Microscopy and X-Ray Applications to Environmental and Occupational Health Analysis, Ann Arbor Sci. Publ., in press (1978)). The next thing I'd like to bring up now is more of an observation. I'd like to quote a paragraph from my paper for this conference. "The crushing and milling of any rock will usually produce mineral particles that are within the size range specified in the OSHA rules. Thus, these regulations present a formidable problem to those analyzing for 'asbestos' minerals in the multitude of materials and products in which they may be found in some amount, for not only must the size and shape of the 'asbestos' particles be determined, but also an exact mineral identification must be made." Now as far as Dr. Anderson's presentation of an amphibole analysis in water samples, with his method you will find asbestos in every mine and mill effluent in the country, unless you make strict rules of identification and characterization of asbestos. To go back to my discussion the first day when I showed the maps of the U. S., you will be affecting every hard rock mining and quarrying operation in the United States unless you can get an identification and a definition of asbestos that does not include every amphibole, pyroxene, zeolite, and gosh knows what else that's in the crust of the earth.

C. RUUD: Listening to what Malcolm Ross says I can't help but agree, but I think if you read the Federal regulations with respect to water, you will find the word asbestos and then several mineral names following. Until it can be demonstrated that a chain silicate is distinguishable from an asbestos chain silicate on a single fiber basis in the microscope, then Chuck Anderson and the rest of us are stuck with the situation that Malcolm points out, that is to say that the whole world is dangerous.

LEE: Clay, I think our point here is that if you look at the electron diffraction pattern from amosite particles, at least 70 percent lie on a 100 face. If they lie on a 100 face, they have to have a b^* component, which is the 18 \AA d-spacing, perpendicular to that face; therefore, it has to be very close to the normal to the electron beam. Hence, within a couple of degrees - we were using about five on this study - of the 00 tilt in your microscope, you should find a strong 9 \AA row through the center of your diffraction pattern. We would say, on the basis of these data, that particular pattern is, as far as we are concerned, close to being diagnostic. Now you also have diffraction patterns from cleavage fragments which tend to lie between 110 and 010, and those patterns can give you the standard kind of pattern that people are using for identification of amphiboles and cleavage fragments in lake water.

RUUD: Rich, you and I have discussed this and I think you have an excellent point and we both agree that it has to be demonstrated. If we can do that, and if our microscopists are able to recognize what you are saying at a glance in the microscope, I think

it will be an important step. I'd like to make one more comment with respect to what Jim Kramer mentioned this morning. Jim was asking Chuck Anderson why he did not outline the method for recognition of an SAED pattern. Well, first of all it takes a highly experienced technician to do good transmission electron microscopy. On top of that it takes a much better technician to do SAED. To train that man to recognize patterns is probably one of the easiest things.

S. COHEN: My question is directed to Dr. Cossette. You mentioned recommending a secondary sampling method using a mini-impinger. I was wondering if you could expand on that and, if any studies have been done, comparing that to the membrane filter.

M. COSSETTE: Yes, some studies have been done. We found better reproducibility, but not that much better. We think it should be used if somebody wants to get correlation data to compare against the epidemiological data that we have. The large epidemiological studies are all based on midget impinger and you cannot translate midget impinger counts to fiber counts, not directly, not right across the board.

I. STEWART: I had a comment which is really diametrically opposed to Clay Ruud's comment. It's my feeling really that everything that we've seen on these requires someone with the knowledge of diffraction. If you're looking for somebody to drive your microscope, this should be a first requirement, a knowledge of the mineralogy of these materials and a knowledge of their diffraction patterns. You can teach any monkey to push the right buttons. I've done it over the phone. This is no respect really to the biologist. I'd like to make this comment, that this is in the health effects field; that a lot of people in the health effects field are biologists. They're damned good electron microscopists; they have never had to do any diffraction in the past; they have never been exposed to diffraction theory, and they are going to have a problem because they have to learn first of all the technique of getting the pattern and then what it all means. Now Rick has mentioned the fact that he had problems with some of the twin materials. There is probably more diffraction done in his field, in metallurgy, particularly in high voltage electron metallography, than there is in any of the other material sciences, and I think this highlights the problem that you need someone who is highly skilled in the interpretation of the diffraction patterns (first requirement); secondly, the knowledge of the variations that you get in mineral structures, the variations you can get in the natural mineral within a single crystal, and then you can say I have a man who is worth training on the electron microscope.

R. FISHER: Perhaps the solution to this - we recognize the difficulties - would be to establish a central facility with a big computer, with an automatic digitizing device, and where people send in their diffraction plates and these are processed in a routine way. The people processing would have no idea what the sample is, they wouldn't have any leanings, whether they want, or do not want, to find amphiboles, and the cost of doing this could be I think reduced considerably over every individual becoming an expert diffractionist, and then measuring them by hand and calculating by hand unless he has a computer and the computer library of data available. This is one possibility of an interim solution I think to set up one facility; the plates are mailed in and they are analyzed and identified on a more routine basis.

K. CHOPRA: I think there will be another problem with respect to giving you the camera constant and operator's judgment on how he got the camera constant, and if you don't have that right you might as well not do an analysis on it.

LEE: I'd like to respond to Dr. Chopra. Let's say you have two minerals that you're interested in identifying and you want to reject any other mineral. In that case I can take the angle between the rows and the ratio of the d-spacings; they are the only two things which are independent of the camera constant and pretty much independent of the operator - from those I think you have a very high certainty of a correct identification or a rejection. There will be cases when you can't accept the identification because there is not enough information available.

J. ZUSSMAN: I'd like to join the others in complementing Dr. Fisher and his group on his very fine presentation of what has obviously been a very careful, painstaking piece of work. After making that comment, I'd like to say that the kind of approach to analytical

Techniques used for a given problem depends very much upon that problem. If there is a completely open new situation where very little or nothing is known about the sample, then I'm quite sure that the approach which Dr. Fisher and his group have explained is the only safe one to adopt, because it's the only way of being sure of your identifications of not only what you think is likely to be there but what you may not expect to be there. But it is obviously a lengthy procedure. I agree fully with what others have said. Ian Stewart talked about the need to have really well-trained people to execute these techniques, and to understand diffraction above all because you need to understand diffraction to interpret not only diffraction patterns but to interpret the electron micrograph as well. They aren't just pretty pictures and shadowgraphs; there's more to it than that. Diffraction comes into it. Not everybody can employ highly trained crystallographers to do lengthy procedures for long periods of time and it isn't always necessary. There may come a stage in a situation where you do know quite a lot of the background of the problem and you don't have to worry too much about unexpected things coming up. In this case you can take shortcuts once you get to know the kind of field you are in. But one should always bear in mind, and there will be enough critics to keep an eye on you I'm sure, that you may have overlooked something unexpected. For example, the question of using in addition to electron microscopy, energy-dispersive, analytical methods has been mentioned, and I think this is a very useful technique to adopt. It can give you clues as to what mineral might or might not be present. If an ambiguity exists in an electron diffraction pattern which doesn't allow you to resolve this, or if you don't have an electron diffraction pattern, the energy-dispersive analysis can narrow down the possibilities. It is done much more rapidly, and less expertise is required perhaps than for the interpretation of electron diffraction patterns. So I do think that perhaps the most powerful, the ultimate technique is the combination of all - electron micrographs, energy-dispersive analysis, and electron diffraction pattern analysis in full. A good approximation can be gotten perhaps in certain circumstances using the x-ray spectrometric analyses to guide you. That's one general point that I wanted to make.

Another point: Dr. Anderson has expressed his worry about not being able to distinguish between what is asbestos and what is not asbestos. We've heard again with great interest the promising signs which seem to show us that it may be possible, even when you have started out with a true asbestos on the one hand, or you have started out with a clearly non-asbestos material on the other, and you grind the hell out of both of them, to recognize one from the other. I think there are promising signs that you can. But, faced with the situation that you're not convinced by this, there's a way out: you just don't commit yourself. Why call something asbestos if you don't know or, in some circumstances, when you know darned well that it started out as being non-asbestos and yet it's listed at the head of table "Content of Asbestos Particles." Why not use a nomenclature in a more sensible way, depending upon the amount of information you have about the specimen? If all you know is that it's crystalline and you say it's a fiber, define the fiber how you like, as long as you tell us, 3 to 1, 5 to 1, but specify what it is you have in mind. Say it's a crystalline fiber and that's all you know, perhaps. At the next stage of knowledge you might say it's a mineral fiber or an inorganic fiber. At the next stage you might say you know it's an amphibole fiber but you don't know which amphibole. That's O.K., say amphibole fiber. You might then have identified it as tremolite: say it's a tremolite fiber. If you know that it's asbestos because it has come from an asbestos deposit, say tremolite asbestos, but if you don't, say tremolite fiber, numbers of fibers, numbers of amphibole fibers, not numbers of asbestos fibers. Those are my general comments.

I'd still like to make two very small points. On technique, I agree with the experience of my colleague in Manchester, Dr. Champness. Our work has been done with the carbon coating method; and we agree that there doesn't seem to be any great percentage loss in carbon coating. Secondly, I wondered if anyone else has this experience: she tells me also that she uses dimethyl sulfoxide as a solvent for getting rid of the nucleopore filter. I haven't heard it mentioned here at all. There's been chloroform and acetone, but Dr. Champness swears by dimethyl sulfoxide as being a solvent which dissolves the plastic more slowly and therefore causes less disruption to the carbon film. Also, it's a more pleasant material to work with. It isn't as volatile and so it has less unpleasant fumes and there are other factors which she thinks favor the use of that solvent.

K. HEINRICH: Would you agree that probably x-ray spectrometry would be more useful in that area if one could determine, for instance, the magnesium-silica ratio with better accuracy than one can presently?

ZUSSMAN: You mean using energy-dispersive methods?

HEINRICH: Yes.

ZUSSMAN: Certainly. The greater accuracy you can get the more satisfactory it will be. But I think with proper use of the energy-dispersive method, and with intelligent application of it to the right kinds of specimens, specimens of the right thickness, that is, you can get very good accuracy which enables you to distinguish nearly all of these various magnesium silicates, but not all. There may be an occasional overlap, but 90 percent of them can be done within the present state of the art for accuracy, I believe.

HEINRICH: Thank you, Prof. Zussman. Would you have any comments as to Prof. Zussman's points?

CHOPRA: I think he's brought up very good points. I think this combination of two which is using EDS/SAED in morphology combination and just calling them fibers is the way to go at it.

A. SUNDARAM: I have to congratulate Dr. Fisher for his braveness in suggesting 10 to 1 ratio and 2 micrometer length. If we accept your definition of asbestos, we having the regulatory responsibility are faced with at least two major problems. Number one, if you insist on a 10 to 1 ratio and have the length as 2 micrometers, that means we've got to have the diameter of the fiber as .2 micrometer. Then immediately the use of optical microscopy for monitoring purposes is ruled out. If we take your method of detecting fibers of only 2 micrometers in diameter (should be, length? [90]), I just would like to know how feasible it is for a routine monitoring basis. Also, as a standard reference method, I'd like you to find out on that; that's number one. Number two, we have another responsibility now to show that fibers below 2 micrometer are not hazardous, so we are faced with that problem as well. Number three, I would like you to comment on the use of the in vivo studies as well as in vitro studies and the use of those to prove that 2 micrometer length is a safe length of choice.

FISHER: Well, working backwards, I can try to comment on the proper testing. What I had in mind is to say, let's divide these particles into domains that can be clearly identified and there's no question that 10 to 1 does that. There's very little overlap between the fragments produced by grinding and the fibers produced by the fibril growth habit that occurs in what is well known as asbestos. When you take 5 to 1, now you kind of get into that middle ground again. When you get down to 3 to 1, why it's just hopeless to run any tests and decide that there's any distinction in the biological activity above and below 3 to 1. You couldn't prepare the samples. There's already a problem with some small fraction of long fibers occurring in the so-called short-fiber specimens and this completely, I think, affects the results. Now your point about at the limit of the 10 to 1 and the smallest fibers getting down to pushing the analytical techniques, that is a good one, that would indicate that some of those would be lost from the analysis.

F. CHUNG: We routinely use x-ray diffraction, x-ray emission and microscopy for material characterization including asbestos. We actually analyzed many hundreds of asbestos samples either on membrane filters or as bulk powder. Based on our experience, I would like to make some comments:

(1) Identification: The term "asbestos fiber" combines two different features: the work "asbestos" indicates chemical composition and crystal structure; the word "fiber" indicates morphology, i. e., external shape and size. The OSHA phase-contrast microscopical method is adequate to count the number of fibers, but not the ASBESTOS fibers. As to the methodology of identification of asbestos (chemical composition and crystal structure) we have to make a distinction between a single fiber and components in a mixture. For components identification, x-ray diffraction is about the only choice; for single fiber identification, combined results of electron diffraction, and x-ray emission

(Mg/Si, Mg/Si/Fe, Mg/Si/Ca ratios) are most convincing. Dispersion staining and polarizing microscopy can give only supplementary information.

(2) Bulk Materials: For asbestos analysis we have to differentiate between membrane filter sample and bulk sample. The OSHA phase-contrast microscopical method cannot be used to obtain a fiber count for bulk samples. A reasonable indicator of asbestos content in bulk samples would be its weight percent, be it amosite, tremolite, or others. X-ray diffraction analysis can provide this weight percent with a precision of about ± 10 percent relative.

(3) Monitoring Methods: An official monitoring method ought to be practical and not too expensive. An optical microscope costs \$1,000~\$2,000. An x-ray diffraction unit costs \$20,000~\$30,000. An electron microscope costs \$100,000~\$200,000. In order to be "practical and not too expensive," I believe the current phase-contrast microscopical method is good enough for fiber counting and the x-ray diffraction method is adequate for identification and/or quantification. Note that if no fiber is observed under a microscope, identification by x-ray diffraction is not necessary. When the combined results of microscopy and x-ray diffraction are doubtful or challenged, then electron diffraction, x-ray emission, dispersion staining, and polarizing microscopy can be called upon for further confirmation.

(4) Definition of Fiber: An important feature of a fiber under a microscope is a pair of sides parallel lengthwise. This feature combined with a high aspect ratio, say 20 to 1, would exclude all the "cleavage fragments" which are non-fibrous and should not be regulated.

FISHER: I think on this identification question the problem has now been defined and recognized and I'm sure methods, reasonably satisfactory methods, will be developed in the near future. Also, on the counting, there are automatic image analysis facilities becoming available on microscopes. So I think the main point is to recognize that the problem is difficult, and the approaches that must be followed to get an absolutely positive identification; there are approaches that will give you a fairly high degree of reliability and I think that the next step now is to really document what these are.

RUUD: I'd like to cast my vote with Dr. Zussman that I think it's high time that we come up with a nomenclature that is clear with respect to what we are trying to describe. Perhaps, Kurt Heinrich and the NBS will have that task. With respect to sending off electron diffraction patterns to a central source: we have been working in our laboratory with metallic substrates for transmission electron microscope samples and have settled upon a fine-grain alloy that gives us some very sharp Debye rings that could well be used to determine the camera constant.

T. ODGEN: I've got a question for Dr. Cossette. Did I understand you to say that you would prefer to use size-selective sampling and then to determine the mass of asbestos? This is the same as giving weight to the larger fibers in the respirable range, isn't it? Have you any medical evidence for this, epidemiological evidence, or is it that you just feel it would be a more accurate thing to determine?

COSSETTE: You're right in your assumption that we would like to classify fibers before we collect them on the filter, eliminate the oversized ones and the undersized ones. We've examined the literature on short fibers and we find generally two situations. In some cases there has been no biological activity, or little activity. In other cases they have shown some biological activity, but in those cases the short fiber invariably contained a significant percentage of long fiber; and this, in our view, faults the results.

J. SAUNDERS: I just have a comment to reply to Dr. Zussman's comment. Asbestos isn't the only thing in the world that has teeth. If I were going to play with dimethyl sulfoxide I'd be very careful to look up and see what it does. It seems to me a number of years ago there was some research done on how it caused other materials to penetrate the skin. So, before I work with DMSO, or other solvents for that matter, I'd be careful.

D. BEAMAN: I'd like to ask Dr. Fisher: is your computer program available and can it be used on anything other than your instrumentation?

LEE: In answer to your second question, as part of this ASTM round robin, I've recently analyzed some diffraction patterns from several labs. There are some labs who properly record the diffraction pattern. I have no problem indexing and interpreting their diffraction patterns, taken on either 100 kV microscopes or 80 kV. I found that other labs weren't as careful with their patterns, and I had difficulty with the measurements. So the answer is: yes, our methods can be used if you get a zone axis. If you get a very incomplete pattern, our methods are unusable. However, our preliminary data, and we want to emphasize it's preliminary data, suggest that the characteristic amphibole pattern that is recognized by people with experience is that of the amphibole cleavage fragment and thus they wouldn't recognize the typical pattern from a single crystal amosite, asbestos particle.

FISHER: You really asked about the availability of the program and I see no difficulty with that, making copies available.

D. GIOIELLO: Question to Dr. Cossette. What TWA is the committee recommending for the two industrial groups that you split up, what excursion or fifteen minute exposure limit, and what is your medical justification for it?

COSSETTE: This is not completely settled and that is why I didn't mention any specific figures. The numbers that we are considering presently for the mines and mills are the same as the MESA regulation, which is five fibers, and for manufacturing and end use industries are the same as the OSHA regulation, which is two fibers, but this is not yet resolved. The justification for it is a review of the literature where we considered all the significant information published, particularly epidemiological data. We were not as strongly concerned with animal experimentation, but with the health effects on humans.

T. PANG: I would like to ask Dr. Fisher to comment on the identification of chrysotile fibers.

LEE: In the quantitative identification of chrysotile fibers, I have very limited experience. We have been working primarily on the identification of amphiboles. I have not obtained chrysotile patterns which I have indexed. I use a reference pattern which looks a lot like that which anyone else would use, as the pattern is diagnostic of rotational symmetry. I think a problem occurs only if you don't have some indication of the chemistry or no SAD pattern, for then you could be talking about a very acicular clay mineral or anything else.

HEINRICH: Would anybody else want to comment on the identification?

ZUSSMAN: The least one can say about chrysotile is that if you are looking at the electron diffraction pattern, now I'm talking about chrysotile asbestos, then the diffraction pattern is simpler to interpret because you don't have a rotation problem. A single fiber has already produced a rotation effect, because it is cylindrical, and no matter how much you turn it about the fiber axis it won't affect the pattern. So you are up against less of a problem than in the amphiboles, of the kind we have heard about. I would have thought that on the whole, if it is true chrysotile asbestos you are interested in, well, rather than with other forms of serpentine (some of which may have greater or less similarities), the problem is very easy because the morphology is also relatively easy to see, the length-to-width ratios are usually extremely high, the diameters are extremely low, and you can often see the central void channel in a number of the fibrils you look at. Other forms of fibrous serpentine, though not asbestiform, not silky, not things which would have on the macro scale the properties of silky asbestos, let's say, give diffraction patterns somewhat similar, similar enough I think to put you on the right track, but not identical to asbestos.

You can index quite a number of the reflexions, quite a number of the spots, but some of the spots are not spots, they are streaks. You can do some sort of approximation to indexing those, but it is not as easy, but again there are fewer of them, and there are not many spots and streaks to index because the structure is rather randomized and not very well crystallized.

ROSS: I would like to make a comment again, concerning health aspects of asbestos. Perhaps we are now beginning to understand which shapes and sizes of certain minerals cause ill health, but it comes down to what actually causes cancer. What are the chemical properties of silicate minerals which relate to cancer development? High health risk is known only for four commercial forms of asbestos. I don't know of any health studies that relate to other types of minerals that may or may not be asbestos, but have never actually been commercial. So I'd like to repeat that we need epidemiological studies in areas other than true asbestos mining, milling, and in the asbestos trades. The Homestake Mine is one. If the miners there can be proven not to have health problems due to amphibole, then there is a very high probability we can quit worrying about the grunerites, cummingtonites, and hornblende and our common rocks. We should also look at the hard rock iron ore miners who are also exposed to these same minerals. I am not impressed with rat and animal studies. A great many solid state materials have been injected into the pleura of animals. Fiberglass may or may not cause disease. I saw one study where actinolite did not cause disease, one study where tremolite did, and so forth. I think it's got to boil down to the health of the people involved in the operations other than strict commercial asbestos mining. If we can find that there is not a health hazard in general mining communities, we can quit worrying about a great deal of country rock and concentrate on true asbestos. I think the mineralogists have shown that there are some very interesting mineralogical properties in what we consider true asbestos that may have something to do with cancer.

R. THOMPSON: Everybody has danced around the issue, but nobody has addressed it. If you are going to set up a method for monitoring, and ultimately that is what you are coming to, you are going to have to have some kind of objective, and your objective is going to determine what method you use. I would contend for the objective I was given; I've got a method that works for chrysotile in ambient air samples. It would not be applicable to anything else, nor do I think that some of the mineralogical work we have done in depth would be possible or necessary on air samples when you are dealing with one part of asbestos in ten to the fourth of the total particulate matter. Then we are going to have everybody talking about a method as though you are going to have one to do everything with, and that is complete balderdash, so we are going to have lots of methods to determine lots of things and ultimately it's going to go back to health effects as has been mentioned. And maybe when the threshold response that was brought up yesterday is answered the main method we've got may prove to be of practical value there, who knows.

QUESTION: Would you comment on the role, if any, of the optical microscope?

THOMPSON: I say, for ambient air samples, optical microscopy is an impractical tool. I proposed in 1970 to do a fence to background study of the distribution of chrysotile by fiber length, to get a fiber length distribution. I believe you will find that if you do this you will be able to establish (up to a point) a ratio between the asbestos by the mass method and the optical count, and that might prove to be a survey tool. If your asbestos count is high enough, x-ray diffraction is very elegant and sophisticated, for survey work it depends on your loading again. Part of our primary concern is particulate matter in ambient air where asbestos is approximately one out of 10^4 , again, one out of ten thousand parts by mass. There you are stuck, you have no choice; your flexibility has been removed. But, if you tell me the context then I think we, or anybody, is going to come up with a set of survey techniques that would be applicable. The ultimate objective of course is cost effectiveness, which I didn't go into this morning and should have, because I think I've got a winner on that basis.

D. WALIA: I would like to commend the U. S. Steel researchers on employing interpretation of electron diffraction patterns for distinguishing fibrous and non-fibrous mineral particles. My optical microscopic observations of known fibrous and non-fibrous amphibole (mineralogical criteria) minerals seem to support that, that the fibrous particle (asbestos forming) tend to sit on 100 plane, and their counterpart non-fibrous particles

sit on 110 plane. This can be easily distinguished by measuring extinction angles. Of course, this is not the case with orthorhombic anthophyllite. I think this methodology should be looked into more, so it can be applied even on optical microscopic determinations.

LEE: Thank you. I think that the only thing we are trying to suggest is that there is not a mystical transition between a massive cleavage fragment that is visible in the optical microscope and a cleavage fragment, at least at a range we are able to work, in the transmission microscope. That was one of them.

H. RHODES: I am speaking for the Asbestos Information Association, which is a group of about 40 companies who produce and use asbestos. The question of the validity of the optical method has been touched on here only briefly and the conference seems to have focused on whether it is SEM or TEM that should be used. We in the industry, and I think the government would agree to this, have generated a lot of useful knowledge and field experience with the membrane filter method. We feel that with chrysotile asbestos and the volume of monitoring that is mandated by regulations, the method has a great deal of utility. It has shortcomings, but as long as you recognize these there are very many situations where this method is quite effective and we would hate to see a move to even scanning electron microscopy mandated as a primary compliance monitoring procedure.

INTRODUCTION

John Martonick, OSHA - Chairman

I would like to make brief comments to put the aspect of regulatory agencies into perspective. First, I think that if we reflect on the information that has been presented over the last 2-1/2 days, we could conclude that there is a considerable amount that we do know about asbestos, with which we can all agree. From this information which we do know about asbestos, the regulatory agencies must constructively formulate their regulatory postures. Their interpretation of this information must be practical in the sense that the job has to be performed and it has to be performed now in many cases. The regulatory agencies don't necessarily have time to reflect on which path they might take, or which path might be better to take. The uncertainties in measurement and health effect that have been discussed thus far must be put into perspective and this perspective must reflect the goals and objectives that a particular agency has.

My second point is: How does an agency determine its goals? Each agency has a defined rule, defined by Congress when they mandated that the agency take certain action. In order to assure that the intent of Congress is being met, the Congress has the General Accounting Office periodically investigate regulatory agencies to see whether or not they are performing as Congress intended. In addition, the public has a great deal of influence on the regulatory agencies. They influence us in all aspects; they influence the Congress, they influence the President, and they have direct influence on the regulatory agencies; through meetings like this, through public hearings, and through general day-to-day interactions. Finally, the courts make decisions which direct the agencies and their activities. If agencies get out of line and assume too much authority, the courts will hopefully bring them into perspective.

These are the introductory comments I wanted to make. If you listen to the papers presented today, you will see that action has taken place, and that certain types of consideration are being made to everyone involved. It would be unfortunate if some of the individuals being regulated feel that the regulatory agencies are insensitive.

THE MINING ENFORCEMENT AND SAFETY ADMINISTRATION - REGULATIONS AND METHODS

Aurel Goodwin

MESA - Metal and Nonmetal
4015 Wilson Blvd.
Arlington, VA 22203

Abstract

MESA regulations for exposure to asbestos require that no employee be exposed to airborne concentrations greater than 5 fibers/mL (soon to be reduced to 2 fibers/mL) greater than 5 micrometers in length on a time-weighted average basis. We are proceeding with public meetings to obtain necessary data to reduce this permissible exposure even further. We use the membrane filter method for sampling and phase contrast microscopy for counting. Our regulations specify that the term asbestos refers to chrysotile, amosite, crocidolite, anthophyllite asbestos, tremolite asbestos, and actinolite asbestos. In order to analyze for specific minerals we have contracted with Dr. Ruud at the University of Denver.

Keywords: Asbestos; dust; fiber; metal and nonmetal mines; optical microscopy; phase contrast.

The Mining Enforcement and Safety Administration (MESA) is responsible for administering two laws for occupational health and safety, The Federal Metal and Nonmetallic Mine Safety Act which was passed in 1966 and the Federal Coal Mine Health and Safety Act of 1969. Regulations for occupational exposure to asbestos have been promulgated under both Acts. The standard for coal mines which is found in Title 30 Code of Federal Regulations (30 CFR) Part 71.202 states:

71.202 Asbestos dust standard; measurement.

(a) The 8-hour average airborne concentration of asbestos dust to which miners are exposed shall not exceed two fibers per cubic centimeter of air. Exposure to a concentration greater than two fibers per cubic centimeter of air, but not to exceed 10 fibers per cubic centimeter of air, may be permitted for a total of 1 hour each 8-hour day. As used in this subpart, the term asbestos means chrysotile, amosite, crocidolite, anthophyllite asbestos, tremolite asbestos, and actinolite asbestos, but does not include nonfibrous or non-asbestiform minerals.

(b) The determination of fiber concentration shall be made by counting all fibers longer than 5 micrometers in length and with a length-to-width ratio of at least 3 to 1 in at least 20 randomly selected fields using phase contrast microscopy at 400-450 magnification.

The standard for metal and nonmetal mines which is found in 30 CFR Part 55.5-1(b), 56.5-1(b), and 57.5-1(b) states:

(b) The 8-hour time-weighted average airborne concentration of asbestos dust to which employees are exposed shall not exceed 5 fibers per milliliter greater than 5 microns in length, as determined by the membrane filter method at 400-450 magnification (4 millimeter objective) phase contrast illumination. No employee shall be exposed at any time to airborne

concentrations of asbestos fibers in excess of 10 fibers longer than 5 micrometers, per milliliter of air, as determined by the membrane filter method over a minimum sampling time of 15 minutes. "Asbestos" is a generic term for a member of hydrated silicates that, when crushed or processed, separate into flexible fibers made up of fibrils.

Although there are many asbestos minerals, the term "asbestos" as used herein is limited to the following minerals: chrysotile, amosite, crocidolite, anthophyllite asbestos, tremolite asbestos, and actinolite asbestos.

MESA has proposed a reduction for metal and nonmetal mines to provide the same exposure level as for coal mines, i.e., 2 fibers/mL for an 8-hour time-weighted average. This proposed change was published in the Federal Register on July 7, 1977.

MESA uses the accepted industrial hygiene method of phase contrast microscopy for counting and the membrane filter method for sampling fibers. A detailed description of the method is given in the NIOSH Analytical Method P & CAM 239.

There are several practical problems with this method for determining exposure. One of the more serious of these is the time and cost required for sampling and counting. In order to measure a worker's exposure, a sampling pump and filter are worn by the worker. Because a heavy accumulation of dust on the filter can hinder or prohibit sample counting, it is usually necessary to change the filter several times during a shift. Anywhere from 2 to 15 filters may be required to determine one person's exposure. Usually 5 to 8 filters are used. It costs a minimum of \$10 to count each filter; thus the cost to determine one person's exposure for one shift ranges from \$20 to \$150. In addition, the cost of analyzing each sample for "asbestos" content increases this cost substantially. We do not have conclusive information on the cost of such analyses on a routine basis, but at present the cost for a single sample may be as high as \$300 for electron microscopic analysis. Besides these counting and analyses costs, the industrial hygienist collecting the samples can, under average conditions, obtain reliable samples for only about five employees in one day. This may go to as high as ten employees under good circumstances, but in other mining situations it may be possible to cover only one or two employees. This will add another \$10 to \$20 for each sample. The total cost for determining time-weighted average exposure is therefore \$400 - \$500 if a single filter is sufficient for an electron microscope analysis, and could be as high as \$3000 if ten filters are analyzed. In any event, the major contribution to cost is the mineralogical analysis by electron microscopy. The MESA Denver Technical Support Center is currently developing an innovative sampling pump which operates intermittently to obtain a time-weighted average exposure on a single filter. The sampling rate now being experimented with is one minute out of every six minutes. That is, the pump is on for one minute and off for 5 minutes. The total "on time" of the pump is accumulated in a memory cell. This avoids the necessity for the industrial hygienist to precisely determine the on/off time of the pump. We will be testing this concept along with a conventional sampling method, such as changing filters during the shift, in the next few weeks. If this is successful then the cost per time-weighted exposure will be reduced to only slightly over the cost of the electron microscopic analysis. Since a single filter would be sufficient to measure the total time-weighted exposure, only a single count and electron microscopic analysis would be needed for each full-shift, time-weighted average exposure.

You might ask, "since it is necessary to use an electron microscope for analysis, why not also use it for counting?" Other than the fact that our current regulations specify the use of phase contrast microscopy, the added cost of electron microscopy for counting, and the correlation of such counts with disease prevalence or with the existing phase-contrast method, are factors which must be considered. However, there are no known technical problems with this approach.

There are several other practical problems with sampling and counting asbestos using the membrane filter method and phase contrast microscopy. One of these is the non-uniformity in the deposition of dust on a filter, which occurs for a number of reasons. One of these reasons is non-uniformity in the filter manufacture. Figure 1 illustrates a pattern of deposition on some filter samples which were collected at a mining operation. The pattern is visible because the air in the workplace contained dark material (probably diesel smoke) which stands out when collected on the white filter.



Figure 1. Photograph showing uniform particulate density on filter.

Usually such patterns are not visible because, when collecting fiber samples, only a light loading is desired and the collected material is often white. However, such patterns, when they do occur, can cause variations in counts between different counters and may be one cause for the non-uniformity discussed in P & CAM 239. Unfortunately, we have no quantitative data on the occurrence of such patterns or on their effect on counting precision.

Another practical problem is that occasionally a filter, after being mounted, will show what are described by our microscopists as radial aggregates. Figure 2 illustrates this condition in an extreme case. Obviously, such samples cannot be counted and would be rejected. Other "artifacts" which may be mistaken for fibers have been observed occasionally in some samples. However, they are usually distributed throughout the depth of the filter material and not on the surface, as is usual for filtered fibrous dust. These artifacts are similar to those obtained in the filters distributed by NIOSH in Round 40 of the PAT program.



Figure 2. Microphotograph showing radial aggregates that form in clearing filters for phase contrast microscopy.

MESA participates in the NIOSH PAT program. We began the program with round 15 and have submitted acceptable results since that time on all subsequent PAT rounds. Although not without problems, the PAT program is worthwhile. One of the problems, however, for mine samples at least, is that the background of non-fibrous particles, as well as the kind of fibrous particles, differ greatly from those found on samples taken in work environments. Figure 3 is an example of a sample collected at a mine not expected to have asbestos. Figure 4 is an example of a PAT sample. It would be extremely difficult to detect fibers in the presence of dust, such as shown in figure 3, particularly if the level is less than current regulations permit.

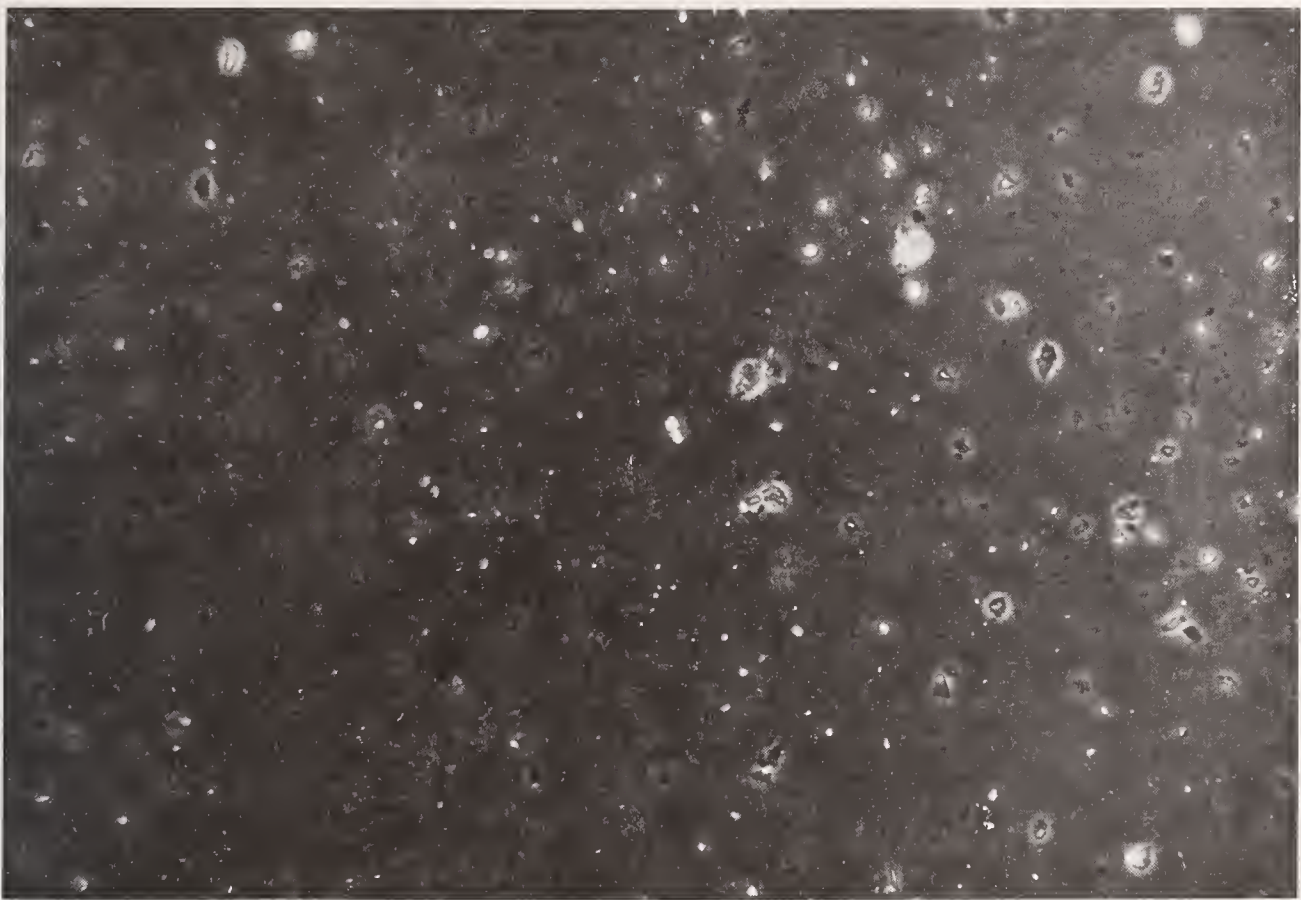

Figure 3. Microphotograph showing typical dust sample collected in a non-asbestos mine.

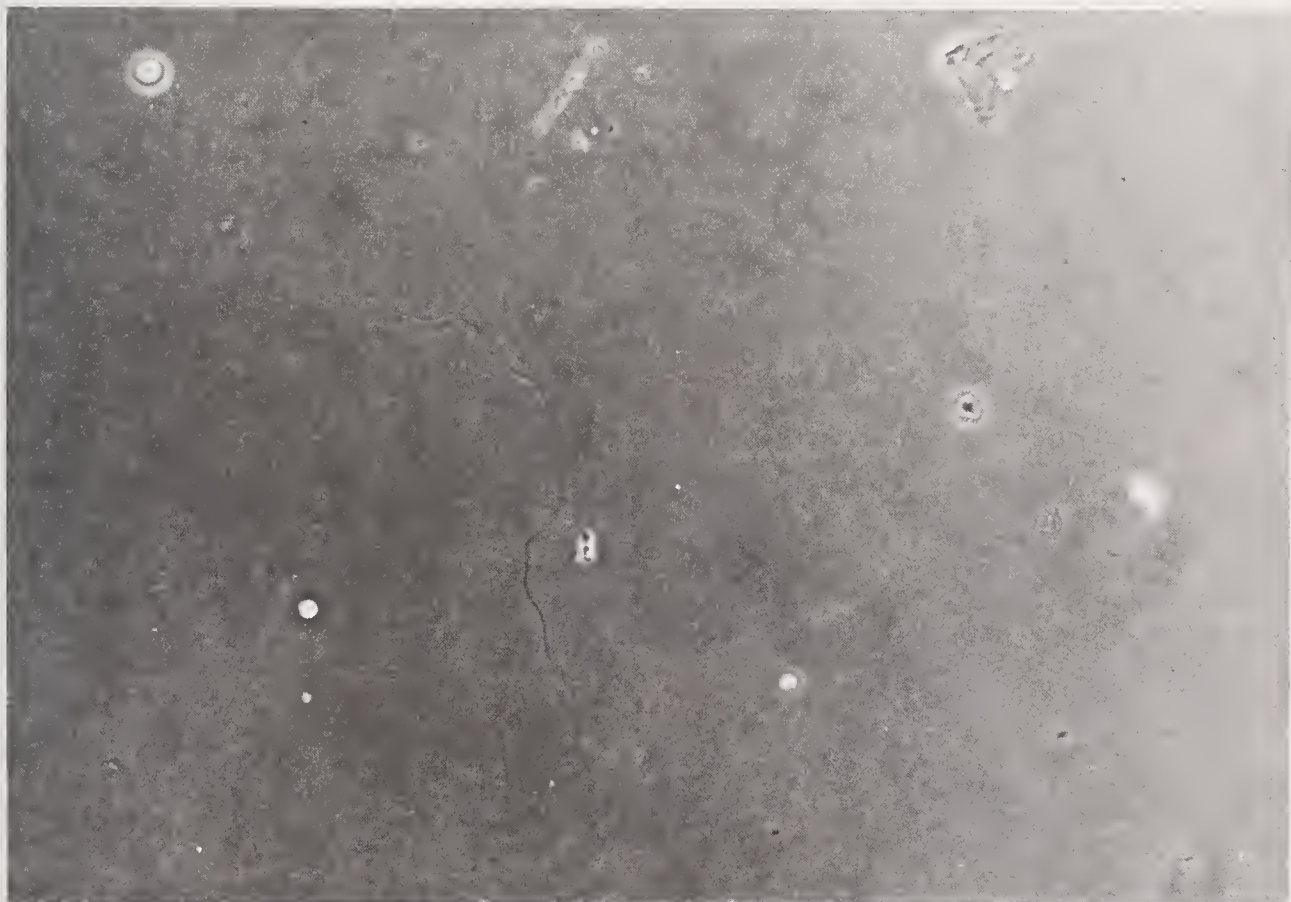

Figure 4. Microphotograph showing typical PAT sample for asbestos counting.

Here I would like to comment on one feature of optical microscopy which has led to some confusion among those persons responsible for counting fibers but who are not experts in optics. This is the concept of "resolution." To some people, "resolution" implies the minimum-sized object which can be seen. "Resolution" refers to the minimum distance between two objects which still allows them to be distinguished as separate. Particles smaller than the "resolution" distance can be seen as a diffraction pattern and hence, fibers as small as 0.1 micrometer (and perhaps smaller) can be reliably counted. Resolution will restrict the size of particles which can be analyzed by some optical microscope techniques. Hence, mineral identification by optical microscope will only be applicable in general to particles with dimensions greater than the microscope resolution. At present we do not do any mineral analyses using optical microscopic techniques. Most of the analyses that we have required have been done by Dr. Clay Ruud who discussed his methods earlier during this conference.

Thus far, I have discussed some methodological and technical considerations inherent in MESA's enforcement of its asbestos fiber standard. Now I would like to address what I believe to be a more fundamental issue, namely, the merits of the standard itself.

The Mining Enforcement and Safety Administration's current and proposed (revised) asbestos standard covers six minerals. At least four of these have definitely been associated with increased cancer incidence in humans. These are crocidolite, chrysotile, amosite, and anthophyllite asbestos. We also know that these four minerals produce tumors in experimental animals. Furthermore, we know that other mineral fibers, whatever their mineralogical nature, produce similar tumors in experimental animals, as reported in this conference by Dr. Mearl Stanton. As a result of these data, MESA proposed to its advisory committee that the asbestos standard be revised to cover all insoluble mineral fibers. In so doing we proposed to continue to use the existing phase contrast, membrane filter method for evaluation.

Using the animal experiments to extrapolate from known human carcinogens to other substances in a similar class seems to me the prudent thing to do. This course of action would not only further reduce human risks, but also eliminate the need for an expensive electron microscopic or petrographic analysis to determine the mineral species of fibers.

There is great concern among mine operators that such a general mineral fiber standard would impact upon every mining operation. All minerals are likely to have fragments that meet the criteria of 3 to 1 aspect ratio for particles longer than five micrometers in length and less than 5 micrometers in diameter. Obviously the impact of such a regulation would also depend on the permissible fiber concentration. If we believe the animal data is valid for extrapolating to humans for cancer induction, should we also not believe the animal data for setting fiber dimension? If so, a minimum length of eight micrometers and a maximum diameter of 0.25 micrometers would be indicated by Dr. Stanton's work. These two parameters (length and diameter) would seem to be a more appropriate specification than an aspect ratio and minimum length. These seem to be the two critical parameters in animal studies for induction of tumors. In a "true" asbestos mining and milling operation, reasonable variation in these parameters will not greatly affect the fiber count. However, in an iron mine or a stone quarry, variations in these parameters could make a great deal of difference in the "fiber" count. If a particle is carcinogenic because of its size and shape, it should be counted; otherwise, it should be considered in another dust category, such as respirable silica or nuisance dust. I would ask the medical-biological researchers to review the information on fiber dimension and arrive at a consensus on the appropriate fiber specifications and also whether the carcinogenic properties are due to chemical or physical properties. This is a crucial issue with the mining industry and is the cause for their great concern that the "asbestos" regulations will affect all mining operations.

Finally, we need an estimate of risk vs exposure from the medical and biological researchers. It is impossible to set a rational standard without this information. To simply set all carcinogens to their lowest detectable limit does not make sense. It is easy to imagine two carcinogens, one very potent and the other weakly carcinogenic. It may be possible to measure the weak one at very low levels and the potent one only at relatively high levels. We should not spend our resources on controlling the weak one with low benefit while the other substance would be relatively uncontrolled. A rational

and equitable standard cannot be set, except perhaps a total ban on exposure to all carcinogens, without knowing the risks and benefits for any man-year's exposure. A total ban is not practical nor necessary for all carcinogens in our modern society.

Discussion

W. SMITH: Dr. Goodwin and others before him here have called upon the medical and biological people to comment on things that might give some clues about the estimate of risk. I am a physican and my patients are mice, hamsters, rats, and so forth, and I have some things to say that the hamsters have been telling us that would be pertinent to this question. We have used six different preparations of crysotile and we put these in the chest cavity, in the pleura space, of the hamsters. In our experiments with intrapleural injection of hamsters, we got many mesotheliomas in response to preparations of commercial asbestos that contained many fibers that I could see with 400X optical (phase) microscopy. We did not get mesotheliomas with three preparations of chrysotile that contained relatively few fibers that I could see with 400X (phase) microscopy. Our experience says that optical microscopy is a more pertinent method than electron microscopy for monitoring dusts for fibers. As I sat here this morning and saw the electron micrographs of these tiny fibers I feel that from what our hamsters are telling us those are not really the problem. Dr. Goodwin, does that give you any comfort in your using phase microscopy?

A. GOODWIN: Well, yes, I believe what you have said is very helpful with our current regulation. However, I am also looking for future revisions to our regulations, both the exposure levels and, more importantly, are we looking at the correct minerals and the correct particles? For those materials that are generally agreed to be asbestos there isn't a great deal of problem, but if we need to look at other minerals as well, is the current definition of fiber too broad?

E. HOOVER: You said we are going to see the mineral fiber standard again in the mining industry, and I missed a point. Are we going to be looking at a 3 to 1 aspect ratio? I thought I heard some reference to the numbers changing a bit; particles over 5 microns long and not wider than 5 microns? Or are we going to look at some other kind of criteria for the fiber standard?

GOODWIN: No, I didn't say that we are necessarily going to have another standard in the mining industry. This is a long process, and advisory committees, public hearings, all these things precede any changes in our regulations. We had proposed to the advisory committee last year that the standard be revised to refer to mineral fibers rather than asbestos; and in that proposal we retained the current phase contrast microscopy technique for counting these fibers, i.e., fibers which have an aspect ratio of 3 to 1 and are greater than 5 microns in length. I am asking the biological and medical people if this is the correct interpretation of the information from animal and human studies. In other words, should we consider all mineral fibers that have a certain physical characteristic, and is this physical characteristic the one we are using now or should it be changed?

HOOVER: I think in view of what you have said I wouldn't want that standard presented again until we can get the medical evidence to support it. I think you are aware of what we have heard here the last three days. Such a standard could wreak havoc on the mining industry in America. It is a serious problem when you define a mineral fiber to include everything, because as your records will indicate, many limestones can be interpreted as being fibrous. I personally feel that this is a problem that will require additional medical studies before proposing a standard. One then has to try to live with it and see how many mining companies would be left after these standards are imposed. If you are thinking about this type of standard, certainly the threshold limit values would have to be adjusted upwards, I would think, because we would have a real problem going to the half of fiber per milliliter or 1/10 of a fiber per milliliter just based on what I have seen so far. Those are my comments, and I am very much concerned about the proposed standard; I have a feeling, I guess a fear that we are going to see it again.

GOODWIN: Well, I can't say what will occur, but much of what I have given you is my opinion, but MESA has no plans to reintroduce a mineral fiber standard at the present time. When we proposed revising our regulation to reduce the standard we have now from 5 fibers

per milliliter to 2 fibers per milliliter we stated that we intend to consider further reductions in light of the OSHA proposal and in light of the NIOSH recommendations to OSHA. We will be conducting some informal meetings with the mining community in different areas of the country to discuss this reduction, however, before any such reductions are proposed. In these discussions we will be considering the NIOSH recommendations and the OSHA proposal which retains the current definition of asbestos and methods for analysis.

HOOVER: One final question: I know with the new Secretary coming to the Interior Dept. that there was some comment about avoiding the use of the Advisory Committees since they, in effect, bottleneck the enforcement of the regulations. My concern is that if we go to a similar situation as we have in coal where we don't have an Advisory Committee to filter proposed standards, this would be a real problem. I would hope that the Advisory Committee will be able to be effective, as they were in September of 1976.

GOODWIN: Well, I don't know what you are referring to about avoiding consulting with the Advisory Committee. Our current law requires that we consult with an Advisory Committee. When I talk about having meetings and discussions with the mining community, this wasn't to circumvent that requirement. It was to get data that would be presented to the Advisory Committee, if we decided that the proposal to reduce the standard further would be prudent.

W. CAMPBELL: If you change the 3 to 1 aspect ratio to 10 to 1, you will eliminate a lot of problems for all of us. I think we all agree that the cleavage fragments would not go beyond 10 to 1 or 15 to 1. So all this semantics of whether one has fibers or fragments could be fairly easily satisfied by going to 10 to 1 or a little higher aspect ratio. The 3 to 1 is really the basic problem, I think.

OCCUPATIONAL SAFETY AND HEALTH ADMINISTRATION METHODS

Willard C. Dixon

Occupational Safety and Health Administration
Salt Lake City, Utah 84117

Abstract

Occupational Safety and Health Administration (OSHA) uses the membrane filter method at 400 - 450X magnification (4 mm objective) with phase contrast illumination for the analysis of asbestos in air. This method is substantially the same as is used by NIOSH.

In an atmosphere known to contain asbestos, all particulates with a length to diameter ratio of 3:1 or greater and a length greater than 5 micrometers are, in the absence of other information, considered to be asbestos fibers and counted as such.

The equipment for optical analysis of asbestos in use at the OSHA Salt Lake City Laboratory includes Zeiss microscopes having 40X objectives and 10X eyepieces, rotating stages, phase contrast illumination, polarized light, and retardation plates. The transmission electron microscope equipment in use by OSHA at the Salt Lake Laboratory is a Jeol model JEM 100C with a side entry goniometer and ASID-45 Model EM-15 SPS-2 scanning image display unit. We also have an Ortec-Delphi x-ray energy dispersive system.

X-ray diffraction, atomic absorption, and other instrumentation are also available.

The techniques used for the identification of asbestos include sight recognition based on morphology, and optical tests including polarized light, index of refraction, angle of extinction, dispersion staining, and retardation. Electron microscopy tests include morphology, selected area diffraction, and a determination of elemental composition by x-ray energy dispersive analysis.

A plan is presented for distinguishing between asbestos and other fibers which may be mistaken for asbestos. A system for differentiating between the various kinds of asbestos fibers is also presented.

Key Words: Airborne fiber; asbestos; bulk samples; dispersion staining; membrane filter; optical microscope; phase contrast.

OSHA performs all routine determinations of airborne concentrations of asbestos fibers by the membrane filter method at 400 to 450X magnification (4 millimeter objective) with phase contrast illumination.

The optical microscopes in use at the Salt Lake City OSHA Laboratory are Zeiss phase contrast microscopes which are also equipped with a polarizer, analyzer, retardation plates, and rotating stage with degree markings at the edge. The objectives are 40X and the eyepieces are 10X. We also have Wild Stereo microscopes equipped with a polarizer, analyzer, retardation plates, and rotating stage.

The primary emphasis in identification of asbestos fibers is optical microscopy. Back-up methods include electron microscopy, x-ray diffraction, atomic absorption, and wet chemistry. Other instrumentation or methods are available if needed.

The Salt Lake City OSHA Laboratory has a Jeol transmission electron microscope, JEM 100C, with a side entry goniometer and ASID-4S model EM-15 SPS-2 scanning image display unit. The system includes an Ortec-Delphi x-ray energy dispersive unit with a PDP 11/05 computer and Digital Decwriter II teletype with AED 3100 P dual drive for floppy disks.

The JEM 100C is basically a transmission microscope, but is equipped to function as a scanner. We can obtain selected area diffraction patterns, or determine which elements are present in particles or fibers, provided that the atomic number is eleven or greater.

The OSHA Salt Lake City Laboratory uses Philips Norelco XRG-3000 x-ray diffractometers. This Lab has eleven goniometers.

Analysis of Bulk Samples

Bulk samples are examined on a reflected light stereo microscope for the presence of fibers. Fibers can be isolated from the matrix at this time for identification by optical methods, x-ray diffraction or electron microscopy, or further analysis can be performed with fibers still in the matrix.

Small fibers not easily identified by optical techniques, samples subject to litigation, or samples which are not positively identified by other means are the most likely candidates for electron microscopy.

Slides are prepared and examined with a Wild transmitted light stereomicroscope having crossed polars and a first order red retardation plate.

Asbestos fibers and bundles are recognized by their appearance. Oftentimes plant fibers will curve a little at the edge. The slides are examined at 6X, then at higher magnifications up to 50X on the stereomicroscope. This is followed by optical examinations at various magnifications, including 400X with a phase contrast microscope. At this point, it would be known whether asbestos is present and in approximately what concentration. If organic materials interfere too greatly, the sample is ashed at 550 °C and re-examined. The percent ash places an upper limit on the possible concentration of asbestos.

X-ray diffraction scans are run between 6° and 60° 2θ. X-ray diffraction can determine the concentration of a mineral but not how fibrous the mineral is. Tremolite may be present in high concentration in a talc sample, for example, but an actual fiber count may show the tremolite asbestos concentration is much lower. For this reason, OSHA does not place its entire reliance on the results of x-ray diffraction without optically confirming the concentration of fibers present.

The percent by number of asbestos in talc samples is determined by particle counting. If a scan of two slides shows no fibers present, the analyst will report no asbestos detected without counting the slide.

If a preliminary scan shows the presence of asbestos fibers, 100 fields or 100 asbestos fibers will be counted with a minimum count of 20 fields.

In order to randomize possible differences between slides, the counts will be divided between four slides taken from different parts of the bulk sample.

A fiber which has the correct size and aspect ratio for counting is not counted if other information is obtained which proves that the fiber is not asbestos. This information may be obtained by any scientifically valid method, including either optical or electron microscopy, x-ray diffraction, or wet chemical tests. In outlining some procedures which have been found useful at the Salt Lake City OSHA Laboratory, it is not intended to imply that other procedures cannot be used.

Many textbooks on mineralogy will include identification tables and systematic outlines for mineral identification. "Optical Mineralogy" by Paul F. Kerr [1]¹ will be useful for the beginning analyst. "The Microscopic Determination of the Non-Opaque Minerals," Geological Survey Bulletin 848 [2] has extensive tables. "Gemstone and Mineral Data Book" by John Sinkankas [3] has specific gravity and other tables for mineral identification.

The optical tests for asbestos or other fibers are divisible into two categories: A, those tests which can be performed while the fiber is still on the membrane, and B, those tests which are performed after fibers have been removed from the membrane.

A - Fibers on the Membrane

In making the distinction between asbestos and non-asbestos fibers, it is highly desirable for the analyst to be familiar with the morphology of asbestos fibers and those fibers which are likely to be confused with asbestos. Thickness, pattern, and morphology will often be a clue that a fiber is fiberglass, fur, hair, plant fiber, or other non-asbestos fiber. If a fiber bundle is more than one or two micrometers thick, striations may be seen or fibrils may be splitting off in a way that is characteristic of asbestos. If long fibrils are seen and no bundles can be seen, the possible presence of fiberglass should indicate a need for further testing. With experience, the analyst will be able to distinguish between chrysotile asbestos, amphibole asbestos, and most non-asbestos fibers by recognizing the morphology as characteristic of one or the other. The fibers of chrysotile have a fine silky appearance. Sometimes a wavy pattern is seen in the bundles.

When an interference is expected, the industrial hygienist collecting the sample should also collect bulk samples of potentially interfering substances so that these can be studied separately and methods found to differentiate between asbestos and the interference. The analyst may have to delay his report until bulk samples are obtained for study in some circumstances. As bulk samples are received for analysis, there will be an opportunity to collect a small library of reference samples. Wards Natural Science Establishment, Inc. [4] sells mineral specimens, including asbestos. The International Union Against Cancer (UICC) asbestos standards can be obtained free from Pneumoconiosis Research Unit [5].

Polarized Light and Retardation Color Patterns

Minerals having directional qualities yielding double refraction are anisotropic. Minerals lacking directional qualities yielding double refraction are dark between crossed polars and are isotropic. By crossing the polarizer and the analyzer, it is possible to determine whether fibers are isotropic or anisotropic. An isotropic fiber has only one index of refraction. Isotropic substances include minerals of the isometric system and amorphous substances, such as glass. By viewing fibers with crossed polars and noting that they remain at extinction (non-visible) at all positions of rotation, it is possible to eliminate interference from fiberglass, perlite veins, or diatomaceous earth. The latter substance may be crystalline, but since the difference between the high and low index of refraction is only 0.003 for cristobalite, this will not present a problem in small diameter particles.

If crocidolite asbestos is present, the crossed polar test must be applied cautiously since crocidolite fibers may not be seen with crossed polars. This is due to the dark

¹Figures in brackets indicate the literature references at the end of this paper.

blue color of crocidolite and its birefringence, which may be as low as 0.004. However, the blue color of crocidolite is itself a clue that crocidolite asbestos may be present. If crocidolite has been heated above 200 °C, the fiber may be brown.

An anisotropic substance has more than one index of refraction, and can include plant and other fibers as well as asbestos fibers. The tetragonal and hexagonal mineral classes have two indexes of refraction, omega and epsilon. The orthorhombic, monoclinic, and triclinic minerals have three indexes of refraction; alpha, beta, and gamma. If an anisotropic fiber is examined with crossed polars, it will have four positions in which it goes to extinction, and four positions in which brightness will be a maximum as the stage is rotated. The positions of extinction will be 90° apart. If a first order red retardation plate is now added to the optical path, a retardation color can be added (or subtracted) to produce a second order blue or first order yellow color in asbestos fibers, depending upon the orientation of the fast or slow rays of the fibers with respect to the slow ray of the retardation plate. The quadrants can be numbered as follows: Upper left and lower right, one and three respectively; upper right and lower left, two and four respectively. Fibers can be described as aligned with quadrants one and three, or aligned with quadrants two and four if the fibers are at maximum brightness. Most asbestos fibers will be yellow if aligned with quadrants one and three, or blue if aligned with quadrants two and four. The exception is crocidolite, which sometimes gives a yellow to greenish color if the fibers are aligned with quadrants two and four, and a blue color if the fibers are aligned with quadrants one and three.

If amorphous (isotropic) fiberglass is present, the first order red plate will make the fibers clearly visible, but they will have the red color of the background and will not change their color as the stage is rotated. Small asbestos fibers, less than about 1.5 micrometers in diameter, may appear as dark lines in which the yellow color is so faint that it is not recognized. It is characteristic of asbestos that the yellow or blue color developed in this way will be pure. A pure color is a single color or shade along the length of the fiber as long as the fiber does not bend or change orientation. Talc fibers may show a variation of color with blue shading slightly toward orange as the fiber varies slightly in thickness. This may be due to the high birefringence of talc, 0.030 to 0.050.

Plant fibers will have a mottled appearance with a recognizable color pattern showing the complicated structure of the fibers. In rare cases, plant fibers will have pure colors like asbestos, and in such cases it will be necessary to pay close attention to the morphology, particularly the thickness of the fibers, the bluntness of the ends, and the way in which fibrils separate from the bundle. In such cases, it is possible to see structures which would not otherwise be visible by looking at the fibers at the extinction position without retardation plates. If morphology and color patterns provide insufficient clues to distinguish plant fibers, it will be necessary to ash the fibers at 500 to 550 °C and re-examine the sample after ashing.

Birefringence has already been mentioned. Birefringence is $n_2 - n_1$, the difference between the high index of refraction and the low index of refraction of a particle. The higher the birefringence or the thicker the particle, the higher the order of color seen when particles are examined with crossed polars. By the use of a Michel-Levy color chart, it is possible to determine the birefringence of particles if their thickness is known. This will help to limit the number of minerals which must be considered in determining what is present.

The following table shows the birefringence of several minerals [6]:

crocidolite	0.004
chrysotile	0.011 to 0.014
anthophyllite	0.016 to 0.025
tremolite-actinolite	0.022 to 0.027
amosite	
(cummingtonite)	0.025 to 0.029
(grunerite)	0.042 to 0.054
gypsum	0.009
wollastonite	0.014
anhydrite	0.044
talc	0.030 to 0.050

Angle of Extinction

Many minerals extinguish between crossed nicols when cleavages or crystal boundaries lie at oblique angles to the planes of vibration of the two nicols. These are said to have inclined extinction.

By measurement of the angle of extinction, anthophyllite and chrysotile can be distinguished from other asbestos minerals. Anthophyllite has parallel extinction: that is, the angle of extinction is zero degrees. The extinction of chrysotile will be close to zero degrees. The angle of extinction of other asbestos minerals is as follows [7]:

tremolite	15-20°
actinolite	10-15°
amosite	10-20°
crocidolite	80-90°

Wollastonite will have parallel or very nearly parallel extinction. If a mineral is known to be either anthophyllite or tremolite by dispersion staining tests, the angle of extinction can then be used to distinguish between the two. Caution: it is possible for a mineral which usually has inclined extinction to have a few fibers with parallel or close to parallel extinction, depending upon orientation.

Measurement of the angle of extinction can be performed as follows: Line up the cross hairs (if the eyepiece does not have a cross hair, it is possible to use the lines of a Patterson Globe and Circle Reticle or a Porton Reticle) with a natrolite particle or fibers of an anthophyllite asbestos standard which is at extinction when the polars are crossed. The fiber should be parallel to the cross hair and displaced slightly to the side so as to be visible in bright field. Tape the eyepiece so that it is immobilized in this position. Check the alignment with several other fibers to be sure that it is exact. Line up an unknown fiber with the same cross hair line. Take a reading of the position of the stage. With the polars crossed, move the fiber by rotation to its position of maximum extinction. Take a reading of the position of the stage again. Repeat the measurement to be sure that it is accurate. If the difference between the two readings is close to zero, the fiber has parallel extinction. If the extinction angle is 15° to 20° and the index of refraction matches tremolite, it is probable that the fiber is tremolite.

In making measurement of angles of extinction, measure the highest angle of extinction obtainable by rotating the fiber around its long axis.

A binocular microscope which is adjustable for various interpupillary distances should always be used on the same interpupillary setting as was used for alignment of the cross hairs for zero extinction.

Determination of the position of maximum extinction of some dark fibers may be difficult. The fibers may appear to be dark over a wide range of rotation of the stage. In such cases, it may be possible to locate the position of maximum brightness. If the position of maximum brightness is 45° from the cross hair, the angle of extinction is zero.

Cleavage

Some minerals which have lathlike cleavage, such as gypsum, may be confused with asbestos by inexperienced analysts. Such particles may have aspect ratios of five to one or greater. Gypsum will often have the appearance of small rectangles. The blocky appearance of gypsum is usually sufficient to make a distinction. The low indexes of refraction of gypsum ($\alpha = 1.520$, $\gamma = 1.529$) can be used to make a distinction if the analyst needs additional clues.

Although wollastonite is similar to tremolite, careful attention to fine details of the cleavage patterns can make distinction between the two minerals. The cleavage lines of tremolite tend to be straight; the cleavage lines of wollastonite tend to curve slightly. The cleavage planes of tremolite tend to be uniform in thickness; wollastonite cleavage planes tend to feather to thin edges. Sides of tremolite particles will be straight or palisaded; wollastonite edges may be serrated. The ends of tremolite are square; wollastonite will be more smoothly rounded. If some fibers are still not recognized, other tests can be applied after removal of the fibers from the membrane.

B - Removal of Fibers from the Membrane

Removal of fibers has the disadvantage that the count of fibers is difficult to relate to a known area and therefore to the concentration of fibers in air. However, it is possible to mark the position of fibers on the membrane and remove selected fibers for further analysis. This particle picking technique is described in "The Particle Atlas" [8].

When asbestos is in a mixture with other fibers, it is possible to bracket the asbestos concentration by determining the percent of asbestos fibers in the mixture removed from the membrane and applying this percentage to the total fiber count on the membrane.

Ashing a Millipore membrane is difficult due to the tendency of the membrane to flash when it is heated. Low temperature ashing is a solution to this problem but low temperature ashing equipment will not be available in every laboratory. A Millipore membrane can be ashed by folding the membrane, sample side in, moistening with alcohol, then igniting the alcohol with a small flame.

Instead of ashing, it is possible to dissolve the membrane in acetone and separate fibers and particles by centrifuging, followed by removal of excess acetone. After the third treatment, an aliquot can then be placed on a slide, and after evaporation of the acetone the particles can be blended into an index of refraction medium selected for identification of the particles present.

A quick and simple separation procedure is to place one drop of the same index of refraction medium on each of three slides, then cut a small segment of the membrane and, holding it with fine tipped tweezers, dip the membrane sample side down successively into each drop of index of refraction medium. After placing a cover slip over the medium, the slides are ready for study.

Dispersion Staining

Dispersion staining is a convenient technique for determining the identity of fibers and particles. If the analyst is unfamiliar with this technique, McCrone Research Institute, Chicago, Illinois, teaches courses in dispersion staining. This training may also be obtained from a university if it has a department of geology or materials science. "The Microscope" [9] has an article entitled "Identification of Asbestos Fibers by Microscopical Dispersion Staining." Other articles on dispersion staining are in "The Microscope," and the techniques are also described in "The Particle Atlas" [10].

The Zeiss microscopes in use at Salt Lake City produce the equivalent of a central stop (dark field) dispersion stain by using a phase 2 16X phase contrast objective with the phase 3 ring in place. Leitz manufactures a phase contrast microscope which produces central stop dispersion colors at 400X. If the microscopes in use at other labs do not produce a central stop dispersion stain in this way, a "dispersion stainer" can be purchased from Walter C. McCrone Associates [11].

For dispersion staining analysis, it is necessary to have quality high dispersion liquids. These are available from R.P. Cargille Laboratories, Inc. [12].

The Appendix of this paper gives directions for the dispersion staining identification of asbestos minerals and wollastonite, a common interference.

In distinguishing between fibers, as many clues as necessary to make the distinction should be used. In most cases, morphology, color patterns with crossed polars and retardation plates, angles of extinction, or central stop dispersion staining colors, especially if tests are made at more than one index of refraction, will give sufficient clues to identify fibers.

Some fibers may remain unidentified after this type of screening. A sample analyzed at the Salt Lake City OSHA Laboratory contained fibers very similar to asbestos. Optical tests, however, indicated that they were not asbestos. X-ray energy dispersive analysis showed a high concentration of silicon in the fibers. It was then suspected that the fibers might be one of the polymorphs of SiO_2 . The fibers were separated from other particles by treating the sample for twelve minutes with hot phosphoric acid. Central stop dispersion staining and x-ray diffraction showed that the fibers were quartz. Quartz fibers have been reported in the literature. However, it was unexpected to find quartz fibers in a sample taken from a vacuum cleaner bag.

References

- [1] Kerr, Paul F., Optical Mineralogy, Third Edition (1959), McGraw Hill Co., NY.
- [2] Geological Survey Bulletin 848, 1934.
- [3] Sinkankas, John, Gemstone and Mineral Data Book, Collier Books, New York, N.Y.
- [4] Wards Natural Science Establishment, Inc., Rochester, N.Y.
- [5] Pneumoconiosis Research Unit, Penarth, Glamorgan, Wales. UICC standards can be purchased from McCrone Accessories and Components, 2820 South Michigan Avenue, Chicago, IL 60616.
- [6] *ibid.* Reference 1.
- [7] Berkley, C., Langer, A., and Baden, V., Instrumental Analysis of Inspired Fibrous Pulmonary Particulates, Transactions, New York Academy of Sciences, pp. 333-350, Dec. 1967.
- [8] The Particle Atlas, Edition Two, Vol. I, pp. 233-258, Ann Arbor Science Publishers.

- [9] The Microscope, Vol. 18, No. 1, pp. 1-18, January-April 1970, Microscope Publications, 2820 South Michigan Avenue., Chicago, IL 60616.
- [10] The Particle Atlas, Ann Arbor Science Publishers.
- [11] Walter C. McCrone Associates, 2820 South Michigan Ave., Chicago, IL 60616.
- [12] R. P. Cargille Laboratories, Inc., 55 Commerce Road, Cedar Grove, NJ 07009.

Appendix

If chrysotile is mounted in 1.546 high dispersion medium, and viewed by a central stop dispersion staining technique with the polarizer in and analyzer out, the colors will be yellow to orange if the fibers are oriented parallel to the polarizer, and orange red to red blue if the fibers are oriented perpendicular to the polarizer, depending upon the index of refraction of the fibers. (In all asbestos fibers except crocidolite, the high or gamma index of refraction will be seen when the fibers are oriented parallel to the polarizer.)

If chrysotile is mounted in 1.560 high dispersion medium, the central stop color will be blue if the fibers are oriented parallel to the polarizer and blue white if the fibers are oriented perpendicular to the polarizer. Amphibole asbestos minerals will not give dispersion colors in 1.560 high dispersion medium, or the color will be straw yellow and easily distinguishable from the colors given by chrysotile asbestos.

It is possible for fiberglass to have the same index as one of the indexes of chrysotile or other asbestos minerals. Fiberglass and other amorphous substances have only one index of refraction. By rotating the stage, this type of interference can easily be detected since fibers oriented parallel or perpendicular to the polarizer will have the same central stop dispersion color. Synthetic polymers may show birefringence, which is due to the orientation of molecules in the drawing process. These fibers will generally be too thick to be confused with asbestos.

Talc fibers can be very similar to anthophyllite asbestos in appearance. Intermediate forms may occur which are between talc and anthophyllite in physical and optical characteristics.

In 1.550 high dispersion medium, talc fibers which are oriented parallel to the polarizer will be yellow, indicating that the index of refraction is higher than 1.550 (gamma and beta). Talc fibers oriented perpendicular to the polarizer will be blue, indicating an alpha index of about 1.550.

In 1.585 high dispersion medium, talc fibers which are oriented parallel to the polarizer will have a blue central stop dispersion color, indicating a gamma index of about 1.585. Fibers which are oriented perpendicular to the polarizer will have a blue white central stop dispersion color, indicating an alpha index less than 1.585.

In 1.585 high dispersion medium, the central stop dispersion colors for tremolite or anthophyllite fibers will be yellow if the fibers are oriented parallel to the polarizer, and orange yellow if the fibers are oriented perpendicular to the polarizer.

In 1.585 high dispersion medium, the central stop dispersion colors for chrysotile will be similar to talc fibers. In 1.550 medium, however, the orange red color of chrysotile fibers oriented parallel to the polarizer compared to a yellow color of talc fibers similarly oriented will serve to make a distinction.

In 1.620 high dispersion medium, actinolite will be yellow if the fibers are oriented parallel to the polarizer and the central stop color for fibers oriented perpendicular will be orange yellow. Large particles will have a natural greenish color which may influence the central stop dispersion color.

In 1.620 high dispersion medium, the central stop dispersion color for anthophyllite, tremolite, and wollastonite will be yellow orange to orange if the fibers are oriented parallel to the polarizer. If the fibers are oriented perpendicular to the polarizer, the colors will range from yellow orange to blue depending upon how the fiber is lying. By rotating the fiber around its own long axis, the fiber can be brought to a position in which it will be blue. Tremolite may be blue green.

The fibers can be caused to rotate about their long axis by gently tapping the coverslip with a dissection needle.

Amosite asbestos can be expected in samples of insulation from steam lines and boilers, especially from ships. If amosite is mounted in 1.670 high dispersion medium, the central stop dispersion color will be yellow if the fibers are oriented parallel to the polarizer, and red violet if the fibers are oriented perpendicular to the polarizer. Other asbestos minerals, except crocidolite, have an index of refraction far enough from amosite that no dispersion color will be developed in 1.670 medium. The central stop dispersion color for crocidolite will be yellow orange if the fibers are oriented parallel to the polarizer, and yellow if the fibers are oriented perpendicular to the polarizer. Crocidolite will show the low (α) index parallel to the polarizer.

If the dispersion staining tests or cleavage patterns show that wollastonite may be present and a test other than cleavage or the angle of extinction is needed to distinguish between wollastonite and tremolite, the following method may be useful. This method can be used in the absence of chrysotile asbestos to distinguish between fairly acid resistant amphibole minerals and wollastonite.

Wash the fibers into a drop of concentrated hydrochloric acid on a slide by dipping a membrane segment sample side down as previously described. Place a coverslip over the drop of hydrochloric acid and heat the slide on a hot plate which is warm to the touch but not hot enough to be uncomfortable. The slides will be dry in one hour. The coverslip will tend to prevent the particles from migrating as the acid evaporates. Let the slide cool, and add a drop of 1.620 high dispersion medium at the edge of the coverslip. Capillary action will immerse the particles in the medium. When the slide is examined, tremolite or anthophyllite will still show central stop dispersion colors; wollastonite will not. Wollastonite will have been decomposed by the hydrochloric acid or partially decomposed with separation of silica, but without formation of a jelly. The wollastonite fibers will still have their original shape, but larger fibers will show a crosshatching pattern, and the anisotropy of the fibers will be greatly reduced.

Fibers which were not previously present in the sample will result from the treatment of wollastonite with hydrochloric acid, followed by evaporation of the acid. These fibers will be needlelike and often form radiating patterns. The highest concentration of these fibers will be in areas in which the hydrochloric acid evaporated last.

In 1.620 high dispersion medium, these artifact fibers will not give a central stop color like that obtained from wollastonite, tremolite, or anthophyllite, and are distinguishable from the fibers which were originally present.

Discussion

W. ROFF: On your Zeiss microscope, maybe I misunderstood, you have the combination phase as well as the optical mineralogy incorporated in one microscope?

W. DIXON: Yes.

ROFF: You do?

DIXON: We have a Zeiss universal; with this microscope we can make the switch back and forth between the two techniques (phase contrast or polarized light) very quickly because of its fingertip control.

ROFF: You mention something about ashing between 500 and 550 °C; well for chrysotile, you have to be very, very careful.....

DIXON: Right, at 650 °C its going to be converted to forsterite.

ROFF: And possibly a little enstatite will keep its fiber form. We really have to do it at a much lower temperature for a longer period of time.

DIXON: What temperature do you use, may I ask?

ROFF: We use 400 °C overnight, or a plasma asher. With respect to the nitric acid for wetting your Millipore, we would rather fold the Millipores carefully and then wick with alcohol and ignite and then put that into the furnace; I think you would find it quite successful. Incidentally, I think your paper was very well done and I think should be commended. There are many people here from the various mining companies, especially from the western part of the U.S. that are concerning themselves with zeolite fibers, and may I suggest that perhaps in your final text you might incorporate a sentence or two on zeolites; how to differentiate the zeolite fibers from the other fibers you are talking about.

DIXON: I can't answer that question at the moment. What I would have to do would be to look up the index of refractions of the zeolites and I would probably find a dispersion staining technique from that which would help me to make a distinction between the two.

FDA PROJECTS AND METHODS

J. A. Wenninger, I. M. Asher, and P. McGrath

Food and Drug Administration
200 "C" Street, S.W.
Washington, D. C. 20204

Abstract

An overview of FDA projects related to asbestos detection and quantitation is presented. The results of a recent FDA symposium on the availability of suitable techniques are included. We then review the technical and regulatory issues in the food and cosmetics area with regard to asbestos contamination with emphasis on the analysis of parenteral drugs and cosmetic talc. For the present, SEM using Nuclepore filters as a substrate and EDXA for chemical analysis appears to be a reasonable, cost effective method for routine detection of asbestos in foods, drugs, and biologicals, although quantitation and reduction in the number of ambiguous fibers is still a problem.

Key Words: Asbestos; cosmetic talc; EDXA; fibers; food; parenteral drugs; SEM.

Part I: An Overview

(I. M. Asher)

Since the Food and Drug Administration (FDA) programs related to asbestos are spread throughout several Bureaus, my colleagues have asked me to give an overview of FDA research efforts and interests. As you know, asbestos contamination of air and water is largely the domain of the EPA, while contamination of the workplace is of direct importance to OSHA, and products for home use are the responsibility of CPSC. Thus, FDA interest has centered on the asbestos contamination of food, cosmetic talcs, and parenteral drugs. A major problem is developing rapid, reliable methods for the monitoring of asbestos in such products. An FDA symposium to evaluate the current state of electron microscopic methods for microfiber detection and analysis was held last August at Penn State University, with many of the current participants present. Naturally enough, the speakers tended to point out the promise of their methods and the weaknesses of alternate methods, but the consensus was that a single method, simple and accurate enough for embodiment in FDA standards and regulations, has yet to be perfected. (Copies of the Proceedings are available, free of charge, from the FDA Office of Science.)

In the interim, the FDA has published a regulation banning the use of asbestos filters and other filters releasing mineral contaminants with aspect ratios of $\geq 3:1$ —in the final stages of manufacture of injectable products, unless followed by a membrane filter (40 FR 11865). It is hoped that this interim regulation can be replaced by appropriate standards, and Phil McGrath's group in the Bureau of Biologics has been trying to perfect and validate an appropriate interim SRM method. An FDA Asbestos Work Group (chaired by Dr. Armand Casola, Bureau of Drugs) meets regularly to discuss these and other issues.

The Bureau of Biologics has its own scanning and transmission electron microscope facilities to detect and identify particulate contaminants in biological products and parenteral drugs. The Bureau of Drugs has also initiated additional studies to identify particulate contaminants in commercial samples of parenteral drugs, under contract at the

University of Kentucky. The Bureau of Foods has an ongoing program of analyzing cosmetic talcs for tremolite and anthophyllite contamination (by contract).

The most ambitious FDA project in this area is an animal study of the carcinogenic effects of subacute, intravenous injection of chrysotile asbestos in Charles River CD rats and CD-1 mice of both sexes. The project is being conducted by the Bureau of Drugs, under contract at the International Research and Development Corporation, Mattawan, Michigan. There are three negative control groups: saline/single injection, saline/4 weekly injections, and kaolin/10 weekly injections ("inert" particulates)—for each species/sex group of animals. There are also positive control groups receiving methylnitrosourethane once weekly throughout the lifetime of the animal. There are six different asbestos dosages—single or four weekly injections of 0.2, 0.4, 0.8 mg/kg—for each species/sex group. This gives a total of 10 dosage groups for each species/sex group and amounts to 3480 animals in all. The FDA chronic study utilizes 18 grams of asbestos sample, prepared to mimic typical releases of pharmaceutical-grade asbestos-cellulose filters. These are typically short and very narrow. The mean fiber length in the sample was 2.34 μm (ranging from $<1 \mu\text{m}$ to 70 μm), and the mean diameter was 0.056 μm (ranging from $<0.01 \mu\text{m}$ to 0.25 μm). So far, at 16 months, too little data is available to report definitive results; however, the incidence of lung tumors at necropsy in the male CD-1 mouse group at the highest asbestos dosage currently exceeds that for the saline controls (i.e., 9/39 compared 2/23 and 3/24). The co-project officers of this study are Jules Lamar and Stephen Crop of the FDA Bureau of Drugs.

Part II: Food and Cosmetics — An FDA Update on the Asbestos Question

(J. A. Wenninger)

My discussion will focus on FDA's activities to prevent the contamination of cosmetics and food by asbestos particles. I have been involved only with the problem of asbestos in cosmetics, but I will extend my discussion to cover food. Cosmetics and food share similar regulatory and physical-science characteristics, but there the similarity ends; to a large degree, the problem with food centers on the ingested fibers, whereas with cosmetics it centers more on inhalation of such fibers.

No regulations for either food or cosmetics have yet been established which either prohibit the use of asbestos-containing filters in food processing or limit the amount of asbestos fiber in talc used as a component of food or cosmetics. A proposal for certain restrictions on food only was published in the Federal Register (38 FR 27076-81), September 28, 1973. However, this regulation has not been published as a final order and is still pending. The comments received in response to this proposal clearly indicated that no regulation for food and food processing was warranted until more reliable data could be obtained on methodology for the determination of asbestos and on a more complete evaluation of the health hazard associated with ingested asbestos fibers. FDA's reply to these comments were published in the Federal Register (40 FR 11865-70), March 14, 1975. It should be emphasized that on the basis of information received the agency did conclude that the asbestos content of talc used in the manufacture of food — or drug — contact paper packaging does not represent a potential contaminant of packaged food or drugs as assessed by current methodology.

With regard to cosmetics it is unlikely that we will be in a position in the near future to propose a limitation on the asbestos fiber content of talc used for cosmetic talcum powders. However, we do have a modest surveillance program under which we monitor the asbestos fiber content of retail units of cosmetic talcum powder products. To date we have not found any grossly contaminated cosmetic talcum powder products on the market. Although this is somewhat reassuring, our sampling of products was small; for example, we looked at only 28 samples by x-ray powder diffraction during 1975 and 1976. Of these, one sample was found to contain 0.7 percent tremolite and three samples contained traces of tremolite (approximately 0.1%) and anthophyllite.

In our laboratories we are now using three basic methods for the evaluation of asbestos contamination of cosmetic talcs. We estimate our limits of detection as follows:

	<u>X-Ray Diffraction</u>	<u>Optical Microscopy</u>	<u>Differential Thermal Analysis</u>
CHRYBOTILE	2% ^a	---	0.5% ^a
TREMOLITE	0.1%	0.1%	
ANTHOPHYLLITE	1%	---	

^a In the absence of interference from chlorite.

The Cosmetic, Toiletry and Fragrance Association, Inc. (CTFA) has continued to cooperate with FDA's Division of Cosmetics Technology in developing reliable methodology for the determination of asbestos in cosmetic talc. Results from a testing program set up by the CTFA to establish the reliability of analytical methodology are expected to be available in the near future. The CTFA has been active in establishing appropriate specifications for cosmetic talc and developing analytical methodology for industry.

An article on cosmetic talc powder which appeared in Lancet (Volume 1, pp. 1348-9, June 25, 1977) concluded: . . . "there is no reason to believe that normal consumer exposure to cosmetic talc in the past led to either cancer at any site or to measurable loss of lung function. It seems unlikely that future exposure to cosmetic talc of the specifications now agreed to by major manufacturers will present a health hazard."

We do not know if this assessment is correct. However, it is the responsibility of all of us to assure that appropriate steps are taken to prevent the use of talc unsuitable for use in food and cosmetics. It now appears that several years may be required to fully clarify some of the scientific questions on this subject. In the meantime it may be prudent to establish by regulation a standard for all to follow. No doubt this approach will be questioned in the absence of widespread contamination. However, we know that efficient enforcement of any specification is very difficult without the assistance of regulation.

Part III: Scanning Electron Microscopy for the Detection of Asbestos in Foods, Drugs, and Biologicals

(P. P. McGrath and J. B. Ewell)

For the past two days we have heard of the many problems associated with detection, identification, and quantification of asbestos and asbestiform minerals in the environment. We have experienced many of these same problems in an attempt to design methods which could be used for routine electron microscopic analysis to detect asbestos contaminants in products regulated by the United States Food and Drug Administration. For routine analysis of these products we feel that scanning electron microscopy (SEM) using energy dispersive x-ray analysis (EDXA) is the most cost effective method.

The rationale for choosing SEM-EDXA over Transmission Electron Microscopy, selected area electron diffraction (TEM-SAED) technique is based on many factors. Since most of the products examined contain very low levels of asbestos, the size limitation imposed by an E.M. grid would interfere with detection of these small numbers of fibers. Most samples are prepared for TEM examination through some type of filtration and the filter must be destroyed by chemical or thermal means to allow examination in the TEM. Filter residue left on the E.M. grid consistently interferes with the analysis and production of diffraction patterns. Many fibers do not produce measurable diffraction patterns or are lost during the preparation of the sample [1,2]¹. Even those fibers which do produce diffraction patterns must be indexed to identify the fibers. To index these patterns is time consuming and requires sophisticated methods such as that developed by Lee at U.S. Steel [3,4].

¹Figures in brackets indicate the literature references at the end of this paper.

For analysis in the SEM, the filter surface itself is examined. If one compares a 47 mm or 13 mm diameter filter with a 3.05 mm diameter electron microscope grid, the difference in the area available for examination is obvious, as for example figure 1. Further, less than 70 percent of the surface area of an E.M. grid is available for TEM examination because of the grid bars which are not penetrated by the electron beam as shown in figure 2.



Figure 1. Comparison of 47 mm and 13 mm diameter filters with 3.05 mm diameter E.M. grid.

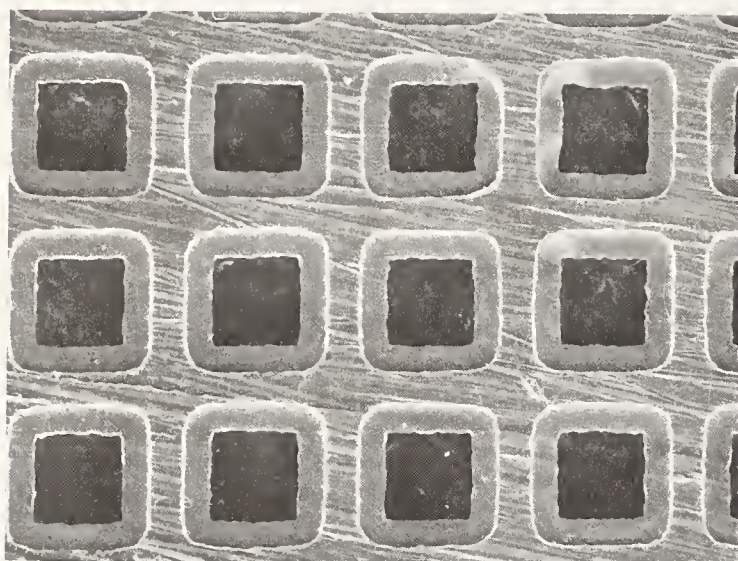

Figure 2. Electron microscope grid illustrating surface area of grid bars.

Arguments against using SEM for this type of analysis cite the limits of resolution in the SEM, the lack of diffraction capabilities; or that the chemical profiles developed by energy dispersive x-ray analysis are not definitive criteria for classification of these asbestos minerals [5,6]. These arguments in our estimation are not valid. The resolution of the majority of scanning electron microscopes is near or below 10 nanometers and most of the newer models guarantee 3 nanometers resolution. The lack of diffraction capabilities is not a major factor because in the TEM a very large percentage of the asbestos fibers do not yield usable diffraction patterns. X-ray analysis of fibers does produce sufficient chemical information to classify fibrous asbestos minerals [7].

One method depends on preparing a clean sample on a Nuclepore filter, enabling the operator to identify the particle of interest in a reasonable length of time [8]. We use Nuclepore filters in preference to Millipore filters because the surface of the Millipore filter interferes with the detection of small fibers as shown in figure 3.

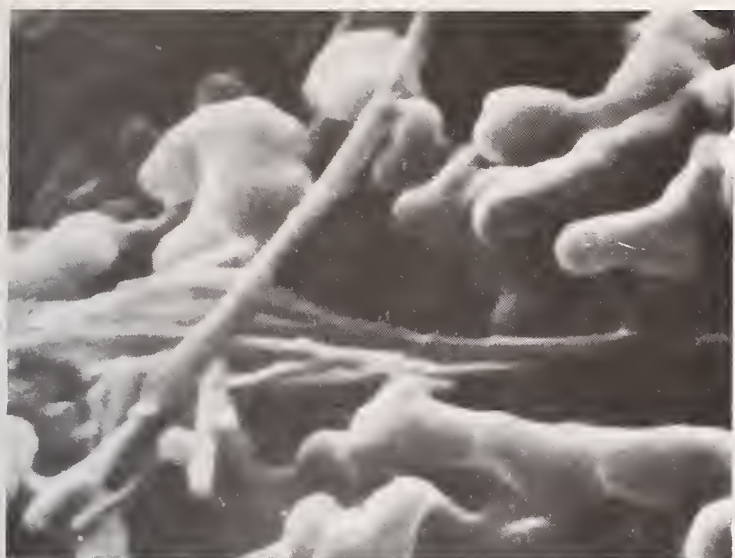

Figure 3. Asbestos fibers partially obscured by configuration of Millipore filter surface.

The filters are first examined in the SEM at low magnification to determine if the preparation is usable and to look for large particulates or product residue which might obscure the small asbestos fibers. If the sample is suitable for examination, representative micrographs are taken of fibers found on the filter surface. Fibers or fiber bundles resembling asbestos are subjected to energy dispersive x-ray analysis for 100 to 400 seconds (machine count time) depending on the spectra developed.

Identification of chrysotile asbestos is based on the morphology of the fibers or fiber bundles, the x-ray counts for magnesium and silicon, and the absence of any appreciable iron or other elemental peaks. We have not established x-ray criteria for amphibole asbestos, but would only record them as a mineral fiber with the chemical profile recorded.

At the present time we are able to routinely identify chrysotile asbestos fibers less than 70 nanometers in diameter on the filter surface using EXDA, but only after long count times, up to 400 seconds. Larger fiber bundles, 1/2 micrometer and above, produce peaks which can be read on the analyzer display CRT in less than a minute, reducing the count time and enabling the operator to go to the next fiber of interest.

To quantitate the number of fibers, we can estimate their size by comparison with a micron marker on the display CRT or by comparing them to the pores in the Nuclepore filter as shown in figure 4. For more accurate counts, SEM micrographs at 5000X or greater are taken and the fiber measured with a ruler and map reader. This is a slow and time-consuming task. We still have problems with uneven filter surfaces and product residue interfering with the analysis, but this is less a problem than it would be in the TEM because the surface examined is so much greater.

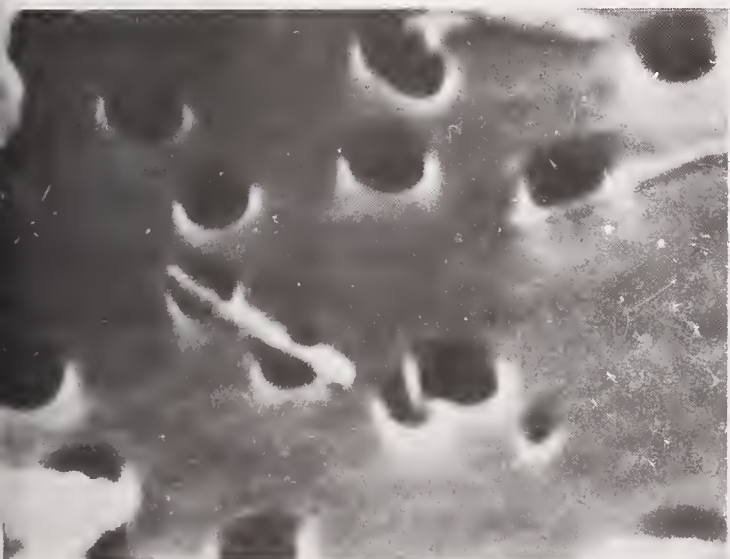

Figure 4. Small asbestos fiber traversing pores of a Nuclepore filter.

In the future we plan to incorporate an automated image analysis system similar to that developed at Penn State University [9]. We also are attempting to develop our own x-ray data reduction system based partially on the work done by Friedman et al., for analysis of neutron activation spectra here at NBS for the Bureau of Foods, FDA [10]. We feel that the SEM-EDXA, automated image analysis system will enhance our ability to do routine analysis for asbestos and other particulate contaminants.

References

- [1] Beaman, D. R., NBS Workshop on Asbestos, July 18-20, 1977.
- [2] Beaman, D. R., Difficulties encountered in the identification of asbestos fibers by analytical transmission electron microscopy in Electron Microscopy of Microfibers - Proceedings of the First FDA Office of Science Summer Symposium, Penn State University, August 23-25, 1976.
- [3] Fisher, R. M. and Lee, R. J., NBS Workshop on Asbestos, July 18-20, 1977.
- [4] Lee, R. J., Computerized SAED and the electron optical identification of particulates in Electron Microscopy of Microfibers - Proceedings of the First FDA Office of Science Summer Symposium, Penn State University, August 23-25, 1976.
- [5] Stewart, I., Selected thoughts on asbestos quantitation in Electron Microscopy of Microfibers - Proceedings of the First FDA Office of Science Summer Symposium, Penn State University, August 23-25, 1976.
- [6] Ruud, C. O., Characteristics of silicate mineral fibers as seen by TEM-SAED and SEM-EDXA in Electron Microscopy of Microfibers - Proceedings of the First FDA Office of Science Summer Symposium, Penn State University, August 23-25, 1976.
- [7] Pooley, F. D., The identification of asbestos dust with an electron microscope microprobe analyzer, Norelco Reporter, 23, No. 2 (October, 1976).
- [8] McGrath, P. P. and Ewell, J. B., Application of electron microscopy to the problem of particulate contaminants in food, drugs, and biologicals in Proceedings of Electron Microscopy, IIT Research Institute, Chicago, Illinois, Part III, 1976.
- [9] Johnson, G. G., Image Analysis Techniques in Electron Microscopy of Microfibers - Proceedings of the First FDA Office of Science Summer Symposium, Penn State University, August 23-25, 1976.
- [10] Friedman, M. H. and Tanner, J. T., A computer language for reducing activation analysis data, submitted to the Journal of Radioanalytical Chemistry, May, 1977.

Discussion

H. RHODE: I have a question for Phil McGrath. We are very much interested in the use of the scanning electron microscope for commercial asbestos samples and the problem you illustrated beautifully there with the Millipore is like looking for a needle in a large haystack, except that the NIOSH procedure requires that Nuclepore not be used for collecting air samples. Thus we are kind of on the horns of a dilemma. Have you done anything in the way of trying to mask the structure of the Millipore?

P. McGRATH: No, but Dave Manolin of Millipore told me that the reverse side of a Millipore filter is smooth. You might reverse the filter. I have not done it. Or, you could ash the Millipore filter, suspend the ash in water, and run it through a Nuclepore filter.

RHODE: We tried controlled exposure to acetone vapor with some promising results, but we are not ready to be sure that we've got it yet. I was hoping that someone else had some ideas about collapsing it rather than dissolving it, but that has some problems too.

J. LEINEWEBER: Our company seems to be the favorite stopping place for everybody who has developed gadgetry of one sort or another to help in the counting of asbestos fiber. We have encouraged this because we would like to see what is happening in this field, and among the things we have done is to follow the methods of automated analysis and everytime we get into the laboratory with some asbestos fiber samples the fiber sizes are too fine, the samples are too complex; we just have not gotten off the ground in that direction. It's an interesting concept.

McGRATH: It is an interesting concept. I have talked to Jerry Johnson of Penn State about the use of image analysis. They probably have the hardware but need to develop programs for fiber analysis. I believe the group at Penn State would be willing to develop the programs if someone would supply the monies.

LEINEWEBER: Another comment on the Millipore texture problem and carbon coating Millipore filters for TEM work--many times you carry this texture along and it kind of interferes in the TEM work; we have found that collapsing with acetone vapor prior to coating with carbon does give a much smoother surface and a lot less interference.

McGRATH: Sometimes we sputter coat the Nuclepore filters with gold-palladium before we use them. This reduces the pore size slightly but also reduces charging.

A. LANGER: The only drama associated with any presentation on asbestos was the drama of Irv Selikoff and myself in 1968 at the Food and Drug Administration, presenting a seminar on the "Contributions of Fibers from Talc to Human Lung Burden." We have given FDA nine years, and I am delighted to hear that you are taking some action.

J. WENNINGER: Let me set the matter straight for the public record of this meeting. The FDA has not taken any action in regard to the possible contamination of cosmetic talc by asbestiform minerals.

LANGER: I won't be quite as dramatic, but this study in Lancet, is that the study of the Italian deposits?

WENNINGER: I don't think it was. It was a general review article summarizing a meeting held in England sometime ago.

LANGER: I think this is based on the study of the Italian talcs, the pure talcs. That's the five nought variety that has very, very little mineral contamination, and I think that your assurances are directed to the users in the United Kingdom and not the users of consumer talcums here in the States.

WENNINGER: That could be correct, however that was not my understanding.

NOTE: The following was a note sent following the meeting and was not part of the verbal discussion at the end of this paper.

G. LEE: In his presentation of the FDA regulatory status with respect to cosmetic talc, Mr. Wenninger quoted from an editorial "Cosmetic Talc Powder" which appeared in the June 25, 1977 issue of The Lancet.

During the ensuing discussion period, Dr. A. H. Langer speculated that conclusions of the safety of cosmetic talc may have been drawn solely from data restricted to the Val Chisone Italian talc and would therefore bear no relevance to American talc products.

To answer this apprehension and to set the records straight, I am including a copy of this precise editorial, which explicitly references data, human and animal, covering cosmetic talcs which are used both in the United Kingdom and the United States.

This editorial conclusion clearly applies to American cosmetic talcs as well.

The following editorial was photographed from The LANCET, Volume 1 for 1977, No. 8026, dated Saturday, 25 June 1977, pages 1348 and 1349. This editorial has been reproduced here by permission of Mr. Ian Munro, Editor, The LANCET.

COSMETIC TALC POWDER

FROM time immemorial man, like his evolutionary predecessors, has been exposed to airborne dusts. Such exposure is a corollary of living and survival. Not unexpectedly, therefore, the lungs have efficient means of clearing themselves of inhaled particles and a functional reserve such that the accumulation of uncleared dust may be considerable before there is any obvious loss of work-capacity. However, it has long been recognised that heavy exposure to dusts, such as quartz and asbestos, may lead to loss of function and, in the case of asbestos, to cancer of the pleura and of the lung itself. The observation that even casual exposure to asbestos may be associated with increased risk of mesothelioma, now occurring at the rate of nearly 200 new cases a year in the United Kingdom,¹ has brought into question the safety of other common dusts such as cosmetic talc. There are two main concerns. Firstly, will inhalation of a dust cause loss of function through fibrosis or emphysema? And, secondly, will it predispose to cancer?

Although talc can cause granulomas when introduced into the tissues or body cavities,² exposure to cosmetic talc has been widely assumed not to predispose to pulmonary fibrosis. However, the fact that no association has been seen between the use of talc and loss of lung function might simply reflect the lack of methods sensitive enough to detect losses of function that are small compared with those due, for example, to smoking and to heterogeneity in α_1 -antitrypsin status. For similar reasons any effect of talc exposure on cancer incidence would probably escape notice unless deliberately sought. Until lately facilities for studying the long-term effects of inhalation of dusts in laboratory animals have been scarce, and even now the predictive value of animal models is questionable. Thus, even in the case of tobacco smoke, where the cancer hazard to man is indisputable, duplication of the effect, by the inhalation route, in laboratory animals has proved difficult or impossible,³ although inhaled asbestos dust has given positive results in animals.⁴

The possibility that talc causes cancer dramatically hit the headlines of the daily Press when workers in Cardiff⁵ reported finding talc particles in cancers of the ovary and uterine cervix. The report was greeted with scepticism because the particles were not positively identified as talc, because their presence did not prove causation, and because they might have found their way onto the sections as a result of contamination of tissues *after* removal from the body. Subsequent mineral analysis failed to confirm that the particles were talc⁶ and the passage of six years without publication of confirmatory evidence suggests that the early scepticism was well-founded. A meeting of talc-powder manufacturers and independent scientists took place at Cardiff during May, 1976, under the chairmanship of Dr J. C. Gilson, director of the Medical Research Council Pneumoconiosis Unit. At that meeting the toxicology of talc was reviewed and the need for further information discussed. Assessment of toxicity necessarily starts with a consideration of the physical and chemical specifications of the test material, and this, unfortunately, is also where much of the assessment ends in the case of cosmetic talc because most of the published reports—epidemiological, clinical, and experimental—concern exposure either to industrial talcs that are variously contaminated with minerals known to be hazardous or to talc of undefined physical and chemical characteristics.

The long thin fibrous shape of asbestos particles enables them to be carried more deeply into the lungs than spherical particles of similar mass. The fact that the normally effective clearance mechanisms have difficulty in coping with large, long thin particles deposited deeply in the lungs is an important determinant of the hazards from asbestos dust. Geologically, talc (which is nominally a hydrated magnesium silicate) and certain amphiboles—tremolite, actinolite, and anthophyllite—may occur in juxtaposition and consequently talc may be contaminated with these minerals. Apart

1. Greenberg, M., Lloyd Davies, T. A. *Br. J. ind. Med.* 1974, **31**, 91.

2. Bluemel, G., Piza, F., Zischka-Konorsa, W. *Wien. klin. Wschr.* 1962, **74**, 12.

3. Davis, B. R., Whitehead, J. K., Gill, M. E., Lee, P. N., Butterworth, A. D., Roe, F. J. C. *Br. J. Cancer*, 1975, **31**, 469.

4. Wagner, J. C., Berry, G., Skidmore, J. W., Timbrell, V. *ibid.* 1974, **29**, 252.

5. Henderson, W. J., Joslin, C. A. F., Turnbull, A. C., Griffiths, K. *J. Obstet. Gynaec. Br. Commonw.* 1971, **78**, 266.

6. Hildick-Smith, G. Y. *Br. J. ind. Med.* 1976, **33**, 217.

from this, talc may contain chlorite, quartz, carbonates (such as calcite, dolomite, and magnesite), and occasionally other minerals in lesser amounts. During the past few years, major cosmetic manufacturers in the United Kingdom and the United States of America, as represented by the Toilet Preparations Federation and the Cosmetic, Toiletry and Fragrance Association, have drawn up specifications for cosmetic talc which ensure the virtual absence of fibrous amphiboles.⁷⁻¹⁰ At present there is no direct statutory control of the quality of cosmetic talc in any country and it is questionable whether such control is necessary to bring minor manufacturers into line with the standards now adopted by the major firms. The presence of fibrous particles in talc reduces its free flow and lubricity, thereby rendering it less cosmetically desirable. Such contamination is thus self-limited. More important, however, is the fact that the fibrous materials most likely to contaminate talcs which do not comply with the specifications—namely, tremolite, anthophyllite, and actinolite—are not those most clearly associated with carcinogenic hazard (crocidolite, amosite, and chrysotile). Furthermore, it would be sensible to consider what controls, if any, are necessary for talc as used in medicines, before introducing legislation specifically in relation to cosmetic talc.

If the inhalation of particles of amphibole and silica contaminated talc dust were found to be harmless, one might reasonably assume that talc free from these materials is safe. Kleinfeld and his colleagues have studied the incidence of cancer and respiratory diseases in talc miners and millers in New York State. The talc concerned, which is heavily contaminated with both amphiboles and free silica, was initially reported to be associated with an increased mortality from mesothelioma and cor pulmonale.¹¹ Later the same workers reported that men employed in the mine after dust levels had been reduced had death-rates from malignant diseases that were similar to those for White males in the U.S.A. generally.¹² Also in the U.S.A., Fine and his colleagues¹³ have reported a higher prevalence of productive cough and chronic obstructive lung disease among rubber workers exposed to a non-fibrous industrial-grade talc than among control workers. From their data they calculated that a safe exposure level would be provided by a threshold limit value of 0.25 mg/m³ mass-respirable particulate talc. In Italy, Rubino and his colleagues¹⁴ compared the spectra of causes of death among talc miners, talc millers, and agricultural workers. The talc miners were exposed to dusts containing 5% silica at levels far in excess of threshold limit value. Significantly more of them than of the controls died from respiratory disease, but death-rates from all forms of cancer, including lung cancer, were significantly lower among the

miners than among the controls. By contrast, among the talc millers, exposed to dusts containing 0.05% silica, but no detectable asbestos, at concentrations of 20 million particles per cubic foot (27 litres), there was no excess of deaths from pulmonary disease or cancer of any site compared with the control group. The deficit of lung cancer among the talc miners is plausible in so far as a similar deficit of lung cancer among coal miners seems to be real.¹⁵ A continuing study of over 3200 persons, mainly women, at a factory in Britain where cosmetic talc has been made and packed for over fifty years, has so far revealed no evidence of health hazard,¹⁶ but follow-up would need to be extended for at least a further decade before one could be confident of a negative result. Other less informative epidemiological studies are reviewed by Hildick-Smith.⁶

In most of the work in animals the quality of the talc has not been specified. An exception is a report by Wehner and others¹⁷ who studied the effects in hamsters of repeated exposure to aerosols of cosmetic talc up to total doses of respirable particles equal to nearly 2000 times those received by humans using cosmetic talc during baby care. Exposure had no adverse effect on body-weight, survival, incidence of pathological changes in the respiratory tract, or incidence of neoplasia at any site. Another exception is the report by Wagner and his colleagues,¹⁸ who saw no mesotheliomas in 48 rats after intrapleural administration of cosmetic talc whereas 18 out of 48 rats similarly exposed to chrysotile asbestos acquired such tumours. The same workers exposed rats to cosmetic talc by the inhalation route on five days a week for up to a year. At the highest level of exposure—about three times that studied by Wehner and his colleagues¹⁷—there was slightly more pulmonary fibrosis than in controls, but no substantial excess of pulmonary neoplasms. A number of less relevant animal studies, all of which gave negative results for carcinogenicity, are reviewed by Hildick-Smith.⁶ In summary, there is no reason to believe that normal consumer exposure to cosmetic talc has in the past led either to cancer at any site or to measurable loss of lung function. It seems unlikely that future exposure to cosmetic talc of the specifications now agreed to by major manufacturers will present a health hazard.

7. Toilet Preparations Federation Ltd., specification no. 12: Cosmetic Talc. 1977.

8. C.F.F.A. Specification: Talc, Cosmetic. Cosmetic, Toiletry and Fragrance Association, Inc., issue 10-7. 1976.

9. Toilet Preparations Federation Ltd., analytical method 77: Cosmetic Talc 1977.

10. Hamer, D. H., Rolle, F. R., Schelz, J. P. *Am. ind. Hyg. Ass. J.* 1976, **37**, 296.

11. Kleinfeld, M., Messite, J., Kooyman, O., Zaki, M. H. *Archs envir. Hlth*, 1967, **14**, 663.

12. Kleinfeld, M., Messite, J., Zaki, M. H. *J. occup. Med.* 1974, **16**, 345.

13. Fine, L. J., Peters, J. M., Burgess, W. A., Di Beradinis, L. J. *Archs envir. Hlth*, 1976, **31**, 195.

14. Rubino, G., Scansetti, G., Piolatto, G., Romano, C. *J. occup. Med.* 1976, **18**, 186.

15. Goldman, K. P. *Br. J. ind. Med.* 1967, **22**, 72.

16. Newhouse, M. L., Miller, B. F., Moore, W. K. S. Paper given at seminar on Biology of Talc Used in Health Products, Cardiff, May, 1976.

17. Wehner, A. P., Zwickel, G. M., Cannon, W. C., Watson, C. R., Carlton, W. W. *Fd Cosmet. Tox.* 1977, **15**, 121.

18. Wagner, J. C., Berry, G., Cooke, T. J., Hill, R. J., Skidmore, J. W. in Proceedings of Fourth International Symposium on Inhaled Particles and Vapour. Oxford, 1977.

CPSC REGULATION OF NON-OCCUPATIONAL EXPOSURE TO ASBESTOS IN CONSUMER PRODUCTS

Robert M. Hehir, Steven P. Bayard, and June Thompson

Consumer Product Safety Commission
5401 Westbard Avenue
Bethesda, Maryland 20207

Abstract

The Consumer Product Safety Commission (CPSC) has found that exposure to respirable free-form asbestos in two consumer products poses an unreasonable health risk. The Commission has recently voted to propose bans on the use of free-form asbestos in consumer patching compounds and in artificial fireplace ash or emberizing materials under Section 8 of the Consumer Product Safety Act. The broad regulatory provisions under CPSA, as well as those under the Federal Hazardous Substances Act (FHSA) are discussed.

Data on consumer exposure to asbestos are very limited. One study of airborne asbestos resulting from use of consumer spackling/patching compounds has reported levels of airborne asbestos fibers exceeding the occupational exposure levels.

Direct evidence exists of asbestos inhalation in non-occupationally exposed individuals from autopsy findings of asbestos fibers in lung tissue and indirect evidence of asbestos-related cancers in non-occupationally exposed individuals from epidemiological studies.

A risk assessment has been made of the potential increase of lung cancer deaths resulting from consumer exposure to asbestos containing patching compounds.

Key Words: Artificial fireplace ash; consumer exposure; Consumer Product Safety Act (CPSA); Consumer Product Safety Commission (CPSC); emberizing material; free-form asbestos; patching compounds; risk assessment.

Introduction

The Consumer Product Safety Commission (CPSC) has broad regulatory authorities under several Acts to help it marshal its resources to reduce unreasonable risk of injury associated with consumer products.

When risks of injury resulting from reasonable or reasonably foreseeable use of consumer products are brought to the Commission's attention, either through petitions or through findings from in-house or externally-sponsored studies, the regulatory mechanism which can most appropriately remedy or prevent an identified hazard is utilized. Thus, in a recent decision, the CPSC Commissioners voted to regulate respirable, free-form asbestos in two consumer products (consumer patching compounds and artificial fireplace ashes) under Section 8 of the Consumer Product Safety Act (CPSA) [16]¹.

It is the sequence of this regulatory process which I will discuss today.

¹Figures in brackets indicate the literature references at the end of this paper.

Prior to promulgating a safety rule under the CPSA, the Commission must first propose a rule for public comment. In issuing a final rule, it must make special findings under sec. (9) subsection (c) of the CPSA. Such findings include:

- (a) the degree and nature of the risk of injury the rule is designed to eliminate or reduce;
- (b) the approximate number of consumer products, types or classes that will be subject to the rule;
- (c) the need of the public for the product and probable effect of such rule upon the utility, cost, or availability of such products to meet such needs; and
- (d) any means of achieving the objective of the order while minimizing adverse effects on competition or disruption or dislocation of manufacturing...etc., consistent with the public health and safety.

In addition, the Commission must consider other things as well:

- (a) Which Act will be used in promulgating the rule. (Sec. 30 CPSA).
- (b) Jurisdiction under Section 3(a) and Section 31 CPSA.
- (c) Under CPSA, if the Commission preliminarily determines that a product presents an unreasonable risk of injury, it could commence proceedings to develop a mandatory safety standard addressed to that risk. If it appears that no feasible standard can adequately protect the public, the Commission could declare that it is a banned hazardous product (Sec. 8 CPSA). Where the Commission concludes that a product presents an imminent and unreasonable risk of death, serious illness, or severe personal injury, the Commission may file in a U.S. district court an action for a court declaration that a product is an imminent hazard (Sec. 12 CPSA).

In the case of asbestos exposure, the injury would not be immediate but may be impending because of the long latency period. In fact, this chronic hazard area is one that is receiving new emphasis in the Commission. By themselves, our methods of emphasizing the acute injuries and toxicities by national surveys of emergency room injuries appear inadequate for chronic hazard evaluation and regulation. Chronic hazard information most frequently comes from retrospective epidemiological occupational studies, case reports, and animal studies. Chronic hazards are the most silent type of hazards because the consumer is unknowingly exposed to chemical products which have hitherto been assumed safe. A partial list of chronic hazards on which the Commission has taken action to regulate or propose to regulate includes:

- Lead (in paint)
- Vinyl Chloride (as an aerosol propellant)
- TRIS (flame retardant)
- CFC's Chlorofluorocarbons (as aerosol propellants)
- Asbestos (fireplace embers, patching compounds)

Petitions

One other factor is important in describing the sequence of events in CPSC's regulatory process. Interested persons may petition the Commission to commence proceedings for the issuance, amendment, or revocation of a rule under any Act administered by the Commission. It was through the petition process that the Commission's regulatory sequence began for asbestos-containing products.

The Commission has considered three petitions [11,15,18] requesting it to ban consumer patching compounds and artificial embers and ash containing respirable, free-form asbestos. The request on artificial embers and ash, received in November 1975, was initially treated

as a consumer complaint, and the staff conducted follow-up investigation on the complaint. Subsequently, in July 1976 and March 1977, two petitions were received seeking bans of free-form asbestos-containing consumer patching compounds.

The Commission then proceeded to investigate:

- (a) what hazard was actually associated with these products,
- (b) how the hazard could be reduced with maximum compliance and minimum disruption, and in addition, to evaluate
- (c) what future protective rules should be made for public safety.

Non-Occupational Exposure

The first step was to decide whether consumers could be exposed to asbestos. Direct and indirect evidence exists that individuals, other than those working directly with asbestos minerals, are being exposed to asbestos. For example, asbestos fibers have been demonstrated at autopsy in the lungs of persons who were not occupationally exposed [6,7,14,23]. Substantial evidence also exists that human lungs may harbor thousands of fibers, some of which are chrysotile. However, the number of asbestiform fibers found in non-occupationally exposed individuals is relatively small compared with the numbers in occupationally exposed individuals [19].

The next step was to decide if there was any risk of injury to exposed consumers. Since the reports from emergency rooms were not suitable for our needs, other data were sought.

Indirect evidence of asbestos-caused adverse health effects was provided by epidemiological studies which showed malignant mesotheliomas, rare in the general population, to be associated with individuals with no occupational exposure to asbestos, but who lived in the vicinity of the asbestos fields or mines [2,12,24].

Another investigation of the extent of asbestos exposure associated with 42 diagnosed mesothelioma cases was conducted in southeastern Pennsylvania. Of these, 8 were neighborhood exposures and 10 had questionable exposure. Among this group was a 14 year old boy who allegedly helped his father replace plasterboard during extensive home remodeling [8].

A short exposure (according to the report) of mixing and applying asbestos cement insulation to a boiler in a consumer's home has also allegedly caused mesothelioma [8].

It has also been suggested that inhalation of small numbers of asbestos fibers over a long period of time could result in focal concentrations at the lung bases, possibly reaching fibrogenic or carcinogenic concentrations [23].

Next, we had to decide just what type of products had asbestos available for respiration, i.e., free vs. bound fiber. In numerous products the fibers are tightly bound to the matrix or are encapsulated. A potential health risk occurs when asbestos fibers become airborne, such as by mixing, sanding, or cleanup operations when using asbestos-containing patching compounds. However, in terms of risk to the public health, a single individual engaged in such a process may inadvertently expose other individuals in the vicinity. The importance to such "bystander" exposure has been emphasized in several reports [1,9,17,20] and we had to consider this also.

Risk Assessment

Another big question: how much risk of injury is associated with the product? A model for lifetime risk assessment of death from respiratory cancer due to consumer use of asbestos-containing wall-taping compounds was prepared by one of the authors (S.B.). In order to compute such a risk assessment for the use of asbestos-containing wall-joint compounds, many assumptions had to be made. The model selected for analysis was that developed by Enterline and Henderson [4], which in turn was derived from data on amosite

asbestos factory workers and asbestos insulation workers [20]. Measurements of asbestos fibers longer than 5 microns from work with wall-taping compounds were taken from data provided by Rohl, Langer, Selikoff, and Nicholson, [17]. Projections of consumer use and exposure were determined and age central death rates from respiratory cancer based on the 1970-71 vital statistics of the United States were utilized.

The assumptions used in the risk assessment model are presented below:

- (a) The dose-response relationship between asbestos and lung cancer is linear [4]. This hypothesis assumes no threshold.
- (b) Time to tumor is dependent on dose and can be described by a log normal distribution with median time to tumor t :

$$t = 98.65 \left(\frac{1}{D} \right)^{1/3}$$

where D = 8-hour time weighted average dose in fibers/cc and a log standard deviation of 1.5. (Enterline and Henderson, 1976, [4] based on Jones and Grindon, 1975 [5]).

- (c) Competing risks of death for the first 40 years following exposure are considered to be normal.
- (d) Risk of asbestos caused death after the first 40 years following exposure is considered to be zero.
- (e) Effect of dose is cumulative and is assumed to have the same effect as if that dose had been accumulated in the first year of exposure.
- (f) Intermittent exposure with occasional high peaks has the same cumulative effect as continuous exposure at double the dose [3,4].

While the assumptions (a through f) may seem at first unclear, the total effect is to present a cumulative dose-response curve of the form log dose-log response. This is shown in figure 1. Explanation of how these figures were derived is given below. It is emphasized, however, that this model is to be used for low exposure estimates. It is not designed to fit data for high or long-term exposure data.

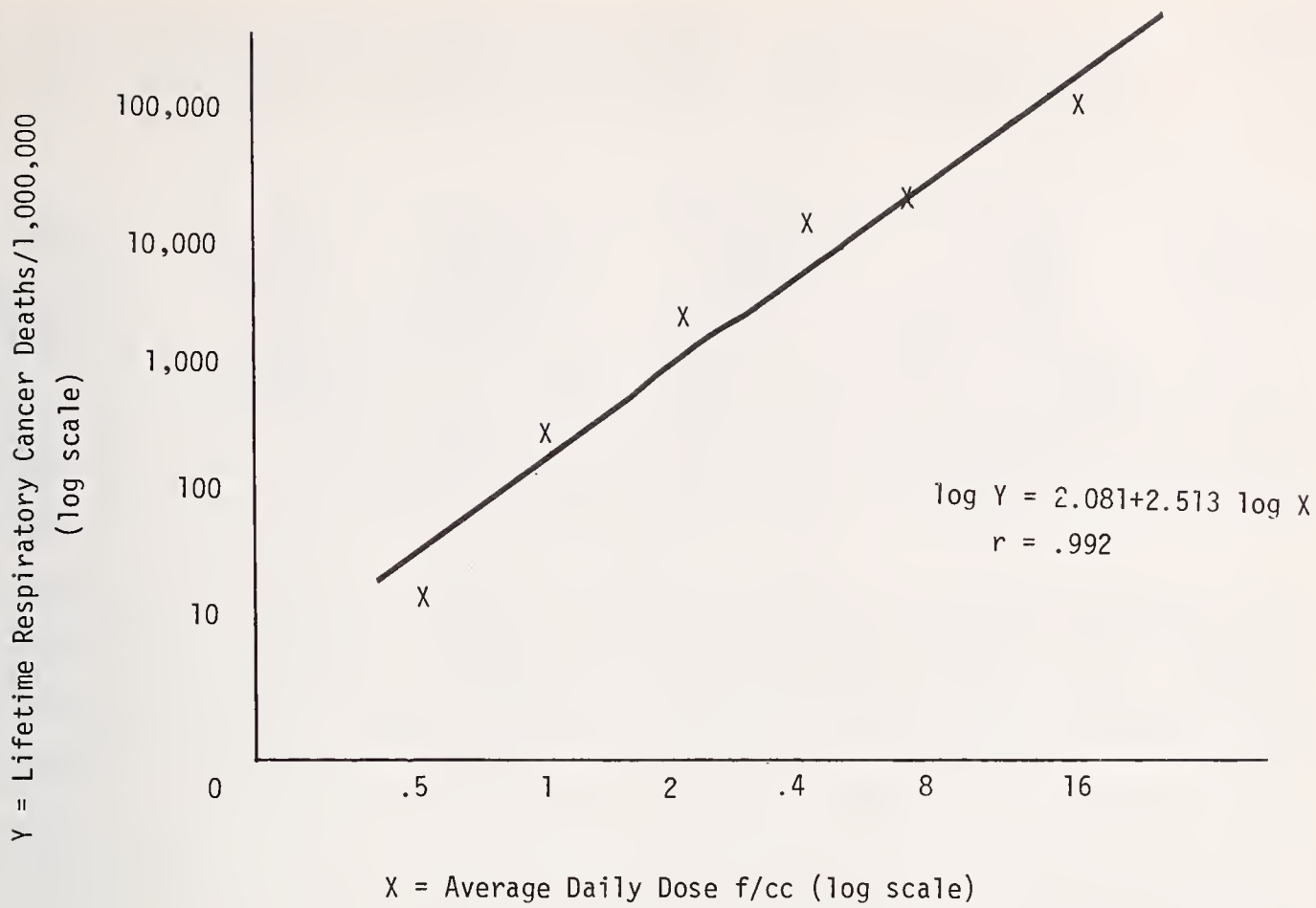

Figure 1. Response vs. dose for low level asbestos.

Exposure: Asbestos induced respiratory cancer deaths per million lifetime vs. daily exposure (f/cc) for 1 year. Estimates based on the model.

Derivation of Total Cases Caused by Asbestos Exposure

Besides the assumptions above, the major data used to estimate the total cancer deaths attributable to dose were the Selikoff data on 294 factory workers who had been exposed to asbestos for 3-11 months during the years 1941-45 [20]. Estimates of the concentration of asbestos dust during this period averaged 30 f/cc. Since the average exposure was only 5/8 year, the equivalent concentration was figured at 18.75 f/cc/day on a 1-year basis. By assumption (b), the median time to death from respiratory cancer is 37.1 years. Also, by assumption (b) the log normal distribution shows that for the 28 years of follow-up used in the Selikoff paper only 24.4 percent of these deaths would have occurred. Since the adjusted relative risk of these workers was 2.95 [4], and the age central death rate from respiratory cancer (ages 35+) was 850/million, the number of respiratory deaths which could have been caused by the asbestos exposure was the solution to:

$$\frac{28(.000850 + .244 X)}{28(.000850)} = 2.95$$

or $X = .190205$ or 190,205 deaths/million. But, since only 40 years of exposure are considered (assumptions c and d), assumption (b) allows only 57.3 percent or 109,000 lifetime cancer respiratory deaths per million exposed.

By assumption (a), the number of potential cases by dose can then be calculated and risk estimates can be derived from these. This is shown in Table 1, along with the calculated relative risks. Here it can be seen that excess deaths and relative risks do not increase linearly with increasing dose but in a geometric manner.

Table 1. Lifetime (40 years) risk estimates of respiratory cancer deaths by dose for a 1-year equivalent exposure. Median latent periods and relative risks are included.

(1) 8-hour Avg. Daily Expo- sure Level D f/cc	(2) Latent Periods Years $t=98.65(\frac{1}{D})^{1/3}$	(3) Potential Cases/ Million (see text)	(4) Proportion Developed in 40 years (log normal)	(5) Asbestos Induced Respir. Cancer Deaths/ (3)x(4)	(6) Relative Risk $\frac{(5)+850 \times 40}{850 \times 40}$
.5	124.3	5,072	.0026	13	1.00038
1	98.6	10,145	.0130	132	1.00388
2	78.3	20,290	.0488	990	1.02912
4	62.1	40,578	.1488	6,038	1.17759
8	49.3	81,155	.3030	24,590	1.72324
16	39.1	162,310	.4776	77,519	3.27997
18.75	37.1	190,205	.5727	109,000	4.20588

Estimates of Exposure Levels of Consumer Users of Wall Taping Compounds

Rohl [17] measured peak fiber concentrations of ten drywall taping compounds during sanding, dry mixing, and floor sweeping. The average peaks were as high as 47 f/cc with the highest individual peak of 59 f/cc. Based on these peaks the 8-hour time weighted average was estimated as 10 f/cc. Taken with assumption (f) that high intermittent exposure was estimated to have doubled the effect of continuous exposure, this estimate was increased to 20 f/cc. If there are four uses projected per year, the estimate of yearly equivalent is:

$$\frac{20 \text{ f/cc/day} \times 4 \text{ days}}{200 \text{ days/year}} = .4 \text{ f/cc/day for 1 year}$$

Thus, based on the results of the model, Table 1, it is estimated that 4 heavy exposures by consumers in one year will cause an additional 10 lifetime respiratory cancer death/million. Continued use for five years will, by assumption (e), raise that estimate to 990 deaths per million (see Table 1).

No quantitative risk assessment was made for asbestos exposure from the artificial embers and ash since there are no known measurements of the airborne fiber content. It can be assumed, however, that whatever air concentrations are present, they expose the home occupant to a continuous inhalation of free fibers vs. only intermittent exposure for the wall-taping compounds. The risk from these embers and ashes, therefore, may be considered at least as high as that from the wall-taping compounds. In our opinion the greatest period of risk for embers, ashes, and patching compounds is both during the application and removal processes.

Regulatory Decision

Since we considered this risk of injury too high, a safety rule was obviously called for. Because of possible cumulative effects of exposure to respirable asbestos, we felt that total exposure should be kept as low as possible and it was, therefore, decided to issue a regulation.

The options available to the Commission were:

- (a) under the Federal Hazardous Substances Act (FHSA) as "banned hazardous substances".
- (b) under Section 8, CPSA, a proposal to ban manufacture, sale, and distribution.

The Commission decided to issue a ban under Section 8 of CPSA.

CPSA Ban

The Commission decided that it was in the public interest to propose the ban of consumer patching compounds and emberizing materials containing respirable free-form asbestos under the CPSA (Sec. 30(d), CPSA), although the petitions were submitted under FHSA and the risk of injury could be eliminated or reduced to a sufficient extent under the FHSA. The Commission believes that the rulemaking proceedings under the FHSA are likely to be lengthy and resource consuming and that those proceedings could make it more difficult for interested persons to participate.

On the other hand, Section 8 of the CPSA, under which a CPSA banning rule would be issued, provides for a period wherein all persons affected by the proposed banning action can submit written comments. An opportunity for oral presentation of data, views, or arguments, is also provided. During this period, any additional information or data that might better define the nature or degree of the hazard associated with the affected products may be brought to the Commission's attention for consideration prior to the promulgation of a final rule.

Removal and Disposal

While the banning rule is considered, the removal and disposal problems associated with artificial asbestos ash/embers will also have to be addressed.

The disposal of the material in the homes of consumers poses a difficult problem.

The Commission has been requested to declare fireplace emberizing materials containing asbestos "to be imminently hazardous consumer products," and to direct manufacturers of such products to remove them from the homes of consumers.

The Commission solicited the advice of experts as to whether consumers could safely remove the asbestos "ashes" from their own fireplaces. While the consensus is that, exercising caution in accordance with available expert advice, they could. However, there was some contradiction among the experts as to how it should be done. The Commission, therefore, will consider various removal procedures before issuing advice to the public.

Guidelines on safe removal may mention disposal instructions for unused patching compounds. The Commission's staff believes that their removal may pose no hazard since, unlike the "ashes", this material is not loosely scattered. The asbestos patching material on the walls is assumed to have already been suitably covered and should not create an unacceptable risk.

Future Commission Actions on Asbestos

Asbestos in consumer products has been established as the Commission's highest priority project for FY 78.

This project will assess the potential hazard of other consumer products containing asbestos. The asbestos content of a given product is not necessarily the sole criterion of that product's relative health risk. A potential hazard occurs when asbestos fibers become airborne and can be inhaled. Thus, the Commission's concern is to determine whether consumer products contain asbestos fibers which can readily become airborne under normal use conditions.

The Commission will then decide if additional rulemaking is required for the protection of the consumer.

References

- [1] Anderson, H. A., Lisis, R., Daum, S. M., Fischbein, A. S. and Selikoff, I. J., Household-Contact Asbestos Neoplastic Risk, Ann. N. Y. Acad. Sci., 271, 311-323 (1976).
- [2] Barow, M. A., Conston, L. L., Livornes, L. L., Schalet, N., Mesothelioma and its Association with Asbestosis, J.A.M.A., 201(8), 93-97 (1967).
- [3] Enterline, P. E., DeCouflé, P., Henderson, V., Mortality in Relation to National Exposure in the Asbestos Industry, JOM, 14(12), 897-903 (Dec. 1972).
- [4] Enterline, P., Henderson, V., A Model for Extrapolating to Low Levels of Asbestos Exposure. Presented at Conference on Problems of Extrapolating the Results of Laboratory Animal Data to Man and Extrapolating the Results from High Dose Level Experiments to Low Dose Level Exposure, Pinehurst, NC (March 11, 1976).
- [5] Jones, H. B., Grindon, A., Environmental Factors in the Origin of Cancer and Estimation of the Possible Hazard to Man, Food, Cosmet. Toxicol., 18, 251-268 (1975).
- [6] Langer, A. M., Ashely, R., Baden, V., Berkley, C., Hammond, E. C., Mackler, A. D., Maggiore, C. J., Nicholson, W. J., Rohl, A. N., Rubin, I. B., Sastre, A., and Selikoff, I. J., Identification of Asbestos in Human Tissues, J. Occup. Med., 15(3), 287-295 (March 1973).
- [7] Langer, A. M., Selikoff, I. J., and Sastre, A., Chrysotile Asbestos in the Lungs of Persons in New York City, Arch. Environ. Health, 14, 559-563 (April 1967).
- [8] Lieben, J., and Pistawka, H., Mesothelioma and Asbestos Exposure, Arch. Environ. Health, 22, 559-563 (April 1967).
- [9] Lillington, G. A., Conjugal Malignant Mesothelioma, New Engl. J. Med., 291(11), 583-584 (September 1974).
- [10] McDonald, J. C., McDonald, A. D., Gibbs, G. W., The Health of Chrysotile Asbestos Mine and Mill Workers of Quebec, Arch Environ. Health, 28, 61 (1974).
- [11] Natural Resources Defense Council (NRDC) Petition, HP 76-18, Consumer Patching Compounds Containing Respirable Asbestos (July 15, 1976).
- [12] Newhouse, M. L. and Thompson, H., Mesothelioma of Pleura and Peritoneum Following Exposure to Asbestos in the London Area, Brit. J. of Indust. Med., 22, 261-269 (1965).
- [13] Nicholson, W. J.,: Case Study 1: Asbestos--The TLV Approach. Occupational Carcinogenesis, Annals of the New York Academy of Sciences, Vol. 271, 152-169 (May 1976).
- [14] Pooley, F. D., Oldham, P. D., Um, C. H., and Wagner, J. C., The Detection of Asbestos in Tissues, Pneumoconiosis Proceedings of the International Conference, 1969, Cape Town: H. A. Shapiro, Ed., Oxford Univ. Press, 108-116 (1970).
- [15] Public Citizens Health Research Group (HRG) Petition, HP 77-9, Patching Compounds with Tremolitic Talc Containing Asbestos Fibers (Asbestiform Tremolite) (February 9, 1977).
- [16] Public Law 92-573; 15 U.S.C. 2051, 92nd Congress, S. 3419, October 27, 1972. Consumer Product Safety Act.
- [17] Rohl, A. N., Langer, A. M., Selikoff, I. J. and Nicholson, W. J., Exposure to Asbestos in the Use of Consumer Spackling, Patching, and Taping Compounds, Science, 189, 551-553 (1975).
- [18] Scott, Ms. Rachel, joined by Environmental Defense Fund (EDF), HP 77-11, Artificial Fireplace Ash Containing Respirable Free-Form Asbestos (April 15, 1977).

- [19] Selikoff, I. J. and Hammond, E. C., Asbestos Bodies in the N.Y. Population in Two Periods of Time, Pneumoconiosis Proceedings of the International Conference, 1969, Cape Town, H. A. Shapiro, Ed., 99-105 (1970).
- [20] Selikoff, I. J., Hammond, E. C., Seidman, H: Cancer Risk of Insulation Workers in the United States. IARC, Biological Effects of Asbestos, Lyon, France, (1973).
- [21] Selikoff, I. J. and Hammond, E. C., III. Community Effects of Nonoccupational Environmental Asbestos Exposure, A.J.P.H., 58(9), 1658-1666 (September 1968).
- [22] Selikoff, I. J., Bader, R. A., Bader, M. E., Churg, J., and Hammond, E. C., Editorial: Asbestosis and Neoplasia; The Amer. J. of Medicine, 42(4), 487-496 (April 1967).
- [23] Thomson, J. G., Asbestos and the Urban Dweller, Ann. N.Y. Academy of Sci., 123, 196-214 (1965).
- [24] Wagner, J. C., Sleggs, C. A., and Marchand, P., Diffuse Pleural Mesothelioma and Asbestos Exposure in the Northwestern Cape Province, Brit. J. Indust. Med. 17, 260-271 (1960).

Discussion

J. LEINEWEBER: I'd like to make the statement that some of the applications of asbestos fiber that you are discussing here are considered among those of us in the asbestos industry as applications that are not necessary and can be eliminated from the workplace and from the environment. I wasn't able to follow several of the arguments you were giving in terms of your risk assessment, and I think for the purposes of bringing a discussion like this to a reasonable conclusion, I for one will appreciate seeing some of this and maybe having an opportunity to rebut it before the final publications of these proceedings are out—is that possible?

R. HEHIR: It certainly is. All the information that we have on risk assessment and all the briefing packages are in the Office of the Secretary of the Commission. They are located at 1111 18th Street, and Mr. Richard Rapp or Miss Sadie Dunn would be very happy to provide all the pertinent information I've discussed here, and any of the additional materials which are submitted should go to that particular office so it can be considered in the rulemaking process.

C. COOPER: I thought that the presentation of the risk assessment was a fascinating exercise, and I too would like to see the details by which these numbers were attained. I thought I heard the figure of an average exposure for a year of 0.4 fibers per cc arising out of four applications.

HEHIR: Yes.

COOPER: That seems to be an extraordinarily high number to arrive at from four applications when compared with the exposures that we observed in insulating workers, for example, who work with insulating materials around the clock. We found average exposures of maybe ten times that for men who work with asbestos year around. It seems to me that your number is an unusually high average concentration for a year, but I am not questioning it but I would like to see some figures from which it was derived.

HEHIR: Dr. Cooper, I'm sure you'll have an opportunity to see the figures. As a matter of fact we received additional information from other people. As I have told you initially, the material on patching compounds was from the publication by Rohl, Langer, Nicholson, and Selikoff, and that was our jumping off point. For example, that was the data we utilized and we came up with the figure based on six assumptions. I'm sorry I was not able to have a slide of the table and the figure and some other mathematical calculations to show you how they are derived; however, the paper will be published and the information is readily available at this point.

COOPER: I do think that this is an interesting approach to this problem and I'm very anxious to see how it was reached.

M. BROWNSTEIN: Two things: you have not mentioned anything about the time table for this proposed ban. I wonder if you could go into that at all. The other area is, how is it planned to differentiate between the products that are intended for the home handy man, or will be used by the home handy man, and those which are used by the construction industry?

HEHIR: Well, we regulate products that come into the home that are sold to the consumer. We don't regulate anything that might be considered an occupational hazard. As far as the risk assessment, and the deliberations on time tables, that is in the hands of the general council. I can't tell you how long it will take; a prudent man could contemplate a year. A person dealing with government knows that the wheels of progress in this particular regulatory forum move ever so slowly; probably in a few years. Since these are my own expressed opinions, I don't feel compelled to tell you that the Commission may have a different view.

BROWNSTEIN: Just to continue on that restriction that you only deal with consumer products, my question was more on how are you planning to differentiate between what is a consumer product? Let's say a building supply store, this sort of thing where you find both groups going to get products from the same outfit.

HEHIR: I find it difficult for similar regulatory agency representatives to ask a question like that. The Act spells out very clearly we handle consumer products which are not food, drugs, cosmetics, or economic poisons; now the interpretation really centers on what constitutes a consumer product. If you can buy it in a hardware store, then we consider it a consumer product. If, however, the manufacturer regulates from point of sale to distribution and can so demonstrate such regulations and such control then, quite frankly, we might not have jurisdiction.

ROSS: Do you have any data on the health of professional plasterers and also professionals in other similar areas, like cement workers?

HEHIR: Dr. Ross - I personally don't, but I'm sure by the end of our rulemaking procedures we will have that kind of information.

IMPACT OF ASBESTOS REGULATIONS ON THE MINING INDUSTRY

C. S. Thompson
R. T. Vanderbilt Company, Inc.
Norwalk, Connecticut 06855

Abstract

No one in the mining industry objects to proper regulation of toxic substances. No one in the mining industry has any objection to the reasonable control of asbestos as long as the regulations apply to the truly asbestiform varieties of specific minerals. Unfortunately, the regulators have ignored basic mineralogical data and have included numerous minerals which bear no resemblance to the asbestos upon which essentially all health data have been obtained. This gross extrapolation of the known health hazards of excessive exposures to true asbestos, to the non-asbestiform varieties of common rock-forming minerals is totally unwarranted.

The full assessment of the economic impact of asbestos regulations, as with other restrictive legislation, will undoubtedly take many years. The impact is also greatly dependent upon the outcome and recommendations resulting from this workshop. As of today, if the regulatory agencies apply their present rules and definitions regarding "asbestos", the entire mining industry and those dependent on it face an adverse economic impact unparalleled in its history. Furthermore, proposed regulations, based on the same erroneous definitions and extrapolations, are so restrictive they threaten the existence of major segments in a wide variety of areas within the mining industry. The continued promulgation and enforcement of mineral legislation based on errors and misconceptions will have severe economic effects on the total U.S. economy and on the individual taxpayer.

Keywords: Amphibole; copper; crushed stone; fiber; iron; minerals; mining; quarrying; solid waste.

First of all I would like to state that I am not a medical doctor and, therefore, will not attempt to evaluate the problems of real or imagined health hazards involved with exposure to minerals. I am a mineralogist and I am here today representing the American Mining Congress to do five things, as follows:

1. Remind everyone of the value of the mining industry to the overall U.S. economy;
2. Point out the widespread geographic distribution of the various segments of our industry;
3. Describe briefly the almost universal occurrence of certain minerals of interest in essentially all mineral deposits;
4. Discuss the confusion resulting from the erroneous and unwarranted expansion of the term "asbestos" to include many non-asbestiform minerals; and
5. Illustrate the inevitable economic disaster the enforcement of the present and/or proposed regulations will have on mineral related industries.

With regard to Item 1, it is probably unnecessary to spend much time pointing out to this audience the value of mineral products to the U.S. economy, but at times all of us forget how important these products are to our everyday life, and most of us are unaware of the quantities we consume in our various work and leisure activities. Figure 1, prepared by the Bureau of Mines, U.S. Department of the Interior, illustrates rather graphically our dependence on materials derived from the mining and related industries. Without detailing the extreme diversity of uses of the basic commodities, it is obvious that the mining and mineral based industries are the very backbone of the economy of this country.

At a time when our nation has finally become aware of the serious problems it faces in the general overall economic situation and in the specific areas of energy and raw material supply, it seems very strange and unfortunate that a small but very vocal segment of our population would insist on legislation that would directly increase the already great burden on the industry responsible for both. This is particularly unfortunate since the intent of the original and subsequent legislation regarding asbestos was to protect workers from excessive exposures in industrial environments where these exposures have been shown to pose a health hazard. No similar hazard has been shown to exist with exposures to the mineral dusts associated with normal mining and mineral handling industries now threatened. Secondly, the widespread geographic distribution of the various segments of our industry has been adequately discussed by several previous speakers - Drs. Zoltai, Ross, and Campbell in particular. To my knowledge, no state is without some form of mining operation, although the type and concentration of mining activities vary greatly.

To illustrate the economic contribution, both in product value and jobs, and the distribution of activities, I have chosen three of the many critical segments of our industry - iron mining (Table 1), copper mining (Table 2), and stone quarrying (Table 3). All the data presented were obtained from U.S. Department of the Interior documents, principally the Commodity Data Summaries 1977 [1]¹.

Table 1. Iron mining industry (1976 estimate).

Mine Production - Ore	78 Million Tons
Value - Ore	1.8 Billion Dollars
No. of Major Companies	86
Major Mines	60
Concentration Plants	44
Pelletizing Plants	20
Employment - Mine/Mill	20,500
Geographic Distribution	
Minn., Mich., Calif., Utah, Wy., Mo., Penn., N.Y., Tex., Wisc.	

¹Figures in brackets indicate the literature references at the end of this paper.

ABOUT 40,000 POUNDS OF NEW MINERAL MATERIALS ARE REQUIRED ANNUALLY FOR EACH U.S. CITIZEN

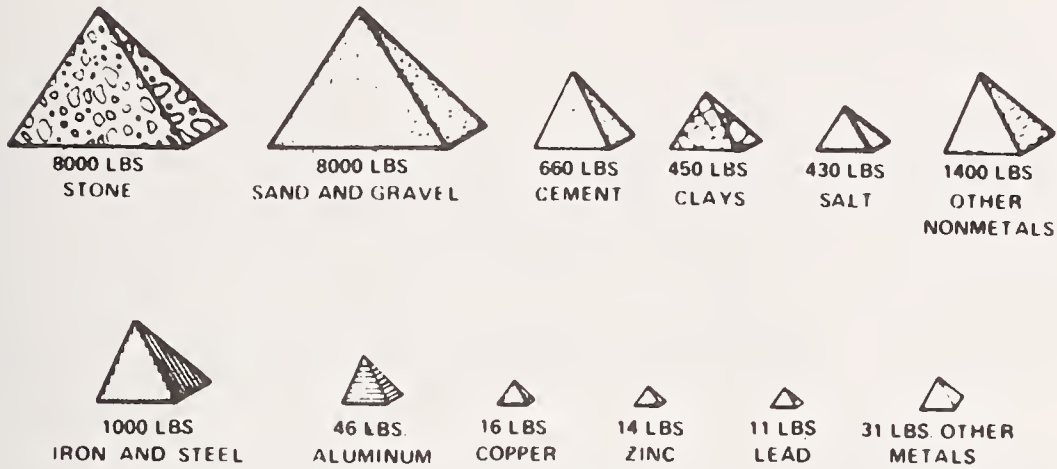

PLUS



TO GENERATE:

ENERGY EQUIVALENT TO 300 PERSONS WORKING AROUND THE CLOCK FOR EACH U.S. CITIZEN

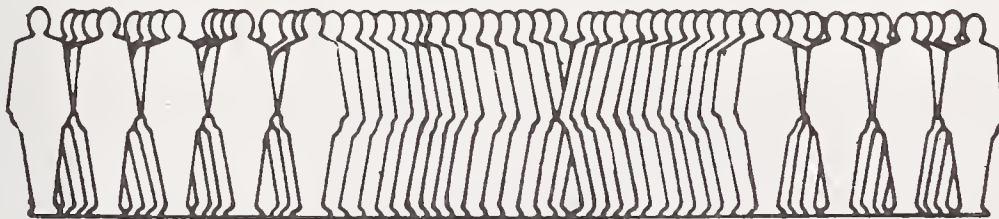

U.S. TOTAL USE OF NEW MINERAL SUPPLIES IN 1975 WAS ABOUT 4 BILLION TONS !

BUREAU OF MINES
U.S. DEPARTMENT OF THE INTERIOR

Figure 1. Mineral use in the USA.

Table 2. Copper mining industry (1976 estimate).

Mine Production	1.6 Million Tons
Value	2.25 Billion Dollars
No. of Major Companies	15
No. of Major Mines	25
Employment - Mine/Mill	34,000
Geographic Distribution	
Ariz., Utah, New Mexico, Mont., Mich., Nev., Mo., Tenn.	

Table 3. Stone quarrying industry (1976 estimate).

Crushed Stone

Production	888 Million Tons
Value	2.02 Billion Dollars

2000 Companies - 5400 Quarries - 49 States

Dimension Stone

Production	1.5 Million Tons
Value	104 Million Dollars

300 Companies - 460 Quarries - 43 States

Total Employment - Quarry/Mill 54,000

It should be emphasized that all data presented are for the mining and milling industries only and do not include the value added by the subsequent beneficiation and ultimate fabrication and use of these materials. This added value, the number of dependent industries with the required employment, and then geographic distribution dwarf the numbers listed in these tables. For example, while the iron mining industry produced ore valued at 1.8 billion dollars in 1976 and employed slightly over 20 thousand workers, the iron, steel, and foundry industries had a combined output valued at an estimated 42 billion dollars and employed nearly three quarters of a million workers.

Several previous speakers have thoroughly discussed the third point on my list, that of the almost universal occurrence of those mineral groups of particular interest to this workshop - the chain silicates (amphiboles and pyroxenes) and serpentines. These minerals are present in varying but significant amounts in all three of the mining industry segments mentioned above, as they are in essentially every other mining operation in the United States, and for that matter the world. I would estimate that the chain silicates and serpentines make up about 15 percent of the earth's crust.

All of the geoscientists, and several others who have addressed this audience, have made it very clear that the mineral species under discussion may occur in nature in both non-asbestiform and asbestiform morphologies. They have also pointed out that the asbestiform varieties are very rare relative to their normal non-asbestiform counterparts,

and in some cases, such as with tremolite and actinolite, the asbestiform varieties are not available commercially and probably exist only in specimen quantities. The lack of understanding of this fact has led to the confusion surrounding the use and misuse of the term "asbestos." As I pointed out in an earlier article [2] the majority of the regulatory agencies developed standards without making use of readily available mineralogical expertise. With the publication of the OSHA Asbestos Standard in July 1972 [3], which listed six (6) minerals as being "asbestos" regardless of their morphology, using the single criterion of aspect ratio (>3:1 length:width) for classification as "fibers" or "non-fibers," the die was cast for all these intervening years. OSHA wrote its own mineralogical dictionary and most other agencies merely followed suit.

Professor Zoltai, speaking earlier in this workshop, most elegantly stated the need "for an unambiguous, interdisciplinary language" in order that medical researchers, regulatory personnel, analysts, and geoscientists can speak together and understand each other. Drs. Zussman, Ross, and Campbell emphatically supported this need. It is my opinion that it is absolutely necessary that the materials being investigated, whether commercial, industrial, or environmental, be correctly defined and thoroughly characterized by geoscientists in order that medical researchers will know what they are testing and evaluating. It is only then that we will know the nature of the mineral particulates which constitute health hazards and be able to delineate the type and degree of such hazards. It does make a difference!

The last and key topic of my presentation is to shed some light on the economic disaster in store for the mining industry if the present, let alone proposed, "asbestos" regulations are enforced.

First of all, who is involved? Not just asbestos miners and millers, not just the small operators (although they would undoubtedly be the first to be hurt), but essentially every mining/milling operation, every taxpayer, every citizen.

At present, OSHA, EPA, and, in practice, MESA consider all mineral particles three times longer than they are wide (3:1 aspect ratio) as "fibers" regardless of whether they grew as fibers or were broken into cleavage or fracture fragments. They list six (6) minerals as being asbestos; chrysotile (a truly fibrous serpentine polymorph) and five amphiboles: crocidolite, "Amosite," anthophyllite, tremolite, and actinolite. Of the agencies mentioned, only MESA states in its regulation that the last three names (underlined) are used for both non-fibrous and fibrous forms and must be qualified by the addition of the term asbestos; i.e., anthophyllite asbestos, etc. The others appear to believe that all forms of these three are asbestos, the only difference being that when they are not long silky fibers, but short stubby cleavage fragments, they become "non-commercial asbestos" [4], another term of convenience created by government bureaucrats.

These regulations, as pointed out by the chairman of this session, were proposed and promulgated under intense public and political pressure in a panic situation without, I'm sure, any intent or realization of the scope of the problems created by the inclusion of mineralogical errors. The mining industry has been faulted because they failed to speak to the issue at the time of the OSHA asbestos hearings in early 1972. Only the asbestos segment of the industry was represented. The fact is that the rest of the mining industry had no need for input at that time because they did not have asbestos in their ores or products. It was only after an erroneous definition was promulgated that the industry gradually became aware that what they knew to be common rock-forming minerals present in essentially all mining operations had suddenly become "Government Asbestos."

Reaction to this problem has been slow in coming, basically because of the great immediate pressure to pour vast amounts of time and money into complying with other government regulations regarding air and water effluents, changes in equipment and material handling procedures, etc. Another reason for a slow reaction, however, has been the general belief that the regulatory agencies, once informed of their error, would immediately seek proper mineralogical information and make the necessary corrections to limit their regulations to deal with the known hazards of true asbestos. This action not only hasn't taken place, but the agencies have continued to propose and/or promulgate regulations aimed at both lowering the permissible level of "government asbestos" and

including more and more mineral particles which bear no resemblance to true asbestos, but which meet the sole criteria for a fiber (three times longer than they are wide).

In the five years since the issuance of the OSHA Asbestos Standard we have seen the permissible levels decrease from 5 fibers/cm³ to 2 fibers/cm³ to a proposed 0.5 fibers/cm³ and a recommended (NIOSH) 0.1 fibers/cm³. Philosophies on measurements are shifting from expression as fiber numbers to weight of total fiber in nanograms/m³. This latter expression could allow for over 90 percent of the total fiber weight to be accounted for by one "fiber". No company or industry can develop a program to improve working conditions when faced with such constantly changing requirements. The zero level or lowest detectable amount philosophy is totally impractical and impossible to achieve.

One clear and very disturbing fact stands out. A huge effort in time, energy, and money has been expended in medical research, development of analytical equipment and techniques, legislative efforts and interminable court battles, all before the material to be studied, detected, quantified, and regulated has even been properly defined or characterized. The cart has been placed before the horse. This situation must be reversed before an additional, and in many cases unbearable, burden is placed upon the backbone industry of the U.S. economy.

My company, R. T. Vanderbilt Company, Inc., has experienced the results of this confusion in "asbestos" definition and characterization. We are obviously not alone, but we have been directly or indirectly involved in two cases where "asbestos" citations were issued by OSHA on preliminary findings. These citations were contested, and in both cases all allegations regarding "asbestos" were dropped before trial when subsequent analytical data failed to show sufficient evidence of a violation of the asbestos standard.

The overall economic impact of enforcement of the present asbestos regulations using the present "asbestos" definitions covers such a broad range of mining/milling activities that it would be impossible to even mention them all in the time or space allotted. I have chosen to illustrate the problem with the discussion of only one factor, which affects the majority of all mining operations, the disposal of waste materials. All metal and many non-metal mines are confronted with this task. In those cases of industrial mineral operations where there are no tailings, since the total material mined becomes the product, the impact of asbestos regulations becomes more complex and acute. In these instances the mining companies and their customers often must comply with the requirements of OSHA, FDA, CPSC, etc., in addition to meeting the regulations of MESA and EPA.

In Table 4, I have selected a typical porphyry copper mining operation and only one of the many "asbestos" regulations governing it. This type of ore body is associated with varying but significant quantities (~2-6%) of amphiboles, present as the normal non-fibrous variety. Assuming a daily ore production of 60,000 tons containing 3 percent amphibole, approximately 58,000 tons of waste containing 1800 tons/day of "government asbestos" would be dumped as waste, most of it meeting the 3:1 aspect ratio, and therefore asbestos. Such a mining operation normally has a 2:1 stripping ratio, thus 120,000 tons of overburden containing (~5 percent) 6000 tons of "government asbestos" is also blasted, moved, and dumped every day, making a total of 7800 tons/day to be dealt with. The one regulation I referred to is the EPA regulation requiring all active mine dumps containing over one percent "asbestos" be covered by at least six inches of compacted non-asbestos containing material at least once every 24 hours [5]. Assuming that it was possible to find soil, pulverized rock, etc. which was free of "government asbestos," and assuming that the farmers or environmentalist groups, etc. would allow it to be moved, it takes little imagination to visualize the costs involved with digging, transporting, spreading, and compacting some 18,000 tons/day of this material. This is the estimated amount of cover needed for a waste dump of 180,000 tons of tailings six feet deep covering 15 acres.

The hypothetical case presented in Table 4 for a copper mining operation will hold true for most other metal and some non-metal mining activities by substitution of the proper numbers. Remember that this case discusses only one factor in any mining operation and only one regulation. The added costs of this one item alone would be prohibitive in most cases, opening the door for our country's dependence on foreign sources for more and more of our raw materials.

Table 4. Copper mining - typical operation.

Material Handled

Ore Mined	60,000 Tons/Day
2-5% Amphiboles	1,800 Tons/Day
Tailings Dumped	58,000 Tons/Day
3-6% Amphiboles	1,800 Tons/Day
Overburden Moved	120,000 Tons/Day
5% Amphiboles	<u>6,000 Tons/Day</u>
TOTAL AMPHIBOLES	7,800 Tons/Day

Area of Dump (6' Depth)

Tailings	5 Acres/Day
Overburden	<u>10 Acres/Day</u>
TOTAL DUMP AREA	15 Acres/Day

Amount of Cover Required - "Asbestos" Free (6" Depth)

Tailings	5,000 Tons/Day
Overburden	<u>10,000 Tons/Day</u>
TOTAL COVER	15,000 Tons/Day

In order to remain viable and serve in its proper place in the U.S. economy, the mining industry needs the following conditions with regard to "asbestos":

1. Correct mineral definitions developed by geoscientists;
2. Adequate analytical methods and qualified analysts for thorough characterizations and quantification of mineral particulates;
3. Medical data on the health effects of such well characterized materials; and
4. Realistic exclusion levels for those materials which will afford acceptable risk.

References

- [1] Commodity Data Summaries - 1977, Bureau of Mines, U. S. Department of the Interior.
- [2] Thompson, C. S., Asbestos In Your Future, Mining Congress Journal, 62, (12) (December 1976).
- [3] Federal Register 37 F.R. 11320-11322 July 7, 1972.
- [4] Federal Register 40 F.R. 47652-47665 October 9, 1975.
- [5] Federal Register 40 F.R. 48292-48302 October 14, 1975.

Discussion

NOTE: Discussion of this paper was included in the General Discussion at the end of this session.

GENERAL DISCUSSION OF REGULATORY ASPECTS

A. WYLIE: I had some comments on the use of the petrographic microscope for distinguishing asbestos. Mr. Dixon gave an eloquent presentation on the many different tests that could be made to describe mineral particles, but no reference was made to the unique optical properties that asbestos has. I've examined many samples of different kinds of asbestos from many localities and they have a characteristic parallel extinction. This is not found in the textbook by Kerr on Optical Properties of Minerals; it is alluded to in Deer, Howie, and Zussman for crocidolite; it is not well described in the literature, but true asbestos, true amphibole asbestos has parallel extinction and, in its optical properties in large size samples (I don't mean air samples or water samples, but samples you can get a little data on) it does not resemble ordinary amphiboles. This criteria has never been mentioned and I think people who are involved in amphibole characterization should be aware of it. I am not referring to anthophyllite asbestos. I am referring to the monoclinic amphiboles that have characteristic parallel extinctions in all orientations. It is not an orientation problem. You can take these fibers, tap them over, they roll around; you can see that the parallel extinction is maintained. This is not just my observation. You'll find it scattered in the literature, and I've spoken to several other optical microscopists here who have done similar work and I think that you should be aware of this in your characterization.

W. DIXON: Crysotile also has the nearly parallel extinction.

WILEY: Yes, but I am talking about the monoclinic amphiboles, crocidolite, amosite (which, by the way, is really both grunerite and actinolite as it is commercially mined), actinolite asbestos, and some forms of tremolite asbestos. These are monoclinic amphiboles which, according to the textbooks, should have inclined extinction, but do not when they have a true asbestiform habit.

DIXON: What would happen then is that a mineral which is thought to be anthophyllite might actually be tremolite in that kind of an error situation.

L. SWENT: I'd like to comment a bit on a factor that was mentioned at the beginning of this Workshop, but has not received much discussion since, although Aurel Goodwin may have been referring to it without naming it.

In the study of biologic effects we must at all times remember the additive effects of asbestos fibers and tobacco smoke on the individuals being studied.

Virtually all studies in which smoking habits have been taken into account show that the biologic effect of asbestos fibers on non-smoking individuals is markedly less than on smokers, and that the elevation of health risk for the non-smokers is small.

Regulatory agencies are faced with a choice between two philosophies in generating regulations and permissible limits of exposure to fibers. These two philosophies are:

1. Set the permissible levels of exposure to fibers so that such exposure is safe for non-smokers.
2. Set the permissible levels of exposure to fibers so that such exposure is safe for smokers.

The first philosophy is a much easier one to regulate and administer, and the individual is left to decide whether not to take on the risks of smoking.

The second philosophy presents many complex problems. It in essence requires the regulators and industry to take responsibility for most of the problems and risks arising from smoking. The cost of doing this, in the long run, will be passed on to the public.

This cost will be very great and will be very inflationary, especially if non-asbestos fibers are regulated.

I urge the regulatory agencies to consider seriously the merits, demerits, and equity of each of these two philosophies and to choose the philosophy of basing permissible exposures on the biologic effects in non-smokers.

Educational campaigns, health risk notices, anti-smoking campaigns, etc., should be the tools used to combat the effects of smoking.

I. STEWART: Phil McGrath made some comments about the scanning electron microscope and some of the conclusions that were derived at the Penn State meeting. Proceedings of this meeting are available, and I suggest that if you were not present you should get this and perhaps get a more objective feeling of what the consensus of the participants was. In connection with the size of the fibers on the SEM and TEM, the large fiber he showed was, based on his pore size of 0.4 μm , approximately 0.1 to 0.2 μm wide, which would have made it maybe 50 to 100 μm long. Dr. Asher referred to the materials shed from filters showing a maximum diameter of 0.25 μm and maximum length of about 70 μm , and these measurements were obtained with the transmission electron microscope. Yes, it (i.e. the TEM) can handle large material.

P. McGRATH: This was also confirmed using the scanning electron microscope.

STEWART: I don't know what work you did, I'm sorry..

McGRATH: One of these fibers measured 70 nanometers in diameter. This is an evolutionary process; for example, at the Penn State Conference last year, Don Beaman felt more sure of his ability to identify chrysotile asbestos fibers than he reported at this conference the other day.

STEWART: At this time I think you should be fair and say that there has been a decrease in confidence as well in the energy dispersive systems...I think...

McGRATH: I think the resolution of the SEM-EDXA system is increasing. I don't believe any system in operation today will give us all the information we need and it is necessary to develop the SEM-EDXA system - not just stay with TEM-SAED, which is essentially the same system we have been using for ten years. I think that many transmission electron microscopists who don't routinely do scanning electron microscopy have a tendency to ignore the dramatic changes in scanning electron microscopy. We routinely identify particulates, including asbestos. Although we can't always completely characterize them, we realize enough information to make decisions relative to these products.

STEWART: You have run nicely into my next comment which was on the nationwide survey on water, which we did. The feature which was evident in asbestos from natural sources was that this tended to be unit fibers, approximately 300 Å in diameter. This was also the sort of size range that we are seeing in ambient air. I'm not talking about material from point sources now. Three to four miles down stream from a point source it is already breaking up to the two or three unit fibril level, and the identification of this, I think, cannot be confidently handled with an energy dispersive system. Now I don't want to go into the whole argument, but you and I do this on a friendly basis every year as you say (at least I hope it is still friendly).

But I would refer people to the review paper that was done by Clay Ruud, which appeared in Micron and was very similar to what he gave at Penn State. Also the work that Rick Lee presented at Penn State on the energy dispersive systems and on the possibilities of error, purely and simply, on the complex chemistry of these materials.

McGRATH: We have to be pragmatic about this. Using TEM-SAED you cannot routinely do any kind of regulatory or survey work because of the cost and problems of sample preparation. Don Beaman said it cost about \$1200 per sample to do a complete analysis. He also said he could only do about five samples per week in his laboratory.

STEWART: Well that figure on his TEM is substantially higher than we charge, and it is also twice the price of some work done on a SEM I heard someone quote, which is again substantially higher than the figure we charge. I am not going to be commercial and say the figure we charge, but I don't think that that \$1200 figure is realistic.

McGRATH: There is a recent EPA report by the Aerospace Corporation comparing TEM and SEM analysis of commercial asbestos fibers. They reported both methods were essentially equal in surveying a population of fibers but that the SEM costs were much less than the cost per TEM analysis.

STEWART: If you were to use the commercial asbestos fibers so you have a standard where you know what you are dealing with, or if you can come up with a technique which will indeed separate the asbestos and ensure that you have only asbestos mineral fibers there, then I will grant you that the SEM could be used as a screening tool. It could indicate fibers that could be asbestos, but I do not think you can positively identify them on the SEM.

McGRATH: We also heard Fisher and Lee report to this conference using a beautiful method to index SAED patterns, but that is a research tool, not a method for routine analysis.

D. SARVATTI: I have one comment in relation to the occupational health standard. Those of you mineralogists and analysts who have been insisting that hygienists and medical people like myself should change our approach in evaluating occupational exposures on the basis of this aspect ratio, I should caution you with one very important point: That analytical technique which we currently use is related to the incidence of disease. If you change the parameters of analysis you may change that relationship and find yourselves with a lower standard. So think about that before you decide on a 10 to 1 or a 5 to 1 or 100 to 1 or a 1 to 1 aspect ratio. It doesn't matter what that aspect ratio is, just so that everybody is using the same one and that there is some relationship to the disease incidence we are trying to prevent. Question for anyone from the Bureau of Standards: I've heard no comments these three days about the NBS report that was requested by OSHA and published in April of this year, and I would like someone from NBS to tell me why they did that study the way they did, especially in light of all the information that we have had here these last three days?

K. HEINRICH: In the first place it would have been difficult for us to put in the report the information we have gotten in the last three days. On the other side I don't know quite what you are referring to with respect to this report, but this was a report an agency asked us to do, and we did it the way we understood the request.

C. GRAVATT: If I may clarify that a bit, the request asked us to perform an analysis according to the procedures and methods specified in the Federal Register. Whether we liked it, or you liked it or not, that locked us into phase contrast microscopy, by legal regulation. If NBS had been asked to measure the eighty samples by anyway it wanted to, we probably would have never done it completely by phase contrast microscopy. However, NBS had to do it that way to respond to the request. The NBS report did not imply that OSHA only uses that one method and technique. They use a number of techniques as specified in the presentation here today by Dixon, which provide them with further information. However, by just the nature of the request, we had to do it the way we did.

SARVATTI: The report, as it stands today, now causes OSHA at least to consider encompassing a number of other minerals under the definition of asbestos, and this is what is so disturbing to those of us who have to deal with this kind of mixture of compounds, and mixture of minerals in the industrial setting. My impression of what Dr. Corn requested the National Bureau of Standards to do (I read that entire report from cover to cover about seven times and I still don't understand it) was to determine whether or not certain industrial talcs currently in use today contain commercial asbestos, one of the six minerals that are defined in the Federal Register. Now it seems to me to do that you have to follow some of the procedures that Mr. Dixon described before you do any kind of fiber count. One of the things that get lost in this whole discussion was brought out by Mr. Dixon. If an industrial hygienist goes out to take an air sample, the sampling method that you use depends on what is there in the factory to begin with. You don't go out and

sample mica using the asbestos sampling technique. Before you go out and take an air sample you determine whether or not one of the six minerals that is included in the asbestos regulation is present and then you take an air sample and you make the assumption that whatever is present in the air is asbestos, and make the particle count accordingly, and then set up your control parameters. But it's just disturbing to me to find reports of fibrous material in a variety of minerals, which people here have been telling us, well yes, maybe it's present, maybe it's not. It's all in how you define a fiber to tell whether or not it is present.

DIXON: We specify in our writeup of the method that any fiber which is known to occur in the environment in which asbestos is used is considered to be asbestos in the absence of other information. The method or technique of getting this other information is left as an open question for people to use the best scientific method they can find to find out what those other fibers are.

A. LANGER: Mr. Chairman, I agree with the thrust of Dr. Thompson's presentation. I think that he is quite correct in suggesting that we may be dealing with different substances which may have different biological activities. This concept is more than just recognized in the United Kingdom where they have two different asbestos standards: One is for crocidolite, which is 0.2 fiber per mL; and one for the other asbestos fibers at 2.0 fibers per mL. So there are workers who support the position that fibers possess a range of properties and subsequent biological potential.

Mr. Swents remarked that smokers have much greater lung cancer risk. That is absolutely correct. There is a synergism between cigarette smoking and asbestos fiber inhalation, now well documented in a number of studies, demonstrating the potency of such combinations in inducing lung cancer. Perhaps the mining industry itself could contribute to the health and protection of their workers if they were to insist that they don't smoke. That would mean that even if these particles were as potent as asbestos you would decrease the associated excess cancer risks by almost one half.

M. BROWNSTEIN: For users of the refractive index (RI) oils who aren't totally aware of their composition, a word of caution is in order. In the past they certainly have been formulated using PCB's (polychlorinatedbiphenols). From various studies it has been observed that these materials are carcinogenic in animals; they cause birth defects in animals, and further that they are absorbable through the skin. Now in time, as the products are reformulated and PCB RI oils disappear from your stock and your shelves, this problem will go away. In the meantime a caution for those who aren't aware of this; caution should be exercised in handling these materials, and also in disposal. In time, with the prohibitions that are coming in on PCB use, say for example in Canada (I'm not familiar with the American regulations), this problem is going to go away. But for now if you have oils and are using them, you should watch how you are doing it.

DIXON: Would you care to comment on the volatility of these dispersion oils, how much is getting into the air?

BROWNSTEIN: I'm not familiar with this aspect, but I presume they have quite low volatility. One of the greater problems would presumably be handling, if you get it on your hands. A year or two ago, this would have been a much greater problem in that some of the microscope immersion oils were formulated with PCB's, which would be used by lab tech's in large scale. I know in Canada this type of usage of PCB's has been banded. I believe most of the manufacturers are reformulating or have reformulated so it shouldn't be a problem in the future. It is a question of getting it on your hands and absorbing it through the skin.

J. MARTONIK: Is there a trace of vinylchloride monomer in the PCB?

BROWNSTEIN: No polychlorinatedbiphenols themselves. Depending on which refractive index you have, some of them have been up to 100 percent PCB. It isn't a trace contaminant.

J. MACLEAR: I'd like to add a little bit to the discussion of methodology for asbestos analysis and to ask that people from EPA (Dr. Anderson) and at OSHA (Mr. Dixon) and the FDA consider the possibility that it might be best to keep the options open as far as techniques are concerned rather than adopting a standard technique for the following reasons. I understand that Chuck Wright at Penn State, at our laboratory, and Dr. Fisher of U. S. Steel, are all in the process of developing automated methods which could lead to asbestos analysis using an image analysis computer system which also detects the x-ray information at the same time and uses this information to distinguish particles not only by size and shape but by chemical composition as well. Whereas this hasn't been applied yet extensively to asbestos, there are several groups that I know of who are working toward this. It is not a matter of hardware but a matter of software now, getting the right programs in and getting them working right. To eliminate the scanning electron microscope, for example from the EPA, regulation would eliminate basically the application of a technology which may promise to gather data about a thousand times more efficiently than we can presently do it. I think this could make an enormous contribution both to the accuracy and to the surveying capability of a very complex analytical problem.

N. TATE: I'd like to comment on the reference to LANCET article on talc. That article says that, with the specification now agreed, talc will present no health hazard in the future. I would like to say that this is the British way of handling these things: introduce measures to deal with a hazard, while denying that the hazard ever existed.

Following the DONIACH study published in 1975 which showed asbestos bodies in the lungs of women dying of breast cancer, we have been asking questions about talc.

There undoubtedly have been fibers in talc in the UK during the last year. I am delighted to hear that they are now saying in the future we will be protected by the use of this specification.

I would like to make a few other comments. Firstly, one of our biggest pharmaceutical companies is now producing a non-asbestos filter for home brewing, which should set people's minds at rest on the use of filters. After all, if you are worried, it is better to use something that you feel is safe.

Secondly, when you have made your regulation, will you look at enforcement, because this has been our biggest problem area at home. At the recent public evidence hearings held by our Government Advisory Committee on asbestos, our biggest company, Turner and Newall, presented data which showed that for only 58 out of a work force of 2000 could they guarantee that exposure had been to only the official limit of 2 fibers a cubic centimeter. For the rest of their workers they could not claim that they had kept within the regulations.

Other companies are not using asbestos now. Our CEGB won't use it; the Post Office won't use it; British Rail won't use it. When they are dealing with existing asbestos, workers are demanding and getting, in those industries, a better level. For existing asbestos, the Post Office works to 0.2 fibers a cubic centimeter; British Rail, when stripping blue asbestos from our passenger carriages, is working to 0.05 fibers cc. If they can do it, so can other people.

However, the biggest step we are taking is to train safety representatives amongst workers. I even heard recently that the Post Office, which put out delagging work to contract and is bound to take the lowest estimate, found that two men with little hammers went to do the work, without any protective equipment. It was only a Post Office worker, on that site, who recognized the danger and was able to save his colleagues from exposure.

Now, if we are going to train safety representatives, then please give us monitoring equipment that they can use. You have produced the technology to get us to the moon; find us simple monitoring equipment which will give men peace of mind when they are using asbestos.

Many of them don't want to cause unemployment by banning it, but they want to know that they are not taking a cancer risk home to their families if they use it.

E. NORTON: I'm a reporter for the Syracuse Post Standard, but I've been here for these three days on vacation as an observer because I need to learn as much as I possibly can as a reporter in the area where talc is mined and has been under question. I am responsible for trying to explain to the miners and to the people of my area, which is very economically depressed, why one of our finest, most modern industries, employing the latest dust pollution controls is losing its competitive position on the American market, because of OSHA regulations of it. I'm trying to explain why it is subjected to a barrage of press attacks based on quotes from government officials in Washington; why this talc product and this talc only has been singled out by OSHA and other environmental health agencies at the federal level for regulating rules that were designed to protect us from asbestos. Our miners know that their mining product is not sold at asbestos prices. I found no mineralogist or geologists in the universities in my area or at this gathering who would include non-asbestiform tremolite, actinolite, or anthophyllite under a list of asbestos minerals headed by chrysotile. But OSHA has done it for five years and has based regulations and industrial enforcement on that definition and on the size and shape definition. Mr. John Dement of NIOSH characterized that size and shape 3 to 1 aspect ratio as an arbitrary figure yesterday. I heard an expert from the Colorado School of Mines and others say that asbestos tremolite is a rarity and asbestos actinolite is almost nonexistent. On the other hand, I heard John Dement say yesterday that five percent of the talc in the United States is contaminated with asbestos. I've heard numerous references to a study of chrysotile and the other three asbestos minerals, but apparently there are none except a Klinefelt study on these three non-asbestos minerals. Klinefelt has been used on both sides to prove whatever anybody seems to want to prove. So I find it inclusive. A question from the representative of the Department of Labor yesterday asked for the toxic quality of talc and there was no one who answered him. Pneumoconiosis has been a problem in northern New York mines, and our talc mines for 100 years. We have three doctors in the area who feel that cancer is not a problem and never has been a problem, who have noticed the phenomena that no new cases of pneumoconiosis are being seen coming out of employees who are employed only in our Governor Talc Mine and have never been employed in the older ones of the area. This is a phenomena; maybe it's not based on studies. Because of all of these contradictions and for the sake of the 180 miners who work in my area and who read my writing, for the economic health of our community which receives annually an estimated six million dollars through this company in salaries and goods purchased, and also gives us a great deal of money for our tax base to help educate our children and for the survival of this industry, I feel that the National Bureau of Standards should be commended for this effort to bring some intellectual integrity into the situation. I ask that those present support the National Bureau of Standards in its efforts to make a two year study to really get into this business of identification, and I ask that until this study is completed or until the definitive medical studies show the hazard of tremolite talc, specifically, that there be a moratorium on what they are doing to our talc mines.

MARTONIK: Are there any comments on that statement?

NORTON: I'd appreciate any comments.

MARTONIK: Thank you, I don't know if Ray McClure of the Health Compliance Programming is in the audience; he might want to make a comment.

R. McCLURE: I don't know what comment I can make to the last participant. I would like to say something quickly though about medical examinations for asbestos. That is a part of our regulations and other people have asked questions about that. Our present policy is under review by the Assistant Secretary. The present policy is that a medical exam starts at a tenth of fiber per cc. Another way of stating a tenth of fiber per cc is a hundred thousand fibers per cubic meter, the fibers being longer than 5 μ m as checked by phase contrast microscopy. These are fibers generated or released at the work place, of greater than 3 to 1 length to width ratio. In a recent District Court case (GAF Company versus the Occupational Safety and Health Review Commission), the court upheld the Review Commission decision of any exposure as a beginning point for medical exams. I do not know if GAF has or will appeal this case. In my opinion, background asbestos levels not released, or generated, due to the work place should be subtracted from sampling data. This opinion is not accepted by all those concerned in OSHA. There may be a background problem due to outdoor ambient air levels of asbestos, in some cases. In my opinion,

periodic chest x-rays of exposed workers does not constitute an unnecessary risk to the worker.

MARTONIK: I want to add one more thing. Since I have been employed by OSHA for the last 18 months, the Agency has in no way gone out to seek a certain company, to single out that particular company, and enforce its regulatory authority. The agency does seek high risk industries in general, and perhaps may exert some effort out of the ordinary where it is deemed that this industry is associated with high risks. But we have not gone into any one of those industries for the last 18 months and chosen a particular company or companies that should be inspected or would be inspected.

P. DeNEE: I have a comment and a question. A comment on Phil McGrath's paper: You mentioned that asbestos and other fibers are more difficult to "see" in the SEM if they are on membrane filters such as those made by Millipore or Gelman and that they should be put on Nuclepore-type filters in order to be seen. I disagree with that conclusion. In the paper that I presented yesterday, I showed how to "see" asbestos fibers on a fibrous type filter in the SEM by using the Backscattered Electron Imaging. The only requirement is that the sample be carbon coated rather than heavy metal coated to prevent specimen charging. (See Philip B. DeNee, "The use of Backscattered Electron Imaging in the Scanning Electron Microscope for the Detection of Microfibers in Airborne Dust Samples and Biological Tissue," published in Proceedings of the First FDA Office of Science Summer Symposium, the Symposium on Electron Microscopy of Microfibers, Penn State University, Aug. 23-25, 1976, U. S. Govt. Printing Office, Washington, D. C., Stock No. - 01701200244-7. Presented at NBS Workshop but not reported in these Proceedings.)

There seems to be some confusion on backscattered electron imaging. Up to a year or so ago, backscattered electron detectors were not really that available for scanning electron microscopes, but they are now available as an accessory. They are at the same state-of-the-art as energy dispersive x-ray detectors were a few years ago since they are just beginning to be put on scanning microscopes. There is one company that I know of, ORTEC, which is making them commercially, and I think they will be available from other companies in the future. Professor White at Penn State, and Dr. Rich Lee of U. S. Steel have also used backscattered electron detectors for detecting particles. Backscattered Electron Imaging is an important way of "seeing" the fibers against a background; a nice way to pick them out.

The question I have is for S. Thompson and Dr. A. Goodwin. Are there engineering methods available for reducing the number of asbestos fibers seen in the mining and processing industry? Since the Coal Mining Industry has been able to reduce their dust levels, there should be technology applicable to the non-coal mining and processing industries as well.

S. THOMPSON: There is no question that there are dust collectors and many mechanisms to reduce the dust under any conditions or circumstances. Many of them are in fact used in all mines and used to a great extent. I'm pointing out that the economics of this can, in order to get to the dust levels that have been suggested by many people who are following the continued zero type level approach, make it really impractical and impossible to engineer toward them. The mining industry is constantly working on the dust problem and I know that MESA reports are constantly coming out on reductions in dust control, and the improvements that have been made under their jurisdictions and their guidance. I think the mining industry is continually trying to do a better job on it. It gets a little difficult when you try and translate or transfer realistic occupational levels, from the controllable indoor processing plant, to the great outdoors. The mills are somewhat easier than the great open pits, where you are at the mercy of nature. But we are trying, and we spray and wet drill, so this is good.

GOODWIN: I really don't have much to add to what he says. We have not had real difficulty with mine operators, and commercial asbestos producers getting in compliance with fine fiber regulation which we have today. Many of them, probably most of them, actually are anticipating reduction to two fibers and are already to date on that level. As Slim indicated in his presentation, these asbestos producers are not nearly as large as the copper mine operations. If you want to talk about feasibility to handle asbestos at very low levels, you can get things like glove boxes and that sort of stuff, and you start

escalating the cost of the material. I can't imagine how to operate a copper mine of sixty thousand tons a day or anything like that where you can bring a railroad car full of ore and dump it; how do you put a dust collector on that? Now there are things you can do; you can isolate the individual who might have to be there and air condition his cubical or whatever, that sort of thing, and that's done. The feasibility of getting whatever level you want depends upon the level.

P. TAYLOR: I'd like to direct my question to Willard Dixon. Would you care to comment on something in the light field optical method? Would you comment on the very poor background or very poor clearing properties of the Millipore filter?

DIXON: The Millipore membranes lately have been a lot poorer in quality than they were several years ago. The Millipore Corporation is aware of this problem, and OSHA has taken the step of reviewing batches of membranes which are going to be purchased before purchase. I might make the additional comment that the Gelman Corporation has developed a membrane which clarifies just as well as the Millipore membrane does, with, I think, very few fibers in it, and we are in the process of evaluating the Gelman membrane for use in addition to the Millipore membrane. The best thing that you can do when you get a membrane that has this kind of background is to look at the membrane structures very carefully to make sure that you are not counting membrane structures rather than fibers in this type of situation. When we encounter this we inform the industrial hygienist that this has occurred and warn them not to use that particular batch of membranes another time. I've sent out a field memorandum requesting that all membranes coming in for analysis in the future shall have the lot number of the membrane with the analysis sheet so we can identify those bad batches of membranes which are in circulation.

TAYLOR: We have done extensive studies on the filters themselves and we have found that even that within the same lot number you will have bad filters and good filters. I have sent quite a few samples back to Millipore showing them blown up pictures of these, and actually sent along the samples of the filters themselves and we have gotten no comment back from the company. I will say that we have looked at the Gelman's and they are not any better.

DIXON: What I am hoping is that by getting a competition going between the two companies, that we can get some benefit from the competition. Hopefully one of them is going to be able to produce a superior quality membrane to what we have been getting in the recent past.

TAYLOR: My feeling is that if you are going to go exclusively to the optical system that you are talking about, you are going to have to have very experienced people looking at these and counting these fibers. If you take a small company that might be doing this and using a person that doesn't count frequently, they will not be able to distinguish a fiber from what we call a ghost fading in and out of this filter background. I think you will have all kinds of serious problems. We are very unhappy with the method.

DIXON: This not only can happen, I've seen it happen with inexperienced counters just starting out to count asbestos fibers. When they get this kind of a membrane, they may be counting membrane structures rather than counting fibers, so it's a situation that has to be watched very closely.

STEWART: May I just ask one quick question on the same thing? There was a Dr. Torem of Millipore technical services at this meeting earlier. Is he here to comment on this?

R. THOMPSON: Mr. Smyrloglou is here from Millipore too. I have spent eight years getting a competitive situation with glass fiber filters. Lots of luck.

J. WARREN: The results of these three days and our firm's recent completion of a study of asbestos in the construction industry leads me to make the suggestion that this conference is the first step. We really need some type of interagency committee on asbestos, however you want to define "asbestos," let's use the term asbestos. Asbestos needs more than just a microscopic approach, you need a wholistic approach; when I use the term macroscopic, you can't just look at the simple approach.

The way this can be done is by agencies getting together. You can talk to people in industry, and this is one of the things usually brought up. This agency says one thing and OSHA comes in and says this: Well, we have to deal with MESA over here and then lo and behold the FTC is looking at our product on the shelf. This is why I think some type of interagency approach might be needed with asbestos and I would suggest very quickly that it: 1) come up with some type of formal definitions that everyone can agree on (we have talked around this, but we have not resolved this in these three days); 2) standardize methodology for different material, whether it is in food, cosmetic talc, or ambient air, for water, or occupational exposure; and 3) review the current state of research, particularly vis-a-vis health effects. These are very difficult studies that Art Langer could tell us about. They require an enormous amount of money. They are not something you can run off in 6 months, tell me what the incidence of cancer was, and what people were exposed to a certain type of asbestos. It is not that easy, and I think that this type of interagency group could come up with some kind of a protocol list of priorities where we need further research. To my knowledge this has not been done, and we looked for this kind of thing when we got into business and it was not there.

I would think that the research should focus on particularly epidemiological evidence of mesothelioma. I think this is really the clincher. This is what I feel like is pushing NIOSH to lower and lower limits. We come up with the data of this very insidious cancer; it appears to occur in people who have very low non-occupational exposure and it scares people. For better or worse they are scared; and Rockville, Maryland is a good example of this. Whether it's rational or not they get scared and they get very emotional. I think this is something that's got to be dealt with. You cannot say: well, those are people; they do not know what they are talking about; that's just the public. You have to deal with them. It's political whether you want it that way or not; it is a fact of life.

I think the interagency group should suggest where we need research, the gentlemen on the stage and other people have suggested areas, but let's get this down in black and white. Here are the fifteen key things we need to do in asbestos and here is why we need to do them, and who is going to pay for it and why.

Finally, I think this group could also put in a good plug for the needed cooperation between these agencies. Gentlemen, it has not been said, but this has not occurred in the past. That is just the long and short of it, and if we are ignoring it we are not facing reality. There has not been cooperation particularly between the regulatory agencies arrayed here, OSHA, MESA, EPA, FDA, CPSC. Then you have NIEHS and NIOSH, and sometimes the left hand does not know what the right hand is doing and we are talking about something that kills people. So I am making a very strong plea for an interagency task force, and I think we have got the people in this room that could put it together. Thank you.

J. LEINEWEBER: I would like to comment on the remarks that were just made. There are selected industry groups that have addressed themselves to the needs for research and other work in these areas. For example, the Asbestos Cement Pipe Industry has had workshops very similar to this (perhaps on a smaller scale) to consider the needs of their particular industry associated with asbestos fiber and water. The Thermal Insulation Manufacturer's Association is conducting studies on so called man-made mineral fibers and their biological effects. Industry itself is doing this. If there are government agencies that wish to do this, these agencies should also include industry in these types of studies. I would suggest that in studying problems of this type we forget the word asbestos for a while. Let's talk about biologically active fibers. Let's move away from "Is this asbestos or is it not?" Let's ask "Is it a biologically active fiber?"

BROWNSTEIN: Dragging Art Langer back into this, I would like to second the comment he made a bit earlier. I am surprised that no one has really taken this up during the conference, well, not surprised a lot, regarding smoking and the allowance of smoking by workers. It has been agreed here that it seems that asbestos is a disease that is dose-response related and we are looking at lower and lower standards to increase the protection. Equally, a greater protection, it seems, could be achieved by the controlling of smoking. For example, a total ban of smoking within the perimeter of the work environment, in the

plant perhaps; in the mine site. I am surprised that this is not taken up and looked on as an alternative for the very large capital cost that the industry is so concerned about. They can achieve similar degrees of protection by other means.

NOTE: The following was a note sent following the meeting and was not part of the verbal discussions at the end of the session.

ZUSSMAN: Although a lot has been said about the difference between real asbestos and the non-asbestos varieties of amphibole and serpentine, I would like to make two further points on this theme, because I was amazed at the continued lack of distinction between the two kinds of material shown in some of this afternoon's papers, both in the use of the word asbestos and in the proposed regulatory procedures.

It has been shown that commercial asbestos can have serious biological effects, but there is little or no evidence that the non-asbestos varieties of amphiboles and serpentines have the same effects. Dr. Goodwin of MESA indicated that in order to know what limits to set for occupational and non-occupational exposure to commercial asbestos you need to know the risk factor. Surely the same applies to the non-asbestos forms of amphibole and serpentine. Do we know the risk factor for these? Should it be assumed the same and the limits the same as for asbestos, with our present knowledge?

One speaker from the floor mentioned the general public's acute concern about asbestos and the fact that it was a highly emotional subject. In view of this, it seems unwise, to say the least, to use the word asbestos and an ore deposit indiscriminately, and perhaps only three years later to say, well - the material isn't really asbestos after all. If it were just a matter of semantics it would not matter so much, but it is precisely because of the now heavy emotional content of the word asbestos that I think much more discrimination should be exercised in its use.

LIST OF ATTENDEES

Frederick R. Allen
N.C. Aggregates Association
P. O. Box 30603
Raleigh, NC 27612

Francis M. Alpiser
Environmental Protection Agency
Region III
Curtis Building, 6th & Walnut
Philadelphia, PA 19106

William Anderl
Minnesota Pollution Control Agency
Division of Water Quality
Roseville, MN 55113

Charles H. Anderson
Athens ERL
Environmental Protection Agency
College Station Road
Athens, GA 30601

Sandra Anderson
Battelle, Columbus Laboratories
505 King Avenue
Columbus, OH 43201

Irvin Asher
Office of Science
Food and Drug Administration
8800 Rockville Pike
Bethesda, MD 20014

William H. Ashton
Johnson & Johnson
U.S. Rt. 202
Raritan, NJ 08869

Steven Aust
Bureau of Air Quality
201 W. Preston Street
O'Connor Building
Baltimore, MD 21201

Russell W. Ayres
Read, Smith, Shaw and McClay
747 Union Trust Building
Pittsburgh, PA 15230

James H. Baird
W. R. Grace & Company
7379 Route 32
Columbia, MD 21044

William G. Banfield
National Cancer Institute
9000 Rockville Pike
Building 10, Rm. 8B19
Bethesda, MD 20014

Walter Bank
Mining Enforcement & Safety Admin.
Denver Technical Support Center
P. O. Box 25367, DFC
Denver, CO 80225

Virgil J. Barczak
Kerr-McGee Corporation
Technical Center
P. O. Box 25861
Oklahoma City, OK 73125

Kenneth Barry
BNA - Occupational Safety and
Health Reporter
1231 - 25th St., NW
Washington, DC 20037

Ian Bartky
Institute for Materials Research
National Bureau of Standards
Washington, DC 20234

D. R. Beaman
Dow Chemical Company
574 Building
Midland, MI 48640

William E. Bell
Division of Resource Protection
Montgomery County Department of
Environmental Protection
6110 Executive Boulevard, Room 340
Rockville, MD 20852

Ed Berg
EMSL
Quality Assurance Branch
Cincinnati, OH 45268

Roy Bernard
MESA
309 Shadeswood Drive
Birmingham, AL 35226

J. Bignon
Universite Paris - Val de Marne
Centre Hospitalier Intercommunal
40 Avenue de Verdun
94010 Creteil
FRANCE

Kyle Bishop
Minnesota Department of Health
717 Delaware Street SE
Minneapolis, MN 55440

Rolland L. Blake
U.S. Bureau of Mines
Metallurgy Research Center
Twin Cities, MN 55111

R. L. Bleifuss
U.S. Steel Corporation
Research Laboratory
Coleraine, MN 55722

Hal Bohmer
PPG Industries, Inc.
P. O. Box 31
Barberton, OH 44203

Krell Bosler
Spartek Inc.
1375 Raff Road, SW
Canton, OH 44711

Fred M. Bowers
FMC Corp.
P. O. Box 8
Princeton, NJ 08540

Kenneth W. Boyer
HFF-147
Food & Drug Administration
200 C Street, SW
Washington, DC 20204

Joseph Breen
Environmental Protection Agency
Office of Toxic Substances
401 M Street, SW
Washington, DC 20460

John A. Breslin
U.S. Bureau of Mines
2401 E Street, NW
Washington, DC 20241

Philip D. Brick
Pickands Mather & Company
811 Sellwood Building
Duluth, MN 55803

Alan T. Broderick
Inland Steel Mining Company
1701 North Ninth Avenue
Virginia, MN 55792

Harlan Browning
Alpha Portland Cement Company
Alpha Building
Easton, PA 18042

Morley Brownstein
Consumer & Corporate Affairs
Product Safety Branch
Ottawa, Ontario K1A 0C9
CANADA

Leonard Bruckman
Department of Environmental Protection
Air Compliance
State Office Building
165 Capitol Avenue
Hartford, CT 06115

Merle Bundy
U.S. Steel Corporation
600 Grant St.
Pittsburgh, PA 15230

Edmund M. Buras, Jr.
Harris Research Laboratories
Gillette Research Institute
1413 Research Boulevard
Rockville, MD 20850

M. Raymond Buyce
N. Y. Geological Survey
Education Building Annex
Albany, NY 12186

Peter Buynok
Naval Facilities Engineering
Command
Alexandria, VA 22332

Daniel Cacchione
Portland Cement Association
5420 Old Orchard Road
Skokie, IL 60076

William J. Campbell
U. S. Bureau of Mines
College Park Metallurgy Research Center
College Park, MD 20740

Melvin C. Cannon, Jr.
Texas A & M University
109 Parkway
Bryan, TX 77801

Armand R. Casola
Food & Drug Administration
Bureau of Drugs
5600 Fishers Lane
Rockville, MD 20857

William A. Cawley
Environmental Protection Agency
Mail Code RD680
401 M Street, SW
Washington, DC 20460

James H. Chapman
Consad Research Corporation
121 North Holland Avenue
Pittsburgh, PA 15206

Eric J. Chatfield
Ontario Research Foundation
Sheridan Park Research Community
Mississauga, Ontario L5K 1B3
CANADA

Chia Ting Chen
OSHA - U.S. Dept. of Labor
Room 602
400 First Street, NW
Washington, DC 20215

Lauren Choate
Interpace Corporation
Mountain View Drive
Willsboro, NY 12996

K. S. Chopra
Union Carbide
4625 Royal Avenue
Niagara Falls, NY 14302

James M. Christie
Vulcan Materials Company
One Metroplex Drive
Box 7497
Birmingham, AL 35223

Frank H. Chung
Sherwin-Williams Company
10909 Cottage Grove Avenue
Chicago, IL 60628

Harold Clements
EMSL
Quality Assurance Branch
Cincinnati, OH 45268

Robert A. Clifton
U.S. Bureau of Mines
2401 E Street, NW
Washington, DC 20241

Jay Coffman
Luck Quarriers, Inc.
P. O. Box 4682
Richmond, VA 23229

Stuart Cohen
Environmental Protection Agency
Pesticides & Toxic Substances
Enforcement
Mail Code EN-342
401 M Street, SW.
Washington, DC 20460

Richard R. Cole
Harry T. Campbell Sons' Company
100 W. Pennsylvania Avenue
Towson, MD 21204

Benjamin Collins
North American Exploration, Inc.
P. O. Box 7584
Charlottesville, VA 22906

Philip M. Cook
U.S. Environmental Protection Agency
Environmental Research Laboratory
6201 Congdon Blvd.
Duluth, MN 55804

W. Clark Cooper
Equitable Environmental Health, Inc.
2020 Milvia Street
Berkeley, CA 94704

Joseph R. Copeland
Interpace Corporation
260 Cherry Hill Road
Parsippany, NJ 07054

R. E. Corcoran
U.S. Bureau of Mines
2401 E Street, NW
Washington, DC 20241

James D. Cornell
U.S. Gypsum Company
101 S. Wacker Drive
Chicago, IL 60606

Marcel Cossette
Centre for Technology of the
Environment
University of Sherbrooke
Sherbrooke, P.Q. J1K 2R1
CANADA

Edwin Cox
Commonwealth Labs, Inc.
P. O. Box 8025
Richmond, VA 23223

Edward Crandall
Maryland State Health Dept.
Division of Employee Health Programs
201 W. Preston St.
Baltimore, MD 21201

Bill Crowley
Maryland Geological Survey
Johns Hopkins University
Baltimore, MD 21218

Alan Davidson
O. M. Scott
Research Building
Marysville, OH 43040

Richard L. Davis
Koppers Co., Inc.
1177 Pinewood Drive
Pittsburgh, PA 15243

E. K. Davison
National Sand and Gravel Association
900 Spring Street
Silver Spring, MD 20910

Peter DeBruyn
Office of the Director
National Bureau of Standards
Washington, DC 20234

John G. Delly
McCrone Associates
2820 S. Michigan Avenue
Chicago, IL 60616

John M. Dement
National Institute for Occupational
Safety and Health
4676 Columbia Parkway
Cincinnati, OH 45226

Phillip B. DeNee
NIOSH-ALOSH
944 Chestnut Ridge Road
Morgantown, WV 26505

Catherine Dentan
Carborundum Corp.
Res. and Dev. Division
P. O. Box 1054
Niagara Falls, NY 14302

Lois Dicker
Occupational Safety & Health Admin.
Division of Occupational Health
Programming
DOL Rm N3119
200 Constitution Avenue
Washington, DC 20210

Robert H. Dickey
MESA
4800 Forbes Avenue
Pittsburgh, PA 15213

Willard C. Dixon
U.S. Department of Labor
Occupational Safety & Health Admin.
390 Wakara Way
Salt Lake City, UT 84117

Ken Doolan
U.S. Coast Guard
400 - 7th Street, SW
Washington, DC 20590

M. J. Doyle
The Hanna Mining Company
100 Erieview Plaza
Cleveland, OH 44114

Ronald G. Draftz
IIT Research Institute
10 West 35th Street
Chicago, IL 60616

Guy F. Driver, Jr.
P. O. Drawer 84
Winston-Salem, NC 27102

James R. Dunn
Dunn Geoscience Corporation
Mountain View Drive
Averill Park, NY 12018

Frank Echelberger
Hooker Chem. & Plastics
P. O. Box 344
Niagara Falls, NY 14302

Richard D. Edsell
U.S. Department of Labor
OSHA, Rm. N-3657
200 Constitution Avenue, NW
Washington, DC 20210

William V. Eisenberg
U.S. Food & Drug Administration
Washington, DC 20234

Michael H. Eisner
U.S. Department of the Interior
Bureau of Mines
College Park Metallurgy Research Center
College Park, MD 20740

Samuel Elkin
Temple University
3307 N. Broad Street
Philadelphia, PA 19116

William Ellis
Maryland Occupational Safety and
Health Service
203 East Baltimore Street
Baltimore, MD 21202

John T. Enwright
NL Industries, Inc.
P. O. Box 700
Hightstown, NJ 08520

Edwin S. Erickson, Jr.
Bethlehem Steel Company
Homer Research Laboratories
Bethlehem, PA 18016

Lidia Farmer
Gillette Research Institute
1413 Research Boulevard
Rockville, MD 20850

William Fassuliotis
GAF Corporation
1361 Alps Road
Wayne, NJ 07470

Donald R. Ferry
Charles Mathieu, Inc.
18-22 Bank Street
P.O. Box A.M.
Summit, NJ 07901

R. M. Fisher
U.S. Steel Research Laboratory
Monroeville, PA 15146

Jean J. Fitzpatrick
Colorado School of Mines
Research Institute
P. O. Box 112
Golden, CO 80401

A. McM. Foster
Hollingsworth & Vose Company
112 Washington Street
East Walpole, MA 02032

Douglas P. Fowler
Stanford Research Institute
333 Ravenswood Avenue
Menlo Park, CA 94025

James E. Fox
Virginia Aggregates Assn.
2317 Westwood Avenue
Richmond, VA 23230

Kenneth S. Freeman
U.S. Gypsum Company
1000 East Northwest Highway
Des Plaines, IL 60016

Melvin H. Friedman
Food & Drug Administration
HFF 147
200 C Street, SW
Washington, DC 20204

Norman E. Fritsche
Environmental Protection Agency
Annapolis Field Office
Annapolis Science Center
Annapolis, MD 21401

Robert M. Furlong
W.W. Box 13527
Boxley Building
Jefferson Street
Roanoke, VA 24035

Arthur E. Gass
Office of Training and Education
OSHA
200 Constitution Avenue, NW
Washington, DC 20101

Lois L. Gerchman
Stanford Research Institute International
333 Ravenswood Avenue
Menlo Park, CA 94025

John C. Gifford
Asarco, Inc.
Oak Tree Road & Park Avenue
S. Plainfield, NJ 07080

Philip Giles
Bethlehem Steel Corp.
Homer Research Labs.
Bethlehem, PA 18016

Gordon J. Gill
Cyprus Industrial Minerals Company
555 S. Flower Street
32nd Floor
Los Angeles, CA 90071

J. K. Gilmore
Vermont Asbestos Group, Inc.
P. O. Box 70
Hyde Park, VT 05655

David M. Gioiello
National Aeronautics & Space Admin.
Goddard Space Flight Center
Health Unit, Bldg. 5
Greenbelt, MD 20771

Samuel Goldberg
MESA
4800 Forbes Avenue
Pittsburgh, PA 15213

David Goldheim
Martin Marietta Corporation
1450 S. Rolling Road
Baltimore, MD 21227

Aurel Goodwin
MESA
4015 Wilson Blvd.
Arlington, VA 22203

Cary Gravatt
Analytical Chemistry Division
National Bureau of Standards
Washington, DC 20234

David Gray
Minnesota Department of Health
717 Delaware Street SE
Minneapolis, MN 55440

Leven B. Gray
Goddard Space Flight Center
Greenbelt, MD 20771

Alice L. Greife
NIOSH/ALOSH
944 Chestnut Ridge Road
Morgantown, WV 26505

Joseph R. Gross
Jones & Laughlin Steel Corp.
504 North 1st Street
Virginia, MN 55792

Paul Gross
Industrial Health Foundation
5231 Centre Avenue
Pittsburgh, PA 15232

Richard Gruenbaum
O. M. Scott
Research Building
Marysville, OH 43040

Fred I. Grunder
Bethlehem Steel Corporation
Homer Research Laboratories
Bethlehem, PA 18016

Richard Gullickson
International Minerals & Chemical Corp.
501 E. Lange
Mundelein, IL 60060

Joe A. Gutierrez
Vulcan Materials Company
P. O. Box 4195
Winston-Salem, NC 27105

Robert A. Haagensen
ASARCO, Inc.
Central Research Department
901 Oak Tree Road
South Plainfield, NJ 07080

Janet C. Haartz
NIOSH-MRB
4676 Colorado Pkwy.
Cincinnati, OH 45226

C. Y. Haas
Minerals & Chemicals Division
Engelhard Minerals & Chemicals Corp.
Menlo Park
Edison, NJ 08817

George Haecker
Plastic Engineering Company
Sheboygan, WI 53081

William Harris
Martin Marietta Corporation
1450 S. Rolling Road
Baltimore, MD 21227

Allan M. Harvey
R. T. Vanderbilt Co., Inc.
30 Winfield Street
Norwalk, CT 06855

Robert Hehir
Consumer Products Safety Commission
Westwood Towers Building, Rm. 712
4501 Westbard Avenue
Bethesda, MD 20207

James Heil
Certain-Teed Corporation
Pipe & Plastics Group
P. O. Box 860
Valley Forge, PA 19482

Kurt F. Heinrich
Analytical Chemistry Division
National Bureau of Standards
Washington, DC 20234

Clarence A. Herbst, Sr.
Resinoid Engineering Corporation
3445 Howard Street
Skokie, IL 60076

John Heter
Interpace Corporation
2901 Los Feliz Blvd.
Los Angeles, CA 90039

John L. S. Hickey
Research Triangle Institute
Research Triangle Park, NC 27709

Gavin Hildick-Smith
Johnson & Johnson
501 George Street
New Brunswick, NJ 08903

William B. Hillegass
O. M. Scott
Research Building
Marysville, OH 43040

J. A. Hodgeson
Office of Air & Water Measurement
National Bureau of Standards
Washington, DC 20234

John D. Hoffman
Institute for Materials Research
National Bureau of Standards
Washington, DC 20234

Liselotte Hochholzer
Armed Forces Institute of Pathology
Washington, DC 20306

Pat Honchar
Preventable Diseases Division
Connecticut State Department of
Health
79 Elm Street
Hartford, CT 06115

Earl G. Hoover
National Crushed Stone Association
1415 Elliot Place, NW
Washington, DC 20007

Emanuel Horowitz
Institute for Materials Research
National Bureau of Standards
Washington, DC 20234

Arthur J. Huetteman
Personal Products Company
Van Liew Avenue
Milltown, NJ 08850

Charles W. Huggins
U.S. Department of the Interior
Bureau of Mines
College Park Metallurgy Research Ctr.
College Park, MD 20740

Ruth Hughes
Western Health Services Research
1213 Varsity Estates Road
Calgary, Alberta T3B 2X1
CANADA

Robert Huntington
Martin Marietta Corporation
1450 S. Rolling Road
Baltimore, MD 21227

Daniel W. Hurley
NL Industries, Inc.
P. O. Box 700
Hightstown, NJ 08520

C. Y. Hwang
McGill University
3775 University Street
Montreal, Quebec
CANADA

Robert Hylan
GAF Corporation
1361 Alps Road
Wayne, NJ 07470

Donald A. Jackson
State of Maryland
Department of Natural Resources
Water Resources Administration
Tawes State Office Bldg.
580 Taylor Avenue
Annapolis, MD 21401

Joseph C. Jackson
A/C Pipe Producers Association
1600 Wilson Boulevard
Suite 1308
Arlington, VA 22209

Harry E. Jaworski
OSHA - Chicago Regional Office
290 South Dearborn St.-Rm. 3263
Chicago, IL 60604

Dale Johnson
GAF Corporation
1361 Alps Road
Wayne, NJ 07470

Frank Johnson
Armed Forces Institute of Pathology
Washington, DC 20306

H. Bradley Johnson
American Mining Congress
1100 Ring Building
Washington, DC 20036

Patricia C. Johnson
Analytical Chemistry Division
National Bureau of Standards
Washington, DC 20234

Ronald B. Johnson
Institute for Materials Research
National Bureau of Standards
Washington, DC 20234

David R. Jones
I. I. T. Research Institute
10 West 35th Street
Chicago, IL 60616

Robert D. Joyce
Bethlehem Steel Corporation
Martin Tower, B-252
Bethlehem, PA 18016

Elizabeth Kaegi
Western Health Services Research Ltd.
1213 Varsity Estates Rd., NW
Calgary, Alberta T3B 2X5
CANADA

Eila Kairinen
Gillette Company Research Institute
1413 Research Blvd.
Rockville, MD 20850

David A. Kandel
Kaiser Steel Corporation
P. O. Box 217
Fontana, CA 92335

Mark D. Kaufman
Sutherland, Asbill & Brennen
3100 First National Bank Tower
Atlanta, GA 30303

Martin G. Kemplin
Nicolet, Inc.
Maple Street
Ambler, PA 19002

Charles B. Kenahan
U.S. Department of the Interior
Bureau of Mines
College Park Metallurgy Research Ctr.
College Park, MD 20740

Robert J. Kilgour
Armstrong Cork Company
Liberty and Charlotte Streets
Lancaster, PA 17604

William B. King
Armstrong Cork Company
Suite 205
1666 K Street, NW
Washington, DC 20006

William H. Kirchhoff
Office of Air & Water Measurement
National Bureau of Standards
Washington, DC 20234

Diana M. Kirkpatrick
Consumer Product Safety Commission
200 C Street, SW
Washington, DC 20204

Owen H. Kittilstad
CertainTeed Corporation
P. O. Box 860
Valley Forge, PA 19482

Partricia B. Klinger
Kennecott Research Center
P. O. Box 11299
1515 Mineral Square
Salt Lake City, UT 84147

Carl E. Kollmar, Jr.
J. M. Huber Corporation
Route 4, Huber
Macon, GA 31201

C. Komminen
NIOSH
DBBS Pathology Section
4676 Columbia Parkway
Cincinnati, OH 45226

Paul Kotin
Johns-Manville Corporation
Ken-Caryl Ranch
Denver, CO 80217

George J. Kraficisin
Kemper/NATLSCO
Long Grove, IL 60049

Sidney Krakauer
Pall Biomedical Products Corporation
30 Sea Cliff Avenue
Glen Cove, NY 11542

James R. Kramer
Department of Geology
McMaster University
Hamilton, Ontario L8S 4M1
CANADA

Jerry Krause
Colorado School of Mines
Research Institute
P. O. Box 112
Golden, CO 80401

Stephen Krop
Food and Drug Administration
Bureau of Drugs
200 C Street, SW
Washington, DC 20204

Edward Kuchar
Olin Corporation
New Haven, CT 06527

Philip D. La Fleur
Analytical Chemistry Division
National Bureau of Standards
Washington, DC 20234

Jule K. Lamar
Food and Drug Administration
Bureau of Drugs
5600 Fishers Lane
Room 18-B-31
Rockville, MD 20857

Helen W. Lang
U.S. Bureau of Mines
4800 Forbes Avenue
Pittsburgh, PA 15213

Arthur Langer
Environmental Sciences Laboratory
Mt. Sinai Hospital
New York, NY 10029

Maxwell W. Layard
National Cancer Institute
Landow Building, Rm C318
Bethesda, MD 20014

A. Philip Leber
Battelle - Columbus Laboratories
505 King Avenue
Columbus, OH 43201

George Lee
Applied Research
Johnson & Johnson Baby Products Co.
Route 202
Raritan, NJ 08869

R. J. Lee
U.S. Steel Research Laboratory
Monroeville, PA 15146

Robert Lee
Rogers Corporation
Rogers, CT 06263

James Leineweber
R&D Center
Johns-Manville Corporation
Denver, Colorado 80229

Robert S. Lemire
Reserve Mining Company
Silver Bay, MN 55614

Jacques Lepoutre
Eternit S.A.
2920 Kapelle-op-den-Bos
BELGIUM

Archie Liao
Prince Georges County Health Dept.
10210 Greenbelt Road
Seabrook, MD 20801

Charles Lichtenwalner
Bell Laboratories
Murray Hill, NJ 07974

Jeff Limoge
Vermont Asbestos Group
P. O. Box 70
Hyde Park, VT 05655

Burt Linck
The Arundel Corporation
110 West Road
Baltimore, MD 21204

C. M. Llewellyn, Jr.
Lone Star Industries, Inc.
P. O. Box 1-J
3011 Dock Street
Richmond, VA 23201

Harold L. Lloyd
Pennsylvania Glass Sand Corp. (ITT)
Berkeley Springs, WV 25411

Thomas Loch
Clayton Environmental Consultants
25711 Southfield
Southfield, MI 48075

Robert H. Locke
W. R. Grace & Company
62 Whittemore Avenue
Cambridge, MA 02140

Howard R. Ludwig
National Institute for Occupational
Safety & Health
Taft Laboratories
4676 Columbia Pkwy
Cincinnati, OH 45226

Bernard S. Mac Cabe
Carborundum Co.
NAO-Water Management Division
P. O. Box 1054
Niagara Falls, NY 14302

John Maciejczyk
Rockwell International
600 Grant Street
Pittsburgh, PA 15219

Joseph Mackey
Analytical Chemistry Division
National Bureau of Standards
Washington, DC 20234

Joseph A. Macko, Jr.
Army Environmental Hygiene Agency
Aberdeen Proving Ground
Edgewood, MD 21010

Lloyd A. Madsen
Occupational Safety & Health Admin.
Analytical Laboratory
390 Wakara Way
Salt Lake City, UT 84108

Ralph E. Magnuson, Jr.
The Cleveland-Cliffs Iron Company
1460 Union Commerce Building
Cleveland, OH 44115

S. E. Malovrh
The Hanna Mining Company
100 Erieview Plaza
Cleveland, OH 44114

Roland E. Manger
Harry T. Campbell Sons' Company
100 W. Pennsylvania Ave.
Towson, MD 21204

Gregory J. Manning
Diamond Shamrock Corporation
T. R. Evans Research Center
P. O. Box 348
Painesville, OH 44077

Thomas J. Manthey
Pickands Mather & Company
1100 Superior Avenue
Cleveland, OH 44114

John Marsh
Raybestos Manhattan Inc.
100 Oakview Drive
Trumbull, CT 06611

Eugene Martin
EDAX International, Inc.
157 Colique Avenue
New Rochelle, NY 10801

Robert F. Martin
Institute for Materials Research
National Bureau of Standards
Washington, DC 20234

John F. Martonik
U.S. Department of Labor
Occupational Safety & Health
Administration
200 Constitution Avenue, NW
Washington, DC 20210

Brian Mason
Mineral Sciences
Smithsonian Institution
Washington, DC 20560

Woodrow W. Massad
Continental Oil Company
Box 1267
Ponca, OK 74601

Darrell K. Mattheis
Occupational Safety and Health Agency
Room N 3603
200 Constitution Avenue
Washington, DC 20210

John Matwey
Analytical Chemistry Division
National Bureau of Standards
Washington, DC 20234

Arthur J. McLaughlin
MESA
9 Mayfair Drive
Slingerlands, NY 12159

Lottie McClendon
Institute for Materials Research
National Bureau of Standards
Washington, DC 20234

Ray McClure
Division of Occupational Health
U.S. Department of Labor
Occupational Safety & Health Admin.
200 Constitution Avenue, NW
Washington, DC 20210

Brian McCoy
The Arundel Corporation
110 West Road
Baltimore, MD 21204

Ronald McCullen
Travelers Insurance Co.
248 CP Lab
1 Tower Sq.
Hartford, CT 06115

Philip P. McGrath
Bureau of Biologics
Food and Drug Administration
8800 Rockville Pike
Bethesda, MD 20014

Douglas McLean
Stauffer Chemical Co.
Eastern Research Center
Dobbs Ferry, NY 10522

James F. McVeigh
American Can Company
U.S. Highway 22
Union, NJ 07083

Carl W. Melton
Battelle, Columbus Laboratories
505 King Avenue
Columbus, OH 43201

Eric S. Mendelsohn
Air Pollution & Noise Control
Department of Environmental Protection
of Montgomery County
Room 340
6110 Executive Building
Rockville, MD 20852

Oscar Menis
Analytical Chemistry Division
National Bureau of Standards
Washington, DC 20234

J. C. Meranger
Environmental Health Center
Health & Welfare
Ottawa, Ontario K1A 0L2
CANADA

Dennis Michalski
International Minerals & Chem. Corp
IMC Plaza
Libertyville, IL 60048

A. P. Middleton
Institute of Occupational Medicine
Roxburgh Place
Edinburgh, EH8 9SU
SCOTLAND

W. J. Miles
Industrial Mineral Ventures, Inc.
5920 McIntyre Street
Golden, CO 80401

Roger N. Miller
Windsor Minerals, Inc.
P. O. Box 680
Windsor, VT 05089

James R. Millette
Environmental Protection Agency
HERL
26 West St. Clair Street
Cincinnati, OH 45268

Robert J. Moolenaar
Dow Chemical Company
1702 Building
Midland, MI 48640

John A. Moore
National Institute of Environmental
Health Sciences
P. O. Box 12233
Research Triangle Park, NC 27709

Sanders Moore
Olin Corporation
P. O. Box 248
Charleston, TN 37311

Robert E. Morgan
Virginia Division of Mines
and Quarries
908 Branchwater Street
Fredericksburg, VA 22401

Bruce Morrissey
Office of the Director
National Bureau of Standards
Washington, DC 20234

J. Fraser Morton
Congoleum Corporation
2700 Emory Road
Finksburg, MD 21048

Wolfgang Mueller
Newmont Exploration Limited
44 Briar Ridge Road
Danbury, CT 06810

Frederick A. Mumpton
State University College
Department of the Earth Sciences
Brockport, NY 14420

Ronald A. Munson
Bureau of Mines
2401 E Street, NW
Washington, DC 20241

Jack C. Murchio
School of Public Health
University of California -
Berkeley
Earl Warren Hall
Berkeley, CA 94720

Charles T. Myers
U.S. Steel Corporation
Room 6044
600 Grant Street
Pittsburgh, PA 15230

Andrew J. Nawa
Mining Enforcement & Safety Admin.
4800 Forbes Avenue
Pittsburgh, PA 15213

Harry Naylor
Moore & Munger
140 Sherman Street
Fairfield, CT 06430

Dale Newberry
Analytical Chemistry Division
National Bureau of Standards
Washington, DC 20234

Marvin W. Nichols, Jr.
MESA
130 North Arlington St.
Salisbury, NC 28144

W. Nicholson
Environmental Sciences Laboratory
Mt. Sinai Hospital
New York, NY 10029

Clifford W. Niemi
U.S. Steel Corporation
Minnesota Ore Operations
P. O. Box 417
Mountain Iron, MN 55768

Gordon L. Nord, Jr.
U.S. Geological Survey
959 National Center
Reston, VA 22092

Robert E. Norwood
Pfizer, Inc.
640 N. 13th Street
P. O. Box 548
Easton, PA 18042

Andrew F. Oberta
A.F. Oberta Consulting Services
1200 Quince Orchard Boulevard
Gaithersburg, MD 20760

John O'Conner
PPG Industries, Inc.
1 Gateway Center
Pittsburgh, PA 10522

Trevor L. Ogden
Health and Safety Executive
403 Edgware Road
London, NW2 6LN
ENGLAND

David McNeil Olds
Read, Smith, Shaw & McClay
747 Union Trust Bldg.
Pittsburgh, PA 15230

Lawrence W. Ortiz
Los Alamos Scientific Laboratory
P. O. Box 1663
Los Alamos, NM 87544

Donald G. Oss
Hanna Mining Company
2125 Second Avenue, East
Box 218
Hibbing, MN 55746

T. Dixon Oulton
Engelhard Minerals & Chemicals Corp.
Menlo Park
Edison, NJ 08817

Lalita D. Palekar
Northrop Services, Inc.
P. O. Box 12313
Research Triangle Park, NC 27709

Thomas Pang
Ministry of Environment
Laboratory Services Branch
French Resource Road
Islington, Rexdale, Ontario
CANADA

Ed Parkison
Martin Marietta Corporation
1450 S. Rolling Road
Baltimore, MD 21227

C. J. Parmentier
Cyprus Industrial Minerals Company
555 S. Flower Street
32nd Floor
Los Angeles, CA 90071

Deran Pashayan
Environmental Protection Agency
401 M St., SW
Washington, DC 20460

Premysl V. Pelnar
Institute of Occupational and
Environmental Health
Suite 603, 3 Place Ville Marie
Montreal, Quebec H3B 2E3
CANADA

Edward T. Peters
Arthur D. Little, Inc.
15 Acorn Park
Cambridge, MA 02140

Daryl E. Peterson
Occupational Safety & Health Admin.
Analytical Laboratory
390 Wakara Way
Salt Lake City, UT 84108

Terry Philippi
IITRI
10 West 35th Street
Chicago, IL 60616

John A. Pickrell
Inhalation Toxicology Research Inst.
Lovelace Biomedical & Environmental
Research Institute
P. O. Box 5890
Albuquerque, NM 87116

Bob J. Pigg
Asbestos Information Association
1835 K Street, NW
Suite 402
Washington, DC 20006

F. D. Pooley
Johnson & Johnson
501 George Street
New Brunswick, NJ 08903

Warren Porter
Consumer Product Safety Comm.
Fed. Bldg. 8, Rm 5844
200 C Street, SW
Washington, DC 20204

Gene Proctor
National Aeronautics & Space
Administration
600 Independence Avenue
Code QG
Washington, DC 20546

David Pytynia
Nalco Chemical Company
6216 West 66th Place
Chicago, IL 60638

Don Quilici
Hanford Environmental Health Foundation
P. O. Box 100
Richmond, WA 99352

Pamela P. Quinn
U.S. Environmental Protection Agency
4th and M Streets, SW
Waterside Mall
Washington, DC 20460

Paul Radauskas
City of Rockville
111 Maryland Avenue
Rockville, MD 20850

Lewis Raymond
MESA
4800 Forbes Avenue
Pittsburgh, PA 15213

Curt W. Reimann
Institute for Materials Research
National Bureau of Standards
Washington, DC 20234

Harrison B. Rhodes
Union Carbide Corporation
Metals Division
P. O. Box 579
4625 Royal Avenue
Niagara Falls, NY 14302

Richard W. Richards
Pennsylvania Glass Sand Corp.
SR 522, North
Berkeley Springs, WV 25411

Roger Riley
Interpace Corporation
3502 Breakwater Court
Hayward, CA 94545

Malcolm L. Roberts
Trudeau Institute, Inc.
Box 59
Saranac Lake, NY 12983

K. Robock
Wirtschaftsverband Asbestzement e.V.
Arbeits- und Umweltschutz
Koelner Str. 102
D - 4040 Neuss
Germany

Fred J. Rogers
Gypsum Association
1603 Orrington Avenue
Evanston, IL 60201

F. Robert Rolle
Johnson & Johnson
501 George Street
New Brunswick, NJ 08903

Harry L. Rook
Analytical Chemistry Division
National Bureau of Standards
Washington, DC 20234

Richard H. Rosenberg
Borg Warner Research Center
Wolf & Algonquin Road
Des Plaines, IL 60091

Joan R. Rosenblatt
National Bureau of Standards
Washington, DC 20234

Malcolm Ross
U.S. Geological Survey
National Center 959
Reston, VA 22092

Robert G. Rucker
Congoleum Corporation
2700 Emory Road
Finksburg, MD 21048

Clyde L. Russell
Kerr-McGee Corporation
P. O. Box 25861
Oklahoma City, OK 73125

Clayton O. Ruud
Denver Research Institute
University of Denver
Denver, CO 80208

A. H. Samuel
Reserve Mining Company
Silver Bay, MN 55614

Joseph K. Samuels
Republic Steel Corporation
6801 Brecksville Road
Independence, OH 44131

David G. Sarvadi
Sherwin-Williams Company
101 Prospect Avenue, NW
Cleveland, OH 44115

James A. Saunders
Bureau of Toxic Substance Info.
Virginia Dept. of Health
109 Gov. Street
Richmond, VA 23219

Jim W. Scales
J. M. Huber Corporation
Route 4 Huber
Macon, GA 31201

Mary Lee Schaefer
Employers Insurance of Wausau
2000 Westwood Drive
Wausau, WI 54401

John P. Schelz
Johnson & Johnson
501 George Street
New Brunswick, NJ 08903

Wayne L. Schiffelbein
U.S. Consumer Product Safety
Commission
111 - 18th Street, NW
Washington, DC 20207

Marvin Schneiderman
National Cancer Institute
National Institutes of Health
Landow Building
Rm. C403
Bethesda, MD 20014

Richard F. Scholl
Fine Particles Research Section
IIT Research Institute
10 West 35th Street
Chicago, IL 60616

George Schwartzman
Food & Drug Administration
Code HFD 402
501 First Street, SE
Washington, DC 20204

J. M. Shackelford
Environmental Protection Agency
401 M Street
Mail Code RD680
Washington, DC 20460

Peter Shaffer
Carborundum Company
P. O. Box 1054
Niagara Falls, NY 14302

Raymond Shapiro
NIEHS
P. O. Box 12233
Research Triangle Park, NC 27709

George Sharpe
Medical Office
National Bureau of Standards
Washington, DC 20234

Lawrence E. Shirley
U.S. Bureau of Mines
Liaison Office
P. O. Box 2828
Raleigh, NC 27602

George R. Simon
Health Effects Div. (RD 683)
U.S. Environmental Protection Agency
401 M. Street, SW
Washington, DC 20460

S. B. Singer
State Department of Health
& Environmental Control
Air Bureau
2600 Bull Street
Columbia, SC 29201

Fred J. Sisson
GSA - Accident & Fire Prevention
Branch (3POA)
7th & D Streets, SW
Room 7712
Washington, DC 20407

Henry J. Smahlik
Dresser Industries, Inc.
Oilfield Products Group
601 Jefferson
Houston, TX 77002

John A. Small
Analytical Chemistry Division
National Bureau of Standards
Washington, DC 20234

William E. Smith
Health Research Institute
Fairleigh Dickinson University
Madison, NJ 07940

Eli Smyrloglou
Millipore Corporation
Ashby Road
Bedford, MA 01730

Vernon R. Snyder
The General Crushed Stone Company
P. O. Box 231
Easton, PA 18042

James A. Soles
Canada Center for Mineral
& Energy Technology (CANMET)
405 Rochester Street
Ottawa, Ontario KIA 0G1
CANADA

Harold Stanley
Pfizer, Inc.
M.P.M. Division
P. O. Box 548
Easton, PA 18042

Mearl F. Stanton
National Cancer Institute
National Institutes of Health
Laboratory of Pathology
Bethesda, MD 20014

David N. Staples
Industrial Hygiene Section
Office of Chief of Naval
Operations
Occupational Safety & Health Div.
(OP-45)
The Pentagon
Washington, DC 20350

John T. Stasny
Structure Probe, Inc.
535 East Gay Street
West Chester, PA 19380

Eric B. Steel
U.S. Department of the Interior
Bureau of Mines
College Park Metallurgy Research Center
College Park, MD 20740

John Steelnack
U.S. Department of Labor
OSHA/Rm. N-3657
200 Constitution Avenue, NW
Washington, DC 20210

Arland Stein
747 Union Trust Building
Pittsburgh, PA 15230

Robert J. Stevenson
Department of Geology & Geophysics
University of Minnesota
Minneapolis, MN 55414

Ian M. Stewart
Walter C. McCrone Assoc., Inc.
2820 S. Michigan Avenue
Chicago, IL 60616

R. L. Stoffer
Standard Oil Research Center
P. O. Box 400
Mail Station B-3
Naperville, IL 60540

Dr. Sundaram
Department of National Health
Ottawa, Ontario
CANADA

Joseph A. Sutton
U.S. Bureau of Mines
2401 E Street, NW
Washington, DC 20241

Louis Swaby
Environmental Protection Agency
401 M St., SW
Washington, DC 20460

Gaylord W. Swelbar
Hanft, Fride, O'Brien & Haines
1200 Alworth Bldg.
Duluth MN 55802

L. W. Swent
Homestake Mining Company
650 California Street
9th Floor
San Francisco, CA 94108

Reginald Sykes
Asbestos Research Council
TBA Industrial Products, Ltd.
P. O. Box 40
Rochdale, Lancs. OL12 7EQ
ENGLAND

Nancy Tait
Churchill Fellow
38 Drapers Road
Enfield, EN2 8LU
ENGLAND

John K. Taylor
Analytical Chemistry Division
National Bureau of Standards
Washington, DC 20234

Linda Lee Taylor
Food and Drug Administration
Bureau of Foods
200 C Street, SW
Washington, DC 20204

Patricia Taylor
General Motors Corporation
G.M. Technical Center
Rm. 3230 Administrative Labs.
12 Mile & Mound Road
Warren, MI 48093

John W. Thatcher
MESA
Denver Technical Support Center
P. O. Box 25367
Denver Federal Center
Denver, CO 80225

C. S. Thompson
R. T. Vanderbilt Co., Inc.
30 Winfield Street
Norwalk, CT 06855

E. June Thompson
Consumer Product Safety Commission
Rm. 700, 5401 Westbard Avenue
Bethesda, MD 20207

George E. Thompson
DHEW/PHS/FDA/BF
Epidemiology Unit, HFF-108
200 C Street, SW
Washington, DC 20204

Richard Thompson
U.S. Environmental Protection Agency
Research Triangle Park, NC 27711

James G. Topper
Rockville Crushed Stone, Inc.
P. O. Box 407
13900 Piney Meeting House Road
Rockville, MD 20850

Barry Torem
Millipore Corporation
Ashby Road
Bedford, MA 01730

Priestley Toulmin, III
U.S. Geological Survey
959 National Center
Reston, VA 22092

Kenneth Trabert
Environmental Protection Agency
(WH550)
401 M Street
Washington, DC 20460

Michael P. Trainor
MESA
4800 Forbes Avenue
Pittsburgh, PA 15213

Emil J. Triglia
Engelhard Minerals & Chemicals Corp.
Menlo Park
Edison, NJ 08817

L. C. Turnock
American Iron Ore Association
1501 Euclid Avenue
514 Bulkley Building
Cleveland, OH 44115

Lansing Tuttle
Warren Brothers Co.
675 Massachusetts Ave.
Cambridge, MA 02139

T. S. Twardowski
Department of Labor
OSHA/Rm. N3657
200 Constitution Avenue
Washington, DC 20210

Steve Urman
Federal Railroad Administration
2100 - 2nd Street, SW
Washington, DC 20590

John T. Vandeberg
DeSoto, Inc.
1700 S. Mount Prospect Road
Des Plaines, IL 60018

Peter G. Veeder
Thorp, Reed & Armstrong
2900 Grant Building
Pittsburgh, PA 15219

Dave K. Verma
Occupational Health & Safety Div.
Government of Alberta
9820 - 106 Street
Edmonton, Alberta, T5K 2J6
CANADA

Richard Viau
Department of Consumer &
Corporate Affairs
Standards Laboratory Building
Tunney's Pasture
Ottawa, Ontario K1A 0C0
CANADA

Robert L. Virta
U.S. Department of the Interior
Bureau of Mines
College Park Metallurgy Res. Ctr.
College Park, MD 20740

Joseph Volk
Gold Bond Building Products Div.
National Gypsum Company
1650 Military Road
Buffalo, NY 14217

John B. Wade
Eagle-Picher Industries, Inc.
580 Walnut Street
Cincinnati, OH 45202

Jack Wagman
U.S. Environmental Protection Agency
Research Triangle Park, NC 27711

Philip Waitkus
Plastic Engineering Company
Sheboygan, WI 53081

Daman S. Walia
IIT Research Institute
10 W 35th Street
Chicago, IL 60616

John L. Warren
Research Triangle Institute
Cornwallis Road
Research Triangle Park, NC 27709

William V. Warren
Occupational Safety & Health Admin.
Room N3660
200 Constitution Avenue, NW
Washington, DC 20210

James R. Weber
The Bendix Corporation
Executive Offices, Bendix Center
Southfield, MI 48076

Richard J. Wedlund
Minnesota Pollution Control Agency
Division of Air Quality
1935 W. Co. Road, B-2
Roseville, MN 55113

John M. Wehrung
EMV Associates, Inc.
15825 Shady Grove Road
Rockville, MD 20850

S. Weiss
The Flintkote Company
365 West Passaic Street
Rochelle Park, NJ 07062

John F. Welch
A/C Pipe Producers Association
1600 Wilson Boulevard
Suite 1308
Arlington, VA 22209

John Wenniger
Bureau of Biologics
Food and Drug Administration
8800 Rockville Pike
Bethesda, MD 20014

Lewis F. Wheatley
Virginia Division of Mines
Drawer V
Big Stone Gap, VA 24219

Judith A. Whelan
Air Pollution & Noise Control
Department of Environmental Protection
of Montgomery County
Room 340
6110 Executive Boulevard
Rockville, MD 20852

Benjamin D. White
Assistant Secretary for Health
Department of Health and Mental
Hygiene
201 West Preston Street
Baltimore, MD 21201

Lowell D. White
ASARCO Incorporated
3422 South 700 West
Salt Lake City, UT 84119

James Whitney
Environmental Protection Agency
401 M Street, SW
Mail Code RD680
Washington, DC 20460

Diane Whittier
University of Pittsburgh
G.S.P.H.
130 DeSoto Street
Pittsburgh, PA 15261

John R. Whyte
The Anaconda Company
P. O. Box 27007
Tucson, AZ 85726

Peter C. Wight
Environmental Quality Control Div.
B-252MT
Ind. Relations Department
Bethlehem Steel Corporation
Bethlehem, PA 18016

Allen Winer
Naval Ship Engineering Center
Crystal City NC-2 (6101E)
Washington, DC 20360

Steven Winzer
Martin Marietta Corporation
1450 S. Rolling Road
Baltimore, MD 21227

George J. Wolfe
JEOL (USA), Inc.
101 Colonial Drive
Irwin, PA 15642

Vladimir E. Wolkodoff
Johns-Manville Corporation
Research and Development Center
Denver, CO 80217

Gilbert H. Wood
Environmental Protection Agency
OAQPS, ESED, ISB, SSS (MD-13)
Research Triangle Park, NC 27711

Sandra Worblewski
Kemper/NATLSCO
Long Grove, IL 60049

George W. Wright
460 S. Marion Parkway
Denver, CO 80209

Gale D. Wyr
Consumer Product Safety Comm.
Directorate for Eng. and Science
200 C Street, SW
Room 5844
Washington, DC 20204

Ann G. Wylie
Department of Geology
University of Maryland
H.J. Patterson Hall
College Park, MD 20740

Julie C. Yang
W. R. Grace & Company
62 Whittemore Avenue
Cambridge, MA 02140

Brian Yawney
Ontario Research Foundation
Sheraton Park
Mississauga, Ontario L5K 1B3
CANADA

J. E. Zatek
Mine Safety Appliances
600 Penn Center Blvd.
Pittsburgh, PA 15235

Carolyn Zelek
Ford Motor Company
Rotundo Blvd., Building 5
Dearborn, MI 48121

F. H. Zimmerman
National Gypsum Company
4100 First International Building
Dalles, TX 75270

Tibor Zoltai
Department of Geology and
Geophysics
University of Minnesota
Minneapolis, MN 55455

Richard M. Zomnir
Thorp, Reed & Armstrong
2900 Grant Building
Pittsburgh, PA 15219

Jack Zussman
Department of Geology
University of Manchester
Manchester M13 9PL
ENGLAND

U.S. DEPT. OF COMM. BIBLIOGRAPHIC DATA SHEET		1. PUBLICATION OR REPORT NO. NBS SP 506	2. Gov't Accession No.	3. Recipient's Accession No.
4. TITLE AND SUBTITLE Proceedings of Workshop on Asbestos: Definitions and Measurement Methods			5. Publication Date November 1978	6. Performing Organization Code
7. AUTHOR(S) C.C. Gravatt, Phillip D. LaFleur, and Kurt F.J. Heinrich			8. Performing Organ. Report No.	
9. PERFORMING ORGANIZATION NAME AND ADDRESS NATIONAL BUREAU OF STANDARDS DEPARTMENT OF COMMERCE WASHINGTON, D.C. 20234			10. Project/Task/Work Unit No.	11. Contract/Grant No.
2. Sponsoring Organization Name and Complete Address (Street, City, State, ZIP) OSHA Department of Labor 200 Constitution Avenue, NW Washington, DC 20210			13. Type of Report & Period Covered	
5. SUPPLEMENTARY NOTES Library of Congress Catalog Card Number 78-600109			14. Sponsoring Agency Code	
6. ABSTRACT (A 200-word or less factual summary of most significant information. If document includes a significant bibliography or literature survey, mention it here.) This document contains invited papers which were given at a workshop on "Asbestos: Definitions and Measurement Methods" which was jointly sponsored by the National Bureau of Standards of the U. S. Department of Commerce and the Occupational Safety and Health Administration of the U. S. Department of Labor. The discussion portions of the Workshop also have been included as has written material appropriate to the topics under consideration which was submitted to the editors at a later date. The Workshop covered four major topics: Mineralogical Aspects, the Relationship Between Chemical and Physical Properties and Health Effects, Analytical Methods, and Regulatory Positions and Criteria. Also included in these Proceedings is a summary of each of these topics. These summaries serve to define those factors for which there was general agreement at the Workshop, identify remaining points of controversy, and, in some cases, describe additional research required to resolve remaining problems.				
7. KEY WORDS (six to twelve entries; alphabetical order; capitalize only the first letter of the first key word unless a proper name; separated by semicolons) Amphibole, asbestos, fibers, light microscopy, mineralogical terminology, scanning electron microscopy, serpentine, talc, transmission electron microscopy.				
18. AVAILABILITY <input type="checkbox"/> For Official Distribution. Do Not Release to NTIS <input checked="" type="checkbox"/> Order From Sup. of Doc., U.S. Government Printing Office Washington, D.C. 20402, SD Stock No. SN003-003 <input type="checkbox"/> Order From National Technical Information Service (NTIS) Springfield, Virginia 22151		19. SECURITY CLASS (THIS REPORT) UNCLASSIFIED		21. NO. OF PAGES. 490
		20. SECURITY CLASS (THIS PAGE) UNCLASSIFIED		22. Price \$6.75

JOURNAL OF RESEARCH

of the National Bureau of Standards

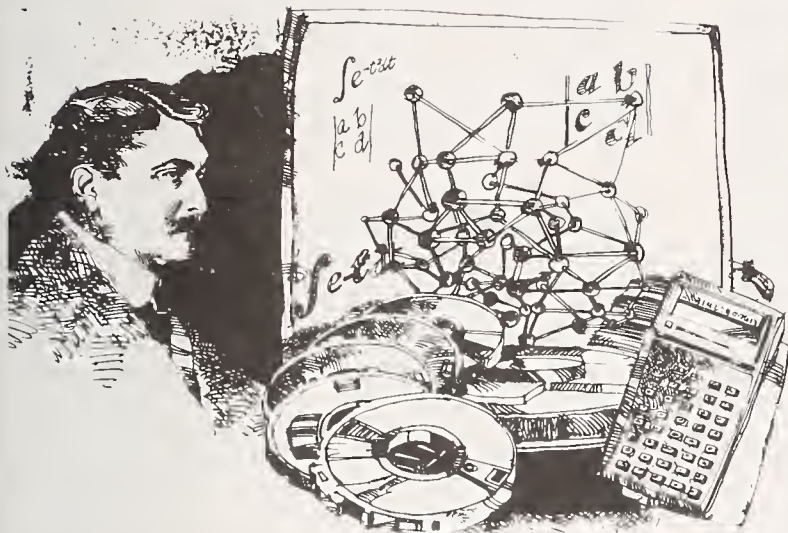

Subscribe now — The new National Bureau of Standards Journal

The expanded Journal of Research of the National Bureau of Standards reports NBS research and development in those disciplines of the physical and engineering sciences in which the Bureau is active. These include physics, chemistry, engineering, mathematics, and computer sciences. Papers cover a broad range of subjects, with major emphasis on measurement methodology, and the basic technology underlying standardization. Also included from time to time are survey articles on topics closely related to the Bureau's technical and scientific programs. As a special service to subscribers each issue contains complete citations to all recent NBS publications in NBS and non-NBS media. Issued six times a year. Annual subscription: domestic \$17.00; foreign \$21.25. Single copy, \$3.00 domestic; \$3.75 foreign.

- Note: The Journal was formerly published in two sections: Section A "Physics and Chemistry" and Section B "Mathematical Sciences."

NBS Board of Editors
Churchill Eisenhart,
Executive Editor (Mathematics)
John W. Cooper (Physics)
Donald D. Wagman (Chemistry)
Andrew J. Fowell (Engineering)
Joseph O. Harrison (Computer Science)
Stephen J. Smith (Boulder Labs.)

For a review copy, write Journal of Research, National Bureau of Standards, U.S. DEPARTMENT OF COMMERCE Washington, D.C. 20234

Subscription Order Form

Enter my subscription to NBS Journal of Research at \$17.00. Add \$4.25 for foreign mailing. No additional postage is required for mailing within the United States or its possessions. (SJR—File Code 2Q)

Send Subscription to:

- Remittance Enclosed
(Make checks payable to Superintendent of Documents)
- Charge to my Deposit Account No.

Name-First, Last

Company Name or Additional Address Line

Street Address

City

State

Zip Code

MAIL ORDER FORM TO:
Superintendent of Documents
Government Printing Office
Washington, D.C. 20402

NBS TECHNICAL PUBLICATIONS

PERIODICALS

JOURNAL OF RESEARCH—The Journal of Research of the National Bureau of Standards reports NBS research and development in those disciplines of the physical and engineering sciences in which the Bureau is active. These include physics, chemistry, engineering, mathematics, and computer sciences. Papers cover a broad range of subjects, with major emphasis on measurement methodology, and the basic technology underlying standardization. Also included from time to time are survey articles on topics closely related to the Bureau's technical and scientific programs. As a special service to subscribers each issue contains complete citations to all recent NBS publications in NBS and non-NBS media. Issued six times a year. Annual subscription: domestic \$17.00; foreign \$21.25. Single copy, \$3.00 domestic; \$3.75 foreign.

Note: The Journal was formerly published in two sections: Section A "Physics and Chemistry" and Section B "Mathematical Sciences."

DIMENSIONS/NBS

This monthly magazine is published to inform scientists, engineers, businessmen, industry, teachers, students, and consumers of the latest advances in science and technology, with primary emphasis on the work at NBS. The magazine highlights and reviews such issues as energy research, fire protection, building technology, metric conversion, pollution abatement, health and safety, and consumer product performance. In addition, it reports the results of Bureau programs in measurement standards and techniques, properties of matter and materials, engineering standards and services, instrumentation, and automatic data processing.

Annual subscription: Domestic, \$11.00; Foreign \$13.75

NONPERIODICALS

Monographs—Major contributions to the technical literature on various subjects related to the Bureau's scientific and technical activities.

Handbooks—Recommended codes of engineering and industrial practice (including safety codes) developed in cooperation with interested industries, professional organizations, and regulatory bodies.

Special Publications—Include proceedings of conferences sponsored by NBS, NBS annual reports, and other special publications appropriate to this grouping such as wall charts, pocket cards, and bibliographies.

Applied Mathematics Series—Mathematical tables, manuals, and studies of special interest to physicists, engineers, chemists, biologists, mathematicians, computer programmers, and others engaged in scientific and technical work.

National Standard Reference Data Series—Provides quantitative data on the physical and chemical properties of materials, compiled from the world's literature and critically evaluated. Developed under a world-wide program coordinated by NBS. Program under authority of National Standard Data Act (Public Law 90-396).

NOTE: At present the principal publication outlet for these data is the Journal of Physical and Chemical Reference Data (JPCRD) published quarterly for NBS by the American Chemical Society (ACS) and the American Institute of Physics (AIP). Subscriptions, reprints, and supplements available from ACS, 1155 Sixteenth St. N.W., Wash., D.C. 20056.

Building Science Series—Disseminates technical information developed at the Bureau on building materials, components, systems, and whole structures. The series presents research results, test methods, and performance criteria related to the structural and environmental functions and the durability and safety characteristics of building elements and systems.

Technical Notes—Studies or reports which are complete in themselves but restrictive in their treatment of a subject. Analogous to monographs but not so comprehensive in scope or definitive in treatment of the subject area. Often serve as a vehicle for final reports of work performed at NBS under the sponsorship of other government agencies.

Voluntary Product Standards—Developed under procedures published by the Department of Commerce in Part 10, Title 15, of the Code of Federal Regulations. The purpose of the standards is to establish nationally recognized requirements for products, and to provide all concerned interests with a basis for common understanding of the characteristics of the products. NBS administers this program as a supplement to the activities of the private sector standardizing organizations.

Consumer Information Series—Practical information, based on NBS research and experience, covering areas of interest to the consumer. Easily understandable language and illustrations provide useful background knowledge for shopping in today's technological marketplace.

Order above NBS publications from: Superintendent of Documents, Government Printing Office, Washington, D.C. 20402.

Order following NBS publications—NBSIR's and FIPS from the National Technical Information Services, Springfield, Va. 22161.

Federal Information Processing Standards Publications (FIPS PUB)—Publications in this series collectively constitute the Federal Information Processing Standards Register. Register serves as the official source of information in the Federal Government regarding standards issued by NBS pursuant to the Federal Property and Administrative Services Act of 1949 as amended, Public Law 89-306 (79 Stat. 1127), and as implemented by Executive Order 11717 (38 FR 12315, dated May 11, 1973) and Part 6 of Title 15 CFR (Code of Federal Regulations).

NBS Interagency Reports (NBSIR)—A special series of interim or final reports on work performed by NBS for outside sponsors (both government and non-government). In general, initial distribution is handled by the sponsor; public distribution is by the National Technical Information Services (Springfield, Va. 22161) in paper copy or microfiche form.

BIBLIOGRAPHIC SUBSCRIPTION SERVICES

The following current-awareness and literature-survey bibliographies are issued periodically by the Bureau:

Cryogenic Data Center Current Awareness Service. A literature survey issued biweekly. Annual subscription: Domestic, \$25.00; Foreign, \$30.00.

Liquefied Natural Gas. A literature survey issued quarterly. Annual subscription: \$20.00.

Superconducting Devices and Materials. A literature survey issued quarterly. Annual subscription: \$30.00. Send subscription orders and remittances for the preceding bibliographic services to National Bureau of Standards, Cryogenic Data Center (275.02) Boulder, Colorado 80302.

U.S. DEPARTMENT OF COMMERCE
National Bureau of Standards

Washington, D.C. 20234

OFFICIAL BUSINESS

Penalty for Private Use, \$300

POSTAGE AND FEES PAID
U.S. DEPARTMENT OF COMMERCE
COM-215



SPECIAL FOURTH-CLASS RATE
BOOK

1298

