

**ENVIRONMENTAL PROTECTION AGENCY****40 CFR Parts 60 and 63**

[EPA-HQ-OAR-2022-0730; FRL-9327-02-OAR]

RIN 2060-AV71

**New Source Performance Standards for the Synthetic Organic Chemical Manufacturing Industry and National Emission Standards for Hazardous Air Pollutants for the Synthetic Organic Chemical Manufacturing Industry and Group I & II Polymers and Resins Industry****AGENCY:** Environmental Protection Agency (EPA).**ACTION:** Final rule.

**SUMMARY:** This action finalizes amendments to the New Source Performance Standards (NSPS) that apply to the Synthetic Organic Chemical Manufacturing Industry (SOCMI) and amendments to the National Emission Standards for Hazardous Air Pollutants (NESHAP) that apply to the SOCMI (more commonly referred to as the Hazardous Organic NESHAP or HON) and Group I and II Polymers and Resins (P&R I and P&R II, respectively) Industries. The EPA is finalizing decisions resulting from the Agency's technology review of the HON and the P&R I and P&R II NESHAP, and its review of the NSPS that apply to the SOCMI. The EPA is also finalizing amendments to the NSPS for equipment leaks of volatile organic compounds (VOC) in SOCMI based on its reconsideration of certain issues raised in an administrative petition for reconsideration. Furthermore, the EPA is finalizing emission standards for ethylene oxide (EtO) emissions and chloroprene emissions after considering the results of a risk assessment for the HON and for Neoprene Production processes subject to the P&R I NESHAP, and is finalizing a fenceline monitoring work practice standard for certain hazardous air pollutants (HAP). Lastly, the EPA is finalizing the removal of exemptions from standards for periods of startup, shutdown, and malfunction (SSM), adding work practice standards for such periods where appropriate, finalizing standards for previously unregulated HAP, and adding provisions for electronic reporting of performance test reports and periodic reports.

**DATES:** This final rule is effective on July 15, 2024. The incorporation by reference (IBR) of certain publications listed in the rule is approved by the Director of

the Federal Register as of July 15, 2024. The incorporation by reference of certain other material listed in the rule was approved by the Director of the Federal Register as of October 17, 2000 and November 16, 2007.

**ADDRESSES:** The U.S. Environmental Protection Agency (EPA) has established a docket for this action under Docket ID No. EPA-HQ-OAR-2022-0730. All documents in the docket are listed on the <https://www.regulations.gov/> website. Although listed, some information is not publicly available, e.g., Confidential Business Information (CBI) or other information whose disclosure is restricted by statute. Certain other material, such as copyrighted material, is not placed on the internet and will be publicly available only in hard copy form. Publicly available docket materials are available either electronically through <https://www.regulations.gov/>, or in hard copy at the EPA Docket Center, WJC West Building, Room Number 3334, 1301 Constitution Ave. NW, Washington, DC. The Public Reading Room hours of operation are 8:30 a.m. to 4:30 p.m. Eastern Standard Time, Monday through Friday. The telephone number for the Public Reading Room is (202) 566-1744, and the telephone number for the EPA Docket Center is (202) 566-1742.

**FOR FURTHER INFORMATION CONTACT:** For questions about the HON and SOCMI NSPS, contact U.S. EPA, Attn: Mr. Andrew Bouchard, Mail Drop: Sector Policies and Programs Division (E143-01), 109 T.W. Alexander Drive, P.O. Box 12055, RTP, North Carolina 27711; telephone number: (919) 541-4036; and email address: [bouchard.andrew@epa.gov](mailto:bouchard.andrew@epa.gov). For questions about the P&R I and P&R II NESHAP, contact U.S. EPA, Attn: Ms. Njeri Moeller, Mail Drop: Sector Policies and Programs Division (E143-01), 109 T.W. Alexander Drive, P.O. Box 12055, RTP, North Carolina 27711; telephone number: (919) 541-1380; and email address: [moeller.njeri@epa.gov](mailto:moeller.njeri@epa.gov). For specific information regarding the risk modeling methodology, contact U.S. EPA, Attn: Mr. Matthew Woody, Mail Drop: Health and Environmental Impacts Division (C539-02), 109 T.W. Alexander Drive, P.O. Box 12055, RTP, North Carolina 27711; telephone number: (919) 541-1535; and email address: [woody.matthew@epa.gov](mailto:woody.matthew@epa.gov).

**SUPPLEMENTARY INFORMATION:**

*Preamble acronyms and abbreviations.* We use multiple acronyms and terms in this preamble. While this list may not be exhaustive, to ease the reading of this preamble and for

reference purposes, the EPA defines the following terms and acronyms here:

ACS American Community Survey  
 AERMOD American Meteorological Society/  
 EPA Regulatory Model dispersion  
 modeling system  
 ANSI American National Standards Institute  
 APCD air pollution control device  
 API American Petroleum Institute  
 ASME American Society of Mechanical  
 Engineers  
 BACT best available control technology  
 BLR basic liquid epoxy resins  
 BPT benefit per-ton  
 BSER best system of emissions reduction  
 BTEX benzene, toluene, ethylbenzene, and  
 xylenes  
 CAA Clean Air Act  
 CBI confidential business information  
 CDX Central Data Exchange  
 CEDRI Compliance and Emissions Data  
 Reporting Interface  
 CFR Code of Federal Regulations  
 CMPU chemical manufacturing process unit  
 CO carbon monoxide  
 CO<sub>2</sub> carbon dioxide  
 CPI consumer price index  
 CRA Congressional Review Act  
 EAV equivalent annual value  
 ECHO Enforcement and Compliance History  
 Online  
 EFR external floating roof  
 EIS Emission Information System  
 EPA Environmental Protection Agency  
 EPPU elastomer product process unit  
 ERT Electronic Reporting Tool  
 EtO ethylene oxide  
 FTIR fourier transform infrared  
 HAP hazardous air pollutant(s)  
 HON Hazardous Organic NESHAP  
 HQ hazard quotient  
 HQ<sub>REL</sub> hazard quotient reference exposure  
 level  
 IBR incorporation by reference  
 ICR information collection request  
 IFR internal floating roof  
 IRIS Integrated Risk Information System  
 ISA Integrated Science Assessment  
 km kilometer  
 LAER lowest achievable emissions rate  
 lb/hr pound per hour  
 lb/yr pound per year  
 LDAR leak detection and repair  
 LDEQ Louisiana Department of  
 Environmental Quality  
 LEL lower explosive limit  
 MACT maximum achievable control  
 technology  
 MDL method detection limit  
 MERP monomer emission reduction project  
 MIR maximum individual lifetime [cancer]  
 risk  
 MON Miscellaneous Organic Chemical  
 Manufacturing NESHAP  
 MTVP maximum true vapor pressure  
 NAICS North American Industry  
 Classification System  
 NAAQS National Ambient Air Quality  
 Standards  
 NATTS National Air Toxic Trends Station  
 NEI National Emissions Inventory  
 NESHAP national emission standards for  
 hazardous air pollutants  
 NO<sub>x</sub> nitrogen oxides  
 N<sub>2</sub>O nitrous oxide

NPDES national pollutant discharge elimination system  
 NRDC Natural Resources Defense Council  
 NSPS new source performance standards  
 NTTAA National Technology Transfer and Advancement Act  
 NYSDEC New York State Department of Environmental Conservation  
 OAR Office of Air and Radiation  
 OEL open-ended valves or lines  
 OGI optical gas imaging  
 OIG Office of Inspector General  
 OMB Office of Management and Budget  
 P&R I Group I Polymers and Resins  
 P&R II Group II Polymers and Resins  
 PDF portable document format  
 PMPU polyether polyol manufacturing process unit  
 POM polycyclic organic matter  
 ppbv parts per billion by volume  
 ppm parts per million  
 ppmv parts per million by volume  
 ppmw parts per million by weight  
 PRA Paperwork Reduction Act  
 psig pounds per square inch gauge  
 PRD pressure relief device  
 PV present value  
 RACT reasonably available control technology  
 RDL representative detection limit  
 REL reference exposure level  
 RFA Regulatory Flexibility Act  
 RIA Regulatory Impact Analysis  
 RIO regenerative thermal oxidizer  
 RTR risk and technology review  
 SCAQMD South Coast Air Quality Management District  
 scfm standard cubic feet per minute  
 scmm standard cubic meter per minute  
 SOCM I Synthetic Organic Chemical Manufacturing Industry  
 SO<sub>2</sub> sulfur dioxide  
 SSM startup, shutdown, and malfunction  
 TAC Texas Administrative Code  
 TCEQ Texas Commission on Environmental Quality  
 TCI total capital investment  
 TOC total organic compounds  
 TOSHI target organ-specific hazard index  
 tpy tons per year  
 TRE total resource effectiveness  
 TRI Toxics Release Inventory  
 UMRA Unfunded Mandates Reform Act  
 URE unit risk estimate  
 U.S.C. United States Code  
 VCS voluntary consensus standards  
 VOC volatile organic compound(s)  
 WSR wet strength resins  
 WWTP wastewater treatment plant

**Background information.** On April 25, 2023, the EPA proposed amendments to the NSPS that apply to the SOCM I, and amendments to the HON and P&R I and P&R II NESHAP. In this action, we are finalizing decisions and revisions for the rule. We summarize some of the more significant comments we timely received regarding the proposed rule and provide our responses in this preamble. A summary of all other public comments on the proposal and the EPA's responses to those comments is available in the document titled *Summary of Public Comments and*

*Responses for New Source Performance Standards for the Synthetic Organic Chemical Manufacturing Industry and National Emission Standards for Hazardous Air Pollutants for the Synthetic Organic Chemical Manufacturing Industry and Group I & II Polymers and Resins Industry*, Docket ID No. EPA-HQ-OAR-2022-0730. A "track changes" version of the regulatory language that incorporates the changes in this action is available in the docket.

**Organization of this document.**

The information in this preamble is organized as follows:

- I. General Information
  - A. Executive Summary
  - B. Does this action apply to me?
  - C. Where can I get a copy of this document and other related information?
  - D. Judicial Review and Administrative Reconsideration
- II. Background
  - A. What is the statutory authority for this action?
  - B. What are the source categories and how did the previous standards regulate emissions?
  - C. What changes did we propose in our April 25, 2023, proposal?
- III. What is included in this final rule?
  - A. What are the final rule amendments based on the risk review for the SOCM I and Neoprene Production source categories NESHAP?
  - B. What are the final rule amendments based on the technology review for the SOCM I, P&R I, and P&R II source categories NESHAP pursuant to CAA section 112(d)(6) and NSPS reviews for the SOCM I source category pursuant to CAA section 111(b)(1)(B)?
  - C. What are the final rule amendments pursuant to CAA sections 112(d)(2) and (3), and 112(h) for the SOCM I, P&R I, and P&R II source categories?
  - D. What are the final rule amendments addressing emissions during periods of SSM?
  - E. What are the final amendments addressing the NSPS Subparts VV and VVa reconsideration?
  - F. What other changes have been made to the NESHAP and NSPS?
  - G. What are the effective and compliance dates of the standards?
- IV. What is the rationale for our final decisions and amendments for the SOCM I, P&R I, and P&R II source categories?
  - A. Residual Risk Review for the SOCM I and Neoprene Production Source Categories NESHAP
  - B. Technology Review for the SOCM I, P&R I, and P&R II Source Categories NESHAP and NSPS Review for the SOCM I Source Category
  - C. Amendments Pursuant to CAA Section 112(d)(2) and (3) and 112(h) for the SOCM I, P&R I, and P&R II Source Categories NESHAP
  - D. Amendments Addressing Emissions During Periods of SSM

- E. Amendments Addressing NSPS Subparts VV and VVa Reconsideration
- F. Other Amendments to the NESHAP and NSPS
- V. Summary of Cost, Environmental, and Economic Impacts and Additional Analyses Conducted
  - A. What are the affected sources?
  - B. What are the air quality impacts?
  - C. What are the cost impacts?
  - D. What are the economic impacts?
  - E. What are the benefits?
  - F. What analysis of environmental justice did we conduct?
  - G. Children's Environmental Health
- VI. Statutory and Executive Order Reviews
  - A. Executive Order 12866: Regulatory Planning and Review and Executive Order 14094: Modernizing Regulatory Review
  - B. Paperwork Reduction Act (PRA)
  - C. Regulatory Flexibility Act (RFA)
  - D. Unfunded Mandates Reform Act (UMRA)
  - E. Executive Order 13132: Federalism
  - F. Executive Order 13175: Consultation and Coordination with Indian Tribal Governments
  - G. Executive Order 13045: Protection of Children from Environmental Health Risks and Safety Risks
  - H. Executive Order 13211: Actions Concerning Regulations that Significantly Affect Energy Supply, Distribution, or Use
  - I. National Technology Transfer and Advancement Act (NTTAA) and 1 CFR part 51
  - J. Executive Order 12898: Federal Actions to Address Environmental Justice in Minority Populations and Low-Income Populations and Executive Order 14096: Revitalizing Our Nation's Commitment to Environmental Justice for All
  - K. Congressional Review Act (CRA)

**I. General Information**

**A. Executive Summary**

**1. Purpose of the Regulatory Action**

The source categories that are the subject of this final action are the SOCM I and various polymers and resins manufacturing source categories. The SOCM I source category includes chemical manufacturing processes producing commodity chemicals while the polymers and resins manufacturing source categories covered in this action include elastomers production processes and resin production processes that use epichlorohydrin feedstocks (see sections I.B and II.B of this preamble for detailed information about these source categories). The EPA has previously promulgated maximum achievable control technology (MACT) standards for certain processes in the SOCM I source category in the HON rulemaking at 40 Code of Federal Regulations (CFR) part 63, subparts F, G, and H. In 1994, the EPA finalized MACT standards in subparts F, G, and

H for SOCM processes (59 FR 19454),<sup>1</sup> and the Agency completed a residual risk and technology review (RTR) for these NESHAP in 2006 (71 FR 76603). In 1995, the EPA finalized MACT standards in the P&R II NESHAP (40 CFR part 63, subpart W) for epoxy resin and non-nylon polyamide resin manufacturing processes (60 FR 12670), and the Agency completed a residual RTR for these standards in 2008 (73 FR 76220). In 1996, the EPA finalized MACT standards in the P&R I NESHAP (40 CFR part 63, subpart U) for various elastomer manufacturing processes (61 FR 46906), and the Agency completed residual RTRs for these standards in 2008 and 2011 (73 FR 76220 and 76 FR 22566).

The EPA has also promulgated NSPS for certain processes in the SOCM source category. In 1983, the EPA finalized NSPS (40 CFR part 60, subpart VV) for equipment leaks of VOC in SOCM (48 FR 48328). In 1990, the EPA finalized NSPS (40 CFR part 60, subparts III and NNN) for VOC from air oxidation unit processes and distillation operations (55 FR 26912 and 55 FR 26931). In 1993, the EPA finalized NSPS (40 CFR part 60, subpart RRR) for VOC from reactor processes (58 FR 45948). In 2007, the EPA promulgated NSPS (40 CFR part 60, subpart VVa) for VOC from certain equipment leaks (72 FR 64883), which reflect the EPA's review and revision of the standards in 40 CFR part 60, subpart VV.

The statutory authority for this action is sections 111, 112, 301(a)(1), and 307(d)(7)(B) of the CAA. Section 111(b)(1)(B) of the CAA requires the EPA to promulgate standards of performance for new sources in any category of stationary sources that the Administrator has listed pursuant to 111(b)(1)(A). Section 111(a)(1) of the CAA provides that these performance standards are to "reflect[] the degree of emission limitation achievable through the application of the best system of emission reduction which (taking into account the cost of achieving such reduction and any nonair quality health and environmental impact and energy requirements) the Administrator determines has been adequately demonstrated." We refer to this level of control as the best system of emissions reduction or "BSER." Section 111(b)(1)(B) of the CAA requires the EPA to "at least every 8 years, review and, if appropriate, revise" the NSPS.

For NESHAP, CAA section 112(d)(2) requires the EPA to establish MACT standards for listed categories of major sources of HAP. Section 112(d)(6) of the CAA requires the EPA to review standards promulgated under CAA section 112, and revise them "as necessary (taking into account developments in practices, processes, and control technologies)," no less often than every eight years following promulgation of those standards. This is referred to as a "technology review" and is required for all standards established under CAA section 112. Section 112(f) of the CAA requires the EPA to assess the risk to public health remaining after the implementation of MACT emission standards promulgated under CAA section 112(d)(2). If the MACT standards for a source category do not provide "an ample margin of safety to protect public health," the EPA must also promulgate health-based standards for that source category to further reduce risk from HAP emissions.

Section 301(a)(1) of the CAA authorizes the Administrator to prescribe such regulations as are necessary to carry out his functions under the CAA. Section 307(d)(7)(B) of the CAA requires the reconsideration of a rule only if the person raising an objection to the rule can demonstrate that it was impracticable to raise such objection during the period for public comment or if the grounds for the objection arose after the comment period (but within the time specified for judicial review), and if the objection is of central relevance to the outcome of the rule.

The final new NSPS for SOCM equipment leaks, air oxidation unit processes, distillation operations, and reactor processes (*i.e.*, NSPS subparts VVb, IIIa, NNNa, and RRRa, respectively) are based on the Agency's review of the current NSPS (subparts VVa, III, NNN, and RRR) pursuant to CAA section 111(b)(1)(B), which requires that the EPA review the NSPS every eight years and, if appropriate, revise them. In addition, the EPA is finalizing amendments to the NSPS for equipment leaks of VOC in SOCM based on its reconsideration of certain aspects of subparts VV and VVa that were raised in an administrative petition which the Agency granted pursuant to section 307(d)(7)(B) of the CAA. The final amendments to the HON (NESHAP subparts F, G, H, and I), the P&R I NESHAP (NESHAP subpart U), and the P&R II NESHAP (NESHAP subpart W) are based on the Agency's review of the current NESHAP (subparts F, G, H, I, U, and W) pursuant to CAA sections 112(d) and (f).

Due to the development of the EPA's Integrated Risk Information System (IRIS) inhalation unit risk estimate (URE) for chloroprene in 2010, the EPA conducted a second CAA section 112(f) risk review for the SOCM source category and Neoprene Production source category. In the first step of the CAA section 112(f)(2) determination of risk acceptability for this rulemaking, the use of the 2010 chloroprene risk value resulted in the EPA identifying unacceptable cancer risk driven by chloroprene emissions from the sole affected source producing neoprene subject to the P&R I NESHAP.<sup>2</sup> Consequently, the final amendments to the P&R I NESHAP address the EPA review of additional control technologies, beyond those analyzed in the technology review conducted for the P&R I source category, to address the unacceptable risk and achieve an ample margin of safety to protect public health at that affected source.

Additionally, in 2016, the EPA updated the IRIS inhalation URE for EtO. In the first step of the CAA section 112(f)(2) determination of risk acceptability for this rulemaking, the use of the updated 2016 EtO risk value resulted in the EPA identifying unacceptable cancer risk driven by EtO emissions from HON processes. Consequently, the final amendments to the HON also address the EPA review of additional control technologies, beyond those analyzed in the technology review conducted for the SOCM source category, to address the unacceptable risk and achieve an ample margin of safety to protect public health at SOCM and P&R I affected sources.

## 2. Summary of the Major Provisions of the Regulatory Action In Question

The most significant amendments that we are finalizing are described briefly below. However, all of our final amendments, including amendments to remove exemptions for periods of SSM, are discussed in detail with rationale in section IV of this preamble or in the document titled *Summary of Public Comments and Responses for New Source Performance Standards for the Synthetic Organic Chemical Manufacturing Industry and National Emission Standards for Hazardous Air Pollutants for the Synthetic Organic Chemical Manufacturing Industry and Group I & II Polymers and Resins Industry*, which is available in the docket for this rulemaking.

<sup>1</sup> Around the same time, the EPA set MACT standards for equipment leaks from certain non-SOCM processes at chemical plants regulated under 40 CFR part 63, subpart I (59 FR 19587).

<sup>2</sup> As discussed in section III.B of the proposal preamble (see 88 FR 25080, April 25, 2023), chloroprene emissions from HON processes do not on their own present unacceptable cancer risk from the SOCM source category.

## a. HON

We are finalizing amendments to the HON for heat exchange systems, process vents, storage vessels, transfer racks, wastewater, and equipment leaks.

## i. NESHAP Subpart F

• As detailed in section II.B.1.a of this preamble, NESHAP subpart F contains provisions to determine which chemical manufacturing processes at a facility are subject to the HON, monitoring requirements for HAP (*i.e.*, HAP listed in Table 4 of NESHAP subpart F) that may leak into cooling water from heat exchange systems, and requirements for maintenance wastewater. For NESHAP subpart F, we are finalizing:

• compliance dates for all of the HON requirements in this action (see 40 CFR 63.100(k)(10) through (12); and section III.G of this preamble).

• the moving of all the definitions from NESHAP subparts G and H (*i.e.*, 40 CFR 63.111 and 40 CFR 63.161, respectively) into the definition section of NESHAP subpart F (see 40 CFR 63.101; and sections III.F and IV.F of this preamble).

• a new definition for “in ethylene oxide service” (for equipment leaks, heat exchange systems, process vents, storage vessels, and wastewater) (see 40 CFR 63.101; and sections III.A and IV.A of this preamble).

• new operating and monitoring requirements for flares (see 40 CFR 63.108; and sections III.C and IV.C of this preamble).

• sampling and analysis procedures for owners and operators to demonstrate that process equipment does, or does not, meet the definition of being “in ethylene oxide service” (see 40 CFR 63.109; and sections III.A and IV.A of this preamble).

For heat exchange systems, we are finalizing:

• requirements that owners or operators must use the Modified El Paso Method and repair leaks of total strippable hydrocarbon concentration (as methane) in the stripping gas of 6.2 parts per million by volume (ppmv) or greater (see 40 CFR 63.104(g) through (j); and sections III.B.1 and IV.B of this preamble).

• requirements for heat exchange systems in EtO service that owners or operators must conduct more frequent leak monitoring (weekly instead of quarterly) and repair leaks of total strippable hydrocarbon concentration (as methane) in the stripping gas of 6.2 ppmv or greater within 15 days from the sampling date (in lieu of the previous 45-day repair requirement after receiving results of monitoring

indicating a leak in the HON), and delay of repair is not allowed unless the equipment can be isolated such that it is no longer in EtO service (see 40 CFR 63.104(g)(6) and (h)(6); and sections III.A.1 and IV.A of this preamble).

• a provision allowing use of the previous leak monitoring requirements for heat exchange systems at 40 CFR 63.104(b) in limited instances in lieu of using the Modified El Paso Method for heat exchange systems cooling process fluids that will remain in the cooling water if a leak occurs (see 40 CFR 63.104(l); and sections III.B.1 and IV.B of this preamble).

## ii. NESHAP Subpart G

As detailed in section II.B.1.b of this preamble, NESHAP subpart G contains requirements for process vents, storage vessels, transfer racks, wastewater streams, and closed vent systems.

For process vents, we are finalizing:

• the removal of the 50 ppmv and 0.005 standard cubic meter per minute (scmm) Group 1 process vent thresholds from the Group 1 process vent definition, and instead we are requiring owners and operators of process vents that emit greater than or equal to 1.0 pound per hour (lb/hr) of total organic HAP to reduce emissions of organic HAP using a flare meeting the operating and monitoring requirements for flares in NESHAP subpart F; or reduce emissions of total organic HAP or total organic compounds (TOC) by 98 percent by weight or to an exit concentration of 20 ppmv, (see 40 CFR 63.101 and 40 CFR 63.113(a)(1) and (2); and sections III.B.1 and IV.B of this preamble).

• the removal of the total resource effectiveness (TRE) concept in its entirety (see 40 CFR 63.113(a)(4); and sections III.B.1 and IV.B of this preamble).

• an emission standard of 0.054 nanograms per dry standard cubic meter (ng/dscm) at 3 percent oxygen (toxic equivalency basis) for dioxins and furans from chlorinated process vents (see 40 CFR 63.113(a)(5); and sections III.C and IV.C of this preamble).

• requirements that owners and operators must reduce emissions of EtO from process vents in EtO service by either: (1) Venting emissions through a closed-vent system to a control device that reduces EtO by greater than or equal to 99.9 percent by weight, to a concentration less than 1 ppmv for each process vent, or to less than 5 pound per year (lb/yr) for all combined process vents per chemical manufacturing process unit (CMPU); or (2) venting emissions through a closed-vent system to a flare meeting the operating and monitoring requirements for flares in

NESHAP subpart F (see 40 CFR 63.113(j), 40 CFR 63.108, and 40 CFR 63.124; and sections III.A.1 and IV.A of this preamble).<sup>3</sup>

• a work practice standard for maintenance vents requiring that, prior to opening process equipment to the atmosphere, the equipment must either: (1) Be drained and purged to a closed system so that the hydrocarbon content is less than or equal to 10 percent of the lower explosive limit (LEL); (2) be opened and vented to the atmosphere only if the 10-percent LEL cannot be demonstrated and the pressure is less than or equal to 5 pounds per square inch gauge (psig), provided there is no active purging of the equipment to the atmosphere until the LEL criterion is met; (3) be opened when there is less than 50 lbs of VOC that may be emitted to the atmosphere; or (4) for installing or removing an equipment blind, depressurize the equipment to 2 psig or less and maintain pressure of the equipment where purge gas enters the equipment at or below 2 psig during the blind flange installation, provided none of the other work practice standards can be met (see 40 CFR 63.113(k); and sections III.C and IV.C of this preamble).

• requirements that owners and operators of process vents in EtO service are allowed to use the maintenance vent work practice standards; however, owners and operators are prohibited from releasing more than 1.0 ton of EtO from all maintenance vents combined on a facility basis in any consecutive 12-month period (see 40 CFR 63.113(k)(4); and sections III.A.1 and IV.A of this preamble).

For storage vessels, we are finalizing:

• requirements that owners and operators must reduce emissions of EtO from storage vessels in EtO service by either: (1) Venting emissions through a closed-vent system to a control device that reduces EtO by greater than or equal to 99.9 percent by weight or to a concentration less than 1 ppmv for each storage vessel vent; or (2) venting emissions through a closed-vent system to a flare meeting the operating and monitoring requirements for flares in NESHAP subpart F (see 40 CFR 63.119(a)(5), 40 CFR 63.108, and 40 CFR

<sup>3</sup> We are also removing the option to allow use of a design evaluation in lieu of performance testing to demonstrate compliance for controlling various emission sources in EtO service. In addition, owners or operators that choose to control emissions with a non-flare control device are required to conduct an initial performance test on each control device in EtO service to verify performance at the required level of control, and are required to conduct periodic performance testing on non-flare control devices in EtO service every 5 years (see 40 CFR 63.124).

63.124; and sections III.A.1 and IV.A of this preamble).<sup>4</sup>

- a work practice standard to allow storage vessels to be vented to the atmosphere once a storage vessel degassing concentration threshold is met (*i.e.*, once a storage vessel degassing organic HAP concentration of 5,000 ppmv as methane is met, or until the vapor space concentration is less than 10 percent of the LEL) and all standing liquid has been removed from the vessel to the extent practicable (see 40 CFR 63.119(a)(6); and sections III.C and IV.C of this preamble).

- a definition for “pressure vessel” and removing the exemption for “pressure vessels designed to operate in excess of 204.9 kilopascals and without emissions to the atmosphere” from the definition of storage vessel (see 40 CFR 63.101); and requirements for initial and annual performance testing of pressure vessels that are considered Group 1 storage vessels using EPA Method 21 of 40 CFR part 60, appendix A–7 to demonstrate no detectable emissions (*i.e.*, required to meet a leak definition of 500 parts per million (ppm) at each point on the pressure vessel where total organic HAP could potentially be emitted) (see 40 CFR 63.119(a)(7); and sections III.C and IV.C of this preamble).

- requirements that all openings in an internal floating roof (IFR) (except those for automatic bleeder vents (vacuum breaker vents), rim space vents, leg sleeves, and deck drains) be equipped with a deck cover; and that the deck cover be equipped with a gasket between the cover and the deck (see 40 CFR 63.119(b)(5)(ix); and sections III.B.1 and IV.B of this preamble).

- control requirements for guidepoles for all storage vessels equipped with an IFR (see 40 CFR 63.119(b)(5)(x), (xi), and (xii); and sections III.B.1 and IV.B of this preamble).

- a work practice standard that applies during periods of planned routine maintenance of a control device, fuel gas system, or process equipment that is normally used for compliance with the storage vessel emissions control requirements; owners and operators are not permitted to fill the storage vessel during these periods (such that working losses are controlled and the vessel only emits HAP to the atmosphere due to breathing losses for a limited amount of time) (see 40 CFR 63.119(e)(7); and sections III.C and IV.C of this preamble).

- revisions to the Group 1 storage capacity criterion (for storage vessels at existing sources) from between 75 cubic meters (m<sup>3</sup>) and 151 m<sup>3</sup> to between 38

m<sup>3</sup> and 151 m<sup>3</sup> (see Table 5 to subpart G; and sections III.B.1 and IV.B of this preamble).

- revisions to the Group 1 stored-liquid maximum true vapor pressure (MTVP) of total organic HAP threshold (for storage vessels at existing and new sources) from greater than or equal to 13.1 kilopascals to greater than or equal to 6.9 kilopascals (see Tables 5 and 6 to subpart G; and sections III.B.1 and IV.B of this preamble).

For transfer racks, we are finalizing:

- removing the exemption for transfer operations that load “at an operating pressure greater than 204.9 kilopascals” from the definition of transfer operation (see 40 CFR 63.101; and sections III.C and IV.C of this preamble).

For wastewater streams, we are finalizing:

- revisions to the Group 1 wastewater stream threshold to include wastewater streams in EtO service (*i.e.*, wastewater streams with total annual average concentration of EtO greater than or equal to 1 parts per million by weight (ppmw) at any flow rate) (see 40 CFR 63.132(c)(1)(iii) and (d)(1)(ii); and sections III.A and IV.A of this preamble).

- requirements prohibiting owners and operators from injecting wastewater into or disposing of water through any heat exchange system in a CMPIU meeting the conditions of 40 CFR 63.100(b)(1) through (3) if the water contains any amount of EtO, has been in contact with any process stream containing EtO, or the water is considered wastewater as defined in 40 CFR 63.101 (see 40 CFR 63.104(k); and sections III.A and IV.A of this preamble).

For closed vent systems, we are finalizing:

- requirements that owners and operators may not bypass an air pollution control device (APCD) at any time (see 40 CFR 63.114(d)(3), 40 CFR 63.127(d)(3), and 40 CFR 63.148(f)(4)), that a bypass is a violation, and that owners and operators must estimate and report the quantity of organic HAP released (see 40 CFR 63.118(a)(5), 40 CFR 63.130(a)(2)(iv), 40 CFR 63.130(b)(3), 40 CFR 63.130(d)(7), and 40 CFR 63.148(i)(3)(iii) and (j)(4); and sections III.C and IV.C of this preamble).

### iii. NESHAP Subparts H and I

As detailed in sections II.B.1.c and II.B.1.d of this preamble, NESHAP subparts H and I contain requirements for equipment leaks. Also, due to space limitations in NESHAP subpart F, we are finalizing fenceline monitoring (*i.e.*, monitoring along the perimeter of the facility’s property line) in NESHAP

subpart H for all emission sources. For equipment leaks and fenceline monitoring, we are finalizing:

- requirements that all connectors in EtO service be monitored monthly at a leak definition of 100 ppm with no skip period, and delay of repair is not allowed unless the equipment can be isolated such that it is no longer in EtO service (see 40 CFR 63.174(a)(3), (b)(3)(vi), and (g)(3), and 40 CFR 63.171(f); and sections III.A and IV.A of this preamble).

- requirements that all gas/vapor and light liquid valves in EtO service be monitored monthly at a leak definition of 100 ppm with no skip period, and delay of repair is not allowed unless the equipment can be isolated such that it is no longer in EtO service (see 40 CFR 63.168(b)(2)(iv) and (d)(5), and 40 CFR 63.171(f); and sections III.A and IV.A of this preamble).

- requirements that all light liquid pumps in EtO service be monitored monthly at a leak definition of 500 ppm, and delay of repair is not allowed unless the equipment can be isolated such that it is no longer in EtO service (see 40 CFR 63.163(a)(1)(iii), (b)(2)(iv), (c)(4), and (e)(7), and 40 CFR 63.171(f); and sections III.A and IV.A of this preamble).

- a work practice standard for pressure relief devices (PRDs) that vent to the atmosphere that require owners and operators to implement at least three prevention measures, perform root cause analysis and corrective action in the event that a PRD does release emissions directly to the atmosphere, and monitor PRDs using a system that is capable of identifying and recording the time and duration of each pressure release and of notifying operators that a pressure release has occurred (see 40 CFR 63.165(e); and sections III.C and IV.C of this preamble).

- requirements that all surge control vessels and bottoms receivers meet the requirements we are finalizing for process vents (see 40 CFR 63.170(b); and sections III.C and IV.C of this preamble).

- requirements that owners and operators may not bypass an APCD at any time (see 40 CFR 63.114(d)(3), 40 CFR 63.127(d)(3), and 40 CFR 63.148(f)(4)), that a bypass is a violation, and that owners and operators must estimate and report the quantity of organic HAP released (see 40 CFR 63.118(a)(5), 40 CFR 63.130(a)(2)(iv), 40 CFR 63.130(b)(3), 40 CFR 63.130(d)(7), and 40 CFR 63.148(i)(3)(iii) and (j)(4); and sections III.C and IV.C of this preamble).

- fenceline monitoring work practice standards requiring owners and operators to monitor for any of six

<sup>4</sup> See footnote 3.

specific HAP (*i.e.*, benzene, 1,3-butadiene, ethylene dichloride, vinyl chloride, EtO, and chloroprene) if their affected source uses, produces, stores, or emits any of them, and conduct root cause analysis and corrective action upon exceeding annual average concentration action levels set forth for each HAP (see 40 CFR 63.184; and sections III.B.1 and IV.B of this preamble).

#### b. P&R I NESHAP

As detailed in section II.B.2 of this preamble, the P&R I NESHAP (40 CFR part 63, subpart U) generally follows and refers to the requirements of the HON, with additional requirements for batch process vents. We are finalizing amendments to the P&R I NESHAP for heat exchange systems, process vents, storage vessels, wastewater, and equipment leaks. For NESHAP subpart U, we are finalizing:

- compliance dates for all of the requirements in this action related to the P&R I NESHAP (see 40 CFR 63.481(n) and (o); and section III.G of this preamble).
- new operating and monitoring requirements for flares (see 40 CFR 63.508; and sections III.C and IV.C of this preamble).
- the removal of the provisions to assert an affirmative defense to civil penalties (see 40 CFR 63.480(j)(4); and sections III.D and IV.D of this preamble).
- the same fence-line monitoring requirements that we are finalizing in Subpart H for HON sources.
- sampling and analysis procedures for owners and operators of affected sources producing neoprene to demonstrate that process equipment does, or does not, meet the definition of being “in chloroprene service” (see 40 CFR 63.509; and sections III.A and IV.A of this preamble).

For heat exchange systems, we are finalizing:

- the same requirements (except for EtO standards) listed in section I.A.2.a.i of this preamble that we are finalizing for heat exchange systems subject to the HON to also apply to heat exchange systems subject to the P&R I NESHAP (see 40 CFR 63.502(n)(7); and sections III.B.1 and IV.B of this preamble).

For continuous front-end process vents, we are finalizing:

- the requirement that owners and operators must reduce emissions of chloroprene from continuous front-end process vents in chloroprene service at affected sources producing neoprene by venting emissions through a closed-vent system to a non-flare control device that reduces chloroprene by greater than or equal to 98 percent by weight, to a

concentration less than 1 ppmv for each process vent, or to less than 5 lb/yr for all combined process vents per elastomer product process unit (EPPU) (see 40 CFR 63.485(y), and 40 CFR 63.510; and sections III.A and IV.A of this preamble).<sup>5</sup>

- the same requirements (except for EtO standards) listed in section I.A.2.a.ii of this preamble that we are finalizing for process vents subject to the HON to also apply to continuous front-end process vents subject to the P&R I NESHAP (see 40 CFR 63.482, 40 CFR 63.485(l)(6), (o)(6), (p)(5), and (x), 40 CFR 63.113(a)(1) and (2), 40 CFR 63.113(a)(4), 40 CFR 63.113(k), 40 CFR 63.114(a)(5)(v); and sections III.B.1 and IV.B of this preamble).

- requirements that owners and operators of continuous front-end process vents in chloroprene service are allowed to use the maintenance vent work practice standards; however, owners and operators are prohibited from releasing more than 1.0 ton of chloroprene from all maintenance vents combined on a facility basis in any consecutive 12-month period (see 40 CFR 63.485(z); and sections III.A and IV.A of this preamble).

- the same dioxins and furans emission standard that we are finalizing for process vents subject to the HON of 0.054 ng/dscm at 3 percent oxygen (toxic equivalency basis) to also apply to chlorinated continuous front-end process vents (see 40 CFR 63.485(x); and sections III.C and IV.C of this preamble).

For batch front-end process vents, we are finalizing:

- the removal of the annual organic HAP emissions mass flow rate, cutoff flow rate, and annual average batch vent flow rate Group 1 process vent thresholds from the Group 1 batch front-end process vent definition (these thresholds were previously determined on an individual batch process vent basis). Instead, owners and operators of batch front-end process vents that release total annual organic HAP emissions greater than or equal to 4,536 kilograms per year (kg/yr) (10,000 pounds per year (lb/yr)) from all batch front-end process vents combined are required to reduce emissions of organic HAP from these process vents using a flare meeting the operating and

monitoring requirements for flares; or reduce emissions of organic HAP or total organic carbon (TOC) by 90 percent by weight (or to an exit concentration of 20 ppmv if considered an “aggregate batch vent stream” as defined by the rule) (see 40 CFR 63.482, 40 CFR 63.487(e)(1)(iv), 40 CFR 63.488(d)(2), (e)(4), (f)(2), and (g)(3); and sections III.B.1 and IV.B of this preamble).

- the same chloroprene standards that we are finalizing for continuous front-end process for batch front-end process vents at affected sources producing neoprene (see 40 CFR 63.487(j); and sections III.A and IV.A of this preamble).

- the same work practice standards that we are finalizing for maintenance vents as described for HON to the P&R I NESHAP (see 40 CFR 63.487(i); and sections III.C and IV.C of this preamble).

- requirements that owners and operators of batch front-end process vents in chloroprene service are allowed to use the maintenance vent work practice standards; however, owners and operators are prohibited from releasing more than 1.0 ton of chloroprene from all maintenance vents combined on a facility basis in any consecutive 12-month period (see 40 CFR 63.487(i)(4); and sections III.A and IV.A of this preamble).

- the same dioxins and furans emission standard that we are finalizing for process vents subject to the HON of 0.054 ng/dscm at 3 percent oxygen (toxic equivalency basis) to also apply to chlorinated batch front-end process vents (see 40 CFR 63.487(a)(3) and (b)(3); and sections III.C and IV.C of this preamble).

For back-end process vents, we are finalizing:

- a requirement that owners and operators reduce emissions of chloroprene from back-end process vents in chloroprene service at affected sources producing neoprene by venting emissions through a closed-vent system to a non-flare control device that reduces chloroprene by greater than or equal to 98 percent by weight, to a concentration less than 1 ppmv for each process vent, or to less than 5 lb/yr for all combined process vents (see 40 CFR 63.494(a)(7); and sections III.A and IV.A of this preamble).

For storage vessels, we are finalizing:

- the requirement that owners and operators reduce emissions of chloroprene from storage vessels in chloroprene service at affected sources producing neoprene by venting emissions through a closed-vent system to a non-flare control device that reduces chloroprene by greater than or equal to 98 percent by weight or to a

<sup>5</sup> We are also removing the option to allow use of a design evaluation in lieu of performance testing to demonstrate compliance for controlling various emission sources in chloroprene service. In addition, owners or operators are required to conduct an initial performance test on each non-flare control device in chloroprene service to verify performance at the required level of control, and are required to conduct periodic performance testing on non-flare control devices in chloroprene service every 5 years (see 40 CFR 63.510).

concentration less than 1 ppmv for each storage vessel vent (see 40 CFR 63.484(u) and 40 CFR 63.510; and sections III.A and IV.A of this preamble).<sup>6</sup>

- the same requirements (except for EtO standards) listed in section I.A.2.a.ii of this preamble that we are finalizing for storage vessels subject to the HON except the requirements apply to storage vessels subject to the P&R I NESHAP (see 40 CFR 63.484(t); and sections III.B.1 and IV.B of this preamble).

For wastewater streams, we are finalizing:

- the Group 1 wastewater stream threshold to include wastewater streams in chloroprene service at affected sources producing neoprene (*i.e.*, wastewater streams with total annual average concentration of chloroprene greater than or equal to 10 ppmw at any flow rate) (see 40 CFR 63.501(a)(10)(iv); and sections III.A and IV.A of this preamble).

- requirements prohibiting owners and operators from injecting wastewater into or disposing of water through any heat exchange system in an EPPU if the water contains any amount of chloroprene, has been in contact with any process stream containing chloroprene, or the water is considered wastewater as defined in 40 CFR 63.482 (see 40 CFR 63.502(n)(8); and sections III.A and IV.A of this preamble).

For equipment leaks and fenceline monitoring, we are finalizing:

- the same requirements (except for EtO standards) listed in section I.A.2.a.iii of this preamble that we are finalizing for equipment leaks subject to the HON except the requirements apply to equipment leaks subject to the P&R I NESHAP (see 40 CFR 63.502(a)(1) through (a)(6); and sections III.C and IV.C of this preamble).

- the cross-reference in the P&R I NESHAP to the fenceline monitoring work practice standards in the HON (see 40 CFR 63.502) requiring owners and operators to monitor for any of six specific HAP (*i.e.*, benzene, 1,3-butadiene, ethylene dichloride, vinyl chloride, EtO, and chloroprene) if their affected source uses, produces, stores, or emits any of them, and conduct root cause analysis and corrective action upon exceeding annual average concentration action levels set forth for each HAP (see sections III.B.1 and IV.B of this preamble), plus a lower annual average concentration action level for chloroprene applicable to neoprene production source category (see sections III.A and IV.A of this preamble).

#### c. P&R II NESHAP

The most significant amendments that we are finalizing for the P&R II NESHAP (40 CFR part 63, subpart W) are requirements for heat exchange systems (see 40 CFR 63.523(d) and 40 CFR 63.524(c); and sections III.C and IV.C of this preamble) and requirements for owners and operators of wet strength resins (WSR) sources to comply with both the equipment leak standards in the HON and the HAP emissions limitation for process vents, storage tanks, and wastewater systems (see 40 CFR 63.524(a)(3) and (b)(3); and sections III.C and IV.C of this preamble). We are also finalizing the same dioxin and furan emission standard of 0.054 ng/dscm at 3 percent oxygen (toxic equivalency basis) for chlorinated process vents as in the HON and the P&R I NESHAP (see 40 CFR 63.523(e) (for process vents associated with each existing, new, or reconstructed affected basic liquid epoxy resins (BLR) source), 40 CFR 63.524(a)(3) (for process vents associated with each existing affected WSR source), and 40 CFR 63.524(b)(3) (for process vents associated with each new or reconstructed affected WSR source); and see sections III.C and IV.C of this preamble).

#### d. NSPS Subparts III, NNN, and RRR

We are amending the applicability of NSPS subparts III, NNN, and RRR so that they only apply to sources constructed, reconstructed, or modified on or before April 25, 2023. Affected facilities that are constructed, reconstructed, or modified after April 25, 2023, are subject to the new NSPS subparts IIIa, NNNa, and RRRa.

#### e. NSPS Subparts IIIa, NNNa, and RRRa

Rather than comply with a TRE concept which is used in NSPS subparts III, NNN, and RRR, we are finalizing in new NSPS subparts IIIa, NNNa, and RRRa a requirement for owners and operators to reduce emissions of TOC (minus methane and ethane) from all vent streams of an affected facility (*i.e.*, SOCM air oxidation unit processes, distillation operations, and reactor processes for which construction, reconstruction, or modification occurs after April 25, 2023) by 98 percent by weight or to a concentration of 20 ppmv on a dry basis corrected to 3 percent oxygen, or combust the emissions in a flare meeting the same operating and monitoring requirements for flares that we are finalizing for flares subject to the HON. We are finalizing a mass-based exemption criterion of 0.001 lb/hr TOC (for which emission controls are not required) in new NSPS subparts IIIa and

NNNa. We are also not including a relief valve discharge exemption in the definition of “vent stream” in new NSPS subparts IIIa, NNNa, and RRRa; instead, any relief valve discharge to the atmosphere of a vent stream is a violation of the emissions standard. In addition, we are finalizing in new NSPS subparts IIIa, NNNa, and RRRa the same work practice standards for maintenance vents that we are finalizing for HON process vents, and the same monitoring requirements that we are finalizing for HON process vents for adsorbers that cannot be regenerated and regenerative adsorbers that are regenerated offsite (see sections III.B.2 and IV.B of this preamble).

#### f. NSPS Subpart VVa

We are amending certain aspects of NSPS subparts VV and VVa to address issues raised in an administrative petition which the Agency granted pursuant to section 307(d)(7)(B) of the CAA. In addition, we are amending the applicability of the existing NSPS subpart VVa so that it applies to sources constructed, reconstructed, or modified after November 6, 2006, and on or before April 25, 2023. Affected facilities that are constructed, reconstructed, or modified after April 25, 2023, are subject to the new NSPS subpart VVb.

#### g. NSPS Subpart VVb

We are finalizing in a new NSPS subpart VVb the same requirements in NSPS subpart VVa plus a requirement that all gas/vapor and light liquid valves be monitored quarterly at a leak definition of 100 ppm and all connectors be monitored once every 12 months at a leak definition of 500 ppm (see sections III.B.2 and IV.B of this preamble). For each of these two additional requirements, we are also finalizing skip periods for good performance.

#### 3. Costs and Benefits

Pursuant to E.O. 12866, the EPA prepared an analysis of the potential costs and benefits associated with this action. This analysis, titled *Regulatory Impact Analysis for the Final New Source Performance Standards for the Synthetic Organic Chemical Manufacturing Industry and National Emission Standards for Hazardous Air Pollutants for the Synthetic Organic Chemical Manufacturing Industry and Group I & II Polymers and Resins Industry* (referred to as the RIA in this document), is available in the docket, and is also briefly summarized in section V of this preamble. The assessment of costs and benefits described herein and in the RIA is

<sup>6</sup> See footnote 5.

presented solely for the purposes of complying with E.O. 12866 and to provide the public with a complete depiction of the impacts of this final action. The EPA notes that analysis of costs and benefits in the RIA is distinct from the determinations finalized in this action under CAA sections 111 and 112, which are based on the statutory factors the EPA is required to consider under those sections.

#### B. Does this action apply to me?

**Regulated entities.** Categories and entities potentially regulated by this action are the SOCMCI source category (and whose facilities, sources and processes we often refer to as “HON facilities,” “HON sources,” and “HON processes” for purposes of the NESHAP) and several Polymers and Resins Production source categories covered in the P&R I and P&R II NESHAP (see section II.B of this preamble for detailed information about the source categories).<sup>7</sup> The North American Industry Classification System (NAICS) code for SOCMCI facilities begins with 325, for P&R I facilities is 325212, and for P&R II facilities is 325211. The list of NAICS codes is not intended to be exhaustive, but rather provides a guide for readers regarding the entities that this final action is likely to affect.

As defined in the *Initial List of Categories of Sources Under Section 112(c)(1) of the Clean Air Act Amendments of 1990* (see 57 FR 31576, July 16, 1992) and *Documentation for Developing the Initial Source Category List, Final Report* (see EPA-450/3-91-030, July 1992), the SOCMCI source category is any facility engaged in “manufacturing processes that produce one or more of the chemicals [listed] that either: (1) Use an organic HAP as a reactant or (2) produce an organic HAP as a product, co-product, by-product, or isolated intermediate.”<sup>8</sup> In the development of NESHAP for this

<sup>7</sup> The P&R I NESHAP includes MACT standards for nine listed elastomer production source categories (i.e., Butyl Rubber Production, Epichlorohydrin Elastomers Production, Ethylene-Propylene Elastomers Production, Hypalon™ Production, Neoprene Production, Nitrile Butadiene Rubber Production, Polybutadiene Rubber Production, Polysulfide Rubber Production, and Styrene-Butadiene Rubber and Latex Production). The P&R II NESHAP includes MACT standards for two listed source categories that use epichlorohydrin feedstock (Epoxy Resins Production and Non-Nylon Polyamides Production).

<sup>8</sup> The original list of chemicals is located in Appendix A (beginning on page A-71) of EPA-450/3-91-030 dated July 1992. Alternatively, the most recent list of chemicals is documented in the HON applicability rule text at 40 CFR 63.100(b)(1) and (2). The original list of organic HAPs for the SOCMCI source category is located in Table 3.1 of Section 3.0 of EPA-450/3-91-030.

source category, the EPA considered emission sources associated with: equipment leaks (including leaks from heat exchange systems), process vents, transfer racks, storage vessels, and wastewater collection and treatment systems. The elastomer production source categories in the P&R I NESHAP and resins produced with epichlorohydrin feedstock in the P&R II NESHAP have many similar emission sources with SOCMCI sources and are discussed further in section II.B of this preamble.

The EPA Priority List (40 CFR 60.16, 44 FR 49222, August 21, 1979) included “Synthetic Organic Chemical Manufacturing”<sup>9</sup> as a source category for which standards of performance were to be promulgated under CAA section 111. In the development of NSPS subparts VVa, III, NNN, and RRR for this source category, the EPA considered emission sources associated with unit processes, storage and handling equipment, fugitive emission sources, and secondary sources.

To determine whether your facility is affected, you should examine the applicability criteria in the appropriate NESHAP or NSPS. If you have any questions regarding the applicability of any aspect of these NESHAP and NSPS, please contact the appropriate person listed in the preceding **FOR FURTHER INFORMATION CONTACT** section of this preamble.

#### C. Where can I get a copy of this document and other related information?

In addition to being available in the docket, an electronic copy of this final action will also be available on the internet. Following signature by the EPA Administrator, the EPA will post a copy of this final action at: <https://www.epa.gov/stationary-sources-air-pollution/synthetic-organic-chemical-manufacturing-industry-organic-national>, <https://www.epa.gov/stationary-sources-air-pollution/group-i-polymers-and-resins-national-emission-standards-hazardous>, and <https://www.epa.gov/stationary-sources-air-pollution/epoxy-resins-production-and-non-nylon-polyamides-national-emission>. Following publication in the **Federal Register**, the EPA will post the **Federal Register** version and key technical documents at these same websites.

Additional information is available on the RTR website at <https://www.epa.gov/stationary-sources-air-pollution/risk-and-technology-review>.

<sup>9</sup> For readability, we also refer to this as the SOCMCI source category for purposes of the NSPS.

*national-emissions-standards-hazardous*. This information includes an overview of the RTR program and links to project websites for the RTR source categories.

#### D. Judicial Review and Administrative Reconsideration

Under CAA section 307(b)(1), judicial review of this final action is available only by filing a petition for review in the United States Court of Appeals for the District of Columbia Circuit (the Court) by July 15, 2024. Under CAA section 307(b)(2), the requirements established by these final rules may not be challenged separately in any civil or criminal proceedings brought to enforce the requirements.

Section 307(d)(7)(B) of the CAA further provides that only an objection to a rule or procedure which was raised with reasonable specificity during the period for public comment (including any public hearing) may be raised during judicial review. This section also provides a mechanism for the EPA to reconsider the rule if the person raising an objection can demonstrate to the Administrator that it was impracticable to raise such objection within the period for public comment or if the grounds for such objection arose after the period for public comment (but within the time specified for judicial review) and if such objection is of central relevance to the outcome of the rule. Any person seeking to make such a demonstration should submit a Petition for Reconsideration to the Office of the Administrator, U.S. EPA, Room 3000, WJC South Building, 1200 Pennsylvania Ave. NW, Washington, DC 20460, with a copy to both the person(s) listed in the preceding **FOR FURTHER INFORMATION CONTACT** section, and the Associate General Counsel for the Air and Radiation Law Office, Office of General Counsel (Mail Code 2344A), U.S. EPA, 1200 Pennsylvania Ave. NW, Washington, DC 20460.

## II. Background

### A. What is the statutory authority for this action?

#### 1. NESHAP

The statutory authority for this action related to NESHAP is provided by sections 112 and 301 of the CAA, as amended (42 U.S.C. 7401 *et seq.*). Section 112 of the CAA establishes a two-stage regulatory process to develop standards for emissions of HAP from stationary sources. “Major sources” are those that emit, or have the potential to emit, any single HAP at a rate of 10 tpy or more, or 25 tpy or more of any combination of HAP. For major sources,



these standards are commonly referred to as MACT standards and must reflect the maximum degree of emission reductions of HAP achievable (after considering cost, energy requirements, and non-air quality health and environmental impacts). In developing MACT standards, CAA section 112(d)(2) directs the EPA to consider the application of measures, processes, methods, systems, or techniques, including, but not limited to, those that reduce the volume of or eliminate HAP emissions through process changes, substitution of materials, or other modifications; enclose systems or processes to eliminate emissions; collect, capture, or treat HAP when released from a process, stack, storage, or fugitive emissions point; are design, equipment, work practice, or operational standards; or any combination of the above. The MACT standards may take the form of design, equipment, work practice or operational standards where the EPA first determines either that (1) a pollutant cannot be emitted through a conveyance designed and constructed to emit or capture the pollutant, or that any requirement for, or use of, such a conveyance would be inconsistent with law; or (2) the application of measurement methodology to a particular class of sources is not practicable due to technological and economic limitations. CAA section 112(h)(1)–(2).

For these MACT standards, the statute specifies certain minimum stringency requirements, which are referred to as MACT floor requirements, and which may not be based on cost considerations. See CAA section 112(d)(3). For new sources, the MACT floor cannot be less stringent than the emission control achieved in practice by the best-controlled similar source. The MACT standards for existing sources can be less stringent than floors for new sources, but they cannot be less stringent than the average emission limitation achieved by the best-performing 12 percent of existing sources in the category or subcategory (or the best-performing five sources for categories or subcategories with fewer than 30 sources). In developing MACT standards, we must also consider control options that are more stringent than the floor under CAA section 112(d)(2). We may establish standards more stringent than the floor, based on the consideration of the cost of achieving the emissions reductions, any non-air quality health and environmental impacts, and energy requirements.

In the second stage of the regulatory process, the CAA requires the EPA to undertake two different analyses, which we refer to as the technology review and the residual risk review. Under the technology review, we must review the technology-based standards and revise them “as necessary (taking into account developments in practices, processes, and control technologies)” no less frequently than every 8 years, pursuant to CAA section 112(d)(6). In conducting this review, the EPA is not required to recalculate the MACT floors that were established in earlier rulemakings. *Natural Resources Defense Council (NRDC) v. EPA*, 529 F.3d 1077, 1084 (D.C. Cir. 2008); *Association of Battery Recyclers, Inc. v. EPA*, 716 F.3d 667 (D.C. Cir. 2013). The EPA may consider cost in deciding whether to revise the standards pursuant to CAA section 112(d)(6). The EPA is required to address regulatory gaps, such as missing standards for listed air toxics known to be emitted from the source category, and any new MACT standards must be established under CAA sections 112(d)(2) and (3), or, in specific circumstances, CAA sections 112(d)(4) or (h). *Louisiana Environmental Action Network v. EPA*, 955 F.3d 1088 (D.C. Cir. 2020). Under the residual risk review, we must evaluate the risk to public health remaining after application of the technology-based standards and revise the standards, if necessary, to provide an ample margin of safety to protect public health or to prevent, taking into consideration costs, energy, safety, and other relevant factors, an adverse environmental effect. The residual risk review is required within 8 years after promulgation of the MACT standards, pursuant to CAA section 112(f). In conducting the residual risk review, if the EPA determines that the current standards provide an ample margin of safety to protect public health, it is not necessary to revise the MACT standards pursuant to CAA section 112(f).<sup>10</sup> For more information on the statutory authority for this rule, see 88 FR 25080, April 25, 2023. Often, the CAA section 112(d)(6) technology review and the CAA section 112(f)(2) residual risk review are combined into a single rulemaking action, commonly called a “risk and technology review” (RTR).

The EPA conducted a combined RTR for the HON in 2006, concluding that

<sup>10</sup> The Court has affirmed this approach of implementing CAA section 112(f)(2)(A): *NRDC v. EPA*, 529 F.3d 1077, 1083 (D.C. Cir. 2008) (“If EPA determines that the existing technology-based standards provide an ‘ample margin of safety,’ then the Agency is free to readopt those standards during the residual risk rulemaking.”).

there was no need to revise the HON under the provisions of either CAA section 112(f) or 112(d)(6). As part of the residual risk review, the EPA conducted a risk assessment and, based on the results of the risk assessment, determined that the then-current level of control called for by the existing MACT standards both reduced HAP emissions to levels that presented an acceptable level of risk and provided an ample margin of safety to protect public health (see 71 FR 76603, December 21, 2006 for additional details). In 2008, the EPA conducted a combined RTR for four of the P&R I source categories (including the Polysulfide Rubber Production, Ethylene-Propylene Elastomers Production, Butyl Rubber Production, and Neoprene Production source categories) and all P&R II source categories (Epoxy Resins Production and Non-Nylon Polyamides Production source categories). In 2011, the EPA completed the combined RTR for the remaining five P&R I source categories (Epichlorohydrin Elastomers Production, Hypalon™ Production, Polybutadiene Rubber Production, Styrene-Butadiene Rubber and Latex Production, and Nitrile Butadiene Rubber Production). The EPA concluded in these actions that there was no need to revise standards for any of the nine P&R I source categories and two P&R II source categories under the provisions of either CAA section 112(f) or 112(d)(6) (see 73 FR 76220, December 16, 2008 and 77 FR 22566, April 21, 2011 for additional details).<sup>11</sup>

This action constitutes another CAA section 112(d)(6) technology review for the HON and the P&R I and P&R II NESHAP. This action also constitutes an updated CAA section 112(f) risk review based on new information for the HON and for affected sources producing neoprene subject to the P&R I NESHAP. We note that although there is no statutory CAA obligation under CAA section 112(f) for the EPA to conduct a second residual risk review of the HON or of standards for affected sources producing neoprene subject to the P&R I NESHAP, the EPA retains discretion to revisit its residual risk reviews where the Agency deems that to be warranted. See, e.g., *Fed. Comm’n’s Comm’n v. Fox Television Stations, Inc.*, 556 U.S. 502,

<sup>11</sup> We note that in the April 21, 2011, rulemaking (see 77 FR 22566), the EPA finalized amendments to eliminate the SSM exemption in the P&R I NESHAP; however, for consistency with the SSM related amendments that we are finalizing for the HON and the P&R II NESHAP, we are also finalizing (as detailed in section IV.D of this preamble) additional amendments to the P&R I NESHAP related to the SSM exemption that were not addressed in the April 21, 2011, P&R I rule.

515 (2009); *Motor Vehicle Mfrs. Ass'n v. State Farm Mut. Auto. Ins. Co.*, 463 U.S. 29, 42 (1983); *Ethylene Oxide Emissions Standards for Sterilization Facilities; Final Decision*, 71 FR 17712, 17715 col. 1 (April 7, 2006) (asserting authority, in residual risk review for EtO, for EPA “to revisit (and revise, if necessary) any rulemaking if there is sufficient evidence that changes within the affected industry or significant improvements to science suggests the public is exposed to significant increases in risk as compared to the risk assessment prepared for the rulemaking (e.g., CAA section 301).”).

Here, the specific changes to health information related to certain pollutants emitted by these unique categories led us to determine that it is appropriate, in this case, to conduct these second residual risk reviews under CAA section 112(f). In particular, the EPA is concerned about the cancer risks posed by the SOGMI source category due to the EPA’s 2016 updated IRIS inhalation URE for EtO, which shows EtO to be significantly more toxic than previously known.<sup>12</sup> This updated URE was not available in 2006, when the EPA conducted its last RTR, but if this URE had been available, the EPA would almost undoubtedly have reached different conclusions about risk acceptability and the need to modify the standards to provide an ample margin of safety to protect public health. Similarly, for chloroprene, when the EPA conducted the first residual risk assessment for the SOGMI and Neoprene Production source categories, there was no inhalation URE for chloroprene. Therefore, in those risk reviews, the EPA attributed no cancer risk to chloroprene. The EPA concluded development of the IRIS inhalation URE for chloroprene in 2010. That URE allows us to assess, for the first time, the cancer risks posed by chloroprene. Had the EPA had the benefit of this new URE at the time it conducted the 2006 and 2008 RTRs, the URE would almost undoubtedly have impacted our conclusions about risk acceptability and the P&R I standards’ provision of an ample margin of safety to protect public

health. Instead, we are conducting that analysis in this action.

In order to ensure our standards provide an ample margin of safety to protect public health following the new IRIS inhalation UREs for EtO and chloroprene, we are exercising our discretion and conducting risk assessments in this action for HON sources and for affected sources producing neoprene subject to the P&R I NESHAP. Finally, we note that on September 15, 2021, the EPA partially granted a citizen administrative petition requesting that the EPA conduct a second residual risk review under CAA section 112(f)(2) for the HON, stating our intent to conduct a human health risk assessment concurrently with the section 112(d)(6) review.<sup>13</sup> Likewise, on March 4, 2022, the EPA partially granted another citizen administrative petition requesting that the EPA also conduct a second residual risk review under CAA section 112(f) for the Neoprene Production source category in the P&R I NESHAP, stating that we intend to conduct a human health risk assessment concurrently with the section 112(d)(6) review.<sup>14</sup> This final rulemaking is partly undertaken in response to those citizen administrative petitions. In sum, even though we do not have a mandatory duty to conduct repeated residual risk reviews under CAA section 112(f)(2), we have the authority to revisit any rulemaking if there is: (1) Significant new scientific information suggesting the public is exposed to higher risks from facilities subject to the HON and the P&R I and P&R II NESHAP than previously realized, as compared to the previous risk assessments prepared for earlier rulemakings, or (2) sufficient evidence that changes within the affected industry are exposing the public to new risks.

## 2. NSPS

The EPA’s authority for the final NSPS rules is CAA section 111, which governs the establishment of standards of performance for stationary sources. Section 111(b)(1)(A) of the CAA requires the EPA Administrator to list categories of stationary sources that in the Administrator’s judgment cause or contribute significantly to air pollution that may reasonably be anticipated to endanger public health or welfare. The

EPA must then issue performance standards for new (and modified or reconstructed) sources in each source category pursuant to CAA section 111(b)(1)(B). These standards are referred to as new source performance standards, or NSPS. The EPA has the authority to define the scope of the source categories, determine the pollutants for which standards should be developed, set the emission level of the standards, and distinguish among classes, types, and sizes within categories in establishing the standards.

CAA section 111(b)(1)(B) requires the EPA to “at least every 8 years review and, if appropriate, revise” NSPS. However, the Administrator need not review any such standard if the “Administrator determines that such review is not appropriate in light of readily available information on the efficacy” of the standard. When conducting a review of an existing performance standard, the EPA has the discretion and authority to add emission limits for pollutants or emission sources not currently regulated for that source category.

In setting or revising a performance standard, CAA section 111(a)(1) provides that performance standards are to reflect “the degree of emission limitation achievable through the application of the BSER which (taking into account the cost of achieving such reduction and any nonair quality health and environmental impact and energy requirements) the Administrator determines has been adequately demonstrated.” The term “standard of performance” in CAA section 111(a)(1) makes clear that the EPA is to determine both the BSER for the regulated sources in the source category and the degree of emission limitation achievable through application of the BSER. The EPA must then, under CAA section 111(b)(1)(B), promulgate standards of performance for new sources that reflect that level of stringency. CAA section 111(h)(1) authorizes the Administrator to promulgate “a design, equipment, work practice, or operational standard, or combination thereof” if in his or her judgment, “it is not feasible to prescribe or enforce a standard of performance.” CAA section 111(h)(2) provides the circumstances under which prescribing or enforcing a standard of performance is “not feasible,” such as, when the pollutant cannot be emitted through a conveyance designed to emit or capture the pollutant, or when there is no practicable measurement methodology for the particular class of sources. CAA section 111(b)(5) precludes the EPA from prescribing a particular technological system that must be used

<sup>12</sup> U.S. EPA. *Evaluation of the Inhalation Carcinogenicity of Ethylene Oxide (CASRN 75-21-8) In Support of Summary Information on the Integrated Risk Information System (IRIS)*. December 2016. EPA/635/R-16/350Fa. Available at: [https://cfpub.epa.gov/ncea/iris/iris\\_documents/documents/toxreviews/1025tr.pdf](https://cfpub.epa.gov/ncea/iris/iris_documents/documents/toxreviews/1025tr.pdf). See also, 87 FR 77985 (Dec. 21, 2022), *Reconsideration of the 2020 National Emission Standards for Hazardous Air Pollutants: Miscellaneous Organic Chemical Manufacturing Residual Risk and Technology Review, Final action; reconsideration of the final rule*.

<sup>13</sup> See letter dated September 15, 2021, from Joseph Goffman to Kathleen Riley, Emma Cheuse, and Adam Kron (see Docket Item No. EPA-HQ-OAR-2022-0730-0047).

<sup>14</sup> See letter dated March 4, 2022, from Joseph Goffman to Emma Cheuse, Deena Tumeah, Michelle Mabson, Maryum Jordan, and Dorian Spence (see Docket Item No. EPA-HQ-OAR-2022-0730-0048).

to comply with a standard of performance. Rather, sources can select any measure or combination of measures that will achieve the standard.

Pursuant to the definition of new source in CAA section 111(a)(2), standards of performance apply to facilities that begin construction, reconstruction, or modification after the date of publication of the proposed standards in the **Federal Register**. Under CAA section 111(a)(4), “modification” means any physical change in, or change in the method of operation of, a stationary source which increases the amount of any air pollutant emitted by such source or which results in the emission of any air pollutant not previously emitted. Changes to an existing facility that do not result in an increase in emissions are not considered modifications. Under the provisions in 40 CFR 60.15, reconstruction means the replacement of components of an existing facility such that: (1) The fixed capital cost of the new components exceeds 50 percent of the fixed capital cost that would be required to construct a comparable entirely new facility; and (2) it is technologically and economically feasible to meet the applicable standards.

In the development of NSPS for the SOCMCI source category, the EPA considered emission sources associated with unit processes, storage and handling equipment, fugitive emission sources, and secondary sources. In 1983, the EPA promulgated NSPS for VOC from equipment leaks in SOCMCI (40 CFR part 60, subpart VV). In 1990, the EPA promulgated NSPS (40 CFR part 60, subparts III and NNN) for VOC from air oxidation unit processes and distillation operations in the SOCMCI (55 FR 26912 and 55 FR 26931). In 1993, the EPA promulgated NSPS (40 CFR part 60, subpart RRR) for VOC from reactor processes in the SOCMCI (58 FR 45948). In 2007, based on its review of NSPS subpart VV, the EPA promulgated certain amendments to NSPS subpart VV and new NSPS (40 CFR part 60, subpart VVa) for VOC from certain equipment leaks in the SOCMCI (72 FR 64883). This final action presents the required CAA 111(b)(1)(B) review of the NSPS for the air oxidation unit processes (subpart III), distillation operations (subpart NNN), reactor processes (subpart RRR), and equipment leaks (subpart VVa).

### 3. Petition for Reconsideration

In addition to the final action under CAA section 111(b)(1)(B) described above, this action includes final amendments to the NSPS subparts VV

and VVa (NSPS for VOC from equipment leaks in SOCMCI) based on its reconsideration of certain aspects of these NSPS subparts that were raised in an administrative petition which the Agency granted pursuant to section 307(d)(7)(B) of the CAA. In January 2008, the EPA received one petition for reconsideration of the NSPS for VOC from equipment leaks in SOCMCI (40 CFR part 60, subparts VV and VVa) and the NSPS for equipment leaks in petroleum refineries (40 CFR part 60, subparts GGG and GGGa) pursuant to CAA section 307(d)(7)(B) from the following petitioners: American Chemistry Council, American Petroleum Institute (API), and National Petrochemical and Refiners Association (now the American Fuel and Petrochemical Manufacturers). A copy of the petition and subsequent EPA correspondence granting reconsideration is provided in the docket for this rulemaking (see Docket No. EPA–HQ–OAR–2022–0730). The petitioners primarily requested that the EPA reconsider four provisions in those rules: (1) The clarification of the definition of process unit in subparts VV, VVa, GGG, and GGGa; (2) the assignment of shared storage vessels to specific process units in subparts VV, VVa, GGG, and GGGa; (3) the monitoring of connectors in subpart VVa; and (4) the definition of capital expenditure in subpart VVa.<sup>15</sup> The rationale for this request is provided in the petition. The petitioners also requested that the EPA stay the effectiveness of these provisions of the rule pending resolution of their petition for reconsideration. On March 4, 2008, the EPA sent a letter to the petitioners informing them that the EPA was granting their request for reconsideration on issues (2) through (4) above. The letter also indicated that the EPA was not taking action on the first issue related to the definition of process unit. Finally, the letter indicated that the EPA was granting a 90-day stay of the provisions of the rules under reconsideration (see CAA section 307(d)(7)(B)), as well as the clarification of the definition of process unit, because of its reliance upon the new provision on the allocation of shared storage vessels. On June 2, 2008, the EPA published three actions in the **Federal Register** relative to extending the 90-day stay. Specifically, the EPA published a direct final rule (73 FR 31372) and a parallel proposal (73 FR 31416) in the

<sup>15</sup> Note that this final action does not respond to the petition for reconsideration of NSPS subparts GGG and GGGa, as the EPA is not reviewing those subparts in this action.

**Federal Register** to extend the stay until we took final action on the issues of which the EPA granted reconsideration. Under the direct final rule, the stay would take effect 30 days after the close of the comment period on the proposed stay if no adverse comments were received. The third notice published that same day was an interim final rule extending the 90-day stay at the time for an additional 60 days so that the stay would not expire before the direct final rule could take effect (73 FR 31376). The EPA did not receive adverse comments on the proposed stay and, as a result, the stay became effective August 1, 2008.

In the three June 2, 2008 actions, the EPA indicated that it would be publishing a **Federal Register** notice in response to the petition; this action constitutes such notice and formally responds to the issues raised in the petition with respect to NSPS subparts VV and VVa. This final action presents the EPA’s revisions to the NSPS for VOC from equipment leaks in SOCMCI based on the EPA’s reconsideration of issues (2) through (4) in the petition. We are also finalizing amendments that address the stay on issue (1) in the petition. See sections III.E and IV.E of this preamble for details about these final amendments.

#### *B. What are the source categories and how did the previous standards regulate emissions?*

The source categories that are the subject of this final action are the SOCMCI source category subject to the HON and 11 Polymers and Resins Production source categories subject to the P&R I and P&R II NESHAP. This final action also addresses equipment leaks in the SOCMCI and SOCMCI air oxidation unit processes, distillation operations, and reactor processes. The NESHAP and NSPS included in this action that regulate emission sources from the SOCMCI and Polymers and Resins Production source categories are described below.

#### 1. HON

The sources affected by the HON include heat exchange systems and maintenance wastewater located at SOCMCI facilities that are regulated under NESHAP subpart F; process vents, storage vessels, transfer racks, and wastewater streams located at SOCMCI facilities that are regulated under NESHAP subpart G; equipment leaks associated with SOCMCI processes regulated under NESHAP subpart H; and equipment leaks from certain non-SOCMCI processes at chemical plants regulated under NESHAP subpart I. As

previously mentioned, these four NESHAP are more commonly referred together as the HON.

In general, the HON applies to CMPUs that: (1) Produce one of the listed SOCOMI chemicals,<sup>16</sup> and (2) either use as a reactant or produce a listed organic HAP in the process. A CMPU means the equipment assembled and connected by pipes or ducts to process raw materials and to manufacture an intended product. A CMPU consists of more than one unit operation. A CMPU includes air oxidation reactors and their associated product separators and recovery devices; reactors and their associated product separators and recovery devices; distillation units and their associated distillate receivers and recovery devices; associated unit operations; associated recovery devices; and any feed, intermediate and product storage vessels, product transfer racks, and connected ducts and piping. A CMPU includes pumps, compressors, agitators, PRDs, sampling connection systems, open-ended valves or lines (OEL), valves, connectors, instrumentation systems, and control devices or systems. A CMPU is identified by its primary product.

#### a. NESHAP Subpart F

NESHAP subpart F contains provisions to determine which chemical manufacturing processes at a SOCOMI facility are subject to the HON. Table 1 of NESHAP subpart F contains a list of SOCOMI chemicals, and Table 2 of NESHAP subpart F contains a list of organic HAP regulated by the HON. In general, if a process both: (1) Produces one of the listed SOCOMI chemicals and (2) either uses as a reactant or produces a listed organic HAP in the process, then that SOCOMI process is subject to the HON. Details on how to determine which emission sources (*i.e.*, heat exchange systems, process vents, storage vessels, transfer racks, wastewater, and equipment leaks) are part of a chemical manufacturing process are also contained in NESHAP subpart F. NESHAP subpart F also contains monitoring requirements for HAP (*i.e.*, HAP listed in Table 4 of NESHAP subpart F) that may leak into cooling water from heat exchange systems. Additionally, NESHAP subpart F requires sources to prepare a description of procedures for managing maintenance wastewater as part of a SSM plan.

#### b. NESHAP Subpart G

NESHAP subpart G contains the standards for process vents, transfer

racks, storage vessels, and wastewater at SOCOMI facilities; it also includes emissions averaging provisions. NESHAP subpart G provides an equation representing a site-specific allowable overall emission limit for the combination of all emission sources subject to the HON at a SOCOMI facility. Existing sources must demonstrate compliance using one of two approaches: the point-by-point compliance approach or the emissions averaging approach. New sources are not allowed to use emissions averaging, but rather must demonstrate compliance using the point-by-point approach. Under the point-by-point approach, the owner or operator would apply control to each Group 1 emission source. A Group 1 emission source is a point which meets the control applicability criteria, and the owner or operator must reduce emissions to specified levels; whereas a Group 2 emission source is one that does not meet the criteria and no additional emission reduction is required. Under the emissions averaging approach, an owner or operator may elect to control different groups of emission sources to different levels than specified by the point-by-point approach, as long as the overall emissions do not exceed the overall allowable emission level. For example, an owner or operator can choose not to control a Group 1 emission source (or to control the emission source with a less effective control technique) if the owner or operator over-controls another emission source. For the point-by-point approach, NESHAP subpart G contains the following standards:

- Group 1 process vents must reduce emissions of organic HAP using a flare meeting 40 CFR 63.11(b); reduce emissions of total organic HAP or TOC by 98 percent by weight or to an exit concentration of 20 ppmv;<sup>17</sup> or achieve and maintain a TRE index value<sup>18</sup> greater than 1.0.<sup>19</sup>

<sup>17</sup> The phrase “whichever is less stringent” was originally used as part of this NESHAP standard; however, we have determined the phrase does not serve any meaningful purpose and are removing it in this final action. For specific details about this editorial correction, refer to section 4.3 of the document titled *Summary of Public Comments and Responses for New Source Performance Standards for the Synthetic Organic Chemical Manufacturing Industry and National Emission Standards for Hazardous Air Pollutants for the Synthetic Organic Chemical Manufacturing Industry and Group I & II Polymers and Resins Industry*, which is available in the docket for this rulemaking.

<sup>18</sup> See section III.C.3.a of the preamble to the proposed rule (88 FR 25080, April 25, 2023) for a description of the TRE index value and how the concept is currently used in the HON.

<sup>19</sup> Halogenated vent streams (as defined in NESHAP subpart G) from Group 1 process vents may not be vented to a flare and must reduce the overall emissions of hydrogen halides and halogens

- Group 1 transfer racks must reduce emissions of total organic HAP by 98 percent by weight or to an exit concentration of 20 ppmv;<sup>20</sup> or reduce emissions of organic HAP using a flare meeting 40 CFR 63.11(b), using a vapor balancing system, or by routing emissions to a fuel gas system or to a process.

- Group 1 storage vessels must reduce emissions of organic HAP using a fixed roof tank equipped with an IFR; using an external floating roof (EFR); using an EFR tank converted to a fixed roof tank equipped with an IFR; by routing emissions to a fuel gas system or to a process; or reduce emissions of organic HAP by 95 percent by weight using a closed vent system (*i.e.*, vapor collection system) and control device, or combination of control devices (or reduce emissions of organic HAP by 90 percent by weight using a closed vent system and control device if the control device was installed before December 31, 1992).

- Group 1 process wastewater streams and equipment managing such streams at both new and existing sources must meet control requirements for: (1) Waste management units including wastewater tanks, surface impoundments, containers, individual drain systems, and oil-water separators; (2) treatment processes including the design steam stripper, biological treatment units, or other treatment devices; and (3) closed vent systems and control devices such as flares, catalytic incinerators, *etc.* Existing sources are not required to meet control requirements if Group 1 process wastewater streams are included in a 1 megagram per year source-wide exemption allowed by NESHAP subpart G.

- In general, Group 2 emission sources are not required to apply any additional emission controls (provided they remain below Group 1 thresholds); however, they are subject to certain monitoring, reporting, and recordkeeping requirements to ensure that they were correctly determined to be Group 2 and that they remain Group 2.

#### c. NESHAP Subpart H

NESHAP subpart H contains the standard for equipment leaks at SOCOMI facilities, including leak detection and repair (LDAR) provisions and other control requirements. Equipment regulated includes pumps, compressors, agitators, PRDs, sampling connection

by 99 percent (or 95 percent for control devices installed prior to December 31, 1992) or reduce the outlet mass emission rate of total hydrogen halides and halogens to less than 0.45 kg/hr.

<sup>20</sup> See footnote 17.

<sup>16</sup> See Table 1 to NESHAP subpart F.

systems, OEL, valves, connectors, surge control vessels, bottoms receivers, and instrumentation systems in organic HAP service. A piece of equipment is in organic HAP service if it contains or contacts a fluid that is at least 5 percent by weight organic HAP. Depending on the type of equipment, the standards require either periodic monitoring for and repair of leaks, the use of specified equipment to minimize leaks, or specified work practices. Monitoring for leaks must be conducted using EPA Method 21 in appendix A–7 to 40 CFR part 60 or other approved equivalent monitoring techniques.

#### d. NESHAP Subpart I

NESHAP subpart I provides the applicability criteria for certain non-SOCMI processes subject to the negotiated regulation for equipment leaks. Regulated equipment is the same as that for NESHAP subpart H.

#### 2. P&R I NESHAP

The P&R I NESHAP generally follows and refers to the requirements of the HON, with additional requirements for batch process vents. Generally, the P&R I NESHAP applies to EPPUs and associated equipment. Similar to a CMPU in the HON, an EPPU means a collection of equipment assembled and connected by hard-piping or duct work used to process raw materials and manufacture elastomer product. The EPPU includes unit operations, recovery operations, process vents, storage vessels, and equipment that are covered by equipment leak standards and produce one of the elastomer types listed as an elastomer product, including: butyl rubber, epichlorohydrin elastomer, ethylene propylene rubber, halobutyl rubber, Hypalon™, neoprene, nitrile butadiene latex, nitrile butadiene rubber, polybutadiene rubber/styrene butadiene rubber by solution, polysulfide rubber, styrene butadiene latex, and styrene butadiene rubber by emulsion. An EPPU consists of more than one unit operation. An EPPU includes, as “equipment,” pumps, compressors, agitators, PRDs, sampling connection systems, OEL, valves, connectors, surge control vessels, bottoms receivers, instrumentation systems, and control devices or systems.

The emissions sources affected by the P&R I NESHAP include heat exchange systems and maintenance wastewater at P&R I facilities regulated under NESHAP subpart F; storage vessels, transfer racks, and wastewater streams at P&R I facilities regulated under NESHAP subpart G; and equipment leaks at P&R I facilities regulated under

NESHAP subpart H. Process vents are also regulated emission sources but, unlike the HON, these emissions sources are subdivided into front and back-end process vents in the P&R I NESHAP. The front-end are unit operations prior to and including the stripping operations. These are further subdivided into continuous front-end process vents regulated under NESHAP subpart G and batch front-end process vents that are regulated according to the requirements within the P&R I NESHAP. Back-end unit operations include filtering, coagulation, blending, concentration, drying, separating, and other finishing operations, as well as latex and crumb storage. The requirements for back-end process vents are not subcategorized into batch or continuous and are also found within the P&R I NESHAP.

#### 3. P&R II NESHAP

The P&R II NESHAP regulates HAP emissions from two source categories, Epoxy Resins Production (also referred to as BLR) and Non-Nylon Polyamides Production (also referred to as WSR). The P&R II NESHAP takes a different regulatory and format approach from the P&R I NESHAP but still refers to HON provisions for a portion of the standards. BLR are resins made by reacting epichlorohydrin and bisphenol A to form diglycidyl ether of bisphenol-A. WSR are polyamide/epichlorohydrin condensates which are used to increase the tensile strength of paper products.

The emission sources affected by the P&R II NESHAP are all HAP emission points within a facility related to the production of BLR or WSR. These emission points include process vents, storage tanks, wastewater systems, and equipment leaks. Equipment includes connectors, pumps, compressors, agitators, PRDs, sampling connection systems, OEL, and instrumentation system in organic HAP service. Equipment leaks are regulated under the HON (*i.e.*, NESHAP subpart H).

Process vents, storage tanks, and wastewater systems combined are regulated according to a production-based emission rate (*e.g.*, pounds HAP per million pounds BLR or WSR produced). For existing sources, the rate shall not exceed 130 pounds per 1 million pounds of BLR produced and 10 pounds per 1 million pounds of WSR produced. For new sources, BLR requires all uncontrolled emissions to achieve 98 percent reduction or limits the total emissions to 5,000 pounds of HAP per year. New WSR sources are limited to 7 pounds of HAP per 1 million pounds of WSR produced.

#### 4. NSPS Subpart VVa

NSPS subpart VVa contains VOC standards for leaks from equipment within a process unit for which construction, reconstruction, or modification commenced after November 7, 2006. Under NSPS subpart VVa, equipment means each pump, compressor, PRD, sampling connection system, OEL, valve, and flange or other connector in VOC service and any devices or systems required by the NSPS. Process units consist of components assembled to produce, as intermediate or final products, one or more of the chemicals listed in 40 CFR 60.489. A process unit can operate independently if supplied with sufficient feed or raw materials and sufficient storage facilities for the product. The standards in NSPS subpart VVa include LDAR provisions and other control requirements. A piece of equipment is in VOC service if it contains or contacts a fluid that is at least 10 percent by weight VOC. Depending on the type of equipment, the standards require either periodic monitoring for and repair of leaks, the use of specified equipment to minimize leaks, or specified work practices. Monitoring for leaks must be conducted using EPA Method 21 in appendix A–7 to 40 CFR part 60 or other approved equivalent monitoring techniques.

#### 5. NSPS Subpart III

NSPS subpart III regulates VOC emissions from SOCMI air oxidation reactors for which construction, reconstruction, or modification commenced after October 21, 1983. For the purpose of NSPS subpart III, air oxidation reactors are devices or process vessels in which one or more organic reactants are combined with air, or a combination of air and oxygen, to produce one or more organic compounds. The affected facility is designated as a single air oxidation reactor with its own individual recovery system (if any) or the combination of two or more air oxidation reactors and the common recovery system they share that produces one or more of the chemicals listed in 40 CFR 60.617 as a product, co-product, by-product, or intermediate. The BSER for reducing VOC emissions from SOCMI air oxidation units was identified as combustion (*e.g.*, incineration, flares) and the standard of performance requires owners and operators of an affected facility to reduce emissions of TOC (minus methane and ethane) by 98 percent by weight or to a concentration of 20 ppmv on a dry basis corrected to

3 percent oxygen;<sup>21</sup> combust the emissions in a flare meeting 40 CFR 60.18(b); or maintain a TRE index value<sup>22</sup> greater than 1.0 without use of VOC emission control devices.

#### 6. NSPS Subpart NNN

NSPS subpart NNN regulates VOC emissions from SOCOMI distillation operations for which construction, reconstruction, or modification commenced after December 30, 1983. For the purpose of NSPS subpart NNN, distillation operations are operations separating one or more feed stream(s) into two or more exit stream(s), each exit stream having component concentrations different from those in the feed stream(s); and the separation is achieved by the redistribution of the components between the liquid and vapor-phase as they approach equilibrium within a distillation unit. The affected facility is designated as a single distillation column with its own individual recovery system (if any) or the combination of two or more distillation columns and the common recovery system they share that is part of a process unit that produces any of the chemicals listed in 40 CFR 60.667 as a product, co-product, by-product, or intermediate. The BSER for reducing VOC emissions from SOCOMI distillation operations was identified as combustion (e.g., incineration, flares) and the standard of performance requires owners and operators of an affected facility to reduce emissions of TOC (minus methane and ethane) by 98 percent by weight or to a concentration of 20 ppmv on a dry basis corrected to 3 percent oxygen;<sup>23</sup> combust the emissions in a flare meeting 40 CFR 60.18(b); or maintain a TRE index value<sup>24</sup> greater than 1.0 without use of VOC emission control devices.

<sup>21</sup> The phrase “whichever is less stringent” was originally used as part of this NSPS standard; however, we have determined the phrase does not serve any meaningful purpose and are removing it in this final action. For specific details about this editorial correction, refer to section 5.1 of the document titled *Summary of Public Comments and Responses for New Source Performance Standards for the Synthetic Organic Chemical Manufacturing Industry and National Emission Standards for Hazardous Air Pollutants for the Synthetic Organic Chemical Manufacturing Industry and Group I & II Polymers and Resins Industry*, which is available in the docket for this rulemaking.

<sup>22</sup> See section III.C.3.b of the preamble to the proposed rule (88 FR 25080, April 25, 2023) for a description of the TRE index value and how the concept is used in NSPS subpart III.

<sup>23</sup> See footnote 21.

<sup>24</sup> See section III.C.3.b of the preamble to the proposed rule (88 FR 25080, April 25, 2023) for a description of the TRE index value and how the concept is used in NSPS subpart NNN.

#### 7. NSPS Subpart RRR

NSPS subpart RRR regulates VOC emissions from SOCOMI reactor processes for which construction, reconstruction, or modification commenced after June 29, 1990. For the purpose of NSPS subpart RRR, reactor processes are unit operations in which one or more chemicals, or reactants other than air, are combined or decomposed in such a way that their molecular structures are altered and one or more new organic compounds are formed. The affected facility is designated as a single reactor process with its own individual recovery system (if any) or the combination of two or more reactor processes and the common recovery system they share that is part of a process unit that produces any of the chemicals listed in 40 CFR 60.707 as a product, co-product, by-product, or intermediate. The BSER for reducing VOC emissions from SOCOMI reactor processes was identified as combustion (e.g., incineration, flares) and the standard of performance requires owners and operators of an affected facility to reduce emissions of TOC (minus methane and ethane) by 98 percent by weight or to a concentration of 20 ppmv on a dry basis corrected to 3 percent oxygen;<sup>25</sup> combust the emissions in a flare meeting 40 CFR 60.18(b); or maintain a TRE index value<sup>26</sup> greater than 1.0 without use of VOC emission control devices.

#### C. What changes did we propose in our April 25, 2023, proposal?

##### 1. NESHAP

###### a. Proposed Actions Related to CAA Section 112(f) Risk Assessment

To reduce risk from the SOCOMI source category to an acceptable level, we proposed under CAA section 112(f) to require (in the HON) control of EtO emissions from: (1) Process vents, (2) storage vessels, (3) equipment leaks, (4) heat exchange systems, and (5) wastewater “in ethylene oxide service” (see 88 FR 25080, April 25, 2023, for our proposed definition of “in ethylene oxide service”). We also proposed requirements to reduce EtO emissions from maintenance vents, flares, and PRDs.

- For process vents and storage vessels in EtO service, we proposed owners and operators reduce emissions of EtO by either: (1) Venting emissions through a closed-vent system to a

<sup>25</sup> See footnote 21.

<sup>26</sup> See section III.C.3.b of the preamble to the proposed rule (88 FR 25080, April 25, 2023) for a description of the TRE index value and how the concept is used in NSPS subpart RRR.

control device that reduces EtO by greater than or equal to 99.9 percent by weight, to a concentration less than 1 ppmv for each process vent and storage vessel, or to less than 5 lb/yr for all combined process vents; or (2) venting emissions through a closed-vent system to a flare meeting the proposed operating and monitoring requirements for flares in NESHAP subpart F.

- For equipment leaks in EtO service, we proposed the following combined requirements: monitoring of connectors in gas/vapor and light liquid service at a leak definition of 100 ppm on a monthly basis with no reduction in monitoring frequency and no delay of repair; light liquid pump monitoring at a leak definition of 500 ppm monthly; and gas/vapor and light liquid valve monitoring at a leak definition of 100 ppm monthly with no reduction in monitoring frequency and no delay of repair.

- For heat exchange systems in EtO service, we proposed to require owners or operators to conduct more frequent leak monitoring (weekly instead of quarterly) and repair leaks within 15 days from the sampling date (in lieu of the current 45-day repair requirement after receiving results of monitoring indicating a leak), and delay of repair would not be allowed.

- For wastewater in EtO service, we proposed to revise the Group 1 wastewater stream threshold for sources to include wastewater streams in EtO service.

- For maintenance vents, we proposed a requirement that owners and operators cannot release more than 1.0 ton of EtO from all maintenance vents combined in any consecutive 12-month period.

- For flares, we proposed a requirement that owners and operators can send no more than 20 tons of EtO to all of their flares combined from all HON emission sources at a facility in any consecutive 12-month period.

- For PRDs in EtO service, we proposed that any atmospheric PRD release is a violation of the standard.

To reduce risk from the Neoprene Production source category to an acceptable level, we proposed under CAA section 112(f) to require (in the P&R I NESHAP) control of chloroprene for: (1) Process vents, (2) storage vessels, and (3) wastewater “in chloroprene service” (see 88 FR 25080, April 25, 2023, for our proposed definition of “in chloroprene service”). We also proposed requirements to reduce chloroprene emissions from maintenance vents and PRDs.

- For process vents and storage vessels in chloroprene service, we

proposed owners and operators reduce emissions of chloroprene by venting emissions through a closed-vent system to a control device that reduces chloroprene by greater than or equal to 99.9 percent by weight, to a concentration less than 1 ppmv for each process vent and storage vessel, or to less than 5 lb/yr for all combined process vents.

- For wastewater in chloroprene service, we proposed to revise the Group 1 wastewater stream threshold for sources to include wastewater streams in chloroprene service.
- For maintenance vents, we proposed a requirement that owners and operators cannot release more than 1.0 ton of chloroprene from all maintenance vents combined in any consecutive 12-month period.
- For PRDs in chloroprene service, we proposed that any atmospheric PRD release is a violation of the standard.
- We also proposed a facility-wide chloroprene emissions cap for all neoprene production emission sources as a backstop.

Based on our ample margin of safety analysis, we proposed that the controls to reduce EtO emissions at HON processes and chloroprene emissions at neoprene production processes to get risks to an acceptable level (described in this section of the preamble) would also provide an ample margin of safety to protect public health. We also proposed that HAP emissions from the source categories do not result in an adverse environmental effect, and that it is not necessary to set a more stringent standard to prevent, taking into consideration costs, energy, safety, and other relevant factors, an adverse environmental effect.

#### b. Proposed Actions Related to CAA Section 112(d)(6) Technology Review

Pursuant to the CAA section 112(d)(6) technology review for the HON and the P&R I, and P&R II NESHAP, we proposed that no revisions to the current standards beyond the fenceline monitoring work practice standard discussed below and those proposed under CAA section 112(f) are necessary for transfer racks, wastewater streams, and equipment leaks; however, we did propose additional changes under CAA section 112(d)(6) for heat exchange systems, storage vessels and process vents.

- For HON and P&R I heat exchange systems, we proposed requirements that owners or operators must use the Modified El Paso Method and repair leaks of total strippable hydrocarbon concentration (as methane) in the stripping gas of 6.2 ppmv or greater. The

P&R II NESHAP currently does not regulate HAP emissions from heat exchange systems.

- For HON and P&R I storage vessels, we proposed to revise applicability thresholds to require existing storage vessels between 38 m<sup>3</sup> (10,000 gal) and 151 m<sup>3</sup> (40,000 gal) with a vapor pressure  $\geq 6.9$  kilopascals to add control, and also require upgraded deck fittings and controls for guidepoles for all IFR storage vessels. For P&R II storage vessels, we proposed that no revisions to the current standards are necessary.
- For HON and P&R I process vents, we proposed to: (1) Remove the TRE concept in its entirety; (2) remove 50 ppmv and 0.005 scmm Group 1 process vent thresholds; and (3) redefine a Group 1 process vent (require control) as any process vent that emits  $\geq 1.0$  lb/hr of total organic HAP. For P&R II process vents, we proposed that no revisions to the current standards are necessary.

Under CAA section 112(d)(6), we also proposed a fenceline monitoring work practice standard requiring owners and operators to monitor for any of six specific HAP (*i.e.*, benzene, 1,3-butadiene, ethylene dichloride, vinyl chloride, EtO, and chloroprene) if their site uses, produces, stores, or emits any of them, and conduct root cause analysis and corrective action upon exceeding the annual average concentration action level set forth for each HAP. We also requested public comments on whether to promulgate the fenceline monitoring work practice standards, including the proposed action levels for EtO and chloroprene, under the second step of the CAA section 112(f)(2) residual risk decision framework to provide an ample margin of safety to protect public health in light of facility-wide risks.

#### c. Proposed Actions Related to CAA Section 112(d)(2) and (3), and 112(h)

We proposed other requirements for the HON and P&R I and P&R II NESHAP based on analyses performed pursuant to CAA sections 112(d)(2) and (3), and 112(h), and that are consistent with *Sierra Club v. EPA*, 551 F.3d 1019 (D.C. Cir. 2008), ensuring that CAA section 112 standards apply continuously, including:

- new monitoring and operational requirements for flares in the HON and P&R I NESHAP;
- work practice standards for periods of SSM for certain HON and P&R I vent streams (*i.e.*, PRD releases, maintenance vents, and planned routine maintenance of storage vessels);
- regulatory provisions for vent control bypasses for certain HON and

P&R I vent streams (*i.e.*, closed vent systems containing bypass lines);

- dioxins and furans emission limits in the HON and the P&R I and P&R II NESHAP;
- new monitoring requirements for HON and P&R I pressure vessels;
- new emission standards for HON & P&R I surge control vessels and bottoms receivers;
- a revised applicability threshold for HON transfer racks;
- requirements in the P&R II NESHAP for heat exchange systems;
- requirements in the P&R II NESHAP for WSR sources and equipment leaks;
- to require owners and operators that use a sweep, purge, or inert blanket between the IFR and fixed roof of a storage vessel to route emissions through a closed vent system and control device;
- to remove exemptions in the HON and the P&R I and P&R II NESHAP from the requirement to comply during periods of SSM; and
- to remove affirmative defense provisions from the P&R I NESHAP that were adopted in 2011.

#### d. Other Proposed Actions

In addition to the actions described in the sections above related to NESHAP, we also proposed:

- changes to the HON and the P&R I and P&R II NESHAP recordkeeping and reporting requirements to require the use of electronic reporting of performance test reports and periodic reports;
- restructuring of all HON definitions;
- monitoring requirements for adsorbers that cannot be regenerated and regenerative adsorbers that are regenerated offsite;
- to require subsequent performance testing on non-flare control devices no later than 60 calendar months after the previous performance test; and
- to correct section reference errors and make other minor editorial revisions.

## 2. NSPS

#### a. Proposed Actions Related to CAA Section 111(b)(1)(B) Review

Pursuant to the CAA section 111(b)(1)(B) reviews for the SOCM I NSPS rules, we proposed new NSPS for equipment leaks (NSPS subpart VVb) and process vents associated with air oxidation units (NSPS subpart IIIa), distillation operations (NSPS subpart NNNa), and reactor processes (NSPS subpart RRRa).

- For NSPS subpart VVb, we proposed the same requirements in

NSPS subpart VVa plus a requirement that all gas/vapor and light liquid valves be monitored monthly at a leak definition of 100 ppm and all connectors be monitored once every 12 months at a leak definition of 500 ppm.

- For NSPS subparts IIIa, NNNa, and RRRa, we proposed the same requirements in NSPS subparts III, NNN, and RRR, except we proposed to: (1) Eliminate the TRE concept in its entirety (including the removal of the alternative of maintaining a TRE index value greater than 1 without the use of control device and the limited applicability exemptions) and instead require owners and operators to reduce emissions of TOC (minus methane and ethane) from all vent streams of an affected facility (*i.e.*, SOCMi air oxidation unit processes, distillation operations, and reactor processes for which construction, reconstruction, or modification commences after April 25, 2023) by 98 percent by weight or to a concentration of 20 ppmv on a dry basis corrected to 3 percent oxygen, or combust the emissions in a flare meeting the same operating and monitoring requirements for flares that we proposed for flares subject to the HON; (2) eliminate the relief valve discharge exemption from the definition of “vent stream” such that any relief valve discharge to the atmosphere of a vent stream is a violation of the emissions standard; (3) require the same work practice standards for maintenance vents that we proposed for HON process vents; and (4) require the same monitoring requirements that we proposed for HON process vents for adsorbers that cannot be regenerated and regenerative adsorbers that are regenerated offsite.

#### b. Proposed Actions Related to NSPS Subparts VV and VVa Reconsideration

In response to the January 2008 petition for reconsideration we proposed: (1) Definitions for “process unit” for NSPS subparts VV and VVa; (2) to remove the requirements in 40 CFR 60.482–1(g) (for NSPS subpart VV) and 40 CFR 60.482–1a(g) (for NSPS subpart VVa) that are related to a method for assigning shared storage vessels to specific process units; (3) to remove the connector monitoring provisions from NSPS subpart VVa at 40 CFR 60.482–11a in their entirety and instead, include connector monitoring provisions in NSPS subpart VVb; and (4) to revise the “capital expenditure” definition in NSPS subpart VVa at 40 CFR 60.481a to reflect the definition used in NSPS subpart VV at 40 CFR 60.481 for owners or operators that start a new, reconstructed, or modified

affected source prior to November 16, 2007.

#### c. Other Proposed Actions

In addition to the actions described in the sections above related to the CAA section 111(b)(1)(B) reviews for the SOCMi NSPS rules and the NSPS subparts VV and VVa reconsideration, we also proposed:

- standards in NSPS subparts VVb, IIIa, NNNa, and RRRa that apply at all times;
- the use of electronic reporting of performance test reports and periodic reports;
- several corrections to the calibration drift assessment requirements in NSPS subpart VVa; and
- to require subsequent performance testing on non-flare control devices no later than 60 calendar months after the previous performance test.

#### III. What is included in this final rule?

This action finalizes the EPA’s determinations pursuant to the applicable provisions of CAA section 112 for the SOCMi source category and various polymers and resins source categories and amends the HON and P&R I and P&R II NESHAP based on those determinations. In addition, this action finalizes determinations of our review of the SOCMi NSPS rules pursuant to CAA section 111(b)(1)(B). This actions also finalizes other changes to the NESHAP, including adding requirements and clarifications for periods of SSM and bypasses; revising the operating and monitoring requirements for flares; adding provisions for electronic reporting; and other editorial and technical changes. Additionally, this action finalizes amendments to NSPS subparts VV and VVa in response to the January 2008 petition for reconsideration. This action also reflects several changes to the April 25, 2023 proposal (88 FR 25080), in consideration of comments received during the public comment period as described in section IV of this preamble.

##### A. What are the final rule amendments based on the risk review for the SOCMi and Neoprene Production source categories NESHAP?

Consistent with the proposal, the EPA determined that the risks for the SOCMi and Neoprene Production source categories under the previous MACT standards are unacceptable. When risks are unacceptable, the EPA must determine the emissions standards necessary to reduce risk to an acceptable level. As such, the EPA is promulgating final amendments to the HON pursuant to CAA section 112(f)(2) that require

control of EtO for: (1) Process vents, (2) storage vessels, (3) equipment leaks, (4) heat exchange systems, and (5) wastewater “in ethylene oxide service.” We are also finalizing requirements to reduce EtO emissions from maintenance vents and PRDs. As discussed in section IV.A of this preamble, implementation of these controls will reduce risk to an acceptable level and provide an ample margin of safety to protect public health from source category emissions points. In addition, the fenceline monitoring requirements being finalized in this action will further reduce whole-facility EtO and chloroprene emissions at facilities with HON and Neoprene Production processes, with consequential reductions in risks from these pollutants. In general, we are finalizing all of the EtO related requirements as proposed (for HON), except: we are not finalizing (in response to persuasive comments received during the public comment period) the proposed requirement at 40 CFR 63.108(p) that would prohibit owners and operators from sending more than 20 tons of EtO to all of their flares combined in any consecutive 12-month period. In addition to the primary CAA section 112(d)(6)-based fenceline monitoring program action levels that we are finalizing for all six HAP that reflect compliance with the source category-specific emissions limits for SOCMi and P&R I source category processes (see section III.B.1 of this preamble), we are also finalizing separately, in the P&R I NESHAP for Neoprene Production sources, an additional secondary action level under CAA section 112(f)(2) for fenceline monitoring of chloroprene emissions. This secondary action level for chloroprene for facilities with Neoprene Production sources is the same action level that was proposed. The primary chloroprene action level, which applies to sources subject to 40 CFR subpart H in the HON, is higher than what was proposed, but reflects the modeled emissions concentrations expected to result from compliance with the other emission standards adopted in the final rule, as we discussed in the proposed rule. See 88 FR at 25145/col. 2. The secondary chloroprene action level will further reduce whole-facility risks caused by such emissions from facilities with Neoprene Production sources, consistent with the goal to provide an ample margin of safety to protect public health. For this reason, for facilities with Neoprene Production sources we are promulgating the secondary chloroprene action level we had proposed under CAA section 112(d)(6)



under our CAA section 112(f)(2) authority, as we requested comment on in the proposed rule. *See id.*, at 25145/col. 3.

Also, based on comments received on the proposed rulemaking, we are clarifying in this final action that:

- we mean “the procedures specified in § 63.109” instead of “sampling and analysis” within the definitions of “in ethylene oxide service” for storage vessels, equipment leaks, and heat exchange systems (see 40 CFR 63.101);
- the sampling site for determining whether an emissions source is in EtO service is after the last recovery device (if any recovery devices are present) but prior to the inlet of any control device that is present and prior to release to the atmosphere (see 40 CFR 63.109(a));
- owners and operators can use good engineering judgment to determine the percent of EtO of the process fluid cooled by the heat exchange system similar to what we are allowing for equipment leaks in 40 CFR 63.109(c)(2) (see 40 CFR 63.109(e));
- the 5 lb/yr EtO mass threshold for combined process vents in EtO service is on a CPMU-by-CPMU basis (see 40 CFR 63.113(j)(2), 40 CFR 63.124(a)(4) and (a)(4)(iii), and within the definition of “in ethylene oxide service” for process vents);
- owners and operators may delay repair of equipment leaks in EtO service, and heat exchange systems in EtO service, indefinitely as long as there is no longer an active EtO leak once the equipment is isolated and not in EtO service (see 40 CFR 63.104(h)(6) and 40 CFR 63.171(b));
- we mean “process wastewater” instead of “wastewater” in 40 CFR 63.132(c)(1)(iii) and (d)(1)(ii);
- owners and operators can demonstrate compliance with the standards for wastewater in EtO service if the concentration of EtO is reduced, by removal or destruction, to a level less than 1 ppmw as determined in the procedures specified in 40 CFR 63.145(b) (see 40 CFR 63.138(b)(3) and (c)(3)); and
- owners and operators can use test methods specified in 40 CFR 63.109(d) for analysis of EtO in wastewater (see 40 CFR 63.144(b)(5)(i)).

Additionally, the EPA is promulgating final amendments to the P&R I NESHAP for Neoprene Production sources pursuant to CAA section 112(f)(2) that require control of chloroprene for: (1) Process vents, (2) storage vessels, (3) wastewater “in chloroprene service.” We are also finalizing requirements to reduce chloroprene emissions from maintenance vents and PRDs. As discussed in section IV.A of this

preamble, implementation of these controls will reduce risk to an acceptable level and provide an ample margin of safety to protect public health from the Neoprene Production source category. In general, we are finalizing all of the chloroprene related requirements as proposed (for Neoprene Production sources in the P&R I NESHAP), except in response to persuasive comments received during the public comment period: (1) We are not finalizing the facility-wide chloroprene emissions cap at 40 CFR 63.483(a)(10) that would prohibit owners and operators from emitting 3.8 tpy of chloroprene in any consecutive 12-month period from all neoprene production emission sources; (2) we are revising the performance standard from a 99.9 percent by weight reduction requirement to a 98 percent by weight reduction requirement for storage vessels in chloroprene service (see 40 CFR 63.484(u) and 40 CFR 53.510), continuous front-end process vents in chloroprene service (see 40 CFR 63.485(y) and 40 CFR 53.510), and batch front-end process vents in chloroprene service (see 40 CFR 63.487(j)); (3) we are finalizing a requirement that owners and operators reduce emissions of chloroprene from back-end process vents in chloroprene service at affected sources producing neoprene by venting emissions through a closed-vent system to a non-flare control device that reduces chloroprene by greater than or equal to 98 percent by weight, to a concentration less than 1 ppmv for each process vent, or to less than 5 lb/yr for all combined process vents (see 40 CFR 63.494(a)(7)); and (4) we are finalizing in the primary CAA section 112(d)(6)-based fenceline monitoring program action levels for all six HAP addressed in the proposal that reflect compliance with the source category-specific emissions limits for SOCM I and P&R I source category processes, and which subject sources are largely already meeting (see section III.B.1 of this preamble). Separately, we are also setting an additional secondary action level under CAA section 112(f)(2) for fenceline monitoring of chloroprene emissions. This standard will further reduce whole-facility risks caused by such emissions, consistent with the goal to provide an ample margin of safety to protect public health. Also, based on comments received on the proposed rulemaking, we are clarifying in this final action that:

- we mean “the procedures specified in § 63.509” instead of “sampling and analysis” within the definitions of “in chloroprene service” for storage vessels (see 40 CFR 63.482);

- the sampling site for determining whether an emissions source is in chloroprene service is after the last recovery device (if any recovery devices are present) but prior to the inlet of any control device that is present and prior to release to the atmosphere (see 40 CFR 63.509(a)); and

- the 5 lb/yr chloroprene mass threshold for combined process vents in chloroprene service is on a EPPU-by-EPPU basis (see the definition of “in chloroprene service” for process vents).

Section IV.A.3 of this preamble provides a summary of key comments we received on the CAA section 112(f) provisions and our responses.

*B. What are the final rule amendments based on the technology review for the SOCM I, P&R I, and P&R II source categories NESHAP pursuant to CAA section 112(d)(6) and NSPS reviews for the SOCM I source category pursuant to CAA section 111(b)(1)(B)?*

#### 1. NESHAP

For transfer racks, wastewater streams, and equipment leaks in the SOCM I, P&R I, and P&R II source categories, the EPA is finalizing its proposed determination in the technology review that there are no developments in practices, processes, and control technologies that warrant revisions to the MACT standards beyond those needed under CAA section 112(f) or for other purposes besides section 112(d)(6). Therefore, with the exception of the fenceline monitoring standards that are discussed further below, we are not finalizing revisions to the MACT standards for these emission sources under CAA section 112(d)(6).

For heat exchange systems, we determined that there are developments in practices, processes, and control technologies that warrant revisions to the MACT standards for heat exchange systems in the SOCM I, P&R I, and P&R II source categories. Therefore, to satisfy the requirements of CAA section 112(d)(6), we are revising the MACT standards, consistent with the proposed rule (88 FR 25080, April 25, 2023), to include revisions to the heat exchange system requirements to require owners or operators to use the Modified El Paso Method and repair leaks of total strippable hydrocarbon concentration (as methane) in the stripping gas of 6.2 ppmv or greater. We are also finalizing, as proposed, that owners and operators may use the current leak monitoring requirements for heat exchange systems at 40 CFR 63.104(b) in lieu of using the Modified El Paso Method provided that 99 percent by weight or more of the

organic compounds that could leak into the heat exchange system are water soluble and have a Henry's Law Constant less than  $5.0E-6$  atmospheres-cubic meters/mol at 25 degrees Celsius. See 40 CFR 63.104(g) through (j) and (l) (for HON), 40 CFR 63.502(n)(7) (for the P&R I NESHAP), and 40 CFR 63.523(d) and 40 CFR 63.524(c) (for the P&R II NESHAP).

For storage vessels, we did not identify any control options for storage tanks subject to the P&R II NESHAP. However, we determined that there are developments in practices, processes, and control technologies that warrant revisions to the MACT standards for storage vessels in the SOCM I and P&R I source categories. Therefore, to satisfy the requirements of CAA section 112(d)(6), we are revising the MACT standards, consistent with the proposed rule (88 FR 25080, April 25, 2023), to include revisions to the storage vessel applicability threshold to require both existing and new storage vessels between  $38\text{ m}^3$  and  $151\text{ m}^3$  with a vapor pressure greater than or equal to 6.9 kilopascals to reduce emissions of organic HAP by 95 percent utilizing a closed vent system and control device, or reduce organic HAP emissions either by utilizing an IFR, an EFR, or by routing the emissions to a process or a fuel gas system, or vapor balancing. We are also finalizing, as proposed, requirements that all openings in an IFR (except those for automatic bleeder vents (vacuum breaker vents), rim space vents, leg sleeves, and deck drains) be equipped with a deck cover; and that the deck cover be equipped with a gasket between the cover and the deck; and control requirements for guidepoles for all storage vessels equipped with an IFR. See Tables 5 and 6 to subpart G, and 40 CFR 63.119(b)(5)(ix), (x), (xi), and (xii) (for HON) and 40 CFR 63.484(t) (for the P&R I NESHAP).

For process vents, we did not identify any control options for process vents subject to the P&R II NESHAP. However, we determined that there are developments in practices, processes, and control technologies that warrant revisions to the MACT standards for process vents in the SOCM I and P&R I source categories. Therefore, to satisfy the requirements of CAA section 112(d)(6), we are revising the MACT standards, consistent with the proposed rule (88 FR 25080, April 25, 2023), to include revisions to the process vent applicability threshold to redefine a HON Group 1 process vent and P&R I Group 1 continuous front-end process vent (*i.e.*, to require control) as any process vent that emits greater than or equal to 1.0 lb/hr of total organic HAP.

We are also removing, as proposed, the TRE concept in its entirety, and removing, as proposed, the 50 ppmv and 0.005 scmm Group 1 process vent thresholds. See 40 CFR 63.101 and 40 CFR 63.113(a)(1), (2), and (4) (for HON) and 40 CFR 63.482 and 40 CFR 63.485(l)(6), (o)(6), (p)(5), and (x) (for the P&R I NESHAP). To satisfy the requirements of CAA section 112(d)(6), we are also revising the MACT standards, consistent with the proposed rule (88 FR 25080, April 25, 2023), to include revisions to the process vent applicability threshold to redefine a P&R I Group 1 batch front-end process vent as process vents that release total annual organic HAP emissions greater than or equal to 4,536 kg/yr (10,000 lb/yr) from all batch front-end process vents combined. See 40 CFR 63.482, 40 CFR 63.487(e)(1)(iv), 40 CFR 63.488(d)(2), (e)(4), (f)(2), and (g)(3) (for the P&R I NESHAP).

Also, to satisfy the requirements of CAA section 112(d)(6), we are revising the MACT standards, consistent with the proposed rule (88 FR 25080, April 25, 2023), to include a fenceline monitoring work practice standard for the SOCM I and P&R I source categories, requiring owners and operators to monitor for any of six specific HAP (*i.e.*, benzene, 1,3-butadiene, ethylene dichloride, vinyl chloride, EtO, and chloroprene) if their affected source uses, produces, stores, or emits any of them, and to conduct root cause analysis and corrective action upon exceeding the annual average concentration action level set forth for each HAP. However, based on comments received on the proposed rulemaking, we are amending the fenceline monitoring work practice standards in the final rule adopted under CAA section 112(d)(6) to include the action level of  $0.8\text{ ug/m}^3$  for chloroprene, which reflects compliance with the source category-specific emissions limits for P&R I source category processes. The action levels for benzene, 1,3-butadiene, ethylene dichloride, EtO, and vinyl chloride will also correspond to the modeled concentrations resulting from compliance with the process emission standards promulgated in the final rule and/or levels that HON-subject sources are largely already meeting. Separately, we are also setting an additional secondary action level of  $0.3\text{ ug/m}^3$  for chloroprene under CAA section 112(f)(2), because this standard will further reduce elevated risks from facility-wide emissions of this pollutant consistent with the goal to provide an ample margin of safety to protect public

health. See 40 CFR 63.184 (for HON) and 40 CFR 63.502 (for the P&R I NESHAP). In addition, the final rule includes burden reduction measures to allow owners and operators to skip fenceline measurement periods for specific monitors with a history of measurements that are at or below certain specified action levels. We have also made a clarification that fenceline monitoring is required for owners and operators with affected sources that produce, store, or emit one or more of the target analytes; and we have reduced the requirements in the final rule for the minimum detection limit of alternative measurement approaches (for fenceline monitoring). In addition, we have made clarifications on the calculation of delta c ( $\Delta c$ )<sup>27</sup> when a site-specific monitoring plan is used to correct monitoring location concentrations due to offsite impacts, and we have made a change in the required method detection limit for alternative test methods from an order of magnitude below the action level to one-third of the action level. Finally, with the exception of fenceline monitoring of chloroprene at P&R I affected sources producing neoprene, discussed below, we have changed the compliance date to begin fenceline monitoring from 1 to 2 years after the effective date of the final rule. For P&R I affected sources producing neoprene, we have changed the compliance date for fenceline monitoring of chloroprene to begin no later than October 15, 2024, or upon startup, whichever is later, subject to the owner or operator seeking the EPA's authorization of an extension of up to 2 years from July 15, 2024.

Section III.G.1 of this preamble provides a more detailed discussion of the effective and compliance dates for the requirements we are finalizing in this action for the HON and the P&R I NESHAP. Section IV.B.3 of this preamble provides a summary of key comments we received on the CAA section 112(d)(6) provisions and our responses.

## 2. NSPS

The EPA is finalizing, as proposed, a determination that the BSER for reducing VOC emissions from SOCM I air oxidation units, distillation operations, and reactor processes remains combustion (*e.g.*, incineration, flares), and we are also maintaining that the standard of performance of 98

<sup>27</sup> Delta c, notated as  $\Delta c$ , represents the concentration difference between the highest measured concentration and lowest measured concentration for a set of samples in one sampling period. The sampling period  $\Delta c$  values are averaged over 1 year to create an annual average; the annual average  $\Delta c$  is compared to the action level.

percent reduction of TOC (minus methane and ethane), or reduction of TOC (minus methane and ethane) to an outlet concentration of 20 ppmv on a dry basis corrected to 3 percent oxygen, continues to reflect the BSER for NSPS subparts IIIa, NNNa, and RRRa. While we are finalizing no changes in the BSER for reducing VOC emissions from SOCM I air oxidation units, distillation operations, and reactor processes, we determined that there are certain advances in process operations that were not identified or considered during development of the original NSPS subparts III, NNN, and RRR (for SOCM I air oxidation units, distillation operations, and reactor processes, respectively), which warrant revisions to the requirements for process vents in the SOCM I source category. Therefore, pursuant to CAA section 111(b)(1)(B), we are finalizing revised process vent requirements in new NSPS subparts IIIa, NNNa, and RRRa (for SOCM I air oxidation unit processes, distillation operations, and reactor processes for which construction, reconstruction, or modification commenced after April 25, 2023), consistent with the proposed rule (88 FR 25080, April 25, 2023). In particular, we are finalizing for NSPS subparts IIIa, NNNa and RRRa, as proposed, the removal of the entire TRE concept (including the removal of the alternative of maintaining a TRE index value greater than 1 without the use of control device and the limited applicability exemptions) such that owners and operators of affected facilities (for which construction, reconstruction, or modification commences after April 25, 2023) are required to reduce emissions of TOC (minus methane and ethane) from all vent streams of an affected facility by 98 percent by weight or to a concentration of 20 ppmv on a dry basis corrected to 3 percent oxygen, or combust the emissions in a flare. The EPA is also finalizing, as proposed, that affected sources that combust the emissions in a flare meet the same operating and monitoring requirements for flares that we are finalizing for flares subject to the HON. However, based on comments received on the proposed rulemaking, we are finalizing a mass-based exemption criteria of 0.001 lb/hr TOC (for which emission controls are not required) in new NSPS subparts IIIa and NNNa. Also, as proposed, we are not including in the final NSPS subparts IIIa, NNNa, and RRRa a relief valve discharge exemption in the definition of “vent stream”; instead, any relief valve discharge to the atmosphere of a vent stream is a violation of the emissions

standard. In addition, we are finalizing, as proposed, the same work practice standards for maintenance vents that we are finalizing for HON process vents, and, as proposed, the same monitoring requirements that we are finalizing for HON process vents for adsorbers that cannot be regenerated and regenerative adsorbers that are regenerated offsite.

For equipment leaks, we determined that there are techniques used in practice related to LDAR of certain equipment that achieve greater emission reductions than those currently required by NSPS subpart VVa. Therefore, pursuant to the requirements of CAA section 111(b)(1)(B), we are finalizing revised equipment leak requirements in new NSPS subpart VVb (for facilities that commence construction, reconstruction, or modification after April 25, 2023), consistent with the proposed rule (88 FR 25080, April 25, 2023). We are finalizing that BSER for gas and light liquid valves is the same monitoring in an LDAR program as NSPS subpart VVa, but now at a leak definition of 100 ppm, and BSER for connectors is monitoring in the LDAR program at a leak definition of 500 ppm and monitored annually, with reduced frequency for good performance. In a change from the proposed rule, we are finalizing a definition of “capital expenditure” in NSPS subpart VVb to use a formula that better reflects the trajectory of inflation.

Section IV.B.3 of this preamble provides a summary of key comments we received on the proposed provisions pursuant to CAA section 111(b)(1)(B) and our responses.

*C. What are the final rule amendments pursuant to CAA sections 112(d)(2) and (3), and 112(h) for the SOCM I, P&R I, and P&R II source categories?*

Consistent with *Sierra Club v. EPA* 551 F. 3d 1019 (D.C. Cir. 2008) and the April 25, 2023, proposal (88 FR 25080), we are revising monitoring and operational requirements for flares to ensure HON and P&R I flares meet the MACT standards at all times when controlling HAP emissions.<sup>28</sup> See 40 CFR 63.108 (for HON) and 40 CFR 63.508 (for the P&R I NESHAP). In addition, we are finalizing provisions and clarifications as proposed for periods of SSM and bypasses, including:

- PRD releases (see 40 CFR 63.165(e) (for HON) and 40 CFR 63.502(a) (for the P&R I NESHAP));
- bypass lines on closed vent systems (see 40 CFR 63.114(d)(3), 40 CFR

<sup>28</sup> P&R II sources do not use flares as APCDs as they are making resins from chlorinated chemicals (i.e., epichlorohydrin feedstocks), and chlorinated chemicals are not controlled with flares.

63.118(a)(5), 40 CFR 63.127(d)(3), 40 CFR 63.130(a)(2)(iv), (b)(3), and (d)(7), and 40 CFR 63.148(f)(4), (i)(3)(iii), and (j)(4) (for HON and the P&R I NESHAP) as well as 40 CFR 63.480(d)(3), 40 CFR 63.491(e)(6), 40 CFR 63.497(d)(3), and 63.498(d)(5)(v) (for the P&R I NESHAP));

- maintenance vents and equipment openings (excluding storage vessel degassing) (see 40 CFR 63.113(k) (for HON) 40 CFR 63.485(x) and 40 CFR 63.487(i) (for the P&R I NESHAP));
- storage vessel degassing (see 40 CFR 63.119(a)(2) (for HON) and 40 CFR 63.484(a) (for the P&R I NESHAP)); and
- planned routine maintenance for storage vessels (see 40 CFR 63.119(e)(3) through (5) (for HON) and 40 CFR 63.484(a) (for the P&R I NESHAP)).

However, in response to comments received on the proposed rulemaking for storage vessel degassing, we are: (1) Clarifying in the final rule at 40 CFR 63.119(a)(6) that the storage vessel degassing work practice standard applies to all Group 1 storage vessels, including storage vessels in EtO service, and (2) revising the storage vessel degassing work practice standard in the final rule at 40 CFR 63.119(a)(6) to allow storage vessels to be vented to the atmosphere once a storage vessel degassing organic HAP concentration of 5,000 ppmv as methane is met, or until the vapor space concentration is less than 10 percent of the LEL. In addition, in response to comments received on the proposed rulemaking for planned routine maintenance of storage vessels, we are clarifying in the final rule at 40 CFR 63.119(f)(3) that the 240-hour planned routine maintenance provisions also apply for breathing losses for fixed roof vessels routed to a fuel gas system or to a process.

To address regulatory gaps, we are also finalizing the emission limits as proposed for polychlorinated dibenzo-p-dioxins (dioxins) and polychlorinated dibenzofurans (furans) for HON, P&R I, and P&R II facilities (see 40 CFR 63.113(a)(5) (for HON), 40 CFR 63.485(x) and 40 CFR 63.487(a)(3) and (b)(3) (for the P&R I NESHAP), and 40 CFR 63.523(e), 40 CFR 63.524(a)(3), and 40 CFR 63.524(b)(3) (for the P&R II NESHAP)). We are also finalizing the requirements as proposed for transfer operations (see 40 CFR 63.101 (for HON)), heat exchange systems (40 CFR 63.523(d) and 40 CFR 63.524(c) (for the P&R II NESHAP)), and WSR sources and equipment leaks (see 40 CFR 63.524(a)(3) and (b)(3) (for the P&R II NESHAP)). In addition, we are finalizing the requirements as proposed for pressure vessels (see 40 CFR 63.119(a)(7) (for HON) and 40 CFR 63.484(t) (for the P&R I NESHAP)), surge

control and bottoms receivers (see 40 CFR 63.170(b) (for HON) and 40 CFR 63.485(d) (for the P&R I NESHAP)), but with a few changes in the final rule in response to persuasive comments received during the public comment period.

In response to comments received on the proposed rulemaking for pressure vessels, we are:

- clarifying that the pressure vessel requirements at 40 CFR 63.119(a)(7) only apply to pressure vessels that are considered Group 1 storage vessels;
- clarifying that if the equipment is not a connector, gas/vapor or light liquid valve, light liquid pump, or PRD in ETO service and the equipment is on a pressure vessel located at a HON or P&R I facility, then that particular equipment is not subject to HON subpart H, but rather the equipment is subject to the pressure vessel requirements we proposed and are finalizing in 40 CFR 63.119(a)(7);
- clarifying that unsafe and difficult/inaccessible to monitor provisions in 40 CFR 63.168(h) and (i) (for valves in gas/vapor service and in light liquid service) and in 40 CFR 63.174(f) and (h) (for connectors in gas/vapor service and in light liquid service) still apply to valves and connectors when complying with 40 CFR 63.119(a)(7); and
- replacing the word “deviation” with “violation” in the final rule text at 40 CFR 63.119(a)(7).

In response to comments received on the proposed rulemaking for surge control and bottoms receivers, we are adding language in the “C” and “Q” terms of the equations at 40 CFR 63.115(g)(3)(ii) and (g)(4)(iv) to allow the use of engineering calculations to determine concentration or flow rate only in situations where measurements cannot be taken with EPA reference methods. We are also adding reference methods for measuring flow rate at 40 CFR 63.115(g)(3)(ii) and 40 CFR 63.115(g)(4)(iv).

Finally, we are finalizing, as proposed, that owners and operators that use a sweep, purge, or inert blanket between the IFR and fixed roof of a storage vessel are required to route emissions through a closed vent system and control device (see 40 CFR 63.119(b)(7)). However, based on comments received on the proposed rulemaking, we are clarifying in the final rule that 40 CFR 63.119(b)(7) applies only if a continuous sweep, purge, or inert blanket is used between the IFR and fixed roof that causes a pressure/vacuum vent to remain continuously open to the atmosphere where uncontrolled emissions are

greater than or equal to 1.0 lb/hr of total organic HAP.

Section IV.C.3 of this preamble provides a summary of key comments we received on the CAA sections 112(d)(2), (d)(3), and (h) provisions and our responses.

#### *D. What are the final rule amendments addressing emissions during periods of SSM?*

##### 1. NESHAP

We are finalizing the proposed amendments to the HON and the P&R I and P&R II NESHAP to remove and revise provisions related to SSM. In its 2008 decision in *Sierra Club v. EPA*, 551 F.3d 1019 (D.C. Cir. 2008), the Court vacated portions of two provisions in the EPA’s CAA section 112 regulations governing the emissions of HAP during periods of SSM. Specifically, the Court vacated the SSM exemptions contained in 40 CFR 63.6(f)(1) and (h)(1), holding that under section 302(k) of the CAA, emissions standards or limitations must be continuous in nature, and that the SSM exemptions violated the CAA’s requirement that some CAA section 112 standards apply at all times. We are finalizing, as proposed, a requirement that the standards apply at all times (see 40 CFR 63.102(e) (for HON) and 40 CFR 63.525(j) (for the P&R II NESHAP)), consistent with the *Sierra Club* decision. We determined that facilities in the SOCM I and P&R II source categories can meet the applicable MACT standards at all times, including periods of startup and shutdown. We note that on April 21, 2011 (see 77 FR 22566), the EPA finalized amendments to eliminate the SSM exemption in the P&R I NESHAP; however, for consistency with the SSM-related amendments that we are finalizing for the HON and the P&R II NESHAP, we are also finalizing, as proposed, additional amendments to the P&R I NESHAP related to the SSM exemption that were not addressed in the April 21, 2011, P&R I rule.

As discussed in the proposal preamble, the EPA interprets CAA section 112 as not requiring emissions that occur during periods of malfunction to be factored into development of CAA section 112 standards, although the EPA has the discretion to set standards for malfunction periods where feasible. Where appropriate, and as discussed in section III.C of this preamble, we are also finalizing alternative standards for certain emission points during periods of SSM to ensure a CAA section 112 standard applies “at all times.” Other than for those specific emission points discussed in section III.C of this

preamble, the EPA determined that no additional standards are needed to address emissions during periods of SSM and that facilities in the SOCM I and P&R II source categories can meet the applicable MACT standards at all times, including periods of startup and shutdown.

We are also finalizing, as proposed, revisions to the HON and P&R II General Provisions tables (Table 3 to subpart F of part 63 and Table 1 to subpart W of part 63, respectively) to eliminate requirements that include rule language providing an exemption for periods of SSM. We note that the EPA already made a similar revision to the General Provisions table to the P&R I NESHAP (see 77 FR 22566, April 21, 2011). Additionally, we are finalizing our proposal to eliminate language related to SSM that treats periods of startup and shutdown the same as periods of malfunction. Finally, we are finalizing our proposal to revise reporting and recordkeeping requirements for deviations as they relate to exemptions for periods of SSM. These revisions are consistent with the requirement in 40 CFR 63.102(e) and 40 CFR 63.525(j) that the standards apply at all times. We are also finalizing, as proposed, a revision to the performance testing requirements. The final performance testing provisions prohibit performance testing during SSM because these conditions are not representative of normal operating conditions. The final rule also requires, as proposed, that operators maintain records to document that operating conditions during the test represent normal operations. In light of *NRDC v. EPA*, 749 F.3d 1055 (D.C. Cir., 2014) (vacating affirmative defense provisions in the CAA section 112 rule establishing emission standards for Portland cement kilns), the EPA is also removing, as proposed, all of the regulatory affirmative defense provisions from the P&R I NESHAP at 40 CFR 480(j)(4) in its entirety and all other rule text that references these provisions (*i.e.*, the definition of affirmative defense in 40 CFR 63.482(b) and the reference to “§ 63.480(j)(4)” in 40 CFR 63.506(b)(1)(i)(A) and (b)(1)(i)(B)); and we did not receive any comments in opposition to these amendments.

The legal rationale and detailed revisions for SSM periods and the affirmative defense provision that we are finalizing here are set forth in the proposal preamble (see 88 FR 25080, April 25, 2023).

##### 2. NSPS

The EPA has determined the reasoning in the court’s decision in *Sierra Club* applies equally to CAA

section 111 because the definition of “emission” or “standard” in CAA section 302(k), and the embedded requirement for continuous standards, also applies to the NSPS.<sup>29</sup> Therefore, we are finalizing, as proposed, standards in NSPS subparts VVb, IIIa, NNNa, and RRRa that apply at all times, and more specifically during periods of SSM. The NSPS general provisions in 40 CFR 60.8(c) currently exempt non-opacity emission standards during periods of SSM. We are finalizing, as proposed, specific requirements in NSPS subparts IIIa, NNNa, and RRRa that override the general provisions for SSM (see 40 CFR 60.612a, 40 CFR 60.662a, and 40 CFR 60.702a, respectively).

#### E. What are the final amendments addressing the NSPS Subparts VV and VVa reconsideration?

In response to the January 2008 petition for reconsideration, we are finalizing, as proposed: (1) Definitions for “process unit” for NSPS subparts VV and VVa; (2) removal of the requirements in 40 CFR 60.482–1(g) (for NSPS subpart VV) and 40 CFR 60.482–1a(g) (for NSPS subpart VVa) that are related to a method for assigning shared storage vessels to specific process units; and (3) removal of the connector monitoring provisions from NSPS subpart VVa at 40 CFR 60.482–11a in their entirety. However, based on comments received on the proposed rulemaking, we are revising the value of “X” in the capital expenditure equation of NSPS subpart VVa to correct an erroneous phrasing that attached the value of “X” in the percent Y equation to the date of construction, reconstruction and modification (as opposed to date of physical or operational change). In the final rule, we have revised the “capital expenditure” definition in NSPS subpart VVa at 40 CFR 60.481a such that for owners or operators that made a physical or operational change to their existing facility prior to November 16, 2007, the percent Y is determined from the following equation:  $Y = 1.0 - 0.575 \log X$ , where the value of “X” is 1982 minus the year of construction, and for owners or operators that made a physical or operational change to their existing facility on or after November 16, 2007, the percent Y is determined from the following equation:  $Y = 1.0 - 0.575 \log$

X, where the value of “X” is 2006 minus the year of construction. Section IV.E.3 of this preamble provides a summary of key comments we received on the NSPS subparts VV and VVa reconsideration issues and our responses.

#### F. What other changes have been made to the NESHAP and NSPS?

This rule also finalizes, as proposed, revisions to several other NESHAP and NSPS requirements. We describe these revisions in this section as well as other proposed provisions that have changed since proposal.

To increase the ease and efficiency of data submittal and data accessibility, we are finalizing, as proposed, a requirement that owners or operators submit electronic copies of certain required performance test reports, flare management plans, and periodic reports (including fenceline monitoring reports for HON and the P&R I NESHAP) through the EPA’s Central Data Exchange (CDX) using the Compliance and Emissions Data Reporting Interface (CEDRI) (see 40 CFR 63.108(e), 40 CFR 63.152(c) and (h), and 40 CFR 63.182(d) and (e) (for HON), 40 CFR 63.506(e)(6), and (i)(3) (for the P&R I NESHAP), and 40 CFR 63.528(a) and (d) (for the P&R II NESHAP), 40 CFR 60.486(l), and 60.487(a) and (g) through (i) (for NSPS subpart VV), 40 CFR 60.486a(l), and 60.487a(a) and (g) through (i) (for NSPS subpart VVa), 40 CFR 60.486b(l), and 60.487b(a) and (g) through (i) (for NSPS subpart VVb), 40 CFR 60.615(b), (j), (k), and (m) through (o) (for NSPS subpart III), 40 CFR 60.615a(b), (h) through (l), and (n), and 40 CFR 619a(e) (for NSPS subpart IIIa), 40 CFR 60.665(b), (l), (m), and (q) through (s) (for NSPS subpart NNN), 40 CFR 60.665a(b), (h), (k) through (n), and (p), and 40 CFR 669a(e) (for NSPS subpart NNNa), 40 CFR 60.705(b), (l), (m), and (u) through (w) (for NSPS subpart RRR), and 40 CFR 60.705a(b), (k) through (o), and (v), and 40 CFR 709a(e) (for NSPS subpart RRRa)). A description of the electronic data submission process is provided in the memorandum, *Electronic Reporting Requirements for New Source Performance Standards (NSPS) and National Emission Standards for Hazardous Air Pollutants (NESHAP) Rules* (see Docket Item No. EPA–HQ–OAR–2022–0730–0002). The final rule requires that performance test results collected using test methods that are supported by the EPA’s Electronic Reporting Tool (ERT) as listed on the ERT website<sup>30</sup> at the time of the test be submitted in the format generated

through the use of the ERT or an electronic file consistent with the xml schema on the ERT website, and other performance test results be submitted in portable document format (PDF) using the attachment module of the ERT. For periodic reports (including fenceline monitoring reports), the final rule requires that owners or operators use the appropriate spreadsheet template to submit information to CEDRI. We have made minor clarifying edits to the spreadsheet templates based on comments received during the public comment period. The final version of the templates for these reports are located on the CEDRI website.<sup>31</sup> The final rule requires that flare management plans be submitted as a PDF upload in CEDRI. Furthermore, we are finalizing, as proposed, provisions in the NSPS that allow facility operators the ability to seek extensions for submitting electronic reports for circumstances beyond the control of the facility, *i.e.*, for a possible outage in the CDX or CEDRI or for a *force majeure* event in the time just prior to a report’s due date, as well as the process to assert such a claim. For a more detailed discussion of these final amendments, see section III.E.3 of the proposal preamble (see 88 FR 25080, April 25, 2023), as well as sections IV.F and VI.B of this preamble.

Also, we are finalizing, as proposed, the restructuring of all HON definitions from NESHAP subparts G and H (*i.e.*, 40 CFR 63.111 and 40 CFR 63.161, respectively) into the definition section of NESHAP subpart F (*i.e.*, 40 CFR 63.101). To consolidate differences between certain definitions in these subparts, we are also finalizing the amendments we proposed in Table 30 of the proposal preamble (88 FR 25080, April 25, 2023), with only minor changes based on comments received on the proposed rulemaking. The comments and our specific responses to these items can be found in the document titled *Summary of Public Comments and Responses for New Source Performance Standards for the Synthetic Organic Chemical Manufacturing Industry and National Emission Standards for Hazardous Air Pollutants for the Synthetic Organic Chemical Manufacturing Industry and Group I & II Polymers and Resins Industry*, which is available in the docket for this rulemaking.

In addition, we are finalizing requirements, as proposed, at 40 CFR 63.114(a)(5)(v), 40 CFR 63.120(d)(1)(iii), 40 CFR 63.127(b)(4), and 40 CFR

<sup>29</sup> See, *e.g.*, 88 FR 11556 (Feb. 23, 2023) (removing SSM exemptions from NSPS for lead acid battery manufacturing plants); 88 FR 80594 (Nov. 20, 2023) (removing SSM exemptions from NSPS for secondary lead smelters); 77 FR 49490 (Aug. 16, 2012) (removing SSM exemptions from NSPS for oil and natural gas sector).

<sup>30</sup> <https://www.epa.gov/electronic-reporting-air-emissions/electronic-reporting-tool-ert>.

<sup>31</sup> <https://www.epa.gov/electronic-reporting-air-emissions/cedri>.

63.139(d)(5) (for HON), and 40 CFR 63.484(t), 40 CFR 63.485(x), and 40 CFR 63.489(b)(10) (for the P&R I NESHAP) for owners or operators using adsorbers that cannot be regenerated and regenerative adsorbers that are regenerated offsite to use dual (two or more) adsorbent beds in series and conduct monitoring of HAP or TOC on the outlet of the first adsorber bed in series using a sample port and a portable analyzer or chromatographic analysis. However, we have clarified in the proposed rule text in this final action that the monitoring plan provisions in 40 CFR 63.120(d)(2) and (3) do not apply to HON sources subject to the monitoring provisions in 40 CFR 63.120(d)(1)(iii); and the monitoring plan provisions in 40 CFR 63.120(d)(2) and (3) do not apply to P&R I sources subject to the monitoring provisions in 40 CFR 63.120(d)(1)(iii) (via 40 CFR 63.484(t) and 40 CFR 63.485(x)). The comments and our specific responses to these items can be found in the document titled *Summary of Public Comments and Responses for New Source Performance Standards for the Synthetic Organic Chemical Manufacturing Industry and National Emission Standards for Hazardous Air Pollutants for the Synthetic Organic Chemical Manufacturing Industry and Group I & II Polymers and Resins Industry*, which is available in the docket for this rulemaking.

We are also finalizing, as proposed, several corrections to the calibration drift assessment requirements in NSPS subpart VVa at 40 CFR 60.485a(b)(2). These amendments include: (1) Correcting a regulatory citation to read “§ 60.486a(e)(8)” instead of “§ 60.486a(e)(7)”; (2) removing the extraneous sentence “Calculate the average algebraic difference between the three meter readings and the most recent readings and the most recent calibration value.”; (3) providing clarity in the mathematical step of the assessment by replacing the sentence “Divide this algebraic difference by the initial calibration value and multiply by 100 to express the calibration drift as a percentage.” with “Divide the arithmetic difference of the initial and post-test calibration response by the corresponding calibration gas value for each scale and multiply by 100 to express the calibration drift as a percentage.”; and (4) providing clarity by making other minor textual changes to the provisions related to the procedures for when a calibration drift assessment shows negative or positive drift of more than 10 percent. We did

not receive any comments in opposition of these amendments.

In addition, we are finalizing, as proposed, the requirement in the HON and the P&R I and P&R II NESHAP, and NSPS subparts IIIa, NNNa, and RRRa to conduct subsequent performance testing on non-flare control devices no later than 60 calendar months after the previous performance test. The comments and our specific response to this item can be found in the document titled *Summary of Public Comments and Responses for New Source Performance Standards for the Synthetic Organic Chemical Manufacturing Industry and National Emission Standards for Hazardous Air Pollutants for the Synthetic Organic Chemical Manufacturing Industry and Group I & II Polymers and Resins Industry*, which is available in the docket for this rulemaking.

Also, we are finalizing, as proposed to: (1) Remove the provisions that allow compliance with certain portions of 40 CFR part 264, subpart AA or CC in lieu of portions of NESHAP subpart G (see 40 CFR 63.110(h)); and (2) remove the provisions that allow compliance with certain portions of 40 CFR part 65 in lieu of portions of NESHAP subparts G and H (see 40 CFR 63.110(i) and 40 CFR 60.160(g)). In addition, based on comments received on the proposed rulemaking, we are: (1) Revising 40 CFR 63.160(b)(1) and (c)(1) in the final rule such that compliance with HON subpart H constitutes compliance with NSPS subpart VVa provided the owner or operator continues to comply with 40 CFR 60.480a(e)(2)(i); and (2) revising 40 CFR 63.160(b)(1) and (c)(1) in the final rule such that compliance with HON subpart H constitutes compliance with NSPS subpart VVb provided the owner or operator continues to comply with 40 CFR 60.480b(e)(2)(i). We have also revised 40 CFR 60.480b(e)(2)(i) in the final rule to require compliance with 40 CFR 60.482–7b (*i.e.*, the standards for gas and light liquid valves in NSPS subpart VVb) in addition to the requirements of 40 CFR 60.485b(d), (e), and (f), and 40 CFR 60.486b(i) and (j). The comments and our specific responses to these items can be found in the document titled *Summary of Public Comments and Responses for New Source Performance Standards for the Synthetic Organic Chemical Manufacturing Industry and National Emission Standards for Hazardous Air Pollutants for the Synthetic Organic Chemical Manufacturing Industry and Group I & II Polymers and Resins Industry*, which is available in the docket for this rulemaking.

Finally, we are finalizing all of the revisions that we proposed for clarifying text or correcting typographical errors, grammatical errors, and cross-reference errors. These editorial corrections and clarifications are discussed in section III.E.5.f of the proposal preamble (see 88 FR 25080, April 25, 2023). We are also including several additional minor clarifying edits in the final rule based on comments received during the public comment period. The comments and our specific responses to these items can be found in the document titled *Summary of Public Comments and Responses for New Source Performance Standards for the Synthetic Organic Chemical Manufacturing Industry and National Emission Standards for Hazardous Air Pollutants for the Synthetic Organic Chemical Manufacturing Industry and Group I & II Polymers and Resins Industry*, which is available in the docket for this rulemaking.

#### G. What are the effective and compliance dates of the standards?

##### 1. HON and the P&R I and P&R II NESHAP

For all of the requirements we are finalizing under CAA sections 112(d)(2), (3), and (6), and 112(h) (except for the removal of affirmative defense provisions in the P&R I NESHAP and fence-line monitoring requirements in HON and the P&R I NESHAP), all existing affected sources and all affected sources that were new sources under the previous HON and P&R I NESHAP (*i.e.*, sources that commenced construction or reconstruction after December 31, 1992 (for HON) or after June 12, 1995 (for the P&R I NESHAP), and on or before April 25, 2023), must comply with all of the amendments no later than July 15, 2027, or upon startup, whichever is later. For existing sources, CAA section 112(i) provides that the compliance date for standards promulgated under section 112(d) shall be as expeditious as practicable, but no later than 3 years after the effective date of the standard. *Association of Battery Recyclers v. EPA*, 716 F.3d 667, 672 (D.C. Cir. 2013) (“Section 112(i)(3)’s three-year maximum compliance period applies generally to any emission standard . . . promulgated under [section 112].”). We agree with the commenters (see section 11.1 of the document titled *Summary of Public Comments and Responses for New Source Performance Standards for the Synthetic Organic Chemical Manufacturing Industry and National Emission Standards for Hazardous Air Pollutants for the Synthetic Organic Chemical Manufacturing Industry and*

*Group I & II Polymers and Resins Industry*, which is available in the docket for this rulemaking) that 3 years is needed for owners and operators to implement the requirements we are finalizing under CAA sections 112(d)(2), (3), and (6). For example, for process vents, if an affected source has uncontrolled process vents that emit greater than or equal to 1.0 lb/hr of total organic HAP, then a new control system, such as a thermal oxidizer with piping, ductwork, etc., may need to be installed (due to the removal of the TRE concept in its entirety in the final rule). Also, additional permits (e.g., New Source Review and/or a Title V permit modifications) may be required for new emission control equipment. Moreover, 3 years is needed to understand the final rule changes; revise site guidance and compliance programs; ensure operations can meet the standards during startup and shutdown; update operation, maintenance, and monitoring plans; upgrade emission capture and control systems; install new flare monitoring equipment; and install new process control systems. As provided in CAA section 112(i) and 5 U.S.C. 801(3), all new affected sources that commenced construction or reconstruction after April 25, 2023, are required to comply with all requirements under CAA sections 112(d)(2), (3), (6), and 112(h) (including fenceline monitoring) by July 15, 2024 or upon startup, whichever is later. We are also finalizing, as proposed, that owners or operators of P&R I affected sources must comply with the removal of the affirmative defense provisions 60 days after the publication date of the final rule (or upon startup, whichever is later). We provided additional rationale for these compliance dates in the preamble to the proposed rule (88 FR 25080, April 25, 2023).

In a change from the proposed rule, we have extended the compliance date for fenceline monitoring (with the exception of fenceline monitoring of chloroprene at P&R I affected sources producing neoprene, which is discussed later in this section) from 1 to 2 years. Owners and operators of all existing sources, and all affected sources that were new under the current rules—i.e., sources that commenced construction or reconstruction after December 31, 1992 (for HON) or after June 12, 1995 (for the P&R I NESHAP), and on or before April 25, 2023—must begin fenceline monitoring 2 years after the effective date of the final rule and, starting 3 years after the effective date of the final rule, must perform root cause analysis and apply corrective action

requirements upon exceedance of an annual average concentration action level. We extended the timeline for fenceline monitoring from 1 to 2 years based on comments received, which indicated that EPA Method 327 will require laboratories to increase their capacity to meet the requirements for fenceline monitoring. We consider this expanded timeline to be necessary to allow commercial labs to conduct the needed method development, expand capacity, and develop the logistics needed to meet the requirements in the final rule. We also agree with commenters' other assertions that more time is needed to read and assess the new fenceline monitoring requirements; prepare sampling and analysis plans; develop and submit site-specific monitoring plans; identify representative, accessible, and secure monitoring locations for offsite monitors and obtain permission from the property owner to both place and routinely access the monitors; make any necessary physical improvements to fencelines to be able to site monitors, including construction of access roads, physical fencing, and potential drainage improvements; and obtain approval of any necessary capital expenditures. We consider 2 years to be necessary to allow for all of these things. For additional details, see section 11.1 of the document titled *Summary of Public Comments and Responses for New Source Performance Standards for the Synthetic Organic Chemical Manufacturing Industry and National Emission Standards for Hazardous Air Pollutants for the Synthetic Organic Chemical Manufacturing Industry and Group I & II Polymers and Resins Industry*, which is available in the docket for this rulemaking.

For all of the requirements we are finalizing under CAA sections 112(f) for the HON, we are finalizing as proposed, except we are clarifying that the compliance dates we proposed are from the effective date of the rule rather than the publication date of the proposal. In other words, all existing affected sources and all affected sources that were new sources under the previous HON (i.e., sources that commenced construction or reconstruction after December 31, 1992, and on or before April 25, 2023) must comply with the EtO requirements no later than July 15, 2026, or upon startup, whichever is later. As explained in the April 25, 2023, proposed rule (88 FR 25080, 25176), CAA section 112(f)(4) prescribes the compliance date for emission standards issued under CAA section 112(f). *Ass'n of Battery Recyclers v.*

*EPA, 716 F.3d 667, 672 (D.C. Cir. 2013)* (“[S]ection 112(f)(4)’s two-year maximum applies more specifically to standards ‘under this subsection,’ i.e., section 112(f).”). For existing sources, the earliest compliance date for CAA section 112(f) standards is 90 days. However, the compliance period can be extended up to 2 years if the EPA finds that more time is needed for the installation of controls. 42 U.S.C. 7412(f)(4)(B). The EPA finds that the new EtO provisions under CAA section 112(f) will require additional time to plan, purchase, and install emission control equipment. For example, for process vents, if an affected source cannot demonstrate 99.9-percent control of EtO emissions, or reduce EtO emissions to less than 1 ppmv (from each process vent) or 5 pounds per year (for all combined process vents), then a new control system, such as a scrubber with piping, ductwork, feed tanks, etc., may need to be installed. Similarly, this same scenario (i.e., installation of a new control system, such as a scrubber with piping, ductwork, feed tanks, etc) may be necessary for storage vessels in order to reduce EtO emissions by greater than or equal to 99.9 percent by weight or to a concentration less than 1 ppmv. Likewise, a new steam stripper may be needed control wastewater with a total annual average concentration of EtO greater than or equal to 1 ppmw. Additionally, we agree with commenters (see section 11.1 of the document titled *Summary of Public Comments and Responses for New Source Performance Standards for the Synthetic Organic Chemical Manufacturing Industry and National Emission Standards for Hazardous Air Pollutants for the Synthetic Organic Chemical Manufacturing Industry and Group I & II Polymers and Resins Industry*, which is available in the docket for this rulemaking) that additional permits may be required for these new emission control equipment (e.g., New Source Review and/or a Title V permit modifications). In other words, sufficient time is needed to properly engineer the project, obtain capital authorization and funding, procure the equipment, obtain permits, and construct and start-up the equipment. Therefore, we are finalizing a compliance date of 2 years after the effective date of the final rule for all existing affected sources to meet the EtO requirements. All new affected sources that commence construction or reconstruction after April 25, 2023, are required to comply with the EtO requirements for the HON by July 15, 2024 or upon startup, whichever is later.

This compliance schedule is consistent with the compliance deadlines outlined in the CAA under section 112(f)(4) and the CRA. We provided additional rationale for these compliance dates in the preamble to the proposed rule (88 FR 25080, April 25, 2023).

In a change from the proposed rule, the EPA is shortening the compliance deadline for affected sources producing neoprene, due to the EPA's finding that chloroprene emissions from the only such source pose an imminent and substantial endangerment under CAA section 303, 42 U.S.C. 7603. *United States v. Denka Performance Elastomer, LLC, et al.*, No. 2:23-cv-00735 (E.D. La. filed Feb. 28, 2023). All existing affected sources producing neoprene and all affected sources producing neoprene that were new sources under the previous P&R I NESHAP (*i.e.*, sources that commenced construction or reconstruction after June 12, 1995, and on or before April 25, 2023) must comply with the chloroprene requirements we are finalizing under CAA section 112(f) for the P&R I NESHAP (see sections III.B.1 and IV.A.3.e of this preamble for a details about these chloroprene requirements) no later than October 15, 2024,<sup>32</sup> or upon startup, whichever is later. However, such sources may seek the EPA's approval of a waiver from the 90-day compliance deadline and obtain a compliance date of up to July 15, 2026 if they demonstrate to the Administrator's satisfaction that "such period is necessary for the installation of controls" and that steps will be taken during the waiver period to assure that the public health of persons will be protected from any imminent endangerment. See 42 U.S.C. 112(f)(4)(B); 40 CFR 63.6(i)(4)(ii).<sup>33</sup>

<sup>32</sup> The compliance date is 90 days after the effective date of this final action due to the Congressional Review Act.

<sup>33</sup> We are revising the General Provisions table to the P&R II NESHAP entry for 40 CFR 63.6(e)(1)(i) by changing the "No" to "Yes" for affected sources producing neoprene. EPA is also retaining authority to grant or deny requests for extensions of the compliance date under 40 CFR 63.6(i)(4)(ii) at 40 CFR 63.507(c)(6), and is not delegating that authority to states.

All new affected sources that commence construction or reconstruction after April 25, 2023, are required to comply with the chloroprene requirements for P&R I affected sources producing neoprene no later than by July 15, 2024 or upon startup, whichever is later. This compliance schedule is consistent with the compliance deadlines outlined in the CAA under section 112(f)(4) and the CRA, 5 U.S.C. 801.

#### 2. NSPS Subparts VV, VVa, VVb, III, IIIa, NNN, NNNa, RRR, RRRa

All sources of equipment leaks in the SOCM I (regulated under NSPS subpart VVb) and all SOCM I air oxidation unit processes, distillation operations, and reactor processes (regulated under NSPS subparts IIIa, NNNa, and RRRa, respectively), that commenced construction, reconstruction, or modification on or after April 25, 2023, must meet the requirements of the new NSPS upon startup of the new, reconstructed or modified facility or by July 15, 2024, whichever is later. This compliance schedule is consistent with the requirements in section 111 of the CAA and the CRA.

Also, for NSPS subparts VV, VVa, III, NNN, and RRR, we are finalizing, as proposed, the change in format of the reporting requirements to require electronic reporting (*i.e.*, we are not finalizing any new data elements); and owners and operators must begin submitting performance test reports electronically beginning on July 15, 2024 and semiannual reports on and after July 15, 2025 or once the report template for the subpart has been available on the CEDRI website (<https://www.epa.gov/electronic-reporting-air-emissions/cedri>) for 1 year, whichever date is later. For NSPS subparts IIIa, NNNa, and RRRa, we are finalizing, as proposed, that owners and operators must submit performance test reports electronically within 60 days after the date of completing each performance test, and for NSPS subparts VVb, IIIa, NNNa, and RRRa, semiannual reports on and after July 15, 2024 or once the report template for the subpart has been

available on the CEDRI website (<https://www.epa.gov/electronic-reporting-air-emissions/cedri>) for 1 year, whichever date is later.

#### IV. What is the rationale for our final decisions and amendments for the SOCM I, P&R I, and P&R II source categories?

For each issue, this section provides a description of what we proposed and what we are finalizing for the issue, the EPA's rationale for the final decisions and amendments, and a summary of key comments and responses. For all comments not discussed in this preamble, comment summaries and the EPA's responses can be found in the document titled *Summary of Public Comments and Responses for New Source Performance Standards for the Synthetic Organic Chemical Manufacturing Industry and National Emission Standards for Hazardous Air Pollutants for the Synthetic Organic Chemical Manufacturing Industry and Group I & II Polymers and Resins Industry*, which is available in the docket for this rulemaking.

##### A. Residual Risk Review for the SOCM I and Neoprene Production Source Categories NESHAP

1. What did we propose pursuant to CAA section 112(f) for the SOCM I and Neoprene Production source categories?

##### a. SOCM I Source Category

Pursuant to CAA section 112(f), the EPA conducted a residual risk review and presented the results of this review, along with our proposed decisions regarding risk acceptability and ample margin of safety, in the April 25, 2023, proposed rule for the SOCM I source category subject to HON (88 FR 25080). The results of the risk assessment for the proposal are presented briefly in Table 1 of this preamble. More detail is in the residual risk technical support document, *Residual Risk Assessment for the SOCM I Source Category in Support of the 2023 Risk and Technology Review Proposed Rule* (see Docket Item No. EPA-HQ-OAR-2022-0730-0085).



**Table 1. SOCMC Source Category Inhalation Risk Assessment Results Based on Actual and Allowable Emissions in Proposal<sup>1</sup>**

Risk Assessment	Number of Facilities <sup>2</sup>	Maximum Individual Cancer Risk (-in-1 million) <sup>3</sup>	Estimated Population at Increased Risk of Cancer		Estimated Annual Cancer Incidence (cases per year)	Maximum Chronic Noncancer TOSHI	Refined Maximum Screening Acute Noncancer HQ
			> 100-in-1 million	≥ 1-in-1 million			
SOCMI Source Category	195	2,000	87,000 (50 kilometers (km))	7.2 million (50 km)	2	2 (maleic anhydride) 2 (chlorine)	HQ <sub>REL</sub> = 3 (chlorine) HQ <sub>REL</sub> = 3 (acrolein)
Facility-wide	195	2,000	95,000 (50 km)	8.9 million (50 km)	2	4 (chlorine, acrylic acid, and acrylonitrile)	--

<sup>1</sup> Actual emissions equal allowable emissions; therefore, risks estimated based on actual emissions equal risks estimated based on allowable emissions.

<sup>2</sup> There are 207 HON facilities; however, only 195 of these facilities are included in the risk assessment based on available data, which corresponds to 222 Emission Information System (EIS) facility IDs.

<sup>3</sup> Maximum individual excess lifetime cancer risk due to HAP emissions.

The results of the proposed chronic baseline inhalation cancer risk assessment at proposal indicated that, based on estimates of current actual and allowable emissions, the maximum individual lifetime cancer risk posed by the source category was 2,000-in-1 million driven by EtO emissions from PRDs (74 percent) and equipment leaks (20 percent). At proposal, the total estimated cancer incidence from this source category was estimated to be 2 excess cancer cases per year. Approximately 7.2 million people were estimated to have cancer risks above 1-in-1 million from HAP emitted from the facilities in this source category. At proposal, the estimated maximum chronic noncancer target organ-specific hazard index (TOSHI) for the source category was 2 for respiratory effects at two different facilities (from maleic anhydride emissions at one facility and chlorine emissions at another facility).

As shown in Table 1 of this preamble, the worst-case acute hazard quotient (HQ) (based on the reference exposure level (REL)) at proposal was 3 based on the RELs for chlorine and acrolein. In addition, at proposal, the multipathway risk screening assessment resulted in a maximum Tier 3 cancer screening value

(SV) of 60 for mercury and 2 for cadmium for the fisher scenario, and 20 for polycyclic organic matter (POM) for the gardener scenario. At proposal, no site-specific assessment using TRIM.FaTE (which incorporates AERMOD deposition, enhanced soil/water run-off calculations, and model boundary identification) was deemed necessary. The EPA determined that it is not necessary to go beyond the Tier 3 lake analysis or conduct a site-specific assessment for cadmium, mercury, or POM. The EPA compared the Tier 3 screening results to site-specific risk estimates for five previously assessed source categories and concluded that if the Agency was to perform a site-specific assessment for the SOCMC source category, the HQ for ingestion exposure, specifically cadmium and mercury through fish ingestion, is at or below 1; and for POM, the maximum cancer risk under the rural gardener scenario would likely decrease to below 1-in-1 million. Also, at proposal, the highest annual average lead concentration of 0.004 micrograms per cubic meter ( $\mu\text{g}/\text{m}^3$ ) was well below the National Ambient Air Quality Standards (NAAQS) for lead, indicating low

potential for multipathway risk of concern due to lead emissions.

At proposal, the maximum lifetime individual cancer risk posed by the 195 modeled facilities, based on whole-facility emissions, was 2,000-in-1 million, with EtO emissions from PRDs (74 percent) and equipment leaks (20 percent) from SOCMC source category emissions driving the risk. Regarding the noncancer risk assessment, the maximum chronic noncancer hazard index (HI) posed by whole-facility emissions was estimated to be 4 (for respiratory effects) due mostly (98 percent) to emissions from 2 facilities.

We weighed all health risk measures and factors, including those shown in Table 1 of this preamble, in our risk acceptability determination and proposed that the risks posed by the SOCMC source category under the current MACT provisions are unacceptable (section III.B of the proposal preamble, 88 FR 25080, April 25, 2023). At proposal, we identified EtO as the driver of the unacceptable risk and evaluated several options to control EtO emissions from (1) process vents, (2) storage vessels, (3) equipment leaks, (4) heat exchange systems, and (5) wastewater “in ethylene oxide service.”

We also proposed requirements to reduce EtO emissions from maintenance vents, flares, and PRDs.

For process vents, we proposed to define “in ethylene oxide service” in the HON at 40 CFR 63.101 to mean each process vent in a process that, when uncontrolled, contains a concentration of greater than or equal to 1 ppmv undiluted EtO, and when combined, the sum of all these process vents would emit uncontrolled EtO emissions greater than or equal to 5 pounds per year (2.27 kilograms per year).

For storage vessels of any capacity and vapor pressure, we proposed to define “in ethylene oxide service” in the HON at 40 CFR 63.101 to mean that the concentration of EtO of the stored liquid is at least 0.1 percent by weight. Additionally, we proposed that unless specified by the Administrator, owners and operators may calculate the concentration of EtO of the fluid stored in a storage vessel if information specific to the fluid stored is available such as concentration data from safety data sheets. We also proposed that the exemption for “vessels storing organic liquids that contain organic hazardous air pollutants only as impurities” listed in the definition of “storage vessel” at 40 CFR 63.101 does not apply for storage vessels in EtO service.

For the EtO equipment leak provisions, we proposed to define “in ethylene oxide service” in the HON at 40 CFR 63.101 to mean any equipment that contains or contacts a fluid (liquid or gas) that is at least 0.1 percent by weight of EtO.

For heat exchange systems, we proposed to define “in ethylene oxide service” in the HON at 40 CFR 63.101 to mean each heat exchange system in a process that cools process fluids (liquid or gas) that are 0.1 percent or greater by weight of EtO.

For wastewater, we proposed to define “in ethylene oxide service” in the HON at 40 CFR 63.101 to mean each wastewater stream that contains total annual average concentration of EtO greater than or equal to 1 ppmw at any flow rate.

To reduce risks from process vents in EtO service, we proposed requirements at 40 CFR 63.113(j) to reduce emissions of EtO by either (1) venting emissions through a closed-vent system to a control device that reduces EtO by greater than or equal to 99.9 percent by weight, to a concentration less than 1 ppmv for each process vent, or to less than 5 lb/yr for all combined process vents; or (2) venting emissions through a closed-vent system to a flare meeting the flare operating requirements discussed in section III.B.4.a.i of the

proposal preamble (88 FR 25080, April 25, 2023).

To reduce risks from storage vessels in EtO service, we proposed a requirement at 40 CFR 63.119(a)(5) to reduce emissions of EtO by either (1) venting emissions through a closed-vent system to a control device that reduces EtO by greater than or equal to 99.9 percent by weight or to a concentration less than 1 ppmv for each storage vessel vent; or (2) venting emissions through a closed-vent system to a flare meeting the flare operating requirements discussed in section IV.A.1 of the proposal preamble (84 FR 69182, December 17, 2019).

To reduce risks from equipment leaks in EtO service, we proposed the following combined requirements: monitoring of connectors in gas/vapor and light liquid service at a leak definition of 100 ppm on a monthly basis with no reduction in monitoring frequency or delay of repair (at 40 CFR 63.174(a)(3) and 40 CFR 63.174(b)(3)(vi)); light liquid pump monitoring at a leak definition of 500 ppm monthly (at 40 CFR 63.163(b)(2)(iv)); and gas/vapor and light liquid valve monitoring at a leak definition of 100 ppm monthly with no reduction in monitoring frequency or delay of repair (at 40 CFR 63.168(b)(2)(iv) and 40 CFR 63.168(d)(5)).

To reduce risks from EtO emissions due to heat exchange system leaks, we proposed at 40 CFR 63.104(g)(6) to require weekly monitoring for leaks for heat exchange systems in EtO service using the Modified El Paso Method, and if a leak is found, we proposed at 40 CFR 63.104(h)(6) that owners and operators must repair the leak to reduce the concentration or mass emissions rate to below the applicable leak action level as soon as practicable, but no later than 15 days after the sample was collected with no delay of repair allowed.

To reduce risks from wastewater in EtO service, we proposed at 40 CFR 63.132(c)(1)(iii) and (d)(1)(ii) that owners and operators of HON sources manage and treat any wastewater streams that are “in ethylene oxide service.” We also proposed at 40 CFR 63.104(k) to prohibit owners and operators from injecting water into or disposing of water through any heat exchange system in a CMPU meeting the conditions of 40 CFR 63.100(b)(1) through (3) if the water contains any amount of EtO, has been in contact with any process stream containing EtO, or the water is considered wastewater as defined in 40 CFR 63.101.

In addition, we proposed at 40 CFR 63.165(e)(3)(v)(D) that any release event

from a PRD in EtO service is a violation of the standard to ensure that these process vent emissions are controlled and do not bypass controls. Also, in order to help reduce EtO risk from the SOCMCI source category to an acceptable level, we proposed: (1) A requirement at 40 CFR 63.113(k)(4) that owners and operators cannot release more than 1.0 ton of EtO from all maintenance vents combined in any consecutive 12-month period; and (2) a requirement at 40 CFR 63.108(p) that owners and operators can send no more than 20 tons of EtO to all of their flares combined in any consecutive 12-month period from all HON emission sources at a facility.

After implementation of the proposed controls for: (1) Process vents, (2) storage vessels, (3) equipment leaks, (4) heat exchange systems, and (5) wastewater “in ethylene oxide service,” as well as implementation of the proposed requirements to reduce EtO emissions from maintenance vents, flares, and PRDs, we proposed that the resulting risks would be acceptable for the SOCMCI source category. We determined at proposal that estimated post-control risks would be reduced to 100-in-1 million (down from 2,000-in-1 million) with no individuals exposed to risk levels greater than 100-in-1 million from HAP emissions from HON processes (see section III.B.2 of the proposal preamble, 88 FR 25080, April 25, 2023).

We then considered whether the existing MACT standards provide an ample margin of safety to protect public health and whether, taking into consideration costs, energy, safety, and other relevant factors, additional standards are required to prevent an adverse environmental effect. We noted that the EPA previously made a determination that the standards for the SOCMCI source category provided an ample margin of safety to protect public health, and that the most significant change since that determination was the revised 2016 IRIS inhalation URE for EtO and new 2010 IRIS inhalation URE for chloroprene. As such, we focused our ample margin of safety analysis on cancer risk for EtO and chloroprene, since these pollutants, even after application of controls needed to get risks to an acceptable level, drive cancer risk and cancer incidence (*i.e.*, 60 percent of remaining cancer incidence is from EtO) for the SOCMCI source category. The ample margin of safety analysis for the SOCMCI source category identified no other control options for EtO beyond those proposed to reduce risks to an acceptable level. For chloroprene emissions from HON-subject sources, we identified control

options for equipment leaks and maintenance activities; however, the options evaluated were found not to be cost-effective (see sections III.C.6 and III.D.4 of the proposal preamble, 88 FR 25080, April 25, 2023). Therefore, we proposed that the requirements that we proposed to achieve acceptable risk would also provide an ample margin of safety to protect public health (section

III.B.3 of the proposal preamble, 88 FR 25080, April 25, 2023).

b. Neoprene Production Source Category

Pursuant to CAA section 112(f), the EPA conducted a residual risk review and presented the results of this review, along with our proposed decisions regarding risk acceptability and ample margin of safety, in the April 25, 2023, proposed rule for the Neoprene Production source category subject to

the P&R I NESHAP (88 FR 25080). The results of the risk assessment for the proposal are presented briefly in Table 2 of this preamble. More detail is in the residual risk technical support document, *Residual Risk Assessment for the Polymers & Resins I Neoprene Production Source Category in Support of the 2023 Risk and Technology Review Proposed Rule* (see Docket Item No. EPA-HQ-OAR-2022-0730-0095).

**Table 2. Neoprene Production Source Category Inhalation Risk Assessment Results Based on Actual and Allowable Emissions in Proposal<sup>1</sup>**

Risk Assessment	Number of Facilities <sup>2</sup>	Maximum Individual Cancer Risk (-in-1 million) <sup>3</sup>	Estimated Population at Increased Risk of Cancer		Estimated Annual Cancer Incidence (cases per year)	Maximum Chronic Noncancer TOSHI	Maximum Screening Acute Noncancer HQ
			> 100-in-1 million	≥ 1-in-1 million			
Neoprene Production Source Category	1	500	2,100 (50 km)	690,000 (50 km)	0.05	0.05 (chloroprene)	HQ <sub>REL</sub> = 0.3 (chloroform)
Facility-wide	1	600	2,300 (50 km)	890,000 (50 km)	0.06	0.3 (chlorine)	--

<sup>1</sup> Actual emissions equal allowable emissions; therefore, risks estimated based on actual emissions equal risks estimated based on allowable emissions.

<sup>2</sup> Number of facilities evaluated in the risk analysis.

<sup>3</sup> Maximum individual excess lifetime cancer risk due to HAP emissions.

The results of the proposed chronic baseline inhalation cancer risk assessment at proposal indicated that, based on estimates of current actual and allowable emissions, the MIR posed by the source category was 500-in-1 million, driven by chloroprene emissions from maintenance vents (67 percent), storage vessels (11 percent), wastewater (8 percent), and equipment leaks (4 percent). At proposal, the total estimated cancer incidence from this source category was estimated to be 0.05 excess cancer cases per year, or 1 cancer case every 20 years. Approximately 690,000 people were estimated to have cancer risks above 1-in-1 million from HAP emitted from this source category. At proposal, the estimated maximum chronic noncancer TOSHI for the source category was 0.05 for respiratory effects from chloroprene emissions.

As shown in Table 2 of this preamble, the worst-case acute HQ at proposal was 0.3 based on the REL for chloroform. In addition, at proposal, we did not

undertake the three-tier human health risk screening assessment that was conducted for the SOCM I source category given that we did not identify reported persistent and bioaccumulative HAP (PB-HAP) emissions from the Neoprene Production source category. Instead, at proposal, we noted that we would expect dioxins likely to be formed by combustion controls used to control chlorinated chemicals such as chloroprene from this source category and concluded that risk from dioxins from the Neoprene Production source category would be lower than they are for the SOCM I source category after compliance with the proposed dioxin limit occurs. Also, because we did not identify reported PB-HAP emissions, we did not undertake the environmental risk screening assessment of PB-HAP for the Neoprene Production source category; however, we did conduct an environmental risk screening assessment for acid gases and concluded

that no ecological benchmark was exceeded.

At proposal, the maximum lifetime individual cancer risk posed by the one neoprene production facility, based on whole-facility emissions, was 600-in-1 million, with chloroprene emissions from maintenance vents (66 percent total, 55 percent from neoprene production sources and 11 percent from HON sources), storage vessels (9 percent total, all from neoprene production sources), equipment leaks (7 percent total, 3 percent from neoprene production sources and 4 percent from HON sources), and wastewater (7 percent, all from neoprene production sources) driving the risk. Regarding the noncancer risk assessment, the maximum chronic noncancer TOSHI posed by whole-facility emissions was estimated to be 0.3 (for respiratory effects) due to chlorine emissions.

We weighed all health risk measures and factors, including those shown in Table 2 of this preamble, in our risk

acceptability determination and proposed that the risks posed by the Neoprene Production source category under the current MACT provisions are unacceptable (section III.B of the proposal preamble, 88 FR 25080, April 25, 2023). At proposal, we identified chloroprene as the driver of the unacceptable risk and evaluated several options to control chloroprene emissions from (1) process vents, (2) storage vessels, and (3) wastewater “in chloroprene service.” We also proposed requirements to reduce chloroprene emissions from maintenance vents and PRDs, as well as a facility-wide chloroprene emissions cap for all neoprene production emission sources as a backstop.

For process vents, we proposed to define “in chloroprene service” in the P&R I NESHAP at 40 CFR 63.482 to mean each continuous front-end process vent and each batch front-end process vent in a process at affected sources producing neoprene that, when uncontrolled, contains a concentration of greater than or equal to 1 ppmv undiluted chloroprene, and when combined, the sum of all these process vents would emit uncontrolled, chloroprene emissions greater than or equal to 5 lb/yr (2.27 kg/yr).

For storage vessels of any capacity and vapor pressure in a process at affected sources producing neoprene, we proposed to define “in chloroprene service” in the P&R I NESHAP at 40 CFR 63.482 to mean that the concentration of chloroprene of the stored liquid is at least 0.1 percent by weight. Additionally, we proposed that unless specified by the Administrator, owners and operators may calculate the concentration of chloroprene of the fluid stored in a storage vessel if information specific to the fluid stored is available such as concentration data from safety data sheets. We also proposed that the exemption for “vessels and equipment storing and/or handling material that contains no organic HAP, or organic HAP as impurities only” listed in the definition of “storage vessel” at 40 CFR 63.482 does not apply for storage vessels in chloroprene service.

For wastewater, we proposed to define “in chloroprene service” in the P&R I NESHAP at 40 CFR 63.482 to mean each wastewater stream that contains total annual average concentration of chloroprene greater than or equal to 10.0 ppmw at any flow rate.

To reduce risks from process vents in chloroprene service, we proposed requirements at 40 CFR 63.485(y)(1) and 40 CFR 63.487(j)(1) to reduce emissions

of chloroprene by either venting emissions through a closed-vent system to a non-flare control device that reduces chloroprene by greater than or equal to 99.9 percent by weight or to a concentration less than 1 ppmv for each process vent, or to less than 5 lb/yr for all combined process vents.

To reduce risks from storage vessels in chloroprene service, we proposed a requirement at 40 CFR 63.484(u)(1) to reduce emissions of chloroprene by either venting emissions through a closed-vent system to a non-flare control device that reduces chloroprene by greater than or equal to 99.9 percent by weight or to a concentration less than 1 ppmv for each storage vessel.

To reduce risks from wastewater in chloroprene service, we proposed at 40 CFR 63.501(a)(10)(iv) that owners and operators of P&R I sources producing neoprene manage and treat any wastewater streams that are “in chloroprene service.” We also proposed at 40 CFR 63.502(n)(8) to prohibit owners and operators from injecting water into or disposing of water through any heat exchange system in an EPPU if the water contains any amount of chloroprene, has been in contact with any process stream containing chloroprene, or the water is considered wastewater as defined in 40 CFR 63.482.

In addition, we proposed at 40 CFR 63.165(e)(3)(v)(D) that any release event from a PRD in chloroprene service is a violation of the standard to ensure that these process vent emissions are controlled and do not bypass controls. Also, in order to help reduce chloroprene risk from the Neoprene Production source category to an acceptable level, we proposed: (1) A requirement at 40 CFR 63.485(z) and 40 CFR 63.487(i)(4) that owners and operators cannot release more than 1.0 ton of chloroprene from all maintenance vents combined in any consecutive 12-month period; and (2) a facility-wide chloroprene emissions cap at 40 CFR 63.483(a)(10) that owners and operators cannot release more than 3.8 tpy in any consecutive 12-month period from all neoprene production emission sources, combined.

After implementation of the proposed controls for: (1) Process vents, (2) storage vessels, and (3) wastewater “in chloroprene service,” as well as implementation of the proposed requirements to reduce chloroprene emissions from maintenance vents, PRDs, and all neoprene production emission sources, combined, we proposed that the resulting risks would be acceptable from HAP emissions from the Neoprene Production source category. We determined at proposal

that estimated post-control risks would be reduced to 100-in-1 million (down from 500-in-1 million) with no individuals exposed to risk levels greater than 100-in-1 million (see section III.B.2 of the proposal preamble, 88 FR 25080, April 25, 2023) from neoprene production emission sources.

We then considered whether the existing MACT standards provide an ample margin of safety to protect public health and whether, taking into consideration costs, energy, safety, and other relevant factors, additional standards are required to prevent an adverse environmental effect. We noted that the EPA previously made a determination that the standards for the Neoprene Production source category provided an ample margin of safety to protect public health, and that the most significant change since that determination was the new 2010 IRIS inhalation URE for chloroprene. As such, we focused our ample margin of safety analysis on cancer risk for chloroprene since this pollutant, even after application of controls needed to get risks to an acceptable level, drives cancer risk and cancer incidence (*i.e.*, 99.995 percent of remaining cancer incidence is from chloroprene) for the Neoprene Production source category. To determine whether the rule provides an ample margin of safety, we considered the chloroprene specific requirements that we proposed to achieve acceptable risks, as well as additional control requirements for chloroprene. The ample margin of safety analysis found that additional chloroprene controls would not be cost-effective, and therefore, we proposed that the requirements that we proposed to achieve acceptable risk would also provide an ample margin of safety to protect public health (section III.B.4 of the proposal preamble, 88 FR 25080, April 25, 2023). See the technical documents titled *Residual Risk Assessment for the Polymers & Resins I Neoprene Production Source Category in Support of the 2023 Risk and Technology Review Proposed Rule; Analysis of Control Options for Process Vents and Storage Vessels to Reduce Residual Risk of Chloroprene Emissions at P&R I Affected Sources Producing Neoprene; and Analysis of Control Options for Wastewater Streams to Reduce Residual Risk of Chloroprene From Neoprene Production Processes Subject to P&R I* (see Docket Item No. EPA-HQ-OAR-2022-0730-0095, -0083 and -0092, respectively).

2. How did the risk review change for the SOCMi and Neoprene Production source categories?

In response to comments received on the proposed rulemaking, we revised the risk assessments for the SOCMi and Neoprene Production source categories. The comments included our approach to modeling flares, which impacted the SOCMi baseline and post control risk assessments, and the performance standard for process vents and storage vessels in chloroprene service, which impacted the Neoprene Production post control risk assessment. The following sections provide the results of the revised risk assessments.

a. SOCMi Source Category

In response to a comment in section 1.1 of the document titled Summary of Public Comments and Responses for New Source Performance Standards for the Synthetic Organic Chemical Manufacturing Industry and National

Emission Standards for Hazardous Air Pollutants for the Synthetic Organic Chemical Manufacturing Industry and Group I & II Polymers and Resins Industry, which is available in the docket for this rulemaking, we modified our approach to modeling flares for the SOCMi source category and performed a revised risk assessment of baseline risk (i.e., risk prior to the implementation of the control requirements described in this final action). Based on this revised risk assessment, the baseline MIR risk posed by the source category is 2,000-in-1 million driven by EtO emissions from PRDs (74 percent) and equipment leaks (20 percent). The total estimated cancer incidence due to emissions from this source category is estimated to be 2 excess cancer cases per year. Within 50 km (~31 miles) of HON-subject facilities, the population exposed to cancer risk greater than 100-in-1 million for HON actual and allowable emissions is approximately 83,000 people, and the

population exposed to cancer risk greater than or equal to 1-in-1 million is approximately 7.17 million people. Of the 195 facilities that were assessed for risk, 8 facilities have an estimated maximum cancer risk greater than 100-in-1 million. In addition, the maximum modeled chronic noncancer TOSHI for the source category based on actual and allowable emissions is estimated to be 2 (for respiratory effects) at two different facilities (from maleic anhydride emissions at one facility and chlorine emissions at another facility). Approximately 83 people are estimated to be exposed to a TOSHI greater than 1. We note that the only change in these results from the proposal is the number of people exposed to cancer risk greater than 100-in-1 million for HON emissions, which decreased from 87,000 people at proposal to 83,000 people here. See Table 3 of this preamble for a summary of the HON baseline inhalation risk assessment results.

**Table 3. SOCMi Source Category Baseline (Pre-Control) Inhalation Risk Assessment Results Based on Actual and Allowable Emissions<sup>1</sup>**

Risk Assessment	Number of Facilities <sup>2</sup>	Maximum Individual Cancer Risk (-in-1 million) <sup>3</sup>	Estimated Population at Increased Risk of Cancer		Estimated Annual Cancer Incidence (cases per year)	Maximum Chronic Noncancer TOSHI	Refined Maximum Screening Acute Noncancer HQ
			> 100-in-1 million	≥ 1-in-1 million			
SOCMI Source Category	195	2,000	83,000 (50 km)	7.17 million (50 km)	2	2 (maleic anhydride) 2 (chlorine)	HQ <sub>REL</sub> = 3 (chlorine) HQ <sub>REL</sub> = 3 (acrolein)
Facility-wide	195	2,000	90,000 (50 km)	8.92 million (50 km)	2	4 (chlorine, acrylic acid, and acrylonitrile)	--

<sup>1</sup> Actual emissions equal allowable emissions; therefore, actual risks equal allowable risks.

<sup>2</sup> There are 207 HON facilities; however, only 195 of these facilities are included in the risk assessment based on available data, which corresponds to 222 Emission Information System (EIS) facility IDs.

<sup>3</sup> Maximum individual excess lifetime cancer risk due to HAP emissions.

We conducted a revised assessment of facility-wide (or “whole-facility”) risk to characterize the source category risk in the context of whole-facility risk. The maximum lifetime individual cancer risk posed based on whole-facility

emissions is 2,000-in-1 million with EtO emissions from PRDs (74 percent) and equipment leaks (20 percent) from SOCMi source category emissions driving the risk. The total estimated cancer incidence based on facility-wide

emission levels is 2 excess cancer cases per year. Within 50 km (~31 miles) of HON-subject facilities, the population exposed to cancer risk greater than 100-in-1 million for HON facility-wide emissions is approximately 90,000

people, and the population exposed to cancer risk greater than or equal to 1-in-1 million is approximately 8.92 million people. The maximum chronic noncancer TOSHI posed by whole-facility emissions is estimated to be 4 (for respiratory effects) due mostly (98 percent) to emissions from 2 facilities. Emissions from one facility contribute to 83 percent of the TOSHI, with approximately 60 percent of the total TOSHI from non-source category emissions of chlorine and another 15 percent from source category emissions of chlorine. Emissions from the second facility contribute to 15 percent of the TOSHI, with approximately 11 percent of the total TOSHI from source category emissions of acrylic acid and 2 percent from source category emissions of acrylonitrile. Approximately 1,100 people are estimated to be exposed to a TOSHI greater than 1 due to whole-facility emissions. Again, we note that the only change in these results from the proposal is the number of people exposed to cancer risk greater than 100-in-1 million, which decreased from 95,000 people at proposal to 90,000 people here (due to our modified approach to modeling flares, discussed above).

Finally, we conducted a revised assessment to evaluate risks after implementation of the control requirements described in this action. After implementation of the controls, the MIR for the SOCMCI source category

is reduced to 100-in-1 million (down from 2,000-in-1 million) with no individuals exposed to risk levels greater than 100-in-1 million from HAP emissions from the SOCMCI source category, which is the same as in the proposal. The total population exposed to risk levels from the SOCMCI source category greater than or equal to 1-in-1 million living within 50 km (~31 miles) of a facility would be reduced from 7.17 million people to 6.27 million people. The cancer incidence would be reduced from 2 excess cancer cases per year to 0.4 excess cancer cases per year. The maximum modeled chronic noncancer TOSHI for the source category remains unchanged. Specifically, the chronic noncancer TOSHI is estimated to be 2 (for respiratory effects) at two different facilities (from maleic anhydride emissions at one facility and chlorine emissions at another facility) with approximately 83 people estimated to be exposed to a TOSHI greater than 1. The estimated worst-case off-site acute exposures to emissions from the SOCMCI source category also remains unchanged, with a maximum modeled acute HQ of 3 based on the RELs for chlorine and acrolein. The only change in these results from proposal is the number of people exposed to cancer risk levels greater than or equal to 1-in-1 million (6.27 million here compared to 5.7 million at proposal) due to us not finalizing (in response to persuasive comments received during the public

comment period) the requirement at 40 CFR 63.108(p) that would prohibit owners and operators from sending more than 20 tons of EtO to all of their flares combined in any consecutive 12-month period (for more information on this, see Section IV.A.3.d.v of this preamble). Table 4 of this preamble summarizes the reduction in risks due to emissions from the SOCMCI source category based on the controls in this action. For further details on the revised risk assessment for the SOCMCI source category, see the document titled *Residual Risk Assessment for the SOCMCI Source Category in Support of the 2024 Risk and Technology Review Final Rule*, which is available in the docket for this rulemaking.

Table 4 of this preamble also summarizes the facility-wide risks for facilities in the SOCMCI source category. The post-control facility-wide MIR remains 2,000-in-1 million, driven by EtO emissions from Polyether Polyols Production source category emissions sources, which the EPA intends to address in a future action. Further, we note that the fence-line monitoring action level of 0.2  $\mu\text{g}/\text{m}^3$  for EtO will reduce EtO emissions and therefore risks below these levels, with the MIR reduced to 1,000-in-1 million or lower and the number of individuals exposed to cancer risk levels greater than 100-in-1 million and greater than or equal to 1-in-1 million expected to be lower than those in Table 4 of this preamble.

**Table 4. SOCFI Source Category and Facility-wide Inhalation Risk Assessment Results Based on Baseline (Pre-Control) Emissions and Post-Control Emissions**

Risk Assessment	Maximum Individual Cancer Risk (-in-1 million) <sup>1</sup>	Estimated Population at Increased Risk of Cancer		Estimated Annual Cancer Incidence (cases per year)	Maximum Chronic Noncancer TOSHI	Refined Maximum Screening Acute Noncancer HQ
		> 100-in-1 million	≥ 1-in-1 million			
SOCFI Source Category						
Pre-Control Baseline	2,000	83,000 (50 km)	7.17 million (50 km)	2	2 (maleic anhydride) 2 (chlorine)	HQ <sub>REL</sub> = 3 (chlorine) HQ <sub>REL</sub> = 3 (acrolein)
Post-Control	100	0	6.27 million (50km)	0.4	2 (maleic anhydride) 2 (chlorine)	HQ <sub>REL</sub> = 3 (chlorine) HQ <sub>REL</sub> = 3 (acrolein)
Facility-wide						
Pre-Control Baseline	2,000	90,000 (50 km)	8.92 million (50 km)	2	4 (chlorine, acrylic acid, and acrylonitrile)	--
Post-Control	2,000	2,900 (50 km)	8.49 million (50 km)	2	4 (chlorine, acrylic acid, and acrylonitrile)	--

<sup>1</sup> Maximum individual excess lifetime cancer risk due to HAP emissions.

**b. Neoprene Source Category**

In response to a comment in section IV.A.3.e.i of this preamble, we revised the performance standard for process vents and storage vessels in chloroprene service for the Neoprene Production source category. This revision did not change the baseline source category or facility-wide risk assessments for the Neoprene Production source category from proposal (see section IV.A.1.b of this preamble and Table 5 of this preamble). The revised assessment indicated that, after implementation of the controls, the MIR for the Neoprene Production source category is 100-in-1 million (down from 500-in-1 million in the pre-control baseline) with no individuals exposed to risk levels greater than 100-in-1 million from HAP

emissions from the Neoprene Production source category. This result is the same as in the proposal. The total population exposed to risk levels from the Neoprene Production source category greater than or equal to 1-in-1 million would be reduced from 690,000 people to 58,000 people. The total estimated cancer incidence of 0.05 drops to 0.01 excess cancer cases per year. For the risk results estimated after implementation of controls, the two changes from proposal are the number of people exposed to risk levels greater than or equal to 1-in-1 million (58,000 here compared to 48,000 at proposal) and the cancer incidence (0.01 here compared to 0.008 at proposal) from HAP emissions from the Neoprene Production source category. All other

results remained the same. Table 5 of this preamble summarizes the reduction in cancer risks due to emissions from the Neoprene Production source category based on the controls in this action. For further details on the revised risk assessment for the Neoprene Production source category, see the document titled *Residual Risk Assessment for the Polymers & Resins I Neoprene Production Source Category in Support of the 2024 Risk and Technology Review Final Rule*, which is available in the docket for this rulemaking.

Table 5 of this preamble also provides the facility-wide risks for the facility in the Neoprene Production source category, which are of increased importance due to the secondary

fenceline action level for chloroprene, before (pre-control baseline) and after controls (post-control) of neoprene production emission sources in this action. The post-control facility-wide MIR is 200-in-1 million, driven by chloroprene emissions from SOCM and

neoprene production emission sources. The secondary fenceline action level of 0.3 µg/m<sup>3</sup> for chloroprene will further reduce chloroprene emissions and therefore risks below these levels, with the MIR expected to be 100-in-1 million or lower, with no individuals exposed

to lifetime cancer risk levels greater than 100-in-1 million, and the number of people exposed to cancer risk levels greater than or equal to 1-in-1 million expected to be lower than those in Table 5 of this preamble.

**Table 5. Neoprene Production Source Category and Facility-wide Inhalation Risk Assessment Results Based on Baseline (Pre-Control) Emissions and Post-Control Emissions**

Risk Assessment	Maximum Individual Cancer Risk (-in-1 million) <sup>1</sup>	Estimated Population at Increased Risk of Cancer		Estimated Annual Cancer Incidence (cases per year)	Maximum Chronic Noncancer TOSHI	Maximum Screening Acute Noncancer HQ
		> 100-in-1 million	≥ 1-in-1 million			
Neoprene Production Source Category						
Pre-Control Baseline	500	2,100 (50 km)	690,000 (50 km)	0.05	0.05 (chloroprene)	HQ <sub>REL</sub> = 0.3 (chloroform)
Post-Control	100	0	58,000 (50 km)	0.01	0.01 (chloroprene)	HQ <sub>REL</sub> = 0.3 (chloroform)
Facility-wide						
Pre-Control Baseline	600	2,300 (50 km)	890,000 (50 km)	0.06	0.3 (chlorine)	--
Post-Control	200	326 (50 km)	87,000 (50 km)	0.02	0.3 (chlorine)	---

<sup>1</sup> Maximum individual excess lifetime cancer risk due to HAP emissions.

3. What key comments did we receive on the risk review, and what are our responses?

This section provides summaries of and responses to the key comments received regarding our risk assessment for the SOCM source category, our risk assessment for the Neoprene Production source category, the proposed requirements to reduce EtO emissions from the SOCM source category, and the proposed requirements to reduce chloroprene emissions from the Neoprene Production source category. We received comments in support of and against the proposed residual risk review, the IRIS URE used in the review, and our determination that additional controls were warranted under CAA section 112(f)(2) for the SOCM and Neoprene Production source categories. Other comments on these issues, as well as the EtO IRIS URE, chloroprene IRIS URE, and on additional issues regarding the residual risk review and the EPA's proposed changes based on the residual risk

review, can be found in the document titled *Summary of Public Comments and Responses for New Source Performance Standards for the Synthetic Organic Chemical Manufacturing Industry and National Emission Standards for Hazardous Air Pollutants for the Synthetic Organic Chemical Manufacturing Industry and Group I & II Polymers and Resins Industry*, which is available in the docket for this rulemaking.

a. EtO IRIS URE

We received numerous comments in support of, and in opposition to, the EPA's use of the EtO IRIS value in assessing cancer risk for a source category under CAA section 112(f)(2) for EtO. After careful review of the comments, the Agency has determined that commenters did not identify new scientific information that would alter aspects of the EPA IRIS assessments or call into question the scientific judgments reflected in those assessments. The EPA continues to

affirm its determination that the IRIS assessments are scientifically sound and robust and represent the best available inhalation cancer risk values for EtO.<sup>34</sup> These comments are not summarized in this preamble. Instead, all of these comments (related to the EPA's use of the EtO IRIS value for CAA section 112(f)(2) risk assessment) and the EPA's responses are in the document titled *Summary of Public Comments and Responses for New Source Performance Standards for the Synthetic Organic Chemical Manufacturing Industry and National Emission Standards for Hazardous Air Pollutants for the Synthetic Organic Chemical Manufacturing Industry and Group I & II Polymers and Resins Industry*, which is available in the docket for this rulemaking.

<sup>34</sup> 87 FR 77985 (Dec. 21, 2022), *Reconsideration of the 2020 National Emission Standards for Hazardous Air Pollutants: Miscellaneous Organic Chemical Manufacturing Residual Risk and Technology Review, Final action*; reconsideration of the final rule.



#### b. Chloroprene IRIS URE

We received numerous comments in support of, and in opposition to, the EPA's use of the chloroprene IRIS value in assessing cancer risk for a source category under CAA section 112(f)(2) for chloroprene. After careful review of the comments, the Agency has determined that commenters did not identify new scientific information that would alter aspects of the EPA IRIS assessments or call into question the scientific judgments reflected in those assessments. The EPA continues to affirm its determination that the IRIS assessments are scientifically sound and robust and represent the best available inhalation cancer risk values for chloroprene.<sup>35</sup> These comments are not summarized in this preamble. Instead, all of these comments (related to the EPA's use of the chloroprene IRIS value for CAA section 112(f)(2) risk assessment) and the EPA's responses are in the document titled *Summary of Public Comments and Responses for New Source Performance Standards for the Synthetic Organic Chemical Manufacturing Industry and National Emission Standards for Hazardous Air Pollutants for the Synthetic Organic Chemical Manufacturing Industry and Group I & II Polymers and Resins Industry*, which is available in the docket for this rulemaking.

#### c. Risk Assessment

Several commenters provided comments on specific facilities in the EPA risk assessment and submitted additional data for the EPA to use for assessing public health risks. We also received comments regarding environmental justice, our community-based risk assessment, and the statutory authority to assess risk. Key comments on these topics are as follows:

#### i. Emissions Data

*Comment:* Commenters objected to the use of the 2017 National Emissions Inventory (NEI) data without corrections or revisions to model risk. These commenters requested that the EPA incorporate all of the revisions that were provided by various companies that participated in the EPA's January 18, 2022, CAA section 114 request. A commenter explained that the EPA allowed facilities to update emissions values so the EPA's assessment was representative of current operations and improvements to both emissions

controls and emissions estimation methodologies. The commenter pointed out that although several facilities provided revisions to the EPA for their NEI modeling file inputs, the EPA rejected many of them. The commenter contended that if the EPA corrected its emissions modeling file to reflect more accurate emissions levels or upgraded emissions controls, it would determine, for a number of facilities, that risks were acceptable, or some emissions units were not meaningfully contributing to risk.

Commenters provided the following specific examples of corrections facilities made to their 2017 NEI data, but were rejected by the EPA:

- Huntsman Petrochemical—Conroe Plant (ID 4945611); Conroe, TX

Used actual emissions for equipment leaks.

Used updated emission rates for holding ponds.

Used actual operation hours for pumps.

- Eastman Chemical Company—Texas Operations (ID 4941511); Longview, TX

Provided consistency with process vent stack test data.

Used refined El Paso Method response factors for cooling towers.

Used updated wastewater emissions calculations.

Used updated fugitive emissions calculations.

- Sasol Chemicals—Lake Charles Chemical Complex (ID 8468011); Westlake, LA

Removed a process vent not subject to HON.

Removed a transfer rack not subject to HON.

- BASF Corporation—Geismar Site (ID 8465611); Geismar, LA

Used more recent process vent stack test data.

- Clear Lake Plant (ID 4057911); Pasadena, TX

Used revised stream compositions to estimate equipment leak emissions.

Used revised calculation methodologies to estimate process vent emissions.

- Shell Chemical—Geismar Plant (ID 7445611); Geismar, LA

Installed a thermal oxidizer to reduce EtO emissions.

Used more accurate concentration data and targeted source control efforts for wastewater.

Used more frequent connector monitoring to estimate equipment leak emissions.

Changed the specification of residual EtO in Ethoxylate product to reduce EtO emissions.

Installed a thermal oxidizer on some process vents.

By incorporating the above revisions, commenters insisted the residual risk attributable to EtO would be reduced and the EPA would conclude that risks are acceptable, even if the current IRIS value for EtO is used.

A different commenter asserted that the EPA cannot rely on a single year of emissions data from HON and P&R I sources to evaluate residual risk. The commenter explained that the NEI does not provide a reliable basis for estimating downwind concentrations of specific HAPs and the resulting cancer or noncancer risk to the communities nearby. The commenter said that, by the EPA's conclusions, fence-line monitoring data has shown that modeled concentrations greatly underestimate monitored concentrations. The commenter contended that the reliance on 2017 NEI data would contradict the EPA's own statements and would not provide the ample margin of safety that the CAA requires. While the NEI can be used as a starting point, the commenter recommended that the EPA should select the highest annual emissions that each source has reported to either the Toxics Release Inventory (TRI) or the NEI within the most recent five-year period for which data are available. The commenter explained that TRI reports are filed annually and may provide a more accurate picture of current emissions, and it would be irrational to base a residual risk assessment for sources on the 2017 NEI when the same sources are reporting higher emissions in the 2017–2021 TRI or 2020 NEI reports.

Similarly, a commenter objected to the EPA's use of the 2019 baseline actual emissions for Denka Performance Elastomers, LLC to assess residual risk of chloroprene emissions. The commenter said that the 2019 baseline actual emissions are substantially lower than historic actual emission levels reported to the Louisiana Department of Environmental Quality (LDEQ) from 1991 through 2017; and the EPA's risk report does not appear to include a description of the primary causes for the observed 2019 emission reductions. The commenter added that the combined average 2019 community monitored chloroprene concentration is 2.5 times the EPA's 2019 modeled average fence-line concentration (0.74 µg/m<sup>3</sup>). The commenter also asserted that the 2019 actual annual baseline emissions do not reflect sustainable chloroprene emission reductions achieved through work practice standards or application of MACT emission controls given that the average chloroprene concentration measured at 5th Ward Elementary during the first 6 months of 2020 were

<sup>35</sup> U.S. EPA. March 14, 2022. *Response to the Request for Correction of the 2010 IRIS Chloroprene Toxicological Review*. [www.epa.gov/system/files/documents/2022-03/ord-22-000-2789-final-rfc-21005-response-03-01-2022-new.pdf](http://www.epa.gov/system/files/documents/2022-03/ord-22-000-2789-final-rfc-21005-response-03-01-2022-new.pdf)

~52 percent higher than the measured 2019 concentrations.

*Response:* We disagree with commenters who object to the use of the 2017 NEI data. We relied on the January 2021 version of the 2017 NEI dataset because it provided the best available data for EtO emissions and other HAP emissions for the SOCM I source category and the Neoprene Production source category covered under the P&R I NESHAP. However, in a few instances where facility-specific data were not available or not reflective of current controls in the 2017 NEI, we attempted to obtain data from a more recent dataset (e.g., review of emissions inventory data from our CAA section 114 request, more recent inventories submitted to states, or the 2018 NEI). Where we did not have better data, we did not update our dataset. Of note, for the one neoprene production facility (which is also part of the SOCM I source category), we used the 2019 emissions inventory that was provided to the EPA from our CAA section 114 request. The NEI data were also used to develop the other parameters needed to perform the risk modeling analysis, including the emissions release characteristics, such as stack heights, stack diameters, flow rates, temperatures, and emission release point locations.

We note that the EPA has an obligation to use the best available data for establishment of risk-based standards and generally updates the dataset where we have sufficient rationale or improved data (e.g., relevant stack test data, documented process concentrations), but the EPA has discretion to reject updated emissions estimates when insufficient rationale and information is provided. In general, we rejected the corrections facilities made to their 2017 NEI data (i.e., the corrections listed by commenters as specified in this comment summary) due to insufficient information when numbers were updated without a clear or substantive explanation of why emissions changed and where EPA could not fully verify the changes. For example, many suggested changes were due to revisions in the engineering calculation methods with no documented detailed calculations shown. Other examples include changing calculation input assumptions for the amount of HAP in process streams where no source testing/sampling was provided by commenters to support their suggested changes. Further, in many cases we also rejected corrections listed by commenters related to pollutants that drive cancer risks for HON (i.e., EtO) and neoprene production sources (i.e., chloroprene)

given that we contend, based on the fenceline data, that the modeling file emissions for these pollutants are underestimated.

Regarding the commenter's objection to the EPA's use of the 2019 baseline actual emissions for Denka Performance Elastomers, LLC to assess residual risk of chloroprene emissions, the facility's emissions inventory was provided to the EPA pursuant to our CAA section 114 request. In particular, the EPA requested emission inventories from the past 5 years (i.e., 2016–2020) from the facility's operations as part of this request. As 2017 NEI data did not represent current controls being employed at Denka Performance Elastomers, LLC, the EPA chose to use the most current data it had available, which is reflective of current operations and emissions. Given the EPA's concerns about decreased production and emissions in 2020 from the COVID–19 pandemic, we elected to use Denka Performance Elastomer, LLC's 2019 emissions inventory submitted as part of the CAA section 114 request in its risk assessment for the HON and Neoprene Production source categories in lieu of the 2017 NEI data. The EPA also reviewed chloroprene emission records to determine whether the emissions were associated with HON processes, neoprene processes, or other non-HON and non-neoprene processes and updated the regulatory code in the risk modeling input files to account for this review.

In summary, we took many steps to develop an emissions modeling file that was representative of emissions from HON and P&R I sources, including declining to revise data where we had insufficient rationale or information to verify commenters' suggested changes. As described in more detail in the preamble to the proposed rulemaking (88 FR 25080, April 25, 2023), the EPA used many sources of information to develop the HAP emissions inventory used to assess risks for this rulemaking, including, but not limited to, the 2017 NEI and information gathered under our CAA section 114 authority. The EPA typically has wide latitude in determining the extent of data-gathering necessary to solve a problem and courts generally defer to the agency's decision to proceed on the basis of imperfect scientific information, rather than to “invest the resources to conduct the perfect study.” *Sierra Club v. EPA*, 167 F. 3d 658, 662 (D.C. Cir. 1999) (“If the EPA were required to gather exhaustive data about a problem for which gathering such data is not yet feasible, the agency would be unable to act even if such inaction had potentially significant consequences . . . [A]n

agency must make a judgment in the face of a known risk of unknown degree.” *Mexichem Specialty Resins, Inc.*, 787 F.3d 561 (D.C. Cir. 2015)).

For further details on the assumptions and methodologies used to estimate actual emissions, see Appendix 1 of the documents titled *Residual Risk Assessment for the SOCM I Source Category in Support of the 2024 Risk and Technology Review Final Rule* and *Residual Risk Assessment for the Polymers & Resins I Neoprene Production Source Category in Support of the 2024 Risk and Technology Review Final Rule*, which are both available in the docket for this rulemaking.

*Comment:* A commenter contended that the EPA's inclusion of infrequent, episodic events in their risk assessment is inappropriate. The commenter explained that short-term or one-time emissions release events are not representative of concentrations an individual would be exposed to over a lifetime. Furthermore, the commenter contended that the EPA should also have excluded EtO emissions related to SSM events from its voluntary risk analysis because the EPA is statutorily obligated to address SSM events under CAA sections 112(d)(2) and (d)(3).

*Response:* If any operating period (including SSM periods) leads to noncompliance with standards, we would not model such noncompliance for purposes of assessing risk in the CAA section 112(f) risk review because the agency estimates risk based on compliance with the established NESHAP. The statute does not require the agency to determine risk based on some assumed level of noncompliance. In addition, the appropriate remedy for noncompliance with a NESHAP is an enforcement action seeking to require the source to come into compliance with the standard.

Emissions events in violation of the standards, whether or not they are caused by malfunction events, are not considered as part of risk analyses. The EPA interprets CAA section 112 as not requiring emissions that occur during periods of malfunction to be factored into development of CAA section 112 standards, and this reading has been upheld as reasonable by the U.S. Court of Appeals for the District of Columbia in *U.S. Sugar Corporation v. EPA*, 830 F.3d 579, 606–10 (D.C. Cir. 2016). Consistent with previous risk assessments, the EPA considered both allowable and actual emissions in assessing chronic inhalation exposure and risk under CAA section 112(f)(2) for the SOCM I source category and the Neoprene Production source category covered under the P&R I NESHAP (see,

e.g., the National Emission Standards for Coke Oven Batteries [70 FR 19998–19999, April 15, 2005] and the proposed and final HON (71 FR 34428, June 14, 2006 and 71 FR 76603, December 21, 2006, respectively)). The final rule is designed to require sources to comply during all periods of operation. As explained in the preamble to the proposed rule (see 88 FR 25080, April 25, 2023), it is not generally possible to model malfunctions in the risk assessment, because by nature they are infrequent and unpredictable, and we generally have insufficient information to model these types of events. The main purpose of the risk review for these source categories is to evaluate whether the emission limits—the “standards promulgated pursuant to subsection (d),” not the non-compliance with those standards—should be made more stringent to reduce the risk posed after compliance with the underlying MACT standards. To the extent that a source is violating an underlying MACT standard, it is unlikely that tightening of the emission standard as a result of the residual risk review will avoid or mitigate such violations. In other words, a source that is violating a MACT emissions standard promulgated under CAA section 112(d) would not be any more likely to be able to avoid such violations and comply with a different presumably more stringent standard promulgated under CAA section 112(f). Such events are violations and subject to enforcement by the EPA, the states, or citizens, and an action for injunctive relief is the most effective means to address violations, whether or not they are caused by malfunctions, if an emissions event poses a significant health or environmental risk.

The EPA notes that the final Petroleum Refinery Sector Rule included a conservative, screening-level assessment (not a refined risk assessment) performed using available information collection response (ICR) data to see the impacts of certain non-routine emissions events from PRDs and flares. [80 FR 75178, December 1, 2015] That assessment conservatively combined routine and non-routine emissions merely to define an upper bound of combined risk, and the EPA ultimately concluded that risks were not significantly different, given the uncertainties and conservative nature of the screening. In this risk assessment, the EPA did have information on EtO emissions from PRD events at one facility as they were reported to the Texas Commission on Environmental Quality (TCEQ). The modeling indicated that emissions from one single PRD

release contributed to the majority of the cancer risk for that facility and as such we proposed and are finalizing requirements that any releases from PRD in EtO service are violations of these emission standards. The EPA did not include other additional emission estimates from non-routine PRD or flare events in the emissions inventory that was used to assess residual risk. Other than for highly toxic compounds such as EtO and chloroprene, we have found that non-routine emissions from PRDs and flares in similar source categories, including ethylene production facilities and petroleum refineries, have not significantly affected risks (see, e.g., 85 FR 75187–75188, December 1, 2015).

#### ii. Environmental Justice

*Comment:* Commenters asserted that the EPA should continue to place environmental justice at the forefront as it moves through the regulatory process and ensure it takes steps to reduce impacts on overburdened communities. A commenter pointed out that populations with lung disease, children, people with heart disease, and others are typically at higher risk of health harm from air pollution. The commenter declared that the EPA must place a priority on ensuring the current administration meets its goals on improving environmental justice, ensuring that people who live near these facilities do not continue to face overlapping health inequities that increase their overall risk. Other commenters called attention to the 7 million people who live near chemical plants who face serious cancer risk from uncontrolled toxic air emissions and are majority Black and Brown residents. Commenters stated that chemical manufacturing facilities are commonly located in communities of color and low-income neighborhoods (especially in Texas and Louisiana) and the emissions reductions from the proposed standards will help reduce the burden on disproportionately impacted communities.

Another commenter asserted that the EPA should strengthen the proposed HON standards to further reduce HAP emissions with the goal of eliminating racial disparities in exposure at all risk levels. The commenter claimed that, even after adoption of the proposed rule, about 1.6 million people of color will still face serious cancer risk at the 1-in-1 million level simply by living within 10 km (6.2 miles) of toxic air emissions emitted by regulated sources from chemical manufacturing plants. The commenter contended that the EPA succeeded at identifying environmental justice concerns, however it failed to

address these concerns. The commenter cited the EPA’s environmental justice web page, specifically the phrase “no group of people should bear a disproportionate share of the negative environmental consequences,” and stated that people of color will still bear a disproportionate share of exposure to HAPs and resulting cancer risk if the HON rule is adopted as proposed. Furthermore, the commenter contended that the EPA failed to cite and analyze the scientific evidence that shows that people of color are also uniquely susceptible to the health effects of toxic air pollutants, in addition to being more highly exposed, due to the cumulative impacts from a combination with other psycho-social stressors including racism, poverty, lack of access to health care and healthful foods.

*Response:* The EPA is directed, to the greatest extent practicable and permitted by law, to make environmental justice part of its mission by identifying and addressing, as appropriate, disproportionate and adverse human health or environmental effects of its programs, policies, and activities on communities with environmental justice concerns. The EPA’s environmental justice policies promote justice, including access to health impact data, by providing information on the types of environmental justice harms and risks that are prevalent in communities with environmental justice concerns. No such policies mandate consideration of any specific factors or particular outcomes from an action, but they direct that environmental justice analysis be performed as part of regulatory impact analysis, as appropriate, so that the public can have this information. As noted above, the assessment of costs and benefits described herein and in the RIA, including the environmental justice analysis, is presented for the purpose of providing the public with as full as possible an understanding of the potential impacts of this final action. The EPA notes that analysis of such impacts is distinct from the determinations finalized in this action under CAA sections 111 and 112, which are based solely on the statutory factors the EPA is required to consider under those sections.

The EPA evaluated the risks for various populations as described in the demographic analysis in the proposed rule preamble and in the documents titled *Analysis of Demographic Factors for Populations Living Near Hazardous Organic NESHAP (HON) Operations—Final*; *Analysis of Demographic Factors for Populations Living Near Hazardous Organic NESHAP (HON) Operations:*

*Whole Facility Analysis—Final; Analysis of Demographic Factors for Populations Living Near Neoprene Production Operations—Final; Analysis of Demographic Factors for Populations Living Near Neoprene Production Operations: Whole Facility Analysis—Final; and Analysis of Demographic Factors for Populations Living Near Polymers and Resins I and Polymer and Resins II Facilities*, which are available in the docket for this rulemaking. The EPA used its Environmental Justice Risk and Proximity Analysis Tool (“EJ Tool”) to link HEM/AERMOD modeling results for the HON and P&R sources with detailed census data, in order to evaluate the distribution of cancer and noncancer risks for different demographic factors (including racial, ethnic, age, economic, educational, and linguistically isolated population categories). In addition to evaluating risk distribution, this analysis also presents the demographic composition of the population located within close proximity (10 km) and within the overall HEM/AERMOD model domain (50 km) of the source category emissions (irrespective of risk). The following demographic groups were included in this risk and proximity analysis:

- Total population;
- White;
- Black (or African American);
- American Indian or Alaska Native;
- Other races and multiracial;
- Hispanic or Latino;
- Children 17 years of age and under;
- Adults 18 to 64 years of age;
- Adults 65 years of age and over;
- Adults without a high school diploma;
- People living below the poverty level, and

Linguistically isolated people. The total population statistics near facilities in the source category, irrespective of risk (*i.e.*, at all risk levels) are in the Analysis of Demographic memorandum. These results indicate that the demographic composition of the population located within close proximity (10 km) and within the overall HEM/AERMOD model domain (50 km) of the source category emissions are the same or lower than the nationwide average for all communities of environmental justice concern.

Considering risk, the post-control scenario is expected to reduce cancer incidence across all demographic groups including communities of environmental justice concern. Regarding the commenter’s concern about the post-control risk exposure of people of color, the requirements for the HON/SOCMI facilities reduce the chronic cancer risks for Black

individuals as follows: >100-in-1 million from 12,000 people to zero people; ≥50-in-1 million from 59,000 to 4,000; and ≥1-in-1 million from 694,000 to 692,000. The rule has the greatest impact at the higher chronic cancer risk levels. Additionally, regarding concern about the unique susceptibility of people of color to the health impacts of toxic air pollutants, the EPA is currently exploring data and methods to make it possible to more explicitly evaluate the role of non-chemical stressors in an environmental justice analysis.

### iii. Community-Based Risk Assessment

*Comment:* Commenters said that they supported the addition of the EPA’s community-based risk assessment in the rulemaking proposal given that it reflects a commitment to evidence-based decision-making and the well-being of communities affected by these facilities, and implored the EPA to continue to employ rigorous community risk assessments in future rulemakings. A commenter remarked that in addition to the communities’ benefit, workers within chemical plants would benefit as well.

Some commenters supported the EPA expanding the community-based risk assessment to include air toxics-related cancer risks from all large facilities in communities in the vicinity, including sources that would not be covered by the rule. The commenters explained that since the public’s exposure is not limited to one chemical or source category at a time, this is a step in the right direction. The commenters suggested these expanded community-based risk assessments be standard practice. Other commenters proposed to expand the community-based risk assessment to not only include all large facilities in the area, but also include other types of sources (*e.g.*, mobile sources), include non-cancer endpoints (*e.g.*, miscarriages, birth defects, neurodevelopmental impacts), and explore other routes of exposure beyond inhalation. Commenters claimed this could be accomplished if the EPA went a step further than the community risk assessment and performed a cumulative risk assessment. The commenter explained that a cumulative risk assessment would take into account chemical and non-chemical stressors, and how these stressors interact to promote adverse health effects.

Other commenters asserted that the EPA should strengthen the proposed HON standards to further reduce HAP emissions with the goal of eliminating or reducing the number of people exposed at or above 1-in-1 million cancer risk to the maximum extent

feasible. A commenter claimed that, under the proposed rule, about 5.7 million people would still face serious cancer risk at the 1-in-1 million level simply by living within 50 km (31 miles) of toxic air emissions that are being emitted by regulated sources from chemical manufacturing plants. The commenter further claimed that, by living within 10 km (6.2 miles), there is only a 10 percent reduction of total people at this risk level. The commenter contended that the EPA has done more in the past, specifically when 99 percent of the population living within 50 km had cancer risk reduced to 1-in-1 million through the Benzene NESHAP rule.

On the contrary, a commenter argued that the EPA’s “whole-facility” and “community-based” risk assessments are irrelevant to the proposed rule because the EPA is limited to considering only risks associated with the source category that is the subject of the risk assessment. The commenter added these broader risk analyses are less reliable due to uncertainties in the data used.

*Response:* We appreciate the commenters’ support of the community-based risk assessment. In response to reducing the number of people exposed at or above 1-in-1 million cancer risk to the maximum extent feasible, the EPA’s ample margin-of-safety determinations are conducted in accord with the two-step framework set forth in the Benzene NESHAP. When making its ample margin of safety determination, the EPA does consider health risks and their associated uncertainties, but also considers costs, technical feasibility, and other factors. For the SOCM I source category, in Step 1 of the Benzene NESHAP framework, the risks were determined to be unacceptable given all of the health information. Standards were proposed to bring the risk down to acceptable levels, not considering costs. Once the risks were determined to be at acceptable levels, Step 2 of the Benzene NESHAP framework requires the EPA to again consider health risks, but also cost, technical feasibility, and other factors, in determining if any additional controls should be required to achieve an ample margin of safety. For the SOCM I source category, the EPA proposed that it was not appropriate to require additional controls (either based on costs, feasibility, or availability) beyond what were proposed to achieve acceptable risks, regardless of health risks, thus we concluded that the proposed standards to address unacceptable risks also achieved an ample margin of safety.

*Comment:* Some commenters asserted that the community-based risk assessments should be used when making regulatory decisions, although there may be implementation challenges due to potential limitations in the EPA's statutory authority. A commenter explained that the CAA requires the EPA to investigate whether its regulations provide an "ample margin of safety" to protect public health, and if a community risk assessment demonstrates that a proposed rule does not provide an "ample margin of safety" (because of other health stressors in the community not captured by other risk assessments), then the EPA should revise the proposed rule.

*Response:* Section 112(f)(2) of the CAA expressly preserves our use of the two-step process for developing standards to address residual risk and interpret "acceptable risk" and "ample margin of safety" as developed in the Benzene NESHAP (54 FR 38044, September 14, 1989). In the Benzene NESHAP, the EPA concluded that "With respect to considering other sources of risk from benzene exposure and determining the acceptable risk level for all exposures to benzene, EPA considered this inappropriate because only the risk associated with the emissions under consideration are relevant to the regulation being established and, consequently, the decisions being made." (54 FR 38044, September 14, 1989). Our authority to use the two-step process set forth in the Benzene NESHAP, and to consider a variety of measures of risk to public health, is discussed more thoroughly in the preamble to the proposed rule (see 88 FR 25080, April 25, 2023). Nothing in the CAA or the Benzene NESHAP in any way forecloses us from considering facility-wide risks in making a determination under CAA section 112(f)(2), as such information can constitute relevant health information.

Although not appropriate for consideration in the determination of acceptable risk presented by just source category emissions, we note that contributions to risk from sources outside the source category under review could be one of the relevant factors considered in the ample margin of safety determination, along with cost and economic factors, technological feasibility and other factors. For the SO2 source category, the EPA proposed that it was not appropriate to require additional controls (either based on costs, feasibility, or availability) beyond what were proposed to achieve acceptable risks, regardless of health risks, thus we concluded that the proposed standards to address

unacceptable risk posed by emissions from the SO2 source category also achieved an ample margin of safety.

The development of community-based estimates provides additional information about the potential cumulative risks in the vicinity of the RTR sources, as one means of informing potential risk-based decisions about the RTR source category in question. We recognize that, because these risk estimates were derived from facility-wide emissions estimates which have not generally been subjected to the same level of engineering review as the source category emission estimates, they may be less certain than our risk estimates for the source category in question, but they remain important for providing context as long as their uncertainty is taken into consideration in the process.

#### iv. Statutory Authority To Conduct Risk Assessment

*Comment:* Commenters argued that the EPA is obligated to consider costs as part of their optional second residual risk review. Some commenters said that the EPA's refusal to consider costs of the controls proposed to reduce EtO emissions is beyond the EPA's statutory authority, and is arbitrary and capricious. The commenters said that unless specifically instructed otherwise, rational decision making requires the consideration of cost. The commenters contended that unless a statute precludes consideration of costs, "[c]onsideration of cost reflects the understanding that reasonable regulation ordinarily requires paying attention to the advantages and the disadvantages of agency decisions." *Michigan v. EPA*, 576 U.S. 743, 754 (2015). Some commenters added that the Supreme Court has before held that consideration of costs must occur when the EPA finds that it is "appropriate and necessary" to regulate emissions under the CAA. *Michigan v. EPA*, 576 U.S. 743, (2015) (holding costs must be considered when determining whether it is "appropriate and necessary" to regulate stationary sources of fossil-fuel fired power plants under CAA section 7412(n)). A commenter opined that because it would be "unreasonable to read an instruction to an administrative agency to determine whether 'regulation is appropriate and necessary' as an invitation to ignore costs," similarly, it would be unreasonable here for the EPA to ignore costs after it discretionally determined that it was "necessary" to "revisit and revise" the residual risk threshold.

The commenters said the residual risk provisions, by reference to the Benzene NESHAP, allow the EPA to exclude

costs only in initially determining acceptable risk, but in setting an ample margin of safety, costs are to be considered. The commenters contended that if the EPA has authority to conduct subsequent residual risk findings (which the commenters dispute), then the entire exercise is a secondary one that must take cost into consideration. A commenter explained that under most circumstances under CAA section 112, even when as an initial step, consideration of cost may be prohibited, the CAA requires consideration of cost in subsequent steps and Congress has constrained circumstances under which cost cannot be considered; therefore, the EPA is acting contrary to Congressional intent by attempting to expand its authority to conduct a risk review more than once, which is the only way in which the EPA could attempt to revise the NESHAP without considering costs.

Commenters cited the following court rulings and other references to support their view that the EPA is obligated to consider costs as part of their optional second residual risk review:

- *White Stallion Energy Center, LLC v. E.P.A.*, 748 F.3d 1222 (2014) (Kavanaugh concurring in part and dissenting in part) (citing and quoting RICHARD L. REVESZ & MICHAEL A. LIVERMORE, RETAKING RATIONALITY 12 (2008) ("For certain kinds of governmental programs, the use of cost-benefit analysis is a requirement of basic rationality.")).
- Richard J. Pierce, Jr., *The Appropriate Role of Costs in Environmental Regulation*, 54 ADMIN. L. REV. 1237, 1247 (2002) ("All individuals and institutions naturally and instinctively consider costs in making any important decision . . . . [I]t is often impossible for a regulatory agency to make a rational decision without considering costs in some way.")

- the Supreme Court pointed out in *Entergy Corp. v. Riverkeeper, Inc.*, 556 U.S. 208, 224 (2009), that the EPA had long determined that it was unreasonable to interpret a statute in a way "as requiring use of technology whose cost is wholly disproportionate to the environmental benefit to be gained." (quoting *In re Public Service Co. of New Hampshire*, 1 E.A.D. 332, 340 (1977)). While *Entergy Corp.* was in the context of the Clean Water Act, the same logic applies equally here. Justice Breyer reiterated in *Entergy Corp.*, agencies should not read statutes in a way that forbids cost-benefit comparisons when the language does not require doing so. As Justice Breyer explained, not only would that be "difficult to enforce" because "every

real choice requires a decisionmaker to weigh advantages against disadvantages, and disadvantages can be seen in terms of (often quantifiable) costs,” but such “absolute prohibition would bring about irrational results.”

• the Supreme Court has concluded that “[n]o regulation is ‘appropriate’ if it does significantly more harm than good,” and reminds agencies that “[c]onsideration of cost reflects the understanding that reasonable regulation ordinarily requires paying attention to the advantages and the disadvantages of agency decisions [reflecting] the reality that too much wasteful expenditure devoted to one problem may well mean considerably fewer resources available to deal effectively with other (perhaps more serious) problems.” *Michigan v. EPA* at 752–53 (internal quotations omitted); see also *id.* (Kagan, J. dissenting) (“Cost is almost always a relevant—and usually, a highly important—factor in regulation”)

*Response:* The EPA disagrees that it was unconditionally obligated to consider costs in this CAA section 112(f)(2) risk review. As explained in response to a comment in section 1.5 of the document titled *Summary of Public Comments and Responses for New Source Performance Standards for the Synthetic Organic Chemical Manufacturing Industry and National Emission Standards for Hazardous Air Pollutants for the Synthetic Organic Chemical Manufacturing Industry and Group I & II Polymers and Resins Industry*, which is available in the docket for this rulemaking, the EPA has the authority to conduct an additional risk review, particularly where new information has come to light making a prior risk review unreliable. New information became available about both chloroprene and EtO in 2010<sup>36</sup> and 2016,<sup>37</sup> respectively. After the EPA completed development of the IRIS inhalation URE for chloroprene in 2010 and updated the IRIS inhalation URE for EtO in 2016, the EPA learned that chloroprene and EtO were more toxic than previously known. These updates came after the first risk reviews were conducted for the SOCM and Neoprene

Production (within the P&R I NESHAP) source categories and therefore prompted the EPA to reevaluate residual cancer risks caused by EtO and chloroprene emissions.

This reevaluation meant that reconsideration of our original decisions under CAA section 112(f)(2) for the SOCM and Neoprene Production source categories is warranted, beginning with whether the existing standards reduce risks to acceptable levels under the Benzene NESHAP. Under the Benzene NESHAP, this meant going through *both* the (1) acceptability and (2) ample margin of safety steps of the section 112(f)(2) analysis. Only by going through both analytical steps anew could the EPA account for the corrected scientific understanding of risks from these HAP and conduct the appropriately updated residual risk reviews.

Under the approach outlined in the Benzene NESHAP, National Emissions Standards for Hazardous Air Pollutants: Benzene Emissions from Maleic Anhydride Plants, Ethylbenzene/Styrene Plants, Benzene Storage Vessels, Benzene Equipment Leaks, and Coke By-Product Recovery Plants (54 FR 38,044, September 14, 1989), the EPA evaluates residual risk and develops standards under CAA section 112(f)(2) in two steps, as some commenters correctly stated. See Proposed Rule, 88 FR at 25,089. In step (1), the EPA determines whether risks are acceptable “consider[ing] all health information, including risk estimation uncertainty, and includes a presumptive limit on maximum individual lifetime [cancer] risk (MIR) of approximately 1 in 10 thousand.” 54 FR at 38,045. If risks are unacceptable, the EPA must determine the emissions standards required to reduce risk to an acceptable level without considering costs. In step (2), the EPA considers whether the emissions standards provide an “ample margin of safety” to protect public health “in consideration of all health information, including the number of persons at risk levels higher than approximately 1 in 1 million, as well as other relevant factors, including costs and economic impacts, technological feasibility, and other factors relevant to each particular decision.” *Id.* (emphasis added). The EPA must then promulgate or revise emission standards necessary to provide an ample margin of safety to protect public health or determine that the standards being reviewed provide an ample margin of safety without any revisions. After conducting the ample margin of safety analysis, we consider whether a more stringent standard is necessary to prevent, taking into

consideration costs, energy, safety, and other relevant factors, an adverse environmental effect.

It is true that CAA section 112(f)(2) does not contain words declaring that consideration of costs in assessing risk acceptability is prohibited. However, this Benzene NESHAP approach was incorporated by Congress into CAA section 112(f)(2) in the 1990 CAA amendments and was upheld by the United States Court of Appeals for the District of Columbia Circuit. See *NRDC v. EPA*, 529 F.3d 1077, 1083 (D.C. Cir. 2008); Proposed Rule, 88 FR at 25,089. The approach is both rational and reasonable. While the statute does not expressly forbid consideration of costs at step (1), the Benzene NESHAP which the EPA promulgated in response to the D.C. Circuit’s ruling in *NRDC v. EPA*, 824 F.2d 1146 (D.C. Cir. 1987) (*Vinyl Chloride*),<sup>38</sup> and Congress’s endorsement of that approach in enacting the 1990 Amendments to section 112, have long been understood to prohibit consideration of costs at step (1).

The new information gained by the 2010 chloroprene and 2016 EtO IRIS inhalation UREs warranted a complete re-analysis of both steps for the HON and Neoprene Production rules. The EPA therefore started back at step (1), acceptability, in which costs are not considered. Starting back at step (1) was essential to ensure that the risks due to EtO and chloroprene were being adequately addressed given the EPA’s new understanding that exposure to EtO and chloroprene poses greater risk than was previously known. The EPA could not simply adjust the risk review at the step (2) ample margin of safety analysis to correct any errors and account for the new understanding. As explained elsewhere in this preamble, the EPA has analyzed acceptability of risks from HON and Neoprene Production processes under step (1) and identified controls necessary to achieve acceptability. Moreover, the EtO and chloroprene emission standards for HON and Neoprene Production processes that the EPA is promulgating are all necessary to reduce risks from HAP emissions from the SOCM and Neoprene Production source categories to acceptable levels, and the EPA is not adopting further source category-

<sup>38</sup> The *Vinyl Chloride* decision required the EPA to exercise its section 112 authority (under the pre-1990 Amendments then in effect) in two steps: first, by determining a “safe” or “acceptable” level of risk considering only health factors; and, second, by setting a standard that provides an “ample margin of safety,” in which costs, feasibility, and other relevant factors also may be considered. 824 F.2d at 1164–65.

<sup>36</sup> U.S. EPA. Toxicological Review of Chloroprene (CASRN 126–99–8) In Support of Summary Information on the Integrated Risk Information System (IRIS). September 2010. EPA/635/R–09/010F. Available at: <https://iris.epa.gov/static/pdfs/1021tr.pdf>

<sup>37</sup> U.S. EPA. Evaluation of the Inhalation Carcinogenicity of Ethylene Oxide (CASRN 75–21–8) In Support of Summary Information on the Integrated Risk Information System (IRIS). December 2016. EPA/635/R–16/350Fa. Available at: [https://cfpub.epa.gov/ncea/iris/iris\\_documents/toxreviews/1025tr.pdf](https://cfpub.epa.gov/ncea/iris/iris_documents/toxreviews/1025tr.pdf).

specific emission standards under CAA section 112(f)(2) under step (2) of the Benzene NESHAP. Consequently, the EPA does not agree that the cases commenters cited require that the EPA must or even can consider costs in determining these risk acceptability-based standards for process emissions from these source categories.

*Comment:* A commenter argued that the EPA should not be carrying out a cost-blind residual risk review for chloroprene when other options to address air toxics risks are available that do take costs into consideration. The commenter pointed out that on May 6, 2021, the EPA's Office of Inspector General (OIG) issued Report No. 21-P-0129: EPA Should Conduct New Residual and Technology Reviews for Chloroprene- and Ethylene July 7, 2023, 61 Oxide-Emitting Source Categories to protect Human Health ("OIG Report"). The commenter said that the EPA's Office of Air and Radiation (OAR) submitted three responses to the OIG Report in which they reiterated: (1) That they are not statutorily required to conduct another residual risk review of chloroprene and (2) that they have multiple options to address risks associated with chloroprene that do not require a cost-blind residual risk review. The commenter stated that OAR explained to OIG that it can consider risks during a technology review and that the EPA has "multiple tools available under the CAA for addressing risk from emissions of air toxics" besides discretionary residual risk reviews under CAA section 112(f).

Other commenters cited various court rulings to support their view that the EPA should withdraw the risk review requirements and repropose with cost consideration under the technology review provisions of the CAA:

- As Justice Kagan noted: "Unless Congress provides otherwise, an agency acts unreasonably in establishing 'a standard-setting process that ignore[s] economic considerations.'" *Id.* (Kagan, J. dissenting) (quoting *Industrial Union Dep't v. American Petroleum Institute*, 448 U.S. 607, 670 (1980) (Powell, J., concurring in part and concurring in judgment)). Commenters argue that the approach that Justice Kagan warned against is exactly what the EPA has done here.

- the EPA has acted unreasonably, particularly as "Federal administrative agencies are required to engage in 'reasoned decision-making.'" *Allentown Mack Sales & Service, Inc. v. NLRB*, 522 U.S. 359, 374 (1998) (internal quotation marks omitted). "Not only must an agency's decreed result be within the scope of its lawful authority, but the

process by which it reaches that result must be logical and rational."

- It follows that agency action is lawful only if it rests "on a consideration of the relevant factors." *State Farm* 463 U.S. at 43, (internal quotation marks omitted)." *Michigan*, 576 U.S. at 750. Commenters argue one of those factors is cost.

*Response:* As explained above, cost is considered in one of the two steps that the EPA undertakes during a residual risk review under 112(f)(2). The residual risk review is not "cost-blind."

The commenter quotes specific portions of OAR's response to OIG, which may not give the full picture of OAR's position in its response. For completion, the response stated:

[I]n those situations where we are reviewing a NESHAP and there is new information on the toxicity of a given chemical of interest (and the statutorily-required residual risk review has already been completed for that source category), we will determine how to best consider the new risk information in the current review. As described in the roadmaps discussed in our response to Recommendation 2, we will evaluate the multiple tools available under the CAA for addressing risk from emissions of air toxics. Those tools include conducting a discretionary residual risk assessment under CAA section 112(f)(2), conducting a review under CAA section 112(d)(6), and/or establishing new standards for unregulated pollutants if the original NESHAP did not regulate all HAP. We intend to use these tools to reduce risk—consistent with the law and in a sequence that provides an ample margin of safety to protect public health.

(Emphasis in original.)<sup>39</sup>

As OAR stated in the above response, there are multiple tools available to "address" risk from emissions of air toxics, and OAR said it would evaluate those tools, which may include a CAA section 112(d)(6) review. But the EPA did not say that it commonly "considers" risk in a CAA section 112(d)(6) review, or that risk is a factor that must drive a regulatory decision under CAA section 112(d)(6). The EPA considers the public health and environmental risks from HAP emissions during the CAA section 112(f) phase of regulation, when the EPA considers any residual risk after technology-based CAA section 112(d)(2) standards are implemented. However, when the EPA revises standards under

CAA section 112(d)(6) and imposes additional controls or work practice standards that lead to HAP emission reductions, risk from those HAP emission reductions is inherently *addressed* to some degree given that reduced emissions will correlate to some degree of reduced risk. While the EPA does not have to directly *consider* risk in the CAA section 112(d)(6) analysis, risks are lowered when additional emission controls are imposed as a result of those standards.

However, in the case of the SOCM and Neoprene Production standards, the risks were so significantly affected by the IRIS values for EtO and chloroprene that it became clear that a full risk review under CAA section 112(f)(2) was warranted, rather than relying on ancillary risk benefits that might result from conducting only a CAA section 112(d)(6) technology review. Consequently, under the Benzene NESHAP approach incorporated by CAA section 112(f), as explained above, we had to re-assess whether the existing standards were sufficiently protective, and we determined that they did not reduce risks to acceptable levels. The standards adopted in the final rulemaking are based on what is necessary to reduce risks to acceptable levels under the Benzene NESHAP, and therefore may not be based on consideration of costs. However, our rulemaking analyses do estimate the costs that will result from compliance with the standards, even if that information did not drive regulatory decisions. For details on the assumptions and methodologies used in the costs and impacts analyses, see the technical documents titled *Analysis of Control Options for Process Vents and Storage Vessels to Reduce Residual Risk of Ethylene Oxide in the SOCM Source Category for Processes Subject to HON; Analysis of Control Options for Equipment Leaks to Reduce Residual Risk of Ethylene Oxide in the SOCM Source Category for Processes Subject to HON; Analysis of Control Options for Heat Exchange Systems to Reduce Residual Risk of Ethylene Oxide in the SOCM Source Category for Processes Subject to HON; Analysis of Control Options for Wastewater Streams to Reduce Residual Risk of Ethylene Oxide in the SOCM Source Category for Processes Subject to HON; Analysis of Control Options for Flares to Reduce Residual Risk of Ethylene Oxide in the SOCM Source Category for Processes Subject to HON; Analysis of Control Options for Process Vents and Storage Vessels to Reduce Residual Risk of Chloroprene Emissions at P&R I*

<sup>39</sup> EPA OAR, Response #3 to OIG Final Report at 2–3 (June 1, 2022) (available at: [https://www.epa.gov/system/files/documents/2022-06/epa\\_oig\\_21-P-0129\\_Agency\\_Response2.pdf](https://www.epa.gov/system/files/documents/2022-06/epa_oig_21-P-0129_Agency_Response2.pdf)).

*Affected Sources Producing Neoprene; and Analysis of Control Options for Wastewater Streams to Reduce Residual Risk of Chloroprene From Neoprene Production Processes Subject to P&R I* (see Docket Item No. EPA–HQ–OAR–2022–0730–0074, –0003, –0071, –0087, –0070, –0083 and –0092, respectively).

*Comment:* A commenter argued that the Agency arbitrarily fails to properly implement the authority it claims to possess. The commenter pointed out that the EPA does not limit its review to chloroprene and EtO (e.g., in presenting the results of its risk assessment, the EPA concludes that maleic anhydride, chlorine, acrylic acid, and acrylonitrile present the highest acute inhalation risks for the SOCM I source category) even though the EPA claims a second residual risk review is only warranted for chloroprene and EtO because of the IRIS reassessments. The commenter claimed that the EPA's approach is arbitrary and unfounded because the Agency asserts no basis for conducting a new risk review for any pollutants other than chloroprene and EtO.

*Response:* As explained above in response to another comment in this section of this preamble, new information about risks of chloroprene and EtO exposure has come to light, warranting an updated residual risk review for the SOCM I and Neoprene Production (within the P&R I NESHAP) source categories. This risk review was conducted in accordance with longstanding, congressionally and judicially approved steps laid out in the 1989 Benzene NESHAP. Those steps account for the risk due to emissions of all HAP from a source category and the risk review is not limited to one or two HAP solely because updated risk information is available for only two HAP. Therefore, in order to make risk acceptability and ample margin of safety determinations for each source category, we assessed risks for all HAP emitted by the SOCM I and Neoprene Production source categories.

Importantly, though, the EPA is only imposing new standards under CAA section 112(f)(2) to control EtO and chloroprene emissions. The EPA is not imposing CAA section 112(f)(2) standards to control maleic anhydride, chlorine, acrylic acid, or acrylonitrile in this rulemaking and we found no new information regarding the health effects associated with these pollutants (like the new information on chloroprene and EtO) that would lead us to amend standards for these pollutants under CAA section 112(f)(2). Commenters do not provide any explanation, therefore, of how they are affected or harmed by

the EPA analyzing other HAP during this risk review. We have concluded that unacceptable risk posed by emissions from these source categories is driven by emissions of EtO and chloroprene and we imposed additional standards under CAA section 112(f)(2) to reduce emissions of EtO and chloroprene to an acceptable level.

*Comment:* A commenter argued that given the EPA's failure to articulate a legal basis for its position to conduct a second risk review violates the Agency's obligation to set forth in a proposed rule "the major legal interpretations and policy considerations underlying the proposed rule" according to CAA section 307(d)(3)(c), the commenter did not have adequate notice or an opportunity to comment on this key issue, which plainly is of central relevance to the rule. The commenter asserted that the EPA must supplement the current proposal to provide the required legal analysis and provide a reasonable opportunity for public comment.

*Response:* The EPA explained in the proposed rule that we were undertaking an updated residual risk review for the SOCM I and Neoprene Production (within the P&R I NESHAP) source categories "due to the development of the EPA's Integrated Risk Information System (IRIS) inhalation unit risk estimate (URE) for chloroprene in 2010" and because "in 2016, the EPA updated the IRIS inhalation URE for EtO." 88 FR at 25083–84.

The EPA explained that, due to the updated chloroprene information, "the EPA conducted a CAA section 112(f) risk review for the SOCM I source category and Neoprene Production source category. In the first step of the CAA section 112(f)(2) determination of risk acceptability for this rulemaking, the use of the 2010 chloroprene risk value resulted in the EPA identifying unacceptable residual cancer risk caused by chloroprene emissions from affected sources producing neoprene subject to P&R I.] Consequently, the proposed amendments to P&R I address the EPA review of additional control technologies, beyond those analyzed in the technology review conducted for P&R I, for one affected source producing neoprene and contributing to unacceptable risk." 88 FR at 25083–84.

Similarly, the EPA explained that, due to updated EtO information, "In the first step of the CAA section 112(f)(2) determination of risk acceptability for this rulemaking, the use of the updated 2016 EtO risk value resulted in the EPA identifying unacceptable residual cancer risk driven by EtO emissions from HON processes. Consequently, the proposed

amendments to the HON also address the EPA review of additional control technologies, beyond those analyzed in the technology review conducted for the HON, focusing on emissions sources emitting EtO that contribute to unacceptable risk." 88 FR at 25084.

The EPA also explained that "even though we do not have a mandatory duty to conduct repeated residual risk reviews under CAA section 112(f)(2), we have the authority to revisit any rulemaking if there is sufficient evidence that changes within the affected industry or significant new scientific information suggesting the public is exposed to significant increases in risk as compared to the previous risk assessments prepared for earlier rulemakings." 88 FR at 25090. See also 88 FR at 25111 ("Considering all of the health risk information and factors discussed above, particularly the high MIR for both the SOCM I and Neoprene Production source categories, the EPA proposes that the risks for both source categories are unacceptable. . . . [W]hen risks are unacceptable, under the 1989 Benzene NESHAP approach and CAA section 112(f)(2)(A), the EPA must first determine the emissions standards necessary to reduce risk to an acceptable level, and then determine whether further HAP emissions reductions are necessary to provide an ample margin of safety to protect public health or to prevent, taking into consideration costs, energy, safety, and other relevant factors, an adverse environmental effect.").

Finally, the scientific and technical bases for the EPA's proposed action are voluminously presented in the numerous supporting memoranda contained in the public docket for the proposed rulemaking. See, e.g., the documents titled *Residual Risk Assessment for the SOCM I Source Category in Support of the 2023 Risk and Technology Review Proposed Rule; Residual Risk Assessment for the Polymers & Resins I Neoprene Production Source Category in Support of the 2023 Risk and Technology Review Proposed Rule; Analysis of Control Options for Process Vents and Storage Vessels to Reduce Residual Risk of Ethylene Oxide in the SOCM I Source Category for Processes Subject to HON; Analysis of Control Options for Equipment Leaks to Reduce Residual Risk of Ethylene Oxide in the SOCM I Source Category for Processes Subject to HON; Analysis of Control Options for Heat Exchange Systems to Reduce Residual Risk of Ethylene Oxide in the SOCM I Source Category for Processes Subject to HON; Analysis of Control Options for Wastewater Streams to*



*Reduce Residual Risk of Ethylene Oxide in the SOCM Source Category for Processes Subject to HON; Analysis of Control Options for Flares to Reduce Residual Risk of Ethylene Oxide in the SOCM Source Category for Processes Subject to HON; Analysis of Control Options for Process Vents and Storage Vessels to Reduce Residual Risk of Chloroprene Emissions at P&R I Affected Sources Producing Neoprene; Analysis of Control Options for Wastewater Streams to Reduce Residual Risk of Chloroprene From Neoprene Production Processes Subject to P&R I; and Analysis of Demographic Factors for Populations Living Near Polymers and Resins I and Polymer and Resins II Facilities* (see Docket Item No. EPA–HQ–OAR–2022–0730–0085, –0095, –0074, –0003, –0071, –0087, –0070, –0083, –0092, and –0060, respectively). Also see the documents titled *Analysis of Demographic Factors for Populations Living Near Hazardous Organic NESHAP (HON) Operations—Final; Analysis of Demographic Factors for Populations Living Near Hazardous Organic NESHAP (HON) Operations: Whole Facility Analysis—Final; Analysis of Demographic Factors for Populations Living Near Neoprene Production Operations—Final; and Analysis of Demographic Factors for Populations Living Near Neoprene Production Operations: Whole Facility Analysis—Final*, which are available in the docket for this rulemaking.

The EPA clearly did articulate its legal position in a manner that was sufficient to provide the public a meaningful opportunity to comment on the basis for its action, as evidenced by the EPA's receipt of comments from several commenters discussing the EPA's use of its CAA section 112(f)(2) authority to conduct an updated residual risk review and discussing the merits of the risk review. As explained in this section, commenters argued on both sides: that the EPA did not have authority to conduct the risk review in this rule, or that the EPA must conduct additional risk reviews during every 112(d)(6) technology review. (See other responses above in this section of this preamble.) While comments may not provide the only evidence that a point was adequately noticed, "insightful comments may be reflective of notice and may be adduced as evidence of its adequacy." *Horsehead Dev. Co. v. Browner*, 16 F.3d 1246 (D.C. Cir. 1994); *Nat'l Rest. Ass'n v. Solis*, 870 F. Supp. 2d 42, 52–53 & n.6 (D.D.C. 2012). With thoughtful comments from both sides of the issue received here, the EPA has met this test.

d. HON Rule Changes Related To EtO  
i. Process Vents and Storage Vessels in EtO Service

*Comment:* A commenter said that they supported the EPA's proposed definition for "in ethylene oxide service" for process vents and the sampling and analysis procedures for owners and operators to demonstrate that each process vent does, or does not, meet the definition. However, other commenters requested the following clarifications or revisions to the proposed text:

- the EPA should revise the definition of "in ethylene oxide service" and the corresponding procedures in 40 CFR 63.109(a) for determining whether a process vent is in EtO service so that the corresponding 1 ppmv cut-off for process vents in the definition of "in ethylene oxide service" applies on an annual average basis. The commenter provided numerous examples showing that EtO concentration in the process or the vent stream can vary over time depending on what material is being produced.
- the EPA should clarify that the 5 lb/yr EtO mass emission rate limit for combined process vents as specified in 40 CFR 63.113(j)(2), 40 CFR 63.124(a)(4) and (a)(4)(iii), and within the definition of "in ethylene oxide service" should be on a CPMU-by-CPMU basis.
- the EPA should clarify at 40 CFR 63.109(a) that the location to measure the EtO concentration for process vents should be after the last recovery device (if any recovery devices are present) but prior to the inlet of any control device that is present and prior to release to the atmosphere to be consistent with requirements elsewhere in the HON (e.g., see 40 CFR 63.115(a)).

Commenters requested that the EPA revise the concentration threshold for process vents from 1 ppmv to 3 ppmv or greater and only require additional control of process vents that total 100 pounds per year or more on an affected source basis. The commenters argued these thresholds would alleviate detection limit challenges; and that process vents with concentrations and mass emissions rates below these thresholds do not significantly contribute to unacceptable risk. A commenter pointed out that moisture and interferences will prevent obtaining measurements down to 1 ppmv in certain streams such as those associated with vacuum distillation operations where motive force is provided by steam jet exhaust, and the emission point contains primarily steam with potentially trace levels of organic HAP,

or in streams at the inlet to control devices.

*Response:* We acknowledge a commenter's support of the definition for "in ethylene oxide service" for process vents and the procedures for owners and operators to demonstrate that process vent does, or does not, meet the definition. However, we are not revising the definition in the final rule as requested by other commenters such that it applies on an annual average basis. We also disagree with the commenters' request to revise the concentration threshold for process vents from 1 ppmv to 3 ppmv or greater and only require additional control of process vents that total 100 pounds per year or more on an affected source basis.

While we agree that the EtO concentration in the process or the vent stream can vary over time depending on what material is being produced, we consider the corresponding 1 ppmv EtO cut-off for process vents reasonable in terms of being measurable and quantifiable, and also appropriate for the vent stream characteristics we intended to regulate that resulted in risk reductions. We acknowledge every facility is different. Some facilities may pose less risks than others, but in a densely populated area with a nearby receptor and under specific conditions, the risks could none-the-less be unacceptable. In order to be protective of public health, we took a conservative approach.

We note that several facilities reported (in response to our CAA section 114 request) EtO measurements below 1 ppm; one of these measurements is equivalent to greater than 0.5 lb/hr and all other measurements below 1 ppm exhibited mass rates less (sometimes much less) than 0.02 lb/hr. Given that there do not appear to be detection limit challenges based on this recent stack test data, we disagree with the commenters' assertion that there is a need to alleviate detection limit challenges. Additionally, the 1 ppmv undiluted EtO threshold is also used in the Miscellaneous Organic Chemical Manufacturing NESHAP (MON) and we are not aware of any detection limit issues within that source category.

With regard to a commenter's request that the 5 lb/yr EtO mass threshold for combined process vents be on a CPMU-by-CPMU basis, we agree that this was our intent; therefore, we have clarified this in the final rule at 40 CFR 63.113(j)(2), 40 CFR 63.124(a)(4) and (a)(4)(iii), and within the definition of "in ethylene oxide service." Finally, as requested by a commenter, we have clarified at 40 CFR 63.109(a)(3) that the

sampling site shall be after the last recovery device (if any recovery devices are present) but prior to the inlet of any control device that is present and prior to release to the atmosphere.

*Comment:* Commenters said that they supported the EPA's proposed definition for "in ethylene oxide service" for storage vessels and the sampling and analysis procedures for owners and operators to demonstrate that each storage vessel does, or does not, meet the definition. However, some commenters requested the following clarifications or revisions to the proposed text:

- the EPA should revise the definition of "in ethylene oxide service" so that the corresponding the 0.1 percent by weight threshold for storage vessels in the definition of "in ethylene oxide service" applies on an annual average basis. The commenter pointed out that this is already allowed for equipment leaks at 40 CFR 63.109(c)(1); therefore, the EPA could amend the language in 40 CFR 63.109(b) to consistent with 40 CFR 63.109(c).

- the EPA should add more flexibility to the alternative approach in 40 CFR 63.109(b)(2) to allow for good engineering judgment and process knowledge similar to the language in 40 CFR 63.109(c)(2) for equipment leaks.

- the EPA should revise the definition to refer to "the procedures specified in § 63.109" instead of "sampling and analysis" to reduce confusion and eliminate the potential safety risks/costs of unnecessary sampling; it is not until proposed 40 CFR 63.109(b)(2) that the reader is informed that one is allowed to use information specific to the stored fluid to calculate the concentration of E.O., which does not necessitate sampling.

A commenter also pointed out that the EPA's proposed definition does not comport with the definition discussed in the Agency's memorandum which states: "For storage vessels of any capacity and vapor pressure, "in ethylene oxide service" means that the concentration of ethylene oxide within the tank liquid is greater than or equal to 1 ppmw. These definitions exclude ethylene oxide that is present as an impurity . . ." (see Docket Item No. EPA-HQ-OAR-2022-0730-0074). The commenter requested that the EPA confirm the threshold for storage vessels is 0.1 percent by weight, as stated in the red-line strike-out version of the proposed rule text, and that the proposed definition should not include the phrase: "The exemption for "vessels storing organic liquids that contain organic hazardous air pollutants only as impurities" listed in the definition of

"storage vessel" in this section does not apply for storage vessels that may be in ethylene oxide service." Commenters added that the EPA should properly justify the 0.1 percent by weight threshold, or revise the threshold to eliminate unnecessary additional control of sources that do not pose unacceptable risk. The commenters asserted that the risks attributable to storage vessels are those storing high concentrations of EtO, not vessels storing low concentration materials, making the EPA's proposed 0.1 percent by weight threshold arbitrary. To address the unnecessary burden imposed by the EPA's proposal, the commenters requested the EPA revise its analysis such that only those storage vessels that significantly contribute to risk (*i.e.*, those storing 100 percent EtO) be subject to additional control requirements for EtO.

*Response:* The EPA acknowledges a commenter's support of the definition for "in ethylene oxide service" for storage vessels and the procedures for owners and operators to demonstrate that each storage vessel does, or does not, meet the definition. However, we are not revising the definition in the final rule as requested by other commenters such that it applies on an annual average basis; these commenters did not provide justification for why this revision is needed. We are finalizing the definition as proposed such that a storage vessel is considered in EtO service anytime it is storing a liquid that is at least 0.1 percent by weight of (or 1,000 ppmw) EtO. We consider the 0.1 percent by weight of EtO threshold reasonable in terms of being measurable and quantifiable, and also appropriate for the vent stream characteristics we intended to regulate that resulted in risk reductions. We acknowledge every facility is different. Some facilities may pose less risks than others, but in a densely populated area with a nearby receptor and under specific conditions, the risks could none-the-less be unacceptable. In order to be protective of public health, we took a conservative approach. We note that a 1,000 ppmw threshold corresponds to the chemical inventory reporting requirements under the Emergency Planning and Community Right-to-Know Act and other supplier notification requirements, so facilities should have knowledge of the amount of EtO stored from these sources.

Regarding the inconsistency between language used in docket item EPA-HQ-OAR-2022-0730-0074 versus language used in the red-line strike-out version of the proposed rule text, we have determined that the language used in

docket item EPA-HQ-OAR-2022-0730-0074 is an error. In other words, we are finalizing the red-line strike-out version of the proposed rule text such that the definition does include the phrase: "The exemption for "vessels storing organic liquids that contain organic hazardous air pollutants only as impurities" listed in the definition of "storage vessel" in this section does not apply for storage vessels that may be in ethylene oxide service." While we believe that emissions from vessels storing impurity levels of EtO are very low and do not result in additional risk, we are not providing additional constraints or clarifications on the determination of the threshold (*e.g.*, providing averaging times) because we anticipate that the Emergency Planning and Community Right-to-Know Act and supplier notifications will generally be the basis for applicability determinations.

Also, we disagree with the commenters' request to add more flexibility to the alternative approach in 40 CFR 63.109(b)(2) for storage vessels to be consistent with the equipment leaks provision at 40 CFR 63.109(c). We believe the rule is already clear regarding determining whether storage vessels are "in ethylene oxide service." In order to determine the requirements for storage vessels in EtO service, facilities must look at both the definition of "in ethylene oxide service" and the requirements in 40 CFR 63.109 together. The definition of "in ethylene oxide service" lets the owner or operator designate a storage vessel based on process knowledge; however, if an owner or operator wants to say a storage vessel is not in EtO service, they must use the procedures in 40 CFR 63.109(b). The rule at 40 CFR 63.109(b)(2) already explicitly allows an avenue for an owner or operator to calculate the concentration of EtO of the fluid stored in the storage vessels if information specific to the fluid stored is available which includes data based on safety data sheets.

With regard to a commenter's request to change the phrasing of "sampling and analysis is performed as specified in § 63.109" to "the procedures specified in § 63.109 are performed" within the definition of "in ethylene oxide service" for storage vessels, we agree this suggested language is more clear and have revised it in the final rule.

*Comment:* A commenter said they support the EPA's proposed rule text at 40 CFR 63.113(j) that requires owners and operators to reduce emissions of EtO from process vents in EtO service by either: (1) Venting emissions through a closed-vent system to a control device that reduces EtO by greater than or

equal to 99.9 percent by weight, to a concentration less than 1 ppmv for each process vent, or to less than 5 lb/yr for all combined process vents; or (2) venting emissions through a closed-vent system to a flare meeting the proposed operating and monitoring requirements for flares in NESHAP subpart F. The commenter also said they support the EPA's proposed rule text at 40 CFR 63.119(a)(5) that requires owners and operators to reduce emissions of EtO from storage vessels in EtO service by either: (1) Venting emissions through a closed-vent system to a control device that reduces EtO by greater than or equal to 99.9 percent by weight or to a concentration less than 1 ppmv for each storage vessel vent; or (2) venting emissions through a closed-vent system to a flare meeting the proposed operating and monitoring requirements for flares in NESHAP subpart F.

However, other commenters argued that the EPA should disallow the use of flares to control EtO from process vents and storage vessels given that flares can only reduce EtO emissions by, at most, 98.6 percent; and therefore, cannot meet the proposed 99.9 percent by weight EtO reduction requirement. The commenters contended that the EPA arbitrarily and unlawfully assumes HON sources will use non-flare control devices instead of flares to reduce EtO from process vents and storage vessels. The commenters added that the Agency's supposition that it is "likely" that sources will not use flares given the flare cap provides no rational or substantial basis for assuming 99.9 percent destruction of EtO from process vents and storage vessels. A commenter contended that the difference between using a flare and a non-flare control device to reduce emissions of EtO from process vents and storage vessels could be significant, and provided an example using an emissions inventory from 2021 for Indorama's Port Neches plant showing this. A commenter asserted that requiring HON sources to use non-flare controls (and disallowing the use of flares) to control EtO from process vents and storage vessels would not result in additional costs beyond those that the EPA has already predicted, since the EPA's cost-effectiveness analysis assumed that all 12 HON facilities that need to control EtO from process vents and storage vessels to reduce risk to acceptable levels would install thermal oxidizers.

The commenters added that unlike the HON, the EPA in its risk proposal for Neoprene Production processes subject to the P&R I NESHAP (appropriately) proposes to require use of non-flare controls that reduce

chloroprene by 99.9 percent. The commenters asserted that if the EPA were to finalize its proposal to allow HON sources to use flares to reduce EtO from process vents and storage vessels (and thus allow destruction efficiencies lower than 99.9 percent), this differing treatment of risk-driving HAPs from HON and P&R I vents and storage vessels would render the Agency's final rule arbitrary and capricious.<sup>40</sup>

*Response:* We acknowledge a commenter's support for 40 CFR 63.113(j) and 40 CFR 63.119(a)(5). We also disagree with other commenters' assertions that the EPA must prohibit the use of flares to control EtO from process vents and storage vessels. In the proposed rule, we recognized flares cannot achieve 99.9 percent EtO reduction and proposed an EtO flare load limit. We also noted that as part of the CAA section 114 request, six facilities measured EtO emissions from their EtO emission points and none of these six facilities currently use a flare to control EtO emissions from process vents or storage vessels. Even so, our modeling file does include several other HON facilities that do use flares to control process vents and storage vessels that emit EtO. Therefore, we accounted for these flares operating at 98 percent EtO reduction in our risk assessment, proposed an EtO flare load limit, and determined that it is not necessary for flares to achieve 99.9 percent EtO reduction in order to reduce risk to an acceptable level and provide an ample margin of safety to protect public health (provided that owners and operators still comply with the entire suite of EtO control requirements that we are finalizing in the rule). However, in response to a comment addressed in section IV.A.3.d.v of this preamble we are not including an EtO flare load limit in the final rule; and we determined that risks are acceptable for flares operating at 98 percent EtO reduction and flares operating at 98 percent EtO reduction provide an ample margin of safety to protect public health, without the need for an EtO flare load limit.

Also, to the commenter's assertion that the EPA is giving differing treatment between HON process vents and storage vessels and P&R I process vents and storage vessels, we note that in the final rule, we require use of non-flare controls to reduce chloroprene by

98 percent<sup>41</sup> (*i.e.*, we prohibit the use of flares to control chloroprene in the Neoprene Production source category) because dioxins and furans can be formed when chlorinated compounds (*i.e.*, chloroprene) are present and combusted, and the more consistent combustion of non-flare controls such as thermal oxidizers is more appropriate than flares to reduce dioxin and furan formation. Dioxin and furan formation is not a concern when combusting EtO in a flare.

#### ii. Equipment Leaks in EtO Service

*Comment:* A commenter said that they supported the EPA's proposed definition for "in ethylene oxide service" for equipment leaks and the sampling and analysis procedures for owners and operators to demonstrate that process equipment does, or does not, meet the definition. However, some commenters requested the EPA revise the 0.1 percent by weight threshold to 5.0 percent by weight.

A commenter argued that most of EtO emissions from equipment leaks come from piping that has an EtO concentration of 5.0 percent by weight or higher. The commenter contended that expanding the new regulatory provisions to streams containing EtO between 0.1 and 5.0 percent by weight will result in a much more stringent LDAR program for components that are primarily in ethylene, methane, nitrogen, and carbon dioxide (CO<sub>2</sub>) service, and will have a minimal to negligible impact on reducing the fugitive emissions of EtO and the resulting residual risk. The commenter also recommended that the EPA revise 40 CFR 63.109(c)(1) and (2) to reflect the 5.0 percent by weight threshold instead of the 0.1 percent by weight threshold.

Other commenters asserted that the EPA does not explain why a 0.1 percent by weight threshold of EtO in equipment presents unacceptable risk; the commenters said based on their revised risk modeling assessment (including their recommended revisions to the HEM4 modeling file inputs such as revised flare parameterization, updates provided by companies, and removal of one time/infrequent release events), equipment containing less than 5 percent EtO does not significantly contribute to risk, nor is it cost-effective when considered in the context of an ample margin of safety analysis.

<sup>40</sup> The commenter cited *Transactive Corp. v. United States*, 91 F.3d 232, 237 (D.C. Cir. 1996) ("A long line of precedent has established that an agency action is arbitrary when the agency offered insufficient reasons for treating similar situations differently.").

<sup>41</sup> In response to a comment in section IV.A.3.e.i of this preamble, we are revising the performance standard for process vents and storage vessels in chloroprene service (from a 99.9 percent by weight reduction requirement as proposed to a 98 percent by weight reduction requirement in the final rule).

A commenter added that the EPA should revise the definition to refer to “the procedures specified in § 63.109” instead of “sampling and analysis” to reduce confusion and eliminate the potential safety risks/costs of unnecessary sampling; it is not until proposed 40 CFR 63.109(c)(2) that the reader is informed that one is allowed to use engineering judgment to determine the EtO concentration of the process fluid, which does not necessitate sampling.

*Response:* The EPA acknowledges a commenter’s support of the definition for “in ethylene oxide service” for equipment leaks and the procedures for owners and operators to demonstrate that process equipment does, or does not, meet the definition. However, we reject other commenters’ requests to revise the 0.1 percent by weight threshold to 5.0 percent by weight. As discussed in the preamble to the proposed rule (see 88 FR 25080, April 25, 2023), results from our risk assessment indicate that, for the source category MIR of 2,000-in-1 million, approximately 20 percent is from emissions of EtO related to HON equipment leaks. We also note that the risk from EtO from HON equipment leaks at seven facilities (including the facility driving the MIR) is  $\geq 100$ -in-1 million. To help reduce the risk from the SOCMi source category to an acceptable level, for EtO emissions from HON equipment leaks, we performed a review of available measures for reducing EtO emissions from components that are most likely to be in EtO service, which include connectors (in gas and vapor service or light liquid service), pumps (in light liquid service), and valves (in gas or light liquid service). Almost all EtO emissions related to equipment leaks come from these three pieces of equipment.

We considered the proposed 0.1 percent by weight threshold reasonable in terms of being measurable and quantifiable, and also appropriate for the vent stream characteristics we intended to regulate that resulted in risk reductions. We acknowledge every facility is different. Some facilities may pose less risks than others, but in a densely populated area with a nearby receptor and under specific conditions, the risks could none-the-less be unacceptable. In order to be protective of public health, we took a conservative approach. Regarding comments that there is no justification for adding additional controls for low risk sources given the cost, in codifying the Benzene NESHAP approach CAA section 112(f)(2) does not allow us to consider cost at the first step of the residual risk

analysis in identifying what standards are needed to reduce unacceptable risk to an acceptable level, and at proposal, and in the final rule, we determined that prior to application of the control requirements being finalized, the risk was unacceptable. It is only if the EPA adopts more stringent standards to further reduce emissions and reduce risks below acceptable levels if needed to provide an ample margin of safety to protect public health, at the second step of the residual risk analysis, that costs may be considered among other relevant factors.

With regard to a commenter’s request to change the phrasing of “sampling and analysis is performed as specified in § 63.109” to “the procedures specified in § 63.109 are performed” within the definition of “in ethylene oxide service” for equipment leaks, we agree this suggested language is more clear and have revised it in the final rule.

*Comment:* Several commenters objected to the EPA’s proposal at 40 CFR 63.171(f) that does not allow delay of repair for equipment in EtO service.

Commenters contended that the EPA did not consider the cost associated with more frequent and/or longer outage times due to removal of the delay of repair option. Commenters stated that most valves and connectors are not configured with in-line spares; and if a repair requires replacement of a leaking component, the equipment must be isolated, and in certain instances the entire process unit must be shutdown. Commenters contended that additional shutdowns directly increase the likelihood of future leaks given that each shutdown and startup cycle subjects equipment to pressure and temperature changes that could negatively impact equipment reliability.

Commenters added that, often, valves or other connectors may not be “off the shelf” so that a facility would be required to special order and wait on the equipment to arrive while shutdown. A commenter stated that lead up times to shutdowns typically provide adequate time for facilities to order and test components; however, if the delay of repair provisions are eliminated, required lead times for these activities will result in extended shutdowns. The commenter also said that facilities must often carefully evaluate the safety considerations of “boxing in” leaking EtO equipment due to the tendency of stagnant EtO to polymerize which can render equipment such as control valves inoperable. The commenter continued that it is often necessary to evaluate and engineer a clamp style solution, a process that can take more than the allotted 15-day repair time.

Commenters also noted additional consequences of more frequent shutdowns including additional wear on rotating equipment, and reduced catalyst life which could result in emission increases and waste generation.

A commenter argued that eliminating delay of repair would generally require a first repair attempt within 5 days of detection, which is an infeasibly short amount of time to safely shutdown one process unit, much less multiple integrated units. The commenter stated that delay of repair provides facilities with time needed to plan and prepare for a shutdown, which minimizes the safety risks that inevitably accompany shutdowns and startups. The commenter added that being required to shutdown abruptly and more frequently will unnecessarily increase safety risks to employees with minimal environmental benefit. The commenter said that they follow standard industry procedures in preparing for a scheduled shutdown, which involves adequate preparation time and personnel to completely purge of all lines containing EtO, using appropriate controls, before shutdown. The commenter said that stagnant EtO polymerizes, creating heat that can cause explosions.

Commenters argued that an increase in number of shutdowns due to the EPA eliminating delay of repair for equipment in EtO service could also result in impact to supply chain. A commenter said that supply chain disruptions pose significant economic, security and health risks. Another commenter added that impacts on supply could well impact broader EPA and Administration priorities such as the EPA’s recent proposal to electrify motor vehicles which is dependent upon EV battery production (and such battery production is currently generally dependent upon ethylene carbonate, which is produced by reacting EtO with CO<sub>2</sub>).

Commenters contended that the EPA failed to explain how eliminating delay of repair for equipment in EtO service would reduce EtO emissions or risks. Commenters argued that eliminating the delay of repair provisions results in an increase in emissions due to more frequent shutdowns. Commenters contended that without the ability to delay repair, it will result in unplanned shutdowns which will result in greater emissions as emissions are expected to be higher during shutdown than emissions from components on delay of repair. A commenter said EtO emissions can range from approximately 5 to 340 lbs per shutdown event and provided calculations showing that a repair of a

leaking valve would have to be delayed for over 10 years before the emissions exceeded those generated by a CMPU shutdown that resulted in 85 lbs of EtO emissions. Some commenters pointed out that delay of repair provisions allow facilities to assess whether allowing a small leak to continue poses less risk and concern than the emissions necessarily associated with a shutdown.

A commenter argued that they would expect only a small number of component(s) in EtO service to use the delay of repair provisions at 40 CFR 63.171 given that HON CMPUs that produce and use EtO as a raw material will typically have a planned process shutdown every 2 to 3 years depending on the specific process.

Another commenter suggested that the EPA adopt the TCEQ delay of repair program as described in 30 Texas Administrative Code (TAC) 115.352(2): If the repair of a component within 15 days after the leak is detected would require a process unit shutdown that would create more emissions than the repair would eliminate, the repair may be delayed until the next scheduled process unit shutdown. The commenter argued that the TCEQ requirement is reasonable given that it allows companies to choose the lowest-emitting option and attain the goal of minimizing emissions.

*Response:* Regarding commenters' assertions about cost and timing of repair, with one exception, we are finalizing the proposed requirements for delay of repair for equipment in EtO service pursuant to CAA section 112(f)(2), on the basis of risks being unacceptable. Where we find risks are unacceptable, the EPA must determine the emissions standards necessary to reduce risk to an acceptable level. The largest contributor to risk from EtO facilities is due to emissions from equipment leaks. Because emissions of EtO from the SOCOMI source category result in unacceptable risks, we proposed and are finalizing requirements that would reduce risks to an acceptable level, including provisions not allowing a delay of repair for equipment in EtO service. Allowing delay of repair would allow increased emissions of EtO and increased risk. The one exception is that we are revising 40 CFR 63.171(b) to allow a delay of repair for equipment if the equipment is isolated from the process and does not remain in organic HAP service.

To the commenters' assertions that increased startup and shutdown events will lead to additional EtO emissions, we disagree. First, we have removed the exemptions for periods of SSM. As a

result, facilities must be in compliance with the rule requirements at all times and must control EtO emissions at all times. Therefore, while there may be additional EtO entering the control device as a result of SSM, the finalized control provisions ensure risk remains acceptable. Second, we are finalizing maintenance vent requirements which are intended to address equipment openings that result from startup, shutdown, maintenance, or inspection of equipment where equipment is emptied, depressurized, degassed, or placed into service. We are finalizing that owners and operators may not release more than 1.0 ton of EtO from all maintenance vents combined per any consecutive 12-month period. An owner or operator may designate any process vent as a maintenance vent if the vent is only used as a result of startup, shutdown, maintenance, or inspection of equipment where equipment is emptied, depressurized, degassed, or placed into service. Thus, shutdowns resulting from the identification of leaks could be included under the 1.0 tpy EtO limit. It is the responsibility of the owner or operator to plan accordingly for equipment replacement and minimizing safety risks during shutdowns. Third, using the commenters' estimates of EtO emissions ranging from 5 to 340 lbs per shutdown event, the number of shutdowns that could fall under the 1 tpy limit could range from almost 6 to 400. Given the typical leak rates seen by industry (as discussed in our responses to comments in section 2.2 of the document titled *Summary of Public Comments and Responses for New Source Performance Standards for the Synthetic Organic Chemical Manufacturing Industry and National Emission Standards for Hazardous Air Pollutants for the Synthetic Organic Chemical Manufacturing Industry and Group I & II Polymers and Resins Industry*, which is available in the docket for this rulemaking) and the variety of process conditions, the EPA believes that it would be unlikely for a facility to develop 5 leaks at the maximum estimated EtO levels warranting shutdown events. We note that even if a facility were to reach the 1.0 tpy maintenance vent limit, they may still shutdown to repair leaking equipment so long as the emissions are controlled.

*Comment:* In response to the EPA soliciting comments on alternative monitoring technologies, a commenter supported optical gas imaging (OGI) be used as an option to find larger equipment leak air emissions and to repair leaks, and that perhaps it could

be used in conjunction with an annual connector monitoring program for connectors in EtO service. Another commenter contended that the EPA failed to include LDAR alternatives for use of OGI despite the agency's recognition of its efficacy in the recent NSPS subpart OOOOb and EG subpart OOOOc proposed rules and development of Appendix K, which specifically states it is the methodology that the EPA plans to incorporate by reference in the different NSPS/NESHAP subparts to enable implementation of this technology. The commenter contended that the EPA should correct this inconsistency. A commenter recommended that if the EPA determines OGI is an appropriate option to include in the final rule, the EPA model the specific OGI requirements after those contained in NSPS subpart OOOOa at 40 CFR 60.5397a(c)(7) and (d)(1) that address fugitive emissions monitoring plans where OGI is used and the requirements in 40 CFR 60.5397a(h)(4)(iv) that address resurveying equipment to verify repair. The commenter noted that some of the requirements in NSPS subpart OOOOa relative to OGI monitoring will need to be adjusted to account for application of OGI to a CMPU and not an oil and gas production site, as there are more potential interferences in a CMPU.

Another commenter contended that the EPA has not clearly addressed the use of any alternative work practices for fugitive monitoring such as OGI but is soliciting technical justification to include or exclude OGI as an option for the proposed low (100 ppmv) detection levels using EPA Method 21. The commenter added that this low concentration has not been evaluated as a level which can be observed reliably and consistently with an OGI camera. The commenter requested that any technical evaluation and proposed outcome be re-published as a proposal to ensure comprehensive evaluation by all potentially affected parties and authorities. The commenter concluded that the EPA should not collect comments, complete a review, and make a final rule change without further opportunity for comment.

A commenter stated that based on publicized research, including the EPA's Optical Gas Imaging Appendix K Technical Support Document, there is a known variability of response factors within chemical plant gas streams and the detection/sensitivity ranges of OGI technology versus legacy technologies. The commenter noted that case-by-case permits have been issued with an OGI alternative; however, each of these

permits has incorporated an annual EPA Method 21 survey to ensure that all components have been properly evaluated for leaks, and the commenter recommended adding this requirement for any OGI alternative for these sites.

A commenter noted that the results obtained using OGI for leak detection can be heavily influenced by instrument performance, environmental conditions, and human factors. The commenter explained that weather conditions such as ambient temperature, wind speed, or wind direction relative to the observer may affect the apparent concentration of any leak when viewed with OGI. The commenter stated that a study of OGI for detection of natural gas leaks found that only 51 percent of leaks were detected at wind speeds above 21 miles per hour. The commenter opined that higher concentrations of gas streams may be needed for detection to occur with OGI technology, especially as it applies to OGI surveys within the chemical sector, whereas the annual EPA Method 21 survey ensures a quantitative measurement and more appropriately demonstrates compliance. The commenter requested the EPA clarify if it plans to include the proposed Appendix K or another monitoring protocol for OGI to be followed so that there are clear and consistent expectations of field experience for camera operators including operator training, component dwell time, required operator breaks, and other criteria which are not addressed in 40 CFR 63.11.

*Response:* We disagree with the commenters that stated the rules should have required the use of OGI. The SOCOMI has been complying with equipment leak regulations since the early 1980s, and leaks are much smaller than those found in the oil and gas industry. As a result, the leak definitions that SOCOMI facilities are complying with are in the area of 500 to 1000 ppm for most equipment, and the proposed and final rule lowers leak definitions to 100 ppm for valves and connectors in EtO service. We acknowledge that OGI is effective at finding large leaks quickly for many compounds. OGI is less effective at finding low-level leaks, especially in the environmental conditions that generally exist during a field survey. As a commenter indicated, the low leak concentrations that were proposed and which we are finalizing (100 ppm) have not been evaluated at a level which can be observed reliably and consistently with an OGI camera. In feasibility studies conducted as part of the development of 40 CFR part 60

appendix K,<sup>42</sup> which are the procedures for using OGI in leak detection, leaks below 500 ppm (or even higher in some circumstances) could not be reliably detected even in a laboratory setting except under the most ideal conditions. We also agree with the commenter who noted that leak detection with an OGI camera is heavily influenced by environmental conditions and human factors. Additionally, as explained more fully in response to a comment in section IV.B.3.b.ii of this preamble, OGI cameras, especially in the most common filter bandwidths, are not sensitive to some of the chemicals found at SOCOMI facilities, which can make leaks difficult or even impossible to see, even for large leaks. In promulgating NSPS subpart OOOOb and EG subpart OOOOc, the EPA considered the level of control required for fugitive emissions in the oil and natural gas sector, as well as the chemical make-up of the expected fugitive emissions. Based on those considerations, we determined that OGI was a viable option for facilities subject to regulation under those subparts through our BSER analysis. However, for the reasons outlined in this response, while the use of OGI is appropriate for the oil and natural gas sector, it would not be appropriate to rely exclusively upon OGI for the SOCOMI source category.

### iii. Heat Exchange Systems in EtO Service

*Comment:* A commenter said that they supported the EPA's proposed definition for "in ethylene oxide service" for heat exchange systems and the sampling and analysis procedures for owners and operators to demonstrate that each heat exchange system does, or does not, meet the definition. However, commenters requested the following clarifications or revisions to the proposed text:

- the EPA should add into the definition an exclusion for EtO present as an impurity consistent with the Agency's memorandum which states: "This definition excludes ethylene oxide that is present as an impurity." (see Docket Item No. EPA-HQ-OAR-2022-0730-0074).
- the EPA should revise 40 CFR 63.109(e) to allow the ability to use good engineering judgment to determine the percent of EtO in the process fluid as they have for equipment leaks in 40 CFR 63.109(c)(2). The commenters said that process fluids serviced by heat exchange systems are the same process fluids contained in equipment that must be evaluated for "in ethylene oxide

service," and this prohibition negates the cost savings and flexibility allowed by the use of good engineering judgment for equipment leaks because facilities will be required to conduct sampling and analysis on the same process streams regardless under the heat exchange system provisions. The commenters added that sampling and analyzing process fluids subject to the monitoring requirements for heat exchange systems presents the same issues and difficulties that the EPA identified as the basis for allowing engineering judgment under the MON RTR.

- the EPA should consider allowing facilities to account for site-specific conversion of EtO to ethylene glycol in water in heat exchange systems based on the characteristics (e.g., temperature and pH) of the heat exchange system in determining the threshold definition.

Some commenters requested the revise the 0.1 percent by weight threshold to at least 0.5 percent by weight. These commenters argued that a heat exchanger with an industry-average flow rate with a leak rate of 3.6 ppmw and a process fluid concentration of 0.5 percent EtO would not pose unacceptable risk if the leak were to occur for 135 days as allowed by the existing heat exchange system monitoring provisions (i.e., quarterly sampling plus a 45-day repair period). A commenter asserted that the EPA does not explain why a 0.1 percent by weight threshold of EtO in process fluid presents unacceptable risk.

*Response:* We acknowledge the commenter's support of the definition for "in ethylene oxide service" for heat exchange systems and the procedures for owners and operators to demonstrate that each heat exchange system does, or does not, meet the definition. However, we disagree with other commenters' requests to revise the 0.1 percent by weight threshold to at least 0.5 percent by weight. We consider the 0.1 percent by weight threshold reasonable in terms of being measurable and quantifiable, and also appropriate for heat exchange system leak characteristics we intended to regulate that resulted in risk reductions. We acknowledge every facility is different. Some facilities may pose less risks than others, but in a densely populated area with a nearby receptor and under specific conditions, the risks could none-the-less be unacceptable. In order to be protective of public health, we took a conservative approach.

We agree to the commenter's request to allow the ability to use good engineering judgment at 40 CFR 63.109(e) to determine the percent of

<sup>42</sup> See 89 FR 16820 (March 8, 2024).

EtO of the process fluid cooled by the heat exchange system similar to what we have allowed for equipment leaks in 40 CFR 63.109(c)(2). We are making this change in the final rule due to the difficulty and issues with sampling and testing fluid in process lines, particularly if the fluid contains EtO. Also, we believe the use of site-specific conversion calculations of EtO to ethylene glycol in heat exchange systems already qualifies as good engineering judgment using calculations based on process stoichiometry; however, due to its relation to risk as previously discussed, the threshold for determining if equipment is “in ethylene oxide service” is not being revised per the commenter’s request.

Regarding the language used in docket item EPA-HQ-OAR-2022-0730-0074 versus it not being included in the red-line strike-out version of the proposed rule text, we have determined that the language used in docket item EPA-HQ-OAR-2022-0730-0074 is an error. In other words, we are finalizing the red-line strike-out version of the proposed rule text and are not including an exclusion for EtO present as an impurity. The 0.1 percent by weight threshold already accounts for impurities.

*Comment:* A commenter said they support the EPA’s proposed rule text at 40 CFR 63.104(g)(6) and (h)(6) that requires owners and operators to conduct more frequent leak monitoring (weekly instead of quarterly) for heat exchange systems in EtO service and repair leaks within 15 days from the sampling date (in lieu of the current 45-day repair requirement after receiving results of monitoring indicating a leak in the HON), and delay of repair would not be allowed.

However, other commenters raised the following concerns with regard to sampling frequency and delay of repair. Commenters recommended that the EPA modify the proposed 40 CFR 63.104(g)(6) to require monthly (in lieu of weekly) sampling via the Modified El Paso Method. A commenter contended that weekly monitoring of each heat exchange system will require either multiple sampling apparatuses or frequent movement of the sampling apparatus from one system to another. Similarly, another commenter argued that weekly sampling presents some logistical problems as typically a contractor brings in the monitoring device, which is a skid mounted unit; the contractor will then move the device from one sampling location to additional sampling locations at the site. In some cases, the commenter said that the monitoring skid must be moved to

other process areas that are subject to the other rules such as the Ethylene MACT and the MON rule; therefore, a requirement to conduct this type of monitoring on a weekly basis will limit the flexibility to move the monitoring skid at the site.

The commenters suggested that the monthly Modified El Paso Method monitoring could be combined with weekly analysis of a surrogate parameter as an alternative to conducting weekly sampling using the Modified El Paso Method. The commenters said that the surrogate parameter could be something like monitoring weekly using a water analytical method to indicate the presence of a leak or monitoring other parameters that would indicate the presence of a leak; and if a surrogate measurement indicates a leak, the facility would be required to confirm the presence of the leak using the Modified El Paso Method and repair as required by the proposed provisions.

A commenter requested that the EPA not eliminate the option that allows facilities to delay the repair provided emissions from the process shutdown needed to repair the leak are greater than the potential emissions of delaying. The commenter said that this option essentially allows facilities to repair the leak with as little emissions and environmental impact as possible by requiring the facility to evaluate the emissions of a continued leak against the emissions from an entire process shutdown. The commenter claimed that allowing a repair to be delayed until the next process unit shutdown, if emissions from the delay would be less than those from the unplanned shutdown itself, has been a longstanding concept in several chemical sector rules (see for example 40 CFR 60.482-9(c), 63.104(e)(2)(i), 63.171(c), 63.1024(d)(3), and 63.105(d)(3)). The commenter contended that by forcing facilities to repair leaks solely based on a concentration-based threshold, facilities with a smaller recirculation rate will likely emit greater amounts of HAP than if they were allowed to assess the overall mass emissions from the leak versus shutdown and choose the option that minimizes emissions.

The commenter also said that it is unclear why the EPA is proposing to not allow facilities to delay a repair by isolating the equipment such that it is no longer in EtO service. The commenter said that in certain instances, a facility may be able to isolate a leaking heat exchanger but cannot open the equipment until a process unit shutdown.

*Response:* We acknowledge the commenter’s support of the rule text at 40 CFR 63.104(g)(6) and (h)(6) that requires owners and operators to conduct more frequent leak monitoring (weekly instead of quarterly) for heat exchange systems in EtO service and repair leaks within 15 days from the sampling date (in lieu of the current 45-day repair requirement after receiving results of monitoring indicating a leak in the HON), and delay of repair would not be allowed.

However, we disagree with other commenters’ request to require monthly (in lieu of weekly) sampling via the Modified El Paso Method. As we stated in the document titled *Analysis of Control Options for Heat Exchange Systems to Reduce Residual Risk of Ethylene Oxide in the SOCM Source Category for Processes Subject to HON* (see Docket Item No. EPA-HQ-OAR-2022-0730-0071), we determined baseline EtO emissions and emissions reductions using information the EPA received from Union Carbide Corporation-Seadrift, TX about an EtO emissions event (Incident 293911) that was reported to the TCEQ on October 21, 2018. Using information provided, we calculated different sampling and repair periods required to reduce risks to an acceptable level. Because at least a 90+ percent reduction in EtO emissions is needed to get to this level (as the risk posed by this large leak is at least 400-in-1-million based on current the HON standards and Union Carbide’s best case emissions estimates and because other emission sources also contribute to risks), we determined that if the facility identifies and repairs an EtO leak (from a heat exchange system) within 15 days from a weekly sampling event, the facility would achieve a 6.06 tpy EtO emission reduction (*i.e.*, 93 percent reduction in EtO emissions). Less frequent sampling (*e.g.*, monthly) and more time to repair the leak from the sampling period does not get to the level of reduction needed to bring facility risk to below 100-in-1 million. We also noted that the facility indicated they are currently conducting weekly sampling for leaks of EtO already and have implemented this type of sampling across all their facilities that have heat exchange systems cooling process streams with EtO.

In addition, we also reject the commenters’ request to use a weekly analysis of a surrogate parameter as an alternative to conducting weekly sampling using the Modified El Paso Method. Surrogate methods via water analysis are less sensitive than the Modified El Paso Method. Therefore, though weekly monitoring via a

surrogate would catch the largest of leaks, there would still be the potential for leaks to go uncaptured until the next monthly check via the Modified El Paso Method. As a result, to keep risk at an acceptable level, we maintain that weekly monitoring via the Modified El Paso Method is appropriate.

Similarly, we reject a commenter's request to allow delay of repair at 40 CFR 63.104(h)(6) for heat exchange systems in EtO service. As previously discussed, our leak analysis is based on reducing the delay of repair to achieve a cancer risk incidence at or below 100-in-1 million. Given that EtO is a major cancer driver, leaks need to be addressed quickly to keep risk at an acceptable level. Having said this, we agree with the commenter that owners and operators should be allowed to delay a repair by isolating the equipment (e.g., a heat exchanger) such that it is no longer in EtO service. It was our intent to allow this type of delay of repair which has always been allowed in the HON at 63.104(e). In this scenario, the owner and operator may delay repair indefinitely as there is no longer an active EtO leak once the equipment is isolated and not in EtO service. For this reason, we are revising 40 CFR 63.104(h)(6) in the final rule to include the following allowance: "Delay of repair of heat exchange systems in ethylene oxide service for which leaks have been detected is allowed if the equipment is isolated from the process such that it is no longer in ethylene oxide service."

#### iv. Wastewater in EtO Service

*Comment:* A commenter said that they supported the EPA's proposed definition for "in ethylene oxide service" for wastewater and the sampling and analysis procedures for owners and operators to demonstrate that each wastewater stream does, or does not, meet the definition. However, other commenters requested the EPA reevaluate the 1 ppmw EtO concentration threshold for wastewater control. These commenters contended that the EPA should make the EtO concentration threshold less stringent (i.e., a value >1ppmw EtO) primarily on the basis that wastewater should not be regulated more strictly than process vents, there is negligible additional benefit for excessive complexity controlling down to 1 ppmw, and the majority of wastewater collection and treatment emissions will be captured even with a less stringent EtO concentration threshold for wastewater control. The commenters said the EPA does not state why a 1 ppmw threshold is necessary to reduce risks or provide

an ample margin of safety, or why Group 1 streams should be classified based solely on this concentration threshold. The commenters recommended the EtO concentration threshold for wastewater control should be changed to an annual average concentration of either 25 or 27 ppmw EtO with an annual average flow rate of 10 liters per minute or higher (in lieu of proposing a no flow rate threshold).

Additionally, commenters requested the EPA establish a mass threshold for wastewater as a "de minimis" value to prevent having to control very small or low flow intermittent wastewater streams that provide little risk reduction, and to raise the concentration commensurate with other rules. A commenter recommended the cutoff for each wastewater stream be a total annual average mass flow rate of EtO to the sewer of at least 0.01 lb/min (0.6 lb/hr). Other commenters requested the EPA add a cutoff such that none of a facility's process wastewater streams should be considered in EtO service if the entire collection of EtO-containing process wastewater streams from HON CMPUs contain no more than 0.24 tpy of EtO. Commenters pointed out that when reviewing the responses to the EPA's CAA section 114 request, typically only one existing Group 2 wastewater stream contributes the majority of the EtO baseload flow to the sewer system; and there are other process wastewater streams in which the EtO concentration is between 1 and 15 ppmw, and the flowrate of the stream is very low or very intermittent, resulting in flows to the sewer systems that are in some cases less than 0.1 lb/hr or even much lower. The commenters argued that it does not make sense to require Group 1 controls for these low volume streams as one is essentially treating almost pure water at this point.

*Response:* The EPA acknowledges commenters' support and opposition to revise the Group 1 wastewater stream threshold to include wastewater streams in EtO service (i.e. wastewater streams with total annual average concentration of EtO greater than or equal to 1 ppmw at any flowrate). We are finalizing the definition of "in ethylene oxide service" definition for wastewater as proposed. With regard to the commenters' assertion that the 1 ppmw threshold was not explained, the document titled *Analysis of Control Options for Wastewater Streams to Reduce Residual Risk of Ethylene Oxide in the SOGMI Source Category for Processes Subject to HON* (see Docket Item No. EPA-HQ-OAR-2022-0730-0087) states that a 1 ppmw threshold is necessary to reduce risk of EtO emissions from wastewater,

as the risk due to wastewater is as high as 200-in-1-million, which contributes to unacceptable risk. Additionally, the data from our CAA section 114 request shows that introducing a flowrate threshold, as one commenter suggested, would leave wastewater streams with large amounts of EtO uncontrolled, and could contribute to increased risk at some facilities over 100-in-1-million.

Similarly, we disagree with the commenters' suggestion to include a mass threshold. We calculated the maximum amount of EtO emissions from wastewater streams that would push a facility over the 100-in-1-million mark, and found the lowest amount of excess EtO emissions to be 0.06 tpy. This is well under the commenters' suggestions for a mass threshold.

*Comment:* A commenter said that they support the proposed provisions at 40 CFR 63.132(c)(1)(iii) and (d)(1)(ii) to revise the Group 1 wastewater stream threshold to include wastewater streams in EtO service (i.e., wastewater streams with total annual average concentration of EtO greater than or equal to 1 ppmw at any flow rate). However, at least one commenter claimed that there is no need for the proposed provisions at 40 CFR 63.132(c)(1)(iii) and (d)(1)(ii) because the current treatment options for process wastewater streams in EtO service are already adequate to meet the ample margin of safety provided the EPA made one edit to 40 CFR 63.138(e)(1) and (2) when controlling streams with lower concentrations of EtO than previously regulated by the EPA. The commenter recommended that the EPA add an option to both 40 CFR 63.138(e)(1) and (2) that allows the owner or operator to demonstrate compliance with the performance standard for EtO if the outlet concentration of EtO is less than 1 ppmw on an annual average basis. The commenter argued that based on the EPA's proposed definition of "in ethylene oxide service" for wastewater streams it may be difficult to demonstrate a 98- or 99-percent mass removal efficiency for EtO especially if the concentration flowing into the treatment device is a very low concentration; for example, if the inlet flow is 0.1 lb/hr then it may be difficult to demonstrate that the outlet flow is 0.002 lb/hr (98 percent efficiency) or 0.001 lb/hr (99 percent efficiency).

The commenter argued that EtO should only be included on Table 9 to NESHAP subpart G and removed from Table 8 to NESHAP subpart G for the following reasons:

- The EPA provides no basis for adding EtO to Table 8 in the document titled *Analysis of Control Options for*



Wastewater Streams to Reduce Residual Risk of Ethylene Oxide in the SOCM I Source Category for Processes Subject to HON (see Docket Item No. EPA-HQ-OAR-2022-0730-0087).

- The original basis for the compounds listed on Table 8 was that this subset of compounds are very volatile compounds. All the compounds listed on Table 8 have a fraction removed (Fr) value<sup>43</sup> equal to 0.99 as stated in 40 CFR 63.138(e)(2); and the Fr value for EtO as stated in Table 9 is equal to 0.98. Pages 4–9 to 4–10 of the HON Background Information Document (see EPA-453/R-94-003b) provides the original basis for which compounds are included on Table 8 versus Table 9.

- The fraction emitted (Fe) value<sup>44</sup> for the compounds listed on Table 8 range from 0.79 to 1. A value of 1 represents 100 percent of the compound in the wastewater is volatilized to the atmosphere; and EtO has a Fe value of 0.5 or only 50 percent is volatilized.

- For new sources, 40 CFR 63.132(b)(2) already requires a determination as to whether each wastewater stream requires control for Table 9 compounds by complying with 40 CFR 63.132(c). 40 CFR 63.132(c)(1)(iii) (as proposed) specifies that a wastewater stream is a Group 1 wastewater stream for Table 9 compounds if the wastewater stream contains EtO such that it is considered to be in EtO service.

The commenter argued that the way the group determination procedures are structured, adding EtO to Table 8 (when it is already included as a Table 9 compound) is not going to change the fact that a stream containing more than 1 ppmw EtO is considered to be in EtO service and subject to further treatment and control regardless of whether the source is existing or new.

*Response:* The EPA acknowledges the commenters' support for and opposition of the proposed wastewater provisions at 40 CFR 63.132(c)(1)(iii) and (d)(1)(ii). We are finalizing these provisions as proposed. We believe the rule is clear with regard to demonstrating compliance with these provisions. A wastewater stream that is less than 1 ppmw EtO is not considered a Group 1 wastewater stream, since it would not

<sup>43</sup> The Fr is the fraction of a HAP that is stripped from wastewater and is an indicator of the extent to which a HAP is effectively removed during the stream-stripping process.

<sup>44</sup> The Fe is the mass fraction of a HAP that is emitted from the wastewater collection and downstream biological treatment system and is an indicator of the fraction of a compound expected to be an air emission out of wastewater in typical chemical sector collection and treatment systems.

meet the Group 1 criteria at 40 CFR 63.132(c)(1)(iii) and (d)(1)(ii), provided it does not meet the criteria at 40 CFR 63.132(c)(1)(i) and (ii), and (d)(1)(i) either.

The EPA does not agree with the commenter that EtO should be removed from Table 8 to NESHAP subpart G. Simply put, the compounds in Table 8 do not biodegrade well and will need to be stripped, while the compounds in Table 9 to NESHAP subpart G can be treated using a biological treatment process. While we acknowledge EtO can be biodegraded (and is included in Table 9), its low Fe value (0.5) suggests that it can only be reduced by half when using a standard biological treatment method, and the remainder would need to be stripped out of the wastewater in order to meet the 1 ppmw threshold. Since we are building on the existing HON standards, we believe it is appropriate to restrict the treatment options given the risk associated with EtO, and have determined facilities will have to use steam stripping to comply with the proposed standards. For these reasons, it is not appropriate to add an option, as requested by the commenter, to both 40 CFR 63.138(e)(1) and (e)(2) that allows the owner or operator to demonstrate compliance with the performance standard for EtO if the outlet concentration of EtO is less than 1 ppmw on an annual average basis regardless of the control method.

However, we agree with the commenter that verifying mass reductions of 99 percent for wastewater streams containing small amounts of EtO may be difficult. As a result, we are providing language in the final rule at 40 CFR 63.138(b)(3) and (c)(3) that allows owners or operators to reduce, by removal or destruction, the concentration of EtO to less than 1 ppmw as determined by the procedures specified at 40 CFR 63.145(b). We believe these revisions add clarity that streams less than 1 ppmw EtO are no longer considered to be "in ethylene oxide service" per the definition and provides unity with the finalized addition of EtO to Table 8 to NESHAP subpart G.

*Comment:* A commenter recommended that the EPA incorporate the test methods specified in 40 CFR 63.109(d) for analysis of EtO in wastewater directly into 40 CFR 63.144(b)(5)(i) to provide consistency and clarity with the regulation and to avoid the need to prepare additional sampling plans and method validation under 40 CFR 63.144(b)(5)(ii) and (iii). The commenter argued that in order to use the test methods specified in 40 CFR 63.109(d) for determining the annual

average concentration of EtO in the wastewater streams (*i.e.*, EPA Method 624.1 of 40 CFR part 136, appendix A, or preparation by either EPA Method 5031 or EPA Method 5030B and analysis by EPA Method 8260D in the SW-846 Compendium), without the additional cost and effort required to prepare sampling plans and validate the test methods per 40 CFR 63.144(b)(5)(ii) and (iii), these methods listed in 40 CFR 63.109(d) for EtO need to either be added to the list of acceptable methods under 40 CFR 63.144(b)(5)(i) or a cross-reference to 40 CFR 63.109(d) needs to be added to 40 CFR 63.144(b)(5)(i).

In addition, the commenter claimed that depending upon what treatment option is selected in 40 CFR 63.138 to meet the requirements for wastewater streams in EtO service, the test methods and procedures in 40 CFR 63.145(b) for determining compliance with concentration limit standards for non-combustion treatment processes in 40 CFR 63.138(b)(1) and (c)(1) cross-reference the methods specified in 40 CFR 63.144(b)(5)(i). The commenter asserted that by adding the methods specified in 40 CFR 63.109(d) for determining the EtO concentration to the list of acceptable test methods in 40 CFR 63.144(b)(5)(i), the EPA would be also fixing other cross-referencing issues in 40 CFR 63.145 at the same time.

*Response:* We are revising the final rule in response to the commenter's request to add the test methods specified in 40 CFR 63.109(d) for analysis of EtO in wastewater to 40 CFR 63.144(b)(5)(i). We agree that these test methods are relevant to calculate the annual average concentration of EtO needed to determine Group status, and, by including them, we should create consistency between 40 CFR 63.109(d), 40 CFR 63.144(b)(5)(i), and 40 CFR 63.145.

*Comment:* A commenter said that they support the proposed provisions at 40 CFR 63.104(k) to prohibit owners and operators from injecting wastewater into or disposing of water through any heat exchange system in a CMPU meeting the conditions of 40 CFR 63.100(b)(1) through (3) if the water contains any amount of EtO, has been in contact with any process stream containing EtO, or the water is considered wastewater as defined in 40 CFR 63.101. On the contrary, other commenters provided suggestions for this prohibition. At least one of these commenters contended that the EPA has not identified any risk associated with EtO-free wastewaters, nor has the EPA otherwise justified why EtO-free wastewaters are prohibited from injection. This commenter said they generally support not allowing

waters containing EtO or chloroprene to be added to the cooling loop of a heat exchange system. However, the commenter noted that in the case of the HON and P&R I rules, a wastewater is “water that is discarded” from a CMPU or an EPPU, respectively; therefore, wastewater that is injected into a cooling loop is not discarded water.

Commenters argued the proposed language prohibiting the use of “wastewater” in heat exchange systems is a significant barrier to, if not total prohibition on, water reuse projects that are under consideration at various member facilities. The commenter requested that the EPA modify the prohibition on using “wastewater” in heat exchange systems to make clear that stormwater collected in process areas and treated wastewater from process areas that may include EtO but still qualify for discharge in accordance with a national pollutant discharge elimination system (NPDES) permit may be used in heat exchange systems.

A commenter said that the EPA should add the requirements into the process wastewater prohibition language that already exists in 40 CFR 63.132(f) (rather than include new provisions at 40 CFR 63.104(k)). The commenter claimed that the intent of the prohibition language in 40 CFR 63.132(f) is to prevent discarding a liquid or solid material containing greater than 10,000 ppmw of a Table 9 (to NESHAP subpart G) HAP to water or wastewater unless it is controlled as a Group 1 wastewater; and as currently proposed, a liquid or solid material that is in EtO service, could be discarded to a wastewater stream without control. The commenter urged the EPA to add the following sentence to the beginning of 40 CFR 63.132(f): “Owners or operators of each source as defined in § 63.101, beginning no later than the compliance dates specified in § 63.100(k)(11), shall not discard liquid or solid stream containing EtO such that it is considered to be in EtO service, as defined in § 63.101 from a chemical manufacturing process unit to water or wastewater, unless the receiving stream is managed and treated as a Group 1 wastewater stream.” Alternatively, the commenter suggested the EPA could revise the proposed rule text in 40 CFR 63.104(k) in lieu of adding their request sentence to the beginning of 40 CFR 63.132(f).

*Response:* The EPA acknowledges the commenters’ support for and opposition to the proposed provisions that prohibit the injection or disposal of wastewater containing or that has come in contact with EtO, through heat exchange systems. We are finalizing these

provisions at 40 CFR 63.104(k) as proposed. We disagree with commenters’ requests to allow stormwater or treated wastewater that may contain EtO but qualify for discharge under the NPDES. We note that in a 1980 document titled *Water Quality Requirements of the Organic Chemicals Industry for Recycle/Reuse Applications*, which is available in the docket for this rulemaking, the potential for increased recycle/reuse for process water in the EtO industry was evaluated. It was found that significant evaporation losses occur from process cooling towers. Any amount of EtO in wastewater sent to cooling towers will inevitably be stripped out and lead to a direct emission event. This is further expanded upon in the preamble to the proposed rule (see 88 FR 25080, April 25, 2023), where we cite emissions events from two HON-subject facilities that reported EtO emissions from heat exchange systems. This was due to combining EtO entrained water with heat exchange water and not due to any heat exchange system leaks, and resulted in ~3 tpy of EtO total emitted. Given the current total risk associated with EtO, allowing any EtO in cooling towers would be unacceptable.

#### v. EtO Flare Load Limit

*Comment:* A commenter said that they support the proposed requirement at 40 CFR 63.108(p) that prohibits owners and operators from sending more than 20 tons of EtO to all of their flares combined in any consecutive 12-month period. Other commenters asserted that the EPA must strengthen the monitoring needed to ensure compliance with the EtO flare load limit proposed at 40 CFR 63.108(p). The commenters stated that the requirement that “the owner or operator must keep monthly records of the quantity in tons of ethylene oxide sent to each flare at the affected source and include a description of the method used to estimate this quantity” is left completely up to HON sources to determine how to calculate the amount of EtO sent to their flares. The commenters contended that this cannot ensure compliance with the EtO flare load limit, and thus, cannot ensure that risk is reduced to an acceptable level or that the standards provide an ample margin of safety to protect public health. The commenters asserted that this monitoring requirement is arbitrary and capricious and contrary to CAA sections 112(f) and 114(a)(3). The commenters suggested that the EPA require HON sources to calculate the amount of EtO sent to their flares by: (i) Continuously measuring the flow rate of the waste gas

to the flare using a continuous emission monitoring system; (ii) continuously measuring the EtO concentration in the waste gas, also by a continuous emission monitoring system; and (iii) using the data from (i) and (ii) to calculate the actual EtO mass that is sent to the flare over a given time period. The commenters added that this calculation can be done every minute if needed or on an hourly average basis, to provide an accurate mass estimate of the flared EtO.

Numerous other commenters opposed the EtO flare load limit for at least one or more of the following reasons:

- it is unwarranted to impose expensive and stringent EtO limitations on flaring on the entire SO2MI source category subject to the HON when unacceptable risk from EtO flaring is driven by a single facility.

- the proposed cap would be problematic for more than just the flares that the EPA identified given that many owners and operators are currently applying a 99 percent EtO control efficiency to their existing flare operations.<sup>45</sup> TCEQ’s control efficiency value for EtO (99 percent) combined with the EPA’s determination that EtO emissions of 0.4 tpy would be acceptable (see Docket Item No. EPA–HQ–OAR–2022–0730–0070) would yield a 40 tpy (not 20 tpy) EtO flare load limit.

- when conducting its dispersion modeling for EtO emissions from flares, the EPA did not use the modeling approach used by TCEQ which takes into account the heat release associated with combustion in a flare; TCEQ’s modeling approach results in lower off-site impacts from flares, which calls into question whether a cap of flaring is necessary.

- flares have been used to control emissions of HAP for decades.

- the combination of the proposed 20 tpy flare cap along with the removal of the delay of repair provisions and the proposed PRD provisions may have unintended consequences leaving owners and operators with very few options for compliance if additional shutdowns and start-ups are needed to address a leaking component and/or if a PRD discharge to a flare occurs.

<sup>45</sup> The commenters cited TCEQ’s “New Source Review (NSR) Emission Calculation” guidance (available at: [https://www.tceq.texas.gov/assets/public/permitting/air/Guidance/NewSourceReview/emiss\\_calc\\_flares.pdf](https://www.tceq.texas.gov/assets/public/permitting/air/Guidance/NewSourceReview/emiss_calc_flares.pdf)) and said that Texas allows owners and operators to apply a 99 percent destruction efficiency for flaring compounds containing no more than 3 carbons that contain no elements other than carbon and hydrogen in addition to a select number of compounds, including EtO.

- the EPA's proposed solution to replace flares with thermal oxidizers is not practical from a timing or cost perspective.

- thermal oxidizers are generally not suitable destruction devices for PRD effluents; therefore, plants would need a new thermal oxidizer along with a flare operating for unplanned discharges like PRD vents, and the EPA's cost estimates are not reflective of the actual costs that would incur in the 2023–2026 timeframe to install a new thermal oxidizer system. It is common practice to size a thermal oxidizer for a normal range of VOC concentrations and normal flow and have an emergency flare to accommodate a higher concentration and flow from an event. Using a thermal oxidizer in lieu of a flare to manage EtO emissions would necessitate designing the oxidizer to accommodate these larger intermittent flows and higher inlet concentrations of VOC; however, such a design might not be feasible because normal operation might represent too much of a “turndown” from emergency operation.

- lead/delivery time for a new thermal oxidizer system could exceed 52 weeks, but 12 months is a best estimate.

- replacing flares with a thermal oxidizer essentially maintains greenhouse gas emissions at the same level since EtO is combusted in both applications.

- there may be safety and reliability considerations not addressed by the EPA with the use of a thermal oxidizer, which would require design and process safety features due to the reactive and flammable nature of EtO.

Commenters said that instead of replacing flares with thermal oxidizers to meet the EPA's proposed EtO flare load limit, owners and operators could potentially add a water scrubber between vent sources like storage vessels and railcar loading/unloading operations and the existing flares; however, this option would likely still need a larger EtO flare load limit than the 20 tpy limit the EPA has proposed. The commenters said that water from the scrubber could then be routed to the EtO manufacturing processes at these sites where the EtO could be recovered as a product stream. However, the commenters pointed out that during times when the EtO manufacturing process unit is not in service, the internal scrubber systems would need to be turned off as there is no viable location to recover the EtO out of the scrubber water stream. Thus, during times when storage vessels and railcar loading/unloading operations would need to occur but the production plant

is not in service, the vent gas from the tank vents and loading/unloading operations would need to be routed to the existing logistics flares. In other words, the commenters contended that the amount of EtO that would be routed to these flares in the future is a function of the operating time of the production plant.

In summary, commenters said they are concerned that projects that would be needed in order to meet the 20 tpy EtO flare load limit could not be implemented within 2 years as proposed in 40 CFR 63.100(k)(11), nor would the EPA's proposed control option achieve the intended reductions and may actually result in an increase in secondary emissions. Thus, these commenters requested that the EPA either refrain from finalizing the proposed flare cap or increase the flare cap based on a 99 percent control efficiency and provide 3 years for facilities to comply with the revision.

*Response:* We are not finalizing the requirement at 40 CFR 63.108(p) that prohibits owners and operators from sending more than 20 tons of EtO to all of their flares combined in any consecutive 12-month period. In other words, we are not including an EtO flare load limit in the final rule. In response to a comment discussed in section 1.1 of the document titled *Summary of Public Comments and Responses for New Source Performance Standards for the Synthetic Organic Chemical Manufacturing Industry and National Emission Standards for Hazardous Air Pollutants for the Synthetic Organic Chemical Manufacturing Industry and Group I & II Polymers and Resins Industry*, which is available in the docket for this rulemaking, we have determined that it is appropriate to use a different modeling approach for the final rule than the approach we used for the proposed rule (*i.e.*, we used the TCEQ modeling guidelines to calculate effective flare stack parameters for the final rule in lieu of modeling all flare releases as standard point sources with temperatures less than 1,000 Kelvin and velocities less than one meter per second for the proposed rule). As explained in that response, modeling flare emissions using effective stack parameters accounts for heat release of the flare and better characterizes plume rise. After applying this approach for the final rule, we have determined the EtO flare load limit is no longer necessary as flares controlling EtO are no longer significant contributors to risk. Using the reported EtO emissions of 2.87 tpy (post-control) from the highest-emitting facility, we estimate that the facility's current combined total

EtO load to flares is about 143.5 tpy (pre-control). Based on the revised modeling, a flare controlling 143.5 tpy (far higher than the proposed 20 tpy flare cap) is not a significant risk driver. Using the TCEQ modeling guidelines for flares, we have determined that risk for the SOCMi source category remains below 100-in-1 million without the need of an EtO flare load limit, but only after implementation of the standards we are finalizing for: (1) Process vents, (2) storage vessels, (3) equipment leaks, (4) heat exchange systems, and (5) wastewater “in ethylene oxide service,” as well as implementation of the final requirements to reduce EtO emissions from maintenance vents and PRDs. We note that by not finalizing an EtO flare load limit we also obviate the inconsistency we unintentionally created in the proposed rule by requiring owners and operators to comply with an EtO flare load limit while also requiring owners and operators to minimize emissions from PRDs by routing them to flares instead of venting to the atmosphere.

#### vi. PRDs in EtO Service

*Comment:* Commenters argued that the requirement at 40 CFR 63.165(e)(3)(v)(D) that considers any atmospheric release from a PRD in EtO service a violation will not reduce risk given that PRD releases are non-routine events that take place to prevent catastrophic equipment failure. The commenters contended that deeming atmospheric PRD releases a violation will not reduce their occurrence. The commenters stated that the proposed work practice standards at 40 CFR 63.165(e) (including the deviation determination criteria at 40 CFR 63.165(e)(3)(v)(A) through (C)) already provide an effective framework for addressing PRD releases.

The commenters added it is not cost-effective to route all PRDs to control devices; and the EPA wrongly assumes that all releases from PRDs in EtO service can and will be controlled as process vents as a result of the prohibition on such releases. The commenters provided numerous examples of why certain PRDs cannot be safely routed to a control device and/or would be technically infeasible in many process designs such as hydraulic limitations of flare systems or other controls, PRD backpressure, EtO incompatibility with other collected compounds, and polymerization of ethylene in closed vent systems. Commenters argued that because PRD releases are usually non-routine, infrequent, and episodic, piping and the control device would have to be sized

to accommodate significantly larger flow than normal process vents, and the control device would be required to operate in an indefinite “stand-by” mode to accommodate unexpected and emergency releases. A commenter said “stand-by” mode may also require significant amounts of fuel and generate secondary combustion emissions on a continuous basis for a release that may or may not occur.

*Response:* We are finalizing these requirements for PRDs in EtO service pursuant to CAA section 112(f)(2), on the basis of risks being unacceptable. Where we find risks are unacceptable, the EPA must determine the emissions standards necessary to reduce risk to an acceptable level. Because emissions of EtO from the SOCMCI source category result in unacceptable risks, we proposed and are finalizing requirements that would reduce risks to an acceptable level, including provisions that would make all PRD releases of EtO directly to the atmosphere a violation of the standard. As explained in response to a comment in section 1.1 of the document titled *Summary of Public Comments and Responses for New Source Performance Standards for the Synthetic Organic Chemical Manufacturing Industry and National Emission Standards for Hazardous Air Pollutants for the Synthetic Organic Chemical Manufacturing Industry and Group I & II Polymers and Resins Industry*, which is available in the docket for this rulemaking, the EPA modeled certain PRD releases of EtO during maintenance events which resulted in very high risk from one facility (*i.e.*, EtO risk from process vent emission sources emitted through PRDs is approximately 75 percent of the Port Neches facility’s total SOCMCI source category risk of 2000-in-1 million). There is no reason for not considering the impact of these events in our risk modeling and rulemaking. In response, we proposed and are finalizing a requirement that releases from PRDs in EtO service are a violation of the emission standard.

#### vii. Other EtO Related Requirements

*Comment:* Commenters asserted that the EPA acted unreasonably in imposing controls across the entire “HON source category.” The commenters contended that the EPA may require those facilities that pose unacceptable risk to implement targeted additional controls, but it is arbitrary and capricious to attempt to impose those same requirements everywhere despite the absence of risk. A commenter provided an example where under the proposed rule, both Huntsman Conroe and

Huntsman Geismar facilities would be heavily burdened by the proposed HON EtO control requirements even though the EPA found that neither facility poses unacceptable risk.

These commenters said that the EPA’s proposed response to 8 facilities with EtO risk above the presumptive limit is a one-size-fits-all approach to addressing risk from the source category that unreasonably imposes stringent control requirements across all emissions sources at every facility, rather than addressing the residual risks that were actually identified. The commenters said the approach is inconsistent with CAA section 112(f) because half of the facilities affected by the proposed EtO standards do not present unacceptable risk to surrounding areas, yet the EPA proposes to impose emissions standards on these facilities that were derived without consideration of cost. A commenter pointed out that Congress explicitly granted the EPA the authority to consider variations among sources in promulgating emission standards under CAA section 112 through subcategorization; yet, the EPA has failed to utilize this statutorily available tool here. Commenters said that even if the Agency chooses not to subcategorize, the EPA has recognized that it is unreasonable to require controls on all facilities when a more targeted and less costly option may achieve an acceptable level of risk. The commenters pointed out that the EPA used a tailored approach in the RTR for sterilization facilities (see 88 FR 22790, 22826–28) and the proposed MON rule (see 84 FR 69182) which applied different levels of stringency in accordance with the different facilities’ MIRs (in other words, the EPA tailored its acceptability analysis to address risk from the highest risk sources).

A commenter added that the EPA’s approach is not sufficiently targeted because the applicability of the new EtO emissions standards would be governed by the definition of “in ethylene oxide service” that the EPA adopted in the MON, which was not derived with any consideration of the emissions characteristics of the SOCMCI source category or the risk profile determined by the EPA’s risk assessment of the SOCMCI source category. The commenter contended that adopting the MON definition of “in ethylene oxide service” results in new EtO emissions standards that apply to approximately twice as many affected facilities as needed to address the risk that the EPA determines to be actionable.

*Response:* We disagree with the commenters that the EPA acted

unreasonably in imposing controls across the entire SOCMCI source category (note the commenter used the phrase “HON source category;” however, the source category covered by the HON is actually the SOCMCI source category). We also disagree with the commenters that our action to impose the same EtO requirements on each owner and operator is arbitrary and capricious.

As stated in the preamble to the proposed rule (see 88 FR 25080, April 25, 2023), we identified EtO as the cancer risk driver from HON sources; and we are aware of 15 HON facilities reporting more than 0.1 tpy of EtO emissions in their emissions inventories from HON processes and two other facilities that are new or under construction with HON processes that we expect will exceed this threshold (but for which we do not yet have emissions inventory information). Of these 17 facilities, 12 facilities produce and emit EtO, which is a process subject to the HON MACT standards. In addition, all 17 of these facilities have additional HON processes that use and emit EtO in the production of glycols, glycol ethers, or ethanolamines. Therefore, we are not imposing EtO controls across the entire SOCMCI source category. Rather, in order to reduce emissions of EtO from HON processes, the EPA is finalizing more stringent control requirements for process vents, storage vessels, equipment leaks, heat exchange systems, wastewater, maintenance vents, and PRDs that emit or have the potential to emit EtO. While it is true from our residual risk assessment that eight of the 17 facilities with emissions of EtO from various HON processes have cancer risks above 100-in-1 million, the standards are national standards that apply to specific types of sources rather than specific facilities, and the revisions ensure that risks from the source category are acceptable and that the standards provide an ample margin of safety to protect public health. As such, we disagree with the commenter that we should target additional controls on only facilities that pose unacceptable risk.

For these same reasons, we also disagree with the commenter that adopting the MON definition of “in ethylene oxide service” results in new EtO emissions standards that apply to approximately twice as many affected facilities as needed to address the risk that the EPA determines to be actionable. Although, as noted in our proposal, similar emission sources and standards exist between the HON and MON, we disagree with the commenter that we did not give any consideration

of the emissions characteristics of the SOCMCI source category or the risk profile determined by the EPA's risk assessment of the SOCMCI source category. The scientific and technical bases for the EPA's proposed action are voluminously presented in the numerous supporting memoranda contained in the public docket for the proposed rulemaking. See, e.g., the documents titled *Residual Risk Assessment for the SOCMCI Source Category in Support of the 2023 Risk and Technology Review Proposed Rule; Analysis of Control Options for Process Vents and Storage Vessels to Reduce Residual Risk of Ethylene Oxide in the SOCMCI Source Category for Processes Subject to HON; Analysis of Control Options for Equipment Leaks to Reduce Residual Risk of Ethylene Oxide in the SOCMCI Source Category for Processes Subject to HON; Analysis of Control Options for Heat Exchange Systems to Reduce Residual Risk of Ethylene Oxide in the SOCMCI Source Category for Processes Subject to HON; Analysis of Control Options for Wastewater Streams to Reduce Residual Risk of Ethylene Oxide in the SOCMCI Source Category for Processes Subject to HON*; (see Docket Item No. EPA-HQ-OAR-2022-0730-0085, -0074, -0003, -0071, and -0087, respectively).

e. P&R I NESHAP Rule Changes Related to Chloroprene

i. Process Vents and Storage Vessels in Chloroprene Service

*Comment:* A commenter argued that the EPA's proposal at 40 CFR 63.484(u), 40 CFR 63.485(y), and 40 CFR 63.487(j) to require a control device that reduces chloroprene by greater than or equal to 99.9 percent by weight is unreasonable in light of the EPA's involvement in the decision to install a regenerative thermal oxidizer (RTO) at one facility with a chloroprene destruction efficiency of 98 percent and the "monomer emission reduction project" (MERP) system<sup>46</sup> with a chloroprene destruction efficiency of 99.3 percent.

<sup>46</sup> The commenter stated that the MERP was installed to route vent emissions from the monomer process unit to the facility's halogen acid production furnace. The MERP is essentially a complex of vent headers (with condensate collection posts) to route emissions predominately from the Monomer area of the Neoprene Facility, as well as emissions from nine permitted hazardous waste tanks (containing liquid hazardous wastes) to the facility's halogen acid production furnace. The MERP conveys approximately 300 to 600 CFM of chloroprene vent emissions from currently "Group 2" classified emission units under the HON subpart G. Stack tests have demonstrated a 99.3 percent destruction or removal efficiency for the halogen acid production furnace.

The commenter made the following points regarding these installations:

During the first six months of 2016, the facility engaged in numerous meetings with both the EPA and the LDEQ to discuss options for reducing chloroprene emissions, including different types of control devices. Records of these discussions show that, in October 2016, the facility presented slides to the EPA and the LDEQ that summarized control device options, including a direct-fired thermal oxidizer (the only option that could achieve a chloroprene destruction efficiency of 99.9 percent) and an RTO, which was expected to have a chloroprene destruction efficiency of 98 percent. As the slide indicated, however, the cost of operating a direct-fired thermal oxidizer would be very high because it would burn enormous amounts of natural gas. This is why in June 2016, the facility proposed to install an RTO, which would have similar up-front capital costs but would have much lower operating costs (and much lower CO<sub>2</sub> emissions) because it would require much less natural gas to operate.

In December 2016, the LDEQ held a large public meeting at its headquarters, with the EPA and the Department of Justice in attendance. Before this meeting, an EPA researcher advised EPA officials that, to achieve a risk-level of 1-in-10,000, ambient concentrations of chloroprene in the community could be no higher than 0.2 ug/m<sup>3</sup>. His memorandum making this assertion was also released publicly. At this meeting, the facility presented results of an air dispersion modeling study, which showed then-existing (2016) ambient concentrations and the concentrations that would be expected if the facility implemented the emission reduction projects it had proposed, including the installation of an RTO with a chloroprene destruction efficiency of 98 percent. The modeling results presented to the EPA, the LDEQ, and the public showed that offsite concentrations would be significantly reduced but would still be higher than 0.2 ug/m<sup>3</sup>.

Following the public hearing, the facility, the EPA, and the LDEQ finalized the terms of a voluntary Administrative Order on Consent, which the facility and the LDEQ signed on January 6, 2017. The EPA and lawyers from the Department of Justice were present for all significant discussions, and the EPA was heavily involved in the Administrative Order on Consent's development, providing numerous comments and making a number of demands reflected in the order. Under the Administrative Order on Consent, the facility agreed to

"install and operate . . . a Regenerative Thermal Oxidizer (RTO)" capable of "achiev[ing] at least a 98 percent [destruction or removal efficiency]." The facility also agreed to install the MERP and to achieve an 85 percent reduction in total chloroprene emissions from the facility, principally from the "Chloroprene" Unit, to the facility's halogen acid production furnace.

The commenter claimed that these projects reduced facility chloroprene emissions by 85 percent at a capital cost of \$35 million, plus a significant increase in annual operating costs; and of the \$35 million, the MERP cost approximately \$9 million. The commenter requested that the EPA take this history into account as it develops the final rule given that it is unreasonable to ignore the investments that the facility recently made to reduce chloroprene emissions when they were made under the oversight of the LDEQ and the EPA, and with the EPA's full knowledge of the 2010 IRIS inhalation URE value for chloroprene. The commenter contended that the very small emission reductions that would be achieved by increasing the chloroprene destruction efficiency to 99.9 percent are enormously expensive, more than \$21 million per ton annually. The commenter said the current chloroprene emissions from the existing RTO are approximately 0.84 tpy; therefore, if all the emission streams currently routed to the existing RTO were instead routed to a new direct-fired thermal oxidizer with a chloroprene destruction efficiency to 99.9 percent, chloroprene emissions would be reduced from 0.84 tpy to 0.04 tpy (an annual reduction of 0.79 tons). The commenter claimed that the annualized cost of achieving this is almost \$3.7 million, and the cost-per-ton of chloroprene emission reduction would be more than \$4.6 million. The commenter submitted a similar analysis for their MERP system and claimed that if all the vent streams currently controlled by the MERP were instead routed to a control device with a chloroprene destruction efficiency of 99.9 percent (testing has demonstrated that the MERP achieves a destruction or removal efficiency of 99.3 percent on an overall basis), the reduction in annual chloroprene emissions would be 50–60 pounds, depending on production.

The commenter said that they hired consultants to evaluate multiple options for control device configuration that would achieve a chloroprene destruction efficiency of 99.9 percent as required by the proposed rule. The commenter said that modifying their existing RTO to achieve a chloroprene destruction efficiency of 99.9 percent is

not possible given that high levels of chlorine in their exhaust streams would poison the catalyst. The commenter added that even if their existing RTO could achieve a chloroprene destruction efficiency of 99.9 percent, it does not have capacity to accommodate the additional streams that would have to be routed to it under the proposed rule; thus, the proposed rule would require the installation of one or more new control devices that could accommodate very high air flows containing very low concentrations of VOC, including chloroprene. The commenter provided specific details of other control options and acknowledged that the destruction efficiency of an RTO can be increased to 99.9 percent by adding an additional oxidation step (which involves the installation of a polishing catalyst bed in the stack that reheats the treated gas); however, the commenter asserted that all other options that they evaluated (e.g., installing new RTOs and/or direct fired thermal oxidizers) would require enormous amounts of fuel consumption, quench water, and power consumption only to achieve minimum reductions.

The commenter asserted that the EPA's cost estimate to install a new direct fired thermal oxidizer is "far from realistic" given that their consultant estimated the equipment purchase costs for a new direct fired thermal oxidizer with recuperative heat exchange capabilities would be approximately \$12 million and total annual costs of \$39 million. The commenter said the EPA assumed a slightly smaller direct fired thermal oxidizer than what they believe would be necessary and the EPA estimated an equipment purchase cost of \$5 million and total annual costs of \$10.1 million; however, the commenter asserted that it is not clear if the EPA's estimate includes the additional scrubber capacity or the high nickel alloy materials that would be needed for certain components. The commenter added that the EPA has not estimated the costs that would be required to upgrade the electrical and natural gas infrastructure, or expand the wastewater treatment plant (WWTP), which are all actions that would be necessary to install a new direct fired thermal oxidizer.

In summary, the commenter claimed that given that it is not possible to modify their existing RTO and MERP to achieve a chloroprene destruction efficiency of 99.9 percent, the proposed rule would leave the facility with \$35 million of stranded investment which was made fewer than 6 years ago to reduce chloroprene emissions in consultation with the EPA. The commenter said that even though the

option of installing a direct-fired thermal oxidizer was discussed in 2016, at no point did the EPA suggest that an RTO would not be sufficient or that a direct-fired thermal oxidizer might be required. The commenter asserted that there has been no change since 2016 in either (1) the EPA's views about the risk of chloroprene exposure or (2) its understanding of the offsite concentrations that would be achieved under the Administrative Order on Consent.

*Response:* We reevaluated whether we could change the proposed 99.9 percent by weight reduction standard to 98 percent by weight given the commenter's arguments that their existing RTO and MERP cannot achieve a chloroprene reduction of 99.9 percent by weight. In our reevaluation for the final rule, we determined that revising the performance standard for process vents and storage vessels in chloroprene service (from a 99.9 percent by weight reduction requirement as proposed to a 98 percent by weight reduction requirement in the final rule) will still maintain the MIR at 100-in-1 million for the Neoprene Production source category and thereby result in the source category chloroprene emissions being reduced to acceptable levels. We have made this change in the final rule at 40 CFR 63.484(u)(1), 40 CFR 63.485(y)(1), 40 CFR 63.487(j)(1), and 40 CFR 63.510(a)(2). While considering the current chloroprene emissions from both the existing RTO (0.84 tpy) and MERP (0.02 tpy based on our review of the emissions inventory calculations), we have determined the revised performance requirements for the final rule will still reduce risk from Neoprene Production source category emissions to an acceptable level and also provide an ample margin of safety to protect public health (as was proposed) for the Neoprene Production source category. We also have determined that no additional requirements are needed to prevent an adverse environmental effect (as was proposed). In light of this, we believe the commenter's existing RTO and MERP can be used to meet the revised requirements for the final rule and would no longer be considered a stranded investment as the commenter has claimed.

*Comment:* A commenter said they support the EPA's proposed rule text at 40 CFR 63.485(y) that requires owners and operators to reduce emissions of chloroprene from continuous front-end process vents in chloroprene service at affected sources producing neoprene by venting emissions through a closed-vent system to a non-flare control device that reduces chloroprene by greater than or

equal to 99.9 percent by weight, to a concentration less than 1 ppmv for each process vent, or to less than 5 lb/yr for all combined process vents. The commenter said they also support the EPA's proposed rule text at 40 CFR 63.487(j) to add these same chloroprene standards for batch front-end process vents at affected sources producing neoprene. However, another commenter argued that the EPA's oversimplification of the design configurations necessary to comply with these proposed performance standards (which the EPA presented in Docket Item No. EPA-HQ-OAR-2022-0730-0083) results in cost estimates that are much too low. The commenter asserted the EPA did not consider in their analysis the following technical and process safety challenges:

- The EPA assumed that all the sources at this commenter's facility are to be enclosed and routed to a new direct fired thermal oxidizer are in close proximity to each other, but the wash belts are actually located in the Finishing building, which is separate from the Poly building.

- The EPA did not account for complicated duct and piping (e.g., unique pipe lengths, diameters, number of bends), which also impacts pump specifications and other equipment such as the blower.

- The existing thermal oxidizer cannot accommodate the additional vent streams from the wash belts (at current flow rates). Each wash belt vent hood operates at approximately 28,000 standard cubic feet per minute (scfm), and total chloroprene emissions for both wash belt vents combined is approximately 3.3 tpy (2022 reported value).

- Installing an enclosure around the wash belts creates safety concerns given that the wash belt blower motors are equipped with variable frequency drives which can change air flow through the vent hoods; the potential variability in air flows would need to be evaluated by an industrial hygienist to ensure compliance with personnel exposure requirements, or to make recommendations for additional protective equipment.

- Wash belts require frequent, manual intervention from area personnel to ensure stable operation; workers must have physical access to the wash belt area to perform routine maintenance and repairs.

- Wash belt enclosures would need to be transparent to allow visual inspection of the process without entry and would also need to be durable enough to withstand frequent disassembly and reassembly.

- Any changes in airflows or pressures, such as those that will occur when installing enclosures and adjusting blower speeds (for the wash belts), will need to be evaluated to ensure that product quality standards are achievable and to ensure that production rates are not negatively impacted. The finishing process is designed to supply very precise air flows and pressure differentials throughout in order to maintain adhesion of the web (Neoprene product film) to the girt (flexible sheeting that guides the web through the process).

The commenter submitted a cost estimate of \$3.6 million for the purchase of a direct fired thermal oxidizer with a chloroprene destruction efficiency of 99.9 percent that would be sized to accommodate waste gas from the wash belts. The commenter estimated the total cost for installing and operating the thermal oxidizer would be about \$18 million. The commenter asserted that because of the low VOC content in the exhaust stream, natural gas consumption would be high, and the total annualized costs would be almost \$3.0 million (not including the capital costs for the enclosure and associated infrastructure). The commenter stated that the cost-per-ton of chloroprene emission reduction would be approximately \$0.9 million (based on the 3.3 tpy of chloroprene emissions reported in their 2022 inventory). The commenter added that operating the new thermal oxidizer would contribute to environmental harm including 16,200 metric tons a year of carbon dioxide equivalents (CO<sub>2</sub>e).

*Response:* We acknowledge commenters' support and opposition for the provision at 40 CFR 63.485(y) that requires owners and operators to reduce emissions of chloroprene from continuous front-end process vents in chloroprene service at affected sources producing neoprene by venting emissions through a closed-vent system to a non-flare control device that reduces chloroprene by greater than or equal to 99 percent by weight, to a concentration less than 1 ppmv for each process vent, or to less than 5 lb/yr for all combined process vents. We also acknowledge commenters' support and opposition for the provision at 40 CFR 63.487(j) to add these same chloroprene standards for batch front-end process vents at affected sources producing neoprene.

As discussed in the preamble to the proposed rule (see 88 FR 25080, April 25, 2023), we had determined that the only viable way to meet these proposed standards is to enclose all of the polymer batch reactors, emulsion

storage vessels, strainers, and wash belt dryers and route the vapors to a thermal oxidizer (and thereby reduce chloroprene emissions from these sources, which are fugitive in nature); and the result of this control option would reduce chloroprene emissions from the polymer building, unstripped resin emulsion storage vessels, and wash belt dryers by 11.3 tpy (from 12 tpy to 0.7 tpy). Although we continue to stand by our analysis that chloroprene emissions from these emission sources must be reduced to decrease risk posed by emissions from neoprene production processes to an acceptable level, we reevaluated whether we could change the 99.9 percent by weight reduction standard to 98 percent by weight given a commenter's arguments (as discussed in section 3.1 of the document titled *Summary of Public Comments and Responses for New Source Performance Standards for the Synthetic Organic Chemical Manufacturing Industry and National Emission Standards for Hazardous Air Pollutants for the Synthetic Organic Chemical Manufacturing Industry and Group I & II Polymers and Resins Industry*, which is available in the docket for this rulemaking) that their existing thermal oxidizer cannot achieve a chloroprene reduction of 99.9 percent by weight. In our reevaluation for the final rule, we determined that revising the performance standard for process vents and storage vessels in chloroprene service (from a 99.9 percent by weight reduction requirement as proposed to a 98 percent by weight reduction requirement in the final rule) will still maintain the MIR at 100-in-1 million for the Neoprene Production source category. The result of this revision in the final rule will reduce chloroprene emissions from the polymer building, unstripped resin emulsion storage vessels, and the wash belt dryers from 12 tpy to 0.9 tpy (*i.e.*, a reduction of 11.1 tpy chloroprene in lieu of 11.3 tpy as proposed). We have determined these revised performance requirements for the final rule will still reduce risk to an acceptable level and also provide an ample margin of safety to protect public health (as was proposed) from P&R I emission sources. We also have determined that no additional requirements are needed to prevent an adverse environmental effect (as was proposed).

We also acknowledge that the wash belt dryers are located in the finishing building, which is separate from the polymer building; and at proposal, we incorrectly assumed these process vents were front-end process vents when in

actuality they are considered back-end process vents according to NESHAP subpart U. As such, we are clarifying in the final rule that the requirements we are finalizing for controlling chloroprene from process vents in the Neoprene Production source category, not only applies to continuous front-end process vents in chloroprene service and batch front-end process vents in chloroprene service, but also back-end process vents in chloroprene service. In other words, we are finalizing at 40 CFR 63.494(a)(7) a requirement that owners and operators reduce emissions of chloroprene from back-end process vents in chloroprene service at affected sources producing neoprene by venting emissions through a closed-vent system to a non-flare control device that reduces chloroprene by greater than or equal to 98 percent by weight, to a concentration less than 1 ppmv for each process vent, or to less than 5 lb/yr for all combined process vents. We anticipate that the facility will still need to install an additional thermal oxidizer in order to comply with the final performance standard for process vents and storage vessels in chloroprene service. We also note that while the commenter claims that the 3.3 tpy chloroprene emissions from the wash belt dryers were reported in their 2022 inventory, we stand by our decision to use the facility's 2019 emissions inventory which shows 3.9 tpy chloroprene emissions from the wash belt dryers. As previously mentioned, the facility's emissions inventory was provided to the EPA pursuant to our CAA section 114 request. In particular, the EPA requested emission inventories from the past 5 years (*i.e.*, 2016–2020) from the facility's operations as part of this request. As 2017 NEI data did not represent current controls being employed at Denka Performance Elastomers, LLC, the EPA chose to use the most current data it had available and that is reflective of current operations and emissions. Given concerns about decreased production and emissions in 2020 from the COVID–19 pandemic, the EPA elected to use Denka Performance Elastomer, LLC's 2019 emissions inventory submitted as part of the CAA section 114 request in its risk assessment for the SOCM I and Neoprene Production source categories in lieu of the 2017 NEI data. Even if we were to revise emissions based on the facility's 2022 emissions inventory, we continue to believe our cost estimate to install permanent total enclosures, a thermal oxidizer, and ductwork and associated support equipment (using the procedures in the EPA's 2002 Control

Cost Manual) is reasonable, and note that cost does not play a role in setting standards that are necessary to reduce risk to an acceptable level under step one of the Benzene NESHAP approach codified in CAA section 112(f). Furthermore, with regard to a commenter's specific objections to installing a permanent total enclosure around their wash belts/dryers, we note that even though we costed out permanent total enclosures for these emission sources in our proposal, there is no explicit requirement in the proposed rule, or final rule, to install permanent total enclosures around these emission sources. We opted for this option as the most conservative way to collect the fugitive chloroprene emissions from the wash belts/dryers and route them to a control device such as a thermal oxidizer. Nothing in the proposed rule, or final rule, prevents the facility from doing something different than installing a permanent total enclosure around their wash belts/dryers so long as the owner or operator can achieve the emission standard we are finalizing at 40 CFR 63.494(a)(7) for back-end process vents (*i.e.*, the requirement that owners and operators reduce emissions of chloroprene from back-end process vents in chloroprene service at affected sources producing neoprene by venting emissions through a closed-vent system to a non-flare control device that reduces chloroprene by greater than or equal to 98 percent by weight, to a concentration less than 1 ppmv for each process vent, or to less than 5 lb/yr for all combined process vents).

Even so, we anticipate cost to be less of a concern for the final rule given that the facility should be able to use their existing thermal oxidizer to meet the revised performance standard (reduce chloroprene by greater than or equal to 98 percent by weight) for at least some of their process vents and storage vessels in chloroprene service.

#### ii. Wastewater in Chloroprene Service

*Comment:* A commenter said that they support the proposed provision at 40 CFR 63.501(a)(10)(iv) to revise the Group 1 wastewater stream threshold to include wastewater streams in chloroprene service (*i.e.*, wastewater streams with total annual average concentration of chloroprene greater than or equal to 10 ppmw at any flow rate). However, another commenter said the EPA's analysis of the costs and emission reductions associated with reducing chloroprene emissions from wastewater streams at neoprene production processes (see Docket Item No. EPA-HQ-OAR-2022-0730-0092)

has several major flaws. The commenter said the EPA's analysis suggests that the proposed control requirements for wastewater would reduce chloroprene emissions by 17.7 tpy, when in fact the emission reductions would be closer to 1 tpy; therefore, the EPA's analysis substantially overstates the emission reductions that would be achieved, and the efficacy and cost-effectiveness of the proposed requirements at 40 CFR 63.501(a)(10)(iv). The commenter provided the following critiques of the EPA's analysis:

- there are approximately 13.5 tpy of wastewater in chloroprene service that pass through the WWTP, not 26.3, which the EPA incorrectly used in their analysis.

- although the EPA acknowledges that some controls may already be in place, their analysis goes on to analyze the effectiveness of the proposed requirements based on the assumption that there are no such controls; however, the facility already employs an air stripping system to treat the decanter and kettle line wastewater streams. The air stripping occurs in the air sparging tank, which is routed to the onsite RTO. Testing suggests that the air sparging tank achieves a control efficiency of approximately 95 percent. Thus, of the 7.5 tpy of chloroprene contained in these 2 streams, all but ~0.4 tpy are removed via air stripping and directed to RTO. This amount, ~0.4 tpy, then goes to the WWTP, which includes a biological treatment system that reduces it by approximately 80 percent, meaning that chloroprene emissions from the decanter and kettle line streams are likely less than 0.1 tpy. Thus, accounting for the control efficiency of the air sparging tank and the biologic treatment system, almost 99 percent of the 7.5 tpy contained in the decanter and kettle line wastewater streams is already controlled. Even if steam stripping achieves a 99 percent capture efficiency in these streams, it would only reduce emissions by about 0.025 tpy (to 0.075 tpy as compared to 0.1 tpy today).

- based on limited testing of the air stripper rundown streams, they contain approximately 6.0 tpy of chloroprene. These streams are routed to the outdoor brine pit, which then discharges to the WWTP. The EPA did not consider that the WWTP includes biological control that currently reduces chloroprene emissions by approximately 80 percent. It is true that some emissions to air occur as the wastewater is conveyed through the outdoor brine pit and to the WWTP, but it is incorrect for the EPA to consider it "uncontrolled." Assuming the Fe of 68 percent suggested by the

EPA, the maximum fraction of the mass of chloroprene that could end up as an air emission is about 4 tpy before biological control. Applying the 80 percent estimated biological control removal rate, current emissions are approximately 0.8 tpy from the air stripper rundown streams. Even if the EPA's assumption of a 99 percent removal efficiency for steam stripping is accurate, it would reduce emissions by about 0.8 tpy from the stripper rundown streams.

The commenter concluded that when adding the 0.8 tpy from the stripper rundown streams to the 0.1 tpy reduction from the decanter and kettle line wastewater streams, the EPA's proposed steam stripping requirement is likely to reduce current chloroprene emissions by about 1 tpy (not by 17.7 tpy as the EPA had determined). The commenter added that there is also uncertainty as to whether steam stripping would actually achieve 99 percent removal of the low concentrations of chloroprene in wastewater given that chloroprene is a halogenated alkane, and no information has been presented that is specific to steam stripping of chloroprene from wastewater at the concentrations present in wastewater at the facility. The commenter deduced that when using their expected actual emissions reductions of about 1 tpy, the cost effectiveness would be closer to \$7.5 million per ton removed (without considering the cost of installing and operating a thermal oxidizer that would be required under the EPA's proposal to handle the chloroprene from the steam stripper unit), and not \$426,900 per ton as the EPA has estimated.

*Response:* The EPA acknowledges the commenters' support for and opposition of the proposed wastewater provisions at 40 CFR 63.501(a)(10)(iv). We are finalizing these provisions as proposed. We disagree with the commenter's assertion that 13.5 tpy of wastewater in chloroprene service pass through the WWTP. We also disagree that our emissions reductions were overestimated. We believe 26.3 tpy of wastewater in chloroprene service pass through the WWTP (*i.e.*, the amount of chloroprene entering the air sparging tank) based on our review of emissions inventory calculations for wastewater entering the WWTP. We maintain that 17.7 tpy of emissions reductions is appropriate, based on a mass balance of the information provided in the emissions inventory calculations. The results of our mass balance suggest that our initial analysis is appropriate.

We also disagree with the commenter and maintain it was appropriate to



assume no controls during our initial analysis such that a steam stripper would be placed before the air sparging tank. Simply put, the P&R I NESHAP (which references the HON wastewater requirements) requires all wastewater collection system components (tanks, surface impoundments, containers, individual drain systems, and oil-water separators) to be covered and upstream of the wastewater treatment process. However, the facility's wastewater treatment system is configured with an air sparging tank (air stripper), followed by an outdoor brine pit (open to the atmosphere), followed by biological treatment. Furthermore, the commenter claims their air stripper achieves approximately 95 percent control, but did not provide any data to corroborate this control efficiency. When taking the configuration of the facility's wastewater treatment system into account, we assumed no controls, since wastewater streams flow through a control device with an unknown control efficiency directly into an open brine pit.

Also, contrary to the commenter's remark regarding steam stripper performance, we believe the use of 99 percent removal of chloroprene from steam stripping is appropriate based on its Fr value. In the document titled *Analysis of Control Options for Wastewater Streams to Reduce Residual Risk of Chloroprene from Neoprene Production Processes Subject to P&R I* (see Docket Item No. EPA-HQ-OAR-2022-0730-0092), we explain that the EPA calculated the Fr values for a variety of HAP during the original rulemaking of the HON. The Fr is the fraction of a HAP that is stripped from wastewater and is an indicator of the extent to which a HAP is effectively removed during the steam stripping process. For chloroprene, the Fr has always been 99 percent in Table 9 to NESHAP subpart G and we maintain this is reflective of the current technology.

Finally, we remind the commenter that, due to the risk associated with chloroprene, cost does not play a role in setting standards that are necessary to reduce risk to an acceptable level under step one of the Benzene NESHAP approach codified in CAA section 112(f). Regardless of whether or not emissions reductions were underestimated (which we disagree with), a higher cost-effectiveness is not grounds for reevaluating the proposed provisions at 40 CFR 63.501(a)(10)(iv).

### iii. Chloroprene Facility-Wide Cap

*Comment:* A commenter said they support the EPA's proposed rule text at

40 CFR 63.483(a)(10) that requires owners and operators to comply with a facility-wide chloroprene emissions cap of 3.8 tpy in any consecutive 12-month period for all neoprene production emission sources. However, another commenter argued that it is impossible to know whether the chloroprene emissions cap of 3.8 tpy is simply a "backstop" or an additional requirement that goes beyond the proposed requirements to control emissions of chloroprene from maintenance vents and PRDs, and process vents, storage vessels, and wastewater "in chloroprene service." The commenter asserted that the EPA does not appear to have determined whether full compliance with the proposed requirements to control chloroprene from maintenance vents and PRDs, and process vents, storage vessels, and wastewater "in chloroprene service" would reduce the facility-wide emissions below the proposed chloroprene emissions cap of 3.8 tpy. The commenter also asserted that the EPA has not estimated the costs of reducing facility-wide emissions below this cap, nor does the EPA provide any details about the type of monitoring that would be required to demonstrate compliance with it. The commenter argued that given the EPA's determination that the chloroprene emissions cap of 3.8 tpy would protect public health with an ample margin of safety, the proposed requirements to control chloroprene from maintenance vents and PRDs, and process vents, storage vessels, and wastewater "in chloroprene service" are unlawful if they would force the facility to reduce emissions appreciably below 3.8 tpy. The commenter said that the EPA does not have authority to require emission reductions that go beyond what is necessary to protect public health with an ample margin of safety, unless they are based on cost-effective improvements in control technology under CAA section 112(d)(6).

Another commenter provided several reasons why the chloroprene emissions cap of 3.8 tpy is inappropriate, including: (1) The EPA back-calculated this cap from a flawed risk assessment; (2) the cap is unverifiable and therefore not enforceable, particularly here where it encompasses not only non-flare point sources (which can, with some effort, be properly monitored) but also flare and numerous fugitive sources (whose emissions simply cannot be tested, monitored, and verified); and (3) there have recently been large problems with "unknown" and therefore unreported emissions at the facility (e.g., in 2022, the EPA discovered that the facility was

using an unpermitted brine pit to allow poly-kettle waste to off-gas chloroprene).

*Response:* We are not finalizing the proposed requirement at 40 CFR 63.483(a)(10) that would have required owners and operators to comply with a chloroprene emissions cap of 3.8 tpy in any consecutive 12-month period for all neoprene production emission sources. The proposed facility-wide chloroprene emissions cap was intended to address unknown or uncertain emission sources in the Neoprene Production source category, including emissions from back-end process operations. However, we agree with a commenter that the proposed facility-wide chloroprene emissions cap is confusing on how it would be applied beyond the proposed requirements for emission sources in chloroprene service. Instead, we believe the fenceline monitoring requirements that we are finalizing will serve as a reasonable backstop for limiting emissions and addressing fugitive and any unknown emission sources in the Neoprene Production source category as well as whole-facility chloroprene emissions. We are also clarifying in the final rule that the requirements we proposed for controlling chloroprene from process vents in the Neoprene Production source category apply not only to continuous front-end process vents in chloroprene service and batch front-end process vents in chloroprene service, but also to back-end process vents in chloroprene service. For more details about this, see our responses to comments in section IV.A.3.e.i of this preamble.

### iv. Other Chloroprene Related Requirements

*Comment:* A commenter said they supported the EPA's proposed rule text at 40 CFR 63.509 sampling and analysis procedures for owners and operators of affected sources producing neoprene to demonstrate that process equipment does, or does not, meet the proposed definition of being "in chloroprene service."

*Response:* The EPA acknowledges the commenter's support of the sampling and analysis procedures used to determine whether process equipment is "in chloroprene service." We are making the following minor changes in the final rule to clarify our intent: (1) For process vents, we have clarified within the definition of "in chloroprene service" that the 5 lb/yr chloroprene mass threshold for combined process vents be on a EPPU-by-EPPU basis; (2) For storage vessels, we are revising the phrasing of "sampling and analysis is performed as specified in § 63.509"

within the definition of “in chloroprene service” to “the procedures specified in § 63.509 are performed”; and (3) we have clarified at 40 CFR 63.509(a) that the sampling site shall be after the last recovery device (if any recovery devices are present) but prior to the inlet of any control device that is present and prior to release to the atmosphere.

*Comment:* A commenter (0172) requested that the EPA recognize in the final rule that OGI is effective for detecting chloroprene leaks and work with their facility to develop a protocol for LDAR that could be included as a compliance option. The commenter claimed that the LDAR requirement in the proposed rule would require them to hire additional technicians (likely 3 additional workers) and purchase additional equipment. The commenter said that they spoke to leak detection experts at Montrose Environmental who said that a forward looking infrared cooled G304 camera would likely be an effective tool for monitoring and detecting chloroprene leaks. The commenter stated that they completed a one-day field test with such a camera and found that it was effective for detecting chloroprene leaks.

*Response:* We did not propose control options for equipment leaks to reduce chloroprene risk from the Neoprene Production source category. To reduce risk from the Neoprene Production source category to an acceptable level, we proposed to require control of chloroprene for: (1) Process vents, (2) storage vessels, and (3) wastewater “in chloroprene service.” We also proposed requirements to reduce chloroprene emissions from maintenance vents and PRDs. See section III.B.2.b of the preamble to the proposed rule for more details (88 FR 25080, April 25, 2023). However, we did make an error in the document titled *Proposed Regulation Edits for 40 CFR part 63 Subpart U: National Emission Standards for Hazardous Air Pollutant Emissions: Group I Polymers and Resins* (see Docket Item No. EPA-HQ-OAR-2022-0730-0066) that suggests at 40 CFR 63.502(a)(6) we were proposing to regulate certain equipment in chloroprene service.

The EPA has not provided an OGI-only option for detection for chloroprene leaks. Although the commenter mentions a one-day study performed by Montrose Environmental on the effectiveness of a particular OGI camera’s ability to see chloroprene emissions, no information from that study was submitted. Additionally, no information on the detection level determined during the study or the environmental conditions of the study

were submitted. Because the detection capabilities of OGI cameras are highly influenced by environmental conditions, this is important data to understand, and it is unlikely that a one-day study would provide information on the capabilities of the camera in the range of environmental conditions under which field surveys would normally be conducted.

Although the EPA recently finalized a protocol for using OGI in the detection of VOC and methane leaks (40 CFR part 60 appendix K), we note that the protocol is geared towards midwave OGI cameras that operate with a filter in a particular spectral range (around 3.3 microns) where methane and many VOC compounds have a spectral peak. The type of OGI camera the protocol is geared towards is not suited to finding leaks of chloroprene because chloroprene does not have a strong peak in the spectral range of these cameras, which means that only very high leaks of chloroprene would be visible to these cameras. The OGI camera mentioned by the commenter has a filter in a different spectral range. The EPA has not studied this camera to understand its detection capabilities, especially in regard to chloroprene, which is a risk driver for the source category, nor could the EPA readily find information on the ability of this OGI camera to see leaks of chloroprene. Because the leak definitions for the source category are low, on the order of 500 to 1000 ppm for most equipment, it is extremely important to understand the detection capability of an OGI camera being used at these sources, especially considering that while the OGI cameras the EPA has studied are effective at finding large leaks for many compounds, OGI cameras tend to be less effective at finding low-level leaks.

Even so, P&R I facilities currently have an option to use OGI through an alternative work practice to detect leaks from equipment at 40 CFR 63.11(c), (d), and (e). This alternative work practice includes provisions for using OGI in combination with annual monitoring using EPA Method 21 (and not as an alternative). The alternative work practice is not geared towards a particular type of OGI camera, and instead, requires owners and operators to perform daily instrument checks based on the detection levels and concentration of detectable chemicals in the equipment being surveyed.

4. What is the rationale for our final approach and final decisions for the risk review?

As noted in our proposal, the EPA sets standards under CAA section

112(f)(2) using “a two-step standard-setting approach, with an analytical first step to determine an ‘acceptable risk’ that considers all health information, including risk estimation uncertainty, and includes a presumptive benchmark on maximum individual lifetime risk (MIR) of approximately 1-in-10 thousand” (88 FR 25080, April 25, 2023; see also 54 FR 38045, September 9, 1989.)<sup>47</sup> We weigh all health risk factors in our risk acceptability determination, including the cancer MIR, cancer incidence, the maximum TOSHI, the maximum acute HQ, the extent and distribution of cancer and noncancer risks in the exposed population, multipathway risks, and the risk estimation uncertainties.

Since proposal, our determinations regarding risk acceptability, ample margin of safety, or adverse environmental effects have not changed. However, after proposal, commenters provided updated information on their facilities, including specific information regarding use of the TCEQ modeling guidelines to calculate effective flare stack parameters. We updated the risk assessment for the SOCMI and Neoprene Production source categories considering the comments received on modeling flares. The revised risk assessment (see the risk reports, *Residual Risk Assessment for the SOCMI Source Category in Support of the 2024 Risk and Technology Review Final Rule* and *Residual Risk Assessment for the Polymers & Resins I Neoprene Production Source Category in Support of the 2024 Risk and Technology Review Final Rule*, which are available in the docket for this rulemaking) shows that, after application of controls finalized in this rulemaking, the MIR for each of the source categories is 100-in-1 million. Therefore, after application of the EtO-specific controls for process vents, storage vessels, equipment leaks, heat exchange systems, and wastewater, and the requirements to reduce EtO emissions from maintenance vents and PRDs, we find that the risks are acceptable for the SOCMI source

<sup>47</sup> We generally draw no “bright lines” of acceptability regarding cancer or noncancer risks from source category HAP emissions, and it is always important to consider the specific uncertainties of the emissions and health effects information regarding the source category in question when deciding exactly what level of cancer and noncancer risk should be considered acceptable. In addition, the source category-specific decision of what constitutes an acceptable level of risk should be a holistic one; that is, it should simultaneously consider all potential health impacts—chronic and acute, cancer and noncancer, and multipathway—along with their uncertainties, when determining the acceptable level of source category risk.

category and that the final HON standards will achieve an ample margin of safety to protect human health from risks presented by HON emission sources. Also, after application of the chloroprene-specific controls for process vents, storage vessels, and wastewater, and the requirements to reduce chloroprene emissions from maintenance vents and PRDs, we find that the risks are acceptable for the Neoprene Production source category and that the final P&R I standards will achieve an ample margin of safety to protect human health from risks presented by neoprene production emission sources.

*B. Technology Review for the SOCM I, P&R I, and P&R II Source Categories NESHAP and NSPS Review for the SOCM I Source Category*

1. What did we propose pursuant to CAA section 112(d)(6) for SOCM I, P&R I, and P&R II source categories and CAA section 111(b)(1)(B) for the SOCM I source category?

a. NESHAP

Based on our technology review for the SOCM I, P&R I, and P&R II source categories, we proposed under CAA section 112(d)(6) changes to the HON and P&R I standards for heat exchange systems, storage vessels, and process vents and we proposed no change under CAA section 112(d)(6) to the P&R II standards for storage vessels and process vents. The P&R II NESHAP currently does not regulate HAP emissions from heat exchange systems, but we are finalizing, as proposed, requirements in the P&R II NESHAP for heat exchange systems pursuant to CAA section 112(d)(2) and (3). In addition, we proposed no change under CAA section 112(d)(6) for transfer racks, wastewater streams, and equipment leaks. We also proposed fence line monitoring requirements under CAA section 112(d)(6). We provide a summary of our findings, as proposed, in this section.

i. Heat Exchange Systems

In our technology review for the SOCM I, P&R I, and P&R II source categories, we identified one development in practices and processes for HON and P&R I heat exchange systems, the use of the Modified El Paso Method<sup>48</sup> for monitoring for leaks from

heat exchange systems. We determined that this method is more effective in identifying leaks and measures a larger number of compounds than the methods previously required in the HON and the P&R I NESHAP. After evaluating state and Federal regulations requiring the Modified El Paso Method, as well as emission data collected for the Ethylene Production RTR (refer to section II.D of the proposal preamble (88 FR 25080, April 25, 2023) and the Ethylene Production RTR rulemaking docket, Docket ID No. EPA-HQ-OAR-2017-0357), we proposed pursuant to CAA section 112(d)(6) to require use of the Modified El Paso Method with a leak definition of 6.2 ppmv of total strippable hydrocarbon concentration (as methane) in the stripping gas to further reduce HAP emissions from both new and existing heat exchange systems, as well as to disallow delay of repair of leaks if the measured concentration meets or exceeds 62 ppmv. Based on an evaluation of incremental HAP cost effectiveness to increase the monitoring frequency, we proposed no changes to the monitoring frequency previously required under the HON and the P&R I NESHAP for monitoring for leaks from heat exchange systems, which continues to be monthly monitoring in the first 6 months following startup of a source and quarterly monitoring thereafter. We also proposed to require re-monitoring at the monitoring location where a leak is identified to ensure that any leaks found are fixed. Further, we proposed that none of these proposed requirements for heat exchange systems apply to heat exchange systems that have a maximum cooling water flow rate of 10 gallons per minute or less. Finally, we proposed that owners and operators may use the current leak monitoring requirements for heat exchange systems at 40 CFR 63.104(b) in lieu of using the Modified El Paso Method provided that 99 percent by weight or more of the organic compounds that could leak into the heat exchange system are water soluble and have a Henry's Law Constant less than 5.0E-6 atmospheres-cubic meters/mol at 25 degrees Celsius. Refer to section III.C.1 of the proposal preamble (88 FR 25080, April 25, 2023) for a summary of our rationale for selecting the proposed leak method, leak definition, and limitation on delay of repairs, as well as our rationale for retaining the previous monitoring schedule.

*Paso Method) for Determination of Volatile Organic Compound (VOC) Emissions from Water Sources.* Appendix P is included in the docket for this rulemaking (see Docket Item No. EPA-HQ-OAR-2022-0730-0032).

For a detailed discussion of the EPA's findings, refer to the document titled Clean Air Act Section 112(d)(6) Technology Review for Heat Exchange Systems Located in the SOCM I Source Category that are Associated with Processes Subject to HON and for Heat Exchange Systems that are Associated with Processes Subject to Group I Polymers and Resins NESHAP; and Control Option Impacts for Heat Exchange Systems that are Associated with Processes Subject to Group II Polymers and Resins NESHAP (see Docket Item No. EPA-HQ-OAR-2022-0730-0075).

ii. Storage Vessels

In our technology review for the SOCM I, P&R I, and P&R II source categories, we identified three options for reducing emissions from HON and P&R I storage vessels. Refer to section III.C.2 of the proposal preamble (88 FR 25080, April 25, 2023) for a summary of the three options. Based on our evaluation of the costs and emission reductions of each of the three options, we proposed pursuant to CAA section 112(d)(6) to: (1) Revise the Group 1 HON and P&R I storage vessel capacity and MTVP thresholds to reflect the MON existing source threshold, which requires existing storage vessels between 38 m<sup>3</sup> and 151 m<sup>3</sup> with a vapor pressure greater than or equal to 6.9 kilopascals to reduce emissions of organic HAP by 95 percent utilizing a closed vent system and control device, or reduce organic HAP emissions by utilizing either an IFR, or an EFR, by routing the emissions to a process or a fuel gas system, or by vapor balancing; and (2) in addition to requirements specified in option 1, require upgraded deck fittings<sup>49</sup> and controls for guidepoles for all storage vessels equipped with an IFR as already required in 40 CFR 63, subpart WW.

For a detailed discussion of the EPA's findings, refer to the document titled Clean Air Act Section 112(d)(6) Technology Review for Storage Vessels Located in the SOCM I Source Category that are Associated with Processes Subject to HON, Storage Vessels Associated with Processes Subject to Group I Polymers and Resins NESHAP, and Storage Vessels Associated with Processes Subject to Group II Polymers and Resins NESHAP (see Docket Item No. EPA-HQ-OAR-2022-0730-0073).

<sup>49</sup>This means that we require all openings in an IFR (except those for automatic bleeder vents (vacuum breaker vents), rim space vents, leg sleeves, and deck drains) to be equipped with a deck cover, and the deck cover would be required to be equipped with a gasket between the cover and the deck.

<sup>48</sup>The Modified El Paso Method uses a dynamic or flow-through system for air stripping a sample of the water and analyzing the resultant off-gases for VOC using a common flame ionization detector analyzer. The method is described in detail in Appendix P of the TCEQ's Sampling Procedures Manual: *The Air Stripping Method (Modified El*

### iii. Process Vents

In our technology review for the SOCOMI, P&R I, and P&R II source categories, we identified three options for reducing emissions from HON process vents and P&R I continuous front-end process vents. Refer to section III.C.3.a of the proposal preamble (88 FR 25080, April 25, 2023) for a summary of the three options. Based on our evaluation of the costs and emission reductions of each of the three options, we proposed pursuant to CAA section 112(d)(6) to revise the process vent applicability threshold to redefine a HON Group 1 process vent and P&R I Group 1 continuous front-end process vent (requiring control) as any process vent that emits greater than or equal to 1.0 lb/hr of total organic HAP. We also proposed removing the TRE concept in its entirety and removing the 50 ppmv and 0.005 scmm Group 1 process vent thresholds. In addition, we identified one option for reducing emissions from P&R I batch front-end process vents and we proposed pursuant to CAA section 112(d)(6) to revise the process vent applicability threshold to redefine a P&R I Group 1 batch front-end process vent as a process vent that releases total annual organic HAP emissions greater than or equal to 4,536 kg/yr (10,000 lb/yr) from all batch front-end process vents combined.

For a detailed discussion of the EPA's findings, refer to the document titled Clean Air Act Section 112(d)(6) Technology Review for Continuous Process Vents Located in the SOCOMI Source Category that are Associated with Processes Subject to HON, Continuous Front-end and Batch Front-end Process Vents Associated with Processes Subject to Group I Polymers and Resins NESHAP, and Process Vents Associated with Processes Subject to Group II Polymers and Resins NESHAP (see Docket Item No. EPA-HQ-OAR-2022-0730-0094).

### iv. Fenceline Monitoring

We proposed a fenceline monitoring standard for the SOCOMI and P&R I source categories requiring owners and operators to monitor for any of six specific HAP (*i.e.*, benzene, 1,3-butadiene, ethylene dichloride, vinyl chloride, EtO, and chloroprene) if their site uses, produces, stores, or emits any of them, and conduct root cause analysis and corrective action upon exceeding the annual average concentration action level set forth for each HAP.

### b. NSPS

#### i. Process Vents

In our review of NSPS subparts III, NNN, and RRR (for SOCOMI air oxidation units, distillation operations, and reactor processes, respectively), we identified certain advances in process operations that were not identified or considered during development of the original NSPS. Refer to section III.C.3.b of the proposal preamble (88 FR 25080, April 25, 2023) for a detailed summary of these advances in process operations. Based on our evaluation of statutory factors, including costs and emission reductions, we proposed pursuant to CAA section 111(b)(1)(B) revised NSPS subparts IIIa, NNNa, and RRRa (which are applicable to affected facilities for which construction, reconstruction, or modification commences after April 25, 2023). We proposed that the revised NSPS subparts encompass a suite of process vent requirements, which include: (1) Removing the TRE index value concept in its entirety and instead requiring owners and operators to reduce emissions of TOC (minus methane and ethane) from all vent streams of an affected facility (*i.e.*, SOCOMI air oxidation unit processes, distillation operations, and reactor processes for which construction, reconstruction, or modification commences after April 25, 2023) by 98 percent by weight or to a concentration of 20 ppmv on a dry basis corrected to 3 percent oxygen, or combust the emissions in a flare meeting the same operating and monitoring requirements for flares that we are finalizing for flares subject to the HON; (2) eliminating the relief valve discharge exemption from the definition of "vent stream" such that any relief valve discharge to the atmosphere of a vent stream is a violation of the emissions standard; (3) prohibiting an owner or operator from bypassing the APCD at any time, and requiring the owner or operator to report any such violation (including the quantity of TOC released to the atmosphere); (4) requiring that flares used to reduce emissions comply with the same flare operating and monitoring requirements as those we have promulgated for flares used in SOCOMI-related NESHAP; (5) requiring work practice standards for maintenance vents during startup, shutdown, maintenance, or inspection of any of the air oxidation units, distillation operations, and reactor processes affected facilities under the applicable NSPS where the affected facility is emptied, depressurized, degassed, or placed into service; and (6) adding control device operational and

monitoring requirements for adsorbers that cannot be regenerated and regenerative adsorbers that are regenerated offsite. For a detailed discussion of the EPA's findings, refer to the document titled *CAA 111(b)(1)(B) review for the SOCOMI air oxidation unit processes, distillation operations, and reactor processes NSPS subparts III, NNN, and RRR* (see Docket Item No. EPA-HQ-OAR-2022-0730-0011).

#### ii. Equipment Leaks

In our review of NSPS subpart VVa (for SOCOMI equipment leaks), we identified emission reduction measures used in practice related to LDAR of certain equipment that achieve greater emission reductions than those currently required by NSPS subpart VVa. Refer to section III.C.6.b of the proposal preamble (88 FR 25080, April 25, 2023) for a summary of these measures. Based on our evaluation of statutory factors, including costs and emission reductions, we proposed pursuant to CAA section 111(b)(1)(B) a revised NSPS subpart VVb applicable to affected facilities for which construction, reconstruction, or modification commences after April 25, 2023. The revised NSPS VVb includes the same requirements as in NSPS subpart VVa plus a requirement that all gas/vapor and light liquid valves be monitored monthly at a leak definition of 100 ppm and all connectors be monitored once every 12 months at a leak definition of 500 ppm.

For a detailed discussion of the EPA's findings, refer to the document titled *CAA 111(b)(1)(B) review for the SOCOMI Equipment Leaks NSPS Subpart VVa* (see Docket Item No. EPA-HQ-OAR-2022-0730-0096).

2. How did the technology review change for the SOCOMI, P&R I, and P&R II source categories, and NSPS review change for the SOCOMI source category?

We are finalizing the results of the NSPS review under CAA section 111(b)(1)(B) for the SOCOMI source category as proposed (88 FR 25080, April 25, 2023), with a change to the definition of "capital expenditure" in NSPS subpart VVb to use a formula that better reflects the trajectory of inflation. We are also finalizing the results of the technology review pursuant to CAA section 112(d)(6) for the SOCOMI, P&R I, and P&R II source categories as proposed (88 FR 25080, April 25, 2023), with some changes to the fenceline monitoring requirements that we proposed under the technology review for the SOCOMI and P&R I source categories, and also a minor change to clarify that, with regard to the storage

vessel portion of the technology review, the Group 1 HON and P&R I storage vessel capacity and MTVP thresholds apply to both new and existing sources. For fenceline monitoring requirements, the final rule establishes two action levels for chloroprene (*i.e.*, one action level under CAA section 112(d)(6) and another action level under CAA section 112(f) in lieu of only one action level for this HAP, as proposed. We are also finalizing: (1) Burden reduction measures to allow owners and operators to skip fenceline measurement periods for specific monitors with a history of measurements that are at or below certain action levels; (2) a clarification that fenceline monitoring is required for owners and operators with affected sources that produce, store, or emit one or more of the target analytes; (3) a reduction in the requirements for the minimum detection limit of alternative measurement approaches; (4) clarifications on establishing the monitoring perimeter for both sorbent tubes and canisters; (5) clarifications on the calculation of  $\Delta c$  when a site-specific monitoring plan is used to correct monitoring location concentrations due to offsite impacts; (6) a change in the required method detection limit for alternative test methods from an order of magnitude below the action level to one-third of the action level; and (7) with the exception of fenceline monitoring of chloroprene at P&R I affected sources producing neoprene, a change in the compliance date in the final rule to begin fenceline monitoring 2 years (instead of 1 year, as proposed) after the effective date of the final rule. For P&R I affected sources producing neoprene, we have changed the compliance date for fenceline monitoring of chloroprene to begin no later than October 15, 2024, or upon startup, whichever is later, subject to the owner or operator seeking the EPA's authorization of an extension of up to 2 years from July 15, 2024.

3. What key comments did we receive on the technology review and NSPS review, and what are our responses?

a. NESHAP

The EPA received comments in support of and against the proposed technology review. We received only minor comments requesting clarifications associated with our technology review for heat exchange systems and storage vessels. The comments and our specific responses to these issues can be found in the document titled *Summary of Public Comments and Responses for New Source Performance Standards for the*

*Synthetic Organic Chemical Manufacturing Industry and National Emission Standards for Hazardous Air Pollutants for the Synthetic Organic Chemical Manufacturing Industry and Group I & II Polymers and Resins Industry*, which is available in the docket for this rulemaking. Based on these comments, we are finalizing revisions to require the Modified El Paso Method for heat exchange systems, and we are finalizing revisions to the Group 1 HON and P&R I storage vessel capacity and MTVP thresholds to reflect the MON existing source threshold for both new and existing sources.

We did not receive any comment with regard to the technology review for transfer racks and wastewater streams. Furthermore, for equipment leaks, the comments were generally either supportive of the determination that no cost-effective developments from the technology review were found, or that the Agency should re-open and reevaluate the MACT standards for new technologies. Based on our review of the comments received for equipment leaks, we are finalizing our determination that no cost-effective developments exist and that it is not necessary to revise these emission standards under CAA section 112(d)(6). For process vents, the EPA received additional information from commenters on costs necessary for control of process vents that emit greater than or equal to 1.0 lb/hr of total organic HAP. We also received several comments regarding the fenceline monitoring requirements that we proposed under the technology review. This section provides summaries of and responses to the key comments received regarding: (1) The technology review amendments we proposed for HON process vents and P&R I continuous front-end process vents, and (2) the proposed fenceline monitoring requirements. Comment summaries and the EPA's responses for additional issues raised regarding the proposed requirements resulting from our technology review for the SOCM, P&R I, and P&R II source categories are in the document titled *Summary of Public Comments and Responses for New Source Performance Standards for the Synthetic Organic Chemical Manufacturing Industry and National Emission Standards for Hazardous Air Pollutants for the Synthetic Organic Chemical Manufacturing Industry and Group I & II Polymers and Resins Industry*, which is available in the docket for this rulemaking.

i. Process Vents

*Comment:* A commenter said they supported the EPA's proposed rule text

at 40 CFR 63.113(a)(4) and 40 CFR 63.485(l)(6), (o)(6), (p)(5), and (x) that removes the TRE concept in its entirety from both the HON and P&R I NESHAP. However, numerous commenters opposed removal and provided the following arguments to reinforce their opposition:

- The EPA lacks the statutory authority to remove the TRE index value concept because it has offered no supportable basis as to why removal would constitute a development in practices, processes, or technologies under CAA section 112(d)(6).

- The fact that another source category's standards do not include the TRE index value concept is not a development in practice, and the EPA offered no argument as to how it could possibly fit within that box.

- The fact that some facilities choose to control process vents that would be exempt using the TRE index value does not indicate that removing the TRE concept is a development in practices, processes, or technologies. Electing not to use the TRE is a business choice, not a technological development.

- Complexity of an established compliance tool is not a technological development.

- The EPA has not adequately supported its proposal to remove the TRE concept.

- While it is true that certain facilities may have designated process vents with a TRE index value above 1.0 as a Group 1 process vent, the reason behind this may not necessarily be voluntary or driven by the desire to avoid the TRE calculation, but rather facilities may be controlling these process vents to comply with state or local regulations regarding VOCs or to meet a best available control technology (BACT) limit.

- The EPA's rationale for eliminating the TRE index value from the HON rule due to variations in other MACT rules is flawed given that the EPA did not remove the TRE index value during the revision of the MON rule and distinguishing between Group 1 and Group 2 process vents in the Ethylene Production source category is irrelevant.

- Even though some process vents with a TRE index value above 1.0 are controlled at certain facilities, that does not imply that controlling all process vents with TRE index values above 1.0 is appropriate or cost-effective.

- Facilities often use source test results to determine TRE calculation inputs (even for vent streams with a TRE index value greater than 4.0), and this approach is neither complex nor uncertain to interpret.

• Despite the EPA's assertion that enforcing the TRE index value "can be" arduous due to its theoretical nature, no instances have been provided where verifying a TRE index value calculation posed challenges for an agency or contradicted actual cost effectiveness at a facility. The number of inputs to the TRE index value calculation is proportional to the number of measurable organic compounds in the vent stream; and some facilities have very few organic compounds in process vents, so the inputs are minimal, and if those inputs are determined by other allowed methods (e.g., source tests, permit limits), then verification of these inputs is clearly not problematic.

• Perceived complexity is not a basis for removing the option.

• The TRE index value has been an integral part of many technology-based air standards since its initial development, serving as a mechanism for determining cost effectiveness and triggering the requirements for process vent control (see, e.g., the preamble to the 1994 HON adoption, which states that the TRE concept is appropriate because it "can be used to reflect all possible combinations of various factors that affect emission rates and likelihood of current control" (59 FR 19416) and "would provide consistency between the HON[,] the recently issued [control techniques guidelines] for SOCM I process vents. . . [and] the applicability criteria for the three SOCM I process vents NSPS" (59 FR 19418)).

• By considering the TRE index value, an owner or operator can allocate their resources more efficiently and concentrate efforts and resources on the vents that have the greatest potential for emission reduction, maximizing the overall environmental benefit. The TRE considers not only the organic HAP emissions but also the volumetric flow and net heating value of the vent gas stream, and thus it takes into consideration the practicality of controlling relatively small organic HAP emission streams using control devices like a flare or a vapor incinerator.

• Use of the TRE index value is a holistic approach that ensures that the most significant emission sources are targeted for control, leading to more effective pollution reduction.

• Uncontrolled Group 2 process vent gas streams typically exhibit minimal emissions of HAP and VOC, possess a low net heating value, may contain steam or water vapor, and have varying volumetric flow rates. Directing these streams to an emission control device, if available in the CMPU capable of handling them, is a complex engineering problem and would yield

negligible emissions reductions. Moreover, it would likely necessitate the addition of significant amounts of supplemental fuel to combust this type of stream and consequently result in additional emissions of carbon monoxide (CO), nitrogen oxides (NO<sub>x</sub>), and CO<sub>2</sub> to control a relatively small quantity of HAP or VOC emissions.

• It is not clear how the emissions averaging program, as it is currently applied under the HON, can continue to exist with the requirement to control process vents that are currently designated as Group 2 vents. The burden of over-control to generate "credits" will effectively render the provisions unattainable or useless.

• Many facilities will still be required to comply with TRE-based determinations according to their title V operating permits and requirements under NSPS subparts NNN and RRR.

Many of the commenters who opposed removing the TRE index value in its entirety suggested that the EPA could potentially consider raising the TRE index value threshold, such as by aligning it with the value in the MON rule or the value indicated in Option 3 of the proposed rule, or by setting it at a level agreed upon as cost-effective by the industry. Other commenters opposed this suggestion.

*Response:* The EPA acknowledges commenters' support for and opposition to the removal of the TRE concept from the HON at 40 CFR 63.113(a)(4) and from the P&R I NESHAP at 40 CFR 63.485(l)(6), (o)(6), (p)(5), and (x). We are finalizing the removal of the TRE concept as proposed. We stand by the rationale we provided in the preamble to the proposed rule (88 FR 25080, April 25, 2023) for removing the TRE concept: (1) We identified at least one more recent (than the HON and the P&R I NESHAP) chemical manufacturing NESHAP (i.e., ethylene production) that does not use the TRE index value as criteria for determining whether a process vent should be controlled; (2) based on the responses to our CAA section 114 request, we observed that some facilities are controlling continuous process vents that are not required by the HON and the P&R I NESHAP to be controlled per the results of the TRE index value calculation; (3) based on the responses to our CAA section 114 request, we observed that facilities are routing multiple continuous process vents to a single APCD; (4) determining a TRE index value for certain process vent streams is often theoretical, can be extremely complicated, and is uncertain; and (5) because the TRE index value is largely

a theoretical characterization tool, it can be very difficult to enforce.

We disagree with commenters that the removal of the TRE concept does not constitute a development in practices, processes, or technologies under CAA section 112(d)(6). We noted in the preamble to the proposed rule (88 FR 25080, April 25, 2023) that some owners and operators do not use the TRE index value to determine whether a vent stream is a Group 1 or Group 2 process vent. While we agree with commenters that owners and operators control Group 2 vent streams for reasons other than the desire to avoid the TRE calculation, the fact is that owners and operators are controlling HON and P&R I Group 2 process vents (possibly to comply with state or local regulations regarding VOCs or to meet a BACT limit), which we consider a development under CAA section 112(d)(6). Given that the TRE concept, as some commenters pointed out, has been used since the original 1994 HON adoption (and even in the 1992 proposed HON rule), we consider owners and operators controlling HON and P&R I Group 2 process vents to be an operational procedure that was not identified or considered during development of the original MACT standards. Additionally, the removal of the TRE concept simplifies the determination as to whether owners and operators must control a vent stream and thus the applicability process is easier to implement.

We disagree with commenters' assertion that the EPA did not provide evidence that the TRE concept is largely theoretical and, as a result, difficult to verify. As identified in the document titled *Clean Air Act Section 112(d)(6) Technology Review for Continuous Process Vents Located in the SOCM I Source Category that are Associated with Processes Subject to HON, Continuous Front-end and Batch Front-end Process Vents Associated with Processes Subject to Group I Polymers and Resins NESHAP, and Process Vents Associated with Processes Subject to Group II Polymers and Resins NESHAP* (Docket Item ID No. EPA-HQ-OAR-2022-0730-0094), one facility that received the CAA section 114 request provided over 300 pages of modeled runs used to determine certain characteristics of their continuous process vents to be utilized as part of the TRE index value calculations. Reviewing this information revealed that in many cases the facility struggled to unify the modeled runs with actual conditions at the facility and in some cases made arbitrary decisions to allow the model to function. While we agree with commenters that the TRE index

value can be derived from less theoretical methods, other responses to the CAA section 114 request did not indicate how parameters used in the TRE index value calculations were determined, and commenters did not provide sufficient information to show which methods were most common throughout industry. Given the theoretical nature of the TRE index value, the EPA maintains that verifying TRE index values is arduous because it can involve relying on significant process knowledge in order to confirm HAP compositions of vent streams, vent stream flowrates, vent stream net heating values, and hourly emissions. It may also require verification of other facility assumptions (e.g., operational conditions and constraints) especially if modeling was used.

We agree with commenters that the TRE index value has been an integral part of many technology-based air standards since its initial development. In fact, we said as much in the document titled *Clean Air Act Section 112(d)(6) Technology Review for Continuous Process Vents Located in the SOCM Source Category that are Associated with Processes Subject to HON, Continuous Front-end and Batch Front-end Process Vents Associated with Processes Subject to Group I Polymers and Resins NESHAP, and Process Vents Associated with Processes Subject to Group II Polymers and Resins NESHAP* (Docket Item ID No. EPA-HQ-OAR-2022-0730-0094). The TRE concept is almost 40 years old as it was first introduced in a December 1984 EPA document (EPA-450/3-84-015; see attachment to Docket Item No. EPA-HQ-OAR-2022-0730-0094). However, even if it has been integral, certain aspects of its underlying development are clearly no longer applicable or appropriate. For example, the EPA stated in the 1984 supporting materials (EPA-450/3-84-015) that the Agency attempted to make the TRE index independent of inflation (e.g., the EPA assumed fixed relative costs of various resources, such as carbon steel and electricity), yet it is impossible to ignore inflation in the TRE calculations due to the time that has passed since it was developed (e.g., costs of carbon steel and electricity have undoubtedly increased since the development of the TRE index).

Although the TRE index value may allow owners and operators to allocate resources efficiently and ensure that the most significant emission sources are targeted for control, the current use of the TRE index value is only based on controlling a single process vent with a single APCD. This is an unrealistic

scenario when compared to how chemical manufacturing facilities actually control their process vents; and it is much more likely that a facility routes numerous process vents to the same APCD (and this is evident from observing the responses to our CAA section 114 request).

We agree with commenters that the removal of the TRE concept may lead to emissions increases due to the use of supplemental fuel in new APCDs that are potentially needed to control Group 2 streams that are currently uncontrolled; and we acknowledged this in our preamble to the proposed rule (88 FR 25080, April 25, 2023) as well as in the RIA accompanying the proposal. However, based on other comments received and discussed elsewhere in this section of this document (regarding the use of low volumetric flow rates in our original proposed cost estimate), we revised our cost analysis to account for higher flow rates to the APCD. As a result of this flow rate adjustment, additional supplemental fuel was needed to control Group 2 vent streams that exhibit minimal emissions of HAP and VOC, possess a low net heating value, and may contain steam or water vapor. Even so, at proposal, we overestimated the amount of supplemental fuel that would be needed nationwide (168 MMscf/yr) to control Group 2 vent streams that exhibit minimal emissions of HAP and VOC, and we continue to believe this estimate is conservatively high even after revising our cost analysis. For this reason, we are not revising our estimate of secondary impacts (including emissions of CO, CO<sub>2</sub>, NO<sub>x</sub> (including nitrous oxide (N<sub>2</sub>O)), particulate matter, and sulfur dioxide (SO<sub>2</sub>)).

With regard to the commenters' assertion that many facilities will still be required to comply with TRE-based determinations according to their title V operating permits and requirements under NSPS subparts NNN and RRR, we note that we are simplifying the HON overlap provisions for NSPS subparts III, NNN, and RRR in the final rule (i.e., we are finalizing, as proposed, that pursuant to 40 CFR 63.110(d)(1), (d)(4), (d)(7), and (d)(10) process vents subject to the emission standards in HON that are also subject to the NSPS subpart III, NNN, and/or RRR are only required to comply with the HON). Also, facilities already have general obligations under title V reopening for cause and 5-year renewals to ensure that permits include all requirements applicable to a facility.

Concerning emissions averaging, we note that the provisions experienced no significant changes as a result of

removing the TRE concept. The only explicit references to the TRE concept as part of the emissions averaging provisions are at 40 CFR 63.150(g)(2)(iii)(B)(2) with respect to a vent transitioning from a Group 1 process vent to a Group 2 process vent and at 40 CFR 63.150(m)(2)(i) related to obligations associated with carbon absorbers, adsorbers, or condensers not equipped with a control device. Both of these references are captured as no longer being required at 40 CFR 63.113(a)(4)(xii) and 40 CFR 63.113(a)(4)(xiii), respectively, and do not affect applicability. Emissions averaging has always been an optional provision with its burden falling on owners or operators to decide if it was appropriate or cost-effective to over-control certain streams while under-controlling other streams. This does not change as a result of redefining Group 2 process vents to be those streams containing less than 1.0 lb/hr of HAP. In addition, we note that credits may be generated from controlling Group 1 process vents at a higher nominal efficiency than the reference technology and from utilizing pollution prevention measures either independently or in combination with Group 1 process vents as specified at 40 CFR 63.150(c). Thus, even if a facility determines that controlling Group 2 process vents is infeasible, there are other avenues to pursuing the emission averaging provisions.

Finally, we disagree with the commenters' suggestion to raise the TRE index value threshold. Regarding a commenter's assertion that removing the TRE concept is flawed given that no action was taken on the TRE concept in the MON RTR, we note that we did not have data related to Group 2 process vents while developing revisions to the MON. Setting an emission threshold with no knowledge as to which Group 2 MON vent streams would be impacted and without knowing the potential cost or reductions associated with that revision would not have been appropriate. Thus, we did not identify any cost-effective developments in practices, processes, or control technologies for process vents. However, as part of this rulemaking, the Group 2 process vent data was collected via a CAA section 114 request. Our analysis of the Group 2 process vent data shows that removing the TRE concept and installing a 1.0 lb/hr of HAP emission threshold is of a similar cost effectiveness to raising the TRE index value to 5.0. However, for the reasons stated earlier in this document, removing the TRE concept was selected.

Given that we determined that a TRE index value of 5.0 was cost effective but opted to remove the TRE concept instead, it would be unreasonable to finalize a TRE index value of 3.0 based on the considerations discussed above and the decreased potential impact.

*Comment:* Commenters said they opposed the EPA's proposed rule text at 40 CFR 63.101 and 40 CFR 63.113(a)(1) and (2) that would remove the 50 ppmv and 0.005 scmm Group 1 process vent thresholds from the Group 1 process vent definition and that would instead require owners and operators of process vents that emit greater than or equal to 1.0 lb/hr of total organic HAP to either reduce emissions of organic HAP using a flare meeting the proposed operating and monitoring requirements for flares in NESHAP subpart F or reduce emissions of total organic HAP or TOC by 98 percent by weight or to an exit concentration of 20 ppmv.

A commenter requested that the EPA explain how it arrived at a 1 lb/hr control threshold. The commenter said that while the simplicity of a 1 lb/hr threshold is admittedly appealing, it is overly simplistic, and because the EPA did not supply any justification for the choice of 1 lb/hr, it appears to be an arbitrary and capricious threshold value.

Another commenter requested that if the EPA decides to keep the proposed Group 1 process vent definition with the 1.0 lb/hr total organic HAP mass flow rate threshold, then these proposed revisions should apply only to new sources in the HON. The commenter asserted that facilities with new sources will have greater flexibility in selecting cost-effective control options during the design and construction phase than the very limited, and climate impacting, options available to retrofit existing sources. The commenter added that additional controls would have virtually no effect on improving ample margin of safety or additional protection of public health.

*Response:* Commenters did not provide sufficient information detailing why requiring the control of process vents that emit greater than 1.0 lb/hr of total organic HAP would be infeasible beyond the arguments related to the removal of the TRE concept which are addressed in response to another comment in this section of this preamble. Consequently, we are finalizing rule text, as proposed at 40 CFR 63.101 and 40 CFR 63.113(a)(1) and (2), that removes the 50 ppmv and 0.005 scmm Group 1 process vent thresholds from the Group 1 process vent definition and instead requires owners and operators to control process vents

that emit greater than or equal to 1.0 lb/hr of total organic HAP.

We disagree with the commenters' contention that the 1.0 lb/hr of total organic HAP threshold is arbitrary and capricious. As stated in the preamble to the proposed rule (88 FR 25080, April 25, 2023), we arrived at the 1.0 lb/hr of total organic HAP threshold using detailed information for 50 Group 2 continuous process vents that was provided by 9 of the 13 HON facilities (including 1 P&R I facility collocated with a HON facility) that received the CAA section 114 request.

We started by performing an analysis of the 50 Group 2 continuous process vents for a simple control scenario. Using vent stream flowrates, vent stream net heating values, VOC and HAP emission rates (which we obtained from TRE index value calculations that facilities provided in their response to the CAA section 114 request), and the methodology from the sixth edition of the EPA Air Pollution Control Cost Manual; we calculated a cost for installing ductwork and a blower on each vent, assuming each of these vents could be routed to an existing control device achieving 98 percent by weight emission reduction. Given that many of the Group 2 continuous process vents have a very low flow rate and/or emission rate, we found that even installing simple ductwork and a blower would not be cost-effective for the majority of these vents. However, we did identify 23 of these Group 2 continuous process vents (a subset of the 50 Group 2 process vents from responses to our CAA section 114 request) for which we found this scenario to be cost-effective (*i.e.*, \$1,100 per ton of VOC/HAP or less).

We then reviewed mass flow rates of total organic HAP within this subset of Group 2 continuous process vents to develop two different thresholds (*i.e.*, 0.10 lb/hr and 1.0 lb/hr) for consideration. We estimated that 48 HON facilities operating 287 HON Group 2 process vents (96 of which are already voluntarily controlled and 191 that are not currently controlled) and 3 P&R I facilities operating 30 P&R II Group 2 continuous front-end process vents (in which all 30 are not currently controlled) would be impacted if we implemented a 0.10 lb/hr total organic HAP mass flow rate threshold. Conversely, only 16 HON facilities operating 48 HON Group 2 process vents (32 of which are already voluntarily controlled and 16 that are not currently controlled) and 3 P&R I facilities operating 9 P&R I Group 2 continuous front-end process vents (in which all 9 are not currently controlled)

would be impacted if we implemented a 1.0 lb/hr total organic HAP mass flow rate threshold. We then estimated costs to control each Group 2 continuous process vent scenario and ultimately concluded that only those streams with greater than or equal to 1.0 lb/hr of total organic HAP would be cost-effective to control. The details of this analysis are discussed in the document titled *Clean Air Act Section 112(d)(6) Technology Review for Continuous Process Vents Located in the SOCM Source Category that are Associated with Processes Subject to HON, Continuous Front-end and Batch Front-end Process Vents Associated with Processes Subject to Group I Polymers and Resins NESHAP, and Process Vents Associated with Processes Subject to Group II Polymers and Resins NESHAP* (Docket Item ID No. EPA-HQ-OAR-2022-0730-0094).

We also disagree with the commenter that the 1.0 lb/hr of total organic HAP threshold should apply only to new sources in the HON. In response to another comment reflected elsewhere in this section of this preamble, we have determined that the threshold is cost-effective for existing sources.

Finally, with regard to comments suggesting that additional controls would have virtually no effect on improving ample margin of safety or additional protection of public health, we note that these provisions are finalized under the authority of the technology review pursuant to CAA section 112(d)(6), which requires us to revise standards as necessary and does not obligate us to consider health impacts or generate an ample margin of safety.

*Comment:* Commenters suggested that the EPA significantly underestimated the cost of installing an additional thermal oxidizer and that therefore the cost effectiveness evaluation for removing the TRE concept is not correct. Many of these commenters contended that the fact that a control device has the capability to control multiple process vents does not automatically imply that controlling all vents together is cost-effective in every scenario; if the cumulative emissions from the Group 2 process vents are relatively low, it would not be economically viable to control all of them using a single control device. A commenter said that although it is reasonable to assume that a single new control device will be installed for facilities that will be controlling existing Group 2 process vents with emissions greater than 1.0 lb/hr, the use of 10 scfm for determining a total capital investment (TCI) for the new control device is not representative. The



commenter contended that although these vents are expected to have lower volumetric flow rates than many existing Group 1 vents, there are logistical and safety concerns that must be considered when designing a closed vent system and thermal oxidizer that necessitate higher flow rates. The commenter added that there are multiple facilities with more than one of these types of vents per facility; thus, multiple vents will need to be collected into a common system which will correspond to a higher flow rate. The commenter said that a reasonable low-end estimate for a new single thermal oxidizer for controlling these process vents is closer to a \$1,000,000 TCI. The commenter also noted that capital costs could range from \$5,000,000 to \$15,000,000. The commenter added that for facilities that produce chlorinated compounds, this cost would be higher because any new thermal oxidizer will need to be equipped with acid gas and dioxin/furan controls. Another commenter agreed that facilities that produce chlorinated compounds would incur higher costs but contended that additional controls for a facility's Group 2 process vents would cost at least \$50,000,000 in engineering and design, equipment, and installation costs.

Another commenter said that for their facility, the addition of a single control device, associated piping, instrumentation, engineering, and installation to control 11 process vents (that are currently considered Group 2 under the HON) will cost \$55,000,000, or approximately \$925,000/ton of HAPs. Another commenter argued that emission sources that are long distances away from existing control devices (e.g., a tank in a remote tank farm) and streams not compatible with a facility's existing control equipment are no more economically feasible for additional controls now than when the HON was originally promulgated.

*Response:* Several commenters provided us with their own capital cost estimates for controlling Group 2 continuous process vents with greater than or equal to 1.0 lb/hr of total organic HAP, resulting in a very wide range of capital costs (i.e., \$1,000,000 to \$55,000,000). However, the commenters did not provide information to fully support these capital costs. For example, commenters did not provide the number of streams nor the flow rate for the new streams needing control, did not provide any related emissions reductions from controlling these streams, and did not provide the annual cost for their scenario. As such, it was not possible to fully evaluate the commenters' provided capital cost data.

However, we do agree with commenters that our proposed cost estimate underestimated flow rates needed to route Group 2 continuous process vents with greater than or equal to 1.0 lb/hr of total organic HAP to APCDs. Although we still believe the use of the EPA's control cost template to estimate the cost of installing a new recuperative thermal oxidizer is appropriate (to control a Group 2 continuous process vent with greater than or equal to 1.0 lb/hr of total organic HAP), we revised our estimates to reflect the limitations of the correlations associated with the EPA's control cost template which starts with a flow rate of 500 scfm. With these corrections, we estimate the average TCI to install a new recuperative thermal oxidizer (for both the HON and the P&R I NESHAP) is about \$167,000 (as opposed to the \$66,000 that we proposed); however, our estimate is still much lower than the wide range of cost estimates provided by commenters. One possible explanation for this difference in cost estimates is that commenters may have used a much higher flow rate (e.g., 5,000 scfm as opposed to 500 scfm) and a "Regenerative Thermal Oxidizer" in their cost analysis instead of a "Recuperative Thermal Oxidizer." Moreover, commenters did not provide supporting information for their estimated capital costs, so we do not have a way to corroborate this possible explanation.

In light of the fact that commenters were generally concerned about the cost estimate, we performed additional analyses to evaluate the cost effectiveness of removing the TRE concept from the HON and the P&R I NESHAP. Using a TCI of \$1,000,000 as provided by the commenter, and the EPA's control cost template (for installing a new recuperative thermal oxidizer with 70 percent energy recovery), we estimated an annual cost of approximately \$330,000 (for the HON) and \$318,000 (for the P&R I NESHAP). Applying this annual cost to our estimated number of HON facilities that would need to install a thermal oxidizer and to our estimated HAP emissions reductions for the HON of 538 tpy, we calculated a cost effectiveness of about \$9,830 per ton, which we consider to be cost-effective. Applying this annual cost to our estimated number of P&R I facilities that would need to install a thermal oxidizer and to our estimated HAP emissions reductions for the P&R I NESHAP of 130 tpy, we calculated a cost effectiveness of about \$7,440 per ton. It is important to note that our analysis considers that 16

HON facilities operating 48 HON Group 2 process vents (32 of which are already controlled by an existing APCD and 16 that are not currently controlled) and 3 P&R I facilities operating 9 P&R I Group 2 continuous front-end process vents (in which all 9 are not currently controlled) would be impacted by the 1.0 lb/hr total organic HAP mass flow rate threshold. We estimated these impacts using the Group 2 process vent data from responses to our CAA section 114 request. As part of our reevaluation, we also revised our HAP emissions reduction estimate for the HON and P&R I process vents that are not currently controlled to reflect the average HAP emissions reductions from the three HON Group 2 process vents and five P&R I Group 2 process vents that would be impacted by the 1.0 lb/hr total organic HAP mass flow rate threshold (based on data from responses to our CAA section 114 request). In our proposal, we took the lowest HAP emission reduction based on a single HON process vent and did not appropriately account for the other HON process vents for which we had data. We corrected a similar issue for the P&R I NESHAP. Therefore, our final calculation for estimating the cost effectiveness for removing the TRE concept in its entirety from the HON includes a total HAP and VOC reduction of 538 tpy (and not 436 tpy as proposed) and for the P&R I NESHAP, a total HAP and VOC reduction of 130 tpy (and not 51 tpy as proposed). It is also possible that the actual emissions reductions may be higher than our estimate because the higher capital costs provided by industry are likely to be for thermal oxidizers that are sized to control higher flow streams with more HAP emissions. For further details on how we revised our estimates of cost and HAP emissions reductions, see the document titled *Clean Air Act Section 112(d)(6) Technology Review for Continuous Process Vents Located in the SOCM I Source Category that are Associated with Processes Subject to HON, Continuous Front-end and Batch Front-end Process Vents Associated with Processes Subject to Group I Polymers and Resins NESHAP, and Process Vents Associated with Processes Subject to Group II Polymers and Resins NESHAP—FINAL*, which is available in the docket for this rulemaking.

Absent additional detailed information from commenters, we are finalizing the removal of the TRE concept as proposed and are requiring control for process vents that emit greater than or equal to 1.0 lb/hr of total organic HAP. We also believe this is

reasonable given that a 1.0 lb/hr total organic HAP mass flow rate threshold for continuous HON and P&R I process vents aligns more closely with the batch process vent control threshold in the MON and the NESHAP for Chemical Manufacturing Area Sources. In each of these NESHAP, the applicability threshold of 10,000 lb/yr per process is used for batch process vents.

*Comment:* Commenters observed that the EPA's favorable cost-effectiveness outcome is based on emissions reductions that have already occurred and that will not occur as a result of the proposed standards (and thus should not be used in the calculus). The commenters remarked that the EPA's final calculation for estimating the cost effectiveness for removing the TRE concept in its entirety included a total annual cost of \$3,150,000 and a HAP and VOC reduction of 436 tpy. The commenters pointed out that process vents that are already voluntarily controlled account for 366 tpy of the total reduction even though they will not have emissions reductions as a result of implementing the new proposed definition of a Group 1 process vent. The commenters argued that if the EPA determines that the emissions reductions from these vents should be included in the analysis, the Agency must account for the entire cost associated with controlling these emissions (*i.e.*, annual costs associated with operating a thermal oxidizer) rather than only the costs associated with the installation and operation of ductwork and blowers. The commenters added that if there are no emissions reductions expected from process vents that are already voluntarily controlled, then the cost effectiveness analysis should be revised such that it does not include reductions from these vents.

*Response:* The EPA maintains that the emission reductions associated with removing the TRE concept and redefining Group 1 process vents to include process vents emitting greater than 1.0 lb/hr of HAP are reasonable, and the EPA is not making any revisions as a result of this comment. Commenters are correct in stating that 366 tpy of HAP emitted by HON process vents exceeding 1.0 lb/hr of HAP are already voluntarily controlled. However, the emission reductions are presented on a basis of allowable emissions. Previously, there were no requirements for process vents exceeding 1.0 lb/hr of HAP. Therefore, under the previous rulemaking, all emissions from these vents were allowable, regardless of whether some facilities were voluntarily controlling these emissions or not. By setting the emission threshold of 1.0 lb/

hr of HAP, the allowable emissions are restricted, resulting in the 366 tpy of emission reductions that the EPA utilized to determine the cost effectiveness of removing the TRE concept and redefining Group 1 process vents. We note that we updated our total HAP reductions and annual cost estimates in response to a comment reflected elsewhere in this section of this preamble. For details on how we revised our estimate of cost and HAP emissions reductions, see the document titled *Clean Air Act Section 112(d)(6) Technology Review for Continuous Process Vents Located in the SOCM I Source Category that are Associated with Processes Subject to HON, Continuous Front-end and Batch Front-end Process Vents Associated with Processes Subject to Group I Polymers and Resins NESHAP, and Process Vents Associated with Processes Subject to Group II Polymers and Resins NESHAP—FINAL*, which is available in the docket for this rulemaking.

We also disagree with commenters that annual operating costs should be considered for the control devices that are controlling the voluntarily controlled streams. These existing control devices are controlling other streams that are regulated (*e.g.*, controlling HON Group 1 process vents), thus the control devices would continue operating regardless of whether the Group 2 streams are sent to them or not.

*Comment:* Commenters requested that the EPA add EPA Method 320 to 40 CFR 63.115(g)(2) and (3) and allow companies to use measurements or testing conducted within the last 5 years to initially demonstrate that a process vent is a Group 2 process vent under 40 CFR 63.115(g) provided that: (1) The prior measurement or test was conducted using the same methods specified in 40 CFR 63.115(g), and (2) either no process changes have been made since the test, or the owner or operator can demonstrate that the results of the measurement or test, with or without adjustments, reliably demonstrate compliance with 40 CFR 63.115(a) despite process changes.

A commenter also requested that the EPA allow companies to use engineering calculations or process knowledge to initially demonstrate that a process vent is a Group 2 process vent under 40 CFR 63.115(g). The commenter pointed out that they already conducted testing and sampling procedures on their emission points corresponding to the EPA's CAA section 114 request which cost \$20,000 to \$30,000 for a single process vent. The commenter added that testing every vent stream is

not necessary where an owner or operator has engineering calculations or process knowledge to demonstrate that a vent stream is a Group 2 process vent; and historically, under the group determination procedures for process vents, the owner or operator of a Group 2 process vent with a TRE index value greater than 4.0 could use measurements, engineering assessments, and calculations to determine the TRE index value of the vent stream. The commenter also said that one of their facilities continuously monitors vent flow and HAP concentration from two HON process vents when they are routed to atmosphere and uses the calculated TRE index value to demonstrate that the vents remain Group 2 on an ongoing basis. The commenter said that this alternative monitoring approach was requested and approved due to the variability of HAP emissions from those vents; and generally, the calculated TRE index value remains well above 5.0. The commenter claimed that this alternative monitoring is used when the site thermal oxidizer is down for preventive maintenance; and meeting the proposed new process vent requirements would require either a significant investment in new control equipment or shutdown of the process during thermal oxidizer maintenance.

*Response:* We are revising the final rule based on the commenter's request to add EPA Method 320 to 40 CFR 63.115(g)(2) and (3) and allow for certain previously conducted performance tests to be exempt from the Group 2 demonstration requirements at 40 CFR 63.115(g) provided the owner or operator can demonstrate: (1) No changes have been made to the process since the time of the previously conducted measurement or emission test; (2) the previously conducted measurement or emission test was conducted using the same methods specified in 40 CFR 63.115(g); and (3) the previously conducted measurement or emission test was completed within the last 60 months. However, we disagree with the commenters' request to allow companies to use engineering calculations or process knowledge to initially demonstrate that a process vent is a Group 2 process vent under 40 CFR 63.115(g). As with our concerns relative to the TRE index value, the ability to use assessments leads to greater uncertainty with regard to characterization of vent streams and their emission potential. We note that as explained in section IV.C.3.e of this preamble, we are finalizing language in the "C" and "Q" terms of the equations

at 40 CFR 63.115(g)(3)(ii) and (g)(4)(iv) allowing the use of engineering calculations to determine concentration or flow rate only in situations where measurements cannot be taken with EPA reference methods.

#### ii. Fenceline Monitoring

*Comment:* Numerous commenters supported the EPA's proposal to require fenceline monitoring at facilities in the SOCFI and P&R I source categories that use, produce, store, or emit benzene, 1,3-butadiene, chloroprene, EtO, ethylene dichloride, or vinyl chloride. These commenters also said they support the requirement to conduct root cause analysis and corrective action. In addition, some commenters voiced their support for requiring monitoring data to be made available to the public in the WebFIRE database, allowing communities to have access to information that impacts them. Some commenters said the fenceline monitoring technology has proven to be a valuable tool for petroleum refineries to timely detect problems and to address them more quickly, substantially reducing emissions from leaks and other fugitives. At least one commenter said fenceline monitoring can provide numerous benefits, including assisting in identifying an accidental release, and in the event of an accidental release, give the community immediate notice of the emergency and any necessary mitigation responses they should employ (shelter in place, close windows, evacuate, *etc.*). This commenter added that fenceline monitoring can also: help communities advocate for vigorous enforcement of regulatory requirements; push companies to use safer chemicals; alert and educate friends, family members, and community members; and encourage the media to report on polluting facilities in their areas. The commenter also suggested that facilities can use fenceline monitoring data to take the initiative to improve safety at their operations. Other commenters requested that EtO emissions be required to be monitored by third-party companies. The commenters explained that current laws in some states allow facilities to monitor their own emissions, which could cause underreported emissions.

A commenter argued that fenceline monitoring requirements are crucial in protecting the communities referred to by the commenter as Cancer Alley, especially in St. John the Baptist Parish, which the commenter claimed has the highest cancer rates in the country. The commenter stated that more and more residents are either facing a cancer

diagnosis or know someone, such as an immediate family, diagnosed with cancer; and asthma rates and hospitalizations from asthma are ever-increasing, especially amongst children. The commenter also said the area is facing increased weather events brought about by climate change. Citing an analysis by the *Times Picayune* and *Advocate* newspapers, the commenter said that 740 toxic sites are at risk from storms, with most of those plants concentrated in the area the commenters refer to as Cancer Alley. The commenter said that after experiencing numerous storms, they personally witnessed the flaring of surrounding plants, including the plants that produce EtO, and are concerned about the increase of pollution before, during, and after weather events.

On the contrary, other commenters opposed the EPA's proposal to require fenceline monitoring at facilities in the SOCFI and P&R I source categories that use, produce, store, or emit benzene, 1,3-butadiene, chloroprene, EtO, ethylene dichloride, or vinyl chloride. These commenters primarily argued that the EPA exceeded its authority under CAA section 112(d)(6) because fenceline monitoring is not a "development[]" in practices, processes, and control technologies" for fugitive EtO emissions. Commenters in opposition of fenceline monitoring made the following points about the EPA's assertion of authority to require fenceline monitoring:

- Fenceline monitoring has been in existence for years, but as recently as 2020 the EPA concluded (in the MON in response to Comment 40 in the document titled *Summary of Public Comments and Responses for the Risk and Technology Review for Miscellaneous Organic Chemical Manufacturing*, see Docket Item No. EPA-HQ-OAR-2018-0746-0200) that they were "not aware of any methodology or technology with the necessary accuracy, precision, and detection sensitivity to require fenceline monitoring for EtO."

- It is unclear what standard the EPA is reviewing or how fenceline monitoring constitutes a review of the existing standards with respect to "developments in practices, processes, and control technologies."

- The EPA does not explain how fenceline monitoring, which by itself does not reduce emissions, is a development.

- The EPA does not provide any analysis as to how "root cause analysis and corrective action" are developments with respect to any particular unit/unit type.

- The EPA does not adequately explain how monitoring methods are a development nor does the EPA explain what development category fenceline monitoring allegedly falls into (*i.e.*, a work practice standard that was not considered previously).

- According to the proposed rule, at least in places, fenceline monitoring (coupled with root cause analysis and corrective action) is a work practice standard "that is a development in practices considered under CAA section 112(d)(6) for the purposes of managing fugitive emissions"; however, the EPA considered two monitoring methods—not action levels, root cause analysis, or corrective action—as developments in practices, and it is unclear how monitoring methods fall under any other of the broad categories of developments previously defined by the EPA.

- If the root cause analysis and the corrective action requirements are the work practice standards—as the EPA stated in the proposed NESHAP for EtO commercial sterilization and fumigation operations—then how are monitoring methods a work practice standard? (And if they are not, they are not a development that can be considered under CAA section 112(d)(6)?).

- Adding data quality requirements and existing best practices does not render EPA Method 327 a new development, nor does it remedy the concerns about facilities' ability to accurately measure fenceline EtO concentrations (*i.e.*, there are still no reliable methods that can measure to the level of precision required).

- Coupling fenceline monitoring with a canister monitoring network and a so-called "new" reference method does not transform the fenceline monitoring as proposed into a new technology that is within the CAA section 112(d)(6) authority.

Some of these commenters contended that even if the proposed fenceline monitoring requirements were within the scope of CAA section 112(d)(6) authority, the EPA failed to adequately consider/quantify a level of emission reduction from the proposed fenceline monitoring and did not account for any of the potential costs associated with achieving such emission reductions (*i.e.*, the EPA only considered the costs of the actual monitoring and not the root cause and corrective action requirements). A commenter asserted that had the EPA appropriately accounted for costs, it would have concluded that the proposed fenceline monitoring requirements are not cost-effective, consistent with the Agency's determination for the options

considered for equipment leaks, PRDs, and storage vessel breathing losses. The commenter argued that the EPA failed to quantify the additional HAP emissions reductions for EtO and chloroprene that the Agency indicates will be required for compliance or to consider the cost of these additional reductions (in addition to the cost of the required root cause and corrective action analyses) as is required to meet the Agency's obligation under CAA section 112(d)(2). The commenter stated that the EPA has not assigned emissions reductions of benzene, 1,3-butadiene, ethylene dichloride, or vinyl chloride as a result of implementing the proposed fenceline monitoring work practice requirements; and with the exception of EtO and chloroprene, the Agency implies that additional reductions beyond those the EPA proposed elsewhere in the rulemaking will be unnecessary to meet the fenceline action levels. The commenter attested that the EPA proposed additional requirements on top of those already required by the existing rules, or that will be required as part of the other proposed revisions (e.g., the proposed flare standards, the existing and proposed monitoring requirements for process vents, and equipment leaks and PRDs), without identifying deficiencies in the current and proposed requirements. Similarly, other commenters stated that the EPA has not demonstrated that fenceline monitoring is necessary to reduce HAP emissions or to provide an ample margin of safety; and the lack of emissions reductions associated with the proposed requirements shows that such requirements are unnecessary to the ultimate goals of CAA section 112.

*Response:* We disagree with the commenters' assertion that the proposed fenceline monitoring work practice standard is not authorized under CAA section 112(d)(6), but we are making certain changes to the fenceline monitoring program in the final rule in response to comments, including adopting a second action level for just chloroprene under CAA section 112(f)(2). Contrary to the commenter's claims, we specifically proposed the fenceline monitoring standard under CAA section 112(d)(6) to be a work practice standard that is applied broadly to target fugitive emissions sources located at HON and P&R I facilities. The proposed standard does more than impose monitoring as some commenters suggested; it also limits emissions from sources because it requires the owner or operator to identify and reduce HAP emissions through a monitoring and repair program, as do many work

practice standards authorized under CAA sections 112(h) and (d). We note that the sources addressed by the fenceline monitoring standard—fugitive emissions sources such as wastewater collection and treatment operations, equipment leaks, heat exchange systems and storage vessels—are already subject to work practice standards. Our review of these requirements indicates that this fenceline monitoring work practice standard would be a further improvement in the way fugitive emissions are managed and would, by providing such further assurance of compliance with emission standards and work practice standards, also provide an extra measure of protection for surrounding communities. Consistent with the criteria in CAA section 112(h)(2), we determined and established that work practice standards are appropriate for fugitive emissions at the time we established the initial MACT standards. Today, we reaffirm that it is impracticable to directly measure all fugitive emission sources at a given source but do not consider it necessary to reiterate these findings as part of this action to add the fenceline monitoring provisions for these sources under CAA sections 112(d)(6) and (f)(2). We note that the commenters do not provide any grounds to support a reevaluation as to whether these fugitive emission sources are appropriately regulated by a work practice standard.

The EPA, in establishing action levels for the fenceline monitoring work practice standard, relied on the authority provided in CAA section 112(d)(6) to set action levels at the highest concentration anticipated, considering the emission reductions anticipated under the additional standards we are adopting under CAA sections 112(d)(6) and 112(f)(2). Again, the section 112(d)(6)-based action levels function to verify the expected emissions reductions resulting from compliance with the final emission standards, and reflect concentration levels that are largely already resulting from sources subject to the rules and are therefore cost-effective. Further, in the proposal the EPA acknowledged that the proposed action levels for EtO and chloroprene of 0.2 ug/m<sup>3</sup> and 0.3 ug/m<sup>3</sup>, respectively, were lower than the fenceline modeled concentrations for EtO and chloroprene from facilities in the SOCOMI and Neoprene Production source categories after implementation of the proposed emission standards, and we took comment on whether we should require these lower action levels under CAA section 112(f)(2). In this final rule, we believe it is reasonable,

given the unique circumstances presented by these source categories, to require these lower action levels. First, for EtO, the lower action level reflects concentrations that all HON-subject facilities, except for one, are currently meeting and are therefore cost-effective under CAA section 112(d)(6). Second, consistent with the second step of the risk review under the Benzene NESHAP approach addressing whole-facility risks, for chloroprene the lower action level reflects concentrations that will result in whole facility risks from this HAP dropping to 100-in-1 million. Further whole-facility reductions in EtO and chloroprene emissions from other sources located at major source facilities subject to these standards, including sources outside the source category, will help reduce risks from the whole-facility emissions of EtO and chloroprene from facilities with sources in the SOCOMI and Neoprene Production source categories.

To reduce risk in the final rule we are making an adjustment from what was proposed. First, we are establishing under CAA section 112(d)(6), for all six of the monitored pollutants, action levels that correspond to the fenceline concentrations expected to result from compliance with the final rule's standards and work practices applicable to HON and P&R I processes and which reflect concentrations that HON and P&R I sources are largely already achieving, such that these action levels function to provide further assurance of such compliance of the emission standards and provide for corrective action when action levels are exceeded. For benzene, 1,3-butadiene, ethylene dichloride, EtO and vinyl chloride, these are the same action levels as proposed. For chloroprene, instead, the action level has been adjusted upward to 0.8 ug/m<sup>3</sup> (see Docket Item No. EPA-HQ-OAR-2022-0730-0091, page 24) to reflect the modeled expected fenceline concentration resulting from the other final standards and work practices chloroprene. This first action level is, therefore, consistent with how we established fenceline monitoring requirements under CAA section 112(d)(6) in the petroleum refineries NESHAP and how we represent the primary CAA section 112(d)(6)-based fenceline monitoring program under the final rule.

Although the EtO action level of 0.2 ug/m<sup>3</sup> is lower than what the EPA's modeling shows will result from compliance with the final CAA section 112(d) and 112(f) SOCOMI source category emission standards in the final HON, as we discussed in the proposed rule, we expect that major sources with

HON processes will be able to employ additional facility-wide measures, including those at other EtO-emitting processes outside of the SOCOMI source category, to obtain additional cost-effective EtO reductions via improvements in maintenance and operations and enable compliance with the CAA section 112(d)(6) EtO action level. This is already being demonstrated by the fact that all HON-subject facilities, except for one, are already showing concentrations at or below the final action level. Moreover, this is reasonable due to the integrated nature of chemical plant operations, where multiple process units may be subject to NESHAP for more than one source category and products of units in some categories may also be feedstocks for units in other source categories. Accordingly, the source category designations, while part of the NESHAP program, are somewhat of an artificial distinction in these highly integrated chemical manufacturing facilities. For example, there are emission sources that often serve the entire facility, such as wastewater treatment systems and heat exchange systems, but they are typically assigned to a single source category or subcategory. Because of the propensity for large integrated chemical plants to contain numerous source categories, and also to contain units that span multiple source categories, we are finalizing fenceline work practice standards with an EtO action level that relies on achieving reductions across the whole HON facility, even if that includes non-HON EtO-emitting processes.

Second, in light of the very high risk presented by chloroprene emissions, we have concluded it is appropriate, in addition to adopting the primary CAA section 112(d)(6)-based action levels and monitoring program for all six subject HAP, to supplement the program with a secondary action level for this pollutant. This secondary action level, equivalent to that proposed, reflects fenceline concentrations for this pollutant that increase the margin of safety and advances the objectives of CAA section 112(f)(2). Although our modeling indicates that compliance with the other emission standards and work practices promulgated for Neoprene Production sources may not produce this secondary level, we anticipate—as explained in the proposal—that major sources will be able to employ additional facility-wide measures, such as maintenance measures, to achieve further chloroprene reductions to reach this

secondary, CAA section 112(f)-based action level.

In the case of chloroprene emitted by the Denka Performance Elastomer, LLC facility (subject to both the P&R I NESHAP and the HON), we do not anticipate taking further source-category-wide rulemaking action that could re-set CAA section 112(d)(6)-based lower action levels to reflect future additional chloroprene reductions from additional source category processes. Consequently, for Denka Performance Elastomer, LLC's chloroprene emissions, this rulemaking is the final opportunity for us to establish an action level with the goal of assuring that whole-facility chloroprene emissions are reduced to a level that provides an ample margin of safety to protect public health.<sup>50</sup> This is consistent with the statute because under the CAA section 112(f)(2) ample margin of safety second step, the Benzene NESHAP approach that is incorporated into the CAA allows the EPA to consider quantified or unquantified health effects, effects due to co-location of facilities, and co-emission of pollutants.

We disagree that the fenceline monitoring standards we are finalizing in this rule are redundant with MACT emissions standards for fugitive HAP emissions sources. The MACT standards impose requirements on fugitive HAP emissions sources consistent with the requirements in CAA section 112(d)(2) and (3), and the fenceline monitoring requirement is not a replacement for those requirements. Rather, based on our review of these standards, we concluded that the primary CAA section 112(d)(6)-based fenceline monitoring program is a development in practices, processes or control technologies that is a necessary revision to the previous standard, as it would improve management of fugitive emissions in a cost-effective manner and help assure compliance with applicable process emission standards under the HON and the P&R I NESHAP. Requiring sources to establish a fenceline monitoring program that identifies HAP emission sources that cause elevated pollutant concentrations at the fenceline, and correcting high emissions through a more focused effort, augments but does not replace the existing requirements. We found that, through early identification of significant fugitive HAP releases through fenceline monitoring, compliance with the Refinery MACT fenceline work practice standard for these similar emissions sources in these source categories has

resulted in a significant reduction in benzene emissions. The action levels for the primary fenceline work practice standard, by contrast, are not based on the best performers but rather on the highest value expected on the fenceline from any source, based largely on the modeling of emission inventories expected to result from compliance with the final emission standards and work practices under the rules.

Lastly, we acknowledge commenters' support for fenceline monitoring. However, with respect to the commenter requesting that a third party be required to monitor the fenceline concentrations, the EPA disagrees. Fenceline monitoring requires a level of access to the facility and measurement devices that would be burdensome to accommodate for facilities. Fenceline monitoring is intended to address concerns with underreported emission inventories and works based on timely root cause analysis. Adding a third-party requirement would slow a facility's ability to respond to fugitive emissions in a timely manner.

*Comment:* A commenter argued that fenceline monitoring is not an emissions standard or work practice within the meaning of CAA section 112. Citing CAA section 302(k), the commenter said that, by itself, fenceline monitoring does not reduce emissions, rather all that fenceline monitoring does is identify ambient concentrations of a specific chemical; it does not even identify whether the chemical is from a regulated source, let alone identify a specific regulated unit at such source. The commenter said that fenceline monitoring can only potentially reduce emissions when coupled with additional requirements, but, at least in this instance, the EPA does not appear to claim associated reductions from the source category. The commenter added that while the EPA is proposing "action levels," again, these levels alone do not "limit the quantity, rate, or concentration of emissions." The commenter said that according to the preamble, if the emissions inventories are accurate, "all facilities should be able to meet the fenceline concentration action levels considering the controls [EPA is] proposing"; therefore, even when coupled with action levels, the EPA's proposal does not claim that fenceline monitoring will result in any meaningful emissions reductions from the source category. The commenter also stated that while exceedance of an action level may trigger further requirements, the action level does not, by itself or combined with fenceline monitoring, limit emissions—additional actions are required; and, because the

<sup>50</sup> See footnote 47.

EPA's proposal measures ambient concentrations, an exceedance of a proposed action level is not necessarily the result of emissions from the facility in question or from an exceedance of a standard.

The commenter noted that while the EPA states that it is proposing fenceline monitoring as a work practice standard, which could fall within the meaning of "any design, equipment, work practice or operational standard promulgated under [the CAA]," the EPA does not explain how fenceline monitoring meets the requirements for a work practice standard. The commenter added that work practice standards are authorized only in limited circumstances under CAA section 112(h)(1) when it is not feasible to prescribe or enforce an emission standard for control of HAPs, and the EPA has not adequately explained what elements of the proposal are work practice standards.

*Response:* Section 112(d)(6) of the CAA requires the EPA to review and revise the MACT standards, as necessary, taking into account developments in "practices, processes and control technologies." Consistent with our long standing practice for the technology review of MACT standards, in section II.G.1 of the proposal preamble, we list five types of "developments" we consider.

Fenceline monitoring fits squarely within two of those five types of developments (emphasis added):

- Any add-on control technology or other equipment that was not identified and considered during development of the original MACT standards.
- Any work practice or operational procedure that was not identified or considered during development of the original MACT standards.

As used here, "other equipment" is clearly separate from and in addition to "add-on control" technology and is broad enough to include monitoring equipment. In this case, fenceline monitoring includes equipment that we did not identify and consider during development of the original MACT standards. Additionally, the primary fenceline standard is a work practice standard, involving monitoring, root cause analysis, and corrective action not identified at the time of the original MACT standards. Therefore, the primary fenceline requirements are a development in practices that will improve how facilities manage fugitive emissions, and the EPA appropriately relied on CAA section 112(d)(6) in requiring this standard. (Note: The EPA is not relying on CAA section 112(f)(2) as the basis for the primary fenceline monitoring work practice standard

established under section 112(d)(6) for benzene, butadiene, vinyl chloride, ethylene dichloride, chloroprene, and EtO, and has set action levels according to the annual average concentrations modeled at the facility fenceline for any facility after compliance with process unit emission standards applicable to HON and P&R I sources and that reflect levels sources are largely already achieving. However, as discussed elsewhere in this section of the preamble, we are also setting a secondary action level of 0.3 ug/m<sup>3</sup> for chloroprene under CAA section 112(f)(2), because this standard will further reduce risks from the whole-facilities consistent with the goal to provide an ample margin of safety to protect public health).

*Comment:* A commenter argued that the EPA's explanation for the basis of selecting the six compounds for fenceline monitoring is inadequate when compared against the rulemaking record. The commenter said that the EPA appears to base its selection of compounds on previous and current risk drivers because the EPA indicates that "[s]everal of these compounds were identified as cancer risk drivers in the prior risk and technology reviews for the HON and P&R I NESHAP conducted in 2006 (HON) and 2008 and 2011 (P&R I). . . ." The commenter contended that, with the exception of EtO, the maximum risk previously found by the EPA in its reviews for the HON and P&R I NESHAP were well below 100-in-1 million (or not identified as a risk driver at all); the commenter provided a table showing the EPA's determinations of 2006 HON, 2008 P&R I and 2011 P&R I MIR for benzene, 1,3-butadiene, chloroprene, EtO, ethylene dichloride, and vinyl chloride. The commenter pointed out that in each of these previous assessments, the EPA found risks acceptable and did not adopt additional standards to address residual risk or to ensure an ample margin of safety. The commenter said the EPA also did not identify benzene, 1,3-butadiene, ethylene dichloride, or vinyl chloride as driving unacceptable risk under the current assessment; thus, while the EPA's selection of benzene, 1,3-butadiene, ethylene dichloride, and vinyl chloride based on risk is questionable under the EPA's framing of the option as part of its CAA section 112(d)(6) technology review, a closer inspection of the EPA's previous risk assessments indicates that in fact, these compounds did not drive any unacceptable risk. The commenter stated that the EPA's proposal to require millions of dollars of monitoring for no

emissions reductions is unjustified under CAA section 112(d)(6) and unnecessary under CAA section 112(f). The commenter added that they acknowledge that the EPA found EtO and chloroprene to be risk drivers as part of their voluntary assessment supporting this proposed rulemaking and are claiming unquantified emissions reductions as a result of implementing fenceline monitoring; however, according to the commenter, the Agency determined that these additional reductions are unnecessary under CAA section 112(f) when it proposed to find acceptable risk and an ample margin of safety after implementation of the controls detailed in section III.B.2.a of the proposal preamble (88 FR 25080, April 25, 2023).

The commenter argued that it would be inappropriate to consider fenceline monitoring in context of the CAA section 112(f) review. The commenter stated that the EPA has already concluded that the controls that it has proposed to impose protect human health and the environment with an ample margin of safety. The commenter added that the EPA has not identified any additional emission reductions from the source category that would be necessary to reduce risk from the source category and that the EPA has failed to demonstrate that any such controls are cost-effective, which would be included as any ample of safety analysis. The commenter also said that the action level is not tied in a meaningful way to reducing risk to an acceptable level.

*Response:* The EPA implemented a fenceline monitoring standard to address emissions of pollutants that it determined could cause unacceptable risk, based on risk modeling of emission inventories and accounting for the range of uncertainty associated with these estimates. When the EPA promulgated the Refinery MACT fenceline work practice standard, the EPA acknowledged that emissions of benzene and indeed, of all other HAP in the source category, did not pose unacceptable risk when emissions from refineries were modeled, but that the work practice standard was put in place to address the uncertainty associated with emission estimates from fugitive sources and to preserve the decisions regarding the findings of acceptable risk and ample margin of safety (79 FR 36290, June 30, 2014). The same uncertainty exists here for the SO<sub>x</sub> and P&R I source categories. As explained in the April 25, 2023 proposal, we collected fenceline measurements in addition to modeling inventories, and our fenceline measurements indicate that

concentrations at the fenceline almost always exceed modeled concentrations, indicating the potential for significant uncertainty with regard to our risk analysis and findings of acceptable risk. As discussed earlier in this document, the EPA is not relying on CAA section 112(f)(2) as the basis for the primary fenceline monitoring work practice standard established under CAA section 112(d)(6) for benzene, butadiene, vinyl chloride, ethylene dichloride, chloroprene, and EtO and has set action levels according to the annual average concentrations modeled at the facility fenceline for any facility after compliance with process unit emission standards applicable to HON and P&R I sources and that are reflective of concentrations subject sources are already achieving. Further, we disagree with the commenters who suggest that the EPA may not require fenceline monitoring pursuant to CAA section 112(d)(6) because the EPA has not determined that fenceline monitoring is necessary to ensure an acceptable level of risk or to provide an ample margin of safety. CAA section 112(d)(6) does not require the EPA to factor in the health considerations provided in CAA section 112(f)(2) when making a determination whether it is “necessary” to revise the previous emission standard.

For chloroprene, we are finalizing in the primary CAA section 112(d)(6)-based program the action level of 0.8 ug/m<sup>3</sup> that reflects compliance with the source category-specific emissions limits for the Neoprene Production source category in the P&R I NESHAP. Separately, we are also setting a secondary action level of 0.3 ug/m<sup>3</sup> for chloroprene under CAA section 112(f)(2), because this standard further reduces from the whole-facility risk from sources emitting chloroprene to levels that are consistent with the goals of CAA section 112(f)(2). As discussed earlier, in the proposal, we acknowledged that the proposed action level of 0.3 ug/m<sup>3</sup> for chloroprene is lower than the fenceline modeled concentrations from facilities in the Neoprene Production source category after implementation of our proposed standards under CAA section 112(f)(2); however, considering whole-facility risks, and in light of the configuration of the emission sources subject to these rules that contribute to whole-facility risk that remain for the impacted communities after the imposition of controls, we are setting the additional second action level for chloroprene at facility boundaries as low as possible (considering method detection limitations) to ensure that the emission

reductions anticipated from implementation of controls used to meet the proposed standards and to achieve additional chloroprene emission reductions are achievable. Reductions to achieve this action level will likely come from controlling additional emission sources at the one Neoprene Production facility that might not be considered part of the source category. Controlling these sources reduces emissions from the entire facility, not just the source category, and makes it possible for operators to achieve the lower action level. Thus, in this final rule, and based on the unique circumstances presented here, we consider facility-wide risk as an additional factor we may consider under CAA section 112(f)(2) and, in addition to the primary CAA section 112(d)(6)-based fenceline monitoring program addressing all six subject HAP, we are promulgating a separate and secondary lower action levels for just chloroprene under CAA section 112(f)(2).

*Comment:* Many commenters requested that the EPA expand the fenceline monitoring requirements to every facility in the SOCOMI, P&R I, and P&R II source categories so owners and operators of these facilities can demonstrate, by representative monitoring data, that pollution from these facilities poses minimal levels of harm to fenceline communities. Some of these commenters pointed out that, as proposed, only about 60 percent of the facilities in these source categories would have to conduct fenceline monitoring. Other commenters contended that, as proposed, 90 facilities would have no fenceline monitoring requirements. A commenter contended that there is no reason or need for the EPA to have selected just six toxic pollutants and used them as basis to omit facilities from fenceline monitoring, given that CAA section 112(d)(6) requires making any changes that are “necessary” to bring standards into full compliance with the CAA, such as setting limits on uncontrolled and inadequately controlled emissions. The commenter pointed out that the EPA set fenceline monitoring requirements that applied to all refineries subject to NESHAP subpart CC and did not omit sources based on the selected constituents to be monitored.

Some commenters suggested that the EPA could add more toxic pollutants to its current list of six fenceline monitoring constituents, in order to ensure that each facility has at least one or more sentinel chemicals that can be monitored. A commenter recommended that the EPA include benzene, toluene, ethylbenzene, and xylenes (BTEX),

methanol, and formaldehyde constituents to the list of pollutants requiring fenceline monitoring. The commenter pointed out that based on TRI data, the inclusion of formaldehyde to the list of pollutants requiring fenceline monitoring would add another 28 facilities, the inclusion of methanol would add another 13 facilities, and the inclusion of BTEX/n-hexane would add another 3 facilities. The commenter also pointed out that it is no surprise that information gathered from only HON and P&R I sources resulted in constituents most representative of those sources and not representative of P&R II sources; and had the EPA included P&R II data in the information it gathered for the purpose of fenceline monitoring constituents, the EPA would have found that all five P&R II sources emit epichlorohydrin and that several of them emit the non-benzene BTEX constituents. Commenters requested that the EPA add formaldehyde to the list of pollutants requiring fenceline monitoring because the IRIS data indicates that as a carcinogen, formaldehyde is even more potent than benzene. A commenter said evidence from emission reports suggests that some facilities may be underreporting or only sporadically reporting formaldehyde emissions (e.g., the Conoco-Phillips/Shell Wood River manufacturing site in Illinois reported very large formaldehyde emissions to the NEI in 2017 and even larger amounts to the 2020 NEI but has not disclosed formaldehyde emissions in any of the TRI reports for the facility for the 5 years between 2017 and 2020). A commenter recommended that the EPA require each facility to select the constituents to be monitored via tailored fenceline monitoring plans that are specific to each facility’s emissions and risk drivers. Additionally, at least one commenter said they hope that EPA will replicate this multi-pollutant monitoring in other rules, including as a supplement to the ethylene production rules.

On the contrary, some commenters argued that the proposed fenceline monitoring requirements would impermissibly regulate emissions from non-HON sources. Citing the proposal at 88 FR 25145–46, some of these commenters pointed out that the EPA expressly notes that facilities are not permitted to exclude non-HON sources of the target pollutants that are within facility property boundaries when determining whether monitored concentrations exceed action levels. The commenters said that regulating emissions from sources outside of the

source category is incompatible with the EPA's statutory mandate to "review and revise" the "emissions standards promulgated under this section," which refers to the source-category MACT standards promulgated under CAA section 112(d). The commenters stated that the EPA may only regulate HON sources under its technology review authority in accordance with the statutory language and structure of the CAA. The commenters reiterated that when enacting CAA section 112, Congress instructed the EPA to promulgate a list of specific source categories and that Congress then instructed the EPA to establish emission standards "[f]or the categories and subcategories the Administrator lists under subsection (d)" of CAA section 112. At least one of these commenters cited CAA sections 112(c), (d)(1), (d)(3)(A), (d)(6), and (f) as examples of how the CAA authorizes the EPA to impose emissions standards only on particular source categories or subcategories. The commenter asserted that none of these provisions expressly authorize or reasonably can be construed to allow the EPA to develop and impose an emissions standard that applies across multiple source categories. The commenter contended that for this reason, the EPA's proposal to apply fenceline monitoring to site-wide emissions, including emissions from source categories beyond the SOCM I source categories addressed in this rulemaking, is legally unfounded; and if the EPA decides to impose a fenceline monitoring program in the final rule, it must be limited such that it applies only to emissions from particular source categories. Other commenters said they were concerned that the proposed approach results in the EPA's establishing the emission point as the facility boundary, thereby expanding the definition of an affected source. The commenters provided an example saying that the proposed rule does not contain provisions that would exclude a site from fenceline monitoring for benzene due to the presence of a gasoline storage tank onsite that is used to refuel mobile equipment and is not even part of the HON process.

Some of the commenters stated that the imposition of fenceline monitoring requirements to non-HON sources is unreasonable, arbitrary, and capricious. One of these commenters said the EPA is conducting the technology review for the SOCM I category and not for other collocated categories; and despite this, the EPA is using this action as a vehicle to impose requirements on other source categories through the HON rather than

evaluating such controls in the context of the applicable CAA section 112 standard. The commenter asserted that such use of a source-specific technology review to promulgate requirements that affect an unknown number of other source categories is arbitrary and capricious and circumvents statutory design. The commenter added that the EPA has not assessed the cost that would fall on other source categories and that the EPA's proposal failed to properly provide notice or provide a meaningful opportunity to comment to all interested stakeholders.

Some commenters said that they support the EPA's proposal to allow facilities to account for offsite, upwind sources through the use of near-field source correction under 40 CFR 63.184(g); however, these commenters said they disagree with the EPA's assertion that this option should not be provided for onsite, non-source category emissions. These commenters asserted that the EPA cannot regulate sources beyond those subject to the technology review; thus, the commenters said, the EPA should add provisions in the final rule similar to those at 40 CFR 63.658(i) from the 2015 Petroleum Refinery Sector Rule to address onsite sources that are not part of the affected source under the HON and P&R I NESHAP. However, at least one commenter objected to adding provisions in the final rule similar to those at 40 CFR 63.658(i) and stated that inclusion of facility-wide emissions in the action level is appropriate because it will support the control of toxic air pollutants emitted from all sources within the facility, all of which affect fenceline communities, and also avoids the development of complex and uncertain processes to attribute emissions from collocated sources and equipment that may be used in processes associated with multiple source categories. This commenter pointed out that only a small number of refineries (13) have approved site-specific monitoring plans, and only five of those plans include procedures for excluding onsite sources owned by the refinery but that do not fall within the refinery source category.

Another commenter provided a real-life example of the difficulty of dealing with onsite, non-source category emissions where Facility A, which is subject to the HON, owns and operates an Industrial Site that supplies services to other tenants, including wastewater treatment. The commenter said that Facility A does not use, produce, or emit EtO from any of its own processes; however, two tenants—Facility B and Facility C—are located inside the

Industrial Site, and both emit EtO (and Facilities B and C are not subject to the HON but are subject to 40 CFR 63, subpart PPP). The commenter said that Facilities B and C send miniscule liquid EtO emissions to the WWTP for disposal; and reported emissions by Facility A of EtO from their WWTP, since taking over the Industrial Site, are less than 1 lb/yr. Using this example, the commenter contested that it is inappropriate to require Facility A to perform EtO fenceline monitoring and conduct a root cause analysis with subsequent corrective action because Facility A does not use, store, or emit EtO from any of their own production processes (*i.e.*, Facility A only has EtO wastewater emissions from treating EtO wastewater from Facility B and Facility C as the site owner). The commenter made the following additional points: (1) The amount of EtO emitted to the air from wastewater obtained and treated by other facilities from Facility A has been less than a pound for the past 3 years; (2) the WWTP is located outside the fenceline of the Industrial Site; (3) Facility A does not have the authority to perform root cause analysis or corrective actions on facilities they do not have operational control over; and (4) if action level concentrations are found, it is not possible to determine whether the EtO comes from Facility B and/or Facility C, nor their individual contributions. For the Facility A WWTP, there is not a logical corrective action for emissions of less than 1 lb/yr that would change the EtO concentrations found in the ambient air. Other commenters provided similar examples and expressed similar concerns.

*Response:* The EPA considered the potential applicability of fenceline monitoring as part of this proposed technology review. Generally, the EPA has found fenceline monitoring to be an effective tool when fugitive or ground-level releases are significant or where we have identified considerable uncertainties in HAP emissions estimates from fugitive emission sources such that they affect our decisions relative to whether there exists residual risk, for example. Other considerations include the types of pollutants that are emitted, the availability of fenceline monitoring measurement methods for the key pollutants, proximity of residences or other areas where people could be exposed to emissions at or near facility fencelines, and the other types of monitoring that are already required or are being considered.

Regarding the question of including onsite, non-source category emissions in the fenceline monitoring work practice standard, we proposed not to allow



corrections to monitoring for onsite non-source category sources, as they were included in emissions sources modeled to develop the action levels. In other words, the action levels in the primary fenceline monitoring program are based on expected facility-wide emissions and account for contributions from these non-source category sources. For more details, see the document titled *Clean Air Act Section 112(d)(6) Technology Review for Fenceline Monitoring located in the SOCM Source Category that are Associated with Processes Subject to HON and for Fenceline Monitoring that are Associated with Processes Subject to Group I Polymers and Resins NESHP* (Docket Item No. EPA-HQ-OAR-2022-0730-0091) and the residual risk technical support document titled *Residual Risk Assessment for the SOCM Source Category in Support of the 2023 Risk and Technology Review Proposed Rule* (Docket Item No. EPA-HQ-OAR-2022-0730-0085). The secondary action level for chloroprene adopted under CAA section 112(f)(2) appropriately anticipates the need for additional reductions of this pollutant in order to further the goal to protect public health from whole-facility chloroprene emissions. Further, in most cases, sources with HON or P&R I source categories also account for a significant portion of the action level at the fenceline such that the option to attribute and correct monitors for emissions from collocated sources and equipment that may be used in processes associated with multiple source categories becomes a very complex and unnecessary process. In the Petroleum Refinery example, we note that the option to correct monitors for non-source category sources within the fenceline was found to be very difficult to implement practically and that the option was subsequently removed from most site-specific monitoring plans.

We agree that the circumstance described by the commenter, although uncommon, might result in a situation where the most significant contribution would not be from the portions of the facility that are subject to the process limits established for the HON or P&R I source itself. In this case we would apply the requirements based on how the source has been defined for the purposes of applicability of CAA section 112 standards, which is any stationary source or group of stationary sources located within a contiguous area and under common control. The commenter indicates that these facilities are not under common control, therefore Facility A would have to conduct

fenceline monitoring because it does use, produce, and emit EtO, and it is subject to the HON, as the commenter indicates that it treats wastewater from Facilities B and C in its wastewater treatment process. In this case, Facility A could correct monitoring readings for offsite impacts using a site-specific monitoring plan. Depending on the orientation of Facilities B and C, this approach would require real-time monitoring of portions of the fenceline bordering Facilities B and/or C and is allowed by the proposed and final rule (see 40 CFR 63.184(g)). The commenter presumes that the amount of EtO emitted by the treatment process is miniscule, but that is precisely the question that fenceline monitoring is envisioned to address and to ensure that emissions are maintained at low levels. We believe even in this situation, the fenceline monitoring standard is reasonable and provides for an approach to address the commenter's concerns. Further, we reject the notion that our proposal failed to properly provide notice or to provide a meaningful opportunity to comment for all interested stakeholders. The major source to which these standards apply is by definition under common control. Unless the sources are subject to the HON and P&R I standards, there is no requirement for operators of other source categories to comply with these requirements. Therefore, we reject the notion that this proposal is arbitrary and capricious and circumvents statutory design.

*Comment:* With regard to the EPA's proposed fenceline monitoring requirements, numerous commenters contended that background concentrations need to be accounted for when calculating the incremental contributions from EtO-emitting facilities. A commenter said that without understanding the significance of high ambient background levels, it is not possible to determine a facility's true impact on ambient concentrations above the background level or the risk of EtO exposure. This commenter added that implementation of fenceline monitoring when background is unknown has the potential to generate data that will not represent what is intended, will require follow up action to correct problems that do not exist, and has the potential to frighten communities near facilities in the absence of elevated risk. Similarly, other commenters asserted that facilities are likely to show exceedances attributable not only to their own emissions, but also from background levels of EtO and emissions of EtO sources from offsite

sources. These commenters said that background concentrations threaten a potentially endless cycle of investigations for the source of emissions which are beyond the EPA's regulatory authority or the facility's control; and the proposed fenceline monitoring requirements improperly attempt to turn facilities into mini ambient air quality regulators, requiring them to investigate and analyze fenceline exceedances that could be caused by another facility, background EtO levels, or simply an error in sampling due to the inability to accurately measure EtO at the incredibly low levels proposed.

Some of these commenters acknowledged that the EPA's proposed sampling protocol attempts to address background concentrations by taking the highest sample and subtracting the lowest sample from it; however, these commenters said it is not clear how the proposed protocol fully addresses background concentrations and other questions that remain regarding high background concentrations that have been present in sampling conducted by other states, including at National Air Toxic Trends Station (NATTS) sites. These commenters as well as others said that background monitors in many cases show higher concentrations than monitors located within or nearby EtO-emitting facilities. Some of these commenters provided additional information about background EtO concentration data available from two studies conducted by state agencies:

- A 2022 study conducted by the Georgia Department of Natural Resources, Environmental Protection Division titled "Ethylene Oxide Monitoring Report" included EtO monitors near known emitters in addition to areas designated as "background" locations away from any known emitters of EtO. The 2020 concentration data for one of the background monitors located in South DeKalb showed that background concentrations ranged from a low of 0.10  $\mu\text{g}/\text{m}^3$  to a high of 3.7  $\mu\text{g}/\text{m}^3$  and that the monthly difference between the highest and lowest reported concentration value ranged from 0.22  $\mu\text{g}/\text{m}^3$  to 3.2  $\mu\text{g}/\text{m}^3$ , with an average monthly difference of 0.88  $\mu\text{g}/\text{m}^3$ .
- A 2022 study conducted by the West Virginia Department of Environmental Protection in the Kanawha Valley, collecting background concentration data in Guthrie and Buffalo, West Virginia, revealed that EtO background measurements were made in Guthrie that ranged from 0.059  $\mu\text{g}/\text{m}^3$  to 1.74  $\mu\text{g}/\text{m}^3$  and in Buffalo that ranged from 0.20  $\mu\text{g}/\text{m}^3$  to 1.31  $\mu\text{g}/\text{m}^3$ .

Commenters claimed that the reports published by the Georgia Department of Natural Resources, Environmental Protection Division, and by the West Virginia Department of Environmental Protection indicate that background concentrations of EtO can vary significantly, including up to more than an order of magnitude greater than EPA's proposed action level of 0.20  $\mu\text{g}/\text{m}^3$ . Other commenters noted that the EPA's AirToxScreen presents EtO background levels as zero (so risks associated with background levels of EtO are not included in AirToxScreen maps and reports); however, according to commenters, this is highly unlikely to be the case, as shown by data in the EPA's NATTS sites, which are designed to be representative of community air toxics concentrations. Another commenter cited the West Virginia final report titled "Ethylene Oxide Monitoring—Characterization of South Charleston and Institute, West Virginia and Surrounding Areas February 21, 2023" and made the following observations of the measured EtO background concentrations from year 2018 through November 2021 at various monitoring points across the United States:

- There is not even a single data point below the EPA's 100-in-1 million threshold of 0.01 parts per billion by volume (ppbv).
- The average concentration is 0.122 ppbv which is 12 times higher than the EPA's 100-in-1 million threshold of 0.01 ppbv.
- Several monitoring sites have an annual average concentration of 0.15 ppbv (0.27  $\mu\text{g}/\text{m}^3$  or higher).
- Many of these values are measured at sites that are not close to industrial sites where EtO is manufactured or used, thus further calling into question whether the EPA really has the correct residual risk value.

Citing the EPA produced document titled "EPA's Work to Understand Background Levels of Ethylene Oxide" (most recently updated in October 2021), another commenter presented the following questions that they claimed to be unanswered: (1) Is EtO in use by unpermitted sites that are causing these levels?; (2) is EtO coming from other activities/sources such as mobile sources, biogenic sources?; and (3) when the IRIS inhalation URE value was developed, did the analysis include consideration of the background dosing?

*Response:* We disagree with the commenters' assertions that background concentrations of EtO are not accounted for in the proposed fenceline monitoring provisions. The primary driving force for determining when a facility must

initiate root cause analysis is the annual average  $\Delta c$  value; a root cause analysis is required whenever the annual average  $\Delta c$  value is higher than the action level. For EtO, the annual average  $\Delta c$  is the average of the most recent 73 individual sampling period  $\Delta c$  measurements. The sampling period  $\Delta c$  is calculated as the sampling period's highest sample result minus the sampling period's lowest sample result. If background EtO levels are persistent in the area, this will be captured by both the high and low concentration measurements used to develop the  $\Delta c$  values and the subtraction will result in only the facility's contributions to the EtO concentrations at the fenceline. As such, background levels are accounted for in the determination of each sampling period's  $\Delta c$  value, and subsequently the annual average  $\Delta c$  value.

If, as commenters indicate, background EtO levels are inconsistent, the annual average  $\Delta c$  value must still shift above the action level before root cause analysis must be performed. The power of a single  $\Delta c$  value to cause undue root cause analysis is mitigated when it is averaged with the other measurements. Single events where background EtO levels are elevated will be insufficient to cause the annual average  $\Delta c$  to exceed the action level. If a single  $\Delta c$  value is large enough to skew the annual average derived from 72 other datapoints above the action level, the EPA expects that an emission event occurred and root cause analysis is appropriate.

Lastly, with respect to commenters' concerns that offsite facilities may contribute to EtO measurements at their facility, we note that owners and operators may submit site-specific monitoring plans to subtract background EtO concentrations from upwind emitters from impacted monitors pursuant to 40 CFR 63.184(g)(1) through (4).

The questions posed by the commenter about unpermitted sites emitting EtO or whether unknown sources are developing EtO are out of scope for this rulemaking. Section IV.A.3.a of this preamble addresses the EtO IRIS URE value.

*Comment:* Several commenters requested that the EPA clarify that very small amounts of the six compounds (*i.e.*, benzene, 1,3-butadiene, chloroprene, ethylene dichloride, EtO, and vinyl chloride) that may be produced, used, or stored at trace levels, as incidental by-products, and as impurities, should not trigger long-term fenceline monitoring requirements. Some of these commenters contended that the proposed applicability is

unjustifiably broad, rendering it arbitrary and capricious. The commenters requested that the EPA provide a de minimis level that would trigger fenceline monitoring requirements; and several of the commenters also requested that the applicability be limited to regulated HON CMPUs. Some of the commenters requested that the EPA create exclusions for predetermined de minimis activities such as: housekeeping or building maintenance, lab and research activities, combustion emissions, transportation emissions, and incidental by-products or impurities. Similarly, a commenter asserted that the EPA uses the phrase "use, emit, or process" without any other criteria or definition of what this language means.

A commenter pointed out that according to the EPA's AP-42 Compilation of Air Emission Factors, the combustion of fuels is likely to generate emissions of benzene and 1,3-butadiene (see AP-42, Tables 1.3-9, 1.4-3, 3.1-3, 3.3-2, and 3.4-3). The commenter added that since nearly all HON and NSPS III/NNN/RRR sources are expected to contain natural gas piping, and natural gas contains benzene, and the applicability of the fenceline monitoring requirement is based on site emissions, it is reasonable to conclude that nearly all HON and NSPS III/NNN/RRR sites are expected to be subject to the fenceline monitoring requirement regardless of whether the SOCMI processes at the site emit benzene or 1,3-butadiene. Another commenter said that implementing a fenceline monitoring program for any by-product/impurity that is intentionally minimized by the owner or operator is not cost-effective or environmentally beneficial, and as such, warrants additional consideration. The commenter stated that chloroprene is a by-product/impurity produced in their vinyl chloride monomer production process and would be emitted at much lower quantities than ethylene dichloride or vinyl chloride; and as described in the HON RTR Proposal, if the purpose of the fenceline program is to determine equipment leaks, the leaks would be more readily detected with vinyl chloride monomer or ethylene dichloride rather than through monitoring for a contaminant that may or may not be present in the process fluid.

Commenters suggested that to avoid trace levels of these compounds triggering the monitoring programs, the EPA should establish additional applicability criteria for triggering the monitoring requirements given that the proposed fenceline air monitoring

provisions are complex, take significant time to implement, and appear to be required for an infinite period. The commenters said the economic burden for fenceline monitoring is not justified for facilities with low levels of emissions (below de minimis thresholds) for any proposed fenceline compound. Some of these commenters recommended that the EPA clarify that when the EPA uses the phrase “if the site uses, produces, stores, or emits” one of the covered chemicals, this means that greater than 25,000 lb/yr of a chemical must be used, produced, or stored in HON CMPUs at the source. Commenters added that in order to trigger fenceline monitoring, the air emissions for a covered chemical should also be greater than 1 tpy (~ 0.23 lb/hr annual average) from HON CMPUs at the source. Commenters said that the rationale for using 25,000 lb/yr aligns with other EPA regulations such as 40 CFR 372.25(a) which is threshold for reporting of air emissions under the EPA’s Superfund Amendments and Reauthorization Act Section 313 program; and a 1 tpy emission threshold (<0.25 lb/hr) is a low threshold for then triggering the fenceline air monitoring program. Another commenter said that, given that the Agency selected the fenceline action levels by modeling emissions from the post-control emissions file in the residual risk assessment and selecting the maximum annual average fenceline concentration, one potential option for adopting a trigger threshold for fenceline monitoring would be to set emission thresholds at 50 percent of the source category emissions for the facilities that were used to set the proposed action level. The commenter said that this approach should also be applied for EtO and chloroprene because the Agency proposed to find acceptable risk and an ample margin of safety for these pollutants after implementation of the controls, thus making additional reductions of EtO and chloroprene unnecessary and unsupported by any rulemaking authority.

A commenter suggested that if the EPA does not establish de minimis applicability thresholds, then the final rule should include a provision that allows for fenceline monitoring to be discontinued at a site after 2 years of non-detect fenceline monitoring concentrations for a compound. The commenter said that a site with non-detect fenceline concentrations does not drive the risk assessment for that compound.

*Response:* The EPA disagrees with commenters that the fenceline monitoring provisions are unjustly

broad. Per 40 CFR 63.184, the fenceline monitoring provisions are applicable “for each source as defined in § 63.101, and for each source as defined in § 63.191.” The definitions of source at 40 CFR 63.101 and 40 CFR 63.191 point to 40 CFR 63.100 and 40 CFR 63.190, respectively, where applicability is stated. For the HON, only those sources manufacturing as a primary product one or more of the chemicals in Table 1 to NESHAP subpart F, or tetrahydrobenzaldehyde, or crotonaldehyde; or using as a reactant or manufacturing as a product, or co-product, one or more of the HAP listed in Table 2 to NESHAP subpart F are subject to the provisions. For NESHAP subpart I, only those emissions specified from the processes subject to 40 CFR 63.190(b)(1) through (6) are subject to the fenceline provisions. Therefore, any concerns about obligations to meet fenceline monitoring requirements for pollutants developed as impurities or found in feedstock in trace amounts are unfounded, as these materials are not “products,” which, by definition, exclude by-products, isolated intermediates, impurities, wastes, and trace contaminants per the definition at 40 CFR 63.101 or, in the case of NESHAP subpart I, are not the specified pollutants from the processes to which the subpart applies. For P&R I sources subject to NESHAP subpart U, we note that the fenceline monitoring requirements reference 40 CFR 63.101 and the same logic can be applied.

To the commenter’s assertion about emissions from boilers, housekeeping, building maintenance, or lab and research activities triggering fenceline monitoring requirements, we note that these are not considered within SOCM I or P&R I sources per the applicability of the term at 40 CFR 63.100. Thus, there would be no need to implement fenceline monitoring if these are the only sources emitting benzene, 1,3 butadiene, ethylene dichloride, vinyl chloride, EtO, or chloroprene at a facility. Therefore, for the reasons previously stated, there is no need to set a minimum threshold for fenceline monitoring as the rule already provides criteria targeting only SOCM I or P&R I sources using, producing, storing, or emitting one or more of the six considered pollutants and will not be triggered by low-level emissions from non-source category processes.

However, we agree with the commenter that the proposed language could be interpreted such that emissions from non-HON or P&R I processes could trigger the fenceline monitoring requirement. As such, we are revising 40 CFR 63.184(a)(1)(i) through (iv) and

40 CFR 63.184(b)(1)(i) and (ii) to state that owners and operators with an affected source that uses, produces, stores, or emits one or more of the target analytes must conduct fenceline monitoring for the analyte(s) at their site. At proposal, we inadvertently used the word site in these sections instead of affected source, which may have led to confusion that non-HON or P&R I processes could have triggered fenceline monitoring obligations when there were no HON or P&R I processes at the site that use, produce, store, or emit benzene, 1,3 butadiene, ethylene dichloride, vinyl chloride, EtO, or chloroprene. We believe this change clarifies our original intent and helps to more clearly target those facilities that were identified as needing fenceline monitoring as part of our original analysis (see Docket Item No. EPA-HQ-OAR-2022-0730-0091).

To address concerns with facilities producing, using, storing, or emitting only low levels of benzene, 1,3-butadiene, ethylene dichloride, or vinyl chloride, we are finalizing burden reduction measures at 40 CFR 63.184(a)(3)(iii) and (b)(2)(iii). These provisions, similar to those provided at 40 CFR 63.658(e)(3) of NESHAP subpart CC for benzene, will allow facilities to skip fenceline measurement periods for specific monitors once a certain number of fenceline measurements are recorded to be one tenth or less than the finalized action levels. We believe the addition of these provisions will unify the finalized fenceline monitoring provisions between NESHAP subpart H and NESHAP subpart CC so that collocated refinery processes will not become subject to additional monitoring if they have already demonstrated levels of benzene at the fenceline that allow the owner or operator to qualify for a reduced sampling frequency and support facilities producing, using, storing, or emitting only low levels of the targeted pollutants from their affected sources. We note that these provisions are not being provided for EtO and chloroprene due to their associated risk and the finalized secondary actions levels having been set at three times the representative detection limit (RDL), and thus demonstrating sufficiently low fenceline concentrations to allow skipping monitoring periods is not possible. Additionally, for both EtO and chloroprene, even for the primary action levels, one-tenth of the action level would be below the method detection limit (MDL), and as such, skipping monitoring periods would not be possible for these pollutants. We also

note that for vinyl chloride, this option is limited to small sites with perimeters less than or equal to 5,000 meters. We have chosen to limit the reduced sampling frequency to these smaller sites because these are the only sites where the canister samples are taken at the same sampling location each sampling period; owners and operators of sites with a perimeter larger than 5,000 meters are required to rotate the sampling locations between sampling periods. As such, this complicates the determination as to whether a larger site has consistently low fenceline readings at a particular monitoring location.

*Comment:* A commenter pointed out that when fenceline monitoring was established for refineries, the EPA stated that benzene was specifically chosen as the target analyte for petroleum refineries with the understanding that a single HAP served as a surrogate for all fugitive HAP, further stating that a single HAP simplified the determination of compliance and set a clear action level. The commenter contested that it is unclear why benzene cannot be the surrogate for the species listed under the proposed EPA Method 325 fenceline monitoring requirements. Moreover, the commenter added that a site should only have to do the chlorinated species or EtO monitoring if it is present in sufficient quantities such that their emissions would create a concentration higher than MDL at the perimeter; the commenter asserted that the EPA set their action levels based on modeling of site emission inventories but did not incorporate any rationale for why sites with less emissions must do such expensive monitoring. The commenter suggested that sites should have the option to model or demonstrate that their emissions would not be expected to exceed the action levels without embarking on a costly monitoring program that will just be reporting below detection level values.

*Response:* Benzene was selected as a surrogate for all HAP as part of the fenceline monitoring provisions of NESHAP subpart CC due to its near universal presence in process streams. HON and P&R I processes are more diverse and there is no single chemical that is found with the same frequency in process streams as benzene in petroleum refineries. Setting one surrogate chemical to represent the variety of HON and P&R I processes considered as part of this rulemaking would not produce effective standards limiting fugitive emissions.

To the commenter's request to be able to model concentrations at the fenceline to show that action levels will not be met, we point to table 2 through table

7 in the document titled *Clean Air Act Section 112(d)(6) Technology Review for Fenceline Monitoring located in the SOCOMI Source Category that are Associated with Processes Subject to HON and for Fenceline Monitoring that are Associated with Processes Subject to Group I Polymers and Resins NESHAP* (see Docket Item No. EPA-HQ-OAR-2022-0730-0091). Fugitive emissions are, by nature, difficult to measure and record and the data collected via the CAA section 114 request indicates that modeling is insufficient to anticipate fenceline concentrations of the six target pollutants considered. Therefore, we maintain that it is reasonable to require monitoring if a facility whose SOCOMI or P&R I affected sources use, produce, store, or emit any of the pollutants specified at 40 CFR 63.184 to verify that actual concentrations at fenceline are below the finalized action levels. No changes are being made as a result of this comment.

*Comment:* Commenters said that they have concerns regarding equipment and lab analytical capabilities on whether any laboratory is capable of performing proposed EPA Method 327. The commenters asserted that they were only able to identify one lab in North America that could meet all requirements of proposed EPA Method 327. A commenter suggested that to the extent that fenceline monitoring for EtO is required, the EPA should allow for the use of EPA Method TO 15 for initial monitoring for at least one (1) year until lab capabilities are further established; or alternatively, the initiation of fenceline monitoring be moved to at least two (2) years after the effective date of the final rule. Another commenter encouraged the EPA to actively engage in dialogue with commercial air laboratories in the method review process to ensure that the procedures meet the EPA's quality objectives of the program and also can be supported on a production scale, both of which will be critical for the successful implementation of the canister fenceline monitoring network. Another commenter requested that the EPA provide a list of laboratories able to perform proposed EPA Method 327.

A commenter recommended that the EPA work with the New York State Department of Environmental Conservation (NYSDEC) to improve proposed EPA Method 327 given that NYSDEC analyzes VOCs in-house and has devoted considerable resources into refining its EtO measurement procedures over a seven year period. The commenter claimed that in a recent EPA performance audit of the NYSDEC laboratory required for NATTS sites,

NYSDEC's EtO results were well within the 20 percent acceptability range and outperformed the referee laboratory. The commenter said proposed EPA Method 327 does not adequately address the issues that lead to inaccurate EtO measurements including, but are not limited to, the following:

- The preconcentration system must be optimized for the elimination of excess CO<sub>2</sub> and water.

- Slip-lining the transfer line in the gas chromatography (GC) oven with the analytical column to minimize contact between the concentrated slug and transfer line ensures that all or most of the transfer takes place directly onto the analytical column, which maximizes performance.

- Ion 44 should be used for quantitation. Use of ions 15 or 29 did not produce acceptable results in the NYSDEC laboratory. Ion 15 was too noisy and ion 29 suffered from interference due to background contributions from nitrogen. For NYSDEC, interference from trans 2-butene for ion 44 was not found to be an issue for normal ambient air samples due to the relatively low concentration of that substance in those samples. However, trans-2-butene can interfere with quantitation using ions 15 or 19, because, unlike ion 44, those are prominent masses in the mass spectrum of trans-2-butene.

- NYSDEC does not agree that bromofluorobenzene should be mandated as a tuning agent. NYSDEC has had success tuning prior to each run using perfluorotributylamine, per the manufacturer's recommendation, and has found that tuning to meet the bromofluorobenzene criteria can actually lower the sensitivity of the instrument.

- The use of internal standards for quantitation should not be mandated, especially for reactive chemicals like EtO and acrolein, as that procedure can produce biased results when the internal standard is not as sensitive to instrumental conditions as the target chemical. A better approach would be to use isotope dilution for the quantitation of these compounds, as the doped compounds would presumably react the same way in the analytical system. Given the anticipated very costly procurement of such internal standards, this should not be mandated, but instead suggested as a means to improve analytical performance for these reactive compounds. NYSDEC calibrates before, during, and after each analysis using the external standard approach and has complete confidence that the instrument is producing the best data within the confines of the system.

The commenter added that they strongly believe that any method refinements that enable more accurate EtO measurements should be implemented in all ambient sampling for that pollutant, including samples collected at NATTS sites, because this would allow for comparison of fenceline and background sites without methodological considerations.

*Response:* The EPA recognizes the commenters' concerns that laboratories may not currently have the capacity to conduct EPA Method 327 according to the timeline we proposed. Therefore, we are revising the final rulemaking at 40 CFR 63.100(k)(12) (for HON) and 40 CFR 63.481(p) (for the P&R I NESHAP) such that with the exception of fenceline monitoring of chloroprene at P&R I affected sources producing neoprene, owners and operators are not required to initiate fenceline monitoring until 2 years after the effective date of the final rulemaking. This expanded timeline is necessary to allow commercial labs to conduct the needed method development, to expand capacity, and to develop the logistics needed to meet the requirements in the final rule. For P&R I affected sources producing neoprene, we have changed the compliance date for fenceline monitoring of chloroprene to begin no later than October 15, 2024, or upon startup, whichever is later subject to the owner or operator seeking the EPA's authorization of an extension of up to 2 years from July 15, 2024. We note that that all affected sources producing neoprene (there is only one) already have a fenceline monitoring network in place for chloroprene as well as a lab contracted to provide analysis.

We developed EPA Method 327 based on the requirements in EPA Method TO-15A, best practices for measuring compounds like EtO, and enhanced QA/QC required for a method that is to be used for compliance purposes. Regarding the specific recommendations made by the commenter, the EPA has made EPA Method 327 as performance-based as possible and considers it important, when possible, to avoid prescriptive requirements to allow commercial laboratories to develop their own approaches for analysis.

*Comment:* Some commenters said that the EPA's proposed 300 parts per trillion (ppt) detection limit for EtO (and 900 ppt fenceline action threshold) are inadequate given that carcinogenic effects can be persistent and cumulative. These commenters claimed that EtO is toxic at 11 ppt in the ambient air; therefore, the EPA should mandate the use of advanced monitoring technologies to achieve lower detection

limits and lower the action levels at the fenceline. A commenter remarked that in Louisiana, the typical residential location is not set at some safe distance from emissions; therefore, it is proper for the EPA to set minimum detection levels at the fenceline of the facility's property line, and not set the minimum detection level scalable to the duration of dispersion from the facility to the residential receptor location. Another commenter argued that developments in monitoring technology that lower the detection levels for listed HAP must be considered technological developments under CAA section 112(d)(6). This commenter contended that new technological developments, such as the use of proton transfer reaction-mass spectrometers and the use of Picarro products that use cavity ring-down spectrometers should be adopted by the EPA in its efforts to lower emissions in these source categories with the proposed fenceline monitoring efforts in the rules.

Another commenter declared that it is important to note that the method detection limit is nearly the same as the concentration that is representative of 100-in-1 million risk; therefore, any detection corresponds to an unacceptable level of risk. On the contrary, a commenter said that given ambient air measurements made using the EPA's TO-15/TO-15A summa canister method have a detection limit for EtO higher than 0.02 ug/m<sup>3</sup>, it is possible that the actual level could be above the EPA's 100-in-1 million risk level even if a regulated source or an agency were to obtain non-detect results. This commenter said that they are very concerned that the EPA has established ambient air targets that neither an industrial source nor a regulatory agency can demonstrate that they are meeting with current air sampling methods; this raises practical questions about how one demonstrates compliance with these air quality targets.

*Response:* The EPA recognizes the feedback from the commenters. We evaluated multiple measurement approaches that could be used for fenceline measurement, and there currently is not a measurement approach with reliable sensitivity at the level representative of 100-in-1 million cancer risk. The EPA found the only technically feasible approach to measure EtO at the fenceline is a canister measurement approach and analysis via gas chromatography/mass spectrometry (GC/MS). We developed EPA Method 327 based on the requirements in TO-15A, the EPA's existing canister method, Best Practices

for measuring compounds like EtO, and enhanced QA/QC required for a method to be used for numerical compliance purposes.

We acknowledge the comment regarding real-time monitoring, and efforts are ongoing to evaluate different real-time monitoring approaches for EtO which could be applied to fenceline monitoring; however, we did not find these approaches to currently be technically or economically feasible. The EPA disagrees with the commenters that these real-time monitoring approaches are currently sensitive enough to currently be applied to fenceline monitoring; however, the EPA has a pathway for the use of these potential approaches through the alternative test method provisions in 40 CFR 63.7(f) when the required sensitivity is met, which is outlined in 40 CFR 63.184(i). We note that based on response to another comment, we are revising the entry for 40 CFR 63.7(f) in the General Provisions table to NESHAP subpart F (Table 3) such that 40 CFR 63.7(f) applies.

*Comment:* Many commenters expressed concerns that the proposed provisions for an alternative test method at 40 CFR 63.184(i)(3) require the method detection limit of the alternative method to be at least an order of magnitude (*i.e.*, ten-fold) below the action level for the compound(s) that will be monitored. A commenter indicated the proposed action level of 0.2 ug/m<sup>3</sup> for EtO will prohibit some otherwise potentially viable alternative monitoring methods, including the Picarro air monitoring system and many open-path technologies. Commenters recommended that the EPA remove 40 CFR 63.184(i)(3) in its entirety. Commenters indicated that this requirement limits flexibility and the ability for evaluation of alternate methods via the EPA's current alternate methods processes.

A commenter further indicated that the proposed action levels for EtO and chloroprene are three times the RDL for each compound and, according to the EPA's technical memorandum, three times the RDL represents the level where a test method performs with acceptable precision. However, the commenter recommended that the EPA increase the multiplier to 5 for EtO for consistency with proposed EPA Method 327. The commenter argued that the requirement at 40 CFR 63.184(i)(3) for a ten-fold reduction in MDL for alternative test methods is so restrictive as to potentially eliminate the flexibility of real-time monitoring because the MDL was only five times lower than an already very low action level. The

commenter suggested the EPA revise the language at 40 CFR 63.184(i)(3) to require methodologies with detection limits at or below those of the reference standard (*i.e.*, EPA Method 325A/B, EPA Method 327).

*Response:* The EPA agrees with the commenters that the proposed requirement that the MDL of the alternative method be at least an order of magnitude less than the action level is too restrictive, and, therefore, in the final rule we have revised the requirement at 40 CFR 63.184(i)(3) that the method detection limit of an alternative test method must be at least one-third of the action level for the compound(s) that will be monitored with the alternative method. The EPA considers three times the MDL to describe the limit of quantification of a method, or the point at which we have confidence in the accuracy and precision of a method. We note this requirement is also consistent with the EPA's approach for setting emission limits that are at least three times the RDL. Such an approach ensures that the standard is at a level that addresses measurement variability and is in a range that can be measured with reasonable precision. Requiring the detection limit of alternative measurement approaches to be at least one-third of the action level will ensure that measurements made near the action level are of reasonable precision.

We note that while the EPA has reduced the requirements for the minimum detection limit of alternative measurement approaches, when calculating the sampling period  $\Delta c$ , an owner or operator must still use zero as the lowest sample result when a measurement is below the MDL and must still use the MDL as the highest sample result if all sample results are below the MDL. The use of this approach in determining  $\Delta c$  incentivizes the use of technology capable of measuring the lowest possible concentration for the target compound.

#### b. NSPS

The EPA received comments in support of and against the proposed NSPS review, including our determination to include more stringent requirements for SOCOMI equipment leaks, air oxidation unit processes, distillation operations, and reactor processes in the new NSPS subparts (*i.e.*, NSPS subparts VVb, IIIa, NNNa, and RRRa, respectively).

This section provides summaries of and responses to the key comments received regarding the NSPS review for SOCOMI equipment leaks, air oxidation unit processes, distillation operations,

and reactor processes. Comment summaries and the EPA's responses to additional issues raised regarding the proposed requirements resulting from our NSPS review are in the document titled *Summary of Public Comments and Responses for New Source Performance Standards for the Synthetic Organic Chemical Manufacturing Industry and National Emission Standards for Hazardous Air Pollutants for the Synthetic Organic Chemical Manufacturing Industry and Group I & II Polymers and Resins Industry*, which is available in the docket for this rulemaking.

#### i. Process Vents

*Comment:* Several commenters said that they opposed the EPA's proposal to eliminate the TRE index value concept in the new NSPS subparts IIIa, NNNa, and RRRa. The commenters provided the following arguments:

- The TRE index value has been an integral part of many technology-based air standards since its initial development, serving as a mechanism for determining cost effectiveness and triggering the requirements for process vent control (see, *e.g.*, the preamble to the 1994 HON adoption, which states that the TRE concept is appropriate because it "can be used to reflect all possible combinations of various factors that affect emission rates and likelihood of current control" (citing 59 FR 19416) and "would provide consistency between the HON[,] the recently issued [control techniques guidelines] for SOCOMI process vents. . . [and] the applicability criteria for the three SOCOMI process vents NSPS" (59 FR 19418)). The EPA determined that BSER was 98 percent control (or an outlet concentration of 20 ppmvd at 3 percent O<sub>2</sub>) of sources with a TRE less than or equal to 1.0 when it promulgated these rules.

- While the EPA discusses its basis for removing the TRE index value > 1.0 alternative emission standard, it provides no discussion for why the limited applicability exemption in the NSPS (TRE > 4.0 for NSPS subpart III and TRE > 8.0 for NSPS subparts NNN and RRR) is proposed to be removed. The EPA must explain why this exemption should be removed and provide an opportunity for the public to comment before taking final action to modify or remove it.

- Voluntary control of some process vents with a TRE index value greater than 1.0 does not imply that controlling all process vents with a TRE index value greater than 1.0 constitutes the BSER. While controlling a subset of process vents with a TRE index value greater

than 1.0 may be cost effective, the EPA's cost analysis for controlling such vents significantly understates the cost of installing additional controls such as a thermal oxidizer.

- The fact that a control device at one stationary source controls multiple process vents (as opposed to a single process vent) does not mean that in all cases control of multiple process vents is cost-effective. If the cumulative emissions from the process vents are small, then even controlling all of them with one control device is not cost effective.

- The EPA's conclusion that the TRE index value calculation is theoretical, complex, uncertain, and difficult to enforce is overly broad and cannot be applied to the regulated industry as a whole. The issues the EPA cites related to calculation of the TRE index value do not apply in instances with few organic compounds in the stream, and in instances where facilities have readily available process data obtained from source testing, other direct measurements, or permit limits. Observations from one facility's TRE index value calculation approach should not be construed as representative of 284 facilities.

- The EPA's cost analysis (see Docket Item No. EPA-HQ-OAR-2022-0730-0011) is not well supported and significantly underestimates the cost of installing and operating a thermal oxidizer. The EPA presents a total annual cost of \$98,429 and a VOC emissions reduction of 9.1 tpy from the elimination of the TRE concept and the imposition of control requirements for all process vents. The EPA references the HON technology review memorandum in support of the cost calculations; however, that memorandum does not include a cost analysis of emission reduction calculations for NSPS sources. Furthermore, the EPA's proposed capital cost of \$65,577 for a thermal oxidizer sized to control a 10 scfm stream is unrealistic; and it is also unrealistic to assume that a facility would install a thermal oxidizer simply for a 10 scfm stream. The EPA's cost algorithm significantly underestimates the costs associated with design and engineering of such projects. A commenter provided an example at one of their existing affected facilities where if NSPS NNNa is triggered via modification or reconstruction, the facility would need to install control equipment estimated at a conservative amount of \$500,000 in order to control 0.07 tpy of VOC result from vents from recovery scrubbers, or about \$7.14M per ton of VOC removed. The commenter

suggested that if the EPA is going to eliminate the TRE concept, that the EPA consider a cost effectiveness cut-off that is scaled to inflation that could avoid absurd results such as this.

- The EPA has ignored the fact that facilities that would now be required to control Group 2 halogenated streams would not only have to control organic HAPs using a thermal oxidizer, but would also have to incur costs to design, engineer, and install controls for acid gas and dioxin/furan emissions.

A commenter questioned why removing the TRE concept for the SOCOMI sector is not arbitrary given that no action was taken on the TRE concept in the recent RTR of the MON, conducted just 3 years ago.

Some commenters suggested that the EPA could keep the TRE index value concept but raise the threshold, or establish a mass-based criterion below which emission controls are not required such that the rules would only require control where it is cost-effective (e.g., limit applicability of the NSPS to affected facilities at a site whose cumulative VOC emissions are greater than 25 tpy). A commenter pointed out that the proposed HON rulemaking requires control of process vents that emit greater than 1.0 lb/hr of total organic HAP, and suggested that a similar mass-based VOC emissions threshold below which control is not required be added to the SOCOMI NSPS rules to avoid control being required for vent streams with very negligible VOC emissions. The commenter pointed out that the EPA included a mass-based emission threshold in NSPS subpart DDD at 40 CFR 60.560(g). The commenter provided an example of one of their distillation columns where the vacuum jet system vent emits very low amounts of VOC emissions (<0.0001 lb/hr uncontrolled), the net heating value is very low or negligible, and the vent stream contains primarily nitrogen and/or water vapor. The commenter said that they would have to then build an emission control device to manage this stream.

*Response:* As stated in the preamble to the proposed rule (88 FR 25080, April 25, 2023), the statutory review of these process vent NSPS (subparts III, NNN, and RRR) focused on whether there are any emission reduction techniques used in practice that achieve greater emission reductions than those currently required by the current NSPS and whether any such practices have become the BSER. Based on this review, we have determined that the BSER for reducing VOC emissions from these SOCOMI processes remains combustion (e.g., incineration, flares), and that the current

emission standard of 98 percent reduction of TOC (minus methane and ethane) or reduction of TOC (minus methane and ethane) to an outlet concentration of 20 ppmv on a dry basis corrected to 3 percent oxygen continues to reflect the BSER.

While we found no change in the BSER for reducing VOC emissions from air oxidation units, distillation operations, and reactor processes, we are finalizing the removal of the entire TRE concept, including the alternative of maintaining a TRE index value greater than 1 without the use of control device and the limited applicability exemptions (i.e., TRE > 4.0 for NSPS subpart III and TRE > 8.0 for NSPS subparts NNN and RRR) for purposes of NSPS subparts IIIa, NNNa, and RRRa. We stand by the rationale we provided in the preamble to the proposed rule for not including the TRE concept in NSPS subparts IIIa, NNNa, and RRRa, which is summarized as follows: (1) Based on the responses to our CAA section 114 request, we observed that some facilities are controlling continuous process vents that are not required by the NSPS subparts III, NNN, or RRR to be controlled per the results of the TRE index value calculation; (2) based on the responses to our CAA section 114 request, we observed that facilities are routing multiple continuous process vents to a single APCD; (3) determining a TRE index value for certain process vent streams is often theoretical, can be extremely complicated, and is uncertain; and (4) because the TRE index value is largely a theoretical characterization tool, it can be very difficult to enforce.

As stated in the preamble to the proposed rule (88 FR 25080, April 25, 2023), in reviewing an NSPS to determine whether it is “appropriate” to revise the standards of performance that reflects the degree of emission limitation achievable through application of BSER, the EPA considers the following information:

- Costs (including capital and annual costs) associated with implementation of the available pollution control measures.
- The amount of emission reductions achievable through application of such pollution control measures.
- Any non-air quality health and environmental impact and energy requirements associated with those control measures.
- Expected growth for the source category, including how many new facilities, reconstructions, and modifications may trigger NSPS in the future.

- Pollution control measures, including advances in control technologies, process operations, design or efficiency improvements, or other systems of emission reduction, that are “adequately demonstrated” in the regulated industry.

- Available information from the implementation and enforcement of current requirements indicating that emission limitations and percent reductions beyond those required by the current standards are achieved in practice.

As previously stated, some owners and operators do not use the TRE index value to determine whether a vent stream is required to be controlled. While we agree with commenters that owners and operators control vent streams that have a TRE index value greater than 1.0 for reasons other than the desire to avoid the TRE calculation, the fact is that owners and operators are controlling vent streams that have a TRE index value greater than 1.0 (possibly to comply with state or local regulations regarding VOCs or to meet a BACT limit), which is information relevant to our CAA section 111(b)(1)(B) review of the standards. Given that the TRE concept has been used since each original NSPS adoption, we consider owners and operators controlling vent streams that have a TRE index value greater than 1.0 to be a pollution control measure (i.e., an advance in process operations) in our analysis. Additionally, the removal of the TRE concept simplifies the determination as to whether owners and operators must control a vent stream and thus, the applicability process is easier to implement.

We disagree with commenters’ assertions that the EPA did not provide evidence that the TRE concept is largely theoretical and, as a result, difficult to verify. As identified in the document titled *Clean Air Act Section 112(d)(6) Technology Review for Continuous Process Vents Located in the SOCOMI Source Category that are Associated with Processes Subject to HON, Continuous Front-end and Batch Front-end Process Vents Associated with Processes Subject to Group I Polymers and Resins NESHAP, and Process Vents Associated with Processes Subject to Group II Polymers and Resins NESHAP* (Docket Item ID No. EPA-HQ-OAR-2022-0730-0094), one facility that received the CAA section 114 request provided over 300 pages of modeled runs used to determine certain characteristics of their continuous process vents to be utilized as part of the TRE index value calculations. Reviewing this information revealed

that in many cases, the facility struggled to unify the modeled runs with actual conditions at the facility and in some cases made arbitrary decisions to allow the model to function. While we agree with commenters that the TRE index value can be derived from less theoretical methods, other responses to the CAA section 114 request did not indicate how parameters used in the TRE index value calculations were determined and commenters did not provide sufficient information to show which methods were most common throughout industry. Given the theoretical nature of the TRE index value, the EPA maintains that verifying TRE index values is arduous because it can involve relying on significant process knowledge in order to confirm compositions of vent streams, vent stream flowrates, vent stream net heating values, and hourly emissions. It may also require verification of other facility assumptions (e.g., operational conditions and constraints), especially if modeling was used. This logic applies equally to existing, new, and modified sources and thus is one of the reasons why the EPA is not including the TRE concept in NSPS subparts IIIa, NNNa, and RRRa as part of this rulemaking.

We agree with commenters that the TRE index value has been an integral part of many technology-based air standards since its initial development. In fact, we said as much in the document titled *CAA 111(b)(1)(B) review for the SOCOMI air oxidation unit processes, distillation operations, and reactor processes NSPS subparts III, NNN, and RRR* (see Docket Item No. EPA-HQ-OAR-2022-0730-0011). The TRE concept is almost 40 years old; it was first introduced in a December 1984 EPA document (EPA-450/3-84-015; see attachment to Docket Item No. EPA-HQ-OAR-2022-0730-0011). However, even if it has been used in the past, we believe that for purposes of the new NSPS subparts NNNa, IIIa, and RRRa, certain aspects of its underlying development are clearly no longer applicable or appropriate. For example, the EPA stated in the 1984 supporting materials (EPA-450/3-84-015) that the Agency attempted to make the TRE index independent of inflation (e.g., the EPA assumed fixed relative costs of various resources, such as carbon steel and electricity), yet it is impossible to ignore inflation in the TRE calculations due to the time that has passed since it was developed (e.g., costs of carbon steel and electricity have undoubtedly increased since the development of the TRE index).

Although the TRE index value may allow owners and operators to allocate

resources efficiently and ensure that the most significant emission sources are targeted for control, the current use of the TRE index value is only based on controlling a single vent stream with a single APCD. This is an unrealistic scenario when compared to how affected facilities actually control their vent streams; it is much more likely that a facility routes numerous vent streams to the same APCD (which is evident from observing the responses to our CAA section 114 request).

We do agree with commenters that our cost estimate for installing a new recuperative thermal oxidizer (to control vent streams subject to the NSPS) included in the proposed rule is unrealistic (e.g., we severely underestimated flow rates needed to route vent streams with low flow to APCDs). Although we still believe the use of the EPA's control cost template is appropriate to estimate the cost of installing a new recuperative thermal oxidizer (to control vent streams subject to the NSPS), we revised our estimates to reflect the limitations of the correlations associated with the EPA's control cost template, which starts with a flow rate of 500 scfm. With these corrections, we estimate that the average TCI to install a new recuperative thermal oxidizer is about \$167,000 (as opposed to the \$66,000 estimate provided in the proposed rule). However, our estimate is still much less than the \$500,000 estimate provided by commenters. One explanation for this is that commenters may have used a much higher flow rate (e.g., 5,000 scfm as opposed to 500 scfm) and a "Regenerative Thermal Oxidizer" in their cost analysis instead of a "Recuperative Thermal Oxidizer." Moreover, commenters did not provide supporting information for their estimated capital costs, so the EPA cannot corroborate their assertions regarding cost.

In light of the fact that commenters were generally concerned about the cost estimate for installing a new recuperative thermal oxidizer (to control vent streams subject to the NSPS), we performed additional analyses to evaluate the cost effectiveness of not including the TRE concept in the new NSPS IIIa, NNNa, and RRRa. Instead of using \$500,000 as suggested by a commenter, we used a TCI of \$1,000,000 and the EPA's control cost template (for installing a new recuperative thermal oxidizer with 70 percent energy recovery). Even with this change in our analysis, we continue to believe that revising the standard from a TRE calculation to control of all vent streams is still cost effective when considered

along with the suite of process vent requirements evaluated as a whole under our NSPS review. As stated in the preamble to the proposed rule (88 FR 25080, April 25, 2023), we considered four different NSPS-triggering scenarios and a suite of proposed process vent requirements combined together (including not only revising the standard from a TRE calculation to control of all vent streams, but also new operating and monitoring requirements for flares, the addition of maintenance vent requirements, and the addition of adsorber monitoring requirements). In this context, we conclude that, even with our reevaluation of TCI for installing a new recuperative thermal oxidizer, the cost-effectiveness value of the suite of process vent requirements evaluated under our NSPS review is \$4,890 per ton VOC (instead of \$4,570 per ton VOC as proposed), which we consider to be reasonable.<sup>51</sup> For further details on how we estimated cost and VOC emissions reductions, see the document titled *CAA 111(b)(1)(B) review for the SOCOMI air oxidation unit processes, distillation operations, and reactor processes NSPS subparts III, NNN, and RRR—FINAL*, which is available in the docket for this rulemaking.

We disagree with the commenters' suggestion to include the TRE concept in the new NSPS subparts NNNa, IIIa, and RRRa but raise the TRE index value threshold to something greater than 1.0 (as opposed to not including the TRE concept in its entirety, as proposed). Regarding a commenter's assertion that removing the TRE concept is arbitrary given no action was taken on the TRE concept in the MON RTR, we note that we did not have data related to Group 2 process vents while developing revisions to the MON. Setting an emission threshold with no knowledge of which Group 2 MON vent streams would be impacted and the potential cost or reductions associated with that revision would not have been appropriate.

Finally, we agree with the commenter's request to include a mass-based criterion below which emission controls are not required, but only for NSPS subparts IIIa and NNNa (not NSPS

<sup>51</sup> This cost effectiveness value is within the range of what the EPA has considered reasonable for the control of VOC emissions in other recent NSPS rulemakings. See, e.g., 88 FR 29982 (May 9, 2023) (finding a value of \$6,800/ton of VOC emissions reductions cost-effective for automobile and light duty truck surface coating operations) (NSPS subpart MMA); see 89 FR 16820 (March 8, 2024) (finding value of \$5,540 per ton of VOC reduction reasonable for controls identified as BSER in Oil and Natural Gas NSPS subpart OOOOb and Emission Guidelines subpart OOOOc).



subpart RRRa). We believe a mass-based exemption criterion is not needed for NSPS subpart RRRa given that we are finalizing, as proposed, a volumetric flowrate-based exemption (0.011 scm/min at 40 CFR 60.700a(c)(3)) as well as a concentration-based exemption (300 ppmv TOC as measured by EPA Method 18 or 150 ppmv TOC as measured by EPA Method 25A at 40 CFR 60.700a(c)(7)) in NSPS subpart RRRa. It is clear from supporting documents that the EPA included the concentration-based exemption in NSPS subpart RRR with the intent to relieve owners and operators of controlling vent streams with very low amounts of VOC emissions (see 58 FR 45948, August 31, 1993, as well as the document titled *Selection of the Low Concentration Cutoff*, which is available in the docket for this rulemaking). Even so, we recognize that NSPS subparts IIIa and NNNa do not contain these same exemptions. Therefore, we are finalizing a mass-based exemption criterion of 0.001 lb/hr TOC (for which emission controls are not required) for NSPS subparts IIIa and NNNa at 40 CFR 60.610a(c)(1) and 40 CFR 60.660a(c)(6), respectively. We based this criterion on the combination of both the volumetric flowrate- and concentration-based exemptions that are included in NSPS subparts RRR and the final RRRa. In other words, the 0.001 lb/hr TOC mass-based exemption criterion which we are finalizing in NSPS subparts IIIa and NNNa is roughly equal to a vent stream with a volumetric flowrate of 0.011 scm/min and a TOC concentration of 300 ppmv (assuming a TOC molecular weight of 80 grams per mole) included in NSPS subparts RRR and the final RRRa. We also note that new affected facilities should have greater flexibility in selecting cost-effective control options during the design and construction phase (e.g., owners and operators at greenfield sources are likely to have more flexibility in spatial considerations compared to those at an existing source leading to a potential reduction in the amount of complex piping and construction materials needed to install an APCD).

*Comment:* A commenter said they support the EPA's proposal to eliminate the relief valve discharge exemption from the definition of "vent stream" in NSPS, subparts IIIa, NNNa, and RRRa such that any relief valve discharge to the atmosphere of a vent stream is a violation of the emissions standard. However, several other commenters opposed this proposal. Commenters requested that the EPA revise the term "violation" to "deviation" in NSPS

subparts IIIa (at 40 CFR 60.612a(b)), NNNa (at 40 CFR 60.662a(b)), and RRRa (at 40 CFR 60.702a(b)) regarding the prohibition of relief valve discharges (e.g., PRD releases to the atmosphere) and use of bypass lines. In addition, the commenters requested that the EPA add the same PRD work practice standard that the EPA has finalized in the MON (at 40 CFR 63.2480(e)(3)-(8)) and Ethylene MACT (at 40 CFR 63.1107(h)(3)-(8)), and proposed in the HON (at 40 CFR 63.165(e)), into NSPS subparts IIIa, NNNa, and RRRa at 40 CFR 60.612a(d), 60.662a(d), and 60.702a(d), respectively. The commenters argued that the proposed regulatory approach regarding eliminating the relief valve discharge exemption does not represent BSER for the SOCOMI source category given that relief valve discharges that are routed to the atmosphere are necessary at times for at least the following reasons:

- Hazardous oxidation products: A discharge to a flare would result in combustion products that are not desirable.
- Chemical reactivity within flare system: Some affected facilities may use a single large flare for emission control for a given process area or group of process areas.
- Physical obstruction within flare header system: In some cases, there is a potential for certain compounds to block or restrict portions of the flare header.
- Streams containing oxygen: Some process streams and equipment that PRDs protect contain mixtures of organic compounds and oxygen especially in air oxidation processes. Some air oxidation reactors have rupture discs as PRDs, and swings in air supply can cause a rupture disc to fail.
- Intolerable backpressure on the PRD: The operating pressure in a large flare header system could increase from just slightly over atmospheric pressure to a pressure in the 10–20 psig range or higher for certain periods of time when upset venting occurs or another highly intermittent flow occurs.
- Intolerable liquid load on the flare Knock Out (KO) drum: If the PRD is in liquid service, it is not acceptable to add a high-volume liquid discharge from a PRD into a flare header. Flare KO drums have a finite liquid capacity. If the liquid is highly volatile, severe pipe contraction (due to auto-refrigeration) can potentially cause a loss-of-containment failure of the flare header piping.
- Technically impossible to collect discharges from PRDs on portable/mobile containers.

- It is not technically or economically feasible to install a new large flare system to capture the discharge from a small number of new PRDs from a new, reconstructed, or especially a modified SOCOMI source regulated under NSPS subparts IIIa, NNNa, and RRRa.

- Any chemical manufacturing facility with the potential to release high volumes of chlorinated (halogenated) material from a PRD release would be required to install and operate an oversized thermal oxidizer equipped with acid gas controls that would be operated on stand-by anytime the facility is in operation; and this operating mode results in the facility also emitting large amounts of secondary emissions such as greenhouse gases, VOCs, NO<sub>x</sub>, and CO.

- PRDs prevent catastrophic breaches of process equipment that could endanger both the lives of plant employees and nearby communities, and result in damage to property; these catastrophic breaches would result in much greater emissions than those resulting from a PRD release. PRDs minimize the loss of process materials to the surrounding environment.

Commenters also argued that it is not cost-effective to route all PRDs to control devices. Some commenters pointed out that given that the EPA concluded it is not cost-effective to route all PRDs to control for HON and P&R (and instead proposed a work practice standard for PRDs that vent to the atmosphere), it is unclear how the Agency could presume such a requirement would be cost-effective as BSER and appropriate to establish as an NSPS requirement. Additionally, the commenters asserted that the only analysis the EPA uses to justify the proposed change is the identification of a single lowest achievable emissions rate (LAER) condition in the reasonably available control technology (RACT)/BACT/LAER clearinghouse database. The commenters argued that by equating a single LAER determination (based on the EPA's RACT/BACT/LAER clearinghouse database search regarding ID TX-0813171 for the "Linear Alpha Olefins Plant," which is operated by INEOS Oligomers USA, LLC) to BSER and not performing any additional analysis, the EPA has ignored the statutory requirements of CAA Section 111(a)(1) in that the Agency did not adequately account for the cost of achieving reductions, nor did the Agency consider non-air quality health and environmental impacts and more specifically, energy requirements.

A commenter added that PRDs serve a vitally important role as the last line of defense to protect vessels and

equipment from mechanical failure should an overpressure situation occur; therefore, it is important that they work correctly. The commenter asserted that in the unlikely event that a pressure relief event occurs, it is important to have the opportunity to analyze such situations and implement corrective actions to further minimize the chance that such an event will occur in the future.

*Response:* We disagree with the commenters that the removal of the exemption for PRD releases to atmosphere is not BSER for NSPS subparts IIIa, NNNa, and RRRa and that the EPA has ignored its obligations to CAA section 111. For a thorough explanation of our BSER analysis and the ways in which the EPA complied with the statutory requirements of CAA section 111, refer to the document titled *CAA 111(b)(1)(B) review for the SOCMi air oxidation unit processes, distillation operations, and reactor processes NSPS subparts III, NNN, and RRR* (see Docket Item No. EPA-HQ-OAR-2022-0730-0011) and section III.C.3.b of the proposal preamble (88 FR 25080, April 25, 2023). No changes are being made to the final rule as a result of this comment.

While commenters state that only one facility was identified as part of the RACT/BACT/LAER clearinghouse database, we note that one additional facility was also identified as having prohibitions on PRDs releasing to the atmosphere and were thus choosing to route those pieces of equipment to an APCD. The Lyondell Chemical Bayport Choate Plant in Harris, TX (permit number 137789) was identified as part of our RACT/BACT/LAER clearinghouse database search, but did not properly state that they were also under restrictions for PRD releases to atmosphere for streams containing more than 1 percent VOC. See the updated document titled *CAA 111(b)(1)(B) review for the SOCMi air oxidation unit processes, distillation operations, and reactor processes NSPS subparts III, NNN, and RRR—FINAL*, which is available in the docket for this rulemaking. Lyondell and the Linear Alpha Olefins Plant were placed under these restrictions by the state of Texas in 2017 and 2015, respectively. In fact, the TCEQ published the document titled *Air Permit Technical Guidance for Chemical Sources Fugitive Guidance* in June 2018, which is available in the docket for this rulemaking. Section III of the document states that “the following practices are generally considered to be the minimum for BACT . . . . New relief valves are required to vent to a control device for any potential releases

and as a result, any fugitive emissions are reduced. Exceptions may be made if venting relief valve to control will result in a safety concern, but this does not exempt the company from controls such as equipping the valve with a rupture disk and pressure sensing-device.” The EPA maintains that between the guidance provided by the TCEQ and ability of the two identified facilities to meet the requirements, prohibiting PRD releases to atmosphere is adequately demonstrated for purposes of determining BSER.

We also disagree with commenters’ descriptions of why PRDs releasing to atmosphere are necessary. We note that owners and operators are not obligated to route PRDs to an APCD. In fact, we agree with commenters that PRDs act as a last line of defense in uncommon process conditions. Therefore, the EPA expects that a well-controlled and rigorously designed process will not experience PRD releases regularly, if at all. In those situations, as described by the commenter, where PRD releases are necessary to prevent further catastrophic failure, we agree with the commenter that safety is a priority and PRD releases may be necessary. However, we note that we are not prohibiting the release of PRDs in totality, just to atmosphere, or their use in general and that process conditions leading to catastrophic failure should be well outside regular operating conditions. Therefore, the EPA expects that PRDs used to prevent catastrophic failure can continue to function without reasonable concern for release to atmosphere during regular operating conditions. If the facility is concerned about a PRD releasing to atmosphere during a catastrophic failure event, which should be exceptionally rare to begin with, they may choose to route those emissions to an APCD to avoid incurring a violation. The EPA maintains that releasing uncontrolled volumes of emissions to atmosphere as a result of preventable process upsets is characteristic of a violation.

To that point, we are not requiring owners or operators to route PRD releases to an APCD, and there are no cost, non-air quality health, environmental, or energy requirements as a result of this change. The EPA expects no additional equipment will be needed for facilities to meet the finalized provisions given our agreement with commenters that PRD releases are unlikely to occur at all assuming a process is rigorously designed, maintained, and controlled. If the owner or operator chooses to control PRD emissions, it is their responsibility to select whichever control method is

most appropriate considering, among other factors, the composition of the release, location of the equipment, and overall safety. We note that facilities with new sources that choose to route PRD emissions to an APCD will have the flexibility in the design and construction phase to select options they consider to be cost-effective and plan based on key criteria like placement of the equipment. For existing sources that trigger the NSPS subpart IIIa, NNNa, or RRRa via a modification or reconstruction, it is the responsibility of the owner or operator to make the determination if retrofitting PRDs to release to an APCD is feasible, cost-effective, and necessary against the potential to incur violations as a result of atmospheric release or if alternative process controls or operational practices are more appropriate. Any cost, non-air quality health, environmental, or energy impacts associated with the owner or operator controlling PRD emissions, including those from halogenated streams as identified by the commenter, were not considered as part of the BSER analysis because they are only incurred at the discretion of an owner or operator if they choose to go beyond the requirements of this rulemaking and pursue control of emissions. For the above reasons, the EPA has met its obligations under CAA section 111(a)(1).

We disagree with the commenter that the use of the term “violation” should be replaced with “deviation” in NSPS subparts IIIa (at 40 CFR 60.612a(b)), NNNa (at 40 CFR 60.662a(b)), and RRRa (at 40 CFR 60.702a(b)). We used the term “violation” in the SOCMi NSPS (subparts IIIa, NNNa, and RRRa) to be consistent with the HON standards that also regulate the SOCMi source category.

#### ii. Equipment Leaks

*Comment:* A commenter contended the EPA’s BSER analysis was insufficient because it failed to consider key equipment leak control technologies, such as OGI, leak detection sensor networks (LDSNs), and even options that the EPA previously considered in 2007 when developing NSPS subpart VVa. The commenter asserted that the EPA must consider these developments when evaluating and establishing the BSER for new, reconstructed, and modified SOCMi process units. The commenter stated that the EPA’s review of the LDAR requirements in NSPS subpart VVa is inconsistent with other reviews of NSPS equipment leak standards. In particular, the commenter noted that in its November 15, 2021 proposal for the

Crude Oil and Natural Gas source category, the EPA evaluated several monitoring techniques, and combinations of techniques, to determine if the BSER for equipment leaks at natural gas processing plants should be revised, including bimonthly and quarterly OGI monitoring in combination with annual EPA Method 21 monitoring at a leak definition of 10,000 ppm, and bimonthly OGI monitoring on all equipment with the potential for VOC emissions. The commenter asserted that the EPA's failure to consider OGI is erroneous considering the EPA has established an Alternative Work Practice at 40 CFR 60.18(g) through (i) that allows sources subject to NSPS subparts VV and VVa to conduct bimonthly OGI monitoring with annual EPA Method 21 surveys at 500 ppm as an alternative to conducting EPA Method 21 monitoring at the leak definitions and frequencies in those subparts. The commenter added that at a minimum, the EPA should evaluate whether this alternative work practice now represents the BSER for NSPS subpart VVb.

*Response:* For the reasons explained below, we find that none of the control options raised in the comment above (*i.e.*, OGI, LDSN and options considered in the last review) is BSER for equipment leaks from new, modified, and reconstructed SOCOMI process units.

Regarding OGI, we do not believe it replaces EPA Method 21 as BSER for equipment leaks from SOCOMI process units for the following reasons. First, as shown by our equipment leaks regulations for the SOCOMI industry since the early 1980s, leaks in the area of 500 to 1000 ppm can be detected using EPA Method 21 and repaired for most equipment in this industry. The EPA acknowledges that OGI is effective at finding large leaks quickly for many compounds, but, while OGI is capable of detecting low-level leaks under certain conditions, it is difficult for a camera operator to find low level-leaks with OGI under the range of conditions that leak surveys are generally conducted, including variable ambient and equipment temperatures, complex backgrounds, and elevated wind speeds. Additionally, the compounds that can be detected by an OGI camera are limited to the compounds that have a peak in the spectral range of the filter on the OGI camera (generally around 3.2–3.4 micron for cameras used to detect hydrocarbons). While many compounds of interest do have a peak in this range, the variety of chemicals found at SOCOMI facilities is very broad, and not all of these chemicals can be observed with an OGI camera. For example, ethylene and

acetaldehyde have very weak peaks in the spectral range common to OGI camera filters, making it extremely difficult to see these compounds with an OGI camera. For those compounds that can be observed with an OGI camera, the detection range of the camera varies, and some compounds must be emitted in high quantities before being observed. For example, it is expected that twice as much styrene must be emitted as xylene (any isomer) before the emissions are visible with an OGI camera.<sup>52</sup> For these reasons, the use of OGI is not appropriate for the SOCOMI source category.<sup>53</sup>

Regarding LDSNs, which use an array of continuous sensors to find leaks, we agree that these systems can effectively be used to trigger and target EPA Method 21 or OGI monitoring and leak repair, but an effective system depends on the sensitivity of the sensors, the spacing of the sensors, and the trigger used to deploy a ground monitoring crew. It is difficult to develop vendor-agnostic monitoring requirements that can be incorporated generically within a rule, and we do not have the necessary information to do so at this time. While we are continuing to look at how to develop a standardized approach for sensor networks, we are not prepared to include provisions for a continuous sensor network for the SOCOMI source category at this time. However, owners or operators can elect to submit a request for an alternative means of emission limitation for using a site-specific sensor network monitoring plan.

Finally, the commenter claims that the EPA must evaluate options that we had previously considered while promulgating NSPS subpart VVa in 2007. The EPA does not have information, nor has the commenter provided any, indicating that there has been development since the last review to any such previously rejected option that warrants evaluation in the present review.

<sup>52</sup> See Technical Support Document, Optical Gas Imaging Protocol (40 CFR part 60, Appendix K), September 2023 for more information related to detection of compounds with OGI.

<sup>53</sup> In contrast, the majority of VOC emissions at onshore natural gas processing plants are expected to be comprised of compounds such as butane, pentane, hexane, benzene, toluene, xylenes, and ethylbenzene; the type of compounds emitted are expected to be fairly uniform from all onshore natural gas processing plants. In addition to VOC, leaks at onshore natural gas processing plants generally contain methane. All of these compounds can be identified with an OGI camera. For this reason, OGI is effective in detecting leaks from onshore natural gas processing plants, as the commenter observes, but may not be effective for certain SOCOMI process units, where makeup of VOC emissions varies widely across the source category.

*Comment:* A commenter stated that the EPA's focus on lowering the leak definition for valves from 500 ppm to 100 ppm is inconsistent with recent EPA focus on targeting large emissions sources, as was done for the oil and gas industry. The commenter stated that rulemaking targeted finding large leaks faster, while in the review for NSPS subpart VVa, the EPA focused on reducing a small population of small leaks by lowering the leak definition for valves from 500 ppm to 100 ppm. The commenter added that the EPA's analysis for NSPS subpart VVa demonstrates this proposed change only results in reducing 0.64 tpy of VOC emissions per affected facility beyond the baseline. The commenter also stated that the facility-level leak inspection data that the EPA has available shows that leaks between 100 ppm and 500 ppm are not very common. The commenter specified that the EPA has access to at least one data set containing leak inspection results for nearly 3,000 components at a chemical manufacturing facility. The commenter added that the average EPA Method 21 reading was over 25,000 ppm, with the minimum reading for valves was 747 ppm and minimum reading for connectors was 1,000 ppm, underscoring the importance of entirely preventing significant leaks (as well as quickly identifying and remediating others). The commenter recommended, in addition to strengthening the standards as it has proposed, that the EPA evaluate the use of additional technology, such as low emission valves and valve packing and connectors less likely to leak, in order to prevent the presence of these large emissions. The commenter concluded that this evaluation would allow the EPA to take action on preventing emissions from occurring at these high rates and potentially result in the determination that a combined program of low-emissions technology with regular EPA Method 21 monitoring and leak repairs is the BSER for SOCOMI equipment leaks.

*Response:* The EPA disagrees that the actions taken in this NSPS rulemaking are inconsistent with the actions taken in other recent NSPS rulemakings, specifically the oil and gas NSPS (see 89 FR 16820 (March 8, 2024)). The rulemaking for the oil and gas sector are focused on finding large leaks faster while the leak regulation for SOCOMI does not, because there are key differences between the oil and gas and the SOCOMI source category. The SOCOMI industry has been complying with equipment leak regulations since the early 1980s, and leaks are expected to be

much lower in SOCOMI than for the oil and gas industry. As a result, the leak definitions that SOCOMI facilities must comply with are already very low, 500 to 1000 ppm for most equipment, and the proposed and final rule lowers leak definitions to 100 ppm for valves to gain even more emissions reductions.

Additionally, the data set referenced by the commenter was collected over several years. The chemical facility associated with the data set conducted an OGI survey and then recorded the EPA Method 21 reading for any leaks found by OGI. However, the data set does not include any information related to leaks that could have been found with EPA Method 21 but not OGI. Therefore, the EPA cannot conclude that there are few leaks between 100 ppm and 500 ppm at chemical plants based on this data set. What this data set does demonstrate is that there is no evidence that OGI can find low-level leaks at chemical plants.

In the final rule (NSPS subpart VVb), we are not requiring specific types of equipment be used to meet the 100 ppm leak definition for valves. However, in order to meet the 100 ppm leak definition for valves, we anticipate that facilities will need to use low-emission valves or packings. The average cost-effectiveness (with recovery credits) of lowering the leak definition for valves in gas/vapor or light liquid service from 500 ppm to 100 ppm, is \$2,780 per ton of VOC reduced, and the EPA estimates this provision could result in reductions of more than 20 tpy of VOC.

*Comment:* A commenter contended that the EPA's proposed definition for capital expenditures in NSPS subpart VVb narrows the reach of modification and would result in the exclusion of certain process units from applicability to the subpart through modification. For NSPS subpart VVb, the commenter opposed the two proposed calculations for "X". The commenter explained that by proposing a value for "X" to be "2023 minus the year of construction" for sources with a construction date after January 6, 1982 and before January 1, 2023, the EPA has categorically exempted any process unit from ever becoming subject to NSPS subpart VVb through modification if its date of construction is prior to January 6, 1982. The commenter contended that this error must be addressed in the final rule to not create a loophole exempting the oldest of these SOCOMI process units from ever becoming subject to NSPS subpart VVb through modification. The commenter suggested revising the value for "X" to mean "2023 minus the year of construction" without the need to bookend this definition with specific

dates. The commenter added that the EPA should first evaluate more recent developments on the definition of "capital expenditure" inclusion in the final NSPS subpart VVb. The commenter also opposed the proposed change of "X" for sources constructed in the year 2023 in order for X to not be equal to zero, which results in an equation that cannot be solved. The commenter noted that the EPA has addressed this same issue recently through specific changes to the definition of capital expenditure promulgated in the technical amendments to NSPS subpart OOOOa for equipment leaks at onshore natural gas processing plants. The commenter explained that in those amendments, the EPA revised the equation used to determine "Y" (the percent of replacement costs) to remove the variable "X" (and logarithmic function) and instead the EPA specifically defined "Y" as "the Consumer Price Index (CPI) of the date of construction divided by the most recently available CPI of the date of the project, or "CPIN/CIPIPD". The commenter contended that at a minimum, the EPA must consider this calculation of "Y" when defining "capital expenditure" in NSPS subpart VVb and discuss why the use of the CPI-based ratio is not appropriate for affected facilities before finalizing the proposed definition with the appropriate revisions to close loopholes.

*Response:* We agree with the commenter that in the proposed definition of "capital expenditure" in NSPS subpart VVb, the value of "X" should not be bounded by the NSPS subpart VV date of January 6, 1982. We also agree with the commenter that we should update the definition of "capital expenditure" to use the CPI in the equation for "Y" in NSPS subpart VVb. For the reasons discussed below, the EPA is finalizing the capital expenditure definition in NSPS subpart VVb to state in part that the value of "Y" is calculated using the CPI of the date of original construction of the process unit divided by the most recently available CPI of the date of the project.

In the early 1980s, some facilities were having trouble determining capital expenditure because records for costs were not available for determining the original basis of the affected facility.<sup>54</sup> The EPA developed an alternative method to NSPS subpart A which enabled companies to use replacement cost rather than original cost. In the

<sup>54</sup> Pursuant to the NSPS subpart A definition of "capital expenditure" companies would need to know the original cost of the affected facility to determine capital expenditure.

alternative method, an inflation index is applied to the replacement cost to approximate the original cost basis of the affected facility. The relationship between the replacement and original cost ultimately ended up in the formulas contained in the definitions of "capital expenditure" in NSPS subparts VV and VVa.<sup>55</sup>

The formulas for "Y" in the definitions of "capital expenditure" in NSPS subparts VV and VVa were intended to adjust the replacement cost for inflation to approximate the original cost basis; however, the formulas were based on analysis of inflation between the years 1947 and 1982 and do not necessarily reflect current economic conditions. In the 2020 amendments to NSPS subpart OOOOa, which covers the oil and natural gas sector, the EPA determined that using a CPI-based ratio is more appropriate under current economic conditions.<sup>56</sup> Similarly, the EPA has determined the CPI-based ratio better reflects the inflation of chemical process facility construction costs over time and thus is more appropriate for use in determining capital expenditure for the SOCOMI source category in NSPS subpart VVb. There are several versions of the CPI published by the U.S. Bureau of Labor Statistics; for simplicity, the EPA is requiring the use of "CPI-U, U.S. city average, all items" (CPI for all urban consumers) for both CPI values.

4. What is the rationale for our final approach and final decisions for the technology review and NSPS review?

a. NESHAP

Our technology review focused on the identification and evaluation of developments in practices, processes, and control technologies that have occurred since the previous technology reviews for the HON and the P&R I and P&R II NESHAP were promulgated (see 71 FR 76603, December 21, 2006; 73 FR 76220, December 16, 2008; and 77 FR 22566, April 21, 2011 for additional details). Specifically, we focused our technology review on all existing MACT standards for the various emission sources in the SOCOMI, P&R I, and P&R

<sup>55</sup> See Office of Air Quality Planning & Standards, U.S. Environmental Protection Agency. EPA-450/3-83-015B, *Petroleum Fugitive Emissions—Background Information For Promulgated Standards* at 4-3 to 4-7 (Oct. 1983), which is available in the docket for this rulemaking.

<sup>56</sup> See Office of Air Quality Planning & Standards, U.S. Environmental Protection Agency. Docket Item No. EPA-HQ-OAR-2017-0483-2291, *EPA Responses to Public Comments on Reconsideration of New Source Performance Standards (NSPS) Oil and Natural Gas Sector: Emission Standards for New, Reconstructed, and Modified Sources Reconsideration 40 CFR part 60, subpart OOOOa* at 11-2 (Sep. 2020).

II source categories, including, heat exchange systems, storage vessels, process vents, transfer racks, wastewater, and equipment leaks. Under CAA section 112(d)(6), we also proposed a fenceline monitoring work practice standard requiring owners and operators to monitor for any of six specific HAP (*i.e.*, benzene, 1,3-butadiene, ethylene dichloride, vinyl chloride, EtO, and chloroprene) if their site uses, produces, stores, or emits any of them, and conduct root cause analysis and corrective action upon exceeding the annual average concentration action level set forth for each HAP. In the proposal, we identified cost-effective developments only for HON and P&R I heat exchange systems, storage vessels, and process vents, and we proposed to revise the standards for these three emissions sources under the technology review. We did not identify developments in practices, processes, or control technologies (beyond the fenceline monitoring work practice standard) for transfer racks, wastewater, and equipment leaks. Further information regarding the technology review can be found in the proposed rule (88 FR 25080, April 25, 2023) and in the supporting materials in the rulemaking docket at Docket ID No. EPA-HQ-OAR-2022-0730.

During the public comment period, we received several comments on our proposed determinations for the technology review. The comments and our specific responses and rationale for our final decisions can be found in section IV.B.3 of this preamble and in the document titled *Summary of Public Comments and Responses for New Source Performance Standards for the Synthetic Organic Chemical Manufacturing Industry and National Emission Standards for Hazardous Air Pollutants for the Synthetic Organic Chemical Manufacturing Industry and Group I & II Polymers and Resins Industry*, which is available in the docket for this rulemaking. No information presented by commenters has led us to change our proposed determination under CAA section 112(d)(6) for transfer racks, wastewater, and equipment leaks, and we are finalizing our determination that no changes to these standards are warranted. However, based on comments received on the proposed revisions for the Group 1 HON and P&R I storage vessels, we are clarifying that the capacity and MTVP thresholds in the final rule apply to both new and existing sources. In addition, some additional cost information was

submitted by commenters on the proposed revisions for HON process vents and P&R I continuous front-end process vents. Based on these comments, we have updated our cost analysis, but continue to believe our revisions for HON process vents and P&R I continuous front-end process vents, as proposed, are still cost-effective. Therefore, for HON process vents and P&R I continuous front-end process vents, we are finalizing, as proposed the: (1) Removal of the TRE concept in its entirety; (2) removal of the 50 ppmv and 0.005 scmm Group 1 process vent thresholds; and (3) redefining of a Group 1 process vent (require control) as any process vent that emits  $\geq 1.0$  lb/hr of total organic HAP. Finally, based on comments received on the proposed fenceline monitoring requirements, we have established two action levels in the final rule for chloroprene (*i.e.*, one action level under CAA section 112(d)(6) for this HAP and another action level under CAA section 112(f) in lieu of only one action level, as proposed). In addition, based on comments received, we are: (1) Finalizing burden reduction measures to allow owners and operators to skip fenceline measurement periods for specific monitors with a history of measurements that are at or below certain action levels; (2) clarifying that fenceline monitoring is required for owners and operators with affected sources that produce, store, or emit one or more of the target analytes; (3) reducing the requirements for the minimum detection limit of alternative measurement approaches; (4) clarifying how owners and operators establish the monitoring perimeter for both sorbent tubes and canisters; (5) clarifying the calculation of  $\Delta c$  when a site-specific monitoring plan is used to correct monitoring location concentrations due to offsite impacts; (6) changing the required method detection limit for alternative test methods from an order of magnitude below the action level to one-third of the action level; and (4) with the exception of fenceline monitoring of chloroprene at P&R I affected sources producing neoprene, we are changing the compliance date in the final rule to begin fenceline monitoring 2 years (instead of 1 year, as proposed) after the effective date of the final rule. For P&R I affected sources producing neoprene, we have changed the compliance date for fenceline monitoring of chloroprene to begin no later than October 15, 2024, or upon startup, whichever is later, subject to the owner or operator seeking the EPA's

authorization of an extension of up to 2 years from July 15, 2024.

#### b. NSPS

For NSPS subparts IIIa, NNNa, and RRRa, we are finalizing the suite of process vent requirements, as proposed.<sup>57</sup> As described in the proposal (88 FR 25080, April 25, 2023) and in consideration of comments received about these new requirements (see section IV.B.3.b.i of this preamble for further detail), we found the requirements to be cost-effective for VOC emission reductions at new, modified, and reconstructed affected facilities.

For NSPS subpart VVb, we are finalizing, as proposed, the same requirements in NSPS subpart VVa with the updated requirement that all gas/vapor and light liquid valves be monitored monthly at a leak definition of 100 ppm instead of 500 ppm, and an additional requirement that all connectors be monitored once every 12 months at a leak definition of 500 ppm, as described in the proposal (88 FR 25080, April 25, 2023).

#### C. Amendments Pursuant to CAA Section 112(d)(2) and (3) and 112(h) for the SOCM, P&R I, and P&R II Source Categories NESHP

1. What did we propose pursuant to CAA section 112(d)(2) and (3) and 112(h) for the SOCM, P&R I, and P&R II source categories?

Under CAA sections 112(d)(2) and (3), we proposed to amend the operating and monitoring requirements for a subset of flares in the SOCM and P&R I source categories. We proposed at 40 CFR 63.108 (for HON) and 40 CFR 63.508 (for the P&R I NESHP) to directly apply the petroleum refinery flare rule requirements in 40 CFR part 63, subpart CC, to the HON and P&R I flares with clarifications, including, but not limited to, specifying that several definitions in 40 CFR part 63, subpart CC, that apply to petroleum refinery flares also apply to the flares in the specified subset, adding a definition and requirements for pressure-assisted multi-point flares, and specifying additional requirements when a gas chromatograph or mass spectrometer is used for compositional analysis. Specifically, we proposed to retain the General Provisions requirements of 40 CFR 63.11(b) and 40 CFR 60.18(b) such that HON and P&R I flares operate pilot flame systems continuously and that these flares operate with no visible emissions (except for periods not to

<sup>57</sup> See section IV.B.1.b.i of this preamble.

exceed a total of 5 minutes during any 2 consecutive hours) when the flare vent gas flow rate is below the smokeless capacity of the flare. We also proposed to consolidate measures related to flare tip velocity and new operational and monitoring requirements related to the combustion zone gas for HON and P&R I flares. Further, in keeping with the elimination of the SSM exemption, we proposed a work practice standard related to the visible emissions limits during periods when a HON or P&R I flare is operated above its smokeless capacity (e.g., periods of emergency flaring). We proposed eliminating the cross-references to the General Provisions and instead specifying all operational and monitoring requirements that are intended to apply to HON and P&R I flares in the applicable subparts.

In addition, we proposed provisions and clarifications in the HON and P&R I and P&R II NESHAP for periods of SSM and bypasses, including PRD releases, bypass lines on closed vent systems, maintenance vents and equipment openings, storage vessel degassing, and planned routine maintenance for storage vessels to ensure that CAA section 112 standards apply continuously, consistent with *Sierra Club v. EPA* 551 F. 3d 1019 (D.C. Cir. 2008).

For PRD releases, we proposed revisions to the definition of “pressure relief device” for the HON and P&R I NESHAP, a definition of “relief valve” for the HON and P&R I NESHAP, and a definition in the P&R II NESHAP for “pressure relief device.” Under CAA section 112(h), we proposed a work practice standard for PRDs at 40 CFR 63.165(e) (for HON) and 40 CFR 63.502(a)(1) and (a)(2) (which references 40 CFR 63.165, for the P&R I NESHAP) that consists of using at least three prevention measures and performing root cause analysis and corrective action in the event that a PRD does release emissions directly to the atmosphere.<sup>58</sup> (Examples of prevention measures include flow indicators, level indicators, temperature indicators, pressure indicators, routine inspection and maintenance programs or operator training, inherently safer designs or safety instrumentation systems, deluge systems, and staged relief systems

where the initial PRD discharges to a control system.) We proposed that PRDs in EtO service (for HON) and PRDs in chloroprene service (for Neoprene Production processes subject to the P&R I NESHAP) may not vent directly to atmosphere. We also proposed to require that sources monitor PRDs that vent to atmosphere using a system that is capable of identifying and recording the time and duration of each pressure release and of notifying operators that a pressure release has occurred. We proposed at 40 CFR 63.165(e)(4) that PRDs that vent through a closed vent system to a control device or to a process, fuel gas system, or drain system must meet minimum requirements for the applicable control system. In addition, we proposed at 40 CFR 63.165(e)(5) that the following types of PRDs would not be subject to the work practice standard for PRDs that vent to the atmosphere: (1) PRDs in heavy liquid service; (2) PRDs that are designed solely to release due to liquid thermal expansion; (3) PRDs on mobile equipment; and (4) pilot-operated and balanced bellows PRDs if the primary release valve associated with the PRD is vented through a control system. Finally, we proposed at 40 CFR 63.165(e)(8) to require future installation and operation of non-flowing pilot-operated PRDs at all affected sources.

For bypass lines on closed vent systems, we proposed at 40 CFR 63.114(d)(3), 40 CFR 63.127(d)(3), 40 CFR 63.148(f)(4), and 40 CFR 63.172(j)(4) (for HON), and 40 CFR 63.485(x), 40 CFR 63.489(d)(3), and 40 CFR 63.502(a)(2) (for the P&R I NESHAP) that an owner or operator may not bypass the APCD at any time, that a bypass is a violation (at 40 CFR 63.118(a)(5) and (f)(7), 40 CFR 63.130(a)(2)(iv), (b)(3), and (d)(7), 40 CFR 63.148(i)(3)(iii) and (j)(4), Tables 3, 7, and 20 to 40 CFR 63, subpart G, 40 CFR 63.181(g)(3)(iii), and 40 CFR 63.182(d)(xix) (for HON), and 40 CFR 63.485(x), 40 CFR 63.489(d)(3), and 40 CFR 63.502(a)(2) (for the P&R I NESHAP)), and the owner or operator must estimate and report the quantity of organic HAP released.

Under CAA section 112(h), we proposed a work practice standard for maintenance vents and equipment openings at 40 CFR 63.113(k)(1)(i) (for HON), and at 40 CFR 63.485(x) and 40 CFR 63.487(i)(1)(i) (for the P&R I NESHAP) requiring that, prior to opening process equipment to the atmosphere, the equipment must either (1) be drained and purged to a closed system so that the hydrocarbon content is less than or equal to 10 percent of the

LEL; (2) be opened and vented to the atmosphere only if the 10-percent LEL cannot be demonstrated and the pressure is less than or equal to 5 psig, provided there is no active purging of the equipment to the atmosphere until the LEL criterion is met; (3) be opened when there is less than 50 lbs of VOC that may be emitted to the atmosphere; or (4) for installing or removing an equipment blind, depressurize the equipment to 2 psig or less and maintain pressure of the equipment where purge gas enters the equipment at or below 2 psig during the blind flange installation, provided none of the other proposed work practice standards can be met.

Also under CAA section 112(h), we proposed a work practice standard for storage vessel degassing at 40 CFR 63.119(a)(6) (for HON) and 40 CFR 63.484(a) and (t) (which references 40 CFR 63.119, for the P&R I NESHAP) to allow storage vessels to be vented to the atmosphere once a storage vessel degassing concentration threshold is met (i.e., once the vapor space concentration is less than 10 percent of the LEL) and all standing liquid has been removed from the vessel to the extent practicable. In addition, we proposed at 40 CFR 63.119(e)(7) that owners and operators would not be permitted to fill the storage vessel during these periods (such that the vessel would emit HAP to the atmosphere for a limited amount of time due to breathing losses only).

To address regulatory gaps, we proposed:

Emission limits for dioxins and furans at 40 CFR 63.113(a)(5) (for HON), 40 CFR 63.485(x) and 40 CFR 63.487(a)(3) and (b)(3) (for the P&R I NESHAP), and 40 CFR 63.523(e), 40 CFR 63.524(a)(3), and 40 CFR 63.524(b)(3) (for the P&R II NESHAP).

To define pressure vessel at 40 CFR 63.101 (for HON) and 40 CFR 63.482 (for the P&R I NESHAP) to mean “a storage vessel that is used to store liquids or gases and is designed not to vent to the atmosphere as a result of compression of the vapor headspace in the pressure vessel during filling of the pressure vessel to its design capacity,” and to remove the exemption for “pressure vessels designed to operate in excess of 204.9 kilopascals and without emissions to the atmosphere” from the definition of storage vessel. We proposed LDAR requirements at 40 CFR 63.119(a)(7) (for HON) and 40 CFR 63.484(t) (for the P&R I NESHAP) requiring no detectable emissions at all times (i.e., would be required to meet a leak definition of 500 ppm at each point on the pressure vessel where total

<sup>58</sup> The P&R II NESHAP is different from the HON and the P&R I NESHAP because the P&R II NESHAP defines a process vent as a “a point of emission from a unit operation. Typical process vents include condenser vents, vacuum pumps, steam ejectors, and atmospheric vents from reactors and other process vessels.” As such, the P&R II NESHAP does not exclude PRD releases from its production-based emission rate MACT standard.

organic HAP could potentially be emitted); initial and annual leak monitoring using EPA Method 21 of 40 CFR part 60, Appendix A-7; and routing organic HAP through a closed vent system to a control device (*i.e.*, no releases to the atmosphere through a pressure vessel's PRD).

A requirement at 40 CFR 63.170(b) (for HON) and 40 CFR 63.485(d) (for the P&R I NESHAP) that owners and operators of all surge control vessels and bottoms receivers that emit greater than or equal to 1.0 lb/hr of total organic HAP would be required to reduce emissions of organic HAP using a flare meeting the proposed operating and monitoring requirements for flares; or reduce emissions of total organic HAP or TOC by 98 percent by weight or to an exit concentration of 20 ppmv.

Removing the exemption for transfer operations that load "at an operating pressure greater than 204.9 kilopascals" from the definition of transfer operation at 40 CFR 63.101 (for HON) such that owners and operators would be required to equip each transfer rack with an operating pressure greater than 204.9 kilopascals with a vapor collection system and control device to reduce total organic HAP emissions by 98 percent by weight or to an exit concentration of 20 ppmv.

Requirements at 40 CFR 63.523(d) (for BLR manufacturers subject to the P&R II NESHAP) and 40 CFR 63.524(c) (for WSR manufacturers subject to the P&R II NESHAP) that owners and operators of each affected source comply with the requirements of 40 CFR 63.104 for heat exchange systems, including quarterly monitoring for existing and new heat exchange systems (after an initial 6 months of monthly monitoring) using the Modified El Paso Method and a leak definition of 6.2 ppmv of total strippable hydrocarbon concentration (as methane) in the stripping gas. We also proposed at 40 CFR 63.104(j)(3) a delay of repair action level of total strippable hydrocarbon concentration (as methane) in the stripping gas of 62 ppmv, that if exceeded during leak monitoring, would require immediate repair (*i.e.*, the leak found cannot be put on delay of repair and would be required to be repaired within 30 days of the monitoring event). In addition, we proposed at 40 CFR 63.104(h) and (i) re-monitoring at the monitoring location where a leak is identified to ensure that any leaks found are fixed. Finally, we proposed that none of these requirements would apply to heat exchange systems that have a maximum cooling water flow rate of 10 gallons per minute or less.

A requirement at 40 CFR 63.524(a)(3) and (b)(3) that owners and operators of existing, new, or reconstructed affected WSR sources subject to the P&R II NESHAP comply with both the equipment leak standards in the HON and the HAP emissions limitation for process vents, storage tanks, and wastewater systems (*i.e.*, we proposed that the alternative standard is no longer optional). For the P&R II NESHAP, we also proposed to include valves in the definition of "equipment leaks" at 40 CFR 63.522 such that owners and operators of an existing, new, or reconstructed affected BLR or WSR source would be required to comply with the same LDAR program that already exists in the HON and the P&R I NESHAP for valves that contain or contact material that is 5 percent by weight or more of organic HAP, operate 300 hours per year or more, and are not in vacuum service.

A requirement at 40 CFR 63.119(b)(7), that owners and operators that use a sweep, purge, or inert blanket between the IFR and fixed roof of a storage vessel would be required to route emissions through a closed vent system and control device.

We proposed that all of these requirements (proposed for the purpose of addressing regulatory gaps) are consistent with CAA section 112(d) controls and reflect the MACT floor, and we did not identify any additional options beyond these (*i.e.*, beyond-the-floor options) for controlling emissions from these emission sources. More information concerning our proposed requirements under CAA section 112(d)(2) and (3) and 112(h) can be found in sections III.D and III.E of the proposal preamble (88 FR 25080, April 25, 2023).

2. How did the revisions pursuant to CAA section 112(d)(2) and (3) and 112(h) change since proposal?

The EPA is finalizing the work practice standard for storage vessel degassing, as proposed, except that we are adding an option at 40 CFR 63.119(a)(6) to allow owners and operators to degas a storage vessel to the atmosphere once a vapor space organic HAP concentration of less than 5,000 ppmv as methane is met (in lieu of having to meet a vapor space concentration threshold of less than 10 percent of the LEL). We are also correcting our use of the term "LEL" versus our use of the term "concentration" in 40 CFR 63.119(a)(6) in that "the concentration" of the vapors in storage vessels be less than 10 percent of the LEL and that owners and operators are required to measure "the

concentration" of the vapors as a percent of the LEL. We are also revising the final rule at 40 CFR 63.119(a)(6) to include storage vessels in EtO service subject to 40 CFR 63.119(a)(5).

The EPA is finalizing the revisions to the work practice standard for planned routine maintenance of storage vessels, as proposed, except that we are clarifying in the final rule at 40 CFR 63.119(f)(3) that the 240-hour planned routine maintenance provisions also apply for breathing losses for fixed roof vessels routed to a fuel gas system or to a process.

The EPA is finalizing the requirements for pressure vessels, as proposed, except that we are: (1) Clarifying that the pressure vessel requirements at 40 CFR 63.119(a)(7) only apply to pressure vessels that are considered Group 1 storage vessels; (2) clarifying that if the equipment is not a connector, gas/vapor or light liquid valve, light liquid pump, or PRD in EtO service and the equipment is on a pressure vessel located at a HON or P&R I facility, then that particular equipment is not subject to HON subpart H, but rather the equipment is subject to the pressure vessel requirements we proposed and are finalizing in 40 CFR 63.119(a)(7); (3) clarifying that unsafe and difficult/inaccessible to monitor provisions in 40 CFR 63.168(h) and (i) (for valves in gas/vapor service and in light liquid service) and in 40 CFR 63.174(f) and (h) (for connectors in gas/vapor service and in light liquid service) still apply to valves and connectors when complying with 40 CFR 63.119(a)(7); and (4) replacing the word "deviation" with "violation" in the final rule text at 40 CFR 63.119(a)(7).

The EPA is finalizing the requirements for surge control vessels and bottoms receivers, as proposed, except that we are adding language in the "C" and "Q" terms of the equations at 40 CFR 63.115(g)(3)(ii) and (g)(4)(iv) to allow the use of engineering calculations to determine concentration or flow rate only in situations where measurements cannot be taken with EPA reference methods. We are also adding reference methods for measuring flow rate at 40 CFR 63.115(g)(3)(ii) and 40 CFR 63.115(g)(4)(iv).

Also, we are clarifying in the final rule that the requirements for sweep, purge, and inert blankets from IFRs at 40 CFR 63.119(b)(7) applies only if a continuous sweep, purge, or inert blanket is used between the IFR and fixed roof that causes a pressure/vacuum vent to remain continuously open to the atmosphere where uncontrolled emissions are greater than

or equal to 1.0 lb/hr of total organic HAP.

3. What key comments did we receive on the proposal revisions pursuant to CAA section 112(d)(2) and (3) and 112(h), and what are our responses?

This section provides summaries of and responses to the key comments received regarding our proposed revisions for periods of SSM, including maintenance vents and equipment openings, storage vessel degassing, planned routine maintenance of storage vessels, pressure vessels, surge control vessels and bottoms receivers, and the requirements for sweep, purge, and inert blankets from IFRs. Other comment summaries and the EPA's responses for additional issues raised regarding these activities, as well as issues raised regarding our proposed revisions for flares, PRDs, bypass lines on closed vent systems, emission limits for dioxins and furans, transfer operations (for HON), heat exchange systems (for the P&R II NESHAP), and equipment leaks (for the P&R II NESHAP) can be found in the document titled *Summary of Public Comments and Responses for New Source Performance Standards for the Synthetic Organic Chemical Manufacturing Industry and National Emission Standards for Hazardous Air Pollutants for the Synthetic Organic Chemical Manufacturing Industry and Group I & II Polymers and Resins Industry*, which is available in the docket for this rulemaking.

#### a. Maintenance Vents

*Comment:* Commenters contended that the EPA misuses the term LEL for the maintenance vents and storage vessel degassing provisions. A commenter said that the regulatory language implies that operators have the ability to change the LEL of a vapor by purging or otherwise removing portions of the vapor from equipment. This commenter said that the concentration of a flammable gas or mixture can be lowered (e.g., by dilution or displacement) to a level that is less than the LEL; thus, they requested that the EPA clarify that concentration of the vapors in equipment be less than 10 percent of the LEL and that facilities are to measure the vapor concentration, not the LEL. Similarly, another commenter requested that the EPA clarify that the concentration of the vapors in equipment and storage vessels be less than 10 percent of the LEL and that facilities are to measure the concentration of the vapors as a percent of the LEL (i.e., with a hand-held analyzer that reports concentration as a percent of LEL, and not the LEL itself).

The commenter suggested that these changes should be made to 40 CFR 63.113(k), 40 CFR 63.118(f) and (m), 40 CFR 63.119(a)(6), 40 CFR 63.486(i), 40 CFR 63.491(h), and 40 CFR 63.492(g). The commenter provided an example saying that in proposed 40 CFR 63.119(a)(6), the second instance of "LEL" should be corrected to read "The owner or operator must determine the concentration using process instrumentation or portable measurement devices . . .".

*Response:* We agree with the commenters that our proposed use of the term LEL improperly implies that operators have the ability to change the LEL of a vapor by purging or otherwise removing portions of the vapor from equipment. In the final rule, we are revising 40 CFR 63.113(k)(1)(i) and (ii) and (k)(2), 40 CFR 63.119(a)(6), 40 CFR 63.118(f)(9)(iii) and (m)(2), (3), and (5), 40 CFR 63.486(i)(1)(i) and (ii) and (i)(2), 40 CFR 63.491(h)(2), (3), and (5), and 40 CFR 63.492(g)(3) to clarify that "the concentration" of the vapors in equipment and storage vessels be less than 10 percent of the LEL and that facilities are to measure "the concentration" of the vapors as a percent of the LEL.

#### b. Storage Vessel Degassing

*Comment:* Several commenters supported the proposed degassing provisions at 40 CFR 63.119(a)(6). However, some commenters requested the EPA also add a concentration limit as an alternative to LEL measurements. The commenters explained that some nonflammable chemicals do not exhibit an LEL, or through the use of an inert blanket, the storage vessel atmosphere would not have an LEL, so owners and operators of storage vessels under these conditions would be unable to comply with the proposed 10 percent LEL threshold. These commenters requested that the EPA allow the storage vessel to be opened after the vapor space organic HAP content has been reduced below 5,000 ppmv, based on the Agency's assertion that this level is equivalent to 10 percent of the LEL. A commenter pointed out that 5,000 ppmv as methane equals 10 percent of the LEL for methane.

*Response:* We agree with commenters that some nonflammable chemicals do not exhibit an LEL, or through the use of an inert blanket, the storage vessel atmosphere would not have an LEL, so owners and operators of storage vessels under these conditions would be unable to comply with the proposed 10 percent LEL threshold. Therefore, we are revising the final rule at 40 CFR 63.119(a)(6) to allow storage vessels to

be vented to the atmosphere once a storage vessel degassing organic HAP concentration of 5,000 ppmv as methane is met, or until the vapor space concentration is less than 10 percent of the LEL. We stated in the preamble to the proposed rule (88 FR 25080, April 25, 2023) that we are aware of three regulations regarding storage vessel degassing, two in the state of Texas and the third for the South Coast Air Quality Management District (SCAQMD) in California. Texas has degassing provisions in the TAC and through permit conditions, while Rule 1149 contains the SCAQMD degassing provisions. The TAC requirements are the least stringent and require control of degassing emissions until the vapor space concentration is less than 35,000 ppmv as methane or 50 percent of the LEL. The Texas permit conditions require control of degassing emissions until the vapor space concentration is less than 10 percent of the LEL or until the VOC concentration is less than 10,000 ppmv, and SCAQMD Rule 1149 requires control of degassing emissions until the vapor space concentration is less than 5,000 ppmv as methane. The Texas permit conditions requiring compliance with 10 percent of the LEL and SCAQMD Rule 1149 control requirements are considered equivalent because 5,000 ppmv as methane equals 10 percent of the LEL for methane.

*Comment:* A commenter remarked that the work practice standard proposed in 40 CFR 63.119(a)(6) should not only apply to degassing Group 1 storage vessels, but should also be applicable for degassing storage vessels in EtO service. The commenter explained that a storage vessel in EtO service (subject to 40 CFR 63.119(a)(5)) may also need to be degassed during storage vessel shutdown operations, but the way the proposed language is currently written, the storage vessel degassing provisions only apply to storage vessels subject to 40 CFR 63.119(a)(1) and (a)(2). The commenter requested the EPA amend the language in 40 CFR 63.119(a)(6) to include storage vessels in EtO service subject to 40 CFR 63.119(a)(5).

*Response:* It was not our intent to exclude storage vessels in EtO service from the work practice standard in 40 CFR 63.119(a)(6); therefore, we are revising the final rule at 40 CFR 63.119(a)(6) to include storage vessels in EtO service subject to 40 CFR 63.119(a)(5). However, owners and operators are still prohibited from releasing more than 1.0 ton of EtO from all maintenance vents combined in any consecutive 12-month period at 40 CFR 63.113(k)(4). In other words, we still



consider degassing a storage vessel a type of maintenance vent. As stated in the final rule (as proposed), an owner or operator may designate any vent stream as a maintenance vent if the vent is only used as a result of startup, shutdown, maintenance, or inspection of equipment where equipment is emptied, depressurized, degassed, or placed into service.

#### c. Planned Routine Maintenance for Storage Vessels

*Comment:* A commenter said they supported the proposed work practice standard for periods of planned routine maintenance for storage vessels including the proposed requirement that owners and operators would not be permitted to fill storage vessels during these periods. However, another commenter pointed out that the 240-hour planned routine maintenance provisions at 40 CFR 63.119(f)(3) (for fixed roof vessels routed to a fuel gas system or to a process) is inconsistent with the parallel requirement at 40 CFR 63.119(e)(7) for fixed roof vessels routed to a control device. The commenter requested the EPA make 40 CFR 63.119(f)(3)(iii) no longer apply on or after the compliance dates specified in 40 CFR 63.100(k)(10) and allow for, in a new paragraph at 40 CFR 63.119(f)(3)(iv), the 240-hour planned routine maintenance provisions for breathing losses for fixed roof vessels routed to a fuel gas system or to a process. Citing page 25161 of the preamble to the proposed rule (88 FR 25080, April 25, 2023), the commenter contended that this recommended change for fixed roof vessels routed to a fuel gas system or to a process would be consistent with the proposed rule text at 40 CFR 63.119(e)(7) for fixed roof vessels routed to a control device. The commenter added that their recommendation is also similar to the approach that the EPA used in the Organic Liquids Distribution MACT (NESHAP subpart EEEE) under 40 CFR 63.2378(d) and (e)(4). The commenter pointed out that the associated recordkeeping requirement in 40 CFR 63.123(h) would also need to be amended slightly to reference the new recommended paragraph at 40 CFR 63.119(f)(3)(iv).

*Response:* We agree with the commenter that the 240-hour planned routine maintenance provisions should apply for breathing losses for fixed roof vessels routed to a fuel gas system or to a process given this would parallel the requirement at 40 CFR 63.119(e)(7). Therefore, we are revising the final rule to sunset 40 CFR 63.119(f)(3)(iii) in

accordance with the schedule specified in 40 CFR 63.100(k)(10), and to include a new paragraph at § 63.119(f)(3)(iv). We are also revising the final rule at 40 CFR 63.123(h)(3) to reference

“§ 63.119(f)(3)(iv)” instead of “§ 63.119(f)(3)(iii).” Additionally, we are revising 40 CFR 63.100(k)(10) to reference “§ 63.119(f)(3)(iv)” as well as the introductory text in 40 CFR 63.119(f)(3) to properly reference the new paragraph at “§ 63.119(f)(3)(iv).” The new paragraph at 40 CFR 63.119(f)(3)(iv) reads: “For each source as defined in § 63.101, beginning no later than the compliance dates specified in § 63.100(k)(10), paragraph (f)(3)(iii) of this section no longer applies. Instead, if you elect to route emissions from storage vessels to a fuel gas system or to a process to comply with the requirements of paragraph (a)(1), (a)(2), or (a)(5) of this section, the fuel gas system or process may only be bypassed when the planned routine maintenance cannot be performed during periods that storage vessel emissions are vented to the fuel gas system or process, and the total aggregate amount of time during which the breathing loss emissions bypass the fuel gas system or process during the calendar year without being routed to a control device must not exceed 240 hours. The level of material in the storage vessel shall not be increased during periods that the fuel gas system or process is bypassed to perform routine maintenance.”

#### d. Pressure Vessels

*Comment:* Some commenters requested that the EPA clarify what is meant by the requirement to monitor “each point on a pressure vessel at § 63.119(a)(7)(ii).” These commenters contested that components such as valves, pumps, and flanges servicing a pressure vessel and that are already subject to LDAR program requirements should be excluded from these provisions.

A commenter added that PRDs associated with pressure vessels should be eligible to comply with the EPA’s proposed PRD work practice standards in 40 CFR 63.165(e) and a release of total organic HAP to the atmosphere through a pressure vessel’s PRD should not be considered a deviation per 40 CFR 63.119(a)(7)(v). The commenter explained that PRDs associated with larger pressure vessels, such a pressure sphere, are typically designed for very rare scenarios like a fire protection case, and thus venting flammable vapors vertically upward to the atmosphere is a safety feature. The commenter said that many engineering design issues

will need to be evaluated before routing PRDs associated with specific pressure vessels to a collection system and control device, such as the potential for back-pressure on the collection header if multiple pressure vessels are included, and the potential for rapidly changing pressures and temperatures that may warrant special designs for the collection header and emission control equipment.

*Response:* It was our intent that if the equipment is not a connector, gas/vapor or light liquid valve, light liquid pump, or PRD in EtO service and the equipment is on a pressure vessel located at a HON or P&R I facility, then that particular equipment is not subject to HON subpart H, but rather the equipment is subject to the pressure vessel requirements we proposed and are finalizing in 40 CFR 63.119(a)(7). Connectors, gas/vapor or light liquid valves, light liquid pumps, and PRDs in EtO service located on a pressure vessel at a HON facility are still subject to HON subpart H; and we are clarifying this in the final rule at 40 CFR 63.119(a)(7). As we stated in the preamble to the proposed rule (88 FR 25080, April 25, 2023), the LDAR requirements at 40 CFR 63.119(a)(7) (for HON) and 40 CFR 63.484(t) (for the P&R I NESHAP) are based on similar no-detectable emission requirements required for closed vent systems in most chemical sector NESHAP. The intent of this language is to impose a standard that requires no detectable emissions at all times (*i.e.*, would be required to meet a leak definition of 500 ppm at each point on the pressure vessel where total organic HAP could potentially be emitted); require initial and annual leak monitoring using EPA Method 21; and require routing organic HAP through a closed vent system to a control device (*i.e.*, no releases to the atmosphere through a pressure vessel’s PRD). Most pressure vessels have relief devices that allow for venting when pressure exceeds setpoints. There are also instances where other components in pressure systems may allow for fugitive releases because of leaks from fittings or cooling systems.

We note that our use of the term “deviation” in the preamble to the proposed rule and in 40 CFR 63.119(a)(7) was an error. While the MON rule text uses the MON-defined term “deviation” to describe emissions events, the current HON rule text uses the term “violation.” There are no uses of the term “deviation” to describe an emissions event in the current HON rule text, nor any definition of that term in the HON. Therefore, given that we are building off the existing HON standards,

we believe it is more appropriate to continue to use the term “violation” (in lieu of the undefined term “deviation”) in all of the HON rule text. We have replaced “deviation” with “violation” in the final rule text at 40 CFR 63.119(a)(7).

*Comment:* Some commenters contended that the pressure vessel monitoring provisions in 40 CFR 63.119(a)(7) are not feasible for some tanks because the pressure vessel is not accessible to monitoring personnel. The commenter explained that some pressure vessels that store regulated chemicals are located inside containment areas or are partially buried such that monitoring of the vessel surface per EPA Method 21 is not possible. The commenter added that some pressure vessels are double walled tanks designed such that there is an additional external shell outside of the pressure vessel shell (*i.e.*, a tank within a tank shell). The commenter suggested: (1) Pressure monitoring of the gas space (typically nitrogen) between the pressure vessel wall and the second exterior wall be conducted to detect a potential leak, and if a pressure increase occurs, then the owner or operator should be allowed to follow a work practice that requires that the leak be repaired as soon as practical; and (2) for situations where a pressure vessel is located inside a containment area or partially buried, the owner or operator should only be required to conduct EPA Method 21 monitoring on potential leak sources that are accessible and are not unsafe-to-monitor. The commenter provided suggested rule text edits in order to accommodate this request. Similarly, another commenter suggested the EPA incorporate “unsafe-to-monitor” and “inaccessible” provisions at 40 CFR 63.119(a)(7) similar to those in other sections of NESHAP subpart H and in NESHAP subpart UU because some pressure vessels are located in concrete containment areas, are partially buried, or are otherwise inaccessible for safety purposes. This commenter pointed out that the EPA did not consider costs for facilities to relocate or install new pressure vessels to make them accessible in order to comply with the proposed requirements.

*Response:* It was our intent that unsafe and difficult/inaccessible to monitor provisions in 40 CFR 63.168(h) and (i) (for valves in gas/vapor service and in light liquid service) and in 40 CFR 63.174(f) and (h) (for connectors in gas/vapor service and in light liquid service) still apply to valves and connectors when complying with 40 CFR 63.119(a)(7). We are clarifying this

in the final rule at 40 CFR 63.119(a)(7)(ii).

*Comment:* A commenter pointed out that the proposed pressure vessel requirements in 40 CFR 63.119(a)(7) appear to apply to any pressure vessel to which NESHAP subpart G applies. The commenter argued that these requirements should only apply to Group 1 storage vessels that are pressure vessels. The commenter explained that with the removal of the pressure vessel exclusion from the storage vessel definition in 40 CFR 63.101 and the addition of the pressure vessel requirements in 40 CFR 63.119(a)(7), the EPA may have inadvertently applied the proposed pressure vessel requirements to all pressure vessels, regardless of whether the pressure vessel is Group 1 or Group 2 or whether the storage vessel is exempt for another reason. The commenter contended that there is no reason that a Group 2 storage vessel (*i.e.*, one not requiring control) or any other vessel that meets an exclusion in the storage vessel definition should be subject to the proposed operating standards for pressure vessels in 40 CFR 63.119(a)(7).

*Response:* We agree with the commenter that 40 CFR 63.119(a)(7) should only apply to pressure vessels that are considered Group 1 storage vessels (as defined in Table 5 to NESHAP subpart G for existing sources and Table 6 to NESHAP subpart G for new sources). Given that we removed the exemption for “pressure vessels designed to operate in excess of 204.9 kilopascals and without emissions to the atmosphere” from the definition of storage vessel in the final rule, all pressure vessels (not just pressure vessels operating less than or equal to 204.9 kilopascals) are now considered storage vessels in the HON. For this reason, we are clarifying in the final rule that “for each pressure vessel as defined in § 63.101 that is considered a Group 1 storage vessel (as defined in Table 5 of this subpart for existing sources and Table 6 of the subpart for new sources), you must operate and maintain the pressure vessel” as specified in paragraphs 40 CFR 63.119(a)(7)(i) through (v).

#### e. Surge Control Vessels and Bottoms Receivers

*Comment:* A commenter requested that the EPA clarify whether the proposed threshold criteria for controlling surge control vessels and bottoms receivers (*i.e.*, the 1.0 lb/hr total organic HAP threshold) is on an annual average basis or based on any intermittent emissions that exceed the 1.0 lb/hr emission standard.

*Response:* As we stated in the preamble to the proposed rule (88 FR 25080, April 25, 2023), emissions from surge control vessels and bottoms receivers are characteristic of process vents, not emissions from storage vessels. Our rationale for making this determination is that these vessels operate at process temperatures, not ambient storage temperatures; typically do not undergo level changes that larger storage vessels undergo; and are most often operated under pressure with and without non-condensable gases flowing into and out of them. The size of these vessels is also typically not correlated with emissions, as are storage vessels. The 1.0 lb/hr total organic HAP threshold is based on any continuous emissions that exceed the 1.0 lb/hr emission standard. This is true for all Group 1 process vents. We are finalizing this threshold as proposed given that we found this threshold to be cost-effective for process vents (see our response to comments in section IV.B.3.a.i of this preamble for further details).

*Comment:* A commenter requested that the EPA provide the option to use engineering calculations if measurements cannot be made using EPA reference methods to determine whether surge control vessels and bottoms receivers are required to be controlled. The commenter said that the vents from surge control vessels and bottoms receivers are configured more like small tanks than process vents and that these vents could be configured in a variety of ways. The commenter provided an example where the vent may be configured as a pressure/vacuum vent for which venting occurs on an intermittent basis, making it difficult to measure volumetric flow rate since the measurements are not made from a straight discharge pipe where the flow measurement device (*e.g.*, a pitot tube) can be inserted.

*Response:* The EPA agrees with the commenter that in certain situations, as a result of how surge vessels and bottoms receivers are configured, taking measurements utilizing EPA reference methods may not be possible. As a result, we are finalizing language in the “C” and “Q” terms of the equations at 40 CFR 63.115(g)(3)(ii) and (g)(4)(iv) allowing the use of engineering calculations to determine concentration or flow rate only in situations where measurements cannot be taken with EPA reference methods. We anticipate that in most situations, as evidenced by one facility’s responses to the CAA section 114 request, facilities will be able to take measurements from surge vessels and bottoms receivers as if they were process vents. In addition, the EPA

notes that while the commenter expressed concern about measuring flow rate, the proposed reference methods (EPA Method 25A or EPA Method 18) are utilized to measure concentration. Given it was the EPA's intent to provide methodology for measuring both flow rate and concentration as part of the proposal, we are adding reference methods for measuring flow rate at 40 CFR 63.115(g)(3)(ii) and 40 CFR 63.115(g)(4)(iv) by adding the following text to the definition of, Q, the flow rate term to remedy the lack of clarity: "determined using Method 2, 2A, 2C, or 2D of 40 CFR part 60, appendix A, as appropriate."

#### f. Control of Sweep, Purge, and Inert Blankets From IFRs

*Comment:* Several commenters objected to the proposed requirements at 40 CFR 63.119(b)(7) that would require owners and operators that use sweep, purge, or inert blankets between the IFR and fixed roof of storage vessels to route emissions through a closed vent system and control device. Some commenters explained that the EPA did not consider the cost-effectiveness of controls under CAA section 112(d)(2) when considering this proposal. A commenter said that most IFR storage vessels are equipped with a sweep, purge, or blanket and the proposed requirements would render these storage vessels obsolete, given that facilities could remove the IFR and route all emissions to a control device while remaining in compliance with the rule. The commenter acknowledged that a continuous purge of an inert blanket will result in higher emissions from an IFR than no purge; however, the commenter added that IFR storage vessels are normally not designed to hold pressure, and the space between the IFR and the fixed roof must vent somewhere when the vessel is being filled, and conversely there must be a mechanism to avoid a vacuum in the vessel when the vessel is being emptied to prevent a vessel failure. To support their objection to the proposed requirements at 40 CFR 63.119(b)(7), the commenter provided a cost analysis for this level of control that resulted in emissions reductions of 0.1 lb/hr of HAP per vessel, which they estimated would cost \$190,000/yr to control and would not be cost-effective. Other commenters agreed with this cost analysis and stated the cost would not justify the additional amount of emissions reductions. These commenters suggested the EPA revise their analysis, and if the proposed level of control was found to be cost-effective,

the commenters requested that the EPA also consider the secondary emissions (*i.e.*, CO, NO<sub>x</sub>, and CO<sub>2</sub>) that would result from the additional fuel required to treat a stream largely comprised of inert gas. A commenter said that adding downstream abatement measures to IFR vessels will require significant structural foundations to and from, or between, as applicable, emission sources, air abatement controls, utilities, and control systems for tanks already located at relatively remote locations, making them more costly than otherwise similar ancillary equipment at locations closer to manufacturing operations. Finally, the commenter requested that the EPA clarify whether the proposed requirements apply to all vessels with a sweep, purge, or blanket, or only a subset, as vessels with IFRs are generally not designed to hold pressure, and would need to vent to avoid negative pressure. The commenter added that the space between the IFR and the fixed roof must vent somewhere when the vessel is being filled and conversely there must be a mechanism to avoid a vacuum in the tank when the vessel is being emptied to prevent a tank failure.

*Response:* Installing a floating roof minimizes evaporative losses of the stored liquid. Both contact and noncontact decks incorporate rim seals and deck fittings to reduce evaporative loss of the stored liquid. Evaporative losses from floating roofs may come from deck fittings, nonwelded deck seams, and the annular space between the deck and vessel wall. In addition, IFRs are freely vented by circulation vents at the top of the fixed roof. The vents minimize the possibility of organic vapor accumulation in the tank vapor space in concentrations approaching the flammable range. An IFR vessel not freely vented is considered an IFR vessel with a closed vent system. Sections 7.1.3 and 7.1.3.8.2 of EPA's AP-42, Fifth Edition,<sup>59</sup> provide emission estimation methods for freely vented IFR vessels and IFR vessels vented only through a pressure/vacuum vent in the fixed roof (*i.e.*, no open vents), respectively.

The HON allows owners or operators to choose from different options to control emissions from storage vessels and comply with the MACT standards (*i.e.*, owners and operators can use a

closed vent system and control device to reduce inlet emissions of total organic HAP by 95 percent or greater, or reduce organic HAP by utilizing a fixed roof and IFR, an EFR, an EFR converted to an IFR, route the emissions to a process or a fuel gas system, or vapor balance). As such, the use of a floating roof that meets the requirements in 40 CFR 63.119(b) is one of the control options owners or operators may choose for control of emissions during normal storage vessel operations.

Section 7.1 of the EPA's AP-42, Fifth Edition suggests a default reduction of 5 percent on total estimated emissions to account for the use of closed vents on an IFR. This recommendation is based on API Technical Report 2569 which we have determined assumes gas blanketing or another method is used (for IFR vessels vented only through a pressure/vacuum vent in the fixed roof) to prevent the development of a combustible gas mixture within the vessel. However, we believe that neither AP-42 or API Technical Report 2569 addresses the scenario where the use of a sweep, purge, or inert blanket between the IFR and fixed roof would cause a pressure/vacuum vent to remain continuously open to the atmosphere; and this scenario was certainly not considered during the development of the HON MACT standard for storage vessels. A pressure/vacuum vent that remains continuously open to the atmosphere while using a sweep, purge, or inert blanket between the IFR and fixed roof is effectively a continuous process vent.

We note that in a 2021 site-specific monitoring plan submitted to the EPA for approval for fence line monitoring at a refinery located in Corpus Christi, Texas (see *Site-Specific Benzene Fence Line Monitoring Plan Corpus Christi Refinery East Plant Revision 2*, CITGO Petroleum Corporation, December 1, 2021, which is available in the docket for this rulemaking), the company identified a slow rise in benzene concentration over the course of about a year. During this period, the company said they investigated the area for potential sources of the elevated benzene concentrations and completed a root cause analysis that identified a HON IFR storage vessel as the primary cause. The particular HON IFR storage vessel uses a nitrogen blanket between the IFR and the fixed roof to protect the storage contents from being contaminated with oxygen. During the investigation, the company found that the nitrogen regulator was malfunctioning which increased the pressure within the tank and ultimately released emissions to the atmosphere

<sup>59</sup> *Compilation of Air Pollutant Emission Factors*. Volume 1: Stationary Point and Area Sources. AP-42, Fifth Edition. Chapter 7: Liquid Storage Tanks. Office of Air Quality Planning and Standards, Research Triangle Park, NC. See <https://www.epa.gov/air-emissions-factors-and-quantification/ap-42-fifth-edition-volume-i-chapter-7-liquid-storage-0>.

(due to a small operating set point range for the nitrogen regulator and relief vent). Ultimately, the company addressed the elevated benzene concentrations by replacing the nitrogen regulator on the HON IFR storage vessel and routing the emissions to a liquid scrubber, carbon absorption system, and a vapor combustion unit. We have also seen other companies acknowledge similar fence-line monitoring scenarios where HON IFR storage vessels (with sweep, purge, or inert blanket between the IFR and the fixed roof of the vessel) are contributing to elevated benzene concentrations (see *Site Specific Monitoring Plan, ExxonMobil Baton Rouge Refinery*, September 27, 2019, which is available in the docket for this rulemaking).

As such, we believe the use of a sweep, purge, or inert blanket between the IFR and fixed roof that would cause a pressure/vacuum vent to remain continuously open to the atmosphere is a regulatory gap. Given that continuous sweeping, purging, or blanketing between the IFR and the fixed roof of the vessel effectively creates a continuous process vent, we proposed to address this regulatory gap pursuant to CAA section 112(d)(2) and (3), by requiring owners and operators that use a sweep, purge, or inert blanket between the IFR and fixed roof of a storage vessel to route emissions through a closed vent system and control device (see 40 CFR 63.119(b)(7)). In light of the comments received, we are clarifying in the final rule at 40 CFR 63.119(b)(7) that owners and operators must route emissions through a closed vent system and control device if they use a continuous sweep, purge, or inert blanket between the IFR and fixed roof that causes a pressure/vacuum vent to remain continuously open to the atmosphere where uncontrolled emissions are greater than or equal to 1.0 lb/hr of total organic HAP. This threshold is consistent with the definition we proposed and are finalizing for Group 1 process vents. These requirements are consistent with CAA section 112(d) controls and reflect the MACT floor. With regard to cost, the MACT floor is the minimum control level allowed for MACT standards promulgated under CAA section 112(d)(3), not CAA section 112(d)(2), and may not be based on cost considerations.

4. What is the rationale for our final approach and final decisions for the revisions pursuant to CAA section 112(d)(2) and (3)?

We evaluated all of the comments on the EPA's proposed amendments to revisions for flares used as APCDs,

clarifications for periods of SSM and bypasses, including PRDs, bypass lines on closed vent systems, and planned routine maintenance of storage vessels, and requirements for maintenance vents and equipment openings, storage vessel degassing, emission limits for dioxins and furans, pressure vessels, surge control vessels and bottoms receivers, sweep, purge, and inert blankets from IFRs, transfer operations (for HON), heat exchange systems (for the P&R II NESHAP), and equipment leaks (for the P&R II NESHAP). For the reasons explained in section III.D of the proposal preamble (88 FR 25080, April 25, 2023), we find that the flare amendments are needed to ensure that flares used as APCDs achieve the required level of MACT control and meet 98-percent destruction efficiency at all times as well as to ensure that CAA section 112 standards apply at all times. Similarly, the clarifications for periods of SSM and bypasses, including PRDs, bypass lines on closed vent systems, and planned routine maintenance of storage vessels, and requirements for maintenance vents and equipment openings, storage vessel degassing, emission limits for dioxins and furans, pressure vessels, surge control vessels and bottoms receivers, sweep, purge, and inert blankets from IFRs, transfer operations (for HON), heat exchange systems (for the P&R II NESHAP), and equipment leaks (for the P&R II NESHAP) are needed to be consistent with *Sierra Club v. EPA*, 551 F.3d 1019 (D.C. Cir. 2008) to ensure that CAA section 112 standards apply at all times. More information and rationale concerning all the amendments we are finalizing pursuant to CAA sections 112(d)(2) and (3) is in the preamble to the proposed rule (88 FR 25080, April 25, 2023), in section IV.C.3 of this preamble, and in the comments and our specific responses to the comments in the document titled *Summary of Public Comments and Responses for New Source Performance Standards for the Synthetic Organic Chemical Manufacturing Industry and National Emission Standards for Hazardous Air Pollutants for the Synthetic Organic Chemical Manufacturing Industry and Group I & II Polymers and Resins Industry*, which is available in the docket for this rulemaking. Therefore, we are finalizing the proposed provisions for flares, finalizing the proposed clarifications for periods of SSM and bypasses, including PRD releases, bypass lines on closed vent systems, and planned routine maintenance of storage vessels, and finalizing standards for maintenance

vents and equipment openings, storage vessel degassing, emission limits for dioxins and furans, pressure vessels, surge control vessels and bottoms receivers, sweep, purge, and inert blankets from IFRs, transfer operations (for HON), heat exchange systems (for the P&R II NESHAP), and equipment leaks (for the P&R II NESHAP).

#### D. Amendments Addressing Emissions During Periods of SSM

1. What amendments did we propose to address emissions during periods of SSM?

We proposed amendments to the HON and the P&R I and P&R II NESHAP to remove and revise provisions related to startup, shutdown, and maintenance (SSM) that are not consistent with the requirement that the standards apply at all times. In a few instances, we are finalizing alternative standards for certain emission points (*i.e.*, emergency flaring, PRDs, maintenance activities, and tank degassing) to minimize emissions during periods of SSM to ensure a continuous CAA section 112 standard applies "at all times" (see section IV.C of this preamble); however for the majority of emission points in the SOCM, P&R I, and P&R II source categories, we proposed eliminating the SSM exemptions and to have the emission standards apply at all times. We note that on April 21, 2011 (see 77 FR 22566), the EPA finalized amendments to eliminate the SSM exemption in the P&R I NESHAP; however, for consistency with the SSM related amendments that we proposed for the HON and P&R II NESHAP, we also proposed additional amendments to the P&R I NESHAP related to the SSM exemption that were not addressed in the April 21, 2011, P&R I rule. More information concerning the elimination of SSM provisions is in section III.E.1 of the proposal preamble (88 FR 25080, April 25, 2023).

We also proposed to remove the affirmative defense provisions at 40 CFR 63.480(j)(4) (for the P&R I NESHAP) to comply with the holding in *NRDC v. EPA*, 749 F.3d 1055 (D.C. Cir., 2014). More information concerning the removal of the affirmative defense provisions is in section III.E.2 of the proposal preamble (88 FR 25080, April 25, 2023).

We proposed standards in the NSPS subparts VVb, IIIa, NNNa, and RRRa that apply at all times. For NSPS VVb, we proposed that the work practice standards will apply at all times, including during SSM. For NSPS subparts IIIa, NNNa, and RRRa, we proposed performance standards and

work practice standards that will apply during periods of startup and shutdown (including when maintenance and inspection activities are being conducted). Although the NSPS general provisions in 40 CFR 60.8(c) contain an exemption from non-opacity standards, we proposed in NSPS subparts IIIa, NNNa, and RRRa specific requirements at 40 CFR 40 CFR 60.612a, 40 CFR 60.662a, and 40 CFR 60.702a, respectively, that override the general provisions for SSM. Accordingly, we proposed NSPS subparts VVb, IIIa, NNNa, and RRRa would include standards that apply at all times, including during periods of startup and shutdown.

## 2. How did the SSM provisions change since proposal?

We are finalizing the SSM provisions as proposed. We are also finalizing, as proposed, the removal of the provisions to assert an affirmative defense to civil penalties in the P&R I NESHAP at 40 CFR 63.480(j)(4). See 88 FR 25080, April 25, 2023.

## 3. What key comments did we receive on the SSM revisions and what are our responses?

To ensure a continuous CAA section 112 standard applies “at all times” (see section IV.C of this preamble), we are finalizing, as proposed, the elimination of the SSM exemptions for the SO2, P&R I, and P&R II source categories. To ensure a continuous CAA section 111 standard applies “at all times,” we are finalizing, as proposed, the requirement that the standards in NSPS subparts VVb, IIIa, NNNa, and RRRa “apply at all times, including periods of startup, shutdown and malfunction.” We are also finalizing some alternative standards in this final rule for certain emission points during periods of SSM. This section provides summaries of and responses to the key comments received regarding our proposed requirements for PRDs at 40 CFR 63.165(e)(3)(v)(B) and (C) and smoking flares at 40 CFR 63.670(o)(7)(ii) and (iv) during malfunctions. Other comment summaries and the EPA’s responses for additional issues raised regarding other SSM issues raised regarding our proposed revisions can be found in the document titled *Summary of Public Comments and Responses for New Source Performance Standards for the Synthetic Organic Chemical Manufacturing Industry and National Emission Standards for Hazardous Air Pollutants for the Synthetic Organic Chemical Manufacturing Industry and Group I & II Polymers and Resins*

*Industry*, which is available in the docket for this rulemaking.

*Comment:* Several commenters generally supported removal of the SSM exemptions in the rules given it is consistent with *Sierra Club v. EPA*, 551 F.3d 1019, 1028 (D.C. Cir. 2008). A commenter said that they agreed with the approach the EPA has taken to amend language throughout the HON to indicate which paragraphs or phrases no longer apply as a result of the proposed SSM revisions.

Other commenters suggested that the EPA also close proposed loopholes for releases from PRDs at 40 CFR 63.165(e)(3)(v)(B) and (C) and smoking flares at 40 CFR 63.670(o)(7)(ii) and (iv) during malfunctions. Some of these commenters said that according to facilities’ self-reported data, SSM emissions are often of the same magnitude as the facilities’ reported routine emissions, and SSM emissions tend to spike during severe weather events. A commenter pointed out specific reportable quantities of emissions resulting from unplanned emissions events and planned SSM activities via the State of Texas Environmental Electronic Reporting System (STEERS). The commenters argued that with the properly installed and executed emission control systems, fail safes, backup power, maintenance procedures and risk management plans, emissions associated with both extreme weather and routine operations are preventable and should not be exempted from legally permitted emission limits. The commenters argued that the EPA erroneously concludes that the malfunction loopholes at 40 CFR 63.165(e)(3)(v)(B) and (C) and smoking flares at 40 CFR 63.670(o)(7)(ii) and (iv) are reasonable.

Commenters contended that these malfunction loopholes have real-world, harmful effects on the health of communities surrounding these facilities. The commenters pointed out that the EPA readily admits, “[p]ressure relief events from PRDs that vent to the atmosphere have the potential to emit large quantities of HAPs” and the EPA also noted that the majority of the Indorama Port Neches Plant’s excess cancer risk is “driven by EtO emissions from PRDs (74 percent).” A commenter added that the EPA similarly found a “high potential risk posed by chloroprene from PRD releases.” The commenter also argued that:

- the PRD and smoking flare loopholes (at 40 CFR 63.165(e)(3)(v)(B) and (C) and 40 CFR 63.670(o)(7)(ii) and (iv)) are just another variation on the original malfunction exemption and the affirmative defense to civil penalties,

each of which the D.C. Circuit has found unlawful under CAA sections 302(k), 304, 113, 112(d), and 112(f).

- the EPA’s creation of these exemptions (at 40 CFR 63.165(e)(3)(v)(B) and (C) and 40 CFR 63.670(o)(7)(ii) and (iv)) runs directly contrary to its own recognition in prior administrative practice citing the EPA’s brief defending the boiler rule.

- even though the EPA included reporting and root cause analysis requirements, the work practice standards still constitute a total exemption from the core requirements for PRDs and flares during malfunctions of unlimited HAP release in amount and duration (in other words, there is no limit on the amount of HAPs emitted that applies during those releases allowed at 40 CFR 63.165(e)(3)(v)(B) and (C) and 40 CFR 63.670(o)(7)(ii) and (iv)); and the EPA attempted to justify its original SSM exemption on similar grounds in *Sierra Club v. EPA*, 551 F.3d 1019, 1028 (D.C. Cir. 2008), stating that reporting and other requirements still applied, but that argument failed.

- the PRD and flare loopholes (at 40 CFR 63.165(e)(3)(v)(B) and (C) and 40 CFR 63.670(o)(7)(ii) and (iv)) are not lawful work practice standards under CAA section 112(h); and even if the EPA could set work practice standards, CAA section 112(h) does not allow the EPA to avoid its obligation to enact standards that restrict emissions of HAPs at all times.

- the EPA has required and recognized the necessity of control for HON, P&R I, and MON PRDs in EtO service, P&R I PRDs in chloroprene service, and all Organic Liquid Distribution and P&R II PRDs, but has not applied equal controls to other PRDs or to flares above their smokeless capacity. This underscores the unlawfulness of the exemptions (at 40 CFR 63.165(e)(3)(v)(B) and (C) and 40 CFR 63.670(o)(7)(ii) and (iv)), and treating these releases so differently is arbitrary and capricious.

Specifically, with regards to 40 CFR 63.670(o)(7)(ii) and (iv), several commenters said that smoking flares produce significant amounts of ‘soot’; and beyond the health risks of particulate matter, smoking flares increase production of ozone, especially in the presence of greater environmental heat. A supporter of 40 CFR 63.670(o)(7)(ii) and (iv) reiterated that the provisions are necessary because the EPA is removing the SSM provisions. The commenter also said that they supported the proposal to operate in accordance with a flare management plan during periods when the flow to

the flare exceeds the smokeless capacity of the flare.

Other supporters of 40 CFR 63.165(e)(3)(v)(B) and (C) argued that there should be no limit on the number of PRD releases allowed to the atmosphere. A commenter cited MACT standards, such as LDAR programs, and contended that generally these programs do not limit the number of leaks allowed. The commenter also added that if the EPA proceeded with the proposed work practice standard, then they agreed with the EPA's decision to allow one or two releases under the conditions set forth in 40 CFR 63.165(e)(3)(v)(B) and (C). Commenters also requested that the EPA clarify that the start date for the initial three-year period for the limit on PRD releases to the atmosphere is the first full calendar year after the compliance date for the PRD work practice standard. The commenters further requested that the EPA include provisions that would not count the second event from the same equipment and same root cause within a 3-year period as a deviation where a) the root cause investigation from the first incident is not yet complete; and/or b) where the corrective action resulting from the root cause investigation requires a capital expenditure and such has been initiated and is being timely pursued.

*Response:* The EPA acknowledges the commenters' support for removing the SSM exemptions in the rules. As we explained in the preamble to the proposed rule (88 FR 25080, April 25, 2023), in *Sierra Club v. EPA*, 551 F.3d 1019 (D.C. Cir. 2008), the Court determined that the SSM exemption violates the CAA. Specifically, the court vacated the SSM exemption contained in 40 CFR 63.6(f)(1) and 40 CFR 63.6(h)(1), holding that under CAA section 302(k), emissions standards or limitations must be continuous in nature and that the SSM exemption violates the CAA's requirement that some section 112 standards apply continuously. With the issuance of the mandate in *Sierra Club v. EPA*, the exemption language in 63.6(f)(1) and (h)(1) is null and void and any cross reference to those provisions has no effect.

However, we disagree with other commenters suggesting that the EPA created loopholes for releases from PRDs at 40 CFR 63.165(e)(3)(v)(B) and (C) and smoking flares at 40 CFR 63.670(o)(7)(ii) and (iv) during malfunctions. At proposal, the EPA explained that "[a]lthough no statutory language compels the EPA to set standards for malfunctions, the EPA has the discretion to do so where feasible."

(88 FR 25167). We further explained that "[t]he EPA will consider whether circumstances warrant setting work practice standards for a particular type of malfunction in the SOCM, P&R I, and P&R II source categories, and, if so, whether the EPA has sufficient information to identify the relevant best performing sources and establish a standard for such malfunctions." (88 FR 25168.) It is very difficult to guard perfectly against acts of God and acts of terrorism. The EPA does not believe it can develop measures that would effectively limit emissions during all such acts.

Regardless, the PRD work practice standard requires redundant prevention measures, which are designed to limit the duration and quantity of releases from all atmospheric PRDs regardless of the cause. Flares are required to comply with the requirements for a continuously lit pilot flame and combustion efficiency standards (*i.e.*, limits on the NHVcz) at all times, including during periods of emergency flaring caused by a *force majeure* event. These requirements apply at all times; thus, the final work practice standards do have requirements that apply to PRDs and flares at all times and they are not contrary to the CAA requirements in CAA section 112. In addition, the work practice standard for PRDs requires installation and operation of continuous monitoring device(s) to identify when a PRD release has occurred. We also note that facilities are required to initiate a root cause analysis to assess the cause of a release, including releases determined to be caused by a *force majeure* event. The count of events at 40 CFR 63.165(e)(3)(v)(B) and (C) and smoking flares at 40 CFR 63.670(o)(7)(ii) and (iv) includes events for which the root cause is determined to be *force majeure*. In other words, there is no categorization or interpretation related to the root cause of the event; and the corrective action component of the work practice standards applies to all events regardless of the root cause and all events would count towards the violation criteria set forth in the standard. We note that further comments on the concept of "*force majeure*" and our responses to these comments can be found in section 7.2 of the document titled *Summary of Public Comments and Responses for New Source Performance Standards for the Synthetic Organic Chemical Manufacturing Industry and National Emission Standards for Hazardous Air Pollutants for the Synthetic Organic Chemical Manufacturing Industry and Group I & II Polymers and Resins*

*Industry*, which is available in the docket for this rulemaking.

We disagree with the comments regarding the exemptions being arbitrary and capricious. We modeled the applicability of the PRD provisions after the SCAQMD rule, based on a MACT floor analysis and considering the appropriate requirements for these types of PRDs. With regard to PRDs in EtO or chloroprene service, we stated in the preamble to the proposed rule (88 FR 25080, April 25, 2023) that any release event from a PRD in EtO (from the SOCM source category) or chloroprene service (from the Neoprene Production source category) is a violation of the standard in order to help reduce risk from these source categories to an acceptable level.

With regard to the request that we clarify the start date for the work practice standards, the regulatory text at 40 CFR 63.165(e)(3)(iv), 40 CFR 63.165(e)(3)(v)(B) and (C) (for PRDs) and at 40 CFR 63.670(o)(7)(ii) and (iv) (for smoking flares), states that the time period is based on a 3-calendar-year period. We consider 2023 to be 1 calendar year. A 3-calendar-year period in 2023 would include events that occurred in 2021, 2022, and 2023. It is a rolling average to the extent that, in 2024, one would consider events that occurred in 2022, 2023, and 2024. As indicated in 40 CFR

63.182(d)(2)(xviii)(C), each pressure release to the atmosphere, including the duration of the release, the estimated quantity of each organic HAP released, and the results of the root cause analysis and corrective action analysis completed during the reporting period must be included as part of the reporting obligation. We disagree with the comment regarding meeting certain criteria and not counting the second event from the same equipment and same root cause as a deviation. First, we want to clarify that we mean violation, not deviation. Our use of the term "deviation" in the preamble to the proposed rule was an error (however, we did use "violation" in the proposed rule text in 40 CFR 63.165). While the MON rule text uses the MON-defined term "deviation" to describe emissions events, the current (and proposed) HON rule text uses the term "violation." There are no uses of the term "deviation" to describe an emissions event in the current HON rule text, nor any definition in the HON of that term. Therefore, given that we are building off the existing HON standards, we believe it is more appropriate to continue to use the term "violation" (in lieu of the undefined "deviation") in all of the HON rule text. Second, at proposal, we

explained that two release events with the same root cause from a single PRD in a 3-year period is a violation from the MACT standard. 88 FR 25157. The commenter requested that if a corrective action has not been implemented to resolve an issue, then related PRD releases should not be counted towards the violation; however, this result is exactly what the EPA wants to prevent by having a lower release threshold for violations when a PRD release results from the same root cause.

4. What is the rationale for our final approach and final decisions to address emissions during periods of SSM?

We evaluated all of the comments on the EPA's proposed amendments to the SSM provisions. For the reasons explained in the proposed rule (88 FR 25080, April 25, 2023), we determined that these amendments, which remove and revise provisions related to SSM, are necessary to be consistent with the requirement that the standards apply at all times. More information concerning the amendments we are finalizing for SSM is in the preamble to the proposed rule (88 FR 25080, April 25, 2023) and in the comments and our specific responses to the comments in the document titled *Summary of Public Comments and Responses for New Source Performance Standards for the Synthetic Organic Chemical Manufacturing Industry and National Emission Standards for Hazardous Air Pollutants for the Synthetic Organic Chemical Manufacturing Industry and Group I & II Polymers and Resins Industry*, which is available in the docket for this rulemaking. Therefore, we are finalizing our approach for the SSM provisions as proposed.

#### E. Amendments Addressing NSPS Subparts VV and VVa Reconsideration

1. What amendments did we propose to address the NSPS subparts VV and VVa reconsideration?

In response to the January 2008 petition for reconsideration, we proposed: (1) Definitions for "process unit" for NSPS subparts VV and VVa that are the same or essentially the same<sup>60</sup> as the definition of "process unit" that was first promulgated in NSPS subpart VV (see 48 FR 48307, October 18, 1983) and that applied

<sup>60</sup> The proposed "process unit" definition in NSPS subpart VV is the same as that initially promulgated in NSPS subpart VV in 1983 (*i.e.*, "components assembled to produce, as intermediate or final products, one or more of the chemicals listed in § 60.489 of this part"). The proposed "process unit" definition in NSPS subpart VVa is the same except that it refers to the chemicals listed in § 60.489a instead of § 60.489.

during the stay of the 2007 amendments to this definition in both NSPS subparts VV and VVa; (2) to remove the requirements in 40 CFR 60.482–1(g) (for NSPS subpart VV) and 40 CFR 60.482–1a(g) (for NSPS subpart VVa) that are related to a method for assigning shared storage vessels to specific process units; (3) to remove the connector monitoring provisions from NSPS subpart VVa at 40 CFR 60.482–11a in their entirety; and (4) to revise the "capital expenditure" definition in NSPS subpart VVa at 40 CFR 60.481a such that for owners or operators that start a new, reconstructed, or modified affected source prior to November 16, 2007,<sup>61</sup> the variable Y (*i.e.*, the percent of a facility's replacement cost used in determining an adjusted annual asset guideline repair allowance) is determined from the following equation:  $Y = 1.0 - 0.575 \log X$ , where the value of "X" is 1982;<sup>62</sup> for owners or operators that start a new, reconstructed, or modified affected source on or after November 16, 2007,<sup>63</sup> for which the NSPS subpart VVa definition of "capital expenditure" was not stayed, we proposed to continue to apply the definition in NSPS subpart VVa (*i.e.*, the value of "X" is 2006 minus the year of construction).<sup>64</sup>

2. How did the revisions addressing the NSPS subparts VV and VVa reconsideration change since proposal?

We are finalizing the changes described in section IV.E.1 of this preamble as proposed, except for certain changes related to the "capital expenditure" definition in NSPS subpart VVa. For NSPS subpart VVa, we

<sup>61</sup> As explained later in section IV.E.3 of this preamble, the proposed definition erroneously refers to "owners or operators that start a new, reconstructed, or modified affected source prior to November 16, 2007" instead of sources that underwent physical or operational change prior to November 16, 2007 (but after November 7, 2006, the NSPS subpart VVa proposal date).

<sup>62</sup> "1982" is the X value presented in our proposed regulatory text. We note that in the preamble to the proposal, we had expressed an intent to define "X" as "1982 minus the year of construction," which reflects the equation for Y in the definition in NSPS subpart VV at 40 CFR 60.481 and which applied during the stay of the "capital expenditure" definition in NSPS subpart VVa. See 40 CFR 60.480a(f)(1) ("Stay of standards").

<sup>63</sup> As explained later in section IV.E.3 of this preamble, the proposed definition erroneously refers to "owners or operators that start a new, reconstructed, or modified affected source on or after November 16, 2007" instead of sources that underwent physical or operational change on or after November 16, 2007.

<sup>64</sup> See the document titled *Proposed Regulation Edits for 40 CFR part 60 Subparts VV, VVa, and VVb: Standards of Performance for Equipment Leaks of VOC in the Synthetic Organic Chemicals Manufacturing Industry* (see Docket Item No. EPA-HQ-OAR-2022-0730-0067).

are finalizing the "capital expenditure" definition in NSPS subpart VVa in place during the stay of the definition for facilities that underwent a physical or operational change prior to November 16, 2007. We recognize, depending on the year a modification took place, this definition may potentially leave an indeterminate outcome (*e.g.*,  $\log(X)$  where X is a negative value) for calculation of the adjusted annual asset guideline repair allowance. However, to the extent there were sources that encountered this scenario (where a physical or operational change between November 7, 2006 and November 16, 2007 triggered an evaluation of whether the capital expenditure was above the threshold to be considered a modification), the NSPS subpart VVa applicability determination would have been resolved a long time ago; thus, finalizing the same definition as applied during the stay would avoid upending any long-standing determinations. Therefore, in the final rule, we are finalizing the definition that was in place during the stay, which include correcting several errors made in our proposed definition and noted by commenters. Specifically, the proposed definition erroneously attached the value of "X" in the percent Y equation to the date of construction, reconstruction, and modification (as opposed to date of physical or operational change); in the final rule, we have replaced that phrasing with a reference to physical and operation change. In addition, we revised the value of "X" from "1982" to "1982 minus the year of construction." Accordingly, in the final rule, we are revising the "capital expenditure" definition in NSPS subpart VVa at 40 CFR 60.481a such that for owners or operators that made a physical or operational change to their existing facility prior to November 16, 2007, the percent Y is determined from the following equation:  $Y = 1.0 - 0.575 \log X$ , where the value of "X" is 1982 minus the year of construction; for owners or operators that made a physical or operational change to their existing facility on or after November 16, 2007, the percent Y is determined from the following equation:  $Y = 1.0 - 0.575 \log X$ , where the value of "X" is 2006 minus the year of construction.

3. What key comments did we receive on the revisions addressing the NSPS subparts VV and VVa reconsideration and what are our responses?

This section provides summaries of and responses to the key comments received regarding our proposed requirements for connectors and

proposed revisions to the requirements in NSPS subpart VVa for capital expenditure. Except for these comments related to the proposed requirements for connectors and capital expenditure, we did not receive many substantive comments on the other amendments related the NSPS subparts VV and VVa reconsideration. The comments we received regarding other amendments generally include issues related to the definition of “process unit.” The comments and our specific responses to these issues can be found in the document titled *Summary of Public Comments and Responses for New Source Performance Standards for the Synthetic Organic Chemical Manufacturing Industry and National Emission Standards for Hazardous Air Pollutants for the Synthetic Organic Chemical Manufacturing Industry and Group I & II Polymers and Resins Industry*, which is available in the docket for this rulemaking.

*Comment:* A commenter objected to the EPA removing the connector monitoring provisions from NSPS subpart VVa and only proposing them in NSPS subpart VVb. The commenter contended that the EPA did not provide sufficient justification for this change, given that the EPA’s rationale was only that they agreed with Petitioners that it had not included those requirements in the November 7, 2006, proposal (72 FR 64860) but then established connector monitoring requirements in the November 16, 2007 final rule without notice and an opportunity to comment. The commenter added that the EPA must also justify why it is not appropriate to lift the stay and require connector monitoring at sources subject to NSPS subpart VVa from this point forward. The commenter listed several issues with the EPA’s decision:

- The EPA must propose and provide opportunity for comment on requiring connector monitoring at sources subject to NSPS subpart VVa. The basis of the reconsideration was a lack of notice and comment, and the EPA is currently in the position to provide an opportunity for comment on those requirements yet fails to do so with no explanation.

- The EPA must justify why additional emissions reductions for sources subject to NSPS subpart VVa are no longer appropriate before simply removing the requirements in their entirety. The EPA found connector monitoring as the “best system of emission reduction” in the November 16, 2007, preamble, and the EPA has not explained why that determination was inappropriate or no longer valid. In EPA’s analysis supporting the final NSPS subpart VVa, it found that the

promulgated connector monitoring requirements were: (1) Common practice at many chemical manufacturing facilities, including through regulations such as HON, MON, Ethylene MACT, and the Generic MACT (40 CFR 63, subpart UU), (2) resulted in greater emission reductions (230 tpy VOC) than the changes the EPA implemented for pumps and valves (94 tpy VOC) in NSPS subpart VVa, and (3) were achieved at a cost \$2,500 per ton of VOC reduced.

- The EPA must justify why the same requirements it is proposing to remove from NSPS subpart VVa are only appropriate for NSPS subpart VVb.

The commenter asserted that the EPA can and must lift the stay as it relates to connector monitoring in 40 CFR 60.482–11a and require compliance with that section from that date forward in order to ensure the critical (and cost-effective) environmental protections are implemented, while avoiding concerns of retroactive application of standards. The EPA could do this through providing language that the standards were stayed from June 2, 2008, until the date of the final rule, but are in effect moving forward.

*Response:* As previously discussed in the preamble to the proposed rule (88 FR 25080, April 25, 2023), we proposed to remove the connector monitoring requirements in NSPS subpart VVa that have been stayed since 2008. The EPA disagrees with the comment that, having granted reconsideration of these requirements because they were finalized without proposal and an opportunity for comment, the EPA must now propose to remove the stay and provide the public an opportunity to comment on the connector requirements. While CAA section 307(d)(7)(B) requires that the EPA grant reconsideration in this situation (where the grounds for objecting to the standard arose after the period for public comment, in this case when the final rule was promulgated), nothing in CAA section 307(d)(7)(B) or elsewhere in the CAA dictates what actions the EPA must take in a reconsideration proceeding, much less requiring that the EPA propose the connector requirements for comment; nor has the commenter cited any legal authority requiring such action from the EPA in an administrative reconsideration proceeding under CAA section 307(d)(7)(B).

In its reconsideration of the connector requirements in NSPS subpart VVa, the EPA took into account that these requirements have been stayed since June 2008, over 15 years ago and shortly after the promulgation of NSPS subpart

VVa in November 2007. In light of the fact that the connector requirements have not been part of NSPS subpart VVa’s long implementation history, the EPA does not think it is appropriate to amend NSPS subpart VVa now to add a new requirement for new equipment (*i.e.*, connectors) for sources constructed, reconstructed or modified between November 7, 2006 and April 26, 2023, which are existing sources for purposes of the newly promulgated NSPS subpart VVb. The EPA believes that standards for previously unregulated sources such as the connectors are better suited moving forward for new and modified sources under NSPS subpart VVb. For the reasons stated above, the EPA is finalizing the removal of the connector requirements in NSPS subpart VVa, as proposed.

*Comment:* Commenters requested the EPA correct the formula for calculating the value of “X” in the definition of “Capital Expenditure” in the proposed NSPS subpart VVa. A commenter explained that the EPA proposed a value of “1982” for “X” for owners or operators “that start a new, reconstructed, or modified affected source prior to November 16, 2007.” The commenter contended that this results in a negative value for “Y” (that is,  $-0.89$ , or  $1.0 - 0.575 \log(1982)$ ), being effectively an indeterminate outcome for calculation of the adjusted annual asset guideline repair allowance. Another commenter recommended that the EPA revise “X” from “1982” to “1982—the year of construction” for owners or operators “that start a new, reconstructed, or modified affected source prior to November 16, 2007.”

Another commenter contended that the EPA’s proposed definition for capital expenditures in NSPS subpart VVa narrows the reach of modification and would result in the exclusion of certain process units from applicability to the subpart through modification. For NSPS subpart VVa, the commenter contended the EPA has made significant errors in defining how sources would determine if modification has occurred and went beyond addressing the issues raised by the petitioners requesting reconsideration of the capital expenditure definition. The commenter asserted that it is inappropriate to include a definition for modification related to a date of construction, reconstruction, or modification that operates apart from the applicability of the individual subpart. The commenter explained that a source that is constructed or reconstructed after the applicability date of the subpart (November 7, 2006, for NSPS subpart



VVa) is automatically subject to the standards of that subpart and modification has no relevance unless a subpart with a later applicability date is promulgated. The commenter added that a source is not defined as modified unless it undergoes a physical or operational change that results in an increase in emissions. The commenter contended that a definition of capital expenditure that is reliant on the dates of “construction, reconstruction, or modification” is not relevant to and has no bearing on whether a source has been modified. The commenter concluded that the EPA must redefine capital expenditure without specifying construction, reconstruction, or modification dates. The commenter recommended that the EPA should seek to address the definition of capital expenditure as it applies to the subset of physical and operational changes that occurred specifically between November 7, 2006, and November 16, 2007. The commenter added that for those sources that would have utilized the capital expenditure equation in NSPS subpart VV, it is appropriate to define the value of “X” as “1982 minus the year of construction” or simply cross-reference the capital expenditure definition at 40 CFR 60.481. The commenter stated that the definition of capital expenditure as it relates to physical and operational changes that take place after November 16, 2007 (the promulgation date of NSPS subpart VVa), was not under reconsideration and should remain as promulgated such that the EPA define “X” based on the dates of “physical or operational changes” regardless of the date of construction, reconstruction, or modification, and specifically, for physical or operational changes that take place after November 16, 2007, “X” should remain defined as “2006 minus the year of construction.”

*Response:* We agree that errors were made in the proposed “capital expenditure” definition in NSPS subpart VVa. The proposed definition, in relevant part, stated that

“(2) The percent Y is determined from the following equation:  $Y = 1.0 - 0.575 \log X$ , where X is:

(i) 2006 minus the year of construction for owners or operators that start a new, reconstructed, or modified affected source on or after November 16, 2007, or

(ii) 1982 for owners or operators that start a new, reconstructed, or modified affected source prior to November 16, 2007;”

We agree with the comment that the proposed definition erroneously relies on a sources’ construction,

reconstruction, or modification date for calculating capital expenditure to determine whether modification has been triggered for that source. Sources constructed, modified, or reconstructed after November 7, 2006, are affected facilities under NSPS subpart VVa (*i.e.*, they are subject to the standards of NSPS subpart VVa); whether any such NSPS subpart VVa affected facility has subsequently incurred capital expenditure that would constitute “modification” is irrelevant as the only purpose for that capital expenditure calculation is to determine NSPS subpart VVa applicability, which we already know it does. The commenter also correctly notes that modification is determined by whether there is a physical or operational change that results in an increase in emissions. See 40 CFR 60.2 and CAA section 111(a)(4). For the reasons stated above, in the final rule, we have revised the proposed “capital expenditure” definition by referencing the date of a physical or operational change to a source instead its construction, modification and reconstruction date.

Regarding the value of “X” for owners and operators that made a physical or operation change to their existing facility prior to November 16, 2007, commenters are correct that the value of “X” being 1982 results in a negative value for the variable “Y”; the proposed regulation edits (see Docket Item No. EPA-HQ-OAR-2022-0730-0067) mistakenly required the value of “X” be 1982 instead of the intended equation. The intended equation for “X” was 1982 minus the year of construction; this equation was described in the proposal preamble (88 FR 25172) and aligns with the commenters’ recommendation, which we acknowledge could still result in a nonsensical value for the variable “Y” for certain scenarios. However, the impact of this issue is unclear, as it would affect only sources that made a physical or operational change within the relevant one-year period (after November 7, 2006 but before November 16, 2007). To the extent there were such sources, we believe that they had long ago found ways to resolve the issue and determine NSPS subpart VVa applicability, perhaps in consultation with the relevant EPA region or delegated State agencies; thus, finalizing the same definition as that which was in effect during the relevant one-year period would avoid upending any such long-standing resolutions or determinations by owners/operators and/or EPA or delegated State agencies.

For the reasons described above, we are finalizing the equation for calculating the variable “Y” in the

definition of “capital expenditure” in NSPS subpart VVa as follows:

(2) The percent Y is determined from the following equation:  $Y = 1.0 - 0.575 \log X$ , where X is:

- (i) 2006 minus the year of construction if the physical or operational change to the existing facility was on or after November 16, 2007, or
- (ii) 1982 minus the year of construction if the physical or operational change to the existing facility was prior to November 16, 2007.

4. What is the rationale for our final approach and final decisions to address the NSPS subparts VV and VVa reconsideration?

The amendments address the following issues raised in the January 2008 petition for reconsideration: (1) The clarification of the definition of process unit in NSPS subparts VV and VVa; (2) the assignment of shared storage vessels to specific process units in NSPS subparts VV and VVa; (3) the monitoring of connectors in NSPS subpart VVa; and (4) the definition of capital expenditure in NSPS subpart VVa. More information concerning the amendments we are finalizing to address these issues is in the preamble to the proposed rule and in the comments and our specific responses to the comments in the document titled *Summary of Public Comments and Responses for New Source Performance Standards for the Synthetic Organic Chemical Manufacturing Industry and National Emission Standards for Hazardous Air Pollutants for the Synthetic Organic Chemical Manufacturing Industry and Group I & II Polymers and Resins Industry*, which is available in the docket for this rulemaking.

#### F. Other Amendments to the NESHAP and NSPS

1. What other amendments did we propose for the SOCOMI, P&R I, and P&R II source categories?

We proposed a requirement that owners or operators submit electronic copies of certain required performance test reports, flare management plans, and periodic reports (including fence-line monitoring reports for HON and the P&R I NESHAP) through the EPA’s CDX using the CEDRI (at 40 CFR 63.108(e), 40 CFR 63.152(c) and (h), and 40 CFR 63.182(d) and (e) (for HON), 40 CFR 63.506(e)(6), and (i)(3) (for the P&R I NESHAP), and 40 CFR 63.528(a) and (d) (for the P&R II NESHAP), 40 CFR 60.486(l), and 60.487(a) and (g) through (i) (for NSPS subpart VV), 40 CFR

60.486a(l), and 60.487a(a) and (g) through (i) (for NSPS subpart VVa), 40 CFR 60.486b(l), and 60.487b(a) and (g) through (i) (for NSPS subpart VVb), 40 CFR 60.615(b), (j), (k), and (m) through (o) (for NSPS subpart III), 40 CFR 60.615a(b), (h) through (l), and (n), and 40 CFR 619a(e) (for NSPS subpart IIIa), 40 CFR 60.665(b), (l), (m), and (q) through (s) (for NSPS subpart NNN), 40 CFR 60.665a(b), (h), (k) through (n), and (p), and 40 CFR 669a(e) (for NSPS subpart NNNa), 40 CFR 60.705(b), (l), (m), and (u) through (w) (for NSPS subpart RRR), and 40 CFR 60.705a(b), (k) through (o), and (v), and 40 CFR 709a(e) (for NSPS subpart RRRa)). We also proposed two narrow circumstances in which owners or operators may seek extensions to the deadline if they are prevented from reporting by conditions outside of their control within five business days of the reporting deadline. We proposed that an extension may be warranted due to outages of the EPA's CDX or CEDRI that precludes an owner or operator from accessing the system and submitting required reports. We also proposed that an extension may be warranted due to a *force majeure* event, such as an act of nature, act of war or terrorism, or equipment failure or safety hazards beyond the control of the facility.

In addition, we proposed the restructuring of all HON definitions from NESHAP subparts G and H (*i.e.*, 40 CFR 63.111 and 40 CFR 63.161, respectively) into the definition section of NESHAP subpart F (*i.e.*, 40 CFR 63.101); and we proposed to consolidate differences between certain definitions in these subparts.

We proposed adding monitoring requirements at 40 CFR 63.114(a)(5)(v), 40 CFR 63.120(d)(1)(iii), 40 CFR 63.127(b)(4), and 40 CFR 63.139(d)(5) (for HON), and 40 CFR 63.484(t), 40 CFR 63.485(x), and 40 CFR 63.489(b)(10) (for the P&R I NESHAP) for owners or operators using adsorbents that cannot be regenerated and regenerative adsorbents that are regenerated offsite. We also proposed that owners or operators of this type of APCD use dual (two or more) adsorbent beds in series and conduct monitoring of HAP or TOC on the outlet of the first adsorbent bed in series using a sample port and a portable analyzer or chromatographic analysis.

In addition, we proposed several corrections to the calibration drift assessment requirements in NSPS subpart VVa at 40 CFR 60.485a(b)(2) including: (1) Correcting a regulatory citation to read “§ 60.486a(e)(8)” instead of “§ 60.486a(e)(7)”; (2) removing the extraneous sentence “Calculate the

average algebraic difference between the three meter readings and the most recent readings and the most recent calibration value.”; (3) providing clarity in the mathematical step of the assessment by replacing the sentence “Divide this algebraic difference by the initial calibration value and multiply by 100 to express the calibration drift as a percentage.” with “Divide the arithmetic difference of the initial and post-test calibration response by the corresponding calibration gas value for each scale and multiply by 100 to express the calibration drift as a percentage.”; and (4) providing clarity by making other minor textural changes to the provisions related to the procedures for when a calibration drift assessment shows negative or positive drift of more than 10 percent.

We also proposed at 40 CFR 63.103(b)(1) (for HON), 40 CFR 63.490(g) and 40 CFR 63.504(a) (for the P&R I NESHAP), and 40 CFR 64.525(a), (e), and (m) (for the P&R II NESHAP) that owners and operators would be required to conduct subsequent performance testing on non-flare control devices no later than 60 calendar months after the previous performance test.

We also proposed to: (1) Remove the provisions at 40 CFR 63.110(h) that allow compliance with certain portions of 40 CFR part 264, subpart AA or CC in lieu of portions of NESHAP subpart G; and (2) remove the provisions at 40 CFR 63.110(i) and 40 CFR 60.160(g) that allow compliance with certain portions of 40 CFR part 65 in lieu of portions of NESHAP subparts G and H.

Finally, we proposed revisions to clarify text or correct typographical errors, grammatical errors, and cross-reference errors. These editorial corrections and clarifications are discussed in section III.E.5.f of the proposal preamble (see 88 FR 25080, April 25, 2023).

2. How did the other amendments for the SOCM, P&R I, and P&R II source categories change since proposal?

Based on comments received on the proposed rulemaking, we are making some changes to the amendments described in section IV.F.1 of this preamble.

With regard to electronic reporting, we are making several minor clarifying edits to the spreadsheet reporting templates (the final versions of the templates will be located on the CEDRI website). We are also making only minor changes to the HON definitions.

In addition, for adsorbents that cannot be regenerated and regenerative adsorbents that are regenerated offsite,

we have clarified the proposed rule text in this final action that the monitoring plan provisions in 40 CFR 63.120(d)(2) and (3) do not apply to HON sources subject to the monitoring provisions in 40 CFR 63.120(d)(1)(iii); and the monitoring plan provisions in 40 CFR 63.120(d)(2) and (3) do not apply to P&R I sources subject to the monitoring provisions in 40 CFR 63.120(d)(1)(iii) (via 40 CFR 63.484(t) and 40 CFR 63.485(x)).

With regard to overlap provisions, we are: (1) Revising 40 CFR 63.160(b)(1) and (c)(1) in the final rule such that compliance with HON subpart H constitutes compliance with NSPS subpart VVa provided the owner or operator continues to comply with 40 CFR 60.480a(e)(2)(i); and (2) revising 40 CFR 63.160(b)(1) and (c)(1) in the final rule such that compliance with HON subpart H constitutes compliance with NSPS subpart VVb provided the owner or operator continues to comply with 40 CFR 60.480b(e)(2)(i). We have also revised 40 CFR 60.480b(e)(2)(i) in the final rule to require compliance with 40 CFR 60.482–7b (*i.e.*, the standards for gas and light liquid valves in NSPS subpart VVb) in addition to the requirements of 40 CFR 60.485b(d), (e), and (f), and 40 CFR 60.486b(i) and (j).

3. What key comments did we receive on the other amendments for the SOCM, P&R I, and P&R II source categories and what are our responses?

We did not receive many substantive comments on the other amendments discussed in this section IV.F of this preamble. The comments we received regarding other amendments generally include issues related to electronic reporting, the restructuring of all HON definitions, adsorbents that cannot be regenerated and regenerative adsorbents that are regenerated offsite, overlap provisions, and revisions that we proposed for clarifying text or correcting typographical errors, grammatical errors, and cross-reference errors. The comments and our specific responses to these issues can be found in the document titled *Summary of Public Comments and Responses for New Source Performance Standards for the Synthetic Organic Chemical Manufacturing Industry and National Emission Standards for Hazardous Air Pollutants for the Synthetic Organic Chemical Manufacturing Industry and Group I & II Polymers and Resins Industry*, which is available in the docket for this rulemaking.

4. What is the rationale for our final approach and final decisions regarding the other amendments for the SOGMI, P&R I, and P&R II source categories?

Based on the comments received for these other amendments, we are generally finalizing all proposed requirements. In a few instances, we received comments that led to additional minor editorial corrections and technical clarifications being made in the final rule, and our rationale for these corrections and technical clarifications can be found in section IV.F.3 of this preamble and in the document titled *Summary of Public Comments and Responses for New Source Performance Standards for the Synthetic Organic Chemical Manufacturing Industry and National Emission Standards for Hazardous Air Pollutants for the Synthetic Organic Chemical Manufacturing Industry and Group I & II Polymers and Resins Industry*, which is available in the docket for this rulemaking.

## V. Summary of Cost, Environmental, and Economic Impacts and Additional Analyses Conducted

### A. What are the affected sources?

There are approximately 207 facilities subject to the HON, 19 P&R I facilities (and 10 of these P&R I facilities are collocated with HON processes), and 5 P&R II facilities (and 3 of these P&R II facilities are collocated with HON processes). We also estimate that two additional HON facilities will be newly constructed over the next 3 years. The Office of Enforcement and Compliance Assurance's ECHO (Enforcement and Compliance History Online) tool (<https://echo.epa.gov>) indicates there are currently 592 SOGMI facilities subject to subpart VV or VVa; and 284 SOGMI facilities subject to at least one of the process vent NSPS subparts III, NNN, and/or RRR. The list of facilities is available in the document titled *Lists of Facilities Subject to the HON, Group I and Group II Polymers and Resins NESHAPs, and NSPS subparts VV, VVa, III, NNN, and RRR* (see Docket Item No. EPA-HQ-OAR-2022-0730-0069). We estimate that there will be one new greenfield facility, six new affected facilities constructed at existing plant sites, and 12 modified/reconstructed facilities subject to NSPS subpart IIIa, NNNa, and/or RRRa in the next 5 years. We estimate there will be one new greenfield facility, 34 new affected facilities constructed at existing plant sites, and one modified facility subject to NSPS subpart VVb in the next 5 years (and no affected facilities will trigger

NSPS subpart VVa reconstruction requirements).

### B. What are the air quality impacts?

This final action will reduce HAP emissions by at least 1,372 tpy and VOC emissions by 3,820 tpy from HON, P&R I, and P&R II emission sources as well as the NSPS SOGMI air oxidation unit processes, distillation operations, reactor processes, and equipment leaks sources. These emission reductions are broken down by rule as follows. Considering reported emissions inventories for EtO and chloroprene, we estimate that the final amendments to the NESHAP will reduce overall HAP emissions from the SOGMI source category by approximately 1,107 tpy (and 1,919 tpy of VOC), reduce overall HAP emissions from the P&R I source categories by approximately 264 tpy (and 278 tpy of VOC), and reduce overall HAP and VOC emissions from the P&R II source categories by approximately 1 tpy. We note that these emissions reductions do not consider the potential excess emissions reductions from flares that could result from the final monitoring requirements; we estimate flare excess emissions reductions of 4,858 tpy HAP and 19,889 tpy VOC. Based on our analysis of the finalized actions described in sections III.B.2, III.D.2, and III.E of this preamble for the NSPS, we estimate that the final amendments to the NSPS would reduce VOC emissions from the SOGMI source category by approximately 1,622 tpy. The Agency was unable to estimate HAP emission reductions for the final amendments to the NSPS in this rulemaking. Emission reductions and secondary impacts (e.g., emission increases associated with supplemental fuel or additional electricity) by rule are listed below. The only change in air impacts since proposal stems from our reevaluation related to the TRE removal for HON and the P&R I NESHAP, and its discontinued use in the new NSPS subparts IIIa, NNNa, and RRRa (based on comments received as discussed in sections IV.B.3.a.i and IV.B.3.b.i of this preamble).

#### 1. HON

For the HON, the EPA estimates HAP and VOC emission reductions of approximately 1,107 and 1,919 tpy, respectively. The EPA estimates these reductions include an approximate 54 tpy reduction in EtO emissions (from reported emissions inventories) and a reduction of 20,177 tpy of methane emissions. The EPA also estimates that the final action would result in additional emissions of 714 tpy of CO; 609,761 tpy of CO<sub>2</sub>; 277 tpy of NO<sub>x</sub>

(including 5.3 tpy of N<sub>2</sub>O); 12.7 tpy of particulate matter; and 1.0 tpy of SO<sub>2</sub>. More information about the estimated emission reductions and secondary impacts of this final action for the HON can be found in the RIA accompanying this rulemaking, the documents referenced in sections III.B through III.D of the preamble to the proposed rule (88 FR 25080, April 25, 2023), and in the document titled *Clean Air Act Section 112(d)(6) Technology Review for Continuous Process Vents Located in the SOGMI Source Category that are Associated with Processes Subject to HON, Continuous Front-end and Batch Front-end Process Vents Associated with Processes Subject to Group I Polymers and Resins NESHAP, and Process Vents Associated with Processes Subject to Group II Polymers and Resins NESHAP—FINAL*, which is available in the docket for this rulemaking.

#### 2. P&R I NESHAP

For the P&R I NESHAP, the EPA estimates HAP and VOC emission reductions of approximately 264 and 278 tpy, respectively. The EPA estimates these reductions include an approximate 14 tpy reduction in chloroprene emissions (from reported emissions inventories); and a reduction of 2,018 tpy of methane emissions. The EPA also estimates that the final action would result in additional emissions of 110 tpy of CO; 115,975 tpy of CO<sub>2</sub>; 75 tpy of NO<sub>x</sub> (including 1.5 tpy of N<sub>2</sub>O); 4.8 tpy of particulate matter; and 0.4 tpy of SO<sub>2</sub>. More information about the estimated emission reductions and secondary impacts of this final action for the P&R I NESHAP can be found in the RIA accompanying this rulemaking, the documents referenced in sections III.B through III.D of the preamble to the proposed rule (88 FR 25080, April 25, 2023), and in the document titled *Clean Air Act Section 112(d)(6) Technology Review for Continuous Process Vents Located in the SOGMI Source Category that are Associated with Processes Subject to HON, Continuous Front-end and Batch Front-end Process Vents Associated with Processes Subject to Group I Polymers and Resins NESHAP, and Process Vents Associated with Processes Subject to Group II Polymers and Resins NESHAP—FINAL*, which is available in the docket for this rulemaking.

#### 3. P&R II NESHAP

For the P&R II NESHAP, the EPA estimates 1 tpy of HAP and VOC emission reductions. The EPA also estimates that the final action would not have any secondary pollutant impacts. More information about the estimated

emission reductions and secondary impacts of this final action for the P&R II NESHAP can be found in the RIA accompanying this rulemaking and the documents referenced in sections III.B through III.D of the preamble to the proposed rule (88 FR 25080, April 25, 2023).

#### 4. NSPS Subpart VVb

For the final NSPS subpart VVb, the EPA estimates VOC emission reductions of approximately 340 tpy. The EPA estimates that the final action would not have any secondary pollutant impacts. More information about the estimated emission reductions and secondary impacts of this final action for NSPS subpart VVb can be found in the RIA accompanying this rulemaking and, in the document titled *CAA 111(b)(1)(B) review for the SOCM I Equipment Leaks NSPS Subpart VVa* (see Docket Item No. EPA-HQ-OAR-2022-0730-0096).

#### 5. NSPS Subparts IIIa, NNNa, and RRRa

For the final NSPS subparts IIIa, NNNa, and RRRa, the EPA estimates VOC emission reductions of approximately 1,281 tpy and a reduction of 757 tpy of methane emissions. The EPA estimates that the

final action result in additional emissions of 21.5 tpy of CO; 15,370 tpy of CO<sub>2</sub>; and 4.0 tpy of NO<sub>x</sub> (including 0.1 tpy of N<sub>2</sub>O). More information about the estimated emission reductions and secondary impacts of this final action for NSPS subparts IIIa, NNNa, and RRRa can be found in the RIA accompanying this rulemaking and in the document titled *CAA 111(b)(1)(B) review for the SOCM I air oxidation unit processes, distillation operations, and reactor processes NSPS subparts III, NNN, and RRR—FINAL*, which is available in the docket for this rulemaking.

#### C. What are the cost impacts?

This final action will cumulatively cost (in 2021 dollars) approximately \$522 million in total capital costs and \$194 million per year in total annualized costs (including product recovery),<sup>65</sup> based on our analysis of the final action described in sections III and IV of this preamble (see table 6 in section V.C.1 of this preamble).<sup>66</sup> Costs by rule are listed below. The only change in cost impacts since proposal stems from our reevaluation related to the TRE removal for HON and the P&R I NESHAP, and its discontinued use in the new NSPS subparts IIIa, NNNa, and

RRRa (based on comments received as discussed in sections IV.B.3.a.i and IV.B.3.b.i of this preamble).

#### 1. HON

For the HON, the EPA estimates this final action will cost approximately \$455 million in total capital costs and \$169 million per year in total annualized costs (including product recovery). More information about the estimated cost of this final action for the HON can be found in the documents referenced in sections III.B through III.D of the preamble to the proposed rule (88 FR 25080, April 25, 2023), and in the document titled *Clean Air Act Section 112(d)(6) Technology Review for Continuous Process Vents Located in the SOCM I Source Category that are Associated with Processes Subject to HON, Continuous Front-end and Batch Front-end Process Vents Associated with Processes Subject to Group I Polymers and Resins NESHAP, and Process Vents Associated with Processes Subject to Group II Polymers and Resins NESHAP—FINAL*, which is available in the docket for this rulemaking. The HON represents the majority of total estimated costs for this action (see Table 6 of this preamble).

**Table 6. Summary of the Total Costs by Final Rule (\$2021)**

Rule	Total Capital Cost (\$)	Total Annual Cost Without Recovery Credits (\$/yr)	Total Annual Cost With Recovery Credits (\$/yr)	Annual Recovery Credits (\$/yr)
HON	455,557,700	169,250,100	168,273,200	983,900
P&R I NESHAP	28,198,300	15,227,100	15,198,000	29,200
P&R II NESHAP	2,932,500	1,667,200	1,667,200	0
NSPS Subpart VVb	7,706,600	1,434,200	1,127,200	307,000
NSPS Subparts IIIa, NNNa, and RRRa	27,844,000	6,269,000	6,269,000	0
<b>Total</b>	<b>522,239,100</b>	<b>193,847,600</b>	<b>192,534,600</b>	<b>1,320,100</b>

#### 2. P&R I NESHAP

For the P&R I NESHAP, the EPA estimates this final action will cost approximately \$28 million in total

capital costs and \$15 million per year in total annualized costs (including product recovery). More information about the estimated cost of this final action for the P&R I NESHAP can be

found in the documents referenced in sections III.B through III.D of the preamble to the proposed rule (88 FR 25080, April 25, 2023), and in the document titled *Clean Air Act Section*

<sup>65</sup> Recovered chemical product affected by this rulemaking is related to LDAR control options for equipment leaks and heat exchange systems, and is monetized as recovery credits by multiplying VOC emissions reductions by a VOC credit of \$900 per ton (2021 dollars). This recovery credit has

historically been used by the EPA to represent the variety of chemicals that are used as reactants and produced at SOCM I facilities.

<sup>66</sup> The annualized costs for each final rule include the costs of compliance, including those for

monitoring, recordkeeping, and reporting. Recordkeeping and reporting costs for each final rule are presented separately in section VI.B of this preamble.

112(d)(6) *Technology Review for Continuous Process Vents Located in the SOCM I Source Category that are Associated with Processes Subject to HON, Continuous Front-end and Batch Front-end Process Vents Associated with Processes Subject to Group I Polymers and Resins NESHAP, and Process Vents Associated with Processes Subject to Group II Polymers and Resins NESHAP—FINAL*, which is available in the docket for this rulemaking.

### 3. P&R II NESHAP

For the P&R II NESHAP, the EPA estimates this final action will cost approximately \$2.9 million in total capital costs and \$1.7 million per year in total annualized costs (including product recovery). More information about the estimated cost of this final action for the P&R II NESHAP can be found in the documents referenced in sections III.B through III.D of the preamble to the proposed rule (88 FR 25080, April 25, 2023).

### 4. NSPS Subpart VVb

For the final NSPS subpart VVb, the EPA estimates this final action will cost approximately \$7.7 million in total capital costs and \$1.1 million per year in total annualized costs (including product recovery). More information about the estimated cost of this final action for NSPS subpart VVb can be found in the document titled *CAA 111(b)(1)(B) review for the SOCM I Equipment Leaks NSPS Subpart VVa* (see Docket Item No. EPA-HQ-OAR-2022-0730-0096).

### 5. NSPS Subparts IIIa, NNNa, and RRRa

For the final NSPS subparts IIIa, NNNa, and RRRa, the EPA estimates this final action will cost approximately \$27.8 million in total capital costs and \$6.3 million per year in total annualized costs (including product recovery). More information about the estimated cost of this final action for NSPS subparts IIIa, NNNa, and RRRa can be found in the document titled *CAA 111(b)(1)(B) review for the SOCM I air oxidation unit processes, distillation operations, and reactor processes NSPS subparts III, NNN, and RRR—FINAL*, which is available in the docket for this rulemaking.

#### D. What are the economic impacts?

The EPA conducted economic impact analyses for this rulemaking, in a

document titled *Regulatory Impact Analysis for the Final New Source Performance Standards for the Synthetic Organic Chemical Manufacturing Industry and National Emission Standards for Hazardous Air Pollutants for the Synthetic Organic Chemical Manufacturing Industry and Group I & II Polymers and Resins Industry*, which is available in the docket for this action. The economic impact analyses contain two parts. The economic impacts of the final rulemaking on small entities are calculated as the percentage of total annualized costs incurred by affected ultimate parent owners to their revenues. This ratio provides a measure of the direct economic impact to ultimate parent owners of HON, P&R I, and P&R II facilities and NSPS subpart VVb, IIIa, NNNa, and RRRa facilities while presuming no impact on consumers. We estimate the average small entity impacted by this final action will incur total annualized costs of 0.5 percent of their revenue, with none exceeding 1.3 percent, not considering product recovery from compliance. With product recovery, the EPA estimates that the average small entity impacted by the rulemaking will incur total annualized costs of 0.49 percent of their revenue, with none exceeding 1.4 percent. We estimate that 25 percent (2 in total) of impacted small entities will incur total annualized costs greater than 1 percent of their revenue, and none will incur total annualized costs greater than 3 percent of their revenue. These estimates are unchanged when including product recovery. This is based on a conservative estimate of costs imposed on ultimate parent companies, where total annualized costs are imposed on a facility are at the upper bound of what is possible under the rule and do not include product recovery as an offset to the annualized costs.

In addition, we provide a fuller economic impact analysis using costs of the HON and P&R I and II NESHAP that estimates changes in affected chemical product price and output related to the impact of the compliance costs on producers and consumers of such chemical products for each of these final rules. There are seven chemical products included in the economic impact analysis—butadiene, styrene, acetone, acrylonitrile, ethylene dichloride, ethylene glycol, and EtO.

For the HON, chemical product prices are estimated to increase from less than 0.01 percent to 0.61 percent, and output by product is estimated to decrease by less than 0.01 percent to 0.54 percent. For the two P&R NESHAP, chemical product prices are estimated to increase by less than 0.01 percent to 0.05 percent, and output by product is estimated to decrease by less than 0.01 percent to 0.09 percent. More explanation of these economic impacts can be found in the Regulatory Flexibility Act (RFA) section later in this preamble and in the economic impact analysis that is included in the RIA for this final rulemaking.

#### E. What are the benefits?

The emissions controls required by these rules are expected to reduce emissions of a number of HAP. As stated in section V.B of this preamble, this final action will reduce HAP emissions by at least 1,372 tpy and VOC emissions by 3,820 tpy from HON, P&R I, and P&R II emission sources as well as the NSPS SOCM I air oxidation unit processes, distillation operations, reactor processes, and equipment leaks sources (see Table 7 of this preamble). The health effects associated with the main HAP of concern from SOCM I (found within the HON), P&R I, and P&R II source categories are discussed fully in Chapter 4 of the RIA: EtO (Section 4.1.1), chloroprene (Section 4.1.2), benzene (Section 4.1.3), 1,3-butadiene (Section 4.1.4), vinyl chloride (Section 4.1.5), ethylene dichloride (Section 4.1.6), chlorine (Section 4.1.7), maleic anhydride (Section 4.1.8) and acrolein (Section 4.1.9). This final action is projected to reduce EtO emissions from HON processes by approximately 54 tpy and reduce chloroprene emissions from Neoprene Production processes subject to the P&R I NESHAP by approximately 14 tpy. We also estimate that the final amendments to the NESHAP will reduce other HAP emissions (excluding EtO and chloroprene) from the SOCM I, P&R I, and P&R II source categories by approximately 1,304 tpy. We also estimate that the final amendments to the NESHAP will reduce excess emissions of HAP from flares in the SOCM I and P&R I source categories by an additional 4,858 tpy. The Agency was unable to estimate HAP emission reductions for the final amendments to the NSPS in this rulemaking.

**Table 7. Summary of the HAP and VOC Emission Reductions per Year by Rule**

Rule	HAP Emission Reductions (tpy)	VOC Emission Reductions (tpy)
HON	1,107	1,919
P&R I NESHAP	264	278
P&R II NESHAP	1	1
NSPS Subpart VVb	N/A <sup>1</sup>	340
NSPS Subparts IIIa, NNNa, and RRRa	N/A	1,281
Flare Excess Reductions	4,858	19,889
<b>Total</b>	<b>6,230</b>	<b>23,708</b>

<sup>1</sup> N/A – not available. No HAP reductions are estimated for the final NSPS included in this rulemaking.

Quantifying and monetizing the economic value of reducing the risk of cancer and non-cancer effects is made difficult by the lack of a central estimate of cancer and non-cancer risk and estimates of the value of an avoided case of cancer (fatal and non-fatal) and morbidity effects. Due to methodology and data limitations, we did not attempt to monetize the health benefits of reductions in HAP in this analysis. Instead, we are providing a qualitative discussion in the RIA of the health effects associated with HAP emitted from sources subject to control under the final action. Health effects from reduced exposure to EtO, chloroprene, benzene, 1,3-butadiene, vinyl chloride, ethylene dichloride, chlorine, maleicanhydride, and acrolein are all HAP emissions expected to be reduced by this rule. These pollutants all have been associated with cancer risk is human among other acute health effects.

The emission controls installed to comply with these final rules are also expected to reduce VOC emissions which, in conjunction with NO<sub>x</sub> and in the presence of sunlight, form ground-level ozone (O<sub>3</sub>). This section reports the estimated ozone-related benefits of reducing VOC emissions in terms of the number and value of avoided ozone-attributable deaths and illnesses.

As a first step in quantifying O<sub>3</sub>-related human health impacts, the EPA consults the *Integrated Science Assessment for Ozone* (Ozone ISA)<sup>67</sup> as

<sup>67</sup> U.S. EPA (2020). *Integrated Science Assessment for Ozone and Related Photochemical*

summarized in the Technical Support Document for the Final Revised Cross State Air Pollution Rule Update.<sup>68</sup> This document synthesizes the toxicological, clinical, and epidemiological evidence to determine whether each pollutant is causally related to an array of adverse human health outcomes associated with either acute (*i.e.*, hours or days-long) or chronic (*i.e.*, years-long) exposure. For each outcome, the Ozone ISA reports this relationship to be causal, likely to be causal, suggestive of a causal relationship, inadequate to infer a causal relationship, or not likely to be a causal relationship.

In brief, the Ozone ISA found short-term (less than one month) exposures to ozone to be causally related to respiratory effects, a “likely to be causal” relationship with metabolic effects and a “suggestive of, but not sufficient to infer, a causal relationship” for central nervous system effects, cardiovascular effects, and total mortality. The Ozone ISA reported that long-term exposures (one month or longer) to ozone are “likely to be causal” for respiratory effects including

*Oxidants*. U.S. Environmental Protection Agency. Washington, DC. Office of Research and Development. EPA/600/R-20/012. Available at: <https://www.epa.gov/isa/integrated-science-assessment-isa-ozone-and-related-photochemical-oxidants>.

<sup>68</sup> U.S. EPA. 2021. Technical Support Document (TSD) for the Final Revised Cross-State Air Pollution Rule Update for the 2008 Ozone Season NAAQS Estimating PM<sub>2.5</sub> and Ozone-Attributable Health Benefits. [https://www.epa.gov/sites/default/files/2021-03/documents/estimating\\_pm2.5\\_and\\_ozone-attributable\\_health\\_benefits\\_tsd.pdf](https://www.epa.gov/sites/default/files/2021-03/documents/estimating_pm2.5_and_ozone-attributable_health_benefits_tsd.pdf).

respiratory mortality, and a “suggestive of, but not sufficient to infer, a causal relationship” for cardiovascular effects, reproductive effects, central nervous system effects, metabolic effects, and total mortality.

The combined total present value (PV) of the monetized human health benefits for this final action are \$77 million and \$690 million at a 3 percent discount rate and \$53 million and \$475 million at a 7 percent discount rate. The combined total PV of the net monetized benefits (monetized health benefits plus monetized climate benefits minus climate disbenefits) for the final amendments are negative \$89 million at the 3 percent discount rate to negative \$110 million at the 7 percent discount rate and \$480 million at the 3 percent discount rate to \$270 million at the 7 percent discount rate. The combined total equivalent annual value (EAV) of the benefits for the final amendments are negative \$7 million at the 3 percent discount rate to negative \$7.7 million at the 7 percent discount rate and \$40 million at the 3 percent discount rate to negative \$34 million at the 7 percent discount rate. See Table 18 in section VI.A of this preamble for additional details. For all estimates, we summarized the monetized ozone-related health benefits using discount rates of 3 percent and 7 percent for the 15-year analysis period of these rules discounted back to 2023 rounded to 2 significant figures. We present two benefits estimates that are separated by the word “and” to signify that they are

two separate estimates. The estimates do not represent lower- and upper-bound estimates. For a full explanation of why we present monetized benefits estimates in this way, please refer to Chapter 4 of the RIA. For the full set of underlying calculations see the benefits workbook in the RIA, which is available in the docket for this rulemaking. In addition, we include the monetized disbenefits<sup>69</sup> (i.e., negative effects) from additional CO<sub>2</sub> and NO<sub>x</sub> emissions, which occur with the HON, the P&R I NESHAP, and NSPS IIIa, NNNa, and RRRa, but not the P&R II NESHAP or NSPS subpart VVb since there are no additional CO<sub>2</sub> emissions as a result of these two final rules.

#### 1. HON

The PV of the monetized human health benefits for the HON are \$70 million and \$630 million at a 3 percent discount rate and \$48 million and \$420 million at a 7 percent discount rate. The PV of the net monetized benefits (monetized health benefits plus monetized climate benefits minus climate disbenefits)<sup>70</sup> for the final amendments for the HON are negative \$70 million at the 3 percent discount rate to negative \$92 million at the 7 percent discount rate and \$490 million at the 3 percent discount rate to \$280 million at the 7 percent discount rate. The EAV of the benefits for the final amendments for the HON are negative \$5.1 million at the 3 percent discount rate to negative \$5.8 million at the 7 percent discount rate and \$42 million at the 3 percent discount rate to negative \$35 million at the 7 percent discount rate. In addition, this rule will provide unmonetized benefits from the reduction of 1,107 tons of HAP emission reductions. This includes positive health effects from reduced exposure to EtO, chloroprene, benzene, 1,3-butadiene, vinyl chloride, ethylene dichloride, chlorine, maleicanhydride, and acrolein.

#### 2. P&R I NESHAP

The PV of the monetized human health benefits for the P&R I NESHAP are negative \$0.2 million and negative \$1.7 million at a 3 percent discount rate and negative \$0.2 million and negative

\$1.5 million at a 7 percent discount rate. The PV of the net monetized benefits (monetized health benefits plus monetized climate benefits minus monetized climate disbenefits) for the final amendments for the P&R I NESHAP are negative \$22 million at the 3 percent discount rate to negative \$22 million at the 7 percent discount rate and negative \$24 million at the 3 percent discount rate to negative \$24 million at the 7 percent discount rate. The EAV of the benefits for the final amendments for the P&R I NESHAP are negative \$1.7 million at the 3 percent discount rate to negative \$1.7 million at the 7 percent discount rate and negative \$1.8 million at the 3 percent discount rate to negative \$1.8 million at the 7 percent discount rate. In addition, this rule will provide unmonetized benefits from 264 tpy of HAP reductions, including an approximate 14 tpy reduction in chloroprene emissions.

#### 3. P&R II NESHAP

The PV of the net monetized benefits (monetized health benefits plus monetized climate benefits minus monetized climate disbenefits) for the final amendments for the P&R II NESHAP are zero since there are minimal VOC emission reductions (no more than 1 tpy), and there are no changes in climate-related emissions (CO<sub>2</sub>, methane, N<sub>2</sub>O).

#### 4. NSPS Subpart VVb

For the final NSPS subpart VVb, the EPA elected to use the benefit per-ton (BPT) approach because we cannot be confident of the location of new facilities that would be subject to these final NSPS, the EPA elected to use the BPT approach. BPT estimates provide the total monetized human health benefits (the sum of premature mortality and premature morbidity) of reducing one ton of the VOC precursor for ozone from a specified source. Specifically, in this analysis, we multiplied the estimates from the SOCMI sector by the corresponding emission reductions. Also, there are no climate benefits or disbenefits associated with this final NSPS. Thus, all monetized benefits are human health benefits from VOC reductions. The PV of the monetized human health benefits from this subpart is \$1.3 million and \$12 million at a 3 percent discount rate and \$0.9 million and \$7.9 million at a 7 percent discount rate. The EAV of the benefits for the final NSPS subpart VVb are \$0.10 million at the 3 percent discount rate to \$0.09 million at the 7 percent discount rate and \$0.93 million at the 3 percent discount rate to \$0.82 million at the 7 percent discount rate.

#### 5. NSPS Subpart IIIa, NNNa, and RRRa

For the final NSPS subparts IIIa, NNNa, and RRRa, the EPA elected to use the BPT approach because we cannot be confident of the location of new facilities that would be subject to these final NSPS. BPT estimates provide the total monetized human health benefits (the sum of premature mortality and premature morbidity) of reducing one ton of the VOC precursor for ozone from a specified source. Specifically, in this analysis, we multiplied the estimates from the SOCMI sector by the corresponding emission reductions. The PV of the monetized human health benefits from these three subparts are \$6 million and \$54 million at a 3 percent discount rate and \$5.3 million and \$47 million at a 7 percent discount rate.

We then add these monetized human health benefits to the monetized climate benefits and disbenefits to provide a total estimate of monetized benefits for these final NSPS. The PV of the net monetized benefits (monetized health benefits plus monetized climate benefits minus monetized climate disbenefits) for the final NSPS subparts IIIa, NNNa, and RRRa are negative \$8 million and negative \$6 million at the 3 percent discount rate and negative \$4 million and negative \$46 million at the 7 percent discount rate. The EAV of the benefits for the final NSPS subparts IIIa, NNNa, and RRRa are negative \$0.6 million at the 3 percent discount rate and negative \$0.3 million at the 7 percent discount rate and negative \$4.7 million at the 3 percent discount rate and negative \$4.9 million at the 7 percent discount rate.

#### F. What analysis of environmental justice did we conduct?

For purposes of analyzing regulatory impacts, the EPA relies upon its June 2016 “Technical Guidance for Assessing Environmental Justice in Regulatory Analysis,” which provides recommendations that encourage analysts to conduct the highest quality analysis feasible, recognizing that data limitations, time, resource constraints, and analytical challenges will vary by media and circumstance. The Technical Guidance states that a regulatory action may involve potential EJ concerns if it could: (1) create new disproportionate impacts on communities with EJ concerns; (2) exacerbate existing disproportionate impacts on communities with EJ concerns; or (3) present opportunities to address existing disproportionate impacts on communities with EJ concerns through this action under development.

<sup>69</sup> Monetized climate benefits and disbenefits are based on changes (increases) in CO<sub>2</sub> and N<sub>2</sub>O emissions and decreases in CH<sub>4</sub> emissions and are calculated using three different estimates of the social cost of each greenhouse gas (SC-GHG) (2.5 percent, 2 percent, and 1.5 percent discount rates). For the presentational purposes, we show the benefits and disbenefits associated with the SC-GHG at a 2 percent discount rate.

<sup>70</sup> Climate disbenefit estimates include CO<sub>2</sub> and N<sub>2</sub>O increases in emissions. Climate benefit estimates include methane decreases in emissions.

The EPA's EJ technical guidance states that "[t]he analysis of potential EJ concerns for regulatory actions should address three questions: (A) Are there potential EJ concerns associated with environmental stressors affected by the regulatory action for population groups of concern in the baseline? (B) Are there potential EJ concerns associated with environmental stressors affected by the regulatory action for population groups of concern for the regulatory option(s) under consideration? (C) For the regulatory option(s) under consideration, are potential EJ concerns created or mitigated compared to the baseline?"<sup>71</sup>

The environmental justice analysis is presented for the purpose of providing the public with as full as possible an understanding of the potential impacts of this final action. The EPA notes that analysis of such impacts is distinct from the determinations finalized in this action under CAA sections 111 and 112, which are based solely on the statutory factors the EPA is required to consider under those sections.

#### 1. SOCM1 Source Category Demographics

For the SOCM1 source category, the EPA examined the potential for the 195 HON facilities (for which the EPA had HAP emissions inventories) to pose concerns to communities living in proximity to facilities, both in the baseline and under the control option established in this final action. Specifically, the EPA analyzed how demographics and risk are distributed both pre- and post-control. The methodology and detailed results of the demographic analysis are presented in the document titled *Analysis of Demographic Factors for Populations Living Near Hazardous Organic NESHAP (HON) Operations—Final*, which is available in the docket for this rulemaking.

To examine the potential for environmental justice concerns, the EPA conducted three different demographic analyses: a baseline proximity analysis, baseline cancer risk-based analysis (*i.e.*, before implementation of any controls required by this final action), and post-control cancer risk-based analysis (*i.e.*, after implementation of the controls required by this final action). The baseline proximity demographic analysis is an assessment of individual demographic groups in the total population living within 10 km (~6.2

miles) and 50 km (~31 miles) of the facilities. The baseline risk-based demographic analysis is an assessment of risks to individual demographic groups in the population living within 10 km and 50 km of the facilities prior to the implementation of any controls required by this final action ("baseline"). The post-control risk-based demographic analysis is an assessment of risks to individual demographic groups in the population living within 10 km and 50 km of the facilities after implementation of the controls required by this final action ("post-control"). In this preamble, we focus on the results from the demographic analyses using a 10 km radius because this buffer distance encompasses all the facility maximum individual risk (MIR) locations, captures 97 percent of the population with baseline cancer risks greater than or equal to 50-in-1 million from SOCM1 source category emissions, and captures 100 percent of the population with such baseline risks greater than 100-in-1 million. The results of the demographic analyses for populations living within 50 km of facilities are included in the document titled *Analysis of Demographic Factors for Populations Living Near Hazardous Organic NESHAP (HON) Operations—Final*, which is available in the docket for this rulemaking.

For all three demographic analyses, the affected populations (*i.e.*, those living within 10 km of the facilities) are compared to the national population. The total population, population percentages, and population count for each demographic group for the entire U.S. population are shown in the column titled "Nationwide Average for Reference" in Tables 8 through 10 of this preamble. These national data are provided as a frame of reference to compare the results of the baseline proximity analysis, the baseline cancer risk-based analysis, and the post-control cancer risk-based analysis.

The results of the baseline proximity analysis indicate that a total of 9.3 million people live within 10 km of the 195 HON facilities. The percent of the population that is Black (25 percent) is more than double the national average (12 percent), and the percent of the population that is Hispanic or Latino (22 percent) is also higher than the national average (19 percent). The percent of people living below the poverty level and the percent of people over the age of 25 without a high school diploma are higher than the national averages. The results of the baseline proximity analysis indicate that the proportion of other demographic groups

living within 10 km of HON facilities is similar to or below the national average.

The baseline cancer risk-based demographic analysis, which focuses on populations that have higher cancer risks, suggests that Hispanic/Latino individuals and Black individuals living near the facilities are overrepresented with respect to the national average at all cancer risk levels greater than 1-in-1 million. In addition, the percent of households with linguistic isolation (in which all household members over the age of 14 only have limited English proficiency) increases as the Hispanic/Latino population increases. At all risk levels greater than or equal to 1-in-1-million, in cases where the percentage of the population below the poverty level is 1.5 to 2 times the national average, these populations are also above the national averages for Black, American Indian or Alaska Native, Hispanic/Latino, or Other Race/Multiracial populations.

The post-control risk-based demographic analysis shows that the controls required by this final action will notably reduce the number of people who are exposed to cancer risks resulting from SOCM1 source category emissions at all risk levels. At greater than or equal to a cancer risk of 1-in-1 million, the number of individuals exposed will decrease from 2.8 million to 2.7 million. At greater than or equal to a cancer risk of 50-in-1 million, the number of individuals exposed will decrease from 300,000 to 30,000. And after the control is implemented, there will be no people who are exposed to cancer risks greater than 100-in-1 million resulting from SOCM1 source category emissions. Although all demographic populations will see reductions in the number of individuals exposed at each level of risk, there will be individuals who still remain at a cancer risk greater than or equal to 1-in-1 million or greater than or equal to 50-in-1 million risk post-control. The demographic composition of those individuals still exposed to risk greater than or equal to 1-in-1 million will be similar to the demographic composition of the individuals exposed at baseline. At the greater than or equal to 50-in-1 million risk level, the percentages of most demographic populations will be similar to the national average percentages with the exception of the Hispanic/Latino population, which will still be overrepresented with respect to the national average. At the greater than 100-in-1 million risk level, there will be no individuals exposed to cancer risk post-control, so there will be no disparities among demographic groups at this risk level. The actions of this

<sup>71</sup> "Technical Guidance for Assessing Environmental Justice in Regulatory Analysis", U.S. EPA, June 2016. Quote is from Section 3—Key Analytic Considerations, page 11.



final rulemaking will improve human health of current and future populations that live near these facilities. For more details see the remainder of this section.

#### a. Baseline Proximity Analysis

The column titled “Baseline Proximity Analysis for Pop. Living within 10 km of HON Facilities” in Tables 8 through 10 of this preamble shows the share and count of people for each of the demographic categories for the total population living within 10 km (~6.2 miles) of HON facilities. These are the results of the baseline proximity analysis and are repeated in Tables 8 through 10 of this preamble for easy comparison to the risk-based analyses discussed later.

Approximately 9.3 million people live within 10 km of the 195 HON facilities assessed. The results of the proximity demographic analysis indicate that the percent of the population that is Black (25 percent, 2.35M people) is more than double the national average (12 percent). The percent of the population that is Hispanic or Latino (22 percent, 2M people) is higher than the national average (19 percent). The percent of people living below the poverty level (19 percent, 1.75M people) and percent of people over the age of 25 without a high school diploma (16 percent, 1.5M people) are higher than the national averages (13 percent and 12 percent, respectively). The baseline proximity analysis indicates that the proportion of other demographic groups living within 10 km of HON facilities is similar to or below the national average.

#### b. Baseline Risk-Based Demographics

The baseline risk-based demographic analysis results are shown in the “baseline” column of Tables 8 through 10 of this preamble. This analysis focused on the populations living within 10 km (~6.2 miles) of the HON facilities with estimated cancer risks greater than or equal to 1-in-1 million resulting from SOCMCI source category emissions (Table 8 of this preamble), greater than or equal to 50-in-1 million (Table 9 of this preamble), and greater than 100-in-1 million (Table 10 of this preamble). The risk analysis indicated that emissions from the source category, prior to the controls required in this final action, expose 2.8 million people living near 111 facilities to a cancer risk greater than or equal to 1-in-1 million, 322,000 people living near 21 facilities to a cancer risk greater than or equal to 50-in-1 million, and 83,000 people living near 8 facilities to a cancer risk greater than 100-in-1 million.

In the baseline, there are 2.8 million people living around 111 HON facilities

with a cancer risk greater than or equal to 1-in-1 million resulting from SOCMCI source category emissions. The 111 HON facilities are located across 17 states, but two-thirds of them are located in Texas and Louisiana (50 in Texas and 33 in Louisiana). Ninety percent of the people with risks greater than or equal to 1-in-1 million are living around 29 of the 111 HON facilities. All but three of these 29 facilities are located in Texas and Louisiana. The percent of the baseline population with estimated cancer risks greater than or equal to 1-in-1 million who are Black (25 percent, 692,000 people) is well above the average percentage of the national population that is Black (12 percent). The Black population living within 10 km of two facilities in Louisiana account for about a quarter of the total Black population with risks greater than or equal to 1-in-1 million resulting from SOCMCI source category emissions.

The percent of the population with cancer risks greater than or equal to 1-in-1 million resulting from SOCMCI source category emissions prior to the controls required in this final action that is Hispanic or Latino (34 percent, 958,000 people) is significantly higher than that in the baseline proximity analysis (22 percent, 2 million people) and well above the national average (19 percent). The population around an Illinois facility is over 75 percent Hispanic or Latino, and accounts for a quarter of the Hispanic/Latino population with risks greater than or equal to 1-in-1 million resulting from SOCMCI source category emissions. Another group of 5 facilities in the Houston/Channelview Texas area have local populations that are between 60 and 90 percent Hispanic/Latino, and those communities account for 31 percent of the Hispanic/Latino population with risks greater than or equal to 1-in-1 million resulting from SOCMCI source category emissions. The percent of the population that is linguistically isolated in the baseline with cancer risks greater than or equal to 1-in-1 million (8 percent, 228,000 people) is higher than the percentage in the baseline proximity analysis (5 percent, 510,000 people). The areas with the highest Hispanic/Latino population are some of those with the highest percent linguistic isolation.

Overall, the percent of the baseline population that is American Indian or Alaska Native with risks greater than or equal to 1-in-1 million resulting from SOCMCI source category emissions (0.2 percent) is well below the national average (0.7 percent). The population with baseline risks resulting from

SOCMI source category emissions greater than or equal to 1-in-1 million have a percent American Indian or Alaska Native population that is more than 2 times the national average. These facilities are located in Texas (3), Louisiana, Montana, Illinois, and Kansas.

The percent of the population below the poverty level with cancer risks greater than or equal to 1-in-1 million resulting from SOCMCI source category emissions (18 percent, 513,000 people) is above the national average (13 percent). The percent of the population living below the poverty level within 10 km of 19 facilities is twice the national average. The percent of the population over 25 years old without a high school diploma with cancer risks greater than or equal to 1-in-1 million resulting from SOCMCI source category emissions (20 percent, 561,000 people) is greater than the national average (13 percent) as well as greater than the overall percent of the population living near HON facilities who are over 25 years old without a high school diploma (16 percent, 1.5 million people).

In the baseline, there are 322,000 people living around 21 HON facilities with a cancer risk greater than or equal to 50-in-1 million resulting from SOCMCI source category emissions. The 21 HON facilities are located across 6 states, but two-thirds of them are located in Texas and Louisiana. Ninety-six percent of the people with risks greater than or equal to 50-in-1 million resulting from SOCMCI source category emissions live around 5 HON facilities, which are located in Texas or Louisiana. The percent of the population that is Black with baseline cancer risk greater than or equal to 50-in-1 million resulting from SOCMCI source category emissions (18 percent, 59,000 people) is above the national average (12 percent) but is significantly lower than the percent of the population that is Black with risks greater than or equal to 1-in-1 million resulting from SOCMCI source category emissions (25 percent, 692,000 people). The percentage of Black individuals is greater than the national average near over half of the facilities (12 facilities) where cancer risk is greater than 50-in-1 million resulting from HON source category emissions. The populations near two facilities in Texas account for about 70 percent of the number of Black individuals with risks greater than or equal to 50-in-1 million resulting from SOCMCI source category emissions.

The percentage of the population that is Hispanic/Latino with risks greater than or equal to 50-in-1 million resulting from SOCMCI source category emissions (25 percent, 81,000 people) is

similar to the percentage of the population that is Hispanic/Latino in the total population living within 10 km of the facilities (22 percent). The percent of population that is Hispanic/Latino with cancer risks greater than or equal to 50-in-1 million resulting from SOCMCI source category emissions is above the national average at over half of the facilities (13 facilities). The population near three facilities in Texas accounts for about 80 percent of the number of Latino/Hispanic people with risks greater than or equal to 50-in-1 million resulting from SOCMCI source category emissions.

Overall, the percent of the population that is American Indian or Alaska Native with risks greater than or equal to 50-in-1 million resulting from SOCMCI source category emissions (0.2 percent) is below the national average (0.7 percent). Populations near four facilities with baseline risks greater than or equal to 50-in-1 million resulting from SOCMCI source category emissions have a percent American Indian or Alaska Native population that is more than 2 times the national average. These facilities are located in Texas (3) and Louisiana.

The percentage of the population with cancer risks resulting from SOCMCI source category emissions greater than or equal to 50-in-1 million that are below the poverty level (15 percent), over 25 years old without a high school diploma (15 percent), or are linguistically isolated (5 percent) are similar to or slightly above the respective national averages. Of the population with risks greater than or equal to 50-in-1 million resulting from SOCMCI source category emissions, the percentage of the population below the poverty level is twice the national average near five facilities. For all 5 of these facilities, the percentage of the population is also 2 times the national average percentage for at least one race/ethnic demographic category.

In the baseline, there are 83,000 people living around 8 HON facilities with a cancer risk resulting from SOCMCI source category emissions greater than 100-in-1 million. These 8 HON facilities are located in Texas and Louisiana. The percent of the population that is Black with baseline cancer risk greater than 100-in-1 million resulting from SOCMCI source category emissions (14 percent) is just above the national average (12 percent). The percentage of the Black population with cancer risks greater than 100-in-1 million resulting from SOCMCI source category emissions is between 2 to 4 times greater than the national average at three facilities in Texas and one in Louisiana.

The percentage of the population that is Hispanic/Latino with risks greater than 100-in-1 million resulting from SOCMCI source category emissions (26 percent, 22,000 people) is above the national average (19 percent) and is similar to the share of the population that is Hispanic/Latino with cancer risks greater than or equal to 50-in-1 million resulting from SOCMCI source category emissions (25 percent, 81,000 people). The share of the Hispanic and Latino population with cancer risks greater than 100-in-1 million resulting from SOCMCI source category emissions is between 2 to 3 times greater than the national average at five facilities in Texas and one in Louisiana.

Overall, the percent of the baseline population that is American Indian or Alaska Native with risks greater than or equal to 100-in-1 million resulting from SOCMCI source category emissions (0.2 percent) is well below the National Average (0.7 percent).

The percentage of the population with cancer risks greater than 100-in-1 million resulting from SOCMCI source category emissions that are below the poverty level (14 percent), over 25 without a high school diploma (14 percent), or linguistically isolated (5 percent) are similar or slightly above the respective national averages. The percent of the population below the poverty level is 1.5 times the national average at five facilities. The population living around three of these facilities is also 1.5 times the national average for at least one race/ethnic demographic category.

In summary, the baseline risk-based demographic analysis, which focuses on populations that are expected to have higher cancer risks resulting from SOCMCI source category emissions, suggests that Hispanic or Latino individuals are disproportionately overrepresented at all cancer risk levels. Specifically, the percentage of the population that is Hispanic/Latino is almost twice the national average at a cancer risk equal to or greater than 1-in-1 million and almost 1.5 times the national average at the 50-in-1-million and 100-in-1-million risk levels. Similarly, the Black population is disproportionately overrepresented at all cancer risk levels in the baseline risk analysis. The percentage of Black individuals with risks greater than or equal to 1-in-1 million resulting from SOCMCI source category emissions is twice the national average and 1.5 times the national average at the 50-in-1-million risk level. In most cases, when the percentage of the population below the poverty level is greater than 1.5 times the national average, the

percentage of the population that is Black, American Indian or Alaska Native, Hispanic/Latino, or Other/Multiracial is above the national average.

#### c. Post-Control Risk-Based Demographics

This analysis focused on the populations living within 10 km (~6.2 miles) of the facilities with estimated cancer risks greater than or equal to 1-in-1 million (Table 8 of this preamble), greater than or equal to 50-in-1 million (Table 9 of this preamble), and greater than 100-in-1 million (Table 10 of this preamble) resulting from SOCMCI source category emissions after implementation of the control options for HON sources investigated under the residual risk analysis as described in section III.B.2.a of this preamble (“post-control”). The results of the post-control risk-based demographics analysis are in the columns titled “Post-Control” of Tables 8 through 10 of this preamble. In this analysis, we evaluated how all of the controls required by this final action and emission reductions for HON processes described in this action affect the distribution of risks. This makes it possible to characterize the post-control risks and to evaluate whether the final action creates or mitigates potential environmental justice concerns as compared to the baseline.

The risk analysis indicated that the number of people within 10 km of a facility exposed to risks greater than or equal to 1-in-1 million resulting from SOCMCI source category emissions (Table 8 of this preamble) is reduced from 2.8 million people in the baseline to approximately 2.7 million people after implementation of the HON controls required by this final action. The populations with a cancer risk greater than or equal to 1-in-1 million resulting from SOCMCI source category emissions are located around 111 facilities for both the baseline and post-control.

The post-control population living within 10 km of a facility with estimated cancer risks greater than or equal to 1-in-1 million resulting from SOCMCI source category emissions (Table 8 of this preamble) has similar demographic percentages to the baseline population with risks greater than or equal to 1-in-1 million. However, the number of individuals with risks greater than or equal to 1-in-1 million resulting from SOCMCI source category emissions is reduced in each demographic. Specifically, the percentage of the population with risks greater than or equal to 1-in-1 million resulting from SOCMCI source category emissions that is

Black remains high at 25 percent in the post-control scenario, but the number of Black individuals with risks at or above 1-in-1 million is reduced by over 25,000 people from 692,000 in the baseline to 664,000 in the post-control scenario.

Similarly, the percentage of the population with risks greater than or equal to 1-in-1 million resulting from SOCMCI source category emissions that is Hispanic/Latino is almost twice the national average in the post-control scenario (35 percent versus 19 percent), but the number of Hispanic/Latino individuals with risks at or above 1-in-1 million is reduced by about 24,000 people from 958,000 in the baseline to 934,000 in the post-control scenario.

The percent of the population that is American Indian or Alaska Native with risks greater than or equal to 1-in-1 million resulting from SOCMCI source category emissions (0.2 percent) is below the national average (0.7 percent) in the post-control analysis.

Nevertheless, there are seven facilities post-control with risks greater than or equal to 1-in-1 million with a percent American Indian or Alaska Native population that is more than 2 times the national average. However, the number of American Indians or Alaska Natives with risks greater than or equal to 1-in-1 million resulting from SOCMCI source category emissions is reduced from 6,000 in the baseline to 5,000 in the post-control scenario.

The percent of the population below the poverty level is the same in the post-control scenario as in the baseline (18 percent), but the number of individuals with risks greater than or equal to 1-in-1 million resulting from SOCMCI source category emissions that are below the poverty level is reduced by 20,000, from 513,000 to 493,000. The percent of individuals over 25 years old without a high school diploma is the same in the post-control scenario as in the baseline (20 percent), but the number of individuals with risks greater than or equal to 1-in-1 million resulting from SOCMCI source category emissions is reduced by almost 23,000, from 561,000 to 538,000. The percentage of the population that is in linguistic isolation with risks greater than or equal to 1-in-1 million resulting from SOCMCI source category emissions is the same in the post-control scenario (8 percent), but the number of individuals is reduced by almost 8,000 compared to the baseline, from 228,000 to 220,000.

The risk analysis indicated that the number of people living within 10 km of a facility and exposed to risks greater

than or equal to 50-in-1 million resulting from SOCMCI source category emissions (Table 9 of this preamble) is reduced significantly from 322,000 people in the baseline to 29,000 after implementation of the controls required by this final action. This represents more than a 90 percent reduction in the number of individuals with risk greater than or equal to 50-in-1 million when compared to the baseline. The populations living within 10 km of a facility and with a cancer risk greater than or equal to 50-in-1 million resulting from SOCMCI source category emissions are located around 13 facilities in the post-control scenario, 8 fewer facilities than in the baseline. These 13 facilities are located in Alabama, Arkansas, Illinois, Kentucky, Louisiana (5 facilities), and Texas (4 facilities). The communities within 10 km of five of those facilities (in Texas (3 facilities), Alabama, and Illinois) comprise 95 percent of the population with risks greater than or equal to 50-in-1 million resulting from SOCMCI source category emissions.

The number of individuals with risks greater than or equal to 50-in-1 million is reduced significantly for each demographic category in the post-control scenario. Specifically, the percentage of the population with risks greater than or equal to 50-in-1 million resulting from SOCMCI source category emissions that is Black decreased in the post-control scenario and is equal to the national average (12 percent). The number of Black individuals with risks at or above 50-in-1 million is reduced from 59,000 in the baseline to 4,000 post-control. The percentage of the population with risks greater than or equal to 50-in-1 million resulting from SOCMCI source category emissions that is Hispanic/Latino increased from 25 percent in the baseline to 29 percent post-control, but the number of Hispanic/Latino individuals with risks at or above 50-in-1 million is reduced from 81,000 in the baseline to 9,000 post-control.

Overall, the percent of the population that is American Indian or Alaska Native with risks greater than or equal to 50-in-1 million resulting from SOCMCI source category emissions (0.3 percent) is well below the national average (0.7 percent) in the post-control scenario. In addition, the number of American Indians or Alaska Natives with risks greater than or equal to 50-in-1 million resulting from SOCMCI source category emissions is reduced from 600 in the baseline to less than 100 post-control.

The percent of the population with risks greater than or equal to 50-in-1 million resulting from SOCMCI source category emissions whose income is below the poverty level (11 percent) is reduced from the baseline (15 percent) post-control. In addition, the number of individuals with risks greater than or equal to 50-in-1 million resulting from SOCMCI source category emissions who are below the poverty level is reduced from 47,000 to 3,000. The number of individuals with risks greater than or equal to 50-in-1 million resulting from SOCMCI source category emissions that are over 25 years old without a high school diploma or are linguistically isolated are also greatly reduced post-control.

The risk analysis indicated that the number of people living within 10 km of a facility with risks greater than 100-in-1 million resulting from SOCMCI source category emissions (Table 10 of this preamble) is reduced from 83,000 individuals in the baseline to zero individuals after application of the SOCMCI controls required by this final action. Therefore, for the post-control risk-based demographic results, there are no greater than 100-in-1 million demographic results to discuss.

In summary, as shown in the post-control risk-based demographic analysis, the controls required by this final action significantly reduce the number of people expected to have cancer risks greater than or equal to 1-in-1 million, greater than or equal to 50-in-1 million, and greater than 100-in-1 million resulting from SOCMCI source category emissions. Although the number of individuals with risks greater than or equal to 1-in-1 million is reduced in the post-control scenario (reduced from 2.8 million people to 2.7 million people), populations of Black individuals, Hispanic/Latino individuals, those living below the poverty level, and those over 25 without a high school diploma remain disproportionately represented. Similarly, the number of individuals with risks greater than or equal to 50-in-1 million is reduced significantly in the post-control scenario (reduced from 322,000 to 29,000), but the population of Black individuals remains disproportionately represented. Post-control, there are no individuals with risks greater than 100-in-1 million resulting from SOCMCI source category emissions (reduced from 83,000 people to 0 people).

**BILLING CODE 6560-50-P**

**Table 8. Source Category: Comparison of Baseline and Post-Control Demographics of Populations with Cancer Risk Greater than or Equal to 1-in-1 Million Resulting from SOCFI Source Category Emissions Living Within 10 km of Facilities to the National Average and Proximity Demographics**

Demographic Group	Nationwide Average for Reference	Baseline Proximity Analysis for Pop. Living within 10 km of HON Facilities	Cancer Risk $\geq$ 1-in-1 Million within 10 km of HON Facilities	
			Baseline	Post-Control
Total Population	328M	9,271,798	2,798,319	2,675,266
Number of Facilities	-	195	111	111
Race and Ethnicity by Percent [number of people]				
White	60 percent [197M]	47 percent [4.4M]	37 percent [1.04M]	37 percent [976K]
Black	12 percent [40M]	25 percent [2.35M]	25 percent [692K]	25 percent [664K]
American Indian or Alaska Native	0.7 percent [2M]	0.2 percent [20K]	0.2 percent [6K]	0.2 percent [5K]
Hispanic or Latino (includes white and nonwhite)	19 percent [62M]	22 percent [2M]	34 percent [958K]	35 percent [934K]
Other and Multiracial	8 percent [27M]	5 percent [493K]	4 percent [101K]	4 percent [96K]
Income by Percent [Number of People]				
Below Poverty Level	13 percent [44M]	19 percent [1.75M]	18 percent [513K]	18 percent [493K]
Above Poverty Level	87 percent [284M]	81 percent [7.5M]	82 percent [2.3M]	82 percent [2.2M]
Education by Percent [Number of People]				
Over 25 and without a High School Diploma	12 percent [40M]	16 percent [1.5M]	20 percent [561K]	20 percent [538K]
Over 25 and with a High School Diploma	88 percent [288M]	84 percent [7.8M]	80 percent [2.2M]	80 percent [2M]
Linguistically Isolated by Percent [Number of People]				
Linguistically Isolated	5 percent [18M]	5 percent [510K]	8 percent [228K]	8 percent [220K]

## Notes:

- There are 207 HON facilities; however, only 195 of these facilities are included in the proximity analysis based on available data, which corresponds to 222 EIS facility IDs.
- Nationwide population and demographic percentages are based on Census' 2015-2019 American Community Survey (ACS) 5-year block group averages. Total population count within 10 km is based on 2010 Decennial Census block population.
- To avoid double counting, the "Hispanic or Latino" category is treated as a distinct demographic category. A person who identifies as Hispanic or Latino is counted as Hispanic or Latino, regardless of race.
- The number of facilities represents facilities with a cancer MIR above level indicated. When the MIR was located at a user assigned receptor at an individual residence and not at a census block centroid, we were unable to estimate population and demographics for that facility.
- The sum of individual populations with a demographic category may not add up to total due to rounding.

**Table 9. Source Category: Comparison of Baseline and Post-Control Demographics of Populations with Cancer Risk Greater than or Equal to 50-in-1 Million Resulting from SOCFI Source Category Emissions Living Within 10 km of Facilities to the National Average and Proximity Demographics**

Demographic Group	Nationwide Average for Reference	Baseline Proximity Analysis for Pop. Living within 10 km of HON Facilities	Cancer Risk $\geq$ 50-in-1 million within 10 km of HON Facilities	
			Baseline	Post-Control
Total Population	328M	9,271,798	322,429	29,482
Number of Facilities	-	195	21	13
Race and Ethnicity by Percent [number of people]				
White	60 percent [197M]	47 percent [4.4M]	51 percent [165K]	54 percent [16K]
Black	12 percent [40M]	25 percent [2.35M]	18 percent [59K]	12 percent [4K]
American Indian or Alaska Native	0.7 percent [2M]	0.2 percent [20K]	0.2 percent [630]	0.3 percent [85]
Hispanic or Latino (includes white and nonwhite)	19 percent [62M]	22 percent [2M]	25 percent [81K]	29 percent [9K]
Other and Multiracial	8 percent [27M]	5 percent [493K]	5 percent [16K]	4 percent [1.2K]
Income by Percent [Number of People]				
Below Poverty Level	13 percent [44M]	19 percent [1.75M]	15 percent [47K]	11 percent [3.3K]
Above Poverty Level	87 percent [284M]	81 percent [7.5M]	85 percent [276K]	89 percent [26K]
Education by Percent [Number of People]				
Over 25 and without a High School Diploma	12 percent [40M]	16 percent [1.5M]	15 percent [48K]	12 percent [4K]
Over 25 and with a High School Diploma	88 percent [288M]	84 percent [7.8M]	85 percent [274K]	88 percent [26K]
Linguistically Isolated by Percent [Number of People]				
Linguistically Isolated	5 percent [18M]	5 percent [510K]	5 percent [15K]	3 percent [767]

## Notes:

- There are 207 HON facilities; however, only 195 of these facilities are included in the proximity analysis based on available data, which corresponds to 222 EIS facility IDs.
- Nationwide population and demographic percentages are based on Census' 2015-2019 ACS 5-year block group averages. Total population count within 10 km is based on 2010 Decennial Census block population.
- To avoid double counting, the "Hispanic or Latino" category is treated as a distinct demographic category. A person who identifies as Hispanic or Latino is counted as Hispanic or Latino, regardless of race.
- The number of facilities represents facilities with a cancer MIR above level indicated. When the MIR was located at a user assigned receptor at an individual residence and not at a census block centroid, we were unable to estimate population and demographics for that facility.
- The sum of individual populations with a demographic category may not add up to total due to rounding.

**Table 10. Source Category: Comparison of Baseline and Post-Control Demographics of Populations with Cancer Risk Greater than 100-in-1 Million Resulting from SO2MI Source Category Emissions Living Within 10 km of Facilities to the National Average and Proximity Demographics**

Demographic Group	Nationwide Average for Reference	Baseline Proximity Analysis for Pop. Living within 10 km of HON Facilities	Cancer Risk >100-in-1 million within 10 km of HON facilities	
			Baseline	Post-Control
Total Population	328M	9,271,798	82,792	0
Number of Facilities	-	195	8	0
Race and Ethnicity by Percent [number of people]				
White	60 percent [197M]	47 percent [4.4M]	53 percent [44K]	- -
Black	12 percent [40M]	25 percent [2.35M]	14 percent [12K]	- -
American Indian or Alaska Native	0.7 percent [2M]	0.2 percent [20K]	0.2 percent [150]	- -
Hispanic or Latino (includes white and nonwhite)	19 percent [62M]	22 percent [2M]	26 percent [22K]	- -
Other and Multiracial	8 percent [27M]	5 percent [493K]	7 percent [5.5K]	- -
Income by Percent [Number of People]				
Below Poverty Level	13 percent [44M]	19 percent [1.75M]	14 percent [12K]	- -
Above Poverty Level	87 percent [284M]	81 percent [7.5M]	86 percent [71K]	- -
Education by Percent [Number of People]				
Over 25 and without a High School Diploma	12 percent [40M]	16 percent [1.5M]	14 percent [12K]	- -
Over 25 and with a High School Diploma	88 percent [288M]	84 percent [7.8M]	86 percent [71K]	- -
Linguistically Isolated by Percent [Number of People]				
Linguistically Isolated	5 percent [18M]	5 percent [510K]	5 percent [4K]	- -



## Notes:

- There are 207 HON facilities; however, only 195 of these facilities are included in the proximity analysis based on available data, which corresponds to 222 EIS facility IDs
- Nationwide population and demographic percentages are based on Census' 2015-2019 ACS 5-year block group averages. Total population count within 10 km is based on 2010 Decennial Census block population.
- To avoid double counting, the "Hispanic or Latino" category is treated as a distinct demographic category. A person who identifies as Hispanic or Latino is counted as Hispanic or Latino, regardless of race.
- The number of facilities represents facilities with a cancer MIR above level indicated. When the MIR was located at a user assigned receptor at an individual residence and not at a census block centroid, we were unable to estimate population and demographics for that facility.
- The sum of individual populations with a demographic category may not add up to total due to rounding.

## BILLING CODE 6560-50-C

## 2. HON Whole-Facility Demographics

As described in Section III.A.5 of this preamble, we assessed the facility-wide (or "whole-facility") risks for 195 HON facilities in order to compare the SOCMC source category risk to the whole-facility risks, accounting for HAP emissions from the entire major source and not just those resulting from SOCMC source category emissions at the major source as discussed in the previous section. The whole-facility risk analysis includes all sources of HAP emissions at each facility as reported in the NEI (described in section III.C of the preamble to the proposed rule). Since HON facilities tend to include HAP emissions sources from many source categories, the EPA conducted a whole-facility demographic analysis focused on post-control risks. This whole-facility demographic analysis characterizes the remaining risks communities face after implementation of the controls required in this final action for both the SOCMC source category and the Neoprene Production source category.

The whole-facility demographic analysis is an assessment of individual demographic groups in the total population living within 10 km (~6.2 miles) and 50 km (~31 miles) of the facilities. In this preamble, we focus on the 10 km radius for the demographic analysis because, based on SOCMC category emissions, this distance includes all the facility MIR locations, includes 97 percent of the population with cancer risks greater than or equal to 50-in-1 million, and includes 100 percent of the population with risks greater than 100-in-1 million. The results of the whole-facility demographic analysis for populations

living within 50 km are included in the document titled *Analysis of Demographic Factors for Populations Living Near Hazardous Organic NESHAP (HON) Operations: Whole Facility Analysis—Final*, which is available in the docket for this rulemaking.

The whole-facility demographic analysis post-control results are shown in Table 11 of this preamble. This analysis focused on the populations living within 10 km of the HON facilities with estimated whole-facility post-control cancer risks greater than or equal to 1-in-1 million, greater than or equal to 50-in-1 million, and greater than 100-in-1 million. The risk analysis indicated that all emissions from the HON facilities, after the reductions imposed by the final rule, expose a total of about 3 million people living around 140 facilities to a cancer risk greater than or equal to 1-in-1 million, 79,000 people living around 24 facilities to a cancer risk greater than or equal to 50-in-1 million, and 2,900 people living around 4 facilities to a cancer risk greater than 100-in-1 million.

When the HON whole-facility populations are compared to the SOCMC source category populations in the post-control scenarios, we see 400,000 additional people with risks greater than or equal to 1-in-1 million, 50,000 additional people with risks greater than or equal to 50-in-1 million, and 2,900 additional people with risks greater than 100-in-1 million. With the exception of a smaller percentage of affected Hispanic/Latino individuals (35 percent for category versus 33 percent whole-facility), the demographic distribution of the whole-facility population with risks greater than or equal to 1-in-million is similar to the source category

population with risks greater than or equal to 1-in-1 million in the post-control scenario. The population with risks greater than or equal to 50-in-1 million in the whole-facility analysis has a lower percent of Hispanic/Latino individuals than the category population with risks greater than or equal to 50-in-1 million (25 percent versus 29 percent). The percentage of the population with risks greater than or equal to 50-in-1 million that is below the poverty level or over 25 years old without a high school diploma is higher for the whole-facility post-control population than for the category post-control population (14 percent versus 11 percent). The SOCMC source category emissions analysis indicated that there are no people with post-control risks greater than 100-in-1 million. Based on results from the whole-facility emissions analysis, there are 2,900 people with post-control risks greater than 100-in-million. The increased cancer risk for most of these 2,900 people is driven by EtO emissions from non-HON processes and whole-facility emissions from the neoprene production facility (a combination of the remaining SOCMC category risk and Neoprene Production category risk at this facility). The percent of the population in the whole-facility analysis with post-control risks greater than 100-in-1 million that is Black (25 percent, 700 individuals) is well above the national average (12 percent). In addition, the percent of the population in the whole-facility analysis with a post control risk greater than 100-in-1 million that is below the poverty level (22 percent, 600 individuals), and the percent of the population that is over 25 years old without a high school diploma (27 percent, 800 individuals) are above the national average (13

percent and 12 percent, respectively). We note that as further discussed in section IV.B of this preamble, the EPA is finalizing a fenceline action level of

0.2  $\mu\text{g}/\text{m}^3$  for EtO for the whole-facility. As such, we believe that once fenceline monitoring is fully implemented, that whole-facility post-control risks will be

lower and the number of people presented in Table 11 of this preamble at each risk threshold will be lower.

**BILLING CODE 6560-50-P**

**Table 11. Whole-Facility: Whole-Facility Post-Control Demographics for HON Facilities by Risk Level for Populations Living Within 10 km of Facilities**

Demographic Group	Nationwide	Post-Control Cancer Risk for Populations within 10 km		
		≥1-in-1 million	≥50-in-1 million	>100-in-1 million
Total Population	328M	3,112,097	79,071	2,868
Number of Facilities	-	140	24	4
Race and Ethnicity by Percent [number of people]				
White	60 percent [197M]	39 percent [1.2M]	57 percent [45K]	53 percent [1.5K]
Black	12 percent [40M]	24 percent [760K]	14 percent [11K]	25 percent [729]
American Indian or Alaska Native	0.7 percent [2M]	0.2 percent [6.5K]	0.2 percent [173]	0.0 percent [1]
Hispanic or Latino (includes white and nonwhite)	19 percent [62M]	33 percent [1M]	25 percent [20K]	21 percent [598]
Other and Multiracial	8 percent [27M]	4 percent [112K]	4 percent [3K]	1 percent [32]
Income by Percent [Number of People]				
Below Poverty Level	13 percent [44M]	18 percent [575K]	14 percent [11K]	22 percent [631]
Above Poverty Level	87 percent [284M]	82 percent [2.5M]	86 percent [68K]	78 percent [2K]
Education by Percent [Number of People]				
Over 25 and without a High School Diploma	12 percent [40M]	20 percent [613K]	16 percent [13K]	27 percent [765]
Over 25 and with a High School Diploma	88 percent [288M]	80 percent [2.5M]	84 percent [66K]	73 percent [2K]
Linguistically Isolated by Percent [Number of People]				
Linguistically Isolated	5 percent [18M]	8 percent [235K]	3 percent [3K]	2 percent [54]

## Notes:

- Nationwide population and demographic percentages are based on Census' 2015-2019 ACS 5-year block group averages. Total population count within 10 km is based on 2010 Decennial Census block population.
- To avoid double counting, the "Hispanic or Latino" category is treated as a distinct demographic category. A person who identifies as Hispanic or Latino is counted as Hispanic or Latino, regardless of race.
- The number of facilities represents facilities with a cancer MIR above level indicated. When the MIR was located at a user assigned receptor at an individual residence and not at a census block centroid, we were unable to estimate population and demographics for that facility.
- The sum of individual populations with a demographic category may not add up to total due to rounding.

### 3. Neoprene Production Source Category Demographics

For the Neoprene Production source category subject to the P&R I NESHAP, the EPA examined the potential for the one neoprene production facility to pose environmental justice concerns to communities both in the baseline and under the control option required in this final action. Specifically, the EPA analyzed how demographics and risk are distributed both pre- and post-controls. The methodology and detailed results of the demographic analysis are presented in a technical report, *Analysis of Demographic Factors for Populations Living Near Neoprene Production Operations—Final*, which is available in the docket for this rulemaking.

To examine the potential for environmental justice concerns in the pre-control baseline, the EPA conducted three different demographic analyses: a baseline proximity analysis, baseline cancer risk-based analysis, and post-control cancer risk-based analysis. These analyses (total baseline, baseline risk, and post-control risks) assessed the demographic groups in the populations living within 5 km (~3.1 miles) and 50 km (~31 miles) of the facility. For the Neoprene Production source category, we focus on the 5 km radius for the demographic analysis because it encompasses the facility MIR location and captures 100 percent of the population with cancer risks resulting from Neoprene Production source category emissions greater than or equal to 50-in-1 million and greater than 100-in-1 million. The results of the proximity analysis for populations living within 50 km are included in the technical report included in the docket for this final action. Nationwide average demographics data are provided as a frame of reference.

The results of the proximity demographic analysis indicate that a total of about 29,000 people live within 5 km of the Neoprene facility. The percent of the population that is Black is more than four times the national average. The percent of people living below the poverty level is almost double the national average.

The baseline risk-based demographic analysis indicates that Black individuals are disproportionately overrepresented at all cancer risk levels resulting from Neoprene Production source category emissions (percent of Black individuals range from 5 to 7 times the national average percent). The percent of the population that is below the poverty level is twice the national average within 5 km of the Neoprene facility.

The post-control risk-based demographic analysis indicates that the controls required for Neoprene Production source category in this final action do not reduce the number of people with cancer risks resulting from Neoprene Production source category emissions greater than or equal to 1-in-1 million at the 5 km distance. However, the controls do significantly reduce the number of people with risks resulting from Neoprene Production source category emissions greater than or equal to 1-in-1 million within 50 km. The populations with risks resulting from Neoprene Production source category emissions greater than or equal to 50-in-1 million and greater than 100-in-1 million are reduced at all distances by more than 88 percent by the controls for the Neoprene Production source category under consideration. In the post-control scenario, there are no people with risks resulting from Neoprene Production source category emissions greater than 100-in-1 million.

#### a. Baseline Proximity Analysis

The column titled “Total Population Living within 5 km of Neoprene Facility” in Tables 12 through 14 of this preamble shows the demographics for the total population living within 5 km (~3.1 miles) of the neoprene facility. A total of about 29,000 people lives within 5 km of the one neoprene facility. The results of the proximity demographic analysis indicate that the percentage of the population that is Black (56 percent, 16,000 people) is more than four times the national average (12 percent). The percentage of people living below the poverty level (23 percent, 6,500 people) and those over the age of 25 without a high school diploma (16 percent, 4,500 people) are higher than the national averages (13 percent and 12 percent, respectively). The baseline proximity analysis indicates that the proportion of other demographic groups living within 5 km of the neoprene facility is similar to or below the national average.

#### b. Baseline Risk-Based Demographics

The baseline risk-based demographic analysis results are shown in the “baseline” column of Tables 12 through 14 of this preamble. This analysis focused on the populations living within 5 km (~3.1 miles) of the neoprene facility with estimated cancer risks resulting from Neoprene Production source category emissions greater than or equal to 1-in-1 million (Table 12 of this preamble), greater than or equal to 50-in-1 million (Table 13 of this preamble), and greater than 100-in-1 million (Table 14 of this preamble) in

the absence of the reductions we are finalizing in this action.

In the baseline, emissions from the Neoprene Production source category expose all individuals within 5 km of the facility (29,000 people) to a cancer risk greater than or equal to 1-in-1 million. Since the entire population within 5 km are exposed to risks greater than or equal to 1-in-1 million, the demographics of the baseline at-risk population are the same as the total baseline population. Specifically, a high percentage of the population is Black (56 percent versus 12 percent nationally), below the poverty line (23 percent versus 13 percent nationally), and over the age of 25 without a high school diploma (16 percent versus 12 percent nationally). The percentages of other demographic groups within the population with risks resulting from Neoprene Production source category emissions greater than or equal to 1-in-1 million living within 5 km of the neoprene facility are similar to or below the national average. Within 50 km (~31 miles) of the facility, about 70 percent of the population (687,000 people of the 1 million total within 50 km) is exposed to a cancer risk resulting from Neoprene Production source category emissions greater than or equal to 1-in-1 million. Additional details on the 50 km results can be found in the demographics report located in the docket.

The risk-based demographics analysis indicates that emissions from the source category, prior to the reductions we are finalizing in this action, expose about 13,000 individuals within 5 km of the facility to a cancer risk greater than or equal to 50-in-1 million (about half of the total population within 5 km). As seen at the lower risk level of greater than or equal to 1-in-1 million, the population with risks greater than or equal to 50-in-1 million has a very high percentage of Black individuals; that percent is almost 6 times the national average (68 percent versus 12 percent nationally). The percentage of the population that is below the poverty line is more than double the national average (27 percent versus 13 percent nationally), and the percentage of the population that is over the age of 25 without a high school diploma is 1.5 times the national average (18 percent versus 12 percent nationally). The percentages of other demographic groups within the population with risks resulting from Neoprene Production source category emissions greater than or equal to 50-in-1 million living within 5 km of the Neoprene facility are similar to or below the national average.

In the baseline, there are 2,000 people living within 5 km of the Neoprene

facility with a cancer risk greater than 100-in-1 million resulting from Neoprene Production source category emissions. The percent of the population that is Black with baseline cancer risk greater than 100-in-1 million (85 percent, 1,750 people) is over 7 times the national average (12 percent). The percentage of the population with cancer risks greater than 100-in-1 million that is below the poverty level (31 percent, 600 people) is about 2.5 times the national average (13 percent). The percent of the population that is over 25 without a high school diploma (14 percent, 300 people) is just above the national average (12 percent).

In summary, the baseline risk-based demographic analysis, which focuses on those specific locations that are expected to have higher cancer risks in the baseline, indicates that Black individuals are disproportionately overrepresented at all cancer risk levels. Specifically, at all risk levels, the percent of the population that is Black is 5 to 7 times the national average and the percent of the population that is below the poverty level is twice the national average within 5 km of the neoprene production facility.

#### c. Post-Control Risk-Based Demographics

This analysis focused on the populations living within 5 km (~3.1 miles) of the facility with estimated cancer risks resulting from Neoprene Production source category emissions greater than or equal to 1-in-1 million (Table 12 of this preamble), greater than or equal to 50-in-1 million (Table 13 of this preamble), and greater than 100-in-1 million (Table 14 of this preamble) after implementation of the Neoprene Production source category control options as described in section III.B.2.b of this preamble. The results of the post-control risk-based demographics analysis are in the columns titled "Post-Control" of Tables 12 through 14 of this preamble. In this analysis, we evaluated how all of the controls required by this final action and emission reductions for the Neoprene Production source category described in this action affect the distribution of risks. This makes it possible to characterize the post-control risks and to evaluate whether the final action creates or mitigates potential environmental justice concerns as compared to the baseline.

The risk analysis indicated that the number of people exposed to risks resulting from Neoprene Production source category emissions greater than or equal to 1-in-1 million within 5 km of the facility (Table 12 of this preamble) is unchanged from the

baseline (29,000 people). Therefore, the population living within 5 km of the facility with estimated cancer risks greater than or equal to 1-in-1 million in the post-control scenario (Table 12 of this preamble) has the same demographic percentages as the total population in the proximity analysis and the population with risks greater than or equal to 1-in-1 million in the baseline risk analysis. Specifically, the percentage of the population with risks resulting from Neoprene Production source category emissions in the post-control analysis that is greater than or equal to 1-in-1 million and is Black (56 percent) is almost 5 times the national average (12 percent), and the percent below the poverty level (23 percent) is almost 2 times the national average (13 percent). However, after control, the number of people exposed to risk greater than or equal to 1-in-1 million within 50 km (~31 miles) of the facility is significantly reduced from 687,000 to 58,000.

The risk analysis indicated that the number of people living within 5 km of the facility and exposed to risks greater than or equal to 50-in-1 million resulting from Neoprene Production source category emissions (Table 13 of this preamble) is reduced significantly from about 13,000 people in the baseline to 1,450 people after implementation of the controls required by this final action. This represents more than an 88 percent reduction in the size of the populations at risk when compared to the baseline population. The post-control population living within 5 km of the facility with estimated cancer risks greater than or equal to 50-in-1 million for post-control (Table 13 of this preamble) is almost entirely Black (92 percent). The number of Black individuals with risks greater than or equal to 50-in-1 million is reduced from about 9,000 in the baseline to 1,350 people post-control. Similarly, the post-control population with risks greater than or equal to 50-in-1 million has a high percent of people below poverty (33 percent). The number of people with risks greater than or equal to 50-in-1 million that are below the poverty level is reduced from 3,400 in the baseline to 500 people post-control.

The risk analysis indicated that the number of people living within 5 km of the facility and exposed to risks greater than 100-in-1 million resulting from Neoprene Production source category emissions (Table 14 of this preamble) is reduced from over 2,000 people in the baseline to zero people after application of the controls required by this final action. Therefore, for the post-control

risk-based demographics, there are no people with risks above 100-in-1 million resulting from Neoprene Production source category emissions.

In summary, as shown in the post-control risk-based demographic analysis, the controls required by this final action do not reduce the number of people expected to have cancer risks resulting from Neoprene Production source category emissions greater than or equal to 1-in-1 million at the 5 km distance. The controls do significantly reduce the number of people with risks resulting from Neoprene Production source category emissions greater than or equal to 1-in-1 million within 50 km. In the post-control population with risks greater than or equal to 1-in-1 million, Black individuals and those living below the poverty level remain disproportionately represented. For the populations with risks greater than or equal to 50-in-1 million and greater than 100-in-1 million, the controls under consideration reduce the at-risk populations by more than 88 percent at all distances. In the post-control population with risks greater than or equal to 50-in-1 million, Black individuals and those living below the poverty level remain disproportionately represented. Post-control, there are no people with risks resulting from Neoprene Production source category emissions greater than 100-in-1 million.

#### 4. Neoprene Production Whole-Facility Demographics

We also evaluated the whole-facility post-control risks at the neoprene production facility. The whole-facility post-control risks include all known sources of HAP emissions at the neoprene production facility, not just those from neoprene production processes. This whole-facility demographic analysis provides a more complete picture of the remaining risks at the facility after implementation of the controls required by this final action and the populations exposed to emissions resulting from them. The post-control whole-facility emissions at the neoprene production facility are a combination of the remaining SOCM I source category risk and Neoprene Production source category risk at this facility. Based on whole-facility emissions, there are a total of about 29,000 people living within 5 km (~3.1 miles) with risks greater than or equal to 1-in-1 million after controls, which is unchanged from the baseline. There are 87,000 people within 50 km of the neoprene facility with post-control whole-facility risks greater than or equal to 1-in-1 million, which is a 90 percent reduction of the 891,000 people in the

baseline. The population within 5 km with post-control whole-facility risks of greater than or equal to 1-in-1 million is 56 percent Black, and 23 percent are below the poverty level. Based on whole-facility emissions there are a total of about 3,000 people remaining after controls living within 5 km and 50 km of the neoprene facility with risks greater than or equal to 50-in-1 million (a reduction of 82 percent from the baseline of 16,000 people). This population is 81 percent Black and 30 percent below the poverty level. Based on whole-facility emissions, about 300 people with risks greater than 100-in-1

million remain after controls are implemented living within 5 km and 50 km of the neoprene production facility (a reduction of 86 percent from the baseline of 2,300 people). This population is 99 percent Black, and 33 percent are below the poverty level. We note that as further discussed in section IV.B of this preamble, the EPA is finalizing a secondary fence line action level of 0.3  $\mu\text{g}/\text{m}^3$  for chloroprene for the whole-facility. As such, we believe once fence line monitoring is fully implemented, that whole-facility post-control risks will be reduced to at or below 100-in-1 million and that 0

people (rather than the approximate 300 people as shown in this analysis) will have lifetime cancer risks greater than 100-in-1 million post-control.

The results of the whole-facility demographic analysis for populations living within 50 km are included in the document titled *Analysis of Demographic Factors for Populations Living Near Neoprene Production Operations: Whole Facility Analysis—Final*, which is available in the docket for this rulemaking.

**BILLING CODE 6560-50-P**

**Table 12. Source Category: Comparison of Baseline and Post-Control Demographics of Populations with Cancer Risk Greater than or Equal to 1-in-1 Million Living Within 5 km of the Neoprene Production Facility to the National Average and the Proximity Demographics**

Demographic Group	Nationwide	Total Population living within 5 km of Neoprene Facility	Cancer Risk $\geq$ 1-in-1 million within 5 km of Neoprene Facility	
			Baseline	Post-Control
Total Population	328M	28,590	28,590	28,590
Number of Facilities	-	1	1	1
Race and Ethnicity by Percent [number of people]				
White	60 percent [197M]	35 percent [10K]	35 percent [10K]	35 percent [10K]
Black	12 percent [40M]	56 percent [16K]	56 percent [16K]	56 percent [16K]
American Indian or Alaska Native	0.7 percent [2M]	0.0 percent 0	0.0 percent 0	0.0 percent 0
Hispanic or Latino (includes white and nonwhite)	19 percent [62M]	5 percent [1.5K]	5 percent [1.5K]	5 percent [1.5K]
Other and Multiracial	8 percent [27M]	3 percent [900]	3 percent [900]	3 percent [900]
Income by Percent [Number of People]				
Below Poverty Level	13 percent [44M]	23 percent [6.5K]	23 percent [6.5K]	23 percent [6.5K]
Above Poverty Level	87 percent [284M]	77 percent [22K]	77 percent [22K]	77 percent [22K]
Education by Percent [Number of People]				
Over 25 and without a High School Diploma	12 percent [40M]	16 percent [4.6K]	16 percent [4.6K]	16 percent [4.6K]
Over 25 and with a High School Diploma	88 percent [288M]	84 percent [24K]	84 percent [24K]	84 percent [24K]
Linguistically Isolated by Percent [Number of People]				
Linguistically Isolated	5 percent [18M]	1 percent [300]	1 percent [300]	1 percent [300]

## Notes:

- Nationwide population and demographic percentages are based on Census' 2015-2019 ACS 5-year block group averages. Total population count within 5 km is based on 2010 Decennial Census block population.
- To avoid double counting, the "Hispanic or Latino" category is treated as a distinct demographic category. A person who identifies as Hispanic or Latino is counted as Hispanic or Latino, regardless of race.
- The number of facilities represents facilities with a cancer MIR above level indicated. When the MIR was located at a user assigned receptor at an individual residence and not at a census block centroid, we were unable to estimate population and demographics for that facility.
- The sum of individual populations with a demographic category may not add up to total due to rounding.

**Table 13. Source Category: Comparison of Baseline and Post-Control Demographics of Populations with Cancer Risk Greater than or Equal to 50-in-1 Million Living Within 5 km of the Neoprene Facility to the National Average and the Proximity Demographics**

Demographic Group	Nationwide	Total Population living within 5 km of the Neoprene Facility	Cancer Risk $\geq$ 50-in-1 million within 5 km of the Neoprene Facility	
			Baseline	Post-Control
Total Population	328M	28,590	16,282	2,996
Number of Facilities	-	1	1	1
Race and Ethnicity by Percent [number of people]				
White	60 percent [197M]	35 percent [10K]	29 percent [4.7K]	14 percent [400]
Black	12 percent [40M]	56 percent [16K]	63 percent [10K]	81 percent [2.5K]
American Indian or Alaska Native	0.7 percent [2M]	0.0 percent 0	0.0 percent [0]	0.0 percent [0]
Hispanic or Latino (includes white and nonwhite)	19 percent [62M]	5 percent [1.5K]	5 percent [800]	4 percent [100]
Other and Multiracial	8 percent [27M]	3 percent [900]	3 percent [500]	0.3 percent [10]
Income by Percent [Number of People]				
Below Poverty Level	13 percent [44M]	23 percent [6.5K]	26 percent [4.2K]	30 percent [900]
Above Poverty Level	87 percent [284M]	77 percent [22K]	74 percent [12K]	70 percent [2.1K]
Education by Percent [Number of People]				
Over 25 and without a High School Diploma	12 percent [40M]	16 percent [4.6K]	18 percent [3.0K]	16 percent [500]
Over 25 and with a High School Diploma	88 percent [288M]	84 percent [24K]	82 percent [13K]	84 percent [2.5K]
Linguistically Isolated by Percent [Number of People]				
Linguistically Isolated	5 percent [18M]	1 percent [300]	1 percent [200]	0.2 percent 6

## Notes:

- Nationwide population and demographic percentages are based on Census' 2015-2019 ACS 5-year block group averages. Total population count within 5 km is based on 2010 Decennial Census block population.
- To avoid double counting, the "Hispanic or Latino" category is treated as a distinct demographic category. A person who identifies as Hispanic or Latino is counted as Hispanic or Latino, regardless of race.
- The number of facilities represents facilities with a cancer MIR above level indicated. When the MIR was located at a user assigned receptor at an individual residence and not at a census block centroid, we were unable to estimate population and demographics for that facility.
- The sum of individual populations with a demographic category may not add up to total due to rounding.



**Table 14. Source Category: Comparison of Baseline and Post-Control Demographics of Populations with Cancer Risk Greater than 100-in-1 Million Living Within 5 km of the Neoprene Facility to the National Average and the Proximity Demographics**

Demographic Group	Nationwide	Total Population living within 5 km of the Neoprene Facility	Cancer Risk >100-in-1 million within 5 km of the Neoprene Facility	
			Baseline	Post-Control
Total Population	328M	28,590	2,332	326
Number of Facilities	-	1	1	1
Race and Ethnicity by Percent [number of people]				
White	60 percent [197M]	35 percent [10K]	13 percent [300]	1 percent [3]
Black	12 percent [40M]	56 percent [16K]	83 percent [1.9K]	99 percent [300]
American Indian or Alaska Native	0.7 percent [2M]	0.0 percent 0	0.0 percent [0]	0.0 percent [0]
Hispanic or Latino (includes white and nonwhite)	19 percent [62M]	5 percent [1.5K]	4 percent [100]	0 percent [0]
Other and Multiracial	8 percent [27M]	3 percent [900]	0.2 percent [6]	0 percent [0]
Income by Percent [Number of People]				
Below Poverty Level	13 percent [44M]	23 percent [6.5K]	30 percent [700]	33 percent [100]
Above Poverty Level	87 percent [284M]	77 percent [22K]	70 percent [1.6K]	67 percent [200]
Education by Percent [Number of People]				
Over 25 and without a High School Diploma	12 percent [40M]	16 percent [4.6K]	15 percent [350]	12 percent [40]
Over 25 and with a High School Diploma	88 percent [288M]	84 percent [24K]	86 percent [2.0K]	88 percent [300]
Linguistically Isolated by Percent [Number of People]				
Linguistically Isolated	5 percent [18M]	1 percent [300]	0.1 percent [3]	0 percent [0]

Notes:

- Nationwide population and demographic percentages are based on Census' 2015-2019 ACS 5-year block group averages. Total population count within 5 km is based on 2010 Decennial Census block population.
- To avoid double counting, the "Hispanic or Latino" category is treated as a distinct demographic category. A person who identifies as Hispanic or Latino is counted as Hispanic or Latino, regardless of race.
- The number of facilities represents facilities with a cancer MIR above level indicated. When the MIR was located at a user assigned receptor at an individual residence and not at a census block centroid, we were unable to estimate population and demographics for that facility.
- The sum of individual populations with a demographic category may not add up to total due to rounding.

#### 5. P&R I and P&R II Source Categories Demographics

As stated above, for the P&R I and P&R II NESHAP, other than the Neoprene Production source category within the P&R I NESHAP, we have not conducted a risk analysis for this final action. Therefore, to examine the potential for any environmental justice concerns that might be associated with P&R I (excluding neoprene) or P&R II facilities, we performed a proximity demographic analysis, which is an assessment of individual demographic groups of the populations living within 5 km (~3.1 miles) and 50 km (~31 miles) of the facilities. The EPA then compared the data from this analysis to the national average for each of the demographic groups. In this preamble, we focus on the proximity results for the populations living within 5 km (~3.1 miles) of the facilities. The results of the proximity analysis for populations

living within 50 km are included in the document titled *Analysis of Demographic Factors for Populations Living Near Polymers and Resins I and Polymer and Resins II Facilities* (see Docket Item No. EPA-HQ-OAR-2022-0730-0060).

The results show that for populations within 5 km of the 18 P&R I facilities (5 in Louisiana, 6 in Texas, 2 in Kentucky, one each in Georgia, Minnesota, Mississippi, Ohio, Michigan), the following demographic groups were above the national average: Black individuals (37 percent versus 12 percent nationally), Hispanic/Latino individuals (24 percent versus 19 percent nationally), people living below the poverty level (24 percent versus 13 percent nationally), people over the age of 25 without a high school diploma (21 percent versus 12 percent nationally), and linguistically isolated households (7 percent versus 5 percent nationally).

The results show that for populations within 5 km of the 5 P&R II facilities (2 in Texas, one each in Alabama, Arkansas, Oregon), the following demographic groups were above the national average: American Indian or Alaska Native individuals (0.9 percent versus 0.7 percent nationally), Hispanic/Latino individuals (27 percent versus 19 percent nationally), and people over the age of 25 without a high school diploma (13 percent versus 12 percent nationally).

A summary of the proximity demographic assessment performed is included as Table 15 of this preamble. The methodology and the results of the demographic analysis are presented in the document titled *Analysis of Demographic Factors for Populations Living Near Polymers and Resins I and Polymer and Resins II Facilities* (see Docket Item No. EPA-HQ-OAR-2022-0730-0060).

**Table 15. Proximity Demographic Assessment Results for Polymers and Resins I and II Facilities**

<b>Demographic Group</b>	<b>Nationwide Average for Reference</b>	<b>P&amp;R I: Population within 5 km of 18 Facilities</b>	<b>P&amp;R II: Population within 5 km of 5 Facilities</b>
Total Population	328M	627,823	124,050
Race and Ethnicity by Percent [number of people]			
White	60 percent [197M]	35 percent [218K]	62 percent [76K]
Black	12 percent [40M]	37 percent [234K]	5 percent [7K]
American Indian or Alaska Native	0.7 percent [2M]	0.2 percent [1K]	0.9 percent [1K]
Hispanic or Latino (includes white and nonwhite)	19 percent [62M]	24 percent [150K]	27 percent [34K]
Other and Multiracial	8 percent [27M]	4 percent [24K]	5 percent [6K]
Income by Percent [Number of People]			
Below Poverty Level	13 percent [44M]	24 percent [150K]	13 percent [16K]
Above Poverty Level	87 percent [284M]	76 percent [478K]	87 percent [108K]
Education by Percent [Number of People]			
Over 25 and without a High School Diploma	12 percent [40M]	21 percent [130K]	13 percent [16K]
Over 25 and with a High School Diploma	88 percent [288M]	79 percent [498K]	87 percent [108K]
Linguistically Isolated by Percent [Number of People]			
Linguistically Isolated	5 percent [18M]	7 percent [43K]	2 percent [3K]

**Notes:**

- Nationwide population and demographic percentages are based on Census' 2015-2019 ACS 5-year block group averages. Total population count within 10 km is based on 2010 Decennial Census block population.
- To avoid double counting, the "Hispanic or Latino" category is treated as a distinct demographic category. A person who identifies as Hispanic or Latino is counted as Hispanic or Latino, regardless of race.
- The sum of individual populations with a demographic category may not add up to total due to rounding.

## 6. Proximity Demographics Analysis for NSPS Subpart VVb

In addition, to provide information for the public's understanding, the Agency conducted an analysis of the impacts of the final NSPS subpart VVb on communities with environmental justice concerns. The final NSPS subpart VVb

covers VOC emissions from certain equipment leaks in the SOCM I from sources that are constructed, reconstructed, or modified after April 25, 2023.

The locations of the new, modified, and reconstructed sources that will become subject to NSPS subpart VVb

are not known. Therefore, to provide information on the potential for any environmental justice issues that might be associated with the final NSPS subpart VVb, we performed a proximity demographic analysis for 575 existing facilities that are currently subject to NSPS subparts VV or VVa. These

represent facilities that might modify or reconstruct in the future and become subject to the NSPS subpart VVb requirements. This proximity demographic analysis characterized the individual demographic groups of the populations living within 5 km and within 50 km (~31 miles) of the existing facilities. The EPA then compared the data from this analysis to the national average for each of the demographic groups.

The proximity demographic analysis shows that, within 5 km of the facilities, the percent of the population that is Black is double the national average (24 percent versus 12 percent) (Table 16 of this preamble). The percent of people within 5 km living below the poverty level is significantly higher than the national average (20 percent versus 13 percent). The percent of people living within 5 km that are over 25 without a high school diploma is also higher than

the national average (17 percent versus 12 percent). The proximity demographics analysis shows that within 50 km of the facilities, the percent of the population that is Black is above the national average (15 percent versus 12 percent). At 50 km, the remaining percentages for the demographics are similar to or below the national average.

**Table 16. Proximity Demographic Assessment Results for Existing Facilities Subject to NSPS Subparts VV and VVa**

<b>Demographic Group</b>	<b>Nationwide</b>	<b>Population within 50 km of 575 Facilities</b>	<b>Population within 5 km of 575 Facilities</b>
Total Population	328,016,242	140,946,443	8,084,246
<b>Race and Ethnicity by Percent</b>			
White	60 percent	62 percent	50 percent
Black	12 percent	15 percent	24 percent
American Indian or Alaska Native	0.7 percent	0.4 percent	0.4 percent
Hispanic or Latino (includes white and nonwhite)	19 percent	15 percent	20 percent
Other and Multiracial	8 percent	8 percent	5 percent
<b>Income by Percent</b>			
Below Poverty Level	13 percent	14 percent	20 percent
Above Poverty Level	87 percent	86 percent	80 percent
<b>Education by Percent</b>			
Over 25 and without a High School Diploma	12 percent	12 percent	17 percent
Over 25 and with a High School Diploma	88 percent	88 percent	83 percent
<b>Linguistically Isolated by Percent</b>			
Linguistically Isolated	5 percent	5 percent	6 percent

Notes:

- The nationwide population count and all demographic percentages are based on the Census’ 2015-2019 ACS five-year block group averages and include Puerto Rico. Demographic percentages based on different averages may differ. The total population counts are based on the 2010 Decennial Census block populations.
- To avoid double counting, the “Hispanic or Latino” category is treated as a distinct demographic category for these analyses. A person is identified as one of five racial/ethnic categories above: White, Black, American Indian or Alaska Native, Other and Multiracial, or Hispanic/Latino. A person who identifies as Hispanic or Latino is counted as Hispanic/Latino for this analysis, regardless of what race this person may have also identified as in the Census.

**BILLING CODE 6560-50-C**

The methodology and the results (including facility-specific results) of the demographic analysis are presented in the document titled *Analysis of Demographic Factors for Populations Living Near Existing Facilities Subject to NSPS Subparts VV or VVa* (see Docket Item No. EPA-HQ-OAR-2022-0730-0058).

**7. Proximity Demographics Analysis for NSPS Subparts IIIa, NNNa, and RRRa**

The final NSPS subparts IIIa, NNNa, and RRRa cover VOC emissions from certain process vents in the SOCM from sources that are constructed, reconstructed, or modified after April 25, 2023.

The locations of the new, modified, and reconstructed sources that will

become subject to NSPS subparts IIIa, NNNa, and RRRa are not known. Therefore, to assess the potential for any environmental justice issues that might be associated with the final subparts, we performed a proximity demographic analysis for 266 existing facilities that are currently subject to NSPS subpart III, NNN, or RRR. These facilities represent facilities that might modify or

reconstruct in the future and thus become subject to the final NSPS requirements. This proximity demographic analysis characterized the individual demographic groups of the populations living within 5 km (~3.1 miles) and within 50 km (~31 miles) of the existing facilities. The EPA then compared the data from this analysis to the national average for each of the demographic groups.

The proximity demographic analysis shows that, within 5 km of the facilities,

the percent of the population that is Black is almost double the national average (23 percent versus 12 percent) (Table 17 of this preamble). In addition, the percentage of the population within 5 km of the facilities that is Hispanic or Latino is also above the national average (23 percent versus 19 percent). The percentage of people within 5 km living below the poverty level is significantly higher than the national average (20 percent versus 13 percent). The percentage of people living within 5 km

that are over 25 without a high school diploma is also higher than the national average (17 percent versus 12 percent). The proximity demographics analysis also shows that within 50 km of the facilities, the percentage of the population that is Black is above the national average (18 percent versus 12 percent). At 50 km, the remaining percentages for the demographics are similar to or below the national average.

**BILLING CODE 6560-50-P**

**Table 17. Proximity Demographic Assessment Results for Existing Facilities Subject to NSPS Subparts III, NNN, or RRR**

<b>Demographic Group</b>	<b>Nationwide</b>	<b>Population within 50 km of 266 Facilities</b>	<b>Population within 5 km of 266 Facilities</b>
Total Population	328,016,242	96,017,770	4,624,154
<b>Race and Ethnicity by Percent</b>			
White	60 percent	59 percent	48 percent
Black	12 percent	18 percent	23 percent
American Indian or Alaska Native	0.7 percent	0.4 percent	0.4 percent
Hispanic or Latino (includes white and nonwhite)	19 percent	15 percent	23 percent
Other and Multiracial	8 percent	7 percent	5 percent
<b>Income by Percent</b>			
Below Poverty Level	13 percent	14 percent	20 percent
Above Poverty Level	87 percent	86 percent	80 percent
<b>Education by Percent</b>			
Over 25 and without a High School Diploma	12 percent	12 percent	17 percent
Over 25 and with a High School Diploma	88 percent	88 percent	83 percent
<b>Linguistically Isolated by Percent</b>			
Linguistically Isolated	5 percent	5 percent	6 percent

**Notes:**

- The nationwide population count and all demographic percentages are based on the Census' 2015-2019 ACS five-year block group averages and include Puerto Rico. Demographic percentages based on different averages may differ. The total population counts are based on the 2010 Decennial Census block populations.
- To avoid double counting, the "Hispanic or Latino" category is treated as a distinct demographic category for these analyses. A person is identified as one of five racial/ethnic categories above: White, Black, American Indian or Alaska Native, Other and Multiracial, or Hispanic/Latino. A person who identifies as Hispanic or Latino is counted as Hispanic/Latino for this analysis, regardless of what race this person may have also identified as in the Census.

The methodology and the results (including facility-specific results) of the demographic analysis are presented in the document titled *Analysis of Demographic Factors for Populations Living Near Existing Facilities Subject to NSPS Subparts III, NNN, or RRR* (see Docket Item No. EPA-HQ-OAR-2022-0730-0059).

**G. Children's Environmental Health**

This action finalizes standards to address risk from, among other HAP, EtO and chloroprene. In addition, the EPA's Policy on Children's Health<sup>72</sup> also applies to this action. Accordingly, we evaluated the environmental health

or safety effects of EtO and chloroprene emissions and exposures on children.

Because EtO and chloroprene are mutagenic (*i.e.*, it can damage DNA), children are expected to be more susceptible to their harmful effects. To take this into account, as part of the risk assessments in support of this rulemaking, the EPA followed its

<sup>72</sup>Children's Health Policy Available at: <https://www.epa.gov/children/childrens-health-policy-and-plan>.

guidelines<sup>73</sup> and applied age-dependent adjustment factors (ADAFs) for childhood exposures (from birth up to 16 years of age). It should be noted that, because EtO and chloroprene are mutagenic, emission reductions finalized in this action will be particularly beneficial to children. The results of this evaluation are contained in section IV.A of this preamble and further documented in the risk reports, *Residual Risk Assessment for the SOCMi Source Category in Support of the 2024 Risk and Technology Review Final Rule* and *Residual Risk Assessment for the Polymers & Resins I*

<sup>73</sup>U.S. EPA. 2005. Supplemental Guidance for Assessing Susceptibility from Early-Life Exposure to Carcinogens. U.S. Environmental Protection Agency, Washington, DC, EPA/630/R-03/003F. [https://www.epa.gov/sites/default/files/2013-09/documents/childrens\\_supplement\\_final.pdf](https://www.epa.gov/sites/default/files/2013-09/documents/childrens_supplement_final.pdf).

*Neoprene Production Source Category in Support of the 2024 Risk and Technology Review Final Rule*, which are available in the docket.

## VI. Statutory and Executive Order Reviews

Additional information about these statutes and Executive Orders can be found at <https://www.epa.gov/laws-regulations/laws-and-executive-orders>.

### A. Executive Order 12866: Regulatory Planning and Review and Executive Order 14094: Modernizing Regulatory Review

This action is a “significant regulatory action” as defined under section 3(f)(1) of Executive Order 12866, as amended by Executive Order 14094. Accordingly, the EPA submitted this action to the Office of Management and Budget

(OMB) for Executive Order 12866 review. Documentation of any changes made in response to the Executive Order 12866 review is available in the docket. The EPA prepared an economic analysis of the potential impacts associated with this action. This analysis, titled *Regulatory Impact Analysis for the Final New Source Performance Standards for the Synthetic Organic Chemical Manufacturing Industry and National Emission Standards for Hazardous Air Pollutants for the Synthetic Organic Chemical Manufacturing Industry and Group I & II Polymers and Resins Industry* (EPA-452/R-24-001), is also available in the docket. Table 18 of this preamble summarizes the PV and EAV of total costs and benefits for the final action.

**BILLING CODE 6560-50-C**



**Table 18. Total Monetized Benefits, Compliance Costs, Emission Reductions, and Net Benefits for the Final Action (dollars in million 2021\$)<sup>1</sup>**

	3 Percent Discount Rate		7 Percent Discount Rate	
	PV	EAV	PV	EAV
Monetized Health Benefits <sup>2</sup>	77 and 690	6.5 and 58	53 and 475	5.9 and 52
Climate Disbenefits <sup>3</sup>	160	13	160	13
Net Compliance Costs <sup>4</sup>	1,770	150	1,370	150
<i>Compliance Costs</i>	1,790	150	1,380	150
<i>Value of Product Recovery</i>	16	1.3	12	1.3
<b>Net Benefits</b>	<b>(1,900) and (1,200)</b>	<b>(160) and (110)</b>	<b>(1,500) and (1,100)</b>	<b>(160) and (110)</b>
Nonmonetized Benefits	6,230 tons/year of HAP Health effects of reduced exposure to EtO, chloroprene, benzene, 1,3-butadiene, vinyl chloride, ethylene dichloride, chlorine, maleic anhydride and acrolein			

<sup>1</sup> Totals may not sum due to independent rounding. Numbers rounded to two significant digits unless otherwise noted. A number in parentheses denotes a negative value. Estimates are impacts for the 15 year analytic period from 2024-2038 (inclusive). PV and EAV estimates are discounted to 2024.

<sup>2</sup> Monetized health benefits include ozone related health benefits associated with reductions in VOC emissions in the ozone season. The health benefits are associated with several point estimates and are presented at real discount rates of 3 and 7 percent. The two benefits estimates are separated by the word “and” to signify that they are two separate estimates. The estimates do not represent lower- and upper-bound estimates. Benefits from HAP reductions and VOC reductions outside of the ozone season remain unmonetized and are thus not reflected in the table. The unmonetized effects also include disbenefits resulting from the secondary impact of an increase in CO emissions.

<sup>3</sup> Monetized climate benefits and disbenefits are based on increases in CO<sub>2</sub> and N<sub>2</sub>O emissions and decreases in CH<sub>4</sub> emissions and are calculated using three different estimates of the social cost of each greenhouse gas (SC-GHG) (under 1.5 percent, 2.0 percent, and 2.5 percent near-term Ramsey discount rates). For the presentational purposes of this table, we show the net disbenefits associated with the SC-GHG at a 2 percent near-term Ramsey discount rate.

<sup>4</sup> Net compliance costs are the engineering control costs minus the value of recovered product. A negative net compliance costs occurs when the value of the recovered product exceeds the compliance costs.

*B. Paperwork Reduction Act (PRA)*

## 1. HON

The information collection activities in this rule have been submitted for approval to OMB under the PRA. The information collection request (ICR) document that the EPA prepared has been assigned EPA ICR number 2753.02. You can find a copy of the ICR in the docket for this rule, and it is briefly summarized here. The information collection requirements are not enforceable until OMB approves them.

The EPA is finalizing amendments to the HON that revise provisions pertaining to emissions from flares, PRDs, process vents, storage vessels, pressure vessels, storage vessel degassing, heat exchange systems, maintenance vents, wastewater, and equipment leaks. The EPA is also finalizing additional requirements pertaining to EIO emissions from process vents, storage vessels, heat exchange systems, equipment leaks, and wastewater; and dioxins and furans emissions from process vents. In addition, the EPA is finalizing amendments to the HON that revise provisions pertaining to emissions during periods of SSM, add requirements for electronic reporting of periodic reports and performance test results, fence line monitoring, carbon adsorbers, and bypass monitoring, and make other minor clarifications and corrections. This information will be collected to assure compliance with the HON.

*Respondents/affected entities:*

Owners or operators of HON facilities.

*Respondent's obligation to respond:*

Mandatory (40 CFR part 63, subparts F, G, H, and I).

*Estimated number of respondents:*

209 (assumes two new respondents over the next 3 years).

*Frequency of response:* Initially, quarterly, semiannually, and annually.

*Total estimated burden:* average annual recordkeeping and reporting burden is 83,500 hours (per year) to comply with the final amendments in HON. Burden is defined at 5 CFR 1320.3(b).

*Total estimated cost:* average annual cost is \$66,000,000 (per year) which includes \$57,500,000 annualized capital and operations and maintenance costs, to comply with the final amendments in HON.

An agency may not conduct or sponsor, and a person is not required to respond to, a collection of information unless it displays a currently valid OMB control number. The OMB control numbers for the EPA's regulations in 40 CFR are listed in 40 CFR part 9. When

OMB approves this ICR, the Agency will announce that approval in the **Federal Register** and publish a technical amendment to 40 CFR part 9 to display the OMB control number for the approved information collection activities in this final rule.

## 2. P&amp;R I NESHAP

The information collection activities in this rule have been submitted for approval to OMB under the PRA. The ICR document that the EPA prepared has been assigned EPA ICR number 2410.07. You can find a copy of the ICR in the docket for this rule, and it is briefly summarized here. The information collection requirements are not enforceable until OMB approves them.

The EPA is finalizing amendments to the P&R I NESHAP that revise provisions pertaining to emissions from flares, PRDs, continuous process vents, batch process vents, storage vessels, pressure vessels, storage vessel degassing, heat exchange systems, maintenance vents, wastewater, and equipment leaks. The EPA is also finalizing requirements pertaining to: chloroprene emissions from process vents, storage vessels, and wastewater; and dioxins and furans emissions from continuous process vents and batch process vents. In addition, the EPA is finalizing amendments to the P&R I NESHAP that revise provisions pertaining to emissions during periods of SSM, add requirements for electronic reporting of periodic reports and performance test results, fence line monitoring, carbon adsorbers, and bypass monitoring, and make other minor clarifications and corrections. This information will be collected to assure compliance with the P&R I NESHAP.

*Respondents/affected entities:*

Owners or operators of P&R I facilities.

*Respondent's obligation to respond:*

Mandatory (40 CFR part 63, subpart U).

*Estimated number of respondents:* 19 (assumes no new respondents over the next 3 years).

*Frequency of response:* Initially, quarterly, semiannually, and annually.

*Total estimated burden:* average annual recordkeeping and reporting burden is 8,126 hours (per year) to comply with the final amendments in the P&R I NESHAP. Burden is defined at 5 CFR 1320.3(b).

*Total estimated cost:* average annual cost is \$3,200,000 (per year) which includes \$2,370,000 annualized capital and operations and maintenance costs, to comply with the final amendments in the P&R I NESHAP.

An agency may not conduct or sponsor, and a person is not required to respond to, a collection of information unless it displays a currently valid OMB control number. The OMB control numbers for the EPA's regulations in 40 CFR are listed in 40 CFR part 9. When OMB approves this ICR, the Agency will announce that approval in the **Federal Register** and publish a technical amendment to 40 CFR part 9 to display the OMB control number for the approved information collection activities in this final rule.

## 3. P&amp;R II NESHAP

The information collection activities in this rule have been submitted for approval to OMB under the PRA. The ICR document that the EPA prepared has been assigned EPA ICR number 1681.12. The OMB Control Number is 2060-0290. You can find a copy of the ICR in the docket for this rule, and it is briefly summarized here. The information collection requirements are not enforceable until OMB approves them.

The EPA is finalizing amendments to the P&R II NESHAP to add requirements pertaining to: heat exchange systems, PRDs, dioxins and furans emissions from process vents, and maintenance vents. In addition, the EPA is finalizing amendments to the P&R II NESHAP that revise provisions pertaining to emissions during periods of SSM, add requirements for electronic reporting of periodic reports and performance test results, and make other minor clarifications and corrections. This information will be collected to assure compliance with the P&R II NESHAP.

*Respondents/affected entities:*

Owners or operators of P&R II facilities.

*Respondent's obligation to respond:*

Mandatory (40 CFR part 63, subpart W).

*Estimated number of respondents:* 5 (assumes no new respondents over the next 3 years).

*Frequency of response:* Initially, semiannually, and annually.

*Total estimated burden:* average annual recordkeeping and reporting burden is 202 hours (per year) to comply with the final amendments in the P&R II NESHAP. Burden is defined at 5 CFR 1320.3(b).

*Total estimated cost:* average annual cost is \$1,780,000 (per year) which includes \$1,760,000 annualized capital and operations and maintenance costs, to comply with the final amendments in the P&R II NESHAP.

An agency may not conduct or sponsor, and a person is not required to respond to, a collection of information unless it displays a currently valid OMB control number. The OMB control

numbers for the EPA's regulations in 40 CFR are listed in 40 CFR part 9. When OMB approves this ICR, the Agency will announce that approval in the **Federal Register** and publish a technical amendment to 40 CFR part 9 to display the OMB control number for the approved information collection activities in this final rule.

#### 4. NSPS Subparts VV, VVa, III, NNN, and RRR

This action does not impose any new information collection burden under the PRA for NSPS subparts VV, VVa, III, NNN, and RRR. OMB has previously approved the information collection activities contained in the existing regulations and has assigned OMB Control number 2060-0443 for 40 CFR part 60 subparts VV, VVa, III, NNN, and RRR (this one OMB Control number is for the Consolidated Federal Air Rule in 40 CFR part 65 which presents the burden for complying with 40 CFR part 65, but also presents the burden for facilities complying with each individual subpart). This action is believed to result in no changes to the information collection requirements of these NSPS, so that the information collection estimate of project cost and hour burden from these NSPS have not been revised.

#### 5. NSPS Subpart VVb

The information collection activities in this rule have been submitted for approval to OMB under the PRA. The ICR document that the EPA prepared has been assigned EPA ICR number 2755.02. You can find a copy of the ICR in the docket for this rule, and it is briefly summarized here. The information collection requirements are not enforceable until OMB approves them.

The EPA is finalizing in a new NSPS subpart VVb the same requirements in NSPS subpart VVa plus requiring that all gas/vapor and light liquid valves be monitored monthly at a leak definition of 100 ppm and all connectors be monitored once every 12 months at a leak definition of 500 ppm. In addition, the EPA is finalizing the removal of SSM provisions (the standards apply at all times), additional requirements for electronic reporting of periodic reports, and other minor clarifications and corrections. This information will be collected to assure compliance with the NSPS subpart VVb.

##### *Respondents/affected entities:*

Owners or operators of certain equipment leaks in the SOCM. I.

*Respondent's obligation to respond:* Mandatory (40 CFR part 60, subpart VVb).

*Estimated number of respondents:* 36 (assumes 36 new respondents over the next 3 years).

*Frequency of response:* Initially, occasionally, and annually.

*Total estimated burden:* average annual recordkeeping and reporting burden is 5,414 hours (per year) to comply with all of the requirements in the NSPS. Burden is defined at 5 CFR 1320.3(b).

*Total estimated cost:* average annual cost is \$3,600,000 (per year) which includes \$3,050,000 annualized capital and operations and maintenance costs, to comply with all of the requirements in the NSPS.

An agency may not conduct or sponsor, and a person is not required to respond to, a collection of information unless it displays a currently valid OMB control number. The OMB control numbers for the EPA's regulations in 40 CFR are listed in 40 CFR part 9. When OMB approves this ICR, the Agency will announce that approval in the *Federal Register* and publish a technical amendment to 40 CFR part 9 to display the OMB control number for the approved information collection activities in this final rule.

#### 6. NSPS Subpart IIIa

The information collection activities in this rule have been submitted for approval to OMB under the PRA. The ICR document that the EPA prepared has been assigned EPA ICR number 2756.02. You can find a copy of the ICR in the docket for this rule, and it is briefly summarized here. The information collection requirements are not enforceable until OMB approves them.

The EPA is finalizing requirements for new, modified, or reconstructed sources as follows: require owners and operators reduce emissions of TOC (minus methane and ethane) from all vent streams of an affected facility (and not including the alternative of maintaining a TRE index value greater than 1 without the use of a control device); require standards apply at all times (including during SSM periods); revise monitoring requirements for flares; add maintenance vent requirements; revise requirements for adsorber monitoring; exclude the relief valve discharge exemption such that any relief valve discharge to the atmosphere of a vent stream is a violation of the emissions standard; and prohibit an owner or operator from bypassing the control device at any time, and to report any such violation. This information will be collected to assure compliance with the NSPS subpart IIIa.

*Respondents/affected entities:* Owners or operators of air oxidation unit processes in the SOCM. I.

*Respondent's obligation to respond:* Mandatory (40 CFR part 60, subpart IIIa).

*Estimated number of respondents:* 6 (assumes 6 new respondents over the next 3 years).

*Frequency of response:* Initially, semiannually, and annually.

*Total estimated burden:* average annual recordkeeping and reporting burden is 275 hours (per year) to comply with all of the requirements in NSPS subpart IIIa. Burden is defined at 5 CFR 1320.3(b).

*Total estimated cost:* average annual cost is \$4,280,000 (per year) which includes \$4,250,000 annualized capital and operations and maintenance costs, to comply with all of the requirements in NSPS subpart IIIa.

An agency may not conduct or sponsor, and a person is not required to respond to, a collection of information unless it displays a currently valid OMB control number. The OMB control numbers for the EPA's regulations in 40 CFR are listed in 40 CFR part 9. When OMB approves this ICR, the Agency will announce that approval in the *Federal Register* and publish a technical amendment to 40 CFR part 9 to display the OMB control number for the approved information collection activities in this final rule.

#### 7. NSPS Subpart NNNa

The information collection activities in this rule have been submitted for approval to OMB under the PRA. The ICR document that the EPA prepared has been assigned EPA ICR number 2757.02. You can find a copy of the ICR in the docket for this rule, and it is briefly summarized here. The information collection requirements are not enforceable until OMB approves them.

The EPA is finalizing requirements for new, modified, or reconstructed sources as follows: require owners and operators reduce emissions of TOC (minus methane and ethane) from all vent streams of an affected facility (and not including the alternative of maintaining a TRE index value greater than 1 without the use of a control device); require the standards apply at all times (including during SSM periods); revise monitoring requirements for flares; add maintenance vent requirements; revise requirements for adsorber monitoring; exclude the relief valve discharge exemption such that any relief valve discharge to the atmosphere of a vent stream is a violation of the emissions standard; and prohibit an owner or

operator from bypassing the control device at any time, and to report any such violation. This information will be collected to assure compliance with the NSPS subpart NNNa.

*Respondents/affected entities:*

Owners or operators of distillation operations in the SOCMCI.

*Respondent's obligation to respond:* Mandatory (40 CFR part 60, subpart NNNa).

*Estimated number of respondents:* 7 (assumes 7 new respondents over the next 3 years).

*Frequency of response:* Initially, semiannually, and annually.

*Total estimated burden:* average annual recordkeeping and reporting burden is 320 hours (per year) to comply with all of the requirements in NSPS subpart NNNa. Burden is defined at 5 CFR 1320.3(b).

*Total estimated cost:* average annual cost is \$4,990,000 (per year) which includes \$4,960,000 annualized capital and operations and maintenance costs, to comply with all of the requirements in NSPS subpart NNNa.

An agency may not conduct or sponsor, and a person is not required to respond to, a collection of information unless it displays a currently valid OMB control number. The OMB control numbers for the EPA's regulations in 40 CFR are listed in 40 CFR part 9. When OMB approves this ICR, the Agency will announce that approval in the **Federal Register** and publish a technical amendment to 40 CFR part 9 to display the OMB control number for the approved information collection activities in this final rule.

## 8. NSPS Subpart RRRa

The information collection activities in this rule have been submitted for approval to OMB under the PRA. The ICR document that the EPA prepared has been assigned EPA ICR number 2759.02. You can find a copy of the ICR in the docket for this rule, and it is briefly summarized here. The information collection requirements are not enforceable until OMB approves them.

The EPA is finalizing requirements for new, modified, or reconstructed sources as follows: require owners and operators reduce emissions of TOC (minus methane and ethane) from all vent streams of an affected facility (and not including the alternative of maintaining a TRE index value greater than 1 without the use of a control device); require the standards apply at all times (including during SSM periods); revise monitoring requirements for flares; add maintenance vent requirements; revise requirements for adsorber monitoring;

exclude the relief valve discharge exemption such that any relief valve discharge to the atmosphere of a vent stream is a violation of the emissions standard; and prohibit an owner or operator from bypassing the control device at any time, and to report any such violation. This information will be collected to assure compliance with the NSPS subpart RRRa.

*Respondents/affected entities:*

Owners or operators of reactor processes in the SOCMCI.

*Respondent's obligation to respond:* Mandatory (40 CFR part 60, subpart RRRa).

*Estimated number of respondents:* 6 (assumes 6 new respondents over the next 3 years).

*Frequency of response:* Initially, semiannually, and annually.

*Total estimated burden:* average annual recordkeeping and reporting burden is 275 hours (per year) to comply with all of the requirements in NSPS subpart RRRa. Burden is defined at 5 CFR 1320.3(b).

*Total estimated cost:* average annual cost is \$4,280,000 (per year) which includes \$4,250,000 annualized capital and operations and maintenance costs, to comply with all of the requirements in NSPS subpart RRRa.

An agency may not conduct or sponsor, and a person is not required to respond to, a collection of information unless it displays a currently valid OMB control number. The OMB control numbers for the EPA's regulations in 40 CFR are listed in 40 CFR part 9. When OMB approves this ICR, the Agency will announce that approval in the **Federal Register** and publish a technical amendment to 40 CFR part 9 to display the OMB control number for the approved information collection activities in this final rule.

### C. Regulatory Flexibility Act (RFA)

I certify that each of the final rules in this action will not have a significant economic impact on a substantial number of small entities under the RFA. The small entities subject to the requirements of this action are small businesses. For the final amendments to the HON, the Agency has determined that all small entities affected by this action, estimated to be 9, may experience an average impact of costs being less than 0.5 percent of revenues, not including product recovery, or about 0.43 percent, including product recovery from compliance. Two of these nine entities experienced costs above one percent of revenues, neither had costs exceeding three percent of revenues and represent a small total number of impacted entities. For the

final amendments to the P&R I NESHAP, one small entity is impacted and its impact is costs less than 0.5 percent of revenues. For the final amendments to the P&R II NESHAP, no small entities are impacted. Details of the analysis for each final rule including the NSPS that are included in this final action are presented in the RIA for this action, which is found in the docket.

### D. Unfunded Mandates Reform Act (UMRA)

This action does not contain an unfunded mandate of \$100 million or more (adjusted for inflation) as described in UMRA, 2 U.S.C. 1531–1538, and does not significantly or uniquely affect small governments. The costs involved in this action are estimated not to exceed \$100 million or more (adjusted for inflation) in any one year.

### E. Executive Order 13132: Federalism

This action does not have federalism implications. It will not have substantial direct effects on the states, on the relationship between the national government and the states, or on the distribution of power and responsibilities among the various levels of government.

### F. Executive Order 13175: Consultation and Coordination With Indian Tribal Governments

This action does not have tribal implications as specified in Executive Order 13175. None of the facilities that have been identified as being affected by this action are owned or operated by tribal governments or located within tribal lands. Thus, Executive Order 13175 does not apply to this action.

### G. Executive Order 13045: Protection of Children From Environmental Health Risks and Safety Risks

Executive Order 13045 directs federal agencies to include an evaluation of the health and safety effects of the planned regulation on children in federal health and safety standards and explain why the regulation is preferable to potentially effective and reasonably feasible alternatives. This action is subject to Executive Order 13045 because it is a significant regulatory action under section 3(f)(1) of Executive Order 12866, and the EPA believes that the environmental health or safety risk addressed by this action may have a disproportionate effect on children. This is because EtO and chloroprene, which are HAP emitted by sources subject to this action, are mutagenic (*i.e.*, it can damage DNA), and children are presented with higher risks based on the

EPA's ADAFs for these HAP. Accordingly, we have evaluated the environmental health or safety effects of EtO and chloroprene emissions on children.

The protection offered by these standards to reduce emissions of EtO and chloroprene accounts for childhood exposures by applying ADAFs to account for greater susceptibility of children to these HAP. The results of this evaluation are contained in section IV.A of this preamble and further documented in the risk reports, *Residual Risk Assessment for the SOCM Source Category in Support of the 2024 Risk and Technology Review Final Rule* and *Residual Risk Assessment for the Polymers & Resins I Neoprene Production Source Category in Support of the 2024 Risk and Technology Review Final Rule*, which are available in the docket. This action is preferred over other regulatory options because a residual risk assessment was performed and options were assessed and finalized to reduce emissions of EtO and chloroprene, which will be extremely beneficial to children. Furthermore, EPA's *Policy on Children's Health* also applies to this action. Information on how the Policy was applied is available under "Children's Environmental Health" in the Supplementary Information section of this preamble.

#### *H. Executive Order 13211: Actions Concerning Regulations That Significantly Affect Energy Supply, Distribution, or Use*

This action is not a "significant energy action" because it is not likely to have a significant adverse effect on the supply, distribution, or use of energy. The EPA expects this final action would not reduce crude oil supply, fuel production, coal production, natural gas production, or electricity production. We estimate that this final action would have minimal impact on the amount of imports or exports of crude oils, condensates, or other organic liquids used in the energy supply industries. Given the minimal impacts on energy supply, distribution, and use as a whole nationally, no significant adverse energy effects are expected to occur. For more information on these estimates of energy effects, please refer to the economic impact analysis contained in the RIA for this final rulemaking.

#### *I. National Technology Transfer and Advancement Act (NTTAA) and 1 CFR Part 51*

This action involves technical standards. As discussed in the proposal preamble (88 FR 25080, April 25, 2023),

the EPA conducted searches for the HON and the P&R I and P&R II NESHAP through the Enhanced National Standards Systems Network Database managed by the American National Standards Institute (ANSI). We also conducted a review of voluntary consensus standards (VCS) organizations and accessed and searched their databases. We conducted searches for EPA Methods 1, 1A, 2, 2A, 2C, 2D, 2F, 2G, 3B, 4, 18, 21, 22, 25A, 25D, 26, 26A, 27 of 40 CFR part 60, Appendix A, 301, 305, 316 and 320 of 40 CFR part 63, Appendix A, 624, 625, 1624, and 1625 of 40 CFR part 136 Appendix A, 624.1 of 40 CFR part 163, Appendix A. During the EPA's VCS search, if the title or abstract (if provided) of the VCS described technical sampling and analytical procedures that are similar to the EPA's reference method, the EPA ordered a copy of the standard and reviewed it as a potential equivalent method. We reviewed all potential standards to determine the practicality of the VCS for this rule. This review requires significant method validation data that meet the requirements of EPA Method 301 for accepting alternative methods or scientific, engineering, and policy equivalence to procedures in the EPA referenced methods. The EPA may reconsider determinations of impracticality when additional information is available for particular VCS. No applicable voluntary consensus standards were identified for EPA Methods 1, 1A, 2, 2A, 2C, 2D, 2F, 2G, 21, 22, 25D, 27, 305, 316, 624, 624.1, 625, 1624 and 1625.

The EPA incorporates by reference VCS ANSI/ASME PTC 19.10-1981—Part 10, "Flue and Exhaust Gas Analyses" as an acceptable alternative to EPA Method 3B (referenced in NSPS subparts IIIa, NNa, RRR, and RRRa, and NESHAP subpart G) for the manual procedures only and not the instrumental procedures. This method is used to quantitatively determine the gaseous constituents of exhausts including oxygen, CO<sub>2</sub>, carbon monoxide, nitrogen, sulfur dioxide, sulfur trioxide, nitric oxide, nitrogen dioxide, hydrogen sulfide, and hydrocarbons. The ANSI/ASME PTC 19.10-1981—Part 10 method incorporates both manual and instrumental methodologies for the determination of oxygen content. The manual method segment of the oxygen determination is performed through the absorption of oxygen. This method is available at the ANSI, 1899 L Street NW, 11th Floor, Washington, DC 20036 and the American Society of Mechanical

Engineers (ASME), Three Park Avenue, New York, NY 10016-5990; telephone number: 1-800-843-5990; and email address: [customer-care@asme.org](mailto:customer-care@asme.org). See <https://www.ansi.org> and <https://www.asme.org>. The standard is available to everyone at a cost determined by ANSI/ASME (\$96). ANSI/ASME also offer memberships or subscriptions for reduced costs. The cost of obtaining these methods is not a significant financial burden, making the methods reasonably available.

The EPA incorporates by reference VCS ASTM D6420-18, "Standard Test Method for Determination of Gaseous Organic Compounds by Direct Interface Gas Chromatography-Mass Spectrometry" as an acceptable alternative to EPA Method 18 (referenced in NSPS subparts VV, VVa, VVb, III, IIIa, NNN, NNNa, RRR, and RRRa, and NESHAP subparts F, G, H, I, U, and W) with the following caveats. This ASTM procedure uses a direct interface gas chromatograph/mass spectrometer to identify and quantify VOC and has been approved by the EPA as an alternative to EPA Method 18 only when the target compounds are all known and the target compounds are all listed in ASTM D6420 as measurable. ASTM D6420-18 should not be used for methane and ethane because the atomic mass is less than 35; and ASTM D6420 should never be specified as a total VOC method. The ASTM D6420-18 test method employs a direct interface gas chromatograph/mass spectrometer to measure 36 VOC. The test method provides onsite analysis of extracted, unconditioned, and unsaturated (at the instrument) gas samples from stationary sources.

The EPA incorporates by reference VCS ASTM D6348-12 (Reapproved 2020), "Standard Test Method for Determination of Gaseous Compounds by Extractive Direct Interface Fourier Transform Infrared (FTIR) Spectroscopy" as an acceptable alternative to EPA Method 320 (referenced in NESHAP subparts F and U) with caveats requiring inclusion of selected annexes to the standard as mandatory. This ASTM procedure uses an extractive sampling system that routes stationary source effluent to an FTIR spectrometer for the identification and quantification of gaseous compounds. We note that we proposed VCS ASTM D6348-12e1 as an alternative to EPA Method 320; however, since proposal, a newer version of the method (VCS ASTM D6348-12 (Reapproved 2020)) is now available and we have determined it to be equivalent to EPA Method 320 with caveats. The VCS ASTM D6348-12

(Reapproved 2020) method is an extractive FTIR Spectroscopy-based field test method and is used to quantify gas phase concentrations of multiple target compounds in emission streams from stationary sources. When using ASTM D6348–12 (Reapproved 2020), the following conditions must be met: (1) Annexes A1 through A8 to ASTM D6348–12 (Reapproved 2020) are mandatory; and (2) in ASTM D6348–12 (Reapproved 2020) Annex A5 (Analyte Spiking Technique), the percent (%) R must be determined for each target analyte (Equation A5.5). In order for the test data to be acceptable for a compound, %R must be  $70\% \leq R \leq 130\%$ . If the %R value does not meet this criterion for a target compound, the test data is not acceptable for that compound and the test must be repeated for that analyte (*i.e.*, the sampling and/or analytical procedure should be adjusted before a retest). The %R value for each compound must be reported in the test report, and all field measurements must be corrected with the calculated %R value for that compound by using the following equation:

$$\text{Reported Results} = \left( \frac{\text{Measured Concentration in Stack}}{\%R} \right) \times 100.$$

The EPA is also incorporating by reference Quality Assurance Handbook for Air Pollution Measurement Systems, Volume IV: Meteorological Measurements, Version 2.0 (Final), March 2008 (EPA–454/B–08–002). The Quality Assurance Handbook for Air Pollution Measurement Systems; Volume IV: Meteorological Measurements is an EPA developed guidance manual for the installation, operation, maintenance and calibration of meteorological systems including the wind speed and direction using anemometers, temperature using thermistors, and atmospheric pressure using aneroid barometers, as well as the calculations for wind vector data for on-site meteorological measurements. This VCS may be obtained from the EPA's National Service Center for Environmental Publications ([www.epa.gov/nscep](http://www.epa.gov/nscep)).

The two ASTM methods (ASTM D6420–18 and ASTM D6348–12 (Reapproved 2020)) are available at ASTM International, 1850 M Street NW, Suite 1030, Washington, DC 20036; telephone number: 1–610–832–9500. See <https://www.astm.org/>. These standards are available to everyone at a cost determined by the ASTM (\$57 and \$76, respectively). The ASTM also offers memberships or subscriptions that allow unlimited access to their methods.

The cost of obtaining these methods is not a significant financial burden, making the methods reasonably available to stakeholders.

While the EPA identified 13 other VCS as being potentially applicable, the Agency decided not to use them because these methods are impractical as alternatives because of the lack of equivalency, documentation, validation date, and other important technical and policy considerations. The search and review results have been documented and are in the memorandum, *Voluntary Consensus Standard Results for National Emission Standards for Hazardous Air Pollutants From the Synthetic Organic Chemical Manufacturing Industry* (see Docket Item No. EPA–HQ–OAR–2022–0730–0008).

Under 40 CFR 63.7(f) and 40 CFR 63.8(f), subpart A—General Provisions, a source may apply to the EPA for permission to use alternative test methods or alternative monitoring requirements in place of any required testing methods, performance specifications, or procedures in the final rule or any amendments.

Also, although not considered a VCS, the EPA incorporates by reference, “Purge-And-Trap For Aqueous Samples” (SW–846–5030B), “Volatile, Nonpurgeable, Water-Soluble Compounds by Azeotropic Distillation” (SW–846–5031), and “Volatile Organic Compounds by Gas Chromatography/Mass Spectrometry (GC/MS)” (SW–846–8260D) into 40 CFR 63.109(b)(1), (c)(1), (d), and (e) (for HON) and 40 CFR 63.510(b)(1) and (c) (for the P&R I NESHAP); and “Air Stripping Method (Modified El Paso Method) for Determination of Volatile Organic Compound Emissions from Water Sources,” into 40 CFR 63.104(g)(3)(i) and (ii), and 40 CFR 63.104(f)(3)(iv)(D)(1). Method SW–846–5030B can be used as a purge-and-trap procedure for the analysis of volatile organic compounds in aqueous samples and water miscible liquid samples. Method SW–846–5031 can be used for separation of nonpurgeable, water-soluble, and volatile organic compounds in aqueous samples or leachates from solid matrices using azeotropic distillation. Method SW–846–8260D can be used to determine VOCs in a variety of solid waste matrices and is applicable to nearly all types of samples, regardless of water content. The Modified El Paso Method utilizes dynamic or flow-through system for air stripping a sample of water and analyzing the resultant off-gases for VOCs using a common flame ionization detector (FID) analyzer. Each of these methods is used

to identify organic HAP in water; however, SW–846–5031, SW–846–8260D, and SW–846–5030B use water sampling techniques and the Modified El Paso Method uses an air stripping sampling technique. The SW–846 methods are reasonably available from the EPA at <https://www.epa.gov/hw-sw846> while the Modified El Paso Method is reasonably available from TCEQ at [https://www.tceq.texas.gov/assets/public/compliance/field\\_ops/guidance/samplingapp.pdf](https://www.tceq.texas.gov/assets/public/compliance/field_ops/guidance/samplingapp.pdf).

In addition, because we are moving all HON definitions from NESHAP subparts G and H (*i.e.*, 40 CFR 63.111 and 40 CFR 63.161, respectively) into the definition section of NESHAP subpart F (*i.e.*, 40 CFR 63.101), we are incorporating by reference, API Manual of Petroleum Measurement Specifications (MPMS) Chapter 19.2 (API MPMS 19.2), “Evaporative Loss From Floating-Roof Tanks,” Fourth Edition, August 2020 and “Standard Test Method for Vapor Pressure-Temperature Relationship and Initial Decomposition Temperature of Liquids by Isotenoscope” (ASTM D2879–23) into 40 CFR 63.101 (for HON). The API method (API MPMS 19.2)<sup>74</sup> contains methodologies for estimating the total evaporative losses of hydrocarbons from various types of floating-roof tanks. The ASTM method (ASTM D2879–23) addresses the determination of the vapor pressure of one or more organic components in a gas stream. In addition, the EPA is adding new NSPS subpart VVb to part 60 and is allowing the use of:

ASTM D240–19, Standard Test Method for Heat of Combustion of Liquid Hydrocarbon Fuels by Bomb Calorimeter and ASTM D4809–18, Standard Test Method for Heat of Combustion of Liquid Hydrocarbon Fuels by Bomb Calorimeter (Precision Method). The ASTM D240–19 method addresses the determination of net heat of combustion of components of liquid hydrocarbon fuels ranging in volatility from that of light distillates to that of residual fuels. The ASTM D4809–18 method is similar to that of ASTM D240–19, though it specifically addresses the determination of net heat of combustion of aviation fuels with high precision. In addition, ASTM D4809–18 can also be used to address the determination of net heat of combustion for a wide range of volatile and non-volatile materials. The EPA currently allows for the use of previous versions of these methods in NSPS

<sup>74</sup> API MPMS 19.2 is a replacement for API publication 2517, which was previously referenced in the HON.

subparts VV and VVa for the determination of net heat of combustion of components in a gas stream; therefore, we are allowing the use of the most recent versions of these methods for this same purpose in NSPS subpart VVb.

ASTM D1945–14 (Reapproved 2019), Standard Test Method for Analysis of Natural Gas by Gas Chromatography. This method addresses the determination of the concentration of a component in a gas stream. The EPA currently allows for the use of previous versions of this method in NSPS subparts VV and VVa for the determination of the concentration of a component in a gas stream; therefore, we are allowing the use of the most recent version of this method for this same purpose in NSPS subpart VVb.

ASTM D2879–23, Standard Test Method for Vapor Pressure-Temperature Relationship and Initial Decomposition Temperature of Liquids by Isoteniscope. This method addresses the determination of the vapor pressure of one or more organic components in a gas stream. The EPA currently allows for the use of previous versions of this method in NSPS subparts VV and VVa for the determination of the vapor pressure of one or more organic components in a gas stream; therefore, we are allowing the use of the most recent version of this method for this same purpose in NSPS subpart VVb.

ASTM E168–16 (Reapproved 2023), Standard Practices for General Techniques of Infrared Quantitative Analysis, ASTM E169–16 (Reapproved 2022): Standard Practices for General Techniques of Ultraviolet-Visible Quantitative Analysis, and ASTM E260–96 (Reapproved 2019), Standard Practice for Packed Column Gas Chromatography. The ASTM E168–16 method addresses the determination of the percent VOC content in the process fluid that is contained in or contacts a piece of equipment using infrared analysis. The ASTM E169–16 is similar to ASTM E168–16, though it uses ultraviolet-visible spectrum analysis rather than infrared analysis. Lastly, ASTM E260–96 is similar to ASTM E168–16 and ASTM E169–16, though it uses gas chromatography rather than infrared or ultraviolet-visible spectrum analysis, respectively. The EPA currently allows for the use of previous versions of these methods in NSPS subparts VV and VVa for the determination of the percent VOC content in the process fluid that is contained in or contacts a piece of equipment; therefore, we are allowing the use of these most recent versions of

these methods for this same purpose in NSPS subpart VVb.

All of the ASTM methods that we are adding into the HON, the P&R I NESHAP, and NSPS subpart VVb are available at the same address and contact information provided earlier in this section of this preamble. The API method that we are adding into the HON is available at 200 Massachusetts Avenue NW, Suite 1100, Washington, DC 20001–5571; telephone number: 1–202–682–8000. See [https://www.apiwebstore.org/standards/19\\_2](https://www.apiwebstore.org/standards/19_2). These standards are available to everyone at a cost determined by the ASTM or API. The ASTM also offers memberships or subscriptions that allow unlimited access to their methods. The cost of obtaining these methods is not a significant financial burden, making the methods reasonably available to stakeholders.

We are also finalizing amendments to 40 CFR part 60, subpart A and 40 CFR part 63, subpart A to address incorporations by reference. We are amending 40 CFR 60.17 and 40 CFR 63.14 to reflect the ANSI, ASTM, EPA SW, and TCEQ methods incorporated by reference. We are also adding 40 CFR 60.485(g)(5) and 40 CFR 60.485a(g)(5) to 40 CFR 60.17—“Incorporations by Reference” paragraph (h)(195) since they were mistakenly not added to 40 CFR 60.17 during the last amendment to this rule.

*J. Executive Order 12898: Federal Actions To Address Environmental Justice in Minority Populations and Low-Income Populations and Executive Order 14096: Revitalizing Our Nation's Commitment to Environmental Justice for All*

The EPA believes that the human health or environmental conditions that exist prior to this action result in or have the potential to result in disproportionate and adverse human health or environmental effects on communities with environmental justice concerns. For the HON, a total of 9.3 million people live within 10 km (~6.2 miles) of the 195 HON facilities that were assessed for risk. The percentages of the population that are Black (25 percent versus 12 percent) and Hispanic or Latino (22 percent versus 19 percent) are higher than the national averages. The proportion of other demographic groups living within 10 km of HON facilities is similar or lower than the national average. For the Neoprene Production source category, a total of 29,000 people live within 5 km of the one neoprene production facility in the country. The percent of the population that is Black (56 percent versus 12

percent) is substantially higher than the national average. The proportion of other demographic groups living within 10 km of HON facilities is similar or lower than the national average. The EPA also conducted a risk assessment of possible cancer risks and other adverse health effects, and found that prior to this final rule, cancer risks were above acceptable levels for a number of areas in which these demographic groups live for the SOCOMI and Neoprene Production source categories. See section V.F for an analysis that characterizes populations living in proximity of facilities and risks prior to the final rule.

The EPA believes that this action is likely to reduce existing disproportionate and adverse effects on communities with environmental justice concerns. This action establishes standards for EtO emission sources at HON processes and chloroprene emission sources at neoprene production processes. This action also corrects and clarifies regulatory provisions related to emissions during periods of SSM, including removing general exemptions for periods of SSM and adding work practice standards for periods of SSM where appropriate, addressing flare combustion efficiency, and requiring fence-line monitoring for pollutants that drive cancer risks for HON and neoprene production sources. As a result of these changes, we expect zero people to be exposed to risk levels above 100-in-1 million due to emissions from each of these source categories. See section IV.A of this preamble for more information about the control requirements of the regulation and the resulting reduction in cancer risks.

The EPA additionally identified and addressed environmental justice concerns by engaging in outreach activities to communities we expect to be impacted by chemical plants that emit EtO.<sup>75</sup>

For additional information on potential impacts, see the document titled *Analysis of Demographic Factors for Populations Living Near Hazardous Organic NESHAP (HON) Operations—Final; Analysis of Demographic Factors for Populations Living Near Hazardous Organic NESHAP (HON) Operations: Whole Facility Analysis—Final; Analysis of Demographic Factors for Populations Living Near Neoprene Production Operations—Final; Analysis of Demographic Factors for Populations Living Near Neoprene Production Operations: Whole Facility Analysis—*

<sup>75</sup> <https://www.epa.gov/hazardous-air-pollutants-ethylene-oxide/inspector-general-follow-ethylene-oxide-0>.

*Final*, which are available in the docket for this rulemaking. Also see the document titled *Analysis of Demographic Factors for Populations Living Near Polymers and Resins I and Polymer and Resins II Facilities* (Docket Item No. EPA-HQ-OAR-2022-0730-0060).

#### K. Congressional Review Act (CRA)

This action is subject to the CRA, and the EPA will submit a rule report to each House of the Congress and to the Comptroller General of the United States. This action meets the criteria set forth in 5 U.S.C. 804(2).

#### List of Subjects

##### 40 CFR Part 60

Environmental protection, Administrative practice and procedure, Air pollution control, Incorporation by reference, Intergovernmental relations, Reporting and recordkeeping requirements.

##### 40 CFR Part 63

Environmental protection, Air pollution control, Hazardous substances, Incorporation by reference, Intergovernmental relations, Reporting and recordkeeping requirements.

**Michael S. Regan,**  
*Administrator.*

For the reasons set out in the preamble, the Environmental Protection Agency amends title 40, chapter I, part 60 of the Code of Federal Regulations as follows:

#### PART 60—STANDARDS OF PERFORMANCE FOR NEW STATIONARY SOURCES

■ 1. The authority citation for part 60 continues to read as follows:

*Authority:* 42 U.S.C. 7401 *et seq.*

#### Subpart A—General Provisions

■ 2. Amend § 60.17 by:

■ a. Revising paragraph (a), paragraphs (c) introductory text, (d) introductory text, and (e) introductory text, and paragraph (g)(14);

■ b. In paragraph (h):

■ i. Redesignating paragraphs (h)(221) through (228) as (h)(226) through (233), (h)(196) through (220) as (h)(200) through (224), (h)(171) through (195) as (h)(174) through (198), (h)(115) through (170) as (h)(117) through (172), and (h)(28) through (114) as (h)(29) through (115);

■ ii. Adding new paragraph (h)(28);

■ iii. Revising newly redesignated paragraph (h)(78);

■ iv. Adding new paragraphs (h)(116), (173), and (199);

■ v. Revising newly redesignated paragraphs (h)(217) and (221), and

■ vi. Adding new paragraph (h)(225); and

■ c. Revising and republishing paragraph (j); and

■ d. Removing note 1 to paragraph (k).

The revisions and additions read as follows:

#### § 60.17 Incorporations by reference.

(a)(1) Certain material is incorporated by reference into this part with the approval of the Director of the Federal Register under 5 U.S.C. 552(a) and 1 CFR part 51. To enforce any edition other than that specified in this section, the U.S. Environmental Protection Agency (EPA) must publish a document in the **Federal Register** and the material must be available to the public. All approved incorporation by reference (IBR) material is available for inspection at the EPA and at the National Archives and Records Administration (NARA). Contact the EPA at: EPA Docket Center, Public Reading Room, EPA WJC West Room 3334, 1301 Constitution Ave. NW, Washington, DC; phone: (202) 566-1744. For information on the availability of this material at NARA, visit [www.archives.gov/federal-register/cfr/ibr-locations](http://www.archives.gov/federal-register/cfr/ibr-locations) or email [fr.inspection@nara.gov](mailto:fr.inspection@nara.gov).

(2) The IBR material may be obtained from the sources in the following paragraphs of this section or from one or more private resellers listed in this paragraph (a)(2). For material that is no longer commercially available, contact: the EPA (see paragraph (a)(1) of this section).

(i) Accuris Standards Store, 321 Inverness Drive, South Englewood, CO 80112; phone: (800) 332-6077; website: <https://store.accuristech.com>.

(ii) American National Standards Institute (ANSI), see paragraph (d) of this section.

(iii) GlobalSpec, 257 Fuller Road, Suite NFE 1100, Albany, NY 12203-3621; phone: (800) 261-2052; website: <https://standards.globalspec.com>.

(iv) Nimonik Document Center, 401 Roland Way, Suite 224, Oakland, CA 94624; phone: (650) 591-7600; email: [info@document-center.com](mailto:info@document-center.com); website: [www.document-center.com](http://www.document-center.com).

(v) Techstreet, phone: (855) 999-9870; email: [store@techstreet.com](mailto:store@techstreet.com); website: [www.techstreet.com](http://www.techstreet.com).

(c) American Hospital Association (AHA) Service, Inc., Post Office Box 92683, Chicago, Illinois 60675-2683.

(d) American National Standards Institute (ANSI), 25 West 43rd Street,

Fourth Floor, New York, NY 10036-7417; phone: (212) 642-4980; email: [info@ansi.org](mailto:info@ansi.org); website: [www.ansi.org](http://www.ansi.org).

(e) American Petroleum Institute (API), 200 Massachusetts Ave. NW, Suite 1100, Washington, DC 20001; phone: (202) 682-8000; website: [www.api.org](http://www.api.org).

(g) \* \* \*  
(14) ASME/ANSI PTC 19.10-1981, Flue and Exhaust Gas Analyses [Part 10, Instruments and Apparatus], Issued August 31, 1981; IBR approved for §§ 60.56c(b); 60.63(f); 60.106(e); 60.104a(d), (h), (i), and (j); 60.105a(b), (d), (f), and (g); 60.106a(a); 60.107a(a), (c), and (d); 60.275(e); 60.275a(e); 60.275b(e); tables 1 and 3 to subpart EEEE; tables 2 and 4 to subpart FFFF; table 2 to subpart JJJJ; §§ 60.285a(f); 60.396(a); 60.614a(b); 60.664a(b); 60.704(b); 60.704a(b); 60.2145(s) and (t); 60.2710(s) and (t); 60.2730(q); 60.4415(a); 60.4900(b); 60.5220(b); tables 1 and 2 to subpart LLLL; tables 2 and 3 to subpart MMMM; §§ 60.5406(c); 60.5406a(c); 60.5406b(c); 60.5407a(g); 60.5407b(g); 60.5413(b); 60.5413a(b) and (d); 60.5413b(d) and (d); 60.5413c(b) and (d).

(h) \* \* \*  
(28) ASTM D240-19, Standard Test Method for Heat of Combustion of Liquid Hydrocarbon Fuels by Bomb Calorimeter, approved November 1, 2019; IBR approved for § 60.485b(g).

(78) ASTM D1945-14 (Reapproved 2019), Standard Test Method for Analysis of Natural Gas by Gas Chromatography, approved December 1, 2019; IBR approved for § 60.485b(g).

(116) ASTM D2879-23, Standard Test Method for Vapor Pressure-Temperature Relationship and Initial Decomposition Temperature of Liquids by Isoteniscope, approved December 1, 2019; IBR approved for § 60.485b(e).

(173) ASTM D4809-18, Standard Test Method for Heat of Combustion of Liquid Hydrocarbon Fuels by Bomb Calorimeter (Precision Method), approved July 1, 2018; IBR approved for § 60.485b(g).

(199) ASTM D6420-18, Standard Test Method for Determination of Gaseous Organic Compounds by Direct Interface Gas Chromatography-Mass Spectrometry, approved November 1, 2018, IBR approved for §§ 60.485(g); 60.485a(g); 60.485b(g); 60.611a;



60.614(b) and (e); 60.614a(b) and (e), 60.664(b) and (e); 60.664a(b) and (f); 60.700(c); 60.704(b) (d), and (h); 60.705(l); 60.704a(b) and (f).

(217) ASTM E168–16 (Reapproved 2023), Standard Practices for General Techniques of Infrared Quantitative Analysis, approved January 1, 2023; IBR approved for § 60.485b(d).

(221) ASTM E169–16 (Reapproved 2022), Standard Practices for General Techniques of Ultraviolet-Visible Quantitative Analysis, approved November 1, 2022; IBR approved for § 60.485b(d).

(225) ASTM E260–96 (Reapproved 2019), Standard Practice for Packed Column Gas Chromatography, approved September 1, 2029; IBR approved for § 60.485b(d).

(j) U.S. Environmental Protection Agency (EPA), 1200 Pennsylvania Avenue NW, Washington, DC 20460; phone: (202) 272–0167; website: www.epa.gov/aboutepa/forms/contact-epa.

(1) EPA–453/R–08–002, Protocol for Determining the Daily Volatile Organic Compound Emission Rate of Automobile and Light-Duty Truck Primer-Surfacers and Topcoat Operations, September 2008, Office of Air Quality Planning and Standards (OAQPS); IBR approved for §§ 60.393a(e) and (h); 60.395a(k); 60.397a(e); appendix A to subpart MMA.

(2) EPA–454/B–08–002, Quality Assurance Handbook for Air Pollution Measurement Systems; Volume IV: Meteorological Measurements, Version 2.0 (Final), March 2008; IBR approved for appendix K to this part.

(3) EPA–454/R–98–015, Office of Air Quality Planning and Standards (OAQPS), Fabric Filter Bag Leak Detection Guidance, September 1997; IBR approved for §§ 60.124(f); 60.124a(f); 60.273(e); 60.273a(e); 60.273b(e); 60.373a(b); 60.2145(r); 60.2710(r); 60.4905(b); 60.5225(b). (Available from: https://nepis.epa.gov/Exe/ZyPDF.cgi?Dockey=2000D5T6.pdf).

(4) EPA–600/R–12/531, EPA Traceability Protocol for Assay and Certification of Gaseous Calibration Standards, May 2012; IBR approved for §§ 60.5413(d); 60.5413a(d); 60.5413b(d); 60.5413c(d).

(5) In EPA Publication No. SW–846, Test Methods for Evaluating Solid Waste, Physical/Chemical Methods (Available from: www.epa.gov/hw-sw846/sw-846-compendium);

(i) SW–846–6010D, Inductively Coupled Plasma-Optical Emission Spectrometry, Revision 5, July 2018; IBR approved for appendix A–5 to this part.

(ii) SW–846–6020B, Inductively Coupled Plasma-Mass Spectrometry, Revision 2, July 2014; IBR approved for appendix A–5 to this part.

■ 3. Amend § 60.480 by revising paragraph (f) to read as follows:

§ 60.480 Applicability and designation of affected facility.

(f) *Overlap with other regulations for flares.* Owners and operators of flares that are subject to the flare related requirements of this subpart and flare related requirements of any other regulation in this part or 40 CFR 61 or 63, may elect to comply with the requirements in § 60.619a, § 60.669a, or § 60.709a, in lieu of all flare related requirements in any other regulation in this part or 40 CFR part 61 or 63.

■ 4. Amend § 60.481 by revising the definition of “Process unit” to read as follows:

§ 60.481 Definitions.

*Process unit* means components assembled to produce, as intermediate or final products, one or more of the chemicals listed in § 60.489 of this part. A process unit can operate independently if supplied with sufficient feed or raw materials and sufficient storage facilities for the product.

§ 60.482–1 [Amended]

■ 5. Amend § 60.482–1 by removing paragraph (g).

■ 6. Amend § 60.485 by revising paragraph (g)(5) to read as follows:

§ 60.485 Test methods and procedures.

(g) \* \* \*

(5) Method 18 of appendix A–6 to this part and ASTM D2504–67, 77 or 88 (Reapproved 1993) (incorporated by reference, see § 60.17) shall be used to determine the concentration of sample component “i.” ASTM D6420–18 (incorporated by reference, see § 60.17) may be used in lieu of Method 18, under the conditions specified in paragraphs (g)(5)(i) through (iii) of this section.

(i) If the target compounds are all known and are all listed in Section 1.1 of ASTM D6420–18 as measurable.

(ii) ASTM D6420–18 may not be used for methane and ethane.

(iii) ASTM D6420–18 may not be used as a total VOC method.

■ 7. Amend § 60.486 by adding paragraph (l) as follows:

§ 60.486 Recordkeeping requirements.

(l) Any records required to be maintained by this subpart that are submitted electronically via the EPA’s Compliance and Emissions Data Reporting Interface (CEDRI) may be maintained in electronic format. This ability to maintain electronic copies does not affect the requirement for facilities to make records, data, and reports available upon request to a delegated air agency or the EPA as part of an on-site compliance evaluation.

■ 8. Amend § 60.487 by revising paragraphs (a) and (f) and adding paragraphs (g), (h), and (i) to read as follows:

§ 60.487 Reporting requirements.

(a) Each owner or operator subject to the provisions of this subpart shall submit semiannual reports to the Administrator beginning six months after the initial startup date. Beginning on July 15, 2025, or once the report template for this subpart has been available on the CEDRI website (https://www.epa.gov/electronic-reporting-air-emissions/cedri) for 1 year, whichever date is later, submit all subsequent reports using the appropriate electronic report template on the CEDRI website for this subpart and following the procedure specified in paragraph (g) of this section. The date report templates become available will be listed on the CEDRI website. Unless the Administrator or delegated state agency or other authority has approved a different schedule for submission of reports, the report must be submitted by the deadline specified in this subpart, regardless of the method in which the report is submitted.

(f) The requirements of paragraphs (a) through (c) of this section remain in force until and unless EPA, in delegating enforcement authority to a State under section 111(c) of the Act, approves reporting requirements or an alternative means of compliance surveillance adopted by such State. In that event, affected sources within the State will be relieved of the obligation to comply with the requirements of paragraphs (a) through (c) of this section, provided that they comply with the requirements established by the State. The EPA will not approve a waiver of electronic reporting to the

EPA in delegating enforcement authority. Thus, electronic reporting to the EPA cannot be waived, and as such, the provisions of this paragraph cannot be used to relieve owners or operators of affected facilities of the requirement to submit the electronic reports required in this section to the EPA.

(g) If an owner or operator is required to submit notifications or reports following the procedure specified in this paragraph (g), the owner or operator must submit notifications or reports to the EPA via CEDRI, which can be accessed through the EPA's Central Data Exchange (CDX) (<https://cdx.epa.gov/>). The EPA will make all the information submitted through CEDRI available to the public without further notice to the owner or operator. Do not use CEDRI to submit information the owner or operator claims as CBI. Although the EPA does not expect persons to assert a claim of CBI, if an owner or operator wishes to assert a CBI claim for some of the information in the report or notification, the owner or operator must submit a complete file in the format specified in this subpart, including information claimed to be CBI, to the EPA following the procedures in paragraphs (g)(1) and (2) of this section. Clearly mark the part or all of the information claimed to be CBI. Information not marked as CBI may be authorized for public release without prior notice. Information marked as CBI will not be disclosed except in accordance with procedures set forth in 40 CFR part 2. All CBI claims must be asserted at the time of submission. Anything submitted using CEDRI cannot later be claimed CBI. Furthermore, under CAA section 114(c), emissions data is not entitled to confidential treatment, and the EPA is required to make emissions data available to the public. Thus, emissions data will not be protected as CBI and will be made publicly available. The owner or operator must submit the same file submitted to the CBI office with the CBI omitted to the EPA via the EPA's CDX as described earlier in this paragraph (g).

(1) The preferred method to receive CBI is for it to be transmitted electronically using email attachments, File Transfer Protocol, or other online file sharing services. Electronic submissions must be transmitted directly to the OAQPS CBI Office at the email address [oaqpscbi@epa.gov](mailto:oaqpscbi@epa.gov), and as described above, should include clear CBI markings. ERT files should be flagged to the attention of the Group Leader, Measurement Policy Group; all other files should be flagged to the attention of the SOCMI NSPS Sector

Lead. Owners and operators who do not have their own file sharing service and who require assistance with submitting large electronic files that exceed the file size limit for email attachments should email [oaqpscbi@epa.gov](mailto:oaqpscbi@epa.gov) to request a file transfer link.

(2) If an owner or operator cannot transmit the file electronically, the owner or operator may send CBI information through the postal service to the following address: OAQPS Document Control Officer (C404-02), OAQPS, U.S. Environmental Protection Agency, 109 T.W. Alexander Drive, P.O. Box 12055, Research Triangle Park, North Carolina 27711. ERT files should be sent to the attention of the Group Leader, Measurement Policy Group, and all other files should be sent to the attention of the SOCMI NSPS Sector Lead. The mailed CBI material should be double wrapped and clearly marked. Any CBI markings should not show through the outer envelope.

(h) Owners and operators required to electronically submit notifications or reports through CEDRI in the EPA's CDX may assert a claim of EPA system outage for failure to timely comply with that reporting requirement. To assert a claim of EPA system outage, owner and operator must meet the requirements outlined in paragraphs (h)(1) through (7) of this section.

(1) The owner or operator must have been or will be precluded from accessing CEDRI and submitting a required report within the time prescribed due to an outage of either the EPA's CEDRI or CDX systems.

(2) The outage must have occurred within the period of time beginning five business days prior to the date that the submission is due.

(3) The outage may be planned or unplanned.

(4) The owner or operator must submit notification to the Administrator in writing as soon as possible following the date the owner or operator first knew, or through due diligence should have known, that the event may cause or has caused a delay in reporting.

(5) The owner or operator must provide to the Administrator a written description identifying:

(i) The date(s) and time(s) when CDX or CEDRI was accessed and the system was unavailable;

(ii) A rationale for attributing the delay in reporting beyond the regulatory deadline to EPA system outage;

(iii) A description of measures taken or to be taken to minimize the delay in reporting; and

(iv) The date by which the owner or operator proposes to report, or if the owner or operator has already met the

reporting requirement at the time of the notification, the date the report was submitted.

(6) The decision to accept the claim of EPA system outage and allow an extension to the reporting deadline is solely within the discretion of the Administrator.

(7) In any circumstance, the report must be submitted electronically as soon as possible after the outage is resolved.

(i) Owners and operators required to electronically submit notifications or reports through CEDRI in the EPA's CDX may assert a claim of *force majeure* for failure to timely comply with that reporting requirement. To assert a claim of *force majeure*, owners and operators must meet the requirements outlined in paragraphs (i)(1) through (5) of this section.

(1) The owner or operator may submit a claim if a *force majeure* event is about to occur, occurs, or has occurred or there are lingering effects from such an event within the period of time beginning five business days prior to the date the submission is due. For the purposes of this section, a *force majeure* event is defined as an event that will be or has been caused by circumstances beyond the control of the affected facility, its contractors, or any entity controlled by the affected facility that prevents the owner or operator from complying with the requirement to submit a report electronically within the time period prescribed. Examples of such events are acts of nature (e.g., hurricanes, earthquakes, or floods), acts of war or terrorism, or equipment failure or safety hazard beyond the control of the affected facility (e.g., large scale power outage).

(2) The owner or operator must submit notification to the Administrator in writing as soon as possible following the date the owner or operator first knew, or through due diligence should have known, that the event may cause or has caused a delay in reporting.

(3) The owner or operator must provide to the Administrator:

(i) A written description of the *force majeure* event;

(ii) A rationale for attributing the delay in reporting beyond the regulatory deadline to the *force majeure* event;

(iii) A description of measures taken or to be taken to minimize the delay in reporting; and

(iv) The date by which the owner or operator proposes to report, or if the owner or operator has already met the reporting requirement at the time of the notification, the date the report was submitted.

(4) The decision to accept the claim of *force majeure* and allow an extension to the reporting deadline is solely within the discretion of the Administrator.

(5) In any circumstance, the reporting must occur as soon as possible after the *force majeure* event occurs.

■ 9. Revise the heading of subpart VVa to read as follows:

**Subpart VVa—Standards of Performance for Equipment Leaks of VOC in the Synthetic Organic Chemicals Manufacturing Industry for Which Construction, Reconstruction, or Modification Commenced After November 7, 2006, and on or Before April 25, 2023**

■ 10. Amend § 60.480a by revising paragraphs (b), revising and republishing paragraph (d), and revising paragraph (f) to read as follows:

**§ 60.480a Applicability and designation of affected facility.**

\* \* \* \* \*

(b) Any affected facility under paragraph (a) of this section that commences construction, reconstruction, or modification after November 7, 2006, and on or before April 25, 2023, shall be subject to the requirements of this subpart.

\* \* \* \* \*

(d)(1) If an owner or operator applies for one or more of the exemptions in this paragraph, then the owner or

operator shall maintain records as required in § 60.486a(i).

(2) Any affected facility that has the design capacity to produce less than 1,000 Mg/yr (1,102 ton/yr) of a chemical listed in § 60.489 is exempt from §§ 60.482–1a through 60.482–10a.

(3) If an affected facility produces heavy liquid chemicals only from heavy liquid feed or raw materials, then it is exempt from §§ 60.482–1a through 60.482–10a.

(4) Any affected facility that produces beverage alcohol is exempt from §§ 60.482–1a through 60.482–10a.

(5) Any affected facility that has no equipment in volatile organic compounds (VOC) service is exempt from §§ 60.482–1a through 60.482–10a.

\* \* \* \* \*

(f) Owners and operators of flares that are subject to the flare related requirements of this subpart and flare related requirements of any other regulation in this part or 40 CFR part 61 or 63, may elect to comply with the requirements in § 60.619a, § 60.669a, or § 60.709a, in lieu of all flare related requirements in any other regulation in this part or 40 CFR part 61 or 63.

■ 11. Amend § 60.481a by revising the definitions of “Capital expenditure” and “Process Unit” to read as follows:

**§ 60.481a Definitions.**

\* \* \* \* \*

*Capital expenditure* means, in addition to the definition in § 60.2, an

expenditure for a physical or operational change to an existing facility that:

(1) Exceeds P, the product of the facility’s replacement cost, R, and an adjusted annual asset guideline repair allowance, A, as reflected by the following equation:  $P = R \times A$ , where:

(i) The adjusted annual asset guideline repair allowance, A, is the product of the percent of the replacement cost, Y, and the applicable basic annual asset guideline repair allowance, B, divided by 100 as reflected by the following equation:

Equation 1 to Capital Expenditure Paragraph (1)(i)

$A = Y \times (B \div 100)$ ;

(ii) The percent Y is determined from the following equation:  $Y = 1.0 - 0.575 \log X$ , where X is:

(A) 2006 minus the year of construction if the physical or operational change to the existing facility was on or after November 16, 2007, or

(B) 1982 minus the year of construction if the physical or operational change to the existing facility was prior to November 16, 2007; and

(iii) The applicable basic annual asset guideline repair allowance, B, is selected from the following table consistent with the applicable subpart:

TABLE 1 TO CAPITAL EXPENDITURE PARAGRAPH (1)(iii)—DETERMINING APPLICABLE VALUE FOR B

Subpart applicable to facility	Value of B to be used in equation
(A) VVa .....	12.5
(B) GGGa .....	7.0

\* \* \* \* \*

*Process unit* means components assembled to produce, as intermediate or final products, one or more of the chemicals listed in § 60.489a. A process unit can operate independently if supplied with sufficient feed or raw materials and sufficient storage facilities for the product.

\* \* \* \* \*

■ 12. Amend § 60.482–1a by revising paragraph (e) introductory text and removing paragraph (g).

The revision reads as follows:

**§ 60.482–1a Standards: General.**

\* \* \* \* \*

(e) Equipment that an owner or operator designates as being in VOC service less than 300 hr/yr is excluded from the requirements of §§ 60.482–2a

through 60.482–10a if it is identified as required in § 60.486a(e)(6) and it meets any of the conditions specified in paragraphs (e)(1) through (3) of this section.

\* \* \* \* \*

**§ 60.482–11a [Removed]**

■ 13. Remove § 60.482–11a.

■ 14. Amend § 60.485a by revising paragraphs (b) and (g)(5) to read as follows:

**§ 60.485a Test methods and procedures.**

\* \* \* \* \*

(b) The owner or operator shall determine compliance with the standards in §§ 60.482–1a through 60.482–10a, 60.483a, and 60.484a as follows:

(1) Method 21 shall be used to determine the presence of leaking sources. The instrument shall be calibrated before use each day of its use by the procedures specified in Method 21 of appendix A–7 of this part. The following calibration gases shall be used:

(i) Zero air (less than 10 ppm of hydrocarbon in air); and

(ii) A mixture of methane or n-hexane and air at a concentration no more than 2,000 ppm greater than the leak definition concentration of the equipment monitored. If the monitoring instrument’s design allows for multiple calibration scales, then the lower scale shall be calibrated with a calibration gas that is no higher than 2,000 ppm above the concentration specified as a leak, and the highest scale shall be calibrated

with a calibration gas that is approximately equal to 10,000 ppm. If only one scale on an instrument will be used during monitoring, the owner or operator need not calibrate the scales that will not be used during that day's monitoring.

(2) A calibration drift assessment shall be performed, at a minimum, at the end of each monitoring day. Check the instrument using the same calibration gas(es) that were used to calibrate the instrument before use. Follow the procedures specified in Method 21 of appendix A-7 to this part, section 10.1, except do not adjust the meter readout to correspond to the calibration gas value. Record the instrument reading for each scale used as specified in § 60.486a(e)(8). Divide the arithmetic difference of the initial and post-test calibration response by the corresponding calibration gas value for each scale and multiply by 100 to express the calibration drift as a percentage.

(i) If a calibration drift assessment shows a negative drift of more than 10 percent, then all equipment with instrument readings between the appropriate leak definition and the leak definition multiplied by (100 minus the percent of negative drift/divided by 100) that was monitored since the last calibration must be re-monitored.

(ii) If any calibration drift assessment shows a positive drift of more than 10 percent from the initial calibration value, then, at the owner/operator's discretion, all equipment with instrument readings above the appropriate leak definition and below the leak definition multiplied by (100 plus the percent of positive drift/divided by 100) monitored since the last calibration may be re-monitored.

\* \* \* \* \*

(g) \* \* \*

(5) Method 18 of appendix A-6 to this part and ASTM D2504-67, 77, or 88 (Reapproved 1993) (incorporated by reference, see § 60.17) shall be used to determine the concentration of sample component "i." ASTM D6420-18 (incorporated by reference, see § 60.17) may be used in lieu of Method 18, under the conditions specified in paragraphs (g)(5)(i) through (iii) of this section.

(i) If the target compounds are all known and are all listed in Section 1.1 of ASTM D6420-18 as measurable.

(ii) ASTM D6420-18 may not be used for methane and ethane.

(iii) ASTM D6420-18 may not be used as a total VOC method.

\* \* \* \* \*

■ 15. Amend § 60.486a by:

- a. Revising paragraphs (a)(3) introductory text and (b) introductory text;
- b. Removing and reserving paragraph (b)(3);
- c. Revising paragraphs (c) introductory text and (e) introductory text;
- d. Removing and reserving paragraph (e)(9);
- e. Revising paragraph (f) introductory text; and
- f. Adding paragraph (l).

The revisions and addition read as follows:

**§ 60.486a Recordkeeping requirements.**

(a) \* \* \*  
 (3) The owner or operator shall record the information specified in paragraphs (a)(3)(i) through (v) of this section for each monitoring event required by §§ 60.482-2a, 60.482-3a, 60.482-7a, 60.482-8a, and 60.483-2a.

\* \* \* \* \*

(b) When each leak is detected as specified in §§ 60.482-2a, 60.482-3a, 60.482-7a, 60.482-8a, and 60.483-2a, the following requirements apply:

\* \* \* \* \*

(c) When each leak is detected as specified in §§ 60.482-2a, 60.482-3a, 60.482-7a, 60.482-8a, and 60.483-2a, the following information shall be recorded in a log and shall be kept for 2 years in a readily accessible location:

\* \* \* \* \*

(e) The following information pertaining to all equipment subject to the requirements in § 60.482-1a to 60.482-10a shall be recorded in a log that is kept in a readily accessible location:

\* \* \* \* \*

(f) The following information pertaining to all valves subject to the requirements of § 60.482-7a(g) and (h), and all pumps subject to the requirements of § 60.482-2a(g) shall be recorded in a log that is kept in a readily accessible location:

\* \* \* \* \*

(l) Any records required to be maintained by this subpart that are submitted electronically via the EPA's Compliance and Emissions Data Reporting Interface (CEDRI) may be maintained in electronic format. This ability to maintain electronic copies does not affect the requirement for facilities to make records, data, and reports available upon request to a delegated air agency or the EPA as part of an on-site compliance evaluation.

■ 16. Amend § 60.487a by:

- a. Revising paragraph (a);
- b. Removing paragraph (b)(5);
- c. Revising paragraph (c)(2)(vi);

- d. Removing and reserving paragraphs (c)(2)(vii) and (viii);
  - e. Revising paragraph (f); and
  - f. Adding paragraphs (g), (h) and (i).
- The revisions and additions read as follows:

**§ 60.487a Reporting requirements.**

(a) Each owner or operator subject to the provisions of this subpart shall submit semiannual reports to the Administrator beginning 6 months after the initial startup date. Beginning on July 15, 2025, or once the report template for this subpart has been available on the CEDRI website (<https://www.epa.gov/electronic-reporting-air-emissions/cedri>) for 1 year, whichever date is later, submit all subsequent reports using the appropriate electronic report template on the CEDRI website for this subpart and following the procedure specified in paragraph (g) of this section. The date report templates become available will be listed on the CEDRI website. Unless the Administrator or delegated state agency or other authority has approved a different schedule for submission of reports, the report must be submitted by the deadline specified in this subpart, regardless of the method in which the report is submitted.

\* \* \* \* \*

(c) \* \* \*

(2) \* \* \*

(vi) Number of compressors for which leaks were not repaired as required in § 60.482-3a(g)(1), and

\* \* \* \* \*

(f) The requirements of paragraphs (a) through (c) of this section remain in force until and unless EPA, in delegating enforcement authority to a state under section 111(c) of the CAA, approves reporting requirements or an alternative means of compliance surveillance adopted by such state. In that event, affected sources within the state will be relieved of the obligation to comply with the requirements of paragraphs (a) through (c) of this section, provided that they comply with the requirements established by the state. The EPA will not approve a waiver of electronic reporting to the EPA in delegating enforcement authority. Thus, electronic reporting to the EPA cannot be waived, and as such, the provisions of this paragraph cannot be used to relieve owners or operators of affected facilities of the requirement to submit the electronic reports required in this section to the EPA.

(g) If an owner or operator is required to submit notifications or reports following the procedure specified in this paragraph (g), the owner or operator

must submit notifications or reports to the EPA via CEDRI, which can be accessed through the EPA's Central Data Exchange (CDX) (<https://cdx.epa.gov/>). The EPA will make all the information submitted through CEDRI available to the public without further notice to the owner or operator. Do not use CEDRI to submit information the owner or operator claims as CBI. Although the EPA does not expect persons to assert a claim of CBI, if you an owner or operator wishes to assert a CBI claim for some of the information in the report or notification, the owner or operator must submit a complete file in the format specified in this subpart, including information claimed to be CBI, to the EPA following the procedures in paragraphs (g)(1) and (2) of this section. Clearly mark the part or all of the information claimed to be CBI. Information not marked as CBI may be authorized for public release without prior notice. Information marked as CBI will not be disclosed except in accordance with procedures set forth in 40 CFR part 2. All CBI claims must be asserted at the time of submission. Anything submitted using CEDRI cannot later be claimed CBI. Furthermore, under CAA section 114(c), emissions data is not entitled to confidential treatment, and the EPA is required to make emissions data available to the public. Thus, emissions data will not be protected as CBI and will be made publicly available. The owner or operator must submit the same file submitted to the CBI office with the CBI omitted to the EPA via the EPA's CDX as described earlier in this paragraph (g).

(1) The preferred method to receive CBI is for it to be transmitted electronically using email attachments, File Transfer Protocol, or other online file sharing services. Electronic submissions must be transmitted directly to the OAQPS CBI Office at the email address [oaqpscbi@epa.gov](mailto:oaqpscbi@epa.gov), and as described above, should include clear CBI markings. ERT files should be flagged to the attention of the Group Leader, Measurement Policy Group; all other files should be flagged to the attention of the SOCOMI NSPS Sector Lead. Owners and operators who do not have their own file sharing service and who require assistance with submitting large electronic files that exceed the file size limit for email attachments should email [oaqpscbi@epa.gov](mailto:oaqpscbi@epa.gov) to request a file transfer link.

(2) If an owner or operator cannot transmit the file electronically, the owner or operator may send CBI information through the postal service to the following address: OAQPS

Document Control Officer (C404-02), OAQPS, U.S. Environmental Protection Agency, 109 T.W. Alexander Drive, P.O. Box 12055, Research Triangle Park, North Carolina 27711. ERT files should be sent to the attention of the Group Leader, Measurement Policy Group, and all other files should be sent to the attention of the SOCOMI NSPS Sector Lead. The mailed CBI material should be double wrapped and clearly marked. Any CBI markings should not show through the outer envelope.

(h) Owners and operators required to electronically submit notifications or reports through CEDRI in the EPA's CDX may assert a claim of EPA system outage for failure to timely comply with that reporting requirement. To assert a claim of EPA system outage, owners and operators must meet the requirements outlined in paragraphs (h)(1) through (7) of this section.

(1) The owner or operator must have been or will be precluded from accessing CEDRI and submitting a required report within the time prescribed due to an outage of either the EPA's CEDRI or CDX systems.

(2) The outage must have occurred within the period of time beginning five business days prior to the date that the submission is due.

(3) The outage may be planned or unplanned.

(4) The owner or operator must submit notification to the Administrator in writing as soon as possible following the date the owner or operator first knew, or through due diligence should have known, that the event may cause or has caused a delay in reporting.

(5) The owner or operator must provide to the Administrator a written description identifying:

(i) The date(s) and time(s) when CDX or CEDRI was accessed and the system was unavailable;

(ii) A rationale for attributing the delay in reporting beyond the regulatory deadline to EPA system outage;

(iii) A description of measures taken or to be taken to minimize the delay in reporting; and

(iv) The date by which the owner or operator proposes to report, or if the owner or operator has already met the reporting requirement at the time of the notification, the date the report was submitted.

(6) The decision to accept the claim of EPA system outage and allow an extension to the reporting deadline is solely within the discretion of the Administrator.

(7) In any circumstance, the report must be submitted electronically as soon as possible after the outage is resolved.

(i) Owners and operators required to electronically submit notifications or reports through CEDRI in the EPA's CDX may assert a claim of *force majeure* for failure to timely comply with that reporting requirement. To assert a claim of *force majeure*, owners and operators must meet the requirements outlined in paragraphs (i)(1) through (5) of this section.

(1) An owner or operator may submit a claim if a *force majeure* event is about to occur, occurs, or has occurred or there are lingering effects from such an event within the period of time beginning five business days prior to the date the submission is due. For the purposes of this section, a *force majeure* event is defined as an event that will be or has been caused by circumstances beyond the control of the affected facility, its contractors, or any entity controlled by the affected facility that prevents the owner or operator from complying with the requirement to submit a report electronically within the time period prescribed. Examples of such events are acts of nature (e.g., hurricanes, earthquakes, or floods), acts of war or terrorism, or equipment failure or safety hazard beyond the control of the affected facility (e.g., large scale power outage).

(2) The owner or operator must submit notification to the Administrator in writing as soon as possible following the date the owner or operator first knew, or through due diligence should have known, that the event may cause or has caused a delay in reporting.

(3) The owner or operator must provide to the Administrator:

(i) A written description of the *force majeure* event;

(ii) A rationale for attributing the delay in reporting beyond the regulatory deadline to the *force majeure* event;

(iii) A description of measures taken or to be taken to minimize the delay in reporting; and

(iv) The date by which the owner or operator proposes to report, or if the owner or operator has already met the reporting requirement at the time of the notification, the date the report was submitted.

(4) The decision to accept the claim of *force majeure* and allow an extension to the reporting deadline is solely within the discretion of the Administrator.

(5) In any circumstance, the reporting must occur as soon as possible after the *force majeure* event occurs.

■ 17. Add subpart VVb to read as follows:

**Subpart VVb—Standards of Performance for Equipment Leaks of VOC in the Synthetic Organic Chemicals Manufacturing Industry for Which Construction, Reconstruction, or Modification Commenced After April 25, 2023**

Sec.

- 60.480b Applicability and designation of affected facility.
- 60.481b Definitions.
- 60.482–1b Standards: General.
- 60.482–2b Standards: Pumps in light liquid service.
- 60.482–3b Standards: Compressors.
- 60.482–4b Standards: Pressure relief devices in gas/vapor service.
- 60.482–5b Standards: Sampling connection systems.
- 60.482–6b Standards: Open-ended valves or lines.
- 60.482–7b Standards: Valves in gas/vapor service and in light liquid service.
- 60.482–8b Standards: Pumps, valves, and connectors in heavy liquid service and pressure relief devices in light liquid or heavy liquid service.
- 60.482–9b Standards: Delay of repair.
- 60.482–10b Standards: Closed vent systems and control devices.
- 60.482–11b Standards: Connectors in gas/vapor service and in light liquid service.
- 60.483–1b Alternative standards for valves—allowable percentage of valves leaking.
- 60.483–2b Alternative standards for valves—skip period leak detection and repair.
- 60.484b Equivalence of means of emission limitation.
- 60.485b Test methods and procedures.
- 60.486b Recordkeeping requirements.
- 60.487b Reporting requirements.
- 60.488b Reconstruction.
- 60.489b List of chemicals produced by affected facilities.

**Subpart VVb—Standards of Performance for Equipment Leaks of VOC in the Synthetic Organic Chemicals Manufacturing Industry for Which Construction, Reconstruction, or Modification Commenced After April 25, 2023**

§ 60.480b Applicability and designation of affected facility.

(a)(1) The provisions of this subpart apply to affected facilities in the synthetic organic chemicals manufacturing industry.

(2) The group of all equipment (defined in § 60.481b) within a process unit is an affected facility.

(b) Any affected facility under paragraph (a) of this section that commences construction, reconstruction, or modification after April 25, 2023, shall be subject to the requirements of this subpart.

(c) Addition or replacement of equipment for the purpose of process improvement which is accomplished without a capital expenditure shall not

by itself be considered a modification under this subpart.

(d)(1) If an owner or operator applies for one or more of the exemptions in this paragraph, then the owner or operator shall maintain records as required in § 60.486b(i).

(2) Any affected facility that has the design capacity to produce less than 1,000 Mg/yr (1,102 ton/yr) of a chemical listed in § 60.489 is exempt from §§ 60.482–1b through 60.482–11b.

(3) If an affected facility produces heavy liquid chemicals only from heavy liquid feed or raw materials, then it is exempt from §§ 60.482–1b through 60.482–11b.

(4) Any affected facility that produces beverage alcohol is exempt from §§ 60.482–1b through 60.482–11b.

(5) Any affected facility that has no equipment in volatile organic compounds (VOC) service is exempt from §§ 60.482–1b through 60.482–11b.

(e)(1) *Option to comply with 40 CFR part 65.* (i) Owners or operators may choose to comply with the provisions of 40 CFR part 65, subpart F, to satisfy the requirements of §§ 60.482–1b through 60.487b for an affected facility. When choosing to comply with 40 CFR part 65, subpart F, the requirements of §§ 60.485b(d), (e), and (f), and 60.486b(i) and (j) still apply. Other provisions applying to an owner or operator who chooses to comply with 40 CFR part 65 are provided in 40 CFR 65.1.

(ii) Owners or operators who choose to comply with 40 CFR part 65, subpart F must also comply with §§ 60.1, 60.2, 60.5, 60.6, 60.7(a)(1) and (4), 60.14, 60.15, and 60.16 for that equipment. All sections and paragraphs that are not mentioned in this paragraph (e)(1)(ii) do not apply to owners or operators of equipment subject to this subpart complying with 40 CFR part 65, subpart F, except that provisions required to be met prior to implementing 40 CFR part 65 still apply. Owners and operators who choose to comply with 40 CFR part 65, subpart F, must comply with 40 CFR part 65, subpart A.

(2) *Option to comply with 40 CFR part 63, subpart H.* (i) Owners or operators may choose to comply with the provisions of 40 CFR part 63, subpart H, to satisfy the requirements of §§ 60.482–1b through 60.487b for an affected facility. When choosing to comply with 40 CFR part 63, subpart H, the requirements of § 60.482–7b, § 60.485b(d), (e), and (f), and § 60.486b(i) and (j) still apply.

(ii) Owners or operators who choose to comply with 40 CFR part 63, subpart H must also comply with §§ 60.1, 60.2, 60.5, 60.6, 60.7(a)(1) and (4), 60.14, 60.15, and 60.16 for that equipment. All

sections and paragraphs that are not mentioned in this paragraph (e)(2)(ii) do not apply to owners or operators of equipment subject to this subpart complying with 40 CFR part 63, subpart H, except that provisions required to be met prior to implementing 40 CFR part 63 still apply. Owners and operators who choose to comply with 40 CFR part 63, subpart H, must comply with 40 CFR part 63, subpart A.

(f) Owners and operators of flares that are subject to the flare related requirements of this subpart and flare related requirements of any other regulation in this part or 40 CFR part 61 or 63, may elect to comply with the requirements in § 60.619a, § 60.669a, or § 60.709a, in lieu of all flare related requirements in any other regulation in this part or 40 CFR part 61 or 63.

**§ 60.481b Definitions.**

As used in this subpart, all terms not defined herein shall have the meaning given them in the Clean Air Act (CAA) or in subpart A of this part, and the following terms shall have the specific meanings given them.

*Capital expenditure* means, in addition to the definition in § 60.2, an expenditure for a physical or operational change to an existing facility that:

(1) Exceeds P, the product of the facility's replacement cost, R, and an adjusted annual asset guideline repair allowance, A, as reflected by the following equation:  $P = R \times A$ , where:

(i) The adjusted annual asset guideline repair allowance, A, is the product of the percent of the replacement cost, Y, and the applicable basic annual asset guideline repair allowance, B, divided by 100 as reflected by the following equation:

Equation 1 to Capital Expenditure Paragraph (1)(i)

$$A = Y \times (B \div 100);$$

(ii) The percent Y is determined from the following equation:  $Y = (\text{CPI of date of construction/most recently available CPI of date of project})$ , where the "CPI-U, U.S. city average, all items" must be used for each CPI value; and

(iii) The applicable basic annual asset guideline repair allowance, B, is 12.5.

*Closed-loop system* means an enclosed system that returns process fluid to the process.

*Closed-purge system* means a system or combination of systems and portable containers to capture purged liquids. Containers for purged liquids must be covered or closed when not being filled or emptied.

*Closed vent system* means a system that is not open to the atmosphere and

that is composed of hard-piping, ductwork, connections, and, if necessary, flow-inducing devices that transport gas or vapor from a piece or pieces of equipment to a control device or back to a process.

*Connector* means flanged, screwed, or other joined fittings used to connect two pipe lines or a pipe line and a piece of process equipment or that close an opening in a pipe that could be connected to another pipe. Joined fittings welded completely around the circumference of the interface are not considered connectors for the purpose of this regulation.

*Control device* means an enclosed combustion device, vapor recovery system, or flare.

*Distance piece* means an open or enclosed casing through which the piston rod travels, separating the compressor cylinder from the crankcase.

*Double block and bleed system* means two block valves connected in series with a bleed valve or line that can vent the line between the two block valves.

*Duct work* means a conveyance system such as those commonly used for heating and ventilation systems. It is often made of sheet metal and often has sections connected by screws or crimping. Hard-piping is not ductwork.

*Equipment* means each pump, compressor, pressure relief device, sampling connection system, open-ended valve or line, valve, and flange or other connector in VOC service and any devices or systems required by this subpart.

*First attempt at repair* means to take action for the purpose of stopping or reducing leakage of organic material to the atmosphere using best practices.

*Fuel gas* means gases that are combusted to derive useful work or heat.

*Fuel gas system* means the offsite and onsite piping and flow and pressure control system that gathers gaseous stream(s) generated by onsite operations, may blend them with other sources of gas, and transports the gaseous stream for use as fuel gas in combustion devices or in-process combustion equipment, such as furnaces and gas turbines, either singly or in combination.

*Hard-piping* means pipe or tubing that is manufactured and properly installed using good engineering judgment and standards such as ASME B31.3, Process Piping (available from the American Society of Mechanical Engineers, P.O. Box 2300, Fairfield, NJ 07007–2300).

*In gas/vapor service* means that the piece of equipment contains process fluid that is in the gaseous state at operating conditions.

*In heavy liquid service* means that the piece of equipment is not in gas/vapor service or in light liquid service.

*In light liquid service* means that the piece of equipment contains a liquid that meets the conditions specified in § 60.485b(e).

*In-situ sampling systems* means nonextractive samplers or in-line samplers.

*In vacuum service* means that equipment is operating at an internal pressure which is at least 5 kilopascals (kPa) (0.7 psia) below ambient pressure.

*In VOC service* means that the piece of equipment contains or contacts a process fluid that is at least 10 percent VOC by weight. (The provisions of § 60.485b(d) specify how to determine that a piece of equipment is not in VOC service.)

*Initial calibration value* means the concentration measured during the initial calibration at the beginning of each day required in § 60.485b(b)(1), or the most recent calibration if the instrument is recalibrated during the day (*i.e.*, the calibration is adjusted) after a calibration drift assessment.

*Liquids dripping* means any visible leakage from the seal including spraying, misting, clouding, and ice formation.

*Open-ended valve or line* means any valve, except safety relief valves, having one side of the valve seat in contact with process fluid and one side open to the atmosphere, either directly or through open piping.

*Pressure release means* the emission of materials resulting from system pressure being greater than set pressure of the pressure relief device.

*Process improvement* means routine changes made for safety and occupational health requirements, for energy savings, for better utility, for ease of maintenance and operation, for correction of design deficiencies, for bottleneck removal, for changing product requirements, or for environmental control.

*Process unit* means components assembled to produce, as intermediate or final products, one or more of the chemicals listed in § 60.489. A process unit can operate independently if supplied with sufficient feed or raw materials and sufficient storage facilities for the product.

*Process unit shutdown* means a work practice or operational procedure that stops production from a process unit or part of a process unit during which it is technically feasible to clear process material from a process unit or part of a process unit consistent with safety constraints and during which repairs

can be accomplished. The following are not considered process unit shutdowns:

(1) An unscheduled work practice or operational procedure that stops production from a process unit or part of a process unit for less than 24 hours.

(2) An unscheduled work practice or operational procedure that would stop production from a process unit or part of a process unit for a shorter period of time than would be required to clear the process unit or part of the process unit of materials and start up the unit and would result in greater emissions than delay of repair of leaking components until the next scheduled process unit shutdown.

(3) The use of spare equipment and technically feasible bypassing of equipment without stopping production.

*Quarter* means a 3-month period; the first quarter concludes on the last day of the last full month during the 180 days following initial startup.

*Repaired* means that equipment is adjusted, or otherwise altered, in order to eliminate a leak as defined in the applicable sections of this subpart and, except for leaks identified in accordance with §§ 60.482–2b(b)(2)(ii) and (d)(6)(ii) and (iii), 60.482–3b(f), and 60.482–10b(f)(1)(ii), is re-monitored as specified in § 60.485b(b) to verify that emissions from the equipment are below the applicable leak definition.

*Replacement cost* means the capital needed to purchase all the depreciable components in a facility.

*Sampling connection system* means an assembly of equipment within a process unit used during periods of representative operation to take samples of the process fluid. Equipment used to take nonroutine grab samples is not considered a sampling connection system.

*Sensor* means a device that measures a physical quantity or the change in a physical quantity such as temperature, pressure, flow rate, pH, or liquid level.

*Storage vessel* means a tank or other vessel that is used to store organic liquids that are used in the process as raw material feedstocks, produced as intermediates or final products, or generated as wastes. Storage vessel does not include vessels permanently attached to motor vehicles, such as trucks, railcars, barges or ships.

*Synthetic organic chemicals manufacturing industry* means the industry that produces, as intermediates or final products, one or more of the chemicals listed in § 60.489.

*Transfer rack* means the collection of loading arms and loading hoses, at a single loading rack, that are used to fill

tank trucks and/or railcars with organic liquids.

*Volatile organic compounds* or VOC means, for the purposes of this subpart, any reactive organic compounds as defined in § 60.2.

**§ 60.482-1b Standards: General.**

(a) Each owner or operator subject to the provisions of this subpart shall demonstrate compliance with the requirements of §§ 60.482-1b through 60.482-11b or § 60.480b(e) for all equipment within 180 days of initial startup.

(b) Compliance with §§ 60.482-1b through 60.482-11b will be determined by review of records and reports, review of performance test results, and inspection using the methods and procedures specified in § 60.485b.

(c)(1) An owner or operator may request a determination of equivalence of a means of emission limitation to the

requirements of §§ 60.482-2b, 60.482-3b, 60.482-5b, 60.482-6b, 60.482-7b, 60.482-8b, and 60.482-10b as provided in § 60.484b.

(2) If the Administrator makes a determination that a means of emission limitation is at least equivalent to the requirements of § 60.482-2b, § 60.482-3b, § 60.482-5b, § 60.482-6b, § 60.482-7b, § 60.482-8b, or § 60.482-10b, an owner or operator shall comply with the requirements of that determination.

(d) Equipment that is in vacuum service is excluded from the requirements of §§ 60.482-2b through 60.482-11b if it is identified as required in § 60.486b(e)(5).

(e) Equipment that an owner or operator designates as being in VOC service less than 300 hr/yr is excluded from the requirements of §§ 60.482-2b through 60.482-11b if it is identified as required in § 60.486b(e)(6) and it meets any of the conditions specified in

paragraphs (e)(1) through (3) of this section.

(1) The equipment is in VOC service only during startup and shutdown, excluding startup and shutdown between batches of the same campaign for a batch process.

(2) The equipment is in VOC service only during process malfunctions or other emergencies.

(3) The equipment is backup equipment that is in VOC service only when the primary equipment is out of service.

(f)(1) If a dedicated batch process unit operates less than 365 days during a year, an owner or operator may monitor to detect leaks from pumps, valves, and open-ended valves or lines at the frequency specified in the following table instead of monitoring as specified in §§ 60.482-2b, 60.482-7b, and 60.483.2a:

TABLE 1 TO PARAGRAPH (f)(1)

Operating time (percent of hours during year)	Equivalent monitoring frequency time in use		
	Monthly	Quarterly	Semiannually
0 to <25 .....	Quarterly .....	Annually .....	Annually.
25 to <50 .....	Quarterly .....	Semiannually .....	Annually.
50 to <75 .....	Bimonthly .....	Three quarters .....	Semiannually.
75 to 100 .....	Monthly .....	Quarterly .....	Semiannually.

(2) Pumps and valves that are shared among two or more batch process units that are subject to this subpart may be monitored at the frequencies specified in paragraph (f)(1) of this section, provided the operating time of all such process units is considered.

(3) The monitoring frequencies specified in paragraph (f)(1) of this section are not requirements for monitoring at specific intervals and can be adjusted to accommodate process operations. An owner or operator may monitor at any time during the specified monitoring period (*e.g.*, month, quarter, year), provided the monitoring is conducted at a reasonable interval after completion of the last monitoring campaign. Reasonable intervals are defined in paragraphs (f)(3)(i) through (iv) of this section.

(i) When monitoring is conducted quarterly, monitoring events must be separated by at least 30 calendar days.

(ii) When monitoring is conducted semiannually (*i.e.*, once every 2 quarters), monitoring events must be separated by at least 60 calendar days.

(iii) When monitoring is conducted in 3 quarters per year, monitoring events must be separated by at least 90 calendar days.

(iv) When monitoring is conducted annually, monitoring events must be separated by at least 120 calendar days.

(g) The standards in §§ 60.482-1b through 60.482-11b apply at all times, including periods of startup, shutdown, and malfunction. As provided in § 60.11(f), this provision supersedes the exemptions for periods of startup, shutdown, and malfunction in the general provisions in subpart A of this part.

**§ 60.482-2b Standards: Pumps in light liquid service.**

(a)(1) Each pump in light liquid service shall be monitored monthly to detect leaks by the methods specified in § 60.485b(b), except as provided in § 60.482-1b(c) and (f) and paragraphs (d), (e), and (f) of this section. A pump that begins operation in light liquid service after the initial startup date for the process unit must be monitored for the first time within 30 days after the end of its startup period, except for a pump that replaces a leaking pump and except as provided in § 60.482-1b(c) and paragraphs (d), (e), and (f) of this section.

(2) Each pump in light liquid service shall be checked by visual inspection each calendar week for indications of

liquids dripping from the pump seal, except as provided in § 60.482-1b(f).

(b)(1) The instrument reading that defines a leak is specified in paragraphs (b)(1)(i) and (ii) of this section.

(i) 5,000 parts per million (ppm) or greater for pumps handling polymerizing monomers;  
(ii) 2,000 ppm or greater for all other pumps.

(2) If there are indications of liquids dripping from the pump seal, the owner or operator shall follow the procedure specified in either paragraph (b)(2)(i) or (ii) of this section. This requirement does not apply to a pump that was monitored after a previous weekly inspection and the instrument reading was less than the concentration specified in paragraph (b)(1)(i) or (ii) of this section, whichever is applicable.

(i) Monitor the pump within 5 days as specified in § 60.485b(b). A leak is detected if the instrument reading measured during monitoring indicates a leak as specified in paragraph (b)(1)(i) or (ii) of this section, whichever is applicable. The leak shall be repaired using the procedures in paragraph (c) of this section.

(ii) Designate the visual indications of liquids dripping as a leak, and repair the leak using either the procedures in



paragraph (c) of this section or by eliminating the visual indications of liquids dripping.

(c)(1) When a leak is detected, it shall be repaired as soon as practicable, but not later than 15 calendar days after it is detected, except as provided in § 60.482–9b.

(2) A first attempt at repair shall be made no later than 5 calendar days after each leak is detected. First attempts at repair include, but are not limited to, the practices described in paragraphs (c)(2)(i) and (ii) of this section, where practicable.

(i) Tightening the packing gland nuts;

(ii) Ensuring that the seal flush is operating at design pressure and temperature.

(d) Each pump equipped with a dual mechanical seal system that includes a barrier fluid system is exempt from the requirements of paragraph (a) of this section, provided the requirements specified in paragraphs (d)(1) through (6) of this section are met.

(1) Each dual mechanical seal system is:

(i) Operated with the barrier fluid at a pressure that is at all times greater than the pump stuffing box pressure; or

(ii) Equipped with a barrier fluid degassing reservoir that is routed to a process or fuel gas system or connected by a closed vent system to a control device that complies with the requirements of § 60.482–10b; or

(iii) Equipped with a system that purges the barrier fluid into a process stream with zero VOC emissions to the atmosphere.

(2) The barrier fluid system is in heavy liquid service or is not in VOC service.

(3) Each barrier fluid system is equipped with a sensor that will detect failure of the seal system, the barrier fluid system, or both.

(4)(i) Each pump is checked by visual inspection, each calendar week, for indications of liquids dripping from the pump seals.

(ii) If there are indications of liquids dripping from the pump seal at the time of the weekly inspection, the owner or operator shall follow the procedure specified in either paragraph (d)(4)(ii)(A) or (B) of this section prior to the next required inspection.

(A) Monitor the pump within 5 days as specified in § 60.485b(b) to determine if there is a leak of VOC in the barrier fluid. If an instrument reading of 2,000 ppm or greater is measured, a leak is detected.

(B) Designate the visual indications of liquids dripping as a leak.

(5)(i) Each sensor as described in paragraph (d)(3) is checked daily or is equipped with an audible alarm.

(ii) The owner or operator determines, based on design considerations and operating experience, a criterion that indicates failure of the seal system, the barrier fluid system, or both.

(iii) If the sensor indicates failure of the seal system, the barrier fluid system, or both, based on the criterion established in paragraph (d)(5)(ii) of this section, a leak is detected.

(6)(i) When a leak is detected pursuant to paragraph (d)(4)(ii)(A) of this section, it shall be repaired as specified in paragraph (c) of this section.

(ii) A leak detected pursuant to paragraph (d)(5)(iii) of this section shall be repaired within 15 days of detection by eliminating the conditions that activated the sensor.

(iii) A designated leak pursuant to paragraph (d)(4)(ii)(B) of this section shall be repaired within 15 days of detection by eliminating visual indications of liquids dripping.

(e) Any pump that is designated, as described in § 60.486b(e)(1) and (2), for no detectable emissions, as indicated by an instrument reading of less than 500 ppm above background, is exempt from the requirements of paragraphs (a), (c), and (d) of this section if the pump:

(1) Has no externally actuated shaft penetrating the pump housing;

(2) Is demonstrated to be operating with no detectable emissions as indicated by an instrument reading of less than 500 ppm above background as measured by the methods specified in § 60.485b(c); and

(3) Is tested for compliance with paragraph (e)(2) of this section initially upon designation, annually, and at other times requested by the Administrator.

(f) If any pump is equipped with a closed vent system capable of capturing and transporting any leakage from the seal or seals to a process or to a fuel gas system or to a control device that complies with the requirements of § 60.482–10b, it is exempt from paragraphs (a) through (e) of this section.

(g) Any pump that is designated, as described in § 60.486b(f)(1), as an unsafe-to-monitor pump is exempt from the monitoring and inspection requirements of paragraphs (a) and (d)(4) through (6) of this section if:

(1) The owner or operator of the pump demonstrates that the pump is unsafe-to-monitor because monitoring personnel would be exposed to an immediate danger as a consequence of complying with paragraph (a) of this section; and

(2) The owner or operator of the pump has a written plan that requires monitoring of the pump as frequently as

practicable during safe-to-monitor times, but not more frequently than the periodic monitoring schedule otherwise applicable, and repair of the equipment according to the procedures in paragraph (c) of this section if a leak is detected.

(h) Any pump that is located within the boundary of an unmanned plant site is exempt from the weekly visual inspection requirement of paragraphs (a)(2) and (d)(4) of this section, and the daily requirements of paragraph (d)(5) of this section, provided that each pump is visually inspected as often as practicable and at least monthly.

#### § 60.482–3b Standards: Compressors.

(a) Each compressor shall be equipped with a seal system that includes a barrier fluid system and that prevents leakage of VOC to the atmosphere, except as provided in § 60.482–1b(c) and paragraphs (h), (i), and (j) of this section.

(b) Each compressor seal system as required in paragraph (a) of this section shall be:

(1) Operated with the barrier fluid at a pressure that is greater than the compressor stuffing box pressure; or

(2) Equipped with a barrier fluid system degassing reservoir that is routed to a process or fuel gas system or connected by a closed vent system to a control device that complies with the requirements of § 60.482–10b; or

(3) Equipped with a system that purges the barrier fluid into a process stream with zero VOC emissions to the atmosphere.

(c) The barrier fluid system shall be in heavy liquid service or shall not be in VOC service.

(d) Each barrier fluid system as described in paragraph (a) of this section shall be equipped with a sensor that will detect failure of the seal system, barrier fluid system, or both.

(e)(1) Each sensor as required in paragraph (d) of this section shall be checked daily or shall be equipped with an audible alarm.

(2) The owner or operator shall determine, based on design considerations and operating experience, a criterion that indicates failure of the seal system, the barrier fluid system, or both.

(f) If the sensor indicates failure of the seal system, the barrier system, or both based on the criterion determined under paragraph (e)(2) of this section, a leak is detected.

(g)(1) When a leak is detected, it shall be repaired as soon as practicable, but not later than 15 calendar days after it is detected, except as provided in § 60.482–9b.

(2) A first attempt at repair shall be made no later than 5 calendar days after each leak is detected.

(h) A compressor is exempt from the requirements of paragraphs (a) and (b) of this section, if it is equipped with a closed vent system to capture and transport leakage from the compressor drive shaft back to a process or fuel gas system or to a control device that complies with the requirements of § 60.482–10b, except as provided in paragraph (i) of this section.

(i) Any compressor that is designated, as described in § 60.486b(e)(1) and (2), for no detectable emissions, as indicated by an instrument reading of less than 500 ppm above background, is exempt from the requirements of paragraphs (a) through (h) of this section if the compressor:

(1) Is demonstrated to be operating with no detectable emissions, as indicated by an instrument reading of less than 500 ppm above background, as measured by the methods specified in § 60.485b(c); and

(2) Is tested for compliance with paragraph (i)(1) of this section initially upon designation, annually, and at other times requested by the Administrator.

(j) Any existing reciprocating compressor in a process unit which becomes an affected facility under provisions of § 60.14 or § 60.15 is exempt from paragraphs (a) through (e) and (h) of this section, provided the owner or operator demonstrates that recasting the distance piece or replacing the compressor are the only options available to bring the compressor into compliance with the provisions of paragraphs (a) through (e) and (h) of this section.

**§ 60.482–4b Standards: Pressure relief devices in gas/vapor service.**

(a) Except during pressure releases, each pressure relief device in gas/vapor service shall be operated with no detectable emissions, as indicated by an instrument reading of less than 500 ppm above background, as determined by the methods specified in § 60.485b(c).

(b)(1) After each pressure release, the pressure relief device shall be returned to a condition of no detectable emissions, as indicated by an instrument reading of less than 500 ppm above background, as soon as practicable, but no later than 5 calendar days after the pressure release, except as provided in § 60.482–9b.

(2) No later than 5 calendar days after the pressure release, the pressure relief device shall be monitored to confirm the conditions of no detectable emissions, as indicated by an instrument reading of

less than 500 ppm above background, by the methods specified in § 60.485b(c).

(c) Any pressure relief device that is routed to a process or fuel gas system or equipped with a closed vent system capable of capturing and transporting leakage through the pressure relief device to a control device as described in § 60.482–10b is exempt from the requirements of paragraphs (a) and (b) of this section.

(d)(1) Any pressure relief device that is equipped with a rupture disk upstream of the pressure relief device is exempt from the requirements of paragraphs (a) and (b) of this section, provided the owner or operator complies with the requirements in paragraph (d)(2) of this section.

(2) After each pressure release, a new rupture disk shall be installed upstream of the pressure relief device as soon as practicable, but no later than 5 calendar days after each pressure release, except as provided in § 60.482–9b.

**§ 60.482–5b Standards: Sampling connection systems.**

(a) Each sampling connection system shall be equipped with a closed-purge, closed-loop, or closed-vent system, except as provided in § 60.482–1b(c) and paragraph (c) of this section.

(b) Each closed-purge, closed-loop, or closed-vent system as required in paragraph (a) of this section shall comply with the requirements specified in paragraphs (b)(1) through (4) of this section.

(1) Gases displaced during filling of the sample container are not required to be collected or captured.

(2) Containers that are part of a closed-purge system must be covered or closed when not being filled or emptied.

(3) Gases remaining in the tubing or piping between the closed-purge system valve(s) and sample container valve(s) after the valves are closed and the sample container is disconnected are not required to be collected or captured.

(4) Each closed-purge, closed-loop, or closed-vent system shall be designed and operated to meet requirements in either paragraph (b)(4)(i), (ii), (iii), or (iv) of this section.

(i) Return the purged process fluid directly to the process line.

(ii) Collect and recycle the purged process fluid to a process.

(iii) Capture and transport all the purged process fluid to a control device that complies with the requirements of § 60.482–10b.

(iv) Collect, store, and transport the purged process fluid to any of the following systems or facilities:

(A) A waste management unit as defined in 40 CFR 63.111, if the waste

management unit is subject to and operated in compliance with the provisions of 40 CFR part 63, subpart G, applicable to Group 1 wastewater streams;

(B) A treatment, storage, or disposal facility subject to regulation under 40 CFR part 262, 264, 265, or 266;

(C) A facility permitted, licensed, or registered by a state to manage municipal or industrial solid waste, if the process fluids are not hazardous waste as defined in 40 CFR part 261;

(D) A waste management unit subject to and operated in compliance with the treatment requirements of 40 CFR 61.348(a), provided all waste management units that collect, store, or transport the purged process fluid to the treatment unit are subject to and operated in compliance with the management requirements of 40 CFR 61.343 through 40 CFR 61.347; or

(E) A device used to burn off-specification used oil for energy recovery in accordance with 40 CFR part 279, subpart G, provided the purged process fluid is not hazardous waste as defined in 40 CFR part 261.

(c) In-situ sampling systems and sampling systems without purges are exempt from the requirements of paragraphs (a) and (b) of this section.

**§ 60.482–6b Standards: Open-ended valves or lines.**

(a)(1) Each open-ended valve or line shall be equipped with a cap, blind flange, plug, or a second valve, except as provided in § 60.482–1b(c) and paragraphs (d) and (e) of this section.

(2) The cap, blind flange, plug, or second valve shall seal the open end at all times except during operations requiring process fluid flow through the open-ended valve or line.

(b) Each open-ended valve or line equipped with a second valve shall be operated in a manner such that the valve on the process fluid end is closed before the second valve is closed.

(c) When a double block-and-bleed system is being used, the bleed valve or line may remain open during operations that require venting the line between the block valves but shall comply with paragraph (a) of this section at all other times.

(d) Open-ended valves or lines in an emergency shutdown system which are designed to open automatically in the event of a process upset are exempt from the requirements of paragraphs (a), (b), and (c) of this section.

(e) Open-ended valves or lines containing materials which would autocatalytically polymerize or would present an explosion, serious overpressure, or other safety hazard if

capped or equipped with a double block and bleed system as specified in paragraphs (a) through (c) of this section are exempt from the requirements of paragraphs (a) through (c) of this section.

**§ 60.482-7b Standards: Valves in gas/vapor service and in light liquid service.**

(a)(1) Each valve shall be monitored monthly to detect leaks by the methods specified in § 60.485b(b) and shall comply with paragraphs (b) through (e) of this section, except as provided in paragraphs (f), (g), and (h) of this section, § 60.482-1b(c) and (f), and §§ 60.483-1b and 60.483-2b.

(2) A valve that begins operation in gas/vapor service or light liquid service after the initial startup date for the process unit must be monitored according to paragraphs (a)(2)(i) or (ii), except for a valve that replaces a leaking valve and except as provided in paragraphs (f), (g), and (h) of this section, § 60.482-1b(c), and §§ 60.483-1b and 60.483-2b.

(i) Monitor the valve as in paragraph (a)(1) of this section. The valve must be monitored for the first time within 30 days after the end of its startup period to ensure proper installation.

(ii) If the existing valves in the process unit are monitored in accordance with § 60.483-1b or § 60.483-2b, count the new valve as leaking when calculating the percentage of valves leaking as described in § 60.483-2b(b)(5). If less than 2.0 percent of the valves are leaking for that process unit, the valve must be monitored for the first time during the next scheduled monitoring event for existing valves in the process unit or within 90 days, whichever comes first.

(b) If an instrument reading of 100 ppm or greater is measured, a leak is detected.

(c)(1)(i) Any valve for which a leak is not detected for 2 successive months may be monitored the first month of every quarter, beginning with the next quarter, until a leak is detected.

(ii) As an alternative to monitoring all of the valves in the first month of a quarter, an owner or operator may elect to subdivide the process unit into two or three subgroups of valves and monitor each subgroup in a different month during the quarter, provided each subgroup is monitored every 3 months. The owner or operator must keep records of the valves assigned to each subgroup.

(2) If a leak is detected, the valve shall be monitored monthly until a leak is not detected for 2 successive months.

(d)(1) When a leak is detected, it shall be repaired as soon as practicable, but

no later than 15 calendar days after the leak is detected, except as provided in § 60.482-9b.

(2) A first attempt at repair shall be made no later than 5 calendar days after each leak is detected.

(e) First attempts at repair include, but are not limited to, the following best practices where practicable:

- (1) Tightening of bonnet bolts;
- (2) Replacement of bonnet bolts;
- (3) Tightening of packing gland nuts;
- (4) Injection of lubricant into lubricated packing.

(f) Any valve that is designated, as described in § 60.486b(e)(2), for no detectable emissions, as indicated by an instrument reading of less than 100 ppm above background, is exempt from the requirements of paragraph (a) of this section if the valve:

(1) Has no external actuating mechanism in contact with the process fluid,

(2) Is operated with emissions less than 100 ppm above background as determined by the method specified in § 60.485b(c), and

(3) Is tested for compliance with paragraph (f)(2) of this section initially upon designation, annually, and at other times requested by the Administrator.

(g) Any valve that is designated, as described in § 60.486b(f)(1), as an unsafe-to-monitor valve is exempt from the requirements of paragraph (a) of this section if:

(1) The owner or operator of the valve demonstrates that the valve is unsafe to monitor because monitoring personnel would be exposed to an immediate danger as a consequence of complying with paragraph (a) of this section, and

(2) The owner or operator of the valve adheres to a written plan that requires monitoring of the valve as frequently as practicable during safe-to-monitor times.

(h) Any valve that is designated, as described in § 60.486b(f)(2), as a difficult-to-monitor valve is exempt from the requirements of paragraph (a) of this section if:

(1) The owner or operator of the valve demonstrates that the valve cannot be monitored without elevating the monitoring personnel more than 2 meters above a support surface.

(2) The process unit within which the valve is located either:

(i) Becomes an affected facility through § 60.14 or § 60.15 and was constructed on or before January 5, 1981; or

(ii) Has less than 3.0 percent of its total number of valves designated as difficult-to-monitor by the owner or operator.

(3) The owner or operator of the valve follows a written plan that requires

monitoring of the valve at least once per calendar year.

**§ 60.482-8b Standards: Pumps, valves, and connectors in heavy liquid service and pressure relief devices in light liquid or heavy liquid service.**

(a) If evidence of a potential leak is found by visual, audible, olfactory, or any other detection method at pumps, valves, and connectors in heavy liquid service and pressure relief devices in light liquid or heavy liquid service, the owner or operator shall follow either one of the following procedures:

(1) The owner or operator shall monitor the equipment within 5 days by the method specified in § 60.485b(b) and shall comply with the requirements of paragraphs (b) through (d) of this section.

(2) The owner or operator shall eliminate the visual, audible, olfactory, or other indication of a potential leak within 5 calendar days of detection.

(b) If an instrument reading of 10,000 ppm or greater is measured, a leak is detected.

(c)(1) When a leak is detected, it shall be repaired as soon as practicable, but not later than 15 calendar days after it is detected, except as provided in § 60.482-9b.

(2) The first attempt at repair shall be made no later than 5 calendar days after each leak is detected.

(d) First attempts at repair include, but are not limited to, the best practices described under §§ 60.482-2b(c)(2) and 60.482-7b(e).

**§ 60.482-9b Standards: Delay of repair.**

(a) Delay of repair of equipment for which leaks have been detected will be allowed if repair within 15 days is technically infeasible without a process unit shutdown. Repair of this equipment shall occur before the end of the next process unit shutdown. Monitoring to verify repair must occur within 15 days after startup of the process unit.

(b) Delay of repair of equipment will be allowed for equipment which is isolated from the process and which does not remain in VOC service.

(c) Delay of repair for valves and connectors will be allowed if:

(1) The owner or operator demonstrates that emissions of purged material resulting from immediate repair are greater than the fugitive emissions likely to result from delay of repair, and

(2) When repair procedures are effected, the purged material is collected and destroyed or recovered in a control device complying with § 60.482-10b.

(d) Delay of repair for pumps will be allowed if:

(1) Repair requires the use of a dual mechanical seal system that includes a barrier fluid system, and

(2) Repair is completed as soon as practicable, but not later than 6 months after the leak was detected.

(e) Delay of repair beyond a process unit shutdown will be allowed for a valve, if valve assembly replacement is necessary during the process unit shutdown, valve assembly supplies have been depleted, and valve assembly supplies had been sufficiently stocked before the supplies were depleted. Delay of repair beyond the next process unit shutdown will not be allowed unless the next process unit shutdown occurs sooner than 6 months after the first process unit shutdown.

(f) When delay of repair is allowed for a leaking pump, valve, or connector that remains in service, the pump, valve, or connector may be considered to be repaired and no longer subject to delay of repair requirements if two consecutive monthly monitoring instrument readings are below the leak definition.

**§ 60.482–10b Standards: Closed vent systems and control devices.**

(a) Owners or operators of closed vent systems and control devices used to comply with provisions of this subpart shall comply with the provisions of this section.

(b) Vapor recovery systems (for example, condensers and absorbers) shall be designed and operated to recover the VOC emissions vented to them with an efficiency of 95 percent or greater, or to an exit concentration of 20 parts per million by volume (ppmv), whichever is less stringent.

(c) Enclosed combustion devices shall be designed and operated to reduce the VOC emissions vented to them with an efficiency of 95 percent or greater, or to an exit concentration of 20 ppmv, on a dry basis, corrected to 3 percent oxygen, whichever is less stringent or to provide a minimum residence time of 0.75 seconds at a minimum temperature of 816 °C.

(d) Flares used to comply with this subpart shall comply with the requirements of § 60.18.

(e) Owners or operators of control devices used to comply with the provisions of this subpart shall monitor these control devices to ensure that they are operated and maintained in conformance with their designs.

(f) Except as provided in paragraphs (i) through (k) of this section, each closed vent system shall be inspected according to the procedures and schedule specified in paragraphs (f)(1) through (3) of this section.

(1) Conduct an initial inspection according to the procedures in § 60.485b(b); and

(2) Conduct annual inspections according to the procedures in § 60.485b(b).

(3) Conduct annual visual inspections for visible, audible, or olfactory indications of leaks.

(g) Leaks, as indicated by an instrument reading greater than 500 ppmv above background or by visual inspections, shall be repaired as soon as practicable except as provided in paragraph (h) of this section.

(1) A first attempt at repair shall be made no later than 5 calendar days after the leak is detected.

(2) Repair shall be completed no later than 15 calendar days after the leak is detected.

(h) Delay of repair of a closed vent system for which leaks have been detected is allowed if the repair is technically infeasible without a process unit shutdown or if the owner or operator determines that emissions resulting from immediate repair would be greater than the fugitive emissions likely to result from delay of repair. Repair of such equipment shall be complete by the end of the next process unit shutdown.

(i) If a vapor collection system or closed vent system is operated under a vacuum, it is exempt from the inspection requirements of paragraphs (f)(1) and (2) of this section.

(j) Any parts of the closed vent system that are designated, as described in paragraph (l)(1) of this section, as unsafe to inspect are exempt from the inspection requirements of paragraphs (f)(1) and (2) of this section if they comply with the requirements specified in paragraphs (j)(1) and (2) of this section:

(1) The owner or operator determines that the equipment is unsafe to inspect because inspecting personnel would be exposed to an imminent or potential danger as a consequence of complying with paragraphs (f)(1) and (2) of this section; and

(2) The owner or operator has a written plan that requires inspection of the equipment as frequently as practicable during safe-to-inspect times.

(k) Any parts of the closed vent system that are designated, as described in paragraph (l)(2) of this section, as difficult to inspect are exempt from the inspection requirements of paragraphs (f)(1) and (2) of this section if they comply with the requirements specified in paragraphs (k)(1) through (3) of this section:

(1) The owner or operator determines that the equipment cannot be inspected

without elevating the inspecting personnel more than 2 meters above a support surface; and

(2) The process unit within which the closed vent system is located becomes an affected facility through §§ 60.14 or 60.15, or the owner or operator designates less than 3.0 percent of the total number of closed vent system equipment as difficult to inspect; and

(3) The owner or operator has a written plan that requires inspection of the equipment at least once every 5 years. A closed vent system is exempt from inspection if it is operated under a vacuum.

(l) The owner or operator shall record the information specified in paragraphs (l)(1) through (5) of this section.

(1) Identification of all parts of the closed vent system that are designated as unsafe to inspect, an explanation of why the equipment is unsafe to inspect, and the plan for inspecting the equipment.

(2) Identification of all parts of the closed vent system that are designated as difficult to inspect, an explanation of why the equipment is difficult to inspect, and the plan for inspecting the equipment.

(3) For each inspection during which a leak is detected, a record of the information specified in § 60.486b(c).

(4) For each inspection conducted in accordance with § 60.485b(b) during which no leaks are detected, a record that the inspection was performed, the date of the inspection, and a statement that no leaks were detected.

(5) For each visual inspection conducted in accordance with paragraph (f)(3) of this section during which no leaks are detected, a record that the inspection was performed, the date of the inspection, and a statement that no leaks were detected.

(m) Closed vent systems and control devices used to comply with provisions of this subpart shall be operated at all times when emissions may be vented to them.

**§ 60.482–11b Standards: Connectors in gas/vapor service and in light liquid service.**

(a) The owner or operator shall initially monitor all connectors in the process unit for leaks by the later of either 12 months after the compliance date or 12 months after initial startup. If all connectors in the process unit have been monitored for leaks prior to the compliance date, no initial monitoring is required provided either no process changes have been made since the monitoring or the owner or operator can determine that the results of the monitoring, with or without adjustments, reliably demonstrate

compliance despite process changes. If required to monitor because of a process change, the owner or operator is required to monitor only those connectors involved in the process change.

(b) Except as allowed in § 60.482–1b(c), § 60.482–10b, or as specified in paragraph (e) of this section, the owner or operator shall monitor all connectors in gas and vapor and light liquid service as specified in paragraphs (a) and (b)(3) of this section.

(1) The connectors shall be monitored to detect leaks by the method specified in § 60.485b(b) and, as applicable, § 60.485b(c).

(2) If an instrument reading greater than or equal to 500 ppm is measured, a leak is detected.

(3) The owner or operator shall perform monitoring, subsequent to the initial monitoring required in paragraph (a) of this section, as specified in paragraphs (b)(3)(i) through (iii) of this section, and shall comply with the requirements of paragraphs (b)(3)(iv) and (v) of this section. The required period in which monitoring must be conducted shall be determined from paragraphs (b)(3)(i) through (iii) of this section using the monitoring results from the preceding monitoring period. The percent leaking connectors shall be calculated as specified in paragraph (c) of this section.

(i) If the percent leaking connectors in the process unit was greater than or equal to 0.5 percent, then monitor within 12 months (1 year).

(ii) If the percent leaking connectors in the process unit was greater than or equal to 0.25 percent but less than 0.5 percent, then monitor within 4 years. An owner or operator may comply with the requirements of this paragraph by monitoring at least 40 percent of the connectors within 2 years of the start of the monitoring period, provided all connectors have been monitored by the end of the 4-year monitoring period.

(iii) If the percent leaking connectors in the process unit was less than 0.25 percent, then monitor as provided in paragraph (b)(3)(iii)(A) of this section and either paragraph (b)(3)(iii)(B) or (C) of this section, as appropriate.

(A) An owner or operator shall monitor at least 50 percent of the connectors within 4 years of the start of the monitoring period.

(B) If the percent of leaking connectors calculated from the monitoring results in paragraph (b)(3)(iii)(A) of this section is greater than or equal to 0.35 percent of the monitored connectors, the owner or operator shall monitor as soon as practical, but within the next 6 months,

all connectors that have not yet been monitored during the monitoring period. At the conclusion of monitoring, a new monitoring period shall be started pursuant to paragraph (b)(3) of this section, based on the percent of leaking connectors within the total monitored connectors.

(C) If the percent of leaking connectors calculated from the monitoring results in paragraph (b)(3)(iii)(A) of this section is less than 0.35 percent of the monitored connectors, the owner or operator shall monitor all connectors that have not yet been monitored within 8 years of the start of the monitoring period.

(iv) If, during the monitoring conducted pursuant to paragraphs (b)(3)(i) through (iii) of this section, a connector is found to be leaking, it shall be re-monitored once within 90 days after repair to confirm that it is not leaking.

(v) The owner or operator shall keep a record of the start date and end date of each monitoring period under this section for each process unit.

(c) For use in determining the monitoring frequency, as specified in paragraphs (a) and (b)(3) of this section, the percent leaking connectors as used in paragraphs (a) and (b)(3) of this section shall be calculated by using the following equation:

Equation 1 to Paragraph (c)

$$\%C_L = C_L/C_t * 100$$

Where:

$\%C_L$  = Percent of leaking connectors as determined through periodic monitoring required in paragraphs (a) and (b)(3)(i) through (iii) of this section.

$C_L$  = Number of connectors measured at 500 ppm or greater, by the method specified in § 60.485b(b).

$C_t$  = Total number of monitored connectors in the process unit or affected facility.

(d) When a leak is detected pursuant to paragraphs (a) and (b) of this section, it shall be repaired as soon as practicable, but not later than 15 calendar days after it is detected, except as provided in § 60.482–9b. A first attempt at repair as defined in this subpart shall be made no later than 5 calendar days after the leak is detected.

(e) Any connector that is designated, as described in § 60.486b(f)(1), as an unsafe-to-monitor connector is exempt from the requirements of paragraphs (a) and (b) of this section if:

(1) The owner or operator of the connector demonstrates that the connector is unsafe-to-monitor because monitoring personnel would be exposed to an immediate danger as a consequence of complying with

paragraphs (a) and (b) of this section; and

(2) The owner or operator of the connector has a written plan that requires monitoring of the connector as frequently as practicable during safe-to-monitor times but not more frequently than the periodic monitoring schedule otherwise applicable, and repair of the equipment according to the procedures in paragraph (d) of this section if a leak is detected.

(f)(1) Any connector that is inaccessible or that is ceramic or ceramic-lined (e.g., porcelain, glass, or glass-lined), is exempt from the monitoring requirements of paragraphs (a) and (b) of this section, from the leak repair requirements of paragraph (d) of this section, and from the recordkeeping and reporting requirements of §§ 63.1038 and 63.1039. An inaccessible connector is one that meets any of the provisions specified in paragraphs (f)(1)(i) through (vi) of this section, as applicable:

(i) Buried;

(ii) Insulated in a manner that prevents access to the connector by a monitor probe;

(iii) Obstructed by equipment or piping that prevents access to the connector by a monitor probe;

(iv) Unable to be reached from a wheeled scissor-lift or hydraulic-type scaffold that would allow access to connectors up to 7.6 meters (25 feet) above the ground;

(v) Inaccessible because it would require elevating the monitoring personnel more than 2 meters (7 feet) above a permanent support surface or would require the erection of scaffold; or

(vi) Not able to be accessed at any time in a safe manner to perform monitoring. Unsafe access includes, but is not limited to, the use of a wheeled scissor-lift on unstable or uneven terrain, the use of a motorized man-lift basket in areas where an ignition potential exists, or access would require near proximity to hazards such as electrical lines, or would risk damage to equipment.

(2) If any inaccessible, ceramic, or ceramic-lined connector is observed by visual, audible, olfactory, or other means to be leaking, the visual, audible, olfactory, or other indications of a leak to the atmosphere shall be eliminated as soon as practical.

(g) Except for instrumentation systems and inaccessible, ceramic, or ceramic-lined connectors meeting the provisions of paragraph (f) of this section, identify the connectors subject to the requirements of this subpart. Connectors need not be individually identified if all

connectors in a designated area or length of pipe subject to the provisions of this subpart are identified as a group, and the number of connectors subject is indicated.

**§ 60.483–1b Alternative standards for valves—allowable percentage of valves leaking.**

(a) An owner or operator may elect to comply with an allowable percentage of valves leaking of equal to or less than 2.0 percent.

(b) The following requirements shall be met if an owner or operator wishes to comply with an allowable percentage of valves leaking:

(1) An owner or operator must notify the Administrator that the owner or operator has elected to comply with the allowable percentage of valves leaking before implementing this alternative standard, as specified in § 60.487b(d).

(2) A performance test as specified in paragraph (c) of this section shall be conducted initially upon designation, annually, and at other times requested by the Administrator.

(3) If a valve leak is detected, it shall be repaired in accordance with § 60.482–7b(d) and (e).

(c) Performance tests shall be conducted in the following manner:

(1) All valves in gas/vapor and light liquid service within the affected facility shall be monitored within 1 week by the methods specified in § 60.485b(b).

(2) If an instrument reading of 500 ppm or greater is measured, a leak is detected.

(3) The leak percentage shall be determined by dividing the number of valves for which leaks are detected by the number of valves in gas/vapor and light liquid service within the affected facility.

(d) Owners and operators who elect to comply with this alternative standard shall not have an affected facility with a leak percentage greater than 2.0 percent, determined as described in § 60.485b(h).

**§ 60.483–2b Alternative standards for valves—skip period leak detection and repair.**

(a)(1) An owner or operator may elect to comply with one of the alternative work practices specified in paragraphs (b)(2) and (3) of this section.

(2) An owner or operator must notify the Administrator before implementing one of the alternative work practices, as specified in § 60.487a(d).

(b)(1) An owner or operator shall comply initially with the requirements for valves in gas/vapor service and valves in light liquid service, as described in § 60.482–7b.

(2) After 2 consecutive quarterly leak detection periods with the percent of valves leaking equal to or less than 2.0, an owner or operator may begin to skip 1 of the quarterly leak detection periods for the valves in gas/vapor and light liquid service.

(3) After 5 consecutive quarterly leak detection periods with the percent of valves leaking equal to or less than 2.0, an owner or operator may begin to skip 3 of the quarterly leak detection periods for the valves in gas/vapor and light liquid service.

(4) If the percent of valves leaking is greater than 2.0, the owner or operator shall comply with the requirements as described in § 60.482–7b but can again elect to use this section.

(5) The percent of valves leaking shall be determined as described in § 60.485b(h).

(6) An owner or operator must keep a record of the percent of valves found leaking during each leak detection period.

(7) A valve that begins operation in gas/vapor service or light liquid service after the initial startup date for a process unit following one of the alternative standards in this section must be monitored in accordance with § 60.482–7b(a)(2)(i) or (ii) before the provisions of this section can be applied to that valve.

**§ 60.484b Equivalence of means of emission limitation.**

(a) Each owner or operator subject to the provisions of this subpart may apply to the Administrator for determination of equivalence for any means of emission limitation that achieves a reduction in emissions of VOC at least equivalent to the reduction in emissions of VOC achieved by the controls required in this subpart.

(b) Determination of equivalence to the equipment, design, and operational requirements of this subpart will be evaluated by the following guidelines:

(1) Each owner or operator applying for an equivalence determination shall be responsible for collecting and verifying test data to demonstrate equivalence of means of emission limitation.

(2) The Administrator will compare test data for demonstrating equivalence of the means of emission limitation to test data for the equipment, design, and operational requirements.

(3) The Administrator may condition the approval of equivalence on requirements that may be necessary to assure operation and maintenance to achieve the same emission reduction as the equipment, design, and operational requirements.

(c) Determination of equivalence to the required work practices in this subpart will be evaluated by the following guidelines:

(1) Each owner or operator applying for a determination of equivalence shall be responsible for collecting and verifying test data to demonstrate equivalence of an equivalent means of emission limitation.

(2) For each affected facility for which a determination of equivalence is requested, the emission reduction achieved by the required work practice shall be demonstrated.

(3) For each affected facility, for which a determination of equivalence is requested, the emission reduction achieved by the equivalent means of emission limitation shall be demonstrated.

(4) Each owner or operator applying for a determination of equivalence shall commit in writing to work practice(s) that provide for emission reductions equal to or greater than the emission reductions achieved by the required work practice.

(5) The Administrator will compare the demonstrated emission reduction for the equivalent means of emission limitation to the demonstrated emission reduction for the required work practices and will consider the commitment in paragraph (c)(4) of this section.

(6) The Administrator may condition the approval of equivalence on requirements that may be necessary to assure operation and maintenance to achieve the same emission reduction as the required work practice.

(d) An owner or operator may offer a unique approach to demonstrate the equivalence of any equivalent means of emission limitation.

(e)(1) After a request for determination of equivalence is received, the Administrator will publish a notice in the **Federal Register** and provide the opportunity for public hearing if the Administrator judges that the request may be approved.

(2) After notice and opportunity for public hearing, the Administrator will determine the equivalence of a means of emission limitation and will publish the determination in the **Federal Register**.

(3) Any equivalent means of emission limitations approved under this section shall constitute a required work practice, equipment, design, or operational standard within the meaning of section 111(h)(1) of the CAA.

(f)(1) Manufacturers of equipment used to control equipment leaks of VOC may apply to the Administrator for determination of equivalence for any

equivalent means of emission limitation that achieves a reduction in emissions of VOC achieved by the equipment, design, and operational requirements of this subpart.

(2) The Administrator will make an equivalence determination according to the provisions of paragraphs (b) through (e) of this section.

#### § 60.485b Test methods and procedures.

(a) In conducting the performance tests required in § 60.8, the owner or operator shall use as reference methods and procedures the test methods in appendix A to this part or other methods and procedures as specified in this section, except as provided in § 60.8(b).

(b) The owner or operator shall determine compliance with the standards in §§ 60.482–1b through 60.482–11b, 60.483a, and 60.484b as follows:

(1) Method 21 of appendix A–7 to this part shall be used to determine the presence of leaking sources. The instrument shall be calibrated before use each day of its use by the procedures specified in Method 21. The following calibration gases shall be used:

(i) Zero air (less than 10 ppm of hydrocarbon in air); and

(ii) A mixture of methane or n-hexane and air at a concentration no more than 2,000 ppm greater than the leak definition concentration of the equipment monitored. If the monitoring instrument's design allows for multiple calibration scales, then the lower scale shall be calibrated with a calibration gas that is no higher than 2,000 ppm above the concentration specified as a leak, and the highest scale shall be calibrated with a calibration gas that is approximately equal to 10,000 ppm. If only one scale on an instrument will be used during monitoring, the owner or operator need not calibrate the scales that will not be used during that day's monitoring.

(2) A calibration drift assessment shall be performed, at a minimum, at the end of each monitoring day. Check the instrument using the same calibration gas(es) that were used to calibrate the instrument before use. Follow the procedures specified in Method 21 of appendix A–7 to this part, section 10.1, except do not adjust the meter readout to correspond to the calibration gas value. Record the instrument reading for each scale used as specified in § 60.486b(e)(8). Divide the arithmetic difference of the initial and post-test

calibration response by the corresponding calibration gas value for each scale and multiply by 100 to express the calibration drift as a percentage.

(i) If a calibration drift assessment shows a negative drift of more than 10 percent, then all equipment with instrument readings between the appropriate leak definition and the leak definition multiplied by (100 minus the percent of negative drift/divided by 100) that was monitored since the last calibration must be re-monitored.

(ii) If any calibration drift assessment shows a positive drift of more than 10 percent from the initial calibration value, then, at the owner/operator's discretion, all equipment with instrument readings above the appropriate leak definition and below the leak definition multiplied by (100 plus the percent of positive drift/divided by 100) monitored since the last calibration may be re-monitored.

(c) The owner or operator shall determine compliance with the non-detectable-emission standards in §§ 60.482–2b(e), 60.482–3b(i), 60.482–4b, 60.482–7b(f), and 60.482–10b(e) as follows:

(1) The requirements of paragraph (b) shall apply.

(2) Method 21 of appendix A–7 to this part shall be used to determine the background level. All potential leak interfaces shall be traversed as close to the interface as possible. The arithmetic difference between the maximum concentration indicated by the instrument and the background level is compared with 500 ppm for determining compliance.

(d) The owner or operator shall test each piece of equipment unless they demonstrate that a process unit is not in VOC service, *i.e.*, that the VOC content would never be reasonably expected to exceed 10 percent by weight. For purposes of this demonstration, the following methods and procedures shall be used:

(1) Procedures that conform to the general methods in ASTM E168–16 (Reapproved 2023), E169–16 (Reapproved 2022), or E260–96 (Reapproved 2019) (incorporated by reference, see § 60.17) shall be used to determine the percent VOC content in the process fluid that is contained in or contacts a piece of equipment.

(2) Organic compounds that are considered by the Administrator to have negligible photochemical reactivity may be excluded from the total quantity of

organic compounds in determining the VOC content of the process fluid.

(3) Engineering judgment may be used to estimate the VOC content, if a piece of equipment had not been shown previously to be in service. If the Administrator disagrees with the judgment, paragraphs (d)(1) and (2) of this section shall be used to resolve the disagreement.

(e) The owner or operator shall demonstrate that a piece of equipment is in light liquid service by showing that all the following conditions apply:

(1) The vapor pressure of one or more of the organic components is greater than 0.3 kPa at 20 °C (1.2 in. H<sub>2</sub>O at 68 °F). Standard reference texts or ASTM D2879–23 (incorporated by reference, see § 60.17) shall be used to determine the vapor pressures.

(2) The total concentration of the pure organic components having a vapor pressure greater than 0.3 kPa at 20 °C (1.2 in. H<sub>2</sub>O at 68 °F) is equal to or greater than 20 percent by weight.

(3) The fluid is a liquid at operating conditions.

(f) Samples used in conjunction with paragraphs (d), (e), and (g) of this section shall be representative of the process fluid that is contained in or contacts the equipment or the gas being combusted in the flare.

(g) The owner or operator shall determine compliance with the standards of flares as follows:

(1) Method 22 of appendix A–7 to this part shall be used to determine visible emissions.

(2) A thermocouple or any other equivalent device shall be used to monitor the presence of a pilot flame in the flare.

(3) The maximum permitted velocity for air assisted flares shall be computed using the following equation:

Equation 1 to Paragraph (g)(3)

$$V_{\max} = K_1 + K_2 H_T$$

Where:

$V_{\max}$  = Maximum permitted velocity, m/sec (ft/sec).

$H_T$  = Net heating value of the gas being combusted, MJ/scm (Btu/scf).

$K_1$  = 8.706 m/sec (metric units) = 28.56 ft/sec (English units).

$K_2$  = 0.7084 m<sup>4</sup>/(MJ-sec) (metric units) = 0.087 ft<sup>4</sup>/(Btu-sec) (English units).

(4) The net heating value (HT) of the gas being combusted in a flare shall be computed using the following equation:

Equation 2 to Paragraph (g)(4)

$$H_T = K \sum_{i=1}^n C_i H_i$$

Where:

K = Conversion constant,  $1.740 \times 10^{-7}$  (g-mole)(MJ)/(ppm-scm-kcal) (metric units) =  $4.674 \times 10^{-6}$  [(g-mole)(Btu)/(ppm-scf-kcal)] (English units).

$C_i$  = Concentration of sample component "i," ppm

$H_i$  = net heat of combustion of sample component "i" at 25 °C and 760 mm Hg (77 °F and 14.7 psi), kcal/g-mole.

(5) Method 18 of appendix A-6 to this part and ASTM D1945-14 (Reapproved 2019) (incorporated by reference, see § 60.17) shall be used to determine the concentration of sample component "i." ASTM D6420-18 (incorporated by reference, see § 60.17) may be used in lieu of Method 18, under the conditions specified in paragraphs (g)(5)(i) through (iii) of this section.

(i) If the target compounds are all known and are all listed in Section 1.1 of ASTM D6420-18 as measurable.

(ii) ASTM D6420-18 may not be used for methane and ethane.

(iii) ASTM D6420-18 may not be used as a total VOC method.

(6) ASTM D240-19 or D4809-18 (incorporated by reference, see § 60.17) shall be used to determine the net heat of combustion of component "i" if published values are not available or cannot be calculated.

(7) Method 2, 2A, 2C, or 2D of appendix A-7 to this part, as appropriate, shall be used to determine the actual exit velocity of a flare. If needed, the unobstructed (free) cross-sectional area of the flare tip shall be used.

(h) The owner or operator shall determine compliance with § 60.483-1b or § 60.483-2b as follows:

(1) The percent of valves leaking shall be determined using the following equation:

Equation 3 to Paragraph (h)(1)

$$\%V_L = (V_L/V_T) * 100$$

Where:

$\%V_L$  = Percent leaking valves.

$V_L$  = Number of valves found leaking.

$V_T$  = The sum of the total number of valves monitored.

(2) The total number of valves monitored shall include difficult-to-monitor and unsafe-to-monitor valves only during the monitoring period in which those valves are monitored.

(3) The number of valves leaking shall include valves for which repair has been delayed.

(4) Any new valve that is not monitored within 30 days of being

placed in service shall be included in the number of valves leaking and the total number of valves monitored for the monitoring period in which the valve is placed in service.

(5) If the process unit has been subdivided in accordance with § 60.482-7b(c)(1)(ii), the sum of valves found leaking during a monitoring period includes all subgroups.

(6) The total number of valves monitored does not include a valve monitored to verify repair.

#### § 60.486b Recordkeeping requirements.

(a)(1) Each owner or operator subject to the provisions of this subpart shall comply with the recordkeeping requirements of this section.

(2) An owner or operator of more than one affected facility subject to the provisions of this subpart may comply with the recordkeeping requirements for these facilities in one recordkeeping system if the system identifies each record by each facility.

(3) The owner or operator shall record the information specified in paragraphs (a)(3)(i) through (v) of this section for each monitoring event required by §§ 60.482-2b, 60.482-3b, 60.482-7b, 60.482-8b, 60.482-11b, and 60.483-2b.

(i) Monitoring instrument identification.

(ii) Operator identification.

(iii) Equipment identification.

(iv) Date of monitoring.

(v) Instrument reading.

(b) When each leak is detected as specified in §§ 60.482-2b, 60.482-3b, 60.482-7b, 60.482-8b, 60.482-11b, and 60.483-2b, the following requirements apply:

(1) A weatherproof and readily visible identification, marked with the equipment identification number, shall be attached to the leaking equipment.

(2) The identification on a valve may be removed after it has been monitored for 2 successive months as specified in § 60.482-7b(c) and no leak has been detected during those 2 months.

(3) The identification on a connector may be removed after it has been monitored as specified in § 60.482-11b(b)(3)(iv) and no leak has been detected during that monitoring.

(4) The identification on equipment, except on a valve or connector, may be removed after it has been repaired.

(c) When each leak is detected as specified in §§ 60.482-2b, 60.482-3b, 60.482-7b, 60.482-8b, 60.482-11b, and 60.483-2b, the following information shall be recorded in a log and shall be

kept for 2 years in a readily accessible location:

(1) The instrument and operator identification numbers and the equipment identification number, except when indications of liquids dripping from a pump are designated as a leak.

(2) The date the leak was detected and the dates of each attempt to repair the leak.

(3) Repair methods applied in each attempt to repair the leak.

(4) Maximum instrument reading measured by Method 21 of appendix A-7 of this part at the time the leak is successfully repaired or determined to be nonrepairable, except when a pump is repaired by eliminating indications of liquids dripping.

(5) "Repair delayed" and the reason for the delay if a leak is not repaired within 15 calendar days after discovery of the leak.

(6) The signature of the owner or operator (or designate) whose decision it was that repair could not be effected without a process shutdown.

(7) The expected date of successful repair of the leak if a leak is not repaired within 15 days.

(8) Dates of process unit shutdowns that occur while the equipment is unrepaired.

(9) The date of successful repair of the leak.

(d) The following information pertaining to the design requirements for closed vent systems and control devices described in § 60.482-10b shall be recorded and kept in a readily accessible location:

(1) Detailed schematics, design specifications, and piping and instrumentation diagrams.

(2) The dates and descriptions of any changes in the design specifications.

(3) A description of the parameter or parameters monitored, as required in § 60.482-10b(e), to ensure that control devices are operated and maintained in conformance with their design and an explanation of why that parameter (or parameters) was selected for the monitoring.

(4) Periods when the closed vent systems and control devices required in §§ 60.482-2b, 60.482-3b, 60.482-4b, and 60.482-5b are not operated as designed, including periods when a flare pilot light does not have a flame.

(5) Dates of startups and shutdowns of the closed vent systems and control devices required in §§ 60.482-2b, 60.482-3b, 60.482-4b, and 60.482-5b.



(e) The following information pertaining to all equipment subject to the requirements in §§ 60.482–1b to 60.482–11b shall be recorded in a log that is kept in a readily accessible location:

(1) A list of identification numbers for equipment subject to the requirements of this subpart.

(2)(i) A list of identification numbers for equipment that are designated for no detectable emissions under the provisions of §§ 60.482–2b(e), 60.482–3b(i), and 60.482–7b(f).

(ii) The designation of equipment as subject to the requirements of § 60.482–2b(e), § 60.482–3b(i), or § 60.482–7b(f) shall be signed by the owner or operator. Alternatively, the owner or operator may establish a mechanism with their permitting authority that satisfies this requirement.

(3) A list of equipment identification numbers for pressure relief devices required to comply with § 60.482–4b.

(4)(i) The dates of each compliance test as required in §§ 60.482–2b(e), 60.482–3b(i), 60.482–4b, and 60.482–7b(f).

(ii) The background level measured during each compliance test.

(iii) The maximum instrument reading measured at the equipment during each compliance test.

(5) A list of identification numbers for equipment in vacuum service.

(6) A list of identification numbers for equipment that the owner or operator designates as operating in VOC service less than 300 hr/yr in accordance with § 60.482–1b(e), a description of the conditions under which the equipment is in VOC service, and rationale supporting the designation that it is in VOC service less than 300 hr/yr.

(7) The date and results of the weekly visual inspection for indications of liquids dripping from pumps in light liquid service.

(8) Records of the information specified in paragraphs (e)(8)(i) through (vi) of this section for monitoring instrument calibrations conducted according to sections 8.1.2 and 10 of Method 21 of appendix A–7 of this part and § 60.485b(b).

(i) Date of calibration and initials of operator performing the calibration.

(ii) Calibration gas cylinder identification, certification date, and certified concentration.

(iii) Instrument scale(s) used.

(iv) A description of any corrective action taken if the meter readout could not be adjusted to correspond to the calibration gas value in accordance with section 10.1 of Method 21 of appendix A–7 of this part.

(v) Results of each calibration drift assessment required by § 60.485b(b)(2)

(i.e., instrument reading for calibration at end of monitoring day and the calculated percent difference from the initial calibration value).

(vi) If an owner or operator makes their own calibration gas, a description of the procedure used.

(9) The connector monitoring schedule for each process unit as specified in § 60.482–11b(b)(3)(v).

(10) Records of each release from a pressure relief device subject to § 60.482–4b.

(f) The following information pertaining to all valves subject to the requirements of § 60.482–7b(g) and (h), all pumps subject to the requirements of § 60.482–2b(g), and all connectors subject to the requirements of § 60.482–11b(e) shall be recorded in a log that is kept in a readily accessible location:

(1) A list of identification numbers for valves, pumps, and connectors that are designated as unsafe-to-monitor, an explanation for each valve, pump, or connector stating why the valve, pump, or connector is unsafe-to-monitor, and the plan for monitoring each valve, pump, or connector.

(2) A list of identification numbers for valves that are designated as difficult-to-monitor, an explanation for each valve stating why the valve is difficult-to-monitor, and the schedule for monitoring each valve.

(g) The following information shall be recorded for valves complying with § 60.483–2b:

(1) A schedule of monitoring.

(2) The percent of valves found leaking during each monitoring period.

(h) The following information shall be recorded in a log that is kept in a readily accessible location:

(1) Design criterion required in §§ 60.482–2b(d)(5) and 60.482–3b(e)(2) and explanation of the design criterion; and

(2) Any changes to this criterion and the reasons for the changes.

(i) The following information shall be recorded in a log that is kept in a readily accessible location for use in determining exemptions as provided in § 60.480b(d):

(1) An analysis demonstrating the design capacity of the affected facility,

(2) A statement listing the feed or raw materials and products from the affected facilities and an analysis demonstrating whether these chemicals are heavy liquids or beverage alcohol, and

(3) An analysis demonstrating that equipment is not in VOC service.

(j) Information and data used to demonstrate that a piece of equipment is not in VOC service shall be recorded in a log that is kept in a readily accessible location.

(k) The provisions of § 60.7(b) and (d) do not apply to affected facilities subject to this subpart.

(l) Any records required to be maintained by this subpart that are submitted electronically via the EPA's Compliance and Emissions Data Reporting Interface (CEDRI) may be maintained in electronic format. This ability to maintain electronic copies does not affect the requirement for facilities to make records, data, and reports available upon request to a delegated air agency or the EPA as part of an on-site compliance evaluation.

#### § 60.487b Reporting requirements.

(a) Each owner or operator subject to the provisions of this subpart shall submit semiannual reports to the Administrator beginning 6 months after the initial startup date. Beginning on July 15, 2024, or once the report template for this subpart has been available on the CEDRI website (<https://www.epa.gov/electronic-reporting-air-emissions/cedri>) for 1 year, whichever date is later, submit all subsequent reports using the appropriate electronic report template on the CEDRI website for this subpart and following the procedure specified in paragraph (g) of this section. The date report templates become available will be listed on the CEDRI website. Unless the Administrator or delegated state agency or other authority has approved a different schedule for submission of reports, the report must be submitted by the deadline specified in this subpart, regardless of the method in which the report is submitted. All semiannual reports must include the following general information: company name, address (including county), and beginning and ending dates of the reporting period.

(b) The initial semiannual report to the Administrator shall include the following information:

(1) Process unit identification.

(2) Number of valves subject to the requirements of § 60.482–7b, excluding those valves designated for no detectable emissions under the provisions of § 60.482–7b(f).

(3) Number of pumps subject to the requirements of § 60.482–2b, excluding those pumps designated for no detectable emissions under the provisions of § 60.482–2b(e) and those pumps complying with § 60.482–2b(f).

(4) Number of compressors subject to the requirements of § 60.482–3b, excluding those compressors designated for no detectable emissions under the provisions of § 60.482–3b(i) and those compressors complying with § 60.482–3b(h).

(5) Number of connectors subject to the requirements of § 60.482–11b.

(c) All semiannual reports to the Administrator shall include the following information, summarized from the information in § 60.486b:

(1) Process unit identification.

(2) For each month during the semiannual reporting period,

(i) Number of valves for which leaks were detected as described in § 60.482–7b(b) or § 60.483–2b,

(ii) Number of valves for which leaks were not repaired as required in § 60.482–7b(d)(1),

(iii) Number of pumps for which leaks were detected as described in § 60.482–2b(b), (d)(4)(ii)(A) or (B), or (d)(5)(iii),

(iv) Number of pumps for which leaks were not repaired as required in § 60.482–2b(c)(1) and (d)(6),

(v) Number of compressors for which leaks were detected as described in § 60.482–3b(f),

(vi) Number of compressors for which leaks were not repaired as required in § 60.482–3b(g)(1),

(vii) Number of connectors for which leaks were detected as described in § 60.482–11b(b)

(viii) Number of connectors for which leaks were not repaired as required in § 60.482–11b(d), and

(ix)–(x) [Reserved]

(xi) The facts that explain each delay of repair and, where appropriate, why a process unit shutdown was technically infeasible.

(3) Dates of process unit shutdowns which occurred within the semiannual reporting period.

(4) Revisions to items reported according to paragraph (b) of this section if changes have occurred since the initial report or subsequent revisions to the initial report.

(d) An owner or operator electing to comply with the provisions of §§ 60.483–1b or 60.483–2b shall notify the Administrator of the alternative standard selected 90 days before implementing either of the provisions.

(e) An owner or operator shall report the results of all performance tests in accordance with § 60.8. The provisions of § 60.8(d) do not apply to affected facilities subject to the provisions of this subpart except that an owner or operator must notify the Administrator of the schedule for the initial performance tests at least 30 days before the initial performance tests.

(f) The requirements of paragraphs (a) through (c) of this section remain in force until and unless EPA, in delegating enforcement authority to a state under section 111(c) of the CAA, approves reporting requirements or an alternative means of compliance

surveillance adopted by such state. In that event, affected sources within the state will be relieved of the obligation to comply with the requirements of paragraphs (a) through (c) of this section, provided that they comply with the requirements established by the state. The EPA will not approve a waiver of electronic reporting to the EPA in delegating enforcement authority. Thus, electronic reporting to the EPA cannot be waived, and as such, the provisions of this paragraph cannot be used to relieve owners or operators of affected facilities of the requirement to submit the electronic reports required in this section to the EPA.

(g) If you are required to submit notifications or reports following the procedure specified in this paragraph (g), you must submit notifications or reports to the EPA via CEDRI, which can be accessed through the EPA's Central Data Exchange (CDX) (<https://cdx.epa.gov/>). The EPA will make all the information submitted through CEDRI available to the public without further notice to you. Do not use CEDRI to submit information you claim as CBI. Although we do not expect persons to assert a claim of CBI, if you wish to assert a CBI claim for some of the information in the report or notification, you must submit a complete file in the format specified in this subpart, including information claimed to be CBI, to the EPA following the procedures in paragraphs (g)(1) and (2) of this section. Clearly mark the part or all of the information that you claim to be CBI. Information not marked as CBI may be authorized for public release without prior notice. Information marked as CBI will not be disclosed except in accordance with procedures set forth in 40 CFR part 2. All CBI claims must be asserted at the time of submission. Anything submitted using CEDRI cannot later be claimed CBI. Furthermore, under CAA section 114(c), emissions data is not entitled to confidential treatment, and the EPA is required to make emissions data available to the public. Thus, emissions data will not be protected as CBI and will be made publicly available. You must submit the same file submitted to the CBI office with the CBI omitted to the EPA via the EPA's CDX as described earlier in this paragraph (g).

(1) The preferred method to receive CBI is for it to be transmitted electronically using email attachments, File Transfer Protocol, or other online file sharing services. Electronic submissions must be transmitted directly to the OAQPS CBI Office at the email address [oaqpscbi@epa.gov](mailto:oaqpscbi@epa.gov), and as described above, should include clear

CBI markings. ERT files should be flagged to the attention of the Group Leader, Measurement Policy Group; all other files should be flagged to the attention of the SOCMI NSPS Sector Lead. If assistance is needed with submitting large electronic files that exceed the file size limit for email attachments, and if you do not have your own file sharing service, please email [oaqpscbi@epa.gov](mailto:oaqpscbi@epa.gov) to request a file transfer link.

(2) If you cannot transmit the file electronically, you may send CBI information through the postal service to the following address: OAQPS Document Control Officer (C404–02), OAQPS, U.S. Environmental Protection Agency, 109 T.W. Alexander Drive, P.O. Box 12055, Research Triangle Park, North Carolina 27711. ERT files should be sent to the attention of the Group Leader, Measurement Policy Group, and all other files should be sent to the attention of the SOCMI NSPS Sector Lead. The mailed CBI material should be double wrapped and clearly marked. Any CBI markings should not show through the outer envelope.

(h) If you are required to electronically submit notifications or reports through CEDRI in the EPA's CDX, you may assert a claim of EPA system outage for failure to timely comply with that reporting requirement. To assert a claim of EPA system outage, you must meet the requirements outlined in paragraphs (h)(1) through (7) of this section.

(1) You must have been or will be precluded from accessing CEDRI and submitting a required report within the time prescribed due to an outage of either the EPA's CEDRI or CDX systems.

(2) The outage must have occurred within the period of time beginning five business days prior to the date that the submission is due.

(3) The outage may be planned or unplanned.

(4) You must submit notification to the Administrator in writing as soon as possible following the date you first knew, or through due diligence should have known, that the event may cause or has caused a delay in reporting.

(5) You must provide to the Administrator a written description identifying:

(i) The date(s) and time(s) when CDX or CEDRI was accessed and the system was unavailable;

(ii) A rationale for attributing the delay in reporting beyond the regulatory deadline to EPA system outage;

(iii) A description of measures taken or to be taken to minimize the delay in reporting; and

(iv) The date by which you propose to report, or if you have already met the reporting requirement at the time of the notification, the date you reported.

(6) The decision to accept the claim of EPA system outage and allow an extension to the reporting deadline is solely within the discretion of the Administrator.

(7) In any circumstance, the report must be submitted electronically as soon as possible after the outage is resolved.

(i) If you are required to electronically submit notifications or reports through CEDRI in the EPA's CDX, you may assert a claim of *force majeure* for failure to timely comply with that reporting requirement. To assert a claim of *force majeure*, you must meet the requirements outlined in paragraphs (i)(1) through (5) of this section.

(1) You may submit a claim if a *force majeure* event is about to occur, occurs, or has occurred or there are lingering effects from such an event within the period of time beginning five business days prior to the date the submission is due. For the purposes of this section, a *force majeure* event is defined as an event that will be or has been caused by circumstances beyond the control of the affected facility, its contractors, or any entity controlled by the affected facility that prevents you from complying with the requirement to submit a report electronically within the time period prescribed. Examples of such events are acts of nature (e.g., hurricanes, earthquakes, or floods), acts of war or terrorism, or equipment failure or safety hazard beyond the control of the affected facility (e.g., large scale power outage).

(2) You must submit notification to the Administrator in writing as soon as possible following the date you first knew, or through due diligence should have known, that the event may cause or has caused a delay in reporting.

(3) You must provide to the Administrator:

(i) A written description of the *force majeure* event;

(ii) A rationale for attributing the delay in reporting beyond the regulatory deadline to the *force majeure* event;

(iii) A description of measures taken or to be taken to minimize the delay in reporting; and

(iv) The date by which you propose to report, or if you have already met the reporting requirement at the time of the notification, the date you reported.

(4) The decision to accept the claim of *force majeure* and allow an extension to the reporting deadline is solely within the discretion of the Administrator.

(5) In any circumstance, the reporting must occur as soon as possible after the *force majeure* event occurs.

**§ 60.488b Reconstruction.**

For the purposes of this subpart:

(a) The cost of the following frequently replaced components of the facility shall not be considered in calculating either the "fixed capital cost of the new components" or the "fixed capital costs that would be required to construct a comparable new facility" under § 60.15: Pump seals, nuts and bolts, rupture disks, and packings.

(b) Under § 60.15, the "fixed capital cost of new components" includes the fixed capital cost of all depreciable components (except components specified in § 60.488b(a)) which are or will be replaced pursuant to all continuous programs of component replacement which are commenced within any 2-year period following the applicability date for the appropriate subpart. (See the "Applicability and designation of affected facility" section of the appropriate subpart.) For purposes of this paragraph, "commenced" means that an owner or operator has undertaken a continuous program of component replacement or that an owner or operator has entered into a contractual obligation to undertake and complete, within a reasonable time, a continuous program of component replacement.

**§ 60.489b List of chemicals produced by affected facilities.**

Process units that produce, as intermediates or final products, chemicals listed in § 60.489 are covered under this subpart. The applicability date for process units producing one or more of these chemicals is April 25, 2023.

■ 18. Revise the heading of subpart III to read as follows:

**Subpart III—Standards of Performance for Volatile Organic Compound (VOC) Emissions From the Synthetic Organic Chemical Manufacturing Industry (SOCMI) Air Oxidation Unit Processes After October 21, 1983, and on or Before April 25, 2023**

■ 19. Amend § 60.610 by revising paragraph (b) introductory text and adding paragraph (e) to read as follows:

**§ 60.610 Applicability and designation of affected facility.**

\* \* \* \* \*

(b) The affected facility is any of the following for which construction, modification, or reconstruction

commenced after October 21, 1983, and on or before April 25, 2023:

\* \* \* \* \*

(e) Owners and operators of flares that are subject to the flare related requirements of this subpart and flare related requirements of any other regulation in this part or 40 CFR part 61 or 63, may elect to comply with the requirements in § 60.619a in lieu of all flare related requirements in any other regulation in this part or 40 CFR part 61 or 63.

■ 20. Amend § 60.611 by revising the definition of "Flame zone" to read as follows:

**§ 60.611 Definitions.**

\* \* \* \* \*

*Flame zone* means the portion of the combustion chamber in a boiler or process heater occupied by the flame envelope.

\* \* \* \* \*

■ 21. Amend § 60.613 by revising paragraphs (e)(1)(i), (e)(2)(i), and (e)(3)(i) to read as follows:

**§ 60.613 Monitoring of emissions and operations.**

\* \* \* \* \*

(e) \* \* \*

(1) \* \* \*

(i) A scrubbing liquid temperature monitoring device having an accuracy of ±1 percent of the temperature being monitored expressed in degrees Celsius or 0.5 °C, whichever is greater, and a specific gravity monitoring device having an accuracy of 0.02 specific gravity units, each equipped with a continuous recorder; or

\* \* \* \* \*

(2) \* \* \*

(i) A condenser exit (product side) temperature monitoring device equipped with a continuous recorder and having an accuracy of ±1 percent of the temperature being monitored expressed in degrees Celsius or 0.5 °C, whichever is greater; or

\* \* \* \* \*

(3) \* \* \*

(i) An integrating steam flow monitoring device having an accuracy of 10 percent, and a carbon bed temperature monitoring device having an accuracy of ±1 percent of the temperature being monitored expressed in degrees Celsius or ±0.5 °C, whichever is greater, both equipped with a continuous recorder; or

\* \* \* \* \*

■ 22. Amend § 60.614 by revising paragraphs (b)(4) introductory text and (e) to read as follows:

**§ 60.614 Test methods and procedures.**

\* \* \* \* \*

(b) \* \* \*

(4) Method 18 of appendix A–6 to this part to determine concentration of TOC in the control device outlet and the concentration of TOC in the inlet when the reduction efficiency of the control device is to be determined. ASTM D6420–18 (incorporated by reference, see § 60.17) may be used in lieu of Method 18, if the target compounds are all known and are all listed in Section 1.1 of ASTM D6420–18 as measurable; ASTM D6420–18 may not be used for methane and ethane; and ASTM D6420–18 may not be used as a total VOC method.

\* \* \* \* \*

(e) The following test methods, except as provided under § 60.8(b), shall be used for determining the net heating value of the gas combusted to determine compliance under § 60.612(b) and for determining the process vent stream TRE index value to determine compliance under § 60.612(c).

(1)(i) Method 1 or 1A of appendix A–1 to this part, as appropriate, for selection of the sampling site. The sampling site for the vent stream flow rate and molar composition determination prescribed in

§ 60.614(e)(2) and (3) shall be, except for the situations outlined in paragraph (e)(1)(ii) of this section, prior to the inlet of any control device, prior to any post-reactor dilution of the stream with air, and prior to any post-reactor introduction of halogenated compounds into the vent stream. No transverse site selection method is needed for vents smaller than 10 centimeters (4 inches) in diameter.

(ii) If any gas stream other than the air oxidation vent stream from the affected facility is normally conducted through the final recovery device.

(A) The sampling site for vent stream flow rate and molar composition shall be prior to the final recovery device and prior to the point at which the nonair oxidation stream is introduced.

(B) The efficiency of the final recovery device is determined by measuring the TOC concentration using Method 18 of appendix A–6 to this part, or ASTM D6420–18 (incorporated by reference, see § 60.17) as specified in paragraph (b)(4) of this section, at the inlet to the final recovery device after the introduction of any nonair oxidation vent stream and at the outlet of the final recovery device.

(C) This efficiency is applied to the TOC concentration measured prior to

the final recovery device and prior to the introduction of the nonair oxidation stream to determine the concentration of TOC in the air oxidation stream from the final recovery device. This concentration of TOC is then used to perform the calculations outlined in § 60.614(e)(4) and (5).

(2) The molar composition of the process vent stream shall be determined as follows:

(i) Method 18 of appendix A–6 to this part, or ASTM D6420–18 (incorporated by reference, see § 60.17) as specified in paragraph (b)(4) of this section, to measure the concentration of TOC including those containing halogens.

(ii) D1946–77 or 90 (Reapproved 1994) (incorporation by reference, see § 60.17) to measure the concentration of carbon monoxide and hydrogen.

(iii) Method 4 of appendix A to this part to measure the content of water vapor.

(3) The volumetric flow rate shall be determined using Method 2, 2A, 2C, or 2D of appendix A–1 to this part, as appropriate.

(4) The net heating value of the vent stream shall be calculated using the following equation:

Equation 6 to Paragraph (e)(4)

$$H_T = K_1 \left( \sum_{j=1}^n C_j H_j \right)$$

Where:

$H_T$  = Net heating value of the sample, MJ/scm (Btu/scf), where the net enthalpy per mole of vent stream is based on combustion at 25 °C and 760 mm Hg (77 °F and 30 in. Hg), but the standard temperature for determining the volume corresponding to one mole is 20 °C (68 °F).

$K_1 = 1.74 \times 10^{-7}$  (1/ppm)(g-mole/scm)(MJ/kcal) (metric units), where standard temperature for (g-mole/scm) is 20 °C.

$= 1.03 \times 10^{-11}$  (1/ppm)(lb-mole/scf)(Btu/kcal) (English units) where standard temperature for (lb-mole/scf) is 68 °F.

$C_j$  = Concentration on a wet basis of compound j in ppm, as measured for organics by Method 18 of appendix A–6 to this part, or ASTM D6420–18 (incorporated by reference, see § 60.17) as specified in paragraph (b)(4) of this section, and measured for hydrogen and carbon monoxide by ASTM D1946–77, 90, or 94 (incorporation by reference, see

§ 60.17) as indicated in paragraph (e)(2) of this section.

$H_j$  = Net heat of combustion of compound j, kcal/(g-mole) [kcal/(lb-mole)], based on combustion at 25 °C and 760 mm Hg (77 °F and 30 in. Hg).

(5) The emission rate of TOC in the process vent stream shall be calculated using the following equation:

Equation 7 to Paragraph (e)(5)

$$E_{TOC} = K_2 \left[ \sum_{j=1}^n C_j M_j \right] Q_s$$

Where:

$E_{TOC}$  = Measured emission rate of TOC, kg/hr (lb/hr).

$K_2 = 2.494 \times 10^{-6}$  (1/ppm)(g-mole/scm)(kg/g)(min/hr) (metric units), where standard temperature for (g-mole/scm) is 20 °C.

$= 1.557 \times 10^{-7}$  (1/ppm)(lb-mole/scf)(min/hr) (English units), where standard temperature for (lb-mole/scf) is 68 °F.

$C_j$  = Concentration on a wet basis of compound j in ppm, as measured by

Method 18 of appendix A–6 to this part, or ASTM D6420–18 (incorporated by reference, see § 60.17) as specified in paragraph (b)(4) of this section, as indicated in paragraph (e)(2) of this section.

$M_j$  = Molecular weight of sample j, g/g-mole (lb/lb-mole).

$Q_s$  = Vent stream flow rate, scm/hr (scf/hr), at a temperature of 20 °C (68 °F).

(6) The total process vent stream concentration (by volume) of compounds containing halogens (ppmv, by compound) shall be summed from the individual concentrations of compounds containing halogens which were measured by Method 18 of appendix A–6 to this part, or ASTM D6420–18 (incorporated by reference,

see § 60.17) as specified in paragraph (b)(4) of this section.

\* \* \* \* \*

■ 23. Amend § 60.615 by revising paragraphs (b) introductory text, (j) introductory text, and (k) and adding paragraphs (m), (n), and (o) to read as follows:

**§ 60.615 Reporting and recordkeeping requirements.**

\* \* \* \* \*

(b) Each owner or operator subject to the provisions of this subpart shall keep up-to-date, readily accessible records of the following data measured during each performance test, and also include the following data in the report of the initial performance test required under § 60.8. Where a boiler or process heater with a design heat input capacity of 44 MW (150 million Btu/hour) or greater is used to comply with § 60.612(a), a report containing performance test data need not be submitted, but a report containing the information of § 60.615(b)(2)(i) is required. The same data specified in this section shall be submitted in the reports of all subsequently required performance tests where either the emission control efficiency of a control device, outlet concentration of TOC, or the TRE index value of a vent stream from a recovery system is determined. Beginning on July 15, 2024, owners and operators must submit the performance test report following the procedures specified in paragraph (m) of this section. Data collected using test methods that are supported by the EPA's Electronic Reporting Tool (ERT) as listed on the EPA's ERT website (<https://www.epa.gov/electronic-reporting-air-emissions/electronic-reporting-tool-ert>) at the time of the test must be submitted in a file format generated using the EPA's ERT. Alternatively, the owner or operator may submit an electronic file consistent with the extensible markup language (XML) schema listed on the EPA's ERT website. Data collected using test methods that are not supported by the EPA's ERT as listed on the EPA's ERT website at the time of the test must be included as an attachment in the ERT or an alternate electronic file.

\* \* \* \* \*

(j) Each owner or operator that seeks to comply with the requirements of this subpart by complying with the requirements of § 60.612 shall submit to the Administrator semiannual reports of the following information. The initial report shall be submitted within 6 months after the initial start-up-date. On and after July 15, 2025 or once the report template for this subpart has been

available on the Compliance and Emissions Data Reporting Interface (CEDRI) website (<https://www.epa.gov/electronic-reporting-air-emissions/cedri>) for 1 year, whichever date is later, owners and operators must submit all subsequent reports using the appropriate electronic report template on the CEDRI website for this subpart and following the procedure specified in paragraph (m) of this section. The date report templates become available will be listed on the CEDRI website. Unless the Administrator or delegated state agency or other authority has approved a different schedule for submission of reports, the report must be submitted by the deadline specified in this subpart, regardless of the method in which the report is submitted.

\* \* \* \* \*

(k) The requirements of § 60.615(j) remain in force until and unless EPA, in delegating enforcement authority to a State under section 111(c) of the Act, approves reporting requirements or an alternative means of compliance surveillance adopted by such State. In that event, affected sources within the State will be relieved of the obligation to comply with § 60.615(j), provided that they comply with the requirements established by the State. The EPA will not approve a waiver of electronic reporting to the EPA in delegating enforcement authority. Thus, electronic reporting to the EPA cannot be waived, and as such, the provisions of this paragraph cannot be used to relieve owners or operators of affected facilities of the requirement to submit the electronic reports required in this section to the EPA.

\* \* \* \* \*

(m) If an owner or operator is required to submit notifications or reports following the procedure specified in this paragraph (m), the owner or operator must submit notifications or reports to the EPA via CEDRI, which can be accessed through the EPA's Central Data Exchange (CDX) (<https://cdx.epa.gov/>). The EPA will make all the information submitted through CEDRI available to the public without further notice to the owner or operator. Do not use CEDRI to submit information the owner or operator claims as CBI. Although the EPA does not expect persons to assert a claim of CBI, if an owner or operator wishes to assert a CBI claim for some of the information in the report or notification, the owner or operator must submit a complete file in the format specified in this subpart, including information claimed to be CBI, to the EPA following the procedures in paragraphs (m)(1) and (2)

of this section. Clearly mark the part or all of the information claimed to be CBI. Information not marked as CBI may be authorized for public release without prior notice. Information marked as CBI will not be disclosed except in accordance with procedures set forth in 40 CFR part 2. All CBI claims must be asserted at the time of submission. Anything submitted using CEDRI cannot later be claimed CBI. Furthermore, under CAA section 114(c), emissions data is not entitled to confidential treatment, and the EPA is required to make emissions data available to the public. Thus, emissions data will not be protected as CBI and will be made publicly available. The owner or operator must submit the same file submitted to the CBI office with the CBI omitted to the EPA via the EPA's CDX as described earlier in this paragraph (m).

(1) The preferred method to receive CBI is for it to be transmitted electronically using email attachments, File Transfer Protocol, or other online file sharing services. Electronic submissions must be transmitted directly to the OAQPS CBI Office at the email address [oaqpscbi@epa.gov](mailto:oaqpscbi@epa.gov), and as described above, should include clear CBI markings. ERT files should be flagged to the attention of the Group Leader, Measurement Policy Group; all other files should be flagged to the attention of the SOCMI NSPS Sector Lead. Owners and operators who do not have their own file sharing service and who require assistance with submitting large electronic files that exceed the file size limit for email attachments should email [oaqpscbi@epa.gov](mailto:oaqpscbi@epa.gov) to request a file transfer link.

(2) If an owner or operator cannot transmit the file electronically, the owner or operator may send CBI information through the postal service to the following address: OAQPS Document Control Officer (C404-02), OAQPS, U.S. Environmental Protection Agency, 109 T.W. Alexander Drive, P.O. Box 12055, Research Triangle Park, North Carolina 27711. ERT files should be sent to the attention of the Group Leader, Measurement Policy Group, and all other files should be sent to the attention of the SOCMI NSPS Sector Lead. The mailed CBI material should be double wrapped and clearly marked. Any CBI markings should not show through the outer envelope.

(n) Owners and operators required to electronically submit notifications or reports through CEDRI in the EPA's CDX may assert a claim of EPA system outage for failure to timely comply with the electronic submittal requirement. To assert a claim of EPA system outage,

owners and operators must meet the requirements outlined in paragraphs (n)(1) through (7) of this section.

(1) The owner or operator must have been or will be precluded from accessing CEDRI and submitting a required report within the time prescribed due to an outage of either the EPA's CEDRI or CDX systems.

(2) The outage must have occurred within the period of time beginning five business days prior to the date that the submission is due.

(3) The outage may be planned or unplanned.

(4) The owner or operator must submit notification to the Administrator in writing as soon as possible following the date the owner or operator first knew, or through due diligence should have known, that the event may cause or has caused a delay in reporting.

(5) The owner or operator must provide to the Administrator a written description identifying:

(i) The date(s) and time(s) when CDX or CEDRI was accessed and the system was unavailable;

(ii) A rationale for attributing the delay in reporting beyond the regulatory deadline to EPA system outage;

(iii) A description of measures taken or to be taken to minimize the delay in reporting; and

(iv) The date by which the owner or operator proposes to report, or if the owner or operator has already met the reporting requirement at the time of the notification, the date the report was submitted.

(6) The decision to accept the claim of EPA system outage and allow an extension to the reporting deadline is solely within the discretion of the Administrator.

(7) In any circumstance, the report must be submitted electronically as soon as possible after the outage is resolved.

(o) Owners and operators required to electronically submit notifications or reports through CEDRI in the EPA's CDX, owners and operators may assert a claim of *force majeure* for failure to timely comply with the electronic submittal requirement. To assert a claim of *force majeure*, you must meet the requirements outlined in paragraphs (o)(1) through (5) of this section.

(1) An owner or operator may submit a claim if a *force majeure* event is about to occur, occurs, or has occurred or there are lingering effects from such an event within the period of time beginning five business days prior to the date the submission is due. For the purposes of this section, a *force majeure* event is defined as an event that will be or has been caused by circumstances

beyond the control of the affected facility, its contractors, or any entity controlled by the affected facility that prevents the owner or operator from complying with the requirement to submit a report electronically within the time period prescribed. Examples of such events are acts of nature (e.g., hurricanes, earthquakes, or floods), acts of war or terrorism, or equipment failure or safety hazard beyond the control of the affected facility (e.g., large scale power outage).

(2) The owner or operator must submit notification to the Administrator in writing as soon as possible following the date the owner or operator first knew, or through due diligence should have known, that the event may cause or has caused a delay in reporting.

(3) The owner or operator must provide to the Administrator:

(i) A written description of the *force majeure* event;

(ii) A rationale for attributing the delay in reporting beyond the regulatory deadline to the *force majeure* event;

(iii) A description of measures taken or to be taken to minimize the delay in reporting; and

(iv) The date by which the owner or operator proposes to report, or if the owner or operator has already met the reporting requirement at the time of the notification, the date the report was submitted.

(4) The decision to accept the claim of *force majeure* and allow an extension to the reporting deadline is solely within the discretion of the Administrator.

(5) In any circumstance, the reporting must occur as soon as possible after the *force majeure* event occurs.

■ 24. Amend § 60.618 by revising paragraph (b) to read as follows:

**§ 60.618 Delegation of authority.**

\* \* \* \* \*

(b) Authorities which will not be delegated to States: § 60.613(e) and approval of an alternative to any electronic reporting to the EPA required by this subpart.

■ 25. Add subpart IIIa to read as follows:

**Subpart IIIa—Standards of Performance for Volatile Organic Compound (VOC) Emissions From the Synthetic Organic Chemical Manufacturing Industry (SOCMI) Air Oxidation Unit Processes for Which Construction, Reconstruction, or Modification Commenced After April 25, 2023**

Sec.

60.610a Am I subject to this subpart?

60.611a What definitions must I know?

60.612a What standards and associated requirements must I meet?

60.613a What are my monitoring, installation, operation, and maintenance requirements?

60.614a What test methods and procedures must I use to determine compliance with the standards?

60.615a What records must I keep and what reports must I submit?

60.616a What do the terms associated with reconstruction mean for this subpart?

60.617a What are the chemicals that I must produce to be affected by subpart IIIa?

60.618a [Reserved]

60.619a What are my requirements if I use a flare to comply with this subpart?

60.620a What are my requirements for closed vent systems?

Table 1 to Subpart IIIa of Part 60—Emission Limits and Standards for Vent Streams

Table 2 to Subpart IIIa of Part 60—Monitoring Requirements for Complying With 98 Weight-Percent Reduction of Total Organic Compounds Emissions or a Limit of 20 Parts Per Million by Volume

Table 3 to Subpart IIIa of Part 60—Operating Parameters, Operating Parameter Limits and Data Monitoring, Recordkeeping and Compliance Frequencies

Table 4 to Subpart IIIa of Part 60—Calibration and Quality Control Requirements for Continuous Parameter Monitoring System (CPMS)

**Subpart IIIa—Standards of Performance for Volatile Organic Compound (VOC) Emissions From the Synthetic Organic Chemical Manufacturing Industry (SOCMI) Air Oxidation Unit Processes for Which Construction, Reconstruction, or Modification Commenced After April 25, 2023**

**§ 60.610a Am I subject to this subpart?**

(a) You are subject to this subpart if you operate an affected facility designated in paragraph (b) of this section that produces any of the chemicals listed in § 60.617a as a product, co-product, by-product, or intermediate, except as provided in paragraph (c) of this section.

(b) The affected facility is any of the following for which construction, modification, or reconstruction commenced after April 25, 2023:

(1) Each air oxidation reactor not discharging its vent stream into a recovery system.

(2) Each combination of an air oxidation reactor and the recovery system into which its vent stream is discharged.

(3) Each combination of two or more air oxidation reactors and the common recovery system into which their vent streams are discharged.

(c) Exemptions from the provisions of paragraph (a) of this section are as follows:

(1) Each affected facility operated with a vent stream flow rate less than

0.001 pound per hour (lb/hr) of TOC is exempt from all provisions of this subpart except for the test method and procedure and the recordkeeping and reporting requirements in § 60.614a(e) and § 60.615a(h), (i)(8), and (n).

(2) A vent stream going to a fuel gas system as defined in § 63.611a.

#### § 60.611a What definitions must I know?

As used in this subpart, all terms not defined herein have the meaning given them in the Clean Air Act and subpart A of this part.

*Air Oxidation Reactor* means any device or process vessel in which one or more organic reactants are combined with air, or a combination of air and oxygen, to produce one or more organic compounds. Ammoxidation and oxychlorination reactions are included in this definition.

*Air Oxidation Reactor Recovery Train* means an individual recovery system receiving the vent stream from at least one air oxidation reactor, along with all air oxidation reactors feeding vent streams into this system.

*Air Oxidation Unit Process* means a unit process, including ammoxidation and oxychlorination unit process, that uses air, or a combination of air and oxygen, as an oxygen source in combination with one or more organic reactants to produce one or more organic compounds.

*Boilers* means any enclosed combustion device that extracts useful energy in the form of steam.

*Breakthrough* means the time when the level of TOC, measured at the outlet of the first bed, has been detected is at the highest concentration allowed to be discharged from the adsorber system and indicates that the adsorber bed should be replaced.

*By Compound* means by individual stream components, not carbon equivalents.

*Closed vent system* means a system that is not open to the atmosphere and is composed of piping, ductwork, connections, and, if necessary, flow inducing devices that transport gas or vapor from an emission point to a control device.

*Continuous recorder* means a data recording device recording an instantaneous data value at least once every 15 minutes.

*Flame zone* means the portion of the combustion chamber in a boiler or process heater occupied by the flame envelope.

*Flow indicator* means a device which indicates whether gas flow is present in a vent stream.

*Fuel gas* means gases that are combusted to derive useful work or heat.

*Fuel gas system* means the offsite and onsite piping and flow and pressure control system that gathers gaseous stream(s) generated by onsite operations, may blend them with other sources of gas, and transports the gaseous stream for use as fuel gas in combustion devices or in in-process combustion equipment such as furnaces and gas turbines either singly or in combination.

*Halogenated vent stream* means any vent stream determined to have a total concentration (by volume) of compounds containing halogens of 20 ppmv (by compound) or greater.

*Incinerator* means any enclosed combustion device that is used for destroying organic compounds and does not extract energy in the form of steam or process heat.

*Pressure-assisted multi-point flare* means a flare system consisting of multiple flare burners in staged arrays whereby the vent stream pressure is used to promote mixing and smokeless operation at the flare burner tips. Pressure-assisted multi-point flares are designed for smokeless operation at velocities up to Mach = 1 conditions (*i.e.*, sonic conditions), can be elevated or at ground level, and typically use cross-lighting for flame propagation to combust any flare vent gases sent to a particular stage of flare burners.

*Primary fuel* means the fuel fired through a burner or a number of similar burners. The primary fuel provides the principal heat input to the device, and the amount of fuel is sufficient to sustain operation without the addition of other fuels.

*Process heater* means a device that transfers heat liberated by burning fuel to fluids contained in tubes, including all fluids except water that is heated to produce steam.

*Process unit* means equipment assembled and connected by pipes or ducts to produce, as intermediates or final products, one or more of the chemicals in § 60.617a. A process unit can operate independently if supplied with sufficient fuel or raw materials and sufficient product storage facilities.

*Product* means any compound or chemical listed in § 60.617a that is produced for sale as a final product as that chemical or is produced for use in a process that needs that chemical for the production of other chemicals in another facility. By-products, co-products, and intermediates are considered to be products.

*Recovery device* means an individual unit of equipment, such as an absorber, condenser, and carbon adsorber, capable of and used to recover chemicals for use, reuse, or sale.

*Recovery system* means an individual recovery device or series of such devices applied to the same process stream.

*Relief valve* means a valve used only to release an unplanned, nonroutine discharge. A relief valve discharge results from an operator error, a malfunction such as a power failure or equipment failure, or other unexpected cause that requires immediate venting of gas from process equipment in order to avoid safety hazards or equipment damage.

*Total organic compounds (TOC)* means those compounds measured according to the procedures of Method 18 of appendix A-6 to this part or ASTM D6420-18 (incorporated by reference, see § 60.17) as specified in § 60.614a(b)(4) or the concentration of organic compounds measured according to the procedures in Method 21 or Method 25A of appendix A-7 to this part.

*Vent stream* means any gas stream, containing nitrogen which was introduced as air to the air oxidation reactor, released to the atmosphere directly from any air oxidation reactor recovery train or indirectly, after diversion through other process equipment. The vent stream excludes equipment leaks including, but not limited to, pumps, compressors, and valves.

#### § 60.612a What standards and associated requirements must I meet?

(a) You must comply with the emission limits and standards specified in Table 1 to this subpart and the requirements specified paragraphs (b) and (c) of this section for each vent stream on and after the date on which the initial performance test required by §§ 60.8 and 60.614a is completed, but not later than 60 days after achieving the maximum production rate at which the affected facility will be operated, or 180 days after the initial start-up, whichever date comes first. The standards in this section apply at all times, including periods of startup, shutdown and malfunction. As provided in § 60.11(f), this provision supersedes the exemptions for periods of startup, shutdown and malfunction in the general provisions in subpart A of this part.

(b) The following release events from an affected facility are a violation of the emission limits and standards specified in table 1 to this subpart.

(1) Any relief valve discharge to the atmosphere of a vent stream.

(2) The use of a bypass line at any time on a closed vent system to divert emissions to the atmosphere, or to a control device or recovery device not

meeting the requirements specified in § 60.613a.

(c) You may designate a vent stream as a maintenance vent if the vent is only used as a result of startup, shutdown, maintenance, or inspection of equipment where equipment is emptied, depressurized, degassed, or placed into service. You must comply with the applicable requirements in paragraphs (c)(1) through (3) of this section for each maintenance vent. Any vent stream designated as a maintenance vent is only subject to the maintenance vent provisions in this paragraph (c) and the associated recordkeeping and reporting requirements in § 60.615a(g), respectively.

(1) Prior to venting to the atmosphere, remove process liquids from the equipment as much as practical and depressurize the equipment to either: A flare meeting the requirements of § 60.619a, as applicable, or using any combination of a non-flare control device or recovery device meeting the requirements in Table 1 to this subpart until one of the following conditions, as applicable, is met.

(i) The vapor in the equipment served by the maintenance vent has a lower explosive limit (LEL) of less than 10 percent.

(ii) If there is no ability to measure the LEL of the vapor in the equipment based on the design of the equipment, the pressure in the equipment served by the maintenance vent is reduced to 5 pounds per square inch gauge (psig) or less. Upon opening the maintenance vent, active purging of the equipment cannot be used until the LEL of the vapors in the maintenance vent (or inside the equipment if the maintenance is a hatch or similar type of opening) is less than 10 percent.

(iii) The equipment served by the maintenance vent contains less than 50 pounds of total VOC.

(iv) If, after applying best practices to isolate and purge equipment served by a maintenance vent, none of the applicable criterion in paragraphs (c)(1)(i) through (iii) of this section can be met prior to installing or removing a blind flange or similar equipment blind, then the pressure in the equipment served by the maintenance vent must be reduced to 2 psig or less before installing or removing the equipment blind. During installation or removal of the equipment blind, active purging of the equipment may be used provided the equipment pressure at the location where purge gas is introduced remains at 2 psig or less.

(2) Except for maintenance vents complying with the alternative in paragraph (c)(1)(iii) of this section, you

must determine the LEL or, if applicable, equipment pressure using process instrumentation or portable measurement devices and follow procedures for calibration and maintenance according to manufacturer's specifications.

(3) For maintenance vents complying with the alternative in paragraph (c)(1)(iii) of this section, you must determine mass of VOC in the equipment served by the maintenance vent based on the equipment size and contents after considering any contents drained or purged from the equipment. Equipment size may be determined from equipment design specifications. Equipment contents may be determined using process knowledge.

**§ 60.613a What are my monitoring, installation, operation, and maintenance requirements?**

(a) Except as specified in paragraphs (a)(5) through (7) of this section, if you use a non-flare control device or recovery system to comply with the TOC emission limit specified in Table 1 to this subpart, then you must comply with paragraphs (a)(1) through (4), (b), and (c) of this section.

(1) Install a continuous parameter monitoring system(s) (CPMS) and monitor the operating parameter(s) applicable to the control device or recovery system as specified in Table 2 to this subpart or established according to paragraph (c) of this section.

(2) Establish the applicable minimum, maximum, or range for the operating parameter limit as specified in Table 3 to this subpart or established according to paragraph (c) of this section by calculating the value(s) as the arithmetic average of operating parameter measurements recorded during the three test runs conducted for the most recent performance test. You may operate outside of the established operating parameter limit(s) during subsequent performance tests in order to establish new operating limits. You must include the updated operating limits with the performance test results submitted to the Administrator pursuant to § 60.615a(b). Upon establishment of a new operating limit, you must thereafter operate under the new operating limit. If the Administrator determines that you did not conduct the performance test in accordance with the applicable requirements or that the operating limit established during the performance test does not correspond to the conditions specified in § 60.614a(a), then you must conduct a new performance test and establish a new operating limit.

(3) Monitor, record, and demonstrate continuous compliance using the

minimum frequencies specified in Table 3 to this subpart or established according to paragraph (c) of this section.

(4) Comply with the calibration and quality control requirements as specified in Table 4 to this subpart or established according to paragraph (c) of this section that are applicable to the CPMS used.

(5) Any vent stream introduced with primary fuel into a boiler or process heater is exempt from the requirements specified in paragraphs (a)(1) through (4) of this section.

(6) If you vent emissions through a closed vent system to an adsorber(s) that cannot be regenerated or a regenerative adsorber(s) that is regenerated offsite, then you must install a system of two or more adsorber units in series and comply with the requirements specified in paragraphs (a)(6)(i) through (iii) of this section in addition to the requirements specified in paragraphs (a)(1) through (4) of this section.

(i) Conduct an initial performance test or design evaluation of the adsorber and establish the breakthrough limit and adsorber bed life.

(ii) Monitor the TOC concentration through a sample port at the outlet of the first adsorber bed in series according to the schedule in paragraph (a)(6)(iii)(B) of this section. You must measure the concentration of TOC using either a portable analyzer, in accordance with Method 21 of appendix A-7 of this part using methane, propane, or isobutylene as the calibration gas or Method 25A of appendix A-7 of this part using methane or propane as the calibration gas.

(iii) Comply with paragraph (a)(6)(iii)(A) of this section, and comply with the monitoring frequency according to paragraph (a)(6)(iii)(B) of this section.

(A) The first adsorber in series must be replaced immediately when breakthrough, as defined in § 60.611a, is detected between the first and second adsorber. The original second adsorber (or a fresh canister) will become the new first adsorber and a fresh adsorber will become the second adsorber. For purposes of this paragraph (a)(6)(iii)(A), "immediately" means within 8 hours of the detection of a breakthrough for adsorbers of 55 gallons or less, and within 24 hours of the detection of a breakthrough for adsorbers greater than 55 gallons. You must monitor at the outlet of the first adsorber within 3 days of replacement to confirm it is performing properly.

(B) Based on the adsorber bed life established according to paragraph (a)(6)(i) of this section and the date the



adsorbent was last replaced, conduct monitoring to detect breakthrough at least monthly if the adsorbent has more than 2 months of life remaining, at least weekly if the adsorbent has between 2 months and 2 weeks of life remaining, and at least daily if the adsorbent has 2 weeks or less of life remaining.

(7) If you install a continuous emissions monitoring system (CEMS) to demonstrate compliance with the TOC standard in Table 1 of this subpart, you must comply with the requirements specified in § 60.614a(f) in lieu of the requirements specified in paragraphs (a)(1) through (4) and (c) of this section.

(b) If you vent emissions through a closed vent system to a boiler or process heater, then the vent stream must be introduced into the flame zone of the boiler or process heater.

(c) If you seek to demonstrate compliance with the standards specified under § 60.612a with control devices other than an incinerator, boiler, process heater, or flare; or recovery devices other than an absorber, condenser, or carbon adsorber, you shall provide to the Administrator prior to conducting the initial performance test information describing the operation of the control device or recovery device and the parameter(s) which would indicate proper operation and maintenance of the device and how the parameter(s) are

indicative of control of TOC emissions. The Administrator may request further information and will specify appropriate monitoring procedures or requirements, including operating parameters to be monitored, averaging times for determining compliance with the operating parameter limits, and ongoing calibration and quality control requirements.

**§ 60.614a What test methods and procedures must I use to determine compliance with the standards?**

(a) For the purpose of demonstrating compliance with the emission limits and standards specified in table 1 to this subpart, all affected facilities must be run at full operating conditions and flow rates during any performance test. Performance tests are not required if you determine compliance using a CEMS that meets the requirements outlined in paragraph (f) of this section.

(1) Conduct initial performance tests no later than the date required by § 60.8(a).

(2) Conduct subsequent performance tests no later than 60 calendar months after the previous performance test.

(b) The following methods, except as provided in § 60.8(b) must be used as reference methods to determine compliance with the emission limit or percent reduction efficiency specified in

table 1 to this subpart for non-flare control devices and/or recovery systems.

(1) Method 1 or 1A of appendix A–1 to this part, as appropriate, for selection of the sampling sites. The inlet sampling site for determination of vent stream molar composition or TOC (less methane and ethane) reduction efficiency shall be prior to the inlet of the control device or, if equipped with a recovery system, then prior to the inlet of the first recovery device in the recovery system.

(2) Method 2, 2A, 2C, or 2D of appendix A–1 to this part, as appropriate, for determination of the volumetric flow rates.

(3) Method 3A of appendix A–2 to this part or the manual method in ANSI/ASME PTC 19.10–1981 (incorporated by reference, see § 60.17) must be used to determine the oxygen concentration (%O<sub>2d</sub>) for the purposes of determining compliance with the 20 ppmv limit. The sampling site must be the same as that of the TOC samples and the samples must be taken during the same time that the TOC samples are taken. The TOC concentration corrected to 3 percent O<sub>2</sub> (C<sub>c</sub>) must be computed using the following equation:

Equation 1 to Paragraph (b)(3)

$$C_c = C_{TOC} \frac{17.9}{20.9 - \%O_{2d}}$$

Where:

C<sub>c</sub> = Concentration of TOC corrected to 3 percent O<sub>2</sub>, dry basis, ppm by volume.

C<sub>TOC</sub> = Concentration of TOC (minus methane and ethane), dry basis, ppm by volume.

%O<sub>2d</sub> = Concentration of O<sub>2</sub>, dry basis, percent by volume.

(4) Method 18 of appendix A–6 to this part to determine concentration of TOC in the control device outlet or in the outlet of the final recovery device in a recovery system, and to determine the

concentration of TOC in the inlet when the reduction efficiency of the control device or recovery system is to be determined. ASTM D6420–18 (incorporated by reference, see § 60.17) may be used in lieu of Method 18, if the target compounds are all known and are all listed in Section 1.1 of ASTM D6420–18 as measurable; ASTM D6420–18 must not be used for methane and ethane; and ASTM D6420–18 may not be used as a total VOC method.

(i) The sampling time for each run must be 1 hour in which either an integrated sample or at least four grab samples must be taken. If grab sampling is used then the samples must be taken at 15-minute intervals.

(ii) The emission reduction (R) of TOC (minus methane and ethane) must be determined using the following equation:

Equation 2 to Paragraph (b)(4)(ii)

$$R = \frac{E_i - E_o}{E_i} \times 100$$

Where:

R = Emission reduction, percent by weight.

E<sub>i</sub> = Mass rate of TOC entering the control device or recovery system, kg/hr (lb/hr).

E<sub>o</sub> = Mass rate of TOC discharged to the atmosphere, kg/hr (lb/hr).

(iii) The mass rates of TOC (E<sub>i</sub>, E<sub>o</sub>) must be computed using the following equations:

Equations 3 and 4 to Paragraph (b)(4)(iii)

$$E_i = K_2 \left( \sum_{j=1}^n C_{ij} M_{ij} \right) Q_i$$

$$E_o = K_2 \left( \sum_{j=1}^n C_{oj} M_{oj} \right) Q_o$$

Where:

$C_{ij}$ ,  $C_{oj}$  = Concentration of sample component “j” of the gas stream at the inlet and outlet of the control device or recovery system, respectively, dry basis ppm by volume.

$M_{ij}$ ,  $M_{oj}$  = Molecular weight of sample component “j” of the gas stream at the inlet and outlet of the control device or

recovery system, respectively, g/g-mole (lb/lb-mole).

$Q_i$ ,  $Q_o$  = Flow rate of gas stream at the inlet and outlet of the control device or recovery system, respectively, dscm/min (dscf/min).

$K_2 = 2.494 \times 10^{-6}$  (1/ppm)(g-mole/scm)(kg/g)(min/hr) (metric units), where standard temperature for (g-mole/scm) is 20 °C.

$= 1.557 \times 10^{-7}$  (1/ppm)(lb-mole/scf)(min/hr) (English units), where standard temperature for (lb-mole/scf) is 68 °F.

(iv) The TOC concentration ( $C_{TOC}$ ) is the sum of the individual components and must be computed for each run using the following equation:

Equation 5 to Paragraph (b)(4)(iv)

$$C_{TOC} = \sum_{j=1}^n C_j$$

Where:

$C_{TOC}$  = Concentration of TOC (minus methane and ethane), dry basis, ppm by volume.

$C_j$  = Concentration of sample components in the sample.

$n$  = Number of components in the sample.

(c) The requirement for initial and subsequent performance tests are waived, in accordance with § 60.8(b), for the following:

(1) When a boiler or process heater with a design heat input capacity of 44 MW (150 million Btu/hour) or greater is used to seek compliance with the emission limit or percent reduction efficiency specified in table 1 to this subpart.

(2) When a vent stream is introduced into a boiler or process heater with the primary fuel.

(3) When a boiler or process heater burning hazardous waste is used for which the owner or operator:

(i) Has been issued a final permit under 40 CFR part 270 and complies with the requirements of 40 CFR part 266, subpart H;

(ii) Has certified compliance with the interim status requirements of 40 CFR part 266, subpart H;

(iii) Has submitted a Notification of Compliance under 40 CFR 63.1207(j)

and complies with the requirements of 40 CFR part 63, subpart EEE; or

(iv) Complies with 40 CFR part 63, subpart EEE and will submit a Notification of Compliance under 40 CFR 63.1207(j) by the date the owner or operator would have been required to submit the initial performance test report for this subpart.

(4) The Administrator reserves the option to require testing at such other times as may be required, as provided for in section 114 of the Act.

(d) For purposes of complying with the 98 weight-percent reduction in § 60.612a(a), if the vent stream entering a boiler or process heater with a design capacity less than 44 MW (150 million Btu/hour) is introduced with the combustion air or as secondary fuel, the weight-percent reduction of TOC (minus methane and ethane) across the combustion device shall be determined by comparing the TOC (minus methane and ethane) in all combusted vent streams, primary fuels, and secondary fuels with the TOC (minus methane and ethane) exiting the combustion device.

(e) Any owner or operator subject to the provisions of this subpart seeking to demonstrate compliance with § 60.610a(c)(1) must use the following methods:

(1) Method 1 or 1A of appendix A–1 to this part, as appropriate.

(2) Method 2, 2A, 2C, or 2D of appendix A–1 to this part, as appropriate, for determination of the gas volumetric flow rates.

(3) Method 18 of appendix A–6 to this part to determine the concentration of TOC. ASTM D6420–18 (incorporated by reference, see § 60.17) may be used in lieu of Method 18, if the target compounds are all known and are all listed in Section 1.1 of ASTM D6420–18 as measurable; ASTM D6420–18 may not be used for methane and ethane; and ASTM D6420–18 must not be used as a total VOC method.

(i) The sampling site must be at a location that provides a representative sample of the vent stream.

(ii) Perform three test runs. The sampling time for each run must be 1 hour in which either an integrated sample or at least four grab samples must be taken. If grab sampling is used then the samples must be taken at 15-minute intervals.

(iii) The mass rate of TOC (E) must be computed using the following equation:

Equation 6 to Paragraph (e)(3)(ii)

$$E = K \left( \sum_{j=1}^n C_j M_j \right) Q$$

Where:

$C_j$  = Concentration of sample component “j” of the gas stream at the representative

sampling location, dry basis, ppm by volume.

$M_j$  = Molecular weight of sample component “j” of the gas stream at the representative sampling location, g/g-mole (lb/lb-mole).

Q = Flow rate of gas stream at the representative sampling location, dscm/min (dscf/min).

K =  $2.494 \times 10^{-6}$  (1/ppm)(g-mole/scm) (kg/g) (min/hr) (metric units), where standard temperature for (g-mole/scm) is 20 °C.

=  $1.557 \times 10^{-7}$  (1/ppm) (lb-mole/scf) (min/hr) (English units), where standard temperature for (lb-mole/scf) is 68 °F.

(f) If you use a CEMS to demonstrate initial and continuous compliance with the TOC standard in table 1 of this subpart, each CEMS must be installed, operated and maintained according to the requirements in § 60.13 and paragraphs (f)(1) through (5) of this section.

(1) You must use a CEMS that is capable of measuring the target analyte(s) as demonstrated using either process knowledge of the control device inlet stream or the screening procedures of Method 18 of appendix A–6 to this part on the control device inlet stream. If your CEMS is located after a combustion device and inlet stream to that device includes methanol or formaldehyde, you must use a CEMS which meets the requirements in Performance Specification 9 or 15 of appendix B to this part.

(2) Each CEMS must be installed, operated, and maintained according to the applicable performance specification of appendix B to this part and the applicable quality assurance procedures of appendix F to this part. Locate the sampling probe or other interface at a measurement location such that you obtain representative measurements of emissions from the affected facility.

(3) Conduct a performance evaluation of each CEMS within 180 days of installation of the monitoring system. Conduct subsequent performance evaluations of the CEMS no later than 12 calendar months after the previous performance evaluation. The results each performance evaluation must be submitted in accordance with § 60.615a(b)(1).

(4) You must determine TOC concentration according to one of the following options. The span value of the TOC CEMS must be approximately 2 times the emission standard specified in table 1 of this subpart.

(i) For CEMS meeting the requirements of Performance Specification 15 of appendix B to this part, determine the target analyte(s) for calibration using either process knowledge of the control device inlet stream or the screening procedures of Method 18 of appendix A–6 to this part on the control device inlet stream. The individual analytes used to quantify

TOC must represent 98 percent of the expected mass of TOC present in the stream. Report the results of TOC as equivalent to carbon (C1).

(ii) For CEMS meeting the requirements of Performance Specification 9 of appendix B to this part, determine the target analyte(s) for calibration using either process knowledge of the control device inlet stream or the screening procedures of Method 18 of appendix A–6 to this part on the control device inlet stream. The individual analytes used to quantify TOC must represent 98 percent of the expected mass of TOC present in the stream. Report the results of TOC as equivalent to carbon (C1).

(iii) For CEMS meeting the requirements of Performance Specification 8 of appendix B to this part used to monitor performance of a combustion device, calibrate the instrument on the predominant organic HAP and report the results as carbon (C1), and use Method 25A of appendix A–7 to this part as the reference method for the relative accuracy tests. You must also comply with procedure 1 of appendix F to this part.

(iv) For CEMS meeting the requirements of Performance Specification 8 of appendix B to this part used to monitor performance of a noncombustion device, determine the predominant organic compound using either process knowledge or the screening procedures of Method 18 of appendix A–6 to this part on the control device inlet stream. Calibrate the monitor on the predominant organic compound and report the results as C<sub>1</sub>. Use Method 25A of appendix A–7 to this part as the reference method for the relative accuracy tests. You must also comply with procedure 1 of appendix F to this part.

(5) You must determine stack oxygen concentration at the same location where you monitor TOC concentration with a CEMS that meets the requirements of Performance Specification 3 of appendix B to this part. The span value of the oxygen CEMS must be approximately 25 percent oxygen. Use Method 3A of appendix A–2 to this part as the reference method for the relative accuracy tests.

(6) You must maintain written procedures for your CEMS. At a minimum, the procedures must include the information in paragraphs (f)(6)(i) through (vi) of this section:

(i) Description of CEMS installation location.

(ii) Description of the monitoring equipment, including the manufacturer and model number for all monitoring

equipment components and the span of the analyzer.

(iii) Routine quality control and assurance procedures.

(iv) Conditions that would trigger a CEMS performance evaluation, which must include, at a minimum, a newly installed CEMS; a process change that is expected to affect the performance of the CEMS; and the Administrator's request for a performance evaluation under section 114 of the Clean Air Act.

(v) Ongoing operation and maintenance procedures.

(vi) Ongoing recordkeeping and reporting procedures.

#### **§ 60.615a What records must I keep and what reports must I submit?**

(a) You must notify the Administrator of the specific provisions of table 1 to this subpart or § 60.612a(c) with which you have elected to comply. Notification must be submitted with the notification of initial start-up required by § 60.7(a)(3). If you elect at a later date to use an alternative provision of table 1 to this subpart with which you will comply, then you must notify the Administrator 90 days before implementing a change and, upon implementing the change, you must conduct a performance test as specified by § 60.614a within 180 days.

(b) If you use a non-flare control device or recovery system to comply with the TOC emission limit specified in table 1 to this subpart, then you must keep up-to-date, readily accessible records of the data measured during each performance test to show compliance with the TOC emission limit. You must also include all of the data you use to comply with § 60.613a(a)(2). The same data specified in this paragraph must also be submitted in the initial performance test required in § 60.8 and the reports of all subsequently required performance tests where either the emission reduction efficiency of a control device or recovery system or outlet concentration of TOC is determined. Alternatively, you must keep records of each CEMS performance evaluation.

(1) Within 60 days after the date of completing each performance test or CEMS performance evaluation required by this subpart, you must submit the results of the performance test or performance evaluation following the procedures specified in paragraph (j) of this section. Data collected using test methods and performance evaluations of CEMS measuring relative accuracy test audit (RATA) pollutants supported by the EPA's Electronic Reporting Tool (ERT) as listed on the EPA's ERT website (<https://www.epa.gov/>

*electronic-reporting-air-emissions/electronic-reporting-tool-ert*) at the time of the test or performance evaluation must be submitted in a file format generated through the use of the EPA's ERT. Alternatively, owners and operators may submit an electronic file consistent with the extensible markup language (XML) schema listed on the EPA's ERT website. Data collected using test methods and performance evaluations of CEMS measuring RATA pollutants that are not supported by the EPA's ERT as listed on the EPA's ERT website at the time of the test must be included as an attachment in the ERT or alternate electronic file.

(2) If you use a boiler or process heater with a design heat input capacity of 44 MW (150 million Btu/hour) or greater to comply with the TOC emission limit specified in Table 1 to this subpart, then you are not required to submit a report containing performance test data; however, you must submit a description of the location at which the vent stream is introduced into the boiler or process heater.

(c) If you use a non-flare control device or recovery system to comply with the TOC emission limit specified in table 1 to this subpart, then you must keep up-to-date, readily accessible records of periods of operation during which the operating parameter limits established during the most recent performance test are exceeded or periods of operation where the TOC CEMS, averaged on a 3-hour block basis, indicate an exceedance of the emission standard in table 1 of this subpart. Additionally, you must record all periods when the TOC CEMS is inoperable. The Administrator may at any time require a report of these data. Periods of operation during which the operating parameter limits established during the most recent performance tests are exceeded are defined as follows:

(1) For absorbers:

(i) All 3-hour periods of operation during which the average absorbing liquid temperature was above the maximum absorbing liquid temperature established during the most recent performance test.

(ii) All 3-hour periods of operation during which the average absorbing liquid specific gravity was outside the exit specific gravity range (*i.e.*, more than 0.1 unit above, or more than 0.1 unit below, the average absorbing liquid specific gravity) established during the most recent performance test.

(2) For boilers or process heaters:

(i) Whenever there is a change in the location at which the vent stream is

introduced into the flame zone as required under § 60.613a(b).

(ii) If the boiler or process heater has a design heat input capacity of less than 44 MW (150 million Btu/hr), then all 3-hour periods of operation during which the average firebox temperature was below the minimum firebox temperature during the most recent performance test.

(3) For catalytic incinerators:

(i) All 3-hour periods of operation during which the average temperature of the vent stream immediately before the catalyst bed is below the minimum temperature of the vent stream established during the most recent performance test.

(ii) All 3-hour periods of operation during which the average temperature difference across the catalyst bed is less than the average temperature difference of the device established during the most recent performance test.

(4) For carbon adsorbers:

(i) All carbon bed regeneration cycles during which the total mass stream flow or the total volumetric stream flow was below the minimum flow established during the most recent performance test.

(ii) All carbon bed regeneration cycles during which the temperature of the carbon bed after regeneration (and after completion of any cooling cycle(s)) was greater than the maximum carbon bed temperature (in degrees Celsius) established during the most recent performance test.

(5) For condensers, all 3-hour periods of operation during which the average exit (product side) condenser operating temperature was above the maximum exit (product side) operating temperature established during the most recent performance test.

(6) For scrubbers used to control halogenated vent streams:

(i) All 3-hour periods of operation during which the average pH of the scrubber effluent is below the minimum pH of the scrubber effluent established during the most recent performance test.

(ii) All 3-hour periods of operation during which the average influent liquid flow to the scrubber is below the minimum influent liquid flow to the scrubber established during the most recent performance test.

(iii) All 3-hour periods of operation during which the average liquid-to-gas ratio flow of the scrubber is below the minimum liquid-to-gas ratio of the scrubber established during the most recent performance test.

(7) For thermal incinerators, all 3-hour periods of operation during which the average firebox temperature was below the minimum firebox temperature established during the most recent performance test.

(8) For all other control devices, all periods (for the averaging time specified by the Administrator) when the operating parameter(s) established under § 60.613a(c) exceeded the operating limit established during the most recent performance test.

(d) You must keep up-to-date, readily accessible continuous records of the flow indication specified in Table 2 to this subpart, as well as up-to-date, readily accessible records of all periods when the vent stream is diverted from the control device or recovery device or has no flow rate, including the records as specified in paragraphs (d)(1) and (2) of this section.

(1) For each flow event from a relief valve discharge subject to the requirements in § 60.612a(b)(1), you must include an estimate of the volume of gas, the concentration of TOC in the gas and the resulting emissions of TOC that released to the atmosphere using process knowledge and engineering estimates.

(2) For each flow event from a bypass line subject to the requirements in §§ 60.612a(b)(2) and 60.620a(e), you must maintain records sufficient to determine whether or not the detected flow included flow requiring control. For each flow event from a bypass line requiring control that is released either directly to the atmosphere or to a control device or recovery device not meeting the requirements in this subpart, you must include an estimate of the volume of gas, the concentration of TOC in the gas and the resulting emissions of TOC that bypassed the control device or recovery device using process knowledge and engineering estimates.

(e) If you use a boiler or process heater with a design heat input capacity of 44 MW (150 million Btu/hour) or greater to comply with the TOC emission limit specified in Table 1 to this subpart, then you must keep an up-to-date, readily accessible record of all periods of operation of the boiler or process heater. (Examples of such records could include records of steam use, fuel use, or monitoring data collected pursuant to other State or Federal regulatory requirements).

(f) If you use a flare to comply with the TOC emission standard specified in Table 1 to this subpart, then you must keep up-to-date, readily accessible records of all visible emission readings, heat content determinations, flow rate measurements, and exit velocity determinations made during the initial visible emissions demonstration required by § 63.670(h) of this chapter, as applicable; and all periods during the

compliance determination when the pilot flame or flare flame is absent.

(g) For each maintenance vent opening subject to the requirements of § 60.612a(c), you must keep the applicable records specified in paragraphs (g)(1) through (5) of this section.

(1) You must maintain standard site procedures used to deinventory equipment for safety purposes (e.g., hot work or vessel entry procedures) to document the procedures used to meet the requirements in § 60.612a(c). The current copy of the procedures must be retained and available on-site at all times. Previous versions of the standard site procedures, as applicable, must be retained for five years.

(2) If complying with the requirements of § 60.612a(c)(1)(i), and the lower explosive limit at the time of the vessel opening exceeds 10 percent, identification of the maintenance vent, the process units or equipment associated with the maintenance vent, the date of maintenance vent opening, and the lower explosive limit at the time of the vessel opening.

(3) If complying with the requirements of § 60.612a(c)(1)(ii), and either the vessel pressure at the time of the vessel opening exceeds 5 psig or the lower explosive limit at the time of the active purging was initiated exceeds 10 percent, identification of the maintenance vent, the process units or equipment associated with the maintenance vent, the date of maintenance vent opening, the pressure of the vessel or equipment at the time of discharge to the atmosphere and, if applicable, the lower explosive limit of the vapors in the equipment when active purging was initiated.

(4) If complying with the requirements of § 60.612a(c)(1)(iii), records of the estimating procedures used to determine the total quantity of VOC in the equipment and the type and size limits of equipment that contain less than 50 pounds of VOC at the time of maintenance vent opening. For each maintenance vent opening that contains greater than 50 pounds of VOC for which the deinventory procedures specified in paragraph (g)(1) of this section are not followed or for which the equipment opened exceeds the type and size limits established in the records specified in this paragraph (g)(4), records that identify the maintenance vent, the process units or equipment associated with the maintenance vent, the date of maintenance vent opening, and records used to estimate the total quantity of VOC in the equipment at the time the

maintenance vent was opened to the atmosphere.

(5) If complying with the requirements of § 60.612a(c)(1)(iv), identification of the maintenance vent, the process units or equipment associated with the maintenance vent, records documenting actions taken to comply with other applicable alternatives and why utilization of this alternative was required, the date of maintenance vent opening, the equipment pressure and lower explosive limit of the vapors in the equipment at the time of discharge, an indication of whether active purging was performed and the pressure of the equipment during the installation or removal of the blind if active purging was used, the duration the maintenance vent was open during the blind installation or removal process, and records used to estimate the total quantity of VOC in the equipment at the time the maintenance vent was opened to the atmosphere for each applicable maintenance vent opening.

(h) If you seek to comply with the requirements of this subpart by complying with the flow rate cutoff in § 60.610a(c)(1) you must keep up-to-date, readily accessible records to indicate that the vent stream flow rate is less than 0.001 lb/hr, and of any change in equipment or process operation that increases the operating vent stream flow rate, including a measurement of the new vent stream flow rate.

(i) You must submit to the Administrator semiannual reports of the information specified in paragraphs (i)(1) through (7) of this section. You are exempt from the reporting requirements specified in § 60.7(c). If there are no exceedances, periods, or events specified in paragraphs (i)(1) through (7) of this section that occurred during the reporting period, then you must include a statement in your report that no exceedances, periods, and events specified in paragraphs (i)(1) through (7) of this section occurred during the reporting period. The initial report must be submitted within 6 months after the initial start-up-date. On and after July 15, 2024 or once the report template for this subpart has been available on the Compliance and Emissions Data Reporting Interface (CEDRI) website (<https://www.epa.gov/electronic-reporting-air-emissions/cedri>) for 1 year, whichever date is later, you must submit all subsequent reports using the appropriate electronic report template on the CEDRI website for this subpart and following the procedure specified in paragraph (j) of this section. The date report templates become available will

be listed on the CEDRI website. Unless the Administrator or delegated state agency or other authority has approved a different schedule for submission of reports, the report must be submitted by the deadline specified in this subpart, regardless of the method in which the report is submitted. All semiannual reports must include the following general information: company name, address (including county), and beginning and ending dates of the reporting period.

(1) Exceedances of monitored parameters recorded under paragraph (c) of this section. For each exceedance, the report must include a list of the affected facilities or equipment, the monitored parameter that was exceeded, the start date and time of the exceedance, the duration (in hours) of the exceedance, an estimate of the quantity in pounds of each regulated pollutant emitted over any emission limit, a description of the method used to estimate the emissions, the cause of the exceedance (including unknown cause, if applicable), as applicable, and the corrective action taken.

(2) All periods recorded under paragraph (d) of this section when the vent stream is diverted from the control device or recovery device, or has no flow rate, including the information specified in paragraphs (i)(2)(i) through (iii) of this section.

(i) For periods when the flow indicator is not operating, the identification of the flow indicator and report the start date, start time, and duration in hours.

(ii) For each flow event from a relief valve discharge subject to the requirements in § 60.612a(b)(1), the semiannual report must include the identification of the relief valve, the start date, start time, duration in hours, estimate of the volume of gas in standard cubic feet, the concentration of TOC in the gas in parts per million by volume and the resulting mass emissions of TOC in pounds that released to the atmosphere.

(iii) For each flow event from a bypass line subject to the requirements in § 60.612a(b)(2) and § 620a(e)(2), the semiannual report must include the identification of the bypass line, the start date, start time, duration in hours, estimate of the volume of gas in standard cubic feet, the concentration of TOC in the gas in parts per million by volume and the resulting mass emissions of TOC in pounds that bypass a control device or recovery device.

(3) All periods when a boiler or process heater was not operating (considering the records recorded under paragraph (e) of this section), including

the start date, start time, and duration in hours of each period.

(4) For each flare subject to the requirements in § 60.619a, the semiannual report must include an identification of the flare and the items specified in § 60.619a(l)(2).

(5) For each closed vent system subject to the requirements in § 60.620a, the semiannual report must include an identification of the closed vent system and the items specified in § 60.620a(i).

(6) Exceedances of the emission standard in table 1 to this subpart as indicated by a 3-hour average of the TOC CEMS and recorded under paragraph (c) of this section. For each exceedance, the report must include a list of the affected facilities or equipment, the start date and time of the exceedance, the duration (in hours) of the exceedance, an estimate of the quantity in pounds of each regulated pollutant emitted over the emission limit, a description of the method used to estimate the emissions, the cause of the exceedance (including unknown cause, if applicable), as applicable, and the corrective action taken.

(7) Periods when the TOC CEMS was inoperative. For each period, the report must include a list of the affected facilities or equipment, the start date and time of the period, the duration (in hours) of the period, the cause of the inoperability (including unknown cause, if applicable), as applicable, and the corrective action taken.

(8) Any change in equipment or process operation that increases the operating vent stream flow rate above the low flow exemption level in § 60.610a(c)(1), including a measurement of the new vent stream flow rate, as recorded under paragraph (h) of this section. These must be reported as soon as possible after the change and no later than 180 days after the change. These reports may be submitted either in conjunction with semiannual reports or as a single separate report. A performance test must be completed with the same time period to verify the recalculated flow value. The performance test is subject to the requirements of § 60.8 of the General Provisions and must be submitted according to paragraph (b)(1) of this section. Unless the facility qualifies for an exemption under § 60.610a(c), the facility must begin compliance with the requirements set forth in § 60.612a.

(j) If you are required to submit notifications or reports following the procedure specified in this paragraph (j), you must submit notifications or reports to the EPA via the CEDRI, which can be accessed through the EPA's Central Data Exchange (CDX) ([\[cdx.epa.gov/\]\(https://cdx.epa.gov/\)\). The EPA will make all the information submitted through CEDRI available to the public without further notice to you. Do not use CEDRI to submit information you claim as CBI. Although we do not expect persons to assert a claim of CBI, if you wish to assert a CBI claim for some of the information in the report or notification, you must submit a complete file in the format specified in this subpart, including information claimed to be CBI, to the EPA following the procedures in paragraphs \(j\)\(1\) and \(2\) of this section. Clearly mark the part or all of the information that you claim to be CBI. Information not marked as CBI may be authorized for public release without prior notice. Information marked as CBI will not be disclosed except in accordance with procedures set forth in 40 CFR part 2. All CBI claims must be asserted at the time of submission. Anything submitted using CEDRI cannot later be claimed CBI. Furthermore, under CAA section 114\(c\), emissions data is not entitled to confidential treatment, and the EPA is required to make emissions data available to the public. Thus, emissions data will not be protected as CBI and will be made publicly available. You must submit the same file submitted to the CBI office with the CBI omitted to the EPA via the EPA's CDX as described earlier in this paragraph \(j\).](https://</a></p></div><div data-bbox=)

(1) The preferred method to receive CBI is for it to be transmitted electronically using email attachments, File Transfer Protocol, or other online file sharing services. Electronic submissions must be transmitted directly to the OAQPS CBI Office at the email address [oaqpscbi@epa.gov](mailto:oaqpscbi@epa.gov), and as described above, should include clear CBI markings. ERT files should be flagged to the attention of the Group Leader, Measurement Policy Group; all other files should be flagged to the attention of the SOCOMI NSPS Sector Lead. If assistance is needed with submitting large electronic files that exceed the file size limit for email attachments, and if you do not have your own file sharing service, please email [oaqpscbi@epa.gov](mailto:oaqpscbi@epa.gov) to request a file transfer link.

(2) If you cannot transmit the file electronically, you may send CBI information through the postal service to the following address: OAQPS Document Control Officer (C404-02), OAQPS, U.S. Environmental Protection Agency, 109 T.W. Alexander Drive, P.O. Box 12055, Research Triangle Park, North Carolina 27711. ERT files should be sent to the attention of the Group Leader, Measurement Policy Group, and all other files should be sent to the

attention of the SOCOMI NSPS Sector Lead. The mailed CBI material should be double wrapped and clearly marked. Any CBI markings should not show through the outer envelope.

(k) If you are required to electronically submit notifications or reports through CEDRI in the EPA's CDX, you may assert a claim of EPA system outage for failure to timely comply with the electronic submittal requirement. To assert a claim of EPA system outage, you must meet the requirements outlined in paragraphs (k)(1) through (7) of this section.

(1) You must have been or will be precluded from accessing CEDRI and submitting a required report within the time prescribed due to an outage of either the EPA's CEDRI or CDX systems.

(2) The outage must have occurred within the period of time beginning five business days prior to the date that the submission is due.

(3) The outage may be planned or unplanned.

(4) You must submit notification to the Administrator in writing as soon as possible following the date you first knew, or through due diligence should have known, that the event may cause or has caused a delay in reporting.

(5) You must provide to the Administrator a written description identifying:

(i) The date(s) and time(s) when CDX or CEDRI was accessed and the system was unavailable;

(ii) A rationale for attributing the delay in reporting beyond the regulatory deadline to EPA system outage;

(iii) A description of measures taken or to be taken to minimize the delay in reporting; and

(iv) The date by which you propose to report, or if you have already met the reporting requirement at the time of the notification, the date you reported.

(6) The decision to accept the claim of EPA system outage and allow an extension to the reporting deadline is solely within the discretion of the Administrator.

(7) In any circumstance, the report must be submitted electronically as soon as possible after the outage is resolved.

(l) If you are required to electronically submit notifications or reports through CEDRI in the EPA's CDX, you may assert a claim of *force majeure* for failure to timely comply with the electronic submittal requirement. To assert a claim of *force majeure*, you must meet the requirements outlined in paragraphs (l)(1) through (5) of this section.

(1) You may submit a claim if a *force majeure* event is about to occur, occurs,

or has occurred or there are lingering effects from such an event within the period of time beginning five business days prior to the date the submission is due. For the purposes of this section, a *force majeure* event is defined as an event that will be or has been caused by circumstances beyond the control of the affected facility, its contractors, or any entity controlled by the affected facility that prevents you from complying with the requirement to submit a report electronically within the time period prescribed. Examples of such events are acts of nature (e.g., hurricanes, earthquakes, or floods), acts of war or terrorism, or equipment failure or safety hazard beyond the control of the affected facility (e.g., large scale power outage).

(2) You must submit notification to the Administrator in writing as soon as possible following the date you first knew, or through due diligence should have known, that the event may cause or has caused a delay in reporting.

(3) You must provide to the Administrator:

- (i) A written description of the *force majeure* event;
- (ii) A rationale for attributing the delay in reporting beyond the regulatory deadline to the *force majeure* event;
- (iii) A description of measures taken or to be taken to minimize the delay in reporting; and
- (iv) The date by which you propose to report, or if you have already met the reporting requirement at the time of the notification, the date you reported.

(4) The decision to accept the claim of *force majeure* and allow an extension to the reporting deadline is solely within the discretion of the Administrator.

(5) In any circumstance, the reporting must occur as soon as possible after the *force majeure* event occurs.

(m) The requirements of paragraph (i) of this section remain in force until and unless EPA, in delegating enforcement authority to a State under section 111(c) of the Act, approves reporting requirements or an alternative means of compliance surveillance adopted by such State. In that event, affected sources within the State will be relieved of the obligation to comply with paragraph (i) of this section, provided that they comply with the requirements established by the State. The EPA will not approve a waiver of electronic reporting to the EPA in delegating enforcement authority. Thus, electronic reporting to the EPA cannot be waived, and as such, the provisions of this paragraph cannot be used to relieve owners or operators of affected facilities of the requirement to submit the

electronic reports required in this section to the EPA.

(n) If you seek to demonstrate compliance with § 60.610(c)(1), then you must submit to the Administrator, following the procedures in paragraph (b)(1) of this section, an initial report including a flow rate measurement using the test methods specified in § 60.614a.

(o) The Administrator will specify appropriate reporting and recordkeeping requirements where the owner or operator of an affected facility seeks to demonstrate compliance with the standards specified under § 60.612a other than as provided under § 60.613a.

(p) Any records required to be maintained by this subpart that are submitted electronically via the EPA's CEDRI may be maintained in electronic format. This ability to maintain electronic copies does not affect the requirement for facilities to make records, data, and reports available upon request to a delegated air agency or the EPA as part of an on-site compliance evaluation.

**§ 60.616a What do the terms associated with reconstruction mean for this subpart?**

For purposes of this subpart "fixed capital cost of the new components," as used in § 60.15, includes the fixed capital cost of all depreciable components which are or will be replaced pursuant to all continuous programs of component replacement which are commenced within any 2-year period following April 25, 2023. For purposes of this section, "commenced" means that you have undertaken a continuous program of component replacement or that you have entered into a contractual obligation to undertake and complete, within a reasonable time, a continuous program of component replacement.

**§ 60.617a What are the chemicals that I must produce to be affected by subpart IIIa?**

Chemical name	CAS No.*
Acetaldehyde .....	75-07-0
Acetic acid .....	64-19-7
Acetone .....	67-64-1
Acetonitrile .....	75-05-8
Acetophenone .....	98-86-2
Acrolein .....	107-02-8
Acrylic acid .....	79-10-7
Acrylonitrile .....	107-13-1
Anthraquinone .....	84-65-1
Benzaldehyde .....	100-52-7
Benzoic acid, tech .....	65-85-0
1,3-Butadiene .....	106-99-0
p-t-Butyl benzoic acid .....	98-73-7
N-Butyric acid .....	107-92-6
Crotonic acid .....	3724-65-0
Cumene hydroperoxide .....	80-15-9

Chemical name	CAS No.*
Cyclohexanol .....	108-93-0
Cyclohexanone .....	108-94-1
Dimethyl terephthalate .....	120-61-6
Ethylene dichloride .....	107-06-2
Ethylene oxide .....	75-21-8
Formaldehyde .....	50-00-0
Formic acid .....	64-18-6
Glyoxal .....	107-22-2
Hydrogen cyanide .....	74-90-8
Isobutyric acid .....	79-31-2
Isophthalic acid .....	121-91-5
Maleic anhydride .....	108-31-6
Methyl ethyl ketone .....	78-93-3
a-Methyl styrene .....	98-83-9
Phenol .....	108-95-2
Phthalic anhydride .....	85-44-9
Propionic acid .....	79-09-4
Propylene oxide .....	75-56-9
Styrene .....	100-42-5
Terephthalic acid .....	100-21-0

\*CAS numbers refer to the Chemical Abstracts Registry numbers assigned to specific chemicals, isomers, or mixtures of chemicals. Some isomers or mixtures that are covered by the standards do not have CAS numbers assigned to them. The standards apply to all of the chemicals listed, whether CAS numbers have been assigned or not.

**§ 60.618a [Reserved]**

**§ 60.619a What are my requirements if I use a flare to comply with this subpart?**

(a) If you use a flare to comply with the TOC emission standard specified in Table 1 to this subpart, then you must meet the applicable requirements for flares as specified in §§ 63.670 and 63.671 of this chapter, including the provisions in tables 12 and 13 to part 63, subpart CC, of this chapter, except as specified in paragraphs (b) through (o) of this section. This requirement also applies to any flare using fuel gas from a fuel gas system, of which 50 percent or more of the fuel gas is derived from an affected facility, as determined on an annual average basis. For purposes of compliance with this paragraph (a), the following terms are defined in § 63.641 of this chapter: Assist air, assist steam, center steam, combustion zone, combustion zone gas, flare, flare purge gas, flare supplemental gas, flare sweep gas, flare vent gas, lower steam, net heating value, perimeter assist air, pilot gas, premix assist air, total steam, and upper steam.

(b) When determining compliance with the pilot flame requirements specified in § 63.670(b) and (g) of this chapter, substitute "pilot flame or flare flame" for each occurrence of "pilot flame."

(c) When determining compliance with the flare tip velocity and combustion zone operating limits specified in § 63.670(d) and (e) of this chapter, the requirement effectively applies starting with the 15-minute

block that includes a full 15 minutes of the flaring event. You are required to demonstrate compliance with the velocity and NHVcz requirements starting with the block that contains the fifteenth minute of a flaring event. You are not required to demonstrate compliance for the previous 15-minute block in which the event started and contained only a fraction of flow.

(d) Instead of complying with § 63.670(o)(2)(i) of this chapter, you must develop and implement the flare management plan no later than startup for a new flare that commenced construction on or after April 25, 2023.

(e) Instead of complying with § 63.670(o)(2)(iii) of this chapter, if required to develop a flare management plan and submit it to the Administrator, then you must also submit all versions of the plan in portable document format (PDF) following the procedures specified in § 60.615a(j).

(f) Section 63.670(o)(3)(ii) of this chapter and all references to it do not apply. Instead, you must comply with the maximum flare tip velocity operating limit at all times.

(g) Substitute “affected facility” for each occurrence of “petroleum refinery.”

(h) Each occurrence of “refinery” does not apply.

(i) If a pressure-assisted multi-point flare is used as a control device, then you must meet the following conditions:

(1) You are not required to comply with the flare tip velocity requirements in of § 63.670(d) and (k) of this chapter;

(2) The NHVcz for pressure-assisted multi-point flares is 800 Btu/scf;

(3) You must determine the 15-minute block average NHVvg using only the direct calculation method specified in § 63.670 (l)(5)(ii) of this chapter;

(4) Instead of complying with § 63.670(b) and (g) of this chapter, if a pressure-assisted multi-point flare uses cross-lighting on a stage of burners rather than having an individual pilot flame on each burner, then you must operate each stage of the pressure-assisted multi-point flare with a flame present at all times when regulated material is routed to that stage of burners. Each stage of burners that cross-lights in the pressure-assisted multi-point flare must have at least two pilots with at least one continuously lit and capable of igniting all regulated material that is routed to that stage of burners. Each 15-minute block during which there is at least one minute where no pilot flame is present on a stage of burners when regulated material is routed to the flare is a deviation of the

standard. Deviations in different 15-minute blocks from the same event are considered separate deviations. The pilot flame(s) on each stage of burners that use cross-lighting must be continuously monitored by a thermocouple or any other equivalent device used to detect the presence of a flame;

(5) Unless you choose to conduct a cross-light performance demonstration as specified in this paragraph (i)(5), you must ensure that if a stage of burners on the flare uses cross-lighting, that the distance between any two burners in series on that stage is no more than 6 feet when measured from the center of one burner to the next burner. A distance greater than 6 feet between any two burners in series may be used provided you conduct a performance demonstration that confirms the pressure-assisted multi-point flare will cross-light a minimum of three burners and the spacing between the burners and location of the pilot flame must be representative of the projected installation. The compliance demonstration must be approved by the permitting authority and a copy of this approval must be maintained onsite. The compliance demonstration report must include: a protocol describing the test methodology used, associated test method QA/QC parameters, the waste gas composition and NHVcz of the gas tested, the velocity of the waste gas tested, the pressure-assisted multi-point flare burner tip pressure, the time, length, and duration of the test, records of whether a successful cross-light was observed over all of the burners and the length of time it took for the burners to cross-light, records of maintaining a stable flame after a successful cross-light and the duration for which this was observed, records of any smoking events during the cross-light, waste gas temperature, meteorological conditions (e.g., ambient temperature, barometric pressure, wind speed and direction, and relative humidity), and whether there were any observed flare flameouts; and

(6) You must install and operate pressure monitor(s) on the main flare header, as well as a valve position indicator monitoring system for each staging valve to ensure that the flare operates within the proper range of conditions as specified by the manufacturer. The pressure monitor must meet the requirements in table 13 to part 63, subpart CC of this chapter.

(7) If a pressure-assisted multi-point flare is operating under the requirements of an approved alternative means of emission limitations, you must

either continue to comply with the terms of the alternative means of emission limitations or comply with the provisions in paragraphs (i)(1) through (6) of this section.

(j) If you choose to determine compositional analysis for net heating value with a continuous process mass spectrometer, then you must comply with the requirements specified in paragraphs (j)(1) through (7) of this section.

(1) You must meet the requirements in § 63.671(e)(2) of this chapter. You may augment the minimum list of calibration gas components found in § 63.671(e)(2) with compounds found during a pre-survey or known to be in the gas through process knowledge.

(2) Calibration gas cylinders must be certified to an accuracy of 2 percent and traceable to National Institute of Standards and Technology (NIST) standards.

(3) For unknown gas components that have similar analytical mass fragments to calibration compounds, you may report the unknowns as an increase in the overlapped calibration gas compound. For unknown compounds that produce mass fragments that do not overlap calibration compounds, you may use the response factor for the nearest molecular weight hydrocarbon in the calibration mix to quantify the unknown component's NHVvg.

(4) You may use the response factor for n-pentane to quantify any unknown components detected with a higher molecular weight than n-pentane.

(5) You must perform an initial calibration to identify mass fragment overlap and response factors for the target compounds.

(6) You must meet applicable requirements in Performance Specification 9 of appendix B of this part, for continuous monitoring system acceptance including, but not limited to, performing an initial multi-point calibration check at three concentrations following the procedure in section 10.1 and performing the periodic calibration requirements listed for gas chromatographs in table 13 to part 63, subpart CC of this chapter, for the process mass spectrometer. You may use the alternative sampling line temperature allowed under Net Heating Value by Gas Chromatograph in table 13 to part 63, subpart CC.

(7) The average instrument calibration error (CE) for each calibration compound at any calibration concentration must not differ by more than 10 percent from the certified cylinder gas value. The CE for each



component in the calibration blend

must be calculated using equation 1 to this paragraph (j)(7).

Equation 1 to Paragraph (j)(7)

$$CE = \frac{C_m - C_a}{C_a} \times 100 \text{ (Eq. 1)}$$

Where:

$C_m$  = Average instrument response (ppm)

$C_a$  = Certified cylinder gas value (ppm)

(k) If you use a gas chromatograph or mass spectrometer for compositional analysis for net heating value, then you

may choose to use the CE of  $NHV_{measured}$  versus the cylinder tag value  $NHV_a$  as the measure of agreement for daily calibration and quarterly audits in lieu of determining the compound-specific CE. The CE for  $NHV$  at any calibration

level must not differ by more than 10 percent from the certified cylinder gas value. The CE must be calculated using equation 2 to this paragraph (k).

Equation 2 to Paragraph (k)

$$CE = \frac{NHV_{measured} - NHV_a}{NHV_a} \times 100 \text{ (Eq. 2)}$$

Where:

$NHV_{measured}$  = Average instrument response (Btu/scf)

$NHV_a$  = Certified cylinder gas value (Btu/scf)

(l) Instead of complying with § 63.670(q) of this chapter, you must comply with the reporting requirements specified in paragraphs (l)(1) and (2) of this section.

(1) The notification requirements specified in § 60.615a(a).

(2) The semiannual report specified in § 60.615a(i)(4) must include the items specified in paragraphs (l)(2)(i) through (vi) of this section.

(i) Records as specified in paragraph (m)(1) of this section for each 15-minute block during which there was at least one minute when regulated material is routed to a flare and no pilot flame or flare flame is present. Include the start and stop time and date of each 15-minute block.

(ii) Visible emission records as specified in paragraph (m)(2)(iv) of this section for each period of 2 consecutive hours during which visible emissions exceeded a total of 5 minutes.

(iii) The periods specified in paragraph (m)(6) of this section. Indicate the date and start and end times for each period, and the net heating value operating parameter(s) determined following the methods in § 63.670(k) through (n) of part 63, subpart CC of this chapter as applicable.

(iv) For flaring events meeting the criteria in § 63.670(o)(3) of this chapter and paragraph (f) of this section:

(A) The start and stop time and date of the flaring event.

(B) The length of time in minutes for which emissions were visible from the flare during the event.

(C) For steam-assisted, air-assisted, and non-assisted flares, the start date, start time, and duration in minutes for periods of time that the flare tip velocity exceeds the maximum flare tip velocity

determined using the methods in § 63.670(d)(2) of this chapter and the maximum 15-minute block average flare tip velocity in ft/sec recorded during the event.

(D) Results of the root cause and corrective actions analysis completed during the reporting period, including the corrective actions implemented during the reporting period and, if applicable, the implementation schedule for planned corrective actions to be implemented subsequent to the reporting period.

(v) For pressure-assisted multi-point flares, the periods of time when the pressure monitor(s) on the main flare header show the burners operating outside the range of the manufacturer's specifications. Indicate the date and start and end times for each period.

(vi) For pressure-assisted multi-point flares, the periods of time when the staging valve position indicator monitoring system indicates a stage should not be in operation and is or when a stage should be in operation and is not. Indicate the date and start and end times for each period.

(m) Instead of complying with § 63.670(p) of this chapter, you must keep the flare monitoring records specified in paragraphs (m)(1) through (14) of this section.

(1) Retain records of the output of the monitoring device used to detect the presence of a pilot flame or flare flame as required in § 63.670(b) of this chapter and the presence of a pilot flame as required in paragraph (i)(4) of this section for a minimum of 2 years. Retain records of each 15-minute block during which there was at least one minute that no pilot flame or flare flame is present when regulated material is routed to a flare for a minimum of 5 years. For a pressure-assisted multi-point flare that uses cross-lighting, retain records of each 15-minute block during which

there was at least one minute that no pilot flame is present on each stage when regulated material is routed to a flare for a minimum of 5 years. You may reduce the collected minute-by-minute data to a 15-minute block basis with an indication of whether there was at least one minute where no pilot flame or flare flame was present.

(2) Retain records of daily visible emissions observations as specified in paragraphs (m)(2)(i) through (iv) of this section, as applicable, for a minimum of 3 years.

(i) To determine when visible emissions observations are required, the record must identify all periods when regulated material is vented to the flare.

(ii) If visible emissions observations are performed using Method 22 of appendix A-7 of this part, then the record must identify whether the visible emissions observation was performed, the results of each observation, total duration of observed visible emissions, and whether it was a 5-minute or 2-hour observation. Record the date and start time of each visible emissions observation.

(iii) If a video surveillance camera is used pursuant to § 63.670(h)(2) of this chapter, then the record must include all video surveillance images recorded, with time and date stamps.

(iv) For each 2-hour period for which visible emissions are observed for more than 5 minutes in 2 consecutive hours, then the record must include the date and start and end time of the 2-hour period and an estimate of the cumulative number of minutes in the 2 hour period for which emissions were visible.

(3) The 15-minute block average cumulative flows for flare vent gas and, if applicable, total steam, perimeter assist air, and pre-mix assist air specified to be monitored under § 63.670(i) of this chapter, along with the date and time

interval for the 15-minute block. If multiple monitoring locations are used to determine cumulative vent gas flow, total steam, perimeter assist air, and premix assist air, then retain records of the 15-minute block average flows for each monitoring location for a minimum of 2 years and retain the 15-minute block average cumulative flows that are used in subsequent calculations for a minimum of 5 years. If pressure and temperature monitoring is used, then retain records of the 15-minute block average temperature, pressure, and molecular weight of the flare vent gas or assist gas stream for each measurement location used to determine the 15-minute block average cumulative flows for a minimum of 2 years, and retain the 15-minute block average cumulative flows that are used in subsequent calculations for a minimum of 5 years.

(4) The flare vent gas compositions specified to be monitored under § 63.670(j) of this chapter. Retain records of individual component concentrations from each compositional analysis for a minimum of 2 years. If an NHVvg analyzer is used, retain records of the 15-minute block average values for a minimum of 5 years.

(5) Each 15-minute block average operating parameter calculated following the methods specified in § 63.670(k) through (n) of this chapter, as applicable.

(6) All periods during which operating values are outside of the applicable operating limits specified in § 63.670(d) through (f) of this chapter and paragraph (i) of this section when regulated material is being routed to the flare.

(7) All periods during which you do not perform flare monitoring according to the procedures in § 63.670(g) through (j) of this chapter.

(8) For pressure-assisted multi-point flares, if a stage of burners on the flare uses cross-lighting, then a record of any changes made to the distance between burners.

(9) For pressure-assisted multi-point flares, all periods when the pressure monitor(s) on the main flare header show burners are operating outside the range of the manufacturer's specifications. Indicate the date and time for each period, the pressure measurement, the stage(s) and number of burners affected, and the range of manufacturer's specifications.

(10) For pressure-assisted multi-point flares, all periods when the staging valve position indicator monitoring system indicates a stage of the pressure-assisted multi-point flare should not be in operation and when a stage of the pressure-assisted multi-point flare

should be in operation and is not. Indicate the date and time for each period, whether the stage was supposed to be open, but was closed or vice versa, and the stage(s) and number of burners affected.

(11) Records of periods when there is flow of vent gas to the flare, but when there is no flow of regulated material to the flare, including the start and stop time and dates of periods of no regulated material flow.

(12) Records when the flow of vent gas exceeds the smokeless capacity of the flare, including start and stop time and dates of the flaring event.

(13) Records of the root cause analysis and corrective action analysis conducted as required in § 63.670(o)(3) of this chapter and paragraph (f) of this section, including an identification of the affected flare, the date and duration of the event, a statement noting whether the event resulted from the same root cause(s) identified in a previous analysis and either a description of the recommended corrective action(s) or an explanation of why corrective action is not necessary under § 63.670(o)(5)(i) of this chapter.

(14) For any corrective action analysis for which implementation of corrective actions are required in § 63.670(o)(5) of this chapter, a description of the corrective action(s) completed within the first 45 days following the discharge and, for action(s) not already completed, a schedule for implementation, including proposed commencement and completion dates.

(n) You may elect to comply with the alternative means of emissions limitation requirements specified in paragraph (r) of § 63.670 of this chapter in lieu of the requirements in § 63.670(d) through (f) of this chapter, as applicable. However, instead of complying with § 63.670(r)(3)(iii) of this chapter, you must also submit the alternative means of emissions limitation request to the following address: U.S. Environmental Protection Agency, Office of Air Quality Planning and Standards, Sector Policies and Programs Division, U.S. EPA Mailroom (C404-02), Attention: SOCM1 NSPS Sector Lead, 4930 Old Page Rd., Durham, NC 27703.

(o) The referenced provisions specified in paragraphs (o)(1) through (4) of this section do not apply when demonstrating compliance with this section.

(1) Section 63.670(o)(4)(iv) of this chapter.

(2) The last sentence of § 63.670(o)(6) of this chapter.

(3) The phrase "that were not caused by a *force majeure* event" in § 63.670(o)(7)(ii) of this chapter.

(4) The phrase "that were not caused by a *force majeure* event" in § 63.670(o)(7)(iv) of this chapter.

#### **§ 60.620a What are my requirements for closed vent systems?**

(a) Except as provided in paragraphs (f) and (g) of this section, you must inspect each closed vent system according to the procedures and schedule specified in paragraphs (a)(1) through (3) of this section.

(1) Conduct an initial inspection according to the procedures in paragraph (b) of this section unless the closed vent system is operated and maintained under negative pressure,

(2) Conduct annual inspections according to the procedures in paragraph (b) of this section unless the closed vent system is operated and maintained under negative pressure, and

(3) Conduct annual inspections for visible, audible, or olfactory indications of leaks.

(b) You must inspect each closed vent system according to the procedures specified in paragraphs (b)(1) through (6) of this section.

(1) Inspections must be conducted in accordance with Method 21 of appendix A of this part.

(2)(i) Except as provided in paragraph (b)(2)(ii) of this section, the detection instrument must meet the performance criteria of Method 21 of appendix A of this part, except the instrument response factor criteria in section 3.1.2(a) of Method 21 must be for the average composition of the process fluid not each individual volatile organic compound in the stream. For process streams that contain nitrogen, air, or other inerts which are not organic hazardous air pollutants or volatile organic compounds, the average stream response factor must be calculated on an inert-free basis.

(ii) If no instrument is available at the plant site that will meet the performance criteria specified in paragraph (b)(2)(i) of this section, the instrument readings may be adjusted by multiplying by the average response factor of the process fluid, calculated on an inert-free basis as described in paragraph (b)(2)(i) of this section.

(3) The detection instrument must be calibrated before use on each day of its use by the procedures specified in Method 21 of appendix A of this part.

(4) Calibration gases must be as follows:

(i) Zero air (less than 10 parts per million hydrocarbon in air); and

(ii) Mixtures of methane in air at a concentration less than 2,000 parts per million. A calibration gas other than methane in air may be used if the instrument does not respond to methane or if the instrument does not meet the performance criteria specified in paragraph (b)(2)(i) of this section. In such cases, the calibration gas may be a mixture of one or more of the compounds to be measured in air.

(5) You may elect to adjust or not adjust instrument readings for background. If you elect to not adjust readings for background, all such instrument readings must be compared directly to the applicable leak definition to determine whether there is a leak.

(6) If you elect to adjust instrument readings for background, you must determine the background concentration using Method 21 of appendix A of this part. After monitoring each potential leak interface, subtract the background reading from the maximum concentration indicated by the instrument. The arithmetic difference between the maximum concentration indicated by the instrument and the background level must be compared with 500 parts per million for determining compliance.

(c) Leaks, as indicated by an instrument reading greater than 500 parts per million above background or by visual, audio, or olfactory inspections, must be repaired as soon as practicable, except as provided in paragraph (d) of this section.

(1) A first attempt at repair must be made no later than 5 calendar days after the leak is detected.

(2) Repair must be completed no later than 15 calendar days after the leak is detected.

(d) Delay of repair of a closed vent system for which leaks have been detected is allowed if the repair is technically infeasible without a shutdown, as defined in § 60.2, or if you determine that emissions resulting from immediate repair would be greater than the fugitive emissions likely to result from delay of repair. Repair of such equipment must be complete by the end of the next shutdown.

(e) For each closed vent system that contains bypass lines that could divert a vent stream away from the control device and to the atmosphere, you must comply with the provisions of either paragraph (e)(1) or (2), except as specified in paragraph (e)(3) of this section.

(1) Install, calibrate, maintain, and operate a flow indicator that determines whether vent stream flow is present at least once every 15 minutes. You must keep hourly records of whether the flow

indicator was operating and whether a diversion was detected at any time during the hour, as well as records of the times and durations of all periods when the vent stream is diverted to the atmosphere or the flow indicator is not operating. The flow indicator must be installed at the entrance to any bypass line; or

(2) Secure the bypass line valve in the closed position with a car-seal or a lock-and-key type configuration. A visual inspection of the seal or closure mechanism must be performed at least once every month to ensure the valve is maintained in the closed position and the vent stream is not diverted through the bypass line.

(3) Open-ended valves or lines that use a cap, blind flange, plug, or second valve and follow the requirements specified in § 60.482–6(a)(2), (b), and (c) or follow requirements codified in another regulation that are the same as § 60.482–6(a)(2), (b), and (c) are not subject to this paragraph (e).

(f) Any parts of the closed vent system that are designated, as described in paragraph (h)(1) of this section, as unsafe to inspect are exempt from the inspection requirements of paragraphs (a)(1) and (2) of this section if:

(1) You determine that the equipment is unsafe to inspect because inspecting personnel would be exposed to an imminent or potential danger as a consequence of complying with paragraphs (a)(1) and (2) of this section; and

(2) You have a written plan that requires inspection of the equipment as frequently as practicable during safe-to-inspect times.

(g) Any parts of the closed vent system are designated, as described in paragraph (h)(2) of this section, as difficult to inspect are exempt from the inspection requirements of paragraphs (a)(1) and (2) of this section if:

(1) You determine that the equipment cannot be inspected without elevating the inspecting personnel more than 2 meters above a support surface; and

(2) You have a written plan that requires inspection of the equipment at least once every 5 years.

(h) You must record the information specified in paragraphs (h)(1) through (5) of this section.

(1) Identification of all parts of the closed vent system that are designated as unsafe to inspect, an explanation of why the equipment is unsafe to inspect, and the plan for inspecting the equipment.

(2) Identification of all parts of the closed vent system that are designated as difficult to inspect, an explanation of why the equipment is difficult to

inspect, and the plan for inspecting the equipment.

(3) For each closed vent system that contains bypass lines that could divert a vent stream away from the control device and to the atmosphere, you must keep a record of the information specified in either paragraph (h)(3)(i) or (ii) of this section in addition to the information specified in paragraph (h)(3)(iii) of this section.

(i) Hourly records of whether the flow indicator specified under paragraph (e)(1) of this section was operating and whether a diversion was detected at any time during the hour, as well as records of the times of all periods when the vent stream is diverted from the control device or the flow indicator is not operating.

(ii) Where a seal mechanism is used to comply with paragraph (e)(2) of this section, hourly records of flow are not required. In such cases, you must record whether the monthly visual inspection of the seals or closure mechanisms has been done, and you must record the occurrence of all periods when the seal mechanism is broken, the bypass line valve position has changed, or the key for a lock-and-key type configuration has been checked out, and records of any car-seal that has broken.

(iii) For each flow event from a bypass line subject to the requirements in paragraph (e) of this section, you must maintain records sufficient to determine whether or not the detected flow included flow requiring control. For each flow event from a bypass line requiring control that is released either directly to the atmosphere or to a control device not meeting the requirements in this subpart, you must include an estimate of the volume of gas, the concentration of VOC in the gas and the resulting emissions of VOC that bypassed the control device using process knowledge and engineering estimates.

(4) For each inspection during which a leak is detected, a record of the information specified in paragraphs (h)(4)(i) through (viii) of this section.

(i) The instrument identification numbers; operator name or initials; and identification of the equipment.

(ii) The date the leak was detected and the date of the first attempt to repair the leak.

(iii) Maximum instrument reading measured by the method specified in paragraph (c) of this section after the leak is successfully repaired or determined to be nonrepairable.

(iv) "Repair delayed" and the reason for the delay if a leak is not repaired within 15 calendar days after discovery of the leak.

(v) The name, initials, or other form of identification of the owner or operator (or designee) whose decision it was that repair could not be effected without a shutdown.

(vi) The expected date of successful repair of the leak if a leak is not repaired within 15 calendar days.

(vii) Dates of shutdowns that occur while the equipment is unrepaired.

(viii) The date of successful repair of the leak.

(5) For each inspection conducted in accordance with paragraph (b) of this section during which no leaks are detected, a record that the inspection was performed, the date of the inspection, and a statement that no leaks were detected.

(6) For each inspection conducted in accordance with paragraph (a)(3) of this section during which no leaks are detected, a record that the inspection was performed, the date of the inspection, and a statement that no leaks were detected.

(i) The semiannual report specified in § 60.615a(i)(5) must include the items specified in paragraphs (i)(1) through (3) of this section.

(1) Reports of the times of all periods recorded under paragraph (h)(3)(i) of this section when the vent stream is diverted from the control device through a bypass line. Include the start date, start time, and duration in hours of each period.

(2) Reports of all periods recorded under paragraph (h)(3)(ii) of this section

in which the seal mechanism is broken, the bypass line valve position has changed, or the key to unlock the bypass line valve was checked out. Include the start date, start time, and duration in hours of each period.

(3) For bypass lines subject to the requirements in paragraph (e) of this section, the semiannual reports must include the start date, start time, duration in hours, estimate of the volume of gas in standard cubic feet, the concentration of VOC in the gas in parts per million by volume and the resulting mass emissions of VOC in pounds that bypass a control device. For periods when the flow indicator is not operating, report the start date, start time, and duration in hours.

TABLE 1 TO SUBPART IIIa OF PART 60—EMISSION LIMITS AND STANDARDS FOR VENT STREAMS

For each. . .	You must. . .
1. Vent stream .....	a. Reduce emissions of TOC (minus methane and ethane) by 98 weight-percent, or to a TOC (minus methane and ethane) concentration of 20 ppmv on a dry basis corrected to 3 percent oxygen by venting emissions through a closed vent system to any combination of non-flare control devices and/or recovery system and meet the requirements specified in § 60.613a and § 60.620a; <i>or</i> b. Reduce emissions of TOC (minus methane and ethane) by venting emissions through a closed vent system to a flare and meet the requirements specified in § 60.619a and § 60.620a.

TABLE 2 TO SUBPART IIIa OF PART 60—MONITORING REQUIREMENTS FOR COMPLYING WITH 98 WEIGHT-PERCENT REDUCTION OF TOTAL ORGANIC COMPOUNDS EMISSIONS OR A LIMIT OF 20 PARTS PER MILLION BY VOLUME

Non-flare control device or recovery device	Parameters to be monitored
1. All control and recovery devices .....	a. Presence of flow diverted to the atmosphere from the control and recovery device; <i>or</i> b. Monthly inspections of sealed valves.
2. Absorber .....	a. Exit temperature of the absorbing liquid; <i>and</i> b. Exit specific gravity. Firebox temperature. <sup>a</sup>
3. Boiler or process heater with a design heat input capacity less than 44 megawatts and vent stream is <i>not</i> introduced with or as the primary fuel.	
4. Catalytic incinerator .....	Temperature upstream and downstream of the catalyst bed.
5. Carbon adsorber, regenerative .....	a. Total regeneration stream mass or volumetric flow during carbon bed regeneration cycle(s); <i>and</i> b. Temperature of the carbon bed after regeneration [and within 15 minutes of completing any cooling cycle(s)].
6. Carbon adsorber, non-regenerative or regenerated offsite .....	Breakthrough.
7. Condenser .....	Exit (product side) temperature.
8. Scrubber for halogenated vent streams .....	a. pH of scrubber effluent; <i>and</i> b. Scrubber liquid and gas flow rates. Firebox temperature. <sup>a</sup>
9. Thermal incinerator .....	As specified by the Administrator.
10. Control devices other than an incinerator, boiler, process heater, or flare; or recovery devices other than an absorber, condenser, or carbon adsorber.	

<sup>a</sup> Monitor may be installed in the firebox or in the ductwork immediately downstream of the firebox before any substantial heat exchange is encountered.

TABLE 3 TO SUBPART IIIa OF PART 60—OPERATING PARAMETERS, OPERATING PARAMETER LIMITS AND DATA MONITORING, RECORDKEEPING AND COMPLIANCE FREQUENCIES

For the operating parameter applicable to you, as specified in Table 2. . .	You must establish the following operating parameter limit. . .	And you must monitor, record, and demonstrate continuous compliance using these minimum frequencies. . .		
		Data measurement	Data recording	Data averaging period for compliance
<b>Absorbers</b>				
1. Exit temperature of the absorbing liquid.	Maximum temperature .....	Continuous .....	Every 15 minutes .....	3-hour block average.
2. Exit specific gravity .....	Exit specific gravity range .....	Continuous .....	Every 15 minutes .....	3-hour block average.
<b>Boilers or process heaters</b> (with a design heat input capacity <44MW and vent stream is not introduced with or as the primary fuel)				
3. Firebox temperature .....	Minimum firebox temperature	Continuous .....	Every 15 minutes .....	3-hour block average.
<b>Catalytic incinerators</b>				
4. Temperature in gas stream immediately before the catalyst bed.	Minimum temperature .....	Continuous .....	Every 15 minutes .....	3-hour block average.
5. Temperature difference between the catalyst bed inlet and the catalyst bed outlet.	Minimum temperature difference.	Continuous .....	Every 15 minutes .....	3-hour block average.
<b>Carbon adsorbers</b>				
6. Total regeneration stream mass flow during carbon bed regeneration cycle(s).	Minimum mass flow during carbon bed regeneration cycle(s).	Continuously during regeneration .....	Every 15 minutes during regeneration cycle.	Total flow for each regeneration cycle.
7. Total regeneration stream volumetric flow during carbon bed regeneration cycle(s).	Minimum volumetric flow during carbon bed regeneration cycle(s).	Continuously during regeneration .....	Every 15 minutes during regeneration cycle.	Total flow for each regeneration cycle.
8. Temperature of the carbon bed after regeneration [and within 15 minutes of completing any cooling cycle(s)].	Maximum temperature of the carbon bed after regeneration.	Continuously during regeneration and for 15 minutes after completing any cooling cycle(s).	Every 15 minutes during regeneration cycle (including any cooling cycle).	Average of regeneration cycle.
9. Breakthrough .....	As defined in § 60.611a .....	As required by § 60.613a(a)(6)(iii)(B) .....	Each monitoring event .....	N/A
<b>Condensers</b>				
10. Exit (product side) temperature.	Maximum temperature .....	Continuous .....	Every 15 minutes .....	3-hour block average.
<b>Scrubbers for halogenated vent streams</b>				
11. pH of scrubber effluent .....	Minimum pH .....	Continuous .....	Every 15 minutes .....	3-hour block average.
12. Influent liquid flow .....	Minimum inlet liquid flow .....	Continuous .....	Every 15 minutes .....	3-hour block average.
13. Influent liquid flow rate and gas stream flow rate.	Minimum influent liquid-to-gas ratio.	Continuous .....	Every 15 minutes .....	3-hour block average.
<b>Thermal incinerators</b>				
14. Firebox temperature .....	Minimum firebox temperature	Continuous .....	Every 15 minutes .....	3-hour block average.
<b>Control devices other than an incinerator, boiler, process heater, or flare; or recovery devices other than an absorber, condenser, or carbon adsorber</b>				
15. As specified by the Administrator.	As specified by the Administrator.	As specified by the Administrator .....	As specified by the Administrator.	As specified by the Administrator.

TABLE 4 TO SUBPART IIIa OF PART 60—CALIBRATION AND QUALITY CONTROL REQUIREMENTS FOR CONTINUOUS PARAMETER MONITORING SYSTEM (CPMS)

If you monitor this parameter. . .	Your accuracy requirements are. . .	And your calibration requirements are. . .
1. Temperature .....	a. $\pm 1$ percent over the normal range of temperature measured or 2.8 degrees Celsius (5 degrees Fahrenheit), whichever is greater, for non-cryogenic temperature ranges. b. $\pm 2.5$ percent over the normal range of temperature measured or 2.8 degrees Celsius (5 degrees Fahrenheit), whichever is greater, for cryogenic temperature ranges.	c. Performance evaluation annually and following any period of more than 24 hours throughout which the temperature exceeded the maximum rated temperature of the sensor, or the data recorder was off scale. d. Visual inspections and checks of CPMS operation every 3 months, unless the CPMS has a redundant temperature sensor. e. Selection of a representative measurement location.
2. Flow Rate .....	a. $\pm 5$ percent over the normal range of flow measured or 1.9 liters per minute (0.5 gallons per minute), whichever is greater, for liquid flow rate. b. $\pm 5$ percent over the normal range of flow measured or 280 liters per minute (10 cubic feet per minute), whichever is greater, for gas flow rate. c. $\pm 5$ percent over the normal range measured for mass flow rate.	d. Performance evaluation annually and following any period of more than 24 hours throughout which the flow rate exceeded the maximum rated flow rate of the sensor, or the data recorder was off scale. e. Checks of all mechanical connections for leakage monthly. f. Visual inspections and checks of CPMS operation every 3 months, unless the CPMS has a redundant flow sensor. g. Selection of a representative measurement location where swirling flow or abnormal velocity distributions due to upstream and downstream disturbances at the point of measurement are minimized.
3. pH .....	a. $\pm 0.2$ pH units .....	b. Performance evaluation annually. Conduct a two-point calibration with one of the two buffer solutions having a pH within 1 of the pH of the operating limit. c. Visual inspections and checks of CPMS operation every 3 months, unless the CPMS has a redundant pH sensor. d. Select a measurement location that provides a representative sample of scrubber effluent and that ensures the fluid is properly mixed.
4. Specific Gravity .....	a. $\pm 0.02$ specific gravity units .....	b. Performance evaluation annually. c. Visual inspections and checks of CPMS operation every 3 months, unless the CPMS has a redundant specific gravity sensor. d. Select a measurement location that provides a representative sample of specific gravity of the absorbing liquid effluent and that ensures the fluid is properly mixed.

■ 26. Revise the heading of subpart NNN to read as follows:

**Subpart NNN—Standards of Performance for Volatile Organic Compound (VOC) Emissions From Synthetic Organic Chemical Manufacturing Industry (SOCMI) Distillation Operations After December 30, 1983, and on or Before April 25, 2023**

■ 27. Amend § 60.660 by revising paragraphs (b) introductory text and (c)(6) and adding paragraph (e) to read as follows:

**§ 60.660 Applicability and designation of affected facility.**

\* \* \* \* \*

(b) The affected facility is any of the following for which construction, modification, or reconstruction commenced after December 30, 1983, and on or before April 25, 2023:

\* \* \* \* \*

(c) \* \* \*

(6) Each affected facility operated with a vent stream flow rate less than 0.008 scm/min is exempt from all provisions of this subpart except for the test method and procedure and the recordkeeping and reporting requirements in §§ 60.664(h) and 60.665(i), (l)(5), and (o).

\* \* \* \* \*

(e) Owners and operators of flares that are subject to the flare related requirements of this subpart and flare related requirements of any other regulation in this part or 40 CFR part 61 or 63, may elect to comply with the requirements in § 60.669a in lieu of all flare related requirements in any other regulation in this part or 40 CFR part 61 or 63.

■ 28. Amend § 60.661 by revising the definition of “Flame zone” to read as follows:

**§ 60.661 Definitions.**

\* \* \* \* \*

*Flame zone* means the portion of the combustion chamber in a boiler or process heater occupied by the flame envelope.

\* \* \* \* \*

■ 29. Amend § 60.664 by revising paragraphs (b)(4) introductory text and (e) to read as follows:

**§ 60.664 Test methods and procedures.**

\* \* \* \* \*

(b) \* \* \*

(4) Method 18 of appendix A–6 to this part to determine the concentration of TOC in the control device outlet and the concentration of TOC in the inlet when the reduction efficiency of the control device is to be determined. ASTM D6420–18 (incorporated by reference, see § 60.17) may be used in lieu of Method 18, if the target compounds are

all known and are all listed in Section 1.1 of ASTM D6420–18 as measurable; ASTM D6420–18 may not be used for methane and ethane; and ASTM D6420–18 may not be used as a total VOC method.

\* \* \* \* \*

(e) The following test methods, except as provided under § 60.8(b), shall be used for determining the net heating value of the gas combusted to determine compliance under § 60.662(b) and for determining the process vent stream TRE index value to determine compliance under § 60.662(c).

(1)(i) Method 1 or 1A of appendix A–1 to this part, as appropriate, for selection of the sampling site. The sampling site for the vent stream flow rate and molar composition determination prescribed in paragraphs (e)(2) and (3) of this section shall be, except for the situations outlined in paragraph (e)(1)(ii) of this section, prior to the inlet of any control device, prior to any post-distillation dilution of the stream with air, and prior to any post-distillation introduction of halogenated compounds into the process vent stream. No transverse site selection method is needed for vents smaller than 10 centimeters (4 inches) in diameter.

(ii) If any gas stream other than the distillation vent stream from the affected facility is normally conducted through the final recovery device.

(A) The sampling site for vent stream flow rate and molar composition shall be prior to the final recovery device and prior to the point at which the nondistillation stream is introduced.

(B) The efficiency of the final recovery device is determined by measuring the TOC concentration using Method 18 of appendix A-6 to this part, or ASTM D6420-18 (incorporated by reference, see § 60.17) as specified in paragraph (b)(4) of this section, at the inlet to the final recovery device after the introduction of any nondistillation vent stream and at the outlet of the final recovery device.

(C) This efficiency is applied to the TOC concentration measured prior to the final recovery device and prior to the introduction of the nondistillation stream to determine the concentration of TOC in the distillation vent stream from the final recovery device. This concentration of TOC is then used to perform the calculations outlined in § 60.664(e)(4) and (5).

(2) The molar composition of the process vent stream shall be determined as follows:

(i) Method 18 of appendix A-6 to this part, or ASTM D6420-18 (incorporated by reference, see § 60.17) as specified in paragraph (b)(4) of this section, to

measure the concentration of TOC including those containing halogens.

(ii) ASTM D1946-77 or 90 (Reapproved 1994) (incorporation by reference as specified in § 60.17 of this part) to measure the concentration of carbon monoxide and hydrogen.

(iii) Method 4 of appendix A-3 to this part to measure the content of water vapor.

(3) The volumetric flow rate shall be determined using Method 2, 2A, 2C, or 2D of appendix A-1 to this part, as appropriate.

(4)(i) The net heating value of the vent stream shall be calculated using the following equation:

$$H_T = K_1 \left( \sum_{j=1}^n C_j H_j \right)$$

Where:

$H_T$  = Net heating value of the sample, MJ/scm (Btu/scf), where the net enthalpy per mole of vent stream is based on combustion at 25 °C and 760 mm Hg (77 °F and 30 in. Hg), but the standard temperature for determining the volume corresponding to one mole is 20 °C (68 °F).

$K_1 = 1.74 \times 10^{-7}$  (1/ppm) (g-mole/scm) (MJ/kcal) (metric units), where standard temperature for (g-mole/scm) is 20 °C.  
 $= 1.03 \times 10^{-11}$  (1/ppm) (lb-mole/scf) (Btu/kcal) (English units) where standard temperature for (lb-mole/scf) is 68 °F.

$C_j$  = Concentration on a wet basis of compound j in ppm, as measured for organics by Method 18 of appendix A-6 to this part, or ASTM D6420-18 (incorporated by reference, see § 60.17) as specified in paragraph (b)(4) of this section, and measured for hydrogen and carbon monoxide by ASTM D1946-77 or 90 (Reapproved 1994) (incorporated by reference, see § 60.17) as indicated in paragraph (e)(2) of this section.

$H_j$  = Net heat of combustion of compound j, kcal/(g-mole) [kcal/(lb-mole)], based on combustion at 25 °C and 760 mm Hg (77 °F and 30 in. Hg).

(ii) The heats of combustion of vent stream components would be required to be determined using ASTM D2382-76 (incorporated by reference as specified in § 60.17) if published values are not available or cannot be calculated.

(5) The emission rate of TOC in the vent stream shall be calculated using the following equation:

$$E_{TOC} = K_2 \left[ \sum_{j=1}^n C_j M_j \right] Q_s$$

Where:

$E_{TOC}$  = Measured emission rate of TOC, kg/hr (lb/hr).  
 $K_2 = 2.494 \times 10^{-6}$  (1/ppm) (g-mole/scm) (kg/g) (min/hr) (metric units), where standard temperature for (g-mole/scm) is 20 °C.

$= 1.557 \times 10^{-7}$  (1/ppm) (lb-mole/scf) (min/hr) (English units), where standard temperature for (lb-mole/scf) is 68 °F.

$C_j$  = Concentration on a wet basis of compound j in ppm, as measured by Method 18 of appendix A-6 to this part, or ASTM D6420-18 (incorporated by reference, see § 60.17) as specified in paragraph (b)(4) of this section, as indicated in paragraph (e)(2) of this section.

$M_j$  = Molecular weight of sample j, g/g-mole (lb/lb-mole).

$Q_s$  = Vent stream flow rate, scm/min (scf/min), at a temperature of 20 °C (68 °F).

by compound) shall be summed from the individual concentrations of compounds containing halogens which were measured by Method 18 of appendix A-6 to this part, or ASTM D6420-18 (incorporated by reference, see § 60.17) as specified in paragraph (b)(4) of this section.

\* \* \* \* \*

■ 30. Amend § 60.665 by revising paragraphs (b) introductory text, (l) introductory text, (l)(5) and (6), and (m) and adding paragraphs (q), (r), and (s) as follows:

**§ 60.665 Reporting and recordkeeping requirements.**

\* \* \* \* \*

(b) Each owner or operator subject to the provisions of this subpart shall keep an up-to-date, readily accessible record of the following data measured during each performance test, and also include

the following data in the report of the initial performance test required under § 60.8. Where a boiler or process heater with a design heat input capacity of 44 MW (150 million Btu/hour) or greater is used to comply with § 60.662(a), a report containing performance test data need not be submitted, but a report containing the information in § 60.665(b)(2)(i) is required. The same data specified in this section shall be submitted in the reports of all subsequently required performance tests where either the emission control efficiency of a control device, outlet concentration of TOC, or the TRE index value of a vent stream from a recovery system is determined. Beginning on July 15, 2024, owners and operators must submit the performance test report following the procedures specified in paragraph (q) of this section. Data collected using test methods that are

(6) The total process vent stream concentration (by volume) of compounds containing halogens (ppmv,

supported by the EPA's Electronic Reporting Tool (ERT) as listed on the EPA's ERT website (<https://www.epa.gov/electronic-reporting-air-emissions/electronic-reporting-tool-ert>) at the time of the test must be submitted in a file format generated using the EPA's ERT. Alternatively, the owner or operator may submit an electronic file consistent with the extensible markup language (XML) schema listed on the EPA's ERT website. Data collected using test methods that are not supported by the EPA's ERT as listed on the EPA's ERT website at the time of the test must be included as an attachment in the ERT or an alternate electronic file.

\* \* \* \* \*

(l) Each owner or operator that seeks to comply with the requirements of this subpart by complying with the requirements of § 60.660 (c)(4), (c)(5), or (c)(6) or § 60.662 shall submit to the Administrator semiannual reports of the following recorded information. The initial report shall be submitted within 6 months after the initial start-up date. On and after July 15, 2025 or once the report template for this subpart has been available on the Compliance and Emissions Data Reporting Interface (CEDRI) website (<https://www.epa.gov/electronic-reporting-air-emissions/cedri>) for 1 year, whichever date is later, owners and operators must submit all subsequent reports using the appropriate electronic report template on the CEDRI website for this subpart and following the procedure specified in paragraph (q) of this section. The date report templates become available will be listed on the CEDRI website. Unless the Administrator or delegated state agency or other authority has approved a different schedule for submission of reports, the report must be submitted by the deadline specified in this subpart, regardless of the method in which the report is submitted.

\* \* \* \* \*

(5) Any change in equipment or process operation that increases the operating vent stream flow rate above the low flow exemption level in § 60.660(c)(6), including a measurement of the new vent stream flow rate, as recorded under § 60.665(i). These must be reported as soon as possible after the change and no later than 180 days after the change. These reports may be submitted either in conjunction with semiannual reports or as a single separate report. A performance test must be completed with the same time period to verify the recalculated flow value and to obtain the vent stream characteristics of heating value and  $E_{\text{TOC}}$ . The performance test is subject to the

requirements of § 60.8, and the performance test must be reported according to paragraph (b) of this section. Unless the facility qualifies for an exemption under the low capacity exemption status in § 60.660(c)(5), the facility must begin compliance with the requirements set forth in § 60.662.

(6) Any change in equipment or process operation, as recorded under paragraph (j) of this section, that increases the design production capacity above the low capacity exemption level in § 60.660(c)(5) and the new capacity resulting from the change for the distillation process unit containing the affected facility. These must be reported as soon as possible after the change and no later than 180 days after the change. These reports may be submitted either in conjunction with semiannual reports or as a single separate report. A performance test must be completed within the same time period to obtain the vent stream flow rate, heating value, and  $E_{\text{TOC}}$ . The performance test is subject to the requirements of § 60.8, and the performance test must be reported according to paragraph (b) of this section. The facility must begin compliance with the requirements set forth in § 60.660(d) or § 60.662. If the facility chooses to comply with § 60.662, the facility may qualify for an exemption in § 60.660(c)(4) or (6).

\* \* \* \* \*

(m) The requirements of § 60.665(l) remain in force until and unless EPA, in delegating enforcement authority to a State under section 111(c) of the Act, approves reporting requirements or an alternative means of compliance surveillance adopted by such State. In that event, affected sources within the State will be relieved of the obligation to comply with § 60.665(l), provided that they comply with the requirements established by the State. The EPA will not approve a waiver of electronic reporting to the EPA in delegating enforcement authority. Thus, electronic reporting to the EPA cannot be waived, and as such, the provisions of this paragraph cannot be used to relieve owners or operators of affected facilities of the requirement to submit the electronic reports required in this section to the EPA.

\* \* \* \* \*

(q) If an owner or operator is required to submit notifications or reports following the procedure specified in this paragraph (q), the owner or operator must submit notifications or reports to the EPA via CEDRI, which can be accessed through the EPA's Central Data Exchange (CDX) (<https://cdx.epa.gov/>).

The EPA will make all the information submitted through CEDRI available to the public without further notice to the owner or operator. Do not use CEDRI to submit information the owner or operator claims as CBI. Although the EPA does not expect persons to assert a claim of CBI, if an owner or operator wishes to assert a CBI claim for some of the information in the report or notification, the owner or operator must submit a complete file in the format specified in this subpart, including information claimed to be CBI, to the EPA following the procedures in paragraphs (q)(1) and (2) of this section. Clearly mark the part or all of the information that claimed to be CBI. Information not marked as CBI may be authorized for public release without prior notice. Information marked as CBI will not be disclosed except in accordance with procedures set forth in 40 CFR part 2. All CBI claims must be asserted at the time of submission. Anything submitted using CEDRI cannot later be claimed CBI. Furthermore, under CAA section 114(c), emissions data is not entitled to confidential treatment, and the EPA is required to make emissions data available to the public. Thus, emissions data will not be protected as CBI and will be made publicly available. The owner or operator must submit the same file submitted to the CBI office with the CBI omitted to the EPA via the EPA's CDX as described earlier in this paragraph (q).

(1) The preferred method to receive CBI is for it to be transmitted electronically using email attachments, File Transfer Protocol, or other online file sharing services. Electronic submissions must be transmitted directly to the OAQPS CBI Office at the email address [oaqpscbi@epa.gov](mailto:oaqpscbi@epa.gov), and as described above, should include clear CBI markings. ERT files should be flagged to the attention of the Group Leader, Measurement Policy Group; all other files should be flagged to the attention of the SOCM I NSPS Sector Lead. Owners and operators who do not have their own file sharing service and who require assistance with submitting large electronic files that exceed the file size limit for email attachments should email [oaqpscbi@epa.gov](mailto:oaqpscbi@epa.gov) to request a file transfer link.

(2) If an owner or operator cannot transmit the file electronically, the owner or operator may send CBI information through the postal service to the following address: OAQPS Document Control Officer (C404-02), OAQPS, U.S. Environmental Protection Agency, 109 T.W. Alexander Drive, P.O. Box 12055, Research Triangle Park,



North Carolina 27711. ERT files should be sent to the attention of the Group Leader, Measurement Policy Group, and all other files should be sent to the attention of the SOCOMI NSPS Sector Lead. The mailed CBI material should be double wrapped and clearly marked. Any CBI markings should not show through the outer envelope.

(r) Owners and operators required to electronically submit notifications or reports through CEDRI in the EPA's CDX may assert a claim of EPA system outage for failure to timely comply with the electronic submittal requirement. To assert a claim of EPA system outage, owners and operators must meet the requirements outlined in paragraphs (r)(1) through (7) of this section.

(1) The owner or operator must have been or will be precluded from accessing CEDRI and submitting a required report within the time prescribed due to an outage of either the EPA's CEDRI or CDX systems.

(2) The outage must have occurred within the period of time beginning five business days prior to the date that the submission is due.

(3) The outage may be planned or unplanned.

(4) The owner or operator must submit notification to the Administrator in writing as soon as possible following the date the owner or operator first knew, or through due diligence should have known, that the event may cause or has caused a delay in reporting.

(5) The owner or operator must provide to the Administrator a written description identifying:

(i) The date(s) and time(s) when CDX or CEDRI was accessed and the system was unavailable;

(ii) A rationale for attributing the delay in reporting beyond the regulatory deadline to EPA system outage;

(iii) A description of measures taken or to be taken to minimize the delay in reporting; and

(iv) The date by which the owner or operator proposes to report, or if the owner or operator has already met the reporting requirement at the time of the notification, the date the report was submitted.

(6) The decision to accept the claim of EPA system outage and allow an extension to the reporting deadline is solely within the discretion of the Administrator.

(7) In any circumstance, the report must be submitted electronically as soon as possible after the outage is resolved.

(s) Owners and operators required to electronically submit notifications or reports through CEDRI in the EPA's CDX may assert a claim of *force majeure*

for failure to timely comply with the electronic submittal requirement. To assert a claim of *force majeure*, owners and operators must meet the requirements outlined in paragraphs (s)(1) through (5) of this section.

(1) An owner or operator may submit a claim if a *force majeure* event is about to occur, occurs, or has occurred or there are lingering effects from such an event within the period of time beginning five business days prior to the date the submission is due. For the purposes of this section, a *force majeure* event is defined as an event that will be or has been caused by circumstances beyond the control of the affected facility, its contractors, or any entity controlled by the affected facility that prevents the owner or operator from complying with the requirement to submit a report electronically within the time period prescribed. Examples of such events are acts of nature (e.g., hurricanes, earthquakes, or floods), acts of war or terrorism, or equipment failure or safety hazard beyond the control of the affected facility (e.g., large scale power outage).

(2) The owner or operator must submit notification to the Administrator in writing as soon as possible following the date the owner or operator first knew, or through due diligence should have known, that the event may cause or has caused a delay in reporting.

(3) An owner or operator must provide to the Administrator:

(i) A written description of the *force majeure* event;

(ii) A rationale for attributing the delay in reporting beyond the regulatory deadline to the *force majeure* event;

(iii) A description of measures taken or to be taken to minimize the delay in reporting; and

(iv) The date by which the owner or operator proposes to report, or if the owner or operator has already met the reporting requirement at the time of the notification, the date the report was submitted.

(4) The decision to accept the claim of *force majeure* and allow an extension to the reporting deadline is solely within the discretion of the Administrator.

(5) In any circumstance, the reporting must occur as soon as possible after the *force majeure* event occurs.

■ 31. Amend § 60.668 by revising paragraph (b) to read as follows:

**§ 60.668 Delegation of authority.**

\* \* \* \* \*

(b) Authorities which will not be delegated to States: § 60.663(e) and approval of an alternative to any

electronic reporting to the EPA required by this subpart.

■ 32. Add subpart NNNa to read as follows:

**Subpart NNNa—Standards of Performance for Volatile Organic Compound (VOC) Emissions From Synthetic Organic Chemical Manufacturing Industry (SOCMI) Distillation Operations for Which Construction, Reconstruction, or Modification Commenced After April 25, 2023**

Sec.

60.660a Am I subject to this subpart?

60.661a What definitions must I know?

60.662a What standards and associated requirements must I meet?

60.663a What are my monitoring, installation, operation, and maintenance requirements?

60.664a What test methods and procedures must I use to determine compliance with the standards?

60.665a What records must I keep and what reports must I submit?

60.666a What do the terms associated with reconstruction mean for this subpart?

60.667a What are the chemicals that I must produce to be affected by subpart NNNa?

60.668a [Reserved]

60.669a What are my requirements if I use a flare to comply with this subpart?

60.670a What are my requirements for closed vent systems?

Table 1 to Subpart NNNa of Part 60—Emission Limits and Standards for Vent Streams

Table 2 to Subpart NNNa of Part 60—Monitoring Requirements for Complying With 98 Weight-Percent Reduction of Total Organic Compounds Emissions or a Limit of 20 Parts Per Million by Volume

Table 3 to Subpart NNNa of Part 60—Operating Parameters, Operating Parameter Limits and Data Monitoring, Recordkeeping and Compliance Frequencies

Table 4 to Subpart NNNa of Part 60—Calibration and Quality Control Requirements for Continuous Parameter Monitoring System (CPMS)

**Subpart NNNa—Standards of Performance for Volatile Organic Compound (VOC) Emissions From Synthetic Organic Chemical Manufacturing Industry (SOCMI) Distillation Operations for Which Construction, Reconstruction, or Modification Commenced After April 25, 2023**

**§ 60.660a Am I subject to this subpart?**

(a) You are subject to this subpart if you operate an affected facility designated in paragraph (b) of this section that produces any of the chemicals listed in § 60.667a as a product, co-product, by-product, or

intermediate, except as provided in paragraph (c) of this section.

(b) The affected facility is any of the following for which construction, modification, or reconstruction commenced after April 25, 2023:

(1) Each distillation unit not discharging its vent stream into a recovery system.

(2) Each combination of a distillation unit and the recovery system into which its vent stream is discharged.

(3) Each combination of two or more distillation units and the common recovery system into which their vent streams are discharged.

(c) Exemptions from the provisions of paragraph (a) of this section are as follows:

(1) Any distillation unit operating as part of a process unit which produces coal tar or beverage alcohols, or which uses, contains, and produces no VOC is not an affected facility.

(2) Any distillation unit that is subject to the provisions of subpart DDD is not an affected facility.

(3) Any distillation unit that is designed and operated as a batch operation is not an affected facility.

(4) Each affected facility in a process unit with a total design capacity for all chemicals produced within that unit of less than one gigagram per year is exempt from all provisions of this subpart except for the recordkeeping and reporting requirements in § 60.665a(h), (j)(6), and (o).

(5) Each affected facility operated with a vent stream flow rate less than 0.008 standard cubic meter per minute (scm/min) is exempt from all provisions of this subpart except for the test method and procedure and the recordkeeping and reporting requirements in § 60.664a(e) and § 60.665a(i), (j)(7), and (p).

(6) Each affected facility operated with a vent stream flow rate less than 0.001 pound per hour (lb/hr) of TOC is exempt from all provisions of this subpart except for the test method and procedure and the recordkeeping and reporting requirements in §§ 60.664a(f) and 60.665a(i), (j)(7), and (p).

(7) A vent stream going to a fuel gas system as defined in § 63.661a.

#### § 60.661a What definitions must I know?

As used in this subpart, all terms not defined herein have the meaning given them in the Clean Air Act and subpart A of this part.

*Batch distillation operation* means a noncontinuous distillation operation in which a discrete quantity or batch of liquid feed is charged into a distillation unit and distilled at one time. After the initial charging of the liquid feed, no

additional liquid is added during the distillation operation.

*Breakthrough* means the time when the level of TOC, measured at the outlet of the first bed, has been detected is at the highest concentration allowed to be discharged from the adsorber system and indicates that the adsorber bed should be replaced.

*Boiler* means any enclosed combustion device that extracts useful energy in the form of steam.

*By compound* means by individual stream components, not carbon equivalents.

*Closed vent system* means a system that is not open to the atmosphere and is composed of piping, ductwork, connections, and, if necessary, flow inducing devices that transport gas or vapor from an emission point to a control device.

*Continuous recorder* means a data recording device recording an instantaneous data value at least once every 15 minutes.

*Distillation operation* means an operation separating one or more feed stream(s) into two or more exit stream(s), each exit stream having component concentrations different from those in the feed stream(s). The separation is achieved by the redistribution of the components between the liquid and vapor-phase as they approach equilibrium within the distillation unit.

*Distillation unit* means a device or vessel in which distillation operations occur, including all associated internals (such as trays or packing) and accessories (such as reboiler, condenser, vacuum pump, steam jet, etc.), plus any associated recovery system.

*Flame zone* means the portion of the combustion chamber in a boiler or process heater occupied by the flame envelope.

*Flow indicator* means a device which indicates whether gas flow is present in a vent stream.

*Fuel gas* means gases that are combusted to derive useful work or heat.

*Fuel gas system* means the offsite and onsite piping and flow and pressure control system that gathers gaseous stream(s) generated by onsite operations, may blend them with other sources of gas, and transports the gaseous stream for use as fuel gas in combustion devices or in in-process combustion equipment such as furnaces and gas turbines either singly or in combination.

*Halogenated vent stream* means any vent stream determined to have a total concentration (by volume) of

compounds containing halogens of 20 ppmv (by compound) or greater.

*Incinerator* means any enclosed combustion device that is used for destroying organic compounds and does not extract energy in the form of steam or process heat.

*Pressure-assisted multi-point flare* means a flare system consisting of multiple flare burners in staged arrays whereby the vent stream pressure is used to promote mixing and smokeless operation at the flare burner tips.

Pressure-assisted multi-point flares are designed for smokeless operation at velocities up to Mach = 1 conditions (i.e., sonic conditions), can be elevated or at ground level, and typically use cross-lighting for flame propagation to combust any flare vent gases sent to a particular stage of flare burners.

*Primary fuel* means the fuel fired through a burner or a number of similar burners. The primary fuel provides the principal heat input to the device, and the amount of fuel is sufficient to sustain operation without the addition of other fuels.

*Process heater* means a device that transfers heat liberated by burning fuel to fluids contained in tubes, including all fluids except water that is heated to produce steam.

*Process unit* means equipment assembled and connected by pipes or ducts to produce, as intermediates or final products, one or more of the chemicals in § 60.667a. A process unit can operate independently if supplied with sufficient fuel or raw materials and sufficient product storage facilities.

*Product* means any compound or chemical listed in § 60.667a that is produced for sale as a final product as that chemical, or for use in the production of other chemicals or compounds. By-products, co-products, and intermediates are considered to be products.

*Recovery device* means an individual unit of equipment, such as an absorber, carbon adsorber, or condenser, capable of and used for the purpose of recovering chemicals for use, reuse, or sale.

*Recovery system* means an individual recovery device or series of such devices applied to the same vent stream.

*Relief valve* means a valve used only to release an unplanned, nonroutine discharge. A relief valve discharge results from an operator error, a malfunction such as a power failure or equipment failure, or other unexpected cause that requires immediate venting of gas from process equipment in order to avoid safety hazards or equipment damage.

*Total organic compounds* (TOC) means those compounds measured according to the procedures in Method 18 of appendix A–6 of this part or the concentration of organic compounds measured according to the procedures in Method 21 or Method 25A of appendix A–7 of this part.

*Vent stream* means any gas stream discharged directly from a distillation facility to the atmosphere or indirectly to the atmosphere after diversion through other process equipment. The vent stream excludes equipment leaks including, but not limited to, pumps, compressors, and valves.

**§ 60.662a What standards and associated requirements must I meet?**

(a) You must comply with the emission limits and standards specified in table 1 to this subpart and the requirements specified in paragraphs (b) and (c) of this section for each vent stream on and after the date on which the initial performance test required by §§ 60.8 and 60.664a is completed, but not later than 60 days after achieving the maximum production rate at which the affected facility will be operated, or 180 days after the initial start-up, whichever date comes first. The standards in this section apply at all times, including periods of startup, shutdown and malfunction. As provided in § 60.11(f), this provision supersedes the exemptions for periods of startup, shutdown and malfunction in the general provisions in subpart A of this part.

(b) The following release events from an affected facility are a violation of the emission limits and standards specified in table 1 to this subpart.

(1) Any relief valve discharge to the atmosphere of a vent stream.

(2) The use of a bypass line at any time on a closed vent system to divert emissions to the atmosphere, or to a control device or recovery device not meeting the requirements specified in § 60.663a.

(c) You may designate a vent stream as a maintenance vent if the vent is only used as a result of startup, shutdown, maintenance, or inspection of equipment where equipment is emptied, depressurized, degassed, or placed into service. You must comply with the applicable requirements in paragraphs (c)(1) through (3) of this section for each maintenance vent. Any vent stream designated as a maintenance vent is only subject to the maintenance vent provisions in this paragraph (c) and the associated recordkeeping and reporting requirements in § 60.665a(g), respectively.

(1) Prior to venting to the atmosphere, remove process liquids from the equipment as much as practical and depressurize the equipment to either: A flare meeting the requirements of § 60.669a, as applicable, or using any combination of a non-flare control device or recovery device meeting the requirements in table 1 to this subpart until one of the following conditions, as applicable, is met.

(i) The vapor in the equipment served by the maintenance vent has a lower explosive limit (LEL) of less than 10 percent.

(ii) If there is no ability to measure the LEL of the vapor in the equipment based on the design of the equipment, the pressure in the equipment served by the maintenance vent is reduced to 5 pounds per square inch gauge (psig) or less. Upon opening the maintenance vent, active purging of the equipment cannot be used until the LEL of the vapors in the maintenance vent (or inside the equipment if the maintenance vent is a hatch or similar type of opening) is less than 10 percent.

(iii) The equipment served by the maintenance vent contains less than 50 pounds of total VOC.

(iv) If, after applying best practices to isolate and purge equipment served by a maintenance vent, none of the applicable criterion in paragraphs (c)(1)(i) through (iii) of this section can be met prior to installing or removing a blind flange or similar equipment blind, then the pressure in the equipment served by the maintenance vent must be reduced to 2 psig or less before installing or removing the equipment blind. During installation or removal of the equipment blind, active purging of the equipment may be used provided the equipment pressure at the location where purge gas is introduced remains at 2 psig or less.

(2) Except for maintenance vents complying with the alternative in paragraph (c)(1)(iii) of this section, you must determine the LEL or, if applicable, equipment pressure using process instrumentation or portable measurement devices and follow procedures for calibration and maintenance according to manufacturer's specifications.

(3) For maintenance vents complying with the alternative in paragraph (c)(1)(iii) of this section, you must determine mass of VOC in the equipment served by the maintenance vent based on the equipment size and contents after considering any contents drained or purged from the equipment. Equipment size may be determined from equipment design specifications.

Equipment contents may be determined using process knowledge.

**§ 60.663a What are my monitoring, installation, operation, and maintenance requirements?**

(a) Except as specified in paragraphs (a)(5) through (7) of this section, if you use a non-flare control device or recovery system to comply with the TOC emission limit specified in table 1 to this subpart, then you must comply with paragraphs (a)(1) through (4), (b), and (c) of this section.

(1) Install a continuous parameter monitoring system(s) (CPMS) and monitor the operating parameter(s) applicable to the control device or recovery system as specified in table 2 to this subpart or established according to paragraph (c) of this section.

(2) Establish the applicable minimum, maximum, or range for the operating parameter limit as specified in table 3 to this subpart or established according to paragraph (c) of this section by calculating the value(s) as the arithmetic average of operating parameter measurements recorded during the three test runs conducted for the most recent performance test. You may operate outside of the established operating parameter limit(s) during subsequent performance tests in order to establish new operating limits. You must include the updated operating limits with the performance test results submitted to the Administrator pursuant to § 60.665a(b). Upon establishment of a new operating limit, you must thereafter operate under the new operating limit. If the Administrator determines that you did not conduct the performance test in accordance with the applicable requirements or that the operating limit established during the performance test does not correspond to the conditions specified in § 60.664a(a), then you must conduct a new performance test and establish a new operating limit.

(3) Monitor, record, and demonstrate continuous compliance using the minimum frequencies specified in table 3 to this subpart or established according to paragraph (c) of this section.

(4) Comply with the calibration and quality control requirements as specified in table 4 to this subpart or established according to paragraph (c) of this section that are applicable to the CPMS used.

(5) Any vent stream introduced with primary fuel into a boiler or process heater is exempt from the requirements specified in paragraphs (a)(1) through (4) of this section.

(6) If you vent emissions through a closed vent system to an adsorber(s) that

cannot be regenerated or a regenerative adsorber(s) that is regenerated offsite, then you must install a system of two or more adsorber units in series and comply with the requirements specified in paragraphs (a)(6)(i) through (iii) of this section in addition to the requirements specified in paragraphs (a)(1) through (4) of this section.

(i) Conduct an initial performance test or design evaluation of the adsorber and establish the breakthrough limit and adsorber bed life.

(ii) Monitor the TOC concentration through a sample port at the outlet of the first adsorber bed in series according to the schedule in paragraph (a)(6)(iii)(B) of this section. You must measure the concentration of TOC using either a portable analyzer, in accordance with Method 21 of appendix A-7 of this part using methane, propane, or isobutylene as the calibration gas or Method 25A of appendix A-7 of this part using methane or propane as the calibration gas.

(iii) Comply with paragraph (a)(6)(iii)(A) of this section and comply with the monitoring frequency according to paragraph (a)(6)(iii)(B) of this section.

(A) The first adsorber in series must be replaced immediately when breakthrough, as defined in § 60.661a, is detected between the first and second adsorber. The original second adsorber (or a fresh canister) will become the new first adsorber and a fresh adsorber will become the second adsorber. For purposes of this paragraph (a)(6)(iii)(A), “immediately” means within 8 hours of the detection of a breakthrough for adsorbers of 55 gallons or less, and within 24 hours of the detection of a breakthrough for adsorbers greater than 55 gallons. You must monitor at the outlet of the first adsorber within 3 days of replacement to confirm it is performing properly.

(B) Based on the adsorber bed life established according to paragraph (a)(6)(i) of this section and the date the

adsorbent was last replaced, conduct monitoring to detect breakthrough at least monthly if the adsorbent has more than 2 months of life remaining, at least weekly if the adsorbent has between 2 months and 2 weeks of life remaining, and at least daily if the adsorbent has 2 weeks or less of life remaining.

(7) If you install a continuous emissions monitoring system (CEMS) to demonstrate compliance with the TOC standard in table 1 of this subpart, you must comply with the requirements specified in § 60.664a(g) in lieu of the requirements specified in paragraphs (a)(1) through (4) and (c) of this section.

(b) If you vent emissions through a closed vent system to a boiler or process heater, then the vent stream must be introduced into the flame zone of the boiler or process heater.

(c) If you seek to demonstrate compliance with the standards specified under § 60.662a with control devices other than an incinerator, boiler, process heater, or flare; or recovery devices other than an absorber, condenser, or carbon adsorber, you shall provide to the Administrator prior to conducting the initial performance test information describing the operation of the control device or recovery device and the parameter(s) which would indicate proper operation and maintenance of the device and how the parameter(s) are indicative of control of TOC emissions. The Administrator may request further information and will specify appropriate monitoring procedures or requirements, including operating parameters to be monitored, averaging times for determining compliance with the operating parameter limits, and ongoing calibration and quality control requirements.

**§ 60.664a What test methods and procedures must I use to determine compliance with the standards?**

(a) For the purpose of demonstrating compliance with the emission limits and standards specified in table 1 to this

subpart, all affected facilities must be run at full operating conditions and flow rates during any performance test. Performance tests are not required if you determine compliance using a CEMS that meets the requirements outlined in paragraph (g) of this section.

(1) Conduct initial performance tests no later than the date required by § 60.8(a).

(2) Conduct subsequent performance tests no later than 60 calendar months after the previous performance test.

(b) The following methods, except as provided in § 60.8(b) must, must be used as reference methods to determine compliance with the emission limit or percent reduction efficiency specified in table 1 to this subpart for non-flare control devices and/or recovery systems.

(1) Method 1 or 1A of appendix A-1 to this part, as appropriate, for selection of the sampling sites. The inlet sampling site for determination of vent stream molar composition or TOC (less methane and ethane) reduction efficiency shall be prior to the inlet of the control device or, if equipped with a recovery system, then prior to the inlet of the first recovery device in the recovery system.

(2) Method 2, 2A, 2C, or 2D of appendix A-1 to this part, as appropriate, for determination of the gas volumetric flow rates.

(3) Method 3A of appendix A-2 to this part or the manual method in ANSI/ASME PTC 19.10-1981 (incorporated by reference, see § 60.17) must be used to determine the oxygen concentration (%O<sub>2d</sub>) for the purposes of determining compliance with the 20 ppmv limit. The sampling site must be the same as that of the TOC samples, and the samples must be taken during the same time that the TOC samples are taken. The TOC concentration corrected to 3 percent O<sub>2</sub> (C<sub>c</sub>) must be computed using the following equation:

Equation 1 to Paragraph (b)(3)

$$C_c = C_{TOC} \frac{17.9}{20.9 - \%O_{2d}}$$

Where:

C<sub>c</sub> = Concentration of TOC corrected to 3 percent O<sub>2</sub>, dry basis, ppm by volume.

C<sub>TOC</sub> = Concentration of TOC (minus methane and ethane), dry basis, ppm by volume.

%O<sub>2d</sub> = Concentration of O<sub>2</sub>, dry basis, percent by volume.

(4) Method 18 of appendix A-6 to this part to determine the concentration of

TOC in the control device outlet or in the outlet of the final recovery device in a recovery system, and to determine the concentration of TOC in the inlet when the reduction efficiency of the control device or recovery system is to be determined. ASTM D6420-18 (incorporated by reference, see § 60.17) may be used in lieu of Method 18, if the target compounds are all known and are

all listed in section 1.1 of ASTM D6420-18 as measurable; ASTM D6420-18 may not be used for methane and ethane; and ASTM D6420-18 must not be used as a total VOC method.

(i) The sampling time for each run must be 1 hour in which either an integrated sample or at least four grab samples must be taken. If grab sampling

is used then the samples must be taken at 15-minute intervals.

(ii) The emission reduction (R) of TOC (minus methane and ethane) must be

determined using the following equation:

Equation 2 to Paragraph (b)(4)(ii)

$$R = \frac{E_i - E_o}{E_i} \times 100$$

Where:

R = Emission reduction, percent by weight.  
 E<sub>i</sub> = Mass rate of TOC entering the control device or recovery system, kg/hr (lb/hr).

E<sub>o</sub> = Mass rate of TOC discharged to the atmosphere, kg/hr (lb/hr).

(iii) The mass rates of TOC (E<sub>i</sub>, E<sub>o</sub>) must be computed using the following equations:

Equations 3 and 4 to Paragraph (b)(4)(iii)

$$E_i = K_2 \left( \sum_{j=1}^n C_{ij} M_j \right) Q_i$$

$$E_o = K_2 \left( \sum_{j=1}^n C_{oj} M_j \right) Q_o$$

Where:

C<sub>ij</sub>, C<sub>oj</sub> = Concentration of sample component “j” of the gas stream at the inlet and outlet of the control device or recovery system, respectively, dry basis, ppm by volume.

M<sub>ij</sub>, M<sub>oj</sub> = Molecular weight of sample component “j” of the gas stream at the inlet and outlet of the control device or

recovery system, respectively, g/g-mole (lb/lb-mole).  
 Q<sub>i</sub>, Q<sub>o</sub> = Flow rate of gas stream at the inlet and outlet of the control device or recovery system, respectively, dscm/min (dscf/min).

K<sub>2</sub> = 2.494 × 10<sup>-6</sup> (1/ppm)(g-mole/scm) (kg/g) (min/hr) (metric units), where standard temperature for (g-mole/scm) is 20 °C.

= 1.557 × 10<sup>-7</sup> (1/ppm) (lb-mole/scf) (min/hr) (English units), where standard temperature for (lb-mole/scf) is 68 °F.

(iv) The TOC concentration (C<sub>TOC</sub>) is the sum of the individual components and must be computed for each run using the following equation:

Equation 5 to Paragraph (b)(4)(iv)

$$C_{TOC} = \sum_{j=1}^n C_j$$

Where:

C<sub>TOC</sub> = Concentration of TOC (minus methane and ethane), dry basis, ppm by volume.  
 C<sub>j</sub> = Concentration of sample components “j”, dry basis, ppm by volume.  
 n = Number of components in the sample.

(c) The requirement for initial and subsequent performance tests are waived, in accordance with § 60.8(b), for the following:

(1) When a boiler or process heater with a design heat input capacity of 44 MW (150 million Btu/hour) or greater is used to seek to comply with the emission limit or percent reduction efficiency specified in table 1 to this subpart.

(2) When a vent stream is introduced into a boiler or process heater with the primary fuel.

(3) When a boiler or process heater burning hazardous waste is used for which the owner or operator:

(i) Has been issued a final permit under 40 CFR part 270 and complies

with the requirements of 40 CFR part 266, subpart H;

(ii) Has certified compliance with the interim status requirements of 40 CFR part 266, subpart H;

(iii) Has submitted a Notification of Compliance under 40 CFR 63.1207(j) and complies with the requirements of 40 CFR part 63, subpart EEE; or

(iv) Complies with 40 CFR part 63, subpart EEE and will submit a Notification of Compliance under 40 CFR 63.1207(j) by the date the owner or operator would have been required to submit the initial performance test report for this subpart.

(4) The Administrator reserves the option to require testing at such other times as may be required, as provided for in section 114 of the Act.

(d) For purposes of complying with the 98 weight-percent reduction in § 60.702a(a), if the vent stream entering a boiler or process heater with a design capacity less than 44 MW (150 million Btu/hour) is introduced with the combustion air or as secondary fuel, the

weight-percent reduction of TOC (minus methane and ethane) across the combustion device shall be determined by comparing the TOC (minus methane and ethane) in all combusted vent streams, primary fuels, and secondary fuels with the TOC (minus methane and ethane) exiting the combustion device.

(e) Any owner or operator subject to the provisions of this subpart seeking to demonstrate compliance with § 60.660a(c)(5) must use Method 2, 2A, 2C, or 2D of appendix A-1 to this part as appropriate, for determination of volumetric flow rate. The owner or operator must conduct three velocity traverses and determine the volumetric flow rate for each traverse. If the pipe or duct is smaller than four inches in diameter, the owner operator may conduct the measurement at the centroid of the duct instead of conducting a traverse; the measurement period must be at least five minutes long and data must be recorded at least once every 30 seconds. Owners and operators who conduct the determination with

Method 2A or 2D must record volumetric flow rate every 30 seconds for at least five minutes.

(f) Any owner or operator subject to the provisions of this subpart seeking to demonstrate compliance with § 60.660a(c)(6) must use the following methods:

(1) Method 1 or 1A of appendix A–1 to this part, as appropriate.

(2) Method 2, 2A, 2C, or 2D of appendix A–1 to this part, as

appropriate, for determination of the gas volumetric flow rates.

(3) Method 18 of appendix A–6 to this part to determine the concentration of TOC. ASTM D6420–18 (incorporated by reference, see § 60.17) may be used in lieu of Method 18, if the target compounds are all known and are all listed in Section 1.1 of ASTM D6420–18 as measurable; ASTM D6420–18 may not be used for methane and ethane; and ASTM D6420–18 must not be used as a total VOC method.

$$E = K \left( \sum_{j=1}^n C_j M_j \right) Q$$

Where:

$C_j$  = Concentration of sample component “j” of the gas stream at the representative sampling location, dry basis, ppm by volume.

$M_j$  = Molecular weight of sample component “j” of the gas stream at the representative sampling location, g/mole (lb/lb-mole).

$Q$  = Flow rate of gas stream at the representative sampling location, dscm/min (dscf/min).

$K = 2.494 \times 10^{-6}$  (1/ppm)(g-mole/scm) (kg/g) (min/hr) (metric units), where standard temperature for (g-mole/scm) is 20 °C.  
 $= 1.557 \times 10^{-7}$  (1/ppm) (lb-mole/scf) (min/hr) (English units), where standard temperature for (lb-mole/scf) is 68 °F.

(g) If you use a CEMS to demonstrate initial and continuous compliance with the TOC standard in table 1 of this subpart, each CEMS must be installed, operated and maintained according to the requirements in § 60.13 and paragraphs (g)(1) through (5) of this section.

(1) You must use a CEMS that is capable of measuring the target analyte(s) as demonstrated using either process knowledge of the control device inlet stream or the screening procedures of Method 18 of appendix A–6 to this part on the control device inlet stream. If your CEMS is located after a combustion device and inlet stream to that device includes methanol or formaldehyde, you must use a CEMS which meets the requirements in Performance Specification 9 or 15 of appendix B to this part.

(2) Each CEMS must be installed, operated, and maintained according to the applicable performance specification of appendix B to this part and the applicable quality assurance procedures of appendix F to this part. Locate the sampling probe or other interface at a measurement location such that you obtain representative

measurements of emissions from the affected facility.

(3) Conduct a performance evaluation of each CEMS within 180 days of installation of the monitoring system. Conduct subsequent performance evaluations of the CEMS no later than 12 calendar months after the previous performance evaluation. The results each performance evaluation must be submitted in accordance with § 60.665a(b)(1).

(4) You must determine TOC concentration according to one of the following options. The span value of the TOC CEMS must be approximately 2 times the emission standard specified in table 1 of this subpart.

(i) For CEMS meeting the requirements of Performance Specification 15 of appendix B to this part, determine the target analyte(s) for calibration using either process knowledge of the control device inlet stream or the screening procedures of Method 18 of appendix A–6 to this part on the control device inlet stream. The individual analytes used to quantify TOC must represent 98 percent of the expected mass of TOC present in the stream. Report the results of TOC as equivalent to carbon (C1).

(ii) For CEMS meeting the requirements of Performance Specification 9 of appendix B of this part, determine the target analyte(s) for calibration using either process knowledge of the control device inlet stream or the screening procedures of Method 18 of appendix A–6 to this part on the control device inlet stream. The individual analytes used to quantify TOC must represent 98 percent of the expected mass of TOC present in the stream. Report the results of TOC as equivalent to carbon (C1).

(i) The sampling site must be at a location that provides a representative sample of the vent stream.

(ii) Perform three test runs. The sampling time for each run must be 1 hour in which either an integrated sample or at least four grab samples must be taken. If grab sampling is used then the samples must be taken at 15-minute intervals.

(iii) The mass rate of TOC (E) must be computed using the following equation: Equation 6 to Paragraph (f)(3)(iii)

(iii) For CEMS meeting the requirements of Performance Specification 8 of appendix B to this part used to monitor performance of a combustion device, calibrate the instrument on the predominant organic HAP and report the results as carbon (C1), and use Method 25A of appendix A–7 to this part as the reference method for the relative accuracy tests. You must also comply with procedure 1 of appendix F to this part.

(iv) For CEMS meeting the requirements of Performance Specification 8 of appendix B to this part used to monitor performance of a noncombustion device, determine the predominant organic compound using either process knowledge or the screening procedures of Method 18 on the control device inlet stream. Calibrate the monitor on the predominant organic compound and report the results as C1. Use Method 25A of appendix A–7 to this part as the reference method for the relative accuracy tests. You must also comply with procedure 1 of appendix F to this part.

(5) You must determine stack oxygen concentration at the same location where you monitor TOC concentration with a CEMS that meets the requirements of Performance Specification 3 of appendix B to this part. The span value of the oxygen CEMS must be approximately 25 percent oxygen. Use Method 3A of appendix A–2 to this part as the reference method for the relative accuracy tests.

(6) You must maintain written procedures for your CEMS. At a minimum, the procedures must include the information in paragraph (g)(6)(i) through (vi) of this section:

(i) Description of CEMS installation location.

(ii) Description of the monitoring equipment, including the manufacturer and model number for all monitoring equipment components and the span of the analyzer.

(iii) Routine quality control and assurance procedures.

(iv) Conditions that would trigger a CEMS performance evaluation, which must include, at a minimum, a newly installed CEMS; a process change that is expected to affect the performance of the CEMS; and the Administrator's request for a performance evaluation under section 114 of the Clean Air Act.

(v) Ongoing operation and maintenance procedures.

(vi) Ongoing recordkeeping and reporting procedures.

**§ 60.665a What records must I keep and what reports must I submit?**

(a) You must notify the Administrator of the specific provisions of table 1 of this subpart or § 60.662a(c) with which you have elected to comply. Notification must be submitted with the notification of initial start-up required by § 60.7(a)(3). If you elect at a later date to use an alternative provision of table 1 to this subpart with which you will comply, then you must notify the Administrator 90 days before implementing a change and, upon implementing the change, you must conduct a performance test as specified by § 60.664a within 180 days.

(b) If you use a non-flare control device or recovery system to comply with the TOC emission limit specified in table 1 to this subpart, then you must keep an up-to-date, readily accessible record of the data measured during each performance test to show compliance with the TOC emission limit. You must also include all of the data you use to comply with § 60.663a(a)(2). The same data specified in this paragraph must also be submitted in the initial performance test required in § 60.8 and the reports of all subsequently required performance tests where either the emission reduction efficiency of a control device or recovery system or outlet concentration of TOC is determined. Alternatively, you must keep records of each CEMS performance evaluation.

(1) Within 60 days after the date of completing each performance test or CEMS performance evaluation required by this subpart, you must submit the results of the performance test or performance evaluation following the procedures specified in paragraph (k) of this section. Data collected using test methods and performance evaluations of CEMS measuring relative accuracy test audit (RATA) pollutants supported

by the EPA's Electronic Reporting Tool (ERT) as listed on the EPA's ERT website (<https://www.epa.gov/electronic-reporting-air-emissions/electronic-reporting-tool-ert>) at the time of the test or performance evaluation must be submitted in a file format generated through the use of the EPA's ERT. Alternatively, owners and operators may submit an electronic file consistent with the extensible markup language (XML) schema listed on the EPA's ERT website. Data collected using test methods and performance evaluations of CEMS measuring RATA pollutants that are not supported by the EPA's ERT as listed on the EPA's ERT website at the time of the test must be included as an attachment in the ERT or alternate electronic file.

(2) If you use a boiler or process heater with a design heat input capacity of 44 MW (150 million Btu/hour) or greater to comply with the TOC emission limit specified in table 1 to this subpart, then you are not required to submit a report containing performance test data; however, you must submit a description of the location at which the vent stream is introduced into the boiler or process heater.

(c) If you use a non-flare control device or recovery system to comply with the TOC emission limit specified in Table 1 to this subpart, then you must keep up-to-date, readily accessible records of periods of operation during which the operating parameter limits established during the most recent performance test are exceeded or periods of operation where the TOC CEMS, averaged on a 3-hour block basis, indicate an exceedance of the emission standard in table 1 to this subpart. Additionally, you must record all periods when the TOC CEMS is inoperable. The Administrator may at any time require a report of these data. Periods of operation during which the operating parameter limits established during the most recent performance tests are exceeded are defined as follows:

(1) For absorbers:

(i) All 3-hour periods of operation during which the average absorbing liquid temperature was above the maximum absorbing liquid temperature established during the most recent performance test.

(ii) All 3-hour periods of operation during which the average absorbing liquid specific gravity was outside the exit specific gravity range (*i.e.*, more than 0.1 unit above, or more than 0.1 unit below, the average absorbing liquid specific gravity) established during the most recent performance test.

(2) For boilers or process heaters:

(i) Whenever there is a change in the location at which the vent stream is introduced into the flame zone as required under § 60.663a(b).

(ii) If the boiler or process heater has a design heat input capacity of less than 44 MW (150 million Btu/hr), then all 3-hour periods of operation during which the average firebox temperature was below the minimum firebox temperature during the most recent performance test.

(3) For catalytic incinerators:

(i) All 3-hour periods of operation during which the average temperature of the vent stream immediately before the catalyst bed is below the minimum temperature of the vent stream established during the most recent performance test.

(ii) All 3-hour periods of operation during which the average temperature difference across the catalyst bed is less than the average temperature difference of the device established during the most recent performance test.

(4) For carbon adsorbers:

(i) All carbon bed regeneration cycles during which the total mass stream flow or the total volumetric stream flow was below the minimum flow established during the most recent performance test.

(ii) All carbon bed regeneration cycles during which the temperature of the carbon bed after regeneration (and after completion of any cooling cycle(s)) was greater than the maximum carbon bed temperature (in degrees Celsius) established during the most recent performance test.

(5) For condensers, all 3-hour periods of operation during which the average exit (product side) condenser operating temperature was above the maximum exit (product side) operating temperature established during the most recent performance test.

(6) For scrubbers used to control halogenated vent streams:

(i) All 3-hour periods of operation during which the average pH of the scrubber effluent is below the minimum pH of the scrubber effluent established during the most recent performance test.

(ii) All 3-hour periods of operation during which the average influent liquid flow to the scrubber is below the minimum influent liquid flow to the scrubber established during the most recent performance test.

(iii) All 3-hour periods of operation during which the average liquid-to-gas ratio flow of the scrubber is below the minimum liquid-to-gas ratio of the scrubber established during the most recent performance test.

(7) For thermal incinerators, all 3-hour periods of operation during which the average firebox temperature was

below the minimum firebox temperature established during the most recent performance test.

(8) For all other control devices, all periods (for the averaging time specified by the Administrator) when the operating parameter(s) established under § 60.663a(c) exceeded the operating limit established during the most recent performance test.

(d) You must keep up to date, readily accessible continuous records of the flow indication specified in table 2 to this subpart, as well as up-to-date, readily accessible records of all periods when the vent stream is diverted from the control device or recovery device or has no flow rate, including the records as specified in paragraphs (d)(1) and (2) of this section.

(1) For each flow event from a relief valve discharge subject to the requirements in § 60.662a(b)(1), you must include an estimate of the volume of gas, the concentration of TOC in the gas and the resulting emissions of TOC that released to the atmosphere using process knowledge and engineering estimates.

(2) For each flow event from a bypass line subject to the requirements in §§ 60.662a(b)(2) and 60.670a(e), you must maintain records sufficient to determine whether or not the detected flow included flow requiring control. For each flow event from a bypass line requiring control that is released either directly to the atmosphere or to a control device or recovery device not meeting the requirements in this subpart, you must include an estimate of the volume of gas, the concentration of TOC in the gas and the resulting emissions of TOC that bypassed the control device or recovery device using process knowledge and engineering estimates.

(e) If you use a boiler or process heater with a design heat input capacity of 44 MW (150 million Btu/hour) or greater to comply with the TOC emission limit specified in Table 1 to this subpart, then you must keep an up-to-date, readily accessible record of all periods of operation of the boiler or process heater. (Examples of such records could include records of steam use, fuel use, or monitoring data collected pursuant to other State or Federal regulatory requirements.)

(f) If you use a flare to comply with the TOC emission standard specified in Table 1 to this subpart, then you must keep up-to-date, readily accessible records of all visible emission readings, heat content determinations, flow rate measurements, and exit velocity determinations made during the initial visible emissions demonstration

required by § 63.670(h) of this chapter, as applicable; and all periods during the compliance determination when the pilot flame or flare flame is absent.

(g) For each maintenance vent opening subject to the requirements of § 60.662a(c), you must keep the applicable records specified in paragraphs (g)(1) through (5) of this section.

(1) You must maintain standard site procedures used to inventory equipment for safety purposes (*e.g.*, hot work or vessel entry procedures) to document the procedures used to meet the requirements in § 60.662a(c). The current copy of the procedures must be retained and available on-site at all times. Previous versions of the standard site procedures, as applicable, must be retained for five years.

(2) If complying with the requirements of § 60.662a(c)(1)(i), and the lower explosive limit at the time of the vessel opening exceeds 10 percent, identification of the maintenance vent, the process units or equipment associated with the maintenance vent, the date of maintenance vent opening, and the lower explosive limit at the time of the vessel opening.

(3) If complying with the requirements of § 60.662a(c)(1)(ii), and either the vessel pressure at the time of the vessel opening exceeds 5 psig or the lower explosive limit at the time of the active purging was initiated exceeds 10 percent, identification of the maintenance vent, the process units or equipment associated with the maintenance vent, the date of maintenance vent opening, the pressure of the vessel or equipment at the time of discharge to the atmosphere and, if applicable, the lower explosive limit of the vapors in the equipment when active purging was initiated.

(4) If complying with the requirements of § 60.662a(c)(1)(iii), records of the estimating procedures used to determine the total quantity of VOC in the equipment and the type and size limits of equipment that contain less than 50 pounds of VOC at the time of maintenance vent opening. For each maintenance vent opening that contains greater than 50 pounds of VOC for which the inventory procedures specified in paragraph (g)(1) of this section are not followed or for which the equipment opened exceeds the type and size limits established in the records specified in this paragraph (g)(4), records that identify the maintenance vent, the process units or equipment associated with the maintenance vent, the date of maintenance vent opening, and records used to estimate the total quantity of

VOC in the equipment at the time the maintenance vent was opened to the atmosphere.

(5) If complying with the requirements of § 60.662a(c)(1)(iv), identification of the maintenance vent, the process units or equipment associated with the maintenance vent, records documenting actions taken to comply with other applicable alternatives and why utilization of this alternative was required, the date of maintenance vent opening, the equipment pressure and lower explosive limit of the vapors in the equipment at the time of discharge, an indication of whether active purging was performed and the pressure of the equipment during the installation or removal of the blind if active purging was used, the duration the maintenance vent was open during the blind installation or removal process, and records used to estimate the total quantity of VOC in the equipment at the time the maintenance vent was opened to the atmosphere for each applicable maintenance vent opening.

(h) If you seek to comply with the requirements of this subpart by complying with the design production capacity provision in § 60.660a(c)(4) you must keep up-to-date, readily accessible records of any change in equipment or process operation that increases the design production capacity of the process unit in which the affected facility is located.

(i) If you seek to comply with the requirements of this subpart by complying with the flow rate cutoff in § 60.660a(c)(5) or (6) you must keep up-to-date, readily accessible records to indicate that the vent stream flow rate is less than 0.008 scm/min (0.3 scf/min) or less than 0.001 lb/hr, and of any change in equipment or process operation that increases the operating vent stream flow rate, including a measurement of the new vent stream flow rate.

(j) You must submit to the Administrator semiannual reports of the information specified in paragraphs (j)(1) through (9) of this section. You are exempt from the reporting requirements specified in § 60.7(c). If there are no exceedances, periods, or events specified in paragraphs (j)(1) through (9) of this section that occurred during the reporting period, then you must include a statement in your report that no exceedances, periods, and events specified in paragraphs (j)(1) through (9) of this section occurred during the reporting period. The initial report must be submitted within 6 months after the initial start-up-date. On and after July 15, 2024 or once the report template for



this subpart has been available on the Compliance and Emissions Data Reporting Interface (CEDRI) website (<https://www.epa.gov/electronic-reporting-air-emissions/cedri>) for 1 year, whichever date is later, you must submit all subsequent reports using the appropriate electronic report template on the CEDRI website for this subpart and following the procedure specified in paragraph (k) of this section. The date report templates become available will be listed on the CEDRI website. Unless the Administrator or delegated state agency or other authority has approved a different schedule for submission of reports, the report must be submitted by the deadline specified in this subpart, regardless of the method in which the report is submitted. All semiannual reports must include the following general information: company name, address (including county), and beginning and ending dates of the reporting period.

(1) Exceedances of monitored parameters recorded under paragraph (c) of this section. For each exceedance, the report must include a list of the affected facilities or equipment, the monitored parameter that was exceeded, the start date and time of the exceedance, the duration (in hours) of the exceedance, an estimate of the quantity in pounds of each regulated pollutant emitted over any emission limit, a description of the method used to estimate the emissions, the cause of the exceedance (including unknown cause, if applicable), as applicable, and the corrective action taken.

(2) All periods recorded under paragraph (d) of this section when the vent stream is diverted from the control device or recovery device, or has no flow rate, including the information specified in paragraphs (j)(2)(i) through (iii) of this section.

(i) For periods when the flow indicator is not operating, report the identification of the flow indicator and the start date, start time, and duration in hours.

(ii) For each flow event from a relief valve discharge subject to the requirements in § 60.662a(b)(1), the semiannual report must include the identification of the relief valve, the start date, start time, duration in hours, estimate of the volume of gas in standard cubic feet, the concentration of TOC in the gas in parts per million by volume and the resulting mass emissions of TOC in pounds that released to the atmosphere.

(iii) For each flow event from a bypass line subject to the requirements in § 60.662a(b)(2) and § 670a(e)(2), the semiannual report must include the

identification of the bypass line, the start date, start time, duration in hours, estimate of the volume of gas in standard cubic feet, the concentration of TOC in the gas in parts per million by volume and the resulting mass emissions of TOC in pounds that bypass a control device or recovery device.

(3) All periods when a boiler or process heater was not operating (considering the records recorded under paragraph (e) of this section), including the start date, start time, and duration in hours of each period.

(4) For each flare subject to the requirements in § 60.669a, the semiannual report must include an identification of the flare and the items specified in § 60.669a(l)(2).

(5) For each closed vent system subject to the requirements in § 60.670a, the semiannual report must include an identification of the closed vent system and the items specified in § 60.670a(i).

(6) Any change in equipment or process operation, as recorded under paragraph (h) of this section, that increases the design production capacity above the low capacity exemption level in § 60.660a(c)(4) and the new capacity resulting from the change for the distillation process unit containing the affected facility. These must be reported as soon as possible after the change and no later than 180 days after the change. These reports may be submitted either in conjunction with semiannual reports or as a single separate report. Unless the facility qualifies for an exemption under § 60.660a(c), the facility must begin compliance with the requirements set forth in § 60.662a.

(7) Any change in equipment or process operation that increases the operating vent stream flow rate above the low flow exemption level in § 60.660a(c)(5) or (6), including a measurement of the new vent stream flow rate, as recorded under paragraph (i) of this section. These must be reported as soon as possible after the change and no later than 180 days after the change. These reports may be submitted either in conjunction with semiannual reports or as a single separate report. A performance test must be completed with the same time period to verify the recalculated flow value. The performance test is subject to the requirements of § 60.8 and must be submitted according to paragraph (b)(1) of this section. Unless the facility qualifies for an exemption under § 60.660a(c), the facility must begin compliance with the requirements set forth in § 60.662a.

(8) Exceedances of the emission standard in Table 1 of this subpart as

indicated by a 3-hour average of the TOC CEMS and recorded under paragraph (c) of this section. For each exceedance, the report must include a list of the affected facilities or equipment, the start date and time of the exceedance, the duration (in hours) of the exceedance, an estimate of the quantity in pounds of each regulated pollutant emitted over the emission limit, a description of the method used to estimate the emissions, the cause of the exceedance (including unknown cause, if applicable), as applicable, and the corrective action taken.

(9) Periods when the TOC CEMS was inoperative. For each period, the report must include a list of the affected facilities or equipment, the start date and time of the period, the duration (in hours) of the period, the cause of the inoperability (including unknown cause, if applicable), as applicable, and the corrective action taken.

(k) If you are required to submit notifications or reports following the procedure specified in this paragraph (k), you must submit notifications or reports to the EPA via CEDRI, which can be accessed through the EPA's Central Data Exchange (CDX) (<https://cdx.epa.gov/>). The EPA will make all the information submitted through CEDRI available to the public without further notice to you. Do not use CEDRI to submit information you claim as CBI. Although we do not expect persons to assert a claim of CBI, if you wish to assert a CBI claim for some of the information in the report or notification, you must submit a complete file in the format specified in this subpart, including information claimed to be CBI, to the EPA following the procedures in paragraphs (k)(1) and (2) of this section. Clearly mark the part or all of the information that you claim to be CBI. Information not marked as CBI may be authorized for public release without prior notice. Information marked as CBI will not be disclosed except in accordance with procedures set forth in 40 CFR part 2. All CBI claims must be asserted at the time of submission. Anything submitted using CEDRI cannot later be claimed CBI. Furthermore, under CAA section 114(c), emissions data is not entitled to confidential treatment, and the EPA is required to make emissions data available to the public. Thus, emissions data will not be protected as CBI and will be made publicly available. You must submit the same file submitted to the CBI office with the CBI omitted to the EPA via the EPA's CDX as described earlier in this paragraph (k).

(1) The preferred method to receive CBI is for it to be transmitted

electronically using email attachments, File Transfer Protocol, or other online file sharing services. Electronic submissions must be transmitted directly to the OAQPS CBI Office at the email address [oaqpscbi@epa.gov](mailto:oaqpscbi@epa.gov), and as described above, should include clear CBI markings. ERT files should be flagged to the attention of the Group Leader, Measurement Policy Group; all other files should be flagged to the attention of the SOCOMI NSPS Sector Lead. If assistance is needed with submitting large electronic files that exceed the file size limit for email attachments, and if you do not have your own file sharing service, please email [oaqpscbi@epa.gov](mailto:oaqpscbi@epa.gov) to request a file transfer link.

(2) If you cannot transmit the file electronically, you may send CBI information through the postal service to the following address: OAQPS Document Control Officer (C404-02), OAQPS, U.S. Environmental Protection Agency, 109 T.W. Alexander Drive, P.O. Box 12055, Research Triangle Park, North Carolina 27711. ERT files should be sent to the attention of the Group Leader, Measurement Policy Group, and all other files should be sent to the attention of the SOCOMI NSPS Sector Lead. The mailed CBI material should be double wrapped and clearly marked. Any CBI markings should not show through the outer envelope.

(l) If you are required to electronically submit notifications or reports through CEDRI in the EPA's CDX, you may assert a claim of EPA system outage for failure to timely comply with the electronic submittal requirement. To assert a claim of EPA system outage, you must meet the requirements outlined in paragraphs (l)(1) through (7) of this section.

(1) You must have been or will be precluded from accessing CEDRI and submitting a required report within the time prescribed due to an outage of either the EPA's CEDRI or CDX systems.

(2) The outage must have occurred within the period of time beginning five business days prior to the date that the submission is due.

(3) The outage may be planned or unplanned.

(4) You must submit notification to the Administrator in writing as soon as possible following the date you first knew, or through due diligence should have known, that the event may cause or has caused a delay in reporting.

(5) You must provide to the Administrator a written description identifying:

(i) The date(s) and time(s) when CDX or CEDRI was accessed and the system was unavailable;

(ii) A rationale for attributing the delay in reporting beyond the regulatory deadline to EPA system outage;

(iii) A description of measures taken or to be taken to minimize the delay in reporting; and

(iv) The date by which you propose to report, or if you have already met the reporting requirement at the time of the notification, the date you reported.

(6) The decision to accept the claim of EPA system outage and allow an extension to the reporting deadline is solely within the discretion of the Administrator.

(7) In any circumstance, the report must be submitted electronically as soon as possible after the outage is resolved.

(m) If you are required to electronically submit notifications or reports through CEDRI in the EPA's CDX, you may assert a claim of *force majeure* for failure to timely comply with the electronic submittal requirement. To assert a claim of *force majeure*, you must meet the requirements outlined in paragraphs (m)(1) through (5) of this section.

(1) You may submit a claim if a *force majeure* event is about to occur, occurs, or has occurred or there are lingering effects from such an event within the period of time beginning five business days prior to the date the submission is due. For the purposes of this section, a *force majeure* event is defined as an event that will be or has been caused by circumstances beyond the control of the affected facility, its contractors, or any entity controlled by the affected facility that prevents you from complying with the requirement to submit a report electronically within the time period prescribed. Examples of such events are acts of nature (e.g., hurricanes, earthquakes, or floods), acts of war or terrorism, or equipment failure or safety hazard beyond the control of the affected facility (e.g., large scale power outage).

(2) You must submit notification to the Administrator in writing as soon as possible following the date you first knew, or through due diligence should have known, that the event may cause or has caused a delay in reporting.

(3) You must provide to the Administrator:

(i) A written description of the *force majeure* event;

(ii) A rationale for attributing the delay in reporting beyond the regulatory deadline to the *force majeure* event;

(iii) A description of measures taken or to be taken to minimize the delay in reporting; and

(iv) The date by which you propose to report, or if you have already met the

reporting requirement at the time of the notification, the date you reported.

(4) The decision to accept the claim of *force majeure* and allow an extension to the reporting deadline is solely within the discretion of the Administrator.

(5) In any circumstance, the reporting must occur as soon as possible after the *force majeure* event occurs.

(n) The requirements of paragraph (j) of this section remain in force until and unless EPA, in delegating enforcement authority to a State under section 111(c) of the Act, approves reporting requirements or an alternative means of compliance surveillance adopted by such State. In that event, affected sources within the State will be relieved of the obligation to comply with paragraph (j) of this section, provided that they comply with the requirements established by the State. The EPA will not approve a waiver of electronic reporting to the EPA in delegating enforcement authority. Thus, electronic reporting to the EPA cannot be waived, and as such, the provisions of this paragraph cannot be used to relieve owners or operators of affected facilities of the requirement to submit the electronic reports required in this section to the EPA.

(o) If you seek to demonstrate compliance with § 60.660(c)(4), then you must submit to the Administrator an initial report detailing the design production capacity of the process unit.

(p) If you seek to demonstrate compliance with § 60.660(c)(5) or (6), then you must submit to the Administrator, following the procedures in paragraph (b)(1) of this section, an initial report including a flow rate measurement using the test methods specified in § 60.664a.

(q) The Administrator will specify appropriate reporting and recordkeeping requirements where the owner or operator of an affected facility complies with the standards specified under § 60.662a other than as provided under § 60.663a.

(r) Any records required to be maintained by this subpart that are submitted electronically via the EPA's CEDRI may be maintained in electronic format. This ability to maintain electronic copies does not affect the requirement for facilities to make records, data, and reports available upon request to a delegated air agency or the EPA as part of an on-site compliance evaluation.

**§ 60.666a What do the terms associated with reconstruction mean for this subpart?**

For purposes of this subpart "fixed capital cost of the new components," as

used in § 60.15, includes the fixed capital cost of all depreciable components which are or will be replaced pursuant to all continuous programs of component replacement which are commenced within any 2-

year period following April 25, 2023. For purposes of this paragraph, “commenced” means that you have undertaken a continuous program of component replacement or that you have entered into a contractual

obligation to undertake and complete, within a reasonable time, a continuous program of component replacement.

**§ 60.667a What are the chemicals that I must produce to be affected by subpart NNNa?**

Chemical name	CAS No.*
Acetaldehyde	75-07-0
Acetaldol	107-89-1
Acetic acid	64-19-7
Acetic anhydride	108-24-7
Acetone	67-64-1
Acetone cyanohydrin	75-86-5
Acetylene	74-86-2
Acrylic acid	79-10-7
Acrylonitrile	107-13-1
Adipic acid	124-04-9
Adiponitrile	111-69-3
Alcohols, C-11 or lower, mixtures	
Alcohols, C-12 or higher, mixtures	
Allyl chloride	107-05-1
Amylene	513-35-9
Amylenes, mixed	
Aniline	62-53-3
Benzene	71-43-2
Benzenesulfonic acid	98-11-3
Benzenesulfonic acid C <sub>10-16</sub> -alkyl derivatives, sodium salts	68081-81-2
Benzoic acid, tech	65-85-0
Benzyl chloride	100-44-7
Biphenyl	92-52-4
Bisphenol A	80-05-7
Brometone	76-08-4
1,3-Butadiene	106-99-0
Butadiene and butene fractions	
n-Butane	106-97-8
1,4-Butanediol	110-63-4
Butanes, mixed	
1-Butene	106-98-9
2-Butene	25167-67-3
Butenes, mixed	
n-Butyl acetate	123-86-4
Butyl acrylate	141-32-2
n-Butyl alcohol	71-36-3
sec-Butyl alcohol	78-92-2
tert-Butyl alcohol	75-65-0
Butylbenzyl phthalate	85-68-7
Butylene glycol	107-88-0
tert-Butyl hydroperoxide	75-91-2
2-Butyne-1,4-diol	110-65-6
Butyraldehyde	123-72-8
Butyric anhydride	106-31-0
Caprolactam	105-60-2
Carbon disulfide	75-15-0
Carbon tetrabromide	558-13-4
Carbon tetrachloride	56-23-5
Chlorobenzene	108-90-7
2-Chloro-4-(ethylamino)-6-(isopropylamino)-s-triazine	1912-24-9
Chloroform	67-66-3
p-Chloronitrobenzene	100-00-5
Chloroprene	126-99-8
Citric acid	77-92-9
Crotonaldehyde	4170-30-0
Crotonic acid	3724-65-0
Cumene	98-82-8
Cumene hydroperoxide	80-15-9
Cyanuric chloride	108-77-0
Cyclohexane	110-82-7
Cyclohexane, oxidized	68512-15-2
Cyclohexanol	108-93-0
Cyclohexanone	108-94-1
Cyclohexanone oxime	100-64-1
Cyclohexene	110-83-8
1,3-Cyclopentadiene	542-92-7

Chemical name	CAS No.*
Cyclopropane	75-19-4
Diacetone alcohol	123-42-2
Dibutanized aromatic concentrate	.....
1,4-Dichlorobutene	110-57-6
3,4-Dichloro-1-butene	64037-54-3
Dichlorodifluoromethane	75-71-8
Dichlorodimethylsilane	75-78-5
Dichlorofluoromethane	75-43-4
Dichlorohydrin	96-23-1
Diethanolamine	111-42-2
Diethylbenzene	25340-17-4
Diethylene glycol	111-46-6
Di-n-heptyl-n-nonyl undecyl phthalate	85-68-7
Di-isodecyl phthalate	26761-40-0
Diisononyl phthalate	28553-12-0
Dimethylamine	124-40-3
Dimethyl terephthalate	120-61-6
2,4-Dinitrotoluene	121-14-2
2,4-(and 2,6)-dinitrotoluene	121-14-2
	606-20-2
Dioctyl phthalate	117-81-7
Dodecene	25378-22-7
Dodecylbenzene, non linear	.....
Dodecylbenzenesulfonic acid	27176-87-0
Dodecylbenzenesulfonic acid, sodium salt	25155-30-0
Epichlorohydrin	106-89-8
Ethanol	64-17-5
Ethanolamine	141-43-5
Ethyl acetate	141-78-6
Ethyl acrylate	140-88-5
Ethylbenzene	100-41-4
Ethyl chloride	75-00-3
Ethyl cyanide	107-12-0
Ethylene	74-85-1
Ethylene dibromide	106-93-4
Ethylene dichloride	107-06-2
Ethylene glycol	107-21-1
Ethylene glycol monobutyl	111-76-2
Ethylene glycol monoethyl ether	110-80-5
Ethylene glycol monoethyl ether acetate	111-15-9
Ethylene glycol monomethyl ether	109-86-4
Ethylene oxide	75-21-8
2-Ethylhexanal	26266-68-2
2-Ethylhexyl alcohol	104-76-7
(2-Ethylhexyl) amine	104-75-6
Ethylmethylbenzene	25550-14-5
6-Ethyl-1,2,3,4-tetrahydro 9,10-anthracenedione	15547-17-8
Formaldehyde	50-00-0
Glycerol	56-81-5
n-Heptane	142-82-5
Heptenes (mixed)	.....
Hexadecyl chloride	.....
Hexamethylene diamine	124-09-4
Hexamethylene diamine adipate	3323-53-3
Hexamethylenetetramine	100-97-0
Hexane	110-54-3
2-Hexenedinitrile	13042-02-9
3-Hexenedinitrile	1119-85-3
Hydrogen cyanide	74-90-8
Isobutane	75-28-5
Isobutanol	78-83-1
Isobutylene	115-11-7
Isobutyraldehyde	78-84-2
Isodecyl alcohol	25339-17-7
Isooctyl alcohol	26952-21-6
Isopentane	78-78-4
Isophthalic acid	121-91-5
Isoprene	78-79-5
Isopropanol	67-63-0
Ketene	463-51-4
Linear alcohols, ethoxylated, mixed	.....
Linear alcohols, ethoxylated, and sulfated, sodium salt, mixed	.....
Linear alcohols, sulfated, sodium salt, mixed	.....
Linear alkylbenzene	123-01-3

Chemical name	CAS No.*
Magnesium acetate	142-72-3
Maleic anhydride	108-31-6
Melamine	108-78-1
Mesityl oxide	141-79-7
Methacrylonitrile	126-98-7
Methanol	67-56-1
Methylamine	74-89-5
ar-Methylbenzenediamine	25376-45-8
Methyl chloride	74-87-3
Methylene chloride	75-09-2
Methyl ethyl ketone	78-93-3
Methyl iodide	74-88-4
Methyl isobutyl ketone	108-10-1
Methyl methacrylate	80-62-6
2-Methylpentane	107-83-5
1-Methyl-2-pyrrolidone	872-50-4
Methyl tert-butyl ether	.....
Naphthalene	91-20-3
Nitrobenzene	98-95-3
1-Nonene	27215-95-8
Nonyl alcohol	143-08-8
Nonylphenol	25154-52-3
Nonylphenol, ethoxylated	9016-45-9
Octene	25377-83-7
Oil-soluble petroleum sulfonate, calcium salt	.....
Oil-soluble petroleum sulfonate, sodium salt	.....
Pentaerythritol	115-77-5
n-Pentane	109-66-0
3-Pentenenitrile	4635-87-4
Pentenes, mixed	109-67-1
Perchloroethylene	127-18-4
Phenol	108-95-2
1-Phenylethyl hydroperoxide	3071-32-7
Phenylpropane	103-65-1
Phosgene	75-44-5
Phthalic anhydride	85-44-9
Propane	74-98-6
Propionaldehyde	123-38-6
Propionic acid	79-09-4
Propyl alcohol	71-23-8
Propylene	115-07-1
Propylene chlorohydrin	78-89-7
Propylene glycol	57-55-6
Propylene oxide	75-56-9
Sodium cyanide	143-33-9
Sorbitol	50-70-4
Styrene	100-42-5
Terephthalic acid	100-21-0
1,1,2,2-Tetrachloroethane	79-34-5
Tetraethyl lead	78-00-2
Tetrahydrofuran	109-99-9
Tetra (methyl-ethyl) lead	.....
Tetramethyl lead	75-74-1
Toluene	108-88-3
Toluene-2,4-diamine	95-80-7
Toluene-2,4-(and, 2,6)-diisocyanate (80/20 mixture)	26471-62-5
Tribromomethane	75-25-2
1,1,1-Trichloroethane	71-55-6
1,1,2-Trichloroethane	79-00-5
Trichloroethylene	79-01-6
Trichlorofluoromethane	75-69-4
1,1,2-Trichloro-1,2,2-trifluoroethane	76-13-1
Triethanolamine	102-71-6
Triethylene glycol	112-27-6
Vinyl acetate	108-05-4
Vinyl chloride	75-01-4
Vinylidene chloride	75-35-4
m-Xylene	108-38-3
o-Xylene	95-47-6
p-Xylene	106-42-3
Xylenes (mixed)	1330-20-7

Chemical name	CAS No.*
m-Xylenol .....	576-26-1

\* CAS numbers refer to the Chemical Abstracts Registry numbers assigned to specific chemicals, isomers, or mixtures of chemicals. Some isomers or mixtures that are covered by the standards do not have CAS numbers assigned to them. The standards apply to all of the chemicals listed, whether CAS numbers have been assigned or not.

#### § 60.668a [Reserved]

#### § 60.669a What are my requirements if I use a flare to comply with this subpart?

(a) If you use a flare to comply with the TOC emission standard specified in Table 1 to this subpart, then you must meet the applicable requirements for flares as specified in §§ 63.670 and 63.671 of this chapter, including the provisions in tables 12 and 13 to part 63, subpart CC, of this chapter, except as specified in paragraphs (b) through (o) of this section. This requirement also applies to any flare using fuel gas from a fuel gas system, of which 50 percent or more of the fuel gas is derived from an affected facility, as determined on an annual average basis. For purposes of compliance with this paragraph (a), the following terms are defined in § 63.641 of this chapter: Assist air, assist steam, center steam, combustion zone, combustion zone gas, flare, flare purge gas, flare supplemental gas, flare sweep gas, flare vent gas, lower steam, net heating value, perimeter assist air, pilot gas, premix assist air, total steam, and upper steam.

(b) When determining compliance with the pilot flame requirements specified in § 63.670(b) and (g) of this chapter, substitute “pilot flame or flare flame” for each occurrence of “pilot flame.”

(c) When determining compliance with the flare tip velocity and combustion zone operating limits specified in § 63.670(d) and (e) of this chapter, the requirement effectively applies starting with the 15-minute block that includes a full 15 minutes of the flaring event. You are required to demonstrate compliance with the velocity and NHVcz requirements starting with the block that contains the fifteenth minute of a flaring event. You are not required to demonstrate compliance for the previous 15-minute block in which the event started and contained only a fraction of flow.

(d) Instead of complying with § 63.670(o)(2)(i) of this chapter, you must develop and implement the flare management plan no later than startup for a new flare that commenced construction on or after April 25, 2023.

(e) Instead of complying with § 63.670(o)(2)(iii) of this chapter, if required to develop a flare management plan and submit it to the Administrator,

then you must also submit all versions of the plan in portable document format (PDF) following the procedures specified in § 60.665a(k).

(f) Section 63.670(o)(3)(ii) of this chapter and all references to it do not apply. Instead, you must comply with the maximum flare tip velocity operating limit at all times.

(g) Substitute “affected facility” for each occurrence of “petroleum refinery.”

(h) Each occurrence of “refinery” does not apply.

(i) If a pressure-assisted multi-point flare is used as a control device, then you must meet the following conditions:

(1) You are not required to comply with the flare tip velocity requirements in § 63.670(d) and (k) of this chapter;

(2) The NHVcz for pressure-assisted multi-point flares is 800 Btu/scf;

(3) You must determine the 15-minute block average NHVvg using only the direct calculation method specified in § 63.670(l)(5)(ii) of this chapter;

(4) Instead of complying with § 63.670(b) and (g) of this chapter, if a pressure-assisted multi-point flare uses cross-lighting on a stage of burners rather than having an individual pilot flame on each burner, then you must operate each stage of the pressure-assisted multi-point flare with a flame present at all times when regulated material is routed to that stage of burners. Each stage of burners that cross-lights in the pressure-assisted multi-point flare must have at least two pilots with at least one continuously lit and capable of igniting all regulated material that is routed to that stage of burners. Each 15-minute block during which there is at least one minute where no pilot flame is present on a stage of burners when regulated material is routed to the flare is a deviation of the standard. Deviations in different 15-minute blocks from the same event are considered separate deviations. The pilot flame(s) on each stage of burners that use cross-lighting must be continuously monitored by a thermocouple or any other equivalent device used to detect the presence of a flame;

(5) Unless you choose to conduct a cross-light performance demonstration as specified in this paragraph (i)(5), you must ensure that if a stage of burners on the flare uses cross-lighting, that the

distance between any two burners in series on that stage is no more than 6 feet when measured from the center of one burner to the next burner. A distance greater than 6 feet between any two burners in series may be used provided you conduct a performance demonstration that confirms the pressure-assisted multi-point flare will cross-light a minimum of three burners and the spacing between the burners and location of the pilot flame must be representative of the projected installation. The compliance demonstration must be approved by the permitting authority and a copy of this approval must be maintained onsite. The compliance demonstration report must include: a protocol describing the test methodology used, associated test method QA/QC parameters, the waste gas composition and NHVcz of the gas tested, the velocity of the waste gas tested, the pressure-assisted multi-point flare burner tip pressure, the time, length, and duration of the test, records of whether a successful cross-light was observed over all of the burners and the length of time it took for the burners to cross-light, records of maintaining a stable flame after a successful cross-light and the duration for which this was observed, records of any smoking events during the cross-light, waste gas temperature, meteorological conditions (e.g., ambient temperature, barometric pressure, wind speed and direction, and relative humidity), and whether there were any observed flare flameouts; and

(6) You must install and operate pressure monitor(s) on the main flare header, as well as a valve position indicator monitoring system for each staging valve to ensure that the flare operates within the proper range of conditions as specified by the manufacturer. The pressure monitor must meet the requirements in table 13 to part 63, subpart CC, of this chapter.

(7) If a pressure-assisted multi-point flare is operating under the requirements of an approved alternative means of emission limitations, you must either continue to comply with the terms of the alternative means of emission limitations or comply with the provisions in paragraphs (i)(1) through (6) of this section.

(j) If you choose to determine compositional analysis for net heating value with a continuous process mass

spectrometer, then you must comply with the requirements specified in paragraphs (j)(1) through (7) of this section.

(1) You must meet the requirements in § 63.671(e)(2) of this chapter. You may augment the minimum list of calibration gas components found in § 63.671(e)(2) with compounds found during a pre-survey or known to be in the gas through process knowledge.

(2) Calibration gas cylinders must be certified to an accuracy of 2 percent and traceable to National Institute of Standards and Technology (NIST) standards.

(3) For unknown gas components that have similar analytical mass fragments to calibration compounds, you may report the unknowns as an increase in the overlapped calibration gas

compound. For unknown compounds that produce mass fragments that do not overlap calibration compounds, you may use the response factor for the nearest molecular weight hydrocarbon in the calibration mix to quantify the unknown component's NHV<sub>avg</sub>.

(4) You may use the response factor for n-pentane to quantify any unknown components detected with a higher molecular weight than n-pentane.

(5) You must perform an initial calibration to identify mass fragment overlap and response factors for the target compounds.

(6) You must meet applicable requirements in Performance Specification 9 of appendix B of this part, for continuous monitoring system acceptance including, but not limited to, performing an initial multi-point

calibration check at three concentrations following the procedure in Section 10.1 and performing the periodic calibration requirements listed for gas chromatographs in table 13 to part 63, subpart CC, of this chapter, for the process mass spectrometer. You may use the alternative sampling line temperature allowed under Net Heating Value by Gas Chromatograph in table 13 to part 63, subpart CC, of this chapter.

(7) The average instrument calibration error (CE) for each calibration compound at any calibration concentration must not differ by more than 10 percent from the certified cylinder gas value. The CE for each component in the calibration blend must be calculated using equation 1 to this paragraph (j)(7).

#### Equation 1 to Paragraph (j)(7)

$$CE = \frac{C_m - C_a}{C_a} \times 100 \text{ (Eq. 1)}$$

Where:

C<sub>m</sub> = Average instrument response (ppm)  
C<sub>a</sub> = Certified cylinder gas value (ppm)

(k) If you use a gas chromatograph or mass spectrometer for compositional analysis for net heating value, then you

may choose to use the CE of NHV<sub>measured</sub> versus the cylinder tag value NHV as the measure of agreement for daily calibration and quarterly audits in lieu of determining the compound-specific CE. The CE for NHV at any calibration

level must not differ by more than 10 percent from the certified cylinder gas value. The CE must be calculated using equation 2 to this paragraph (k).

#### Equation 2 to Paragraph (k)

$$CE = \frac{NHV_{measured} - NHV_a}{NHV_a} \times 100 \text{ (Eq. 2)}$$

Where:

NHV<sub>measured</sub> = Average instrument response (Btu/scf)  
NHV<sub>a</sub> = Certified cylinder gas value (Btu/scf)

(l) Instead of complying with § 63.670(q) of this chapter, you must comply with the reporting requirements specified in paragraphs (l)(1) and (2) of this section.

(1) The notification requirements specified in § 60.665a(a).

(2) The semiannual report specified in § 60.665a(j)(4) must include the items specified in paragraphs (l)(2)(i) through (vi) of this section.

(i) Records as specified in paragraph (m)(1) of this section for each 15-minute block during which there was at least one minute when regulated material is routed to a flare and no pilot flame or flare flame is present. Include the start and stop time and date of each 15-minute block.

(ii) Visible emission records as specified in paragraph (m)(2)(iv) of this section for each period of 2 consecutive hours during which visible emissions exceeded a total of 5 minutes.

(iii) The periods specified in paragraph (m)(6) of this section. Indicate the date and start and end times for each period, and the net heating value operating parameter(s) determined following the methods in § 63.670(k) through (n) of this chapter as applicable.

(iv) For flaring events meeting the criteria in § 63.670(o)(3) of this chapter and paragraph (f) of this section:

(A) The start and stop time and date of the flaring event.

(B) The length of time in minutes for which emissions were visible from the flare during the event.

(C) For steam-assisted, air-assisted, and non-assisted flares, the start date, start time, and duration in minutes for periods of time that the flare tip velocity exceeds the maximum flare tip velocity determined using the methods in § 63.670(d)(2) of this chapter and the maximum 15-minute block average flare tip velocity in ft/sec recorded during the event.

(D) Results of the root cause and corrective actions analysis completed during the reporting period, including the corrective actions implemented

during the reporting period and, if applicable, the implementation schedule for planned corrective actions to be implemented subsequent to the reporting period.

(v) For pressure-assisted multi-point flares, the periods of time when the pressure monitor(s) on the main flare header show the burners operating outside the range of the manufacturer's specifications. Indicate the date and start and end times for each period.

(vi) For pressure-assisted multi-point flares, the periods of time when the staging valve position indicator monitoring system indicates a stage should not be in operation and is or when a stage should be in operation and is not. Indicate the date and start and end times for each period.

(m) Instead of complying with § 63.670(p) of this chapter, you must keep the flare monitoring records specified in paragraphs (m)(1) through (14) of this section.

(1) Retain records of the output of the monitoring device used to detect the presence of a pilot flame or flare flame as required in § 63.670(b) of this chapter

and the presence of a pilot flame as required in paragraph (i)(4) of this section for a minimum of 2 years. Retain records of each 15-minute block during which there was at least one minute that no pilot flame or flare flame is present when regulated material is routed to a flare for a minimum of 5 years. For a pressure-assisted multi-point flare that uses cross-lighting, retain records of each 15-minute block during which there was at least one minute that no pilot flame is present on each stage when regulated material is routed to a flare for a minimum of 5 years. You may reduce the collected minute-by-minute data to a 15-minute block basis with an indication of whether there was at least one minute where no pilot flame or flare flame was present.

(2) Retain records of daily visible emissions observations as specified in paragraphs (m)(2)(i) through (iv) of this section, as applicable, for a minimum of 3 years.

(i) To determine when visible emissions observations are required, the record must identify all periods when regulated material is vented to the flare.

(ii) If visible emissions observations are performed using Method 22 of appendix A-7 of this part, then the record must identify whether the visible emissions observation was performed, the results of each observation, total duration of observed visible emissions, and whether it was a 5-minute or 2-hour observation. Record the date and start time of each visible emissions observation.

(iii) If a video surveillance camera is used pursuant to § 63.670(h)(2) of this chapter, then the record must include all video surveillance images recorded, with time and date stamps.

(iv) For each 2-hour period for which visible emissions are observed for more than 5 minutes in 2 consecutive hours, then the record must include the date and start and end time of the 2-hour period and an estimate of the cumulative number of minutes in the 2-hour period for which emissions were visible.

(3) The 15-minute block average cumulative flows for flare vent gas and, if applicable, total steam, perimeter assist air, and premix assist air specified to be monitored under § 63.670(i) of this chapter, along with the date and time interval for the 15-minute block. If multiple monitoring locations are used to determine cumulative vent gas flow, total steam, perimeter assist air, and premix assist air, then retain records of the 15-minute block average flows for each monitoring location for a minimum of 2 years, and retain the 15-minute block average cumulative flows that are

used in subsequent calculations for a minimum of 5 years. If pressure and temperature monitoring is used, then retain records of the 15-minute block average temperature, pressure, and molecular weight of the flare vent gas or assist gas stream for each measurement location used to determine the 15-minute block average cumulative flows for a minimum of 2 years, and retain the 15-minute block average cumulative flows that are used in subsequent calculations for a minimum of 5 years.

(4) The flare vent gas compositions specified to be monitored under § 63.670(j) of this chapter. Retain records of individual component concentrations from each compositional analysis for a minimum of 2 years. If an NHVvg analyzer is used, retain records of the 15-minute block average values for a minimum of 5 years.

(5) Each 15-minute block average operating parameter calculated following the methods specified in § 63.670(k) through (n) this chapter, as applicable.

(6) All periods during which operating values are outside of the applicable operating limits specified in § 63.670(d) through (f) of this chapter and paragraph (i) of this section when regulated material is being routed to the flare.

(7) All periods during which you do not perform flare monitoring according to the procedures in § 63.670(g) through (j) of this chapter.

(8) For pressure-assisted multi-point flares, if a stage of burners on the flare uses cross-lighting, then a record of any changes made to the distance between burners.

(9) For pressure-assisted multi-point flares, all periods when the pressure monitor(s) on the main flare header show burners are operating outside the range of the manufacturer's specifications. Indicate the date and time for each period, the pressure measurement, the stage(s) and number of burners affected, and the range of manufacturer's specifications.

(10) For pressure-assisted multi-point flares, all periods when the staging valve position indicator monitoring system indicates a stage of the pressure-assisted multi-point flare should not be in operation and when a stage of the pressure-assisted multi-point flare should be in operation and is not. Indicate the date and time for each period, whether the stage was supposed to be open, but was closed or vice versa, and the stage(s) and number of burners affected.

(11) Records of periods when there is flow of vent gas to the flare, but when there is no flow of regulated material to

the flare, including the start and stop time and dates of periods of no regulated material flow.

(12) Records when the flow of vent gas exceeds the smokeless capacity of the flare, including start and stop time and dates of the flaring event.

(13) Records of the root cause analysis and corrective action analysis conducted as required in § 63.670(o)(3) of this chapter and paragraph (f) of this section, including an identification of the affected flare, the date and duration of the event, a statement noting whether the event resulted from the same root cause(s) identified in a previous analysis and either a description of the recommended corrective action(s) or an explanation of why corrective action is not necessary under § 63.670(o)(5)(i) of this chapter.

(14) For any corrective action analysis for which implementation of corrective actions are required in § 63.670(o)(5) of this chapter, a description of the corrective action(s) completed within the first 45 days following the discharge and, for action(s) not already completed, a schedule for implementation, including proposed commencement and completion dates.

(n) You may elect to comply with the alternative means of emissions limitation requirements specified in § 63.670(r) of this chapter in lieu of the requirements in § 63.670(d) through (f) of this chapter, as applicable. However, instead of complying with § 63.670(r)(3)(iii) of this chapter, you must also submit the alternative means of emissions limitation request to the following address: U.S. Environmental Protection Agency, Office of Air Quality Planning and Standards, Sector Policies and Programs Division, U.S. EPA Mailroom (C404-02), Attention: SOCM I NSPS Sector Lead, 4930 Old Page Rd., Durham, NC 27703.

(o) The referenced provisions specified in paragraphs (o)(1) through (4) of this section do not apply when demonstrating compliance with this section.

(1) Section 63.670(o)(4)(iv) of this chapter.

(2) The last sentence of § 63.670(o)(6) of this chapter.

(3) The phrase "that were not caused by a *force majeure* event" in § 63.670(o)(7)(ii) of this chapter.

(4) The phrase "that were not caused by a *force majeure* event" in § 63.670(o)(7)(iv) of this chapter.

#### **§ 60.670a What are my requirements for closed vent systems?**

(a) Except as provided in paragraphs (f) and (g) of this section, you must inspect each closed vent system



according to the procedures and schedule specified in paragraphs (a)(1) through (3) of this section.

(1) Conduct an initial inspection according to the procedures in paragraph (b) of this section unless the closed vent system is operated and maintained under negative pressure;

(2) Conduct annual inspections according to the procedures in paragraph (b) of this section unless the closed vent system is operated and maintained under negative pressure; and

(3) Conduct annual inspections for visible, audible, or olfactory indications of leaks.

(b) You must inspect each closed vent system according to the procedures specified in paragraphs (b)(1) through (6) of this section.

(1) Inspections must be conducted in accordance with Method 21 of appendix A of this part.

(2)(i) Except as provided in paragraph (b)(2)(ii) of this section, the detection instrument must meet the performance criteria of Method 21 of appendix A of this part, except the instrument response factor criteria in section 3.1.2(a) of Method 21 must be for the average composition of the process fluid not each individual volatile organic compound in the stream. For process streams that contain nitrogen, air, or other inerts which are not organic hazardous air pollutants or volatile organic compounds, the average stream response factor must be calculated on an inert-free basis.

(ii) If no instrument is available at the plant site that will meet the performance criteria specified in paragraph (b)(2)(i) of this section, the instrument readings may be adjusted by multiplying by the average response factor of the process fluid, calculated on an inert-free basis as described in paragraph (b)(2)(i).

(3) The detection instrument must be calibrated before use on each day of its use by the procedures specified in Method 21 of appendix A of this part.

(4) Calibration gases must be as follows:

(i) Zero air (less than 10 parts per million hydrocarbon in air); and

(ii) Mixtures of methane in air at a concentration less than 2,000 parts per million. A calibration gas other than methane in air may be used if the instrument does not respond to methane or if the instrument does not meet the performance criteria specified in paragraph (b)(2)(i) of this section. In such cases, the calibration gas may be a mixture of one or more of the compounds to be measured in air.

(5) You may elect to adjust or not adjust instrument readings for background. If you elect to not adjust readings for background, all such instrument readings must be compared directly to the applicable leak definition to determine whether there is a leak.

(6) If you elect to adjust instrument readings for background, you must determine the background concentration using Method 21 of appendix A of this part. After monitoring each potential leak interface, subtract the background reading from the maximum concentration indicated by the instrument. The arithmetic difference between the maximum concentration indicated by the instrument and the background level must be compared with 500 parts per million for determining compliance.

(c) Leaks, as indicated by an instrument reading greater than 500 parts per million above background or by visual, audio, or olfactory inspections, must be repaired as soon as practicable, except as provided in paragraph (d) of this section.

(1) A first attempt at repair must be made no later than 5 calendar days after the leak is detected.

(2) Repair must be completed no later than 15 calendar days after the leak is detected.

(d) Delay of repair of a closed vent system for which leaks have been detected is allowed if the repair is technically infeasible without a shutdown, as defined in § 60.2, or if you determine that emissions resulting from immediate repair would be greater than the fugitive emissions likely to result from delay of repair. Repair of such equipment must be complete by the end of the next shutdown.

(e) For each closed vent system that contains bypass lines that could divert a vent stream away from the control device and to the atmosphere, you must comply with the provisions of either paragraph (e)(1) or (2), except as specified in paragraph (e)(3) of this section.

(1) Install, calibrate, maintain, and operate a flow indicator that determines whether vent stream flow is present at least once every 15 minutes. You must keep hourly records of whether the flow indicator was operating and whether a diversion was detected at any time during the hour, as well as records of the times and durations of all periods when the vent stream is diverted to the atmosphere or the flow indicator is not operating. The flow indicator must be installed at the entrance to any bypass line; or

(2) Secure the bypass line valve in the closed position with a car-seal or a lock-

and-key type configuration. A visual inspection of the seal or closure mechanism must be performed at least once every month to ensure the valve is maintained in the closed position and the vent stream is not diverted through the bypass line.

(3) Open-ended valves or lines that use a cap, blind flange, plug, or second valve and follow the requirements specified in § 60.482–6(a)(2), (b), and (c) or follow requirements codified in another regulation that are the same as § 60.482–6(a)(2), (b), and (c) are not subject to this paragraph (e) of this section.

(f) Any parts of the closed vent system that are designated, as described in paragraph (h)(1) of this section, as unsafe to inspect are exempt from the inspection requirements of paragraphs (a)(1) and (2) of this section if:

(1) You determine that the equipment is unsafe to inspect because inspecting personnel would be exposed to an imminent or potential danger as a consequence of complying with paragraphs (a)(1) and (2) of this section; and

(2) You have a written plan that requires inspection of the equipment as frequently as practicable during safe-to-inspect times.

(g) Any parts of the closed vent system are designated, as described in paragraph (h)(2) of this section, as difficult to inspect are exempt from the inspection requirements of paragraphs (a)(1) and (2) of this section if:

(1) You determine that the equipment cannot be inspected without elevating the inspecting personnel more than 2 meters above a support surface; and

(2) You have a written plan that requires inspection of the equipment at least once every 5 years.

(h) You must record the information specified in paragraphs (h)(1) through (5) of this section.

(1) Identification of all parts of the closed vent system that are designated as unsafe to inspect, an explanation of why the equipment is unsafe to inspect, and the plan for inspecting the equipment.

(2) Identification of all parts of the closed vent system that are designated as difficult to inspect, an explanation of why the equipment is difficult to inspect, and the plan for inspecting the equipment.

(3) For each closed vent system that contains bypass lines that could divert a vent stream away from the control device and to the atmosphere, you must keep a record of the information specified in either paragraph (h)(3)(i) or (ii) of this section in addition to the

information specified in paragraph (h)(3)(iii) of this section.

(i) Hourly records of whether the flow indicator specified under paragraph (e)(1) of this section was operating and whether a diversion was detected at any time during the hour, as well as records of the times of all periods when the vent stream is diverted from the control device or the flow indicator is not operating.

(ii) Where a seal mechanism is used to comply with paragraph (e)(2) of this section, hourly records of flow are not required. In such cases, you must record whether the monthly visual inspection of the seals or closure mechanisms has been done, and you must record the occurrence of all periods when the seal mechanism is broken, the bypass line valve position has changed, or the key for a lock-and-key type configuration has been checked out, and records of any car-seal that has broken.

(iii) For each flow event from a bypass line subject to the requirements in paragraph (e) of this section, you must maintain records sufficient to determine whether or not the detected flow included flow requiring control. For each flow event from a bypass line requiring control that is released either directly to the atmosphere or to a control device not meeting the requirements in this subpart, you must include an estimate of the volume of gas, the concentration of VOC in the gas and the resulting emissions of VOC that bypassed the control device using

process knowledge and engineering estimates.

(4) For each inspection during which a leak is detected, a record of the information specified in paragraphs (h)(4)(i) through (viii) of this section.

(i) The instrument identification numbers; operator name or initials; and identification of the equipment.

(ii) The date the leak was detected and the date of the first attempt to repair the leak.

(iii) Maximum instrument reading measured by the method specified in paragraph (c) of this section after the leak is successfully repaired or determined to be nonrepairable.

(iv) "Repair delayed" and the reason for the delay if a leak is not repaired within 15 calendar days after discovery of the leak.

(v) The name, initials, or other form of identification of the owner or operator (or designee) whose decision it was that repair could not be effected without a shutdown.

(vi) The expected date of successful repair of the leak if a leak is not repaired within 15 calendar days.

(vii) Dates of shutdowns that occur while the equipment is unrepaired.

(viii) The date of successful repair of the leak.

(5) For each inspection conducted in accordance with paragraph (b) of this section during which no leaks are detected, a record that the inspection was performed, the date of the inspection, and a statement that no leaks were detected.

(6) For each inspection conducted in accordance with paragraph (a)(3) of this section during which no leaks are detected, a record that the inspection was performed, the date of the inspection, and a statement that no leaks were detected.

(i) The semiannual report specified in § 60.665a(j)(5) must include the items specified in paragraphs (i)(1) through (3) of this section.

(1) Reports of the times of all periods recorded under paragraph (h)(3)(i) of this section when the vent stream is diverted from the control device through a bypass line. Include the start date, start time, and duration in hours of each period.

(2) Reports of all periods recorded under paragraph (h)(3)(ii) of this section in which the seal mechanism is broken, the bypass line valve position has changed, or the key to unlock the bypass line valve was checked out. Include the start date, start time, and duration in hours of each period.

(3) For bypass lines subject to the requirements in paragraph (e) of this section, the semiannual reports must include the start date, start time, duration in hours, estimate of the volume of gas in standard cubic feet, the concentration of VOC in the gas in parts per million by volume and the resulting mass emissions of VOC in pounds that bypass a control device. For periods when the flow indicator is not operating, report the start date, start time, and duration in hours.

TABLE 1 TO SUBPART NNNa OF PART 60—EMISSION LIMITS AND STANDARDS FOR VENT STREAMS

For each . . .	You must . . .
1. Vent stream .....	a. Reduce emissions of TOC (minus methane and ethane) by 98 weight-percent, or to a TOC (minus methane and ethane) concentration of 20 ppmv on a dry basis corrected to 3 percent oxygen by venting emissions through a closed vent system to any combination of non-flare control devices and/or recovery system and meet the requirements specified in § 60.663a and § 60.670a; <i>or</i> b. Reduce emissions of TOC (minus methane and ethane) by venting emissions through a closed vent system to a flare and meet the requirements specified in § 60.669a and § 60.670a.

TABLE 2 TO SUBPART NNNa OF PART 60—MONITORING REQUIREMENTS FOR COMPLYING WITH 98 WEIGHT-PERCENT REDUCTION OF TOTAL ORGANIC COMPOUNDS EMISSIONS OR A LIMIT OF 20 PARTS PER MILLION BY VOLUME

Non-flare control device or recovery device	Parameters to be monitored
1. All control and recovery devices .....	a. Presence of flow diverted to the atmosphere from the control and recovery device; <i>or</i> b. Monthly inspections of sealed valves
2. Absorber .....	a. Exit temperature of the absorbing liquid; <i>and</i> b. Exit specific gravity Firebox temperature <sup>a</sup>
3. Boiler or process heater with a design heat input capacity less than 44 megawatts and vent stream is <i>not</i> introduced with or as the primary fuel.	Temperature upstream and downstream of the catalyst bed
4. Catalytic incinerator .....	a. Total regeneration stream mass or volumetric flow during carbon bed regeneration cycle(s); <i>and</i> b. Temperature of the carbon bed after regeneration [and within 15 minutes of completing any cooling cycle(s)]
5. Carbon adsorber, regenerative .....	

TABLE 2 TO SUBPART NNNa OF PART 60—MONITORING REQUIREMENTS FOR COMPLYING WITH 98 WEIGHT-PERCENT REDUCTION OF TOTAL ORGANIC COMPOUNDS EMISSIONS OR A LIMIT OF 20 PARTS PER MILLION BY VOLUME—Continued

Non-flare control device or recovery device	Parameters to be monitored
6. Carbon adsorber, non-regenerative or regenerated offsite .....	Breakthrough Exit (product side) temperature a. pH of scrubber effluent; <i>and</i> b. Scrubber liquid and gas flow rates Firebox temperature <sup>a</sup> As specified by the Administrator
7. Condenser .....	
8. Scrubber for halogenated vent streams .....	
9. Thermal incinerator .....	
10. Control devices other than an incinerator, boiler, process heater, or flare; or recovery devices other than an absorber, condenser, or carbon adsorber.	

<sup>a</sup> Monitor may be installed in the firebox or in the ductwork immediately downstream of the firebox before any substantial heat exchange is encountered.

TABLE 3 TO SUBPART NNNA OF PART 60—OPERATING PARAMETERS, OPERATING PARAMETER LIMITS AND DATA MONITORING, RECORDKEEPING AND COMPLIANCE FREQUENCIES

For the operating parameter applicable to you, as specified in table 2	You must establish the following operating parameter limit . . .	And you must monitor, record, and demonstrate continuous compliance using these minimum frequencies . . .		
		Data measurement	Data recording	Data averaging period for compliance
<b>Absorbers</b>				
1. Exit temperature of the absorbing liquid.	Maximum temperature	Continuous .....	Every 15 minutes .....	3-hour block average.
2. Exit specific gravity	Exit specific gravity range.	Continuous .....	Every 15 minutes .....	3-hour block average.
<b>Boilers or process heaters (with a design heat input capacity &lt;44MW and vent stream is not introduced with or as the primary fuel)</b>				
3. Firebox temperature.	Minimum firebox temperature.	Continuous .....	Every 15 minutes .....	3-hour block average.
<b>Catalytic incinerators</b>				
4. Temperature in gas stream immediately before the catalyst bed.	Minimum temperature	Continuous .....	Every 15 minutes .....	3-hour block average.
5. Temperature difference between the catalyst bed inlet and the catalyst bed outlet.	Minimum temperature difference.	Continuous .....	Every 15 minutes .....	3-hour block average.
<b>Carbon adsorbers</b>				
6. Total regeneration stream mass flow during carbon bed regeneration cycle(s).	Minimum mass flow during carbon bed regeneration cycle(s).	Continuously during regeneration .....	Every 15 minutes during regeneration cycle.	Total flow for each regeneration cycle.
7. Total regeneration stream volumetric flow during carbon bed regeneration cycle(s).	Minimum volumetric flow during carbon bed regeneration cycle(s).	Continuously during regeneration .....	Every 15 minutes during regeneration cycle.	Total flow for each regeneration cycle.
8. Temperature of the carbon bed after regeneration [and within 15 minutes of completing any cooling cycle(s)].	Maximum temperature of the carbon bed after regeneration.	Continuously during regeneration and for 15 minutes after completing any cooling cycle(s).	Every 15 minutes during regeneration cycle (including any cooling cycle).	Average of regeneration cycle.
9. Breakthrough .....	As defined in § 60.661a.	As required by § 60.663a(a)(6)(iii)(B) .....	Each monitoring event	N/A.

TABLE 3 TO SUBPART NNA OF PART 60—OPERATING PARAMETERS, OPERATING PARAMETER LIMITS AND DATA MONITORING, RECORDKEEPING AND COMPLIANCE FREQUENCIES—Continued

For the operating parameter applicable to you, as specified in table 2	You must establish the following operating parameter limit . . .	And you must monitor, record, and demonstrate continuous compliance using these minimum frequencies . . .		
		Data measurement	Data recording	Data averaging period for compliance
<b>Condensers</b>				
10. Exit (product side) temperature.	Maximum temperature	Continuous .....	Every 15 minutes .....	3-hour block average.
<b>Scrubbers for halogenated vent streams</b>				
11. pH of scrubber effluent.	Minimum pH .....	Continuous .....	Every 15 minutes .....	3-hour block average.
12. Influent liquid flow	Minimum inlet liquid flow.	Continuous .....	Every 15 minutes .....	3-hour block average.
13. Influent liquid flow rate and gas stream flow rate.	Minimum influent liquid-to-gas ratio.	Continuous .....	Every 15 minutes .....	3-hour block average.
<b>Thermal incinerators</b>				
14. Firebox temperature.	Minimum firebox temperature.	Continuous .....	Every 15 minutes .....	3-hour block average.
<b>Control devices other than an incinerator, boiler, process heater, or flare; or recovery devices other than an absorber, condenser, or carbon adsorber</b>				
15. As specified by the Administrator.	15. As specified by the Administrator.	15. As specified by the Administrator .....	15. As specified by the Administrator.	15. As specified by the Administrator.

TABLE 4 TO SUBPART NNA OF PART 60—CALIBRATION AND QUALITY CONTROL REQUIREMENTS FOR CONTINUOUS PARAMETER MONITORING SYSTEM (CPMS)

If you monitor this parameter . . .	Your accuracy requirements are . . .	And your calibration requirements are . . .
1. Temperature .....	a. $\pm 1$ percent over the normal range of temperature measured or 2.8 degrees Celsius (5 degrees Fahrenheit), whichever is greater, for non-cryogenic temperature ranges. b. $\pm 2.5$ percent over the normal range of temperature measured or 2.8 degrees Celsius (5 degrees Fahrenheit), whichever is greater, for cryogenic temperature ranges.	c. Performance evaluation annually and following any period of more than 24 hours throughout which the temperature exceeded the maximum rated temperature of the sensor, or the data recorder was off scale. d. Visual inspections and checks of CPMS operation every 3 months, unless the CPMS has a redundant temperature sensor. e. Selection of a representative measurement location.
2. Flow Rate .....	a. $\pm 5$ percent over the normal range of flow measured or 1.9 liters per minute (0.5 gallons per minute), whichever is greater, for liquid flow rate. b. $\pm 5$ percent over the normal range of flow measured or 280 liters per minute (10 cubic feet per minute), whichever is greater, for gas flow rate. c. $\pm 5$ percent over the normal range measured for mass flow rate.	d. Performance evaluation annually and following any period of more than 24 hours throughout which the flow rate exceeded the maximum rated flow rate of the sensor, or the data recorder was off scale. e. Checks of all mechanical connections for leakage monthly. f. Visual inspections and checks of CPMS operation every 3 months, unless the CPMS has a redundant flow sensor. g. Selection of a representative measurement location where swirling flow or abnormal velocity distributions due to upstream and downstream disturbances at the point of measurement are minimized.
3. pH .....	a. $\pm 0.2$ pH units .....	b. Performance evaluation annually. Conduct a two-point calibration with one of the two buffer solutions having a pH within 1 of the pH of the operating limit. c. Visual inspections and checks of CPMS operation every 3 months, unless the CPMS has a redundant pH sensor. d. Select a measurement location that provides a representative sample of scrubber effluent and that ensures the fluid is properly mixed.

TABLE 4 TO SUBPART NNNa OF PART 60—CALIBRATION AND QUALITY CONTROL REQUIREMENTS FOR CONTINUOUS PARAMETER MONITORING SYSTEM (CPMS)—Continued

If you monitor this parameter . . .	Your accuracy requirements are . . .	And your calibration requirements are . . .
4. Specific Gravity .....	a. ± 0.02 specific gravity units .....	b. Performance evaluation annually. c. Visual inspections and checks of CPMS operation every 3 months, unless the CPMS has a redundant specific gravity sensor. d. Select a measurement location that provides a representative sample of specific gravity of the absorbing liquid effluent and that ensures the fluid is properly mixed.

■ 33. Revise the heading for subpart RRR to read as follows:

**Subpart RRR—Standards of Performance for Volatile Organic Compound Emissions From Synthetic Organic Chemical Manufacturing Industry (SOCMI) Reactor Processes After June 29, 1990, and on or Before April 25, 2023**

■ 34. Amend § 60.700 by revising paragraphs (b) introductory text and (c)(5) and (8) and adding paragraph (e) to read as follows:

**§ 60.700 Applicability and designation of affected facility.**

\* \* \* \* \*

(b) The affected facility is any of the following for which construction, modification, or reconstruction commenced after June 29, 1990, and on or before April 25, 2023:

(c) \* \* \*

(5) If the vent stream from an affected facility is routed to a distillation unit subject to subpart NNN of this part or subpart NNNa of this part, and has no other releases to the air except for a pressure relief valve, the facility is exempt from all provisions of this subpart except for § 60.705(r).

\* \* \* \* \*

(8) Each affected facility operated with a concentration of total organic compounds (TOC) (less methane and ethane) in the vent stream less than 300 ppmv as measured by Method 18 of appendix A–6 to this part or ASTM D6420–18 (incorporated by reference, see § 60.17) as specified in § 60.704(b)(4), or a concentration of TOC in the vent stream less than 150 ppmv as measured by Method 25A of appendix A–7 to this part is exempt from all provisions of this subpart except for the test method and procedure and the reporting and recordkeeping requirements in §§ 60.704(h) and 60.705(j), (l)(8), and (p).

\* \* \* \* \*

(e) Owners and operators of flares that are subject to the flare related requirements of this subpart and flare related requirements of any other regulation in this part or 40 CFR part 61 or 63, may elect to comply with the requirements in § 60.709a in lieu of all flare related requirements in any other regulation in this part or 40 CFR part 61 or 63.

■ 35. Amend § 60.701 by revising the definition of “Flame zone” as follows to read as follows:

**§ 60.701 Definitions.**

\* \* \* \* \*

*Flame zone* means the portion of the combustion chamber in a boiler or process heater occupied by the flame envelope.

\* \* \* \* \*

■ 36. Amend § 60.704 by revising paragraphs (b)(3), (b)(4) introductory text, (d), and (h)(2) and (3) to read as follows:

**§ 60.704 Test methods and procedures.**

\* \* \* \* \*

(b) \* \* \*

(3) The emission rate correction factor, integrated sampling and analysis procedures of Method 3B of appendix A–2 to this part, or the manual method in ANSI/ASME PTC 19.10–1981 incorporated by reference, see § 60.17), shall be used to determine the oxygen concentration (%O<sub>2d</sub>) for the purposes of determining compliance with the 20 ppmv limit. The sampling site shall be the same as that of the TOC samples, and the samples shall be taken during the same time that the TOC samples are taken. The TOC concentration corrected to 3 percent O<sub>2</sub> (C<sub>c</sub>) shall be computed using the following equation:

$$C_c = C_{TOC} \frac{17.9}{20.9 - \%O_{2d}}$$

Where:

C<sub>c</sub> = Concentration of TOC corrected to 3 percent O<sub>2</sub>, dry basis, ppm by volume.

C<sub>TOC</sub> = Concentration of TOC (minus methane and ethane), dry basis, ppm by volume.

%O<sub>2d</sub> = Concentration of O<sub>2</sub>, dry basis, percent by volume.

(4) Method 18 of appendix A–6 to this part to determine the concentration of TOC in the control device outlet and the concentration of TOC in the inlet when the reduction efficiency of the control device is to be determined. ASTM

D6420–18 (incorporated by reference, see § 60.17) may be used in lieu of Method 18 of appendix A–6 to this part, if the target compounds are all known and are all listed in Section 1.1 of ASTM D6420–18 as measurable; ASTM D6420–18 may not be used for methane and ethane; and ASTM D6420–18 may not be used as a total VOC method.

\* \* \* \* \*

(d) The following test methods, except as provided under § 60.8(b), shall be used for determining the net heating

value of the gas combusted to determine compliance under § 60.702(b) and for determining the process vent stream TRE index value to determine compliance under §§ 60.700(c)(2) and 60.702(c).

(1)(i) Method 1 or 1A of appendix A–1 to this part, as appropriate, for selection of the sampling site. The sampling site for the vent stream flow rate and molar composition determination prescribed in § 60.704(d)(2) and (3) shall be, except

for the situations outlined in paragraph (d)(1)(ii) of this section, prior to the inlet of any control device, prior to any postreactor dilution of the stream with air, and prior to any postreactor introduction of halogenated compounds into the process vent stream. No traverse site selection method is needed for vents smaller than 4 inches in diameter.

(ii) If any gas stream other than the reactor vent stream is normally conducted through the final recovery device:

(A) The sampling site for vent stream flow rate and molar composition shall be prior to the final recovery device and prior to the point at which any nonreactor stream or stream from a nonaffected reactor process is introduced.

(B) The efficiency of the final recovery device is determined by measuring the TOC concentration using Method 18 of

appendix A-6 to this part, or ASTM D6420-18 (incorporated by reference, see § 60.17) as specified in paragraph (b)(4) of this section, at the inlet to the final recovery device after the introduction of any vent stream and at the outlet of the final recovery device.

(C) This efficiency of the final recovery device shall be applied to the TOC concentration measured prior to the final recovery device and prior to the introduction of any nonreactor stream or stream from a nonaffected reactor process to determine the concentration of TOC in the reactor process vent stream from the final recovery device. This concentration of TOC is then used to perform the calculations outlined in paragraphs (d)(4) and (5) of this section.

(2) The molar composition of the process vent stream shall be determined as follows:

$$H_T = K_1 \sum_{j=1}^n C_j H_j \quad 1 - B_{ws}$$

Where:

$H_T$  = Net heating value of the sample, MJ/scm, where the net enthalpy per mole of vent stream is based on combustion at 25 °C and 760 mm Hg, but the standard temperature for determining the volume corresponding to one mole is 20 °C, as in the definition of  $Q_s$  (vent stream flow rate).

$K_1$  = Constant,  $1.740 \times 10^{-7}$  (l/ppm) (g-mole/scm) (MJ/kcal), where standard temperature for (g-mole/scm) is 20 °C.

$C_j$  = Concentration on a dry basis of compound  $j$  in ppm, as measured for organics by Method 18 of appendix A-6 to this part, or ASTM D6420-18 (incorporated by reference, see § 60.17) as specified in paragraph (b)(4) of this section, and measured for hydrogen and carbon monoxide by ASTM D1946-77 or 90 (Reapproved 1994) (incorporated by reference, see § 60.17) as indicated in paragraph (d)(2) of this section.

$H_j$  = Net heat of combustion of compound  $j$ , kcal/g-mole, based on combustion at 25

(i) Method 18 of appendix A-6 to this part, or ASTM D6420-18 (incorporated by reference, see § 60.17) as specified in paragraph (b)(4) of this section, to measure the concentration of TOC including those containing halogens.

(ii) ASTM D1946-77 or 90 (Reapproved 1994) (incorporation by reference as specified in § 60.17 of this part) to measure the concentration of carbon monoxide and hydrogen.

(iii) Method 4 of appendix A-3 to this part to measure the content of water vapor.

(3) The volumetric flow rate shall be determined using Method 2, 2A, 2C, or 2D of appendix A-1 to this part, as appropriate.

(4) The net heating value of the vent stream shall be calculated using the following equation:

°C and 760 mm Hg. The heats of combustion of vent stream components would be required to be determined using ASTM D2382-76 or 88 or D4809-95 (incorporated by reference, see § 60.17) if published values are not available or cannot be calculated.

$B_{ws}$  = Water vapor content of the vent stream, proportion by volume.

(5) The emission rate of TOC in the vent stream shall be calculated using the following equation:

$$E_{TOC} = K_2 \sum_{j=1}^n C_j M_j Q_s$$

Where:

$E_{TOC}$  = Emission rate of TOC in the sample, kg/hr.

$K_2$  = Constant,  $2.494 \times 10^{-6}$  (l/ppm) (g-mole/scm) (kg/g) (min/hr), where standard temperature for (g-mole/scm) is 20 °C.

$C_j$  = Concentration on a dry basis of compound  $j$  in ppm as measured by Method 18 of appendix A-6 to this part, or ASTM D6420-18 (incorporated by reference, see § 60.17) as specified in paragraph (b)(4) of this section, as indicated in paragraph (d)(2) of this section.

$M_j$  = Molecular weight of sample  $j$ , g/g-mole.

$Q_s$  = Vent stream flow rate (dscm/min) at a temperature of 20 °C.

(6) The total vent stream concentration (by volume) of compounds containing halogens (ppmv, by compound) shall be summed from the individual concentrations of

compounds containing halogens which were measured by Method 18 of appendix A-6 to this part, or ASTM D6420-18 (incorporated by reference, see § 60.17) as specified in paragraph (b)(4) of this section.

\* \* \* \* \*

(h) \* \* \*  
(2) Method 18 of appendix A-6 or Method 25A of appendix A-7 to this part shall be used to measure concentration. ASTM D6420-18 (incorporated by reference, see § 60.17) may be used in lieu of Method 18 as specified in paragraph (b)(4) of this section.

(3) Where Method 18 of appendix A-6 to this part, or ASTM D6420-18 (incorporated by reference, see § 60.17) as specified in paragraph (b)(4) of this

section, is used to qualify for the low concentration exclusion in § 60.700(c)(8), the procedures in paragraphs (b)(4)(i) and (iv) of this section shall be used to measure TOC concentration, and the procedures of paragraph (b)(3) of this section shall be used to correct the TOC concentration to 3 percent oxygen. To qualify for the exclusion, the results must demonstrate that the concentration of TOC, corrected to 3 percent oxygen, is below 300 ppm by volume.

\* \* \* \* \*

■ 37. Amend § 60.705 by revising paragraphs (b) introductory text, (l), and (m) and adding paragraphs (u), (v), and (w) to read as follows:

**§ 60.705 Reporting and recordkeeping requirements.**

\* \* \* \*

(b) Each owner or operator subject to the provisions of this subpart shall keep an up-to-date, readily accessible record of the following data measured during each performance test, and also include the following data in the report of the initial performance test required under § 60.8. Where a boiler or process heater with a design heat input capacity of 44 MW (150 million Btu/hour) or greater is used or where the reactor process vent stream is introduced as the primary fuel to any size boiler or process heater to comply with § 60.702(a), a report containing performance test data need not be submitted, but a report containing the information in paragraph (b)(2)(i) of this section is required. The same data specified in this section shall be submitted in the reports of all subsequently required performance tests where either the emission control efficiency of a combustion device, outlet concentration of TOC, or the TRE index value of a vent stream from a recovery system is determined. Beginning on July 15, 2024, owners and operators must submit the performance test report following the procedures specified in paragraph (u) of this section. Data collected using test methods that are supported by the EPA's Electronic Reporting Tool (ERT) as listed on the EPA's ERT website (<https://www.epa.gov/electronic-reporting-air-emissions/electronic-reporting-tool-ert>) at the time of the test must be submitted in a file format generated using the EPA's ERT. Alternatively, the owner or operator may submit an electronic file consistent with the extensible markup language (XML) schema listed on the EPA's ERT website. Data collected using test methods that are not supported by the EPA's ERT as listed on the EPA's ERT website at the time of the test must be included as an attachment in the ERT or an alternate electronic file.

\* \* \* \*

(l) Each owner or operator that seeks to comply with the requirements of this subpart by complying with the requirements of § 60.700(c)(2), (3), or (4) or § 60.702 shall submit to the Administrator semiannual reports of the following recorded information. The initial report shall be submitted within 6 months after the initial start-up date. On and after July 15, 2025 or once the report template for this subpart has been available on the Compliance and Emissions Data Reporting Interface (CEDRI) website (<https://www.epa.gov/electronic-reporting-air-emissions/cedri>) for 1 year, whichever date is later,

owners and operators must submit all subsequent reports using the appropriate electronic report template on the CEDRI website for this subpart and following the procedure specified in paragraph (u) of this section. The date report templates become available will be listed on the CEDRI website. Unless the Administrator or delegated state agency or other authority has approved a different schedule for submission of reports, the report must be submitted by the deadline specified in this subpart, regardless of the method in which the report is submitted.

(1) Exceedances of monitored parameters recorded under paragraphs (c), (f), and (g) of this section.

(2) All periods and duration recorded under paragraph (d) of this section when the vent stream is diverted from the control device to the atmosphere.

(3) All periods recorded under paragraph (e) of this section in which the pilot flame of the flare was absent.

(4) Any change in equipment or process operation that increases the operating vent stream flow rate above the low flow exemption level in § 60.700(c)(4), including a measurement of the new vent stream flow rate, as recorded under paragraph (i) of this section. These must be reported as soon as possible after the change and no later than 180 days after the change. These reports may be submitted either in conjunction with semiannual reports or as a single separate report. A performance test must be completed within the same time period to verify the recalculated flow value and to obtain the vent stream characteristics of heating value and  $E_{TOC}$ . The performance test is subject to the requirements of § 60.8, and the performance test must be reported according to paragraph (b) of this section. Unless the facility qualifies for an exemption under any of the exemption provisions listed in § 60.700(c), except for the total resource effectiveness index greater than 8.0 exemption in § 60.700(c)(2), the facility must begin compliance with the requirements set forth in § 60.702.

(5) Any change in equipment or process operation, as recorded under paragraph (i) of this section, that increases the design production capacity above the low capacity exemption level in § 60.700(c)(3) and the new capacity resulting from the change for the reactor process unit containing the affected facility. These must be reported as soon as possible after the change and no later than 180 days after the change. These reports may be submitted either in conjunction with semiannual reports or as a single

separate report. A performance test must be completed within the same time period to obtain the vent stream flow rate, heating value, and  $E_{TOC}$ . The performance test is subject to the requirements of § 60.8, and the performance test must be reported according to paragraph (b) of this section. The facility must begin compliance with the requirements set forth in § 60.702 or § 60.700(d). If the facility chooses to comply with § 60.702, the facility may qualify for an exemption under § 60.700(c)(2), (4), or (8).

(6) Any recalculation of the TRE index value, as recorded under paragraph (g) of this section.

(7) All periods recorded under paragraph (d) of this section in which the seal mechanism is broken or the bypass line valve position has changed. A record of the serial number of the car-seal or a record to show that the key to unlock the bypass line valve was checked out must be maintained to demonstrate the period, the duration, and frequency in which the bypass line was operated.

(8) Any change in equipment or process operation that increases the vent stream concentration above the low concentration exemption level in § 60.700(c)(8), including a measurement of the new vent stream concentration, as recorded under paragraph (j) of this section. These must be reported as soon as possible after the change and no later than 180 days after the change. These reports may be submitted either in conjunction with semiannual reports or as a single separate report. If the vent stream concentration is above 300 ppmv as measured using Method 18 of appendix A-6 to this part, or ASTM D6420-18 (incorporated by reference, see § 60.17) as specified in § 60.704(b)(4), or above 150 ppmv as measured using Method 25A of appendix A-7 to this part, a performance test must be completed within the same time period to obtain the vent stream flow rate, heating value, and  $E_{TOC}$ . The performance test is subject to the requirements of § 60.8, and the performance test must be reported according to paragraph (b) of this section. Unless the facility qualifies for an exemption under any of the exemption provisions listed in § 60.700(c), except for the TRE index greater than 8.0 exemption in § 60.700(c)(2), the facility must begin compliance with the requirements set forth in § 60.702.

(m) The requirements of paragraph (l) of this section remain in force until and unless EPA, in delegating enforcement authority to a State under section 111(c)

of the Act, approves reporting requirements or an alternative means of compliance surveillance adopted by such State. In that event, affected sources within the State will be relieved of the obligation to comply with paragraph (l), provided that they comply with the requirements established by the State. The EPA will not approve a waiver of electronic reporting to the EPA in delegating enforcement authority. Thus, electronic reporting to the EPA cannot be waived, and as such, the provisions of this paragraph cannot be used to relieve owners or operators of affected facilities of the requirement to submit the electronic reports required in this section to the EPA.

\* \* \* \* \*

(u) If an owner or operator is required to submit notifications or reports following the procedure specified in this paragraph (u), the owner or operator must submit notifications or reports to the EPA via CEDRI, which can be accessed through the EPA's Central Data Exchange (CDX) (<https://cdx.epa.gov/>). The EPA will make all the information submitted through CEDRI available to the public without further notice to the owner or operator. Do not use CEDRI to submit information the owner or operator claims as CBI. Although the EPA does not expect persons to assert a claim of CBI, if an owner or operator wishes to assert a CBI claim for some of the information in the report or notification, the owner or operator must submit a complete file in the format specified in this subpart, including information claimed to be CBI, to the EPA following the procedures in paragraphs (u)(1) and (2) of this section. Clearly mark the part or all of the information claimed to be CBI. Information not marked as CBI may be authorized for public release without prior notice. Information marked as CBI will not be disclosed except in accordance with procedures set forth in 40 CFR part 2. All CBI claims must be asserted at the time of submission. Anything submitted using CEDRI cannot later be claimed CBI. Furthermore, under CAA section 114(c), emissions data is not entitled to confidential treatment, and the EPA is required to make emissions data available to the public. Thus, emissions data will not be protected as CBI and will be made publicly available. The owner or operator must submit the same file submitted to the CBI office with the CBI omitted to the EPA via the EPA's CDX as described earlier in this paragraph (u).

(1) The preferred method to receive CBI is for it to be transmitted

electronically using email attachments, File Transfer Protocol, or other online file sharing services. Electronic submissions must be transmitted directly to the OAQPS CBI Office at the email address [oaqpscbi@epa.gov](mailto:oaqpscbi@epa.gov), and as described above, should include clear CBI markings. ERT files should be flagged to the attention of the Group Leader, Measurement Policy Group; all other files should be flagged to the attention of the SOCOMI NSPS Sector Lead. Owners and operators who do not have their own file sharing service and who require assistance with submitting large electronic files that exceed the file size limit for email attachments should email [oaqpscbi@epa.gov](mailto:oaqpscbi@epa.gov) to request a file transfer link.

(2) If an owner or operator cannot transmit the file electronically, the owner or operator may send CBI information through the postal service to the following address: OAQPS Document Control Officer (C404-02), OAQPS, U.S. Environmental Protection Agency, 109 T.W. Alexander Drive, P.O. Box 12055, Research Triangle Park, North Carolina 27711. ERT files should be sent to the attention of the Group Leader, Measurement Policy Group, and all other files should be sent to the attention of the SOCOMI NSPS Sector Lead. The mailed CBI material should be double wrapped and clearly marked. Any CBI markings should not show through the outer envelope.

(v) Owners and operators required to electronically submit notifications or reports through CEDRI in the EPA's CDX may assert a claim of EPA system outage for failure to timely comply with the electronic submittal requirement. To assert a claim of EPA system outage, owners and operators must meet the requirements outlined in paragraphs (v)(1) through (7) of this section.

(1) The owner or operator must have been or will be precluded from accessing CEDRI and submitting a required report within the time prescribed due to an outage of either the EPA's CEDRI or CDX systems.

(2) The outage must have occurred within the period of time beginning five business days prior to the date that the submission is due.

(3) The outage may be planned or unplanned.

(4) The owner or operator must submit notification to the Administrator in writing as soon as possible following the date the owner or operator first knew, or through due diligence should have known, that the event may cause or has caused a delay in reporting.

(5) The owner or operator must provide to the Administrator a written description identifying:

(i) The date(s) and time(s) when CDX or CEDRI was accessed and the system was unavailable;

(ii) A rationale for attributing the delay in reporting beyond the regulatory deadline to EPA system outage;

(iii) A description of measures taken or to be taken to minimize the delay in reporting; and

(iv) The date by which the owner or operator proposes to report, or if the owner or operator has already met the reporting requirement at the time of the notification, the date the report was submitted.

(6) The decision to accept the claim of EPA system outage and allow an extension to the reporting deadline is solely within the discretion of the Administrator.

(7) In any circumstance, the report must be submitted electronically as soon as possible after the outage is resolved.

(w) Owners and operators required to electronically submit notifications or reports through CEDRI in the EPA's CDX may assert a claim of *force majeure* for failure to timely comply with the electronic submittal requirement. To assert a claim of *force majeure*, owners and operators must meet the requirements outlined in paragraphs (w)(1) through (5) of this section.

(1) An owner or operator may submit a claim if a *force majeure* event is about to occur, occurs, or has occurred or there are lingering effects from such an event within the period of time beginning five business days prior to the date the submission is due. For the purposes of this section, a *force majeure* event is defined as an event that will be or has been caused by circumstances beyond the control of the affected facility, its contractors, or any entity controlled by the affected facility that prevents the owner or operator from complying with the requirement to submit a report electronically within the time period prescribed. Examples of such events are acts of nature (e.g., hurricanes, earthquakes, or floods), acts of war or terrorism, or equipment failure or safety hazard beyond the control of the affected facility (e.g., large scale power outage).

(2) The owner or operator must submit notification to the Administrator in writing as soon as possible following the date the owner or operator first knew, or through due diligence should have known, that the event may cause or has caused a delay in reporting.

(3) The owner or operator must provide to the Administrator:

(i) A written description of the *force majeure* event;



(ii) A rationale for attributing the delay in reporting beyond the regulatory deadline to the *force majeure* event;

(iii) A description of measures taken or to be taken to minimize the delay in reporting; and

(iv) The date by which the owner or operator proposes to report, or if the owner or operator has already met the reporting requirement at the time of the notification, the date the report was submitted.

(4) The decision to accept the claim of *force majeure* and allow an extension to the reporting deadline is solely within the discretion of the Administrator.

(5) In any circumstance, the reporting must occur as soon as possible after the *force majeure* event occurs.

■ 38. Amend § 60.708 by revising paragraph (b) to read as follows:

**§ 60.708 Delegation of authority.**

\* \* \* \* \*

(b) Authorities which will not be delegated to States: § 60.703(e) and approval of an alternative to any electronic reporting to the EPA required by this subpart.

■ 39. Add subpart RRRa to read as follows:

**Subpart RRRa—Standards of Performance for Volatile Organic Compound Emissions From Synthetic Organic Chemical Manufacturing Industry (SOCMI) Reactor Processes for Which Construction, Reconstruction, or Modification Commenced After April 25, 2023**

Sec.

60.700a Am I subject to this subpart?

60.701a What definitions must I know?

60.702a What standards and associated requirements must I meet?

60.703a What are my monitoring, installation, operation, and maintenance requirements?

60.704a What test methods and procedures must I use to determine compliance with the standards?

60.705a What records must I keep and what reports must I submit?

60.706a What do the terms associated with reconstruction mean for this subpart?

60.707a What are the chemicals that I must produce to be affected by subpart RRRa?

60.708a [Reserved]

60.709a What are my requirements if I use a flare to comply with this subpart?

60.710a What are my requirements for closed vent systems?

Table 1 to Subpart RRRa of Part 60—Emission Limits and Standards for Vent Streams

Table 2 to Subpart RRRa of Part 60—Monitoring Requirements for Complying With 98 Weight-Percent Reduction of Total Organic Compounds Emissions or a Limit of 20 Parts per Million by Volume

Table 3 to Subpart RRRa of Part 60—Operating Parameters, Operating Parameter Limits and Data Monitoring, Recordkeeping and Compliance Frequencies

Table 4 to Subpart RRRa of Part 60—Calibration and Quality Control Requirements for Continuous Parameter Monitoring System (CPMS)

**§ 60.700a Am I subject to this subpart?**

(a) You are subject to the provisions of this subpart if you operate an affected facility designated in paragraph (b) of this section that is part of a process unit that produces any of the chemicals listed in § 60.707a as a product, co-product, by-product, or intermediate, except as provided in paragraph (c) of this section.

(b) The affected facility is any of the following for which construction, modification, or reconstruction commenced after April 25, 2023:

(1) Each reactor process not discharging its vent stream into a recovery system.

(2) Each combination of a reactor process and the recovery system into which its vent stream is discharged.

(3) Each combination of two or more reactor processes and the common recovery system into which their vent streams are discharged.

(c) Exemptions from the provisions of paragraph (a) of this section are as follows:

(1) Any reactor process that is designed and operated as a batch operation is not an affected facility.

(2) Each affected facility in a process unit with a total design capacity for all chemicals produced within that unit of less than 1 gigagram per year (1,100 tons per year) is exempt from all provisions of this subpart except for the recordkeeping and reporting requirements in § 60.705a(h), (k)(6), and (p).

(3) Each affected facility operated with a vent stream flow rate less than 0.011 scm/min is exempt from all provisions of this subpart except for the test method and procedure and the recordkeeping and reporting requirements in §§ 60.704a(e) and 60.705a(i), (k)(7), and (q).

(4) If the vent stream from an affected facility is routed to a distillation unit subject to subpart NNNa of this part and has no other releases to the air except for a pressure relief valve, the facility is exempt from all provisions of this subpart except for § 60.705a(r).

(5) Any reactor process operating as part of a process unit which produces beverage alcohols, or which uses, contains, and produces no VOC is not an affected facility.

(6) Any reactor process that is subject to the provisions of subpart DDD is not an affected facility.

(7) Each affected facility operated with a concentration of total organic compounds (TOC) (less methane and ethane) in the vent stream less than 300 ppmv as measured by Method 18 or a concentration of TOC in the vent stream less than 150 ppmv as measured by Method 25A is exempt from all provisions of this subpart except for the test method and procedure and the reporting and recordkeeping requirements in § 60.704a(f) and § 60.705a(j), (k)(8), and (s).

(8) A vent stream going to a fuel gas system as defined in § 63.701a.

**§ 60.701a What definitions must I know?**

As used in this subpart, all terms not defined herein have the meaning given them in the Clean Air Act and subpart A of this part.

*Batch operation* means any noncontinuous reactor process that is not characterized by steady-state conditions and in which reactants are not added and products are not removed simultaneously.

*Boiler* means any enclosed combustion device that extracts useful energy in the form of steam and is not an incinerator.

*Breakthrough* means the time when the level of TOC, measured at the outlet of the first bed, has been detected is at the highest concentration allowed to be discharged from the adsorber system and indicates that the adsorber bed should be replaced.

*By compound* means by individual stream components, not carbon equivalents.

*Car-seal* means a seal that is placed on a device that is used to change the position of a valve (e.g., from opened to closed) in such a way that the position of the valve cannot be changed without breaking the seal.

*Closed vent system* means a system that is not open to the atmosphere and is composed of piping, ductwork, connections, and, if necessary, flow inducing devices that transport gas or vapor from an emission point to a control device.

*Combustion device* means an individual unit of equipment, such as an incinerator, flare, boiler, or process heater, used for combustion of a vent stream discharged from the process vent.

*Continuous recorder* means a data recording device recording an instantaneous data value at least once every 15 minutes.

*Flame zone* means the portion of the combustion chamber in a boiler or

process heater occupied by the flame envelope.

*Flow indicator* means a device which indicates whether gas flow is present in a line.

*Fuel gas* means gases that are combusted to derive useful work or heat.

*Fuel gas system* means the offsite and onsite piping and flow and pressure control system that gathers gaseous stream(s) generated by onsite operations, may blend them with other sources of gas, and transports the gaseous stream for use as fuel gas in combustion devices or in in-process combustion equipment such as furnaces and gas turbines either singly or in combination.

*Halogenated vent stream* means any vent stream determined to have a total concentration (by volume) of compounds containing halogens of 20 ppmv (by compound) or greater.

*Incinerator* means an enclosed combustion device that is used for destroying organic compounds. If there is energy recovery, the energy recovery section and the combustion chambers are not of integral design. That is, the energy recovery section and the combustion section are not physically formed into one manufactured or assembled unit but are joined by ducts or connections carrying flue gas.

*Pressure-assisted multi-point flare* means a flare system consisting of multiple flare burners in staged arrays whereby the vent stream pressure is used to promote mixing and smokeless operation at the flare burner tips. Pressure-assisted multi-point flares are designed for smokeless operation at velocities up to Mach = 1 conditions (i.e., sonic conditions), can be elevated or at ground level, and typically use cross-lighting for flame propagation to combust any flare vent gases sent to a particular stage of flare burners.

*Primary fuel* means the fuel fired through a burner or a number of similar burners. The primary fuel provides the principal heat input to the device, and the amount of fuel is sufficient to sustain operation without the addition of other fuels.

*Process heater* means a device that transfers heat liberated by burning fuel directly to process streams or to heat transfer liquids other than water.

*Process unit* means equipment assembled and connected by pipes or ducts to produce, as intermediates or final products, one or more of the chemicals in § 60.707a. A process unit can operate independently if supplied with sufficient feed or raw materials and sufficient product storage facilities.

*Product* means any compound or chemical listed in § 60.707a which is produced for sale as a final product as that chemical, or for use in the production of other chemicals or compounds. By-products, co-products, and intermediates are considered to be products.

*Reactor processes* are unit operations in which one or more chemicals, or reactants other than air, are combined or decomposed in such a way that their molecular structures are altered and one or more new organic compounds are formed.

*Recovery device* means an individual unit of equipment, such as an absorber, carbon adsorber, or condenser, capable of and used for the purpose of recovering chemicals for use, reuse, or sale.

*Recovery system* means an individual recovery device or series of such devices applied to the same vent stream.

*Relief valve* means a valve used only to release an unplanned, nonroutine discharge. A relief valve discharge results from an operator error, a malfunction such as a power failure or equipment failure, or other unexpected cause that requires immediate venting of gas from process equipment in order to avoid safety hazards or equipment damage.

*Secondary fuel* means a fuel fired through a burner other than a primary fuel burner. The secondary fuel may provide supplementary heat in addition to the heat provided by the primary fuel.

*Total organic compounds or TOC* means those compounds measured according to the procedures of Method 18 of appendix A-6 of this part or the concentration of organic compounds measured according to the procedures in Method 21 or Method 25A of appendix A-7 of this part.

*Vent stream* means any gas stream discharged directly from a reactor process to the atmosphere or indirectly to the atmosphere after diversion through other process equipment. The vent stream excludes and equipment leaks, including, but not limited to, pumps, compressors, and valves.

#### **§ 60.702a What standards and associated requirements must I meet?**

(a) You must comply with the emission limits and standards specified in Table 1 to this subpart and the requirements specified in paragraphs (b) and (c) of this section for each vent stream on and after the date on which the initial performance test required by §§ 60.8 and 60.704a is completed, but not later than 60 days after achieving the maximum production rate at which the affected facility will be operated, or

180 days after the initial start-up, whichever date comes first. The standards in this section apply at all times, including periods of startup, shutdown and malfunction. As provided in § 60.11(f), this provision supersedes the exemptions for periods of startup, shutdown and malfunction in the general provisions in subpart A of this part.

(b) The following release events from an affected facility are a violation of the emission limits and standards specified in table 1 to this subpart.

(1) Any relief valve discharge to the atmosphere of a vent stream.

(2) The use of a bypass line at any time on a closed vent system to divert emissions to the atmosphere, or to a control device or recovery device not meeting the requirements specified in § 60.703a.

(c) You may designate a vent stream as a maintenance vent if the vent is only used as a result of startup, shutdown, maintenance, or inspection of equipment where equipment is emptied, depressurized, degassed, or placed into service. You must comply with the applicable requirements in paragraphs (c)(1) through (3) of this section for each maintenance vent. Any vent stream designated as a maintenance vent is only subject to the maintenance vent provisions in this paragraph (c) and the associated recordkeeping and reporting requirements in § 60.705a(g), respectively.

(1) Prior to venting to the atmosphere, remove process liquids from the equipment as much as practical and depressurize the equipment to either: A flare meeting the requirements of § 60.709a, as applicable, or using any combination of a non-flare control device or recovery device meeting the requirements in table 1 to this subpart until one of the following conditions, as applicable, is met.

(i) The vapor in the equipment served by the maintenance vent has a lower explosive limit (LEL) of less than 10 percent.

(ii) If there is no ability to measure the LEL of the vapor in the equipment based on the design of the equipment, the pressure in the equipment served by the maintenance vent is reduced to 5 pounds per square inch gauge (psig) or less. Upon opening the maintenance vent, active purging of the equipment cannot be used until the LEL of the vapors in the maintenance vent (or inside the equipment if the maintenance is a hatch or similar type of opening) is less than 10 percent.

(iii) The equipment served by the maintenance vent contains less than 50 pounds of total VOC.

(iv) If, after applying best practices to isolate and purge equipment served by a maintenance vent, none of the applicable criterion in paragraphs (c)(1)(i) through (iii) of this section can be met prior to installing or removing a blind flange or similar equipment blind, then the pressure in the equipment served by the maintenance vent must be reduced to 2 psig or less before installing or removing the equipment blind. During installation or removal of the equipment blind, active purging of the equipment may be used provided the equipment pressure at the location where purge gas is introduced remains at 2 psig or less.

(2) Except for maintenance vents complying with the alternative in paragraph (c)(1)(iii) of this section, you must determine the LEL or, if applicable, equipment pressure using process instrumentation or portable measurement devices and follow procedures for calibration and maintenance according to manufacturer's specifications.

(3) For maintenance vents complying with the alternative in paragraph (c)(1)(iii) of this section, you must determine mass of VOC in the equipment served by the maintenance vent based on the equipment size and contents after considering any contents drained or purged from the equipment. Equipment size may be determined from equipment design specifications. Equipment contents may be determined using process knowledge.

**§ 60.703a What are my monitoring, installation, operation, and maintenance requirements?**

(a) Except as specified in paragraphs (a)(5) through (7) of this section, if you use a non-flare control device or recovery system to comply with the TOC emission limit specified in table 1 to this subpart, then you must comply with paragraphs (a)(1) through (4), (b), and (c) of this section.

(1) Install a continuous parameter monitoring system(s) (CPMS) and monitor the operating parameter(s) applicable to the control device or recovery system as specified in table 2 to this subpart or established according to paragraph (c) of this section.

(2) Establish the applicable minimum, maximum, or range for the operating parameter limit as specified in Table 3 to this subpart or established according to paragraph (c) of this section by calculating the value(s) as the arithmetic average of operating parameter measurements recorded during the three test runs conducted for the most recent performance test. You may operate outside of the established operating

parameter limit(s) during subsequent performance tests in order to establish new operating limits. You must include the updated operating limits with the performance test results submitted to the Administrator pursuant to § 60.705a(b). Upon establishment of a new operating limit, you must thereafter operate under the new operating limit. If the Administrator determines that you did not conduct the performance test in accordance with the applicable requirements or that the operating limit established during the performance test does not correspond to the conditions specified in § 60.704a(a), then you must conduct a new performance test and establish a new operating limit.

(3) Monitor, record, and demonstrate continuous compliance using the minimum frequencies specified in Table 3 to this subpart or established according to paragraph (c) of this section.

(4) Comply with the calibration and quality control requirements as specified in table 4 to this subpart or established according to paragraph (c) of this section that are applicable to the CPMS used.

(5) Any vent stream introduced with primary fuel into a boiler or process heater is exempt from the requirements specified in paragraphs (a)(1) through (4) of this section.

(6) If you vent emissions through a closed vent system to an adsorber(s) that cannot be regenerated or a regenerative adsorber(s) that is regenerated offsite, then you must install a system of two or more adsorber units in series and comply with the requirements specified in paragraphs (a)(6)(i) through (iii) of this section in addition to the requirements specified in paragraphs (a)(1) through (4) of this section.

(i) Conduct an initial performance test or design evaluation of the adsorber and establish the breakthrough limit and adsorber bed life.

(ii) Monitor the TOC concentration through a sample port at the outlet of the first adsorber bed in series according to the schedule in paragraph (a)(6)(iii)(B) of this section. You must measure the concentration of TOC using either a portable analyzer, in accordance with Method 21 of appendix A-7 of this part using methane, propane, or isobutylene as the calibration gas or Method 25A of appendix A-7 of this part using methane or propane as the calibration gas.

(iii) Comply with paragraph (a)(6)(iii)(A) of this section and comply with the monitoring frequency according to paragraph (a)(6)(iii)(B) of this section.

(A) The first adsorber in series must be replaced immediately when breakthrough, as defined in § 60.611a, is detected between the first and second adsorber. The original second adsorber (or a fresh canister) will become the new first adsorber and a fresh adsorber will become the second adsorber. For purposes of this paragraph (a)(6)(iii)(A), "immediately" means within 8 hours of the detection of a breakthrough for adsorbers of 55 gallons or less, and within 24 hours of the detection of a breakthrough for adsorbers greater than 55 gallons. You must monitor at the outlet of the first adsorber within 3 days of replacement to confirm it is performing properly.

(B) Based on the adsorber bed life established according to paragraph (a)(6)(i) of this section and the date the adsorbent was last replaced, conduct monitoring to detect breakthrough at least monthly if the adsorbent has more than 2 months of life remaining, at least weekly if the adsorbent has between 2 months and 2 weeks of life remaining, and at least daily if the adsorbent has 2 weeks or less of life remaining.

(7) If you install a continuous emissions monitoring system (CEMS) to demonstrate compliance with the TOC standard in Table 1 of this subpart, you must comply with the requirements specified in § 60.704a(g) in lieu of the requirements specified in paragraphs (a)(1) through (4) and (c) of this section.

(b) If you vent emissions through a closed vent system to a boiler or process heater, then the vent stream must be introduced into the flame zone of the boiler or process heater.

(c) If you seek to demonstrate compliance with the standards specified under § 60.702a with control devices other than an incinerator, boiler, process heater, or flare; or recovery devices other than an absorber, condenser, or carbon adsorber, you shall provide to the Administrator prior to conducting the initial performance test information describing the operation of the control device or recovery device and the parameter(s) which would indicate proper operation and maintenance of the device and how the parameter(s) are indicative of control of TOC emissions. The Administrator may request further information and will specify appropriate monitoring procedures or requirements, including operating parameters to be monitored, averaging times for determining compliance with the operating parameter limits, and ongoing calibration and quality control requirements.

**§ 60.704a What test methods and procedures must I use to determine compliance with the standards?**

(a) For the purpose of demonstrating compliance with the emission limits and standards specified in table 1 to this subpart, all affected facilities must be run at full operating conditions and flow rates during any performance test. Performance tests are not required if you determine compliance using a CEMS that meets the requirements outlined in paragraph (g) of this section.

(1) Conduct initial performance tests no later than the date required by § 60.8(a).

(2) Conduct subsequent performance tests no later than 60 calendar months after the previous performance test.

(b) The following methods in appendix A to this part, except as provided in § 60.8(b), must be used as reference methods to determine compliance with the emission limit or percent reduction efficiency specified in table 1 to this subpart for non-flare control devices and/or recovery systems.

(1) Method 1 or 1A of appendix A-1 to this part, as appropriate, for selection of the sampling sites. The inlet sampling site for determination of vent stream molar composition or TOC (less methane and ethane) reduction efficiency shall be prior to the inlet of the control device or, if equipped with a recovery system, then prior to the inlet of the first recovery device in the recovery system.

(2) Method 2, 2A, 2C, or 2D of appendix A-1 to this part, as appropriate, for determination of the gas volumetric flow rates.

(3) Method 3A of appendix A-2 to this part or the manual method in ANSI/ASME PTC 19.10-1981—Part 10 (incorporated by reference, see § 60.17) must be used to determine the oxygen concentration (%O<sub>2d</sub>) for the purposes of determining compliance with the 20 ppmv limit. The sampling site must be the same as that of the TOC samples, and the samples must be taken during the same time that the TOC samples are taken. The TOC concentration corrected to 3 percent O<sub>2</sub> (C<sub>c</sub>) must be computed using the following equation:

**Equation 1 to Paragraph (b)(3)**

$$C_c = C_{\text{TOC}} \frac{17.9}{20.9 - \%O_{2d}}$$

Where:

C<sub>c</sub> = Concentration of TOC corrected to 3 percent O<sub>2</sub>, dry basis, ppm by volume.

C<sub>TOC</sub> = Concentration of TOC (minus methane and ethane), dry basis, ppm by volume.

%O<sub>2d</sub> = Concentration of O<sub>2</sub>, dry basis, percent by volume.

(4) Method 18 of appendix A-6 to this part to determine the concentration of TOC in the control device outlet or in the outlet of the final recovery device in a recovery system, and to determine the

concentration of TOC in the inlet when the reduction efficiency of the control device or recovery system is to be determined. ASTM D6420-18 (incorporated by reference, see § 60.17) may be used in lieu of Method 18, if the target compounds are all known and are all listed in section 1.1 of ASTM D6420-18 as measurable; ASTM D6420-18 may not be used for methane and ethane; and ASTM D6420-18 must not be used as a total VOC method.

(i) The minimum sampling time for each run must be 1 hour in which either an integrated sample or at least four grab samples must be taken. If grab sampling is used, then the samples must be taken at approximately 15-minute intervals.

(ii) The emission reduction (R) of TOC (minus methane and ethane) must be determined using the following equation:

**Equation 2 to Paragraph (b)(4)(ii)**

$$R = \frac{E_i - E_o}{E_i} \times 100$$

Where:

R = Emission reduction, percent by weight.

E<sub>i</sub> = Mass rate of TOC entering the control device or recovery system, kg TOC/hr.

E<sub>o</sub> = Mass rate of TOC discharged to the atmosphere, kg TOC/hr.

(iii) The mass rates of TOC (E<sub>i</sub>, E<sub>o</sub>) must be computed using the following equations:

$$E_i = K_2 \sum_{j=1}^n C_{ij} M_{ij} Q_i$$

$$E_o = K_2 \sum_{j=1}^n C_{oj} M_{oj} Q_o$$

Where:

C<sub>ij</sub>, C<sub>oj</sub> = Concentration of sample component “j” of the gas stream at the inlet and outlet of the control device or recovery system, respectively, dry basis, ppm by volume.

M<sub>ij</sub>, M<sub>oj</sub> = Molecular weight of sample component “j” of the gas stream at the

inlet and outlet of the control device or recovery system, respectively, g/g-mole (lb/lb-mole).

Q<sub>i</sub>, Q<sub>o</sub> = Flow rate of gas stream at the inlet and outlet of the control device or recovery system, respectively, dscm/min (dscf/hr).

K<sub>2</sub> = Constant, 2.494 × 10<sup>minus;6</sup> (l/ppm) (g-mole/scm) (kg/g) (min/hr), where standard temperature for (g-mole/scm) is 20 °C (metric units); or = Constant, 1.557 × 10<sup>minus;7</sup> (1/ppm)(lb-mole/scf)(min/hr), where standard temperature for (lb-mole/scf) is 68 °F (English units).

**Equations 3 and 4 to Paragraph (b)(4)(iii)**

(iv) The TOC concentration ( $C_{TOC}$ ) is the sum of the individual components

and must be computed for each run using the following equation:

$$C_{TOC} = \sum_{j=1}^n C_j$$

Where:

$C_{TOC}$  = Concentration of TOC (minus methane and ethane), dry basis, ppm by volume.

$C_j$  = Concentration of sample components “j”, dry basis, ppm by volume.

$n$  = Number of components in the sample.

(c) The requirement for initial and subsequent performance tests are waived, in accordance with § 60.8(b), for the following:

(1) When a boiler or process heater with a design heat input capacity of 44 MW (150 million Btu/hour) or greater is used to seek compliance with § 60.702a(a).

(2) When a vent stream is introduced into a boiler or process heater with the primary fuel.

(3) When a boiler or process heater burning hazardous waste is used for which the owner or operator:

(i) Has been issued a final permit under 40 CFR part 270 and complies with the requirements of 40 CFR part 266, subpart H;

(ii) Has certified compliance with the interim status requirements of 40 CFR part 266, subpart H;

(iii) Has submitted a Notification of Compliance under 40 CFR 63.1207(j) and complies with the requirements of 40 CFR part 63, subpart EEE; or

(iv) Complies with 40 CFR part 63, subpart EEE, and will submit a Notification of Compliance under 40 CFR 63.1207(j) by the date the owner or operator would have been required to submit the initial performance test report for this subpart.

(4) The Administrator reserves the option to require testing at such other times as may be required, as provided for in section 114 of the Act.

(d) For purposes of complying with the 98 weight-percent reduction in § 60.702a(a), if the vent stream entering a boiler or process heater with a design capacity less than 44 MW (150 million Btu/hour) is introduced with the combustion air or as secondary fuel, the weight-percent reduction of TOC (minus methane and ethane) across the combustion device shall be determined by comparing the TOC (minus methane and ethane) in all combusted vent streams, primary fuels, and secondary fuels with the TOC (minus methane and ethane) exiting the combustion device.

(e) Any owner or operator subject to the provisions of this subpart seeking to

demonstrate compliance with § 60.700a(c)(3) shall use Method 2, 2A, 2C, or 2D of appendix A–1 to this part, as appropriate, for determination of volumetric flow rate. The owner or operator must conduct three velocity traverses and determine the volumetric flow rate for each traverse. If the pipe or duct is smaller than four inches in diameter, the owner operator may conduct the measurement at the centroid of the duct instead of conducting a traverse; the measurement period must be at least five minutes long and data must be recorded at least once every 30 seconds. Owners and operators who conduct the determination with Method 2A or 2D must record volumetric flow rate every 30 seconds for at least five minutes.

(f) Each owner or operator seeking to demonstrate that a reactor process vent stream has a TOC concentration for compliance with the low concentration exemption in § 60.700a(c)(7) shall conduct an initial test to measure TOC concentration.

(1) The sampling site shall be selected as specified in paragraph (d)(1)(i) of this section.

(2) Method 18 of appendix A–6 or Method 25A of appendix A–7 to this part shall be used to measure concentration. ASTM D6420–18 (incorporated by reference, see § 60.17) may be used in lieu of Method 18, if the target compounds are all known and are all listed in Section 1.1 of ASTM D6420–18 as measurable; ASTM D6420–18 may not be used for methane and ethane; and ASTM D6420–18 must not be used as a total VOC method.

(3) Where Method 18 of appendix A–6 to this part is used to qualify for the low concentration exclusion in § 60.700a(c)(7), the procedures in paragraphs (b)(4)(i) and (iv) of this section shall be used to measure TOC concentration, and the procedures of paragraph (b)(3) of this section shall be used to correct the TOC concentration to 3 percent oxygen. To qualify for the exclusion, the results must demonstrate that the concentration of TOC, corrected to 3 percent oxygen, is below 300 ppm by volume.

(4) Where Method 25A of appendix A–7 to this part is used, the following procedures shall be used to calculate

#### Equation 5 to Paragraph (b)(4)(iv)

ppm by volume TOC concentration, corrected to 3 percent oxygen:

(i) Method 25A of appendix A–7 to this part shall be used only if a single organic compound is greater than 50 percent of total TOC, by volume, in the reactor process vent stream. This compound shall be the principal organic compound.

(ii) The principal organic compound may be determined by either process knowledge or test data collected using an appropriate EPA Reference Method. Examples of information that could constitute process knowledge include calculations based on material balances, process stoichiometry, or previous test results provided the results are still relevant to the current reactor process vent stream conditions.

(iii) The principal organic compound shall be used as the calibration gas for Method 25A of appendix A–7 to this part.

(iv) The span value for Method 25A of appendix A–7 to this part shall be 300 ppmv.

(v) Use of Method 25A of appendix A–7 to this part is acceptable if the response from the high-level calibration gas is at least 20 times the standard deviation of the response from the zero calibration gas when the instrument is zeroed on the most sensitive scale.

(vi) The owner or operator shall demonstrate that the concentration of TOC including methane and ethane measured by Method 25A of appendix A–7 to this part, corrected to 3 percent oxygen, is below 150 ppm by volume to qualify for the low concentration exclusion in § 60.700a(c)(7).

(vii) The concentration of TOC shall be corrected to 3 percent oxygen using the procedures and equation in paragraph (b)(3) of this section.

(g) If you use a CEMS to demonstrate initial and continuous compliance with the TOC standard in table 1 of this subpart, each CEMS must be installed, operated and maintained according to the requirements in § 60.13 and paragraphs (f)(1) through (5) of this section.

(1) You must use a CEMS that is capable of measuring the target analyte(s) as demonstrated using either process knowledge of the control device inlet stream or the screening procedures of Method 18 of appendix A–6 to this

part on the control device inlet stream. If your CEMS is located after a combustion device and inlet stream to that device includes methanol or formaldehyde, you must use a CEMS which meets the requirements in Performance Specifications 9 or 15 of appendix B to this part.

(2) Each CEMS must be installed, operated, and maintained according to the applicable performance specification of appendix B of this part and the applicable quality assurance procedures of appendix F to this part. Locate the sampling probe or other interface at a measurement location such that you obtain representative measurements of emissions from the affected facility.

(3) Conduct a performance evaluation of each CEMS within 180 days of installation of the monitoring system. Conduct subsequent performance evaluations of the CEMS no later than 12 calendar months after the previous performance evaluation. The results each performance evaluation must be submitted in accordance with § 60.705a(b)(1).

(4) You must determine TOC concentration according to one of the following options. The span value of the TOC CEMS must be approximately 2 times the emission standard specified in table 1 of this subpart.

(i) For CEMS meeting the requirements of Performance Specification 15 of appendix B to this part, determine the target analyte(s) for calibration using either process knowledge of the control device inlet stream or the screening procedures of Method 18 of appendix A–6 to this part on the control device inlet stream. The individual analytes used to quantify TOC must represent 98 percent of the expected mass of TOC present in the stream. Report the results of TOC as equivalent to carbon (C1).

(ii) For CEMS meeting the requirements of Performance Specification 9 of appendix B to this part, determine the target analyte(s) for calibration using either process knowledge of the control device inlet stream or the screening procedures of Method 18 of appendix A–6 to this part on the control device inlet stream. The individual analytes used to quantify TOC must represent 98 percent of the expected mass of TOC present in the stream. Report the results of TOC as equivalent to carbon (C1).

(iii) For CEMS meeting the requirements of Performance Specification 8 of appendix B to this part used to monitor performance of a combustion device, calibrate the instrument on the predominant organic

HAP and report the results as carbon (C1), and use Method 25A of appendix A–7 to this part as the reference method for the relative accuracy tests. You must also comply with procedure 1 of appendix F to this part.

(iv) For CEMS meeting the requirements of Performance Specification 8 of appendix B to this part used to monitor performance of a noncombustion device, determine the predominant organic compound using either process knowledge or the screening procedures of Method 18 of appendix A–6 to this part on the control device inlet stream. Calibrate the monitor on the predominant organic compound and report the results as C<sub>1</sub>. Use Method 25A of appendix A–7 to this part as the reference method for the relative accuracy tests. You must also comply with procedure 1 of appendix F to this part.

(5) You must determine stack oxygen concentration at the same location where you monitor TOC concentration with a CEMS that meets the requirements of Performance Specification 3 of appendix B of this part. The span value of the oxygen CEMS must be approximately 25 percent oxygen. Use Method 3A of appendix A–2 to this part as the reference method for the relative accuracy tests.

(6) You must maintain written procedures for your CEMS. At a minimum, the procedures must include the information in paragraph (f)(6)(i) through (vi) of this section:

(i) Description of CEMS installation location.

(ii) Description of the monitoring equipment, including the manufacturer and model number for all monitoring equipment components and the span of the analyzer.

(iii) Routine quality control and assurance procedures.

(iv) Conditions that would trigger a CEMS performance evaluation, which must include, at a minimum, a newly installed CEMS; a process change that is expected to affect the performance of the CEMS; and the Administrator's request for a performance evaluation under section 114 of the Clean Air Act.

(v) Ongoing operation and maintenance procedures.

(vi) Ongoing recordkeeping and reporting procedures.

**§ 60.705a What records must I keep and what reports must I submit?**

(a) You must notify the Administrator of the specific provisions in table 1 to this subpart or § 60.702a(c) with which you have elected to comply. Notification shall be submitted with the notification

of initial start-up required by § 60.7(a)(3). If you elect at a later date to comply with an alternative provision of § 60.702a, then you must notify the Administrator 90 days before implementing a change and, upon implementing the change, you must conduct a performance as specified by § 60.704a within 180 days.

(b) If you use a non-flare control device or recovery system to comply with the TOC emission limit specified in table 1 to this subpart, then you must keep an up-to-date, readily accessible record of the data measured during each performance test to show compliance with the TOC emission limit. You must also include all of the data you use to comply with § 60.703a(a)(2). The same data specified in this paragraph must also be submitted in the initial performance test required in § 60.8 and the reports of all subsequently required performance tests where either the emission reduction efficiency of a combustion device or recovery system or outlet concentration of TOC is determined. Alternatively, you must keep records of each CEMS performance evaluation.

(1) Within 60 days after the date of completing each performance test or CEMS performance evaluation required by this subpart, you must submit the results of the performance test or performance evaluation following the procedures specified in paragraph (l) of this section. Data collected using test methods and performance evaluations of CEMS measuring relative accuracy test audit (RATA) pollutants supported by the EPA's Electronic Reporting Tool (ERT) as listed on the EPA's ERT website (<https://www.epa.gov/electronic-reporting-air-emissions/electronic-reporting-tool-ert>) at the time of the test or performance evaluation must be submitted in a file format generated through the use of the EPA's ERT. Alternatively, owners and operators may submit an electronic file consistent with the extensible markup language (XML) schema listed on the EPA's ERT website. Data collected using test methods and performance evaluations of CEMS measuring RATA pollutants that are not supported by the EPA's ERT as listed on the EPA's ERT website at the time of the test must be included as an attachment in the ERT or alternate electronic file.

(2) If you use a boiler or process heater with a design heat input capacity of 44 MW (150 million Btu/hour) or greater to comply with the TOC emission limit specified in table 1 to this subpart, then you are not required to submit a report containing performance test data; however, you

must submit a description of the location at which the vent stream is introduced into the boiler or process heater.

(c) If you use a non-flare control device or recovery system to comply with the TOC emission limit specified in table 1 to this subpart, then you must keep up-to-date, readily accessible records of periods of operation during which the operating parameter limits established during the most recent performance test are exceeded or periods of operation where the TOC CEMS, averaged on a 3-hour block basis, indicate an exceedance of the emission standard in table 1 of this subpart. Additionally, you must record all periods when the TOC CEMS is inoperable. The Administrator may at any time require a report of these data. Periods of operation during which the operating parameter limits established during the most recent performance tests are exceeded are defined as follows:

(1) For absorbers:

(i) All 3-hour periods of operation during which the average absorbing liquid temperature was above the maximum absorbing liquid temperature established during the most recent performance test; and

(ii) All 3-hour periods of operation during which the average absorbing liquid specific gravity was outside the exit specific gravity range (*i.e.*, more than 0.1 unit above, or more than 0.1 unit below, the average absorbing liquid specific gravity) established during the most recent performance test.

(2) For boilers or process heaters:

(i) Whenever there is a change in the location at which the vent stream is introduced into the flame zone as required under § 60.703a(b); and

(ii) If the boiler or process heater has a design heat input capacity of less than 44 MW (150 million Btu/hr), then all 3-hour periods of operation during which the average firebox temperature was below the minimum firebox temperature during the most recent performance test.

(3) For catalytic incinerators:

(i) All 3-hour periods of operation during which the average temperature of the vent stream immediately before the catalyst bed is below the minimum temperature of the vent stream established during the most recent performance test.

(ii) All 3-hour periods of operation during which the average temperature difference across the catalyst bed is less than the average temperature difference of the device established during the most recent performance test.

(4) For carbon adsorbers:

(i) All carbon bed regeneration cycles during which the total mass stream flow or the total volumetric stream flow was below the minimum flow established during the most recent performance test, or

(ii) All carbon bed regeneration cycles during which the temperature of the carbon bed after regeneration (and after completion of any cooling cycle(s)) was greater than the maximum carbon bed temperature (in degrees Celsius) established during the most recent performance test.

(5) For condensers, all 3-hour periods of operation during which the average exit (product side) condenser operating temperature was above the maximum exit (product side) operating temperature established during the most recent performance test.

(6) For scrubbers used to control halogenated vent streams:

(i) All 3-hour periods of operation during which the average pH of the scrubber effluent is below the minimum pH of the scrubber effluent established during the most recent performance test,

(ii) All 3-hour periods of operation during which the average influent liquid flow to the scrubber is below the minimum influent liquid flow to the scrubber established during the most recent performance test, or

(iii) All 3-hour periods of operation during which the average liquid-to-gas ratio flow of the scrubber is below the minimum liquid-to-gas ratio of the scrubber established during the most recent performance test.

(7) For thermal incinerators, all 3-hour periods of operation during which the average firebox temperature was below the minimum firebox temperature established during the most recent performance test.

(8) For all other control devices, all periods (for the averaging time specified by the Administrator) when the operating parameter(s) established under § 60.703a(c) exceeded the operating limit established during the most recent performance test.

(d) You must keep up-to-date, readily accessible continuous records of the flow indication specified in table 2 to this subpart, as well as up-to-date, readily accessible records of all periods when the vent stream is diverted from the control device or recovery device or has no flow rate, including the records as specified in paragraphs (d)(1) and (2) of this section.

(1) For each flow event from a relief valve discharge subject to the requirements in § 60.702a(b)(1), you must include an estimate of the volume of gas, the concentration of TOC in the gas and the resulting emissions of TOC

that released to the atmosphere using process knowledge and engineering estimates.

(2) For each flow event from a bypass line subject to the requirements in §§ 60.702a(b)(2) and 60.710a(e), you must maintain records sufficient to determine whether or not the detected flow included flow requiring control. For each flow event from a bypass line requiring control that is released either directly to the atmosphere or to a control device or recovery device not meeting the requirements in this subpart, you must include an estimate of the volume of gas, the concentration of TOC in the gas and the resulting emissions of TOC that bypassed the control device or recovery device using process knowledge and engineering estimates.

(e) If you use a boiler or process heater with a design heat input capacity of 44 MW (150 million Btu/hour) or greater to comply with the TOC emission limit specified in table 1 to this subpart, then you must keep an up-to-date, readily accessible record of all periods of operation of the boiler or process heater. (Examples of such records could include records of steam use, fuel use, or monitoring data collected pursuant to other State or Federal regulatory requirements).

(f) If you use a flare to comply with the TOC emission standard specified in table 1 to this subpart, then you must keep up-to-date, readily accessible records of all visible emission readings, heat content determinations, flow rate measurements, and exit velocity determinations made during the initial visible emissions demonstration required by § 63.670(h) of part 63, subpart CC of this chapter, as applicable; and all periods during the compliance determination when the pilot flame or flare flame is absent.

(g) For each maintenance vent opening subject to the requirements of § 60.702a(c), you must keep the applicable records specified in paragraphs (g)(1) through (5) of this section.

(1) You must maintain standard site procedures used to deinventory equipment for safety purposes (*e.g.*, hot work or vessel entry procedures) to document the procedures used to meet the requirements in § 60.702a(c). The current copy of the procedures must be retained and available on-site at all times. Previous versions of the standard site procedures, as applicable, must be retained for five years.

(2) If complying with the requirements of § 60.702a(c)(1)(i), and the lower explosive limit at the time of the vessel opening exceeds 10 percent,

identification of the maintenance vent, the process units or equipment associated with the maintenance vent, the date of maintenance vent opening, and the lower explosive limit at the time of the vessel opening.

(3) If complying with the requirements of § 60.702a(c)(1)(ii), and either the vessel pressure at the time of the vessel opening exceeds 5 psig or the lower explosive limit at the time of the active purging was initiated exceeds 10 percent, identification of the maintenance vent, the process units or equipment associated with the maintenance vent, the date of maintenance vent opening, the pressure of the vessel or equipment at the time of discharge to the atmosphere and, if applicable, the lower explosive limit of the vapors in the equipment when active purging was initiated.

(4) If complying with the requirements of § 60.702a(c)(1)(iii), records of the estimating procedures used to determine the total quantity of VOC in the equipment and the type and size limits of equipment that contain less than 50 pounds of VOC at the time of maintenance vent opening. For each maintenance vent opening that contains greater than 50 pounds of VOC for which the inventory procedures specified in paragraph (g)(1) of this section are not followed or for which the equipment opened exceeds the type and size limits established in the records specified in this paragraph (g)(4), records that identify the maintenance vent, the process units or equipment associated with the maintenance vent, the date of maintenance vent opening, and records used to estimate the total quantity of VOC in the equipment at the time the maintenance vent was opened to the atmosphere.

(5) If complying with the requirements of § 60.702a(c)(1)(iv), identification of the maintenance vent, the process units or equipment associated with the maintenance vent, records documenting actions taken to comply with other applicable alternatives and why utilization of this alternative was required, the date of maintenance vent opening, the equipment pressure and lower explosive limit of the vapors in the equipment at the time of discharge, an indication of whether active purging was performed and the pressure of the equipment during the installation or removal of the blind if active purging was used, the duration the maintenance vent was open during the blind installation or removal process, and records used to estimate the total quantity of VOC in the equipment at the time the maintenance

vent was opened to the atmosphere for each applicable maintenance vent opening.

(h) If you seek to comply with the requirements of this subpart by complying with the design production capacity provision in § 60.700a(c)(2) you must keep up-to-date, readily accessible records of any change in equipment or process operation that increases the design production capacity of the process unit in which the affected facility is located.

(i) If you seek to comply with the requirements of this subpart by complying with the flow rate cutoff in § 60.700a(c)(3) you must keep up-to-date, readily accessible records to indicate that the vent stream flow rate is less than 0.011 scm/min and of any change in equipment or process operation that increases the operating vent stream flow rate, including a measurement of the new vent stream flow rate.

(j) If you seek to comply with the requirements of this subpart by complying with the low concentration exemption in § 60.700a(c)(7) you must keep up-to-date, readily accessible records of any change in equipment or process operation that increases the concentration of the vent stream of the affected facility.

(k) You must submit to the Administrator semiannual reports of the information specified in paragraphs (k)(1) through (10) of this section. You are exempt from the reporting requirements specified in § 60.7(c). If there are no exceedances, periods, or events specified in paragraphs (k)(1) through (10) of this section that occurred during the reporting period, then you must include a statement in your report that no exceedances, periods, and events specified in paragraphs (k)(1) through (10) of this section occurred during the reporting period. The initial report must be submitted within 6 months after the initial start-up-date. On and after July 15, 2024 or once the report template for this subpart has been available on the Compliance and Emissions Data Reporting Interface (CEDRI) website (<https://www.epa.gov/electronic-reporting-air-emissions/cedri>) for 1 year, whichever date is later, you must submit all subsequent reports using the appropriate electronic report template on the CEDRI website for this subpart and following the procedure specified in paragraph (l) of this section. The date report templates become available will be listed on the CEDRI website. Unless the Administrator or delegated state agency or other authority has approved a different schedule for submission of

reports, the report must be submitted by the deadline specified in this subpart, regardless of the method in which the report is submitted. All semiannual reports must include the following general information: company name, address (including county), and beginning and ending dates of the reporting period.

(1) Exceedances of monitored parameters recorded under paragraph (c) of this section. For each exceedance, the report must include a list of the affected facilities or equipment, the monitored parameter that was exceeded, the start date and time of the exceedance, the duration (in hours) of the exceedance, an estimate of the quantity in pounds of each regulated pollutant emitted over any emission limit, a description of the method used to estimate the emissions, the cause of the exceedance (including unknown cause, if applicable), as applicable, and the corrective action taken.

(2) All periods recorded under paragraph (d) of this section when the vent stream is diverted from the control device or recovery device, or has no flow rate, including the information specified in paragraphs (k)(2)(i) through (iii) of this section.

(i) For periods when the flow indicator is not operating, report the identification of the flow indicator and the start date, start time, and duration in hours.

(ii) For each flow event from a relief valve discharge subject to the requirements in § 60.702a(b)(1), the semiannual report must include the identification of the relief valve, the start date, start time, duration in hours, estimate of the volume of gas in standard cubic feet, the concentration of TOC in the gas in parts per million by volume and the resulting mass emissions of TOC in pounds that released to the atmosphere.

(iii) For each flow event from a bypass line subject to the requirements in §§ 60.702a(b)(2) and 60.710a(e)(2), the semiannual report must include the identification of the bypass line, the start date, start time, duration in hours, estimate of the volume of gas in standard cubic feet, the concentration of TOC in the gas in parts per million by volume and the resulting mass emissions of TOC in pounds that bypass a control device or recovery device.

(3) All periods when a boiler or process heater was not operating (considering the records recorded under paragraph (e) of this section), including the start date, start time, and duration in hours of each period.

(4) For each flare subject to the requirements in § 60.709a, the



semiannual report must include an identification of the flare and the items specified in § 60.709a(l)(2).

(5) For each closed vent system subject to the requirements in § 60.710a, the semiannual report must include an identification of the closed vent system and the items specified in § 60.710a(i).

(6) Any change in equipment or process operation, as recorded under paragraph (h) of this section, that increases the design production capacity above the low capacity exemption level in § 60.700a(c)(2) and the new capacity resulting from the change for the reactor process unit containing the affected facility. These must be reported as soon as possible after the change and no later than 180 days after the change. These reports may be submitted either in conjunction with semiannual reports or as a single separate report. Unless the facility qualifies for an exemption under § 60.700a(c), the facility must begin compliance with the requirements set forth in § 60.702a.

(7) Any change in equipment or process operation that increases the operating vent stream flow rate above the low flow exemption level in § 60.700a(c)(3), including a measurement of the new vent stream flow rate, as recorded under paragraph (i) of this section. These must be reported as soon as possible after the change and no later than 180 days after the change. These reports may be submitted either in conjunction with semiannual reports or as a single separate report. Unless the facility qualifies for an exemption under § 60.700a(c), the facility must begin compliance with the requirements set forth in § 60.702a.

(8) Any change in equipment or process operation that increases the vent stream concentration above the low concentration exemption level in § 60.700a(c)(7), including a measurement of the new vent stream concentration, as recorded under paragraph (j) of this section. These must be reported as soon as possible after the change and no later than 180 days after the change. These reports may be submitted either in conjunction with semiannual reports or as a single separate report. The performance test is subject to the requirements of § 60.8 and must be submitted according to paragraph (b)(1) of this section. Unless the facility qualifies for an exemption under § 60.700a(c), the facility must begin compliance with the requirements set forth in § 60.702a.

(9) Exceedances of the emission standard in table 1 of this subpart as indicated by a 3-hour average of the

TOC CEMS and recorded under paragraph (c) of this section. For each exceedance, the report must include a list of the affected facilities or equipment, the start date and time of the exceedance, the duration (in hours) of the exceedance, an estimate of the quantity in pounds of each regulated pollutant emitted over the emission limit, a description of the method used to estimate the emissions, the cause of the exceedance (including unknown cause, if applicable), as applicable, and the corrective action taken.

(10) Periods when the TOC CEMS was inoperative. For each period, the report must include a list of the affected facilities or equipment, the start date and time of the period, the duration (in hours) of the period, the cause of the inoperability (including unknown cause, if applicable), as applicable, and the corrective action taken.

(l) If you are required to submit notifications or reports following the procedure specified in this paragraph (l), you must submit notifications or reports to the EPA via CEDRI, which can be accessed through the EPA's Central Data Exchange (CDX) (<https://cdx.epa.gov/>). The EPA will make all the information submitted through CEDRI available to the public without further notice to you. Do not use CEDRI to submit information you claim as CBI. Although we do not expect persons to assert a claim of CBI, if you wish to assert a CBI claim for some of the information in the report or notification, you must submit a complete file in the format specified in this subpart, including information claimed to be CBI, to the EPA following the procedures in paragraphs (l)(1) and (2) of this section. Clearly mark the part or all of the information that you claim to be CBI. Information not marked as CBI may be authorized for public release without prior notice. Information marked as CBI will not be disclosed except in accordance with procedures set forth in 40 CFR part 2. All CBI claims must be asserted at the time of submission. Anything submitted using CEDRI cannot later be claimed CBI. Furthermore, under CAA section 114(c), emissions data is not entitled to confidential treatment, and the EPA is required to make emissions data available to the public. Thus, emissions data will not be protected as CBI and will be made publicly available. You must submit the same file submitted to the CBI office with the CBI omitted to the EPA via the EPA's CDX as described earlier in this paragraph (l).

(1) The preferred method to receive CBI is for it to be transmitted electronically using email attachments,

File Transfer Protocol, or other online file sharing services. Electronic submissions must be transmitted directly to the OAQPS CBI Office at the email address [oaqpscbi@epa.gov](mailto:oaqpscbi@epa.gov), and as described above, should include clear CBI markings. ERT files should be flagged to the attention of the Group Leader, Measurement Policy Group; all other files should be flagged to the attention of the SOCOMI NSPS Sector Lead. If assistance is needed with submitting large electronic files that exceed the file size limit for email attachments, and if you do not have your own file sharing service, please email [oaqpscbi@epa.gov](mailto:oaqpscbi@epa.gov) to request a file transfer link.

(2) If you cannot transmit the file electronically, you may send CBI information through the postal service to the following address: OAQPS Document Control Officer (C404-02), OAQPS, U.S. Environmental Protection Agency, 109 T.W. Alexander Drive, P.O. Box 12055, Research Triangle Park, North Carolina 27711. ERT files should be sent to the attention of the Group Leader, Measurement Policy Group, and all other files should be sent to the attention of the SOCOMI NSPS Sector Lead. The mailed CBI material should be double wrapped and clearly marked. Any CBI markings should not show through the outer envelope.

(m) If you are required to electronically submit notifications or reports through CEDRI in the EPA's CDX, you may assert a claim of EPA system outage for failure to timely comply with the electronic submittal requirement. To assert a claim of EPA system outage, you must meet the requirements outlined in paragraphs (m)(1) through (7) of this section.

(1) You must have been or will be precluded from accessing CEDRI and submitting a required report within the time prescribed due to an outage of either the EPA's CEDRI or CDX systems.

(2) The outage must have occurred within the period of time beginning five business days prior to the date that the submission is due.

(3) The outage may be planned or unplanned.

(4) You must submit notification to the Administrator in writing as soon as possible following the date you first knew, or through due diligence should have known, that the event may cause or has caused a delay in reporting.

(5) You must provide to the Administrator a written description identifying:

(i) The date(s) and time(s) when CDX or CEDRI was accessed and the system was unavailable;

(ii) A rationale for attributing the delay in reporting beyond the regulatory deadline to EPA system outage;

(iii) A description of measures taken or to be taken to minimize the delay in reporting; and

(iv) The date by which you propose to report, or if you have already met the reporting requirement at the time of the notification, the date you reported.

(6) The decision to accept the claim of EPA system outage and allow an extension to the reporting deadline is solely within the discretion of the Administrator.

(7) In any circumstance, the report must be submitted electronically as soon as possible after the outage is resolved.

(n) If you are required to electronically submit notifications or reports through CEDRI in the EPA's CDX, you may assert a claim of *force majeure* for failure to timely comply with the electronic submittal requirement. To assert a claim of *force majeure*, you must meet the requirements outlined in paragraphs (n)(1) through (5) of this section.

(1) You may submit a claim if a *force majeure* event is about to occur, occurs, or has occurred or there are lingering effects from such an event within the period of time beginning five business days prior to the date the submission is due. For the purposes of this section, a *force majeure* event is defined as an event that will be or has been caused by circumstances beyond the control of the affected facility, its contractors, or any entity controlled by the affected facility that prevents you from complying with the requirement to submit a report electronically within the time period prescribed. Examples of such events are acts of nature (e.g., hurricanes, earthquakes, or floods), acts of war or terrorism, or equipment failure or safety hazard beyond the control of the affected facility (e.g., large scale power outage).

(2) You must submit notification to the Administrator in writing as soon as possible following the date you first knew, or through due diligence should have known, that the event may cause or has caused a delay in reporting.

(3) You must provide to the Administrator:

(i) A written description of the *force majeure* event;

(ii) A rationale for attributing the delay in reporting beyond the regulatory deadline to the *force majeure* event;

(iii) A description of measures taken or to be taken to minimize the delay in reporting; and

(iv) The date by which you propose to report, or if you have already met the reporting requirement at the time of the notification, the date you reported.

(4) The decision to accept the claim of *force majeure* and allow an extension to the reporting deadline is solely within the discretion of the Administrator.

(5) In any circumstance, the reporting must occur as soon as possible after the *force majeure* event occurs.

(o) The requirements of paragraph (k) of this section remain in force until and unless EPA, in delegating enforcement authority to a State under section 111(c) of the Act, approves reporting requirements or an alternative means of compliance surveillance adopted by such State. In that event, affected sources within the State will be relieved of the obligation to comply with paragraph (k) of this section, provided that they comply with the requirements established by the State. The EPA will not approve a waiver of electronic reporting to the EPA in delegating enforcement authority. Thus, electronic reporting to the EPA cannot be waived, and as such, the provisions of this paragraph cannot be used to relieve owners or operators of affected facilities of the requirement to submit the electronic reports required in this section to the EPA.

(p) If you seek to demonstrate compliance with § 60.700a(c)(2), then you must submit to the Administrator an initial report detailing the design production capacity of the process unit.

(q) If you seek to demonstrate compliance with § 60.700a(c)(3), then you must submit to the Administrator an initial report including a flow rate measurement using the test methods specified in § 60.704a.

(r) If you seek to demonstrate compliance with § 60.700a(c)(4), then you must submit to the Administrator a process design description as part of the initial report. This process design description must be retained for the life

of the process. No other records or reports would be required unless process changes are made.

(s) If you seek to demonstrate compliance with § 60.700a(c)(7), then you must submit to the Administrator an initial report including a concentration measurement using the test method specified in § 60.704a.

(t) The Administrator will specify appropriate reporting and recordkeeping requirements where the owner or operator of an affected facility complies with the standards specified under § 60.702a other than as provided under § 60.703a.

(u) If you seek to demonstrate compliance with § 60.702a using a control device, then you must maintain on file a schematic diagram of the affected vent streams, collection system(s), fuel systems, control devices, and bypass systems as part of the initial report. This schematic diagram must be retained for the life of the system.

(v) Any records required to be maintained by this subpart that are submitted electronically via the EPA's CEDRI may be maintained in electronic format. This ability to maintain electronic copies does not affect the requirement for facilities to make records, data, and reports available upon request to a delegated air agency or the EPA as part of an on-site compliance evaluation.

**§ 60.706a What do the terms associated with reconstruction mean for this subpart?**

For purposes of this subpart "fixed capital cost of the new components," as used in § 60.15, includes the fixed capital cost of all depreciable components which are or will be replaced pursuant to all continuous programs of component replacement which are commenced within any 2-year period following April 25, 2023. For purposes of this paragraph, "commenced" means that you have undertaken a continuous program of component replacement or that you have entered into a contractual obligation to undertake and complete, within a reasonable time, a continuous program of component replacement.

**§ 60.707a What are the chemicals that I must produce to be affected by subpart RRRa?**

Chemical	CAS No. <sup>1</sup>
Acetaldehyde .....	75-07-0
Acetic acid .....	64-19-7
Acetic anhydride .....	108-24-7
Acetone .....	67-64-1
Acetone cyanohydrin .....	75-86-5
Acetylene .....	74-86-2

Chemical	CAS No. <sup>1</sup>
Acrylic acid	79-10-7
Acrylonitrile	107-13-1
Adipic acid	124-04-9
Adiponitrile	111-69-3
Alcohols, C-11 or lower, mixtures.	
Alcohols, C-12 or higher, mixtures.	
Alcohols, C-12 or higher, unmixed.	
Allyl chloride	107-05-1
Amylene	513-35-9
Amylenes, mixed.	
Aniline	62-53-3
Benzene	71-43-2
Benzenesulfonic acid	98-11-3
Benzenesulfonic acid C <sub>10-16</sub> -alkyl derivatives, sodium salts	68081-81-2
Benzyl chloride	100-44-7
Bisphenol A	80-05-7
Brometone	76-08-4
1,3-Butadiene	106-99-0
Butadiene and butene fractions.	
n-Butane	106-97-8
1,4-Butanediol	110-63-4
Butanes, mixed.	
1-Butene	106-98-9
2-Butene	25167-67-3
Butenes, mixed.	
n-Butyl acetate	123-86-4
Butyl acrylate	141-32-2
n-Butyl alcohol	71-36-3
sec-Butyl alcohol	78-92-2
tert-Butyl alcohol	75-65-0
Butylbenzyl phthalate	85-68-7
tert-Butyl hydroperoxide	75-91-2
2-Butyne-1,4-diol	110-65-6
Butyraldehyde	123-72-8
Butyric anhydride	106-31-0
Caprolactam	105-60-2
Carbon disulfide	75-15-0
Carbon tetrachloride	56-23-5
Chloroacetic acid	79-11-8
Chlorobenzene	108-90-7
Chlorodifluoromethane	75-45-6
Chloroform	67-66-3
p-Chloronitrobenzene	100-00-5
Citric acid	77-92-9
Cumene	98-82-8
Cumene hydroperoxide	80-15-9
Cyanuric chloride	108-77-0
Cyclohexane	110-82-7
Cyclohexane, oxidized	68512-15-2
Cyclohexanol	108-93-0
Cyclohexanone	108-94-1
Cyclohexanone oxime	100-64-1
Cyclohexene	110-83-8
Cyclopropane	75-19-4
Diacetone alcohol	123-42-2
1,4-Dichlorobutene	110-57-6
3,4-Dichloro-1-butene	64037-54-3
Dichlorodifluoromethane	75-71-8
Dichlorodimethylsilane	75-78-5
Dichlorodifluoromethane	75-43-4
Diethanolamine	111-42-2
Diethylbenzene	25340-17-4
Diethylene glycol	111-46-6
Di-isodecyl phthalate	26761-40-0
Dimethyl terephthalate	120-61-6
2,4-(and 2,6)-dinitrotoluene	121-14-2
	606-20-2
Dioctyl phthalate	117-81-7
Dodecene	25378-22-7
Dodecylbenzene, nonlinear.	
Dodecylbenzenesulfonic acid	27176-87-0
Dodecylbenzenesulfonic acid, sodium salt	25155-30-0
Epichlorohydrin	106-89-8
Ethanol	64-17-5

Chemical	CAS No. <sup>1</sup>
Ethanolamine	141-43-5
Ethyl acetate	141-78-6
Ethyl acrylate	140-88-5
Ethylbenzene	100-41-4
Ethyl chloride	75-00-3
Ethylene	74-85-1
Ethylene dibromide	106-93-4
Ethylene dichloride	107-06-2
Ethylene glycol	107-21-1
Ethylene glycol monobutyl ether	111-76-2
Ethylene glycol monoethyl ether acetate	111-15-9
Ethylene glycol monomethyl ether	109-86-4
Ethylene oxide	75-21-8
2-Ethylhexyl alcohol	104-76-7
(2-Ethylhexyl) amine	104-75-6
6-Ethyl-1,2,3,4-tetrahydro 9,10-anthracenedione	15547-17-8
Formaldehyde	50-00-0
Glycerol	56-81-5
n-Heptane	142-82-5
Heptenes (mixed).	
Hexamethylene diamine	124-09-4
Hexamethylene diamine adipate	3323-53-3
Hexamethylenetetramine	100-97-0
Hexane	110-54-3
Isobutane	75-28-5
Isobutanol	78-83-1
Isobutylene	115-11-7
Isobutyraldehyde	78-84-2
Isopentane	78-78-4
Isoprene	78-79-5
Isopropanol	67-63-0
Ketene	463-51-4
Linear alcohols, ethoxylated, mixed.	
Linear alcohols, ethoxylated, and sulfated, sodium salt, mixed.	
Linear alcohols, sulfated, sodium salt, mixed.	
Linear alkylbenzene	123-01-3
Maleic anhydride	108-31-6
Mesityl oxide	141-79-7
Methanol	67-56-1
Methylamine	74-39-5
ar-Methylbenzenediamine	25376-45-8
Methyl chloride	74-87-3
Methylene chloride	75-09-2
Methyl ethyl ketone	78-93-3
Methyl isobutyl ketone	108-10-1
Methyl methacrylate	80-62-6
1-Methyl-2-pyrrolidone	872-50-4
Methyl tert-butyl ether.	
Naphthalene	91-20-3
Nitrobenzene	98-95-3
1-Nonene	27215-95-8
Nonyl alcohol	143-08-8
Nonylphenol	25154-52-3
Nonylphenol, ethoxylated	9016-45-9
Octene	25377-83-7
Oil-soluble petroleum sulfonate, calcium salt.	
Pentaerythritol	115-77-5
3-Pentenenitrile	4635-87-4
Pentenes, mixed	109-67-1
Perchloroethylene	127-18-4
Phenol	108-95-2
1-Phenylethyl hydroperoxide	3071-32-7
Phenylpropane	103-65-1
Phosgene	75-44-5
Phthalic anhydride	85-44-9
Propane	74-98-6
Propionaldehyde	123-38-6
Propyl alcohol	71-23-8
Propylene	115-07-1
Propylene glycol	57-55-6
Propylene oxide	75-56-9
Sorbitol	50-70-4
Styrene	100-42-5
Terephthalic acid	100-21-0

Chemical	CAS No. <sup>1</sup>
Tetraethyl lead .....	78-00-2
Tetrahydrofuran .....	109-99-9
Tetra (methyl-ethyl) lead.	
Tetramethyl lead .....	75-74-1
Toluene .....	108-88-3
Toluene-2,4-diamine .....	95-80-7
Toluene-2,4-(and, 2,6)-diisocyanate (80/20 mixture) .....	26471-62-5
1,1,1-Trichloroethane .....	71-55-6
1,1,2-Trichloroethane .....	79-00-5
Trichloroethylene .....	79-01-6
Trichlorofluoromethane .....	75-69-4
1,1,2-Trichloro-1,2,2-trifluoroethane .....	76-13-1
Triethanolamine .....	102-71-6
Triethylene glycol .....	112-27-6
Vinyl acetate .....	108-05-4
Vinyl chloride .....	75-01-4
Vinylidene chloride .....	75-35-4
m-Xylene .....	108-38-3
o-Xylene .....	95-47-6
p-Xylene .....	106-42-3
Xylenes (mixed) .....	1330-20-7

<sup>1</sup> CAS numbers refer to the Chemical Abstracts Registry numbers assigned to specific chemicals, isomers, or mixtures of chemicals. Some isomers or mixtures that are covered by the standards do not have CAS numbers assigned to them. The standards apply to all of the chemicals listed, whether CAS numbers have been assigned or not.

#### § 60.708a [Reserved]

#### § 60.709a What are my requirements if I use a flare to comply with this subpart?

(a) If you use a flare to comply with the TOC emission standard specified in table 1 to this subpart, then you must meet the applicable requirements for flares as specified in §§ 63.670 and 63.671 of this chapter, including the provisions in tables 12 and 13 to part 63, subpart CC, of this chapter, except as specified in paragraphs (b) through (o) of this section. This requirement also applies to any flare using fuel gas from a fuel gas system, of which 50 percent or more of the fuel gas is derived from an affected facility, as determined on an annual average basis. For purposes of compliance with this paragraph (a), the following terms are defined in § 63.641 of this chapter: Assist air, assist steam, center steam, combustion zone, combustion zone gas, flare, flare purge gas, flare supplemental gas, flare sweep gas, flare vent gas, lower steam, net heating value, perimeter assist air, pilot gas, premix assist air, total steam, and upper steam.

(b) When determining compliance with the pilot flame requirements specified in § 63.670(b) and (g) of this chapter, substitute “pilot flame or flare flame” for each occurrence of “pilot flame.”

(c) When determining compliance with the flare tip velocity and combustion zone operating limits specified in § 63.670(d) and (e) of this chapter, the requirement effectively applies starting with the 15-minute block that includes a full 15 minutes of the flaring event. You are required to

demonstrate compliance with the velocity and NHVcz requirements starting with the block that contains the fifteenth minute of a flaring event. You are not required to demonstrate compliance for the previous 15-minute block in which the event started and contained only a fraction of flow.

(d) Instead of complying with § 63.670(o)(2)(i) of this chapter, you must develop and implement the flare management plan no later than startup for a new flare that commenced construction on or after April 25, 2023.

(e) Instead of complying with § 63.670(o)(2)(iii) of this chapter, if required to develop a flare management plan and submit it to the Administrator, then you must also submit all versions of the plan in portable document format (PDF) following the procedures specified in § 60.705a(l).

(f) Section 63.670(o)(3)(ii) of this chapter and all references to it do not apply. Instead, you must comply with the maximum flare tip velocity operating limit at all times.

(g) Substitute “affected facility” for each occurrence of “petroleum refinery.”

(h) Each occurrence of “refinery” does not apply.

(i) If a pressure-assisted multi-point flare is used as a control device, then you must meet the following conditions:

(1) You are not required to comply with the flare tip velocity requirements in § 63.670(d) and (k) of this chapter;

(2) The NHVcz for pressure-assisted multi-point flares is 800 Btu/scf;

(3) You must determine the 15-minute block average NHVvg using only the

direct calculation method specified in § 63.670(l)(5)(ii) of this chapter;

(4) Instead of complying with § 63.670(b) and (g) of this chapter, if a pressure-assisted multi-point flare uses cross-lighting on a stage of burners rather than having an individual pilot flame on each burner, then you must operate each stage of the pressure-assisted multi-point flare with a flame present at all times when regulated material is routed to that stage of burners. Each stage of burners that cross-lights in the pressure-assisted multi-point flare must have at least two pilots with at least one continuously lit and capable of igniting all regulated material that is routed to that stage of burners. Each 15-minute block during which there is at least one minute where no pilot flame is present on a stage of burners when regulated material is routed to the flare is a deviation of the standard. Deviations in different 15-minute blocks from the same event are considered separate deviations. The pilot flame(s) on each stage of burners that use cross-lighting must be continuously monitored by a thermocouple or any other equivalent device used to detect the presence of a flame;

(5) Unless you choose to conduct a cross-light performance demonstration as specified in this paragraph (i)(5), you must ensure that if a stage of burners on the flare uses cross-lighting, that the distance between any two burners in series on that stage is no more than 6 feet when measured from the center of one burner to the next burner. A distance greater than 6 feet between any two burners in series may be used

provided you conduct a performance demonstration that confirms the pressure-assisted multi-point flare will cross-light a minimum of three burners and the spacing between the burners and location of the pilot flame must be representative of the projected installation. The compliance demonstration must be approved by the permitting authority and a copy of this approval must be maintained onsite. The compliance demonstration report must include: a protocol describing the test methodology used, associated test method QA/QC parameters, the waste gas composition and NHV<sub>cz</sub> of the gas tested, the velocity of the waste gas tested, the pressure-assisted multi-point flare burner tip pressure, the time, length, and duration of the test, records of whether a successful cross-light was observed over all of the burners and the length of time it took for the burners to cross-light, records of maintaining a stable flame after a successful cross-light and the duration for which this was observed, records of any smoking events during the cross-light, waste gas temperature, meteorological conditions (e.g., ambient temperature, barometric pressure, wind speed and direction, and relative humidity), and whether there were any observed flare flameouts; and

(6) You must install and operate pressure monitor(s) on the main flare header, as well as a valve position indicator monitoring system for each staging valve to ensure that the flare operates within the proper range of conditions as specified by the

manufacturer. The pressure monitor must meet the requirements in Table 13 to part 63, subpart CC of this chapter.

(7) If a pressure-assisted multi-point flare is operating under the requirements of an approved alternative means of emission limitations, you must either continue to comply with the terms of the alternative means of emission limitations or comply with the provisions in paragraphs (i)(1) through (6) of this section.

(j) If you choose to determine compositional analysis for net heating value with a continuous process mass spectrometer, then you must comply with the requirements specified in paragraphs (j)(1) through (7) of this section.

(1) You must meet the requirements in § 63.671(e)(2) of this chapter. You may augment the minimum list of calibration gas components found in § 63.671(e)(2) of this chapter with compounds found during a pre-survey or known to be in the gas through process knowledge.

(2) Calibration gas cylinders must be certified to an accuracy of 2 percent and traceable to National Institute of Standards and Technology (NIST) standards.

(3) For unknown gas components that have similar analytical mass fragments to calibration compounds, you may report the unknowns as an increase in the overlapped calibration gas compound. For unknown compounds that produce mass fragments that do not overlap calibration compounds, you

may use the response factor for the nearest molecular weight hydrocarbon in the calibration mix to quantify the unknown component's NHV<sub>g</sub>.

(4) You may use the response factor for n-pentane to quantify any unknown components detected with a higher molecular weight than n-pentane.

(5) You must perform an initial calibration to identify mass fragment overlap and response factors for the target compounds.

(6) You must meet applicable requirements in Performance Specification 9 of appendix B of this part, for continuous monitoring system acceptance including, but not limited to, performing an initial multi-point calibration check at three concentrations following the procedure in section 10.1 and performing the periodic calibration requirements listed for gas chromatographs in table 13 to part 63, subpart CC, of this chapter, for the process mass spectrometer. You may use the alternative sampling line temperature allowed under Net Heating Value by Gas Chromatograph in table 13 to part 63, subpart CC, of this chapter.

(7) The average instrument calibration error (CE) for each calibration compound at any calibration concentration must not differ by more than 10 percent from the certified cylinder gas value. The CE for each component in the calibration blend must be calculated using Equation 1 to this paragraph (j)(7).

**Equation 1 to Paragraph (j)(7)**

$$CE = \frac{C_m - C_a}{C_a} \times 100 \text{ (Eq. 1)}$$

Where:

C<sub>m</sub> = Average instrument response (ppm)  
C<sub>a</sub> = Certified cylinder gas value (ppm)

(k) If you use a gas chromatograph or mass spectrometer for compositional analysis for net heating value, then you

may choose to use the CE of NHV<sub>measured</sub> versus the cylinder tag value NHV as the measure of agreement for daily calibration and quarterly audits in lieu of determining the compound-specific CE. The CE for NHV at any calibration

level must not differ by more than 10 percent from the certified cylinder gas value. The CE must be calculated using equation 2 to this paragraph (k).

**Equation 2 to Paragraph (k)**

$$CE = \frac{NHV_{measured} - NHV_a}{NHV_a} \times 100 \text{ (Eq. 2)}$$

Where:

NHV<sub>measured</sub> = Average instrument response (Btu/scf)  
NHV<sub>a</sub> = Certified cylinder gas value (Btu/scf)

(l) Instead of complying with paragraph (q) of § 63.670 of this chapter, you must comply with the reporting requirements specified in paragraphs (l)(1) and (2) of this section.

(1) The notification requirements specified in § 60.705a(a).

(2) The semiannual report specified in § 60.705a(k)(4) must include the items specified in paragraphs (l)(2)(i) through (vi) of this section.

(i) Records as specified in paragraph (m)(1) of this section for each 15-minute block during which there was at least one minute when regulated material is routed to a flare and no pilot flame or

flare flame is present. Include the start and stop time and date of each 15-minute block.

(ii) Visible emission records as specified in paragraph (m)(2)(iv) of this section for each period of 2 consecutive hours during which visible emissions exceeded a total of 5 minutes.

(iii) The periods specified in paragraph (m)(6) of this section. Indicate the date and start and end times for each

period, and the net heating value operating parameter(s) determined following the methods in § 63.670(k) through (n) of part 63, subpart CC of this chapter as applicable.

(iv) For flaring events meeting the criteria in § 63.670(o)(3) of this chapter and paragraph (f) of this section:

(A) The start and stop time and date of the flaring event.

(B) The length of time in minutes for which emissions were visible from the flare during the event.

(C) For steam-assisted, air-assisted, and non-assisted flares, the start date, start time, and duration in minutes for periods of time that the flare tip velocity exceeds the maximum flare tip velocity determined using the methods in § 63.670(d)(2) of this chapter and the maximum 15-minute block average flare tip velocity in ft/sec recorded during the event.

(D) Results of the root cause and corrective actions analysis completed during the reporting period, including the corrective actions implemented during the reporting period and, if applicable, the implementation schedule for planned corrective actions to be implemented subsequent to the reporting period.

(v) For pressure-assisted multi-point flares, the periods of time when the pressure monitor(s) on the main flare header show the burners operating outside the range of the manufacturer's specifications. Indicate the date and start and end times for each period.

(vi) For pressure-assisted multi-point flares, the periods of time when the staging valve position indicator monitoring system indicates a stage should not be in operation and is or when a stage should be in operation and is not. Indicate the date and start and end times for each period.

(m) Instead of complying with § 63.670(p) of this chapter, you must keep the flare monitoring records specified in paragraphs (m)(1) through (14) of this section.

(1) Retain records of the output of the monitoring device used to detect the presence of a pilot flame or flare flame as required in § 63.670(b) of this chapter and the presence of a pilot flame as required in paragraph (i)(4) of this section for a minimum of 2 years. Retain records of each 15-minute block during which there was at least one minute that no pilot flame or flare flame is present when regulated material is routed to a flare for a minimum of 5 years. For a pressure-assisted multi-point flare that uses cross-lighting, retain records of each 15-minute block during which there was at least one minute that no pilot flame is present on each stage

when regulated material is routed to a flare for a minimum of 5 years. You may reduce the collected minute-by-minute data to a 15-minute block basis with an indication of whether there was at least one minute where no pilot flame or flare flame was present.

(2) Retain records of daily visible emissions observations as specified in paragraphs (m)(2)(i) through (iv) of this section, as applicable, for a minimum of 3 years.

(i) To determine when visible emissions observations are required, the record must identify all periods when regulated material is vented to the flare.

(ii) If visible emissions observations are performed using Method 22 of appendix A-7 of this part, then the record must identify whether the visible emissions observation was performed, the results of each observation, total duration of observed visible emissions, and whether it was a 5-minute or 2-hour observation. Record the date and start time of each visible emissions observation.

(iii) If a video surveillance camera is used pursuant to § 63.670(h)(2) of this chapter, then the record must include all video surveillance images recorded, with time and date stamps.

(iv) For each 2-hour period for which visible emissions are observed for more than 5 minutes in 2 consecutive hours, then the record must include the date and start and end time of the 2-hour period and an estimate of the cumulative number of minutes in the 2-hour period for which emissions were visible.

(3) The 15-minute block average cumulative flows for flare vent gas and, if applicable, total steam, perimeter assist air, and premix assist air specified to be monitored under § 63.670(i) of this chapter, along with the date and time interval for the 15-minute block. If multiple monitoring locations are used to determine cumulative vent gas flow, total steam, perimeter assist air, and premix assist air, then retain records of the 15-minute block average flows for each monitoring location for a minimum of 2 years and retain the 15-minute block average cumulative flows that are used in subsequent calculations for a minimum of 5 years. If pressure and temperature monitoring is used, then retain records of the 15-minute block average temperature, pressure, and molecular weight of the flare vent gas or assist gas stream for each measurement location used to determine the 15-minute block average cumulative flows for a minimum of 2 years, and retain the 15-minute block average cumulative flows that are used in subsequent calculations for a minimum of 5 years.

(4) The flare vent gas compositions specified to be monitored under § 63.670(j) of this chapter. Retain records of individual component concentrations from each compositional analysis for a minimum of 2 years. If an NHVvg analyzer is used, retain records of the 15-minute block average values for a minimum of 5 years.

(5) Each 15-minute block average operating parameter calculated following the methods specified in § 63.670(k) through (n) of this chapter, as applicable.

(6) All periods during which operating values are outside of the applicable operating limits specified in § 63.670(d) through (f) of this chapter and paragraph (i) of this section when regulated material is being routed to the flare.

(7) All periods during which you do not perform flare monitoring according to the procedures in § 63.670(g) through (j) of this chapter.

(8) For pressure-assisted multi-point flares, if a stage of burners on the flare uses cross-lighting, then a record of any changes made to the distance between burners.

(9) For pressure-assisted multi-point flares, all periods when the pressure monitor(s) on the main flare header show burners are operating outside the range of the manufacturer's specifications. Indicate the date and time for each period, the pressure measurement, the stage(s) and number of burners affected, and the range of manufacturer's specifications.

(10) For pressure-assisted multi-point flares, all periods when the staging valve position indicator monitoring system indicates a stage of the pressure-assisted multi-point flare should not be in operation and when a stage of the pressure-assisted multi-point flare should be in operation and is not. Indicate the date and time for each period, whether the stage was supposed to be open, but was closed or vice versa, and the stage(s) and number of burners affected.

(11) Records of periods when there is flow of vent gas to the flare, but when there is no flow of regulated material to the flare, including the start and stop time and dates of periods of no regulated material flow.

(12) Records when the flow of vent gas exceeds the smokeless capacity of the flare, including start and stop time and dates of the flaring event.

(13) Records of the root cause analysis and corrective action analysis conducted as required in § 63.670(o)(3) of this chapter and paragraph (f) of this section, including an identification of the affected flare, the date and duration

of the event, a statement noting whether the event resulted from the same root cause(s) identified in a previous analysis and either a description of the recommended corrective action(s) or an explanation of why corrective action is not necessary under § 63.670(o)(5)(i) of this chapter.

(14) For any corrective action analysis for which implementation of corrective actions are required in § 63.670(o)(5) of this chapter, a description of the corrective action(s) completed within the first 45 days following the discharge and, for action(s) not already completed, a schedule for implementation, including proposed commencement and completion dates.

(n) You may elect to comply with the alternative means of emissions limitation requirements specified in § 63.670(r) of this chapter in lieu of the requirements in § 63.670(d) through (f) of this chapter, as applicable. However, instead of complying with § 63.670(r)(3)(iii) of this chapter, you must also submit the alternative means of emissions limitation request to the following address: U.S. Environmental Protection Agency, Office of Air Quality Planning and Standards, Sector Policies and Programs Division, U.S. EPA Mailroom (C404-02), Attention: SOCM1 NSPS Sector Lead, 4930 Old Page Rd., Durham, NC 27703.

(o) The referenced provisions specified in paragraphs (o)(1) through (4) of this section do not apply when demonstrating compliance with this section.

(1) Section 63.670(o)(4)(iv) of this chapter.

(2) The last sentence of § 63.670(o)(6) of this chapter.

(3) The phrase “that were not caused by a *force majeure* event” in § 63.670(o)(7)(ii) of this chapter.

(4) The phrase “that were not caused by a *force majeure* event” in § 63.670(o)(7)(iv) of this chapter.

#### **§ 60.710a What are my requirements for closed vent systems?**

(a) Except as provided in paragraphs (f) and (g) of this section, you must inspect each closed vent system according to the procedures and schedule specified in paragraphs (a)(1) through (3) of this section.

(1) Conduct an initial inspection according to the procedures in paragraph (b) of this section unless the closed vent system is operated and maintained under negative pressure,

(2) Conduct annual inspections according to the procedures in paragraph (b) of this section unless the closed vent system is operated and

maintained under negative pressure, and

(3) Conduct annual inspections for visible, audible, or olfactory indications of leaks.

(b) You must inspect each closed vent system according to the procedures specified in paragraphs (b)(1) through (6) of this section.

(1) Inspections must be conducted in accordance with Method 21 of appendix A of this part.

(2)(i) Except as provided in paragraph (b)(2)(ii) of this section, the detection instrument must meet the performance criteria of Method 21 of appendix A of this part, except the instrument response factor criteria in section 3.1.2(a) of Method 21 must be for the average composition of the process fluid not each individual volatile organic compound in the stream. For process streams that contain nitrogen, air, or other inerts which are not organic hazardous air pollutants or volatile organic compounds, the average stream response factor must be calculated on an inert-free basis.

(ii) If no instrument is available at the plant site that will meet the performance criteria specified in paragraph (b)(2)(i) of this section, the instrument readings may be adjusted by multiplying by the average response factor of the process fluid, calculated on an inert-free basis as described in paragraph (b)(2)(i) of this section.

(3) The detection instrument must be calibrated before use on each day of its use by the procedures specified in Method 21 of appendix A of this part.

(4) Calibration gases must be as follows:

(i) Zero air (less than 10 parts per million hydrocarbon in air); and

(ii) Mixtures of methane in air at a concentration less than 2,000 parts per million. A calibration gas other than methane in air may be used if the instrument does not respond to methane or if the instrument does not meet the performance criteria specified in paragraph (b)(2)(i) of this section. In such cases, the calibration gas may be a mixture of one or more of the compounds to be measured in air.

(5) You may elect to adjust or not adjust instrument readings for background. If you elect to not adjust readings for background, all such instrument readings must be compared directly to the applicable leak definition to determine whether there is a leak.

(6) If you elect to adjust instrument readings for background, you must determine the background concentration using Method 21 of appendix A of this part. After monitoring each potential leak interface, subtract the background

reading from the maximum concentration indicated by the instrument. The arithmetic difference between the maximum concentration indicated by the instrument and the background level must be compared with 500 parts per million for determining compliance.

(c) Leaks, as indicated by an instrument reading greater than 500 parts per million above background or by visual, audio, or olfactory inspections, must be repaired as soon as practicable, except as provided in paragraph (d) of this section.

(1) A first attempt at repair must be made no later than 5 calendar days after the leak is detected.

(2) Repair must be completed no later than 15 calendar days after the leak is detected.

(d) Delay of repair of a closed vent system for which leaks have been detected is allowed if the repair is technically infeasible without a shutdown, as defined in § 60.2, or if you determine that emissions resulting from immediate repair would be greater than the fugitive emissions likely to result from delay of repair. Repair of such equipment must be complete by the end of the next shutdown.

(e) For each closed vent system that contains bypass lines that could divert a vent stream away from the control device and to the atmosphere, you must comply with the provisions of either paragraph (e)(1) or (2), except as specified in paragraph (e)(3) of this section.

(1) Install, calibrate, maintain, and operate a flow indicator that determines whether vent stream flow is present at least once every 15 minutes. You must keep hourly records of whether the flow indicator was operating and whether a diversion was detected at any time during the hour, as well as records of the times and durations of all periods when the vent stream is diverted to the atmosphere or the flow indicator is not operating. The flow indicator must be installed at the entrance to any bypass line; or

(2) Secure the bypass line valve in the closed position with a car-seal or a lock-and-key type configuration. A visual inspection of the seal or closure mechanism must be performed at least once every month to ensure the valve is maintained in the closed position and the vent stream is not diverted through the bypass line.

(3) Open-ended valves or lines that use a cap, blind flange, plug, or second valve and follow the requirements specified in § 60.482-6(a)(2), (b), and (c) or follow requirements codified in another regulation that are the same as



§ 60.482–6(a)(2), (b), and (c) are not subject to this paragraph (e) of this section.

(f) Any parts of the closed vent system that are designated, as described in paragraph (h)(1) of this section, as unsafe to inspect are exempt from the inspection requirements of paragraphs (a)(1) and (2) of this section if:

(1) You determine that the equipment is unsafe to inspect because inspecting personnel would be exposed to an imminent or potential danger as a consequence of complying with paragraphs (a)(1) and (2) of this section; and

(2) You have a written plan that requires inspection of the equipment as frequently as practicable during safe-to-inspect times.

(g) Any parts of the closed vent system are designated, as described in paragraph (h)(2) of this section, as difficult to inspect are exempt from the inspection requirements of paragraphs (a)(1) and (2) of this section if:

(1) You determine that the equipment cannot be inspected without elevating the inspecting personnel more than 2 meters above a support surface; and

(2) You have a written plan that requires inspection of the equipment at least once every 5 years.

(h) You must record the information specified in paragraphs (h)(1) through (5) of this section.

(1) Identification of all parts of the closed vent system that are designated as unsafe to inspect, an explanation of why the equipment is unsafe to inspect, and the plan for inspecting the equipment.

(2) Identification of all parts of the closed vent system that are designated as difficult to inspect, an explanation of why the equipment is difficult to inspect, and the plan for inspecting the equipment.

(3) For each closed vent system that contains bypass lines that could divert a vent stream away from the control device and to the atmosphere, you must keep a record of the information specified in either paragraph (h)(3)(i) or (ii) of this section in addition to the information specified in paragraph (h)(3)(iii) of this section.

(i) Hourly records of whether the flow indicator specified under paragraph

(e)(1) of this section was operating and whether a diversion was detected at any time during the hour, as well as records of the times of all periods when the vent stream is diverted from the control device or the flow indicator is not operating.

(ii) Where a seal mechanism is used to comply with paragraph (e)(2) of this section, hourly records of flow are not required. In such cases, you must record whether the monthly visual inspection of the seals or closure mechanisms has been done, and you must record the occurrence of all periods when the seal mechanism is broken, the bypass line valve position has changed, or the key for a lock-and-key type configuration has been checked out, and records of any car-seal that has broken.

(iii) For each flow event from a bypass line subject to the requirements in paragraph (e) of this section, you must maintain records sufficient to determine whether or not the detected flow included flow requiring control. For each flow event from a bypass line requiring control that is released either directly to the atmosphere or to a control device not meeting the requirements in this subpart, you must include an estimate of the volume of gas, the concentration of VOC in the gas and the resulting emissions of VOC that bypassed the control device using process knowledge and engineering estimates.

(4) For each inspection during which a leak is detected, a record of the information specified in paragraphs (h)(4)(i) through (viii) of this section.

(i) The instrument identification numbers; operator name or initials; and identification of the equipment.

(ii) The date the leak was detected and the date of the first attempt to repair the leak.

(iii) Maximum instrument reading measured by the method specified in paragraph (c) of this section after the leak is successfully repaired or determined to be nonrepairable.

(iv) “Repair delayed” and the reason for the delay if a leak is not repaired within 15 calendar days after discovery of the leak.

(v) The name, initials, or other form of identification of the owner or

operator (or designee) whose decision it was that repair could not be effected without a shutdown.

(vi) The expected date of successful repair of the leak if a leak is not repaired within 15 calendar days.

(vii) Dates of shutdowns that occur while the equipment is unrepaired.

(viii) The date of successful repair of the leak.

(5) For each inspection conducted in accordance with paragraph (b) of this section during which no leaks are detected, a record that the inspection was performed, the date of the inspection, and a statement that no leaks were detected.

(6) For each inspection conducted in accordance with paragraph (a)(3) of this section during which no leaks are detected, a record that the inspection was performed, the date of the inspection, and a statement that no leaks were detected.

(i) The semiannual report specified in § 60.705a(k)(5) must include the items specified in paragraphs (i)(1) through (3) of this section.

(1) Reports of the times of all periods recorded under paragraph (h)(3)(i) of this section when the vent stream is diverted from the control device through a bypass line. Include the start date, start time, and duration in hours of each period.

(2) Reports of all periods recorded under paragraph (h)(3)(ii) of this section in which the seal mechanism is broken, the bypass line valve position has changed, or the key to unlock the bypass line valve was checked out. Include the start date, start time, and duration in hours of each period.

(3) For bypass lines subject to the requirements in paragraph (e) of this section, the semiannual reports must include the start date, start time, duration in hours, estimate of the volume of gas in standard cubic feet, the concentration of VOC in the gas in parts per million by volume and the resulting mass emissions of VOC in pounds that bypass a control device. For periods when the flow indicator is not operating, report the start date, start time, and duration in hours.

TABLE 1 TO SUBPART RRRR OF PART 60—EMISSION LIMITS AND STANDARDS FOR VENT STREAMS

For each. . .	You must. . .
1. Vent stream .....	<p>a. Reduce emissions of TOC (minus methane and ethane) by 98 weight-percent, or to a TOC (minus methane and ethane) concentration of 20 ppmv on a dry basis corrected to 3 percent oxygen by venting emissions through a closed vent system to any combination of non-flare control devices and/or recovery system and meet the requirements specified in § 60.703a and § 60.710a; or</p> <p>b. Reduce emissions of TOC (minus methane and ethane) by venting emissions through a closed vent system to a flare and meet the requirements specified in § 60.709a and § 60.710a.</p>

TABLE 2 TO SUBPART RRRa OF PART 60—MONITORING REQUIREMENTS FOR COMPLYING WITH 98 WEIGHT-PERCENT REDUCTION OF TOTAL ORGANIC COMPOUNDS EMISSIONS OR A LIMIT OF 20 PARTS PER MILLION BY VOLUME

Non-flare control device or recovery device	Parameters to be monitored
1. All control and recovery devices .....	a. Presence of flow diverted to the atmosphere from the control and recovery device; <i>or</i> b. Monthly inspections of sealed valves
2. Absorber .....	a. Exit temperature of the absorbing liquid; <i>and</i> b. Exit specific gravity
3. Boiler or process heater with a design heat input capacity less than 44 megawatts and vent stream is <i>not</i> introduced with or as the primary fuel.	Firebox temperature <sup>a</sup>
4. Catalytic incinerator .....	Temperature upstream and downstream of the catalyst bed
5. Carbon adsorber, regenerative .....	a. Total regeneration stream mass or volumetric flow during carbon bed regeneration cycle(s); <i>and</i> b. Temperature of the carbon bed after regeneration [and within 15 minutes of completing any cooling cycle(s)]
6. Carbon adsorber, non-regenerative or regenerated offsite .....	Breakthrough
7. Condenser .....	Exit (product side) temperature
8. Scrubber for halogenated vent streams .....	a. pH of scrubber effluent; <i>and</i> b. Scrubber liquid and gas flow rates
9. Thermal incinerator .....	Firebox temperature <sup>a</sup>
10. Control devices other than an incinerator, boiler, process heater, or flare; or recovery devices other than an absorber, condenser, or carbon adsorber.	As specified by the Administrator

<sup>a</sup>Monitor may be installed in the firebox or in the ductwork immediately downstream of the firebox before any substantial heat exchange is encountered.

TABLE 3 TO SUBPART RRRa OF PART 60—OPERATING PARAMETERS, OPERATING PARAMETER LIMITS AND DATA MONITORING, RECORDKEEPING AND COMPLIANCE FREQUENCIES

For the operating parameter applicable to you, as specified in Table 2 . . . .	You must establish the following operating parameter limit . . . .	And you must monitor, record, and demonstrate continuous compliance using these minimum frequencies . . . .		
		Data measurement	Data recording	Data averaging period for compliance
<b>Absorbers</b>				
1. Exit temperature of the absorbing liquid.	Maximum temperature	Continuous .....	Every 15 minutes .....	3-hour block average
2. Exit specific gravity	Exit specific gravity range.	Continuous .....	Every 15 minutes .....	3-hour block average
<b>Boilers or process heaters (with a design heat input capacity &lt;44MW and vent stream is not introduced with or as the primary fuel)</b>				
3. Firebox temperature.	Minimum firebox temperature.	Continuous .....	Every 15 minutes .....	3-hour block average
<b>Catalytic incinerators</b>				
4. Temperature in gas stream immediately before the catalyst bed.	Minimum temperature	Continuous .....	Every 15 minutes .....	3-hour block average
5. Temperature difference between the catalyst bed inlet and the catalyst bed outlet.	Minimum temperature difference.	Continuous .....	Every 15 minutes .....	3-hour block average
<b>Carbon adsorbers</b>				
6. Total regeneration stream mass flow during carbon bed regeneration cycle(s).	Minimum mass flow during carbon bed regeneration cycle(s).	Continuously during regeneration .....	Every 15 minutes during regeneration cycle.	Total flow for each regeneration cycle

TABLE 3 TO SUBPART RRRa OF PART 60—OPERATING PARAMETERS, OPERATING PARAMETER LIMITS AND DATA MONITORING, RECORDKEEPING AND COMPLIANCE FREQUENCIES—Continued

For the operating parameter applicable to you, as specified in Table 2 . . . .	You must establish the following operating parameter limit . . . .	And you must monitor, record, and demonstrate continuous compliance using these minimum frequencies . . . .		
		Data measurement	Data recording	Data averaging period for compliance
7. Total regeneration stream volumetric flow during carbon bed regeneration cycle(s).	Minimum volumetric flow during carbon bed regeneration cycle(s).	Continuously during regeneration . . . . .	Every 15 minutes during regeneration cycle.	Total flow for each regeneration cycle
8. Temperature of the carbon bed after regeneration [and within 15 minutes of completing any cooling cycle(s)].	Maximum temperature of the carbon bed after regeneration.	Continuously during regeneration and for 15 minutes after completing any cooling cycle(s).	Every 15 minutes during regeneration cycle (including any cooling cycle).	Average of regeneration cycle
9. Breakthrough . . . . .	As defined in § 60.701a.	As required by § 60.703a(a)(6)(iii)(B) . . . . .	Each monitoring event	N/A
<b>Condensers</b>				
10. Exit (product side) temperature.	Maximum temperature	Continuous . . . . .	Every 15 minutes . . . . .	3-hour block average
<b>Scrubbers for halogenated vent streams</b>				
11. pH of scrubber effluent.	Minimum pH . . . . .	Continuous . . . . .	Every 15 minutes . . . . .	3-hour block average
12. Influent liquid flow	Minimum inlet liquid flow.	Continuous . . . . .	Every 15 minutes . . . . .	3-hour block average
13. Influent liquid flow rate and gas stream flow rate.	Minimum influent liquid-to-gas ratio.	Continuous . . . . .	Every 15 minutes . . . . .	3-hour block average
<b>Thermal incinerators</b>				
14. Firebox temperature.	Minimum firebox temperature.	Continuous . . . . .	Every 15 minutes . . . . .	3-hour block average
<b>Control devices other than an incinerator, boiler, process heater, or flare; or recovery devices other than an absorber, condenser, or carbon adsorber</b>				
15. As specified by the Administrator.	As specified by the Administrator.	As specified by the Administrator . . . . .	As specified by the Administrator.	As specified by the Administrator

TABLE 4 TO SUBPART RRRa OF PART 60—CALIBRATION AND QUALITY CONTROL REQUIREMENTS FOR CONTINUOUS PARAMETER MONITORING SYSTEM (CPMS)

If you monitor this parameter . . . .	Your accuracy requirements are . . . .	And your calibration requirements are . . . .
1. Temperature . . . . .	<p>a. ±1 percent over the normal range of temperature measured or 2.8 degrees Celsius (5 degrees Fahrenheit), whichever is greater, for non-cryogenic temperature ranges.</p> <p>b. ±2.5 percent over the normal range of temperature measured or 2.8 degrees Celsius (5 degrees Fahrenheit), whichever is greater, for cryogenic temperature ranges.</p>	<p>c. Performance evaluation annually and following any period of more than 24 hours throughout which the temperature exceeded the maximum rated temperature of the sensor, or the data recorder was off scale.</p> <p>d. Visual inspections and checks of CPMS operation every 3 months, unless the CPMS has a redundant temperature sensor.</p> <p>e. Selection of a representative measurement location.</p>

TABLE 4 TO SUBPART RRRa OF PART 60—CALIBRATION AND QUALITY CONTROL REQUIREMENTS FOR CONTINUOUS PARAMETER MONITORING SYSTEM (CPMS)—Continued

If you monitor this parameter . . .	Your accuracy requirements are . . .	And your calibration requirements are . . .
2. Flow Rate .....	a. $\pm 5$ percent over the normal range of flow measured or 1.9 liters per minute (0.5 gallons per minute), whichever is greater, for liquid flow rate. b. $\pm 5$ percent over the normal range of flow measured or 280 liters per minute (10 cubic feet per minute), whichever is greater, for gas flow rate. c. $\pm 5$ percent over the normal range measured for mass flow rate.	d. Performance evaluation annually and following any period of more than 24 hours throughout which the flow rate exceeded the maximum rated flow rate of the sensor, or the data recorder was off scale. e. Checks of all mechanical connections for leakage monthly. f. Visual inspections and checks of CPMS operation every 3 months, unless the CPMS has a redundant flow sensor. g. Selection of a representative measurement location where swirling flow or abnormal velocity distributions due to upstream and downstream disturbances at the point of measurement are minimized.
pH .....	a. $\pm 0.2$ pH units .....	b. Performance evaluation annually. Conduct a two-point calibration with one of the two buffer solutions having a pH within 1 of the pH of the operating limit. c. Visual inspections and checks of CPMS operation every 3 months, unless the CPMS has a redundant pH sensor. d. Select a measurement location that provides a representative sample of scrubber effluent and that ensures the fluid is properly mixed.
4. Specific Gravity .....	a. $\pm 0.02$ specific gravity units .....	b. Performance evaluation annually. c. Visual inspections and checks of CPMS operation every 3 months, unless the CPMS has a redundant specific gravity sensor. d. Select a measurement location that provides a representative sample of specific gravity of the absorbing liquid effluent and that ensures the fluid is properly mixed.

**PART 63—NATIONAL EMISSION STANDARDS FOR HAZARDOUS AIR POLLUTANTS FOR SOURCE CATEGORIES**

■ 40. The authority citation for part 63 continues to read as follows:

Authority: 42 U.S.C. 7401 *et seq.*

**Subpart A—General Provisions**

- 41. Amend § 63.14 by:
  - a. Revising paragraphs (a), (c), and (f), and (i) introductory text;
  - b. Redesignating paragraphs (i)(33) through (91) as (i)(34) through (92);
  - c. Adding new paragraph (i)(33);
  - d. Revising newly redesignated paragraphs (i)(89) and (96);
  - e. Removing note 1 to paragraph (i);
  - f. Revising and republishing paragraph (o); and
  - g. Revising paragraph (u).

The revisions, addition, and republication read as follows:

**§ 63.14 Incorporations by reference.**

(a)(1) Certain material is incorporated by reference into this part with the approval of the Director of the Federal Register under 5 U.S.C. 552(a) and 1 CFR part 51. To enforce any edition other than that specified in this section, the U.S. Environmental Protection

Agency (EPA) must publish a document in the **Federal Register** and the material must be available to the public. All approved incorporation by reference (IBR) material is available for inspection at the EPA and at the National Archives and Records Administration (NARA). Contact the EPA at: EPA Docket Center, Public Reading Room, EPA WJC West, Room 3334, 1301 Constitution Ave. NW, Washington, DC; phone: (202) 566–1744. For information on the availability of this material at NARA, visit [www.archives.gov/federal-register/cfr/ibr-locations](http://www.archives.gov/federal-register/cfr/ibr-locations) or email [fr.inspection@nara.gov](mailto:fr.inspection@nara.gov).

(2) The IBR material may be obtained from the sources in the following paragraphs of this section or from one or more private resellers listed in this paragraph (a)(2). For material that is no longer commercially available, contact the EPA (see paragraph (a)(1) of this section).

(i) Accuris Standards Store, 321 Inverness Drive, South Englewood, CO, 80112; phone: (800) 332–6077; website: <https://store.accuristech.com>.

(ii) American National Standards Institute (ANSI), 25 West 43rd Street, Fourth Floor, New York, NY 10036–7417; phone: (212) 642–4980; email: [info@ansi.org](mailto:info@ansi.org); website: [www.ansi.org](http://www.ansi.org).

(iii) GlobalSpec, 257 Fuller Road, Suite NFE 1100, Albany, NY 12203–3621; phone: (800) 261–2052; website: <https://standards.globalspec.com>.

(iv) Nimonik Document Center, 401 Roland Way, Suite 224, Oakland, CA, 94624; phone (650) 591–7600; email: [info@document-center.com](mailto:info@document-center.com); website: [www.document-center.com](http://www.document-center.com).

(v) Techstreet, phone: (855) 999–9870; email: [store@techstreet.com](mailto:store@techstreet.com); website: [www.techstreet.com](http://www.techstreet.com).

\* \* \* \* \*

(c) American Petroleum Institute (API), 200 Massachusetts Ave. NW, Suite 1100, Washington, DC 20001; phone: (202) 682–8000; website: [www.api.org](http://www.api.org).

(1) API Publication 2517, *Evaporative Loss from External Floating-Roof Tanks*, Third Edition, February 1989; IBR approved for §§ 63.111; 63.1402; 63.2406; 63.7944.

(2) API Publication 2518, *Evaporative Loss from Fixed-roof Tanks*, Second Edition, October 1991; IBR approved for § 63.150(g).

(3) API Manual of Petroleum Measurement Specifications (MPMS) Chapter 19.2 (API MPMS 19.2), *Evaporative Loss From Floating-Roof Tanks*, First Edition, April 1997; IBR approved for §§ 63.1251; 63.12005.

(4) API Manual of Petroleum Measurement Specifications (MPMS) Chapter 19.2 (API MPMS 19.2), Evaporative Loss From Floating-Roof Tanks, Fourth Edition, August 2020; IBR approved for § 63.101(b).

\* \* \* \* \*

(f) American Society of Mechanical Engineers (ASME), Two Park Avenue, New York, NY 10016-5990; phone: (800) 843-2763; email: *CustomerCare@asme.org*; website: *www.asme.org*.

(1) ANSI/ASME PTC 19.10-1981, Flue and Exhaust Gas Analyses [Part 10, Instruments and Apparatus], issued August 31, 1981, IBR approved for §§ 63.116(c) and (h); 63.128(a); 63.145(i); 63.309(k); 63.365(b); 63.457(k); 63.490(g); 63.772(e) and (h); 63.865(b); 63.997(e); 63.1282(d) and (g); 63.1625(b); table 5 to subpart EEEE; §§ 63.3166(a); 63.3360(e); 63.3545(a); 63.3555(a); 63.4166(a); 63.4362(a); 63.4766(a); 63.4965(a); 63.5160(d); table 4 to subpart UUUU; table 3 to subpart YYYY; §§ 63.7822(b); 63.7824(e); 63.7825(b); 63.8000(d); 63.9307(c); 63.9323(a); 63.9621(b) and (c); 63.11148(e); 63.11155(e); 63.11162(f); 63.11163(g); 63.11410(j); 63.11551(a); 63.11646(a); 63.11945; table 4 to subpart AAAAA; table 5 to subpart DDDDD; table 4 to subpart JJJJJ; table 4 to subpart KKKKK; table 4 to subpart SSSSS; tables 4 and 5 to subpart UUUUU; table 1 to subpart ZZZZZ; table 4 to subpart JJJJJJ.

(2) [Reserved]

\* \* \* \* \*

(i) ASTM International, 100 Barr Harbor Drive, P.O. Box CB700, West Conshohocken, Pennsylvania 19428-2959; phone: (800) 262-1373; website: *www.astm.org*.

\* \* \* \* \*

(33) ASTM D2879-23, Standard Test Method for Vapor Pressure-Temperature Relationship and Initial Decomposition Temperature of Liquids by Isotenoscope, approved December 1, 2023; IBR approved for § 63.101(b).

\* \* \* \* \*

(89) ASTM D6348-12 (Reapproved 2020), Standard Test Method for Determination of Gaseous Compounds by Extractive Direct Interface Fourier Transform Infrared (FTIR) Spectroscopy, approved December 1, 2020; IBR approved for §§ 63.109(a); 63.365(b); 63.509(a); 63.7825(g) and (h).

\* \* \* \* \*

(96) ASTM D6420-18, Standard Test Method for Determination of Gaseous Organic Compounds by Direct Interface Gas Chromatography-Mass Spectrometry, approved November 1, 2018; IBR approved for §§ 63.101(b); 63.115(g); 63.116(c); 63.126(d); 63.128(a); 63.139(c); 63.145(d) and (i);

63.150(g); 63.180(d); 63.482(b); 63.485(t); 63.488(b); 63.490(c) and (e); 63.496(b); 63.500(c); 63.501(a); 63.502(j); 63.503(a) and (g); 63.525(a) and (e); 63.987(b); 63.997(e); 63.2354(b), table 5 to subpart EEEE; §§ 63.2450(j); 63.8000(d).

\* \* \* \* \*

(o) U.S. Environmental Protection Agency (EPA), 1200 Pennsylvania Avenue NW, Washington, DC 20460; phone: (202) 272-0167; website: *www.epa.gov/aboutepa/forms/contact-epa*.

(1) EPA-453/R-08-002, Protocol for Determining the Daily Volatile Organic Compound Emission Rate of Automobile and Light-Duty Truck Primer-Surfacer and Topcoat, published September 2008; IBR approved for §§ 63.3130(c); 63.3161(d) and (g); 63.3165(e); appendix A to subpart IIII.

(2) EPA-453/R-01-005, National Emission Standards for Hazardous Air Pollutants (NESHAP) for Integrated Iron and Steel Plants—Background Information for Proposed Standards, Final Report, January 2001; IBR approved for § 63.7491(g).

(3) EPA-454/B-08-002, Quality Assurance Handbook for Air Pollution Measurement Systems; Volume IV: Meteorological Measurements, Version 2.0 (Final), Issued March 2008; IBR approved for §§ 63.184(c); 63.7792(b).

(4) EPA-454/R-98-015, Office of Air Quality Planning and Standards (OAQPS), Fabric Filter Bag Leak Detection Guidance, September 1997; IBR approved for §§ 63.548(e); 63.864(e); 63.7525(j); 63.8450(e); 63.8600(e); 63.9632(a); 63.9804(f); 63.11224(f); 63.11423(e). (Available at: *https://nepis.epa.gov/Exe/ZyPDF.cgi?Dockey=2000D5T6.pdf*).

(5) EPA-454/R-99-005, Office of Air Quality Planning and Standards (OAQPS), Meteorological Monitoring Guidance for Regulatory Modeling Applications, February 2000; IBR approved for appendix A to this part.

(6) EPA/600/R-12/531, EPA Traceability Protocol for Assay and Certification of Gaseous Calibration Standards, May 2012; IBR approved for § 63.2163(b).

(7) EPA-625/3-89-016, Interim Procedures for Estimating Risks Associated with Exposures to Mixtures of Chlorinated Dibenzo-p-Dioxins and -Dibenzofurans (CDDs and CDFs) and 1989 Update, March 1989; IBR approved for § 63.1513(d).

(8) EPA-821-R-02-019, Method 1631 Revision E, Mercury in Water by Oxidation, Purge and Trap, and Cold Vapor Atomic Absorption Fluorescence Spectrometry, Revision E, August 2002;

IBR approved for table 6 to subpart DDDDD.

(9) EPA Method 200.8, Determination of Trace Elements in Waters and Wastes by Inductively Coupled Plasma—Mass Spectrometry, Revision 5.4, 1994; IBR approved for table 6 to subpart DDDDD.

(10) In EPA Publication No. SW-846, Test Methods for Evaluating Solid Waste, Physical/Chemical Methods (Available from: *www.epa.gov/hw-sw846/sw-846-compendium*);

(i) SW-846-0011, Sampling for Selected Aldehyde and Ketone Emissions from Stationary Sources, Revision 0, December 1996; IBR approved for table 4 to subpart DDDD.

(ii) SW-846-3020A, Acid Digestion of Aqueous Samples And Extracts For Total Metals For Analysis By GFAA Spectroscopy, Revision 1, July 1992; IBR approved for table 6 to subpart DDDDD; table 5 to subpart JJJJJ.

(iii) SW-846-3050B, Acid Digestion of Sediments, Sludges, and Soils, Revision 2, December 1996; IBR approved for table 6 to subpart DDDDD; table 5 to subpart JJJJJ.

(iv) SW-846-5030B, Purge-And-Trap For Aqueous Samples, Revision 2, December 1996; IBR approved for §§ 63.109(b), (c), (d), and (e); 63.509(b) and (c); 63.2492(b) and (c).

(v) SW-846-5031, Volatile, Nonpurgeable, Water-Soluble Compounds by Azeotropic Distillation, Revision 0, December 1996; IBR approved for §§ 63.109(b), (c), (d), and (e); 63.509(b) and (c); 63.2492(b) and (c).

(vi) SW-846-7470A, Mercury In Liquid Waste (Manual Cold-Vapor Technique), Revision 1, September 1994; IBR approved for table 6 to subpart DDDDD; table 5 to subpart JJJJJ.

(vii) SW-846-7471B, Mercury In Solid Or Semisolid Waste (Manual Cold-Vapor Technique), Revision 2, February 2007; IBR approved for table 6 to subpart DDDDD; table 5 to subpart JJJJJ.

(viii) SW-846-8015C, Nonhalogenated Organics by Gas Chromatography, Revision 3, February 2007; IBR approved for §§ 63.11960; 63.11980; table 10 to subpart HHHHHH.

(ix) SW-846-8260B, Volatile Organic Compounds by Gas Chromatography/Mass Spectrometry (GC/MS), Revision 2, December 1996; IBR approved for §§ 63.1107(a); 63.11960; 63.11980; table 10 to subpart HHHHHH.

(x) SW-846-8260D, Volatile Organic Compounds By Gas Chromatography/Mass Spectrometry, Revision 4, June 2018; IBR approved for §§ 63.109(b), (c), (d), and (e); 63.509(b) and (c); 63.2492(b) and (c).

(xi) SW-846-8270D, Semivolatile Organic Compounds by Gas Chromatography/Mass Spectrometry (GC/MS), Revision 4, February 2007; IBR approved for §§ 63.1107(a); 63.11960; 63.11980; table 10 to subpart HHHHHHH.

(xii) SW-846-8315A, Determination of Carbonyl Compounds by High Performance Liquid Chromatography (HPLC), Revision 1, December 1996; IBR approved for §§ 63.11960; 63.11980; table 10 to subpart HHHHHHH.

(xiii) SW-846-5050, Bomb Preparation Method for Solid Waste, Revision 0, September 1994; IBR approved for table 6 to subpart DDDDD.

(xiv) SW-846-6010C, Inductively Coupled Plasma-Atomic Emission Spectrometry, Revision 3, February 2007; IBR approved for table 6 to subpart DDDDD.

(xv) SW-846-6020A, Inductively Coupled Plasma-Mass Spectrometry, Revision 1, February 2007; IBR approved for table 6 to subpart DDDDD.

(xvi) SW-846-7060A, Arsenic (Atomic Absorption, Furnace Technique), Revision 1, September 1994; IBR approved for table 6 to subpart DDDDD.

(xvii) SW-846-7740, Selenium (Atomic Absorption, Furnace Technique), Revision 0, September 1986; IBR approved for table 6 to subpart DDDDD.

(xviii) SW-846-9056, Determination of Inorganic Anions by Ion Chromatography, Revision 1, February 2007; IBR approved for table 6 to subpart DDDDD.

(xix) SW-846-9076, Test Method for Total Chlorine in New and Used Petroleum Products by Oxidative Combustion and Microcoulometry, Revision 0, September 1994; IBR approved for table 6 to subpart DDDDD.

(xx) SW-846-9250, Chloride (Colorimetric, Automated Ferricyanide AAI), Revision 0, September 1986; IBR approved for table 6 to subpart DDDDD.

(u) Texas Commission on Environmental Quality (TCEQ) Library, Post Office Box 13087, Austin, Texas 78711-3087; phone: (512) 239-0028; email: [info@www.tceq.texas.gov](mailto:info@www.tceq.texas.gov); website: [www.tceq.texas.gov](http://www.tceq.texas.gov).

(1) "Air Stripping Method (Modified El Paso Method) for Determination of Volatile Organic Compound Emissions from Water Sources," Revision Number One, dated January 2003, Sampling Procedures Manual, Appendix P: Cooling Tower Monitoring, January 31, 2003; IBR approved for §§ 63.104(f) and (g); 63.654(c) and (g); 63.655(i); 63.1086(e); 63.1089; 63.2490(d);

63.2525(r); 63.11920. (Available from: [www.tceq.texas.gov/downloads/compliance/investigations/assistance/samplingapp.pdf](http://www.tceq.texas.gov/downloads/compliance/investigations/assistance/samplingapp.pdf)).

(2) [Reserved]

■ 42. Revise the heading of subpart F to read as follows:

**Subpart F—National Emission Standards for Hazardous Air Pollutants From the Synthetic Organic Chemical Manufacturing Industry**

■ 43. Amend § 63.100 by:

■ a. Revising paragraphs (a), (e)(1) and (3), (f)(8) and (11), (j)(3), (k) introductory text, (k)(4) introductory text, (k)(5)(ii), and (k)(6)(i);

■ b. Adding paragraphs (k)(10) through (12);

■ c. Revising paragraphs (l)(1)(iii), (l)(4)(ii)(B), (m) introductory text, (q) introductory text, (q)(3), and (q)(4)(i) introductory text;

■ d. Adding paragraph (q)(4)(iii); and

■ e. Revising paragraph (q)(5).

The revisions and additions read as follows:

**§ 63.100 Applicability and designation of source.**

(a) This subpart provides applicability provisions, definitions, and other general provisions that are applicable to subparts G and H of this part. This subpart also provides requirements for certain heat exchange systems, maintenance wastewater, and flares.

\* \* \* \* \*

(e) \* \* \*

(1) This subpart applies to maintenance wastewater and heat exchange systems within a source that is subject to this subpart; and also applies to flares used to reduce organic HAP emissions from a source.

\* \* \* \* \*

(3) This subpart and subpart H of this part apply to pumps, compressors, agitators, pressure relief devices, sampling connection systems, open-ended valves or lines, valves, connectors, instrumentation systems, surge control vessels, and bottoms receivers within a source that is subject to this subpart. Subpart H also contains fenceline monitoring requirements that apply to all emission sources (*i.e.*, maintenance wastewater, heat exchange systems, process vents, storage vessels, transfer racks, equipment identified in § 63.149, wastewater streams and associated treatment residuals within a source, and pumps, compressors, agitators, pressure relief devices, sampling connection systems, open-ended valves or lines, valves, connectors, instrumentation systems, surge control vessels, and bottoms

receivers within a source). If specific items of equipment, comprising part of a chemical manufacturing process unit subject to this subpart, are managed by different administrative organizations (*e.g.*, different companies, affiliates, departments, divisions, etc.), those items of equipment may be aggregated with any chemical manufacturing process unit within the source for all purposes under subpart H, providing there is no delay in the applicable compliance date in § 63.100(k).

(f) \* \* \*

(8) Except for storage vessels in ethylene oxide service, vessels storing organic liquids that contain organic hazardous air pollutants only as impurities;

\* \* \* \* \*

(11) Equipment that is intended to operate in organic hazardous air pollutant service, as defined in § 63.101, for less than 300 hours during the calendar year.

\* \* \* \* \*

(j) \* \* \*

(3) Ethylene production units, regardless of whether the units supply feedstocks that include chemicals listed in table 1 of this subpart to chemical manufacturing process units that are subject to the provisions of subpart F, G, or H of this part.

\* \* \* \* \*

(k) Except as provided in paragraphs (l), (m), and (p) of this section, sources subject to subpart F, G, or H of this part are required to achieve compliance on or before the dates specified in paragraphs (k)(1) through (8) and (11) of this section.

\* \* \* \* \*

(4) Existing chemical manufacturing process units in Groups I and II as identified in table 1 of this subpart shall be in compliance with the requirements of § 63.164 no later than May 10, 1995, for any compressor meeting one or more of the criteria in paragraphs (k)(4)(i) through (iv) of this section, if the work can be accomplished without a process unit shutdown, as defined in § 63.101.

\* \* \* \* \*

(5) \* \* \*

(ii) The work can be accomplished without a process unit shutdown as defined in § 63.101;

\* \* \* \* \*

(6)(i) If compliance with the compressor provisions of § 63.164 cannot reasonably be achieved without a process unit shutdown, as defined in § 63.101, the owner or operator shall achieve compliance no later than April 22, 1996, except as provided for in paragraph (k)(6)(ii) of this section. The

owner or operator who elects to use this provision shall comply with the requirements of § 63.103(g).

\* \* \* \* \*

(10) All affected sources that commenced construction or reconstruction on or before April 25, 2023, must be in compliance with the requirements listed in paragraphs (k)(10)(i) through (viii) of this section upon initial startup or on July 15, 2027, whichever is later. All affected sources that commenced construction or reconstruction after April 25, 2023, must be in compliance with the requirements listed in paragraphs (k)(10)(i) through (viii) of this section upon initial startup, or on July 15, 2024, whichever is later.

(i) The general requirements specified in paragraph (q)(4)(iii) of this section, §§ 63.102(e) and (f), 63.103(b)(1), (b)(3)(ii), and (c)(2)(iv), 63.107(j), 63.108, 63.110(h)(2) and (j)(1), and § 63.148(f)(4), (i)(3)(iii), and (j)(4).

(ii) For heat exchange systems, the requirements specified in § 63.104(a)(3) and (a)(4)(v) (g), (h), (i), (j), and (l).

(iii) For process vents, the requirements specified in §§ 63.113(a)(4) and (5), (k), and (l), 63.114(a)(5)(v) and (d)(3), 63.115(g), 63.116(g), 63.117(g), and 63.118(f)(7) and (n).

(iv) For storage vessels, the requirements specified in §§ 63.119(a)(6), 63.119(b)(5)(ix) through (xii), 63.119(b)(7), 63.119(f)(3)(iv), 63.120(d)(1)(iii), and footnotes b and c of tables 5 and 6 to subpart G of this part. For pressure vessels, the requirements specified in §§ 63.119(a)(7), 63.122(j), and 63.123(b).

(v) For transfer operations, the requirements specified in §§ 63.126(h)(1), 63.127(b)(4) and (d)(3), and 63.130(a)(2)(iv), (b)(3), and (d)(7).

(vi) For process wastewater, the requirements specified in §§ 63.132(a)(2)(i)(C) and (b)(3)(i)(C), 63.135(b)(4), 63.139(d)(5), and 63.145(a)(10).

(vii) For equipment leaks and pressure relief devices, the requirements specified in §§ 63.165(a) and (e), 63.170(b), 63.172(j)(4), 63.181(g)(3)(iii), and 63.182(d)(2)(xix).

(viii) The other notification, reports, and records requirements specified in § 63.152(c)(2)(ii)(F), table 3 to subpart G of this part, item 3 in column 3 for presence of flow and monthly inspections of sealed valves for all control devices, table 7 to subpart G of this part, item 3 in column 3 for presence of flow and monthly inspections of sealed valves for all control devices and vapor balancing

systems, and table 20 to subpart G of this part, item (8)(iii).

(11) All affected sources that commenced construction or reconstruction on or before April 25, 2023, must be in compliance with the ethylene oxide requirements in §§ 63.104(k), 63.109, 63.113(j), 63.119(a)(5), 63.120(d)(9), 63.124, 63.163(a)(1)(iii), (b)(2)(iv), (c)(4), and (e)(7), 63.168(b)(2)(iv) and (d)(5), 63.171(f), and 63.174(a)(3), (b)(3)(vi), (b)(5), and (g)(3), upon initial startup or on July 15, 2026, whichever is later. All affected sources that commenced construction or reconstruction after April 25, 2023, must be in compliance with the ethylene oxide requirements listed in §§ 63.104(k), 63.109, 63.113(j), 63.119(a)(5), 63.120(d)(9), § 63.124, 63.163(a)(1)(iii), (b)(2)(iv), (c)(4), and (e)(7), 63.168(b)(2)(iv) and (d)(5), § 63.171(f), and 63.174(a)(3), (b)(3)(vi), (b)(5), and (g)(3), upon initial startup or on July 15, 2024, whichever is later.

(12) All affected sources that commenced construction or reconstruction on or before April 25, 2023, must commence fenceline monitoring according to the requirements in § 63.184 by no later than July 15, 2026, however requirements for corrective actions are not required until on or after July 15, 2027. All affected sources that commenced construction or reconstruction after April 25, 2023, must be in compliance with the fenceline monitoring requirements listed in § 63.184 upon initial startup, or on July 15, 2024, whichever is later.

(l) \* \* \*

(1) \* \* \*

(iii) The addition has the potential to emit 10 tons per year or more of any HAP or 25 tons per year or more of any combination of HAP's, unless the Administrator establishes a lesser quantity.

\* \* \* \* \*

(4) \* \* \*

(ii) \* \* \*

(B) If a deliberate operational process change to an existing chemical manufacturing process unit causes a Group 2 emission point to become a Group 1 emission point, if a surge control vessel or bottoms receiver becomes subject to § 63.170, or if a compressor becomes subject to § 63.164, the owner or operator shall be in compliance upon initial start-up or by 3 years after April 22, 1994, whichever is later, unless the owner or operator demonstrates to the Administrator that achieving compliance will take longer than making the change. If this demonstration is made to the

Administrator's satisfaction, the owner or operator shall follow the procedures in paragraphs (m)(1) through (3) of this section to establish a compliance date.

\* \* \* \* \*

(m) If a change that does not meet the criteria in paragraph (l)(4) of this section is made to a chemical manufacturing process unit subject to subparts F and G of this part, and the change causes a Group 2 emission point to become a Group 1 emission point (as defined in § 63.101), then the owner or operator shall comply with the requirements of subpart G of this part for the Group 1 emission point as expeditiously as practicable, but in no event later than 3 years after the emission point becomes Group 1.

\* \* \* \* \*

(q) If the owner or operator of a process vent, or of a gas stream transferred subject to § 63.113(i), is unable to comply with the provisions of §§ 63.113 through 63.118 by the applicable compliance date specified in paragraph (q)(1), (3), or (5) of this section, the owner or operator shall comply with the applicable provisions in §§ 63.113 through 63.118 as expeditiously as practicable, but in no event later than the date approved by the Administrator pursuant to paragraph (q)(2), (4), or (6) of this section, respectively. For requests under paragraph (q)(1) or (3) of this section, the date approved by the Administrator may be earlier than, and shall not be later than, the later of January 22, 2004, or 3 years after the transferee's refusal to accept the stream for disposal. For requests submitted under paragraph (q)(5) of this section, the date approved by the Administrator may be earlier than, and shall not be later than, 3 years after the date of publication of the amendments to this subpart or to subpart G of this part which created the need for an extension of the compliance.

\* \* \* \* \*

(3) Except as specified in paragraph (q)(4)(iii) of this section, if the owner or operator has been sending the gas stream for disposal as described in § 63.113(i) to a transferee who had submitted a written certification as described in § 63.113(i)(2), and the transferee revokes its written certification, the owner or operator shall comply with paragraphs (q)(4)(i) and (ii) of this section. During the period between the date when the owner or operator receives notice of revocation of the transferee's written certification and the compliance date established under paragraph (q)(4) of this section, the

owner or operator shall implement, to the extent reasonably available, measures to prevent or minimize excess emissions to the extent practical. For purposes of this paragraph (q)(3), the term “excess emissions” means emissions in excess of those that would have occurred if the transferee had continued managing the gas stream in compliance with the requirements in §§ 63.113 through 63.118. The measures to be taken shall be identified in the applicable startup, shutdown, and malfunction plan. If the measures that can be reasonably taken will change over time, so that a more effective measure which could not reasonably be taken initially would be reasonable at a later date, the Administrator may require the more effective measure by a specified date (in addition to or instead of any other measures taken sooner or later than that date) as a condition of approval of the compliance schedule.

(4) \* \* \*

(i) An owner or operator directed to comply with this paragraph (q)(4) shall submit to the Administrator for approval the documents specified in paragraphs (q)(4)(i)(A) through (E) of this section no later than 90 days after the owner or operator receives notice of revocation of the transferee’s written certification.

\* \* \* \* \*

(iii) For each source as defined in § 63.101, beginning no later than the compliance dates specified in § 63.100(k)(10), paragraph (q)(3) of this section no longer applies.

(5) If the owner’s or operator’s inability to meet otherwise applicable compliance deadlines is due to amendments of this subpart or of subpart G of this part published on or after January 22, 2001, and neither condition specified in paragraph (q)(1) or (3) of this section is applicable, the owner or operator shall comply with paragraph (q)(6) of this section.

\* \* \* \* \*

■ 44. Amend § 63.101 by revising paragraph (b) to read as follows:

**§ 63.101 Definitions.**

\* \* \* \* \*

(b) All other terms used in this subpart and subparts G and H of this part shall have the meaning given them in the Act and in this section. If the same term is defined in subpart A of this part and in this section, it shall have the meaning given in this section for purposes of subparts F, G, and H of this part.

*Air oxidation reactor* means a device or vessel in which air, or a combination of air and oxygen, is used as an oxygen

source in combination with one or more organic reactants to produce one or more organic compounds. Air oxidation reactor includes the product separator and any associated vacuum pump or steam jet.

*Ancillary activities* means boilers and incinerators (not used to comply with the emission limits of subparts F, G, and H of this part), chillers and refrigeration systems, and other equipment and activities that are not directly involved (*i.e.*, they operate within a closed system and materials are not combined with process fluids) in the processing of raw materials or the manufacturing of a product or isolated intermediate.

*Annual average concentration*, as used in the wastewater provisions, means the flow-weighted annual average concentration, as determined according to the procedures specified in § 63.144(b).

*Annual average flow rate*, as used in the wastewater provisions, means the annual average flow rate, as determined according to the procedures specified in § 63.144(c).

*Automated monitoring and recording system* means any means of measuring values of monitored parameters and creating a hard copy or computer record of the measured values that does not require manual reading of monitoring instruments and manual transcription of data values. Automated monitoring and recording systems include, but are not limited to, computerized systems and strip charts.

*Batch operation* means a noncontinuous operation in which a discrete quantity or batch of feed is charged into a unit operation within a chemical manufacturing process unit and processed at one time. Batch operation includes noncontinuous operations in which the equipment is fed intermittently or discontinuously. Addition of raw material and withdrawal of product do not occur simultaneously in a batch operation. After each batch operation, the equipment is generally emptied before a fresh batch is started.

*Batch process* means a process in which the equipment is fed intermittently or discontinuously. Processing then occurs in this equipment after which the equipment is generally emptied. Examples of industries that use batch processes include pharmaceutical production and pesticide production.

*Batch process vent* means gaseous venting to the atmosphere from a batch operation.

*Batch product-process equipment train* means the collection of equipment (*e.g.*, connectors, reactors, valves,

pumps, etc.) configured to produce a specific product or intermediate by a batch process.

*Bench-scale batch process* means a batch process (other than a research and development facility) that is operated on a small scale, such as one capable of being located on a laboratory bench top. This bench-scale equipment will typically include reagent feed vessels, a small reactor and associated product separator, recovery and holding equipment. These processes are only capable of producing small quantities of product.

*Boiler* means any enclosed combustion device that extracts useful energy in the form of steam and is not an incinerator. Boiler also means any industrial furnace as defined in 40 CFR 260.10.

*Bottoms receiver* means a tank that collects distillation bottoms before the stream is sent for storage or for further downstream processing.

*Breakthrough* means the time when the level of HAP or TOC, measured at the outlet of the first bed, has been detected is at the highest concentration allowed to be discharged from the adsorber system and indicates that the adsorber bed should be replaced.

*By compound* means by individual stream components, not carbon equivalents.

*By-product* means a chemical that is produced coincidentally during the production of another chemical.

*Car-seal* means a seal that is placed on a device that is used to change the position of a valve (*e.g.*, from opened to closed) in such a way that the position of the valve cannot be changed without breaking the seal.

*Chemical manufacturing process unit or CMPU* means the equipment assembled and connected by pipes or ducts to process raw materials and to manufacture an intended product. A chemical manufacturing process unit consists of more than one unit operation. For the purpose of this subpart, chemical manufacturing process unit includes air oxidation reactors and their associated product separators and recovery devices; reactors and their associated product separators and recovery devices; distillation units and their associated distillate receivers and recovery devices; associated unit operations; associated recovery devices; and any feed, intermediate and product storage vessels and pressure vessels, product transfer racks, and connected ducts and piping. A chemical manufacturing process unit includes pumps, compressors, agitators, pressure relief devices, sampling connection systems,



open-ended valves or lines, valves, connectors, instrumentation systems, and control devices or systems. A chemical manufacturing process unit is identified by its primary product. Ancillary activities are not considered a process or part of any process. Quality assurance/quality control laboratories are not considered part of any process.

*Closed biological treatment process* means a tank or surface impoundment where biological treatment occurs and air emissions from the treatment process are routed to either a control device by means of a closed vent system or to a fuel gas system by means of hard-piping. The tank or surface impoundment has a fixed roof, as defined in this section, or a floating flexible membrane cover that meets the requirements specified in § 63.134.

*Closed-loop system* means an enclosed system that returns process fluid to the process and is not vented to the atmosphere except through a closed-vent system.

*Closed-purge system* means a system or combination of system and portable containers, to capture purged liquids. Containers must be covered or closed when not being filled or emptied.

*Closed vent system* means a system that is not open to the atmosphere and is composed of piping, ductwork, connections, and, if necessary, flow inducing devices that transport gas or vapor from an emission point to a control device.

*Combustion device* means an individual unit of equipment, such as a flare, incinerator, process heater, or boiler, used for the combustion of organic hazardous air pollutant emissions.

*Compliance date* means the dates specified in § 63.100(k) or (l)(3) for process units subject to subpart F of this part; the dates specified in § 63.190(e) for process units subject to subpart I of this part. For sources subject to other subparts in this part that reference this subpart, compliance date will be defined in those subparts. However, the compliance date for § 63.170 shall be no later than 3 years after the effective date of those subparts unless otherwise specified in such other subparts.

*Connector* means flanged, screwed, or other joined fittings used to connect two pipe lines or a pipe line and a piece of equipment. A common connector is a flange. Joined fittings welded completely around the circumference of the interface are not considered connectors for the purpose of this regulation. For the purpose of reporting and recordkeeping, connector means joined fittings that are not inaccessible,

glass, or glass-lined as described in § 63.174(h).

*Container*, as used in the wastewater provisions, means any portable waste management unit that has a capacity greater than or equal to 0.1 m<sup>3</sup> in which a material is stored, transported, treated, or otherwise handled. Examples of containers are drums, barrels, tank trucks, barges, dumpsters, tank cars, dump trucks, and ships.

*Continuous record* means documentation, either in hard copy or computer readable form, of data values measured at least once every 15 minutes and recorded at the frequency specified in § 63.152(f) or (g).

*Continuous recorder* means a data recording device that either records an instantaneous data value at least once every 15 minutes or records 15-minute or more frequent block average values.

*Continuous seal* means a seal that forms a continuous closure that completely covers the space between the wall of the storage vessel and the edge of the floating roof. A continuous seal may be a vapor-mounted, liquid-mounted, or metallic shoe seal. A continuous seal may be constructed of fastened segments so as to form a continuous seal.

*Continuous vapor processing system* means a vapor processing system that treats total organic compound vapors collected from tank trucks or railcars on a demand basis without intermediate accumulation in a vapor holder.

*Control device* means any combustion device, recovery device, or recapture device. Such equipment includes, but is not limited to, absorbers, carbon adsorbers, condensers, incinerators, flares, boilers, and process heaters. For process vents, recapture devices are considered control devices but recovery devices are not considered control devices, and for a steam stripper, a primary condenser is not considered a control device.

*Co-product* means a chemical that is produced during the production of another chemical.

*Cover*, as used in the wastewater provisions, means a device or system which is placed on or over a waste management unit containing wastewater or residuals so that the entire surface area is enclosed to minimize air emissions. A cover may have openings necessary for operation, inspection, and maintenance of the waste management unit such as access hatches, sampling ports, and gauge wells provided that each opening is closed when not in use. Examples of covers include a fixed roof installed on a wastewater tank, a lid installed on a container, and an air-

supported enclosure installed over a waste management unit.

*Dioxins and furans* means total tetra-through octachlorinated dibenzo-p-dioxins and dibenzofurans.

*Distillate receiver* means overhead receivers, overhead accumulators, reflux drums, and condenser(s) including ejector-condenser(s) associated with a distillation unit.

*Distillation unit* means a device or vessel in which one or more feed streams are separated into two or more exit streams, each exit stream having component concentrations different from those in the feed stream(s). The separation is achieved by the redistribution of the components between the liquid and the vapor phases by vaporization and condensation as they approach equilibrium within the distillation unit. Distillation unit includes the distillate receiver, reboiler, and any associated vacuum pump or steam jet.

*Double block and bleed system* means two block valves connected in series with a bleed valve or line that can vent the line between the two block valves.

*Duct work* means a conveyance system such as those commonly used for heating and ventilation systems. It is often made of sheet metal and often has sections connected by screws or crimping. Hard-piping is not ductwork.

*Emission point* means an individual process vent, storage vessel, transfer rack, wastewater stream, or equipment leak.

*Empty or emptying* means the removal of the stored liquid from a storage vessel. Storage vessels where stored liquid is left on the walls, as bottom clingage, or in pools due to bottom irregularities are considered empty. Lowering of the stored liquid level, so that the floating roof is resting on its legs, as necessitated by normal vessel operation (for example, when changing stored material or when transferring material out of the vessel for shipment) is not considered emptying.

*Enhanced biological treatment system or enhanced biological treatment process* means an aerated, thoroughly mixed treatment unit(s) that contains biomass suspended in water followed by a clarifier that removes biomass from the treated water and recycles recovered biomass to the aeration unit. The mixed liquor volatile suspended solids (biomass) is greater than 1 kilogram per cubic meter throughout each aeration unit. The biomass is suspended and aerated in the water of the aeration unit(s) by either submerged air flow or mechanical agitation. A thoroughly mixed treatment unit is a unit that is designed and operated to approach or

achieve uniform biomass distribution and organic compound concentration throughout the aeration unit by quickly dispersing the recycled biomass and the wastewater entering the unit.

*Equipment leak* means emissions of organic hazardous air pollutants from a connector, pump, compressor, agitator, pressure relief device, sampling connection system, open-ended valve or line, valve, surge control vessel, bottoms receiver, or instrumentation system in organic hazardous air pollutant service as defined in this section.

*Equipment* means each pump, compressor, agitator, pressure relief device, sampling connection system, open-ended valve or line, valve, connector, surge control vessel, bottoms receiver, and instrumentation system in organic hazardous air pollutant service; and any control devices or systems required by this subpart.

*Ethylene production unit* means a chemical manufacturing process unit in which ethylene and/or propylene are produced by separation from petroleum refining process streams or by subjecting hydrocarbons to high temperatures in the presence of steam. The ethylene process unit includes the separation of ethylene and/or propylene from associated streams such as a C<sub>4</sub> product, pyrolysis gasoline, and pyrolysis fuel oil. The ethylene process does not include the manufacture of SOCOMI chemicals such as the production of butadiene from the C<sub>4</sub> stream and aromatics from pyrolysis gasoline.

*External floating roof* means a pontoon-type or double-deck-type cover that rests on the liquid surface in a storage vessel or waste management unit with no fixed roof.

*Fill or filling* means the introduction of organic hazardous air pollutant into a storage vessel or the introduction of a wastewater stream or residual into a waste management unit, but not necessarily to complete capacity.

*First attempt at repair* means to take action for the purpose of stopping or reducing leakage of organic material to the atmosphere, followed by monitoring as specified in § 63.180(b) and (c), as appropriate, to verify whether the leak is repaired, unless the owner or operator determines by other means that the leak is not repaired.

*Fixed roof* means a cover that is mounted on a waste management unit or storage vessel in a stationary manner and that does not move with fluctuations in liquid level.

*Flame zone* means the portion of the combustion chamber in a boiler or process heater occupied by the flame envelope.

*Flexible operation unit* means a chemical manufacturing process unit that manufactures different chemical products periodically by alternating raw materials or operating conditions. These units are also referred to as campaign plants or blocked operations.

*Floating roof* means a cover consisting of a double deck, pontoon single deck, internal floating cover or covered floating roof, which rests upon and is supported by the liquid being contained, and is equipped with a closure seal or seals to close the space between the roof edge and waste management unit or storage vessel wall.

*Flow indicator* means a device which indicates whether gas flow is, or whether the valve position would allow gas flow to be, present in a line.

*Fuel gas* means gases that are combusted to derive useful work or heat.

*Fuel gas system* means the offsite and onsite piping and flow and pressure control system that gathers gaseous stream(s) generated by onsite operations, may blend them with other sources of gas, and transports the gaseous stream for use as fuel gas in combustion devices or in in-process combustion equipment such as furnaces and gas turbines either singly or in combination.

*Group 1 process vent* means, before July 15, 2027, a process vent for which the vent stream flow rate is greater than or equal to 0.005 standard cubic meter per minute, the total organic HAP concentration is greater than or equal to 50 parts per million by volume, and the total resource effectiveness index value, calculated according to § 63.115, is less than or equal to 1.0. On and after July 15, 2027, Group 1 process vent means a process vent that emits greater than or equal to 1.0 pound per hour of total organic HAP.

*Group 1 storage vessel* means a storage vessel that meets the criteria for design storage capacity and stored-liquid maximum true vapor pressure specified in table 5 to subpart G of this part for storage vessels at existing sources, and in table 6 to subpart G of this part for storage vessels at new sources.

*Group 1 transfer rack* means a transfer rack that annually loads greater than or equal to 0.65 million liter of liquid products that contain organic hazardous air pollutants with a rack weighted average vapor pressure greater than or equal to 10.3 kilopascals.

*Group 1 wastewater stream* means a wastewater stream consisting of process wastewater as defined in this section at an existing or new source that meets the criteria for Group 1 status in § 63.132(c)

for table 9 compounds and/or a wastewater stream consisting of process wastewater at a new source that meets the criteria for Group 1 status in § 63.132(d) for table 8 compounds.

*Group 2 process vent* means, before July 15, 2027, a process vent for which the vent stream flow rate is less than 0.005 standard cubic meter per minute, the total organic HAP concentration is less than 50 parts per million by volume or the total resource effectiveness index value, calculated according to § 63.115, is greater than 1.0. On and after July 15, 2027, Group 2 process vent means a process vent that emits less than 1.0 pound per hour of total organic HAP.

*Group 2 storage vessel* means a storage vessel that does not meet the definition of a Group 1 storage vessel.

*Group 2 transfer rack* means a transfer rack that does not meet the definition of Group 1 transfer rack.

*Group 2 wastewater stream* means any process wastewater stream that does not meet the definition of a Group 1 wastewater stream.

*Halogenated vent stream or halogenated stream* means a vent stream from a process vent or transfer operation determined to have a mass emission rate of halogen atoms contained in organic compounds of 0.45 kilograms per hour or greater determined by the procedures presented in § 63.115(d)(2)(v).

*Halogens and hydrogen halides* means hydrogen chloride (HCl), chlorine (Cl<sub>2</sub>), hydrogen bromide (HBr), bromine (Br<sub>2</sub>), and hydrogen fluoride (HF).

*Hard-piping* means pipe or tubing that is manufactured and properly installed using good engineering judgment and standards such as American National Standards Institute (ANSI) B31-3 (see § 63.14 for ANSI contact information).

*Heat exchange system* means a device or collection of devices used to transfer heat from process fluids to water without intentional direct contact of the process fluid with the water (*i.e.*, non-contact heat exchanger) and to transport and/or cool the water in a closed-loop recirculation system (cooling tower system) or a once-through system (*e.g.*, river or pond water). For closed-loop recirculation systems, the heat exchange system consists of a cooling tower, all CMPU heat exchangers that are in organic HAP service, as defined in this subpart, servicing that cooling tower, and all water lines to and from these process unit heat exchangers. For once-through systems, the heat exchange system consists of all heat exchangers that are in organic HAP service, as defined in this subpart, servicing an individual CMPU and all water lines to and from these heat exchangers. Sample coolers or pump seal coolers are not

considered heat exchangers for the purpose of this definition and are not part of the heat exchange system. Intentional direct contact with process fluids results in the formation of a wastewater.

*Impurity* means a substance that is produced coincidentally with the primary product or is present in a raw material. An impurity does not serve a useful purpose in the production or use of the primary product and is not isolated.

*In ethylene oxide service* means the following:

(i) For equipment leaks, any equipment that contains or contacts a fluid (liquid or gas) that is at least 0.1 percent by weight of ethylene oxide. If information exists that suggests ethylene oxide could be present in equipment, the equipment is considered to be “in ethylene oxide service” unless the procedures specified in § 63.109 are performed to demonstrate that the equipment does not meet the definition of being “in ethylene oxide service”. Examples of information that could suggest ethylene oxide could be present in equipment, include calculations based on safety data sheets, material balances, process stoichiometry, or previous test results provided the results are still relevant to the current operating conditions.

(ii) For heat exchange systems, any heat exchange system in a process that cools process fluids (liquid or gas) that are 0.1 percent or greater by weight of ethylene oxide. If knowledge exists that suggests ethylene oxide could be present in a heat exchange system, then the heat exchange system is considered to be “in ethylene oxide service” unless the procedures specified in § 63.109 are performed to demonstrate that the heat exchange system does not meet the definition of being “in ethylene oxide service”. Examples of information that could suggest ethylene oxide could be present in a heat exchange system, include calculations based on safety data sheets, material balances, process stoichiometry, or previous test results provided the results are still relevant to the current operating conditions.

(iii) For process vents, each Group 1 and Group 2 process vent in a process that, when uncontrolled, contains a concentration of greater than or equal to 1 ppmv undiluted ethylene oxide, and when combined, the sum of all these process vents within the process would emit uncontrolled, ethylene oxide emissions greater than or equal to 5 lb/yr (2.27 kg/yr). If information exists that suggests ethylene oxide could be present in a Group 1 or Group 2 process vent, then the Group 1 or Group 2

process vent is considered to be “in ethylene oxide service” unless an analysis is performed as specified in § 63.109 to demonstrate that the Group 1 or Group 2 process vent does not meet the definition of being “in ethylene oxide service”. Examples of information that could suggest ethylene oxide could be present in a Group 1 or Group 2 process vent, include calculations based on safety data sheets, material balances, process stoichiometry, or previous test results provided the results are still relevant to the current operating conditions.

(iv) For storage vessels, storage vessels of any capacity and vapor pressure storing a liquid that is at least 0.1 percent by weight of ethylene oxide. If knowledge exists that suggests ethylene oxide could be present in a storage vessel, then the storage vessel is considered to be “in ethylene oxide service” unless the procedures specified in § 63.109 are performed to demonstrate that the storage vessel does not meet the definition of being “in ethylene oxide service”. The exemption for “vessels storing organic liquids that contain organic hazardous air pollutants only as impurities” listed in the definition of “storage vessel” in this section does not apply for storage vessels that may be in ethylene oxide service. Examples of information that could suggest ethylene oxide could be present in a storage vessel, include calculations based on safety data sheets, material balances, process stoichiometry, or previous test results provided the results are still relevant to the current operating conditions.

(v) For wastewater streams, any wastewater stream that contains total annual average concentration of ethylene oxide greater than or equal to 1 parts per million by weight at any flow rate. If knowledge exists that suggests ethylene oxide could be present in a wastewater stream, then the wastewater stream is considered to be “in ethylene oxide service” unless sampling and analysis is performed as specified in § 63.109 to demonstrate that the wastewater stream does not meet the definition of being “in ethylene oxide service”. Examples of information that could suggest ethylene oxide could be present in a wastewater stream, include calculations based on safety data sheets, material balances, process stoichiometry, or previous test results provided the results are still relevant to the current operating conditions.

*In food/medical service* means that a piece of equipment in organic hazardous air pollutant service contacts a process stream used to manufacture a Food and Drug Administration

regulated product where leakage of a barrier fluid into the process stream would cause any of the following:

(i) A dilution of product quality so that the product would not meet written specifications,

(ii) An exothermic reaction which is a safety hazard,

(iii) The intended reaction to be slowed down or stopped, or

(iv) An undesired side reaction to occur.

*In gas/vapor service* means that a piece of equipment in organic hazardous air pollutant service contains a gas or vapor at operating conditions.

*In heavy liquid service* means that a piece of equipment in organic hazardous air pollutant service is not in gas/vapor service or in light liquid service.

*In light liquid service* means that a piece of equipment in organic hazardous air pollutant service contains a liquid that meets the following conditions:

(i) The vapor pressure of one or more of the organic compounds is greater than 0.3 kilopascals at 20 °C,

(ii) The total concentration of the pure organic compounds constituents having a vapor pressure greater than 0.3 kilopascals at 20 °C is equal to or greater than 20 percent by weight of the total process stream, and

(iii) The fluid is a liquid at operating conditions.

Note 1 to *In light liquid service*: Vapor pressures may be determined by the methods described in § 60.485(e)(1) of this chapter.

*In liquid service* means that a piece of equipment in organic hazardous air pollutant service is not in gas/vapor service.

*In organic hazardous air pollutant or in organic HAP service* means that a piece of equipment or heat exchange system either contains or contacts a fluid (liquid or gas) that is at least 5 percent by weight of total organic HAP's as determined according to the provisions of § 63.180(d). The provisions of § 63.180(d) also specify how to determine that a piece of equipment is not in organic HAP service. For purposes of the definition of “heat exchange system”, the term “equipment” in § 63.180(d) includes heat exchange systems.

*In vacuum service* means that equipment is operating at an internal pressure which is at least 5 kilopascals below ambient pressure.

*In volatile organic compound or in VOC service* means, for the purposes of subpart H of this part, that:

(i) The piece of equipment contains or contacts a process fluid that is at least

10 percent VOC by weight (see § 60.2 of this chapter for the definition of VOC, and § 60.485(d) of this chapter to determine whether a piece of equipment is not in VOC service); and

(ii) The piece of equipment is not in heavy liquid service as defined in § 60.481 of this chapter.

*Incinerator* means an enclosed combustion device that is used for destroying organic compounds. Auxiliary fuel may be used to heat waste gas to combustion temperatures. Any energy recovery section present is not physically formed into one manufactured or assembled unit with the combustion section; rather, the energy recovery section is a separate section following the combustion section and the two are joined by ducts or connections carrying flue gas. The above energy recovery section limitation does not apply to an energy recovery section used solely to preheat the incoming vent stream or combustion air.

*Individual drain system* means the stationary system used to convey wastewater streams or residuals to a waste management unit or to discharge or disposal. The term includes hard-piping, all process drains and junction boxes, together with their associated sewer lines and other junction boxes, manholes, sumps, and lift stations, conveying wastewater streams or residuals. A segregated stormwater sewer system, which is a drain and collection system designed and operated for the sole purpose of collecting rainfall runoff at a facility, and which is segregated from all other individual drain systems, is excluded from this definition.

*Initial start-up* means the first time a new or reconstructed source begins production, or, for equipment added or changed as described in § 63.100(l) or (m), the first time the equipment is put into operation. Initial start-up does not include operation solely for testing equipment. For purposes of subpart G of this part, initial start-up does not include subsequent start-ups (as defined in this section) of chemical manufacturing process units following malfunctions or shutdowns or following changes in product for flexible operation units or following recharging of equipment in batch operation. For purposes of subpart H of this part, initial start-up does not include subsequent start-ups (as defined in this section) of process units (as defined in § this section) following malfunctions or process unit shutdowns.

*In-situ sampling systems* means nonextractive samplers or in-line samplers.

*Instrumentation system* means a group of equipment components used to condition and convey a sample of the process fluid to analyzers and instruments for the purpose of determining process operating conditions (e.g., composition, pressure, flow, etc.). Valves and connectors are the predominant type of equipment used in instrumentation systems; however, other types of equipment may also be included in these systems. Only valves nominally 0.5 inches and smaller, and connectors nominally 0.75 inches and smaller in diameter are considered instrumentation systems for the purposes of subpart H of this part. Valves greater than nominally 0.5 inches and connectors greater than nominally 0.75 inches associated with instrumentation systems are not considered part of instrumentation systems and must be monitored individually.

*Intermittent vapor processing system* means a vapor processing system that employs an intermediate vapor holder to accumulate total organic compound vapors collected from tank trucks or railcars, and treats the accumulated vapors only during automatically controlled cycles.

*Internal floating roof* means a cover that rests or floats on the liquid surface (but not necessarily in complete contact with it) inside a storage vessel or waste management unit that has a permanently affixed roof.

*Junction box* means a manhole or access point to a wastewater sewer line or a lift station.

*Liquid-mounted seal* means a foam- or liquid-filled seal mounted in contact with the liquid between the wall of the storage vessel or waste management unit and the floating roof. The seal is mounted continuously around the circumference of the vessel or unit.

*Liquids dripping* means any visible leakage from the seal including dripping, spraying, misting, clouding, and ice formation. Indications of liquid dripping include puddling or new stains that are indicative of an existing evaporated drip.

*Loading cycle* means the time period from the beginning of filling a tank truck or railcar until flow to the control device ceases, as measured by the flow indicator.

*Loading rack* means a single system used to fill tank trucks and railcars at a single geographic site. Loading equipment and operations that are physically separate (i.e., do not share common piping, valves, and other equipment) are considered to be separate loading racks.

*Maintenance wastewater* means wastewater generated by the draining of process fluid from components in the chemical manufacturing process unit into an individual drain system prior to or during maintenance activities. Maintenance wastewater can be generated during planned and unplanned shutdowns and during periods not associated with a shutdown. Examples of activities that can generate maintenance wastewaters include descaling of heat exchanger tubing bundles, cleaning of distillation column traps, draining of low legs and high point bleeds, draining of pumps into an individual drain system, and draining of portions of the chemical manufacturing process unit for repair.

*Maximum true vapor pressure* means the equilibrium partial pressure exerted by the total organic HAP's in the stored or transferred liquid at the temperature equal to the highest calendar-month average of the liquid storage or transfer temperature for liquids stored or transferred above or below the ambient temperature or at the local maximum monthly average temperature as reported by the National Weather Service for liquids stored or transferred at the ambient temperature, as determined:

(i) In accordance with methods described in API MPMS 19.2

(incorporated by reference as specified in § 63.14); or

(ii) As obtained from standard reference texts; or

(iii) As determined by the ASTM D2879-23 (incorporated by reference as specified in § 63.14); or

(iv) Any other method approved by the Administrator.

*Metallic shoe seal or mechanical shoe seal* means metal sheets that are held vertically against the wall of the storage vessel by springs, weighted levers, or other mechanisms and connected to the floating roof by braces or other means. A flexible coated fabric (envelope) spans the annular space between the metal sheet and the floating roof.

*Non-automated monitoring and recording system* means manual reading of values measured by monitoring instruments and manual transcription of those values to create a record. Non-automated systems do not include strip charts.

*Nonrepairable* means that it is technically infeasible to repair a piece of equipment from which a leak has been detected without a process unit shutdown.

*Oil-water separator or organic-water separator* means a waste management unit, generally a tank used to separate oil or organics from water. An oil-water

or organic-water separator consists of not only the separation unit but also the forebay and other separator basins, skimmers, weirs, grit chambers, sludge hoppers, and bar screens that are located directly after the individual drain system and prior to additional treatment units such as an air flotation unit, clarifier, or biological treatment unit. Examples of an oil-water or organic-water separator include, but are not limited to, an American Petroleum Institute separator, parallel-plate interceptor, and corrugated-plate interceptor with the associated ancillary equipment.

*On-site* or *On site* means, with respect to records required to be maintained by this subpart, that the records are stored at a location within a major source which encompasses the affected source. On-site includes, but is not limited to, storage at the chemical manufacturing process unit to which the records pertain, or storage in central files elsewhere at the major source.

*Open biological treatment process* means a biological treatment process that is not a closed biological treatment process as defined in this section.

*Open-ended valve or line* means any valve, except pressure relief valves, having one side of the valve seat in contact with process fluid and one side open to atmosphere, either directly or through open piping.

*Operating permit* means a permit required by 40 CFR part 70 or 71.

*Organic hazardous air pollutant* or *organic HAP* means one of the chemicals listed in table 2 of this subpart.

*Organic monitoring device* means a unit of equipment used to indicate the concentration level of organic compounds exiting a recovery device based on a detection principle such as infra-red, photoionization, or thermal conductivity.

*Petroleum refining process*, also referred to as a *petroleum refining process unit*, means a process that for the purpose of producing transportation fuels (such as gasoline and diesel fuels), heating fuels (such as fuel gas, distillate, and residual fuel oils), or lubricants separates petroleum or separates, cracks, or reforms unfinished derivatives.

Examples of such units include, but are not limited to, alkylation units, catalytic hydrotreating, catalytic hydrorefining, catalytic hydrocracking, catalytic reforming, catalytic cracking, crude distillation, and thermal processes.

*Plant site* means all contiguous or adjoining property that is under common control, including properties that are separated only by a road or other public right-of-way. Common

control includes properties that are owned, leased, or operated by the same entity, parent entity, subsidiary, or any combination thereof.

*Point of determination* means each point where process wastewater exits the chemical manufacturing process unit. This subpart and subpart G of this part allow point of determination of the characteristics of a wastewater stream:

(i) At the point of determination or  
(ii) Downstream of the point of determination if corrections are made for changes in flow rate and annual average concentration of table 8 or table 9 compounds as determined in § 63.144. Such changes include losses by air emissions; reduction of annual average concentration or changes in flow rate by mixing with other water or wastewater streams; and reduction in flow rate or annual average concentration by treating or otherwise handling the wastewater stream to remove or destroy hazardous air pollutants.

*Point of transfer* means:

(i) If the transfer is to an off-site location for control, the point where the conveyance crosses the property line; or  
(ii) If the transfer is to an on-site location not owned or operated by the owner or operator of the source, the point where the conveyance enters the operation or equipment of the transferee.

*Polymerizing monomer* means a molecule or compound usually containing carbon and of relatively low molecular weight and simple structure (e.g., hydrogen cyanide, acrylonitrile, styrene), which is capable of conversion to polymers, synthetic resins, or elastomers by combination with itself due to heat generation caused by a pump mechanical seal surface, contamination by a seal fluid (e.g., organic peroxides or chemicals that will form organic peroxides), or a combination of both with the resultant polymer buildup causing rapid mechanical seal failure.

*Pressure release* means the emission of materials resulting from the system pressure being greater than the set pressure of the pressure relief device. This release can be one release or a series of releases over a short time period.

*Pressure relief device or valve* means a valve, rupture disk, or similar device used only to release an unplanned, nonroutine discharge of gas from process equipment in order to avoid safety hazards or equipment damage. A pressure relief device discharge can result from an operator error, a malfunction such as a power failure or equipment failure, or other unexpected cause. Such devices include

conventional, spring-actuated relief valves, balanced bellows relief valves, pilot-operated relief valves, rupture disks, and breaking, buckling, or shearing pin devices. Devices that are actuated either by a pressure of less than or equal to 2.5 pounds per square inch gauge or by a vacuum are not pressure relief devices.

*Pressure-assisted multi-point flare* means a flare system consisting of multiple flare burners in staged arrays whereby the vent stream pressure is used to promote mixing and smokeless operation at the flare burner tips. Pressure-assisted multi-point flares are designed for smokeless operation at velocities up to Mach = 1 conditions (i.e., sonic conditions), can be elevated or at ground level, and typically use cross-lighting for flame propagation to combust any flare vent gases sent to a particular stage of flare burners.

*Pressure vessel* means a storage vessel that is used to store liquids or gases and is designed not to vent to the atmosphere as a result of compression of the vapor headspace in the pressure vessel during filling of the pressure vessel to its design capacity.

*Primary fuel* means the fuel that provides the principal heat input to the device. To be considered primary, the fuel must be able to sustain operation without the addition of other fuels.

*Process heater* means a device that transfers heat liberated by burning fuel directly to process streams or to heat transfer liquids other than water.

*Process unit* means a chemical manufacturing process unit as defined in subpart F of this part, a process subject to the provisions of subpart I of this part, or a process subject to another subpart in this part that references this subpart.

*Process unit shutdown* means a work practice or operational procedure that stops production from a process unit or part of a process unit during which it is technically feasible to clear process material from a process unit or part of a process unit consistent with safety constraints and during which repairs can be effected. An unscheduled work practice or operational procedure that stops production from a process unit or part of a process unit for less than 24 hours is not a process unit shutdown. An unscheduled work practice or operational procedure that would stop production from a process unit or part of a process unit for a shorter period of time than would be required to clear the process unit or part of the process unit of materials and start up the unit, and would result in greater emissions than delay of repair of leaking components until the next scheduled process unit

shutdown, is not a process unit shutdown. The use of spare equipment and technically feasible bypassing of equipment without stopping production are not process unit shutdowns.

*Process vent* means the point of discharge to the atmosphere (or the point of entry into a control device, if any) of a gas stream if the gas stream has the characteristics specified in § 63.107(b) through (h), or meets the criteria specified in § 63.107(i). For purposes of §§ 63.113 through 63.118, all references to the characteristics of a process vent (e.g., flow rate, total HAP concentration, or TRE index value) shall mean the characteristics of the gas stream.

*Process wastewater* means wastewater which, during manufacturing or processing, comes into direct contact with or results from the production or use of any raw material, intermediate product, finished product, by-product, or waste product. Examples are product tank drawdown or feed tank drawdown;

water formed during a chemical reaction or used as a reactant; water used to wash impurities from organic products or reactants; water used to cool or quench organic vapor streams through direct contact; and condensed steam from jet ejector systems pulling vacuum on vessels containing organics.

*Process wastewater stream* means a stream that contains process wastewater.

*Product* means a compound or chemical which is manufactured as the intended product of the chemical manufacturing process unit. By-products, isolated intermediates, impurities, wastes, and trace contaminants are not considered products.

*Product separator* means phase separators, flash drums, knock-out drums, decanters, degassers, and condenser(s) including ejector-condenser(s) associated with a reactor or an air oxidation reactor.

*Product tank drawdown* means any material or mixture of materials

discharged from a product tank for the purpose of removing water or other contaminants from the product tank.

*Product tank*, as used in the wastewater provisions, means a stationary unit that is designed to contain an accumulation of materials that are fed to or produced by a process unit, and is constructed primarily of non-earthen materials (e.g., wood, concrete, steel, plastic) which provide structural support. This term has the same meaning as a product storage vessel.

*Rack-weighted average partial pressure* means the throughput weighted average of the average maximum true vapor pressure of liquids containing organic HAP transferred at a transfer rack. The rack-weighted average partial pressure shall be calculated using the equation below:

Equation 1 to Paragraph (b) Rack-Weighted Average Partial Pressure

$$P = \frac{\sum P_i G_i}{\sum G_i}$$

Where:

P = Rack-weighted average partial pressure, kilopascals.

P<sub>i</sub> = Individual HAP maximum true vapor pressure, kilopascals, = X<sub>i</sub>\*P, where X<sub>i</sub> is the mole fraction of compound i in the liquid.

G<sub>i</sub> = Yearly volume of each liquid that contains organic HAP that is transferred at the rack, liters.

I = Each liquid that contains HAP that is transferred at the rack.

*Reactor* means a device or vessel in which one or more chemicals or reactants, other than air, are combined or decomposed in such a way that their molecular structures are altered and one or more new organic compounds are formed. Reactor includes the product separator and any associated vacuum pump or steam jet.

*Recapture device* means an individual unit of equipment capable of and used for the purpose of recovering chemicals, but not normally for use, reuse, or sale. For example, a recapture device may recover chemicals primarily for disposal. Recapture devices include, but are not limited to, absorbers, carbon adsorbers, and condensers.

*Recovery device* means an individual unit of equipment capable of and normally used for the purpose of recovering chemicals for fuel value (i.e., net positive heating value), use, reuse or

for sale for fuel value, use, or reuse. Examples of equipment that may be recovery devices include absorbers, carbon adsorbers, condensers, oil-water separators or organic-water separators, or organic removal devices such as decanters, strippers, or thin-film evaporation units. For purposes of the monitoring, recordkeeping, and reporting requirements of subparts G and H of this part, recapture devices are considered recovery devices.

*Reference control technology for process vents* means a combustion device or recapture device used to reduce organic hazardous air pollutant emissions by 98 percent, or to an outlet concentration of 20 parts per million by volume.

*Reference control technology for storage vessels* means an internal floating roof meeting the specifications of § 63.119(b), an external floating roof meeting the specifications of § 63.119(c), an external floating roof converted to an internal floating roof meeting the specifications of § 63.119(d), or a closed-vent system to a control device achieving 95-percent reduction in organic HAP emissions. For purposes of emissions averaging, these four technologies are considered equivalent.

*Reference control technology for transfer racks* means a combustion device, recapture device, or recovery

device used to reduce organic hazardous air pollutants emissions by 98 percent, or to an outlet concentration of 20 parts per million by volume; or a vapor balancing system.

*Reference control technology for wastewater* means the use of:

(i) Controls specified in §§ 63.133 through 63.137;

(ii) A steam stripper meeting the specifications of § 63.138(d) or any of the other alternative control measures specified in § 63.138(b), (c), (e), (f), (g), or (h); and

(iii) A control device to reduce by 95 percent (or to an outlet concentration of 20 parts per million by volume for combustion devices or for noncombustion devices controlling air emissions from waste management units other than surface impoundments or containers) the organic hazardous air pollutants emissions in the vapor streams vented from wastewater tanks, oil-water separators, containers, surface impoundments, individual drain systems, and treatment processes (including the design steam stripper) managing wastewater.

*Relief valve* means a type of pressure relief device that is designed to re-close after the pressure relief.

*Repaired* means that equipment:

(i) Is adjusted, or otherwise altered, to eliminate a leak as defined in the

applicable sections of subpart H of this part, and

(ii) Unless otherwise specified in applicable provisions of subpart H of this part, is monitored as specified in § 63.180(b) and (c), as appropriate, to verify that emissions from the equipment are below the applicable leak definition.

*Research and development facility* means laboratory and pilot plant operations whose primary purpose is to conduct research and development into new processes and products, where the operations are under the close supervision of technically trained personnel, and is not engaged in the manufacture of products for commercial sale, except in a *de minimis* manner.

*Residual* means any liquid or solid material containing table 9 compounds that is removed from a wastewater stream by a waste management unit or treatment process that does not destroy organics (nondestructive unit). Examples of residuals from nondestructive wastewater management units are: the organic layer and bottom residue removed by a decanter or organic-water separator and the overheads from a steam stripper or air stripper. Examples of materials which are not residuals are: silt; mud; leaves; bottoms from a steam stripper or air stripper; and sludges, ash, or other materials removed from wastewater being treated by destructive devices such as biological treatment units and incinerators.

*Routed to a process or route to a process* means the emissions are conveyed to any enclosed portion of a process unit where the emissions are predominately recycled and/or consumed in the same manner as a material that fulfills the same function in the process; and/or transformed by chemical reaction into materials that are not organic hazardous air pollutants; and/or incorporated into a product; and/or recovered.

*Sampling connection system* means an assembly of equipment within a process unit used during periods of representative operation to take samples of the process fluid. Equipment used to take non-routine grab samples is not considered a sampling connection system.

*Screwed connector* means a threaded pipe fitting where the threads are cut on the pipe wall and the fitting requires only two pieces to make the connection (*i.e.*, the pipe and the fitting).

*Secondary fuel* means a fuel fired through a burner other than the primary fuel burner that provides supplementary heat in addition to the heat provided by the primary fuel.

*Sensor* means a device that measures a physical quantity or the change in a physical quantity, such as temperature, pressure, flow rate, pH, or liquid level.

*Set pressure* means the pressure at which a properly operating pressure relief device begins to open to relieve atypical process system operating pressure.

*Sewer line* means a lateral, trunk line, branch line, or other conduit including, but not limited to, grates, trenches, etc., used to convey wastewater streams or residuals to a downstream waste management unit.

*Shutdown* means for purposes including, but not limited to, periodic maintenance, replacement of equipment, or repair, the cessation of operation of a chemical manufacturing process unit or a reactor, air oxidation reactor, distillation unit, waste management unit, equipment required or used to comply with this subpart, subpart G or H of this part, or the emptying and degassing of a storage vessel. Shutdown does not include the routine rinsing or washing of equipment in batch operation between batches.

*Simultaneous loading* means, for a shared control device, loading of organic HAP materials from more than one transfer arm at the same time such that the beginning and ending times of loading cycles coincide or overlap and there is no interruption in vapor flow to the shared control device.

*Single-seal system* means a floating roof having one continuous seal that completely covers the space between the wall of the storage vessel and the edge of the floating roof. This seal may be a vapor-mounted, liquid-mounted, or metallic shoe seal.

*Source* means the collection of emission points to which this subpart applies as determined by the criteria in § 63.100. For purposes of subparts F, G, and H of this part, the term *affected source* as used in subpart A of this part has the same meaning as the term *source* defined here.

*Specific gravity monitoring device* means a unit of equipment used to monitor specific gravity and having a minimum accuracy of  $\pm 0.02$  specific gravity units.

*Start-up* means the setting into operation of a chemical manufacturing process unit or a reactor, air oxidation reactor, distillation unit, waste management unit, or equipment required or used to comply with this subpart, subpart G or H of this part, or a storage vessel after emptying and degassing. Start-up includes initial start-up, operation solely for testing equipment, the recharging of equipment in batch operation, and transitional

conditions due to changes in product for flexible operation units.

*Start-up, shutdown, and malfunction plan* means the plan required under § 63.6(e)(3). This plan details the procedures for operation and maintenance of the source during periods of start-up, shutdown, and malfunction. For each source as defined in this section, this definition no longer applies on and after July 15, 2027.

*Steam jet ejector* means a steam nozzle which discharges a high-velocity jet across a suction chamber that is connected to the equipment to be evacuated.

*Storage vessel* means a tank or other vessel that is used to store organic liquids that contain one or more of the organic HAP's listed in table 2 to this subpart and that has been assigned, according to the procedures in § 63.100(g), to a chemical manufacturing process unit that is subject to this subpart. Storage vessel does not include:

(i) Vessels permanently attached to motor vehicles such as trucks, railcars, barges, or ships;

(ii) Vessels with capacities smaller than 38 cubic meters;

(iii) Except for storage vessels in ethylene oxide service, vessels storing organic liquids that contain organic hazardous air pollutants only as impurities;

(iv) Bottoms receiver tanks;

(v) Surge control vessels; or

(vi) Wastewater storage tanks.

Wastewater storage tanks are covered under the wastewater provisions.

*Surface impoundment* means a waste management unit which is a natural topographic depression, manmade excavation, or diked area formed primarily of earthen materials (although it may be lined with manmade materials), which is designed to hold an accumulation of liquid wastes or waste containing free liquids. A surface impoundment is used for the purpose of treating, storing, or disposing of wastewater or residuals, and is not an injection well. Examples of surface impoundments are equalization, settling, and aeration pits, ponds, and lagoons.

*Surge control vessel* means feed drums, recycle drums, and intermediate vessels. Surge control vessels are used within a chemical manufacturing process unit when in-process storage, mixing, or management of flow rates or volumes is needed to assist in production of a product.

*Table 8 compound* means a compound listed in table 8 to subpart G of this part.

*Table 9 compound* means a compound listed in table 9 to subpart G of this part.

*Temperature monitoring device* means a unit of equipment used to monitor temperature and having a minimum accuracy of (a)  $\pm 1$  percent of the temperature being monitored expressed in degrees Celsius ( $^{\circ}\text{C}$ ) or (b)  $\pm 0.5$  degrees ( $^{\circ}\text{C}$ ), whichever is greater.

*The 33/50 program* means a voluntary pollution prevention initiative established and administered by the EPA to encourage emissions reductions of 17 chemicals emitted in large volumes by industrial facilities. The EPA Document Number 741-K-92-001 provides more information about the 33/50 program.

*Total organic compounds (TOC)*, as used in the process vents provisions, means those compounds measured according to the procedures of Method 18 of appendix A-6 to 40 CFR part 60, ASTM D6420-18 (incorporated by reference, see § 63.14) may be used in lieu of Method 18, if the target compounds are all known and are all listed in Section 1.1 of ASTM D6420-18 as measurable; ASTM D6420-18 must not be used for methane and ethane; and ASTM D6420-18 may not be used as a total VOC method.

*Total resource effectiveness index value* or *TRE index value* means a measure of the supplemental total resource requirement per unit reduction of organic HAP associated with a process vent stream, based on vent stream flow rate, emission rate of organic HAP, net heating value, and corrosion properties (whether or not the vent stream contains halogenated compounds), as quantified by the equations given under § 63.115.

*Transfer operation* means the loading, into a tank truck or railcar, of organic liquids that contain one or more of the organic hazardous air pollutants listed in table 2 of this subpart from a transfer rack (as defined in this section). Transfer operations do not include loading at an operating pressure greater than 204.9 kilopascals. For each source as defined in this section, the greater than 204.9 kilopascals exemption in this definition no longer applies on and after July 15, 2027.

*Transfer rack* means the collection of loading arms and loading hoses, at a single loading rack, that are assigned to a chemical manufacturing process unit subject to this subpart according to the procedures specified in § 63.100(h) and are used to fill tank trucks and/or railcars with organic liquids that contain one or more of the organic hazardous air pollutants listed in table 2 to this subpart. Transfer rack includes

the associated pumps, meters, shutoff valves, relief valves, and other piping and valves. Transfer rack does not include:

(i) Racks, arms, or hoses that only transfer liquids containing organic hazardous air pollutants as impurities; or

(ii) Racks, arms, or hoses that vapor balance during all loading operations.

*Treatment process* means a specific technique that removes or destroys the organics in a wastewater or residual stream such as a steam stripping unit, thin-film evaporation unit, waste incinerator, biological treatment unit, or any other process applied to wastewater streams or residuals to comply with § 63.138. Most treatment processes are conducted in tanks. Treatment processes are a subset of waste management units.

*Unit operation* means one or more pieces of process equipment used to make a single change to the physical or chemical characteristics of one or more process streams. Unit operations include, but are not limited to, reactors, distillation units, extraction columns, absorbers, decanters, dryers, condensers, and filtration equipment.

*Vapor balancing system* means a piping system that is designed to collect organic hazardous air pollutants vapors displaced from tank trucks or railcars during loading; and to route the collected organic hazardous air pollutants vapors to the storage vessel from which the liquid being loaded originated, or to another storage vessel connected by a common header or to compress and route to a process or a fuel gas system the collected organic hazardous air pollutants vapors.

*Vapor collection system*, as used in the transfer provisions, means the equipment used to collect and transport organic HAP vapors displaced during the loading of tank trucks or railcars. This does not include the vapor collection system that is part of any tank truck or railcar vapor collection manifold system.

*Vapor-mounted seal* means a continuous seal that completely covers the annular space between the wall of the storage vessel or waste management unit and the edge of the floating roof and is mounted such that there is a vapor space between the stored liquid and the bottom of the seal.

*Vent stream*, as used in the process vent provisions, means the gas stream flowing through the process vent.

*Waste management unit* means the equipment, structure(s), and/or device(s) used to convey, store, treat, or dispose of wastewater streams or residuals. Examples of waste

management units include: Wastewater tanks, surface impoundments, individual drain systems, and biological wastewater treatment units. Examples of equipment that may be waste management units include containers, air flotation units, oil-water separators or organic-water separators, or organic removal devices such as decanters, strippers, or thin-film evaporation units. If such equipment is used for recovery then it is part of a chemical manufacturing process unit and is not a waste management unit.

*Wastewater* means water that:

(i) Contains either:

(A) An annual average concentration of table 9 compounds of at least 5 parts per million by weight and has an annual average flow rate of 0.02 liter per minute or greater, or

(B) An annual average concentration of table 9 compounds of at least 10,000 parts per million by weight at any flow rate, and that

(ii) Is discarded from a chemical manufacturing process unit that meets all of the criteria specified in § 63.100 (b)(1) through (3). Wastewater is process wastewater or maintenance wastewater.

*Wastewater stream* means a stream that contains only wastewater.

*Wastewater tank* means a stationary waste management unit that is designed to contain an accumulation of wastewater or residuals and is constructed primarily of non-earthen materials (e.g., wood, concrete, steel, plastic) which provide structural support. Wastewater tanks used for flow equalization are included in this definition.

*Water seal controls* means a seal pot, p-leg trap, or other type of trap filled with water (e.g., flooded sewers that maintain water levels adequate to prevent air flow through the system) that creates a water barrier between the sewer line and the atmosphere. The water level of the seal must be maintained in the vertical leg of a drain in order to be considered a water seal.

■ 45. Revise and republish § 63.102 to read as follows:

#### § 63.102 General standards.

(a) Except as specified in paragraph (e) of this section, owners and operators of sources subject to this subpart shall comply with the requirements of subparts G and H of this part as specified in paragraphs (a)(1) through (4) of this section.

(1) The provisions set forth in this subpart and subpart G of this part shall apply at all times except during periods of start-up or shutdown (as defined in § 63.101 of this subpart), malfunction, or non-operation of the chemical



manufacturing process unit (or specific portion thereof) resulting in cessation of the emissions to which this subpart and subpart G of this part apply. However, if a start-up, shutdown, malfunction or period of non-operation of one portion of a chemical manufacturing process unit does not affect the ability of a particular emission point to comply with the specific provisions to which it is subject, then that emission point shall still be required to comply with the applicable provisions of this subpart and subpart G of this part during the start-up, shutdown, malfunction or period of non-operation. For example, if there is an overpressure in the reactor area, a storage vessel in the chemical manufacturing process unit would still be required to be controlled in accordance with § 63.119. Similarly, the degassing of a storage vessel would not affect the ability of a process vent to meet the requirements of § 63.113.

(2) The provisions set forth in subpart H of this part shall apply at all times except during periods of start-up or shutdown, malfunction, or process unit shutdown (as defined in § 63.101(b)), or non-operation of the chemical manufacturing process unit (or specific portion thereof) in which the lines are drained and depressurized resulting in cessation of the emissions to which subpart H of this part applies.

(3) The owner or operator shall not shut down items of equipment that are required or utilized for compliance with the provisions of this subpart or subpart G or H of this part during times when emissions (or, where applicable, wastewater streams or residuals) are being routed to such items of equipment, if the shutdown would contravene requirements of this subpart or subpart G or H of this part applicable to such items of equipment. This paragraph does not apply if the item of equipment is malfunctioning, or if the owner or operator must shut down the equipment to avoid damage due to a contemporaneous start-up, shutdown, or malfunction of the chemical manufacturing process unit or portion thereof.

(4) During start-ups, shutdowns, and malfunctions when the requirements of this subpart and subparts G and/or H of this part do not apply pursuant to paragraphs (a)(1) through (3) of this section, the owner or operator shall implement, to the extent reasonably available, measures to prevent or minimize excess emissions to the extent practical. The general duty to minimize emissions during a period of startup, shutdown, or malfunction does not require the owner or operator to achieve emission levels that would be required

by the applicable standard at other times if this is not consistent with safety and good air pollution control practices, nor does it require the owner or operator to make any further efforts to reduce emissions if levels required by the applicable standard have been achieved. Determination of whether such operation and maintenance procedures are being used will be based on information available to the Administrator which may include, but is not limited to, monitoring results, review of operation and maintenance procedures (including the startup, shutdown, and malfunction plan required in § 63.6(e)(3)), review of operation and maintenance records, and inspection of the source. The measures to be taken may include, but are not limited to, air pollution control technologies, recovery technologies, work practices, pollution prevention, monitoring, and/or changes in the manner of operation of the source. Back-up control devices are not required but may be used if available.

(b) If, in the judgment of the Administrator, an alternative means of emission limitation will achieve a reduction in organic HAP emissions at least equivalent to the reduction in organic HAP emissions from that source achieved under any design, equipment, work practice, or operational standards in subpart G or H of this part, the Administrator will publish in the **Federal Register** a notice permitting the use of the alternative means for purposes of compliance with that requirement.

(1) The notice may condition the permission on requirements related to the operation and maintenance of the alternative means.

(2) Any notice under this paragraph (b) shall be published only after public notice and an opportunity for a hearing.

(3) Any person seeking permission to use an alternative means of compliance under this section shall collect, verify, and submit to the Administrator information showing that the alternative means achieves equivalent emission reductions.

(c) Each owner or operator of a source subject to this subpart shall obtain a permit under 40 CFR part 70 or part 71 from the appropriate permitting authority by the date determined by 40 CFR part 70 or part 71, as appropriate.

(1) If the EPA has approved a State operating permit program under 40 CFR part 70, the permit shall be obtained from the State authority. If the State operating permit program has not been approved, the source shall apply to the EPA Regional Office.

(2) [Reserved]

(d) The requirements in this subpart and subparts G and H of this part are federally enforceable under section 112 of the Act on and after the dates specified in § 63.100(k) of this subpart.

(e) For each source as defined in § 63.101, beginning no later than the compliance dates specified in § 63.100(k)(10), paragraph (a) of this section does not apply. Instead, owners and operators of sources as defined in § 63.101 shall comply with the requirements in this subpart and subparts G and H of this part at all times, except during periods of nonoperation of the source (or specific portion thereof) resulting in cessation of the emissions to which this subpart or subpart G or H of this part applies.

(f) For each source as defined in § 63.101, beginning no later than the compliance dates specified in § 63.100(k)(10), at all times, owners and operators must operate and maintain any source, including associated air pollution control equipment and monitoring equipment, in a manner consistent with safety and good air pollution control practices for minimizing emissions. The general duty to minimize emissions does not require owners and operators to make any further efforts to reduce emissions if levels required by the applicable standard have been achieved. Determination of whether a source is operating in compliance with operation and maintenance requirements will be based on information available to the Administrator which may include, but is not limited to, monitoring results, review of operation and maintenance procedures, review of operation and maintenance records, and inspection of the source.

■ 46. Amend § 63.103 by revising paragraphs (b) introductory text, (b)(1) and (3), adding paragraph (b)(3)(ii), revising and republishing paragraphs (c)(2) and (3), and revising paragraphs (d) through (h) to read as follows:

**§ 63.103 General compliance, reporting, and recordkeeping provisions.**

\* \* \* \* \*

(b) Performance tests and initial compliance determinations shall be required only as specified in subparts G and H of this part.

(1) Initial performance tests and compliance determinations shall be conducted according to the schedule and procedures in § 63.7(a) and the applicable sections of subparts G and H of this part. Beginning no later than the compliance dates specified in § 63.100(k)(10), except as outlined in subpart H of this part, conduct subsequent performance tests no later

than 60 calendar months after the previous performance test.

\* \* \* \* \*

(3) Performance tests shall be conducted as specified in paragraph (b)(3)(i) or (ii) of this section.

(i) Except as specified in paragraph (b)(3)(i) of this section, performance tests shall be conducted according to the provisions of § 63.7(e), except that performance tests shall be conducted at maximum representative operating conditions for the process. During the performance test, an owner or operator may operate the control or recovery device at maximum or minimum representative operating conditions for monitored control or recovery device parameters, whichever results in lower emission reduction.

(ii) For each source as defined in § 63.101, beginning no later than the compliance dates specified in § 63.100(k)(10), paragraph (b)(3)(i) of this section no longer applies and instead the owner or operator may not conduct performance tests during periods of malfunction. Owners and operators must record the process information that is necessary to document operating conditions during the test and include in such record an explanation to support that such conditions represent normal operation. Upon request, owners and operators must make available to the Administrator such records as may be necessary to determine the conditions of performance tests.

\* \* \* \* \*

(c) \* \* \*

(2) The owner or operator subject to subparts F, G, and H of this part shall keep the records specified in this paragraph, as well as records specified in subparts G and H.

(i) Records of the occurrence and duration of each start-up, shutdown, and malfunction of operation of process equipment or of air pollution control equipment or continuous monitoring systems used to comply with this subpart or subpart G or H of this part during which excess emissions (as defined in § 63.102(a)(4)) occur. For each source as defined in § 63.101, on and after July 15, 2027, this paragraph (c)(2)(i) no longer applies; however, for historical compliance purposes, a copy of these records must be retained and available on-site for at least five years after the date of occurrence.

(ii) For each start-up, shutdown, and malfunction during which excess emissions (as defined in § 63.102(a)(4)) occur, records that the procedures specified in the source's start-up, shutdown, and malfunction plan were

followed, and documentation of actions taken that are not consistent with the plan. For example, if a start-up, shutdown, and malfunction plan includes procedures for routing a control device to a backup control device (e.g., the incinerator for a halogenated stream could be routed to a flare during periods when the primary control device is out of service), records must be kept of whether the plan was followed. These records may take the form of a "checklist," or other form of recordkeeping that confirms conformance with the start-up, shutdown, and malfunction plan for the event. For each source as defined in § 63.101, on and after July 15, 2027, this paragraph (c)(2)(ii) no longer applies; however, for historical compliance purposes, a copy of the plan and these records must be retained and available on-site for 5 years after July 15, 2027.

(iii) For continuous monitoring systems used to comply with subpart G of this part, records documenting the completion of calibration checks and maintenance of continuous monitoring systems that are specified in the manufacturer's instructions or other written procedures that provide adequate assurance that the equipment would reasonably be expected to monitor accurately.

(iv) Beginning no later than the compliance dates specified in § 63.100(k)(10), the manufacturer's specifications specified in paragraph (c)(2)(iii) of this section must include a schedule for calibrations, preventative maintenance procedures, a schedule for preventative maintenance, and corrective actions to be taken if a calibration fails. If a continuous monitoring system calibration fails, the continuous monitoring system is considered to be inoperative until the owner or operator takes corrective action and the system passes calibration. The owner or operator must record the nature and cause of instances when the continuous monitoring system is inoperative and the corrective action taken.

(3) Records of start-up, shutdown and malfunction and continuous monitoring system calibration and maintenance are not required if they pertain solely to Group 2 emission points, as defined in § 63.101, that are not included in an emissions average. For each source as defined in § 63.101, on and after July 15, 2027, the phrase "start-up, shutdown and malfunction and" in this paragraph (c)(3) no longer applies.

(d) Unless required to be submitted electronically via the EPA's CEDRI, all reports required under this subpart and subparts G and H of this part must be

sent to the Administrator at the addresses listed in § 63.13, except that requests for permission to use an alternative means of compliance as provided for in § 63.102(b) of this subpart and application for approval of a nominal efficiency as provided for in § 63.150 (i)(1) through (6) must be submitted to the Director of the EPA Office of Air Quality Planning and Standards rather than to the Administrator or delegated authority.

(1) Wherever subpart A of this part specifies "postmark" dates, submittals may be sent by methods other than the U.S. Mail (e.g., by fax or courier). Submittals shall be sent on or before the specified date.

(2) If acceptable to both the Administrator and the owner or operator of a source, reports may be submitted on electronic media.

(e) The owner or operator of a chemical manufacturing process unit which meets the criteria of § 63.100(b)(1) and (3), but not the criteria of § 63.100(b)(2), shall comply with the requirements of either paragraph (e)(1) or (2) of this section.

(1) Retain information, data, and analysis used to determine that the chemical manufacturing process unit does not use as a reactant or manufacture as a product or co-product any organic hazardous air pollutant. Examples of information that could document this include, but are not limited to, records of chemicals purchased for the process, analyses of process stream composition, engineering calculations, or process knowledge.

(2) When requested by the Administrator, demonstrate that the chemical manufacturing process unit does not use as a reactant or manufacture as a product or co-product any organic hazardous air pollutant.

(f) To qualify for the exemption specified in § 63.100(b)(4), the owner or operator shall maintain the documentation of the information required pursuant to § 63.100(b)(4)(i), and documentation of any update of this information requested by the EPA Regional Office, and shall provide the documentation to the EPA Regional Office upon request. The EPA Regional Office will notify the owner or operator, after reviewing such documentation, if the source does not qualify for the exemption specified in § 63.100(b)(4). In such cases, compliance with subpart H shall be required no later than 90 days after expiration of the applicable compliance date in § 63.100(k)(3), but in no event earlier than 90 days after the date of such notification by the EPA Regional Office. Compliance with this

subpart and subpart G of this part shall be no later than April 22, 1997, or as otherwise specified in § 63.100(k)(2)(ii), unless an extension has been granted by the EPA Regional Office or permitting authority as provided in § 63.6(i).

(g) An owner or operator who elects to use the compliance extension provisions of § 63.100(k)(6)(i) or (ii) shall submit a compliance extension request to the appropriate EPA Regional Office no later than 45 days before the applicable compliance date in § 63.100(k)(3), but in no event is submittal required earlier than May 10, 1995. The request shall contain the information specified in § 63.100(k)(5)(iv) and the reason compliance cannot reasonably be achieved without a process unit shutdown, as defined in 40 CFR 63.101 or without replacement of the compressor or recasting of the distance piece.

(h) An owner or operator who elects to use the compliance extension provisions of § 63.100(k)(8) shall submit to the appropriate EPA Regional Office a brief description of the process change, identify the HAP eliminated, and the expected date of cessation of use or production of HAP. The description shall be submitted no later than May 10, 1995, or with the Notice of Compliance Status as required in § 63.182(c), whichever is later.

■ 47. Amend § 63.104 by revising paragraphs (a) and (f) and adding paragraphs (g) through (l) to read as follows:

**§ 63.104 Heat exchange system requirements.**

(a) Unless one or more of the conditions specified in paragraphs (a)(1) through (6) or paragraph (l) of this section are met, owners and operators of sources subject to this subpart shall monitor each heat exchange system used to cool process equipment in a chemical manufacturing process unit meeting the conditions of § 63.100(b)(1) through (3), except for chemical manufacturing process units meeting the condition specified in § 63.100(c), according to the provisions in either paragraph (b) or (c) of this section, and if applicable, paragraph (g) of this section. Whenever a leak is detected, the owner or operator shall comply with the requirements in paragraph (d) of this section, and if applicable, paragraphs (h) through (j) of this section. Owners and operators of heat exchange systems in a chemical manufacturing process unit meeting the conditions of § 63.100(b)(1) through (3) must also comply with paragraph (k) of this section.

(1) The heat exchange system is operated with the minimum pressure on the cooling water side at least 35 kilopascals greater than the maximum pressure on the process side.

(2) There is an intervening cooling fluid, containing less than 5 percent by weight of total hazardous air pollutants listed in table 4 of this subpart, between the process and the cooling water. This intervening fluid serves to isolate the cooling water from the process fluid and the intervening fluid is not sent through a cooling tower or discharged. For purposes of this section, discharge does not include emptying for maintenance purposes.

(3) The once-through heat exchange system is subject to a National Pollution Discharge Elimination System (NPDES) permit with an allowable discharge limit of 1 part per million or less above influent concentration or 10 percent or less above influent concentration, whichever is greater. For each source as defined in § 63.101, beginning no later than the compliance dates specified in § 63.100(k)(10), this paragraph (a)(3) no longer applies.

(4) Except as specified in paragraph (a)(4)(v) of this section, the once-through heat exchange system is subject to an NPDES permit that:

(i) Requires monitoring of a parameter(s) or condition(s) to detect a leak of process fluids into cooling water;

(ii) Specifies or includes the normal range of the parameter or condition;

(iii) Requires monitoring for the parameters selected as leak indicators no less frequently than monthly for the first six months and quarterly thereafter; and

(iv) Requires the owner or operator to report and correct leaks to the cooling water when the parameter or condition exceeds the normal range.

(v) For each source as defined in § 63.101, beginning no later than the compliance dates specified in § 63.100(k)(10), this paragraph (a)(4) no longer applies.

\* \* \* \* \*

(f)(1) *Required records.* The owner or operator shall retain the records identified in paragraphs (f)(1)(i) through (iv) of this section, and if applicable, paragraph (f)(3) of this section, as specified in § 63.103(c)(1).

(i) Monitoring data required by this section indicating a leak and the date when the leak was detected, and if demonstrated not to be a leak, the basis for that determination;

(ii) Records of any leaks detected by procedures subject to paragraph (c)(2) of this section and the date the leak was discovered;

(iii) The dates of efforts to repair leaks; and

(iv) The method or procedure used to confirm repair of a leak and the date repair was confirmed.

(2) *Reports.* If an owner or operator invokes the delay of repair provisions for a heat exchange system, the following information shall be submitted in the next semi-annual periodic report required by § 63.152(c). If the leak remains unrepaired, the information shall also be submitted in each subsequent periodic report, until repair of the leak is reported. In addition, if an owner or operator is complying with paragraph (g) or (l) of this section, then the semi-annual periodic report must include the information specified in paragraph (f)(2)(vi) of this section.

(i) The owner or operator shall report the presence of the leak by identifying the heat exchange system and the date that the leak was detected.

(ii) The owner or operator shall report whether or not the leak has been repaired.

(iii) The owner or operator shall report the reason(s) for delay of repair. If delay of repair is invoked due to the reasons described in paragraph (e)(2) of this section, documentation of emissions estimates must also be submitted.

(iv) If the leak remains unrepaired, the owner or operator shall report the expected date of repair.

(v) If the leak is repaired, the owner or operator shall report the date the leak was successfully repaired.

(vi) For each heat exchange system subject to paragraph (g) or (l) of this section, the following information must be submitted in each semi-annual periodic report required by § 63.152(c). (A) The number of heat exchange systems at the plant site subject to the monitoring requirements in paragraph (g) or (l) of this section during the reporting period.

(B) The number of heat exchange systems subject to the monitoring requirements in paragraph (g) or (l) of this section at the plant site found to be leaking during the reporting period.

(C) For each monitoring location where a leak was identified during the reporting period, identification of the monitoring location (*e.g.*, unique monitoring location or heat exchange system ID number), the measured total strippable hydrocarbon concentration (in ppmv as methane) or total hydrocarbon mass emissions rate (in kg/hr as methane) (if complying with paragraph (g) of this section) or the measured concentration of the monitored substance(s) (in ppmv) (if

complying with paragraph (l) of this section), the date the leak was first identified, and, if applicable, the date the source of the leak was identified;

(D) For leaks that were repaired during the reporting period (including delayed repairs), identification of the monitoring location associated with the repaired leak, the total strippable hydrocarbon concentration or total hydrocarbon mass emissions rate (if complying with paragraph (g) of this section) or the measured concentration of the monitored substance(s) (if complying with paragraph (l) of this section) measured during re-monitoring to verify repair, and the re-monitoring date (*i.e.*, the effective date of repair); and

(E) For each delayed repair, identification of the monitoring location associated with the leak for which repair is delayed, the date when the delay of repair began, the date the repair was completed or is expected to be completed (if the leak is not repaired during the reporting period), the total strippable hydrocarbon concentration or total hydrocarbon mass emissions rate (if complying with paragraph (g) of this section) or the measured concentration of the monitored substance(s) (if complying with paragraph (l) of this section) and date of each monitoring event conducted on the delayed repair during the reporting period, and an estimate in pounds of the potential total hydrocarbon emissions or monitored substance(s) emissions over the reporting period associated with the delayed repair.

(3) *Additional records.* For each heat exchange system subject to paragraph (g) or (l) of this section, owners and operators must also keep records in paragraphs (f)(3)(i) through (iv) of this section.

(i) Monitoring data required by paragraph (g) or (l) of this section that indicate a leak, the date the leak was detected, or, if applicable, the basis for determining there is no leak.

(ii) The dates of efforts to repair leaks.

(iii) The method or procedures used to confirm repair of a leak and the date the repair was confirmed.

(iv) Documentation of delay of repair as specified in paragraphs (f)(3)(iv)(A) through (f)(3)(iv)(D) of this section.

(A) The reason(s) for delaying repair.

(B) A schedule for completing the repair as soon as practical.

(C) The date and concentration or mass emissions rate of the leak as first identified and the results of all subsequent monitoring events during the delay of repair.

(D) An estimate of the potential total hydrocarbon emissions (if monitoring

the cooling water for leaks according to paragraph (g)(1) of this section) or monitored substance(s) emissions (if monitoring the cooling water for leaks according to paragraph (l) of this section) from the leaking heat exchange system or heat exchanger for each required delay of repair monitoring interval following the procedures in paragraphs (f)(3)(iv)(D)(1) through (4) of this section.

(1) If an owner or operator complies with the total strippable hydrocarbon concentration leak action level, as specified in paragraph (g)(4) of this section, then the owner or operator must calculate the mass emissions rate by complying with the requirements of paragraph (g)(3)(ii) of this section or by determining the mass flow rate of the cooling water at the monitoring location where the leak was detected. If the monitoring location is an individual cooling tower riser, determine the total cooling water mass flow rate to the cooling tower. Cooling water mass flow rates may be determined using direct measurement, pump curves, heat balance calculations, or other engineering methods. If an owner or operator determines the mass flow rate of the cooling water, calculate the mass emissions rate by converting the stripping gas leak concentration (in ppmv as methane) to an equivalent liquid concentration, in parts per million by weight (ppmw), using equation 7-1 from "Air Stripping Method (Modified El Paso Method) for Determination of Volatile Organic Compound Emissions from Water Sources" (incorporated by reference—see § 63.14) and multiply the equivalent liquid concentration by the mass flow rate of the cooling water.

(2) For delay of repair monitoring intervals prior to repair of the leak, calculate the potential total hydrocarbon emissions or monitored substance(s) emissions for the leaking heat exchange system or heat exchanger for the monitoring interval by multiplying the mass emissions rate, determined in paragraph (g)(3)(ii) or (f)(3)(iv)(D)(1) or (4) of this section, by the duration of the delay of repair monitoring interval. The duration of the delay of repair monitoring interval is the time period starting at midnight on the day of the previous monitoring event or at midnight on the day the repair would have had to be completed if the repair had not been delayed, whichever is later, and ending at midnight of the day of the current monitoring event.

(3) For delay of repair monitoring intervals ending with a repaired leak, calculate the potential total hydrocarbon emissions or monitored substance(s)

emissions for the leaking heat exchange system or heat exchanger for the final delay of repair monitoring interval by multiplying the duration of the final delay of repair monitoring interval by the mass emissions rate determined for the last monitoring event prior to the re-monitoring event used to verify the leak was repaired. The duration of the final delay of repair monitoring interval is the time period starting at midnight of the day of the last monitoring event prior to re-monitoring to verify the leak was repaired and ending at the time of the re-monitoring event that verified that the leak was repaired.

(4) If an owner or operator monitors the cooling water for leaks according to paragraph (l) of this section, then the owner or operator must calculate the mass emissions rate by determining the mass flow rate of the cooling water at the monitoring location where the leak was detected. Cooling water mass flow rates may be determined using direct measurement, pump curves, heat balance calculations, or other engineering methods. Once determined, multiply the mass flow rate of the cooling water by the concentration of the measured substance(s).

(g) For each source as defined in § 63.101, beginning no later than the compliance dates specified in § 63.100(k)(10), owners and operators must monitor the cooling water for the presence of total strippable hydrocarbons that indicate a leak according to paragraph (g)(1) of this section, and if an owner or operator detects a leak pursuant to the procedures in this paragraph, then the owner or operator must repair it according to paragraphs (h) and (i) of this section, unless repair is delayed according to paragraph (j) of this section. The requirements in this paragraph do not apply to heat exchange systems that have a maximum cooling water flow rate of 10 gallons per minute or less.

(1) For each recirculating heat exchange system subject to the requirements of paragraph (g) of this section, owners and operators must collect and analyze a sample from the location(s) described in either paragraph (g)(1)(i) or (ii) of this section.

(i) Each cooling tower return line or any representative riser within the cooling tower prior to exposure to air for each heat exchange system.

(ii) Selected heat exchanger exit line(s), so that each heat exchanger or group of heat exchangers within a heat exchange system is covered by the selected monitoring location(s).

(2) For each once-through heat exchange system, owners and operators

must collect and analyze a sample from the location(s) described in paragraph (g)(2)(i) of this section. The owner or operator may also elect to collect and analyze an additional sample from the location(s) described in paragraph (g)(2)(ii) of this section.

(i) Selected heat exchanger exit line(s), so that each heat exchanger or group of heat exchangers within a heat exchange system is covered by the selected monitoring location(s). The selected monitoring location may be at a point where discharges from multiple heat exchange systems are combined provided that the combined cooling water flow rate at the monitoring location does not exceed 40,000 gallons per minute.

(ii) The inlet water feed line for a once-through heat exchange system prior to any heat exchanger. If multiple heat exchange systems use the same water feed (*i.e.*, inlet water from the same primary water source), the owner or operator may monitor at one representative location and use the monitoring results for that sampling location for all heat exchange systems that use that same water feed.

(3) If an owner or operator complies with the total strippable hydrocarbon concentration leak action level as specified in paragraph (g)(4) of this section, then the owner or operator must comply with the requirements in paragraph (g)(3)(i) of this section. If an owner or operator complies with the total hydrocarbon mass emissions rate leak action level as specified in paragraph (g)(4) of this section, then the owner or operator must comply with the requirements in paragraphs (g)(3)(i) and (ii) of this section.

(i) Owners and operators must determine the total strippable hydrocarbon concentration (in parts per million by volume (ppmv) as methane) at each monitoring location using the "Air Stripping Method (Modified El Paso Method) for Determination of Volatile Organic Compound Emissions from Water Sources" (incorporated by reference—see § 63.14) using a flame ionization detector (FID) analyzer for on-site determination as described in Section 6.1 of the Modified El Paso Method.

(ii) Owners and operators must convert the total strippable hydrocarbon concentration (in ppmv as methane) to a total hydrocarbon mass emissions rate (as methane) using the calculations in Section 7.0 of "Air Stripping Method (Modified El Paso Method) for Determination of Volatile Organic Compound Emissions from Water Sources" (incorporated by reference—see § 63.14).

(4) Except as specified in paragraph (g)(6) of this section, for each heat exchange system, owners and operators must initially monitor monthly for 6-months beginning upon startup and monitor quarterly thereafter using a leak action level defined as a total strippable hydrocarbon concentration (as methane) in the stripping gas of 6.2 ppmv or, for heat exchange systems with a recirculation rate of 10,000 gallons per minute or less, the owner or operator may monitor quarterly using a leak action level defined as a total hydrocarbon mass emissions rate from the heat exchange system (as methane) of 0.18 kg/hr. If a leak is detected as specified in paragraph (g)(5) of this section, then owners and operators must monitor monthly until the leak has been repaired according to the requirements in paragraph (h) or (i) of this section. Once the leak has been repaired according to the requirements in paragraph (h) or (i) of this section, quarterly monitoring for the heat exchange system may resume. The monitoring frequencies specified in this paragraph also apply to the inlet water feed line for a once-through heat exchange system, if monitoring of the inlet water feed is elected as provided in paragraph (g)(2)(ii) of this section.

(5) A leak is defined as described in paragraph (g)(5)(i) or (ii) of this section, as applicable.

(i) For once-through heat exchange systems for which the inlet water feed is monitored as described in paragraph (g)(2)(ii) of this section, a leak is detected if the difference in the measurement value of the sample taken from a location specified in paragraph (g)(2)(i) of this section and the measurement value of the corresponding sample taken from the location specified in paragraph (g)(2)(ii) of this section equals or exceeds the leak action level.

(ii) For all other heat exchange systems, a leak is detected if a measurement value of the sample taken from a location specified in paragraph (g)(1)(i) or (ii) or (g)(2)(i) of this section equals or exceeds the leak action level.

(6) For heat exchange systems in ethylene oxide service, as defined in § 63.101, the monitoring frequency is weekly.

(h) If a leak is detected using the methods described in paragraph (g) of this section, owners and operators must repair the leak to reduce the concentration or mass emissions rate to below the applicable leak action level as soon as practicable, but no later than 45 days after identifying the leak, except as specified in paragraph (h)(6) or (j) of this section. Repair must include re-

monitoring at the monitoring location where the leak was identified according to the method specified in paragraph (g)(3) of this section to verify that the total strippable hydrocarbon concentration or total hydrocarbon mass emissions rate is below the applicable leak action level. Repair may also include performing the additional monitoring in paragraph (i) of this section to verify that the total strippable hydrocarbon concentration or total hydrocarbon mass emissions rate is below the applicable leak action level. Actions that can be taken to achieve repair include but are not limited to:

(1) Physical modifications to the leaking heat exchanger, such as welding the leak or replacing a tube;

(2) Blocking the leaking tube within the heat exchanger;

(3) Changing the pressure so that water flows into the process fluid;

(4) Replacing the heat exchanger or heat exchanger bundle; or

(5) Isolating, bypassing, or otherwise removing the leaking heat exchanger from service until it is otherwise repaired.

(6) For heat exchange systems in ethylene oxide service, as defined in § 63.101, paragraph (j) of this section does not apply, and owners and operators must repair the leak to reduce the concentration or mass emissions rate to below the applicable leak action level as soon as practicable, but no later than 15 days after the sample was collected. Delay of repair of heat exchange systems in ethylene oxide service for which leaks have been detected is allowed if the equipment is isolated from the process such that it is no longer in ethylene oxide service.

(i) If an owner or operator detects a leak when monitoring a cooling tower return line under paragraph (g)(1)(i) of this section, then the owner or operator may conduct additional monitoring of each heat exchanger or group of heat exchangers associated with the heat exchange system for which the leak was detected, as provided in paragraph (g)(1)(ii) of this section. If no leaks are detected when monitoring according to the requirements of paragraph (g)(1)(ii) of this section, the heat exchange system is considered to have met the repair requirements through re-monitoring of the heat exchange system, as provided in paragraph (h) of this section.

(j) Owners and operators may delay repair when one of the conditions in paragraph (j)(1) or (2) of this section is met and the leak is less than the delay of repair action level specified in paragraph (j)(3) of this section. Owners and operators must determine if a delay of repair is necessary as soon as

practicable, but no later than 45 days after first identifying the leak.

(1) If the repair is technically infeasible without a shutdown and the total strippable hydrocarbon concentration or total hydrocarbon mass emissions rate is initially and remains less than the delay of repair action level for all monitoring periods during the delay of repair, then the owner or operator may delay repair until the next scheduled shutdown of the heat exchange system. If, during subsequent monitoring, the delay of repair action level is exceeded, then owners and operators must repair the leak within 30 days of the monitoring event in which the leak was equal to or exceeded the delay of repair action level.

(2) If the necessary equipment, parts, or personnel are not available and the total strippable hydrocarbon concentration or total hydrocarbon mass emissions rate is initially and remains less than the delay of repair action level for all monitoring periods during the delay of repair, then the owner or operator may delay the repair for a maximum of 120 calendar days. Owners and operators must demonstrate that the necessary equipment, parts, or personnel were not available. If, during subsequent monitoring, the delay of repair action level is exceeded, then owners and operators must repair the leak within 30 days of the monitoring event in which the leak was equal to or exceeded the delay of repair action level.

(3) The delay of repair action level is a total strippable hydrocarbon concentration (as methane) in the stripping gas of 62 ppmv or, for heat exchange systems with a recirculation rate of 10,000 gallons per minute or less, the delay of repair action level is a total hydrocarbon mass emissions rate (as methane) of 1.8 kg/hr. The delay of repair action level is assessed as described in paragraph (j)(3)(i) or (ii) of this section, as applicable.

(i) For once-through heat exchange systems for which the inlet water feed is monitored as described in paragraph (g)(2)(ii) of this section, the delay of repair action level is exceeded if the difference in the measurement value of the sample taken from a location specified in paragraph (g)(2)(i) of this section and the measurement value of the corresponding sample taken from the location specified in paragraph (g)(2)(ii) of this section equals or exceeds the delay of repair action level.

(ii) For all other heat exchange systems, the delay of repair action level is exceeded if a measurement value of the sample taken from a location specified in paragraph (g)(1)(i), (1)(ii), or

(2)(i) of this section equals or exceeds the delay of repair action level.

(k) For each source as defined in § 63.101, beginning no later than the compliance dates specified in § 63.100(k)(11), owners and operators must not inject water into or dispose of water through any heat exchange system in a chemical manufacturing process unit meeting the conditions of § 63.100(b)(1) through (3) if the water contains any amount of ethylene oxide, has been in contact with any process stream containing ethylene oxide, or the water is considered wastewater as defined in § 63.101.

(l) If 99 percent by weight or more of the organic compounds that could leak into the heat exchange system are water soluble and have a Henry's Law Constant less than 5.0E-6 atmospheres-cubic meters/mol at 25 degrees Celsius, beginning no later than the compliance dates specified in § 63.100(k)(10), owners and operators may monitor the cooling water for leaks according to the requirements in paragraph (b) of this section in lieu of using the Modified El Paso Method. If an owner or operator detects a leak according to paragraph (b) of this section, then the owner or operator must repair it according to paragraph (l)(1) of this section, unless repair is delayed according to paragraph (l)(2) of this section.

(1) If a leak is detected using the methods described in paragraph (l) of this section, the owner or operator must repair the leak as soon as practicable, but no later than 45 days after identifying the leak, except as specified in paragraph (l)(2) of this section. Repair must include re-monitoring at the monitoring location where the leak was identified to verify that the criteria in paragraph (b)(6) of this section is no longer met. Actions that can be taken to achieve repair include but are not limited to:

(i) Physical modifications to the leaking heat exchanger, such as welding the leak or replacing a tube;

(ii) Blocking the leaking tube within the heat exchanger;

(iii) Changing the pressure so that water flows into the process fluid;

(iv) Replacing the heat exchanger or heat exchanger bundle; or

(v) Isolating, bypassing, or otherwise removing the leaking heat exchanger from service until it is otherwise repaired.

(2) The owner or operator may delay repair when the conditions in paragraph (e) of this section are met.

■ 48. Amend § 63.105 by revising paragraphs (d) and (e) to read as follows:

**§ 63.105 Maintenance wastewater requirements.**

\* \* \* \* \*

(d) The owner or operator shall incorporate the procedures described in paragraphs (b) and (c) of this section as part of the startup, shutdown, and malfunction plan required under § 63.6(e)(3). For each source as defined in § 63.101, on and after July 15, 2027, this paragraph no longer applies.

(e) The owner or operator shall maintain a record of the information required by paragraphs (b) and (c) of this section as part of the start-up, shutdown, and malfunction plan required under § 63.6(e)(3). For each source as defined in § 63.101, on and after July 15, 2027, the phrase "as part of the start-up, shutdown, and malfunction plan required under § 63.6(e)(3)" in this paragraph no longer applies.

■ 49. Amend § 63.107 by revising paragraph (i) and adding paragraph (j) to read as follows:

**§ 63.107 Identification of process vents subject to this subpart.**

\* \* \* \* \*

(i) Except as specified in paragraph (j) of this section, the gas stream would meet the characteristics specified in paragraphs (b) through (g) of this section, but, for purposes of avoiding applicability, has been deliberately interrupted, temporarily liquefied, routed through any item of equipment for no process purpose, or disposed of in a flare that does not meet the criteria in § 63.11(b), or an incinerator that does not reduce emissions of organic HAP by 98 percent or to a concentration of 20 parts per million by volume, whichever is less stringent.

(j) For each source as defined in § 63.101, beginning no later than the compliance dates specified in § 63.100(k)(10), the phrase "disposed of in a flare that does not meet the criteria in § 63.11(b)" in paragraph (i) of this section is replaced with "disposed of in a flare that does not meet the criteria in § 63.108".

■ 50. Add § 63.108 to read as follows:

**§ 63.108 Flare requirements.**

(a) For any flare that is used to reduce organic HAP emissions from a chemical manufacturing process unit, the owner or operator may elect to comply with the requirements in this section in lieu of the requirements of § 63.11(b) and the requirements referenced therein. The owner or operator may also elect to comply with the requirements in this section pursuant to the overlap provisions provided in § 63.110(j). However, for each source as defined in

§ 63.101 and for each source as defined in § 63.191, beginning no later than the compliance dates specified in § 63.100(k)(10), the provisions specified in paragraphs (a)(1) through (22) of this section no longer apply. Instead, if an owner or operator reduces organic HAP emissions from a chemical manufacturing process unit by venting emissions through a closed-vent system to a steam-assisted, air-assisted, non-assisted, or pressure-assisted multi-point flare, then the owner or operator must meet the applicable requirements for flares as specified in §§ 63.670 and 63.671, including the provisions in tables 12 and 13 to subpart CC of this part, except as specified in paragraphs (b) through (o) of this section. This requirement also applies to any flare using fuel gas from a fuel gas system, of which 50 percent or more of the fuel gas is derived from a chemical manufacturing process unit, as determined on an annual average basis. For purposes of compliance with this paragraph, the following terms are defined in § 63.641: Assist air, assist steam, center steam, combustion zone, combustion zone gas, flare, flare purge gas, flare supplemental gas, flare sweep gas, flare vent gas, lower steam, net heating value, perimeter assist air, pilot gas, premix assist air, total steam, and upper steam.

(1) Section 63.107(i) related to criteria in § 63.11(b);

(2) Section 63.113(a)(1);

(3) Section 63.114(a)(2);

(4) Section 63.116(a)(1) through (3);

(5) Section 63.117(a)(5)(i) through (iii);

(6) Section 63.118(f)(5);

(7) The last sentence in § 63.119(e)(1) related to flares;

(8) Section 63.120(e)(1) through (6);

(9) Section 63.122(c)(2) and (g)(3);

(10) Section 63.126(b)(2)(i);

(11) Section 63.127(a)(2);

(12) Section 63.128(b)(1) through (3);

(13) Section 63.129(a)(5)(i) through (iii);

(14) Section 63.130(a)(2)(i), (c), and (d)(5);

(15) Section 63.139(c)(3) and (d)(3);

(16) Section 63.145(j)(1) through (3);

(17) Section 63.146(b)(7)(i)(A) through (C);

(18) V63.147(d)(1);

(19) Section 63.172(d);

(20) Section 63.180(e)(1) through (3);

(21) Section 63.181(g)(1)(iii); and

(22) The phrase “including periods when a flare pilot light system does not have a flame” in § 63.181(g)(2)(i) of subpart H of this part.

(b) When determining compliance with the pilot flame requirements specified in § 63.670(b) and (g),

substitute “pilot flame or flare flame” for each occurrence of “pilot flame.”

(c) When determining compliance with the flare tip velocity and combustion zone operating limits specified in § 63.670(d) and (e), the requirement effectively applies starting with the 15-minute block that includes a full 15 minutes of the flaring event. The owner or operator is required to demonstrate compliance with the velocity and NHVcz requirements starting with the block that contains the fifteenth minute of a flaring event. The owner or operator is not required to demonstrate compliance for the previous 15-minute block in which the event started and contained only a fraction of flow.

(d) Instead of complying with § 63.670(o)(2)(i), owners and operators must develop and implement the flare management plan no later than the compliance dates specified in § 63.100(k)(10).

(e) Instead of complying with § 63.670(o)(2)(iii), if required to develop a flare management plan and submit it to the Administrator, then owners and operators must also submit all versions of the plan in portable document format (PDF) to the EPA following the procedure specified in § 63.9(k), except any medium submitted through mail must be sent to the attention of the Hazardous Organic Chemical Manufacturing Sector Lead.

(f) Section 63.670(o)(3)(ii) and all references to it do not apply. Instead, the owner or operator must comply with the maximum flare tip velocity operating limit at all times.

(g) Substitute “chemical manufacturing process unit” for each occurrence of “petroleum refinery.”

(h) Each occurrence of “refinery” does not apply.

(i) If a pressure-assisted multi-point flare is used as a control device, then owners and operators must meet the following conditions:

(1) The owner or operator is not required to comply with the flare tip velocity requirements in § 63.670(d) and (k);

(2) The NHVcz for pressure-assisted multi-point flares is 800 Btu/scf;

(3) Owners and operators must determine the 15-minute block average NHVvg using only the direct calculation method specified in § 63.670(l)(5)(ii);

(4) Instead of complying with § 63.670(b) and (g), if a pressure-assisted multi-point flare uses cross-lighting on a stage of burners rather than having an individual pilot flame on each burner, then owners and operators must operate each stage of the pressure-assisted multi-point flare with a flame present at

all times when regulated material is routed to that stage of burners. Each stage of burners that cross-lights in the pressure-assisted multi-point flare must have at least two pilots with at least one continuously lit and capable of igniting all regulated material that is routed to that stage of burners. Each 15-minute block during which there is at least one minute where no pilot flame is present on a stage of burners when regulated material is routed to the flare is a violation of the standard. Violations in different 15-minute blocks from the same event are considered separate violations. The pilot flame(s) on each stage of burners that use cross-lighting must be continuously monitored by a thermocouple or any other equivalent device used to detect the presence of a flame;

(5) Unless the owner or operator chooses to conduct a cross-light performance demonstration as specified in this paragraph, owners and operators must ensure that if a stage of burners on the flare uses cross-lighting, that the distance between any two burners in series on that stage is no more than 6 feet when measured from the center of one burner to the next burner. A distance greater than 6 feet between any two burners in series may be used provided the owner or operator conducts a performance demonstration that confirms the pressure-assisted multi-point flare will cross-light a minimum of three burners and the spacing between the burners and location of the pilot flame must be representative of the projected installation. The compliance demonstration must be approved by the permitting authority and a copy of this approval must be maintained onsite. The compliance demonstration report must include: a protocol describing the test methodology used, associated test method QA/QC parameters, the waste gas composition and NHVcz of the gas tested, the velocity of the waste gas tested, the pressure-assisted multi-point flare burner tip pressure, the time, length, and duration of the test, records of whether a successful cross-light was observed over all of the burners and the length of time it took for the burners to cross-light, records of maintaining a stable flame after a successful cross-light and the duration for which this was observed, records of any smoking events during the cross-light, waste gas temperature, meteorological conditions (e.g., ambient temperature, barometric pressure, wind speed and direction, and relative humidity), and whether there were any observed flare flameouts; and

(6) Owners and operators must install and operate pressure monitor(s) on the

main flare header, as well as a valve position indicator monitoring system for each staging valve to ensure that the flare operates within the proper range of conditions as specified by the manufacturer. The pressure monitor must meet the requirements in table 13 to subpart CC of this part.

(7) If a pressure-assisted multi-point flare is operating under the requirements of an approved alternative means of emission limitations, owners and operators must either continue to comply with the terms of the alternative means of emission limitations or comply with the provisions in paragraphs (i)(1) through (6) of this section.

(j) If an owner or operator chooses to determine compositional analysis for net heating value with a continuous process mass spectrometer, then the owner or operator must comply with the requirements specified in paragraphs (j)(1) through (7) of this section.

(1) Owners and operators must meet the requirements in § 63.671(e)(2). The owner or operator may augment the minimum list of calibration gas components found in § 63.671(e)(2) with

compounds found during a pre-survey or known to be in the gas through process knowledge.

(2) Calibration gas cylinders must be certified to an accuracy of 2 percent and traceable to National Institute of Standards and Technology (NIST) standards.

(3) For unknown gas components that have similar analytical mass fragments to calibration compounds, the owner or operator may report the unknowns as an increase in the overlapped calibration gas compound. For unknown compounds that produce mass fragments that do not overlap calibration compounds, the owner or operator may use the response factor for the nearest molecular weight hydrocarbon in the calibration mix to quantify the unknown component's NHV<sub>vg</sub>.

(4) The owner or operator may use the response factor for n-pentane to quantify any unknown components detected with a higher molecular weight than n-pentane.

(5) Owners and operators must perform an initial calibration to identify mass fragment overlap and response factors for the target compounds.

(6) Owners and operators must meet applicable requirements in Performance Specification 9 in appendix B to part 60 of this chapter for continuous monitoring system acceptance including, but not limited to, performing an initial multi-point calibration check at three concentrations following the procedure in section 10.1 and performing the periodic calibration requirements listed for gas chromatographs in table 13 to subpart CC of this part, for the process mass spectrometer. The owner or operator may use the alternative sampling line temperature allowed under Net Heating Value by Gas Chromatograph in table 13 to subpart CC of this part.

(7) The average instrument calibration error (CE) for each calibration compound at any calibration concentration must not differ by more than 10 percent from the certified cylinder gas value. The CE for each component in the calibration blend must be calculated using equation 1 to this paragraph.

Equation 1 to Paragraph (j)(7)

$$CE = \frac{C_m - C_a}{C_a} \times 100 \text{ (Eq. 1)}$$

Where:

$C_m$  = Average instrument response (ppm)  
 $C_a$  = Certified cylinder gas value (ppm)

(k) If an owner or operator use a gas chromatograph or mass spectrometer for compositional analysis for net heating

value, then the owner or operator may choose to use the CE of NHV<sub>measured</sub> versus the cylinder tag value NHV as the measure of agreement for daily calibration and quarterly audits in lieu of determining the compound-specific

CE. The CE for NHV at any calibration level must not differ by more than 10 percent from the certified cylinder gas value. The CE for must be calculated using equation 2 to this paragraph.

Equation 2 to Paragraph (k)

$$CE = \frac{NHV_{measured} - NHV_a}{NHV_a} \times 100 \text{ (Eq. 2)}$$

Where:

NHV<sub>measured</sub> = Average instrument response (Btu/scf)  
 NHV<sub>a</sub> = Certified cylinder gas value (Btu/scf)

(l) Instead of complying with § 63.670(q), owners and operators must comply with the reporting requirements specified in paragraphs (l)(1) and (2) of this section.

(1) The initial notification requirements specified in § 63.152(b)(7).

(2) The Periodic Report required by § 63.152(c) must include the items specified in paragraphs (l)(2)(i) through (vi) of this section.

(i) Records as specified in paragraph (m)(1) of this section for each 15-minute block during which there was at least one minute when regulated material is routed to a flare and no pilot flame or

flare flame is present. Include the start and stop time and date of each 15-minute block.

(ii) Visible emission records as specified in paragraph (m)(2)(iv) of this section for each period of 2 consecutive hours during which visible emissions exceeded a total of 5 minutes. Indicate the date and start and end times for each period.

(iii) The periods specified in paragraph (m)(6) of this section. Indicate the date and start and end times for each period, and the net heating value operating parameter(s) determined following the methods in § 63.670(k) through (n) as applicable.

(iv) For flaring events meeting the criteria in § 63.670(o)(3) and paragraph (f) of this section:

(A) The start and stop time and date of the flaring event.

(B) The length of time in minutes for which emissions were visible from the flare during the event.

(C) For steam-assisted, air-assisted, and non-assisted flares, the start date, start time, and duration in minutes for periods of time that the flare tip velocity exceeds the maximum flare tip velocity determined using the methods in § 63.670(d)(2) and the maximum 15-minute block average flare tip velocity in ft/sec recorded during the event.

(D) Results of the root cause and corrective actions analysis completed during the reporting period, including the corrective actions implemented during the reporting period and, if applicable, the implementation



schedule for planned corrective actions to be implemented subsequent to the reporting period.

(v) For pressure-assisted multi-point flares, the periods of time when the pressure monitor(s) on the main flare header show the burners operating outside the range of the manufacturer's specifications. Indicate the date and start and end times for each period.

(vi) For pressure-assisted multi-point flares, the periods of time when the staging valve position indicator monitoring system indicates a stage should not be in operation and is or when a stage should be in operation and is not. Indicate the date and start and end times for each period.

(m) Instead of complying with § 63.670(p), owners and operators must keep the flare monitoring records specified in paragraphs (m)(1) through (14) of this section.

(1) Retain records of the output of the monitoring device used to detect the presence of a pilot flame or flare flame as required in § 63.670(b) and the presence of a pilot flame as required in paragraph (i)(4) of this section for a minimum of 2 years. Retain records of each 15-minute block during which there was at least one minute that no pilot flame or flare flame is present when regulated material is routed to a flare for a minimum of 5 years. For a pressure-assisted multi-point flare that uses cross-lighting, retain records of each 15-minute block during which there was at least one minute that no pilot flame is present on each stage when regulated material is routed to a flare for a minimum of 5 years. The owner or operator may reduce the collected minute-by-minute data to a 15-minute block basis with an indication of whether there was at least one minute where no pilot flame or flare flame was present.

(2) Retain records of daily visible emissions observations as specified in paragraphs (m)(2)(i) through (iv) of this section, as applicable, for a minimum of 3 years.

(i) To determine when visible emissions observations are required, the record must identify all periods when regulated material is vented to the flare.

(ii) If visible emissions observations are performed using Method 22 in appendix A-7 to part 60 of this chapter, then the record must identify whether the visible emissions observation was performed, the results of each observation, total duration in minutes of observed visible emissions, and whether it was a 5-minute or 2-hour observation. Record the date and start time of each visible emissions observation.

(iii) If a video surveillance camera is used pursuant to § 63.670(h)(2), then the record must include all video surveillance images recorded, with time and date stamps.

(iv) For each 2-hour period for which visible emissions are observed for more than 5 minutes in 2 consecutive hours, then the record must include the date and start and end time of the 2-hour period and an estimate of the cumulative number of minutes in the 2-hour period for which emissions were visible.

(3) The 15-minute block average cumulative flows for flare vent gas and, if applicable, total steam, perimeter assist air, and pre-mix assist air specified to be monitored under § 63.670(i), along with the date and time interval for the 15-minute block. If multiple monitoring locations are used to determine cumulative vent gas flow, total steam, perimeter assist air, and pre-mix assist air, then retain records of the 15-minute block average flows for each monitoring location for a minimum of 2 years and retain the 15-minute block average cumulative flows that are used in subsequent calculations for a minimum of 5 years. If pressure and temperature monitoring is used, then retain records of the 15-minute block average temperature, pressure, and molecular weight of the flare vent gas or assist gas stream for each measurement location used to determine the 15-minute block average cumulative flows for a minimum of 2 years, and retain the 15-minute block average cumulative flows that are used in subsequent calculations for a minimum of 5 years.

(4) The flare vent gas compositions specified to be monitored under § 63.670(j). Retain records of individual component concentrations from each compositional analysis for a minimum of 2 years. If an NHVvg analyzer is used, retain records of the 15-minute block average values for a minimum of 5 years.

(5) Each 15-minute block average operating parameter calculated following the methods specified in § 63.670(k) through (n) as applicable.

(6) All periods during which operating values are outside of the applicable operating limits specified in § 63.670(d) through (f) and paragraph (i) of this section when regulated material is being routed to the flare.

(7) All periods during which the owner or operator does not perform flare monitoring according to the procedures in § 63.670(g) through (j).

(8) For pressure-assisted multi-point flares, if a stage of burners on the flare uses cross-lighting, then a record of any

changes made to the distance between burners.

(9) For pressure-assisted multi-point flares, all periods when the pressure monitor(s) on the main flare header show burners are operating outside the range of the manufacturer's specifications. Indicate the date and time for each period, the pressure measurement, the stage(s) and number of burners affected, and the range of manufacturer's specifications.

(10) For pressure-assisted multi-point flares, all periods when the staging valve position indicator monitoring system indicates a stage of the pressure-assisted multi-point flare should not be in operation and when a stage of the pressure-assisted multi-point flare should be in operation and is not. Indicate the date and time for each period, whether the stage was supposed to be open, but was closed or vice versa, and the stage(s) and number of burners affected.

(11) Records of periods when there is flow of vent gas to the flare, but when there is no flow of regulated material to the flare, including the start and stop time and dates of periods of no regulated material flow.

(12) Records when the flow of vent gas exceeds the smokeless capacity of the flare, including start and stop time and dates of the flaring event.

(13) Records of the root cause analysis and corrective action analysis conducted as required in § 63.670(o)(3) and paragraph (f) of this section, including an identification of the affected flare, the date and duration of the event, a statement noting whether the event resulted from the same root cause(s) identified in a previous analysis and either a description of the recommended corrective action(s) or an explanation of why corrective action is not necessary under § 63.670(o)(5)(i).

(14) For any corrective action analysis for which implementation of corrective actions are required in § 63.670(o)(5), a description of the corrective action(s) completed within the first 45 days following the discharge and, for action(s) not already completed, a schedule for implementation, including proposed commencement and completion dates.

(n) The owner or operator may elect to comply with the alternative means of emissions limitation requirements specified in § 63.670(r) in lieu of the requirements in § 63.670(d) through (f), as applicable. However, instead of complying with § 63.670(r)(3)(iii), owners and operators must also submit the alternative means of emissions limitation request to the following address: U.S. Environmental Protection

Agency, Office of Air Quality Planning and Standards, Sector Policies and Programs Division, U.S. EPA Mailroom (C404-02), Attention: Hazardous Organic Chemical Manufacturing Sector Lead, 4930 Old Page Rd., Durham, NC 27703.

(o) The referenced provisions specified in paragraphs (o)(1) through (4) of this section do not apply when demonstrating compliance with this section.

(1) Section 63.670(o)(4)(iv) of subpart CC of this part.

(2) The last sentence of § 63.670(o)(6).

(3) The phrase “that were not caused by a *force majeure* event” in § 63.670(o)(7)(ii).

(4) The phrase “that were not caused by a *force majeure* event” in § 63.670(o)(7)(iv).

■ 51. Add § 63.109 to read as follows:

**§ 63.109 Procedures for determining whether process vents, storage vessels, equipment, wastewater, and heat exchange systems are in ethylene oxide service.**

This section applies beginning no later than the compliance dates specified in § 63.100(k)(11). To determine if process vents, storage vessels, equipment leaks, wastewater, and heat exchange systems are in ethylene oxide service, as defined in § 63.101, owners and operators must comply with the requirements in paragraphs (a) through (e) of this section, as applicable.

(a) Except as specified in paragraph (a)(7) of this section, for each Group 1 and Group 2 process vent stream, owners and operators must measure the flow rate and concentration of ethylene oxide of each process vent as specified in paragraphs (a)(1) through (6) of this section.

(1) Measurements must be made prior to any dilution of the vent streams.

(2) Measurements may be made on the combined vent streams at a chemical manufacturing process unit or for each separate vent stream.

(3) The sampling site shall be after the last recovery device (if any recovery devices are present) but prior to the inlet of any control device that is present and prior to release to the atmosphere. Method 1 or 1A of appendix A-1 to part 60 of this chapter, as appropriate, must be used for the selection of the sampling sites. For vents smaller than 0.10 meter in diameter, sample at one point at the center of the duct.

(4) The gas volumetric flow rate must be determined using Method 2, 2A, 2C, 2D, 2F, or 2G of appendices A-1 and A-2 to part 60 of this chapter (respectively), as appropriate.

(5) Except as specified in paragraph (a)(6) of this section, the concentration of ethylene oxide must be determined using Method 18 of appendix A-6 to part 60 of this chapter, or Method 320 of appendix A to this part.

(6) You may elect to use ASTM D6348-12 (Reapproved 2020) (incorporated by reference, § 63.14) in lieu of Method 320 of appendix A to this part as specified in paragraph (a)(5) of this section. To comply with this paragraph, annexes A1 through A8 to ASTM D6348-12 (Reapproved 2020) are mandatory; the percent (%) R must be determined for each target analyte using Equation A5.5 of ASTM D6348-12 (Reapproved 2020) Annex A5 (Analyte Spiking Technique); and in order for the test data to be acceptable for a compound, the %R must be  $70\% \leq R \leq 130\%$ . If the %R value does not meet this criterion for a target compound, then the test data is not acceptable for that compound and the test must be repeated for that analyte (*i.e.*, the sampling and/or analytical procedure should be adjusted before a retest). The %R value for each compound must be reported in the test report, and all field measurements must be corrected with the calculated %R value for that compound by using the following equation:

Equation 1 to Paragraph (a)(6)

$$\text{Reported Results} = (\text{Measured Concentration in the Stack} \times 100) / \%R.$$

(7) The requirements specified in paragraphs (a)(1) through (6) of this section for an initial measurement or initial performance test do not apply if the conditions specified in paragraphs (a)(7)(i) through (iv) of this section are met for a previously conducted measurement or performance test.

(i) No changes have been made to the process since the time of the measurement or performance test;

(ii) The operating conditions and test methods used during measurement or performance test conform to the ethylene oxide related requirements of this subpart;

(iii) The control device and process parameter values established during the previously conducted measurement or performance test are used to demonstrate continuous compliance with the ethylene oxide related requirements of this subpart; and

(iv) The previously conducted measurement or performance test was completed within the last 60 months.

(b) For storage vessels, owners and operators must determine the concentration of ethylene oxide of the fluid stored in the storage vessels by

complying with the requirements in paragraph (b)(1) or (2) of this section.

(1) The owner or operator must measure concentration of ethylene oxide of the fluid stored in the storage vessel using Method 624.1 of appendix A to 40 CFR part 136, or preparation by Method SW-846-5031 or SW-846-5030B and analysis by Method SW-846-8260D (incorporated by reference, see § 63.14). The owner or operator may not use a preservative in the collected sample; the owner or operator must store the sample with minimal headspace as cold as possible and at least below 4 degrees C; and the owner or operator must analyze the sample as soon as possible, but in no case longer than 7 days from the time the sample was collected. If owners and operators collect a sample from a pressure vessel, then the owner or operator must maintain the sample under pressure both during and following sampling.

(2) Unless specified by the Administrator, the owner or operator may calculate the concentration of ethylene oxide of the fluid stored in the storage vessels if information specific to the fluid stored is available. Information specific to the fluid stored includes concentration data from safety data sheets.

(c) For equipment leaks, owners and operators must comply with the requirements in paragraphs (c)(1) through (4) of this section.

(1) Each piece of equipment within a chemical manufacturing process unit that can reasonably be expected to contain equipment in ethylene oxide service is presumed to be in ethylene oxide service unless the owner or operator demonstrates that the piece of equipment is not in ethylene oxide service. For a piece of equipment to be considered not in ethylene oxide service, it must be determined that the percent ethylene oxide content of the process fluid that is contained in or contacts equipment can be reasonably expected to not exceed 0.1 percent by weight on an annual average basis. For purposes of determining the percent ethylene oxide content of the process fluid, owners and operators must use Method 18 of appendix A-6 to part 60 of this chapter, for gaseous process fluid, and Method 624.1 of appendix A to part 136 of this chapter, or preparation by Method SW-846-5031 and analysis by Method SW-846-8260D (both incorporated by reference, see § 63.14) for liquid process fluid. In lieu of preparation by Method SW-846-5031, owners and operators may use Method SW-846-5030B (incorporated by reference, see § 63.14), as long as: the owner or operator does not use a

preservative in the collected sample; the owner or operator stores the sample with minimal headspace as cold as possible and at least below 4 degrees C; and the owner or operator analyzes the sample as soon as possible, but in no case longer than 7 days from the time the sample was collected.

(2) Unless specified by the Administrator, owners and operators may use good engineering judgment rather than the procedures specified in paragraph (c)(1) of this section to determine that the percent ethylene oxide content of the process fluid that is contained in or contacts equipment does not exceed 0.1 percent by weight.

(3) Owners and operators may revise a determination for whether a piece of equipment is in ethylene oxide service by following the procedures in paragraph (c)(1) of this section, or by documenting that a change in the process or raw materials no longer causes the equipment to be in ethylene oxide service.

(4) Samples used in determining the ethylene oxide content must be representative of the process fluid that is contained in or contacts the equipment.

(d) For wastewater, owners and operators must determine the concentration of ethylene oxide of each wastewater stream using Method 624.1

of appendix A to part 136 of this chapter, or preparation by either Method SW-846-5031 or SW-846-5030B and analysis by Method SW-846-8260D (incorporated by reference, see § 63.14). The owner or operator may not use a preservative in the collected sample; the owner or operator must store the sample with minimal headspace as cold as possible and at least below 4 degrees C; and the owner or operator must analyze the sample as soon as possible, but in no case longer than 7 days from the time the sample was collected.

(e) For heat exchange systems, owners and operators must comply with the requirements in paragraph (e)(1) or (2) of this section.

(1) Determine the concentration of ethylene oxide of the process fluid cooled by the heat exchange system using Method 624.1 of appendix A to part 136 of this chapter, or preparation by either Method SW-846-5031 or SW-846-5030B and analysis by Method SW-846-8260D (incorporated by reference, see § 63.14). The owner or operator may not use a preservative in the collected sample; the owner or operator must store the sample with minimal headspace as cold as possible and at least below 4 degrees C; and the owner or operator must analyze the sample as soon as possible, but in no

case longer than 7 days from the time the sample was collected. soon as possible, but in no case longer than 7 days from the time the sample was collected.

(2) Unless specified by the Administrator, owners and operators may use good engineering judgment rather than the procedures specified in paragraph (e)(1) of this section to determine that the percent ethylene oxide content of the process fluid cooled by the heat exchange system does not exceed 0.1 percent by weight.

- 52. Amend table 3 to subpart F by:
  - a. Revising entries “63.6(d)”, “63.6(e)”, “63.6(e)(1)(i)”, “63.6(e)(1)(ii)”, “63.6(e)(2)”, “63.6(e)(3)(i)”, “63.6(e)(3)(i)(B)”, “63.6(e)(3)(i)(C)”, “63.6(e)(3)(ii)”, “63.6(e)(3)(vi)” and “63.6(e)(3)(vii)”;
  - b. Removing entries “63.6(e)(3)(vii)(A)”, “63.6(e)(3)(vii)(B)” and “63.6(e)(3)(vii)(C)”;
  - c. Revising entries “63.6(e)(3)(viii)”, “63.6(e)(3)(ix)” and “63.6(f)(1)”,
  - d. Adding the entry for “63.7(a)(4)”;
  - and
  - e. Revising entries “63.7(e)(1)”, “63.7(f)”, “63.8(a)(3)”, “63.8(a)(4)”, “63.8(c)(1)(i)”, “63.8(c)(1)(iii)”, “63.9(k)”, “63.10(d)(5)” and “63.11-63.15”.

The revisions and additions read as follows:

TABLE 3 TO SUBPART F OF PART 63—GENERAL PROVISIONS APPLICABILITY TO SUBPARTS F, G, AND H<sup>A</sup> TO SUBPART F

Reference	Applies to subparts F, G, and H	Comment
63.6(d) .....	[Reserved].	
63.6(e) .....	Yes <sup>c</sup> .....	Except as otherwise specified for individual paragraphs. Does not apply to Group 2 emission points unless they are included in an emissions average. <sup>b,c</sup>
63.6(e)(1)(i) .....	No .....	This is addressed by § 63.102(a)(4) and (f) of subpart F.
63.6(e)(1)(ii) .....	Yes, before July 15, 2027. No, beginning on and after July 15, 2027.	
63.6(e)(2) .....	[Reserved].	
63.6(e)(3)(i) .....	Yes, before July 15, 2027. No, beginning on and after July 15, 2027.	
63.6(e)(3)(i)(B) .....	Yes, before July 15, 2027. No, beginning on and after July 15, 2027.	
63.6(e)(3)(i)(C) .....	Yes, before July 15, 2027. No, beginning on and after July 15, 2027.	
63.6(e)(3)(ii) .....	[Reserved].	
63.6(e)(3)(vi) .....	Yes, before July 15, 2027. No, beginning on and after July 15, 2027.	
63.6(e)(3)(vii) .....	Yes, before July 15, 2027. No, beginning on and after July 15, 2027.	
63.6(e)(3)(viii) .....	Yes, before July 15, 2027. No, beginning on and after July 15, 2027.	
63.6(e)(3)(ix) .....	Yes, before July 15, 2027. No, beginning on and after July 15, 2027.	

TABLE 3 TO SUBPART F OF PART 63—GENERAL PROVISIONS APPLICABILITY TO SUBPARTS F, G, AND H<sup>A</sup> TO SUBPART F—Continued

Reference	Applies to subparts F, G, and H	Comment
63.6(f)(1) .....	No .....	§ 63.102(a) and (e) of subpart F specifies when the standards apply.
* .....	* .....	* .....
63.7(a)(4) .....	Yes.	
* .....	* .....	* .....
63.7(e)(1) .....	Yes, before July 15, 2027. No, beginning on and after July 15, 2027.	See § 63.103(b)(3).
* .....	* .....	* .....
63.7(f) .....	Yes.	
* .....	* .....	* .....
63.8(a)(3) .....	[Reserved].	
63.8(a)(4) .....	Yes, except for flares subject to § 63.108.	
* .....	* .....	* .....
63.8(c)(1)(i) .....	Yes, before July 15, 2027. No, beginning on and after July 15, 2027.	
* .....	* .....	* .....
63.8(c)(1)(iii) .....	Yes, before July 15, 2027. No, beginning on and after July 15, 2027.	
* .....	* .....	* .....
63.9(k) .....	Yes.	
* .....	* .....	* .....
63.10(d)(5) .....	Yes, before July 15, 2027. No, beginning on and after July 15, 2027.	Except that, before July 15, 2027, reports required by § 63.10(d)(5) shall be submitted at the time specified in § 63.152(d) of subpart G and in § 63.182(d) of subpart H.
* .....	* .....	* .....
63.11–63.15 .....	Yes, except 63.11(b) does not apply to flares subject to § 63.108.	

<sup>a</sup>Wherever subpart A specifies “postmark” dates, submittals may be sent by methods other than the U.S. Mail (e.g., by fax or courier). Submittals shall be sent by the specified dates, but a postmark is not necessarily required.

<sup>b</sup>Except as specified in footnote c of this table, the plan, and any records or reports of start-up, shutdown, and malfunction do not apply to Group 2 emission points unless they are included in an emissions average.

<sup>c</sup>On and after July 15, 2027, footnote b of this table does not apply and the row for the “63.6(e)” entry of this table is no longer applicable.

**Table 4 to Subpart F of Part 63 [Amended]**

- 53. Amend table 4 to subpart F by removing the entry for “Ethylene glycol monobutyl ether”.
- 54. Revise the heading to subpart G to read as follows:

**Subpart G—National Emission Standards for Hazardous Air Pollutants From the Synthetic Organic Chemical Manufacturing Industry for Process Vents, Storage Vessels, Transfer Operations, and Wastewater**

- 55. Amend § 63.110 by:
  - a. Revising paragraphs (b)(3) and (c)(2)(i);
  - b. Revising paragraphs (d)(2) introductory text, (d)(3), (d)(5) introductory text, (d)(6), (d)(8) introductory text, and (d)(9);
  - c. Revising paragraphs (e)(1) introductory text, (f)(2) introductory

text, (f)(3), (f)(4) introductory text and (h);

- d. Revising paragraphs (i) introductory text, and (i)(1)(iv); and
  - e. Adding paragraph (j).
- The revisions and addition read as follows:

**§ 63.110 Applicability.**

\* \* \* \* \*

(b) \* \* \*

(3) Except as specified in paragraph (j) of this section, after the compliance dates specified in § 63.100, a Group 2 storage vessel that is also subject to the provisions of 40 CFR part 61, subpart Y is required to comply only with the provisions of part 61, subpart Y, of this chapter. The recordkeeping and reporting requirements of part 61, subpart Y, will be accepted as compliance with the recordkeeping and reporting requirements of this subpart.

(c) \* \* \*

(2) \* \* \*

(i) Except as provided in paragraph (j) of this section, if the transfer rack is subject to the control requirements specified in § 61.302 of this chapter, then the transfer rack is required to comply with the control requirements of § 61.302. The owner or operator may elect to comply with either the associated testing, monitoring, reporting, and recordkeeping requirements of part 61, subpart BB, of this chapter or with the testing, monitoring, recordkeeping, and reporting requirements specified in this subpart for Group 1 transfer racks. The owner or operator shall indicate this decision in either the Notification of Compliance Status specified in § 63.152(b) or in an operating permit application or amendment.

\* \* \* \* \*

(d) \* \* \*

(2) After the compliance dates specified in § 63.100, the owner or

operator of a Group 2 process vent that is also subject to the provisions of part 60, subpart III, of this chapter shall determine requirements according to paragraphs (d)(2)(i) and (ii) of this section. For each source as defined in § 63.101, on and after July 15, 2027, this paragraph no longer applies.

(3) After the compliance dates specified in 63.100, if an owner or operator of a process vent subject to this subpart that is also subject to the provisions of part 60, subpart III, of this chapter elects to control the process vent to the levels required in § 63.113(a)(1) or (2) without calculating the TRE index value for the vent according to the procedures specified in § 63.115(d), then the owner or operator shall comply with the testing, monitoring, reporting, and recordkeeping provisions of this subpart and shall be exempt from the testing, monitoring, reporting, and recordkeeping provisions of part 60, subpart III. For each source as defined in § 63.101, on and after July 15, 2027, this paragraph no longer applies.

(5) After the compliance dates specified in § 63.100, the owner or operator of a Group 2 process vent that is also subject to the provisions of 40 CFR part 60, subpart NNN shall determine requirements according to paragraphs (d)(5)(i) and (ii) of this section. For each source as defined in § 63.101, on and after July 15, 2027, this paragraph no longer applies.

(6) After the compliance dates specified in § 63.100, if an owner or operator of a process vent subject to this subpart that is also subject to the provisions of part 60, subpart NNN, of this chapter elects to control the process vent to the levels required in § 63.113(a)(1) or (2) without calculating the TRE index value for the vent according to the procedures specified in § 63.115(d), then the owner or operator shall comply with the testing, monitoring, reporting, and recordkeeping provisions of this subpart and shall be exempt from the testing, monitoring, reporting, and recordkeeping provisions of part 60, subpart NNN. For each source as defined in § 63.101, on and after July 15, 2027, this paragraph no longer applies.

(8) After the compliance dates specified in § 63.100, the owner or operator of a Group 2 process vent that is also subject to the provisions of part 60, subpart RRR, of this chapter shall determine requirements according to

paragraphs (d)(8)(i) and (ii) of this section. For each source as defined in § 63.101, on and after July 15, 2027, this paragraph no longer applies.

(9) After the compliance dates specified in § 63.100, if an owner or operator of a process vent subject to this subpart that is also subject to the provisions of part 60, subpart RRR, of this chapter elects to control the process vent to the levels required in § 63.113(a)(1) or (2) without calculating the TRE index value for the vent according to the procedures specified in § 63.115(d), then the owner or operator shall comply with the testing, monitoring, reporting, and recordkeeping provisions of this subpart and shall be exempt from the testing, monitoring, reporting, and recordkeeping provisions of part 60, subpart RRR. For each source as defined in § 63.101, on and after July 15, 2027, this paragraph no longer applies.

(1) Except as specified in paragraph (j) of this section, after the compliance dates specified in § 63.100, the owner or operator of a Group 1 or Group 2 wastewater stream that is also subject to the provisions of part 61, subpart FF, of this chapter is required to comply with the provisions of both this subpart and part 61, subpart FF. Alternatively, the owner or operator may elect to comply with the provisions of paragraphs (e)(1)(i) and (ii) of this section, which shall constitute compliance with the provisions of part 61, subpart FF.

(2) Except as specified in paragraph (j) of this section, after the compliance dates specified in § 63.100, the owner or operator of any Group 2 process vent that is also subject to the provisions of part 61, subpart F, of this chapter shall comply with the provisions specified in either paragraph (f)(2)(i) or (ii) of this section.

(3) After the compliance dates specified in § 63.100, if an owner or operator of a process vent subject to this subpart that is also subject to the provisions of part 61, subpart F, of this chapter elects to control the process vent to the levels required in § 63.113(a)(1) or (2) without calculating the TRE index value for the vent according to the procedures specified in § 63.115(d), then the owner or operator shall comply with the testing, monitoring, reporting, and recordkeeping provisions of this subpart and shall be exempt from the testing,

monitoring, reporting, and recordkeeping provisions of part 61, subpart F. For each source as defined in § 63.101, on and after July 15, 2027, this paragraph no longer applies.

(4) Except as specified in paragraph (j) of this section, after the compliance dates specified in § 63.100, the owner or operator of a Group 1 or Group 2 wastewater stream that is also subject to the provisions of 40 CFR part 61, subpart F shall comply with the provisions of either paragraph (f)(4)(i) or (ii) of this section.

(h) *Overlap with other regulations for monitoring, recordkeeping, or reporting with respect to combustion devices, recovery devices, or recapture devices.*

(1) Except as specified in paragraph (h)(2) of this section, after the compliance dates specified in § 63.100, if any combustion device, recovery device, or recapture device subject to this subpart is also subject to monitoring, recordkeeping, and reporting requirements in part 264, subpart AA or CC, of this chapter or is subject to monitoring and recordkeeping requirements in part 265, subpart AA or CC, of this chapter and the owner or operator complies with the periodic reporting requirements under 40 CFR part 264, subpart AA or CC that would apply to the device if the facility had final-permitted status, the owner or operator may elect to comply either with the monitoring, recordkeeping, and reporting requirements of this subpart, or with the monitoring, recordkeeping, and reporting requirements in parts 264 and/or 265, as described in this paragraph, which shall constitute compliance with the monitoring, recordkeeping, and reporting requirements of this subpart. The owner or operator shall identify which option has been selected in the Notification of Compliance Status required by § 63.152(b).

(2) For each source as defined in § 63.101, beginning no later than the compliance dates specified in § 63.100(k)(10) of subpart F of this part, paragraph (h)(1) of this section no longer applies.

(i) *Alternative means of compliance—* For each source as defined in § 63.101, on and after July 15, 2027, this paragraph (i) no longer applies.

(iv) For equipment, comply with § 63.160(g).

(j) *Overlap with other regulations for flares.* (1) For each source as defined in § 63.101, beginning no later than the compliance dates specified in

§ 63.100(k)(10), flares used as a control device to comply with the overlap provisions in either paragraph (b)(3), (c)(2)(i), (e)(1), (f)(2)(i), (f)(2)(ii), or (f)(4)(i) or (ii) of this section must comply with the provisions specified in § 63.108 and are no longer subject to any flare related provisions of part 61, subparts F, Y, BB, and FF, of this chapter or § 60.18 of this chapter.

(2) Owners and operators of flares that are subject to the flare related requirements of this subpart and flare related requirements of any other regulation in part 60, 61, or 63 of this chapter, may elect to comply with the requirements in § 63.108 in lieu of all flare related requirements in any other regulation in part 60, 61, or 63.

■ 56. Revise § 63.111 to read as follows:

**§ 63.111 Definitions.**

All terms used in this subpart shall have the meaning given them in the Act and in subpart F of this part.

■ 57. Revise and republish § 63.113 to read as follows:

**§ 63.113 Process vent provisions—reference control technology.**

(a) The owner or operator of a Group 1 process vent as defined in this subpart shall comply with the requirements of paragraph (a)(1), (2), (3), or (4) of this section, and paragraph (a)(5) of this section. The owner or operator who transfers a gas stream that has the characteristics specified in § 63.107(b) through (h) or meets the criteria specified in § 63.107(i) to an off-site location or an on-site location not owned or operated by the owner or operator of the source for disposal shall comply with the requirements of paragraph (i) of this section.

(1) Reduce emissions of organic HAP using a flare.

(i) Except as specified in § 63.108(a), the flare shall comply with the requirements of § 63.11(b).

(ii) Halogenated vent streams, as defined in § 63.111, shall not be vented to a flare.

(2) Reduce emissions of total organic hazardous air pollutants by 98 weight-percent or to a concentration of 20 parts per million by volume. For combustion devices, the emission reduction or concentration shall be calculated on a dry basis, corrected to 3-percent oxygen, and compliance can be determined by measuring either organic hazardous air pollutants or total organic carbon using the procedures in § 63.116.

(i) Compliance with paragraph (a)(2) of this section may be achieved by using any combination of combustion, recovery, and/or recapture devices, except that a recovery device may not be

used to comply with paragraph (a)(2) of this section by reducing emissions of total organic hazardous air pollutants by 98 weight-percent, except as provided in paragraph (a)(2)(ii) of this section.

(ii) An owner or operator may use a recovery device, alone or in combination with one or more combustion or recapture devices, to reduce emissions of total organic hazardous air pollutants by 98 weight-percent if all the conditions of paragraphs (a)(2)(ii)(A) through (a)(2)(ii)(D) of this section are met.

(A) The recovery device (and any combustion device or recapture device which operates in combination with the recovery device to reduce emissions of total organic hazardous air pollutants by 98 weight-percent) was installed before the date of proposal of the subpart of this part 63 that makes this subpart G applicable to process vents in the chemical manufacturing process unit.

(B) The recovery device that will be used to reduce emissions of total organic hazardous air pollutants by 98 weight-percent is the last recovery device before emission to the atmosphere.

(C) The recovery device, alone or in combination with one or more combustion or recapture devices, is capable of reducing emissions of total organic hazardous air pollutants by 98 weight-percent, but is not capable of reliably reducing emissions of total organic hazardous air pollutants to a concentration of 20 parts per million by volume.

(D) If the owner or operator disposed of the recovered material, the recovery device would comply with the requirements of this subpart for recapture devices.

(3) Except as specified in paragraph (a)(4) of this section, achieve and maintain a TRE index value greater than 1.0 at the outlet of the final recovery device, or prior to release of the vent stream to the atmosphere if no recovery device is present. If the TRE index value is greater than 1.0, the process vent shall comply with the provisions for a Group 2 process vent specified in either paragraph (d) or (e) of this section, whichever is applicable.

(4) For each source as defined in § 63.101, beginning no later than the compliance dates specified in § 63.100(k)(10), the provisions specified in paragraphs (a)(4)(i) through (xv) of this section no longer apply. Instead, an owner or operator of a Group 1 process vent as defined in § 63.101 must comply with the requirements of paragraph (a)(1) or (2) of this section; and an owner or operator of a Group 2 process vent as defined in § 63.101 must comply with

the requirements of paragraph (f) or (g) of this section.

(i) Paragraphs (a)(3), (d), and (e) of this section;

(ii) Section 63.114(b) and (c)(2);

(iii) Section 63.115(d), except (d)(2)(v);

(iv) The following phrases in § 63.115(e): “TRE index value”, “changes that are within the range on which the original TRE calculation was based”, and “the recalculated TRE index value is less than or equal to 1.0, or less than or equal to 4.0 but greater than 1.0”;

(v) The following phrases in § 63.115(f): “TRE index value”, and “regardless of the TRE index value determined at the location specified in § 63.115(a)”;

(vi) The last two sentences in § 63.115(f)(2): “If the combined vent stream is a Group 2 process vent as determined by the previous sentence, but one or more of the HON streams, or combinations of HON streams, has a TRE index value greater than 1 but less than or equal to 4, the combined vent stream is a process vent with a TRE index value greater than 1 but less than or equal to 4. In this case, the owner or operator shall monitor the combined vent stream as required by § 63.114(b).”;

(vii) The phrase in § 63.117(a): “or the provisions for Group 2 process vents with a TRE index value greater than 1.0 but less than or equal to 4.0 in § 63.113(d)”;

(viii) The phrase in § 63.117(a)(3): “TRE determinations or”;

(ix) Section 63.117(a)(7) and (b);

(x) Section 63.118(b), (c), (d)(3), (e)(3), (h), (i), (j), and (k)(4);

(xi) The following phrase in § 63.118(g)(2): “and TRE index value”;

(xii) The last sentence in § 63.150(g)(2)(iii)(B)(2);

(xiii) The phrase in § 63.150(m)(2)(i): “and TRE index value”;

(xiv) The last sentence in § 63.151(d)(6)(i); and

(xv) Table 4 to subpart G of this part.

(5) For each source as defined in § 63.101, beginning no later than the compliance dates specified in § 63.100(k)(10), an owner or operator of a Group 1 process vent as defined in § 63.101 that contains chlorine, hydrogen chloride, or any other chlorinated compound must reduce emissions of dioxins and furans (toxic equivalency basis) to a concentration of 0.054 nanograms per standard cubic meter on a dry basis corrected to 3 percent oxygen.

(b) If a boiler or process heater is used to comply with the percent reduction requirement or concentration limit specified in paragraph (a)(2) of this

section, then the vent stream shall be introduced into the flame zone of such a device.

(c) Halogenated vent streams from Group 1 process vents that are combusted shall be controlled according to paragraph (c)(1) or (2) of this section.

(1) If a combustion device is used to comply with paragraph (a)(2) of this section for a halogenated vent stream, then the gas stream exiting the combustion device shall be conveyed to a halogen reduction device, such as a scrubber, before it is discharged to the atmosphere.

(i) Except as provided in paragraph (c)(1)(ii) of this section, the halogen reduction device shall reduce overall emissions of hydrogen halides and halogens, as defined in § 63.111 of this subpart, by 99 percent or shall reduce the outlet mass of total hydrogen halides and halogens to less than 0.45 kilogram per hour.

(ii) If a scrubber or other halogen reduction device was installed prior to December 31, 1992, the device shall reduce overall emissions of hydrogen halides and halogens, as defined in § 63.111, by 95 percent or shall reduce the outlet mass of total hydrogen halides and halogens to less than 0.45 kilograms per hour.

(2) A halogen reduction device, such as a scrubber or other technique, may be used to reduce the vent stream halogen atom mass emission rate to less than 0.45 kilogram per hour prior to any combustion control device, and thus make the vent stream nonhalogenated; the vent stream must comply with the requirements of paragraph (a)(1) or (2) of this section.

(d) Except as specified in paragraph (a)(4) of this section, the owner or operator of a Group 2 process vent having a flow rate greater than or equal to 0.005 standard cubic meter per minute, a HAP concentration greater than or equal to 50 parts per million by volume, and a TRE index value greater than 1.0 but less than or equal to 4.0 shall maintain a TRE index value greater than 1.0 and shall comply with the monitoring of recovery device parameters in § 63.114(b) or (c), the TRE index calculations of § 63.115 of this subpart, and the applicable reporting and recordkeeping provisions of §§ 63.117 and 63.118. Such owner or operator is not subject to any other provisions of §§ 63.114 through 63.118.

(e) Except as specified in paragraph (a)(4) of this section, the owner or operator of a Group 2 process vent with a TRE index value greater than 4.0 shall maintain a TRE index value greater than 4.0, comply with the provisions for calculation of a TRE index value in

§ 63.115 and the reporting and recordkeeping provisions in §§ 63.117(b) and 63.118(c) and (h), and is not subject to monitoring or any other provisions of §§ 63.114 through 63.118.

(f) Except as specified in paragraph (l) of this section, the owner or operator of a Group 2 process vent with a flow rate less than 0.005 standard cubic meter per minute shall maintain a flow rate less than 0.005 standard cubic meter per minute; comply with the Group determination procedures in § 63.115 (a), (b), and (e); and the reporting and recordkeeping requirements in §§ 63.117(c), 63.118(d), and 63.118(i); and is not subject to monitoring or any other provisions of §§ 63.114 through 63.118.

(g) Except as specified in paragraph (l) of this section, the owner or operator of a Group 2 process vent with a total organic HAP concentration less than 50 parts per million by volume shall maintain a total organic HAP concentration less than 50 parts per million by volume; comply with the Group determination procedures in § 63.115(a), (c), and (e); the reporting and recordkeeping requirements in §§ 63.117(d) and 63.118(e) and (j); and is not subject to monitoring or any other provisions of §§ 63.114 through 63.118.

(h) The owner or operator of a process vent complying with paragraph (a)(1) or (2) of this section is not required to perform the group determination described in § 63.115.

(i) *Off-site control or on-site control not owned or operated by the source.* This paragraph (i) applies to gas streams that have the characteristics specified in § 63.107(b) through (h) or meet the criteria specified in § 63.107(i); that are transferred for disposal to an on-site control device (or other compliance equipment) not owned or operated by the owner or operator of the source generating the gas stream, or to an off-site control device or other compliance equipment; and that have the characteristics (*e.g.*, flow rate, total organic HAP concentration, or TRE index value as applicable) of a Group 1 process vent, determined at the point of transfer.

(i) Comply with the provisions specified in § 63.114(d) for each gas stream prior to transfer.

(ii) Notify the transferee that the gas stream contains organic hazardous air pollutants that are to be treated in accordance with the provisions of this subpart. The notice shall be submitted to the transferee initially and whenever there is a change in the required control.

(2) The owner or operator may not transfer the gas stream unless the transferee has submitted to the EPA a

written certification that the transferee will manage and treat any gas stream transferred under this paragraph (i) and received from a source subject to the requirements of this subpart in accordance with the requirements of either §§ 63.113 through 63.118, or § 63.102(b), or subpart D of this part if alternative emission limitations have been granted the transferor in accordance with those provisions. The certifying entity may revoke the written certification by sending a written statement to EPA and the owner or operator giving at least 90 days notice that the certifying entity is rescinding acceptance of responsibility for compliance with the regulatory provisions listed in this paragraph (i). Upon expiration of the notice period, the owner or operator may not transfer the gas stream to the transferee. Records retained by the transferee shall be retained in accordance with § 63.103(c).

(3) By providing this written certification to EPA, the certifying entity accepts responsibility for compliance with the regulatory provisions listed in paragraph (i)(2) of this section with respect to any transfer covered by the written certification. Failure to abide by any of those provisions with respect to such transfers may result in enforcement action by EPA against the certifying entity in accordance with the enforcement provisions applicable to violations of these provisions by owners or operators of sources.

(4) Written certifications and revocation statements to EPA from the transferees of such gas streams shall be signed by a responsible official of the certifying entity, provide the name and address of the certifying entity, and be sent to the appropriate EPA Regional Office at the addresses listed in § 63.13. Such written certifications are not transferable by the transferee.

(j) For each source as defined in § 63.101, beginning no later than the compliance dates specified in § 63.100(k)(11), if the Group 1 or Group 2 process vent contains ethylene oxide such that it is considered to be in ethylene oxide service, as defined in § 63.101, then the owner or operator must comply with the requirements of paragraphs (j)(1) or (2) of this section in addition to all other applicable requirements specified elsewhere in this section.

(1) Reduce emissions of ethylene oxide by venting emissions through a closed vent system to a flare; or

(2) Reduce emissions of ethylene oxide by venting emissions through a closed vent system to a control device that reduces ethylene oxide by greater than or equal to 99.9 percent by weight,

or to a concentration less than 1 ppmv for each process vent or to less than 5 pounds per year for all combined process vents within the process. If a combustion device is used, the ethylene oxide concentration of 1 ppmv must be corrected to 3 percent oxygen.

(k) For each source as defined in § 63.101, beginning no later than the compliance dates specified in § 63.100(k)(10), an owner or operator may designate a process vent as a maintenance vent if the vent is only used as a result of startup, shutdown, maintenance, or inspection of equipment where equipment is emptied, depressurized, degassed, or placed into service. The owner or operator must comply with the applicable requirements in paragraphs (k)(1) through (4) of this section for each maintenance vent. Any vent designated as a maintenance vent is only subject to the maintenance vent provisions in this paragraph (k) and the associated reporting and recordkeeping requirements in § 63.118(f)(9) and (m), respectively. The owner or operator does not need to designate a maintenance vent as a Group 1 or Group 2 process vent nor identify maintenance vents in a Notification of Compliance Status report.

(1) Prior to venting to the atmosphere, remove process liquids from the equipment as much as practical and depressurize the equipment to either: A flare meeting the requirements of § 63.108, as applicable, or using any combination of a non-flare combustion, recovery, and/or recapture device meeting the requirements in paragraph (a)(2) of this section until one of the following conditions, as applicable, is met.

(i) The concentration of the vapor in the equipment served by the maintenance vent is less than 10 percent of its lower explosive limit (LEL) and has an outlet concentration less than or equal to 20 ppmv hydrogen halide and halogen HAP.

(ii) If there is no ability to measure the concentration of the vapor in the equipment based on the design of the equipment, the pressure in the equipment served by the maintenance vent is reduced to 5 pounds per square inch gauge (psig) or less. Upon opening the maintenance vent, active purging of the equipment cannot be used until the concentration of the vapors in the maintenance vent (or inside the equipment if the maintenance is a hatch or similar type of opening) is less than 10 percent of its LEL.

(iii) The equipment served by the maintenance vent contains less than 50

pounds of total volatile organic compounds (VOC).

(iv) If, after applying best practices to isolate and purge equipment served by a maintenance vent, none of the applicable criterion in paragraphs (k)(1)(i) through (iii) of this section can be met prior to installing or removing a blind flange or similar equipment blind, then the pressure in the equipment served by the maintenance vent must be reduced to 2 psig or less before installing or removing the equipment blind. During installation or removal of the equipment blind, active purging of the equipment may be used provided the equipment pressure at the location where purge gas is introduced remains at 2 psig or less.

(2) Except for maintenance vents complying with the alternative in paragraph (k)(1)(iii) of this section, the owner or operator must determine the concentration or, if applicable, equipment pressure using process instrumentation or portable measurement devices and follow procedures for calibration and maintenance according to manufacturer's specifications.

(3) For maintenance vents complying with the alternative in paragraph (k)(1)(iii) of this section, the owner or operator must determine mass of VOC in the equipment served by the maintenance vent based on the equipment size and contents after considering any contents drained or purged from the equipment. Equipment size may be determined from equipment design specifications. Equipment contents may be determined using process knowledge.

(4) In addition to complying with the requirements in paragraphs (k)(1) through (3) of this section, for process vents in ethylene oxide service, subject to the requirements of § 63.124 that are designated as maintenance vents, owners and operators may not release more than 1.0 tons of ethylene oxide from all maintenance vents combined per any consecutive 12-month period. The owner or operator must keep monthly records of the quantity in tons of ethylene oxide released from each maintenance vent and include a description of the method used to estimate this quantity.

(l) For each source as defined in § 63.101, beginning no later than the compliance dates specified in § 63.100(k)(10), paragraphs (f) and (g) of this section no longer apply. Instead, the owner or operator of a Group 2 process vent with a total organic HAP mass flow rate less than 1.0 pound per hour shall maintain a total organic HAP mass flow rate less than 1.0 pound per hour;

comply with the Group determination procedures in § 63.115(g); and the reporting and recordkeeping requirements in §§ 63.117(g) and 63.118(n); and is not subject to monitoring or any other provisions of §§ 63.114 through 63.118.

■ 58. Revise and republish § 63.114 to read as follows:

**§ 63.114 Process vent provisions—monitoring requirements.**

(a) Each owner or operator of a process vent that uses a combustion device to comply with the requirements in § 63.113(a)(1), (2), or (5), or that uses a recovery device or recapture device to comply with the requirements in § 63.113(a)(2), shall install monitoring equipment specified in paragraph (a)(1), (2), (3), (4), (5), or (6) of this section, depending on the type of device used. All monitoring equipment shall be installed, calibrated, maintained, and operated according to manufacturer's specifications or other written procedures that provide adequate assurance that the equipment would reasonably be expected to monitor accurately.

(1) Where an incinerator is used, a temperature monitoring device equipped with a continuous recorder is required.

(i) Where an incinerator other than a catalytic incinerator is used, a temperature monitoring device shall be installed in the firebox or in the ductwork immediately downstream of the firebox in a position before any substantial heat exchange occurs.

(ii) Where a catalytic incinerator is used, temperature monitoring devices shall be installed in the gas stream immediately before and after the catalyst bed.

(2) Where a flare is used, except as specified in § 63.108(a), the following monitoring equipment is required: A device (including but not limited to a thermocouple, ultra-violet beam sensor, or infrared sensor) capable of continuously detecting the presence of a pilot flame.

(3) Where a boiler or process heater of less than 44 megawatts design heat input capacity is used, the following monitoring equipment is required: a temperature monitoring device in the firebox equipped with a continuous recorder. This requirement does not apply to gas streams that are introduced with primary fuel or are used as the primary fuel.

(4) Where a scrubber is used with an incinerator, boiler, or process heater in the case of halogenated vent streams, the following monitoring equipment is required for the scrubber.



(i) A pH monitoring device equipped with a continuous recorder shall be installed to monitor the pH of the scrubber effluent.

(ii) A flow meter equipped with a continuous recorder shall be located at the scrubber influent for liquid flow. Gas flow rate shall be determined using one of the procedures specified in paragraphs (a)(4)(ii)(A) through (C) of this section.

(A) The owner or operator may determine gas flow rate using the design blower capacity, with appropriate adjustments for pressure drop.

(B) If the scrubber is subject to rules in 40 CFR parts 264 through 266 that have required a determination of the liquid to gas (L/G) ratio prior to the applicable compliance date for this subpart specified in § 63.100(k), the owner or operator may determine gas flow rate by the method that had been utilized to comply with those rules. A determination that was conducted prior to the compliance date for this subpart may be utilized to comply with this subpart if it is still representative.

(C) The owner or operator may prepare and implement a gas flow rate determination plan that documents an appropriate method which will be used to determine the gas flow rate. The plan shall require determination of gas flow rate by a method which will at least provide a value for either a representative or the highest gas flow rate anticipated in the scrubber during representative operating conditions other than startups, shutdowns, or malfunctions. The plan shall include a description of the methodology to be followed and an explanation of how the selected methodology will reliably determine the gas flow rate, and a description of the records that will be maintained to document the determination of gas flow rate. The owner or operator shall maintain the plan as specified in § 63.103(c). For each source as defined in § 63.101, on and after July 15, 2027, the phrase "other than startups, shutdowns, or malfunctions" in this paragraph no longer applies.

(5) Where a recovery device or recapture device is used to comply with the requirements of § 63.113(a)(2) or (5), the owner or operator shall utilize the appropriate monitoring device identified in paragraph (a)(5)(i), (ii), (iii), (iv), or (v) of this section. All monitoring equipment shall be installed, calibrated, and maintained according to the manufacturer's specifications or other written procedures that provide adequate assurance that the equipment would reasonably be expected to monitor accurately.

(i) Install either an organic monitoring device equipped with a continuous recorder;

(ii) Where an absorber is the final recovery device in the recovery system, a scrubbing liquid temperature monitoring device and a specific gravity monitoring device, each equipped with a continuous recorder shall be used;

(iii) Where a condenser is the final recovery device in the recovery system, a condenser exit (product side) temperature monitoring device equipped with a continuous recorder shall be used;

(iv) Except as specified in paragraph (a)(5)(v) of this section, where a carbon adsorber is the final recovery device in the recovery system, an integrating regeneration stream flow monitoring device having an accuracy of  $\pm 10$  percent or better, capable of recording the total regeneration stream mass or volumetric flow for each regeneration cycle; and a carbon bed temperature monitoring device, capable of recording the carbon bed temperature after each regeneration and within 15 minutes of completing any cooling cycle shall be used.

(v) Beginning no later than the compliance dates specified in § 63.100(k)(10), if the owner or operator vents emissions through a closed vent system to an adsorber(s) that cannot be regenerated or a regenerative adsorber(s) that is regenerated offsite, then the owner or operator must install a system of two or more adsorber units in series and comply with the requirements specified in paragraphs (a)(5)(v)(A) through (C) of this section.

(A) Conduct an initial performance test or design evaluation of the adsorber and establish the breakthrough limit and adsorber bed life.

(B) Monitor the HAP or total organic compound (TOC) concentration through a sample port at the outlet of the first adsorber bed in series according to the schedule in paragraph (a)(5)(v)(C)(2) of this section. The owner or operator must measure the concentration of HAP or TOC using either a portable analyzer, in accordance with Method 21 of appendix A-7 to part 60 of this chapter using methane, propane, isobutylene, or the primary HAP being controlled as the calibration gas or Method 25A of part 60, appendix A-7, using methane, propane, or the primary HAP being controlled as the calibration gas.

(C) Comply with paragraph (a)(5)(v)(C)(1) of this section and comply with the monitoring frequency according to paragraph (a)(5)(v)(C)(2) of this section.

(1) The first adsorber in series must be replaced immediately when

breakthrough, as defined in § 63.101, is detected between the first and second adsorber. The original second adsorber (or a fresh canister) will become the new first adsorber and a fresh adsorber will become the second adsorber. For purposes of this paragraph, "immediately" means within 8 hours of the detection of a breakthrough for adsorbers of 55 gallons or less, and within 24 hours of the detection of a breakthrough for adsorbers greater than 55 gallons. The owner or operator must monitor at the outlet of the first adsorber within 3 days of replacement to confirm it is performing properly.

(2) Based on the adsorber bed life established according to paragraph (a)(5)(v)(A) of this section and the date the adsorbent was last replaced, conduct monitoring to detect breakthrough at least monthly if the adsorbent has more than 2 months of life remaining, at least weekly if the adsorbent has between 2 months and 2 weeks of life remaining, and at least daily if the adsorbent has 2 weeks or less of life remaining.

(6) Where sorbent injection is used, the following monitoring equipment is required for the sorbent injection system:

(i) A sorbent injection rate monitoring device (*e.g.*, weigh belt, weigh hopper, hopper flow measurement device) installed in a position that provides a representative measurement equipped with a continuous recorder to monitor the sorbent injection rate; and

(ii) A flow measurement device equipped with a continuous recorder to monitor the carrier gas flow rate.

(b) Except as specified in § 63.113(a)(4), each owner or operator of a process vent with a TRE index value greater than 1.0 as specified under § 63.113(a)(3) or (d) that uses one or more recovery devices shall install either an organic monitoring device equipped with a continuous recorder or the monitoring equipment specified in paragraph (b)(1), (2), or (3) of this section, depending on the type of recovery device used. All monitoring equipment shall be installed, calibrated, and maintained according to the manufacturer's specifications or other written procedures that provide adequate assurance that the equipment would reasonably be expected to monitor accurately. Monitoring is not required for process vents with TRE index values greater than 4.0 as specified in § 63.113(e).

(1) Where an absorber is the final recovery device in the recovery system, a scrubbing liquid temperature monitoring device and a specific gravity monitoring device, each equipped with a continuous recorder shall be used;

(2) Where a condenser is the final recovery device in the recovery system, a condenser exit (product side) temperature monitoring device equipped with a continuous recorder shall be used;

(3) Where a carbon adsorber is the final recovery device in the recovery system, an integrating regeneration stream flow monitoring device having an accuracy of  $\pm 10$  percent or better, capable of recording the total regeneration stream mass or volumetric flow for each regeneration cycle; and a carbon bed temperature monitoring device, capable of recording the carbon bed temperature after each regeneration and within 15 minutes of completing any cooling cycle shall be used.

(c) An owner or operator of a process vent may request approval to monitor parameters other than those listed in paragraph (a) or (b) of this section. The request shall be submitted according to the procedures specified in § 63.151(f) or § 63.152(e) of this subpart. Approval shall be requested if the owner or operator:

(1) Uses a combustion device other than an incinerator, boiler, process heater, or flare; or

(2) Except as specified in § 63.113(a)(4), maintains a TRE greater than 1.0 but less than or equal to 4.0 without a recovery device or with a recovery device other than the recovery devices listed in paragraphs (a) and (b) of this section; or

(3) Uses one of the combustion or recovery or recapture devices listed in paragraphs (a) and (b) of this section, but seeks to monitor a parameter other than those specified in paragraphs (a) and (b) of this section.

(d) The owner or operator of a process vent shall comply with paragraphs (d)(1) or (2) and (d)(3) of this section for any bypass line between the origin of the gas stream (*i.e.*, at an air oxidation reactor, distillation unit, or reactor as identified in § 63.107(b)) and the point where the gas stream reaches the process vent, as described in § 63.107, that could divert the gas stream directly to the atmosphere. Except as specified in paragraph (d)(3)(ii) of this section, equipment such as low leg drains, high point bleeds, analyzer vents, open-ended valves or lines, and pressure relief valves needed for safety purposes are not subject to this paragraph (d).

(1) Properly install, maintain, and operate a flow indicator that takes a reading at least once every 15 minutes. Records shall be generated as specified in § 63.118(a)(3). The flow indicator shall be installed at the entrance to any bypass line that could divert the gas stream to the atmosphere; or

(2) Secure the bypass line valve in the non-diverting position with a car-seal or a lock-and-key type configuration. A visual inspection of the seal or closure mechanism shall be performed at least once every month to ensure that the valve is maintained in the non-diverting position and the gas stream is not diverted through the bypass line

(3) For each source as defined in § 63.101, beginning no later than the compliance dates specified in § 63.100(k)(10):

(i) The use of a bypass line at any time on a closed vent system to divert emissions (subject to the emission standards in § 63.112) to the atmosphere or to a control device not meeting the requirements specified in this subpart is an emissions standards violation.

(ii) The last sentence in paragraph (d) of this section no longer applies. Instead, the exemptions specified in paragraphs (d)(3)(ii)(A) and (B) of this section apply.

(A) Except for pressure relief devices subject to § 63.165(e)(4) of subpart H of this part, equipment such as low leg drains and equipment subject to the requirements of subpart H of this part are not subject to this paragraph (d) of this section.

(B) Open-ended valves or lines that use a cap, blind flange, plug, or second valve and follow the requirements specified in § 60.482–6(a)(2), (b), and (c) of this chapter or follow requirements codified in another regulation that are the same as § 60.482–6(a)(2), (b), and (c) are not subject to this paragraph (d).

(e) The owner or operator shall establish a range that indicates proper operation of the control or recovery device for each parameter monitored under paragraphs (a), (b), and (c) of this section based on the results of the most recent performance test. In order to establish the range, the information required in § 63.152(b) shall be submitted in the Notification of Compliance Status or the operating permit application or amendment. The range may be based upon a prior performance test conducted for determining compliance with a regulation promulgated by the EPA, and the owner or operator is not required to conduct an initial performance test under § 63.116, if the prior performance test was conducted using the same methods specified in § 63.116 and either no process changes have been made since the test, or the owner or operator can demonstrate that the results of the performance test, with or without adjustments, reliably demonstrate compliance despite process changes. Subsequent performance tests must be conducted according to § 63.103(b)(1).

■ 59. Amend § 63.115 by revising paragraphs (a) introductory text, (b) introductory text, (c) introductory text, (d) introductory text, (e) introductory text and (f) introductory text and adding paragraph (g) to read as follows:

**§ 63.115 Process vent provisions—methods and procedures for process vent group determination.**

(a) For purposes of determining vent stream flow rate, total organic HAP or total organic carbon concentration or TRE index value as applicable, as specified under paragraph (b), (c), or (d) of this section, the sampling site shall be after the last recovery device (if any recovery devices are present) but prior to the inlet of any control device that is present and prior to release to the atmosphere.

\* \* \* \* \*

(b) Except as specified in paragraph (g) of this section, to demonstrate that a vent stream flow rate is less than 0.005 standard cubic meter per minute in accordance with the Group 2 process vent definition of this subpart, the owner or operator shall measure flow rate by the following procedures:

\* \* \* \* \*

(c) Except as specified in paragraph (g) of this section, each owner or operator seeking to demonstrate that a vent stream has an organic HAP concentration below 50 parts per million by volume in accordance with the Group 2 process vent definition of this subpart shall measure either total organic HAP or TOC concentration using the following procedures:

\* \* \* \* \*

(d) Except as specified in § 63.113(a)(4), to determine the TRE index value, the owner or operator shall conduct a TRE determination and calculate the TRE index value according to the procedures in paragraph (d)(1) or (2) of this section and the TRE equation in paragraph (d)(3) of this section.

\* \* \* \* \*

(e) Except as specified in § 63.113(a)(4), the owner or operator of a Group 2 process vent shall recalculate the TRE index value, flow, or organic hazardous air pollutants concentration for each process vent, as necessary to determine whether the vent is Group 1 or Group 2, whenever process changes are made that could reasonably be expected to change the vent to a Group 1 vent. Examples of process changes include, but are not limited to, changes in production capacity, production rate, feedstock type, or catalyst type, or whenever there is replacement, removal, or addition of recovery equipment. For purposes of this paragraph, process

changes do not include: Process upsets; unintentional, temporary process changes; and changes that are within the range on which the original TRE calculation was based.

\* \* \* \* \*

(f) Except as specified in § 63.113(a)(4), notwithstanding any other provisions of this subpart, in any case where a process vent includes one or more gas streams that are not from a source subject to this subpart (hereafter called “non-HON streams” for purposes of this paragraph), and one or more gas streams that meet the criteria in § 63.107(b) through (h) or the criteria in § 63.107(i) (hereafter called “HON streams” for purposes of this paragraph), the owner or operator may elect to comply with paragraphs (f)(1) through (3) of this section.

\* \* \* \* \*

(g) For each source as defined in § 63.101, beginning no later than the compliance dates specified in § 63.100(k)(10), paragraphs (b) and (c) of this section no longer apply. Instead, to demonstrate that a vent stream total organic HAP mass flow rate is less than 1.0 pound per hour in accordance with the Group 2 process vent definition of this subpart, the owner or operator must use the following procedures:

(1) The sampling site must be selected as specified in paragraph (a) of this section.

(2) Method 18 or Method 25A of appendices A–6 and A–7 to 40 CFR part 60 of this chapter, respectively, or Method 320 of appendix A to this part must be used to measure concentration. ASTM D6420–18 (incorporated by reference, see § 63.14) may also be used in lieu of Method 18 or Method 320, if the target compounds are all known and

are all listed in section 1.1 of ASTM D6420–18 as measurable; ASTM D6420–18 must not be used for methane and ethane; and ASTM D6420–18 may not be used as a total VOC method.

(3) Where Method 18 of appendix A–6 to part 60 of this chapter, Method 320 of appendix A to this part, or ASTM D6420–18 is used, the following procedures must be used to calculate the total organic HAP mass flow rate:

(i) The minimum sampling time for each run must be 1 hour in which either an integrated sample or four grab samples must be taken. If grab sampling is used, then the samples must be taken at approximately equal intervals in time, such as 15 minute intervals during the run.

(ii) The mass rate of total organic HAP for each run must be computed using the following equation:

Equation 6 to Paragraph (g)(3)(ii)

$$E_{HAP} = KQ \sum_{j=1}^n C_j M_j$$

Where:

$E_{HAP}$  = Emission rate of total organic HAP, lb/hr.

$K = 1.675 \times 10^{-7}$  (parts per million)<sup>-1</sup> (lb-mole per standard cubic feet) (minutes per hour), where standard temperature is 68 °F (20 °C).

$Q$  = Flowrate of gas stream, dry standard cubic feet per minute), where standard temperature is 68 °F (20 °C), determined using Method 2, 2A, 2C, or 2D of 40 CFR part 60, appendix A, as appropriate. The flowrate may be based solely on an engineering assessment if measurements cannot be made with EPA reference methods.

$C_j$  = Concentration of organic compound  $j$  in the gas stream as measured by Method 18 of appendix A–6 to 40 CFR part 60, Method 320 of appendix A to this part, or ASTM D6420–18 (incorporated by reference, see § 63.14), ppmv dry basis. The concentration may be based solely on an engineering assessment if measurements cannot be made with EPA reference methods.

$M_j$  = Molecular weight of organic compound  $j$ , lb/lb-mole.

$j$  = Individual organic HAP compound in the gas stream. The list of organic HAPs is provided in table 2 of subpart F of this part.

$n$  = Number of organic HAP compounds  $j$  in the gas stream.

(iii) The owner or operator must demonstrate that the emission rate of total organic HAP is less than 1.0 pound per hour for the vent stream to be considered a Group 2 process vent.

(4) Where Method 25A of appendix A–7 to part 60 of this chapter is used, the following procedures must be used to calculate parts per million by volume TOC concentration:

(i) Method 25A of appendix A–7 to part 60 of this chapter must be used only if a single organic HAP compound is greater than 50 percent of total organic HAP, by volume, in the vent stream.

(A) This organic HAP must be used as the calibration gas for Method 25A of appendix A–7 to part 60 of this chapter.

(B) Use of Method 25A of appendix A–7 to part 60 of this chapter is acceptable if the response from the high-level calibration gas is at least 20 times the standard deviation of the response from the zero calibration gas when the instrument is zeroed on the most sensitive scale.

(ii) The span value for Method 25A of appendix A–7 to part 60 of this chapter must be equal to approximately twice the expected concentration of TOC in the gas stream.

(iii) The minimum sampling time for each run must be 1 hour. The results must be corrected to a dry basis. You must use Method 4 of appendix A–3 to part 60 of this chapter to convert the Method 25A results to a dry basis.

(iv) The mass rate of TOC for each run must be computed using the following equation:

Equation 7 to Paragraph (g)(4)(iv)

$$E_{TOC} = KCMQ$$

Where:

$E_{TOC}$  = Emission rate of TOC, lb/hr.

$K = 1.675 \times 10^{-7}$  (parts per million)<sup>-1</sup> (lb-mole per standard cubic feet) (minutes per hour), where standard temperature is 68 °F (20 °C).

$C$  = Concentration of TOC in the gas stream as measured by Method 25A of appendix

A to part 60 of this chapter ppmv dry basis. The concentration may be based solely on an engineering assessment if measurements cannot be made with EPA reference methods.

$M$  = Molecular weight of the organic HAP used as the calibration gas, lb/lb-mole.

$Q$  = Flowrate of gas stream, dry standard cubic feet per minute), where standard temperature is 68 °F (20 °C), determined using Method 2, 2A, 2C, or 2D of appendix A–1 to part 60 of this chapter, as appropriate. The flowrate may be based solely on an engineering

assessment if measurements cannot be made with EPA reference methods.

(v) The owner or operator must demonstrate that the emission rate of TOC is less than 1.0 pound per hour for the vent stream to be considered a Group 2 process vent.

(5) The requirements specified in paragraphs (g)(1) through (4) of this section for an initial measurement or initial performance test do not apply if the conditions specified in paragraphs (g)(5)(i) through (iv) of this section are met for a previously conducted measurement or performance test.

(i) No changes have been made to the process since the time of the measurement or performance test;

(ii) The operating conditions and test methods used during measurement or performance test conform to the requirements in paragraphs (g)(1) through (4) of this section;

(iii) The control device and process parameter values established during the previously conducted measurement or performance test are used to demonstrate continuous compliance with the related requirements of this subpart, if applicable; and

(iv) The previously conducted measurement or performance test was completed within the last 60 months.

■ 60. Amend § 63.116 by:

■ a. Revising paragraphs (a) introductory text, (b)(3) through (5), (c) introductory text, (c)(3) introductory text, (c)(3)(iii)(A), (c)(4) introductory text, (c)(4)(ii)(B), and (d) introductory text; and

■ b. Adding paragraphs (f) through (h).  
The revisions and additions read as follows:

**§ 63.116 Process vent provisions—performance test methods and procedures to determine compliance.**

(a) When a flare is used to comply with § 63.113(a)(1), the owner or operator shall comply with paragraphs (a)(1) through (3) of this section except as specified in § 63.108(a). The owner or operator is not required to conduct a performance test to determine percent emission reduction or outlet organic HAP or TOC concentration.

\* \* \* \* \*

(b) \* \* \*

(3) A control device for which a performance test was conducted for determining compliance with a regulation promulgated by the EPA and the test was conducted using the same methods specified in this section and either no process changes have been made since the test, or the owner or operator can demonstrate that the results of the performance test, with or

without adjustments, reliably demonstrate compliance despite process changes is not required to conduct an initial performance test. Subsequent performance tests must be conducted according to § 63.103(b)(1).

(4) A boiler or process heater burning hazardous waste for which the owner or operator:

(i) Has been issued a final permit under part 270 of this chapter and complies with the requirements of part 266, subpart H, of this chapter;

(ii) Has certified compliance with the interim status requirements of part 266, subpart H, of this chapter;

(iii) Meets the requirement specified in paragraph (b)(4)(v) of this section, and has submitted a Notification of Compliance under § 63.1207(j) and complies with the requirements of subpart EEE of this part; or

(iv) Meets the requirement specified in paragraph (b)(4)(v) of this section, complies with subpart EEE of this part, and will submit a Notification of Compliance under § 63.1207(j) by the date the owner or operator would have been required to submit the initial performance test report for this subpart.

(v) The owner and operator may not waive performance testing pursuant to § 63.1207(d)(4) and each performance test required by § 63.1207(d) must show compliance with the dioxins and furans emission limit specified in § 63.113(a)(5).

(5) A hazardous waste incinerator for which the owner or operator:

(i) Has been issued a final permit under 40 CFR part 270 and complies with the requirements of part 264, subpart O, of this chapter;

(ii) Has certified compliance with the interim status requirements of part 265, subpart O, of this chapter.

(iii) Meets the requirement specified in paragraph (b)(5)(v) of this section, and has submitted a Notification of Compliance under § 63.1207(j) and complies with the requirements subpart EEE of this part; or

(iv) Meets the requirement specified in paragraph (b)(5)(v) of this section, complies with the requirements subpart EEE of this part, and will submit a Notification of Compliance under § 63.1207(j) by the date the owner or operator would have been required to submit the initial performance test report for this subpart.

(v) The owner and operator may not waive performance testing pursuant to § 63.1207(d)(4) and each performance test required by § 63.1207(d) must show compliance with the dioxins and furans emission limit specified in § 63.113(a)(5).

(c) Except as provided in paragraphs (a) and (b) of this section, an owner or operator using a control device to comply with the organic HAP concentration limit or percent reduction efficiency requirements in § 63.113(a)(2) of this subpart shall conduct performance tests using the procedures in paragraphs (c)(1) through (4) of this section according to the schedule in § 63.103(b)(1) of subpart F of this part. The organic HAP concentration and percent reduction may be measured as either total organic HAP or as TOC minus methane and ethane according to the procedures specified.

\* \* \* \* \*

(3) To determine compliance with the 20 parts per million by volume total organic HAP limit in § 63.113(a)(2) of this subpart, the owner or operator shall use Method 18 of appendix A-6 to part 60 of this chapter to measure either TOC minus methane and ethane or total organic HAP. ASTM D6420-18 (incorporated by reference, see § 63.14) may also be used in lieu of Method 18, if the target compounds are all known and are all listed in Section 1.1 of ASTM D6420-18 as measurable; ASTM D6420-18 must not be used for methane and ethane; and ASTM D6420-18 may not be used as a total VOC method. Alternatively, any other method or data that has been validated according to the applicable procedures in Method 301 of appendix A of this part, may be used. The following procedures shall be used to calculate parts per million by volume concentration, corrected to 3 percent oxygen:

\* \* \* \* \*

(iii) \* \* \*

(A) Method 3A of appendix A-2 to part 60 of this chapter or the manual method in ANSI/ASME PTC 19.10-1981 (incorporated by reference, see § 63.14) shall be used to determine the oxygen concentration (%O<sub>2</sub>d). The samples shall be taken during the same time that the TOC (minus methane or ethane) or total organic HAP samples are taken.

\* \* \* \* \*

(4) To determine compliance with the 98 percent reduction requirement of § 63.113(a)(2), the owner or operator shall use Method 18 of appendix A-6 to part 60 of this chapter; alternatively, any other method or data that has been validated according to the applicable procedures in Method 301 of appendix A to this part may be used. ASTM D6420-18 (incorporated by reference, see § 63.14) may also be used in lieu of Method 18, if the target compounds are all known and are all listed in section 1.1 of ASTM D6420-18 as measurable; ASTM D6420-18 must not be used for

methane and ethane; and ASTM D6420–18 may not be used as a total VOC method. The following procedures shall be used to calculate percent reduction efficiency:

\* \* \* \* \*

(ii) \* \* \*

(B) Where the mass rate of TOC is being calculated, all organic compounds (minus methane and ethane) measured by Method 18 of appendix A–6 to part 60 of this chapter or ASTM D6420–18 (incorporated by reference, see § 63.14) are summed using the equation in paragraph (c)(4)(ii)(A) of this section.

\* \* \* \* \*

(d) An owner or operator using a combustion device followed by a scrubber or other halogen reduction device to control halogenated vent streams in compliance with § 63.113(c)(1) shall conduct performance tests to determine compliance with the control efficiency or emission limits for hydrogen halides and halogens according to the schedule in § 63.103(b)(1).

\* \* \* \* \*

(f) To demonstrate compliance with the emission limits and work practice standards specified in § 63.113(j) for process vents in ethylene oxide service, owners and operators must meet the requirements specified in § 63.124.

(g) For each source as defined in § 63.101, beginning no later than the

compliance dates specified in § 63.100(k)(10), an owner or operator using a recapture device to comply with the organic HAP concentration limit or percent reduction efficiency requirements in § 63.113(a)(2) shall conduct a performance test using the same procedures specified in paragraph (c) of this section, except the term “recapture device” is substituted for “control device.”

(h) To demonstrate compliance with the dioxins and furans emission limit specified in § 63.113(a)(5), owners and operators must conduct performance tests using the procedures in paragraphs (h)(1) through (6) of this section according to the schedule in § 63.103(b)(1).

(1) The performance test must consist of three test runs. Collect at least 3 dry standard cubic meters of gas per test run.

(2) Use Method 1 or 1A of appendix A–1 to 40 CFR part 60 to select the sampling sites at the sampling location. The sampling location must be at the outlet of the final control device.

(3) Determine the gas volumetric flowrate using Method 2, 2A, 2C, or 2D of appendix A–1 to part 60 of this chapter.

(4) Use Method 4 of appendix A–3 to part 60 of this chapter to convert the volumetric flowrate to a dry basis.

(5) Measure the concentration of each tetra- through octa-chlorinated dioxin

and furan congener emitted using Method 23 of appendix A–7 to part 60 of this chapter.

(i) For each dioxin and furan congener, multiply the congener concentration by its corresponding toxic equivalency factor specified in table 38 to this subpart. For determination of toxic equivalency, zero may be used for congeners with a concentration less than the estimated detection limit (EDL). For congeners with estimated maximum pollutant concentration (EMPC) results, if the value is less than the EDL, zero may be used. Otherwise, the EMPC value must be used in the calculation of toxic equivalency.

(ii) Sum the products calculated in accordance with paragraph (h)(5)(i) of this section to obtain the total concentration of dioxins and furans emitted in terms of toxic equivalency.

(6) The concentration of dioxins and furans shall be corrected to 3 percent oxygen. Use Method 3A of 40 CFR part 60, appendix A, or the manual method in ANSI/ASME PTC 19.10–1981 (incorporated by reference, see § 63.14) to determine the oxygen concentration (%O<sub>2d</sub>). The oxygen concentration must be determined concurrently with Method 23 of appendix A–7 to part 60 of this chapter. The concentration corrected to 3 percent oxygen (C<sub>c</sub>) shall be computed using the following equation:

$$C_c = C_m \left( \frac{17.9}{20.9 - \%O_{2d}} \right)$$

Where:

C<sub>c</sub> = Concentration of dioxins and furans corrected to 3 percent oxygen, dry basis, nanograms per standard cubic meter.

C<sub>m</sub> = Concentration of dioxins and furans, dry basis, nanograms per standard cubic meter.

%O<sub>2d</sub> = Concentration of oxygen, dry basis, percent by volume.

■ 61. Revise and republish § 63.117 to read as follows:

**§ 63.117 Process vent provisions—reporting and recordkeeping requirements for group and TRE determinations and performance tests.**

(a) Except as specified in § 63.113(a)(4), each owner or operator subject to the control provisions for Group 1 process vents in § 63.113(a) or the provisions for Group 2 process vents with a TRE index value greater than 1.0 but less than or equal to 4.0 in § 63.113(d) shall:

(1) Keep an up-to-date, readily accessible record of the data specified in

paragraphs (a)(4) through (10) of this section, as applicable, and

(2) Include the data in paragraphs (a)(4) through (10) of this section in the Notification of Compliance Status report as specified in § 63.152(b) of this subpart.

(3) Except as specified in § 63.113(a)(4), if any subsequent TRE determinations or performance tests are conducted after the Notification of Compliance Status has been submitted, report the data in paragraphs (a)(4) through (a)(10) of this section in the next Periodic Report as specified in § 63.152(c).

(4) Record and report the following when using a combustion device to achieve a 98 weight percent reduction in organic HAP or an organic HAP concentration of 20 parts per million by volume, as specified in § 63.113(a)(2):

(i) The parameter monitoring results for incinerators, catalytic incinerators, boilers or process heaters specified in

table 3 of this subpart, and averaged over the same time period of the performance testing.

(ii) For an incinerator, the percent reduction of organic HAP or TOC achieved by the incinerator determined as specified in § 63.116(c), or the concentration of organic HAP or TOC (parts per million by volume, by compound) determined as specified in § 63.116(c) at the outlet of the incinerator on a dry basis corrected to 3 percent oxygen.

(iii) For a boiler or process heater, a description of the location at which the vent stream is introduced into the boiler or process heater.

(iv) For a boiler or process heater with a design heat input capacity of less than 44 megawatts and where the vent stream is introduced with combustion air or used as a secondary fuel and is not mixed with the primary fuel, the percent reduction of organic HAP or

TOC, or the concentration of organic HAP or TOC (parts per million by volume, by compound) determined as specified in § 63.116(c) at the outlet of the combustion device on a dry basis corrected to 3 percent oxygen.

(5) Except as specified in § 63.108(a), record and report the following when using a flare to comply with § 63.113(a)(1):

(i) Flare design (*i.e.*, steam-assisted, air-assisted, or non-assisted);

(ii) All visible emission readings, heat content determinations, flow rate measurements, and exit velocity determinations made during the compliance determination required by § 63.116(a); and

(iii) All periods during the compliance determination when the pilot flame is absent.

(6) Record and report the following when using a scrubber following a combustion device to control a halogenated vent stream:

(i) The percent reduction or scrubber outlet mass emission rate of total hydrogen halides and halogens as specified in § 63.116(d);

(ii) The pH of the scrubber effluent; and

(iii) The scrubber liquid to gas ratio.

(7) Except as specified in § 63.113(a)(4), record and report the following when achieving and maintaining a TRE index value greater than 1.0 but less than 4.0 as specified in § 63.113(a)(3) or (d):

(i) The parameter monitoring results for absorbers, condensers, or carbon adsorbers, as specified in table 4 to this subpart, and averaged over the same time period of the measurements of vent stream flow rate and concentration used in the TRE determination (both measured while the vent stream is normally routed and constituted), and

(ii) The measurements and calculations performed to determine the TRE index value of the vent stream.

(8) Record and report the halogen concentration in the vent stream determined according to the procedures specified in § 63.115(d)(2)(v).

(9) When using a recapture device to achieve a 98 weight percent reduction in organic HAP or an organic HAP concentration of 20 parts per million by volume, as specified in § 63.113(a)(2), record and report the parameter monitoring results for absorbers, condensers, or carbon adsorbers, as specified in table 3 of this subpart, and averaged over the same time period of the performance testing.

(10) Record and report the following when using a control device, recapture device, or recovery device to meet the dioxins and furans emissions limit.

(i) The parameter monitoring results, as specified in table 3 of this subpart, for the applicable device and averaged over the same time period of the performance testing.

(ii) The dioxins and furans concentration on a toxic equivalency basis (nanograms per standard cubic meter on a dry basis corrected to 3 percent oxygen) determined as specified in § 63.116(h).

(b) Except as specified in § 63.113(a)(4), the owner or operator of a Group 2 process vent with a TRE index greater than 4.0 as specified in § 63.113(e), shall maintain records and submit as part of the Notification of Compliance Status specified in § 63.152, measurements, engineering assessments, and calculations performed to determine the TRE index value of the vent stream. Documentation of engineering assessments shall include all data, assumptions, and procedures used for the engineering assessments, as specified in § 63.115(d)(1).

(c) Except as specified in paragraph (g) of this section, each owner or operator who elects to demonstrate that a process vent is a Group 2 process vent based on a flow rate less than 0.005 standard cubic meter per minute must submit to the Administrator the flow rate measurement using methods and procedures specified in § 63.115(a) and (b) with the Notification of Compliance Status specified in § 63.152.

(d) Except as specified in paragraph (g) of this section, each owner or operator who elects to demonstrate that a process vent is a Group 2 process vent based on organic HAP or TOC concentration less than 50 parts per million by volume must submit to the Administrator an organic HAP or TOC concentration measurement using the methods and procedures specified in § 63.115(a) and (c) with the Notification of Compliance Status specified in § 63.152.

(e) If an owner or operator uses a control or recovery device other than those listed in tables 3 and 4 to this subpart or requests approval to monitor a parameter other than those specified in tables 3 and 4 to this subpart, the owner or operator shall submit a description of planned reporting and recordkeeping procedures as required under § 63.151(f) or § 63.152(e). The Administrator will specify appropriate reporting and recordkeeping requirements as part of the review of the permit application or by other appropriate means.

(f) For each parameter monitored according to tables 3 or 4 to this subpart or paragraph (e) of this section, the owner or operator shall establish a range

for the parameter that indicates proper operation of the control or recovery device. In order to establish the range, the information required in § 63.152(b) shall be submitted in the Notification of Compliance Status or the operating permit application or amendment.

(g) For each source as defined in § 63.101, beginning no later than the compliance dates specified in § 63.100(k)(10), paragraphs (c) and (d) of this section no longer apply. Instead, each owner or operator demonstrating that a process vent is a Group 2 process vent based on total organic HAP mass flow rate less than 1.0 pound per hour must submit to the Administrator a total organic HAP measurement using the methods and procedures specified in § 63.115(g) with the Notification of Compliance Status specified in § 63.152.

■ 62. Revise and republish § 63.118 to read as follows:

**§ 63.118 Process vent provisions—periodic reporting and recordkeeping requirements.**

(a) Each owner or operator using a control device to comply with § 63.113(a)(1), (2), or (5) shall keep the following records up-to-date and readily accessible:

(1) Continuous records of the equipment operating parameters specified to be monitored under § 63.114(a) to this subpart and listed in table 3 to this subpart or specified by the Administrator in accordance with § 63.114(c) and § 63.117(e). For flares, the hourly records and records of pilot flame outages specified in table 3 to this subpart shall be maintained in place of continuous records.

(2) Records of the daily average value of each continuously monitored parameter for each operating day determined according to the procedures specified in § 63.152(f). For flares complying with § 63.11(b), records of the times and duration of all periods during which all pilot flames are absent shall be kept rather than daily averages. For flares complying with § 63.108, the owner or operator must comply with the recordkeeping requirements specified therein.

(3) Hourly records of whether the flow indicator specified under § 63.114(d)(1) was operating and whether a diversion was detected at any time during the hour, as well as records of the times and durations of all periods when the gas stream is diverted to the atmosphere or the monitor is not operating.

(4) Where a seal mechanism is used to comply with § 63.114(d)(2), hourly records of flow are not required. In such cases, the owner or operator shall record that the monthly visual inspection of

the seals or closure mechanism has been done, and shall record the duration of all periods when the seal mechanism is broken, the bypass line valve position has changed, or the key for a lock-and-key type lock has been checked out, and records of any car-seal that has broken.

(5) For each source as defined in § 63.101, beginning no later than the compliance dates specified in § 63.100(k)(10), the owner or operator must comply with this paragraph in addition to the requirements in paragraphs (a)(1) through (4) of this section. For each flow event from a bypass line subject to the requirements in § 63.114(d), the owner or operator must maintain records sufficient to determine whether or not the detected flow included flow requiring control. For each flow event from a bypass line requiring control that is released either directly to the atmosphere or to a control device not meeting the requirements in this subpart, the owner or operator must include an estimate of the volume of gas, the concentration of organic HAP in the gas and the resulting emissions of organic HAP that bypassed the control device using process knowledge and engineering estimates.

(b) Except as specified in § 63.113(a)(4), each owner or operator using a recovery device or other means to achieve and maintain a TRE index value greater than 1.0 but less than 4.0 as specified in § 63.113(a)(3) or (d) shall keep the following records up-to-date and readily accessible:

(1) Continuous records of the equipment operating parameters specified to be monitored under § 63.114(b) to this subpart and listed in table 4 to this subpart or specified by the Administrator in accordance with § 63.114(c) and § 63.114(e) and

(2) Records of the daily average value of each continuously monitored parameter for each operating day determined according to the procedures specified in § 63.152(f). If carbon adsorber regeneration stream flow and carbon bed regeneration temperature are monitored, the records specified in table 4 to this subpart shall be kept instead of the daily averages.

(c) Except as specified in § 63.113(a)(4), each owner or operator subject to the provisions of this subpart and who elects to demonstrate compliance with the TRE index value greater than 4.0 under § 63.113(e) or greater than 1.0 under § 63.113(a)(3) or (d) shall keep up-to-date, readily accessible records of:

(1) Any process changes as defined in § 63.115(e); and

(2) Any recalculation of the TRE index value pursuant to § 63.115(e).

(d) Except as specified in paragraph (n) of this section, each owner or operator who elects to comply by maintaining a flow rate less than 0.005 standard cubic meter per minute under § 63.113(f), shall keep up-to-date, readily accessible records of:

(1) Any process changes as defined in § 63.115(e) that increase the vent stream flow rate,

(2) Any recalculation or measurement of the flow rate pursuant to § 63.115(e), and

(3) Except as specified in § 63.113(a)(4), if the flow rate increases to 0.005 standard cubic meter per minute or greater as a result of the process change, the TRE determination performed according to the procedures of § 63.115(d).

(e) Except as specified in paragraph (n) of this section, each owner or operator who elects to comply by maintaining an organic HAP concentration less than 50 parts per million by volume organic HAP concentration under § 63.113(g) shall keep up-to-date, readily accessible records of:

(1) Any process changes as defined in § 63.115(e) that increase the organic HAP concentration of the vent stream,

(2) Any recalculation or measurement of the concentration pursuant to § 63.115(e), and

(3) Except as specified in § 63.113(a)(4), if the organic HAP concentration increases to 50 parts per million by volume or greater as a result of the process change, the TRE determination performed according to the procedures of § 63.115(d).

(f) Each owner or operator who elects to comply with the requirements of § 63.113 of this subpart shall submit to the Administrator Periodic Reports of the following recorded information according to the schedule in § 63.152.

(1) Reports of daily average values of monitored parameters for all operating days when the daily average values recorded under paragraphs (a) and (b) of this section were outside the ranges established in the Notification of Compliance Status or operating permit, including the date that the parameter was outside the range.

(2) For Group 1 points, reports of the duration (in hours) of periods when monitoring data is not collected for each excursion caused by insufficient monitoring data as defined in § 63.152(c)(2)(ii)(A), including the start date of such periods.

(3) Reports of the times and durations of all periods recorded under paragraph (a)(3) of this section when the gas stream is diverted to the atmosphere through a bypass line and if applicable,

the information in paragraph (f)(7) of this section. Include the start date, start time and duration in hours of each period.

(4) Reports of all periods recorded under paragraph (a)(4) of this section in which the seal mechanism is broken, the bypass line valve position has changed, or the key to unlock the bypass line valve was checked out and if applicable, the information in paragraph (f)(7) of this section. Include the start date, start time and duration in hours of each period.

(5) Except as specified in paragraph (a) of § 63.108, reports of the times and durations of all periods recorded under paragraph (a)(2) of this section in which all pilot flames of a flare were absent.

(6) Reports of all carbon bed regeneration cycles during which the parameters recorded under paragraph (b)(2)(v) of this section were outside the ranges established in the Notification of Compliance Status or operating permit. Include the identification of the carbon bed, the monitored parameter that was outside the established range, and the start date, start time and duration in hours of the regeneration cycle.

(7) For each source as defined in § 63.101, beginning no later than the compliance dates specified in § 63.100(k)(10), the owner or operator must comply with this paragraph in addition to the requirements in paragraphs (f)(3) and (4) of this section. For bypass lines subject to the requirements in § 63.114(d), the Periodic Report must include the start date, start time, duration in hours, estimate of the volume of gas in standard cubic feet, the concentration of organic HAP in the gas in parts per million by volume and the resulting mass emissions of organic HAP in pounds that bypass a control device. For periods when the flow indicator is not operating, report the start date, start time, and duration in hours.

(8) For process vents in ethylene oxide service subject to the requirements of § 63.124, the Periodic Report must include the records for periods specified in paragraph (l)(2) of this section. Indicate the start date and time and end date and time for each period.

(9) For any maintenance vent release exceeding the applicable limits in § 63.113(k)(1), the compliance report must include the information specified in paragraphs (f)(9)(i) through (iv) of this section. For the purposes of this reporting requirement, if an owner or operator complies with § 63.113(k)(1)(iv) then the owner or operator must report each venting event conducted under those provisions and

include an explanation for each event as to why utilization of this alternative was required.

(i) Identification of the maintenance vent and the equipment served by the maintenance vent.

(ii) The date and time the maintenance vent was opened to the atmosphere.

(iii) The LEL in percent, vessel pressure in psig, or mass in pounds of VOC in the equipment, as applicable, at the start of atmospheric venting. If the 5 psig vessel pressure option in § 63.113(k)(1)(ii) was used and active purging was initiated while the concentration of the vapor was 10 percent or greater of its LEL, also include the concentration of the vapors at the time active purging was initiated.

(iv) An estimate of the mass in pounds of organic HAP released during the entire atmospheric venting event.

(g) Whenever a process change, as defined in § 63.115(e), is made that causes a Group 2 process vent to become a Group 1 process vent, the owner or operator shall submit a report within 180 calendar days after the process change as specified in § 63.151(j). The report shall include:

(1) A description of the process change;

(2) Except as specified in § 63.113(a)(4), the results of the recalculation of the flow rate, organic HAP concentration, and TRE index value required under § 63.115(e) and recorded under paragraph (c), (d), or (e) of this section; and

(3) A statement that the owner or operator will comply with the provisions of § 63.113 for Group 1 process vents by the dates specified in subpart F of this part.

(h) Except as specified in § 63.113(a)(4), whenever a process change, as defined in § 63.115(e), is made that causes a Group 2 process vent with a TRE greater than 4.0 to become a Group 2 process vent with a TRE less than 4.0, the owner or operator shall submit a report within 180 calendar days after the process change. The report may be submitted as part of the next periodic report. The report shall include:

(1) A description of the process change,

(2) The results of the recalculation of the TRE index value required under § 63.115(e) and recorded under paragraph (c) of this section, and

(3) A statement that the owner or operator will comply with the requirements specified in § 63.113(d).

(i) Except as specified in § 63.113(a)(4), whenever a process change, as defined in § 63.115(e), is

made that causes a Group 2 process vent with a flow rate less than 0.005 standard cubic meter per minute to become a Group 2 process vent with a flow rate of 0.005 standard cubic meter per minute or greater and a TRE index value less than or equal to 4.0, the owner or operator shall submit a report within 180 calendar days after the process change. The report may be submitted as part of the next periodic report. The report shall include:

(1) A description of the process change,

(2) The results of the recalculation of the flow rate and the TRE determination required under § 63.115(e) and recorded under paragraph (d) of this section, and

(3) A statement that the owner or operator will comply with the requirements specified in § 63.113(d).

(j) Except as specified in § 63.113(a)(4), whenever a process change, as defined in § 63.115(e), is made that causes a Group 2 process vent with an organic HAP concentration less than 50 parts per million by volume to become a Group 2 process vent with an organic HAP concentration of 50 parts per million by volume or greater and a TRE index value less than or equal to 4.0, the owner or operator shall submit a report within 180 calendar days after the process change. The report may be submitted as part of the next periodic report. The report shall include:

(1) A description of the process change,

(2) The results of the recalculation of the organic HAP concentration and the TRE determination required under § 63.115(e) and recorded under paragraph (e) of this section, and

(3) A statement that the owner or operator will comply with the requirements specified in § 63.113(d).

(k) The owner or operator is not required to submit a report of a process change if one of the conditions listed in paragraph (k)(1), (2), (3), or (4) of this section is met.

(1) The process change does not meet the definition of a process change in § 63.115(e), or

(2) The vent stream flow rate is recalculated according to § 63.115(e) and the recalculated value is less than 0.005 standard cubic meter per minute, or

(3) The organic HAP concentration of the vent stream is recalculated according to § 63.115(e) and the recalculated value is less than 50 parts per million by volume, or

(4) Except as specified in § 63.113(a)(4), the TRE index value is recalculated according to § 63.115(e) and the recalculated value is greater than 4.0.

(l) For process vents in ethylene oxide service subject to the requirements of § 63.124, owners and operators must keep the records specified in paragraphs (l)(1) and (2) of this section in addition to those records specified elsewhere in this section.

(1) For process vents, include all uncontrolled, undiluted ethylene oxide concentration measurements, and the calculations used to determine the total uncontrolled ethylene oxide mass emission rate for the sum of all vent gas streams.

(2) If emissions are vented through a closed-vent system to a non-flare control device, then the owner or operator must keep records of all periods during which operating values are outside of the applicable operating limits specified in § 63.124(b)(4) through (6) when regulated material is being routed to the non-flare control device. The record must specify the identification of the control device, the operating parameter, the applicable limit, and the highest (for maximum operating limits) or lowest (for minimum operating limits) value recorded during the period. (m) For each maintenance vent opening subject to the requirements of § 63.113(k), owners and operators must keep the applicable records specified in paragraphs (m)(1) through (5) of this section.

(1) Owners and operators must maintain standard site procedures used to deinventory equipment for safety purposes (e.g., hot work or vessel entry procedures) to document the procedures used to meet the requirements in § 63.113(k). The current copy of the procedures must be retained and available on-site at all times. Previous versions of the standard site procedures, as applicable, must be retained for 5 years.

(2) If complying with the requirements of § 63.113(k)(1)(i), and the concentration of the vapor at the time of the vessel opening exceeds 10 percent of its LEL, identification of the maintenance vent, the process units or equipment associated with the maintenance vent, the date of maintenance vent opening, and the concentration of the vapor at the time of the vessel opening.

(3) If complying with the requirements of § 63.113(k)(1)(ii), and either the vessel pressure at the time of the vessel opening exceeds 5 psig or the concentration of the vapor at the time of the active purging was initiated exceeds 10 percent of its LEL, identification of the maintenance vent, the process units or equipment associated with the maintenance vent, the date of maintenance vent opening, the pressure of the vessel or equipment at the time



of discharge to the atmosphere and, if applicable, the concentration of the vapors in the equipment when active purging was initiated.

(4) If complying with the requirements of § 63.113(k)(1)(iii), records of the estimating procedures used to determine the total quantity of VOC in the equipment and the type and size limits of equipment that contain less than 50 pounds of VOC at the time of maintenance vent opening. For each maintenance vent opening that contains greater than 50 pounds of VOC for which the deinventory procedures specified in paragraph (m)(1) of this section are not followed or for which the equipment opened exceeds the type and size limits established in the records specified in this paragraph (m)(4), records that identify the maintenance vent, the process units or equipment associated with the maintenance vent, the date of maintenance vent opening, and records used to estimate the total quantity of VOC in the equipment at the time the maintenance vent was opened to the atmosphere.

(5) If complying with the requirements of § 63.113(k)(1)(iv), identification of the maintenance vent, the process units or equipment associated with the maintenance vent, records documenting actions taken to comply with other applicable alternatives and why utilization of this alternative was required, the date of maintenance vent opening, the equipment pressure and concentration of the vapors in the equipment at the time of discharge, an indication of whether active purging was performed and the pressure of the equipment during the installation or removal of the blind if active purging was used, the duration the maintenance vent was open during the blind installation or removal process, and records used to estimate the total quantity of VOC in the equipment at the time the maintenance vent was opened to the atmosphere for each applicable maintenance vent opening.

(n) For each source as defined in § 63.101, beginning no later than the compliance dates specified in § 63.100(k)(10), paragraphs (d) and (e) of this section no longer apply. Instead, each owner or operator demonstrating that a process vent is a Group 2 process vent based on total organic HAP mass flow rate less than 1.0 pound per hour under § 63.113(l), shall keep up-to-date, readily accessible records of:

(1) Any process changes that increase the vent stream mass flow rate, and

(2) Any recalculation or measurement of the mass flow rate pursuant to § 63.115(g).

■ 63. Amend § 63.119 by:

- a. Revising paragraph (a) introductory text;
- b. Adding paragraphs (a)(5) through (7);
- c. Revising paragraphs (b) introductory text, (b)(5) introductory text, and (b)(5)(ii);
- d. Adding paragraphs (b)(5)(ix) through (xii) and (b)(7);
- e. Revising and publishing paragraph (e);
- f. Revising paragraphs (f)(3) and revising and republishing paragraph (g).

The revisions, additions and republications read as follows:

**§ 63.119 Storage vessel provisions—reference control technology.**

(a) For each storage vessel to which this subpart applies, the owner or operator shall comply with the requirements of paragraphs (a)(1) through (6) of this section according to the schedule provisions of § 63.100. For each pressure vessel to which this subpart applies, the owner or operator must comply with the requirements of paragraph (a)(7) of this section.

\* \* \* \* \*

(5) For each source as defined in § 63.101, beginning no later than the compliance dates specified in § 63.100(k)(11), if the storage vessel (of any capacity and vapor pressure) stores liquid containing ethylene oxide such that the storage vessel is considered to be in ethylene oxide service, as defined in § 63.101, then the owner or operator must comply with the requirements of paragraph (a)(5)(i) or (ii) of this section in addition to all other applicable requirements specified elsewhere in this section.

(i) Reduce emissions of ethylene oxide by venting emissions through a closed vent system to a flare; or

(ii) Reduce emissions of ethylene oxide by venting emissions through a closed vent system to a control device that reduces ethylene oxide by greater than or equal to 99.9 percent by weight, or to a concentration less than 1 ppmv for each storage vessel vent.

(6) For each source as defined in § 63.101, beginning no later than the compliance dates specified in § 63.100(k)(10), for each storage vessel subject to paragraph (a)(1), (2), or (5) of this section, the owner or operator must comply with paragraphs (a)(6)(i) through (iv) of this section during storage vessel shutdown operations (*i.e.*, emptying and degassing of a storage vessel) until the vapor space concentration in the storage vessel is

less than 10 percent of the LEL, or the organic HAP concentration in the vapor space is equal to or less than of 5,000 ppmv as methane. The owner or operator must determine the concentration using process instrumentation or portable measurement devices and follow procedures for calibration and maintenance according to manufacturer's specifications. The owner or operator must determine the organic HAP concentration using Method 18 or Method 25A of appendix A to part 60 of this chapter; or alternatively, any other method or data that has been validated according to the protocol in Method 301 of appendix A of this part.

(i) Remove liquids from the storage vessel as such as practicable.

(ii) Comply with one of the following:

(A) Reduce emissions of total organic HAP by venting emissions through a closed vent system to a flare.

(B) Reduce emissions of total organic HAP by 95 weight-percent by venting emissions through a closed vent system to any combination of non-flare control devices.

(C) Reduce emissions of total organic HAP by routing emissions to a fuel gas system or process and meet the requirements specified in paragraph (f) of this section.

(iii) Maintain records necessary to demonstrate compliance with the requirements in § 63.102(f) of subpart F of this part including, if appropriate, records of existing standard site procedures used to empty and degas (deinventory) equipment for safety purposes.

(iv) For floating roof storage vessels, the storage vessel may be opened to set up equipment (*e.g.*, making connections to a temporary control device) for the shutdown operations but must not be actively degassed during this time period.

(7) For each source as defined in § 63.101, beginning no later than the compliance dates specified in § 63.100(k)(10), for each pressure vessel as defined in § 63.101 that is considered a Group 1 storage vessel (as defined in table 5 of this subpart for existing sources and table 6 of the subpart for new sources), you must operate and maintain the pressure vessel, as specified in paragraphs (a)(7)(i) through (v) of this section.

(i) The pressure vessel must be designed to operate with no detectable emissions at all times.

(ii) Except for connectors in ethylene oxide service, gas/vapor or light liquid valves in ethylene oxide service, light liquid pumps in ethylene oxide service,

and PRDs in ethylene oxide service, and except for equipment that meet the criteria specified in § 63.168(h) and (i) (for valves in gas/vapor service and in light liquid service) and in § 63.174(f) and (h) (for connectors in gas/vapor service and in light liquid service), you must monitor each point on the pressure vessel through which total organic hazardous air pollutants could potentially be emitted by conducting initial and annual performance tests using Method 21 of appendix A-7 to part 60 of this chapter

(iii) Each instrument reading greater than 500 ppmv is a violation.

(iv) Estimate the flow rate and total regulated material emissions from the defect. Assume the pressure vessel has been emitting for half of the time since the last performance test, unless other information supports a different assumption.

(v) Whenever total organic hazardous air pollutants are in the pressure vessel, you must operate the pressure vessel as a closed system that vents through a closed vent system to a control device as specified in paragraph (e) of this section, as applicable. For purposes of compliance with this paragraph, a release of total organic hazardous air pollutants through a pressure vessel's pressure relief device to the atmosphere is a violation.

(b) The owner or operator who elects to use a fixed roof and an internal floating roof, as defined in § 63.111, to comply with the requirements of paragraph (a)(1) of this section shall comply with the requirements specified in paragraphs (b)(1) through (7) of this section.

**Note:** The intent of paragraphs (b)(1) and (2) of this section is to avoid having a vapor space between the floating roof and the stored liquid for extended periods. Storage vessels may be emptied for purposes such as routine storage vessel maintenance, inspections, petroleum liquid deliveries, or transfer operations. Storage vessels where liquid is left on walls, as bottom clingage, or in pools due to floor irregularity are considered completely empty.

\* \* \* \* \*

(5) Except as provided in paragraph (b)(5)(viii) of this section, each internal floating roof shall meet the specifications listed in paragraphs (b)(5)(i) through (vii) of this section, and (b)(5)(ix) through (xii) of this section.

\* \* \* \* \*

(ii) Except as specified in paragraph (b)(5)(ix) of this section, each opening in the internal floating roof except for leg sleeves, automatic bleeder vents, rim space vents, column wells, ladder wells, sample wells, and stub drains shall be

equipped with a cover or lid. The cover or lid shall be equipped with a gasket.

\* \* \* \* \*

(ix) For each source as defined in § 63.101, beginning no later than the compliance dates specified in § 63.100(k)(10), paragraph (b)(5)(i) of this section no longer applies. Instead, each opening in the internal floating roof except those for automatic bleeder vents (vacuum breaker vents), rim space vents, leg sleeves, and deck drains shall be equipped with a deck cover. The deck cover shall be equipped with a gasket between the cover and the deck.

(x) For each source as defined in § 63.101, beginning no later than the compliance dates specified in § 63.100(k)(10), each opening for an unslotted guidepole shall be equipped with a pole wiper, and each unslotted guidepole shall be equipped with a gasketed cap on the top of the guidepole.

(xi) For each source as defined in § 63.101, beginning no later than the compliance dates specified in § 63.100(k)(10), each opening for a slotted guidepole shall be equipped with one of the control device configurations specified in paragraphs (b)(5)(xi)(A) and (B) of this section.

(A) A pole wiper and a pole float. The wiper or seal of the pole float shall be at or above the height of the pole wiper.

(B) A pole wiper and a pole sleeve.

(xii) Each unslotted guidepole cap shall be closed at all times except when gauging the liquid level or taking liquid samples.

\* \* \* \* \*

(7) For each source as defined in § 63.101, beginning no later than the compliance dates specified in § 63.100(k)(10), owners and operators that use a continuous sweep, purge, or inert blanket between the internal floating roof and fixed roof that causes a pressure/vacuum vent to remain continuously open to the atmosphere where uncontrolled emissions are greater than or equal to 1.0 pound per hour of total organic HAP must route emissions through a closed vent system and control device and comply with paragraph (e) of this section.

\* \* \* \* \*

(e) The owner or operator who elects to use a closed vent system and control device, as defined in § 63.111, to comply with the requirements of paragraph (a)(1) or (2) of this section, or the owner or operator who meets the requirements specified in paragraph (b)(7) of this section, shall comply with the requirements specified in paragraphs (e)(1) through (7) of this section.

(1) Except as provided in paragraph (e)(2) of this section, the control device shall be designed and operated to reduce inlet emissions of total organic HAP by 95 percent or greater. Except as specified in § 63.108(a), if a flare is used as the control device, it shall meet the specifications described in the general control device requirements of § 63.11(b).

(2) If the owner or operator can demonstrate that a control device installed on a storage vessel on or before December 31, 1992 is designed to reduce inlet emissions of total organic HAP by greater than or equal to 90 percent but less than 95 percent, then the control device is required to be operated to reduce inlet emissions of total organic HAP by 90 percent or greater.

(3) Except as specified in (e)(7) of this section, periods of planned routine maintenance of the control device, during which the control device does not meet the specifications of paragraph (e)(1) or (2) of this section, as applicable, shall not exceed 240 hours per year.

(4) Except as specified in (e)(7) of this section, the specifications and requirements in paragraphs (e)(1) and (2) of this section for control devices do not apply during periods of planned routine maintenance.

(5) Except as specified in (e)(7) of this section, the specifications and requirements in paragraphs (e)(1) and (2) of this section for control devices do not apply during a control system malfunction.

(6) An owner or operator may use a combination of control devices to achieve the required reduction of total organic hazardous air pollutants specified in paragraph (e)(1) of this section. An owner or operator may use a combination of control devices installed on a storage vessel on or before December 31, 1992 to achieve the required reduction of total organic hazardous air pollutants specified in paragraph (e)(2) of this section.

(7) For each source as defined in § 63.101, beginning no later than the compliance dates specified in § 63.100(k)(10), paragraphs (e)(3) through (5) of this section no longer apply. Instead, whenever gases or vapors containing total organic HAP are routed from a storage vessel through a closed vent system connected to a control device used to comply with the requirements of paragraph (e)(1) or (2) of this section, the control device must be operating, except the control device may only be bypassed for the purpose of performing planned routine maintenance of the control device. When the control device is bypassed,

the owner or operator must comply with paragraphs (e)(7)(i) through (iii) of this section.

(i) The control device may only be bypassed when the planned routine maintenance cannot be performed during periods that storage vessel emissions are vented to the control device.

(ii) On an annual basis, the total time that the closed-vent system or control device is bypassed to perform planned routine maintenance shall not exceed 240 hours per each calendar year.

(iii) The level of material in the storage vessel shall not be increased during periods that the closed vent system or control device is bypassed to perform planned routine maintenance.

(f) \* \* \*

(3) The fuel gas system or process shall be operating at all times when organic hazardous air pollutants emissions are routed to it except as provided in § 63.102(a)(1) and in paragraphs (f)(3)(i) through (iv) of this section. Whenever the owner or operator bypasses the fuel gas system or process, the owner or operator shall comply with the recordkeeping requirement in § 63.123(h). Bypassing is permitted if the owner or operator complies with one or more of the conditions specified in paragraphs (f)(3)(i) through (iv) of this section.

(i) The liquid level in the storage vessel is not increased;

(ii) The emissions are routed through a closed vent system to a control device complying with § 63.119(e); or

(iii) Except as specified in paragraph (f)(3)(iv) of this section, the total aggregate amount of time during which the emissions bypass the fuel gas system or process during the calendar year without being routed to a control device, for all reasons (except start-ups/shutdowns/malfuctions or product changeovers of flexible operation units and periods when the storage vessel has been emptied and degassed), does not exceed 240 hours.

(iv) For each source as defined in § 63.101, beginning no later than the compliance dates specified in § 63.100(k)(10), paragraph (f)(3)(iii) of this section no longer applies. Instead, if you elect to route emissions from storage vessels to a fuel gas system or to a process to comply with the requirements of paragraph (a)(1), (2), or (5) of this section, the fuel gas system or process may only be bypassed when the planned routine maintenance cannot be performed during periods that storage vessel emissions are vented to the fuel gas system or process, and the total aggregate amount of time during which the breathing loss emissions bypass the

fuel gas system or process during the calendar year without being routed to a control device must not exceed 240 hours. The level of material in the storage vessel shall not be increased during periods that the fuel gas system or process is bypassed to perform routine maintenance.

(g) The owner or operator who elects to vapor balance to comply with the requirements of paragraphs (a)(1) and (2) of this section shall comply with paragraphs (g)(1) through (7) of this section and the recordkeeping requirements of § 63.123(i).

(1) The vapor balancing system must be designed and operated to route organic HAP vapors displaced from loading of the storage vessel to the railcar, tank truck, or barge from which the storage vessel is filled.

(2) Tank trucks and railcars must have a current certification in accordance with the U.S. Department of Transportation pressure test requirements of 49 CFR part 180 for tank trucks and 49 CFR 173.31 for railcars. Barges must have a current certification of vapor-tightness through testing in accordance with 40 CFR 63.565.

(3) Hazardous air pollutants must only be unloaded from tank trucks or railcars when vapor collection systems are connected to the storage vessel's vapor collection system.

(4) No pressure relief device on the storage vessel, or on the railcar or tank truck, shall open during loading or as a result of diurnal temperature changes (breathing losses).

(5) Pressure relief devices must be set to no less than 2.5 psig at all times to prevent breathing losses. Pressure relief devices may be set at values less than 2.5 psig if the owner or operator provides rationale in the notification of compliance status report explaining why the alternative value is sufficient to prevent breathing losses at all times. The owner or operator shall comply with paragraphs (g)(5)(i) through (iii) of this section for each pressure relief valve.

(i) The pressure relief valve shall be monitored quarterly using the method described in § 63.180(b).

(ii) An instrument reading of 500 ppmv or greater defines a leak.

(iii) When a leak is detected, it shall be repaired as soon as practicable, but no later than 5 days after it is detected, and the owner or operator shall comply with the recordkeeping requirements of § 63.181(d)(1) through (4).

(6) Railcars, tank trucks, or barges that deliver HAP to a storage vessel must be reloaded or cleaned at a facility that utilizes the control techniques specified

in paragraph (g)(6)(i) or (ii) of this section.

(i) The railcar, tank truck, or barge must be connected to a closed vent system with a control device that reduces inlet emissions of HAP by 95 percent by weight or greater.

(ii) A vapor balancing system designed and operated to collect organic HAP vapor displaced from the tank truck, railcar, or barge during reloading must be used to route the collected HAP vapor to the storage vessel from which the liquid being transferred originated.

(7) The owner or operator of the facility where the railcar, tank truck, or barge is reloaded or cleaned must comply with paragraphs (g)(7)(i) through (iii) of this section.

(i) Submit to the owner or operator of the storage vessel and to the Administrator a written certification that the reloading or cleaning facility will meet the requirements of this section. The certifying entity may revoke the written certification by sending a written statement to the owner or operator of the storage vessel giving at least 90 days notice that the certifying entity is rescinding acceptance of responsibility for compliance with the requirements of this paragraph (g)(7).

(ii) If complying with paragraph (g)(6)(i) of this section, comply with the requirements for closed vent system and control device specified in §§ 63.119 through 63.123. The notification and reporting requirements in § 63.122 do not apply to the owner or operator of the offsite cleaning or reloading facility.

(iii) If complying with paragraph (g)(6)(ii) of this section, keep the records specified in § 63.123(i)(3).

(iv) After the compliance dates specified in § 63.100(k) at an offsite reloading or cleaning facility subject to paragraph (g) of this section, compliance with the monitoring, recordkeeping, and reporting provisions of any other subpart of this part 63 constitutes compliance with the monitoring, recordkeeping, and reporting provisions of paragraph (g)(7)(ii) or (iii) of this section. You must identify in your Notification of Compliance Status report required by § 63.152(b), the subpart to the part 63 with which the owner or operator of the reloading or cleaning facility complies.

■ 64. Amend § 63.120 by:

■ a. Revising paragraphs (b)(9);

■ b. Revising and republishing paragraph (d);

■ c. Revising paragraphs (e)

introductory text and (e)(3); and

■ d. Adding paragraph (g).

The revisions, addition, and republication read as follows:

**§ 63.120 Storage vessel provisions—  
procedures to determine compliance.**

\* \* \* \* \*

(b) \* \* \*

(9) The owner or operator shall notify the Administrator in writing at least 30 calendar days in advance of any gap measurements required by paragraph (b)(1) or (2) of this section to afford the Administrator the opportunity to have an observer present.

\* \* \* \* \*

(d) To demonstrate compliance with § 63.119(e) (storage vessel equipped with a closed vent system and control device) using a control device other than a flare, the owner or operator shall comply with the requirements in paragraphs (d)(1) through (7) of this section, except as provided in paragraphs (d)(8) and (9) of this section.

(1) Except as provided in paragraph (d)(1)(iii) of this section, the owner or operator shall either prepare a design evaluation, which includes the information specified in paragraph (d)(1)(i) of this section or submit the results of a performance test as described in paragraph (d)(1)(ii) of this section.

(i) The design evaluation shall include documentation demonstrating that the control device being used achieves the required control efficiency during reasonably expected maximum filling rate. This documentation is to include a description of the gas stream which enters the control device, including flow and organic HAP content under varying liquid level conditions, and the information specified in paragraphs (d)(1)(i)(A) through (E) of this section, as applicable.

(A) If the control device receives vapors, gases or liquids, other than fuels, from emission points other than storage vessels subject to this subpart, the efficiency demonstration is to include consideration of all vapors, gases, and liquids, other than fuels, received by the control device.

(B) If an enclosed combustion device with a minimum residence time of 0.5 seconds and a minimum temperature of 760 °C is used to meet the emission reduction requirement specified in § 63.119 (e)(1) or (2), as applicable, documentation that those conditions exist is sufficient to meet the requirements of paragraph (d)(1)(i) of this section.

(C) Except as provided in paragraph (d)(1)(i)(B) of this section, for thermal incinerators, the design evaluation shall include the autoignition temperature of the organic HAP, the flow rate of the organic HAP emission stream, the combustion temperature, and the

residence time at the combustion temperature.

(D) For carbon adsorbers, the design evaluation shall include the affinity of the organic HAP vapors for carbon, the amount of carbon in each bed, the number of beds, the humidity of the feed gases, the temperature of the feed gases, the flow rate of the organic HAP emission stream, the desorption schedule, the regeneration stream pressure or temperature, and the flow rate of the regeneration stream. For vacuum desorption, pressure drop shall be included.

(E) For condensers, the design evaluation shall include the final temperature of the organic HAP vapors, the type of condenser, and the design flow rate of the organic HAP emission stream.

(ii) If the control device used to comply with § 63.119(e) is also used to comply with § 63.113(a)(2), § 63.126(b)(1), or § 63.139(c), the performance test required by § 63.116(c), § 63.128(a), or § 63.139(d)(1) is acceptable to demonstrate compliance with § 63.119(e). The owner or operator is not required to prepare a design evaluation for the control device as described in paragraph (d)(1)(i) of this section, if the performance tests meets the criteria specified in paragraphs (d)(1)(ii)(A) and (B) of this section.

(A) The performance test demonstrates that the control device achieves greater than or equal to the required control efficiency specified in § 63.119 (e)(1) or (2), as applicable; and

(B) The performance test is submitted as part of the Notification of Compliance Status required by § 63.151(b). If the performance test report is submitted electronically through the EPA's CEDRI in accordance with § 63.152(h), the process unit(s) tested, the pollutant(s) tested, and the date that such performance test was conducted may be submitted in the notification of compliance status report in lieu of the performance test results. The performance test results must be submitted to CEDRI by the date the notification of compliance status report is submitted.

(iii) For each source as defined in § 63.101, beginning no later than the compliance dates specified in § 63.100(k)(10), if the owner or operator vents emissions through a closed vent system to an adsorber(s) that cannot be regenerated or a regenerative adsorber(s) that is regenerated offsite, then the owner or operator must install a system of two or more adsorber units in series and comply with the requirements specified in paragraphs (d)(1)(iii)(A) through (C) of this section.

(A) Conduct an initial performance test or design evaluation of the adsorber and establish the breakthrough limit and adsorber bed life.

(B) Monitor the HAP or total organic compound (TOC) concentration through a sample port at the outlet of the first adsorber bed in series according to the schedule in paragraph (d)(1)(iii)(C)(2) of this section. The owner or operator must measure the concentration of HAP or TOC using either a portable analyzer, in accordance with Method 21 of appendix A-7 to part 60 of this chapter using methane, propane, isobutylene, or the primary HAP being controlled as the calibration gas or Method 25A of appendix A-7 to part 60 using methane, propane, or the primary HAP being controlled as the calibration gas.

(C) Comply with paragraph (d)(1)(iii)(C)(1) of this section and comply with the monitoring frequency according to paragraph (d)(1)(iii)(C)(2) of this section.

(1) The first adsorber in series must be replaced immediately when breakthrough, as defined in § 63.101, is detected between the first and second adsorber. The original second adsorber (or a fresh canister) will become the new first adsorber and a fresh adsorber will become the second adsorber. For purposes of this paragraph, "immediately" means within 8 hours of the detection of a breakthrough for adsorbers of 55 gallons or less, and within 24 hours of the detection of a breakthrough for adsorbers greater than 55 gallons. The owner or operator must monitor at the outlet of the first adsorber within 3 days of replacement to confirm it is performing properly.

(2) Based on the adsorber bed life established according to paragraph (d)(1)(iii)(A) of this section and the date the adsorbent was last replaced, conduct monitoring to detect breakthrough at least monthly if the adsorbent has more than 2 months of life remaining, at least weekly if the adsorbent has between 2 months and 2 weeks of life remaining, and at least daily if the adsorbent has 2 weeks or less of life remaining.

(2) The owner or operator shall submit, as part of the Notification of Compliance Status required by § 63.151 (b), a monitoring plan containing the information specified in paragraph (d)(2)(i) of this section and in either paragraph (d)(2)(ii) or (iii) of this section. This paragraph does not apply if the owner or operator complies with paragraph (d)(1)(iii) of this section.

(i) A description of the parameter or parameters to be monitored to ensure that the control device is being properly operated and maintained, an explanation of the criteria used for

selection of that parameter (or parameters), and the frequency with which monitoring will be performed (e.g., when the liquid level in the storage vessel is being raised); and either

(ii) The documentation specified in paragraph (d)(1)(i) of this section, if the owner or operator elects to prepare a design evaluation; or

(iii) The information specified in paragraph (d)(2)(iii) (A) and (B) of this section if the owner or operator elects to submit the results of a performance test.

(A) Identification of the storage vessel and control device for which the performance test will be submitted, and

(B) Identification of the emission point(s) that share the control device with the storage vessel and for which the performance test will be conducted.

(3) The owner or operator shall submit, as part of the Notification of Compliance Status required by § 63.152(b) of this subpart, the information specified in paragraphs (d)(3)(i) and, if applicable, (d)(3)(ii) of this section. This paragraph does not apply if the owner or operator complies with paragraph (d)(1)(iii) of this section.

(i) The operating range for each monitoring parameter identified in the monitoring plan. The specified operating range shall represent the conditions for which the control device is being properly operated and maintained.

(ii) Results of the performance test described in paragraph (d)(1)(ii) of this section. If the performance test report is submitted electronically through the EPA's CEDRI in accordance with § 63.152(h), the process unit(s) tested, the pollutant(s) tested, and the date that such performance test was conducted may be submitted in the notification of compliance status report in lieu of the performance test results. The performance test results must be submitted to CEDRI by the date the notification of compliance status report is submitted.

(4) The owner or operator shall demonstrate compliance with the requirements of §§ 63.119(e)(3) and (7) (planned routine maintenance of a control device, during which the control device does not meet the specifications of § 63.119 (e)(1) or (2), as applicable, shall not exceed 240 hours per year) by including in each Periodic Report required by § 63.152(c) the information specified in § 63.122(g)(1).

(5) The owner or operator shall monitor the parameters specified in the Notification of Compliance Status required in § 63.152(b) or in the operating permit and shall operate and maintain the control device such that

the monitored parameters remain within the ranges specified in the Notification of Compliance Status.

(6) Except as provided in paragraph (d)(7) of this section, each closed vent system shall be inspected as specified in § 63.148. The initial and annual inspections required by § 63.148(b) shall be done during filling of the storage vessel.

(7) For any fixed roof tank and closed vent system that are operated and maintained under negative pressure, the owner or operator is not required to comply with the requirements specified in § 63.148.

(8) A design evaluation or performance test is not required, if the owner or operator uses a combustion device meeting the criteria in paragraph (d)(8)(i), (ii), (iii), or (iv) of this section.

(i) A boiler or process heater with a design heat input capacity of 44 megawatts or greater.

(ii) A boiler or process heater burning hazardous waste for which the owner or operator:

(A) Has been issued a final permit under part 270 of this chapter and complies with the requirements of part 266, subpart H, of this chapter;

(B) Has certified compliance with the interim status requirements of part 266, subpart H, of this chapter;

(C) Has submitted a Notification of Compliance under § 63.1207(j) and complies with the requirements of subpart EEE of this part; or

(D) Complies with subpart EEE of this part and will submit a Notification of Compliance under § 63.1207(j) by the date the owner or operator would have been required to submit the initial performance test report for this subpart.

(iii) A hazardous waste incinerator for which the owner or operator:

(A) Has been issued a final permit under part 270 of this chapter and complies with the requirements of part 264, subpart O, of this chapter;

(B) Has certified compliance with the interim status requirements of part 265, subpart O, of this chapter;

(C) Has submitted a Notification of Compliance under § 63.1207(j) and complies with the requirements subpart EEE of this part; or

(D) Complies with the requirements subpart EEE of this part and will submit a Notification of Compliance under § 63.1207(j) by the date the owner or operator would have been required to submit the initial performance test report for this subpart.

(iv) A boiler or process heater into which the vent stream is introduced with the primary fuel.

(9) For each source as defined in § 63.101, beginning no later than the

compliance dates specified in § 63.100(k)(11), paragraph (d)(1)(i) of this section no longer applies to storage vessels in ethylene oxide service, as defined in § 63.101.

(e) Except as specified in paragraph (a) of § 63.108, to demonstrate compliance with § 63.119(e) (storage vessel equipped with a closed vent system and control device) using a flare, the owner or operator shall comply with the requirements in paragraphs (e)(1) through (6) of this section.

\* \* \* \* \*

(3) The owner or operator shall demonstrate compliance with the requirements of §§ 63.119(e)(3) and (7) (planned routine maintenance of a flare, during which the flare does not meet the specifications of § 63.119(e)(1), shall not exceed 240 hours per year) by including in each Periodic Report required by § 63.152(c) the information specified in § 63.122(g)(1).

\* \* \* \* \*

(g) To demonstrate compliance with the emission limits and work practice standards specified in § 63.119(a)(5) for storage vessels in ethylene oxide service, owners and operators must meet the requirements specified in § 63.124.

- 65. Amend § 63.122 by:
- a. Revising paragraphs (a)(4) and (c)(2);
- b. Revising and republishing paragraph (g); and
- c. Adding paragraph (i).

The revisions, addition, and republication read as follows:

**§ 63.122 Storage vessel provisions—reporting.**

(a) \* \* \*

(4) The owner or operator shall submit Periodic Reports as required by § 63.152(c) of this subpart and shall submit as part of the Periodic Reports the information specified in paragraphs (d), (e), (f), (g), and (i) of this section.

\* \* \* \* \*

(c) \* \* \*

(2) Except as specified in paragraph (a) of § 63.108, if a flare is used, the owner or operator shall submit the information specified in § 63.120(e)(2)(i), (e)(2)(ii) through (iii).

\* \* \* \* \*

(g) An owner or operator who elects to comply with § 63.119(e) by installing a closed vent system and control device shall submit, as part of the next Periodic Report required by § 63.152(c), the information specified in paragraphs (g)(1) through (4) of this section.

(1) As required by § 63.120(d)(4) and (e)(3), the Periodic Report shall include the information specified in paragraphs

(g)(1)(i) through (iii) of this section for those planned routine maintenance operations that would require the control device not to meet the requirements of § 63.119 (e)(1) or (2), as applicable.

(i) A description of the planned routine maintenance that is anticipated to be performed for the control device during the next 6 months. This description shall include the type of maintenance necessary, planned frequency of maintenance, and lengths of maintenance periods.

(ii) A description of the planned routine maintenance that was performed for the control device during the previous 6 months. This description shall include the type of maintenance performed and the total number of hours during those 6 months that the control device did not meet the requirements of § 63.119 (e)(1) or (2), as applicable, due to planned routine maintenance.

(iii) For each source as defined in § 63.101, beginning no later than the compliance dates specified in § 63.100(k)(10), for each storage vessel for which planned routine maintenance was performed during the previous 6 months, report the identification of the storage vessel and the height of the liquid in the storage vessel at the time the control device is bypassed to conduct the planned routine maintenance and at the time the control device is placed back in service after completing the routine maintenance. These reports shall include the date and time the liquid height was measured.

(2) If a control device other than a flare is used, the Periodic Report shall describe each occurrence when the monitored parameters were outside of the parameter ranges documented in the Notification of Compliance Status in accordance with § 63.120(d)(3)(i). The description shall include the information specified in paragraphs (g)(2)(i) and (ii) of this section.

(i) Identification of the control device for which the measured parameters were outside of the established ranges, the date, and the parameter that was outside of the established ranges, and

(ii) Cause for the measured parameters to be outside of the established ranges.

(3) Except as specified in paragraph (a) of § 63.108, if a flare is used, the Periodic Report shall describe each occurrence when the flare does not meet the general control device requirements specified in § 63.11(b) and shall include the information specified in paragraphs (g)(3)(i) and (ii) of this section.

(i) Identification of the flare which does not meet the general requirements specified in § 63.11(b), and

(ii) Reason the flare did not meet the general requirements specified in § 63.11(b).

(4) For each nonregenerative adsorber and regenerative adsorber that is regenerated offsite subject to the requirements in § 63.120(d)(1)(iii), the owner or operator must report the date of each instance when breakthrough, as defined in § 63.101, is detected between the first and second adsorber and the adsorber is not replaced according to § 63.120(d)(1)(iii)(C)(1) and an identification of the adsorber for which breakthrough was detected.

(i) For pressure vessels subject to the requirements of § 63.119(a)(7), if you obtain an instrument reading greater than 500 ppmv of a leak when monitoring a pressure vessel in accordance with § 63.119(a)(7)(ii), then the Periodic Report must include an identification of the pressure vessel and a copy of the records specified in § 63.123(b)(2).

■ 66. Amend § 63.123 by adding paragraph (b), revising paragraphs (h) and (i)(3)(i), and adding paragraphs (j) and (k) to read as follows:

**§ 63.123 Storage vessel provisions—recordkeeping.**

\* \* \* \* \*

(b) Each owner or operator of a pressure vessel subject to the requirements of § 63.119(a)(7) shall keep readily accessible records as specified in paragraphs (b)(1) and (2) of this section.

(1) The date of each performance test conducted according to § 63.119(a)(7)(ii).

(2) The record of each performance test conducted according to § 63.119(a)(7)(ii), including the following:

(i) Date each defect was detected and the instrument reading (in ppmv) during the performance test.

(ii) Date of the next performance test that shows the instrument reading is less than 500 ppmv and the instrument reading (in ppmv) during the performance test.

(iii) Start and end dates of each period after the date in paragraph (b)(2)(i) of this section when the pressure vessel was completely empty.

(iv) Estimated emissions from each defect.

\* \* \* \* \*

(h) An owner or operator who uses the bypass provisions of § 63.119(f)(3) shall keep in a readily accessible location the records specified in paragraphs (h)(1) through (3) of this section.

(1) The reason it was necessary to bypass the process equipment or fuel gas system;

(2) The duration of the period when the process equipment or fuel gas system was bypassed;

(3) Documentation or certification of compliance with the applicable provisions of § 63.119(f)(3)(i) through (iv).

(i) \* \* \*

(3) \* \* \*

(i) A record of the equipment to be used and the procedures to be followed when reloading the railcar, tank truck, or barge and displacing vapors to the storage vessel from which the liquid originates.

\* \* \* \* \*

(j) For each nonregenerative adsorber and regenerative adsorber that is regenerated offsite subject to the requirements in § 63.120(d)(1)(iii), the owner or operator must keep the applicable records specified in (j)(1) through (3) of this section.

(1) Breakthrough limit and bed life established according to § 63.120(d)(1)(iii)(A).

(2) Each outlet HAP or TOC concentration measured according to § 63.120(d)(1)(iii)(B) and (C).

(3) Date and time you last replaced the adsorbent.

(k) For storage vessels in ethylene oxide service, subject to the requirements of § 63.124, owners and operators must keep the records specified in paragraphs (k)(1) and (2) of this section in addition to those records specified elsewhere in this section.

(1) For storage vessels in ethylene oxide service, records of the concentration of ethylene oxide of the fluid stored in each storage vessel.

(2) If emissions are vented through a closed-vent system to a non-flare control device, then the owner or operator must keep records of all periods during which operating values are outside of the applicable operating limits specified in § 63.124(b)(4) through (6) when regulated material is being routed to the non-flare control device. The record must specify the operating parameter, the applicable limit, and the highest (for maximum operating limits) or lowest (for minimum operating limits) value recorded during the period.

■ 67. Add § 63.124 to read as follows:

**§ 63.124 Process vents and storage vessels that are in ethylene oxide service—procedures to determine compliance.**

This section applies beginning no later than the compliance dates specified in § 63.100(k)(11). In order to demonstrate compliance with the emission limits and work practice

standards specified in § 63.113(j) (for process vents in ethylene oxide service) and § 63.119(a)(5) (for storage vessels in ethylene oxide service), owners and operators must meet the requirements specified in paragraphs (a) and (b) of this section.

(a) For initial compliance, owners and operators must comply with paragraphs (a)(1) through (4) of this section, as applicable.

(1) If an owner or operator chooses to reduce emissions of ethylene oxide by venting emissions through a closed vent system to a flare as specified in § 63.113(j)(1) or § 63.119(a)(5)(i), then the owner or operator must comply with § 63.148 and conduct the initial visible emissions demonstration required by § 63.670(h) as specified in § 63.108.

(2) If an owner or operator chooses to reduce emissions of ethylene oxide by venting emissions through a closed vent system to a non-flare control device that reduces ethylene oxide by greater than or equal to 99.9 percent by weight as specified in § 63.113(j)(2) or § 63.119(a)(5)(ii), then the owner or operator must comply with § 63.148 and paragraphs (a)(2)(i) through (viii) of this section.

(i) Conduct an initial performance test of the control device that is used to comply with the percent reduction requirement at the inlet and outlet of the control device. For purposes of compliance with this paragraph, owners and operators may not use a design evaluation. This paragraph does not apply if the conditions specified in paragraphs (a)(2)(i)(A) through (D) of this section are met for a previously conducted measurement or performance test.

(A) No changes have been made to the process since the time of the measurement or performance test;

(B) The operating conditions and test methods used during measurement or performance test conform to the ethylene oxide related requirements of this subpart;

(C) The control device and process parameter values established during the previously conducted measurement or performance test are used to demonstrate continuous compliance with the ethylene oxide related requirements of this subpart; and

(D) The previously conducted measurement or performance test was completed within the last 60 months.

(ii) Conduct the performance test according to the procedures in § 63.116(c). Except as specified in § 63.109(a)(6), use Method 18 of appendix A–6 to part 60 of this chapter or Method 320 of appendix A to this part to determine the ethylene oxide

concentration. Use Method 1 or 1A of appendix A–1 to part 60 of this chapter to select the sampling sites at each sampling location. Determine the gas volumetric flowrate using Method 2, 2A, 2C, or 2D of appendix A–2 to part 60 of this chapter. Use Method 4 of appendix A–3 to part 60 of this chapter convert the volumetric flowrate to a dry basis.

(iii) Calculate the mass emission rate of ethylene oxide entering the control device and exiting the control device using equations 1 and 2 to this paragraph.

Equations 1 and 2 to Paragraph (a)(2)(iii)

$$E_{\text{inlet}} = K C_{\text{inlet}} M Q_{\text{inlet}} \text{ (Eq. 1)}$$

$$E_{\text{outlet}} = K C_{\text{outlet}} M Q_{\text{outlet}} \text{ (Eq. 2)}$$

Where:

$E_{\text{inlet}}$ ,  $E_{\text{outlet}}$  = Mass rate of ethylene oxide at the inlet and outlet of the control device, respectively, kilogram per hour.

$C_{\text{inlet}}$ ,  $C_{\text{outlet}}$  = Concentration of ethylene oxide in the gas stream at the inlet and outlet of the control device, respectively, dry basis, parts per million by volume.

$M$  = Molecular weight of ethylene oxide, 44.05 grams per gram-mole.

$Q_{\text{inlet}}$ ,  $Q_{\text{outlet}}$  = Flow rate of the gas stream at the inlet and outlet of the control device, respectively, dry standard cubic meter per minute.

$K$  = Constant,  $2.494 \times 10^{-6}$  (parts per million) – 1 (gram-mole per standard cubic meter) (kilogram per gram) (minutes per hour), where standard temperature (gram-mole per standard cubic meter) is 20 °C.

(iv) Calculate the percent reduction from the control device using equation 3 to this paragraph. An owner or operator has demonstrated initial compliance with § 63.113(j)(2) or § 63.119(a)(5)(ii) if the overall reduction of ethylene oxide is greater than or equal to 99.9 percent by weight.

Equation 3 to Paragraph (a)(2)(iv)

$$\text{Percent reduction} = (E_{\text{inlet}} - E_{\text{outlet}}) / E_{\text{inlet}} * 100 \text{ (Eq. 3)}$$

Where:

$E_{\text{inlet}}$ ,  $E_{\text{outlet}}$  = Mass rate of ethylene oxide at the inlet and outlet of the control device, respectively, kilogram per hour, calculated using Equations 1 and 2 to paragraph (a)(2)(iii) of this section.

(v) If a new control device is installed, then conduct a performance test of the new device following the procedures in paragraphs (a)(2)(i) through (iv) of this section.

(vi) If an owner or operator vents emissions through a closed vent system to a scrubber with a reactant tank, then the owner or operator must establish operating parameter limits by monitoring the operating parameters specified in paragraphs (a)(2)(vi)(A) through (C) of this section during the performance test.

(A) Scrubber liquid-to-gas ratio (L/G), determined from the total scrubber liquid inlet flow rate and the inlet or exit gas flow rate. Determine the average L/G during the performance test as the average of the test run averages.

Alternatively, separately monitor the total scrubber liquid flow rate and gas flow rate through the scrubber.

Determine the average total scrubber liquid flow rate and gas flow through the scrubber as the average of the test run averages.

(B) Scrubber liquid pH of the liquid in the reactant tank. The pH may be measured at any point between the discharge from the scrubber column and the inlet to the reactant tank. Determine the average pH during the performance test as the average of the test run averages.

(C) Temperature of the scrubber liquid entering the scrubber column. The temperature may be measured at any point after the heat exchanger and prior to entering the top of the scrubber column. Determine the average inlet scrubber liquid temperature as the average of the test run averages.

(vii) If an owner or operator vents emissions through a closed vent system to a thermal oxidizer, then the owner or operator must establish operating parameter limits by monitoring the operating parameters specified in paragraphs (a)(2)(vii)(A) and (B) of this section during the performance test.

(A) Combustion chamber temperature. Determine the average combustion chamber temperature during the performance test as the average of the test run averages.

(B) Flue gas flow rate. Determine the average flue gas flow rate during the performance test as the average of the test run averages.

(viii) If an owner or operator vents emissions through a closed vent system to a control device other than a flare, scrubber with a reactant tank, or thermal oxidizer, then the owner or operator must notify the Administrator of the operating parameters that are planned to be monitored during the performance test prior to establishing operating parameter limits for the control device.

(3) If an owner or operator chooses to reduce emissions of ethylene oxide by venting emissions through a closed vent system to a non-flare control device that reduces ethylene oxide to less than 1 ppmv as specified in § 63.113(j)(2) or § 63.119(a)(5)(ii), then the owner or operator must comply with § 63.148 and either paragraph (a)(3)(i) or (ii) of this section.

(i) Install a continuous emissions monitoring system (CEMS) to continuously monitor the ethylene

oxide concentration at the exit of the control device. The CEMS must meet the requirements of either paragraph (a)(3)(i)(A) or (B) of this section. Comply with the requirements specified in § 63.2450(j) for CEMS.

(A) An FTIR CEMS meeting the requirements of Performance Specification 15 of appendix B to part 60 of this chapter.

(B) A gas chromatographic CEMS meeting the requirements of Performance Specification 9 of appendix B to part 60 of this chapter.

(i) If the owner or operator does not install a CEMS under paragraph (a)(3)(i) of this section, then the owner or operator must comply with paragraphs (a)(3)(ii)(A) through (C) of this section.

(A) Conduct an initial performance test at the outlet of the control device that is used to comply with the concentration requirement.

(B) Conduct the performance test according to the procedures in § 63.116(c). Except as specified in § 63.109(a)(6), use Method 18 of appendix A–6 to part 60 of this chapter or Method 320 of appendix A to this part to determine the ethylene oxide concentration. If the non-flare control device is a combustion device, correct the ethylene oxide concentration to 3 percent oxygen according to § 63.116(c)(iii)(B), except “TOC or organic HAP” and “TOC (minus methane and ethane) or organic HAP” in the Variables  $C_a$  and  $C_m$  must be replaced with “ethylene oxide”. An owner or operator has demonstrated initial compliance with § 63.113(j)(2) or § 63.119(a)(5)(ii), if the ethylene oxide concentration is less than 1 ppmv.

(C) Comply with the requirements specified in paragraphs (a)(2)(v) through (viii) of this section, as applicable.

(4) If owners and operators choose to reduce emissions of ethylene oxide by venting emissions through a closed vent system to a non-flare control device that reduces ethylene oxide to less than 5 pounds per year for all combined process vents within the process as specified in § 63.113(j)(2), then the owner or operator must comply with § 63.148 and paragraphs (a)(4)(i) through (iv) of this section.

(i) Conduct an initial performance test of the control device that is used to comply with the mass emission limit requirement at the outlet of the control device.

(ii) Conduct the performance test according to the procedures in § 63.116(c). Except as specified in § 63.109(a)(6), use Method 18 of appendix A–6 to part 60 of this chapter or Method 320 of appendix A to this part to determine the ethylene oxide

concentration. Use Method 1 or 1A of appendix A–1 to part 60 of this chapter to select the sampling site. Determine the gas volumetric flowrate using Method 2, 2A, 2C, or 2D of 40 CFR part 60, appendix A–2. Use Method 4 of appendix A–3 to part 60 of this chapter to convert the volumetric flowrate to a dry basis.

(iii) Calculate the mass emission rate of ethylene oxide exiting the control device using Equation 2 to paragraph (a)(2)(iii) of this section. An owner or operator has demonstrated initial compliance with § 63.113(j)(2) if the ethylene oxide from all process vents (controlled and uncontrolled) within the process is less than 5 pounds per year when combined.

(iv) Comply with the requirements specified in paragraphs (a)(2)(v) through (viii) of this section, as applicable.

(b) For continuous compliance, owners and operators must comply with paragraphs (b)(1) through (6) of this section, as applicable.

(1) If an owner or operator chooses to reduce emissions of ethylene oxide by venting emissions through a closed vent system to a flare as specified in § 63.113(j)(1) or § 63.119(a)(5)(i), then the owner or operator must comply with §§ 63.148 and 63.108.

(2) If you choose to reduce emissions of ethylene oxide by venting emissions through a closed-vent system to a non-flare control device that reduces ethylene oxide to less than 1 ppmv as specified in § 63.113(j)(2) or § 63.119(a)(5)(ii), and you choose to comply with paragraph (a)(3)(i) of this section, then continuously monitor the ethylene oxide concentration at the exit of the control device using an FTIR CEMS meeting the requirements of Performance Specification 15 of appendix B to part 60 of this chapter and § 63.2450(j). If an owner or operator uses an FTIR CEMS, then the owner or operator does not need to conduct the performance testing required in paragraph (b)(3) of this section or the operating parameter monitoring required in paragraphs (b)(4) through (6) of this section.

(3) Conduct a performance test no later than 60 months after the previous performance test and reestablish operating parameter limits following the procedures in paragraph (a)(2) through (4) of this section. The Administrator may request a repeat performance test at any time. For purposes of compliance with this paragraph, owners and operators may not use a design evaluation.

(4) If an owner or operator vents emissions through a closed vent system to a scrubber with a reactant tank, then

the owner or operator must comply with § 63.148 and meet the operating parameter limits specified in paragraphs (b)(4)(i) through (v) of this section.

(i) Minimum scrubber liquid-to-gas ratio (L/G), equal to the average L/G measured during the most recent performance test. Determine total scrubber liquid inlet flow rate with a flow sensor with a minimum accuracy of at least  $\pm 5$  percent over the normal range of flow measured, or 1.9 liters per minute (0.5 gallons per minute), whichever is greater. Determine gas flow rate at either the inlet or the exit of the scrubber with a flow sensor with a minimum accuracy of at least  $\pm 5$  percent over the normal range of flow measured, or 280 liters per minute (10 cubic feet per minute), whichever is greater. If gas flow rate is determined at the inlet of the scrubber, ensure that all gas flow through the scrubber is accounted for at the measurement location. Compliance with the minimum L/G operating limit must be determined continuously on a 1-hour block basis. Alternatively, minimum total scrubber liquid flow rate, equal to the average total scrubber liquid inlet flow rate measured during the most recent performance test, and maximum gas flow rate through the scrubber, equal to the average gas flow rate through the scrubber during the most recent performance test. Compliance with the total scrubber liquid flow rate and gas flow rate through the scrubber must be determined continuously on a 1-hour block basis.

(ii) Maximum scrubber liquid pH of the liquid in the reactant tank, equal to the average pH measured during the most recent performance test. Compliance with the pH operating limit must be determined continuously on a 1-hour block basis. Use a pH sensor with a minimum accuracy of  $\pm 0.2$  pH units.

(iii) Pressure drop across the scrubber column, within the pressure drop range specified by the manufacturer or established based on engineering analysis. Compliance with the pressure drop operating limit must be determined continuously on a 1-hour block basis. Use pressure sensors with a minimum accuracy of  $\pm 5$  percent over the normal operating range or 0.12 kilopascals, whichever is greater.

(iv) Maximum temperature of the scrubber liquid entering the scrubber column, equal to the average temperature measured during the most recent performance test. Compliance with the inlet scrubber liquid temperature operating limit must be determined continuously on a 1-hour block basis. Use a temperature sensor



with a minimum accuracy of ±1 percent over the normal range of the temperature measured, expressed in degrees Celsius, or 2.8 degrees Celsius, whichever is greater.

(v) Liquid feed pressure to the scrubber column within the feed pressure range specified by the manufacturer or established based on engineering analysis. Compliance with the liquid feed pressure operating limit must be determined continuously on a 1-hour block basis. Use a pressure sensor with a minimum accuracy of ±5 percent over the normal operating range or 0.12 kilopascals, whichever is greater.

(5) If an owner or operator vents emissions through a closed vent system to a thermal oxidizer, then the owner or operator must comply with § 63.148, and the owner or operator must meet the operating parameter limits specified in paragraphs (b)(5)(i) and (ii) of this section and the requirements in paragraph (b)(5)(iii) of this section.

(i) Minimum combustion chamber temperature, equal to the average combustion chamber temperature measured during the most recent performance test. Determine combustion chamber temperature with a temperature sensor with a minimum accuracy of at least ±1 percent over the normal range of temperature measured, expressed in degrees Celsius, or 2.8 degrees Celsius, whichever is greater. Compliance with the minimum combustion chamber temperature operating limit must be determined continuously on a 1-hour block basis.

(ii) Maximum flue gas flow rate, equal to the average flue gas flow rate measured during the most recent performance test. Determine flue gas flow rate with a flow sensor with a minimum accuracy of at least ±5 percent over the normal range of flow measured, or 280 liters per minute (10 cubic feet per minute), whichever is greater. Compliance with the maximum flue gas flow rate operating limit must be determined continuously on a 1-hour block basis.

(iii) The owner or operator must maintain the thermal oxidizer in accordance with good combustion practices that ensure proper combustion. Good combustion practices include, but are not limited to, proper burner maintenance, proper burner alignment, proper fuel to air distribution and mixing, routine inspection, and preventative maintenance.

(6) If an owner or operator vents emissions through a closed vent system to a control device other than a flare, scrubber with a reactant tank, or thermal oxidizer, then the owner or operator must comply with § 63.148, and the

owner or operator must monitor the operating parameters identified in paragraph (a)(2)(viii) of this section and meet the established operating parameter limits to ensure continuous compliance. The frequency of monitoring and averaging time will be determined based upon the information provided to the Administrator.

■ 68. Amend § 63.126 by revising paragraphs (b)(1), (b)(2)(i), (d)(1)(i) and (ii), (d)(3)(i), (h) and (i) to read as follows:

**§ 63.126 Transfer operations provisions—reference control technology.**

\* \* \* \* \*

(b) \* \* \*

(1) Use a control device to reduce emissions of total organic hazardous air pollutants by 98 weight-percent or to an exit concentration of 20 parts per million by volume. For combustion devices, the emission reduction or concentration shall be calculated on a dry basis, corrected to 3-percent oxygen. If a boiler or process heater is used to comply with the percent reduction requirement, then the vent stream shall be introduced into the flame zone of such a device. Compliance may be achieved by using any combination of combustion, recovery, and/or recapture devices.

(2) \* \* \*

(i) Except as specified in § 63.108(a), the flare shall comply with the requirements of § 63.11(b).

\* \* \* \* \*

(d) \* \* \*

(1) \* \* \*

(i) Except as provided in paragraph (d)(1)(ii) of this section, the halogen reduction device shall reduce overall emissions of hydrogen halides and halogens, as defined in § 63.111, by 99 percent or shall reduce the outlet mass emission rate of total hydrogen halides and halogens to 0.45 kilograms per hour or less.

(ii) If a scrubber or other halogen reduction device was installed prior to December 31, 1992, the halogen reduction device shall reduce overall emissions of hydrogen halides and halogens, as defined in § 63.111, by 95 percent or shall reduce the outlet mass of total hydrogen halides and halogens to less than 0.45 kilograms per hour.

\* \* \* \* \*

(3) \* \* \*

(i) The vent stream concentration of each organic compound containing halogen atoms (parts per million by volume by compound) shall be determined based on the following procedures:

(A) Process knowledge that no halogen or hydrogen halides are present in the process, or

(B) Applicable engineering assessment as specified in § 63.115(d)(1)(iii), or

(C) Concentration of organic compounds containing halogens measured by Method 18 of appendix A to part 60 of this chapter,

(D) Any other method or data that has been validated according to the applicable procedures in Method 301 of appendix A of this part, or

(E) ASTM D6420–18 (incorporated by reference, see § 63.14) may also be used in lieu of Method 18 of appendix A–6 to part 60 of this chapter, if the target compounds are all known and are all listed in section 1.1 of ASTM D6420–18 as measurable; ASTM D6420–18 must not be used for methane and ethane; and ASTM D6420–18 may not be used as a total VOC method.

\* \* \* \* \*

(h) Except as specified in paragraph (h)(1) of this section, the owner or operator of a transfer rack subject to the provisions of this subpart shall ensure that no pressure-relief device in the transfer rack's vapor collection system or in the organic hazardous air pollutants loading equipment of each tank truck or railcar shall begin to open during loading. Pressure relief devices needed for safety purposes are not subject to this paragraph (h).

(1) For each source as defined in § 63.101, beginning no later than the compliance dates specified in § 63.100(k)(10), this paragraph (h) does not apply. Instead, pressure relief devices are subject to the requirements specified in § 63.165(e).

(2) [Reserved]

(i) Each valve in the vent system that would divert the vent stream to the atmosphere, either directly or indirectly, shall be secured in a non-diverting position using a carseal or a lock-and-key type configuration, or shall be equipped with a flow indicator. Except as specified in paragraph (i)(1) of this section, equipment such as low leg drains, high point bleeds, analyzer vents, open-ended valves or lines, and pressure relief devices needed for safety purposes is not subject to this paragraph (i).

(1) For each source as defined in § 63.101, on and after July 15, 2027, the last sentence in paragraph (i) of this section no longer applies. Instead, the exemptions specified in paragraphs (i)(1)(i) and (ii) of this section apply.

(i) Except for pressure relief devices subject to § 63.165(e)(4) of subpart H of this part, equipment such as low leg

drains and equipment subject to the requirements of subpart H of this part are not subject to this paragraph (i).

(ii) Open-ended valves or lines that use a cap, blind flange, plug, or second valve and follow the requirements specified in § 60.482–6(a)(2), (b), and (c) or follow requirements codified in another regulation that are the same as § 60.482–6(a)(2), (b), and (c) are not subject to this paragraph (i).

(2) [Reserved]

■ 69. Amend § 63.127 by:

■ a. Revising paragraphs (a)(2), (a)(4)(ii)(C), and (b)(3);

■ b. Adding paragraph (b)(4); and

■ c. Revising and republishing paragraph (d).

The revisions, addition, and republication read as follows:

**§ 63.127 Transfer operations provisions—monitoring requirements.**

(a) \* \* \*

(2) Where a flare is used, except as specified in § 63.108(a), a device (including but not limited to a thermocouple, infrared sensor, or an ultra-violet beam sensor) capable of continuously detecting the presence of a pilot flame is required.

\* \* \* \* \*

(4) \* \* \*

(ii) \* \* \*

(C) The owner or operator may prepare and implement a gas stream flow determination plan that documents an appropriate method which will be used to determine the gas stream flow. The plan shall require determination of gas stream flow by a method which will at least provide a value for either a representative or the highest gas stream flow anticipated in the scrubber during representative operating conditions other than start-ups, shutdowns, or malfunctions. The plan shall include a description of the methodology to be followed and an explanation of how the selected methodology will reliably determine the gas stream flow, and a description of the records that will be maintained to document the determination of gas stream flow. The owner or operator shall maintain the plan as specified in § 63.103(c). For each source as defined in § 63.101, on and after July 15, 2027, the phrase “other than start-ups, shutdowns, or malfunctions” in this paragraph no longer applies.

(b) \* \* \*

(3) Except as specified in paragraph (b)(4) of this section, where a carbon adsorber is used, an integrating regeneration stream flow monitoring device having an accuracy of ±10 percent or better, capable of recording the total regeneration stream mass flow

for each regeneration cycle; and a carbon bed temperature monitoring device, capable of recording the temperature of the carbon bed after regeneration and within 15 minutes of completing any cooling cycle shall be used.

(4) Beginning no later than the compliance dates specified in § 63.100(k)(10), if the owner or operator vents emissions through a closed vent system to an adsorber(s) that cannot be regenerated or a regenerative adsorber(s) that is regenerated offsite, then the owner or operator must install a system of two or more adsorber units in series and comply with the requirements specified in paragraphs (b)(4)(i) through (iii) of this section.

(i) Conduct an initial performance test or design evaluation of the adsorber and establish the breakthrough limit and adsorber bed life.

(ii) Monitor the HAP or total organic compound (TOC) concentration through a sample port at the outlet of the first adsorber bed in series according to the schedule in paragraph (b)(4)(iii)(B) of this section. The owner or operator must measure the concentration of HAP or TOC using either a portable analyzer, in accordance with Method 21 of appendix A–7 to part 60 of this chapter using methane, propane, isobutylene, or the primary HAP being controlled as the calibration gas or Method 25A of part 60, appendix A–7, using methane, propane, or the primary HAP being controlled as the calibration gas.

(iii) Comply with paragraph (b)(4)(iii)(A) of this section and comply with the monitoring frequency according to paragraph (b)(4)(iii)(B) of this section.

(A) The first adsorber in series must be replaced immediately when breakthrough, as defined in § 63.101, is detected between the first and second adsorber. The original second adsorber (or a fresh canister) will become the new first adsorber and a fresh adsorber will become the second adsorber. For purposes of this paragraph, “immediately” means within 8 hours of the detection of a breakthrough for adsorbers of 55 gallons or less, and within 24 hours of the detection of a breakthrough for adsorbers greater than 55 gallons. The owner or operator must monitor at the outlet of the first adsorber within 3 days of replacement to confirm it is performing properly.

(B) Based on the adsorber bed life established according to paragraph (b)(4)(i) of this section and the date the adsorber was last replaced, conduct monitoring to detect breakthrough at least monthly if the adsorbent has more than 2 months of life remaining, at least

weekly if the adsorbent has between 2 months and 2 weeks of life remaining, and at least daily if the adsorbent has 2 weeks or less of life remaining.

\* \* \* \* \*

(d) The owner or operator of a Group 1 transfer rack using a closed vent system that contains bypass lines that could divert a vent stream flow away from the control device used to comply with § 63.126(b) shall comply with paragraph (d)(1) or (2) and (d)(3) of this section. Except as specified in paragraph (d)(3) of this section, equipment such as low leg drains, high point bleeds, analyzer vents, open-ended valves or lines, and pressure relief valves needed for safety purposes are not subject to this paragraph.

(1) Properly install, maintain, and operate a flow indicator that takes a reading at least once every 15 minutes. Records shall be generated as specified in § 63.130(b). The flow indicator shall be installed at the entrance to any bypass line that could divert the vent stream away from the control device to the atmosphere; or

(2) Secure the bypass line valve in the closed position with a car-seal or a lock-and-key type configuration.

(i) A visual inspection of the seal or closure mechanism shall be performed at least once every month to ensure that the valve is maintained in the closed position and the vent stream is not diverted through the bypass line.

(ii) If a car-seal has been broken or a valve position changed, the owner or operator shall record that the vent stream has been diverted. The car-seal or lock-and-key combination shall be returned to the secured position as soon as practicable but not later than 15 calendar days after the change in position is detected.

(3) For each source as defined in § 63.101, beginning no later than the compliance dates specified in § 63.100(k)(10):

(i) The use of a bypass line at any time on a closed vent system to divert emissions (subject to the emission standards in § 63.112) to the atmosphere or to a control device not meeting the requirements specified in this subpart is an emissions standards violation.

(ii) The last sentence in paragraph (d) of this section no longer applies. Instead, the exemptions specified in paragraph (d)(3)(ii)(A) and (B) of this section apply.

(A) Except for pressure relief devices subject to § 63.165(e)(4), equipment such as low leg drains and equipment subject to the requirements of subpart H of this part are not subject to this paragraph (d).

(B) Open-ended valves or lines that use a cap, blind flange, plug, or second valve and follow the requirements specified in § 60.482–6(a)(2), (b), and (c) or follow requirements codified in another regulation that are the same as § 60.482–6(a)(2), (b), and (c) are not subject to this paragraph (d).

\* \* \* \* \*

- 70. Amend § 63.128 by:
- a. Revising and republishing paragraphs (a)(9) and (10);
- b. Adding paragraph (a)(12); and
- c. Revising paragraphs (b) introductory text, (c)(2) and (7), (f)(2), and (h)(1)(iv).

The revisions, addition, and republications read as follows:

**§ 63.128 Transfer operations provisions—test methods and procedures.**

(a) \* \* \*

(9) For the purpose of determining compliance with the 20 parts per million by volume limit in § 63.126(b)(1), Method 18 or Method 25A of appendices A–6 and A–7 to part 60 of this chapter, respectively, shall be used to measure either organic compound concentration or organic HAP concentration, except as provided in paragraphs (a)(11) and (12) of this section.

(i) If Method 25A of appendix A–7 to part 60 of this chapter is used, the following procedures shall be used to calculate the concentration of organic compounds (C<sub>T</sub>):

(A) The principal organic HAP in the vent stream shall be used as the calibration gas.

(B) The span value for Method 25A of appendix A–7 to part 60 of this chapter shall be between 1.5 and 2.5 times the concentration being measured.

(C) Use of Method 25A of appendix A–7 to part 60 of this chapter is acceptable if the response from the high-level calibration gas is at least 20 times the standard deviation of the response from the zero calibration gas when the instrument is zeroed on the most sensitive scale.

(D) The concentration of TOC shall be corrected to 3 percent oxygen using the procedures and equation in paragraph (a)(9)(v) of this section.

(ii) If Method 18 of appendix A–6 to 40 CFR part 60 is used to measure the concentration of organic compounds or ASTM D6420–18 (incorporated by reference, see § 63.14), the organic compound concentration (C<sub>T</sub>) is the sum of the individual components and shall be computed for each run using the following equation:

Equation 1 to Paragraph (a)(9)(ii)

$$C_T = \sum_{j=1}^n C_j$$

Where:

C<sub>T</sub> = Total concentration of organic compounds (minus methane and ethane), dry basis, parts per million by volume.

C<sub>j</sub> = Concentration of sample components j, dry basis, parts per million by volume.

n = Number of components in the sample.

(iii) If an owner or operator uses Method 18 of appendix A–6 to 40 CFR part 60 or ASTM D6420–18 (incorporated by reference, see § 63.14) to compute total organic HAP concentration rather than organic compounds concentration, the equation in paragraph (a)(9)(ii) of this section shall be used except that only organic HAP species shall be summed. The list of organic HAP's is provided in table 2 to subpart F of this part.

(iv) Method 3A of appendix A–2 to 40 CFR part 60 or the manual method in ANSI/ASME PTC 19.10–1981 (incorporated by reference, see § 63.14) shall be used to determine the oxygen concentration. The sampling site shall be the same as that of the organic hazardous air pollutants or organic compound samples, and the samples shall be taken during the same time that the organic hazardous air pollutants or organic compound samples are taken.

(v) The organic compound concentration corrected to 3 percent oxygen (C<sub>c</sub>) shall be calculated using the following equation:

Equation 2 to Paragraph (a)(9)(v)

$$C_c = C_T \left( \frac{17.9}{20.9 - \%O_{2d}} \right)$$

Where:

C<sub>c</sub> = Concentration of organic compounds corrected to 3 percent oxygen, dry basis, parts per million by volume.

C<sub>T</sub> = Total concentration of organic compounds, dry basis, parts per million by volume.

%O<sub>2d</sub> = Concentration of oxygen, dry basis, percent by volume.

(10) For the purpose of determining compliance with the 98-percent reduction requirement in § 63.126(b)(1), Method 18 or Method 25A of appendices A–6 and A–7 to part 60 of this chapter, respectively, shall be used, except as provided in paragraphs (a)(11) and (12) of this section.

(i) For the purpose of determining compliance with the reduction efficiency requirement, organic compound concentration may be

measured in lieu of organic HAP concentration.

(ii) If Method 25A of appendix A–7 to part 60 of this chapter is used to measure the concentration of organic compounds (C<sub>T</sub>), the principal organic HAP in the vent stream shall be used as the calibration gas.

(A) An emission testing interval shall consist of each 15-minute period during the performance test. For each interval, a reading from each measurement shall be recorded.

(B) The average organic compound concentration and the volume measurement shall correspond to the same emissions testing interval.

(C) The mass at the inlet and outlet of the control device during each testing interval shall be calculated as follows:

Equation 3 to Paragraph (a)(10)(ii)(C)

$$M_j = FKVs C_T$$

Where:

M<sub>j</sub> = Mass of organic compounds emitted during testing interval j, kilograms.

V<sub>s</sub> = Volume of air-vapor mixture exhausted at standard conditions, 20 °C and 760 millimeters mercury, standard cubic meters.

C<sub>T</sub> = Total concentration of organic compounds (as measured) at the exhaust vent, parts per million by volume, dry basis.

K = Density, kilograms per standard cubic meter organic HAP, 659 kilograms per standard cubic meter organic HAP.

(Note: The density term cancels out when the percent reduction is calculated. Therefore, the density used has no effect. The density of hexane is given so that it can be used to maintain the units of M<sub>j</sub>.)

F = 10<sup>-6</sup> = Conversion factor, (cubic meters organic HAP per cubic meters air) \* (parts per million by volume)<sup>-1</sup>.

(D) The organic compound mass emission rates at the inlet and outlet of the control device shall be calculated as follows:

Equations 4 and 5 to Paragraph (a)(10)(ii)(D)

$$E_i = \frac{\sum_{j=1}^n M_{ij}}{T}$$

$$E_o = \frac{\sum_{j=1}^n M_{oj}}{T}$$

Where:

E<sub>i</sub>, E<sub>o</sub> = Mass flow rate of organic compounds at the inlet (i) and outlet (o) of the combustion or recovery device, kilograms per hour.

$M_{ij}$ ,  $M_{oj}$  = Mass of organic compounds at the inlet (i) or outlet (o) during testing interval j, kilograms.  
 T = Total time of all testing intervals, hours.  
 n = Number of testing intervals.

(iii) If Method 18 of appendix A–6 to 40 CFR part 60 or ASTM D6420–18 (incorporated by reference, see § 63.14) is used to measure organic compounds, the mass rates of organic compounds ( $E_i$ ,  $E_o$ ) shall be computed using the following equations:

Equations 6 and 7 to Paragraph (a)(10)(iii)

$$E_i = K_2 \left( \sum_{j=1}^n C_{ij} MW_{ij} \right) Q_i$$

$$E_o = K_2 \left( \sum_{j=1}^n C_{oj} MW_{oj} \right) Q_o$$

Where:

$C_{ij}$ ,  $C_{oj}$  = Concentration of sample component j of the gas stream at the inlet and outlet of the control device, respectively, dry basis, parts per million by volume.  
 $MW_{ij}$ ,  $MW_{oj}$  = Molecular weight of sample component j of the gas stream at the inlet and outlet of the control device, respectively, gram/gram-mole.  
 $Q_i$ ,  $Q_o$  = Flow rate of gas stream at the inlet and outlet of the control device, respectively, dry standard cubic meter per minute.  
 $K_2$  = Constant,  $2.494 \times 10^{-6}$  (parts per million)<sup>-1</sup> (gram-mole per standard cubic meter) (kilogram/gram) (minute/hour), where standard temperature for (gram-mole per standard cubic meter) is 20 °C.

(iv) Where Method 18 or 25A of appendices A–6 and A–7 to part 60 of this chapter, respectively, or ASTM D6420–18 (incorporated by reference, see § 63.14) is used to measure the percent reduction in organic compounds, the percent reduction across the control device shall be calculated as follows:

Equation 8 to Paragraph (a)(10)(iv)

$$R = \frac{E_i - E_o}{E_i} (100)$$

Where:

R = Control efficiency of control device, percent.  
 $E_i$  = Mass emitted or mass flow rate of organic compounds at the inlet to the combustion or recovery device as calculated under paragraph (a)(10)(ii)(D) or (a)(10)(iii) of this section, kilogram per hour.  
 $E_o$  = Mass emitted or mass flow rate of organic compounds at the outlet of the combustion or recovery device, as calculated under paragraph (a)(10)(ii)(D)

or (a)(10)(iii) of this section, kilogram per hour.

\* \* \* \* \*  
 (12) ASTM D6420–18 (incorporated by reference, see § 63.14) may also be used in lieu of Method 18 of appendix A–6 to part 60 of this chapter, if the target compounds are all known and are all listed in section 1.1 of ASTM D6420–18 as measurable; ASTM D6420–18 must not be used for methane and ethane; and ASTM D6420–18 may not be used as a total VOC method.

(b) Except as specified in § 63.108(a), when a flare is used to comply with § 63.126(b)(2), the owner or operator shall comply with paragraphs (b)(1) through (3) of this section. The owner or operator is not required to conduct a performance test to determine percent emission reduction or outlet organic HAP or TOC concentration.

\* \* \* \* \*  
 (c) \* \* \*  
 (2) When a boiler or process heater burning hazardous waste is used for which the owner or operator:

- (i) Has been issued a final permit under part 270 of this chapter and complies with the requirements of part 266, subpart H, of this chapter;
- (ii) Has certified compliance with the interim status requirements of part 266, subpart H, of this chapter;
- (iii) Has submitted a Notification of Compliance under § 63.1207(j) and complies with the requirements of subpart EEE of this part; or
- (iv) Complies with subpart EEE of this part and will submit a Notification of Compliance under § 63.1207(j) by the date the owner or operator would have been required to submit the initial performance test report for this subpart.

\* \* \* \* \*  
 (7) When a hazardous waste incinerator is used for which the owner or operator:

- (i) Has been issued a final permit under part 270 of this chapter and complies with the requirements of part 264, subpart O, of this chapter;
- (ii) Has certified compliance with the interim status requirements of part 265, subpart O, of this chapter;
- (iii) Has submitted a Notification of Compliance under § 63.1207(j) and complies with the requirements subpart EEE of this part; or
- (iv) Complies with the requirements subpart EEE of this part and will submit a Notification of Compliance under § 63.1207(j) by the date the owner or operator would have been required to submit the initial performance test report for this subpart.

\* \* \* \* \*  
 (f) \* \* \*

(2) A pressure measurement device which has a precision of ±2.5 millimeters of mercury or better and which is capable of measuring above the pressure at which the tank truck or railcar is to be tested for vapor tightness.

(h) \* \* \*  
 (1) \* \* \*  
 (iv) Except as provided in § 63.127(b)(4), for carbon adsorbers, the design evaluation shall include the affinity of the organic HAP vapors for carbon, the amount of carbon in each bed, the number of beds, the humidity of the feed gases, the temperature of the feed gases, the flow rate of the organic HAP emission stream, the desorption schedule, the regeneration stream pressure or temperature, and the flow rate of the regeneration stream. For vacuum desorption, pressure drop shall be included.

\* \* \* \* \*  
 ■ 71. Amend § 63.129 by revising paragraphs (a)(2), (a)(5) introductory text and (d) to read as follows:

**§ 63.129 Transfer operations provisions—reporting and recordkeeping for performance tests and notification of compliance status.**

(a) \* \* \*  
 (2) Include the data specified in paragraphs (a)(4) through (a)(7) of this section in the Notification of Compliance Status report as specified in § 63.152(b) of this subpart. If the performance test report is submitted electronically through the EPA’s CEDRI in accordance with § 63.152(h), the process unit(s) tested, the pollutant(s) tested, and the date that such performance test was conducted may be submitted in the notification of compliance status report in lieu of the performance test results. The performance test results must be submitted to CEDRI by the date the notification of compliance status report is submitted.

\* \* \* \* \*  
 (5) Except as specified in paragraph (a) of § 63.108, record and report the following when using a flare to comply with § 63.126(b)(2):

\* \* \* \* \*  
 (d) Each owner or operator shall maintain a record describing in detail the vent system used to vent each affected transfer vent stream to a control device. This document shall list all valves and vent pipes that could vent the stream to the atmosphere, thereby bypassing the control device; identify which valves are secured by car-seals or lock-and-key type configurations; and indicate the position (open or closed) of those valves which have car-seals.

Except as specified in paragraph (d)(1) of this section, equipment leaks such as low leg drains, high point bleeds, analyzer vents, open-ended valves or lines, and pressure relief valves needed for safety purposes are not subject to this paragraph.

(1) For each source as defined in § 63.101, on and after July 15, 2027, the last sentence in paragraph (d) of this section no longer applies. Instead, the exemptions specified in paragraph (d)(1)(i) and (d)(1)(ii) of this section apply.

(i) Except for pressure relief devices subject to § 63.165(e)(4) of subpart H of this part, equipment such as low leg drains and equipment subject to the requirements of subpart H of this part are not subject to this paragraph (d) of this section.

(ii) Open-ended valves or lines that use a cap, blind flange, plug, or second valve and follow the requirements specified in 40 CFR 60.482–6(a)(2), (b), and (c) or follow requirements codified in another regulation that are the same as 40 CFR 60.482–6(a)(2), (b), and (c) are not subject to this paragraph (d) of this section.

(2) [Reserved]

\* \* \* \* \*

■ 72. Amend § 63.130 by:

- a. Revising paragraph (a)(1);
- b. Revising and publishing paragraphs (a)(2) and (b);
- c. Revising paragraph (c); and
- d. Revising and republishing paragraph (d).

The revisions and republications read as follows:

**§ 63.130 Transfer operations provisions—periodic recordkeeping and reporting.**

(a) \* \* \*

(1) While the transfer vent stream is being vented to the control device, continuous records of the equipment operating parameters specified to be monitored under § 63.127, and listed in table 7 of this subpart or specified by the Administrator in accordance with §§ 63.127(c) and 63.129(b). For flares complying with § 63.11(b), the hourly records and records of pilot flame outages specified in table 7 shall be maintained in place of continuous records. For flares complying with § 63.108, the owner or operator must comply with the recordkeeping requirements specified therein.

(2) Records of the daily average value of each monitored parameter for each operating day determined according to the procedures specified in § 63.152(f), except as provided in paragraphs (a)(2)(i) through (a)(2)(iv) of this section.

(i) For flares, except as specified in paragraph (a) of § 63.108, records of the

times and duration of all periods during which the pilot flame is absent shall be kept rather than daily averages.

(ii) If carbon adsorber regeneration stream flow and carbon bed regeneration temperature are monitored, the records specified in table 7 to this subpart shall be kept instead of the daily averages.

(iii) Except as specified in paragraph (a)(2)(iv) of this section, records of the duration of all periods when the vent stream is diverted through bypass lines shall be kept rather than daily averages.

(iv) For each flow event from a bypass line subject to the requirements in § 63.127(d) for each source as defined in § 63.101, beginning no later than the compliance dates specified in § 63.100(k)(10), the owner or operator must also maintain records sufficient to determine whether or not the detected flow included flow requiring control. For each flow event from a bypass line requiring control that is released either directly to the atmosphere or to a control device not meeting the requirements in this subpart, the owner or operator must include an estimate of the volume of gas, the concentration of organic HAP in the gas and the resulting emissions of organic HAP that bypassed the control device using process knowledge and engineering estimates.

\* \* \* \* \*

(b) If a vapor collection system containing valves that could divert the emission stream away from the control device is used, each owner or operator of a Group 1 transfer rack subject to the provisions of § 63.127(d) shall keep up-to-date, readily accessible records of:

(1) Hourly records of whether the flow indicator specified under § 63.127(d)(1) was operating and whether a diversion was detected at any time during the hour, as well as records of the times of all periods when the vent stream is diverted from the control device or the flow indicator is not operating.

(2) Where a seal mechanism is used to comply with § 63.127(d)(2), hourly records of flow are not required. In such cases, the owner or operator shall record that the monthly visual inspection of the seals or closure mechanisms has been done, and shall record the occurrence of all periods when the seal mechanism is broken, the bypass line valve position has changed, or the key for a lock-and-key type lock has been checked out, and records of any car-seal that has broken, as listed in table 7 of this subpart.

(3) For each source as defined in § 63.101, beginning no later than the compliance dates specified in § 63.100(k)(10), the owner or operator

must comply with this paragraph in addition to the requirements in paragraphs (b)(1) and (b)(2) of this section. For each flow event from a bypass line subject to the requirements in § 63.127(d), the owner or operator must maintain records sufficient to determine whether or not the detected flow included flow requiring control. For each flow event from a bypass line requiring control that is released either directly to the atmosphere or to a control device not meeting the requirements in this subpart, the owner or operator must include an estimate of the volume of gas, the concentration of organic HAP in the gas and the resulting emissions of organic HAP that bypassed the control device using process knowledge and engineering estimates.

(c) Except as specified in paragraph (a) of § 63.108, each owner or operator of a Group 1 transfer rack who uses a flare to comply with § 63.126(b)(2) shall keep up-to-date, readily accessible records of the flare pilot flame monitoring specified under § 63.127(a)(2).

(d) Each owner or operator of a transfer rack subject to the requirements of § 63.126 shall submit to the Administrator Periodic Reports of the following information according to the schedule in § 63.152(c):

(1) Reports of daily average values of monitored parameters for all operating days when the daily average values were outside the range established in the Notification of Compliance Status or operating permit. Additionally, report the identification of the transfer rack, the monitored parameter out of range, and the date of such occurrences.

(2) Reports of the start date and duration (in hours) of periods when monitoring data are not collected for each excursion caused by insufficient monitoring data as defined in § 63.152(c)(2)(ii)(A).

(3) Reports of the start date and time and duration (in hours) of all periods recorded under paragraph (b)(1) of this section when the vent stream was diverted from the control device, and if applicable, the information in paragraph (d)(7) of this section.

(4) Reports of the start date and time and duration (in hours) recorded under paragraph (b)(2) of this section when maintenance is performed on car-sealed valves, when the car seal is broken, when the bypass line valve position is changed, or the key for a lock-and-key type configuration has been checked out, and if applicable, the information in paragraph (d)(7) of this section.

(5) Except as specified in paragraph (a) of § 63.108, reports of the times and durations of all periods recorded under

paragraph (a)(2)(i) of this section in which all pilot flames of a flare were absent.

(6) Reports of all carbon bed regeneration cycles during which the parameters recorded under paragraph (a)(2)(ii) of this section were outside the ranges established in the Notification of Compliance Status or operating permit. Include the identification of the carbon bed, the monitored parameter that was outside the established range, and the start date, start time, and duration (in hours) for the regeneration cycle in the report.

(7) For each source as defined in § 63.101, beginning no later than the compliance dates specified in § 63.100(k)(10), the owner or operator must comply with this paragraph in addition to the requirements in paragraphs (d)(3) and (d)(4) of this section. For bypass lines subject to the requirements in § 63.127(d), the Periodic Report must include the start date, start time, duration in hours, estimate of the volume of gas in standard cubic feet, the concentration of organic HAP in the gas in parts per million by volume and the resulting mass emissions of organic HAP in pounds that bypass a control device. For periods when the flow indicator is not operating, report the start date, start time, and duration in hours.

\* \* \* \* \*

■ 73. Amend § 63.132 by:

- a. Revising paragraphs (a)(2)(i), (b)(3)(i), and (c)(1);
- b. Revising and republishing paragraph (d);
- c. Revising paragraph (f)(2); and
- d. Adding paragraph (f)(5).

The revisions, addition and republication read as follows:

**§ 63.132 Process wastewater provisions—general.**

- (a) \* \* \*
- (2) \* \* \*

(i) Comply with the applicable requirements for wastewater tanks, surface impoundments, containers, individual drain systems, and oil/water separators as specified in § 63.133 through § 63.137 of this subpart, except as provided in paragraphs (a)(2)(i)(A) through (a)(2)(i)(C) of this section and § 63.138(a)(3).

(A) Except as specified in paragraph (a)(2)(i)(C) of this section, the waste management units may be equipped with pressure relief devices that vent directly to the atmosphere provided the pressure relief device is not used for planned or routine venting of emissions.

(B) Except as specified in paragraph (a)(2)(i)(C) of this section, the pressure relief device remains in a closed

position at all times except when it is necessary for the pressure relief device to open for the purpose of preventing physical damage or permanent deformation of the waste management unit in accordance with good engineering and safety practices.

(C) For each source as defined in § 63.101, beginning no later than the compliance dates specified in § 63.100(k)(10), paragraphs (a)(2)(i)(A) and (a)(2)(i)(B) of this section do not apply. Instead, pressure relief devices are subject to the requirements specified in § 63.165(e) of subpart H of this part.

\* \* \* \* \*

(b) \* \* \*

(3) \* \* \*

(i) Comply with the applicable requirements for wastewater tanks, surface impoundments, containers, individual drain systems, and oil/water separators specified in the requirements of § 63.133 through § 63.137 of this subpart, except as provided in paragraphs (b)(3)(i)(A) through (b)(3)(i)(C) of this section and § 63.138(a)(3) of this subpart.

(A) Except as specified in paragraph (b)(3)(i)(C) of this section, the waste management units may be equipped with pressure relief devices that vent directly to the atmosphere provided the pressure relief device is not used for planned or routine venting of emissions.

(B) Except as specified in paragraph (b)(3)(i)(C) of this section, the pressure relief device remains in a closed position at all times except when it is necessary for the pressure relief device to open for the purpose of preventing physical damage or permanent deformation of the waste management unit in accordance with good engineering and safety practices.

(C) For each source as defined in § 63.101, beginning no later than the compliance dates specified in § 63.100(k)(10), paragraphs (b)(3)(i)(A) and (b)(3)(i)(B) of this section do not apply. Instead, pressure relief devices are subject to the requirements specified in § 63.165(e).

\* \* \* \* \*

(c) \* \* \*

(1) A wastewater stream is a Group 1 wastewater stream for Table 9 compounds if:

(i) The total annual average concentration of Table 9 compounds is greater than or equal to 10,000 parts per million by weight at any flow rate;

(ii) The total annual average concentration of Table 9 compounds is greater than or equal to 1,000 parts per million by weight and the annual average flow rate is greater than or equal to 10 liters per minute; or

(iii) For each source as defined in § 63.101, beginning no later than the compliance dates specified in § 63.100(k)(11), the process wastewater stream contains ethylene oxide such that it is considered to be in ethylene oxide service, as defined in § 63.101.

\* \* \* \* \*

*(d) How to determine Group 1 or Group 2 status for Table 8 compounds.*

This paragraph provides instructions for determining whether a wastewater stream is Group 1 or Group 2 for Table 8 compounds. Annual average concentration for each Table 8 compound shall be determined according to the procedures specified in § 63.144(b). Annual average flow rate shall be determined according to the procedures specified in § 63.144(c).

(1) A wastewater stream is a Group 1 wastewater stream for Table 8 compounds if:

(i) The annual average flow rate is 0.02 liter per minute or greater and the annual average concentration of any individual table 8 compound is 10 parts per million by weight or greater; or

(ii) For each source as defined in § 63.101, beginning no later than the compliance dates specified in § 63.100(k)(11), the process wastewater stream contains ethylene oxide such that it is considered to be in ethylene oxide service, as defined in § 63.101.

(2) A wastewater stream is a Group 2 wastewater stream for Table 8 compounds if it does not meet the criteria specified in paragraph (d)(1)(ii) of this section, and the annual average flow rate is less than 0.02 liter per minute or the annual average concentration for each individual Table 8 compound is less than 10 parts per million by weight.

(3) The owner or operator of a Group 2 wastewater shall re-determine group status for each Group 2 stream, as necessary, to determine whether the stream is Group 1 or Group 2 whenever process changes are made that could reasonably be expected to change the stream to a Group 1 stream. Examples of process changes include, but are not limited to, changes in production capacity, production rate, feedstock type, or whenever there is a replacement, removal, or addition of recovery or control equipment. For purposes of this paragraph (d)(3), process changes do not include: Process upsets; unintentional, temporary process changes; and changes that are within the range on which the original determination was based.

\* \* \* \* \*

(f) \* \* \*

(2) Except as specified in paragraph (f)(5) of this sections, activities included

in maintenance or startup/shutdown/malfunction plans;

\* \* \* \* \*

(5) For each source as defined in § 63.101, on and after July 15, 2027, the phrase "or startup/shutdown/malfunction" in paragraph (f)(2) of this section does not apply.

\* \* \* \* \*

■ 74. Amend § 63.133 by revising paragraphs (a)(2)(i), (b) introductory text, (b)(3) and (b)(4) to read as follows:

**§ 63.133 Process wastewater provisions—wastewater tanks.**

- (a) \* \* \*
(2) \* \* \*

(i) A fixed roof and a closed vent system that routes the organic hazardous air pollutants vapors vented from the wastewater tank to a control device.

\* \* \* \* \*

(b) If the owner or operator elects to comply with the requirements of paragraph (a)(2)(i) of this section, the fixed roof shall meet the requirements of paragraph (b)(1) of this section, the control device shall meet the requirements of paragraph (b)(2) of this section, and the closed vent system shall meet the requirements of paragraph (b)(3) of this section.

\* \* \* \* \*

(3) Except as provided in paragraph (b)(4) of this section, the closed vent system shall be inspected in accordance with the requirements of § 63.148.

(4) For any fixed roof tank and closed vent system that is operated and maintained under negative pressure, the owner or operator is not required to comply with the requirements specified in § 63.148.

\* \* \* \* \*

■ 75. Amend § 63.134 by revising paragraphs (b) introductory text, (b)(4) and (b)(5) to read as follows:

**§ 63.134 Process wastewater provisions—surface impoundments.**

\* \* \* \* \*

(b) The owner or operator shall operate and maintain on each surface impoundment either a cover (e.g., air-supported structure or rigid cover) and a closed vent system that routes the organic hazardous air pollutants vapors vented from the surface impoundment to a control device in accordance with paragraph (b)(1) of this section, or a floating flexible membrane cover as specified in paragraph (b)(2) of this section.

\* \* \* \* \*

(4) Except as provided in paragraph (b)(5) of this section, the closed vent

system shall be inspected in accordance with § 63.148.

(5) For any cover and closed vent system that is operated and maintained under negative pressure, the owner or operator is not required to comply with the requirements specified in § 63.148.

\* \* \* \* \*

■ 76. Amend § 63.135 by revising paragraph (b)(3), adding paragraph (b)(4), and revising paragraphs (d) introductory text, (d)(3) and (d)(4) to read as follows:

**§ 63.135 Process wastewater provisions—containers.**

\* \* \* \* \*

(b) \* \* \*

(3) Except as specified in paragraph (b)(4) of this section, the cover and all openings shall be maintained in a closed position (e.g., covered by a lid) at all times that a Group 1 wastewater stream or residual removed from a Group 1 wastewater stream is in the container except when it is necessary to use the opening for filling, removal, inspection, sampling, or pressure relief events related to safety considerations.

(4) For each source as defined in § 63.101, beginning no later than the compliance dates specified in § 63.100(k)(10), pressure relief devices are subject to the requirements specified in § 63.165(e) of subpart H of this part.

\* \* \* \* \*

(d) During treatment of a Group 1 wastewater stream or residual removed from a Group 1 wastewater stream, including aeration, thermal or other treatment, in a container, whenever it is necessary for the container to be open, the container shall be located within an enclosure with a closed vent system that routes the organic hazardous air pollutants vapors vented from the container to a control device.

\* \* \* \* \*

(3) Except as provided in paragraph (d)(4) of this section, the closed vent system shall be inspected in accordance with § 63.148 of this subpart.

(4) For any enclosure and closed vent system that is operated and maintained under negative pressure, the owner or operator is not required to comply with the requirements specified in § 63.148 of this subpart.

\* \* \* \* \*

■ 77. Amend § 63.136 by revising paragraphs (b)(3) and (4) to read as follows:

**§ 63.136 Process wastewater provisions—individual drain systems.**

\* \* \* \* \*

(b) \* \* \*

(3) Except as provided in paragraph (b)(4) of this section, the closed vent

system shall be inspected in accordance with § 63.148.

(4) For any cover and closed vent system that is operated and maintained under negative pressure, the owner or operator is not required to comply with the requirements specified in § 63.148.

\* \* \* \* \*

■ 78. Amend § 63.137 by revising paragraphs (a)(1), (b) introductory text, (b)(3) and (4) to read as follows:

**§ 63.137 Process wastewater provisions—oil-water separators.**

(a) \* \* \*

(1) A fixed roof and a closed vent system that routes the organic hazardous air pollutants vapors vented from the oil-water separator to a control device. The fixed roof, closed vent system, and control device shall meet the requirements specified in paragraph (b) of this section;

\* \* \* \* \*

(b) If the owner or operator elects to comply with the requirements of paragraphs (a)(1) or (a)(2) of this section, the fixed roof shall meet the requirements of paragraph (b)(1) of this section, the control device shall meet the requirements of paragraph (b)(2) of this section, and the closed vent system shall meet the requirements of paragraph (b)(3) of this section.

\* \* \* \* \*

(3) Except as provided in paragraph (b)(4) of this section, the closed vent system shall be inspected in accordance with the requirements of § 63.148.

(4) For any fixed roof and closed vent system that is operated and maintained under negative pressure, the owner or operator is not required to comply with the requirements of § 63.148.

\* \* \* \* \*

■ 79. Amend § 63.138 by:
■ a. Revising paragraph (b) introductory text and adding paragraph (b)(3);
■ b. Revising paragraph (c) introductory text and adding paragraph (c)(3); and
■ c. Revising paragraphs (h)(1) and (2).

The revisions and additions read as follows:

**§ 63.138 Process wastewater provisions—performance standards for treatment processes managing Group 1 wastewater streams and/or residuals removed from Group 1 wastewater streams.**

\* \* \* \* \*

(b) Control options: Group 1 wastewater streams for Table 9 compounds. The owner or operator shall comply with either paragraph (b)(1) or (b)(2) of this section, and paragraph (b)(3) of this section, if applicable, for the control of Table 9 compounds at new or existing sources.

\* \* \* \* \*

(3) *1 ppmw ethylene oxide concentration.* Reduce, by removal or destruction, the concentration of ethylene oxide to a level less than 1 parts per million by weight as determined in the procedures specified in § 63.145(b) of this subpart.

(c) *Control options: Group 1 wastewater streams for Table 8 compounds.* The owner or operator shall comply with either paragraph (c)(1) or (c)(2) of this section, and paragraph (c)(3) of this section, if applicable, for the control of Table 8 compounds at new sources.

\* \* \* \* \*

(3) *1 ppmw ethylene oxide concentration.* Reduce, by removal or destruction, the concentration of ethylene oxide to a level less than 1 parts per million by weight as determined in the procedures specified in § 63.145(b).

\* \* \* \* \*

(h) \* \* \*

(1) The wastewater stream or residual is discharged to a hazardous waste incinerator for which the owner or operator:

(i) Has been issued a final permit under 40 CFR part 270 and complies with the requirements of 40 CFR part 264, subpart O;

(ii) Has certified compliance with the interim status requirements of 40 CFR part 265, subpart O;

(iii) Has submitted a Notification of Compliance under § 63.1207(j) and complies with the requirements subpart EEE of this part; or

(iv) Complies with the requirements subpart EEE of this part and will submit a Notification of Compliance under § 63.1207(j) by the date the owner or operator would have been required to submit the initial performance test report for this subpart.

(2) The wastewater stream or residual is discharged to a process heater or boiler burning hazardous waste for which the owner or operator:

(i) Has been issued a final permit under 40 CFR part 270 and complies with the requirements of 40 CFR part 266, subpart H;

(ii) Has certified compliance with the interim status requirements of 40 CFR part 266, subpart H;

(iii) Has submitted a Notification of Compliance under § 63.1207(j) and complies with the requirements of subpart EEE of this part; or

(iv) Complies with subpart EEE of this part and will submit a Notification of Compliance under § 63.1207(j) by the date the owner or operator would have been required to submit the initial performance test report for this subpart.

\* \* \* \* \*

■ 80. Amend § 63.139 by revising paragraphs (c) and (d) to read as follows:

**§ 63.139 Process wastewater provisions—control devices.**

\* \* \* \* \*

(c) The control device shall be designed and operated in accordance with paragraph (c)(1), (2), (3), (4), or (5) of this section.

(1) An enclosed combustion device (including but not limited to a vapor incinerator, boiler, or process heater) shall meet the conditions in paragraph (c)(1)(i), (ii), or (iii) of this section, alone or in combination with other control devices. If a boiler or process heater is used as the control device, then the vent stream shall be introduced into the flame zone of the boiler or process heater.

(i) Reduce the total organic compound emissions, less methane and ethane, or total organic hazardous air pollutants emissions vented to the control device by 95 percent by weight or greater;

(ii) Achieve an outlet total organic compound concentration, less methane and ethane, or total organic hazardous air pollutants concentration of 20 parts per million by volume on a dry basis corrected to 3 percent oxygen. The owner or operator shall use either Method 18 of appendix A–6 to part 60 of this chapter, any other method or data that has been validated according to the applicable procedures in Method 301 of appendix A of this part, or ASTM D6420–18 (incorporated by reference, see § 63.14) may also be used in lieu of Method 18, if the target compounds are all known and are all listed in Section 1.1 of ASTM D6420–18 as measurable; ASTM D6420–18 must not be used for methane and ethane; and ASTM D6420–18 may not be used as a total VOC method; or

(iii) Provide a minimum residence time of 0.5 seconds at a minimum temperature of 760 °C.

(2) A vapor recovery system (including but not limited to a carbon adsorption system or condenser), alone or in combination with other control devices, shall reduce the total organic compound emissions, less methane and ethane, or total organic hazardous air pollutants emissions vented to the control device of 95 percent by weight or greater or achieve an outlet total organic compound concentration, less methane and ethane, or total organic hazardous air pollutants concentration of 20 parts per million by volume. The 20 parts per million by volume performance standard is not applicable to compliance with the provisions of § 63.134 or § 63.135.

(3) Except as specified in paragraph (a) of § 63.108, a flare shall comply with the requirements of § 63.11(b).

(4) A scrubber, alone or in combination with other control devices, shall reduce the total organic compound emissions, less methane and ethane, or total organic hazardous air pollutants emissions in such a manner that 95 weight-percent is either removed, or destroyed by chemical reaction with the scrubbing liquid or achieve an outlet total organic compound concentration, less methane and ethane, or total organic hazardous air pollutants concentration of 20 parts per million by volume. The 20 parts per million by volume performance standard is not applicable to compliance with the provisions of § 63.134 or § 63.135.

(5) Any other control device used shall, alone or in combination with other control devices, reduce the total organic compound emissions, less methane and ethane, or total organic hazardous air pollutants emissions vented to the control device by 95 percent by weight or greater or achieve an outlet total organic compound concentration, less methane and ethane, or total organic hazardous air pollutants concentration of 20 parts per million by volume. The 20 parts per million by volume performance standard is not applicable to compliance with the provisions of § 63.134 or § 63.135.

(d) Except as provided in paragraphs (d)(4) and (5) of this section, an owner or operator shall demonstrate that each control device or combination of control devices achieves the appropriate conditions specified in paragraph (c) of this section by using one or more of the methods specified in paragraphs (d)(1), (2), or (3) of this section.

(1) Performance tests conducted using the test methods and procedures specified in § 63.145(i) for control devices other than flares; or

(2) A design evaluation that addresses the vent stream characteristics and control device operating parameters specified in paragraphs (d)(2)(i) through (vii) of this section.

(i) For a thermal vapor incinerator, the design evaluation shall consider the vent stream composition, constituent concentrations, and flow rate and shall establish the design minimum and average temperature in the combustion zone and the combustion zone residence time.

(ii) For a catalytic vapor incinerator, the design evaluation shall consider the vent stream composition, constituent concentrations, and flow rate and shall establish the design minimum and average temperatures across the catalyst bed inlet and outlet.



(iii) For a boiler or process heater, the design evaluation shall consider the vent stream composition, constituent concentrations, and flow rate; shall establish the design minimum and average flame zone temperatures and combustion zone residence time; and shall describe the method and location where the vent stream is introduced into the flame zone.

(iv) For a condenser, the design evaluation shall consider the vent stream composition, constituent concentrations, flow rate, relative humidity, and temperature and shall establish the design outlet organic compound concentration level, design average temperature of the condenser exhaust vent stream, and the design average temperatures of the coolant fluid at the condenser inlet and outlet.

(v) For a carbon adsorption system that regenerates the carbon bed directly on-site in the control device such as a fixed-bed adsorber, the design evaluation shall consider the vent stream composition, constituent concentrations, flow rate, relative humidity, and temperature and shall establish the design exhaust vent stream organic compound concentration level, adsorption cycle time, number and capacity of carbon beds, type and working capacity of activated carbon used for carbon beds, design total regeneration stream mass or volumetric flow over the period of each complete carbon bed regeneration cycle, design carbon bed temperature after regeneration, design carbon bed regeneration time, and design service life of carbon.

(vi) For a carbon adsorption system that does not regenerate the carbon bed directly on-site in the control device such as a carbon canister, the design evaluation shall consider the vent stream composition, constituent concentrations, mass or volumetric flow rate, relative humidity, and temperature and shall establish the design exhaust vent stream organic compound concentration level, capacity of carbon bed, type and working capacity of activated carbon used for carbon bed, and design carbon replacement interval based on the total carbon working capacity of the control device and source operating schedule.

(vii) For a scrubber, the design evaluation shall consider the vent stream composition; constituent concentrations; liquid-to-vapor ratio; scrubbing liquid flow rate and concentration; temperature; and the reaction kinetics of the constituents with the scrubbing liquid. The design evaluation shall establish the design exhaust vent stream organic compound

concentration level and will include the additional information in paragraphs (d)(2)(vii)(A) and (B) of this section for trays and a packed column scrubber.

(A) Type and total number of theoretical and actual trays;

(B) Type and total surface area of packing for entire column, and for individual packed sections if column contains more than one packed section.

(3) For flares, except as specified in paragraph (a) of § 63.108, the compliance determination specified in § 63.11(b) and § 63.145(j) of this subpart.

(4) An owner or operator using any control device specified in paragraphs (d)(4)(i) through (iv) of this section is exempt from the requirements in paragraphs (d)(1) through (3) of this section and from the requirements in § 63.6(f), and from the requirements of paragraph (e) of this section.

(i) A boiler or process heater with a design heat input capacity of 44 megawatts or greater.

(ii) A boiler or process heater into which the emission stream is introduced with the primary fuel.

(iii) A boiler or process heater burning hazardous waste for which the owner or operator:

(A) Has been issued a final permit under part 270 of this chapter and complies with the requirements of part 266, subpart H of this chapter;

(B) Has certified compliance with the interim status requirements of part 266, subpart H of this chapter;

(C) Has submitted a Notification of Compliance under § 63.1207(j) and complies with the requirements of subpart EEE of this part; or

(D) Complies with subpart EEE of this part and will submit a Notification of Compliance under § 63.1207(j) by the date the owner or operator would have been required to submit the initial performance test report for this subpart.

(iv) A hazardous waste incinerator for which the owner or operator:

(A) Has been issued a final permit under part 270 of this chapter and complies with the requirements of part 264, subpart O of this chapter;

(B) Has certified compliance with the interim status requirements of part 265, subpart O of this chapter;

(C) Has submitted a Notification of Compliance under § 63.1207(j) and complies with the requirements subpart EEE of this part; or

(D) Complies with the requirements subpart EEE of this part and will submit a Notification of Compliance under § 63.1207(j) by the date the owner or operator would have been required to submit the initial performance test report for this subpart.

(5) For each source as defined in § 63.101, beginning no later than the

compliance dates specified in § 63.100(k)(10), if the owner or operator vents emissions through a closed vent system to an adsorber(s) that cannot be regenerated or a regenerative adsorber(s) that is regenerated offsite, then the requirements specified in paragraphs (d)(1) and (2) of this section do not apply. Instead, the owner or operator must install a system of two or more adsorber units in series and comply with the requirements specified in paragraphs (d)(5)(i) through (iii) of this section.

(i) Conduct an initial performance test or design evaluation of the adsorber and establish the breakthrough limit and adsorber bed life.

(ii) Monitor the HAP or total organic compound (TOC) concentration through a sample port at the outlet of the first adsorber bed in series according to the schedule in paragraph (d)(5)(iii)(B) of this section. The owner or operator must measure the concentration of HAP or TOC using either a portable analyzer, in accordance with Method 21 of appendix A-7 to 40 CFR part 60, using methane, propane, isobutylene, or the primary HAP being controlled as the calibration gas or Method 25A of appendix A-7 to 40 CFR part 60, using methane, propane, or the primary HAP being controlled as the calibration gas.

(iii) Comply with paragraph (d)(5)(iii)(A) of this section, and comply with the monitoring frequency according to paragraph (d)(5)(iii)(B) of this section.

(A) The first adsorber in series must be replaced immediately when breakthrough, as defined in § 63.101, is detected between the first and second adsorber. The original second adsorber (or a fresh canister) will become the new first adsorber and a fresh adsorber will become the second adsorber. For purposes of this paragraph, "immediately" means within 8 hours of the detection of a breakthrough for adsorbers of 55 gallons or less, and within 24 hours of the detection of a breakthrough for adsorbers greater than 55 gallons. The owner or operator must monitor at the outlet of the first adsorber within 3 days of replacement to confirm it is performing properly.

(B) Based on the adsorber bed life established according to paragraph (d)(5)(i) of this section and the date the adsorbent was last replaced, conduct monitoring to detect breakthrough at least monthly if the adsorbent has more than 2 months of life remaining, at least weekly if the adsorbent has between 2 months and 2 weeks of life remaining, and at least daily if the adsorbent has 2 weeks or less of life remaining.

\* \* \* \* \*

■ 81. Amend § 63.143 by revising paragraph (c) to read as follows:

**§ 63.143 Process wastewater provisions—inspections and monitoring of operations.**

(c) If the owner or operator elects to comply with Item 1 in table 12 to this subpart, the owner or operator shall request approval to monitor appropriate parameters that demonstrate proper operation of the biological treatment unit. The request shall be submitted according to the procedures specified in § 63.151(f), and shall include a description of planned reporting and recordkeeping procedures. The owner or operator shall include as part of the submittal the basis for the selected monitoring frequencies and the methods that will be used. The Administrator will specify appropriate reporting and recordkeeping requirements as part of the review of the permit application or by other appropriate means.

■ 82. Amend § 63.144 by adding paragraph (b)(5)(i)(I) to read as follows:

**§ 63.144 Process wastewater provisions—test methods and procedures for determining applicability and Group 1/ Group 2 determinations (determining which wastewater streams require control).**

- (b) \* \* \*
- (5) \* \* \*
- (i) \* \* \*

(I) *Methods for ethylene oxide.* Methods specified in § 63.109(d) for analysis of ethylene oxide in wastewater.

■ 83. Amend § 63.145 by:

- a. Revising paragraph (a)(3),
- b. Adding paragraph (a)(10), and
- c. Revising paragraphs (d)(4), (i) introductory text, (i)(2), (i)(6)(i), and (j) introductory text.

The revisions and additions read as follows:

**§ 63.145 Process wastewater provisions—test methods and procedures to determine compliance.**

(a) \* \* \*

(3) *Representative process unit operating conditions.* Except as specified in paragraph (a)(10) of this section, compliance shall be demonstrated for representative operating conditions. Operations during periods of startup, shutdown, or malfunction and periods of nonoperation shall not constitute representative conditions. The owner or operator shall record the process information that is necessary to

document operating conditions during the test.

(10) For each source as defined in § 63.101, beginning no later than the compliance dates specified in § 63.100(k)(10), the requirement of paragraph (a)(3) of this section no longer applies. Instead, owners and operators must comply with the conditions specified in § 63.103(b)(3)(ii) of subpart F of this part.

(4) *Concentration in vented gas stream exiting the combustion treatment process.* The concentration of table 8 and/or table 9 compounds exiting the combustion treatment process in any vented gas stream shall be determined as provided in this paragraph. Samples may be grab samples or composite samples. Samples shall be taken at approximately equally spaced time intervals over a 1-hour period. Each 1-hour period constitutes a run, and the performance test shall consist of a minimum of 3 runs. Concentration measurements shall be determined using Method 18 of appendix A–6 to 40 CFR part 60. ASTM D6420–18 (incorporated by reference, see § 63.14) may also be used in lieu of Method 18, if the target compounds are all known and are all listed in Section 1.1 of ASTM D6420–18 as measurable; ASTM D6420–18 must not be used for methane and ethane; and ASTM D6420–18 may not be used as a total VOC method. Alternatively, any other test method validated according to the procedures in Method 301 of appendix A to this part may be used.

(i) *Performance tests for control devices other than flares.* This paragraph applies to performance tests that are conducted to demonstrate compliance of a control device with the efficiency limits specified in § 63.139(c). If complying with the 95-percent reduction efficiency requirement, comply with the requirements specified in paragraphs (i)(1) through (i)(9) of this section. If complying with the 20 ppm by volume requirement, comply with the requirements specified in paragraphs (i)(1) through (6) and (9) of this section. The 20 ppm by volume limit or 95-percent reduction efficiency requirement shall be measured as either total organic hazardous air pollutants or as TOC minus methane and ethane. Performance tests must be conducted according to the schedule in § 63.103(b)(1) of subpart F of this part.

(2) *Concentration in gas stream entering or exiting the control device.* The concentration of total organic hazardous air pollutants or TOC in a gas stream shall be determined as provided in this paragraph. Samples may be grab samples or composite samples (*i.e.*, integrated samples). Samples shall be taken at approximately equally spaced time intervals over a 1-hour period. Each 1-hour period constitutes a run, and the performance test shall consist of a minimum of 3 runs. Concentration measurements shall be determined using Method 18 of appendix A–6 to 40 CFR part 60. ASTM D6420–18 (incorporated by reference, see § 63.14) may also be used in lieu of Method 18, if the target compounds are all known and are all listed in Section 1.1 of ASTM D6420–18 as measurable; ASTM D6420–18 must not be used for methane and ethane; and ASTM D6420–18 may not be used as a total VOC method. Alternatively, any other test method validated according to the procedures in Method 301 of appendix A to this part may be used.

(6) \* \* \*

(i) *Oxygen concentration.* The concentration of TOC or total organic hazardous air pollutants shall be corrected to 3 percent oxygen if the control device is a combustion device. Method 3A of appendix A–2 to 40 CFR part 60 or the manual method in ANSI/ASME PTC 19.10–1981 (incorporated by reference, see § 63.14) shall be used to determine the actual oxygen concentration (%O<sub>2</sub>d). The samples shall be taken during the same time that the TOC (minus methane or ethane) or total organic hazardous air pollutants samples are taken.

(j) Except as specified in paragraph (a) of § 63.108, when a flare is used to comply with § 63.139(c), the owner or operator shall comply with paragraphs (j)(1) through (3) of this section. The owner or operator is not required to conduct a performance test to determine percent emission reduction or outlet organic HAP or TOC concentration.

■ 84. Amend § 63.146 by revising paragraphs (b)(7)(i) introductory text, (b)(7)(ii)(C), (b)(9)(ii), and revising and republishing paragraphs (d) and (e) to read as follows:

**§ 63.146 Process wastewater provisions—reporting.**

- (b) \* \* \*
- (7) \* \* \*

(i) Except as specified in paragraph (a) of § 63.108, for each flare, the owner or operator shall submit the information specified in paragraphs (b)(7)(i)(A) through (b)(7)(i)(C) of this section.

\* \* \* \* \*

(ii) \* \* \*

(C) Results of the performance test specified in § 63.139(d)(1) of this subpart. Performance test results shall include operating ranges of key process and control parameters during the performance test; the value of each parameter being monitored in accordance with § 63.143 of this subpart; and applicable supporting calculations. If the performance test report is submitted electronically through the EPA's CEDRI in accordance with § 63.152(h), the process unit(s) tested, the pollutant(s) tested, and the date that such performance test was conducted may be submitted in the notification of compliance status report in lieu of the performance test results. The performance test results must be submitted to CEDRI by the date the notification of compliance status report is submitted.

\* \* \* \* \*

(9) \* \* \*

(ii) Results of the performance test specified in § 63.138(j)(2) of this subpart. Performance test results shall include operating ranges of key process and control parameters during the performance test; the value of each parameter being monitored in accordance with § 63.143 of this subpart; and applicable supporting calculations. If the performance test report is submitted electronically through the EPA's CEDRI in accordance with § 63.152(h), the process unit(s) tested, the pollutant(s) tested, and the date that such performance test was conducted may be submitted in the notification of compliance status report in lieu of the performance test results. The performance test results must be submitted to CEDRI by the date the notification of compliance status report is submitted.

\* \* \* \* \*

(d) Except as provided in paragraph (f) of this section, for each treatment process used to comply with § 63.138(b)(1), (c)(1), (d), (e), (f), or (g), the owner or operator shall submit as part of the next Periodic Report required by § 63.152(c) the information specified in paragraphs (d)(1), (2), and (3) of this section for the monitoring required by § 63.143(b), (c), and (d).

(1) For Item 1 in table 12, the owner or operator shall submit the results of measurements that indicate that the biological treatment unit is outside the

range established in the Notification of Compliance Status or operating permit. Include the identification of the biological treatment unit, the parameter that was out of range and the date that the parameter is out of range.

(2) For Item 2 in table 12, the owner or operator shall submit the monitoring results for each operating day during which the daily average value of a continuously monitored parameter is outside the range established in the Notification of Compliance Status or operating permit. Include the identification of the treatment process, the parameter that was out of range, and the date the parameter was out of range.

(3) For Item 3 in table 12 of this subpart, the owner or operator shall submit the monitoring results for each operating day during which the daily average value of any monitored parameter approved in accordance with § 63.151 (f) was outside the range established in the Notification of Compliance Status or operating permit. Include the identification of the treatment process, the parameter that was out of range, and the date the parameter was out of range.

(e) Except as provided in paragraph (f) of this section, for each control device used to comply with §§ 63.133 through 63.139, the owner or operator shall submit as part of the next Periodic Report required by § 63.152(c) the information specified in either paragraph (e)(1) or (e)(2) of this section.

(1) The information specified in table 20 of this subpart, including the date of each occurrence, or

(2) If the owner or operator elects to comply with § 63.143(e)(2) of this subpart, *i.e.*, an organic monitoring device installed at the outlet of the control device, the owner or operator shall submit the date and the monitoring results for each operating day during which the daily average concentration level or reading is outside the range established in the Notification of Compliance Status or operating permit.

\* \* \* \* \*

■ 85. Amend § 63.147 by revising and republishing paragraph (d) to read as follows:

**§ 63.147 Process wastewater provisions—recordkeeping.**

\* \* \* \* \*

(d) The owner or operator shall keep records of the daily average value of each continuously monitored parameter for each operating day as specified in § 63.152(f), except as provided in paragraphs (d)(1) through (4) of this section.

(1) For flares, except as specified in paragraph (a) of § 63.108, records of the times and duration of all periods during which the pilot flame is absent shall be kept rather than daily averages.

(2) *Regenerative carbon adsorbers.* Except as specified in paragraph (d)(4) of this section, for regenerative carbon adsorbers, the owner or operator shall keep the records specified in paragraphs (d)(2)(i) and (ii) of this section instead of daily averages.

(i) Records of the total regeneration stream mass flow for each carbon bed regeneration cycle.

(ii) Records of the temperature of the carbon bed after each regeneration cycle.

(3) *Non-regenerative carbon adsorbers.* Except as specified in paragraph (d)(4) of this section, for non-regenerative carbon adsorbers using organic monitoring equipment, the owner or operator shall keep the records specified in paragraph (d)(3)(i) of this section instead of daily averages. For non-regenerative carbon adsorbers replacing the carbon adsorption system with fresh carbon at a regular predetermined time interval that is less than the carbon replacement interval that is determined by the maximum design flow rate and organic concentration in the gas stream vented to the carbon adsorption system, the owner or operator shall keep the records specified in paragraph (d)(3)(ii) of this section instead of daily averages.

(i)(A) Record of how the monitoring frequency, as specified in table 13 of this subpart, was determined.

(B) Records of when organic compound concentration of adsorber exhaust was monitored.

(C) Records of when the carbon was replaced.

(ii)(A) Record of how the carbon replacement interval, as specified in table 13 of this subpart, was determined.

(B) Records of when the carbon was replaced.

(4) For each nonregenerative adsorber and regenerative adsorber that is regenerated offsite subject to the requirements in § 63.139(d)(5), the owner or operator must keep the applicable records specified in (d)(4)(i) through (d)(4)(iii) of this section.

(i) Breakthrough limit and bed life established according to § 63.139(d)(5)(i).

(ii) Each outlet HAP or TOC concentration measured according to §§ 63.139(d)(5)(ii) and (d)(5)(iii).

(iii) Date and time you last replaced the adsorbent.

\* \* \* \* \*

■ 86. Amend § 63.148 by:

- a. Revising paragraphs (a), (b) introductory text, (f) introductory text and (f)(3);
- b. Adding paragraph (f)(4);
- c. revising paragraph (i)(3) introductory text and adding paragraph (i)(3)(iii); and
- d. Revising paragraphs (j) and (k).

The revisions and additions read as follows:

**§ 63.148 Leak inspection provisions.**

(a) Except as provided in paragraph (k) of this section, for each vapor collection system, closed vent system, fixed roof, cover, or enclosure required to comply with this section, the owner or operator shall comply with the requirements of paragraphs (b) through (j) of this section.

(b) Except as provided in paragraphs (g) and (h) of this section, each vapor collection system and closed vent system shall be inspected according to the procedures and schedule specified in paragraphs (b)(1) and (b)(2) of this section and each fixed roof, cover, and enclosure shall be inspected according to the procedures and schedule specified in paragraph (b)(3) of this section.

\* \* \* \* \*

(f) For each vapor collection system or closed vent system that contains bypass lines that could divert a vent stream away from the control device and to the atmosphere, the owner or operator shall comply with the provisions of either paragraph (f)(1) or (f)(2), and (f)(4) of this section, except as provided in paragraph (f)(3) of this section.

\* \* \* \* \*

(3) Except as specified in paragraph (f)(4) of this section, equipment such as low leg drains, high point bleeds, analyzer vents, open-ended valves or lines, and pressure relief valves needed for safety purposes are not subject to this paragraph.

(4) For each source as defined in § 63.101, beginning no later than the compliance dates specified in § 63.100(k)(10):

(i) The use of a bypass line at any time on a closed vent system to divert emissions (subject to the emission suppression requirements specified in §§ 63.133 through 63.137) to the atmosphere or to a control device not meeting the requirements specified in this subpart is an emissions standards violation.

(ii) Paragraph (f)(3) of this section no longer applies. Instead, the exemptions specified in paragraphs (f)(4)(i)(A) and (f)(4)(i)(B) of this section apply.

(A) Except for pressure relief devices subject to § 63.165(e)(4), equipment such as low leg drains and equipment subject to the requirements of subpart H of this part are not subject to this paragraph (f) of this section.

(B) Open-ended valves or lines that use a cap, blind flange, plug, or second valve and follow the requirements specified in 40 CFR 60.482–6(a)(2), (b), and (c) or follow requirements codified in another regulation that are the same as 40 CFR 60.482–6(a)(2), (b), and (c) are not subject to this paragraph (f) of this section.

\* \* \* \* \*

(i) \* \* \*

(3) For each vapor collection system or closed vent system that contains bypass lines that could divert a vent stream away from the control device and to the atmosphere, the owner or operator shall keep a record of the information specified in either paragraph (i)(3)(i) or (i)(3)(ii) of this section in addition to the information specified in paragraph (i)(3)(iii) of this section.

\* \* \* \* \*

(iii) For each source as defined in § 63.101, beginning no later than the compliance dates specified in § 63.100(k)(10), the owner or operator must comply with this paragraph in addition to the requirements in paragraphs (i)(3)(i) or (i)(3)(ii) of this section. For each flow event from a bypass line subject to the requirements in paragraph (f) of this section, the owner or operator must maintain records sufficient to determine whether or not the detected flow included flow requiring control. For each flow event from a bypass line requiring control that is released either directly to the atmosphere or to a control device not meeting the requirements in this subpart, the owner or operator must include an estimate of the volume of gas, the concentration of organic HAP in the gas and the resulting emissions of organic HAP that bypassed the control device using process knowledge and engineering estimates.

\* \* \* \* \*

(j) The owner or operator shall submit with the reports required by § 63.182(b) of subpart H of this part or with the reports required by § 63.152(c) of this subpart, the information specified in paragraphs (j)(1) through (3) of this section and if applicable, the information in paragraph (j)(4) of this section.

(1) The information specified in paragraph (i)(4) of this section;

(2) Reports of the times of all periods recorded under paragraph (i)(3)(i) of this section when the vent stream is diverted from the control device through a bypass line, including the start date, start time, and duration in hours; and

(3) Reports of all periods recorded under paragraph (i)(3)(ii) of this section in which the seal mechanism is broken, the bypass line valve position has changed, or the key to unlock the bypass line valve was checked out. Include the start date, start time, and duration in hours for each period.

(4) For each source as defined in § 63.101, beginning no later than the compliance dates specified in § 63.100(k)(10), the owner or operator must comply with this paragraph in addition to the requirements in paragraphs (j)(1) through (3) of this section. For bypass lines subject to the requirements in paragraph (f) of this section, the Periodic Report must include the start date, start time, duration in hours, estimate of the volume of gas in standard cubic feet, the concentration of organic HAP in the gas in parts per million by volume and the resulting mass emissions of organic HAP in pounds that bypass a control device. For periods when the flow indicator is not operating, report the start date, start time, and duration in hours.

(k) If a closed vent system subject to this section is also subject to § 63.172, the owner or operator shall comply with the provisions of § 63.172 and is exempt from the requirements of this section.

■ 87. Amend § 63.150 by revising paragraphs (f)(2), (g)(2)(ii), (g)(2)(iii)(B)(2), (m)(1)(ii) and (m)(2)(i) to read as follows:

**§ 63.150 Emissions averaging provisions.**

\* \* \* \* \*

(f) \* \* \*

(2) Periods of start-up, shutdown, and malfunction as described in the source's start-up, shutdown, and malfunction plan required by § 63.6(e)(3). For each source as defined in § 63.101, on and after July 15, 2027, this paragraph no longer applies.

\* \* \* \* \*

(g) \* \* \*

(2) \* \* \*

(ii) The following equation shall be used for each process vent *i* to calculate  $EPV_{iu}$ :

$$EPV_{iu} = (2.494 \times 10^{-9}) Qh \left( \sum_{j=1}^n C_j M_j \right)$$

Where:

- EPV<sub>iu</sub> = Uncontrolled process vent emission rate from process vent i, megagrams per month.
- Q = Vent stream flow rate, dry standard cubic meters per minute, measured using Method 2, 2A, 2C, or 2D of part 60, appendix A, as appropriate.
- h = Monthly hours of operation during which positive flow is present in the vent, hours per month.
- C<sub>j</sub> = Concentration, parts per million by volume, dry basis, of organic HAP j as measured by Method 18 of part 60, appendix A, or ASTM D6420-18 (incorporated by reference, see § 63.14).
- M<sub>j</sub> = Molecular weight of organic HAP j, gram per gram-mole.
- n = Number of organic HAP's.

(A) The values of Q, C<sub>j</sub>, and M<sub>j</sub> shall be determined during a performance test conducted under representative operating conditions as specified in § 63.103(b)(3). The values of Q, C<sub>j</sub>, and M<sub>j</sub> shall be established in the Notification of Compliance Status and must be updated as provided in paragraph (g)(2)(ii)(B) of this section.

\* \* \* \* \*

(iii) \* \* \*

(B) \* \* \*

(2) For determining debits from Group 1 process vents, recovery devices shall not be considered control devices and cannot be assigned a percent reduction in calculating EPV<sub>I<sub>ACTUAL</sub></sub>. The sampling site for measurement of uncontrolled emissions is after the final recovery device. However, as provided in § 63.113(a)(3), except as specified in § 63.113(a)(4), a Group 1 process vent may add sufficient recovery to raise the TRE index value above 1.0, thereby becoming a Group 2 process vent.

\* \* \* \* \*

(m) \* \* \*

(1) \* \* \*

(ii) Conduct performance tests to determine percent reduction as specified in § 63.116 of this subpart;

\* \* \* \* \*

(2) \* \* \*

(i) Except as specified in § 63.113(a)(4), determine, consistent with paragraph (g)(2)(i) of this section, the flow rate, organic HAP concentration, and TRE index value using the methods specified in § 63.115;

\* \* \* \* \*

■ 88. Amend § 63.151 by revising paragraphs (d)(6)(i) and (d)(6)(v) as follows:

§ 63.151 Initial notification.

\* \* \* \* \*

(d) \* \* \*

(6) \* \* \*

(i) The values of the parameters used to determine whether the emission point is Group 1 or Group 2. Except as specified in § 63.113(a)(4), where TRE index value is used for process vent group determination, the estimated or measured values of the parameters used in the TRE equation in § 63.115(d) (flow rate, organic HAP emission rate, TOC emission rate, and net heating value) and the resulting TRE index value shall be submitted.

\* \* \* \* \*

(v) The operating plan required in § 63.122(a)(2) and (b) for each storage vessel controlled with a closed vent system with a control device other than a flare.

\* \* \* \* \*

■ 89. Amend § 63.152 by:

- a. Revising paragraph (b)(1)(i);
- b. Adding paragraphs (b)(7) through (b)(10);
- c. Revising and republishing paragraph (c);
- d. Revising paragraphs (d)(1), (f) introductory text and (f)(7) introductory text;
- e. Adding paragraph (f)(7)(vi);
- f. Revising and republishing paragraphs (g)(1) and (2); and
- g. Adding paragraph (h) as follows:

§ 63.152 General reporting and continuous records.

\* \* \* \* \*

(b) \* \* \*

(1) \* \* \*

(i) For performance tests and group determinations that are based on measurements, the Notification of Compliance Status shall include one complete test report for each test method used for a particular kind of emission point. For additional tests performed for the same kind of emission point using the same method, the results and any other information required in § 63.117 for process vents, § 63.129 for transfer, and § 63.146 for process wastewater shall be submitted, but a complete test report is not required. If the performance test report is submitted electronically through the EPA's CEDRI in accordance with paragraph (h) of this section, the process unit(s) tested, the pollutant(s) tested, and the date that such performance test was conducted may be submitted in the notification of

compliance status report in lieu of the performance test results. The performance test results must be submitted to CEDRI by the date the notification of compliance status report is submitted.

\* \* \* \* \*

(7) For flares subject to the requirements in § 63.108, owners and operators must also submit the information in this paragraph in a supplement to the Notification of Compliance Status within 150 days after the first applicable compliance date for flare monitoring. The supplement to the Notification of Compliance Status must include flare design (e.g., steam-assisted, air-assisted, non-assisted, or pressure-assisted multi-point); all visible emission readings, heat content determinations, flow rate measurements, and exit velocity determinations made during the initial visible emissions demonstration required by § 63.670(h) of subpart CC of this part, as applicable; and all periods during the compliance determination when the pilot flame or flare flame is absent.

(8) For process vents and storage vessels subject to the requirements of § 63.124, owners and operators must also submit the information in this paragraph in a supplement to the Notification of Compliance Status within 150 days after the first applicable compliance date. The supplement to the Notification of Compliance Status must identify all process vents and storage vessels that are in ethylene oxide service as defined in § 63.101, the method(s) used to control ethylene oxide emissions from each process vent and storage vessel (i.e., use of a flare, scrubber, or other control device) and the information specified in paragraphs (b)(8)(i) and (b)(8)(ii) of this section, as applicable.

(i) For process vents, all uncontrolled, undiluted ethylene oxide concentration measurements, and the calculations used to determine the total uncontrolled ethylene oxide mass emission rate for the sum of all vent gas streams; and

(ii) For storage vessels, include the concentration of ethylene oxide of the fluid stored in each storage vessel.

(9) For adsorbers subject to the requirements of §§ 63.114(a)(5)(v), 63.120(d)(1)(iii), 63.127(b)(4), and 63.139(d)(5), you must also submit the information listed in paragraphs (b)(9)(i) and (ii) of this section in a supplement

to the Notification of Compliance Status within 150 days after the first applicable compliance date.

(i) Whether the adsorber cannot be regenerated or is a regenerative adsorber(s) that is regenerated offsite.

(ii) The breakthrough limit and adsorber bed life established during the initial performance test or design evaluation of the adsorber.

(10) For Group 2 process vents subject to the requirements in § 63.113(l), owners and operators must also submit the information in this paragraph in a supplement to the Notification of Compliance Status within 150 days after the first applicable compliance date. The supplement to the Notification of Compliance Status must identify each Group 2 process vent and include the data and calculations specified in § 63.115(g) that are used to demonstrate that the total organic HAP mass flow rate of each vent stream is less than 1.0 pound per hour.

(c) The owner or operator of a source subject to this subpart shall submit Periodic Reports. On and after July 15, 2027 or once the reporting template for this subpart has been available on the CEDRI website for 1 year, whichever date is later, owners and operators must submit all subsequent reports following the procedure specified in § 63.9(k), except any medium submitted through mail must be sent to the attention of the Hazardous Organic Chemical Manufacturing Sector Lead. Owners and operators must use the appropriate electronic report template on the CEDRI website (<https://www.epa.gov/electronic-reporting-air-emissions/cedri>) for this subpart. The date report templates become available will be listed on the CEDRI website. Unless the Administrator or delegated state agency or other authority has approved a different schedule for submission of reports under § 63.9(i) and § 63.10(a), the report must be submitted by the deadline specified in this subpart, regardless of the method in which the report is submitted.

(1) Except as specified under paragraphs (c)(5) and (c)(6) of this section, a report containing the information in paragraphs (c)(2), (c)(3), (c)(4), and (c)(7) of this section shall be submitted semiannually no later than 60 calendar days after the end of each 6-month period. The first report shall be submitted no later than 8 months after the date the Notification of Compliance Status is due and shall cover the 6-month period beginning on the date the Notification of Compliance Status is due. All periodic reports must contain the company name and address (including county), as well as the

beginning and ending dates of the reporting period.

(2) Except as provided in paragraph (c)(2)(iv) of this section, for an owner or operator of a source complying with the provisions of §§ 63.113 through 63.147 for any emission points, Periodic Reports shall include all information specified in §§ 63.117 and 63.118 for process vents, § 63.122 for storage vessels, §§ 63.129 and 63.130 for transfer operations, and § 63.146 for process wastewater, including reports of each excursion (*i.e.*, each period when a monitored parameter is outside the established range and periods of insufficient monitoring data) using the procedures described in paragraphs (c)(2)(i) through (c)(2)(iv) of this section.

(i) Report the affected sources or equipment, the monitored parameter that was exceeded and the date of each excursion.

(ii) The parameter monitoring data for Group 1 emission points and emission points included in emissions averages that are required to perform continuous monitoring shall be used to determine compliance with the required operating conditions for the monitored control devices or recovery devices. For each excursion as specified in paragraphs (c)(2)(ii)(A) through (c)(2)(ii)(E) of this section, or paragraph (g)(2)(iv) of this section, except for excused excursions described therein, the owner or operator shall be deemed to have failed to have applied the control in a manner that achieves the required operating conditions and must report the information specified in paragraph (c)(2)(ii)(F) of this section.

(A) An excursion means any of the three cases listed in paragraph (c)(2)(ii)(A)(1), (c)(2)(ii)(A)(2), or (c)(2)(ii)(A)(3) of this section. For a control device or recovery device where multiple parameters are monitored, if one or more of the parameters meets the excursion criteria in paragraph (c)(2)(ii)(A)(1), (c)(2)(ii)(A)(2), or (c)(2)(ii)(A)(3) of this section, this is considered a single excursion for the control device or recovery device.

(1) When the daily average value of one or more monitored parameters is outside the permitted range.

(2) When the period of control device or recovery device operation is 4 hours or greater in an operating day and monitoring data are insufficient to constitute a valid hour of data for at least 75 percent of the operating hours.

(3) When the period of control device or recovery device operation is less than 4 hours in an operating day and more than one of the hours during the period of operation does not constitute a valid

hour of data due to insufficient monitoring data.

(4) Monitoring data are insufficient to constitute a valid hour of data, as used in paragraphs (c)(2)(ii)(A)(2) and (c)(2)(ii)(A)(3) of this section, if measured values are unavailable for any of the 15-minute periods within the hour. For data compression systems approved under § 63.151(g)(4), monitoring data are insufficient to calculate a valid hour of data if there are less than 4 data values recorded during the hour.

(B) The number of excused excursions for each control device or recovery device for each semiannual period is specified in paragraphs (c)(2)(ii)(B)(1) through (c)(2)(ii)(B)(6) of this section. This paragraph applies to sources required to submit Periodic Reports semiannually or quarterly. The first semiannual period is the 6-month period starting the date the Notification of Compliance Status is due.

(1) For the first semiannual period—six excused excursions.

(2) For the second semiannual period—five excused excursions.

(3) For the third semiannual period—four excused excursions.

(4) For the fourth semiannual period—three excused excursions.

(5) For the fifth semiannual period—two excused excursions.

(6) For the sixth and all subsequent semiannual periods—one excused excursion.

(C) A monitored parameter that is outside its established range or monitoring data that are not collected are excursions. However, if the conditions in paragraph (c)(2)(ii)(C)(1) or (c)(2)(ii)(C)(2) of this section are met, these excursions are not violations and do not count toward the number of excused excursions for determining compliance.

(1) *Periods of startup, shutdown, or malfunction.* During periods of startup, shutdown, or malfunction when the source is operated during such periods in accordance with § 63.102(a)(4). For each source as defined in § 63.101, on and after July 15, 2027, this paragraph no longer applies.

(2) *Periods of nonoperation.* During periods of nonoperation of the chemical manufacturing process unit, or portion thereof, that results in cessation of the emissions to which the monitoring applies.

(D) Nothing in paragraph (c)(2)(ii) of this section shall be construed to allow or excuse a monitoring parameter excursion caused by any activity that violates other applicable provisions of subpart A, F, or G of this part.

(E) Paragraph (c)(2)(ii) of this section, except paragraph (c)(2)(ii)(C) of this section, shall apply only to emission points and control devices or recovery devices for which continuous monitoring is required by §§ 63.113 through 63.150.

(F) For each source as defined in § 63.101, beginning no later than the compliance dates specified in § 63.100(k)(10), for each excursion that is not an excused excursion, the report must include a list of the affected sources or equipment, the monitored parameter for which there was an excursion, the date of the excursion, an estimate of the quantity in pounds of each regulated pollutant emitted over any emission limit, a description of the method used to estimate the emissions, the cause of the excursion (including unknown cause, if applicable), as applicable, and the corrective action taken.

(iii) Periodic Reports shall include the daily average values of monitored parameters for both excused and unexcused excursions, as defined in paragraph (c)(2)(ii)(A) of this section. For excursions caused by lack of monitoring data, the affected equipment or source, the monitored parameter, the start date and duration in hours of periods when monitoring data were not collected shall be specified.

(iv) The provisions of paragraphs (c)(2) of this section, and (c)(2)(i) through (iii) of this section, do not apply to any storage vessel for which the owner or operator is not required, by the applicable monitoring plan established under § 63.120(d)(2), to keep continuous records. If continuous records are required, the owner or operator shall specify, in the monitoring plan, whether the provisions of paragraphs (c)(2) of this section, and (c)(2)(i) through (iii) of this section apply.

(3) Except as specified in paragraph (c)(3)(iii) of this section, if any performance tests are reported in a Periodic Report, the following information shall be included:

(i) One complete test report shall be submitted for each test method used for a particular kind of emission point tested. A complete test report shall contain the information specified in paragraph (b)(1)(ii) of this section.

(ii) For additional tests performed for the same kind of emission point using the same method, results and any other information required in § 63.117 for process vents, § 63.129 for transfer, and § 63.146 for process wastewater shall be submitted, but a complete test report is not required.

(iii) If the performance test report is submitted electronically through the

EPA's CEDRI in accordance with paragraph (h) of this section, the process unit(s) tested, the pollutant(s) tested, and the date that such performance test was conducted may be submitted in the Periodic Report in lieu of the performance test results. The performance test results must be submitted to CEDRI by the date the Periodic Report is submitted.

(4) Periodic Reports shall include the information in paragraphs (c)(4)(i) through (iv) of this section, as applicable:

(i) For process vents, reports of process changes as required under § 63.118(g), (h), (i), and (j).

(ii) Any supplements required under § 63.151(i) and (j).

(iii) Notification if any Group 2 emission point becomes a Group 1 emission point, including a compliance schedule as required in § 63.100, and

(iv) For gas streams sent for disposal pursuant to § 63.113(i) or for process wastewater streams sent for treatment pursuant to § 63.132(g), reports of changes in the identity of the transferee.

(5) The owner or operator of a source shall submit quarterly reports for all emission points included in an emissions average.

(i) The quarterly reports shall be submitted no later than 60 calendar days after the end of each quarter. The first report shall be submitted with the Notification of Compliance Status no later than 5 months after the compliance date specified in § 63.100.

(ii) The quarterly reports shall include the information specified in this paragraph for all emission points included in an emissions average.

(A) The credits and debits calculated each month during the quarter;

(B) A demonstration that debits calculated for the quarter are not more than 1.30 times the credits calculated for the quarter, as required under § 63.150(e)(4).

(C) The values of any inputs to the credit and debit equations in § 63.150(g) and (h) that change from month to month during the quarter or that have changed since the previous quarter;

(D) Results of any performance tests conducted during the reporting period including one complete report for each test method used for a particular kind of emission point as described in paragraph (c)(3) of this section. If the performance test report is submitted electronically through the EPA's CEDRI in accordance with paragraph (h) of this section, the process unit(s) tested, the pollutant(s) tested, and the date that such performance test was conducted may be submitted in the Periodic Report in lieu of the performance test results.

The performance test results must be submitted to CEDRI by the date the Periodic Report is submitted.;

(E) Reports of daily average values of monitored parameters for both excused and unexcused excursions as defined in paragraph (c)(2)(ii)(A) of this section. For excursions caused by lack of monitoring data, the duration of periods when monitoring data were not collected shall be specified. Include the affected sources or equipment, monitored parameter, and the date for each excursion.

(iii) Paragraphs (c)(2)(i) through (iii) of this section shall govern the use of monitoring data to determine compliance for Group 1 and Group 2 points included in emissions averages. For storage vessels to which the provisions of paragraphs (c)(2)(i) through (iii) of this section do not apply (as specified in paragraph (c)(2)(iv) of this section), the owner or operator is required to comply with the provisions of the applicable monitoring plan, and monitoring records may be used to determine compliance.

(iv) Every fourth quarterly report shall include the following:

(A) A demonstration that annual credits are greater than or equal to annual debits as required by § 63.150(e)(3); and

(B) A certification of compliance with all the emissions averaging provisions in § 63.150.

(6) The owner or operator of a source shall submit reports quarterly for particular emission points not included in an emissions average under the circumstances described in paragraphs (c)(6)(i) through (v) of this section.

(i) The owner or operator of a source subject to this subpart shall submit quarterly reports for a period of one year for an emission point that is not included in an emissions average if:

(A) The emission point has more excursions, as defined in paragraph (c)(2)(ii) of this section, than the number of excused excursions allowed under paragraph (c)(2)(ii)(B) of this section for a semiannual reporting period; and

(B) The Administrator requests the owner or operator to submit quarterly reports for the emission point.

(ii) The quarterly reports shall include all information in paragraphs (c)(2), (3), and (4) of this section applicable to the emission point(s) for which quarterly reporting is required under paragraph (c)(6)(i) of this section. Information applicable to other emission points within the source shall be submitted in the semiannual reports required under paragraph (c)(1) of this section.

(iii) Quarterly reports shall be submitted no later than 60 calendar days after the end of each quarter.

(iv) After quarterly reports have been submitted for an emission point for one year, the owner or operator may return to semiannual reporting for the emission point unless the Administrator requests the owner or operator to continue to submit quarterly reports.

(v) Paragraphs (c)(2)(i) through (iii) of this section shall govern the use of monitoring data to determine compliance for Group 1 emission points. For storage vessels to which the provisions of paragraphs (c)(2)(i) through (iii) of this section do not apply (as specified in paragraph (c)(2)(iv) of this section), the owner or operator is required to comply with the provisions of the applicable monitoring plan, and monitoring records may be used to determine compliance.

(7) The information specified in § 63.108(l)(2) of subpart F of this part.

(d) \* \* \*

(1) Reports of start-up, shutdown, and malfunction required by § 63.10(d)(5). The start-up, shutdown and malfunction reports may be submitted on the same schedule as the Periodic Reports required under paragraph (c) of this section instead of the schedule specified in § 63.10(d)(5). For each source as defined in § 63.101, on and after July 15, 2027, this paragraph no longer applies.

\* \* \* \* \*

(f) Owners or operators required to keep continuous records by §§ 63.118, 63.130, 63.147, 63.150, or other sections of this subpart shall keep records as specified in paragraphs (f)(1) through (f)(7) of this section, unless an alternative recordkeeping system has been requested and approved under § 63.151(f) or (g) or § 63.152(e) or under § 63.8(f), and except as provided in paragraph (c)(2)(ii)(C) of this section or in paragraph (g) of this section. If a monitoring plan for storage vessels pursuant to § 63.120(d)(2)(i) requires continuous records, the monitoring plan shall specify which provisions, if any, of paragraphs (f)(1) through (f)(7) of this section apply. Any records required to be maintained by this part that are submitted electronically via the EPA's CEDRI may be maintained in electronic format. This ability to maintain electronic copies does not affect the requirement for facilities to make records, data, and reports available upon request to a delegated air agency or the EPA as part of an on-site compliance evaluation.

\* \* \* \* \*

(7) Except as specified in paragraph (f)(7)(vi) of this section monitoring data

recorded during periods identified in paragraphs (f)(7)(i) through (f)(7)(v) of this section shall not be included in any average computed under this subpart. Records shall be kept of the times and durations of all such periods and any other periods during process or control device operation when monitors are not operating.

\* \* \* \* \*

(vi) For each source as defined in § 63.101, on and after July 15, 2027, paragraphs (f)(7)(ii) through (f)(7)(iv) no longer apply.

(g) \* \* \*

(1) The owner or operator may retain only the daily average value, and is not required to retain more frequent monitored operating parameter values, for a monitored parameter with respect to an item of equipment, if the requirements of paragraphs (g)(1)(i) through (vi) of this section are met. An owner or operator electing to comply with the requirements of paragraph (g)(1) of this section shall notify the Administrator in the Notification of Compliance Status or, if the Notification of Compliance Status has already been submitted, in the periodic report immediately preceding implementation of the requirements of paragraph (g)(1) of this section.

(i) The monitoring system is capable of detecting unrealistic or impossible data during periods of operation other than startups, shutdowns, or malfunctions (e.g., a temperature reading of  $-200\text{ }^{\circ}\text{C}$  on a boiler), and will alert the operator by alarm or other means. The owner or operator shall record the occurrence. All instances of the alarm or other alert in an operating day constitute a single occurrence. For each source as defined in § 63.101, on and after July 15, 2027, the phrase "other than startups, shutdowns, or malfunctions (e.g., a temperature reading of  $-200\text{ }^{\circ}\text{C}$  on a boiler)," in this paragraph no longer applies.

(ii) The monitoring system generates, updated at least hourly throughout each operating day, a running average of the monitoring values that have been obtained during that operating day, and the capability to observe this average is readily available to the Administrator on-site during the operating day. The owner or operator shall record the occurrence of any period meeting the criteria in paragraphs (g)(1)(ii)(A) through (C) of this section. All instances in an operating day constitute a single occurrence.

(A) The running average is above the maximum or below the minimum established limits;

(B) The running average is based on at least 6 1-hour average values; and

(C) The running average reflects a period of operation other than a startup, shutdown, or malfunction. For each source as defined in § 63.101, on and after July 15, 2027, the phrase "other than a startup, shutdown, or malfunction" in this paragraph no longer applies.

(iii) The monitoring system is capable of detecting unchanging data during periods of operation other than startups, shutdowns, or malfunctions, except in circumstances where the presence of unchanging data is the expected operating condition based on past experience (e.g., pH in some scrubbers), and will alert the operator by alarm or other means. The owner or operator shall record the occurrence. All instances of the alarm or other alert in an operating day constitute a single occurrence. For each source as defined in § 63.101, on and after July 15, 2027, the phrase "other than startups, shutdowns, or malfunctions" in this paragraph no longer applies.

(iv) The monitoring system will alert the owner or operator by an alarm or other means, if the running average parameter value calculated under paragraph (g)(1)(ii) of this section reaches a set point that is appropriately related to the established limit for the parameter that is being monitored.

(v) The owner or operator shall verify the proper functioning of the monitoring system, including its ability to comply with the requirements of paragraph (g)(1) of this section, at the times specified in paragraphs (g)(1)(v)(A) through (C) of this section. The owner or operator shall document that the required verifications occurred.

(A) Upon initial installation.

(B) Annually after initial installation.

(C) After any change to the programming or equipment constituting the monitoring system, which might reasonably be expected to alter the monitoring system's ability to comply with the requirements of this section.

(vi) The owner or operator shall retain the records identified in paragraphs (g)(1)(vi)(A) through (C) of this section.

(A) Identification of each parameter, for each item of equipment, for which the owner or operator has elected to comply with the requirements of paragraph (g) of this section.

(B) A description of the applicable monitoring system(s), and of how compliance will be achieved with each requirement of paragraph (g)(1)(i) through (g)(1)(v) of this section. The description shall include monitoring equipment manufacturer(s) and model number(s) and the pollutant or parameter monitored, and identify the location and format (e.g., on-line



storage; log entries) for each required record. If the description changes, the owner or operator shall retain both the current and the most recent superseded description. The description, and the most recent superseded description, shall be retained as provided in § 63.103(c) of subpart F of this part, except as provided in paragraph (g)(1)(vi)(D) of this section.

(C) A description, and the date, of any change to the monitoring system that would reasonably be expected to affect its ability to comply with the requirements of paragraph (g)(1) of this section.

(D) Owners and operators subject to paragraph (g)(1)(vi)(B) of this section shall retain the current description of the monitoring system as long as the description is current, but not less than 5 years from the date of its creation. The current description shall, at all times, be retained on-site or be accessible from a central location by computer or other means that provides access within 2 hours after a request. The owner or operator shall retain the most recent superseded description at least until 5 years from the date of its creation. The superseded description shall be retained on-site (or accessible from a central location by computer that provides access within 2 hours after a request) at least 6 months after its creation. Thereafter, the superseded description may be stored off-site.

(2) If an owner or operator has elected to implement the requirements of paragraph (g)(1) of this section, and a period of 6 consecutive months has passed without an excursion as defined in paragraph (g)(2)(iv) of this section, the owner or operator is no longer required to record the daily average value for that parameter for that unit of equipment, for any operating day when the daily average value is less than the maximum, or greater than the minimum established limit. With approval by the Administrator, monitoring data generated prior to the compliance date of this subpart shall be credited toward the period of 6 consecutive months, if

the parameter limit and the monitoring was required and/or approved by the Administrator.

(i) If the owner or operator elects not to retain the daily average values, the owner or operator shall notify the Administrator in the next periodic report. The notification shall identify the parameter and unit of equipment.

(ii) If, on any operating day after the owner or operator has ceased recording daily averages as provided in paragraph (g)(2) of this section, there is an excursion as defined in paragraph (g)(2)(iv) of this section, the owner or operator shall immediately resume retaining the daily average value for each day, and shall notify the Administrator in the next periodic report. The owner or operator shall continue to retain each daily average value until another period of 6 consecutive months has passed without an excursion as defined in paragraph (g)(2)(iv) of this section.

(iii) The owner or operator shall retain the records specified in paragraphs (g)(1) (i), (ii), (iii), (iv), (v), and (vi) of this section. For any calendar week, if compliance with paragraphs (g)(1) (i), (ii), (iii), and (iv) of this section does not result in retention of a record of at least one occurrence or measured parameter value, the owner or operator shall record and retain at least one parameter value during a period of operation other than a startup, shutdown, or malfunction. For each source as defined in § 63.101, on and after July 15, 2027, the phrase “other than a startup, shutdown, or malfunction” in this paragraph no longer applies.

(iv) For purposes of paragraph (g) of this section, an excursion means that the daily average value of monitoring data for a parameter is greater than the maximum, or less than the minimum established value, except as provided in paragraphs (g)(2)(iv)(A) and (B) of this section.

(A) The daily average value during any startup, shutdown, or malfunction shall not be considered an excursion for purposes of this paragraph (g)(2), if the owner or operator operates the source

during such periods in accordance with § 63.102(a)(4). For each source as defined in § 63.101, on and after July 15, 2027, this paragraph no longer applies.

(B) An excused excursion, as described in § 63.152(c)(2)(ii)(B) and (C), shall not be considered an excursion for purposes of this paragraph (g)(2).

(h) Beginning no later than July 15, 2024, owners and operators must submit performance test reports in accordance with this paragraph. Unless otherwise specified in this subpart, within 60 days after the date of completing each performance test required by this subpart, owners and operators must submit the results of the performance test following the procedures specified in § 63.9(k). Data collected using test methods supported by the EPA’s Electronic Reporting Tool (ERT) as listed on the EPA’s ERT website (<https://www.epa.gov/electronic-reporting-air-emissions/electronic-reporting-tool-ert>) at the time of the test must be submitted in a file format generated through the use of the EPA’s ERT. Alternatively, owners and operators may submit an electronic file consistent with the extensible markup language (XML) schema listed on the EPA’s ERT website. Data collected using test methods that are not supported by the EPA’s ERT as listed on the EPA’s ERT website at the time of the test must be included as an attachment in the ERT or alternate electronic file.

■ 90. Amend § 63.153 by revising paragraph (c) introductory text and adding paragraph (c)(5) as follows:

**§ 63.153 Implementation and enforcement.**

\* \* \* \* \*

(c) The authorities that cannot be delegated to State, local, or Tribal agencies are as specified in paragraphs (c)(1) through (5) of this section.

\* \* \* \* \*

(5) Approval of an alternative to any electronic reporting to the EPA required by this subpart.

■ 91. Revise table 3 to subpart G to read as follows:

**TABLE 3 TO SUBPART G OF PART 63—PROCESS VENTS—MONITORING, RECORDKEEPING, AND REPORTING REQUIREMENTS FOR CONTROL DEVICES AND RECAPTURE DEVICES**

Control or recapture device	Parameters to be monitored <sup>a</sup>	Recordkeeping and reporting requirements for monitored parameters
Thermal incinerator, other than a thermal oxidizer used to comply with § 63.124.	Firebox temperature <sup>b</sup> [63.114(a)(1)(i)] .....	1. Continuous records. <sup>c</sup> 2. Record and report the firebox temperature averaged over the full period of the performance test—NCS. <sup>d</sup> 3. Record the daily average firebox temperature for each operating day. <sup>e</sup> 4. Report all daily average temperatures that are outside the range established in the NCS or operating permit and all operating days when insufficient monitoring data are collected—PR. <sup>g</sup>
Thermal oxidizer used to comply with § 63.124.	Combustion chamber temperature [63.124(b)(5)(i)].	1. Continuous records. <sup>c</sup> 2. Record and report the combustion chamber temperature averaged over the full period of the performance test—NCS. <sup>d</sup>

TABLE 3 TO SUBPART G OF PART 63—PROCESS VENTS—MONITORING, RECORDKEEPING, AND REPORTING REQUIREMENTS FOR CONTROL DEVICES AND RECAPTURE DEVICES—Continued

Control or recapture device	Parameters to be monitored <sup>a</sup>	Recordkeeping and reporting requirements for monitored parameters
Thermal oxidizer used to comply with § 63.124 (Continued).	Flue gas flow rate [63.124(b)(5)(ii)] .....	3. Record each 1-hour block average firebox temperature for each operating day. 4. Report all 1-hour block temperatures that are outside the range established in the NCS or operating permit and all operating days when insufficient monitoring data are collected <sup>f</sup> —PR. <sup>g</sup> 1. Continuous records. <sup>c</sup> 2. Record and report the flue gas flow rate averaged over the full period of the performance test—NCS. <sup>d</sup> 3. Record each 1-hour block average flue gas flow rate for each operating day. 4. Report all 1-hour block flue gas flow rates that are outside the range established in the NCS or operating permit and all operating days when insufficient monitoring data are collected <sup>f</sup> —PR. <sup>g</sup>
Catalytic incinerator .....	Temperature upstream and downstream of the catalyst bed [63.114(a)(1)(ii)].	1. Continuous records. <sup>c</sup> 2. Record and report the upstream and downstream temperatures and the temperature difference across the catalyst bed averaged over the full period of the performance test—NCS. <sup>d</sup> 3. Record the daily average upstream temperature and temperature difference across the catalyst bed for each operating day. <sup>e</sup> 4. Report all daily average upstream temperatures that are outside the range established in the NCS or operating permit—PR. 5. Report all daily average temperature differences across the catalyst bed that are outside the range established in the NCS or operating permit—PR. <sup>g</sup> 6. Report all operating days when insufficient monitoring data are collected. <sup>f</sup>
Flare (if meeting the requirements of § 63.11(b)).	Presence of a flame at the pilot light [§ 63.114(a)(2)].	1. Hourly records of whether the monitor was continuously operating and whether the pilot flame was continuously present during each hour. 2. Record and report the presence of a flame at the pilot light over the full period of the compliance determination—NCS. <sup>d</sup> 3. Record the times and durations of all periods when all pilot flames are absent or the monitor is not operating. 4. Report the times and durations of all periods when all pilot flames of a flare are absent—PR. <sup>g</sup>
Flare (if meeting the requirements of § 63.108).	The parameters are specified in § 63.108 ....	1. Records as specified in § 63.108(m) of subpart F of this part. 2. Report information as specified in § 63.108(l) of subpart F of this part—PR. <sup>g</sup>
Boiler or process heater with a design heat input capacity less than 44 megawatts and vent stream is <i>not</i> introduced with or as the primary fuel.	Firebox temperature <sup>b</sup> [§ 63.114(a)(3)] .....	1. Continuous records. <sup>c</sup> 2. Record and report the firebox temperature averaged over the full period of the performance test—NCS. <sup>d</sup> 3. Record the daily average firebox temperature for each operating day. <sup>e</sup> 4. Report all daily average firebox temperatures that are outside the range established in the NCS or operating permit and all operating days when insufficient monitoring data are collected <sup>f</sup> —PR. <sup>g</sup>
Scrubber for halogenated vent streams (Note: Controlled by a combustion device other than a flare).	pH of scrubber effluent [§ 63.114(a)(4)(i)], and	1. Continuous records. <sup>c</sup> 2. Record and report the pH of the scrubber effluent averaged over the full period of the performance test—NCS. <sup>d</sup> 3. Record the daily average pH of the scrubber effluent for each operating day. <sup>e</sup> 4. Report all daily average pH values of the scrubber effluent that are outside the range established in the NCS or operating permit and all operating days when insufficient monitoring data are collected <sup>f</sup> —PR. <sup>g</sup>
Scrubber for halogenated vent streams (Note: Controlled by a combustion device other than a flare) (Continued).	Scrubber liquid and gas flow rates [§ 63.114(a)(4)(ii)].	1. Continuous records of scrubber liquid flow rate. <sup>c</sup> 2. Record and report the scrubber liquid/gas ratio averaged over the full period of the performance test—NCS. <sup>d</sup> 3. Record the daily average scrubber liquid/gas ratio for each operating day. <sup>e</sup> 4. Report all daily average scrubber liquid/gas ratios that are outside the range established in the NCS or operating permit and all operating days when insufficient monitoring data are collected <sup>f</sup> —PR. <sup>g</sup>
All control devices .....	Presence of flow diverted to the atmosphere from the control device [§ 63.114(d)(1)] or	1. Hourly records of whether the flow indicator was operating and whether diversion was detected at any time during each hour. 2. Record and report the times and durations of all periods when the vent stream is diverted through a bypass line or the monitor is not operating—PR. <sup>g</sup> 3. For each source as defined in § 63.101, beginning no later than the compliance dates specified in § 63.100(k)(10), record and report the start date, start time, duration in hours, estimate of the volume of gas in standard cubic feet, the concentration of organic HAP in the gas in parts per million by volume and the resulting mass emissions of organic HAP in pounds that bypass a control device. For periods when the flow indicator is not operating, report the start date, start time, and duration in hours—PR. <sup>g</sup>
All control devices (Continued) .....	Monthly inspections of sealed valves [§ 63.114(d)(2)].	1. Records that monthly inspections were performed. 2. Record and report all monthly inspections that show the valves are moved to the diverting position or the seal has been changed—PR. <sup>g</sup>

TABLE 3 TO SUBPART G OF PART 63—PROCESS VENTS—MONITORING, RECORDKEEPING, AND REPORTING REQUIREMENTS FOR CONTROL DEVICES AND RECAPTURE DEVICES—Continued

Control or recapture device	Parameters to be monitored <sup>a</sup>	Recordkeeping and reporting requirements for monitored parameters
All recapture devices (as an alternative to the below for absorbers, condensers, and carbon adsorbers).	Concentration level or reading indicated by an organic monitoring device at the outlet of the recovery device [§ 63.114(a)(5)(i)].	<p>3. For each source as defined in § 63.101, beginning no later than the compliance dates specified in § 63.100(k)(10), record and report the start date, start time, duration in hours, estimate of the volume of gas in standard cubic feet, the concentration of organic HAP in the gas in parts per million by volume and the resulting mass emissions of organic HAP in pounds that bypass a control device. For periods when the flow indicator is not operating, report the start date, start time, and duration in hours—PR.<sup>g</sup></p> <ol style="list-style-type: none"> <li>1. Continuous records.<sup>c</sup></li> <li>2. Record and report the concentration level or reading averaged over the full period of the performance test—NCS.<sup>d</sup></li> <li>3. Record the daily average concentration level or reading for each operating day.<sup>e</sup></li> <li>4. Report all daily average concentration levels or readings that are outside the range established in the NCS or operating permit—PR.<sup>g</sup></li> </ol>
Absorber <sup>h</sup> .....	Exit temperature of the absorbing liquid [§ 63.114(a)(5)(ii)], and	<ol style="list-style-type: none"> <li>1. Continuous records.<sup>c</sup></li> <li>2. Record and report the exit temperature of the absorbing liquid averaged over the full period of the performance test—NCS.<sup>d</sup></li> <li>3. Record the daily average exit temperature of the absorbing liquid for each operating day.<sup>e</sup></li> <li>4. Report all the daily average exit temperatures of the absorbing liquid that are outside the range established in the NCS or operating permit—PR.<sup>g</sup></li> </ol>
Absorber <sup>h</sup> (Continued) .....	Exit specific gravity [§ 63.114(a)(5)(ii)]	<ol style="list-style-type: none"> <li>1. Continuous records.<sup>c</sup></li> <li>2. Record and report the exit specific gravity averaged over the full period of the performance test—NCS.<sup>d</sup></li> <li>3. Record the daily average exit specific gravity for each operating day.<sup>e</sup></li> <li>4. Report all daily average exit specific gravity values that are outside the range established in the NCS or operating permit—PR.<sup>g</sup></li> </ol>
Condenser <sup>h</sup> .....	Exit (product side) temperature [§ 63.114(a)(5)(iii)].	<ol style="list-style-type: none"> <li>1. Continuous records.<sup>c</sup></li> <li>2. Record and report the exit temperature averaged over the full period of the performance test—NCS.<sup>d</sup></li> <li>3. Record the daily average exit temperature for each operating day.<sup>e</sup></li> <li>4. Report all daily average exit temperatures that are outside the range established in the NCS or operating permit—PR.<sup>g</sup></li> </ol>
Carbon adsorber <sup>h</sup> .....	Total regeneration stream mass or volumetric flow during carbon bed regeneration cycle(s) [§ 63.114(a)(5)(iv)], and	<ol style="list-style-type: none"> <li>1. Record of total regeneration stream mass or volumetric flow for each carbon bed regeneration cycle.</li> <li>2. Record and report the total regeneration stream mass or volumetric flow during each carbon bed regeneration cycle during the period of the performance test—NCS.<sup>d</sup></li> <li>3. Report all carbon bed regeneration cycles when the total regeneration stream mass or volumetric flow is outside the range established in the NCS or operating permit—PR.<sup>g</sup></li> </ol>
Carbon adsorber <sup>h</sup> (Continued) .....	Temperature of the carbon bed after regeneration [and within 15 minutes of completing any cooling cycle(s)] [§ 63.114(a)(5)(iv)].	<ol style="list-style-type: none"> <li>1. Records of the temperature of the carbon bed after each regeneration.</li> <li>2. Record and report the temperature of the carbon bed after each regeneration during the period of the performance test—NCS.<sup>d</sup></li> <li>3. Report all carbon bed regeneration cycles during which temperature of the carbon bed after regeneration is outside the range established in the NCS or operating permit—PR.<sup>g</sup></li> </ol>
Carbon adsorber <sup>h</sup> (Continued) .....	Outlet HAP or TOC concentration [§ 63.114(a)(5)(v)].	<p>For each nonregenerative adsorber and regenerative adsorber that is regenerated offsite subject to the requirements in § 63.114(a)(5)(v), the owner or operator must record each outlet HAP or TOC concentration measured according to §§ 63.114(a)(5)(v)(B) and (C).</p>
Carbon adsorber <sup>h</sup> (Continued) .....	Adsorbent replacement [§ 63.114(a)(5)(v)] ...	<ol style="list-style-type: none"> <li>1. For each nonregenerative adsorber and regenerative adsorber that is regenerated offsite subject to the requirements in § 63.114(a)(5)(v), the owner or operator must record date and time the adsorbent was last replaced.</li> </ol>
Carbon adsorber <sup>h</sup> (Continued) .....	Breakthrough [§ 63.114(a)(5)(v)] .....	<p>For each nonregenerative adsorber and regenerative adsorber that is regenerated offsite subject to the requirements in § 63.114(a)(5)(v), the owner or operator must:</p> <ol style="list-style-type: none"> <li>1. Record breakthrough limit and bed life established according to § 63.114(a)(5)(v)(A).</li> <li>2. Report the date of each instance when breakthrough, as defined in § 63.101, is detected between the first and second adsorber and the adsorber is not replaced according to § 63.114(a)(5)(v)(A)(7)—PR.<sup>g</sup></li> </ol>
Scrubber with a reactant tank used to comply with § 63.124.	Liquid-to-gas ratio [§ 63.124(b)(4)(i)] .....	<ol style="list-style-type: none"> <li>1. Continuous records.<sup>c</sup></li> <li>2. Record and report the L/G of the scrubber averaged over the full period of the performance test—NCS.<sup>d</sup></li> <li>3. Record each 1-hour block L/G of the scrubber for each operating day.</li> <li>4. Report all 1-hour block L/G values of the scrubber that are outside the range established in the NCS or operating permit and all operating days when insufficient monitoring data are collected<sup>f</sup>—PR.<sup>g</sup></li> </ol>
Scrubber with a reactant tank used to comply with § 63.124 (Continued).	In lieu of liquid-to-gas ratio, scrubber total liquid flow rate and gas flow rate through scrubber [§ 63.124(b)(4)(i)].	<ol style="list-style-type: none"> <li>1. Continuous records.<sup>c</sup></li> <li>2. Record and report both the total scrubber liquid flow rate and gas flow rate through the scrubber averaged over the full period of the performance test—NCS.<sup>d</sup></li> </ol>

TABLE 3 TO SUBPART G OF PART 63—PROCESS VENTS—MONITORING, RECORDKEEPING, AND REPORTING REQUIREMENTS FOR CONTROL DEVICES AND RECAPTURE DEVICES—Continued

Control or recapture device	Parameters to be monitored <sup>a</sup>	Recordkeeping and reporting requirements for monitored parameters
Scrubber with a reactant tank used to comply with § 63.124 (Continued).	pH of liquid in reactant tank [§ 63.124(b)(4)(ii)].	3. Record each 1-hour block total scrubber liquid flow rate and each 1-hour block gas flow rate through the scrubber for each operating day. 4. Report all 1-hour block total scrubber liquid flow rate values and all 1-hour block gas flow rate through the scrubber values that are outside the range established in the NCS or operating permit and all operating days when insufficient monitoring data are collected <sup>1</sup> —PR. <sup>g</sup> 1. Continuous records. <sup>c</sup> 2. Record and report the pH of liquid in reactant tank averaged over the full period of the performance test—NCS. <sup>d</sup> 3. Record each 1-hour block pH of liquid in reactant tank for each operating day. 4. Report all 1-hour block values of the pH of liquid in reactant tank that are outside the range established in the NCS or operating permit and all operating days when insufficient monitoring data are collected <sup>1</sup> —PR. <sup>g</sup>
Scrubber with a reactant tank used to comply with § 63.124 (Continued).	Pressure drop [§ 63.124(b)(4)(iii)] .....	1. Continuous records. <sup>c</sup> 2. Record and report the pressure drop of the scrubber averaged over the full period of the performance test—NCS. <sup>d</sup> 3. Record each 1-hour block pressure drop of the scrubber for each operating day. 4. Report all 1-hour block pressure drop values that are outside the range established in the NCS or operating permit and all operating days when insufficient monitoring data are collected <sup>1</sup> —PR. <sup>g</sup>
Scrubber with a reactant tank used to comply with § 63.124 (Continued).	Temperature of scrubbing liquid entering column [§ 63.124(b)(4)(iv)].	1. Continuous records. <sup>c</sup> 2. Record and report the temperature of scrubbing liquid entering column averaged over the full period of the performance test—NCS. <sup>d</sup> 3. Record each 1-hour block temperature of scrubbing liquid entering column for each operating day. 4. Report all 1-hour block values of the temperature of scrubbing liquid entering column that are outside the range established in the NCS or operating permit and all operating days when insufficient monitoring data are collected <sup>1</sup> —PR. <sup>g</sup>
Scrubber with a reactant tank used to comply with § 63.124 (Continued).	Liquid feed pressure [§ 63.124(b)(4)(v)] .....	1. Continuous records. <sup>c</sup> 2. Record and report the liquid feed pressure of the scrubber averaged over the full period of the performance test—NCS. <sup>d</sup> 3. Record each 1-hour block liquid feed pressure of the scrubber for each operating day. 4. Report all 1-hour block liquid feed pressure values that are outside the range established in the NCS or operating permit and all operating days when insufficient monitoring data are collected <sup>1</sup> —PR. <sup>g</sup>
Sorbent injection .....	Sorbent injection rate <sup>b</sup> [§ 63.114(a)(6)(i)] .....	1. Continuous records. <sup>c</sup> 2. Record and report the sorbent injection rate averaged over the full period of the performance test—NCS. <sup>d</sup> 3. Record the daily average sorbent injection rate for each operating day. <sup>e</sup> 4. Report all daily average sorbent injection rates that are outside the range established in the NCS or operating permit and all operating days when insufficient monitoring data are collected <sup>1</sup> —PR. <sup>g</sup>
Sorbent injection (Continued) .....	Carrier gas flow rate <sup>b</sup> [§ 63.114(a)(6)(ii)] .....	1. Continuous records. <sup>c</sup> 2. Record and report the carrier gas flow rate averaged over the full period of the performance test—NCS. <sup>d</sup> 3. Record the daily average carrier gas flow rate for each operating day. <sup>e</sup> 4. Report all daily average carrier gas flow rates that are outside the range established in the NCS or operating permit and all operating days when insufficient monitoring data are collected <sup>1</sup> —PR. <sup>g</sup>

<sup>a</sup> Regulatory citations are listed in brackets.  
<sup>b</sup> Monitor may be installed in the firebox or in the ductwork immediately downstream of the firebox before any substantial heat exchange is encountered.  
<sup>c</sup> “Continuous records” is defined in § 63.111 of this subpart.  
<sup>d</sup> NCS = Notification of Compliance Status described in § 63.152 of this subpart.  
<sup>e</sup> The daily average is the average of all recorded parameter values for the operating day. If all recorded values during an operating day are within the range established in the NCS or operating permit, a statement to this effect can be recorded instead of the daily average.  
<sup>f</sup> The periodic reports shall include the duration of periods when monitoring data is not collected for each excursion as defined in § 63.152(c)(2)(ii)(A) of this subpart.  
<sup>g</sup> PR = Periodic Reports described in § 63.152 of this subpart.  
<sup>h</sup> Alternatively, these devices may comply with the organic monitoring device provisions listed at this table under “All recapture devices.”.

■ 92. Revise the heading of table 4 to subpart G to read as follows:

**Table 4 to Subpart G of Part 63—  
 Process Vents—Monitoring,  
 Recordkeeping, and Reporting  
 Requirements for Maintaining a TRE  
 Index Value >1.0 and. ≤4.0 [No Longer  
 Applicable in Accordance With  
 § 63.113(a)(4)]**

\* \* \* \* \*

■ 93. Revise table 5 to subpart G to read as follows:

TABLE 5 TO SUBPART G OF PART 63—GROUP 1 STORAGE VESSELS AT EXISTING SOURCES

Vessel capacity (cubic meters)	Vapor pressure <sup>a</sup> (kilopascals)
75 ≤ capacity <151 <sup>b</sup> .....	<sup>b</sup> ≥13.1
38 ≤ capacity <151 <sup>c</sup> .....	<sup>c</sup> ≥6.9
151 ≤ capacity .....	≥5.2

<sup>a</sup> Maximum true vapor pressure of total organic HAP at storage temperature.  
<sup>b</sup> For each source as defined in § 63.101, beginning no later than the compliance dates specified in § 63.100(k)(10), these vessel capacity and vapor pressure criterion no longer apply.  
<sup>c</sup> For each source as defined in § 63.101, beginning no later than the compliance dates specified in § 63.100(k)(10), these vessel capacity and vapor pressure criterion apply.

■ 94. Revise table 6 to subpart G to read as follows:

TABLE 6 TO SUBPART G OF PART 63—GROUP 1 STORAGE VESSELS AT NEW SOURCES

Vessel capacity (cubic meters)	Vapor pressure <sup>a</sup> (kilopascals)
38 ≤ capacity <151 <sup>b</sup> .....	≥13.1 <sup>b</sup>
38 ≤ capacity <151 <sup>c</sup> .....	≥6.9 <sup>c</sup>
151 ≤ capacity .....	≥0.7

<sup>a</sup> Maximum true vapor pressure of total organic HAP at storage temperature.  
<sup>b</sup> For each source as defined in § 63.101, beginning no later than the compliance dates specified in § 63.100(k)(10), these vessel capacity and vapor pressure criterion no longer apply.  
<sup>c</sup> For each source as defined in § 63.101, beginning no later than the compliance dates specified in § 63.100(k)(10), these vessel capacity and vapor pressure criterion apply.

■ 95. Revise table 7 to subpart G to read as follows:

TABLE 7 TO SUBPART G OF PART 63—TRANSFER OPERATIONS—MONITORING, RECORDKEEPING, AND REPORTING REQUIREMENTS FOR COMPLYING WITH 98 WEIGHT-PERCENT REDUCTION OF TOTAL ORGANIC HAZARDOUS AIR POLLUTANTS EMISSIONS OR A LIMIT OF 20 PARTS PER MILLION BY VOLUME

Control device	Parameters to be monitored <sup>a</sup>	Recordkeeping and reporting requirements for monitored parameters
Thermal incinerator .....	Firebox temperature <sup>b</sup> [§ 63.127(a)(1)(i)] .....	<ol style="list-style-type: none"> <li>1. Continuous records<sup>c</sup> during loading.</li> <li>2. Record and report the firebox temperature averaged over the full period of the performance test—NCS.<sup>d</sup></li> <li>3. Record the daily average firebox temperature for each operating day.<sup>e</sup></li> <li>4. Report daily average temperatures that are outside the range established in the NCS or operating permit and all operating days when insufficient monitoring data are collected<sup>f</sup>—PR.<sup>g</sup></li> </ol>
Catalytic incinerator .....	Temperature upstream and downstream of the catalyst bed [§ 63.127(a)(1)(ii)].	<ol style="list-style-type: none"> <li>1. Continuous records during loading.</li> <li>2. Record and report the upstream and downstream temperatures and the temperature difference across the catalyst bed averaged over the full period of the performance test—NCS.</li> <li>3. Record the daily average upstream temperature and temperature difference across catalyst bed for each operating day.<sup>e</sup></li> <li>4. Report all daily average upstream temperatures that are outside the range established in the NCS or operating permit—PR.</li> <li>5. Report all daily average temperature differences across the catalyst bed that are outside the range established in the NCS or operating permit—PR.</li> <li>6. Report all operating days when insufficient monitoring data are collected.<sup>f</sup></li> </ol>
Boiler or process heater with a design heat input capacity less than 44 megawatts and vent stream is not introduced with or as the primary fuel.	Firebox temperature <sup>b</sup> [§ 63.127(a)(3)] .....	<ol style="list-style-type: none"> <li>1. Continuous records during loading.</li> <li>2. Record and report the firebox temperature averaged over the full period of the performance test—NCS.</li> <li>3. Record the daily average firebox temperature for each operating day.<sup>e</sup></li> <li>4. Report all daily average firebox temperatures that are outside the range established in the NCS or operating permit and all operating days when insufficient data are collected<sup>f</sup>—PR.</li> </ol>
Flare (if meeting the requirements of § 63.126(b)(2)(i)).	Presence of a flame at the pilot light [§ 63.127(a)(2)].	<ol style="list-style-type: none"> <li>1. Hourly records of whether the monitor was continuously operating and whether the pilot flame was continuously present during each hour.</li> <li>2. Record and report the presence of a flame at the pilot light over the full period of the compliance determination—NCS.</li> <li>3. Record the times and durations of all periods when all pilot flames are absent or the monitor is not operating.</li> </ol>

TABLE 7 TO SUBPART G OF PART 63—TRANSFER OPERATIONS—MONITORING, RECORDKEEPING, AND REPORTING REQUIREMENTS FOR COMPLYING WITH 98 WEIGHT-PERCENT REDUCTION OF TOTAL ORGANIC HAZARDOUS AIR POLLUTANTS EMISSIONS OR A LIMIT OF 20 PARTS PER MILLION BY VOLUME—Continued

Control device	Parameters to be monitored <sup>a</sup>	Recordkeeping and reporting requirements for monitored parameters
Flare (if meeting the requirements of § 63.108).	The parameters are specified in § 63.108 ....	4. Report the duration of all periods when all pilot flames of a flare are absent—PR. 1. Records as specified in § 63.108(m) of subpart F of this part. 2. Report information as specified in § 63.108(l) of subpart F of this part—PR.
Scrubber for halogenated vent streams (Note: Controlled by a combustion device other than a flare).	pH of scrubber effluent [§ 63.127(a)(4)(i)], and.	1. Continuous records during loading. 2. Record and report the pH of the scrubber effluent averaged over the full period of the performance test—NCS. 3. Record the daily average pH of the scrubber effluent for each operating day. <sup>e</sup>
	Scrubber liquid and gas flow rates [§ 63.127(a)(4)(ii)].	4. Report all daily average pH values of the scrubber effluent that are outside the range established in the NCS or operating permit and all operating days when insufficient monitoring data are collected—PR. 1. Continuous records during loading of scrubber liquid flow rate. 2. Record and report the scrubber liquid/gas ratio averaged over the full period of the performance test—NCS. 3. Record the daily average scrubber liquid/gas ratio for each operating day. <sup>e</sup> 4. Report all daily average scrubber liquid/gas ratios that are outside the range established in the NCS or operating permit and all operating days when insufficient monitoring data are collected—PR.
Absorber <sup>h</sup> .....	Exit temperature of the absorbing liquid [§ 63.127(b)(1)], and	1. Continuous records during loading. 2. Record and report the exit temperature of the absorbing liquid averaged over the full period of the performance test—NCS. 3. Record the daily average exit temperature of the absorbing liquid for each operating day. <sup>e</sup> 4. Report all daily average exit temperatures of the absorbing liquid that are outside the range established in the NCS or operating permit and all operating days when insufficient monitoring data are collected—PR.
	Exit specific gravity [§ 63.127(b)(1)] .....	1. Continuous records during loading. 2. Record and report the exit specific gravity averaged over the full period of the performance test—NCS. 3. Record the daily average exit specific gravity for each operating day. <sup>e</sup> 4. Report all daily average exit specific gravity values that are outside the range established in the NCS or operating permit and all operating days when insufficient monitoring data are collected—PR.
Condenser <sup>h</sup> .....	Exit (product side) temperature [§ 63.127(b)(2)].	1. Continuous records during loading. 2. Record and report the exit temperature averaged over the full period of the performance test—NCS. 3. Record the daily average exit temperature for each operating day. <sup>e</sup> 4. Report all daily average exit temperatures that are outside the range established in the NCS or operating permit and all operating days when insufficient monitoring data are collected—PR.
Carbon adsorber <sup>h</sup> .....	Total regeneration stream mass or volumetric or volumetric flow during carbon bed regeneration cycle(s) [§ 63.127(b)(3)], and	1. Record of total regeneration stream mass or volumetric flow for each carbon bed regeneration cycle. 2. Record and report the total regeneration stream mass or volumetric flow during each carbon bed regeneration cycle during the period of the performance test—NCS. 3. Report all carbon bed regeneration cycles when the total regeneration stream mass or volumetric flow is outside the range established in the NCS or operating permit and all operating days when insufficient monitoring data are collected—PR.
	Temperature of the carbon bed after regeneration [and within 15 minutes of completing any cooling cycle(s)] [§ 63.127(b)(3)].	1. Records of the temperature of the carbon bed after each regeneration. 2. Record and report the temperature of the carbon bed after each regeneration during the period of the performance test—NCS. 3. Report all the carbon bed regeneration cycles during which the temperature of the carbon bed after regeneration is outside the range established in the NCS or operating permit and all operating days when insufficient monitoring data are collected—PR.
	Outlet HAP or TOC concentration [§ 63.127(b)(4)].	For each nonregenerative adsorber and regenerative adsorber that is regenerated offsite subject to the requirements in § 63.127(b)(4), the owner or operator must record each outlet HAP or TOC concentration measured according to §§ 63.127(b)(4)(ii) and (iii).
	Adsorbent replacement [§ 63.127(b)(4)] .....	1. For each nonregenerative adsorber and regenerative adsorber that is regenerated offsite subject to the requirements in § 63.127(b)(4), the owner or operator must record date and time the adsorbent was last replaced.
	Breakthrough [§ 63.127(b)(4)] .....	For each nonregenerative adsorber and regenerative adsorber that is regenerated offsite subject to the requirements in § 63.127(b)(4), the owner or operator must: 1. Record breakthrough limit and bed life established according to § 63.127(b)(4)(i). 2. Report the date of each instance when breakthrough, as defined in § 63.101, is detected between the first and second adsorber and the adsorber is not replaced according to § 63.127(b)(4)(iii)(A)—PR.

TABLE 7 TO SUBPART G OF PART 63—TRANSFER OPERATIONS—MONITORING, RECORDKEEPING, AND REPORTING REQUIREMENTS FOR COMPLYING WITH 98 WEIGHT-PERCENT REDUCTION OF TOTAL ORGANIC HAZARDOUS AIR POLLUTANTS EMISSIONS OR A LIMIT OF 20 PARTS PER MILLION BY VOLUME—Continued

Control device	Parameters to be monitored <sup>a</sup>	Recordkeeping and reporting requirements for monitored parameters
All recovery devices (as an alternative to the above).	Concentration level or reading indicated by an organic monitoring device at the outlet of the recovery device [§ 63.127(b)].	<ol style="list-style-type: none"> <li>1. Continuous records during loading.</li> <li>2. Record and report the concentration level or reading averaged over the full period of the performance test—NCS.</li> <li>3. Record the daily average concentration level or reading for each operating day.<sup>d</sup></li> <li>4. Report all daily average concentration levels or readings that are outside the range established in the NCS or operating permit and all operating days when insufficient monitoring data are collected—PR.</li> </ol>
All control devices and vapor balancing systems.	Presence of flow diverted to the atmosphere from the control device [§ 63.127(d)(1)] or  Monthly inspections of sealed valves [§ 63.127(d)(2)].	<ol style="list-style-type: none"> <li>1. Hourly records of whether the flow indicator was operating and whether a diversion was detected at any time during each hour.</li> <li>2. Record and report the duration of all periods when the vent stream is diverted through a bypass line or the monitor is not operating—PR.</li> <li>3. For each source as defined in § 63.101, beginning no later than the compliance dates specified in § 63.100(k)(10), record and report the start date, start time, duration in hours, estimate of the volume of gas in standard cubic feet, the concentration of organic HAP in the gas in parts per million by volume and the resulting mass emissions of organic HAP in pounds that bypass a control device. For periods when the flow indicator is not operating, report the start date, start time, and duration in hours—PR.</li> </ol> <ol style="list-style-type: none"> <li>1. Records that monthly inspections were performed.</li> <li>2. Record and report all monthly inspections that show the valves are moved to the diverting position or the seal has been changed.</li> <li>3. For each source as defined in § 63.101, beginning no later than the compliance dates specified in § 63.100(k)(10), record and report the start date, start time, duration in hours, estimate of the volume of gas in standard cubic feet, the concentration of organic HAP in the gas in parts per million by volume and the resulting mass emissions of organic HAP in pounds that bypass a control device. For periods when the flow indicator is not operating, report the start date, start time, and duration in hours—PR.</li> </ol>

<sup>a</sup> Regulatory citations are listed in brackets.

<sup>b</sup> Monitor may be installed in the firebox or in the ductwork immediately downstream of the firebox before any substantial heat exchange is encountered.

<sup>c</sup> “Continuous records” is defined in § 63.111 of this subpart.

<sup>d</sup> NCS = Notification of Compliance Status described in § 63.152 of this subpart.

<sup>e</sup> The daily average is the average of all recorded parameter values for the operating day. If all recorded values during an operating day are within the range established in the NCS or operating permit, a statement to this effect can be recorded instead of the daily average.

<sup>f</sup> The periodic reports shall include the duration of periods when monitoring data are not collected for each excursion as defined in § 63.152(c)(2)(ii)(A) of this subpart.

<sup>g</sup> PR = Periodic Reports described in § 63.152 of this subpart.

<sup>h</sup> Alternatively, these devices may comply with the organic monitoring device provisions listed at the end of this table under “All Recovery Devices.”

■ 96. Amend table 8 to subpart G by adding the entry for “Ethylene oxide” in alphabetical order to read as follows:

TABLE 8 TO SUBPART G OF PART 63—ORGANIC HAP’S SUBJECT TO THE WASTEWATER PROVISIONS FOR PROCESS UNITS AT NEW SOURCES

Chemical name	CAS No. <sup>a</sup>
Ethylene oxide .....	75218

TABLE 8 TO SUBPART G OF PART 63—ORGANIC HAP’S SUBJECT TO THE WASTEWATER PROVISIONS FOR PROCESS UNITS AT NEW SOURCES—Continued

Chemical name	CAS No. <sup>a</sup>
Ethylene oxide .....	75218

TABLE 8 TO SUBPART G OF PART 63—ORGANIC HAP’S SUBJECT TO THE WASTEWATER PROVISIONS FOR PROCESS UNITS AT NEW SOURCES—Continued

Chemical name	CAS No. <sup>a</sup>
Ethylene oxide .....	75218

■ 97. Revise table 13 to subpart G to read as follows:

TABLE 13 TO SUBPART G OF PART 63—WASTEWATER—MONITORING REQUIREMENTS FOR CONTROL DEVICES

Control device	Monitoring equipment required	Parameters to be monitored	Frequency
All control devices .....	<ol style="list-style-type: none"> <li>1. Flow indicator installed at all bypass lines to the atmosphere and equipped with continuous recorder<sup>b</sup> or</li> <li>2. Valves sealed closed with car-seal or lock-and-key configuration.</li> </ol>	<ol style="list-style-type: none"> <li>1. Presence of flow diverted from the control device to the atmosphere or</li> <li>2. Monthly inspections of sealed valves</li> </ol>	Hourly records of whether the flow indicator was operating and whether a diversion was detected at any time during each hour.  Monthly.
Thermal Incinerator .....	Temperature monitoring device installed in firebox or in ductwork immediately downstream of firebox <sup>a</sup> and equipped with a continuous recorder <sup>b</sup> .	Firebox temperature .....	Continuous.

TABLE 13 TO SUBPART G OF PART 63—WASTEWATER—MONITORING REQUIREMENTS FOR CONTROL DEVICES—  
Continued

Control device	Monitoring equipment required	Parameters to be monitored	Frequency
Catalytic Incinerator .....	Temperature monitoring device installed in gas stream immediately before and after catalyst bed and equipped with a continuous recorder <sup>b</sup> .	1. Temperature upstream of catalyst bed <i>or</i> 2. Temperature difference across catalyst bed.	Continuous.
Flare (if meeting the requirements of § 63.139(c)(3)).	Heat sensing device installed at the pilot light and equipped with a continuous recorder <sup>a</sup> .	Presence of a flame at the pilot light ....	Hourly records of whether the monitor was continuously operating and whether the pilot flame was continuously present during each hour. The frequency is specified in § 63.108.
Flare (if meeting the requirements of § 63.108).	The monitoring equipment is specified in § 63.108.	The parameters are specified in § 63.108.	
Boiler or process heater <44 megawatts and vent stream is not mixed with the primary fuel.	Temperature monitoring device installed in firebox <sup>a</sup> and equipped with continuous recorder <sup>b</sup> .	Combustion temperature .....	Continuous.
Condenser .....	Temperature monitoring device installed at condenser exit and equipped with continuous recorder <sup>b</sup> .	Condenser exit (product side) temperature.	Continuous.
Carbon adsorber (regenerative, regenerated onsite).	Integrating regeneration stream flow monitoring device having an accuracy of ±10 percent, <i>and</i> Carbon bed temperature monitoring device.	Total regeneration stream mass or volumetric flow during carbon bed regeneration cycle(s). Temperature of carbon bed after regeneration [and within 15 minutes of completing any cooling cycle(s)].	For each regeneration cycle, record the total regeneration stream mass or volumetric flow. For each regeneration cycle and within 15 minutes of completing any cooling cycle, record the carbon bed temperature.
Carbon adsorber (Non-regenerative or regenerative, regenerated offsite).	Organic compound concentration monitoring device <sup>c</sup> .	Organic compound concentration of adsorber exhaust.	Daily or at intervals no greater than 20 percent of the design carbon replacement interval, whichever is greater.
Organic monitoring device <sup>d</sup> .....	The monitoring equipment is specified in § 63.139(d)(5). Organic monitoring device installed at the outlet of the control device.	The parameters are specified in § 63.139(d)(5). Organic compound concentration of control device exhaust.	The frequency is specified in § 63.139(d)(5). Continuous.
Alternative monitoring parameters .....	Other parameters may be monitored upon approval from the Administrator in accordance with the requirements in § 63.143(e)(3).		

<sup>a</sup> Monitor may be installed in the firebox or in the ductwork immediately downstream of the firebox before any substantial heat exchange is encountered.

<sup>b</sup> "Continuous recorder" is defined in § 63.111 of this subpart.

<sup>c</sup> As an alternative to conducting this monitoring, an owner or operator may replace the carbon in the carbon adsorption system with fresh carbon at a regular predetermined time interval that is less than the carbon replacement interval that is determined by the maximum design flow rate and organic concentration in the gas stream vented to the carbon adsorption system. For each source as defined in § 63.101, on and after July 15, 2027, this footnote no longer applies.

<sup>d</sup> A continuous organic monitoring device may be used in lieu of the requirements outlined for thermal incinerators, catalytic incinerators, boilers, process heaters, condensers, and carbon adsorbers.

■ 98. Revise table 20 to subpart G to read as follows:

TABLE 20 TO SUBPART G OF PART 63—WASTEWATER—PERIODIC REPORTING REQUIREMENTS FOR CONTROL DEVICES  
SUBJECT TO § 63.139 USED TO COMPLY WITH §§ 63.13 THROUGH 63.139

Control device	Reporting requirements
(1) Thermal Incinerator.	Report all daily average <sup>a</sup> temperatures that are outside the range established in the NCS <sup>b</sup> or operating permit and all operating days when insufficient monitoring data are collected. <sup>c</sup>
(2) Catalytic Incinerator .....	(i) Report all daily average <sup>a</sup> upstream temperatures that are outside the range established in the NCS <sup>b</sup> or operating permit. (ii) Report all daily average <sup>a</sup> temperature differences across the catalyst bed that are outside the range established in the NCS <sup>b</sup> or operating permit. (iii) Report all operating days when insufficient monitoring data are collected. <sup>c</sup>
(3) Boiler or Process Heater with a design heat input capacity less than 44 megawatts and vent stream is not mixed with the primary fuel.	Report all daily average <sup>a</sup> firebox temperatures that are outside the range established in the NCS <sup>b</sup> or operating permit and all operating days when insufficient monitoring data are collected. <sup>c</sup>
(4a) Flare (if meeting the requirements of § 63.139(c)(3))	Report the duration of all periods when all pilot flames are absent.
(4b) Flare (if meeting the requirements of § 63.108) .....	The reporting requirements are specified in § 63.108(l) of subpart F of this part.
(5) Condenser .....	Report all daily average <sup>a</sup> exit temperatures that are outside the range established in the NCS <sup>b</sup> or operating permit and all operating days when insufficient monitoring data are collected. <sup>c</sup>
(6) Carbon Adsorber (Regenerative) .....	(i) Report all carbon bed regeneration cycles when the total regeneration stream mass or volumetric flow is outside the range established in the NCS <sup>b</sup> or operating permit. (ii) Report all carbon bed regeneration cycles during which the temperature of the carbon bed after regeneration is outside the range established in the NCS <sup>b</sup> or operating permit.



TABLE 20 TO SUBPART G OF PART 63—WASTEWATER—PERIODIC REPORTING REQUIREMENTS FOR CONTROL DEVICES SUBJECT TO § 63.139 USED TO COMPLY WITH §§ 63.13 THROUGH 63.139—Continued

Control device	Reporting requirements
(7) Carbon Adsorber (Non-Regenerative) .....	(iii) Report all operating days when insufficient monitoring data are collected. <sup>c</sup> (iv) For each regenerative adsorber that is regenerated offsite subject to the requirements in § 63.139(d)(5) report the date of each instance when breakthrough, as defined in § 63.101, is detected between the first and second adsorber and the adsorber is not replaced according to § 63.139(d)(5)(iii)(A). (i) Report all operating days when inspections not done according to the schedule developed as specified in table 13 of this subpart. (ii) Report all operating days when carbon has not been replaced at the frequency specified in table 13 of this subpart.
(8) All Control Devices .....	(iii) For each nonregenerative adsorber subject to the requirements in § 63.139(d)(5), report the date of each instance when breakthrough, as defined in § 63.101, is detected between the first and second adsorber and the adsorber is not replaced according to § 63.139(d)(5)(iii)(A). (i) Report the times and durations of all periods when the vent stream is diverted through a bypass line or the monitor is not operating, or (ii) Report all monthly inspections that show the valves are moved to the diverting position or the seal has been changed. (iii) For each source as defined in § 63.101, beginning no later than the compliance dates specified in § 63.100(k)(10), report the start date, start time, duration in hours, estimate of the volume of gas in standard cubic feet, the concentration of organic HAP in the gas in parts per million by volume and the resulting mass emissions of organic HAP in pounds that bypass a control device. For periods when the flow indicator is not operating, report the start date, start time, and duration in hours.
(9) Thermal Incinerator, Catalytic Incinerator, Boiler, Process Heater, Condenser, or Carbon Adsorber using a continuous organic monitoring device as specified in § 63.143(e)(2).	(i) Report all daily average <sup>a</sup> concentration levels or readings that are outside the range established in the NCS or operating permit. <sup>c</sup> (ii) Report all operating days when insufficient monitoring data are collected. <sup>c</sup>

<sup>a</sup> The daily average is the average of all values recorded during the operating day, as specified in § 63.147(d).

<sup>b</sup> NCS = Notification of Compliance Status described in § 63.152.

<sup>c</sup> The periodic reports shall include the duration of periods when monitoring data are not collected for each excursion as defined in § 63.152(c)(2)(ii)(A).

■ 99. Add table 38 to subpart G to read as follows:

TABLE 38 TO SUBPART G OF PART 63—TOXIC EQUIVALENCY FACTORS

Dioxin and furan congener	Toxic equivalency factor
1,2,3,7,8-pentachlorodibenzo-p-dioxin .....	1
1,2,3,4,7,8-hexachlorodibenzo-p-dioxin .....	0.1
1,2,3,7,8,9-hexachlorodibenzo-p-dioxin .....	0.1
1,2,3,6,7,8-hexachlorodibenzo-p-dioxin .....	0.1
1,2,3,4,6,7,8-heptachlorodibenzo-p-dioxin .....	0.01
octachlorodibenzo-p-dioxin .....	0.0003
2,3,7,8-tetrachlorodibenzofuran .....	0.1
2,3,4,7,8-pentachlorodibenzofuran .....	0.3
1,2,3,7,8-pentachlorodibenzofuran .....	0.03
1,2,3,4,7,8-hexachlorodibenzofuran .....	0.1
1,2,3,6,7,8-hexachlorodibenzofuran .....	0.1
1,2,3,7,8,9-hexachlorodibenzofuran .....	0.1
2,3,4,6,7,8-hexachlorodibenzofuran .....	0.1
1,2,3,4,6,7,8-heptachlorodibenzofuran .....	0.01
1,2,3,4,7,8,9-heptachlorodibenzofuran .....	0.01
Octachlorodibenzofuran .....	0.0003

■ 100. Revise the heading to subpart H to read as follows:

**Subpart H—National Emission Standards for Hazardous Air Pollutants for Equipment Leaks and Fenceline Monitoring for All Emission Sources**

- 101. Amend § 63.160 by:
  - a. Revising paragraph (b)(1);

■ b. Revising and republishing paragraph (c); and

■ c. Revising paragraphs (g) introductory text and (g)(1).

The revisions and republication read as follows:

**§ 63.160 Applicability and designation of source.**

\* \* \* \* \*

(b) \* \* \*

(1) Part 60 of this chapter will be required to comply only with the provisions of this subpart, except as specified in §§ 60.480a(e)(2)(i) and 60.480b(e)(2)(i) of this chapter.

\* \* \* \* \*

(c) If a process unit subject to the provisions of this subpart has equipment to which this subpart does not apply, but which is subject to a standard identified in paragraph (c)(1), (2), or (3) of this section, the owner or operator may elect to apply this subpart to all such equipment in the process unit. If the owner or operator elects this method of compliance, all VOC in such equipment shall be considered, for purposes of applicability and compliance with this subpart, as if it were organic hazardous air pollutant (HAP). Compliance with the provisions of this subpart, in the manner described in this paragraph, shall be deemed to constitute compliance with the standard identified in paragraph (c)(1), (2), or (3) of this section.

(1) Part 60, subpart VV, VVa, VVb, GGG, or KKK, of this chapter, except as specified in §§ 60.480a(e)(2)(i) and 60.480b(e)(2)(i) of this chapter;

(2) Part 61, subpart F or J of this chapter; or

(3) Part 264, subpart BB of this chapter or part 265, subpart BB of this chapter.

\* \* \* \* \*

(g) *Alternative means of compliance*—For each source as defined in § 63.101, and for each source as defined in § 63.191, on and after July 15, 2027, this paragraph no longer applies.

(1) *Option to comply with 40 CFR part 65.* Owners or operators of CMPU that are subject to § 63.100 may choose to comply with the provisions of 40 CFR part 65 for all Group 1 and Group 2 process vents, Group 1 storage vessels, Group 1 transfer operations, and equipment that are subject to § 63.100, that are part of the CMPU. Other provisions applying to an owner or operator who chooses to comply with 40 CFR part 65 are provided in 40 CFR 65.1.

\* \* \* \* \*

■ 102. Revise § 63.161 to read as follows:

**§ 63.161 Definitions.**

All terms used in this subpart shall have the meaning given them in the Act and in subpart F of this part, except as provided in any subpart that references this subpart.

■ 103. Amend § 63.163 by:

■ a. Adding paragraph (a)(1)(iii);

■ b. Revising paragraph (b)(2) introductory text and adding paragraph (b)(2)(iv);

■ c. Revising paragraph (c)(3) and adding paragraph (c)(4);

■ d. Revising paragraph (e) introductory text and adding paragraph (e)(7); and

■ e. Revising paragraphs (g), (j) introductory text and (j)(1).

The revisions and additions read as follows:

**§ 63.163 Standards: Pumps in light liquid service.**

(a) \* \* \*

(1) \* \* \*

(iii) For each source as defined in § 63.101, and for each source as defined in § 63.191, beginning no later than the compliance dates specified in § 63.100(k)(11), for each pump in ethylene oxide service, as defined in § 63.101, that is added to a CMPU, and for each pump in ethylene oxide service, that replaces a pump in ethylene oxide service, owners and operators must initially monitor for leaks within 5 days after initial startup of the equipment.

\* \* \* \* \*

(b) \* \* \*

(2) Except as specified in paragraph (b)(2)(iv) of this section, the instrument reading, as determined by the method as specified in § 63.180(b), that defines a leak in each phase of the standard is:

\* \* \* \* \*

(iv) For each source as defined in § 63.101, and for each source as defined in § 63.191, beginning no later than the compliance dates specified in § 63.100(k)(11), for pumps in ethylene oxide service, as defined in § 63.101, the instrument reading that defines a leak for pumps is 500 parts per million or greater.

\* \* \* \* \*

(c) \* \* \*

(3) Except as specified in paragraph (c)(4) of this section, for pumps in Phase III to which a 1,000 parts per million leak definition applies, repair is not required unless an instrument reading of 2,000 parts per million or greater is detected.

(4) For each source as defined in § 63.101, and for each source as defined in § 63.191, beginning no later than the compliance dates specified in § 63.100(k)(11), for pumps in ethylene oxide service, as defined in § 63.101, paragraph (c)(3) of this section is not applicable.

\* \* \* \* \*

(e) Except as specified in paragraph (e)(7) of this section, each pump

equipped with a dual mechanical seal system that includes a barrier fluid system is exempt from the requirements of paragraphs (a) through (d) of this section, provided the following requirements are met:

\* \* \* \* \*

(7) For each source as defined in § 63.101, and for each source as defined in § 63.191, beginning no later than the compliance dates specified in § 63.100(k)(11), for pumps in ethylene oxide service, as defined in § 63.101, paragraph (e) of this section is not applicable.

\* \* \* \* \*

(g) Any pump that is routed to a process or fuel gas system or equipped with a closed vent system capable of capturing and transporting leakage from the pump to a control device meeting the requirements of § 63.172 is exempt from the requirements of paragraphs (a)(1)(iii), and (b) through (e) of this section.

\* \* \* \* \*

(j) Any pump that is designated, as described in § 63.181(b)(7)(i), as an unsafe-to-monitor pump is exempt from the requirements of paragraphs (a)(1)(iii), and (b) through (e) of this section if:

(1) The owner or operator of the pump determines that the pump is unsafe to monitor because monitoring personnel would be exposed to an immediate danger as a consequence of complying with paragraphs (a)(1)(iii), and (b) through (d) of this section; and

\* \* \* \* \*

■ 104. Amend § 63.164 by revising paragraph (h) to read as follows:

**§ 63.164 Standards: Compressors.**

\* \* \* \* \*

(h) A compressor is exempt from the requirements of paragraphs (a) through (g) of this section if it is equipped with a system to capture and transport leakage from the compressor drive shaft seal to a process or a fuel gas system or to a closed vent system that captures and transports leakage from the compressor to a control device meeting the requirements of § 63.172 of this subpart.

\* \* \* \* \*

■ 105. Revise and republish § 63.165 to read as follows:

**§ 63.165 Standards: Pressure relief devices in gas/vapor service or light liquid service.**

(a) Except during pressure releases, each pressure relief device in gas/vapor service shall be operated with an instrument reading of less than 500 parts per million above background

except as provided in paragraph (b) of this section, as measured by the method specified in § 63.180(c). For each source as defined in § 63.101, and for each source as defined in § 63.191, beginning no later than the compliance dates specified in § 63.100(k)(10), this paragraph (a) no longer applies and instead the owner or operator must comply with paragraph (e) of this section.

(b) Except as specified in paragraph (e) of this section, comply with paragraphs (b)(1) and (b)(2) of this section.

(1) After each pressure release, the pressure relief device shall be returned to a condition indicated by an instrument reading of less than 500 parts per million above background, as soon as practicable, but no later than 5 calendar days after each pressure release, except as provided in § 63.171.

(2) No later than 5 calendar days after the pressure release and being returned to organic HAP service, the pressure relief device shall be monitored to confirm the condition indicated by an instrument reading of less than 500 parts per million above background, as measured by the method specified in § 63.180(c).

(c) Except as specified in paragraph (e) of this section, any pressure relief device that is routed to a process or fuel gas system or equipped with a closed-vent system capable of capturing and transporting leakage from the pressure relief device to a control device as described in § 63.172 is exempt from the requirements of paragraphs (a) and (b) of this section.

(d) Except as specified in paragraph (e) of this section, comply with paragraphs (d)(1) and (d)(2) of this section.

(1) Any pressure relief device that is equipped with a rupture disk upstream of the pressure relief device is exempt from the requirements of paragraphs (a) and (b) of this section, provided the owner or operator complies with the requirements in paragraph (d)(2) of this section.

(2) After each pressure release, a rupture disk shall be installed upstream of the pressure relief device as soon as practicable, but no later than 5 calendar days after each pressure release, except as provided in § 63.171.

(e) For each source as defined in § 63.101, and for each source as defined in § 63.191, beginning no later than the compliance dates specified in § 63.100(k)(10), except as specified in paragraph (e)(4) of this section, owners and operators must comply with the requirements specified in paragraphs (e)(1) and (2) of this section for pressure

relief devices, such as relief valves or rupture disks, in organic HAP gas or vapor service instead of the pressure relief device requirements of paragraph (a) through (d) of this section. Except as specified in paragraphs (e)(4) and (5) of this section, owners and operators must also comply with the requirements specified in paragraphs (e)(3), (6), (7), and (8) of this section for all pressure relief devices in organic HAP service.

(1) *Operating requirements.* Except during a pressure release, operate each pressure relief device in organic HAP gas or vapor service with an instrument reading of less than 500 ppm above background as measured by the method in § 63.180(c).

(2) *Pressure release requirements.* For pressure relief devices in organic HAP gas or vapor service, owners and operators must comply with the applicable requirements paragraphs (e)(2)(i) through (iii) of this section following a pressure release.

(i) If the pressure relief device does not consist of or include a rupture disk, conduct instrument monitoring, as specified in § 63.180(c), no later than 5 calendar days after the pressure relief device returns to organic HAP gas or vapor service following a pressure release to verify that the pressure relief device is operating with an instrument reading of less than 500 ppm.

(ii) If the pressure relief device includes a rupture disk, either comply with the requirements in paragraph (e)(2)(i) of this section (and do not replace the rupture disk) or install a replacement disk as soon as practicable after a pressure release, but no later than 5 calendar days after the pressure release.

(iii) If the pressure relief device consists only of a rupture disk, install a replacement disk as soon as practicable after a pressure release, but no later than 5 calendar days after the pressure release. Owners and operators must not initiate startup of the equipment served by the rupture disk until the rupture disc is replaced.

(3) *Pressure release management.* Except as specified in paragraphs (e)(4) and (5) of this section, owners and operators must comply with the requirements specified in paragraphs (e)(3)(i) through (v) of this section for all pressure relief devices in organic HAP service.

(i) Owners and operators must equip each affected pressure relief device with a device(s) or use a monitoring system that is capable of:

- (A) Identifying the pressure release;
- (B) Recording the time and duration of each pressure release; and

(C) Notifying operators immediately that a pressure release is occurring. The device or monitoring system must be either specific to the pressure relief device itself or must be associated with the process system or piping, sufficient to indicate a pressure release to the atmosphere. Examples of these types of devices and systems include, but are not limited to, a rupture disk indicator, magnetic sensor, motion detector on the pressure relief valve stem, flow monitor, or pressure monitor.

(ii) Owners and operators must apply at least three redundant prevention measures to each affected pressure relief device and document these measures. Examples of prevention measures include:

(A) Flow, temperature, liquid level and pressure indicators with deadman switches, monitors, or automatic actuators. Independent, non-duplicative systems within this category count as separate redundant prevention measures.

(B) Documented routine inspection and maintenance programs and/or operator training (maintenance programs and operator training may count as only one redundant prevention measure).

(C) Inherently safer designs or safety instrumentation systems.

(D) Deluge systems.

(E) Staged relief system where the initial pressure relief device (with lower set release pressure) discharges to a flare or other closed vent system and control device.

(iii) If any affected pressure relief device releases to atmosphere as a result of a pressure release event, owners and operators must perform root cause analysis and corrective action analysis according to the requirement in paragraph (e)(6) of this section and implement corrective actions according to the requirements in paragraph (e)(7) of this section. Owners and operators must also calculate the quantity of organic HAP released during each pressure release event and report this quantity as required in § 63.182(d)(2)(xviii). Calculations may be based on data from the pressure relief device monitoring alone or in combination with process parameter monitoring data and process knowledge.

(iv) Owners and operators must determine the total number of release events that occurred during the calendar year for each affected pressure relief device separately.

(v) Except for pressure relief devices described in paragraphs (e)(4) and (5) of this section, the following release events from an affected pressure relief device

are a violation of the pressure release management work practice standards.

(A) Except as specified in paragraph (e)(3)(v)(D) of this section, any release event for which the root cause of the event was determined to be operator error or poor maintenance.

(B) Except as specified in paragraph (e)(3)(v)(D) of this section, a second release event from a single pressure relief device in a 3 calendar year period for the same root cause for the same equipment.

(C) Except as specified in paragraph (e)(3)(v)(D) of this section, a third release event from a single pressure relief device in a 3 calendar year period for any reason.

(D) Paragraphs (e)(3)(v)(A) through (e)(3)(v)(C) of this section do not apply to pressure relief devices in ethylene oxide service, as defined in § 63.101; instead, any release event from an affected pressure relief device in ethylene oxide service is a violation of the pressure release management work practice standards.

(4) *Pressure relief devices routed to a control device, process, fuel gas system, or drain system.* (i) If all releases and potential leaks from a pressure relief device are routed through a closed vent system to a control device, back into the process, to the fuel gas system, or to a drain system, then owners and operators are not required to comply with paragraph (e)(1), (2), or (3) of this section.

(ii) Both the closed vent system and control device (if applicable) referenced in paragraph (e)(4)(i) of this section must meet the applicable requirements specified in § 63.172.

(iii) The drain system (if applicable) referenced in paragraph (e)(4)(i) of this section must meet the applicable requirements specified in § 63.136(e).

(5) *Pressure relief devices exempted from pressure release management requirements.* The following types of pressure relief devices are not subject to the pressure release management requirements in paragraph (e)(3) of this section.

(i) Pressure relief devices in heavy liquid service, as defined in § 63.161.

(ii) Thermal expansion relief valves.

(iii) Pressure relief devices on mobile equipment.

(iv) Pilot-operated pressure relief devices where the primary release valve is routed through a closed vent system to a control device or back into the process, to the fuel gas system, or to a drain system.

(v) Balanced bellows pressure relief devices where the primary release valve is routed through a closed vent system to a control device or back into the

process, to the fuel gas system, or to a drain system.

(6) *Root cause analysis and corrective action analysis.* A root cause analysis and corrective action analysis must be completed as soon as possible, but no later than 45 days after a release event. Special circumstances affecting the number of root cause analyses and/or corrective action analyses are provided in paragraphs (e)(6)(i) through (iii) of this section.

(i) Owners and operators may conduct a single root cause analysis and corrective action analysis for a single emergency event that causes two or more pressure relief devices installed on the same equipment to release.

(ii) [Reserved]

(iii) Except as provided in paragraph (e)(6)(i) of this section, if more than one pressure relief device has a release during the same time period, an initial root cause analysis must be conducted separately for each pressure relief device that had a release. If the initial root cause analysis indicates that the release events have the same root cause(s), the initially separate root cause analyses may be recorded as a single root cause analysis and a single corrective action analysis may be conducted.

(7) *Corrective action implementation.* Owners and operators must conduct a root cause analysis and corrective action analysis as specified in paragraphs (e)(3)(iii) and (e)(6) of this section, and owners and operators must implement the corrective action(s) identified in the corrective action analysis in accordance with the applicable requirements in paragraphs (e)(7)(i) through (iii) of this section.

(i) All corrective action(s) must be implemented within 45 days of the event for which the root cause and corrective action analyses were required or as soon thereafter as practicable. If the owner or operator concludes that no corrective action should be implemented, the owner or operator must record and explain the basis for that conclusion no later than 45 days following the event.

(ii) For corrective actions that cannot be fully implemented within 45 days following the event for which the root cause and corrective action analyses were required, owners and operators must develop an implementation schedule to complete the corrective action(s) as soon as practicable.

(iii) No later than 45 days following the event for which a root cause and corrective action analyses were required, owners and operators must record the corrective action(s) completed to date, and, for action(s) not

already completed, a schedule for implementation, including proposed commencement and completion dates.

(8) *Flowing pilot-operated pressure relief devices.* For affected sources that commenced construction or reconstruction on or before April 25, 2023, owners and operators are prohibited from installing a flowing pilot-operated pressure relief device or replacing any pressure relief device with a flowing pilot-operated pressure relief device after July 15, 2027. For affected sources that commenced construction or reconstruction after April 25, 2023, owners and operators are prohibited from installing and operating flowing pilot-operated pressure relief devices. For purpose of compliance with this paragraph, a flowing pilot-operated pressure relief device means the type of pilot-operated pressure relief device where the pilot discharge vent continuously releases emissions to the atmosphere when the pressure relief device is actuated.

■ 106. Amend § 63.168 by:

■ a. Revising paragraph (b)(2) introductory text and adding paragraph (b)(2)(iv); and

■ b. Revising paragraph (d) introductory text and adding paragraph (d)(5).

The revisions and additions read as follows:

**§ 63.168 Standards: Valves in gas/vapor service and in light liquid service.**

\* \* \* \* \*

(b) \* \* \*

(2) Except as specified in paragraph (b)(2)(iv) of this section, the instrument reading that defines a leak in each phase of the standard is:

\* \* \* \* \*

(iv) For each source as defined in § 63.101, and for each source as defined in § 63.191, beginning no later than the compliance dates specified in § 63.100(k)(11), for valves in ethylene oxide service, as defined in § 63.101, that are either in gas service or in light liquid service the instrument reading that defines a leak is 100 parts per million or greater.

\* \* \* \* \*

(d) Except as specified in paragraph (d)(5) of this section, in Phase III, the owner or

\* \* \* \* \*

(5) For each source as defined in § 63.101, and for each source as defined in § 63.191, beginning no later than the compliance dates specified in § 63.100(k)(11), for valves in ethylene oxide service, as defined in § 63.101, that are either in gas service or in light

liquid service the monitoring period is once per month.

\* \* \* \* \*

■ 107. Revise § 63.170 to read as follows:

**§ 63.170 Standards: Surge control vessels and bottoms receivers.**

(a) Except as specified in paragraph (b) of this section, each surge control vessel or bottoms receiver that is not routed back to the process and that meets the conditions specified in table 2 or table 3 of this subpart shall be equipped with a closed-vent system that routes the organic vapors vented from the surge control vessel or bottoms receiver back to the process or to a control device that complies with the requirements in § 63.172, except as provided in § 63.162(b), or comply with the requirements of § 63.119(b) or (c).

(b) For each source as defined in § 63.101, and for each source as defined in § 63.191, beginning no later than the compliance dates specified in § 63.100(k)(10), paragraph (a) of this section no longer applies. Instead, each surge control vessel and bottoms receiver that is not routed back to the process and emits greater than or equal to 1.0 lb/hr of total organic HAP must be equipped with a closed-vent system that routes the organic vapors vented from the surge control vessel or bottoms receiver back to the process or to a control device that complies with the requirements in § 63.172, except as provided in § 63.162(b), or comply with the requirements of § 63.113(a)(1) or (a)(2).

■ 108. Amend § 63.171 by revising paragraphs (a), (c) introductory text, (d) introductory text and (e), and adding paragraph (f) to read as follows:

**§ 63.171 Standards: Delay of repair.**

(a) Except as specified in paragraph (f) of this section, delay of repair of equipment for which leaks have been detected is allowed if repair within 15 days is technically infeasible without a process unit shutdown. Repair of this equipment shall occur by the end of the next process unit shutdown.

\* \* \* \* \*

(c) Except as specified in paragraph (f) of this section, delay of repair for valves, connectors, and agitators is also allowed if:

\* \* \* \* \*

(d) Except as specified in paragraph (f) of this section, delay of repair for pumps is also allowed if:

\* \* \* \* \*

(e) Except as specified in paragraph (f) of this section, delay of repair beyond a process unit shutdown will be allowed

for a valve if valve assembly replacement is necessary during the process unit shutdown, valve assembly supplies have been depleted, and valve assembly supplies had been sufficiently stocked before the supplies were depleted. Delay of repair beyond the second process unit shutdown will not be allowed unless the third process unit shutdown occurs sooner than 6 months after the first process unit shutdown.

(f) For each source as defined in § 63.101, and for each source as defined in § 63.191, beginning no later than the compliance dates specified in § 63.100(k)(11), delay of repair is not allowed for light liquid pumps in ethylene oxide service, gas/vapor and light liquid valves in ethylene oxide service, and connectors in ethylene oxide service.

■ 109. Amend § 63.172 by revising paragraphs (b), (d), (j) introductory text and (j)(3), and adding paragraph (j)(4) to read as follows:

**§ 63.172 Standards: Closed-vent systems and control devices.**

\* \* \* \* \*

(b) Recovery or recapture devices (e.g., condensers and absorbers) shall be designed and operated to recover the organic hazardous air pollutant emissions or volatile organic compounds emissions vented to them with an efficiency of 95 percent or greater, or to an exit concentration of 20 parts per million by volume, whichever is less stringent. The 20 parts per million by volume performance standard is not applicable to the provisions of § 63.179.

\* \* \* \* \*

(d) Except as specified in paragraph (a) of § 63.108, flares used to comply with this subpart shall comply with the requirements of § 63.11(b).

\* \* \* \* \*

(j) For each closed-vent system that contains bypass lines that could divert a vent stream away from the control device and to the atmosphere, the owner or operator shall comply with the provisions of either paragraphs (j)(1) or (j)(2), and (j)(4) of this section, except as provided in paragraph (j)(3) of this section.

\* \* \* \* \*

(3) Except as specified in paragraph (j)(4) of this section, equipment such as low leg drains, high point bleeds, analyzer vents, open-ended valves or lines, and pressure relief valves needed for safety purposes are not subject to this paragraph.

(4) For each source as defined in § 63.101, and for each source as defined in § 63.191, beginning no later than the

compliance dates specified in § 63.100(k)(10):

(i) The use of a bypass line at any time on a closed vent system (used to comply with the provisions of this subpart) to divert emissions to the atmosphere or to a control device not meeting the requirements specified in this subpart is an emissions standards violation.

(ii) Paragraph (j)(3) of this section does not apply. Instead, the exemptions specified in paragraph (j)(4)(ii)(A) and (j)(4)(ii)(B) of this section apply.

(A) Except for pressure relief devices subject to § 63.165(e)(4), equipment such as low leg drains and equipment subject to the requirements specified in subpart H of this part are not subject to this paragraph (j) of this section.

(B) Open-ended valves or lines that use a cap, blind flange, plug, or second valve and follow the requirements specified in 40 CFR 60.482–6(a)(2), (b), and (c) or follow requirements codified in another regulation that are the same as 40 CFR 60.482–6(a)(2), (b), and (c) are not subject to this paragraph (j) of this section.

\* \* \* \* \*

■ 110. Amend § 63.173 by revising paragraph (f) as follows:

**§ 63.173 Standards: Agitators in gas/vapor service and in light liquid service.**

\* \* \* \* \*

(f) Any agitator if it is equipped with a system to capture and transport leakage from the agitator to a process or a fuel gas system or to a closed vent system that captures and transports leakage from the agitator to a control device meeting the requirements of § 63.172 is exempt from the requirements of paragraphs (a) through (c) of the section.

\* \* \* \* \*

- 111. Amend § 63.174 by:
  - a. Revising paragraph (a)(2) and adding (a)(3);
  - b. Revising paragraphs (b) introductory text, (b)(3) introductory text, and adding paragraphs (b)(3)(vi) and (b)(5); and
  - c. Revising paragraphs (g) introductory text and (g)(3).

The revisions and additions read as follows:

**§ 63.174 Standards: Connectors in gas/vapor service and in light liquid service.**

(a) \* \* \*

(2) Except as specified in paragraph (a)(3) of this section, if an instrument reading greater than or equal to 500 parts per million is measured, a leak is detected.

(3) For each source as defined in § 63.101, and for each source as defined

in § 63.191, beginning no later than the compliance dates specified in § 63.100(k)(11), for connectors in ethylene oxide service, as defined in § 63.101, the instrument reading that defines a leak for connectors is 100 parts per million or greater.

(b) The owner or operator shall monitor for leaks at the intervals specified in either paragraph (b)(1) or (b)(2) of this section and in paragraphs (b)(3) through (b)(5) of this section.

(3) After conducting the initial survey required in paragraph (b)(1) or (b)(2) of this section, the owner or operator shall perform all subsequent monitoring of connectors at the frequencies specified in paragraphs (b)(3)(i) through (b)(3)(v) of this section, except as provided in paragraphs (b)(3)(vi) and (c)(2) of this section:

(vi) For each source as defined in § 63.101, and for each source as defined in § 63.191, beginning no later than the compliance dates specified in § 63.100(k)(11), for connectors in ethylene oxide service, as defined in § 63.101, the monitoring period is once every month and paragraph (c)(2) of this section is not applicable.

(5) For each source as defined in § 63.101, and for each source as defined in § 63.191, beginning no later than the compliance dates specified in § 63.100(k)(11), for each connector in ethylene oxide service, as defined in § 63.101, that is added to a CMPU, and for each connector in ethylene oxide service that replaces a connector in ethylene oxide service, owners and operators must initially monitor for leaks within 5 days after initial startup of the equipment.

(g) Except as specified in paragraph (g)(3) of this section, any connector that is designated, as described in § 63.181(b)(7)(iii), as an unsafe-to-repair connector is exempt from the requirements of paragraphs (a), (d), and (e) of this section if:

(3) For each source as defined in § 63.101, and for each source as defined in § 63.191, beginning no later than the compliance dates specified in § 63.100(k)(11), for connectors in ethylene oxide service, as defined in § 63.101, paragraph (g) of this section is no longer applicable.

■ 112. Amend § 63.180 by revising paragraphs (c) introductory text, (d)(1) and (e) introductory text to read as follows:

**§ 63.180 Test methods and procedures.**

(c) When equipment is monitored for compliance as required in §§ 63.164(i), 63.165(a) or (e)(1), and 63.172(f) or when equipment subject to a leak definition of 500 ppm is monitored for leaks as required by this subpart, the owner or operator may elect to adjust or not to adjust the instrument readings for background. If an owner or operator elects to not adjust instrument readings for background, the owner or operator shall monitor the equipment according to the procedures specified in paragraphs (b)(1) through (4) of this section. In such case, all instrument readings shall be compared directly to the applicable leak definition to determine whether there is a leak. If an owner or operator elects to adjust instrument readings for background, the owner or operator shall monitor the equipment according to the procedures specified in paragraphs (c)(1) through (c)(4) of this section.

(d)(1) Each piece of equipment within a process unit that can reasonably be expected to contain equipment in organic HAP service is presumed to be in organic HAP service unless an owner or operator demonstrates that the piece of equipment is not in organic HAP service. For a piece of equipment to be considered not in organic HAP service, it must be determined that the percent organic HAP content can be reasonably expected not to exceed 5 percent by weight on an annual average basis. For purposes of determining the percent organic HAP content of the process fluid that is contained in or contacts equipment, Method 18 of 40 CFR part 60, appendix A shall be used. ASTM D6420–18 (incorporated by reference, see § 63.14) may also be used in lieu of Method 18, if the target compounds are all known and are all listed in Section 1.1 of ASTM D6420–18 as measurable; ASTM D6420–18 must not be used for methane and ethane; and ASTM D6420–18 may not be used as a total VOC method.

(e) When a flare is used to comply with § 63.172(d), the owner or operator shall comply with paragraphs (e)(1) through (3) of this section, except as specified in paragraph (a) of § 63.108. The owner or operator is not required to conduct a performance test to determine percent emission reduction or outlet organic HAP or TOC concentration.

■ 113. Amend § 63.181 by:

- a. Revising paragraphs (b)(2)(i) and (b)(3), and adding paragraphs (b)(11) and (12);
  - b. Revising paragraphs (d)(5)(i), (g)(1)(iii), (g)(2)(i) and (g)(3) introductory text; and
  - c. Adding paragraphs (g)(3)(iii) and (l).
- The revisions and additions read as follows:

**§ 63.181 Recordkeeping requirements.**

(2)(i) A list of identification numbers for equipment that the owner or operator elects to equip with a closed-vent system and control device, under the provisions of § 63.163(g), § 63.164(h), § 63.165(c) or (e)(4), or § 63.173(f), as applicable.

(3)(i) A list of identification numbers for pressure relief devices subject to the provisions in § 63.165(a) or (e)(1), as applicable.

(ii) A list of identification numbers for pressure relief devices equipped with rupture disks, under the provisions of § 63.165(d), (e)(2)(ii), or (e)(2)(iii), as applicable.

(11) For each pressure relief device subject to the pressure release management work practice standards in § 63.165(e), owners and operators must keep the records specified in paragraphs (b)(11)(i) through (iii) of this section in addition to the records specified in paragraph (f) of this section.

(i) Records of the prevention measures implemented as required in § 63.165(e)(3)(ii).

(ii) Records of the number of releases during each calendar year. Keep these records for the current calendar year and the past 5 calendar years.

(iii) For each release to the atmosphere, owners and operators must keep the records specified in paragraphs (b)(11)(iii)(A) through (D) of this section.

(A) The start and end time and date of each pressure release to the atmosphere.

(B) Records of any data, assumptions, and calculations used to estimate of the mass quantity of each organic HAP released during the event.

(C) Records of the root cause analysis and corrective action analysis conducted as required in § 63.165(e)(3)(iii), including an identification of the affected facility, a statement noting whether the event resulted from the same root cause(s) identified in a previous analysis and either a description of the recommended corrective action(s) or an explanation of why corrective action is not necessary under § 63.165(e)(7)(i).

(D) For any corrective action analysis for which implementation of corrective actions are required in § 63.165(e)(7), a description of the corrective action(s) completed within the first 45 days following the discharge and, for action(s) not already completed, a schedule for implementation, including proposed commencement and completion dates.

(12) For equipment in ethylene oxide service, as defined in § 63.101, records of the percent ethylene oxide content of the process fluid and the method used to determine it.

\* \* \* \* \*

(d) \* \* \*

(5) \* \* \*

(i) The owner or operator may develop a written procedure that identifies the conditions that justify a delay of repair. The written procedures may be included as part of the startup/shutdown/malfunction plan, required by § 63.6(e)(3), for the source or may be part of a separate document that is maintained at the plant site. In such cases, reasons for delay of repair may be documented by citing the relevant sections of the written procedure. For each source as defined in § 63.101, and for each source as defined in § 63.191, on and after July 15, 2027, the sentence "The written procedures may be included as part of the startup/shutdown/malfunction plan, required by § 63.6(e)(3), for the source or may be part of a separate document that is maintained at the plant site." in this paragraph no longer applies.

\* \* \* \* \*

(g) \* \* \*

(1) \* \* \*

(iii) Except as specified in paragraph (a) of § 63.108, the flare design (i.e., steam-assisted, air-assisted, or non-assisted) and the results of the compliance demonstration required by § 63.11(b).

\* \* \* \* \*

(2) \* \* \*

(i) Except as specified in paragraph (a) of § 63.108, dates and durations when the closed-vent systems and control devices required in §§ 63.163 through 63.166, and § 63.170 are not operated as designed as indicated by the monitored parameters, including periods when a flare pilot light system does not have a flame.

\* \* \* \* \*

(3) Records of inspections of closed-vent systems subject to the provisions of § 63.172, as specified in paragraphs (g)(3)(i) through (iii) of this section.

\* \* \* \* \*

(iii) For each source as defined in § 63.101, and for each source as defined

in § 63.191, beginning no later than the compliance dates specified in § 63.100(k)(10), the owner or operator must comply with this paragraph in addition to the requirements in paragraphs (g)(3)(i) and (ii) of this section. For each flow event from a bypass line subject to the requirements in § 63.172(j), the owner or operator must maintain records sufficient to determine whether or not the detected flow included flow requiring control. For each flow event from a bypass line requiring control that is released either directly to the atmosphere or to a control device not meeting the requirements in this subpart, the owner or operator must include an estimate of the volume of gas, the concentration of organic HAP in the gas and the resulting emissions of organic HAP that bypassed the control device using process knowledge and engineering estimates.

\* \* \* \* \*

(1) For fenceline monitoring systems subject to § 63.184, each owner or operator must keep the records specified in paragraphs (l)(1) through (11) of this section.

(1) Coordinates of all passive tube and canister monitors, including co-located samplers and field blanks, and if applicable, the meteorological station. The owner or operator shall determine the coordinates using an instrument with an accuracy of at least 3 meters. The coordinates shall be in decimal degrees with at least five decimal places.

(2) The start and stop times and dates for each sample, as well as the tube or canister identifying information.

(3) Sampling period average temperature and barometric pressure measurements.

(4) For each outlier determined in accordance with Section 9.2 of Method 325A of appendix A of this part the sampler location of and the concentration of the outlier and the evidence used to conclude that the result is an outlier. The evidence must include documentation of accidental contamination by the sample handler. High sample results attributed to unknown causes are not outliers if there is no evidence of sample contamination and the sample does not meet the requirements in Section 9.2 of Method 325A of appendix A of this part.

(5) For samples that will be adjusted for offsite impacts, the location of and the concentration measured simultaneously by the additional sampler(s), and the perimeter samplers to which it applies.

(6) Individual sample results, the calculated Δc for each monitored

compound for each sampling period and the two samples used to determine it, whether correction for offsite impacts was used, and the annual average Δc for each monitored compound calculated after each sampling period.

(7) Method detection limit for each sample, including co-located samples and blanks.

(8) Documentation of the root cause analysis and any resulting corrective action taken each time an action level is exceeded, including the dates the root cause analysis was initiated and the resulting correction action(s) were taken. If real-time sampling techniques are required under § 63.184(e)(3)(B), the location of the real-time monitors for each 48-hour period.

(9) Any corrective action plan developed under § 63.184(f).

(10) Other records as required by Methods 325A, 325B, and 327 of appendix A of this part.

(11) If monitoring is conducted using canisters in accordance with § 63.184(b), if a near-field source correction is used as provided in § 63.184(g), or if an alternative test method is used that provides time-resolved measurements, records of hourly meteorological data, including temperature, barometric pressure, wind speed and wind direction, calculated daily unit vector wind direction and daily sigma theta, and other records specified in the site-specific monitoring plan.

- 114. Amend § 63.182 by:
- a. Revising paragraph (a)(3) and adding paragraph (a)(4);
- b. Revising paragraph (c) introductory text and adding paragraphs (c)(5) and (6);
- c. Revising paragraphs (d) introductory text and (d)(2) introductory text; and
- d. Adding paragraphs (d)(2)(xviii) and (xix) and (e).

The revisions and additions read as follows:

**§ 63.182 Reporting requirements.**

(a) \* \* \*

(3) Periodic Reports described in paragraph (d) of this section,

(4) Fenceline Monitoring Reports described in paragraph (e) of this section, and

\* \* \* \* \*

(c) Each owner or operator of a source subject to this subpart shall submit a Notification of Compliance Status within 90 days after the compliance dates specified in the subpart in this part 63 that references this subpart, except as provided in paragraph (c)(4) of this section. The owner or operator shall also submit a supplement to the

Notification of Compliance Status as specified in paragraphs (c)(5) and (6) of this section, if applicable.

\* \* \* \* \*

(5) For pressure relief devices subject to the pressure release management work practice standards in § 63.165(e), owners and operators must also submit the information listed in paragraphs (c)(5)(i) and (ii) of this section in a supplement to the Notification of Compliance Status within 150 days after the first applicable compliance date for pressure relief device monitoring.

(i) A description of the monitoring system to be implemented, including the relief devices and process parameters to be monitored, and a description of the alarms or other methods by which operators will be notified of a pressure release.

(ii) A description of the prevention measures to be implemented for each affected pressure relief device.

(6) For equipment that are in ethylene oxide service, as defined in § 63.101, owners and operators must also submit the information in this paragraph in a supplement to the Notification of Compliance Status within 150 days after the first applicable compliance date. The supplement to the Notification of Compliance Status must identify all equipment that are in ethylene oxide service, and include the percent ethylene oxide content of the process fluid and the method used to determine it.

(d) The owner or operator of a source subject to this subpart shall submit Periodic Reports. On and after July 15, 2027 or once the reporting template for this subpart has been available on the CEDRI website for 1 year, whichever date is later, owners and operators must submit all subsequent reports following the procedure specified in § 63.9(k), except any medium submitted through mail must be sent to the attention of the Hazardous Organic Chemical Manufacturing Sector Lead. Owners and operators must use the appropriate electronic report template on the CEDRI website (<https://www.epa.gov/electronic-reporting-air-emissions/cedri>) for this subpart. The date report templates become available will be listed on the CEDRI website. Unless the Administrator or delegated state agency or other authority has approved a different schedule for submission of reports under § 63.9(i) and § 63.10(a), the report must be submitted by the deadline specified in this subpart, regardless of the method in which the report is submitted. All Periodic Reports must include the following general information: company name, address

(including county), and beginning and ending dates of the reporting period.

\* \* \* \* \*

(2) For each process unit complying with the provisions of § 63.163 through § 63.174, the summary information listed in paragraphs (d)(2)(i) through (xix) of this paragraph for each monitoring period during the 6-month period.

\* \* \* \* \*

(xviii) Compliance reports for pressure relief devices subject to the requirements § 63.165(e) must include the information specified in paragraphs (d)(2)(xviii)(A) through (C) of this section.

(A) For pressure relief devices in organic HAP gas or vapor service, pursuant to § 63.165(e)(1), report the instrument readings and dates for all readings of 500 ppm or greater.

(B) For pressure relief devices in organic HAP gas or vapor service subject to § 63.165(e)(2), report the instrument readings and dates of instrument monitoring conducted.

(C) For pressure relief devices in organic HAP service subject to § 63.165(e)(3), report each pressure release to the atmosphere, including pressure relief device identification name or number, the start date, start time, and duration (in minutes) of the pressure release; an estimate of the mass quantity in pounds of each organic HAP released; the results of any root cause analysis and corrective action analysis completed during the reporting period, including the corrective actions implemented during the reporting period; and, if applicable, the implementation schedule for planned corrective actions to be implemented subsequent to the reporting period.

(xix) For each source as defined in § 63.101, and for each source as defined in § 63.191, beginning no later than the compliance dates specified in § 63.100(k)(10), the owner or operator must comply with this paragraph in addition to the requirements in paragraphs (d)(2)(i) through (d)(2)(xviii) of this section. For bypass lines subject to the requirements in § 63.172(j), the Periodic Report must include the start date, start time, duration in hours, estimate of the volume of gas in standard cubic feet, the concentration of organic HAP in the gas in parts per million by volume and the resulting mass emissions of organic HAP in pounds that bypass a control device. For periods when the flow indicator is not operating, report the start date, start time, and duration in hours.

\* \* \* \* \*

(e) For fenceline monitoring systems subject to § 63.184, each owner or operator must submit Fenceline Monitoring Reports on a quarterly basis using the appropriate electronic report template on the CEDRI website (<https://www.epa.gov/electronic-reporting-air-emissions/cedri>) for this subpart and following the procedure specified in § 63.9(k), except any medium submitted through mail must be sent to the attention of the Hazardous Organic Chemical Manufacturing Sector Lead. The first quarterly report must be submitted once the owner or operator has obtained 12 months of data. The first quarterly report must cover the period beginning on the compliance date that is specified in § 63.100(k)(12) and ending on March 31, June 30, September 30 or December 31, whichever date is the first date that occurs after the owner or operator has obtained 12 months of data (*i.e.*, the first quarterly report will contain between 12 and 15 months of data). Each subsequent quarterly report must cover one of the following reporting periods: Quarter 1 from January 1 through March 31; Quarter 2 from April 1 through June 30; Quarter 3 from July 1 through September 30; and Quarter 4 from October 1 through December 31. Each quarterly report must be electronically submitted no later than 45 calendar days following the end of the reporting period.

(1) Facility name and address (including the county).

(2) Year and reporting quarter (*i.e.*, Quarter 1, Quarter 2, Quarter 3, or Quarter 4).

(3) For each passive tube or canister monitor: The latitude and longitude location coordinates; the sampler name; and identification of the type of sampler (*i.e.*, regular monitor, extra monitor, duplicate, field blank, inactive). Coordinates must be in decimal degrees with at least five decimal places.

(4) The beginning and ending dates for each sampling period.

(5) Individual sample results for each monitored compound, reported in units of µg/m<sup>3</sup>, for each monitor for each sampling period that ends during the reporting period. Results below the method detection limit must be flagged as below the detection limit and reported at the method detection limit.

(6) Data flags for each outlier determined in accordance with Section 9.2 of Method 325A of appendix A of this part. For each outlier, the owner or operator must submit the individual sample result of the outlier, as well as the evidence used to conclude that the result is an outlier. The evidence must include documentation of accidental



contamination by the sample handler. High sample results attributed to unknown causes are not outliers if there is no evidence of sample contamination and the sample does not meet the requirements in Section 9.2 of Method 325A of appendix A of this part.

(7) The concentration difference ( $\Delta c$ ) for each monitored compound for each sampling period and the annual average  $\Delta c$  for each monitored compound for each sampling period.

(8) Indication of whether the owner or operator was required to develop a corrective action plan under § 63.184(f).

(9) Data flags for each monitor for each analyte that was skipped for the sampling period, if the owner or operator uses an alternative sampling frequency under § 63.184(a)(3)(iii) or § 63.184(b)(2)(iii).

■ 115. Amend § 63.183 by revising paragraph (c) introductory text and adding paragraph (c)(5) to read as follows:

**§ 63.183 Implementation and enforcement.**

\* \* \* \* \*

(c) The authorities that cannot be delegated to State, local, or Tribal agencies are as specified in paragraphs (c)(1) through (5) of this section.

\* \* \* \* \*

(5) Approval of an alternative to any electronic reporting to the EPA required by this subpart.

■ 116. Add § 63.184 to read as follows:

**§ 63.184 Fenceline monitoring provisions.**

For each source as defined in § 63.101, and for each source as defined in § 63.191, beginning no later than the compliance dates specified in § 63.100(k)(12), the owner or operator must conduct sampling along the facility property boundary and analyze the samples in accordance with paragraphs (a) through (i) of this section. Sampling of benzene, 1,3-butadiene, chloroprene, and ethylene dichloride must be conducted in accordance with paragraph (a) of this section. Sampling of ethylene oxide and vinyl chloride must be conducted in accordance with paragraph (b) of this section. Paragraphs (c) through (i) of this section apply for any compound required to be sampled.

(a) The owner or operator must conduct sampling along the facility property boundary and analyze the samples in accordance with Methods 325A and 325B of appendix A to this part and paragraphs (a)(1) through (3) of this section. The monitoring perimeter may be located inside the facility, away from the facility property boundary. However, the monitoring perimeter must encompass all potential sources of

the target analyte(s) specified in paragraph (a)(1) of this section that are located within the facility's property boundary.

(1) The owner or operator must monitor the target analyte(s), as specified in paragraphs (a)(1)(i) through (iv) of this section. The owner or operator must follow the procedure in Section 9.6 of Method 325B of appendix A to this part to determine the detection limit of benzene, 1,3-butadiene, chloroprene, and ethylene dichloride for each sampler used to collect samples and blanks.

(i) If an affected source uses, produces, stores, or emits benzene, the owner or operator must include benzene as a target analyte.

(ii) If an affected source uses, produces, stores, or emits 1,3-butadiene, the owner or operator must include 1,3-butadiene as a target analyte.

(iii) If an affected source uses, produces, stores, or emits chloroprene, the owner or operator must include chloroprene as a target analyte.

(iv) If an affected source uses, produces, stores, or emits ethylene dichloride, the owner or operator must include ethylene dichloride as a target analyte.

(2) The owner or operator must determine passive monitor locations in accordance with Section 8.2 of Method 325A of appendix A to this part.

(i) As it pertains to this subpart, known sources of VOCs, as used in Section 8.2.1.3 in Method 325A of appendix A to this part for siting passive monitors, means a wastewater treatment unit, process unit, or any emission source requiring control according to the requirements of this subpart, including marine vessel loading operations. For marine vessel loading operations, one passive monitor should be sited on the shoreline adjacent to the dock. For this subpart, an additional monitor is not required if the only emission sources within 50 meters of the monitoring boundary are equipment leak sources satisfying all of the conditions in paragraphs (a)(2)(i)(A) through (C) of this section. If a leak is found, it must be repaired no later than 15 calendar days after it is detected with no provisions for delay of repair. If a repair is not completed within 15 calendar days, the additional passive monitor specified in Section 8.2.1.3 in Method 325A of appendix A to this part must be used.

(A) The equipment leak sources in organic HAP service within 50 meters of the monitoring boundary are limited to valves, pumps, connectors, sampling connections, and open-ended lines. If compressors, pressure relief devices, or

agitators in organic HAP service are present within 50 meters of the monitoring boundary, the additional passive monitoring location specified in Section 8.2.1.3 in Method 325A of appendix A to this part must be used.

(B) All equipment leak sources in gas or light liquid service (and in organic HAP service), including valves, pumps, connectors, sampling connections and open-ended lines, must be monitored using Method 21 of appendix A-7 to 40 CFR part 60 no less frequently than quarterly with no provisions for skip period monitoring, or according to the provisions of § 63.11(c) Alternative Work practice for monitoring equipment for leaks. For the purpose of this provision, a leak is detected if the instrument reading equals or exceeds the applicable limits in paragraphs (a)(2)(i)(B)(1) through (5) of this section:

(1) For valves, pumps or connectors at an existing source, an instrument reading of 10,000 ppmv.

(2) For valves or connectors at a new source, an instrument reading of 500 ppmv.

(3) For pumps at a new source, an instrument reading of 2,000 ppmv.

(4) For sampling connections or open-ended lines, an instrument reading of 500 ppmv above background.

(5) For equipment monitored according to the Alternative Work practice for monitoring equipment for leaks, the leak definitions contained in § 63.11(c)(6)(i) through (iii).

(C) All equipment leak sources in organic HAP service, including sources in gas, light liquid and heavy liquid service, must be inspected using visual, audible, olfactory, or any other detection method at least monthly. A leak is detected if the inspection identifies a potential leak to the atmosphere or if there are indications of liquids dripping.

(ii) If there are 19 or fewer monitoring locations, the owner or operator must collect at least one co-located duplicate sample per sampling period and at least one field blank per sampling period. If there are 20 or more monitoring locations, the owner or operator must collect at least two co-located duplicate samples per sampling period and at least one field blank per sampling period. The co-located duplicates may be collected at any of the perimeter sampling.

(iii) Samplers are not required to be placed along internal roads, waterways, or other right of ways that may bisect the facility. If a facility is bounded by a waterway on one or more sides, the shoreline is considered the facility property boundary.

(3) The owner or operator must use a sampling period and sampling frequency as specified in paragraphs (a)(3)(i) through (iii) of this section.

(i) *Sampling period.* A 14-day sampling period must be used, unless a shorter sampling period is determined to be necessary under paragraph (e) or (g) of this section. A sampling period is defined as the period during which sampling tube is deployed at a specific sampling location with the diffusive sampling end cap in-place and does not include the time required to analyze the sample. For the purpose of this subpart, a 14-day sampling period may be no shorter than 13 calendar days and no longer than 15 calendar days, but the routine sampling period must be 14 calendar days.

(ii) *Base sampling frequency.* Except as provided in paragraph (a)(3)(iii) of this section, the frequency of sample collection must be once each contiguous 14-day sampling period, such that the beginning of the next 14-day sampling period begins immediately upon the completion of the previous 14-day sampling period.

(iii) *Alternative sampling frequency for burden reduction.* When an individual monitor consistently achieves results for a particular analyte at or below the level specified in paragraph (a)(4) of this section, the owner or operator may elect to use the applicable minimum sampling frequency specified in paragraphs (a)(3)(iii)(A) through (E) of this section for that monitoring site for that analyte. When calculating  $\Delta c$  for the monitoring period when using this alternative for burden reduction, use zero for the lowest sampling result for each monitoring period where one or more samples was not taken and/or analyzed for the analyte(s) that qualifies for this alternative sampling frequency. This alternative for burden reduction is determined on an analyte specific basis. If an owner or operator is not required to sample for a particular analyte for a particular monitoring site in accordance with this paragraph (a)(3)(iii), the owner or operator must still sample for any other analytes required by paragraph (a)(1) of this section at the frequency specified in paragraph (a)(3)(ii) of this section, unless the other analyte(s) also qualifies for this alternative for burden reduction.

(A) For the analyte of interest, if every sample at a monitoring site is at or below the level specified in paragraph (a)(4) of this section for 2 years (52 consecutive samples), every other sampling period can be skipped for that analyte for that monitoring site, *i.e.*,

sampling will occur approximately once per month.

(B) For the analyte of interest, if every sample at a monitoring site that is monitored at the frequency specified in paragraph (a)(3)(iii)(A) of this section is at or below the level specified in paragraph (a)(4) of this section for 2 years (*i.e.*, 26 consecutive "monthly" samples), five 14-day sampling periods can be skipped for that analyte for that monitoring site following each period of sampling, *i.e.*, sampling will occur approximately once per quarter.

(C) For the analyte of interest, if every sample at a monitoring site that is monitored at the frequency specified in paragraph (a)(3)(iii)(B) of this section is at or below the level specified in paragraph (a)(4) of this section for 2 years (*i.e.*, 8 consecutive quarterly samples), twelve 14-day sampling periods can be skipped for that analyte for that monitoring site following each period of sampling, *i.e.*, sampling will occur twice a year.

(D) For the analyte of interest, if every sample at a monitoring site that is monitored at the frequency specified in paragraph (a)(3)(iii)(C) of this section is at or below the level specified in paragraph (a)(4) of this section for 2 years (*i.e.*, 4 consecutive semiannual samples), only one sample per year is required for that analyte for that monitoring site. For yearly sampling, samples shall occur at least 10 months but no more than 14 months apart.

(E) If at any time a sample for a monitoring site that is monitored for the analyte at the frequency specified in paragraph (a)(3)(iii)(A) through (D) of this section returns a result for the analyte that is above the level specified in paragraph (a)(4) of this section, the sampling site must return to the original sampling requirements for the analyte of contiguous 14-day sampling periods with no skip periods for one quarter (six 14-day sampling periods). If every sample collected for the analyte during this quarter is at or below the level specified in paragraph (a)(4) of this section, the owner or operator may revert back to the reduced monitoring schedule applicable for that analyte for that monitoring site prior to the sample reading exceeding the level specified in paragraph (a)(4) of this section. If any sample collected for the analyte during this quarter is above the level specified in paragraph (a)(4) of this section, that monitoring site must return to the original sampling requirements for that analyte of contiguous 14-day sampling periods with no skip periods for a minimum of two years. The burden reduction requirements can be used again for that analyte for that monitoring

site once the requirements of paragraph (a)(3)(iii)(A) of this section are met again, *i.e.*, after 52 contiguous 14-day samples with no results above the level specified in paragraph (a)(4) of this section.

(4) To use the alternative sampling frequency outlined in paragraph (a)(3) of this section, an individual monitor must consistently achieve results for the analyte at or below the level specified in paragraphs (a)(4)(i) through (iii) of this section.

(i) For benzene, the results must be consistently at or below  $0.9 \mu\text{g}/\text{m}^3$ .

(ii) For 1,3-butadiene, the results must be consistently at or below  $0.3 \mu\text{g}/\text{m}^3$ .

(iii) For ethylene dichloride, the results must be consistently at or below  $0.4 \mu\text{g}/\text{m}^3$ .

(b) The owner or operator must conduct sampling along the facility property boundary and analyze the samples in accordance with Method 327 of appendix A to this part and paragraphs (b)(1) through (3) of this section.

(1) The owner or operator must monitor the target analyte(s), as specified in paragraphs (b)(1)(i) and (ii) of this section.

(i) If an affected source uses, produces, stores, or emits ethylene oxide, the owner or operator must include ethylene oxide as a target analyte.

(ii) If an affected source uses, produces, stores, or emits vinyl chloride, the owner or operator must include vinyl chloride as a target analyte.

(2) The owner or operator must use a sampling period and sampling frequency as specified in paragraphs (b)(2)(i) and (ii) of this section.

(i) *Sampling period.* A 24-hour sampling period must be used, unless a shorter sampling period is determined to be necessary under paragraph (e) or (g) of this section. A sampling period is defined as the period during which the canister is deployed at a specific sampling location and actively sampling and does not include the time required to analyze the sample. For the purpose of this subpart, a 24-hour sampling period may be no shorter than 23 hours and no longer than 25 hours.

(ii) *Base sampling frequency.* Except as provided in paragraph (b)(2)(iii) of this section, the frequency of sample collection must be once every 5 calendar days, such that the beginning of each sampling period begins approximately 96 hours ( $\pm 24$  hours) from the end of the previous sample.

(iii) *Alternative sampling frequency for burden reduction.* This alternative is only applicable for the measurement of

vinyl chloride from sites with a monitoring perimeter less than or equal to 5,000 meters. When an individual sampling point consistently achieves results at or below  $0.3 \mu\text{g}/\text{m}^3$ , the owner or operator may elect to use the applicable minimum sampling frequency specified in paragraphs (b)(2)(iii)(A) through (E) of this section for that sampling site for vinyl chloride. If ethylene oxide is a required analyte, the owner or operator must continue to monitor ethylene oxide at the frequency specified in paragraph (b)(2)(ii) of this section. When calculating  $\Delta c$  for the monitoring period when using this alternative for burden reduction, use zero for the lowest sampling result for each monitoring period where one or more samples was not taken for vinyl chloride.

(A) If every sample at a monitoring site is at or below  $0.3 \mu\text{g}/\text{m}^3$  for 2 years (52 consecutive samples), every other sampling period can be skipped for that sampling site, *i.e.*, sampling will occur approximately once per month.

(B) If every sample at a sampling site that is monitored at the frequency specified in paragraph (b)(2)(iii)(A) of this section is at or below  $0.3 \mu\text{g}/\text{m}^3$  for 2 years (*i.e.*, 26 consecutive "monthly" samples), five 14-day sampling periods can be skipped for that sampling site following each period of sampling, *i.e.*, sampling will occur approximately once per quarter.

(C) If every sample at a sampling site that is monitored at the frequency specified in paragraph (b)(2)(iii)(B) of this section is at or below  $0.3 \mu\text{g}/\text{m}^3$  for 2 years (*i.e.*, 8 consecutive quarterly samples), twelve 14-day sampling periods can be skipped for that sampling site following each period of sampling, *i.e.*, sampling will occur twice a year.

(D) If every sample at a sampling site that is monitored at the frequency specified in paragraph (b)(2)(iii)(C) of this section is at or below  $0.3 \mu\text{g}/\text{m}^3$  for 2 years (*i.e.*, 4 consecutive semiannual samples), only one sample per year is required for that sampling site. For yearly sampling, samples shall occur at least 10 months but no more than 14 months apart.

(E) If at any time a sample for a sampling site that is monitored at the frequency specified in paragraphs (b)(2)(iii)(A) through (E) of this section returns a result that is above  $0.3 \mu\text{g}/\text{m}^3$ , the sampling site must return to the original sampling requirements of sampling every 5 calendar days with no skip periods for one quarter (18 5-day sampling periods). If every sample collected during this quarter is at or below  $0.3 \mu\text{g}/\text{m}^3$ , the owner or operator

may revert back to the reduced monitoring schedule applicable for that sampling site prior to the sample reading exceeding  $0.3 \mu\text{g}/\text{m}^3$ . If any sample collected during this quarter is above  $0.3 \mu\text{g}/\text{m}^3$ , that sampling site must return to the original sampling requirements of sampling every 5 calendar days with no skip periods for a minimum of two years. The burden reduction requirements can be used again for that sampling site once the requirements of paragraph (b)(2)(ii)(A) of this section are met again, *i.e.*, after 146 consecutive samples with no results above  $0.3 \mu\text{g}/\text{m}^3$ .

(3) The owner or operator must determine canister sample locations in accordance with paragraphs (b)(3)(i) through (v) of this section.

(i) The monitoring perimeter must be located on or inside the facility property boundary. If the monitoring perimeter is located away from the facility property boundary, the monitoring perimeter must encompass all potential sources of the target analyte(s) specified in paragraph (b)(1) of this section that are located within the facility's property boundary. If the site contains process units that are disconnected (*i.e.*, one or more process areas are not within the boundary of the main facility), the owner or operator must follow the requirements in paragraph (b)(3)(v) of this section. Canisters are not required to be placed along internal roads, waterways, or other right of ways that may bisect the facility. If a facility is bounded by a waterway on one or more sides, the shoreline is considered the facility property boundary.

(ii) The owner or operator must place 8 canisters around the monitoring perimeter during each sampling period.

(iii) To determine sampling locations, measure the length of the monitoring perimeter.

(A) Locate the point on the monitoring perimeter that is closest to sources of the target analyte(s). If one of the target analytes is ethylene oxide, this point must be the point on the monitoring perimeter that is closest to the sources of ethylene oxide.

(B) If the monitoring perimeter is less than or equal to 5,000 meters, divide the monitoring perimeter into 8 evenly spaced sampling points, with one point located in accordance with the requirements of paragraph (b)(3)(iii)(A) of this section.

(C) If the monitoring perimeter is greater than 5,000 meters, but less than or equal to 10,000 meters, divide the monitoring perimeter into 16 evenly spaced sampling points, with one point located in accordance with the

requirements of paragraph (b)(3)(iii)(A) of this section.

(D) If the monitoring perimeter is greater than 10,000 meters, divide the monitoring perimeter into 24 evenly spaced sampling points, with one point located in accordance with the requirements of paragraph (b)(3)(iii)(A) of this section.

(iv) Place canisters on the monitoring perimeter at the sampling points as follows.

(A) If there are only 8 sampling points for the site, monitor each sampling point during each sampling period.

(B) If there are 16 sampling points for the site, number the sampling points consecutively along the monitoring perimeter. During the first sampling period, monitor the odd numbered sampling points. During the second sampling period, monitor the even numbered sampling points. Continue to alternate between the odd numbered and even numbered sampling points in subsequent sampling periods.

(C) If there are 24 sampling points for the site, number the sampling points consecutively along the monitoring perimeter. During the first sampling period, monitor every third sampling point starting with the first sampling point (*i.e.*, points 1, 4, 7, etc.). During the second sampling period, monitor every third sampling point starting with the second sampling point (*i.e.*, points 2, 5, 8, etc.). During the third sampling period, monitor every third sampling point starting with the third sampling point (*i.e.*, points 3, 6, 9, etc.). Continue to alternate between these placements for each subsequent sampling period (*i.e.*, the fourth sampling period will include every third sampling point starting with the first sampling point, the fifth sampling period will include every third sampling point starting with the second sampling point, and so on).

(v) If the site consists of small areas disconnected from the main facility, additional monitors must be placed on these areas in accordance with paragraphs (b)(3)(v)(A) through (C) of this section. The monitoring perimeter for the disconnected area(s) must be located between the property boundary of the area and the process unit(s), such that the monitoring perimeter for the disconnected area encompasses all potential sources of the target analyte(s) specified in paragraph (b)(1) of this section.

(A) If the disconnected area is less than 50 acres, the owner or operator must sample at two locations each sampling period. One location must be placed in the expected prevailing wind direction for the sampling period, downwind of the main source of

emissions of the target analyte(s). The other location must be located on the monitoring perimeter at 180 degrees from the first sample location.

(B) If the disconnected area is equal to or greater than 50 acres but less than or equal to 150 acres, the owner or operator must sample at four equally spaced locations. One sampling point must be located on the monitoring perimeter at the point that is closest to sources of the target analyte(s). If one of the target analytes is ethylene oxide, this point must be the point on the monitoring perimeter that is closest to the sources of ethylene oxide.

(C) If the disconnected area is greater than 150 acres, the sampling points for the disconnected area must be determined according to paragraphs (b)(3)(i) through (iv) of this section.

(4) At least one co-located duplicate sample and at least one field blank must be collected per sampling period.

(5) The owner or operator must follow the procedures in Method 327 of appendix A to this part to determine the detection limit of the target analyte(s) and requirements for quality assurance samples.

(c) The owner or operator must collect and record meteorological data according to the applicable requirements in paragraphs (c)(1) through (3) of this section.

(1) If monitoring is conducted under paragraph (b) of this section, if a near-field source correction is used as provided in paragraph (g)(2) of this section, or if an alternative test method is used that provides time-resolved measurements, the owner or operator must use an on-site meteorological station in accordance with Section 8.3 of Method 325A of appendix A to this part. Collect and record hourly average meteorological data, including temperature, barometric pressure, wind speed and wind direction and calculate daily unit vector wind direction and daily sigma theta.

(2) For cases other than those specified in paragraph (c)(1) of this section, the owner or operator must collect and record sampling period average temperature and barometric pressure using either an on-site meteorological station in accordance with Section 8.3 of Method 325A of appendix A to this part or, alternatively, using data from a National Weather Service (NWS) meteorological station provided the NWS meteorological station is within 40 kilometers (25 miles) of the facility.

(3) If an on-site meteorological station is used, the owner or operator must follow the calibration and standardization procedures for

meteorological measurements in EPA-454/B-08-002 (incorporated by reference, see § 63.14).

(d) Within 45 days of completion of each sampling period, the owner or operator must determine whether the results are above or below the action level for each measured compound as follows. If the owner or operator is required to monitor any small disconnected area(s) of the facility under paragraph (b)(3)(v) of this section, the procedure for determining whether the results are above or below the action level for each measured compound must be performed for the disconnected area(s) separately.

(1) The owner or operator must determine the facility impact on the concentration ( $\Delta c$ ) of each compound for each sampling period according to either paragraph (d)(1)(i) or (ii) of this section, as applicable.

(i) Except when near-field source correction is used as provided in paragraph (d)(1)(ii) of this section, the owner or operator must determine the highest and lowest sample results for each compound individually from the sample pool and calculate each compound's  $\Delta c$  as the difference in these concentrations. Co-located samples must be averaged together for the purposes of determining the concentration at a particular sampling location, and, if applicable, for determining  $\Delta c$ . The owner or operator must adhere to the following procedures when one or more samples for the sampling period are below the method detection limit for a particular compound:

(A) If the lowest detected value of a compound is below detection, the owner or operator must use zero as the lowest sample result when calculating  $\Delta c$ .

(B) If all sample results are below the method detection limit, the owner or operator must use the highest method detection limit for the sample set as the highest sample result and zero as the lowest sample result when calculating  $\Delta c$ .

(C) In the case of co-located samples, if one sample is above the method detection limit while the other sample is below the method detection limit, the owner or operator must use the method detection limit as the result for the sample that is below the method detection limit for purposes of averaging the results to determine the concentration at a particular sampling location, and, if applicable, for determining  $\Delta c$ .

(ii) When near-field source correction for a compound is used as provided in paragraph (g) of this section, the owner

or operator must determine  $\Delta c$  using the calculation protocols outlined in paragraph (d)(1)(i) of this section, except as provided in this paragraph (d)(1)(ii), and the additional requirements in paragraph (g)(2) of this section, as well as any additional requirements outlined in the approved site-specific monitoring plan. The  $\Delta c$  for the compound for the sampling period is equal to the higher of the values in paragraphs (d)(1)(ii)(A) and (B) of this section.

(A) The highest corrected sample result for the compound from a sampling location where near-field source correction for the compound is used during the sampling period.

(B) The difference in concentration between the highest sample result that was not corrected for a near-field source for the compound during the sampling period and the lowest sample result for the compound for the sampling period.

(2) The owner or operator must calculate the annual average  $\Delta c$  for each monitored compound as follows:

(i) For sampling conducted under paragraph (a) of this section, the annual average  $\Delta c$  for each compound is based on the average of the  $\Delta c$  values for the 26 most recent 14-day sampling periods. The owner or operator must update this annual average value after receiving the results of each subsequent 14-day sampling period.

(ii) For sampling conducted under paragraph (b) of this section, the annual average  $\Delta c$  for each compound is based on the average of the  $\Delta c$  values for the 73 most recent sampling periods. The owner or operator must update this annual average value after receiving the results of each subsequent sampling period.

(3) The action level for each compound is listed in paragraphs (d)(3)(i) through (vi) of this section. If the annual average  $\Delta c$  value for a compound is greater than the listed action level for the compound, the concentration is above the action level, and the owner or operator must conduct a root cause analysis and corrective action in accordance with paragraph (e) of this section.

(i) The action level for benzene is 9 micrograms per cubic meter ( $\mu\text{g}/\text{m}^3$ ) on an annual average basis.

(ii) The action level for 1,3-butadiene is 3  $\mu\text{g}/\text{m}^3$  on an annual average basis.

(iii) The action level for chloroprene is 0.8  $\mu\text{g}/\text{m}^3$  on an annual average basis.

(iv) The action level for ethylene oxide is 0.2  $\mu\text{g}/\text{m}^3$  on an annual average basis.

(v) The action level for vinyl chloride is 3  $\mu\text{g}/\text{m}^3$  on an annual average basis.

(vi) The action level for ethylene dichloride is  $4 \mu\text{g}/\text{m}^3$  on an annual average basis.

(e) Once any action level in paragraph (d)(3) of this section has been exceeded, the owner or operator must take the following actions to bring the annual average  $\Delta\text{c}$  back below the action level(s).

(1) Within 5 days of updating the annual average value as required in paragraph (d)(2) of this section and determining that any action level in paragraph (d)(3) of this section has been exceeded (*i.e.*, in no case longer than 50 days after completion of the sampling period), the owner or operator must initiate a root cause analysis to determine appropriate corrective action. A root cause analysis is an assessment conducted through a process of investigation to determine the primary underlying cause and all other contributing causes to an exceedance of an action level(s) set forth in paragraph (d)(3) of this section.

(i) The initial root cause analysis may include, but is not limited to:

(A) Leak inspection using Method 21 of appendix A-7 to 40 CFR part 60, optical gas imaging, or handheld monitors.

(B) Visual inspection to determine the cause of the high emissions.

(C) Operator knowledge of process changes (*e.g.*, a malfunction or release event).

(ii) If the initial root cause cannot be identified using the type of techniques described in paragraph (e)(1)(i) of this section, the owner or operator must employ more frequent sampling and analysis to determine the root cause of the exceedance.

(A) The owner or operator may first employ additional monitoring points and shorter sampling periods for Methods 325A and 325B of appendix A to this part for benzene, 1,3-butadiene, chloroprene, or ethylene dichloride or more frequent sampling with Method 327 of appendix A to this part for ethylene oxide or vinyl chloride to determine the root cause of the exceedance.

(B) If the owner or operator has not determined the root cause of the exceedance within 30 days of determining that the action level has been exceeded, the owner or operator must employ the appropriate real-time sampling techniques (*e.g.*, mobile gas chromatographs, optical spectroscopy instruments, sensors) to locate the cause of the exceedance. If the root cause is not identified after 48 hours, either the real-time monitor must be relocated or an additional real-time monitor must be added. Relocation or addition of extra

real-time monitors must continue after each 48-hour period of nonidentification until the owner or operator can identify the root cause of the exceedance.

(2) If the underlying primary and other contributing causes of the exceedance are deemed to be under the control of the owner or operator, the owner or operator must take appropriate corrective action as expeditiously as possible to bring annual average fenceline concentrations back below the action level(s) set forth in paragraph (d)(3) of this section. At a minimum, the corrective actions taken must address the underlying primary and other contributing cause(s) determined in the root cause analysis to prevent future exceedances from the same underlying cause(s).

(3) The root cause analysis must be completed and initial corrective actions taken no later than 45 days after determining there is an exceedance of an action level.

(4) Until the annual average  $\Delta\text{c}$  is below the action level again, following completion of the initial corrective action, the owner or operator must conduct a new root cause analysis according to this paragraph (e), and if required, submit a corrective action plan under paragraph (f) of this section following any sampling period for which the sampling start time begins after the completion of the initial corrective actions and for which the  $\Delta\text{c}$  for the sampling period is greater than the level specified in paragraphs (e)(4)(i) through (vi) of this section for the compound(s) that initially exceeded the action level.

(i) For benzene, a sampling period  $\Delta\text{c}$  of  $9 \mu\text{g}/\text{m}^3$ .

(ii) For 1,3-butadiene, a sampling period  $\Delta\text{c}$  of  $3 \mu\text{g}/\text{m}^3$ .

(iii) For chloroprene, a sampling period  $\Delta\text{c}$  of  $0.8 \mu\text{g}/\text{m}^3$ .

(iv) For ethylene dichloride, a sampling period  $\Delta\text{c}$  of  $4 \mu\text{g}/\text{m}^3$ .

(v) For ethylene oxide, a sampling period  $\Delta\text{c}$  of  $0.2 \mu\text{g}/\text{m}^3$ .

(vi) For vinyl chloride, a sampling period  $\Delta\text{c}$  of  $3 \mu\text{g}/\text{m}^3$ .

(f) An owner or operator must develop a corrective action plan if the conditions in paragraphs (f)(1), (2), or (3) of this section are met. The corrective action plan must describe the corrective action(s) completed to date, additional measures that the owner or operator proposes to employ to reduce annual average fenceline concentrations below the action level(s) set forth in paragraph (d)(3) of this section, and a schedule for completion of these measures. The corrective action plan does not need to be approved by the Administrator.

However, if upon review, the Administrator disagrees with the additional measures outlined in the plan, the owner or operator must revise and resubmit the plan within 7 calendar days of receiving comments from the Administrator.

(1) If the compound that exceeded the action level was benzene, 1,3-butadiene, chloroprene, or ethylene dichloride, the owner or operator must develop a corrective action plan if, upon completion of the root cause analysis and initial corrective actions required in paragraph (e) of this section, the  $\Delta\text{c}$  value for the next sampling period, for which the sampling start time begins after the completion of the initial corrective actions, is greater than the level specified in paragraphs (f)(1)(i) through (iv) of this section for the compound(s) that initially exceeded the action level. The corrective action plan must include the implementation of real-time sampling techniques to locate the primary and other contributing causes of the exceedance. The owner or operator must submit the corrective action plan to the Administrator within 60 days after receiving the analytical results indicating that the  $\Delta\text{c}$  value for the sampling period following the completion of the initial corrective action is greater than the level specified in paragraphs (f)(1)(i) through (iv) of this section.

(i) For benzene, a sampling period  $\Delta\text{c}$  of  $9 \mu\text{g}/\text{m}^3$ .

(ii) For 1,3-butadiene, a sampling period  $\Delta\text{c}$  of  $3 \mu\text{g}/\text{m}^3$ .

(iii) For chloroprene, a sampling period  $\Delta\text{c}$  of  $0.8 \mu\text{g}/\text{m}^3$ .

(iv) For ethylene dichloride, a sampling period  $\Delta\text{c}$  of  $4 \mu\text{g}/\text{m}^3$ .

(2) If the compound that exceeded the action level was ethylene oxide or vinyl chloride, the owner or operator must develop a corrective action plan if, upon completion of the root cause analysis and initial corrective actions required in paragraph (e) of this section, the  $\Delta\text{c}$  value for any of the next three sampling periods, for which the sampling start time begins after the completion of the initial corrective actions, is greater than the level specified in paragraphs (f)(2)(i) and (ii) of this section for the compound(s) that initially exceeded the action level. The corrective action plan must include the implementation of real-time sampling techniques to locate the primary and other contributing causes of the exceedance. The owner or operator must submit the corrective action plan to the Administrator within 60 days after receiving the analytical results indicating that the  $\Delta\text{c}$  value for the sampling period following the completion of the initial corrective

action is greater than the level specified in paragraphs (f)(2)(i) and (ii) of this section.

(i) For ethylene oxide, a sampling period  $\Delta c$  of 0.2  $\mu\text{g}/\text{m}^3$ .

(ii) For vinyl chloride, a sampling period  $\Delta c$  of 3  $\mu\text{g}/\text{m}^3$ .

(3) The owner or operator must develop a corrective action plan if complete implementation of all corrective measures identified in the root cause analysis required by paragraph (e) of this section will require more than 45 days. The owner or operator must submit the corrective action plan to the Administrator no later than 60 days following the completion of the root cause analysis required in paragraph (e) of this section.

(g) An owner or operator may request approval from the Administrator for a site-specific monitoring plan to account for offsite upwind sources according to the requirements in paragraphs (g)(1) through (4) of this section.

(1) The owner or operator must prepare and submit a site-specific monitoring plan and receive approval of the site-specific monitoring plan prior to using the near-field source alternative calculation for determining  $\Delta c$  provided in paragraph (g)(2) of this section. The site-specific monitoring plan must include, at a minimum, the elements specified in paragraphs (g)(1)(i) through (vi) of this section. The procedures in Section 12 of Method 325A of appendix A to this part are not required, but may be used, if applicable, when determining near-field source contributions.

(i) Identification of the near-field source or sources.

(ii) Location of the additional monitoring stations that will be used to determine the near-field source concentration contribution. The owner or operator must use additional monitoring stations to determine the near-field source contribution.

(iii) Identification of the fenceline monitoring locations impacted by the near-field source. If more than one near-field source is present, identify the near-field source or sources that are expected to contribute to the concentration at that monitoring location.

(iv) A description of (including sample calculations illustrating) the planned data reduction; the treatment of invalid data, data below detection limits, and data collected during calm wind periods; and calculations to determine the near-field source concentration contribution for each monitoring location.

(v) A detailed description of the measurement technique, measurement location(s), the standard operating

procedures, measurement frequency, recording frequency, measurement detection limit, and data quality indicators to ensure accuracy, precision, and validity of the data.

(vi) A detailed description of how data will be handled during periods of calm wind conditions (*i.e.*, less than 2 miles per hour).

(2) When an approved site-specific monitoring plan is used, the owner or operator must determine  $\Delta c$  for comparison with the action level according to paragraph (d) of this section. When determining the highest and lowest sample results for use in the  $\Delta c$  calculation, the concentration for any monitor that has been corrected using an approved site-specific monitoring plan will be corrected according to the procedures specified in paragraphs (g)(2)(i) and (ii) of this section.

(i) For each monitoring location corrected using the site-specific monitoring plan, the corrected fenceline concentration at that monitoring station will be equal to the fenceline concentration measured with Methods 325A and 325B or Method 327 of appendix A to this part minus the near-field source contributing concentration at the measurement location determined using the additional measurements and calculation procedures included in the site-specific monitoring plan.

(ii) If the fenceline concentration at the monitoring station is below the method detection limit for Methods 325A and 325B or Method 327 of appendix A to this part, no near-field source contribution can be subtracted from that monitoring station for that sampling period.

(3) The site-specific monitoring plan must be submitted and approved as described in paragraphs (g)(3)(i) through (iv) of this section.

(i) The site-specific monitoring plan must be submitted to the Administrator for approval.

(ii) The site-specific monitoring plan must also be submitted to the following address: U.S. Environmental Protection Agency, Office of Air Quality Planning and Standards, Sector Policies and Programs Division, U.S. EPA Mailroom (E143-01), Attention: Hazardous Organic Chemical Manufacturing Sector Lead, 109 T.W. Alexander Drive, P.O. Box 12055, Research Triangle Park, NC 27711. Electronic copies in lieu of hard copies may also be submitted to [fencelineplan@epa.gov](mailto:fencelineplan@epa.gov).

(iii) The Administrator will approve or disapprove the plan in 90 days. The plan is considered approved if the Administrator either approves the plan in writing or fails to disapprove the plan in writing. The 90-day period begins

when the Administrator receives the plan.

(iv) If the Administrator finds any deficiencies in the site-specific monitoring plan and disapproves the plan in writing, the owner or operator may revise and resubmit the site-specific monitoring plan following the requirements in paragraphs (g)(3)(i) and (ii) of this section. The 90-day period starts over with the resubmission of the revised monitoring plan.

(4) The approval by the Administrator of a site-specific monitoring plan will be based on the completeness, accuracy and reasonableness of the request for a site-specific monitoring plan. Factors that the Administrator will consider in reviewing the request for a site-specific monitoring plan include, but are not limited to, those described in paragraphs (g)(4)(i) through (v) of this section.

(i) The identification of the near-field source or sources and evidence of how the sources impact the fenceline concentrations.

(ii) The location(s) selected for additional monitoring to determine the near-field source concentration contribution.

(iii) The identification of the fenceline monitoring locations impacted by the near-field source or sources.

(iv) The appropriateness of the planned data reduction and calculations to determine the near-field source concentration contribution for each monitoring location, including the handling of invalid data, data below the detection limit, and data during calm periods.

(v) The adequacy of the description of and rationale for the measurement technique, measurement location(s), the standard operation procedure, measurement frequency, recording frequency, measurement detection limit, and data quality indicators to ensure accuracy, precision, and validity of the data.

(h) The owner or operator must comply with the applicable recordkeeping and reporting requirements in §§ 63.181 and 63.182.

(i) As outlined in § 63.7(f), the owner or operator may submit a request for an alternative test method. At a minimum, the request must follow the requirements outlined in paragraphs (i)(1) through (7) of this section.

(1) The alternative method may be used in lieu of all or a partial number of passive samplers required in Method 325A of appendix A to this part or the canister sampling locations required under paragraph (b) of this section.

(2) The alternative method must be validated according to Method 301 in

appendix A to this part or contain performance-based procedures and indicators to ensure self-validation.

(3) The method detection limit must nominally be at least one-third of the action level for the compound(s) that will be monitored with the alternative method. The alternate test method must describe the procedures used to provide field verification of the detection limit.

(4) If the alternative test method will be used to replace some or all passive samplers required under paragraph (a) of this section, the spatial coverage must be equal to or better than the spatial coverage provided in Method 325A of appendix A to this part. If the alternative test method will be used to replace some or all canisters required under paragraph (b) of this section, the spatial coverage must be equal to or better than the spatial coverage provided under paragraph (b) of this section.

(i) For path average concentration open-path instruments, the physical path length of the measurement must be no more than a passive sample footprint

(the spacing that would be provided by the sorbent traps when following Method 325A of appendix A to this part) or canister sample footprint, as applicable. For example, if Method 325A requires spacing monitors A and B 610 meters (2,000 feet) apart, then the physical path length limit for the measurement at that portion of the fence line must be no more than 610 meters (2,000 feet).

(ii) For range resolved open-path instrument or approach, the instrument or approach must be able to resolve an average concentration over each passive sampler footprint or canister sample footprint within the path length of the instrument.

(iii) The extra samplers required in Sections 8.2.1.3 of Method 325A of appendix A to this part may be omitted when they fall within the path length of an open-path instrument.

(5) At a minimum, non-integrating alternative test methods must provide a minimum of one cycle of operation (sampling, analyzing, and data

recording) for each successive 15-minute period.

(6) For alternative test methods capable of real time measurements (less than a 5 minute sampling and analysis cycle), the alternative test method may allow for elimination of data points corresponding to outside emission sources for purpose of calculation of the high point for the two week average. The alternative test method approach must have wind speed, direction and stability class of the same time resolution and within the footprint of the instrument.

(7) For purposes of averaging data points to determine the Δc for the individual sampling period, all results measured under the method detection limit must use the method detection limit. For purposes of averaging data points for the individual sampling period low sample result, all results measured under the method detection limit must use zero.

■ 117. Revise tables 1 through 4 to subpart H to read as follows:

TABLE 1 TO SUBPART H OF PART 63—BATCH PROCESSES

[Monitoring frequency for equipment other than connectors]

Operating time (% of year)	Equivalent continuous process monitoring frequency time in use		
	Monthly	Quarterly	Semiannually
0 to <25 .....	Quarterly .....	Annually .....	Annually.
25 to <50 .....	Quarterly .....	Semiannually .....	Annually.
50 to <75 .....	Bimonthly .....	Three times .....	Semiannually.
75 to 100 .....	Monthly .....	Quarterly .....	Semiannually.

TABLE 2 TO SUBPART H OF PART 63—SURGE CONTROL VESSELS AND BOTTOMS RECEIVERS AT EXISTING SOURCES

Vessel capacity (cubic meters)	Vapor pressure <sup>1</sup> (kilopascals)
75 ≤ capacity <151 .....	≥13.1
151 ≤ capacity .....	<sup>a</sup> ≥5.2

<sup>1</sup> Maximum true vapor pressure of total organic HAP at operating temperature as defined in subpart G of this part.

TABLE 3 TO SUBPART H OF PART 63—SURGE CONTROL VESSELS AND BOTTOMS RECEIVERS AT NEW SOURCES

Vessel capacity (cubic meters)	Vapor pressure <sup>1</sup> (kilopascals)
38 ≤ capacity <151 .....	≥13.1
151 ≤ capacity .....	≥0.7

<sup>1</sup> Maximum true vapor pressure of total organic HAP at operating temperature as defined in subpart G of this part.

TABLE 4 TO SUBPART H OF PART 63—APPLICABLE 40 CFR PART 63 GENERAL PROVISIONS

40 CFR part 63, subpart A, provisions applicable to subpart H

- § 63.1(a)(1), (a)(2), (a)(3), (a)(13), (a)(14), (b)(2) and (c)(4).
- § 63.2.
- § 63.5(a)(1), (a)(2), (b), (d)(1)(ii), (d)(4), (e), (f)(1) and (f)(2).
- § 63.6(a), (b)(3), (c)(5), (i)(1), (i)(2), (i)(4)(i)(A), (i)(5) through (i)(14), (i)(16) and (j).
- § 63.9(a)(2), (b)(4)(i),<sup>a</sup> (b)(4)(ii), (b)(4)(iii), (b)(5),<sup>a</sup> (c), (d), (j) and (k).
- § 63.10(d)(4).
- § 63.11 (c), (d), and (e).

TABLE 4 TO SUBPART H OF PART 63—APPLICABLE 40 CFR PART 63 GENERAL PROVISIONS—Continued

40 CFR part 63, subpart A, provisions applicable to subpart H

§ 63.12(b).

<sup>a</sup> The notifications specified in § 63.9(b)(4)(i) and (b)(5) shall be submitted at the times specified in 40 CFR part 65.

■ 118. Revise the heading to subpart I to read as follows:

**Subpart I—National Emission Standards for Hazardous Air Pollutants for Certain Processes Subject to the Negotiated Regulation for Equipment Leaks**

■ 119. Amend § 63.192 by:

■ a. Revising paragraphs (b)(6), (7) and (10), and adding paragraph (b)(12); revising paragraph (c)(3) and adding paragraph (c)(5); and

■ b. Revising and republishing paragraph (f)(2) and revising (g) introductory text.

The revisions, additions and republication read as follows:

**§ 63.192 Standard.**

\* \* \* \* \*

(b) \* \* \*

(6)(i) Except as specified in paragraph (b)(12) of this section, the compliance with standards and maintenance requirements of § 63.6(a), (b)(3), (c)(5), (e), (i)(1), (i)(2), (i)(4)(i)(A), (i)(6)(i), (i)(8) through (i)(10), (i)(12) through (i)(14), (i)(16), and (j);

(ii) Except as specified in paragraph (b)(12) of this section, the operational and maintenance requirements of § 63.6(e). The startup, shutdown, and malfunction plan requirement of § 63.6(e)(3) is limited to control devices subject to the provisions of subpart H of this part and is optional for other equipment subject to subpart H. The startup, shutdown, and malfunction plan may include written procedures that identify conditions that justify a delay of repair. On and after July 15, 2027, the last two sentences of this paragraph do not apply.

(7) With respect to flares, except as specified in paragraph (b)(12) of this section, the performance testing requirements of § 63.7(a)(3), (d), (e)(1), (e)(2), (e)(4), and (h);

\* \* \* \* \*

(10) Except as specified in paragraph (b)(12) of this section, the control device requirements of § 63.11(b); and

\* \* \* \* \*

(12) On and after July 15, 2027, § 63.6(e)(1)(i), (e)(1)(ii), and (e)(3), § 63.7(e)(1), and § 63.11(b) do not apply. Instead, you must comply with paragraphs (b)(12)(i) through (iii) of this section.

(i) The owner or operator of a source subject to this subpart shall comply with the requirements at all times, except during periods of nonoperation of the source (or specific portion thereof) resulting in cessation of the emissions to which this subpart or subpart H of this part applies.

(ii) At all times, owners and operators subject to this subpart must operate and maintain any source, including associated air pollution control equipment and monitoring equipment, in a manner consistent with safety and good air pollution control practices for minimizing emissions. The general duty to minimize emissions does not require owners and operators to make any further efforts to reduce emissions if levels required by the applicable standard have been achieved.

Determination of whether a source is operating in compliance with operation and maintenance requirements will be based on information available to the Administrator which may include, but is not limited to, monitoring results, review of operation and maintenance procedures, review of operation and maintenance records, and inspection of the source.

(iii) Owners and operators that use a flare to comply with this subpart must comply with § 63.108.

(c) \* \* \*

(3) Performance tests shall be conducted according to the provisions of § 63.7(e), except that performance tests shall be conducted at maximum representative operating conditions for the process except as specified in paragraph (c)(5) of this section. During the performance test, an owner or operator may operate the control or recovery device at maximum or minimum representative operating conditions for monitored control or recovery device parameters, whichever results in lower emission reduction.

\* \* \* \* \*

(5) On and after July 15, 2027, in lieu of the requirements specified in § 63.7(e)(1) you must conduct performance tests under such conditions as the Administrator specifies based on representative performance of the affected source for the period being tested. Representative conditions exclude periods of startup and shutdown. You may not conduct performance tests during periods of

malfunction. You must record the process information that is necessary to document operating conditions during the test and include in such record an explanation to support that such conditions represent normal operation. Upon request, you must make available to the Administrator such records as may be necessary to determine the conditions of performance tests.

\* \* \* \* \*

(f) \* \* \*

(2) The owner or operator subject to subparts I and H of this part shall keep the records specified in this paragraph, as well as records specified in subpart H of this part.

(i) Records of the occurrence and duration of each start-up, shutdown, and malfunction of operation of a process subject to this subpart as specified in § 63.190(b). On and after July 15, 2027, this paragraph no longer applies; however, for historical compliance purposes, a copy of these records must be retained and available on-site for at least five years after the date of occurrence.

(ii) Records of the occurrence and duration of each malfunction of air pollution control equipment or continuous monitoring systems used to comply with subparts I and H of this part.

(iii) For each start-up, shutdown, and malfunction, records that the procedures specified in the source's start-up, shutdown, and malfunction plan were followed, and documentation of actions taken that are not consistent with the plan. These records may take the form of a "checklist," or other form of recordkeeping that confirms conformance with the startup, shutdown, and malfunction plan for the event. On and after July 15, 2027, this paragraph no longer applies; however, for historical compliance purposes, a copy of the plan and these records must be retained and available on-site for at least five years after the date of occurrence.

(g) All reports required under subpart H shall be submitted as required in § 63.182.

\* \* \* \* \*

■ 120. Amend § 63.480 by revising paragraphs (j) introductory text and (j)(4) introductory text as follows:



**§ 63.480 Applicability and designation of affected sources.**

\* \* \* \* \*

(j) *Applicability of this subpart.* Paragraphs (j)(1) through (3) of this section must be followed during periods of non-operation of the affected source or any part thereof.

\* \* \* \* \*

(4) Beginning on July 15, 2024, this paragraph (j)(4) no longer applies. In response to an action to enforce the standards set forth in this subpart, an owner or operator may assert an affirmative defense to a claim for civil penalties for exceedances of such standards that are caused by a malfunction, as defined in § 63.2. Appropriate penalties may be assessed, however, if the owner or operator fails to meet the burden of proving all the requirements in the affirmative defense. The affirmative defense shall not be available for claims for injunctive relief.

\* \* \* \* \*

■ 121. Amend § 63.481 by revising paragraph (a), (b), (c) introductory text, (d) introductory text, (k), and adding paragraphs (k)(2) and (n) through (p) as follows:

**§ 63.481 Compliance dates and relationship of this subpart to existing applicable rules.**

(a) Affected sources are required to achieve compliance on or before the dates specified in paragraphs (b) through (d) of this section and paragraphs (n) and (o) of this section. Paragraph (e) of this section provides information on requesting compliance extensions. Paragraphs (f) through (l) of this section discuss the relationship of this subpart to subpart A and to other applicable rules. Where an override of another authority of the Act is indicated in this subpart, only compliance with the provisions of this subpart is required. Paragraph (m) of this section specifies the meaning of time periods.

(b) Except as specified in paragraphs (n) and (o) of this section, new affected sources that commence construction or reconstruction after June 12, 1995 shall be in compliance with this subpart upon initial start-up or by June 19, 2000, whichever is later.

(c) With the exceptions provided in paragraphs (c)(1) through (3) of this section and paragraphs (n) and (o) of this section, existing affected sources shall be in compliance with this subpart no later than June 19, 2001, as provided in § 63.6(c), unless an extension has been granted as specified in paragraph (e) of this section.

\* \* \* \* \*

(d) Except as provided for in paragraphs (d)(1) through (d)(6) of this

section, and paragraphs (n) and (o) of this section, existing affected sources shall be in compliance with § 63.502 no later than July 31, 1997, unless an extension has been granted pursuant to paragraph (e) of this section.

\* \* \* \* \*

(k) *Applicability of other regulations for monitoring, recordkeeping or reporting with respect to combustion devices, recovery devices, or recapture devices.* (1) After the compliance dates specified in this subpart, if any combustion device, recovery device or recapture device subject to this subpart is also subject to monitoring, recordkeeping, and reporting requirements in 40 CFR part 264 subpart AA or CC, or is subject to monitoring and recordkeeping requirements in 40 CFR part 265 subpart AA or CC and the owner or operator complies with the periodic reporting requirements under 40 CFR part 264 subpart AA or CC that would apply to the device if the facility had final-permitted status, the owner or operator may elect to comply either with the monitoring, recordkeeping and reporting requirements of this subpart, or with the monitoring, recordkeeping and reporting requirements in 40 CFR parts 264 and/or 265, as described in this paragraph, which shall constitute compliance with the monitoring, recordkeeping and reporting requirements of this subpart. The owner or operator shall identify which option has been selected in the Notification of Compliance Status required by § 63.506(e)(5).

(2) Owners and operators of flares that are subject to the flare related requirements of this subpart and are also subject to flare related requirements of any other regulation in this part or 40 CFR part 61 or 63, may elect to comply with the requirements in § 63.508 in lieu of all flare related requirements in any other regulation in this part or 40 CFR part 61 or 63.

\* \* \* \* \*

(n) All affected sources that commenced construction or reconstruction on or before April 25, 2023, must be in compliance with the requirements listed in paragraphs (n)(1) through (9) of this section upon initial startup or on July 15, 2027, whichever is later. All affected sources that commenced construction or reconstruction after April 25, 2023, must be in compliance with the requirements listed in paragraphs (n)(1) through (9) of this section upon initial startup, or on July 15, 2024, whichever is later.

(1) The general requirements specified in § 63.483(e), § 63.504(a),

§ 63.504(a)(1)(iii), and § 63.506(e)(6)(iii)(C).

(2) For flares, the requirements specified in § 63.508.

(3) For storage vessels, the requirements specified in § 63.484(t) and § 63.506(e)(4)(ii)(F)(6).

(4) For continuous front-end process vents, the requirements specified in §§ 63.485(l)(6), (o)(6), (p)(5), (q)(1)(vii), (x), § 63.503(g)(2)(iii)(B)(4), and § 63.506(e)(4)(ii)(F)(6).

(5) For batch front-end process vents, the requirements specified in §§ 63.487(a)(3), (b)(3), and (e)(1)(iv) and (i), §§ 63.488(d)(2), (e)(4), (f)(2), and (g)(3), §§ 63.489(b)(10) and (d)(3), §§ 63.491(d)(1)(iii), (e)(6), and (h), § 63.492(g), and Table 6 to this subpart, item 3 in column 3 for diversion to the atmosphere and monthly inspections of sealed valves for all control devices.

(6) For back-end processes, the requirements specified in §§ 63.497(a)(8) and (d)(3), and § 63.498(d)(5)(v).

(7) For wastewater, the requirements specified in §§ 63.501(d), (e), and (f).

(8) For equipment leaks, the requirements specified in §§ 63.502(a)(2) and (k)(2).

(9) For heat exchange systems, the requirements specified in §§ 63.502(n)(7) and (n)(8).

(o) All affected sources that commenced construction or reconstruction on or before April 25, 2023, must be in compliance with the chloroprene requirements in §§ 63.484(u), 63.485(y) and (z), 63.487(j), 63.494(a)(7), 63.501(a)(10)(iv), 63.502(a)(3) and (a)(7), 63.509, and 63.510 upon initial startup or on October 15, 2024, whichever is later. All affected sources that commenced construction or reconstruction after April 25, 2023, must be in compliance with the chloroprene requirements in §§ 63.484(u), 63.485(x) and (z), 63.487(j), 63.494(a)(7), § 63.501(a)(10)(iv), 63.502(q), 63.502(a)(3) and (a)(7), 63.509, and 63.510 upon initial startup, or on July 15, 2024, whichever is later.

(p) The compliance schedule for fenceline monitoring is specified in paragraphs (p)(1) and (2) of this section.

(1) Except as specified in paragraph (p)(2) of this section, all affected sources that commenced construction or reconstruction on or before April 25, 2023, must commence fenceline monitoring according to the requirements in § 63.502(a)(4) by no later than July 15, 2026, however requirements for corrective actions are not required until on or after July 15, 2027. All affected sources that commenced construction or

reconstruction after April 25, 2023, must be in compliance with the fenceline monitoring requirements listed in § 63.502(a)(4) upon initial startup, or on July 15, 2024, whichever is later.

(2) For affected sources producing neoprene, the compliance schedule specified in paragraph (p)(1) of this section does not apply for chloroprene. Instead, all affected sources producing neoprene that commenced construction or reconstruction on or before April 25, 2023, must be in compliance with the fenceline monitoring requirements for chloroprene listed in § 63.502(a)(4) and (a)(7) upon initial startup or on October 15, 2024, whichever is later. All affected sources producing neoprene that commenced construction or reconstruction after April 25, 2023, must be in compliance with the fenceline monitoring requirements for chloroprene listed in § 63.502(a)(4) and (a)(7) upon initial startup, or on July 15, 2024, whichever is later.

■ 122. Revise and republish § 63.482 to read as follows:

**§ 63.482 Definitions.**

(a) The following terms used in this subpart shall have the meaning given them in § 63.2, § 63.101, or the Act, as specified after each term:

Act (§ 63.2)  
 Administrator (§ 63.2)  
 Automated monitoring and recording system (§ 63.101)  
 Boiler (§ 63.101)  
 Bottoms receiver (§ 63.101)  
 Breakthrough (§ 63.101)  
 By compound (§ 63.101)  
 By-product (§ 63.101)  
 Car-seal (§ 63.101)  
 Closed-vent system (§ 63.101)  
 Combustion device (§ 63.101)  
 Commenced (§ 63.2)  
 Compliance date (§ 63.2)  
 Connector (§ 63.101)  
 Continuous monitoring system (§ 63.2)  
 Distillation unit (§ 63.101)  
 Duct work (§ 63.101)  
 Emission limitation (Section 302(k) of the Act)  
 Emission standard (§ 63.2)  
 Emissions averaging (§ 63.2)  
 EPA (§ 63.2)  
 Equipment leak (§ 63.101)  
 External floating roof (§ 63.101)  
 Fill or filling (§ 63.101)  
 Fixed capital cost (§ 63.2)  
 Flame zone (§ 63.101)  
 Floating roof (§ 63.101)  
 Flow indicator (§ 63.101)  
 Fuel gas system (§ 63.101)  
 Halogens and hydrogen halides (§ 63.101)  
 Hard-piping (§ 63.101)

Hazardous air pollutant (§ 63.2)  
 Heat exchange system (§ 63.101)  
 Impurity (§ 63.101)  
 Incinerator (§ 63.101)  
 In organic hazardous air pollutant service or in organic HAP service (§ 63.101)  
 Instrumentation system (§ 63.101)  
 Internal floating roof (§ 63.101)  
 Lesser quantity (§ 63.2)  
 Major source (§ 63.2)  
 Malfunction (§ 63.2)  
 Oil-water separator or organic-water separator (§ 63.101)  
 Open-ended valve or line (§ 63.101)  
 Operating permit (§ 63.101)  
 Organic monitoring device (§ 63.101)  
 Owner or operator (§ 63.2)  
 Performance evaluation (§ 63.2)  
 Performance test (§ 63.2)  
 Permitting authority (§ 63.2)  
 Plant site (§ 63.101)  
 Potential to emit (§ 63.2)  
 Pressure release (§ 63.101)  
 Primary fuel (§ 63.101)  
 Pressure release (§ 63.101)  
 Pressure relief device (§ 63.101)  
 Pressure vessel (§ 63.101)  
 Process heater (§ 63.101)  
 Process unit shutdown (§ 63.101)  
 Process wastewater (§ 63.101)  
 Process wastewater stream (§ 63.101)  
 Reactor (§ 63.101)  
 Recapture device (§ 63.101)  
 Relief valve (§ 63.101)  
 Repaired (§ 63.101)  
 Research and development facility (§ 63.101)  
 Routed to a process or route to a process (§ 63.101)  
 Run (§ 63.2)  
 Secondary fuel (§ 63.101)  
 Sensor (§ 63.101)  
 Specific gravity monitoring device (§ 63.101)  
 Start-up, shutdown, and malfunction plan (§ 63.101) On and after July 15, 2027, this definition no longer applies.  
 State (§ 63.2)  
 Stationary Source (§ 63.2)  
 Surge control vessel (§ 63.101)  
 Temperature monitoring device (§ 63.101)  
 Test method (§ 63.2)  
 Treatment process (§ 63.101)  
 Unit operation (§ 63.101)  
 Visible emission (§ 63.2)  
 Secondary fuel (§ 63.101)  
 Sensor (§ 63.101)  
 Specific gravity monitoring device (§ 63.101)  
 Start-up, shutdown, and malfunction plan (§ 63.101) On and after July 15, 2027, this definition no longer applies.  
 State (§ 63.2)  
 Stationary Source (§ 63.2)  
 Surge control vessel (§ 63.101)

Temperature monitoring device (§ 63.101)  
 Test method (§ 63.2)  
 Treatment process (§ 63.101)  
 Unit operation (§ 63.101)  
 Visible emission (§ 63.2)

(b) All other terms used in this subpart shall have the meaning given them in this section. If a term is defined in a subpart referenced in this section, it shall have the meaning given in this section for purposes of this subpart.

*Affected source* is defined in § 63.480(a).

*Affirmative defense* means, in the context of an enforcement proceeding, a response or a defense put forward by a defendant, regarding which the defendant has the burden of proof, and the merits of which are independently and objectively evaluated in a judicial or administrative proceeding. Beginning on July 15, 2024, this definition of *affirmative defense* no longer applies.

*Aggregate batch vent stream* means a gaseous emission stream containing only the exhausts from two or more batch front-end process vents that are ducted, hard-piped, or otherwise connected together for a continuous flow.

*Annual average batch vent concentration* is determined using Equation 17, as described in § 63.488(h)(2) for halogenated compounds.

*Annual average batch vent flow rate* is determined by the procedures in § 63.488(e)(3).

*Annual average concentration*, as used in the wastewater provisions, means the flow-weighted annual average concentration, as determined according to the procedures specified in § 63.144(b), with the exceptions noted in § 63.501, for the purposes of this subpart.

*Annual average flow rate*, as used in the wastewater provisions, means the annual average flow rate, as determined according to the procedures specified in § 63.144(c), with the exceptions noted in § 63.501, for the purposes of this subpart.

*Average batch vent concentration* is determined by the procedures in § 63.488(b)(5)(iii) for HAP concentrations and is determined by the procedures in § 63.488(h)(1)(iii) for organic compounds containing halogens and hydrogen halides.

*Average batch vent flow rate* is determined by the procedures in § 63.488(e)(1) and (2).

*Back-end* refers to the unit operations in an EPPU following the stripping operations. Back-end process operations include, but are not limited to, filtering,

coagulation, blending, concentration, drying, separating, and other finishing operations, as well as latex and crumb storage. Back-end does not include storage and loading of finished product or emission points that are regulated under § 63.484, § 63.501, or § 63.502.

*Batch cycle* means the operational step or steps, from start to finish, that occur as part of a batch unit operation.

*Batch emission episode* means a discrete emission venting episode associated with a single batch unit operation. Multiple batch emission episodes may occur from a single batch unit operation.

*Batch front-end process vent* means a process vent with annual organic HAP emissions greater than 225 kilograms per year from a batch unit operation within an affected source and located in the front-end of a process unit. Annual organic HAP emissions are determined as specified in § 63.488(b) at the location specified in § 63.488(a)(2).

*Batch mass input limitation* means an enforceable restriction on the total mass of HAP or material that can be input to a batch unit operation in one year.

*Batch mode* means the discontinuous bulk movement of material through a unit operation. Mass, temperature, concentration, and other properties may vary with time. For a unit operation operated in a batch mode (*i.e.*, batch unit operation), the addition of material and withdrawal of material do not typically occur simultaneously.

*Batch process* means, for the purposes of this subpart, a process where the reactor(s) is operated in a batch mode.

*Batch unit operation* means a unit operation operated in a batch mode.

*Block polymer* means a polymer where the polymerization is controlled, usually by performing discrete polymerization steps, such that the final polymer is arranged in a distinct pattern of repeating units of the same monomer.

*Butyl rubber* means a copolymer of isobutylene and other monomers. Typical other monomers include isoprene and methylstyrene. A typical composition of butyl rubber is approximately 85- to 99-percent isobutylene, and 1- to 15-percent other monomers. Most butyl rubber is produced by precipitation polymerization, although other methods may be used. Halobutyl rubber is a type of butyl rubber elastomer produced using halogenated copolymers.

*Combined vent stream*, as used in reference to batch front-end process vents, continuous front-end process vents, and aggregate batch vent streams, means the emissions from a combination of two or more of the aforementioned types of process vents.

The primary occurrence of a combined vent stream is as combined emissions from a continuous front-end process vent and a batch front-end process vent.

*Combustion device burner* means a device designed to mix and ignite fuel and air to provide a flame to heat and oxidize waste organic vapors in a combustion device.

*Compounding unit* means a unit operation which blends, melts, and resolidifies solid polymers for the purpose of incorporating additives, colorants, or stabilizers into the final elastomer product. A unit operation whose primary purpose is to remove residual monomers from polymers is not a compounding unit.

*Construction* means the on-site fabrication, erection, or installation of an affected source. Construction also means the on-site fabrication, erection, or installation of a process unit or combination of process units which subsequently becomes an affected source or part of an affected source, due to a change in primary product.

*Continuous front-end process vent* means a process vent located in the front-end of a process unit and containing greater than 0.005 weight percent total organic HAP from a continuous unit operation within an affected source. The total organic HAP weight percent is determined after the last recovery device, as described in § 63.115(a), and is determined as specified in § 63.115(c).

*Continuous mode* means the continuous movement of material through a unit operation. Mass, temperature, concentration, and other properties typically approach steady-state conditions. For a unit operation operated in a continuous mode (*i.e.*, continuous unit operation), the simultaneous addition of raw material and withdrawal of product is typical.

*Continuous process* means, for the purposes of this subpart, a process where the reactor(s) is operated in a continuous mode.

*Continuous record* means documentation, either in hard copy or computer readable form, of data values measured at least once every 15 minutes and recorded at the frequency specified in § 63.506(d) or (h).

*Continuous recorder* means a data recording device that either records an instantaneous data value at least once every 15 minutes or records 1-hour or more frequent block average values.

*Continuous unit operation* means a unit operation operated in a continuous mode.

*Control device* is defined in § 63.111, except that the term “continuous front-end process vent” shall apply instead of

the term “process vent,” for the purpose of this subpart.

*Crumb rubber dry weight* means the weight of the polymer, minus the weight of water and residual organics.

*Dioxins and furans* means total tetra-through octachlorinated dibenzo-p-dioxins and dibenzofurans.

*Drawing unit* means a unit operation which converts polymer into a different shape by melting or mixing the polymer and then pulling it through an orifice to create a continuously extruded product.

*Elastomer* means any polymer having a glass transition temperature lower than  $-10^{\circ}\text{C}$ , or a glass transition temperature between  $-10^{\circ}\text{C}$  and  $25^{\circ}\text{C}$  that is capable of undergoing deformation (stretching) of several hundred percent and recovering essentially when the stress is removed. For the purposes of this subpart, resins are not considered to be elastomers.

*Elastomer product* means one of the following types of products, as they are defined in this section:

- (i) Butyl Rubber;
- (ii) Epichlorohydrin Elastomer;
- (iii) Ethylene Propylene Rubber;
- (iv) Hypalon™;
- (v) Neoprene;
- (vi) Nitrile Butadiene Rubber;
- (vii) Nitrile Butadiene Latex;
- (viii) Polybutadiene Rubber/Styrene Butadiene Rubber by Solution;
- (ix) Polysulfide Rubber;
- (x) Styrene Butadiene Rubber by Emulsion; and
- (xi) Styrene Butadiene Latex.

*Elastomer product process unit (EPPU)* means a collection of equipment assembled and connected by hard-piping or duct work, used to process raw materials and to manufacture an elastomer product as its primary product. This collection of equipment includes unit operations; recovery operations equipment; process vents; storage vessels, as determined in § 63.480(g); equipment that is identified in § 63.149; and the equipment that is subject to the equipment leak provisions as specified in § 63.502. Utilities, lines and equipment not containing process fluids, and other non-process lines, such as heating and cooling systems which do not combine their materials with those in the processes they serve, are not part of an elastomer product process unit. An elastomer product process unit consists of more than one unit operation.

*Elastomer type* means one of the elastomers listed under “elastomer product” in this section. Each elastomer identified in that definition represents a different elastomer type.

*Emission point* means an individual continuous front-end process vent,

batch front-end process vent, back-end process vent, storage vessel, waste management unit, heat exchange system, or equipment leak, or equipment subject to § 63.149.

*Emulsion process* means a process where the monomer(s) is dispersed in droplets throughout a water phase, with the aid of an emulsifying agent such as soap or a synthetic emulsifier. The polymerization occurs either within the emulsion droplet or in the aqueous phase.

*Epichlorohydrin elastomer* means an elastomer formed from the polymerization or copolymerization of epichlorohydrin (EPI). The main epichlorohydrin elastomers are polyepichlorohydrin, epi-ethylene oxide (EO) copolymer, epi-allyl glycidyl ether (AGE) copolymer, and epi-EO-AGE terpolymer. Epoxies produced by the copolymerization of EPI and bisphenol A are not epichlorohydrin elastomers.

*Equipment* means, for the purposes of the provisions in § 63.502(a) through (m) and the requirements in subpart H that are referred to in § 63.502(a) through (m), each pump, compressor, agitator, pressure relief device, sampling connection system, open-ended valve or line, valve, connector, surge control vessel, bottoms receiver, and instrumentation system in organic hazardous air pollutant service; and any control devices or systems required by subpart H of this part.

*Ethylene-propylene rubber* means an ethylene-propylene copolymer or an ethylene-propylene terpolymer. Ethylene-propylene copolymers (EPM) result from the polymerization of ethylene and propylene and contain a saturated chain of the polymethylene type. Ethylene-propylene terpolymers (EPDM) are produced in a similar manner as EPM, except that a third monomer is added to the reaction sequence. Typical third monomers include ethylidene norbornene, 1,4-hexadiene, or dicyclopentadiene. Ethylidene norbornene is the most commonly used. The production process includes, but is not limited to, polymerization, recycle, recovery, and packaging operations. The polymerization reaction may occur in either a solution process or a suspension process.

*Existing affected source* is defined in § 63.480(a)(3).

*Existing process unit* means any process unit that is not a new process unit.

*Extruding unit* means a unit operation which converts polymer into a different shape by melting or mixing the polymer and then forcing it through an orifice to create a continuously extruded product.

*Flexible operation unit* means a process unit that manufactures different chemical products, polymers, or resins periodically by alternating raw materials or operating conditions. These units are also referred to as campaign plants or blocked operations.

*Front-end* refers to the unit operations in an EPPU prior to, and including, the stripping operations. For all gas-phased reaction processes, all unit operations are considered to be front-end.

*Gas-phased reaction process* means an elastomer production process where the reaction occurs in a gas phase, fluidized bed.

*Glass transition temperature* means the temperature at which an elastomer polymer becomes rigid and brittle.

*Grade* means a group of recipes of an elastomer type having similar characteristics such as molecular weight, monomer composition, significant mooney values, and the presence or absence of extender oil and/or carbon black. More than one recipe may be used to produce the same grade.

*Group 1 batch front-end process vent* means, before July 15, 2027, a batch front-end process vent releasing annual organic HAP emissions greater than or equal to 11,800 kg/yr and with a cutoff flow rate, calculated in accordance with § 63.488(f), greater than or equal to the annual average batch vent flow rate. Annual organic HAP emissions and annual average batch vent flow rate are determined at the exit of the batch unit operation, as described in § 63.488(a)(2). Annual organic HAP emissions are determined as specified in § 63.488(b), and annual average batch vent flow rate is determined as specified in § 63.488(e). On and after July 15, 2027, Group 1 batch front-end process vent means, each batch front-end process vent that, when combined, the sum of all these process vents would release annual organic HAP emissions greater than or equal to 4,536 kg/yr (10,000 lb/yr) as determined using the procedures specified in § 63.488(b).

*Group 2 batch front-end process vent* means a batch front-end process vent that does not fall within the definition of a Group 1 batch front-end process vent.

*Group 1 continuous front-end process vent* means, before July 15, 2027, a continuous front-end process vent for which the flow rate is greater than or equal to 0.005 standard cubic meter per minute, the total organic HAP concentration is greater than or equal to 50 parts per million by volume, and the total resource effectiveness index value, calculated according to § 63.115, is less than or equal to 1.0. On and after July 15, 2027, Group 1 continuous front-end

process vent means a process vent that emits greater than or equal to 1.0 pound per hour of total organic HAP.

*Group 2 continuous front-end process vent* means, before July 15, 2027, a continuous front-end process vent for which the flow rate is less than 0.005 standard cubic meter per minute, the total organic HAP concentration is less than 50 parts per million by volume, or the total resource effectiveness index value, calculated according to § 63.115, is greater than 1.0. On and after July 15, 2027, Group 2 continuous front-end process vent means a process vent that emits less than 1.0 pound per hour of total organic HAP.

*Group 1 storage vessel* means a storage vessel at an existing affected source that meets the applicability criteria specified in Table 3 of this subpart, or a storage vessel at a new affected source that meets the applicability criteria specified in Table 4 of this subpart.

*Group 2 storage vessel* means a storage vessel that does not fall within the definition of a Group 1 storage vessel.

*Group 1 wastewater stream* means a wastewater stream consisting of process wastewater from an existing or new affected source that meets the criteria for Group 1 status in § 63.132(c), with the exceptions listed in § 63.501(a)(10) for the purposes of this subpart (*i.e.*, for organic HAP as defined in this section).

*Group 2 wastewater stream* means any process wastewater stream that does not meet the definition of a Group 1 wastewater stream.

*Halogenated aggregate batch vent stream* means an aggregate batch vent stream determined to have a total mass emission rate of halogen atoms contained in organic compounds of 3,750 kg/yr or greater determined by the procedures presented in § 63.488(h).

*Halogenated batch front-end process vent* means a batch front-end process vent determined to have a mass emission rate of halogen atoms contained in organic compounds of 3,750 kg/yr or greater determined by the procedures presented in § 63.488(h).

*Halogenated continuous front-end process vent* means a continuous front-end process vent determined to have a mass emission rate of halogen atoms contained in organic compounds of 0.45 kg/hr or greater determined by the procedures presented in § 63.115(d)(2)(v).

*High conversion latex* means a latex where all monomers are reacted to at least 95 percent conversion.

*Highest-HAP recipe* for a product means the recipe of the product with the highest total mass of HAP charged to the

reactor during the production of a single batch of product.

*Hypalon*<sup>TM</sup> means a chlorosulfonated polyethylene that is a synthetic rubber produced for uses such as wire and cable insulation, shoe soles and heels, automotive components, and building products.

*In chloroprene service* means the following:

(i) For process vents, each continuous front-end process vent, each batch front-end process vent, and each back-end process vent in a process at affected sources producing neoprene that, when uncontrolled, contains a concentration of greater than or equal to 1 ppmv undiluted chloroprene, and when combined, the sum of all these process vents within the process would emit uncontrolled, chloroprene emissions greater than or equal to 5 lb/yr (2.27 kg/yr). If information exists that suggests chloroprene could be present in a continuous front-end process vent, batch front-end process vent, or back-end process vent, then the process vent is considered to be “in chloroprene service” unless an analysis is performed as specified in § 63.509 to demonstrate that the process vent does not meet the definition of being “in chloroprene service”. Examples of information that could suggest chloroprene could be present in a process vent, include calculations based on safety data sheets, material balances, process stoichiometry, or previous test results provided the results are still relevant to the current operating conditions.

(ii) For storage vessels, storage vessels of any capacity and vapor pressure in a process at affected sources producing neoprene storing a liquid that is at least 0.1 percent by weight of chloroprene. If knowledge exists that suggests chloroprene could be present in a storage vessel, then the storage vessel is considered to be “in chloroprene service” unless the procedures specified in § 63.509 are performed to demonstrate that the storage vessel does not meet the definition of being “in chloroprene service”. The exemption for vessels “storing and/or handling material that contains no organic HAP, or organic HAP as impurities only” listed in the definition of “storage vessel” in this section does not apply for storage vessels that are in chloroprene service. Examples of information that could suggest chloroprene could be present in a storage vessel, include calculations based on safety data sheets, material balances, process stoichiometry, or previous test results provided the results are still relevant to the current operating conditions.

(iii) For wastewater streams, any wastewater stream in a process at affected sources producing neoprene that contains total annual average concentration of chloroprene greater than or equal to 10 parts per million by weight at any flow rate. If knowledge exists that suggests chloroprene could be present in a wastewater stream, then the wastewater stream is considered to be “in chloroprene service” unless sampling and analysis is performed as specified in § 63.509 to demonstrate that the wastewater stream does not meet the definition of being “in chloroprene service”. Examples of information that could suggest chloroprene could be present in a wastewater stream, include calculations based on safety data sheets, material balances, process stoichiometry, or previous test results provided the results are still relevant to the current operating conditions.

*Initial start-up* means the first time a new or reconstructed affected source begins production of an elastomer product, or, for equipment added or changed as described in § 63.480(i), the first time the equipment is put into operation to produce an elastomer product. Initial start-up does not include operation solely for testing equipment. Initial start-up does not include subsequent start-ups of an affected source or portion thereof following shutdowns, or following changes in product for flexible operation units, or following recharging of equipment in batch operation.

*Latex* means a colloidal aqueous emulsion of elastomer. A latex may be further processed into finished products by direct use as a coating or as a foam, or it may be precipitated to separate the rubber particles, which are then used in dry state to prepare finished products.

*Latex weight* includes the weight of the polymer and the weight of the water solution.

*Maintenance wastewater* is defined in § 63.101, except that the term “elastomer product process unit” shall apply whenever the term “chemical manufacturing process unit” is used. Further, the generation of wastewater from the routine rinsing or washing of equipment in batch operation between batches is not maintenance wastewater, but is considered to be process wastewater, for the purposes of this subpart.

*Maximum true vapor pressure* is defined in § 63.111, except that the terms “transfer” and “transferred” shall not apply for the purposes of this subpart.

*Multicomponent system* means, as used in conjunction with batch front-end process vents, a stream whose

liquid and/or vapor contains more than one compound.

*Neoprene* means a polymer of chloroprene (2-chloro-1,3-butadiene). The free radical emulsion process is generally used to produce neoprene, although other methods may be used.

*New process unit* means a process unit for which the construction or reconstruction commenced after June 12, 1995.

*Nitrile butadiene latex* means a polymer consisting primarily of unsaturated nitriles and dienes, usually acrylonitrile and 1,3-butadiene, that is sold as a latex.

*Nitrile butadiene rubber* means a polymer consisting primarily of unsaturated nitriles and dienes, usually acrylonitrile and 1,3-butadiene, not including nitrile butadiene latex.

*On-site or on site* means, with respect to records required to be maintained by this subpart or required by another subpart referenced by this subpart, that records are stored at a location within a major source which encompasses the affected source. On-site includes, but is not limited to, storage at the affected source or EPPU to which the records pertain, or storage in central files elsewhere at the major source.

*Operating day* means the period defined by the owner or operator in the Notification of Compliance Status required by § 63.506(e)(5). The operating day is the period for which daily average monitoring values and batch cycle daily average monitoring values are determined.

*Organic hazardous air pollutant(s) (organic HAP)* means one or more of the chemicals listed in table 5 to this subpart or any other chemical which:

- (i) Is knowingly produced or introduced into the manufacturing process other than as an impurity; and
- (ii) Is listed in table 2 to subpart F of this part.

*Polybutadiene rubber by solution* means a polymer of 1,3-butadiene produced using a solution process.

*Polysulfide rubber* means a polymer produced by reacting sodium polysulfide and chloroethyl formal. Polysulfide rubber may be produced as latexes or solid product.

*Primary product* is defined in and determined by the procedures specified in § 63.480(f).

*Process section* means the equipment designed to accomplish a general but well-defined task in polymers production. Process sections include raw materials preparation, polymerization reaction, and material recovery. A process section may be dedicated to a single EPPU or may be common to more than one EPPU.

*Process unit* means a collection of equipment assembled and connected by hard-piping or duct work, used to process raw materials and to manufacture a product.

*Process vent* means a gaseous emission stream from a unit operation that is discharged to the atmosphere either directly or after passing through one or more control, recovery, or recapture devices. Unit operations that may have process vents are condensers, distillation units, reactors, or other unit operations within the EPPU. Process vents exclude pressure releases, gaseous streams routed to a fuel gas system(s), and leaks from equipment regulated under § 63.502. A gaseous emission stream is no longer considered to be a process vent after the stream has been controlled and monitored in accordance with the applicable provisions of this subpart.

*Product* means a polymer produced using the same monomers, and varying in additives (e.g., initiators, terminators, etc.); catalysts; or in the relative proportions of monomers, that is manufactured by a process unit. With respect to polymers, more than one recipe may be used to produce the same product, and there can be more than one grade of a product. As an example, styrene butadiene latex and butyl rubber each represent a different product. Product also means a chemical that is not a polymer, is manufactured by a process unit. By-products, isolated intermediates, impurities, wastes, and trace contaminants are not considered products.

*Recipe* means a specific composition, from among the range of possible compositions that may occur within a product, as defined in this section. A recipe is determined by the proportions of monomers and, if present, other reactants and additives that are used to make the recipe. For example, styrene butadiene latex without additives; styrene butadiene latex with an additive; and styrene butadiene latex with different proportions of styrene to butadiene are all different recipes of the same product, styrene butadiene latex.

*Reconstruction* means the replacement of components of an affected source or of a previously unaffected stationary source that becomes an affected source as a result of the replacement, to such an extent that:

(i) The fixed capital cost of the new components exceeds 50 percent of the fixed capital cost that would be required to construct a comparable new source; and

(ii) It is technologically and economically feasible for the

reconstructed source to meet the provisions of this subpart.

*Recovery device* means:

(i) An individual unit of equipment capable of and normally used for the purpose of recovering chemicals for:

(A) Use;

(B) Reuse;

(C) Fuel value (i.e., net heating value); or

(D) For sale for use, reuse, or fuel value (i.e., net heating value).

(ii) Examples of equipment that may be recovery devices include absorbers, carbon adsorbers, condensers, oil-water separators or organic-water separators, or organic removal devices such as decanters, strippers, or thin film evaporation units. For the purposes of the monitoring, recordkeeping, or reporting requirements of this subpart, recapture devices are considered recovery devices.

*Recovery operations equipment* means the equipment used to separate the components of process streams. Recovery operations equipment includes distillation units, condensers, etc. Equipment used for wastewater treatment and recovery or recapture devices used as control devices shall not be considered recovery operations equipment.

*Residual* is defined in § 63.111, except that when the definition in § 63.111 uses the term “table 9 compounds,” the term “organic HAP listed in table 5 to subpart U of this part” shall apply, for the purposes of this subpart.

*Resin*, for the purposes of this subpart, means a polymer with the following characteristics:

(i) The polymer is a block polymer;

(ii) The manufactured polymer does not require vulcanization to make useful products;

(iii) The polymer production process is operated to achieve at least 99 percent monomer conversion; and

(iv) The polymer process unit does not recycle unreacted monomer back to the process.

*Shutdown* means for purposes including, but not limited to, periodic maintenance, replacement of equipment, or repair, the cessation of operation of an affected source, an EPPU within an affected source, a waste management unit or unit operation within an affected source, or equipment required or used to comply with this subpart, or the emptying or degassing of a storage vessel. For purposes of the wastewater provisions of § 63.501, shutdown does not include the routine rinsing or washing of equipment in batch operation between batches. For purposes of the batch front-end process vent provisions in §§ 63.486 through

63.492, the cessation of equipment in batch operation is not a shutdown, unless the equipment undergoes maintenance, is replaced, or is repaired.

*Solution process* means a process where both the monomers and the resulting polymers are dissolved in an organic solvent.

*Start-up* means the setting into operation of an affected source, an EPPU within the affected source, a waste management unit or unit operation within an affected source, or equipment required or used to comply with this subpart, or a storage vessel after emptying and degassing. For both continuous and batch front-end processes, start-up includes initial start-up and operation solely for testing equipment. For both continuous and batch front-end processes, start-up does not include the recharging of equipment in batch operation. For continuous front-end processes, start-up includes transitional conditions due to changes in product for flexible operation units. For batch front-end processes, start-up does not include transitional conditions due to changes in product for flexible operation units.

*Steady-state conditions* means that all variables (temperatures, pressures, volumes, flow rates, etc.) in a process do not vary significantly with time; minor fluctuations about constant mean values may occur.

*Storage vessel* means a tank or other vessel that is used to store liquids that contain one or more organic HAP.

Storage vessels do not include:

(i) Vessels permanently attached to motor vehicles such as trucks, railcars, barges, or ships;

(ii) Except for storage vessels in chloroprene service, vessels with capacities smaller than 38 cubic meters;

(iii) Except for storage vessels in chloroprene service, vessels and equipment storing and/or handling material that contains no organic HAP, or organic HAP as impurities only;

(iv) Surge control vessels and bottoms receivers; and

(v) Wastewater storage tanks.

*Stripper* means a unit operation where stripping occurs.

*Stripping* means the removal of organic compounds from a raw elastomer product. In the production of an elastomer, stripping is a discrete step that occurs after the reactors and before the dryers (other than those dryers with a primary purpose of devolatilization) and other finishing operations. Examples of types of stripping include steam stripping, direct volatilization, chemical stripping, and other methods of devolatilization. For the purposes of this subpart, devolatilization that occurs

in dryers (other than those dryers with a primary purpose of devolatilization), extruders, and other finishing operations is not stripping.

*Styrene butadiene latex* means a polymer consisting primarily of styrene and butadiene monomer units produced using an emulsion process and sold as a latex.

*Styrene butadiene rubber by emulsion* means a polymer consisting primarily of styrene and butadiene monomer units produced using an emulsion process. Styrene butadiene rubber by emulsion does not include styrene butadiene latex.

*Styrene butadiene rubber by solution* means a polymer that consists primarily of styrene and butadiene monomer units and is produced using a solution process.

*Supplemental combustion air* means the air that is added to a vent stream after the vent stream leaves the unit operation. Air that is part of the vent stream as a result of the nature of the unit operation is not considered supplemental combustion air. Air required to operate combustion device burner(s) is not considered supplemental combustion air. Air required to ensure the proper operation of catalytic oxidizers, to include the intermittent addition of air upstream of the catalyst bed to maintain a minimum threshold flow rate through the catalyst bed or to avoid excessive temperatures in the catalyst bed, is not considered to be supplemental combustion air.

*Suspension process* means a polymerization process where the monomer(s) is in a state of suspension, with the help of suspending agents in a medium other than water (typically an organic solvent). The resulting polymers are not soluble in the reactor medium.

*Total organic compounds (TOC)* means those compounds, excluding methane and ethane, measured according to the procedures of Method 18 or Method 25A of appendices A-6 and A-7 to 40 CFR part 60, respectively, or ASTM D6420-18 (incorporated by reference, see § 63.14) as specified in this subpart.

*Total resource effectiveness index value or TRE index value* means a measure of the supplemental total resource requirement per unit reduction of organic HAP associated with a continuous front-end process vent stream, based on vent stream flow rate, emission rate of organic HAP, net heating value, and corrosion properties (whether or not the continuous front-end process vent stream contains halogenated compounds), as quantified by the equations given under § 63.115, with the exceptions noted in § 63.485.

*Vent stream*, as used in reference to batch front-end process vents, continuous front-end process vents, and aggregate batch vent streams, means the emissions from one or more process vents.

*Waste management unit* is defined in § 63.111, except that where the definition in § 63.111 uses the term “chemical manufacturing process unit,” the term “EPPU” shall apply for the purposes of this subpart.

*Wastewater* means water that:  
(i) Contains either:

(A) An annual average concentration of organic HAP listed in table 5 to this subpart of at least 5 parts per million by weight and has an annual average flow rate of 0.02 liter per minute or greater; or

(B) An annual average concentration of organic HAP listed in table 5 to this subpart of at least 10,000 parts per million by weight at any flow rate; and

(ii) Is discarded from an EPPU that is part of an affected source. Wastewater is process wastewater or maintenance wastewater.

*Wastewater stream* means a stream that contains wastewater as defined in this section.

■ 123. Amend § 63.483 by revising paragraph (a) introductory text and adding paragraph (e) to read as follows:

**§ 63.483 Emission standards.**

(a) At all times, each owner or operator must operate and maintain any affected source subject to the requirements of this subpart, including associated air pollution control equipment and monitoring equipment, in a manner consistent with safety and good air pollution control practices for minimizing emissions. The general duty to minimize emissions does not require the owner or operator to make any further efforts to reduce emissions if levels required by this standard have been achieved. Determination of whether a source is operating in compliance with operation and maintenance requirements will be based on information available to the Administrator which may include, but is not limited to, monitoring results, review of operation and maintenance procedures, review of operation and maintenance records, and inspection of the source. Except as allowed under paragraphs (b) through (d) of this section, the owner or operator of an existing or new affected source shall comply with the provisions in paragraphs (a)(1) through (a)(9) of this section.

\* \* \* \* \*

(e) For each affected source as described in § 63.480, beginning no later

than the compliance dates specified in § 63.481(n), owners and operators of sources as defined in § 63.480 shall comply with the requirements of this subpart at all times, except during periods of nonoperation of the source (or specific portion thereof) resulting in cessation of the emissions to which this subpart applies.

■ 124. Amend § 63.484 by revising paragraphs (a) and (i)(2), and adding paragraphs (t) and (u) to read as follows:

**§ 63.484 Storage vessel provisions.**

(a) This section applies to each storage vessel that is assigned to an affected source, as determined by § 63.480(g). Except for those storage vessels exempted by paragraph (b) of this section, the owner or operator of affected sources shall comply with the requirements of §§ 63.119 through 63.123 and 63.148, with the differences noted in paragraphs (c) through (u) of this section, for the purposes of this subpart.

\* \* \* \* \*

(i) \* \* \*

(2) The performance test is submitted as part of the Notification of Compliance Status required by § 63.506(e)(5). If the performance test report is submitted electronically through the EPA’s CEDRI in accordance with § 63.152(h), the process unit(s) tested, the pollutant(s) tested, and the date that such performance test was conducted may be submitted in the notification of compliance status report in lieu of the performance test results. The performance test results must be submitted to CEDRI by the date the notification of compliance status report is submitted.

\* \* \* \* \*

(t) Owners and operators of affected sources must make the substitutions as specified in paragraphs (t)(1) through (4) of this section:

(1) Substitute “For each affected source as described in § 63.480” for each occurrence of the phrase “For each source as defined in § 63.101”.

(2) Substitute “beginning no later than the compliance dates specified in § 63.481(n)” for each occurrence of the phrase “beginning no later than the compliance dates specified in § 63.100(k)(10)”.

(3) Substitute “owners and operators of affected sources as described in § 63.480” for each occurrence of the phrase “owners and operators of sources as defined in § 63.101”.

(4) Substitute “§ 63.508” for each occurrence of “§ 63.108”.

(u) For each affected source as described in § 63.480, beginning no later

than the compliance dates specified in § 63.481(o), if the storage vessel (of any capacity and vapor pressure) stores liquid containing chloroprene such that the storage vessel is considered to be in chloroprene service, as defined in § 63.482, then the owner or operator must comply with the requirements of paragraphs (u)(1) through (3) of this section in addition to all other applicable requirements specified in § 63.483 and elsewhere in this section.

(1) Reduce emissions of chloroprene by venting emissions through a closed vent system to a non-flare control device that reduces chloroprene by greater than or equal to 98 percent by weight, or to a concentration less than 1 ppmv for each storage vessel vent. If a combustion device is used, the chloroprene concentration of 1 ppmv must be corrected to 3 percent oxygen.

(2) To demonstrate compliance with the emission limits specified in paragraph (u)(1) of this section for storage vessels in chloroprene service, owners and operators must meet the requirements specified in § 63.510.

(3) Owners and operators must keep the records specified in paragraphs (u)(3)(i) and (u)(3)(ii) of this section in addition to those records specified elsewhere in this section.

(i) For storage vessels in chloroprene service, records of the concentration of chloroprene of the fluid stored in each storage vessel.

(ii) The owner or operator must keep records of all periods during which operating values are outside of the applicable operating limits specified in § 63.510(b)(4) through (6) when regulated material is being routed to the non-flare control device. The record must specify the operating parameter, the applicable limit, and the highest (for maximum operating limits) or lowest (for minimum operating limits) value recorded during the period.

- 125. Amend § 63.485 by:
  - a. Revising paragraphs (a), (l), (o) and (p)(3);
  - b. Adding paragraph (p)(5);
  - c. Revising paragraphs (q)(1) introductory text, (q)(1)(ii), and (q)(2);
  - d. Adding paragraph (q)(3);
  - e. Revising paragraphs (s) introductory text, (s)(5), and (t); and
  - f. Adding paragraphs (x), (y) and (z).

The revisions and additions read as follows:

**§ 63.485 Continuous front-end process vent provisions.**

(a) For each continuous front-end process vent located at an affected source, the owner or operator shall comply with the requirements of §§ 63.113 through 63.118, except as

provided for in paragraphs (b) through (z) of this section. The owner or operator of continuous front-end process vents that are combined with one or more batch front-end process vents shall comply with paragraph (o) or (p) of this section.

\* \* \* \* \*

(l) When reports of process changes are required under § 63.118(g), (h), (i), or (j), paragraphs (l)(1) through (4) and (l)(6) of this section shall apply for the purposes of this subpart. In addition, for the purposes of this subpart paragraph (l)(5) of this section applies, and § 63.118(k) does not apply to owners or operators of affected sources.

\* \* \* \* \*

(2) Except as specified in paragraph (l)(6) of this section, whenever a process change, as defined in § 63.115(e), is made that causes a Group 2 continuous front-end process vent with a TRE greater than 4.0 to become a Group 2 continuous front-end process vent with a TRE less than 4.0, the owner or operator shall submit a report within 180 days after the process change is made or with the next Periodic Report, whichever is later. A description of the process change shall be submitted with the report of the process change, and the owner or operator shall comply with the provisions in § 63.113(d) by the dates specified in § 63.481.

(3) Except as specified in paragraph (l)(6) of this section, whenever a process change, as defined in § 63.115(e), is made that causes a Group 2 continuous front-end process vent with a flow rate less than 0.005 standard cubic meter per minute (scmm) to become a Group 2 continuous front-end process vent with a flow rate of 0.005 scmm or greater and a TRE index value less than or equal to 4.0, the owner or operator shall submit a report within 180 days after the process change is made or with the next Periodic Report, whichever is later. A description of the process change shall be submitted with the report of the process change, and the owner or operator shall comply with the provisions in § 63.113(d) by the dates specified in § 63.481.

(4) Except as specified in paragraph (l)(6) of this section, whenever a process change, as defined in § 63.115(e), is made that causes a Group 2 continuous front-end process vent with an organic HAP concentration less than 50 parts per million by volume (ppmv) to become a Group 2 continuous front-end process vent with an organic HAP concentration of 50 ppmv or greater and a TRE index value less than or equal to 4.0, the owner or operator shall submit a report within 180 days after the

process change is made or with the next Periodic Report, whichever is later. A description of the process change shall be submitted with the report of the process change, and the owner or operator shall comply with the provisions in § 63.113(d) by the dates specified in § 63.481.

(5) \* \* \*

(iv) Except as specified in paragraph (l)(6) of this section, the TRE index value is recalculated according to § 63.115(e) and the recalculated value is greater than 4.0.

(6) For each affected source as described in § 63.480, beginning no later than the compliance dates specified in § 63.481(n), paragraphs (l)(2), (3), (4), and (l)(5)(iv) of this section no longer apply.

\* \* \* \* \*

(o) If a batch front-end process vent or aggregate batch vent stream is combined with a continuous front-end process vent, the owner or operator of the affected source containing the combined vent stream shall comply with paragraph (o)(1); with paragraph (o)(2) and (o)(6) with paragraph (o)(3) or (o)(4); or with paragraph (o)(5) of this section, as appropriate.

\* \* \* \* \*

(2) Except as specified in paragraph (o)(6) of this section, if a batch front-end process vent or aggregate batch vent stream is combined with a continuous front-end process vent prior to the combined vent stream being routed to a recovery device, the TRE index value for the combined vent stream shall be calculated at the exit of the last recovery device. The TRE shall be calculated during periods when one or more batch emission episodes are occurring that result in the highest organic HAP emission rate (in the combined vent stream that is being routed to the recovery device) that is achievable during the 6-month period that begins 3 months before and ends 3 months after the TRE calculation, without causing any of the situations described in paragraphs (o)(2)(i) through (o)(2)(iii) of this section to occur.

\* \* \* \* \*

(3) Except as specified in paragraph (o)(6) of this section, if the combined vent stream described in paragraph (o)(2) of this section meets the requirements in paragraphs (o)(3)(i), (o)(3)(ii), and (o)(3)(iii) of this section, the combined vent stream shall be subject to the requirements for Group 1 process vents in §§ 63.113 through 63.118, except as otherwise provided in this section, as applicable. Performance tests for the combined vent stream shall be conducted at maximum



representative operating conditions, as described in paragraph (o)(1) of this section.

\* \* \* \* \*

(4) Except as specified in paragraph (o)(6) of this section, if the combined vent stream described in paragraph (o)(2) of this section meets the requirements in paragraph (o)(4)(i), (ii), or (iii) of this section, the combined vent stream shall be subject to the requirements for Group 2 process vents in §§ 63.113 through 63.118, except as otherwise provided in this section, as applicable.

\* \* \* \* \*

(6) For each affected source as described in § 63.480, beginning no later than the compliance dates specified in § 63.481(n), paragraphs (o)(2) through (4) of this section no longer apply.

(p) \* \* \*

(3) Except as specified in paragraph (p)(5) of this section, the efficiency of the final recovery device (determined according to paragraph (p)(4) of this section) shall be applied to the total organic HAP or TOC concentration measured at the sampling site described in paragraph (p)(2) of this section to determine the exit concentration. This exit concentration of total organic HAP or TOC shall then be used to perform the calculations outlined in § 63.115(d)(2)(iii) and § 63.115(d)(2)(iv), for the combined vent stream exiting the final recovery device.

\* \* \* \* \*

(5) For each affected source as described in § 63.480, beginning no later than the compliance dates specified in § 63.481(n), the last sentence in paragraph (p)(3) of this section: "This exit concentration of total organic HAP or TOC shall then be used to perform the calculations outlined in § 63.115(d)(2)(iii) and § 63.115(d)(2)(iv), for the combined vent stream exiting the final recovery device." no longer applies.

(q) \* \* \*

(1) Group 1 halogenated continuous front-end process vents at existing affected sources producing butyl rubber or ethylene propylene rubber using a solution process are exempt from the provisions of § 63.113(a)(1)(ii) and § 63.113(c) if the conditions in paragraphs (q)(1)(i) and (ii) of this section are met, and shall comply with the requirements in paragraphs (q)(1)(iii) through (vi) of this section. Group 1 halogenated continuous front-end process vents at new affected sources producing butyl rubber or ethylene propylene rubber using a

solution process are not exempt from § 63.113(a)(1)(ii) and § 63.113(c).

\* \* \* \* \*

(ii) Except as specified in paragraph (q)(3) of this section, if the requirements of § 63.113(a)(2); § 63.113(a)(3); § 63.113(b) and the associated testing requirements in § 63.116; or § 63.11(b) and § 63.504(c) are met.

\* \* \* \* \*

(2) Except as specified in paragraph (q)(3) of this section, Group 1 halogenated continuous front-end process vents at new and existing affected sources producing an elastomer using a gas-phased reaction process, provided that the requirements of § 63.113(a)(2); § 63.113(a)(3); § 63.113(b) and the associated testing requirements in § 63.116; or § 63.11(b) and § 63.504(c) are met.

(3) For each affected source as described in § 63.480, beginning no later than the compliance dates specified in § 63.481(n), paragraphs (q)(1)(ii) and (q)(2) of this section no longer apply. Instead, the requirements of § 63.113(a)(2); §§ 63.113(b) and the associated testing requirements in § 63.116; or § 63.508 must be met.

\* \* \* \* \*

(s) *Internal combustion engines.* In addition to the three options for the control of a Group 1 continuous front-end process vent listed in § 63.113(a)(1) through (3), except as specified in § 63.113(a)(4) of subpart G of this part, an owner or operator will be permitted to route emissions of organic HAP to an internal combustion engine, provided the conditions listed in paragraphs (s)(1) through (s)(5) of this section are met.

\* \* \* \* \*

(5) The owner or operator shall include in the Periodic Report a report of all times that the internal combustion engine was not operating while emissions were being routed to it. Include the start date and time and end date and time for all such periods.

\* \* \* \* \*

(t) When the provisions of § 63.116(c)(3) and (4) specify that Method 18 of appendix A-6 to 40 CFR part 60 must be used, Method 18 or Method 25A of appendices A-6 and A-7 to 40 CFR part 60, respectively, may be used for the purposes of this subpart. ASTM D6420-18 (incorporated by reference, see § 63.14) may also be used in lieu of Method 18, if the target compounds are all known and are all listed in Section 1.1 of ASTM D6420-18 as measurable; ASTM D6420-18 must not be used for methane and ethane; and ASTM D6420-18 may not be used as a total VOC method. The use of Method 25A must conform with the

requirements in paragraphs (t)(1) and (2) of this section.

(1) The organic HAP used as the calibration gas for Method 25A of appendix A-7 to 40 CFR part 60 must be the single organic HAP representing the largest percent by volume of the emissions.

\* \* \* \* \*

(x) Owners and operators of affected sources must make the substitutions as specified in paragraphs (x)(1) through (4) of this section:

(1) Substitute "For each affected source as described in § 63.480" for each occurrence of the phrase "For each source as defined in § 63.101".

(2) Substitute "beginning no later than the compliance dates specified in § 63.481(n)" for each occurrence of the phrase "beginning no later than the compliance dates specified in § 63.100(k)(10)".

(3) Substitute "owners and operators of affected sources as described in § 63.480" for each occurrence of the phrase "owners and operators of sources as defined in § 63.101".

(4) Substitute "§ 63.508" for each occurrence of "§ 63.108".

(y) For each affected source as described in § 63.480, beginning no later than the compliance dates specified in § 63.481(o), if the Group 1 or Group 2 continuous front-end process vent contains chloroprene such that it is considered to be in chloroprene service, as defined in § 63.482, then the owner or operator must comply with the requirements of paragraphs (y)(1) through (4) of this section in addition to all other applicable requirements specified in § 63.483 and elsewhere in this section.

(1) Reduce emissions of chloroprene by venting emissions through a closed vent system to a non-flare control device that reduces chloroprene by greater than or equal to 98 percent by weight, or to a concentration less than 1 ppmv for each process vent or to less than 5 pounds per year for all combined process vents within the process. If a combustion device is used, the chloroprene concentration of 1 ppmv must be corrected to 3 percent oxygen.

(2) To demonstrate compliance with the emission limits specified in paragraph (y)(1) of this section for continuous front-end process vents in chloroprene service, owners and operators must meet the requirements specified in § 63.510.

(3) Owners and operators must keep the records specified in paragraphs (y)(3)(i) and (y)(3)(ii) of this section in addition to those records specified elsewhere in this section.

(i) For process vents, include all uncontrolled, undiluted chloroprene concentration measurements, and the calculations used to determine the total uncontrolled chloroprene mass emission rate for the sum of all vent gas streams.

(ii) The owner or operator must keep records of all periods during which operating values are outside of the applicable operating limits specified in § 63.510(b)(4) through (6) when regulated material is being routed to the non-flare control device. The record must specify the operating parameter, the applicable limit, and the highest (for maximum operating limits) or lowest (for minimum operating limits) value recorded during the period.

(4) The Periodic Report must include the records for the periods specified in paragraph (y)(3)(ii) of this section. Indicate the start date, start time and duration in hours for each period.

(z) For continuous front-end process vents that are in chloroprene service and subject to the requirements of § 63.510, the requirements in 40 CFR 63.113(k)(4) do not apply. Instead, in addition to complying with the requirements in paragraphs 40 CFR 63.113(k)(1) through (3), for continuous front-end process vents that are in chloroprene service and subject to the requirements of § 63.510 that are designated as maintenance vents, owners and operators may not release more than 1.0 tons of chloroprene from all maintenance vents combined (*i.e.*, including maintenance vents subject to this paragraph (z), § 63.487(i)(4), or § 63.494(a)(7)(iii)) per any consecutive 12-month period. The owner or operator must keep monthly records of the quantity in tons of chloroprene released from each maintenance vent and include a description of the method used to estimate this quantity.

■ 126. Amend § 63.487 by:

■ a. Revising and republishing paragraphs (a) and (b);

■ b. Revising paragraphs (c) introductory text, (c)(1) and (e)(1)(iii);

■ c. Adding paragraph (e)(1)(iv);

■ d. Revising paragraphs (f) introductory text and (g) introductory text; and

■ e. Adding paragraphs (i) and (j).

The revisions, additions and republications read as follows:

**§ 63.487 Batch front-end process vents—reference control technology.**

(a) *Batch front-end process vents.* Except as specified in paragraph (j) of this section, the owner or operator of an affected source with a Group 1 batch front-end process vent, as determined using the procedures in § 63.488, shall

comply with the requirements of either paragraph (a)(1) or (a)(2) of this section, and paragraph (a)(3) of this section. Compliance may be based on either organic HAP or TOC.

(1) For each batch front-end process vent, reduce organic HAP emissions using a flare.

(i) Except as specified in paragraph (a)(1)(iii) of this section, the owner or operator of the affected sources shall comply with the requirements of § 63.504(c) for the flare.

(ii) Halogenated batch front-end process vents, as defined in § 63.482, shall not be vented to a flare.

(iii) For each affected source as described in § 63.480, beginning no later than the compliance dates specified in § 63.481(n), paragraph (a)(1)(i) of this section no longer applies and instead the owner or operator of the affected sources must comply with § 63.508 for the flare.

(2) For each batch front-end process vent, reduce organic HAP emissions for the batch cycle by 90 weight percent using a control device. Owners or operators may achieve compliance with this paragraph through the control of selected batch emission episodes or the control of portions of selected batch emission episodes. Documentation demonstrating how the 90 weight percent emission reduction is achieved is required by § 63.490(c)(2).

(3) For each affected source as described in § 63.480, beginning no later than the compliance dates specified in § 63.481(n), for each batch front-end process vent that contains chlorine, HCl, or any other chlorinated compound, reduce emissions of dioxins and furans (toxic equivalency basis) to a concentration of 0.054 nanograms per standard cubic meter on a dry basis corrected to 3 percent oxygen.

(b) *Aggregate batch vent streams.* Except as specified in paragraph (j) of this section the owner or operator of an aggregate batch vent stream that contains one or more Group 1 batch front-end process vents shall comply with the requirements of either paragraph (b)(1) or (b)(2) of this section, and paragraph (b)(3) of this section. Compliance may be based on either organic HAP or TOC.

(1) For each aggregate batch vent stream, reduce organic HAP emissions using a flare.

(i) Except as specified in paragraph (b)(1)(iii) of this section, the owner or operator of the affected source shall comply with the requirements of § 63.504(c) for the flare.

(ii) Halogenated aggregate batch vent streams, as defined in § 63.482, shall not be vented to a flare.

(iii) For each affected source as described in § 63.480, beginning no later than the compliance dates specified in § 63.481(n), paragraph (b)(1)(i) of this section no longer applies and instead the owner or operator of the affected source must comply with § 63.508 for the flare.

(2) For each aggregate batch vent stream, reduce organic HAP emissions by 90 weight percent or to a concentration of 20 ppmv, on a continuous basis using a control device. For purposes of complying with the 20 ppmv outlet concentration standard, the outlet concentration shall be calculated on a dry basis. When a combustion device is used for purposes of complying with the 20 ppmv outlet concentration standard, the concentration shall be corrected to 3 percent oxygen if supplemental combustion air is used to combust the emissions. If supplemental combustion air is not used, a correction to 3 percent oxygen is not required.

(3) For each affected source as described in § 63.480, beginning no later than the compliance dates specified in § 63.481(n), for each aggregate batch vent stream that contains chlorine, HCl, or any other chlorinated compound, reduce emissions of dioxins and furans (toxic equivalency basis) to a concentration of 0.054 nanograms per standard cubic meter on a dry basis corrected to 3 percent oxygen

(c) *Halogenated emissions.* Halogenated Group 1 batch front-end process vents, halogenated aggregate batch vent streams, and halogenated continuous front-end process vents that are combusted as part of complying with paragraph (a)(2), (a)(3), (b)(2), or (b)(3) of this section, shall be controlled according to either paragraph (c)(1) or (c)(2) of this section.

(1) If a combustion device is used to comply with paragraph (a)(2), (a)(3), (b)(2), or (b)(3) of this section for a halogenated batch front-end process vent or halogenated aggregate batch vent stream, the emissions exiting the combustion device shall be ducted to a halogen reduction device that reduces overall emissions of hydrogen halides and halogens by at least 99 percent before discharge to the atmosphere.

\* \* \* \* \*

(e) \* \* \*

(1) \* \* \*

(iii) Except as specified in paragraph (e)(1)(iv) of this section, the batch front-end process vent or aggregate batch vent stream is combined with a continuous front-end process vent stream prior to being routed to a recovery device. In this paragraph (e)(1)(iii), the definition

of recovery device as it relates to continuous front-end process vents shall be used. Furthermore, the combined vent stream discussed in this paragraph (e)(1)(iii) shall be subject to § 63.485(o)(2).

(iv) For each affected source as described in § 63.480, beginning no later than the compliance dates specified in § 63.481(n), paragraph (e)(1)(iii) of this section no longer applies.

\* \* \* \* \*

(f) *Group 2 batch front-end process vents with annual emissions greater than or equal to the level specified in § 63.488(d).* Except as specified in paragraph (j) of this section, the owner or operator of a Group 2 batch front-end process vent with annual emissions greater than or equal to the level specified in § 63.488(d) shall comply with the provisions of paragraph (f)(1), (f)(2), or (h) of this section.

\* \* \* \* \*

(g) *Group 2 batch front-end process vents with annual emissions less than the level specified in § 63.488(d).* Except as specified in paragraph (j) of this section, the owner or operator of a Group 2 batch front-end process vent with annual organic HAP emissions less than the level specified in § 63.488(d), shall comply with paragraph (g)(1), (g)(2), (g)(3), or (g)(4) of this section.

\* \* \* \* \*

(i) For each affected source as described in § 63.480, beginning no later than the compliance dates specified in § 63.481(n), an owner or operator may designate a batch front-end process vent as a maintenance vent if the vent is only used as a result of startup, shutdown, maintenance, or inspection of equipment where equipment is emptied, depressurized, degassed, or placed into service. The owner or operator must comply with the applicable requirements in paragraphs (i)(1) through (i)(4) of this section for each maintenance vent. Any vent designated as a maintenance vent is only subject to the maintenance vent provisions in this paragraph (i) and the associated recordkeeping and reporting requirements in § 63.491(h) and § 63.492(g), respectively. The owner or operator does not need to designate a maintenance vent as a Group 1 or Group 2 batch front-end process vent nor identify maintenance vents in a Notification of Compliance Status report.

(1) Prior to venting to the atmosphere, remove process liquids from the equipment as much as practical and depressurize the equipment to either: A flare meeting the requirements of § 63.508, as applicable, or using any

combination of a non-flare combustion, recovery, and/or recapture device meeting the requirements in paragraph (a)(2) of this section until one of the following conditions, as applicable, is met.

(i) The concentration of the vapor in the equipment served by the maintenance vent is less than 10 percent of its lower explosive limit (LEL) and has an outlet concentration less than or equal to 20 ppmv hydrogen halide and halogen HAP.

(ii) If there is no ability to measure the concentration of the vapor in the equipment based on the design of the equipment, the pressure in the equipment served by the maintenance vent is reduced to 5 pounds per square inch gauge (psig) or less. Upon opening the maintenance vent, active purging of the equipment cannot be used until the concentration of the vapors in the maintenance vent (or inside the equipment if the maintenance is a hatch or similar type of opening) is less than 10 percent of its LEL.

(iii) The equipment served by the maintenance vent contains less than 50 pounds of total volatile organic compounds (VOC).

(iv) If, after applying best practices to isolate and purge equipment served by a maintenance vent, none of the applicable criterion in paragraphs (i)(1)(i) through (i)(1)(iii) of this section can be met prior to installing or removing a blind flange or similar equipment blind, then the pressure in the equipment served by the maintenance vent must be reduced to 2 psig or less before installing or removing the equipment blind. During installation or removal of the equipment blind, active purging of the equipment may be used provided the equipment pressure at the location where purge gas is introduced remains at 2 psig or less.

(2) Except for maintenance vents complying with the alternative in paragraph (i)(1)(iii) of this section, the owner or operator must determine the concentration or, if applicable, equipment pressure using process instrumentation or portable measurement devices and follow procedures for calibration and maintenance according to manufacturer's specifications.

(3) For maintenance vents complying with the alternative in paragraph (i)(1)(iii) of this section, the owner or operator must determine mass of VOC in the equipment served by the maintenance vent based on the equipment size and contents after considering any contents drained or purged from the equipment. Equipment size may be determined from equipment

design specifications. Equipment contents may be determined using process knowledge.

(4) In addition to complying with the requirements in paragraphs (i)(1) through (i)(3) of this section, for batch front-end process vents that are in chloroprene service and subject to the requirements of § 63.510 that are designated as maintenance vents, owners and operators may not release more than 1.0 tons of chloroprene from all maintenance vents combined (*i.e.*, including maintenance vents subject to this paragraph (i)(4), § 63.485(z), or § 63.494(a)(7)(iii)) per any consecutive 12-month period. The owner or operator must keep monthly records of the quantity in tons of chloroprene released from each maintenance vent and include a description of the method used to estimate this quantity.

(j) For each affected source as described in § 63.480, beginning no later than the compliance dates specified in § 63.481(o), if the Group 1 or Group 2 batch front-end process vent contains chloroprene such that it is considered to be in chloroprene service, as defined in § 63.482, then the owner or operator must comply with the requirements of paragraphs (j)(1) through (j)(4) of this section in addition to all other applicable requirements specified in § 63.483 and elsewhere in this section.

(1) Reduce emissions of chloroprene by venting emissions through a closed vent system to a non-flare control device that reduces chloroprene by greater than or equal to 98 percent by weight, or to a concentration less than 1 ppmv for each process vent or to less than 5 pounds per year for all combined process vents within the process. If a combustion device is used, the chloroprene concentration of 1 ppmv must be corrected to 3 percent oxygen.

(2) To demonstrate compliance with the emission limits specified in paragraph (j)(1) of this section for batch front-end process vents in chloroprene service, owners and operators must meet the requirements specified in § 63.510.

(3) Owners and operators must keep the records specified in paragraphs (j)(3)(i) and (j)(3)(ii) of this section in addition to those records specified elsewhere in this section.

(i) For process vents, include all uncontrolled, undiluted chloroprene concentration measurements, and the calculations used to determine the total uncontrolled chloroprene mass emission rate for the sum of all vent gas streams.

(ii) The owner or operator must keep records of all periods during which operating values are outside of the

applicable operating limits specified in § 63.510(b)(4) through (6) when regulated material is being routed to the non-flare control device. The record must specify the operating parameter, the applicable limit, and the highest (for maximum operating limits) or lowest (for minimum operating limits) value recorded during the period.

(4) The Periodic Report must include the records of periods specified in paragraph (j)(3)(ii) of this section. Indicate the start date, start time and duration in hours for each period.

- 127. Amend § 63.488 by:
  - a. Revising paragraphs (b)(5)(iii), (d), and (e) introductory text,
  - b. Adding paragraph (e)(4); and
  - c. Revising paragraphs (f) and (g).

The revisions and addition read as follows:

**§ 63.488 Methods and procedures for batch front-end process vent group determination.**

\* \* \* \* \*

- (b) \* \* \*
- (5) \* \* \*

(iii) Method 18 or Method 25A of appendices A–6 and A–7 to 40 CFR part 60, respectively, must be used to determine the concentration of TOC or organic HAP, as appropriate. ASTM D6420–18 (incorporated by reference, see § 63.14) may also be used in lieu of Method 18, if the target compounds are all known and are all listed in Section 1.1 of ASTM D6420–18 as measurable; ASTM D6420–18 must not be used for methane and ethane; and ASTM D6420–18 may not be used as a total VOC method. The use of Method 25A must conform with the requirements in paragraphs (b)(5)(iii)(A) and (B) of this section.

(A) The organic HAP used as the calibration gas for Method 25A of appendix A–7 to 40 CFR part 60 must be the single organic HAP representing the largest percent by volume of the emissions.

\* \* \* \* \*

(d) *Minimum emission level exemption.* (1) Except as specified in paragraph (d)(2) of this section, a batch front-end process vent with annual emissions of TOC or organic HAP less than 11,800 kg/yr is considered a Group 2 batch front-end process vent and the owner or operator of that batch front-end process vent shall comply with the requirements in § 63.487(f) or (g). Annual emissions of TOC or organic HAP are determined at the exit of the batch unit operation, as described in paragraph (a)(2) of this section, and are determined as specified in paragraph (b) of this section. The owner or operator of that batch front-end process vent is not

required to comply with the provisions in paragraphs (e) through (g) of this section.

(2) For each affected source as described in § 63.480, beginning no later than the compliance dates specified in § 63.481(n), paragraph (d)(1) of this section no longer applies and instead the collection of all batch front-end process vents with combined total annual emissions of TOC or organic HAP less than 4,536 kg/yr (10,000 lb/yr) are considered Group 2 batch front-end process vents. Annual emissions of TOC or organic HAP are determined at the exit of each batch unit operation, as described in paragraph (a)(2) of this section, and are determined as specified in paragraph (b) of this section.

(e) *Determination of average batch vent flow rate and annual average batch vent flow rate.* Except as specified in paragraph (e)(4) of this section, the owner or operator shall determine the average batch vent flow rate for each batch emission episode in accordance with one of the procedures provided in paragraphs (e)(1) through (e)(2) of this section. The annual average batch vent flow rate for a batch front-end process vent shall be calculated as specified in paragraph (e)(3) of this section.

\* \* \* \* \*

(4) For each affected source as described in § 63.480, beginning no later than the compliance dates specified in § 63.481(n), paragraph (e) of this section no longer applies.

(f) *Determination of cutoff flow rate.*

(1) Except as specified in paragraph (f)(2) of this section, for each batch front-end process vent, the owner or operator shall calculate the cutoff flow rate using Equation 15.

Equation 15 to Paragraph (f)  
 $CFR = (0.00437)(AE) - 51.6$  [Eq. 15]

Where:

CFR = Cutoff flow rate, scmm.  
 AE = Annual TOC or organic HAP emissions, as determined in paragraph (b)(8) of this section, kg/yr.

(2) For each affected source as described in § 63.480, beginning no later than the compliance dates specified in § 63.481(n), paragraph (f) of this section no longer applies.

(g) *Group 1/Group 2 status determination.* Except as specified in paragraph (g)(3) of this section, the owner or operator shall compare the cutoff flow rate, calculated in accordance with paragraph (f) of this section, with the annual average batch vent flow rate, determined in accordance with paragraph (e)(3) of this section. The group determination status for each batch front-end process vent

shall be made using the criteria specified in paragraphs (g)(1) and (g)(2) of this section.

(1) If the cutoff flow rate is greater than or equal to the annual average batch vent flow rate of the stream, the batch front-end process vent is classified as a Group 1 batch front-end process vent.

(2) If the cutoff flow rate is less than the annual average batch vent flow rate of the stream, the batch front-end process vent is classified as a Group 2 batch front-end process vent.

(3) For each affected source as described in § 63.480, beginning no later than the compliance dates specified in § 63.481(n), paragraph (g) of this section no longer applies.

\* \* \* \* \*

- 128. Amend § 63.489 by:
  - a. Revising paragraphs (a) introductory text, (b) introductory text, (b)(2), and (b)(7);
  - b. Adding paragraphs (b)(9), (10) and (11);
  - c. Revising paragraph (d) introductory text and adding paragraph (d)(3); and
  - d. Revising paragraph (e)(1)(i), and adding paragraph (e)(1)(iii).

The revisions and additions read as follows:

**§ 63.489 Batch front-end process vents—monitoring equipment.**

(a) *General requirements.* Each owner or operator of a batch front-end process vent or aggregate batch vent stream that uses a control device to comply with the requirements in § 63.487(a)(2) or (3) or § 63.487(b)(2) or (3) shall install the monitoring equipment specified in paragraph (b) of this section. All monitoring equipment shall be installed, calibrated, maintained, and operated according to the manufacturer's specifications or other written procedures that provide adequate assurance that the equipment would reasonably be expected to monitor accurately.

\* \* \* \* \*

(b) *Batch front-end process vent and aggregate batch vent stream monitoring equipment.* The monitoring equipment specified in paragraphs (b)(1) through (b)(11) of this section shall be installed as specified in paragraph (a) of this section. The parameters to be monitored are specified in Table 6 of this subpart.

\* \* \* \* \*

(2) Where a flare is used, except as specified in paragraph (b)(9) of this section, a device (including, but not limited to, a thermocouple, ultra-violet beam sensor, or infrared sensor) capable of continuously detecting the presence of a pilot flame is required.

\* \* \* \* \*

(7) Except as specified in paragraph (b)(10) of this section, where a carbon adsorber is used, an integrating regeneration steam flow, nitrogen flow, or pressure monitoring device having an accuracy of ±10 percent of the flow rate, level, or pressure, or better, capable of recording the total regeneration steam flow or nitrogen flow, or pressure (gauge or absolute) for each regeneration cycle; and a carbon bed temperature monitoring device, capable of recording the carbon bed temperature after each regeneration and within 15 minutes of completing any cooling cycle are required.

\* \* \* \* \*

(9) For each affected source as described in § 63.480, beginning no later than the compliance dates specified in § 63.481(n), paragraph (b)(2) of this section no longer applies and instead the owner or operator of the affected source must comply with § 63.508 for the flare.

(10) Beginning no later than the compliance dates specified in § 63.481(n), if the owner or operator vents emissions through a closed vent system to an adsorber(s) that cannot be regenerated or a regenerative adsorber(s) that is regenerated offsite, then the owner or operator must install a system of two or more adsorber units in series and comply with the requirements specified in paragraphs (b)(10)(i) through (b)(10)(iii) of this section.

(i) Conduct an initial performance test or design evaluation of the adsorber and establish the breakthrough limit and adsorber bed life.

(ii) Monitor the HAP or total organic compound (TOC) concentration through a sample port at the outlet of the first adsorber bed in series according to the schedule in paragraph (b)(10)(iii)(B) of this section. The owner or operator must measure the concentration of HAP or TOC using either a portable analyzer, in accordance with Method 21 of 40 CFR part 60, appendix A-7 using methane, propane, isobutylene, or the primary HAP being controlled as the calibration gas or Method 25A of 40 CFR part 60, appendix A-7 using methane, propane, or the primary HAP being controlled as the calibration gas.

(iii) Comply with paragraph (b)(10)(iii)(A) of this section, and comply with the monitoring frequency according to paragraph (b)(10)(iii)(B) of this section.

(A) The first adsorber in series must be replaced immediately when breakthrough, as defined in § 63.482, is detected between the first and second adsorber. The original second adsorber (or a fresh canister) will become the new

first adsorber and a fresh adsorber will become the second adsorber. For purposes of this paragraph, “immediately” means within 8 hours of the detection of a breakthrough for adsorbers of 55 gallons or less, and within 24 hours of the detection of a breakthrough for adsorbers greater than 55 gallons. The owner or operator must monitor at the outlet of the first adsorber within 3 days of replacement to confirm it is performing properly.

(B) Based on the adsorber bed life established according to paragraph (b)(10)(i) of this section and the date the adsorbent was last replaced, conduct monitoring to detect breakthrough at least monthly if the adsorbent has more than 2 months of life remaining, at least weekly if the adsorbent has between 2 months and 2 weeks of life remaining, and at least daily if the adsorbent has 2 weeks or less of life remaining.

(11) Where sorbent injection is used, the following monitoring equipment is required for the sorbent injection system:

(i) A sorbent injection rate monitoring device (e.g., weigh belt, weigh hopper, hopper flow measurement device) installed in a position that provides a representative measurement equipped with a continuous recorder to monitor the sorbent injection rate; and

(ii) A flow measurement device equipped with a continuous recorder to monitor the carrier gas flow rate.

\* \* \* \* \*

(d) *Monitoring of bypass lines.* The owner or operator of a batch front-end process vent or aggregate batch vent stream using a vent system that contains bypass lines that could divert emissions away from a control device used to comply with § 63.487(a) or § 63.487(b) shall comply with either paragraph (d)(1) or (d)(2), and (d)(3) of this section. Except as specified in paragraph (d)(3) of this section, equipment such as low leg drains, high point bleeds, analyzer vents, open-ended valves or lines, and pressure relief valves needed for safety purposes are not subject to this paragraph (d).

\* \* \* \* \*

(3) For each affected source as described in § 63.480, beginning no later than the compliance dates specified in § 63.481(n):

(i) The use of a bypass line at any time on a closed vent system to divert emissions (subject to the emission standards in § 63.487) to the atmosphere or to a control device not meeting the requirements specified in this subpart is an emissions standards violation.

(ii) The last sentence in paragraph (d) of this section no longer applies.

Instead, the exemptions specified in paragraph (d)(3)(ii)(A) and (d)(3)(ii)(B) of this section apply.

(A) Except for pressure relief devices subject to § 63.165(e)(4) of subpart H of this part, equipment such as low leg drains and equipment subject to the requirements of subpart H of this part are not subject to this paragraph (d).

(B) Open-ended valves or lines that use a cap, blind flange, plug, or second valve and follow the requirements specified in 40 CFR 60.482-6(a)(2), (b), and (c) or follow requirements codified in another regulation that are the same as 40 CFR 60.482-6(a)(2), (b), and (c) are not subject to this paragraph (d) of this section.

(e) \* \* \*

(1) \* \* \*

(i) For batch front-end process vents using a control device to comply with § 63.487(a)(2), the established level shall reflect the control efficiency established as part of the most recent compliance demonstration specified in § 63.490(c)(2).

\* \* \* \* \*

(iii) For batch front-end process vents using a control device to comply with § 63.487(a)(3) and aggregate batch vent streams using a control device to comply with § 63.487 (b)(3), the established level shall reflect the level of control established as part of the most recent compliance demonstration specified in § 63.490(g).

\* \* \* \* \*

■ 129. Amend § 63.490 by revising paragraphs (a), (c)(1)(i)(D), and (e)(1), and adding paragraph (g) as follows:

**§ 63.490 Batch front-end process vents—performance test methods and procedures to determine compliance.**

(a) *Use of a flare.* (1) Except as specified in paragraph (a)(2) of this section, when a flare is used to comply with § 63.487(a)(1) or (b)(1), the owner or operator of an affected source shall comply with § 63.504(c).

(2) For each affected source as described in § 63.480, beginning no later than the compliance dates specified in § 63.481(n), paragraph (a)(1) of this section no longer applies and instead the owner or operator of the affected source must comply with § 63.508 for the flare.

\* \* \* \* \*

(c) \* \* \*

(1) \* \* \*

(i) \* \* \*

(D) Method 18 or Method 25A of appendices A-6 and A-7 to 40 CFR part 60, respectively must be used to determine the concentration of organic HAP or TOC, as appropriate. ASTM

D6420–18 (incorporated by reference, see § 63.14) may also be used in lieu of Method 18, if the target compounds are all known and are all listed in Section 1.1 of ASTM D6420–18 as measurable; ASTM D6420–18 must not be used for methane and ethane; and ASTM D6420–18 may not be used as a total VOC method. Alternatively, any other method or data that has been validated according to the applicable procedures in Method 301 of appendix A to this part may be used. The use of Method 25A must conform with the requirements in paragraphs (c)(1)(i)(D)(1) and (2) of this section.

(1) The organic HAP used as the calibration gas for Method 25A appendix A–7 to 40 CFR part 60 must be the single organic HAP representing the largest percent by volume of the emissions.

(2) The use of Method 25A appendix A–7 to 40 CFR part 60 is acceptable if the response from the high-level calibration gas is at least 20 times the standard deviation of the response from the zero calibration gas when the instrument is zeroed on the most sensitive scale

\* \* \* \* \*

(e) \* \* \*

(1) For the purposes of this subpart, when the provisions of § 63.116(c) specify that Method 18 of appendix A–6 to 40 CFR part 60 must be used, Method 18 or Method 25A of appendix A–7 to 40 CFR part 60 may be used. ASTM D6420–18 (incorporated by reference, see § 63.14) may also be used in lieu of Method 18, if the target compounds are all known and are all listed in Section 1.1 of ASTM D6420–18 as measurable; ASTM D6420–18

must not be used for methane and ethane; and ASTM D6420–18 may not be used as a total VOC method. The use of Method 25A of appendix A–7 to 40 CFR part 60 must conform with the requirements in paragraphs (e)(1)(i) and (ii) of this section.

(i) The organic HAP used as the calibration gas for Method 25A of appendix A–7 to 40 CFR part 60 must be the single organic HAP representing the largest percent by volume of the emissions.

(ii) The use of Method 25A of appendix A–7 to 40 CFR part 60 is acceptable if the response from the high-level calibration gas is at least 20 times the standard deviation of the response from the zero calibration gas when the instrument is zeroed on the most sensitive scale.

\* \* \* \* \*

(g) *Testing for compliance with § 63.487(a)(3) and (b)(3) [dioxins and furans]*. Except as specified in paragraph (g)(7) of this section, an owner or operator complying with § 63.487(a)(3) and/or (b)(3) must conduct a performance test using the procedures in paragraphs (g)(1) through (6) of this section. Conduct subsequent performance tests no later than 60 calendar months after the previous performance test.

(1) The performance test must consist of three test runs. Collect at least 3 dry standard cubic meters of gas per test run.

(2) Use Method 1 or 1A of appendix A–1 to 40 CFR part 60 to select the sampling sites at the sampling location. The sampling location must be at the outlet of the final control device.

(3) Determine the gas volumetric flowrate using Method 2, 2A, 2C, or 2D of appendix A–2 to 40 CFR part 60.

(4) Use Method 4 of appendix A–3 to 40 CFR part 60 to convert the volumetric flowrate to a dry basis.

(5) Measure the concentration of each tetra- through octa-chlorinated dioxin and furan congener emitted using Method 23 of appendix A–7 to 40 CFR part 60.

(i) For each dioxin and furan congener, multiply the congener concentration by its corresponding toxic equivalency factor specified in table 10 to this subpart. For determination of toxic equivalency, zero may be used for congeners with a concentration less than the estimated detection limit (EDL). For congeners with estimated maximum pollutant concentration (EMPC) results, if the value is less than the EDL, zero may be used. Otherwise, the EMPC value must be used in the calculation of toxic equivalency.

(ii) Sum the products calculated in accordance with paragraph (g)(5)(i) of this section to obtain the total concentration of dioxins and furans emitted in terms of toxic equivalency.

(6) The concentration of dioxins and furans shall be corrected to 3 percent oxygen. Use Method 3A of appendix A–2 to 40 CFR part 60 or the manual method in ANSI/ASME PTC 19.10–1981 (incorporated by reference, see § 63.14) to determine the oxygen concentration (%O<sub>2d</sub>). The oxygen concentration must be determined concurrently with Method 23 of appendix A–7 to 40 CFR part 60. The concentration corrected to 3 percent oxygen (C<sub>c</sub>) shall be computed using the following equation:

$$C_c = C_m \left( \frac{17.9}{20.9 - \%O_{2d}} \right)$$

Where:

C<sub>c</sub> = Concentration of dioxins and furans corrected to 3 percent oxygen, dry basis, nanograms per standard cubic meter.

C<sub>m</sub> = Concentration of dioxins and furans, dry basis, nanograms per standard cubic meter.

%O<sub>2d</sub> = Concentration of oxygen, dry basis, percent by volume.

(7) An owner or operator is not required to conduct a performance test when either a boiler or process heater burning hazardous waste, or hazardous waste incinerator, is used for which the owner or operator:

(i) Has been issued a final permit under 40 CFR part 270 and complies

with the requirements of 40 CFR part 266, subpart H;

(ii) Has certified compliance with the interim status requirements of 40 CFR part 266, subpart H;

(iii) Meets the requirement specified in paragraph (g)(7)(v) of this section, and has submitted a Notification of Compliance under § 63.1207(j) and complies with the requirements of subpart EEE of this part; or

(iv) Meets the requirement specified in paragraph (g)(7)(v) of this section, complies with subpart EEE of this part, and will submit a Notification of Compliance under § 63.1207(j) by the date the owner or operator would have

been required to submit the initial performance test report for this subpart.

(v) The owner and operator may not waive performance testing pursuant to § 63.1207(d)(4) and each performance test required by § 63.1207(d) must show compliance with the dioxins and furans emission limit specified in § 63.487(a)(3) and (b)(3), as applicable.

■ 130. Amend § 63.491 by:

■ a. Revising paragraph (b)(3) introductory text;

■ b. Adding paragraphs (b)(3)(iv) and (b)(6);

■ c. Revising and republishing paragraph (d)(1);

- d. Revising paragraphs (e)(3) and (e)(4) introductory text;
- e. Adding paragraph (e)(6);
- f. Revising paragraph (f)(3); and
- g. Adding paragraph (h).

The revisions, additions and republication read as follows:

**§ 63.491 Batch front-end process vents—recordkeeping requirements.**

\* \* \* \* \*

(b) \* \* \*

(3) Except as specified in paragraph (b)(3)(iv) of this section, when using a flare to comply with § 63.487(a)(1):

\* \* \* \* \*

(iv) For each affected source as described in § 63.480, beginning no later than the compliance dates specified in § 63.481(n), paragraphs (b)(3)(i) through (b)(3)(iii) of this section no longer apply and instead the owner or operator of the affected source must keep the records specified in § 63.108(m) of subpart F of this part and § 63.508, readily accessible when using a flare to comply with § 63.487(a)(1).

\* \* \* \* \*

(6) Records of the dioxins and furans concentration, as determined in § 63.490(g).

\* \* \* \* \*

(d) \* \* \*

(1) The owner or operator of a Group 2 batch front-end process vent required to comply with § 63.487(g) shall keep the following records readily accessible:

(i) Except as specified in paragraph (d)(1)(iii) of this section, records designating the established batch mass input limitation required by § 63.487(g)(1) and specified in § 63.490(f).

(ii) Records specifying the mass of HAP or material charged to the batch unit operation.

(iii) For each affected source as described in § 63.480, beginning no later than the compliance dates specified in § 63.481(n), paragraph (d)(1)(i) of this section no longer applies.

\* \* \* \* \*

(e) \* \* \*

(3) Except as specified in paragraph (e)(6) of this section, hourly records of whether the flow indicator for bypass lines specified under § 63.489(d)(1) was operating and whether a diversion was detected at any time during the hour. Also, records of the times of all periods when the vent is diverted from the control device, or the flow indicator specified in § 63.489(d)(1) is not operating.

(4) Except as specified in paragraph (e)(6) of this section, where a seal or closure mechanism is used to comply with § 63.489(d)(2), hourly records of

whether a diversion was detected at any time are not required.

\* \* \* \* \*

(6) For each flow event from a bypass line subject to the requirements in § 63.489(d) for each affected source as described in § 63.480, beginning no later than the compliance dates specified in § 63.481(n), the owner or operator must also maintain records sufficient to determine whether or not the detected flow included flow requiring control. For each flow event from a bypass line requiring control that is released either directly to the atmosphere or to a control device not meeting the requirements in this subpart, the owner or operator must include an estimate of the volume of gas, the concentration of organic HAP in the gas and the resulting emissions of organic HAP that bypassed the control device using process knowledge and engineering estimates.

(f) \* \* \*

(3) For demonstrating compliance with the monitoring of bypass lines as specified in § 63.489(d), records as specified in paragraph (e)(3) or (4) of this section, and (e)(6) of this section as appropriate.

\* \* \* \* \*

(h) *Maintenance vent compliance records for batch front-end process vents.* For each maintenance vent opening subject to the requirements of § 63.487(i), owners and operators must keep the applicable records specified in paragraphs (h)(1) through (5) of this section.

(1) Owners and operators must maintain standard site procedures used to deinventory equipment for safety purposes (e.g., hot work or vessel entry procedures) to document the procedures used to meet the requirements in § 63.487(i). The current copy of the procedures must be retained and available on-site at all times. Previous versions of the standard site procedures, as applicable, must be retained for five years.

(2) If complying with the requirements of § 63.487(i)(1)(i), and the concentration of the vapor at the time of the vessel opening exceeds 10 percent of its LEL, identification of the maintenance vent, the process units or equipment associated with the maintenance vent, the date of maintenance vent opening, and the concentration of the vapor at the time of the vessel opening.

(3) If complying with the requirements of § 63.487(i)(1)(ii), and either the vessel pressure at the time of the vessel opening exceeds 5 psig or the concentration of the vapor at the time of the active purging was initiated exceeds

10 percent of its LEL, identification of the maintenance vent, the process units or equipment associated with the maintenance vent, the date of maintenance vent opening, the pressure of the vessel or equipment at the time of discharge to the atmosphere and, if applicable, the concentration of the vapors in the equipment when active purging was initiated.

(4) If complying with the requirements of § 63.487(i)(1)(iii), records of the estimating procedures used to determine the total quantity of VOC in the equipment and the type and size limits of equipment that contain less than 50 pounds of VOC at the time of maintenance vent opening. For each maintenance vent opening that contains greater than 50 pounds of VOC for which the deinventory procedures specified in paragraph (h)(1) of this section are not followed or for which the equipment opened exceeds the type and size limits established in the records specified in this paragraph (h)(4), records that identify the maintenance vent, the process units or equipment associated with the maintenance vent, the date of maintenance vent opening, and records used to estimate the total quantity of VOC in the equipment at the time the maintenance vent was opened to the atmosphere.

(5) If complying with the requirements of § 63.487(i)(1)(iv), identification of the maintenance vent, the process units or equipment associated with the maintenance vent, records documenting actions taken to comply with other applicable alternatives and why utilization of this alternative was required, the date of maintenance vent opening, the equipment pressure and concentration of the vapors in the equipment at the time of discharge, an indication of whether active purging was performed and the pressure of the equipment during the installation or removal of the blind if active purging was used, the duration the maintenance vent was open during the blind installation or removal process, and records used to estimate the total quantity of VOC in the equipment at the time the maintenance vent was opened to the atmosphere for each applicable maintenance vent opening.

■ 131. Amend § 63.492 by revising paragraph (f) and adding paragraph (g) to read as follows:

**§ 63.492 Batch front-end process vents—reporting requirements.**

\* \* \* \* \*

(f) Owners or operators of affected sources complying with § 63.489(d),

shall comply with paragraph (f)(1) or (2) of this section, as appropriate.

(1) Submit reports of the times of all periods recorded under § 63.491(e)(3) when the batch front-end process vent is diverted away from the control device through a bypass line, with the next Periodic Report. Include the start date, start time and duration in hours of each period.

(2) Submit reports of all occurrences recorded under § 63.491(e)(4) in which the seal mechanism is broken, the bypass line damper or valve position has changed, or the key to unlock the bypass line damper or valve was checked out, with the next Periodic Report. Include the start date, start time and duration in hours of each period.

(g) For any maintenance vent release exceeding the applicable limits in § 63.487(i)(1), the Periodic Report must include the information specified in paragraphs (g)(1) through (4) of this section. For the purposes of this reporting requirement, if an owner or operator complies with § 63.487(i)(1)(iv), then the owner or operator must report each venting event conducted under those provisions and include an explanation for each event as to why utilization of this alternative was required.

(1) Identification of the maintenance vent and the equipment served by the maintenance vent.

(2) The date and time the maintenance vent was opened to the atmosphere.

(3) The LEL in percent, vessel pressure in psig, or mass in pounds of VOC in the equipment, as applicable, at the start of atmospheric venting. If the 5 psig vessel pressure option in § 63.487(i)(1)(ii) was used and active purging was initiated while the concentration of the vapor was 10 percent or greater of its LEL, also include the concentration of the vapors at the time active purging was initiated.

(4) An estimate of the mass in pounds of organic HAP released during the entire atmospheric venting event.

■ 132. Amend § 63.494 by revising paragraph (a)(4) introductory text, adding paragraph (a)(7), revising paragraph (d), and adding paragraph (e) to read as follows:

**§ 63.494 Back-end process provisions—residual organic HAP and emission limitations.**

(a) \* \* \*

(4) In addition to the requirements specified in paragraph (a)(7) of this section, the organic HAP emissions from back-end processes at affected sources producing butyl rubber, epichlorohydrin elastomer, neoprene,

and nitrile butadiene rubber shall not exceed the limits determined in accordance with paragraphs (a)(4)(i) through (iv) of this section for any consecutive 12-month period. The specific limitation for each elastomer type shall be determined based on the calculation or the emissions level provided in paragraphs (a)(4)(i) through (iv) of this section divided by the base year elastomer product that leaves the stripping operation (or the reactor(s), if the plant has no stripper(s)). The limitation shall be calculated and submitted in accordance with § 63.499(f)(1).

\* \* \* \* \*

(7) For each affected source as described in § 63.480, beginning no later than the compliance dates specified in § 63.481(o), if the back-end process vent contains chloroprene such that it is considered to be in chloroprene service, as defined in § 63.482, then the owner or operator must comply with the requirements of paragraphs (a)(7)(i) through (iii) of this section in addition to all other applicable requirements specified in § 63.483 and elsewhere in this section.

(i) Reduce emissions of chloroprene by venting emissions through a closed vent system to a non-flare control device that reduces chloroprene by greater than or equal to 98 percent by weight, or to a concentration less than 1 ppmv for each process vent or to less than 5 pounds per year for all combined process vents within the process. If a combustion device is used, the chloroprene concentration of 1 ppmv must be corrected to 3 percent oxygen.

(ii) To demonstrate compliance with the emission limits specified in paragraph (a)(7)(i) of this section for back-end process vents in chloroprene service, owners and operators must meet the requirements specified in § 63.510.

(iii) An owner or operator may designate a back-end process vent in chloroprene service as a maintenance vent if the vent is only used as a result of startup, shutdown, maintenance, or inspection of equipment where equipment is emptied, depressurized, degassed, or placed into service; however, owners and operators may not release more than 1.0 tons of chloroprene from all maintenance vents combined (*i.e.*, including maintenance vents subject to this paragraph (a)(7)(iii), § 63.485(z), or § 63.487(i)(4)) per any consecutive 12-month period. The owner or operator must keep monthly records of the quantity in tons of chloroprene released from each maintenance vent and include a

description of the method used to estimate this quantity.

\* \* \* \* \*

(d) Except as specified in paragraph (e) of this section, if the owner or operator complies with the residual organic HAP limitations in paragraph (a)(1) through (3) of this section using a flare, the owner or operator of an affected source shall comply with the requirements in § 63.504(c).

(e) For each affected source as described in § 63.480, beginning no later than the compliance dates specified in § 63.481(n), paragraph (d) of this section no longer applies and instead if the owner or operator complies with the residual organic HAP limitations in paragraph (a)(1) through (3) of this section using a flare, the owner or operator of the affected source must comply with § 63.508 for the flare.

■ 133. Amend § 63.496 by revising paragraphs (b)(5)(iii) and (b)(7)(i) to read as follows:

**§ 63.496 Back-end process provisions—procedures to determine compliance with residual organic HAP limitations using control or recovery devices.**

\* \* \* \* \*

(b) \* \* \*

(5) \* \* \*

(iii) To determine the inlet and outlet total organic HAP concentrations, the owner or operator must use Method 18 or Method 25A of appendices A–6 and A–7 to 40 CFR part 60, respectively. ASTM D6420–18 (incorporated by reference, see § 63.14) may also be used in lieu of Method 18, if the target compounds are all known and are all listed in Section 1.1 of ASTM D6420–18 as measurable; ASTM D6420–18 must not be used for methane and ethane; and ASTM D6420–18 may not be used as a total VOC method. Alternatively, any other method or data that has been validated according to the applicable procedures in Method 301 of appendix A to this part may be used. The minimum sampling time for each run must be in accordance with paragraph (b)(1) of this section, during which either an integrated sample or grab samples shall be taken. If grab sampling is used, then the samples must be taken at approximately equal intervals during the run, with the time between samples no greater than 15 minutes.

\* \* \* \* \*

(7) \* \* \*

(i) A flare. (A) Except as specified in paragraph (b)(7)(i)(B) of this section, the owner or operator shall demonstrate compliance as provided in § 63.504(c).

(B) For each affected source as described in § 63.480, beginning no later



than the compliance dates specified in § 63.481(n), paragraph (b)(7)(i)(A) of this section no longer applies and instead the owner or operator of the affected source must comply with § 63.508 for the flare.

\* \* \* \* \*

■ 134. Amend § 63.497 by revising paragraphs (a) introductory text, (a)(2) and (6), adding paragraphs (a)(7) and (8), revising paragraph (d) introductory text, and adding paragraph (d)(3) to read as follows:

**§ 63.497 Back-end process provisions— monitoring provisions for control and recovery devices used to comply with residual organic HAP limitations.**

(a) An owner or operator complying with the residual organic HAP limitations in § 63.494(a)(1) through (3) using control or recovery devices, or a combination of stripping and control or recovery devices, shall install the monitoring equipment specified in paragraphs (a)(1) through (7) of this section, as appropriate.

\* \* \* \* \*

(2) Where a flare is used, except as specified in paragraph (a)(7) of this section, a device (including, but not limited to, a thermocouple, ultra-violet beam sensor, or infrared sensor) capable of continuously detecting the presence of a pilot flame is required.

\* \* \* \* \*

(6) Except as specified in paragraph (a)(8) of this section, for a carbon adsorber, an integrating regeneration steam flow, nitrogen flow, or pressure monitoring device having an accuracy of at least ±10 percent of the flow rate, level, or pressure, capable of recording the total regeneration steam flow or nitrogen flow, or pressure (gauge or absolute) for each regeneration cycle; and a carbon bed temperature monitoring device, capable of recording the carbon bed temperature after each regeneration and within 15 minutes of completing any cooling cycle are required.

(7) For each affected source as described in § 63.480, beginning no later than the compliance dates specified in § 63.481(n), paragraph (a)(2) of this section no longer applies and instead the owner or operator of the affected source must comply with § 63.508 for the flare.

(8) Beginning no later than the compliance dates specified in § 63.481(n), if the owner or operator vents emissions through a closed vent system to an adsorber(s) that cannot be regenerated or a regenerative adsorber(s) that is regenerated offsite, then the owner or operator must install a system

of two or more adsorber units in series and comply with the requirements specified in paragraphs (a)(8)(i) through (iii) of this section.

(i) Conduct an initial performance test or design evaluation of the adsorber and establish the breakthrough limit and adsorber bed life.

(ii) Monitor the HAP or total organic compound (TOC) concentration through a sample port at the outlet of the first adsorber bed in series according to the schedule in paragraph (a)(8)(iii)(B) of this section. The owner or operator must measure the concentration of HAP or TOC using either a portable analyzer, in accordance with Method 21 of 40 CFR part 60, appendix A–7 using methane, propane, isobutylene, or the primary HAP being controlled as the calibration gas or Method 25A of 40 CFR part 60, appendix A–7 using methane, propane, or the primary HAP being controlled as the calibration gas.

(iii) Comply with paragraph (a)(8)(iii)(A) of this section, and comply with the monitoring frequency according to paragraph (a)(8)(iii)(B) of this section.

(A) The first adsorber in series must be replaced immediately when breakthrough, as defined in § 63.482, is detected between the first and second adsorber. The original second adsorber (or a fresh canister) will become the new first adsorber and a fresh adsorber will become the second adsorber. For purposes of this paragraph, “immediately” means within 8 hours of the detection of a breakthrough for adsorbers of 55 gallons or less, and within 24 hours of the detection of a breakthrough for adsorbers greater than 55 gallons. The owner or operator must monitor at the outlet of the first adsorber within 3 days of replacement to confirm it is performing properly.

(B) Based on the adsorber bed life established according to paragraph (a)(8)(i) of this section and the date the adsorbent was last replaced, conduct monitoring to detect breakthrough at least monthly if the adsorbent has more than 2 months of life remaining, at least weekly if the adsorbent has between 2 months and 2 weeks of life remaining, and at least daily if the adsorbent has 2 weeks or less of life remaining.

\* \* \* \* \*

(d) The owner or operator of an affected source with a controlled back-end process vent using a vent system that contains bypass lines that could divert a vent stream away from the control or recovery device used to comply with § 63.494(a)(1) through (3), shall comply with either paragraph (d)(1) or (d)(2), and (d)(3) of this section.

Except as specified in paragraph (d)(3) of this section, equipment such as low leg drains, high point bleeds, analyzer vents, open-ended valves or lines, and pressure relief valves needed for safety purposes are not subject to this paragraph.

\* \* \* \* \*

(3) For each affected source as described in § 63.480, beginning no later than the compliance dates specified in § 63.481(n):

(i) The use of a bypass line at any time on a closed vent system to divert emissions (subject to the emission standards in § 63.487) to the atmosphere or to a control device not meeting the requirements specified in this subpart is an emissions standards violation.

(ii) The last sentence in paragraph (d) of this section no longer applies. Instead, the exemptions specified in paragraph (d)(3)(ii)(A) and (d)(3)(ii)(B) of this section apply.

(A) Except for pressure relief devices subject to § 63.165(e)(4) of subpart H of this part, equipment such as low leg drains and equipment subject to the requirements of subpart H of this part are not subject to this paragraph (d) of this section.

(B) Open-ended valves or lines that use a cap, blind flange, plug, or second valve and follow the requirements specified in 40 CFR 60.482–6(a)(2), (b), and (c) or follow requirements codified in another regulation that are the same as 40 CFR 60.482–6(a)(2), (b), and (c) are not subject to this paragraph (d) of this section.

- 135. Amend § 63.498 by:
  - a. Revising paragraph (a) introductory text;
  - b. Revising and republishing paragraph (d); and
  - c. Adding paragraph (f).
- The addition, revisions and republication read as follows:

**§ 63.498 Back-end process provisions— recordkeeping.**

(a) Each owner or operator shall maintain the records specified in paragraphs (a)(1) through (4), and paragraphs (b) through (f) of this section, as appropriate.

\* \* \* \* \*

(d) Each owner or operator of a back-end process operation using control or recovery devices to comply with a residual organic HAP limitation in § 63.494(a)(1) through (3), shall maintain the records specified in paragraphs (d)(1) through (5) of this section. The recordkeeping requirements contained in paragraphs (d)(1) through (4) pertain to the results of the testing required by § 63.496(b), for each of the three required test runs.

(1) The uncontrolled residual organic HAP content in the latex or dry crumb rubber, as required to be determined by § 63.496(b)(3), including the test results of the analysis;

(2) The total quantity of material (weight of latex or dry crumb rubber) processed during the test run, recorded in accordance with § 63.496(b)(4);

(3) The organic HAP emissions at the inlet and outlet of the control or recovery device, determined in accordance with § 63.496(b)(5) through (8), including all test results and calculations.

(4) The residual organic HAP content, adjusted for the control or recovery device emission reduction, determined in accordance with § 63.496(c)(1).

(5) Each owner or operator using a control or recovery device shall keep the following records readily accessible:

(i) Continuous records of the equipment operating parameters specified to be monitored under § 63.497(a) or specified by the Administrator in accordance with § 63.497(b). For flares, the records specified in § 63.508, if applicable, and table 3 to subpart G of this part shall be maintained in place of continuous records.

(ii) Records of the daily average value of each continuously monitored parameter for each operating day, except as provided in paragraphs (d)(5)(ii)(D) through (d)(5)(ii)(F) of this section.

(A) The daily average shall be calculated as the average of all values for a monitored parameter recorded during the operating day, except as provided in paragraph (d)(5)(ii)(B) of this section. The average shall cover a 24-hour period if operation is continuous, or the number of hours of operation per operating day if operation is not continuous.

(B) Monitoring data recorded during periods of monitoring system breakdowns, repairs, calibration checks, and zero (low-level) and high-level adjustments, shall not be included in computing the hourly or daily averages. In addition, monitoring data recorded during periods of non-operation of the EPPU (or specific portion thereof) resulting in cessation of organic HAP emissions, shall not be included in computing the hourly or daily averages. Records shall be kept of the times and durations of all such periods and any other periods of process or control device operation when monitors are not operating.

(C) The operating day shall be the period defined in the operating permit or the Notification of Compliance Status in § 63.506(e)(5) or (8). It may be from

midnight to midnight or another 24-hour period.

(D) If all recorded values for a monitored parameter during an operating day are below the maximum, or above the minimum, level established in the Notification of Compliance Status in § 63.506(e)(5) or in the operating permit, the owner or operator may record that all values were below the maximum or above the minimum level, rather than calculating and recording a daily average for that operating day.

(E) Except as specified in paragraph (d)(5)(ii)(F) of this section, for flares, records of the times and duration of all periods during which the pilot flame is absent, shall be kept rather than daily averages. The records specified in this paragraph are not required during periods when emissions are not routed to the flare.

(F) For each affected source as described in § 63.480, beginning no later than the compliance dates specified in § 63.481(n), paragraph (d)(5)(ii)(E) of this section no longer applies and instead the owner or operator of the affected source must keep the records specified in § 63.108(m) of subpart F of this part and § 63.508.

(iii) Except as specified in paragraph (d)(5)(v) of this section, hourly records of whether the flow indicator specified under § 63.497(d)(1) was operating and whether a diversion was detected at any time during the hour, as well as records of the times of all periods when the vent stream is diverted from the control device or the flow indicator is not operating.

(iv) Except as specified in paragraph (d)(5)(v) of this section, where a seal mechanism is used to comply with § 63.497(d)(2), hourly records of flow are not required.

(A) For compliance with § 63.497(d)(2), the owner or operator shall record whether the monthly visual inspection of the seals or closure mechanisms has been done, and shall record instances when the seal mechanism is broken, the bypass line damper or valve position has changed, or the key for a lock-and-key type configuration has been checked out, and records of any car-seal that has broken.

(B) [Reserved]

(v) For each flow event from a bypass line subject to the requirements in § 63.127(d) of subpart G of this part for each affected source as described in § 63.480, beginning no later than the compliance dates specified in § 63.481(n), the owner or operator must also maintain records sufficient to determine whether or not the detected flow included flow requiring control. For each flow event from a bypass line

requiring control that is released either directly to the atmosphere or to a control device not meeting the requirements in this subpart, the owner or operator must include an estimate of the volume of gas, the concentration of organic HAP in the gas and the resulting emissions of organic HAP that bypassed the control device using process knowledge and engineering estimates.

\* \* \* \* \*

(f) Owners and operators subject to § 63.494(a)(7), must keep the records specified in paragraphs (f)(1) and (2) of this section in addition to those records specified elsewhere in this section.

(1) For back-end process vents in chloroprene service, include all uncontrolled, undiluted chloroprene concentration measurements, and the calculations used to determine the total uncontrolled chloroprene mass emission rate for the sum of all vent gas streams.

(2) The owner or operator must keep records of all periods during which operating values are outside of the applicable operating limits specified in § 63.510(b)(4) through (6) when regulated material is being routed to the non-flare control device. The record must specify the operating parameter, the applicable limit, and the highest (for maximum operating limits) or lowest (for minimum operating limits) value recorded during the period.

■ 136. Amend § 63.499 by adding paragraph (g) as follows:

**§ 63.499 Back-end process provisions—reporting.**

\* \* \* \* \*

(g) Owners and operators subject to § 63.494(a)(7), must include in the periodic report, the records for the periods specified in § 63.498(f)(2). Indicate the start date, start time and duration in hours for each period.

■ 137. Amend § 63.500 by revising paragraph (c)(1)(iii) introductory text to read as follows:

**§ 63.500 Back-end process provisions—carbon disulfide limitations for styrene butadiene rubber by emulsion processes.**

\* \* \* \* \*

(c) \* \* \*

(1) \* \* \*

(iii) To determine compliance with the carbon disulfide concentration limit in paragraph (a) of this section, the owner or operator shall use Method 18 or Method 25A of appendices A–6 and A–7 to 40 CFR part 60, respectively to measure carbon disulfide. ASTM D6420–18 (incorporated by reference, see § 63.14) may also be used in lieu of Method 18, if the target compounds are all known and are all listed in Section

1.1 of ASTM D6420–18 as measurable; ASTM D6420–18 must not be used for methane and ethane; and ASTM D6420–18 may not be used as a total VOC method. Alternatively, any other method or data that has been validated according to the applicable procedures in Method 301 of appendix A to this part, may be used. The following procedures shall be used to calculate carbon disulfide concentration:

\* \* \* \* \*

■ 138. Amend § 63.501 by revising paragraphs (a) introductory text, revising and republishing (a)(10) and (20), and (b), and adding paragraphs (d), (e), and (f) to read as follows:

**§ 63.501 Wastewater provisions.**

(a) Except as specified in paragraphs (c) through (f) of this section, the owner or operator of each affected source shall comply with the requirements of §§ 63.132 through 63.147 for each process wastewater stream originating at an affected source, with the requirements of § 63.148 for leak inspection provisions, and with the requirements of § 63.149 for equipment that is subject to § 63.149, with the differences noted in paragraphs (a)(1) through (23) of this section. Further, the owner or operator of each affected source shall comply with the requirements of § 63.105(a) for maintenance wastewater, as specified in paragraph (b) of this section.

\* \* \* \* \*

(10) The provisions of paragraphs (a)(10)(i) through (iv) of this section clarify the organic HAP that an owner or operator must consider when complying with the requirements of §§ 63.132 through 63.149.

(i) Owners and operators are exempt from all requirements in §§ 63.132 through 63.149 that pertain solely and exclusively to organic HAP listed on table 8 to 40 CFR part 63, subpart G.

(ii) When §§ 63.132 through 63.149 refer to table 9 compounds, the owner or operator is only required to consider compounds that meet the definition of organic HAP in § 63.482 and that are listed in table 9 to 40 CFR part 63, subpart G, for the purposes of this subpart.

(iii) When §§ 63.132 through 63.149 refer to compounds in table 36 to 40 CFR part 63, subpart G, or compounds in List 1 and/or List 2, as listed in table 36 to 40 CFR part 63, subpart G, the owner or operator is only required to consider compounds that meet the definition of organic HAP in § 63.482 and that are listed in table 36 to 40 CFR part 63, subpart G, for the purposes of this subpart.

(iv) For each affected source as described in § 63.480, beginning no later than the compliance dates specified in § 63.481(o), the provisions specified in § 63.132(c)(1)(iii) do not apply. Instead, if the wastewater stream contains chloroprene such that it is considered to be in chloroprene service, as defined in § 63.482, then the wastewater stream is a Group 1 wastewater stream. For wastewater streams in chloroprene service, owners and operators must also meet the requirements specified in § 63.510.

\* \* \* \* \*

(20) When the provisions of § 63.139(c)(1)(ii), § 63.145(d)(4), or § 63.145(i)(2) specify that Method 18 of appendix A–6 to 40 CFR part 60 must be used, Method 18 or Method 25A of appendices A–6 and A–7 to 40 CFR part 60, respectively, may be used for the purposes of this subpart. ASTM D6420–18 (incorporated by reference, see § 63.14) may also be used in lieu of Method 18, if the target compounds are all known and are all listed in Section 1.1 of ASTM D6420–18 as measurable; ASTM D6420–18 must not be used for methane and ethane; and ASTM D6420–18 may not be used as a total VOC method. The use of Method 25A must conform with the requirements in paragraphs (a)(20)(i) and (ii) of this section.

(i) The organic HAP used as the calibration gas for Method 25A of appendix A–7 to 40 CFR part 60 must be the single organic HAP representing the largest percent by volume of the emissions.

(ii) The use of Method 25A of appendix A–7 to 40 CFR part 60 is acceptable if the response from the high-level calibration gas is at least 20 times the standard deviation of the response from the zero calibration gas when the instrument is zeroed on the most sensitive scale

(b) Except for those streams exempted by paragraphs (c) and (d) of this section, the owner or operator of each affected source shall comply with the requirements for maintenance wastewater in § 63.105, except that when § 63.105(a) refers to “organic HAPs listed in table 9 to subpart G of this part,” the owner or operator is only required to consider compounds that meet the definition of organic HAP in § 63.482 and that are listed in table 9 to subpart G of this part, for the purposes of this subpart.

\* \* \* \* \*

(d) Substitute “For each affected source as described in § 63.480, on and after July 15, 2027,” for each occurrence

of “For each source as defined in § 63.101, on and after July 15, 2027,”.

(e) Substitute “For each affected source as described in § 63.480, beginning no later than the compliance dates specified in § 63.481(n),” for each occurrence of “For each source as defined in § 63.101, beginning no later than the compliance dates specified in § 63.100(k)(10),”.

(f) Substitute “§ 63.508” for each occurrence of “§ 63.108”.

■ 139. Amend § 63.502 by revising the section heading, paragraphs (a) (j), (k), and (n) to read as follows:

**§ 63.502 Equipment leak, fenceline monitoring, and heat exchange system provisions.**

(a) The owner or operator of each affected source, shall comply with the requirements of subpart H of this part, with the exceptions noted in paragraphs (a)(1) through (7), and (b) through (m) of this section. Except as specified in § 63.170(b), surge control vessels required to be controlled by subpart H may, alternatively, comply with the Group 1 storage vessel provisions specified in § 63.484.

(1) Substitute “For each affected source as described in § 63.480, on and after July 15, 2027,” for each occurrence of “For each source as defined in § 63.101, on and after July 15, 2027,”.

(2) Substitute “For each affected source as described in § 63.480, beginning no later than the compliance dates specified in § 63.481(n),” for each occurrence of “For each source as defined in § 63.101, and for each source as defined in § 63.191, beginning no later than the compliance dates specified in § 63.100(k)(10),”.

(3) Substitute “For each affected source as described in § 63.480, beginning no later than the compliance dates specified in § 63.481(o),” for each occurrence of “For each source as defined in § 63.101, and for each source as defined in § 63.191, beginning no later than the compliance dates specified in § 63.100(k)(11),”.

(4) Substitute “For each affected source as described in § 63.480, beginning no later than the compliance dates specified in § 63.481(p),” for each occurrence of “For each source as defined in § 63.101, and for each source as defined in § 63.191, beginning no later than the compliance dates specified in § 63.100(k)(12),”.

(5) Substitute “§ 63.508” for each occurrence of “§ 63.108”.

(6) Substitute “in chloroprene service” for each occurrence of “in ethylene oxide service”.

(7) If an affected source uses, produces, stores, or emits chloroprene, the action level for chloroprene in § 63.184(d)(3) is 0.3 µg/m<sup>3</sup> on an annual average basis for the purposes of this subpart. Additionally, the sampling period Δc in § 63.184(e)(4)(iii) and (f)(1)(iii) is 0.3 µg/m<sup>3</sup> instead of 0.8 µg/m<sup>3</sup> for the purposes of this subpart.

\* \* \* \* \*

(j) When the provisions of subpart H of this part specify that Method 18 of appendix A–6 to 40 CFR part 60 must be used, either Method 18 or Method 25A of appendices A–6 and A–7 to 40 CFR part 60, respectively, may be used for the purposes of this subpart. ASTM D6420–18 (incorporated by reference, see § 63.14) may also be used in lieu of Method 18, if the target compounds are all known and are all listed in Section 1.1 of ASTM D6420–18 as measurable; ASTM D6420–18 must not be used for methane and ethane; and ASTM D6420–18 may not be used as a total VOC method. The use of Method 25A must conform with the requirements in paragraphs (j)(1) and (2) of this section.

(1) The organic HAP used as the calibration gas for Method 25A of appendix A–7 to 40 CFR part 60 must be the single organic HAP representing the largest percent by volume of emissions.

(2) The use of Method 25A of appendix A–7 to 40 CFR part 60 is acceptable if the response from the high-level calibration gas is at least 20 times the standard deviation of the response from the zero calibration gas when the instrument is zeroed on the most sensitive scale.

(k)(1) Except as specified in paragraph (k)(2) of this section, an owner or operator using a flare to comply with the requirements of this section shall conduct a compliance demonstration as specified in § 63.504(c).

(2) For each affected source as described in § 63.480, beginning no later than the compliance dates specified in § 63.481(n), paragraph (k)(1) of this section no longer applies and instead the owner or operator of the affected source must comply with § 63.508 for the flare.

\* \* \* \* \*

(n) The owner or operator of each affected source shall comply with the requirements of § 63.104 for heat exchange systems, with the exceptions

noted in paragraphs (n)(1) through (8) of this section.

(1) When the term “chemical manufacturing process unit” is used in § 63.104, the term “elastomer product process unit” (or EPPU) shall apply for the purposes of this subpart, with the exception noted in paragraph (n)(2) of this section.

(2) When the phrase “a chemical manufacturing process unit meeting the conditions of § 63.100(b)(1) through (b)(3) of this subpart, except for chemical manufacturing process units meeting the condition specified in § 63.100(c) of this subpart” is used in the first sentence of § 63.104(a), the term “an EPPU, except for EPPUs meeting the condition specified in § 63.480(b)” shall apply for the purposes of this subpart. When the phrase “a chemical manufacturing process unit meeting the conditions of § 63.100(b)(1) through (b)(3),” is used in the last sentence of § 63.104(a) of subpart F of this part, the term “an EPPU” shall apply for purposes of this subpart.

(3) When § 63.104 refers to table 4 to subpart F of this part or table 9 to subpart G of this part, the owner or operator is only required to consider organic HAP listed on table 5 to this subpart.

(4) When § 63.104(c)(3) specifies the monitoring plan retention requirements, and when § 63.104(f)(1) refers to the record retention requirements in § 63.103(c)(1), the requirements in § 63.506(a) and § 63.506(h) shall apply, for the purposes of this subpart.

(5) When § 63.104(f)(2) requires information to be reported in the Periodic Reports required by § 63.152(c), the owner or operator shall instead report the information specified in § 63.104(f)(2) in the Periodic Reports required by § 63.506(e)(6), for the purposes of this subpart.

(6) The compliance date for heat exchange systems subject to the provisions of this section is specified in § 63.481(d)(6).

(7) Substitute “Beginning no later than the compliance dates specified in § 63.481(n),” for each occurrence of “Beginning no later than the compliance dates specified in § 63.100(k)(10),”.

(8) § 63.104(k) of subpart F of this part does not apply. Instead for each source as described in § 63.480, beginning no later than the compliance dates

specified in § 63.481(n), owners and operators must not inject water into or dispose of water through any heat exchange system in an EPPU if the water contains any amount of chloroprene, has been in contact with any process stream containing chloroprene, or the water is considered wastewater as defined in § 63.482.

■ 140. Amend § 63.503 by revising paragraphs (a)(3), (g)(2)(ii) introductory text and (g)(2)(iii)(B)(2), adding paragraph (g)(2)(iii)(B)(4), and revising paragraphs (g)(7)(ii) introductory text, (m)(1)(ii) and (m)(2)(i) to read as follows:

**§ 63.503 Emissions averaging provisions.**

(a) \* \* \*

(3) For the purposes of the provisions in this section, whenever Method 18 of appendix A–6 to 40 CFR part 60 is specified within the paragraphs of this section or is specified by reference through provisions outside this section, Method 18 or Method 25A of appendices A–6 and A–7 to 40 CFR part 60, respectively, may be used. ASTM D6420–18 (incorporated by reference, see § 63.14) may also be used in lieu of Method 18, if the target compounds are all known and are all listed in Section 1.1 of ASTM D6420–18 as measurable; ASTM D6420–18 must not be used for methane and ethane; and ASTM D6420–18 may not be used as a total VOC method. The use of Method 25A, must conform with the requirements in paragraphs (a)(3)(i) and (ii) of this section.

(i) The organic HAP used as the calibration gas for Method 25A of appendix A–7 to 40 CFR part 60 must be the single organic HAP representing the largest percent by volume of the emissions.

(ii) The use of Method 25A of appendix A–7 to 40 CFR part 60, is acceptable if the response from the high-level calibration gas is at least 20 times the standard deviation of the response from the zero calibration gas when the instrument is zeroed on the most sensitive scale.

\* \* \* \* \*

(g) \* \* \*

(2) \* \* \*

(ii) ECFEPV<sub>in</sub> for each continuous front-end process vent i shall be calculated using equation 34.

$$ECFEPV_{in} = (2.494 \times 10^{-9}) Q_h \left( \sum_{j=1}^n C_j M_j \right) \quad [Eq. 34]$$

Where:

ECFEPV<sub>iu</sub> = Uncontrolled continuous front-end process vent emission rate from continuous front-end process vent i, Mg/month.

Q = Vent stream flow rate, dry standard m<sup>3</sup>/min, measured using Method 2, 2A, 2C, or 2D of 40 CFR part 60, appendix A, as appropriate.

h = Monthly hours of operation during which positive flow is present in the continuous front-end process vent, hr/month.

C<sub>j</sub> = Concentration, ppmv, dry basis, of organic HAP j as measured by Method 18 or Method 25A of appendices A-6 and A-7 to 40 CFR part 60, respectively, or ASTM D6420-18 (incorporated by reference, see § 63.14).

M<sub>j</sub> = Molecular weight of organic HAP j, gram per gram-mole.

n = Number of organic HAP in stream.

\* \* \* \* \*

(iii) \* \* \*

(B) \* \* \*

(2) For determining debits from Group 1 continuous front-end process vents, product recovery devices shall not be considered control devices and shall not be assigned a percent reduction in calculating ECFEPV<sub>iACTUAL</sub>. The sampling site for measurement of uncontrolled emissions shall be after the final uncontrolled recovery device. However, as provided in § 63.113(a)(3), a Group 1 continuous front-end process vent may add sufficient product recovery to raise the TRE index value above 1.0, thereby becoming a Group 2 continuous front-end process vent. Such

a continuous front-end process vent is not a Group 1 continuous front-end process vent and should, therefore, not be included in determining debits under this paragraph, except as specified in paragraph (g)(2)(iii)(B)(4) of this section.

\* \* \* \* \*

(4) For each affected source as described in § 63.480, beginning no later than the compliance dates specified in § 63.481(n), that last two sentences of paragraph (g)(2)(iii)(B)(2) of this section no longer apply.

\* \* \* \* \*

(7) \* \* \*

(ii) EABV<sub>iu</sub> for each aggregate batch vent i shall be calculated using equation 39.

EABV<sub>iu</sub> = (2.494 × 10<sup>-9</sup>) Qh (∑<sub>j=1</sub><sup>n</sup> C<sub>j</sub>M<sub>j</sub>) [Eq. 39]

Where:

EABV<sub>iu</sub> = Uncontrolled aggregate batch vent emission rate from aggregate batch vent i, Mg/month.

Q = Vent stream flow rate, dry standard cubic meters per minute, measured using Method 2, 2A, 2C, or 2D of 40 CFR part 60, appendix A, as appropriate.

h = Monthly hours of operation during which positive flow is present from the aggregate batch vent stream, hr/month.

C<sub>j</sub> = Concentration, ppmv, dry basis, of organic HAP j as measured by Method 18 of appendix A-6 to 40 CFR part 60 or ASTM D6420-18 (incorporated by reference, see § 63.14).

M<sub>j</sub> = Molecular weight of organic HAP j, gram per gram-mole.

n = Number of organic HAP in the stream.

\* \* \* \* \*

(m) \* \* \*

(1) \* \* \*

(ii) Conduct initial and subsequent performance tests to determine percent reduction as specified in § 63.116 and as required by § 63.485; and

\* \* \* \* \*

(2) \* \* \*

(i) Determine the flow rate, organic HAP concentration, and TRE index value according to the procedures specified in § 63.115, except as specified in § 63.113(a)(4) and § 63.485(x); and

\* \* \* \* \*

■ 141. Amend § 63.504 by revising paragraphs (a) introductory text and (a)(1) introductory text, adding paragraph (a)(1)(iii), revising paragraph (c) introductory text and adding paragraph (c)(4) to read as follows:

§ 63.504 Additional requirements for performance testing.

(a) Performance testing shall be conducted in accordance with § 63.7(a)(1), (a)(3), (d), (e)(1) and (2), (e)(4), (g), and (h), with the exceptions specified in paragraphs (a)(1) through (5) of this section and the additions specified in paragraph (b) of this section. Sections 63.484 through 63.501 also contain specific testing requirements. Beginning no later than the compliance dates specified in § 63.481(n), conduct subsequent performance tests no later than 60 calendar months after the previous performance test.

(1) Except as specified in paragraph (a)(1)(iii) of this section, performance tests shall be conducted at maximum representative operating conditions achievable during one of the time periods described in paragraph (a)(1)(i) of this section, without causing any of the situations described in paragraph (a)(1)(ii) of this section to occur. Upon request, the owner or operator shall make available to the Administrator such records as may be necessary to determine the conditions of performance tests.

\* \* \* \* \*

(iii) Beginning no later than the compliance dates specified in § 63.481(n), paragraphs (a)(1)(i) and (ii) of this section no longer applies and instead the owner or operator must conduct performance tests under such conditions as the Administrator specifies based on representative performance of the affected source for the period being tested. Representative

conditions exclude periods of startup and shutdown. You may not conduct performance tests during periods of malfunction. You must record the process information that is necessary to document operating conditions during the test and include in such record an explanation to support that such conditions represent normal operation. Upon request, you must make available to the Administrator such records as may be necessary to determine the conditions of performance tests.

\* \* \* \* \*

(c) Except as specified in paragraph (c)(4) of this section, notwithstanding any other provision of this subpart, if an owner or operator of an affected source uses a flare to comply with any of the requirements of this subpart, the owner or operator shall comply with paragraphs (c)(1) through (3) of this section. The owner or operator is not required to conduct a performance test to determine percent emission reduction or outlet organic HAP or TOC concentration. If a compliance demonstration has been conducted previously for a flare, using the techniques specified in paragraphs (c)(1) through (3) of this section, that compliance demonstration may be used to satisfy the requirements of this paragraph if either no deliberate process changes have been made since the compliance demonstration, or the results of the compliance demonstration reliably demonstrate compliance despite process changes.

\* \* \* \* \*

(4) For each affected source as described in § 63.480, beginning no later

than the compliance dates specified in § 63.481(n), paragraphs (c)(1) through (c)(3) of this section no longer apply and instead the owner or operator of the affected source must comply with § 63.508 for the flare.

■ 142. Amend § 63.505 by:

■ a. Revising and republishing paragraph (b); and

■ b. Revising paragraph (g)(2)(ii)(B) introductory text and adding paragraph (g)(2)(ii)(B)(5).

The addition, revisions, and republication read as follows:

**§ 63.505 Parameter monitoring levels and excursions.**

\* \* \* \* \*

(b) *Establishment of parameter monitoring levels based exclusively on performance tests.* In cases where a performance test is required by this subpart, or the owner or operator of the affected source elects to do a performance test in accordance with the provisions of this subpart, and an owner or operator elects to establish a parameter monitoring level for a control, recovery, or recapture device based exclusively on parameter values measured during the performance test, the owner or operator of the affected source shall comply with the procedures in paragraphs (b)(1) through (b)(5) of this section, as applicable.

(1) [Reserved]

(2) *Back-end process operations using a control or recovery device to comply with §§ 63.493 through 63.500 and continuous front-end process vents.* During each compliance test, the appropriate parameter shall be continuously monitored during the required 1-hour runs. The monitoring level(s) shall then be established as the average of the maximum (or minimum) point values from the three test runs. The average of the maximum values shall be used when establishing a maximum level, and the average of the minimum values shall be used when establishing a minimum level.

(3) *Batch front-end process vents.* The monitoring level(s) shall be established using the procedures specified in either paragraph (b)(3)(i) or (b)(3)(ii) of this section, except as specified in paragraph (b)(5) of this section. The procedures specified in this paragraph (b)(3) may only be used if the batch emission episodes, or portions thereof, selected to be controlled were tested, and monitoring data were collected, during the entire period in which emissions were vented to the control device, as specified in § 63.490(c)(1)(i). If the owner or operator chose to test only a portion of the batch emission episode, or portion thereof, selected to be

controlled, the procedures in paragraph (c) of this section shall be used.

(i) If more than one batch emission episode or more than one portion of a batch emission episode has been selected to be controlled, a single level for the batch cycle shall be calculated as follows:

(A) The average monitored parameter value shall be calculated for each batch emission episode, or portion thereof, in the batch cycle selected to be controlled. The average shall be based on all values measured during the required performance test.

(B) If the level to be established is a maximum operating parameter, the level shall be defined as the minimum of the average parameter values of the batch emission episodes, or portions thereof, in the batch cycle selected to be controlled (*i.e.*, identify the emission episode, or portion thereof, which requires the lowest parameter value in order to assure compliance. The average parameter value that is necessary to assure compliance for that emission episode, or portion thereof, shall be the level for all emission episodes, or portions thereof, in the batch cycle, that are selected to be controlled).

(C) If the level to be established is a minimum operating parameter, the level shall be defined as the maximum of the average parameter values of the batch emission episodes, or portions thereof, in the batch cycle selected to be controlled (*i.e.*, identify the emission episode, or portion thereof, which requires the highest parameter value in order to assure compliance. The average parameter value that is necessary to assure compliance for that emission episode, or portion thereof, shall be the level for all emission episodes, or portions thereof, in the batch cycle, that are selected to be controlled).

(D) Alternatively, an average monitored parameter value shall be calculated for the entire batch cycle based on all values measured during each batch emission episode, or portion thereof, selected to be controlled.

(ii) Instead of establishing a single level for the batch cycle, as described in paragraph (b)(3)(i) of this section, an owner or operator may establish separate levels for each batch emission episode, or portion thereof, selected to be controlled. Each level shall be determined as specified in paragraph (b)(3)(i)(A) of this section.

(iii) The batch cycle shall be defined in the Notification of Compliance Status, as specified in § 63.506(e)(5). The definition shall include an identification of each batch emission episode and the information required to determine parameter monitoring

compliance for partial batch cycles (*i.e.*, when part of a batch cycle is accomplished during two different operating days).

(4) *Aggregate batch vent streams.* For aggregate batch vent streams, except as specified in paragraph (b)(5) of this section, the monitoring level shall be established in accordance with paragraph (b)(2) of this section.

(5) *Batch front-end process vents and aggregate batch vent streams testing for dioxins and furans.* During each compliance test using the procedures specified in § 63.490(g), the appropriate parameter shall be continuously monitored during the required test runs. The monitoring level(s) shall then be established as the average of the maximum (or minimum) point values from the three test runs. The average of the maximum values shall be used when establishing a maximum level, and the average of the minimum values shall be used when establishing a minimum level.

\* \* \* \* \*

(g) \* \* \*

(2) \* \* \*

(ii) \* \* \*

(B) Except as specified in paragraph (g)(2)(ii)(B)(5) of this section, subtract the time during the periods identified in paragraphs (g)(2)(ii)(B)(1) through (4) of this section from the total amount of time determined in paragraph (g)(2)(ii)(A) of this section, to obtain the operating time used to determine if monitoring data are insufficient.

\* \* \* \* \*

(5) On and after July 15, 2027, paragraphs (g)(2)(ii)(B)(1) through (4) of this section no longer apply.

\* \* \* \* \*

■ 143. Amend § 63.506 by:

■ a. Revising and republishing paragraph (b)(1);

■ b. Revising paragraph (e)(4)(ii)(F)(1);

■ c. Adding paragraph (e)(4)(ii)(F)(6);

■ d. Revising paragraph (e)(5) introductory text;

■ e. Revising and republishing paragraph (e)(5)(i);

■ f. Adding paragraph (e)(5)(xiii);

■ g. Revising and republishing paragraph (e)(6);

■ h. Revising paragraph (e)(7) introductory text;

■ i. Adding paragraph (e)(7)(vi);

■ j. Revising paragraph (i)(1); and

■ k. Adding paragraph (i)(3).

The additions, revisions, and republications read as follows:

**§ 63.506 General recordkeeping and reporting provisions.**

\* \* \* \* \*

(b) \* \* \*

(1) *Malfunction records.* Each owner or operator of an affected source subject to this subpart shall maintain records of the occurrence and duration of each malfunction of operation (i.e., process equipment), air pollution control equipment, or monitoring equipment. Each owner or operator shall maintain records of actions taken during periods of malfunction to minimize emissions in accordance with § 63.483(a), including corrective actions to restore malfunctioning process and air pollution control and monitoring equipment to its normal or usual manner of operation.

(i) *Records of start-up, shutdown, and malfunction.* Except as specified in paragraph (b)(1)(i)(D) of this section, the owner or operator shall keep the records specified in paragraphs (b)(1)(i)(A) through (b)(1)(i)(C) of this section.

(A) Records of the occurrence and duration of each start-up, shutdown, and malfunction of operation of process equipment or control devices or recovery devices or continuous monitoring systems used to comply with this subpart during which excess emissions occur.

(B) For each start-up, shutdown, or malfunction during which excess emissions occur, records reflecting whether the procedures specified in the affected source's start-up, shutdown, and malfunction plan were followed, and documentation of actions taken that are not consistent with the plan. For example, if a start-up, shutdown, and malfunction plan includes procedures for routing a control device to a backup control device, records shall be kept of whether the plan was followed. These records may take the form of a "checklist," or other form of recordkeeping that confirms conformance with the start-up, shutdown, and malfunction plan for the event.

(C) Records specified in paragraphs (b)(1)(i)(A) and (B) of this section are not required if they pertain solely to Group 2 emission points that are not included in an emissions average.

(D) On and after July 15, 2027, paragraphs (b)(1)(i)(A) through (b)(1)(i)(C) no longer apply; however, for historical compliance purposes, a copy of these records must be retained and available on-site for five years after July 15, 2027.

(ii) *Reports of start-up, shutdown, and malfunction.* For the purposes of this subpart, the semiannual start-up, shutdown, and malfunction reports shall be submitted on the same schedule as the Periodic Reports required under paragraph (e)(6) of this section instead of the schedule specified in

§ 63.10(d)(5)(i). The reports shall include the information specified in § 63.10(d)(5)(i). On and after July 15, 2027, this paragraph no longer applies.

- \* \* \* \* \*
- (e) \* \* \*
- (4) \* \* \*
- (ii) \* \* \*
- (F) \* \* \*

(1) The required documentation shall include the values of the parameters used to determine whether the emission point is Group 1 or Group 2. Except as specified in paragraph (e)(4)(ii)(F)(6) of this section, where a TRE index value is used for continuous front-end process vent group determination, the estimated or measured values of the parameters used in the TRE equation in § 63.115(d) and the resulting TRE index value shall be submitted.

\* \* \* \* \*

(6) For each affected source as described in § 63.480, beginning no later than the compliance dates specified in § 63.481(n), that last sentence of paragraph (e)(4)(ii)(F)(1) of this section no longer applies.

\* \* \* \* \*

(5) *Notification of Compliance Status.* For existing and new affected sources, a Notification of Compliance Status shall be submitted. For equipment leaks subject to § 63.502, the owner or operator shall submit the information required in § 63.182(c) in the Notification of Compliance Status within 150 days after the first applicable compliance date for equipment leaks in the affected source, and an update shall be provided in the first Periodic Report that is due at least 150 days after each subsequent applicable compliance date for equipment leaks in the affected source. For all other emission points, including heat exchange systems, the Notification of Compliance Status shall contain the information listed in paragraphs (e)(5)(i) through (xiii) of this section, as applicable, and shall be submitted no later than 150 days after the compliance dates specified in this subpart.

(i) The results of any emission point group determinations, process section applicability determinations, performance tests, inspections, any other information used to demonstrate compliance, values of monitored parameters established during performance tests, and any other information required to be included in the Notification of Compliance Status under §§ 63.122 and 63.484 for storage vessels, § 63.117 for continuous front-end process vents, § 63.492 for batch front-end process vents, § 63.499 for back-end process operations, § 63.146

for process wastewater, and § 63.503 for emission points included in an emissions average. In addition, the owner or operator of an affected source shall comply with paragraphs (e)(5)(i)(A) and (B) of this section.

(A) For performance tests, group determinations, and process section applicability determinations that are based on measurements, the Notification of Compliance Status shall include one complete test report, except as specified in paragraph (e)(5)(i)(B) of this section, for each test method used for a particular kind of emission point. For additional tests performed for the same kind of emission point using the same method, the results and any other information, from the test report, that is requested on a case-by-case basis by the Administrator shall be submitted, but a complete test report is not required.

(B) If the performance test results have been submitted electronically via the Compliance and Emissions Data Reporting Interface (CEDRI) in accordance with paragraph (i) of this section, the unit(s) tested, the pollutant(s) tested, and the date that such performance test was conducted may be submitted in the Notification of Compliance Status in lieu of the performance test report. The performance test results must be submitted to CEDRI by the date the Notification of Compliance Status is submitted. A complete test report shall include a brief process description, sampling site description, description of sampling and analysis procedures and any modifications to standard procedures, quality assurance procedures, record of operating conditions during the test, record of preparation of standards, record of calibrations, raw data sheets for field sampling, raw data sheets for field and laboratory analyses, documentation of calculations, and any other information required by the test method.

\* \* \* \* \*

(xiii) For flares subject to the requirements in § 63.508, owners and operators must also submit the information in this paragraph in a supplement to the Notification of Compliance Status within 150 days after the first applicable compliance date for flare monitoring. The supplement to the Notification of Compliance Status must include flare design (e.g., steam-assisted, air-assisted, or non-assisted); all visible emission readings, heat content determinations, flow rate measurements, and exit velocity determinations made during the initial visible emissions demonstration required by § 63.670(h), as applicable;

and all periods during the compliance determination when the pilot flame or flare flame is absent.

(6) *Periodic Reports.* For existing and new affected sources, the owner or operator shall submit Periodic Reports as specified in paragraphs (e)(6)(i) through (xiii) of this section. In addition, for equipment leaks subject to § 63.502, the owner or operator shall submit the information specified in § 63.182(d) under the conditions listed in § 63.182(d) as part of the Periodic Report required by this paragraph (e)(6), and for heat exchange systems subject to § 63.502(n), the owner or operator shall submit the information specified in § 63.104(f)(2) as part of the Periodic Report required by this paragraph (e)(6). Section § 63.505 shall govern the use of monitoring data to determine compliance for Group 1 emission points and for Group 1 and Group 2 emission points included in emissions averages with the following exception: As discussed in § 63.484(k), for storage vessels to which the provisions of § 63.505 do not apply, as specified in the monitoring plan required by § 63.120(d)(2), the owner or operator is required to comply with the requirements set out in the monitoring plan, and monitoring records may be used to determine compliance. On and after July 15, 2027 or once the reporting template for this subpart has been available on the CEDRI website for 1 year, whichever date is later, owners and operators must submit all subsequent reports following the procedure specified in § 63.9(k), except any medium submitted through mail must be sent to the attention of the Polymers and Resins Sector Lead. Owners and operators must use the appropriate electronic report template on the CEDRI website (<https://www.epa.gov/electronic-reporting-air-emissions/cedri>) for this subpart. The date report templates become available will be listed on the CEDRI website. Unless the Administrator or delegated state agency or other authority has approved a different schedule for submission of reports under § 63.9(i) and § 63.10(a), the report must be submitted by the deadline specified in this subpart, regardless of the method in which the report is submitted.

(i) Except as specified in paragraphs (e)(6)(xi) and (xii) of this section, a report containing the information in paragraph (e)(6)(ii) of this section or paragraphs (e)(6)(iii) through (x) and (xiii) of this section, as appropriate, shall be submitted semiannually no later than 60 days after the end of each 6-month period. The first report shall be submitted no later than 240 days after

the date the Notification of Compliance Status is due and shall cover the 6-month period beginning on the date the Notification of Compliance Status is due. All periodic reports must contain the company name and address (including county), as well as the beginning and ending dates of the reporting period.

(ii) If none of the compliance exceptions in paragraphs (e)(6)(iii) through (ix) or (xiii) of this section occurred during the 6-month period, the Periodic Report required by paragraph (e)(6)(i) of this section shall be a statement that there were no compliance exceptions as described in this paragraph for the 6-month period covered by that report and that none of the activities specified in paragraphs (e)(6)(iii) through (ix) or (xiii) of this section occurred during the 6-month period covered by that report.

For an owner or operator of an affected source complying with the provisions of §§ 63.484 through 63.501 for any emission point, Periodic Reports shall include:

(A) All information specified in § 63.122(a)(4) for storage vessels, §§ 63.117(a)(3) and 63.118(f) and 63.485(s)(5) for continuous front-end process vents, § 63.492 for batch front-end process vents and aggregate batch vent streams, § 63.499 for back-end process operations, § 63.104(f)(2) for heat exchange systems, and §§ 63.146(c) through 63.146(g) for process wastewater.

(B) The daily average values or batch cycle daily average values of monitored parameters for all excursions, as defined in § 63.505(g) and § 63.505(h). For excursions caused by lack of monitoring data, the start date and time and duration (in hours) of periods when monitoring data were not collected shall be specified.

(C) For each affected source as described in § 63.480, beginning no later than the compliance dates specified in § 63.481(n), for each excursion that is not an excused excursion, the report must include the date of the excursion, a list of the affected sources or equipment, an estimate of the quantity in pounds of each regulated pollutant emitted over any emission limit, a description of the method used to estimate the emissions, the cause of the excursion (including unknown cause, if applicable), as applicable, and the corrective action taken.

(D) The information in paragraphs (e)(6)(iii)(D)(1) through (e)(6)(iii)(D)(5) of this section, as applicable:

(1) Any supplements to the Emissions Averaging Plan, as required in paragraph (e)(4)(iii) of this section;

(2) Notification if a process change is made such that the group status of any emission point changes from Group 2 to Group 1. The owner or operator is not required to submit a notification of a process change if that process change caused the group status of an emission point to change from Group 1 to Group 2. However, until the owner or operator notifies the Administrator that the group status of an emission point has changed from Group 1 to Group 2, the owner or operator is required to continue to comply with the Group 1 requirements for that emission point. This notification may be submitted at any time.

(3) Notification if one or more emission points (other than equipment leaks) or one or more EPPU is added to an affected source. The owner or operator shall submit the information contained in paragraphs (e)(6)(iii)(D)(3)(i) through (e)(6)(iii)(D)(3)(ii) of this section.

(i) A description of the addition to the affected source; and

(ii) Notification of the group status of the additional emission point or all emission points in the EPPU.

(4) Notification if a standard operating procedure, as defined in § 63.500(a)(2), is changed and the change has the potential for increasing the concentration of carbon disulfide in the crumb dryer exhaust. This notification shall also include a summary of the test results of the carbon disulfide concentration resulting from the new standard operating procedure. The results of the performance test must be submitted according to paragraph (i) of this section by the date the Periodic Report is submitted.

(5) For process wastewater streams sent for treatment pursuant to § 63.132(g), reports of changes in the identity of the treatment facility or transferee.

(E) The start date, start time, duration in hours, and a brief description for each type of malfunction which occurred during the reporting period and which caused or may have caused any applicable emission limitation to be exceeded. The report must also include a description of actions taken by an owner or operator during a malfunction of an affected source to minimize emissions in accordance with § 63.483(a), including actions taken to correct a malfunction.

(iv) For each batch front-end process vent with a batch mass input limitation, every second Periodic Report shall include the mass of HAP or material input to the batch unit operation during the 12-month period covered by the preceding and current Periodic Reports, and a statement of whether the batch



front-end process vent was in or out of compliance with the batch mass input limitation.

(v) Except as specified in paragraph (i) of this section, if any performance tests are reported in a Periodic Report, the following information shall be included:

(A) One complete test report shall be submitted for each test method used for a particular kind of emission point tested. A complete test report shall contain the information specified in paragraph (e)(5)(i)(B) of this section.

(B) For additional tests performed for the same kind of emission point using the same method, results and any other information, pertaining to the performance test, that is requested on a case-by-case basis by the Administrator shall be submitted, but a complete test report is not required.

(vi) Notification of a change in the primary product of an EPPU, in accordance with the provisions in § 63.480(f). This includes a change in primary product from one elastomer product to either another elastomer product or to a non-elastomer product.

(vii) The results for each change made to a predominant use determination made under § 63.480(g) for a storage vessel that is assigned to an affected source subject to this subpart after the change.

(viii) The results for each change made to a predominant use determination made under § 63.480(h) for recovery operations equipment assigned to an affected source subject to this subpart after the change.

(ix) An owner or operator complying with paragraph (h)(1) of this section shall notify the Administrator of the election to comply with paragraph (h)(1) of this section as part of the Periodic Report or as part of the Notification of Compliance Status as specified in paragraph (e)(5)(xi) of this section.

(x) An owner or operator electing not to retain daily average or batch cycle daily average values under paragraph (h)(2) of this section shall notify the Administrator as specified in paragraph (h)(2)(i) of this section.

(xi) The owner or operator of an affected source shall submit quarterly reports for all emission points included in an emissions average as specified in paragraphs (e)(6)(xi)(A) through (C) of this section.

(A) The quarterly reports shall be submitted no later than 60 days after the end of each quarter. The first report shall be submitted with the Notification of Compliance Status no later than 150 days after the compliance date.

(B) The quarterly reports shall include the information specified in paragraphs (e)(6)(xi)(B)(1) through (e)(6)(xi)(B)(7) of

this section for all emission points included in an emissions average.

(1) The credits and debits calculated each month during the quarter;

(2) A demonstration that debits calculated for the quarter are not more than 1.30 times the credits calculated for the quarter, as required under § 63.503(e)(4);

(3) The values of any inputs to the debit and credit equations in § 63.503(g) and (h) that change from month to month during the quarter or that have changed since the previous quarter;

(4) Except as specified in paragraph (i) of this section, results of any performance tests conducted during the reporting period including one complete report for each test method used for a particular kind of emission point as described in paragraph (e)(6)(v) of this section. If the performance test was submitted to CEDRI, include the unit(s) tested, the pollutant(s) tested, and the date of the performance test(s) in the quarterly report. The performance test results must be submitted to CEDRI by the date the quarterly report is due;

(5) Reports of daily average values or batch cycle daily averages of monitored parameters for excursions as defined in § 63.505(g) or (h) and the date of the excursion;

(6) For excursions caused by lack of monitoring data, the start date and time and duration in hours of periods when monitoring data were not collected shall be specified; and

(7) Any other information the affected source is required to report under the operating permit or Emissions Averaging Plan for the affected source.

(C) Every fourth quarterly report shall include the following:

(1) A demonstration that annual credits are greater than or equal to annual debits as required by § 63.503(e)(3); and

(2) A certification of compliance with all the emissions averaging provisions in § 63.503.

(xii) The owner or operator of an affected source shall submit quarterly reports for particular emission points and process sections not included in an emissions average as specified in paragraphs (e)(6)(xii)(A) through (D) of this section.

(A) The owner or operator of an affected source shall submit quarterly reports for a period of 1 year for an emission point or process section that is not included in an emissions average if:

(1) A control or recovery device for a particular emission point or process section has more excursions, as defined in § 63.505(g) or (h), than the number of excused excursions allowed under

§ 63.505(i) for a semiannual reporting period; or

(2) The Administrator requests that the owner or operator submit quarterly reports for the emission point or process section.

(B) The quarterly reports shall include all information specified in paragraphs (e)(6)(iii) through (ix) of this section, as applicable to the emission point or process section for which quarterly reporting is required under paragraph (e)(6)(xii)(A) of this section. Information applicable to other emission points within the affected source shall be submitted in the semiannual reports required under paragraph (e)(6)(i) of this section.

(C) Quarterly reports shall be submitted no later than 60 days after the end of each quarter.

(D) After quarterly reports have been submitted for an emission point for 1 year without more excursions occurring (during that year) than the number of excused excursions allowed under § 63.505(i), the owner or operator may return to semiannual reporting for the emission point or process section.

(xiii) The information specified in § 63.108(l)(2).

(7) *Other reports.* Other reports shall be submitted as specified in paragraphs (e)(7)(i) through (vi) of this section.

\* \* \* \* \*

(vi) For fenceline monitoring systems subject to § 63.184, each owner or operator must submit the Fenceline Monitoring Reports required by § 63.182(e) on a quarterly basis following the procedures specified in § 63.182(e).

\* \* \* \* \*

(i)(1) Except as specified in paragraph (i)(3) of this section, as of January 1, 2012, and within 60 days after the date of completing each performance test, as defined in § 63.2 and as required in this subpart, you must submit performance test data, except opacity data, electronically to EPA's Central Data Exchange by using the Electronic Reporting Tool (ERT) (see <http://www.epa.gov/ttn/chief/ert/erttool.html/>) or other compatible electronic spreadsheet. Only data collected using test methods compatible with ERT are subject to this requirement to be submitted electronically into EPA's WebFIRE database.

\* \* \* \* \*

(3) Beginning no later than July 15, 2024, owners and operators must submit performance test reports in accordance with this paragraph. Unless otherwise specified in this subpart, within 60 days after the date of completing each performance test required by this

subpart, owners and operators must submit the results of the performance test following the procedures specified in § 63.9(k). Data collected using test methods supported by the EPA's Electronic Reporting Tool (ERT) as listed on the EPA's ERT website (<https://www.epa.gov/electronic-reporting-air-emissions/electronic-reporting-tool-ert>) at the time of the test must be submitted in a file format generated through the use of the EPA's ERT. Alternatively, owners and operators may submit an electronic file consistent with the extensible markup language (XML) schema listed on the EPA's ERT website. Data collected using test methods that are not supported by the EPA's ERT as listed on the EPA's ERT website at the time of the test must be included as an attachment in the ERT or alternate electronic file.

■ 144. Amend § 63.507 by revising paragraph (c) introductory text and adding paragraphs (c)(5) and (6) to read as follows:

**§ 63.507 Implementation and enforcement.**

\* \* \* \* \*

(c) The authorities that cannot be delegated to State, local, or Tribal agencies are as specified in paragraphs (c)(1) through (6) of this section.

\* \* \* \* \*

(5) Approval of an alternative to any electronic reporting to the EPA required by this subpart.

(6) Approval of an extension request under § 63.6(i)(4)(ii).

■ 145. Add § 63.508 to read as follows:

**§ 63.508 Flare requirements.**

(a) For any flare that is used to reduce organic HAP emissions from an EPPU, the owner or operator may elect to comply with the requirements in this section in lieu of the requirements of § 63.11(b) and the requirements referenced therein. The owner or operator may also elect to comply with the requirements in this section pursuant to the overlap provisions provided in § 63.481(k)(2). However, beginning no later than the compliance dates specified in § 63.481(n), the provisions specified in paragraphs (a)(1) through (32) of this section no longer apply. Instead, if an owner or operator reduces organic HAP emissions from an EPPU by venting emissions through a closed-vent system to a steam-assisted, air-assisted, or non-assisted flare, then the owner or operator must meet the applicable requirements for flares as specified in §§ 63.670 and 63.671, including the provisions in tables 12 and 13 to subpart CC of this part, except as specified in paragraph (b) of this

section. This requirement also applies to any flare using fuel gas from a fuel gas system, of which 50 percent or more of the fuel gas is derived from a EPPU, as determined on an annual average basis. For purposes of compliance with this paragraph, the following terms are defined in § 63.641 of subpart CC of this part: Assist air, assist steam, center steam, combustion zone, combustion zone gas, flare, flare purge gas, flare supplemental gas, flare sweep gas, flare vent gas, lower steam, net heating value, perimeter assist air, pilot gas, premix assist air, total steam, and upper steam.

(1) §§ 63.487(a)(1)(i) and (b)(1)(i);  
 (2) § 63.489(b)(2);  
 (3) § 63.490(a)(1);  
 (4) §§ 63.491(b)(3)(i) through (b)(3)(iii);  
 (5) § 63.494(d);  
 (6) § 63.496(b)(7)(i)(A);  
 (7) § 63.497(a)(2);  
 (8) § 63.498(d)(5)(ii)(E);  
 (9) § 63.502(k)(1);  
 (10) §§ 63.504(c)(1) through (c)(3);  
 (11) § 63.107(h)(9)(i) related to criteria

in § 63.11(b);  
 (12) § 63.113(a)(1);  
 (13) § 63.114(a)(2);  
 (14) §§ 63.116(a)(1) through (a)(3);  
 (15) §§ 63.117(a)(5)(i) through (a)(5)(iii);

(16) § 63.118(f)(5);  
 (17) The last sentence in

§ 63.119(e)(1);

(18) §§ 63.120(e)(1) through (e)(6);

(19) §§ 63.122(c)(2) and (g)(3);

(20) § 63.126(b)(2)(i);

(21) § 63.127(a)(2);

(22) §§ 63.128(b)(1) through (b)(3);

(23) §§ 63.129(a)(5)(i) through

(a)(5)(iii);

(24) §§ 63.130(a)(2)(i), (c), and (d)(5);

(25) §§ 63.139(c)(3) and (d)(3);

(26) §§ 63.145(j)(1) through (j)(3);

(27) §§ 63.146(b)(7)(i)(A) through

(b)(7)(i)(C);

(28) § 63.147(d)(1);

(29) §§ 63.172(d);

(30) §§ 63.180(e)(1) through (e)(3);

(31) § 63.181(g)(1)(iii); and

(32) The phrase “including periods

when a flare pilot light system does not have a flame” in § 63.181(g)(2)(i).

(b) The exceptions specified in paragraphs (b) through (o) of § 63.108 apply, except as specified in paragraphs (b)(1) through (5) of this section.

(1) Where the term “chemical manufacturing process unit” is used, the term “EPPU” applies instead for the purposes of this subpart.

(2) Where the reference “§ 63.100(k)(10)” is used, the reference § 63.481(n) applies instead for the purposes of this subpart.

(3) Where the phrase “Hazardous Organic Chemical Manufacturing” is

used, the phrase “Polymers and Resins” applies instead for the purposes of this subpart.

(4) Where the reference “§ 63.152(b)(7) of subpart G of this part” is used, the reference

“§ 63.506(e)(5)(xiii)” applies instead for the purposes of this subpart.

(5) Section 63.108(i) does not apply.

■ 146. Add § 63.509 to read as follows:

**§ 63.509 Procedures for determining whether process vents, storage vessels, or wastewater are in chloroprene service.**

This section applies beginning no later than the compliance dates specified in § 63.481(o). To determine if process vents, storage vessels, or wastewater in a process at affected sources producing neoprene are in chloroprene service, as defined in § 63.482, owners and operators must comply with the requirements in paragraphs (a) through (c) of this section, as applicable.

(a) For each continuous front-end process vent, each batch front-end process vent, and each back-end process vent in a process at affected sources producing neoprene, owners and operators must measure the flow rate and concentration of chloroprene of each process vent as specified in paragraphs (a)(1) through (5) of this section.

(1) Measurements must be made prior to any dilution of the vent streams.

(2) Measurements may be made on the combined vent streams at an elastomer product process unit or for each separate vent stream.

(3) The sampling site shall be after the last recovery device (if any recovery devices are present) but prior to the inlet of any control device that is present and prior to release to the atmosphere. Method 1 or 1A of appendix A–1 to 40 CFR part 60, as appropriate, must be used for the selection of the sampling sites. For vents smaller than 0.10 meter in diameter, sample at one point at the center of the duct.

(4) The gas volumetric flow rate must be determined using Method 2, 2A, 2C, 2D, 2F, or 2G of appendices A–1 and A–2 to 40 CFR part 60, as appropriate.

(5) Except as specified in paragraph (a)(6) of this section, the concentration of chloroprene must be determined using Method 18 of appendix A–6 to 40 CFR part 60 or Method 320 of appendix A to this part.

(6) You may elect to use ASTM D6348–12 (Reapproved 2020) (incorporated by reference, § 63.14) in lieu of Method 320 of appendix A to this part as specified in paragraph (a)(5) of this section. To comply with this

paragraph, Annexes A1 through A8 to ASTM D6348–12 (Reapproved 2020) are mandatory; the percent (%) R must be determined for each target analyte using Equation A5.5 of ASTM D6348–12 (Reapproved 2020) Annex A5 (Analyte Spiking Technique); and in order for the test data to be acceptable for a compound, the %R must be  $70\% \geq R \leq 130\%$ . If the %R value does not meet this criterion for a target compound, then the test data is not acceptable for that compound and the test must be repeated for that analyte (*i.e.*, the sampling and/or analytical procedure should be adjusted before a retest). The %R value for each compound must be reported in the test report, and all field measurements must be corrected with the calculated %R value for that compound by using the following equation:

Equation 1 to Paragraph (a)(6)

Reported Results = (Measured Concentration in the Stack  $\times$  100) / %R.

(b) For storage vessels in a process at affected sources producing neoprene, owners and operators must determine the concentration of chloroprene of the fluid stored in the storage vessels by complying with the requirements in paragraph (b)(1) or (2) of this section.

(1) The owner or operator must measure concentration of chloroprene of the fluid stored in the storage vessel using Method 624.1 of appendix A to 40 CFR part 136 or preparation by Method SW–846–5030B (incorporated by reference, see § 63.14) and analysis by Method SW–846–8260D (incorporated by reference, see § 63.14). If owners and operators collect a sample from a pressure vessel, then the owner or operator must maintain the sample under pressure both during and following sampling.

(2) Unless specified by the Administrator, the owner or operator may calculate the concentration of chloroprene of the fluid stored in the storage vessels if information specific to the fluid stored is available. Information specific to the fluid stored includes concentration data from safety data sheets.

(c) For wastewater in a process at affected sources producing neoprene, owners and operators must measure concentration of chloroprene of the fluid stored in the storage vessel using Method 624.1 of appendix A to 40 CFR part 136, or preparation by Method SW–846–5030B (incorporated by reference, see § 63.14) and analysis by Method SW–846–8260D (incorporated by reference, see § 63.14). If owners and operators collect a sample from a

pressure vessel, then the owner or operator must maintain the sample under pressure both during and following sampling.

■ 147. Add § 63.510 to read as follows:

**§ 63.510 Process vents, storage vessels, and wastewater that are in chloroprene service—procedures to determine compliance.**

This section applies beginning no later than the compliance dates specified in § 63.481(o). In order to demonstrate compliance with the emission limits and work practice standards specified in § 63.485(y) (for continuous front-end process vents in chloroprene service), § 63.487(j) (for batch front-end process vents in chloroprene service), § 63.494(a)(7) (for back-end process vents in chloroprene service), § 63.484(u) (for storage vessels in chloroprene service), and § 63.501(a)(10)(iv) (for wastewater in chloroprene service), owners and operators must meet the requirements specified in paragraphs (a) and (b) of this section.

(a) For initial compliance, owners and operators must comply with paragraphs (a)(1) through (4) of this section, as applicable.

(1) [Reserved]

(2) If an owner or operator chooses to reduce emissions of chloroprene by venting emissions through a closed vent system to a non-flare control device that reduces chloroprene by greater than or equal to 98 percent by weight as specified in § 63.484(u), § 63.485(y), § 63.487(j), or § 63.494(a)(7) then the owner or operator must comply with § 63.148 and paragraphs (a)(2)(i) through (viii) of this section.

(i) Conduct an initial performance test of the control device that is used to comply with the percent reduction requirement at the inlet and outlet of the control device. For purposes of compliance with this paragraph, owners and operators may not use a design evaluation. This paragraph does not apply if the conditions specified in paragraphs (a)(2)(i)(A) through (D) of this section are met for a previously-conducted measurement or performance test.

(A) No changes have been made to the process since the time of the measurement or performance test;

(B) The operating conditions and test methods used during measurement or performance test conform to the chloroprene related requirements of this subpart;

(C) The control device and process parameter values established during the previously-conducted measurement or performance test are used to

demonstrate continuous compliance with the chloroprene related requirements of this subpart; and

(D) The previously-conducted measurement or performance test was completed within the last 60 months.

(ii) Conduct the performance test according to the procedures in § 63.504 and in § 63.116(c). Except as specified in § 63.509(a)(6), use Method 18 of 40 CFR part 60, appendix A–6 or Method 320 of appendix A to this part to determine the chloroprene concentration. Use Method 1 or 1A of 40 CFR part 60, appendix A–1 to select the sampling sites at each sampling location. Determine the gas volumetric flowrate using Method 2, 2A, 2C, or 2D of 40 CFR part 60, appendix A–2. Use Method 4 of 40 CFR part 60, appendix A–3 to convert the volumetric flowrate to a dry basis.

(iii) Calculate the mass emission rate of chloroprene entering the control device and exiting the control device using Equations 1 and 2 to this paragraph.

Equations 1 and 2 to Paragraph (a)(2)(iii)

$$E_{i,inlet} = K C_{i,inlet} M Q_{i,inlet} \text{ (Eq. 1)}$$

$$E_{o,outlet} = K C_{o,outlet} M Q_{o,outlet} \text{ (Eq. 2)}$$

Where:

$E_{i,inlet}$ ,  $E_{o,outlet}$  = Mass rate of chloroprene at the inlet and outlet of the control device, respectively, kilogram per hour.

$C_{i,inlet}$ ,  $C_{o,outlet}$  = Concentration of chloroprene in the gas stream at the inlet and outlet of the control device, respectively, dry basis, parts per million by volume.

$M$  = Molecular weight of chloroprene, 88.54 grams per gram-mole.

$Q_{i,inlet}$ ,  $Q_{o,outlet}$  = Flow rate of the gas stream at the inlet and outlet of the control device, respectively, dry standard cubic meter per minute.

$K$  = Constant,  $2.494 \times 10^{-6}$  (parts per million) $^{-1}$  (gram-mole per standard cubic meter) (kilogram per gram) (minutes per hour), where standard temperature (gram-mole per standard cubic meter) is 20 °C.

(iv) Calculate the percent reduction from the control device using equation 3 to this paragraph. An owner or operator has demonstrated initial compliance with § 63.113(j)(2) or § 63.119(a)(5)(ii) if the overall reduction of chloroprene is greater than or equal to 98 percent by weight.

Equation 3 to Paragraph (a)(2)(iv)

$$\text{Percent reduction} = (E_{i,inlet} - E_{o,outlet}) / E_{i,inlet} * 100 \text{ (Eq. 3)}$$

Where:

$E_{i,inlet}$ ,  $E_{o,outlet}$  = Mass rate of chloroprene at the inlet and outlet of the control device, respectively, kilogram per hour, calculated using Equations 5 and 6 to paragraph (a)(2)(iii) of this section.

(v) If a new control device is installed, then conduct a performance test of the new device following the procedures in paragraphs (a)(2)(i) through (iv) of this section.

(vi) [Reserved]

(vii) If an owner or operator vents emissions through a closed vent system to a thermal oxidizer, then the owner or operator must establish operating parameter limits by monitoring the operating parameters specified in paragraphs (a)(2)(vii)(A) and (B) of this section during the performance test.

(A) Combustion chamber temperature. Determine the average combustion chamber temperature during the performance test as the average of the test run averages.

(B) Flue gas flow rate. Determine the average flue gas flow rate during the performance test as the average of the test run averages.

(viii) If an owner or operator vents emissions through a closed vent system to a control device other than a thermal oxidizer, then the owner or operator must notify the Administrator of the operating parameters that are planned to be monitored during the performance test prior to establishing operating parameter limits for the control device.

(3) If an owner or operator chooses to reduce emissions of chloroprene by venting emissions through a closed vent system to a non-flare control device that reduces chloroprene to less than 1 ppmv as specified in § 63.484(u), § 63.485(y), § 63.487(j), or § 63.494(a)(7) then the owner or operator must comply with § 63.148 and either paragraph (a)(3)(i) or (ii) of this section.

(i) Install an FTIR CEMS meeting the requirements of Performance Specification 15 of 40 CFR part 60, appendix B to continuously monitor the chloroprene concentration at the exit of the control device. Comply with the requirements specified in § 63.2450(j) for CEMS.

(ii) If the owner or operator does not install a CEMS under paragraph (a)(3)(i) of this section, then the owner or operator must comply with paragraphs (a)(3)(ii)(A) through (C) of this section.

(A) Conduct an initial performance test at the outlet of the control device that is used to comply with the concentration requirement.

(B) Conduct the performance test according to the procedures in § 63.504 and in § 63.116(c). Except as specified in § 63.509(a)(6), use Method 18 of 40 CFR part 60, appendix A–6 or Method 320 of appendix A to this part to determine the chloroprene concentration. If the non-flare control device is a combustion device, correct the chloroprene concentration to 3

percent oxygen according to § 63.116(c)(iii)(B), except “TOC or organic HAP” and “TOC (minus methane and ethane) or organic HAP” in the Variables Cc and Cm must be replaced with “chloroprene”. An owner or operator has demonstrated initial compliance with § 63.484(u), § 63.485(y), § 63.487(j), or § 63.494(a)(7) if the chloroprene concentration is less than 1 ppmv.

(C) Comply with the requirements specified in paragraphs (a)(2)(v) through (viii) of this section, as applicable.

(4) If owners and operators choose to reduce emissions of chloroprene by venting emissions through a closed vent system to a non-flare control device that reduces chloroprene to less than 5 pounds per year for all combined process vents within the process as specified in § 63.113(j)(2), then the owner or operator must comply with § 63.148 and paragraphs (a)(4)(i) through (iv) of this section.

(i) Conduct an initial performance test of the control device that is used to comply with the mass emission limit requirement at the outlet of the control device.

(ii) Conduct the performance test according to the procedures in § 63.504 and in § 63.116(c). Except as specified in § 63.509(a)(6), use Method 18 of 40 CFR part 60, appendix A–6 or Method 320 of appendix A to this part to determine the chloroprene concentration. Use Method 1 or 1A of 40 CFR part 60, appendix A–1 to select the sampling site. Determine the gas volumetric flowrate using Method 2, 2A, 2C, or 2D of 40 CFR part 60, appendix A–2. Use Method 4 of 40 CFR part 60, appendix A–3 to convert the volumetric flowrate to a dry basis.

(iii) Calculate the mass emission rate of chloroprene exiting the control device using Equation 2 to paragraph (a)(2)(iii) of this section. An owner or operator has demonstrated initial compliance with § 63.113(j)(2) if the chloroprene from all process vents (controlled and uncontrolled) within the process is less than 5 pounds per year when combined.

(iv) Comply with the requirements specified in paragraphs (a)(2)(v) through (viii) of this section, as applicable.

(b) For continuous compliance, owners and operators must comply with paragraphs (b)(1) through (6) of this section, as applicable.

(1) [Reserved]

(2) If you choose to reduce emissions of chloroprene by venting emissions through a closed-vent system to a non-flare control device that reduces chloroprene to less than 1 ppmv as specified in § 63.113(j)(2) or

§ 63.119(a)(5)(ii) of subpart G of this part, and you choose to comply with paragraph (a)(3)(i) of this section, then continuously monitor the chloroprene concentration at the exit of the control device using an FTIR CEMS meeting the requirements of Performance Specification 15 of 40 CFR part 60, appendix B and § 63.2450(j). If an owner or operator uses an FTIR CEMS, then the owner or operator does not need to conduct the performance testing required in paragraph (b)(3) of this section or the operating parameter monitoring required in paragraphs (b)(4) through (6) of this section.

(3) Conduct a performance test no later than 60 months after the previous performance test and reestablish operating parameter limits following the procedures in paragraph (a)(2) through (4) of this section. The Administrator may request a repeat performance test at any time. For purposes of compliance with this paragraph, owners and operators may not use a design evaluation.

(4) [Reserved]

(5) If an owner or operator vents emissions through a closed vent system to a thermal oxidizer, then the owner or operator must comply with § 63.148, and the owner or operator must meet the operating parameter limits specified in paragraphs (b)(5)(i) and (ii) of this section and the requirements in paragraph (b)(5)(iii) of this section.

(i) Minimum combustion chamber temperature, equal to the average combustion chamber temperature measured during the most recent performance test. Determine combustion chamber temperature with a temperature sensor with a minimum accuracy of at least  $\pm 1$  percent over the normal range of temperature measured, expressed in degrees Celsius, or 2.8 degrees Celsius, whichever is greater. Compliance with the minimum combustion chamber temperature operating limit must be determined continuously on a 1-hour block basis.

(ii) Maximum flue gas flow rate, equal to the average flue gas flow rate measured during the most recent performance test. Determine flue gas flow rate with a flow sensor with a minimum accuracy of at least  $\pm 5$  percent over the normal range of flow measured, or 280 liters per minute (10 cubic feet per minute), whichever is greater. Compliance with the maximum flue gas flow rate operating limit must be determined continuously on a 1-hour block basis.

(iii) The owner or operator must maintain the thermal oxidizer in accordance with good combustion practices that ensure proper

combustion. Good combustion practices include, but are not limited to, proper burner maintenance, proper burner alignment, proper fuel to air distribution and mixing, routine inspection, and preventative maintenance.

(6) If an owner or operator vents emissions through a closed vent system to a control device other than a thermal oxidizer, then the owner or operator

must comply with § 63.148, and the owner or operator must monitor the operating parameters identified in paragraph (a)(2)(viii) of this section and meet the established operating parameter limits to ensure continuous compliance. The frequency of monitoring and averaging time will be determined based upon the information provided to the Administrator.

■ 148. Amend Table 1 to Subpart U by revising entry “§ 63.6(e)(1)(i)”, adding entry “§ 63.7(a)(4)”, revising entries “§ 63.8(c)(1)(i)”, “§ 63.8(c)(1)(iii)”, “§ 63.9(k)” and “63.10(d)(5)(i)”, removing entry “§ 63.10(d)(5)(ii)”, revising entry “§ 63.11”, and removing note a to read as follows:

TABLE 1 TO SUBPART U OF PART 63—APPLICABILITY OF GENERAL PROVISIONS TO SUBPART U AFFECTED SOURCES

Reference	Applies to subpart U	Explanation
§ 63.6(e)(1)(i)	No	See § 63.483(a) for general duty requirement. Any cross reference to § 63.6(e)(1)(i) in any other general provision incorporated by reference shall be treated as a cross reference to § 63.483(a).
§ 63.6(i)(4)(ii)	No; except yes for affected sources producing neoprene.	
§ 63.7(a)(4)	Yes.	
§ 63.8(a)(3)	No	[Reserved].
§ 63.8(a)(4)	Yes, except for flares subject to § 63.508.	
§ 63.8(b)(1)	Yes.	
§ 63.8(b)(2)	No	Subpart U specifies locations to conduct monitoring.
§ 63.8(b)(3)	Yes.	
§ 63.8(c)(1)(i)	Yes, before July 15, 2027. No, beginning on and after July 15, 2027.	
§ 63.8(c)(1)(iii)	Yes, before July 15, 2027. No, beginning on and after July 15, 2027.	
§ 63.9(k)	Yes.	
63.10(d)(5)	No.	
§ 63.11	Yes	Except for flares subject to § 63.508, § 63.11(b) specifies requirements for flares used to comply with provisions of this subpart. § 63.504(c) contains the requirements to conduct compliance demonstrations for flares subject to this subpart that are not subject to § 63.508. § 63.11(c), (d), and (e) specifies requirements for an alternative work practice for equipment leaks.

■ 149. Revise table 6 to subpart U to read as follows:

TABLE 6 TO SUBPART U OF PART 63—GROUP 1 BATCH FRONT-END PROCESS VENTS AND AGGREGATE BATCH VENT STREAMS—MONITORING, RECORDKEEPING, AND REPORTING REQUIREMENTS

Control/recovery device	Parameter to be monitored	Recordkeeping and reporting requirements for monitored parameters
Thermal incinerators other than those used for vents in chloroprene service.	Firebox temperature <sup>a</sup>	1. Continuous records as specified in § 63.491(e)(1). <sup>b</sup> 2. Record and report the average firebox temperature measured during the performance test—NCS. <sup>c</sup>

TABLE 6 TO SUBPART U OF PART 63—GROUP 1 BATCH FRONT-END PROCESS VENTS AND AGGREGATE BATCH VENT STREAMS—MONITORING, RECORDKEEPING, AND REPORTING REQUIREMENTS—Continued

Control/recovery device	Parameter to be monitored	Recordkeeping and reporting requirements for monitored parameters
Thermal oxidizers used for vents in chloroprene service.	a. Combustion chamber temperature .....  b. Flue gas flow rate .....	3. Record the batch cycle daily average firebox temperature as specified in § 63.491(e)(2). 4. Report all batch cycle daily average temperatures that are below the minimum operating value established in the NCS or operating permit and all instances when monitoring data are not collected—PR. <sup>d,e</sup> 1. Continuous records as specified in § 63.491(e)(1). <sup>b</sup>  2. Record and report the average firebox temperature measured during the performance test—NCS. <sup>c</sup> 3. Record the 1-hour block average firebox temperature as specified in § 63.510(b)(5)(i). 4. Report all 1-hour block average temperatures that are below the minimum operating value established in the NCS or operating permit and all instances when monitoring data are not collected—PR. <sup>d,e</sup> 1. Continuous records as specified in § 63.491(e)(1). <sup>b</sup> 2. Record and report the average flue gas flow rate measured during the performance test—NCS. <sup>c</sup> 3. Record the 1-hour block average flue gas flow rate as specified in § 63.510(b)(5)(ii). 4. Report all 1-hour block average flow rates that are above the maximum operating value established in the NCS or operating permit and all instances when monitoring data are not collected—PR. <sup>d,e</sup> 1. Continuous records as specified in § 63.491(e)(1). <sup>b</sup>
Catalytic incinerator .....	Temperature upstream and downstream of the catalyst bed.	2. Record and report the average upstream and downstream temperatures and the average temperature difference across the catalyst bed measured during the performance test—NCS. <sup>c</sup> 3. Record the batch cycle daily average upstream temperature and temperature difference across catalyst bed as specified in § 63.491(e)(2). 4. Report all batch cycle daily average upstream temperatures that are below the minimum upstream value established in the NCS or operating permit—PR. <sup>d,e</sup> 5. Reporting all batch cycle daily average temperature differences across the catalyst bed that are below the minimum difference established in the NCS or operating permit—PR. <sup>d,e</sup> 6. Report all instances when monitoring data are not collected. 1. Continuous records as specified in § 63.491(e)(1). <sup>b</sup>
Boiler or process heater with a design heat input capacity less than 44 megawatts and where the batch front-end process vents or aggregate batch vent streams are “not” introduced with or used as the primary fuel.	Firebox temperature <sup>a</sup> .....	1. Continuous records as specified in § 63.491(e)(1). <sup>b</sup>  2. Record and report the average firebox temperature measured during the performance test—NCS. <sup>c</sup> 3. Record the batch cycle daily average firebox temperature as specified in § 63.491(e)(2). <sup>d</sup> 4. Report all batch cycle daily average temperatures that are below the minimum operating value established in the NCS or operating permit and all instances when monitoring data are not collected—PR. <sup>d,e</sup>
Flare (if meeting the requirements of § 63.487(a)(1)(i) or (b)(1)(i)).	Presence of a flame at the pilot light .....	1. Hourly records of whether the monitor was continuously operating during light batch emission episodes selected for control and whether a flame was continuously present at the pilot light during each hour. 2. Record and report the presence of a flame at the pilot light over the full period of the compliance determination—NCS. <sup>c</sup> 3. Record the times and durations of all periods during batch emission episodes when all flames at the pilot light of a flare are absent or the monitor is not operating. 4. Report the times and durations of all periods during batch emission episodes selected for control when all flames at the pilot light of a flare are absent—PR. <sup>d</sup>
Flare (if meeting the requirements of § 63.487(a)(1)(iii) or (b)(1)(iii)).	The parameters are specified in paragraphs (b) through (o) of § 63.108 and § 63.508.	1. Records as specified in paragraph (m) of § 63.108 and § 63.508. 2. Report information as specified in paragraph (l) of § 63.108 and § 63.508—PR.
Scrubber for halogenated batch front-end process vents or aggregate batch vent streams (Note: Controlled by a combustion device other than a flare).	a. pH of scrubber effluent, and .....  b. Scrubber liquid and gas flow rates (§ 63.489(b)(4)(ii)).	1. Continuous records as specified in § 63.491(e)(1). <sup>b</sup> 2. Record and report the average pH of the scrubber effluent measured during the performance test—NCS. <sup>c</sup>  3. Record the batch cycle daily average pH of the scrubber effluent as specified in § 63.491(e)(2). 4. Report all batch cycle daily average pH values of the scrubber effluent that are below the minimum operating value established in the NCS or operating permit and all instances when insufficient monitoring data are collected—PR. <sup>d,e</sup> 1. Records as specified in § 63.491(e)(1). <sup>b</sup> 2. Record and report the scrubber liquid/gas ratio averaged over the full period of the performance test—NCS. <sup>c</sup> 3. Record the batch cycle daily average scrubber liquid/gas ratio as specified in § 63.491(e)(2).

TABLE 6 TO SUBPART U OF PART 63—GROUP 1 BATCH FRONT-END PROCESS VENTS AND AGGREGATE BATCH VENT STREAMS—MONITORING, RECORDKEEPING, AND REPORTING REQUIREMENTS—Continued

Control/recovery device	Parameter to be monitored	Recordkeeping and reporting requirements for monitored parameters
Absorber <sup>f</sup> .....	a. Exit temperature of the absorbing liquid, and.	4. Report all batch cycle daily average scrubber liquid/gas ratios that are below the minimum value established in the NCS or operating permit and all instances when insufficient monitoring data are collected—PR. <sup>d,e</sup> 1. Continuous records as specified in § 63.491(e)(1). <sup>b</sup>  2. Record and report the average exit temperature of the absorbing liquid measured during the performance test—NCS. <sup>c</sup> 3. Record the batch cycle daily average exit temperature of the absorbing liquid as specified in § 63.491(e)(2) for each batch cycle. 4. Report all the batch cycle daily average exit temperatures of the absorbing liquid that are above the maximum operating temperature established in the NCS or operating permit and all instances when monitoring data are not collected—PR. <sup>d,e</sup>
	b. Exit specific gravity of the absorbing liquid	1. Continuous records as specified in § 63.491(e)(1). <sup>b</sup> 2. Record and report the average exit specific gravity measured during the performance test—NCS. 3. Record the batch cycle daily average exit specific gravity as specified in § 63.491(e)(2). 4. Report all batch cycle daily average exit specific gravity values that are below the minimum operating value established in the NCS or operating permit and all instances when monitoring data are not collected—PR. <sup>d,e</sup>
Condenser <sup>f</sup> .....	Exit (product side) temperature .....	1. Continuous records as specified in § 63.491(e)(1). <sup>b</sup> 2. Record and report the average exit temperature measured during the performance test—NCS. 3. Record the batch cycle daily average exit temperature as specified in § 63.491(e)(2). 4. Report all batch cycle daily average exit temperatures that are above the maximum operating value established in the NCS or operating permit and all instances when monitoring data are not collected—PR. <sup>d,e</sup>
Carbon adsorber <sup>f</sup> .....	a. Total regeneration steam flow or nitrogen flow, or pressure gauge or absolute) during carbon bed regeneration cycle(s), and.	1. Record of total regeneration steam flow or nitrogen flow, or pressure for each carbon bed regeneration cycle.  2. Record and report the total regeneration steam flow or nitrogen flow, or pressure during each carbon bed regeneration cycle during the performance test—NCS. <sup>c</sup> 3. Report all carbon bed regeneration cycles when the total regeneration steam flow or nitrogen flow, or pressure is above the maximum value established in the NCS or operating permit—PR. <sup>d,e</sup>
	b. Temperature of the carbon bed after regeneration and within 15 minutes of completing any cooling cycle(s).	1. Record the temperature of the carbon bed after each regeneration and within 15 minutes of completing any cooling cycle(s).  2. Record and report the temperature of the carbon bed after each regeneration and within 15 minutes of completing any cooling cycle(s) measured during the performance test—NCS. <sup>c</sup> 3. Report all carbon bed regeneration cycles when the temperature of the carbon bed after regeneration, or within 15 minutes of completing any cooling cycle(s), is above the maximum value established in the NCS or operating permit—PR. <sup>d,e</sup>
	Outlet HAP or TOC concentration .....	For each nonregenerative adsorber and regenerative adsorber that is regenerated offsite subject to the requirements in § 63.489(b)(10), the owner or operator must record each outlet HAP or TOC concentration measured according to §§ 63.489(b)(10)(i) and (b)(10)(ii).
	Adsorbent replacement .....	1. For each nonregenerative adsorber and regenerative adsorber that is regenerated offsite subject to the requirements in § 63.489(b)(10), the owner or operator must record date and time the adsorbent was last replaced.
	Breakthrough .....	For each nonregenerative adsorber and regenerative adsorber that is regenerated offsite subject to the requirements in § 63.489(b)(10), the owner or operator must: 1. Record breakthrough limit and bed life established according to § 63.489(b)(10)(i). 2. Report the date of each instance when breakthrough, as defined in § 63.101, is detected between the first and second adsorber and the adsorber is not replaced according to § 63.489(b)(10)(iii)(A)—PR. <sup>g</sup>
Sorbent injection .....	a. Sorbent injection rate .....	1. Continuous records as specified in § 63.491(e)(1). <sup>b</sup> 2. Record and report the average sorbent injection rate measured during the performance test—NCS. <sup>c</sup> 3. Record the batch cycle daily average sorbent injection rate as specified in § 63.491(e)(2). 4. Report all batch cycle daily average sorbent injection rates that are below the minimum value established in the NCS or operating permit and all instances when insufficient monitoring data are collected—PR. <sup>d,e</sup>
	b. Carrier gas flow rate .....	1. Continuous records as specified in § 63.491(e)(1). <sup>b</sup> 2. Record and report the average carrier gas flow rate measured during the performance test—NCS. <sup>c</sup>

TABLE 6 TO SUBPART U OF PART 63—GROUP 1 BATCH FRONT-END PROCESS VENTS AND AGGREGATE BATCH VENT STREAMS—MONITORING, RECORDKEEPING, AND REPORTING REQUIREMENTS—Continued

Control/recovery device	Parameter to be monitored	Recordkeeping and reporting requirements for monitored parameters
All control devices .....	a. Diversion to the atmosphere from the control device <i>or</i> .  b. Monthly inspections of sealed valves .....	<ol style="list-style-type: none"> <li>Record the batch cycle daily average carrier gas flow rate as specified in § 63.491(e)(2).</li> <li>Report all batch cycle daily average carrier gas flow rates that are below the minimum value established in the NCS or operating permit and all instances when insufficient monitoring data are collected—PR.<sup>d,e</sup></li> <li>Hourly records of whether the flow indicator was operating during batch emission episodes selected for control and whether a diversion was detected at any time during the hour, as specified in § 63.491(e)(3).</li> <li>Record and report the times of all periods during batch emission episodes selected for control when emissions are diverted through a bypass line, or the flow indicator is not operating—PR.<sup>d</sup></li> <li>For each affected source as described in § 63.480, beginning no later than the compliance dates specified in § 63.481(n), record and report the start date, start time, duration in hours, estimate of the volume of gas in standard cubic feet, the concentration of organic HAP in the gas in parts per million by volume and the resulting mass emissions of organic HAP in pounds that bypass a control device. For periods when the flow indicator is not operating, report the start date, start time, and duration in hours—PR.<sup>d</sup></li> <li>Records that monthly inspections were performed as specified in § 63.491(e)(4)(i).</li> <li>Record and report all monthly inspections that show that valves are in the diverting position or that a seal has been broken—PR.<sup>d</sup></li> <li>For each affected source as described in § 63.480, beginning no later than the compliance dates specified in § 63.481(n), record and report the start date, start time, duration in hours, estimate of the volume of gas in standard cubic feet, the concentration of organic HAP in the gas in parts per million by volume and the resulting mass emissions of organic HAP in pounds that bypass a control device. For periods when the flow indicator is not operating, report the start date, start time, and duration in hours—PR.<sup>d</sup></li> </ol>
Absorber, condenser, and carbon adsorber (as an alternative to the above).	Concentration level or reading indicated by an organic monitoring device at the outlet of the recovery device.	<ol style="list-style-type: none"> <li>Continuous records as specified in § 63.491(e)(1).<sup>b</sup></li> <li>Record and report and average batch vent concentration level or reading measured during the performance test—NCS.</li> <li>Record the batch cycle daily average concentration level or reading as specified in § 63.491(e)(2).</li> <li>Report all batch cycle daily average concentration levels or readings that are above the maximum values established in the NCS or operating permit and all instances when monitoring data are not collected—PR.<sup>d,e</sup></li> </ol>

<sup>a</sup> Monitor may be installed in the firebox or in the duct work immediately downstream of the firebox before any substantial heat exchange is encountered.

<sup>b</sup> “Continuous records” is defined in § 63.111.

<sup>c</sup> NCS = Notification of Compliance Status described in § 63.506(e)(5).

<sup>d</sup> PR = Periodic Reports described in § 63.506(e)(6).

<sup>e</sup> The periodic reports shall include the duration of periods when monitoring data are not collected as specified in § 63.506(e)(6)(iii)(C).

<sup>f</sup> Alternatively, these devices may comply with the organic monitoring device provisions listed at the end of this table.

■ 150. Revise table 7 to subpart U to read as follows:

TABLE 7 TO SUBPART U OF PART 63—OPERATING PARAMETERS FOR WHICH MONITORING LEVELS ARE REQUIRED TO BE ESTABLISHED FOR CONTINUOUS AND BATCH FRONT-END PROCESS VENTS AND AGGREGATE BATCH VENT STREAMS

Control/recovery device	Parameters to be monitored	Established operating parameter(s)
Thermal incinerator .....	Firebox temperature .....	Minimum temperature.
Thermal oxidizers used for vents in chloroprene service.	Combustion chamber temperature .....	Minimum temperature.
Thermal oxidizers used for vents in chloroprene service.	Flue gas flow rate .....	Maximum flue gas flow rate.
Catalytic incinerator .....	Temperature upstream and downstream of the catalyst bed.	Minimum upstream temperature; and minimum temperature difference across the catalyst bed.
Boiler or process heater .....	Firebox temperature .....	Minimum temperature.
Scrubber for halogenated vents ...	pH of scrubber effluent; and scrubber liquid and gas flow rates [§ 63.489(b)(4)(ii)].	Minimum pH; and minimum liquid/gas ratio.
Absorber .....	Exit temperature of the absorbing liquid; and exit specific gravity of the absorbing liquid.	Maximum temperature; and maximum specific gravity.
Condenser .....	Exit temperature .....	Maximum temperature.
Carbon adsorber .....	Total regeneration steam flow or nitrogen flow, or pressure (gauge or absolute) <sup>a</sup> during carbon bed regeneration cycle; and temperature of the carbon bed after regeneration (and within 15 minutes of completing any cooling cycle(s)).	Maximum flow or pressure; and maximum temperature.



TABLE 7 TO SUBPART U OF PART 63—OPERATING PARAMETERS FOR WHICH MONITORING LEVELS ARE REQUIRED TO BE ESTABLISHED FOR CONTINUOUS AND BATCH FRONT-END PROCESS VENTS AND AGGREGATE BATCH VENT STREAMS—Continued

Control/recovery device	Parameters to be monitored	Established operating parameter(s)
Sorbent injection .....	Sorbent injection rate .....	Minimum injection rate.
Sorbent injection .....	Carrier gas flow rate .....	Minimum carrier gas flow rate.
Other devices (or as an alternate to the above) <sup>b</sup> .	HAP concentration level or reading at outlet of device.	Maximum HAP concentration or reading.

<sup>a</sup> 25 to 50 mm (absolute) is a common pressure level obtained by pressure swing absorbers.

<sup>b</sup> Concentration is measured instead of an operating parameter.

■ 151. Amend table 9 to subpart U by adding an entry for § 63.506(e)(7)(vi) to read as follows:

TABLE 9 TO SUBPART U OF PART 63—ROUTINE REPORTS REQUIRED BY THIS SUBPART

Reference	Description of report	Due date
* * * * *	* * * * *	* * * * *
§ 63.506(e)(7)(vi) .....	Fenceline Monitoring Reports.	Quarterly, no later than 45 calendar days following the end of each quarterly reporting period. See § 63.182(e) of subpart H of this part for the due date for this report.

<sup>a</sup> There may be two versions of this report due at different times; one for equipment subject to § 63.502 and one for other emission points subject to this subpart.

<sup>b</sup> There will be two versions of this report due at different times; one for equipment subject to § 63.502 and one for other emission points subject to this subpart.

<sup>c</sup> Note that the EPPU remains subject to this subpart until the notification under § 63.480(f)(3)(i) is made.

■ 152. Add table 10 to subpart U to read as follows:

TABLE 10 TO SUBPART U OF PART 63—TOXIC EQUIVALENCY FACTORS

Dioxin and Furan Congener	Toxic equivalency factor
1,2,3,7,8-pentachlorodibenzo-p-dioxin .....	1
1,2,3,4,7,8-hexachlorodibenzo-p-dioxin .....	0.1
1,2,3,7,8,9-hexachlorodibenzo-p-dioxin .....	0.1
1,2,3,6,7,8-hexachlorodibenzo-p-dioxin .....	0.1
1,2,3,4,6,7,8-heptachlorodibenzo-p-dioxin .....	0.01
octachlorodibenzo-p-dioxin .....	0.0003
2,3,7,8-tetrachlorodibenzofuran .....	0.1
2,3,4,7,8-pentachlorodibenzofuran .....	0.3
1,2,3,7,8-pentachlorodibenzofuran .....	0.03
1,2,3,4,7,8-hexachlorodibenzofuran .....	0.1
1,2,3,6,7,8-hexachlorodibenzofuran .....	0.1
1,2,3,7,8,9-hexachlorodibenzofuran .....	0.1
2,3,4,6,7,8-hexachlorodibenzofuran .....	0.1
1,2,3,4,6,7,8-heptachlorodibenzofuran .....	0.01
1,2,3,4,7,8,9-heptachlorodibenzofuran .....	0.01
Octachlorodibenzofuran .....	0.0003

■ 153. Amend § 63.521 by adding paragraph (c) to read as follows:

**§ 63.521 Compliance schedule.**

\* \* \* \* \*

(c) All affected sources that commenced construction or reconstruction on or before April 25, 2023, must be in compliance with the requirements in § 63.523(d), § 63.524(a)(3), (b)(3), and (c), § 63.525(a), (e), (j), (k), and (l), § 63.527(f) and (g),

and § 63.528(a)(4) upon initial startup or on July 15, 2027, whichever is later. All affected sources that commenced construction or reconstruction after April 25, 2023, must be in compliance with the requirements in § 63.523(d), § 63.524(a)(3), (b)(3), and (c), § 63.525(a), (e), (j), (k), and (l), § 63.527(f) and (g), and § 63.528(a)(4) upon initial startup, or on July 15, 2024, whichever is later.

■ 154. Amend § 63.522 by:

■ a. Revising the definition of “Affected source”;

■ b. Adding the definition of “Dioxins and furans”;

■ c. Revising the definition of “Equipment leaks” and

■ d. Adding definitions of “Heat Exchange System”, “In organic hazardous air pollutant or in organic HAP service” and “Pressure relief device or valve”.

The additions and revisions read as follows:

**§ 63.522 Definitions.**

\* \* \* \* \*

*Affected source* means all HAP emission points within a facility that are related to the production of BLR or WSR, including process vents, storage tanks, wastewater systems, equipment leaks, and heat exchange systems.

\* \* \* \* \*

*Dioxins and furans* means total tetra-through octachlorinated dibenzo-p-dioxins and dibenzofurans.

\* \* \* \* \*

*Equipment leaks* means, before July 15, 2027, emissions of hazardous air pollutants from a connector, pump, compressor, agitator, pressure relief device, sampling connection system, open-ended valve or line, or instrumentation system in organic hazardous air pollutant service. On and after July 15, 2027, equipment leaks means emissions of hazardous air pollutants from a connector, pump, compressor, agitator, pressure relief device, sampling connection system, open-ended valve or line, valve, or instrumentation system in organic hazardous air pollutant service.

*Heat Exchange System* means any cooling tower system or once-through cooling water system (e.g., river or pond water). A heat exchange system can include more than one heat exchanger and can include an entire recirculating or once-through cooling system.

*In organic hazardous air pollutant or in organic HAP service* means that a piece of equipment either contains or contacts a fluid (liquid or gas) that is at least 5 percent by weight of total organic HAP's as determined according to the provisions of § 63.180(d). The provisions of § 63.180(d) also specify how to determine that a piece of equipment is not in organic HAP service.

*Pressure relief device or valve* means a valve, rupture disk, or similar device used only to release an unplanned, nonroutine discharge of gas from process equipment in order to avoid safety hazards or equipment damage. A pressure relief device discharge can result from an operator error, a malfunction such as a power failure or equipment failure, or other unexpected cause. Such devices include conventional, spring-actuated relief valves, balanced bellows relief valves, pilot-operated relief valves, rupture disks, and breaking, buckling, or shearing pin devices. Devices that are actuated either by a pressure of less than or equal to 2.5 pounds per square inch

gauge or by a vacuum are not pressure relief devices.

\* \* \* \* \*

■ 155. Amend § 63.523 by revising paragraph (a), and adding paragraphs (d) and (e) as follows:

**§ 63.523 Standards for basic liquid resins manufacturers.**

(a) Owners or operators of existing affected BLR sources shall operate sources such that the rate of emissions of hazardous air pollutants from all process vents, storage tanks, and wastewater systems combined shall not exceed 130 pounds per 1 million pounds of BLR produced, and comply with the dioxin and furans emissions limit for process vents specified in paragraph (e) of this section.

\* \* \* \* \*

(d) For each existing, new, or reconstructed affected BLR source, beginning no later than the compliance dates specified in § 63.521(c), the owner or operator must comply with the requirements of § 63.104 for heat exchange systems, with the exceptions noted in paragraphs (d)(1) through (8) of this section.

(1) When the term “chemical manufacturing process unit” is used in § 63.104, the term “existing, new, or reconstructed affected BLR source” shall apply for the purposes of this subpart.

(2) When the phrase “a chemical manufacturing process unit meeting the conditions of § 63.100(b)(1) through (b)(3), except for chemical manufacturing process units meeting the condition specified in § 63.100(c)” is used in the first sentence of § 63.104(a), the term “an existing, new, or reconstructed affected BLR source” shall apply for the purposes of this subpart. When the phrase “a chemical manufacturing process unit meeting the conditions of § 63.100(b)(1) through (b)(3),” is used in the last sentence of § 63.104(a), the term “an existing, new, or reconstructed affected BLR source” shall apply for purposes of this subpart.

(3) When § 63.104 refers to table 4 to subpart F of this part or table 9 of subpart G of this part, the owner or operator is required to consider all hazardous air pollutants.

(4) When § 63.104(c)(3) specifies the monitoring plan retention requirements, and when § 63.104(f)(1) refers to the record retention requirements in § 63.103(c)(1) of subpart F of this part, the requirements in § 63.527(d) shall apply, for the purposes of this subpart.

(5) When § 63.104(f)(2) requires information to be reported in the Periodic Reports required by § 63.152(c),

the owner or operator shall instead report the information specified in § 63.104(f)(2) in the Periodic Reports required by § 63.528(a), for the purposes of this subpart.

(6) The compliance date for heat exchange systems subject to the provisions of this section is specified in § 63.521(c).

(7) Substitute “Beginning no later than the compliance dates specified in § 63.521(c),” for each occurrence of “Beginning no later than the compliance dates specified in § 63.100(k)(10),”.

(8) § 63.104(k) does not apply. Instead for each existing, new, or reconstructed affected BLR source, beginning no later than the compliance dates specified in § 63.521(c), owners and operators must not inject water into or dispose of water through any heat exchange system in an affected source if the water is considered wastewater as defined in § 63.522.

(e) For each existing, new, or reconstructed affected BLR source, beginning no later than the compliance dates specified in § 63.521(c), the owner or operator of a process vent that contains chlorine, hydrogen chloride, or any other chlorinated compound must reduce emissions of dioxins and furans (toxic equivalency basis) to a concentration of 0.054 nanograms per standard cubic meter on a dry basis corrected to 3 percent oxygen.

■ 156. Amend § 63.524 by revising paragraph (a) introductory text, adding paragraph (a)(3), revising paragraph (b) introductory text, and adding paragraphs (b)(3) and (c) as follows:

**§ 63.524 Standards for wet strength resins manufacturers.**

(a) In addition to the requirements specified in paragraph (c) of this section, and except as specified in paragraph (a)(3) of this section, owners or operators of existing affected WSR sources shall either:

\* \* \* \* \*

(3) For each existing affected WSR source, beginning no later than the compliance dates specified in § 63.521(c), the owner or operator shall comply with both paragraphs (a)(1) and (a)(2) of this section and must reduce emissions of dioxins and furans (toxic equivalency basis) from each process vent that contains chlorine, hydrogen chloride, or any other chlorinated compound to a concentration of 0.054 nanograms per standard cubic meter on a dry basis corrected to 3 percent oxygen.

(b) In addition to the requirements specified in paragraph (c) of this section, and except as specified in paragraph (b)(3) of this section, owners

or operators of new or reconstructed affected WSR sources shall either:

\* \* \* \* \*

(3) For each new or reconstructed affected WSR source, beginning no later than the compliance dates specified in § 63.521(c), the owner or operator shall comply with both paragraphs (b)(1) and (2) of this section and must reduce emissions of dioxins and furans (toxic equivalency basis) from each process vent that contains chlorine, hydrogen chloride, or any other chlorinated compound to a concentration of 0.054 nanograms per standard cubic meter on a dry basis corrected to 3 percent oxygen.

(c) For each existing, new, or reconstructed affected WSR source, beginning no later than the compliance dates specified in § 63.521(c), the owner or operator shall comply with the requirements of § 63.104 for heat exchange systems, with the exceptions noted in paragraphs (d)(1) through (8) of this section.

(1) When the term “chemical manufacturing process unit” is used in § 63.104, the term “existing, new, or reconstructed affected WSR source” shall apply for the purposes of this subpart.

(2) When the phrase “a chemical manufacturing process unit meeting the conditions of § 63.100(b)(1) through (b)(3) of this subpart, except for chemical manufacturing process units meeting the condition specified in § 63.100(c) of this subpart” is used in the first sentence of § 63.104(a), the term “an existing, new, or reconstructed affected WSR source” shall apply for the purposes of this subpart. When the phrase “a chemical manufacturing process unit meeting the conditions of § 63.100(b)(1) through (b)(3),” is used in the last sentence of § 63.104(a), the term “an existing, new, or reconstructed affected WSR source” shall apply for purposes of this subpart.

(3) When § 63.104 refers to table 4 of subpart F of this part or Table 9 of subpart G of this part, the owner or operator is required to consider all hazardous air pollutants.

(4) When § 63.104(c)(3) specifies the monitoring plan retention requirements, and when § 63.104(f)(1) refers to the record retention requirements in § 63.103(c)(1), the requirements in § 63.527(d) shall apply, for the purposes of this subpart.

(5) When § 63.104(f)(2) requires information to be reported in the Periodic Reports required by § 63.152(c), the owner or operator shall instead report the information specified in § 63.104(f)(2) in the Periodic Reports

required by § 63.528(a), for the purposes of this subpart.

(6) The compliance date for heat exchange systems subject to the provisions of this section is specified in § 63.521(c).

(7) Substitute “Beginning no later than the compliance dates specified in § 63.521(c),” for each occurrence of “Beginning no later than the compliance dates specified in § 63.100(k)(10),”

(8) § 63.104(k) of subpart F of this part does not apply. Instead for each existing, new, or reconstructed affected WSR source, beginning no later than the compliance dates specified in § 63.521(c), owners and operators must not inject water into (or dispose of water through) any heat exchange system in an affected source if the water is considered wastewater as defined in § 63.522.

■ 157. Amend § 63.525 by:

- a. Revising paragraphs (a) and (b)(1);
- b. Adding paragraph (d)(3);
- c. Revising paragraphs (e) introductory text and (e)(2)(iii);
- d. Adding paragraph (e)(3);
- e. Revising paragraphs (f), (g), (h) introductory text, and (i); and
- f. Adding paragraphs (j) through (m) as follows:

**§ 63.525 Compliance and performance testing.**

(a) The owner or operator of any existing affected BLR source shall, in order to demonstrate compliance with the applicable emission limits, determine the emission rate from all process vent, storage tank, and wastewater system emission points using the methods described below. Except as specified in paragraph (l) of this section, compliance tests shall be performed under normal operating conditions. Beginning no later than the compliance dates specified in § 63.521(c), conduct subsequent performance tests no later than 60 calendar months after the previous performance test.

(1) Except as specified in paragraph (m) of this section, the owner or operator shall use the EPA test methods from 40 CFR part 60, listed in paragraphs (a)(1) (i) through (iii) of this section, to determine emissions from process vents. Testing of process vents on equipment operating as part of a continuous process will consist of conducting three 1-hour runs. Gas stream volumetric flow rates shall be measured every 15 minutes during each 1-hour run. Organic HAP or TOC concentration shall be determined from samples collected in an integrated sample over the duration of each 1-hour test run, or from grab samples collected

simultaneously with the flow rate measurements (every 15 minutes). If an integrated sample is collected for laboratory analysis, the sampling rate shall be adjusted proportionally to reflect variations in flow rate. If the flow of gaseous emissions is intermittent, determination of emissions from process vents shall be performed according to the methods specified in paragraph (e) of this section. For process vents with continuous gas streams, the emission rate used to determine compliance shall be the average emission rate of the 3 test runs. For process vents with intermittent emission streams, the calculated emission rate or the emission rate from a single test run may be used to determine compliance.

(i) Method 1 or 1A of appendix A–1 to 40 CFR part 60 as appropriate, shall be used for selection of the sampling sites if the flow measuring device is a pitot tube. A traverse shall be conducted before and after each 1-hour sampling period. No traverse is necessary when using Method 2A or 2D of appendix A–2 to 40 CFR part 60 to determine flow rate.

(ii) Method 2, 2A, 2C or 2D of appendix A–1 to part 60 of this chapter, as appropriate, shall be used for the determination of gas stream volumetric flow rate. If Method 2 or 2C is used, the velocity measurements shall be made at a single point, in conjunction with the traverse, to establish an average velocity across the stack.

(iii) Method 25A and/or Methods 18 and 25A of appendices A–6 and A–7 to 40 CFR part 60, as appropriate, must be used to determine the concentration of HAP in the streams. ASTM D6420–18 (incorporated by reference, see § 63.14) may also be used in lieu of Method 18, if the target compounds are all known and are all listed in Section 1.1 of ASTM D6420–18 as measurable; ASTM D6420–18 must not be used for methane and ethane; and ASTM D6420–18 may not be used as a total VOC method.

(iv) Initial determination of de minimis status for process vents may be made by engineering assessment, as specified in § 63.526(a)(1)(iv).

(2) Emissions from wastewater treatment systems shall be determined in accordance with the methods described in 40 CFR part 63, appendix C.

(3) Emissions from storage tanks shall be calculated in accordance with the methods specified in § 63.150(g)(3).

(b) \* \* \*

(1) The production-based emission rate for process vents shall be calculated by dividing the average emission rate by the average production rate.

\* \* \* \* \*

(d) \* \* \*

(3) To demonstrate compliance with the process vent dioxins and furans emission limit, the owner or operator must use the procedures of paragraph (m) of this section.

(e) The owner or operator of any existing, new, or reconstructed WSR source that is subject to the emission limit for process vents, storage tanks, and wastewater systems shall demonstrate compliance by determining emissions for all process vent, storage tank, and wastewater systems emission points using the methods described in this section. The owner or operator of any existing, new, or reconstructed WSR source that is subject to the process vent dioxins and furans emission limit must demonstrate compliance by following the procedures in paragraph (e)(3) of this section. Beginning no later than the compliance dates specified in § 63.521(c), conduct subsequent performance tests no later than 60 calendar months after the previous performance test.

\* \* \* \* \*

(2) \* \* \*

\* \* \* \* \*

(iii) Method 25A and/or Methods 18 and 25A of appendices A-6 and A-7 to 40 CFR part 60, as appropriate, must be used to determine the concentration of HAP in the streams. ASTM D6420-18 (incorporated by reference, see § 63.14) may also be used in lieu of Method 18, if the target compounds are all known and are all listed in Section 1.1 of ASTM D6420-18 as measurable; ASTM D6420-18 must not be used for methane and ethane; and ASTM D6420-18 may not be used as a total VOC method.

\* \* \* \* \*

(3) To demonstrate compliance with the process vent dioxins and furans emission limit, the owner or operator must use the procedures of paragraph (m) of this section. Testing shall be performed for each unit operation.

(f) The owner or operator of any affected WSR source that is subject to the emissions limit for process vents, storage tanks, and wastewater systems shall calculate emissions from storage tanks in accordance with the methods specified in § 63.150(g)(3).

(g) The owner or operator of any affected WSR source that is subject to the emission limit for process vents, storage tanks, and wastewater systems shall calculate emissions from wastewater treatment systems (if applicable) in accordance with the methods described in 40 CFR part 63, appendix C.

(h) The owner or operator of any affected WSR source that is subject to

the emission limit for process vents, storage tanks, and wastewater systems shall calculate the average amount of WSR product manufactured per batch, using data from performance tests or from emission calculations, as applicable, to determine the average WSR production per-batch production data for an annual period representing normal operating conditions.

\* \* \* \* \*

(i) The owner or operator of any affected BLR source or any affected WSR source that is subject to the requirements of subpart H of this part must demonstrate the ability of its specific program to meet the compliance requirements therein to achieve initial compliance.

(j) For each existing, new, or reconstructed affected BLR and WSR source, beginning no later than the compliance dates specified in § 63.521(c), owners and operators of sources as defined in § 63.520 shall comply with the requirements of this subpart at all times, except during periods of nonoperation of the source (or specific portion thereof) resulting in cessation of the emissions to which this subpart applies.

(k) For each existing, new, or reconstructed affected BLR and WSR source, beginning no later than the compliance dates specified in § 63.521(c), at all times, owners and operators must operate and maintain any source, including associated air pollution control equipment and monitoring equipment, in a manner consistent with safety and good air pollution control practices for minimizing emissions. The general duty to minimize emissions does not require owners and operators to make any further efforts to reduce emissions if levels required by the applicable standard have been achieved. Determination of whether a source is operating in compliance with operation and maintenance requirements will be based on information available to the Administrator which may include, but is not limited to, monitoring results, review of operation and maintenance procedures, review of operation and maintenance records, and inspection of the source.

(l) For each existing, new, or reconstructed affected BLR and WSR source, beginning no later than the compliance dates specified in § 63.521(c), the owner or operator may not conduct performance tests during periods of malfunction. Owners and operators must record the process information that is necessary to document operating conditions during

the test and include in such record an explanation to support that such conditions represent normal operation. Upon request, owners and operators must make available to the Administrator such records as may be necessary to determine the conditions of performance tests.

(m) Except as specified in paragraph (m)(7) of this section, to demonstrate compliance with the process vent dioxins and furans emission limit, the owner or operator must conduct a performance test using the procedures in paragraphs (m)(1) through (m)(6) of this section. Conduct subsequent performance tests no later than 60 calendar months after the previous performance test.

(1) The performance test must consist of three test runs. Collect at least 3 dry standard cubic meters of gas per test run.

(2) Use Method 1 or 1A of 40 CFR part 60, appendix A-1 to select the sampling sites at the sampling location. The sampling location must be at the outlet of the final control device.

(3) Determine the gas volumetric flowrate using Method 2, 2A, 2C, or 2D of 40 CFR part 60, appendix A-2.

(4) Use Method 4 of 40 CFR part 60, appendix A-3 to convert the volumetric flowrate to a dry basis.

(5) Measure the concentration of each tetra- through octa-chlorinated dioxin and furan congener emitted using Method 23 at 40 CFR part 60, appendix A-7.

(i) For each dioxin and furan congener, multiply the congener concentration by its corresponding toxic equivalency factor specified in table 2 to this subpart. For determination of toxic equivalency, zero may be used for congeners with a concentration less than the estimated detection limit (EDL). For congeners with estimated maximum pollutant concentration (EMPC) results, if the value is less than the EDL, zero may be used. Otherwise, the EMPC value must be used in the calculation of toxic equivalency.

(ii) Sum the products calculated in accordance with paragraph (m)(5)(i) of this section to obtain the total concentration of dioxins and furans emitted in terms of toxic equivalency.

(6) The concentration of dioxins and furans shall be corrected to 3 percent oxygen. Use Method 3A of 40 CFR part 60, appendix A to determine the oxygen concentration (%O<sub>2d</sub>). Method 3A of 40 CFR part 60, appendix A must be run concurrently with Method 23 of 40 CFR part 60, appendix A-7. The concentration corrected to 3 percent oxygen (C<sub>c</sub>) shall be computed using the following equation:

$$C_c = C_m \left( \frac{17.9}{20.9 - \%O_{2d}} \right)$$

Where:

- C<sub>c</sub> = Concentration of dioxins and furans corrected to 3 percent oxygen, dry basis, nanograms per standard cubic meter.
- C<sub>m</sub> = Concentration of dioxins and furans, dry basis, nanograms per standard cubic meter.
- %O<sub>2d</sub> = Concentration of oxygen, dry basis, percent by volume.

(7) An owner or operator is not required to conduct a performance test when either a boiler or process heater burning hazardous waste, or hazardous waste incinerator, is used for which the owner or operator:

- (A) Has been issued a final permit under part 270 of this chapter and complies with the requirements of 40 CFR part 266, subpart H;
- (B) Has certified compliance with the interim status requirements of part 266, subpart H, of this chapter;
- (C) Meets the requirement specified in paragraph (g)(7)(i)(E) of this section, and has submitted a Notification of Compliance under § 63.1207(j) and complies with the requirements of subpart EEE of this part; or
- (D) Meets the requirement specified in paragraph (g)(7)(i)(E) of this section, complies with subpart EEE of this part, and will submit a Notification of Compliance under § 63.1207(j) by the date the owner or operator would have been required to submit the initial performance test report for this subpart.
- (E) The owner and operator may not waive performance testing pursuant to § 63.1207(d)(4) and each performance test required by § 63.1207(d) must show compliance with the dioxins and furans emission limit specified in § 63.523(e) and § 63.524(a)(3) and (b)(3), as applicable.

- 158. Amend § 63.526 by:
  - a. Revising paragraphs (a) introductory text, (a)(2), (3) and (4);
  - b. Adding paragraph (a)(7);
  - c. Revising paragraphs (b) introductory text, (b)(1)(i), (b)(2), (3), and (4);
  - d. Adding paragraph (b)(7); and
  - e. Revising paragraphs (c) and (d).

The additions and revisions read as follows:

**§ 63.526 Monitoring requirements.**

(a) The owner or operator of any existing, new, or reconstructed affected BLR source shall provide evidence of continued compliance with the standard. During each compliance demonstration, maximum or minimum operating parameters, as appropriate,

shall be established for processes and control devices that will indicate the source is in compliance. If the operating parameter to be established is a maximum, the value of the parameter shall be the average of the maximum values from each of the three test runs. If the operating parameter to be established is a minimum, the value of the parameter shall be the average of the minimum values from each of the three test runs. Parameter values for process vents with intermittent emission streams shall be determined as specified in paragraph (b)(1) of this section. The owner or operator shall operate processes and control devices within these parameters to ensure continued compliance with the standard. A de minimis level is specified in paragraph (a)(1) of this section. Monitoring parameters are specified for various process vent control scenarios in paragraphs (a) (2) through (7) of this section.

\* \* \* \* \*

(2) For affected sources using water scrubbers, the owner or operator shall establish a minimum scrubber water flow rate as a site-specific operating parameter which must be measured and recorded every 15 minutes. The affected source will be considered to be out of compliance if the scrubber water flow rate, averaged over any continuous 24-hour period, is below the minimum value established during the most recent compliance demonstration.

(3) For affected sources using condensers, the owner or operator shall establish the maximum condenser outlet gas temperature as a site-specific operating parameter which must be measured and recorded every 15 minutes. The affected source will be considered to be out of compliance if the condenser outlet gas temperature, averaged over any continuous 24-hour period, is greater than the maximum value established during the most recent compliance demonstration.

(4) For affected sources using carbon adsorbers or having uncontrolled process vents, the owner or operator shall establish a maximum outlet HAP concentration as the site-specific operating parameter which must be measured and recorded every 15 minutes. The affected source will be considered to be out of compliance if the outlet HAP concentration, averaged over any continuous 24-hour period, is greater than the maximum value

established during the most recent compliance demonstration.

\* \* \* \* \*

(7) For affected sources using sorbent injection, the owner or operator shall establish both a minimum sorbent injection rate and minimum carrier gas flow rate as site-specific operating parameters which must be measured and recorded every 15 minutes. The affected source will be considered to be out of compliance if the sorbent injection rate or the carrier gas flow rate, averaged over any continuous 24-hour period, is below the minimum values established during the most recent compliance demonstration.

(b) The owner or operator of any existing, new, or reconstructed affected WSR source that is subject to the emission limit for process vents, storage tanks, and wastewater systems and/or is subject to the dioxins and furans emission limit for process vents shall provide evidence of continued compliance with the standard. As part of each compliance demonstrations for batch process vents, test data or compliance calculations shall be used to establish a maximum or minimum level of a relevant operating parameter for each unit operation. The parameter value for each unit operation shall represent the worst case value of the operating parameter from all episodes in the unit operation. The owner or operator shall operate processes and control devices within these parameters to ensure continued compliance with the standard.

(1) \* \* \*

(i) If testing is used to demonstrate compliance, the appropriate parameter shall be monitored during all batch emission episodes in the unit operation.

\* \* \* \* \*

(2) Affected sources with condensers on process vents shall establish the maximum condenser outlet gas temperature as a site-specific operating parameter, which must be measured every 15 minutes, or at least once for batch emission episodes less than 15 minutes in duration. The affected source will be considered to be out of compliance if the maximum condenser outlet gas temperature, averaged over the duration of the batch emission episode or unit operation, is greater than the value established during the most recent compliance demonstration.

(3) For affected sources using water scrubbers, the owner or operator shall establish a minimum scrubber water flow rate as a site-specific operating parameter which must be measured and recorded every 15 minutes, or at least once for batch emission episodes less than 15 minutes in duration. The affected source will be considered to be out of compliance if the scrubber water flow rate, averaged over the duration of the batch emission episode or unit operation, is below the minimum flow rate established during the most recent compliance demonstration.

(4) For affected sources using carbon adsorbers or having uncontrolled process vents, the owner or operator shall establish a maximum outlet HAP concentration as the site-specific operating parameter which must be measured and recorded every 15 minutes, or at least once for batch emission episodes of duration shorter than 15 minutes. The affected source will be considered to be out of compliance if the outlet HAP concentration, averaged over the duration of the batch emission episode or unit operation, is greater than the value established during the most recent compliance demonstration.

(7) For affected sources using sorbent injection, the owner or operator shall establish both a minimum sorbent injection rate and minimum carrier gas flow rate flow rate as site-specific operating parameters which must be measured and recorded every 15 minutes. The affected source will be considered to be out of compliance if the sorbent injection rate or the carrier gas flow rate flow rate, averaged over any continuous 24-hour period, is below the minimum values established during the most recent compliance demonstration.

(c) Periods of time when monitoring measurements exceed the parameter values do not constitute a violation if they occur during a startup, shutdown, or malfunction, and the facility is operated in accordance with § 63.6(e)(1). For each existing, new, or reconstructed affected BLR and WSR source, on and after July 15, 2027, this paragraph no longer applies.

(d) The owner or operator of any affected WSR source that is subject to the requirements of subpart H of this part shall meet the monitoring requirements of subpart H of this part.

■ 159. Amend § 63.527 by revising paragraphs (b), (c) introductory text and (d), and adding paragraphs (f) and (g) as follows:

**§ 63.527 Recordkeeping requirements.**

\* \* \* \* \*

(b) The owner or operator of any affected WSR source subject to the emission limit for process vents, storage tanks, and wastewater systems and/or subject to the dioxins and furans emission limit for process vents shall keep records of values of equipment operating parameters specified to be monitored under § 63.526(b) or specified by the Administrator. The records that shall be kept are the average values of operating parameters, determined for the duration of each unit operation. Records shall be kept in accordance with the requirements of applicable paragraphs of § 63.10, as specified in the General Provisions applicability table in this subpart. The owner or operator shall keep records up-to-date and readily accessible. In the event of an excursion, the owner or operator must keep records of each 15-minute reading for the entire unit operation in which the excursion occurred.

(c) The owner or operator of any affected BLR source, as well the owner or operator of any affected WSR source that is subject to the emission limit for process vents, storage tanks, and wastewater systems, who demonstrates that certain process vents are below the de minimis cutoff for continuous monitoring specified in § 63.526(a)(1)(i), shall maintain up-to-date, readily accessible records of the following information to document that a HAP emission rate of less than one pound per year is maintained:

\* \* \* \* \*

(d) The owner or operator of any affected BLR source, as well as the owner or operator of any affected WSR source subject to the leak detection and repair program specified in subpart H of this part, shall implement the recordkeeping requirements outlined therein. All records shall be retained for a period of 5 years, in accordance with the requirements of 40 CFR 63.10(b)(1).

\* \* \* \* \*

(f) For each existing, new, or reconstructed affected BLR and WSR source, beginning no later than the compliance dates specified in § 63.521(c), the owner or operator of any affected BLR source, as well the owner or operator of any affected WSR source subject to the emission limit for process vents, storage tanks, and wastewater systems, must keep the records specified in paragraphs (f)(1) through (3) of this section each pressure relief device, as defined in § 63.522.

(1) The start and end time and date of each pressure release to the atmosphere.

(2) An estimate of the mass quantity in pounds of each organic HAP released.

(3) Records of any data, assumptions, and calculations used to estimate of the mass quantity of each organic HAP released during the event.

(g) For each existing, new, or reconstructed affected BLR and WSR source, beginning no later than the compliance dates specified in § 63.521(c), the owner or operator of any affected BLR source, as well the owner or operator of any affected WSR source subject to the emission limit for process vents, storage tanks, and wastewater systems, must keep the records specified in paragraphs (g)(1) through (3) of this section for each maintenance vent release. A process vent is considered a maintenance vent if the process vent is only used as a result of startup, shutdown, maintenance, or inspection of equipment where equipment is emptied, depressurized, degassed, or placed into service.

(1) Identification of the maintenance vent and the equipment served by the maintenance vent.

(2) The date and time the maintenance vent was opened to the atmosphere.

(3) An estimate of the mass in pounds of organic HAP released during the entire atmospheric venting event.

■ 160. Revise and republish § 63.528 to read as follows:

**§ 63.528 Reporting requirements.**

(a) The owner or operator of any affected BLR source, as well as the owner or operator of any affected WSR source that is subject to the emission limit for process vents, storage tanks, and wastewater systems and/or is subject to the dioxins and furans emission limit for process vents, shall comply with the reporting requirements of applicable paragraphs of § 63.10, as specified in the General Provisions applicability table in this subpart. The owner or operator shall also submit to the Administrator, as part of the quarterly excess emissions and continuous monitoring system performance report and summary report required by § 63.10(e)(3), the following recorded information. On and after July 15, 2027 or once the reporting template for this subpart has been available on the CEDRI website for 1 year, whichever date is later, owners and operators must submit all subsequent reports following the procedure specified in § 63.9(k), except any medium submitted through mail must be sent to the attention of the Polymers and Resins Sector Lead. Owners and operators must use the appropriate electronic report template on the CEDRI website (<https://>

[www.epa.gov/electronic-reporting-air-emissions/cedri](http://www.epa.gov/electronic-reporting-air-emissions/cedri)) for this subpart. The date report templates become available will be listed on the CEDRI website. Unless the Administrator or delegated state agency or other authority has approved a different schedule for submission of reports under § 63.9(i) and § 63.10(a), the report must be submitted by the deadline specified in this subpart, regardless of the method in which the report is submitted. If a report is submitted via CEDRI, the certifier's electronic signature during the submission process replaces the requirements in § 63.10(e)(3)(v), § 63.10(e)(3)(vi)(L), and § 63.10(e)(3)(vi)(M) to submit the date of the report and the name, title, and signature of the responsible official who is certifying the accuracy of the report.

(1) Reports of monitoring data, including 15-minute monitoring values as well as daily average values or per-unit operation average values, as applicable, of monitored parameters for all operating days or unit operations when the average values were outside the ranges established in the Notification of Compliance Status or operating permit, including reports specified in paragraph (a)(4) of this section.

(2) Reports of the duration of periods when monitoring data is not collected for each excursion caused by insufficient monitoring data, including reports specified in paragraph (a)(4) of this section. An excursion means any of the three cases listed in paragraph (a)(2)(i) or (a)(2)(ii) of this section. For a control device where multiple parameters are monitored, if one or more of the parameters meets the excursion criteria in paragraph (a)(2)(i) or (a)(2)(ii) of this section, this is considered a single excursion for the control device. In the report, include the identification of the source, start date, start time, duration in hours, and monitored parameter(s) meeting the excursion criteria.

(i) When the period of control device operation is 4 hours or greater in an operating day and monitoring data are insufficient to constitute a valid hour of data, as defined in paragraph (a)(2)(iii) of this section, for at least 75 percent of the operating hours.

(ii) When the period of control device operation is less than 4 hours in an operating day and more than one of the hours during the period of operation does not constitute a valid hour of data due to insufficient monitoring data.

(iii) Monitoring data are insufficient to constitute a valid hour of data, as

used in paragraphs (a)(2)(i) and (ii) of this section, if measured values are unavailable for any of the 15-minute periods within the hour.

(3) Whenever a process change, as defined in § 63.115(e), is made that causes the emission rate from a de minimis emission point to become a process vent with an emission rate of one pound per year or greater, the owner or operator shall submit a report within 180 calendar days after the process change. The report may be submitted as part of the next summary report required under § 63.10(e)(3). The report shall include:

(i) A description of the process change; and

(ii) The results of the recalculation of the emission rate.

(4) For each existing, new, or reconstructed affected BLR and WSR source, beginning no later than the compliance dates specified in § 63.521(c), for each excursion that is not an excused excursion, the report must include a list of the affected sources or equipment, the monitored parameter, an estimate of the quantity in pounds of each regulated pollutant emitted over any emission limit, a description of the method used to estimate the emissions, the cause of the excursion (including unknown cause, if applicable), as applicable, and the corrective action taken. Include the start date, start time, and duration in hours of each excursion.

(5) For pressure relief device subject to § 63.527(f), report each pressure release to the atmosphere, including pressure relief device identification name or number, the start date, start time, and duration (in minutes) of the pressure release; and an estimate of the mass quantity in pounds of each organic HAP released.

(6) For heat exchangers subject to § 63.104 of subpart F of this part, the information specified in § 63.104(f)(2) of subpart F of this part.

(b) The owner or operator of any affected BLR source, as well as the owner or operator of any affected WSR source who is subject to the leak detection and repair program specified in subpart H of this part, shall implement the reporting requirements outlined therein. Copies of all reports shall be retained as records for a period of 5 years, in accordance with the requirements of 40 CFR 63.10(b)(1).

(c) The owner or operator of any affected BLR source, as well as the owner or operator of any affected WSR source that is subject to the emission

limit for process vents, storage tanks, and wastewater systems shall include records of all monitoring parameters in the Notification of Compliance Status and summary reports required by subpart A of this part.

(d) Beginning no later than July 15, 2024, owners and operators must submit performance test reports in accordance with this paragraph. Unless otherwise specified in this subpart, within 60 days after the date of completing each performance test required by this subpart, owners and operators must submit the results of the performance test following the procedures specified in § 63.9(k). Data collected using test methods supported by the EPA's Electronic Reporting Tool (ERT) as listed on the EPA's ERT website (<https://www.epa.gov/electronic-reporting-air-emissions/electronic-reporting-tool-ert>) at the time of the test must be submitted in a file format generated using the EPA's ERT. Alternatively, owners and operators may submit an electronic file consistent with the extensible markup language (XML) schema listed on the EPA's ERT website. Data collected using test methods that are not supported by the EPA's ERT as listed on the EPA's ERT website at the time of the test must be included as an attachment in the ERT or alternate electronic file.

■ 161. Amend § 63.529 by revising paragraph (c) introductory text, and adding paragraph (c)(5) as follows:

**§ 63.529 Implementation and enforcement.**

\* \* \* \* \*

(c) The authorities that cannot be delegated to State, local, or Tribal agencies are as specified in paragraphs (c)(1) through (5) of this section.

\* \* \* \* \*

(5) Approval of an alternative to any electronic reporting to the EPA required by this subpart.

■ 162. Amend table 1 to subpart W by:

- a. Revising the header row;
- b. Revising entry “§ 63.6(e)(1)(i)”;
- c. Adding entries “§ 63.6(e)(1)(ii)”, “§ 63.6(e)(1)(iii)”, “63.6(e)(2)”, and “63.6(e)(3)”;
- d. Revising entry “§ 63.6(g)”;
- e. Adding entry “§ 63.7(a)(4)”;
- f. Revising entries “§ 63.7(e)(1)”, “§ 63.7(g)(1)”, “§ 63.8(c)(1)(i)”, “§ 63.8(c)(1)(iii)”, “§ 63.9(k)”, “§ 63.10(d)(2)”, “§ 63.10(d)(5)” and “§ 63.10(e)(3)”.

The revisions and additions read as follows:

TABLE 1 TO SUBPART W OF PART 63—GENERAL PROVISIONS APPLICABILITY TO SUBPART W

Reference	Applies to subpart W			Comment
	BLR	WSR	WSR equipment leak standard, and BLR equipment leak standard (40 CFR part 63, subpart H)	
* § 63.6(e)(1)(i) .....	*	*	*	* Yes, before July 15, 2027. No, beginning on and after July 15, 2027. See § 63.525(k) for general duty requirement.
* § 63.6(e)(1)(ii) .....		*	*	* Yes, before July 15, 2027. No, beginning on and after July 15, 2027.
* § 63.6(e)(1)(iii) .....	Yes .....	Yes .....	Yes.	
* 63.6(e)(2) .....	N/A .....	N/A .....	N/A .....	* Reserved.
* 63.6(e)(3) .....		*	*	* Yes, before July 15, 2027. No, beginning on and after July 15, 2027.
* § 63.6(g) .....	Yes .....	Yes .....	Yes .....	* Affected sources have the opportunity to demonstrate other alternatives to the Administrator.
* § 63.7(a)(4) .....	Yes .....	Yes .....	Yes.	
* § 63.7(e)(1) .....	Yes, before July 15, 2027. No, beginning on and after July 15, 2027.			* See § 63.525(l). Subpart W also contains test methods specific to BLR and WSR sources.
* § 63.7(g)(1) .....	Yes .....	Yes .....	No .....	* Subpart H specifies performance test reporting. Additionally, this subpart specifies how and when the performance test results are reported for BLR and WSR.
* § 63.8(b)(3) .....	Yes .....	Yes .....	Yes.	
* § 63.8(c)(1)(i) .....	Yes, before July 15, 2027. No, beginning on and after July 15, 2027.			
* § 63.8(c)(1)(iii) .....	Yes, before July 15, 2027. No, beginning on and after July 15, 2027.			
* § 63.9(k) .....	Yes .....	Yes .....	Yes.	
* § 63.10(d)(2) .....	No .....	No .....	No .....	* This subpart and Subpart H specify performance test reporting requirements.
* § 63.10(d)(5) .....	Yes, before July 15, 2027. No, beginning on and after July 15, 2027.			
* § 63.10(e)(3) .....	Yes .....	Yes .....	No .....	* Except that on and after July 15, 2027, the reports shall be submitted according to and in the format required by § 63.528(a).

■ 163. Add table 2 to subpart W to read as follows:

TABLE 2 TO SUBPART W OF PART 63—TOXIC EQUIVALENCY FACTORS

Dioxin and Furan Congener	Toxic equivalency factor
1,2,3,7,8-pentachlorodibenzo-p-dioxin .....	1
1,2,3,4,7,8-hexachlorodibenzo-p-dioxin .....	0.1
1,2,3,7,8,9-hexachlorodibenzo-p-dioxin .....	0.1
1,2,3,6,7,8-hexachlorodibenzo-p-dioxin .....	0.1



TABLE 2 TO SUBPART W OF PART 63—TOXIC EQUIVALENCY FACTORS—Continued

Dioxin and Furan Congener	Toxic equivalency factor
1,2,3,4,6,7,8-heptachlorodibenzo-p-dioxin .....	0.01
octachlorodibenzo-p-dioxin .....	0.0003
2,3,7,8-tetrachlorodibenzofuran .....	0.1
2,3,4,7,8-pentachlorodibenzofuran .....	0.3
1,2,3,7,8-pentachlorodibenzofuran .....	0.03
1,2,3,4,7,8-hexachlorodibenzofuran .....	0.1
1,2,3,6,7,8-hexachlorodibenzofuran .....	0.1
1,2,3,7,8,9-hexachlorodibenzofuran .....	0.1
2,3,4,6,7,8-hexachlorodibenzofuran .....	0.1
1,2,3,4,6,7,8-heptachlorodibenzofuran .....	0.01
1,2,3,4,7,8,9-heptachlorodibenzofuran .....	0.01
Octachlorodibenzofuran .....	0.0003

■ 164. Add Method 327 to appendix A of part 63 to read as follows:

**Method 327—Fugitive and Area Source Measurement of Selected Volatile Organic Hazardous Air Pollutants Using Specially Prepared Canisters**

**1.0 Scope and Application**

1.1 This method describes the sampling and analysis of emissions from fugitive and area sources collected using specially prepared canisters and analyzed using a gas chromatograph (GC) coupled with a low- or high-resolution mass spectrometer (MS) for the determination of the airborne concentration of selected volatile organic hazardous air pollutants (oHAPs) such as ethylene oxide or vinyl chloride.

1.2 Applicability. The use of this method is strictly intended for determining airborne concentrations of selected speciated oHAPs to determine compliance with a fenceline emission standard and/or work practices when specified by the applicable regulation. This method includes data quality objectives (DQOs) specific to the measurement of airborne concentrations of speciated oHAPs and must not be used for other compliance purposes (*i.e.*, measurements from ducted sources).

1.3 The analytical approach for this method uses a GC coupled with a low- or high-resolution MS, which may consist of a linear quadrupole, ion trap, or time-of-flight (TOF) system. Speciated oHAPs are identified by a combination of the retention times (RTs) and the associated mass spectra by comparing observed fragmentation patterns to reference spectral patterns and relative ion abundances established during calibration. For the speciated oHAPs, the intensity of the observed quantitation ion in the unknown sample is compared with the system response to

the same ion for known amounts of the compound.

1.4 The sampling and analytical approach included in this method is based on previously published EPA guidance in Compendium Method TO-15A, which describes the sampling and analytical procedures for measuring volatile organic compounds (VOCs) in ambient air.

**2.0 Summary of Method**

2.1 In this method, a whole air sample is collected through a particulate filter with a flow control device into an evacuated, specially prepared canister for a length of time specified by the applicable regulation, typically 24 hours. After the air sample is collected, the canister valve is closed, the canister pressure is measured, and the canister is transported to the laboratory for analysis. Upon receipt at the laboratory, the sample collection information is verified, the canister pressure is measured, and the canister is stored at ambient laboratory temperature until analysis. For analysis, a known volume of the sample is directed from the canister into a preconcentrator to collect speciated oHAPs from the sample aliquot and to allow the majority of bulk gases (*e.g.*, nitrogen, oxygen, argon, and carbon dioxide) and water vapor to be vented.

2.2 The laboratory, field laboratory, and field personnel must have experience with sampling trace-level oHAPs using specially prepared canisters and with operating preconcentrator/GC/multidetector instrumentation (*e.g.*, MS) for trace-level analysis.

2.3 This method is performance-based and includes a description of the equipment, instruments, operations, and acceptance and performance criteria. EPA developed these criteria to ensure the collection of high-quality data. Laboratories must develop their own standard operating procedure (SOP)

documents describing the equipment, equipment management, targeted compounds, procedures, and quality assurance (QA) activities specific to that laboratory, instrumentation, and potentially specific for the targeted analyte.

2.4 The key steps of this method required for the collection of each sample include stringent leak testing under stop flow, using certified and clean canisters, using certified sampling devices, collecting accurate field data, and collecting field blanks and duplicates. The key steps of this method required for sample analysis include the analysis of blanks, use of high-quality reference standards, and initial and ongoing calibration checks of the instruments used.

**3.0 Definitions**

3.1 *Absolute pressure* means the pressure measured with reference to absolute zero pressure, usually expressed in units of kilopascal (kPa) absolute or pounds per square inch absolute (psia).

3.2 *Analytical batch* means the batch of samples analyzed over a 24-hour period beginning with the daily instrument tune performance check.

3.2 *Collocated precision* means the precision determined from the analyzed concentrations of samples collected simultaneously from the same air mass using two discrete canisters and collected through two separate sampling devices with separate inlets. This determines the precision of the method including the sampling and analysis processes. Collocated precision is determined by calculating the absolute relative percent difference (RPD) for the collocated measurements (the absolute value of the difference between the two collocated sample results divided by their average value and expressed as a percentage).

3.3 *Continuing calibration verification sample (CCV)* means single

level calibration samples run conducted periodically to confirm that the analytical system continues to generate sample results within acceptable agreement to the current calibration curve.

3.4 *Cryogen* means a refrigerant used to obtain sub-ambient temperatures in the preconcentrator and/or the GC oven. Typical cryogenes are liquid nitrogen (boiling point [BP] – 195.8 °C), liquid argon (BP – 185.7 °C), and liquid carbon dioxide (BP – 79.5 °C).

3.5 *Deionized water* means ASTM Type I water or equivalent.

3.6 *Diluent gas* means hydrocarbon-free (HCF) synthetic “zero” air.

3.7 *Dynamic dilution* means a technique for preparing calibration mixtures in which standard gas(es) from pressurized cylinders are continuously blended with a diluent gas (such as humidified HCF zero air) in a mixing chamber or manifold so that a flowing stream of calibration mixture is created.

3.8 *Gauge pressure* means the pressure measured with reference to the surrounding atmospheric pressure, usually expressed in units of kPa or inches of mercury (Hg). Gauge pressure is zero-referenced against ambient air pressure; zero is equal to the local atmospheric (barometric) pressure, which is nominally 101.3 kPa (29.92 in. Hg or 14.7 psia) at sea level.

3.9 *Mass spectrometer* means an instrument that ionizes molecules and atoms (typically into electrically charged fragments), separates these ions according to their mass-to-charge ratio ( $m/z$  or  $m/e$ ), and responds to the impact of the ions based on their population. MS systems suitable for this method include quadrupole, ion trap, and TOF detectors. Quadrupole and ion trap MS operating modes (*i.e.*, full-scan, selected ion monitoring [SIM], and selected ion storage [SIS] modes) can be selected to optimize the ion mass collection range.

3.10 *Mechanical Flow Controlling Device (MFC/D)* means a device that is used to ensure constant flow to an evacuated canister to near ambient pressure. MFC/D are designed to maintain a constant pressure drop (and thus a constant flow rate) across a restrictive orifice by allowing a constant leak rate of sample into the canister as the canister vacuum decreases to near ambient pressure without power.

3.11 *Nominal concentration* means a requested, target, or named concentration that approximates the true, reference, or certified concentration. For example, a nominal 200 parts per trillion by volume (pptv) standard may have an actual certified concentration of 206 pptv.

3.12 *Preconcentrator* means a device used to concentrate the target compound(s) while the bulk gases are effectively removed. The target compound(s) are then desorbed and injected into a GC–MS system.

3.13 *Quantitative accuracy* means the degree of measurement accuracy required to measure the concentration of an identified compound, within a given tolerance of uncertainty, with an analytical system.

3.14 *Replicate precision* means the precision determined from repeated analysis of a gas sample from one canister, which may be evaluated by calculating the absolute RPD for pairwise measurements ( $N = 2$ ) or by determining the relative standard deviation (RSD) for replicate measurements where  $N \geq 3$ . Replicate analyses are used to determine precision of the analysis processes and do not provide information on sampling precision.

3.15 *Second Source Calibration Verification (SSCV) Standard* means a humidified calibration standard prepared from a calibration stock gas procured from a separate supplier. An SSCV can only be prepared with a calibration stock from the same supplier if it is unavailable from another supplier and is prepared from a different lot of source material as the primary calibration stock.

3.16 *Static dilution* means a technique for preparing calibration mixtures in which standard and diluent gases are added to a fixed-volume vessel or chamber at a known ratio. Standard and diluent gas amounts may be measured gravimetrically, by volume, and/or by pressure differential from pressurized cylinders or as neat materials and blended with a known amount of diluent gas (such as humidified zero air) in a mixing chamber or manifold.

3.17 *Target concentration* means desired, estimated, or approximate concentration (see “nominal concentration” above).

3.18 *Theoretical concentration* means a reference concentration derived by applying measurements performed with calibrated instruments with known tolerances to a certified reference standard concentration value. Measurements of the target compound(s) concentrations are to be determined using a calibration that is developed based on theoretical concentrations.

3.19 *Time-of-flight (TOF) mass spectrometry* means a MS method that determines the ion’s mass-to-charge ratio by measuring the time the ion takes to reach the detector.

3.20 *Wetted surfaces* mean the surfaces of the flow path, canister, valving, pumps, etc., that contact the gas undergoing collection, mixing, transfer, or analysis.

#### 4.0 Interferences

4.1 *Sample Collection*. There are potential physical interferences which could impact the ability to properly time-integrate the sampling, such as leaks of the sampling system or introduction of foreign material (*e.g.*, particulate matter [PM], insect nests, spider webs). These interferences are mitigated by closely following the sampling protocols included in this method (*e.g.*, leak check procedures and sampling system requirements).

4.2 *Canister Sampling Media Interferences*. Each canister will have its own specific performance characteristics and appropriate cleaning, sampling, and handling procedures are required for attainment of acceptable initial and ongoing method performance. Failure to adhere to the cleaning and certification requirements included in this method may lead to the following interference issues:

(1) Incomplete deactivation of canister interior surfaces (*e.g.*, canister welds) may result in active sites for adsorption or surfaces that facilitate the decomposition of labile VOCs to form other VOCs within the canister. Other potential sources of active sites include canister valves, valve stems, and ferrules. Damage to the canister interior that exposes untreated surfaces may also result in active sites.

(2) Entrained PM deposited in the canister sampling pathway can adsorb VOCs making them unavailable in the canister gas phase which interferes with collected samples. Such trapped VOCs can potentially desorb later and result in the inability to achieve canister cleanliness performance specifications and/or contaminate subsequent canister sampling events. Additionally, organic PM can react with co-sampled ozone or other oxidative species to form target VOCs. PM can also clog tiny openings in critical or restrictive orifices, which impacts collection flow rates.

(3) Under certain conditions, the composition of an air sample may change upon its introduction into the canister and over time such that the air in the canister no longer represents the air sampled. Such changes may be caused by interactions of the VOCs with the interior canister surface or between chemicals in the air matrix. The activity of the interior canister surface is unique to each canister and is based on several factors, including variability in canister manufacturing defects, differences in

canister surface deactivation treatments, the presence of PM and co-collected moisture in the canister, and artifacts from reactions of VOCs on the canister walls.

(4) Condensed water within the canister can result in corrosion of the interior surface of canisters with weak or deficient coatings and can result in the partitioning of hydrophilic polar VOCs to liquid water. Under such circumstances, concentrations of these analytes in the gas phase will be biased low until the condensation is eliminated by reduction of the canister pressure below the vapor saturation pressure of water.

**4.3 Analytical Interferences.** Contamination within the analytical system may come from several sources including, but not limited to, off-gassing of materials within the sample introduction or preconcentrator flow path, carryover from high-concentration samples or standards, and solvent vapors within the laboratory.

(1) Active sites within the sample introduction or preconcentration flow path are often caused by use of improper materials or degradation of deactivated surfaces.

(2) Impurities in source materials or diluent gases for internal standard (IS) gas mixtures may result in contamination of target VOCs.

(3) Water and the delivery systems used to humidify canisters or diluent gas streams may contaminate the canister contents or humidified gases.

(4) Moisture in the sample gas may interfere with VOC analysis by GC-MS. Poor or inconsistent water management during preconcentration can cause peak broadening and RT shifts that can result in peak misidentification, particularly for hydrophilic polar compounds. Water management systems that use semipermeable fluoropolymer membranes remove oxygenated and polar VOCs from the sample matrix and exhibit memory effects for several VOCs. VOCs entrained in the fluoropolymer membrane can convert to ketones and alcohols, which are transported across the membrane bidirectionally such that these ketones and alcohols can contaminate the sample stream and VOCs in the sample stream can be adsorbed into the fluoropolymer and removed from the sample stream.

(5) Carbon dioxide in the collected sample can coelute with more volatile VOCs eluting early in the GC-MS run and interfere with their quantitation.

(6) Artifacts in chromatograms, such as silanol compounds formed from the breakdown of silicon-ceramic linings of canisters and siloxane compounds from

the breakdown of the stationary phase in an analytical column, can interfere with identification and quantitation of less volatile VOCs.

(7) Be cognizant of compounds that interfere with target analytes when operating in MS modes that do not provide full-scan ion spectra (*i.e.*, selected ion monitoring [SIM] and selected ion storage [SIS]). Such interfering coeluting compounds may share common ions, may have similar mass spectra, and may be difficult or impossible to separate from target VOCs.

## 5.0 Safety

This method does not address all the safety concerns associated with its use. It is the responsibility of the user of this standard to establish appropriate field and laboratory safety and health practices prior to use.

## 6.0 Equipment and Supplies

**6.1 Specially Prepared Canisters.** You must use specially prepared canisters at least 6 liters in volume that are suitable for trace gas analysis of the target compounds, such that they meet the requirements in Section 8.3 of this method. Canisters must be able to withstand numerous cycles of evacuation to high vacuum of 0.0067 kPa (0.002 in. Hg) and pressurization to 377 kPa (40 pounds per square inch gauge, psig).

**6.2 Valves.** Valves. You must use canisters with valves that are designed specifically for trace level measurements. The wetted portions of the valve must, at a minimum, be constructed of chromatographic-grade stainless steel (preferably type 316), and the valve seal surfaces must be metal to metal to minimize absorption and off-gassing of VOCs and other potential contaminants. It is recommended that valve designs have minimal internal volume and surface area to minimize the risk of contamination.

**6.3 Canister Cleaning System.** You must use a canister cleaning system that includes the following components.

**6.3.1 Manifold** constructed of chromatographic-grade stainless-steel tubing and connections for multiple canisters.

**6.3.2 Oil-free vacuum pump** capable of achieving vacuum of approximately 3.4 kPa absolute (1 in. Hg absolute or 0.5 psia).

**6.3.3 High-vacuum pump** for achieving a final canister vacuum of approximately 0.0067 kPa (0.002 in. Hg) or less.

**6.3.4 Heating oven** that can contain the canister and allow heating of the valve. The oven is also used to bake sampling system components.

**6.3.5 Humidification system**, such as humidifier impinger or bubbler, capable of achieving relative humidity (RH) of at least 50% in the canister.

**6.3.6 Programmable controller** for selecting temperature and cycle time and for manually or automatically switching between evacuation and pressurization.

**6.3.7 A pressure release valve** to minimize the likelihood of system over pressurization.

**6.3.8 Tubing and connections** constructed of borosilicate glass, quartz glass, or chromatographic-grade stainless-steel (minimum type 316 or silicon-ceramic coated) to minimize dead volume of the system. You must not use butyl rubber or perfluoroalkoxy (PFA) materials. If needed for connections or seals, minimize the use of Viton and Teflon to avoid adsorption and/or off-gassing of compounds of interest or introduction of other potential interferences.

**6.3.9 Purge gas** such as HCF zero air or ultra-high purity (UHP)-grade cylinder nitrogen or liquid nitrogen dewar headspace.

**6.3.10 Charcoal scrubber**, catalytic oxidizer, or other systems for eliminating trace contaminants from the purge gas.

**6.4 Sampling Device.** The sampling device consists of the following equipment and for the purpose of this method, the sampling device consists of the aggregation of equipment in this section. The sampling device must be individually named with an alpha-numeric serial number that is unique.

**6.4.1 A stainless-steel particulate filter** with pore size of 2 to 7 micrometers ( $\mu\text{m}$ ) installed on the sampling device inlet.

**6.4.2 Sampling Probe.** The internal volume of the sample probe must be less than 1% of the volume collected by the sample container with an inverted inlet (*e.g.*, sampling cane to prevent the entry of water droplets) consisting of only chromatographic-grade stainless steel (including silicon-ceramic lined steel) placed 1.5 to 3 meters (4.9 to 9.8 feet) above the ground.

**6.4.3 You must use an MFCD** to regulate the flow at a constant flow rate over the 24-hour collection period into an evacuated stainless-steel canister.

**6.4.4 Canister Sampling Timers (Optional).** A device with an inert valve that can be programmed to automatically start and stop canister sampling periods

**6.5 Vacuum/Pressure Gauges.**

**6.5.1 Field Pressure Measurement Gauge.** A vacuum/pressure gauge or pressure transducer with an accuracy of  $\pm 0.25\%$  full scale calibrated over the

range of use for the application with sufficient resolution to permit precise measurement of pressure differentials must be used for field sampling purposes. The accuracy of the vacuum gauge must be measured verified on an annual basis against a National Institute of Standards and Technology (NIST)-certified standard.

6.5.2 Laboratory Canister Pressure Measurement Gauge. A vacuum/pressure gauge or pressure transducer with an accuracy of  $\pm 0.1\%$  full scale or 0.13 kPa, whichever is smaller, calibrated over the range of use for the application with sufficient resolution to permit precise measurement of canister pressure must be used for pressurizing field samples with HCF zero air or ultrapure nitrogen for analysis. The accuracy of the vacuum gauge must be measured verified on an annual basis against a NIST-certified standard for analysis.

6.6 Gas Regulators. Regulators for high-pressure cylinders of dilution gas, stock standard gases, and internal standard gases must be constructed of non-reactive material, such as high-purity stainless steel, and may be lined with an appropriate material that is inert to the targeted VOC (*e.g.*, silicon-ceramic). Do not use regulators that contain PFA materials (*e.g.*, for seals and diaphragms) and avoid using regulators that contain Teflon products such as polytetrafluoroethylene (PTFE) and fluoroethylenepropylene (FEP), where possible, to minimize memory effects. All regulators must be rated for the pressure and flow expected during use. Regulators must be dedicated to a specific task and labeled for use (*e.g.*, do not use the same regulator on a high-concentration stock VOC standard cylinder and a low-concentration stock VOC cylinder).

**Note:** Some new regulators (*e.g.*, stainless steel regulators) should be sufficiently passivated prior to use to prevent potential sample loss.

#### 6.7 Reference Flow Meters.

6.7.1 A flow meter (*e.g.*, a calibrated mass flow meter (MFM), a volumetric reference standard, or other similar measurement device) calibrated to measurement range appropriate to measure continuous flow must be used. The flow meter must not interfere with the flow measurement (*i.e.*, the pressure drop across the flow meter may affect the flow being measured).

6.7.2 Reference flow meters must be calibrated on an annual basis and be able to measure within  $\pm 2\%$  of the predicted values (*e.g.*, cubic centimeters per minute) against a NIST-traceable volumetric standard.

6.8 Tubing and Fittings. Connecting tubing and fittings for dilution and standard gases must be constructed of chromatographic-grade stainless steel (*e.g.*, 316 type), which includes silicon-ceramic-treated stainless steel.

Connections must be metal to metal. Lines may need to be heated to ensure that there is no condensation. You must not use PTFE thread sealants or Buna-N rubber components on any wetted surface in a sampling and analytical system.

6.9 Analytical Instrumentation. Conduct analyses under this method using any combination of preconcentrator, GC, and MS provided the equipment meets the performance specifications of this method.

#### 6.9.1 Gas Chromatographic–Mass Spectrometric (GC–MS) System.

6.9.1.1 Gas Chromatograph. The GC used for analysis under this method must allow temperature programming with quick and accurate temperature ramping. If needed for separation of very light VOCs from the targeted oHAPs, the GC must be capable of sub-ambient cooling (*e.g.*,  $-50\text{ }^{\circ}\text{C}$ ). Carrier gas connections must be constructed of stainless-steel or copper tubing.

6.9.1.2 Chromatographic Column. The capillary chromatographic column must be capable of achieving separation of target compounds and any potential interferences per Section 4 and maintaining retention time stability as required in Section 9.

6.9.1.3 Mass Spectrometer. The MS may be a linear quadrupole, ion trap, or TOF unit, and must have minimum resolution of 1 atomic mass unit (amu) or less. The MS must be capable of analyzing the desired mass range every 1 second or less and operate with an acquisition rate such that at least 12 measurements are performed over a typical chromatographic peak. Quadrupole and ion trap systems employing electron impact (EI) ionization mode must provide nominal 70 volt (V) electron energy in EI mode to produce a bromofluorobenzene (BFB) mass spectrum that meets all the instrument performance acceptance criteria as specified in this method.

6.10 Calibration Gas Standard Preparation Equipment. This section discusses the equipment needed to prepare working-level standards for calibrating the GC–MS by dilution of a higher concentration stock standard gas.

#### 6.10.1 Dynamic Dilution System Instrumentation.

6.10.1.1 The dynamic dilution system must include, at a minimum, calibrated electronic mass flow controllers (MFCs) for the diluent gas and each standard gas to be diluted, a

humidifier for the diluent gas, and a manifold or mixing chamber where the diluent and standard gases can be sufficiently combined before introduction to the preconcentrator or canister. The gas dilution system must produce calibration gases whose measured values are within  $\pm 2\%$  of the predicted values. The predicted values are calculated based on the certified concentration of the supply gas (protocol gases, when available, are recommended for their accuracy) and the gas flow rates (or dilution ratios) through the gas dilution system.

6.10.1.2 Connection tubing for the dynamic dilution system must be constructed of chromatographic-grade or silicon-ceramic-coated stainless steel. Mixing chambers or manifolds must be constructed of chromatographic-grade or silicon-ceramic-coated stainless steel, borosilicate, or quartz glass.

6.10.1.3 The gas dilution system must be recalibrated at least once per two calendar years using NIST-traceable primary flow standards with an uncertainty  $\leq 0.25\%$ . You must report the results of the calibration whenever the dilution system is used, listing the date of the most recent calibration, the due date for the next calibration, calibration point, reference flow device (device identification [ID], serial number [SN], and acceptance criteria.

6.10.1.4 The gas dilution system must be verified to be non-biasing under HFC zero air and known standards at least one per calendar year for each reactive target compounds (*e.g.*, ethylene oxide and vinyl chloride). Zero air must be flowed through all applicable MFCs, tubing, and manifold used and verified to not be detectable for the target compounds. Additionally, a known standard within the calibration range of the analytical system for each target compound must be flowed through all applicable MFCs, tubing, and manifold to allow equilibration and verified to not bias the standard by  $\pm 15\%$  of the concentrations in the reference sample. The equilibration time for the bias verification must be used at a minimum for the development of standards.

6.10.1.5 The gas dilution system MFCs used must be verified quarterly, at a minimum, per Section 3.2 of Method 205 using any available protocol gas and corresponding reference method.

#### 6.10.2 Static Dilution System Instrumentation.

6.10.2.1 The static dilution system must include, at a minimum, a calibrated pressure transducer or pressure gauge to measure the partial pressures of each standard gas to be diluted and the balance gas, and a

manifold to introduce the gases into the working standard canister or vessel. Pressure transducer(s) or pressure gauge(s) used for static dilution must have an accuracy of  $\pm 0.1\%$  full scale or 0.13 kPa, whichever is smaller, calibrated over the range of use for the application with sufficient resolution to permit precise measurement of pressure differentials.

6.10.2.2 Connection tubing for the static dilution system must be constructed of chromatographic-grade or silicon-ceramic-coated stainless steel. Manifolds must be constructed of chromatographic-grade or silicon-ceramic-coated stainless steel, borosilicate, or quartz glass.

6.10.2.3 The static gas dilution system must be recalibrated once per calendar year using NIST-traceable primary pressure gauge with an uncertainty  $\leq 0.1\%$ . You must report the results of the calibration whenever the dilution system is used, listing the date of the most recent calibration, the due date for the next calibration, calibration point, reference flow device (ID, S:N ratio), and acceptance criteria.

6.10.2.4 The gas dilution system must be verified to be non-biasing under HCF zero air and known standards at least one per calendar year for each reactive target compounds (*e.g.*, ethylene oxide and vinyl chloride). Zero air must be flowed through all applicable tubing and manifold used and verified to not be detectable for the target compounds. Additionally, a known standard within the calibration range of the analytical system for each target compound must be flowed through all applicable tubing and manifold into the standard canister or vessel and verified to not bias the standard by  $\pm 15\%$  of the concentrations in the reference sample.

#### 6.11 Calibrated Hygrometer.

6.11.1 The calibrated hygrometer must be capable of a 1% RH resolution with a yearly calibration to a NIST-traceable accuracy of  $\pm 3\%$  RH within the range of 20% to 80% RH.

6.11.2 The calibration hygrometer calibration must be verified weekly or per use (whichever is less stringent) at a single point that is approximately 40 to 50% RH to within  $\pm 5\%$  using a second calibrated hygrometer or a saturated salt solution.

### 7.0 Reagent and Standards

7.1 You must use only NIST-certified or NIST-traceable calibration standards, standard reference materials, and reagents that are stable through certification and recertification for the tests and procedures required by this method. You must use standards and

reagents within their expiration period and evaluate working-level standards prepared in canisters within 30 days of preparation. The concentrations of the target compounds in the mixture must be commensurate with the anticipated dilution factor achievable by the laboratory needed to dilute the mixture to the desired working range. You must retain and report the gas standard certificates of analysis.

7.2 Carrier Gas. Use helium, hydrogen, or nitrogen as the carrier gas in the GC. Carrier gas must be ultrapure (99.999% pure or better).

7.3 HCF Zero Air. Purchase HCF zero air in high-pressure cylinders from reputable gas vendors or prepare HCF zero air by passing ambient air through molecular sieves, catalytic oxidizers, and subsequent charcoal filters or similar substrate. HCF zero air must contain impurities less than 20 pptv or undetected (whichever is more stringent) per compound of interest.

7.5 Nitrogen. Use ultrapure (99.999% pure or better) nitrogen from cylinders procured from commercial gas vendors or from the headspace gas from a liquid nitrogen dewar.

7.6 Cryogenics. Cryogenics (*e.g.*, liquid nitrogen, liquid argon, and liquid carbon dioxide) specified by the instrument manufacturer, if needed.

7.7 Water for Canister Humidification. ASTM Type I (resistivity  $\geq 18$  megaohm-centimeter [ $M\Omega\text{-cm}$ ]) or equivalent.

### 8.0 Sample Collection and Preparation

This section presents the sample collection and handling procedures of this method with the initial and ongoing performance evaluation of materials used in sampling and analysis. This method allows the user to choose the materials used for sampling. You must record the exact materials used when conducting this method and include that information in any report associated with sampling according to this method.

8.1 Sampling Device Performance Tests. Prior to initial field deployment and as directed in this section, you must verify that all equipment used to conduct this method meets the performance criteria specified in this section. The primary objectives of the performance tests in this section are to characterize the sampling system and to verify that the sampling system used meets the criteria in the method. The sampling system performance tests include the following:

- (a) Flow control verification test,
- (b) Flow control flow check,
- (c) Sampling device leak check,

- (d) Sampling device bias check, and
- (e) Sampling device standard check.

8.1.1 Flow Control Verification Test. Prior to initial field deployment and at least every twelve months, you must verify that the sampling device's ability to control flow to the canister is acceptable. Assemble an evacuated canister with the sampling device including filter connected to a certified flow meter. Figure 1 of Section 17 of this method provides an illustration of the apparatus for characterizing the flow control device.

8.1.1.1 Open the evacuated canister, monitor and record (manually or electronically) the canister pressure downstream of the flow control device and the flow upstream of the flow control device on an hourly basis over the period of 24-hours.

8.1.1.2 The flow control verification test is considered acceptable when the sampling apparatus maintains a constant flow rate for 24-hours and until at least 75% of the canister volume is collected, which is equivalent to approximately 28 kPa (7 in. Hg or 4 psia) below atmospheric pressure.

8.1.1.3 Record the average flow rate during this test. This value will be the reference flow rate for the sampling device until the next verification test. Maintain the results as part of a laboratory record associated with the sampling device.

#### 8.1.2 Flow Control Flow Check.

Prior to and after each field sampling event, establish or verify the flow rate of the sampling apparatus. This verification must occur in the field prior to and after each field event.

8.1.2.1 Assemble an evacuated canister and the sampling device connected to a certified flow meter in the same manner used for the flow control verification test discussed above.

8.1.2.2 Open the evacuated canister, allow sufficient time for the system to stabilize, and record the flowrate upstream of the flow control device. Collect two additional flow rate measurements.

8.1.2.3 Calculate the average flowrate. The flow control flow check is considered valid if within  $\pm 10\%$  of the reference flow rate.

8.1.2.4 If the flow rate has changed and is outside the desired range, you must either adjust or replace the controller and repeat the flow check.

8.1.3 Sampling Device Leak Check. You must demonstrate the sampling device and sampling system are leak-free immediately before you begin sampling.

8.1.3.1 Install the sampling device on an evacuated canister equipped with

a MFC and tightly cap the inlet to the sampling device.

8.1.3.2 Open the canister valve fully, and then re-close the valve and observe the vacuum/pressure gauge for a minimum of 2 minutes.

8.1.3.3 If you observe an increase in pressure, the sampling device does not qualify as leak-free. If no changes are observed, record the data and time of the leak check on the Field Data Page (see Figure 4 in Section 17 of this method for an example).

8.1.4 Sampling Device Bias Check. You must demonstrate that sampling device is non-biasing under zero-air and known-standard conditions. For the procedures in Sections 8.1.5 and 8.1.6 of this method, you must use only canisters that have been qualified as specified in Section 8.3 of this method.

8.1.5 Sampling Device Zero-Air Challenge. You must conduct the sampler bias test at least every twelve months, and after cleaning, replacement of components, or collection of potentially contaminating samples. The volume of air analyzed for the zero-air and reference standard gas must be consistent with the laboratory's typical canister sample injection volume or nominal volume.

8.1.5.1 Provide humidified (>40% RH) HCF zero air through the sampling device into the canister, and then analyze the sample according to Section 11 of this method and record the concentration measurement and maintain the results as part of a laboratory record associated with the sampling device.

8.1.5.2 The results must show that the concentration of the target compounds in the zero-air challenge sample collected through the sampling unit is not greater than 20 pptv higher than the native concentration of the target compounds in the reference sample (sample of zero-air collected upstream of the sampling device) or not detected at 22.1 psi absolute (152 kPa absolute) whichever is more stringent. If a sampling device does not meet this performance criteria, take action to remove the contamination attributable to the sampling unit (e.g., purging with humidified HCF zero air overnight or longer) and repeat the zero-air challenge. You must not use a sampling device that has not met the standards in this section.

**Note:** If extended purging durations are not adequate to eliminate contaminants, then disassemble and clean according to Section 8.4 of this method. If the unit cannot be cleaned to meet the specifications, retire the unit from use or repurpose for source sampling.

8.1.6 Sampling Device Standard Check. You must conduct the sampling device standard check prior to initial use and at least every twelve months, and after replacement of components, or collection of potentially contaminating samples. For the procedures specified below, you must use only canisters that have been qualified as specified in Section 8.3 of this method.

8.1.6.1 Collect a humidified (>40% RH) known-standard challenge gas through the sampling device and into a canister. The challenge gas must contain the target oHAPs at 100 to 500 pptv each and you must choose the selected challenge concentration considering the expected measured concentration at the deployment location(s).

8.1.6.2 Analyze the sample according to Section 11 of this method and record the concentration measurement and maintain the results as part of a laboratory record associated with the sampling device. The results must demonstrate that each oHAP in the sample collected through the sampling device must be within  $\pm 15\%$  of the concentrations in the reference sample. For compounds exceeding this criterion, you must take steps to eliminate the bias (e.g., cleaning as specified in Section 8.6.1 of this method or replacement of compromised parts) and repeat the known-standard challenge.

8.1.6.3 Following successful completion of the known-standard challenge, flush the sampling device or system with humidified (>50% RH) HCF zero-air or ultrapure nitrogen until the device meets the criteria specified in Section 8.1.5.2 prior field deployment.

8.2 Qualification of Analytical Instrumentation. Prior to initial use and as directed in this section, you must verify that the analytical equipment used in performing this method meets the performance criteria in this section. The primary objectives of these performance tests are to characterize the analytical instrumentation and verify that the analytical instrumentation meets the criteria in this method. The analytical instrumentation performance tests consist of the following:

- (a) Analytical zero-air verification,
- (b) Analytical known-standard challenge for analytical instrumentation, and
- (c) Autosampler verification.

8.2.1 Analytical Zero-Air Verification. Prior to initial use and as part of an instrument's annual calibration, you must demonstrate that the analytical instrumentation (preconcentrator, GC-MS system, and all connections) is non-biasing under zero-air. The volume of air analyzed

must be consistent with the laboratory's nominal injection volume.

8.2.1.1 Use the analytical instrumentation to analyze humidified (40 to 50% RH) HCF zero air from a known clean source (e.g., certified clean canister, clean cylinder gas, zero-air generator) at the installation prior to initial use of the instrument.

8.2.1.2 Examine chromatograms for interferences and other chromatographic artifacts such as nontarget peak responses, large peaks or rises in the chromatogram due to undifferentiated compounds, and baseline anomalies. The analysis must show that the concentration of any detected target compounds in the zero-air challenge sample is <20 pptv or undetected (whichever is more stringent) per compound of interest.

8.2.1.3 If you identify exceedances of target compounds in the zero-air challenge, take steps (e.g., analyzing replicates of humidified clean gas until the contamination is eliminated) to remove the contamination attributable to the analytical instrumentation by following the manufacturer's instructions.

8.2.1.4 You must repeat the analytical zero-air verification to ensure that you have mitigated any problems before using the analytical instrumentation.

8.2.2 Analytical Known-Standard Challenge for Analytical Instrumentation. Prior to initial use and as part of an instrument's annual calibration, you must demonstrate that the analytical instrumentation (preconcentrator, GC-MS system, and all connections) is non-biasing under known standards. The volume of air analyzed must be consistent with the laboratory's nominal canister sample injection volume.

8.2.2.1 Analyze a humidified (40 to 50% RH) reference standard in duplicate containing all target compounds at approximately 100 to 500 pptv each, chosen in consideration of the expected concentration at the deployment locations.

8.2.2.2 The results must demonstrate that the target compounds in the sample collected through the sampling device are within  $\pm 15\%$  of the expected concentrations in the sample.

8.2.2.3 Compounds demonstrating poor response as indicated by peak absence or minimal peak area may be a result of active sites in the analytical system, cold spots in transfer lines, gas impurities, improper choice of preconcentrator sorbent traps or GC columns, system leaks, and/or poor moisture management. If you identify problems, consult the instrument

manufacturer to determine the necessary steps to eliminate the bias.

### 8.2.3 Autosampler Verification.

Prior to initial use and as part of an instrument's annual calibration, you must demonstrate that the auto sampling equipment is non-biasing under zero-air.

8.2.3.1 If you use an autosampler to facilitate analysis of multiple canisters, you must test all ports, transfer lines, and connections of the autosampler after you have calibrated the analytical system and prior to conducting the canister, sampling device and system qualifications, or upon replacement of transfer lines or after analysis of potentially contaminating samples.

8.2.3.2 Connect humidified (40 to 50% RH) HCF zero air to each port and verify that the concentration for each target compound is <20 pptv or undetected (whichever is more stringent) per compound of interest using the procedures in Section 11 of this method.

8.2.3.3 After the zero-air test, challenge each port of the autosampler with a reference standard (approximately 100 to 500 pptv) to verify that the autosampler is not causing bias using the procedures in Section 11 of this method). The concentration of each target compound must be within  $\pm 15\%$  of the theoretical concentration of the reference standard.

8.3 Qualification of Canisters. Prior to initial use and as directed in this section, sampling canisters must meet the performance criteria in this section. The primary objectives of these performance tests are to ensure canisters are well characterized and to verify they are non-biasing. The performance criteria in this section are specific to the application of fenceline measurements for regulatory purposes at stationary sources. The performance test consists of the following:

- (a) Canister design,
- (b) Canister leak check,
- (c) Canister zero-air verification, and
- (d) Canister known-standard verification.

#### 8.3.1 Canister Design.

8.3.1.1 You must use specially prepared canisters at least 6-liters volume in size that are suitable for trace gas analysis of the target compounds. The canister must include a fixed on/off valve made from chromatographic-grade stainless with metal valve seal surfaces. Each canister must also include a permanent alpha-numeric serial number for identification purposes. Alternative canister volumes may be used, subject to approval by the Administrator.

**Note:** Specially prepared canisters are commercially available with a modest range

of options for surface preparation of the canister interior surfaces, valves, and connections. Currently, canister interior surfaces are typically passivated by electropolishing or coating with a silicon-ceramic film. EPA does not require a specific treatment or design and any canister type may be used for this method contingent on meeting the performance criteria in this section; however, silicon-ceramic coated canisters have demonstrated superior performance when used to sample reactive compounds, (e.g., ethylene oxide).

8.3.1.2 Canisters should be handled with care to ensure that the interior canister surface is not compromised, the valve-to-canister connection remains intact, and weld integrity is maintained. Excessive torque on unbraced canister valve stems when making connections may cause damage and potentially leaks in the valve stem weld or at the ferrule sealing the canister valve and canister stem. Shocks resulting in dents to the surface of the canister may damage welds or create small cracks in the interior canister surface that may expose active sites. You must not use any canister with dents or compromised welds.

8.3.1.3 You must maintain a record of the results for all canisters used for this method. It is recommended that you evaluate the results for any potential trends that could result in erroneous data.

8.3.2 Canister Leak Check. You must qualify each canister as being acceptably leak-tight to ensure sample validity. Qualify new canisters before initial use and qualify all canisters used for sampling at least annually.

8.3.2.1 Leak Check. In conducting the canister leak check, you can either evacuate the canister to high vacuum  $\leq 0.0067$  kPa absolute (0.002 in. Hg or 0.001 psia) or pressurize the canister with clean fill gas to  $>203$  kPa absolute (60 in. Hg or 29.4 psia).

8.3.2.2 After establishing the target pressure in the canister, close the valve and attach a vacuum/pressure gauge.

8.3.2.3 Open the valve and record the initial pressure reading.

8.3.2.4 Close the valve, remove the vacuum/pressure gauge, and loosely cap the canister using a cap fitting to ensure that leakage through the valve is accurately assessed while avoiding potential entry of debris into the valve during storage.

8.3.2.5 After a minimum of two days in storage, reinstall the vacuum/pressure gauge, open the valve, and record the canister pressure reading.

8.3.2.6 Determine the pressure decay rate as the absolute value of the difference between the initial and post-storage canister pressures. You must remove the canister from service if the

pressure decay rate exceeds 0.69 kPa/storage day (0.2 in. Hg or 0.1 psia/storage day).

8.3.3 Canister Zero-Air Verification. You must qualify each canister as being acceptably non-biasing under zero-air conditions to ensure sample validity. Qualify new canisters before initial use and qualify all canisters used for sampling at least once every 18 months.

8.3.3.1 Pressurize the clean evacuated canister with humidified ( $>50\%$  RH) HCF zero air to 152 kPa absolute (22.1 psia). Do not use ultrapure nitrogen to pressurize the canister because the inert nitrogen atmosphere does not permit reactions within the canister that may occur under sampling conditions.

**Note:** Canister Zero-Air Verifications must also be performed after canister disassembly and/or replacement of components. Also, more frequent zero-air verifications may be appropriate when canisters are used in areas with higher ambient VOC concentrations or for collection of potentially contaminating samples.

8.3.3.2 Allow the canister to equilibrate for a minimum of 24 hours.

8.3.3.3 After the equilibration period, conduct an initial cleanliness analysis as specified in Section 8.4 of this method.

8.3.3.4 Store the canister for a holding period equal to or exceeding the typical laboratory holding time, nominally 8 days from the canister fill date.

8.3.3.5 After the holding period, conduct a subsequent cleanliness analysis as specified in Section 8.5 of this method.

8.3.3.6 The results of both the initial and subsequent cleanliness analysis must meet the cleanliness criteria specified in Section 8.5 of this method to be used for sampling. You must reclean and retest canisters that fail the zero-air challenge.

**Note:** If necessary, use more aggressive cleaning techniques such as water rinses or other rinses as specified by manufacturers. If a canister continues to fail the zero-air challenges, remove the canister from service.

8.3.4 Canister Known-Standard Verification. You must qualify each canister as being acceptably non-biasing under known-standard conditions to ensure sample validity. Qualify new canisters before initial use and qualify all canisters used for sampling at least every 18 months.

8.3.4.1 Fill the clean evacuated canister with a humidified (40 to 50% RH) standard gas in HCF zero air with each target compound at approximately 100 to 500 pptv. Choose the selected challenge concentration based on the

concentration expected to be measured during the sampling event.

8.3.4.2 Allow the canister to equilibrate for a minimum of 24 hours.

8.3.4.3 After the equilibration period, conduct an initial analysis according to Section 11 of this method.

8.3.4.4 Store the canister for a holding period equal to or exceeding the typical laboratory holding time, nominally 8 days from the canister fill date.

8.3.4.5 After the holding period, conduct a subsequent analysis.

8.3.4.6 The results of both the initial and subsequent analysis must show that the measured concentrations of the target analytes are within  $\pm 30\%$  of the theoretical spiked concentration for each target compound. You must reclean and retest canisters that fail the known-standard verification.

8.4 Canister Cleaning. Clean canisters using repeated cycles of evacuation and pressurization. Table 1 in Section 17 of this method summarizes the canister cleaning procedures.

8.4.1 Gas Source for Canister Cleaning, Pressurization, and Flushing.

8.4.1.1 Verify, by direct analysis, the cleanliness of the purge gas upon initial setup. The analysis must show that the concentration of the individual target compounds is  $\leq 20$  pptv or undetected (whichever is more stringent) per compound of interest at 101.3 kPa absolute (29.92 in. Hg or 14.7 psia).

8.4.1.2 Humidify the purge gas to  $>50\%$  RH and measure the humidity by placing a calibrated hygrometer probe in the humidified gas stream.

8.4.1.3 If using a bubbler-type humidifier, ensure that the downstream pressure is lower than the humidifier upstream pressure to avoid backflow of the water.

8.4.2 Pre-Evacuation of Canisters. You may need to repeat the pre-evacuation process for canisters that contain VOCs at higher concentrations.

8.4.2.1 Pre-evacuate canisters to be cleaned prior to connection to the canister cleaning system. To reduce the potential for contamination of the system, attach the canisters to an oil-free roughing pump and evacuate to approximately 7 kPa absolute (28 in. Hg vacuum or 1.0 psia) with the exhaust of the pump directed to a fume hood or passed through a charcoal trap.

8.4.2.2 Refill canisters to ambient pressure with HCF zero air.

8.4.2.3 Attach the canisters to the cleaning system after completing the pre-evacuation and refilling steps.

8.4.3 Canister Heating During Cleaning.

8.4.3.1 Heat canisters by placing them in an enclosed oven during

cleaning to facilitate removal of compounds. Do not use heat bands or heating jackets.

8.4.3.2 Table 1 of Section 17 of this method specifies the temperatures to use for canister cleaning procedures.

8.4.4 Canister Evacuation and Pressurization Cycling.

8.4.4.1 Evacuate canisters to minimally 7 kPa absolute (28 in. Hg vacuum or 1 psia) and maintain this vacuum for a at least 1 minute.

8.4.4.2 Pressurize canisters to 414kPa absolute ( $\leq 30$  psig) with humidified ( $>50\%$  RH) HCF zero air and maintain this pressure for a minimum of 1 minute.

8.4.4.3 Repeat the cycle of canister evacuation and pressurization specified in Sections 8.4.4.1 and 8.4.4.2 of this method at least 5 times. You may need to perform 10 to 20 cycle repetitions or use other ancillary procedures to remove stubborn interferents or oxygenated compounds such as ketones, alcohols, and aldehydes (U.S. EPA, 2016b).

8.5 Verification of Canister Cleanliness Prior to Sample Collection.

8.5.1 After cleaning, pressurize each canister from the batch with humidified HCF zero air and maintain that pressure for at least 24 hours.

8.5.2 Connect each canister to the analytical system and measure the concentration of each target compound according to the procedures in Section 11 of this method.

8.5.3 The canister background concentration for each target compound must be  $\leq 20$  pptv (0.02 ppbv) or undetected (whichever is more stringent) when a canister is filled to 22.1 psi absolute (152 kPa absolute).

8.5.4 Canisters that meet the blank criteria are suitable to be evacuated for use. If a canister fails to meet the criteria, you must not use that canister until it has been re-cleaned and has met the requirements in Section 8.5.3 of this method.

8.5.5 Prior to field deployment, evacuate canisters to  $\leq 0.0067$  kPa ( $\leq 0.002$  in. Hg or 0.001 psia).

8.6 Cleaning of Sampling Components.

8.6.1 Follow the manufacturer's instructions for cleaning components such as flow controllers and sampling unit parts, when necessary.

**Note:** *Disassembly of such instruments may void warranties or calibrations.*

8.6.1.1 Flush the sampling units with humidified HCF zero air to remove contamination for at least 15 minutes.

8.6.1.2 Disassemble sampling components and visually inspect for cracks, abrasions, and residue prior to

sonicating in deionized water for at least 30 minutes.

8.6.1.3 After flushing/sonication, rinse the components with clean deionized water and dry the components in an enclosed oven set to at least 50 °C for a minimum of 12 hours.

8.6.1.4 Following drying, reinspect components for defects, reassemble, and flush the sampler with humidified HCF zero air or ultrapure nitrogen for at least 12 hours.

**Note:** *To avoid damage to deactivated stainless-steel components due to oxidation in the presence of oxygen-containing atmospheres (e.g., HCF zero air), you should not heat components treated with silicon-ceramic coatings above 80 °C unless evacuated or under an inert atmosphere (e.g., nitrogen).*

8.7 Sample Collection. Persons collecting field samples should be familiar with all aspects of this sampling protocol. It is suggested that those collecting these measurements for regulatory purposes develop site-specific SOPs to ensure samples are collected consistently and those doing the sampling are sufficiently trained on this method and the SOP.

8.7.1 Pre-Sampling Activities.

8.7.1.1 Clean canisters and verify that the canisters meet cleanliness and vacuum criteria specified in Sections 8.3 through 8.5 of this method.

8.7.1.2 If canisters were previously cleaned and stored under pressure while awaiting use, you must evacuate the canisters prior to field deployment. If canisters were stored under vacuum, you must verify that the canisters continue to meet vacuum threshold requirements.

8.7.1.3 Clean and verify the cleanliness and flowrates of sample devices that you will use for sampling and ensure that a clean particulate filter is placed in the inlet of the sampling device.

8.7.1.4 Establish sample codes (unique identifiers) and develop field data page and/or chain of custody (COC)/sample collection data form(s).

8.7.1.5 If shipping equipment into the field, make sure you have the proper number of canisters and sampling devices for the number of samples required for the sampling location and QC samples, allowing for sufficient timing for samples to arrive at the site.

8.7.1.6 Develop a unique sampling location ID. The sampling location must meet any requirements set in the applicable regulation and be in a secure location that protects the canister and sampling inlet from unwanted tampering or damage. The sampling location must also be located away from



the immediate vicinity of any biasing sources (*e.g.*, outdoor smoking areas; vehicle exhaust; heating, ventilation, and air conditioning units/building exhaust; outdoor fuel storage areas; shelter roofing materials; or exhaust from other sample collection devices). In general, horizontal distances should be >10 meters (m) from biasing sources.

#### 8.7.2 Sample Setup Activities.

8.7.2.1 You must place the canister in a location that protects the canister and sampling inlet from unwanted tampering, damage, or theft.

8.7.2.2 Protect the canister and sampling inlets by placing the canister under shelter, if possible. Do not restrict air flow around inlets and do not locate inlets under building overhangs.

8.7.2.3 Do not place the canister near vegetation or structures that block or significantly restrict air flow to the MFCD inlet or manifold. Ensure that rain cannot be drawn directly into the MFCD, and the inlet heights must be approximately 1.5 to 3 m above ground level.

8.7.3 Sample Setup and Deployment. Perform the following steps at the time of sample setup and deployment.

8.7.3.1 Based on the applicable standard, determine the appropriate number and placement of sampling locations at the fenceline. The applicable standard will define the sampling schedule (*e.g.*, one sampling event over a 5-day period) and the sampling period. All sampling locations must initiate sampling within 60 minutes of each other.

8.7.3.2 You must document all activities associated with sampling on the field data page. (See Figure 4 in Section 17 of this method for an example field data page.) You may choose to use this field data page as the COC, or you may choose to establish a separate COC form. The chain of custody will accompany the canisters during shipment and collection to document sample handling and transport.

8.7.3.4 Verify that each canister has been blanked within the last 30 days. Label each canister with a sample ID code and record the canister and sample ID on the field data page. You must not use a use a canister for sampling that has not been blanked within 30 days of sampling.

8.7.3.5 Verify the sample device is in working order and calibrate/verify the flow rate setting, if applicable, with a reference flow meter. Record the sample device ID, expected flowrate, and the reference flowrate if calibrated/verified in the field, including the reference flow meter if applicable.

8.7.3.6 Attach the sampling device to the canister and locate at the appropriate sampling location. Record the sampling location ID, latitude, longitude, date, and time that you installed the canister on the field data page.

8.7.3.7 Measure and record the canister vacuum using the field pressure measurement gauge, and verify that the canister has not leaked and has sufficient vacuum to collect the sample. You must replace the canister if the initial pressure is not within  $-1$  in. Hg absolute zero ( $-3.39$  kPa or  $0.5$  psi).

8.7.3.8 Conduct leak checks as specified in Section 8.3.2 of this method and record the results on the field data page.

8.7.3.9 Open the canister valve. Record the date and time that you opened the valve as the start time, and record the initial canister vacuum/pressure and any other comments such as unusual events or conditions that may impact sample results on the field data page.

8.7.3.10 Sample for the period as defined in the applicable standard (*e.g.*, 24 hours  $\pm 1$  hour).

8.7.3.11 At the end of the sampling period, close the valve. Record the date and time that you closed the valve as the end time.

8.7.3.12 Remove the sampling device and attach the field pressure measurement gauge.

8.7.3.13 Open the canister valve and measure and record the final canister vacuum/pressure and any other comments such as unusual events or conditions that may impact sample results on the field data page. Flag any canisters with a final pressure greater than  $-3$  in. Hg gauge pressure ( $10.2$  kPag or  $-1.5$  psig).

8.7.3.14 Disconnect the field canister pressure measurement gauge and replace with a cap.

8.7.3.15 If applicable, verify the sample device is still in working order and verify the flow rate setting with a reference flow meter. Record the final flowrate on the field data page.

8.7.4 Field Duplicates. For each sampling day, you must include the collection of a separate co-located sample for at least one sampling location. The collocated duplicate must be sampled using a discrete MFCD. The collection of the field duplicates must follow the same procedure and occur at the same time as the co-located field sample.

8.7.5 Canister Field Blanks. For each sample day, you must collect canister field blanks. A canister blank is prepared by filling a canister with humidified clean diluent gas (prepared

in the same manner as the method blank (MB) described in Section 9.3.2 of this method) to approximately 15 in. Hg  $\pm 1$  in. Hg. Record the pressure and transport to the field site(s) to accompany field-collected canisters. Canister field blanks are to be treated identically to field-collected samples in the field and laboratory including pressure checks, MFCD leak checks, etc. The field blanks are analyzed by interspersing them among the field samples.

8.7.6 Canister Field Spike. For each sample day, you must collect a canister field spike. A canister field spike is prepared by filling a canister with humidified standard gas at a concentration in the lower third of the calibration curve for the target compound to approximately  $-15$  in. Hg  $\pm 1$  in. Hg. The field spike canister is transported to the field site to accompany field-collected canisters and treated identically to field-collected samples in the field and laboratory, including pressure checks, MFCD leak checks, etc. The field spikes are analyzed by interspersing them among the field samples. Field spike acceptance criteria should be within  $\pm 30\%$  of the theoretical spiked concentrations.

8.7.7 Prepare and secure the canisters for transport. You must ship canisters in protective hard-shell boxes and/or sturdy cardboard boxes to ensure canister longevity. Do not use boxes that have lost integrity or rigidity.

8.8 Method Detection Limit (MDL) Determination. Determine the MDL under the analytical conditions selected (see Section 11 of this method) using the procedures in this section.

8.8.1 Prepare at least seven blank samples according to the procedures Section 9.3.2 of this method using sampling media (*i.e.*, canisters) that have been deployed in the field, and cleaned per Section 8.4 of this method. The blank samples must be prepared in at least three batches on three separate calendar dates and analyzed on three separate calendar dates according to the procedures in Section 11 of this method.

8.8.2 Prepare at least seven spike samples according to the procedures in either Section 10.2 or 10.3 of this method, at a concentration of the target compound within a factor of five of the expected detection limits. The spike samples must be prepared in at least three batches on three separate calendar dates and analyzed on three separate calendar dates according to the procedures in Section 11 of this method.

8.8.3 Compute the standard deviation for the replicate blank samples concentrations and multiply

this value by 3.14 to determine the blank MDL (MDLb).

8.8.4 Compute the standard deviation for the replicate spike sample concentrations and multiply this value by 3.14 to determine the spike MDL (MDLs).

8.8.5 Select the greater of MDLb or MDLs as the MDL for the compound of interest. The results must demonstrate that the method is able to detect analytes such as ethylene oxide at concentrations less than 20 pptv and at least 1/10th of the lowest concentration of interest (*i.e.*, action-level), whichever is larger. If the MDL does not meet the concentration requirement, perform corrective action and repeat the MDL determination.

8.8.6 MDL determinations must be repeated at least annually or whenever significant changes have been made to the sampling or analytical system.

**Note:** *The MDL calculation is based on single-tailed 99th percentile t static at six degrees of freedom. Additional blank or spike samples would increase the degrees of freedom.*

## 9.0 Quality Control

Table 9–1 in this section lists the quality control (QC) parameters and performance specifications for this method.

### 9.1 Second Source Calibration Verification (SSCV) Standard.

9.1.1 Prepare a humidified SSCV standard in a canister at a concentration in the lower third of the calibration curve. The SSCV standard must contain all compounds in the calibration mixture. The SSCV standard must be prepared independently from the calibration standards using a certified secondary source calibration standard.

9.1.2 Analyze the SSCV after the initial calibration (ICAL). Recovery of each target oHAP in the SSCV standard must be within  $\pm 30\%$  of the theoretical concentration.

9.2 Continuing Calibration Verification (CCV) Standard. Prepare a humidified CCV standard as a dilution

of a certified standard in a canister at a concentration in the lower third of the calibration curve. This certified standard must be prepared from the same standard used for the ICAL standards.

9.2.1 Analyze a CCV for each target oHAP prior to analyzing samples, after every 10 sample injections, and at the end of the analytical sequence. Prepare a humidified CCV standard as a dilution of a certified standard in a canister at a concentration in the lower third of the calibration curve. This certified standard must be prepared from the cylinder used for the ICAL standards.

9.2.2 The internal standard (IS) area responses for each CCV standard must meet the criteria outlined in Section 10.8.1.5 of this method, and the quantitated concentrations of the target compounds for each CCV standard must be within  $\pm 30\%$  of the theoretical concentrations as determined using Equation 4 in Section 12 of this method.

9.2.3 If the CCV is not within specifications, you must invalidate any results after the last successful CCV. You must investigate and address CCV failures and initiate corrective actions, including, for example, reanalyzing the CCV, preparing and analyzing a new CCV or standard canister, and performing a new ICAL.

9.3 Blank Analyses. Analysis of all blanks must demonstrate each target compound is  $< 20$  pptv 14.7 psia or undetected (whichever is more stringent) per compound of interest. Unless otherwise stated, the volume used for analysis of blanks must match the volume of sample to be analyzed.

9.3.1 Instrument Blanks (IB). Analyze an IB at the beginning of the sequence and prior to analysis of the ICAL standard and daily CCV standard.

9.3.2 Method Blanks (MB). Analyze a laboratory MB prior to and following the ICAL in an ICAL sequence and prior to analyzing the CCV standard. The MB consists of a canister filled with humidified (40 to 50% RH) clean diluent gas and is analyzed via the same

instrument method as the standards and field samples in the analytical sequence. Your MB must be the same diluent used for sample dilution.

9.3.3 Canister Field Blank. Analyze the canister field blank as part of the same analytical sequence as the accompanying field samples.

9.3.4 Calibration Blank (CB). Analyze the CB when the ICAL is established and when preparing any new CCV standard using the same instrument method that was used for standards and field samples when establishing the ICAL. The CB consists of a canister filled with the humidified (40 to 50% RH) clean diluent gas sourced through the dilution system employed to prepare standards. For laboratories that do not employ a dynamic or automated static dilution system, the CB consists of a humidified (40 to 50% RH) canister of the gas used to dilute the calibration standard.

9.4 Duplicate samples must be analyzed and reported as part of this method. They are used to evaluate sampling and/or analytical precision.

9.4.1 Field Duplicate. The level of agreement between duplicate field samples is a measure of the precision achievable for the entire sampling and analysis. Analyze the field duplicate during the same analytical sequence as the accompanying field sample. The RPD of the precision measurements should agree within  $\pm 30\%$  when both measurements are  $\geq 5$  times the MDL. Flag associated results to indicate if the RPD indicates poor method precision.

9.4.2 Replicate Analysis. The level of agreement between replicate samples is a measure of precision achievable for the analysis. Analyze at least one replicate analysis for each set of field-collected samples. The RPD of the precision measurements should agree within  $\pm 25\%$  when both measurements are  $\geq 5$  times the MDL. Flag associated results to indicate if the RPD indicates poor method precision.

TABLE 9–1—QUALITY CONTROL PARAMETERS AND PERFORMANCE SPECIFICATIONS

Parameter	Description and details	Required frequency	Acceptance criteria	Corrective action
Analytical zero-air verification.	Test of instrumentation to demonstrate cleanliness (positive bias) by analyzing humidified zero air; performed by connecting the clean humidified gas sample to the pre-concentrator to verify that the analytical instrument and all connections are sufficiently clean.	At installation prior to initial use of the instrument.	Analysis must show that any detected target compounds in the zero-air challenge sample are at response levels that are expected to be $< 20$ pptv or not detected.	Take steps to remove contamination attributable to the analytical instrumentation by following the manufacturer's instructions ( <i>e.g.</i> , analyzing replicates of humidified clean gas).

TABLE 9–1—QUALITY CONTROL PARAMETERS AND PERFORMANCE SPECIFICATIONS—Continued

Parameter	Description and details	Required frequency	Acceptance criteria	Corrective action
Analytical known-standard challenge for analytical instrumentation.	Test to demonstrate that the analytical instrumentation (preconcentrator and GC–MS system) is not causing loss of compounds (negative bias).	At installation prior to initial use of the instrument and with instrument's annual calibration.	Verifies that all target compounds are detected by the system, that they respond consistently upon repeated injection, and that they exhibit sufficient response to be quantifiable at low concentrations (see Section 8.2.2 of this method).	Check for cold spots in transfer line, gas impurities, sorbent traps, GC column, system leaks, and/or poor moisture management. Consult instrument manufacturer for steps to eliminate bias, as necessary.
Zero-air challenge of autosamplers associated with analytical instrument systems.	After establishing the ICAL, each port of the autosampler is tested to demonstrate cleanliness (positive bias) by analyzing humidified zero air; performed by connecting the clean humidified gas sample to the port to verify that transfer lines and all connections are sufficiently clean.	Prior to initial use, upon replacement of transfer lines, or after analysis of potentially contaminating samples.	Each target VOC's concentration must be <20 pptv or preferably not detected (see Section 8.2.3 of this method).	(1) Heat and purge any lines, and/or (2) Rinse with deionized water, dry, and purge any lines that fail.
Known-standard challenge of autosamplers associated with analytical instrument systems.	After establishing the ICAL, each port of the autosampler is tested with a reference standard (approximately 100 to 500 pptv) to demonstrate that the autosampler is not causing bias (typically loss of compounds or negative bias).	Prior to initial use and upon replacement of transfer lines.	Each target VOC's concentration within $\pm 15\%$ of theoretical concentration (see Section 8.2.3 of this method).	(1) Heat and purge any lines, and/or (2) Rinse with deionized water, dry, and purge any lines that fail.
Canister leak check ...	Verification that canisters are leak-free by performing a pressure decay test of a canister pressurized to approximately 203 kPa absolute (29.4 psia) over the course of two days.	Prior to initial use and annually thereafter.	A pressure change $\geq 0.69$ kPa/day (see Section 8.3.2 of this method).	(1) Remove from service, and (2) Repair canister connections and/or valve.
Canister zero-air verification.	Test of canisters to determine that they are and remain acceptably clean (show acceptably low positive bias) over the course of 7 days, by filling with humidified zero air (not nitrogen).	Initially upon receipt in the laboratory and every 18 months thereafter.	Upon initial analysis after a minimum of 24 hours and after 7 days, each target VOC's concentration $\leq 20$ pptv at 152 kPa absolute (22.1 psia).	(1) Clean and retest canisters that fail the zero-air verification. (2) Remove canisters from service that cannot pass the zero-air verification after the cleaning process.
Known-standard challenge of canisters for qualification.	Test of canisters to determine bias by filling with a known reference standard (approximately 100 to 500 pptv) prepared in humidified zero air (not nitrogen) and analyzing.	Initially upon receipt in the laboratory and every 18 months thereafter.	Upon initial analysis after a minimum of 24 hours and subsequent analysis at 30 days or typical laboratory holding time, each target VOC's concentration must remain within $\pm 30\%$ of theoretical concentration (see Section 8.3.4 of this method).	(1) Clean and retest canisters that fail the zero-air verification. (2) Remove canisters from service that cannot pass the zero-air verification after the cleaning process.
Zero-air challenge of sampling devices.	Assessment of positive bias of sampling system by collecting humidified zero air through the sampling device/system and comparing it to the reference sample collected upstream of the sampling device/system.	Prior to initial field deployment and every twelve months thereafter, following maintenance (component replacement), or after collection of potentially contaminating samples.	Analysis must show that the target compounds in the zero-air challenge sample collected through the sampling unit are not >20 pptv higher than the concentration in the reference sample (see Section 8.1.5 of this method).	(1) Take steps to remove the contamination attributable to the sampling unit (e.g., purging with HCF zero air overnight or longer). (2) Disassemble and clean. See Section 8.6 of this method.
Flow control flow check.	Verification of the mechanical flow control device (MFCD) flow rate.	Prior to and after each field sampling event	Flow measurement must demonstrate that the MFCD flow rate is within $\pm 10\%$ of the calibrated flow setting.	(1) Recalibrate or use a different MFCD for the sampling event as appropriate. (2) Flag any sample(s) collected with a failing post-flow control flow check.
Known-standard challenge of sampling devices/systems.	Assessment of bias of sampling system by collecting a known reference standard (approximately 100 to 500 pptv) through the sampling device/system and comparing it to the reference standard collected upstream of the sampling device/system.	Prior to initial field deployment and at least every twelve months thereafter, following maintenance (component replacement), or after collection of potentially contaminating samples or damaging sample matrices that may impact the activity of the flow path surfaces.	Each target VOC's concentration within $\pm 15\%$ of concentrations in the reference sample.	(1) Take steps to remove the contamination attributable to the sampling unit (e.g., purging with HCF zero air overnight or longer). (2) Disassemble and clean. See Section 8.6 of this method.
Purge gas check .....	Analysis of canister cleaning purge gas to ensure contaminants are acceptably low.	Verified upon initial setup and in the event of changes in gas sourcing or after the replacement of scrubbers such as hydrocarbon traps and moisture traps, or following maintenance of zero-air generator.	Each target VOC's concentration <20 pptv (see Section 8.4.1 of this method).	Replace hydrocarbon trap, catalytic oxidizer, contaminated tubing, etc.

TABLE 9–1—QUALITY CONTROL PARAMETERS AND PERFORMANCE SPECIFICATIONS—Continued

Parameter	Description and details	Required frequency	Acceptance criteria	Corrective action
Canister cleaning blank check.	Analysis of a sample of humidified diluent gas in a canister after cleaning to ensure acceptably low levels of VOCs in the cleaned canisters.	Every canister from each batch of cleaned canisters.	Upon analysis 24 hours after filling, each target VOC's concentration must meet the canister blank acceptance criterion ( <i>i.e.</i> , $\leq 20$ pptv at 152 kPa absolute, 22.1 psia) (see Section 8.5 of this method).	(1) Reclean canister, and/or (2) Disassemble and clean the components according to Section 8.6 of this method.
Holding time .....	Duration from end of sample collection or canister preparation to analysis.	Each field-collected or laboratory QC (standard or blank) canister.	$\leq 8$ days	(1) Reprepare any lab standard or blank. (2) Flag the results of any sample analyzed outside of holding time.
Bromofluorobenzene instrument tune performance check.	Injection of 1 to 2 nanograms (ng) BFB for tune verification of quadrupole or ion trap MS detector.	Prior to ICAL and prior to analysis of each day's analytical batch.	Abundance criteria for BFB listed in Table 5 in Section 17 of this method (see Section 10.7.2 of this method)	(1) Retune, and/or (2) Perform maintenance.
Retention time (RT) ...	RT of each IS and target compound.	All qualitatively identified compounds and internal standards.	IS compounds and target oHAP within $\pm 2$ seconds of most recent calibration check.	Flag data for possible invalidation.
Samples—internal standards (IS).	Deuterated or other compounds not typically found in ambient air co-analyzed with samples to monitor instrument response and assess matrix effects.	All laboratory QC samples, and field-collected samples.	Area response for each IS compound must be within $\pm 30\%$ of the average response as determined from the most recent calibration check.	Flag data for possible invalidation.
Initial calibration (ICAL).	Analysis of a minimum of five calibration levels covering approximately 20 to 5000 pptv.	Before sample analysis, following failed BFB tune check (as applicable), failed IS criteria, or failed CCV criteria; annually, or when changes/maintenance to the instrument affect calibration response.	Average Relative Response Factor (RRF) $\leq 30\%$ RSD and each calibration level within $\pm 30\%$ of theoretical concentration; Relative Retention Times (RRTs) for target peaks within 0.06 units from mean RRT.	(1) Repeat calibration standard analysis. (2) Repeat linearity check. (3) Prepare new calibration standards as necessary and repeat analysis.
Second source calibration verification (SSCV).	Analysis of a secondary source standard in the lower third of the calibration curve to verify ICAL accuracy for each target analyte.	Immediately after each ICAL.	Measured concentrations of VOCs must be within $\pm 30\%$ of theoretical concentration (see Section 9.1 of this method).	(1) Repeat SSCV analysis. (2) Reprepare and reanalyze SSCV standard.
Continuing calibration verification (CCV).	Analysis of a known standard in the lower third of the calibration curve to verify ongoing instrument calibration for each target analyte.	Prior to analyzing samples in an analytical sequence and at the end of a sequence, unless the sequence begins with an ICAL; and after every 10 sample injections.	Measured concentrations of VOCs within $\pm 30\%$ of theoretical concentration (see Section 9.2 of this method).	(1) Repeat CCV analysis. (2) Repeat ICAL.
Instrument blank (IB)	Analysis of an injection where no sample or standard is introduced to the preconcentrator to preliminarily demonstrate the carrier gas and instrument are sufficiently clean to begin analysis.	Prior to ICAL and at the beginning of an analytical sequence.	Each target VOC's concentration must be $< 20$ pptv (see Section 9.3.1 of this method).	(1) Repeat IB analysis. (2) Bakeout preconcentrator system and repeat IB analysis. (3) Replace contaminated tubing/traps as needed.
Method blank (MB) ....	Canister filled with clean, humidified diluent gas; indicates that target VOCs and potential interferences are at acceptably low levels in the system as a whole; the MB is to help assess overall quality of the data.	Prior to and following the ICAL and daily following the IB/BFB and prior to the initial daily CCV/SSCV.	This must demonstrate acceptably low carryover in the analytical system prior to analysis of samples; each target VOC's concentration must be $< 20$ pptv (see Section 9.3.2 of this method).	(1) Repeat analysis. (2) Reprepare the MB canister and reanalyze. (3) Check the system for leaks.
Calibration blank (CB)	Canister filled with clean, humidified diluent gas sourced through the standard preparation dilution system; indicates that diluent gas and dilution apparatus do not contribute target VOCs, imparting a positive bias to the ICAL	Prepare one CB with each set of calibration standard canisters and analyze with each ICAL	CB must be sufficiently clean such that little or no positive bias is imparted to the calibration (see Section 9.3.3 of this method).	(1) Reanalyze CB. (2) Reprepare CB and ICAL canister standards.
Method precision .....	Duplicate samples: precision is determined from the analyzed concentrations of collocated samples.	Applicable to the collection of samples: one per sampling day.	Precision $\leq 30\%$ RPD of target VOCs in the compared samples when both measurements are $\geq$ fivefold MDL (see Section 9.4 of this method).	(1) Check for preconcentrator volume measurement error. (2) Reanalyze primary sample and collocated duplicate. (3) Flag data for possible invalidation.
Instrument precision ..	Precision is determined from repeated analyses of a sample from a single canister; replicate analyses are used to determine precision of the analysis processes and do not provide information on sampling precision.	One replicate analysis to be performed with each sampling day.	Precision $\leq 25\%$ RPD for target VOCs when both measurements are $\geq$ fivefold MDL (see Section 9.4 of this method).	(1) Check for preconcentrator volume measurement error. (2) Reanalyze primary sample and collocated duplicate. (3) Flag data for possible invalidation.

TABLE 9–1—QUALITY CONTROL PARAMETERS AND PERFORMANCE SPECIFICATIONS—Continued

Parameter	Description and details	Required frequency	Acceptance criteria	Corrective action
Preconcentrator leak check.	Pressurize or evacuate the canister connection to verify as leak-free.	Each canister connected to the instrument prior to analysis.	<3.4 kPa (0.5 psi) change per minute or as recommended by the manufacturer (see Section 11.4.2 of this method).	Check the tightness of all fittings and recheck.

**10.0 Calibration and Standardization**

**10.1 Humidification of Canisters.**

10.1.1 Calculate the volume of water you must add to standard and blank canisters to achieve 40 to 50% RH at ambient laboratory temperature. (See Equation 6 in Section 12 of this method).

10.1.2 Use a bubbler or impinger within the dilution gas stream, add water to the canister, or use a combination of these two methods to add the calculated volume of deionized water to the canister necessary to achieve internal RH of approximately 40 to 50% at ambient laboratory temperature. For direct injection of water into a canister with a syringe, install a high-pressure PTFE-sealed septum on the canister. For canisters that are to be connected to a gas source for pressurization via a dynamic or static dilution system, you can add the deionized water to the valve opening of the evacuated canister prior to connecting to the dilution system. Do not add water to the canister using a syringe via rubber septum or other materials that may introduce target or interfering compounds.

**10.2 Dynamic Dilution.**

10.2.1 Gas Dilution System. The gas dilution system must produce calibration gases whose measured concentration values are within ±2% of the predicted values. The predicted values are calculated based on the certified concentration of the supply gas (Protocol gases, when available, are recommended for their accuracy) and the gas flow rates (or dilution ratios) through the gas dilution system.

10.2.2 The gas dilution system must be calibrated and verified per Section 6.10.1 of this method.

**10.2.3 Standards Preparation by Dynamic Dilution.**

10.2.3.1 Prior to use, power on the dynamic dilution system and allow the diluent and stock gases to flow through the respective MFC at operating flow rates. Allow gases to flow for at least the minimum time used during the yearly bias check in Section 6.10.1.3 of this method, to ensure the concentrations of the oHAPs in the blended gas are stable prior to transferring to the humidified canister (or directly to the preconcentrator).

10.2.3.2 You must prepare humidified (40 to 50% RH) standards in canisters from low concentration to high concentration. When changing stock gas flow rate(s) to prepare a different concentration, allow the calibration gas sufficient time to flow through the system prior to preparation of the working calibration canister (or delivering the working standard directly to the preconcentrator).

10.2.3.3 The final pressure of the calibration standard canister must not exceed the maximum pressure permitted by the preconcentrator.

10.2.2.4 Calculate the final concentration of the diluted standard using Equation 7 in Section 12 of this method.

**10.3 Static Dilution.**

10.3.1 Static Gas Dilution System. The gas dilution system shall produce calibration gases whose measured values are within ±2% of the predicted values. The predicted values are calculated based on the certified concentration of the supply gases (Protocol gases, when available, are recommended for their accuracy) and their partial pressure measurements (or dilution ratios) in the prepared standard canister.

**10.3.2 Static Dilution by Addition of Partial Pressures into a Canister.**

10.3.2.1 Connect a pressure transducer or gauge to an evacuated canister to monitor the canister pressure as you add gases. The pressure transducer or gauge must meet the requirements in Section 6.5 of this method.

10.3.2.2 Add stock and diluent gases separately through a manifold or by direct connection of the gas to the standard canister or vessel.

10.3.2.3 Measure the canister pressure before and after standard and diluent gases are bled into the canister and input these pressures into the calculation of the dilution factor and final concentrations.

10.3.2.4 Calculate the final concentration of each target compound in the diluted standard using Equation 8 in Section 12 of this method.

10.4 Storage of Standards. Standards prepared in canisters at ambient laboratory conditions must be stored in locations that are free of potential contaminants for up to 7 days.

10.5 Pre-Concentration System Operation. Condition preconcentrator traps when first installed to eliminate contaminants that act as interferences or chromatographic artifacts, per manufacturer recommendation. After the recommended conditioning procedure is completed, analyze the IBs and MBs to verify the preconcentrator system meets the method criteria.

**Note:** For preconcentrator traps that contain multiple types of sorbent beds, the oven temperature must not exceed the lowest conditioning temperature of the sorbents contained in the trap.

10.6 GC–MS System. Optimize GC conditions for compound separation and sensitivity as indicated by baseline separation for the targeted compounds by establishing GC carrier gas flow rates, oven temperature program, and instrument run time based on the manufacturer’s recommendations and customize, as needed, to separate the desired target oHAPs.

**10.7 MS Tuning/Optimizing and Verification.**

10.7.1 General. Tune/optimize the MS (quadrupole, ion trap, or TOF MS) to demonstrate acceptable performance across the selected ion mass range according to the manufacturer’s specifications upon initial installation of the instrument and following significant preventive maintenance or repair activities that impact the performance of the GC–MS system (e.g., cleaning the ion source or analyzer; trimming or replacing the capillary column; and adjusting MS tune or optimization parameters).

10.7.2 BFB Tuning Check. Before the ICAL and at least once during every 24-hour period of analyzing samples, blanks, or calibration standards thereafter, you must conduct a BFB tuning check for linear quadrupole or ion trap MS instruments. The BFB tuning check may be combined with the IB.

10.7.2.1 Introduce 1 to 2 ng of BFB into the preconcentrator and analyze the standard using the preconcentrator parameters established and used for the analysis of calibration standards, QC samples, and field samples. You must also use the method integration and analysis parameters employed for

routine analysis of standards, QC samples, and field samples.

10.7.2.2 The BFB tuning check must show that the GC-MS system meets the mass spectral ion abundance criteria listed in Table 2 in Section 17 of this method for the target compounds before you can use the system for any analysis. If the GC-MS system cannot meet the BFB tuning criteria, adjust the tuning of the MS or take corrective actions. You must not use this system until the abundance criteria has been met.

#### 10.8 Internal Standards and Calibration.

Method users must meet acceptance criteria for the calibration and QC listed in the following section for the suite of target compounds.

##### 10.8.1 Selection and Use of Internal Standards (IS).

10.8.1.1 Select IS compound(s) to be used for oHAP analysis. At a minimum, you must use a single IS compound. IS compounds must have similar retention times to the compounds being detected. Typical IS compounds include bromochloromethane; 1,4-difluorobenzene; chlorobenzene-d5; 1,2-dichloroethane-d4; hexane-d14; toluene-d8; and 1,2-dichlorobenzene-d4.

10.8.1.2 If using purchased IS stock gases, evaluate the IS upon receipt for the presence of contaminants that may interfere with the quantitation of target compounds by analyzing increasing volumes of the IS (e.g., 25, 50, 100, 250 milliliters [mL]) and examining the results for compound contaminants whose responses increase proportionally with the increasing volume of IS analyzed. Do not use IS gas standards that fail the MB acceptance criteria.

10.8.1.3 You must add the IS through a dedicated non-sample port in the preconcentrator at the same concentration for each injection (e.g., standard, sample, blank) to monitor instrument sensitivity and assess potential matrix effects. Choose the concentration of IS added to each injection such that the peak area response for the IS compound approximates the area responses for target compounds in the lower half of the calibration curve range, but that minimally provides a peak that is on scale and does not exceed the area response of the highest calibration standard.

10.8.1.4 Internal Standard Retention Time (RT). Each IS compound in each sample injection must be within  $\pm 2$  seconds of the RT for each IS compound in the most recent calibration.

10.8.1.5 Internal Standard Response. The area response for each IS compound in each injection (e.g., calibration

standard, field sample, blank, CCV) must be within  $\pm 30\%$  of the mean area response of the IS compound determined from the ICAL determined using Equation 10 in Section 12 of this method or most recent calibration check, whichever is most appropriate.

10.8.1.6 Choose the quantitation ion for each IS compound as the most abundant ion (base peak) unless there is a spectral interference from a coeluting or nearby compound or interference that impacts the quantitation of the base peak. In such cases, select another abundant ion that is distinguishable from the other compounds for quantitation.

10.8.1.7 You must invalidate then reanalyze any samples for which the IS area response differs by more than 30% from the mean IS area response.

10.8.2 Establishing Calibration. Calibrate the GC-MS initially, annually, whenever CCV standards exceed acceptance criteria, or when the system is out of control as indicated by IS responses. Prior to calibration, analyze a sufficient number of humidified (40 to 50% RH) HCF zero air blanks or humidified check standards to verify that instrument sensitivity is stable, as indicated by IS response.

##### 10.8.2.1 Preparation for Calibration.

10.8.2.1.1 Prepare the calibration curve by preparing standards that bracket the expected concentration levels at the sampling location(s).

10.8.2.1.2 You must include at least five levels in the ICAL to approximate concentrations of target oHAPs expected at the deployment location(s), including one level within a factor of five of the detection limits of the compounds of interest, and another level within 10% of the compound specific action-level, as defined in the applicable standard.

**Note:** *To establish the calibration curve, the theoretical concentrations of the working calibration standards must be calculated using the certified concentration from the gas vendor or neat standard provider. Certificates of analysis for stock standard gas mixtures typically include both a nominal (or "requested") concentration (e.g., 100 ppbv) for each analyte and a certified concentration (e.g., 108 ppbv), which should be within a specified tolerance (e.g.,  $\pm 10\%$ ). These tolerances may permit the certified concentration to differ from the nominal concentration by 10% to 20%, resulting in final theoretical concentration errors for the working-level standards when the nominal concentration is input into standard concentration calculations instead of the certified concentration. Calibration standards prepared with neat materials must account for the standard purity when calculating the working standard concentrations.*

##### 10.8.2.2 Calibration Curve.

10.8.2.2.1 Following analysis of all calibration standards, prepare a

calibration curve for each target analyte by determining the relative response factor (RRF) of each concentration level. Following data acquisition for the calibration standards, calculate the RRF of each target compound in each calibration level using Equation 10 in Section 12 of this method.

10.8.2.2.2 Choose the quantitation ion for each target compound as the most abundant ion (base peak) unless there is a spectral interference from a coeluting or nearby compound or interference that impacts the quantitation of the base peak. In such cases, select another abundant ion that is distinguishable from the other compounds for quantitation.

10.8.2.2.3 The %RSD of the RRFs of the ICAL levels for each target compound using Equation 17 in Section 12. The %RSD must be  $\leq 30\%$  for the ICAL to be considered acceptable.

10.8.2.2.4 The calculated concentration for each target compound(s) at each calibration level must be within  $\pm 30\%$  of the theoretical concentration when quantitated against the resulting calibration curve.

## 11.0 Analytical Procedures

### 11.1 Measurement of Canister Receipt Pressure.

11.1.1 Upon receipt at the laboratory, review the sample collection information documented on the field data page and/or COC form(s) for completeness and accuracy. Compare the canister label with the sample collection data sheet and verify that the canister and sample IDs are correct.

11.1.2 Measure and record the canister pressure using a calibrated vacuum/pressure gauge or transducer. The measured canister absolute pressure must be within  $\pm 3.5$  kPa (1 in. Hg or 0.5 psi) of that measured upon collection in the field. Pressure differences exceeding this criterion indicate the canister has leaked and you must flag the results as invalid.

11.2 Dilution of Canister Samples. A canister must be pressurized to provide sufficient pressure for removing an aliquot from the canister for analysis. Pressurize the canister with diluent gas to a pressure less than or equal to the final pressure of the standard gas canisters.

**Note:** *Minimum sample pressures will depend on the size of the canister and the capability of the preconcentrator to remove the desired aliquot of the sample and will be indicated by the instrument manufacturer.*

11.2.2 Measure the canister pressure using a calibrated vacuum/pressure gauge or pressure transducer just prior to dilution and immediately following

dilution and calculate the canister dilution correction factor (DFC) from the two absolute pressure readings (see Equation 12 in Section 12 of this method).

11.2.3 You must allow diluted canisters to equilibrate for a minimum of 12 hours before analysis.

11.3 Sample Preconcentration. Draw a measured aliquot of the whole air sample (typically 100 to 1000 mL) from the sample canister by vacuum through a preconcentrator to minimize the moisture and bulk atmospheric gases (e.g., oxygen, nitrogen, argon, and carbon dioxide) from the sample aliquot prior to introduction of the target compounds to the GC.

**Note:** Preconcentrator instrument manufacturers will typically indicate the optimum factory default settings for the sample aliquot volume, trapping time, trapping temperature, gas flows, and additional preconcentration parameters. Adjust each of these variables as needed for the target compounds.

11.4 Sample Analysis. You must analyze samples using the same acquisition methods you used for establishing calibration (i.e., preconcentrator operation parameters, GC oven program, MS parameters, and integration methods). Field-collected samples and QC samples must be at ambient laboratory temperature for analysis. You must use approximately the same sample aliquot volume for all samples unless dilution is required. Adjustment of this sample aliquot volume requires adjustment of a dilution factor to account for the difference in relative analyzed volume, as discussed in Section 11.4.4 of this method.

11.4.1 Leak Check of Preconcentrator Connections.

11.4.1.1 Prior to beginning an analytical sequence, including an ICAL sequence, verify each canister connection as leak-free through the preconcentrator.

11.4.1.2 During the leak check, connect canisters to the autosampler or sample introduction lines and maintain the canister valves in the closed position.

11.4.1.3 Evacuate each port of the autosampler or sample introduction line and monitor for a change in pressure for 1 minute. The pressure must not change by more than 0.5 psig/minute.

11.4.1.4 If a sample line fails the leak check, implement corrective actions (e.g., rechecking the tightness of all fittings) and then retest. Do not perform analysis using any canister connection that does not pass the leak check.

11.4.1.5 Following the successful leak check, evacuate all autosampler ports or sample introduction lines, open the canister valves, and document the leak check results in the analysis records.

11.4.2 Sample Introduction.

11.4.2.1 Prior to each sample analysis sequence, you must connect each sample canister to the preconcentration unit through a port and verify each canister as having a leak-free connection.

11.4.2.2 Accurately measure the sample aliquot volume for analysis by metering the sample with an MFC or with the combination of a fixed-volume vessel and a pressure transducer. Sample introduction volume measurements must be made by the same device as the calibration standards to ensure that analyzed volumes of samples and standards are consistent.

11.4.3 Analysis of Field Samples. Perform the following steps for readying the system and performing the GC-MS analytical sequence. Once these checks meet criteria (summarized in Table 9-1 of this method), verify the instrument calibration by analysis of a CCV and begin sample analysis.

11.4.3.1 Perform an air/water check of the MS prior to any analyses to ensure that the system is acceptably leak-free.

11.4.3.2 Conduct a thorough system bakeout per the manufacturer's instructions for the preconcentrator and ramp the GC column temperature.

11.4.3.3 Analyze a preliminary IB or perform the BFB instrument tuning check.

11.4.3.4 Analyze a laboratory MB to demonstrate that the system is acceptably clean and that each target compound is <20 pptv or undetected (whichever is more stringent) per compound of interest.

11.4.3.5 Analyze a CCV to verify the instrument calibration.

11.4.3.6 Analyze field samples and additional CCV standards (every 10 samples) and MBs to complete the sequence, ending with a CCV, as discussed in Section 9.2 of this method.

11.4.4 Sample Dilution. If the on-column concentration of any compound in any sample exceeds the calibration range, you must dilute the sample for reanalysis by either reducing the sample aliquot volume for an effective dilution or adding diluent gas to the sample canister to physically dilute the sample.

11.5 Compound Identification.

11.5.1 After completing data acquisition, examine each chromatogram. Chromatographic peaks for the target compounds must be appropriately resolved, and integration

must not include peak shoulders or inflections indicative of a coelution. If a peak has not been integrated properly, you may choose to manually integrate the peak. If a peak has been manually integrated, you must flag the results and report how and why the peak was manually integrated.

**Note:** Deconvolution techniques may be available to the operator to help resolve compound coelutions, depending on the particular instrument and chromatography software package that is in use.

11.5.2 Identify target compounds qualitatively based on their RT and the relative abundance of their characteristic ions from the MS by satisfying the following four criteria. If any of the four criteria are not met, the compound cannot be positively identified.

**Note:** Target compounds detected below the lowest calibration standard are estimated and may not be able to satisfy all four criteria.

11.5.2.1 The RT of the compound must be within the RT window of  $\pm 2$  seconds of the most recent calibration check.

11.5.2.2 The relative abundance ratio of qualifier ion response to target ion response for at least one qualifier ion must be within  $\pm 30\%$  of the average relative abundance ratio from the ICAL.

11.5.2.3 The S:N ratio of the target and qualifier ions must be  $>3:1$ .

11.5.2.4 The target and qualifier ion peaks must be co-maximized (i.e., peak apexes within one scan of each other).

11.6 Compound Quantitation. After determining the peak areas, initiate the quantitation process using the software package of choice to provide quantitative results compound using the RRF of the daily CCV for each target compound to quantitate the samples for the analytical batch.

11.6.2 Dilution Correction Factors.

11.6.2.1 Calculate an instrument dilution correction factor (DFI) if you analyzed an aliquot from the sample canister that is different from the typical analysis volume (as described in Section 11.4.4 of this method for performing effective dilution) using Equation 14 in Section 12 of this method.

11.6.2.2 Use Equation 15 in Section 12 of this method to determine the final concentration of each target compound in air by multiplying the instrument-detected concentration by the dilution factor from sample pressurization (DFC) (see Section 11.2 of this method) and the DFI.

**Note:** The MDL reported with the final concentration data will be corrected by multiplying the MDL by the DFC and DFI applied to the sample concentrations.

## 12.0 Data Analysis and Calculations

### 12.1 Canister Final Air/Nitrogen Volume ( $V_{calc}$ ).

$$V_{calc} = \left( \left( \frac{P_i - P_{std}}{P_{std}} \right) * V_{can} \right) + V_{can} \quad \text{Eq. 1}$$

Where:

$P_{clean}$  = absolute pressure of canister cleaning batch blank, kPa absolute.

$P_{std}$  = 152.3 kPa absolute, standard atmospheric pressure.

$V_{can}$  = volume of the canister (mL) at standard conditions (101.3 kPa absolute and 25 °C).

### 12.2 Acceptable Blank Canister Concentration Criterion ( $C_{acc}$ ).

$$C_{acc} = C_{atm} * \left( \frac{P_{ref}}{P_{clean}} \right) \quad \text{Eq. 2}$$

Where:

$C_{acc}$  = acceptance limit concentration at measured canister pressure (pptv).

$C_{atm}$  = 20 pptv, acceptance limit concentration at standard atmospheric pressure.

$P_{ref}$  = 152 kPa absolute, reference pressure.

$P_{clean}$  = absolute pressure of cleaned canister, kPa absolute.

### 12.3 Percent Difference of the Measured Concentration of Each Target Compound in the CCV Standard (% $D_{CCV}$ ) from the Theoretical Concentration.

$$\%D_{CCV} = \frac{C_{CCV} - C_{theoretical}}{C_{theoretical}} \times 100 \quad \text{Eq. 3}$$

Where:

% $D_{CCV}$  = percent difference of the measured concentration of each target compound

in the CCV standard from the theoretical concentration.

$C_{CCV}$  = measured concentration of the CCV for each target compound (pptv).

$C_{theoretical}$  = theoretical concentration of the CCV for each target compound (pptv).

### 12.4 Percent Recovery (% $Recovery_{CCV}$ ).

$$\%Recovery_{CCV} = \frac{C_{CCV}}{C_{theoretical}} \times 100 \quad \text{Eq. 4}$$

Where:

% $Recovery_{CCV}$  = percent recovery of measured versus actual concentration.

$C_{theoretical}$  = theoretical concentration of the CCV for each target compound (pptv).

### 12.5 Relative Percent Difference (RPD).

$$RPD = \left| \frac{X_1 - X_2}{\left( \frac{X_1 + X_2}{2} \right)} \right| \times 100 \quad \text{Eq. 5}$$

Where:

RPD = relative percent difference.

$X_1$  = target compound concentration measured in first measurement of the precision pair (pptv).

$X_2$  = target compound concentration measured in second measurement of the precision pair (pptv).

### 12.6 Water Volume to Add to Canister ( $V_w$ ).

$$V_w = D_{sat} \cdot RH_d \cdot V_c \cdot \frac{P_c}{P_s} \cdot \frac{1}{D_w} \quad \text{Eq. 6}$$

Where:

$D_{sat}$  = saturation vapor density of water (mg/ $\mu$ L) at ambient laboratory temperature (refer to Table 3 in Section 17 of this method).

$RH_d$  = desired RH level expressed as a decimal.

$V_c$  = nominal internal volume of canister (L).

$P_c$  = final absolute canister pressure (kPa absolute).

$P_s$  = standard ambient pressure (101.3 kPa absolute).

$D_w$  = density of water (1 mg/ $\mu$ L).

**Note:** The equation assumes the density of water to be 1 g/mL and that 100% of the added water to the canister is in the gas phase. The equation does not correct the density of water for the ambient temperature.



12.7 Final Concentration of the Diluted Standard ( $C_f$ )—Dynamic Dilution.

$$C_f = \frac{C_s \cdot F_s}{F_s + F_d} \quad \text{Eq. 7}$$

Where:

$C_f$  = final concentration of the diluted standard.

$C_s$  = certified concentration of stock standard (pptv).

$F_d$  = flow of diluent gas (mL/min).

$F_s$  = flow of stock standard (mL/min).

**Note:** If you combine multiple gas standards for dilution, the equation

denominator is the sum of all gas flows combined for preparing the dilution.

12.8 Final Concentration of the Diluted Standard ( $C_f$ )—Static Dilution.

$$C_f = \frac{C_s \cdot (P_{sa} - P_{sb})}{P_f} \quad \text{Eq. 8}$$

Where:

$C_s$  = certified concentration of stock standard (pptv).

$P_{sa}$  = absolute pressure of canister after adding standard gas (kPa).

$P_{sb}$  = absolute pressure of canister before adding standard gas (kPa).

$P_f$  = final absolute pressure of canister after adding standard and diluent gases (kPa).

12.9 Average Retention Time ( $\overline{RT}$ ).

$$\overline{RT} = \sum_{i=1}^n \frac{RT_i}{n} \quad \text{Eq. 9}$$

Where:

$\overline{RT}$  = average RT for the IS compound (min).

$RT_i$  = RT for the IS compound for each calibration level (min).

$n$  = number of units used to generate a sum.

12.10 Relative Response Factor (RRF).

$$RRF = \frac{A_s \cdot C_{IS}}{A_{IS} \cdot C_s} \quad \text{Eq. 10}$$

Where:

$A_s$  = peak area for quantitation ion of the target compound.

$A_{IS}$  = peak area for quantitation ion of the assigned IS compound.

$C_s$  = certified concentration of stock standard (pptv).

$C_{IS}$  = concentration of the assigned IS compound (pptv).

12.11 Average Area Response for the Given IS Compound ( $\overline{Y}$ ).

$$\overline{Y} = \sum_{i=1}^n \frac{Y_i}{n} \quad \text{Eq. 11}$$

Where:

$Y_i$  = area response for an IS compound at calibration concentration  $i$ .

$n$  = number of units used to generate a sum.

12.12 Dilution factor for sample pressurization ( $DF_C$ ).

$$DF_C = \frac{P_d}{P_i} \quad \text{Eq. 12}$$

Where:

$P_d$  = pressure of the canister following dilution (kPa).

$P_i$  = absolute pressure of the canister immediately preceding dilution (kPa).

12.13 Instrument-Detected Analyte Concentration ( $C_D$ ) in pptv.

$$C_D = \frac{A_E \cdot C_{IS}}{A_{IS} \cdot RRF} \quad \text{Eq. 13}$$

Where:

$C_D$  = instrument-detected analyte concentration (pptv).

$A_{IS}$  = peak area for quantitation ion of the assigned IS compound.

12.14 Instrument Dilution Correction Factor ( $DF_I$ ).

$$DF_I = \frac{V_{nom}}{V_{inj}} \quad \text{Eq. 14}$$

Where:

$V_{nom}$  = The laboratory's typical canister sample injection volume (mL).

$V_{inj}$  = The actual volume of any given sample injection (mL).

12.15 Concentration of the Target Compound in Air ( $C_F$ ).

$$C_F = C_D \cdot DF_I \cdot DF_C \quad \text{Eq. 15}$$

Where:

$C_D$  = measured concentration of the target compound in the canister as analyzed sample.

12.16 Standard Deviation of the Response Factors ( $SD_{RRF}$ ).

$$SD_{RRF} = \sqrt{\frac{\sum_{i=1}^n (RRF_i - \overline{RRF})^2}{(n-1)}} \quad \text{Eq. 16}$$

12.17 Percent Relative Deviation (%RSD).

$$\%RSD = SD_{RRF} \div \overline{RRF} \times 100 \quad \text{Eq. 17}$$

### 13.0 Method Performance

Table 9–1 of this method lists the QC parameters and performance specifications for this method. The method performance will be determined by the specific performance of each specific target compound, laboratory, and the associated equipment.

### 14.0 Pollution Prevention

[Reserved].

### 15.0 Waste Management

[Reserved].

### 16.0 References

1. *Quality Assurance Handbook for Air Pollution Measurement Systems*, Volume II, Ambient Air Quality Monitoring Program, U.S. Environmental Protection Agency, EPA-454/B-17-001, January 2017.
2. Technical Assistance Document for the National Air Toxics Trends Stations Program, Revision 4, U.S. Environmental Protection Agency, July 2022.
3. Clean Air Act Amendments of 1990, U.S. Congress, Washington, DC, November 1990.
4. Method D1356, Standard Terminology Relating to Sampling and Analysis of Atmospheres.
5. Method E355-96, Standard Practice for Gas Chromatography Terms and Relationships.
6. Method D5466, Standard Test Method for Determination of Volatile Organic Compounds in Atmospheres (Canister Sampling Methodology).
7. Agilent Technologies, Inc. (2017, July 11). Innovative Cryogen-Free Ambient Air Monitoring in Compliance with US EPA Method TO-15. Application Note 081, 5991-2829EN. Available at <https://www.agilent.com/cs/library/applications/5991-2829EN.pdf> (accessed September 21, 2019).
8. ASTM International. (2014). Active Standard ASTM E2655-14: Standard Guide for Reporting Uncertainty of Test Results and Use of the Term Measurement Uncertainty in ASTM Test Methods. West Conshohocken, PA: ASTM International. doi: 10.1520/E2655-14.
9. Boyd, R.K., Basic, C., & Bethem, R.A. (2008). *Trace Quantitative Analysis by Mass Spectrometry*, Figure 6.7, p. 260. Hoboken, NJ: John Wiley and Sons.
10. Brown, J. (2013, October 22). Choosing the Right Adsorbent for your Thermal Desorption Gas Chromatography Applications. Presented at the Separation Science Webinar for Supelco. Available at <https://www.sigmaaldrich.com/content/dam/sigma-aldrich/docs/Supelco/Posters/1/Adsorbent-Selection-TD-GC-Apps.pdf> (accessed September 21, 2019).
11. *Code of Federal Regulations*, 40 CFR part 58 Appendices D and E, Network Design Criteria for Ambient Air Quality Monitoring. Available at <https://www.govinfo.gov/app/details/CFR-2012-title40-vol6/CFR-2012-title40-vol6-part58-appD> (accessed September 22, 2019).
12. *Code of Federal Regulations*, 40 CFR part 136 Appendix B, Definition and Procedure for the Determination of the Method Detection Limit, Revision 2. Available at <https://www.govinfo.gov/app/search/%7B%22query%22%3A%2249%20CFR%20%22offset%22%3A0%7D> (accessed September 23, 2019).
13. *Code of Federal Regulations*, 40 CFR 173.306 (g), Limited quantities of compressed gases. Available at <https://www.govinfo.gov/app/search/%7B%22query%22%3A%2249%20CFR%20%22offset%22%3A0%7D> (accessed September 23, 2019).
14. Coutant, R.W. (1992). Theoretical Evaluation of the Stability of Volatile Organic Chemicals and Polar Volatile Organic Chemicals in Canisters. Report EPA/600/R-92/055 prepared under contract 68-DO-0007 for U.S. EPA by Battelle, Columbus, OH.
15. Entech Instruments. (2015, August 25). 3-Stage Preconcentration: Why 3-Stage Preconcentration is Superior for TO-14A and TO-15 Air Methods. Available at <http://www.entechinstrument.com/3-stage-preconcentration-is-superior-for-to-14a-and-to-15-air-methods/#> (accessed September 21, 2019).
16. Herrington, J.S. (2013, August 5). TO-15 Canister Relative Humidity: Part II (Examples and Calculations) [Blog post]. Available at <https://blog.restek.com/?p=7766> (accessed September 21, 2019).
17. Keith, L.H. (1991). *Environmental Sampling and Analysis: A Practical Guide*. Boca Raton, FL: CRC Press, pp. 93-119.
18. Kelly T.J., & Holdren, M.W. (1995). Applicability of canisters for sample storage in the determination of hazardous air pollutants. *Atmospheric Environment*, 29(19), 2595-2608. doi: 10.1016/1352-2310(95)00192-2.
19. McClenny, W.A., Schmidt, S.M., & Kronmiller, K.G. (1999). Variation of the relative humidity of air released from canisters after ambient sampling. *Journal of the Air & Waste Management Association*, 49(1), 64-69. doi:10.1080/10473289.1999.10463774.
20. Nave, C.R. (2017). Relative Humidity. HyperPhysics website, Department of Physics and Astronomy, Georgia State University, Atlanta, GA. Available at <http://hyperphysics.phy-astr.gsu.edu/hbase/Kinetic/relhum.html#c3> (accessed September 21, 2019).
21. Ochiai, N., Daishima, S., & Cardin, D.B. (2003). Long-term measurement of volatile organic compounds in ambient air by canister-based one-week sampling method. *Journal of Environmental Monitoring*, 5(6), 997-1003. doi:10.1039/b307777m.
22. Ochiai, N., Tsuji, A., Nakamura, N., Daishima, S., & Cardin, D.B. (2002). Stabilities of 58 volatile organic compounds in fused-silica-lined and SUMMA polished canisters under various humidified conditions. *Journal of Environmental Monitoring*, 4(6), 879-889.
23. Restek. (2010). A Guide to Whole Air Canister Sampling: Equipment Needed and Practical Techniques for Collecting Air Samples. Technical Guide. Literature Catalog # EVTG1073A. Available at <http://www.restek.com/pdfs/EVTG1073A.pdf> (accessed September 21, 2019).
24. U.S. Environmental Protection Agency (EPA). (2017). *Quality Assurance Handbook for Air Pollution Measurement Systems*, Volume II, Ambient Air Quality Monitoring Program, EPA-454/B-17-001. Research Triangle Park, NC: EPA Office of Air

Quality Planning and Standards, Air Quality Assessment Division. Available at <https://www3.epa.gov/ttnamti1/files/ambient/pm25/qa/Final%20Handbook%20Document%2017.pdf> (accessed September 23, 2019).

25. U.S. Environmental Protection Agency (EPA). (2016a). Definition and Procedure for the Determination of the Method Detection Limit, Revision 2. U.S. EPA Office of Water, EPA 821-R-16-006. Available at [https://www.epa.gov/sites/production/files/2016-12/documents/mdl-procedure\\_rev2\\_12-13-2016.pdf](https://www.epa.gov/sites/production/files/2016-12/documents/mdl-procedure_rev2_12-13-2016.pdf) (accessed September 21, 2019).

26. U.S. Environmental Protection Agency (EPA). (2016b). EPA NATTS Proficiency Testing Results Calendar Year 2016 Quarter 1—Referee Results from EPA Region V. Available from U.S. EPA, Office of Air Quality Planning and Standards (OAQPS), Ambient Air Monitoring Group, Mail Code C304-06, Research Triangle Park, NC 27711.

27. U.S. Environmental Protection Agency (EPA). (2015). OSWER Technical Guide for Assessing and Mitigating the Vapor Intrusion Pathway from Subsurface Vapor Sources to Indoor Air. EPA Office of Solid Waste and Emergency Response (OSWER) Publication 9200.2-154. Available at <https://www.epa.gov/vaporintrusion/technical-guide-assessing-and-mitigating-vapor-intrusion-pathway-subsurface-vapor> (accessed September 22, 2019).

28. Wang, D.K., & Austin, C.C. (2006). Determination of complex mixtures of volatile organic compounds in ambient air: canister methodology. *Analytical and Bioanalytical Chemistry*, 386(4), 1099–1120. doi:10.1007/s00216-006-0466-6.

29. Batelle. (2016). Technical Assistance Document for the National Air Toxics Trends Stations Program, Revision 3. Prepared for U.S. EPA by Battelle, Columbus, OH. Available at [https://www3.epa.gov/ttn/amtic/files/ambient/airtox/NATTS%20TAD%20Revision%203\\_FINAL%20October%202016.pdf](https://www3.epa.gov/ttn/amtic/files/ambient/airtox/NATTS%20TAD%20Revision%203_FINAL%20October%202016.pdf) (accessed September 22, 2019).

30. Daughtrey, E.H. Jr., Oliver, K.D., Jacumin, H.H. Jr., & McClenny, W.A. (2004, April 20–22). Supplement to EPA Compendium Method TO-15—Reduction of Method Detection Limits to Meet Vapor Intrusion Monitoring Needs. Presented at Symposium on Air Quality Measurement Methods and Technology, Research Triangle Park, NC. Available at [https://cfpub.epa.gov/si/si\\_public\\_record\\_report.cfm?Lab=NERL&dirEntryId=76137](https://cfpub.epa.gov/si/si_public_record_report.cfm?Lab=NERL&dirEntryId=76137) (accessed September 22, 2019).

31. Entech Instruments. (2019). Articles and documents. Available at <https://www.entechinst.com/technical-library/application-notes-applets-chromatograms/> (accessed September 23, 2019).

32. Kelly, T., Gordon, S., Mukund, R., & Hays, M. (1994). Ambient Measurement Methods and Properties of the 189 Clean Air Act Hazardous Air Pollutants. Report EPA/600/R-94/187 prepared under contract 68-DO-0007, work assignment 44, for U.S. EPA by Battelle, Columbus, OH.

33. Kelly, T.J., Callahan, P.J., Pleil, J., & Evans, G.F. (1993). Method development and field measurements for polar volatile organic compounds in ambient air. *Environmental Science & Technology*, 27(6), 1146–1153.

34. McClenny, W.A., Oliver, K.D., & Daughtrey, E.H. Jr. (1995). Analysis of VOCs in ambient air using multisorbent packings for VOC accumulation and sample drying. *Journal of the Air & Waste Management Association*, 45(10), 792–800.

35. Morris, C., Berkley, R., & Bumgarner, J. (1983). Preparation of multicomponent volatile organic standards using static dilution bottles. *Analytical Letters*, 16(20), 1585–1593.

36. Oliver, K.D., Adams, J.R., Daughtrey, E.H., McClenny, W.A., Yoong, M.J., Pardee, M.A., Almasi, E.B., & Kirshen, N.A. (1996). Technique for monitoring toxic VOCs in air: Sorbent preconcentration, closed-cycle cooler cryofocusing, and GC/MS analysis. *Environmental Science & Technology*, 30(6), 1939–1945.

37. Pleil, J.D., & Lindstrom, A.B. (1995). Collection of a single alveolar exhaled breath for volatile organic compound analysis. *American Journal of Industrial Medicine*, 28(1), 109–121.

38. Pleil, J.D., McClenny, W.A., Holdren, M.W., Pollack, A.J., & Oliver, K.D. (1993). Spatially resolved monitoring for volatile organic compounds using remote sector sampling. *Atmospheric Environment, Part A*, 27(5), 739–747.

39. Pollack, A.J., Holdren, M.W., & McClenny, W.A. (1991). Multi-adsorbent preconcentration and gas chromatographic analysis of air toxics with an automated collection/analytical system. *Journal of the Air & Waste Management Association*, 41(9), 1213–1217.

40. Restek. (2019). Restek Technical Library: Air Sampling. Available at <https://www.restek.com/Technical-Resources/Technical-Library/Air-Sampling> (accessed September 23, 2019).

41. Stephenson, J., Allen, F., & Slagle, T. (1990). Analysis of volatile organics in air via water methods. In *Proceedings of the 1990 EPA/AWMA International Symposium: Measurement of Toxic and Related Air Pollutants*, EPA 600/9-90-026. Research Triangle Park, NC: U.S. Environmental Protection Agency.

42. U.S. Environmental Protection Agency (EPA). (1997). Method TO-14A: Determination of volatile organic compounds (VOCs) in ambient air using specially prepared canisters with subsequent analysis by gas chromatography, EPA 600/625/R-96/010b. In *Compendium of Methods for the Determination of Toxic Organic Compounds in Ambient Air*, Second Edition. Cincinnati, OH: U.S. EPA Center for Environmental Research Information, Office of Research and Development.

43. Whitaker, D.A., Fortmann, R.C., & Lindstrom, A.B. (1995). Development and testing of a whole-air sampler for measurement of personal exposure to volatile organic compounds. *Journal of Exposure Analysis & Environmental Epidemiology*, 5(1), 89–100.

**17.0 Tables, Diagrams, Flow Charts, etc.**

TABLE 1—CANISTER CLEANING PARAMETERS

Canister type	Pre-evacuate canister	Suggested maximum canister temperature <sup>a</sup>	Humidity	Minimum number of pressure/evacuation cycles	Cycle time
All .....	Yes .....	80 °C .....	50%	5	Varies by system.

<sup>a</sup> Higher purge gas temperatures may be required depending on the canister type—do not exceed the manufacturer’s recommended maximum temperatures for component parts such as valves and gauges.

TABLE 2—BFB TUNING CHECK KEY IONS AND ABUNDANCE CRITERIA

Mass	Ion abundance criteria <sup>a</sup>
50 .....	8.0% to 40.0% of <i>m/z</i> 95.
75 .....	30.0% to 66.0% of <i>m/z</i> 95.
95 .....	Base peak, 100% relative abundance.
96 .....	5.0% to 9.0% of <i>m/z</i> 95.
173 .....	<2.0% of <i>m/z</i> 174.
174 .....	50.0% to 120.0% of <i>m/z</i> 95.

TABLE 2—BFB TUNING CHECK KEY IONS AND ABUNDANCE CRITERIA—Continued

Mass	Ion abundance criteria <sup>a</sup>
175 .....	4.0% to 9.0% of <i>m/z</i> 174.
176 .....	93.0% to 101.0% of <i>m/z</i> 174.
177 .....	5.0% to 9.0% of <i>m/z</i> 176.

<sup>a</sup>All ion abundances must be normalized to *m/z* 95, the nominal base peak, even though the ion abundance of *m/z* 174 may be up to 120% that of *m/z* 95.

TABLE 3—WATER SATURATION VAPOR DENSITY AT VARIOUS TEMPERATURES

Temperature (°C)	Water saturation vapor density (mg/L) <sup>a</sup>
15 .....	12.8
16 .....	13.6
17 .....	14.4
18 .....	15.3
19 .....	16.3
20 .....	17.3
21 .....	18.3
22 .....	19.4
23 .....	20.6

TABLE 3—WATER SATURATION VAPOR DENSITY AT VARIOUS TEMPERATURES—Continued

Temperature (°C)	Water saturation vapor density (mg/L) <sup>a</sup>
24 .....	21.8
25 .....	23.1
26 .....	24.4
27 .....	25.9
28 .....	27.3
29 .....	28.9
30 .....	30.5
31 .....	32.2

TABLE 3—WATER SATURATION VAPOR DENSITY AT VARIOUS TEMPERATURES—Continued

Temperature (°C)	Water saturation vapor density (mg/L) <sup>a</sup>
32 .....	34.0
33 .....	35.8

<sup>a</sup>Values are generated according to the following formula (Nave, 2017): *vapor density (mg/L)* = 5.018 + 0.32321 \* *T* + 8.1847 × 10<sup>-3</sup> \* *T*<sup>2</sup> + 3.1243 × 10<sup>-4</sup> \* *T*<sup>3</sup>, where: *T* = temperature in °C.

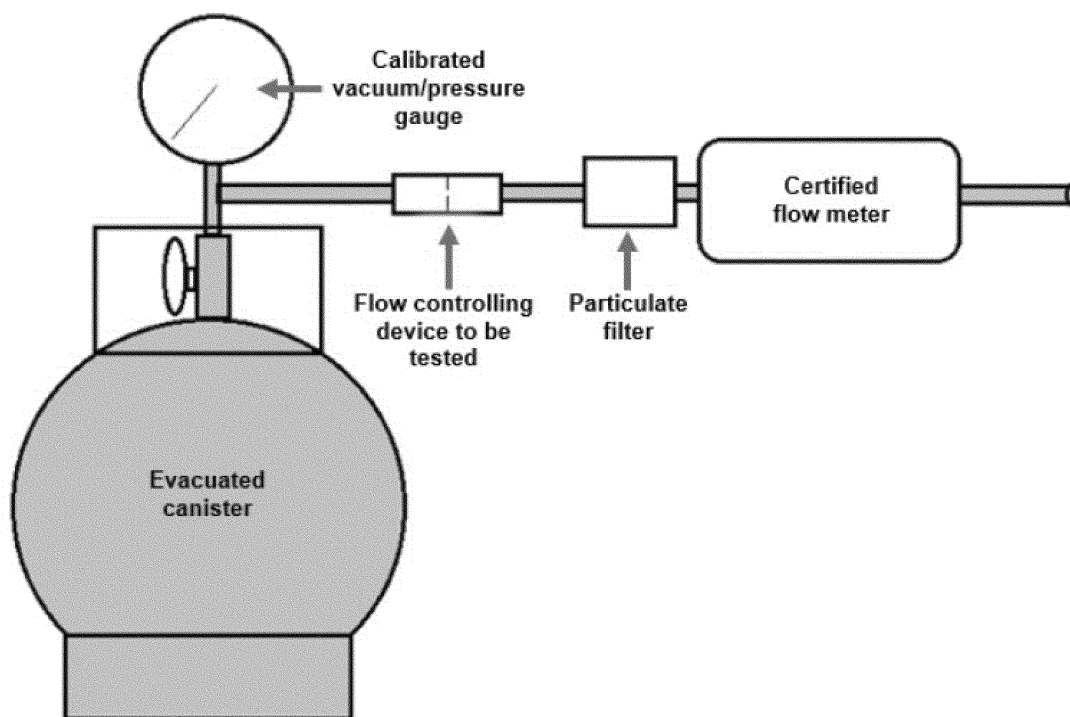

Figure 1. Apparatus for Characterizing the Flow Control Device

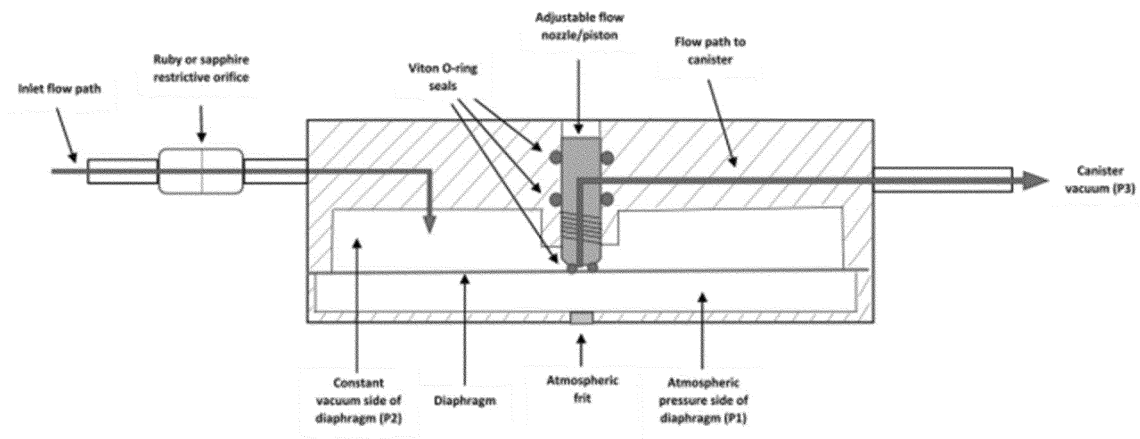

Figure 2. Mechanical Flow Control Device

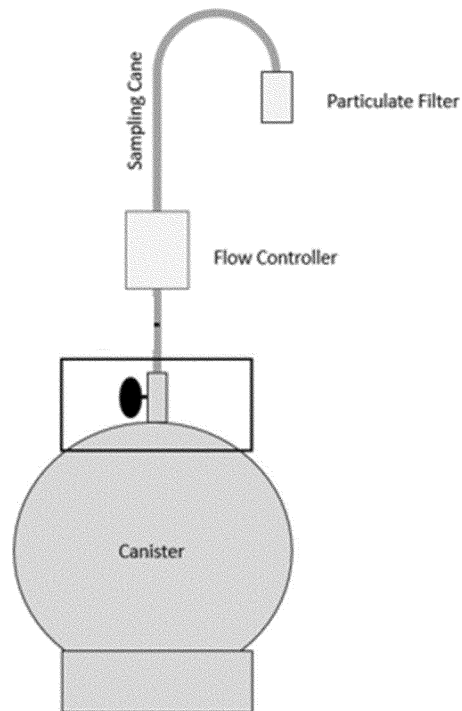

Figure 3. Method 327 Sampler

Method 327 Field Data Page

Sampling Personnel	
Sampling Location ID	
Longitude	Latitude

Sampling Equipment Information

Sampling Canister ID	
Sampling Canister Received Date	
Sampling Canister Clean Date	
Sampling Canister Pressure Reading	
Sampling Device ID	
Reference Flow Meter S/N (if applicable)	
Reference Flow Meter Calibration Date	
Sampling Device Expected Flow Rate	
Sampling Device Actual Flow Rate (if applicable)	
Sampling Device Flow Adjusted (Yes/No)	

Sampling Information

Sample Date	
Leak Check (Date/Time)	
Leak Check Results (Pass/Fail)	
Start Time	
Start Vacuum/Pressure	
Comments:	
End Time	
End Vacuum/Pressure	
Comments:	

Custody Transfer

Relinquished/Received	Name	Signature	Date
Comments:			

Figure 4. Example Field Data Page

[FR Doc. 2024-07002 Filed 5-15-24; 8:45 am]  
 BILLING CODE 6560-50-P