

For the reasons explained here and in the Notification of Petition for Waiver, absent a waiver the basic models identified by Hercules in its petition cannot be tested and rated for energy consumption on a basis representative of their true energy consumption characteristics. DOE has reviewed the recommended procedure suggested by Hercules and concludes that it will allow for the accurate measurement of the energy use of the equipment, while alleviating the testing issues associated with Hercules's implementation of DOE's applicable walk-in door test procedure for the specified basic models.

Thus, DOE is requiring that Hercules test and rate specified walk-in door basic models according to the alternate test procedure specified in this Decision and Order, which is identical to the procedure provided in the interim waiver.

This Decision and Order is applicable only to the basic models listed and does not extend to any other basic models. DOE evaluates and grants waivers for only those basic models specifically set out in the petition, not future models that may be manufactured by the petitioner. Hercules may request that DOE extend the scope of this waiver to include additional basic models that employ the same technology as those listed in this waiver. 10 CFR 431.401(g). Hercules may also submit another petition for waiver from the test procedure for additional basic models that employ a different technology and meet the criteria for test procedure waivers. 10 CFR 431.401(a)(1).

DOE notes that it may modify or rescind the waiver at any time upon DOE's determination that the factual basis underlying the petition for waiver is incorrect, or upon a determination that the results from the alternate test procedure are unrepresentative of the basic models' true energy consumption characteristics. 10 CFR 431.401(k)(1). Likewise, Hercules may request that DOE rescind or modify the waiver if the company discovers an error in the information provided to DOE as part of its petition, determines that the waiver is no longer needed, or for other appropriate reasons. 10 CFR 431.401(k)(2).

### III. Order

After careful consideration of all the material that was submitted by Hercules, the various public-facing materials (e.g., product literature, installation manuals) for the units identified in the petition, in this matter, it is *ordered* that:

(1) Hercules must, as of the date of publication of this Order in the **Federal Register**, test and rate the basic models listed in Appendix I of its October 14, 2020 petition as provided in Docket Number EERE-2020-BT-WAV-0027-0002 with the alternate test procedure as set forth in paragraph (2):

(2) The alternate test procedure for the Hercules basic models identified in paragraph (1) of this Order is the test procedure for walk-in doors prescribed by DOE at 10 CFR part 431, subpart R, appendix A, except that the PTO value specified in section 4.5.2 "Direct Energy Consumption of Electrical Components of Non-Display Doors" shall be 92 percent for door motors. All other requirements of 10 CFR part 431, subpart R, appendix A and DOE's regulations remain applicable.

(3) *Representations.* Hercules may not make representations about the energy use of a basic model listed in paragraph (1) of this Order for compliance or marketing, unless the basic model has been tested in accordance with the provisions set forth above and such representations fairly disclose the results of such testing.

(4) This waiver shall remain in effect according to the provisions of 10 CFR 431.401.

(5) DOE issues this waiver on the condition that the statements, representations, and information provided by Hercules are valid. If Hercules makes any modifications to the controls or configurations of these basic models, such modifications will render the waiver invalid with respect to that basic model, and Hercules will either be required to use the current Federal test method or submit a new application for a test procedure waiver. DOE may rescind or modify this waiver at any time if it determines the factual basis underlying the petition for waiver is incorrect, or the results from the alternate test procedure are unrepresentative of a basic model's true energy consumption characteristics. 10 CFR 431.401(k)(1). Likewise, Hercules may request that DOE rescind or modify the waiver if Hercules discovers an error in the information provided to DOE as part of its petition, determines that the waiver is no longer needed, or for other appropriate reasons. 10 CFR 431.401(k)(2).

(6) Hercules remains obligated to fulfill all applicable requirements set forth at 10 CFR part 429.

### Signing Authority

This document of the Department of Energy was signed on March 31, 2021 by Kelly J. Speakes-Backman, Principal Deputy Assistant Secretary and Acting

Assistant Secretary for Energy Efficiency and Renewable Energy, pursuant to delegated authority from the Secretary of Energy. That document with the original signature and date is maintained by DOE. For administrative purposes only, and in compliance with requirements of the Office of the Federal Register, the undersigned DOE **Federal Register** Liaison Officer has been authorized to sign and submit the document in electronic format for publication, as an official document of the Department of Energy. This administrative process in no way alters the legal effect of this document upon publication in the **Federal Register**.

Signed in Washington, DC, on March 31, 2021.

**Treena V. Garrett,**

*Federal Register Liaison Officer, U.S. Department of Energy.*

[FR Doc. 2021-06991 Filed 4-5-21; 8:45 am]

BILLING CODE 6450-01-P

## DEPARTMENT OF ENERGY

[Case Number 2020-006; EERE-2020-BT-WAV-0023]

### Energy Conservation Program: Notification of Petition for Waiver of GD Midea Air Conditioning Equipment Co. LTD From the Department of Energy Portable Air Conditioner Test Procedure and Notification of Grant of Interim Waiver

**AGENCY:** Office of Energy Efficiency and Renewable Energy, Department of Energy.

**ACTION:** Notification of petition for waiver and grant of an interim waiver; request for comments.

**SUMMARY:** This notification announces receipt of and publishes a petition for waiver and interim waiver from GD Midea Air Conditioning Equipment Co. LTD ("Midea"), which seeks a waiver for specified portable air conditioner basic models from the U.S. Department of Energy ("DOE") test procedure used for determining the efficiency of portable air conditioners. DOE also gives notice of an Interim Waiver Order that requires Midea to test and rate the specified portable air conditioner basic models in accordance with the alternate test procedure set forth in the Interim Waiver Order. DOE solicits comments, data, and information concerning Midea's petition and its suggested alternate test procedure to inform DOE's final decision on Midea's waiver request.

**DATES:** The Interim Waiver Order is effective on April 6, 2021. Written

comments and information are requested and will be accepted on or before May 6, 2021.

**ADDRESSES:** Interested persons are encouraged to submit comments using the Federal eRulemaking Portal at <http://www.regulations.gov>.

Alternatively, interested persons may submit comments, identified by case number “2020–006”, and Docket number “EERE–2020–BT–WAV–0023,” by any of the following methods:

- *Federal eRulemaking Portal:* <http://www.regulations.gov>. Follow the instructions for submitting comments.

- *Email:* [AS\\_Waiver\\_Requests@ee.doe.gov](mailto:AS_Waiver_Requests@ee.doe.gov). Include Case No. 2020–006 in the subject line of the message.

No telefacsimilies (“faxes”) will be accepted. For detailed instructions on submitting comments and additional information on this process, see the **SUPPLEMENTARY INFORMATION** section of this document.

*Although DOE has routinely accepted public comment submissions through a variety of mechanism, including the Federal eRulemaking Portal, email, postal mail, or hand delivery/courier, the Department has found it necessary to make temporary modifications to the comment submission process in light of the ongoing Covid–19 pandemic. DOE is currently suspending receipt of public comments via postal mail and hand delivery/courier. If a commenter finds that this change poses an undue hardship, please contact Appliance Standards Program staff at (202) 586–1445 to discuss the need for alternative arrangements. Once the Covid–19 pandemic health emergency is resolved, DOE anticipates resuming all of its regular options for public comment submission, including postal mail and hand delivery/courier.*

**Docket:** The docket, which includes **Federal Register** notices, comments, and other supporting documents/materials, is available for review at <http://www.regulations.gov>. All documents in the docket are listed in the <http://www.regulations.gov> index. However, some documents listed in the index, such as those containing information that is exempt from public disclosure, may not be publicly available.

The docket web page can be found at <https://www.regulations.gov/docket?D=EERE-2020-BT-WAV-0023>. The docket web page contains instruction on how to access all documents, including public comments, in the docket. See the **SUPPLEMENTARY INFORMATION** section for information on how to submit comments through <http://www.regulations.gov>.

**FOR FURTHER INFORMATION CONTACT:**

Ms. Lucy deButts, U.S. Department of Energy, Office of Energy Efficiency and Renewable Energy, Building Technologies Office, Mailstop EE–5B, 1000 Independence Avenue SW, Washington, DC 20585–0121. Email: [AS\\_Waiver\\_Request@ee.doe.gov](mailto:AS_Waiver_Request@ee.doe.gov).

Ms. Sarah Butler, U.S. Department of Energy, Office of the General Counsel, Mail Stop GC–33, Forrestal Building, 1000 Independence Avenue SW, Washington, DC 20585–0103. Telephone: (202) 586–1777. Email: [Sarah.Butler@hq.doe.gov](mailto:Sarah.Butler@hq.doe.gov).

**SUPPLEMENTARY INFORMATION:** DOE is publishing Midea’s petition for waiver in its entirety, pursuant to 10 CFR 430.27(b)(1)(iv),<sup>1</sup> absent any confidential business information. DOE invites all interested parties to submit in writing by May 6, 2021, comments and information on all aspects of the petition, including the alternate test procedure. Pursuant to 10 CFR 430.27(d), any person submitting written comments to DOE must also send a copy of such comments to the petitioner. The contact information for the petitioner is Daniel L. Atkins, [daniel.atkins@midea.com](mailto:daniel.atkins@midea.com), Midea America Research Center, 2700 Chestnut Station Court, Louisville, KY 40299.

*Submitting comments via http://www.regulations.gov.* The <http://www.regulations.gov> web page will require you to provide your name and contact information. Your contact information will be viewable to DOE Building Technologies staff only. Your contact information will not be publicly viewable except for your first and last names, organization name (if any), and submitter representative name (if any). If your comment is not processed properly because of technical difficulties, DOE will use this information to contact you. If DOE cannot read your comment due to technical difficulties and cannot contact you for clarification, DOE may not be able to consider your comment.

However, your contact information will be publicly viewable if you include it in the comment or in any documents attached to your comment. Any information that you do not want to be publicly viewable should not be

included in your comment, nor in any document attached to your comment. If this instruction is followed, persons viewing comments will see only first and last names, organization names, correspondence containing comments, and any documents submitted with the comments.

Do not submit to <http://www.regulations.gov> information for which disclosure is restricted by statute, such as trade secrets and commercial or financial information (hereinafter referred to as Confidential Business Information (“CBI”). Comments submitted through <http://www.regulations.gov> cannot be claimed as CBI. Comments received through the website will waive any CBI claims for the information submitted. For information on submitting CBI, see the Confidential Business Information section.

DOE processes submissions made through <http://www.regulations.gov> before posting. Normally, comments will be posted within a few days of being submitted. However, if large volumes of comments are being processed simultaneously, your comment may not be viewable for up to several weeks. Please keep the comment tracking number that <http://www.regulations.gov> provides after you have successfully uploaded your comment.

*Submitting comments via email.* Comments and documents submitted via email also will be posted to <http://www.regulations.gov>. If you do not want your personal contact information to be publicly viewable, do not include it in your comment or any accompanying documents. Instead, provide your contact information on a cover letter. Include your first and last names, email address, telephone number, and optional mailing address. The cover letter will not be publicly viewable as long as it does not include any comments.

Include contact information each time you submit comments, data, documents, and other information to DOE.

Comments, data, and other information submitted to DOE electronically should be provided in PDF (preferred), Microsoft Word or Excel, WordPerfect, or text (ASCII) file format. Provide documents that are not secured, written in English and free of any defects or viruses. Documents should not contain special characters or any form of encryption and, if possible, they should carry the electronic signature of the author.

*Campaign form letters.* Please submit campaign form letters by the originating organization in batches of between 50 to

<sup>1</sup> On December 11, 2020, DOE published an amendment to 10 CFR 430.27 regarding the processing of petitions for an interim waiver, which became effective beginning January 11, 2021. 85 FR 79802. Midea’s petition for waiver and petition for interim waiver were received prior to the effective date of that amendment. The interim waiver therefore is being processed pursuant to the regulation in effect at the time of receipt, *i.e.*, 10 CFR 430.27 in the 10 CFR parts 200 to 499 edition revised as of January 1, 2020.

500 form letters per PDF or as one form letter with a list of supporters' names compiled into one or more PDFs. This reduces comment processing and posting time.

**Confidential Business Information.** According to 10 CFR 1004.11, any person submitting information that he or she believes to be confidential and exempt by law from public disclosure should submit via email two well-marked copies: One copy of the document marked confidential including all the information believed to be confidential, and one copy of the document marked "non-confidential" with the information believed to be confidential deleted. DOE will make its own determination about the confidential status of the information and treat it according to its determination.

It is DOE's policy that all comments may be included in the public docket, without change and as received, including any personal information provided in the comments (except information deemed to be exempt from public disclosure).

## Case Number 2020-006

### Interim Waiver Order

#### I. Background and Authority

The Energy Policy and Conservation Act, as amended ("EPCA"),<sup>1</sup> authorizes the U.S. Department of Energy ("DOE") to regulate the energy efficiency of a number of consumer products and certain industrial equipment. (42 U.S.C. 6291-6317) Title III, Part B<sup>2</sup> of EPCA established the Energy Conservation Program for Consumer Products Other Than Automobiles, which sets forth a variety of provisions designed to improve energy efficiency for certain types of consumer products. In addition to specifying a list of covered products and industrial equipment, EPCA contains provisions that enable the Secretary of Energy to classify additional types of consumer products as covered products. (42 U.S.C. 6292(a)(20)) In a final determination of coverage published in the **Federal Register** on April 18, 2016, DOE classified portable air conditioners as covered products under EPCA. 81 FR 22514.

The energy conservation program under EPCA consists essentially of four parts: (1) Testing, (2) labeling, (3) Federal energy conservation standards, and (4) certification and enforcement

procedures. Relevant provisions of EPCA include definitions (42 U.S.C. 6291), test procedures (42 U.S.C. 6293), labeling provisions (42 U.S.C. 6294), energy conservation standards (42 U.S.C. 6295), and the authority to require information and reports from manufacturers (42 U.S.C. 6296).

The Federal testing requirements consist of test procedures that manufacturers of covered products must use as the basis for: (1) Certifying to DOE that their products comply with the applicable energy conservation standards adopted pursuant to EPCA (42 U.S.C. 6295(s)), and (2) making representations about the efficiency of that product (42 U.S.C. 6293(c)). Similarly, DOE must use these test procedures to determine whether the product complies with relevant standards promulgated under EPCA. (42 U.S.C. 6295(s))

Under 42 U.S.C. 6293, EPCA sets forth the criteria and procedures DOE is required to follow when prescribing or amending test procedures for covered products. EPCA requires that any test procedures prescribed or amended under this section must be reasonably designed to produce test results which reflect the energy efficiency, energy use or estimated annual operating cost of a covered product during a representative average use cycle or period of use and requires that test procedures not be unduly burdensome to conduct. (42 U.S.C. 6293(b)(3)) The test procedure for portable air conditioners is contained in the Code of Federal Regulations ("CFR") at 10 CFR part 430, subpart B, appendix CC ("Appendix CC").

Under 10 CFR 430.27, any interested person may submit a petition for waiver from DOE's test procedure requirements. DOE will grant a waiver from the test procedure requirements if DOE determines either that the basic model for which the waiver was requested contains a design characteristic that prevents testing of the basic model according to the prescribed test procedures, or that the prescribed test procedures evaluate the basic model in a manner so unrepresentative of its true energy consumption characteristics as to provide materially inaccurate comparative data. 10 CFR 430.27(f)(2). A petitioner must include in its petition any alternate test procedures known to the petitioner to evaluate the performance of the product type in a manner representative of the energy consumption characteristics of the basic model. 10 CFR 430.27(b)(1)(iii). DOE may grant the waiver subject to conditions, including adherence to alternate test procedures. 10 CFR 430.27(f)(2).

As soon as practicable after the granting of any waiver, DOE will publish in the **Federal Register** a notice of proposed rulemaking to amend its regulations to eliminate any need for the continuation of such waiver. 10 CFR 430.27(l). As soon thereafter as practicable, DOE will publish in the **Federal Register** a final rule to that effect. *Id.*

The waiver process also provides that DOE may grant an interim waiver if it appears likely that the underlying petition for waiver will be granted and/or if DOE determines that it would be desirable for public policy reasons to grant immediate relief pending a determination on the underlying petition for waiver. 10 CFR 430.27(e)(2). Within one year of issuance of an interim waiver, DOE will either: (i) Publish in the **Federal Register** a determination on the petition for waiver; or (ii) publish in the **Federal Register** a new or amended test procedure that addresses the issues presented in the waiver. 10 CFR 430.27(h).

When DOE amends the test procedure to address the issues presented in a waiver, the waiver will automatically terminate on the date on which use of that test procedure is required to demonstrate compliance. *Id.*

#### II. Midea's Petition for Waiver and Interim Waiver

On June 29, 2020, Midea filed a petition for waiver and petition for interim waiver from the test procedure for portable air conditioners set forth at Appendix CC. (Midea, No. 1 at pp. 2-3)<sup>3</sup> On July 10, 2020, Midea submitted a revised petition for waiver and application for interim waiver.<sup>4</sup> On September 11, 2020, Midea submitted a request<sup>5</sup> to include five additional basic models in their petition for waiver and petition for interim waiver. On November 17, 2020, Midea submitted a request<sup>6</sup> to include three additional

<sup>3</sup> A notation in this form provides a reference for information that is in the docket for this test procedure waiver (Docket No. EERE-2020-BT-WAV-0023) (available at <https://www.regulations.gov/docket/EERE-2020-BT-WAV-0023>). This notation indicates that the statement preceding the reference is document number 1 in the docket and appears at pages 2-3 of that document.

<sup>4</sup> The revised petition for waiver and application for interim waiver is available at <https://www.regulations.gov/document?D=EERE-2020-BT-WAV-0023-0002>.

<sup>5</sup> The request to include additional basic models is available at <https://www.regulations.gov/document?D=EERE-2020-BT-WAV-0023-0003>.

<sup>6</sup> The request to include additional basic models is available at <https://www.regulations.gov/document?D=EERE-2020-BT-WAV-0023-0004>.

<sup>1</sup> All references to EPCA in this document refer to the statute as amended through the Energy Act of 2020, Public Law 116-260 (Dec. 27, 2020).

<sup>2</sup> For editorial reasons, upon codification in the U.S. Code, Part B was redesignated as Part A.

basic models in their petition for waiver and petition for interim waiver.<sup>7</sup> The current DOE test procedure at Appendix CC tests dual-duct portable air conditioners at two operating conditions, one measuring performance at a high outdoor operating temperature and one measuring performance at a lower outdoor operating temperature. Midea asserts that this testing does not address the ability of variable-speed compressors to adjust their operating speed based on the demand load of the conditioned space. Because of this, Midea indicated that the test procedure does not take into account the full range of performance and efficiency benefits of a variable-speed compressor operating under part-load conditions. Midea cited DOE's test procedure for central air conditioners, which includes part-load test conditions that account for the improved efficiency benefit from variable-speed compressors at 10 CFR 430 subpart B, appendix M1, section 3.2.4. Midea also referenced several waivers; first were two test procedure waivers for room air conditioners that contain variable-speed compressors: Midea's, granted on May 26, 2020, and LG Electronics Inc. ("LG")'s, granted on May 8, 2019. 85 FR 31481; 84 FR 20111. Second was the portable air conditioner waiver DOE granted to LG on June 2, 2020. That waiver includes part-load test conditions to account for the improved efficiency benefit from variable-speed compressors. 85 FR 33643. Midea asserted that the basic models listed in the petition cannot be tested according to the test procedure at Appendix CC because their condenser inlet and outlet air streams are incorporated into the same structure

<sup>7</sup> The brand and basic model numbers specified by Midea in its petition (including the September 11, 2020 and November 17, 2020 submissions) are: Midea, US-KC35Y1/BP3N8-PTB(CH3); Midea, US-KC30Y1/BP3N8-PTB(CG8); Perfect aire, 1PORTV10000; Danby, DPA100B9IWDDB-6; Heat Controller LLC, PSV-101D; Whynter, ARC-1030WN; Whynter, ARC-1030BN; Whynter, ARC-1030GN; hOme, HME020373N; Vremi, VRM050703N; Wappliance, BPI10MW; Perfect aire, 1PORTVP10000; Danby, DPA100HB9IWDDB-6; Heat Controller LLC, PSHV-101D; Whynter, ARC-1030WNH; Whynter, ARC-1030GNH; Whynter, ARC-1030BNH; hOme, HME020374N; Vremi, VRM050704N; Wappliance, BPI10HMW; Perfect aire, 1PORTV12000; Danby, DPA120B9IWDDB-6; Heat Controller LLC, PSV-121D; Whynter, ARC-1230WN; Whynter, ARC-1230BN; Whynter, ARC-1230GN; hOme, HME020375N; Vremi, VRM050705N; Wappliance, BPI12MW; Perfectaire, 1PORTVP12000; Danby, DPA120HB9IWDDB-6; Heat Controller LLC, PSHV-121D; Whynter, ARC-1230WNH; Whynter, ARC-1230GNH; Whynter, ARC-1230BNH; hOme, HME020376N; Vremi, VRM050706N; Wappliance, BPI12HMW; Toshiba, RAC-PT1411HWRU; Toshiba, RAC-PT1411CWRU; Toshiba, RAC-PT1211CWRU; Danby, DPA100HB9IBDB-6; Danby, DPA120B9IBDB-6; Midea, MPPTB-12HRN8-BCH4; Midea, MPPTB-12CRN8-BCH4; Midea, MPPTB-10CRN8-BCG8.

using "combined-duct technology." Midea stated that the test procedure does not provide for measuring airflow in and out of a single condenser duct at the same time, as would be required for units with a combined duct.

Midea also requested an interim waiver from the existing DOE test procedure. DOE will grant an interim waiver if it appears likely that the petition for waiver will be granted, and/or if DOE determines that it would be desirable for public policy reasons to grant immediate relief pending a determination of the petition for waiver. 10 CFR 430.27(e)(2).

Based on the assertions in the petition, absent an interim waiver, Midea's specified portable air conditioner basic models contain design characteristics which prevent testing of the basic model according to the prescribed test procedures and cause the prescribed test procedures to be tested in a manner that is unrepresentative of their actual efficiency.

### III. Requested Alternate Test Procedure

EPCA requires that manufacturers use DOE test procedures when making representations about the energy consumption and energy consumption costs of covered products. (42 U.S.C. 6293(c)) Consistency is important when making representations about the energy efficiency of covered products, including when demonstrating compliance with applicable DOE energy conservation standards. Pursuant to 10 CFR 430.27, and after consideration of public comments on the petition, DOE may establish in a subsequent Decision and Order an alternate test procedure for the basic models addressed by the Interim Waiver Order.

Midea seeks to use an alternate test procedure to test and rate specific portable air conditioner basic models. The alternate test procedure is the test procedure for portable air conditioners prescribed by DOE in Appendix CC, with the combined-duct variable-speed portable air conditioners tested at both the high- and low-temperature outdoor operating conditions to measure a weighted-average combined energy efficiency ratio ("CEER"), except the compressor speed is fixed at "full" and "low" in accordance with manufacturer instructions at the two outdoor conditions, respectively. Midea suggests an additional set of calculations to model the CEER of a theoretical comparable dual-duct single-speed portable air conditioner twice—once with cycling losses and once without cycling losses—based on the performance of the combined-duct variable-speed portable air conditioner

at full compressor speed at the low-outdoor temperature condition. From these results, a "performance adjustment factor" is calculated, representing the performance improvement associated with avoiding cycling losses. The performance adjustment factor is then multiplied by the measured CEER value for the variable-speed portable air conditioner according to Appendix CC to determine the test unit's final rated CEER value. Midea states that this approach takes into account performance and efficiency improvements associated with combined-duct variable-speed portable air conditioners as compared to dual-duct portable air conditioners with single-speed compressors. In addition to the provisions for variable-speed compressors, Midea's suggested alternate test procedure also adds provisions to the test procedure in Appendix CC to test combined-duct portable air conditioners using an adapter to interface with the combined duct and additional thermocouples to measure temperature variations on the surface of the combined duct.

### IV. Interim Waiver Order

DOE has reviewed Midea's application for an interim waiver, the alternate test procedure requested by Midea, diagrams and renderings, and confidential performance data Midea provided to DOE. Based on this review, the alternate test procedure, with modifications discussed in the following paragraphs, appears to allow for the accurate measurement of the efficiency of the specified basic models, while alleviating the problems Midea identified in testing these basic models.

DOE has made four modifications to the alternate test procedure as presented in the Midea petition. First, at Midea's request, DOE removed an adjustment factor that was originally requested in the alternate test procedure to account for different full compressor speeds for single-speed and variable-speed portable air conditioners at the lower outdoor temperature operating condition. Second, DOE doubled the number of thermocouples on the combined duct from eight to sixteen. Third, DOE is altering the cycling loss factor ("CLF") to reflect the most recent data and analysis. Last, DOE is requiring the use of a unit setpoint of 75 °F at the 95 °F fixed chamber test condition to improve test representativeness.

In its petition, Midea suggested an adjustment factor for the purpose of providing a more appropriate comparison between the measured capacity and power when testing the variable-speed portable air conditioner

with a full compressor speed at the lower outdoor operating conditions and that of a single-speed portable air conditioner operating under those conditions. In a communication following the July 2020 revised petition, Midea requested that the adjustment factor be retracted stating that due to subsequent modifications to the subject basic models the adjustment factor is now not necessary. DOE has therefore removed this adjustment factor from the alternate test procedure.

Additionally, DOE has initially determined that the use of 16 thermocouples better assesses the average temperature on the combined duct given that it contains both the condenser inlet and exhaust air streams. Section 3.1.1.6 of Appendix CC requires four thermocouples per duct. With the basic models at issue, both of the air streams are contained in the same combined duct. The combined duct potentially results in more significant temperature gradients along its length and perimeter, necessitating the use of 16 thermocouples.

Also, DOE considered data collected in support of the ongoing room air conditioner test procedure rulemaking,<sup>8</sup> given the certain similarities of these products to portable air conditioners, to assess the portable air conditioner CLF proposed in Midea’s petition. The data for cooling degradation coefficient (“Cd”), presented below in Table IV–1, summarize the results from load-based testing of two single-speed room air conditioners at an outdoor temperature of 82 °F and cooling loads between 49 and 55 percent of the full load (*i.e.*, the cooling capacity resulting from maximum cooling at the 95 °F test condition).

TABLE IV–1—TESTED AND EXTRAPOLATED COOLING DEGRADATION COEFFICIENT

Unit	Load %	Cd
Unit 1 .....	52	0.42
	54	0.39
	* 55	* 0.38
Unit 2 .....	49	0.39
	54	0.30
	* 55	* 0.28

\* Represent extrapolated values to estimate the Cd at a 55% load.

<sup>8</sup>The data were collected following publication of the notice of proposed rulemaking, “Energy Conservation Program: Test Procedure for Room Air Conditioners” (85 FR 35700; Jun. 11, 2020), and will be considered as part of that rulemaking.

Extrapolating from the data collected, the average Cd at 55 percent of the full cooling load (*i.e.*, the center of the acceptable range specified in the low compressor speed definition of this waiver) would be 0.332, suggesting a CLF of 0.8 would be more appropriate at the 83 °F test condition as opposed to the 0.875 CLF suggested in the Midea petition. The analysis above represents the best available information to date regarding single-speed room air conditioner cycling at reduced cooling loads, which DOE believes is reflective of the expected cycling that would be observed for single-speed portable air conditioners. Therefore, DOE is adopting the use of 0.8 as the CLF for the 83 °F test condition in this interim waiver.

Furthermore, during the room air conditioner test procedure rulemaking, DOE observed that for units produced by certain manufacturers, variable-speed room air conditioners performed differently depending on the method used to produce maximum cooling capacity. Testing of variable-speed room air conditioners was conducted at maximum cooling capacity for the “full speed” 95 °F test condition, achieved either with (1) the user settings (*e.g.*, fan speed, grille position) and thermostat setpoint selected to produce maximum cooling capacity in accordance with the DOE room air conditioner test procedure at 10 CFR part 430, subpart B, appendix F (“appendix F”) (*i.e.*, the unit automatically selected the compressor speed); or (2) using the user settings, in accordance with appendix F, but applying the manufacturer’s confidential testing instructions to achieve a fixed “full” compressor speed (*i.e.*, the control setting specified in the room air condition waiver and suggested by Midea in their petition). One test unit was 10 percent more efficient when using only the appendix F user settings than when using fixed compressor speed controls, while another unit was 11 percent less efficient.

Based on the observed differences in room air conditioner performance when using the fixed “full” compressor speed (*i.e.*, applying the confidential manufacturer instructions) as compared to using only the appendix F settings, described above, DOE concludes that similar differences may occur when testing portable air conditioners and is requiring a unit setpoint of 75 °F for the portable air conditioner “full speed”

95 °F test condition, as it would be more representative of typical consumer settings than reliance on the confidential manufacturer instructions to achieve maximum cooling capacity. In evaluating potential thermostat setpoints, DOE reviewed data for 19 portable air conditioners that were field metered in a 2014 study conducted by Lawrence Berkeley National Laboratory.<sup>9</sup> Among these units, the thermostat setpoints selected by consumers ranged from 66 °F to 76 °F, with a median value of 74.5 °F. DOE expects, therefore, that 75 °F is a typical consumer setpoint for portable air conditioners that would achieve the maximum cooling (given the differential between the setpoint and the fixed indoor test chamber dry-bulb temperature of 80 °F), in accordance with appendix CC. DOE is also modifying the definition of “full compressor speed” accordingly in this interim waiver.

DOE notes that while variable-speed waivers granted for other products numerically estimate performance of a theoretical single-speed product at reduced outdoor temperature conditions, given the complex heat transfer dynamics related to the ducts, infiltration air, and internal air mixing within the chassis of the combined duct used in the basic models specified by Midea in its petition, DOE believes that the approach proposed by Midea to estimate performance of the theoretical single-speed dual-duct portable air conditioner using the performance of the variable-speed combined-duct portable air conditioner at the low-outdoor temperature condition, modified as discussed above, is appropriate and reasonable. Consequently, DOE has determined that Midea’s petition for waiver likely will be granted. Furthermore, DOE has determined that it is desirable for public policy reasons to grant Midea immediate relief pending a determination of the petition for waiver.

For the reasons stated, it is *ordered* that:

- (1) Midea must test and rate the following portable air conditioner basic models with the alternate test procedure set forth in paragraph (2).

<sup>9</sup>T. Burke *et al.*, “Using Field-Metered Data to Quantify Annual Energy Use of Portable Air Conditioners,” Lawrence Berkeley National Laboratory, LBNL–6868E, December 2014.

Brand	Model No.
Midea	US-KC35Y1/BP3N8-PTB(CH3)
Midea	US-KC30Y1/BP3N8-PTB(CG8)
Perfect aire	1PORTV10000
Danby	DPA100B9IWDB-6
Heat Controller LLC	PSV-101D
Whynter	ARC-1030WN
Whynter	ARC-1030BN
Whynter	ARC-1030GN
hOme	HME020373N
Vremi	VRM050703N
Wappliance	BPI10MW
Perfect aire	1PORTVP10000.
Danby	DPA100HB9IWDB-6
Heat Controller LLC	PSHV-101D
Whynter	ARC-1030WNH
Whynter	ARC-1030GNH
Whynter	ARC-1030BNH
hOme	HME020374N
Vremi	VRM050704N
Wappliance	BPI10HMMW
Perfect aire	1PORTV12000
Danby	DPA120B9IWDB-6
Heat Controller LLC	PSV-121D
Whynter	ARC-1230WN
Whynter	ARC-1230BN
Whynter	ARC-1230GN
hOme	HME020375N
Vremi	VRM050705N
Wappliance	BPI12MW
Perfectaire	1PORTVP12000
Danby	DPA120HB9IWDB-6
Heat Controller LLC	PSHV-121D
Whynter	ARC-1230WNH
Whynter	ARC-1230GNH
Whynter	ARC-1230BNH
hOme	HME020376N
Vremi	VRM050706N
Wappliance	BPI12HMMW
Toshiba	RAC-PT1411HWRU
Toshiba	RAC-PT1411CWRU
Toshiba	RAC-PT1211CWRU
Danby	DPA100HB9IBDB-6
Danby	DPA120B9IBDB-6
Midea	MPPTB-12HRN8-BCH4
Midea	MPPTB-12CRN8-BCH4
Midea	MPPTB-10CRN8-BCG8

(2) The alternate test procedure for the Midea basic models identified in paragraph (1) of this Interim Waiver Order is the test procedure for portable air conditioners prescribed by DOE at Appendix CC and 10 CFR 430.23(dd), with three exceptions. First, install the unit under test as detailed below. Second, determine combined energy efficiency ratio (CEER) as detailed below. Third, calculate the estimated annual operating cost in 10 CFR 430.23(dd)(2) as detailed below. In addition, for each basic model listed in paragraph (1), maintain the compressor speed at each test condition, and set the control settings used for the variable components, according to the instructions submitted to DOE by Midea (<https://www.regulations.gov/docket/EERE-2020-BT-WAV-0023>). Upon the compliance date of any new energy

conservation standards for portable air conditioners, Midea must report product specific information pursuant to 10 CFR 429.12(b)(13) and 10 CFR 429.62(b). All other requirements of Appendix CC and DOE's regulations remain applicable.

In 10 CFR 430.2, add in alphabetical order:

*Combined-duct portable air conditioner* means a dual-duct portable air conditioner with the condenser inlet and outlet air streams flowing through separate ducts housed in a single overall duct structure.

In 10 CFR 430.23, in paragraph (dd) revise paragraph (2) to read as follows:

(2) Determine the estimated annual operating cost for a combined-duct variable-speed portable air conditioner, expressed in dollars per year, by multiplying the following two factors:

(i) The sum of the following three values:  $AEC_{95}$  multiplied by 0.2,  $AEC_{83\_Low}$  multiplied by 0.8, and  $AEC_T$ , as calculated in section 5.3 of appendix CC of this subpart; and

(ii) A representative average unit cost of electrical energy in dollars per kilowatt-hour as provided by the Secretary.

(iii) Round the resulting product to the nearest dollar per year.

In Appendix CC:  
Add in Section 2, Definitions:  
2.11 *Single-speed* means a type of portable air conditioner that cannot adjust the compressor speed.

2.12 *Variable-speed* means a type of portable air conditioner that can automatically adjust the compressor speed.

2.13 *Full compressor speed (full)* means the compressor speed at which the unit operates at full load test

conditions, when using user settings to achieve maximum cooling capacity, and with the thermostat setpoint set at 75 °F.

2.14 *Low compressor speed (low)* means the compressor speed specified by Midea (Docket No. EERE–2020–BT–WAV–0023–0006), at which the unit operates at low load test conditions, such that Capacity<sub>83\_Low</sub>, the measured cooling capacity at this speed at Test Condition 3 in Table 1 of this appendix, is no less than 50 percent and no greater than 60 percent of Capacity<sub>95</sub>, the measured cooling capacity with the full compressor speed at Test Condition 1 in Table 1 of this appendix.

2.15 *Theoretical comparable single-speed portable air conditioner* means a theoretical single-speed portable air conditioner with the same cooling capacity and electrical power input as the variable-speed portable air conditioner under test, with no cycling losses considered, when operating with the full compressor speed and at Test Condition 1 in Table 1 of this appendix.

Replace section 3.1.1.1 *Test conduct* with the following:

*Test conduct.* The test apparatus and instructions for testing portable air conditioners in cooling mode and off-cycle mode must conform to the requirements specified in Section 4, “Definitions” and Section 7, “Tests,” of ANSI/AHAM PAC–1–2015 (incorporated by reference; see § 430.3), except as otherwise specified in this appendix. Measure duct heat transfer and infiltration air heat transfer according to section 4.1.1 and section 4.1.2 of this appendix, respectively.

Replace section 3.1.1.1 *Duct Setup* with the following:

Use only ducting components provided by the manufacturer, including, where provided by the

manufacturer, ducts, connectors for attaching the duct(s) to the test unit, sealing, insulation, and window mounting fixtures. Do not apply additional sealing or insulation. To measure the condenser inlet and outlet airflows in the combined duct, use an adapter provided by the manufacturer, which allows for the individual connection of the condenser inlet and outlet airflows to the test lab’s airflow measuring apparatuses.

Replace section 3.1.1.6 *Duct temperature measurements* with the following:

*Duct temperature measurements.* Install any insulation and sealing provided by the manufacturer. Then adhere sixteen thermocouples to the outer surface of the duct, spaced evenly around the circumference (four thermocouples, each 90 degrees apart, radially) and down the length of the duct (four sets of four thermocouples, evenly placed along the length of the duct), ensuring that the thermocouples are distributed equally on the entire surface of the combined duct. Ensure that at least one thermocouple is placed next to the condenser inlet aperture and at least one thermocouple is placed on the duct surface adjacent to or nearest to the condenser outlet aperture. Measure the surface temperature of the combined duct at each thermocouple. Temperature measurements must have an error no greater than ±0.5 °F over the range being measured.

Add to the end of Section 3.1.2, *Control settings*:

Set the compressor speed during cooling mode testing as described in section 4.1 of this appendix, as amended by this Order.

Replace Section 4.1, *Cooling mode* with the following:

*Cooling mode.* Instead of the test conditions in Table 3 of ANSI/AHAM PAC–1–2015, establish the test conditions presented in Table 1 of this appendix. Test each sample unit three times, once at each test condition in Table 1. For each test condition, measure the sample unit’s indoor room cooling capacity and overall power input in cooling mode in accordance with Section 7.1.b and 7.1.c of ANSI/AHAM PAC–1–2015 (incorporated by reference; see § 430.3), respectively, and determine the test duration in accordance with Section 8.7 of ASHRAE Standard 37–2009 (incorporated by reference; § 430.3). Conduct the first test in accordance with ambient conditions for Test Condition 1 in Table 1 of this appendix, achieving the full compressor speed, as defined in section 2.13 of this appendix, with user settings, for the duration of cooling mode testing (Capacity<sub>95</sub>, P<sub>95</sub>). Conduct the second test in accordance with the ambient conditions for Test Condition 2, in Table 1 of this appendix, with the compressor speed set to full, for the duration of cooling mode testing (Capacity<sub>83\_Full</sub>, P<sub>83\_Full</sub>). To confirm the same full compressor speed is used, the average compressor frequency for the second test must equal that observed for the first test, with a tolerance of +/– 10% of the nominal average compressor frequency of the first test. Conduct the third test in accordance with the ambient conditions for Test Condition 3, with the compressor speed set to low for the duration of cooling mode testing (Capacity<sub>83\_Low</sub>, P<sub>83\_Low</sub>). Set the compressor speed required for each test condition in accordance with the instructions Midea submitted to DOE (Docket No. EERE–2020–BT–WAV–0023–0006).

TABLE 1—EVAPORATOR AND CONDENSER INLET TEST CONDITIONS

Test condition	Evaporator inlet air °F (°C)		Condenser inlet air °F (°C)		Compressor speed
	Dry bulb	Wet bulb	Dry bulb	Wet bulb	
Test Condition 1 .....	80 (26.7)	67 (19.4)	95 (35.0)	75 (23.9)	Full.
Test Condition 2 .....	80 (26.7)	67 (19.4)	83 (28.3)	67.5 (19.7)	Full.
Test Condition 3 .....	80 (26.7)	67 (19.4)	83 (28.3)	67.5 (19.7)	Low.

Replace Section 4.1.1, *Duct Heat Transfer*, with the following:

*Duct Heat Transfer.* Measure the circumference of the duct by wrapping a flexible measuring tape, or equivalent, around the outside of the combined duct, making sure the tape is on the outermost ridges. Calculate the surface area of the combined duct as follows:

$$A_{CD} = C \times L$$

Where:

- A<sub>CD</sub> = the outer area of the combined duct, in square feet.
- C = the circumference of the combined duct, as measured in this section, in feet.
- L = the extended length of the combined duct while under test, in feet.

Calculate the average temperature at each individual location. Then calculate the average surface temperature of the duct by averaging the sixteen average

temperature measurements taken on the duct. Calculate the total heat transferred from the surface of the combined duct to the indoor conditioned space while operating in cooling mode at each test condition in Table 1 of this appendix, according to the following equations:

$$Q_{CD_{95}} = 3 \times A_{CD} \times (T_{CD_{95}} - T_{ei})$$

$$Q_{CD_{83\_Full}} = 3 \times A_{CD} \times (T_{CD_{83\_Full}} - T_{ei})$$

$$Q_{CD_{83\_Low}} = 3 \times A_{CD} \times (T_{CD_{83\_Low}} - T_{ei})$$

Where:

$Q_{CD\_95}$ ,  $Q_{CD\_83\_Full}$ , and  $Q_{CD\_83\_Low}$  = the total heat transferred from the combined duct to the indoor conditioned space in cooling mode, in Btu/h, when tested at Test Condition 1, Test Condition 2, and Test Condition 3 in Table 1 of this appendix, respectively.

3 = convection coefficient in Btu/h per square foot per °F.

$A_{CD}$  = surface area of the combined duct, as

calculated in this section, in square feet.  
 $T_{CD\_95}$ ,  $T_{CD\_83\_Full}$ , and  $T_{CD\_83\_Low}$  = average surface temperature for the combined duct, in °F, as measured at Test Condition 1, Test Condition 2, and Test Condition 3 in Table 1 of this appendix, respectively, as calculated in this section.

$T_{ci}$  = average evaporator inlet air dry-bulb temperature, as measured in section 4.1 of this appendix, in °F.

Replace Section 4.1.2, *Infiltration Air Heat Transfer* with the following:

*Infiltration Air Heat Transfer.*

Calculate the sample unit's heat contribution from infiltration air into the conditioned space for each cooling mode test. Calculate the dry air mass flow rate of infiltration air according to the following equations:

$$\dot{m}_{95} = \frac{V_{co\_95} \times \rho_{co\_95}}{(1 + \omega_{co\_95})} - \frac{V_{ci\_95} \times \rho_{ci\_95}}{(1 + \omega_{ci\_95})}$$

$$\dot{m}_{83} = \frac{V_{co\_83\_Full} \times \rho_{co\_83\_Full}}{(1 + \omega_{co\_83\_Full})} - \frac{V_{ci\_83\_Full} \times \rho_{ci\_83\_Full}}{(1 + \omega_{ci\_83\_Full})}$$

$$\dot{m}_{83\_Low} = \frac{V_{co\_83\_Low} \times \rho_{co\_83\_Low}}{(1 + \omega_{co\_83\_Low})} - \frac{V_{ci\_83\_Low} \times \rho_{ci\_83\_Low}}{(1 + \omega_{ci\_83\_Low})}$$

Where:

$\dot{m}_{95}$ ,  $\dot{m}_{83\_Full}$  and  $\dot{m}_{83\_Low}$  = dry air mass flow rate of infiltration air for combined-duct portable air conditioners, in lb/m, when tested at Test Condition 1, Test Condition 2, and Test Condition 3 in Table 1 of this appendix, respectively.

$V_{co\_95}$ ,  $V_{co\_83\_Full}$  and  $V_{co\_83\_Low}$  = average volumetric flow rate of the condenser outlet air, in cubic feet per minute (cfm), as measured at Test Condition 1, Test Condition 2, and Test Condition 3 in Table 1 of this appendix, respectively, as required in section 4.1 of this appendix.

$V_{ci\_95}$ ,  $V_{ci\_83\_Full}$  and  $V_{ci\_83\_Low}$  = average volumetric flow rate of the condenser inlet air, in cfm, as measured at Test Condition 1, Test Condition 2, and Test Condition 3 in Table 1 of this appendix, respectively, as required in section 4.1 of this appendix.

$\rho_{co\_95}$ ,  $\rho_{co\_83\_Full}$  and  $\rho_{co\_83\_Low}$  = average density of the condenser outlet air, in pounds mass per cubic foot (lb<sub>m</sub>/ft<sup>3</sup>), as measured at Test Condition 1, Test Condition 2, and Test Condition 3 in Table 1 of this appendix, respectively, as required in section 4.1 of this appendix.

$\rho_{ci\_95}$ ,  $\rho_{ci\_83\_Full}$  and  $\rho_{ci\_83\_Low}$  = average density of the condenser inlet air, in lb<sub>m</sub>/ft<sup>3</sup>, as measured at Test Condition 1, Test Condition 2, and Test Condition 3 in Table 1 of this appendix, respectively, as required in section 4.1 of this appendix.

$\omega_{co\_95}$ ,  $\omega_{co\_83\_Full}$  and  $\omega_{co\_83\_Low}$  = average humidity ratio of condenser outlet air, in pounds mass of water vapor per pounds mass of dry air (lb<sub>w</sub>/lb<sub>da</sub>), as measured at Test Condition 1, Test Condition 2, and Test Condition 3 in Table 1 of this appendix, respectively, as required in section 4.1 of this appendix.

$\omega_{ci\_95}$ ,  $\omega_{ci\_83\_Full}$  and  $\omega_{ci\_83\_Low}$  = average humidity ratio of condenser inlet air, in lb<sub>w</sub>/lb<sub>da</sub>, as measured at Test Condition 1, Test Condition 2, and Test Condition 3 in Table 1 of this appendix, respectively,

as required in section 4.1 of this appendix.

Calculate the sensible component of infiltration air heat contribution according to the following equations:

$$Q_{s\_95} = \dot{m}_{95} \times 60 \times [c_{p\_da} \times (95 - 80) + (c_{p\_wv} \times (0.0141 \times 95 - 0.0112 \times 80))]$$

$$Q_{s\_83\_Full} = \dot{m}_{83\_Full} \times 60 \times [(c_{p\_da} \times (83 - 80) + (c_{p\_wv} \times (0.01086 \times 83 - 0.0112 \times 80))]$$

$$Q_{s\_83\_Low} = \dot{m}_{83\_Low} \times 60 \times [(c_{p\_da} \times (83 - 80) + (c_{p\_wv} \times (0.01086 \times 83 - 0.0112 \times 80))]$$

Where:

$Q_{s\_95}$ ,  $Q_{s\_83\_Full}$  and  $Q_{s\_83\_Low}$  = sensible heat added to the room by infiltration air, in Btu/h, when tested at Test Condition 1, Test Condition 2, and Test Condition 3 in Table 1 of this appendix, respectively.

$\dot{m}_{95}$ ,  $\dot{m}_{83\_Full}$  and  $\dot{m}_{83\_Low}$  = dry air mass flow rate of infiltration air for combined-duct portable air conditioners, in lb/m, when tested at Test Condition 1, Test Condition 2, and Test Condition 3 in Table 1 of this appendix, respectively, as calculated in section 4.1.2 of this appendix.

$c_{p\_da}$  = specific heat of dry air, 0.24 Btu/(lb<sub>m</sub> °F).

$c_{p\_wv}$  = specific heat of water vapor, 0.444 Btu/(lb<sub>m</sub> °F).

80 = indoor chamber dry-bulb temperature, in °F.

95 = infiltration air dry-bulb temperature for Test Condition 1 in Table 1 of this appendix, in °F.

83 = infiltration air dry-bulb temperature for Test Conditions 2 and 3 in Table 1 of this appendix, in °F.

0.0141 = humidity ratio of the dry-bulb infiltration air for Test Condition 1 in Table 1 of this appendix, in lb<sub>w</sub>/lb<sub>da</sub>.

0.01086 = humidity ratio of the dry-bulb infiltration air for Test Conditions 2 and

3 in Table 1 of this appendix, in lb<sub>w</sub>/lb<sub>da</sub>.  
 0.0112 = humidity ratio of the indoor chamber air, in lb<sub>w</sub>/lb<sub>da</sub> ( $\omega_{indoor}$ ).  
 60 = conversion factor from minutes to hours.

Calculate the latent heat contribution of the infiltration air according to the following equations:

$$Q_{l\_95} = \dot{m}_{95} \times 60 \times 1061 \times (0.0141 - 0.0112)$$

$$Q_{l\_83\_Full} = \dot{m}_{83\_Full} \times 60 \times 1061 \times (0.01086 - 0.0112)$$

$$Q_{l\_83\_Low} = \dot{m}_{83\_Low} \times 60 \times 1061 \times (0.01086 - 0.0112)$$

Where:

$Q_{l\_95}$ ,  $Q_{l\_83\_Full}$  and  $Q_{l\_83\_Low}$  = latent heat added to the room by infiltration air, when tested at Test Conditions 1, 2, and 3 in Table 1 of this appendix, respectively, in Btu/h.

$\dot{m}_{95}$ ,  $\dot{m}_{83\_Full}$  and  $\dot{m}_{83\_Low}$  = dry air mass flow rate of infiltration air, in lb/m, when tested at Test Condition 1, Test Condition 2, and Test Condition 3 in Table 1 of this appendix, respectively, as calculated in section 4.1.2 of this appendix.

1061 = latent heat of vaporization for water vapor, in Btu/lb<sub>m</sub> ( $H_{fg}$ ).

0.0141 = humidity ratio of the dry-bulb infiltration air for Test Condition 1 in Table 1 of this appendix, in lb<sub>w</sub>/lb<sub>da</sub>.

0.01086 = humidity ratio of the dry-bulb infiltration air for Test Conditions 2 and 3 in Table 1 of this appendix, in lb<sub>w</sub>/lb<sub>da</sub>.

0.0112 = humidity ratio of the indoor chamber air, in lb<sub>w</sub>/lb<sub>da</sub>.

60 = conversion factor from minutes to hours.

Calculate the total heat contribution of the infiltration air at each test condition by adding the sensible and latent heat according to the following equations:

$$Q_{infiltration\_95} = Q_{s\_95} + Q_{l\_95}$$

$$Q_{infiltration\_83\_Full} = Q_{s\_83\_Full} + Q_{l\_83\_Full}$$



$$Q_{\text{infiltration}_{83\_Low}} = Q_{s_{83\_Low}} + Q_{L_{83\_Low}}$$

Where:

$Q_{\text{infiltration}_{95}}$ ,  $Q_{\text{infiltration}_{83\_Full}}$  and  $Q_{\text{infiltration}_{83\_Low}}$  = total infiltration air heat in cooling mode, when tested at Test Conditions 1, 2, and 3 in Table 1 of this appendix, respectively, in Btu/h

$Q_{s_{95}}$ ,  $Q_{s_{83\_Full}}$  and  $Q_{s_{83\_Low}}$  = sensible heat added to the room by infiltration air, when tested at Test Conditions 1, 2, and 3 in Table 1 of this appendix, respectively, in Btu/h, as calculated in this section.

$Q_{L_{95}}$ ,  $Q_{L_{83\_Full}}$  and  $Q_{L_{83\_Low}}$  = latent heat added to the room by infiltration air, when tested at Test Conditions 1, 2, and 3 in Table 1 of this appendix, respectively, in Btu/h, as calculated in this section.

Replace Section 5.1, *Adjusted Cooling Capacity* with the following:

*Adjusted Cooling Capacity.* Calculate the adjusted cooling capacity at each outdoor temperature operating condition,  $ACC_{95}$  and  $ACC_{83\_Low}$ , expressed in Btu/h, according to the following equations:

$$ACC_{95} = Capacity_{95} - Q_{CD_{95}} -$$

$$ACC_{83\_Low} = Capacity_{83\_Low} - Q_{CD_{83\_Low}} - Q_{\text{infiltration}_{83\_Low}}$$

Where:

$Capacity_{95}$  and  $Capacity_{83\_Low}$  = cooling capacity, as measured in section 4.1 of this appendix, at Test Condition 1 and Test Condition 3 in Table 1 of this appendix, respectively, in Btu/h.

$Q_{CD_{95}}$  and  $Q_{CD_{83\_Low}}$  = combined duct heat transfer while operating in cooling mode at Test Condition 1 and Test Condition

3 in Table 1 of this appendix, respectively, in Btu/h, as calculated in section 4.1.1 of this appendix.

$Q_{\text{infiltration}_{95}}$  and  $Q_{\text{infiltration}_{83\_Low}}$  = total infiltration air heat transfer in cooling mode at Test Condition 1 and Test Condition 3 in Table 1 of this appendix, respectively, in Btu/h, as calculated in section 4.1.2 of this appendix.

Replace Section 5.3, *Annual Energy Consumption* with the following: *Annual Energy Consumption.* Calculate the sample unit's annual energy consumption in each operating mode according to the equation below. For each operating mode, use the following annual hours of operation and equation:

Operating mode	Subscript	Annual operating hours
Cooling Mode, Test Condition 1 <sup>1</sup> .	95 .....	750
Cooling Mode, Test Condition 2 <sup>1</sup> .	83_Full .....	750
Cooling Mode, Test Condition 3 <sup>1</sup> .	83_Low .....	750
Off-Cycle .....	oc .....	880
Inactive or Off .....	ia or om .....	1,355

<sup>1</sup> These operating mode hours are for the purposes of calculating annual energy consumption under different ambient conditions and are not a division of the total cooling mode operating hours. The total cooling mode operating hours are 750 hours.

$$AEC_m = P_m \times t_m \times 0.001$$

Where:

$AEC_m$  = annual energy consumption in the

operating mode, in kWh/year.  $m$  represents the operating mode ("95" for Test Condition 1, "83\_Full" for Test Condition 2, "83\_Low" for Test Condition 3, "oc" for off cycle, and "ia" for inactive or "om" for off mode).

$P_m$  = average power in the operating mode, in watts.

$t_m$  = number of annual operating time in each operating mode, in hours.

0.001 kWh/Wh = conversion factor from watt-hours to kilowatt-hours.

Calculate the sample unit's total annual energy consumption in off cycle mode and inactive or off mode as follows:

$$AEC_T = \sum_m AEC_m$$

Where:

$AEC_T$  = total annual energy consumption attributed to off cycle mode and inactive or off mode, in kWh/year;

$AEC_m$  = total annual energy consumption in the operating mode, in kWh/year.

$m$  represents the following two operating modes: Off cycle mode and inactive or off mode.

Replace Section 5.4, *Combined Energy Efficiency Ratio* with the following:

*Unadjusted Combined Energy Efficiency Ratio.* Calculate the sample unit's unadjusted combined energy efficiency ratio,  $CEER_{UA}$ , expressed in Btu/Wh, as follows:

$$CEER_{UA} = \left[ \frac{ACC_{95}}{\left( \frac{AEC_{95} + AEC_T}{750 \times 0.001} \right)} \right] \times 0.2 + \left[ \frac{ACC_{83\_Low}}{\left( \frac{AEC_{83\_Low} + AEC_T}{750 \times 0.001} \right)} \right] \times 0.8$$

Where:

$CEER_{UA}$  = unadjusted combined energy efficiency ratio for the sample unit, in Btu/Wh.

$ACC_{95}$  and  $ACC_{83\_Low}$  = adjusted cooling capacity, tested at Test Condition 1 and Test Condition 3 in Table 1 of this appendix, respectively, as calculated in section 5.1 of this appendix, in Btu/h.

$AEC_{95}$  and  $AEC_{83\_Low}$  = annual energy consumption for cooling mode operation at Test Condition 1 and Test Condition 3 in Table 1 in this appendix that represent operation at 95 °F and 83 °F dry-bulb outdoor temperature operating conditions, respectively, as calculated in section 5.3 of this appendix, in kWh/year.

$AEC_T$  = total annual energy consumption attributed to off cycle mode and inactive or off mode, in kWh/year, calculated in section 5.3 of this appendix.

750 = number of cooling mode hours per

year.

0.001 kWh/Wh = conversion factor for watt-hours to kilowatt-hours.

0.2 = weighting factor for the 95 °F dry-bulb outdoor temperature operating condition.

0.8 = weighting factor for the 83 °F dry-bulb outdoor temperature operating condition.

Add after Section 5.4, *Combined Energy Efficiency Ratio:*

5.5 *Adjustment of the Combined Energy Efficiency Ratio.* Adjust the sample unit's unadjusted combined energy efficiency ratio as follows.

5.5.1 *Theoretical Comparable Single-Speed Portable Air Conditioner Cooling Capacity and Power at the Lower Outdoor Temperature Operating Condition.* Calculate the cooling capacity and cooling capacity with

cycling losses, expressed in British thermal units per hour (Btu/h), and electrical power input, expressed in watts, for a theoretical comparable single-speed portable air conditioner at an 83 °F outdoor dry-bulb outdoor temperature operating condition (Test Condition 2 in Table 1 of this appendix) according to the following equations:

$$Capacity_{83\_SS} = Capacity_{83\_Full}$$

$$Capacity_{83\_SS\_CLF} = Capacity_{83\_SS} \times 0.8$$

$$P_{83\_SS} = P_{83\_Full}$$

Where:

$Capacity_{83\_SS}$  = cooling capacity of a theoretical comparable single-speed portable air conditioner, calculated for the 83 °F dry-bulb outdoor temperature operating condition (Test Condition 2 in Table 1 of this appendix), in Btu/h.

$Capacity_{83\_SS\_CLF}$  = cooling capacity of a theoretical comparable single-speed

portable air conditioner with cycling losses, in Btu/h, calculated for the 83 °F dry-bulb outdoor temperature operating condition (Test Condition 2 in Table 1 of this appendix).

Capacity<sub>83\_Full</sub> = cooling capacity of the sample unit, measured in section 4.1 of this appendix at Test Condition 2 in Table 1 of this appendix, in Btu/h.

P<sub>83\_SS</sub> = power input of a theoretical comparable single-speed portable air conditioner calculated for the 83 °F dry-bulb outdoor temperature operating condition (Test Condition 2 in Table 1 of this appendix), in watts.

P<sub>83\_Full</sub> = electrical power input of the sample unit, measured in section 4.1 of this appendix at Test Condition 2 in Table 1 of this appendix, in watts.

0.8 = cycling loss factor for the 83 °F dry-bulb outdoor temperature operating condition.

**5.5.2 Duct Heat Transfer for a Theoretical Comparable Single-Speed Portable Air Conditioner at the Lower Outdoor Temperature Operating Condition.** Calculate the combined duct heat transfer to the conditioned space for a theoretical comparable single-speed portable air conditioner at the 83 °F dry-bulb outdoor temperature operating condition (Test Condition 2 in Table 1 of this appendix), as follows:

$$Q_{CD\_83\_SS} = Q_{CD\_83\_Full}$$

Where:

Q<sub>CD\_83\_SS</sub> = total heat transferred from the combined duct to the indoor conditioned space in cooling mode, for a theoretical comparable single-speed portable air conditioner at the 83 °F dry-bulb outdoor temperature operating condition, in Btu/h.

Q<sub>CD\_83\_Full</sub> = combined duct heat transfer for the sample unit while operating in cooling mode at Test Condition 2 in Table 1 of this appendix (the 83 °F dry-bulb outdoor temperature operating condition), in Btu/h, as calculated in section 4.1.1 of this appendix.

**5.5.3 Infiltration Air Heat Transfer for a Theoretical Comparable Single-Speed Portable Air Conditioner at the Lower Outdoor Temperature Operating Condition.** Calculate the heat contribution from infiltration air for a theoretical comparable single-speed portable air conditioner at the 83 °F dry-bulb outdoor temperature operating condition (Test Condition 2 in Table 1 of this appendix), as detailed below. Calculate the dry air mass flow rate of infiltration air as follows:

$$\dot{m}_{83\_SS} = \dot{m}_{83\_Full}$$

Where:

m<sub>83\_SS</sub> = dry air mass flow rate of infiltration air for a theoretical comparable single-speed portable air conditioner at the 83 °F dry-bulb outdoor temperature operating condition (Test Condition 2 in Table 1 of this appendix), in lb/m.

m<sub>83\_Full</sub> = dry air mass flow rate of infiltration

air for the sample unit when tested at Test Condition 2 in Table 1 of this appendix (the 83 °F dry-bulb outdoor temperature operating condition), as calculated in section 4.1.2 of this appendix, in lb/m.

Calculate the sensible component of infiltration air heat contribution for a theoretical comparable single-speed portable air conditioner at the 83 °F dry-bulb outdoor temperature operating condition (Test Condition 2 in Table 1 of this appendix) as follows:

$$Q_{s\_83\_SS} = Q_{s\_83\_Full}$$

Where:

Q<sub>s\_83\_SS</sub> = sensible heat added to the room by infiltration air for a theoretical comparable single-speed portable air conditioner, at the 83 °F dry-bulb outdoor temperature operating condition (Test Condition 2 in Table 1 of this appendix), in Btu/h.

Q<sub>s\_83\_Full</sub> = sensible heat added to the room by infiltration air, when testing the sample unit at Test Condition 2 in Table 1 of this appendix (the 83 °F dry-bulb outdoor temperature operating condition), as calculated in section 4.1.2 of this appendix, in Btu/h.

Calculate the latent component of infiltration air heat contribution for a theoretical comparable single-speed portable air conditioner at the 83 °F dry-bulb outdoor temperature operating condition (Test Condition 2 in Table 1 of this appendix) as follows:

$$Q_{l\_83\_SS} = Q_{l\_83\_Full}$$

Where:

Q<sub>l\_83\_SS</sub> = latent heat added to the room by infiltration air for a theoretical comparable single-speed portable air conditioner, at the 83 °F dry-bulb outdoor temperature operating condition (Test Condition 2 in Table 1 of this appendix), in Btu/h.

Q<sub>l\_83\_Full</sub> = latent heat added to the room by infiltration air during testing of the sample unit, when tested at Test Condition 2 in Table 1 of this appendix (the 83 °F dry-bulb outdoor temperature operating condition), as calculated in section 4.1.2 of this appendix, in Btu/h.

Calculate the total heat contribution of the infiltration air for a theoretical comparable single-speed portable air conditioner at the 83 °F dry-bulb outdoor temperature operating condition (Test Condition 2 in Table 1 of this appendix) as follows:

$$Q_{infiltration\_83\_SS} = Q_{infiltration\_83\_Full}$$

Where:

Q<sub>infiltration\_83\_SS</sub> = total infiltration air heat in cooling mode for a theoretical comparable single-speed portable air conditioner at the 83 °F dry-bulb outdoor temperature operating condition (Test Condition 2 in Table 1 of this appendix), in Btu/h.

Q<sub>infiltration\_83\_Full</sub> = total infiltration air heat transfer of the sample unit in cooling

mode at Test Condition 2 in Table 1 of this appendix (the 83 °F dry-bulb outdoor temperature operating condition), as calculated in section 4.1.2 of this appendix, in Btu/h.

**5.5.4 Adjusted Cooling Capacity for a Theoretical Comparable Single-Speed Portable Air Conditioner at the Lower Outdoor Temperature Operating Condition.** Calculate the adjusted cooling capacity for a theoretical comparable single-speed portable air conditioner at the 83 °F dry-bulb outdoor temperature operating condition (Test Condition 2 in Table 1 of this appendix) both without cycling losses, ACC<sub>83\_SS</sub>, and with cycling losses, ACC<sub>83\_SS\_CLF</sub>, in Btu/h, according to the following equations:

$$\begin{aligned} ACC_{83\_SS} &= Capacity_{83\_SS} - Q_{CD\_83\_SS} \\ &\quad - Q_{infiltration\_83\_SS} \\ ACC_{83\_SS\_CLF} &= Capacity_{83\_SS\_CLF} - \\ &\quad Q_{CD\_83\_SS} - Q_{infiltration\_83\_SS} \end{aligned}$$

Where:

ACC<sub>83\_SS</sub> and ACC<sub>83\_SS\_CLF</sub> = adjusted cooling capacity for a theoretical comparable single-speed portable air conditioner at the 83 °F dry-bulb outdoor temperature operating condition (Test Condition 2 in Table 1 of this appendix) without and with cycling losses, respectively, in Btu/h.

Capacity<sub>83\_SS</sub> and Capacity<sub>83\_SS\_CLF</sub> = cooling capacity of a theoretical comparable single-speed portable air conditioner without and with cycling losses, respectively, at Test Condition 2 in Table 1 of this appendix (the 83 °F dry-bulb outdoor temperature operating condition), calculated in section 5.5.1 of this appendix, in Btu/h.

Q<sub>CD\_83\_SS</sub> = total heat transferred from the ducts to the indoor conditioned space in cooling mode for a theoretical comparable single-speed portable air conditioner at the 83 °F dry-bulb outdoor temperature operating condition (Test Condition 2 in Table 1 of this appendix), in Btu/h, calculated in section 5.5.2 of this appendix.

Q<sub>infiltration\_83\_SS</sub> = total infiltration air heat in cooling mode for a theoretical comparable single-speed portable air conditioner at the 83 °F dry-bulb outdoor temperature operating condition (Test Condition 2 in Table 1 of this appendix), calculated in section 5.5.3 of this appendix, in Btu/h.

**5.5.5 Annual Energy Consumption in Cooling Mode for a Theoretical Comparable Single-Speed Portable Air Conditioner at the Lower Outdoor Temperature Operating Condition.** Calculate the annual energy consumption in cooling mode for a theoretical comparable single-speed portable air conditioner at the 83 °F dry-bulb outdoor temperature operating condition (Test Condition 2 in Table 1 of this appendix), in kWh/year, as follows:

$$AEC_{83\_SS} = P_{83\_SS} \times 750 \times 0.001$$

Where:

$AEC_{83\_SS}$  = annual energy consumption for a theoretical comparable single-speed portable air conditioner in cooling mode at the 83 °F dry-bulb outdoor temperature operating condition (Test Condition 2 in Table 1 of this appendix), in kWh/year.

$P_{83\_SS}$  = electrical power input for a

theoretical comparable single-speed portable air conditioner at the 83 °F dry-bulb outdoor temperature operating condition (Test Condition 2 in Table 1 of this appendix) as calculated in section 5.5.1 of this appendix, in watts.

750 = number of cooling mode hours per year, as defined in section 5.3 of this appendix.

0.001 kWh/Wh = conversion factor from watt-hours to kilowatt-hours.

5.5.6 *Combined Energy Efficiency Ratio for a Theoretical Comparable Single-Speed Portable Air Conditioner.* Calculate the combined energy efficiency ratios for a theoretical comparable single-speed portable air conditioner both without cycling losses,  $CEER_{SS}$ , and with cycling losses,  $CEER_{SS\_CLF}$ , in Btu/Wh, according to the following equations:

$$CEER_{SS} = \left[ \frac{ACC_{95}}{\left( \frac{AEC_{95} + AEC_T}{750 \times 0.001} \right)} \right] \times 0.2 + \left[ \frac{ACC_{83\_SS}}{\left( \frac{AEC_{83\_SS} + AEC_T}{750 \times 0.001} \right)} \right] \times 0.8$$

$$CEER_{SS\_CLF} = \left[ \frac{ACC_{95}}{\left( \frac{AEC_{95} + AEC_T}{750 \times 0.001} \right)} \right] \times 0.2 + \left[ \frac{ACC_{83\_SS\_CLF}}{\left( \frac{AEC_{83\_SS} + AEC_T}{750 \times 0.001} \right)} \right] \times 0.8$$

Where:

$CEER_{SS}$  and  $CEER_{SS\_CLF}$  = combined energy efficiency ratio for a theoretical comparable single-speed portable air conditioner without and with cycling losses considered, respectively, in Btu/Wh.

$ACC_{95}$  = adjusted cooling capacity for the sample unit, as calculated in section 5.1 of this appendix, when tested at Test Condition 1 in Table 1 of this appendix, in Btu/h.

$ACC_{83\_SS}$  and  $ACC_{83\_SS\_CLF}$  = adjusted cooling capacities for a theoretical comparable single-speed portable air conditioner at the 83 °F dry-bulb outdoor temperature operating condition (Test Condition 2 in Table 1 of this appendix) without and with cycling losses, respectively, as calculated in section 5.5.4 of this appendix, in Btu/h.

$AEC_{95}$  = annual energy consumption for the sample unit, as calculated in section 5.3 of this appendix, for cooling mode operation at Test Condition 1 in Table 1 of this appendix, in kWh/year.

$AEC_{83\_SS}$  = annual energy consumption for a theoretical comparable single-speed portable air conditioner in cooling mode at the 83 °F dry-bulb outdoor temperature operating condition (Test Condition 2 in Table 1 of this appendix), calculated in section 5.5.5 of this appendix, in kWh/year.

$AEC_T$  = total annual energy consumption attributed to all operating modes except cooling for the sample unit, calculated in section 5.3 of this appendix, in kWh/year.

750 and 0.001 as defined previously in this section.

0.2 = weighting factor for the 95 °F dry-bulb outdoor temperature operating condition.

0.8 = weighting factor for the 83 °F dry-bulb outdoor temperature operating condition.

#### 5.5.7 *Combined-Duct Variable-Speed Portable Air Conditioner Performance Adjustment Factor.*

Calculate the sample unit's performance adjustment factor,  $F_p$ , as follows:

$$F_p = \frac{(CEER_{SS} - CEER_{SS\_CLF})}{CEER_{SS\_CLF}}$$

Where:

$CEER_{SS}$  and  $CEER_{SS\_CLF}$  = combined energy efficiency ratios for a theoretical comparable single-speed portable air conditioner without and with cycling losses, respectively, calculated in section 5.5.6 of this appendix, in Btu/Wh.

#### 5.5.8 *Dual-Duct Variable-Speed Portable Air Conditioner Combined Energy Efficiency Ratio.* Calculate the sample unit's final combined energy efficiency ratio, $CEER$ , in Btu/Wh, as follows:

$$CEER = CEER_{UA} \times (1 + F_p)$$

Where:

$CEER$  = combined energy efficiency ratio for the sample unit, in Btu/Wh.

$CEER_{UA}$  = unadjusted combined energy efficiency ratio for the sample unit, calculated in section 5.4 of this appendix, in Btu/Wh.

$F_p$  = sample unit's performance adjustment factor, calculated in section 5.5.7 of this appendix."

(3) Representations. Midea may not make representations about the efficiency of a basic model listed in paragraph (1) of this Interim Waiver Order for compliance, marketing, or other purposes unless that basic model has been tested in accordance with the provisions set forth in this alternate test procedure and such representations

fairly disclose the results of such testing.

(4) This Interim Waiver Order shall remain in effect according to the provisions of 10 CFR 430.27.

(5) This Interim Waiver Order is issued on the condition that the statements, representations, test data, and documentary materials provided by Midea are valid. If Midea makes any modifications to the controls or configurations of a basic model subject to this Interim Waiver Order, the waiver will be invalid with respect to that basic model Midea either would be required to use the current Federal test method or submit a new application for a test procedure waiver. DOE may rescind or modify this waiver at any time if it determines the factual basis underlying the petition for the Interim Waiver Order is incorrect, or the results from the alternate test procedure are unrepresentative of the basic model's true energy consumption characteristics. 10 CFR 430.27(k)(1). Likewise, Midea may request that DOE rescind or modify the Interim Waiver Order if Midea discovers an error in the information provided to DOE as part of its petition, determines that the interim waiver is no longer needed, or for other appropriate reasons. 10 CFR 430.27(k)(2).

(6) Issuance of this Interim Waiver Order does not release Midea from the applicable requirements set forth at 10 CFR part 429.

DOE makes decisions on waivers and interim waivers for only those basic models specifically set out in the petition, not future models that Midea may manufacture. Midea may submit a new or amended petition for waiver and

request for grant of interim waiver, as appropriate, for additional basic models of portable air conditioners.

Alternatively, if appropriate, Midea may request that DOE extend the scope of a waiver or an interim waiver to include additional basic models employing the same technology as the basic model(s) set forth in the original petition consistent with 10 CFR 430.27(g).

**Signing Authority**

This document of the Department of Energy was signed on March 31, 2021, by Kelly J. Speakes-Backman, Principal Deputy Assistant Secretary and Acting Assistant Secretary for Energy Efficiency and Renewable Energy, pursuant to delegated authority from the Secretary of Energy. That document with the original signature and date is maintained by DOE. For administrative purposes only, and in compliance with requirements of the Office of the Federal Register, the undersigned DOE Federal Register Liaison Officer has been authorized to sign and submit the document in electronic format for publication, as an official document of the Department of Energy. This administrative process in no way alters the legal effect of this document upon publication in the **Federal Register**.

Signed in Washington, DC, on April 1, 2021.

**Treena V. Garrett,**

*Federal Register Liaison Officer, U.S. Department of Energy.*

**BEFORE THE UNITED STATES DEPARTMENT OF ENERGY WASHINGTON, DC 20585**

*In the Matter of:* Energy Efficiency Program: Test Procedure for Portable Air Conditioners

**Petition of Midea for Waiver, and Application for Interim Waiver, of Test Procedure for Portable Air Conditioners**

*Introduction*

GD Midea Air Conditioning Equipment Co. LTD. (Midea) hereby submits this Petition for Waiver, and Application for Interim Waiver, of the Department of Energy (DOE) Test Procedure for dual-duct portable air conditioners (PACs) in 10 CFR part 430, subpart B, Appendix CC, pursuant to 10 CFR 430.27. Midea requests expedited treatment of the Petition and Application.

Midea requests that DOE grant the requested Waiver and Interim Waiver because the current test procedure cannot be used to test dual-duct PACs with Midea’s duct-in-duct (combined-duct) technology, which combines the condenser inlet and outlet ducts into a single structure. Furthermore, the current test procedure does not properly measure the energy consumption of combined-duct PACs with variable-speed compressors (VSCs).<sup>11</sup> This request is consistent with the approach used for VSCs in the Waiver granted to LG Electronics Inc. (LG) published June 2, 2020, 85 FR 33,643, for testing single-duct PACs with VSCs. It simply adds procedures to accommodate Midea’s combined-duct technology. Under DOE rules, this Waiver request should be granted. DOE also has authority to grant an Interim Waiver because the requested Waiver is likely be granted, because it would avoid economic hardship and competitive disadvantage to Midea, and because it would reflect sound public policy.

*Analysis*

**I. Midea Group**

The Midea Group, of which Midea is a part, is the world’s largest producer of major appliances, and the world’s No. 1 brand of air-treatment products, air-coolers, kettles, and rice cookers. It is also a world-leading technologies group in consumer appliances and HVAC systems. It offers diversified products, comprising consumer appliances (kitchen appliances, refrigerators, laundry appliances, and various small home appliances) and HVAC (residential air-conditioning, commercial air-conditioning, heating & ventilation). The Midea Group is committed to improving lives by adhering to the principle of “Creating Value for Customers.” It focuses on continuous technological innovation to improve products and services to make life more comfortable. The Midea Group’s worldwide headquarters are located at Midea Group headquarter building, No. 6 Midea Avenue, Beijiao, Shunde, Foshan, Guangdong, 528311 P.R. China; (tel. 011-86-757-2633-888); URL: [www.midea.com/global](http://www.midea.com/global). GD Midea Air Conditioning Equipment Co. LTD, is located at No 6. Midea Avenue, Shunde Foshan, Guangdong, 528311 P.R. China.

**II. Basic Models Subject to the Waiver Request**

This Petition for Waiver, and Application for Interim Waiver, are for the following basic models of residential PACs manufactured by Midea. All models have Midea’s combined-duct technology:

Brand	Model No.	Compressor type	Unit type
Midea	US-KC35Y1/BP3N8-PTB(CH3)	Variable-Speed	Cool-only.
Midea	US-KC30Y1/BP3N8-PTB(CG8)	Variable-Speed	Cool-only.
Perfect aire	1PORTV10000	Variable-Speed	Cool-only.
Danby	DPA100B9IWDB-6	Variable-Speed	Cool-only.
Heat Controller LLC	PSV-101D	Variable-Speed	Cool-only.
Whynter	ARC-1030WN	Variable-Speed	Cool-only.
Whynter	ARC-1030BN	Variable-Speed	Cool-only.
Whynter	ARC-1030GN	Variable-Speed	Cool-only.
hOme	HME020373N	Variable-Speed	Cool-only.
Vremi	VRM050703N	Variable-Speed	Cool-only.
Wappliance	BPI10MW	Variable-Speed	Cool-only.
Perfect aire	1PORTVP10000	Variable-Speed	Heat-Cool.
Danby	DPA100HB9IWDB-6	Variable-Speed	Heat-Cool.
Heat Controller LLC	PSHV-101D	Variable-Speed	Heat-Cool.
Whynter	ARC-1030WNH	Variable-Speed	Heat-Cool.
Whynter	ARC-1030GNH	Variable-Speed	Heat-Cool.
Whynter	ARC-1030BNH	Variable-Speed	Heat-Cool.
hOme	HME020374N	Variable-Speed	Heat-Cool.
Vremi	VRM050704N	Variable-Speed	Heat-Cool.

<sup>11</sup> Midea intends to manufacture such units using both standard compressors and VSCs. It expects to

add models that do not have VSCs to this waiver request.

Brand	Model No.	Compressor type	Unit type
Wappliance	BPI10HMW	Variable-Speed	Heat-Cool.
Perfect aire	1PORTV12000	Variable-Speed	Cool-only.
Danby	DPA120B9IWDB-6	Variable-Speed	Cool-only.
Heat Controller LLC	PSV-121D	Variable-Speed	Cool-only.
Whynter	ARC-1230WN	Variable-Speed	Cool-only.
Whynter	ARC-1230BN	Variable-Speed	Cool-only.
Whynter	ARC-1230GN	Variable-Speed	Cool-only.
hOme	HME020375N	Variable-Speed	Cool-only.
Vremi	VRM050705N	Variable-Speed	Cool-only.
Wappliance	BPI12MW	Variable-Speed	Cool-only.
Perfectaire	1PORTVP12000	Variable-Speed	Heat-Cool.
Danby	DPA120HB9IWDB-6	Variable-Speed	Heat-Cool.
Heat Controller LLC	PSHV-121D	Variable-Speed	Heat-Cool.
Whynter	ARC-1230WNH	Variable-Speed	Heat-Cool.
Whynter	ARC-1230GNH	Variable-Speed	Heat-Cool.
Whynter	ARC-1230BNH	Variable-Speed	Heat-Cool.
hOme	HME020376N	Variable-Speed	Heat-Cool.
Vremi	VRM050706N	Variable-Speed	Heat-Cool.
Wappliance	BPI12HMW	Variable-Speed	Heat-Cool.
Midea	MPPTB-12HRN8-BCH4	Variable-Speed	Heat-Cool.
Midea	MPPTB-12CRN8-BCH4	Variable-Speed	Cool-only.
Midea	MPPTB-10CRN8-BCG8	Variable-Speed	Cool-only.

### III. Requested Waiver

Midea requests a waiver to test the energy consumption of the above residential PACs using the test procedure detailed in the waiver for PACs granted to LG.2 published on June 2, 2020, with modifications needed to account for dual-duct units incorporating Midea's combined-duct technology.

Strong demand for advanced energy efficient PACs led Midea to design dual-duct PACs with dramatic energy savings, and the ability to maintain the desired temperature without cycling the compressor motor and fans on and off by using inverter driven VSCs. The unit responds automatically to surrounding conditions by adjusting the compressor rotational speed based upon demand. This results in faster cooling and much more efficient operation through optimizing the speed of the compressor to make minimal adjustments as the room temperature rises and falls.

The current DOE test procedure tests dual-duct PACs at two operating conditions, one measuring performance at a high outdoor operating temperature and one measuring performance at a lower outdoor operating temperature, without addressing the ability of VSCs to adjust their operating speed based on the demand load of the conditioned space. As such, the test procedure does not take into account the full range of performance and efficiency benefits of a VSC operating under part-load conditions. Other DOE test standards,

such as for central air conditioners—and the test procedures approved through waivers granted to Midea and LG for room air conditioners and to LG for PACs—include part-load test conditions that account for the improved efficiency benefit from VSCs that modulate their operation to account for changing conditions to the environment, rather than cycling the compressor on and off.

Additionally, the current test procedure prevents the testing of Midea's combined-duct technology because the condenser inlet and outlet air streams are incorporated into the same structure. Since the airflow both in and out of the condenser must be measured at the same time, modifications are needed to adapt Midea's combined-duct technology to DOE's test procedure and standard airflow measurement lab apparatuses. The DOE test procedure does not take into account a specially designed adapter that is needed for measuring the airflows.

### IV. Regulatory Framework

DOE's regulations provide that the Assistant Secretary "will" grant a Petition to a manufacturer upon a "determination that the basic model for which the waiver was requested contains a design characteristic which either prevents testing of the basic model according to the prescribed test procedures, or the prescribed test procedures may evaluate the basic model in a manner so unrepresentative of its true energy consumption

characteristics as to provide materially inaccurate comparative data." See 10 CFR 430.27 (emphasis supplied).

As noted, the current DOE test procedure, 10 CFR part 430, subpart B, Appendix CC, requires that dual-duct PACs be tested at two operating conditions, one measuring peak load performance at a high outdoor operating temperature, and one measuring a reduced load performance at a lower outdoor operating temperature, and does not make any account for dual-duct PACs offering variable speed operation based upon different air test conditions. As a result, Midea's new dual-duct VSC PACs cannot be tested in a way that accurately reflects the energy saving benefits of VSC technology. If Midea were to test its dual-duct VSC PACs to the current test procedure the results would be wholly unrepresentative of their true energy consumption.

Moreover, the models in Section II of this application cannot be tested using the current test procedure because the combined-duct design means that airflows from the inlet and outlet of the condenser must be measured together, at the same time, as seen in Figure 1. This requires a specially designed adapter that, naturally, is not part of the current test procedure. In addition, the duct heat transfer for the combined duct requires specific instructions on where to place the thermocouples so the heat transfer can be accounted for, which the current test procedure does not provide.

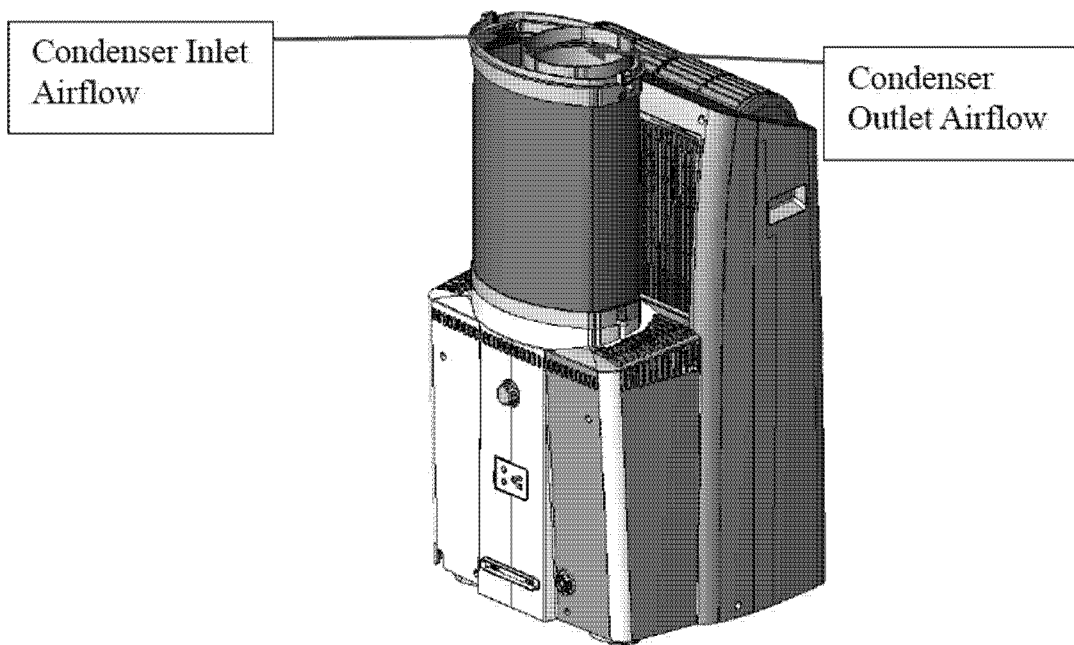

Figure 1: PAC with combined-duct technology

#### V. Other Manufacturers With Similar Design Characteristics

To the best of Midea's knowledge, (i) Midea is the only manufacturer of dual-duct PACs with combined-duct technology, both with and without VSCs, in the U.S. market; and (ii) Midea and LG are the only manufacturers of PACs with VSC technology in the U.S. market.

#### VI. Proposed Modifications to the Test Procedure

Midea proposes the following alternative test method to evaluate the performance of the basic models listed in Section II. This alternative test method is the same as the existing procedure for PACs per Appendix CC, except it accounts for the combined-duct technology by describing the means to measure and calculate duct heat transfer and by providing a provision that requires a special adapter be used during testing and evaluation to measure the inlet and outlet condenser airflows. Additionally, the modified test procedure accounts for the increased efficiency of using VSCs, similar to the approach in the waiver granted to LG published June 2, 2020.<sup>12</sup> Specifically:

Midea shall be required to test the performance of the basic models listed in the Section II hereto according to the test procedure for portable air conditioners in 10 CFR, Part 430, Subpart B, Appendix CC, and the waiver granted to LG published on June 2, 2020, except as follows:

Add the following after "This appendix covers the test requirements used to measure the energy performance of single-duct and dual-duct" in section 1 of Appendix CC: ", including combined-duct,".

Include the following sections from the LG waiver:

"2.11 Single-speed means a type of portable air conditioner that does not automatically adjust either the compressor or fan speed, or both, based on the detected outdoor conditions."

"2.12 Variable-speed means a type of portable air conditioner that can automatically adjust compressor and fan speed, only compressor speed, or only fan speed, based on the detected outdoor conditions."

Replace the following sections from the LG waiver, with:

"2.13 Full compressor speed (full) means the compressor speed specified by the manufacturer at which the unit operates at full load testing conditions. Note—full compressor speed may be different at different test conditions."

"2.14 Low compressor speed (low) means the compressor speed specified by the manufacturer at which the unit operates at low load test conditions, such that Capacity<sub>83\_Low</sub>, the measured cooling capacity at test condition 3 in Table 1 of this appendix, is no less than 50 percent and no greater than 60 percent of the measured cooling capacity with the full compressor speed at test condition 1 in Table 1 of this appendix."

Modify section 2.15 of the LG waiver by replacing the word "single" with the

word "dual". Add new section 2.16 to Appendix CC as follows:

"2.16 Combined-duct portable air conditioner—a version of dual-duct portable air conditioner where the ducts for the condenser inlet and outlet air are housed in the same structure."

Replace the sentence "Note that if a product is able to operate as both a single-duct and dual-duct portable AC as distributed in commerce by the manufacturer, it must be tested and rated for all applicable duct configurations." in section 3.1.1 of Appendix CC with:

"Note that if a product is able to operate in multiple duct configurations, including single-duct, combined-duct, and dual-duct portable AC as distributed in commerce by the manufacturer, it must be tested and rated for all applicable duct configurations."

Add the following after "Do not apply additional sealing or insulation." to Appendix CC section 3.1.1.1:

"For combined-duct portable air conditioners a special adapter is needed for testing to properly measure the condenser inlet and outlet airflows. This adapter must be provided by the manufacturer and allow connection of the condenser inlet and outlet airflows to the test lab's airflow measuring apparatuses."

Replace the sentence in Appendix CC section 3.1.1.6 with the following to account for the combination duct temperature measurements:

"Duct temperature measurements. Install any insulation and sealing

<sup>12</sup> *Id.*

provided by the manufacturer. Then adhere eight equally spaced thermocouples to the outer surface of the duct, ensuring that the thermocouples are distributed equally on both the inlet and outlet portion of the combined-duct. Measure the surface temperature of the combined duct. Temperature measurements must have an error no greater than ±0.5 °F over the range being measured.”

Include the modifications for section 3.1.2 of Appendix CC as defined in the LG waiver:

“3.1.2 Control settings. Set the controls to the lowest available temperature setpoint for cooling mode. If the portable air conditioner has a user-adjustable fan speed, select the maximum fan speed setting. If the portable air conditioner has an automatic louver oscillation feature, disable that feature throughout testing. If the louver oscillation feature is included but there is no option to disable it, test with the louver oscillation enabled. If the portable air conditioner has adjustable louvers, position the louvers parallel with the air flow to maximize air flow and minimize static pressure loss. Set the compressor

speed during cooling mode testing as described in section 4.1, as amended by this interim waiver.”

Replace section 4.1 of Appendix CC with the following to account for both single-speed and variable-speed compressor units as listed in Section II of this petition:

“4.1 Cooling mode. Instead of the test conditions in Table 3 of ANSI/AHAM PAC–1–2015, establish the test conditions presented in Table 1 of this appendix. Test each single-speed sample unit twice, once at test condition 1 and once at test condition 2 in Table 1. Test each variable-speed sample unit three times, once at each test condition in Table 1. For each test condition, measure the sample unit’s indoor room cooling capacity and overall power input in cooling mode in accordance with Section 7.1.b and 7.1.c of ANSI/AHAM PAC–1–2015 (incorporated by reference; see § 430.3), respectively, and determine the test duration in accordance with Section 8.7 of ASHRAE Standard 37–2009 (incorporated by reference; § 430.3). Conduct the first test, for both single and variable-speed units, in accordance with ambient conditions for test condition 1 in Table

1 of this appendix, with the compressor speed set to full, for the duration of cooling mode testing (Capacity<sub>95</sub>, P<sub>95</sub>), which represents an outdoor temperature operating condition of 95 °F dry-bulb and 67 °F wet-bulb temperatures. Conduct the second test in accordance with the ambient conditions for test condition 2 in Table 1 of this appendix, with the compressor speed set to full, for the duration of cooling mode testing (Capacity<sub>83</sub>, P<sub>83</sub>), which represents an outdoor temperature operating condition of 83 °F dry-bulb and 67.5 °F wet-bulb temperatures. For variable-speed units only, conduct the third test in accordance with the ambient conditions for test condition 3 in Table 1 of this appendix, with the compressor speed set to low for the duration of the cooling mode testing (Capacity<sub>83\_Low</sub>, P<sub>83\_Low</sub>), which represents an outdoor temperature operating condition of 83 °F dry-bulb and 67.5 °F wet-bulb temperatures. Set the compressor speed required for each test condition in accordance with the manufacturer’s instructions.”

Replace Table 1 of Appendix CC with the following:

TABLE 1—EVAPORATOR (INDOOR) AND CONDENSER (OUTDOOR) INLET TEST CONDITIONS

Test configuration	Evaporator inlet air, °F (°C)		Condenser inlet air, °F (°C)		Condenser speed
	Dry bulb	Wet bulb	Dry bulb	Wet bulb	
Dual-Duct, Condition 1 .....	80 (26.7)	67 (19.4)	95 (35.0)	75 (23.9)	Full.
Dual-Duct, Condition 2 .....	80 (26.7)	67 (19.4)	83 (28.3)	67.5 (19.7)	Full.
Dual-Duct, Condition 3 .....	80 (26.7)	67 (19.4)	83 (28.3)	67.5 (19.7)	Low.

Modify Appendix CC section 4.1.1 with the following after “Calculate the surface area”: , A<sub>CD</sub>, to the following equation:

For combined-duct portable air conditioners:

$$A_{CD} = P \times L$$

Where:

A<sub>CD</sub> = the outer area of the combined-duct, in square feet.

L = the extended length of the combined-duct while under test, in feet.

P = the perimeter of the combined-duct, as measured following the instructions below, in ft.

Measure the perimeter of the combined-duct air conditioners using a flexible measuring tape, or equivalent, by wrapping the measuring tape around the outside of the combined-duct, making sure the tape is on the outermost ridges.

Calculate the total heat transferred from the surface of the duct(s) to the indoor conditioned space while operating in cooling mode for the outdoor test conditions in Table 1 of this appendix, as follows.

For combined-duct portable air conditioners:

$$Q_{CD-95} = h \times A_{CD} \times (T_{CD-95} - T_{ei})$$

$$Q_{CD-83} = h \times A_{CD} \times (T_{CD-83} - T_{ei})$$

$$Q_{CD-83-Low} = h \times A_{CD} \times (T_{CD-83-Low} - T_{ei})$$

Where:

Q<sub>CD-95</sub>, Q<sub>CD-83</sub>, and Q<sub>CD-83-Low</sub> = for combined-duct portable air conditioners, the total heat transferred from the ducts to the indoor conditioned space in cooling mode, in Btu/h, when tested according to test condition 1, 2, and 3 in Table 1 of this appendix, respectively.

T<sub>CD-95</sub>, T<sub>CD-83</sub>, and T<sub>CD-83-Low</sub> = average surface temperature for the duct, as

measured during testing according to the three outdoor test conditions in Table 1 of this appendix, in °F.

A<sub>CD</sub> = the outer area of the combined-duct, in square feet.

h = convection coefficient, 3 Btu/h per square foot per °F.

Replace section 4.1.2 in Appendix CC with the following:

“4.1.2 Infiltration Air Heat Transfer. Measure the heat contribution from infiltration air for dual- duct portable air conditioners that draw at least part of the condenser air from the conditioned space. Calculate the heat contribution from infiltration air for dual-duct portable air conditioners for all cooling mode outdoor test conditions, as described in this section. Calculate the dry air mass flow rate of infiltration air according to the following equations:

$$\dot{m}_{95} = \left[ \frac{V_{co\_95} \times \rho_{co\_95}}{(1 + \omega_{co\_95})} \right] - \left[ \frac{V_{ci\_95} \times \rho_{ci\_95}}{(1 + \omega_{ci\_95})} \right]$$

$$\dot{m}_{83\_Low} = \left[ \frac{V_{co\_83} \times \rho_{co\_83}}{(1 + \omega_{co\_83})} \right] - \left[ \frac{V_{ci\_83} \times \rho_{ci\_83}}{(1 + \omega_{ci\_83})} \right]$$

$$\dot{m}_{83\_low} = \left[ \frac{V_{co\_83\_Low} \times \rho_{co\_83\_Low}}{(1 + \omega_{co\_83\_Low})} \right] - \left[ \frac{V_{ci\_83\_Low} \times \rho_{ci\_83\_Low}}{(1 + \omega_{ci\_83\_Low})} \right]$$

Where:

$\dot{m}_{95}$ ,  $\dot{m}_{83}$  and  $\dot{m}_{83\_Low}$  = dry air mass flow rate of infiltration air for dual-duct portable air conditioners, as calculated based on testing according to the test conditions in Table 1 of this appendix, in lb/m.

$V_{co\_95}$ ,  $V_{co\_83}$  and  $V_{co\_83\_Low}$  = average volumetric flow rate of the condenser outlet air during cooling mode testing for single-duct portable air conditioners; and at the 95 °F and 83 °F dry-bulb outdoor conditions for dual-duct portable air conditioners, respectively, in cubic feet per minute (cfm).

$V_{ci\_95}$ ,  $V_{ci\_83}$  and  $V_{ci\_83\_Low}$  = average volumetric flow rate of the condenser inlet air during cooling mode testing at the 95 °F and 83 °F dry-bulb outdoor conditions for dual-duct portable air conditioners, respectively, in cfm.

$\rho_{co\_95}$ ,  $\rho_{co\_83}$  and  $\rho_{co\_83\_Low}$  = average density of the condenser outlet air during cooling mode testing for single-duct portable air conditioners, and at the 95 °F and 83 °F dry-bulb outdoor conditions for dual-duct portable air conditioners, respectively, in pounds mass per cubic foot (lb<sub>m</sub>/ft<sup>3</sup>).

$\rho_{ci\_95}$ ,  $\rho_{ci\_83}$  and  $\rho_{ci\_83\_Low}$  = average density of the condenser inlet air during cooling mode testing at the 95 °F and 83 °F dry-bulb outdoor conditions for dual-duct portable air conditioners, respectively, in lb<sub>m</sub>/ft<sup>3</sup>.

$\omega_{co\_95}$ ,  $\omega_{co\_83}$  and  $\omega_{co\_83\_Low}$  = average humidity ratio of condenser outlet air during cooling mode testing for single-duct portable air conditioners, and at the 95 °F and 83 °F dry-bulb outdoor conditions for dual-duct portable air conditioners, respectively, in pounds mass of dry air (lb<sub>w</sub>/lb<sub>da</sub>).

$\omega_{ci\_95}$ ,  $\omega_{ci\_83}$  and  $\omega_{ci\_83\_Low}$  = average humidity ratio of condenser inlet air during cooling mode testing at the 95 °F and 83 °F dry-bulb outdoor conditions for dual-duct portable air conditioners, respectively, in lb<sub>w</sub>/lb<sub>da</sub>.

Calculate the sensible component of infiltration air heat contribution according to:

$$Q_{s\_95} = \dot{m} \times 60 \times [C_{p\_da} \times (T_{ia\_95} - T_{indoor}) + (C_{p\_wv} \times (\omega_{ia\_95} \times T_{ia\_95} - \omega_{indoor} \times T_{indoor}))]$$

$$Q_{s\_83} = \dot{m} \times 60 \times [(C_{p\_da} \times (T_{ia\_83} - T_{indoor}) + (C_{p\_wv} \times (\omega_{ia\_83} \times T_{ia\_83} - \omega_{indoor} \times T_{indoor}))]$$

$$Q_{s\_83\_Low} = \dot{m} \times 60 \times [(C_{p\_da} \times (T_{ia\_83} - T_{indoor}) + (C_{p\_wv} \times (\omega_{ia\_83} \times T_{ia\_83} - \omega_{indoor} \times T_{indoor}))]$$

Where:

$Q_{s\_95}$ ,  $Q_{s\_83}$  and  $Q_{s\_83\_Low}$  = sensible heat added to the room by infiltration air, calculated at the 1, 2, and 3 test conditions respectively in Table 1 of this appendix, in Btu/h.

$\dot{m}$  = dry air mass flow rate of infiltration air,  $\dot{m}_{SD}$  or  $\dot{m}_{95}$  when calculating  $Q_{s\_95}$  and  $\dot{m}_{SD}$  or  $\dot{m}_{83}$  when calculating  $Q_{s\_83}$  and  $\dot{m}_{83\_Low}$  when calculating  $Q_{s\_83\_Low}$ , in lb/m.

$C_{p\_da}$  = specific heat of dry air, 0.24 Btu/lb<sub>m</sub> - °F.

$C_{p\_wv}$  = specific heat of water vapor, 0.444 Btu/lb<sub>m</sub> - °F.  $T_{indoor}$  = indoor chamber dry-bulb temperature, 80 °F.

$T_{ia\_95}$  and  $T_{ia\_83}$  = infiltration air dry-bulb temperatures for the three test conditions in Table 1 of this appendix, 95 °F and 83 °F, respectively.

$\omega_{ia\_95}$  and  $\omega_{ia\_83}$  = humidity ratios of the 95 °F and 83 °F dry-bulb infiltration air, 0.0141 and 0.01086 lb<sub>w</sub>/lb<sub>da</sub>, respectively.

$\omega_{indoor}$  = humidity ratio of the indoor chamber air, 0.0112 lb<sub>w</sub>/lb<sub>da</sub>.

60 = conversion factor from minutes to hours.

Calculate the latent heat contribution of the infiltration air according to:

$$Q_{L\_95} = \dot{m} \times 60 \times H_{fg} \times (\omega_{ia\_95} - \omega_{indoor})$$

$$Q_{L\_83} = \dot{m} \times 60 \times H_{fg} \times (\omega_{ia\_83} - \omega_{indoor})$$

$$Q_{L\_83\_Low} = \dot{m} \times 60 \times H_{fg} \times (\omega_{ia\_83} - \omega_{indoor})$$

Where:

$Q_{L\_95}$ ,  $Q_{L\_83}$  and  $Q_{L\_83\_Low}$  = latent heat added to the room by infiltration air, calculated at the 1, 2, and 3 test conditions respectively in Table 1 of this appendix, in Btu/h.

$\dot{m}$  = mass flow rate of infiltration air,  $\dot{m}_{SD}$  or  $\dot{m}_{95}$  when calculating  $Q_{L\_95}$  and  $\dot{m}_{SD}$  or  $\dot{m}_{83}$  when calculating  $Q_{L\_83}$  and  $\dot{m}_{83\_Low}$  when calculating  $Q_{s\_83\_Low}$ , in lb/m.

$H_{fg}$  = latent heat of vaporization for water vapor, 1061 Btu/lb<sub>m</sub>.

$\omega_{ia\_95}$  and  $\omega_{ia\_83}$  = humidity ratios of the 95 °F and 83 °F dry-bulb infiltration air, 0.0141 and 0.01086 lb<sub>w</sub>/lb<sub>da</sub>, respectively.

$\omega_{indoor}$  = humidity ratio of the indoor chamber air, 0.0112 lb<sub>w</sub>/lb<sub>da</sub>.

60 = conversion factor from minutes to hours.

The total heat contribution of the infiltration air is the sum of the sensible and latent heat:

$$Q_{infiltration\_95} = Q_{s\_95} + Q_{L\_95}$$

$$Q_{infiltration\_83} = Q_{s\_83} + Q_{L\_83}$$

$$Q_{infiltration\_83\_Low} = Q_{s\_83\_Low} + Q_{L\_83\_Low}$$

Where:

$Q_{infiltration\_95}$ ,  $Q_{infiltration\_83}$  and  $Q_{infiltration\_83\_Low}$  = total infiltration air heat in cooling mode, calculated at the 1, 2, and 3 test conditions respectively in Table 1 of this appendix, in Btu/h.

$Q_{s\_95}$ ,  $Q_{s\_83}$  and  $Q_{s\_83\_Low}$  = sensible heat added to the room by infiltration air, calculated at the 1, 2, and 3 test conditions respectively in Table 1 of this appendix, in Btu/h.

$Q_{L\_95}$ ,  $Q_{L\_83}$  and  $Q_{L\_83\_Low}$  = latent heat added to the room by infiltration air, calculated at the 1, 2, and 3 test conditions respectively in Table 1 of this appendix, in Btu/h.

Modify section 5.1 of Appendix CC after "Calculate the adjusted cooling capacities for portable air conditioners, ACC<sub>95</sub>, ACC<sub>83</sub>," with the following:

"and ACC<sub>83\\_Low</sub> expressed in Btu/h, according to the following equations:

$$ACC_{95} = Capacity_{95} - Q_{CD\_95} - Q_{infiltration\_95}$$

$$ACC_{83} = Capacity_{83} - Q_{CD\_83} - Q_{infiltration\_83}$$

$$ACC_{83\_Low} = Capacity_{83\_Low} - Q_{CD\_83\_Low} - Q_{infiltration\_83\_Low}$$

Where:

Capacity<sub>95</sub>, Capacity<sub>83</sub>, and Capacity<sub>83\\_Low</sub> = cooling capacity measured in section 4.1.1 of this appendix.

Q<sub>CD\\_95</sub>, Q<sub>CD\\_83</sub>, and Q<sub>CD\\_83\\_Low</sub> = duct heat transfer while operating in cooling mode, calculated in section 4.1.1.1 of this appendix.

Q<sub>infiltration\\_95</sub>, Q<sub>infiltration\\_83</sub>, and Q<sub>infiltration\\_83\\_Low</sub> = total infiltration air heat transfer in cooling mode, calculated in section 4.1.1.2 of this appendix."

Replace the table of Annual Operating Hours in Appendix CC section 5.3 with the following:



Operating mode	Annual operating hours
Cooling Mode, Dual-Duct test condition 1 .....	750
Cooling Mode, Dual-Duct test condition 2 .....	750
Cooling Mode, Dual-Duct, test condition 3 .....	750
Off-Cycle .....	880
Inactive or Off .....	1,355

Change the definition of variable “m” in Appendix CC section 5.3 to the following:

“m represents the operating mode (“95” for test condition 1, “83” for test condition 2, “83\_Low” for test condition 3, “oc” off cycle, and “ia” inactive or “om” off mode).”

Replace section 5.4 of Appendix CC with the following:

“5.4 Combined Energy Efficiency Ratio. Using the annual operating hours, as outlined in section.

5.3 of this appendix, calculate the combined energy efficiency ratios, CEER<sub>SS</sub> and CEER<sub>UA</sub>, expressed in Btu/Wh, according to the following:

For Single-Speed Units:

$$CEER_{SS} = \left[ \frac{ACC_{95}}{\left(\frac{AEC_{95} + AEC_T}{750 \times 0.001}\right)} \right] \times 0.2 + \left[ \frac{ACC_{83}}{\left(\frac{AEC_{83} + AEC_T}{750 \times 0.001}\right)} \right] \times 0.8$$

For Variable Speed Units:

$$CEER_{UA} = \left[ \frac{ACC_{95}}{\left(\frac{AEC_{95} + AEC_T}{750 \times 0.001}\right)} \right] \times 0.2 + \left[ \frac{ACC_{83\_Low}}{\left(\frac{AEC_{83\_Low} + AEC_T}{750 \times 0.001}\right)} \right] \times 0.8$$

Where:

- CEER<sub>SS</sub> = combined energy efficiency ratio for the single-speed portable air conditioner, in Btu/Wh.
- ACC<sub>95</sub>, ACC<sub>83</sub> and ACC<sub>83\_Low</sub> = adjusted cooling capacity, in Btu/h, calculated in section 5.1 of this appendix.
- CEER<sub>UA</sub> = combined energy efficiency ratio for the variable-speed portable air conditioner, in Btu/Wh.
- AEC<sub>95</sub>, AEC<sub>83</sub>, and AEC<sub>83\_Low</sub> = annual energy consumption for the cooling mode tests, in kWh/year, calculated in section 5.3 of this appendix.
- AEC<sub>T</sub> = total annual energy consumption attributed to all modes except cooling, in kWh/year, calculated in section 5.3 of this appendix.
- 750 = number of cooling mode hours per year.
- 0.01 kWh/Wh = conversion factor for watt-hours to kilowatt-hours.
- 0.2 = weighting factor for the 95 °F dry-bulb outdoor condition test.
- 0.8 = weighting factor for the 83 °F dry-bulb outdoor condition test.”

Modify section 5.5 of the LG waiver by adding the following after “Adjust the combined energy efficiency ratio” and before “as follows.”: “for variable speed units”

Modify section 5.5.1 of the LG waiver by replacing everything after “Calculate the cooling capacity and cooling capacity with cycling losses, expressed in British thermal units per hour (Btu/h), and electrical power input, expressed in watts, for a theoretical comparable single-speed portable air conditioner” with the following:

“at test condition 2 in Table 1 of this appendix. A theoretical comparable single-speed compressor has the same cooling capacity and electrical input, with cycling losses, as the tested per test condition 2 in Table 4.1 of this appendix and further adjusted to account for the different compressor speeds.

$$\begin{aligned} \text{Capacity}_{83\_SS} &= \text{Capacity}_{83} \times F_{\text{Cap}} \\ \text{Capacity}_{83\_SS\_CLF} &= \text{Capacity}_{83\_SS} \times 0.875 \\ P_{83\_SS} &= P_{83} \times F_{\text{Cap}} \end{aligned}$$

Where:

- Capacity<sub>83\_SS</sub> = theoretical comparable single-speed portable air conditioner cooling capacity, in Btu/h, calculated for test condition 2 in Table 1.
- Capacity<sub>83\_SS\_CLF</sub> = theoretical comparable single-speed portable air conditioner cooling capacity with cycling losses, in Btu/h, calculated for test condition 2 in Table 1.
- Capacity<sub>83</sub> = variable-speed portable air conditioner cooling capacity, in Btu/h, determined in section 4.1 of this appendix for test condition 2 in Table 1.
- P<sub>83\_SS</sub> = theoretical comparable single-speed portable air conditioner electrical power input, in watts, calculated for test condition 2 in Table 1.
- P<sub>83</sub> = variable-speed portable air conditioner electrical power input, in watts, determined in section 4.1 of this appendix for test condition 2 in Table 1.
- 0.875 = cycling loss factor for the 83 °F dry-bulb outdoor temperature operating condition.
- F<sub>Cap</sub> = adjustment factor to account for different compressor speeds at test condition 2 in Table 1 of this appendix

between single-speed and variable-speed compressors, 0.92.”

Delete section 5.5.2 from the LG waiver. This section is not needed, and instead the duct loss for a comparable single speed unit is accounted for in section 4.1.1.

Delete section 5.5.3 from the LG waiver. This section is not needed, and instead the infiltration for a comparable single speed unit is accounted for in section 4.1.2.

Replace section 5.5.4 in the LG waiver with the following:

“5.5.4 Adjusted Cooling Capacity for a Theoretical Comparable Single-Speed Portable Air Conditioner at the Lower Outdoor Test Condition. Calculate the adjusted cooling capacity for a theoretical comparable single-speed portable air conditioner operating at test condition 2 in Table 1 of this appendix with and without cycling losses, ACC<sub>83\_SS</sub> and ACC<sub>83\_SS\_CLF</sub>, respectively, expressed in Btu/h, according to the following equation:

$$\begin{aligned} ACC_{83\_SS} &= \text{Capacity}_{83\_SS} - Q_{\text{CD}_83} - Q_{\text{infiltration}_83} \\ ACC_{83\_SS\_CLF} &= \text{Capacity}_{83\_SS\_CLF} - Q_{\text{CD}_83} - Q_{\text{infiltration}_83} \end{aligned}$$

Where:

- ACC<sub>83\_SS</sub> and ACC<sub>83\_SS\_CLF</sub> = adjusted cooling capacity for a theoretical comparable single-speed portable air conditioner at test condition 2 in Table 1 of this appendix without and with cycling losses, respectively, in Btu/h.
- Capacity<sub>83\_SS</sub> and Capacity<sub>83\_SS\_CLF</sub> = theoretical comparable single-speed

portable air conditioner cooling capacity without and with cycling losses, respectively, in Btu/h, at test condition 2 in Table 1 of this appendix, calculated in section 5.5.1 of this appendix.

$Q_{CD\_83}$  = total heat transferred from the ducts to the indoor conditioned space in cooling mode for a theoretical comparable single-speed portable air conditioner at test condition 2 in Table 1 of this appendix, in Btu/h, calculated in section 4.1.1 of this appendix.

$Q_{infiltration\_83\_SS}$  = total infiltration air heat in cooling mode for a theoretical comparable single-speed portable air conditioner at test condition 2 in Table 1 of this appendix, in Btu/h, calculated in section 4.1.2 of this appendix.”

Modify section 5.5.5 in the LG waiver by replacing everything after “Calculate

the annual energy consumption in cooling mode for a theoretical comparable single-speed portable air conditioner at” with the following: “test condition 2 in Table 1 of this appendix, in kWh/year, according to the following equations:

$$AEC_{83\_SS} = P_{83\_SS} \times 750 \times 0.001$$

Where:

$AEC_{83\_SS}$  = annual energy consumption for a theoretical comparable single-speed portable air conditioner in cooling mode at test condition 2 in Table 1 of this appendix, in kWh/year.

$P_{83\_SS}$  = electrical power input for a theoretical comparable single-speed portable air conditioner electrical power input at condition 2 in Table 1 of this appendix, in watts, calculated in section

5.5.1 of this appendix.

750 = number of cooling mode hours per year, as defined in section 5.3 of this appendix.

0.001 kWh/Wh = conversion factor from watt-hours to kilowatt-hours.

Replace section 5.5.6 of the LG waiver with the following:

“5.5.6 Combined Energy Efficiency Ratio for a Theoretical Comparable Single-Speed Portable Air Conditioner. Calculate the combined energy efficiency ratio for a theoretical comparable single-speed portable air conditioner without and with cycling,  $CEER_{SS}$ , and with cycling losses,  $CEER_{SS\_CLF}$ , in Btu/Wh, according to the following equations:

$$CEER_{SS} = \left[ \frac{ACC_{95}}{(AEC_{95} + AEC_T)} \right] \times 0.2 + \left[ \frac{ACC_{83\_SS}}{(AEC_{83\_SS} + AEC_T)} \right] \times 0.8$$

$$CEER_{SS\_CLF} = \left[ \frac{ACC_{95}}{(AEC_{95} + AEC_T)} \right] \times 0.2 + \left[ \frac{ACC_{83\_SS\_CLF}}{(AEC_{83\_SS} + AEC_T)} \right] \times 0.8$$

Where:

$CEER_{SS}$  and  $CEER_{SS\_CLF}$  = combined energy efficiency ratio for a theoretical comparable single-speed portable air conditioner without and with cycling losses considered, respectively, in Btu/Wh.

$ACC_{95}$  = adjusted cooling capacity for the sample unit, as calculated in section 5.1 of this appendix, when tested at test condition 1 in Table 1 of this appendix that is representative of operation at the 95 °F dry-bulb outdoor temperature operating condition, in Btu/h.

$ACC_{83}$  and  $ACC_{83\_SS\_CLF}$  = adjusted cooling capacity for a theoretical comparable single-speed portable air conditioner at test condition 2 in Table 1 of this appendix without and with cycling losses, respectively, as calculated in section 5.5.4 of this appendix, in Btu/h.

$AEC_{95}$  = annual energy consumption for the sample unit, as calculated in section 5.3 of this appendix, for cooling mode operation at test condition 1 in Table 1 of this appendix that represents operation at a 95 °F dry-bulb outdoor temperature operating condition, in kWh/year.

$AEC_{83\_SS}$  = annual energy consumption for a theoretical comparable single-speed portable air conditioner in cooling mode at test condition 2 in Table 1 of this appendix, calculated in section 5.5.5 of this appendix, in kWh/year.

$AEC_T$  = total annual energy consumption attributed to all operating modes except cooling for the sample unit, calculated in section 5.3 of this appendix, in kWh/year.

750 and 0.001 as defined previously in this section.

0.2 = weighting factor for the 95 °F dry-bulb outdoor temperature operating condition.

0.8 = weighting factor for the 83 °F dry-bulb outdoor temperature operating condition.”

#### VII. Additional Justification for Interim Waiver Application

##### a. There Is a Strong Likelihood That the Waiver Will Be Granted

This Petition provides strong evidence that the Waiver will be granted. A Waiver is appropriate because the current test procedure does not accurately reflect the energy efficiency of models with VSCs since it tests only in the full load condition at two test points. These compressors can vary the rotational speed based upon the difference in unit set-point and the ambient temperature of the conditioned space, and will optimize the energy usage based on these conditions that can result in a greater compressor speed at less load. A PAC without a VSC cannot operate in this fashion as the compressor is either on at full capacity or off. The test procedure in the waiver granted to LG published on June 2, 2020, will account for energy being used at different test conditions with some modification for Midea’s units.

Additionally, the current test procedure does not account for Midea’s unique combined-duct technology that requires special provisions to measure the inlet and outlet condenser airflow

and measure the duct heat transfer. Midea has also demonstrated that its approach is consistent with waivers granted by DOE to other manufacturers with VSC technology.

##### b. Economic Hardship Would Be Caused by Denial of an Interim Waiver

In the absence of an Interim Waiver, Midea will lack certainty as to whether it can launch these combined-duct PACs with VSCs. Midea believes there will be strong consumer demand for these PACs, and the inability to market due to the denial of an Interim Waiver will cause economic hardship and competitive disadvantage to Midea. This is because there are exceptionally long lead times and significant expenses associated with the design and manufacturer of PACs. Compliance with energy consumption standards is a critical design factor for all of Midea’s PACs. Any delay in obtaining clarity on this issue will force Midea to postpone key decisions regarding its investments to build, launch and market these PACs. In the event that this Interim Waiver is not approved, Midea would not be able to move forward with the launch of these models, resulting in a multi-million-dollar impact to the company and would require costly contingency plans and put us at a competitive disadvantage to competitors.

### C. Sound Public Policy Supports Grant of the Interim Waiver

The grant of an Interim Waiver is also supported by sound public policy. The models for which an interim waiver is sought utilize technological advances that increase energy efficiency, reduce energy consumption, lower costs for consumers, and provide enhanced comfort.

### Conclusion

Midea respectfully requests that DOE grant this Petition for Waiver and Application for Interim Waiver. By granting this Waiver, DOE will ensure that consumers will have access to new, innovative and energy efficient combined-duct PACs with and without VSCs.

Respectfully submitted,

/s/

Scott Blake Harris

John Hodges

Harris, Wiltshire & Grannis LLP, 1919 M Street NW, Washington, DC 20036, Counsel for GD Midea Air Conditioning Equipment Co. LTD.

[FR Doc. 2021-07025 Filed 4-5-21; 8:45 am]

**BILLING CODE 6450-01-P**

## DEPARTMENT OF ENERGY

### Federal Energy Regulatory Commission

#### Notice of Waiver Period for Water Quality Certification Application

	Project No.
Eagle Creek Hydro Power, LLC .....	10482-122
Eagle Creek Water Resources, LLC	
Eagle Creek Land Resources, LLC	
Eagle Creek Hydro Power, LLC .....	10481-069
Eagle Creek Water Resources, LLC	
Eagle Creek Land Resources, LLC	
Eagle Creek Hydro Power, LLC .....	9690-115
Eagle Creek Water Resources, LLC	
Eagle Creek Land Resources, LLC	

On March 30, 2021, Eagle Creek Hydro Power, LLC, Eagle Creek Water Resources, LLC, and Eagle Creek Land Resources, LLC (co-licensees) submitted to the Federal Energy Regulatory Commission a copy of their application for a Clean Water Act section 401(a)(1) water quality certification filed with the New York State Department of Environmental Conservation (New York DEC), in conjunction with the above captioned projects. Pursuant to 40 CFR 121.6, we hereby notify the New York DEC of the following:

*Date of Receipt of the Certification Request:* March 30, 2021.

*Reasonable Period of Time to Act on the Certification Request:* One year.

*Date Waiver Occurs for Failure to Act:* March 30, 2022.

If the New York DEC fails or refuses to act on the water quality certification request by the above waiver date, then the agency's certifying authority is deemed waived pursuant to section 401(a)(1) of the Clean Water Act, 33 U.S.C. 1341(a)(1).

Dated: March 31, 2021.

**Kimberly D. Bose,**

Secretary.

[FR Doc. 2021-07076 Filed 4-5-21; 8:45 am]

**BILLING CODE P**

## DEPARTMENT OF ENERGY

### Federal Energy Regulatory Commission

#### Combined Notice of Filings #1

Take notice that the Commission received the following electric rate filings:

*Docket Numbers:* ER15-705-008.

*Applicants:* Pacific Gas and Electric Company.

*Description:* Compliance filing: Compliance filing CCSF IA and TFAs Following Order on Compliance (TO SA 284) to be effective 7/23/2015.

*Filed Date:* 3/30/21.

*Accession Number:* 20210330-5158

*Comments Due:* 5 p.m. ET 4/20/21.

*Docket Numbers:* ER15-705-009.

*Applicants:* Pacific Gas and Electric Company.

*Description:* Compliance filing: Compliance filing CCSF IA and TFAs Following Order on Compliance (TO SA 284) to be effective 7/1/2015.

*Filed Date:* 3/30/21.

*Accession Number:* 20210330-5159.

*Comments Due:* 5 p.m. ET 4/20/21.

*Docket Numbers:* ER15-2013-010; ER12-2510-009; ER15-2014-005; ER10-2435-016; ER10-2440-012; ER10-2442-014; ER12-2512-009; ER19-481-002; ER15-2018-005; ER18-2252-001; ER10-3286-013; ER15-2022-005; ER10-3299-012; ER10-2444-016; ER10-2446-012; ER15-2026-005; ER15-2020-008; ER10-2449-014; ER19-2250-002.

*Applicants:* Talen Energy Marketing, LLC, Brandon Shores LLC, Brunner Island, LLC, Camden Plant Holding, L.L.C., Dartmouth Power Associates Limited Partnership, Elmwood Park Power, LLC, H.A. Wagner LLC, LMBE Project Company LLC, Martins Creek, LLC, MC Project Company LLC, Millennium Power Partners, LP, Montour, LLC, New Athens Generating Company, LLC, Newark Bay Cogeneration Partnership, L.P,

Pedricktown Cogeneration Company LP, Susquehanna Nuclear, LLC, Talen Montana, LLC, York Generation Company LLC, TrailStone Energy Marketing, LLC.

*Description:* Supplement to April 27, 2020 Notification of Change in Status of the Indicated MBR Sellers.

*Filed Date:* 3/29/21.

*Accession Number:* 20210329-5273.

*Comments Due:* 5 p.m. ET 4/19/21.

*Docket Numbers:* ER21-772-000.

*Applicants:* Resi Station, LLC.

*Description:* Response to February 24, 2021 Deficiency Letter of Resi Station, LLC.

*Filed Date:* 3/26/21.

*Accession Number:* 20210326-5228.

*Comments Due:* 5 p.m. ET 4/16/21.

*Docket Numbers:* ER21-787-001.

*Applicants:* ISO New England Inc.

*Description:* Tariff Amendment: ISO New England Inc.; Response to Commission Deficiency Notice; ER21-787-000 to be effective 5/29/2021.

*Filed Date:* 3/30/21.

*Accession Number:* 20210330-5269.

*Comments Due:* 5 p.m. ET 4/20/21.

*Docket Numbers:* ER21-1553-000.

*Applicants:* Luna Storage, LLC.

*Description:* § 205(d) Rate Filing: Luna Storage, LLC MISA Certificate of Concurrence to be effective 3/31/2021.

*Filed Date:* 3/30/21.

*Accession Number:* 20210330-5002.

*Comments Due:* 5 p.m. ET 4/20/21.

*Docket Numbers:* ER21-1554-000.

*Applicants:* Luna Storage, LLC.

*Description:* § 205(d) Rate Filing: Luna Storage, LLC LGIA Certificate of Concurrence to be effective 3/31/2021.

*Filed Date:* 3/30/21.

*Accession Number:* 20210330-5003.

*Comments Due:* 5 p.m. ET 4/20/21.

*Docket Numbers:* ER21-1555-000.

*Applicants:* New Mexico Wind, LLC.

*Description:* Baseline eTariff Filing: Reactive Power Compensation Filing to be effective 3/31/2021.

*Filed Date:* 3/30/21.

*Accession Number:* 20210330-5004.

*Comments Due:* 5 p.m. ET 4/20/21.

*Docket Numbers:* ER21-1556-000.

*Applicants:* TGE Pennsylvania 202, LLC, TGE Pennsylvania 203, LLC.

*Description:* Petition for Waiver, et al. of TGE Pennsylvania 202, LLC, et al.

*Filed Date:* 3/29/21.

*Accession Number:* 20210329-5316.

*Comments Due:* 5 p.m. ET 4/8/21.

*Docket Numbers:* ER21-1557-000.

*Applicants:* Leeward Renewable Energy, LLC.

*Description:* Petition for Limited Waiver, et al. of Leeward Renewable Energy, LLC.

*Filed Date:* 3/29/21.