

Rules and Regulations

Federal Register

Vol. 82, No. 90

Thursday, May 11, 2017

This section of the FEDERAL REGISTER contains regulatory documents having general applicability and legal effect, most of which are keyed to and codified in the Code of Federal Regulations, which is published under 50 titles pursuant to 44 U.S.C. 1510.

The Code of Federal Regulations is sold by the Superintendent of Documents.

DEPARTMENT OF TRANSPORTATION

Federal Aviation Administration

14 CFR Part 39

[Docket No. FAA-2016-6651; Directorate Identifier 2016-SW-015-AD; Amendment 39-18867; AD 2017-09-05]

RIN 2120-AA64

Airworthiness Directives; Airbus Helicopters

AGENCY: Federal Aviation Administration (FAA), Department of Transportation (DOT).

ACTION: Final rule; request for comments.

SUMMARY: We are adopting a new airworthiness directive (AD) for Airbus Helicopters Model AS332C, AS332C1, AS332L, AS332L1, AS332L2, and EC225LP helicopters. This AD requires repetitively checking screws in the emergency flotation gear. This AD is prompted by a report that a screw ruptured on a Model AS332 helicopter's emergency flotation gear. These actions are intended to correct an unsafe condition on these products.

DATES: This AD becomes effective May 26, 2017.

We must receive comments on this AD by July 10, 2017.

ADDRESSES: You may send comments by any of the following methods:

- *Federal eRulemaking Docket:* Go to <http://www.regulations.gov>. Follow the online instructions for sending your comments electronically.
- *Fax:* 202-493-2251.
- *Mail:* Send comments to the U.S. Department of Transportation, Docket Operations, M-30, West Building Ground Floor, Room W12-140, 1200 New Jersey Avenue SE., Washington, DC 20590-0001.

- *Hand Delivery:* Deliver to the "Mail" address between 9 a.m. and 5 p.m., Monday through Friday, except Federal holidays.

Examining the AD Docket

You may examine the AD docket on the Internet at <http://www.regulations.gov> by searching for and locating Docket No. FAA-2016-6651; or in person at the Docket Operations Office between 9 a.m. and 5 p.m., Monday through Friday, except Federal holidays. The AD docket contains this AD, the European Aviation Safety Agency (EASA) AD, the economic evaluation, any comments received, and other information. The street address for the Docket Operations Office (telephone 800-647-5527) is in the **ADDRESSES** section. Comments will be available in the AD docket shortly after receipt.

For service information identified in this final rule, contact Airbus Helicopters, 2701 N. Forum Drive, Grand Prairie, TX 75052; telephone (972) 641-0000 or (800) 232-0323; fax (972) 641-3775; or at <http://www.airbushelicopters.com/techpub>. You may review the referenced service information at the FAA, Office of the Regional Counsel, Southwest Region, 10101 Hillwood Pkwy, Room 6N-321, Fort Worth, TX 76177.

FOR FURTHER INFORMATION CONTACT: Matt Fuller, Senior Aviation Safety Engineer, Safety Management Group, Rotorcraft Directorate, FAA, 10101 Hillwood Pkwy., Fort Worth, TX 76177; telephone (817) 222-5110; email matthew.fuller@faa.gov.

SUPPLEMENTARY INFORMATION:

Comments Invited

This AD is a final rule that involves requirements affecting flight safety, and we did not provide you with notice and an opportunity to provide your comments prior to it becoming effective. However, we invite you to participate in this rulemaking by submitting written comments, data, or views. We also invite comments relating to the economic, environmental, energy, or federalism impacts that resulted from adopting this AD. The most helpful comments reference a specific portion of the AD, explain the reason for any recommended change, and include supporting data. To ensure the docket does not contain duplicate comments, commenters should send only one copy of written comments, or if comments are filed electronically, commenters should submit them only one time. We will file in the docket all comments that we

receive, as well as a report summarizing each substantive public contact with FAA personnel concerning this rulemaking during the comment period. We will consider all the comments we receive and may conduct additional rulemaking based on those comments.

Discussion

EASA, which is the Technical Agent for the Member States of the European Union, has issued EASA Emergency AD No. 2015-0239-E, dated December 18, 2015, to correct an unsafe condition for Airbus Helicopters Model AS 332 C, AS 332 C1, AS 332 L, AS 332 L1, AS 332 L2, and EC 225 LP helicopters with emergency flotation gear. EASA advises that a screw ruptured on the rear upper fitting on the left-hand (LH) emergency flotation gear of an AS332 helicopter. EASA states that this condition, if not detected and corrected, could result in the failure of an emergency flotation system when ditching and unstable floating of the helicopter, possibly resulting in injury to the occupants. EASA consequently requires repetitive inspections of the lower attachment screws of rear upper fitting on the rear LH and right-hand (RH) emergency flotation gears. According to EASA, the root cause of the failure has not yet been identified.

FAA's Determination

These helicopters have been approved by the aviation authority of France and are approved for operation in the United States. Pursuant to our bilateral agreement with France, EASA, its technical representative, has notified us of the unsafe condition described in the EASA AD. We are issuing this AD because we evaluated all information provided by EASA and determined the unsafe condition exists and is likely to exist or develop on other helicopters of these same type designs.

Related Service Information

We have reviewed Airbus Helicopters Emergency Alert Service Bulletin (EASB) No. 05.01.06, Revision 0, dated December 18, 2015, for Model AS332C, AS332C1, AS332L, AS332L1, and AS332L2 helicopters and for military Model AS332B, AS332B1, AS332F1, AS332M, and AS332M1 helicopters, and EASB No. 05A047, Revision 0, dated December 18, 2015, for Model EC225LP helicopters. This service information specifies repetitively

inspecting the lower screws of the rear upper fitting on the rear LH and RH emergency floating gears for the presence of the heads and stressing the screw heads using a tool to make sure that the screw head does not move. If all screw heads are present, the service information requires no further action. If at least one screw head is missing or moves, the service information specifies replacing the two lower screws and the upper screw and informing Airbus Helicopters.

AD Requirements

This AD requires, within 15 hours time-in-service (TIS) and thereafter before each flight over water, visually checking the rear upper fittings of the LH and RH emergency flotation gears for the presence of screw heads and looseness. An owner/operator (pilot) may perform the required visual check and must enter compliance with the applicable paragraph of the AD into the helicopter maintenance records in accordance with 14 CFR 43.9(a)(1) through (4) and 91.417(a)(2)(v). A pilot may perform this check because it involves visually checking the rear upper fittings of the LH and RH emergency flotation gears for the presence of screw heads and twisting the screws by hand, which can be performed equally well by a pilot or a mechanic. This check is an exception to our standard maintenance regulations. If any screw heads are missing, loose, or twist off with hand pressure, this AD requires replacing all screws in the fitting before the next flight over water.

Differences Between This AD and the EASA AD

The EASA AD allows using tools for the inspection, while this AD requires checking by hand. The EASA AD requires that repetitive inspections occur at intervals not to exceed 15 hours TIS, while this AD requires the repetitive checks before each flight over water. The EASA AD requires contacting Airbus Helicopters if a screw is missing or loose, while this AD does not.

Interim Action

We consider this AD interim action. The design approval holder is currently investigating the root cause for this unsafe condition and may develop a modification that will address this unsafe condition. If this modification is developed, approved and available, we might consider additional rulemaking.

Costs of Compliance

We estimate that this AD affects 24 helicopters of U.S. Registry and that

labor costs average \$85 per work-hour. Based on these estimates, we expect the following costs:

- Checking the screws requires about 1/10 of a work-hour and no parts are needed, for a cost of \$9 per helicopter and \$216 for the U.S. fleet.
- Replacing the screws requires 8 work-hours for a labor cost of \$680. Parts cost \$150 for a total cost of \$830 per helicopter.

FAA's Justification and Determination of the Effective Date

Providing an opportunity for public comments prior to adopting these AD requirements would delay implementing the safety actions needed to correct this known unsafe condition. Therefore, we find that the risk to the flying public justifies waiving notice and comment prior to the adoption of this rule because the required corrective actions must be accomplished within 15 hours TIS.

Since an unsafe condition exists that requires the immediate adoption of this AD, we determined that notice and opportunity for public comment before issuing this AD are impracticable and that good cause exists for making this amendment effective in less than 30 days.

Authority for This Rulemaking

Title 49 of the United States Code specifies the FAA's authority to issue rules on aviation safety. Subtitle I, section 106, describes the authority of the FAA Administrator. "Subtitle VII: Aviation Programs," describes in more detail the scope of the Agency's authority.

We are issuing this rulemaking under the authority described in "Subtitle VII, Part A, Subpart III, Section 44701: General requirements." Under that section, Congress charges the FAA with promoting safe flight of civil aircraft in air commerce by prescribing regulations for practices, methods, and procedures the Administrator finds necessary for safety in air commerce. This regulation is within the scope of that authority because it addresses an unsafe condition that is likely to exist or develop on products identified in this rulemaking action.

Regulatory Findings

We determined that this AD will not have federalism implications under Executive Order 13132. This AD will not have a substantial direct effect on the States, on the relationship between the national Government and the States, or on the distribution of power and responsibilities among the various levels of government.

For the reasons discussed, I certify that this AD:

1. Is not a "significant regulatory action" under Executive Order 12866;
2. Is not a "significant rule" under DOT Regulatory Policies and Procedures (44 FR 11034, February 26, 1979);
3. Will not affect intrastate aviation in Alaska to the extent that it justifies making a regulatory distinction; and
4. Will not have a significant economic impact, positive or negative, on a substantial number of small entities under the criteria of the Regulatory Flexibility Act.

We prepared an economic evaluation of the estimated costs to comply with this AD and placed it in the AD docket.

List of Subjects in 14 CFR Part 39

Air transportation, Aircraft, Aviation safety, Incorporation by reference, Safety.

Adoption of the Amendment

Accordingly, under the authority delegated to me by the Administrator, the FAA amends 14 CFR part 39 as follows:

PART 39—AIRWORTHINESS DIRECTIVES

- 1. The authority citation for part 39 continues to read as follows:

Authority: 49 U.S.C. 106(g), 40113, 44701.

§ 39.13 [Amended]

- 2. The FAA amends § 39.13 by adding the following new airworthiness directive (AD):

2017-09-05 Airbus Helicopters:

Amendment 39-18867; Docket No. FAA-2016-6651; Directorate Identifier 2016-SW-015-AD.

(a) Applicability

This AD applies to Airbus Helicopters Model AS332C, AS332C1, AS332L, AS332L1, AS332L2, and EC225LP helicopters with emergency flotation gear installed, certificated in any category.

(b) Unsafe Condition

This AD defines the unsafe condition as failure of a rear upper screw fitting on the emergency flotation gear. This condition, if not detected and corrected, could result in failure of the emergency flotation system and subsequent capsizing of the helicopter.

(c) Effective Date

This AD becomes effective May 26, 2017.

(d) Compliance

You are responsible for performing each action required by this AD within the specified compliance time unless it has already been accomplished prior to that time.

(e) Required Actions

Within 15 hours time-in-service, and before each flight over water thereafter:

(1) Visually check each emergency flotation gear left hand and right hand rear upper fitting to determine whether the heads of the lower screws are present. Figure 1 to paragraph (e)(1) of this AD depicts where the lower three screws (noted as B and E) are located. Check each screw for looseness by

determining whether it can be rotated by hand. The actions required by paragraph (e)(1) of this AD may be performed by the owner/operator (pilot) holding at least a private pilot certificate and must be entered into the aircraft records showing compliance with this AD in accordance with Title 14

Code of Federal Regulations (14CFR) §§ 43.9(a)(1)–(4) and 14 CFR 91.417(a)(2)(v). The record must be maintained as required by 14 CFR 91.417, 121.380, or 135.439.

BILLING CODE 4910-13-P

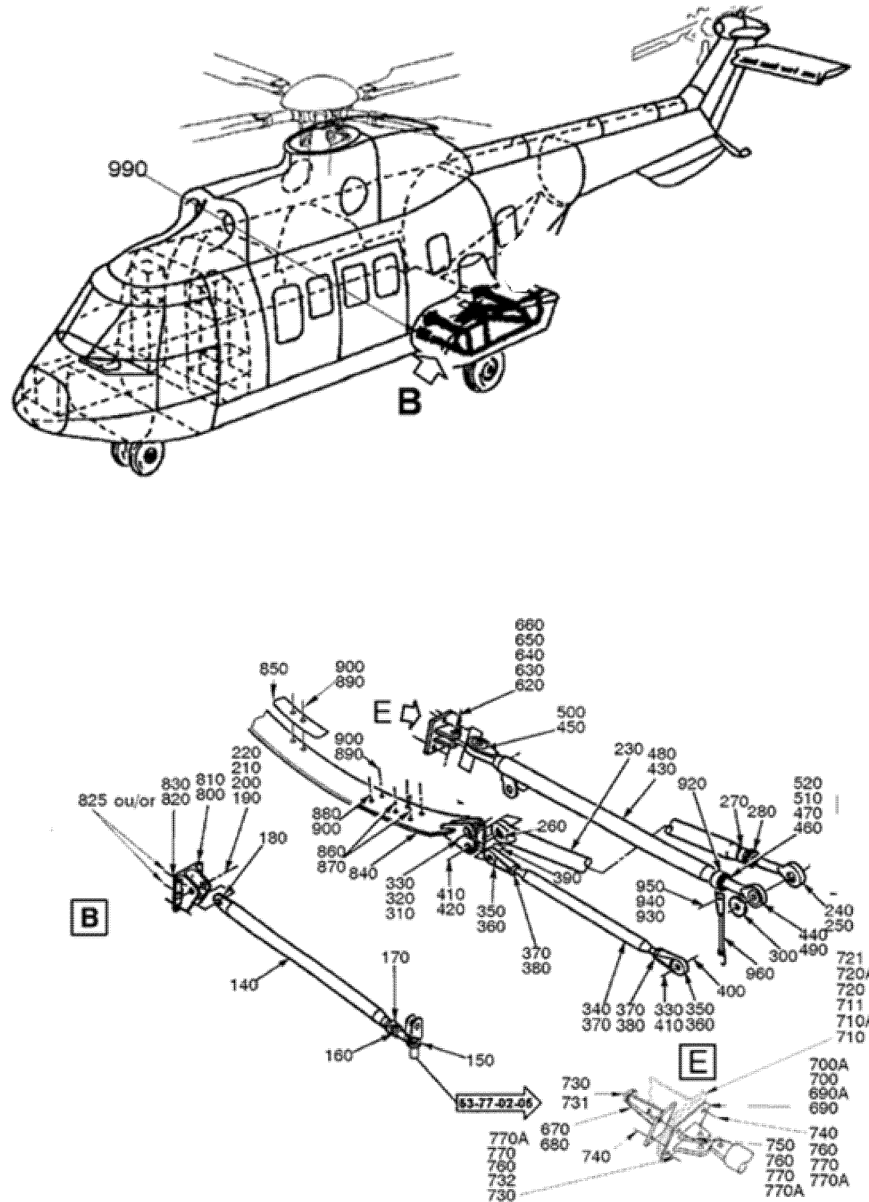

Figure 1 to Paragraph (e)(1) of this AD

(2) If a screw head is missing or if a screw is loose, before further flight over water, replace all screws in the fitting. Replacing the screws is not a terminating action for the repetitive checks required by this AD.

(f) Special Flight Permits

Special flight permits are prohibited for flight over water.

(g) Alternative Methods of Compliance (AMOCs)

(1) The Manager, Safety Management Group, FAA, may approve AMOCs for this AD. Send your proposal to: Matt Fuller, Senior Aviation Safety Engineer, Safety Management Group, Rotorcraft Directorate, FAA, 10101 Hillwood Pkwy., Fort Worth, TX 76177; telephone (817) 222-5110; email 9-ASW-FTW-AMOC-Requests@faa.gov.

(2) For operations conducted under a 14 CFR part 119 operating certificate or under 14 CFR part 91, subpart K, we suggest that you notify your principal inspector, or lacking a principal inspector, the manager of the local flight standards district office or certificate holding district office, before operating any aircraft complying with this AD through an AMOC.

(h) Additional Information

(1) Airbus Helicopters Emergency Alert Service Bulletin No. 05.01.06, and Airbus Helicopters Emergency Alert Service Bulletin No. 05A047, both Revision 0, and both dated December 18, 2015, which are not incorporated by reference, contain additional information about the subject of this AD. For service information identified in this AD, contact Airbus Helicopters, 2701 N. Forum Drive, Grand Prairie, TX 75052; telephone (972) 641-0000 or (800) 232-0323; fax (972) 641-3775; or at <http://www.airbushelicopters.com/techpub>. You may review a copy of the service information at the FAA, Office of the Regional Counsel, Southwest Region, 10101 Hillwood Pkwy., Room 6N-321, Fort Worth, TX 76177.

(2) The subject of this AD is addressed in European Aviation Safety Agency (EASA) Emergency AD No. 2015-0239-E, dated December 18, 2015. You may view the EASA AD on the Internet at <http://www.regulations.gov> by searching for and locating it in Docket No. FAA-2016-6651.

(i) Subject

Joint Aircraft Service Component (JASC) Code: 3212, Emergency Flotation Section.

Issued in Fort Worth, Texas, on April 24, 2017.

Scott A. Horn,

Acting Manager, Rotorcraft Directorate, Aircraft Certification Service.

[FR Doc. 2017-09376 Filed 5-10-17; 8:45 am]

BILLING CODE 4910-13-P

DEPARTMENT OF LABOR

Employment and Training Administration

20 CFR Part 620

RIN 1205-AB63

Federal State Unemployment Compensation Program; Middle Class Tax Relief and Job Creation Act of 2012 Provision on Establishing Appropriate Occupations for Drug Testing of Unemployment Compensation Applicants

AGENCY: Employment and Training Administration, Labor.

ACTION: Final rule; CRA Revocation.

SUMMARY: Under the Congressional Review Act, Congress has passed, and the President has signed a public law disapproving the Employment and Training Administration's (ETA's) final rule establishing appropriate occupations for State drug testing of unemployment compensation claimants. ETA published the final rule on August 1, 2016, and the rule became effective on September 30, 2016. Because the public law invalidates the rule, ETA is hereby removing it from the Code of Federal Regulations.

DATES: This final rule is effective May 11, 2017.

FOR FURTHER INFORMATION CONTACT:

Adele Gagliardi, Administrator, Office of Policy Development and Research, Employment and Training Administration, U.S. Department of Labor, 200 Constitution Ave. NW., Suite N-5641, Washington, DC 20210, or by phone at 202-693-3700.

SUPPLEMENTARY INFORMATION: On August 1, 2016, ETA issued a final rule in accordance with Section 2105 of the Middle Class Tax Relief and Job Creation Act of 2012, Public Law 112-96 (2012), titled Federal-State Unemployment Compensation Program; Middle Class Tax Relief and Job Creation Act of 2012 Provision on Establishing Appropriate Occupations for Drug Testing of Unemployment Compensation Applicants (20 CFR part 620) (81 FR 50298). The final rule became effective on September 30, 2016. On February 15, 2017, the United States House of Representatives passed a resolution of disapproval (H.J. Res. 42) under the Congressional Review Act (5 U.S.C. 801 *et seq.*). The United States Senate passed H.J. Res. 42 on March 14, 2017. President Donald J. Trump signed the resolution into law as Public Law 115-17 on March 31, 2017. Accordingly, ETA is hereby removing the rule from the Code of Federal Regulations.

List of Subjects in 20 CFR Part 620

Unemployment compensation.

Signed at Washington, DC

Byron Zuidema,

Deputy Assistant Secretary for Employment and Training.

For the reasons discussed in the preamble, and under the authority of the Congressional Review Act (5 U.S.C. 801 *et seq.*) and Public Law 115-17 (March 31, 2017), the ETA amends 20 CFR chapter V as follows:

PART 620—[Removed]

■ 1. Remove part 620.

[FR Doc. 2017-09374 Filed 5-10-17; 8:45 am]

BILLING CODE 4510-30-P

DEPARTMENT OF HOMELAND SECURITY

Coast Guard

33 CFR Part 117

[Docket No. USCG-2017-0161]

Drawbridge Operation Regulation; Canaveral Barge Canal, Canaveral, FL

AGENCY: Coast Guard, DHS.

ACTION: Notice of deviation from drawbridge regulation with request for comments; modification.

SUMMARY: The Coast Guard has modified a temporary deviation from the operating schedule that governs the SR 401 Drawbridge, mile 5.5 at Port Canaveral, Florida. This modified deviation is necessary to reduce vehicular traffic congestion and to ensure the safety of the roadways while passengers are transiting to and from Cruise Terminal 10, which is used by Norwegian Cruise Line at Port Canaveral. Since the arrival of the cruise ship Norwegian Epic to the Port of Canaveral, massive traffic back-ups have been caused by the drawbridge openings. This modified deviation allows the bridge to not open to navigation during prime cruise ship passenger loading and unloading times on Saturdays and Sundays.

DATES: This modified deviation is effective without actual notice from May 11, 2017 until October 23, 2017. Submit comments by June 26, 2017.

ADDRESSES: The docket for this deviation, [USCG-2017-0161] is available at <http://www.regulations.gov>. Type the docket number in the "SEARCH" box and click "SEARCH". Click on Open Docket Folder on the line associated with this deviation.