

repaired in accordance with Sikorsky Overhaul and Repair Instruction (ORI) No. 76350-065, Revision A through Revision E, certificated in any category.

**(b) Unsafe Condition**

This AD defines the unsafe condition as an unsecured MGB lower housing jet bore liner. This condition may cause the liner to move out of place, allowing oil to leak from the MGB, resulting in MGB failure and subsequent loss of control of the helicopter.

**(c) Comments Due Date**

We must receive comments by August 1, 2014.

**(d) Compliance**

You are responsible for performing each action required by this AD within the specified compliance time unless it has already been accomplished prior to that time.

**(e) Required Action**

(1) Within 50 hours time-in-service (TIS), and thereafter at intervals not to exceed 6 hours TIS, inspect each MGB lower housing jet bore (jet bore), as depicted in Figures 3 and 4 of Sikorsky S-76 Alert Service Bulletin 76-66-50, Basic Issue, dated January 14, 2013 (ASB 76-66-50), for liner protrusion or movement, paint or caulk blistering, or oil leakage.

(i) If there is any liner protrusion or movement, before further flight, replace the MGB with an MGB that has not been repaired in accordance with Sikorsky ORI No. 76350-065, Revision A through Revision E, unless it has been subsequently repaired in accordance with Sikorsky ORI No. 76350-065, Revision F, dated May 10, 2012.

(ii) If there is any oil leakage or paint or caulk blistering, inspect the jet bore for liner protrusion and perform a leakage check by following the Accomplishment Instructions, Paragraphs 3.C.(1) through 3.C.(6)(a), of ASB 76-66-50.

(iii) If any moisture or droplets of MGB oil are visible on a jet bore after accomplishing the leakage check specified in paragraph 3.C.(6)(a) of ASB 76-66-50, repeat paragraphs 3.C.(4) through 3.C.(6) of ASB 76-66-50. If any moisture or droplets of MGB oil are still visible, before further flight, replace the MGB with an MGB that has not been repaired in accordance with Sikorsky ORI No. 76350-065, Revision A through Revision E, unless it has been subsequently repaired in accordance with Sikorsky ORI No. 76350-065, Revision F.

(2) Within 1500 hours TIS, replace the MGB with an MGB that has not been repaired in accordance with Sikorsky ORI No. 76350-065, Revision A through Revision E, unless it has been subsequently repaired in accordance with Sikorsky ORI No. 76350-065, Revision F. This is terminating action for the repetitive inspections required by this AD.

**(f) Alternative Methods of Compliance (AMOC)**

(1) The Manager, Boston Aircraft Certification Office, FAA, may approve AMOCs for this AD. Send your proposal to: Jeffrey Lee, Aviation Safety Engineer, Boston Aircraft Certification Office, Engine &

Propeller Directorate, 12 New England Executive Park, Burlington, Massachusetts 01803; telephone (781) 238-7161; email [jeffrey.lee@faa.gov](mailto:jeffrey.lee@faa.gov).

(2) For operations conducted under a 14 CFR part 119 operating certificate or under 14 CFR part 91, subpart K, we suggest that you notify your principal inspector, or lacking a principal inspector, the manager of the local flight standards district office or certificate holding district office before operating any aircraft complying with this AD through an AMOC.

**(h) Additional Information**

Sikorsky Overhaul and Repair Instruction No. 76350-065, Revision F, dated May 10, 2012, which is not incorporated by reference, contains additional information about the subject of this AD. You may review copies of information at the FAA, Office of the Regional Counsel, Southwest Region, 2601 Meacham Blvd., Room 663, Fort Worth, Texas 76137. For information on the availability of this material at the FAA, call (817) 222-5110.

**(i) Subject**

Joint Aircraft Service Component (JASC) Code: 6320: Main Rotor Gearbox.

Issued in Fort Worth, Texas, on May 21, 2014.

**Lance T. Gant,**

*Acting Directorate Manager, Rotorcraft Directorate, Aircraft Certification Service.*

[FR Doc. 2014-12738 Filed 5-30-14; 8:45 am]

**BILLING CODE 4910-13-P**

**DEPARTMENT OF TRANSPORTATION**

**Federal Aviation Administration**

**14 CFR Part 39**

**[Docket No. FAA-2014-0337; Directorate Identifier 2013-SW-029-AD]**

**RIN 2120-AA64**

**Airworthiness Directives; Various Restricted Category Helicopters**

**AGENCY:** Federal Aviation Administration (FAA), DOT.

**ACTION:** Notice of proposed rulemaking (NPRM).

**SUMMARY:** We propose to supersede airworthiness directive (AD) 2012-14-11 for Arrow Falcon Exporters, Inc. (AFE), Rotorcraft Development Corporation (RDC), and San Joaquin Helicopters (SJH) Model OH-58A, OH-58A+, and OH-58C helicopters. AD 2012-14-11 currently requires inspecting the main rotor mast (mast) for a crack. Since we issued AD 2012-14-11, we have determined that the area of the mast requiring inspection should be expanded and repetitive inspections of the mast should be accomplished. This proposed AD would expand the

area of the mast that requires an inspection for a crack and would require repetitive inspections of the mast. The proposed actions are intended to prevent failure of the mast and subsequent loss of control of the helicopter.

**DATES:** We must receive comments on this proposed AD by August 1, 2014.

**ADDRESSES:** You may send comments by any of the following methods:

- *Federal eRulemaking Docket:* Go to <http://www.regulations.gov>. Follow the online instructions for sending your comments electronically.

- *Fax:* 202-493-2251.

- *Mail:* Send comments to the U.S. Department of Transportation, Docket Operations, M-30, West Building Ground Floor, Room W12-140, 1200 New Jersey Avenue SE., Washington, DC 20590-0001.

- *Hand Delivery:* Deliver to the "Mail" address between 9 a.m. and 5 p.m., Monday through Friday, except Federal holidays.

**Examining the AD Docket**

You may examine the AD docket on the Internet at <http://www.regulations.gov> or in person at the Docket Operations Office between 9 a.m. and 5 p.m., Monday through Friday, except Federal holidays. The AD docket contains this proposed AD, the economic evaluation, any comments received and other information. The street address for the Docket Operations Office (telephone 800-647-5527) is in the **ADDRESSES** section. Comments will be available in the AD docket shortly after receipt.

**FOR FURTHER INFORMATION CONTACT:** John Cecil, Aviation Safety Engineer, Los Angeles Aircraft Certification Office, Transport Airplane Directorate, FAA, 3960 Paramount Blvd., Lakewood, CA 90712; telephone (562) 627-5228; email [john.cecil@faa.gov](mailto:john.cecil@faa.gov); or Roger Caldwell, Aerospace Engineer, Denver Aircraft Certification Office, FAA, 26805 East 68th Ave., Room 214, Denver, CO 80249; telephone (303) 342-1086; email [roger.caldwell@faa.gov](mailto:roger.caldwell@faa.gov).

**SUPPLEMENTARY INFORMATION:**

**Comments Invited**

We invite you to participate in this rulemaking by submitting written comments, data, or views. We also invite comments relating to the economic, environmental, energy, or federalism impacts that might result from adopting the proposals in this document. The most helpful comments reference a specific portion of the proposal, explain the reason for any recommended change, and include

supporting data. To ensure the docket does not contain duplicate comments, commenters should send only one copy of written comments, or if comments are filed electronically, commenters should submit only one time.

We will file in the docket all comments that we receive, as well as a report summarizing each substantive public contact with FAA personnel concerning this proposed rulemaking. Before acting on this proposal, we will consider all comments we receive on or before the closing date for comments. We will consider comments filed after the comment period has closed if it is possible to do so without incurring expense or delay. We may change this proposal in light of the comments we receive.

### Discussion

On July 5, 2012, we issued AD 2012–14–11, amendment 39–17125 (77 FR 42971, July 23, 2012) for AFE, RDC, and SJH Model OH–58A, OH–58A+, and OH–58C helicopters. AD 2012–14–11 requires overhauling the mast and performing magnetic particle, fluorescent penetrant, and visual inspections for a crack, pitting, or corrosion in the threaded area of the mast and associated parts. If there is a crack, pitting, or corrosion, AD 2012–14–11 requires replacing the mast with an airworthy mast and reporting any crack, pitting, or corrosion found during the inspections. AD 2012–14–11 was prompted by two mast failures, one on an OH–58A+ and one on an OH–58C helicopter, both used in agricultural spraying operations. Investigation revealed that the mast failures were caused by fatigue cracking, which initiated from corrosion pitting found in or adjacent to the threaded section of the mast approximately 45 inches from the top of the mast. The actions of AD 2012–14–11 were intended to prevent failure of the mast and subsequent loss of control of the helicopter.

### Comments

After we issued AD 2012–14–11, amendment 39–17125 (77 FR 42971, July 23, 2012), we received comments from two commenters.

### Request

RDC requested that we change the applicability of AD 2012–14–11, amendment 39–17125 (77 FR 42971, July 23, 2012), to include Bell Model 206A and 206B helicopters, stating that these models have an identical configuration and could be susceptible to the same corrosion and fatigue cracking as the OH–58. We do not agree. A number of hardware components on

the Bell Model 206A and 206B helicopter masts including the seals, packing, and shims are not identical to components used on the OH–58. These differences are sufficient to exclude the Bell Model 206A and 206B helicopters from the applicability of this AD.

RDC also requested that the use of Grade 1 corrosion preventative compound (CPC) be allowed as it provides better protection and more adequate sealing of the mast and locking plate, and it is used on similar structures on the Bell Model 206A and 206B helicopters. We agree with this comment. The proposed AD does not specify the use of any particular CPC, and therefore operators may comply using any compound and method as long as all work is done as prescribed in the manufacturer's maintenance manual or Instructions for Continued Airworthiness, or using other methods acceptable to the FAA.

RDC further recommended installing the lock bead over a seal of 8802 Type B (ProSeal) sealant and applying a bead on top of the joint to enhance seal properties and prevent corrosion. We agree with this comment. The proposed AD does not specify the use of any particular sealant or prohibit application of an extra bead of sealant. Operators may comply as long as all work is done as prescribed in the manufacturer's maintenance manual or Instructions for Continued Airworthiness, or using other methods acceptable to the FAA.

RDC also emphasized that keeping the mast support drain holes unobstructed and prohibiting pressure washing in the area around the support would minimize the amount of water intrusion inside the support around the mast seal area. We partially agree with this comment. While it is important to emphasize that the mast drain holes remain unobstructed and that pressure washing of the mast support area should be minimized, we do not agree that these concerns should be mandated by the proposed AD.

RDC further requested that the overhaul interval of the masts should be reduced from 2,400 hours time-in-service (TIS) to 1,200 hours TIS. We agree. The proposed AD includes a requirement to overhaul and inspect the mast at intervals not exceeding 1,200 hours TIS or 3 years, whichever occurs earlier.

The National Transportation Safety Board (NTSB) commented in support of the required inspection of the threaded area of the mast for a crack, pitting, or corrosion, but requested that the area adjacent to the threaded area (identified in AD 2012–14–11 as “area J”) be added

to the visual inspection requirements of the proposed AD. The NTSB states that a prior accident investigation revealed the mast had fractured in this section. We agree with this comment. Although AD 2012–14–11 does contain a requirement for magnetic particle inspecting the entire mast for a crack, we have included the expanded area in the visual inspection requirements in the proposed AD.

### Actions Since AD 2012–14–11 Was Issued

Since we issued AD 2012–14–11, amendment 39–17125 (77 FR 42971, July 23, 2012) we have determined that visually inspecting the area of the mast adjacent to the threaded portion should be included in the overhaul and that the inspection should be repetitive. We have also determined that reporting the findings of any inspection required by AD 2012–14–11 is unnecessary, and have removed this requirement from the proposed AD. Lastly, we have revised the order of the inspections so that removing any surface corrosion and performing the visual inspection are completed prior to the magnetic particle inspection.

### FAA's Determination

We are proposing this AD because we evaluated all the relevant information and determined the unsafe condition described previously is likely to exist or develop in other products of these same type designs.

### Related Service Information

AFE issued Alert Service Bulletin (ASB): 2012–58–01, Revision 1, dated February 20, 2012 (ASB 2012–58–01), which specifies overhauling and inspecting the mast for any cracks, pitting, or corrosion by following the procedures in the United States Army Aviation Unit and Intermediate Maintenance Manual TM55–1520–228–23. ASB 2012–58–01 further specifies replacing any mast with a crack, pitting, or corrosion beyond surface rust that is removed with a wire brush or steel wool in the threaded portion of the mast.

RDC has issued ASB No. OH–58–13–01, dated January 30, 2013 (OH–58–13–01), which describes additional procedures for inspecting the mast and establishes an overhaul interval of 1,200 hours TIS or 3 years, whichever occurs first.

### Proposed AD Requirements

This proposed AD would retain the mast inspection and overhaul requirements of AD 2012–14–11, amendment 39–17125 (77 FR 42971, July 23, 2012), and would:

- Change the compliance time for the inspection from within 30 days to within 90 days (unless accomplished previously within the last 12 months);
- Require repeating the inspection every 1,200 hours TIS or 3 years, whichever occurs earlier;
- Require inspecting, with a 10X or higher magnifying glass, the area adjacent to the threaded area of the mast for a crack or corrosion pitting; and
- Remove the reporting requirement of AD 2012–14–11.

#### Differences Between This AD and the Service Information

The service information does not apply to SJH helicopters. Those helicopters are included in this AD because they have the same mast design and are operated similarly to the AFE and RDC fleets.

#### Costs of Compliance

We estimate that this proposed AD would affect 80 helicopters of U.S. Registry, and that operators may incur the following costs in order to comply with this AD. At an average labor rate of \$85 per hour, inspecting the mast would require about 20 work hours, for a total cost of \$1,700 per helicopter, and a total cost to the U.S. operator fleet of \$136,000. Replacing a cracked main rotor mast would require about 20 work hours, and required parts would cost about \$11,891 for a total cost per helicopter of \$13,591.

#### Authority for This Rulemaking

Title 49 of the United States Code specifies the FAA's authority to issue rules on aviation safety. Subtitle I, section 106, describes the authority of the FAA Administrator. "Subtitle VII: Aviation Programs," describes in more detail the scope of the Agency's authority.

We are issuing this rulemaking under the authority described in "Subtitle VII, Part A, Subpart III, Section 44701: General requirements." Under that section, Congress charges the FAA with promoting safe flight of civil aircraft in air commerce by prescribing regulations for practices, methods, and procedures

the Administrator finds necessary for safety in air commerce. This proposed regulation is within the scope of that authority because it addresses an unsafe condition that is likely to exist or develop on products identified in this rulemaking action.

#### Regulatory Findings

We determined that this proposed AD would not have federalism implications under Executive Order 13132. This proposed AD would not have a substantial direct effect on the States, on the relationship between the national Government and the States, or on the distribution of power and responsibilities among the various levels of government.

For the reasons discussed, I certify this proposed regulation:

1. Is not a "significant regulatory action" under Executive Order 12866;
2. Is not a "significant rule" under the DOT Regulatory Policies and Procedures (44 FR 11034, February 26, 1979);
3. Will not affect intrastate aviation in Alaska to the extent that it justifies making a regulatory distinction; and
4. Will not have a significant economic impact, positive or negative, on a substantial number of small entities under the criteria of the Regulatory Flexibility Act.

We prepared an economic evaluation of the estimated costs to comply with this proposed AD and placed it in the AD docket.

#### List of Subjects in 14 CFR Part 39

Air transportation, Aircraft, Aviation safety, Incorporation by reference, Safety.

#### The Proposed Amendment

Accordingly, under the authority delegated to me by the Administrator, the FAA proposes to amend 14 CFR part 39 as follows:

#### PART 39—AIRWORTHINESS DIRECTIVES

- 1. The authority citation for part 39 continues to read as follows:

**Authority:** 49 U.S.C. 106(g), 40113, 44701.

#### § 39.13 [Amended]

- 2. The FAA amends § 39.13 by removing airworthiness directive (AD) 2012–14–11, Amendment 39–17125 (77 FR 42971, July 23, 2012), and adding the following new AD:

#### Various Restricted Category Helicopters:

Docket No. FAA–2014–0337; Directorate Identifier 2013–SW–029–AD.

#### (a) Applicability

This AD applies to Arrow Falcon Exporters, Inc. (AFE), Rotorcraft Development Corporation (RDC) (formerly Garlick Helicopter Corporation, and Garlick Helicopter, Inc.), and San Joaquin Helicopters (SJH) Model OH–58A, OH–58A+, and OH–58C helicopters, certificated in any category.

#### (b) Unsafe Condition

This AD defines the unsafe condition as a crack in the main rotor mast, which could result in failure of the mast and subsequent loss of control of the helicopter.

#### (c) Affected AD

This AD supersedes AD 2012–14–11, Amendment 39–17125 (77 FR 42971, July 23, 2012).

#### (d) Comments Due Date

We must receive comments by August 1, 2014.

#### (e) Compliance

You are responsible for performing each action required by this AD within the specified compliance time unless it has already been accomplished prior to that time.

#### (f) Required Actions

(1) Within 90 days, unless accomplished previously within the last 12 months, and thereafter at intervals not exceeding 1,200 hours TIS or 3 years, whichever occurs earlier:

- (i) Remove any surface rust with a wire brush or steel wool and, using a 10X or higher power magnifying glass, inspect the areas of the mast as shown in area E and area J of Figure 1 to Paragraph (f) of this AD for pitting, corrosion, or a crack.
- (ii) Overhaul the main rotor mast assembly and magnetic particle inspect the mast; mast bearing nut; plate, mast and seal; and bearing liner for a crack.
- (iii) Fluorescent penetrant inspect the locking plate for a crack.

Figure 1 to Paragraph (f)

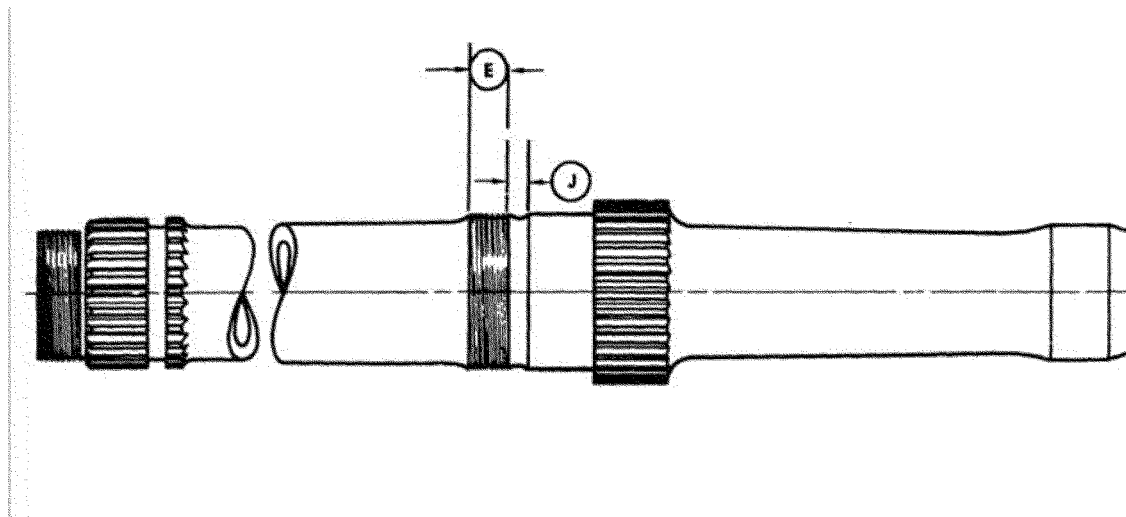

(2) If there is a crack, pitting, or corrosion, before further flight, replace the mast with an airworthy mast.

**(g) Alternative Methods of Compliance (AMOCs)**

(1) For AFE and SJH helicopters, the Manager, Los Angeles Aircraft Certification Office, FAA, may approve AMOCs for this AD. Send your proposal to: John Cecil, Aviation Safety Engineer, Los Angeles Aircraft Certification Office, Transport Airplane Directorate, FAA, 3960 Paramount Blvd., Lakewood, CA 90712; telephone (562) 627-5228; email [john.cecil@faa.gov](mailto:john.cecil@faa.gov).

(2) For RDC helicopters, the Manager, Denver Aircraft Certification Office, FAA, may approve AMOCs for this AD. Send your proposal to: Roger Caldwell, Aerospace Engineer, Denver Aircraft Certification Office, FAA, 26805 East 68th Ave., Room 214, Denver, CO 80249; telephone (303) 342-1086; email [roger.caldwell@faa.gov](mailto:roger.caldwell@faa.gov).

(3) For operations conducted under a 14 CFR part 119 operating certificate or under 14 CFR part 91, subpart K, we suggest that you notify your principal inspector, or lacking a principal inspector, the manager of the local flight standards district office or certificate holding district office before operating any aircraft complying with this AD through an AMOC.

**(h) Additional Information**

(1) Arrow Falcon Exporters, Inc., Alert Service Bulletin: 2012-58-01, Revision 1, dated February 20, 2012, which is not incorporated by reference, contains more information about the subject of this AD. For Arrow Falcon Exporters, Inc. service information identified in this AD, contact Arrow Falcon Exporters, Inc., 2081 South Wildcat Way, Porterville, CA 93257; telephone (559) 781-8604; fax (559) 781-9271; email [afe@arrowfalcon.com](mailto:afe@arrowfalcon.com).

(2) Rotorcraft Development Corporation Alert Service Bulletin No. OH58-13-01,

dated January 30, 2013, which is not incorporated by reference, contains more information about the subject of this AD. For Rotorcraft Development Corporation service information, contact Rotorcraft Development Corporation, PO Box 430, 1004 Eastside Highway, Corvallis, MT 59828; telephone (406) 961-4100; fax (406) 961-4101; or at <http://www.rotorcraftdevelopment.com>.

(3) United States Army Technical Manual Aviation Unit and Intermediate Maintenance Manual Army Model OH-58A and OH-58C Helicopters, TM 55-1520-228-23-1, which is not incorporated by reference, contains more information about the subject of this AD. For United States Army service information, contact Commander, U.S. Army Aviation and Missile Command, ATTN: AMSAM-MMA-NP, Redstone Arsenal, AL 35898-5000, telephone (256) 876-4044; or at <https://www.logsa.army.mil/etmpdf/files/030000/035016.pdf>.

(4) You may review the service information at the FAA, Office of the Regional Counsel, Southwest Region, 2601 Meacham Blvd., Room 663, Fort Worth, Texas 76137.

**(i) Subject**

Joint Aircraft Service Component (JASC)  
Code: 6300: Main Rotor Drive.

Issued in Fort Worth, Texas, on May 21, 2014.

**Lance T. Gant,**

*Acting Directorate Manager, Rotorcraft Directorate, Aircraft Certification Service.*

[FR Doc. 2014-12737 Filed 5-30-14; 8:45 am]

**BILLING CODE 4910-13-P**

**DEPARTMENT OF TRANSPORTATION**

**Federal Aviation Administration**

**14 CFR Part 71**

[Docket No. FAA-2013-0441; Airspace Docket No. 13-ASO-11]

**Proposed Establishment of Class E Airspace; Pine Knot, KY**

**AGENCY:** Federal Aviation Administration (FAA), DOT.

**ACTION:** Notice of proposed rulemaking (NPRM).

**SUMMARY:** This action proposes to establish Class E airspace at Pine Knot, KY, to accommodate a new Area Navigation (RNAV) Global Positioning System (GPS) Standard Instrument Approach Procedure (SIAP) serving McCreary County Airport. This action would enhance the safety and airspace management of Instrument Flight Rules (IFR) operations within the National Airspace System.

**DATES:** Comments must be received on or before July 17, 2014.

**ADDRESSES:** Send comments on this rule to: U.S. Department of Transportation, Docket Operations, West Building Ground Floor, Room W12-140, 1200 New Jersey, SE., Washington, DC 20590-0001; Telephone: 1-800-647-5527; Fax: 202-493-2251. You must identify the Docket Number FAA-2013-0441; Airspace Docket No. 13-ASO-11, at the beginning of your comments. You may also submit and review received comments through the Internet at <http://www.regulations.gov>.